

THE "FOUR-VALVE FAMILY" UP TO DATE. By P. W. HARRIS

Popular Wireless

Every Thursday
PRICE
3d.

No. 235. Vol. X.

Scientific Adviser : SIR OLIVER LODGE, F.R.S.

December 4th, 1926.

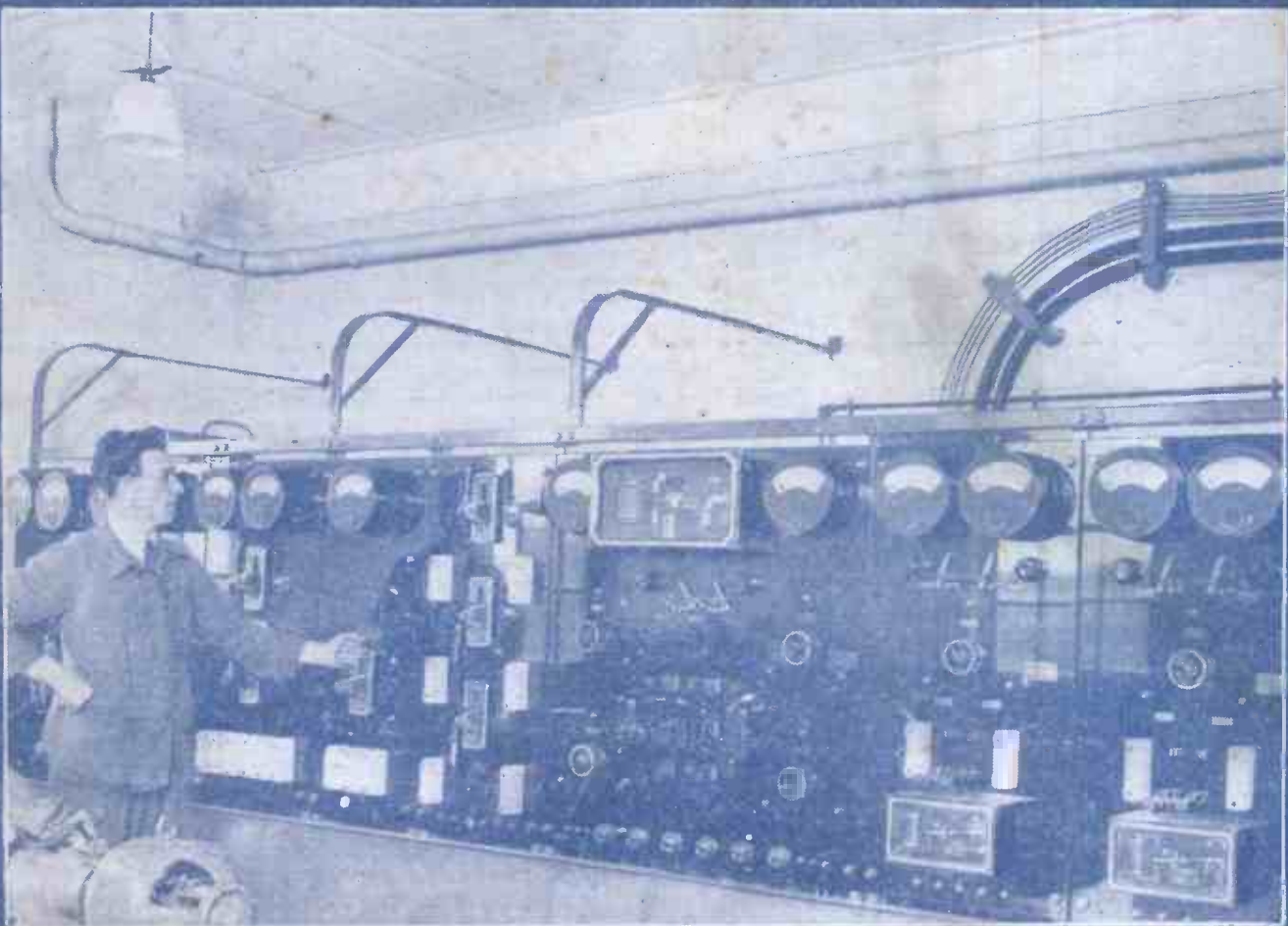

Special Features In This Issue

- | | |
|---|------------------------------|
| Local Interference in Crystal Reception | How to Read Circuit Diagrams |
| The Quest for the Cold Valve | Radio Indicators and Alarms |
| The Two-Plate Valve | Some Crystal Valve Circuits |
| Fitting a Separate Oscillator | The Range of a Station |
| And a special eight-page Supplement devoted to the interests of the constructor | |

Our cover photograph shows the main switchboard at the new G.P.O. wireless station at St. Albans.

In two sizes:
 .0003 mfd. ... 14/6
 .0005 mfd. ... 15/6
 Vernier Dial
 as illustrated
 4/6 extra.

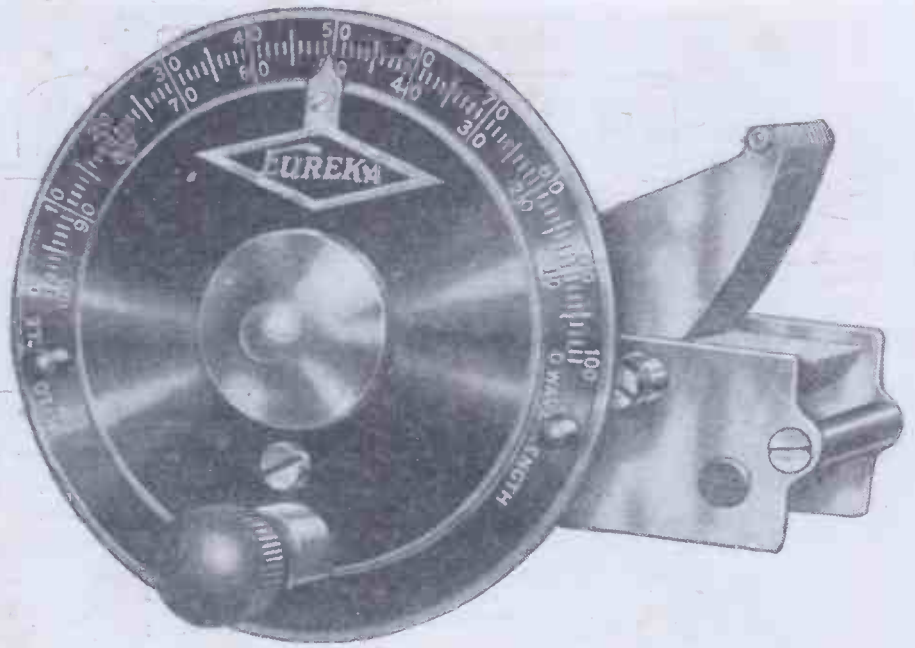

Is there anything so absurd?

—under the new Geneva plan the ordinary Condenser covers 39 Wavelengths between 0 and 10 on the dial, but only 2 wavelengths between 90° and 100°.

WITH Jazz Bands and Grand Opera almost inextricably intermixed in an overcrowded ether no wonder the new Geneva wavelength plan was necessary! What is this plan and how does it affect you?

Briefly, the Geneva plan is to apportion a share of the ether to all countries wishing to Broadcast. Not every country can obtain as many wavelengths as it requires. Great Britain receives nine exclusive wavelengths. But—and here is the great point to bear in mind—there is to be a separation of 10 kilocycles between each wavelength. Not 10 metres but 10 kilocycles. Metres have been ignored in these calculations. The Eureka Condenser also abandons metres and deals with kilocycles. It gives orthocyclic tuning. That is to say, it gives an even separation between wavelengths no matter where they may appear on the dial—crowding is impossible. With the Eureka Orthocyclic 10 degrees cover 10 wavelengths precisely—

no more, no less. From end to end of the dial therefore 100 wavelengths each of 10 kilocycles separation are covered.

But compare this new standard of performance with the ordinary condenser. From 0 to 10—bearing in mind of course, that all other conditions are unaltered—the ordinary condenser covers 39 wavelengths. Practically 4 wavelengths to every degree on the dial, while at the opposite end of the scale the last ten degrees will barely span 2 wavelengths.

How absurd! Such a jostling of stations just where we need the most effective separation.

The new conditions of Broadcasting demand the use of a Eureka Orthocyclic with its even separation, step by step, all the way up the scale.

Instal these magnificent Condensers on your Set now and enjoy real selectivity. The velvety smooth Vernier dial—all metal and therefore a perfect shield—is a pleasure to use. Because gears are eliminated, backlash is impossible, while the superb workmanship of the whole instrument will improve the appearance of any Receiver. Order them from your Dealer without delay.

**The Eureka
gives you real
selectivity**

EUREKA CONDENSER

ORTHOCYCLIC

MARCONI THE NEW POWER VALVE D.E.P. 215



PRICE
18/6

The Marconi International Marine Communication Co., Ltd., require 500 qualified Wireless Operators. Apply to Service Manager, Marconi House, Strand, London, W.C.2

Write for the Marconi Valve Literature—containing detailed particulars of the D.E.P. 215 and other types.

MARCONI POWER VALVE TYPE D.E.P. 215

for 2-Volt Accumulators

Fil. volts 2.0 max.
Fil. current 0.15 amps.
Anode volts 120 max.
Amplification factor 6.25
Impedance 6250 ohms



AN ENTIRELY NEW type of Dull Emitter Power Valve combining outstanding performance with economy in operation.

The D.E.P. 215 is for use in the last stages of Receiver or Amplifiers operating from a two-volt accumulator.

It embodies just those characteristics which combine to make the ideal power valve:—

MAJESTIC VOLUME,
CRYSTAL-CLEAR TONE,
LONG LIFE and
VERY LOW CURRENT CONSUMPTION.

The filament is exceptionally robust and rigid, and has a large emission surface.

Type D.E.P. 215 used with the correct H.T. and grid bias voltage recommended in the accompanying table will handle great volume with a purity of reproduction hitherto unobtainable.

	Marconi Valve Type	Position	Filament		Grid Bias Volts	High Tension		Low Tension Battery Supply
			Volts	Amps		Volts	M. Amps.	
Two-Valve Set	D.E.2 H.F.	Det.	1.8	0.12	+2	80	1.6	Two-volt Accumulator
	D.E.P. 215	L.F.	1.8	0.15	-9	120	4.6	
Three-Valve Set	D.E.2 H.F.	Det.	1.8	0.12	+2	60	1.0	
	D.E.P. 215	1 L.F.	1.8	0.15	-3	60	2.5	
	D.E.P. 215	2 L.F.	1.8	0.15	-9	120	4.6	
Four-Valve Set	D.E.2 H.F.	H.F.	1.8	0.12	0	60	0.8	
	D.E.2 H.F.	Det.	1.8	0.12	+2	60	1.0	
	D.E.P. 215	1 L.F.	1.8	0.15	-4.5	80	3.3	
	D.E.P. 215	2 L.F.	1.8	0.15	-9	120	4.6	

Marconi Type D.E.R. or other 2-volt valves are also suitable for the high frequency detector or first low frequency stages.

THE MARCONIPHONE COMPANY LTD.,

Regd. Office:—
Marconi House, Strand, London, W.C.2.

Head Office:—
210 212, Tottenham Court Rd., London, W.1.

THE NEWEST RADIO TRIUMPH

Christmas Gifts that last a Year!

BEAUTIFUL BOOKS FOR CHILDREN OF ALL AGES

ANY one of the jolly books illustrated here will give a child more lasting joy and pleasure than a toy costing two or three times as much. Ask your newsagent to show you these books TO-DAY! Each book is strongly bound in boards, with an attractive coloured cover, and is packed with jolly stories and coloured pictures. All of them make ideal Christmas gifts. BRUIN BOYS' ANNUAL is new this year. It contains many jolly-tales of the world-famous Bruin Boys and the popular Wee Woolly Boys. MRS. HIPPO'S ANNUAL is devoted almost entirely to the merry pranks of Tiger Tilly and the favourite characters from the picture paper, Playbox.

RAINBOW ANNUAL contains many amusing adventures of the world-famous Tiger Tim and the popular Bruin Boys. CHICKS' OWN ANNUAL is for very little children just learning to read. BUBBLES ANNUAL features popular characters from the weekly coloured paper, Bubbles.

3/6 net each.

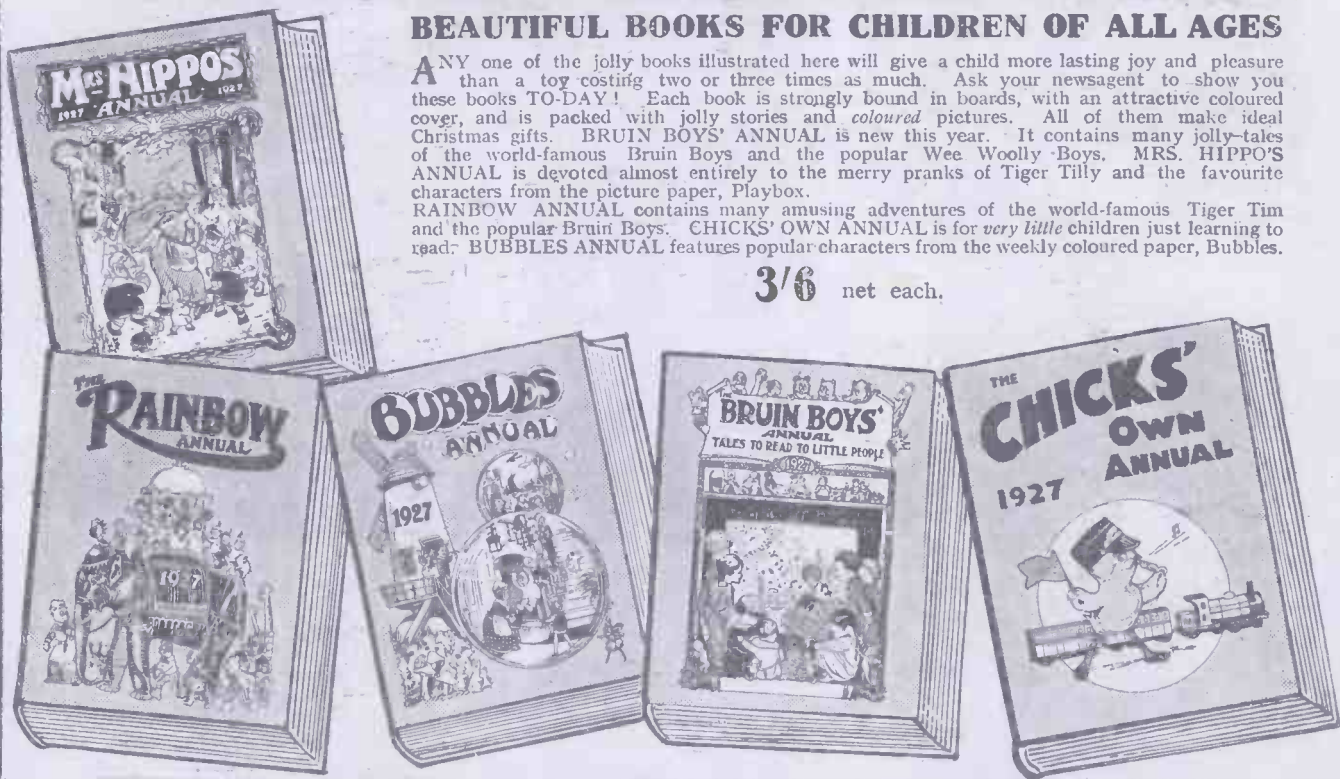

"BEST WAY"

GUIDES FOR WIRELESS CONSTRUCTORS

The Two Latest Numbers Now On Sale Everywhere.

MODERN LOUDSPEAKER SETS

This book contains straightforward, amply illustrated directions for constructing three of the latest valve sets. The first is a two-valve household loudspeaker set. The second is a sensitive three-valver incorporating a novel reflex principle which will receive European stations with ease. The third set described is a four-valver including every possible modern refinement.

CONSTRUCTORS USING THESE BOOKS CANNOT GO WRONG.

PICTORIAL BLUE PRINTS

This book consists of an up-to-date and comprehensive range of blue print diagrams drawn in a simplified pictorial style so that the amateur constructor cannot possibly go wrong when building up a set on the lines of any of the circuits with which the book deals. There are 11 circuits in all.

**6^d.
EACH**

AT ALL NEWSAGENTS AND BOOKSTALLS EVERYWHERE.

XMAS GIFTS

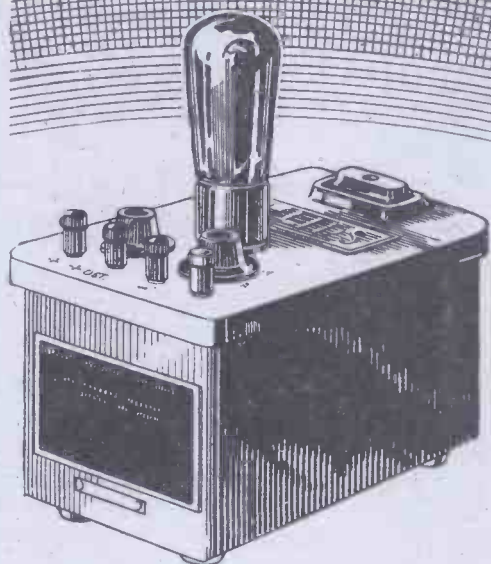

PHILIPS H.T. SUPPLY UNIT

Gives from 20 to 160 volts approximately. Ensures a supply of current to work any set efficiently using standard types of valves. Consumption is approximately 5-10 watts. Output variable from 2 tappings. Safe and silent in use. Price complete £7 : 10 : 0

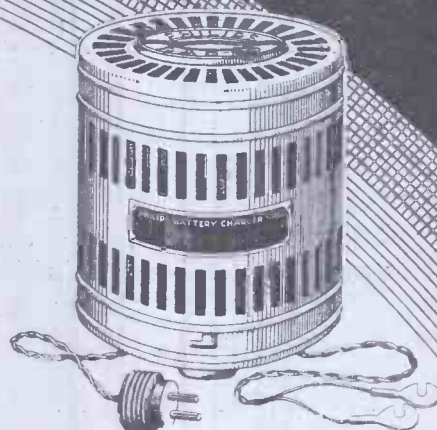

PHILIPS RECTIFIER TYPE 450.

Charges radio batteries from 2-6 volts at 13 amps. consuming 30 watts. A full wave valve rectifier using the specially constructed Philips Rectifier Valve and Resistance Lamp which automatically regulates the current supply. Needs no attention. Price complete £4 : 0 : 0

Both Units for Alternating Current.

TWO PHILIPS PRODUCTS VERY SUITABLE FOR XMAS PRESENTS

Ask your dealer to demonstrate.

PHILIPS

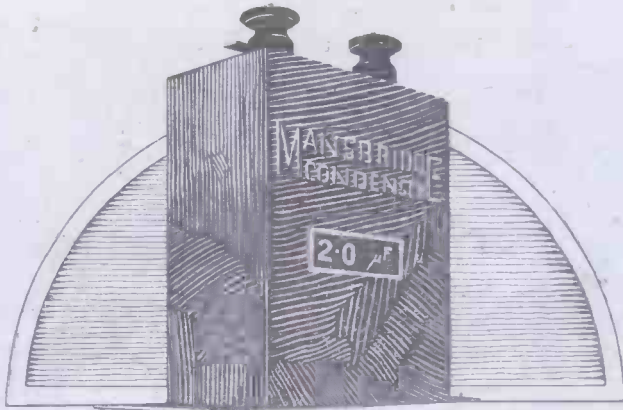

TWO HEADS....

Two heads are, proverbially, better than one. Therefore when you require a Mansbridge Condenser, see that you get a Dubilier-Mansbridge, the condenser which has been designed specially for wireless purposes.

G. F. Mansbridge originated this type of condenser over 20 years ago, and his unique experience is found combined with that of Dubilier in each Dubilier - Mansbridge Condenser.

Take advantage of this combined experience which is to be found in no other condenser and ask your Dealer for Dubilier-Mansbridge Condensers.

The colour of these condensers is Maroon, they bear the words "Mansbridge Condenser" embossed on the case and they carry the full Dubilier Guarantee.



ADVT. OF DUBILIER CONDENSER CO. (1925) LTD.
DUGON WORKS, VICTORIA ROAD, H. ACTON, W.3.
E.P.S. 247



*A touch
adjusts them!*

YOU can adjust the earpieces of B.T.H. Headphones in a second. There are no screws or nuts to undo and tighten. Just a touch of the finger! and the earpieces retain their position until deliberately re-adjusted.

B.T.H. Headphones are amazingly sensitive. They are also extremely light (9½ ozs.) and cannot catch in the hair or cause headaches.

BRITISH and B.T.H.

PRICE
15/-
Per Pair
(outside Irish
Free State.)



HEADPHONES

Sold by all good Radio Dealers

The British Thomson-Houston Co. Ltd.

2689 A



The little brown box that brings Valve results to Crystal users

WHERE is the owner-of-a Crystal Set who has not longed for the results enjoyed by his friend the valve user? Who has not envied those able to fill their whole room with the music and speech of the night's broadcast? But now since the advent of the little 'brown box', anyone with a Crystal Set living within fifteen miles of a broadcasting station [or eighty miles of Daven-try] is on a complete level with the Valve Set owner. The Brown Crystal Amplifier, brings to the Crystal Set user the priceless

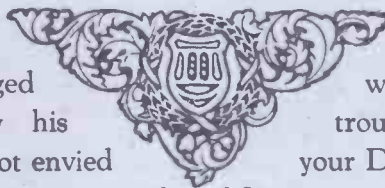

boon of Loud Speaker reproduction without any of the upkeep cost and trouble inseparable from the valve. Get your Dealer to demonstrate the Crystal Amplifier to you on one of the nine Brown Loud Speakers. You'll be charmed. Most probably you'll agree with most people that Wireless reproduction is at its very best when the Crystal Amplifier and a Brown Loud Speaker is used. A purity that is unrivalled. Volume full and adequate. A fidelity of reproduction which is almost uncanny. Yours for £4 4s. 0d.

and whichever Brown Loud Speaker you desire.

Brown Crystal Amplifier
puts Crystal users on a level
with the Valve Set owner



The H1.

120 ohms. £5. 5. 0.
2000 ohms. £5. 8. 0.
4000 ohms. £5. 10. 0.



The Disc.

2000 ohms.
Black and gold
£7. 7. 0.
Oxydised Silver
£8. 8. 0.

S. G. BROWN, LTD., Western Avenue, North Acton, W.1.

Retail Showrooms: 19, Mortimer Street, W.1; 15, Moorfields, Liverpool; 67, High Street, Southampton.
Wholesale Depots: 2, Lansdowne Place, West Bath; 120, Wellington St., Glasgow; 5-7, Godwin Street,
Bradford; Cross House, Westgate Road, Newcastle; Howard S. Cooke & Co., 59, Caroline Street, Birmingham;
Robert Garmany, Union Chambers, Union Street, Belfast, N. Ireland.



Heat —the Destroyer

WITHIN every valve lurks the grim spectre of heat. Sometimes—as in the case of a bright emitter—he completes his deadly work speedily. The frequent stretching and contracting when the current is turned on. The crystallisation of the metal due to the filament being incandescent. These are his two favourite avenues of attack.

But even Dull Emitters are not free from his insidious onslaughts. Quite a number work at a comparatively high temperature and the fragile filaments fall easy victims.

There is one valve however, which bids him do his worst. The Cossor with its Kalanised filament. Because not even a suspicion of a glow is visible when the

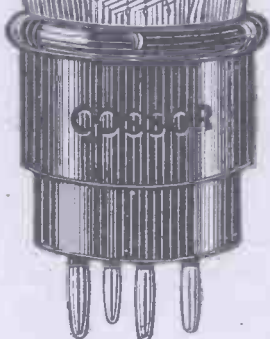

Cossor bids him do his worst

new Cossor Point One is working you have direct evidence that the harmful effect of heat has at last been countered. After 2,000 hours of continuous use the Cossor Kalanised filament is as supple and as pliable as on the day it was first made. This is equivalent to two years of ordinary wear and tear.

The Valve with the Kalanised filament

TYPES AND PRICES.	
No. 210D. With Black Band. An ideal super-sensitive Detector. Consumption: 1 amp. at 1'8 volts	14/-
No. 210H. With Red Band. Pre-eminent among H.F. valves. Consumption 1 amp at 1'8 volts	14/-
The new Cossor Stentor Two	
No. 215P. With Green Band. For Power Valve use—ideal for Super Sets. Consumption .15 amp. at 1'8 volts	18/6

Small wonder that tens of thousands of wireless enthusiasts are turning to this long-life valve as a means of cutting down the cost of Radio. For the Cossor Point One in addition to giving an exceptionally long service—consumes only one-tenth of an ampere. Seven of them take less current than one bright emitter. While its electron emission is so intense and the user obtains such a wonderful wealth of power and richness of tone that Broadcasting takes on a new standard of performance.

See your Dealer about these new valves without delay—they will improve any Receiver.

Cossor Point One

Popular Wireless

Scientific Adviser.
 Sir OLIVER LODGE, F.R.S.
 Technical Editor:
 G. V. DOWDING,
 Grad.I.E.E.
 Assistant Technical
 Editors:
 K. D. ROGERS,
 P. R. BIRD.

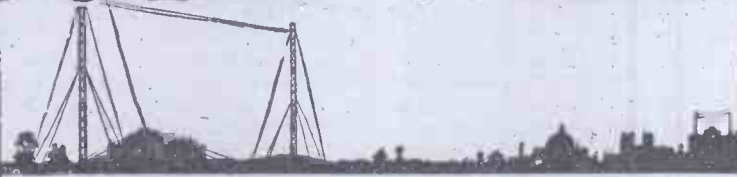

Editor: NORMAN EDWARDS, M.Inst.R.E., M.R.S.L., F.R.G.S.

Consultants:
 Dr. J. H. T. ROBERTS,
 F.Inst.P.
 J. F. CORRIGAN, M.Sc.,
 A.I.C.
 C. E. FIELD, B.Sc.
 E. J. SIMMONDS,
 M.I.R.E., F.R.S.A.

RADIO NOTES AND NEWS.

"P.W.'s" Christmas Number—Free Licences for the Blind—"Alternative Programmes"—The Quick-Change Loud Speaker—Wireless Police Van in Trouble—The Broadcasting Charter—San Sebastian's Slip.

"P.W.'s" Christmas Number.

NEXT week's "P.W." is the Christmas Number. And as I was saying last week, it's going to be *some* issue. Instead of the familiar blue-and-yellow cover there will be a coloured pictorial one, and inside that cover will be pages, and pages, and pages, of the best Christmas radio fare ever offered.

A Word to the Wise.

OF course, *extra size, isn't always an advantage*—as the paperhanger said, when his lunch fell into the bucket.

But the extra size of "P.W." next week is certainly very gratifying, considering that the price remains at 3d.

There is, in fact, only one drawback. And that is, there is sure to be a run on them, and you may miss your copy unless you order it. (I hate to rub it in, but again last year dozens of you wrote and asked me to send you a Christmas Number, long after the last had gone!)

Broadcasting and Opera.

IT is suggested that when the new British Broadcasting Corporation comes into being on January 1st, it should give a leg-up to British opera. The idea is that part of its revenue could be set aside for the British National Opera Company, in return for the right to broadcast extracts from the B.N.O.C.'s performances. What most listeners think about it is not yet clear, but in some operatic quarters the project has been hailed like a reprieve from the grave.

Radio for Air Liner.

IT was revealed to the Dominion Premiers that the great new British Airship, R 101, will be provided with loud speakers, so that its passengers may listen to wireless programmes.

The great vessel will have a cruising range of 4,000 miles or so, at an altitude of

5,000 ft., and a minimum speed of 50 miles per hour.

Free Licences for the Blind.

CAPTAIN IAN FRASER'S face was fairly wreathed in smiles when his Bill for Free Wireless for the Blind passed the House of Commons in ten minutes. Part of that time was taken up by cheering; and it is hoped that its passage through the Lords will be equally expeditious!

It is estimated that from 25,000 to 30,000 people will benefit by the measure.

A Queer Case.

TALKING about alternative programmes, here's the queerest instance that I've heard about, that happened just before the wave-length alterations.

A schoolmaster's wife in the Yarrow district tuned in Newcastle one evening on the loud speaker (four-valve set, 1-v-2). The set was in the drawing-room, and there were extension leads to the living-room as well. Presently she took the loud speaker to the living-room, plugged in there, and found that the programme was now *coming from Dublin!*

The Quick-Change Loud Speaker.

PUZZLED to account for this, she took the loud speaker back to the drawing-room, plugged in again, and the set responded by giving Newcastle again. But as soon as the loud speaker was put in the other room once more, the loud speaker voiced Dublin's programme, and gave 5 NO the go-by!

My informant says: "I suppose the additional capacity of the loud speaker leads altered the tuning." But I must admit that I can't see how it could. Has any other reader had a similar experience?

SALE OF RADIO PRESS JOURNALS. IMPORTANT ANNOUNCEMENT.

We have to inform our readers that the proprietors of POPULAR WIRELESS, the Amalgamated Press (1922), Ltd., have acquired from the Radio Press, Ltd., the following journals: "Wireless," "Modern Wireless," and "The Wireless Constructor."

"Wireless," the 2d. weekly, will be incorporated with POPULAR WIRELESS. The two monthly magazines will be continued as before, "The Wireless Constructor" being edited by Mr. Percy W. Harris, whose special supplement in this journal will shortly be discontinued. Mr. Harris will, however, continue to contribute constructional articles to "P.W." and to "Modern Wireless."

"Modern Wireless" and "The Wireless Constructor" will, in the near future, be issued from the offices of POPULAR WIRELESS, and queries relating to these journals should be temporarily addressed to Queries Editor, POPULAR WIRELESS, Fleetway House, Farringdon Street, London, E.C.4.

Further details regarding a revised scale of charges for the Queries and Blue Print Services will be published shortly.

THE EDITOR.

Alternative Programmes.

"CERTAINLY we now have Birmingham mixed up with Aberdeen, but where is the scheme for regional stations, and alternative programmes? What about that?" writes an indignant and sarcastic Aberdonian.

Well, what about it, ma bonny Scot? When the British Broadcasting Corporation takes over at the end of the year, the uncertain finance which handicapped the B.B.C. will be no bar to the regional stations scheme. It seems likely that we shall have a definite announcement on the subject ere long.

Manchester Medley.

THE new wave-lengths, which came into operation last month under the Geneva wave-plan, appear to have hit Manchester listeners rather badly. 2 Z Y itself is still clear enough, but valve-set owners there used to enjoy Nottingham and Liverpool, whilst Stoke also was good, and Sheffield quite a favourite. Now that nearly all the relay stations are on one wave-length, all these programmes are "stringy," as one Atherton reader calls it. And it's useless to turn to Birmingham for relief, for a skirl of the Aberdeen pipes has been mixed with the 5 IT items!

(Continued on next page.)

NOTES AND NEWS

(Continued from previous page.)

"Mother Goose."

"MOTHER GOOSE," of the 5 I T Children's Corner, has sent me a copy of "The Twilight Book," containing many of the charming verses and lullabies that have been read to the kiddies from the Birmingham studio. Some of them are simply topping.

Published at 5s., as a Christmas gift-book for children, the proceeds are to go towards wireless sets for the sick and the blind.

The Continent on a Crystal.

I AM still hearing frequently of Continental stations being picked up on crystal sets. One Thornton Heath (Croydon) reader, who made up the "P.W." Ultra, not only gets 2 L O and 5 X X, but on Sunday mornings Radio-Paris as well. Pretty good going, isn't it?

Can You Beat It?

WRITING to one of the London dailies, a correspondent says "I think I may venture to assert, without fear of contradiction, that the gramophone is far ahead of wireless, not only in 'how' it gives, but also in 'what' it gives."

He ought to try and think again, especially about that contradiction bit!

"And So to Bed."

NOBODY dislikes talkee-talkie in the programmes more than I. Yet lately I've enjoyed several, so I think they must be brightening them.

The A. A. chat on the Pillion Girl, for instance, was well done, and there was an excellent one recently upon that old rascal, Pepys. By the way, Miss Yvonne Arnaud, who is playing Mrs. Pepys in "And So to Bed," will be broadcasting from London on December 12th.

Wireless Police Van in Trouble.

ONE of Scotland Yard's wireless patrol vans was involved in a collision recently, and for the first time the interior was disclosed to public view. The van was returning home after a late night out, when a taxi crashed into it, and an interested crowd soon gathered to see all that could be seen of the transmitting and receiving sets.

The Yard uses six of these vans, which keep the flying squad in constant touch with headquarters when a police raid is being carried out.

Committees' Control of Broadcasting.

NONE of these wireless control committees seem to be very gay, or cheery, do they? The new Irish Free State Wireless Bill provides for a committee of at least five members, one of whom will be nominated by the Minister of Education, and another by the Minister of Agriculture. One more good kill-joy on that committee, and the Irish ether will be about as light and joyous as an Irish bog!

The Broadcasting Charter.

I HAVE just been reading the full term of the draft of the Royal Charter for Broadcasting. (It is obtainable from H.M. Stationery Office, in booklet form, for

a few pence.) As might be expected it is full of rich jocund phrases and good round legal terms, but the King's declaration that "We deem it desirable that the service should be developed and exploited to the best advantage and in the national interest," will meet with approval everywhere.

More Wave-length Changes.

AS might have been expected, the wave-length-sharing of Aberdeen and Birmingham did not last long without an outcry being raised. Consequently, the B.B.C. announced that on November 24th Aberdeen would transmit on 500 metres, whilst Birmingham remained upon 491.8 metres.

TECHNICAL TERMS ILLUSTRATED

The Loud Speaker.

A HAPPY young Daddy named Meaker,
Found his love getting weaker and weaker,

Because his new baby boy,
Who at first was a joy,
Became a noisy



The "P.W." Constructors' Competition.

THE Editor tells me that he hopes to be able to announce the result of the £200 Prize Competition in next week's issue of "Popular Wireless."

SHORT WAVES

Mr. Justice Astbury has asked: "What is 2-L O?" It is becoming impossible to keep anything from these inquisitive judges.—("Punch.")

A writer points out that wireless enthusiasts have difficulty in getting a good earth. There's no doubt that something seems to have spoilt this one.—("Passing Show.")

With a deft movement of his hands, the boy put the finishing touches to his set.—(Suburban Paper.)
There was evidently method in his madness.

Listeners who have not got a wireless licence, declares an authority, have not got the right spirit. But we understand that the amateur crystal user who got America the other night had the right spirit, even if it was a wet one.—(Popular Radio Weekly.)

Radio without a set is the latest invention of a post-office worker. As a radio receiver, we should think it would make a very good pillar box.

Mr. Clement Jeffery holds that it is as great a crime to empty rubbish into the air as it is into the street. Do the B.B.C. know this?—("Punch.")

The Chairman of the Society said he saw no reason why the lady members should not try the short waves.—(Provincial Paper.)
He was probably under the impression that the results were more permanent.

Heave a deep sigh
For all of the boobs
Who cross up their batteries
And burn out five tubes.
("Radio Digest.")

One who is disgusted with the programmes provided by the B.B.C., writes that he switches off each evening depressed and desperate. He should try non-audible headphones.—("Birmingham Gazette and Express.")

A Swiss scientist says that the nerve centres which react to music are in the feet. Possibly this is why I often want to kick the wireless set out of the window.—("Sunday Pictorial.")

Round the Empire Radio.

A ROUND-THE-WORLD radio scheme for broadcasting simultaneously to every part of the Empire, has been getting itself talked about a good deal recently. The idea is that a special station should be erected at Daventry, with a duplicate staff. This station would push out a 24-hour programme, on short waves, to be picked up by a well-equipped chain of receiving stations in the Empire, and relayed to the various countries in both hemispheres.

Links in the Chain.

SUGGESTED links in the Empire broadcasting chain are at Moncton, N.B.; Vancouver, Fanning Island, Sydney, New Zealand, Perth, Cape Town, Colombo, Bombay, and Malta.

I think the scheme is hardly likely to materialise yet. The new Broadcasting Corporation is going to have a pretty hectic time when it takes over on January 1st, and it is hardly likely that such a bold scheme could be entered upon for a year or two.

Unidyne and New Wave-lengths.

WRITING of results on the new wave-lengths, a Darlington reader says "Frankfort, Hamburg, Berne, Toulouse, Leipzig, and Dublin came through on two pairs of 'phones nearly up to the local station in strength. Starting at Munster, and going up to Frankfort, I received twenty-eight stations without changing a coil. Of these, twenty-four stations were definitely identified by their call sign, clearly spoken."

What set was he using, did you say? Oh, our old friend the Unidyne (Det. and L.F., 1926 model).

San Sebastian's Slip.

THEY say that if you took all the worms in the world and arranged them in one long, straight line, one of them would be sure to wriggle and spoil the whole effect!

Whatever the truth about that may be, it is certain that at the great change-over, when every broadcasting station in Europe should have adopted the Geneva wave-plan, one of them apparently forgot all about it! San Sebastian was the bad boy of the piece, and horrified listeners found him still banging away on his old position on the dials, after everybody else had changed, like a sturdy old Don Quixote.

I haven't heard the explanation yet, but I guess it was something to do with a bright-eyed señorita.

A Brighter Ether.

THERE's to be great radio doings on the Continent, I hear. Several schemes for a brighter ether are being prepared, the two that will affect British listeners most being the broadcasting of pictures and the proposed reorganisation of the French radio service.

Pictures from Paris?

THE former scheme is for pictures to be sent from Vienna and Radio-Paris, and Mr. Thorne Baker—the inventor of the "teletograph," which is used by listeners to receive the pictures—hopes to get going in a week or so.

The projected French reorganisation may mean the erection of more stations, and the doubling of the power of Radio-Paris.

IT is well known that the fundamental frequency of a tuned circuit is affected by the proximity of any outside body. When the disturbing body is a non-conductor introduced near a point of varying H.F. potential, the electrostatic field of the tuned circuit is increased and its normal wave-length changes accordingly.

An example of this is seen in the peculiar way in which the effect of hand-capacity alters the tuning of a sensitive receiver, particularly when searching for a distant station.

In the case of a conducting body, such as a metal sheet, the magnetic field from the tuned circuit sets up induction currents in the metal. These induced currents, in turn, produce a secondary magnetic flux which opposes the first, and so changes the original tuning.

This effect is illustrated in the so-called "spade" or shadow systems of tuning-control, where the wave-length of a receiving circuit is adjusted by moving a metal disc towards or from the aerial or tuned-anode inductance.

If, therefore, an accurately tuned circuit is energised by means of a thermionic valve, it is easy to see that once the circuit has been set into a steady state of oscillation, the system can be utilised as a highly sensitive means of detecting or indicating any change in its immediate neighbourhood. For instance, such a circuit can be employed as a burglar alarm by locating a part of the tuning coil around or near the door or window of a house, or near any particular object to be guarded, such as a safe.

A Novel Alarm.

The approach of a burglar alters the normal tuning, and therefore the value of the current flowing in the circuit. This in turn releases the armature of an electromagnet and so operates a relay, which may be made to sound an alarm either in the house or, by arrangement, at the local telephone exchange.

An arrangement of this type is at present being used in a German factory as a means of detecting pifering. As the employees leave the works at the end of the day, they pass through a narrow door which forms the open centre of a loop winding or solenoid.

The presence of any metallic body, either in the pockets or otherwise hidden about the person of the workmen, is at once detected by an alteration in the normal "tuning" note produced by the solenoid winding and a heterodyne receiver, the telephones of which are worn by the door-keeper.

Dr. Lowy, an Austrian professor, has employed a similar principle as a means of prospecting for minerals in the Sinai Peninsula. A symmetrical aerial or Hertzian oscillator is suspended from an airship or aeroplane, as shown diagrammatically in

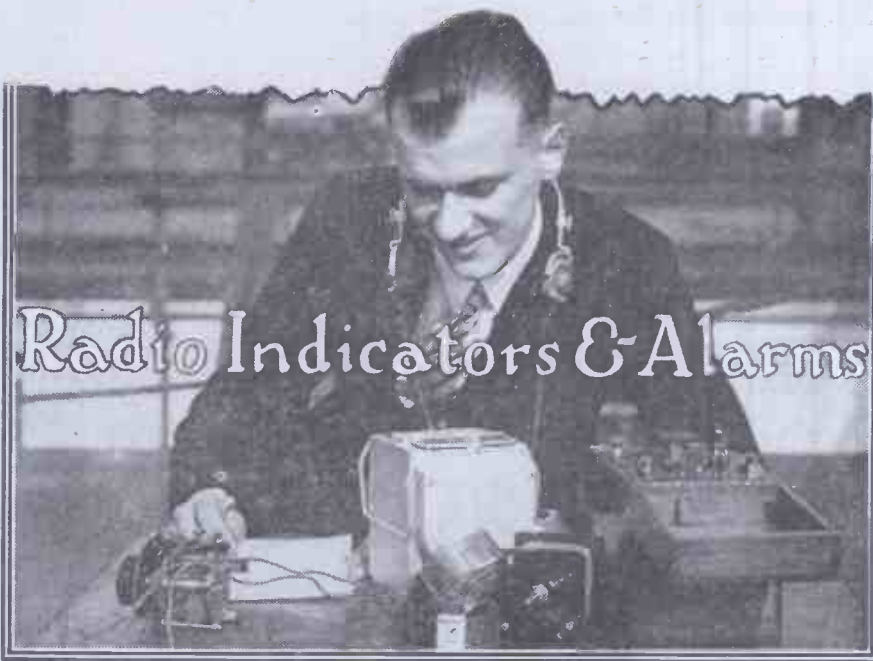

 An Interesting Article on a New
 Radio Development.
 By SEXTON O'CONNOR

Fig. 1. The aerial is energised from a valve set carried by the airship through a central coupling coil and is arranged to trail at a short distance above the ground.

Although the varying damping effects upon the aerial system, as it passes over hidden minerals or water are small, they are sufficiently pronounced to be detected as a change in the heterodyne note given by a specially sensitive wave-meter of the four-electrode type.

In order to minimise fluctuation in the beat note due to swaying movements of the aerial, the latter is suspended by supports which are semi-rigid, although sufficiently flexible to prevent damage by accidental collision.

The same inventor has also developed an ingenious apparatus for ascertaining the actual distance between a conducting body and a local transmitter, by measuring the time-interval which elapses between the dispatch of an outgoing signal and the receipt of the reflected wave. In this way the height of an aeroplane, or the depth of a mineral deposit below the surface of the earth, can be estimated.

Measuring the Velocity of Light.

The principle is somewhat similar to that used by Fizeau when first measuring the velocity of light. A light ray is projected outwards through the space between two

teeth on a rotating wheel, and is then reflected back from a distant mirror along the same path. The wheel meanwhile is rotated at such a speed that the returning ray is blocked by the next tooth which has just moved into position. When this occurs continuously the ray is entirely cut off from an observer at the starting point.

Knowing the distance travelled by the ray to and from the toothed wheel, and also the time taken for the wheel to rotate through the angle between a "space" and the adjacent tooth, the velocity of light is easily determined.

In the same way, Dr. Lowy utilises the apparatus shown diagrammatically in Fig. 2 first to transmit a pulse of radio energy and then to catch the "echo" reflected back from the aeroplane or other conducting body under survey.

Calculating Distance.

Owing to the enormous velocity at which ether waves travel, it is necessary to employ a special form of interrupter for breaking the transmitter at very rapid intervals. Also the receiving aerial must be protected from the shock of transmission and only thrown into circuit, so as to intercept the reflected wave during the periods when the transmitter is quiescent.

The "interrupter" consists of a discharge tube, somewhat similar to a Braun oscillograph, but provided with a number of separate anodes. The electron stream from the filament is vibrated to and fro, across the row of anodes, at a rapid rate by applying an electrostatic field across a pair of

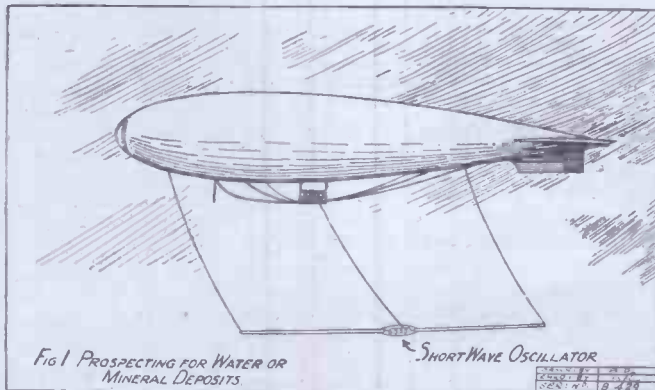

electrodes C, mounted inside the tube and connected to a separate H.F. generator, the frequency of which is under control.

As the stream passes from one anode to the next, the plate circuit of the transmitter valve is broken, and that of the receiving valve is made. The shock effect of the transmitting aerial on the receiver is mean-

(Continued on next page.)

THE RANGE OF A STATION

Some interesting details on the various factors which govern the range over which a wireless receiver will pick up, and adequately reproduce, broadcasting.
FROM A CORRESPONDENT.

QUITE close to a broadcasting station transmissions cause considerable disturbances in the ether, disturbances sufficient in magnitude to induce currents in receiving aeriels large enough to actuate comparatively insensitive receivers. Thus a crystal set connected to an antennae erected two miles from that used by 2 L O, generally gives very good signals, but a hundred miles away from 2 L O a crystal set is useless for 2 L O's ether shaking at that distance will be quite feeble, and an aerial would be lucky if it had induced in it as much as one millionth of a watt of energy. In some cases it might be a little more certainly, but in others it might be considerably less.

Many Variable Factors.

Now the rated power of a transmitting station is no real indication at all as to the amount of energy that it will induce in a certain receiving aerial situated at a certain number of miles away from it. There are so many variable factors to be taken into consideration that it is impossible to calculate a station's transmitting range with any real degree of accuracy. And as the old, old enquiry, "What stations will I receive?" depends on this as much as on the nature of the receiving equipment, it might be interesting if we enumerate just a few of the stumbling blocks.

1. The wave-length of the transmitting station is of initial importance, the shorter (but not very short) waves being more easily absorbed than the longer ones.
2. The current in the aerial and the effective height of the aerial of the transmitting station determine the "power" of the station more accurately than "kilowatts."
3. Transmission is better by night than

by day, and better still when it is a moonless night.

4. Transmission is better over sea or other stretches of water than over land, while large mineral deposits in and the geographical formation of the land over which they pass affect the passage of ether waves.

5. Rain and snow will affect transmissions, for by covering the earth with a less electrically insulative layer there will be less absorption of the ether waves.

6. Transmission will be better during the winter months because there are less statics.

At the actual receiving end local conditions will affect results, and the presence of large buildings, trees, etc., all have to be taken into consideration. With a super-het. of really modern design, distance is, to a certain extent, annihilated in the truest sense of the word, but even with such a receiver as this, various limits are imposed by local conditions.

for holes up to three-eighths of an inch. Chatterton's has the disadvantage of being rather sticky and difficult to rub down so as to leave a neat repair, and it is not easy to buy, although it is cheap enough when it can be obtained.

Easily Carried Out.

The best way to use it is to make a pellet by rolling a scrap of warmed compound between moistened fingers and pressing the pellet into the hole until this is rather more than filled. The pellet should then be lighted and allowed to burn for a second or two. As it melts it will spread. It should be left for

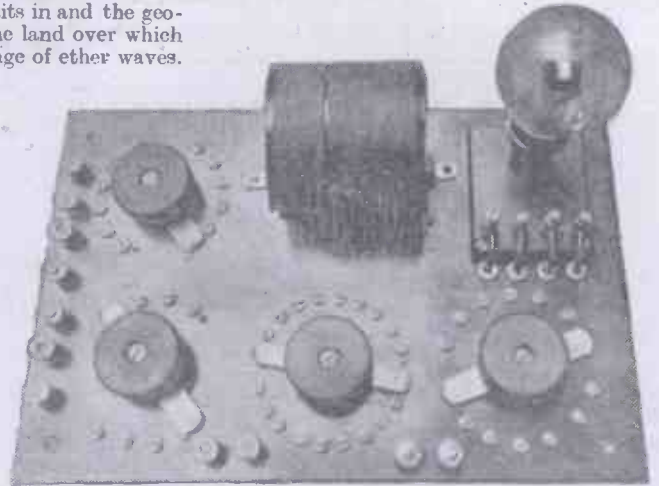

A sensitive type of receiver. This set utilises the Rehnartz circuit and was constructed by the students of an Italian radio school.

FILLING UP HOLES IN PANELS

THE two materials most commonly used for filling up holes in ebonite are Chatterton's Compound and cobbler's heel-ball. Both may be used successfully

about half an hour to set, after which time any surplus may be removed with a sharp knife and the panel finished off with sandpaper.

Heel-ball presents its own difficulties in that, when melted and dropped into a hole, it usually drips through. This may be prevented by screwing a bolt half-way into the hole from the under-side, so that the wax cannot drip. When the wax has set (in a few seconds) the middle of the blob will sink, and it will be necessary to add another drop on top of that already partly filling the hole. Any surplus should be removed carefully with a knife, as the wax has a tendency to chip.

RADIO INDICATORS AND ALARMS

(Continued from previous page.)

while neutralised by means of a special decoupling circuit not shown in the diagram.

The sequence of events is as follows: First, the transmission outwards of a pulse of energy as the circuit of the transmitter valve is completed through the interrupter. During this time the circuit of the receiving valve is broken by the interrupter. Immediately afterwards the circuit of the transmitting valve is broken as the discharge stream inside the interrupter moves on to the next anode segment. Simultaneously the receiving valve is energised ready to pick up the reflected wave.

The speed of the generator feeding the control electrodes C is adjusted until maximum signal strength is heard in the receiver.

When this occurs, the transmitted wave has travelled towards the given object, and the reflected energy or "echo" has just returned.

The time interval between these two events is given by the setting of the local

generator governing the speed of the discharge stream in the interrupter. As the velocity of the wave is already known, the required distance of the body under observation becomes a matter of simple calculation.

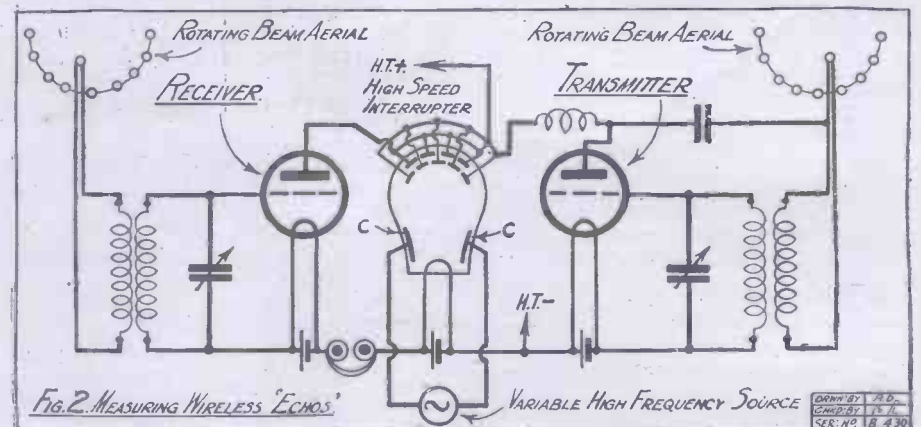

FIG. 2. MEASURING WIRELESS ECHOS.

DRAWN BY: P. D. GARDNER, T. A. SER. NO. B. 430

FITTING A SEPARATE OSCILLATOR

It is a recognised fact that the super-het. is essentially a long-distance receiver, capable, when working properly, of the reception of telephony over surprising ranges with only a small frame aerial as "pick-up." Unfortunately, however, it is not always easy to get such a receiver (when home built) to operate successfully.

In the experience of the Query Department of this journal the main cause for the failure of super-hets. can be confidently stated as one of valves. In many cases valves have to be matched exceedingly carefully before satisfactory—sometimes before any—results are obtained. The first detector, especially when used as an oscillator as well, is a frequent offender.

To make a super-het. "foolproof" would be an exceedingly difficult task, but a great deal can be done to obviate the valve-matching trouble by altering the initial stages of the set. In this article we have taken as an example a set operating on the well-known Tropadyne system—the "P.W." Super Het.

This can easily be converted, so that the careful matching process of the intermediate stages is unnecessary, and by the simple process of converting the H.F. valve into a separate oscillator and doing away with the tropadyne portion of the circuit.

Perhaps it would be well to mention here also that the new arrangement can be adapted to any super-het. operating on the ordinary fundamental harmonic principle, and is therefore particularly useful if, say, the prospective constructor has a set of intermediate H.F. transformers, including a filter, on hand.

The Oscillator Coupler.

Referring first to the theoretical circuit of the arrangement, it will be seen the action centres round an interesting, if simple, oscillator-coupler. This coupler consists of a grid, plate, and a "reaction" coil which is situated exactly in the centre of the first-named two coils. The "reaction" coil is, in effect, an aerial coil, which must be coupled equally to the grid and plate coils for good results.

Should the reader not feel competent enough to undertake its construction, a suitable one can be obtained from Messrs. Peto-Scott, 77, City Road, London, E.C.1.

For the benefit of those who care to make the coupler, the following particulars should prove useful.

* ————— *

By G. V. COLLE
(Technical Staff.)

* ————— *

The grid and plate coils, which consist of 45 turns each of No. 28 D.C.C. or S.S.C. wire, are wound on a cardboard former of 2 in. external diameter by 3½ in. long. The coils should be both wound in the same direction, with a gap of ¾ in. between them. This gap can be reduced to ¼ in. if necessary, but the number of turns in each case must be identical. Bring all leads out the same side of the former.

Constructional Details.

The reaction coil can next be taken in hand. This consists of a piece of wooden rod or a cardboard former, 1½ in. in diameter and ¾ in. wide. Before winding this

sharply from one side to the other on the completion of the first 11 turns. When the correct numbers of turns are wound on, the wire can be fastened by passing the ends through little holes bored in the former with a sharp pin or compass point. Sufficient lengths of the wire must be left to take leads to the + L.T. lead of the oscillator valve (through its rheostat) and the tap terminal for the frame aerial.

This "reaction" coil is fitted inside the 2-in. diameter former by making holes again exactly in the diameter of the latter in the space left between the grid and plate coils. A piece of stiff No. 16 gauge S.W.G. copper wire passed through the holes so provided, and again through the "reaction" coil, will then compete the coupler, which can be fitted to the baseboard of the set in any manner satisfactory to the constructor.

As far as the construction of the oscillator coupler affects the "P.W." Super-Het., the exact layout of the various components

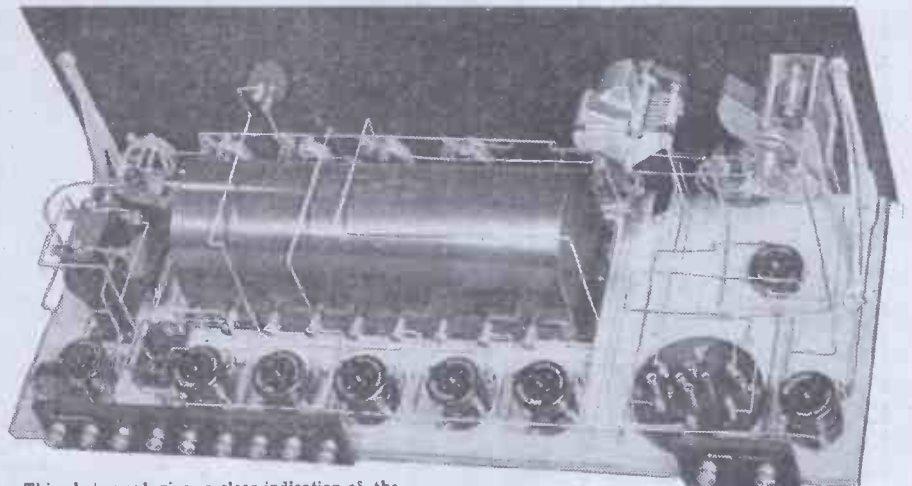

This photograph gives a clear indication of the original layout of the Super-Het. described in "P.W." No. 196, and to which the modifications dealt with in the accompanying article mainly refer.

a hole sufficiently large to take a length of No. 16 S.W.G. copper wire (bare) should be drilled through its exact diameter and exactly in the centre of its width (¾ in.). The little former can then be wound with 11 turns of No. 32 or 34 each side of the hole, so that altogether 22 turns are wound on in one length, the wire being taken over

will be clearly seen from the accompanying photographs (no reference should yet be made to the wiring diagram).

The alterations to the original wiring of the set will be: removal of the tropadyne unit, first potentiometer, H.F. transformer (resistaformer) base, variable grid leak, and

(Continued on next page.)

FITTING A SEPARATE OSCILLATOR.

(Continued from previous page.)

the alteration in the positions of the first two valve holders. All the wiring of these units can be destroyed as well as the connections to the two variable condensers.

Before rearranging or fitting the new components, another terminal must be fitted on the ebonite strip holding the frame aerial terminals, and the - H.T. terminal must be joined to - L.T. instead of + L.T. The latter can easily be done by removing the lead between the - H.T. terminal and the left-hand filament socket of the seventh (last) valve holder, and connecting the - H.T. terminal direct to the - L.T. terminal instead.

Mounting the New Components.

A Peto-Scott panel mounting neutrodyne condenser can be fitted in the hole which previously accommodated the first potentiometer, and the hole left by the variable grid leak can either be filled in with a piece of ebonite or Chatterton's compound.

Another grid leak and condenser will then be needed (.0002 mfd. and 2 megs.), a Lissenor Dubilier unit being O.K. for the purpose.

For the exact position of this, the oscillator coupler and the two valve holders, reference can be made to the two photographs and the wiring diagram.

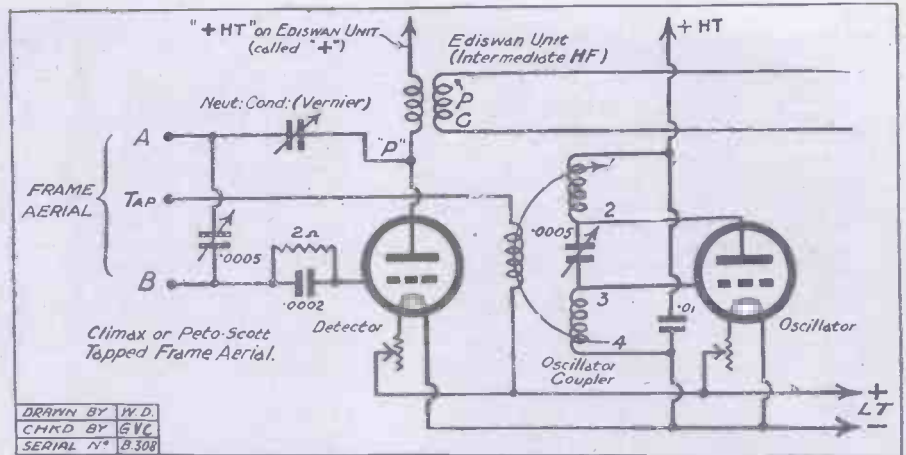

This theoretical diagram clearly shows the circuits of the first two stages subsequent to the alterations.

It is important, especially if grid and plate leads are to be kept short (which is strongly recommended), that the valve holders are arranged in the positions indicated on the latter diagram, with the oscillator-coupler leads facing the oscillator valve; and a .01 mfd. fixed condenser (T.C.C.) close up to both. This condenser is placed across the outside leads of the grid and plate coils and acts as a by-pass condenser across the H.T. battery.

With all the components now in position and arranged as shown, the wiring can be commenced, the wire used being No. 22 S.W.G. round tinned copper.

For best results all leads should be taken direct from point to point, right-angle bends being avoided.

So as to have a check on the wiring, a

POINT-TO-POINT CONNECTIONS.

One side of the first rheostat to one filament socket of the first detector valve holder (other side of rheostat to + L.T.).

One side of the second rheostat to one filament socket of the oscillator valve holder (other side of rheostat to + L.T.). Remaining filament sockets of both valve holders joined together, to one tag of the .01 mfd. fixed condenser and to the bottom end of the bottom coil of the oscillator coupler (4) and to L.T.

"B" frame aerial terminal to one side of the grid leak and condenser (.0002 and 2 megs.) and to the moving vanes of the first .0005 variable condenser.

Fixed vanes of same condenser to the moving vanes of the neutrodyne condenser and to the "A" frame aerial terminal.

Other side of the grid leak and condenser to the grid socket of the first detector valve holder.

Top terminal of the frame aerial to one end of the "reaction" coil of the oscillator coupler. Other end of "reaction" coil to the + L.T. filament socket of the oscillator valve holder (to + L.T. via the second rheostat).

Plate socket of the first detector valve to the fixed vanes of the neutrodyne condenser and to the first "P" terminal on the Edison intermediate unit (or to the primary of the filter if other makes of intermediate H.F. transformers are used).

Grid socket of the oscillator valve holder to the inner end of the bottom coil or oscillator coupler (3) and to the fixed vanes of the second .0005 variable condenser.

Moving vanes of same condenser to the plate socket of the oscillator valve holder and to the inner end of the top coil of the oscillator coupler (2). Outer end of same coil to the remaining tag on the .01 mfd. fixed condenser and to the + H.T. terminal (previously representing the H.F. valve).

This completes the wiring.

list of point-to-point connections is included and will be found above.

If all is correct, the soldered joints should be carefully examined to see if any have become "dry" (no uncommon occurrence).

(Continued on next page.)

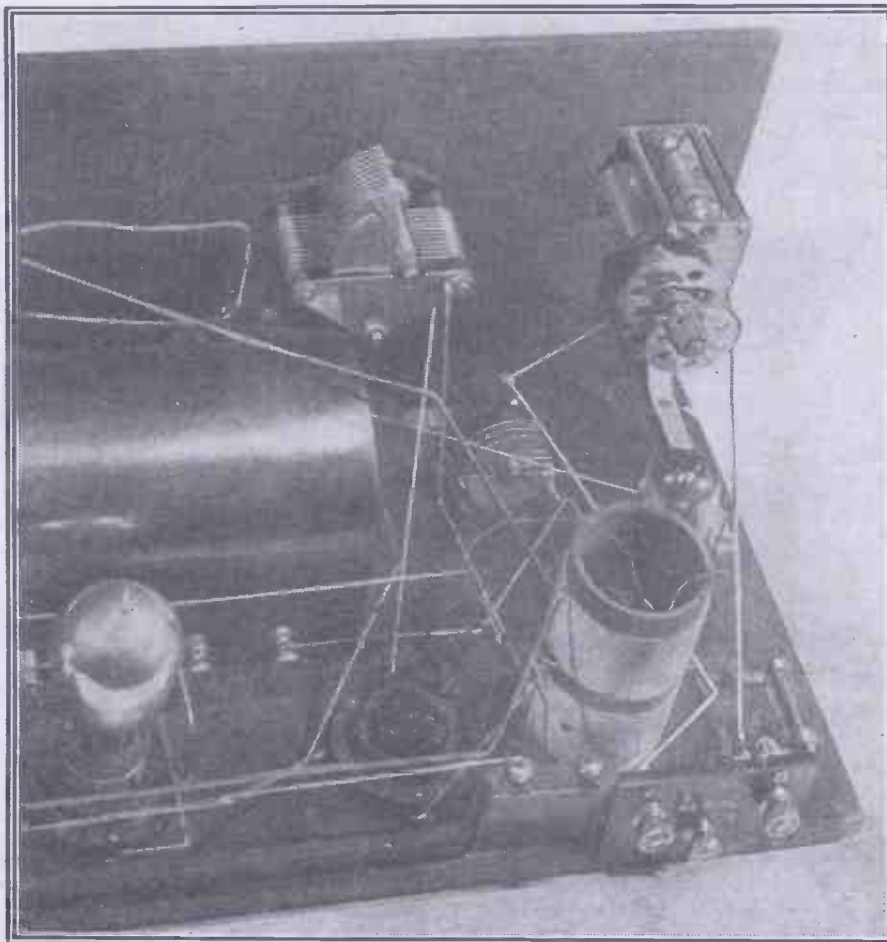

Showing the disposition of the various components affected after the separate oscillator modification has been made.

FITTING A SEPARATE OSCILLATOR.

(Continued from previous page.)

unfortunately), and if also found O.K. the receiver can be "hooked up."

During tests, all the + H.T. terminals, except the last (for the L.F. valve), can be joined together and one lead taken from the whole, as the combination of valves used will take approximately the same H.T. voltage.

It should be pointed out that a centre tapped frame aerial will be necessary with this set, and a Peto-Scott or Climax is recommended.

Final Adjustments.

Further, great care must be taken in seeing that the second .0005 variable condenser does not short-circuit.

Finally, do not expect to pick up distant transmissions immediately, as it will take some time to understand the exact functioning of the set.

The neutrodyne condenser (which acts as a small reaction condenser) should be set about a quarter of the way in, and the "reaction" coil on the oscillator-coupler set at about 45 degrees to the outside coils.

All controlling will be done (when the

set is operating properly) with the potentiometer, the two variable condensers and the frame aerial, other controls being left "set."

Forty Stations.

For the benefit of those who are interested in this superhet., it may be mentioned that one made exactly as above (a revision of the one described in "P.W." No. 196) and situated approximately six miles from 2 L O, brings in regularly at least 20 stations on the loud speaker, the log altogether being 40 stations, the remainder either being receivable on the 'phones or else being spoilt by Moree, heterodyning and other forms of interference.

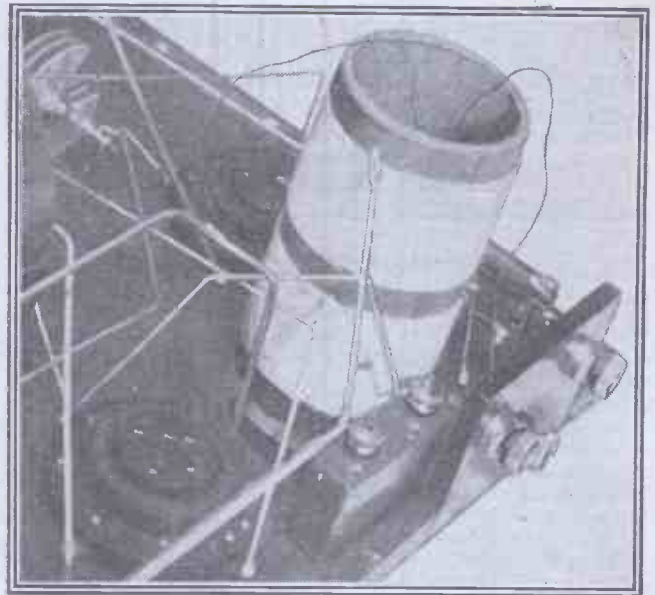

A close-up of the new oscillator coupler. The first detector valve-holder can be seen behind the coupler, with the oscillator valve-holder and .01 fixed condenser in the foreground.

SUITABLE COMBINATIONS OF VALVES.

- 2 volts.
- First detector.—Cossor red or plain top or Mullard P.M.1. H.F.
 - Oscillator.—Ediswan P.V.6 D.E., Osram D.E.6 or Mullard P.M.2.
 - Intermediate H.F.—Three Cossor red top, three Osram D.E.R., or three Mullard P.M.1 H.F.
 - Second detector.—Cossor plain top, Mullard P.M.1 or Osram D.E.2 L.F.
 - L.F.—Cossor Stentor green top, Mullard P.M.2, Ediswan P.V.6 D.E. or Osram D.E.6.
- 4 volts.
- First detector.—Osram D.E.3, B.T.H. B.5, Radio-Micro or Mullard P.M.3.
 - Oscillator.—Osram D.E.4, Mullard P.M.4 or Ediswan P.V.8 D.E.
 - Intermediate H.F.—Three Osram D.E.3b, three B.T.H. B.5.H., or three Mullard P.M.3.
 - Second detector.—Osram D.E.3, B.T.H. B.5, or Mullard P.M.3.
 - L.F.—Mullard P.M.4, Osram D.E.4, Ediswan P.V.8 D.E., Radio-Micro Power or Cosmos A.45.
- 6 volts.
- First detector.—Osram D.E.8 H.F., Mullard D.F.A.4 or B.T.H. R.
 - Oscillator.—D.E.5, B.T.H. B.4 or Mullard P.M.6.
 - Intermediate H.F.—Three Mullard D.F.A. 4, three D.E.5b or three B.T.H. B.4.H.
 - Second detector.—Osram D.E.8 L.F., Cosmos A.45, Mullard D.F.A.4 or Cleartron C.T. 25.
 - L.F.—Osram D.E.5, B.T.H. B.4, Osram L.S. 5 or Ediswan P.V.5 D.E.

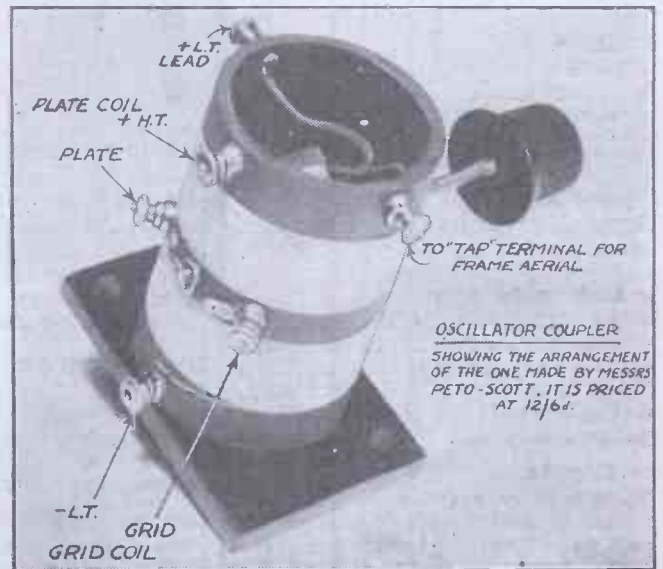
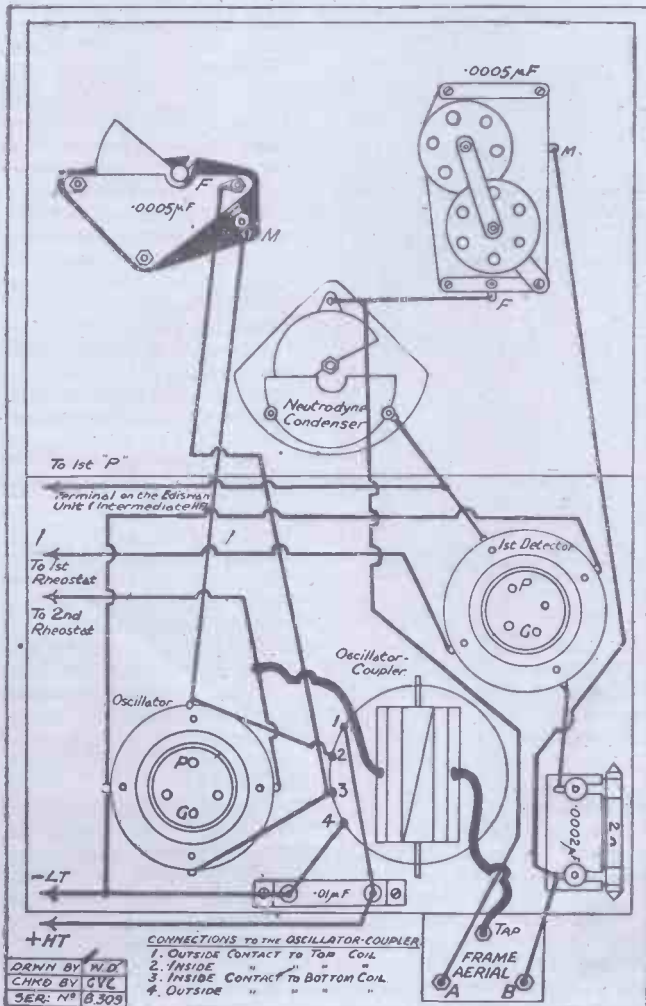

The commercial model of the oscillator-coupler used in the set described above.

BROADCAST NOTES.

The Broadcast Debate—Beethoven Centenary—Christmas Dancing—Community Singing at Newcastle—New Wave-length Difficulties—Queen's Hall Broadcast?—The News Bulletins.

BY OUR BROADCASTING CORRESPONDENTS.

THE much-heralded Parliamentary Debate on Broadcasting fizzled out.

Not more than twenty members of a House of 600 were sufficiently interested to put in an appearance. True, those who were present were keen enough, but hardly any of them had taken the trouble to acquaint themselves with the rudiments of the problem. Nevertheless, the P.M.G. had prepared his statement in expectation of a critical House, and it was on the whole eminently satisfactory. There would appear to be no real intention at least on his part to apply the restrictive clauses of the Charter and Licence. If the P.M.G.'s pledges are carried out, the Corporation should have considerably greater freedom than the B.B.C. has had. On the all-important aspect of finance, the P.M.G. was disposed to unexpected generosity. If the present arrangement is inadequate he will reconsider it in two years. The income of the Corporation exclusive of profits on "Radio Times" will next year not be less than £800,000. The B.B.C. has been asking for a million; but I doubt if they really expect to get more than £750,000. There was considerable interest in a point made by Sir Harry Brittain. This had to do with the wording on the front cover of the White Paper. It was stated there that the terms of the Charter and Licence had been "mutually agreed" between the P.M.G. and the Governors Designate of the Corporation. In the circumstances this was clearly an inaccurate description, and some unpleasantness was avoided by the reading of Lord Clarendon's letter of acceptance. In a case of a Charter or Licence such as these, there is no "give and take" in the ordinary way of negotiation. Settlements are imposed in accordance with Government decisions, and the wording is that of the legal draftsmen of Government Departments.

An Audition.

There is a good deal of curiosity about the methods of the B.B.C. in conducting auditions. This should be partly satisfied by the mock audition that will be broadcast from London on December 6th.

A Nativity Play.

A Medieval Nativity Play will be broadcast on December 22nd from 8 to 9 o'clock.

The Beethoven Centenary.

March 26th, 1927, is the Beethoven Centenary, and the B.B.C. is making special plans for an appropriate celebration. There is likely to be a special Beethoven week, including a Beethoven Concert broadcast from the Queen's Hall.

Mass Telepathy.

There is to be a serious experiment in broadcast mass telepathy on February 16th. This is under the expert management of the Psychic Research Society, and will be radiated after programme time.

The Eton Concert.

The end-of-term concert which is to be relayed from Eton on Wednesday, December 8th, will include the overture "King Otho" and Stanford's "Phaudrig Croboore" for chorus and orchestra. The winner of the House Instrument Competition will play a pianoforte solo.

Lord Northesk on Winter Sport.

Lord Northesk will broadcast on winter sports in Switzerland on Tuesday, December 7th. Last year Lord Northesk won both the Grand National and the Curzon Cup in tobogganing at St. Moritz.

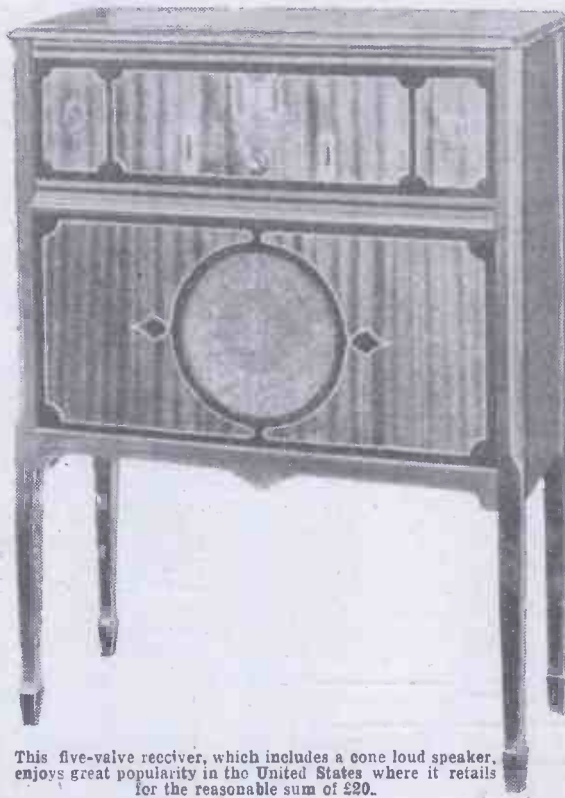

This five-valve receiver, which includes a cone loud speaker, enjoys great popularity in the United States where it retails for the reasonable sum of £20.

Christmas Dancing.

There will be supplemented dance broadcasts every night during Christmas week from both London and Daventry. On Christmas Eve there will be an extension of dance music to 2 a.m. at both stations.

John Ireland at Glasgow.

John Ireland, the eminent composer, will visit the Glasgow Studio on Sunday, December 5th, to conduct one of his own works, in addition to playing a group of his own pianoforte solos.

Community Singing at Newcastle.

Community Singing is taking on afresh in the Newcastle area. The Community Singing concert at Victoria Hall, Sunder-

land, on Thursday, December 9th, is to be broadcast from Newcastle Station.

New Wave-length Difficulties.

The chief troubles experienced in connection with the new wave-lengths are due to the obstruction of the French Government, which ignores the International Union of Broadcasters at Geneva, and disregards its decisions. If this attitude is continued it may become necessary for the members of the Union to take reprisals by blotting out all French Government transmissions. But it is still hoped that such severe measures will be avoided.

An Announcer's Adventures.

Those listeners who heard the special message sent out from Daventry after the morning shipping forecast, the other day, may not have understood its full significance. It was a greeting to Mr. McCulloch, the B.B.C. announcer, who had been sent to Germany to undergo a special operation. The events leading up to this operation are particularly romantic. Mr.

McCulloch was taken prisoner-of-war by the Germans on the Western Front. He was badly wounded, having one eye knocked out by shrapnel, and three bullets lodged in his lungs. The Germans cared for him with great skill, and miraculously saved his life. But the treatment is still unfinished and the patient visits Germany at intervals for further attention.

A Queen's Hall Move.

Mr. Roger Eckersley, the head of B.B.C. programmes, and Mr. Herman Dareswki, Musical Director of People's Popular Concerts, were seen luncheon together the other day. There is no doubt considerable significance in this meeting. People's Popular Concerts propose to take over the Queen's Hall, and their plans include active and continuous co-operation with the B.B.C.

News Collection by the B.B.C.

In view of the fact that there is so far no certainty of a new agreement between the broadcasters and the Press, the B.B.C. are understood to be making arrangements for the collection of both news at home and abroad if they are thrown back on their own resources in this respect. This would be prodigiously expensive and surely should be unnecessary.

Heavy Music Later.

Among the more pronounced tendencies being observed in future programme building is the putting back of serious music and the putting forward of light music. Those who are fond of the lighter brands of music will in future have their wishes gratified before nine o'clock; whereas the devotees of heavy harmonics will get more thrills after nine.

LOCAL INTERFERENCE IN CRYSTAL RECEPTION

BY the term "local interference" in crystal reception, or in valve reception, for that matter, we include local generator hum, interference from passing electric trains or cars, and other more or less persistent noises which are, in general, due to the presence in the set of stray currents set up by similar causes. Local interference, in the sense in which it is used in this article, does not include disturbances in reception due to the mistaken activities of some neighbouring oscillator.

In many districts favourably situated for crystal reception, troubles of the above description are fairly common, and in some cases the trouble attains such a degree of intensity as to render comfortable reception totally impossible.

Can be Cured.

Crystal set owners who are subjected to the above trouble may be divided into two general classes with reference to the



Fig. 1. A wall pattern.

frame of mind in which they regard the annoyance. Members of the first class, being more or less technically minded, rapidly diagnose the trouble, and then take the requisite steps to put an end to it. Individuals belonging to the second class mentioned above (and they are surprisingly numerous), however, adopt a different attitude. They seem to regard the presence of a persistent hum in the headphones of the set as a sort of incurable visitation of Providence, and, with a fortitude worthy of better ends, they proceed to sit back and endure the trouble to the best of their ability.

Now, all this sort of radio martyrdom is quite unnecessary. For, as a rule, the elimination of noises due to local electrical reception is a matter quite easy of attainment. Let us, therefore, deal with some of the best modes of putting an end to troubles of this nature.

Now, it is obvious that it is impossible

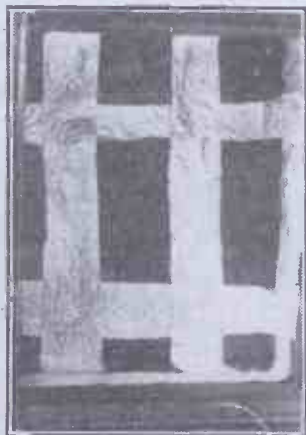

Fig. 2. The tinfoil strip method.



between the body and the earth. Theoretically, some of the actual signal current received by the set is led away also, but this current is

so small that it does not make any appreciable difference in the signal strength of the reception. As a matter of illustration, a crystal set troubled with a most annoying generator hum gave a current reading of 58 micro-amperes when its 'phone terminals were connected up to a sensitive microammeter. On placing a finger on the earth terminal of the set, the current reading decreased to 52 microamperes, the annoying hum entirely disappeared and, at the same time, no appreciable difference in the signal strength of the broadcast could be detected by the headphones.

Quite Successful.

A simple method of getting rid of generator hum and other similar disturbances is to attach a bare wire to the earth terminal of the set, and to let it dangle on the floor, preferably in contact with some metallic object. In many cases, this procedure will result in the complete elimination of the disturbances.

In many houses there is placed behind the wallpaper a layer of lead foil (known in the

An article of special interest to all listeners, and especially those using crystal sets, troubled by interference from electric trains, trams, mains, and other similar causes.
By J. F. CORRIGAN, M.Sc., A.I.C.
(Staff Consultant.)

to prevent the electrical generators situated in the neighbourhood from broadcasting their unwelcome buzzes and hums. What we have to do in such cases as these is to adopt some means whereby the locally generated interference is prevented from reaching the set; or, if it does reach the set, of leading it away to earth in such a manner that the signals are not diminished in strength.

The "classical" method of preventing interference of this nature consists in the use of a counterpoise aerial, in place of the earth. Such an aerial may be erected by providing an aerial identical in dimensions with the elevated aerial, and by suspending it immediately under the main aerial of the set, and at a distance of about one foot above the ground. This method is effective, but the use of the counterpoise aerial is, in most cases, inconvenient, and, what is more, some decrease in signal strength is usually noticed when this method is put into operation.

A Practical Illustration.

Let us consider another point now. If your crystal set gives a continual hum in the 'phones, you will almost invariably be able to make this noise disappear by the simple method of placing a slightly moistened finger on the earth terminal of the set. In fact, even in very bad cases this moistened finger method is wonderfully effective. But naturally one cannot stand, finger on earth terminal of the set, like a wooden image, during the whole of the listening-in period. Hence some more suitable means of procedure must be adopted.

The success of the above method is due to the fact that when a finger is placed on the earth terminal of the set the currents responsible for the interference are led away to earth via the body, and in virtue of the capacity leakage which is set up

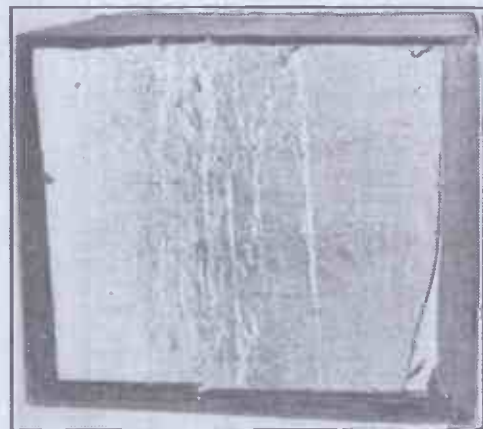

Fig. 3. Screening the base of a cabinet.

decorating trade as "laminated lead"), the object of the lead foil being to prevent the dampness of the wall from reaching the wallpaper. Now, if this protecting device exists in the house, an easy cure of generator hum in radio reception can be made. Simply run a lead from the earth terminal of the set to the lead foil under the paper, and the annoyance will cease immediately.

(Continued on next page.)

LOCAL INTERFERENCE IN CRYSTAL RECEPTION

(Continued from previous page.)

Fig. 1 depicts a wall pattress situated in an ordinary room. For a considerable distance around the room, sheets of lead foil have been placed under the wallpaper

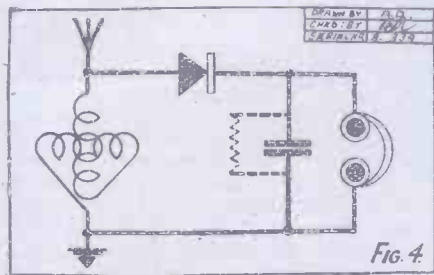

in order to keep out the damp. The wall pattress illustrated is one of many which are wired up to a central crystal set. A lead is taken from one of the pattress terminals to the lead sheet under the wallpaper. (In actual fact, the lead is run under the wallpaper, but in the photograph shown at Fig. 1 a duplicate lead is included merely for the sake of illustration.)

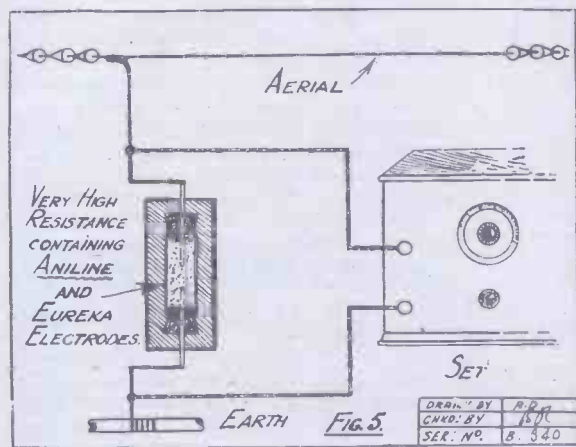

Now, before this system was rigged up, the owner of the crystal set (situated seven miles from a main B.B.C. station) was troubled incessantly with local generator hum in the headphones. The above method of earthing the set, however, has resulted in a complete cure.

Extension Leads.

It may be mentioned, in passing, that crystal set owners who run leads from their sets up and down the house are very much less troubled with interference than are individuals who merely connect their 'phones directly to the panel of the set. In cases of slight generator hum, the adoption of long 'phone extensions up and down the house will remove the trouble, some slight capacity leakage of the offending currents occurring in the 'phone extension leads.

The method of "screening" is also of very great use for eliminating local electrical disturbances. Such a method is readily put into practice by pasting a number of strips along the inner sides and base of the cabinet containing the set. The metal strips are all interconnected, and a wire lead is taken from them to a large sheet of tin or lead foil, which is pasted on to the outside base of the cabinet. The metal foil is heavily shellacked in order to prevent the possibility of any short circuit being set up if any of the connecting wires of the receiver happen to touch the metal foil inside the cabinet.

Screening.

A cabinet so treated with tinfoil on its inside is shown at Fig. 2, whilst Fig. 3 depicts the outside base of the same cabinet. In both cases, the tinfoil used has been cemented to the cabinet with ordinary paste, and a thick layer of pure shellac varnish has been applied to the surface of the foil.

Such an arrangement forms a screen which, in many cases, prevents interfering currents from reaching the coils of the set. Any interfering current flowing into the set from the aerial may be eliminated by making a connection between the underside of the earth terminal of the set and one of the strips of metal foil on the inner side of the cabinet. Under these conditions, stray currents are earthed via the metal foil strips, and the capacity leakage due to the sheet of metal foil on the outer base of the cabinet.

Two Novel Methods.

Another method of eliminating local electrical disturbances, such as those due to passing electric trains and cars, and to the presence in the neighbourhood of electrical generators, consists in placing a small fixed condenser (with or without a variable high-resistance grid leak across it) in circuit between the earth end of the variometer, or other tuner used in the set, and the crystal cup. Such an arrangement is shown at Fig. 4. In some cases, however, this method may fail to act owing to the shorting of some of the signal current. Nevertheless, for the amateur who is persistently bothered with local interference troubles, the method is certainly worth while experimenting with.

Disturbances in crystal reception set up through passing tramcars and electric trains are sometimes eradicated merely by altering the direction of the aerial. The aerial should, whenever possible, be run in a direction at right angles to the source of the disturbances. If this simple

rearrangement of the aerial does not completely eliminate the interference, it will almost invariably be found to do so if one of the methods outlined above is brought into operation.

Finally, two novel methods of dealing with bad disturbance troubles may be of interest to the experimenter. I do not put these methods forward as being absolutely



A new American Amplion hornless loudspeaker which retails at about £8 in the United States.

effective, but nevertheless, they are ones which I have seen in actual experimental practice, and, from all appearances, they would seem to give promising results.

The first of these methods consists in placing an extremely high resistance directly between the aerial and the earth. A small cylindrical vessel containing aniline, or some other organic oil of high resistance, contains two electrodes consisting of fine Eureka wire. The electrodes are situated at variable distances apart (generally about an inch and a half). The whole arrangement is then placed in circuit directly between the aerial and the earth, as indicated in the diagram, Fig. 5, the idea being to short away the disturbing currents without interfering with the actual reception currents. On paper, the idea certainly does not look at all promising, but nevertheless in actual practice it has been found to be fairly efficient.

The second method takes the form of having a special aerial wire composed of the usual enamel insulated 7/22's wire, over which is wound a single layer of well insulated wire of about No. 30's gauge. The turns of the latter wire are spaced at a distance of approximately one inch apart, and both ends of this winding are earthed, in the manner shown in the diagram, Fig. 6.

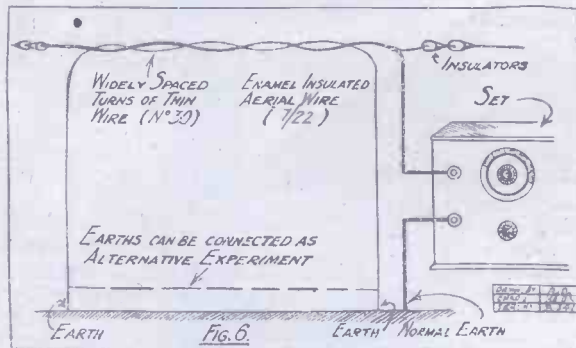

READERS will have noticed on page 1 of "Radio Notes and News" in this issue an announcement concerning the change in proprietorship of certain organs published by the Radio Press, Ltd., viz. "Wireless," "Modern Wireless," and "The Wireless Constructor."

The purchase has been effected by the proprietors of POPULAR WIRELESS, the Amalgamated Press (1922), Ltd., and in future "Wireless"—the 2d. wireless weekly, recently produced by the Radio Press—will be incorporated with this journal.

As our readers know, some weeks ago we invited Mr. Percy W. Harris, late Editor of "The Wireless Constructor," to produce a special eight-page supplement for the constructor in this journal. The success of this supplement has been very great, and we are pleased to announce that now that we have acquired "The Wireless Constructor," we have invited Mr. Percy W. Harris to edit it.

The Radio Supplement.

The special supplement conducted by Mr. HARRIS in POPULAR WIRELESS will, in due course, be discontinued in its present form, but Mr. Harris will still continue special constructional and other technical articles in these pages, so readers of POPULAR WIRELESS will not lose the benefit of his invaluable knowledge of amateur radio technique.

In the meantime, will readers who have in the past purchased any of the above-mentioned journals please make it known to their friends that a change in proprietorship has been effected. Incidentally, many readers of the Radio Press journals may be wondering as to how their queries in connection with sets described in those journals will be dealt with.

In the course of a few issues of POPULAR WIRELESS, full details about the new Query Scheme in connection with POPULAR WIRELESS, "Modern Wireless" and "The Wireless Constructor" will be published, but we can now announce in this issue that Mr. G. P. Kendall, B.Sc., has joined our staff, and will occupy the position of Chief of the Queries Department, while Mr. P. R. Bird, who has hitherto filled that position, has been transferred to another important editorial appointment in connection with POPULAR WIRELESS and the two other magazines mentioned.

Blue Print Service.

The free Blue Print service hitherto carried on by the Radio Press will be revised, and particulars will be published very shortly. We have every intention of continuing to maintain the high standard set by Mr. John Scott-Taggart, the founder of "Modern Wireless" and "The Wireless Constructor," and it is our intention to invite Mr. Scott-Taggart to contribute from time to time, not only to POPULAR WIRELESS but to "Modern Wireless" and "The Wireless Constructor."

As our readers are well aware, Mr. John Scott-Taggart has relinquished his control of the Radio Press and has commenced active operations as a valve manufacturer,

CURRENT TOPICS.

By THE EDITOR.

"P.W." and the Radio Press Ltd.—New Queries Scheme—Major Corbett Smith's New Book—The Geneva Wavelength Changes

We should like to take this opportunity of wishing Mr. Scott-Taggart every success in his new venture, and we are sure our readers will join with us in expressing the hope that he will continue to write from time to time his valuable and interesting articles on wireless subjects.

We hope to publish further details concerning the future of the above-mentioned journals in early issues of those journals and in POPULAR WIRELESS.

An Amusing Book.

We have received from Major Corbett-Smith, one time director of the Cardiff station, a booklet entitled: "Our Radio Programmes; What is Wrong and Why," published at the price of 1s. net by Messrs. John Bale, Sons & Danielson, Ltd., of 83-91, Great Titchfield Street, London, W.1.

Major Corbett-Smith sets himself out to teach the B.B.C. how to run the business, especially the programme side of the busi-

criticisms, indeed of the programmes department can only be referred to as being one-sided and illogical.

Here is a quotation of Major Corbett-Smith's of the programmes department:

"One industrial firm appointed a Director of Programmes. He was an enthusiast on the technical side, well-known during the Great War and a capable journalist. But, again, art and entertainment were quite outside his ken. Another firm appointed an Organiser of Programmes—a young Flying Officer lately returned from trying to teach the Chinese something of the science. He, too, very naturally knew nothing of enlightenment work. . . . A Controller or Chief of Staff was appointed—a retired Admiral of the Royal Navy. He, too, had no knowledge of entertainment work, and as a Senior Naval Officer his outlook on the subject may be readily gauged."

These criticisms of gentlemen who have helped to make a great success of British Broadcasting are made by one who himself has now left the staff of the B.B.C., and cannot be regarded as up to date.

But it is futile to go on criticising this little booklet. Although it makes amusing reading, it is absolutely of no value as a constructive criticism of British Broadcasting matters, and we can only hope that in future Major Corbett-Smith will leave broadcasting alone and turn his undoubted energies in the direction of matters of which he is more competent to criticise.

NEXT WEEK

GREATLY ENLARGED XMAS DOUBLE NUMBER.

Same Price 3d.!

Look out for "P.W.'s" special coloured cover Xmas Double Number, on Sale next Thursday. It will be full of first-rate features, including the first published details of

"THE KING OF THE AIR."

A new and original receiver by Mr. Percy Harris.

Mr. Marconi also explains many points about the "Beam" System; Captain Eckersley, Captain Round and other well-known people will also contribute to our Xmas Double Number.

Order Your Copy Now!

ness, and although there is much amusing reading in his pages and all the signs and portents of a good amateur journalist, his arguments are somewhat fallacious.

Major Corbett-Smith has, in fact, attempted to emulate and to put into practice that old saying: "Teach your grandmother to suck eggs!" He has undoubtedly failed.

Illogical Criticisms.

His remarks about the B.B.C. are by no means harsh but, on the other hand, there is an air of condescending superiority in his criticisms which makes one glad that Major Corbett-Smith is not on the Board of the new B.B.C. We venture to think that Major Corbett-Smith has absolutely no idea of what constitutes a popular programme. His

The New Wave-lengths.

More details about the effect of the change in wave-lengths continue to come into this office. The results in the North of England seem to be as anticipated. There seems to be a loss of reception from all the Relay Stations and of interrupted reception from two main stations, Birmingham and Aberdeen.

Reception from these and the remaining British stations within range seem to vary considerably, but are at all times, according to the reports we have received, in conflict with other transmissions, resulting in a heterodyne whistle. Owing to the change of the wave-length of Newcastle from 404 to 312.5 metres, many listeners in that district have had to make alterations in their sets; but, on the whole, it seems that reception shows an improvement.

Further Reports Required.

There has been some heterodyne trouble between this station and Bournemouth, the latter working on 306.1 metres, although, as has been pointed out, this may be caused by Marsilles or Leningrad working on 309.3 and 310 metres respectively.

We hear that 2 L O is now received in the north-east district at a greatly enhanced strength and, on the whole, Continental stations are now being received with greater ease.

We should welcome further reports from readers in other parts of the country, for it is only by collating these reports that a really satisfactory idea as to the efficiency of the new wave-length scheme can be gauged.

THE TWO-PLATE VALVE

Some details of a recent development that is being tested out in France.

By O. J. RANKIN.

MANY French amateurs are now busy experimenting with a new type of valve which was recently placed on the market by the Compagnie Radio-technique, and, judging by the few reports received up to the time of writing these remarks, it would seem that some extremely interesting developments are likely to take place in the near future. The valve, which is called the "lampe bi-plaque," has, as its name implies, two separate plates, the

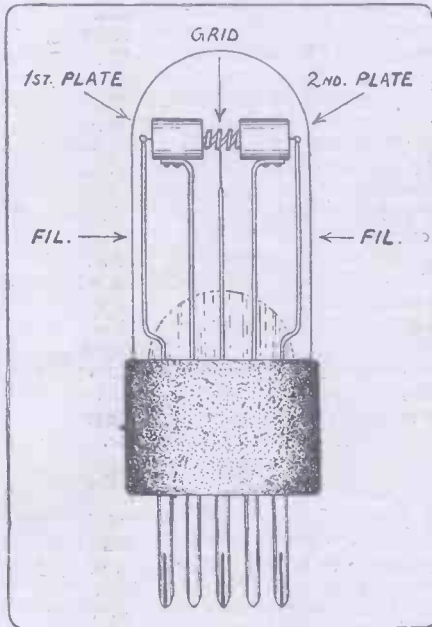

arrangement of same being shown in the accompanying sketch. The mutual capacity of the plates is said to be practically nil.

Push-Pull Amplification.

So far the most successful circuit used in conjunction with these valves consists of two stages of H.F. amplification with "push-pull" transformer couplings, valve detector, and two stages of "push-pull" L.F. amplification. The undeveloped circuit is given below. It is claimed that for sensitivity and good loud undistorted signals such an arrangement leaves nothing to be desired, and that by adding an extra stage of L.F. amplification the circuit is capable of operating three large loud speakers.

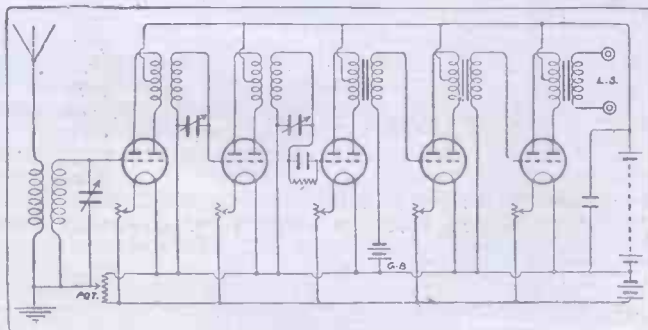

The development of new circuits for use with these valves is naturally attracting the attention of many experimenters who, like most of us here, have almost reached "saturation point" as far as circuit designing is concerned, and in this respect the two-plate valve is regarded as something really new, and given very warm welcome.

Whether it will eventually replace the ordinary single plate valve is, of course, a matter to be yet proved. French technicians have reported very favourably on its possibilities, and many "fans" declare it is the much hoped for "invention revolutionnaire" of the radio world.

THE LATEST IN LOUD SPEAKERS

From a Correspondent.

WHILST much careful thought and ingenuity has been expended on research into resonance problems connected with the development of loud speakers, it is perhaps rather surprising that until now very little attention has been given to any serious effort to replace the vibrating column of air in a loud speaker with another sound-transmitting medium, to wit, a liquid.

Recently, however, a French journal has published an article in which is described a new form of loud speaker in which the greater portion of the resonating column of air is replaced by water. The basic idea of a liquid as a transmitter of vibrations is, of course, not new. In fact, a system of transmitting vibrational impulses through a column of oil was employed during the late war for the purpose of synchronising bullets fired from an aeroplane machine gun with the revolutions of the propeller. In this way it became possible for the observer in the plane to actually fire through the

revolving propeller without in any way hitting the blades.

In the past, also, there are quite a number of experiments which have been carried out in the sphere of sound transmission through liquids, but nevertheless the present hydraulic form of loud speaker, said to be the invention of a M. Polatzek, appears to be the first of its kind.

In its essentials, the new form of water loud speaker consists of a heavy wooden cabinet in which is securely mounted a metal horn, fitted at both ends with a skin diaphragm. The smaller diaphragm is vibrated by means of an ordinary electromagnetic telephone receiver into which the signal current from the receiving set is fed in the usual manner.

The instrument is illustrated in sectional fashion in the diagram Fig. 1. It will be observed that the horn must be com-

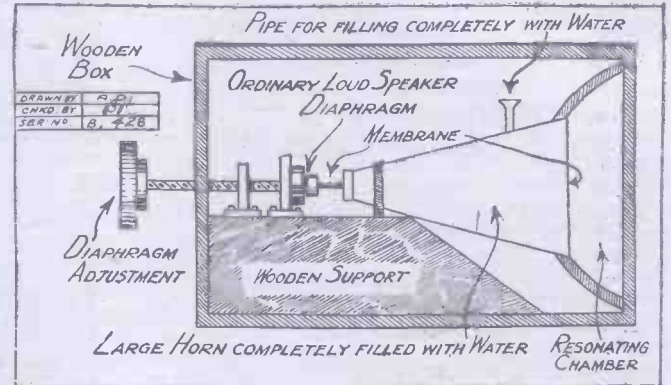

pletely filled with water, and for this purpose a water vent or entrance is provided so that the liquid can completely fill the horn and be brought up to a higher level than the highest portion of the latter.

Amplified Sound.

Water, as is well known, is extremely incompressible, and, in fact, it is upon this characteristic property that the functioning of all hydraulic devices rests. If, now, the smaller skin diaphragm of the water-horn is compressed, a wave will travel through the water and will cause the larger skin diaphragm to be pushed outwards.



Further, water being so greatly incompressible, the wave transmission through it will not be liable to become distorted in any way at all. Thus, if clear and accurate reproduction of the transmitted speech or music is attained at the small diaphragm, this undistorted reproduction will be faithfully transmitted through the water, and will give rise to a greater volume of sound at the larger diaphragm.

(Christmas in Three Weeks)

TWO GIANTS IN PERFORMANCE—

Now a *LISSENOLA HORN*

as well as a *UNIT!*



12" flare 13/6
14" flare 17/6
Sold separately or
with LISSENOLA
Unit complete.



13/6
Sold separately or
with LISSENOLA
horn complete.

THE CHALLENGE:

Try the LISSENOLA Unit now with the LISSENOLA Horn fitted to it—made in 12-in. and 14-in. flares—we challenge comparison of this fine combination against any loud speaker selling at any price up to £20—that means *any* loud speaker on the market *irrespective of price*. Yet this LISSENOLA combination will only cost you 31/-. Compare what you pay for an expensive loud speaker with what this fine LISSENOLA combination costs you.

If you do not prefer the LISSENOLA Combination to any other loud speaker for tone, quality and volume, your money will be willingly refunded, if you ask your dealer within 7 days of purchase.

If you already have a LISSENOLA Unit, now get this handsome factory-made LISSENOLA horn, 12 in. or 14 in. flare—GET IT NOW BEFORE CHRISTMAS. If unable to obtain from your dealer send direct, and add 2/- to price to cover part cost of packing and carriage. AND PLEASE MENTION DEALER'S NAME AND ADDRESS.

YOU CAN NOW OBTAIN THE LISSENOLA UNIT COMPLETE WITH FINE HORN—or purchase either separately. Any dealer will obtain for you.

LISSEN LTD., 8-16, FRIARS LANE, RICHMOND, SURREY
(Managing Director : Thomas N. Cole)

BENJAMIN

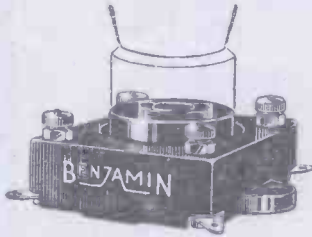

VALVE HOLDER

This is the usual view of the Benjamin Valve Holder without attachments.

Price 2/9 each.

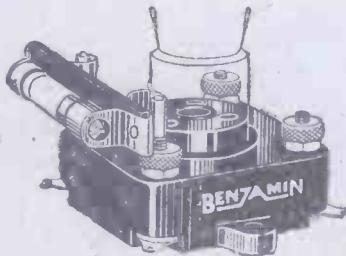

VALVE HOLDER AND GRID LEAK

Nickel-plated copper clips on a rigid insulating bar carry a Dubilier Dumetohm 2 megohm Grid Leak. Wiring and space saved, perfect connections assured.

Price 5/3 complete.

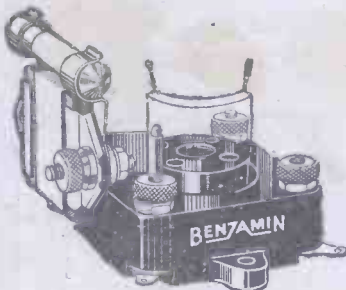

VALVE HOLDER, GRID LEAK AND CONDENSER

The same as above but with the addition of a Dubilier Fixed Condenser (.0003 mfd.). Grid Leak can be in series or parallel. Wiring entirely dispensed with, space saved, installation simplified, connection troubles banished.

Price 7/- complete.

PATENT NOS:

222085-1923 250431-1925
REGD. DESIGN: No. 714847

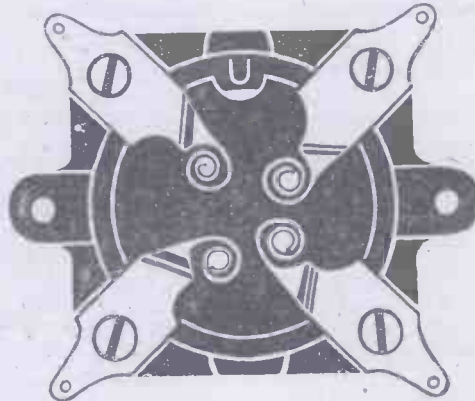

The one-piece spring feature

This is a BENJAMIN Anti-Microphonic Valve Holder turned upside down. The four metal strips you see are the patent BENJAMIN one-piece springs—each a complete length of tempered metal, cut and shaped to form the soldering tag and the valve pin socket, and the spring.

Most anti-microphonic valve holders have in place of this two or three strips of metal soldered or rivetted together. In time, the joints work loose and become 'noisy.' The BENJAMIN Valve Holder with its one-piece spring feature overcomes this difficulty.

The BENJAMIN Valve Holder has also four other important features:—

- (1) It allows the valve to float in any direction.
- (2) Valves can be inserted or removed easily and safely.
- (3) Valve legs cannot possibly foul the baseboard.
- (4) Both terminals and soldering tags are provided.

This world-famous component, which trebles the life of your valves and completely disperses all microphonic noises, can be purchased either alone or with the attachments shown on the left. Sold by radio retailers everywhere.

BENJAMIN

Clearer Tone, Anti-microphonic VALVE HOLDER

British Made

THE BENJAMIN ELECTRIC LTD.
Brantwood Works Tottenham, London, N.17

BENJAMIN—Makers of things more useful

The Quest for the Cold Valve

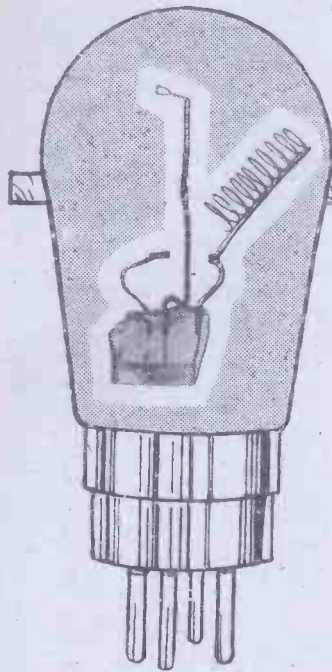

There is a fortune awaiting the inventor of a valve that needs no L.T. supply—the cold valve. In this article our Contributor discusses some of the problems to be overcome before such a valve can be made possible.

FROM A SPECIAL CORRESPONDENT

PERHAPS if we use the term in an extremely wide sense, the cold valve may be said to be, and, indeed, to have long been, an accomplished fact. For, after all, the multitudinous variety of crystal rectifiers, film coherers, electrolytic detectors, and other rectifying devices of an allied nature are nothing else but cold working valve-like arrangements for providing a one-way conducting path for high-frequency oscillatory current impulses.

Dream of the Future.

The common and acknowledged usage of the term "cold valve," however, has a very definite implication, a meaning which is very greatly different from that expressed by any other term. The hypothetical "cold valve" nowadays is taken to mean some type of rectifying and amplifying device which will work on a principle similar to that of the present-day valve, and which will only differ fundamentally from the latter in possessing some means of generating a steady, abundant and perfectly controllable electron stream without the aid of filament heating arrangements and the like.

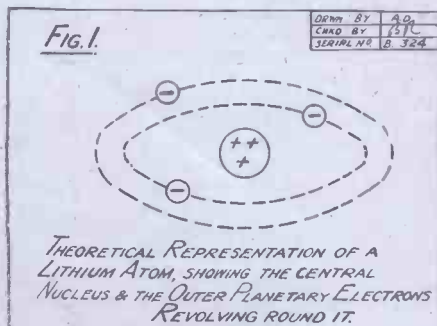

Such an ideal valve is, of course, entirely in the nature of a dream of the future. It is very definitely not a practical proposition at the present day. Nevertheless, there is growing evidence of the fact that serious attention is being turned towards the possibility of producing such a valve for

practical use. Thus, on account of the widely increasing interest in the subject, it is proposed in this article to place before the reader some considerations concerning the matter, and to indicate, also, some of the general lines upon which the cold valve of the future may ultimately come about.

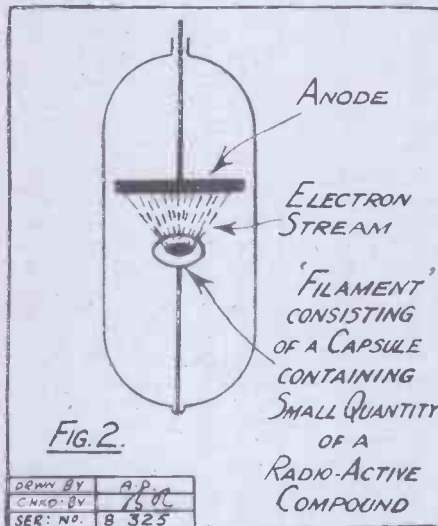

The basic fact the application of which makes the present-day valve possible is, as every reader is aware, the well-known principle of electronic emission from the surface of a heated filament. The present-day valve filament in action is nothing more or less than an electron fountain. It emits a continuous stream of electrons in all directions, and it is a portion of this electron stream which is used as the current conducting path in the valve. All of which will, no doubt, be perfectly familiar matter to the reader.

Electron Emission.

Now let us consider in rather more detail the nature of electron emission. According to the modern theories concerning the constitution of matter, an atom is no longer considered to be the hard, solid, impenetrable particle of matter which the earlier scientists believed it to be. It is now certain that an atom is really a very complex system of electrically charged particles.

Every atom contains a central nucleus, and one or more negatively charged par-

ticles called "electrons," revolving round the nucleus, in a manner similar to that in which the earth and the planets revolve round the sun. The electrons revolving round the nucleus of the atom are therefore termed "planetary electrons," whilst the electrons in the nucleus of the atoms are known as "nuclear electrons."

The nucleus of the atom consists of an agglomeration of electrons, and positively charged particles called "protons." And further, as the central nucleus of the atom is always found to be positively charged as a whole, it follows that there are always more protons in the nucleus than there are electrons.

Construction of the Atom.

In an atom, as we have seen, there is a central nucleus of protons and electrons, around which a number of electrons revolve in planetary fashion. An atom itself, however, is quite a neutral body. Thus we conclude that the positive charge on the nucleus is just balanced by the combined negative charges of the planetary or outer revolving electrons.

Fig. 1 will serve to make the above explanation rather more clear. It shows the constitution of an atom of the metal lithium. In a lithium atom there are three positive charges on the nucleus, these being balanced by a like number of negatively charged electrons revolving around the nucleus.

When a current of electricity flows through a wire, what really happens is that there is an interchange of electrons between the atoms of the wire, and it is this exceedingly

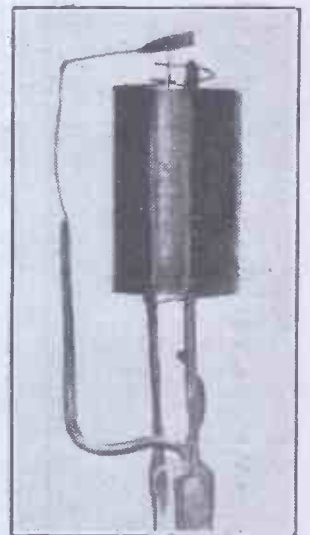

The three electrodes of the present-day valve—the filament, grid and plate.

(Continued on next page.)

THE QUEST FOR THE COLD VALVE.

(Continued from previous page.)

rapid electron drift which forms the current. It must be noted, however, that only the planetary electrons of the atom are concerned in this electron drift, the nuclear electrons being too firmly fixed to be moved in that manner.

When a wire or a filament is heated, the energy of the planetary electrons increases, so much so that a number of them literally jump out of the attractive sphere of the nucleus of the atom. Thus, a valve filament heated to redness is continuously ejecting electrons from its surface owing to the additional energy of motion which has been given to the electrons by the influence of heat.

Action of Heat.

We have now two important facts to notice. The first is that, as in the case of a wire carrying a current, only the planetary electrons are affected by the heating energy, and that the electrons associated with the protons in the atomic nucleus remain fixed. The second fact about which we ought to be quite clear is that it is not necessary to pass a current through a filament or a wire in order to obtain an electron emission. A wire will emit electrons if it is heated to redness in the flame of a candle. A red-hot poker or soldering iron is an electron emitter also. Thus, in a valve it is not the current passing through the filament which serves to make the latter emit electrons. It is the heat energy which does the trick, and the filament current is only used on account of its extremely great convenience for use in heating the filament.

All material bodies emit electrons to a greater or less extent when they are heated, but, nevertheless, they do not all emit the same number of electrons at the same

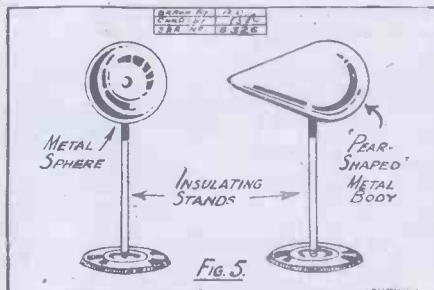

temperature. To take a practical example. A plain tungsten filament does not throw off an electron stream sufficiently abundant to form the conducting path in a valve until its temperature is raised to a bright red heat at least.

If, however, such a filament is given a coating of certain rare metal oxides, or if similar materials are incorporated in the body of the filament, the latter, under these conditions, becomes endowed with the property of being able to emit an abundant stream of electrons at a very much lower temperature. This forms the principle of the well-known dull emitter

valves, and the development of this basic idea within the last few years has resulted in the production of valve filaments which, even at a temperature very considerably below that of dull red heat, give rise to an electron emission equal to that obtained from a plain tungsten filament working at bright red heat.

Different Principle Required.

In view of the great improvements which have been made and are still being effected in the sphere of these low temperature emitting filaments, one is sometimes apt, rather hastily to conclude that it is in this direction that the solution of the cold valve lies. A little thought, however, will show that such a solution to the problem is impossible. For, as only the outer planetary electrons of the atom are concerned in this electron emission from the filament, it follows that some external supply of energy must always be needed in order to displace the electrons from their orbits. The energy which does this in the most convenient way is heat energy, and although it is very possible, of course, that filaments may be devised which will be able to give a satisfactory electronic emission at temperatures even still lower than those at which the present dull emitter filaments work; it is nevertheless a logical conclusion that a valve working on this principle will always require some external source of energy, however small, to be applied to its filament in order to get some of the planetary electrons away from the attractive spheres of the atoms.

The cold valve, therefore, must of necessity be devised on a different principle. Such a valve requires a filament, or something in place of the filament, which will emit a satisfactory stream of electrons without the application of any external source of energy.

The Radium Valve.

Now we have a number of spontaneously electron-emitting materials available in the form of the radio-active substances, particularly the salts of radium. Radium and its various compounds all emit perfectly spontaneously three types of emanation or "rays," these being known as the "alpha," "beta," and "gamma" rays. The alpha rays from radium are really positively charged atoms of helium. The beta rays comprise electrons, pure and simple, whilst the gamma rays are not material particles at all, but are in reality a species of wave-motion in the ether.

It would be with the beta rays that the production of a radium cold valve would be concerned. The electrons which comprise the beta rays come from the nuclei of the atoms. They are shot out spontaneously by some mysterious internal disruptive

force in the atom, and their production is well-nigh a perpetual one, for a radium salt will go on generating a continuous stream of beta ray electrons for at least 20,000 years.

In a cold valve working on this principle, the radium salt contained in a small capsule would take the place of the filament as it stands at present. This would be sealed up in the valve, together with the anode and grid, or, alternatively, some other device to take the place of these components.

A sketch of this hypothetical future cold valve employing a radium compound is given at Fig. 2, and it is interesting to compare it with an actual photograph of the internal parts of the present-day valve (Fig. 3), and also with an illustration of the valve's precursor—the Edison electric lamp of 1879 (Fig. 4).

It would probably be possible to produce commercial cold valves of this nature at a cost round about £15-£20, a price which, considering the fact that with ordinary care such a valve would last not only for one lifetime, but for a few thousand lifetimes, could not, after all, be called excessive.

A Further Method.

The principle of the cold-working radium valve would be based on the fact that radium compounds act as permanent emitters of electrons. However, the radium valve is not so practicable as it looks at first sight. In fact, the whole idea is a veritable quagmire of snags. In the first place, the electron stream emitted in the form of beta rays from radium compounds is absolutely uncontrollable in amount.

Again, in an ordinary valve, nothing but electrons are shot off from the filament. In a radium cold valve, however, the emanation from the "filament" would consist of negatively charged electrons, positively charged helium atoms, and short-wave ether vibrations all mixed up together. These would surely cause trouble, especially in view of the fact that the gamma rays of radium (short-wave ether vibrations) give rise to still further waves.

Another suggested principle for the basis of a cold valve was put forward some five or six years ago, and, indeed, a few experiments were carried out on the subject.

Glance at Fig. 5 for a moment. Here are represented two metallic objects mounted on insulating stands. If such objects are equally electrified, the spherical one will retain its charge for a long period, but the charge on the pear-shaped body will quickly leak off at the pointed end.

Now, by having bodies which are sharpened off to extremely fine points, and by charging them up electrically, it is possible to produce a silent discharge from the sharp point. This discharge is, of course, nothing else than a stream of electrons. In a valve the filament might be replaced by a pointed metallic body. This body would derive its charge from the H.T. battery. Rapid accumulation of the charge on its surface would take place, and then the charge would leak off continuously in the form of an electron stream.

The reader will now see that the cold valve is really a very difficult proposition. Nevertheless, it is not to be doubted that at some future time—probably a distant one—the cold and permanent valve will make its appearance and oust all its predecessors.

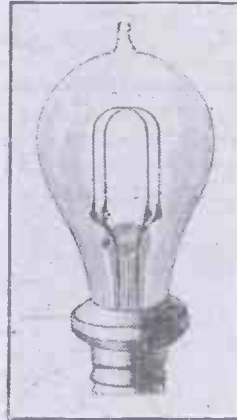
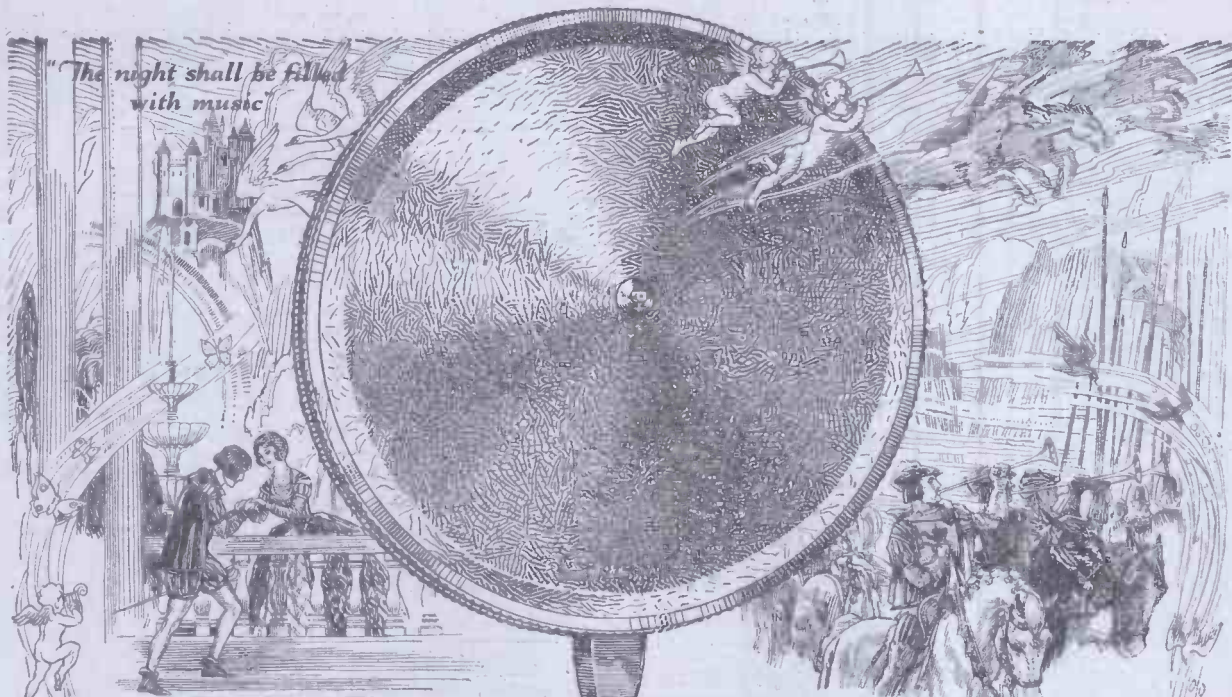

Fig. 4. The precursor of the modern valve.



The New

CONE **LOUD SPEAKER**

Cultured refinement, unequalled delicacy, accuracy and fidelity of reproduction are idealized in the new GECOPHONE Cone Loud Speaker. The artistic lines give to it a charm of its own; and the coin-bronze finish of the metalwork, with the self-coloured and beautifully-grained cone, place this instrument far above the ordinary.

It is perfectly balanced, the base being heavy and generous in dimensions. The cone can be tilted to any angle desired.

The moderate price of the GECOPHONE Cone Loud Speaker permits all to experience the joys of pride of possession, and the infinite satisfaction that ensues after the best has been strived for, and gained.

PRICE SIX GUINEAS

GECOPHONE

**BRITAIN'S BEST BROADCASTING
SETS AND LOUD SPEAKERS**

The G.E.C.-your guarantee

Sold by all Wireless Dealers and Stores.

Advt. of The General Electric Co., Ltd., Magnet House, Kingsway, London, W.C.2.

SOME VALVES ARE VALVES

(CONTINUED)

IT was surprising when the first "Cosmos" SHORTPATH Valves were put on the market, only some two years ago, the number of letters received from purchasers to whom the S.P. Valves came as a revelation. They could not understand it.

Now, of course, the Valve is well known and in the greatest demand, not brought about by immense sums spent in advertising—relatively speaking, very little money is spent in this direction; the supreme position the "Cosmos" S.P. Valve has attained is largely due to the generous personal recommendation of the enthusiastic constructor, who, on to a good thing himself, must let his friends into it too.

And how were such revolutionary results obtained? Not by mysterious filaments, though S.P. filaments are of the very best oxide-coated type; not by extraordinary manufacturing skill or marvellous supervision, although the Metropolitan-Vickers Electrical Co. are recognized throughout the world as setting a very high standard in such matters. No, the secret lies in the discovery of an entirely novel and scientific method of construction, marking the greatest advance in Valve construction since their conception.

SHORTPATH is not merely a name, it means something—namely, that this method of construction provides the shortest possible path for the electrons to travel, and it is this that enables such remarkable results to be obtained. "Cosmos" Valves also have this distinction: they are designed to be most efficient for a particular purpose. They are not general purpose Valves in the commonly accepted sense, and while they will function admirably in many positions, there is always one particular application in which they will give super results.

It is a significant fact that at the Manchester Wireless Exhibition, in the £500 Wireless Research Competition, all prize winners in the Four-valve Receiving Set class used "Cosmos" SHORTPATH Valves.

1st prize winner used 4	"Cosmos"	S.P. Valves.
2nd " " 3	" "	" "
3rd " " 2	" "	" "
4th " " 1	" "	Valve.

"Cosmos" SHORTPATH Valves are and always have been *tested dynamically*.

If you are interested rather in Sets than Valves, ask your dealer for the "Cosmos" Five-Valve Musician's Set, as supplied to recognized musical authorities like Sir Landon Ronald and Mr. Percy Scholes. Fitted with "Cosmos" Valves, to a critical ear, such a set is a pure joy. The Baby Grand Three-valve Set for smaller rooms has the same distinctive purity of reproduction.

Cosmos

VALVES

Advert. of Metro-Vick Supplies Ltd., 155, Charing Cross Road, London, W.C.2

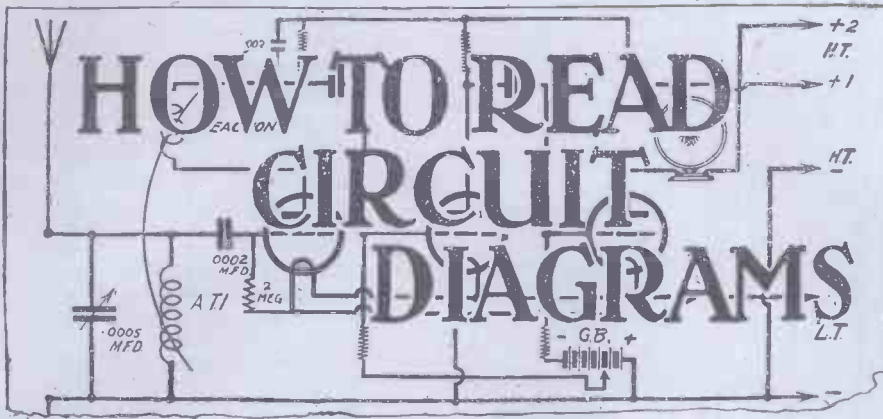

By C. E. FIELD, B.Sc.

Part I. Discussing some of the simpler circuits and the more usual symbols employed.

ONE of the many difficulties encountered by wireless amateurs is that of understanding the circuit diagrams with which nearly all wireless articles are illustrated. Many readers ask for diagrams to be given in pictorial form, but there are several reasons why a theoretical circuit diagram is much to be preferred.

For one thing, of course, a circuit diagram is very easy to construct, and the full

First of all, it is necessary to be able to recognise the symbols which are used to represent wireless components.

This presents very little difficulty, because the symbols employed are really very simple sketches of the apparatus which they represent, as will be seen from the accompanying list.

A few words of explanation in connection with one or two of these may prove helpful.

No. 1, of course, represents wires crossing one another without touching.

The symbol given in No. 4 is used to represent a battery, because a single cell consists essentially of two plates immersed in a conducting liquid. These are represented by two strokes, one short and thick, the other longer and thinner, and one pair of these indicate a single dry cell, or two-volt accumulator, and so forth. The longer stroke is the positive terminal.

Battery Symbols.

The battery employed for lighting valve filaments in a wireless set is usually referred to as the low-tension (L.T.) battery, to distinguish

it from the high-tension (H.T.) or plate battery shown in No. 5.

A resistance, as represented in No. 6, may have a low value, as in the case of a filament rheostat, or it may be exceedingly high, as in the case of a grid leak. Low resistances are measured in ohms, for which the Greek letter ω is employed, high values being measured in megohms, symbolised by Ω .

One megohm is one million ohms, so that when we see a grid leak, for example, labelled 2Ω , we know that the resistance between its terminals is two million ohms.

Condensers, Nos. 8 and 9, are measured

in terms of their capacity, which is expressed in microfarads (mfd.). If a diagram shows a variable condenser with, say, .0005 printed by it, this means that the maximum capacity of the condenser in question is .0005 microfarad.

The symbol given in No. 10 represents a coil of wire, such as a cylindrical, honey-comb, or spider coil. The same symbol is employed whatever the function of the coil, which might be an aerial tuner, or a high-frequency choke, or an anode coupling coil.

Transformers and Coupled Coils.

The value of an inductance coil is properly expressed in henries, but, for convenience in wireless work, it is customary to mark a coil with the number of turns of wire with which it is wound.

When two coils are wound and mounted in such a way that one influences the other, they are said to be coupled, and constitute a high-frequency transformer, shown in

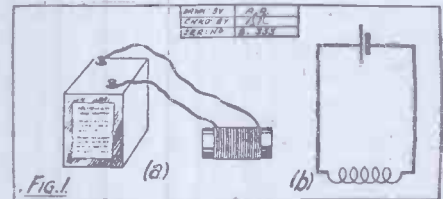

No. 18. If their relative positions and degree of coupling are adjustable, the symbol given in No. 13 is employed. This might represent a loose-coupler, consisting of one cylindrical coil sliding inside a larger one, or two plug-in coils mounted in a two-way coil holder.

With regard to the symbol for a valve, given in No. 17, the dotted line in the centre represents the grid. Below this is the filament, and at the top is the plate, or anode.

These three portions are connected to four legs at the base of the valve. It will be seen that if opposite pairs of valve legs are joined, a cross is formed. The head of the cross is the grid terminal, the ends of the cross-arm are the filament pins, and the foot of the cross is the plate connection.

It is, perhaps, hardly necessary to add (Continued on next page.)

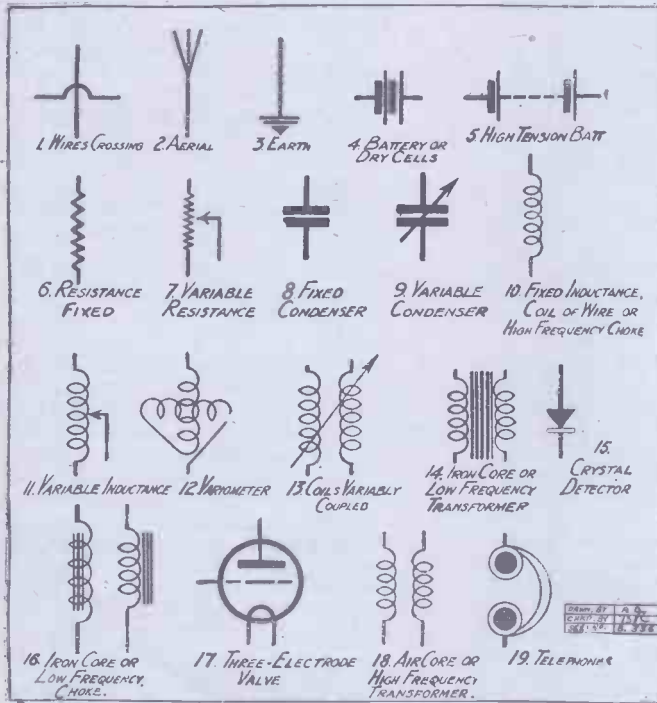

wiring of the most complicated set may be sketched out in one or two minutes.

This, however, is a minor point, the greatest advantage being the ease with which it is possible to see at a glance the type of circuit, and to gain an idea as to how it operates.

Theoretical Circuits Best.

No one who can understand a circuit diagram would ever dream of using the pictorial form, and there is no reason why everybody interested in wireless should not be able to discuss circuits with the aid of intelligible diagrams.



The 2-valve Lodge "N" Receiver, as made by the Cleartron Radio Co.

HOW TO READ CIRCUIT DIAGRAMS

(Continued from previous page.)

that straight lines represent connecting wires, but it does not follow that in the construction of a set the arrangement of wires is exactly the same as that shown on the circuit diagram. Similarly, the theoretical diagram for a given circuit may be arranged in a variety of ways:

Let us take some examples.

If we wished to join a battery to a coil of wire in order to cause a current to flow through the latter, the two battery terminals would be joined respectively to the two ends of the coil, as shown in Fig. 1a. In a theoretical diagram, similarly, each side of the battery is connected (by a line) to one end of the spiral, which symbolises the coil (Fig. 1b).

Now, imagine that we require to connect up three coils of wire to the battery in such a way that the current from the latter divides into three portions, one flowing through each coil.

Synonymous Circuits.

Perhaps the most obvious way of carrying this out is to connect three wires to each battery terminal as shown in Fig. 2a, but there are many ways in which the same connections might be shown in a diagram.

For instance, in order to render a diagram more easy to follow in certain circumstances, the circuit might be given in any one of the forms shown in Fig. 2.

At first sight it may appear as if these diagrams represent different circuits, but this is not so, for it will be seen that in each case a current leaving the battery, say, at A will divide and take three paths to B, C, and D, pass through the coils to E, F, and G, and return to the battery at H.

This example is given to emphasise the fact that there are a great many different ways of drawing a diagram of one circuit, or, alternatively, of connecting

up a circuit represented by one particular diagram.

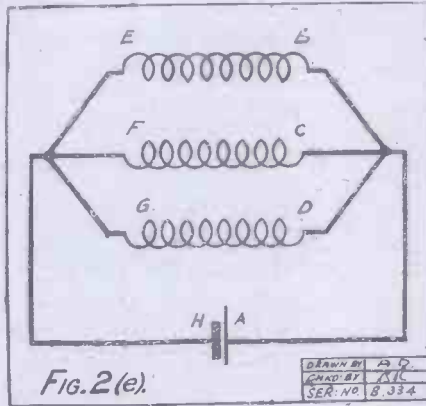

Although, in practice, it is generally desirable to keep all wiring as short as

NOVEL RADIO BAROMETER

By NORMAN C. McLOUD

WATCHING the heavens for the signs of a coming storm is one of the uses of radio few people probably suspect, yet on the roof of Waterside Station, in New York, there is a radio apparatus the sole function of which is this sort of mechanical star-gazing.

It serves the interests of the New York Edison system generating stations. A sudden storm, the lowering of the clouds obscuring the daylight means that in thousands of New York offices and homes the electric light is suddenly switched on; within two or three minutes this may mean that the power required is increased by something like 60,000 horse power.

Should the generating stations be taken by surprise by such a sudden demand, it would be unable to cope with it; electricity, in such large quantities as are required by the city of New York, cannot be stored, but must be generated as it is required. Yet it is obvious that they cannot be run on the extravagant lines that would be rendered necessary were the average power generated vastly superior to the amount normally used. Early notice of a coming of the storm clouds is therefore essential to the efficient and economical working of the system.

For this purpose, in the days before the coming of radio, a man used to be employed doing nothing else than scouring the heavens with his telescope, watching the gathering of the clouds. This was the best possible, but it was not very

possible, it must be remembered that so long as two points in a circuit are shown joined by a piece of wire, it does not matter how long the wire is, or how often it may divide, provided that the current flowing along it does not have to pass through other apparatus on the way.

In Fig. 2, for instance, H and G are joined directly in b, whereas in d, G is on a branch from the wire joining H and E. In Fig. 2c they are almost together.

In all these cases the points G and H are joined by lines (wires) without intervening apparatus, and so may be regarded as being electrically the same point.

Once this fact is fully appreciated, half the difficulties in connection with the use of circuit diagrams disappear.

In another article we will consider some combinations of components which appear in nearly all wireless circuits, and also some of the expressions which constantly recur in technical articles.

satisfactory, for a storm will sometimes break with great suddenness, and the watcher could not notify the generating stations in time since they require about an hour to get activity pitched up to the required degree.

With radio it is different. The apparatus gives warning of a storm when it is still 50 miles away, in many cases hours before it actually breaks over the city.

This little radio device, unlike an ordinary receiving set, is helped, not hurt, by static; the atmospheric conditions that operate the storm detector are precisely those which cause static.

Automatic Warning.

The storm detector consists of an ordinary radio aerial, a short-circuiting switch, a spark gap, a coherer, a relay and battery, a bell, and a condenser with an earth condenser.

It stands behind the desk of the System Operator at Waterside, upon whom rests the responsibility for the maintenance of efficient service throughout the city. On the big board in front of the desk are hundreds of little coloured lights indicating the conditions of every generator and every transmission line; meters show the capacity of the entire system and the current transmitted on the various feeders. On the desk is direct telephone transmission with 80 men. At the left of the desk is a tele-

NEXT WEEK

Don't Miss "P.W.'s"

SPECIAL XMAS NUMBER

ORDER YOUR COPY NOW

graphic signal apparatus, similar to that used in the fire department, enabling the system operator to give a message simultaneously to all the forty sub- and generating stations in the system.

When the radio storm detector gives warning of the approach of the clouds, by quiet, intermittent ringing, the system operator is thus able to broadcast to all stations the signal to get ready for a bigger output. As the storm draws nearer, the ringing gets more frequent and more insistent, thus affording exact guidance to the operator until the very moment when the clouds burst over the city.

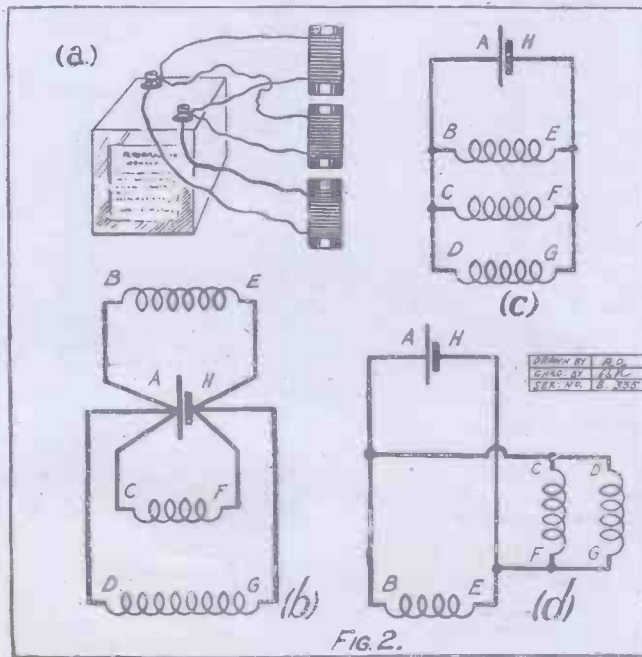

ORMOND GANG CONDENSERS

THESE CONDENSERS are similar to our Low Loss models and are designed for use in circuits of the "Single Dial Control" Type.

EACH IS composed of two or more separate condensers, insulated from each other, of maximum capacity .0005 microfarad.

The ORMOND 3-Gang Condenser

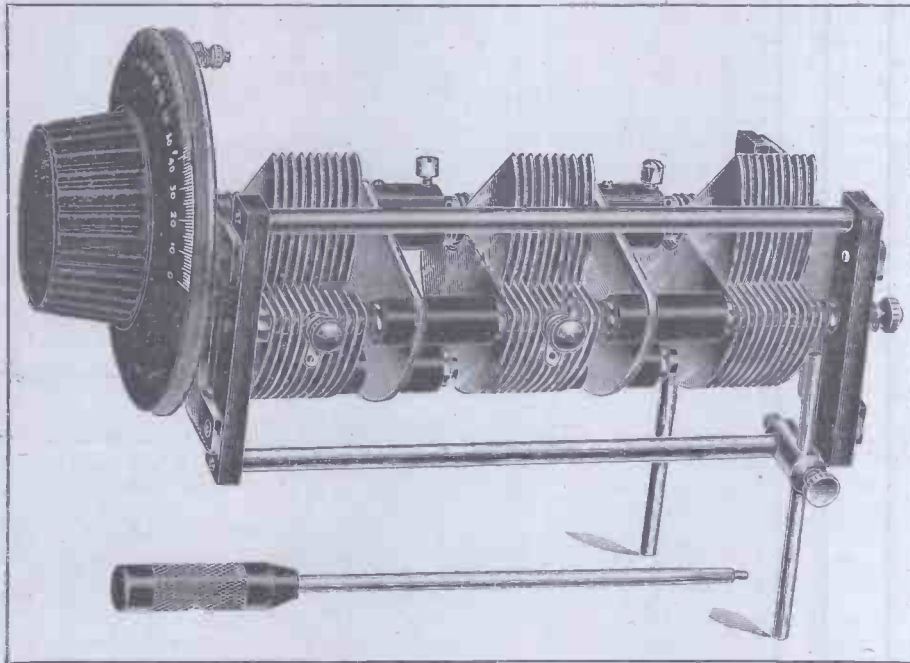

Mark the low prices:—

Two-Gang 32/- Tri-Gang 40/- Four-Gang 50/-

An easy independent adjustment of rotors is provided, for balancing out circuit variations.

Special ball bearings on each rotor, ensure a smooth action, giving a liquid-like movement, facilitating precise tuning with noiseless operation.

Construction is very rigid.

An anti-capacity earthing shield is supplied which may be insulated from Condenser and earthed by separate connection.

For panel mounting the "One Hole" fixing method is used, and two adjustable legs are attached to truss rods for rear support.

Complete with 4 in. Knob and Dial, shield, and Tommy Bar with insulated handle for bank adjustment.

Terminals and soldering tags for connections.

These Condensers are not fitted with 'slow-motion' movement.

When fitted with 4 in. Slow-Motion Dial ratio 55-1, these prices are 8/- extra respectively.



199-205, PENTONVILLE ROAD, KING'S CROSS, LONDON, N.1.

Telephone: Clerkenwell 9344-5-6.

Telegrams: "Ormondengi, Kinross."

Factories: Whiskin Street and Hardwick Street, Clerkenwell, E.C.1.

Continental Agents: Messrs. Pettigrew & Meriman, Ltd., "Phonos House," 2-4, Bucknall Street, New Oxford Street, W.C.1.

ANNOUNCEMENT BY THE BOWYER-LOWE CO. LTD. LETCHWORTH. HERTS.

The BOWYER-LOWE PRINCIPLE

is to give clear evidence, by performance, of being beyond comparison—that evidence is unmistakable in the Bowyer-Lowe range of Components now available

Wireless enthusiasts and dealers everywhere recognise the significance of the Bowyer-Lowe name-plate on components. It is a definite Guarantee of mechanical and electrical perfection, as a free replacement is effected within twelve months of purchase should a component prove unsatisfactory.

Look for the name—Bowyer-Lowe—it stands high in the company of fine Radio products.

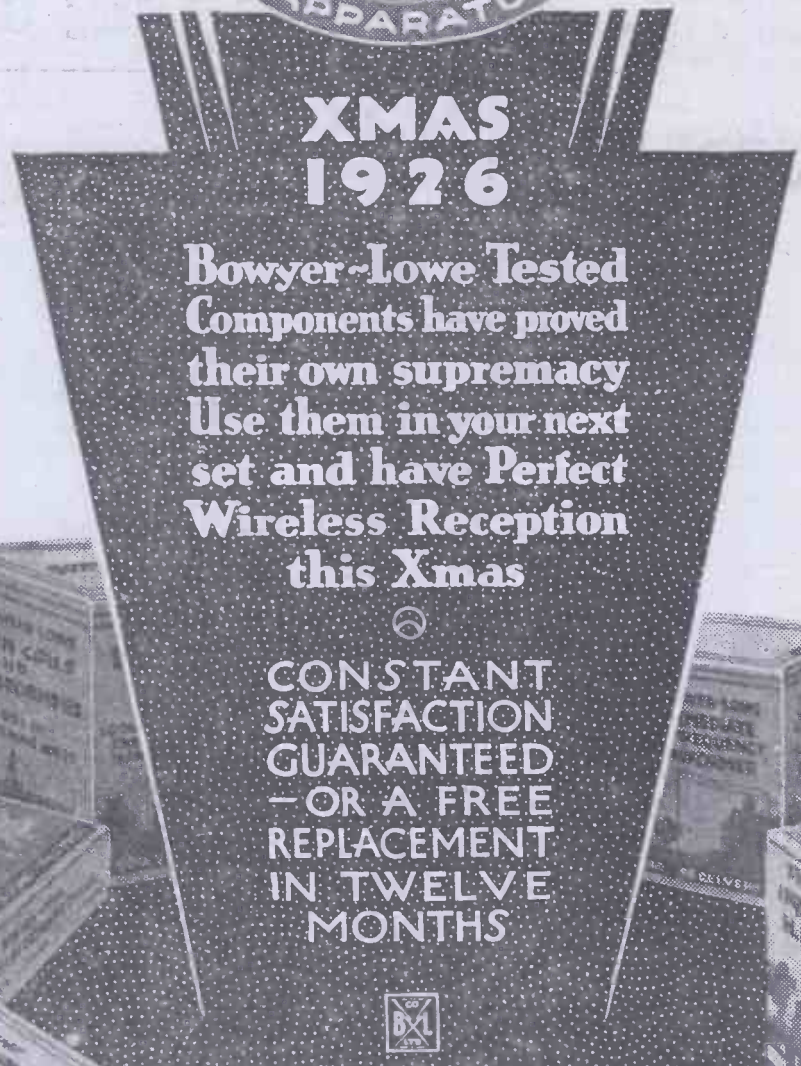

XMAS 1926

Bowyer-Lowe Tested Components have proved their own supremacy Use them in your next set and have Perfect Wireless Reception this Xmas

CONSTANT SATISFACTION GUARANTEED — OR A FREE REPLACEMENT IN TWELVE MONTHS

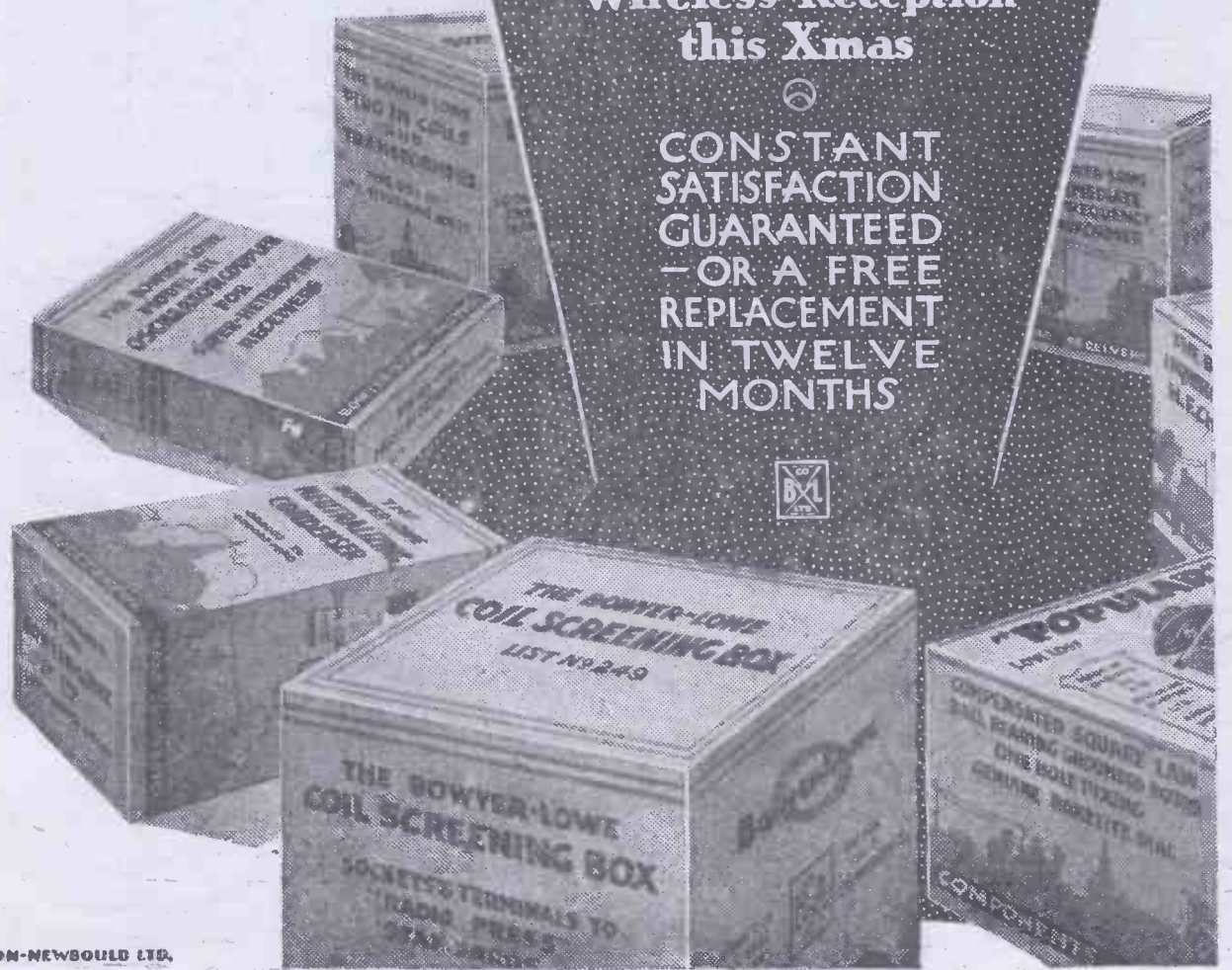

The RADIO CONSTRUCTOR

Edited by PERCY W. HARRIS, M.I.R.E.



This valuable eight-page supplement, devoted to the interests of amateur wireless constructors, appears every week in POPULAR WIRELESS. Tell your friends about it, for it is only in "P.W." that they will find the radio articles by the leading constructor expert, Mr. Percy W. Harris.

THE wireless correspondent of a well-known London daily paper, in devoting a column to the Hale circuit and the remarkable results he has achieved with it, was venturesome enough to declare, "I am positively convinced that the circuit was invented by accident." So anxious is he that the reader should grasp this point of view that he finishes off the article with the same statement: "I repeat, I am certain it was discovered by accident."

It so happens that I know the facts relating to the Hale circuit very accurately. Mr. Hale is the inventor of several devices and a very careful and painstaking research worker. He has a number of wireless inventions to his credit, and the Hale circuit, which I had the privilege of introducing to the wireless public in the first issue of "The Radio Constructor," was the result of many months of investigation and careful test, and was logically worked out from certain deductions.

Chance Discoveries.

Yet, although our newspaper correspondent is wrong in this respect, it is quite true that many important inventions have originated from chance discoveries, and in radio such discoveries may come the way of almost any experimenter, provided he is sufficiently observant. I always do all I can to encourage experimental work, and I would like to take this opportunity of impressing upon every reader that he has an excellent chance of discovering something important. So many experimenters have said to me, "What is the use of my trying to discover something new? Look at all the famous scientists who are investigating radio in well-equipped laboratories. What chance is there for me to pit my few months' experience against theirs of many years? Besides, I cannot afford the elaborate apparatus necessary for such work."

This attitude is quite wrong. Firstly, the trained investigators, working either in private laboratories or in conjunction with big commercial companies, have all far more problems waiting solutions than they can possibly handle. It must not be forgotten that in a commercial company it is the commercial problems that call for first solution. Senatore Marconi himself told me recently that his company had given comparatively little attention to telephony on very short waves, owing to the need of developing the telegraphic side for commercial purposes. Major Armstrong, when he discovered regeneration (or "reaction," as we call it in this country), had just left college and lacked funds to take out a patent.

Armstrong and the Lawyer.

Undaunted, he went to a lawyer friend and swore an affidavit relating to certain rough sketches and notes which he then had in his possession. Years later, in a law action, the fact that he had made this declaration was taken as proof of priority of invention,

although the actual patent had a later date. His rights were purchased by one of the big commercial companies of America for a sum sufficient to allow him to live in affluence for the rest of his life.

From time to time I meet well-known research engineers, and only too frequently suggestions are made that amateur experimenters should develop certain ideas. The Hale circuit uses no more parts and no different components from those built into a thousand sets throughout this country. It was evolved as the result of logical reasoning and gives, as readers are certifying, very remarkable results. May there not be many other combinations with possibilities of still better results?



Mr. G. W. Hale, inventor of the "Hale" circuit which is proving so popular with our readers.

Don't Take it for Granted!

Do not take too much for granted in radio experimental work. In particular, beware of assuming that an arrangement will not work because it does not fit in with preconceived theories. When enough data has been collected on a particular subject, when this data has been sorted out, collated, and studied, we can frequently deduce laws, and these may prove very useful in predicting what will happen in still other sets of circumstances.

But do not forget that much of our radio theory is based on very incomplete data. Only the very new experimenter is dogmatic on theoretical subjects. Too many people confine their wireless experimental work to sketches on the back of an envelope. Within the last twenty-four hours I have received a letter from a critic of the Hale circuit pointing out a number of points "wrong with it," and indicating how, "theoretically," it cannot equal a much older circuit which he names. But there is internal evidence in the letter that he has not even tried the circuit, and his theory is certainly erroneous.

The Walking Stick.

By all means learn all the useful theory you can, and try and reason out *why* circuits work as they do; but always remember that, however good a walking-stick theory may be, it is a very bad crutch and, if you rely too much upon it, will let you down badly.

In the next issue will appear first details of the "King of the Air," which, in its final and fully developed form (slightly modified, by the way, from the first scheme) gives remarkable results in selectivity, sensitiveness and purity. Those readers who think that quality must be sacrificed in obtaining long-distance reception will be agreeably surprised when they build it!!

Percy W. Harris

All Hail the HALE!

"IT DOES BRING THEM IN!"

Dear Sir,—You were correct in saying that the Hale receiver set was astonishing. It is great! Here are my results of last evening on this simple set wired as in Fig. 1, using 45 volts only H.T. My aerial is 50 ft. single, about 30 ft. high, screened by trees and houses.

2 LO came in loud and clear on my Dinkie loud speaker. Other results were:

Dial Readings.

5 degrees	Spanish station, "Cartagena."
12 "	French station.
15 "	Tenor singing (? language).
20 "	Orchestra.
26 "	Opera (? Leipzig).
32 "	German station, a talk (? Hamburg).
35 "	Young lady singing (? language).
100 "	Frankfort.
110 "	Birmingham.
122 "	Brussels.
140 "	A band.
180 "	Duet with orchestral accompaniment.

Without magnifying the results that one can get I can only say that "it does bring them in."

Wishing you luck, and also "Popular."

Yours, etc.,

L. SHERSBY.

Beverly Road,
Bermundsey, S.E.

REALLY ASTOUNDING

Dear Sir,—It is with pleasure that I submit my experiences with an experimental "Hale" circuit receiver, for, in my opinion, you deserve the best thanks of every enthusiast for bringing to your readers' notice such an interesting design.

You could have used the word "astounding" in classifying it, for it is nothing less.

A "hook-up" using home-made basket-weave coils, "Brownie" crystal, permanent detector (a badly used one, too), with D.E.5 valve, given voltages as recommended by the makers on plate and grid, brings in during daylight (i.e., prior to 4 p.m.) loud on Cardiff, Manchester, Newcastle, Plymouth, and Birmingham, with many foreign stations I have been too impatient to identify. On loud speakers (Primax and Sterling Baby in series), 5 X X, Radio-Paris, Hilversum, Bournemouth and 2 LO, at strength sufficient to permit persons of normal hearing who are listening to get comfortable reception anywhere in a 16 ft. by 15 ft. room, speech being word perfect.

Appreciating your articles to the full, believe me to remain,

Yours truly,

W. M. CARR.

Hove, Sussex.

IN SPITE OF DIFFICULTIES

Dear Sir,—Congratulations to Mr. Hale and yourself for designing and publishing the Hale receiver. With a "hook-up" collection of more or less scrap parts, and on a small indoor aerial only 8 ft. 9 in. from the ground and 3 in. from the ceiling, I got London at really good loud-speaker strength. The volume equal to and much better than a two-valve Reinartz receiver used on the same aerial but made with first-class components.

Bearing in mind that the aerial was so poor—it will not work a crystal set—the variable condenser, an ordinary cheap all-loss pattern of two years ago, the coil holder suffering from severe rheumatism, the valve holder of guaranteed maximum capacity, the crystal detector of the whisker type, and that no condensers were fitted across either the loud speaker or the H.T. battery, no distant reception was to be hoped for. The valve and transformer were of the best quality, being P.M.4 and a Marconiphone Ideal Junior respectively.

Owing to the large capacity of the aerial it was necessary to insert a small fixed condenser in series with it before a proper reaction effect could be obtained.

Having in the past made many sets, I can honestly support your "nine good points" (with the exception of No. 1). Upon each of these points the Hale receiver is superior to any other reflex set I have so far handled.

In fact, I am so impressed with the results obtained that I shall build the set with the highest quality components, and use the Reinartz form of reaction, which is, in my opinion, miles ahead of the swing coil type I used in this hook-up, and then probably

I shall write and support your point No. 1.

Wishing you every success.

Yours faithfully,

F. C. YEOMANS.

Newton Avenue,
Acton, W.3.

60 MILES FROM DAVENTRY

Dear Sir,—I hooked up last week's Hale circuit and used practically all parts as per "P.W." and here, 60 miles (approx.) from London and Daventry, I get results too strong for 'phones, but hardly loud enough for speaker, and it is very fine tuning. In fact, I can get three stations in two degrees of condenser quite distinct from each other. That is with Goswell quality coils and Marconi D.E.6, with 2 volts L.T. and about 120 volts H.T. I have tried several transformer stage valves at 2, 4, and 6 volts, also power, but the Marconi D.E.6 is by far the best, and this is only on my testing aerial, about 30 ft. high and 60 ft. long, with about 30 telegraph wires a few feet above my aerial. I have still to test it on my big aerial. The reaction is controlled beautifully and smooth with an Ormond 0003 variable condenser.

Yours faithfully,
S. S.

Soham, Cambs.

"OUT AND AWAY THE BEST!"

Dear Sir,—Re "Hale Receiver." I made up this circuit last week with a number of components I had about, viz., K.L. transformer, an old 5—1 ratio, two very ordinary condensers, Lissen H.F. choke, an ordinary cat's-whisker crystal, valve Mullard P.M.2.

Using a 35 aerial coil tapped in the centre, and a home-made 80 basket coil in the plate circuit, the

Here are a few of the hundreds of letters received. Have you tried the 'Hale' yet?

result was a very pleasant surprise. Quite up to the average two-valve for volume, and its purity delightful.

I adopted the Reinartz reaction, suggested by you, and beg to express my thanks for out and away the best one-valve I have yet come across. I do not see how more could be got out of a one-valve. Looks like finality. I am much struck by its purity of reproduction.

I tried other two-valve valves, but none functioned so well as the one mentioned (P.M.2). I also found a biggish coil in the reaction necessary. During the middle of the day I picked up Dublin and the relay station nicely with a one-valve amplifier behind it.

Again thanking you and wishing you every success in your endeavours to help amateurs,

Yours etc.,

JOHN H. LEEK.

Pendleton, Salford.

5 X X IN DEVON

Dear Sir,—Although I expect you will have been snowed under by letters of appreciation since you published details of the Hale receiver, yet I feel that I must add my "Thank you" to the others.

I altered the wiring, but not the lay-out, of my two-valve set to make up the one-valve Hale, and was more than astonished at the volume it gave, together with purity of signals; 5 X X simply barked. Although I only wired it yesterday, I have already added one recruit to this circuit. I do hope you will let us have particulars of a Hale receiver with one stage of neat H.F. following recent practice, and add to the indebtedness which everyone who tries the Hale must feel towards you and Mr. Hale.

Yours gratefully,

E. PRIESTLEY.

Budleigh Salterton,
Devon.



STUTTGART IN THE AFTERNOON.

Dear Sir,—As you have asked for letters, I am writing to thank you for publishing this most excellent circuit. I have tried many one-valves, and thought I had found finality in the set, of which I have been singing the praises of the past twelve months, and I am now astonished at the superiority of the "Hale."

I made the Hale up from odd components on a base-board in about twenty minutes, and was so satisfied with the results that I immediately started to modify my existing set.

I am using Reinartz reaction, and with a Radio-micro 3.5 valve and galena crystal and 30 and 60 Igantic coils, the result was excellent on the loud speaker from 2 LO, four miles, but I found an improvement in changing the transformer leads. I also tried a .001 fixed condenser across the transformer primary without appreciable difference. I then changed the valve for a Cosmo S.P.18 Blue Spot, with a further increase in volume, although I have only 56 volts on the plate.

I logged Stuttgart this afternoon at weak loud speaker strength, and got two other continental stations comfortably audible in the 'phones, and successfully cut out a local transmitter. Daventry comes in at better strength than I have had it before, but I cannot cut 2 LO. One trouble I have, and that is a strong hand capacity effect on the reaction condenser, and this is only evident in trying for distant stations. I can swing the condenser right round the dial on 2 LO without much effect, yet I get ample reaction on the same coils when trying for distant stations.

Yours faithfully,

A. E. AVENT.

Kilburn, N.W.6.

DID NOT SPEND 10/-

Dear Sir,—Following my letter of yesterday, I am very pleased to tell you that I have mastered the Hale one-valve set you designed in POPULAR WIRELESS after a little patience.

It is going splendidly. It is, as you claim, sufficient for the ordinary small room. I wish you could hear it, and no doubt your skill would put 50 per cent on its volume. I am asking my friends to come and hear it. I am working it thus: 90 volts H.T.; 4-volt accumulator; Marconi valve; grid bias, 1½ volts; Amplion loud speaker, A.R.111; resistance, an old one, but only just touches the coil of resistance, and I fancy it would even be better if I could take it off more; transformer Croix, 5—1, secondhand; Lissen H.F. choke; 2 mfd. condenser, secondhand, foreign make; jack I did not use, but fitted old terminals.

I did not spend 10s., but used up any old stuff I laid my hands on. Now I am only waiting for you to give us the two-valve design of same Hale receiver. If one valve gives the volume I am getting, what will two valves give?

I heard Paris and Daventry this morning through the loud speaker, but softly, of course.

Thanking you.

Yours faithfully,

THOS. PIZEY.

P.S.—Paris and Daventry: my wife, grandson, and granddaughter all heard this themselves, so I am not without witnesses.
Ilford, Essex.

The "4 Valve Family" Up-to-Date

SO many readers have written asking me to publish particulars of how to bring the "Four-Valve Family" receiver up-to-date that I have decided to make this the first of the older and popular receiving sets to be modernised in detail. The receiver, as many experimenters know, was first published two or three years ago, and for this reason lacks a number of refinements and improvements which have been popularised since that time.

The set consists in its essentials of a four-valve receiver, all the parts being mounted on a horizontal panel, as was the vogue at the time the set was first published.

The first is a high-frequency amplifier, and this is followed by a detector and two low-frequency stages, transformer coupled. The high-frequency coupling is of the tuned anode variety, reaction on to the tuned anode coil being provided with a movable coil holder. The aerial is directly coupled, and three terminals are provided so that series and parallel arrangements on the aerial tuning condenser can be made. No separate grid bias is provided on the low-frequency stages, as when the receiver was first produced bright emitters were in universal use with 6-volt accumulators on 4-volt filament. It was thus possible to arrange for a grid bias of two volts by connecting the grid return of the transformers to the negative battery lead, the filament resistance being placed in the negative leg of the valve. This arrangement gave the difference between the 6-volt accumulator and the 4-volt supplied to the filament—i.e. two volts—as negative grid bias, which with the voltages then generally used for high tension was reasonably adequate for the particular valve.

New Switching Scheme.

Furthermore, for simplicity's sake, one high-tension voltage was supplied to all valves.

One of the most popular features of the set was the switching scheme, which enabled several interesting arrangements and combinations to be tried. For example, it was possible to cut out the high-frequency stage and work on the detector alone or on the detector followed by one or two note magnifying valves. Similarly, one could use the high-frequency preceding the detector alone, the high frequency, detector and one note mag., or the high frequency, detector and two note mags.

The switching system to obtain this flexibility was rather peculiar, and in the arrangement published it was not very practicable to arrange for separate high tension voltages without making drastic changes. Lastly, a switch was provided so



By PERCY W. HARRIS, M.I.R.E.

For an expenditure of about thirty shillings this well-known and very popular receiver can be greatly improved in both selectivity and sensitiveness.

that one could change from telephones to loud speaker by simply turning a knob.

When there were few broadcasting stations working and selectivity was a factor of no particular value and we had not the specially designed high-frequency valves, power valves and the like, the set gave results which have been very flatteringly described from time to time. In studying the question of modernising the receiver it has occurred to me that relatively few structural changes and at a comparatively small expenditure of money would bring this set up to date in many features, giving results which, while not quite so good as a specially designed modern receiver, would yet be very little behind modern practice and, indeed, in most respects quite equal to the best. The changes I had in mind were as follows:

- (1) Introduction of separate grid bias for the note-magnifying valves;
- (2) Provision of separate supply for high frequency and detector, first note magnifying valve and second note magnifying valve;
- (3) Substitution of a coupled aerial for the direct connection, for the purpose of improving selectivity;
- (4) Neutralisation of the high-frequency stage so as to simultaneously improve both the sensitivity and selectivity;
- (5) The substitution of jack switching so that the voltages applied to the detector and note magnifying valves would not be

altered when changing over from one combination to another;

- (6) Provision of certain shunting condensers where needed.

I have now taken a standard four-valve family set and modified it in accordance with the above six points. I can say at once that both sensitivity and selectivity have been very considerably improved, while on the audio-frequency side the wide variety of valves now made possible, together with the correct adjustment of grid bias, makes the quality far better than was previously possible. As an example of the additional selectivity I may say that on the large outdoor aerial in the London district there is no difficulty in separating Radio-Paris from Daventry, and vice versa. For tests I have made in broad daylight have shown both stations to be free from one another when giving full loud-speaker results. On the shorter waves—i.e. between 300 and 600 metres—the selectivity is also very similarly improved, but it cannot be clearly defined for everyone by a general statement. For example, the man who

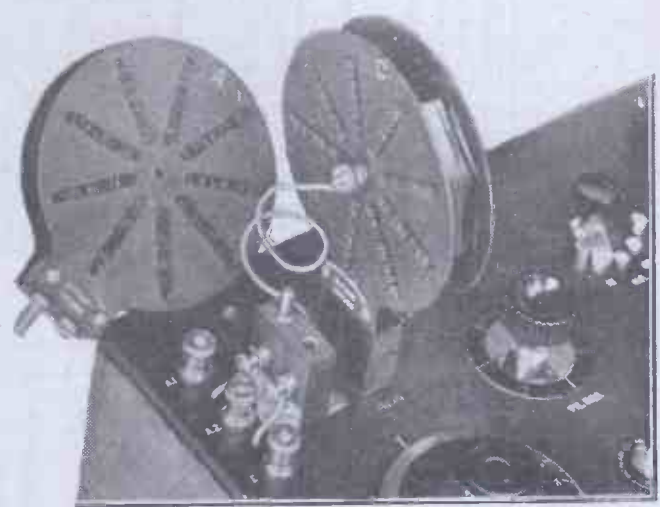

The first change. Adding a coupling coil for the aerial and a centre tapped coil for the grid circuit.

lives, say, five miles from a broadcasting station will not be able to get the selectivity given at, say, ten miles, but here at Wimbledon a very large number of stations can be received while London is working, and there was not a great deal of interference on Bournemouth's old wave from London.

Selectivity.

As I have already indicated in a weekly chat published in a recent issue, some readers will get better results and

(Continued on next page.)

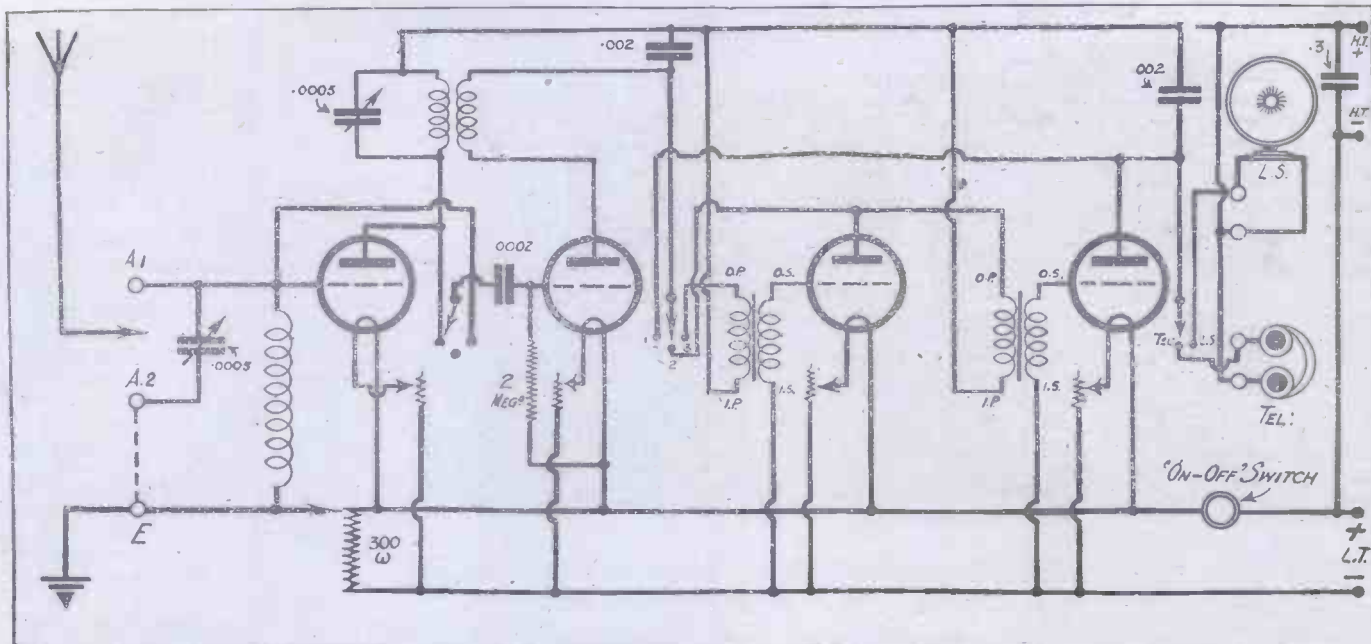

The original circuit. Compare this with the new arrangement below.

The "4-VALVE FAMILY"
UP-TO-DATE

(Continued from previous page.)

others not so good; so much depends upon local conditions.

Do not forget, too, that selectivity must be considered from two angles. First of all, we must consider the selectivity which enables us to differentiate between two stations with very little wave length separation and not very near to our receiver. Secondly, there is the selectivity which is dependent upon getting rid of the interference of a powerful nearby station. The first kind of selectivity will be found excellent on the modernised four-valve family receiver, and will give, I think,

practically everything that the reader may require. On the second type, however, the selectivity is not so good as the best modern

type of sets, but will still be very much better than the existing "four-valve family."
(Continued on next page.)

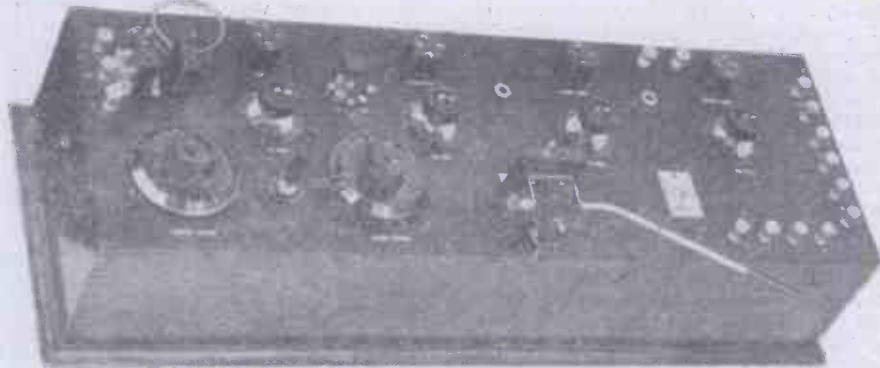

The external appearance is very little changed.

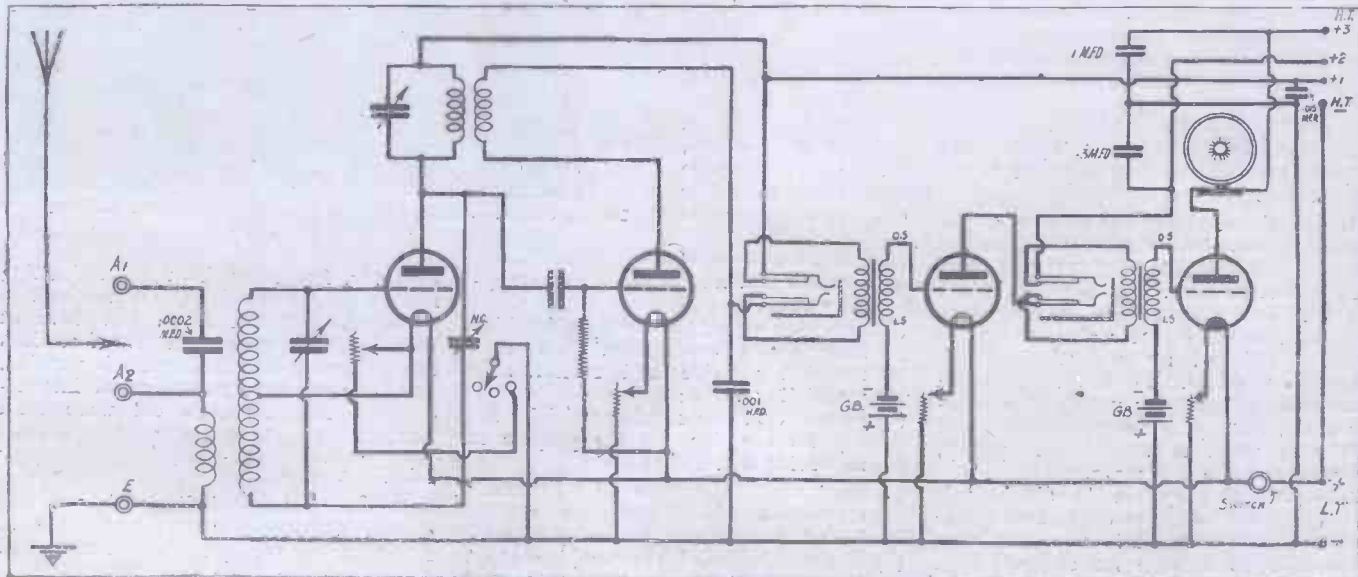

The new circuit, showing neutralising, grid bias, and separate H.T., with jack switches.

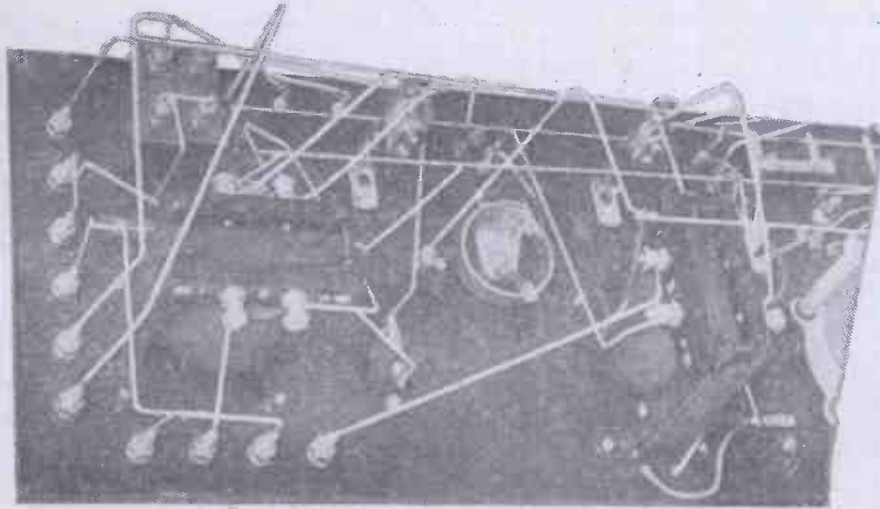

This photograph shows the grid bias connections.

witch-arms went, and two or three smaller holes. In each of the larger holes you can place the jacks, while the smaller holes can

ADDITIONAL PARTS REQUIRED FOR CONVERSION

- One fixed coil socket for panel mounting.
- One .0002 mfd. fixed condenser, T.C.C. Dubilier, Igranic or other good make.
- One neutralising condenser, one hole fixing type (Gambrell, Neutrovernier; Polar. Keystone, or other well-known makes.)
- Two terminals.
- Two double circuit jacks, Bowyer-Lowe, Frost, Lotus, etc.
- One plug for same.
- One 1 mfd. Mansbridge condenser (T.C.C., Dubilier, or other good make).
- One .01 mfd. fixed condenser.
- And in addition to present coils one or two centre tapped plug in coils to be described. Approximate cost of above additional parts, 30s.

The "4-VALVE FAMILY" UP-TO-DATE

(Continued from previous page.)

in this respect. Before long I hope readers who have made the changes in design will write to me and tell me the results they get compared with what they used to get, and a publication of such actual results from readers themselves will be a much better guide than any form of test report that I could give.

The circuit changes are shown in the previous page, in which the first depicts the original diagram as published with the set, and the second the circuit as modified. I have been able to arrange the changes so that the panel is not spoilt and that as far as possible the existing appearance is retained. Most of the changes are in the wiring beneath the panel.

The first step in modernising, then, is to remove the potentiometer (which is probably of the one-hole-fixing type) and substitute for it the modern neutralising condenser. Ignore the wiring for the

moment. Now remove the second and third switches ("one, two and three valves," and "telephones" and "loud speaker"), and you will have two large holes where the

be filled up quite unobtrusively by using black wax. A stick of such black wax is obtainable from any stationer's, where it is

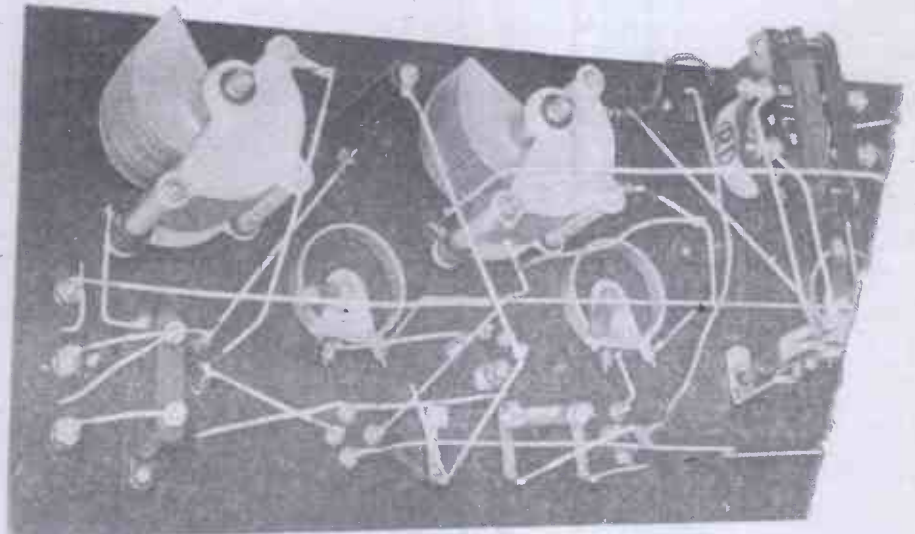

The black tube between the variable condensers is the neutralising condenser.

sold under the title of "Glitterwax" for children's modelling. The two holes for the terminals at the back of the panel must now be drilled, as shown in the photograph, and the single coil holder placed alongside the existing single coil holder at the left end of the panel. Near by the original coil holder drill a hole to take the flexible lead to the centre tap of the coil.

The terminal markings on the right-hand end of the panel will remain the same, but the four terminals in front, previously marked for telephones positive and negative, will now be used for grid bias, so remove any indicating marks you may have made by them. By the use of a jack you will be able to plug in after the detector valve, when by inserting the plug into the jack the next valve is automatically disconnected. By plugging in the second jack you will listen after the first note magnifying valve, the last valve being automatically disconnected.

(To be continued.)

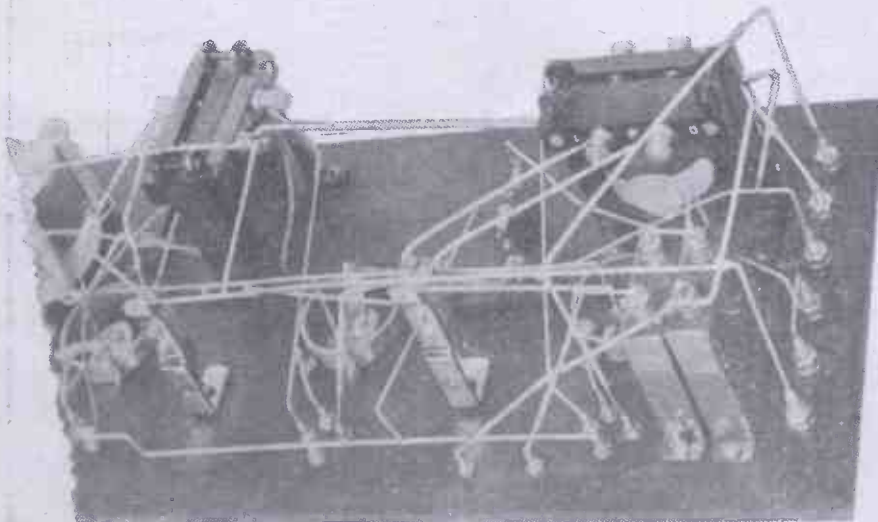

Showing the jack switches.

MORE ABOUT THE "STATION MASTER" SUPER-HETERODYNE

Valve Notes and Test Report.

By PERCY W. HARRIS, M.I.R.E.

SO far as the mounting of the Indigraph dial is concerned this is fully explained by the makers in a leaflet issued with the dials, so that I need not go into that matter here. In any case, only two holes are required for this, one to take the spindle of the condenser itself and the other to take the screw which prevents the dial rotating bodily. You will notice that a Mansbridge condenser connected on one side of the negative H.T., and the other side not to the positive H.T. terminal but to the positive telephone terminal. This shortens the wiring somewhat, and is quite satisfactory as the positive telephone terminal is directly connected to the positive H.T. terminal. Notice, too, that the positive flexible lead from the H.T. accumulator goes to the on-and-off switch, the other terminal of which is connected by stiff wire to the supersonic unit. Two flexible leads from the H.T. positive and H.T. negative respectively go to the H.T. battery which is contained in the back of the cabinet.

Valves.

In a fixed unit of this type where the coupling of the oscillator coils and other adjustments are fixed once for all there is not the same variety of valves available as is the case with some instruments. There is no filament resistance included in this set as it is intended that it should be used with 2-volt valves throughout, and the makers recommend the Marconi or Oram D.E.2 L.F. for the first socket, D.E.2 H.F. for the second, third and fourth, and D.E.2 L.F. for the fifth respectively.

While all of these work excellently, I have found the following combination to give good results. First, Burndept H.L. 213; second, third and fourth, Cossor 1 H.F.; and the fifth valve practically any 2-volt detector valve on the market. The use of 2-volt H.F. valves in the second, third and fourth stages is strongly recommended, and the first valve socket seems to be the tricky one.

While I have tried a number of valves in this I have not found that they are all equally good, as with some the set tends

to squeak on the lowest readings of the oscillator condenser. In any case they will have a slight tendency to squeak on readings below 10, but these will not be used on the oscillator condenser on the wave-lengths for which the receiver is designed. This tendency to squawk I have often found in sets using the combined detector and oscillator valve circuit. If the D.E.2 L.F. Marconi and Oram is used the reader will have the satisfaction of knowing that this is a valve recommended by the makers of the units.

If it is desired to use valves other than two volts a variable filament resistance can be mounted on the wooden panel acting as a partition between the set and the battery compartment, and the flexible leads from the positive of the accumulator



The "Station master" out of its cabinet.

can be taken to grid filament resistance and from the other terminal of the filament resistance to the on-and-off switch.

It should be remembered that this one filament resistance will control all valves, and should therefore be of such a value as to give the requisite control. For example, '06-ampere valves running from a 4-volt accumulator will require a variable filament resistance of 6 ohms.

Operation.

When the set is wired up put the on-and-off switch at "off," then the potentiometer knob as far as it will go to the left and set the two variable condensers at about 50 deg. each. Now join up the accumulator

and H.T. battery by means of the flexible leads indicated and join the frame aerial to the two front terminals. Connect a pair of 'phones to the plug, plug in the jack, and pull the on-and-off switch out, which will then be at the "on" position. Turn the potentiometer knob slowly in a clockwise direction until you hear the set oscillate, whereupon it should be turned back again below the oscillation point.

Now simultaneously rotate the two tuning controls and you will soon pick up your nearest station. If the set tends to oscillate turn back the potentiometer a little way in the anti-clockwise position. It may be found that there is a slight hand capacity effect on the oscillator (left) condenser due to the particular form of circuit used to combine the detector and oscillator functions in one, but you will soon get used to this and will be able to compensate for it on the tuning dial.

After about a quarter of an hour's practice you will find the searchings for stations a very easy matter, for the two dials read about the same over a large portion of their tuning range.

As with other supersonic heterodyne receivers, you will find that a given station will come in at two positions on the positions on the oscillating dial, one of which will probably be slightly better than the other. To give you a few readings that I have taken, with this instrument, using the frame with 2-volt valves and 60 volts H.T., I quote the following figures. I have taken only one reading of the oscillator condenser:

Station	Oscillator Dial	Frame Aerial Dial
Birmingham	45	15½
Bournemouth	31½	30½
London	28½	25
Breslau	36½	37
Unione Radio Madrid	29	27
Barcelona	22½	19
Oslo	31	29½
Hamburg	32½	31½
Dublin	34	34
Münster	36	36
Stuttgart	37	37
Berne	38	49
600-metre signal	72	94



A few of the types of super-heterodyne intermediate transformers used in my experiments. Some are British, some American.

A FOUR-SHILLING FRAME AERIAL FOR THE "STATION-MASTER" RECEIVER

By THE EDITOR

LAST week, in describing "The Station Master," a five-valve super-sonic heterodyne receiver, I promised to describe how to build a suitable frame aerial for the instrument. Fortunately, I have been able to hit upon a method of construction which, while giving an efficiency equal to the best of many frames I have tried, is extraordinarily simple to make. The whole cost is just 4s., assuming that you have to buy two perfectly new broomsticks at 3d. each. If you are lawless enough surreptitiously to remove the heads of two domestic brooms and thus obviate the expense referred to, you will only have to buy 100 ft. of special frame aerial wire at a cost of 3s. 6d.

Simple Work.

The constructional work is of the simplest, and provided reasonable care is taken, a sound, workmanlike job will result, while you will be able to obtain results which,

material. The particular wire used is made up of a multitude of fine strands with braided silk insulating covering. The wire has the advantage of being extremely flexible, and is such as to enable tappings to be taken in a manner subsequently to be described. Furthermore, the braided silk covering gives a smart appearance and helps to provide insulation where needed.

Cutting the Sticks.

The first step is to cut one of the broomsticks to a length of about 3 ft., and the other to about 3 ft. 6 in. Then slot the middle of the shorter of the two, in the manner shown, by sawing two cuts half-way through the stick, the width between the cuts being equal to the diameter of the stick. Be careful not to cut more than half-way through, and then remove the wood between the cuts. Repeat the process with the longer stick, but in this case cut, not in the middle, but a distance from one end equal to half the length of the shorter piece. You can then push the two sticks together, one fitting into the other and making a neat joint. It is advisable to use a touch of glue before joining the two pieces together, and then a single screw (preferably of brass) can be driven through the joint, thus holding it tight.

You will now have a cross with three equal, and one unequal, arms. The next step is to measure off 14 in. from the centre point on each stick. Make a pencil mark for this, and then make five other marks half an inch apart. There will thus be six marks on each arm all half an inch apart.

Now repeat the process on the other side of the frame, and then, with a saw, cut in diagonally for about a third of an inch into each side of each arm, as shown. When you have done this, bore two holes about an eighth of an inch diameter in the longest arm of the four, about an inch below the bottom slot (considering the frame to be held vertically with the longest arm at the bottom). Now pass one end of your wire temporarily to the stick. Take the wire to the innermost slot on the left-hand transverse arm, from there to the top arm, down to the right arm, and back again to the longest arm. On reaching point, turn over the frame and slip the wire into the bottom slot on the other side. Now carry on for one complete turn on that side, and when

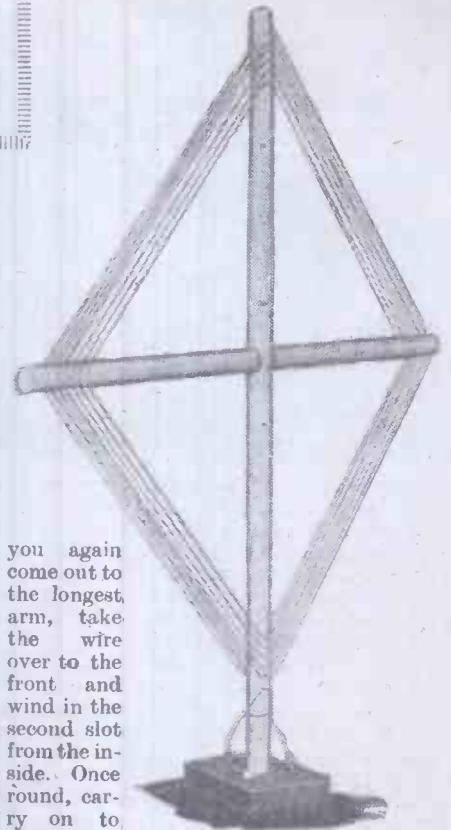

As efficient as it is inexpensive!

you again come out to the longest arm, take the wire over to the front and wind in the second slot from the inside. Once round, carry on to the back, and so on,

being careful to take one complete turn round the front and then round the back until the whole frame is filled. You will find that the hundred feet of wire will just about fill the frame as indicated.

On completion of winding pass the end through the other hole and secure. The method of fixing the ends is not important so long as they are properly secured. Probably the best way is to pass the wire twice through each hole with a knot. Enough wire should be left at the end to connect to your set, or, if you like, you can do as I have done, complete each wire by a Clix terminal.

There now remains only the base to be made. This can consist of any heavy piece of wood that may be handy.

How to make Tappings.

In a previous paragraph I have referred to the ability to make tappings in this frame. The method is very simple, if unconventional. It consists in soldering a piece of flexible wire to a pin and then pushing the pin through the frame wire at any point where a tapping is desired. The pin makes good electrical contact, and the strands of the wire are not appreciably injured by its insertion. By adopting this method an infinite number of tappings is made available for experimental work without the need of bringing them out to terminals or interfering with the general winding.

Many readers have asked how they can use Reinartz reaction with a frame aerial on the Hale receiver, and the diagram given last week showed how this can be done. The frame now described suits excellently, and the choice of a suitable tapping should be left to experiment.

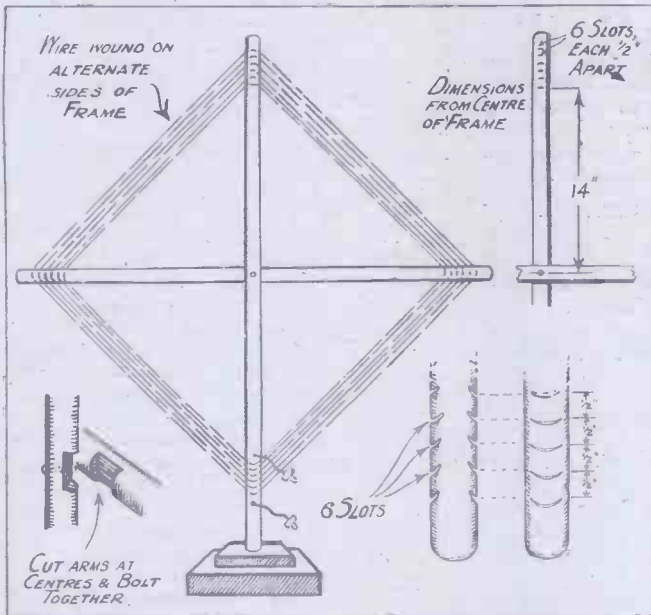

The whole job can be finished in the spare time of one evening.

I can assure you from personal tests in my laboratory, are not excelled by the ready-made article selling for twenty times the cost. The appearance and finish, of course, will be largely determined by your own personal taste, and if you are skilled in woodwork, french polishing, or wood turnery, you should be able to make a frame aerial which would not disgrace the most tastefully furnished room. If, as is often the case, you are mainly interested in electrical results, the whole job can be finished during an evening.

Apart from the two broomsticks or other similar pieces of wood required to make the frame, you will need to purchase one 100-ft. carton of frame aerial wire at a cost of 3s. 6d. from The London Electric Wire Co., Ltd., or any other firm making similar

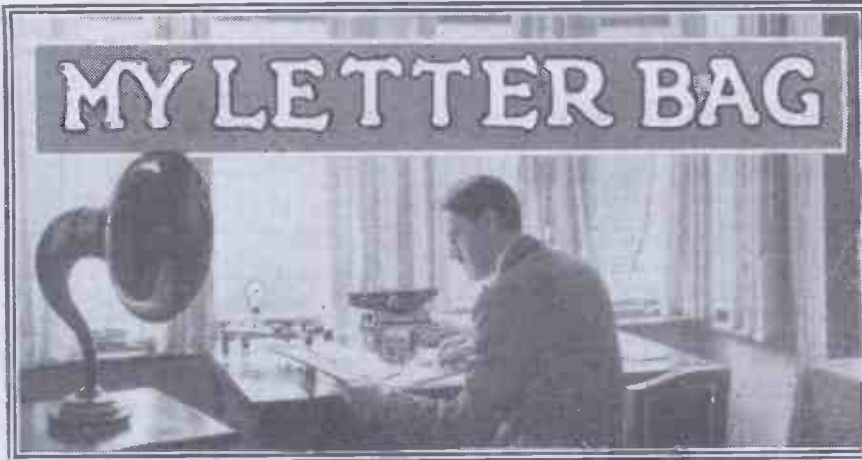

Note.—In this section Mr. Harris will discuss each week interesting points from the large correspondence he regularly receives. Readers are invited to write to him on matters of interest, and extracts from their letters, together with Mr. Harris' comments, will be published from time to time. It must be pointed out, however, that general and technical queries cannot be answered in this section, but should be addressed to the Technical Query Department, complying with the conditions laid down under the heading "Technical Queries" in each week's issue of POPULAR WIRELESS.

"I AM going abroad," writes a reader from the South of England, "and I shall be very glad of your advice about my wireless set while I am away. I shall be away for at least six months, and the house will be unoccupied. I have a five-valve set with 100 ampere (actual) accumulators and 120-volts high-tension in dry battery form; which I have just purchased."

The first precaution in leaving a wireless set is to disconnect the aerial and connect it directly to earth. This should be done outside of the house, and the wires preferably completely removed from the leading insulator and joined to a wire connected directly to the earth, if this is external. If an indoor earth has been used on a water-pipe, I would suggest obtaining one of the copper earth tubes now sold, fix it into the ground, and connect the aerial lead-in to this.

Lowering the Aerial.

Of course, if it is convenient to do so, it is better still to lower the whole aerial on to the ground. In many cases it is not practicable to effect the lowering, and in such a case the direct earth connection indicated should be used. As the six months will cover the very windy period at the beginning of the spring, make quite sure that the mast is well-supported and that the guy ropes are in good condition. In some forms of staying the breaking or loosening of a single guy rope will throw a tremendous strain upon the whole mast, and probably cause it to collapse.

With regard to the set itself, all batteries should be completely disconnected, not forgetting those used for grid bias. The valves should be packed away in some place out of harm's way, and the whole set covered with a cloth, in particular protecting the ebonite panel from exposure to the sun or even bright light. The set should preferably be placed in the driest room of the house, since damp plays havoc with the best wireless apparatus.

Special care is required with regard to the accumulators. These should be fully charged up when the set is left, even if they

have been charged within the last week or two and have not been used much. A slightly discharged accumulator will not keep in condition half so well as one which is fully charged.

If you have a good and reliable battery service station in your neighbourhood, it is worth paying a little to deposit the accumulator at this station, where it can be watched and kept in good condition by occasional charge and discharge.

IN THE NEXT ISSUE :

FIRST PARTICULARS AND
PHOTOGRAPHS OF

"THE KING OF THE AIR."

By PERCY W. HARRIS, M.I.R.E.

In any case, H.T. batteries deteriorate generally from the time that they are made, whether they are used or not, and at the end of six months my correspondent must not expect to find them in as good condition as when they were left, even if they have been most carefully put away. This steady deterioration of dry batteries is one of the reasons why I advise readers to purchase their H.T. batteries from a dealer who does a good, brisk trade, and any battery that looks shabby, dusty, or soiled, or in any other way gives evidence

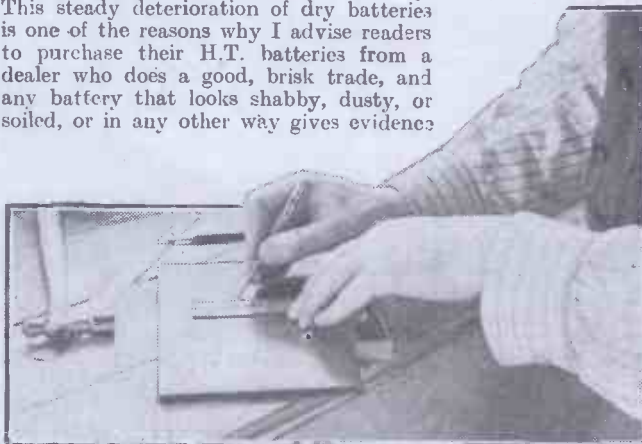

Using a Scriber to mark the panel.

of having been kept in stock for a long time, should be rejected and not even accepted at a reduced price.

There are no other special precautions, except that it is just as well to make sure that your wireless licence does not expire while you are away. If the date falls in the period covered by the holiday, make a note of it in your diary, and see that you remit the amount, otherwise you are liable to forget until you return and get yourself in trouble.

A Frank Talk.

"I am very anxious to obtain a transmitting licence, as I want to amuse my friends with the reproduction of some excellent gramophone records I have available," writes a North of England reader. "I do not know much about wireless, but have been operating a five valve receiving set successfully for the last two years, and am able to remedy the usual obvious faults."

At the risk of causing offence, I am going to talk to this correspondent very frankly. First of all, the possession of a transmitting licence is a greatly valued privilege, and is rightly only granted after the applicant has shown the Post Office authorities that (1) he has a really sound knowledge of the art, and (2) that if a licence should be granted to him it would be properly used for general experimental work. Even then the applicant has to give the authorities some kind of indication of the line of experiments he is going to undertake, and mere general claims such as "improvements of modulation," "experimental work on microphones," "evolving new transmitting circuits," and the like, are not sufficient evidence of the line of work.

Abusing a Privilege.

In the past too many experimenters have abused the privileges conferred upon them by grinding out gramophone records for the presumed amusement of their friends, thus occupying one of the few wave-bands available to the genuine experimenter and doing nothing whatever to further the art. It is quite evident that my correspondent's sole motive in desiring to obtain a transmitting licence is one of what is commonly called "swank." This is evident from several phrases in his letter which I have not quoted. Furthermore, my correspondent is completely unknown to me, and I do not

appreciate being asked to "vouch for him," and to endorse his application for a transmitting licence just because he pays me the compliment of reading the "Radio Constructor" each week.

This Week's Practical Hint.

Scratch a centre line on the back of every panel as a guide in laying out.

Also mark the width of the box beading in the same way.



GUARANTEED
for 12 months.

Turns ratio 3 to 1.
Resistance ratio 4 to 1.
Use it for 1, 2, or 3 stages L.F.

It is suitable for all circuits and all valves you will want to use.

8/6

PERFORMANCE WINS

CURVES, curves, curves, and talk, talk talk about a transformer, curves and claims and claims and curves—all mean nothing against performance under actual working conditions:

AND WHO ELSE BUT LISSEN HAS THE COURAGE TO GIVE YOU A 7-DAY TRIAL OF A TRANSFORMER WHICH HAS REVOLUTIONIZED ALL PREVIOUS IDEAS OF PERFORMANCE AND PRICE ?

Who else but LISSEN has removed the last obstacle of price which stood in the way of the widespread use of loud speakers and powerful amplification ?

Who else but LISSEN NOW GIVES YOU SUCH A TRANSFORMER AT SUCH A PRICE WHICH AMPLIFIES EVERY TONE, EVERY HARMONIC, EVERY OVERTONE ?

Never again be ill advised enough to pay a high price for a transformer—LISSEN has unhesitatingly withdrawn all their own expensive transformers which have been on the market and largely sold for several years past, IN FAVOUR OF THIS NEW LISSEN—A BETTER TRANSFORMER THAN ANY THAT HAVE BEEN BEFORE.

7 DAYS' TEST OFFER

If within 7 days of purchase you can find a better transformer at any price, take the LISSEN back to your dealers and get your money back.

Obtainable at any dealers, or direct from factory. If any difficulty post free, but please mention dealer's name and address.

Let nobody persuade you there is any valve or circuit you cannot use it with—REMEMBER THE 7 DAYS' TEST OFFER.

The unheard-of low price for such a high grade master-part is made possible by a huge production, special plant, a determination to place big powerful amplifiers within the reach of all who cared to build them, and to our new direct-to-dealer policy of distribution which cuts out all wholesale profits for your benefit.

LISSEN LTD., 8-16, FRIARS LANE, RICHMOND, SURREY
(Managing Director : Thomas N. Cole)

SMALL ENERGY-CONSERVING CONDENSERS—

Fit LISSEN—these small condensers deliver all their stored-up energy. The following capacities are made in mica (LISSEN also make the Mansbridge type in larger capacities). Leaky condensers waste energy—fit LISSEN and save it.

Capacities *0001 to *001 1/- each (much reduced).
*002 to *006 1/6 each (much reduced).



Note the new case which enables the condenser to be fitted upright or used flat. At present the new case is available in the capacities most used, but will quickly become standard for all capacities.

ADD 10% MORE LIFE TO YOUR H.T. BATTERY

—merely by using a LISSEN 2 mfd. or 1 mfd. (Mansbridge type) condenser across your H.T. battery. It cuts out all the noise from your H.T. battery when the battery is old, and keeps the energy flow steady and quiet in the meantime. One LISSEN condenser will outlast many batteries, and the lengthened life you get out of your battery will pay for the cost of the LISSEN condenser over and over again. Your dealer will tell you how you can easily connect the condenser when buying it. Use either 2 mfd. or 1 mfd. capacity—the larger condenser is more effective.

LISSEN (Mansbridge type) condenser :
2 mfd. 4/8 1 mfd. 3/10
Other capacities made are :
*01 2/4 *25 3/-
*025 2/4 *5 3/4
*05 2/4 1*0 3/10
1 2/6 2*0 4/8

Instead of a tin case, the LISSEN Condenser, unlike all other condensers of the Mansbridge type, has a specially moulded case which IN ITSELF IS A SOLID INSULATOR. That is why it is impossible for the LISSEN condenser to short circuit on to its case, an important protection for the user when the condensers are being used in a circuit connected straight on to the electric light mains. And due to our new direct-to-dealer policy of distribution THESE LISSEN CONDENSERS COST YOU NO MORE THAN THE ORDINARY KIND.

LISSEN GRID LEAKS THAT DEFIED BOTH RAIN & SUN—

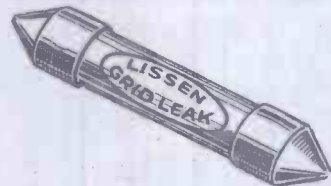

During the summer of 1925 a number of LISSEN Fixed Grid Leaks was left on our factory roof—soaked by rain and baked by sun, yet the resistance in each grid leak never altered. All capacities one price, previously 1/8, NOW 1/-.

AMAZING RESPONSE

to our FREE offer of Blue Print and Instruction Book.

Results from our first announcements have been positively amazing! . . . Tens of thousands of FREE Blue Prints and Instruction Books have been issued in response to coupons received . . . wireless enthusiasts—as never before—are now enjoying clear, undistorted tone, made possible by the wonderful R. C. Threesome. Using the new Ediswan Valves—R.C.2. and P.V.2.—in the new quarter-watt POINT ONE ECONOMY Range—the R. C. Threesome is, without doubt, the receiver of to-day.

Make the R. C. Threesome Now.

It's simple—you can build it in 3 hours for less than £3. One dial tuning!—High-power station and local station come through with absolute purity and abundant volume. The new Ediswan POINT ONE ECONOMY Valves are renowned for tonal quality . . . for long service . . . for irreducible economy. Get EDISWAN Valves for your R. C. Threesome, and be sure of perfect reception.

Send for this FREE BLUE PRINT & BOOK

Don't wait. Tear out the coupon and post it right away!

Don't forget your name and address—many coupons, sent in haste, have been received blank. Avoid disappointment—do it NOW!

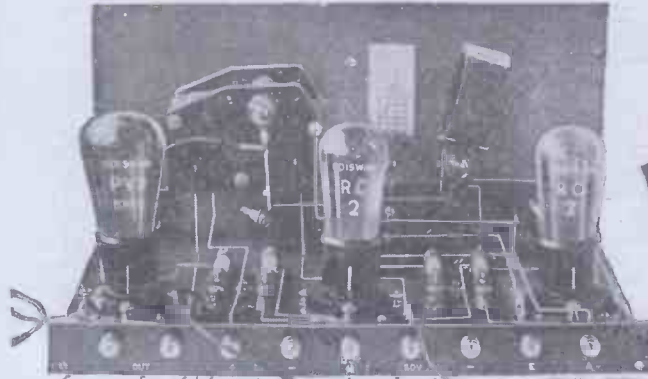

Ask your dealer about the new **EDISWAN ECONOMY VALVES**

QUARTER-WATT POINT ONE RANGE

There is an Ediswan Valve for every Wireless Purpose.

FIT EDISWAN VALVES AND NURSE YOUR SET

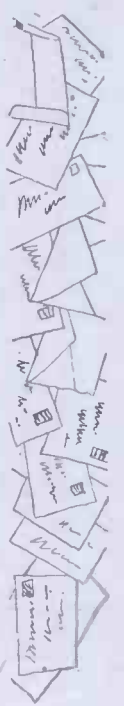

EDISWAN

<p>To THE EDISON SWAN ELECTRIC CO., LTD. (Publicity), 122/5, Queen Victoria Street, London, E.C. 4</p>	<p>Name P.W. 4.12.26</p>
<p>Please send, post free, presentation copies of the "R.C. Threesome" Instruction Book and Blue Print.</p>	<p>Address PLEASE USE BLOCK LETTERS</p>

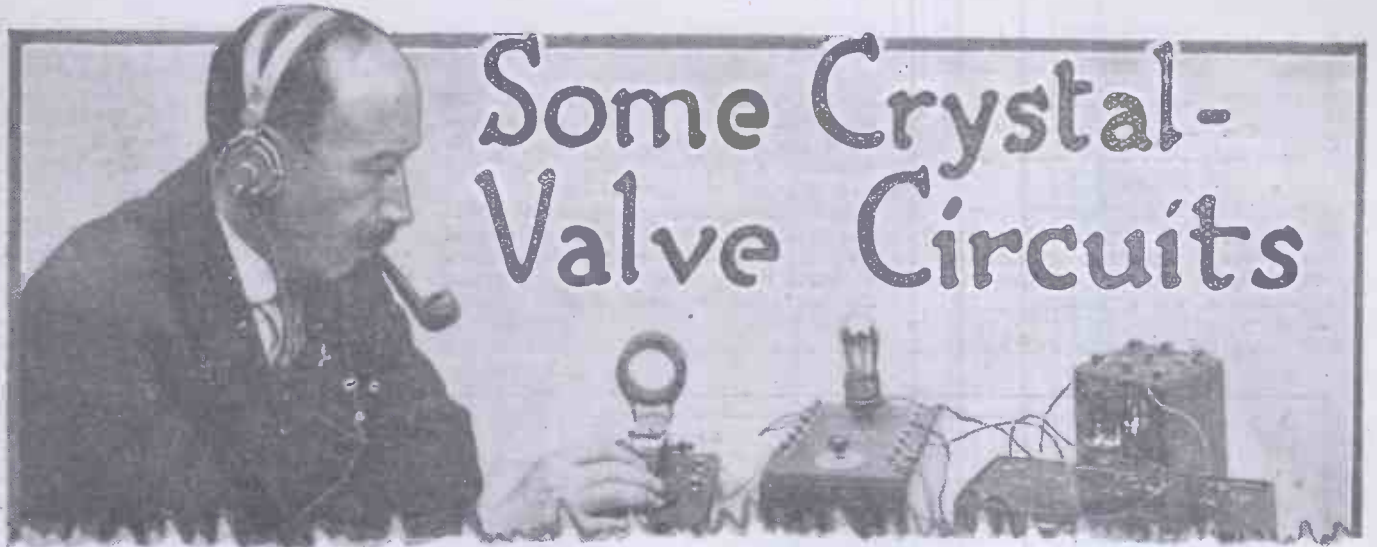

Some Crystal-Valve Circuits

CRYSTAL-VALVE combinations have always been of particular interest to the experimenter and many are the circuits, both straight and reflex, that have achieved popularity in the past. More recently, attention has been drawn to circuits in which the crystal is used as a potential rectifier. In previous circuits, whether connected across the tuned circuit, as in the reflex, or across the grid

◆◆◆◆◆
 An Analysis of the Use of a Crystal as a Potential Rectifier.
 By J. ENGLISH
 ◆◆◆◆◆

overcome by increasing the amount of H.F. energy reaching the grid. Usually the crystal detector passes on sufficient, but where this is not so, a very small condenser such as a neutrodyne balancing condenser, can be connected across the crystal. This capacity bypasses sufficient H.F. energy without appreciably decreasing the efficiency of the detector. The capacity of this condenser is usually less than .0001 mfd.

Before proceeding with the consideration of other circuits a few important points

upon the tuned circuit to which it is connected. This load, unless counteracted by reaction, results in flat tuning, while the input and output loads of the crystal detector must be properly adjusted for maximum efficiency. In contrast to this, when the crystal is used as a potential rectifier there is no L.F. current-producing stage, so that the load on the tuned circuit is infinitely smaller. This entails a smaller degree of reaction for sharp tuning. In addition, the efficiency of the crystal as a detector is considerably increased. Although the step-up effect of the reflexing transformer is lost, it will be obvious that the advantages of potential rectification more than make up for this.

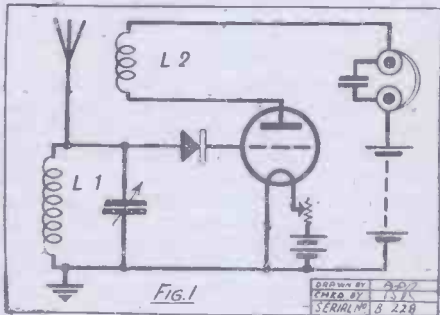

circuit, as in the Trindync, the crystal detector transforms the H.F. energy into L.F. currents. These currents are then converted into L.F. voltages by means of the iron-cored transformer and fed back to the grid circuit. The crystal used as a potential rectifier, however, transforms the H.F. voltage impulses direct into L.F. voltage impulses; the crystal being connected to the grid as in Fig. 1.

Now, when the crystal detector is used to produce an L.F. current, it places a load

Smoother Reaction.

A typical circuit embodying potential rectification is that of Fig. 1. A proportion of the H.F. signal voltage reaches the grid of the valve, where it is amplified and fed back to the grid circuit by the coupling of L₂ and L₁. This provides the reaction effect as in the normal one-valve set with a reaction coil.

Instead of magnetic coupling, a condenser coupling can be used to obtain reaction as in Fig. 2. The control of reaction in this circuit by means of C₂ is similar to that used in the popular modified Reinartz receiver. The advantages of this form of control are too well-known to need a further description.

The circuits of Figs. 1 and 2 both function identically, the second having the smoother reaction control. It may be noticed that either circuit will not oscillate on certain wave-lengths, especially if the damping of the aerial circuit is large. This can be

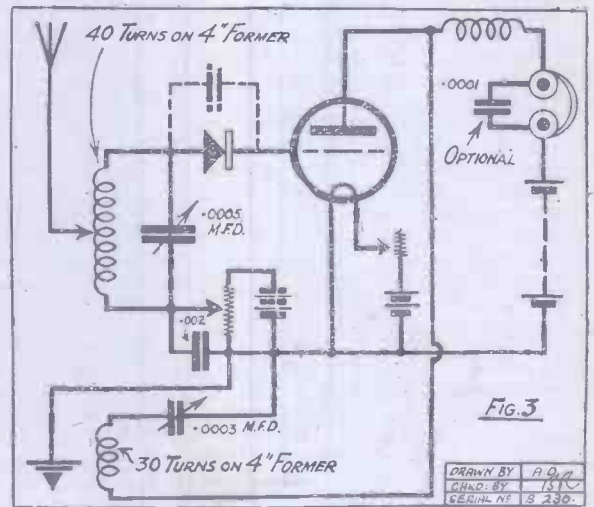

about the valve itself should be noted. As in the reflex, the valve functions in a dual capacity, amplifying both L.F. and H.F. voltage impulses, the L.F. coming direct from the crystal, while the H.F. is part of the initial signal voltage. Considered as an L.F. amplifier, the most important point is the adjustment of anode and grid bias voltages for distortionless amplification as in the normal L.F. valve. As an H.F. amplifier, it provides the reaction effect which is used to obtain sharper tuning and louder signals.

Some Detector Observations.

The circuits so far analysed are most suitable for the reception of strong signals,
 (Continued on next page.)

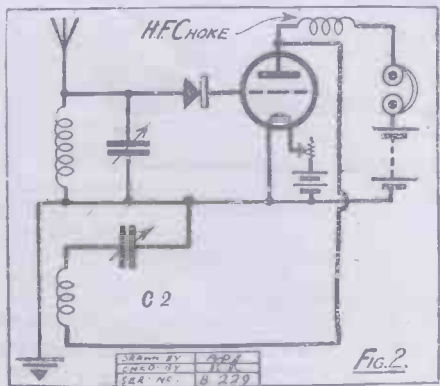

SOME CRYSTAL-VALVE CIRCUITS

(Continued from previous page.)

such as the local station's programmes, upon which they give very excellent results. Now, given strong incoming signals, the connections of the crystal detector are of importance as will be shown.

Some observations were made upon the reception of 2 L O using the circuit of Fig. 2,

when sufficient reaction was used the volume and purity of signals was remarkably good. Unlike the detector valve, more reaction could be used without introducing distortion. A curious effect was noticed when the grid circuit was very slightly detuned. A sudden "peak" effect was then obtained resulting in loud and pure signals. This setting required critical tuning of the grid circuit. The addition of an L.F. valve to this circuit constitutes a powerful receiver for the faithful reproduction of the local programme.

The particular adjustment of grid bias mentioned above applies to the reception

current rectifier, is very small when the H.F. input is extremely weak. Therefore, if the circuit is preceded by a stage of H.F. amplification, the H.F. input to the crystal will be stronger and the corresponding increase in efficiency of the latter as a rectifier will result in a greater range for the set.

Adding An H.F. Stage.

It is sometimes said that a single H.F. valve is useless and does nothing to earn its "juice." The H.F. valve of Fig. 4, however, does increase considerably the efficiency of the receiver while adding but one more tuning control. This circuit constitutes an excellent two-valve receiver for pure reception of distant stations, and is well worth a trial. The tuning, while not difficult, is sufficiently selective to confine the local station to a very narrow wave-band. The "peak" effect mentioned above was noticeable on several of the stronger stations.

Regarding components it is essential for maximum H.F. amplification that the choke K_1 should possess large inductance and small self-capacity, and be wound with not too thin a gauge of wire. A No. 1,500 Igranico coil proved very satisfactory for wave-lengths up to 3,000 metres, while for the choke K_2 a No. 250 was used. Another 1,500 coil would be even better. Values of other components are given in the diagram. It may be noted that the coupling condenser C_2 has been given a value of .0005 mfd. instead of the conventional .0003 mfd. This improves slightly both amplification and stability.

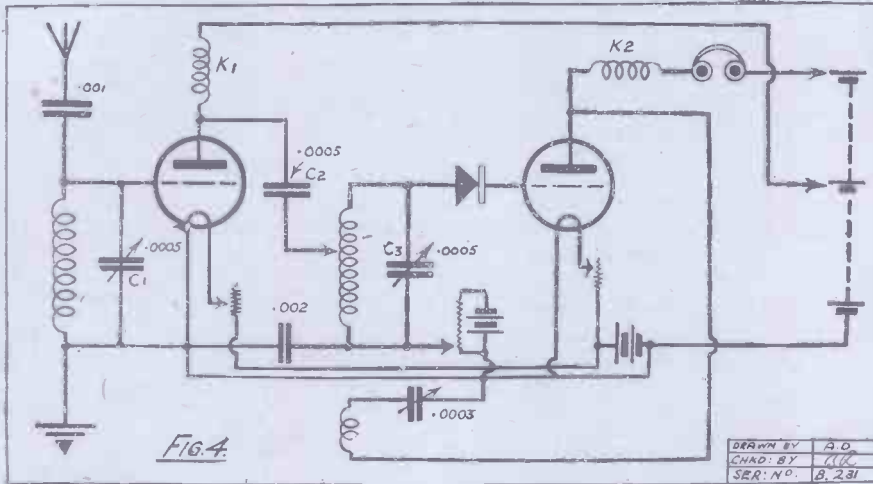

FIG. 4

with a zincite-tellurium detector. When reaction was adjusted well off the oscillation point, it was found that a positive potential of 2 volts was automatically applied to the grid with tellurium connected to grid. With zincite connected to grid, a negative potential of 2 volts was produced. Obviously, this fact influences the amount of negative grid bias to be used for distortionless amplification and allowance has to be made for the automatic grid bias set up by the crystal itself. The value of this automatic bias is proportional to the amplitude of the incoming signal.

A Curious Effect.

At six miles from 2 L O, using a D.E.3 valve with 56 volts H.T., tellurium to grid, the best value of negative grid bias was

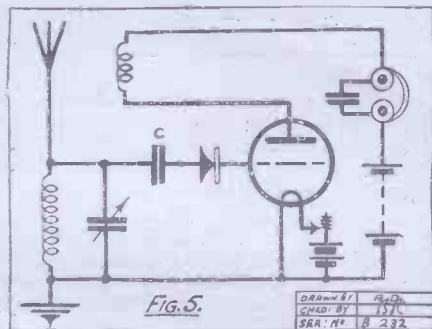

FIG. 5

found to be 4.2 volts, or .2 volts with zincite to grid. It will be seen that either value gives the grid a bias of 2.2 volts negative, which is approximately correct for the anode voltage used. Tellurium to grid appeared to give the best results, and

of loud signals, and only then does the "peak" effect take place. The amount of grid bias needs to be much smaller when receiving weak signals and a potentiometer is then more satisfactory for controlling the grid potential.

A "DX" One-Valver.

Now for real DX work the circuits already described are hardly satisfactory. In working out a suitable circuit, due attention must be devoted to those details observed in the usual detector valve circuits, such as a selective form of aerial coupling and a smooth control of reaction free from "backlash." A single-valve circuit capable of good DX work is that of Fig. 3, wherein these details have been observed as closely as possible. The type of crystal detector used is of importance and some combinations may give better results than others. The cat's-whisker and galena detector, although the most sensitive, is somewhat erratic when used in these circuits and the more stable "Perikon" type, such as the combinations zincite-tellurium or zincite-pyrites, work better. In the experiments described in this article, the zincite-tellurium combination was used. This detector proved quite satisfactory, both as regards stability and sensitivity to weak signals.

Now the efficiency of the crystal as a detector, whether used as a potential or a

A Satisfactory Compromise.

Another important feature is the connection from this coupling condenser to the grid coil of the second valve. Tapping points are provided on this coil and the smaller the number of turns in circuit with the condenser C_2 , the greater the selectivity. Amplification, however, is reduced correspondingly. A satisfactory compromise is obtained by connecting C_2 to about the 10th turn counted from the

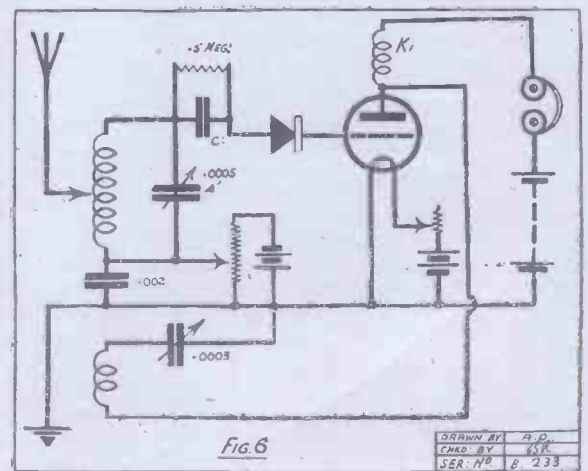

FIG. 6

filament end. Where a high degree of selectivity is desired a tapped coil should be used for the grid coil of the first valve, thus forming an auto-coupled aerial circuit, as in Fig. 3.

Returning once more to the single valve circuits, there is a development of Fig. 1

(Continued on next page).

Look! Here's the 'STEEP SLOPE'

"A WONDERFUL new power valve for 2-volt-users. It more than justifies the name 'Steep Slope.' Really a remarkable curve, see how sharply it rises and what splendid overall amplification that means," so remarked our friend POWER.

"I quite agree, POWER, but tell the public exactly what you mean by 'Steep Slope,'" replied TONE.

"Well, you know," said POWER, "I cannot do my work properly unless the loudspeaker is fed with plenty of current, and the strength of my voice depends on the fluctuations of this current. 'Steep Slope' means that very large fluctuations of anode current are produced by minute changes of grid voltage, so that a valve which has a 'Steep Slope' characteristic is extremely sensitive and powerful."

"I think you are getting it all your own way and leaving me out," complained TONE. "Mere loudness is not what the public wants."

"Sure thing," answered POWER, "but these new OSRAM POWER VALVES look after you all right. The fellows who designed them have had their eyes on both of us. It is wonderful how pure and mellow is the tone of

The New Osram 'STEEP SLOPE' Power Valve
Type D·E·P· 215

Osram Valves



The New
Osram 'STEEP SLOPE' Power Valve
2 Volt Power Amplifier
(TYPE D·E·P· 215)
PRICE 18'6

The Osram 'STEEP SLOPE' is the Masterpiece of 'TONE' & 'POWER'

The "IDEAL" Christmas Present

THE BLUE-SPOT TONE CLARIFIER

Entirely New.
Scientific.
Perfect.



It will
surprise
you.

Make your reception perfect by fitting a Blue-Spot Tone Clarifier

EVERY wireless enthusiast can now obtain a "Blue-Spot" Tone Clarifier, the result of which is the last word in purity of reception. It is accurately adjustable to the finest degree in 6 stages, so that by degrees a clearer tone can be obtained without damping or reducing the volume of sound.

By turning the milled ring, 6 stages can be obtained which are shown 0 to 6 on the dial.

At 0, the instrument is switched off, whilst the figures 1 to 6 give different degrees of clarification, the best of which is invariably perceptible and gives surprisingly good results.

The "Blue-Spot" Tone Clarifier will fit any set, either Crystal or Valve without alteration.

One end connects to your set terminals, the other to the Headphones or Loudspeaker wires.

PRICE 9/6 EACH

An "Ideal"
Christmas
Present



The "IDEAL"
LOUD SPEAKER UNIT and
GRAMOPHONE ATTACHMENT

On Test it is the Best!

The finest unit yet offered to the public. It makes a wonderful Loud-speaker.
The unit is the secret of all good Loudspeakers.
Ask your Dealer for demonstration and Catalogue, or we will forward post free to your address by return, Cash on delivery.

PRICE:
17/9
EACH

LINDALLS, LIMITED
70, Lombard Street
BIRMINGHAM

'Phone: Mid. 596.

'Grams: "Lifelike."

SOME CRYSTAL-VALVE CIRCUITS.

(Continued from page 828.)

due to A. W. Sharman. This is shown in Fig. 5. The important feature of this circuit is the introduction of the condenser C in front of the crystal. This condenser should have a very small capacity, say .00005 mfd., and the highest possible insulation resistance. Its introduction into the circuit improves the function of the

Under the best conditions of operation the response of the detector valve with reaction does not exceed that of this circuit, which appears to combine all the sensitivity and selectivity of the regenerative valve with the distortionless rectification of the crystal.

The insertion of the leak resistance across the condenser C involves a departure from the requirements of the Sharman circuit, and this modified circuit would appear not to function in the same way as the former.

A really satisfactory DX circuit that can be thoroughly recommended is one

should be obtainable when the more favourable winter season arrives.

A Frame Aerial Circuit.

Experimenters interested in frame aerial reception should try out the interesting circuit of Fig. 8, which is an adaption of the Hartley oscillator circuit, using a crystal as a potential rectifier. The frame aerial constitutes the inductance L_1 , the centre tapping going to filament negative, either through bias cells or a potentiometer. Reaction is controlled by a three-plate condenser C_2 . This circuit is excellent for the pure reception of the local station.

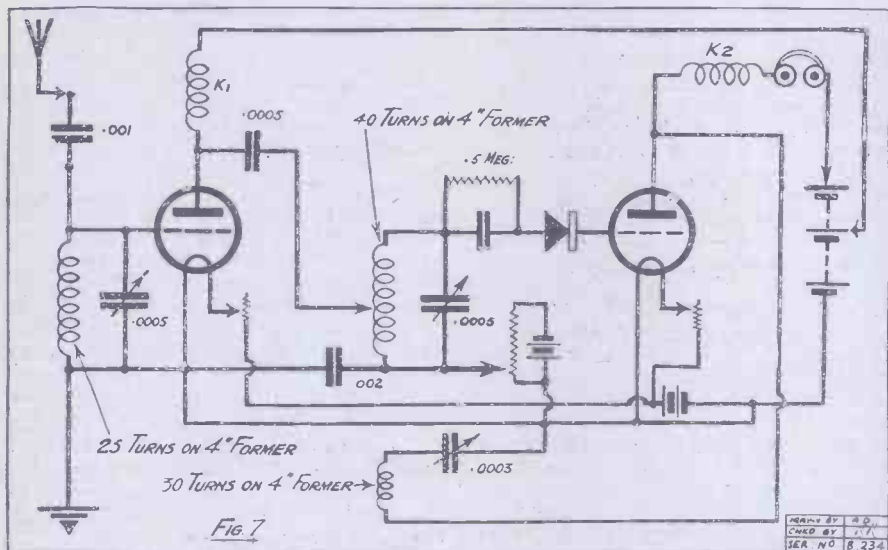

crystal as a potential rectifier. While bypassing freely the H.F. signal voltages, this condenser C appears to serve the purpose of preventing the rectified L.F. voltages from flowing back to the filament end of the circuit. Reaction is obtained by coupling L_2 and L_1 , or by a capacity coupling, as in the circuits previously mentioned.

Sensitive and Stable.

While the Sharman circuit works very well on loud signals, its disadvantage, in the writer's opinion, is the "free" grid. It will be evident from the circuit diagram that the grid is effectively insulated by the condenser C, and thus no control of the working grid potential is possible. This results in inefficiency and unstable reaction control when receiving weak signals.

Attempts were made to overcome this disadvantage by connecting a grid leak with grid bias cells in series between the grid and filament negative, as in the usual method for an amplifying valve. Provided the grid leak had a high value of several megohms, this method worked satisfactorily, but much better results were obtained by connecting a resistance of .5 to 1 megohm across the condenser C with potentiometer control of grid bias, as in Fig. 6, capacity reaction control being used. This circuit was now quite stable and gave full undistorted amplification of loud signals, the "peak" effect being noticeable. Moreover, its response to weak signals was much better, and in this respect superior to the circuits previously mentioned.

shown in Fig. 7. This is a development of Fig. 6, an H.F. valve having been added, choke coupled, as in Fig. 4. The values of components and details of connections given for that circuit apply equally well here. As mentioned pre-

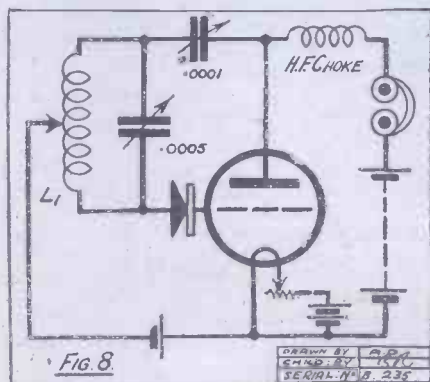

viously, the crystal detector can be bridged by a very small capacity to obtain sufficient reaction, but this should be used only as a last resort.

This circuit, even when roughly wired up, proved very selective and stable in operation. Under the adverse conditions of full daylight during midsummer, several B.B.C. and Continental stations were received at good 'phone strength. The addition of one L.F. valve brought in several foreign stations at quiet loud-speaker strength after dark, and full loud-speaker strength

TWO USEFUL HINTS.

By J. F. C.

THE amateur is often apt to become rather puzzled over the matter of the best fixed condenser capacity to use for the purpose of placing across the headphones of a set. Happily, although to a certain extent every receiver has its own individual requirements, so to speak, a few general rules for guidance in this matter can be laid down.

For use with a crystal set, a telephone condenser having a capacity of about .002 mfd. will be found to give the best results. Higher value condensers may, of course, sometimes be used effectively with crystal sets, but very often their employment reduces the signal strength in the 'phones.

For a 1-valver, use a telephone condenser having a value somewhere between .002 and .005 mfd. Two-valve sets can do with a 'phone condenser of .01 mfd. capacity, or even more. In fact, with multi-valve receivers it is a good plan to try the effect of placing a fixed condenser of large capacity, say a .05 mfd. condenser, across the 'phones. Sometimes the use of such a condenser, despite all theory, will be found to have surprisingly effective results in toning up the signal clarity, and in freeing the reception from extraneous noise.

IT is often very necessary to make soldered connections to tinfoil. Especially is this so in the case of small fixed condenser construction. Unfortunately, the amateur does not always find it an easy job to effect these soldered joints, the reason being, of course, that the metal foil is so thin that it quickly oxidises and sometimes even burns away when heat is applied to it.

Such soldering operations, however, can be made very much easier by the use of a special type of flux. Flux suitable for the above type of work may be prepared by heating equal parts of vaseline and high-grade wax. After the ingredients have become intimately mixed, finely ground sal-ammoniac is added in the proportion of 1 part of the vaseline-wax mixture to 1½ parts of the sal-ammoniac. The resulting mixture should be thoroughly well stirred, after which it may be stored in small tins or other containers.

When dealing with tinfoil soldering work, only use the slightest smear of the above flux. It will be found to be very efficient, and will considerably lighten the labour incurred by the delicate soldering work.

An interesting invention in connection with the cone loud speaker consists of a conical diaphragm in which the apex is not at the centre; the base of the cone is an ellipse, and therefore the distance from the apex to the edge is different in different directions.

The reason for this arrangement may not at first be evident. But a little reflection will show that in the case of a circular and perfectly symmetrical diaphragm, which is excited at the geometrical centre, there will be a definite frequency of vibrations and definite overtones.

Non-resonant Diaphragm.

In the case of the elliptical diaphragm, however, owing to the unsymmetrical arrangement, it is intended that the fundamental tone may be suppressed; that is to say, it is intended in general that the diaphragm shall vibrate or respond more or less uniformly at all frequencies within the required range.

Before discussing this matter further, it should be mentioned that the idea of an elliptical diaphragm is by no means new. Elliptical diaphragms were used during the war for various acoustical reception purposes.

Furthermore, it does not appear to be a proper conclusion that the displacement of the point of excitation to an unsymmetrical position will have the effect of making the diaphragm aperiodic.

If it becomes truly aperiodic it will inevitably suffer from the insensitiveness which is characteristic of all aperiodic or quasi-aperiodic systems and, in fact, one of the outstanding advantages of a resonant system is its greatly enhanced sensitivity. A very familiar example of this is to be found in the electrically resonant circuit of a receiving set; it goes without saying that every experimenter is aware of the great difference between a tuned and an untuned receiver.

In any case, it is practically certain that the elliptical diaphragm is not by any means an aperiodic system, but that it has definite natural frequencies of vibration.

In a particular form of the cone type loud-speaker diaphragm the principal cone is secured at its edge to another cone, which forms the support and which is secured to a suitable stand. The reproducer unit is introduced between the two diaphragms, and is secured to the first-mentioned diaphragm at its apex.

A New Rectifier.

A new type of gas-discharge rectifier has recently been introduced from the United States. It is a full-wave rectifier, and consists essentially of a central plate of nickel or molybdenum, this plate being placed in a vertical plane (that is to say, when the valve is in a vertical position the central plate is vertical), on each side of the plate being a wire of tungsten or nickel, the plate being the cathode and the two tungsten wires acting as anodes alternately in accordance with the alternations in the A.C. current. The valve contains a gas which has a comparatively low ionisation potential; this gas may be either helium and neon mixed, or helium alone. The pressure of the gas which gives the best results depends, of course, upon the actual size and the geometrical features of the

TECHNICAL NOTES

A Weekly Feature
Conducted by

Dr. J. H. T. ROBERTS, F.Inst.P.
(Staff Consultant.)

bulb and the electrodes, as well as upon the voltage at which it is intended to work the rectifier. Pressures from 5 millimetres of mercury up to 80 millimetres have been used, but when helium gas alone is employed, a pressure of about 20 millimetres of mercury has been found to be the best.

"Silite" Electrodes.

Magnesium or calcium is introduced into the valve in order to get rid of gaseous impurities, and the potential drop across the rectifier is considerably reduced by introducing an alkaline metal caesium or rubidium before the "getter" is volatilised. There is a good deal of interesting information in this new definition of vice, and itself

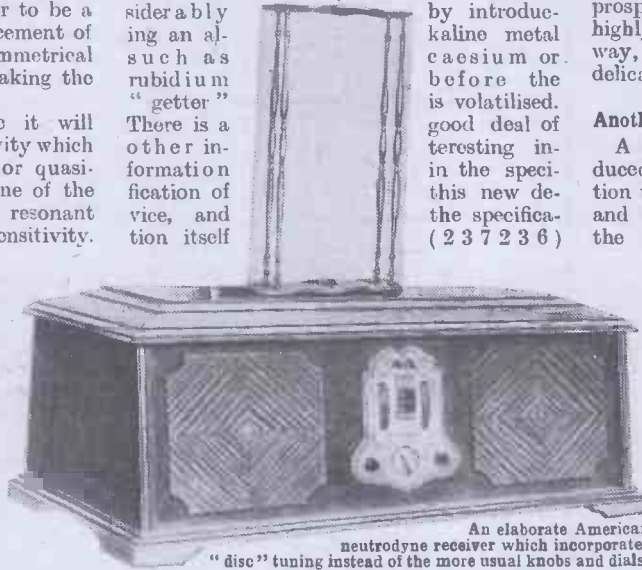

An elaborate American neutrodyne receiver which incorporates "disc" tuning instead of the more usual knobs and dials.

should be consulted by those who require further details.

It is well known that silicon has a rectifying action for A.C. current, and a considerable amount of experimental work has been carried out upon this effect. As a result, a new type of material for the electrodes in an electrolytic rectifier has been developed, known as "Silite." These Silite electrodes are metallic-glass rectifying elements based upon the rectifying property of silicon. They are said to give a higher charging rate than most other electrodes and by means of the Silite electrodes it is a comparatively simple matter to convert an L.T. battery into a power unit.

Copper Crystals.

Those experimenters who take an interest in crystal structure, and its influence upon contact-rectification will be interested to know of some experiments which have recently been made at the General Electric Company's laboratories in the United States upon the growth of large single

metal crystals, in particular crystals of copper. One of the most remarkable properties of a single copper crystal is that its electrical conductivity is up to 13 per cent higher than that of ordinary copper, which consists, of course, of a vast assemblage of tiny crystals without any particular method of arrangement.

In the laboratories mentioned above a single crystal of copper has been produced of the amazing size of 17 inches in length and over 2 inches in diameter and weighing about 12 pounds. This crystal was withdrawn from the electric furnace in which it was produced at the rate of a quarter-of-an-inch per hour; that is, it took about three days to withdraw it entirely from the furnace. This very careful annealing permitted the copper atoms to arrange themselves in regular formation.

A curious property of these large single crystals is that they can be bent quite easily by hand, but once having been so bent they become practically like ordinary copper, and cannot be straightened with the same ease! At the same time, their electrical conductivity falls to about the same value as that of ordinary copper.

Unfortunately, there is no immediate prospect of utilising this newly discovered highly-conducting copper in a commercial way, owing to the single crystals being so delicate and difficult to manufacture.

Another New Condenser.

A new die-cast condenser has been produced by the Unicondenser Corporation which, in addition to having the stator and rotor each cast as a single unit in the usual way, obtains a straight-line

frequency reading with circular plates. This effect is achieved by tapering the circular segments in an appropriate way so that as the rotor is moved the clearance between the plates is varied. The condenser has also certain other novel features in connection with the method of mounting the rotor in its bearings. It is claimed that by the use of circular plates, instead of the usual off-set plates which are commonly employed for straight-line frequency condensers, the size of the condenser is considerably reduced.

Automatic Aerial Switch.

A new and interesting little device consists of an electro-magnetic arrangement which automatically connects the aerial to the set (thereby disconnecting it from earth, to which it is ordinarily connected) when the valves are switched on. It will not take the reader more than a few moments to think out how this is done. The device contains a small electro-magnet and a rocking bar, the two ends of which dip alternately into mercury cups. A spring keeps one end in the mercury cup, which is connected to earth, unless the electro-magnet is energised, in which case the other end of the rocking lever dips into its appropriate mercury cup. The aerial is connected to the rocking bar, one mercury cup to earth, the other mercury cup to the aerial terminal of the set. The filament current for the valves passes through the electro-magnet. It is easy to see that on switching on the filaments the aerial is instantly and automatically disconnected from earth and connected to the set.

(Continued on page 852.)



Igranic Radio Devices for short-wave work

IGRANIC Short-Wave Coils are wound with heavy gauge wire, rigidly supported with a minimum of insulating material, which accurately preserves the spacing between turns. The self-capacity and losses are particularly low so that oscillation is obtained easily.

Igranic Short-Wave Coils are made in four sizes for wave-lengths of 10 to 100 metres.

PRICES: 2 (turns) 2/6 6 (turns) 2/8
 4 " 2/7 9 " 2/9
 Set of four, 10/-



Igranic 'NONMIC' (Regd.) Valve Holder

IGRANIC "Nonmic" Valve Holders have extremely low self-capacity and are, therefore, particularly suitable for short-wave work. The sockets are suspended by means of special springs, which give extreme resiliency and effectively absorb all shocks.

Made in two types for panel or baseboard mounting; both types fitted with terminals and soldering tags.

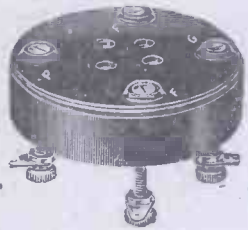

Prices for Panel
or Baseboard
Mounting, 3/- each

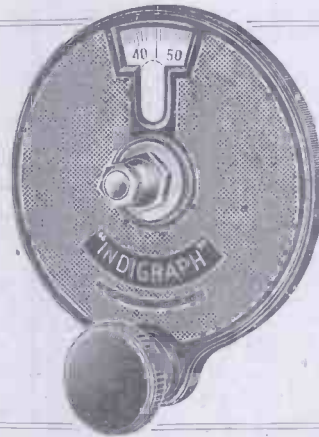

"INDIGRAPH" (Regd.) Vernier Knob and Dial

FOR smooth control, entirely free from backlash, always use "Indigraph" Vernier Knobs and Dials. Two scales are provided, reading in opposite directions, so that the "Indigraph" Vernier is suitable for condensers having a clockwise or anti-clockwise movement. Space is provided opposite the dial readings so that records can be made of tuning positions. The Igranic Vernier, Knob and Dial is simple to fix and very handsome in appearance. The metal dial acts as a shield against hand-capacity effects. Price 7/6

Write for the new Igranic Catalogue List No. R. 37.

IGRANIC ELECTRIC CO. LTD

149, Queen Victoria Street, LONDON.

Igranic-Pacent S.L.F. Variable Condenser

IGRANIC-PACENT Straight-Line Frequency Condensers are particularly suitable for short-wave work as the gradual increase in capacity near the minimum position greatly facilitates fine tuning.

Extremely low losses and negligible minimum capacity.

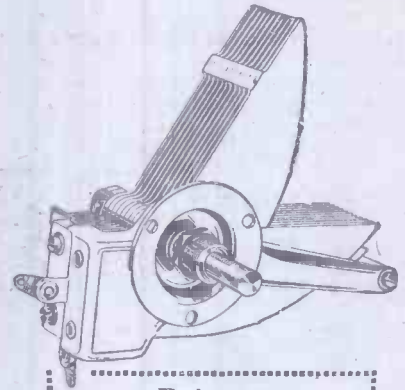

Prices:

00035 mfd. - 14/6
 0005 mfd. - 18/6

"The CHALLENGE" Build this fine Set for Xmas.

is designed first for easy handling—a real family set which will delight the lady of the house.

Tuning is ideally easy, and the smooth reaction control brings up strength as required without altering the tuning a scrap. And yet, a large number of distant stations are easily brought in.

There is unlimited opportunity for searching the ether, always some new interest, and always an alternative programme.

You can build it easily. It is a standard factory type, tested and tried, but sent out in parts with full plans, instructions etc.

Cabinet is a handsome double-door enclosed type, in brown oak.

Prices.	3 Valve.	4 Valve.	
Kit of Components	5 5 0	6 2 0	If panel and components are purchased at the same time, the Marconi Royalty of 12/6 per value is payable.
Panel Engraved	10 6	14 6	
Cabinet & Baseboard	1 16 0	2 2 0	



State in catalogue of all our manufactures and components required also.
RADIAX LTD., 10, Accessory House, Palmer Place, London, N.7.

Parrs Ad.



Registered Trade Mark.



Makers of the
**ORIGINAL world-famous
 BECOL LOW LOSS FORMER**

As used in sets that took the first four prizes at the 1926 "Manchester Evening Chronicle" Wireless Exhibition and the set that won the Gold Medal at the 1926 Amsterdam Exhibition.

Size: 3 inches diameter to outside of wings. Prices:
 6 inch lengths 3/- (Postage 9d.);
 4 inch lengths 2/- (Postage 6d.);
 3 inch lengths 1 6 (Postage 6d.);
 Up to 36 in. lengths.
 Write for List "C."

Ebonite Rods, Tubes and Sheets. Panels guaranteed free from surface leakage.
THE BRITISH EBONITE Co., Ltd., Hanwell, London, W.7.



The Truth about the Tests

Not only do S.T. Valves represent the highest level of valve design and manufacture to-day, but whenever or wherever you get an S.T., you know that *that particular valve* has been approved by John Scott-Taggart, F. Inst. P., A.M.I.E.E. You take your package home, knowing it has actually been in his own hands; and it is almost as if Scott-Taggart himself were standing by you, confidently waiting for your set to spring into new life as you put his picked valve into your set. If it sounds too good to be true, read the following Statutory Declaration made before a Commissioner for Oaths:

Statutory Declaration

I, John Scott-Taggart, of 2, Melbourne Place, in the County of London, do solemnly and sincerely declare that:

1. I am the Managing and Technical Director of S.T. Limited and am responsible for the maintenance of the high standard of S.T. valves.
 2. The test department is under my immediate control and every S.T. valve is given a number of tests which include a factory test, a laboratory test in which a minimum of nine electrical measurements are taken with precision meters, a test in a receiver on broadcasting and a final laboratory test identical to the previous one, in which the same nine or more measurements are taken by a different technical assistant.
 3. Only those valves which pass all four independent tests are sold and after I have satisfied myself that a valve is within this specification, it is packed in a carton bearing a certificate containing a white space on which I sign my initials.
 4. No single valve has been issued by S.T. Limited which has not passed the required tests and every carton bears my initials which, without exception, have been affixed with my own hand and pen.
- And I make this solemn declaration conscientiously believing the same to be true and by virtue of the Provisions of the Statutory Declarations Act of 1935.

John Scott-Taggart

Declared at 10, Norfolk Street, Strand,
in the County of London, this 19th
day of November, 1926, before me

W. H. Smith & Sons A Commissioner
for Oaths.

TYPES AND PRICES :

S.T.21 (H.F.) 0.1 amp.	14/-	S.T.41 (H.F. and Det.) 0.1 amp.	14/-
S.T.22 (L.F. and Det.) 0.1 amp.	14/-	S.T.42 (Power) 0.1 amp.	18/6
S.T.23 (Power) 0.15 amp.	18/6	S.T.43 (Super Power) 0.25 amp.	22/6
S.T.61 (H.F. and Det.) 0.1 amp.	18/6		
S.T.62 (Power) 0.1 amp.	18/6		
S.T.63 (Super Power) 0.25 amp.	22/6		

The Championship Winner's Recommendation

Messrs. S.T. Ltd. have received a letter (open to inspection at their offices) from Mr. R. W. Emerson, the British Amateur who won, in the face of world-wide competition, the championship at the International Exhibition at Amsterdam. This letter is of extreme interest to "Popular Wireless" readers because it bears eloquent testimony to S.T. valves and further offers readers the opportunity of hearing them for themselves. You cannot do better than follow the advice of the world's leading amateur and use S.T.'s in your Elstree Six, Solodyne or other set.

EXTRACT FROM MR. EMERSON'S LETTER.

You will, no doubt, be interested to hear the results I have obtained with the new S.T. valves, which I immediately obtained on seeing the announcements. First of all I tried them in the actual Elstree Set with which I won the International Gold Medal at Amsterdam. Using S.T.61, S.T.62, S.T.63, in this order, I obtained with the set results considerably better than those given by other makes I had been using, and that is saying a great deal. I have since tried them in several other sets I have built, including the Solodyne, with equal success, and I am frankly delighted with the results, and as the current consumption is so small they are extremely economical. They give really high amplification and are exceptionally pure in reproduction. My Elstree Six has created so much interest that I am having to give demonstrations to friends, etc., and I shall be happy to let anyone hear it working with S.T. valves if an appointment is made.

R. WALDO EMERSON.

3, St. Ann's Terrace, St. John's Wood, N.W.8.

KEEP IT

S.T. VALVE GUIDE

IT'S VALUABLE

1 VALVE				3 VALVES—contd.				5 VALVES—contd.			
	2 Volt	4 Volt	6 Volt		2 Volt	4 Volt	6 Volt		2 Volt	4 Volt	6 Volt
Detector	1 S.T.22	S.T.41	S.T.61	Dual, Detector, L.F. (e.g., 3 valve Dual)	1 S.T.23	S.T.42	S.T.62	2 H.F., Det., 2 L.F. (resistance or choke followed by transformer), e.g., Nighthawk	1 S.T.21	S.T.41	S.T.61
Dual valve and crystal	1 S.T.23	S.T.42	S.T.62		2 S.T.22	S.T.41	S.T.61		2 S.T.21	S.T.41	S.T.61
2 VALVES					3 S.T.23	S.T.42	S.T.62		3 S.T.21	S.T.41	S.T.61
Det & L.F. (transformer)	1 S.T.22	S.T.41	S.T.61	H.F. Dual & Detector (e.g., Mewflex)	1 S.T.21	S.T.41	S.T.61		4 S.T.22	S.T.42	S.T.62
	2 S.T.23	S.T.42	S.T.62		2 S.T.23	S.T.42	S.T.62		5 S.T.23	S.T.42	S.T.62
Det. & L.F. (resistance or choke)	1 S.T.21	S.T.41	S.T.61	4 VALVES					1 S.T.21	S.T.41	S.T.61
	2 S.T.23	S.T.42	S.T.62	H.F., Det., 2 L.F. (transformer), e.g., Monodial, 4-Valve Family	1 S.T.21	S.T.41	S.T.61		2 S.T.21	S.T.41	S.T.61
H.F. & detector	1 S.T.21	S.T.41	S.T.61		2 S.T.22	S.T.42	S.T.62		3 S.T.22	S.T.42	S.T.62
	2 S.T.22	S.T.41	S.T.61		3 S.T.22	S.T.42	S.T.62		4 S.T.22	S.T.42	S.T.62
Dual, crystal and L.F. (e.g., S.T.100, Elstreflex, etc.)	1 S.T.23	S.T.42	S.T.62		4 S.T.23	S.T.43	S.T.63		5 S.T.23	S.T.42	S.T.62
	2 S.T.23	S.T.42	S.T.62								
Dual & Detector (e.g. Twin Valve)	1 S.T.23	S.T.42	S.T.62								
	2 S.T.22	S.T.41	S.T.61								
Two duals and crystal (e.g. Distaflex)	1 S.T.23	S.T.42	S.T.62								
		or									
		S.T.43	S.T.63								
		or									
		S.T.42	S.T.62								
		or									
		S.T.43	S.T.63								
3 VALVES											
Det. & 2 L.F. (both trans.)	1 S.T.22	S.T.41	S.T.61								
	2 S.T.22	S.T.42	S.T.62								
	3 S.T.23	S.T.42	S.T.62								
		or									
		S.T.43	S.T.63								
Det. & L.F. (choke or resistance followed by transformer)	1 S.T.21	S.T.41	S.T.61								
	2 S.T.22	S.T.42	S.T.62								
	3 S.T.23	S.T.42	S.T.62								
		or									
		S.T.43	S.T.63								
Det. & 2 L.F. (two resist. or two chokes)	1 S.T.21	S.T.41	S.T.61								
	2 S.T.21	S.T.41	S.T.61								
	3 S.T.23	S.T.42	S.T.62								
		or									
		S.T.43	S.T.63								
H.F.; detector, L.F. (transformer), e.g. Spanspace Three, All Concert, and Simplicity Three	1 S.T.21	S.T.41	S.T.61								
	2 S.T.22	S.T.41	S.T.61								
	3 S.T.23	S.T.42	S.T.62								
H.F., detector, L.F. (resistance or choke)	1 S.T.21	S.T.41	S.T.61								
	2 S.T.21	S.T.41	S.T.61								
	3 S.T.23	S.T.42	S.T.62								
2 H.F. & Detector	1 S.T.21	S.T.41	S.T.61								
	2 S.T.21	S.T.41	S.T.61								
	3 S.T.22	S.T.41	S.T.61								

If you are unable to obtain an S.T. valve from your local retailer write direct to us, or call. All valves will be sent by post and insured by us against breakage. C.O.D. orders executed on receipt of post-card.

S.T. LTD., 2, Melbourne Place, Aldwych, LONDON, W.C.2
(Next to Australia House).

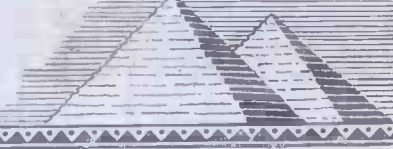



The TANGENT
"TOUCHTONE"
Loudspeaker

A RADIO CHRISTMAS

Snug and warm by the fire with "Touchtone's" wonderful music—what could be better? Make this a real radio Christmas by assuring yourself that your reception will be perfect. A "Touchtone" Loudspeaker will help you.

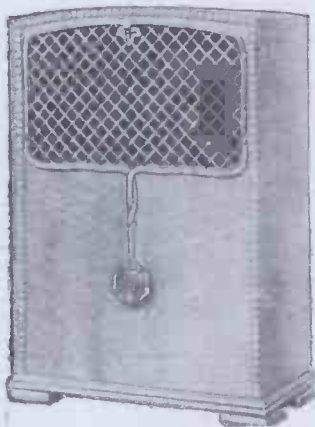

Perfectly constructed and beautifully designed. The attractive cabinet harmonises with any furniture.

Price in Oak - - - £6 : 6 : 0
Mahogany - - - £7 : 0 : 0



London : 25, Vintoria Street, E.W.1
Newcastle-on-Tyne : TANGENT House, Blackett Street.

RADIOTORIAL

All Editorial Communications to be addressed to The Editor, POPULAR WIRELESS, The Fleetway House, Farringdon Street, London, E.C.4.

Editor :
NORMAN EDWARDS, M.Inst.R.E., M.R.S.L., F.R.G.S.
Technical Editor :
G. V. DOWDING, Grad.I.E.E.
Assistant Technical Editors :
K. D. ROGERS. P. R. BIRD.
Scientific Adviser :
Sir OLIVER LODGE, F.R.S.
Staff Consultants :
Dr. J. H. T. ROBERTS, F.Inst.P.; J. F. CORRIGAN, M.Sc., A.I.C.; C.E. FIELD, B.Sc.; E. J. SIMMONDS, M.I.R.E., F.R.S.A.
Foreign Correspondents :
F. M. DELANO, Paris; Dr. ALFRED GRADENWITZ, Berlin; L. W. CORBETT, New York; P. F. MARTIN, Italy; W. PEETERS, Holland.

The Editor will be pleased to consider articles and photographs dealing with all subjects appertaining to wireless work. The Editor cannot accept responsibility for manuscripts and photos. Every care will be taken to return MSS. not accepted for publication. A stamped and addressed envelope must be sent with every article. All inquiries concerning advertising rates, etc., to be addressed to the Sole Agents, Messrs. John H. Lile, Ltd., 4, Ludgate Circus, London, E.C.4. As much of the information given in the columns of this paper concerns the most recent developments in the radio world, some of the arrangements and specialities described may be the subject of Letters Patent, and the amateur and the trader would be well advised to obtain permission of the patentees to use the patents before doing so. Readers' letters dealing with patent questions, if sent to the Editor, will be forwarded to our own patent advisers, where every facility and help will be afforded to readers. The envelope should be clearly marked "Patent Advice."

TECHNICAL QUERIES.
Letters should be addressed to: Technical Query Dept., "Popular Wireless," The Fleetway House, Farringdon Street, London, E.C.4.
They should be written on one side of the paper only, and MUST be accompanied by a stamped addressed envelope.

Queries should be asked in the form of the numbered questions: (1), (2), (3), etc., but may be accompanied by a short letter giving any necessary additional particulars as briefly as possible.
For every question asked a fee of 6d. should be enclosed. A copy of the numbered questions should be kept, so that the replies may be given under the numbers. (It is not possible to reproduce the question in the answer.)

BACK OF PANEL DIAGRAMS can be specially drawn up to suit the requirements of individual readers at the following rates: Crystal Sets, 6d.; One-Valve Sets, 6d.; One-Valve and Crystal (Reflex), 1s.; Two-Valve and Crystal (Reflex), 1s.; Two-Valve Sets, 1s.; Three-Valve Sets, 1s.; Three-Valve and Crystal (Reflex), 1s. 6d.; Four-valve Sets, 1s. 6d.; Multi-Valve Sets (straight Circuits), 1s. 6d. Except SUPER-HETERODYNE DIAGRAMS, all of which, irrespective of number of Valves used, are 2s. 6d.
If a panel lay-out or list of point-to-point connections is required an additional fee of 1s. must be enclosed.

Wiring diagrams of commercial apparatus, such as sets of any particular manufacture, etc., cannot be supplied. (Such particulars can only be obtained from the makers.)
Readers may submit their own diagrams, etc., for correction or for criticism. The fee is 1s. per diagram, and these should be large, and as clear as possible.
No questions can be answered by 'phone.
Remittances should be in the form of Postal Orders.

BLUE PRINTS.
Details of the "P.W." 6d. Blue Prints will be found on page 845.

Questions and Answers

CURRENT THROUGH A VALVE.

S. W. H. (Waterloo, Liverpool).—How does a wireless valve pass an electric current through the vacuum?

This is too large a question to answer in detail, but the following brief account—taken from "The Story of the Marconi Valve"—gives a good idea of the process:

The standard type of valve contains three essential parts, or electrodes as they are sometimes called. The first is the filament. This is a very fine piece of wire—usually of tungsten—which is connected up to an accumulator or L.T. battery. The current from the accumulator heats the filament and in so doing causes it to emit a stream of electrons.

An electron is the fundamental unit or "atom" of electricity. It is inconceivably small, having a mass only one two-thousandth that of an atom of hydrogen, but it constitutes the very essence of electricity. One can safely say that whenever electrons are in motion there is an electric current in being.

The electrons given off by the heated filament may, in the first place, be considered as behaving in a similar way to the tiny bubbles that are sometimes to be seen over a glass of champagne or aerated water. These shoot up a little way into the air and then fall back on to the liquid surface. The electrons emitted by the heated filament would fall back in much the same way, were it not for the action of the second electrode called the plate or anode.

The plate is a hollow cylinder of nickel (sometimes in oval form), which surrounds the filament, and is

connected to the H.T. battery so that it carries a strong positive voltage. As the electrons are negative in character, they are strongly attracted towards the positively-charged plate.

"P.W." COIL TABLES.
No. 5.—Honeycomb Type Coils.
(B) AERIAL COILS WITH SERIES TUNING CONDENSER.

No. of Turns.	Gauge of Wire S.W.G.	Wave-length, in Metres.				Suitable No. of turns in reaction coil.
		Capacity of Series Condenser in mfd. = .0003		Capacity of Series Condenser in mfd. = .0005		
20	24	Max. 155	Min. 100	Max. 165	Min. 105	20-40
40	24	250	165	270	170	20-40
60	24	350	230	375	240	20-60
80	24	455	295	485	310	20-60
100	24	565	370	605	390	40-80
125	26	700	460	755	480	40-80
150	26	840	550	900	575	40-80
175	26	980	640	1050	670	40-80
200	26	1130	740	1210	775	40-80
250	28	1440	940	1540	985	40-80
300	28	1740	1140	1860	1190	60-100
350	28	1980	1300	2120	1350	60-100
400	28	2240	1470	2400	1530	60-100
450	30	2510	1640	2680	1710	60-100
500	30	2860	1880	3070	1960	60-100
600	30	3480	2270	3720	2360	100-150
700	32	4120	2700	4410	2810	100-150
800	32	4720	3090	5050	3220	100-150
900	32	5350	3500	5730	3650	100-150
1000	36	5950	3890	6350	4050	100-150
1250	36	7360	4830	7880	5030	100-200
1500	36	9000	5880	9600	6150	100-200

The result is that instead of falling aimlessly back on to the filament, the electrons are sucked forward and impact on the plate in a continuous stream. From there they pass on, through the telephones in the outside circuit, and so back to the L.T. battery from

(Continued on page 842.)

Pat. No.
256833

Pro. Pat.
No. 20339



The Grid Leak is not discernible, being totally enclosed in Bakelite Valve Holder Base.

Something new and good in component design

The latest LOTUS triumph is a Combination Grid Leak and Valve Holder which eliminates unnecessary wiring and soldering and makes for economy in cost and space.

Guaranteed efficient in construction and design.

From all Radio Dealers

Combination Grid Leak and Terminal Valve Holder	3/9
Terminal Valve Holder	2/6
Valve Holder without Terminals	2/3

All Anti-Microphonic Type.

LOTUS

Combination

GRID LEAK AND BUOYANCY VALVE HOLDER
Anti-Microphonic

Garnett, Whiteley & Co. Ltd.

Lotus Works, Broadgreen Road, Liverpool.

Makers of the famous
"Lotus" Vernier Coil Holders.



Your Last Chance to Win

£200



The closing date for the Dubilicon competition is now fixed for **DECEMBER 31st.**

If you have not already entered for this novel competition, do so to-day.

All you have to do is to buy a Dubilicon Multiple fixed Condenser, price 30/- (which is in itself a most valuable acquisition for any wireless man) and then calculate the number of different capacities which it is possible to obtain from various combinations of the eight separate capacities.

Your dealer will be glad to explain the scheme fully, or, in case of difficulty, we will furnish full particulars.

No entries reaching us after first post on December 31st can be considered.

The name of the winner will be published in the Press in due course—will it be your name?



ADVERT. OF THE DUBILIER CONDENSER CO., (1925)
LTD., DUCON WORKS, VICTORIA ROAD, N. ACTON, W.3.
P.S. 246



Apparatus Tested

Traders and manufacturers are invited to submit wireless sets and components to the "P.W." Technical Dept. for test. All tests are carried out with strict impartiality in the "P.W." Test room under the supervision of the Technical Editor, and the general reader is asked to note that this weekly article is also intended to provide a reliable and unbiased guide as to what to buy and what to avoid.—EDITOR.

BRETWOOD PATENT VARIABLE CONDENSER

Probably readers will have noted how frequently of late we have had occasion to comment on variable condensers of novel design. Well, here we have another variable that comes into the same category. Indeed, it is of an exceptionally novel character, and really deserves greater space than we are able to devote to its description.

In the first place, the movement is a worm-gear one, which provides a reduction ratio equivalent to about 10 to 1. The vanes are of a peculiar shape, and lie at right angles to the dial. The fixed set is vertically placed, the moving set falling away from them or coming upwards into mesh in accordance with the direction of the dial rotation. An indicator is provided to show on which of the ten revolutions the dial readings are being taken. The overall width of the variable behind the panel is only about 3 in., and its greatest

depth (with vanes "all out") barely $4\frac{1}{2}$ in. This "Bretwood" gives true "square law" variations and is designed on modern low loss lines. The workmanship is first-class and the movement as positive and free from backlash as could be. The result of having a worm-gear is not only that these desirable qualities obtain, but also that the vanes cannot be moved independently of the dial.

We consider that the makers would have pleased many constructors if they had provided for more than "one hole fixing," more especially as the indicator requires to be kept in alignment with an observation aperture in the panel, but this is a small point, and must not be allowed to weigh against the many excellent features embodied in the component.

Electrically the device is as good as it is mechanically, and its minimum is low and its maximum as stated. A "megger" test between its terminals recorded "infinity."

The price of this Bretwood Patent Variable Condenser is 17s. 6d. (capacity .0005 mfd.).

SOME FORMO COMPONENTS

The Formo Co. seem to have stopped producing variable condensers with corrugated vanes, and, personally, we do not think that this will cause much sorrow. The latest Formo variable, a straight-line-frequency, low loss component, has normal vanes, and is as good as anything going at the price asked for it—9s. without dial. Its design is not outstandingly original, although it has one or two features of a novel character. The moving vanes are securely held together at their ends by a metal bar similarly to the fixed vanes, but "shorting" cannot possibly occur owing to the incorporation of a stop of a most positive nature. A very small amount of insulating material figures in this Formo product, merely that required to form two large bushes to insulate the fixed vanes from the frame to which they are fixed.

The single bearing is of cone form, and, besides introducing a smooth movement, it wears concentrically, and thus the alignment of the instrument is preserved however hard and for whatever period it is used. Single hole mounting is provided for, and, as previously indicated, this Formo variable operates smoothly throughout the whole arc of its movement, and there is an entire absence of backlash and "rough spots." The maximum capacity was found to be .0005 mfd. as stated. A plain dial is available for 1s. 6d. extra, although we would recommend purchasers of the Formo S.L.F.

(Continued on page 840.)

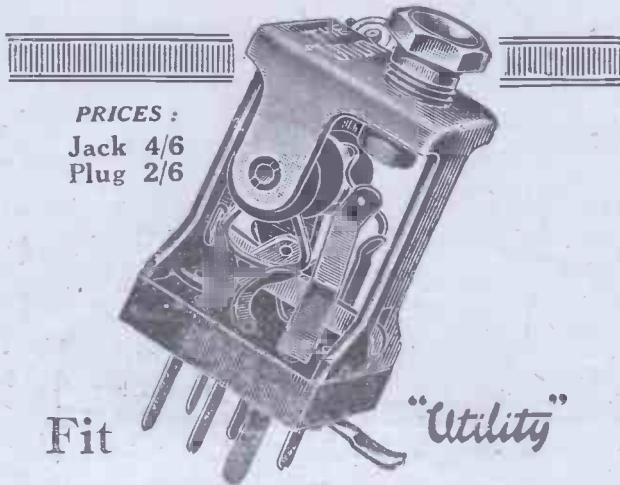

PRICES:
Jack 4/6
Plug 2/6

Fit

"Utility"

Guaranteed Components

Another popular 'Utility' Component—the Jack and Plug—is shown above. Designed by skilled electrical engineers and constructed with the same attention to detail that distinguishes all 'Utility' Guaranteed Components.

Low capacity, smooth action and perfect contact ensure best results in actual use.

Insist upon—"Utility" Jack and Plug, Micro Dial, No-Capacity Change-Over Switch, Low-Loss Condenser, Push-Pull Switch. All good dealers stock them.

WILKINS & WRIGHT LTD
KENYON ST. *Utility* BIRMINGHAM

Losses and Gains

Losses are disastrous in S.L.F. Condenser design.

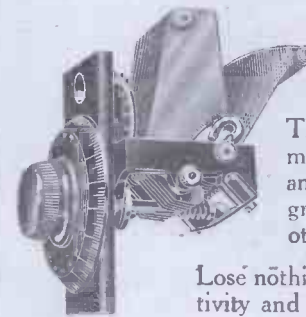

The more supports there are between the fixed and moving vanes, the greater is the leakage.

The Bretwood is the only condenser made that has only TWO supports, and losses are therefore reduced to a greater minimum than that of any other design.

Lose nothing, but rather gain greatly in selectivity and general reception results by fitting

BRETWOOD

S.L.F. LOW-LOSS CONDENSERS.

Free illustrated folders of all Bretwood Components on request.

Grid Leak de Luxe—Auto-Audio Frequency Amplifier—Filament Rheostats—Valve Holders—Coil Plugs—Switches.

Prices:
.0005 - 17/6
.0003 - 14/9
.00025 - 14/-
.00015 - 13/6

Obtainable From all Dealers.

Send p.c. for copies by return of post.

BRETWOOD LTD.,

16, LONDON MEWS, MAPLE ST., LONDON, W.I.



Have You Heard?

—the “Beco” Rose Bowl Hornless Loud Speaker? It reproduces faithfully, with a pure, clear tone, and—if desired—sufficient volume for dancing. Apart from its perfect performance the “Beco” Rose Bowl Model is of really beautiful appearance. Combining as it does, a perfect loud speaker with a useful and artistic flower bowl, the “Beco” Rose Bowl Model makes a cherished addition to the furnishing of the home. Whether the bowl is empty, or filled with water and flowers, the splendid tone remains unaltered. Obtainable in three varieties: Nickel Plate £5 5 0. Oxyd. Silver, £5 17 6. Antique Bronze, £5 17 6.

BECO

ROSE BOWL Hornless Loud Speaker

Deferred payments can be arranged on application to the address below.

Ask your dealer to demonstrate.

Other “Beco” Models from 52/6.

If your dealer cannot supply write to:

Dept. P.W., BRITISH ELECTRICAL SALES ORGANISATION,
625, Australia House, Strand, London, W.C.2
Telephone. City 7665; Telegrams: “Becospeker, Estrand, London.”



SUPERIAL

SIMPLE-STRIP

**SHARPER TUNING. 100% EFFICIENCY.
MORE POWERFUL SIGNALS. DELIGHTFUL TO USE.**

Entirely British Manufacture.

“SIMPLE-STRIP” is made of the finest hard-drawn copper—heavily tinned—perforated to take 4.B.A. connections, and will stay put without solder. No need for bits and pieces. One length of “Simple-Strip” will cover several connections. And between these connections it will turn and twist as you will.

The most complicated circuit can now be wired by any amateur without difficulty and without waste.

Simple Strip may be cut with an ordinary pair of scissors, bends and twists can be made with the fingers to any angle.

12 FEET

2/-

POST FREE.

Any length obtainable.

ON SALE

EVERYWHERE.



Simple-Strip must be included in the kit of every wireless enthusiast. It has many uses: A spade terminal with one snip of the scissors: A battery or accumulator connection: an excellent earth clip for gas or water pipe—and 101 other uses.

THE NEW LONDON ELECTRON WORKS, Ltd.

(Members of the B.B.C.)

(Dept. 19), EAST HAM, LONDON, E.6.

Telegrams: Stannum, London. Telephone: Grangewood 1408.

APPARATUS TESTED.

(Continued from page 50)

variable to obtain at the same time a Formo dial, which, selling at a modest 6s., has a 16 to 1 vernier movement, and is one of the best propositions of its kind we have seen. We particularly like the "hair line" and the finely engraved dial marked off for kilocycle and wave-length readings with which it is possible to obtain extremely delicate adjustments. The drive is a direct frictional one on to a large aluminium plate, which also acts as a shielding plate. An opening is cut in the clear celluloid window so that the matt surface of the aluminium plate can be written on. The action of this dial is silent and smooth.

The Formo shrouded L.F. transformer, which, we believe, was one of the earliest of all shielded radio components, has now assumed a very attractive appearance. Both its casing and its terminals are of golden hue, the latter items being very strongly mounted in an even row on the top of the component. Terminal indications are in the form of embossed lettering on the casing itself. The Formo shrouded L.F. transformer can be obtained with any of the following ratios: 1-1, 1-2, 1-3, 1-4, and 1-5.

We incorporated that one sent us for test in a straight Det.—L.F. 2-valver, and it gave good results. Sold at the reasonable price of 10s. 6d., it should attract many amateurs both by its appearance and performance.

SOME "EDDYSTONE" COMPONENTS

We recently received a number of "Eddystone" components from the makers, Stratton & Co., Ltd., Kent Street, Birmingham. Of particular interest to constructors are the "Eddystone" panel supports, which are supplied with screws and nuts, and are nicely nickelled and of just the right shape for most baseboard sets. The "Eddystone" absorbers are refinements which will appeal to many amateurs. They are springy rubber fittings for attaching to the bottom of receivers to absorb vibration and prevent the scratching of furniture. A special feature is the easy method in which they can be fixed by means of one small screw in the centre of each one.

But the most interesting of all is the "Eddystone" Short Wave Unit. This is suitable for a range between 15 and 200 metres. Four coils are supplied, and these are exceptionally well made and are designed to conform with all modern S.W., L.L. and other "fan" requirements. Complete with stand, the units cost 15s. 6d., for which price we consider it good value for money. A sheet of thoughtfully prepared instructions for the use of the unit is supplied. It includes a diagram of a recom-

mended circuit, together with full details of the necessary additional components. The circuit in question is a Reinartz and will meet with general approval.

PENTON THREE-WAY COIL-HOLDER

The Penton Engineering Co. recently sent us one of their three-way coil-holders, but, as it operates on the same principle as their two-way model which we recently reported on, it is unnecessary to describe it at length. It is known as the "A" type geared. It is an excellent piece of apparatus. Carefully designed and nicely made and finished, it is a component that should meet with the approval of the most critical of amateurs. The retail price is 10s. 6d.



A handsome cabinet loud speaker built up with a Lissenola unit and a set of parts supplied by Messrs. Hobbies.

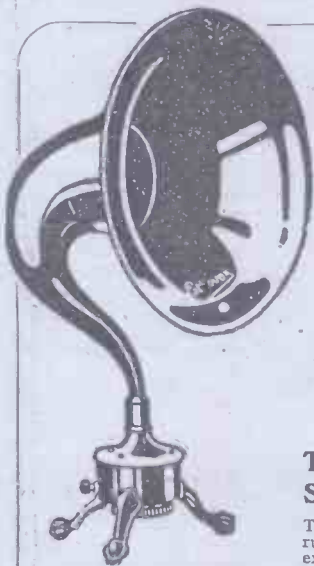

The Public and the Trade alike acclaim "The ETHOVOX" LOUD-SPEAKERS

They say the results are simply amazing and that our claims have been too modest. They write us to this effect. Have you heard broadcast *via* the "Ethovox"? It has to be heard to be believed.

Ask your local dealer for a demonstration.

The "ETHOVOX" LOUD-SPEAKER with Metal Horn

The Standard full-size "Ethovox" with rubber-covered feet. Finished in Burndept exclusive dustproof rich mahogany colour. Imitated but unequalled. Height 26 ins. Flare diam. 15 ins. No. 963 "Ethovox" (Type 750), with Metal Horn; for use direct in the plate circuit. Price **£4:10:0**

The "ETHOVOX" LOUD-SPEAKER with Mahogany Horn

Similar to above, but the flare is of dark coloured polished mahogany and constructed by a special process which gives it great strength, and is particularly neat in appearance. No vibration is possible. No. 966 "Ethovox" (Type 750), with Mahogany Horn; for use direct in the plate circuit. Price **£5:5:0**

Also a "Junior" Model at **£2-2-0**

Head Office and Factory:
Blackheath, London, S.E.3.

London Office & Showrooms:
where you are invited to hear
demonstrations during broad-
casting hours—
15, Bedford St., Strand, W.C.2.

BURNDEPT

WIRELESS LIMITED

The Burndept range includes everything for efficient radio reception. Guaranteed Super Valves, Components, Loud-Speakers and complete installations. Write for lists.

Louden Valves

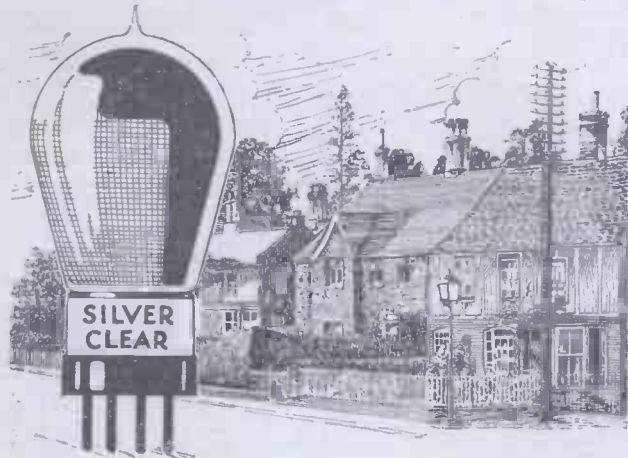

The Street, Long Stratton

The two original valves have been working all the time."

Mr. P. Hearn, of Long Stratton, has had over 12 months satisfactory use from the two Loudon Valves in his Little Giant Set.

Like all other Loudon Valve users, Mr. Hearn is highly satisfied with the results, and he shows it by ordering two more Loudens.

Read what he says:—

"Dear Sir,
 "Enclosed please find P.O. for 9/6. Please forward, if possible by return, two
 "Louden Valves (F1 at 4/6 each).
 "My 'Little Giant' two valve set has now been in use for twelve months, and
 "has given me every satisfaction. The two original valves have been working all
 "the time.
 "I feel that everything that bears the stamp of 'Fellows' is worthy of recom-
 "mendation, and it gives me pleasure in being able to thus express my satisfaction.
 "Yours truly,
 "P. HEARN (Long Stratton)."

Louden Valves are made by British labour in a British factory with British capital and can be depended upon for the finest volume, range and silver clearness. They can only be offered at such low prices because of our well-known policy of selling direct to the public and cutting out the middleman's profit.

The list below gives prices and full particulars.

Order your Loudon Valves from us by post.

<p>4/6</p> <p>Bright Emitters. L.F. Amplifier. F.1. H.F. Amplifier. F.2. Detector. F.3.</p> <p>5.5 volts 0.4 amps.</p>	<p>8/-</p> <p>Dull Emitters. L.F. Amplifier. L.E.R.1. H.F. Amplifier. L.E.R.2. Detector. L.E.R.3.</p> <p>2 volts 0.2 amps.</p>	<p>8/-</p> <p>Dull Emitters. L.F. Amplifier. F.E.R.1. H.F. Amplifier. F.E.R.2. Detector. F.E.R.3.</p> <p>4 volts 0.1 amps.</p>
<p>9/-</p> <p>Dull Emitters. L.F. Amplifier. F.E.R.1. H.F. Amplifier. F.E.R.2. Detector. F.E.R.3.</p> <p>6 volts 0.1 amps.</p>	<p>11/-</p> <p>D.E. Power Valves. Trans. Amplifiers P.E.R.1 Resist. Amplifiers P.E.R.2.</p> <p>4 volts 0.2 amps.</p>	<p>12/-</p> <p>D.E. Power Valves. Trans. Amplifiers P.E.R.1 Resist. Amplifiers P.E.R.2.</p> <p>6 volts 0.2 amps.</p>

Postage and packing: 1 Valve, 4d. 2 or 3 Valves, 6d. 4, 5 or 6 Valves, 9d.

FELLOWS, PARK ROYAL, N.W.10.

Branches:

- LONDON: 20, Store Street, Tottenham Court Rd., W.C. (Museum 9200).
- BIRMINGHAM: 248, Corporation Street (Central 435).
- BRIGHTON: 31, Queen's Road (Brighton 899).
- BRISTOL: 36, Narrow Wine Street (Bristol 7972).
- CARDIFF: Dominions Arcade, Queen St. (Cardiff 7685).
- LEEDS: 65, Park Lane (Leeds 21479).
- MANCHESTER: 33, John Dalton Street.
- NOTTINGHAM: 30, Bridlesmith Gate (Nottingham 5551).
- TONBRIDGE: 34 Quarry Hill (Tonbridge 172).

WRITE FOR
 48 pp.
 ILLUSTRATED
 CATALOGUE
 No. 33 FREE.

BUY DIRECT AND SAVE MONEY

E.P.S. 97.

BLACKADDA

RADIO BUILDING SYSTEM

offers you these advantages

- Economy.** No scrap or waste, all parts interchangeable and reasonably priced
- Simplicity.** Everything ready for assembly, no cutting, drilling, filing, screwing or soldering.
- Speed.** Sets of any power can be constructed or dismantled in the minimum of time.
- Adaptability.** The constructor can start in a small way, if so inclined, completing, say, an efficient one-valve receiver, then adding another section converting to two-valve, and so on.
- Variety.** New circuits can be "tried out" the same evening with ease, and valuable data recorded.
- No Tools.** With the exception of a small box spanner we supply, tools are unnecessary.
- Supplies.** We list everything required to build a crystal, single or multi-valve receiver, also series of adaptors for use with user's own components.
- Prices.** All parts numbered and technically described with prices. The components are of the highest quality and can be supplied singly or as required.
- Service.** Our Service Sheets (price 3d. each) printed in loose-leaf form, can be obtained and give Blackadda enthusiasts easily understood information and diagrams of various up-to-date circuits of merit.
- Efficiency.** Results from our sets are equal to any on the market of the same power, and the veriest novice who follows our Instructions can feel confidence in the result.
- Finally.** Our method of numbering the holes in the ready-drilled base, as well as all components and wiring points, renders construction literally "as easy as A.B.C."

The Blackadda renders obsolete the old-fashioned laborious method of home construction and opens fresh vistas for amateur and expert alike.

Have you written for the Blackadda Circuit Book (price 1/-)?

**BLACKADDA RADIO CO., LTD.,
 SADLER GATE, DERBY.**

'Phone: Derby 1820.
 'Grams: Blackadda, Derby.

THE FINEST VALVE CONTROL
Can be assured by using only the

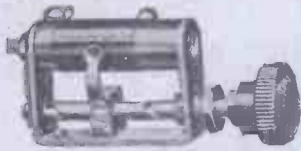

NEW TCB GUARANTEED RESISTANCE

(Patent No. 225,132)

Smooth and dead silent in operation; perfect insulation; positive stops for "Off" and "Full On" positions; a travel from "Off" to "On" in two turns of the knob; easy to fit; occupies minimum panel space. Illustration is three-fifths actual size.

Every one carries our written guarantee to replace it free if the slightest defect be found within three months from date of purchase.

Resistance 6, 13, or 30 ohms 2s. 6d.
Resistance 50 ohms 3s.
Potentiometer 300 ohms 3s. 6d.

BRITISH THROUGHOUT

Of all dealers or direct, post free, from the sole manufacturers. If ordering direct, state whether one or two hole fixing is desired.

Descriptive folder on request.

Wavio Ltd

Dept. P., Queen Street, Hitchin.

VALVES · BATTERIES

Radio Micro 2-v. '06, each 7/-	Radio Micro Power, 3-v. 1, each 10/9	Radio 2-v. '06 each 6/3	2-v. 2. " 4/-	Power 2-v. " 8/8	30-v. Batteries, guaranteed.
Fama 4-v. '06, " 5/9	3-v. 3-v. Tappings, each 7/6	TRADE ENQUIRIES INVITED WRITE FOR LISTS.			

ALL Goods sent post free.
BISHOPSGATE ELECTRIC SUPPLY CO.
180, Bishopsgate, London, E.C.2

RADIOTORIAL QUESTIONS AND ANSWERS.

(Continued from page 836.)

whence they came. In short, the filament and plate co-operate to set up a constant one-way electron stream or current flowing through the valve and thence through the outside circuit containing the 'phones or loud speaker.

OHM'S LAW IN PRACTICE.

P. B. D. (Cricklewood).—I always thought that the current passing through a conductor was proportional to the pressure present at each end. If this is really the case, and across the 'phone terminals of a receiving set there exists a certain voltage, why is it that if such terminals are connected together with a short piece of wire no signals are heard in the 'phones? Surely, according to Ohm's law, a proportion of the current should still flow through them?

When such terminals are so "shorted" the pressure across them is reduced to an almost negligible quantity, and subsequently the current flowing through the telephone receivers drops to practically nothing. The pressure, or, rather, potential difference existing between any two points in an electrical circuit is directly proportional to the resistance existing between such points and the total resistance of the complete circuit. For instance, supposing a battery of negligible internal resistance had its terminals externally connected to four 10-ohm resistances in series, these forming with the battery a complete closed circuit. If 4-volts' pressure exists across the terminals of the battery on open circuit, when the circuit is closed by the resistances, measurements would prove that 1 volt potential difference exists across each of the four resistances, of equal value, 2 volts across two of them, and 3 volts across three. Now, in the case of the telephone terminals, the "shorting" wire would have a very small resistance in comparison with the rest of the circuit, which, in the case of a valve set would consist of the valve (about 10,000 ohms), H.T. battery, etc., so that the potential difference existing across the shorted terminals would not be sufficient to cause appreciable current to flow through the 'phones. Signals would therefore be nil.

POSITION OF THE LOUD SPEAKER.

E. A. (Streatham Hill, S.W.).—Is it a fact that the position of the loud speaker affects the performance of the receiving set?

Yes; a loud speaker should be carefully placed in a room and not set down haphazardly in the most convenient spot; that is, if first-class results are

For the Constructor

No. 10—Separate H.T.

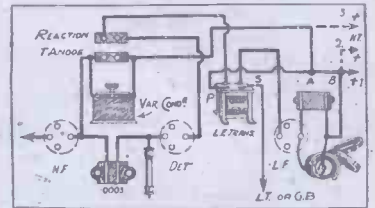

A typical three-valve circuit (H.F., Det. and L.F.) is shown here, all wiring not affected by the change for separate H.T. being eliminated. The dotted connections show how the new wiring differs from the old (providing only one H.T.). At the end of each dotted section a winder plug for insertion in the H.T. battery should be fixed. The original tapping (from 'phones to H.T.) will be retained, and the wires from the anode coil and condenser, and the L.F. transformer, should be disconnected at A and B, and taken to terminals so that winder plugs may be attached. The final connections read: Anode coil to one H.T. tapping, L.F. trans. to second H.T. tapping and 'phones to third H.T. tapping.

(Continued on page 845.)

The children drink food in



BOURNVILLE COCOA

It has delicious flavour too and is— food below pre-war price

'Keep fit on Cocoa'

See the name 'Cadbury' on every piece of chocolate

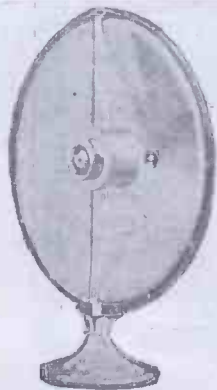

£2 10 0

Christmas Music!

BE SURE OF A "GOOD RECEPTION" wherever you go this Christmas.

TAKE AND GIVE A **SFERAVOX** THE "PERFECT LOUD SPEAKER"

Obtainable everywhere. Ask your local retailer to let you hear it.

SFERAVOX, 130, Fenchurch St., E.C.3
Tel.: Avenue 2481 (2 lines).

PROTECT YOUR VALVES

BY USING W.B. ANTI-PHONIC

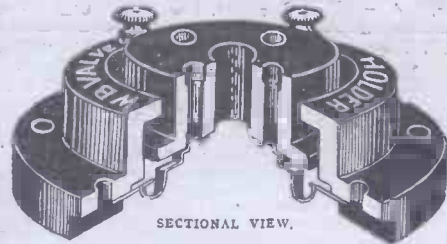

SECTIONAL VIEW.

LOW LOSS VALVE HOLDERS

PRICE Complete with Terminals

2/3

If unable to obtain from your dealer write direct, Manufactured by **WHITELEY, BONEHAM & CO., LTD.**, Duke Street, MANSFIELD, NOTTS.



CYLDON

(PRONOUNCED SIL-DON)

triumphs at NEW YORK & AMSTERDAM

At Amsterdam the International Gold Medal was awarded to an "Elstree Six" fitted with CYLDON Condensers. At the Radio World's Fair, New York, September 1926, 2nd and 3rd prizes were won by receivers fitted with CYLDON Condensers. These were a "Mewflex" and "All British Six" respectively. All in competition with American and European receivers. *Verb. sap.*

There is a complete range of CYLDON Condensers in all capacities—Square Law, S.L.F., Dual, 2-Gang, Triple Gang, and 4 Gang condensers. Each is the premier of its class—exceptionally well designed and finished.

SQUARE LAW. '0005 mfd. 17/6, '0003 mfd. 16/6, '00025 mfd. 16/-, '0002 mfd. 15/6. With dials.
S.L.F. '0005 mfd. 15/6, '00035 mfd. 15/-, '00025 mfd. 14/6. Dials 2/- extra.
DUAL CONDENSERS. '0005 mfd. 27/6, '0003 mfd. 25/-. With dials.
2-GANG, £2:10:0. TRIPLE GANG (as illustrated), £3:10:0. 4-GANG, £4:10:0.

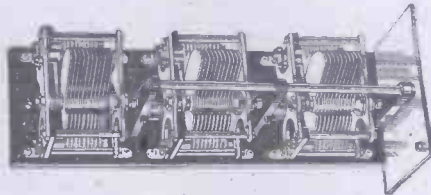

CYLDON TEMPRYTES.
The best means of valve control. British made and fully guaranteed. Can be supplied in correct resistance for any valve. State resistance (ohms) required when buying or be sure to give name of valve and voltage of accumulator supplying current to the valve.
CYLDON TEMPRYTES 2/6 each
HOLDER MOUNTINGS 1/6 each

Get full particulars of the **CYLDON WAVE-METER** (identifies unknown stations and makes searching and testing simplicity itself) and all the other **CYLDON** products from your dealer. If unable to obtain **CYLDON** products locally, send direct to:—

SYDNEY S. BIRD & SONS,
"CYLDON" WORKS, Sarnesfield Road, Enfield Town, MIDDLESEX
Telephone: Enfield 0672.



A Mile of Wire,
wound the Watmel
Way, in the

Watmel

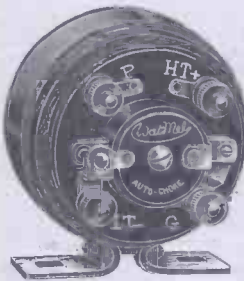

AUTO-CHOKE

The special windings are done by expensive and absolutely up-to-date machines which lay the wire exactly parallel and interweave cotton strands between each layer. Cotton acts as binder and ensures perfect insulation. Get to know the other reasons for the fine amplification and natural-toned reproduction, possible only with the **WATMEL AUTO-CHOKE**. Write for N.P.L. Curve 105/1, and Booklet describing Auto-Choke.

Price 18/6. From your dealer or direct from **THE WATMEL WIRELESS CO. LTD.,** 332a, Goswell Road, London. E.C.1.
Telephone: Clerkenwell 7990.

Lancs., Yorks., and Cheshire Representative: Mr. J. B. Levee, 23, Hartley Street, Levenshulme, Manchester. Telephone: 475 Heaton Moor.

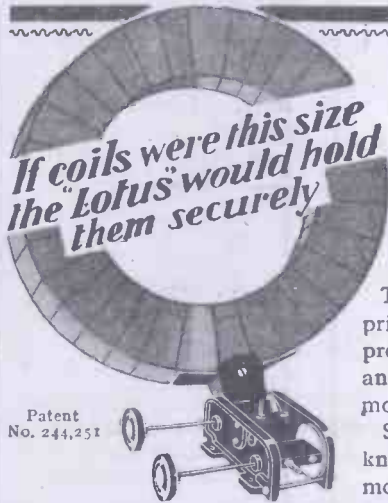

Patent No. 244,251

PRICES:
Two Types:
For outside panel mounting:
Two-way 7/-
Three-way 10/6
For inside baseboard mounting, with 6-in. handle:
Two-way 8/-
Three-way 12/6

Made by the makers of the famous Lotus Buoyancy Valve Holder.

The
Moving Block
Cannot Fall

The vernier movement comprises three sets of enclosed precision machine-cut gears, and reduces the speed of the moving block by eight times.

Side plates, coil blocks, and knobs in artistic bakelite mouldings. All metal parts heavily nickel plated. Made for left as well as right hand.

LOTUS

VERNIER
COIL HOLDERS

GARNETT, WHITELEY & CO., LTD.,
Lotus Works, Broadgreen Rd., LIVERPOOL

Don't forget to use

GLAZITE

BRITISH MADE REGD

COLOURED CONNECTING WIRE

[RED YELLOW BLUE · BLACK · WHITE and GREEN]

Write for descriptive leaflet to
The LONDON ELECTRIC WIRE CO & SMITHS LTD
Playhouse Yard, Golden Lane, London, E.C.1.

Makers of Electric Wire  for over 40 years

Element showing signs of glass stress.

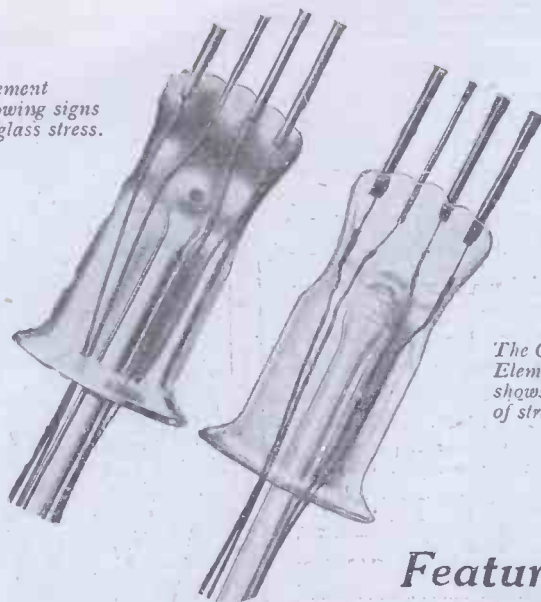

The Ocron Element shows no sign of stress.

Features of the OCTRLON Radio Valve

No. 3 Glass Stress

The strength of a Valve is in proportion to its weakest point—usually the glass. Much depends on the care devoted to this in manufacture. Inefficient methods result in stress and strain being put upon the glass components—resulting in frequent breakages. Above are two illustrations of Ocron Valve parts, the one on the left having been tested by our special method. This part shows signs of stress* in the glass. The element on the right has been made with the up-to-date "Ocron" plant and shows no strain or stress under test. Every element is carefully tested at every stage of manufacture to ensure the long life of Ocron Valves. You can fit Ocron Valves safe in the knowledge that they will give long and efficient service.

*A simple explanation of glass stress is as follows:—If a plain piece of glass is held in a clip it can be held firmly without undue strain, but if pressure is applied, defective glass tends to show signs of stress. This stress can be discovered and measured by suitable scientific instruments as used by the manufacturers of Ocron Valves.

Every Ocron Valve is tested in this manner before being sent out, thus minimising the risk of breakage.

The OCTRLON VALVE IS BRITISH MADE

Prices from 12/6

Manufacturers: H. S. ELECTRIC LTD., Electrical Engineers, 32, Charlotte Street, Birmingham. Telephone Central 7460. Telegrams: Hosaval, Birmingham.



FINSTON SCREENED COLLS. B.C. Aerial Coil, 5/6. Split Primary H.F. Transformer with reaction, 7/6. 88 H.P.T., 7/6. Reinartz, 7/6. 5XX, above, 5/6. 7/6. 11/-; Saren and 6 1/2 Base, 9/-.



THIS MAGNIFICENT 2-VALVE SET (D & L.F.P.) As shown, an handsome polished American type cabinet, with 2 Dull emitter Valves and Coils. 65/- Car. 3/6. OR with Valves, Igranite Coils, H.T. 100-v. L.T. Aerial Equipment, Leads, and 25/- Loud Speaker, tax paid. The Lot, £5.10.0

OUR NOVEL VALVE and CRYSTAL SET, in solid polished cabinet, complete with valves, phones, H.T. and L.T. Units, Aerial Equipment, Daventry Coil, Extraordinary value, 45/11. Carriage, 2/-.

Special Products. 50/- & 60/- Low Loss Condensers, 2/6. Friction Geared, 0005. 15/-; 0005. 14/6; 00025. 13/6. Straight Line Frequency Priorities. Geared 0005 20/-; 00035. 19/6 S.L.P. 0005. 12/-; 00025. 11/-.

CHOKES.—Cosmos H.F. 6/6; Lissen H.F. or L.F. 10/- each; Success L.F. or H.F. 10/- each; Bowyer Lowe H.F. with base, 9/-.

THORPE K4 9/6 VALVES, 5-pin. McMICHAEL.—Bal. Condenser, 4/9. All Fixed Condensers, H.F. Transformers, each 10/-; Dime Coils, 10/-; Bases, 2/6.

FRANCO.—Midget Bal. Cond., 3/9. Panel Brackets, pair 1/-.

COIL STANDS.—Lotus 2-way, 7/-; 3-way, 10/6 (extension handles extra). Polar 2-way, 6/-; 3-way, 9/6. Sterling Triple, 21/-; Kay Ray, geared 2-way, 3/11; 3-way geared, 6/11; Penton 2-way, geared 6/-; Imperial 2-way vernier knob, 6/-.

WATMEL PRODUCTS. 0002 or 0005 and Grid Leak, 2/6. Fixed Condenser, all caps, 2/-. Variable G.L., 2/6 (3 to 5 meg.). Anode, 50,000 to 100,000, 3/6. Ditto, 10,000 to 75,000, 3/6. Auto Choke L.P. Coupling, 18/6. Post extra.

FIXED CONDENSERS. Dubilier, 0001, 2, 3, 4, 5, each 2/6. 001, 2, 3, 4, 5, 6, each 3/-. Grid Leak, 2/6. Edison Bell, 001, 0001, 2, 3, 4, 5, 1/-; 002, 3, 4, 5, 6, 1/6. 0005 and grid leak, 2/-.

MONODIAL RECEIVER COMPONENTS £7 : 0 : 0. All as specified. Kay Ray LOW LOSS SQUARE LAW CONDENSER. This variable Condenser is simply marvelous value. It cannot be equalled in price or quality.

With Post 5 11/6 0003 or 4 11/6 With VERNIER 1/- extra. S.L.F. CONDENSERS. LATEST MODEL. 6/11 POST 6d.

0003 or 0005 6/11 With knob and dial 7/11. JACKSON BROS. T.J. & L.F.P. 0005, 11/6; 0005, 10/6. Brix Vanes, 4-in. dial, Geared, Sq. Law, Twingank stocked.

ALL CIRCUITS, PARTS, COILS & SETS STOCKED. RADIO MICRO VALVES. .06, 3-v., 6/11; .25, 2-v., 6/11; Power, .3, 8/6; Power, .9, 9/11 (Power are 3-4 volts), Phillips 2. Electrode, 4-pin for Unidyne, 8/11. Post 6d. each.

CALLER'S COLUMN NOT SENT BY POST. Terminals with N. and W. 1d.; Nickel, 1 1/2d. Spade Tags, 5 a 1d. Soldering, 3d. do. 10. Bushes, 1d. Screw Winder Plugs 2d., 3d., 4d. pair. Plug and Socket, R. or B. 3d. Staples 4 a 1d. Valve Pins 2 a 1d. 4 or 2 B.A. Rods, 3d. E. Earth Tubes-Copper, 2/3; Climax, 5/-; Fine 7/22 Aerial, 100 ft. 1/1. Special Heavyweight 2/3. Phosphor Bronze, 4s. strands, 100ft. 1/- (limited).

MONODIAL RECEIVER COMPONENTS £7 : 0 : 0. All as specified. KAY RAY LOW LOSS SQUARE LAW CONDENSER. This variable Condenser is simply marvelous value. It cannot be equalled in price or quality.

STOP! Adjustable 4,000 ohm Headphones (Nesper pattern) double leather headbands, 7/11. SPECIAL OFFER. YOU LIST FOR A SPECIAL OFFER.

CALL HERE FOR LISSON, BENJAMIN, DETEX, COSMOS, MULLARD, EDISWAN, MARCONI, C. O. S. S. O. R., OSRAM, JACKSON (J. B.), DUBILIER, McMICHAEL, SUCCESS, BEARD & FITCH, BOWYER-LOWE, LEWCOX, IGRANIC, EURKA, ORMOND, J. J. FORMO, EDISON BELL, FERRANTI, R.I., POLAR, NEWBY, P. & M., MAGNUM. We have the goods! Call and see us. All lines in demand stocked. Special terms to Radio Clubs, genuine exporters.

WEST END DEPOT FOR "MAGNUM" Newley 2-way geared coil stand, 7/6. 4-point condenser, 17/6. 18/- "R.I." New Type Aerial Tuner, 39/6. Gambrell Neutrovornia, 5/6.

K. RAYMOND 27 & 28a, LISLE STREET, LEICESTER SQUARE W.C.2. HOURS: 9.15 to 7.45 SATURDAY: 9 to 8.45 SUNDAY: 11 to 1. Back of Daly's Theatre. Nearest Tube, Leicester Square. Phone: Gerrard 4637.

RADIOTORIAL QUESTIONS & ANSWERS.

(Continued from page 842.)

desired. Many people stand their loud speakers on the top of their receiving sets, little realising that by so doing they may be seriously impairing the quality of their signals. A loud speaker vibrates when in operation, and it is liable to transmit this vibration through the cabinet of the set to the valves and cause "roughness" and sometimes even howling. Contrary to general belief the use of anti-microphonic valve holders is not a sure prevention against the above taking place.

WAVE-LENGTH OF AN AERIAL.

"CURIOUS" (Southampton).—What is meant by the "natural" wave-length of an aerial?

The "natural" or fundamental wave-length of an aerial is that wave-length it possesses, and to which it will respond without "tuning." Wave-length

"P.W." 6d. BLUE PRINTS.

A Series of 20 Blue Prints can be obtained from the Query Dept., PRICE 6d. PER BLUE PRINT. (A stamped addressed envelope must accompany each application, and the number of the required Blue Print must be given when ordering.)

The following are the numbers, and the circuits covered.

P.W. BLUE PRINT

Number

1. DETECTOR VALVE WITH REACTION.
2. UNIDYNE DETECTOR VALVE WITH REACTION.
3. 1-VALVE L.F. AMPLIFIER.
4. CRYSTAL DETECTOR WITH L.F. AMPLIFIER.
5. H.F. (Tuned Anode) AND CRYSTAL WITH REACTION.
6. H.F. AND CRYSTAL (Transformer Coupled, Without Reaction).
7. 1-VALVE REFLEX WITH CRYSTAL DETECTOR (Tuned Anode).
8. 1-VALVE REFLEX AND CRYSTAL DETECTOR (H.F. Transformer, without Reaction).
9. H.F. AND DETECTOR (Tuned Anode, Reaction on Anode).
10. H.F. AND DETECTOR (Transformer Coupled, with Reaction).
11. DETECTOR AND L.F. (Switch to Cut Out L.F.).
12. DETECTOR AND L.F. UNIDYNE (Switch to Cut Out L.F.).
13. 2-VALVE REFLEX (Valve Detector).
14. 2-VALVE L.F. AMPLIFIER (Transformer-coupled with Switch).
15. 2-VALVE L.F. AMPLIFIER (Transformer-Resistance Coupled with Switch).
16. H.F. (Tuned Anode), CRYSTAL DETECTOR AND L.F. (with Switch for Last Valve).
17. CRYSTAL DETECTOR WITH TWO L.F. AMPLIFIERS (with Switching).
18. 1-VALVE REFLEX AND CRYSTAL DETECTOR, with 1-VALVE L.F. AMPLIFIER, controlled by Switch.
19. H.F. DETECTOR AND L.F. (with Switch for the Last Valve).
20. DETECTOR AND 2 L.F. AMPLIFIERS (Switches for 1, 2, or 3 Valves).

Note: All these sets are of the flat panel type.

is readily altered by inductance (in the form of a coil) or by capacity (in the form of a condenser), but if neither coil or condenser is used, every aerial has a certain inductance and capacity of its own, and it is the product of these two properties that determine its wave-length. The natural wave-length of a standard P.M.G. aerial, for instance (100 feet), is approximately 135 metres, and its natural capacity approximately .0002 mfd.

ADDING AN AMPLIFIER.

"INTERESTED" (Colchester).—I have a 2-valve detector and L.F. Unidyne set which I have made from your blue print No. 12. This set is giving splendid results, music and speech coming through at good 'phone strength. Can you please tell me if a microphone amplifier would be a sufficient addition to work a small loud speaker, or would it be better to add a 1-valve amplifier as your blue print No. 3?

As valves are already in use we should prefer to use a third valve for increasing the volume. The arrangement shown on blue print No. 3 is quite suitable for your purpose.

EXPERTS IN RADIO ACOUSTICS SINCE 1908



TWO NEW CONES THE ELLIPTICON TABLE CONE

(Registered Trade-mark)

(Trade-mark)

The handsome cabinet is finished in dark walnut and will admirably harmonise with any decorative scheme or furnishings. The elliptical concavity of this casing reflects the full body of sound with wonderful depth and sweetness. The large vibrating area of the cone, together with a driving unit of special design, brings pleasing and natural tone with plenty of power. The magnets in the cone unit are very large. There is no diaphragm, but a small armature which, reacting to the faintest impulse, faithfully reproduces extremely low and high tones.

The cone is housed in an attractive cabinet of unique design, which has a walnut finish. The circular diaphragm has an extremely sensitive driving unit which brings a wealth of volume with pure and effortless ease. The magnet in the cone unit is unusually large. The instrument is supplied complete with cord connection, and is a proposition of excellent value. It has a genuine claim to be better than any similar instrument at the price.

Height 13½ ins. at base, depth 9½ ins.

£2:15

Brandes

From any reputable Dealer.

BRANDES LIMITED, 296 REGENT ST., LONDON, W.1

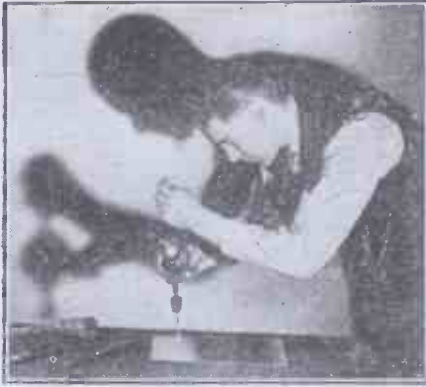

Panel Talks: No. 5.

Here is a Panel that will not split or break or crack

Do you know how it feels to split your panel just when you have almost completed your drilling? No, you don't—if your choice fell on Resiston.

For Resiston Panels (like Radion) are made throughout from nothing but pure rubber. Because of this they are tough yet not brittle. They are strong. They will not break. Or split. Or crack. They can be sawn with ease and with safety. They can be drilled without difficulty and, when tapped, will take a good thread.

Thus, when the home constructor buys a Radion or Resiston Panel, in one of its 17 sizes, he knows that even though he is not quite an expert with the drill or the saw, he is in very little danger of ruining his panel. Its very constitution facilitates easy working.

If, in the past, your experience of ebonite has been discouraging, you'll appreciate the worth of Resiston. Its perfect insulation. Its superfine surface (which no hand has touched since it left the factory). Its colour permanence and its strength.

For the sake, perhaps, of a few pence, will you court failure and disappointment by choosing an unnamed panel in preference to one bearing such a name as Radion or Resiston—names which give you positive assurance of lasting satisfaction?

Send for the Radion Book

In its twenty-four fully illustrated pages are details for building four unique Receivers together with many useful wireless hints

Please send me, free, the 'Radion Book' together with the booklet, 'The Gentle Art of choosing one's Panel.' P.V., Dec. 4.

Name.....
Address.....



American Hard Rubber Co., Ltd., 13a, Fore St., E.C.2

G.A. 6493.

CORRESPONDENCE.

Letters from readers discussing interesting and topical wireless events, or recording unusual experiences, are always welcomed; but it must be clearly understood that the publication of such does in no way indicate that we associate ourselves with the views expressed by our correspondents, and we cannot accept any responsibility for information given.—Editor.

SPARK JAMMING.

The Editor, POPULAR WIRELESS.

Dear Sir,—I write this letter in protest at the many selfish grumbles one hears re the interference of ships' wireless transmitters with the broadcast programmes. So-called wireless experts have dipped their pens in vitrol and written scathing indictments in various journals against marine operators and the way they handle their sets.

The usual complaints from these writers are (1) The broad band of wavelengths covered by a ship's spark transmitter; (2) The obsolete apparatus employed on so many ships which causes this flat tuning; (3) Unnecessary information to various coast stations such as where the steamer is bound and where from.

Point (1)—Each ship station uses a commercial wavelength of 600 metres for ordinary traffic. As there are so many ships working at the same time it is obvious that were they all working exactly on that wavelength absolute chaos would ensue. A more important point, and one which has been entirely overlooked by the grumblers, is the utility of this broad tuning in cases of distress. An operator on watch cannot be varying the controls of his receiver for four hours on end in the hope of picking up a distress call. Lately, some ships have been fitted with tonic train transmitters which are extremely selective, but what is the result? They call a station and are only heard by accident. Imagine if every steamer were fitted with this type of apparatus what a nice mess commercial working would be in through delay of traffic.

Point (2)—This is more or less a corollary of Point (1), but there is one thing I would like to draw the attention of the grumblers to, and that is: the apparatus on most ships is fitted under contract with some wireless company for a certain number of years, and should all the old types of gear be dispensed with and more up-to-date apparatus fitted a very heavy financial loss would be entailed. It is hardly to be expected that the shipowners or wireless company will be philanthropic enough to pander to the desires of a selfish minority.

Point (3)—A ship's T.R. consists of the steamer's name, her destination and the most recent port she has left, also the distance in nautical miles of the ship from the coast station with which she is working. People who call this unnecessary working must have very little intelligence not to see that these particulars are of vital importance to a coast station in determining how long the ship will be within range. There are many other advantages of this T.R. business too numerous to mention. Such things as operators' chats around the coasts of any country in the world are very few and far between, as the offenders are visited with the most rigorous penalties.

I should like some of these misinformed grumblers to spend a day in the wireless cabin of a ship at sea when jamming is pretty bad, then they would see what their professional confreres have to put up with. We operators don't growl at QRM. It is part of our day's work.

Yours faithfully,
JAMES L. MAITLAND,
Operator, S.S. "Fezara."

S.S. "Fezara,"
Alexandria.

BUY BRITISH GOODS.

The Editor, POPULAR WIRELESS.

Dear Sir,—I have just read Mr. Cumming's letter under the heading "It Pays to Buy British," and I am afraid that I am not in agreement with him.

While I have known of repairs to burnt-out loud-speaker bases for a very small figure, I think that the manufacturers are quite capable of doing so seeing that they charge so high a price in the first case.

Take, for instance, valves. If foreign manufacturers can put on the market valves that cost less than two-thirds of the price asked for by British manufacturers, surely the valve manufacturers in the combine in England could do so.

Perhaps they have not heard of the saying "Small profits, quick returns." By foreign manufactures I do not mean all the valves that come from Germany or France (although anybody outside the combine must be "foreigners" to the combine), but a certain firm that is claimed to be of American origin (they have just put a gas-filled detector valve on the market) whose valves were 12s. 6d. and 15s. before they joined the combine, now they range from 18s. 0d. The query is, who gets the difference? In fact, it is a wonder to me that the combine do not hold a pistol at your head for accepting advertisements that state valve prices lower than they do. I have not the slightest doubt they will do when they get a better grip.

(Continued on page 848.)

EVERY LOUDSPEAKER

DESERVES MULLARD MASTER VALVES

— Ask for —
Mullard P. M. Power Valves.

RELIABILITY WIRELESS GUIDE

New Edition No. 9 ready. Complete Reference Book and Price List of everything in Wireless. Send Postcard Now. It's FREE. Trade Supplied.

J. H. TAYLOR & CO
4, RADIO HOUSE
MACAULAY ST. HUDDERSFIELD

A BOON to the HOME CABINET Maker

Do Your Own French Polishing

Anyone, without even the slightest knowledge of French polishing, can obtain highly pleasing and satisfactory results with S.P. FRENCH POLISH. The S.P. OUTFIT contains woodfiller, stains, polish, accessories, and complete yet simple instructions. Price **4/6**

Post Paid from:
S.P. POLISHES, 5, High Holborn, W.C.1
An Ideal Xmas Gift for Your Boy

PLEASE be sure to mention "POPULAR WIRELESS" when communicating with Advertisers. THANKS!

AMPLIFIERS!—Treble that weak Crystal (or Valve) Amplifier. Reception with "New Vares" Micro Amplifier. It's guaranteed to do the job. Simple and cheap to make from our special electrodes, filling, with plans, diagrams, instructions, 2/6 post free. No valves, buttons, etc. Worked by two 1.5-v. dry cells.

DEBENEAM & CO., 28, Castlards Road, LONDON, S.E.6.

AERMONIC

VALVE HOLDER

1/9

DONT PAY MORE

Don't pay more. You can't buy more. New design eliminates losses. New springing system gives better results.

JAMES CHRISTIE & SONS, Ltd.
246, West Street, SHEFFIELD.
London Agents: A. F. BULGIN & CO.,
10, Dursitor Street London, E.C.4

The High Tension System of the Future
WET H.T. BATTERIES

Due to the silent background and great economy of working, WET H.T. Batteries have almost everything to recommend them. They offer all the advantages of an H.T. accumulator, with none of the disadvantages such as the inconvenience of charging and the liability to sulphate if left run down. The cost is less than 3d. a volt, and upkeep 1d. per volt per annum.

Send 1d. for full details.

Jars 2 1/2" high, 11 x 1 1/2"	dozen	1/3
8oz Elements	..	1/6
Zincs	..	1/-

Carriage Extra.

WET H.T. BATTERY CO., 23, Coldharbour Lane, Amberwell Green, S.E.5.
Phone: Brixton 2539.

Multum in parvo!

(Latin, you know, meaning 'much in little'.)

THE fixed Condenser is the smallest component in your set. Yet, like the sparking plug of the car, it is one of the most vital parts of your Receiver. It is like a cog in a machine—if it is faulty the success of your whole Receiver will be prejudiced.

When you ask your Dealer for a Condenser, he may show you two which look alike. Yet the one which has no name may cost a little less than the one which has the letters 'T.C.C.' stamped on its case. If you buy the unnamed Condenser you do not know for what you are paying. But if you choose the T.C.C. you know that, because of the reputation T.C.C. have had for more than a score of years, it will give absolute satisfaction. That it is dead accurate. That it is leak-proof. That it is impervious to all climatic conditions. That it, in short, is the perfect Condenser.

'Multum in parvo' which, being interpreted means 'much in little,' is an apt description of the T.C.C. For—little though it be—the T.C.C. contains much—in fact, everything which a master Condenser should.



Prices:
No. 33, all capacities between .004 and .001 mfd., 2s. 4d.

Prices:
No. 34, all capacities between .009 and .001 mfd., 2s. 4d.

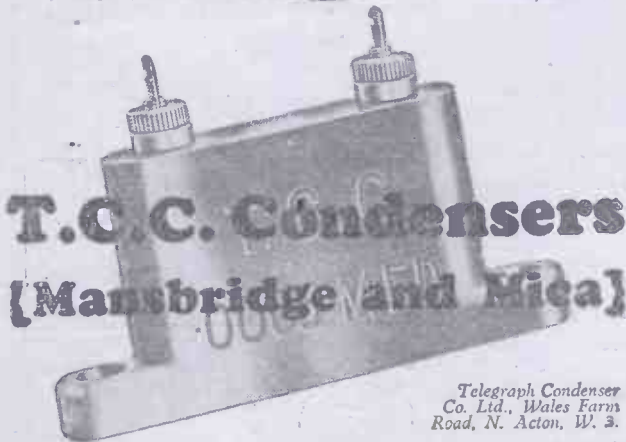

Telegraph Condenser Co. Ltd., Wales Farm Road, N. Acton, W. 3.

Gilbert Ad. 6503.



RECUPERATING AGENT IN THE HELLESEN DRY BATTERIES

Is the secret of uniform, silent and economical H.T. supply. Choose a Helleesen Dry Battery as a Xmas gift for your wireless friends and you have the two-fold satisfaction of knowing that your gift is "the best in the world" of its kind and also that it will be appreciated.

Wireless reception to-day demands H.T. Batteries with recuperating power to withstand long and frequent usage. Make the Helleesen secret your Xmas gift and long though the battery may last the appreciation will out-live it.

Ask your dealer for a Helleesen Dry Battery, it will cost you no more, it only gives you more.

60 volt "WIRIN" 12/6

99 volt "WIRUP" 21/-

(Postage Extra)

All types, voltages, etc., in Double and Treble capacities for H.T. and L.T. Supply. Ask your dealer for the type to suit your set and get the maximum service, or write us for full particulars.

Obtainable at all Radio, Electrical and General Stores, Harrods, Selfridges, etc., or direct from

A. H. HUNT, Ltd. (Dept. 12), CROYDON, SURREY

TRADE

HUNTS

MARK

They Last Longer

THE NEW LOTUS JACKS & PLUGS

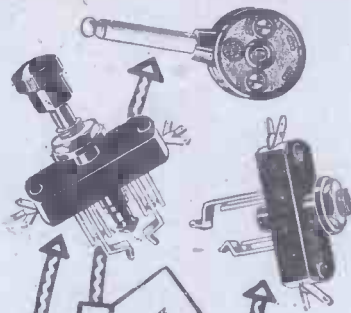

LOTUS JACK PLUGS
Designed for use with most of the popular make of headphones and nickel plated. The wires are clipped in position by a turn of the screw cap.
Price: 2/-

LOTUS JACK SWITCHES
This push-pull switch is designed to occupy the minimum space, being only 1 1/2 in. deep. Of the finest nickelite, it has nickel silver springs and contacts of pure silver. Soldering contacts can be made to suit any wiring.
Prices:
No. 9, as illus. 4/-
Others from 2/6

LOTUS JACKS
Designed to take up the least space, the depth back of panel being only 1 1/2 in. One hole fitting. So the silver springs and contacts are brought into position.
Prices:
No. 3, as illus. 2/6
Others from 2/-

The name 'LOTUS' is your guarantee of sound results and solid satisfaction.

From all Radio Dealers.

LOTUS

JACKS · SWITCHES · PLUGS

Made by the makers of the famed 'LOTUS' Vernier Coil Holders and 'LOTUS' Buoyancy Valve Holders.

Garnett, Whiteley & Co., Ltd.

Lotus Works,
Broadgreen Road, Liverpool.

CORRESPONDENCE.

(Continued from page 846.)

It is absolutely no use saying that British goods are better than anybody else's in the world, therefore we have to pay more, because one has only to go through the experience of screwing the rod of a well-known grid leak home and find on trying to withdraw the rod that the microscopic nut under the flanged knob has come loose, to get those ideas knocked out of his head.

Fixed condensers make another case of sheer robbery.

I think manufacturers are trying to get back to the prices I am just reading in your No. 2 issue of June 10th, 1922, and if they had any hand in the picking of the new B.B. Corporation I will think still less of them, seeing that there appears to be only one out of the whole bunch that knows anything about wireless, namely Mr. Relth.

Anyhow, whatever comes or goes, please keep the same standard of publication that you are now issuing, which is, shall we say, R 9.

Yours faithfully,
DAVID FULLELOVE.

85, Addison Crescent,
Old Trafford, Manchester.

The Editor, POPULAR WIRELESS.
Dear Sir,—Re the letter headed "It Pays to Buy British" in your issue dated November 20th.

May I add further testimony to the wisdom and advantage of buying British goods.

Recently I bought a .0003 Newey four-point condenser which developed a slight fault. I wrote Messrs. Newey, and they immediately sent me a .0005 condenser, apologising for any inconvenience and asking me to return my condenser. No charge whatever was made.

In my ignorance I built the .0005 into my tuned anode circuit, with the result that reception was badly affected.

I was at a loss to understand the reason until a wireless enthusiast told me that the value of the condenser was too high.

I wrote to Messrs. Newey explaining the circumstances, and they immediately and without demur changed the condenser a second time without any charge.

Further comment on the advisability of dealing with British firms of repute is unnecessary.

Yours faithfully,
E. H. WEBSTER.

90, Marshall Road,
Woodseats, Sheffield.

RE THE HOME-MADE H.T. BATTERY.

The Editor, POPULAR WIRELESS.

Dear Sir,—Some time ago I built up an H.T. battery on the same principle as that described by W. F. Whitby in this week's "P.W." No. 232. The one drawback I find is that the sal-ammoniac eats the zinc plates away very quickly, otherwise it is a great success. If Mr. Whitby would tell us in your esteemed paper how this could be remedied he would earn the thanks of a great number of "P.W." readers, including, of course,

Yours faithfully,
ALFRED TIMSON.

Manton House,
42, Uppingham Road, Leicester.

[Rubbing the clean zinc with mercury in order to produce an amalgamated surface may assist in decreasing the action on the metal.—EDITOR.]

B.B.C. PROGRAMMES.

The Editor, POPULAR WIRELESS.

Dear Sir,—Your correspondent, "Anti-Grouser," is right to some extent, but like a great many other people who prefer a certain portion of the programme to some other portion, he immediately labels anyone a "jazzite" who does not appreciate talks or music of a certain type. First of all, I might say that we all admire the way in which the B.B.C. keeps up its variety. Few of us could do as well, and we certainly would make a complete hash of the programmes for the first week or so. At the same time, however, I do not think that the great majority of licence-payers desire high-grade heavy music of the type supplied so often, and I doubt also if jazz music or talks early in the evening are very popular. It is not that the music is high-class which is the objection, but because a lot of it lacks melody, and it is not educational talks which cause the loud speaker to be switched off, but the fact that the average listener doesn't want any deep thoughts after his day's work. I am of the opinion, wrongly or rightly, that the B.B.C. type of programme which appeals to the majority is, alas, the afternoon concert type—and these are given when the "majority" of people are at work.

Yours faithfully,
ZERO.

Bedford.

CONGRATULATIONS.

The Editor, POPULAR WIRELESS.

Dear Sir,—I feel I must congratulate you upon obtaining the services of Mr. Percy Harris, who was undoubtedly the one bright spot in the Radio Press, no doubt thousands more will write to you, but I must do it.

(Continued on page 850.)

20/-
down



Great New Wireless Offer

Our wonderful 2-valve set with loud speaker and headphones installed free in your own home—anywhere—by our own Installation Engineers for £12 cash; or £1 down and 20/- a month for twelve months only. And we guarantee satisfaction.

There is nothing else to buy—the set is complete with all accessories.

When our Engineers have installed the set just switch on and enjoy perfect and powerful loud-speaker reception. You are also entitled to two free calls from our Engineers after the set is working.

The General Radio set is British made, unsurpassed in efficiency and purity of tone. It has no superfluous controls and is as easy to work as turning on the light.

Send a postcard to-day for free illustrated catalogue No. 5W and full particulars of this offer.

General Radio
GENERAL RADIO CO. LTD.
RADIO HOUSE
235 Regent Street, W1



REPAIRS SETS, PHONES, TRANSFORMERS.
Officially Approved by Radio Association.
ALL WORK GUARANTEED LOWEST RATES 24 HOUR SERVICE
Cash on Delivery if Desired.
JOHN W. MILLER, 68, Farringdon St., E.C.4.
'Phone: Central 1950

AGAR'S

Resin-Cored Radio Solder.

Guaranteed Non-Corrosive

(British Made).

Used exclusively by all Telephone Manufacturers, Government Departments, etc. No Flux required. Makes a perfect joint. Low melting point. Eliminates messy Flux.

The Safe Solder for Radio and Electrical Work.

1/- Per Carton. Obtainable from Leading Stores, Electricians, Radio Dealers, Ironmongers, or Post Free direct from:

W. H. AGAR, 19, Whitecross Place, Wilson Street, LONDON E.C.2



ACCUMULATORS ON EASY PAYMENTS

High-Tension Accumulators built up from 20-volt sections (15/- each). Example: 60-Volt H.T. 45/- CASH or 12/6 DOWN and 6 monthly payments of 6/-. Carriage Paid. Satisfaction or money back. Write for Lists to DEPT. 11, JOVENTRY DIRECT SUPPLIES LTD., 23, Warwick Row, COVENTRY. Any Wireless Goods supplied on easy payments.



EDISON BELL RADIO

SOFT LIGHTS — TRIED FRIENDS
AN EDISON BELL SET AND SPEAKER

THIS HAPPY COMBINATION WILL ALWAYS ENSURE AN ENJOYABLE EVENING

2-VALVE SET as ILLUSTRATED
PRICE
£4 10 0
Valves, Batteries and Maroon Lenses extra.

No. need to go out in the rain, get damp and run risk of cold in a chilly Concert Hall when you can obtain perfect radio reception in your own comfortable home by merely switching on your set. Your friends will enjoy it, too.

SPEAKER AS ILLUSTRATED
PRICE
42/-



MULTIPLE CONNECTOR

Non-reversible, detachable name plates, built with Eelex standardised Plugs and Sockets. All parts are standard, detachable and interchangeable. Coloured flexibles can be supplied in the following colours: red, blue, green, yellow, black, white and maroon at 1/6d. per yard. If at any time sets change so that multiple connectors are no longer required, then the parts can be put to other uses. It will pay you to adopt the Eelex Standardised system of Connections.

5/6

Complete

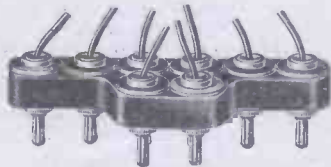

5/6

Complete



TREBLE DUTY TERMINAL

Made in 26 different lettered tops and six different coloured indications. Standardised connections, absolutely unique and priced at 4 1/2d. each.

Nickel finish.

Write for illustrated list No. P W 5.

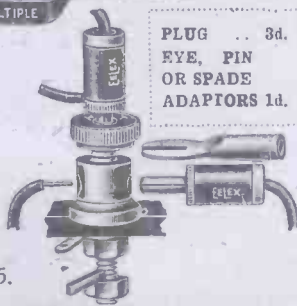

PLUG ... 3d.
EYE, PIN
OR SPADE
ADAPTIORS 1d.



Eelex House, 118, Parkhill Rd., E.C. Phone: Clerkenwell 9282, 9283

CONDENSER

be sure you get a reliable

HYDRA
CONDENSER

The Zenith of Quality

.041 μF
10 000 cm

Although the standard of quality has been raised prices are very reasonable. Capacities stocked are from .00011 mfd. to 10 mfd. 1 mfd. 2/9; 2 mfd., 3/9; 4 mfd., 6/-; etc., etc.

Hydra Condensers operate perfectly at all voltages up to 700 D.C. Guaranteed precise within 5 to 10 per cent. of their rated capacity and to maintain rated capacity through all variations in temperature. From all good dealers.

Hydra Condensers have a resistance of 200 megohms per 1 mfd. guaranteed.

Louis Holzman

109 KINGSWAY, LONDON, W.C. 2

GRAVES

2-VALVE LOUD SPEAKER BARGAIN.

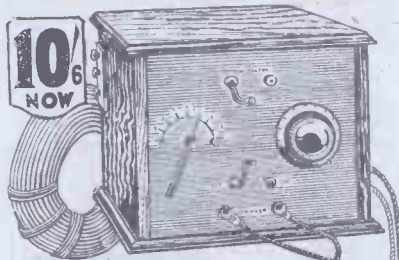

This highly efficient 2-Valve Loud-Speaker Set is the finest wireless value ever offered.

It gives a volume and quality of tone unattained by any instrument of a similar price and is the essence of simplicity. Fitted with coils covering all the British wave-lengths, including Daventry.

THE CABINET is of beautifully polished Oak, & all components are of the highest quality. Dull Emitter Valves with patent valve holders, H.T. Battery, 2-volt accumulator and complete Aerial Outfit. **LOUD SPEAKER** of exclusive design with unique magnetic system and improved mica diaphragm. Price **£7:17:6**

TERMS: Our Bargain Price is for deferred payments. Send 10/6 now, & complete purchase in 14 monthly payments of 10/6. If you wish to pay cash, 5 percent discount is allowed. **Catalogue Post Free.** Up-to-date Crystal & Valve sets at keenest prices.

J. G. Graves Ltd. Sheffield

fullest Approval



TRANSFORMERS REWOUND

Transformers, Phones, Loudspeakers, Rewound and Repaired to Maximum Efficiency. All One Price 4/- each. Don't discard if burnt out. All work guaranteed for 12 months. Write for trade terms. **TRANSFORM CO., 115, LINKS RD., TOOTING, LONDON, S.W.17**

RADIO

- Inches
- 7 x 5, 1/-
- 7 x 6, 1/3
- 8 x 6, 1/4
- 10 x 8, 2/1
- 10 x 9, 2/4
- 12 x 10, 3/-
- 14 x 12, 4/-



PANELS

- Inches
- 6 x 6, 1/-
- 8 x 5, 1/2
- 9 x 6, 1/7
- 11 x 8, 2/3
- 12 x 8, 2/6
- 12 x 9, 2/10
- 14 x 10, 3/5
- 3/4 in. thick
- Post Free.

Money back guarantee that each and all Panels are free from surface leakage. Megger test Infinity. Callers cut any size. Quotations by post, or 'phone Clerkenwell 7853. Samples and prices post free to the Trade.

CROXSONIA CO., 10, South St., MOORGATE, E.C.2

Valves Repaired

AS GOOD AS NEW!!



(Except Waco, S.P.'s and low capacity types). Minimum D.E. Current 0.15 amps when repaired. **ALL BRIGHT & DULL EMITTERS** Listed at less than 10/- Minimum charge 5/- **VALCO LTD., Dept. P.W. Tabor Grove, Wimbledon, S.W.**



BUILD A LOUDSPEAKER

WITH OUR NEW **SEAMLESS MOULDED CONE** (Prov. Patent 25069/26.) and a **BROWN A.** or **LISSENOLA.** You will obtain **PERFECT RESULTS.** Successful Construction for a minimum outlay is ensured with our Specialities. *Illustrated Lists and full particulars by Stamp.*

300DMAN'S, 27, FARRINGTON ST., E.C.4.

CORRESPONDENCE.

(Continued from page 848.)

Your journal appears to be the only one which has kept up its general interest to the enthusiast, and which still has unatrophied brains on its staff, and is not developing into a COMIC PAPER!

One of the most interesting parts of your journal is the answers to correspondents and readers' views and experiments, and in the others you will notice these features have gradually been squeezed out, I believe to the detriment of circulation.

I hope you will never forget that your biggest customer is the dabbling experimenter with very little scientific knowledge.

Wishing your paper every success.

Yours faithfully,

A. WRIGHT.

Russington, Shepperton.

ONE VALVE RESULTS.

The Editor, POPULAR WIRELESS.

Dear Sir.—I have read with interest a letter appearing in a recent issue of your journal, and beg to agree with Mr. W. F. Wilbee when he suggests that B. P. S., of Warrington, either uses a poor circuit or lives in a very unfavourable reception district.

I have built the one-valver described in "P.W." (Jan. 30th, 1926), and the results obtained with it leave nothing to be desired.

Using a Cossor Wuncell and 67½ volts tapped H.T., I have received Radio-Paris, Daventry, Königswusterhausen, Hilversum, Dublin, Manchester, London, Glasgow, Aberdeen, Newcastle, Bournemouth, Cardiff, Belfast, Birmingham, Frankfurt, Hamburg, Munich (?), Breslau, Radio-Vienna (531 m.), San Sebastian and Cassel, along with a couple of unknown stations.

All these were well received with the exception of Cardiff and Birmingham. My aerial-earth system is good, the former being about 40 ft. high.

Thanking you for your excellent paper and advising B.P.S. to build this set if he has not done so.

Yours faithfully,

JOHN D. HOUSTON.

P.S.—I found that a .001 condenser across the 'phones, and the reversal of L.T. connections improved control and results.

26, Sandymount Avenue, Ballsbridge, Dublin.

ARTIFICIAL "Xs."

The Editor, POPULAR WIRELESS.

Dear Sir,—Noticing in your "Radio Notes and News" in "P.W.," Nov. 23th, a paragraph or two about a reader hearing atmospherics in his 'phones when stroking a cat, reminded me that I had a similar experience two or three months ago.

I also noticed that crackles occurred when my hand touched the cat's ears after stroking from head to tail.

What the cat felt I don't know, but did not appear to like it, and finally got up and walked away in disgust.

Best wishes and long life to "P.W." from a No. 1 reader.

Yours, faithfully,

ERIC BATES.

30, Spausyke St., Hexthorpe, Doncaster.

INTERESTING TESTS OF INSULATION.

The Editor, POPULAR WIRELESS.

Dear Sir.—In reply to the letter of Mr. E. H. Wood in No. 232, of November 13, 1926, it is quite correct that some of the wood in question must have been damp. But this was not shown by inspection, and the result proves the need of testing it. Untreated, or unbrushed, wood may let a man down badly at any time, by accidental exposure to damp air; but ebony will not. Some wood, especially American whitewood, is known to be a good practical insulator, if it can be kept dry; but how is an experimenter to do this in England?

As to a suitable valve it is clearly advisable for the grid-filament resistance to be low (other factors keeping the same), and I should think the impedance of the valve used by Mr. Wood was far too high, judging by its amplification factor of 32. There is no direct connection between the amplification factor, and the multiplier due to the use of a valve, over direct testing with the same H.T. battery. The valve increases the current very much more than by the amplification factor, in some cases. The matter needs further investigation. I have used a low resistance, bright emitter, Cossor valve and another soft valve; but a correspondent writes that he finds a power valve best, and I should like to hear that someone has tried the four-electrode type.

The best way to insulate the valve, and to get rid of all leakage, or capacity, effects, in the holder, is simply to cast it, upside down, in a small earthenware pot in paraffin wax. This will not melt. Then sufficiently puzzling static effects, for a beginner, can be got by rubbing a stick of celluloid on a piece of flannel, and holding the stick near the wire joined to the grid, while watching the milliammeter. After that, connect the grid to a well-insulated wire, stretched overhead across a room, where the air and everything else is dry; and the mystery of the cause of the movements of the needle will deepen.

Yours faithfully,

LESLIE MILLER.

23 Rural Way, Streatham London, S.W.16.

Britain's Best in Radio

LAMPLUGH

RHEOSTAT and POTENTIOMETER

Using the famous Lamplugh Buffer Contact, ensuring absolutely silent operation. Resistance 500 ohms.

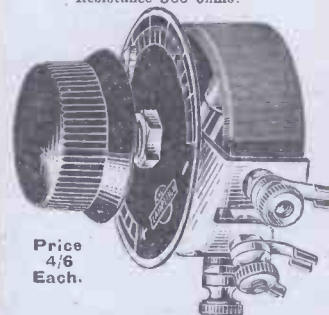

Price 4/6 Each.

S. A. LAMPLUGH LTD.

King's Road, Tyseley, BIRMINGHAM.

Sole Distributors for London and Southern Counties: The Empire Electric Co., 303, Euston Road, London, N.W.

Scottish Depot: 58, Montrose Street, Glasgow.

Obtainable from all leading Wireless Dealers.

Send for RADIO Lists.



This mark is our Guarantee

ET H.T. BATERI S
BUY BRITISH. Complete Units 3/6 per doz. All goods BRITISH MADE BY BRITISH LABOUR. Jars 1/3. Zincs 1/-. Sacs 1/6 per doz. Carriage and Packing extra. Trade inquiries invited.—**Demon Battery Co., 59, Badlis Rd., Walthamstow, E.17**

Pay while you Listen!

Don't deny yourself the joys of Radio because of the initial cost of a complete Receiver. We can supply the latest "Popular Wireless" and other well-known sets, guaranteed Components and Accessories on the Easy Payment System. Technical advice free. Write at once for our comprehensive Catalogue "P" and let us know your requirements.

New Times SALES CO., 77, CITY ROAD, E.C.1. 6503

ADVERTISEMENTS

As far as possible all advertisements appearing in "P.W." are subjected to careful scrutiny before publication, but should any reader experience delay or difficulty in getting orders fulfilled, or should the goods supplied not be as advertised, information should be sent to the Advertisement Manager, "Popular Wireless," 4, Ludgate Circus, London, E.C.4

SAVE YOUR VALVES

PRICE complete 2/-



New Bulbs 6d. each

HUNTS "SAVE IT"

SAFETY FUSE COSTS PENCE A. H. HUNT, LTD.

WANDER PLUG SAVES POUNDS (Sept. 12, Wrodon, Surty)

Orphean

LOUDSPEAKERS

Are unsurpassed for Purity of Tone. TEST ONE FOR YOURSELF FREE OF CHARGE.

Your wireless dealer will let you test either of these Orphean instruments on your set at home. If it is not better than any loud-speaker you have heard, return it within seven days. There is no obligation to purchase.

The No. 12 model gives the power, volume and purity of tone that has hitherto been the justification of the £5 5 0 loudspeaker. Model No 12 is similar to that illustrated, but a smaller size. Mahogany finish, height 21", flare 12".

Price 50/-



Price 90/- De Luxe Mahogany finish, Red and Black Knobs to indicate Polarity. Height 24". Dia. of Flare 16". Wheel adjustment.

LONDON RADIO MANUFACTURING Co., Ltd.

Loudspeaker Specialists

61, Borough Road, London, S.E.1.

The New VALVES

MICROLUX



A-1 SINGLE FILAMENT 0.06 amp.

Bi-2 DOUBLE FILAMENT 0.06 amp.

The valve with two lives.

C-3 SUPER AMPLIODYNE 0.1 amp.

Power valve for low frequency amplification.

Ets. A. BERTRAND,

1 Rue de Metz, PARIS (X^e), France

CHARGE YOUR ACCUMULATORS

AT HOME

NO TECHNICAL KNOWLEDGE OR ATTENTION REQUIRED. RELIABLE AND EFFICIENT.

Simply plug-in to any convenient lampholder. Each Outfit supplied complete with Adaptor, Connecting Cords and full instructions.

"Goltone Pendelton" (Patent App.)

(Alternating Current.)

Charges the Low Tension Accumulator economically and effectively at minimum cost. No Renewals. Charging rate approx. 2 Amps. Price complete .. £2 12 6

Fitted with Ammeter, as illustrated £3 7 6

When ordering please state voltage and frequency of Lighting Mains.

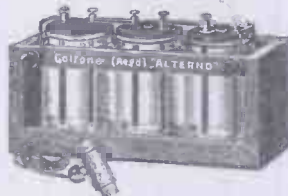

Fully illustrated Catalogue No. R/116 Free on request.

"INDISPENSO" (Direct Current.)

Charges the High Tension Accumulator at no extra cost when light is in use.

Price complete .. 6/-

"ALTERNO" (Alternating Current.)

Charges the High Tension Accumulator at negligible cost. Price complete .. 21/-

Stocked by the Leading Stores. Refuse Substitutes.

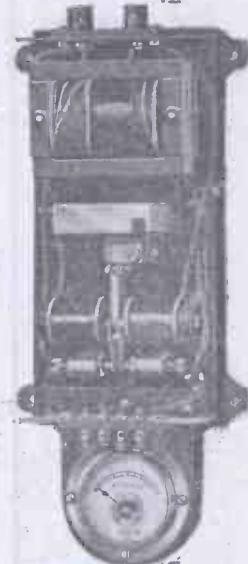

"Pendelton" Charger with cover removed.



"POPULAR WIRELESS" ADVERTISEMENT RATES

WHOLE PAGE £40 QUARTER PAGE £10

HALF PAGE - £20 EIGHTH PAGE - £5

Narrow Column Advts. (3 columns to page) per inch 30/-
Minimum Space accepted - - - - - half inch 15/-

NO SERIES DISCOUNTS. ALL ADVERTISEMENT COPY SUBJECT TO EDITORIAL APPROVAL

COPY AND BLOCKS MUST BE IN HAND 11 DAYS BEFORE DATE OF ISSUE TO ENSURE PROOFS

ALL Communications respecting advertising must be made to

JOHN H. LILE LTD., 4, Ludgate Circus, London, E.C.4.

Phone: City 7261.



A MONUMENT IN THE MARCH OF PROGRESS

The Formo Shrouded Transformer is the universal favourite.

Made in Ratios 1-1, 1-2, 1-3, 1-4 and 1-5

10/6 1-3 and 1-5 for 1st and 2nd stages

Send for Catalogue and Descriptive Literature of Complete Formo Range

THE FORMO COMPANY Crown Works, Cricklewood, N.W.2

Phone: Hampstead 1787.

Manchester: Mr. J. B. Love, 23, Hartley St., Lovenshulme.

Phone: Heaton Moor 475.



HIGH & LOW TENSION ACCUMULATOR HIRE SERVICE

Rotax High Tension Accumulators greatly improve Loud Speaker reception eliminating the uncanny noises caused by partly run down dry batteries and may be hired ready for use.

Here's a way of improving reception, saving money, time, and trouble for all valve set users who live within 12 miles of Charing Cross. Write now for particulars of the unique service.

RADIO SERVICE COMPANY,
105, Torrington Avenue, N.W.5.
Phone North 0523. (3 lines).

Our Low Tension Hire Service effects a considerable saving if you add the depreciation in value to the cost of having your own accumulator unskillfully recharged.

ELECTRADIX BARGAINS!

No. 208.
ACCUMULATOR SALE.—Fuller "BJX₂₁," 2 volt 24 amp., 6/-; 4 volt 24 amp., 11/-; 6 volt 24 amp., 18/-; "BJX₃₀," 2 volt 30 amp., 8/8; 4 volt 30 amp., 12/-; 6 volt 30 amp., 17/-; Fuller—2 volt 45 amp., 10/-; 4 volt 50 amp., 20/-; 2 volt 80 amp., 13/-; Exide—6 volt 8 amp., 6/8; H.D., 2 volt 40 amp., 7/-; H.D., 4 volt 40 amp., 13/6.
HIGH TENSION ACCUMULATORS.—6d. per volt. H.D. Co., 80-volt 1 amp. with taps, ebonite case and lid, glass cells, new, 40/-.
THE DIXON ULTRA ONEMETER is a Radio Standard Instrument, 50/-; Multipliers, 6/6. Order now.
STAMPINGS FOR TRANSFORMERS AND CHOKES.—E or T, 10d. per doz. Hedghog wire for Transformers or Chokes, 1/- lb.
SILVER POLAR PANEL CRYSTAL DETECTORS. EVERSET HERTZITE, at half-price, 2/-.
LEATHER-COVERED WOOD CABINETS, with lid and handle, for portable sets, 12 in. by 8 in.; depth, 6 in. Cases only, 7/6. With ebonite panel, 10/6.
POLAR SURPLUS ALL NEW.—Precision Condensers, list 12/6. Sale, 4/6, 3 gang Vario Cond, 10/-; Polar Varia H.F. Transformers, 300/500, 3/6. Dubilier Anode Res., all sizes, 3/6. Holders on ebonite, 1/-; Polar Cosmos Variometer, on panel, scale and dial. List, 21/-. Sale, 8/6.
COIL HOLDERS.—Polar Panel 2-way Vernier, 4/-; Geared 2-way, 4/6. 2-Way Quality, back of panel, 5/-; 3-Way "Hava," 6/8. Long Handles, 4d. H. & B., back of panel, 3-coil, 7/6.
AMPLIFIERS.—Brown's Micro for Crystals, works Loud-speaker, 50/-; 1-valve Sterlings, brand new, 32/6; R.A.F. 2-valve T.B., 35/-; Marconi 3-valve L.F., with Selector Switch for 1, 2, or 3, £2 10s. Tested and guaranteed H.F. Amplifiers for Super Hets., 3-valve, 40/-; 7-valve, £5; 7-valve Marconi Straight D55, £3.
P.O. 2-RANGE NO. 146 TESTERS.—250 m/a and 2.3 volts 7/6 each. 3-range Milliammeter, 37/6. Capacity and Insulation Testers in stock, £7 10s., £12. Have you ordered your "One-meter" yet? You must have one.
SWITCHES.—Lucas panel 3-lever flush, 1/3, quarter price, 8-way, 4/6. Plugs and Jacks, 2/6 pair. 4-pin plug and socket with switch, 4/6. Earth Aerial, 1/-. Arresters, 3d. Dewars, 1/8 and 2/8.
TRANSFORMERS.—Intervalve Marconi, 10/-; Dix Ironclad, 10/-; Microphone, 5/-; 220 volt to 3, 5 and 8 volt, 12/6; Dixon H.T. for Receivers, 220 to 150 volt, tapped for Rectifying, 25/-; Fuller type Chokes, 200 to 1,000 ohms, 1/6. 2 mid. W.D. Condensers, 2/6. New 2 mf., 4/3. 4 mf., 6/6.
D.C. H.T. MAINS UNITS.—220 volt to 60 volt, 80 volt and 120 volt, 35/-. DIX L.T. and H.T. from Mains, £3 10s. H.T. from A.C. Mains, £5.
GYROSCOPES.—Navy, cost £25. Sale, 15/-.
AERIALS.—R.A.F. 110 ft. 7-strand bronze pocket, 1/3. Navy 7/23-strand enam., 3/- 100 ft. Indoor Special Aerial, 1/- 100 ft. Small Frame Aerials, 10/-.
INSULATORS.—R.A.F. Drip-proof 2d. Bulldix, 1/-; Porcelain Tubes, 6d. and 9d. All sizes. Egg and Shell, 1d. Mica, 2 in. by 2 in. by 100z, 1/- doz.
EARTH-MATS.—Galv., with Electron wire, 2/6; Copper Mesh, 2/6. Earth Spikes, 1/3.
PIASTES.—R.A.F. "Esel" Tube, 15 ft., 7/6; 20 ft., 10/-; 30 ft., 14/-, in 2 ft. 6d. in. by 1 1/2 in. sections. Heavy Mast Sections, 4 ft. 3 in. by 2 1/2 in., 5/- each.
ELECTRIC HEATERS.—Immersion, 4/-; Toasters, 7/6; Hotplates, 7/6; Flat Irons, 10/-; Soldering Irons, 7/6. Massage Vibrator Sets, list £4. Sale, 21/6. Violet Ray Sets, 45/-.
NEW 45-METRE MARCONI SETS, with 2-valve Telephony Transmitters, with 6-valve Receiver, 3 H.F. and 2 L.F. Transformers, Tuning Coils, Condensers, etc. Siemens' Microphones on arm. Mod. Transformer, Choke, 2 Potentiometers, Weston combined Amp. and Milliammeter, 0-5 amp., 0-120 milliamps. Instrument alone is worth £3. We offer the whole of above, 6-valve Receiver and 2-valve Transmitter, in mahogany case, complete, tested. These sets cost £45. Our price £5 10s.; carriage 3/6. Trans. Valves, 15/- each.
PHONES.—R.A.F. 3,000 ohms with fur headband, 6/6; with Brown's Alumina swivel, 8/6. Marconi, 12/-; B.T.H., 12/-; Heath's, 11/-; New Mello, 7/6 pair. Single receivers, H.R., 3/9. Sullivan's L.R., 3/6 pair. All parts for Paper Loud-speakers. Brown's "A," 12/6. 12 in. Twin Brass Rings, 5/- pair. Stays, 3 for 1/2. Machine Pleated Parch-Paper for Diaphragms, 2/3.
MARCONI RB10 CRYSTAL DET. and 1-VALVE L.F. AMPLIFIERS.—Engraved Ebonite Panel, Spade Variable Vernier Condenser, T.C.C. Condenser, 2 high-freq. Chokes, Crystal Detector, Valve Holder, Terminals, L. and S-wave Switch, etc. In hided black leather-covered case. New and partly wired. With diagram and 1 Osram Valve. Our price to clear, 10/- each. Post, 1/3. All parts mentioned above are contained in sets.
SENSITIVE MICROPHONE BUTTONS.—For amplifying without valves. Speech transmission, detectaphone work and other applications: List price, 8/-; Clearing these at 1/- each, post 2d. Microphone Transformers, 5/-.
POLAR Patent Filament Rheostats, 10 ohms, 1/3. Post 3d. Polar Precision Condensers, .0003, list 12/6. Sale, 4/6. Polar H.F. Varia Transformers, B.B.C., 3/6. Polar Cosmos Variometer, list 21/-; Sale, 8/6. Polar 3-gang Condensers for Treble Tuning, list 25/-; Sale, 10/4.
ELECTRADIX RADIOS.
218, Upper Thames St., E.C.
 Blackfriars Sta., Met. Rly. City 191

TECHNICAL NOTES

(Continued from page 832)

Experimenters may have remarked that the anode resistances which are now used are in general smaller and more compact than those which were sold a year or two ago. There are two main reasons for this, these reasons being connected firstly with the development of the resistance-coupled valve, and secondly with the nature of the resistance elements. In the case of a resistance-coupled amplifying valve having an amplification factor of, say, 20 and an impedance of perhaps 20,000 to 30,000 ohms, the value of the anode resistance for the best result would probably be about 100,000 to 150,000 ohms. But these resistances had to carry a current of several milliamps., and consequently, if they were of the ordinary type they had to be made somewhat bulky or alternatively they required to be wound with fine metal wire, the windings being, of course, arranged non-inductively.

More Efficient Design.

The design of resistance-coupled amplifying valves has, however, undergone considerable developments during the past two years with the result that valves are now available having a very high impedance (100,000 ohms) and a high amplification factor, as high as 40. With such valves it is necessary to employ—for the best results—an anode resistance of perhaps half a megohm, and evidently such a resistance, if made in the conventional form, or even in the wire-wound form, to carry a current of several milliampères would become unduly bulky.

Easy to Manufacture.

Owing, however, to the fact that the current-carrying capacity with this type of valve is very much smaller, the same applies to the anode-resistance, and it is possible to use a resistance-element consisting of a metallised insulator, such as a strip of mica upon which metallic vapour has been condensed to the required thickness. This type of anode-resistance and grid-leak is rapidly gaining favour, as it is very compact in size and constant in operation. Moreover, it is comparatively cheap and easy to manufacture.

As a matter of fact recent design in valves and anode resistances is advancing even still further and sets are appearing on the market with resistances of 3 megohms in the anode circuits.

Give Books This Year!

There is nothing that will give the children greater pleasure at Christmas or Birthday than a copy of their favourite picture and story Annual. Such gifts are of lasting popularity—they will be read again and again. Among the many excellent gift-books available this winter, none are more attractive than those which are issued in connection with the popular coloured papers which delight boys and girls every week. Those famous characters, Tiger Tim and the Bruin Boys, who play the leading part in "Rainbow" and "Tiger Tim's Weekly," appear in **PLAYBOX ANNUAL** and **TIGER TIM'S ANNUAL**, both of which are published at 6/-.

Children who read "Playtime" will find all their favourites in the new **PLAYTIME ANNUAL** (6/-), and all the little people from "Puck," appear in the **PUCK ANNUAL** (6/-).

All these annuals are profusely illustrated, contain many pages and plates in colour, and are packed with entertaining stories, jokes, riddles, poems, etc. They can be obtained from booksellers and newsagents everywhere.

Put on a little—

FLUSOLDA

(Patent Applied For) —and Heat it— That's All

The Secret
of Simple Soldering

One clean handy fluid—no tinning, no flux—now enables expert or novice to handle any soldering job with complete confidence.

"Flusolda" has made soldering simple at last. Just apply "Flusolda" and then apply heat and a perfect joint must result.

In tins at 1/3 from Wireless Dealers and Ironmongers.

Trade Enquiries to the Sole Manufacturers:—

THE TRANSPORT SUPPLY CO., LTD., WARRINGTON.

Telephone: Warrington 459.

(S.A.S.)

WIRELESS.—Capable, trustworthy men with spare time who wish to substantially increase income required where we are not fully represented. Applicants must have practical knowledge of installation of Set and Aerial, be a householder or live with parents, and be able to give references; state age and experience. Address: Dept. 32, General Radio Company, Limited, Radio House, Regent Street, London, W.1

ABOLISH SOLDERING TROUBLES
 Blowing Soldering Iron for Flexible Gas Tube "Dwarf," 3/11; Largest size, 9/9 & 7/6. Post Free. Straight or Hatched Bit, as desired. **ADJUSTABLE TOOLS, LTD., Fitzroy St., ASHTON-under-LYNE.**



Trelleborgs

GENUINE EBONITE
Experts choose it—
—its Choice

STOCKED BY ALL THE BEST DEALERS
TRELLEBORGS EBONITE WORKS Ltd. Andrey House, E.C.1.

EASY PAYMENTS Finest 2-valve amplifier set, including loud speaker, 120 H.T., D.E. valves, £7 10s for 18/9 down and 11 instalments of 15/-.

CASH BARGAINS.
 Amplifiers, 17/6 and 21/-. Phones, Telefunken type, 7/9; Fr. T. Houston, 11/-. Good H.T. 60-volt, 5/9, or 4/-v. (laboratory test), 4/- doz. Famous Metal Valves (French), 2-v., 2/5; 2-v., 0/6. 5/9; 2-v., 5. Power, 2/9; 4-v., 0/6, 5/6. Straight Line Condensers, 5/9; Ditto, 4" dial, 7/3. Transformers: Habana, 3/6; Radiolys, 3/8; Fr. T. Houston, 8/3; Brunet, 7/9. Also Ferranti, Elreks, Formo, etc. Postage extra. Everything in wireless, reliable and cheap. Satisfaction or cash refunded.
MUSIC ROLL EXCHANGE, 29, High St., Clapham, London, S.W.4.

HEADPHONES REPAIRED
 Re-wound and re-magnetised 5/- per pair. Loud Speakers repaired 5/-. Transformers re-wound 5/- each. All work guaranteed and tested before delivery. Write for Trade Prices. Phone: Clerk, 1795.
MASON & CO., 44, East Road, City Road, N.1.

4 - ELECTRODE VALVES



We are the suppliers of the genuine U.O. and Thorpe valves, as specially tested and recommended by the "Undivided" inventors and "Popular Wireless." U.C.5 and Thorpe K.4 (both 4-electrode 6-pin valves), each, post free—

10/6

Order direct from— Cash with Order

LUDGATE RADIO CO.,
56, LUDGATE HILL, LONDON, E.C.4

R/B

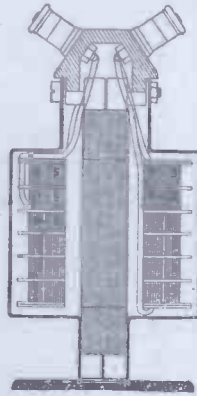

MAKES THE MOST OF ANY VALVE

Now that the tendency in modern radio valves is towards a high emission current it is essential that these filaments shall not be choked by excessive transformer impedance and D.C. resistance.

The R.I. Multi-Ratio Transformer is absolutely suitable for use with these valves. The quality of the iron used in the core ensures very low losses, while the unique patented system of coil winding reduces the self-capacity to the extraordinarily low figure of only 18 micro-microfarads.

From its range of impedance values you can always choose one to operate correctly in conjunction with the valve without choking the filament emission.

Therefore, to obtain the best results from any amplifying valve use the R.I. Multi-Ratio Transformer—the Transformer for every valve and every circuit.

The Wireless Journals are now including this transformer in all their latest circuits. It has solved the problem of distortion.

PRICE 25/-



The mark of
Better Radio

Write for the R.I. Catalogue—

R.I. Ltd., 12, Hyde Street, New Oxford Street, London, W.C.1.



OF VITAL IMPORTANCE TO ALL VALVE USERS



WRITE NOW

for your copy of the complete N.P.L. Report giving irrefutable proof of the value and merits of Mullard P.M. Valves with the wonderful P.M. Filament.

Full valve guide and instructions to secure better results from your radio.

An opportunity that should not be missed by any radio valve user.

Mullard

THE MASTER VALVE

THE RADIO VALVE WITH A PUBLISHED NATIONAL PHYSICAL LABORATORY TEST

FILL IN THIS COUPON TO-DAY.

The Mullard Wireless Service Co., Ltd.
Mullard House, Denmark St. London, W.C.2

Please send me a copy of your N.P.L. Brochure and Valve Guide giving me full particulars why valves with the wonderful P.M. Filament will improve my radio receiver.

M.....

Address.....

P.W.

All applications for Advertisement space in POPULAR WIRELESS to be made to JOHN H. LILE, LTD. (Sole Agents), 4, Ludgate Circus, London, E.C.4. Phone: City 761.

Popular Wireless 3d

SPECIAL
CHRISTMAS
NUMBER



Popular Wireless, December 11th, 1926.

Registered at the G.P.O. as a Newspaper

Contents

The Beam: A Chat with Marconi

Looking Back By CAPTAIN ECKERSLEY

A Brighter Radio Xmas

Choosing Your Wireless Xmas Presents

Notes on the "Hale" By CAPTAIN ROUND

And Many Bright and Valuable Features

No. 236. Vol. X.

ANGNEY



'Emas, 1926.

ONCE again at this season of Goodwill we take this opportunity of expressing our thanks to those loyal Cossor enthusiasts who have continued to use—and to recommend—Cossor valves. The knowledge that such a large pro-

portion of the wireless public favour the valve with the Kalenised filament is a constant spur to our activities and an incentive to maintain the high standard which has always been associated with the name Cossor.

Cossor Valves

Red Band, No. 210H. For H.F. use.
Black Band, No. 210D. For Detector use. 1'8 volts., 1 amp.

14/-

Stentor Two Power Valves No. 215P. For Loud Speaker use. 1'8 volts., 15 amp.

18/6



A Good Reception

Read **GEORGE ROBEY**
in the Christmas
AMPLION MAGAZINE.
A 1/- Magazine for 6d.

A good reception is
always assured if
the present is a
Radiolux Amplion

Type R.S.I.O.
(Oak)
£7 : 7 : 0
Other AMPLION
models from 38/-

**Radiolux
AMPLION**

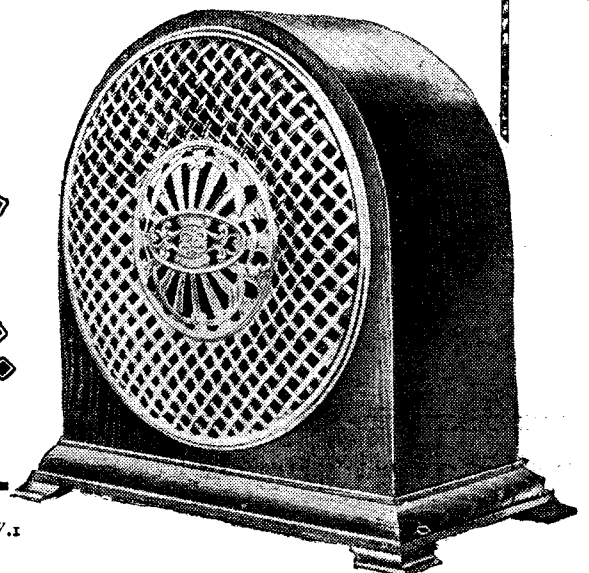

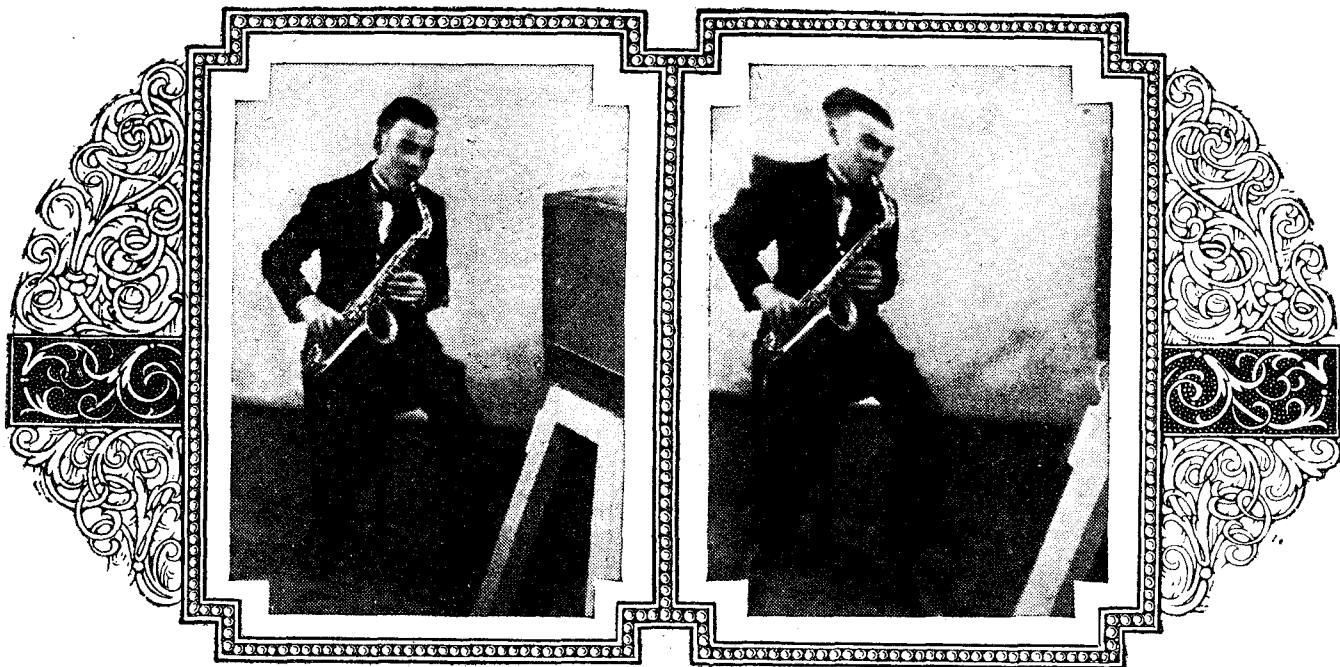

Does your Set need new 'Specs'!

EYE specialists tell us that tens of thousands of people are walking about with defective vision—but they don't know it. Because they have never seen clearly they do not appreciate what it is to enjoy perfect sight. Yet a visit to an optician and the choice of suitable glasses would effect a cure.

Much the same applies to many wireless enthusiasts. They possess Sets which can only create a travesty of the music which is being broadcast. Really good lifelike reproduction they have never enjoyed. And because they have never heard it they don't know the limitations of their own Receiving Sets. The root of their trouble lies in their transformers. Just as a good pair of 'specs' will give back the vision of

youth to the aged, so a really good L.F. Transformer like the Eureka, will rejuvenate a Receiver and enable it to "re-create the living Artists. No other alterations are required—merely take out the old L.F. Transformer and substitute a Eureka in one of its several types. The Eureka is a scientifically designed transformer. It amplifies evenly throughout the whole harmonic range. The deep notes of the 'cello, the pleasing notes of the flute, the mellow strains of the oboe come through with wonderful realism. Your Set deserves a Eureka—the long-lasting transformer which is hermetically sealed within a coppered steel case proof against the influence of the atmosphere and free from the possibility of inter-action.

Available in six different types

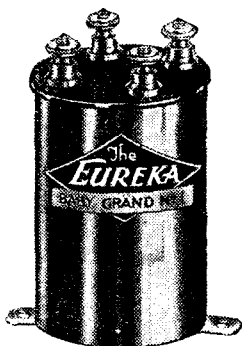

Eureka Concert Grand

A superb L.F. Transformer hermetically enclosed in a coppered steel case proof against atmospheric influences. For second stage use there is the No. 2 which is designed for work in perfect partnership with the Concert Grand. Designed under identical principles.

Concert Grand 25/- No. 2 21/-

Eureka Reflex

For reflex work a special Eureka is available. Gives an exceptional volume of mellow clear tone.

Fully guaranteed 15/-

Eureka Baby Grand

For those who cannot afford the necessary higher price of the larger Concert Grand we have introduced the Baby Grand. Fully up to the same high standards of workmanship and carrying the same generous guarantee. Chosen by many manufacturers of Broadcast Receivers.

No. 1 15/- No. 2 15/-

Eureka L.F. Choke Unit

The L.F. Choke method of amplification is gaining in popular favour among seasoned experimenters. The Eureka Choke Unit, incorporating grid leak and condenser is the finest instrument of its type.

Fully guaranteed 25/-

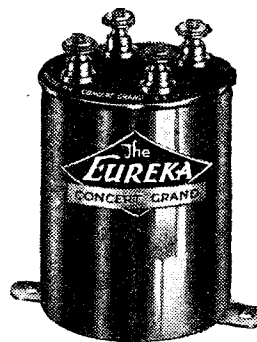

Portable Utilities Co., Ltd., Fisher St., W.C.1.

Sole Manufacturers of Eureka Radio Products

Re-creates the **EUREKA** Living Artists

Gilbert Ad. 6543.



The New
B.5.H. FOR USE WITH 4 VOLT.
 ACCUMULATOR OR DRY CELLS

This new valve has been expressly designed to work in conjunction with the famous B.5. Valve. It is intended primarily for the high frequency stages, using a tuned anode coil or high resistance of low self capacity. The B.5.H. has a very

much higher amplification factor than the B.5. It can also be employed in the detector and low-frequency stages, with high resistance or low ratio transformer coupling. The B.5.H. will solve your high frequency problems. Buy one now.

Filament Volts 2.8
 Filament Current 0.06 amp
 Anode Volts 40-120
 Amplification Factor 17.5
 Impedance.... 55,000 ohms

PRICE

14/-

(OUTSIDE THE IRISH FREE STATE)



VALVES

Sold by all Good Radio Dealers

The British Thomson-Houston Co. Ltd.



Evolved to meet the new conditions of Radio

THE new Oldham O.V.D. cannot be compared with any other accumulator. It is unique. It has been specially evolved to meet the new conditions created by the growing popularity of dull emitter valves. The O.V.D. is the first slow discharge accumulator which can be charged rapidly. The idea of a slow discharge accumulator is not new. They have been on the market for years. But—owing to the thickness of their plates—the greatest possible care has been necessary to ensure the full charge being given. Common sense will prove why this is so. The ordinary slow discharge accumulator holds its charge because it has two thick plates—negative and positive. But because its plates are so thick it takes many hours for the electrolytic action to penetrate its inmost recesses. And long slow charging is a nuisance.

Oldham saw the disadvantages of the thick plate and has evolved the new laminode plate possessing all the advantages of thickness but none of its disadvantages. The Laminode plate fitted to the O.V.D. is three plates in one. It uses a girder-like construction which prevents buckling. And yet because of its greater surface area it can be charged within 8 hours. Any Oldham O.V.D. will hold its charge for weeks—even months—without attention. Local action has been practically eliminated.

FACTS FOR VALVE USERS.

If you have a one-valve Set an O.V.D. will last you 180 hours at a charge if you use the new valves taking 1 amp. With a two-valve Set you will get 72 hours use. If you use 06 valves you will require two O.V.D. cells in series. Under these conditions the two-valve Set user will get 140 hours and with three valves 80 hours. The O.V.D. is thus the most economical accumulator you can buy for dull emitter use.



The new

Special Activation Process Batteries
OLDHAM

O.V.D.

—the slow discharge Accumulator
which can be fully charged in 8 hours

OLDHAM & SON, LTD.

Denton, Manchester

London Office & Service Depot:

: 6, Eccleston Place, S.W.1. :

: Phone: Sloane 2701 :

5/6

(Charged ready for use
—merely add acid)

: Made by the Makers of the :
: Oldham H.T. Accumulator :

60 volts £2 10 0 80 volts £3 6 8
100 volts £4 3 4 120 volts £5 0 0

Solid oak base 3/6 extra if required.

Gilbert Ad 6548.

**AN
IDEAL
CHRISTMAS
GIFT**

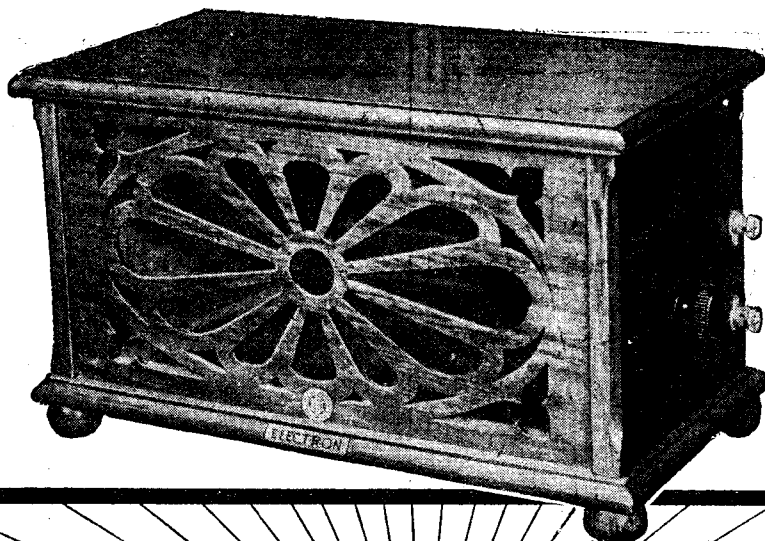

**THINK OF
A BETTER
XMAS GIFT
IF YOU CAN**

ELECTRON

CABINET LOUDSPEAKER

ANOTHER ELECTRON SUCCESS

The Most Handsome Cabinet LOUDSPEAKER ever offered!

£3

CARRIAGE PAID.

Here is another triumph by the proprietors of ELECTRON WIRE, the Aerial which made broadcasting popular by bringing it within easy reach of everybody.

For £3 we offer a very handsome, beautifully constructed cabinet, highly polished, thoroughly seasoned oak or mahogany, measuring 14½ by 8 by 8½ ins., enclosed within which is the very latest product of mechanical science for the reproduction of true musical and vocal tones.

After the expenditure of vast amounts of time, thought and money, it is now possible to offer the

WORLD'S FINEST LOUDSPEAKER AT A POPULAR PRICE

The sound-magnifying and diffusing apparatus has been specially devised with a regard to the true values of musical notes and speech and, by the adoption of mass production methods we are able to carry out our well-known policy of "the best at the lowest price."

Purchasers may rest assured not only of the craftsmanship of the ELECTRON CABINET LOUDSPEAKER but also of its

EXQUISITE TONAL QUALITY

No matter how poor the reception the ELECTRON CABINET LOUDSPEAKER to a very large extent automatically corrects this and sends forth a volume of the purest sound. Until you have seen and heard it you cannot know the joys of a perfect loudspeaker

Go to your dealer to-day or send remittance (£3) to us.

NEW LONDON ELECTRON WORKS, LTD.

Dept. 19.

(Members of the B.B.C.)

EAST HAM, Telegrams: "Stannum. London" Telephone: Grangewood, 1408-1409-1363. **LONDON, E.6**

**14 DAYS
FREE
TRIAL**

Try the ELECTRON CABINET LOUDSPEAKER for 14 days, then if you are not more than satisfied return it direct to us and the full purchase price will be refunded.

THE NEW No 7



RECUPERATING AGENT IN THE HELLESEN DRY BATTERIES

Is the secret of uniform, silent and economical H.T. supply. Your wireless set will play a big part in your Xmas programme, and the burden will fall on your H.T. Dry Battery. Get a Helleesen now and set your mind at rest with the assurance that whatever else may cause you worry, your H.T. supply will not.

Again, you will probably delay buying your Xmas gifts until the last moment, and then a self-choosing gift is a blessing. Make it a Helleesen Dry Battery, and long though the battery may last, the appreciation will outlive it.

Ask your dealer for a Helleesen Dry Battery, it will cost you no more, it only gives you better and longer service.

60 volt "WIRIN" 12/6
99 volt "WIRUP" 21/-

(Postage Extra)

All types, voltages, etc., in Double and Treble capacities for H.T. and L.T. Supply. Ask your dealer for the type to suit your set and get the maximum service, or write us for full particulars.

Obtainable at all Radio, Electrical, and General Stores, HARRODS, SELFRIDGES, BARKERS, etc., or direct from

A. H. HUNT, Ltd. (Dept. 12), CROYDON, SURREY

TRADE

HUNTS

MARK

They Last Longer

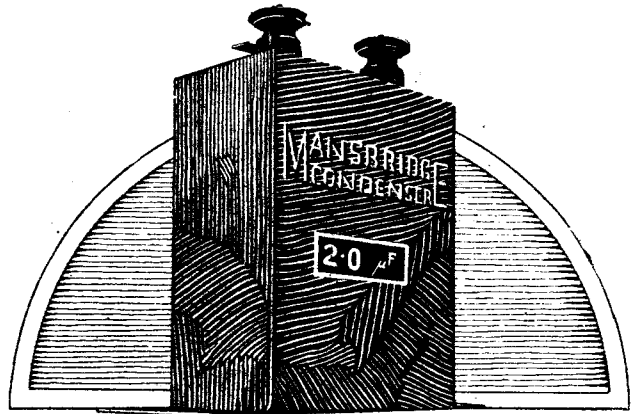

TWO HEADS....

Two heads are, proverbially, better than one. Therefore when you require a Mansbridge Condenser, see that you get a Dubilier-Mansbridge, the condenser which has been designed specially for wireless purposes.

G. F. Mansbridge originated this type of condenser over 20 years ago, and his unique experience is found combined with that of Dubilier in each Dubilier - Mansbridge Condenser.

Take advantage of this combined experience which is to be found in no other condenser and ask your Dealer for Dubilier-Mansbridge Condensers.

The colour of these condensers is Maroon, they bear the words "Mansbridge Condenser" embossed on the case and they carry the full Dubilier Guarantee.

DUBILIER

ADVT. OF DUBILIER CONDENSER CO. (1925) LTD.
DUCON WORKS, VICTORIA ROAD, N. ACTON, W.3.
E.P.S. 247

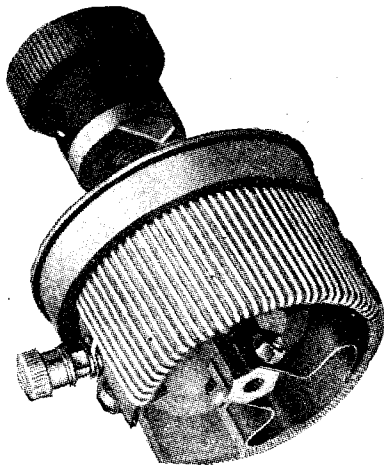

The "Cosmos" Rheostat.

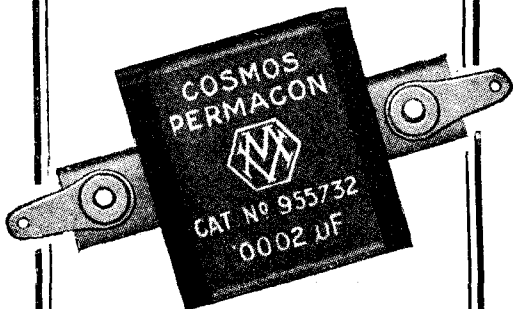

The "Cosmos" Permacon.

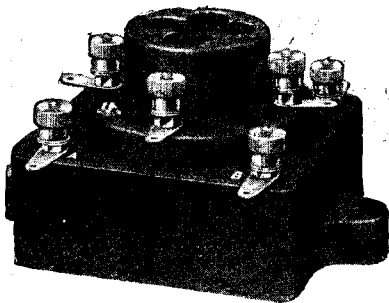

The "Cosmos" Coupling Unit and spring valve holder.



Ask your dealer for these attractive Folders on "Cosmos" Valves, Sets and Components.

Cosmos

(RADIO COMPONENTS)

ensure reliable sets.

Constructors who desire smooth working and efficient sets use "Cosmos" Precision components.

The "Cosmos" Rheostat. The principal features of the "Cosmos" Filament Rheostat are its sturdy construction and reliable, smooth movement. The contact arm cannot easily be damaged, having its movement on the inner side of a porcelain bobbin which carries the windings. Other pleasing features of this Precision Rheostat are the handsome knob and dial, ONE HOLE fixing, and the small space it occupies.

Made in four types, two of which are double-wound for DULL or BRIGHT Valves and one a Potentiometer.

Description	Ohms	Current	Price	
			s.	d.
Single Wound	6'0	1'0 amp.	4	6
Double ..	20	'4 "	5	0
" "	34	'2 "	5	0
Potentiometer	300	—	6	0

The "Cosmos" Permacon is an ideal fixed condenser, being light in weight, of guaranteed accurate capacity, and having the lowest possible losses.

The dielectric is mica, and each condenser is tested at 500 volts during inspection. Nickel-plated cases give them a particularly neat appearance.

'0001 mfd.	1/6	'001 mfd.	1/8
'0002 "	1/8	'002 "	1/10
'0005 "	1/8	'005 "	2/8
'0003 " (with clips for grid leak)	1/8	'01 "	3/9

The "Cosmos" Resistance Coupling Unit.—Real purity of reproduction can only be obtained with resistance capacity coupling. The "Cosmos" Coupling Unit with a suitable valve is as effective as an ordinary transformer coupled stage. It avoids all distortion and effects considerable economies in first and operating costs. Designed primarily for use with the "Cosmos" S.P. Blue Spot Valves, it can be used successfully with any valve having an amplification factor of 30 or more. Special attention is directed to the following advantages of the "Cosmos" Coupling Unit:

- (1) It takes up little space in a set.
- (2) It is not liable to be broken.
- (3) It has permanent resistance values.
- (4) It allows for simplified wiring.
- (5) It is economical in L.T. current (S.P. Blue Spot Valves consume 0.09).
- (6) It is economical in H.T. Battery consumption (less than 1/20 normal).

And lastly its use results in purity of reproduction without loss in volume.

Type "O," the Unit alone 8/6
 Type "V," the Unit incorporating spring valve holder (as illustrated) 10/6
 Suitable valves for use with this unit are "Cosmos" S.P. 18/B at 14/- and "Cosmos" S.P. 55/BL at 18/6.

METRO-VICK SUPPLIES LTD.

(Proprietors: Metropolitan-Vickers Electrical Co., Ltd.),

METRO-VICK HOUSE,
 155, CHARING CROSS ROAD, LONDON, W.C.2

R P50

Player's please!



100

**PLAYER'S "MEDIUM"
NAVY CUT CIGARETTES**

4/8

**A Gift
that gives a
Hundred Happy Memories**

NCC 5

ALSO PACKED IN 10's, 20's AND 50's

Excellent Christmas Presents to give or to receive

THESE CONDENSERS are similar to our Low Loss models and are designed for use in circuits of the "Single Dial Control" Type. EACH IS composed of two or more separate condensers, insulated from each other, of maximum capacity '0005 microfarad.

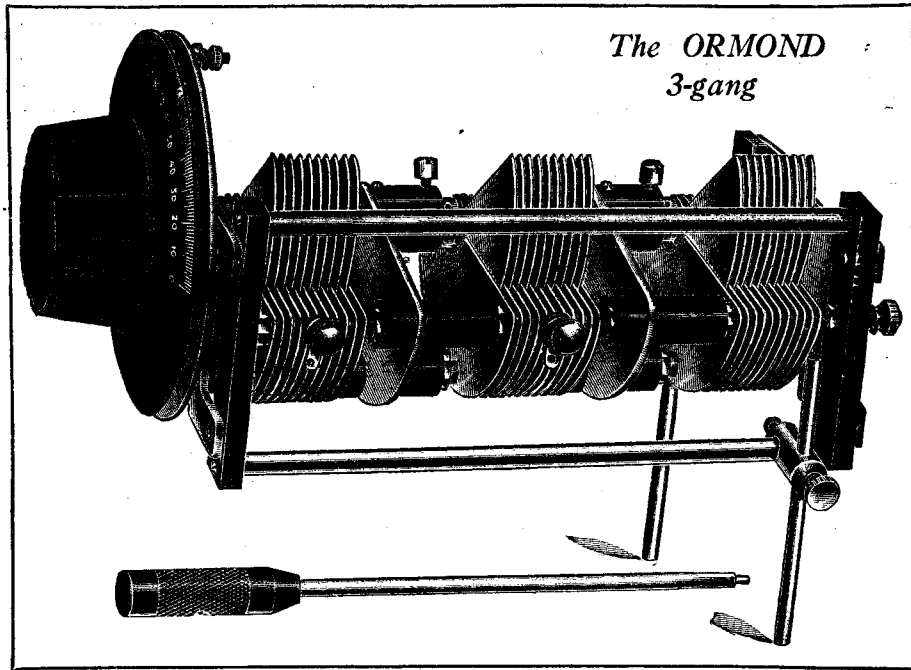

The ORMOND
3-gang

ORMOND GANG CONDENSERS

Mark the low prices:—

Two-Gang 32/- Tri-Gang 40/- Four-Gang 50/-

An easy independent adjustment of rotors is provided, for balancing out circuit variations.

Special ball bearings on each rotor ensure a smooth action, giving a liquid-like movement facilitating precise tuning with noiseless operation.

Construction is very rigid.

An anti-capacity earthing shield is supplied which may be insulated from Condenser and earthed by separate connection.

For panel mounting the "One Hole" fixing method is used, and two adjustable legs are attached to truss rods for rear support.

Complete with 4-in. Knob and Dial, shield, and Tommy Bar with insulated handle for bank adjustment.

Terminals and soldering tags for connections.

These Condensers are not fitted with slow-motion movement.

When fitted with 4-in. Slow-Motion Dial, ratio 55-1, these prices are 8/- extra respectively.

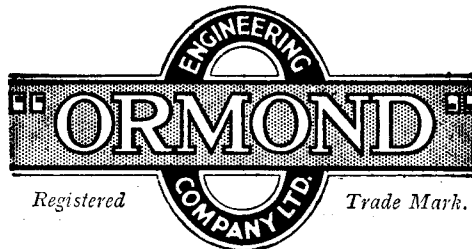

199-205, PENTONVILLE ROAD, KING'S CROSS, LONDON, N.1.

Telephone: Clerkenwell 9344-5-6.

Telegrams: "Ormondengi, Kinross."

Factories: Whiskin Street and Hardwick Street, Clerkenwell, E.C.1.

Continental Agents: Messrs. Pettigrew & Merriman, Ltd., "Phonos House," 2-4, Bucknall Street, New Oxford Street, W.C.1.

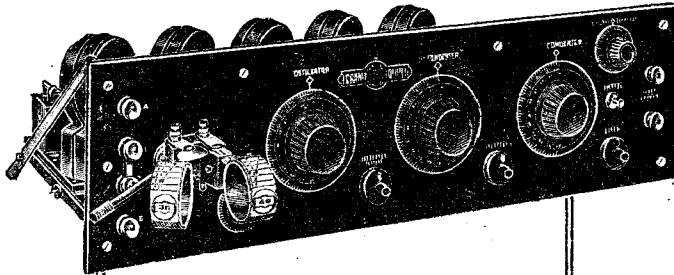

Igranitic Supersonic Heterodyne Receiver

The Igranitic Super-Heterodyne Outfit is the ideal present for all wireless enthusiasts. The instructions for building are so complete and the constructional work so simple that the Igranitic Outfit can be built into a powerful six-valve Super Het receiver even by those who do not possess any previous wireless knowledge.

Receivers built from the Igranitic Outfit are wonderfully selective, sensitive and stable. Stations can be tuned in all round the dial at full loud-speaker strength using a frame aerial only.

The purity of reproduction is of a very high order such as is seldom associated with Super-Heterodyne receivers.

By means of interchangeable units the receiver has a wave-length range of approximately 40 to 3,500 metres.

Igranitic Supersonic Heterodyne Outfit £15:15:0

IGRANIC INSTRUCTIONAL CARTON

contains a full illustrated handbook, full-size wiring diagrams, layout drawings, drilling template and much useful information regarding the Super-Heterodyne principle.

Price - - - 2/6



Give Igranitic Radio Devices—the ideal Xmas Presents

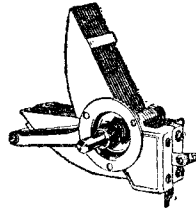

WRITE FOR THE NEW IGRANIC CATALOGUE. LIST No. R.38.

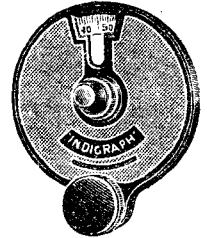

IGRANIC VARIABLE CONDENSERS

Igranitic Variable Condensers are always acceptable, they have become known as the "choice of experts—and amateurs." Made in several different capacities and as single, dual, twin gang, and triple gang patterns. Single patterns are made for square law and straight-line-frequency tuning.

Prices are from 14/6 each.

IGRANIC "INDIGRAPH"

If you have 7/6 to spend give an Indigraph Vernier Knob and Dial. It gives smooth slow motion control entirely free from backlash. Scale readings pass under a hairline enabling very accurate readings to be made, and space is provided on the dial for recording station settings. The Indigraph is of very handsome appearance.

Price - - 7/6

IGRANIC SHORT WAVE COILS

Igranitic Short Wave Coils are particularly acceptable at this time of the year when conditions are so good for long distance short wave work. Igranitic Short Wave Coils are wound with heavy gauge bare wire, rigidly supported with a minimum of solid material.

They are made in four sizes covering wavelengths of 10 to 100 metres.

Prices: 2 (turn) 2/6
4 " 2/7
6 " 2/8
9 " 2/9

Or 10/- per set of four.

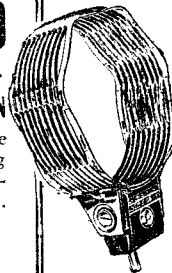

IGRANIC "XLLOS" COILS

Give a set of Igranitic "XLLOS" (Extra Low Loss) Coils and you will be giving the means for better reception. They are wound in a special manner which results in very high efficiency. The winding is enclosed in a sealed Bakelite shell which excludes dust and moisture and prevents the coil being damaged.

Pin and socket are separated by an air space and the spacing is adjustable from 1/8 up to 2".

Made in 10 sizes for wavelengths 220 to 3,200 metres.

Prices from 3/9 each.

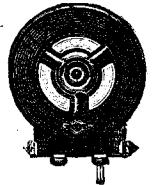

IGRANIC ELECTRIC CO LTD

149, QUEEN VICTORIA STREET, LONDON

WORKS: BEDFORD

Make your own H.T.

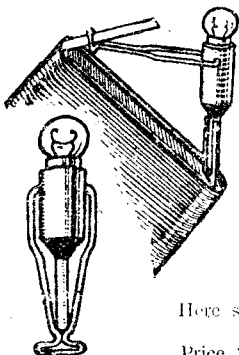

"C.W." (Combined).

- (1) SAFETY WANDER PLUG.
- (2) BATTERY TESTER
- (3) INSPECTION LAMP.

(Patent No. 218957).

Here shown when used as an Inspection Lamp.

Price 1/3 complete with bulb.

THERE is no better or cheaper H.T. Unit than that made up by yourself with 4 1/2 v. Pocket Lamp Batteries connected together with "C.W." Links.

When the Unit is placed in the "C.W." Extending Battery Container you have a neat, useful and Portable H.T.

Test the Batteries occasionally with the "C.W." Battery Tester, and if an emergency lamp is required disconnect a Battery from the Unit and fix to the terminals as illustration. This Tester can also be used as a Safety Wander Plug.

"C.W." Specialities can be obtained from your local Dealer.

ADVT. OF THE JEB TRADING CO.,
49, AVENUE ROAD, ACTON, W.3.



"C.W." BATTERY LINKS. (Patent No. 217141). Actual size. Price 6d. per doz. With hole for Wander Plug. Every link stamped. Look for the name and refuse imitations.

"C.W." EXTENDING BATTERY CONTAINER.

(Reg. Design No. 709874). Closed, holding 16 Batteries. Connected with "C.W." Links = 72 volts.

Same Container, fully extended, holding 30 Batteries = 135 volts. Price 4/6 each.



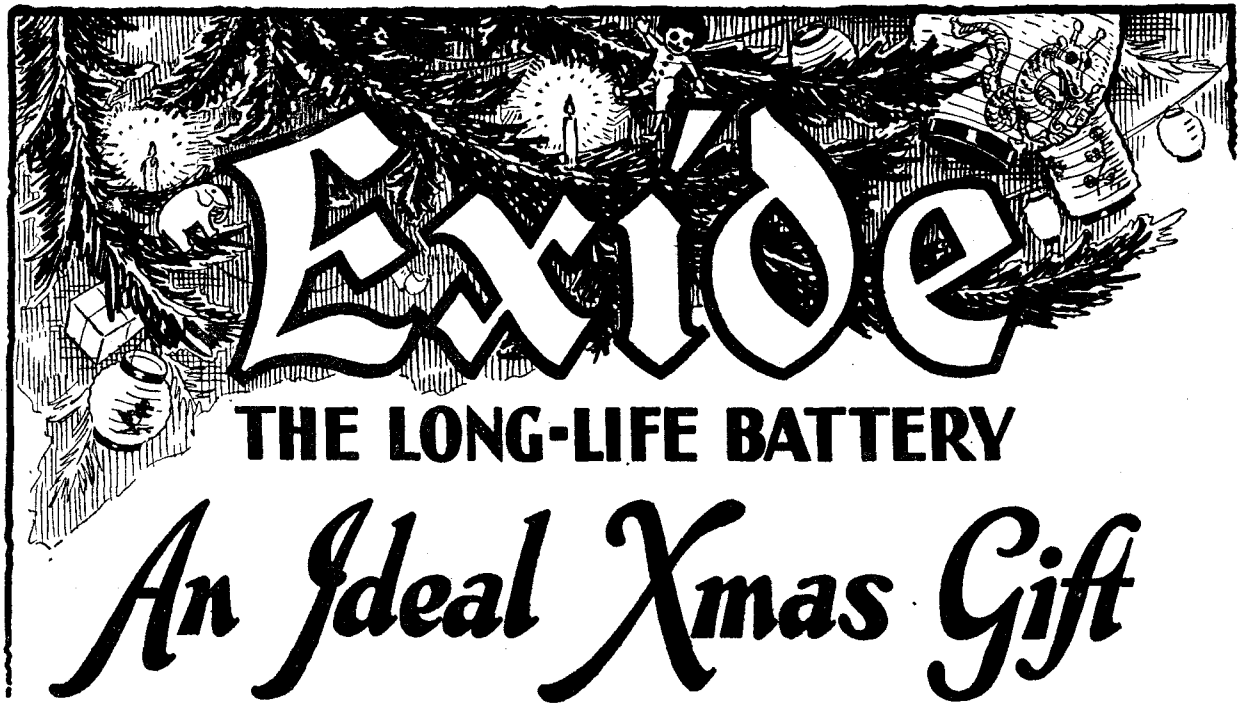

EXIDE

THE LONG-LIFE BATTERY

An Ideal Xmas Gift

Types DTG and DFG.

Specially designed for small discharge currents, and to hold their charge, when not in use, for long periods. Suitable for small Dull Emitter valve sets.

Capacity.

DTG.	DFG.
20 amp. hrs.	45 amp. hrs.
Price 4/6	8/6

Type HZ.

Combines the advantages of the DTG and the CZ—a De Luxe battery suitable for all types of receiving sets.

Capacities 40 to 80 amp. hrs. Prices from 17/6

Type WJ.

Give steady, even discharge free from fluctuations.

Capacity 2,500 milli-amp. hrs. 20 volts. Price 15/-

Better batteries mean better wireless.

Better wireless means a better Christmas.

There can be no more suitable gift—to the family or the wireless enthusiast—than an Exide Battery. In the great range of types there is just that battery to fill each individual need—to suit every wireless requirement. And every one of these types is specially designed for the work it has to do by the world's greatest experts. Any reputable dealer will help you to select the best type.

Exide Batteries suit your set and suit your purse.

Type WH.

The most satisfactory source of High Tension supply, giving purity of reception against a dead silent background.

Capacity.

5,000 milli-amp. hrs. 24 volts. Price 30/-

Type CZ.

The standard popular type of Low Tension battery giving comparatively heavy currents for long periods, with minimum voltage drop.

Supplied in 2, 4, and 6-volt units, capacities 20 to 60 amp. hrs. From 11/3 upwards.

Prices from

4/6

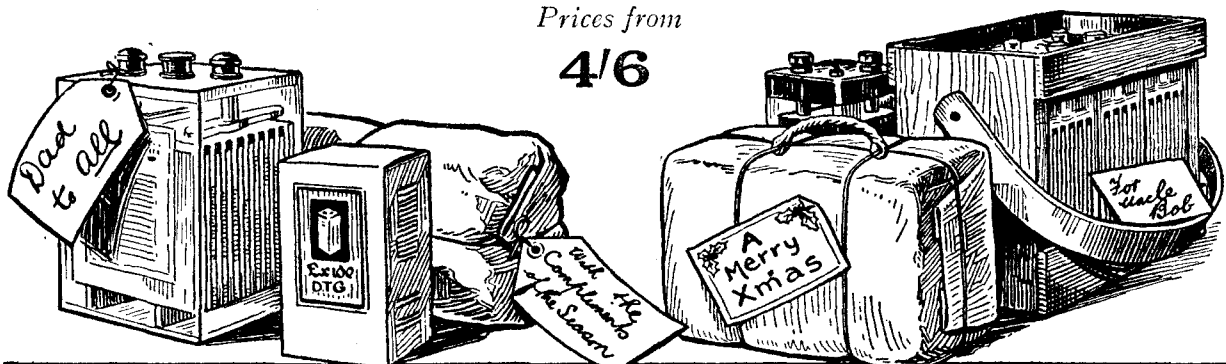

"NO CRYSTAL SET IS COMPLETE WITHOUT THIS WONDERFUL ATTACHMENT"

Extract from an entirely unsolicited testimonial recently received from a customer situated 80 miles from Daventry

The WONDERFUL ATTACHMENT referred to is the

MAGNETIC MICROPHONE BAR AMPLIFIER

(Patent No. 248581/25.)

Not only will this marvellous device give really good **LOUD-SPEAKER RESULTS** from **CRYSTAL RECEPTION** of average strength, but it is absolutely the **ONLY** means of increasing the strength of weak signals in headphones without using valves.

Works perfectly on one or two dry cells.

A BOON TO DEAF PERSONS

EQUALLY EFFICIENT ON VALVE SETS

If your dealer cannot supply order direct from Sole Manufacturers and Patentees

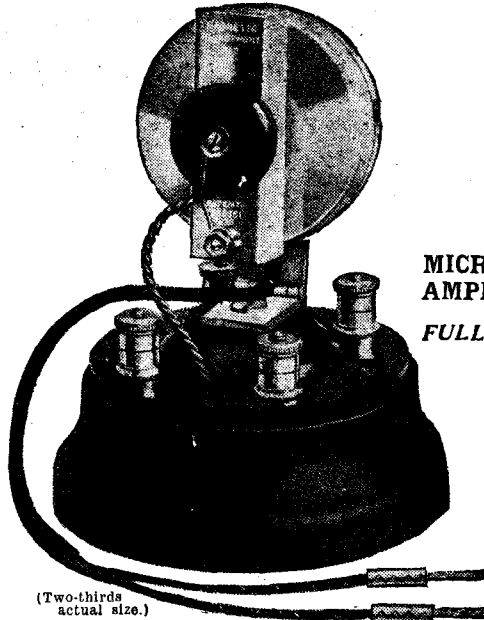

(Two-thirds actual size.)

NOT a Microphone Button.

NO Valves, Accumulators or H.T. Batteries. Fragile parts. Distortion.

Simple as A B C.

MICROPHONE AND OTHER PARTS OF AMPLIFIER SUPPLIED SEPARATELY

FULLY ILLUSTRATED LISTS FREE

COMPLETE AMPLIFIER as shown PRICE post free **38/-** 3-volt DRY BATTERY lasting over three months **4/-** extra. No other accessories required.

DELIVERY BY RETURN FROM STOCK. EVERY AMPLIFIER GUARANTEED.

NEW WILSON ELECTRICAL MANUFACTURING CO., LTD., 18, FITZROY STREET, EUSTON ROAD, LONDON, W.1. Phone: Museum 8974.

Xmas Gifts that last a Year!

BEAUTIFUL BOOKS FOR CHILDREN OF ALL AGES

Make sure of these splendid Annuals NOW—they are the most popular gift books on the market. All are packed with jolly stories, pictures and COLOURED plates that children love. **TIGER TIM'S**, **PLAYBOX**, **PUCK**, and **PLAYTIME** Annuals are suitable for boys and girls between the ages of 5 and 12. The **HOLIDAY**, **SCHOOLGIRLS' OWN**, **SCHOOL FRIEND** and **HOBBY** Annuals are suitable for boys and girls at school, while the **CHAMPION** Annual is for older boys and youths. Take this advertisement to your bookseller. He will be pleased for you to look through these jolly gift books.

Buy these Splendid Books To-day

NET 6/- EACH

At all Newsagents and Booksellers

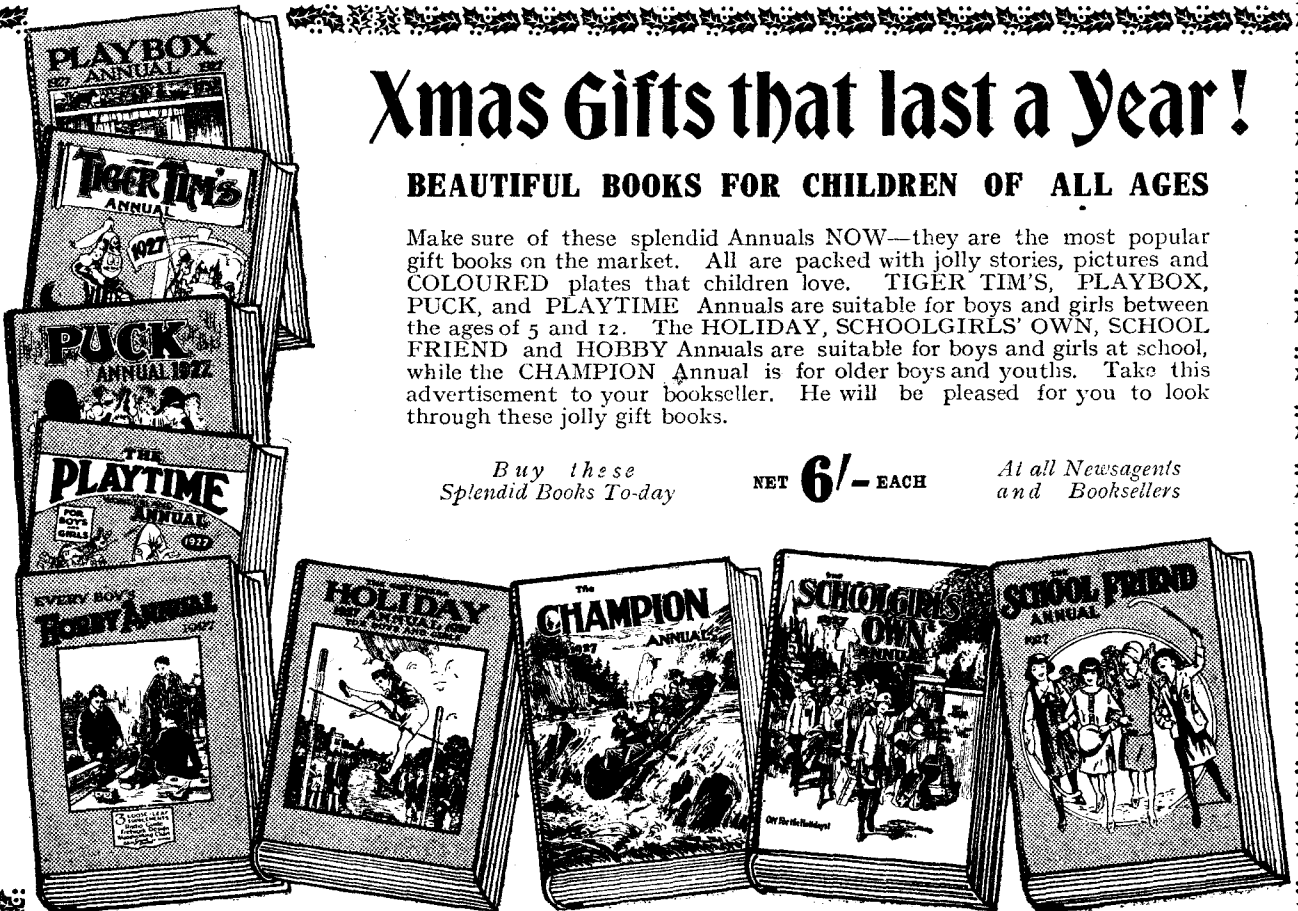

Silvertown

WIRELESS ACCESSORIES

Ensure Perfect Reception

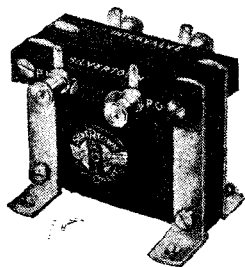

B.500. INTERVAL TRANSFORMER.

Guaranteed for 12 months.
Price 21/- each.

This Transformer has been adopted by leading manufacturers of Wireless Receiving Sets and discriminating amateurs in all parts of the world. Excellent results have been obtained on tests carried out by the National Physical Laboratory. Copy of the curve can be had on application.

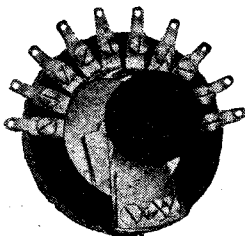

B.570. 10-WAY INDUCTANCE OR CAPACITY SWITCH. (Patent 226245.)

This switch is of the under-panel mounting type, and is fitted to the panel by means of the two counter-sunk head screws supplied. It enables the experimenter to build up large capacities, and is an invaluable addition to any set.

Price 5/6 each.

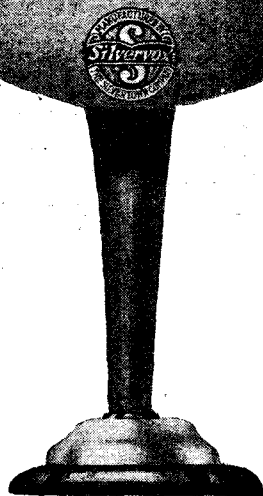

The **SILVERVOX**

The "Silvervox" Loud Speaker will reproduce both speech and music without the loss of its original tone and quality. Coils wound to either 120 or 2,000 ohms. The tone arm is a heavy aluminium casting. Total height, 20 inches. Size of trumpet, 12½ inches diameter.

Price £3-0-0 each.

AN AID TO ENTHUSIASTS.

We have prepared a logging chart for recording wavelengths, condenser settings, etc., of those stations which require careful calibration to tune in. Wireless enthusiasts all over the country are being invited to apply to you for their copy. Have you sufficient stocks? Ample supplies will be immediately forwarded on request.

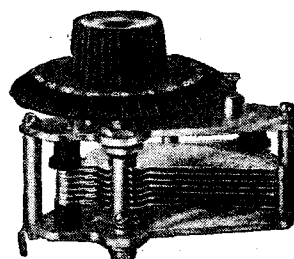

STRAIGHT LINE FREQUENCY CONDENSER (Low Loss)

A precision instrument, the design of which ensures perfect mechanical construction with high electrical efficiency. The rotor plates are earthed, eliminating hand capacity effects. It is also completely silent when adjustments are being made. Perfect electrical contact is obtained by means of a flexible phosphor bronze pig-tail connection.

B.615 0'00025 mfd. .. 11/6
B.606 0'0005 mfd. .. 13/-

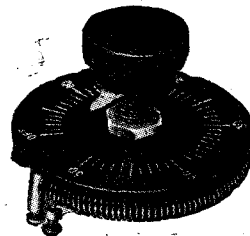

B.599. SILVERTOWN FILAMENT RHEOSTAT. ONE-HOLE FIXING.

Circular pattern, on ebonite former, complete with knob, pointer, black celluloid scale engraved in white, and two terminals for connections. The resistance wire is wound on an insulating rod, thereby giving a perfectly smooth adjustment. B.599—Wound to approximately 5 ohms resistance. Price 3/- each. B.600—Wound to approximately 30 ohms resistance. Price 3/6 each.

THE SILVERTOWN COMPANY

106, Cannon Street, London, E.C.4.

Works: Silvertown, E.16

BELFAST: 75, Ann Street.
BIRMINGHAM: 15, Martineau St.
BRISTOL: 4, Victoria Street.
CARDIFF: Pier Head Chambers,
Bute Docks.
DUBLIN: 70, Middle Abbey Street.

GLASGOW: 15, Royal Exchange
Square.
LEEDS: 39, York Place.
LIVERPOOL: 54, Castle Street.
LONDON: 100 and 102, Cannon
Street.

MANCHESTER: 16, John Dalton
Street.
NEWCASTLE-ON-TYNE: 59, West-
gate Road.
PORTSMOUTH: 49, High Street.
SHEFFIELD: 88-90, Queen Street.



EDISON BELL RADIO



CHARM!

Charm is expressed both in the tone and design of the

NEW MODEL EDISON BELL SPEAKER

the artistic appearance of which is second only to its tonal reproduction.

PRICE 42/-
An Ideal Xmas Present

Ask your dealer for attractive new season's catalogue, or write direct to the company for same.

EDISON BELL, LIMITED,
London, S.E.15. And at Huntingdon.

TESTED 500 VOLTS

FLAT TYPE



TESTED 500 VOLTS

UPRIGHT TYPE



INSIST ON EDISON BELL CONDENSERS

THEY ARE BRITISH MADE AND GUARANTEED BY A NAME WITH 30 YEARS REPUTATION BEHIND IT

All enquiries for Lewcos Radio Products should be made to your local dealer.

TABLE 1			TABLE 2			
Coil	Inductance in microhenries	Self-capacity in micro-microfarads	Coil	Parallel capacity in micro-microfarads	Wave-lengths in metres	Effective resistance in ohms.
35	61	15	35	300	264	2.8
40	90	15	40	"	318	2.9
50	150	9	50	"	406	3.3
60	200	13	60	"	472	4.4
75	295	12	75	"	573	5.3
100	540	11	100	"	774	6.6
150	1,410	12	150	"	1,250	15.8
200	2,220	17	200	"	1,580	19.7
250	3,070	17	250	"	1,860	24.9
300	4,800	14	300	"	2,320	28.2

Results of independent H.F. tests made by the N.P.L.

Here are the figures — judge for yourself!

The National Physical Laboratory figures fully bear out our claim that the LEWCOS Coil is the most efficient produced. In the design of radio inductances, the smaller the R/L value for any circuit, the greater is the selectivity and the signal strength. This fact has predominated over all other considerations in producing Lewcos Inductance Coils with the



result that we can publish without fear the R/L values for LEWCOS Inductance Coils as obtained from the N.P.L. measurements together with the wave length at which measurement was made. LEWCOS Coils make all the difference in reception. Ask your wireless dealer to demonstrate the Lewcos Coil on his set. Descriptive leaflet gladly sent on application.

LEWCOS Inductance COIL

The LONDON ELECTRIC WIRE COMPANY and SMITHS, LIMITED
 Phone : C'erkenwell 1388 Playhouse Yard, Golden Lane, London, E.C.1 Telegrams : Electric, London

CHRISTMAS GIFTS

**TWO PHILIPS PRODUCTS
VERY SUITABLE FOR
XMAS PRESENTS.**

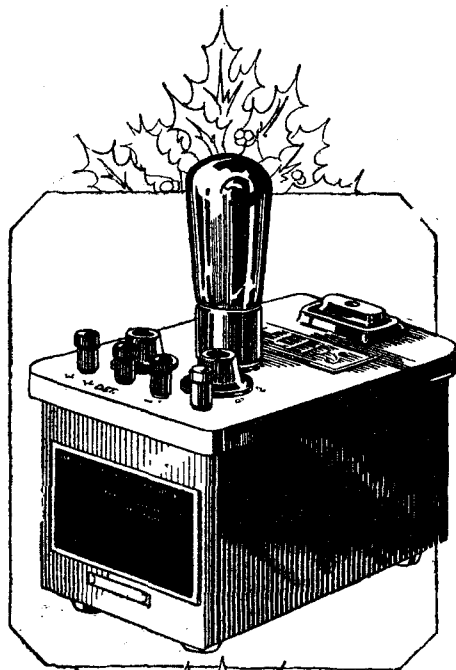

PHILIPS H.T. SUPPLY UNIT

Gives from 20 to 160 volts approximately. Ensures a supply of current to work any set efficiently, using standard types of valves. Consumption is approximately 5-10 watts. Output variable from 2 tapings. Safe and silent in use. Price complete **£7 : 10 : 0**

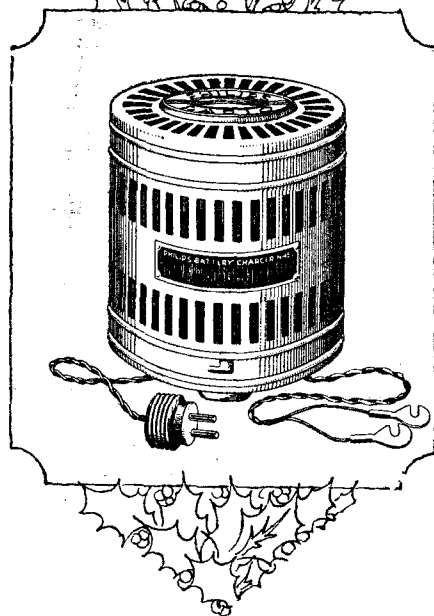

PHILIPS RECTIFIER

Type 450

Charges radio batteries from 2 to 6 volts at 1.3 amps., consuming 30 watts. A full wave valve rectifier, using the specially constructed Philips Rectifier Valve and Resistance Lamp, which automatically regulates the current supply. Needs no attention.

Price complete **£4 : 0 : 0**

Both Units for Alternating Current.

Ask your dealer to demonstrate.

PHILIPS

Louden Valves

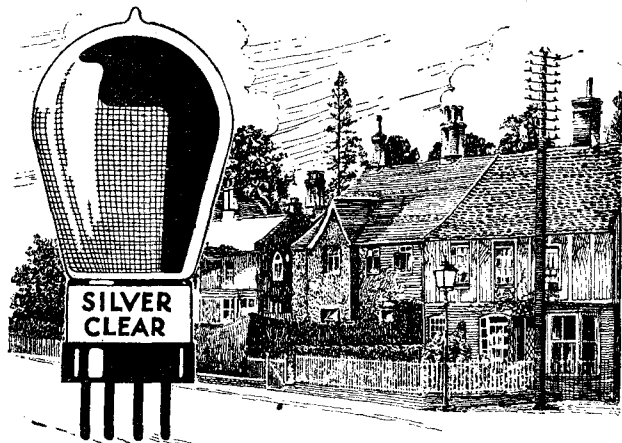

The Street, Long Stratton

"The two original valves have been working all the time."

Mr. P. Hearn, of Long Stratton, has had over 12 months satisfactory use from the two Loudens in his Little Giant Set.

Like all other Louden Valve users, Mr. Hearn is highly satisfied with the results, and he shows it by ordering two more Loudens.

Read what he says:—

*"Dear Sir,
Enclosed please find P.O. for 9/6. Please forward, if possible by return, two Louden Valves (F1 at 4/6 each).
My 'Little Giant' two valve set has now been in use for twelve months, and has given me every satisfaction. The two original valves have been working all the time.
I feel that everything that bears the stamp of 'Fellows' is worthy of recommendation, and it gives me pleasure in being able to thus express my satisfaction.
Yours truly,
P. HEARN (Long Stratton)."*

Louden Valves are made by British labour in a British factory with British capital and can be depended upon for the finest volume, range and silver clearness. They can only be offered at such low prices because of our well-known policy of selling direct to the public and cutting out the middleman's profit.

The list below gives prices and full particulars.

Order your Louden Valves from us by post.

4/6 Bright Emitters. L.F. Amplifier. F.1. H.F. Amplifier. F.2. Detector. F.3. 5.5 volts 0.4 amps.	8/- Dull Emitters. L.F. Amplifier. L.E.R.1. H.F. Amplifier. L.E.R.2. Detector. L.E.R.3. 2 volts 0.2 amps.	8/- Dull Emitters. L.F. Amplifier. F.E.R.1. H.F. Amplifier. F.E.R.2. Detector. F.E.R.3. 4 volts 0.1 amps.
9/- Dull Emitters. L.F. Amplifier. F.E.R.1. H.F. Amplifier. F.E.R.2. Detector. F.E.R.3. 6 volts 0.1 amps.	11/- D.E. Power Valves. Trans. Amplifiers P.E.R.1. Resist. Amplifiers P.E.R.2. 4 volts 0.2 amps.	12/- D.E. Power Valves. Trans. Amplifiers P.E.R.1. Resist. Amplifiers P.E.R.2. 6 volts 0.2 amps.

Postage and packing: 1 Valve, 4d. 2 or 3 Valves, 6d. 4, 5 or 6 Valves, 9d.

FELLOWS, PARK ROYAL, N.W.10.

Branches:

LONDON: 20, Store Street, Tottenham Court Rd., W.C. (Museum 9200).
BIRMINGHAM: 248, Corporation Street (Central 435).
BRIGHTON: 31, Queen's Road (Brighton 899).
BRISTOL: 36, Narrow Wine Street (Bristol 7972).
CARDIFF: Dominions Arcade, Queen St. (Cardiff 7685).
LEEDS: 65, Park Lane (Leeds 21479).
MANCHESTER: 33, John Dalton Street.
NOTTINGHAM: 30, Bridlesmith Gate (Nottingham 5551).
TONBRIDGE: 34 Quarry Hill (Tonbridge 172).

WRITE FOR
48 pp.
ILLUSTRATED
CATALOGUE
No. 33 FREE.

BUY DIRECT AND SAVE MONEY

E.P.S. 97.

21 days test at our expense

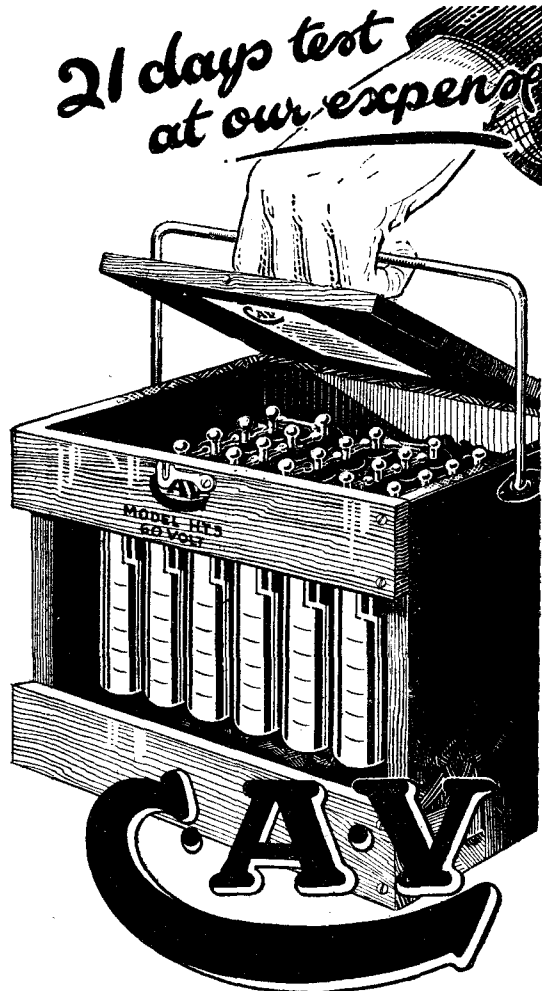

1927 IMPROVED MODEL H.T. ACCUMULATOR

TO prove our absolute confidence in these accumulators to satisfy you, we guarantee, if you are not satisfied, to accept return within 21 days from purchase date, and refund money in full provided battery is returned intact to the Agent from whom it was purchased.

C.A.V. H.T. Accumulators represent an epoch-making advance as compared with dry batteries. When dry batteries are down they are done, and frequent renewals make them more expensive. C.A.V. H.T. Accumulators will last for years, and only need recharging approximately every four months. They give bigger volume and are silent in operation.

Every Accumulator is supplied fully charged ready for use, absolutely complete in case, and with distilled water filler, all included in the price, viz.:

60 Volts **60/-**

Size 8½ ins. by 7 ins. by 7¾ ins. height.

Catalogue supplied on application.

Have you entered our 100 Guineas H.T. Accumulator Name Competition? WRITE FOR FULL PARTICULARS.

C.A.V. Vandervell & Co. Ltd.
ACTON, LONDON, W. 3.

Telephone: Chiswick 3801
(Private Branch Exchange)

Telegrams: "Vanteria-Act-London."

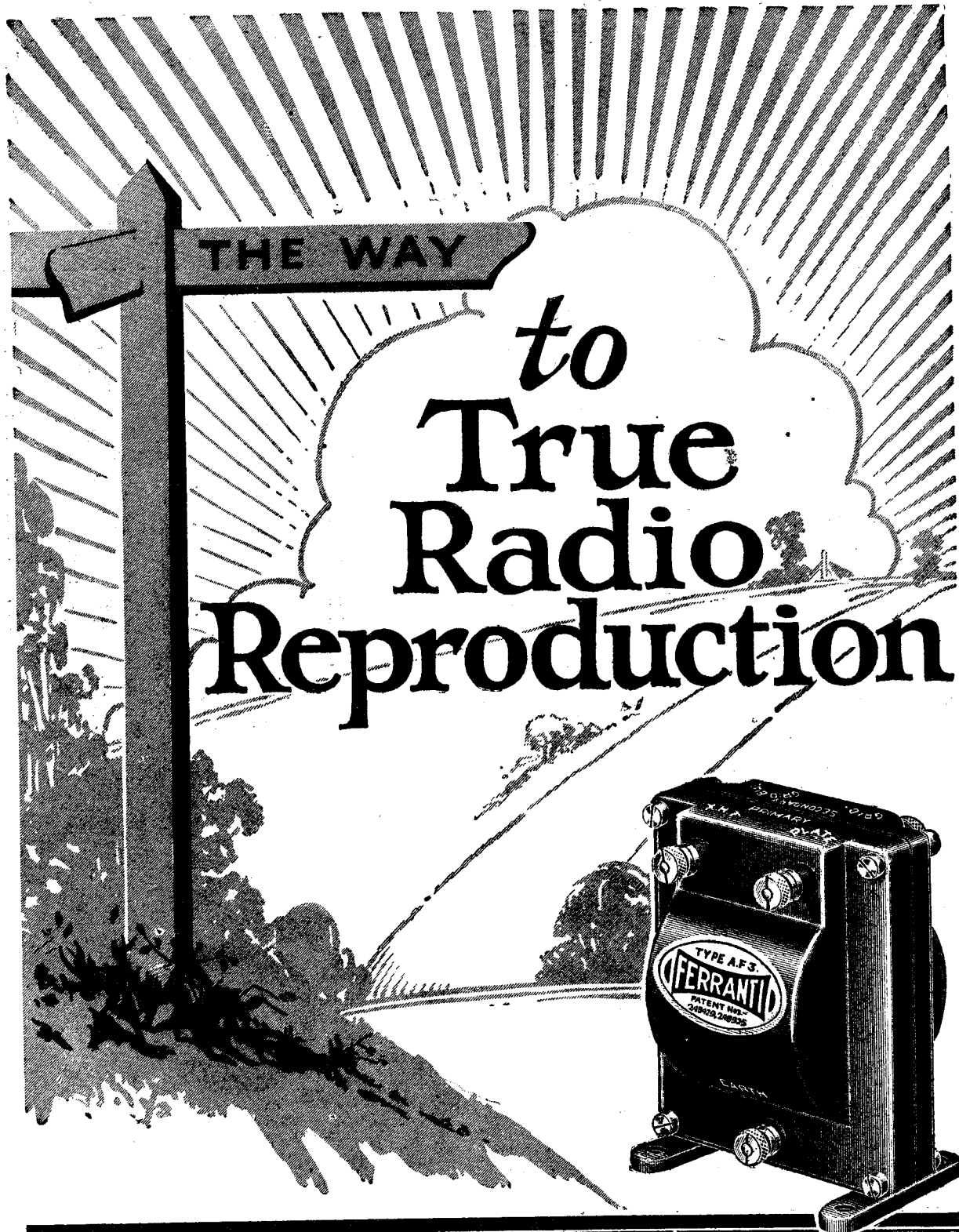

FERRANTI
TRANSFORMERS



FELLOWS WIRELESS

60 Volts
8/9

THIS H.T. BATTERY

- costs only 8/9,
- is made throughout in London,
- is sent post and packing free,
- reaches you, brim full of energy, within a few hours of manufacture owing to the enormous number we sell daily,
- maintains its voltage for the longest possible time owing to the extremely generous "elements" of which it is made,
- will give you a long life of loud, clear reception free from all crackling noises,
- is tapped every 3 volts enabling you to apply the exact voltage required by your valves for best results,
- is supplied complete with Red and Black wander plugs—no extras to buy,
- is, in short, the **FINEST IN THE WORLD** because no other H.T. Battery made (except other Fellophone batteries) can come anywhere near it in performance or value.

Other Fellophone Batteries are listed below. We can only offer you this astounding value because, by supplying you direct we can save all the middleman's profits and so give you a better battery for less money.

Order from us or from our Branches to-night.

54 Volt (with 3 volt tap for grid bias). Post FREE **6/6**

60 Volt (tapped every 3 volts and supplied complete with Red and Black wander plugs). Post FREE **8/9**

108 Volt (tapped every 6 volts and supplied complete with Red and Black wander plugs). Post FREE **13/-**

FELLOWS, PARK ROYAL, N.W.10

Branches:

- LONDON: 20, Store Street, Tottenham Court Road, W.C. (Museum 9200).
- BIRMINGHAM: 248, Corporation Street. (Central 435).
- BRIGHTON: 31, Queen's Road. (Brighton 899).
- BRISTOL: 36, Narrow Wine Street. (Bristol 7972.)
- CARDIFF: Dominions Arcade, Queen Street. (Cardiff 7685.)
- LEEDS: 65, Park Lane. (Leeds 21479.)
- MANCHESTER: 33, John Dalton Street. (Central 1164.)
- NOTTINGHAM: 30, Bridlesmith Gate. (Nottingham 5551).
- TONBRIDGE: 34, Quarry Hill. (Tonbridge 172).

Send for
48-page
Catalogue
No. 33,
FREE.

BUY DIRECT AND SAVE MONEY

E.P.S. 278

METAL FOR PERFECT INSULATION

SECRET OF T.C.C.'s. SUCCESS

THE VALUE OF TWENTY YEARS' MANUFACTURING EXPERIENCE

THE position of the Telegraph Condenser Co. Ltd., in the Condenser world is unrivalled. In twenty years of manufacturing, millions of condensers have been made. Large Power Factor Condensers weighing over three tons. Little Mica Condensers and the famous Mansbridge Condensers only

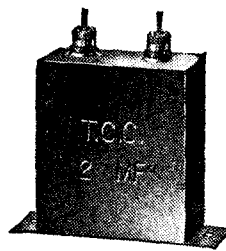

'The famous little green fellow'

two ounces in weight. Yet a common feature in each—the letters 'T.C.C.' stamped on the case.

Twenty years of success! Millions of the small Wireless Condensers have been sold. In every country in the World you'll find them. Long ago the Admiralty standardised on T.C.C. Power Condensers. The G.P.O. and the World's Cable Companies, too, pay tribute by choosing them year after year.

Such success is not brought about by ac-

cident. During twenty years spent in the making of nothing but high-grade Condensers, T.C.C. have acquired a vast specialised knowledge. This is

what you get when you choose the T.C.C. Mansbridge Condenser.

The secret of the perfection of the T.C.C. Mansbridge is in the experience with

which it is designed and constructed. In the high grade copper and mica used. Finally—and perhaps most important of all—in its metal case. Metal is proof against atmospheric conditions.

Metal is robust. Metal is highly efficient in its insulation properties—twenty-four hours in water is not too strenuous a test for the insulation of the T.C.C. Moreover you can use the T.C.C. with absolute confidence that it will never short circuit on to its metal case.

You can have faith in T.C.C. Faith that the qualities which have made the name famous during twenty fruitful years, will be apparent in that which you buy.



The symbol of Condenser perfection

T.C.C.

MANSBRIDGE CONDENSERS

Advt. Telegraph Condenser Co., Ltd., Wales Farm Rd. W.3. G.A. 6567

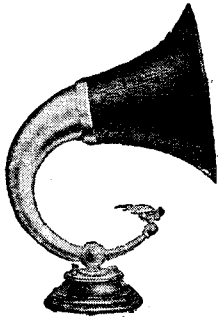

The Q.

120, 2000 or 4000 ohms.
£15 15 0



The Disc.

2000 ohms.
Black and Gold,
Brown and Gold,
White and Gold,
£7 7 0
Oxydised Steel finish,
£8 8 0



The H3Q.

2000 or 4000 ohms.
£3 5 0

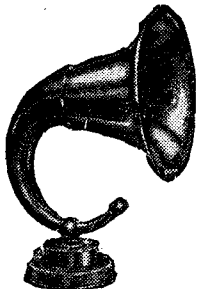

The H.Q.

20 inches high.
2000 or 4000 ohms.
£6 0 0

A Gift that speaks

—every day of the year—to remind the recipient of the donor

CHRISTMAS 1926, unlike previous years, has not the problematical question of 'what to give.' Mostly all your gift problems are solved this year by the one word 'wireless.'

Nearly every fellow, nowadays, would thank you for a Wireless gift. Here's one which this Christmas and throughout the year will be a constant testimony to your excellent of choice. When you give a **Brown** Loud Speaker or Headphone you are bestowing a real boon. The priceless possession of an instrument which day in and day out will faithfully interpret all that is best in the World's music, drama and speech.

The **Brown** range of instruments is so complete that almost for whatever you wish to pay there is a Loud Speaker or Headphone to meet your needs.

Yet whether you pay 20/- for the famous Featherweights or £15 15s. 0d. for the Q. Loud Speaker, you can be certain that your gift will give accurate service—now and in the years to come.



Type A2 Headphones.

4,000 ohms. ... £1 10 0
Also
Type A. 120, 2,000 4,000 ohms., 50/-; 8,000 ohms., 60/-
Type F. (6 ozs.) 4,000 ohms. 20/-

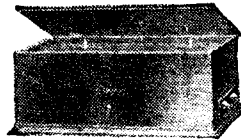

Crystal Amplifier.

Enables a Crystal Set to work a Loud Speaker without Valves, within 15 miles of B.B.C Station or 80 miles of Daventry.

£4 4 0



The H1.

120 ohms. £5 5 0
2000 ohms. £5 8 0
4000 ohms. £5 10 0

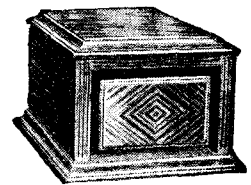

The Cabinet.

In Mahogany or Oak.
2000 or 4000 ohms.
£6 6 0

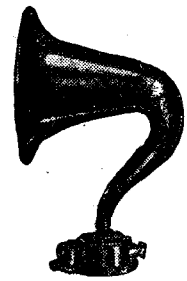

The H3.

2000 or 4000 ohms, resistance.
£3 0 0



The H4.

(Only 10 inches high).
2000 ohms.
30/-

Brown

S. G. BROWN, LTD., Western Avenue, North Acton, W.1.

Retail Showrooms: 19, Mortimer Street, W.1; 15, Moorfields, Liverpool; 67, High Street, Southampton. Wholesale Depots: 2, Lansdown Place West, Bath; 120, Wellington St., Glasgow; 5-7, Godwin Street, Bradford; Cross House, Westgate Road, Newcastle; Howard S. Cooke & Co., 59, Caroline Street, Birmingham; Robert Garmany, Union Chambers, Union Street, Belfast, N. Ireland.

Pliable after 2,500 hours of Continuous Service

—a triumph for the new
Cossor Kalenised filament

HERE is a startling example of the superiority of the Cossor Kalenised Filament. The valve shown in this photograph—after a life test of 2,500 hours at 1.8 volts—was broken open and suspended by its filament. Even after this abnormal period of use—which is equivalent to 2½ years' ordinary wear—the filament was still supple and strong enough to bear the whole weight of the valve. It showed no signs of crystallisation. In fact, there was no reason why the valve would not have given satisfactory service for an even greater period.

No visible glow means long life.

Every wireless enthusiast must appreciate the significance of this test. It means that at last there is available a filament which operates practically without heat. For heat is the one great destructive force which ultimately weakens the filament and causes a fracture. Obviously the Cossor Kalenised filament is no ordinary filament.

The torrent of electrons come—not from the metal core—but from the kalenised layers surrounding it. The sole purpose of the metal core is to carry the trifling current required.

Wide range of filament voltage.

This prolific electron stream commences to flow at 1.1 volts. It reaches its maximum at 1.8 volts. But even though a fully charged accumulator (reading 2.2 volts) be used no harm will be done—although there will be little or no increase in emission. It is quite immaterial, therefore, whether you use rheostats or not in your Set.

Co-axial Mounting ensures uniformity.

The second great fundamental improvement pioneered by Cossor this season is Co-axial Mounting. All Cossor valves in the same class are absolutely alike. Variation is impossible because the filament, grid and anode are secured by a seonite insulator in permanent



The valve which
serves you longest

After the
equivalent of
2½ years use

alignment. Co-axial Mounting finally abolishes microphonic noises and ensures a rich volume of tone upon a background of dead silence. Remember that only Cossor has the Kalenised filament and Co-axial Mounting—there is no substitute for a Cossor Dull Emitter.

In three types

Black Band Detector Valve. Also Red Band for H.F. use. Consumption '1 amp. Voltage 18.

14/-

Stentor Two Power Valve. Consumption '15 amp. Voltage 18.

18/6

Cossor Point One

Popular Wireless

Scientific Adviser :
Sir OLIVER LODGE, F.R.S.
 Technical Editor :
G. V. DOWDING, Grad. I.E.E.
 Assistant Technical Editors :
K. D. ROGERS, P. R. BIRD.

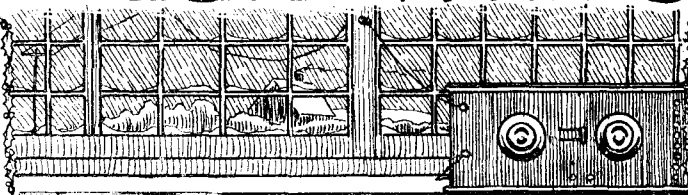

Consultants :
Dr. J. H. T. ROBERTS, F.Inst.P.
J. F. CORRIGAN, M.Sc., A.I.C.
C. E. FIELD, B.Sc.
E. J. SIMMONDS, M.I.R.E., F.R.S.A.

Editor : **NORMAN EDWARDS, M.Inst.R.E., M.R.S.L., F.R.G.S.**

RADIO NOTES AND NEWS OF THE WEEK.

Christmas Good Tidings—Radio on the Air Routes—Aerial Trespass—The Six Pips Signal—Keeping the Aerial Warm—"P.W." Constructors' Competition.

Christmas Good Tidings.

LISTENERS, awake! Are you feeling downhearted? Do you get peevish, or peckish, or peaky? Is everything dismal, and down, and dark and dreary—and all those other d's that you know as well as I do?

Well, now. Listen! Hark to Uncle Ariel calling! Hear the glad tidings. I'm gonna put you wise. Read on, Macduff, Herbert, or whatever your name is, and your depression will vanish into thin, thin air!

A Cheerful Crowd Calling.

THERE is no need whatever for all this funereal foolishness and sepulchral gloom. For at this very moment of time, right now, and instant, the antidote is prepared. Dozens of cheery souls are busily banging drums, twanging harps, biffing lyres, and kicking up no end of a how-d'you-do with the sole idea of amusing you, and passing your hours away happily. Laugh! Why, man, if you could only hear them you would be tickled to the point of ultimate extinction.

Tune in Your Share.

"WHERE are they?" you say. Why, they're on the ether, of course. They stand in front of microphones—hundreds of them in Europe alone—and all day they try to tickle your ears. (They regard you as John Listener, the biggest pot in the broadcasting world to-day!) And all that you have to do to hitch on to some of this fine music and entertainment is to get busy on your wireless set, and tune in your share. So pull up your socks, put up your pole, and give old Gloom the go-by!

Radio on the Air Routes.

THE new air route to India and Egypt, which is being opened by Imperial Airways at the beginning of next year, is to have a chain of wireless aerodrome

A Christmas Coincidence.

"Popular Wireless"! How true are these words
 That appear on our cover each week.
 The whole world is flocking to listen in herds
 When funny foud speakers loud speak.
 Husbands all stay at home, wives spend the day at home
 Joining the radio clique.

"Popular Wireless"! And as this is so
 It came as a Christmastide salve,
 For my schedule of suitable presents, although
 Long, was disposed of by twelve.
 To friends and relations I've made presentations
 Of wireless sets (crystal and valve).

"Popular Wireless"! To nephew and niece,
 To cousin and uncle and aunt,
 I sent off a beautifully-made set apiece
 Thinking: "Now, really, I can't
 Possibly do better, for how can you better
 Highest-grade radio plant?"

"Popular Wireless"! I realised that,
 But my estimate must have been wrong,
 For now in each part of my bachelor flat
 There's a talk or a waltz or a song.
 With no exception, rooms all are
 "reception" rooms
 Going it steady and strong!

"Popular Wireless"! Each nephew and niece,
 Each cousin and uncle and aunt,
 Has sent me a beautifully-made set apiece
 Thinking (like I did) "We can't
 Possibly do better, for how can you better
 Highest-grade radio plant?"

L. E. V.

ground stations. The giant D.H. 66 multiple-engined aircraft that will fly on this route will all be fitted with the latest aircraft wireless equipment, so that they are never out of touch when flying.

Even in the unlikely event of a forced landing in the desert, wireless communication could easily be established with the nearest ground station.

Aerial Trespass.

IT does not seem to be generally known that if you want your aerial to dingle-dangle across other people's property, you must get their permission. Settling a dispute between neighbours some weeks ago, the Old Street magistrate told a man: "Your neighbour owns everything above his property, right up to Heaven, and I am afraid you will have to take your aerial down."

A Trinadyne Triumph.

I MADE up a Trinadyne, as described in 'P.W.' 145," writes a Stonham reader, "and finished it off at 11.55 p.m., just in time to catch dance-music from 2 L.O. and to hear Big Ben strike twelve. "Then I heard an American station, just above 400 metres, and tuned in W G Y, on 379 metres. Not so bad, is it? Anyhow, it beats my four-valver for range!"

L.C.C. Wireless Lectures.

IF your aerial hangs out Streatham way, or at Balham, Tooting, Clapham, Wandsworth, or the adjacent suburbs, you will be interested to know of the L.C.C. lectures. A series has been arranged for Tuesday evenings, 7.30 to 9.30, to continue to Easter, for the attractive fee of 4s. the course!

(Continued on next page.)

A Record Radio Xmas Number.

112 Pages for 3d.!

This issue of "P.W." is the largest we have ever published, and offers unprecedented value for the low price of 3d. The editorial pages are full of matter of interest to all readers, and the advertisement pages, both in design and contents, are of the greatest credit to the Radio Industry of Great Britain.—THE EDITOR.

NOTES AND NEWS.

(Continued from previous page.)

Captain Jack Frost is the lecturer, and a very attractive syllabus has been drawn up. Full particulars are obtainable from The Bee Secondary School, Tooting, S.W.17.

Can You Contradict This?

LOOKING through the "Times" the other day, I rubbed my eyes to see the following statement. "Without a shadow of doubt, our main broadcasting stations, with the exception of Daventry, cannot give crystal reception at distances of more than 50 miles or so, at the outside."

Condemning the Crystal.

THE writer goes on to say that long-distance crystal reception is all a matter of re-radiation from a neighbouring valve set, and that this is "what undoubtedly happens in every instance."

Now there must be a good many "P.W." readers who can disprove this from their experience, and I should like to hear of cases, especially where re-radiation can be ruled out, such as those where a lucky listener can get a Continental station any old night when it is transmitting.

Now, Knights of the Cat's-whisker! It's up to you, for the honour of the crystal detector! Let's hear from you!

Did Shakespeare Listen-In?

WRITING to me all the way from Dunedin, New Zealand, the President of the Otago Radio Association calls my attention to his society's Shakespearian broadcasting motto, which is printed upon the Association's notepaper. It is taken from "The Tempest," where Caliban says:

"The Isle is full of noises,
Sounds and sweet airs that give delight
and hurt not,
Sometimes a thousand twanging instruments
will hum about mine ears,
And sometimes voices."

Sick Man's S O S for War-Time Nurse.

STAFF NURSE MARY BATLEY, for whom a dramatic appeal was broadcast last month, has not yet come forward. Mr. H. G. Hobden, on whose behalf the appeal was made, is lying seriously ill in a sanatorium at Robertsbridge, Sussex, and only his former hospital nurse, Mary Batley, can establish the fact that he was ill at Salonica, and thus secure for him an Army pension of 45s. per week. Can anyone help the B.B.C. to trace Nurse Batley for the stricken ex-soldier?

Short-Wave Transmissions.

READERS who are able to tune down to the short waves will be interested in the following, received by Mr. W. R. George, of Worthing, in a letter from the Schenectady broadcasting station. Congratulating him upon his reception of the short-wave transmissions from 2 X A F, the station director makes the following statement regarding future transmissions:—

Sending Out the Schedule.

WITH reference to the present short-wave schedules, 2 X A F (32.79 metres) transmits W G Y's evening programmes on Tuesdays and Saturdays. Transmissions from 2 X A D (22 or 26.8 metres) are subject to frequent changes,

TECHNICAL TERMS ILLUSTRATED.

The Cell.

THE burglar was getting on well,
When clean off the veranda he fell!
By police he was caught,
And next morning he thought,

"Well, this is a horrible ———"

making it impossible to keep listeners fully acquainted with all schedules; however, at 6.45 p.m. E.S.T., the complete schedule for the ensuing week is transmitted by I C W from 2 X A F."

The Six-Pips Signal.

DOTS, dots, dots. If the B.B.C. is getting many more letters than I am about their alteration of the six-dot signal from Greenwich, they must now think it was a dotty thing to do!

Everybody seems to have liked those dots. However good the music happened to be at the moment when the six pips came through, they never seemed to be intruding, did they? So I'm all for the super-imposed time-signals again, and the renewal of those pert little pips from Greenwich.

SHORT WAVES.

It is rumoured that we are to have radio carols again this year, but wireless waits will never be really satisfactory until somebody invents a method of broadcasting a pail of water. —"Punch."

Miss Hinton . . . was listening to a wireless concert and, suddenly taking off the headphones, without a word lay back on a couch. Month after month she lay like a marble statue, and doctors were completely baffled by her condition. —"Reynold's Illustrated News."

Perhaps they have never listened-in themselves.

Wireless fiends in the West End have been trying to get Pittsburg. As far as the rest of America goes, we understand, they can have it. —"The Star."

Headline in the "Manchester Guardian": "Listening in to Mr. Smith's face." This will be especially noticeable during the Christmas festivities.

Going cheap in a wireless accessories list: "Fault detectors and transformers." Great time savers in the homes of newly-married couples. —"Daily News."

Three-valve loud-speaker set, complete; first seasonable offer secures. —Advt. in Local Paper. Unfortunately these things are never out of season. —"Humorist."

With a crystal set, using no connections or crystal whatever, I have picked up the following stations: Aberdeen, Cardiff, Liverpool, Daventry, Chelmsford, Birmingham, Manchester, Bournemouth, Newcastle, London, Frankfort and Madrid. —Extract from letter received from a Wigan reader.

We always knew that, given a chance, Wigan would one day justify its existence.

A well-known actress recently returned from Africa, where she has been for several years, said she wanted to sing over the radio badly. She did!

A gossip writer says that since a friend of his fastened one end of his aerial to a pear-tree no blossom has appeared on the tree. Perhaps that is why Blossom is sometimes broadcast by the B.B.C. —"Electrician."

An up-to-date youth, tuning his wireless set: "I wonder who's at the mike now?" Grandmother: "Don't say Mike, dear; it's Michael!"

Keeping the Aerial Warm.

SWEDEN'S huge broadcasting station, now being erected at Motal by the Marconi Co., is to be finished in the spring. It will be far more powerful than any European station now in existence, and amongst other refinements its aerial is to be kept heated by electricity! In order to prevent damage during the intense cold, arrangements will be made to run a current through the aerial wires, sufficient to keep them warm! The crystal range of the station is to be 200 miles.

A Greeting from Mr. Reith.

THE following cheery message was one of the first Christmas greetings to reach me this year.

"I hope readers of POPULAR WIRELESS will have an enjoyable Christmas season, and that in 1927 they will achieve happiness and success. No doubt the B.B.C. can contribute to these latter.—Yours sincerely, J. C. W. REITH (Managing Director, B.B.C.)."

More Low-Power Short-wave Successes.

USING a Burndopt L525 valve, and 4.8 watts supplied from Hart accumulators to the anode, my signals were received in Winnipeg, on an indoor aerial, at strength 4." So says Mr. J. Ridley, alias G 5 N N, who shakes the Norwood ether to some purpose, as his bag of radio records will show!

Fifteen American stations also picked up G 5 N N, in two days, the strength of signals in every case being "the cat's pyjamas"!

"P.W." Constructors' Competition.

I AM sorry to have to announce that the result of the "P.W." Constructors' Competition—which it was hoped to publish this week—is not yet available. The awards, however, will be announced as soon as possible.

Shortage of Iron Pyrites.

CRYSTAL users who favour iron pyrites will be interested in the news that there is a shortage of this mineral. Crystal manufacturers are finding the greatest difficulty in renewing their supplies of raw material, and I see that the cost of the N.M.C. Detector has been doubled for this reason.

For a very limited period "P.W." readers may obtain supplies at the old price by means of the coupon that appears in our advertisement pages this week.

Quick Legislation.

THEY say that when Capt. Ian Fraser, the blind M.P., went to the House of Lords to hear the second reading of his Free Wireless for the Blind Bill, it was passed so quickly that he hardly realised it was through! Good Lords!

My Radio Christmas Dish.

TAKE half a dozen leaks, one pound of H.F. currents, and one pint of ether.

Remove the cores from the leaks, and carefully stone and insulate the H.F. currents.

Strain the ether through a fine-mesh grid, to remove electrons. Beat well, in a heterodyne receiver, and ionize for 20 minutes. Place in a transformer until done to an ampere turn, and serve with a garnish of statics, on a hot plate!

And a very happy radio Christmas to you all!

ARIEL.

A Merry Radio Christmas to You All

ONCE more we are able to place before our readers a bumper Christmas Number—one hundred and twelve pages! We have again followed our policy of not increasing the price for this special Christmas Number—a record number, too!

There is, indeed, not very much to say this week in connection with POPULAR WIRELESS, except that we want to wish every reader the very happiest Christmas and the most prosperous New Year. This is the fourth Christmas Number we have placed before our readers, and a glance at the editorial contents and at the advertisement contents will convince the sceptic that wireless is by no means a played-out hobby.

If anything, it is increasing by leaps and bounds in popularity, and it is obviously going to be one of those hobbies which go on for ever. It has, indeed, taken a firm hold on the imagination of a large section of the public. Whereas in the old days hobbies sprang up, achieved a certain amount of popularity, and

From
It gives me great pleasure to greeting to "Popular Wireless" and broadcasters, and listeners generally remarkable invention which for service of the public. As Chair-Vice-Chairman of the new, I can did tradition established during the trary, I believe my colleagues on Board agree with me that the best hope to do is to carry forward the on the lines already laid down.

LORD GAINFORD.
accede to your request to send a Christmas its readers. Wireless journalists, amateurs, ally are all participants in the blessings of a tunately in this country is devoted solely to the man of the old Broadcasting Authority and vouch for one thing, and that is that the splen-past four years is not in jeopardy. On the con-the new we can good work

jeopardy. On the contrary, I believe my colleagues on the new Board agree with me that the best we can hope to do is to carry forward the good work on the lines already laid down.

That message from Lord Gainford must raise the spirits of many of us who have been dubious about the future of British broad-

casting, and we can only say that if that spirit is carried out in practice, then we shall not have any regrets about the future of broadcasting. The close of this year sees the death of the old British Broadcasting Company.

although, like the Phoenix, it will arise from its ashes in its new form as the British Broadcasting Corporation.

New names have joined those in authority, but we still have, as Executive Chief and Director-General, Mr. J. C. W. Reith, the present Managing Director of the British Broadcasting Company. Mr. Reith's continuation and his decision to link himself up with the

realise that the subject of wireless does, if handled properly, lend itself to the imagination and abilities of the artistic advertiser.

Christmas presents this year are again to the fore, and in the special article in this issue, Mr. Dowding offers some very useful advice to the prospective purchaser. On this page we also print several messages from well-known radio personalities, wishing our readers a happy Christmas and a merry New Year. In particular we would draw attention to the



From SIR OLIVER LODGE, F.R.S.

To you and to all your readers, let me send a cordial greeting and all good wishes both for Christmas and for the New Year, upon which we are entering.

We have all been through troublous times together, but this last year has been by no means all bad. Friendliness among the nations is increasing, and must continue to increase now that methods of intercommunication are so rapidly developing.

All English-speaking nations are now welded together by the possibility of actual speech across the oceans. We have lived to see great discoveries, and many of you will live to see more. May all advances conduce to peace and happiness and goodwill.

Oliver Lodge



A recent photo of Senatore Marconi.

From CAPTAIN P. P. ECKERSLEY, M.I.E.E.

May I take the opportunity of wishing all your readers and the staff of "Popular Wireless" continued prosperity and happiness? I feel that by the unique co-operation that is possible through the technical press and readers generally, we in Britain can be proud to have built up a service which is second to none. This certainly could not have been done without the loyal co-operation of listeners, amateurs and professionals alike. I hope that this same spirit, which it is so easy to remember at Christmas, will persist through the years to come.

P. P. Eekersley

then faded away into insignificance, wireless seems to have proved an exception to all other kinds of hobbies.

It certainly did start with a bang, as they say, but the bang has gone on and it is amazing to find that year by year the interest, instead of waning, is increasing.

The reader will also find it interesting to compare this Christmas issue with our first Christmas issue, and one of the things that will strike him most forcibly is the great increase in the quality of the goods offered by our advertisers; and in connection with this it will be seen that a new art has sprung up in advertising, and that many of the advertisements in this issue are masterpieces of their kind.

Wireless advertising, the layman would think, would not lend itself to artistic display, but you have only to glance at some of the very fine advertisements appearing in this issue to

From SENATORE G. MARCONI, G.C.V.O.

I send my best wishes to "Popular Wireless" and its many readers for a happy Christmas and prosperous New Year.

G. Marconi

message from Lord Gainford, and it is good news to note in his message that he says: "As Chairman of the old Broadcasting authority and Vice-Chairman of the new, I can vouch for one thing, and that is that the splendid tradition established during the past four years is not in

fortunes of the new British Broadcasting Corporation is very welcome indeed, and it seems a suitable moment to wish him the very best of luck in his new post.

Most of the old staff—those who from the very beginning have built up the prestige and popularity of broadcasting—will stand by the new Corporation and on the engineering side our old friend, Captain Eekersley, will still carry on as Chief Engineer.

In this issue, by the way, Captain Eekersley writes a very interesting article on "Looking Back," and every reader who remembers his old days at Writtle, when he was the life and soul of that mushroom broadcasting station, cannot fail to wonder at the amazing progress which has been made in the last four and a half years, or to realise that much of it, from a technical point of view, has been due to the energy and progressive instincts of Captain Eekersley.

THE EDITOR.

THE P.M.G.'s Programme



I'd worried about wireless things a bit that night, I guess,
And wondered, too, if Government would make a ghastly mess
Of the policies and programmes of the good old B.B.C.
When it was taken over by a red-tape P.M.G.

And thus, when down I lay to sleep upon my truckle bed,
A lot of dark, disturbing thoughts were huriling through my head,
And I was not a bit surprised to hear the Announcer say :
"The Telephone Quartette will sing their usual song to-day."

Ah, then began staccato sounds I oft before had heard :
"Ho ! Seving-double-thr-r-r-re-e Gerrard"—or words quite as absurd—
"Wrong Number? Sorrrree! Battersee; Thr-r-r-r-ee double Seving HO!"
All to the tune of the Whistling Coon mixed up with Poor Old Joe!

I tried in vain to ring 'em off ; those girls grew bolder still,
And turned on television—disbelieve me, if you will—
And I SAW the face behind the voice, the voice that calmly said:
"Sorrrrrr-eee to have tr-r-r-r-rubbed you!"—and then went off my head.



I seemed to hear the P.M.G. say : "Jazz is out of date,
And Lauder and his foolish like I wipe clean off the slate;
Whilst as for comic opera, I'll have your ruddy gore
And call the yeomen of the guard if you even ask for more.



"In lieu of such tomfoolery I'll give you high-brow turns,
A nightly spell in Parliament, for which the public yearns,
A digest of political and local social news,
As the brand, say, of the chewing gum which Winston Churchill chews.

"The bacca Mister Baldwin smokes, and what its price per ounce,
The little tricks of Joynson-Hicks which foolish folk denounce,
The window-pane of Chamberlain which makes him look so wise,
And what is said of Birkenhead—on whom there are no flies !

"Then, just by way of change and rest, my postmen's choir shall chant
About some dear old MOTHER or some dear old MAIDEN AUNT ;
But love and stolen kisses—even under mistletoe—
Shall never more be spoken of—that is, from 2 L O.

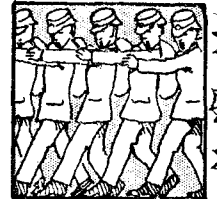

"And my music must be solid, with no lilt, no fal-lal-la,
And my readings will be culled from the Encyclopedia,
And you will know how careful is my choice when I remark
That not a joke is passed by me not first heard in the Ark.

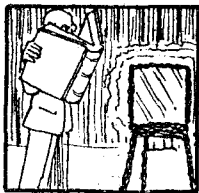

"If Noah whispered it to Ham, and Japheth unto Shem,
I'll pass the ripest chestnut or the stalest apothegm,
And should it antedate the Flood and come from Eden's shade,
It's younger than the eggs the dinosaur of Gobi laid !"

He ceased ; I cried : "Oh, save us from this fate, great P.M.G.
I grovel here before thee, grovel on my bended knee.
I care not if you sing the songs my mother used to sing,
But prehistoric jokes and gags I hate like anything !"

Then suddenly the P.M.G. bounced right into my room,
And yelled : "L. O. ! I come at last to execute thy doom !"
And straight produced ten billion miles of tape of such a hue
That poppies of the deepest dye ne'er looked so red to you.

He wound the red tape round my limbs, the fingers of my hands,
Until I woke up in a fright and burst these frightful bands,
But though I woke, I half believed the wretched dream too true,
Unless the P.M.G. bites off much more than he can chew.

A. B. COOPER.

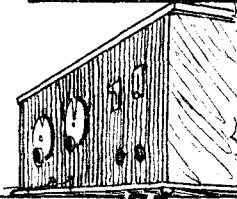
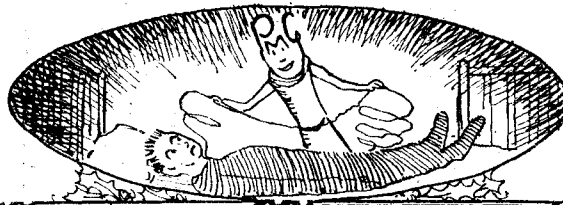
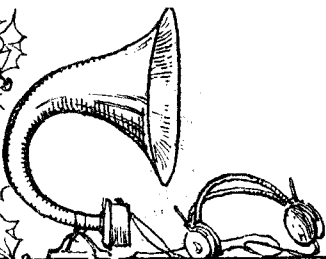



ASK people where and how broadcasting began, and they will reply: "Oh, in America!" Possibly force of habit prompts the reply. It is difficult to find a beginning, since the term itself, when dissected, defies a definition. As a small boy I can remember my incredulous wonder at hearing that one, Mr. Marconi, had signalled without the aid of wires across the Channel; at the age of fourteen, when I was already the devoted "lab. boy" to an elder and wirelessly knowledgeable brother, I heard with some envy that the human voice had been transmitted through "wireless" space. I say some envy, because I felt that all development should be part of my brother's work!

Precursor of Broadcasting.

Early in 1919 Capt. Round, Mr. Ditcham, and Mr. Mogridge erected a 15-kilowatt set at Chelmsford, capable of transmitting the voice and music [*sic*] by wireless, and, to my mind, this station was the world's pioneer broadcasting station. Its power was sufficient to make its presence felt over most of Europe, and the occasional concerts transmitted were of great interest to the few enthusiasts who were the "amateurs" of those days. Some fine performers sang from the station, among them being Melchior, the Danish tenor, and Dame Nellie Melba. I remember the excitement when Melba came to Chelmsford. Her studio was a store-room with a concrete floor and a hired piano. To make it look better a large rug was spread on the floor, but Dame Melba would have no singing on rugs, as you who are singers may well appreciate.

The transmissions, which proved to the full the potential value of broadcasting, received little public notice, and the Government in time withdrew the licence.

A Famous Station.

Broadcast silence fell upon Britain, and meanwhile in America a start had been made, and from 1919 to 1922 the States forged ahead, leaving us, in actual broadcasting, far behind. The flag of enthusiasm had been kept flying, however, by the "amateur" people, who in those days would sit up all night to catch a mere whiff of telephony. Eventually, they got together a petition to ask for a broadcasting station.

A Special Article for our Xmas Number by the Chief Engineer of the B.B.C.

After some delays, permission was granted to erect such a station, and by the law of chance that seems always to pitch me into these sorts of efforts, I was given the job to erect the station. No, it was nothing like 2 L O, that station; look first of all at some of the restrictions.

Power 250 watts (the power of London today is 3,000 watts, and Daventry is 25,000 watts); this power to include the power used in lighting the filaments of the valves. Incidentally, we found it took 300 watts to light our valves adequately, so really we



Dame Nellie Melba broadcasting for the first time from the experimental station at Chelmsford.

are owing the then Postmaster-General some watts!

Time of working, 15 minutes per week!

Shut down periods. Between every item to have to shut down for two minutes. It left us little time to transmit if we had eight items!

Call sign, 2 M T.

Memorable Programmes.

This colossal undertaking did not occupy our staff for seven days a week. The transmissions were done after hours; 8 o'clock till 8.15 on Tuesdays saw us hard at it. Writtle was the village near our station, and "Two Emma Toc Wrrittle" is probably a familiar cry to many an early enthusiast.

There were no news bulletins and special shipping forecasts, no dulcet-toned announcers; just a gramophone (sometimes with orch!), and a lively and irresponsible staff. May I say that we were never very serious, but that we foreshadowed every programme ever given! We had our Children's Hour, but it was largely technical. For instance, nursery rhymes:

Four-and-twenty B valves standing on a shelf;
Ash couldn't find 'em, I had to go myself.
When the circuit opened, the 'phones began to sing.
Don't you think that I was right to smash the beastly thing?

Or:

Hey diddle dodrode,
Two grids in one quadrode;
The outer one forming the plate.
The electrons got muddled with so many grids,
But the final M value was eight.

We had some fairly highbrow poetry readings, too:

"Oh, heterodyne, why are you moaning?

Oh, stop and hear our telephoning.

As you swoo-op both high and low—" but that was never finished.

To-day they do radio drama in the B.B.C., but we began at least by having a wireless play. Two friends, Robert and Agnes Travers, and myself, did that part

(Continued on next page.)

"LOOKING BACK"

(Continued from previous page.)

of Cyrano de Bergerac, where the two, Cyrano and the pretty count, make twilight love to Roxane on her balcony. When they do radio drama now at 2 L O they have soft lights, a microphone that never obtrudes, wonderful noises off, a beautiful room; there are real actors now! You must imagine us in an Army hut, the walls festooned with wires, a kitchen table in the middle, and us seated round, reading our impassioned lines into hand-held microphones, which are no different from the ones you use when you ring up Hop 101, or whatever it may be. The heroine had a tendency to use her microphone as a teacup; the impassioned lover suddenly found his arm's gesture robbing the microphone of its wanted nearness to his mouth! But it was the first wireless play.

Writtle Closes Down.

The days of Writtle were numbered in August of 1922, because the great 2 L O, a station on top of Marconi House, started to give occasional transmissions. It was not until well after the B.B.C. was formally constituted, however, that the switch was pulled out for the last time, and 2 Emma Toe was but a soon-forgotten name. I still have letters, however, from listeners asking if nothing could be done to close down London on Tuesdays so that Writtle might be heard!

So I drifted back to my work and forgot about broadcasting. I had never looked upon it, I must confess, with any but a scientific interest, and had never thought of the matter broadcast other than a means of amusing a dilettante hour. Some time

in January of 1923, however, my whole outlook changed.

I heard opera by wireless. Broadcasting has given me many thrills, but I doubt if I ever had such a burst of revelation as when casually I donned a pair of 'phones one evening to hear a Covent Garden opera. Suddenly I had that spacious feeling of sitting in a great auditorium, I sensed atmosphere, and then, as silence fell to the conductor's baton and the violins crooned the opening bars, I knew I was a convert for ever. I spent a week listening to a series of operas. The sun might shine, the open road invite, the roses want pruning, tea and bridge with friends might press, but I sat, 'phones on ears, through matinées and every performance. I bought a loud speaker—that loud speaker was always dud—and with my ear in it listened with cooler ears and cooler judgment to other items; but oh, for opera!

Birth of the B.B.C.

I had heard that the Chief Engineer of the B.B.C. was to be appointed. Imagine my surprise in getting a letter to say I might put in for it with some hope of success. And so in February, 1923, I found myself in Magnet House along with Arthur Burrows and C. A. Lewis as colleagues, with Mr. Reith as my chief, and three months' arrears of work to catch up with.

Well-remembered days when work began at 9.30 and left off about midnight; when one might go off to Glasgow, sans pyjamas, toothbrush, on the midnight train, with no very clear idea how one was to deal with the other end's difficulties!

Slowly, amid a maze of detail, certain concrete ideas began to take shape. We were a public service first. Commercialism was done with; let there be more and more people who could listen with ease. Death to spark jamming! Up with the strong signal! Let us spread our service over the

land; let us bring every inhabitant within reach of what should be the greatest boon science has bestowed during an eventful century. Lord Burnham, in opening the Bournemouth station, spoke of broadcasting as bearing potentialities as great as Caxton's Printing Press in its time. His speech was, to me, truth, not rhetoric.

Chelmsford and Daventry.

The relay station developed to bring in more and more subscribers within a working range of a station, and in a year 65 per cent of the population could hear an uninterrupted programme. Many in the light of after days have attacked the relay station policy, saying that so many small stations take up valuable wave-lengths, and do in an extravagant way what one or two big stations could do. This may be so, but in those days municipalities were clamouring for their own stations, money was scarce, and as each town, so to speak, by increased subscribers paid for its own station, we mounted by easy steps rather than having to put our eggs in one most fragile and costly basket. Besides, local interest always helped, and now helps to maintain an intimacy for the local staff and station that no large, impersonal, high-power station could do as well.

After the relay station came Chelmsford. There, on the site where, in 1919, the first broadcasting set was erected, an experimental long wave, high-power station, now finally crystallised in Daventry, began its work of interesting the country user. If the towns, with their many other distractions, find an interest in broadcasting, imagine how the country benefits from Daventry, with its twenty-two million potential listeners, its crystal range of one hundred miles, and its wave-length far removed from the ship jamming.

Between 1923 and 1925 we erected 21 stations, and made Britain one great area of "perfect" reception. I think I may say, without boasting, that unified control of National Broadcasting enabled us in two and a half years to pursue, catch up, and overtake our cousins in America. At any rate, if quantity appeals, we have a greater proportion of people listening-in in Britain than in America, and we require far fewer stations per unit area to have achieved that result—and we have achieved it in half the time. This is simply for one reason, that we have seen our work as a public service, as a national service; we have put this first, and we have never commercialised the service in any way. Our life-blood is the licence fee you, in your enthusiasm, have given us; that small ten shillings a year which has enabled us to build up the service.

The S.B. System.

Then, of course, to-day you are switched from Eastbourne to Aberdeen, from Oxford to the Manchester Hallé concert, back and forth, annihilating space by a movement of an engineer's wrist. It was not always thus. Well I remember in 1923 trying out, with the able help of the Western Electric engineers, the S.B. system whereby trunk lines could link all stations together. We sat in a room in Marconi House with a tangle of wires, amplifiers and such like, and we tried to relay opera to all other stations. All we got one night was an infuriated telephone subscriber asking why the — he could only get — music instead of his friend in Newcastle. Another

(Continued on page 942.)

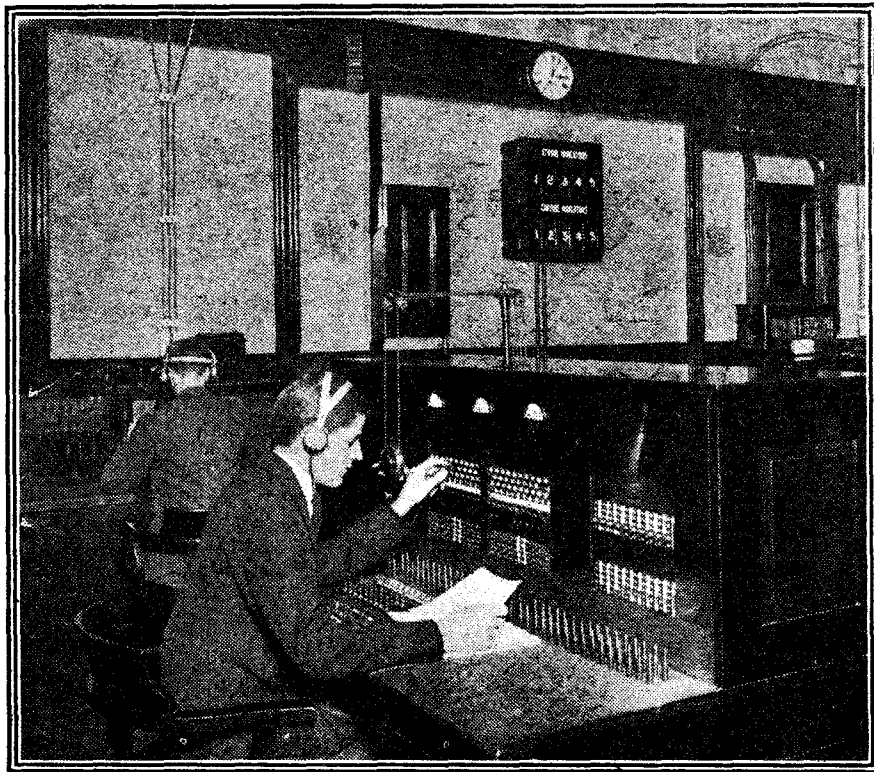

The present-day S.B. switchboard and indicator system installed at the London broadcasting station.

THE BEAM

A Chat With Marconi

A QUIETLY furnished yet imposing room, a large globe here and there, a table with charts and graphs—these were the surroundings amid which Senatore Marconi was kind enough to grant me an interview on the beam system, for the benefit of readers of POPULAR WIRELESS.

Much has recently been written about the beam system and its success in passing the rigid tests imposed by the Post Office. It is, for example, common knowledge that by utilising the very short waves in conjunction with reflectors, the wireless wave can be projected in a chosen direction, giving not only a very useful directional effect with a large measure of secrecy, but what is just as important, a very considerable economy in the energy required to communicate over a given distance. The Marconi beam system is now working daily with Canada, while experimental transmissions are taking place between this country and South Africa and Australia. Much, I repeat, is already known about this beam system, but I was very anxious to obtain from the great inventor many details on matters which are not common knowledge.

Australia Next.

"Now that the Canadian service is under way, the South African, I presume, will be the next to be taken over?" I asked.

"No," replied Senatore Marconi, "I think I can say that the Australian will be next and the South African a little later. Although the Australian service will span the greater distance, experiments show that communication by the beam with the Antipodes will be particularly easy.

"Our agreement with the Government calls for the use of 20 kilowatts, but the beam system has proved so efficient that we have ample power to spare. The intensity of the signal received is amazing, and aural reception is completely supplanted by automatic apparatus. Having such strong signals with such regularity, we can work at very high speed; and although, for example, the contract calls for one hundred words per minute, the Canadian service has worked at two hundred and fifty words per minute without the slightest difficulty."

"This, of course, is not the limit of speed possible with the beam?" I asked.

"By no means! Experimentally, in the laboratory, we have been able to record successfully speeds as high as two thousand

We publish below an exclusive interview with Senatore Marconi, by Mr. Percy W. Harris. Senatore Marconi reveals many new facts in connection with the Beam System, which have not as yet appeared in print elsewhere.

THE EDITOR.

words a minute, although on the commercial service such speeds are not yet practicable, even if they were necessary!"

"Much has been written about the short wave 'jumping' long distances, and being inaudible until they are a very long distance away from the transmitting station. Have your experiments confirmed this?"

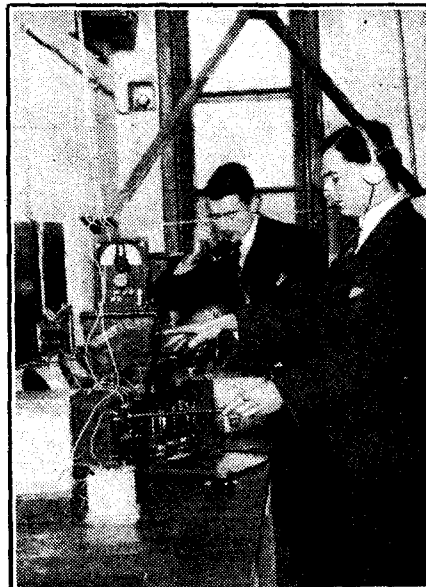

Carrying out short-wave reception experiments at Biggin Hill.

"No, on the contrary, the experiments I have conducted on the 'Elettra' and elsewhere show that many of the wave-lengths alleged to be inaudible at certain distances are received quite well. I disagree with much that has been published in this regard. In any case, I am afraid there is not sufficient experimental data available to draw a sound conclusion on this matter."

"To what extent is the energy radiated from a beam station confined to the beam?"

How much stronger are the signals in the beam than outside of it?"

"The width of the beam, with the present arrangement, is about eight degrees, and thus the width of the beam increases as the distance increases. Our measurements show that on signals transmitted to this country from America the width of the beam would be about forty miles per degree. This indicates a total width of about three hundred and twenty miles, and opens up very interesting possibilities in the transmission of broadcasting from the United States to England. You will see that the energy could be concentrated in such a way as to cover practically the whole of England, but no more.

X's Eliminated.

"Some people have criticised the beam for not being entirely 'self-contained,' but in this matter it is interesting to take the analogy of the searchlight ray. Such a beam is frequently visible even when one is not in its direct path, but the amount of light which reaches the eye is only a small fraction of that which is actually confined to the ray itself. Using a reflector at the transmitting end only the strength of signal in the wireless beam is about ten times as great as that outside its path, but by using a reflector at the receiving end, the received energy is approximately one hundred times as great.

"One of the great advantages of the wireless beam system is the way in which it eliminated atmospheric trouble. It is now generally known that atmospherics originate in certain relatively small areas. When using a reflector at the receiving end, atmospherics which are arriving from a point not directly in the line of the beam have very little effect on reception.

"As some of our beam stations have two reflectors facing in opposite directions, if it should happen that an 'X storm' occurs in the line of the beam between, say, England and South Africa (let us assume for the moment that it originates in the Atlantic) and it was causing trouble, we can immediately switch over and send the beam over the North Pole to reach South Africa via the longer route round the other side of the world."

"Are there any special troubles that have been encountered?"

"Very few. Very occasionally there is trouble from sunspots and the Aurora

(Continued on page 881.)

THE NEW BEAM STATIONS

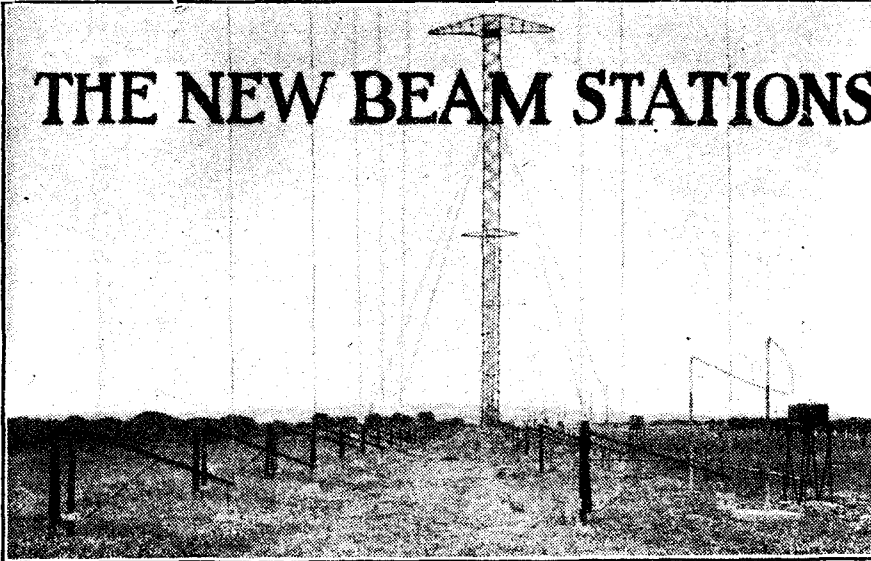

Above: The lower wave-band aerial system employed at Bodmin for the beam transmission to Canada. The aerial system is on the right and the reflector on the left.

Below: Part of the transmitting gear at Bodmin. the condensers and chokes forming the smoothing unit for the H.T. supply.

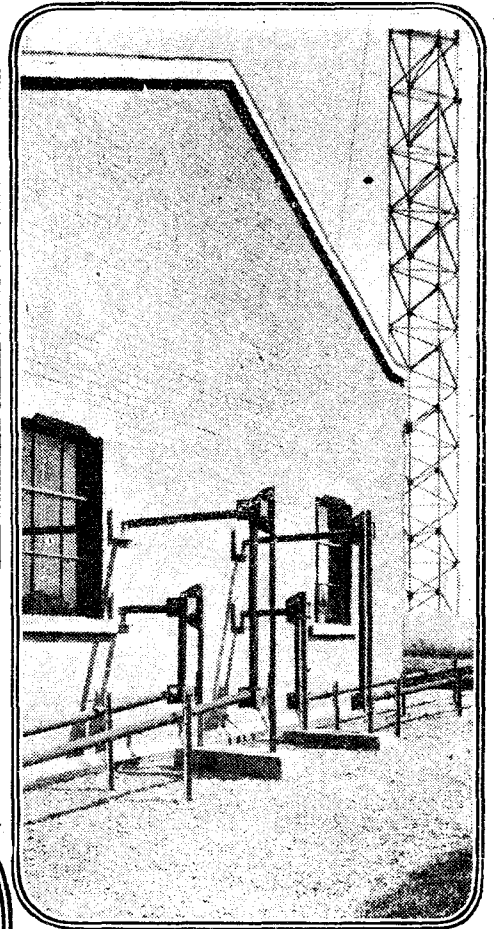

The receiving station at Bridgwater showing the tubular feeder systems. The two tubes going to the left are for the aerials picking up the Canadian signals, while the other two are to do with South African traffic.

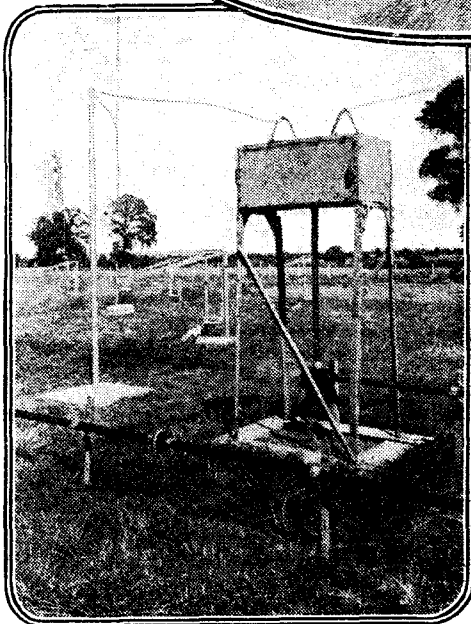
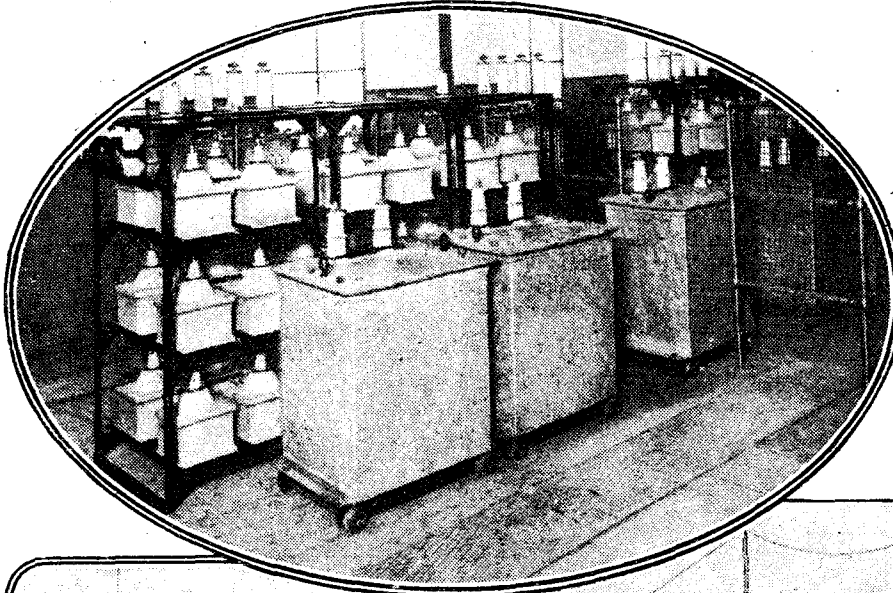

A portion of the feeder system at Bridgwater. Note the aerial coupling box on the left and the balance weight system (background) for keeping the wires at the same strain, regardless of weather conditions.

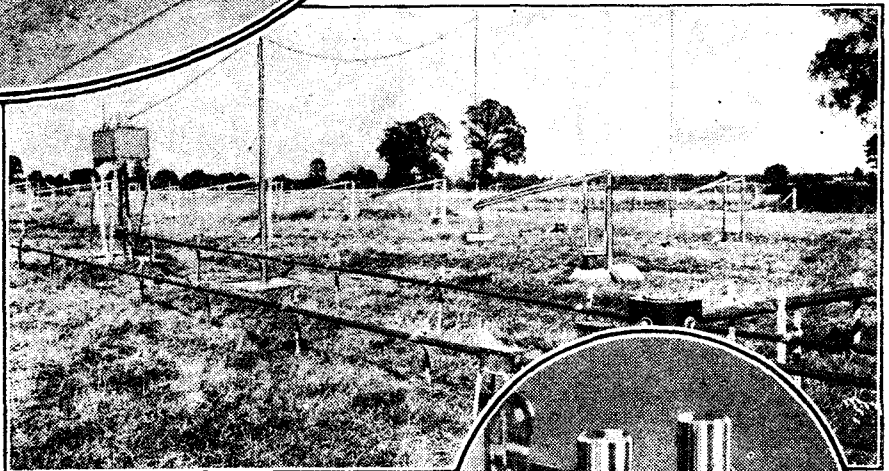

Two relays used in conjunction with the beam transmitter at Bodmin.

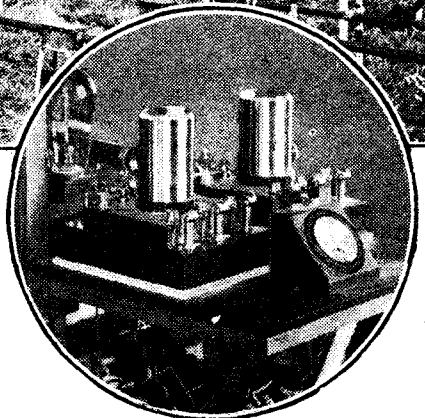

A close-up of one of the aerial coupling boxes which connect the feeder system to the vertical aerial wires. Special balance coils have to be incorporated in each box.

THE BEAM.

(Continued from page 879.)

Borealis. Since the Canadian service was handed over to the Government, it has been working uninterruptedly, but prior to this time there were one or two short periods—in one case for about thirty hours and in another for about a few hours—when signals were practically unreceivable, due probably to absorption by the ionised air. It is interesting to note, however, that during this time the cables were also interrupted, as they, too, are susceptible to the electrical storms which often occur when there are auroral displays.

Peculiar Effects.

"It is, however, a fact that 'fading' still exists to a certain extent on the Bodmin-Canada circuit, but, as it was noticed that signals could be received across the Atlantic when using still shorter waves, provision has now been made for the use of two waves of different length at the beam stations, so that a shorter wave can be employed during any exceptional conditions as appear to interfere with transmissions on the twenty-six-metre wave."

"With regard to the wave-length the Bodmin station is using for the Canadian service, a wave-length of approximately twenty-six metres is adopted, I believe?"

"Yes, this has proved a very satisfactory wave-length, and the other beam stations will probably work near to this figure. The Canadian wave-length is a fraction less than two centimetres longer than that from England to Canada."

"You asked whether we had noticed any peculiar effects. There are one or two of interest. For example, it has been found that engineers standing near very short-wave transmitters sometimes become exceedingly warm in, say, the arm nearest the apparatus. This effect is not caused by radiation of heat from the set, but by currents induced in the human body from the apparatus. The heat is very appreciable at times and it is possible that good use may be made of this phenomenon in medical research."

"Have these powerful short-wave transmissions been found to have any deleterious effect on the health of those operating these stations?" I asked.

High-Power Stations Doomed.

"No, I am pleased to say not only have no harmful effects been found, but I am inclined to believe that the health of the staff working in these stations has been benefited. We have had no cases of illness, and on the contrary the general impression is that those who are working the stations have distinctly improved in health. Personally, I have felt better. Possibly the presence of a certain amount of ozone in the air had something to do with this."

"You think the beam stations will supplant the present high-power long-wave stations in time?"

"Yes, it seems the logical development in wireless. On the short waves we can obtain far higher speeds than are possible on the longer waves; we are getting a reliability and economy in the use of power never

previously obtained, while, in addition, the ability to project a beam in a given direction at a narrow band of energy rather than spreading it out broadcast is a very valuable feature."

"What methods do you use for stabilising the frequency of the transmitter?"

Wave-length Variations Beneficial.

"We have found the master-oscillator method quite satisfactory and we do not use crystal control. As a matter of fact, it is doubtful whether a perfectly constant frequency is really desirable in short-wave telegraphic work. I have not come to any final conclusion on the matter, but I am inclined to believe that a slight variation of frequency is of value, as if the wave is changing slightly all the time the fading on the longer and shorter components of the wave will not be the same, and in this way we may largely overcome fading troubles."

At this point Senatore Marconi rose and walked across to a table to pick up a blue print.

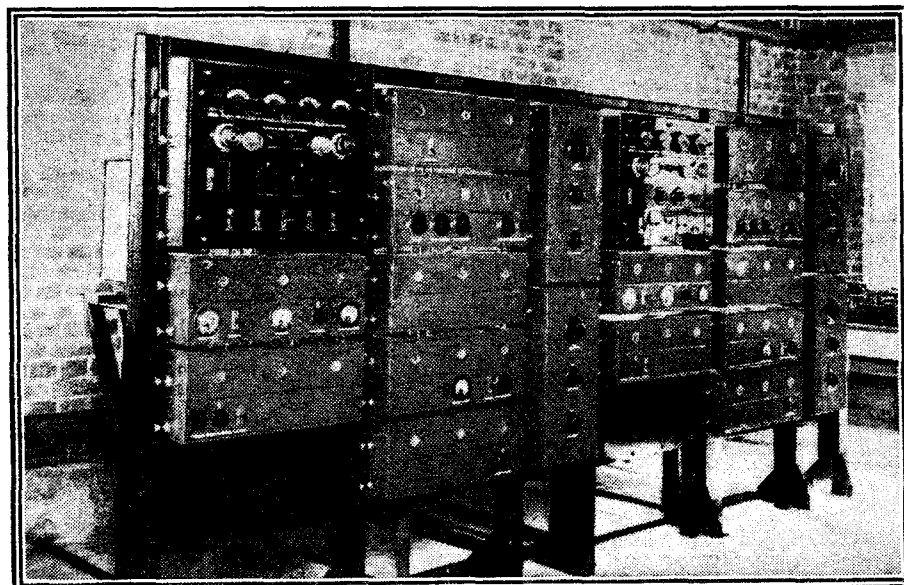

The two beam receivers used at Bodmin for the reception of signals from South Africa (left) and Canada.

"This shows you the variation of signal strength on the South African service for one day. You will notice that as the route is almost directly north and south, sunrise and sunset occur at very nearly the same time in England and in South Africa. Notice that signals steadily fall in strength from midnight to about the middle of the darkest period and rise again until dawn. During daylight they are maintained at a fairly uniform strength, but two or three hours before sunset they start to rise in strength and reach a maximum late in the evening. Although this chart shows that we may have even a hundred per cent variation during the day the strength of signals at the weakest time is ample for our requirements."

"Do you think the beam system will be adopted for telephony?"

"Yes, I think it very probable for long distance transmissions and for such matters as I have mentioned—the broadcasting of speech and music from Europe to America and vice versa. I must admit that we have been so busy developing the telegraph side that we have not yet done much experimental work on telephony which may require new technique in many respects."

"Working with such short waves must require great accuracy in apparatus. Do you find, for example, working is interfered with by wind causing swinging of your aerial?"

"No. Strangely enough, even to-day when a gale is blowing, I have just heard from Bodmin that they are experiencing no trouble in this regard. Both the aerial wires and the reflector wires are swaying simultaneously and perhaps one counteracts the effect of the other."

"As the amateur transmitter has done a great deal in developing short-wave work," I said, "I am sure they would appreciate any suggestions you would be good enough to make."

"I would certainly suggest the collection of data on these short waves, and its collation," responded Senatore Marconi, "but it is, of course, essential that some kind of agreement as to standards of strength and quality should be reached. Unfortunately in the case of many experimenters one man regards signals as good and loud whereas

another would call the same signals only medium in strength."

"What is the shortest wave-length upon which you have yet experimented?" was my next question.

"We have done a certain amount of work on wave-lengths as short as half a metre, but not enough to pass definite opinions upon the commercial possibilities of these waves. Just what path such waves will take we do not know, but it is possible that we may be able to shoot them up against the Heaviside layer at a certain angle and know definitely that they will come down again at so many thousand miles away."

Further Possibilities.

"Or perhaps," he added with a laugh, "they may not come down at all! That is one of the things we shall have to investigate."

There are some matters which cannot easily be put into words, but as we shook hands I could not help forming the opinion that Senatore Marconi feels very happy about the success of the beam, and with so much already achieved, who knows what else he has still in store for us?

GEARY'S TERRIBLE CHRISTMAS EVE.

By HIGHAM BURLAC.

WHEN Geary came into my study a few days before Christmas his eyes lacked their usual glare, that predatory, ruthless shine which characterises his eyes when he is within scrounging distance of any apparatus smaller than a table-mangle. Instead his gaze was fixed like that of a scammambulist. He shook hands with himself and sat heavily on his hat. All of which argued in favour of a Geary "stunt" and an unusually fat-headed one.

"Well, Aloysius?" I said cheerily. "It's very good of you to drop in and bring back that ammeter. Sort of Christmas good deed, what?"

"N-no ammeter. Must be mistaken," he replied.

"That N.P.L. calibrated condenser, then."

"N-no—quite a mistake. L-look here, Higham, you know I've been busy for months on an improved Direction-finder? Well, it's done; in fact, two of 'em. Absolutely the friskiest things in radio since I produced my all-frequency, non-vibrating, noiseless loud-speaker."

"I see. What direction does it find? And why?"

"Dash it, Higham, you need not be so sarcastic. All directions, of course."

"All at once?"

"Ass! But seriously, Higham, I want you to come over and witness a demonstration on Christmas Eve. Tugg and Calver on their car are sending out signals every now and then from a portable transmitter, while I and Jones, with my new D.F. sets, are going to plot out their course on the map. Jones, whose place is at Highgate, will send his bearings to me by wireless telephony. That beats any show ever put up by an amateur before, doesn't it?"

Hurried Preparations.

I paused and considered, seeing in the affair far more than Geary.

"Well," I answered, "It may. Have you got any of my apparatus on you?"

"Really, Higham, you pain me."

"All right," I replied, "I'll come and help you." Geary had a £10 bet on the result with Tugg and Calver, and another with me.

When he had gone I telephoned to Tugg and Calver and afterwards to Billy Swift, who does not appear again in this narrative though some of his property does. That done, I began to chuckle so demoniacally that my wife accused me of flirting with Bolshevism.

Seven o'clock. Geary put on his telephones and I put on mine. My job was to take the bearings from Jones. At seven-fifteen Jones came through smartly with the first reading. Geary got his, too, and solemnly marked a cross on the chart somewhere in the region of Croydon.

"I'm a bloodhound for tracking, Higham," he chuckled, taking a hasty sluice and a bite at a sandwich.

A quarter of an hour passed, during which Geary told me how his D.F. system could detect which side of the road a man in Ramsgate was walking and whether a car at Bath went off the white line. Meanwhile, I kept myself properly irrigated and nourished, seeing that I was in for a heavy evening.

The Apparatus Fails.

Geary started. Signals again! Then Jones came through with another bearing and we seized the chart.

"I say, Geary," I began, "your D.F. seems to be a bit previous, doesn't it? Fifteen minutes ago it told us your pals were at Croydon. Now it says they are in the middle of Windsor Great Park. What have they got? A racer?"

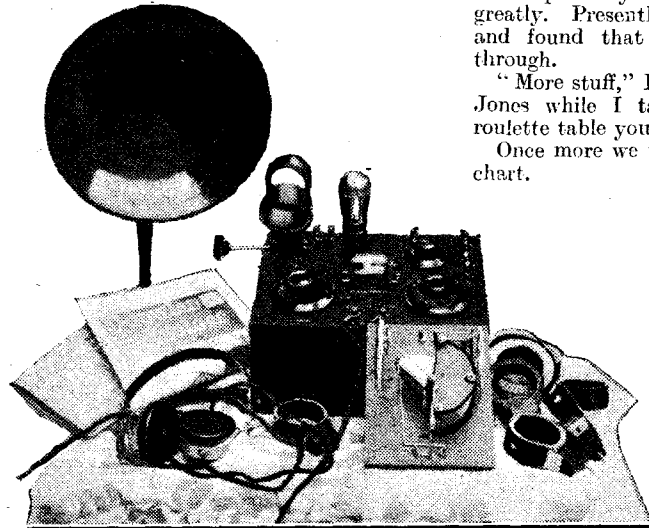

Two famous "P.W." sets—the "P.W." Ultra and a reflex receiver—built by Mr. C. Cope, of 58, Thorne Villas, Holloway, N.7.

"Shove it down, Higham. This D.F. is like a camera. It can't lie."

Half an hour passed. Then another bearing from Jones. I jotted it down and turned to Geary.

"Come on! What are you dawdling for? Jones has the legs of you this time. Call yourself an operator?"

Geary twiddled the knobs like a madman.

"Higham," he gasped, "the bally thing won't give a reading at all. The signals are there—but absolutely all round the dial alike. I can't think—"

"Sure you haven't been trying to D.F. a balloon? I said, hugging myself with wicked joy and splashing the siphon all over the shop.

"Well, we'll leave it blank and wait for the next bearing," said he.

In ten minutes he howled, "Got 'em. Good and strong. Where's Jones?"

"Here he is," I replied, "and using awful language, too."

Jones, it appeared, was suffering from "signals all round the dial," just as Geary had on the previous occasion.

"Sure your pals are not up in a Zepp, Geary?" I jeered. According to the last result they must have been hovering over this house, and now, so it seems, they are over Jones'. This thing isn't a D.F.—it's a threepenny wire puzzle."

"I can't understand it, Higham," whined Geary, turning a piteous face to me. "The design is perfect. And yet—the results—"

"The results up to now are, (1) Croydon, (2) Windsor Great Park, (3) your house, and (4) Jones' house. Queer motor ride, I call it. Have another go. Perhaps you'll get Wigan or Billingsgate."

Another thirty minutes passed and more signals began to arrive. Geary got a beautiful reading and Jones was up to the mark this time. Again we grabbed the chart.

"Oh! Bountiful Mike," groaned Geary. "They're off the Nore, according to this blighted contraption. Er—would you mind? Thanks! A spot more soda."

We sat and chatted sadly for a little while, of the blasting of ambitions and the death of kings; of cataclysms, revolutions, graves, corpses and ghosts. Geary seemed to be perfectly chastened and I rejoiced greatly. Presently I put on his telephones and found that more v's were coming through.

"More stuff," I said. "You hang on to Jones while I take the reading on this roulette table you call a D.F."

Once more we waved our noses over the chart.

"This is madness," cried Geary. "Utter madness. Why—~~now~~ they're near the Crystal Palace."

Poor Geary got up, wearily, creakily, like a nonagenarian with a liver and rheumatism.

"Twenty quid gone west," he murmured. "Twenty quid! Or rather, ten. Ten to the fellows in the car and ten I'll owe you. Do you know, Higham, this unmentionable

fungus, this glandered outbreak, this pestilent, festering, monstrosity of a set wants to make me believe that the car is now at Norwich. Pinch me, Higham, and tell me I dream."

Higham Settles Up.

"I'm sorry, old man," I replied, "you had better get some good elementary work on Direction-finding, and then, when you have mastered the principles, I'll show you how to make a D.F. set. It's a little bit in advance of you at present—evidently," and I pointed to the chart. "Give me a cheque, please."

I helped Geary to welcome Christmas in a manner which left him tolerably happy though none too clear as to whether he was at home or in the car, and then went off to Hendon to pay over his cheque to Tugg and Calver, those good sports who, at my suggestion, had spent the evening in Billy Swift's aeroplane, incidentally hovering over the houses of Geary and Jones in turn.

A CHAT ON VALVES.

By D. K.

Spend a few moments in considering your valves. The time will not be wasted.

OF all the wonderful pieces of apparatus that will work together (more or less) to bring us our broadcast entertainment this Christmas, probably the valve is the most amazing. It has often been described as the Aladdin's lamp of wireless, but with dull emitters getting duller and duller there is not much resemblance to a "lamp" in the modern "tube." True, some people try to brighten things up by pushing the H.T. through the filaments of their valves, but this is a somewhat expensive method of obtaining illumination, and is certainly a "blow" to the valve.

Perhaps it would be as well if, while enjoying our Christmas radio fare, we were to spend a few minutes in solemn meditation upon the wonders of those little quadrupeds perched up on their pedestals in our receivers. There they are apparently doing nothing, full of nothing, but in reality veritable hives of industry. To the eye whose detection is keen enough the interior of a valve must appear like the entrance to a Cup Final—one mass of surging movement, of electrons hurrying away from the filament, through the turnstiles of the grid and on to the plate, where they race away to the H.T. battery through the external circuit. A truly amazing state of affairs and worthy of the attention of every one of us.

Treat Them Gently.

Valves are delicate things, too. They have to be treated gently, or they may sulk for days, or even go on strike altogether. Their feeding must be regular, not too much and not too little, or the valves will object and refuse to operate properly. Try to run a dull emitter on too much filament juice. What happens? The valve gets "fed up" and refuses to emit, signals become weak, and you either have to doctor the valve back to health or else buy a new one.

The same moodiness is noticeable if the valve is asked to work with companions (or components) it doesn't like. Put a high impedance valve in the last stage of a set and ask it to carry a considerable volume, it merely distorts and refuses to function properly.

Some valves are more obliging and will work anywhere in the set, provided their companions are not too disagreeable, but these are in the minority, and if you want the best from your valves, as from everything else in this world, you must treat them properly, and care for them as you would your favourite dog—or perhaps your wife if you have one.

Has it ever occurred to you that there are over 600 receiving valves to choose from if you have an average 4-valve set? That there are over 35 main firms distributing those valves; that on the British market there are over 40 makes, and many makes have as many as 20 types?

All these valves have their own little characteristics—often portrayed by makers by awe-inspiring but, unless you intend to study them carefully, meaningless curves—



The first-comedy opera to be broadcast. A scene at the Birmingham station.

YOU MUST HAVE DISTORTIONLESS MUSIC.

(Continued from previous page.)

the highest plate voltage recommended by the makers.

For the successful operation of a medium-sized speaker in a small room, this should be at least five milliamps, while twice this amount is necessary for good results from a large speaker, or from one of the many types of cone speaker now available. If we desire really loud music in a large room, or small hall, a still larger valve, such as the D.E. 5A. should be employed, and a second speaker connected in parallel with the first.

Distortion, of course, may arise from many other sources.

We may find that although there is no evidence of overrunning either valves or speaker, our set does not give life-like reproduction.

Perhaps the sopranos shriek at us, while organ music lacks body and seems to come from a glorified concertina, indicating that

and these characteristics should be taken into consideration when choosing a valve to work in your set, whatever task it may have to perform. And, by the way, when studying those characteristics don't go by the appearance of the published curves—go by the figures given. Those curves are often as misleading as a hill seen from the top of another hill. From a distance it looks steep, but when you get "to the bottom of it" it flattens out in a peculiar manner. Curves are not always what they seem.

The valve is a wonderful piece of apparatus, and we shall not do better than spend a few minutes in reflecting what it is, what it does and—what we should do without it.

we are amplifying high notes much more than low ones. On the other hand, our set and speaker combined may exaggerate low tones and cut out very high ones, with the result that the basses boom as through a megaphone, while speech is woolly, and stringed instruments sound lifeless.

Much of this distortion may be due to inherent defects in the speaker, which cannot be easily remedied, but in the first case a great improvement may be effected by shunting the loud speaker with a fixed condenser of about .005 mfd.

In the latter case, a larger condenser of from 0.1 to 0.5 mfd. may be connected in series with the speaker, the two being shunted with an iron-cored choke coil.

Too Much Reaction.

Distortion may also be introduced at the H.F. end of the set by the use of too much reaction, leading to a serious cutting off of very high notes, without undue prominence being given to the middle and lower ranges, the result being that speech is very inarticulate, and music sounds to be low-pitched. The use of reaction should be reduced to a minimum, and for really high quality reproduction should be omitted entirely.

CHOOSING YOUR WIRELESS CHRISTMAS PRESENTS.

(Continued from previous page.)

which enthusiasts have been heard to declare is "As good as another valve." It costs 25/-, but the poor amateur who has hitherto been confined to "tishy" little "foreigners" will ever be grateful to the donor who provides him with an A.F.3.

Then there is the R.I. Multi-ratio L.F. transformer, another 25/- component that will give endless pleasure to both the experimenter and the constructor listener. One cannot go far wrong when one buys things such as these, for however many transformers an amateur has he always has a use for another really first-class one. And the same applies to many other components, more especially the variable condensers. There has been a radical change in variable condenser design during the last year or so, and few amateurs would, for choice, use one manufactured before the straight line, low-loss era. Anything from 10/- to 30/- can be paid for a

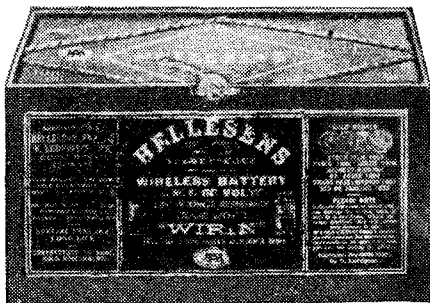

A new H.T. battery, especially in the case of a multi-valve set owner, is always a welcome gift.

modern variable. The choice lies between the Bowyer-Lowe "Popular" type and the "super de-luxe" Ormond Straight Line, Gecophone, etc. Midway we have the Eureka Orthocyclic, A.J.S., Lamplugh, J.B., and many others, every one of which has distinctive features and is a beautiful piece of mechanism, besides being as efficient as this efficient age demands.

Plenty to Choose From.

Naturally, it is always advisable to obtain some idea as to the immediate requirements of a person upon whom one desires to bestow a gift before making the proverbial plunge. A chance remark may give the necessary clue. For instance, the owner of a crystal set murmurs longingly, "Not s'bad, but I wish I had a speaker going." From this one could infer that an amplifier complete with speaker and batteries would prove a welcome gift. And such an outfit need not be expensive. Messrs. S. G. Brown, for instance, have recently introduced a new microphone amplifier which operates on one small battery and gives extraordinarily good results. The instrument costs £4 4s., and is very well worth the money. Anybody could handle it, even a maiden aunt!

The speaker need not cost much. The Lissenola loud speaker unit retails at 13/6,

and fitted to a wooden horn costing another few shillings results are obtainable which seriously rival those given by loud speakers costing several guineas.

And talking about loud speakers, here is an entirely new field open to the present giver. Even a man who has one loud speaker already can do with another, especially if it be one of the new artistic efforts.

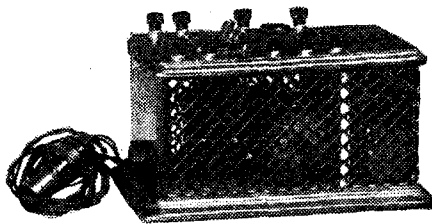

A Rectalloy Trickle Charger, which forms a modern solution to the accumulator charging problem.

Anything from one to sixteen or more guineas can be paid for a loud speaker. Some of the modern speakers are art productions suitable for a place of honour in the drawing-room of a castle. For instance, there is the Sterling Primax Statuette model at £10 10s., the B.T.H. Table Lamp model at £3 minus shade, the Amplion Radiolux, which is obtainable in different sizes at prices ranging from £4 15s., to one supplied with satin silver fittings and art pearl inlaid casing at £16 16s.

Matter of Individual Taste.

Certainly there is no lack of choice among the ranges of Browns, Brandes, C.A.V.'s, etc., although it must be pointed out that loud speakers are tricky sorts of things to buy unless one knows a good deal about them. By this we do not mean that there are good and bad speakers to choose from, for, as a matter of fact, the majority of the speakers on the market are very good and the minority are by no means bad. But where they differ is in tone. Some, mostly the wooden horn types, are mellow, but this mellowness is regarded by some people as "woolliness" or "sonority," they prefer the rather strident tones of some cones and some metal horns. Lovers of strings prefer loud speakers which do not handle the brasses as well as they do violin solos, etc., etc. And so the only absolutely safe way of choosing a loud speaker is for the person who is to use it to hear several in operation before the final choice is made.

The "Duplication" Bogey.

One endeavours to keep the traditional surprise element in one's Christmas gift schemes, but is this really wise? We have all experienced duplication, and such is a disappointment to both donor and recipient. When there is any doubt it is decidedly worth while to take the people concerned into one's confidence, although, as previously indicated, there are cases where this is not at all necessary.

Haphazard selection is very risky. Supposing one purchased a beautiful Tungstone H.T. accumulator and gave it to a friend who had in use an H.T. from the mains unit! He would not appreciate the gift; but a man who was using cheap flash-lamp batteries to run a super-hot, would be delighted with it.

Now, it is probable that wealthier folk will be considering the bestowal of fool-proof drawing-room outfits on their friends. Sets which can be switched on by pressing a button. A word of warning to these people may be as well. There is no really foolproof loud speaker set on the market. Wireless has not yet reached the point of simplicity of the gramophone. In the hands of people who know just a tiny bit about radio sets, some of the "fool-proof" sets will give reliable service over very long periods; but no valve set has yet been produced that, left in the hands of none but an elderly relation who knows nothing about wireless at all, will stand up to a year's hard use without the attention of at least a minor expert.

A Word of Warning.

Batteries run down, a valve may give out, a connection may loosen, and there are so many variable factors in radio, so many little things that can cause complete failure, little things obscure to the tyro, although they might be immediately apparent to the expert.

We do not wish to give the impression that broadcast reception is a very tricky business, but while salesmen are salesmen and tend to over-optimism it is as well that someone should throw in a steadying word.

But there is not so much exploitation these days, thank goodness, and honest conscientious traders are displacing the junk men who rushed into radio during the first boom. And as we have previously indicated, so long as one confines one's purchases to those products bearing the names of well-known British manufacturers one stands no risk of being let down.

We have been unable to deal with the subject of choosing Radio Christmas presents as exhaustively as it deserves, but the space available renders that impossible.

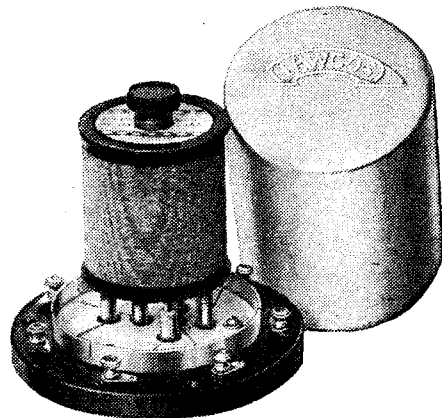

Anything new in the way of a radio component will delight the "fan." For example, here is a Lewcos screened "split primary" H.F. transformer.

The array is too enormous, including as it does thousands of items ranging between sets of parts for making a crystal detector costing 9d., and suitable as a "stocking present" for a very young enthusiast, to complete sets costing up to £100.

Therefore, in conclusion, we would draw the attention of all our readers to the many advertisement pages which appear in this issue. These give a pretty clear idea of what a lot of really fine gear there is available and should prove invaluable to the Christmas radio shopper.

RADIO IN THE ARCTIC

COMMANDER MacMILLAN was staying at the Astor Hotel, and he was in the act of taking a lift as I caught him.

"Pardon me, Commander, may I have a few words for POPULAR WIRELESS?"

"Surely you may. What would you like to know?"

"You only returned this afternoon to New York from Arctic regions," I said. "Please tell me if you have found out anything new about the Aurora Borealis?"

As I asked this question, I had in mind Commander MacMillan's statements during the last International Tests that the Aurora did not effect radio reception.

"I have not changed my former opinion that the Aurora Borealis has no harmful effect on wireless reception. In fact, if anything, I found on this trip that signals were perhaps a little better when the Aurora was at its height. I do not wish to go on record as saying

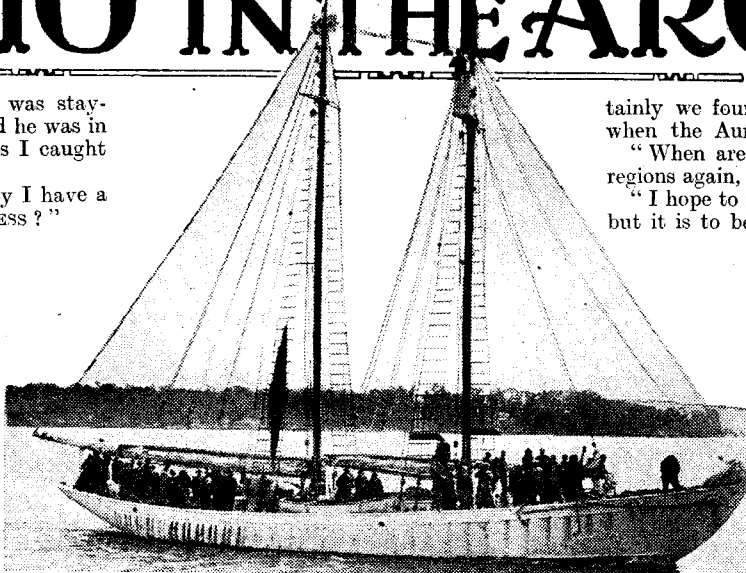

A Chat with Commander MacMillan.

By OUR NEW YORK CORRESPONDENT.

definitely that the Aurora betters radio reception under all conditions, but cer-

tainly we found signals were often louder when the Aurora was most manifest."

"When are you going up to the Arctic regions again, Commander?"

"I hope to make another trip next June, but it is to be a long one, perhaps of five years' duration. We shall certainly need wireless then more than at any other time. We are making arrangements to erect a broadcasting station for operation on short waves at Kowk, in Labrador.

"I intend to broadcast Esquimaux entertainment from this Kowk station to regular broadcasting stations in the United States, who will, in turn, relay it for the benefit of the listening public at large. Probably W J A Z at Chicago will play an important rôle in the re-broadcasting of the Kowk

programmes."

"What power do you intend using at Kowk, and what wave-length?" I questioned.

"That has as yet not been settled. Maybe we shall only use a hundred watts or so. Perhaps more. That depends upon experiments we shall carry out before the final erection. The distance from Kowk to W J A Z, at Chicago, is about 1,800 miles."

"What do you think of the broadcasting system in England?"

English Amateurs' Help.

"I really have not studied it thoroughly," replied the Commander. "I have not even been to England, although I hope to do so some day. I have often been asked to go there to lecture, but I have not been able to make the time. I certainly want to thank the English amateur for his splendid co-operation with us while we were up in the Arctic."

Several lifts had gone up by this time; the voice of a brass-buttoned starter announcing in stentorian tones "Going up," brought me to the realisation that perhaps the Commander wished to be abed.

Reading my thoughts, he said:

"No, I'm not for bed; but I really must request your indulgence, for I'm just motoring down to Roosevelt Field to see Fonck off. I hear that he is starting for Paris at dawn to-morrow."

We stood chatting for a few minutes longer, while Commander MacMillan told me a few of his adventures in the Arctic, apart from the wireless aspect, and then he wished me and "POPULAR WIRELESS" readers "good-bye" and rushed out to board his car.

Your writer also spent an all-night vigil at Roosevelt Field, only to be disappointed, for, at the eleventh hour, a leak in the petrol tank prevented the hop off of the giant Sikorsky plane.

Later, of course, the huge airplane met with disaster, and the wireless operator was killed, though Fonck miraculously escaped.

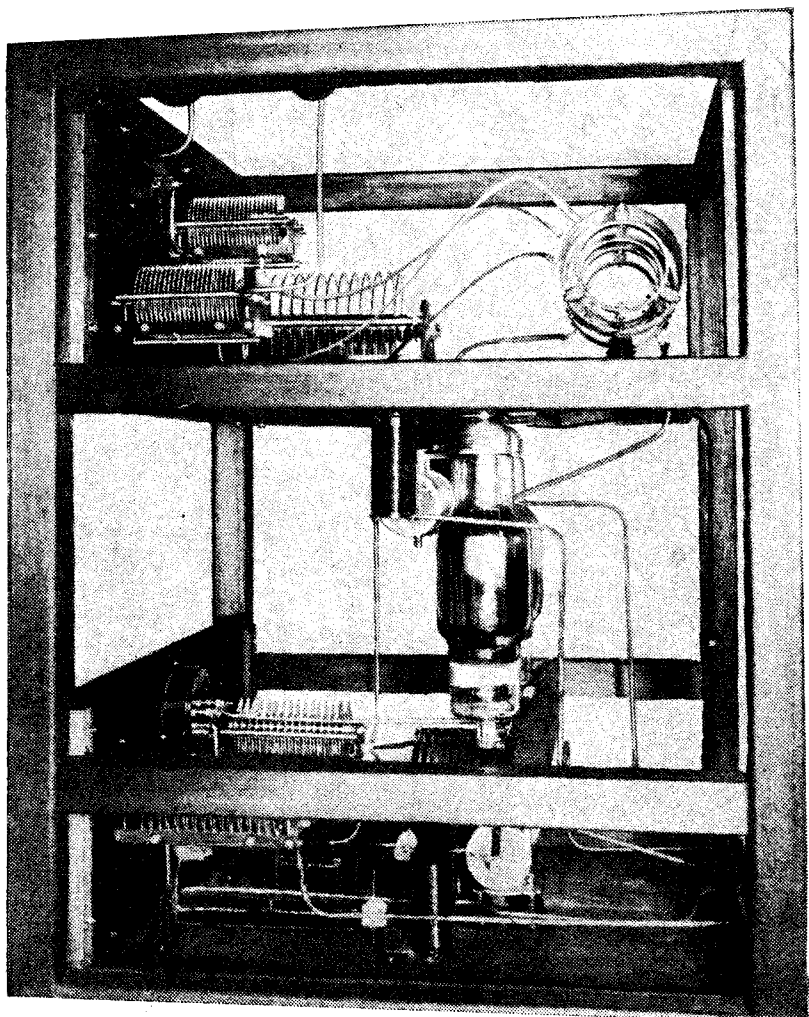

An interesting photograph of the 250-watt Cardwell transmitter being used on the Roosevelt Memorial Association Expedition now exploring in Brazil.

Percy Lays a Ghost

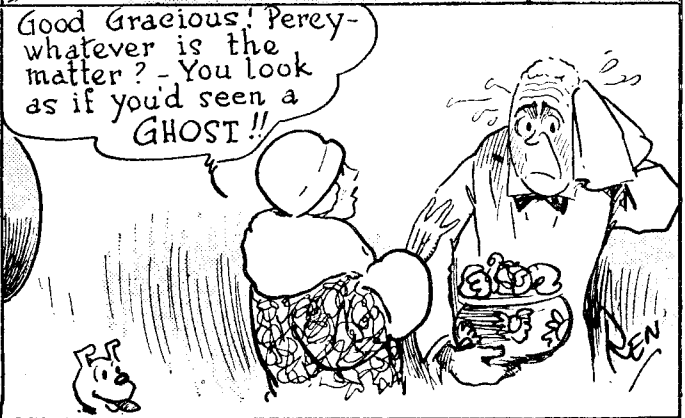
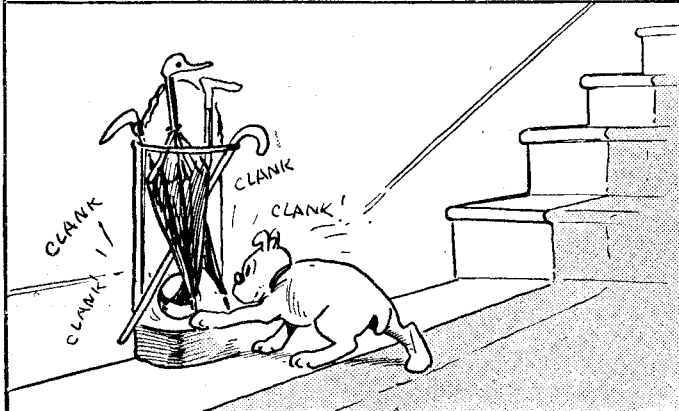
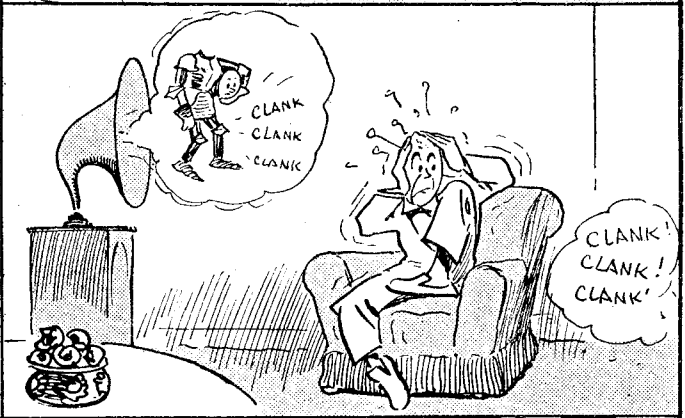
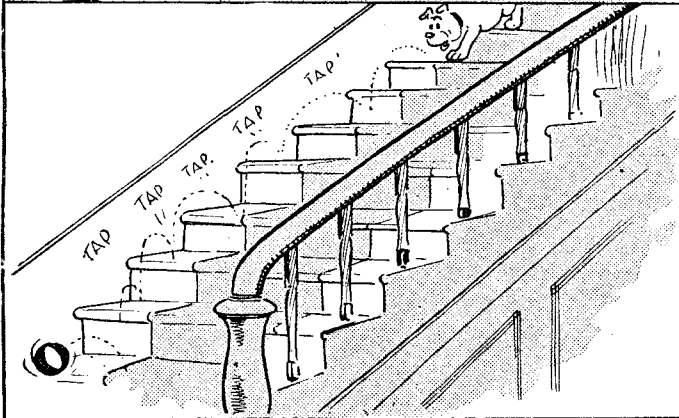
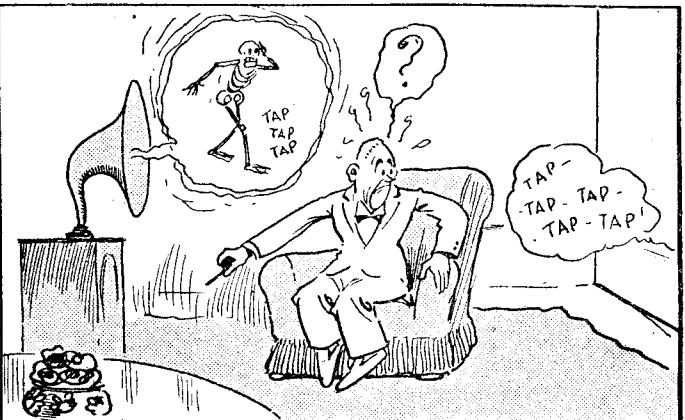

You Must Have Distortionless Music

WHATEVER may be said against broadcasting in general, or against B.B.C. programmes in particular, no one will deny the pleasures afforded by wireless at Christmas time, or the excellence of the special fare which has been served by the B.B.C. in past years, and we may confidently expect something worth having for our Christmas season this year.

Are we ready to receive it, and to do it justice?

Whether we are giving children's parties, holding dances, or spending quiet evenings round the fireside, we owners of wireless sets all feel that now, more than at any other time, it is up to us to vindicate our hobby and make it a real pleasure to others as well as to ourselves.

Let us see to it, then, that we are fully prepared when the time comes—that our sets are in working order, and, above all, that we are getting the best possible quality from them.

We may be perfectly satisfied with our reception of the news items in the even tones of the B.B.C. announcer, but critical listeners will expect more than that. We must be able to reproduce the deepest notes of the organ, or separate the various instruments of the dance band. Drums must roll and not simply clatter, bells must chime and not jangle, and we must be able to reproduce the majestic unison in the Hallelujah Chorus without the jarring produced by an over-run valve or loud speaker.

Overhaul Your Set.

In short, we must overhaul our set, or modify it if necessary, in order to bring it as near to perfection as possible.

We cannot do better than commence with the batteries, first of all taking precautions to avoid the humiliation of having to close down because our accumulator requires re-charging.

The H.T. battery, the heart of our set, deserves special attention. Even though our existing battery may appear to be in good condition, we should be well advised to purchase a new one, and put the other aside for less important occasions. Here it must be emphasised that it pays to buy a battery of ample capacity, and in general it may be said that a battery costing twice as much will last about three times as long (the voltage being the same in the two cases), especially when a large power valve is being employed.

The same applies to the grid battery. Faulty grid cells will produce just as disastrous an effect upon quality as will a run-down H.T. battery and they should be changed just as frequently.

Assuming that our set is normally perfectly satisfactory, little more should be necessary in the way of an overhaul—but let us be certain that it is satisfactory.

For instance, if we switch on when nothing is coming through, there should be absolutely no sound in the speaker. If there is, distortion will be inevitable, even although the background may be apparently drowned when signals are received. These background noises can be very largely prevented by connecting across the H.T.

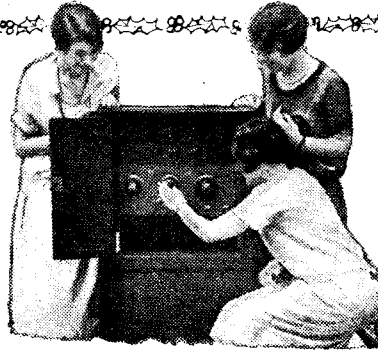

By C. E. FIELD, B.Sc.

(Staff Consultant.)

battery terminals a condenser of at least half a microfarad capacity.

Now, let us listen critically to some orchestral music. We may find that soft music, or instrumental solos are reproduced excellently, but that the full orchestra, or even loud pianoforte passages become confused and lose their musical quality.

This is almost certainly an indication that either the loud speaker or the last valve in the set is being over-run. If the speaker is a small one and a power valve is employed in the last stage, we are almost certainly overrunning the former, and good quality will probably be obtained by de-tuning the set, and so reducing the

volume. Alternatively, a large speaker, or a larger horn on the same unit, will enable us to obtain greater volume without sacrificing quality.

It may happen, however, that we are trying to work a large speaker from an ordinary general-purpose valve, as was common practice two or three years ago. In order to obtain good loud-speaker results, whatever the type of set or speaker, a power valve in the last stage is essential. It may safely be stated that no amateur who has once used a power valve would ever dream of being without one for loud-speaker work.

Moreover, the valve must be operated correctly.

Choosing the Valves.

We should take this opportunity, therefore, of either substituting in our last stage a really good power valve, and adjusting the grid bias and H.T. voltage to suit, or else adding a power stage to the output of our set, the 'phone terminals being connected to the primary of an intervalve transformer, or to a coupling choke.

When selecting a valve for this purpose, we must make certain that our choice will do all that is required of it. We should examine the characteristics of the valve before purchasing, and note the plate current flowing at zero grid voltage, using

(Continued on next page.)



Mr. De Groot, the famous violinist so well known to listeners, is an ardent listener.

A CHAT ON VALVES.

By D. K.

Spend a few moments in considering your valves. The time will not be wasted.

OF all the wonderful pieces of apparatus that will work together (more or less) to bring us our broadcast entertainment this Christmas, probably the valve is the most amazing. It has often been described as the Aladdin's lamp of wireless, but with dull emitters getting duller and duller there is not much resemblance to a "lamp" in the modern "tube." True, some people try to brighten things up by pushing the H.T. through the filaments of their valves, but this is a somewhat expensive method of obtaining illumination, and is certainly a "blow" to the valve.

Perhaps it would be as well if, while enjoying our Christmas radio fare, we were to spend a few minutes in solemn meditation upon the wonders of those little quadrupeds perched up on their pedestals in our receivers. There they are apparently doing nothing, full of nothing, but in reality veritable hives of industry. To the eye whose detection is keen enough the interior of a valve must appear like the entrance to a Cup Final—one mass of surging movement, of electrons hurrying away from the filament, through the turnstiles of the grid and on to the plate, where they race away to the H.T. battery through the external circuit. A truly amazing state of affairs and worthy of the attention of every one of us.

Treat Them Gently.

Valves are delicate things, too. They have to be treated gently, or they may sulk for days, or even go on strike altogether. Their feeding must be regular, not too much and not too little, or the valves will object and refuse to operate properly. Try to run a dull emitter on too much filament juice. What happens? The valve gets "fed up" and refuses to emit, signals become weak, and you either have to doctor the valve back to health or else buy a new one.

The same moodiness is noticeable if the valve is asked to work with companions (or components) it doesn't like. Put a high impedance valve in the last stage of a set and ask it to carry a considerable volume, it merely distorts and refuses to function properly.

Some valves are more obliging and will work anywhere in the set, provided their companions are not too disagreeable, but these are in the minority, and if you want the best from your valves, as from everything else in this world, you must treat them properly, and care for them as you would your favourite dog—or perhaps your wife if you have one.

Has it ever occurred to you that there are over 600 receiving valves to choose from if you have an average 4-valve set? That there are over 35 main firms distributing those valves; that on the British market there are over 40 makes, and many makes have as many as 20 types?

All these valves have their own little characteristics—often portrayed by makers by awe-inspiring but, unless you intend to study them carefully, meaningless curves—



The first comedy opera to be broadcast. A scene at the Birmingham station.

YOU MUST HAVE DISTORTIONLESS MUSIC.

(Continued from previous page.)

the highest plate voltage recommended by the makers.

For the successful operation of a medium-sized speaker in a small room, this should be at least five milliamps, while twice this amount is necessary for good results from a large speaker, or from one of the many types of cone speaker now available. If we desire really loud music in a large room, or small hall, a still larger valve, such as the D.E. 5A. should be employed, and a second speaker connected in parallel with the first.

Distortion, of course, may arise from many other sources.

We may find that although there is no evidence of overrunning either valves or speaker, our set does not give life-like reproduction.

Perhaps the sopranos shriek at us, while organ music lacks body and seems to come from a glorified concertina, indicating that

and these characteristics should be taken into consideration when choosing a valve to work in your set, whatever task it may have to perform. And, by the way, when studying those characteristics don't go by the appearance of the published curves—go by the figures given. Those curves are often as misleading as a hill seen from the top of another hill. From a distance it looks steep, but when you get "to the bottom of it" it flattens out in a peculiar manner. Curves are not always what they seem.

The valve is a wonderful piece of apparatus, and we shall not do better than spend a few minutes in reflecting what it is, what it does and—what we should do without it.

we are amplifying high notes much more than low ones. On the other hand, our set and speaker combined may exaggerate low tones and cut out very high ones, with the result that the basses boom as through a megaphone, while speech is woolly, and stringed instruments sound lifeless.

Much of this distortion may be due to inherent defects in the speaker, which cannot be easily remedied, but in the first case a great improvement may be effected by shunting the loud speaker with a fixed condenser of about .005 mfd.

In the latter case, a larger condenser of from 0.1 to 0.5 mfd. may be connected in series with the speaker, the two being shunted with an iron-cored choke coil.

Too Much Reaction.

Distortion may also be introduced at the H.F. end of the set by the use of too much reaction, leading to a serious cutting off of very high notes, without undue prominence being given to the middle and lower ranges, the result being that speech is very inarticulate, and music sounds to be low-pitched. The use of reaction should be reduced to a minimum, and for really high quality reproduction should be omitted entirely.

THE BRANDES AUDIO TRANSFORMER

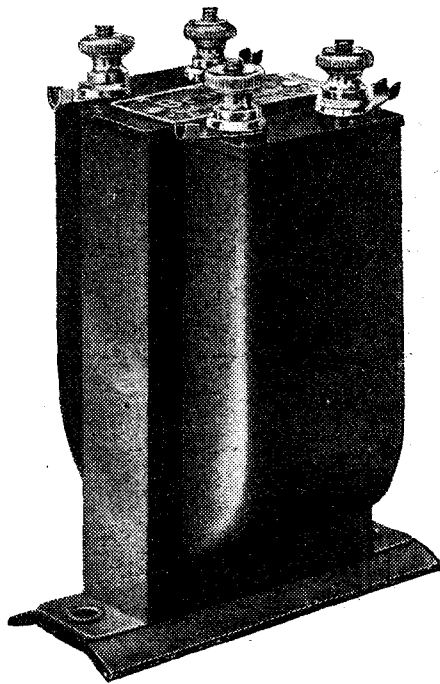

Connect it this way:—

CONNECTIONS FOR ONE STAGE OF L.F. AMPLIFICATION

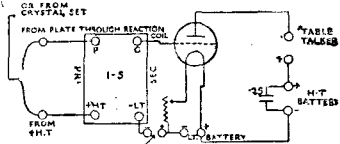

CONNECTIONS FOR TWO STAGES L.F. AMPLIFICATION

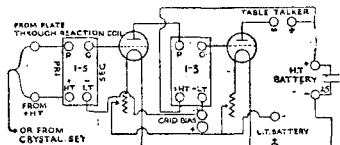

- (1) Connect Pri. P. to plate of det. valve through reaction coil or direct to plate if 2nd stage L.F. connection is being made.
- (2) Pri. + H.T. to + terminal of H.T. Battery.
- (3) Terminal marked G. Sec. to grid of next valve.
- (4) Terminal - L.T. Sec. to - of grid batt.
- (5) + of grid batt. to - terminal of L.T. batt.

HIGH AMPLIFICATION OF APPLIED VOLTAGE AND A STRAIGHT LINE AMPLIFICATION FREQUENCY CURVE

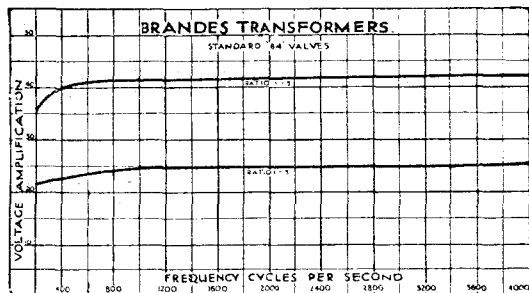

The unit is well protected mechanically, and the shielding is such that transformers may be placed close together without interaction. The insulation between primary and secondary coils and also from these to laminations is very high. Each transformer is tested against a Standard before leaving the factory at 200, 600, 1,600 and 4,000 cycles per second. The ratio of turns between secondary and primary is 1 to 5 for the First Stage Transformer and 1 to 3 for Second Stage Transformer. They are ideal in first and second stage work respectively.

As well as ordinary terminals for connection, soldering tags are provided, giving the user a decided advantage.

For many years Brandes specialised in acoustical research and the improvement of the audio circuit of the receiving set which so essentially determines the quality of reception.

One result is the Brandes *Audio Transformer*. Developed along sound engineering lines, the main object in view is a high constant voltage amplification-frequency curve. That is to say, for a given input voltage the amplification is constant over a wide band of frequencies, thus eliminating resonance. The inductance of the primary winding is much larger than usual, giving good amplification at low frequencies, and bringing beautiful reproduction more particularly in the lower registers.

No condenser need be shunted across the primary winding. When used, it may be found necessary to use grid cells for biasing purposes to obtain purest results. To use grid bias all that is necessary is to insert cells between L.T. Sec. and the negative terminal of the L.T. Battery such that the L.T. Sec. terminal is connected to negative terminal of cell, and the negative terminal of L.T. Battery is joined to positive terminal of cell. Cells from 1.5 to 3 volts should be tried.

G. P. Kendal, B.Sc., writing in the WIRELESS CONSTRUCTOR on the building of the "Spanspace Three" recommends the inclusion of the Brandes L.F. Transformer.

Ratio 1-5
17/6
(Black case)

Brandes
AUDIO TRANSFORMERS

Ratio 1-3
17/6
(Brown case)

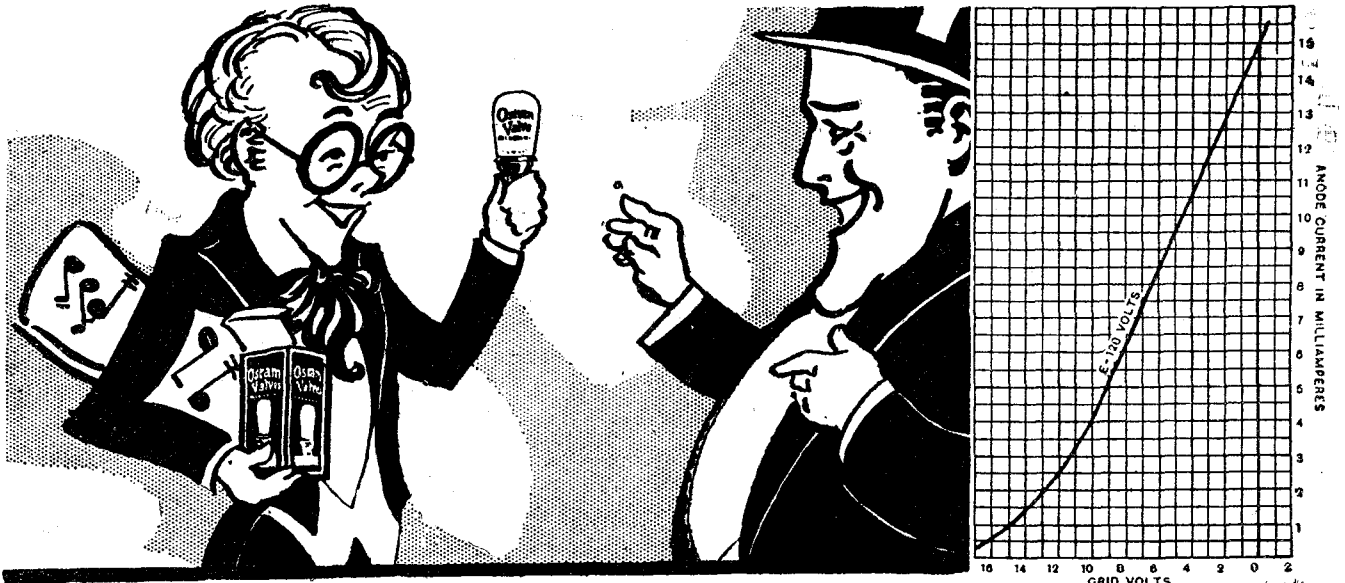

“A Wonderful New—OSRAM VALVE”

(D.E.P. 215)

‘TONE’ and ‘POWER’ examine the “*STEEP SLOPE*” Valve.

Said POWER to ‘TONE’ recently “This new OSRAM ‘*STEEP SLOPE*’ VALVE is undoubtedly the best thing yet. I like the tremendous mechanical strength, and the great overall amplification. It means even more volume for these listeners.”

“More than that” replied TONE. “Do you notice the extreme accuracy in spacing between filament, grid and anode, and the carefully designed grid to control the electron stream accurately? That means that we can give them greater purity than ever.”

“In every way—a wonderful valve!” was the joint exclamation of our two friends. “Listeners will be glad when they get it.”

Osram Valves

STEEP SLOPE

for TONE & POWER



TONE & POWER
The Boon Companions of
OSRAM VALVES

The G.E.C. - your guarantee

THE NEW OSRAM ‘*STEEP SLOPE*’ 2 Volt POWER VALVE (TYPE D.E.P. 215)

THE characteristic curve of this new valve is exceptionally steep, thus ensuring greater overall amplification, better volume and less distortion.

The design of this valve comprises the new OSRAM Electronised Filament giving enormously increased electron emission, lower working temperature and longer life.

This filament requires a 2-volt accumulator only, a minimum of current, and is of great mechanical strength.

The accuracy in spacing between filament, grid and anode is carefully carried out, whilst the special grid gives a fine control of the electron stream

The valve gives a great response in the anode circuit to weak signals imposed on the grid—in other words, the OSRAM *STEEP SLOPE* (DEP 215) POWER VALVE is sensitive, stable, gives great volume and absolute purity, and possesses the added advantages of long life, mechanical strength and low current consumption

PRICE 18/6

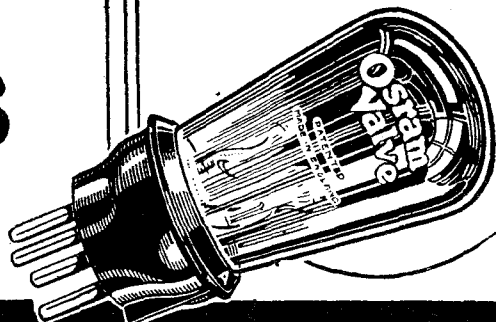



I HAVE always considered one loud speaker in a man's house sufficient, and until recently have kept my home free from the competition of a wireless installation and a "Man with a Golden Voice."

But a week before Christmas, H. T. Bee, a wireless wizard with oscillating eyes and a short-wave length tongue, led me astray.

Chancing to meet him at the station he took me affectionately by the arm.

"I say," he breathed in inviting tones, "can I tempt you to a w.s.?"

I thought it a good idea for a chilly evening and signified my assent.

"Good!" he said. "How many valves?"

Then I knew he was talking about a wireless set and not a whisky-and-soda. My heart "plonked."

"I don't like wireless," I said stiffly.

"I'll build you a set for fifteen pounds," urged H. T. Bee. "And when you've got the loud speaker going, your missus and young George will sit silent in rapture."

The idea of Hilda my wife and George my son sitting silent in anything, pleased me so much that I told H. T. Bee to get busy.

"You shall have it on Christmas Eve," he promised. "I'll send the aerial and earth along, and you can get the one up and the other down in your spare time."

I Commence Preparations.

I said I would, and when on Friday, reaching home about two-thirty, I found a larch-pole, earth-plate and coil of wireless wire awaiting me, I stripped off my coat eagerly.

"Leave those things to me, George," I said to my son who was tinkering with the insulators.

"I was only putting——" commenced George.

"Don't argue," I said with the decision of the expert.

George went off sulkily and I started digging.

At half-past four, notwithstanding a running fire of advice from George and Hilda, which I ignored, and the loss of considerable quantities of skin and sweat, I had the pole erected and rammed home with all the brick-ends from our last delivery of coal. You can guess it was firm!

"That won't move easily," I sighed

AN AMUSING XMAS RADIO STORY.
By EDWARD WOODWARD.

happily, getting the aerial wire and insulators.

Something seemed to be missing. I looked at the wire and then at the top of the thirty-foot pole. How was I going to make the two ends meet without felling the pole?

"I kept on trying to tell you," said George.

"But you wouldn't listen," added my wife.

I felt nettled, and with frigid dignity requested them to withdraw. Then, alone

with my grief, I commenced to unearth the pole. But nothing would move it, so, being dauntless, I started to climb it.

I'm a good swimmer—a regular bee, in fact—and soon reached the top, with the aerial wire in a neat coil at the foot.

There are moments in a man's life when words fail him, at that instant I sighed for a really clever fish-porter.

Success at Last.

However, dropping down, I slipped the coil of wire round my neck, put the insulators between my teeth and climbed up again. I did it that time, and by eight o'clock had finished everything, and nearly myself, owing to my Adam's apple fouling a loop of wire as I was descending from the roof.

H. T. Bee arrived with the set at eight-thirty, and, thanks to the thorough way I

(Continued on next page.)

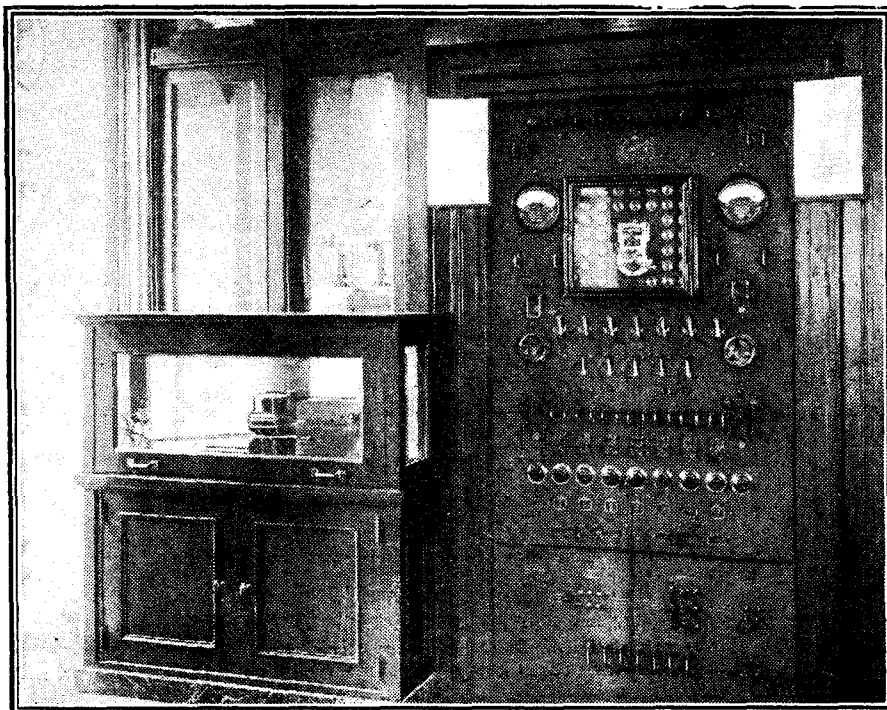

A recently designed radio system which is used in America for the detection of storm centres.

EXPLORING BY THE FIRESIDE.

By I. N. TREPID.

This breezy little article tells us what sort of results we should expect on our Radio sets during Xmas time.

WHAT does a wireless set think of Christmas? Of course, the question is absurd because a wireless set can't think, so let us frame another. Do the seasons affect a radio outfit? In other words, is a receiver sensitive to changes in temperature and atmospheric conditions similarly to a motor-car? And if the answer is "yes," then, again, in what condition should a receiver be on Christmas Day?

Well, in the first place, the set itself is not likely to be affected one way or another if it is kept in a nice dry room and not in the garden. In the latter case it would be advisable to provide it with an umbrella and a nice warm blanket. But the seasons

Atmospherics (grrrh! crash!) are, flylike, fewer in the winter time and, lastly, radio waves tend to penetrate very dry ground, but are reflected away from ground that is covered with moisture or snow or frost. Therefore, Christmas is right in the middle of the real radio season, so let us all join together and sing:

A fig for your dances and parties,
I've got a super-het.

Come, twiddle these dials, my hearties,
And see what we can get.

Berlin, Frankfort, Nice and fair Parree,
Rolling home! Rolling home!

A life on the ether wave for me,
Just see how I can Rome!

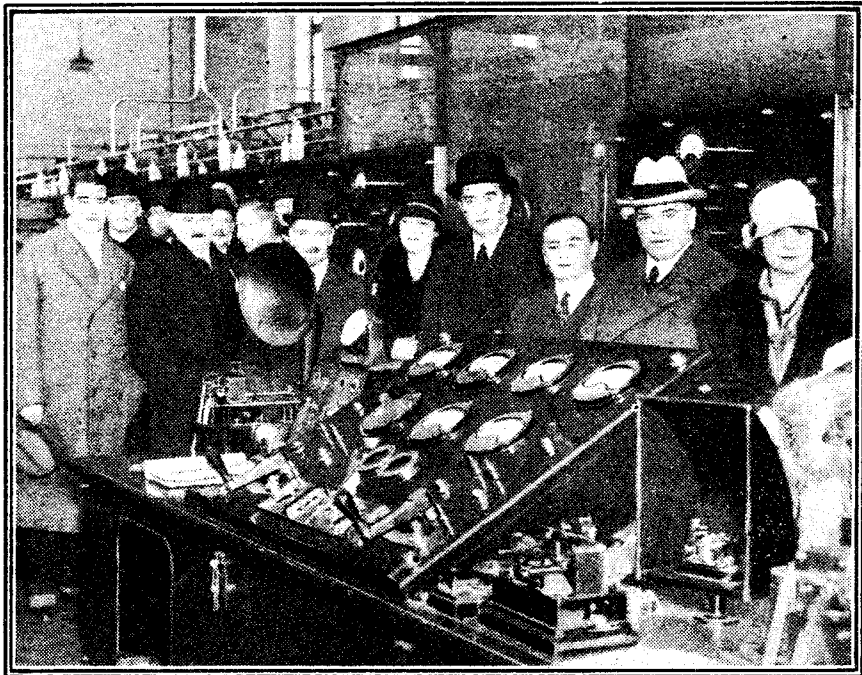

A photograph of some of the control gear at the Rugby station taken during a recent visit of the Dominion Premiers.

do affect radio reception and transmission to a considerable extent. And, curiously enough, the colder and darker and wetter the night the better the ether waves wave. This is, of course, as it should be, a wise providence ruling that "the dirtier the night the better the receiver."

When Darkness Comes.

There are many reasons for this, the outstanding one being that broadcast waves, like owls and bats, modestly prefer the dark of night to the light of day. As soon as the sun sinks over the horizon (you might not see it but it always does do this) the ether vibrations of 2 L O and all the other stations start to ginger themselves up. It is as though they were dazzled by the light of the sun and had to wait until this departed before they could really start extending themselves.

MY RADIO ACTIVITY.

(Continued from previous page.)

had done my work, got everything fixed up, including the outside "tempest switch," we very quickly tested the reception with the headphones.

"Very pure," he announced; and then putting the thing "in neutral," handed me the 'phones and told me to "tune in."

I had just started when Bee was called away by his wife owing to some unimportant thing like his house being on fire or some trivial matter, and without a word he left me alone with the crackling infernal machine.

However, a man can only die once, and so steeling my heart, I twisted the off-side condenser.

I got condensed scream of the richest sort, and for a minute I believed both my ear-drums had been perforated. I dashed the 'phones off my head with a cry of anguish, and Hilda ran forward.

"What is the matter?" she cried.

"A slight shock," I murmured, in the voice of a martyr to science; and picked up the ear-'phones again. The scream was still going on, but after I'd twisted some more knobs it changed to a growl, and then abruptly came music. Immediately I disconnected the 'phones and switched on the loud speaker.

Paris—or 5 X X ?

"There!" I said with pardonable pride. "That's something like, isn't it?"

"Rather faint," grumbled Hilda, with her head half-way down the loud-speaker horn.

"You haven't——" commenced George. But I cut in haughtily:

"You can't expect to get Paris very loud."

"Oh!" gasped Hilda. "Is it Paris?"

"Undoubtedly," I said. "Can't you hear that woman singing in French?"

"Wonderful!" ejaculated my wife, giving me a thrill of pride.

The whisper of music ceased, and:

"This is Daventry calling," said the "Man with the Golden Voice."

I was rather busy on Christmas afternoon, and when I woke up it was four o'clock, and I was only just in time to prevent George trying to tune in.

"Don't you dare touch that instrument," I told him. "In untutored hands it might explode and set the house on fire."

George grinned foolishly and stood watching me as I connected up, switched on, and listened.

There was nothing doing.

"Hadn't you better——" commenced George.

"Be silent!" I thundered, examining the H.T.

At seven o'clock I was without tea or sound. At nine I had tears in my eyes but no music—not even a few words of explanation—in my ears, and at eleven George came in from the other room to know whether I'd like the gramophone on. I threw the headphones at him, and rushed out to fetch H. T. Bee. He was just getting into bed, but he came back with me.

Entering the hall I heard music, and going into the room I found Hilda reclining on the settee, eating chocolates and listening to the Wireless Orchestra, whilst George was tinkering with the set.

Real Activity.

"How—what have you done?" I gasped.

Hilda looked up with a smile.

"Just lifted the 'tempest switch,'" she said. "George kept trying to tell you it was down, as you left it last night, but you wouldn't listen."

H. T. Bee started one of his ill-timed cackles, but I shut him up.

"But how did you tune in?" I asked.

"Oh, George managed that," explained Hilda. "They teach him all about Radio Activity at school."

I had to give H. T. Bee a real w. and s. to check his insane laughter.

MARCONI



THE NEW POWER VALVE D.E.P. 215 Price 18/6

THE ENCHANTMENT of those after-dinner hours, spent in the cheerful warmth of the cosy fireside, are so much more intriguing when your set is capable of lucid expression while handling a wealth of volume. The new Marconi Power Valve inspires your receiver to this end: Symphony and song come to you with crystal-clear sweetness, yet filling the whole room with music. Economy is another strong point—it handles the current judiciously and lives a long and useful life. The D.E.P. 215 is for use in the last stages of Receivers and Amplifiers operating from a 2-volt Accumulator. The filament of the D.E.P. 215 is robust and rigid; the grid is unusually large and has a great emission

surface. Used with the correct H.T. and grid-bias voltage it will handle great volume with a purity of reproduction hitherto unobtainable.

A FEW RECOMMENDED COMBINATIONS:

	Marconi Valve Type	Position	Filament		Grid Bias Volts	High Tension		L.T. Batt. Supply.
			Volts	Amps		Volts	M. Amps	
2-Valve Set	D.E. 2H.F.	Det.	1.8	0.12	+2	60	1.6	Two-volt Accumulator
	D.E.P. 215	L.F.	1.8	0.15	-9	120	4.6	
Three-Valve Set	D.E. 2H.F.	Det.	1.8	0.12	+2	60	1.0	
	D.E.P. 215	1L.F.	1.8	0.15	-3	60	2.5	
	D.E.P. 215	2L.F.	1.8	0.15	-9	120	4.6	
Four-Valve Set	D.E. 2H.F.	H.F.	1.8	0.12	0	60	0.8	
	D.E. 2H.F.	Det.	1.8	0.12	+2	60	1.0	
	D.E.P. 215	1L.F.	1.8	0.15	-4.5	80	3.3	
	D.E.P. 215	2L.F.	1.8	0.15	-9	120	4.6	

Marconi Type D.E.R. or other 2-volt valves are also suitable for the H.F. detector or first L.F. stages.

Fil. volts 2.0 max.
 Fil. current .. 0.15 amps.
 Anode volts .. 120 max.
 Amplification factor 6.25
 Impedance .. 6250 ohms.

The Marconi International Marine Communication Co., Ltd., require 500 qualified Wireless Operators. Apply to Service Manager, Marconi House, Strand, London, W.C.2.

Write for the Marconi Valve Literature—containing detailed particulars of the D.E.P. 215 and of other types.

THE MARCONIPHONE  COMPANY LIMITED

Regd. Office :
 Marconi House, Strand, London, W.C.2.

Head Office :
 210-212 Tottenham Court Rd., London, W.1

WITH the Bowyer-Lowe Super Heterodyne Kit, all the components are of the highest quality, and each carries an unqualified guarantee in keeping with Bowyer-Lowe Standards.

Built according to the diagram supplied, these components will make a set that will bring Radio to its peak of power and performance.

Include the Bowyer-Lowe Super Heterodyne Kit in your Gifts this Christmas. It will bring lasting and constant pleasure.

Supplied in an attractive Box

£10

LIST OF COMPONENTS SUPPLIED IN THE BOWYER-LOWE SUPER HETERODYNE KIT :—

- 1 Panel, $24 \times 8 \times \frac{1}{4}$ in., drilled, polished and engraved.
- 1 Panel, $5 \times 3 \times \frac{1}{4}$ in., drilled, polished and engraved.
- 1 Panel, $2 \times 2 \times \frac{1}{4}$ in., drilled, polished and engraved.
- 1 Panel, $22 \times 2\frac{1}{2} \times \frac{1}{4}$ in., drilled and polished.
- 1 Baseboard, $24 \times 9 \times \frac{1}{4}$ in., and four supports, $2\frac{1}{2} \times 2\frac{1}{4} \times \frac{1}{4}$ in.
- 1 Set of Four Matched Intermediate Frequency Transformers.
- 1 Oscillator Coupler, 500-2,000 metres.
- 1 Base to hold above.
- 2 Square Law Condensers, '0005.
- 2 Vernier Condensers.
- 1 Single Filament Control Jack.
- 7 Anti-capacity Valve Holders.
- 2 Brass Brackets.
- 36 Tinned Copper Soldering Lugs.
- 24 Lengths Square Tinned Copper Wire.



The "POPULAR" CONDENSER

is an example of Bowyer-Lowe precision and quality. Tested and guaranteed accurate before dispatch. Recommended by foremost experimenters. Supplied with 3-in. dial.

-0003 mf. ... 10/-
-0005 mf. ... 10/6

THE SUPER HETERODYNE KIT

The BOWYER-LOWE RADIO NEWS

contains particulars and illustrations of all our trustworthy components, also two constructional articles of interest to amateurs. A portable set and a four-valve receiver are fully illustrated and described. 1/4d. in stamps will secure your copy. Get it now.

BOWYER-LOWE

Announcement by the Bowyer-Lowe Co., Ltd., Letchworth, Herts.

Notes on the Hale

by CAPT. H. J. ROUND

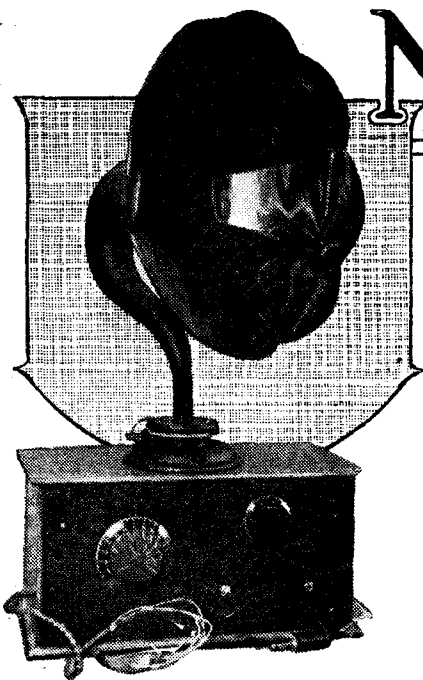

The Hale receiver as constructed by Mr. Percy W. Harris.

The popularity of the Hale circuit has been amazing, and in this special article Captain Round makes some valuable observations on the circuit, which should appeal to all who have built up the set as described in recent issues by Mr. Percy W. Harris.

former connection is in some way a method of by-passing the H.F. into the L.F. valve.

First of all let us, by a series of diagrams, get the rectification and L.F. amplification part straight.

of Fig. 8, where C_5 is added to give a coupling, and we can easily see why this may be not so good if we draw its H.F. part out.

First of all the resistance (or crystal) is shunted with a condenser, and secondly, unless C_5 is kept very small, C_2 has C_3 and C_1 , and C_4 in shunt across it.

And so C_5 is really an additional condenser added across the transformer secondary, like in reflex work, which always tends to spoil a transformer.

In fact, what the Hale circuit does is to use stray capacities of the transformer as a by-pass.

MR. HARRIS asked me a few days ago if I could analyse the Hale circuit and say exactly how it worked! I took a diagram of connections home, and I was glad I had done so, because by the time dinner was over I had forgotten the arrangement.

Experimenters are always hitting on comic arrangements like this, and I wonder

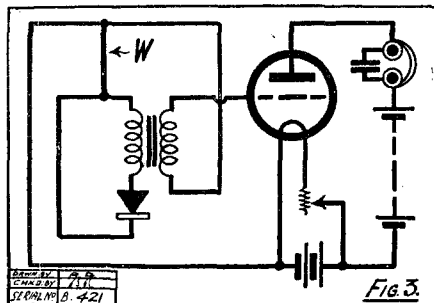
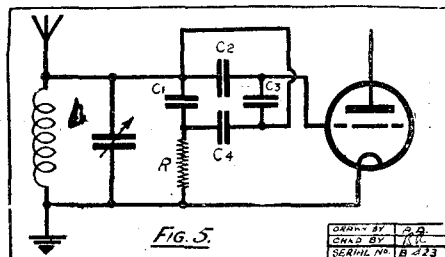
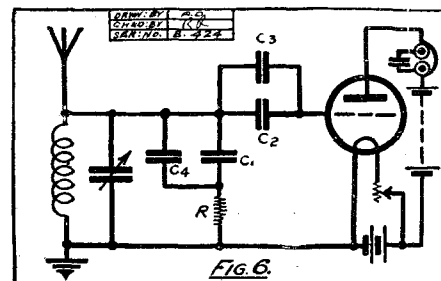

Fig. 1 is the Hale circuit, and in Fig. 2 I have cut out all the H.F. parts.

Fig. 2 is still a bit mystifying until we shift one lead to the other end of the short piece of wire which replaces the H.F. input circuit (Fig. 3), and then we can clearly see that the crystal circuit and the valve circuit are only connected at one point, W. For L.F. this can do nothing, so that we finally end with Fig. 4, which is an ordinary L.F. mag. working from a crystal through a ratio transformer, and our previous experience says use a high ratio transformer, such as 6-1 or 8-1. So much for the L.F. part; and to analyse out the H.F. part we will put a set of capacities in the diagram, representing stray capacities,



I should, however, recommend insulating the transformer and keeping it away from earth leads or plates for very best results. And I suggest the slight alteration of a grid leak and condenser to get the grid



bias on in a better way; although this may not work so well near the reaction point. Some trick like this Hale scheme might be used to get the by-pass condenser out of

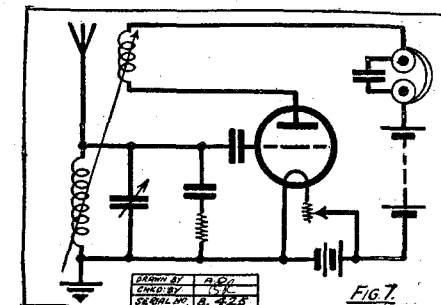

(Continued on next page.)

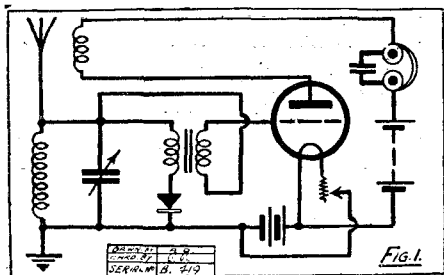

sometimes how they do it. Friends bring circuits to my house to make work, and the hardest work is nearly always finding out the meaning of the circuit.

A full-blown radio engineer seldom gets a thing like the Hale circuit. He would start with the general idea and build it up systematically, with the result that in this case it would probably not be so good.

Well, obviously the general idea involved in this circuit is to crystal rectify, then L.F. amplify, and finally use the L.F. valve to produce reaction, and the curious trans-

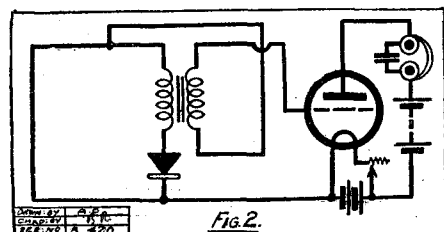

Analysing the Circuit

Now R in Fig. 5 represents the crystal resistance. C_1 the stray capacity across the transformer primary. C_3 the stray capacity across the transformer secondary. C_2 the stray capacity between the top ends of the transformer winding. C_4 the stray capacity between the bottom ends of the transformer winding.

Without altering a single connection, let

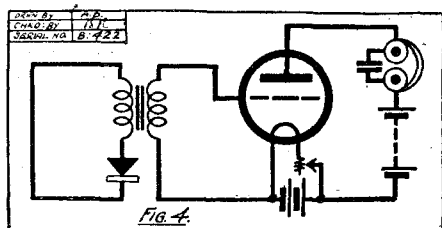

us redraw Fig. 5 as Fig. 6, and then as Fig. 7, and the arrangement becomes quite obviously a condenser arrangement to supply the necessary H.F. to the valve to enable reaction to be applied.

But can't we do it in a more straightforward way. Thus I suggest the circuit

SHORT-WAVE NOTES.

By E. J. SIMMONDS, F.R.S.A., M.I.R.E.

(Staff Consultant.)

SINCE writing my last jottings the reception conditions on short waves have completely changed, and signals from all quarters are coming in with quite unusual strength. This is especially noticeable in the case of the American signals in the band 37 to 42 metres, many stations being heard quite early in the evening and by 23.00 G.M.T., 1st, 2nd and 3rd also 8th district amateurs can be logged in scores on a simple two-valve receiver.

In the wave-band 30 to 35 metres good signals are coming in from Australian, South African and Far East stations from 19.00 G.M.T. These signals, however, rarely exceed R.6 in strength, while the American 1st and 2nd districts, notably U I S W, often exceed R.8 at 23.30 G.M.T. This change is most remarkable in view of the conditions ruling a fortnight ago, when electrical storms were raging in many parts of the world, and in consequence the working of even *high-power* short-wave commercial stations was most adversely affected.

Remarkable Signal Strength.

This present period of intense signal strength has synchronised with very low barometer readings in this country and abroad, and as a point of interest, when the writer was carrying out some tests with U I S W at 23.45 G.M.T. on 8th ult., it was noted that the signals from U I S W were really too strong for comfortable headphone reception. Enquiry regarding the weather conditions ruling at U I S W at this time was made, and it was found that the local barometer readings were remarkably low, coupled with wind and rain.

The same weather conditions prevailed at G 2 O D with a barometer reading of only 28.6 inches, indicating the presence of a deep depression, and there would seem to be a close connection between these changes in signal intensity and the weather conditions prevailing at both the transmitter and receiver.

The recollection of readers is directed to a very interesting transmission which took place from the short-wave American broadcasting station 2 X A F Schenectady on 32.79 metres.

Through the courtesy of the General Electric Co., the president of the A.R.R.L., Mr. Maxim, and other prominent A.R.R.L. officials, broadcast a special international programme at 23.00 G.M.T., November 27th, and in addition to speeches, etc., some novelties which involved modulated radio telegraphy were transmitted.

In view of the ease with which telephony from this station can be received on an ordinary two-valve receiver, it is thought that listeners will find this station of especial interest, and it is hoped that many were able to "tune in" at the above-mentioned time.

While discussing the programmes of 2 X A F, I wonder how many listeners heard the relaying of the inaugural programme of the National Broadcasting Co. of America from that station some weeks ago. The signal strength and clarity on three valves enabled the programme—a remarkably good one—to be put on the loud speaker of a friend of mine who makes no pretence of being a short-wave enthusiast.

Another good one is the world-famous Pittsburg station, K D K A, which, on 60 odd metres, is coming over with great regularity and consistency.



Mr. Arthur Burrows, who became the first announcer in the B.B.C., and is now Manager of the International Radiophone Bureau at Geneva.

A SUPER-HET. AT CHRISTMAS.

WITH the advent of another Christmas the super-het. is still finding great favour among that class of amateur keen on long-distance reception. Even with the rivalry of the Neutrodyne, which came to the fore during the latter part of 1925, the super-het. still stands supreme where sensitivity is concerned. For reception in cities where it is impossible to erect an outdoor aerial, it is unapproachable in its performance. For ease of control it has yet to be bettered.

Contrary to the belief of many, it does not require an expert to operate it. What

can be more simple than two dials to tune, one potentiometer to adjust (infrequently) and a frame aerial to turn? Compare these manipulations with those on an ordinary "straight" 4 or 5-valve receiver, and it will be agreed that it is no more difficult, but probably easier, to tune than the latter.

Not the least of its assets is its reliability. With a couple of good variable condensers incorporating vernier movements, a "velvet" potentiometer, and a good frame aerial it is possible always to find a station again once it has been "logged."

Unlike an ordinary set, where there are coils to be plugged in, condensers to be reset, etc., all its coil arrangements are fixed, and therefore there is little to get out of order.

All Europe Available.

Further, with the introduction of H.T. battery eliminators, there need be no fear of the H.T. running down in the middle of a programme, nor causing crackling and other unpleasant noises on distant stations.

Talking about distant stations, the man with a super-het. this Christmas will have a wonderful time. Everywhere special programmes will be put out, and the Christmas party will be able to range all over Europe, pulling in dance music, songs, orchestral items, carols, as they require them. Nothing could be more convenient than a good super during such festivities, acting as it will as a veritable Father Christmas, dealing out music wherever and whenever it is required.

NOTES ON THE HALE.

(Continued from previous page.)

reflex circuits, but I have had no time to think it out yet.

The Hale-circuit should be extremely good for short-wave telephony, and for this a modified reaction will probably be more suitable.

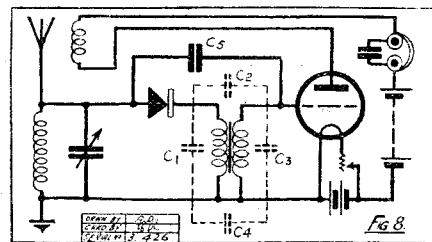

I am not very expert with these short-wave reaction arrangements which enable one to vary reaction without shifting the tune, so that I think it will be wiser to let Mr. Harris show you now to get K D K A on one valve.

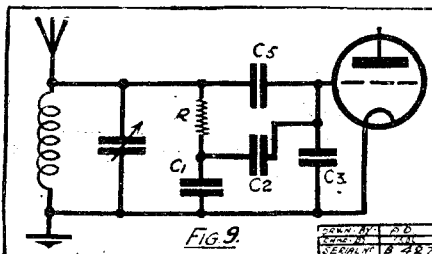

URNS
RATIO, 3 to 1.
RESISTANCE
RATIO, 4 to 1.
 Use it for 1,
 2, or 3 stages
L.F.
 It is suitable
 for all circuits
 and valves
 you will want
 to use.

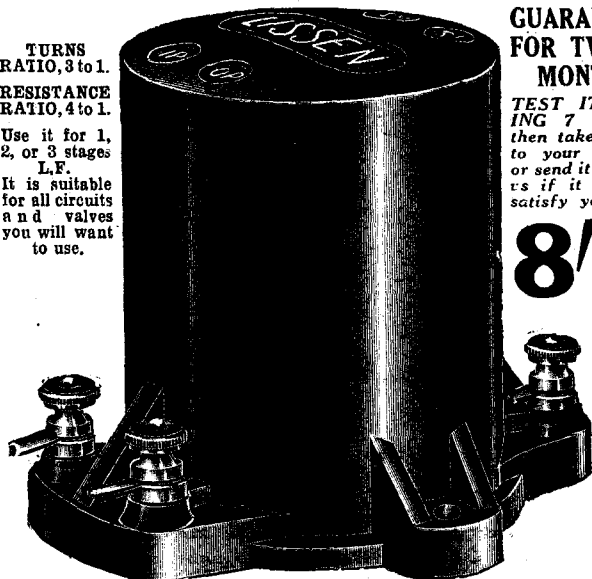

**GUARANTEED
FOR TWELVE
MONTHS.**

TEST IT DUR-
ING 7 DAYS—
 then take it back
 to your dealer's,
 or send it back to
 us if it fails to
 satisfy you.

8/6

**SAVING SET - BUILDERS
£30,000 A MONTH!**

To the set builder who wants a good transformer and is willing to pay 23/6 for it, LISSEN say—DON'T! For LISSEN now saves the set builder who wishes to pay that price 15/- on every transformer, AND GIVES HIM A TRANSFORMER YIELDING INCOMPARABLE AMPLIFICATION BESIDES.

A saving of 15/- on every transformer—multiply that by 10,000 purchasers a week of a single transformer each, and you have users of this new LISSEN Transformer actually saving on their radio bills £7,500 A WEEK — £30,000 A MONTH—ON TRANSFORMERS ALONE.

This is a staggering figure—BUT IT IS AN UNDER-ESTIMATED POSSIBILITY. And not only is this huge amount of money saved to purchasers of the new LISSEN Transformer, but better sets and better amplifiers are now being built than before. WE HAVE THE COURAGE TO OFFER YOU A 7 DAYS' TEST OF THIS NEW LISSEN—and our courage is born of knowledge. FOR WE KNOW WHAT THIS FINE LISSEN TRANSFORMER IS CAPABLE OF, and we stand behind our claims with a 7 days' test offer so that you shall prove them for yourself.

How has this remarkable achievement been made possible? Huge production, special plant, matchless ingenuity of design, our new direct-to-dealer policy of distribution to cut out all wholesale profits—our determination to place BIG, POWERFUL AMPLIFIERS WITHIN THE REACH OF ALL WHO CARED TO BUILD THEM—these are some of the things which have brought this new LISSEN within your reach.

AND IT HAS SWEEPED THE COUNTRY.

Never again pay a high price for a transformer—we have unhesitatingly withdrawn all our own high-priced transformers, which had been on the market and largely sold for several years past.

Compare this new LISSEN against the most high-priced transformer you know of. You will find it FULLY AMPLIFIES EVERY NOTE, EVERY TONE, EVERY HARMONIC, EVERY OVERTONE. Many expensive transformers will not do that, BUT THIS NEW LISSEN DOES.

Obtainable at any good dealer's, or if any difficulty, direct from factory. Please mention dealer's name and address.

LISSEN LTD., 8-16, FRIARS LANE, RICHMOND, SURREY
(Managing Director : Thomas N. Cole)

L.137.

QUALITY RHEOSTATS

previously

4/-

NOW

2/6

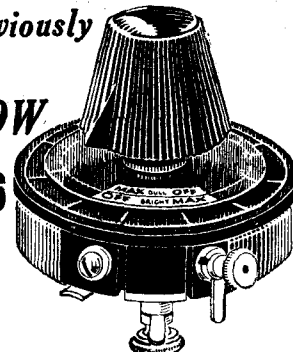

LISSEN quality—look how they are made—the wires cannot move and short circuit—the contact brush rides firmly yet smoothly—the heat-resisting former cannot soften—there are accessible terminals—and the combined knob and pointer will fit flush with the neat photo-engraved dial when mounted. Lastly, note the irresistible appeal of the price, made possible by our big production programme backed by our new direct-to-dealer distribution policy which cuts out all wholesale profits.

Previously NOW

LISSEN 7 ohms rheostat, patented	4 -	2/6
LISSEN 35 ohms rheostat, patented	4 -	2/6
LISSEN Dual rheostat, patented	6 -	4/6
LISSEN Potentiometer, 400 ohms	4/6	2/6

EVERY ONE LISSEN ONE-HOLE FIXING, OF COURSE.

Baseboard mounting type same price as above.

A VALVE HOLDER FOR CLEARER, BETTER SIGNALS

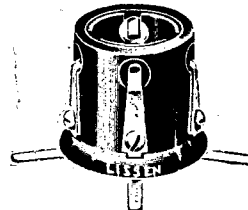

Because of its low loss and low capacity qualities, the LISSEN Valve Holder plays its part in getting clearer, louder signals. Sent out ready for baseboard mounting, as shown, it can also be used for panel mounting by bending the springs straight.

LISSEN VALVE HOLDER
(patented), previously 1/8

NOW 1/- each

IMPORTANT TO THE TRADE.—Retailers who have not already been notified of our new direct-to-dealer policy of distribution should, in their own interests, communicate with us without delay. All orders must now be sent to us at Richmond, and not to usual wholesale factor.



Everybody's Xmas Tree!

Stone's Ginger Wine has good things galore for everyone at Christmas. Every glass is brimming with good cheer—every sip has a smile in it for someone!



Come on everybody! Share in its genial glow.....

Sip it—Drink it—Drain it—and warm up to the fun!

STONE'S GINGER WINE

Famous since 1740.





IT will be extremely interesting to know what the British Broadcasting Company has up its sleeve in the way of happier programmes for Christmas and the New Year. During the past few weeks there have been some very bright spots in, now, almost perfect hours of light entertainment.

There is every reason, then, that the B.B.C. will continue on the road of progress, and that the Christmas evenings by the side of the fire will prove an added delight with the help of broadcasting.

I am sure that Savoy Hill will have many good things for listeners-in during the usually dismal wet nights of December, and also as it is the last month of the present independent regime, before the government takes over, the powers that be are sure to play their trump cards.

It is interesting, however, to hear what various famous people have to say with regard to Christmas wireless programmes, and the following include some very sound suggestions which the B.B.C. might like to consider and perhaps carry out.

In every case the slogan seems to be "brighter programmes." There seems to be a general demand for laughter, and it is up to Savoy Hill to provide it.



Mr. George Grossmith.

MR. GEORGE GROSSMITH
(the famous actor-manager, and a member of the British Broadcasting Committee).

Personally, I am very fond of ghost stories, but I am afraid there will be no ghost stories in the Christmas wireless programmes. At least, not as far as any of the British stations are concerned.

Wireless programmes at Christmas will be as happy and as merry as it is possible to make them. No pains will be spared to see that the programmes will be as perfect as possible, and suit all tastes.

The energy of all concerned at Savoy Hill is concentrating on making the festive programmes full of originality and as entertaining as possible, and naturally, wherever and whenever possible, they will be of a light nature.

I think you will find that dance bands will

The slogan for the B.B.C. this Xmas is "Brighter Programmes." Below, "Ariel" reports the views and suggestions of some famous artistes in the entertainment world on "how it should be done."

form the most popular feature, and the sessions will possibly be augmented. There is more dancing done at Christmas than at any other time of the year, and it is only natural that the B.B.C. will see to it that there will be as much music as is required.

FAY MARBÉ

(the famous musical comedy actress sees Christmas radio from an American point of view).

I certainly think that broadcasting in England will do a great deal to liven up matters at Christmas. Personally, I think that there should be ghost stories on Christmas Day and Christmas Eve.

There is nothing so thrilling than to listen to a ghost story in the dark, and it is even more weird when it is only a voice from somewhere.

Of course, unfortunately there are always some people who might listen to these stories and to whom it might have harmful effect. Old people and patients particularly.

If I were to draw up a broadcasting programme I should make it as merry and musical as possible. Everyone who is in a festive mood asks for music, and therefore the more music there is in the programmes, the better.

I think that the talks, weather forecasts, lessons, and other serious subjects should be cut down to a minimum during the month of December.

In America radio entertainments round about Christmas are a very light-hearted affair indeed, and they are mostly humorous or consist almost entirely of dance music. Famous people are invited to come and give Christmas greetings, and this is an amusing originality which might be included in the British programmes.



Alice Delysia,

ROY ROYSTON

(the well-known musical comedy actor).

Broadcasting has always been full of interest for me, and I would be lost without my wireless. I do not think that the B.B.C. could do better than continue with the kind of stuff they have been giving lately, which, to my mind, is original and entertaining from all points of view.

There should be as much humour and excerpts of theatrical shows as possible.

It ought to be the intention of the B.B.C. to bring the theatre to the front in their Christmas programmes, and excerpts of shows and various entertainments of the light types should be included.

All the serious stuff ought to be left out, and the complete description might be, "Humour and Dance Music."



Kreisler (the famous violinist).

ALICE DELYSIA
(Princess Charming.)

I hope to spend Christmas by my fireside, and if it is really anything I look forward to it is my 2-valve set. I look forward also to the Christmas programmes.

I love music, and I hope there will be a lot of it at Noel.

Christmas always makes me very gay, and so I like everything else to be gay, and that is why I am hoping that the radio programmes will follow the example.

I do think, however, that there should be quite a lot of good, dreamy music, for at Christmas everyone dreams.

There should be selections from French, Italian, Spanish, Eastern and all the classics. *Ca ramene toujours les memoirs.*

And these memories brought back by music are always the sweetest, *n'est ce pas, monsieur?*

Then I shall want to hear a lot of that most pleasing contrast, jazz. I want to hear all those songs which to-day are so popular.

KREISLER
(the violinist).

I am afraid I have nothing much to tell you. I am sure, however, that broadcasting will liven up the home at Christmas.

Always, of course, it brings within the reach of all, no matter how small the purse, a great entertainment, in its own particular way.

(Continued on next page.)



By C. A. J. MEADOWS.

ALTHOUGH December the 25th comes but once a year, and is always associated with snow, holly and log fires, it is getting into step with modern forms of entertainment, and Father Christmas is now portrayed bearing his bulky sack filled to overflowing, not only with toys and games, but with loud speakers, 'phones, and all the impedimenta essential to wireless.

At Christmas, nowadays, wireless plays an important part, and if the proposed parts is to be a success, it is worth while to ensure that the set will do its best. To be let down while the fun is at its height by some slight fault which a little foresight would have prevented, is ten times worse than gall and wormwood to the real wireless man, whether he is one of the John Blunt type who calls himself an amateur and the toolshed his "workshop," or one of these highbrow persons who refers to himself as an "advanced experimenter," and is in the habit of terming his shed full of gear "the laboratory."

Making Preparations.

Imagine the sorry figure cut by a keen wireless fan, who, while entertaining a company of rich and elderly relatives, hears the signals from his loud speaker gradually fade away. You know the tragedy that ensues; the frenzied rush to the set, testing this, that, tuning and re-tuning, changing valves, coils, and colour; losing terminal heads, wander plugs and all hope of regaining a reputation as a wireless expert. And the final discovery that an almost discharged "juice-box" is connected up in place of the one delivered the previous day from the charging station.

Little things like that do not assist matters, and therefore, if you are going to rely on the set for any part of your Christmas entertainment, see that everything is in order. Have, if possible, one or two spare valves, in case one in the set burns out. Have a freshly-charged accumulator connected up; see that all leads to batteries, loud-speaker extensions, etc., are in good condition; overhaul the set and all its accessories; remove all superfluous leads and other oddments. Then, if you must go to the workshop (or laboratory) on Christmas Day, you can indulge in a little clean up. All small boxes should be stowed away neatly, and if not already labelled, mark them suitably, as for instance, "Nuts—brass. 2, 4, and 6 B.A." Small wooden boxes, if handy, can be easily divided into two or three sections. Even better containers

for metal parts are glass jars with good, tight stoppers; pickle jars are excellent.

Any pieces of mica lying about should be placed between two pieces of wood, or ebonite, and held by rubber bands; a flat tin is best to store mica, and if bound in this fashion it will be kept flat and cannot become "splintered" or split.

If a drill stand is not included in the workshop equipment get a suitable piece of wood, and make a hole with each of the drills it is intended to hold. But before putting the drills away, give them a rub over with an oily rag, as a rusty drill soon loses its cutting edge. Clean up all the tools, and place in their racks, keeping all files, say, in one group—graduated, all chisels in another group, screwdrivers in another, and so forth.

And, after all, where is the most natural place for half a dozen keen amateurs, full of the spirit of Christmas, and burning to discuss the latest "P.W." set? If your workshop is "poshed up" there is no need to hesitate; take them in.



There are lots of things to be said against wireless, but I will admit that at Christmas it will prove a great boon in the home.

Where it proves its great utility is by bringing happiness into a home where, because of poverty and illness, it had not been possible, before the advent of wireless.

I have no suggestions to make as to how the programmes should be changed, or improved. I suppose as they do please a lot of people to-day there is no reason why they shall not do so at Christmas.



Miss Evelyn Laye.

Christmas should be one long laugh from beginning to end.

There is nothing an Englishman likes so much as real good humour, and it is even more acceptable to radio audiences, who at that particular time of the year will be in search of all the funniest things.

Broadcasting ought to be able to provide some of the best entertainment over the end of the year holidays, and myself I cannot quite see Christmas this year without the radiö.

I know that I shall listen in, but if I don't laugh and laugh I shall be terribly disappointed.

It is there to make Christmas more Christmassy than it has ever been. It has everything in its power to do so, so I cannot see it fail to make us really happy and amused.

The B.B.C. will not go very far wrong if it puts plenty of humour and music into its programmes on this festive occasion. Their public demand it, anyway.

CHARLES B. COCHRAN

Public taste does not change very much at Christmas, and I feel certain that if the programmes constitute real entertainment there will not be any out-of-the-ordinary demands just because it happens to be Christmas.

In my opinion broadcasting programmes have improved a great deal in the past few months.

It is simple enough to see what is most popular in a wireless programme, and the Christmas programmes should include all the most popular items.

Items such as dance music, and musical entertainment of any kind, of a bright, cheery nature, should be made the most of. Broadcasting at Christmas should make the happy revellers happier.

SIR GERALD DU MAURIER

The B.B.C. cannot do better than continue its present policy. I feel sure that the programmes have improved enormously lately, and it is those things that one likes best in the programmes of to-day that one would like to hear at Christmas.



Sir Gerald Du Maurier.

But as every desire could not be possibly satisfied, there must be a general opinion on the best items to include at Christmas.

I suggest that Fairyland should not be left sleeping. I presume that the Children's Hour will contain quite a lot about Fairyland.

EVELYN LAYE.

The Famous Musical Comedy Actress.

I think that present-day broadcasting programmes are extremely bright, and I really don't see how they can be improved at Christmas to any very great extent.

The item I like best in the B.B.C. programmes is good music, and I shall never be tired to hear quite a lot of this.

At Christmas I think a very popular item indeed would be some good organ recitals. I always think that organ recitals get over very well on the wireless, and I am particularly fond of them.

My opinion is that the Christmas entertainment should be as musical as possible; and the music should be divided between good straight symphony, and then plenty of jazz. And don't forget the organ recitals!

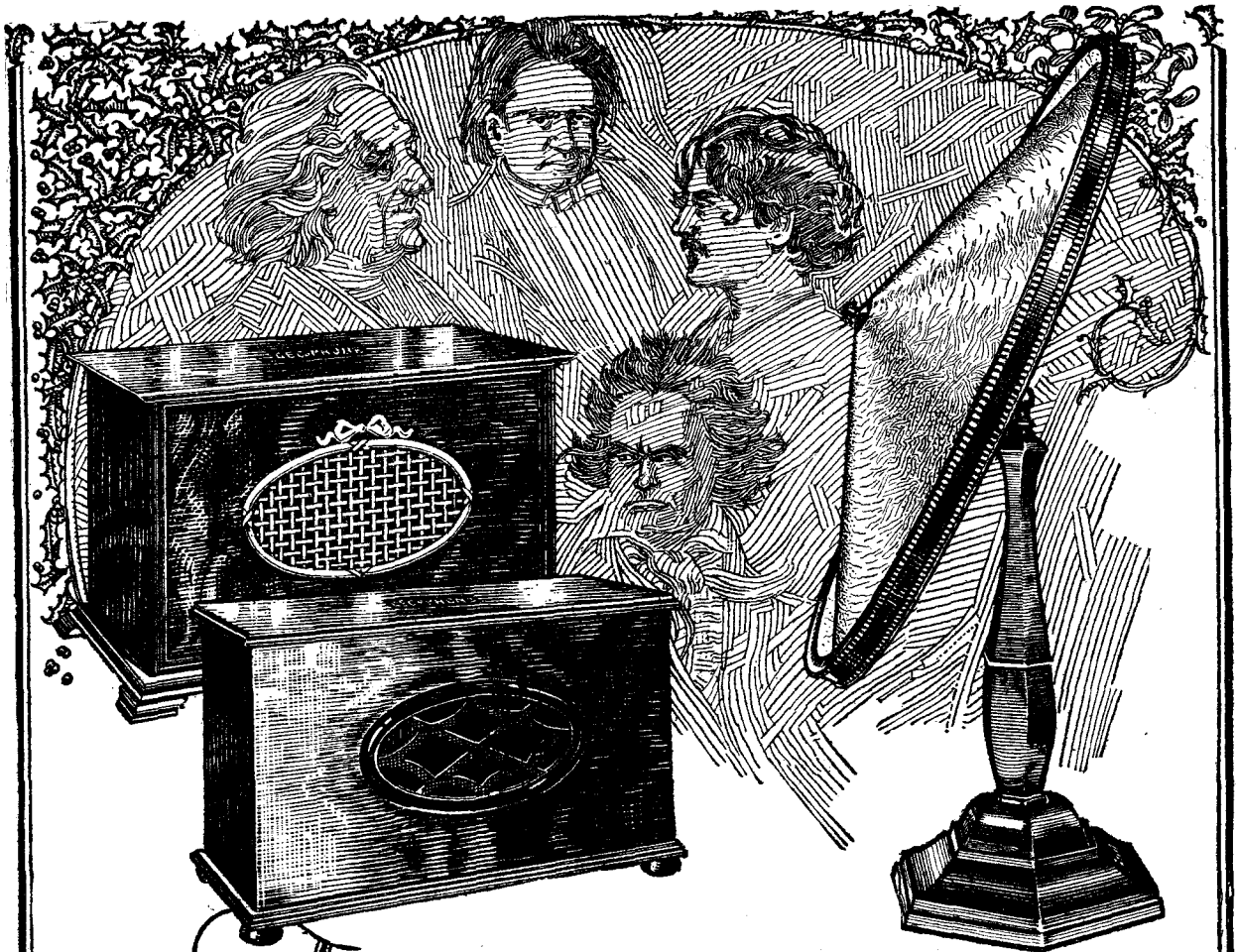

Three superb Loud Speakers — Britain's Best

CHRISTMAS GIFTS THAT DELIGHT.

A GECophone Loud Speaker is a gift in the best of taste, and one that is certain to delight. It is a tribute of friendship which will continually revive memories of Christmas 1926 for many years to come.

GECophone CONE LOUD SPEAKER. Unequaled delicacy and fidelity of reproduction. Perfectly balanced with heavy base Metalwork of coin-bronze finish, cone self-coloured and beautifully grained, adjustable to any angle desired. Price **£6:6:0**

GECophone CABINET LOUD SPEAKER (Model B). Beautiful cabinet work in solid mahogany or oak. Handsome Florentine bronze grill. A credit to any wireless set and furnishing scheme. Price **£4:4:0**

GECophone CABINET LOUD SPEAKER (Model C). Attractive in design with fine mahogany finish. Mellow and true reproduction. A wonderful loud speaker at a bargain price Price **£2:10:0**

Write for GECophone Loud Speakers illustrated leaflet B.C. 4324.



**BRITAIN'S BEST BROADCASTING
SETS AND LOUD SPEAKERS**

The G.E.C.-your guarantee

SOLD BY ALL WIRELESS DEALERS AND STORES

Advt. of The General Electric Co., Ltd., Magnet House, Kingsway, London, W.C.2

FIT BENJAMIN COMPONENTS

BENJAMIN VALVE HOLDER

complete with Dubilier Fixed Condenser (0003) and Dumetohm Grid Leak (2 megohms)—series or parallel.

Price 7/- each

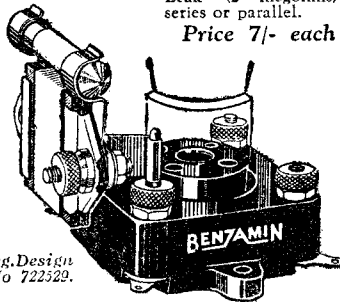

Reg. Design No. 722529.

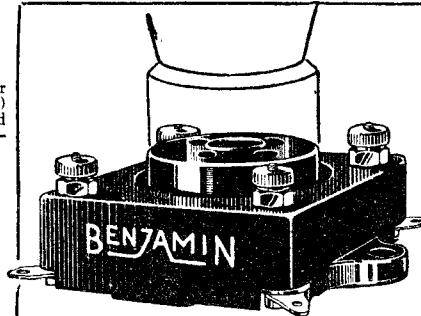

BENJAMIN Clearer-Tone Anti-Microphonic VALVE HOLDER

Price 2/9 each

BENJAMIN VALVE HOLDER

complete with Dumetohm Grid Leak (2 megohms).

Price 5/3 each

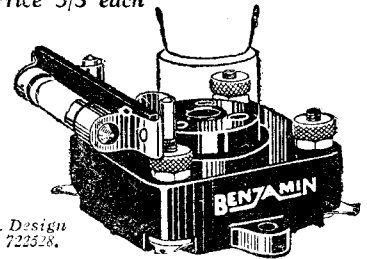

Reg. Design No. 722528.

FIVE EXCLUSIVE FEATURES:—

- (1) Valve sockets and springs are made in one piece, with no joints or rivets to work loose and cause faulty connections.
- (2) Valves are free to float in every direction.
- (3) Valves can be inserted and removed easily and safely.
- (4) Valve legs cannot possibly foul the base-board.
- (5) Both terminals and soldering tags are provided.

Patent Nos. 222086—1923, 250431—1925. Registered Design No. 714847.

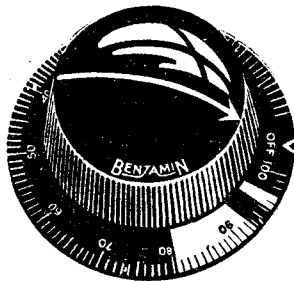

BENJAMIN Self-Contained RHEOSTAT

The resistance is *inside* the dial. Nothing behind the panel except lock-nut and soldering tags. Panel space saved, wiring and mounting simplified and the appearance of the panel improved.

Made of genuine Bakelite. Three windings as standard—6, 15 and 30 ohms.

Price 2/9 each

Patent No. 216435.

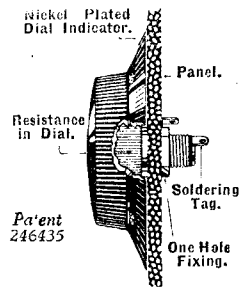

BENJAMIN BATTERY SWITCH

A sturdy, positive action switch for high or low tension. It's OFF when it's IN, thus preventing the accidental turning

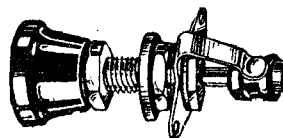

on of current. Single contact, one-hole fixing.

Price 1/3 each

Ask your dealer or write for particulars.

THE BENJAMIN ELECTRIC LIMITED

Brantwood Works, Tottenham, London, N.17

MAKERS OF THINGS MORE USEFUL

The RADIO CONSTRUCTOR

Edited by PERCY W. HARRIS, M.I.R.E.



This valuable eight-page supplement, devoted to the interests of amateur wireless constructors, appears every week in POPULAR WIRELESS. Tell your friends about it, for it is only in "P.W." that they will find the radio articles by the leading constructor expert, Mr. Percy W. Harris.

THE new rearrangement of wave-lengths by which it is hoped to eliminate the interference problems in Europe will take some time to settle down, and listeners must not be too impatient if they still have to put up with a certain amount of interference. In any case, there is, already a distinct improvement, if only by the withdrawal of the British relays from the number of different wave-bands they previously occupied, and their concentration within one or two.

It is only natural, in view of the allocation of the new wave-lengths on a frequency rather than a wave-length basis, that many readers should desire a little information on the relative merits of straight-line frequency and straight-line wave-length condensers.

There have been fashions in radio, just as there have been fashions in other arts and hobbies. To judge by the jubilation of some variable condenser makers, the straight-line frequency condenser possesses some extraordinary merits and is even able to replace the vernier dial!

It is just as well to face the plain facts of the situation and to examine just what are the merits of straight-line frequency arrangement. To understand the relation of the various condensers, let us consider three condensers each of .0003 mfd., one of straight line capacity, one straight line wave-length and one straight line frequency.

Condenser No. 1. is of the semi-circular plate type, in universal use before the introduction of the straight-line wave-length variety. I think I can claim to have been the first constructional writer to point out the tuning disadvantages of such a condenser; for if between the 250 and 500 metre limit we have 25 stations each separated by ten metres, then the tuning positions of these 25 stations will not be evenly distributed over the dial but will have roughly half of them in the first third of the condenser and the other half in the remaining two thirds. Stations will thus be rather crowded at the bottom end and fairly widely separated at the upper end.

Truth about "Straight Lines."

Now with the straight-line wave-length condenser the distribution of wave-lengths will be far more uniform and will approximate to equal spacing, particularly if the coil is part of a loosely-coupled circuit. Some amateurs may complain that one rarely gets a dead straight line when plotting the wave-length readings against condenser degree readings, but no one will dispute the fact that the introduction of such condensers has considerably helped tuning.

A point that is not generally realised is that stations using the shorter waves tune much more sharply than those occupying the longer. Owing to the fact that the musical and speech frequencies are added to and subtracted from the fundamental frequency of the transmission, each telephony transmission requires not merely one frequency but a band of frequencies on either side of its wave-length.

Tuning and Wave-bands.

For example, the 300-metre transmission has a carrier wave of one million per second frequency. Allowing 5,000 as a useful band of frequencies for telephony transmission, it will be seen that the 300-metre wave-length really occupies frequencies from 995,000 to 1,005,000. If the frequency bands of other stations overlap the bands already occupied we shall get interference. Now translated into terms of wave-length, we can say that the 300-metre transmission really

occupies a metre or two on either side of the transmission, and round about this figure the Geneva conference has decided that a metre and a half on either side of the main frequency is needed to prevent interference, so that if you examine the new lists you will find stations on 297 metres, 300 metres and 303 metres.

From this you might imagine that it would be a simple matter to allow three metres difference all the way up the scale and thus avoid interference, but you must not overlook the fact that the longer the

wave the wider the band needed. For example, between 300 metres and 310 metres is a frequency difference of 32,300, but between 500 and 510 metres the difference is only 11,800.

The position, briefly, is that, provided stations are uniformly spaced according to frequency difference, then to get them uniformly distributed over our condenser dial we must have a straight-line frequency condenser. Beyond this there are no special virtues in the type. You cannot get any stronger signals with a straight-line frequency condenser, and if on your set you are getting interference between two stations when using a straight-line wave-length condenser, you will get precisely the same interference when using a straight-line frequency condenser, unless you are very clumsy in handling your tuning controls.



Send your own "Wireless" greetings at Christmas! See "Radio Hints for Xmas Parties" in this issue.

Percy W. Harris

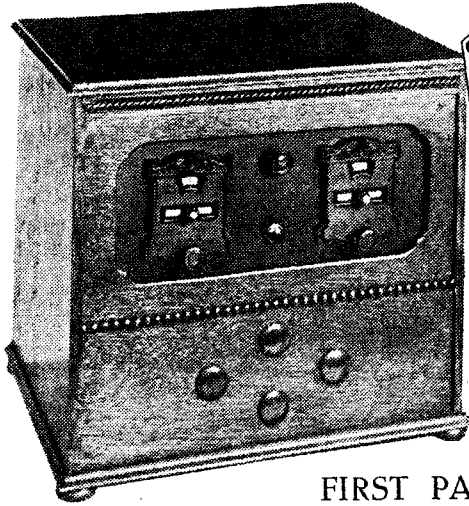

KING of the AIR

by Percy W. Harris



FIRST PARTICULARS OF A NEW RECEIVER.

I AM glad to be able to introduce to "Radio Constructor" readers in this the Christmas issue, my new set, "The King of the Air," about which I have already written and which has been occupying a great deal of my time for many months past. The set as a whole has passed through many phases, and in the process of development points have been added, changes made, and promising ideas discarded as one after the other tests have been built and substitute parts tried so that the reader shall not be tied down too rigidly to one particular set of components.

In designing a really good set so many points have to be taken into consideration, and the position of the designer who sets out to supply the needs of the home constructor is quite different to that of the man whose work it is to evolve sets for factory building. The simplicity with which a wireless set can now be built, and the multitude of designs available, may lead the reader to imagine that the subject has been shorn of all its difficultness and set designing is an easy matter to those who have a good knowledge of circuits.

In the course of many years' experience in building sets for the home constructor to copy, I have come to acquire a very considerable suspicion of all ideas that have not been practically tried out in normal and abnormal conditions. Too many good ideas have a habit of petering out in the practical application, for which reason I have always made a point of myself building up all the

sets described under my name, even to the simplest of the wiring. Even a simple single-valve circuit can give different results when wired up in a different way, and when one comes to multi-valve receivers practical considerations loom very large.

"The King of the Air" has been designed to fill the following important requirements:

THIS SET IN A NUTSHELL.

Circuit used: Neutralised H.F. stage, detector, one transformer and one resistance-coupled note magnifier with reaction.

Special points. High selectivity, purity and sensitiveness.

Set, complete with batteries, contained in one cabinet with only aerial and earth connections taken outside.

- (1) High selectivity.
- (2) High standard of purity of reproduction.
- (3) High sensitivity.
- (4) Wide wave-length range.
- (5) Compactness.
- (6) Freedom from matching parts, double condensers, etc.
- (7) Simplicity of tuning.
- (8) Handsome appearance.
- (9) Batteries and set in one cabinet.

The circuit finally chosen is that given below, and is different from that in which the set was originally made up. Later, I

hope to tell you about the original form of the "King of the Air" which worked admirably, but in the course of a series of tests proved to be somewhat difficult to reproduce if a particular set of components was not adhered to. Furthermore, there were one or two factors which led me to think that the average constructor would not be able to carry out the balancing up necessary, and so that particular circuit had to be discarded almost at the last moment.

You will notice on examination that there is one high-frequency stage neutralised, a detector with reaction, one stage of transformer-coupled amplification and one resistance stage. There are but two tuning condensers fitted with vernier dials, and as these are of the single type they are both inexpensive and require no matching.

As readers of the "Radio Constructor" know, I always endeavour to keep as far away as possible from the need of buying special components which have only a limited use, but in the present case there are two which are really vital to the success of the instrument. One is the binocular or fieldless coil for the aerial coupling, and the other the special high-frequency transformer which is the result of a good deal of experiment and the windings of which have been particularly worked out for this receiver.

The idea of using one fieldless coil and one of the ordinary type is that the latter has a slightly high efficiency and, provided

{(Continued on next page.)

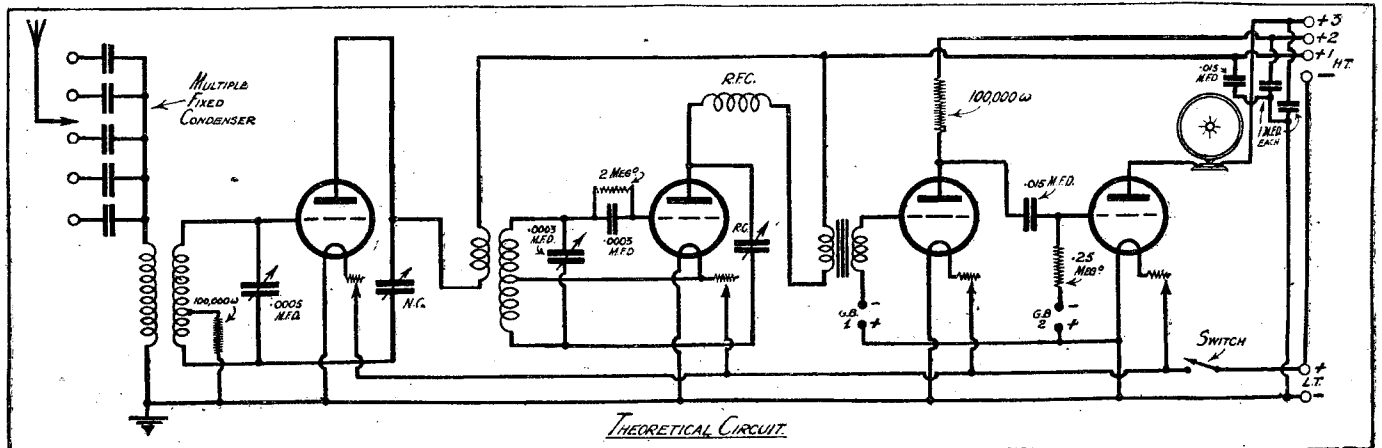

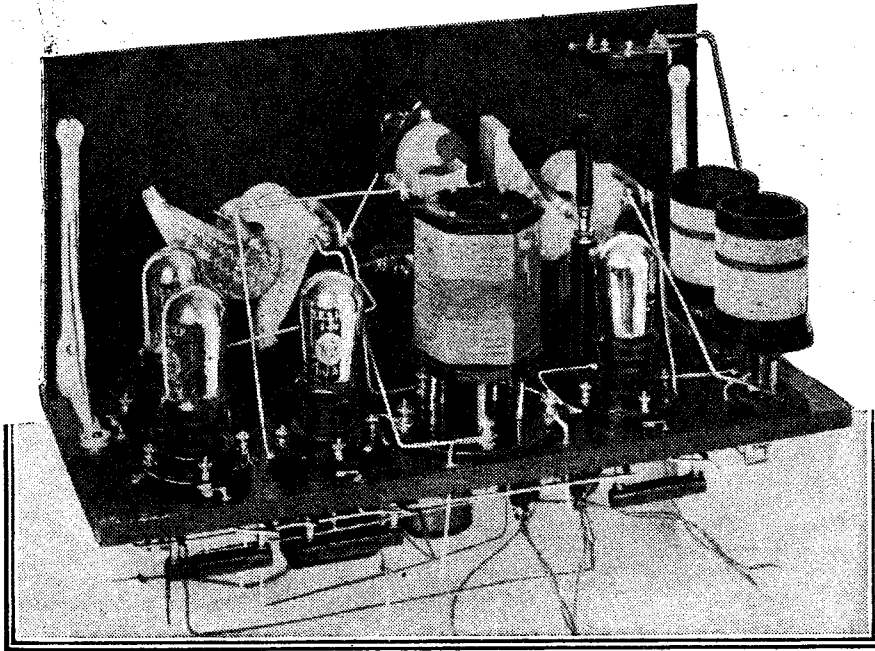

Both top and underside of the baseboard are used to carry components.

(Continued from previous page.)

one of the two coils in the set is of the fieldless variety, there will be no interaction between them. This interaction of the coils of the set is a fruitful source of trouble both in the production of oscillation and the reduction of sensitivity, not to mention the lack of selectivity which arises in such circumstances.

It will be noticed that quite a new style of make-up has been adopted in this receiver, affecting a considerable economy of space and leading to a greater simplification of wiring. The front panel, as is usual in modern receivers, carries the variable condensers and on-and-off switch and the reaction control only, the old-fashioned array of knobs making no appeal to the modern constructor. On the baseboard are carried (on top) the coils, four valve holders, and a neutralising condenser, while a fixed condenser in series with the aerial lead is carried on the back of the panel in one corner.

The remaining components in the set, comprising the low-frequency transformer, resistance coupling parts, Mansbridge condensers, radio-frequency choke, fixed condensers, leaks, etc., are carried beneath the baseboard, which is mounted in a special cabinet, allowing ample room underneath and a space at the back for high-tension and low-tension batteries. The conventional terminal strip has been dispensed with, its place being taken by the more modern pigtail connections, thus saving expense and trouble.

Returning now to the circuit itself, it will be noticed that the Rice method of neutralising has been adopted, a 100,000-ohm resistance being inserted between the centre tap of the first grid coil and the filament. The purpose of this fixed resistance is to obviate the generation of parasitic oscillations, and the idea of using a resistance in this way will be found in the Western Electric Company's patent which was

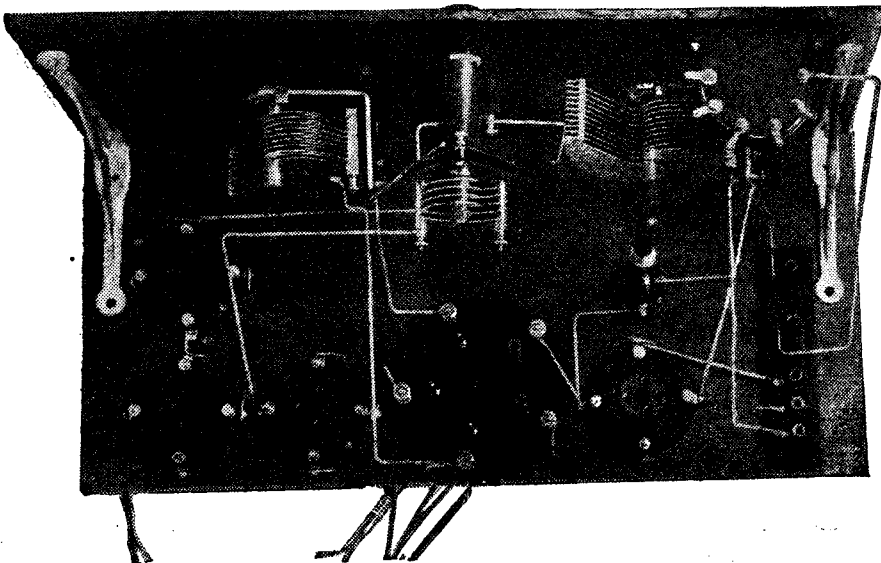

The "top and bottom" wiring method makes for great simplicity.

published not long ago. This company has been responsible for the development of many excellent ideas relating to wireless circuits, and is not always given the credit it deserves.

A fixed condenser in series with the aerial is often a considerable aid to selectivity, and reduces unwanted aerial damping in cases where the aerial is very inefficient. The choice of the optimum value of fixed

COMPONENTS REQUIRED FOR THIS SET.

One ebonite panel, 16 in. x 8 in. x 1/4 in. Any good make of guaranteed ebonite will suit here. See note below on panel.

One "King of the Air" cabinet. Unica Cabinet Co. See note below.

Baseboard as supplied with cabinet, measuring 16 in. x 7 1/2 in.

One multiple fixed condenser. C.A.V.

One variable condenser, .0005 mfd.

One variable condenser, .0003 mfd.

Straight line frequency or straight-line wave-length pattern. Any good make can be used. These illustrated are the Formo S.L.F.

Two vernier dials. See note below.

One neutralising condenser for baseboard mounting. Gambrell's Neutro-vernier or other reliable make.

One reaction condenser (Peto-Scott, etc.)

Four anti-vibratory valve sockets. Those illustrated are W.B.

One binocular coil for each wavelength range required, mounted on "Special Five" base. These are made by Peto-Scott, and Lissen, Ltd.

One H.F. transformer, Eureka. It is also possible to use the popular screened coils here.

One on-and-off switch, Bulgin, etc.

Four fixed resistors to suit the valves chosen. See later note. Any well-known type. Those shown in the set are Magnum.

One L.F. transformer of good make. I have used the Gecophone 2-1 ratio.

One radio frequency choke. See special note.

Two Mansbridge condensers, 1 mfd. These are made by a number of manufacturers. Those in the photographs are Lissen, Ltd.

Two 100,000 ohm resistances with bases. These are preferably wire wound, and can be obtained from Mullard, Varley, and Dubilier.

Two fixed condensers, .015 mfd. These must be mica insulated, otherwise any reliable make can be used.

One grid leak holder. Dumetohm holder or similar device.

One fixed condenser, .0003 mfd., with 2 megohm grid leak.

One grid leak, .25 megohm.

Two brackets for supporting front panel.

Valves, batteries, etc., to be described.

condenser is not an easy one and cannot be decided once and for all for every set. For this reason I have used a type of fixed condenser which has a number of tapings, so that all values from .0001 to .0015 mfd. are available. Methods of adjusting this fixed condenser will be described in later operating notes.

(Continued on next page.)

KING OF THE AIR

(Continued from previous page.)

The choice of a combination of one transformer and one-resistance coupled stage has been dictated by the fact that it is relatively difficult to obtain good results with two transformers, unless these are carefully chosen and matched to one another. Shortly, I hope to contribute to this paper an article dealing with a number of considerations in transformer design from which you will find that it is quite possible to obtain serious distortion from two excellent low-frequency transformers when these are improperly used.

In using one transformer and one resistance, L.F. reaction effects (the bugbear of amplifier design) are reduced, and the reader has a far wider choice of transformers than otherwise would be the case. There is, it is true, a slight reduction in volume over the results obtained with two transformers; but if suitable valves are used the reduction is not great, and the excellent quality obtained is well worth the slight sacrifice made to obtain it.

Constructional Details.

You might imagine, on first consideration, that mounting components on both sides of the baseboard makes complicated wiring and difficulty in construction; but,

on the contrary, the simplicity of work is one of the greatest charms of this method. For this reason I should be surprised if the "King of the Air" does not set a new fashion in home construction. The components are first of all screwed down in place on the top of the baseboard, and when this has been done, the necessary holes are drilled alongside the components to take the leads as indicated. These holes act as a valuable guide in placing the components on the back of the baseboard.

By the way, it is advisable, before beginning work of this kind, to construct a small stand so that the baseboard can be turned from front to back as many times as are necessary without inconvenience.

The front panel is, as indicated in the list of component parts, of a standard size, but, owing to the fact that a good portion is covered by the front of the cabinet, it can, if desired, be made smaller. However, cutting ebonite is neither easy nor pleasant, and in many cases the fine appearance of a good panel will be injured if unskilled attempts are made to cut it.

The two variable condensers and the reaction condenser are all one-hole fixing. The base of the fixed condenser is secured to the panel by screws, but as the screw heads come behind the wooden facing, they will be concealed when the panel is put into the cabinet. Once the panel has been drilled and the components mounted in place upon it, the brackets should be fixed to the baseboard, and then, by placing the panel against the baseboard, the position of the holes for securing the panel to the brackets can be found. Be careful to mark these accurately or you will have trouble in mounting. The screw heads securing the brackets to the panel are also concealed. I do not advise fitting the panel to the brackets until all of the components have been mounted on the baseboard, for it will be found

much more convenient to add the panel just before wiring.

A suitable support for carrying the baseboard, while you are fixing the parts and wiring it up, can be made from a piece of board and four short lengths of broomstick secured to it by wood screws from the back of the board. The support will resemble a table with its legs in the air, and if care is taken to space the four "legs" so that when the baseboard is resting upon them they fit into vacant spaces, the board will save a great deal of time and trouble. A makeshift expedient is to use two piles of books, but my experience with this method is that, just at some critical moment in soldering, the baseboard will slide off one of the piles and cause a great deal of trouble in bending the wires.

Special Notes on Components.

In the list of components given in this article, I have made reference to special notes on components. This is necessary, as in one or two cases substitution may not be advisable, or if undertaken must be done with great care. The great popularity of split-coil circuits and the many experiments recently carried out, have indicated the great importance of radio-frequency chokes and the difficulties which may arise in connection with them. The difficulty would not present itself if we were designing sets for the shorter broadcast wave-band from 200 to 600 metres, but as we have to include a band covering Königswusterhausen, Daventry and Radio-Paris, certain difficulties present themselves.

Without going into details, I may say that the choke chosen for this set is the Varley "split coil," which has been specially designed to overcome the difficulties which sometimes possess themselves in connection with split-coil circuits. Some otherwise excellent chokes happen to have a natural frequency which falls within one or other of the actual bands of wave-lengths which we desire to cover, and may give rise to uncontrollable oscillation or complete absence of reaction effects.

(To be continued.)

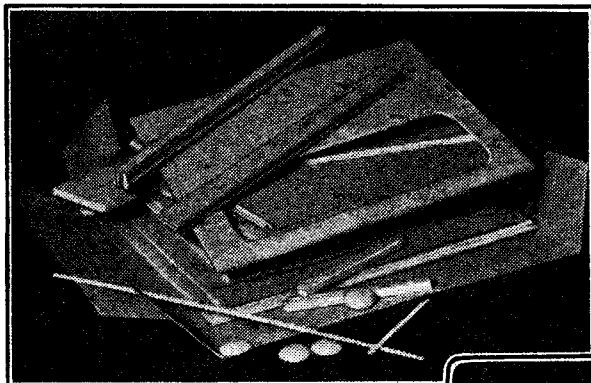

The cabinet as received. The wood is accurately cut to size.

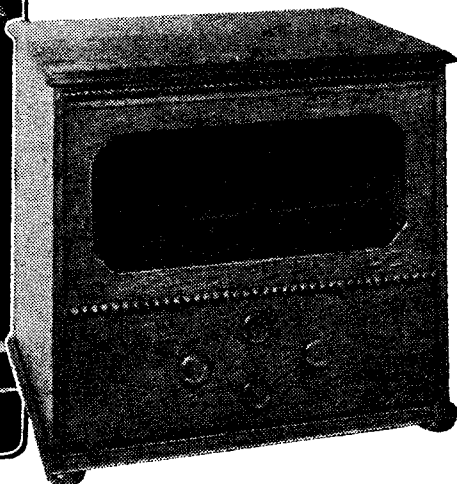
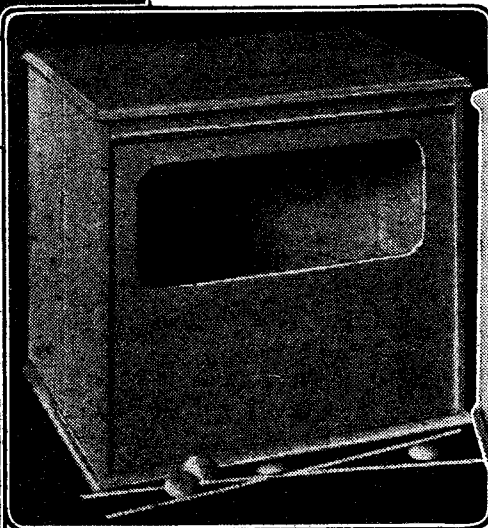
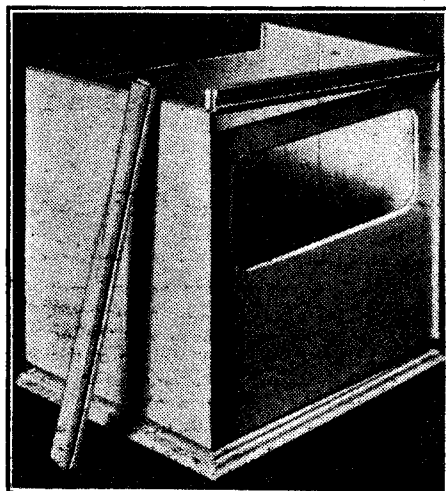

The cabinet can be purchased much cheaper in "knock-down" form, and can be re-assembled by the home constructor quite easily. Stain and polish are provided with the outfit.

Radio Hints for Xmas Parties

By THE EDITOR.

A LITTLE attention given to one's wireless apparatus can do a great deal to add to the enjoyment of a Christmas party, particularly when the children are present. Some little experiences in organising wireless stunts has taught me some of the things which are likely to happen, and which should be guarded against, and a few of the tricks which will produce a great deal of amusement and surprise.

First of all, be sure to have a spare accumulator ready fully charged. You may make up your mind to have the battery

MYSTERIOUS WIRELESS MESSAGES FOR THE CHILDREN AND "GROWN-UPS."

For example, if you are using resistance capacity amplification and a valve designed for this purpose, there will be a great loss in volume if you substitute for this resistance-capacity coupling valve one not designed for this position.

As a change, after a few warnings of the kind which many of you will probably not need, let me tell you one amusing "stunt" which is quite simple to fix up if you have some spare apparatus handy. You will require for it the following: A complete one-valve amplifier,

to be described later, suitable box, terminals, loud speaker and a pair of telephones.

It is not generally known that a loud speaker can be used as a microphone for the transmission of speech or music, although it is very insensitive compared

with the proper microphones as used in the studios. Nevertheless, let a loud speaker be connected to the primary of an L.F. transformer the secondary of which is connected to a valve in the usual way, and as shown in the circuit accompanying this article. The output side of the valve can be connected to telephones, and, when you listen in to the telephones you will hear anything spoken into the loud speaker

(which may be in another room) just as clearly as if you were listening in to an ordinary wireless transmission.

This phenomenon is the basis of the following trick. Connect your loud speaker to an amplifier, as described, and take a pair of leads from the output into another room, and to terminals on a box made up to look like a pretentious wireless set. The "set," of course, contains nothing whatever, and is merely a means of connecting a pair of telephones to the leads from the amplifier in the other room, but the more mysterious it looks the better. I can leave it to the ingenuity of the reader to make something suitable for a children's party.

Now, the fact that this loud speaker and improvised microphone arrangement is in the house should be carefully concealed from the visiting party. During the children's party it can be announced that a special transmission will take place at a certain hour and that Father Christmas will send special messages to the little guests. This idea can be worked up in all kinds of ways, and after suitable preliminaries, which can include the drawing of lots for the first and subsequent "turns," the children can be taken one by one into a room where the listening set is on a table.

A special message can be given to each child, giving very intimate details, addressing the child by name, and promising that some little gift will be found somewhere in another room. Do not forget in passing

(Continued on next page.)

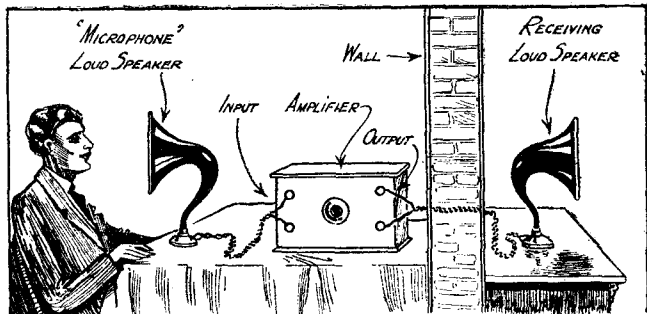

How to use the loud speaker as a microphone.

charged just before Christmas so that it will be ready for the party, but do not forget that thousands of other people will probably make the same decision, and the accumulator charging plant will be working at full pressure all through the holidays. Make sure you have a fully charged accumulator in the house before you let one go away to be recharged, even if most faithful promises are given that it will be returned in time for Christmas or the party. Even should it come back there is always a possibility that it may have been given an inadequate charge or even overlooked in the rush. If you charge your own accumulators, of course, you will have no trouble in this regard, but the majority of people have to rely on some service station.

If you can, have one or two spare valves available, or if you have valves already in stock, make sure that you have one for every purpose. I have known occasions where people have relied upon their spare valves only to find in an emergency that a much-treasured spare will not work properly in the particular position for which it is required.

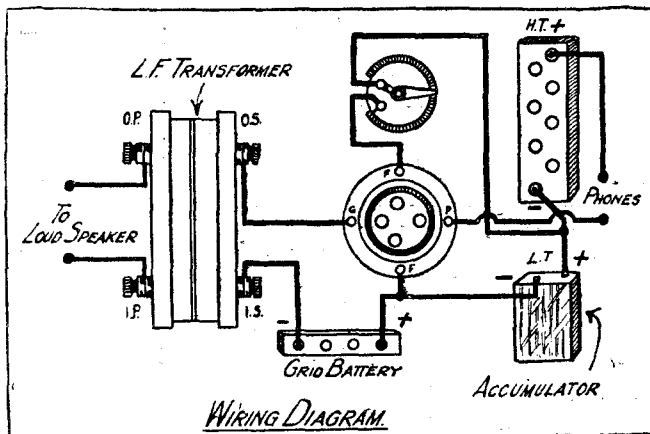

WIRING DIAGRAM.

A quickly improvised amplifier.

RADIO HINTS FOR XMAS PARTIES

(Continued from previous page.)

The message to each child to refer to something which has actually happened at the party. This will create immense surprise even to grown-ups, who have not been "let into the know." So far as the grown-ups are concerned, a great deal of leg pulling can be indulged in, and do not forget that the distortion introduced by the loud speaker when acting as a microphone (however perfect this may be as a sound reproducer) will

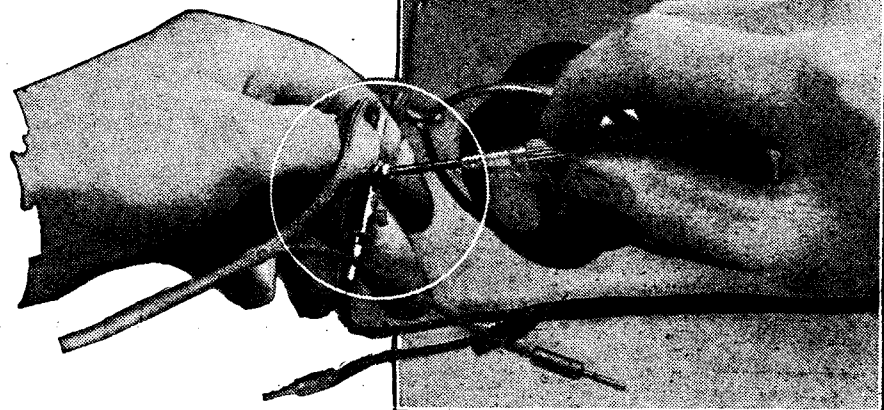

'Phones can be quickly joined with connectors.

be in most cases sufficient to render the voice of the speaker unrecognisable, although everything said will be clearly audible.

If a really efficient two-valve amplifier is available, the telephones can be dispensed with, and the sound made to issue from a second loud speaker. A further elaboration is to arrange a change-over switch by which the input and output leads can be reversed, so that between "announcements" the operator in the other room can hear what is being said in the other room. For example, the "announcer" may have made a certain humorous statement regarding some member of the audience who is likely to make some comment. With a quick change-over to the other room, this comment will be heard by the operator, and can be replied to, creating further mystery.

Many variations of the ideas suggested are possible, and no doubt readers who ring the changes will write and tell us how they have carried them out.

MORE HALE LETTERS

Dear Sir,—I have tried out the above receiver in the de luxe form, as described in POPULAR WIRELESS, only I have used none of the components mentioned, having used others of good make. Also, it is only in the hook-up stage.

Using a B.4. valve with 100 volts H.T., Manchester (23 miles), Liverpool (16 miles), and Daventry came through at moderate L.S. strength, which many people would call sufficient.

This I consider excellent, in view of the fact that the aerial consists of some sort of covered wire

without further insulation, wedged down the door of my workshop, and attached to a metal spout at the other end.

I have had to put a '0001 mfd. condenser across the secondary of the transformer, as apparently the self-capacity was too small to bypass the H.F. current.

I am going to make it up properly, with the addition of an extra stage of L.F., and will report how it goes on.

I am using one of the carborundum stabilising units which gives an excellent vernier control of reaction.

Wishing you every success,
Yours faithfully,
ALAN DOUGLAS.
Wrightington, Near Wigan.

In, and mine looks like losing its job after next week's issue of "P.W."

I took the Hale down in the valley, and it is quite loud on London. Sixty volts H.T.

Yours faithfully,
F. CHEELD.
Chesham.

Dear Sir,—Having built up your Hale receiver, I write to say what a fine set it is. I have made it up as a Reinartz, with the coils 50 and 75 wound end to end on a cardboard former, otherwise wiring is as per your diagram.

This gives very good loud-speaker results here at 10 miles from 2 L O, not too loud, but speaking can be heard anywhere on the ground floor and music anywhere in the house.

I have also heard Hamburg and Frankfurt on the speaker; the announcer's voice could easily be heard anywhere in a quiet room; and in addition quite a number of stations on the 'phones.

Selectivity is not very good with me, but I think my aerial is partly at fault. At any rate, I am trying to correct it. The valve is a Cossor Stentor, with about 100 volts on the plate.

I must say I like the very lucid way in which you write (everything is so clear), and I am looking forward to the two-valve set as I have a spare valve. Before building this I had a two-valve Reinartz, and the Hale gives me nearly the same volume on one valve.

Again thanking you.
Yours faithfully,
C. O. BOWLES.
Surbiton.

Dear Sir,—I am taking advantage of your invitation to write you with reference to the Hale circuit. I made it up in its first form—reaction coil—last Thursday evening with components I had handy, an old Bower-Lowe condenser '0005, a small American reaction condenser, and a 250 coil for a choke, and found it so excellent at Norbury where I live, eight miles from 2 L O, that I decided to make up the Reinartz. I did so the following night with a Newey '0005, a junior polar '0003, a Varley choke, an R.I. crystal, Royal transformer, and Igranic coils, and found this much better. With a D.E.5 valve it worked a Brown's small gramophone attachment at decent loud-speaker strength for a small room on band performances and clear on speech. On Sunday I added an amplifying valve with a Ferranti A.F.3 transformer and using a Cleartron '25 as the first valve and the D.E.5 as the second. I got 2 L O much too loud to be comfortable, but clear. I found I could not cut 2 L O out in order to get any other station in the U.K., but when 2 L O was closed down I could get quite a number of Continental stations on the 'phones.

Yours faithfully,
J. D.
London, S.W.1.

Dear Sir,—Regarding the Hale circuit you published in No. 230 of POPULAR WIRELESS, my set was an ordinary reflex, so I dismantled it and wired it up as in the Hale circuit. The results were beyond my expectations. Radio-Paris came in at good strength on two pairs of 'phones. Daventry could be heard 20 ft. from speaker, also Manchester at about the same strength. The local station at gramophone strength. In conclusion I thank you for publishing such a fine circuit.

Yours gratefully,
J. F.
Belfast, Ireland.



Listening to the Christmas greetings.

If you keep your loud speaker permanently connected to the loud-speaker terminals, as already indicated, you can plug in after the detector or first note magnifying valve with the telephones whenever you desire. I have not made any arrangement to listen on all four valves, as experience shows that it is practically impossible to stand the strength obtained in this way.

One thus uses telephones for listening in on detector or one note-magnifying stage and the loud speaker on two. If you wish to connect the loud speaker to one note-magnifying valve, you can join it to

THE "4 VALVE FAMILY" UP TO DATE.

By PERCY W. HARRIS, M.I.R.E.

Last week the first practical details were given. Here we have further hints, and a complete new wiring diagram.

the work of a moment to disconnect the two leads from the loud-speaker terminals and to plug in the jack as required.

Readers will appreciate that the introduction of the switching system to change over from telephones to loud speaker as well as the jack system would involve further

the potentiometer entirely. The .002 mfd. fixed condenser connected to the old telephone loud-speaker switch can be discarded, and in this position I suggest you mount the .015 fixed condenser referred to in the list of parts required.

The second Mansbridge condenser which I have suggested should be 1 mfd., although any expedient value from .3 upwards can be used, should be placed as near as possible to the existing one. When these parts are fitted you are ready for the wiring changes.

Those readers who are accustomed to read circuit diagrams will themselves be able to make the changes necessary by examining the two diagrams in the last article. The less experienced reader will prefer to work from the complete detailed wiring diagram below.

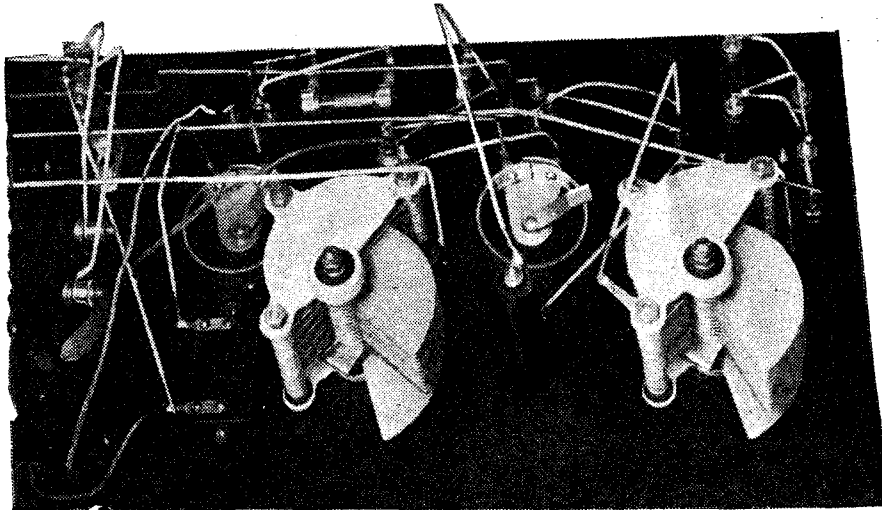

A "close-up" of the rewired set.

a plug, but generally the arrangement adopted will be found satisfactory all round.

For those people who do occasionally wish to change their loud speaker over, it is very simple to connect a plug in parallel with the lead going to the set. If, then, it is desired to use the loud speaker with one note-magnifying stage only, it is

complications which I did not think it warranted, as the jacks themselves provide practically all the switching that is generally required.

Very few changes.

Underneath the panel it will be necessary to mount the .0002 mfd. fixed condenser in

AN INDOOR AERIAL HINT.

MANY people use needlessly heavy and unsightly wire for their indoor aerials. Where it is desired to fix an indoor aerial in the picture moulding, there is nothing to equal the cotton or silk-covered electric lighting flex obtainable from any electrician's shop. There is no need to untwist this double flex, for the two ends can be joined together by baring and twisting, giving us two wires in parallel, which is a slight advantage.

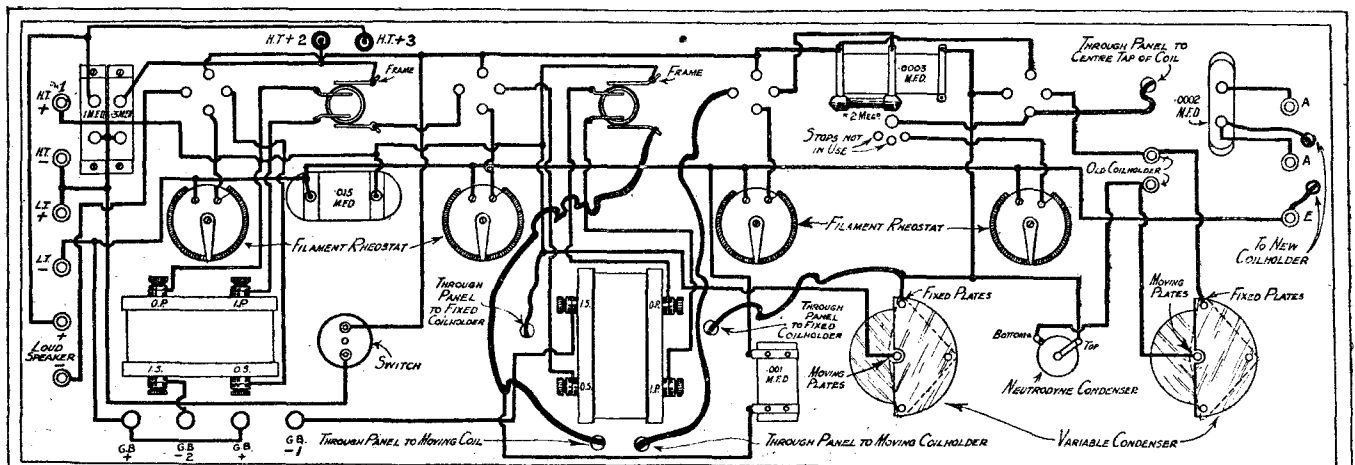

WIRING DIAGRAM



Note.—In this section Mr. Harris will discuss each week interesting points from the large correspondence he regularly receives. Readers are invited to write to him on matters of interest, and extracts from their letters, together with Mr. Harris' comments, will be published from time to time. It must be pointed out, however, that general and technical queries cannot be answered in this section, but should be addressed to the Technical Query Department, complying with the conditions laid down under the heading "Technical Queries" in each week's issue of POPULAR WIRELESS.

I HAVE before me a letter from a reader in Worcestershire who, in speaking of his Hale set, said: "I am using a B.5 valve, and I hope to be able to put on the second valve before this week's POPULAR WIRELESS. I note you say valves should be of the same type. Perhaps you will be good enough to say whether I should use another B.5 general purposes, or, if not, what would you suggest?"

In "The Guaranteed Reflex" the reason for saying valves should be of the same type is that, for simplicity, both are controlled by the same filament resistance and have a common grid bias. My correspondent can certainly use another B.5, which, as readers probably know, is a .06 ampere valve, but he is not limited to this one make, as provided he uses any other .06 ampere valve with similar characteristics (such as the Marconi or Osram D.E. 3, Mullard D.06 L.F., or Ediswan A.R.06 green line), he will get satisfaction, and these valves are all the same price.

More Suitable Valves.

While the .06 ampere valves are very convenient where a low consumption is desired, they do not give such good results in the Hale receiver as valves specially designed for low-frequency magnification. The Hale receiver, particularly the two-valve form, gives such strong signals that the .06 ampere cannot possibly handle the energy without distortion. This is no reflection on this type of valve, for it is not recommended by the makers for really great volume.

Here is another letter typical of many: "Dear Sir,—I am contemplating building The Guaranteed Reflex. Can I use two orange spot Weeco valves in this set?"

The orange spot Weeco valves are two-volt type, actually working at a filament voltage of from .8 to 1.1 with a filament current of a quarter ampere. The makers recommended anode volts from 17 to 60, and my correspondent wondered whether this voltage is high enough.

First of all, where the makers recommend anode voltages within certain limits you can take it as certain that the life of the valve will be considerably shortened if the maxi-

mum voltage is exceeded. In any case, as the orange spot valves are the L.F. model, they can be expected to give good results in the Hale receiver, provided they are not expected to give very great volume free from distortion. Ordinary low frequency valves (as distinct from the special power valves) are excellent for general work on ordinary room loud speakers, but practically every valve manufacturer now makes special types for use where very large undistorted volume is required.

NEXT WEEK:

Full Wiring Diagrams of

"THE KING OF THE AIR"

and

DETAILS OF ADJUSTMENT

Loud-speaker Queries.

There seems to be considerable doubt in some readers' minds on the question of loud speakers and the differences between the large and small models in various makes. Quite a number of readers apparently hold the view that a large loud speaker would "strain" their set, and they fail to realise just how these instruments work.

The output of a wireless receiver is in the form of varying electric currents carrying the modulations of the received signals. The stronger the variations of the currents, the stronger the signals that will be obtained. When these variations are very powerful they produce, when passed through the windings of a telephone, so much sound that we cannot bear the earpieces near our ears.

Now, as the sounds are being produced in the telephones and are too loud for head wear, is it not possible to distribute the sound by some other means? That is what the loud speaker does, and indeed many of the cheap and small loud speakers

consist of a single earpiece (as used in telephone headgear) attached to a loud-speaker horn. Such loud speakers are really single telephone receivers attached to a megaphone.

Now, when the volume is not too great, such devices can give excellent results, but their construction and, particularly, the small diaphragm used, is not suitable for the large variations of current obtainable from many wireless receivers. It is much better to design a special base containing the electro-magnetic portion, so that we avoid the necessity of overloading inadequate apparatus.

A Comparison.

Let us assume for a moment that we have a certain strength of output from our wireless receiver and we have before us a pair of telephones, a small loud speaker, and a full-size model.

On connecting the telephones to the output of the instrument we hear a rattling and distorted reproduction due to the gross overloading of the telephones and the vibration of the telephone diaphragm against the magnetic poles. On replacing the telephones by the small loud speaker we get quite good reproduction which will satisfy many people; but, now, on replacing the small loud speaker by the large model, we get, in most cases, an increased volume (due to the greater efficiency of the horn), and in nearly every case greater purity and naturalness.

The small loud speakers made by many manufacturers are undoubtedly excellent and splendid value for the money, but for those who care to pay extra and obtain a full-size model, the expenditure is well worth while. As distributors of sound the large loud speakers are more efficient in volume and quality than the smaller types, and if a set works well with a small loud speaker you can be perfectly certain that it will work still better with a full-size model.

A Valve Question.

"What has happened to my dull emitter valve?" writes a reader in Edinburgh. "The signals have entirely disappeared although the filament is still intact (I can see it burning), and it is not shorted to plate or grid. It was giving splendid results until recently. I thought it had 'gone off' a few weeks ago and increased the filament voltage, but the fault then turned out to be in my condenser. Soon after curing this the present trouble developed, and although I have tested every component, I cannot find what is the matter."

Dull emitter valves very rarely burn out except by accidents with the high-tension battery or really gross abuse. A filament rated at 2.8 to 3 volts will burn for some time with 4 or 5, or even more volts, but its sensitiveness will disappear in a very short time.

Dull emitter filaments as used to-day are capable of giving off a copious stream of electrons at comparatively low temperatures, and many of the filaments have a special coating on the surface which gives them this property. Running the filament at a higher temperature than normal will cause this coating to be dissipated, and the uncoated wire will fail to give any emission of a practical value.

Don't let your H.T. Battery prevent your loud speaker doing what it wants to do!

We do not advise you to discard your present battery if your loud speaker is performing moderately well, but immediately it is clear you ought to get a new H.T. battery be sure you put in the **LISSEN NEW PROCESS BATTERY**. Notice then bigger volume, purer reproduction than you have ever had—notice particularly how smoothly sound seems to flow from your loud speaker.

Your H.T. battery is the power plant behind the loud speaker—the quality of the energy it supplies is just as important as the quantity. Two or three hours' use of an ordinary battery alters the quality of the loud speaker reproduction. Not so with the **LISSEN NEW PROCESS H.T.** This goes on hour after hour yielding its steady, unvarying, quiet yet forceful flow of energy, whose quality purifies your loud speaker utterance, keeping it crystal clear all the time. And when you shut down, the **LISSEN Battery** immediately begins to build up through the night ready to perform the same unvarying service the next night, and night after night after that, until it really almost seems to go on for ever.

This new **LISSEN Battery** excels all others because we have discovered a new combination of chemicals not hitherto used in battery making. The unique new process, which naturally is a closely-guarded secret, yields far clearer loud speaker reproduction than any previous H.T. battery, and the success of the new process is now a definitely established fact.

We could not have sold this battery under 13/- but for our putting into operation a new policy of direct-to-dealer distribution which cuts out all wholesale profits; besides which the **LISSEN BATTERIES** go straight into dealers' shops—they are actually on sale within three days of being made in our Richmond factory. **LISSEN New Process Batteries**, therefore, have yet another supreme advantage in being absolutely fresh—every one is brimful of *new* energy when you put it into your set.

Made only in the popular block type with socket tappings—an additional advantage are the four 1½-volt tappings provided for grid bias use at one end of the battery, while the other usual tappings give any voltage required.

Obtainable at any dealer's—but if any difficulty, send direct to factory. Include nothing for postage, but please mention dealer's name and address.

LISSEN NEW PROCESS BATTERY is rated at 60 volts, but goes considerably over.

10/6

(Price would have been 13/- but for new policy.)

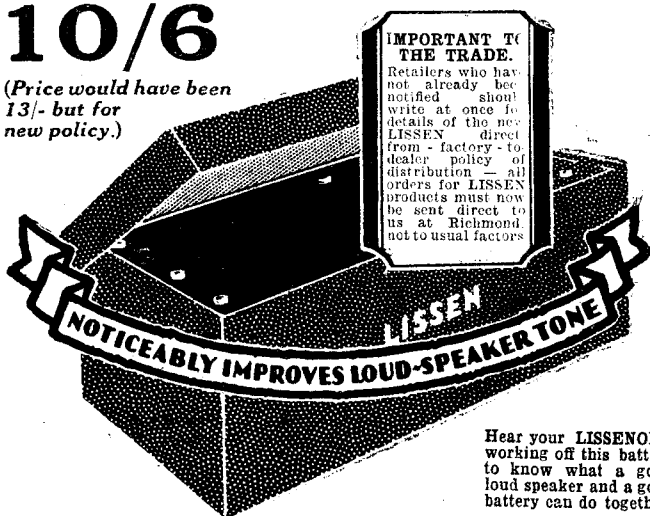

Hear your **LISSENOLA** working off this battery to know what a good loud speaker and a good battery can do together.

Improve Your Xmas Radio With This Better Battery.

USE LISSEN FIXED CONDENSERS, TOO, Mica & Mansbridge Type

LISSEN Mica Type CONDENSERS

Small energy-conserving condensers—note the new case which enables the condenser to be used upright or flat. At present the new case is available only in the most used capacities, but will quickly become a **LISSEN** standard.

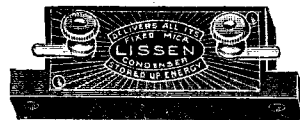

Capacities—
 .001 to .001 1/- each (much reduced).
 .002 to .006 1/6 each (much reduced).
 Accurate to 5%—they never leak—they never vary.

LISSEN Mansbridge Type CONDENSERS

To a fine **LISSEN** quality condenser is added the specially moulded case—the condenser cannot short circuit on to its case. The new **LISSEN** case protects you if the condenser is used in any circuit connected straight on to the electric light mains. And due to our new policy of direct-to-dealer distribution this **LISSEN** Condenser costs no more than the ordinary type.



.01 to .09	2 4
.1	2 6
.2	2 8
.25	3 -
.5	3 4
1'0	3 10
2'0	4 8

LISSEN FIXED GRID LEAKS

A case of these was left on our factory roof during the summer of 1925, soaked in rain, baked by sun, and the resistance value of these leaks never altered.

All capacities, previously 1/8. Now 1/- each.



Improve every circuit by using **LISSEN** parts wherever you can—save money too—for now you get keen prices as well as fine quality.

LISSEN LTD., 8-16, FRIARS LANE, RICHMOND, SURREY
 (Managing Director: Thos. N. Cole.)

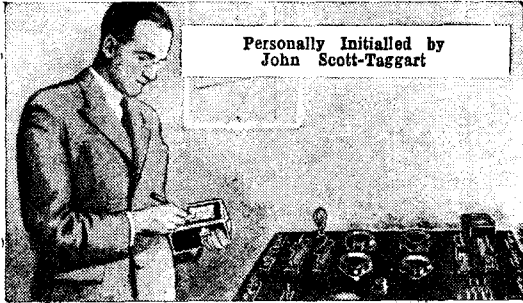

Personally Initialed by
John Scott-Taggart

TESTS

- (1) The filament current must be right for a given filament voltage.
- (2) The total emission of electrons from the torodium filament must exceed a certain figure which gives a very big factor of safety.
- (3) The voltage amplification of the valve must be right.
- (4) Every valve is tested for mutual conductance, *i.e.*, slope (milliamps. per grid volt).
- (5) The merit of the valve as indicated by $\frac{M^2}{R}$ must reach the very high standard established by the designer.
- (6) The impedance of the valve must be within certain limits.
- (7) The straightness of the dynamic curve is ascertainable from the readings.
- (8) Uniformity of the valves and correct relative spacing of the electrodes are tested by ascertaining the position of a given characteristic curve relative to the grid zero ordinate.
- (9) The very high vacuum obtained by the Barguet process is measured by the ionisation system, using a special meter which reads to a fraction of a microampere.
- (10) The perfect insulation, internal and external, of the valve is ensured.

Users'

"UNEQUALLED,"

says 1st International Prize Winner

May I be one of many to congratulate you on your valves. I have now tried them out thoroughly and words fail me to express my admiration. I really think that they should be labelled "S.T." a second time, the first "S.T." standing for Superb Tone.

I have used them in the Solodyne circuit with which I was lucky enough to be awarded first prize in Chicago, U.S.A.; and I find the combination of S.T.61 in the first three stages, S.T.62 for the first low frequency, and S.T.63 in the last stage, are not to be equalled by any other valve made.

Wishing you every success, which I am sure you deserve, and also rest assured that I shall recommend them to every wireless man who seeks the best results.

H. H. ANSPACH.

(Who won with a Solodyne the 1st prize at The Chicago International Wireless Competition).

"Lorraine," 18, Watling Street, Dartford.

SILVER CUP Winner Speaks of "Extraordinarily Good Results"

I have just tested your new S.T. valves and find them in every way most satisfactory. Their main features are economy in both filament and anode current (the readings in each case being extremely low), a high standard of efficiency, and they are inexpensive. On a very old 3-valve set (on which very unsatisfactory signals were usual) both the 2-volt, 4-volt, and 6-volt types gave extraordinarily good results. On the whole I can thoroughly recommend these valves for all receiving purposes, and I am highly satisfied with the results obtained from them.

J. A. E. BLACK.

(Winner of a 2nd prize and silver cup at the New York International Wireless Amateur Competition, 1926).

School House, Mill Hill School,
London, N.W.7.

Built like the Pyramids—to last

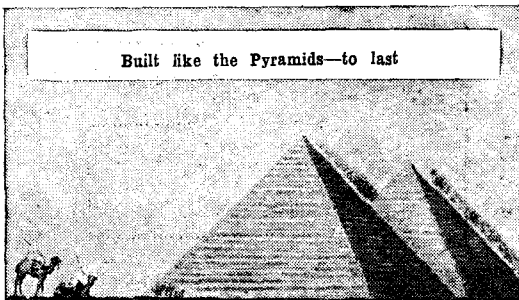

TYPES and PRICES

2 VOLT.		4 VOLT.		6 VOLT.	
S.T.21 (H.F.)	14/-	S.T.41 (H.F. and Det.)	14/-	S.T.61 (H.F. and Det.)	18/6
S.T.22 (L.F. and Det.)	14/-	S.T.42 (Power)	18/6	S.T.62 (Power)	18/6
S.T.23 (Power)	18/6	S.T.43 (Super Power)	22/6	S.T.63 (Super Power)	22/6
	0'15 amp.		0'25 amp.		0'25 amp.

S.T. LTD.,

Views

America on One S.T.

You may possibly be interested to know the results of a few days' tests of an S.T.61 valve in a single-valve receiver (with condenser-controlled reaction) on the normal broadcast band.

On Friday morning, November 19th, I received the U.S. Municipal Broadcasting Station at Atlantic City, between the hours of 12.15 a.m. and 2.30 a.m. (G.M.T.). The programme heard included the following :

A portion of the news bulletin.

Organ Soli (including the " Londonderry Air.")

Morton Hotel Quartet.

A talk (one of a series) on " The Sphinx."

A lecture recital by Mr. S. Thunder, " From Beethoven to Liszt " (arranged by the Board of Education). Items heard included " Moonlight Sonata " and " Liebestraume."

Songs : " O dear, what can the matter be?" and " Mighty like a rose."

I have received U.S. stations on previous occasions on single valve receivers, but have never had such excellent signal strength on the 300/500 metre band.

On Sunday and Monday last I continued with tests on B.B.C. and Continental stations and heard, among a host of unidentified stations, the following : 2 L O, Belfast, Dublin, Glasgow, Newcastle, 5 W A, 6 B M, Stuttgart, Hamburg, Barcelona, Milan, Toulouse, E A J 7, Madrid, Dortmund.

I think that the above results are highly creditable to one of your valves, which assisted the reception by its extremely smooth reaction control and absence of parasitic noises.

I. B. MILLER.

St. Andrew Street, Wells, Somerset.

If you are unable to obtain an S.T. valve from your local retailer write direct to us, or call. All valves will be sent by post and insured by us against breakage. C.O.D. orders executed on receipt of post card.

2, MELBOURNE PLACE,
ALDWYCH, LONDON, W.C.2
(Next to Australia House).

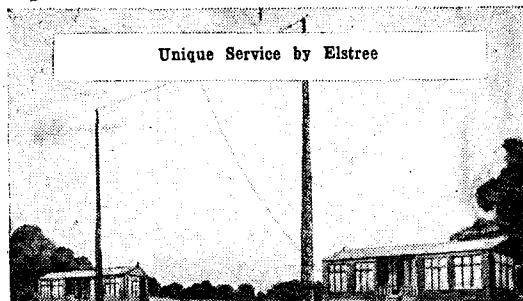

WATCH OUT !

Due to the fact that the terms on which S.T. valves are sold to the trade are different from those of other leading manufacturers, be prepared for attempts to persuade you to buy substitutes which may be represented as " just as good " or " much the same." This may particularly happen where we confine the sale of our valves to certain retailers in a town. There is no other valve which can be substituted for an S.T., and you will, no doubt, oppose any attempt to stop you buying the valve you want.





A Complete Radio course is contained in these two Volumes

HISTORY and PRESENT POSITION of WIRELESS TELEGRAPHY and TELEPHONY

by G. G. Blake, M.I.E.E., A.Inst.P.

In the compilation of this history the author presents a comprehensive review of the historical aspect of Wireless Telegraphy and Telephony.

This History comprises over 350 pages of text, over 1,100 references and 270 illustrations. The Index fills 21 pages—the detailed list of Contents covers six pages. These two features are so arranged that the reader may readily and rapidly turn without difficulty to any required section of the volume in which he may be interested.

Chapters on the discovery of ether waves, the invention of the coherer and other detectors, the development of the telephone and its subsequent application to radio telegraphy; an account of the early pioneer work of Clerk Maxwell, Hertz, Sir Oliver Lodge, Marconi, and other distinguished scientists and inventors; the story of the Edison effect, the development of the thermionic valve, direction-finding work, Beam Wireless and an account of the first Amateur Trans-Atlantic Tests convey the extreme interest and usefulness of this comprehensive volume.

Price
25/-

Post Free 25/9

Publishers' Note :

Every effort has been made on the part of the authors to include in these two books all available information on their subjects. You, who may be reading this advertisement, are assured of spending many interesting hours with the volumes, and we recommend any reader anxious to improve his wireless knowledge rapidly, easily, and pleasurably that he purchases both—either from his usual newsagent or bookseller. Should any difficulty be met, we shall, of course, be pleased to send copies direct.

THE ILLUSTRATED WIRELESS DICTIONARY

Compiled by E. H. Chapman, M.A., D.Sc.

This book comprises an alphabetical arrangement of over 2,000 Wireless Technical Terms and Expressions. However unfamiliar any word you encounter may appear, reference to this volume will provide its meaning and application both clearly and concisely.

It is particularly compiled for the benefit of the enthusiast who desires thoroughly to understand everything he reads, and to render the book indispensable, the author has endeavoured to explain every known term from the earliest days to those of the present. Astatic Coils, Screened Coils, Continuous Waves, Cycle, Double Reaction, Edison Effect, Farad, Electron, Frequency, Harmonics, Impedance, Hot Wire Ammeter, Ionising Potential, Kenotron, Litzendraht, Logarithmic Decrement, Magnetic Permeability, Mutual Inductance, Reactance, Resonance and Wave-group are a few terms chosen at random. This dictionary is complete from A to Z.

Price
3/6

Post Free 3/9

Send your order for one or both of these notable books to Sales Department :

RADIO PRESS LIMITED, Bush House, Strand, London, W.C.2

XMAS RADIO GIFTS

What could be more acceptable Christmas present? This and the following pages give suggestions in pictorial form.

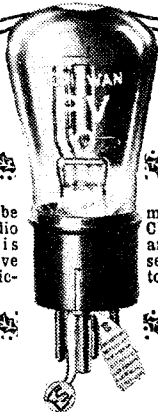

One of the well-known Edison valves is shown above, and below is a handsome "Lamp-shade" Loudspeaker. (B.T.H. Co.)

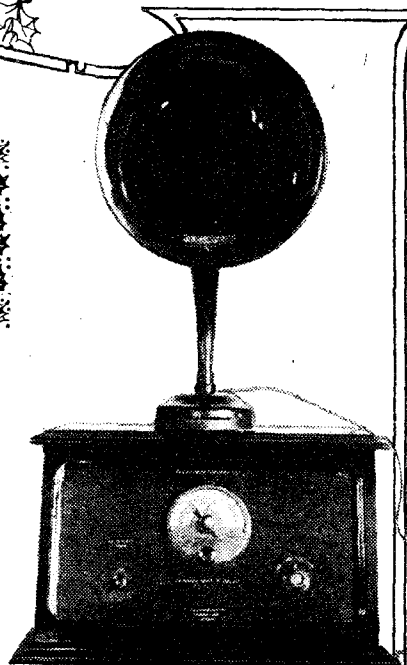
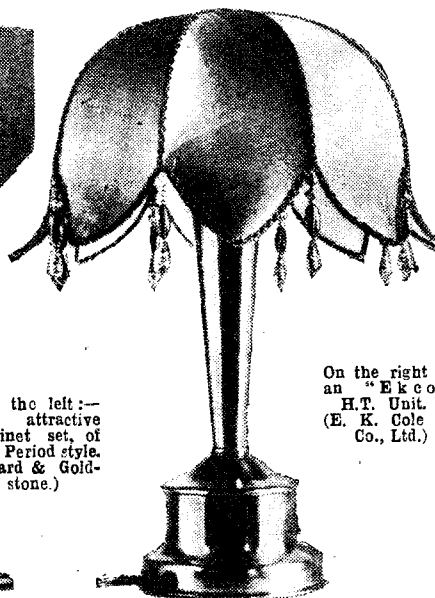

Sir Oliver Lodge's 2-valve "N" circuit complete with Loudspeaker, as marketed by Cleartron Radio Ltd.

Above:—The Lissenola Loudspeaker Unit, built into a wooden cabinet.

On the left:—An attractive cabinet set, of the Period style. (Ward & Goldstone.)

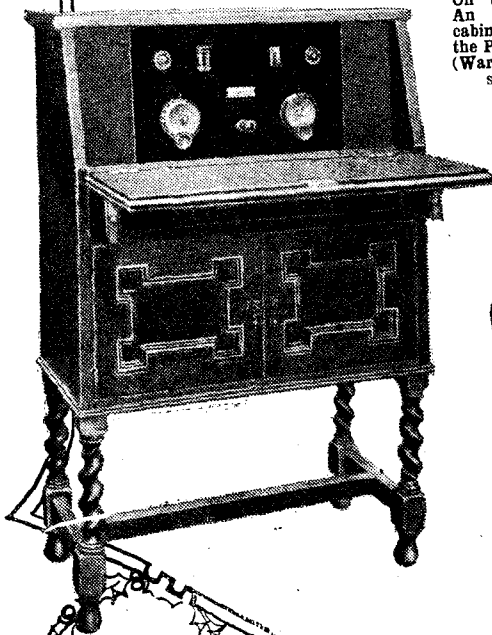

On the right is an "E.K.C." H.T. Unit. (E. K. Cole & Co., Ltd.)

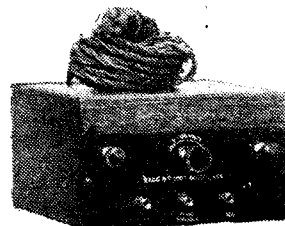

The "Hiton" Battery Eliminator (below) is made by the Dubilier Condenser Co., Ltd.

To the left is illustrated one of the new "S.T." Valves, a very complete range of which is available at standard prices.

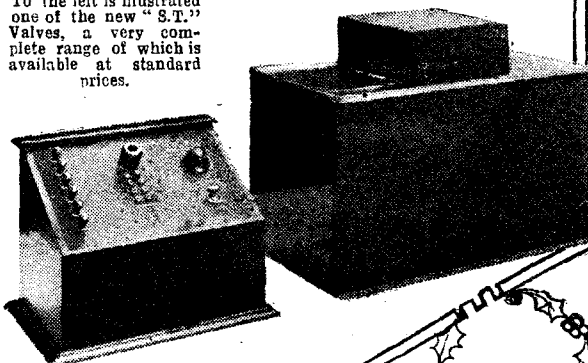

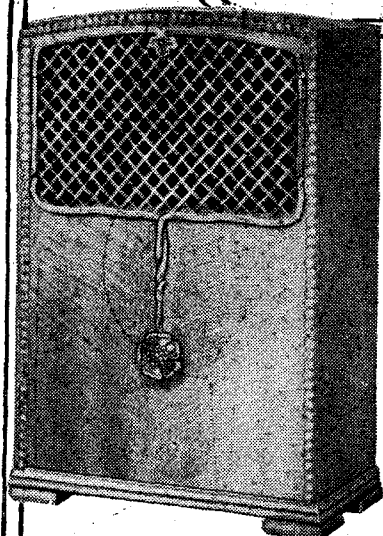

Distinctive design marks the Touchtone Loudspeaker (Gent & Co., Ltd.) Beside it is the well-known R.I. Tuner.

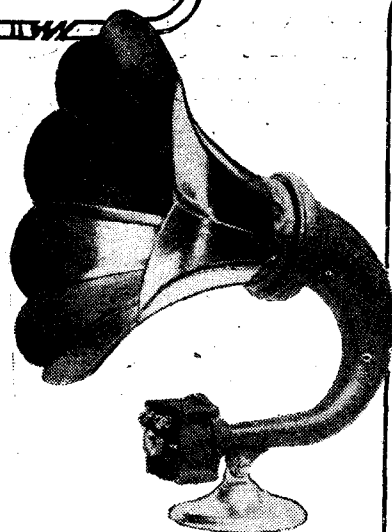
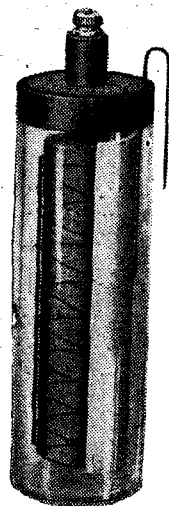
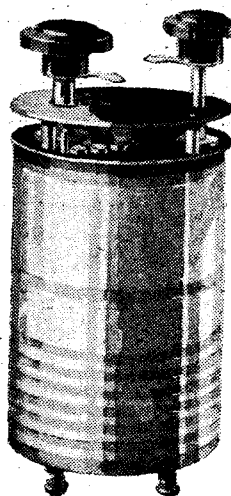

The fluid cell for H.T. is by Siemens Ltd., and the "Amplion Dragon" Loudspeaker is the latest A.R.19 model (Alfred Graham & Co., Ltd.)

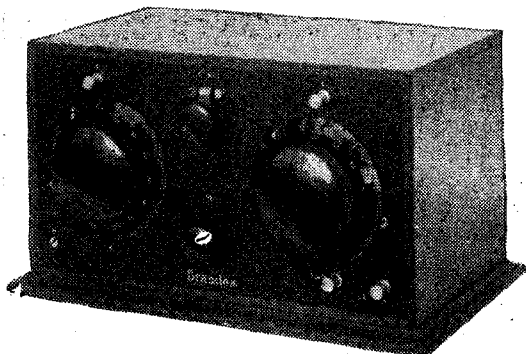

The Brandeset II is shown above, whilst below is the famous Marconiphone "Straight Eight."

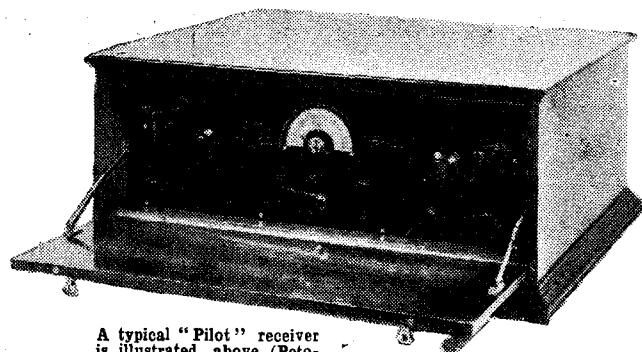

A typical "Pilot" receiver is illustrated above (Peto-Scott, Ltd.).

The valve on the right is the "Cossor, Point One."

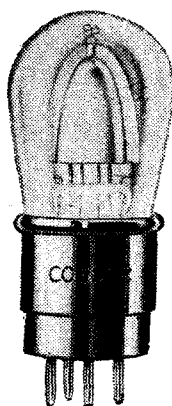

The T.C.C. fixed condenser "speaks for itself."

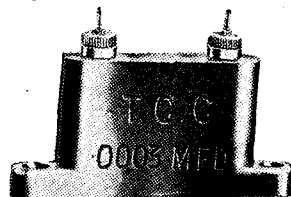

Examples of the Mullard P.M. Valves and a G.E.C. Cone-type Loudspeaker are illustrated on the right.

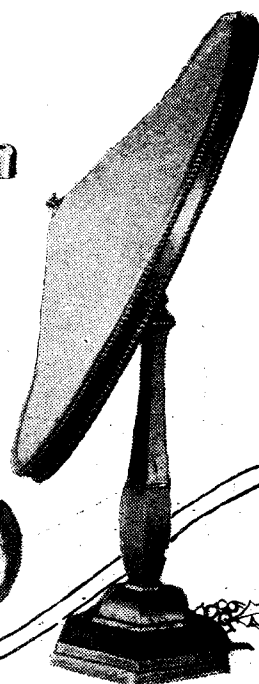
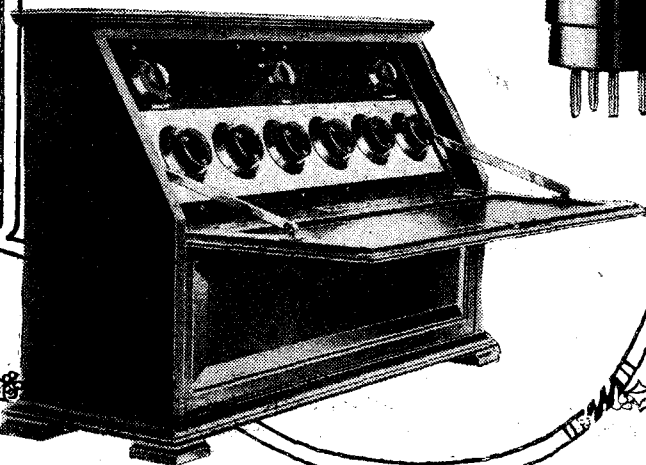

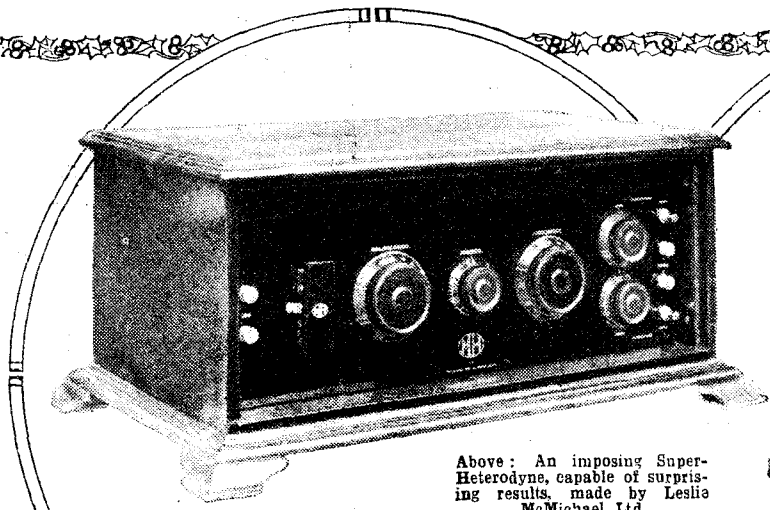

Above: An imposing Super-Heterodyne, capable of surprising results, made by Leslie McMichael, Ltd.

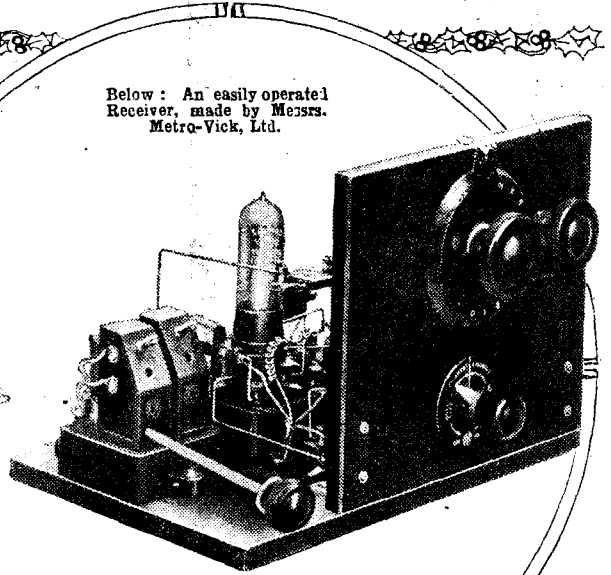

Below: An easily operated Receiver, made by Messrs. Metro-Vick, Ltd.

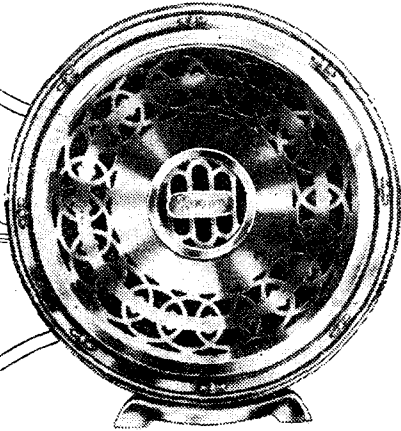

Below: A compact H.T. Accumulator by Oldham & Co.

Left: The Brown New Disc - type Loud Speaker.

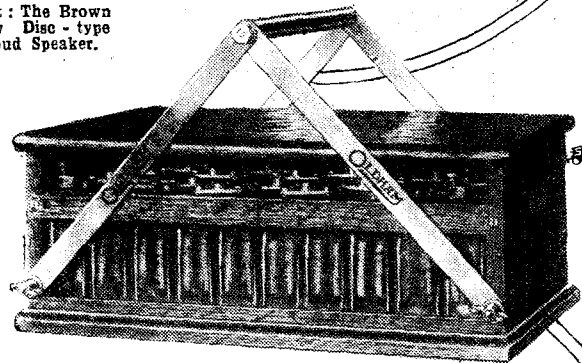

Below: The new type C.A.V. Cone Loud Speaker.

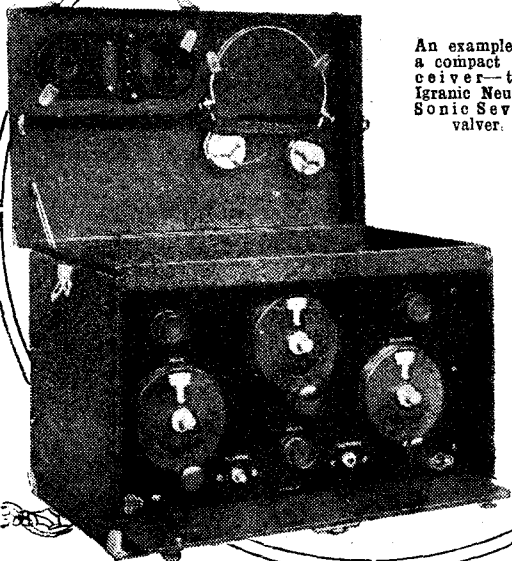

An example of a compact Receiver—the Igranic Neutro-Sonic Seven-valver.

Left: A useful component—the Eureka 2nd stage Concert Grand L.F. Transformer.

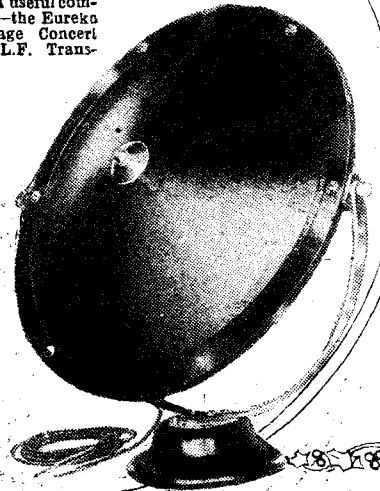
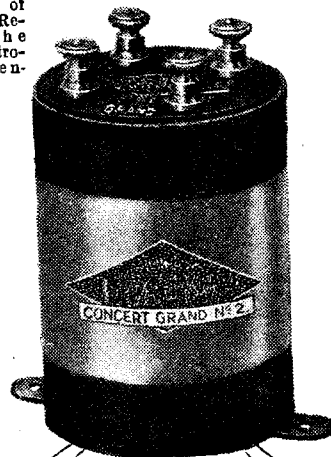

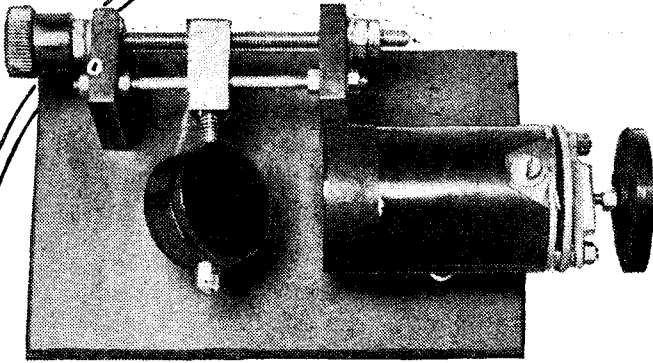

An Ormsby R.T.C. Unit which provides a Universal Aerial Tuner with variable reaction.

A neat crystal receiver — the "Bijou"—manufactured by the B.T.H. Co., Ltd.

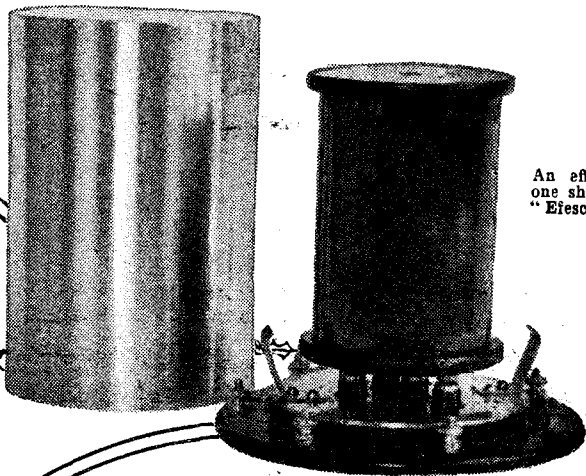
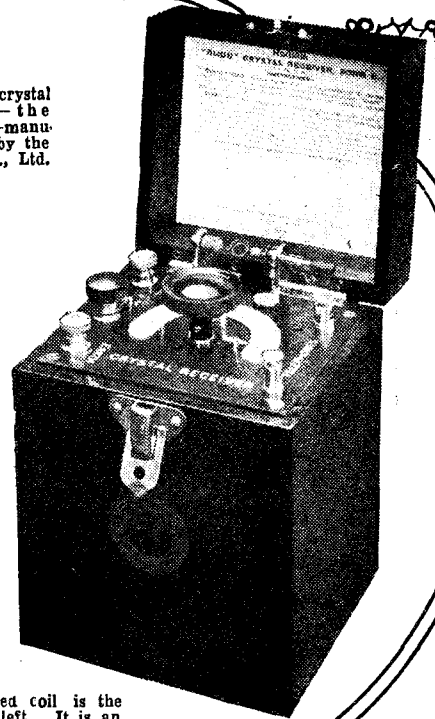

An efficient screened coil is the one shown on the left. It is an "Efesca Centadyne" with detachable screen.

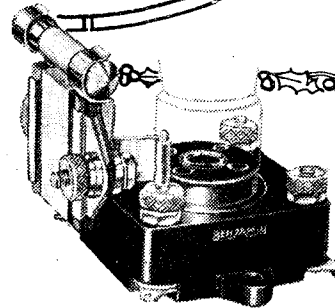

Above: A recent valve holder made by the Benjamin Electric, Ltd., incorporating a special grid leak and condenser fitting.

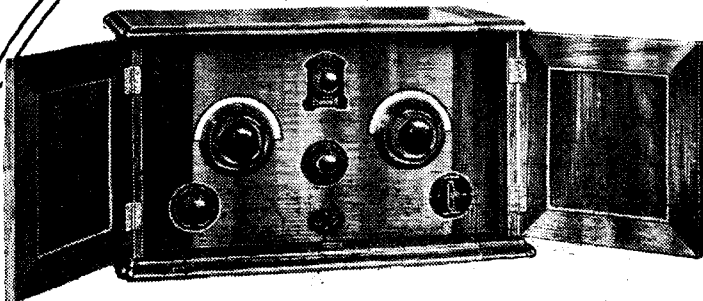

Left: The "Ethophore" Four" is a handsome instrument and makes an ideal Xmas present.

Below: A new type of H.T. accumulator—the Hart "Ray" type 20-volt unit.

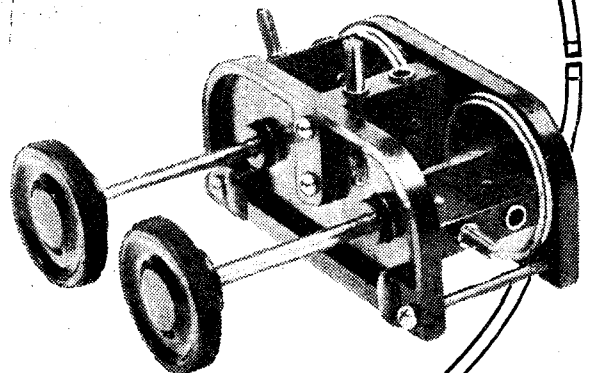
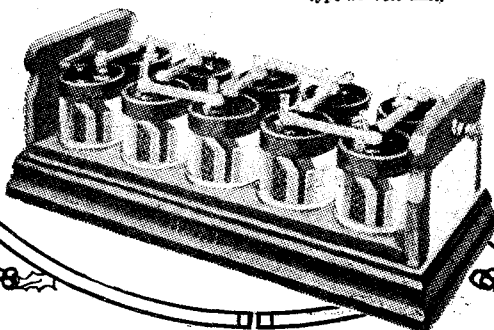

The "Lotus" vernier coil holder is a very popular component of high-class construction.

STERLING CONDENSERS

SQUARE LAW and MANSBRIDGE TYPES

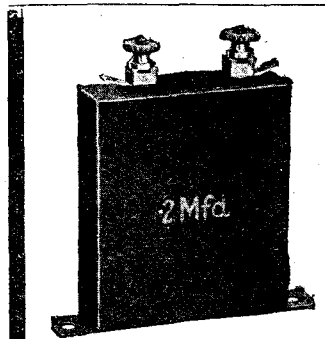

STERLING

MANSBRIDGE TYPE

Supplied in a complete range of capacities enclosed in thin steel cases, and each instrument is tested at a considerably higher voltage than that for which it is rated.

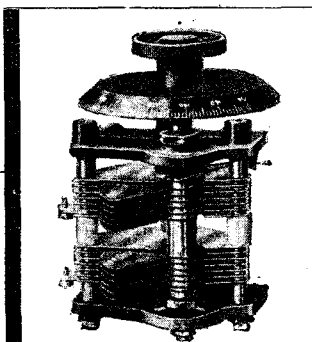

Double Type

STERLING

Double and Triple Types

Specially suited for simultaneously tuning two or three circuits respectively. Each section is .00025 mfd. capacity.
Double Type . . . 11/6 Triple Type . . . 15/-

Particularly suitable for blocking condensers—for the purpose of shunting high frequencies across telephones, high tension batteries, etc.

- .1 mfd. 2/6; .2 mfd. 2/8; .25 mfd. 3/-; .3 mfd. 3/-; .4 mfd. 3/2;
- .5 mfd. 3/4; 1 mfd. 3/10; 2 mfd. 4/8; 4 mfd. 10/-; 6 mfd. 14/-; 10 mfd. 20/-.

STERLING MINILOSS Square Law Type

Ideal condensers for "low-loss" working, fitted with a slow motion movement, perfectly smooth in operation, and with no "back-lash" action. "Pyrex" glass plugs insulate the fixed plates—these plugs are outside the electrostatic field, reducing High Frequency losses to the minimum; no side play is possible with the moving vanes, which are permanently attached to the frame with a flexible connection, obviating grating due to bar or high resistance contact.

Capacity, .00025 mfd. 14/- Capacity, .0005 mfd. 15/-
Capacity, .001 mfd. 16/-

Sterling Condensers give consistently perfect results and satisfy the most exacting experimenter. Correctly designed and made from finest materials, they are unsurpassed for all-round efficiency.

Sterling publication No. 440 will give you full particulars—write for a copy.

The Marconi International Marine Communication Co., Ltd., require 500 qualified Wireless Operators. Apply to Service Manager, Marconi House, Strand, London, W.C.2.

STERLING "TYPE 33" SPEAKER

THIS model has been designed primarily to improve the reproduction of the lower notes without sacrificing the higher tones, in order to effect a more faithful rendering of broadcast music than has heretofore been possible with commercial loud-speakers.

In the past all efforts to successfully reproduce the low tones, whether by horn or cone, have resulted in a general falling off in the efficiency of the in-

strument, thus increasing the number of valves required in the receiving set. The volume of output for a given input will be found to be greater than with the majority of loud-speakers, while the range is far greater. From the pedal notes of the organ to the top notes of the piccolo, the music is reproduced with great faithfulness. Height 23 ins.; diameter of flare, 14 1/2 ins.

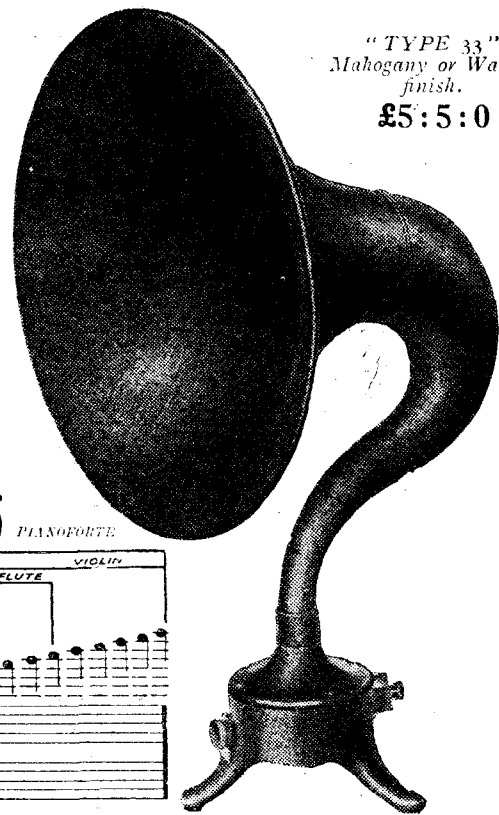

"TYPE 33"
Mahogany or Walnut
finish.
£5:5:0

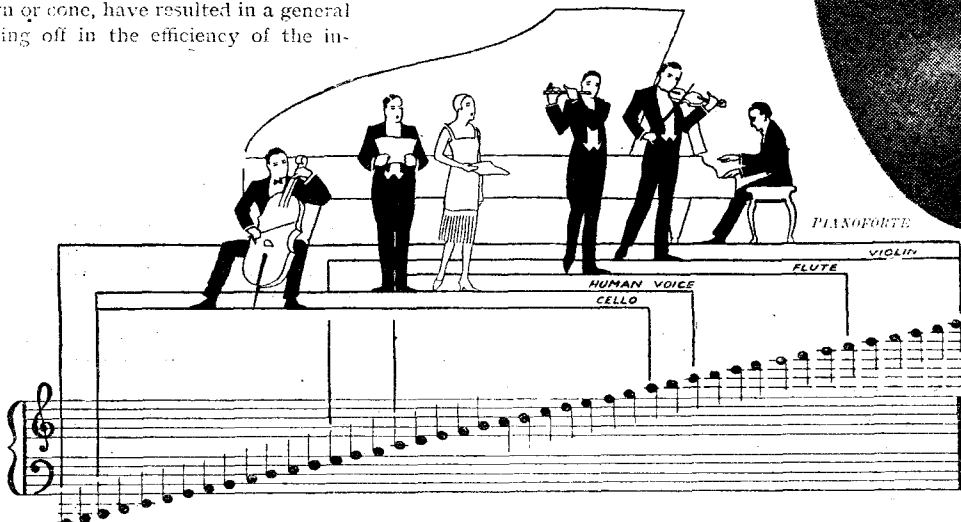

THE MARCONIPHONE COMPANY, LIMITED,

(Sole Agents for Sterling Telephone & Electric Co., Ltd.)

Regd. Office:
Marconi House, Strand, London, W.C.2.

Head Office:
210-212, Tottenham Court Road, London, W.1.

Send for literature describing the full range of Sterling loud-speakers.

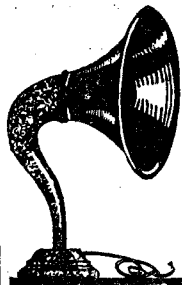

Throw away the headphones buy this loud Speaker

LET all the family enjoy the radio. Here is a Loud Speaker that was bound to come—it has long been needed. Matching in tone and volume any £5-5-0 instrument, it has been costed low so that thousands can buy and enjoy where before high prices prohibited. Profits are cut to a minimum, quality achieves a maximum and so great is our faith in the Allhall Speaker that we sell it to you with a

MONEY BACK GUARANTEE

Buy one, try it, and if you are not satisfied send it back within 7 days and your money is return without any questions being asked.

Obtainable from all Radio Dealers.

READ THIS DESCRIPTION

The Allhall Loud Speaker stands 21 in. high and has a depth of 14 in. from back to front; the base is 6 1/2 in. overall and is finished in teed black lacquer, relieved by a nickel plated diaphragm control, and supplied complete with long plug-in cords. The neck is of teed black lacquer, and 3 nickel screws secure the horn which is finished in matt black and has a flare of 14 in., ensuring resonance and volume.

276

L.K. Kremner

Radio Engineers
49a, Shudehill, Manchester.

An Ideal Gift!

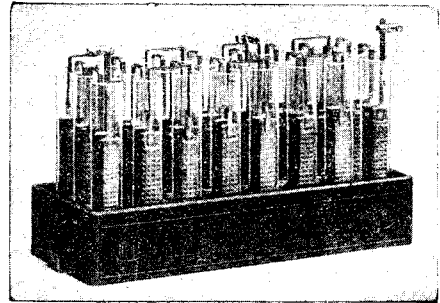

STEEL PLATE H.T. BATTERIES

30 Volts - - - 30/-

Last a Lifetime. No Noise. No Self-discharge. No Sulphation.

BATTERIES LIMITED, REDDITCH.

London Showroom: 220, Shaftesbury Avenue. W.C.2.

JACKS 4-POINT 1-Hole Fixing 1/9 '0003 '0005	S.L.F. CONDENSER With 4-in. dial. '0003 .. 7/- '0005 .. 7/3	RELIABILITY CONDENSERS Mids. Type. '25, 1/6 1 mls. 2/6 '5, 1/9 2 mls. 3/6	WIRELESS CABINETS For Panels 7 in. high Width 8 in. Hinged Lid Oak 12 in. 17/- 14 in. 17/6, 18 in. 18/6. Mahogany 1/- extra. 	DEWAR SWITCH 12-Contact 2 6
---	---	---	--	--

READ THIS LIST AND SAVE MONEY ON COMPONENTS

EBONITE.—Any size cut; Clayton brand, 1 in., 3d. sq. in.; 3 in. by 6, 2/3; 12 in. by 8, 4/2; 15 in. by 9, 9/6; 3/16 in. 25 per cent. less. Farson and Radion, 1d. per sq. in.

AERIALS.—100 ft., 4 in. copper tape, 1/6; 7/25s Bright, 2/3; Enamelled, 3/3; Electron, 1/8; Superial, 2/6; Mars, 9/8; Ashton Spreaders, 12/- per pair; O.V., complete, 2/6; INSULATORS.—Large, 3d.; Reel or Egg, 1d.; Climax, 6d.; Ditto, with shock absorbers, 3/- pr.; Gal. Pulleys, 4d.; 100 ft. Gal. Straining Wire, 1/6; Straining Bolts, 6d.

TERMINALS & ACCESSORIES.—Single W. Office N.P. or Pol. Brass with nut and washer, 1d.; Phone and Castle type, 1d.; Double Mark, 3/2d.; 4-way Phone Connector, 6d.; Pole-landing paper, 3d.; Flux, 2d.; Black Tape, 6d. coil; 4 in. Empire Tape, 6d.; dozen yards; Insulating tube, 3d. yard; Glazite, 1/2, 10 ft. coil; Shellac Varnish, 6d.; Mica 2 in. x 1 1/2 in., 4d. dozen; Chattertons Compound, 9d.; Hand Drills, 3/6, Drills, 1/1.

ACCUMULATORS.—Exide, D.T.G., 4/6; D.F.G., 6/6; W.J., 20 v., H.T. type, 15/-; Oldham H.T. 10d. per volt, complete; Duros 20 v., 11/-; 10 v., 5/6; Repairing Outfit, 2/6.

CONDENSERS.—Low Loss, Square Law, with knob and dial, '0005, 5/-; '0005, 4/6; with Vernier Blade, 1/4 extra; Twin '0005, for Ektree Six, unequalled value, 9/6; Cydon Twin for ditto, 27/6; Ormond, J.B. Utility, Sterling, Foliar, Formo, Igranac, G.E.C. Var. in all capacities. Neutrodyne types, Ormond, 2/-; Colvern, 3/6; Gambriel, 5/6.

FIXED CONDENSERS.—Dubilier, Edison Bell, Lissen, Watmel, Mullard, McMichael, at advertised prices. Special Reliability Fallon—.0003 mid. 2 meg. Leak, 1/3; Cases only 4d.

BATTERIES.—Reliability, 30 v., 11/-; 60 v., 7/6; 36 v., 4/6; 15 v., 1/10; Ever Ready, Siemens, Helleon, 100 v., 21/-; 86 v., 12/6; 36 v., 7/6; Flashlight Battery Cases for 14 Batts., 3/6; 4 v. Batts., 4d.; 60 v. Unequalled, 6/6; Wan. Plugs, 1d.; Cliz Type, 2d.

L.F. TRANSFORMERS.—R.I. Multi-Ratio, 25/-; Marconi Ideal, 25/-; Junior, 18/6; Ferranti A.F.3, 25/-; A.F.4, 17/6; Formo, 10/6; H.T.C. Empire, 7/6; Croix 5 to 1, 6/-; Lissen new type, 6/6; Igranac, 15/-; Eureka Concert Grand, 25/-; No. 2, 21/-; Baby Grand, 15/-; Ormond, 11/-; Royal, 20/-; Success, All Royal, 21/-; Silvertown, 21/-; G.R.C., 15/-; Brandes, 17/6; Brurndet, 16/6; Special Value, 7/6; Modulation, 7/6.

VALVE HOLDERS.—Anti-Phonic Benjamin, 2/9; Lotus, 2/3; with terminals, 2/6; Burndet, 2/6; Harlie, 1/6; Reliability, unequalled, 2/-; all baseboard types, ord. ditto, 6d.; N.P. Valve Sockets, flush fitting, 1d.; Superior Panel Type, 6d.; All Ebonite, 10d.

HEADPHONES.—B.T.H., 15/-; Brown's 'F' Type, 20/-; Reliability, 7/6; Adjustable, 8/-; Dr. Nipper, 12/11; T.M.C., 17/6; Western Electric, 20/-; all 4,000 ohms; Sullivan, 120 ohm Double, Ex-Govt., New, 4/-; 120 ohm Single Phone, 2/6; Long Phone Cord, 1/-.

RECENT REDUCTIONS.—Sterling '0005 Square Law Condensers with Vernier, 9/8; Geared 12/-; Miniloos, 15/-; '00025, 8/6; Geared, 10/6; Miniloos, 14/-; Marconi Automatic Detector, 2/6; Series Parallel Variometer, 10/6; Eddystone Absorbos Feet, set of 4, 2/3; Benjamin S.F. Switch, 1/3; N.P. Cliz Plug & Insulator, 24d.; Adaptor, 11d.; Socket 2d.

LATEST COMPONENTS.—6-Way Coil Stand, 2/9; Colvern Low Loss Inductance Former, 3/-; Formo Straight Line '0005 Condenser, 10/6; Success, 18/6; Eureka, 15/6; Cydon, 15/6; Lissen 60 v. H.T. New Process Battery, 10/6; Valve Vibrating Springs, 6d. set of 4.

VALVES.—"Radion" all types, Frelat 2 volt. 3 amp., 4/11. All advertised makes stocked.

EXPERIMENTERS' PARCELS. Accessories of Various Types, worth 20/-, post paid, 5/6.

Send for New RELIABILITY WIRELESS GUIDE No. Free on Request Trade Supplied.

J.H. TAYLOR & CO.
4. RADIO HOUSE,
MACAULAY ST., HUDDERSFIELD.
Tel: 341. Grams: THOROUGH HUDDERSFIELD.

Orders 5/6 Value Carriage Paid. Under 5/6 2d. per 1/- for Packing, etc.

FRELAT D.E. VALVES

4/11 8/6

TYPE K.
Detector and amplifier
2 volt 3 amp.

TYPE D.K.P.
1.8-2v. 3 amp.
New 2 volt power-valve.



MUCH MORE FOR MUCH LESS.

CUT out the high maintenance cost in Radio and use Frelat Dull Emitter Valves. For performance and long life they are unexcelled and yet the Type K valve costs only 4/11. Next time put Frelat to the test and let this guaranteed valve prove that high prices are not necessarily the key to the best reception.—If your dealer cannot supply, send direct: For C.O.D. terms add 4d.—postage free.

CONTINENTAL RADIO IMPORT CO., LTD.,
8, SPITAL SQUARE, LONDON, E.C.1.



20/- down buys any of these superb Sets for Xmas

YOU buy your House by deferred payments. You purchase your furniture out of income and perhaps even your motor-car by the same up-to-date methods. Then why not choose a really good Wireless Set and pay for it as you use it. How much more satisfactory to buy out of income a worthwhile Set capable of giving excellent results in preference to something considerably cheaper and less satisfactory.



The 4-Valve Family

A Set which can be thoroughly recommended for home use. Splendid Loud Speaker results and ideal for long distance reception when required.

£1

down and 11 monthly payments of 24 --

The Puriflex
A Splendid Set for purity of tone. Ideal for local reception where perfect reproduction is essential.

£1

down and 11 monthly payments of 15 6.

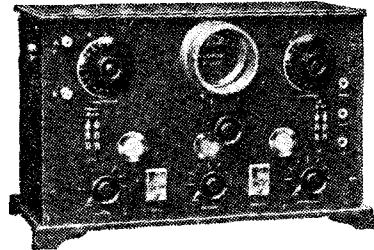
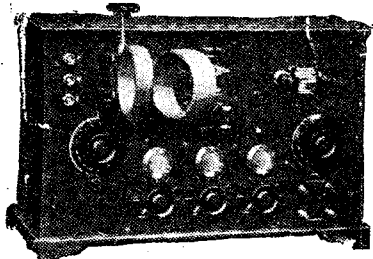

The All Concert-de-luxe

An excellent all-round Set suitable for all purposes.

£1

down and 11 monthly payments of 21.

Two-Valve Reflex
A famous 2-Valve Reflex Receiver of great power and extreme sensitivity.

£1

down and 11 monthly payments of 15 --

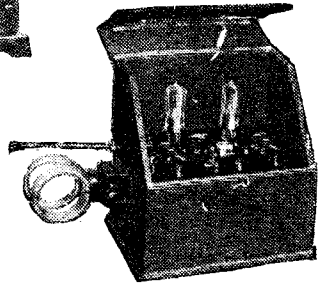

All the above Receivers are fully guaranteed and prices include Marconi Royalties. These sets are also available for home assembly at a saving in cost. Send coupon for further particulars

SEND FOR NEW CATALOGUE!

In our latest catalogue there are details of a wide range of guaranteed receivers which are available to all responsible readers of this journal. Send for a copy to-day, and mention the type of set you require. Catalogue "P.R." Post Free 6d.

New Times Sales Company,
77, City Road, London, E.C.1.

P.S. 6554.

WE DO NOT TALK ABOUT SUCCESS—WE GUARANTEE IT

Guarantee.

I hereby guarantee that I will provide each Student of The Bennett College with tuition until he has passed the examination for which he has enrolled.

I further guarantee to provide all the necessary books free of charge and undertake that no further fees will be required other than those stated on the form of enrolment.

WE GIVE A WRITTEN COPY OF THIS GUARANTEE TO EVERY STUDENT.

M. Bennett

F.R.S.A., M.I.Mar.E., A.I.Struct.E., etc. (GOVERNOR), THE BENNETT COLLEGE, SHEFFIELD.

Having helped thousands of others to achieve success and advancement, it may be possible that we can help YOU.

I am assisted by a large and expert staff, and the advice we give is sound. If we cannot help you we will say so; if we can we will tell you how.

We have FREE booklets setting out the possibilities in connection with each of the subjects shown in the lists; send for the one in which you are interested, or ask for MY PRIVATE ADVICE, which also is free. You incur no obligation.



Most Moderate Charges, Payable Monthly.

EXPERT TUTOR FOR EVERY DEPARTMENT.

Have You ANY Ambition?

WE TEACH ALL THE FOLLOWING SUBJECTS:

COMMERCIAL.

Accountancy
Advert. Writing
Salesmanship
Army Certfct. Courses
Auctioneering and Estate Agency
Auditing
Banking
Book-keeping
Commercial Arithmetic
Commercial Law
Company Law
Costing
Economics
English and French
Executorship Law
Foreign Exchange
General Education
Modern Business Methods
Police Entrance and Promotion Courses

COMMERCIAL—Con.

Secretaryship
Workshop Organisation
TECHNICAL.
Applied Mechanics
Architectural Drawing
Building Construction
Clerk of Works' Duties
Boiler Engineering
Boiler Making
Chemistry
Civil Engineering
Concrete and Steel
Draughtsmanship
Electricity
Engineering
Engineering Costing, Quantities and Specifications
Foundry Work
Heat Engines

TECHNICAL—Con.

Internal Combustion Engines
Marine Eng. B.O.T.
Mathematics
Matriculation
Metallurgy
Mining
Mine Surveying
Motor Engineering
Naval Architecture
Pattern Making
Post Office Examinations
Quantity Surveying
Sanitation
Shipbuilding
Structural Engineering
Surveying and Levelling
Telegraphy and Telephony
Town Planning
Wireless Telegraphy
Works Managers' Course

WE SPECIALISE IN PREPARATION FOR ALL EXAMINATIONS.

WE TEACH BY POST IN ALL PARTS OF THE WORLD.

Note THE BENNETT COLLEGE, Address: Dept. 106 SHEFFIELD.



HIGH & LOW TENSION ACCUMULATOR HIRE SERVICE

Here's a way of improving reception, saving money, time, and trouble for all valve set users who live within 12 miles of Charing Cross. Write now for particulars of the unique service.

RADIO SERVICE COMPANY,
105, Torrington Avenue, N. W. 5.
Phone North 0623. (3 lines).

Our Low Tension Hire Service effects a considerable saving if you add the depreciation in value to the cost of having your own accumulator unskillfully recharged.

Rots High Tension Accumulators greatly improve Loud Speaker reception eliminating the uncanny noises caused by partly run down dry batteries and may be hired ready for use.

The "IDEAL" Christmas Present

THE BLUE-SPOT TONE CLARIFIER

Entirely New.
Scientific.
Perfect.

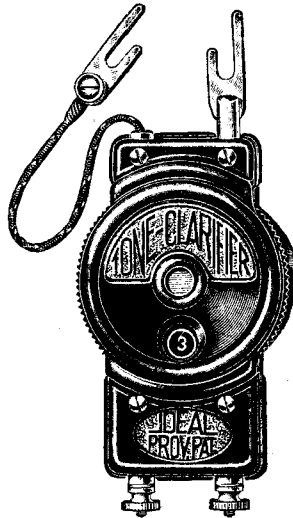

It will
surprise
you.

Make your reception perfect by fitting a Blue-Spot Tone Clarifier

EVERY wireless enthusiast can now obtain a "Blue-Spot" Tone Clarifier, the result of which is the last word in purity of reception. It is accurately adjustable to the finest degree in 6 stages, so that by degrees a clearer tone can be obtained without damping or reducing the volume of sound.

By turning the milled ring, 6 stages can be obtained which are shown 0 to 6 on the dial.

At 0, the instrument is switched off, whilst the figures 1 to 6 give different degrees of clarification, the best of which is invariably perceptible and gives surprisingly good results.

The "Blue-Spot" Tone Clarifier will fit any set, either Crystal or Valve, without alteration.

One end connects to your set terminals, the other to the Headphones or Loudspeaker wires.

PRICE 9/6 EACH

An "Ideal"
Christmas
Present

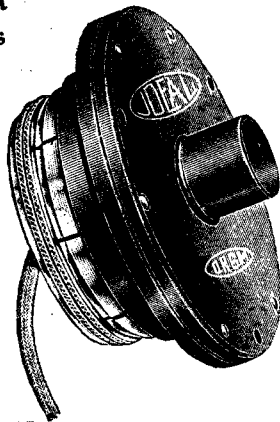

The "IDEAL" LOUD SPEAKER UNIT and GRAMOPHONE ATTACHMENT

On Test it is the Best!

The finest unit yet offered to the public. It makes a wonderful Loud-speaker.
The unit is the secret of all good Loudspeakers.
Ask your Dealer for demonstration and Catalogue, or we will forward post free to your address by return, Cash on delivery.

PRICE:
17/9
EACH

LINDALLS, LIMITED
70, Lombard Street
BIRMINGHAM

'Phone : Mid. 596.

'Grams : "Lifelike."

Why the Crystal Interests Me



An article that will prove of absorbing interest to all readers whether they be users of the humble Crystal or pin their faith on super-hets. Mr. Corrigan is one of the foremost authorities on the Radio Crystal.
 By J. F. CORRIGAN, M.Sc. A.I.C. (Staff Consultant).

UNDUE reminiscences, they often say, savour of garrulous old age and decrepitude. Well, that may be so. But surely, if at any time of the year one feels inclined to cry halt to the usual order of things and to indulge in the gentle art of reminiscence, the present season of festivity is the most favourable. For, indeed, with the spirit of Christmas in the air, few amateurs are inclined to give their minds over wholly to technicalities.

perfectly and efficient application of the thermionic valve.

Now, it is an extraordinarily difficult matter to set down briefly the reasons why you are interested in a thing. It's like being in love. What adoring Romeo ever did attempt to account dispassionately for the mental disturbance afflicting him? In fact, such an introspective task. I am credibly informed, is rarely attempted—in pre-matrimonial periods, at any rate! And so, in some ways, one attains a somewhat similar mental attitude with regard to any material interest. Nevertheless, so many people seem to be interested in my interest in the crystal, and in, may we put it, matters crystalline, that I think the present opportunity is suitable for attempting to account for my attitude concerning these matters.

My first introduction to the crystal as a radio rectifier took place, if my memory serves me correctly, during the autumn months of the year 1907. For some time previous to this period I had been experimenting with a small home-made spark transmitter, employing a 2-3 in. induction coil, and running off a 12-volt accumulator. The whole affair worked well so far as the transmissions were concerned, and, of course, at that time it was considered wonderful.

Early Experiments.

The great bane of the whole thing, however, was the receiver. This simply would not work in a reliable manner. It contained a coherer—a professionally-made instrument—together with the necessary decohering or tapping device. It was the tapper which caused all the trouble. At times, it would tap the coherer wonderfully well, but at other times, and especially during demonstrations, the wretched thing would, metaphorically speaking, lie down like an obstinate mule and simply refuse to take any part in the game at all.

In the midst of all these vexations, a naval wireless operator sent me a carborundum crystal, and, shortly afterwards, one of the silicon variety, together with accounts of the trials which had then recently been made with them. I gave these crystals a test. They gave remarkable results, so much so that I threw the miserable coherer into the dustbin, an action for which I am now heartily sorry, for such an article is an interesting historical curiosity in these days.

Thus came my introduction to the crystal of radio science. Naturally, in those days crystals were only employed by amateurs for Morse reception and for Eiffel Tower transmissions. I think I am right in saying that fused silicon was the most popular crystal among amateurs at that period. It was more sensitive than carborundum, and, although it was not so stable, it retained its sensitive properties excellently: I have, in fact, even now a number of silicon crystals whose working history dates back to the year 1909, and which still rectify efficiently.

Origin of the Cat's-whisker.

Surprising as it may seem, galena crystals were not very greatly used during those days. For one thing, the popular brands of galena—that is to say, the brilliantly glittering, silvery-grey crystals of the present day amateur—were unknown. The galena to be had took the form of dull grey cubical crystals, very often of indifferent sensitivity. Moreover, such crystals, were used in conjunction with a rigid steel, brass, or copper contact, which, of course, made them even less efficient.

Cat's-whiskers, I think, were invented about the year 1910. The first type of cat's-whisker had the redeeming feature of bearing some resemblance to its namesake. It took the form of a curved piece of wire, fastened down at one end, the other end making light contact with the crystal.

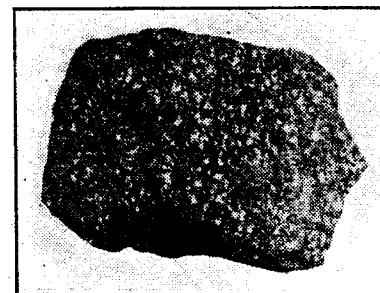

Fig. 2. A specimen of fine grained galena.

Then somebody or other hit upon the brilliant idea of making the contact wire of the crystal into a little spiral.

The rectifying crystal became completely overshadowed by the introduction of the valve as a radio receiver. In fact, one supposed at the time that it had passed into
 (Continued on next page.)



Fig. 1. The Abbe Haüy, the founder of crystal science.

Christmas is a season of goodwill. Still more in the modern world, it brings with it a period of relaxation, a brief respite from the ordinary duties of existence. One expects even the most fiendish oscillator to relax his efforts at Christmastide, and to reduce his soul-shattering disturbances to a minimum. I say one *expects* such a gentleman to effect this temporary change in his behaviour.

My First Introduction.

Anent the main subject of my article, however. It is rather a peculiar fact that nearly every wireless enthusiast I meet trots out the one question, "Look here, old man, why are you so jolly interested in crystals; why don't you give more specialised attention to valve circuits, and what not, instead of bothering over fiddly bits of minerals?" I suppose, in some ways, it is a natural sort of question to ask, especially in view of the fact that nearly all the main commercial developments taking place in the science of radio within the last ten or fifteen years have been concerned with the

WHY THE CRYSTAL INTERESTS ME.

(Continued from previous page.)

the limbo of the forgotten to keep company with the coherer. However, as the present reader will be well aware, the case turned out otherwise. The introduction of broadcasting after the war not only resurrected the crystal as a rectifier, but it also gave to that formerly discarded article a tremendous lease of really servicable life. The radio rectifying crystal of the present day has

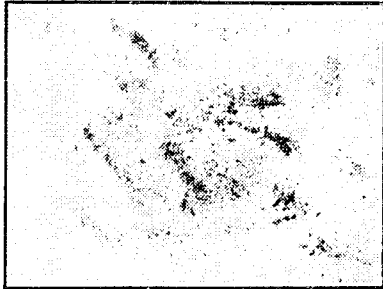

Fig. 3. Galena crystal dust.

brought more real happiness and knowledge into many of our country's homes than possibly any other creation of science.

That, I think, is one of the main reasons why my interest in wireless lies to such an extent in the direction of crystal reception. If you consider things dispassionately, it becomes very evident that the crystal set of the present day is really an extraordinarily remarkable and wonderful instrument. Without demanding any technical knowledge of wireless science on the part of its owner, the crystal radio set brings into the home a stream of broadcast news, speech, and music. It provides an ever open door for the local broadcast.

Many Advantages.

The advantages of the average crystal set are well known—low initial expense, no cost of upkeep, efficiency, and reliability—and there is no need for me to enlarge upon them. Surely, therefore, facts such as these are sufficient to make any average individual interested in such methods of obtaining broadcast reception.



Fig. 4. Crystal dust highly magnified.

We know so much about the radio-sensitive crystal, and about crystals in general, and yet we know so little. It seems to me that Nature has made use of the crystal as a safe in which to store many of her most treasured secrets. At the present time, we are merely utilising a mere handful of the numerous powers present within the crystal. We use certain naturally-occurring crystals and minerals for the purpose of rectification. More recently we have discovered that some crystals are capable of acting as oscillation generators and radio amplifiers.

Still further, other varieties of crystals are now being rapidly brought into use for the purpose of accurately controlling the wavelengths of transmitting stations. Again, crystals can be used as sound-wave amplifiers, and it is now being strongly suspected that many of them possess the capability of converting light waves into electric currents, thus acting as miniature photo-electric cells.

Various Uses.

Crystals of one substance or another form the basis of other useful applications, as well. For instance, the sensitivity of the photographic plate or film depends upon the crystalline structure of the silver salts which are incorporated into its emulsion. Crystals can be used as heat indicators, as weather recorders, light analysers, and as a host of other things. The crystal's influence, therefore, in the modern scientific world is very nearly universal, and thus the rectifying properties of crystals, which we radio enthusiasts dwell so greatly upon, form but one of the many-sided capabilities of these wonder creations of Nature. There are many other powers inherent in crystals, discovered and undiscovered. Is it, therefore, a matter for wonder that scientists, as a whole, are becoming more and more interested in crystal phenomena? The first individual to undertake the scientific investigation of crystals was Haiüy, an Abbé, who lived a little over a hundred years ago. Haiüy separated natural substances into two divisions, crystalline and non-crystalline, or amorphous. He measured the sides and angles of crystals, classified them according to their natural shapes, and so forth. But, of course, he knew nothing about the many electrical properties which they possessed. Such knowledge has only come within the last twenty years or so.

Haiüy's view that everything material could be divided into crystalline and non-crystalline substances was followed up to very recent times. Lately, however, it has been fairly conclusively proved that there are no such things as entirely non-crystalline or amorphous bodies. Everything solid in the whole realm of Nature possesses a very definite crystalline structure. Metals, rubber, glass, cements, flour, paper, cotton, silk, wood, and hundreds of other similar materials which were until recently thought to possess no crystalline structure at all are now fairly well known to be entirely crystalline.

Nature's Crystalline Structures.

The atoms of the elements, with their internal constituent protons and electrons are Nature's bricks. Nature, however, does not effect her constructions by heaping her bricks together anyhow. On the contrary, she constructs everything solid on a regular plan, and a crystalline structure is the result.

The series of photographs, Figs. 2, 3, and 4, will perhaps go some way to illustrate this statement. At any rate, it will show how thoroughly ingrained and indestructible is the crystalline structure of Nature's creations.

Fig. 2 is a photograph of a crystal of fine-grained galena taken from the detector cup of an ordinary crystal set. In the illustration, the crystal is enlarged to about twice its natural size. Now, after photographing, the crystal was broken up into small pieces. A few of the fragments were then taken and ground up very finely in an agate mortar. The resulting blue-black powder was then sifted through coarse muslin cloth, this process giving a practically impalpable powder.

Next, a small quantity of this powder was sandwiched between two thin slips of glass, and subsequently photographed. Fig. 3 is the result. Here, again, the photograph is on an enlarged scale, a necessity arising out of the practical difficulty of reproducing an extremely fine-grained image.

Finally, a speck of this powder was mounted on a microscope slip, and photomicrographed under high magnification. Fig. 4 depicts the photomicrograph of the impalpable crystal powder. Clearly, from the photograph it is evident that all the powdering, grinding, and sifting of the original crystal have not destroyed its crystalline nature in the slightest degree. All that such processes have effected is to split the original crystal up into a multitude of infinitely small crystals, each separate one of which retains its definite crystalline proportions and characteristics.

A crystal, therefore, is an imperishable thing. You cannot destroy it, any more



An original crystal.

than you can, by any practical means, destroy an atom or an electron. There are forces within the crystal which hold it together. Forces, the applications of which are possibly undreamt of at the present day.

Immense Possibilities.

I know that many of my readers will imagine that the possibilities which I hold forth for the crystal are too brightly painted. I do not think they are, however. "The secret of all who make discoveries is to look upon nothing as impossible," says the eminent chemist and scientist, Liebig; and even our own poet Tennyson, who knew nothing at all about modern science, has intuitively stated that:

"Men, thro' novel spheres of thought,
Still moving after truth long sought,
Will learn new things."

Such, therefore, are some Christmas considerations on the crystal which I offer to my readers. And I would be guilty of a great neglect of opportunity if I did not seize upon this occasion to offer my reader-friends, known and unknown, the time-honoured greeting—a hearty good Christmas and still further prosperity in the New Year.

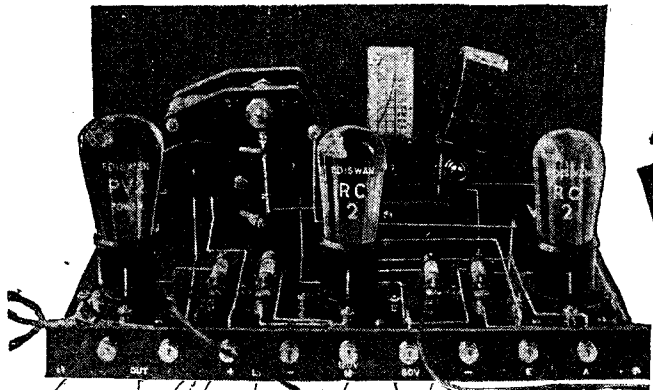

AMAZING RESPONSE

to our FREE offer of Blue Print and Instruction Book.

Results from our first announcements have been positively amazing! . . . Tens of thousands of FREE Blue Prints and Instruction Books have been issued in response to coupons received . . . wireless enthusiasts—as never before—are now enjoying clear, undistorted tone, made possible by the wonderful R. C. Threesome. Using the new Ediswan Valves—R.C.2. and P.V.2.—in the new quarter-watt POINT ONE ECONOMY Range—the R. C. Threesome is, without doubt, the receiver of to-day.



Ask your dealer about the new **EDISWAN ECONOMY VALVES**

QUARTER-WATT POINT ONE RANGE

There is an Ediswan Valve for every Wireless Purpose, FIT EDISWAN VALVES AND NURSE YOUR SET

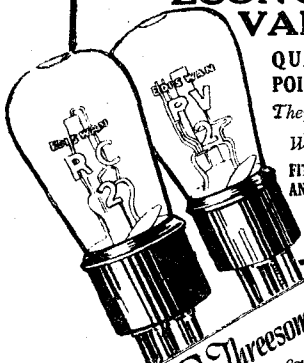

Make the R. C. Threesome Now.

It's simple—you can build it in 3 hours for less than £3. One dial tuning!—High-power station and local station come through with absolute purity and abundant volume. The new Ediswan POINT ONE ECONOMY Valves are renowned for tonal quality . . . for long service . . . for irreducible economy. Get EDISWAN Valves for your R. C. Threesome, and be sure of perfect reception.

Send for this FREE BLUE PRINT & BOOK

Don't wait. *Tear out the coupon and post it right away!*

Don't forget your name and address—many coupons, sent in haste, have been received blank. Avoid disappointment—do it NOW!



EDISWAN

<p>To THE EDISON SWAN ELECTRIC CO. LTD. (Publicity), 128/5, Queen Victoria Street, London, E.C. 4</p> <p>Please send, post free, presentation copies of the "R. C. Threesome" Instruction Book and Blue Print.</p>	<p>Name</p> <p>Address</p> <p>PLEASE USE BLOCK LETTERS</p>
--	--

P.W. 11.12.26

V. 10

Your Last Chance
to Win

£200

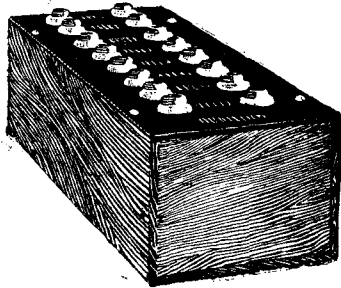

The closing date for the
Dubilicon competition
is now fixed for
DECEMBER 31st.

If you have not already
entered for this novel com-
petition, do so to-day.

All you have to do is to buy
a Dubilicon Multiple fixed
Condenser, price 30/- (which
is in itself a most valuable
acquisition for any wireless
man), and then calculate the
number of different capacities
which it is possible to obtain
from various combinations of
capacities specified in the
instructions.

Your dealer will be glad to
explain the scheme fully, or,
in case of difficulty, we will
furnish full particulars.

No entries reaching us after first post
on December 31st, can be considered.

The name of the winner will be pub-
lished in the Press in due course—
will it be your name?



ADVERT. OF THE DUBILIER CONDENSER CO., (1925)
LTD., DUCON WORKS, VICTORIA ROAD, N. ACTON, W.3.
E.P.S. 246

It stands to reason !

WHO would compare the BLARE of a TIN trumpet
with the pure natural sweetness of a wooden
instrument, such as a flute or a violin ???

WHY no one of DISCRETION and TASTE.

THEN IS THERE ANY DOUBT IN YOUR MIND THAT

**W.B. All Wood
Loud Speakers**

Offer the highest standard possible
in the reproduction of Radio Re-
ception? Of course there is not,
and if there is, well, hear a com-
parative test and be convinced.

Send for our leaflet at once, we will assist
you to make your choice, and supply you
through your local dealer so that you may
hear it before you part with any money.
COULD ANYTHING BE FAIRER?



Manufacturers & World Patentees :
Messrs. WALKER BROTHERS, This model with special move-
St. Joseph Works, ment by Messrs. S. G. Brown,
Bramley, Guildford. Ltd., only 24 : 0 : 0.

If you have just purchased a "tin" speaker, DON'T DESPAIR
but SCRAP THE HORN. We can supply you with a beautiful
wooden horn of correct shape to fit your base, and so save you
complete disappointment. Prices to suit all pockets.

Special Distributors :
LONDON : Messrs. Gamage, Ltd., Holborn ; Will Day,
Ltd., Lisle St. ; London Electric Co., Sherborne Lane.
BRISTOL AND THE WEST : Messrs. The Bristol Wire-
less Co., Queen's Road, Bristol.

BUY DIRECT at HALF PRICE

	Plated H.T. Tester with Lamp 9d.		Bus Bar with Tags 1/- doz.		Base-board A.C. Valve Holder Lowest Capacity 9d. each
	Lissen Type Rheostat 1/9		Tinned Tags 2/- gross		Sorbo Rubber Bases, 6d. set of 4.
	Porcelain Base Rheostat 10 or 30 ohms 1/9		Strip Aerials 1/6		Miniature Plated Switch Arm 9d. each
	Friction Geared Coil Holders 2-way 2/3 3-way 3/3		Plug-in Terminals 4d. set		Plated Studs 6d. dozen
	All Goods Post Free		Wedge Coil Holders Plated 8d.		Send for Special Bargain List and Free Station Log Card

P.W. SPARKS RADIO SUPPLIES
43 GREAT PORTLAND ST., LONDON, W.1

**FOR BEST RESULTS
USE W.B.
ANTI-PHONIC
LOW LOSS
VALVE
HOLDERS**

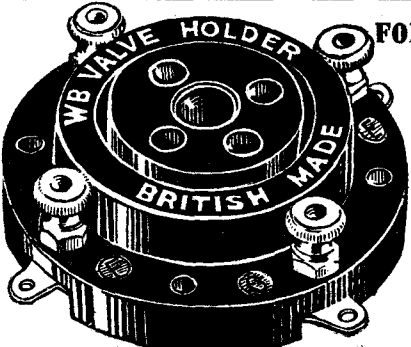

PRICE Complete with Terminals 2/3

If unable to obtain from your dealer write direct.
Manufactured by **WHITELEY, BONEHAM & CO., LTD.,**
Duke Street, MANSFIELD, NOTTS.

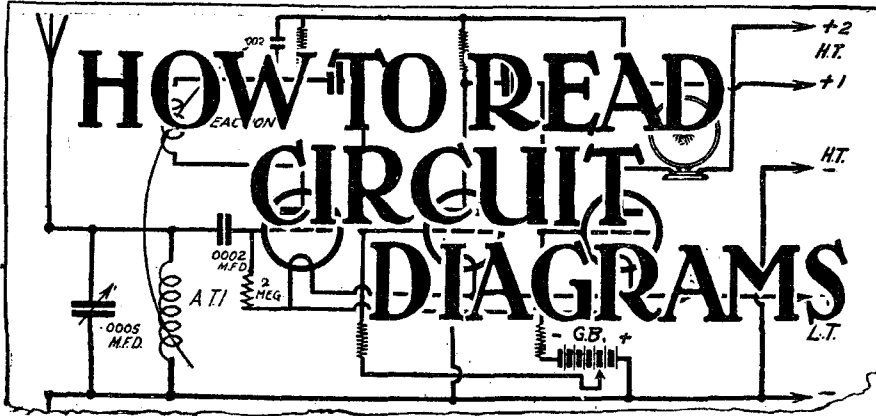

By C. E. FIELD, B.Sc. (Staff Consultant).

PART II.—Showing how the various symbols can be grouped together.

ALTHOUGH nearly all wireless circuit diagrams will be found to consist of the symbols which were given in the previous article, there are certain combinations of components which frequently recur in receiving sets, and it is a great help to

the signal currents can divide between the coil and condenser, and part flow through each.

One or other of these arrangements, or something very similar, is present in nearly every set, because they constitute the most usual means of tuning-in, or selecting, the required signals.

The combination is known as the *aerial circuit*, and the coil and condenser, when used in this position, are referred to as the *aerial tuning coil* and *aerial tuning condenser* respectively.

In the first case, the two are said to be connected in *series*, and in the second case in *parallel*. In the latter instance the condenser is sometimes said to be *connected across the coil* or the coil is said to be *shunted by the condenser*.

The aerial circuit, by the way, is nearly always shown at the left-hand side of a diagram, because it is the point at which signals are received, and we can then

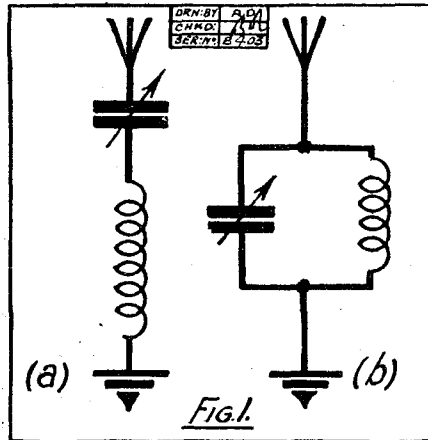

Fig. 1.

the understanding of a diagram if the group of symbols representing these can be readily recognised.

For instance, at the left-hand side of most diagrams will be seen one of the two arrangements shown in Fig. 1, which consist of an aerial, variable condenser, inductance coil, and earth, connected in two different ways.

In Fig. 1a they are so arranged that the received signals in the aerial, which always endeavour to flow to earth, must pass first through the condenser and then through the inductance. In the second diagram

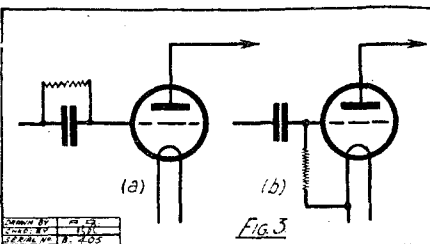

Fig. 3.

follow their progress through the circuit from left to right, just as in reading a book.

A coil and condenser connected in parallel, as in the second sketch, constitute an *oscillatory circuit*, sometimes called a *rejector circuit*, which has the property of selecting, and passing on, only signals of a certain wave-length, to which the circuit is tuned by means of the condenser.

Tuned-Anode Coupling.

An arrangement which is very frequently employed consists of a rejector circuit connected in the lead joining the plate, or anode, of a valve to the high tension battery, as indicated in Fig. 2.

This circuit selects—i.e. *rejects*, signals of the wave-length to which it is tuned, and forces them to pass along to the grid of the next valve, or to a crystal detector.

When such a circuit couples two valves—i.e. to pass signals from one valve to another, the arrangement is referred to as *tuned-anode coupling*, because the plate, or anode, circuit of the valve is tuned.

This is an expression which is constantly occurring in wireless articles, and the experimenter should be able to see at a glance, from a diagram, when coupling of this kind is employed, by recognising the oscillatory circuit in the valve plate lead.

An Important Group.

Fig. 3 shows another combination occurring in the majority of circuits, comprising a small fixed condenser, usually with a capacity of about .0003 mfd., connected in the lead to a valve grid. A high resistance, generally of about two megohms, is joined either in parallel with this, as in a, or between the valve grid and one filament connection, as in b. This condenser and resistance are known respectively as *grid condenser* and *grid leak*, and their presence in the form shown in Fig. 3a indicates that the valve in question is the detector. This is often the case when the second arrangement is shown, but not always so, for it is sometimes necessary to supply an

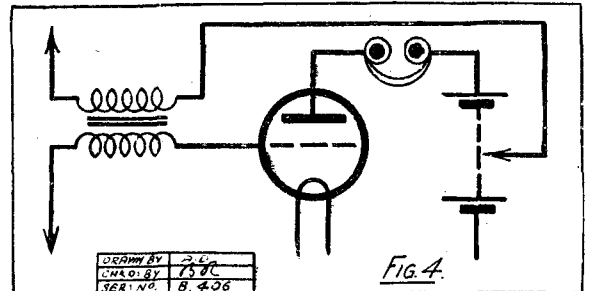

Fig. 4.

amplifying valve with a grid leak and condenser arranged in this way.

When confronted with a complicated diagram of a multi-valve set, the understanding of the circuit is simplified if we can at once spot which is the detector valve, for we know then that all valves to the left of that are dealing with impulses similar to those picked up by the aerial, whilst valves to the right of the detector are handling low-frequency impulses like those which pass through the telephones.

At the right-hand side or bottom of a circuit diagram we sometimes find an arrangement like that shown in Fig. 4, in which a lead, usually from a transformer winding, terminates in an arrow, which points somewhere between the ends of the high-tension battery.

(Continued on next page.)

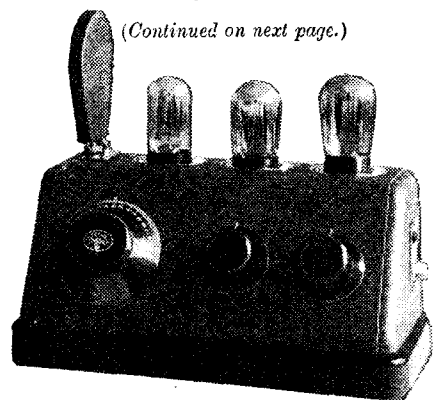

Recent design in German receivers tends to provide metal casing for the whole of the set, as the above photo shows.

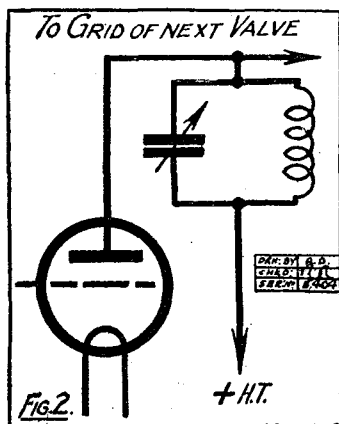

Fig. 2.

HOW TO READ CIRCUIT DIAGRAMS

(Continued from previous page.)

The arrow here represents a wander-plug or other connection taken to a tapping point on the battery, in order that the high-tension voltage applied to the valve from which the lead is taken may be varied at will, and extra voltage may be applied to the last valve.

Various Styles.

In Fig. 5 is shown a diagram of connections which very often appears as part of a valve circuit diagram, and ought to be easily recognised. A lead from a valve plate goes back (i.e. towards the beginning of the circuit) to a coil, which is variably coupled to some other coil in the circuit, such as the aerial tuning coil, or the coil of an inter-valve oscillatory circuit.

The coil in the valve plate lead is known as a *reaction coil*, and its use and abuse are probably well known to readers. The

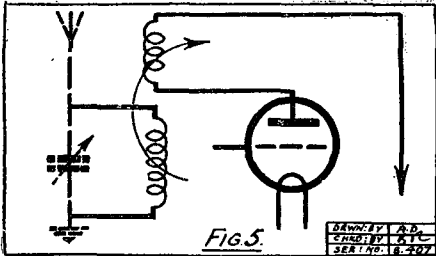

occurrence of these connections in a circuit diagram tells us, therefore, that the set employs reaction, with the consequent increase of sensitivity and volume, lack of stability, and so forth.

As has been previously pointed out, there are many ways of drawing the diagram for a particular circuit.

The particular style employed, of course, makes no difference to the wiring of a set which might be constructed from the illustration in question, but some diagrams are much easier to follow than others.

Mention may be made of one method of making a diagram which is becoming increasingly popular, and which is largely employed in articles in "P.W." Although at first sight these diagrams may appear a little difficult for the constructor to work from, once they are understood they are

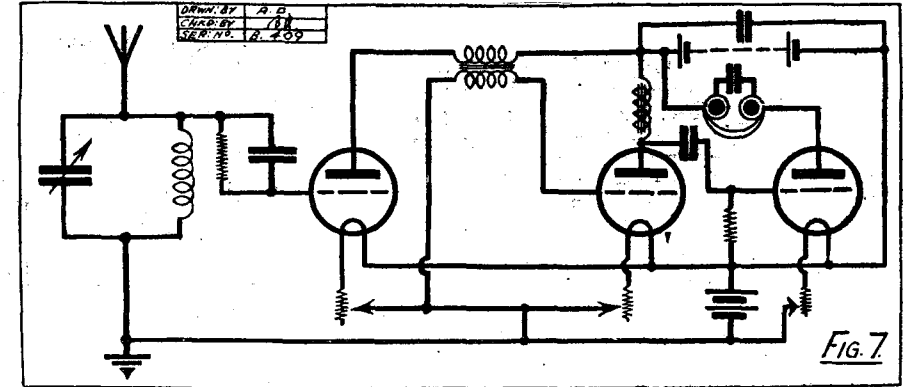
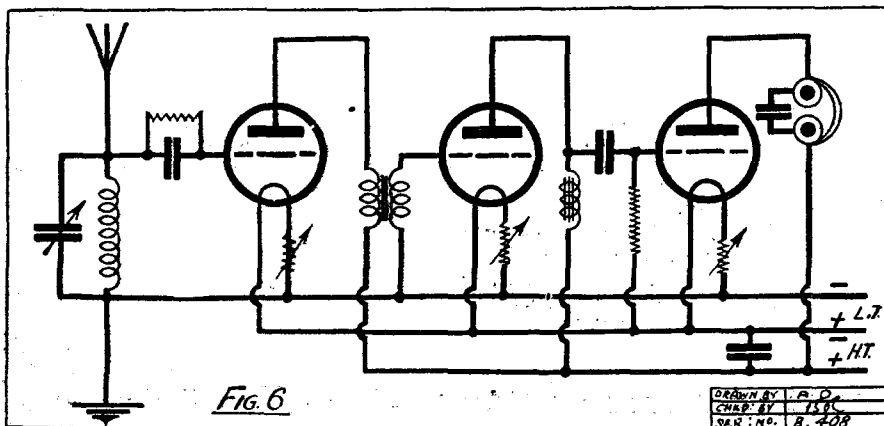

very easy to follow, especially when we wish to find out just how a circuit is supposed to work.

Their chief feature is that three or four horizontal lines are drawn, usually at the bottom of the diagram, each one representing a battery lead, either high or low tension, and designated accordingly. Then all wires which are in direct connection with a battery are shown by lines dropping vertically on to one or other of these, without having been previously joined to

condensers, etc.), no circuit diagrams should present any difficulty.

In a final article we will take some examples of practical circuits, and see how it is possible for the more advanced amateur to analyse the theoretical diagrams.

MAKING POLE INDICATING PAPER

THE manufacture of pole indicating paper is one of those spare time jobs which can readily be undertaken by any amateur. The materials which are necessary for the job are few and simple, and they are not expensive.

Obtain a quarter of an ounce of phenolphthalein (the current price of this substance at any large firm of chemists being ninepence per ounce) and dissolve it in about an eggcupful of *rectified spirit* (not methylated spirits). After the phenolphthalein has completely dissolved in the spirit, add to the liquid approximately three times its bulk of clean, cold water.

Prepare a number of strips of clean white blotting paper, and soak them for a few minutes in the above solution, afterwards taking them out, and allowing them to dry thoroughly.

Then prepare a solution of sodium sulphate by dissolving half an ounce of sodium sulphate in a teacupful of warm water.

Useful Accessory.

Soak the above strips which have been treated with phenolphthalein in the above solution for two or three minutes. Then take them out and allow them to dry.

The pole indicating paper will now be ready for use, and if it is kept between the leaves of a book, out of the influence of any fumes, it will retain its properties for an indefinite time.

In order to use the paper for the purpose of discovering the polarity of a battery or accumulator, moisten a piece of the paper with a little clean water, and place both leads of the accumulator or battery in contact with it, and at a distance of about an inch apart. The area of paper which is in contact with the *negative* pole of the battery will turn bright red.

This test is a perfectly good one for use with any cell, battery, or accumulator of average voltage, but for E.M.F.'s below one volt, the test is not to be relied upon. However, a supply of this readily-made paper will be found to be of the very greatest use to the busy amateur.



A handsome loud speaker constructed by Mr. B. Willis, of Coombe Down, Bath. The horn is made of cardboard.

one another. By this means crossing and branching wires, which tend to confuse a diagram, are largely avoided, as will be seen from the example shown in Fig. 6. An alternative symbol representing the variable filament resistance is shown in this diagram. Fig. 7 shows another diagram of exactly the same circuit.

If a reader can fully appreciate that these two diagrams are electrically identical, and could construct a set from either of them (knowing, of course, the values of coils,

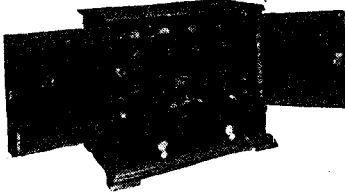

A triumph of multivalve set construction. In beautiful mahogany case. All parts enclosed. Switches for selecting 2, 3 or 4 valves and from "1.s." to 'phones. Dual resistances. Very fine reaction control. Incorporated wave-trap for cutting out "locals." All B.B.C. stations at full "1.s." strength and most Continentals. **£25** (Royalties included).

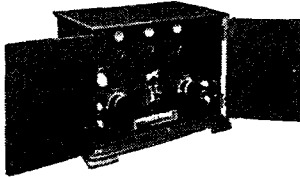

A beautiful and efficient 3-valve receiver. Highly finished. Switches for 2 or 3 valves, and 'phones to "1.s." L.T. switch. Price of set only **£18** (Royalties included).

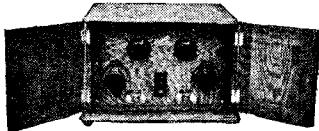

Probably Britain's most popular "2-valver" or "1.s." reception—the Ericsson "Family Two." Extraordinarily powerful and gives reproduction of a beautiful quality. Parts totally enclosed. In highly polished oak cabinet. Will bring in any main B.B.C. station at full "1.s." strength up to 50 miles and 5 X X up to 150. Price **£8-15-0** (Royalties included).

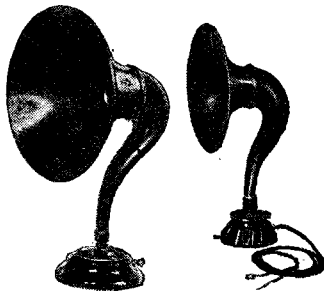

The Senior Ericsson Super Tone—a really pure-toned distortionless Loud Speaker. To hear one coupled to an Ericsson Receiver is a revelation in pure reproduction. 18 in. high on wood base. **65/-**

For small rooms or where great volume is not required, select the Ericsson Super Tone Junior Loud Speaker. 15 1/2 in. high. Very sweet and clear. Complete with lead. **32/6**



Adopt as standard for your headphone gifts the headphones used by the B.B.C. (A tribute if you like!) Ericsson Headphones are comfortable and really wonderful for tone, and matchless for sensitivity. Three resistances one price (120, 2,000, 4,000 ohms). **20/-**



Ericsson Transformers are distortion-free and give wonderful amplification. In two ratios, 1:1, 1:2. Price **17/6**



Ericsson Tested Condensers—high in efficiency; low in losses. Beautifully made and fit for any set. Plain 0005 **10/6** 001 **12/6**



The Ericsson dual Rheostat makes a nice little present. Controls any temperature valve. **8/6**

Ericsson Ericsson Ericsson Ericsson Ericsson Ericsson Ericsson Ericsson

Make every broadcast of 27 a reminder of YOU

-give *Ericsson* apparatus this Xmas!

A FOUR-VALVE Set for Father—a Speaker for Aunt—a set of parts for your youngster (they must be Ericsson!). These are the gifts that will keep your memory green for the years to come.

Take your pick from the wonderful Ericsson range—2, 3 and 4 Valve sets, Senior and Junior Loud Speakers (alone in their class!), Headphones, Crystal sets, Rheostats, Condensers, Transformers, etc., etc.

No article stamped "Ericsson" will ever let you down on the score of quality or service. You give your gifts in confidence, and twelve months hence your choice will be endorsed in the praise of the recipients. Make your choice to-day at any good dealers, or send for fully illustrated lists.

ERICSSON TELEPHONES LTD.,
67/73, Kingsway, London, W.C.2.

Ericsson

TESTED APPARATUS

Ericsson Ericsson Ericsson Ericsson Ericsson Ericsson Ericsson Ericsson

A GOOD deal is heard about efficiency and selectivity in relation to a wireless set, but it is not usually pointed out that these two qualities, although not of course identical, are to a large extent dependent upon one another; in actual practice the connection is so close that they may be said to amount more or less to the same thing. If a set is efficient, the losses being reduced to a minimum and damping eliminated, the set is likely to be, or can easily be made, very selective. The set cannot, however, be selective if the losses are high, that is, if the efficiency is low.

When designing a wireless circuit or building a receiver, the experimenter has to consider whether he is desirous of obtaining reception of volume and purity, or whether he looks forward to extreme selectivity and to separating weak or long-distance stations whose wave-lengths may be close together.

Distance or Quality?

It should be borne in mind that although there is a great fascination in receiving distant stations and in hearing them come in one after another with comparatively small movements of the tuning dial, at the same time this type of reception is not the best from the point of view of purity, and certainly not from that of volume. Where exceedingly fine tuning is employed, that is to say, in the ultra-selective set, there is apt to be distortion or roughness.

For the best loud-speaker results it is certainly preferable to have fairly broad tuning, as this gives much more scope for proper adjustment. Magnetic reaction had better be avoided for the best results, so far as purity is concerned, and where H.F.

TECHNICAL NOTES

A Weekly Feature Conducted by

Dr. J. H. T. ROBERTS, F.Inst.P.
(Staff Consultant.)

amplification is used it is better to employ some form of aperiodic coupling rather than a tuned circuit coupling.

But, as already mentioned above, a great deal naturally turns upon the question as to whether you are seeking for distance on the one hand, or quality and volume on the other hand.

Different Points of View.

If you are intent upon long-distance reception, then, of course, the set must be as efficient as possible, especially upon the H.F. side. Here magnetic reaction or capacity reaction is desirable, and very sharp tuning should be used. The experimenter who is looking for distant reception gets his satisfaction from tuning-in the desired stations without a great deal of regard to the quality or to the signal strength.

Any experimenter who has, for example, listened in to American stations, will

readily agree that it is not much use expecting quality over such a great distance. I know that this observation will bring me many letters from enthusiastic all-night experimenters to the effect that they have had "perfect reception" on different occasions. This may be true, but the fact remains that in the vast majority of cases reception over such distances as I have indicated above is only just reception, and nothing more.

Bright Emitter Valves.

Although the dull emitter valve is now rapidly ousting the bright emitter, there is still a section of the wireless public who believe, rightly or wrongly, that for careful experimental work, where questions of filament efficiency are not of great importance, the old-fashioned bright emitter is to be preferred.

It is true that in the earlier days of dull emitters considerable variations in their performance were common, but in the modern types now on the market a very high standard has been reached, and in spite of the greatly reduced wattage consumption the performance of the modern dull emitter is, in my opinion, in every way equal to that of the bright emitter.

After all, there is no particular virtue in a high filament temperature; it is necessary to raise the filament of a bright emitter to a high temperature in order to cause it to emit electrons in sufficient quantity, and the simple fact is that if it would emit electrons in the same quantity at a lower temperature, or without heating at all, it would serve its purpose equally well.

(Continued on page 932.)

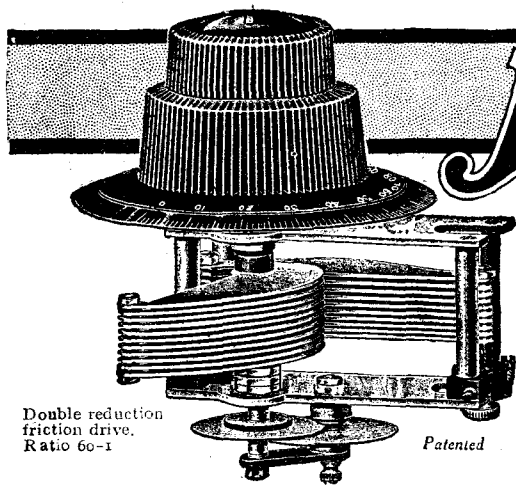

Double reduction friction drive. Ratio 60-1

Patented

JACKSON CONDENSERS

The Ideal Gift for Christmas

GIVE your friends a Condenser that not only looks a perfect job, but is as efficient as it looks. A combination of the three essentials—precision, efficiency, finish—that's what has made JACKSON CONDENSERS foremost on the market to-day. J.B. Condensers embody all the most modern developments in Condenser design, and their inclusion in practically all the Star Sets of 1926 is an indication of the value placed on them by the scientific radio experts of the present day.

THE J.B., S.L.F.

PRICES, complete with 4" Bakelite Dial.

'0005 mfd. .. 11/6 '00035 mfd. .. 10/6 '00025 mfd. .. 10/-

J.B. Condensers are precision instruments, made to last a lifetime, and designed to simplify tuning and yet possess that selectivity which marks a really good condenser. In both the original J.B., S.L.F., and also the True Tuning S.L.F., the vanes are designed on a new principle to avoid crowding at any part of the scale. In addition, the vanes are supported at tips to ensure correct spacing. Friction surfaces are machined to a fine limit of accuracy, preventing all possibility of lost motion.

THE J.B., TRUE TUNING S.L.F.

PRICES, complete with 4" Bakelite Dial.

'0005 mfd. .. 16/6 '00035 mfd. .. 15/6 '00025 mfd. .. 15/-

All the best Dealers stock Jackson Condensers. If you have any difficulty, we can supply direct. Postage extra.

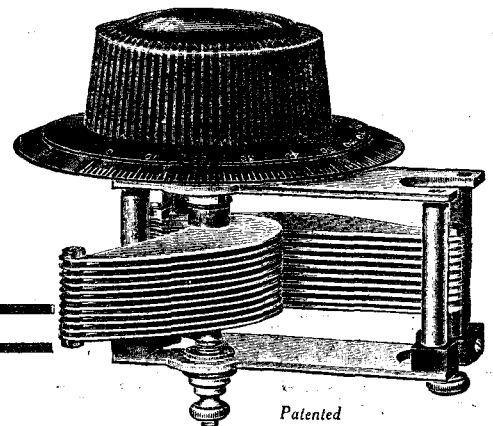

Patented

JACKSON BROS.
8, POLAND ST-OXFORD ST
LONDON - W.1 Telephone - GERRARD 7414

A Happy Xmas

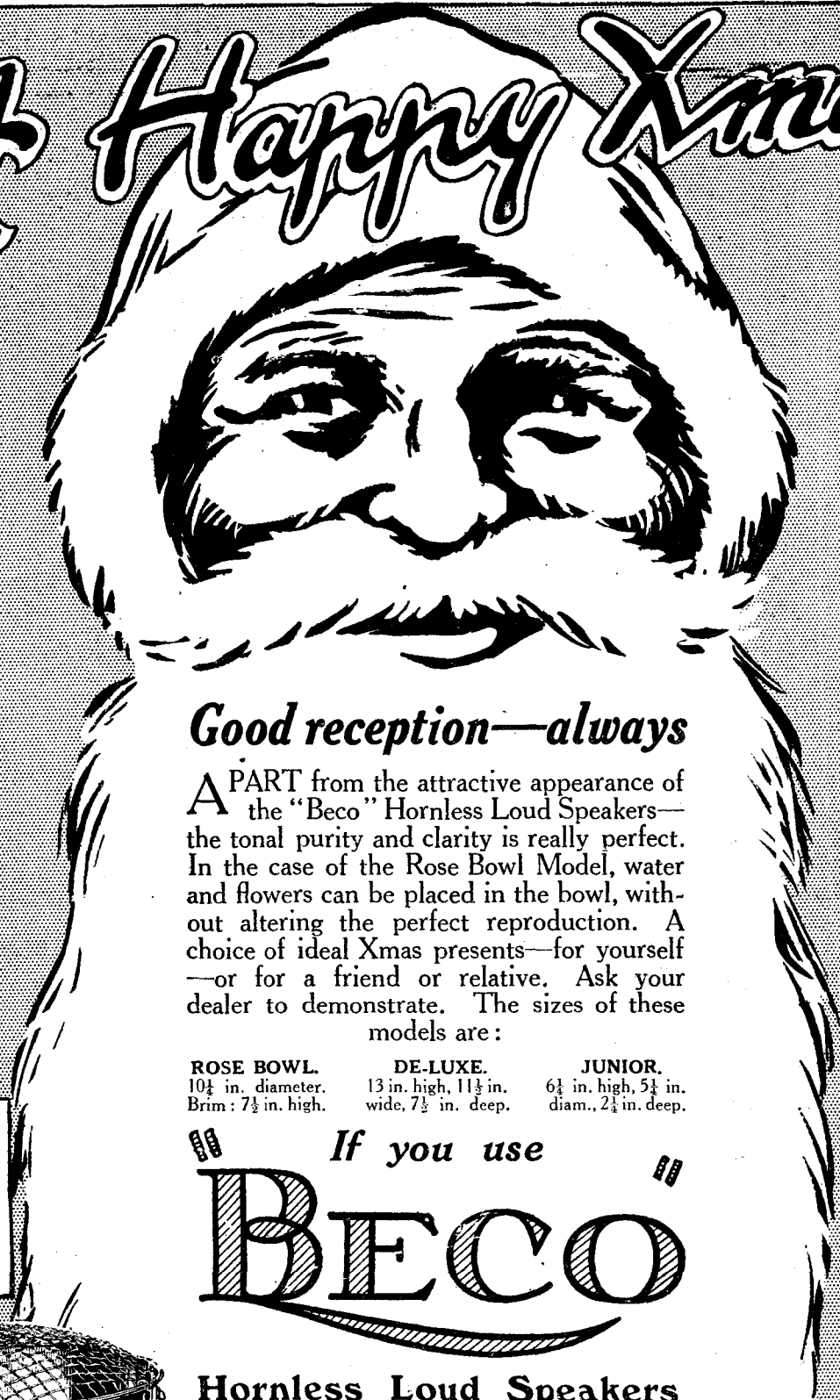

Good reception—always

A PART from the attractive appearance of the "Beco" Hornless Loud Speakers—the tonal purity and clarity is really perfect. In the case of the Rose Bowl Model, water and flowers can be placed in the bowl, without altering the perfect reproduction. A choice of ideal Xmas presents—for yourself—or for a friend or relative. Ask your dealer to demonstrate. The sizes of these models are:

ROSE BOWL.	DE-LUXE.	JUNIOR.
10½ in. diameter.	13 in. high, 11½ in.	6½ in. high, 5½ in.
Brim: 7½ in. high.	wide, 7½ in. deep.	diam., 2½ in. deep.

"BECO" ROSE BOWL.

Nickel Plate :
£5 : 5 : 0
 Oxidised Silver or
 Antique Bronze :
£5 17 6

If you use

BECO

"BECO" DE-LUXE.

Jacobean Oak :
£5 : 0 : 0
 Mahogany :
£5 : 5 : 0

Hornless Loud Speakers



"BECO" JUNIOR.

Nickel Plated :  Oxidised Silver or Copper :
£2 : 12 : 6 **£2 : 15 : 0**

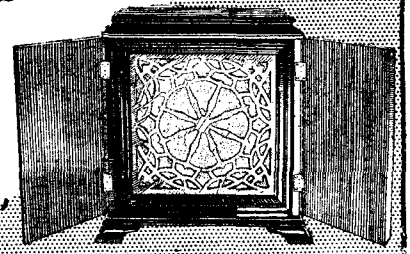

TECHNICAL NOTES

(Continued from page 930.)

The only drawback, therefore, from which a dull-emitter filament has ever suffered has been, as already mentioned, the unreliability in the earlier stages, when the manufacture of specially treated filaments was not well understood. The bright emitter simply dissipates a large proportion of the filament watts supplied to it in the shape of heat and, of course, a small proportion in the form of light, the proportion which is represented by the electron emission being a very small percentage of the whole. In the case of the dull emitter filament, since for the same electron emission the heat and light dissipation are very much smaller, it follows that the overall efficiency is much greater.

Useful Soldering Advice.

Probably there is none of the experimenter's tools which is more abused than the soldering iron. This is continually left in the flame to burn, and is then subjected to a drastic and ruinous filing in order to remove the consequent scales of oxide.

Not only is the copper bit soon reduced by this treatment, but the tip of the copper becomes pitted and altogether unsuitable for good work. This raises the question as to the correct temperature at which the soldering iron should be used, and also the question as to how the experimenter is to know when the iron has attained the proper temperature.

Of course, as in so many practical matters, an experienced eye is the best guide,

and anyone who has done much soldering is able to tell at a glance when a soldering iron in a blue bunsen gas flame is getting beyond a safe temperature. If the temperature of the iron is about right it will be noticed that the flame is *beginning* to be tinged with a characteristic greenish yellow coloration. (Those readers who have some knowledge of science will know that this is due to the vaporisation of the metal and constitutes an elementary experiment in spectroscopic analysis.)

If, however, the greenish yellow coloration is masked by an ordinary whitish flame, this shows that the iron is burning and it should be removed from the flame.

If the iron has become red hot it is quite useless to attempt to use it in that state, and even if you can succeed in getting the solder to wet it, the solder itself will be immediately burnt. It is necessary, therefore, to cool the iron to the right temperature, then to file and clean up the tip, and finally to "tin" the iron by means of flux and solder.

A.C. Main's Interference.

A simple test which may be of use to those constructors who are not very much accustomed to using a soldering iron is to remove the iron from the flame and to press it into contact with a sheet of ordinary white paper such as notepaper. If after a second or two in contact with the paper the latter shows a brown discoloration the temperature of the iron is about right. If the discoloration is much too rapid the iron is too hot, of course; whilst if an insufficient discoloration results it is an indication that the iron requires further heating.

Readers in whose homes the electric light supply is of the A.C. variety may often experience trouble with their receiving sets, owing to induction and the consequent production of a hum in the loud speaker or headphones. This hum, of course, corresponds exactly in frequency with the periodicity of the A.C. supply. It is more likely to arise if the aerial or any part of the H.F. side of the set comes into close proximity with any of the electric light cables or such-like conductors.

Methods of Elimination.

There are several ways in which this difficulty may be reduced or eliminated. For one thing, the cabinet containing the set may be pasted inside with tinfoil, the tinfoil being secured in position by means of wax or other suitable adhesive, and the six sheets on the six sides of the cabinet being electrically connected together and connected also to earth. This amounts to placing the whole of the set within a closed metal conductor connected to earth and, as is well known, such an arrangement provides an excellent shield.

Of course, any form of shielding of this kind is apt to detract from the efficiency of a set, and therefore in some cases it may be more desirable to employ some other method for overcoming the interference.

A loose-coupled tuner will be found to be helpful in this direction, but a connection should always be taken from the L.T. battery to earth. Another point to remember is that if very much L.F. amplification is used in the set the A.C. hum will be amplified at the same time.

READY-TO-MAKE CABINETS



The Simplest and Cheapest Method

Each parcel contains good quality Mahogany, supplied planed, cut true, and ready for making up into a useful and handsome cabinet. There is a variety of sizes and styles, and an illustrated construction sheet is supplied with each. You can't go wrong.



No. 6 To take panel 16x8 Cabinet 17 1/2 x 9 1/2 x 8 1/2 **10/-**

No. 7 To take panel 12x6 Cabinet 13 1/2 x 7 1/2 x 6 1/2 **4/9**

No. 8 To take panel 9x6 Cabinet 10 1/2 x 7 1/2 x 6 1/2 **3/9**

Post 1/- - 9 - 9d

A Loud Speaker Cabinet for 10/6

A large 9d. design for making a handsome Speaker Cabinet (at a cost of 10s. 6d. for wood) is given free with the Christmas Number of HOBBIES magazine on sale. Ask any newsagent (price 4/3) or send 5d. in stamps to Darham.

HOBBIES also supply Fancy Beading, Transfers, Stripwood, Moulding, Polish, Stains, etc., especially suitable to the cabinet maker.

FREE

Illustrated lists of these Cabinets, the Beading, Transfers, etc., will be sent on application, post free.

HOBBIES LTD. (Dept. 69), **DEREHAM, NORFOLK.**

Or from Branches at London, Manchester, Birmingham, Glasgow, Leeds, Southampton, Sheffield, Brighton.

WIRELESS PICTURES AND TELEVISION

By **T. THORNE BAKER, F.C.S., F.R.P.S.**

At all Booksellers. Fully Illustrated, 6/6 net.

Mr. T. Thorne Baker will control the transmission of wireless photographs from the Paris broadcasting station "Radiola."

Read the book and see how it is done and learn how, yourself, to receive wireless pictures.

Constable & Co., Ltd., 10-12, Orange Street, W.C. 2.

Every Pair Guaranteed.



12/6
per pair.

"Phone-Joy"

Only truly experienced when listening-in on Bowerman's Phones. There is a charm, comfort and clarity about these instruments that is beyond praise and beyond rival. Get a pair to-day—they will amaze and delight you and reveal undreamt-of powers in your sets. Obtainable from Harrods, Benefinks, and all leading wireless dealers or direct under guarantee. P.O. 12/6.

Bowerman's

SUPER POWER HEAD PHONES

For B.E.C. Reception
Bowerman's Phones, 10-12, Ludgate Hill, London, Eng.



(Regd.)

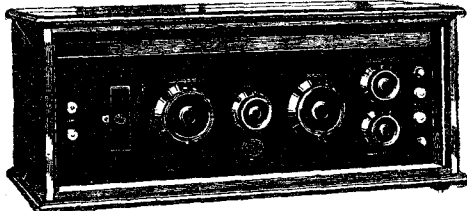
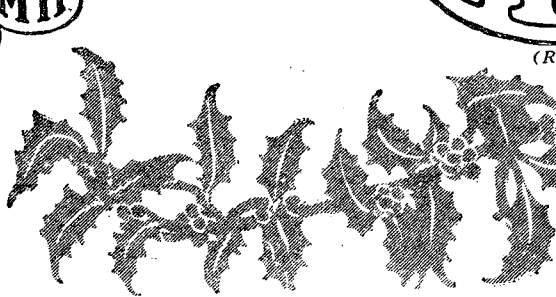

MH 7-VALVE SUPERSONIC RECEIVER.
 By the slightest movement of the Dial you can cut out at will uninteresting stations. Highly selective.
PRICE: Without Cabinet £17 17 0
 In Handsome Mahogany Cabinet £19 19 0
 (Royalties Extra.) Carriage Paid U.K. or F.O.B. London.

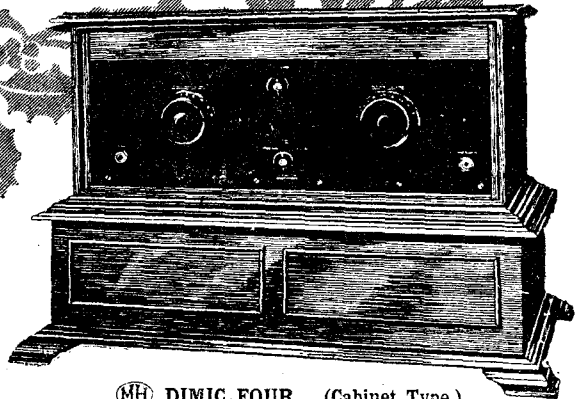

MH DIMIC FOUR. (Cabinet Type.)
 25 British and Continental Stations can be easily tuned in at loud-speaker strength, and many others with varying degree of clarity.
 The simple movement of a switch transfers reception from the lower broadcast band (British, Irish, Continental and American stations), to the upper broadcast band (Daventry, Radio-Paris, etc.)
PRICE (as illustrated) £15 15 0
 (Royalties £2 : 10 : 0 Extra.)

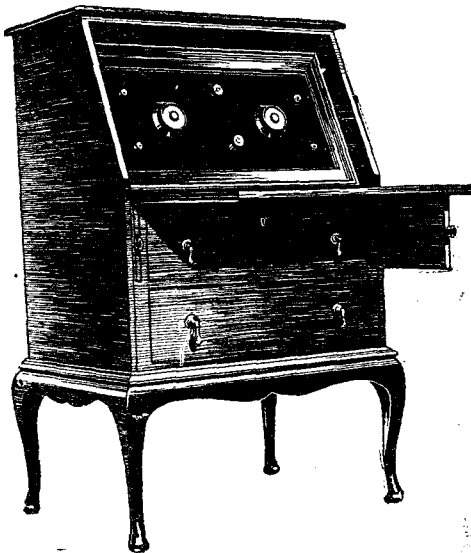

MH DIMIC FOUR. (Bureau Type.)
 Incorporating the same set as the Cabinet type.
 A Really Handsome Gift. **PRICE . . . 33 Guineas**
 (Royalties £2 : 10 : 0 Extra.)

Everybody's Choice!

Xmas—the time of good cheer—is upon us. The Xmas spirit—that feeling of well-being which makes us feel at peace with all the world, has taken its grip on us. A cosy room—all sitting round the fire—a good radio set and loud-speaker pouring forth strains of music in keeping with the atmosphere. And what better than an **MH**—whether it is a one-valve or eight-valve set. The fact that it bears the sign **MH** is our guarantee to you.

Inspection invited at our London Showrooms :
179, STRAND, W.C.2.

Telephone:
 SLOUGH
 441/442

L.M. MICHAEL LTD
 Manufacturers of Wireless and Scientific Apparatus
WEXHAM ROAD, SLOUGH, BUCKS
 IRISH AGENTS: B.N.B.Ltd., DUBLIN and BELFAST.

Telegrams :
 Radiether
 Slough.



BROADCAST NOTES.

Olczewska at Christmas—A Star Variety Broadcast—Mr. Cochran and the B.B.C.—An Albert Hall Incident—Character Reading by Radio—A New Musical Treat—Comedy Actor in a New Rôle—Captain Eckersley's Programme—Three New Songs—The Eckersley Versatility—A Wessex Programme—Better Broadcast News.

BY OUR BROADCASTING CORRESPONDENTS.

Olczewska at Christmas.

OLCZEWSKA is likely to be the star singer of the Christmas programmes. It is hoped to include this great artiste from 9 to 9.30 p.m. on December 27th.

A Star Variety Broadcast.

Turning to account the valuable experience of National Wireless Week, the B.B.C. are organising a special variety hour from 8 to 9 on December 28th.

Mr. Cochran and the B.B.C.

It appears that fresh trouble is brewing, this time between Mr. C. B. Cochran and the B.B.C. The immediate cause is the refusal of the B.B.C. to pay £100 for an excerpt from the "Faust" film which Mr. Cochran is producing at the Albert Hall on Sunday, January 2nd. Mr. Cochran sought the broadcast, and was amazed when he was turned down. First of all the offer was declined on the ground of Sunday policy in

broadcasting. Then when the offer was renewed for a weekday it was found to be too expensive. In all the circumstances most listeners would be disposed to agree that the B.B.C. should have the right to use discretion in these matters.

An Albert Hall Incident.

On the morning of November 20th, after the B.B.C. engineers had installed and tested the gear required for broadcasting the "Daily Express" Community Singing concert from the Albert Hall on that evening, the wires were disconnected and the apparatus forcibly disengaged by persons professing to be acting under the instructions of a certain society. Considerable unnecessary damage was caused, and the success of the evening broadcast was gravely imperilled. There was also a lamentable display of spleen against the B.B.C. This was a most unfortunate incident, and it is to be hoped that the society in question will lose little time in disclaiming its official cognizance of such vandalism.

Character Reading by Radio.

Manchester Station is toying with an idea for developing scientific experiments in character reading. Under the guidance of Professor Pear of Manchester University, the Manchester B.B.C. people hope to devise a system whereby a listener may appraise the character and personality of a broadcaster.

A New Musical Treat.

Sir Frederic Cowen will conduct a special orchestral programme from London early in the New Year.

Comedy Actor in a New Rôle.

Mr. Seymour Hicks is reading portions of Dickens' Christmas Carol on Sunday afternoons during December.

Captain Eckersley's Programme.

After a programme entitled "Reminiscences of 1926" in which some "Kitesh" music will be featured, Captain P. P. Eckersley will broadcast the final programme of the B.B. Company. He is writing the music, the words, and the patter all by himself. He will introduce characteristic imitations of early attempts at Writtle. No doubt this will be an amusing farewell for listeners, but it is to be hoped that the purely "domestic" side does not predominate. The great listening public of December, 1926 is not much interested in the broadcasting of even a year ago, let alone four years ago. What listeners want all the time is first-class entertainment. They take a mild interest in the personalities of the announcers,

(Continued on page 936.)

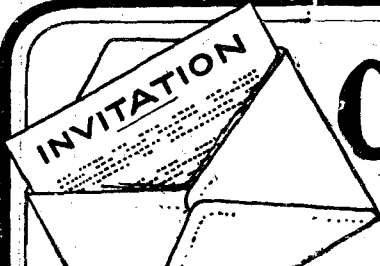

COME and SEE

for yourself how

BURNDEPT SUPER VALVES

ARE MADE IN OUR OWN FACTORY

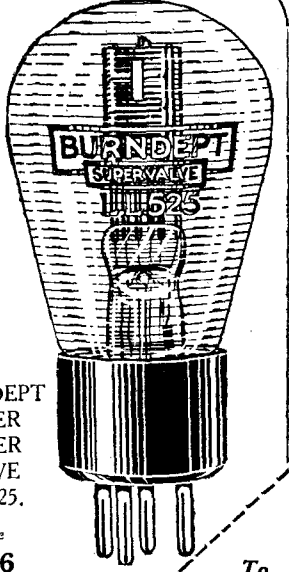

YOU have had experience with many valves since you first installed a wireless set—now come and see our manufactured. Every Thursday afternoon, for the next few weeks, we are arranging to give a practical demonstration to 100 wireless enthusiasts of how Burndept Super Valves are made. If you would like to come fill in the coupon below and post it at once. One hundred will be selected each week, and the senders will receive invitation tickets giving full details. The following facts about Burndept Super Valves will interest you in any case.

BURNDEPT

WIRELESS VALVES

FACTS ABOUT BURNDEPT Super VALVES

Filament efficiency is greater than any other valve. The current consumption is low. At no time during manufacture is the filament heated to a temperature higher than that when in actual use. The filament can be overrun, within reasonable limits, without damaging the valve. Only the latest and up-to-date appliances are used and include automatic vacuum pumps. Every valve is tested twice before it reaches the user. The factory limits, strictly improved, ensure uniformity in characteristics and mechanical construction. Burndept Valves are good valves, honest values and absolutely reliable—and we make them ourselves.

You will see the thoroughness with which every Valve is tested.

BURNDEPT SUPER POWER VALVE.
LL. 525.

Price **22/6**

One of the famous BURNDEPT range.

To BURNDEPT WIRELESS LTD.

I should like to be included in the party to visit your Valve Works on Dec. 16th.

NAME.....

ADDRESS.....

P.W.

Head Offices and Factory: **Blackheath, London, S.E.3.**
 London Showrooms: 15, Bedford Street, Strand, W.C.2.
AGENTS AND BRANCHES EVERYWHERE.

RADIO XMAS GIFTS

GIVE "JOY" and "PLEASURE" EVERY DAY THROUGHOUT THE YEAR.

Our large Radio Catalogue, No R/116, illustrating a most complete range of "Wireless Receivers" and Component Parts, post free on request. Traders should enclose Business Card for Trade Terms. "Goltone" (Regd.) Components are stocked by the leading Radio Stores. Firmly refuse substitutes.

"Goltone" RADIO METERS (British Made)

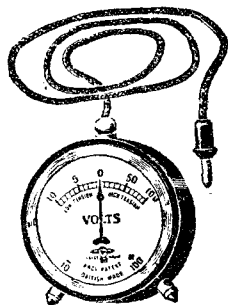

Accurately calibrated. Double reading, 10 volts and 120 volts.

POCKET TYPES
Centre Zero Reading. (Patent App.) Price 10/6
Side Reading. Price 8/6
Strong lined cases, 1/8 each

PANEL-MOUNTING TYPE
Flush type. Centre Zero Reading. (Patent App.)
Diameter of dial, 1 1/4 ins. Price 12/9
Panel-Mounting Push Buttons, 1/6 pair.

NO "XMAS GIFT" WILL BE MORE APPRECIATED. "Goltone" (Regd.) HIGH TENSION BATTERY ELIMINATOR

Serves a practical purpose by entirely eliminating the troubles, worries and uncertainties associated with High Tension Dry Batteries and Accumulators. The Constant voltage adds considerably to the volume and purity of reception. SAVES ITS FIRST COST IN A SHORT TIME. Connect to any convenient lampholder and "Switch-on." Current consumed negligible. Complete with Lampholder Adaptor, Connecting Cords, and full instructions.

DIRECT CURRENT MODELS.
Type "D.J." Approx. tappings, 45 and 100 Volts. Price 32/6.
Type "D." Approx. tappings, 30, 50, 75, 90 and 120 Volts. Price £3.
Type "D.N." Possesses the latest refinements. Perfectly silent. Suitable for voltages from 200/250. Voltage tappings as Model "D." Price £3 12s. 6d.

ALTERNATING CURRENT MODEL.
Approx. Tappings, 30, 60, 90 and 130 Volts. Dual tappings are taken from each voltage, thus providing 8 separate tappings. Price £5 10s., including valve. Fully illustrated Folder, giving extracts from many unsolicited testimonials received, on request. See Catalogue No. R/116 for details of "Constructional Kits."

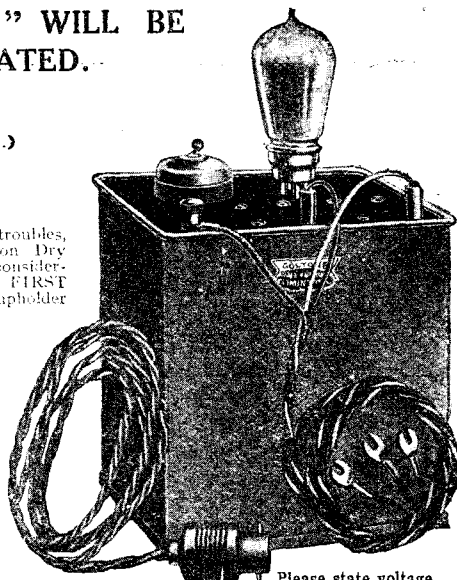

Please state voltage and frequency of Lighting Mains when ordering.

USERS

Mr. G. J., Acton, London.
"The H.T. Eliminator is giving great satisfaction. It is the best we have seen."
Mr. L. M., Great Crosby.
"It is without doubt the best I have handled."
Mr. H., Kirkby Stephen.
"We have had several which have given every satisfaction."

WRITE!

Mr. J. W. G., Fulwell, Sunderland.
"I am delighted with results. I did not think my set could do what it does. The increase of volume is great."
Mr. P. S., Westcliff-on-Sea.
"I have found it far superior to dry batteries, and the increase in volume and clarity is surprising."

"Goltone" Pentlodyne Receiving Sets

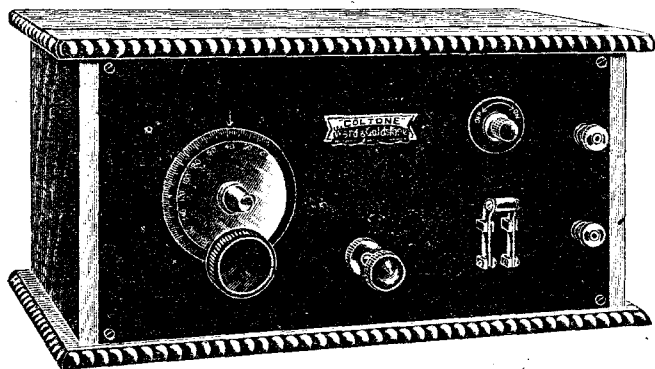

**SIMPLICITY OF CONTROL
MAXIMUM VOLUME AND PURITY
LONG-DISTANCE RECEPTIVITY**
Jacobean Oak Cabinet

The Valves and Tuning Coils are concealed inside the Cabinet, giving the "Outfit" a neat and refined appearance. The Top of the cabinet is hinged, permitting easy access to all the components. Prices include Set of 5 Basket Coils covering all B.B.C. Wavelengths, including "Daventry."

TWO-VALVE SET £5 : 10 : 0
Marconi Royalties 25/-
THREE-VALVE SET £7 : 10 : 0
Marconi Royalties 37/6
FOUR-VALVE SET £10 : 0 : 0
Marconi Royalties 50/-

See Catalogue R/116 for full details, free on request.

ACCUMULATOR CHARGING SETS for Home Service

NO TECHNICAL KNOWLEDGE OR ATTENTION REQUIRED.

CLEAN, ECONOMICAL, AND EFFICIENT.

Plug-in to any Convenient Lampholder. Supplied complete with Adaptor, Flexible Cords and full instructions.

The "ALTERNO" (As illustrated).
Alternating Current.

Charges the High Tension Accumulator at negligible cost ... Price 21/-

The "INDISPENSO." Direct Current.
Charges the High Tension Accumulator at no extra cost when light is in use ... Price 6/-

GOLTONE "PENDELTON." (Patent App.)
Alternating Current.

Charges the Low Tension 2, 4 or 6 volt Accumulator economically and effectively. No Valves or renewals. Charging Rate approx. 2 Amps. ... Price £2:12:6

Fitted with Ammeter for ascertaining rate of charge (as illustrated) ... £3:7:6
State voltage and frequency of Lighting Main when ordering.

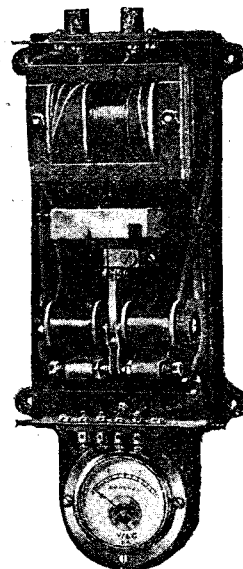

"PENDELTON" CHARGER with Cover Removed.

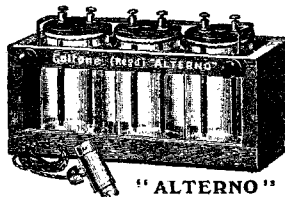

"ALTERNO"

Extract from POPULAR WIRELESS, Sept. 11th, 1926:

"GOLTONE ALTERNO" CHARGER.

"It is highly efficient in operation and will rectify up to a charging rate of 2 amp. with the greatest ease and freedom from heating. It is, moreover, quite easy to handle."

Mr. J. W. D., Ormskirk Road, Aintree:
"I bought an 'Alterno' and was quite surprised at the results. I think it the most wonderful and simple arrangement I ever saw for so little money."



FREDERICK ROAD, PENDLETON, MANCHESTER.

BROADCAST NOTES.

(Continued from page 934.)

and in that of the popular chief engineer, but they are inclined to resent the assumption that this is more than a mild interest.

Three New Songs.

The Three Arts Club has carried out a competition for song writers, offering prizes for unpublished songs which may be demonstrated to have a wide, popular appeal. The selection of the prize-winning song will depend first on the approval of the musical committee of the Club, and then on the verdict of the public represented by the audience in attendance at a public concert to be given on December 28th. The three successful songs will be broadcast between 8.50 and 9 o'clock on the night of December 28th, just before the beginning of Sir Landon Ronald's popular concert in the London studio.

The Eckersley Versatility.

There seems no end to the possibilities of the Eckersley family. Peter, still, is probably more popular and better known than many Cabinet Ministers. Roger, now head of the B.B.C. programmes, came to broadcasting much later than his brother, but has made such rapid progress that he, too, is now a public character.

As a side-line Roger Eckersley composes light music. One of his recent fox trots, "Pig-Tail Alley," is doing very well both here and in the United States. Roger, of course, is a recognised poultry expert. His place at Farnham Royal attracts visitors from all over the country and from abroad as well. He has about four thousand hens, and the system applied to their maintenance is considered ideal.

And then, when Roger is not building programmes, writing fox trots, or looking after his hens, he is going round Stoke Poges well under bogey. He was for some

H.T. and L.T.
from electric
mains.

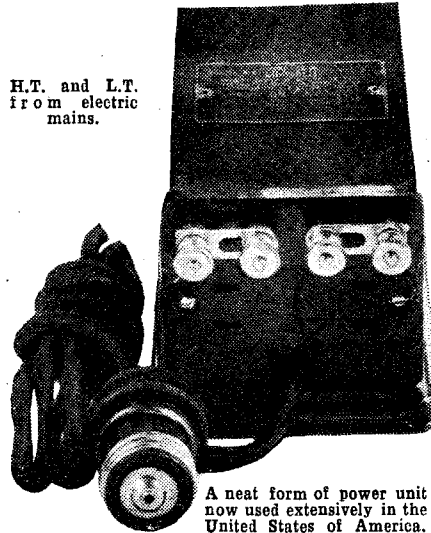

A neat form of power unit
now used extensively in the
United States of America.

time secretary of the Stoke Club, and during his term in this job he set up several course records that have not yet been touched. Incidentally, few people know that the Eckersleys are first cousins of the corresponding generation of Huxleys.

A Wessex Programme.

To-night (Thursday, December 9th) there is a special Wessex Programme S.B. from Bournemouth. This has been arranged by Mr. Thomas Hardy, O.M., and it will be introduced by Mrs. Hardy. A one-act play, "The Three Wayfarers," dramatised by Mr. Hardy from his well-known story, will be the principal item. It will be presented by the Hardy Players. Old-time songs, dances, and carols from the old records in the possession of Mr. Hardy will be included.

Petter Broadcast News.

There is as yet no official news of the progress of the negotiations between the B.B.C. and the Press. It is understood, however, that while the danger of a rupture is not entirely eliminated, the two parties have managed to clear up a good many of their preliminary difficulties.

Listeners are more concerned about getting a better service, particularly of sporting events, than they are about the persistence of good relations between the Press and the B.B.C. The B.B.C. are alive to this fact. Whatever eventuates it can be confidently reaffirmed that listeners will be given running narratives of all the chief sporting events of 1927.

Do not risk disappointment for your Xmas reception

We have made special arrangements to carry a huge stock of EXIDE W.J. 20V. and Oldham H.T. Accumulators fully charged and ready for immediate use—also Dry—for dispatch by rail.

Full Range of all LOTUS goods, Coil Holders, Switches, Packs, etc., etc.

T.M.C. Units Loud Speaker, 13s. 6d.

AMPLION CABINET LOUD SPEAKER,
£3 3s. Od.

NEW BASE BOARD. Variable Fixed Resistance Microstats, etc.

SPECIAL—THE AMPLIFEX LOOP.

The only loop aerial adapted for the reception of all European Broadcasting, £3.

Don't fail to send that little 6d. along for our new Tannerlogue—the real guide to wireless.

WILL DAY, Ltd. (Dept. 14),
19, LISLE ST., LEICESTER SQUARE,
LONDON, W.C.2.

Telephone:
Regent 4577

Telegrams:
Titles. Westrand, London.

Well Worth Giving - Waterman's Ideal Fountain Pen

For over 40 years Waterman's has been recognised as the Pen of all Pens. It is a gift that everyone likes to have—Father, Mother, Sister, Brother, Relative, Friend, or Employee. Pens from 12/6, Pencils from 3/-.

See the new Ripple Rubber Pens, and the Ripple Rubber Pencils with expanding tip and Rigid lead. Ripple Rubber Writing Sets, 32/6, 42/6, 47/6.

Of Stationers and Jewellers.

The Pen Book free from

L. G. Sloan, Ltd.

The Pen Corner

Kingsway, London, W.C.2



You can construct this or this with equal ease

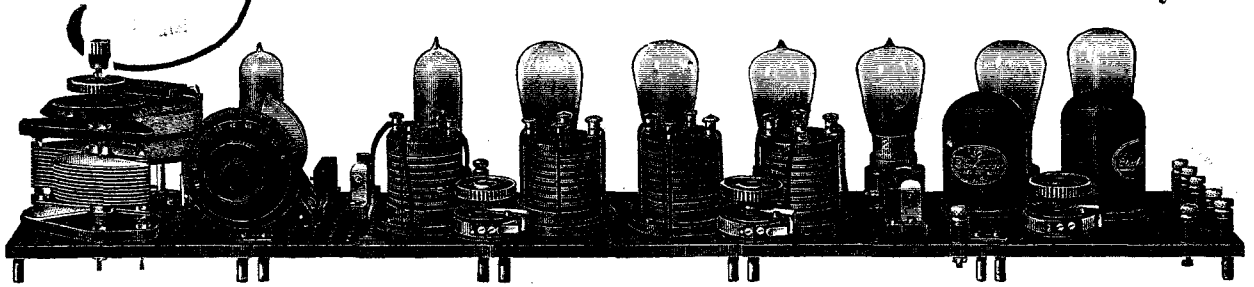
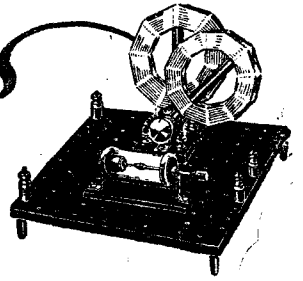

If you adopt

BLACKADDA

RADIO BUILDING SYSTEM

As an example of prices the cost of the complete set for constructing a 1-valve Receiver is £2 12/6, made up as follows:—

Base or "table"	3/6
Seven Terminals	3/6
Variable Condenser	14/6
Fixed Coil Holder	1/-
Swivel Coil Holder	4/6
Air-spaced Coil	5/-
Ditto	5/6
Fixed Condenser '0003	2/-
Resistance Holder	1/8
Grid Leak	2/6
Valve Holder	2/6
Rheostat	5/-
Box Spanner	6d.
Set of Connectors	10s.

It will be of interest to constructors to know that the Blackadda "table" included in the above list can be used as a base board for any cabinet set, since it can be added to and extended in any direction to make up multiples of 6 in. This "table" is composed of first-class insulating material already drilled.

*Any Circuit
Constructed
Without
Technical Knowledge*

Write for advance particulars of new sub-panel system, possessing the new Blackadda advantages of ease of construction, and enabling you to make recently-described receivers giving marvellous results. The most interesting radio proposition of the season.

**THE BLACKADDA RADIO Co., Ltd.,
SADLER GATE, DERBY**

Phone: Derby 1823. Grams: "Blackadda, Derby."
If your dealer is unable to supply, we will forward direct on receipt of remittance or C.O.D.

Agents Wanted in London and Provinces.

THE MODERN METHOD.

From our previous advertisements in "Popular Wireless" you will have gathered some idea of the advantages of our system. Too much stress cannot be laid on its simplicity and economy. It is difficult to realise the ease and speed of constructing even the most intricate set until you actually try our method.

RECEIVING SET MADE IN 20 MINUTES!

"At 7.40 p.m. I commenced building a Crystal receiver, at 8 p.m. that same evening I was listening to the programme from Daventry on the completed set. The only implement I used was a small box spanner"
—BARTEX. (Extract from the "Derby Daily Express," March 16th, 1926.) The foregoing is just an example of an actual user's experience. A multi-valve receiver can be constructed, without effort or tools, in a minimum space of time.

WHAT "CONSTRUCTION BY NUMBERS" MEANS.

To the average amateur the descriptions of new circuits with their technical details present a considerable amount of confusion and difficulty. With our system, and on our service sheets, all components, wiring points, etc., bear numbers, as also do the ready drilled holes in the base or "table"; it is only necessary to place the components indicated in their correct positions as shown by the numbers, and connect in the same manner from point to point with our standard lengths of wire, the points also being plainly indicated by numbers. Nothing could be more simple, no tools, no soldering, no drilling, nor cutting. Anyone who can read will be able to follow our instructions without the slightest difficulty.

FOR NOVICE AND EXPERT ALIKE.

To those with little or no technical knowledge, the Blackadda System will hold a strong appeal, in addition to making the task of the home constructor easy and removing any doubts as to the ultimate efficiency of the finished set, it enables him or her to gradually acquire a valuable knowledge of the principles of Wireless and consequently increases interest and arouses enthusiasm such as the purchaser of a ready-made set cannot experience. For the expert, the Blackadda System offers opportunities for countless experiments, various new circuits can be built and "tried out" the same evening under the same conditions and valuable data obtained from the results. Again, being able to make use of the same components, base board and wiring when conducting experiments, without "scrap," the facility with which components of various makes can be tested and compared by using our adaptors, these are advantages that only the Blackadda offers.

HELPFUL SERVICE.

So that Blackadda enthusiasts shall be afforded every assistance, we publish regularly Service sheets illustrating and describing new circuits. These are issued in loose leaf form, price 3d. each.

THE REAL DELIGHTS OF WIRELESS.

The growth of interest in radio and the perfecting of transmission and reception has caused a wireless set to be regarded as an indispensable part of the modern home. The full enjoyment from this delightful form of entertainment, however, is for those who keep their receivers up-to-date. Every week one reads of new and improved circuits: how keen is frequently the desire to put these to the test, but how often in the case of a possessor of a ready-made or home-built set that has been laboriously

constructed, drilled, screwed and soldered, is the wish to experiment unfulfilled owing to the time, trouble and expense involved? Change over to the Blackadda System and you can always be up-to-date, as well as save money.

Let us send you the Blackadda Circuit book, price 1/-. This volume contains details and illustrations of over 50 modern circuits, as well as a fund of useful radio information, also description and prices of Blackadda parts and components.



Traders and manufacturers are invited to submit wireless sets and components to the "P.W." Technical Dept. for test. All tests are carried out with strict impartiality in the "P.W." Test room under the supervision of the Technical Editor, and the general reader is asked to note that this weekly article is also intended to provide a reliable and unbiased guide as to what to buy and what to avoid.—EDITOR.

The Marconi D.E.P.215.

It will be observed that a new style of nomenclature has been adopted by the Marconi people, and one that is directly informative. As the letters imply, the D.E.P.215 is a dull-emitter power valve, and the figures give its filament voltage as 2 volts and its current consumption as .15 amps. Two parallel straight filaments are used.

It will be interesting to compare the characteristics of the D.E.P. 215 with the Marconi D.E.6, which is, of course, also a 2-volt power valve. First of all, the filament voltage of the D.E.P.215 is less than one-third of that of the D.E.6, while its amplification factor is 6.25, as against 5.5. Even so, its impedance is only 6,250 ohms, while that of the D.E.6 is 10,000. Therefore it will be seen that the D.E.P.215 is a great advance in every respect.

At 120 volts H.T. and 9 volts grid

negative the emission is 4.8 milliamps. as against 4.2 for the D.E.6, while the total emission is also higher at about 18 to 20 milliamps.

All the above ratings are on the conservative side; for instance, the amplification factor from the curves being 6.5, as compared with the stated value of 6.25.

The D.E.6 could not be regarded as anything else but a first-class 2-volt power valve, but the D.E.P.215 is superior to it and delivers a slightly greater volume, and can deal with larger inputs. In our opinion, the addition of this valve to the already pre-eminently comprehensive Marconi range will do much to bring the 2-volters greater popularity than ever.

Two Brandes Components.

Messrs. Brandes recently sent us one of their new S.L.F. variable condensers and one of their L.F. transformers. The

variable will be of unique interest to constructors in that although it gives true S.L.F. variations of capacity, it retains a compact form, and its vanes do not describe a large arc when moving towards the "out" position.

It is provided with a very efficient slow-motion movement, a large central milled knob smoothly operating the moving vanes through a semi-friction gearing. The control of the dial, which provides a direct drive, is equally smooth and free from backlash. Ball-bearings are employed.

The variable is practically all metal, very little solid dielectric, indeed, being used. The vanes are of hard, springy brass. The variable is designed for one-hole panel mounting, but the nut has a knurled face to prevent the component turning, and to ensure that a hold is retained on the panel.

Throughout this Brandes variable is a most excellent piece of workmanship, both from a mechanical and from an electrical point of view. It retails at 18s. with a .0003 mfd. capacity, and at 18s. 6d. with a capacity of .0005 mfd.

The Brandes audio (L.F.) transformer is supplied complete with an excellent little instruction book in which are given amplifier diagrams and much useful operating data. With a ratio of 1 to 5, it costs 17s. 6d. It is a "shrouded" type of very distinctive design, and has four well-spaced, clearly marked terminals (with soldering tags) fitted to an insulating panel on its top. We gave the sample sent us a series of careful tests, and obtained results quite as good as those with other transformers of the same make and price.

(Continued on page 940.)

IMMUNE FROM VIBRATION

Banishes Ringing Noises

The new Nelson Non-Phonic Valve eliminates all "ringing" noises caused by shocks and vibration and which are increased by the use of dull emitter valves.

Perfect reception is assured by "floating" the glass envelope on a rubber cushion so that the greatest shocks to the set cannot be transmitted to the delicate internal parts of the valve.

You will find Nelson Non-Phonic far superior to the combination of valve and so-called anti-microphonic valve-holder.

THREE TYPES ARE AVAILABLE:—
 For 2 Volt Accumulators For 3-4 Volt Dry Cells
TYPE G220. **TYPE G306.**

2 Volts, .2 amps. Impedance 20,000 ohms. Amplification Factor 7.
 3 Volts, .06 amps. Impedance 25,000 ohms. Amplification Factor 7.

11/- 11/-
 For 1 Volt Accumulator **TYPE G410.**
 3.8 Volts, 0.10 amps. Impedance 20,000 ohms. Amplification Factor 7. 11/-

If unable to obtain from your dealer, apply direct to actual manufacturers.

NELSON ELECTRIC Co., Ltd. 138, Kingston Rd., London, S.W. 19.



NELSON NON-PHONIC VALVE
Single Filament

Branch Offices: 1, Cathedral Gates, Manchester, and 11, Bothwell Street, Glasgow.

"EKCO" H.T. UNITS

SCRAP DRY BATTERIES!

By obtaining H.T. Current from Electric Supply Mains (D.C. & A.C.) by just attaching adaptor to Electric Light Lampholder.

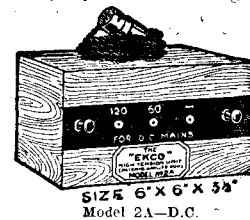

SAFE!

SILENT!

SOUND!

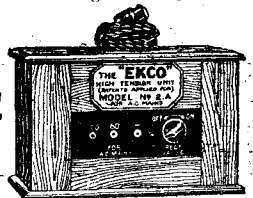

Model 2A-A.C.

"EKCO" H.T. UNITS ARE:

THE BEST OBTAINABLE as we **SPECIALISE** solely in their manufacture. **THE "EKCO" IS NOT A "SIDE LINE!"**
AT A REASONABLE PRICE because our enormous output enables us to cut the manufacturing costs to a minimum.
THE MOST POPULAR on the WORLD MARKET as proved by huge sales at home and abroad.

READ WHAT THEY ALL SAY!

THE PRESS.
 "Amateur Wireless," 9/10/26.
 "We have tested this Unit. No trace of 'hum' could be heard."
 "British Trade Jnl." 1/10/26.
 "We have tested the 'EKCO' H.T. Unit and found the instrument efficient in every way. It is one of the few exceptions that has reached the commercial stage."
 "Wireless World," 11/8/26.
 "No 'hum' was discernible—the Unit is a good practical proposition and can be relied upon."

USERS.
 S. B., Doncaster: "The reception was first-class."

W. W., St. John's Wood: "Your 'EKCO' H.T. Unit has been a great success with my Marconi Straight B. I think the reception is more silent than with dry batteries."

H. J., Newcastle: "H.T. worries are over for everyone who possesses an 'EKCO' H.T. Unit."

ILLUSTRATED CATALOGUE FREE.

UNITS TO SUIT ALL SETS from **42/6** Obtainable from all the leading Wireless Stores or direct from

E. K. COLE, Ltd. (DEPT A), 513, LONDON ROAD, WESTCLIFF-ON-SEA.

A Perfect Accumulator for 6/-

ENDURO

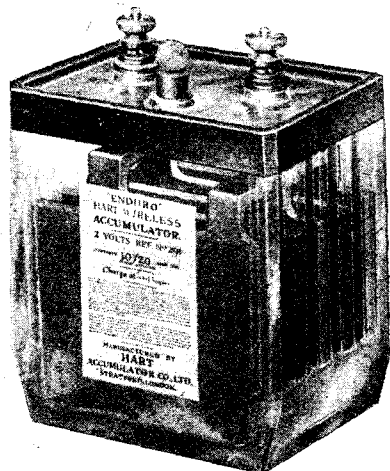

THE "HART" "ENDURO" 2-VOLT ACCUMULATOR. PRICE 6/- ONLY. (Carriage Paid)

USERS of both dull and bright Emitter Valves are welcoming this really efficient accumulator, having in mind particularly its very moderate cost. Assembled in an attractive glass container, with a capacity of 10 ampere hours (at the 20 hour rate of discharge), the 5 plates of the "HART" 2-Volt "Enduro" Cell are designed specifically to give steady discharge and long life—both of which essential features they embody in a marked degree. The "HART" "Enduro" Cell is safely and easily sent by POST, and forms

AN IDEAL CHRISTMAS PRESENT FOR YOUR WIRELESS FRIENDS

HART

THE BATTERY OF QUALITY

Write to Dept. "P.W." 6 for Free Booklet, "The Right Way to Use Your Wireless Batteries."

HART ACCUMULATOR COMPANY, LIMITED,
STRATFORD, LONDON, E.15

APPARATUS TESTED

(Continued from page 938.)

A CHEAP S.L.F. VARIABLE.

We recently received a .0005 mfd. straight-line-frequency variable condenser from Messrs. The Ison Radio Stores, 47, Orford Road, E.17. It is quite well made and, due to the ball-bearing which is fitted, its action is smooth and free from "backlash." It is fitted with ebonite-end plates, and is minus a "pigtail," but in other respects it is an excellent piece of work. It costs only 7s. 6d. (post free), complete with dial, so that it brings the S.L.F. variable within the reach of the most impecunious of constructors.

AN INTERESTING COMPONENT.

Over a mile of wire is stated to be used in the Watmel Auto-choke. And the method of winding this wire is very interesting. The Watmel people recently sent us some samples clearly illustrating the system which, by the way, must be a rather expensive one, and must necessitate the use of very special machinery. Each layer is perfectly insulated with an interweaving of cotton. It is re-assuring to discover what scrupulous care manufacturers are paying to the unseen "innards" of radio components these days.

THE MULLARD D.U.5.

To their already very comprehensive range of valves, Messrs. Mullard have

recently added the D.U.5., a low temperature filament, low power rectifying valve. It is of the half wave, three-pin base type, and consumes .77 amperes at 2.7 volts. It is very stoutly constructed and should safely resist very rough handling (to which it should, of course, never be subjected!).

When used as an ordinary half-wave rectifier the D.U.5. proved very satisfactory, the filament adjustment not being critical (as is the case when an ordinary three-electrode receiving valve is used for half-wave rectification). The receiver used was a straightforward detector and two L.F.

When two D.U.5.'s were used together to give full-wave rectification the result was almost perfection. Even when a four valver was employed (H.F., Det., 2 L.F.) there was no "hum." As the total power consumption, even with two D.U.'s, is only a matter of two or three watts, such a system is a particularly economical one.

We believe the D.U.5. is the lowest wattage valve of its type on the market, and as it is also exceptionally efficient, it should prove a very popular rectifier indeed. The retail price of the D.U.5. is 15s.

REDFERN'S EBONITE PANELS.

We recently received an "Ebonart" radio panel from Messrs. Redfern. It is provided with a brilliantly polished surface, but this is obtained without employing tin-foil or any other metallic agency. Thus its sheen is free from suspicion, and does not need to be removed in the interests of "low loss" edicts.

It works freely, is not too brittle, and, from an electrical point of view, is as high-

class an ebonite as we have tested. Despite the fact that "Ebonart" is of the highest grade, it is not expensive. For instance, a panel measuring 10 in. by 7 in. by $\frac{1}{8}$ in. costs 4s. 3d., and this, it will be agreed, represents excellent value for money.

Redfern's "Ebonart" is also supplied with a mahogany finish at a slightly higher price. A large range of standard sizes is available.

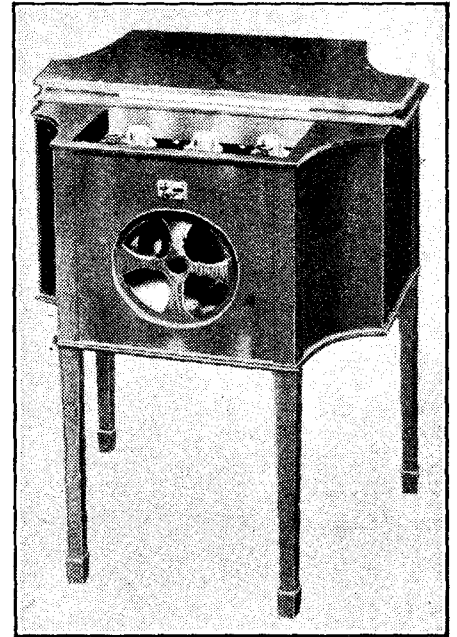

This handsome set is one of the latest C.A.V. models.

(Christmas in Two Weeks)

TWO GIANTS IN PERFORMANCE—

Now a LISSENOLA HORN as well as a UNIT!

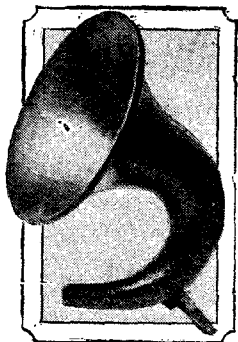

12" flare 13/6

14" flare 17/6

Sold separately or
with LISSENOLA
Unit complete.

THE CHALLENGE:

Try the LISSENOLA Unit now with the LISSENOLA Horn fitted to it—made in 12-in. and 14-in. flares—we challenge

comparison of this fine combination against any loud speaker selling at any price up to £20—that means *any* loud speaker on the market *irrespective of price*. Yet this LISSENOLA combination will only cost you 31/-. Compare what you pay for an expensive loud speaker with what this fine LISSENOLA combination costs you.

13/6

Sold separately
or with
LISSENOLA
horn complete.

If you do not prefer the LISSENOLA Combination to any other loud speaker for tone, quality and volume, your money will be willingly refunded, if you ask your dealer within 7 days of purchase. If you already have a LISSENOLA Unit, now get this handsome factory-made LISSENOLA horn, 12-in. or 14-in. flare—GET IT NOW BEFORE CHRISTMAS. If unable to obtain from your dealer send direct, and add 2/- to price to cover part cost of packing and carriage. AND PLEASE MENTION DEALER'S NAME AND ADDRESS. YOU CAN NOW OBTAIN THE LISSENOLA UNIT COMPLETE WITH FINE HORN—or purchase either separately. Any dealer will obtain for you.

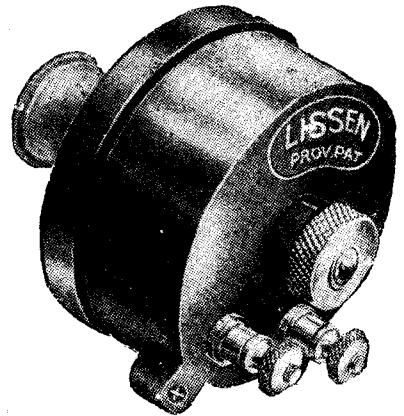

LISSEN LTD., 8-16, FRIARS LANE, RICHMOND, SURREY

(Managing Director: Thomas N. Cole)

L.127a

If you are making the R.C. Threesome—

TO get the wonderful results obtained with the original R.C. Threesome Set, you should use identical components.

The Coil Holder used is a "Lotus" Left Hand Two-Way Coil Holder; the three Valve Holders are "Lotus" Buoyancy Valve Holders, with terminals.

Wireless experts decided that these were best for a very important experiment; that they would get most out of the set on which depended the very high reputation of the famous Ediswan Valves.

They were not disappointed. YOU will be more than pleased with the R.C. Threesome performance, if you fit "Lotus" Valve Holders and Coil Holder.

From all Radio Dealers.

LOTUS

COMPONENTS

"LOTUS" COMPONENTS USED IN THE R.C. THREESOME RESISTANCE COUPLING SET:

Two-Way Inside Mounting Left Hand Coil Holder	7/-
"Lotus" Buoyancy Valve Holder with Terminals	2/6

GAXTON WIRELESS CABINETS

LOOKING BACK.

(Continued from page 878.)

All Polished with new enamel that gives a glass hard surface that cannot be soiled or scratched. Ebonite or Radion Panels Supplied and Perfectly Fitted at low extra cost. SENT FREE.— Catalogue of Standard Wireless Cabinets in various sizes and woods.

THOUSANDS OF SATISFIED CUSTOMERS.

ELSTREE SOLODYNE. Panel 21" x 7" fitted 16" Baseboard, drop down Beaded Front Door. Fumed Oak 61/-, Dark Oak 65/-, Mahogany polished 68/6. Raised Panel 5/- extra. Packing Case 5/- extra.

ELSTREE SIX. Panel 42" x 9" fitted 13 1/2" Baseboard. Open Type. Fumed or Dark Oak 80/-, Mahogany polished 90/-, Packing Case 7/6 extra.

MONODIAL. Panel 14" x 7" fitted 14" Baseboard. Fumed Oak 33/6, Dark Oak 35/-, Mahogany polished 39/6. Packing Case 6/- extra.

NIGHT HAWK. Panel 16" x 8" fitted 14" Baseboard. Open Type. Fumed Oak 33/6, Dark Oak 35/-, Mahogany polished 39/6. Packing Case 7/- extra.

FIVE FIFTEEN. Panel 24" x 7" fitted 8 3/4" Baseboard two Front Doors. Fumed Oak 40/-, Dark Oak 42/6, Mahogany polished 48-. Packing Case 7/6 extra.

THE 1927 FIVE. Panel 27 1/2" x 7" Sloping Front, as originally described. Fumed or Dark Oak 38/-, Mahogany polished 48/-, Packing Case 7/6 extra.

EVERYMAN THREE. Panel 20" x 8" fitted 8" Baseboard. Fumed Oak 33/6, Dark Oak 35/-, Mahogany polished 39/6. Packing Case 6/- extra.

EVERYMAN FOUR. Panel 26" x 8" fitted 8" Baseboard. Fumed Oak 35/6, Dark Oak 37/6, Mahogany polished 41/6. Packing Case 7/- extra.

CASH WITH ORDER. CARRIAGE PAID U.K. PROMPT DELIVERY.

Packing Case Money repaid if Case returned within 14 days
Carriage paid to Works.

CAXTON WOOD TURNERY CO., MARKET HARBOROUGH

BUILD A LOUDSPEAKER

WITH OUR NEW SEAMLESS MOULDED CONE (Prov. Patent 25069/26.) and a BROWN A or LISSNOLA. You will obtain PERFECT RESULTS. Successful Construction for a minimum outlay is ensured with our Specialities. Illustrated List and full particulars for Stamp.

GOODMAN'S 27 FARRINGDON ST. E.C.4

EASY PAYMENTS Finest 2-valve amplifier set, including loud speaker, 120 H.T., D.E. valves, £7 10s.; or 18/9 down and 11 instalments of 15/-.

CASH BARGAINS.

Amplifiers, 17/6 and 21/-; Phones, Telefunken type, 7/9; Fr. T. Houston, 11/-; Good H.T. 60 volt, 5/9 or 4/-; (laboratory test) 4/- doz. Famous Metal Valves (French), 2-v. -2.5/-; 2-v. .06, 5/9; 2-v. .5, Power, 8/9; 4-v. .06, 5/6. Straight Line Condensers, 5/9; Ditto, 4" dial, 7/3. Transformers: Habana, 3/6; Radios, 3/8; Fr. T. Houston, 2/3; Brunet, 7/9. Also Ferranti, Eureka, Formo, etc. Postage extra. Everything in wireless, reliable and cheap. Satisfaction or cash refunded.

MUSIC ROLL EXCHANGE, 29, High St., Clapham, London, S.W.4.

The High Tension System of the Future
WET H.T. BATTERIES

Due to the silent background and great economy of working, WET H.T. Batteries have almost everything to recommend them. They offer all the advantages of an H.T. accumulator, with none of the disadvantages such as the inconvenience of charging and the liability to sulphate if left run down. The cost is less than 3d. a volt, and upkeep 1d. per volt per annum.

Send 1d. for full details.

Jars 2 1/2" high, 1 1/2 x 1 1/2, waxed, ..dozen 1/3
Sac Elements .. 1/6
Zincs .. 1/-
Carriage Extra.

WET H.T. BATTERY CO., 23, Coldharbour Lane, Gunpowder Green, S.E.5. Phone: Brixton 2539.

WIRELESS.—Capable, trustworthy men with spare time who wish to substantially increase income required where we are not fully represented. Applicants must have practical knowledge of installation of Set and Aerial, be a householder or live with parents, and be able to give references: state age and experience. Address: Dept. 32, General Radio Company, Limited, Radio House, Regent Street, London, W.1.

TRADE MARK **FINEST QUALITY**

RED DIAMOND RADIO COMPONENTS

EVERY COMPONENT IS PERFECT.

REGISTERED

R.D. 40 Perm. Detector, 2/- each.
Also in Red Mottled (R.D. 40A), 3/- each.



Of all High-class Radio Dealers or Sole Makers.
JEWEL PEN CO., LTD., Radio Dept. 46, 21/22, Gt. Sutton St., London, E.C.1.

"Two Valve VALVE"

MEANS DOUBLE POWER

For use in both H.T.-less and ordinary circuits, B.E., D.E. and '06, 10/6 to 14/-

Send card for Radio press reports and booklet. This valve can be used in any set without alteration and will give 50% to 150% increase in power.

ANELOY PRODUCTS,
Eton Works, East Dulwich London, S.E.22.
CALLERS 36a, Forest Hill Road, East Dulwich.

time, by a mistake, the whole of the conversation between the station directors in Aberdeen and Glasgow was radiated from every station. The Scottish directors were discussing how to economise in orchestras. I dare not put down what they said.

At last it worked, and for the first time one Sunday afternoon a voice actuated every transmitter simultaneously, and we looked at one another and beamed. My wife might have been the first S.B. feminine talker, but refused even to say "Hullo!" She sought not the bubble reputation even in the (microphone's) mouth.

An Epic Transmission.

Of the more epic transmissions I always think of the radiating of the opening of the Wembley Exhibition as the greatest. Everywhere demonstrations by loud speaker had been arranged in little village halls, in huge parks, in Trafalgar Square; the newspapers, one and all, ran some demonstration.

To say I was nervous, with the King to speak, with the difficulties of picking up all the noises of that vast arena, of working out the switching systems, the visual and telephone signalling, was to put it mildly. But I have a staff that never lets me down. All through a broiling Easter I left them to rig up the scheme on the lines of a long-discussed plan.

"Imagine My Agony—"

Need I say that the show went off marvellously? I had a good seat and had nothing to do with operations. Imagine my agony on seeing, ten minutes before the show, one of the engineers double up to the dais and start talking. I sat like a broody hen; nothing that I could do was of any use now!

Plans were made. The agony to see a drummer beating for dear life about one foot from the microphone. To hear the speeches and the prayers; to realise the wonder of the occasion; to hope, to pray that all this great thing was being heard by hundreds of thousands. The show over, I ran to my kiosk and saw the face of Mr. Bishop—the top of his head was nearly off, he was smiling so. I dropped my umbrella on the grass and danced. I even drove our Ford van home. I met Round at lunch, and he had a great tale to tell of the Trafalgar Square demonstration. "Round," I said, "you'll get a knighthood. You will be called Sir Cumference." One person, at least, saw my joke and published it later as someone else's.

There have been many other great transmissions, but never a one to compare with Wembley.

Future Plans.

Now we face the future with more confidence, because all has logically developed. We are recognised and respected, but there is to be no rest. We shall not be content until everyone in Britain has a choice of two or three programmes on the simplest set. Even now plans are laid that this shall be done. Perhaps I shall be asked to write again of our doings in three years' time. Doubtless to-day will seem to that to-morrow as crude as yesterday seems to to-day.

ALL APPLICATIONS FOR ADVERTISING SPACE IN "POPULAR WIRELESS" MUST BE MADE TO THE SOLE ADVERTISING AGENTS JOHN H. LILE, LTD., 4, LUDGATE CIRCUS, LONDON, E.C.4.

All About H. T. From the Mains



Whatever you want to know about H.T. from the mains, either Alternating Current or Direct Current, you will find it in the new Climax Brochure. These components were chosen by "Popular Wireless" when describing how to build A.C. and D.C. Units.

- CLIMAX AUTO-BAT TRANSFORMER**
- | | | |
|---------------------------------|----------------|---------------------|
| Ref. No. CN 257. | 200-250 volts | } Price 39/6 |
| " " CN 258. | 100-125 volts | |
| Double-wave Model | | |
| Ref. No. CN 259. | 200-250 volts | } Price 27/6 |
| " " CN 260. | 100-125 volts | |
| Single-wave Model | | |
| CLIMAX SPECIAL CHOKE | | |
| Ref. No. CN 256 | | Price 10/6 |
| CLIMAX POTENTIAL DIVIDER | | |
| Ref. No. CN 200. | 20,000 ohms .. | Price 5/- |
| Ref. No. CN 201. | 10,000 ohms .. | Price 5/- |

CLIMAX

CLIMAX RADIO ELECTRIC LTD.,
Head Office and Works:
Quill Works, Putney, London,
S.W.15.

All communications to above address.
Telephone: Putney 2599.

Showrooms:
257, HIGH HOLBORN,
LONDON, W.C.1.
Telephone:
Holborn 2538.

Please send me post free, Brochure describing all about H.T. from the mains and particulars of components as recommended by "Popular Wireless," September 11th and October 10th.

NAME

ADDRESS

CLIMAX RADIO ELECTRIC LTD.,
Quill Works, Putney, London, S.W.15.

Appreciation!

TYLDESLEY.

11th October, 1926.

"Your letter to hand regarding the Leclanche Cells. You are quite at liberty to publish the extract from my letter regarding your Leclanche Cells. I consider they are the best and cheapest H.T. yet on the market. I have my bill from you dated October 8th, 1923. I can recommend them to all wireless fans. I may add that I have been interested in wireless long before broadcasting started. I have had your Leclanche Cells with my set in several large halls in the district, and they have been highly recommended."

Extract of a letter from MR. HARRY PARR

READING.

11/11/26.

Dear Sirs,—

Will you please send me one of your new Catalogues No. 650 (Siemens' Radio Batteries), and oblige. May I say that out of about half a dozen different H.T. Batteries I have used on my set, Siemens' Batteries last 1½ times as long as any of the others.

Yours truly
V. G. HUSSEY.

BIRMINGHAM.

November 19th, 1926.

Dear Sirs,—

Please forward Catalogue 650. I am a regular user of your excellent batteries, and would value very much your valuable information on the care and maintenance of these batteries. I have found none to equal them.

Yours, etc.,
W. H. E.

A copy of our Catalogue 650 will be sent, post free, on application

SIEMENS BROTHERS & CO., Ltd., WOOLWICH, S.E.18

The latest in Jacks & Plugs

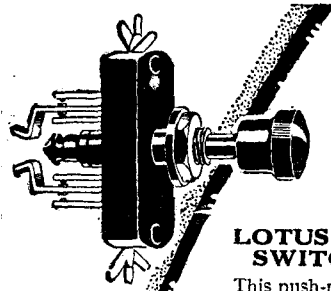

LOTUS JACK SWITCHES

This push-pull switch is designed to occupy the minimum space, being only 1 1/4 in. deep. Of the finest Bakelite, it has nickel silver springs and contacts of pure silver. Soldering contacts can be made to suit any wiring.

PRICES:
No. 9, as illustrated .. 4/-
Others from .. 2/9

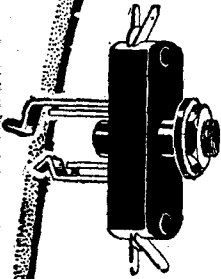

LOTUS JACK

Designed to take up the least space, the depth back of panel being 1 1/4 in. Made from best Bakelite mouldings with nickel silver springs and pure silver contacts. One-hole fixing. Soldering contacts can be brought into any position.

PRICES:
No. 3, as illustrated .. 2/6
Others from 2/- to 3/-

LOTUS JACK PLUGS

Designed for use with Lotus Jacks. Made from best Bakelite mouldings and nickel-plated brass. To fix, the wires are placed in slots and gripped in position by a turn of the screw cams.

PRICE 2/-

LOTUS JACKS-SWITCHES-PLUGS

Garnett, Whiteley & Co., Ltd.

LOTUS Works, Broadgreen Road, Liverpool.

RADIOTORIAL

The Editor will be pleased to consider articles and photographs dealing with all subjects appertaining to wireless work. The Editor cannot accept responsibility for manuscripts and photos. Every care will be taken to return MSS. not accepted for publication. A stamped and addressed envelope must be sent with every article. All inquiries concerning advertising rates, etc., to be addressed to the Sole Agents, Messrs. John H. Tate, Ltd., 4, Ludgate Circus, London, E.C.4.

As much of the information given in the columns of this paper concerns the most recent developments in the Radio world, some of the arrangements and specialties described may be the subject of Letters Patent, and the amateur and the trader would be well advised to obtain permission of the patentees to use the patents before doing so.

Readers' letters dealing with patent questions, if sent to the Editor, will be forwarded to our own patent advisers, where every facility and help will be afforded to readers. The envelope should be clearly marked "Patent Advice."

TECHNICAL QUERIES.

Letters should be addressed to: Technical Query Dept., "Popular Wireless," The Fleetway House, Farringdon Street, London, E.C.4.

They should be written on one side of the paper only, and MUST be accompanied by a stamped addressed envelope.

Queries should be asked in the form of the numbered questions: (1), (2), (3), etc., but may be accompanied by a short letter giving any necessary additional particulars as briefly as possible.

For every question asked a fee of 6d. should be enclosed. A copy of the numbered questions should be kept, so that the replies may be given under the numbers. (It is not possible to reproduce the question in the answer.)

BACK OF PANEL DIAGRAMS can be specially drawn up to suit the requirements of individual readers at the following rates: Crystal Sets, 6d.; One-Valve Sets, 6d.; One-Valve and Crystal (Reflex), 1s.; Two-Valve and Crystal (Reflex), 1s.; Three-Valve Sets, 1s.; Three-Valve and Crystal (Reflex), 1s. 6d.; Four-valve Sets, 1s. 6d.; Multi-Valve Sets (straight Circuits), 1s. 6d. Except **SUPER-HETERODYNE DIAGRAMS**, all of which, irrespective of number of Valves used, are 2s. 6d.

If a panel lay-out or list of point-to-point connections is required an additional fee of 1s. must be enclosed.

Wiring diagrams of commercial apparatus, such as sets of any particular manufacture, etc., cannot be supplied. (Such particulars can only be obtained from the makers.)

Readers may submit their own diagrams, etc., for correction or for criticism. The fee is 1s. per diagram, and these should be large, and as clear as possible.

No questions can be answered by phone. Remittances should be in the form of Postal Orders.

BLUE PRINTS.

Details of the "P.W." 6d. Blue Prints will be found on page 946.

Questions and Answers

WIRING DIAGRAM WANTED.

A. M. (Edinburgh).—I have a copy of "P.W." of February 13th, 1926, and the relative blue print circuit No. 19 describing the construction of an H.F. detector and L.F. receiver. I am desirous of making such a receiver, but on the "all-enclosed" pattern, and would be glad to know if such has been described in detail in any recent issue of "P.W." or blue print. If not, would you undertake to furnish me with a panel and baseboard lay-out incorporating provision for grid bias, etc., and any recent improvement in the above-mentioned receiver?

A set of this type, in an "enclosed" cabinet, was fully described in "P.W." No. 226 (The Imperial Three).

The full conditions under which diagrams can be specially drawn up by the Query Department will be found above.

(Continued on page 946.)

Put on a little ~
FLUSOLDA (Resd.)
(Patent Applied For)
~and Heat it~ That's All

The Secret of Simple Soldering

One clean handy fluid—no tinning, no flux—now enables expert or novice to handle any soldering job with complete confidence.

"Flusolda" has made soldering simple at last. Just apply "Flusolda" and then apply heat and a perfect joint must result.

In tins at 1/3 from Wireless Dealers and Ironmongers.

Trade Enquiries to the Sole Manufacturers:—

THE TRANSPORT SUPPLY CO., LTD., WARRINGTON.

Telephone: Warrington 459.

(S.A.S.)

2-VALVE AMPLIFIER, 35/-

1-Valve Amplifier, 20/-, as new; Valves, D.E. '06, 7/-; Headphones, 3/6 pair; new 4-Volt Accumulator, 13/-; new 60-Volt H.T., guaranteed 7/-; 2-Valve All-Station Set, £4. Approval willingly. Write for free bargain list.

P. Taylor, 57, Studley Rd., Stockwell, London.

ADANA AUTOMATIC SELF-INKING
PRINTING MACHINE

45/-

Complete Plant.

THIS massively constructed Printing Machine is the most wonderful of its kind. There are now over 10,000 users of these plants, many saving enormously in their own work, others making an excellent living.

Will print any class of matter from a **CHEMIST'S LABEL TO AN ILLUSTRATED MAGAZINE** including Perforating, Creasing and Box-making. The finest malleable iron and mild steel used in construction. Simplicity to the extreme. No special skill required. Large numbers of boys are producing their School and Scout Magazines. Printers' metal type, case, complete accessories, and excellently illustrated instructional book included. Illus. particulars in two colours, and sample of work, sent on receipt of stamped addressed envelope. Also sold by small weekly instalments. Ask for Terms. The "ADANA" AGENCY (Dept. P.W.5) 34, King Street, Twickenham, Middlesex.

Printers should write for particulars of new system of supplying First-Class Founders' Type.

EVERY LOUDSPEAKER
DESERVES
MULLARD
MASTER
VALVES

— Ask for —
Mullard P. M. Power Valves.

*Will interest everyone
who "listens-in."*

PITMAN'S 1927 RADIO YEAR BOOK

Contents of the 1927 Year Book include:

The FIRST ARTICLE written by J. L. BAIRD since his successful demonstration of "SEEING BY WIRELESS."

An official Account, fully illustrated, of all Notable Broadcasts during 1926.

An Account of the New British Broadcasting Corporation.

Wireless on Tap: How to Wire Several Rooms for Loud Speakers or Earphones.

Recent Advances in Theory and Practice.

Oscillating Crystals.

SPECIALLY CONTRIBUTED ARTICLES BY—DR. J. A. FLEMING, M.A., D.Sc., F.R.S., SIR JAMES SWINBURNE, F.R.S., LT.-COL. CRAWLEY, M.I.E.E., CAPT. P. P. ECKERSLEY, MR. NORMAN EDWARDS, *Editor of "Popular Wireless,"* MR. J. A. CORRIGAN, M.Sc., A.I.C., AND OTHERS.

SPLENDIDLY ILLUSTRATED

WITH PHOTOGRAPHS OF NOTABLE CELEBRITIES TAKEN WHILE BROADCASTING—including SIR HARRY LAUDER, SIR ALAN COBHAM, JACK HOBBS, STEVE DONOGHUE, LESLIE HENSON, BILLIE MERSON, PLUM WARNER, THE VICAR OF MIRTH, ETC., ETC.

A DIRECTORY AND COMPLETE LIST OF
RADIO SOCIETIES

NOW ON SALE at all Newsagents
and Booksellers

Price **1/6 net.**

SIR ISAAC PITMAN & SONS, LTD.,
PARKER STREET, KINGSWAY, LONDON, W.C.2



*If preferred, the
book can be posted direct*



ULTRA LOW-LOSS

Straight Line Frequency Condenser

Cone Bearings Braced Vanes. Positive

Collector. A real precision job.

Condenser only, '0003uF., '0005uF. .. 9/-

Condenser with plain Dial, Standard 10/6

1/2" dial shaft 6/-

New Vernier Dial 6/-

Reduction Ratio 16-1, No Backlash.

THE FORMO COMPANY.

Crown Works, Cricklewood, N.W.2

Phone: Hampstead 1787. 4

Manchester: Mr. J. B. Levee,

23, Hartley St., Levenshulme.

Phone: Heaton Moor 475

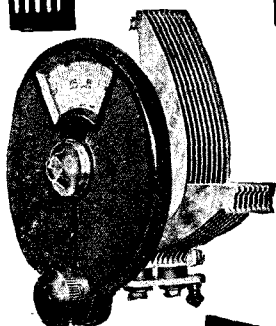

A Mile of Wire,
wound the Watmel
Way, in the



AUTO-CHOKE

The special windings are done by expensive and absolutely up-to-date machines which lay the wire exactly parallel and interweave cotton strands between each layer. Cotton acts as binder and ensures perfect insulation. Get to know the other reasons for the fine amplification and natural-toned reproduction, possible only with the **WATMEL AUTO-CHOKE**. Write for N.P.L. Curve 103/1, and Booklet describing Auto-Choke.

Price **18/6**. From your dealer or direct from
THE WATMEL WIRELESS CO. LTD.,
332a, Goswell Road, London, E.C.1.

Telephone: Clerkenwell 7990.

Lancs., Yorks., and Cheshire Representative:
Mr. J. B. Levee, 23, Hartley Street, Levenshulme,
Manchester. Telephone: 475 Heaton Moor.

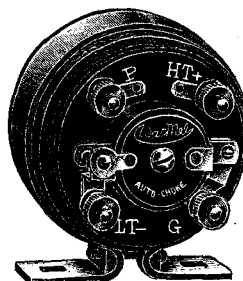

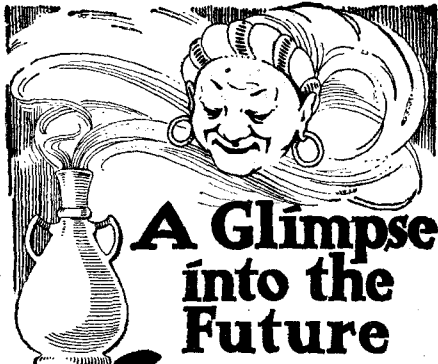

A Glimpse into the Future

Varley

After all, this was only to be expected. Wireless enthusiasts having tested for themselves the wonderful purity of tone obtainable with Varley Anode Resistances, and also the remarkable efficiency of the Varley Multi-cellular H.F. Choke, began to clamour for the extension of this famous Varley Bi-duplex winding to other wireless components.

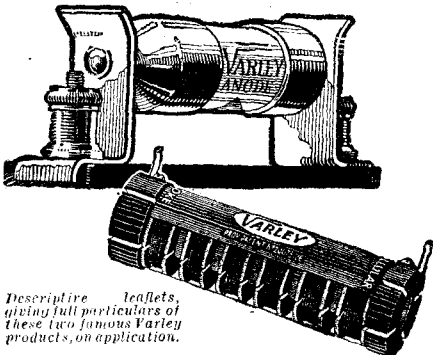

Already the Varley Magnet Company has acceded to numerous requests and has marketed a *Special Tapped Resistance*, and also a new form of H.F. Choke suitable for use in circuits of the *Split Coil Type*.

This is only the beginning. Realising the value of our long and successful experience in every form of coil winding, we have decided, in the interests of the Radio public, to increase the number of our wire-wound components so as to enable wireless enthusiasts to reap the full benefit of the Varley Bi-duplex winding.

Full particulars of later products will be announced in the Wireless Press from time to time. Readers who have not yet taken advantage of existing Varley Radio components are strongly advised to do so without further delay. *All the best Dealers stock Varley products. If you have any difficulty send us the name and address of your Dealer; we will supply immediately.*



THE VARLEY MAGNET CO.
(Proprietors: Oliver Peil Control Ltd.)
Granville House, Arundel Street, London, W.C.2.
Telephone: City 3293. V11.

RADIOTORIAL QUESTIONS & ANSWERS.

(Continued from page 944.)

NUMBER OF LAMPS IN CHARGING CIRCUITS.

E. M. P. (Worthing).—I have direct current lighting, and wish to charge accumulators off the mains, regulating the charging rate by the insertion of lamps between the accumulators and the mains. How do I find out how many lamps I need?

In the first place, the current required depends upon the charging rate desired, and this is regulated by the insertion of suitable lamps or "banks" of lamps in series with the mains, so that only the required current shall pass. In order to find out what arrangement of lamps is necessary, you must pick on the lamp you are going to use, and then work out how much current it will pass. For instance, the best lamp to use for charging is the carbon filament type, because this class of lamp passes more current than the metal filament type. You want to choose

"P.W." 6d. BLUE PRINTS.

A Series of 20 Blue Prints can be obtained from the Query Dept., PRICE 6d. PER BLUE PRINT. (A stamped addressed envelope must accompany each application, and the number of the required Blue Print must be given when ordering.)

The following are the numbers, and the circuits covered.

P.W. BLUE PRINT

Number

1. DETECTOR VALVE WITH REACTION.
2. UNIDYNE DETECTOR VALVE WITH REACTION.
3. 1-VALVE L.F. AMPLIFIER.
4. CRYSTAL DETECTOR WITH L.F. AMPLIFIER.
5. H.F. (Tuned Anode) AND CRYSTAL, WITH REACTION.
6. H.F. AND CRYSTAL (Transformer Coupled, Without Reaction).
7. 1-VALVE REFLEX WITH CRYSTAL DETECTOR (Tuned Anode).
8. 1-VALVE REFLEX AND CRYSTAL DETECTOR (H.F. Transformer, without Reaction).
9. H.F. AND DETECTOR (Tuned Anode, Reaction on Anode).
10. H.F. AND DETECTOR (Transformer Coupled, with Reaction).
11. DETECTOR AND L.F. (Switch to Cut Out L.F.).
12. DETECTOR AND L.F. UNIDYNE (Switch to Cut Out L.F.).
13. 2-VALVE REFLEX (Valve Detector).
14. 2-VALVE L.F. AMPLIFIER (Transformer-coupled with Switch).
15. 2-VALVE L.F. AMPLIFIER (Transformer-Resistance Coupled with Switch).
16. H.F. (Tuned Anode). CRYSTAL DETECTOR AND L.F. (With Switch for Last Valve).
17. CRYSTAL DETECTOR WITH TWO L.F. AMPLIFIERS (with Switching).
18. 1-VALVE REFLEX AND CRYSTAL DETECTOR, with 1-VALVE L.F. AMPLIFIER, controlled by Switch.
19. H.F. DETECTOR AND L.F. (with Switch for the Last Valve).
20. DETECTOR AND 2 L.F. AMPLIFIERS (Switches for 1, 2, or 3 Valves).

Note: All these sets are of the flat panel type.

a lamp of the same voltage as your mains (say 220 volts) and rated at about 32 candle-power. The current that this lamp will pass is determined by the following formula:

VA (watts supplied) = c.p. × c.p. rating for this type of lamp. In this case the lamp will rate from 3.5 to 4 watts per c.p., so that VA = 32 × 4 = 128 watts.

Now the current that this lamp will pass is found by

$$A \text{ (amperes)} = \frac{VA}{V} \text{ where } V = \text{voltage of mains.}$$

$$\therefore A = \frac{VA}{V} = \frac{128}{220} = .58 \text{ amp. (approx.)}$$

Now we find that one lamp passes .58 amp. and for the sake of example, let us say we wish to charge at a 3 amp. rate. One lamp in series with the mains will only give us .58, and if we place two together in series with one another, we shall have still less, so that evidently we must arrange the lamps in parallel so that though each lamp only passes .58 amp. the whole "bank" will pass somewhere about 3 amp.

(Continued on page 948.)

Britain's Best in Radio.

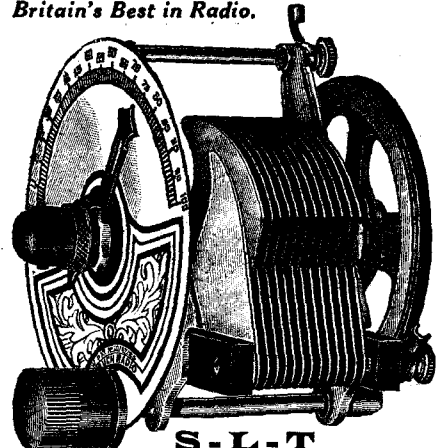

S-L-T STRAIGHT LINE TUNING CONDENSERS

separate stations on all wavelengths. Lowest minimum capacity and the most positive slow-motion control.

Prices:—'0005 13/- '0003 12/6 '0002 12/-
Gang of Three '0003 50/-

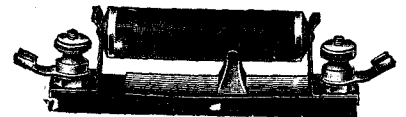

VARO-FIX FILAMENT RHEOSTAT

Interchangeable elements and each one adjustable. More positive than automatic devices.

6 ohm, 2/3; 15 ohm, 2/6; 30 ohm, 2/9

S. A. LAMPLUGH LTD.

King's Road, Tyseley, BIRMINGHAM.

Our high-grade components are obtainable from all first-class Radio Dealers

REPAIRS SETS. PHONES. TRANSFORMERS

Officially Approved by Radio Association
ALL WORK GUARANTEED LOWEST RATES 24 HOURS SERVICE
Cash on Delivery if Desired.
JOHN W. MILLER, 68, Farringdon St., E.C.4.
Phone: Central 1950

A Set before Christmas—payment after!

YOU can have that new Set in time for Christmas. Under the New Times system you can have any Receiver upon a small initial payment—the balance in easy monthly instalments. Components and Accessories, too! Send to-day for Catalogue "P" to:
New Times SALES CO., 77, CITY ROAD, E.C.1.

G.A. 6551

"HARTEL" WET H.T. BATTERIES

Cannot be equalled for Reception, and charge themselves. As recommended by "Popular Wireless", Aug. 14th.

60 volts, in Case with lid 25/- Post 1/4
30 volts " " 13/6 " 10/-

If you wish to build your own—
Glass Containers 2/- doz. } Send 6d.
Sacks " " 2/- doz. } stamps for
Zincs " " 1/6 doz. } Sample Cell.

THE "HARTEL" BATTERY CO.,
3, Broomhall Street, SHEFFIELD.

Trade and Factor Supply.

MAKE OR BUY A GRAMOPHONE

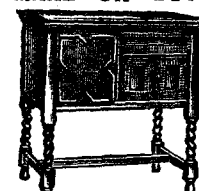

100 per cent. cheaper than others. Jacobean Oak Side-board RIFANCO-PHONE as shown, size 32 x 30 x 16, with double spring motor, 3 records one winding, 12-in. Velvet table, Swan tone-arm, full tone sound-box, needle cups.
£6 15 0 Carr. Paid or 18/- down and 11 monthly instalments of 11/9 indirect. All the above fittings, less Cabinet, £22 0 0. Cash only.

No. 18a. £6/15/0
Approval 7 days. Money back.
Other Gramos. from 22/-.
Mechanical Sets, 18/-.
Motors, 9/-.
Accessories, Accordeons, Violins, cheaply.
Agents wanted. Lists Free, 64-p. Catalogue, Hints and Drawings. How to Make Gramophones, 3d. Estab. 23 years. Thousands Testimonials.



No. 114a. £2/5/0.
Regent Fittings Co., P.W., 120, Old St., London, E.C.1.

XMAS BARGAINS FOR ALL!

Have a "PILOT" Set this Christmas and be sure of your entertainment!

FINISHED INSTRUMENTS.

SETS OF PARTS.

If you want to be absolutely certain of your wireless entertainment this Christmas, you cannot do better than purchase one of these "Pilot" Sets. They are designed by acknowledged experts, made by skilled workmen, and thoroughly tested on a large number of stations under normal working conditions. Moreover, we will install any one of these sets free of charge within 50 miles of any of our branches. Order at once for installation before Christmas.

On the other hand, if you prefer to assemble your own set—and there is no finer hobby for the long winter evenings—the famous "Pilot" Service is a veritable insurance against failure. Our Technical and Service Department, under the supervision of a skilled Radio engineer, is ready to help you at all times should you encounter any little difficulties. This service is entirely free of charge.

IN EITHER CASE WE GUARANTEE YOU GOOD RESULTS!



A Typical "PILOT" Set—

THE SOLODYNE (5 Valves—1 Dial—50 Stations)

Easily the most popular set this season. Merely rotating the one dial brings in station after station at full loud-speaker strength. The set is so simple that a child could operate it, and yet its range includes all the important B.B.C. and Continental Broadcasting stations, which can be heard with amazing clarity.

Finished instrument, complete with B.B.C. coils, but less valves, etc., Marconi Royalty paid	£ s. d.
.. .. .	27 7 6
Complete set of parts	13 17 0
Polished and drilled Ebonite panel	11 6
Polished Mahogany Cabinet	4 5 0

BEST-WAY "DE LUXE" LOUD-SPEAKER SET (4 Valves)

Another receiver designed for simplicity of operation, with tuning arrangements covering all normal broadcasting without the necessity for changing coils. For all-round work at a moderate price, this is the receiver "par excellence."

Finished instrument, Marconi Royalty paid, but less valves, etc.	£ s. d.
.. .. .	19 10 0
Complete set of parts	9 2 6
Polished and drilled Ebonite panel	11 6
Polished Mahogany 2-door Cabinet	2 5 0

BEST-WAY "EUROPEAN" LOUD-SPEAKER SET (3 Valves)

In this receiver is embodied the four important qualities which every really efficient Set should possess, namely:—Sensitivity, selectivity, stability and simplicity. Although the set employs only three valves, with the resultant low cost of upkeep, it is capable of giving full, mellow-toned loud-speaker reproduction over very excellent ranges.

Finished instrument, Marconi Royalty paid, but less valves, etc.	£ s. d.
.. .. .	14 5 0
Complete set of parts	5 1 6
Polished and drilled ebonite panel	10 6
Polished Mahogany Cabinet	1 10 0

"P.W. CONTINENTAL"—THOUSANDS SOLD.

This famous receiver is absolutely ideal for the man who wants an inexpensive set, which will give him reception on a number of Continental stations as well as the principal B.B.C. ones. Whilst it is not designed for use with a Loud Speaker, we can supply a two-valve Amplifier to bring the signals up to the full loud-speaker strength. We can thoroughly recommend this fine set to the man of moderate means.

Finished instrument, complete with B.B.C. coils, Marconi Royalty paid	£ s. d.
.. .. .	6 0 0
Complete set of parts	1 16 9
Drilled Ebonite panel	6 0
Polished Mahogany Cabinet	1 1 0

2-VALVE AMPLIFIER.

Specially designed for use with the "P.W. Continental." Finished Instrument, Royalty paid £6 6s. 0d.

If a complete set of parts is purchased Marconi Royalties are payable at the rate of 12/6 per valve holder.

Details of the above and many other up-to-date sets appear in the new edition of the "Pilot Manual." Fully illustrated and containing much useful advice, this book should be in the hands of every enthusiast. 6d. Post free



THE IDEAL XMAS GIFT.
If your friend is a wireless enthusiast, he will appreciate an "Emerald" Wavemeter—calibrated to within 1 metre, and guaranteed accurate within that limit. A delightful precision instrument. Price, including Royalty, £8 2s. 6d. Valve extra, 14/-. Full details on request.

THE PILOT MANUAL

PETO-SCOTT CO., LTD.
Head Office & Works: 77, City Road, LONDON, E.C.1
Branches: 82, High Holborn, London, W.C.1. WALTHAMSTOW—230, Wood Street. PLYMOUTH—Bank of England Place. LIVERPOOL—4, Manchester Street.

Give EFESCA Gifts this Christmas!

HERE are a few selections from the extensive and all-embracing range of EFESCA Wireless specialities. Famed for their unfailing reliability and efficiency, they are absolutely certain to delight any wireless enthusiast who may receive them as presents this Christmas. There are scores of novel components described in Catalogue 573/6 which you can obtain free on application.

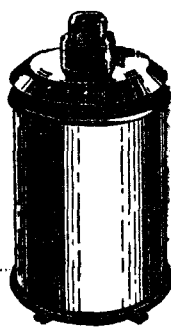

THE EFESCA REGENERATIVE AERIAL TUNER

has an inductance equal to a whole range of plug-in type coils, from No. 30 to No. 300. In addition to possessing the tuning range of a whole set of coils in a single self-contained unit, it has the following advantages: A turn of the switch covers both low and high wavelengths; obviates the bother of choosing coil combinations; losses eliminated; reaction under perfect control; convenient to mount and simple to operate.

Price 35s. complete.

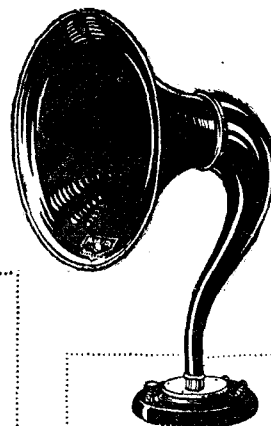

THE EFESCA "PURA VOX" LOUD SPEAKERS

are constructed with specially robust pole piece carriers, fitted with fine adjusting screw with positive stops. The horn is symmetrical and acoustically correct in design; the principle employed ensuring quite exceptional purity & volume.

- Standard Model 80/-
- Medium - - 48/-
- New Junior - 38/-
- Miniature - 25/-

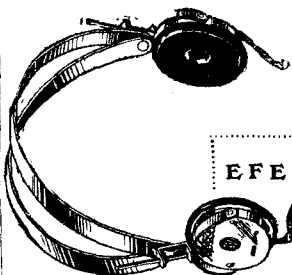

EFESCA HEADPHONES

are exceptionally clear and evenly matched in tone. They provide both faithful reproduction and full volume of sound. 4,000 ohms with 6 ft. of flexible cord.

Reduced to 15/-

Ask your retailer, or write to-day for CATALOGUE 573/6 of Efesca Components, with diagrams illustrating their use and various circuits.

It is more than a list—it is a fine 72-page book of great value, containing much technical information which you will greatly appreciate.

FALK STADELMANN & CO., Ltd.
83-93, FARRINGDON ROAD, E.C.1.,

and at Glasgow, Manchester, Birmingham, Newcastle, and Dublin.

Use Efesca High Tension Batteries



Above the snow-line

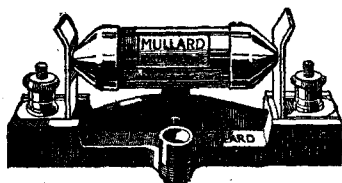

Constancy, silence and strength, planned to nature's generous scale, the very qualities which are essential in a small wire wound anode resistance if it is to achieve its object—purity of reception. The Mullard EVER-REST Wire Wound Anode Resistance is constant in value and silent in operation, and possesses a degree of mechanical strength which is unique, inasmuch as it is achieved without sacrificing efficiency or bulk.

A Resistance wound on a textile fibre core, perfectly covered and interlaid with the same material, eliminating all self-capacity, with this advantage, that the fine metallic wire is rendered absolutely free from every particle of mechanical shock. The temperature coefficient is negligible, the resistance is not set in wax but simply covered with a thin layer to allow perfect dissipation of heat.

Ask for the resistance which has behind it all that is behind the finest valve.

Mullard EVER-REST Wire Wound Anode Resistance (80,000 and 100,000 ohms) - - - 5/-
Complete with Holder 6/6

Other Values to Specification.

Mullard Grid Leaks and Condensers.
Type Grid B 0.5 to 5.0 megohms - - - 2/6
Type Grid B combined with .0003 mfd. Condenser Type MA - - - 5/-
Type MA Condenser .0001 to .0009 mfd. 2/6
Type MB Condenser .001 to .01 mfd. - 3/-



WIRE WOUND ANODE RESISTANCE

The MULLARD WIRELESS SERVICE Co., Ltd.
Mullard House, Denmark St., London, W.C.2.

QUESTIONS AND ANSWERS.

(Continued from page 946.)

Two in parallel will give $.58 \times 2 = 1.16$ amp.; but we need nearly three times that amount. Five lamps will give us $.58 \times 5 = 2.90$ amp., which is just below the maximum charging rate of our accumulator. It is better to be below the given rate than above it, and so if we use five lamps in parallel with one another, but the "bank" or collection of them in series with the accumulator and the mains, we shall be able to charge the battery at a convenient and safe rate. The formula given above holds good for any kind of carbon lamp and any voltage of D.C. main, provided that the lamp and main voltages are the same or thereabouts, and that the wattage of the lamp is 4 watts per c.p.

NOVEL RECTIFICATION.

S. K. (Aldgate High Street, London, E.).—In the article on "Novel Rectification" ("P.W.," No. 232, Nov. 13th) the first diagram seems to have a short between aerial and earth.

Should not the earth connection be taken from the left-hand corner of diagram, under

For the Constructor

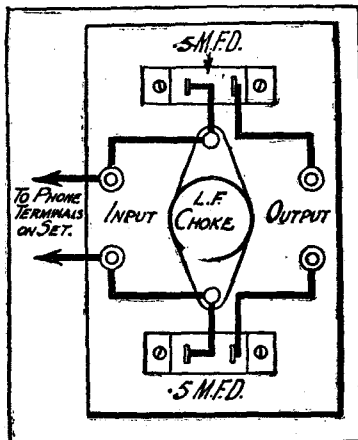

No. 11—SHUNT LOUD-SPEAKER OUTPUT.

The method of "shunting" the loud speaker, as shown above, is extremely useful where long extension leads are employed.

All the steady H.T. current, to the plate of the last valve, passes through an L.F. choke, and is excluded by condensers from the long extension leads to the different rooms.

The varying potentials at the ends of the choke, which are due to the speech or music, are not stopped by the large fixed condensers; but they cause fluctuating "output" currents that operate the loud speaker, or loud speakers, just as well as if these were in the direct path of the current.

The connections for a "shunt-output" unit are shown above. The choke, condensers, and terminals, may be made up on a separate unit, as shown, or may be included in the present set, if there is room.

the variometer—i.e. between the variometer and the metal plate?

Yes. The earth connection should be made at a point between the variometer and that metallic plate which is not connected to the telephones.

CUTTING OUT THE LOCAL STATION.

E. J. (Romford Road, Forest Gate).—In an endeavour to cut out the local station I have tried several wave-traps, and was recently advised to use "The Complete Eliminator." I have obtained a diagram of this instrument from the Queries Dept., but should be glad of advice as to how to use the Eliminator, as the number of POPULAR WIRELESS giving these details is now "out of print."

Connecting up the Eliminator.
Aerial to the terminal marked A. Earth to the terminal marked B. For all interference on waves longer than the desired one, the terminal marked G2 should be connected to the aerial terminal on the set instead of G1, as usual.

(Continued on page 950.)

20/- down

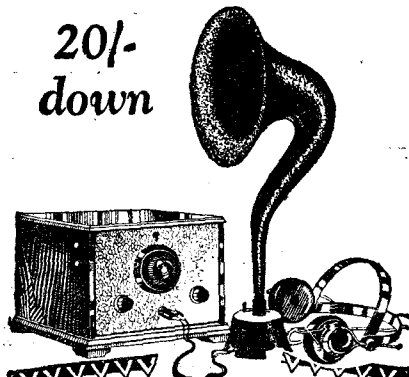

Great New Wireless Offer

Our wonderful 2-valve set with loud speaker and headphones installed free in your own home—anywhere—by our own Installation Engineers for £12 cash; or £1 down and 20/- a month for twelve months only. And we guarantee satisfaction.

There is nothing else to buy—the set is complete with all accessories.

When our Engineers have installed the set just switch on and enjoy perfect and powerful loud-speaker reception. You are also entitled to two free calls from our Engineers after the set is working.

The General Radio set is British made, unsurpassed in efficiency and purity of tone. It has no superfluous controls and is as easy to work as turning on the light.

Send a postcard to-day for free illustrated catalogue No. 6W and full particulars of this offer.

General Radio
GENERAL RADIO CO. LTD
RADIO HOUSE
235 Regent Street, W1



HEADPHONES REPAIRED
Re-wound and re-magnetised 5/- per pair Loud Speakers repaired 5/- Transformers re-wound 5/- each. All work guaranteed and tested before delivery. Write for Trade Prices. Phone: Clerk 1795. MASON & CO., 44, East Road, City Road, N.1.

Valves Repaired AS GOOD AS NEW!!

HALF PRICE (Except Weco, S.P.'s and low capacity types). Minimum D.E. Current 0-15 amps when repaired. ALL BRIGHT & DULL EMITTERS Listed at less than 10/- Minimum charge - - - 5/- VALCO LTD., Dept. P.W. Tabor Grove, Wimbledon, S.W.

EBONITE BUSHES

FOR MOUNTING ON WOOD. PERFECT INSULATION. Orders under 1/- send 14d. postage. Two required for each hole. NUMBER 0 1 2 3 4 5 6 Hole in Bush... 6BA, 4BA, 2BA, 1/4" 5/16" 3/8" 7/16" Price each: 1d. 1d. 1d. 1d. 2d. 2d. DAREX RADIO CO., Waldram Road, Forest Hill, London, S.E.23. TRADE SUPPLIED.

1/9 DON'T PAY MORE AERMONIC

VALVE HOLDER. Anti-capacity. Anti-phonetic. Don't pay more than 1/9. If hard to get, drop us a line. James Christie & Sons, Ltd., 246, West Street, Sheffield. London Agents: A.F. BULGIN & Co., 10, Cursitor St., London, E.C.4.

**ABSOLUTELY NEW—
—WONDERFULLY EFFICIENT**

The **“Z”**
FILAMENTLESS VACUUM TUBE RECTIFIER
for H.T. ACCUMULATORS.

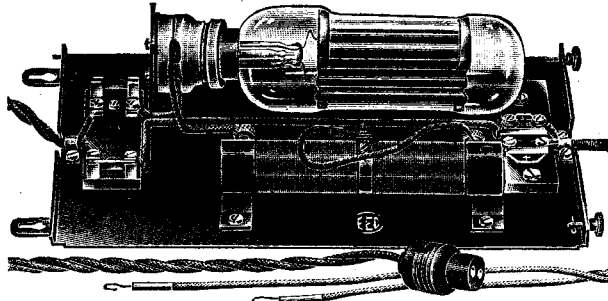

Don't go on buying dry H.T. Batteries when you can save time and money by using E.E.C. Monoblock H.T. ACCUMULATORS, and charging them at home with the new **“Z” FILAMENTLESS VACUUM TUBE RECTIFIER**. Remember E.E.C. Monoblock H.T. Accumulators immensely improve the quality of your reception—much of the noise attributed to atmospheric emanates from your dry battery—and the saving effected wipes out the initial expenditure in a very few months. The new **“Z” Rectifier works SILENTLY and AUTOMATICALLY** and consumes *only 1 UNIT in 50 hours*. Unlike other rectifiers it operates perfectly on 200-220 Volt A.C. mains, irrespective of the periodicity; further, by using a special Transformer which we can supply, the **“Z” Rectifier can be used with any voltage.**

PRICE complete with input and output leads, variable resistance and fuses **£3-0-0**

We stock components, valves and accessories of every description for sets described in this and in all other Wireless Publications. We have a highly organised and efficient Mail Order Department and guarantee not only safe but prompt delivery. Why waste time and money when you can send your order direct to us? Your enquiries will receive our careful and prompt attention.

Economic Electric Ltd., 10, FITZROY SQ., LONDON, W. 1.

**LOUDSPEAKER Strength
on a CRYSTAL**

With the new E.E.C.
**MAGNETIC MICROPHONE
BAR AMPLIFIER**

**PRICE
38/-
Complete**

*No separate
Transformer re-
quired.*

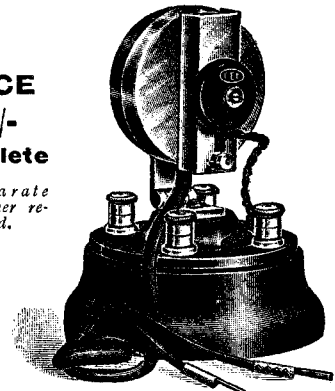

An efficient **NON-VALVE NOTE AMPLIFIER** which yields Three- to Tenfold Amplification from the 'Phone Terminals of any Crystal or Valve Set. **NO ACCUMULATORS REQUIRED. NO H.T. BATTERIES.** Six pairs of Wireless Headphones, or any 2,000 ohms Loud Speaker may be operated from a single 3-volt Dry Battery.

LOW CURRENT CONSUMPTION.

The Magnetic Microphone Bar Amplifier uses less than $\frac{1}{4}$ of an ampere, one 3-volt dry cell, at a cost of 3/-, lasting upwards of 300 working hours. **No Diaphragms. No Distortion. No Fragile Parts. Nothing to get out of order. No microphonic noises. Unaffected by vibration. Compact and easily portable. ANYONE CAN ADJUST IT!** Amplified Speech and Music as clear as from a good Valve Set. A boon to persons of impaired hearing.

CROSS JOINS

BUTT JOINS

TERMINAL JOINS

See how it joins.

JUNIT *Wire*
PATENTED
Needs no Solder

17 S.W.G. In coils (in cartons), per coil 1/- (Square section) In 2 feet lengths, per length 2d.

**DON'T SAY WIRE
— SAY JUNIT!**

If unobtainable at your local dealer, send P.O. for coils required (Post Free) to:
**REXO ENGINEERING CO.,
2, RAVENSCOURT SQ., LONDON, W.6.**

**“Money saved is Money earned—
So when your ‘VALVES’ get old or burned
Send them to us—and we, to you,
Will send them back ‘MADE GOOD AS NEW.’”**

*Manufacturers of Auto-
veyors Thermionic Re-
lays, and new valves of
all types. Write for par-
ticulars and list price.*

**Restored to function
with original charac-
teristics.**

**EFFICIENCY MAINTAINED!
RESULTS GUARANTEED.**
on application.

**B.E. 4/-; D.E. 2v. 3
7/6; D.E. '06 8/-.**

*Price List for Power Valves
We return the actual Valve you
send us, post free, within 3 days.*

**THE NORTH LONDON VALVE CO., LTD.,
22½, Cazenove Road : Stoke Newington, N.16.
*Liberal Discounts to Wireless Agents***

**“RELIANCE”
LOUD SPEAKER**

Height 22½ in. 14 in. diam. flare.

**ESTABLISHED
1870.**

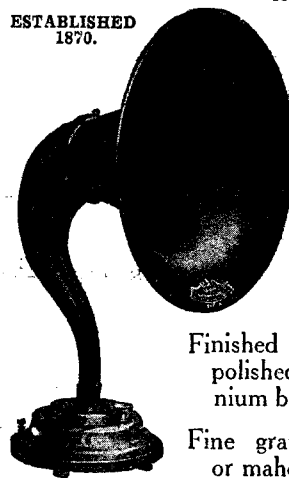

This excellent speaker
is the last word in
quality and tone at
a price which will
appeal to all.

Finished ebonite black on flare and
polished alumi- **£3: 5: 6**
nium base

Fine grained oak **£3: 12: 6**
or mahogany

**PROVISIONAL
PATENT.**

*The Public are requested to communicate
with the makers for further information.*

**CHATHAM & SON, LD.,
RELIANCE WORKS, WOLVERHAMPTON**



USE DRY CELLS INSTEAD OF ACCUMULATORS

COLUMBIA Dry Batteries are much safer, cleaner and convenient to handle besides eliminating trouble and expense occasioned by the frequent recharging needed by the ordinary accumulator. You can eliminate the inconvenience of storage batteries entirely—there is a Columbia Dry Battery for every radio battery need.



Send for our useful and informative battery instruction books "How to get the most out of your radio batteries" and "Choosing and using the right radio batteries." They are sent post free on request.

Columbia Dry Batteries

Ask your Dealer for full particulars concerning the complete range of Columbia Batteries or send direct to us.

J. R. MORRIS,

15-19, KINGSWAY, LONDON, W.C.2.
Telegrams: Colcarprod, London.
Phone: Gerrard 3038.
Scottish Representative: John T. Cartwright,
7, Cadogan Street GLASGOW

RADIOTORIAL QUESTIONS & ANSWERS.

(Continued from page 948.)

The L.T. — terminal on the eliminator should be joined to the earth terminal on the set.

For interference from ships on 600 metres the terminals E and E1 should be short-circuited, earth joined to E, aerial to A, while G2 should be connected to the aerial terminal on the set instead of G1. This latter arrangement holds good for 5 X X providing the coils are substituted by larger ones.

Using the Eliminator.

There are several ways of using the Complete Eliminator according to the type of interference experienced, as described above. For ordinary cases, such as interference from the local station, the switch should be placed at A, and the interfering station tuned in to maximum strength, on the set itself, without touching the eliminator. Then the switch should be moved to B, and the adjustment of coils and condensers in the eliminator should be made until the interfering signal is reduced to a minimum, or completely cut out. Leave the eliminator for the time, and return to the tuning arrangements in the set proper, and tune in the desired station. The interfering station will not be heard so long as the adjustment of the eliminator remains unaltered.

By attaching the eliminator to any set, apart from cutting out interference, it is possible to materially strengthen signals. This should be done in the following manner. Switch at A, tune in the desired station on existing tuning arrangements. Move switch to B, leaving tuning arrangements on set, and manipulate eliminator coils and condenser until signals are increased.

"P.W." COIL TABLES.

No. 6.—Honeycomb Type Coils.

(c) ANODE COILS WITH PARALLEL TUNING CONDENSERS.

No. of Turns.	Gauge of Wire S.W.G.	Wave-length, in Metres.				Suitable No. of turns in reaction coil
		Capacity of Parallel Condenser in microfarads = .0002		Capacity of Parallel Condenser in microfarads = .0003		
		Max.	Min.	Max.	Min.	
20	24	155	65	185	70	20-40
40	24	265	115	315	125	20-40
60	24	420	185	500	195	20-60
80	24	550	240	660	255	20-60
100	24	690	300	825	315	40-80
125	26	865	380	1030	400	40-80
150	26	1030	455	1230	480	40-80
175	26	1210	530	1445	560	40-80
200	26	1400	615	1675	650	40-80
250	28	1780	780	2130	825	40-80
300	28	2145	940	2560	990	60-100
350	28	2450	1070	2925	1130	60-100
400	28	2775	1210	3310	1280	60-100
450	30	3100	1360	3700	1450	60-100
500	30	3540	1550	4230	1640	60-100
600	30	4280	1880	5120	1980	100-150
700	32	5090	2230	6080	2350	100-150
800	32	5830	2550	6970	2690	100-150
900	32	6610	2980	7900	3050	100-150
1000	36	7330	3210	8760	3380	100-150
1250	36	9100	3980	10860	4190	100-200
1500	36	11100	4860	13250	5120	100-200

Wind coils on a former having two rows of 23 spokes separated by 1 inch, with an inside diameter of 2 inches.

The table assumes the use of a normal P.M.G. aerial, general-purpose valves, and conventional moving-plate variable condensers. The values would be considerably modified by the use of special anti-capacity valves and valve-holders, or condensers with specially low minimum capacity.

CAPACITIES OF VARIABLE CONDENSERS.

T. S. (Southampton).—I have purchased several variable condensers which have no capacities stated on them. Can you oblige me by giving a rough table showing the number of vanes required for various capacities, as I shall be able to gauge from such a table the approximate capacities of my condensers.

Assuming the spacing of the vanes to be 1/4-inch the following numbers of plates will be required for the capacities stated:

No. of Fixed Plates.	No. of Moving Plates.	Capacity in microfarads approx.
29	28	.001
22	21	.00075
15	14	.0005
10	9	.0003
7	6	.0001

(Continued on page 953.)

THE MODERN WAY THE EFFICIENT WAY

THE "REGENTONE" Complete Battery Eliminator

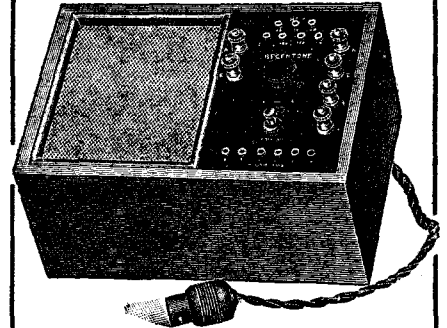

5 AMP. MODEL £6 10

Supplying combined High-Tension, Low-Tension, and Grid Bias current for the operation of your receiver from your Household Electric Supply (D.C.) by simply attaching adaptor to electric light lamp holder.

Why use H.T. Batteries and Accumulators?

No Replacements Necessary.
No Attention Required.

H.T. MODEL (FIVE TAPPINGS) £2 10

A COMPLETE SET OF PARTS OF "REGENTONE ELIMINATORS" ARE SUPPLIED FOR HOME CONSTRUCTION.

Price List and Descriptive Leaflets FREE on Application.

150-page catalogue, 2,000 illustrations of components and accessories, post free 4d. stamps.

Sole Manufacturers:

REGENT RADIO SUPPLY CO.,
45, FLEET STREET, E.C.4.

Phone: Central 9661.

A HOME FOR YOUR WIRELESS SET

OUR STANDARD CABINETS

are DUSTPROOF and house the whole apparatus, leaving no parts to be interfered with. All you do is UNLOCK & TUNE IN. Made on mass production lines, hence the low price. Provision is made to take panels from 10 x 7 up to 30 x 18 in.

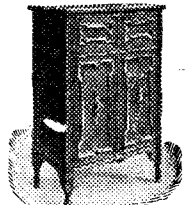

From £4 15 0

Write to-day for descriptive pamphlet and suggestions for adapting your receiver or panel in our Standard Cabinets. Immediate Delivery. Dept. 5, Melville Chambers, 56a, Lord St., LIVERPOOL.

EASY PAYMENTS

We supply apparatus of the following brands for 10% down. Balance spread over 10 months.
Lotus Watmel Benjamin Radion Valves
Lissen Oldham Britmax Ever-Ready
Ultra Brandes Dubilier McMichael
and many other Brands.

LONDON RADIO SUPPLY COMPANY,
11, Oat Lane, London, E.C.2. Phone City 1977

TRUMP ELECTRICAL Soldering Iron

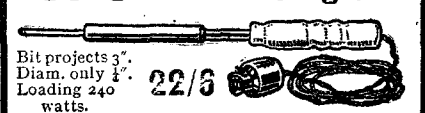

Bit projects 3".
Diam. only 1".
Loading 240 watts.

22/6

BARREL GETS RED HOT. Slip in element and replaceable by anyone.
LONG LIFE GUARANTEE.

ARDEA VULCANIZER SYNDICATE LTD.,
318, King Street, Hammersmith, W.6.

KINGSWAY RADIO, LTD.,

92, CANNON STREET, LONDON, E.C.4.

The City Firm for Wireless.

The Famous Ericsson Loud-Speaker Set.

Complete with all Valves, Batteries, and Loud Speaker **£10 10**

A high-class instrument at a popular price.

Loud Speakers in Stock

by Amplion, Brown, Priory, Becco, B.T.H. Special lounge for testing above.
 Battery eliminators, **Echo D.C. £2 15s.**; A.C. **£6 15s.**
 Croxsonia Panels, every size in stock, $\frac{1}{4}$ d. square inch.
 First quality Ebonite, machine cut, ground edges, any size cut, polished and matt.

Cabinets—over 50 sizes in stock.

Micro-Radio Valves: '06, 6-; 2 Volt., 6-; Power. 10 6.

H.T. Accumulators: 20 volt, Exide, and Ever-Ready, 15- each.

H.T. Batteries (delivered from Works weekly): Adico, 36 v., 4 6, 60 v., 7 6, 100 v., 13 6; Ever-Ready, 36 v., 7 6, 66 v., 12 6, 108 v., 21-; Lissen, 60 v., 7 11, 10 6 (with Grid Bias).

L.T. Accumulators, 2 v. 40 .. 10/- 4 v. 40 .. 17 6 6 v. 40 .. 26 -
 2 v. 60 .. 12 6 4 v. 60 .. 21- 6 v. 60 .. 33 -
 Charged Accumulators always in stock.

Solodyne components in stock: Cyldon Triple, 70-, dual '0003 25/-, '0005 27 6. Single condensers. Ormond Triple, 40/-

Lewcos, Colvern, and Melbourne Screened Coils.

Variable Condensers (special line) straight line frequency, '0003 6-, '0003 5 9. Coils. Igranite, Edison Belt, Lissen, and Finston.

THE LATEST AND GREATEST NOVELTY.

A perfect Miniature Cinematograph Projector, using Pathé Films, worked by a Pocket Flash Lamp **37 6**

Come and see it.

We keep in stock components by all the leading Makers: **DUBILIER, ORMOND, G.E.C., MARCONI, B.T.H., ERICSSON, BURNDIPT, EVER-READY, AMPLION, BROWN, Baby Pathe Cinema, etc.** Send for Complete List.

REDFERN'S COIL FORMER

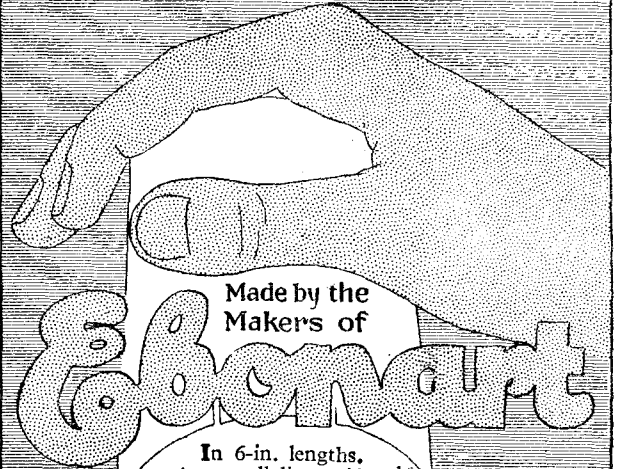

Made by the Makers of

Ebonart

In 6-in. lengths,
 2-in. overall diam. 1/6 each
 2 3/4-in. " " 1/9 "
 3 1/2-in. " " 2/3 "

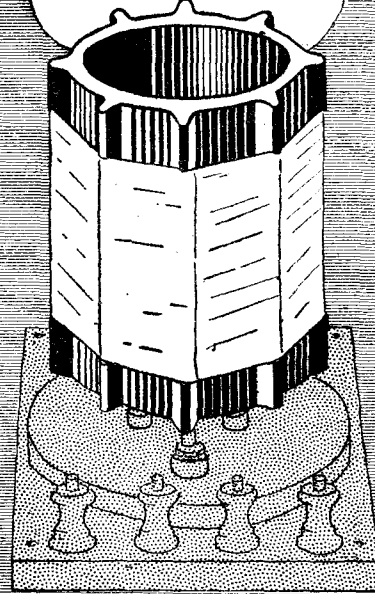

WITH this soundly designed low-loss former you can construct any kind of solenoid coil—coils for screening, loose couplers, low loss single-layer coils, H.F. transformers and other types demanded for the most modern circuits. These formers have numerous ribs of such height that the winding is almost circular and the air space unusually big, while the ebonite is of a "horny" consistency which makes working easy and accurate.

Write for Folder A262 to
REDFERN'S RUBBER WORKS, LTD.,
 Hyde, Cheshire.

Weak Joints need Strong Treatment

An imperfect joint . . . a tiny leakage . . . gone are the chances of good, long-distance reception.

The Fluxite Soldering Set will fix all joints quickly, and for ever. No trouble . . . no mess . . . and so simple.

FLUXITE SOLDERING SET—Complete 7/6

All Hardware and Ironmongery Stores sell FLUXITE in tins, price 3d., 1/4 and 2/8. Another use for Fluxite—Hardening Tools and Case Hardening. Ask for leaflet on improved methods.

FLUXITE Ltd. (Dept. 324), Rotherhithe, S.E.16.

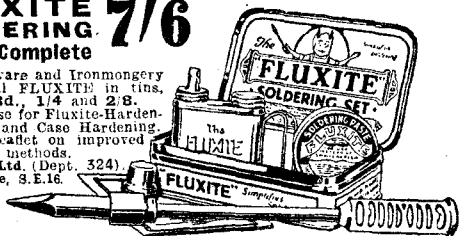

FLUXITE



Charge Your H.T. Accumulators at home with a **BURNDEPT High Tension Accumulator CHARGER**

If you have Alternating Current house mains charge your H.T. Accumulator regularly without moving the Accumulators from their usual position. Using a Burndeft H.T. Accumulator Charger this can be done with ease, with certainty, and *without skilled knowledge.*

"ETHOTRON" Rectifying VALVE

*The Valve without a
Filament.*

Not a receiving valve for wireless sets but for rectifying Alternating Current (changing it into direct current) so that the house mains (A.C.) may be used for supplying high tension current needed by all valve sets.

The charger is screwed to the wall and *wired up permanently* to (i) electric mains, (ii) accumulator and (iii) H.T. Terminals of the Receiving Set. Key switch connects accumulator alternatively to mains for charging or to set when charging is finished. *It is impossible to connect the mains to the set.* It will charge any H.T. Accumulator from 40 to 150 volts, at a rate of about 60 milliamperes.

The rectifying element is a special BURNDEPT TYPE U695 RECTIFYING VALVE.

Beautifully finished in polished mahogany cabinet, with ebonite control and valve panels. Price **£6:17:6**

Very little more than it would cost you to make one for yourself, and in return for which you have a guaranteed charger of proved reliability,

WRITE TO US FOR FULL PARTICULARS, OR

Ask your Local Burndeft Dealer about it.

Head Offices and
Factory:
Blackheath,
London, S.E.3.



London
Showrooms:
15, Bedford St.,
Strand, W.C.2

AGENTS AND BRANCHES EVERYWHERE

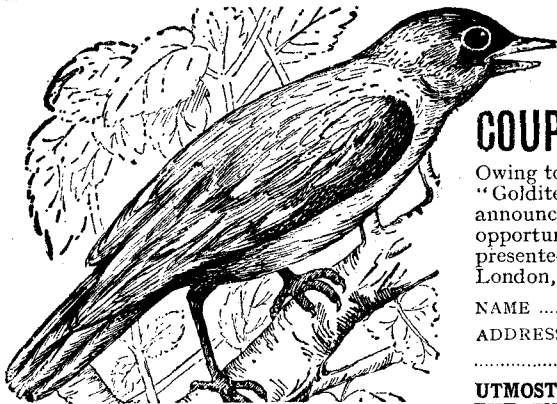

Trade "NIGHTINGALE" Mark

PHOSPHOR BRONZE—GOLDITE! THE WONDERFUL "Nightingale" Master Crystal Detector

Trade Mark. Patent applied for.

COUPON VALUE 2/6. Available for seven days (thirty days for overseas).

Owing to the great demand for the N.M.C. Detector and the extremely limited supplies of "Goldite," the price has now been raised from 2/6 to 5/-. We are pleased to be able to announce, however, that arrangements have been made to give "P.W." readers the opportunity of obtaining the N.M.C. Detector at its original price. This Coupon may be presented to your dealer, or forwarded direct to N.M.C. Detectors, 30, Princes Parade, London, N.3, together with 2/6 only.

NAME
ADDRESS

CLEAR
BLOCK
CAPITALS,
PLEASE.

**UTMOST TONAL PURITY—ELECTRICAL AND MECHANICAL STABILITY—VOLUME.
THE FINEST DETECTOR IN THE WORLD—AND GUARANTEED FOR FIVE YEARS!**

"All through the night, until the hour before the dawn, that marvellous voice shall hold the woodland spellbound."

Have a "POWQUIP" Transformer this Christmas.



OF sound design and workmanship—of unequalled performance—"POWQUIP" Guaranteed Transformers are now reduced in price, and are better value than ever. Ask to see these popular models at your dealers.

	Old Price	New Price
1 Standard Model	14/6	10/6
2 Manchester "	15/6	12/6
3 Shrouded "	18/-	12/6
4 Orchestral "	31/6	22/6

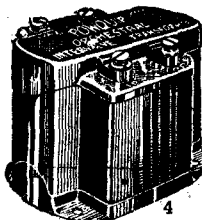

POWQUIP COMPONENTS

If any difficulty in obtaining "POWQUIP" Transformers write to:—

THE POWER EQUIPMENT COMPANY LTD.
Kingsbury Works, The Hyde, Hendon, N.W.9.

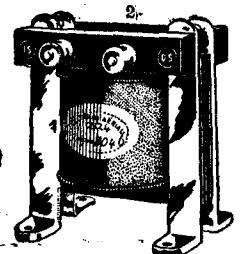
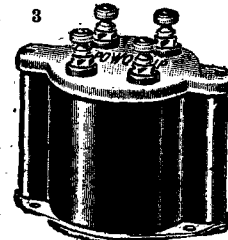

RADIOTORIAL QUESTIONS AND ANSWERS.

(Continued from page 950.)

CONNECTIONS FOR 1-VALVE REFLEX.

I have the parts for a 1-valve reflex set mounted on a 10 x 10 in. flat panel. The set will use two aerial terminals (series parallel tuning), a 2-coil holder, 2 variable condensers, and a crystal detector, etc.

I have a .001 condenser for the 'phone terminals, another for the primary winding of the L.F. transformer, and a .0002 for the secondary.

What are the point-to-point connections ?

Aerial parallel terminal to one side of .0005 variable condenser, one side of A.T.I., and to grid socket of valve holder.

Aerial series terminal to other side of .0005 variable condenser. Earth terminal to other side of A.T.I., one side of .0002 fixed condenser, and to one secondary terminal of L.F. transformer. Other side of .0002 and other secondary terminal to L.T. negative, which also goes to H.T. negative, and to one side of rheostat. Other side of rheostat to one filament socket of valve holder, other filament socket to L.T. positive.

Plate socket to one side of .0003 variable condenser, one side of anode (moving) coil, and to one side of crystal detector. Other side of anode coil and .0003 variable condenser to one primary terminal of L.F. transformer.

Other side of crystal detector to other primary terminal. A .001 fixed condenser is joined across the primary terminals. The lead connecting the anode coil to the primary of the transformer is also taken to one 'phone terminal; other 'phone terminal to H.T. positive.

A .001 fixed condenser connected across the 'phone terminals completes the wiring.

JUST LISTEN!

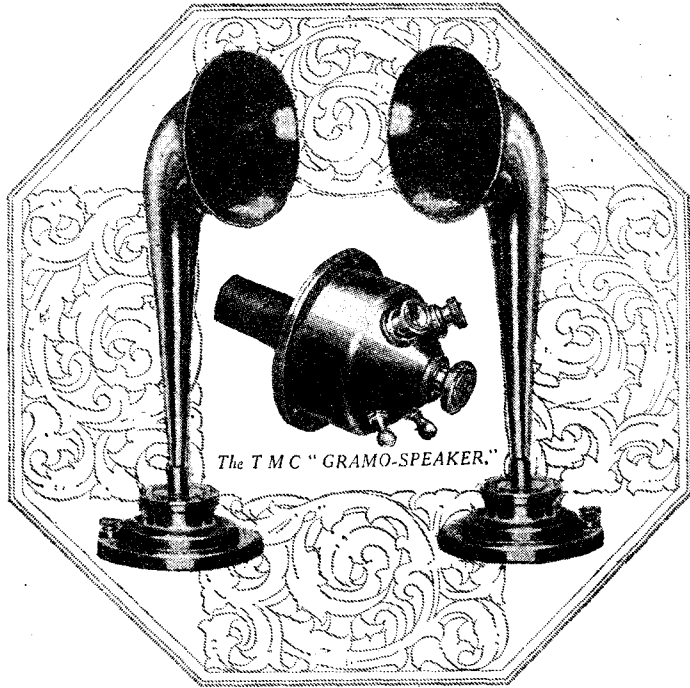

The T.M.C. "GRAMO-SPEAKER."

THE most critical test of any Loud-Speaker is to listen—not look.

The tone of the T.M.C. Junior will surprise you. Mellow, round, silver-toned music—full-bodied, clear, natural speech is what the T.M.C. Junior gives. The softest whisper is clear and audible—the full volume of a symphony Orchestra comes through without any blast or throatiness. So reasonably priced, too. Now only 30/-.

Another popular member of the T.M.C. Loud-Speaker family is the Minor. A fine little fellow with a rich, melodious voice. The T.M.C. Minor is inexpensive. Price 17.6.

Now comes the baby of the T.M.C. family—the Gramo-Speaker. This splendid unit will instantly transform your gramophone into a Loud-Speaker of highest merits. The Gramo-Speaker is mechanically sound—not an adapted earpiece, and it costs but 13.6.



The T.M.C. "MINOR."

Go to your dealer—ask to hear them, then take your choice.
We invite comparison.

T.M.C.

Telephone Manufacturing Co. Ltd.
HOLLINGSWORTH WORKS, WEST DULWICH, S.E. 21

CORRESPONDENCE.

Letters from readers discussing interesting and topical wireless events, or recording unusual experiences, are always welcomed; but it must be clearly understood that the publication of such does in no way indicate that we associate ourselves with the views expressed by our correspondents, and we cannot accept any responsibility for information given.—Editor.

2 VALVES D.X. RESULT.

The Editor, POPULAR WIRELESS.

Sir,—I thought I would write and let you know the results I get with my two-valve set (detector and L.F. amplifier), the construction of which was in POPULAR WIRELESS, dated October 25th, 1925. I have had two American stations as yet (K D K A and W B Z), and other distant stations on 'phones, including Rome and Berlin, Warsaw, and dozens of others, of which I do not know the calls. I can get Daventry and London on a loud speaker, loud enough for an ordinary size room, and lots of other B.B.C. stations on 'phones. Hoping this will interest you,
Yours faithfully,

W. A. DEVONSHIRE.

54, Cambridge Road, Strood, Kent.

RE CRYSTAL SETS ON LOW WAVES.

The Editor, POPULAR WIRELESS.

Dear Sir,—With reference to P. R. T.'s letter in this week's issue of "P.W." as to getting below 200 metres on a crystal set, I should like to say that about a year or two ago I was able to get down to 90 metres quite easily.

The circuit used was simply a 25-turn coil tuned by a series condenser. No attempt to get below this wave length was made although no doubt this could have been done with a little trouble.

Transmissions from 2 O O (Hendon) on 100 metres were often received with this set.

It is interesting to note that this station could be tuned in on an ordinary broadcast set, variometer tuned, by simply disconnecting the earth wire. 2 O O (Two, Oh, Oh) was admittedly a fairly powerful station, but amateurs working on about 150-180 metres could also be heard quite easily on either of these sets. I do not think that 90 metres is by any means the limit for a crystal set, and probably some of your readers have got down considerably lower than this.

If "P. R. T." or any other readers desire further information, I shall be very pleased to hear from them.
Yours faithfully,

F. K. BRITAIN.

16, Puller Road, Barnet, Herts.

An Ideal Xmas Gift

What more acceptable than ELECTONE? Beautifully finished in polished mahogany or oak, it is a handsome reliable timepiece and, of course, so much more.

ELECTONE AUTOMATIC PROGRAMME SELECTOR

AUTOMATICALLY SWITCHES ON YOUR SET FOR THE ITEMS YOU WISH TO HEAR AND SWITCHES OFF WHEN OVER. It consumes no current as it operates by clockwork. Saves battery consumption and valves.

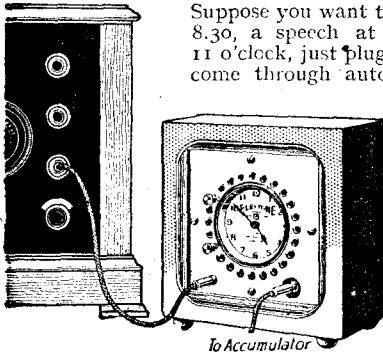

Suppose you want to hear a concert from 7.30 to 8.30, a speech at 9.30, and dance music at 11 o'clock, just plug in at those times and they come through automatically. When the final item is over, ELECTONE automatically switches off the set for the night.

PRICE 27/6

Stocked by:
CATESBYS
GAMAGES
HARRODS
SELFRIDGES
WHITELEYS

If any difficulty in obtaining, write direct to:

FREDK. J. GORDON & Co., Ltd., 92, CHARLOTTE ST., LONDON, W.1.
Phone: Museum 5189.

THIS IS THE VERNI-NOB!

PRICE
6d.

From all dealers.
By post 7½d.

The Verni-Nob does all the work of a Vernier attachment or Vernier dial and increases the selectivity of your set.

Positive drive—No back-lash.
10 to 1 reduction with 3" dial.
16 to 1 reduction with 4" dial.
Over 8,000 were sold during the Wireless Exhibition at Olympia!

Fitted in a few moments.

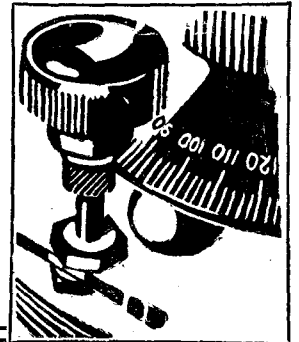

The
M.A.P.
Company,
246, Great Lister Street,
BIRMINGHAM.

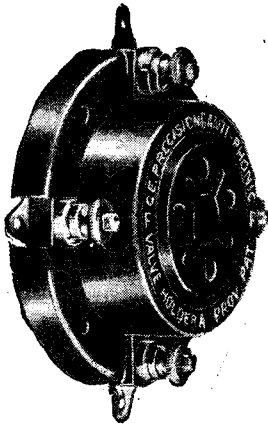

OUR latest production, the C.E. PRECISION FLOATING VALVE HOLDER, shows great improvements upon others. By its use, the distortion due to vibrations transmitted to valve filaments is entirely eliminated and a receiver fitted with it acquires a perfectly clear background which facilitates the reception of distant stations. Of very low capacity and entirely non-microphonic, the C.E. PRECISION FLOATING VALVE HOLDER is ideal for its purpose. Made from Bakelite and fitted with soldering tags and terminals.

2/3 each.

C.E. PRECISION RHEOSTATS AND POTENTIOMETERS have so frequently been specified by the Wireless Press that they need little description. The special care taken in their production ensures a perfectly smooth and silent action. Bakelite formers; silvered dials; fitted with soldering tags and terminals.

7 and 15 ohms - 2/9 each
30 and 50 ohms - 3/- each
Dual Rheostats & Potentiometers - 3/9 each

FOR UTMOST
C.E. PRECISION
EFFICIENCY

C. EDE & CO., LTD., BYFLEET, SURREY

Telephone: Byfleet 226.

Telegrams: "Ceprecise, Byfleet."

ELECTRIC SOLDERING IRON

For constructing
your New Set -

In Various
Sizes

Send P.O. for 10/-
and the Iron will
be forwarded
Post Free
State Voltage

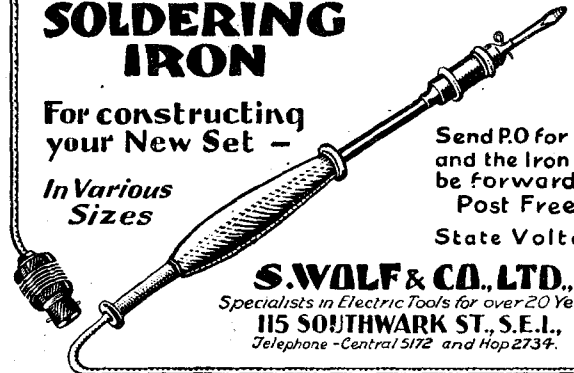

S. WOLF & CO., LTD.
Specialists in Electric Tools for over 20 Years
115 SOUTHWARK ST., S.E.1.,
Telephone - Central 5172 and Hop 2734.

BECOL

Registered Trade Mark.

Makers of the
**ORIGINAL world-famous
BECOL LOW LOSS FORMER**

As used in sets that took the first four prizes at the 1926 "Manchester Evening Chronicle" Wireless Exhibition and the set that won the Gold Medal at the 1926 Amsterdam Exhibition.

Notice:—Do not be put off with an imitation. Ask for BECOL and use the Former with a reputation.

Size: 3 inches diameter to outside of wings. Prices:
6 inch lengths 3/- (Postage 9d.)
4 inch lengths 2/- (Postage 6d.)
3 inch lengths 1 6 (Postage 6d.)
Up to 36 in. lengths.

Write for List "C."

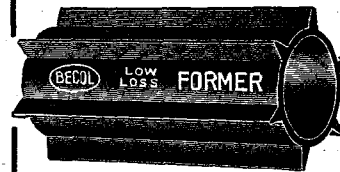

Ebonite Rods, Tubes and Sheets. Panels guaranteed free from surface leakage.
THE BRITISH EBONITE Co., Ltd., Hanwell, London, W.7.

**AN IMPROVED
LOUD SPEAKER**

AT Christmas-time you are sure to want to "Let Your Friends Listen" (to quote the familiar Wireless Week slogan), and unless you possess a loud speaker they will have to take it in turns to listen with the headphones, which is apt to be rather annoying.

The simplest way out of the difficulty is to improvise a loud speaker, provided, of course, that your set is capable of giving signals of sufficient strength or that you can borrow an amplifier to enable it to do so.

You can make an improvised loud speaker quite easily out of three very simple components at a cost not exceeding sixpence. In addition to the ordinary headphones, the only parts required are a large sheet of thick, stiff paper and a cardboard tube about six inches long.

Artistic as well as Useful !

The paper may be what is known as "poster paper," which you can buy at most shops which sell artists' materials, at about fourpence per large sheet. As this is made in a wide range of colours, you can choose a shade that will harmonise pleasantly with the wallpaper, etc., and so make the loud speaker quite artistic and ornamental as well as useful.

The diameter of the cardboard tube should be just a shade larger than that of the ebonite ear-caps on your 'phones, so that the latter will fit inside the ends of the tube. In all probability you will be able to find an old carton of some description which will meet these requirements.

Cut a strip of the coloured paper measuring six inches in width and the length of the sheet, and roll this round the tube until the latter is completely covered, finishing it off by gumming down the edge of the paper. When the gum is dry, cut a hole in the side of the tube, measuring exactly one inch in diameter.

How to Use it.

The horn is formed out of the remainder of the sheet of coloured paper by rolling it into a sugar-bag shape. The mouth of the horn may be almost any convenient size, but it must taper down to a diameter of exactly one inch at the narrow end. The paper must be held in place by gumming it along the edges. The top of the horn should afterwards be trimmed carefully with a sharp pair of scissors so that the edge is neat and even.

The narrow end of the horn should then be pressed firmly into the one-inch hole in the side of the tube. If you find it has a tendency to wobble, you can make it more secure by running a little sealing-wax round the joint. The improvised "L. S." is then complete and ready for use.

Connect a pair of headphones to your set, and tune the signals up to maximum strength in the usual way. In order to

(Continued on next page.)

**High Recommendation by
"Popular Wireless."**



Entirely of British Origin and Workmanship.

Editor writes in issue of June 12th, 1926:—

AMATEURS who are fortunate enough to own motor-cars need not worry about accumulator charging during the summer. Current can be tapped off from the dashboard to supply portable sets, while, if a "Tungstone" accumulator is used, a cell or two can be removed for running a "household" receiver when the car is in the garage. Better still, extra cells can be purchased and interchanged with those on the "auto." During summer months the car accumulator is not called upon to do much work, so the foregoing is an economical proposition. The "Tungstone" is eminently suitable for the purpose, as its cells can be detached with the greatest of ease. As a matter of fact, the plates themselves can be removed from an individual cell in a few minutes. And this is but one of the many unique features of the Tungstone Accumulator. Its design throughout, from the construction and composition of its plates to its patent "Vislok" terminal locknuts, is a triumph of thoughtful attention to both details as well as essentials.

We have had a 6-volt "Tungstone" in use on a car for a period of about six-months, and six months, moreover, of mainly hard winter work. The self-starter must have been used thousands of times, frequently on very cold mornings, and on one occasion the car was driven a distance of over 100 yards on the starter motor. Additionally, the accumulator has been used for wireless work as well, and yet, when recently we examined its plates, no signs of deterioration were in evidence. Our previous accumulator accumulated a deposit of "mud" half an inch in thickness after a similar period of not quite such hard usage, but the "Tungstone" did not need washing out. It is still in commission and no doubt will remain at work for many years.

We have not sufficient space at our disposal to describe these products in the detail they deserve.

TUNGSTONE High Tension 60 Volt Battery 3 a.h. is sold in the United Kingdom on monthly payments over extended period. Apply for particulars. Further interesting information on points of this advertisement are to be found on pages 58, 59, and 67 to 73 of the Illustrated Booklet "Photography tells the Story" which will be sent free on application to— T.A.55

TUNGSTONE ACCUMULATOR CO., LTD.,
St. Bride's House, Salisbury Square, Fleet Street, London E.C.4.

PATENTS, TRADE MARKS.
Inventions Advice Handbook & Consultations FREE.—B. T. KING, C.I.M.E., Regd. Patent Agent (G.B., U.S. & Canada), 146a, Queen Victoria Street, London, E.C.4.
40 years' references. Phone: Cent 682

"GREEN DRAGON" DIAPHRAGM PAPER
40" x 6", 1/6 per roll.
As reviewed in "Popular Wireless," 23rd Oct., 1926, p. 442.
F. J. EASTOE, 29, Prince's Parade, LONDON, N.3

Real UKULELES

REDUCED PRICE 10/-
Guaranteed 12 mths. Complete with our Lightning Tutor.
POST FREE. SEND TO-DAY.
Prepare for Xmas and learn this melodious Jazz instrument in 30 days. Entertain your friends and make your song and dance parties go with a swing. Outfit includes handsome silver-toned instrument, case, plectrum and speedy self-tutor. No musical knowledge necessary. Variety Theatre, London, W.C. "The best Ukuleles and Jazz Set. I think they are wonderful value."—ROBERT HALE.
Hand & J. Melly, 43, Highgate Hill, London, N.19.

REPAIRS

Headphones, Loudspeakers, and Transformers re-wound & reconditioned equal to new.
AN UNSOLICITED TESTIMONIAL
"Thanks to the excellent manner in which it was reconditioned, the results achieved have been astounding. It is very gratifying to find a firm that really turns out a first-class job, as I have had very disappointing experiences with firms who have advertised as experts, and whose workmanship has been far from good."
Varley Magnet Co., Proprietors.
Repairs Dept., Oliver Fell
Woolwich, Control,
S.E.18. Ltd.

The Gift for Xmas!!!

30/- ONLY.

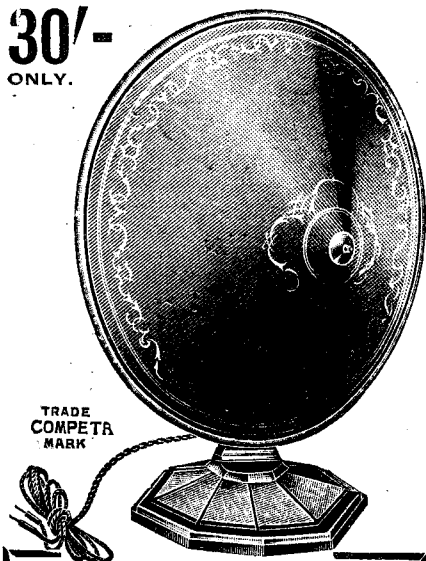

TRADE MARK COMPETRA MARK

Ahead of all Competitors TRUE REPRODUCTION

12 in. Cone. Adjustable diaphragm. Handsome appearance. Crystalline brown and fine gold border design.

A remarkable instrument in every way. **SPLENDID VALUE for 30/- only.** Including extension cord. Post 1/- extra.
A. F. BULGIN & CO., 9-10-11, Cursitor St., Chancery Lane, LONDON, E.C.4.

Paris Ad.

WET H.T. BATTERIES
 BUY BRITISH. Complete Units 3/6 per doz. All goods BRITISH MADE BY BRITISH LABOUR.
 Jars 1/3, Zincs 1/-. Sacs 1/6 per doz. Carriage and Packing extra. Trade inquiries invited.—**Demon Battery Co., 59, Badlis Rd., Walthamstow, E.17**

RADIO REGISTERED PANELS

Inches
 7 x 5, 1/2
 7 x 6, 1/8
 8 x 6, 1/4
 10 x 8, 2/1
 10 x 9, 2/4
 12 x 10, 3/-
 14 x 12, 4/-

Inches
 6 x 6, 1/4
 8 x 5, 1/2
 9 x 6, 1/7
 11 x 8, 2/8
 12 x 8, 2/6
 12 x 9, 2/10
 14 x 10, 3/5
 3 in. thick
 Post Free.

TRADE MARK

Money back guarantee that each and all Panels are free from surface leakage. Megger test Infinitly. Callers cut any size. Quotations by post, or 'phone Clerkenwell 7853. Samples and prices post free to the Trade.

CROXSONIA CO., 10, South St., MOORGATE, E.C.2

EASY PAYMENTS

LOUD-SPEAKERS, HEADPHONES, H.T. ACCUMULATORS. Anything Wireless. Send a list of the parts you are requiring, and we will send you a quotation on monthly payments.
H. W. HOLMES, 29, FOLEY STREET, Phone Museum 1414. Gt. Portland St., W.1

JARS, Waxed, ZINCS, SACS
 1/6 DOZ. 1/- DOZ. 1/6 DOZ.
 For making Wet H.T. Batteries, post free on 3 doz. or over. Packed in special carton with division for each cell. This can be used as a container for the battery when made up. Send 6d. for sample complete unit, particulars and instructions.
SPENCER'S STORES, LTD., 4-5, Masons Avenue, Coleman Street, London, E.C.2. Phone: London Wall 2292. (Nr. Bank).

AN IMPROVED LOUD SPEAKER.

(Continued from previous page.)

change over to the loud speaker, simply push the cap of one earpiece into each end of the tube. In this way, of course, both earpieces are utilised, while at the same time the 'phones can be instantly removed and used in the ordinary way any time you wish to do so.

The simplest way to support the loud speaker is to place the whole arrangement on the table and allow the horn to rest on the head-bands of the 'phones. The horn can then be tilted at almost any angle by merely adjusting the head-bands, provided, of course, that these are adjustable on the usual "scissors" principle.

If it is used in conjunction with a good pair of 'phones and a suitable receiving set, this improvised loud speaker will generally be found to give surprisingly good results, considering its extremely low cost and ease of construction.

Give Books This Year!

There is nothing that will give the children greater pleasure at Christmas or Birthday than a copy of their favourite picture and story Annual. Such gifts are of lasting popularity—they will be read again and again. Among the many excellent gift-books available this winter, none are more attractive than those which are issued in connection with the popular coloured papers which delight boys and girls every week. Those famous characters, Tiger Tim and the Bruin Boys, who play the leading part in "Rainbow" and "Tiger Tim's Weekly," appear in **PLAYBOX ANNUAL** and **TIGER TIM'S ANNUAL**, both of which are published at 6/-.

Children who read "Playtime" will find all their favourites in the new **PLAYTIME ANNUAL** (6/-), and all the little people from "Puck," appear in the **PUCK ANNUAL** (6/-).

All these annuals are profusely illustrated, contain many pages and plates in colour, and are packed with entertaining stories, jokes, riddles, poems, etc. They can be obtained from booksellers and newsagents everywhere.

SPUN COPPER SCREENS—

With six-pin ebonite base with terminals, standard fitting, accurate workmanship, for ALL screened coil circuits. Complete, 9/-. Copper screen, drilled, 5/-. Six-pin ebonite base with terminals, 4/6. Special ebonite base, with six pins and terms, for monodial, etc., 2/6. Immediate delivery. Post free. Cross P.O.'s Barclays. Trade enquiries invited.
COLDER ENGINEERING CO., 45, Burma Road, London, N.16.

SPECIAL NOTE

All communications concerning advertising in "Popular Wireless," "Modern Wireless," and "The Wireless Constructor," must be sent to

JOHN H. LILE Ltd.
 4, LUDGATE CIRCUS, London, E.C.4.
 (Phone: CITY 7261)
 and NOT to the Editorial or Publishing Offices.

THE FINEST VALVE CONTROL

Can be assured by using only the

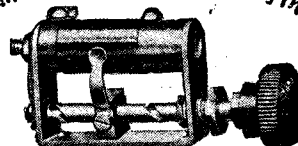

NEW T.C.B. GUARANTEED RESISTANCE

(PATENT No. 225,132)
 Perfect contact; smooth and dead silent in operation; perfect insulation; positive stops for "Off" and "Full On" positions; a travel from "Off" to "On" in two turns of the knob; easy to fit; occupies minimum panel space (illustration is three-fifths actual size).

Every one carries our written guarantee to replace it free if the slightest defect be found within three months from date of purchase.

Resistance 6, 13, or 30 ohms - - - - - 2s. 6d.
 Resistance 50 ohms - - - - - 3s. 0d.
 Potentiometer 300 ohms - - - - - 3s. 6d.

BRITISH THROUGHOUT

Of all dealers or direct, post free, from the sole manufacturers. If ordering direct, state whether one or two hole fixing is desired.

Descriptive folder on request.

Wavio Ltd

DEPT. P., QUEEN STREET, HITCHIN.

JUST THE THING!!

What better present could you buy yourself or your friends than our **AUTOMATIC CONTROL APPARATUS?** It consists of an Alarm Clock fitted with our famous Attachment, with which you may start or stop your Wireless Set automatically at any time you like to set the alarm to operate. **COMPLETE APPARATUS - 7/9 post free.** **ATTACHMENT ONLY** (will fit any ordinary alarm clock), 2/9 post free, with full instructions. Further particulars free. Order early from—
A. R. ELLIS (Dept. P), 5, Arthur St., Luton, Beds.

PICKETTS-CABINETS

For every Constructor. Estimates to your OWN sizes and **LISTS FREE.** Picketts Cabinet (P.W.) Works, Bexleyheath.

VALVES REPAIRED

WHY WASTE MONEY?

Let us RE-MAKE your old ones as good or BETTER than NEW D.E. 4/6 ea. Power 8 - ea. All work thoroughly TESTED, GUARANTEED and promptly dispatched by Post C.O.D.
"NuVal," 64, Mill Hill Road, London, W.3.

REPAIRS

Headphones and loudspeakers rewound and remagnetized H.F. and L.F. Transformers rewound and repaired **EQUAL TO NEW** by skilled mechanics on the latest automatic coil winding machines.

From 2/6

B. KIMBER, ALLEN & COY., 39, BARGERY RD., CATFORD, LONDON, S.E.6. TRADE ENQUIRIES SOLICITED.

TRANSFORMERS REWOUND

Transformers, Phones, Loudspeakers, Rewound and Repaired to Maximum Efficiency. All One Price 4/- each. Don't discard if burnt out. All work guaranteed for 12 months. Write for trade terms. **TRANSFORM CO., 115, LINKS RD., TOTTING, LONDON, S.W.17**

AGAR'S

Resin-Cored Radio Solder.

Guaranteed Non-Corrosive

(British Made). Used exclusively by all Telephone Manufacturers, Government Departments, etc. No Flux required. Makes a perfect joint. Low melting point. Eliminates messy Flux.



The Safe Solder for Radio and Electrical Work.

1/- Per Carton. Obtainable from Leading Stores, Electricians, Radio Dealers, Ironmongers, or Post Free direct from **W. H. AGAR, 19, Whitecross Place, Wilson Street, LONDON, E.C.2**

The Master Non-Vibratory Valve Holder

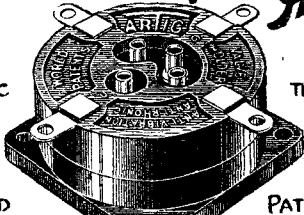

ANTI-MICROPHONIC - VIBRATION - SHOCK - CAPACITY

SPRUNG - YET THERE ARE NO SPRINGS OR RUBBER SUSPENSION PATENTS.

The Artic Valve Holder represents a real step forward in valve-holder design at a small extra cost, a De Luxe Holder giving results obtainable in no other type.

Used in De Luxe 2 and Spider 3, and recommended by "Popular Wireless" to all its readers.

The Artic suspension is used by the Admiralty and all large Industrial Concerns for preventing the destruction of metallic filaments through vibration and shock. What better recommendation can be had than that of experts who have tested all devices?

ORDER NOW—DON'T DELAY!

THE ULTRA SENSITIVE VALVE HOLDER



FROM YOUR DEALER OR DIRECT **3/9** EACH POST FREE

Cut out the WORRY

of uncertain High Tension Batteries.

Install one of "ATLAS" "B" BATTERY ELIMINATORS and lead the way to Brighter Radio



Models for A.C. & D.C. Current. Variable Voltages. Grid Bias. Full wave rectification.

Upkeep negligible. Silent and Efficient.

WE GUARANTEE every instrument.

We make them good! Good judges make them famous!

Manufacturers of the famous "Atlas" Plug-in Coils and Fixed and Variable Condensers; also sole manufacturers of the Super Selective Reactor Formers.

H. Clarke & Co. (Mer.) Ltd., "Atlas" Works, Old Trafford, Manchester.

A. MUNDAY, LTD.

59, WATLING ST., 45, EASTCHEAP, E.C.4 E.C.3
 (one door from Queen Street and Queen Victoria Street)
 Tele: - - - CITY 2972 Tele: - - - ROYAL 4632

WHAT ABOUT THOSE OTHER STATIONS?

- Madrid
- London
- Cardiff
- San Sebastian
- Petit Parisien
- Barcelona
- Milan
- Dundee
- Bradford
- Oslo
- Bournemouth
- Hamburg
- Dublin
- Newcastle
- Munster
- Glasgow
- Rome
- Radio-Toulouse
- Stockholm
- Berne
- Belfast
- Leipzig
- Ecole
- Superieure
- Frankfurt
- Birmingham
- Brussels
- Aberdeen
- Berlin
- Munich
- Swansea

Use one of these to get them—

- ELSTREE SOLODYNE with LEWCOS COILS
- ALL BRITISH SIX with LEWCOS COILS
- EVERY MAN FOUR
- THE MONODIAL
- IGRANIC SUPERHETRODYNE

Complete finished Receiver in Mahogany, Oak or Walnut Cabinets or parts only for home construction.

DRY BATTERY BOX WITH GRADUATED SWITCH.

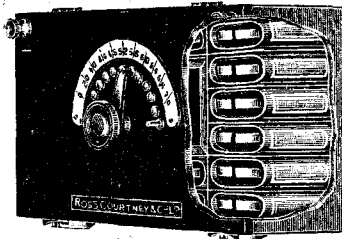

USE ORDINARY DRY FLASH LAMP CELLS AND MAINTAIN YOUR H.T. AT EFFICIENT STRENGTH AT LOW COST.

NO WANDER PLUGS. FIND THE REQUIRED VOLTAGE BY SIMPLY TURNING THE KNOB.

"HIGHTENSWITCH" Battery Box. Price 25/- each. Post Free.
 ROSS, COURTNEY & Co. Ltd., Ashbrook Rd., London, N.19

"TROMBA" H.T. UNITS

are not the CHEAPEST on the market, they are the BEST! Constructed of finest quality components. "Creeping" of salts entirely eliminated. The Saes for these units are specially made to give a constant current, and last indefinitely. Very thick zines are used, ensuring long life. Made in small and large capacities, suitable for power valves. Large, 6/10 doz.; small, 5/5 doz. Sample unit and large capacity Sae, post free, 1/-. Foreign Orders, 1/6. Also in 60 v., 80 v., & 100 v. batteries in mahogany cases with glass covers. Send to-day for free descriptive folders, etc.

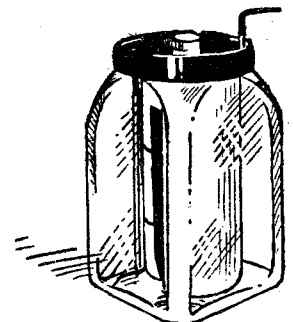

TROMBA ELECTRICAL COMPANY,
 17, WHITE HART LANE, TOTTENHAM, N.17



Christmas—

How will you spend it?

JUST sitting in front of the fire, listening-in, snug and happy. It's something to look forward to as long as you know the Radio will be in perfect order. Here's a suggestion—invest in a TANGENT H.T. Battery Eliminator and your Radio will not let you down. Give yourself one for a Christmas present. Absolutely silent in operation. Ample output for the largest receiving set.

Price complete in metal case with connecting plate - - **£7-15-0**



LONDON: 25 Victoria Street, S.W.1.
NEWCASTLE/TYNE: TANGENT House, Blakett Street.

GENT & CO. Ltd., Faraday Works, LEICESTER.

HEARING THROUGH THE HANDS.

By J. F. C.

A MOST noteworthy series of experiments has recently been conducted in one of the foremost American colleges. Essentially this series of experiments has comprised the practical part of an investigation which was started with the object of ascertaining to what extent radio signals can be received by deaf persons.

Peculiar Effects.

One or two of these experiments are interesting enough to be repeated by the average listener. It is stated that a person wearing an ordinary pair of headphones was able to convey the received radio signals to a non-listener merely by lightly shaking hands with the latter individual, and, furthermore, that this individual was able to pass on the signals to still another person by making a similar light hand contact with him. Thus the signals received by one individual wearing a pair of 'phones were passed on to two more individuals.

Working on this apparently chance discovery, the investigators have been able to show that this effect, while being comparatively rare in the case of normal persons, is fairly common in deaf or partially deaf individuals, and, therefore, that an almost totally deaf person may have radio signals conveyed to him in this novel and strange manner.

It is very possible that this effect may be able to occur with some peculiarly sensitive individuals, and, in view of this fact, the reader may be encouraged to carry out a few similar experiments for himself.

Probable Explanation.

An explanation of the phenomenon has been based on the supposed presence of a number of unreal factors of inductance and capacity present in the human body. It seems more likely, however, that the effect is merely due to microphonic sound transference through the human body, particularly through the bones. That such a feat is possible is very easily proved by the following experiment.

Grip the stem or chain ring of a watch between the front teeth, at the same time tightly stopping up the ears with the fingers. The ticking of the watch will be very distinctly audible, thus proving that the sound has been transmitted to the ears not through the medium of the external air, but along the upper jaw and facial bones.

Further Experiments.

Another experiment in bodily sound transmission which will be of still more interest to the radio listener is the following:

Get another person to hold a single earpiece from a pair of headphones tightly

(Continued on page 960.)

PEERLESS FIXED RESISTOR

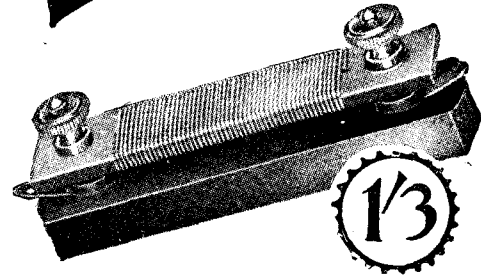

Efficient, Neat and Cheap

YOU can see from the illustration what a neat job this "Peerless" Fixed Resistor is. The base is solid insulation and the former a strong impregnated material that atmospheric conditions will not affect. The wire is wound evenly and firmly and terminals and soldering tags are fitted. One hole fixing. A very thoroughly assembled and finely finished unit in all.

- OTHER BEDFORD PRODUCTS:**
- "Peerless" Dual Rheostat 3/9
 - "Peerless" Junior Rheostat 2/6
 - (already over half a million sold)
 - "Peerless" Resicon Variable Condenser, from 15/- to 18/-
 - (Dial and Vernier 2/6 extra)
 - "Peerless" Master Switch 2/9
 - "Peerless" Valve Switch 3/-

From all good dealers or direct.

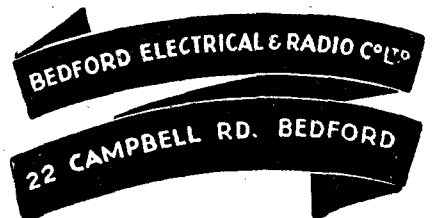

BARGAINS

No. 201.

EVERYTHING FOR THE AERIAL—MASTS, PUL-
LIES, WIRES, &c.—R.A.F. Steel, 10 ft., 5/-.
LEAD-IN TUBES, good quality, 6d., 8d., 10d.
WIRE, 110 ft. 7-strand R.A.F., aerial 1/3; 100 ft.
Navy Special 7-23 super enamel Bronze, 3/-.
R.A.F. MASTS.—2 ft. 8 in. Steel Tube, 11-in. sockets,
sections, 15 ft., 7/6; 20 ft. 10/-; and 30 ft., 14/-;
4 ft. 3 in. sections, 2 1/2 in. dia., 5/- each.
MORSE TRANSMITTING SETS, with Key, 10 to miles
range on 6 volts, any wave-length, 12/6 each.
MICROPHONES, 1/-; Button's 1/- MICRO.
TRANSFORMERS, 5/- each; smaller size, 4/6 each.
ELECTRAX INTERVALVE.—New L.F. Trans-
formers, for power 5 to 1 or 3 to 1, 7/8 each;
Polar Intervalve, 10/-; G.R.C. and Maxtone, 8/-.
CONDENSERS.—025 Mansbridge, 6d. each; '001
Mica, unmounted, 6d.; also '002; 7d. each;
Marconi Variable, 6/-; '002 High Tension, 1,000
volts, 5/- each; '001, '002, '003, '005, 6d. each;
Ex W.D. '03, 6d.; 2 mfd., 2/6. New, '25 mfd. and
50 mfd., 2/6; 1 mfd., 3/3; 2 mfd., 4/3; 4 mfd., 6/6; 10
mfd., 15/-; 1000 v. 1 mfd., 17/6; 2000 v. 2 mfd., 27/6.
NEUTRODYNE CONDENSERS, variable, '000,025,
minimum cap. '000002 U.F., max. cap. '0025
U.F., 3/6. **MICRO-CONDENSER**, '00004, 5/6.
LOW LOSS INDUCTANCE, 10 taps to plugs, 5/-.
COUPLER.—250-500 M., 4/6.
DUAL VARIABLE CONDENSERS, '0005 Square Law
10/-; 3-gang Polarenco, 12/-, Polar enclo. '0003, 4/6
WAVEMETERS of all types and ranges, Townsend
Broadcast, reduced to 35/-. All guaranteed.
CORDS.—Twin for single 'phone or battery, 1/-.
Brown cords, double, with 2-pin plug, 1/6. With jack
and plug, 3/-; 4-way for H.T. and L.T. Neat 1/-.
CHOKES.—1,000 ohms ironclad, 40 s.w.g. silk, 1/6,
others 1/-, H.F. Chokes on ebonite, 1/6. Large
Chokes for H.T. transmitting, Smoother, &c.,
10/-. Chatterton's ebonite compound, 1/- stick.
THE GENEROMETER supersedes H.T. batteries.
For your H.T. supply from d.c. mains. Perfect
control, 40 to 120 volts for Plate, 3 taps, 35/-.
INSTRUMENTS.—Special Valve Testing Sets, 3
moving coil instruments on panel cabinet. New.
Cost £8. Sale, £5. Six only.
Get the best out of your set. The Multi-Range **DIXON**
ULTRA ONE-METER enables you to correct faults
in wireless. For real efficiency One Meters are
practically indispensable, 50/-. Multipliers 6/6.
MINIATURE PANEL METERS.—Voltmeters, 0-3,
0-6 and 0-10 volts. Price 7/6 each. Ammeters—
0-1, 0-3 and 0-6 amps. Price, 7/6 each. Milliam-
meters, 0-20, 0-30 and 0-40 M.A. Price 10/3 each.
Combined Voltmeters, 0-6 and 0-120 volts. 11/6.
VALVES.—Microsil D.E. '06 9/-, Transmitting
A.T. 40 new Osram and Cossor, 12/6; 250-watt do.
40/-; Cunningham Power, 17/6. Rectifying, 8/6.
"STAR" MOUNTED COILS, centre tapped, 25,
1/6; 35, 1/6; 50, 1/9; 75, 2/-; 100, 2/3; 150,
2/9; 175, 3/-; 200, 3/-.
MOUNTED COILS.—No. 25, 35, 50, each 2/-; 75,
2/6; 100, 3/-; 150, 3/6; 200, 250, 300, each 4/-.
MOUNTED LOSS.—25, 1/2; 35, 1/4; 50, 1/3;
75, 1/11; 100, 2/-; 150, 2/6; 200, 2/10; 250, 3/-;
300, 3/3; 400, 3/6.
WESTERN ELECTRIC LOUD SPEAKER, 17/6.
EBONITE STANDS, 2-way, 2/11, 3/3, 3/6.
Ebonite plugs, extra quality, 7d. Plated, 3d. pair.
COIL HOLDERS, 2-WAY.—Lotus, 7/-; Dixon,
geared, 6/-; Polar 2-coil, 4/6; Newey, 6/6;
Woodall, 10/6; Reliability, geared, 3/6; good
quality, 2/6; 'ernier Friction Drive Type, 3/6;
Single Moving Holder, 1/9. For inside baseboard
mounting, with 6-in. handle, two-way, 7/-; 3-
way, 8/-.
BATTERY BOXES, 63-v.—Metal, take 14 batteries,
3/6. Fitted Clips. Battery Testers, 4d. Bull's-
eye Bulbs, 3d.; 6 for 1/3. Torches all sizes.
H.T. BATTERIES.—Ever-ready, 66-v., 12/6; 103-v.,
21/-, L.T. for D.E. Valves, 7/6 and 9/-, Siemens
H.T., 60-v., 12/6. Hellesen's 60-v., 14/6. Various
1 1/2 D.E. Batteries, 1/6 to 3/6.
BATTERY CHARGERS, 100 or 200 volts D.C. or
A.C. £3 10s. Motor generators, all sizes. See list.
BUZZERS, 2/6, 3/-, and 3/6. With key and 'phone,
7/6. Signal sets, 22/6. **BOXES**. 1 1/2 in. by 10 in.
by 2 in., for storing coils, 2-hinge tops, 2/- Boxes
with plugs for H.T. Batteries, 5/-, 12 by 8 by 6 1/2
in., covered boxes, hinged lid and ebonite panel for
portables, 10/6. Brown's 2-relay cabinets, with fit-
tings, 5/-, Three-cell valve boxes, padded, 1/6 each.
CRYSTAL REFLEX CIRCUITS.—Marconi pattern for
panels, 2/6 set. Polar Semi-fixed, 2/-, Card Sets, 9d.
DETECTOR CATWHISKERS.—2 in. box, 4d. pair.
700 G.P.O. 2-RANGE DETECTORS.—Ediswan,
G.E.C., etc. Brand new, 5/6 each. Siemen's Cell
Testers, M.C., 15/-.
**1,000 VOLT GEARED DRIVE MEGGER DYNA-
MOS** for H.T. testing. Cost £30. Sale, £3 10s.
in case. Brand new, cost £12. Carriage, 4s.
DYNAMOS.—Charging 12 volt Lucas 8 amp., 50/-;
Crompton 30 volt 15 amps., £5. M.G. 220 volt
A.C. to 8 volt 1 1/2 amp. D.C., 70/-; 1,000 volt,
£3 10s. All sizes in stock.
PRECISION INSTRUMENTS — ONE-METERS.
—ONE-VALVE TO SIX-VALVE RECEIVERS—
RECORDERS—RELAYS—DYNAMOS—MOTORS.
New Winter Bargain Catalogue Will Save You Pounds
—4d. Stamps.

ELECTRAX RADIOS.
218, Upper Thames St., E.C.
Blackfriars Stn., Met. Rly. City 0191

HEARING THROUGH THE HANDS.

(Continued from page 958.)

up against the jaw or cheek bone, and at the same time place the two index fingers tightly in the ears. The signals from the 'phone will be distinctly audible under these conditions, particularly if they are of good strength in the 'phone itself. Here again we are faced with the phenomenon of sound transmission through the human body.

It is thus, working on these basic principles, that certain investigators have shown that radio signals can be transmitted not only for considerable distances through one individual's body, but also from person to person by light bodily contact only. Whether any important application of this fact will be forthcoming, particularly in the matter of helping the deaf to hear radio signals, remains to be seen. Nevertheless the whole subject is of interest, as a few experiments conducted on the lines mentioned above will prove.



Do you remember Scrooge of "Christmas Carol" fame? If you do you will recollect that one night he went home fully anticipating that he would find his front door had a knocker, only to discover, subsequently, that the excrescence was merely somebody's face.

The moral is, obviously, that things are not always what they seem. Therefore, we must always be prepared for the worst and not the best. If your set gives nice loud-speaker results from the local station when everything is "just so," what will happen when something is not "quite so"? Naturally, the receiver must not be expected to give better results, although it would not be the first time if the effect of doing something supposed to be wrong did improve matters.

Capable of More.
However, at Christmas-time if at no other time, a really nice margin of safety is really essential. A motor-car engine is never kept running year in and year out at its maximum speed—it couldn't do it, anyway—so why should we expect our set to give of its best over long periods running "all out" all the time.

For many reasons your own set, the set you give somebody as a present, in fact, all sets, should be capable of doing just a little more than it is probable they will ever be asked to do. In that way lies reliability, purity and peace in the ether of space.

Printed and published every Thursday by the Proprietors, The Amalgamated Press (1922), Ltd., The Fleetway House, Farringdon Street, London, E.C.4. Advertisement Offices: Messrs. J. H. Lile, Ltd., 4, Ludgate Circus, London, E.C.4. Registered as a newspaper and for transmission by Canadian Magazine Post. Subscription rates: Inland, 17/6 per annum, 9/6 for six months; Abroad, 19/6 per annum, 9/9 for six months. Sole Agents for South Africa: Central News Agency, Ltd.; Sole Agents for Australia and New Zealand: Messrs. Gordon & Gotch, Ltd.; and for Canada: The Imperial News Co. (Canada), Ltd. Saturday, December 11th, 1926.

GRAVES

2-VALVE LOUD SPEAKER BARGAIN.

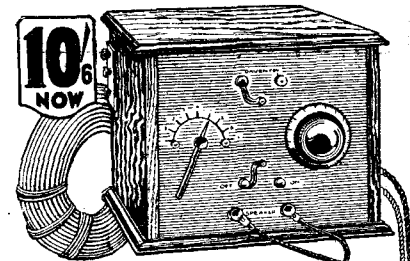

This highly efficient 2-Valve Loud Speaker Set is the finest wireless value ever offered.

It gives a volume and quality of tone unattained by any instrument of a similar price and is the essence of simplicity. Fitted with coils covering all the British wave-lengths, including Daventry. THE CABINET is of beautifully polished Oak, & all components are of the highest quality. Dull Emitter Valves with patent valve holders, &c.; H.T. Battery, 2-volt accumulator and complete Aerial outfit. LOUD SPEAKER of exclusive design with unique magnetic system and improved mica diaphragm. Price £7:17:6

TERMS: Our Bargain Price is for deferred payments. Send 10/6 now, & complete purchase in 14 monthly payments of 10/6. If you wish to pay cash, 5 per cent discount is allowed. Catalogue Post Free. Up-to-date Crystal & Valve sets at keenest prices. J. G. Graves Ltd. Sheffield

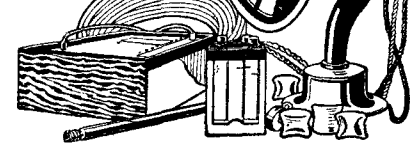

A.C. MAINS TRANSFORMERS. As specified for Radio Constructor H.T. Battery Charger Unit, in "P.W." issue, Nov. 6. 200/250 volts. A.C. current, 50 cycles, 1 amp. Satisfaction guaranteed, 9/6 each, post free. STOREY BROS. & CO. Radio Engineers, 2-4, Regent Street, RUNCORN.

A BOON to the HOME CABINET Maker

Do Your Own French Polishing
Anyone, without even the slightest knowledge of French polishing, can obtain highly pleasing and satisfactory results with S.P. FRENCH POLISH. The S.P. OUTFIT contains woodfiller, stains, polish, accessories, and complete yet simple instructions. . . . Price 4/6
Post Paid from: S.P. POLISHES, 5, High Holborn, W.C.1
An Ideal Xmas Gift for Your Boy



STOCKED BY ALL THE BEST DEALERS
TRELLEBORGS EBONITE WORKS Ltd. Audrey House, E.C.4

4 - ELECTRODE VALVES

We are the suppliers of the genuine U.O. and Thorne valves, as specially tested and recommended by the "Undrime" inventors and "Popular Wireless" U.C.5 and Thorne K.4 (both 4-electrode 5-pin valves), each, post free. 10/6
Order direct from— Cash with order
LUDGATE RADIO CO.,
55, LUDGATE HILL, LONDON, E.C.4
R.R.

Children love good Radio



You can improve any wireless receiver by using Mullard P.M. Valves with the wonderful P.M. Filament.

Valves with the wonderful P.M. Filament give greater volume, last longer and cost less to run. Obtainable from all radio dealers.

Mullard

THE MASTER VALVE

IMPROVES ALL RADIO RECEIVERS



GIFTS YOUR WIRELESS FRIENDS APPRECIATE

Give a man something that he wants, something that he would otherwise buy himself, and he will value your token and your discrimination the more highly.

Take the three R.I. components illustrated above. There's the Retroactive Tuner for the man who is still losing efficiency with a set of plug-in-coils, or the Multi-Ratio Transformer for he who wants just another stage of L.F. to discard his 'phones and "put it through on a 'speaker.'" And for that budding wireless expert of a nephew there is no more obvious gift than the Permanent Mineral Detector.

All these are precision instruments designed and manufactured to the highest standards and as Christmas gifts show a clear expression of personal judgment and good taste. Their merits are well known to your wireless friends, to whom they will have a far greater appeal than the superfluous oddments so frequently regarded as tokens of remembrance.

PRICES:

Retroactive Tuner, 39/6. Multi Ratio Transformer, 25/- . Permanent Mineral Detector, 6/- & 6/6.

R.I. Ltd., 12, Hyde Street, New Oxford Street, London, W.C.1



The "P.W." Constructors' Competition: Prize Winners

Popular Wireless

Every Thursday
PRICE
3d.

No. 237. Vol. X.

INCORPORATING "WIRELESS"

December 18th, 1926.



Special Features In This Issue

H.F. Amplification Crystals in Valve Circuits Do Sunspots Affect Our Radio
 Further Notes on the "Hale" Circuit When the Set Won't Oscillate
 Lacking the Essentials More About The King of the Air, By Percy W. Harris

A group of enthusiastic young sailors receiving radio instruction on the famous flagship H.M.S. "Iron Duke" is shown on our cover this week.

There are many valves —



over 100 different makes are obtainable in this country alone—there are many to choose from and correct choice is essential to good results. Most important of all is the selection of suitable valves for *loud speaker* operation.

You can avoid all possibility of error by asking for

AMPLION VALVES

Every Amplion Valve is backed by the reputation of the House of Graham, manufacturers of The World's Standard **AMPLION** Wireless Loud Speaker

Obtainable of all accredited AMPLION STOCKISTS, Radio Dealers or Stores.

Patentees and Manufacturers:

GRAHAM AMPLION LIMITED, 25 SAVILE ROW LONDON W.1

MARCONI

NEW POWER VALVE

Disciplined Volume

A wealth of deep sonorous volume; clear, well defined, perfectly expressed, admirably controlled.

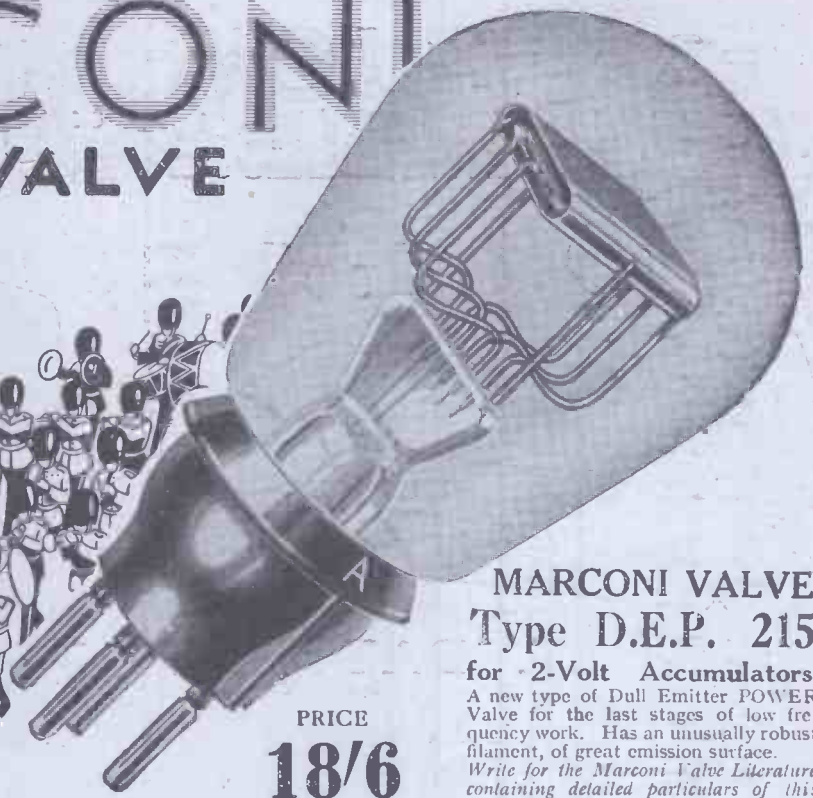
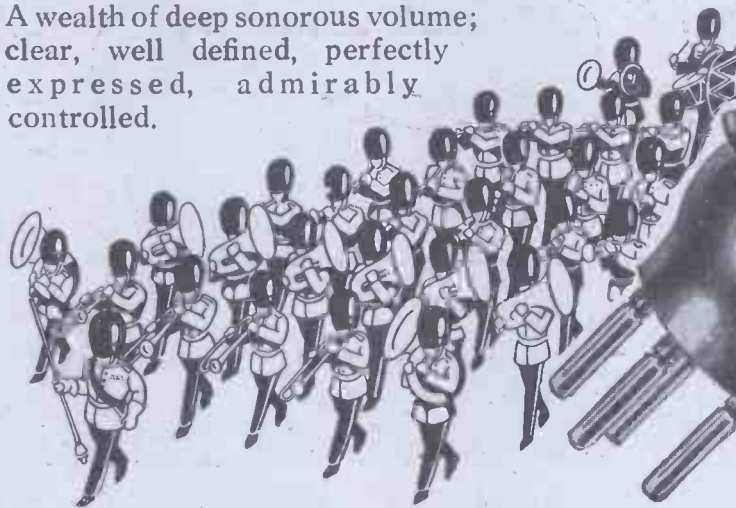

MARCONI VALVE Type D.E.P. 215

for 2-Volt Accumulators
A new type of Dull Emitter POWER Valve for the last stages of low frequency work. Has an unusually robust filament, of great emission surface. Write for the Marconi Valve Literature containing detailed particulars of this and other types.

PRICE

18/6

THE MARCONIPHONE



COMPANY LIMITED

Registered Office: - Marconi House, Strand, W.C.2.
M.P.O. 796D

Head Office: - 210-212, Tottenham Court Road, W.1

POWER AMPLIFICATION FROM YOUR HOUSE LIGHTING

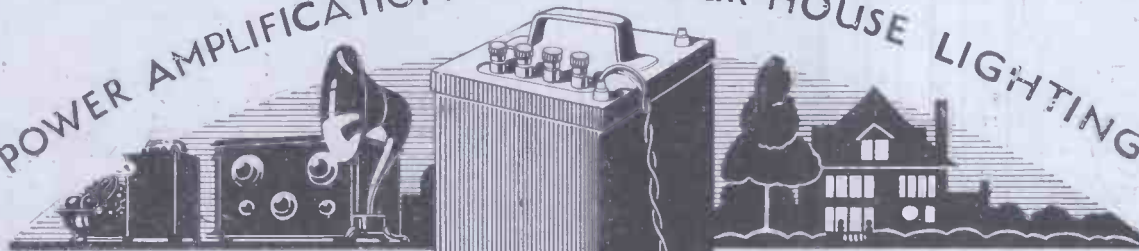

MARCONIPHONE H.T. SUPPLY UNIT FOR ALTERNATING CURRENT

This instrument works without "hum" on any supply. The output, which can be taken in three pressures, viz., 42, 84 and 126 volts, is sufficient to operate any set on the market and permits the use of power valves on full load. By using alternative terminals provided on the unit, it can be utilised on mains of different pressures, varying from 95 to 240 volts, and on all frequencies above 32.

The current is rectified by a Marconi U5 valve, the filament of which is heated through the medium of a specially wound transformer contained in the instrument.

No. B925, Marconiphone A.C. High Tension Supply Unit	£ 9 5 0
Royalty	12 6
Marconi U5 Rectifying Valve Instrument, complete with Valve, including Royalty	1 10 0
	£11 7 6

Designed by the Marconi Company's Engineers to obtain high tension current from house mains, without using High Tension Batteries. Suitable for all types of Receivers

MARCONIPHONE H.T. SUPPLY UNIT FOR DIRECT CURRENT

Similar in appearance to the A.C. unit, but as its purpose is to smooth out direct-current, no valve is necessary. Different types of D.C. Supply Mains, however, require different smoothing circuits, and this has been surmounted by providing adjustable connecting links to enable the unit to be connected up by the user in a way most suitable to the supply system—full instructions are furnished with the unit. Output tappings at 42, 84 and 100/120 volts are provided. Can be used on mains of 100/120 or 200/240 volts. In the latter case a pair of ordinary metal filament lamps are inserted in the instrument. A variety of output voltages can be obtained by the use of different lamps. This instrument can be used for charging H.T. accumulators of voltages not exceeding 90/100.

No. B926, Marconiphone D.C. High Tension Supply Unit	£ 6 0 0
--	---------

Write for Booklet No. 364G.

Marconiphone

HIGH TENSION SUPPLY UNITS

THE MARCONIPHONE



COMPANY LIMITED.

Regd. Office: Marconi House, Strand, W.C.2.

Head Office: 210-212, Tottenham Court Road, W.1.

The Marconi International Marine Communication Co., Ltd., require 500 qualified Wireless Operators. Apply to Service Manager, Marconi House, Strand, London, W.C.2.



**FELLOWS
WIRELESS**

60 Volts
8/9

THIS H.T. BATTERY

- costs only 8/9,
- is made throughout in London,
- is sent post and packing free,
- reaches you, brim full of energy, within a few hours of manufacture owing to the enormous number we sell daily,
- maintains its voltage for the longest possible time owing to the extremely generous "elements" of which it is made,
- will give you a long life of loud, clear reception free from all crackling noises,
- is tapped every 3 volts enabling you to apply the exact voltage required by your valves for best results,
- is supplied complete with Red and Black wander plugs—no extras to buy,
- is, in short, the **FINEST IN THE WORLD** because no other H.T. Battery made (except other Fellophone batteries) can come anywhere near it in performance or value.

Other Fellophone Batteries are listed below. We can only offer you this astounding value because, by supplying you direct we can save all the middleman's profits and so give you a better battery for less money.

Order from us or from our Branches to-night.

54 Volt (with 3 volt tap for grid bias). Post FREE **6/6**

60 Volt (tapped every 3 volts and supplied complete with Red and Black wander plugs). Post FREE **8/9**

108 Volt (tapped every 6 volts and supplied complete with Red and Black wander plugs). Post FREE **13/-**

FELLOWS, PARK ROYAL, N.W.10

Branches: [(Museum 9200).

- LONDON: 20, Store Street, Tottenham Court Road, W.C.
- BIRMINGHAM: 24B, Corporation Street. (Central 435).
- BRIGHTON: 31, Queen's Road (Brighton 899).
- BRISTOL: 36, Narrow Wine Street. (Bristol 7972).
- CARDIFF: Dominions Arcade, Queen Street. (Cardiff 7685).
- LEEDS: 65, Park Lane. (Leeds 21479).
- MANCHESTER: 33, John Dalton Street. (Central 1164).
- NEWCASTLE: 36, Grey Street.
- NOTTINGHAM: 30 Bridlesmith Gate. (Nottingham 5551).
- TONBRIDGE: 34, Quarry Hill. (Tonbridge 172).

Send for
48-page
Catalogue
No. 33,
FREE.

BUY DIRECT AND SAVE MONEY

E.P.S. 273

THE
"UNIVANE"

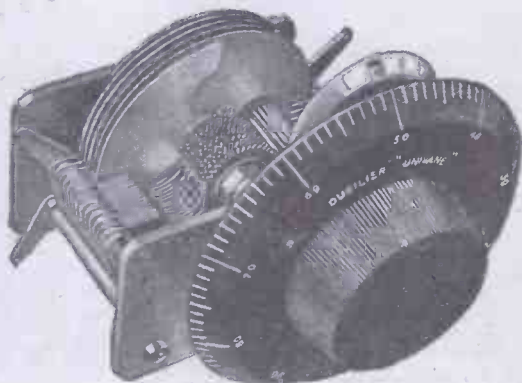

Over 4,600 degrees
of Vernier Tuning!

The "Univane" gives the equivalent of a continuous Vernier adjustment between minimum capacity and 0.0005 mfd. Rotation of the scale moves one vane at a time, adding it to or subtracting it from those already in opposition.

This enables you to pick up station after station with the greatest accuracy, and the figures on the small dial can be noted to form a permanent log of all stations heard.

The "Univane" is intended for use on every occasion where the ordinary variable condenser is now employed. It is in no sense a condenser for special circuits, and in these days of ultra fine tuning it is a necessity whether you "search the ether" or merely listen to your local station.

It is backed by the full Dubilier guarantee and is further described in our new Catalogue. May we send you a copy?

Price, of all dealers

25/-



ADVT. OF THE DUBILIER CONDENSER CO. (1925) LTD.
DUCON WORKS, VICTORIA ROAD, N. ACTON, W.3
TELEPHONE: CHISWICK 2241-2-3. E.P.S. 250

The
ideal combination
for
6 volt accumulators

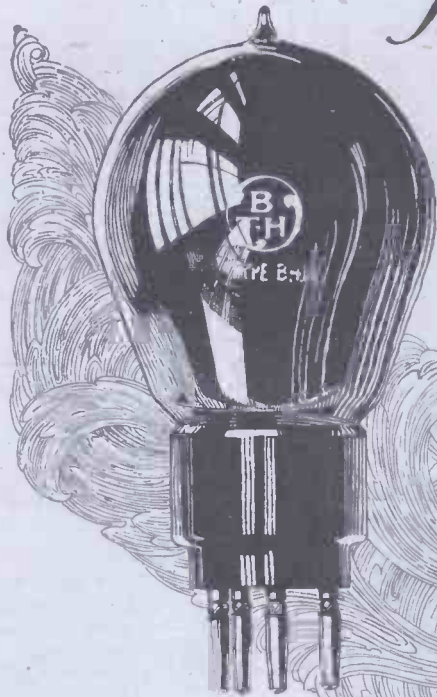

	B.4.H.	B.4.
L.T. { Volts	6	6
{ Amps	0.25	0.25
H.T. Volts	60 to 120	40 to 120
Ampn. Fac.	20	6.5
Impedance	28000 ohms	6000 ohms
PRICE	18/6	18/6

THE famous B.4. Valve—the finest power-amplifying valve ever made—has now its counterpart in the new B.4.H. In these two valves we have provided the ideal combination for 6-volt accumulators. The B.4.H. is intended for H.F., detector and early L.F. stages, and the B.4. for the final L.F. stage.

Those who have had experience of the B.4 valve will find the B.4.H. no less remarkable in its own sphere, while from the combination they will obtain a quality of reproduction hitherto undreamed of.

If you have a B.4, buy a B.4.H. If you haven't, buy both

B.T.H. VALVES

WHY PAY MORE THAN DOUBLE for other amplifiers
or for a valve set, when you can get as good results with THE
MAGNETIC MICROPHONE BAR AMPLIFIER

(Patent No. 248551/25.)

"NO-CRYSTAL SET IS COMPLETE WITHOUT THIS WONDERFUL ATTACHMENT."

Not only will this marvellous device give really good LOUD-SPEAKER RESULTS from CRYSTAL RECEPTION of average strength, but it is absolutely the ONLY means of increasing the strength of weak signals in HEADPHONES without using valves.

Works perfectly on one or two dry cells.

A BOON TO DEAF PERSONS

EQUALLY EFFICIENT ON VALVE SETS

IF YOUR DEALER CANNOT SUPPLY ORDER DIRECT FROM SOLE MANUFACTURERS AND PATENTEES:



(Two-thirds actual size.)

NOT a Microphone Button.

NO Valves, Accumulators or H.T. Batteries. Fragile parts. Distortion.

Simple as A B C.

MICROPHONE AND OTHER PARTS OF AMPLIFIER SUPPLIED SEPARATELY

FULLY ILLUSTRATED LISTS FREE

COMPLETE AMPLIFIER as shown PRICE post free **38/-** 3-volt DRY BATTERY lasting over three months 4/- extra. No other accessories required.

DELIVERY BY RETURN FROM STOCK EVERY AMPLIFIER GUARANTEED.

NEW WILSON ELECTRICAL MANUFACTURING CO., LTD., 18, FITZROY STREET, EUSTON ROAD, LONDON, W.1. Phone: Museum 8974.

Here are the Parts for the 'KING of the AIR' Receiver

(described by Mr. Percy W. Harris in last week's issue of "P.W.")

2	Keystone S.L.F. Condensers, .0005 and .0003 mfd.	17	6
2	Pilot Vernier Dials	10	0
1	Keystone B.M. Neutralising Condenser	5	0
1	Keystone P.M. Reaction Condenser	6	3
4	W.B. Valve Holders	9	0
1	Keystone Binocular Coil (250-550m) with Base	12	6
1	Copex H.F. Transformer (250-550m) with Special 6-pin base	13	0
1	On and Off Switch	1	9
4	Keystone Fixed Resistors and Bases	10	0
1	Geophone L.F. Transformer, 2-1 ratio	17	6
1	Varley Split-Coil H.F. Choke	12	6
2	T.C.C. Mansbridge Condensers, 1 mfd.	7	8
2	Mullard Wire-wound Resistances, 100,000 ohms and bases	11	0
2	Dubilier Fixed Mica Condensers, .015 mfd.	9	0
1	Dubilier Grid Condenser, .0003 mfd., and Grid Leak, .25 meg.	5	0
2	Aluminium Angle Brackets	2	6
1	C.A.V. Multiple Fixed Condenser	5	0
	Wire, Screws, Nuts, etc.	1	10
		27	17 0

1 Red Triangle Ebon. s. d. ite Panel, 16 in. by 8 in. by 1/2 in. drilled 10 0 (Price of Cabinet on application.)

When complete Sets of parts and panel are purchased together a Marconi royalty of 12/6 per valve must be remitted.

Let us put your name down for an early copy of the new 24-page edition of the 'Pilot Manual' now at press. Fully illustrated, it gives details of the latest Receivers and much other useful information. Post free 6d.



THE PILOT MANUAL

PETO-SCOTT CO., LTD.

Head Office & Works: 77, City Road, LONDON, E.C.1
Branches: 62, High Holborn, London, W.C.1. WALTHAMSTOW—230, Wood Street. PLYMOUTH—Bank of England Place. LIVERPOOL—4, Manchester Street.

P.S. 6764

FRELAT D.E. VALVES

4/11 8/6

TYPE K. Detector and amplifier 2 volt 3 amp.

TYPE D.K.P. 1.8-2v. 3 amp. New 2 volt power-valve.



MUCH MORE FOR MUCH LESS.

CUT out the high maintenance cost in Radio and use Frelat Dull Emitter Valves. For performance and long life they are unexcelled and yet the Type K. valve costs only 4/11. Next time put Frelat to the test and let this guaranteed valve prove that high prices are not necessarily the key to the best reception.—If your dealer cannot supply, send direct: For C.O.D. terms add 4d.—postage free.

CONTINENTAL RADIO IMPORT CO., LTD., 8, SPITAL SQUARE, LONDON, E.C.1.





The "Cosmos" Rheostat.



The "Cosmos" Permacon.



The "Cosmos" Coupling Unit and spring valve holder.



Ask your dealer for these attractive Folders on "Cosmos" Values, Sets and Components.

Cosmos

RADIO COMPONENTS

ensure reliable sets.

Constructors who desire smooth working and efficient sets use "Cosmos" Precision components.

The "Cosmos" Rheostat. The principal features of the "Cosmos" Filament Rheostat are its sturdy construction and reliable, smooth movement. The contact arm cannot easily be damaged, having its movement on the inner side of a porcelain bobbin which carries the windings. Other pleasing features of this Precision Rheostat are the handsome knob and dial, ONE HOLE fixing, and the small space it occupies.

Made in four types, two of which are double-wound for DULL or BRIGHT Valves and one a Potentiometer.

Description	Ohms	Current	Price	
			s.	d.
Single Wound	6'0	1'0 amp.	4	6
Double "	20	'4 "	5	0
"	34	'2 "	5	0
Potentiometer	300	—	6	0

The "Cosmos" Permacon is an ideal fixed condenser, being light in weight, of guaranteed accurate capacity, and having the lowest possible losses.

The dielectric is mica, and each condenser is tested at 500 volts during inspection. Nickel-plated cases give them a particularly neat appearance.

.0001 mfd.	1/8	.001 mfd.	1/8
.0002 "	1/8	.002 "	1/10
.0005 "	1/8	.005 "	2/8
.0003 " (with clips for grid leak)	1/8	.01 "	3/9

The "Cosmos" Resistance Coupling Unit.—Real purity of reproduction can only be obtained with resistance capacity coupling. The "Cosmos" Coupling Unit with a suitable valve is as effective as an ordinary transformer-coupled stage. It avoids all distortion and effects considerable economies in first and operating costs. Designed primarily for use with the "Cosmos" S.P. Blue Spot Valves, it can be used successfully with any valve having an amplification factor of 30 or more. Special attention is directed to the following advantages of the "Cosmos" Coupling Unit:

- (1) It takes up little space in a set.
- (2) It is not liable to be broken.
- (3) It has permanent resistance values.
- (4) It allows for simplified wiring.
- (5) It is economical in L.T. current (S.P. Blue Spot Valves consume 0.09).
- (6) It is economical in H.T. Battery consumption (less than 1/20 normal).

And lastly its use results in purity of reproduction without loss in volume.

Type "O," the Unit alone 8/8
 Type "V," the Unit incorporating spring valve holder (as illustrated) 10/8
 Suitable valves for use with this unit are "Cosmos" S.P. 18/B at 14/- and "Cosmos" S.P. 55/BL at 18/6.

METRO-VICK SUPPLIES LTD.

(Proprietors: Metropolitan-Vickers Electrical Co., Ltd.)

METRO-VICK HOUSE,
 155, CHARING CROSS ROAD, LONDON, W.C.2 R P60

Louden Valves

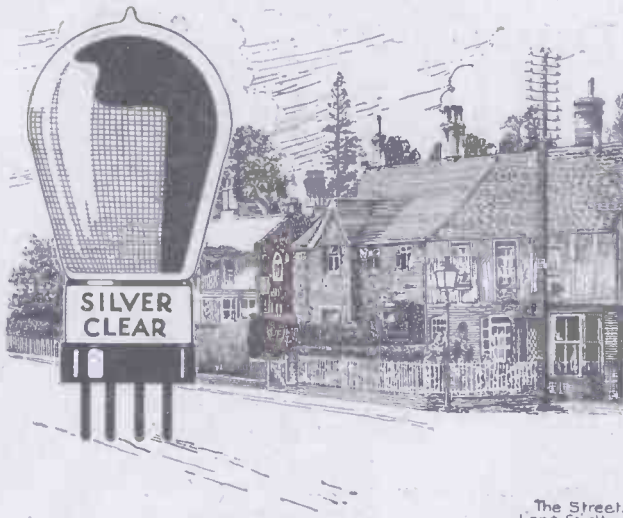

"The two original valves have been working all the time."

Mr. P. Hearn, of Long Stratton, has had over 12 months satisfactory use from the two Louden Valves in his Little Giant Set. Like all other Louden Valve users, Mr. Hearn is highly satisfied with the results, and he shows it by ordering two more Loudens.

Read what he says:—

"Dear Sir,
 "Enclosed please find P.O. for 9/6. Please forward, if possible by return, two Louden Valves (F1 at 4/6 each).
 "My 'Little Giant' two valve set has now been in use for twelve months, and has given me every satisfaction. The two original valves have been working all the time.
 "I feel that everything that bears the stamp of 'Fellows' is worthy of recommendation, and it gives me pleasure in being able to thus express my satisfaction.
 Yours truly,
 P. HEARN (Long Stratton)."

Louden Valves are made by British labour in a British factory with British capital and can be depended upon for the finest volume, range and silver clearness. They can only be offered at such low prices because of our well-known policy of selling direct to the public and cutting out the middleman's profit.

The list below gives prices and full particulars. Order your Louden Valves from us by post.

4/6	8/-	8/-
Bright Emitters. L.F. Amplifier. F.1. H.F. Amplifier. F.2. Detector. F.3.	Dull Emitters. L.F. Amplifier. L.E.R.1. H.F. Amplifier. L.E.R.2. Detector. L.E.R.3.	Dull Emitters. L.F. Amplifier. F.E.R.1. H.F. Amplifier. F.E.R.2. Detector. F.E.R.3.
5.5 volts 0.4 amps.	2 volts 0.2 amps.	4 volts 0.1 amps.
9/-	11/-	12/-
Dull Emitters. L.F. Amplifier. F.E.R.1. H.F. Amplifier. F.E.R.2. Detector. F.E.R.3.	D.E. Power Valves. Trans. Amplifiers P.E.R.1. Resist. Amplifiers P.E.R.2.	D.E. Power Valves. Trans. Amplifiers P.E.R.1. Resist. Amplifiers P.E.R.2.
6 volts 0.1 amps.	4 volts 0.2 amps.	6 volts 0.2 amps.

Postage and packing: 1 Valve, 4d. 2 or 3 Valves, 6d. 4, 5 or 6 Valves, 9d.

FELLOWS, PARK ROYAL, N.W.10.

Branches:

LONDON: 20, Store Street, Tottenham Court Rd., W.C. (Museum 9200).
 BIRMINGHAM: 248, Corporation Street (Central 435).
 BRIGHTON: 31, Queen's Road (Brighton 899).
 BRISTOL: 36, Narrow Wine Street (Bristol 7972).
 CARDIFF: Dominions Arcade, Queen St. (Cardiff 7685).
 LEEDS: 65, Park Lane (Leeds 21479).
 MANCHESTER: 33, John Dalton Street (Central 1164).
 NEWCASTLE: 36, Grey Street.
 NOTTINGHAM: 30, Bridlesmith Gate (Nottingham 5551).
 TONBRIDGE: 34, Quarry Hill (Tonbridge 172).

WRITE FOR
 48 pp.
 ILLUSTRATED
 CATALOGUE
 No. 33 FREE.

BUY DIRECT AND SAVE MONEY

L. P. S. 52.



No. 1

Things are not always what they seem.

"The Cowl does not make the Monk"

"THINGS are not always what they seem," says the old adage. A man may wear cloak and cowl, yet who can tell he is of the Monastery—until he probes beneath. Who knows but that the sacred cowl may be but the shield of an impostor? Is there a "Judas" in your Wireless Set? Those constant cracklings and that worrying weakening of your signals—where do you suspect, lies the culprit? You examine the components, check over the wiring—everything seems correct. Are you sure of the fixed Condenser? Of all the faults in a Receiver more are traceable to the fixed condenser than to any other component. Yet you buy it on faith: you may have the choice of two Condensers—alike in outward appearance, except that one bears the name "T.C.C." stamped upon its case. The unnamed condenser may be nothing but a case shielding inferior materials and bad workmanship—an impostor. To buy such is false economy.

Although to buy T.C.C. may cost a few pence more in the first place, it will assuredly save you time, money and temper, for when you buy a T.C.C. Mica or Mansbridge Condenser you obtain a product behind which is the experience of England's Condenser pioneers. Because only the finest materials available are used, by men with more-than-a-score years' experience in Condenser manufacturing, you know you are buying a Component whose capacity is guaranteed to be within an ace of accuracy, and that your set will be entirely free from leakage and all other condenser-troubles.

T. C. C. Mansbridge Condensers are priced from 2s.0d. upwards; Mica are from 2s. 4d.

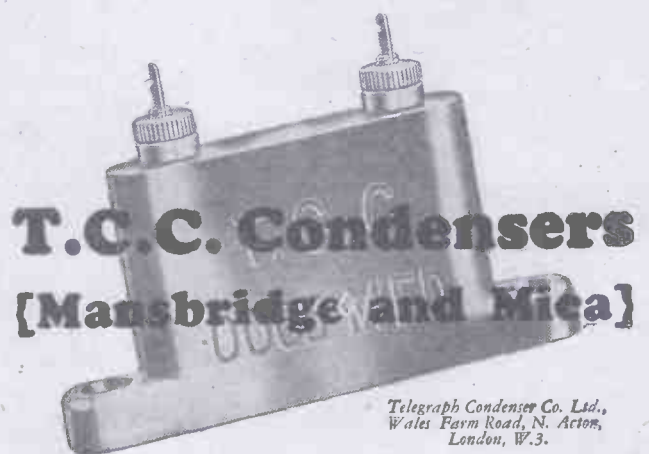

Telegraph Condenser Co. Ltd.,
 Wales Farm Road, N. Acton,
 London, W.3.

G. A. 6619

These are the 'phones that B. T. H. build.



15/ PER PAIR
(OUTSIDE IRISH FREE EXPORT)



This is the diaphragm, smooth, unfrilled, Used in the 'phones that B.T.H. build.



These are the poles, ground square and true, That draw the diaphragm, smooth, unfrilled, Used in the 'phones that B.T.H. build.



This is the magnet, hidden from view Behind the poles, ground square and true, That draw the diaphragm, smooth, unfrilled, Used in the 'phones that B.T.H. build.



These are the spools, with wire wound, That help the magnet, hidden from view Behind the poles, ground square and true, That draw the diaphragm, smooth, unfrilled, Used in the 'phones that B.T.H. build.



These are the leads, sinuous, sound, Connecting the spools, with wire wound, That help the magnet, hidden from view Behind the poles, ground square and true, That draw the diaphragm, smooth, unfrilled, Used in the 'phones that B.T.H. build.



This is the body of good Fabrolite, Whence come the leads, sinuous, sound, Connecting the spools, with wire wound, That help the magnet, hidden from view Behind the poles, ground square and true, That draw the diaphragm, smooth, unfrilled, Used in the 'phones that B.T.H. build.



This is the cap, both light and tight, Which screws on the body of good Fabrolite, Whence come the leads, sinuous, sound, Connecting the spools, with wire wound, That help the magnet, hidden from view Behind the poles, ground square and true, That draw the diaphragm, smooth, unfrilled, Used in the 'phones that B.T.H. build.



This is the stirrup, of screws quite bare, Holding the cap, both light and tight, Which screws on the body of good Fabrolite, Whence come the leads, sinuous, sound, Connecting the spools, with wire wound, That help the magnet, hidden from view Behind the poles, ground square and true, That draw the diaphragm, smooth, unfrilled, Used in the 'phones that B.T.H. build.



This is the headband, easy to wear, Attached to the stirrup, of screws quite bare, Holding the cap, both light and tight, Which screws on the body of good Fabrolite, Whence come the leads, sinuous, sound, Connecting the spools, with wire wound, That help the magnet, hidden from view Behind the poles, ground square and true, That draw the diaphragm, smooth, unfrilled, Used in the 'phones that B.T.H. build.

for NATURAL TONE & PERFECT COMFORT



HEADPHONES

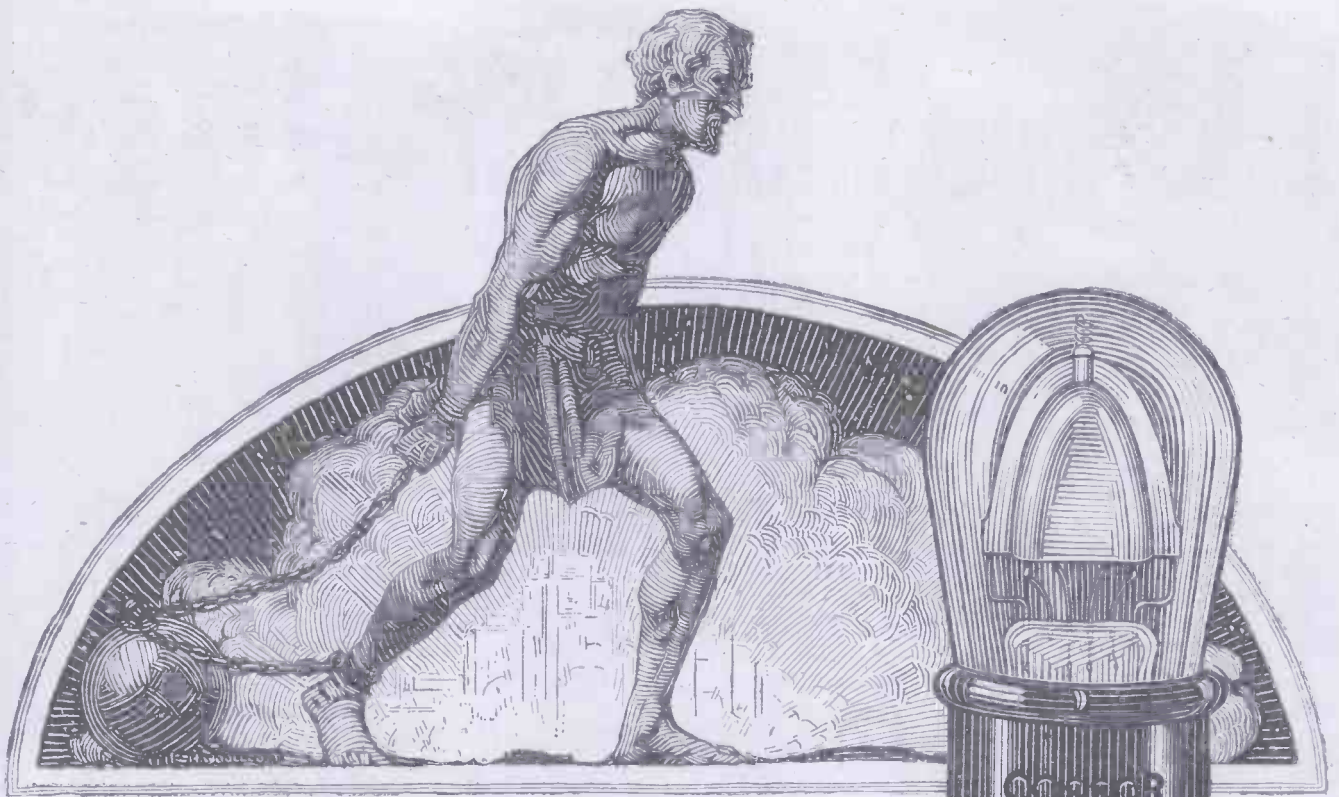

HEAT

—shackled and harmless—
cannot damage the new
Cossor Kalenised filament

H EAT is a good servant but a bad master. When Heat gets the upper hand he commences to play havoc. Particularly does this apply to metals. The moment a metal gets excessively hot its molecules get distorted. It begins to crystallise—or in other words—becomes brittle. And brittle metal is easily fractured. Look at the damage Heat can do when he is let loose in a valve. That slender thread of metal which we call the filament becomes incandescent. It is always expanding and contracting. No wonder it has a short life. In fact, it is a marvel that the filament in the ordinary valve lasts as long as it does. But now a filament has been produced which operates practically without heat at all. It

is the new Cossor Kalenised filament. The familiar glow is entirely absent. But the torrent of electrons emitted is hundreds of times greater than that given off by an ordinary filament.

The Kalenised filament is one of two fundamental improvements pioneered this season by Cossor. The other is Co-axial Mounting. Under this system all Cossor valves in the same class are absolutely uniform. The filament, grid and anode are secured in permanent alignment proof against individual movement even under the severest blow.

When you buy a Cossor Point One therefore, you obtain not only an abnormal length of service, but a higher standard of performance than has ever before been possible.

*“The Valve which
serves you longest”*

In three types

Red Band
For H.F. use
1.8 volts 1 amp. . . . 14/-

Black Band
The Detector
1.8 volts 1 amp. . . . 14/-

Stentor Two
Power Valve
1.8 volts 15 amp. . . . 18/6

A. C. Cossor Ltd.,
Highbury Grove, N.5.

Cossor Point One

Popular Wireless

Scientific Adviser:
 Sir OLIVER LODGE, F.R.S.
 Technical Editor:
 G. V. DOWDING,
 Grad.I.E.E.
 Assistant Technical
 Editors:
 K. D. ROGERS,
 P. R. BIRD.



Editor: NORMAN EDWARDS, M.Inst.R.E., M.R.S.L., F.R.G.S.

Consultants:
 Dr. J. H. T. ROBERTS,
 F.Inst.P.
 J. F. CORRIGAN, M.Sc.,
 A.I.C.
 O. E. FIELD, B.Sc.
 E. J. SIMMONDS,
 M.I.R.E., F.R.S.A.

RADIO NOTES AND NEWS.

Television and Twins—Those Versatile Loud-speakers—Morning Broadcasting—Russian Radio—Marconi's Historic Experiments—Wavelength Revision.

The Weekly Tonic.

THE dark days before Christmas." The phrase was invented, of course, long before "P.W." appeared in the solar system, and now no longer applies. How can it? With "P.W." for enlightenment and a "P.W."-designed receiver in full shouting order, the days are merry and bright. So let's keep the home valves burning—and hang dull care.

Free Wireless for the Blind.

IT is appropriate to note after that, that Captain Ian Fraser's Bill on behalf of blind persons was passed by the House of Lords in a gallop. Naturally! A distinguished foreigner said to me, the other day, "The finest trait of the English people is that they are at all times so human."

Television and Twins.

MR. J. L. BAIRD, the inventor of a very promising system of television, has been lecturing at Newcastle-upon-Tyne under the auspices of the Northumberland and Durham Group of Radio Associations. I presume the subject was strictly television, and not coal. I have been amused by the pictures which have appeared showing Mr. Baird demonstrating his apparatus, for he uses the heads of two ventriloquists' dolls of engaging countenance. Can it possibly be that these twin gargoyles represent Mr. Baird's idea of the average broadcaster's beauty? John Henry will set Blossom on to him if my fear should be realised. Ah, well!

Oslo Looks and Listens.

A VERY interesting claim that the problem of broadcasting pictures has been solved, comes from Oslo. The inventor of the system is the government's chief telegraph engineer, and he claims that it can work with long or short waves, or from a crystal set. Scenes in a broadcasting studio have been successfully transmitted to "listeners" who were supplied with specially prepared paper upon which the pictures were reproduced.

Have You Heard These?

THIS week's Explorer: The tired man who said he was looking for a portable accumulator.

This week's Inventor: The man who is trying to devise a means of preventing valve filaments from heating up, and a silencer for loud speakers.

This week's Cheerful Ass: The man who asked whether if he gave up the gramophone in favour of wireless his 12-inch records would fit a 3-valve set.

Those Versatile Loud Speakers.

A PROPOS my recent note about the lady at Yarrow, whose sigs pierced the ear like an arrow—no! whose loud speaker changed its tune when it



2 L O's Foreign Announcer, Mr. R. C. Michaelson, who speaks French, German, Swedish, Norwegian, Dutch, Danish, and Spanish!

changed its room, a Manchester reader reports a similar effect. In one room he can get Frankfurt, but on moving the loud speaker to the next it cannot do better than Birmingham.

Well, if you saw the wallpaper that some people live with—

Anyway, I can beat that, for it is a fact that when I take my loud speaker into the next room it becomes dumb. I shall have an extension fitted one day, however.

A Modern Alexander.

THAT indefatigable transmitter, Mr. Gerald Marcuse, has added to his laurels by "putting across" a two-way communication with Singapore. As Singapore is about 4 degrees north of the Equator, and is in one of the worst places on earth for X's, Mr. Marcuse and his Straits friend deserve congratulations from all amateur and professional ether-shakers. If this sort of thing goes on much longer, Mr. Marcuse will, like Alexander the Great, be miserable for more worlds to conquer. But there remains Mars, Mr. Marcuse, so we look to you.

Morning Broadcasting.

A CYNICAL friend told me at the time morning broadcasting started from 5 X X, that it would soon degenerate into a sort of rehearsal for the evening programmes; and that nobody would listen to morning programmes regularly.

Time has falsified the prophecy, for a tremendous number of "shut-ins" and invalids now enjoy Daventry's morning fare, precisely because it comes at the loneliest period of the day. The standard, too, is high; though the programmes are bound to lack that "pep" that comes only with the big audience of evening.

What's Wrong with G.M.T.?

A CORRESPONDENT to a daily newspaper caused me to neigh uproariously by complaining that the B.B.C.'s time signals are not reliable. I had an idea that the Greenwich Observatory supplied quite a good brand of *tempus*, and in my innocence I have always altered my watch when it has not agreed with the flippant "pip pip" from 2 L O. It never struck me that the Astronomer Royal might be nodding, and that my Ingersoll was incorruptible. Anyway, if the complainant has his own observatory, why should he trouble to take B.B.C. time?

(Continued on next page.)

NOTES AND NEWS

(Continued from previous page.)

South Africa's Ups and Downs,

BBROADCASTING in South Africa is not in a flourishing condition commercially, judging from reports which reach me, and I learn that the deficit of the Durban station increases at a rate calculated to give a chartered accountant double entry paralysis. Technically, however, South Africa is a whale. Take the Cape Town station, for instance. The "Cape Argus" states that during the past year this transmitter, out of 1821 hours of service, broke down for a total of only 2 hours 32 minutes, or 0.137 per cent. That is good going, but it is to be noted that of this period 68 minutes are accounted for by failure of power supply. During the year only one valve has been replaced. The air there is evidently not dangerous to engineers.

Russian Radio.

RRADIO seems to appeal strongly to the Russians. There are said to be now about 1,500,000 listeners—they are peasants for the greater part—and 300,000 amateurs. Very roughly speaking—for the population of Russia is a statistic one has to be trusting with—this works out to one listener per hundred head of Bolsheviks. I shall suggest to the Editor the desirability of a Russian edition of "P.W." How he would enjoy reading over the proofs!

Twenty-fifth Birthday of Long-distance Wireless.

SSUNDAY, Dec. 12th, was the 25th anniversary of the experiments carried out by Senatore Marconi between Poldhu, Cornwall, and St. John's, Newfoundland, during which he succeeded in receiving intelligible Morse signals across the Atlantic ocean, a feat the report of which was received with scepticism in some quarters. Nowadays, however, the general public are so attuned to the apparently miraculous, that each new achievement is taken almost as a matter of course.

Marconi's Historic Experiments.

THE aerial at Poldhu was first erected on a ring of masts each 200 feet high. These were blown down in a gale and another aerial had to be put up at break-neck speed; it consisted of a fan of sixty bare 7/22 tinned copper wire suspended from a triatic slung between two 170 feet masts. Meanwhile, in Newfoundland, Marconi and his assistants, rather than waste time in erecting masts, were experiencing the dubious joys of maintaining an aerial aloft by means of kites and balloons. One can imagine the struggle they had—in winter on the Newfoundland coast!

An Interesting Diary.

IHAVE had the luck to secure a few extracts from the diary kept in December, 1901, by Mr. G. S. Kemp, one of Mr. Marconi's assistants at St. John's, and I will quote several entries.
Dec. 10th.—Flying No. 1 kite with 600 ft. of aerial wire.
Dec. 11th.—Sent up No. 1 balloon; Mr. Marconi at the receivers and calling me in to assist at intervals. Lost this balloon in a squall at 3 p.m.

Dec. 12th.—Flying No. 1 kite with twin wires each 500 ft. long. *Lost this kite in a squall after first-hour. Then got up No. 2 kite and kept it up for three hours; received perfect signals to-day.* (My italics.)

Dec. 13th.—"Graphic" artist made a sketch of receiving-house, etc. Flying No. 2 kite and received more signals, but not so good as yesterday. Lost this kite at 2:30 p.m., a squall taking it to sea.

TECHNICAL TERMS ILLUSTRATED.

The Connection.

THE recent outbreak of infection The new doctor regards with affection.
"Till then," he told me,
"I had scarcely one fee,
Now I've worked up a splendid



A Lesson to Learn.

AFTER that, with all the disappointments and difficulties it leaves unrecorded, but which must have been terrific, let us not register undue emotion if, in the process of putting up our tuppenny aerials, the hammer should strike the thumb. Suck the member and think of kites.

A Query.

ACORRESPONDENT tells me that he sees many references in the Press to "Electricity Bill," and is anxious to know whether this is a colloquialism for "Wireless Willie."

The Latest Wave-length Revision.

THE B.B.C. announces that sufficient data has now accumulated to render possible the considerations of what modifications in the recently-altered wave-lengths are necessary. As regards Great

SHORT WAVES

What do they know of England who stick to 2 L O P—"Daily News."
The question is, of course, a "capital" one.

If the Martians really can pick up wireless rays from this earth, perhaps this explains the reason for some of these unearthly radio programmes.—"Passing Show."

Wireless Programme.—9 o'clock: Dance Music. "She was a Sailor's Sweetheart," "Who?" "Sunny." "Are you sorry?"

According to D.O.R.A. one must not buy tripe after eight o'clock at night. The B.B.C. should be notified of this.

We hear reports of a crime-wave, and a daily paper remarks that "Modern criminals are making constant use of wireless telephony." It would be interesting to know what crime wave-length they are using.—"Punch."

"I am not," says Mr. Boosey, "uncompromisingly hostile to broadcasting music."—"Evening Standard."
That IS good news.

Quite a soleful experience befell a listener while fishing from a moving yacht in the Solent. He wrote to the Station Director at Bournemouth: "We had a record catch—42 dozen all told—which we put down to the splendid concert you gave us."—"News of the World."

Mistress: "Do you listen-in, Mrs. Jones?"
Charlady: "No, ma'am. I should hope not! I've worked for lots of ladies in my time and am proud to say none of 'em ever caught me with my ear at the keyhole."

Britain, the experiment of working Aberdeen and Birmingham on one wave-length was not considered a success, and it was decided to raise the wave-length of Aberdeen to 500 metres, though some interference on this wave is still to be expected.

Recent Changes.

BELFAST and Bournemouth have exchanged wave-lengths, and of the relay stations which share the 288.5 metres wave, some still retain that wave-length.

Present Wave-lengths (dating from Dec. 5) in metres: Daventry, 1600; Aberdeen, 500; Birmingham, 491.8; Glasgow, 405.4; Manchester, 384.6; London, 361.4; Cardiff, 353; Bournemouth, 326.1; Newcastle, 312.5; Belfast, 306.1; Edinburgh, 294.1; Liverpool, 297; Bradford, 254.2; Leeds, 277.8; Nottingham, 275.2; Sheffield, 272.7; Plymouth, 400; Hull, Stoke, Dundee, and Swansea, 288.5.

B.B.C. Dinner.

ON December 17th the B.B.C. entertain the Governors of the B.B.C. Corporation to dinner at the Metropole Hotel, the Prime Minister being the guest of honour. No doubt we shall learn in due time how the affair passed off, but I imagine the meeting of the old and new authorities will be fraught with a certain quality of piquancy. I wonder, too, whether any thought will be given to the great, palpitating body outside the Metropole which is known as "the listener's"?

Mr. T. Thorne Baker to Lecture.

ON December 17th, at the Albert Hall, Leeds, at 7.30 p.m. Mr. T. Thorne Baker, the inventor of the well-known system of photo-telegraphy bearing his name. Subject, "his system, with demonstration. Seats: Apply "Yorkshire Evening News" (Wireless Editor), Leeds. Seats gratis. Will friends accept this notice, etc.

Progress with Imperial Beams.

TESTS between England and Australia on the beam system have begun and, according to reports from Melbourne, the results are apparently most satisfactory. These tests are, however, preliminary ones conducted by the Marconi Company, the contractors; the official tests will probably not be undertaken till late this month, and if these are satisfactory we may look for the service to be opened in March.

What is the B.B.C.'s Job?

IHOPe you noticed that the other day a speaker at the 2 L O "mike" told us that the B.B.C. had decided to publish a book giving the names of places the pronunciation of which is not in accordance with the spelling. He even asked us to help on that beneficent enterprise by sending in such names as we might know. I don't think that the public pays the expenses of the B.B.C. for the purpose of encouraging the publication of books, especially books which do not matter.

I foresee—but I won't curdle your blood with my acute imagination. Let's hope the Directors of the B.B.C.'s successor will earn their—our money.

Adios—and don't enbarrass us with so many compliments about our last week's Christmas number, please.

CRYSTALS IN VALVE CIRCUITS



By H. C. RYLATT.

Some interesting circuits in which a crystal is used for rectification.

SOME little while ago there appeared in this journal an article from the pen of Lieut.-Commander Shove, R.N., in which a plea was raised for more originality

though occasionally the anode bend method of rectification is employed.

Broadly speaking, the function of a rectifier is to suppress each alternate half cycle of the incoming wave, and to secure undistorted reproduction this should be accomplished without the introduction of parasitic currents. For this reason the crystal detector is unequalled for purity of signals. Next in order of signal quality comes the valve operating on the lower bend of the anode curve: in sensitivity there is not much gain over the crystal, although an increase of signal strength is obtained owing to

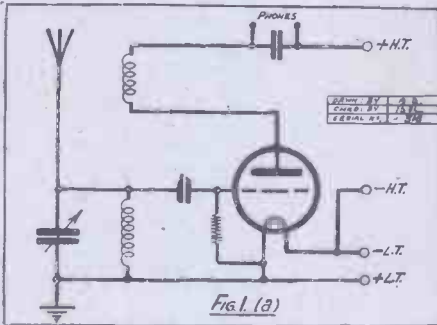

Fig. 1 (a)

in the design of radio receivers. It seems unlikely that any radical change in the design of the average receiver may be expected for the present, chiefly owing to the childlike faith with which so many amateurs embrace the creed of the straight receiver. There are, however, many ways in which even this type of circuit can be improved and an existing set may be made more sensitive and selective and capable of purer reproduction.

Better Rectification.

Of course, there are other ways in which the performance of a set may be improved, but it is the writer's present purpose to deal only with the question of rectification. In valve receivers (reflex circuits are outside the scope of this article) rectification is invariably obtained by the action of a valve, usually operating on the leaky grid principle,

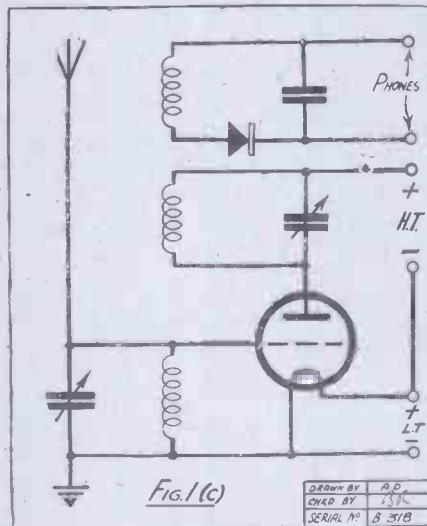

Fig. 1 (c)

DESIGNED BY A.D.
CHECKED BY J.S.K.
SERIAL NO. B 3118

the natural amplification of the valve.

Finally, we have the leaky grid valve detector, which is in the greatest favour owing to its great sensitivity, but unfortunately this method fails to give pure reproduction owing to the introduction of parasitic currents in the grid circuit, due to the fact that rectification occurs most readily when the

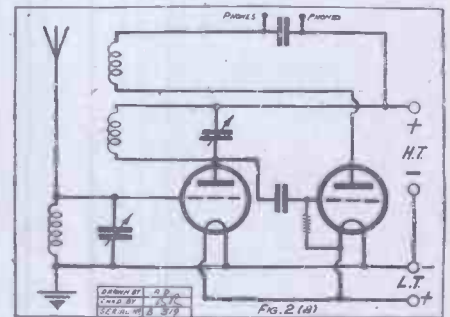

Fig. 2 (a)

grid is made permanently positive by connecting the grid leak to the positive end of the filament, under which condition grid current is bound to flow.

In view of these facts it appears to the writer that a considerable increase in selectivity, sensitivity and purity can be effected in almost any type of valve circuit with little additional outlay and no increase in running costs. The circuits illustrated are those commonly in use, with the modifications necessary to permit the use of a crystal.

Some Tested Circuits.

No L.F. amplification is indicated, as this is a matter for individual taste, but any standard form can be added, though it is desirable that a good make of high ratio (from 5:1 to 8:1) should be used between the crystal output and the first L.F. valve.

(Continued on next page.)

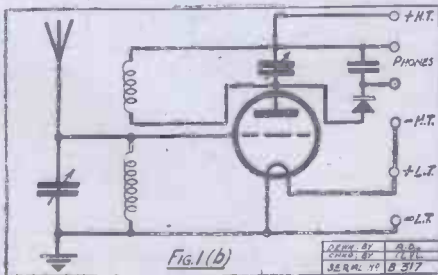

Fig. 1 (b)

DESIGNED BY A.D.
CHECKED BY J.S.K.
SERIAL NO. B 3117

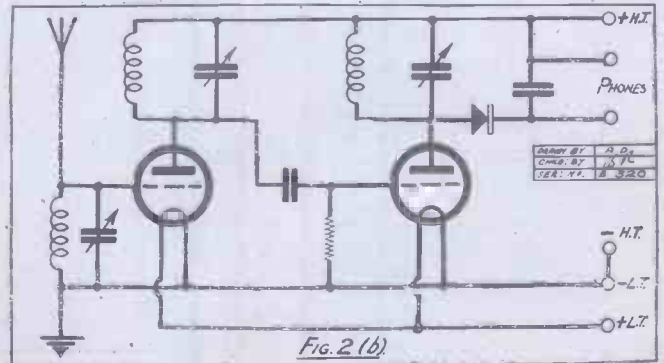

Fig. 2 (b)

DESIGNED BY A.D.
CHECKED BY J.S.K.
SER. NO. B 3120

CRYSTALS IN VALVE CIRCUITS.

(Continued from previous page.)

Fig. 1 (a) shows an ordinary valve detector with magnetic reaction; Fig. 2 (b) is an H.F. amplifier with reaction and a crystal rectifier.

Owing to the L.F. circuit, consisting of crystal and headphones, being shunted directly across the tuned anode circuit, a certain amount of damping occurs, resulting in a slight loss of selectivity. This can be obviated by using a third coil coupled to the tuned anode as in Fig. 1 (c). This circuit will be found far superior to Fig. 1 (a) and Fig. 1 (b), having a good reception range as well as sharp and selective tuning characteristics.

Alternative Arrangements.

Fig. 2 (a) shows a straight H.F. and detector, which may be converted as shown in Fig. 2 (b), (c) and (d). The converted circuit as shown in Fig. 2 (b) suffers from the same damping effects as mentioned in connection with Fig. 1 (b), though, owing to the existence of two preceding tuned circuits this is not so noticeable. The anode coil of Fig. 2 (c) consists of the primary winding of an ordinary H.F. transformer, the secondary winding having the detector and 'phones shunted across it. An aperiodic transformer may be used in this part of the

The circuit most favoured by the writer, who lives almost under the shadow of a coast station, is shown in Fig. 3. This was designed after much experimental work in

All the true poets, saints, and sages were the same. Look at Longfellow. If his aerial-support broke away from the chimney, and the roof was too slippery with snow and frost to climb, would he repine and grumble and grouse? Not he!

"I shot an arrow into the air," he says. Every listener who has flung a potato over the roof in a similar predicament will admire his ingenuity. Longfellow, too, would have had the highest aerial he could get. (And a regular long-fellow, at that.)

Truly interpreted, history is full of instances of the importance of the aerial. Right in the early days of Christmases, we have the case of Good King Wenceslas, as you have read:

Good King Wenceslas looked up
How-to-make directions.
Still he could not find the fault
In his grid connections.
Brightly shone his valves that night,
But his grief was cruel,
For he could not get a sound
From his 3-valve Dual."

If the first grid had been connected to the aerial properly, the trouble would never have arisen.

Omar's Portable Set.

Then there was the case of Omar Khayyam. He did not spend his Christmas—or the Persian equivalent—hanging about "In a Persian Garden," but he got right out with his portable set, and rigged up an aerial to the nearest tree. You remember he describes it:

"Here, with a loaf of bread, beneath the bough,
A book of verse, a flask of wine, and Thou
Beside me, singing in the wilderness.
And wilderness is Paradise now."

"Thou," of course, refers to the loud speaker, and he got beneath the bough because his aerial was fixed to it.

Finally, there is the good old phrase: "Yule Log." Many historians have tried to explain Yule Log, but surely the explanation is the simple wireless one—unless you keep your aerial up you'll log no distant stations!

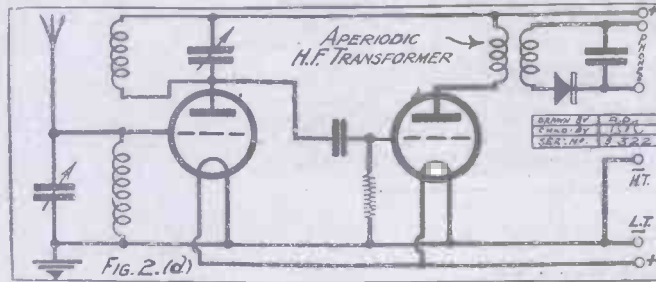

search of a circuit which would give a large range of available programmes on the loud speaker, and the writer's tuning chart shows over thirty stations which are considered reliable for loud-speaker reception.

AERIALS—AND CHRISTMAS.

SOME people pretend that aerials are out of place at Christmas. That they are too scientific—not in keeping with the fine old festival.

They prefer to believe in Santa Claus, and keep up the legend of his appearance amongst

the chimney-pots. But, consider, what is an aerial if it is not a kind of *Father Christmas come true*? Like him it rides over roofs and between chimney-pots. Like him it represents good cheer, and companionship, even for the loneliest in the land. Like him, too, it is time-effacing, distance-dispelling. Could anything be more true to the spirit of Christmas?

Charles Dickens would have had an enormous aerial up if he had been alive to-day. As it was, aerials were unknown, but he tried his hardest to get a better Earth.

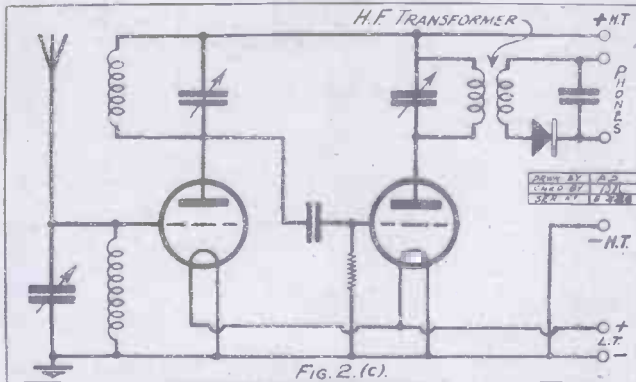

circuit with some advantage, however, the tuning controls being brought more within reasonable limits. See Fig. 2 (d).

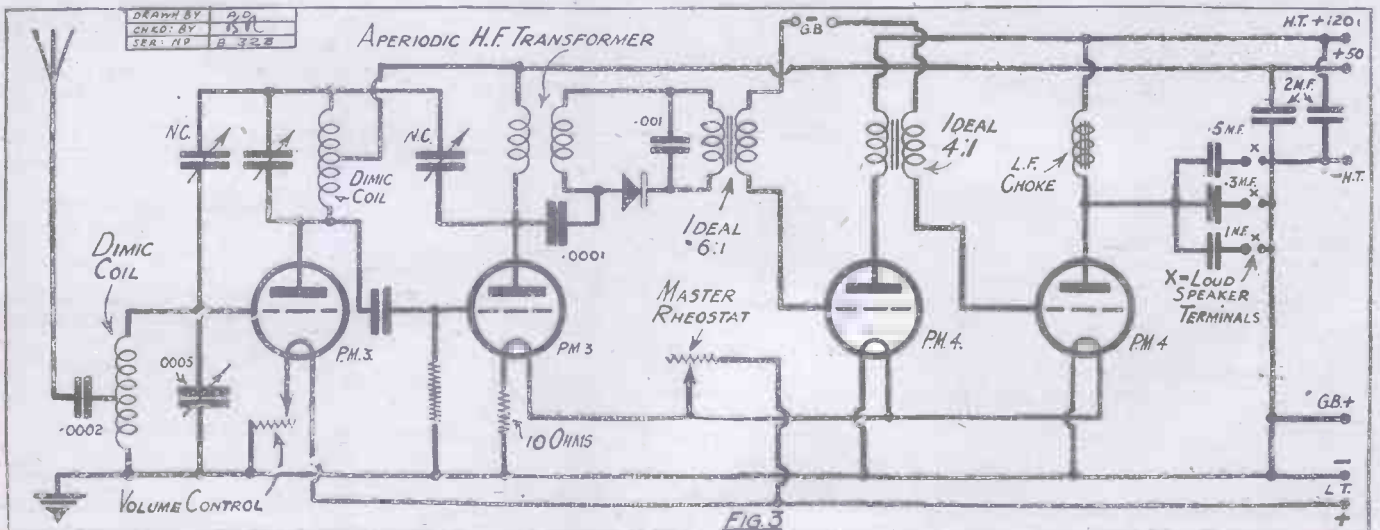

FURTHER NOTES ON THE HALE CIRCUIT.

Some more details concerning one of the most popular circuits "P.W." has ever published.

By PERCY W. HARRIS, M.I.R.E.

THE remarkable popularity and success of the "Hale" circuit has brought me a very large volume of correspondence and quite a number of queries from readers who have not yet obtained success with the arrangement. It has been quite impossible to reply to each querist individually, for if I were to do so my whole day would be occupied in correspondence. However, in this article I suggest a few arrangements which may be tried to overcome a few difficulties.

Grid Bias Essential.

First of all, I must again emphasise the importance of grid bias in this circuit. A number of readers have written to say that they get far better results with the cat's-whisker removed from the crystal face, or in the case of a permanent detector when the two crystals are separated, and a number have expressed great surprise that signals can be received at all in such conditions. Without grid bias, or with very tight reaction the valve will not only amplify but also detect, although the results obtained in this way are far inferior from those yielded when the set is functioning properly. If all is well with the circuit no signals will be heard when the crystal contacts are separated, and signals will be very loud when they are brought together.

It is, then, essential to make sure that the valve is acting purely as an amplifier (both high and low frequency) and *not* as a rectifier. The use of grid bias is essential in such circumstances, and if you are not yet using it this may overcome your difficulties. Again, it must not be forgotten that the crystal itself introduces a considerable

amount of damping, and in some circumstances may introduce so much damping as to make it practically impossible to bring the set near the oscillation point. Aerial damping also has a considerable effect, and in the case of some aerials this factor may be the cause of the trouble.

In all cases where the set cannot be made to oscillate at all, or where it will only oscillate with very tight reaction and then stop suddenly, try a lighter adjustment of the cat's-whisker or a permanent detector. Most of the permanent detectors use a perikon combination or something similar

crystal as with the normal arrangement, and some care is necessary in finding the best position.

Reversing the connections to the crystal often effects considerable improvement, particularly in the smoothness of reaction, and as the construction of low-frequency transformers varies between different makes, the effect of reversing I.P. and O.P. can also be tried. In some transformers I have found that leaving the primary terminal which had previously been connected to the aerial, quite free, has improved signals, while in other transformers the opposite result has been found.

Another cure for trouble in the Hale

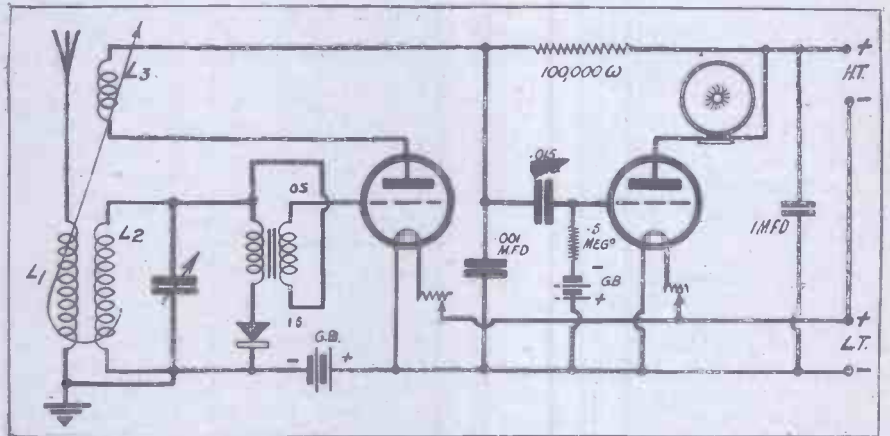

How to add a resistance-coupled stage to the "Hale" circuit.

to it, and experience goes to show that the perikon type of detector is the best in the Hale circuit.

This point has been confirmed by some experiments Mr. Hale himself has conducted within the last week or two, although with care excellent results may be obtained with the whisker type. However, compared with the ordinary circuit, it will be found that there are not so many good spots on the

circuit through lack of oscillation is the placing of a series condenser of, say, .0001 or .0002 mfd. in the aerial lead. This has the effect of considerably reducing aerial damping in cases where it is too great for satisfactory working. A similar effect will also be obtained by using a semi-periodic aerial coupling as it is generally termed—that is to say, placing a coil in the aerial without any other tuning device and coupling to it the grid circuit. Several readers have found that this series condenser has effected great improvement.

Resistance-Capacity L.F.

In those cases where results have been disappointing on Daventry it will generally be found that excessive damping set up by the crystal is the cause. Where you have two or three coils, all of which will tune to Daventry with different condenser readings, you will generally find that the coil which requires most capacity across it will give the best result.

Several readers have asked whether it is possible to add resistance amplification to the original single valve Hale circuit, the purity of which has pleased them far more than any other set they have tried. The addition of resistance capacity amplification is quite easy, and is illustrated in the diagrams accompanying this article.

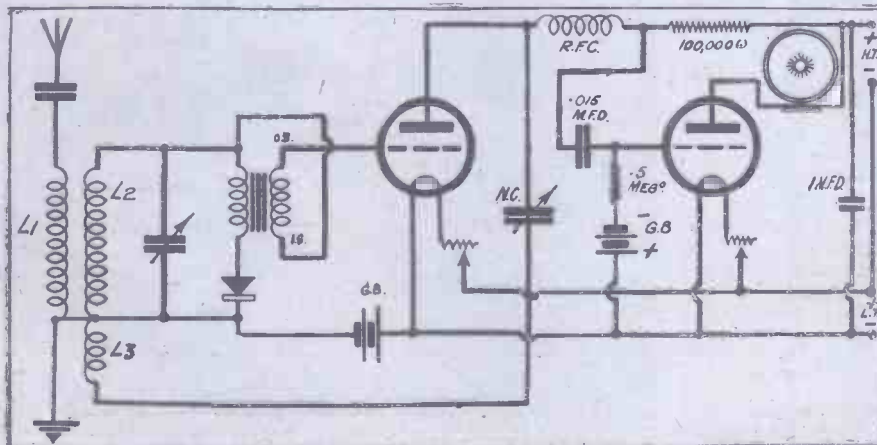

"Reinartz" reaction and resistance amplification with the "Hale" circuit.



By H. J. BARTON CHAPPLE, Wh. Sch., B.Sc. (Hons.), A.C.G.I., D.I.C., A.M.I.E.E.

"WHAT is all this talk about wireless components being made to conform to low-loss principles, and does my receiving set lack the essentials?" This is a question that is often put to me by people when we are indulging in a friendly discussion on the problems of wireless. Perhaps there are readers of this journal who on the one hand find themselves faced with a similar question, or on the other hand are themselves in the dark as to what is actually meant by low-loss coils, low-loss condensers, etc. No doubt all the visitors to the recent National Radio Exhibition at Olympia were struck with the enormous strides which have been made in the construction of wireless components during the past year. More attention is being paid to detail, indeed some of the components have undergone radical changes in their construction.

What is to be deplored is that the efforts of many wireless engineers have been misdirected through a failure to understand thoroughly where the problems of low-loss begin and where they end. Let us then take a brief survey of the principal components and see where these losses are likely to occur, and what steps must be taken to avoid them. Complete harmony must exist between the coils, condensers, valve holders, transformers, etc., that together make up our receiver, and if one of the components is "shoddy" it is possible that it will have the effect of upsetting the whole performance of the receiver.

Low Loss Condensers.

In any variable condenser, whether it be S.L.F., S.L.W., or S.L.C., the possible losses are not accounted for from one particular source, but are due to a variety. Naturally, material of the finest quality should be used in constructing the condenser, while the fixed and movable plates ought to be made from a non-oxidisable metal. Any oxidation on the plate surface not only upsets the capacity calibration, but introduces losses and collects dust. Contact resistance between the moving plates' spindle and the connecting terminal often causes a relatively serious loss, and the connection is usually best carried out by means of an insulated pigtail or thin spring. The insulating material—the seat of what is known as the dielectric losses—must be reduced to a minimum, and located as far

outside the field of the condenser as possible. Now for the purposes of comparison the losses in a condenser can be looked upon as being due to a resistance in series with a perfect condenser of the same capacity, and with condensers of reputable make this equivalent resistance value is always less than half an ohm. Thus when we consider that the variable condensers are used in conjunction with coils whose high-frequency resistance may run into several ohms, its loss is negligible. Hence it will be appreciated that we can regard the present-day condenser as naturally conforming to the principles of low-loss, provided it does not lack the essentials just indicated.

Concerning Coils.

Coming to the question of coils, we are at once faced with the fact that the resistance should be kept as low as possible—i.e. the high-frequency resistance, in order to reduce the necessity for pushing reaction too far with a view to overcoming this resistance—as this produces instability in the receiver. To keep this resistance low recourse is made to special types of coil mounting and winding, thus reducing the self-capacity of the coil, since this capacity influences the resistance and increases the minimum capacity of the variable condenser employed in conjunction with it. Where possible, single-layer coils are to be preferred and if formers are used they should be of skeleton construction to reduce the amount of dielectric material to the barest minimum, while supports, etc., must have a minimum of metal present.

There is a greater tendency at present

to use finer gauge wire for coils, and while this means that the wire has a higher D.C. resistance per yard, since a given inductance can be wound into a smaller space, thus using less wire, the two effects tend to counterbalance. Where possible, multi-stranded wire is to be preferred for winding coils, as the individual strands are in parallel and the high-frequency resistance is lowered.

With valve holders once more we must stress the point that good quality insulating material, such as ebonite, must be employed while the amount of solid dielectric between the sockets should be kept at a minimum in order to reduce the self-capacity between the individual sockets.

In connection with high-frequency transformers the main problem is that associated with stray magnetic fields, as this contributes in such a large measure to the instability of receiving sets. There are many types on the market now which have been specifically designed to reduce this stray field, and thus the losses will of course be reduced as well.

The Aerial System.

Another important section where losses should be kept as low as possible is in the aerial system. See that a good earth with ample surface is installed with the earth lead properly soldered to it and kept as short as possible, and preferably insulated or mounted on insulators. Induced currents in gutterings, fall pipes, stray wires, etc., due to bad orientation of the aerial wires and down lead constitutes a serious loss, while impure dielectric material such as trees, brickwork, etc., all contrive to reduce the amount of power.

These few notes will have given an indication as to the points to be noted when examining your receiver, components, and associated apparatus, and efforts directed towards their appreciation will ensure that in your own particular case the essentials are not lacking.



Mr. E. Megan of Belfast, who recently carried out some short-wave tests between that city and Montreal on board the s.s. "Carigan Head."

Do Sunspots Affect Our Radio?

A Fascinating Article on a Fascinating Subject:

By J. F. CORRIGAN, M.Sc., A.I.C. (Staff Consultant).

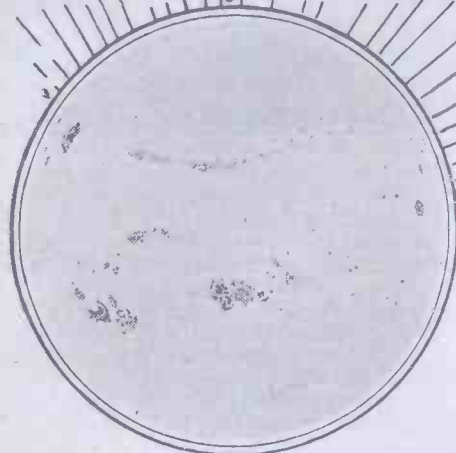

Fig. 1.—Sunspots as seen through a small powered telescope.

THE ever present interest in the subject of "Messages from Mars" has been the occasion of many thousands of curious eyes being directed in upward gazes towards the ruddy planet which during the autumn months has occupied a prominent position in the night sky. Even that most prosaic individual, the man-in-the-street, has at least once or twice been impelled to give a passing attention to the subject.

Messages from Mars?

Mars, they say, is inhabited by a race of intelligent beings. Now, whether there is any truth in this assertion is a matter which present-day science cannot prove. Yet, ever since that considerably far-distant period at which telescopes were first turned skywards, there have always been people who have believed our planetary neighbour to be inhabited by some race of animate beings not unlike ourselves. In recent years, as the reader will probably be quite aware, many attempts have been made to prove the existence of intelligent life on the planet Mars. Indeed, so many redoubtable facts have been brought forward in support of this contention that the whole question has now assumed a status of definitely scientific importance.

In view of facts such as these, and in consequence, also, of the almost endless



A well-known photograph of Mars—the mystery planet.

possibilities which the applications of wireless science hold forth, what is more natural that an explanation for the mysterious signals which have from time to time been picked up by receiving sets should be looked for in the supposed fact that such disturbing signals have their origin on the surface of the planet Mars, and that they in reality represent attempts on the part of the inhabitants of that world to get into some form of communication with us through the agency of radio?

This view—and it is one which has gained a great deal of discussion in authoritative quarters—is, indeed, a very fascinating one, and if the truth of it could be merely proved in general outline, a field of radio research and applications almost endless in scope and in possibilities would at once be opened up.

Hence it is that during the recent weeks many radio enthusiasts have been on the alert and have made attempts to pick up any possible signals which, having an unknown origin, might have their sources ascribed to the planet Mars. Early in November, the planet came within 42,700,000 miles of the earth, a distance, it is true, exceeding by some 8,000,000 miles its distance from the earth two years ago. On the present occasion, however, the planet has occupied a much more favourable position in the sky for observational purposes.

Now, if Mars is inhabited by intelligent beings who, like us, have obtained some degree of mastery over the natural sciences, and if it is possible for radio to span the gulf which intervenes between Mars and our earth, it would be very possible that some attempt would have been made on the part of the Martians to conduct experiments in inter-planetary transmission.

Mysterious Signals.

This is all mere speculation, of course, and, against it, we have to come down to the fact that during recent weeks no even moderately conclusive evidence has been gained to support the above contentions. Hence we may say, or rather tentatively suggest, that, if Mars is inhabited, the occupants of that planet either do not wish to communicate with us, or else they do not possess the ability to do so.

There is still, however, the matter of the mysterious signals which are received on

this earth from time to time. Where do they come from, if their origin cannot be ascribed to the planet Mars? Such signals take the form of fragmentary dots and dashes. Unlike atmospherics, however, they are not received equally on all wave-lengths, but they would appear to preponderate on the higher wave-lengths. Also, in many cases, they have been stated to be very well defined and rhythmical in character.

The Sunspot Theory.

Now, if we do not accept the theory of the Martian origin of these signals, we are bound to look for another source for them. That the signals are due to common atmospherics is not very probable, although there is something to be said in support of the view that they may be due to electrical disturbances taking place at the very limit of the terrestrial atmosphere.



Fig. 2.—A drawing made from observation of the sun through a powerful telescope.

If, however, we refuse to accept the Martian theory of these signals, one of the most likely alternative suggestions which has been brought up to explain them is that which suggests that they may have their origin on the sun itself, and that, like many other natural electrical phenomena, they may be very closely associated with the presence of sunspots.

Let us deal with this suggestion a little more closely. If you look at the sun through a good pair of binoculars (or better still, a small portable telescope), the object glasses of which have been covered with two sheets of dark red glass, the surface of Old Sol will be observed on frequent occasions to exhibit a number of black spots. In fact, the sun's appearance will be something akin to the illustration depicted at Fig. 1, but on a rather less scale of magnification.

(Continued on next page.)

DO SUNSPOTS AFFECT OUR RADIO?

(Continued from previous page.)

These dark spots are commonly known as "sunspots." Their exact nature and causation is unknown, but that their presence on the sun has a great influence on electrical phenomena taking place on the earth is an indisputable fact. Fig. 2 is reproduced from a drawing made with the aid of a telescope of considerable power, and it depicts the appearance of a group of sunspots on a more magnified scale. Fig. 3 presents the greatest interest, however. This is an actual photograph of a sunspot taken through a high-powered telescope.

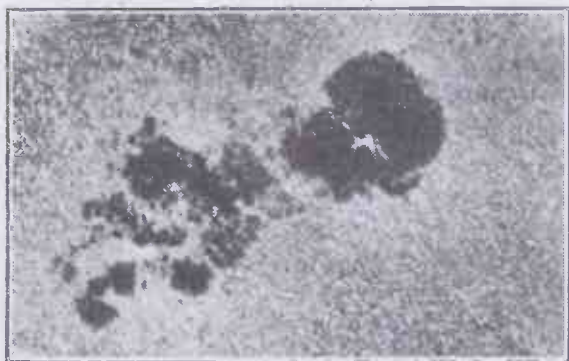

Fig. 3. A remarkable photograph of a portion of the sun's surface, showing the larger sunspots and luminous cloud.

Now, in Fig. 3 each of the small dots with which the background of the photograph is made up really consists of a luminous cloud, not the sort of vapour clouds which we have on earth, but, on the contrary, clouds of highly incandescent gas covering an area of many hundreds of square miles. Such is the constitution of the sun's surface. A sunspot, as will be evident from Fig. 3, is really a hole in the sun's upper surface through which we can look down into the interior of the sun, which interior, although it looks dark in contrast with the brighter and more luminous surface, has a temperature far exceeding that of the electric arc.

Surprising Effects.

Sunspots, therefore, are holes in the sun's gaseous surface. They are not permanent holes, however, for they come and go with very great frequency.

Although the exact causation of sunspots is unknown at present, there seems to be no doubt that they have an electrical origin. As such, they represent vast areas of highly incandescent gases which have been torn apart by stupendous electrical forces. The presence of these spots on the sun has been conclusively proved to affect the stability of magnetic compasses. Sometimes, also, they have put long-distance land telegraphs out of action. Further, they are responsible for electrical disturbances in the earth's atmosphere. How they exert these effects, however, is quite unknown.

In view of these acknowledged facts, therefore, there has now been put forward the suggestion that these sunspots may have something to do with the mysterious signals which have from time to time been received by terrestrial radio sets. The

matter, of course, is completely one of mere speculation and hypothesis, but, nevertheless, there is a good deal to be said for it. In fact, many theorists find it easier to accept the sunspot theory of the mysterious signals than they do the idea that such signals have been originated by a supposed race of highly intelligent beings on Mars.

Unfortunately, however, these sunspot theorists have little or no data to go on. Sunspots have been known and observed for centuries. Wireless reception is barely a quarter of a century old. And so it is that until these sunspot enthusiasts can collect sufficient data concerning both the presence of spots on the sun, and the frequency of the occurrence of the mysterious signals, they will have little or no evidence to go on. Nevertheless, the whole suggestion that sunspots may cause disturbances in wireless reception in this manner is a very interesting one, and also, let it be suggested, a highly possible one.

Observation Needed.

We have still a long way to go in our researches into the electrical phenomena associated with and caused by matter in a highly vaporised and incandescent state. The degree of incandescence at the sun's surface is something like six or seven times as great as that of the



Fig. 4. A photograph of a portion of the Corona taken during a recent eclipse.

brightest electric arc lamp, whilst the temperature of the sun is more than twice as high as the latter. Further, the sun is able to shoot off flames of burning gases to distances of many thousand miles above its surface. These flames are shot off from the sun at a speed exceeding by 200 times the velocity of a rifle bullet. They are only visible to us, however, during a total eclipse of the sun, and at that time they have an appearance similar to that shown in the illustration, Fig. 4.

It is now thought that many of these stupendous solar flames have a great deal to do with the causation of sunspots, and thus they are associated in some way or other with the electrical disturbances taking place on the earth. Whether all these immense influences put together can be shown to give rise to the mysterious radio signals which are sometimes received by terrestrial instruments, or whether the latter disturbances are actually due to the endeavours of intelligent beings in Mars to communicate with us, is a matter which only the future will decide. For the present, therefore, we must each hold our individual views on the subject, bearing in mind the fact that any observance of such unknown signals constitutes an important occurrence, and one which should be carefully recorded.

STANDARD H.T. AND L.T. CONNECTIONS.

By J. MACINTOSH.

FEW amateurs realise the importance of the connection between the L.T. (- or +) and the H.T. -

With certain connections if a short occurs between the primary and secondary coils of either an H.F. or L.F. transformer the valves will be burned out. Either type of short is not uncommon, and valves may be burned out by the two plates of a neutralising condenser touching. One type of connection, however, will give immunity from these burn-outs, although the H.T. battery may suffer. See diagram.

The rule is: Connect all grid return leads to the same pole of the L.T. accumulator as the H.T. - is connected to. With the usual grid rectification the return lead is connected to positive, and a short between P and S of

the H.F. transformer means all valves are burned out if the common negative connection is in use. In practice, the L.T. - and H.T. - should be linked together, and the grid return of the rectifying valve taken to L.T. +. The leak goes directly to L.T. + not across the condenser.

Alternative Leak Connections.

The three-terminal arrangement, A B C, allows of anode bend rectification at will. For grid rectification, B is connected to C, and for bottom bend rectification a small battery of the requisite value (perhaps 1½ or 3 volts) is connected between A and B.

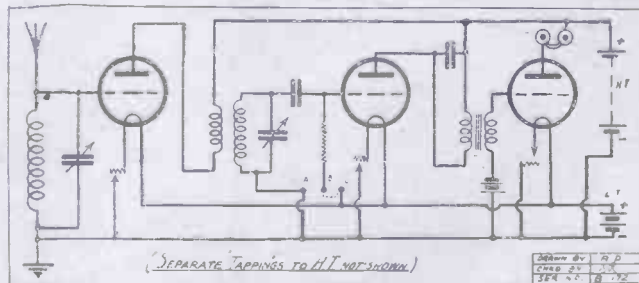

The positive pole goes to A; the negative pole to B. Such an arrangement of the connections is well worth while and does not entail any loss in the efficiency of the receiver.

NOTES ON INSULATION.

By G. E. C.

THERE are certain parts of the average wireless enthusiast's receiving gear which are invariably badly insulated.

It may be that it is through carelessness, or it may be through lack of knowledge; anyhow, there always seems to be one or two points where insulation has been sadly neglected.

For example: The use of wood in H.F. circuits is quite a common practice and in many cases the efficiency of this material is even greater than that of ebonite. But what is the good of using wood where it is coated with lead paint?

Quite often the writer has found lead paint used as an insulating varnish!

Covered Aerial Wire.

Ninety-nine out of a hundred would say that it did not matter whether or not the aerial wire was covered. If we stop to think it will be seen that there is no doubt that the aerial should be of bare wire. The reason:

Cheap ebonite sometimes possesses a partially metallic surface and should therefore be avoided. Also poor ebonite may absorb moisture with consequent deterioration of insulation.

A good example of this was obtained at the "P.W." experimental station some time ago. A short-wave receiver was constructed and, as an experiment, inferior ebonite was used. On certain occasions it was found that the receiver would not oscillate below about 30 metres; nothing would induce it to do so until the whole set was placed in front of the fire and the moisture driven out of the ebonite.

Manufacturers are to blame for the poor insulation of telephones. Often, the writer has received an unpleasant shock through the head from the H.T. battery, caused by the H.T. shorting to earth through the body.

The remedy in this case is, of course, to buy a reliable make of telephones.

It should be hardly necessary to say that the greatest care must be taken over the insulation of all wires connected with electric

doors corrode so quickly that there is bound to be a loss of efficiency before long by reason of faulty contact. Similarly, there is a serious risk of loss in the screw-down contacts to the switch end to the lead-in tube, and a risk of leakage across the switch.

Protected Against the Set.

If one is prepared to take the risk of the aerial being struck by lightning (which is, after all, a small risk) a much sounder

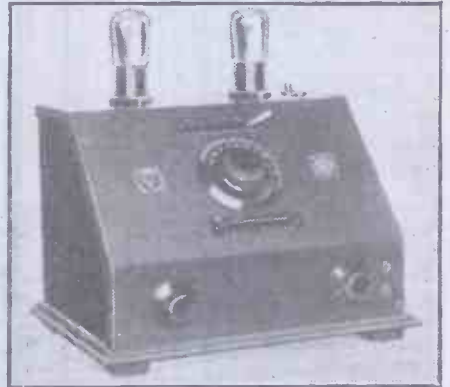

A typical German broadcast receiver: a two-valver manufactured by the Telefunken Company.

arrangement is to obtain a length of heavily insulated lead-in wire, solder it to the near end of the aerial, and take it through a hole drilled in the window frame direct to the set. The hole may be bushed, or lined with a short length of ebonite tube, if desired. An excellent lead-in wire consists of a single strand of No. 18 S.W.G. copper wire, with an insulated covering about one-eighth of an inch thick. The type of lead-in which consists of one thin strand of copper and several strands of tinned steel wire is quite satisfactory, but the joint between this wire and the end of the aerial must be protected against the weather in order to prevent rust.

If it is desired to respect the lightning risk, a lightning arrester is to be preferred to a switch, although there are one or two satisfactory combined lead-in tubes and switches on the market. A lightning arrester is always on duty, whereas if an ordinary switch is installed out of doors, there are many occasions when it is too much trouble to go out, or to open the window in order to throw the switch over to earth.

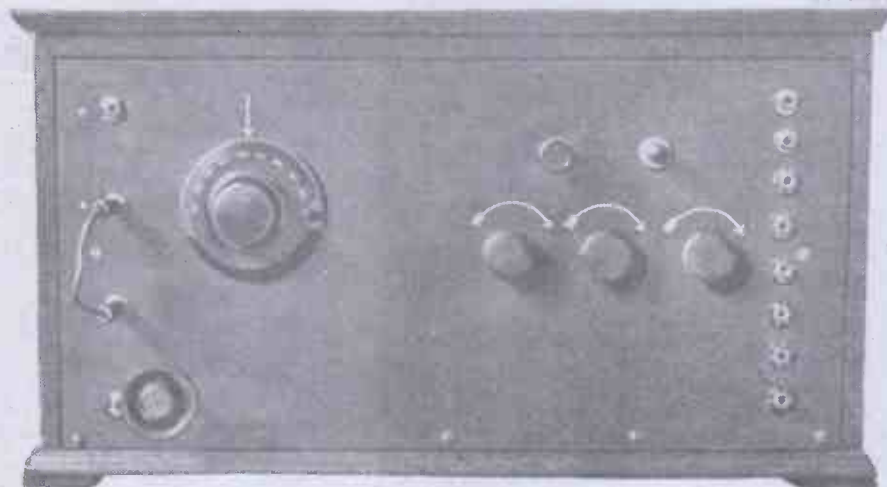

A P.W. "Suburban Three," constructed by Mr. F. S. Tivey, "South View," Victoria Street, Melbourne, Derby.

We know that high-frequency currents, owing to what is known as "skin effect," tends to travel on, or at, the surface of the conductor. If, now, the aerial has a covering, that covering will gradually become coated with dirt from the atmosphere. The greater part of this dirt consists of very fine particles of carbon. Carbon is a conductor. Hence the dirt on the covering forms a complete path along, but not in contact with, the wire. The H.F. energy induced in the aerial wire itself will not remain wholly on the surface of the wire, but part of it will flow on the outermost conductor (i.e. the carbon layer on the insulated covering), and thus be wasted, remembering that the outermost conductor is insulated from the aerial wire.

Certainly, one might argue that bare wire becomes coated with carbon. It does: but then it should be remembered that the carbon is in direct contact with the aerial wire.

light mains, both to prevent shorting and earthing.

It is best to stand a receiver which is worked from the mains on porcelain.

Accumulators being charged direct from the mains should also be mounted on porcelain.

THE LEAD-IN WIRE.

By HUMPHREY PURCELL.

THE conventional method of hooking the aerial to an earthing switch, and the switch to one end of a lead-in tube, and taking a piece of flex or bell-wire from the other end of the tube to the set, is not the best possible arrangement. In the first place, the contacts of a switch used out of

WATCH THAT AERIAL.

NOW that the winter has properly set in those listeners with more or less temporary aerial arrangements will be well advised to give the whole outdoor system an overhaul. "Lash-ups" and similar methods of suspending the aerial should be done away with before the gales begin and should be replaced by something more substantial and capable of withstanding the vagaries of our winter weather.

It would be worth while to examine the whole system—if it has not been done during the summer—as a cracked pole may cause no end of trouble if it is allowed to stay in position to face really bad weather.

I FREQUENTLY receive queries with reference to the relative capacities of the aerial and anode condensers, and particularly as to the reason for the latter being smaller than the former. In connection with the size of a condenser in an oscillatory circuit, it should be remembered that for a given frequency of oscillation (or wave-length), the larger the inductance, the smaller must be the capacity of the condenser.

Now, it is desirable to use as large an inductance as possible, as by this means the potential differences set up at its ends are made as large as possible. On the other hand, if it be desired to use a very small condenser, it may be necessary to use an inconveniently large inductance. Consequently, it becomes to some extent a question of using a condenser as small as possible, but big enough to cover the desired wave-length range.

In the aerial circuit, there is already the capacity-to-earth of the aerial wire in parallel with the tuning coil, and this may have a value up to 0.0003 mfd. The wave-length varies with the square of the capacity and so it is necessary, to cover the ordinary broadcast wave-length range, to use an aerial condenser, with most circuits, of not less than 0.0005 mfd.

In the anode circuit, on the other hand, we have only to deal with certain stray capacities, which will generally have a small value, and a condenser in this circuit of a value of 0.0003 mfd. will generally be found to be quite sufficient. By using a smaller condenser in the anode circuit, it is possible to make the adjustments of the two condensers, the aerial condenser and the anode condenser, roughly the same for any given wave-length—at any rate, reasonably similar—whereas, if the maximum values of these two condensers were the same, it would be found that the adjustments for a given wave-length would be apt to be very different.

It may seem to the amateur that there is nothing of value in all this unless the adjustments of the two condensers may be identical. But it is an advantage to approach the ideal condition, even if that condition cannot be easily reached.

Non-Inductive Resistances.

The experimenter is often faced with the problem of winding a non-inductive resistance and, although the general procedure is well known, the work can be much simplified by the following method.

In the first place, in order to make the winding non-inductive, it is necessary to arrange that one half of the total amount of wire shall be wound in the opposite direction to the other half, so that the inductive effect of one half neutralises the inductive effect of the other half. Obviously, if half the wire be wound upon the spool or former, and then the winding be reversed, the desired result will be attained.

But the trouble is to know when half the wire has been put on.

If you have two reels of the wire which

TECHNICAL NOTES.

A Weekly Feature
Conducted by

Dr. J. H. T. ROBERTS, F.Inst.P.
(Staff Consultant.)

you intend to use, you can mount them both in a suitable position for unwinding and then, taking the wire from each reel, join the two ends (or "beginnings") together, and proceed to wind the double wire, putting on, of course, half the total number of turns instructed (since you are winding two turns at a time). Care should be taken that the bare ends of the wire (where they were first joined together) are properly protected, so as not to make unwanted contacts.

If, however, as is more likely to be the case, you have only a single reel of the wire to start with, you will be best advised to

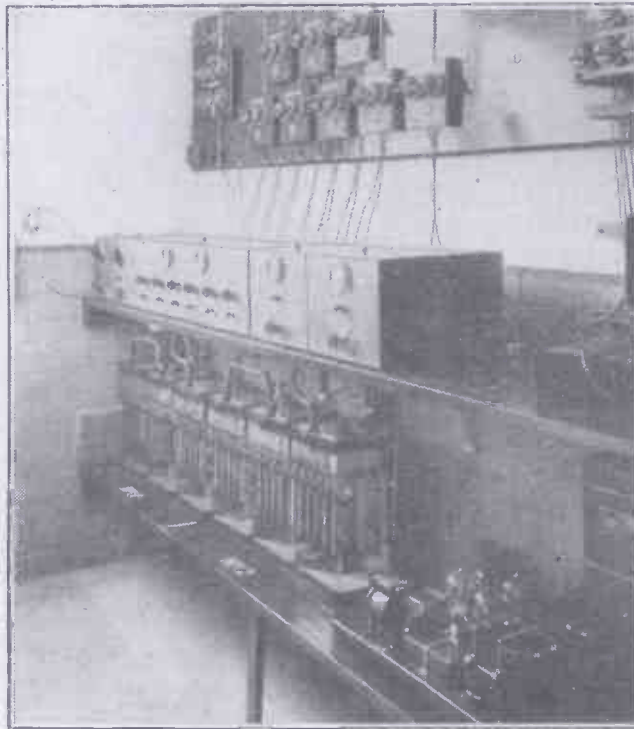

Part of the wireless receiving installation fitted up in a Leicester infirmary. 670 pairs of phones and 20 loud speakers are used, 14 valves being employed.

secure a couple of empty reels and to wind these first with approximately half the total stock of wire first. Then commence operations with these two specially prepared reels exactly as instructed above.

If you have a lathe the work is much simplified and you can, in fact, wind from a single reel, removing the "former" or spool from the chuck after half the wire has been wound on and reversing it end-for-end and then winding the other half number of turns (taking care to secure the wire, when reversing, with a speck of "Chatter-ton").

But it is much preferable to wind the

double wire, as, then you get a practically truly non-inductive winding, whereas, if you wind half the number of turns on first, then reverse and wind the other half number of turns on the top, the inductive effects of the two half-windings are apt to differ, with the result that the finished winding coil is not truly non-inductive.

It should also always be borne in mind that a non-inductive coil made by any of the methods discussed above is not without capacity, and, in fact, the method which gives the best non-inductive result, namely, the double winding, is apt to give the highest self-capacity effect. Therefore do not assume that because the coil is without inductance it is also without capacity.

Tuned Plate Reaction.

A question which often crops up in one form or another is as to whether it is an advantage to tune the reaction coil or anode circuit to the incoming signals by means of a variable condenser. Of course, the first answer is that the signals should be stronger with the anode circuit so tuned, but when the tuning of the plate and that of the grid circuit approach one another, there is a great tendency for oscillation to set in, and this places a limit on the nearness to which these two circuits may be tuned.

In American sets these two circuits are often tuned almost to the same wave-length by means of a variometer, in which case the valve capacity and the capacity between the leads and components of the plate circuit and the grid circuit form a regenerative coupling.

Provided satisfactory reproduction can be obtained and oscillation avoided, this forms a very convenient method of increasing signal strength.

Metallised Leaks.

Following the remarks I recently made on the subject of permanent grid leaks, several readers have asked questions as to the method by which the so-called "metal" leaks are made. Of course, a metal grid leak, or "metallised" as it is sometimes called, is not to be confused with a wire-wound resistance.

The metallised leak is really an adaptation of the metallic deposit which is to be seen on the interior of the glass bulb of most modern receiving valves. This silvery-looking deposit is really a thin deposit of metallic magnesium, which, as everyone now knows, is vaporised within the valve in the final stages of the exhaustion process in order to improve the vacuum by combining with and absorbing traces of residual gas.

It is probable that the idea of the metallised grid leak arose out of the above-mentioned process, although on that point I cannot be sure. At any rate, the metallised grid leak consists of a short length of glass rod, which may be of very small diameter, upon which an exceedingly fine metallic film is deposited. The deposit may be made either by well-known chemical methods, such as those which have long

(Continued on page 1022.)

(One week to Christmas)

TWO GIANTS IN PERFORMANCE—

Now a **LISSENOLA HORN**

as well as a **UNIT**



12" flare 13/6

14" flare 17/6

Sold separately or with LISSENOLA Unit complete.



LISSENOLA LOUD SPEAKING UNIT

13/6

Sold separately or with LISSENOLA Horn complete.

THE CHALLENGE!

Try the LISSENOLA Unit now with the LISSENOLA Horn fitted to it—made in 12-in. and 14-in. flares—we challenge comparison of this fine combination against any loud speaker selling at any price up to £20—that means *any* loud speaker on the market *irrespective of price*. Yet this LISSENOLA combination will only cost you 31/-. Compare what you pay for an expensive loud speaker with what this fine LISSENOLA combination costs you.

If you do not prefer the LISSENOLA Combination to any other loud speaker for tone, quality and volume, your money will be willingly refunded, if you ask your dealer within 7 days of purchase.

If you already have a LISSENOLA Unit, now get this handsome factory-made LISSENOLA horn, 12-in. or 14-in. flare—GET IT NOW BEFORE CHRISTMAS. If unable to obtain from your dealer send direct, and add 2/- to price to cover part cost of packing and carriage. AND PLEASE MENTION DEALER'S NAME AND ADDRESS. YOU CAN NOW OBTAIN THE LISSENOLA UNIT COMPLETE WITH FINE HORN—or purchase either separately. Any dealer will obtain for you.

QUALITY RHEOSTATS

Previously

4/-

NOW

2/6

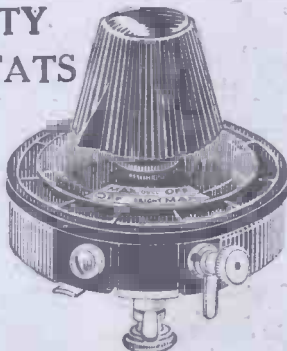

LISSEN quality—look how they are made—the wires cannot move and short circuit—the contact brush rides firmly yet smoothly—the heat-resisting former cannot soften—there are accessible terminals—and the combined knob and pointer will fit flush with the neat photo-engraved dial when mounted. Lastly, note the irresistible appeal of the price, made possible by our big production programme backed by our new direct-to-dealer distribution policy which cuts out all wholesale profits.

	Previously	NOW
LISSEN 7 ohms rheostat, patented	4/-	2/6
" 35 " " "	4/-	2/6
" Dual " " "	6/-	4/6
" Potentiometer, 400 ohms	4/6	2/6

Every One LISSEN One-Hole Fixing, of Course. Baseboard mounting type same prices as above.

A VALVE HOLDER FOR CLEARER, BETTER SIGNALS

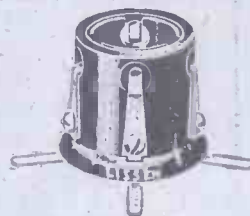

Because of its low loss and low capacity qualities, the LISSEN Valve Holder plays its part in getting clearer, louder signals. Sent out ready for baseboard mounting, as shown, it can also be used for panel mounting by bending the springs straight.

LISSEN VALVE HOLDER
patented, previously 1/8
Now 1/- each

QUICK TO FIX AND HANDY TO USE

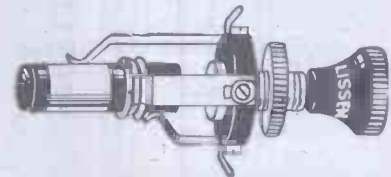

Series Parallel Switch

There is a LISSEN switch for everything you want a switch to do. Ask your dealer for the appropriate LISSEN switch, and you will get a real radio switch. LISSEN one-hole fixing explains itself.

	Previously	NOW
LISSEN 2-way	2/9	1/6
Series parallel	3/9	2/6
Double Pole, Double Throw	4/-	2/6
Key Switch	2/6	1/6

IMPORTANT TO THE TRADE.—Retailers who have not already been notified of our new direct-to-dealer policy of distribution should, in their own interests, communicate with us without delay. All orders must now be sent to us at Richmond, and not to usual wholesale factor.

LISSEN LTD., 8-16, FRIARS LANE, RICHMOND, SURREY

Managing Director: Thomas N. Cole.

L.160.

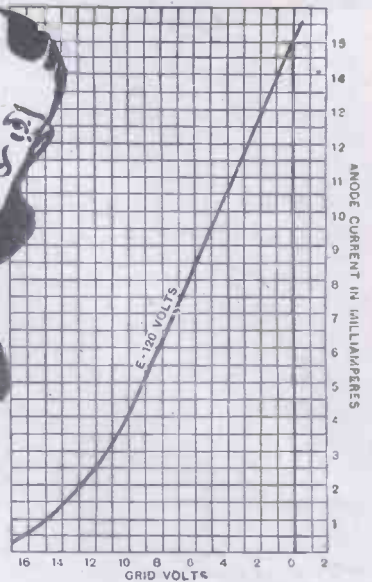
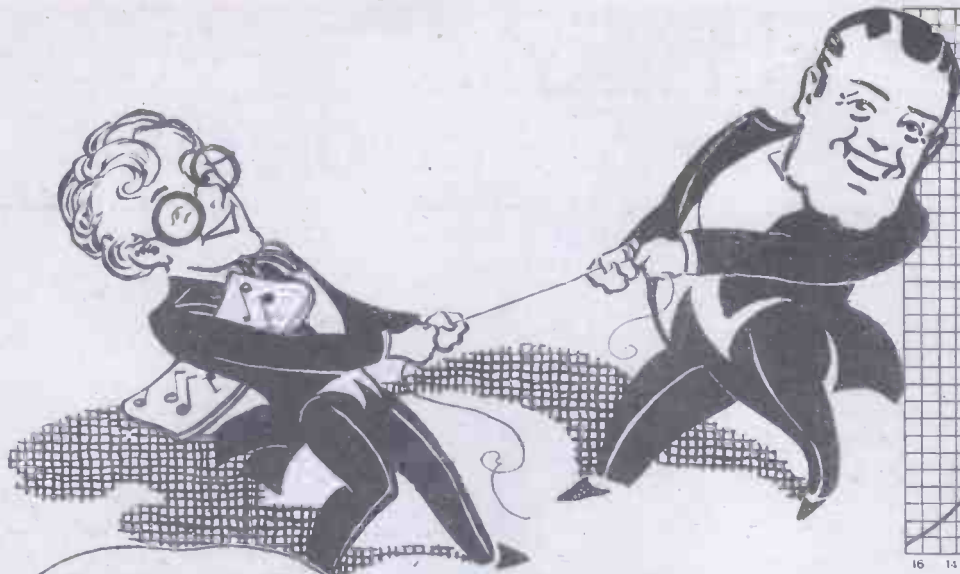

**The Wonderful
NEW OSRAM
'STEEP SLOPE'
2 Volt
POWER VALVE
(TYPE D.E.P. 215)**

THE characteristic curve of the new valve is exceptionally steep, thus ensuring greater overall amplification, better volume and less distortion.

The design of this valve comprises the new OSRAM ELECTRONISED FILAMENT, giving enormously increased electron emission, lower working temperature, and longer life.

This filament requires a 2-volt accumulator only, a minimum of current, and is of great mechanical strength.

The accuracy in spacing between filament, grid and anode is carefully carried out, whilst the special grid gives a fine control of the electron stream.

The valve gives a great response in the anode circuit to weak signals imposed on the grid—in other words, the OSRAM STEEP SLOPE (D.E.P. 215) POWER VALVE is sensitive, stable, gives great volume and absolute purity, and possesses the added advantages of long life, mechanical strength and low current consumption.

PRICE 18/6

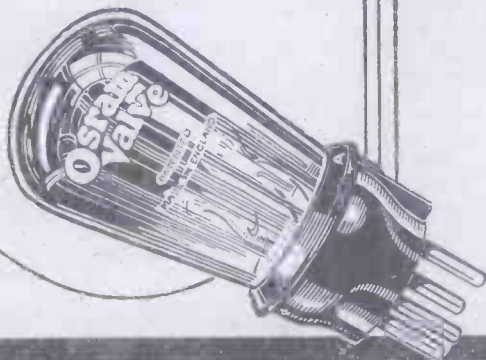

**“Look at the Strength
of the — D.E.P. 215
FILAMENT”**

“I was down at the works this morning, ‘TONE,’ and I’ve got a piece of the new STEEP SLOPE Filament. Get hold of the other end and test its strength—Isn’t it amazing?”

“The ELECTRONISING process means greater emission too! The amplification will be wonderful.”

“At any rate,” replied ‘TONE,’ “we’re keeping faith with these listeners. This new valve will give better reception than ever.”

**The finest 2-Volt Power
Valve in the World**

**Osram
Valves**
for **STEEP SLOPE**
TONE & POWER

The G.E.C.—your guarantee



TONE & POWER
The Boon Companions of
OSRAM VALVES

H.F. AMPLIFICATION

A Commentary Upon Radio Frequency Amplifiers and the Difficulties Encountered in Multi-Valve Receivers.

By C. H. GARDNER, F.R.A.

DURING the past twelve months a great deal of controversy has taken place regarding the utility of H.F. amplification, and opinion has been most sharply divided, probably largely due to the fact that the various parties discussing the matter have been building receivers for entirely different purposes. Whereas one field of thought has led to a large amount of experimental work on low-loss apparatus and the use of a detector valve immediately after the aerial circuit, the other side have been busy, going to an enormous amount of trouble, devising stable circuits which allow of the utilisation of two or three stages of H.F. amplification, hence we get the super-heterodyne circuit and the ever-popular neutrodyne, of such great favour in the United States.

It therefore seems as though it will pay every amateur constructor to sit down for a while and carefully consider the pros and cons of H.F. amplification before embarking upon the construction of a receiver for any particular purpose.

Useless on Short Waves.

In the first place, there is little doubt that under the present stages of development little or nothing is to be gained by the use of any form of H.F. amplification for use in receivers designed to operate much below 100 metres. Even an extremely skilled amateur constructor would have the greatest difficulty in obtaining any appreciable amplification of these very high frequencies owing to the great losses caused by minute capacities in the apparatus and the arrangement thereof; and, indeed, unless the constructor is a very careful and painstaking individual, with considerable technical knowledge and practical experience, he will obtain little gain by the use of H.F. amplification of frequencies corresponding to a wave-length of 200 metres or so.

Above 200 metres there can be no doubt that very considerable amplification of signals can be obtained by the proper use of a correctly designed and laid-out H.F. amplifier, and the chief consideration then becomes the number of valves that may be usefully and conveniently employed for the particular requirements of the designer.

Much Experiment Necessary.

A very considerable amount of experimental work, including the making up of a large number of receivers, has been carried out by the writer on this very point, and the results cannot be considered other than interesting and informative. It should here be stated that it is quite useless to commence experimental work of this nature unless one is prepared to build up complete instruments. Results obtained by linking up components and units on the bench are entirely misleading, as quite different results may be obtained by very small movements of one part in relation to another or by slight alterations in the scheme of wiring.

If the amateur wishes to embark on what cannot be described other than as a somewhat tedious though highly interesting task of such a nature, he must be prepared to spend considerable time and money on the work and to develop a highly acute radio sense—by which I mean an instinctive knowledge that certain results are due to certain causes, so that they may be analysed and the facts verified or disproved as the case may be.

Without this natural instinct wrong conclusions would be come to time after time and much time wasted, to say the least of it. This applies to all works of scientific research and is a point well worthy of more earnest attention by the amateur and many "expert" investigators who are apt to rush into print in the correspondence columns of the press, with results which must often be sadly misleading to newcomers to the ranks of radio constructors.

This digression is perhaps rather apart from the heading of the article, but perhaps the Editor will be kind enough to hold his blue pencil in check and allow the hint of one who reads and digests every British wireless journal each week or month as it comes out, and received his early scientific

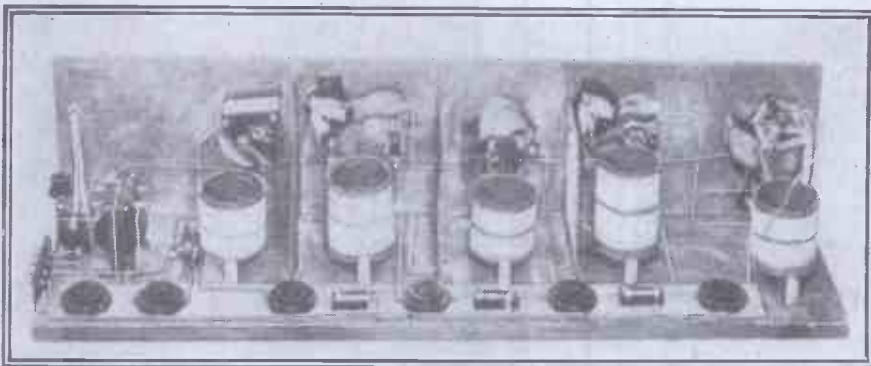

An experimental multi-stage H.F. receiver which utilised screened coils and gave very interesting results.

training from a gentleman to whom he owes many thanks for having removed that dangerous habit of jumping to conclusions and replaced it by one which desires to know the logical and basic reason "why" before feeling satisfied on any point that might arise in experimental work.

Until twelve months or so ago it was common practice to employ two stages of H.F. coupling in commercial broadcast receivers employing more than four valves. The reason appeared at first sight to be due to the inability on the part of the designers to make three stages of L.F. amplification function correctly. As a curious fact, it may be noted that nearly all such receivers employed some damping device on the H.F. side. In other words, a valve was added, and most of its effect removed in an endeavour to stabilise the receiver.

Later, by the general improvement of

design, the two H.F. valves were replaced by one valve, and practically the same results were obtainable, provided a reasonably good aerial-earth system was utilised. In cases where a heavily damped aerial-earth system was used, this had the effect of considerably stabilising the receiver which employed the two H.F. valves, and this receiver gave the better results. This is logical and exactly what would be expected.

A further advantage of the two H.F. valves was the employment of two tuned circuits which greatly added to the selectivity of the set, if not to the actual signal strength;—but it should be borne in mind that sets employing "constant tuned" H.F. circuits (many of which are available to the constructor to-day) cannot perforce be as selective as those employing properly tuned circuits, though the latter may present more difficulty in operation.

The Neutrodyne Method.

A great deal of misunderstanding is prevalent regarding the neutrodyne type of circuit. So often is this circuit described as the circuit which allows two H.F. valves to be utilised without oscillation. It is the easiest matter in the world to build a set utilising two sharply tuned undamped stages of H.F. amplification which will not oscillate under ordinary circumstances, provided that proper attention is paid to the disposition of the components and wiring. The point to realise is that if *everything else is perfectly designed and arranged*, the valve capacity itself prevents the absolute maximum amplification being obtained *without oscillation*, and it is only by neutralisation of this unwanted self-

capacity of the valve that the maximum results can be truly obtained.

One part of the experimental work previously mentioned was to discover in practice how much the limits of H.F. amplification were due to the self-capacity of the valves and how much due to other causes, such as coupling between components and wiring and incorrect use of the valve.

Three H.F. Stages.

The result was interesting in so much as it was found possible to utilise three stages of H.F. amplification with standard R valves, sharply tuned efficient tuned-anode circuits, full negative grid potentials, 120 volts H.T. supply, and very high amplification per valve. (With one stage of added L.F. 2L0 was loud on a loud-

(Continued on next page.)

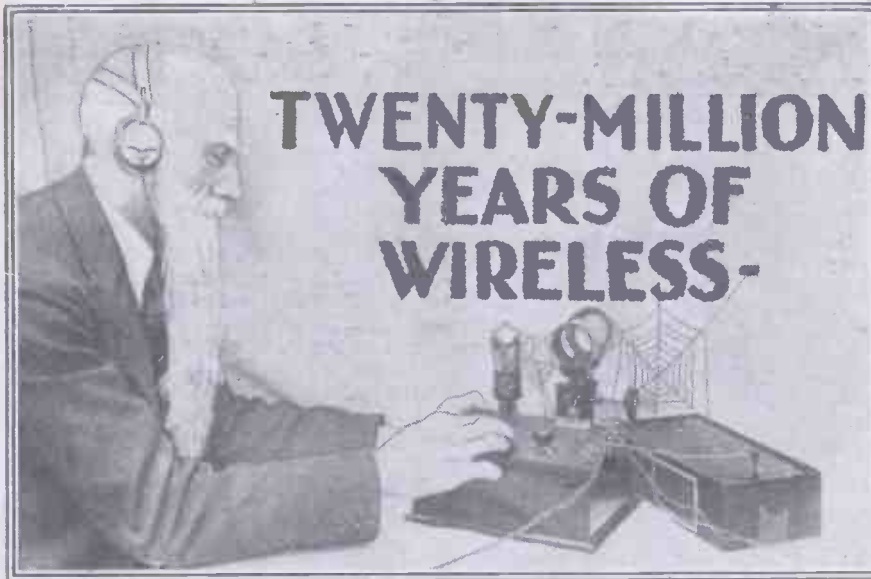

A Speculative Article, by G. H. DALY.

WHAT effect will broadcasting and radio communication generally have upon the human race?

Not the race merely of to-morrow, but the people of the dim distant time, highly intelligent beings who will regard us as we regard our ancestors of twenty million years ago or more.

If evolution is a fact and not a theory, there will be no wireless sets then, no valves to burn out, no crystal sets with their finicky cat's-whiskers. Nor will unsightly aerials mar the beauty of the ultra-cultivated land. For the wireless sense will have developed.

Basing our forecast on what has gone before, it must be obvious that in just the same imponderable way as our sight and hearing were created and developed, as the necessity arose, as there came to be a use for them in the great natural scheme of things, so will a wireless sense be developed in the super beings of that time.

The "Radio" Sense.

That such a sense must develop—absurd as it sounds—is a natural sequence. We have reached the limits of our orthodox five senses; we want more. With our eyes we can see but a very short distance, as distances go in the world. Likewise do we hear but over a short distance, except by artificial means. The human race is ever trying to see farther, to hear more. Thus radio has been discovered—a step towards greater things; such a little elementary step—the groping of a blind man in a world of light.

Similar but more elemental, from our point of view, must have been the striving of the early forms of life after a sense of hearing and sight—groping blindly and deafly, but unceasingly.

In radio we have got at a natural phenomenon artificially; radio is our stepping-stone to another sense. Our sense of sight is now developed to a maximum capacity; our eyes have not the capacity for further expansion, as it were; something more is needed, which in due course will be supplied by nature.

We have commenced to tackle the problem artificially in radio-television, and from that we shall develop another sense

—a sense of infinite vision, to be accomplished via the medium of the wireless waves, ethereal vibrations, or whatever they turn out to be, when discovered, and the only apparatus required will be the cells of our own brain.

No Jamming.

Examination of the ninety million cells forming the most important part of the human brain shows that about 99 per cent of these cells are inactive. This 99 per cent of the brain is awaiting development, and its development must be in the direction of new senses—new forces of untold magnitude which will be possessed by our descendants.

But, says the matter-of-fact, common-sense critic, if the race develops a wireless sense of hearing thus outlined, the individual will hear everything at once, he will be overwhelmed. What discord! What jamming.

Not at all. Take the case of sight. The jamming and discord with regard to sight is appalling, if one can but realise it. When we look out across the street or over the countryside, hundreds of different colours and tints strike the eye. This means that hundreds of sight waves—i.e. wireless waves of different wave-lengths, are striking the retinae of our eyes. Yet we have no sense of the chaotic jamming which is in reality taking place.

In that remote time when sight was slowly coming to the human animal, he was possibly worried by visual jamming, as even we to-day can be worried by a combination of inharmonious colours. But custom gradually overcame the jamming as age followed age, and to-day a thousand different tints do not trouble our sensitive eyes.

Distance Annihilated.

So it will be with these greater senses of sight and sound which are coming to us. The jamming will be as unnoticed as the jamming which goes on in sight to-day, and just as we can look at one particular thing amongst a multitude of others, so will our descendants be able to concentrate on one particular station, as it were, taking no notice of anyone else.

This phenomenon will mean that wherever

life exists on this planet our descendants will be able to speak to or see it instantaneously, should they desire, distance being immaterial. Wireless waves have a speed of 186,000 miles per second: thus a person in Central Australia will be able to see and talk with another in England as quietly and easily as we talk to our friends across the dinner-table to-day.

Again, should life exist on other planets of the universe (and it is rather infantile to imagine that the earth is the only planet on which intelligent life exists), we shall be able to converse with them even if their language is not ours, as it is bound not to be, of course; for by that time the rudiments of speech and sound will have been mastered so thoroughly, and so be well under the control of the intellect, that new languages, if they then exist, will be easily understood by any of our super-intelligent children.

Looking "Backwards."

But when we speak of communication with beings of other worlds, the simple proportions of our little world are upset. Some of the stars, similar to our sun, which may have similar planets circulating around them, are so far away that even travelling at the speed of light it would take us many millions of years to get there.

Thus, if our descendants' new senses enable them to see or hear the people of a planet which is twenty million light years distant from the earth, our descendants will only see or hear the beings that are existing at the present time on the planet. For those light and other wireless waves will have taken twenty million years to reach the earth. And we of to-day will have been dead and buried for twenty million years.

H.F. AMPLIFICATION.

(Continued from previous page.)

speaker 120 miles away on a two-foot frame.) It is quite useless to go to the trouble of neutralising this small valve self-capacity if the other parts of the circuits are inefficiently arranged. Self-oscillation may be stopped, but the results will be most disappointing.

The super-heterodyne has a fascination all of its own, inasmuch as it is the receiver which you really can put down on the drawing-room table and go round the stations on a loud speaker, utilising a very small frame aerial and without having to adjust a multiplicity of controls, but there is an appalling fundamental fact about this circuit which must go against the grain of every true experimenter.

One employs a large number of valves for the simple reason that the stations you desire to receive use an H.F. transmission, and you admit your inability to build a short-wave amplifier which is efficient, stable, and sufficiently simply controlled to do the work direct. I cannot help but feel this circuit is a monument of shame to the ingenuity of wireless designers, and whenever I utilise or demonstrate my own it is with a feeling that it has to be made excuses for rather than to be boasted about.

Polar Christmas Presents



The "Polar-Twin" Loudspeaker Set

The famous "Polar-Twin" is a 2-valve Set which gives really GOOD Loud speaker reproduction within 50 miles' range of a main B.B.C. Station. It combines real purity with magnificent volume.

The "Polar-Twin" is sensitive to long-distance signals, and the "Polar" Coil Unit system of tuning allows the fullest use of reaction without danger of oscillation.

Control is simplicity itself: two adjustments only for tuning. One knob only for switching on and off.

Complete, ready to connect to aerial
£10.10.0
 Royalties paid.

Handsome carved Oak Cabinet to contain entire Equipment, except Loud Speaker.
 Extra **£1.1.0**

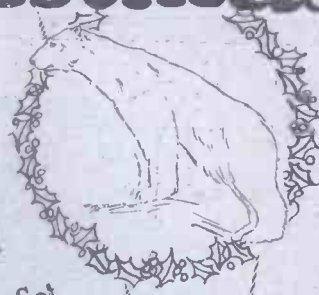

The "Polar" Coil Unit Outfit.

Here is a gift that will especially please the owner of a valve Set. Not only is this particularly useful to those who use "Polar" Sets, but it also enables any constructor to increase the efficiency of his Set, and to listen to programmes from Stations hitherto difficult to tune in.

A complete range of eleven coils, up to 4,000 metres, and one spare reaction coil, together with carrier and full instructions, fitted into the handsome velvet-lined leatherette case illustrated.



The "Polar" Coil Unit Outfit... **39/-**



The "Polar-Three" Set.

The "Polar-Three" Receiver is the outcome of a careful study of present requirements. It embodies the latest and most efficient methods of tuning and amplification, at the same time retaining complete simplicity of control.

Dual tuning arrangements are incorporated so that either of two Stations may be switched in, giving alternate programmes at will.

Purity of reproduction is ensured by one stage resistance coupling in the second stage; the instrument consisting of a detector valve and two stages of low frequency.

Set Complete.
£16.17.9
 Royalties paid.

With Amplion, type AR 65 L.S.,
£19.12.9
 Royalties paid.

*"A most
 Delightful Present"*

Imagine the expressions of real enthusiasm that are heard on Christmas morning! And what gifts are better calculated to please than those that bring to the home of your friends Radio and all that Radio means?

All good Radio Dealers have these "Polar" Christmas Presents in stock, and will readily give a demonstration of "Polar" Sets.

Radio Communication Co., Ltd.,

66, Oxford Road,
 MANCHESTER.

Barnes,
 LONDON, S.W.13.

125, Hope Street,
 GLASGOW.

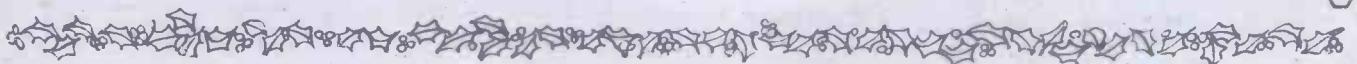

BENJAMIN

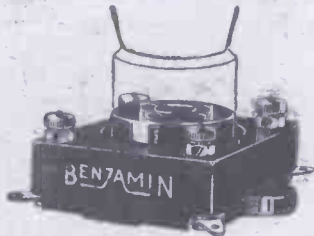

VALVE HOLDER

This is the usual view of the Benjamin Valve Holder without attachments.

Price 2/9 each.

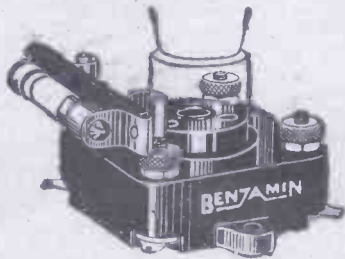

VALVE HOLDER AND GRID LEAK

Nickel-plated copper clips on a rigid insulating bar carry a Dubilier Dumetohm 2 megohm Grid Leak. Wiring and space saved, perfect connections assured.

Price 5/3 complete.

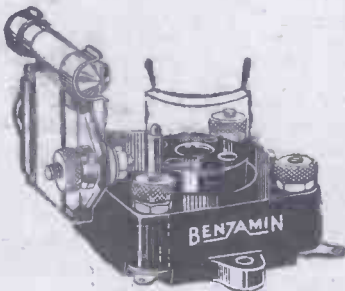

VALVE HOLDER, GRID LEAK AND CONDENSER

The same as above but with the addition of a Dubilier Fixed Condenser (.0203 mfd.). Grid Leak can be in series or parallel. Wiring entirely dispensed with, space saved, installation simplified, connection troubles banished.

Price 7/- complete.

PATENT NOS:

222085-1923 250431-1925
REGD. DESIGN: No. 714847

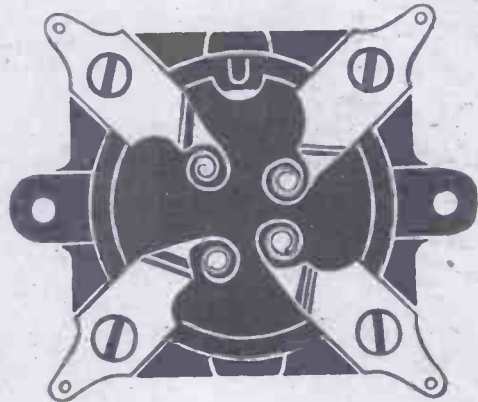

The one-piece spring feature

This is a BENJAMIN Anti-Microphonic Valve Holder turned upside down. The four metal strips you see are the patent BENJAMIN one-piece springs—each a complete length of tempered metal; cut and shaped to form the soldering tag and the valve pin socket, and the spring.

Most anti-microphonic valve holders have in place of this two or three strips of metal soldered or rivetted together. In time, the joints work loose and become 'noisy.' The BENJAMIN Valve Holder with its one-piece spring feature overcomes this difficulty.

The BENJAMIN Valve Holder has also four other important features:—

- (1) It allows the valve to float in any direction.
- (2) Valves can be inserted or removed easily and safely.
- (3) Valve legs cannot possibly foul the baseboard.
- (4) Both terminals and soldering tags are provided.

This world-famous component, which trebles the life of your valves and completely disperses all microphonic noises, can be purchased either alone or with the attachments shown on the left. Sold by radio retailers everywhere.

BENJAMIN

Clearer Tone, Anti-microphonic VALVE HOLDER

British Made

THE BENJAMIN ELECTRIC LTD.
Brantwood Works Tottenham, London, N.17

BENJAMIN—Makers of things more useful

MORE ABOUT "THE KING OF THE AIR."

By PERCY W. HARRIS, M.I.R.E.

Mr. Harris continues in this article to give readers further important details about his latest and most interesting receiver—"The King of the Air."

THE vernier dials illustrated in this set are made by the Brooklyn Metal Stamping Co., and are obtainable in this country from The Rothermel Radio Corporation. I have chosen them because their appearance seems to suit the particular type of cabinet I had in mind, but there are a number of other excellent vernier dials available which can be substituted without loss of efficiency.

The Cabinet.

An experienced constructor may desire to put the set into a cabinet of his own choice or one that he happens to have by him, but if this is done no attempt should be made to alter the relative positions of parts, for the set has been worked out to the parts in their positions, and I cannot indicate that it will function correctly if the disposition of parts is altered.

The more efficient the H.F. portions of a set, the more important becomes the question of detail lay-out. A number of changes could probably be made without sacrificing efficiency, but whether or not certain changes would be efficient can only be decided by practical trials.

The cabinet is rather an expensive item in the construction of a set, but I have always felt that a good set merits a good cabinet. However, in order that readers may obtain a suitable cabinet at a minimum cost, I have arranged with the Unica Cabinet Co. to supply this particular cabinet in "knock-down form," which means that after the wood has been cut and made ready for fitting, it is packed up in a parcel and despatched to the reader, together with a bottle of stain and varnish and full particulars for assembly.

Concerning the Wiring.

How the cabinet will arrive and how it is assembled was indicated in the photographs that appeared last week. The cost of the cabinet in this form is 35s. but, of course, it can be obtained finished for £2 12s. 6d., if the reader does not desire to carry out this portion of the work himself. Many, I am sure, will like to assemble from the parts indicated. All the wood is cut ready to fit and, indeed, the whole cabinet can be fitted together without the use of a single screw, nail or brad, although the use of these, together with glue, is recommended for a permanent job.

Owing to adoption of the "top and bottom" method of fixing components to the baseboard in the "King of the Air," the wiring diagram has to be shown in a different form from usual. On the other hand, the method of mounting parts makes the wiring both short and simple, although the method of wiring up is slightly different from the normal.

In wiring up the components on the front panel to those on the top of the baseboard one naturally follows the usual practice. The method of joining the components on the top of the baseboard to those below is as follows:

As an example, take the method of joining the filament connection of the valve socket to the wiring underneath the panel. For this purpose I suggest that you take a piece of insulated wire, remove the insulation from the tip of one end, and bend this over L fashion, so that the longer part of the wire can be pushed through the hole in the

procedure with all the other parts requiring connection to the back of the panel.

Some readers may wonder why I have used one condenser of .0005 mfd. and one of .0003 mfd., when both the coils to which these condensers are connected are coupled coils, and it might appear that the same size of condenser would suit each. The reason for the choice is that as different types of coils are used, and as one is affected by the aerial coupling, the use of a larger condenser with the first coil makes sure that the full tuning range of the second coil is also covered by the first.

The use of the multiple fixed condenser in series with the aerial is a considerable advantage. In the particular form of aerial coupling so popular at present the method in which a definite size of coil in the aerial circuit serves to couple the aerial to a second circuit which is tuned, the first coil having no tuning of its own; has many advantages.

Series Condensers.

Now that the "broadcast range" on the shorter waves is from 200 to 600 metres, and not, as used to be the case, 300 to 500 metres, there is always a danger that the size of the coil with a particular aerial will be such that it will exactly tune with one particular station on the broadcast band, completely upsetting the normal functioning of this type of coupling, which is dependent for its efficiency upon the fact that the aerial coil is not exactly tuned to the wave-length that we are to receive.

Imagining, then, that the aerial coil happens to tune with the aerial to a particular wave-length, how can we detune it? Obviously, by putting in series a fixed condenser. If we use such a condenser we alter the wave-length to which the aerial is now tuned, but there will still be one frequency in which the state will be found as before. We now understand that when endeavouring to cover a very large wave-band it is advisable to have two or three fixed condensers available, and the particular model—made by the C.A.V. Ltd.—gives the home constructor a choice of any value between .0001 and .0015 mfd. by using combinations of five fixed condensers moulded into the one casing.

The values of these condensers are .0001, .0002, .0003, .0005, but in my set

(Continued on next page.)

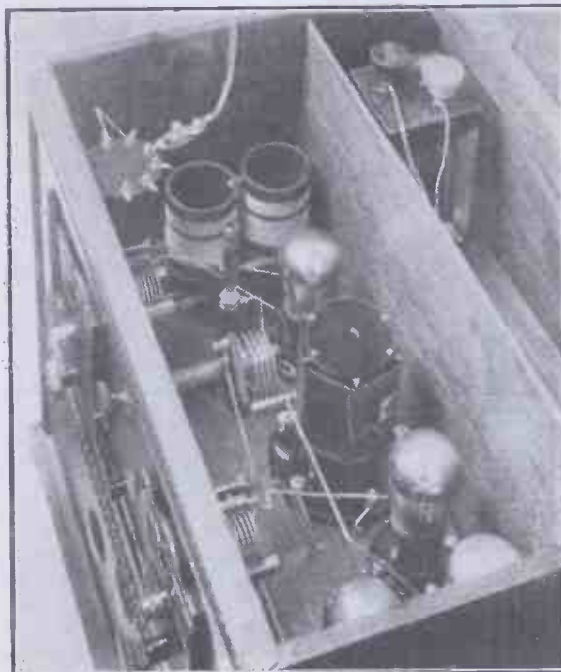

Looking down into the finished set, showing battery compartment.

panel and the bent-over portion will just reach to the particular soldering lug to which it is to be connected. Having passed the wire through the panel in this way, solder the connection to the particular lug, and repeat the process with all the other parts that require connection from front to back. When you have made the connections to the front, turn the panel over, and you will naturally find a large number of projecting wires.

The Tuning Controls.

On consulting the back-of-panel wiring diagram you will be able to take each of these wires individually and bend them over to make connection with the fixed resistors and the common negative bus-bar. You can now follow a similar

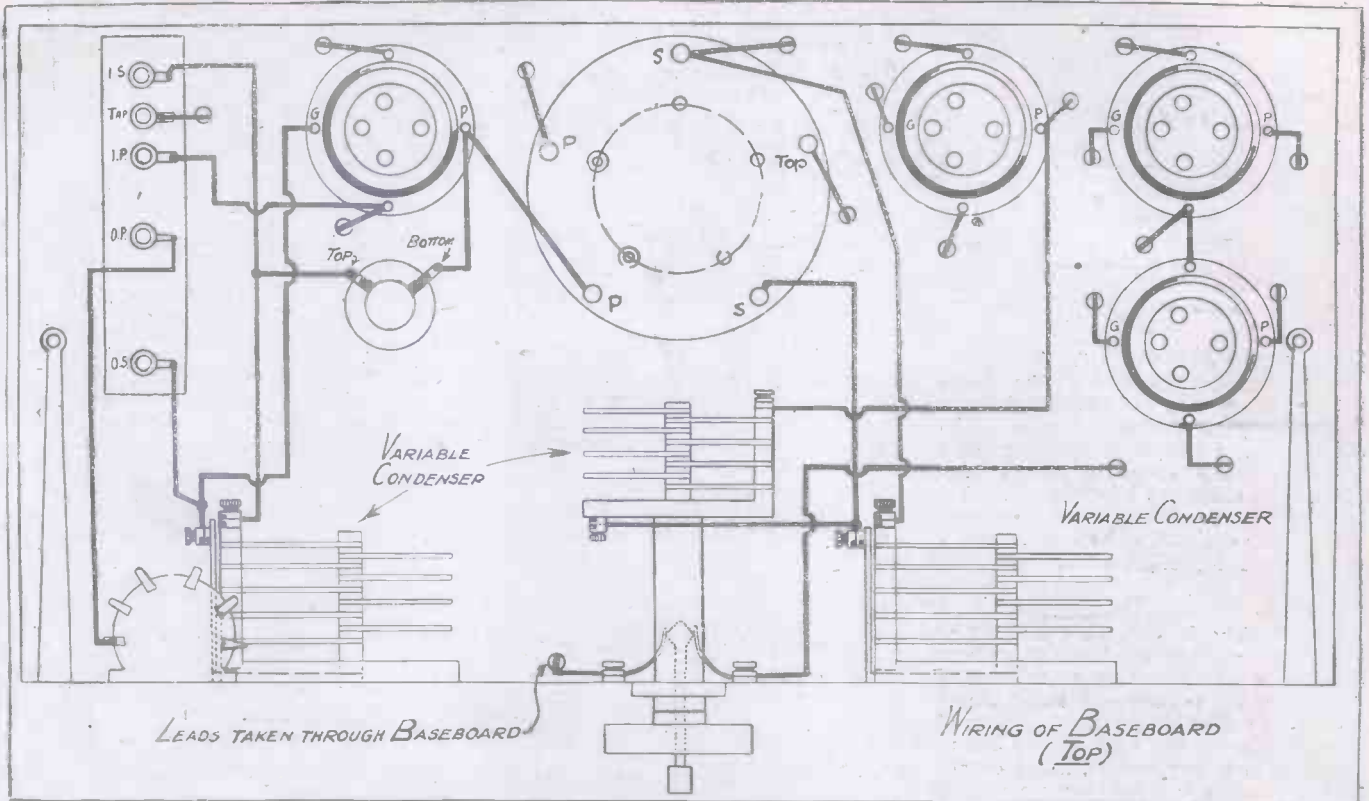

Note particularly the position of the H.F. transformer. The terminals marked P P are adjacent to the sockets. The smaller circles are pins.

"KING OF THE AIR."

(Continued from previous page.)

I have soldered the coil connection on the set to the common terminal, which has simply 000 printed on it. The aerial lead is brought to a spring clip of any suitable

type—Burndept make a good clip for this purpose, or one can use the old-fashioned tie-clip just as effectively, or even a small bulldog paper clip—and it is but the work of a moment to try which of the fixed condensers suits the wave-length we are covering.

Do not imagine, however, that the constant readjustment of the fixed condenser

is necessary when tuning—you will be able to cover a wide band of wave-lengths with one value only, and it is only when you are endeavouring to get rid of a flatness of tuning on one particular wave-length that you will be compelled to change the value.

Another value of the series condenser is that it increases the selectivity of the set,

(Continued on page 989.)

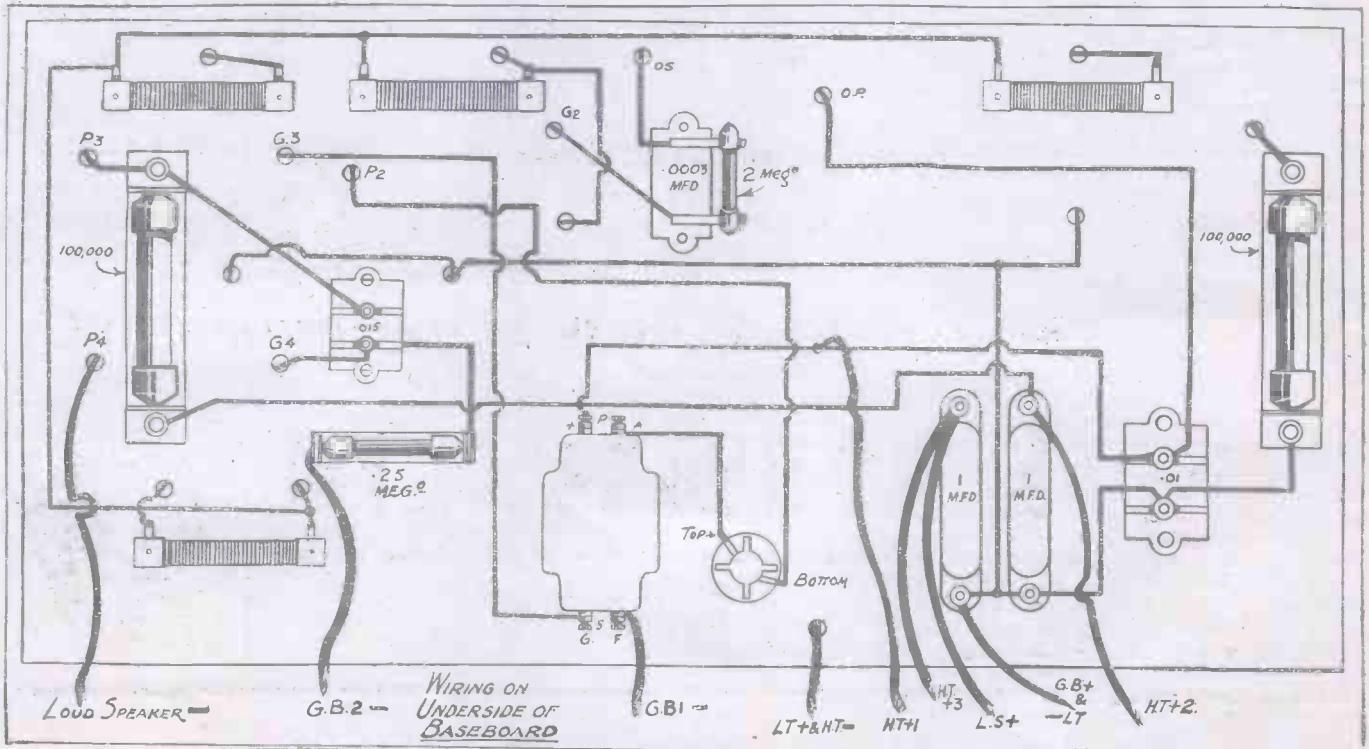

This diagram shows the connections made by the wires coming through the baseboard, as described on another page.

THERE IS A WINDOW IN THIS VALVE



Because when the filament is "lighted" the glow is so dull that Ediswan found it essential to provide an "inspection window" to enable the user to see whether the valve is operating. The low current consumption of the new Quarter-Watt POINT ONE ECONOMY Valves is a remarkable feature in itself.

The moment you buy a valve you are either investing your money in years of enjoyment . . . or disappointment. The new Ediswan Quarter-Watt POINT ONE ECONOMY Valves are specially made to render a service entirely free from trouble, with absolute purity of tone, full volume, absence of microphonic noises, with *low current consumption*. They last, and last, and last!

2-VOLT TYPES:
D.R.2. DETECTOR
G.P.2. GENERAL PURPOSE
R.C.2. RESISTANCE COUPLING

Use TYPE P.V.2. with above (and in all 2-volt stages) for **LOUD-SPEAKER** Results.

HAVE YOU MADE THE R.C. THREESOME ?

This remarkable resistance-coupled receiver (employing R.C.2. and P.V.2. Valves and the Ediswan Coupling Unit) has proved itself to be unexcelled for pure, undistorted reception, with an abundance of volume. You can make it in an evening for £3, or less. Do it now! Let the R.C. Threesome provide the music for your Christmas party.

BLUE-PRINT & INSTRUCTION BOOK FREE

Fill in the Coupon . . . tear it out . . . Send it now!

EDISWAN



Fit EDISWAN VALVES and nurse your set.



To THE EDISON SWAN ELECTRIC CO., LTD. (Publicity) P.W. 18-12-1926.

Name

123 1/2, Queen Victoria St., London, E.C.4

Please send, post free, presentation copies of the "R.C. Threesome" Instruction Book and Blue Print.

Address

PLEASE USE BLOCK LETTERS

If you are making the R.C. Threesome—

TO get the wonderful results obtained with the original R.C. Threesome Set, you should use identical components.

The Coil Holder used is a "Lotus" Left Hand Two-Way Coil Holder; the three Valve Holders are "Lotus" Buoyancy Valve Holders, with terminals.

Wireless experts decided that these were best for a very important experiment; that they would get most out of the set on which depended the very high reputation of the famous Ediswan Valves.

They were not disappointed. YOU will be more than pleased with the R.C. Threesome performance, if you fit "Lotus" Valve Holders and Coil Holder.

From all Radio Dealers.

LOTUS COMPONENTS

"LOTUS" COMPONENTS USED IN THE R.C. THREESOME RESISTANCE COUPLING SET:

Two-Way Inside Mounting Left Hand Coil Holder	7/-
"Lotus" Buoyancy Valve Holder with Terminals	2/6

"KING OF THE AIR."

(Continued from page 986.)

and in some cases, where the volume of the station you are receiving is ample, and you can afford to cut it down, your selectivity may be greatly increased by altering the fixed condenser value by trial.

Choice of Valves.

While this set works well with two, four, or six-volt valves, it is necessary that the first three valves should be of the H.F.

a wide band) where the set will burst into oscillation. When this point has been found adjust the neutralising condenser turn by turn, at each adjustment swinging the second condenser backwards and forwards, until a point is found where the set just does oscillate. Repeat the process by setting the first condenser about half-way, and if the set is stable there repeat it at the top end of the scale. It is highly probable that if the stabilisation has been carried out at the bottom end of the reading, the set will be stable throughout the whole range.

Now try the reaction control, and if all is well and the correct voltages have been

one of the several makes of spade terminal fitted with coloured insulators with red for positive and black for negative. The grid bias leads (one positive and two negatives) should be fitted with wander plugs, preferably of a different colour from those used for the H.T. leads.

There are, as you will notice, three H.T. positives. The H.T. negative is not taken to the set, but goes straight from the H.T. negative terminal of the H.T. battery to the positive terminal of the accumulator. Similarly the positive grid bias connection goes straight to the negative of the accumulator, and the earth lead is also taken to the negative of the accumulator.

As an aid to identifying the H.T. leads quickly, I would suggest you put one knot in the H.T. positive 1, two knots in the H.T. positive 2, and three knots on the H.T. positive 3.

Choice of Voltages.

The L.T. accumulator will, of course, be that of the valves you happen to be using, and you will naturally choose the fixed resistors according to the valves adopted. For H.T. positives the following are suggested:

H.T. positive 1 feeds both the H.F. valve and the detector. About 60 volts generally serves here.

H.T. positive 2 feeds the first note magnifier through the 100,000 ohms high resistance. A voltage of 120 should be used here.

H.T. positive 3 feeds the last power valve or super power valve, as the case may be, and here you should use 120 volts (unless the particular valve you are using is designed for work for a lower maximum voltage than this), and the grid bias must be carefully adjusted according to the maker's directions.

(Continued on page 1019.)

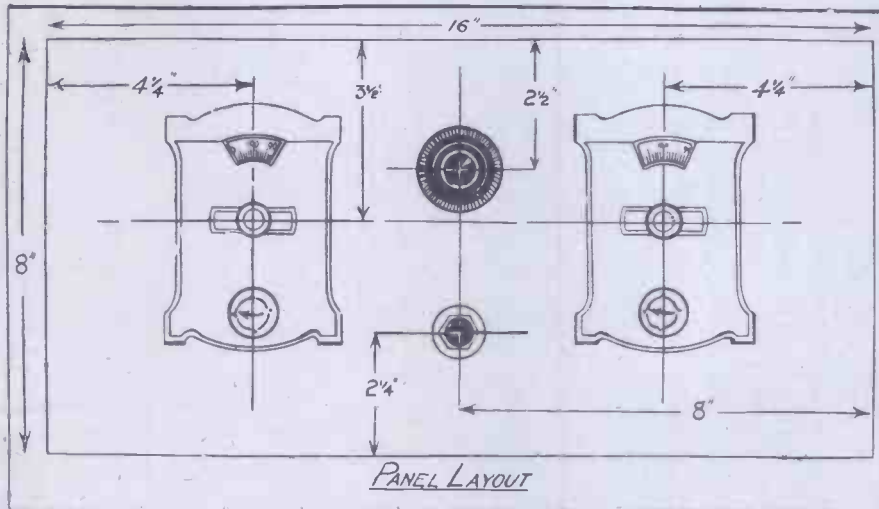

type, and the last is preferably a power valve. —or, better still, particularly for the local station, one of the newer super power valves, in two, four, or six-volt variety. It is not generally realised that the choice of the correct valves is becoming increasingly important, and an unsuitable valve will not only give poor signals, but may reduce the selectivity to a very marked extent.

At the same time, those amateurs who are fortunate enough to possess several valves should try experiments, particularly in the detector stage, although personally I have found the H.F. valve (not because of any special "H.F." properties, but because it happens to suit the transformer) to be particularly suitable here.

Neutralising.

One generally speaks of "neutralising" such a circuit, but I think the better term would really be stabilising, for a complete neutralisation is not always a most desirable state. So long as the set will not oscillate without reaction over the whole wave-band for which it is designed, a slight amount of "feed-back" can be allowed to remain, giving us additional reaction amplification, and reducing the damping in the circuit, thus adding to its selectivity.

In stabilising the present set, the reaction condensers should be set at zero, the aerial disconnected, and the first condenser set at a low value, say ten degrees. The second condenser should then be moved backwards and forwards, when, if the neutralising condenser has been set at a minimum position, a point will be found (sometimes

used, the set should pass in and out of oscillation quite smoothly. You can then connect the aerial and earth as previously described.

Aerial Earth and Battery Connections.

The aerial connection is taken to the spring clip referred to, and the earth is connected to the negative of the L.T. battery or accumulator. The flexible leads passing from the set to the batteries are already indicated on the wiring diagram, so will give no trouble. In the particular form of cabinet used there is space at the back for an H.T. battery (or rather two separate H.T. batteries) giving in all 120 volts.

Above this is a shelf upon which the accumulator may be stood, together with the grid bias battery. Although a partition is provided to separate the battery compartment from the set compartment, this is not necessary, and indeed I would suggest it be dispensed with so as to enable you to make adjustments to the leads conveniently. However, some readers may prefer the partition and the manufacturers are therefore supplying it.

Once the leads have been connected you may have a slight trouble in identifying them if you are not careful, and for this reason I suggest that the positive and negative battery leads be finished in

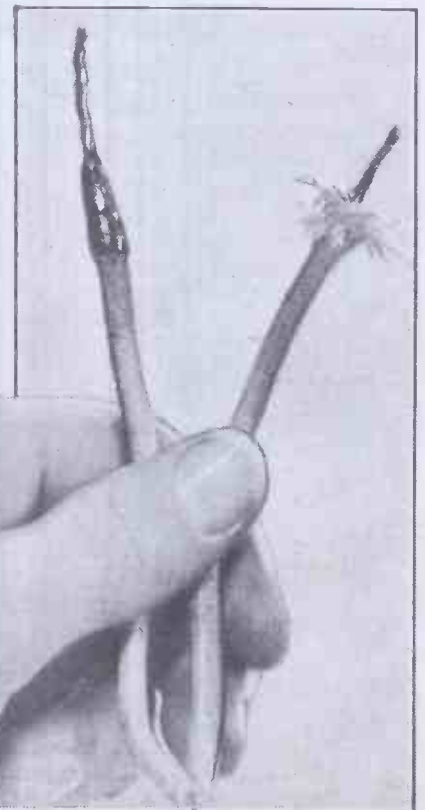

Finish off the "pigtails" with sealing wax or Chatterton's compound.



“Do You See What S.T.’s Have Done?”

“They’ve insured every one of their valves with Lloyd’s; not just against breakage or anything like that, but against them going phut in your set. When you heard what a big improvement I got on my Solodyne when I changed over to S.T.’s, you said it was too good to last—in spite of their talk about them being built like the Pyramids. Well, I don’t know what you think, but when the best known insurance people in the world will take on a thing like that, which for 22 years has been considered far too much of a risk, it’s certain, *they’re* convinced, anyway.

S.T.’s say, here, in their advertisement that they’ll replace instantly any valve which does not give a thoroughly satisfactory life. They can’t treat you any more decently than that, can they?

What’s good enough for Lloyd’s ought to be good enough for you. It’s not my affair, but if I were you, I’d buy S.T.’s at once. But don’t be put off with something ‘just as good.’ Walk out if they try that stunt on you.”

TYPES & PRICES.

2-VOLT.		4-VOLT.		6-VOLT.	
S.T.21 (H.F.) 0.1 amp.	14/-	S.T.41 (H.F. and Det.)	14/-	S.T.61 (H.F. and Det.)	18/6
S.T.22 (L.F. and Det.)	14/-	0.1 amp.	14/-	0.1 amp.	18/6
0.1 amp.	14/-	S.T.42 (Power) 0.1 amp.	18/6	S.T.62 (Power) 0.1 amp.	18/6
S.T.23 (Power) 0.15	18/6	S.T.43 (Super Power)	22/6	S.T.63 (Super Power)	22/6
amp.	18/6	0.25 amp.	22/6	0.25 amp.	22/6

If you are unable to obtain an S.T. valve from your local retailer, write direct to us, or call. All valves will be sent by post and insured by us against breakage. C.O.D. orders executed on receipt of post card.

S.T. LTD., 2, Melbourne Place, Aldwych, LONDON, W.C.2.
(Next to Australia House).



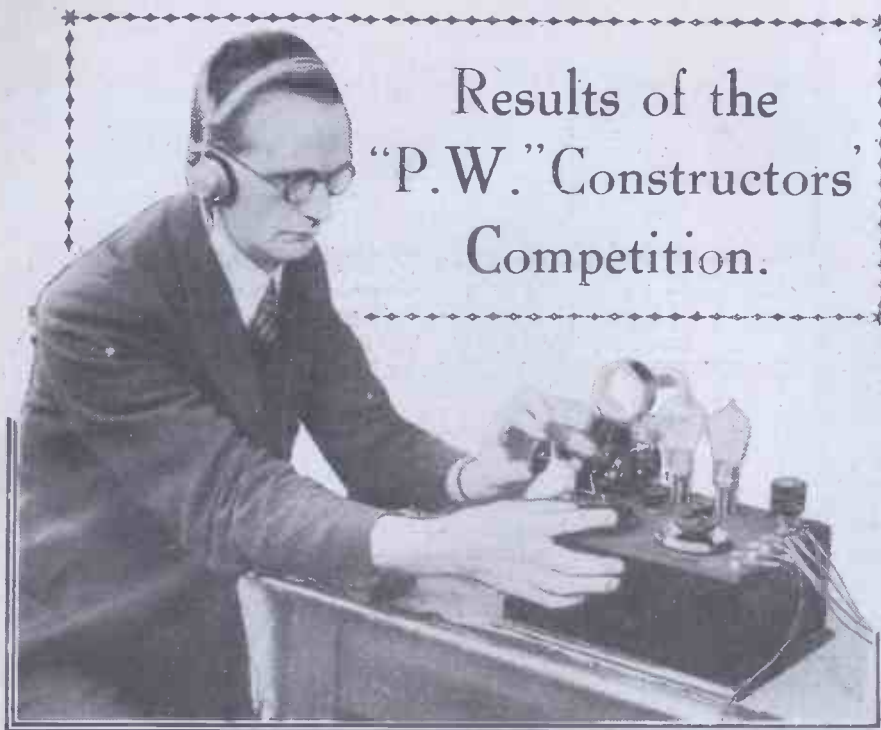

Results of the "P.W." Constructors' Competition.

FIVE huge tables each stacked with hundreds of pieces of apparatus—that was the sight that greeted us as we entered the large room set aside for the entries to "P.W.'s" great constructors' competition. And our first glimpse of that orderly assembly assured us that the task of adjudication was going to be no easy one. But after two days' hard work we had eliminated all but a few of the entries, these being set aside for further examination and, where necessary, further careful tests.

But it was a most interesting experience, even if it had been a somewhat arduous one, and at its conclusion we felt that we had been in really close touch with hundreds of our readers. Here we had had before us a multitudinity of the products of their workshops, workshops which no doubt in cases extended no farther than kitchen tables. And what of it—probably a large percentage of the prizewinners had facilities no more elaborate than this. But under whatever handicaps our competitors laboured, their efforts were, on the whole, very creditable indeed.

"Home-made" Apparatus.

Some of the entries simply glowed with evidence of careful, painstaking workmanship, although, on the other hand, there were many that hardly merited a second glance. It was disappointing to note that in class "A" (home-made amplifier units) many readers submitted instruments consisting of manufactured components throughout. It will be remembered that we stated in our every announcement that "in all cases workmanship and design and the amount of actual 'home-made' apparatus will be primarily considered in the judging." Therefore, although in appearance the units submitted by the prizewinners in Class A did not reach the standard of many other entries, both were sufficiently far ahead in novelty of design and preponderance of "home-made" parts to give them the leading places.

Also a number of entries that would, perhaps, in other circumstances have merited much closer attention, failed to gain this because they did not answer to the

LIST OF PRIZE WINNERS.

CLASS "A."

(L.F. Amplifier Unit).

- 1st.—E. DELLAMORE, 20, Cassellden Road, Harlesden, N.W.
2nd.—R. G. F. MILLER, 3, Rutland Square, Edinburgh.

CLASS "B."

(Variable Condensers).

- 1st.—F. R. SCOGINGS, 9, Keppel Road, East Ham.
2nd.—Geo. EDWARDS, 4, Bray Road, Buddicum Park, Chester.

CLASS "C."

(Original Components).

- 1st.—J. H. FLETCHER, 30, Greenfoot Lane, Old Town, Barnsley, Yorks.
2nd.—S. BECKWITH, 78, Dawlish Road, Leyton.

CLASS "D."

(Variometers).

- 1st.—P. G. BAILEY, 27, Bowrons Road, Wembley.
2nd.—All RODGES, 224, High Street, Harlesden, N.W.

CLASS "E."

(One Valve Set—limited to constructors under 16)

- 1st.—F. FISHER, 67, Edenbridge Road, Enfield. (Age 13½ years.)
2nd.—J. V. MIDWINTER, 17, Augustus Road, Southfields. (Age 15 years.)

initial category requirements. Thus loud speakers, frame aerials and other accessories were entered for Class C, which we specifically stated was to be devoted to original wireless receiving set COMPONENTS.

Many excellent variable condensers were entered in Class B, although we noted with

sorrow that it was the minority that embodied novel or even modern designs. For instance, there were very few "straight line" models and fewer still employing dual or gang controls. Also very little heed appeared to have been paid to capacity values—these seem to have been given very cavalier consideration. Capacities ranged from .0002 to .002 mfd. and very infrequently was anything near to .001 registered. The standard of workmanship was, however, very high throughout this class.

In Class C, which was devoted to novel receiving set components, there appeared to be considerable unconscious imitation of manufactured components. At least we trust it was unconscious, because the word "original" clearly does not apply to home-made versions of standard radio products. For instance, there were dozens of regenerative and tapped tuners and fine tuning devices absolutely identical in design to similar articles as seen in catalogues and shop windows.

Original but Not Practical.

The anti-microphonic valve holder received close attention, but there were very few that had the slightest pretensions to originality. Some of the devices submitted were weird and wonderful, and it would be impossible to describe them in words. On the other hand, instruments were submitted that were distinctly original and were beautifully made, but from a practical point of view they would not have been of any very great value to the average constructor.

The object of including this class (Class C) was to stimulate inventive genius, and without question the entries taken as a whole showed that "P.W." readers at least are not lacking in that essential inventor's quality—imagination.

Many and varied were the variometers submitted for inclusion in Class D. They ranged in size from one measuring two feet across down to a tiny little affair that was not much larger than a pea. And, by the way, many competitors seemed to think it was a competition for "freaks" and curiosities instead of the straightforward constructional contest we intended it to be. We had all types of variometers lined up in front of us in their hundreds, but all too many were eliminated almost at first sight.

The Most Interesting Entry.

It was interesting to note that "self-supported" windings were well in evidence, and that the ball type was well represented. Basket coil and spider-web types were there in fair number, but the "D" coil form was in the minority.

In our opinion the most interesting and most prize-deserving entry in the whole competition was the set that gained the first prize in Class E. Built by a boy aged 13, the one-valver was home-made practically throughout, and very nicely home-made at that. But most of the other sets submitted were pretty poor affairs, more especially in comparison with the above-mentioned one. We must take it that these entries were fairly representative of the sort of sets our junior amateurs are turning out, and we can only trust that the radio societies connected with large schools or groups of schools will endeavour further to spread the cult of careful craftsmanship among our potential Lodges and Marconis.

"P.W." Prize Winners

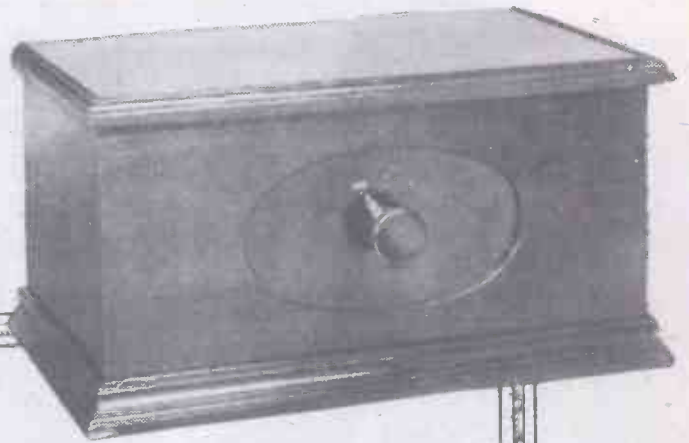

The amplifier unit which gains the first prize in Class A. Practically every component used was "home-made," and yet the instrument gave most excellent results on test.

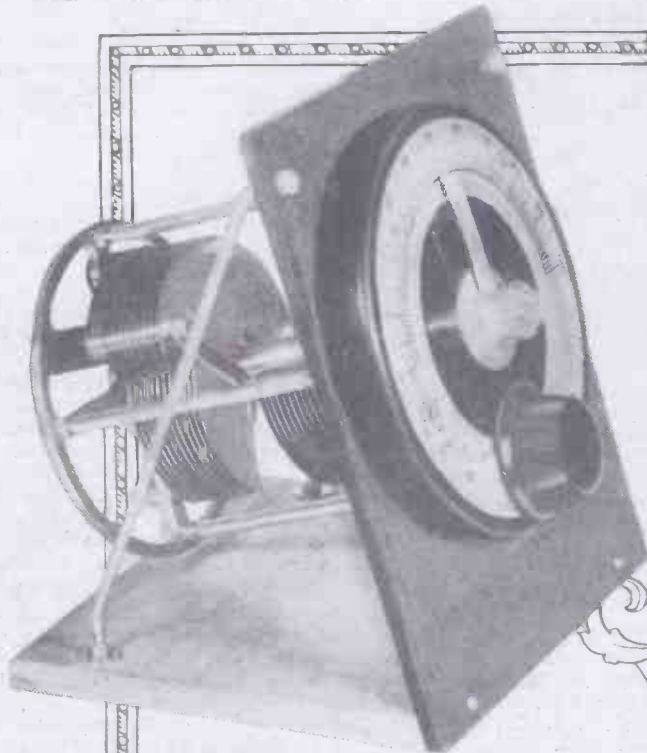

The first prize in Class B is given to the amateur who made the above variable condenser. It embodies a novel "dual," or "gang," arrangement.

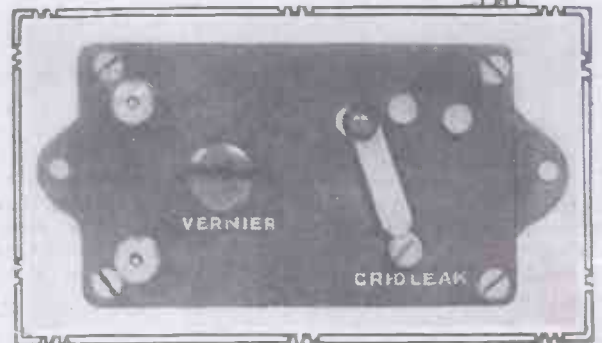

This baseboard mounting of combined variable grid condenser and variable grid leak achieves the premier position in Class C.

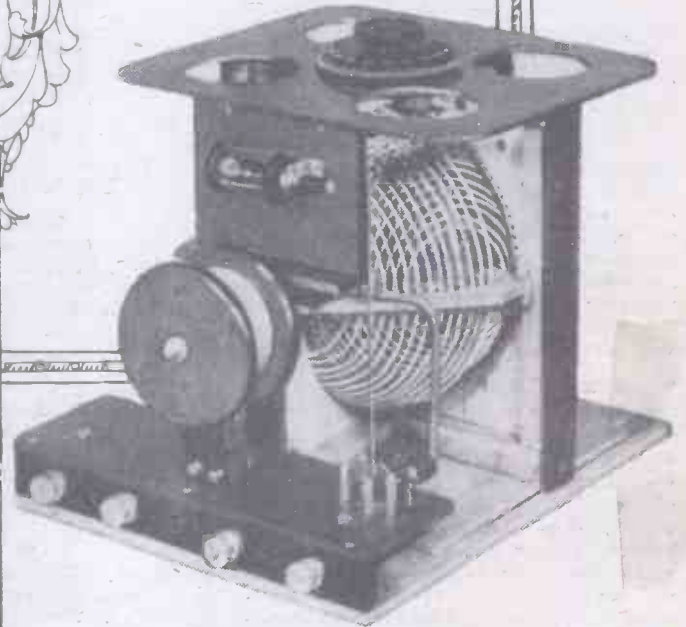
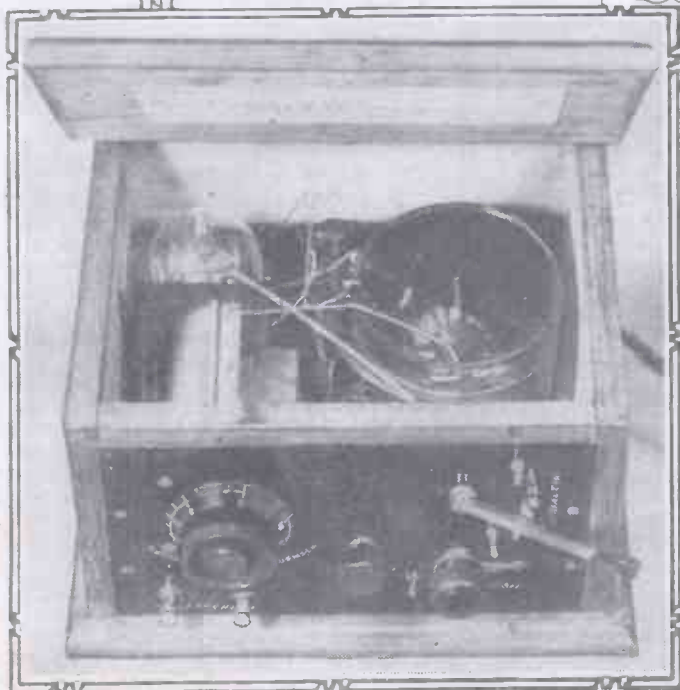

(Above) The variometer which is the Class D first prize winner. It stands over a foot high and has a very smooth action.

(Left) This one-valve set embodying a majority of home-made components is an easy first in Class E. The set was constructed by a 13½-year-old boy.

The first and second prizes in each of the five classes are respectively \$25 and \$15 in cash.



The five second prize winning pieces of apparatus entered for "P.W." Constructors' Competition are shown on this page. There is very little to choose between the firsts and seconds in Classes B, C and D, and but small points decided their respective places. The first prize winners in Classes A and E are, however, "miles ahead" of any of the other entries in their own sections.

On the left is shown the amplifier which is awarded second prize in Class A. The valve is contained in the case, and choke, resistance-capacity, and transformer units can be plugged in as desired.

(Below). A flexible coil-holder control which allows a dial to be placed anywhere on a panel and the coil-holder to be mounted at the most convenient point on the baseboard gains the second prize in Class C.

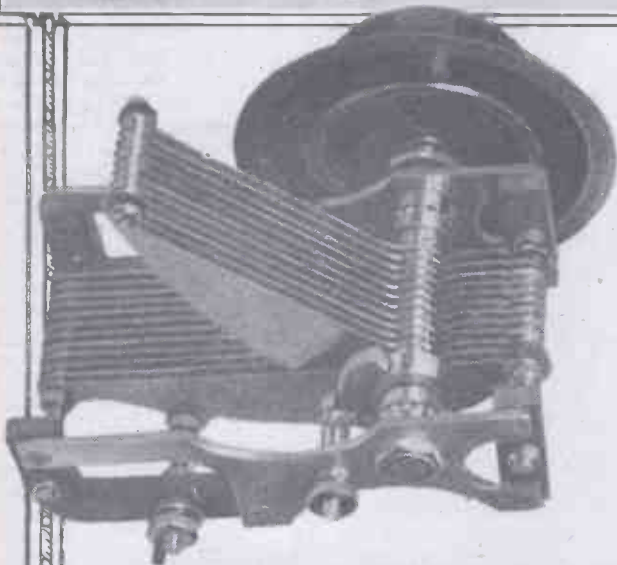

This variable condenser is a beautiful piece of work and deservedly gains the second award in Class B. As will be noticed, it is an S.L.F. model and is provided with ball bearings.

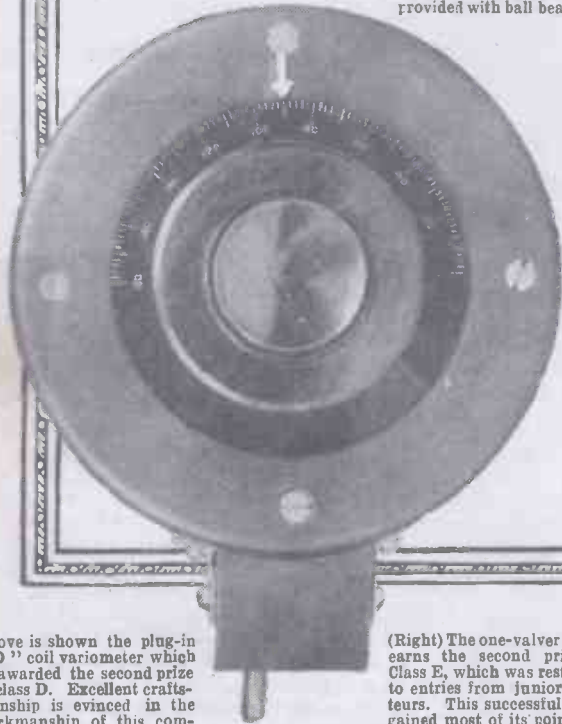
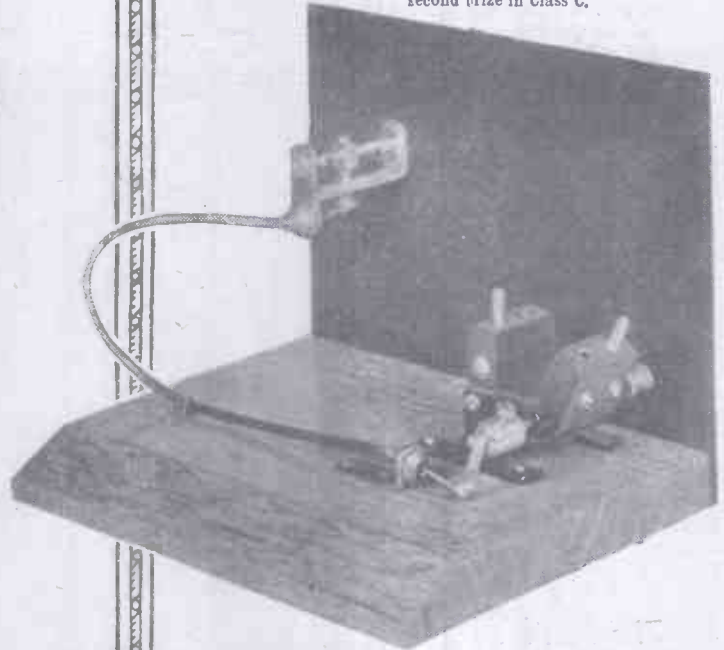

Above is shown the plug-in "D" coil variometer which is awarded the second prize in class D. Excellent craftsmanship is evinced in the workmanship of this component.

(Right) The one-valver which earns the second prize in Class E, which was restricted to entries from junior amateurs. This successful entry gained most of its points for performance.

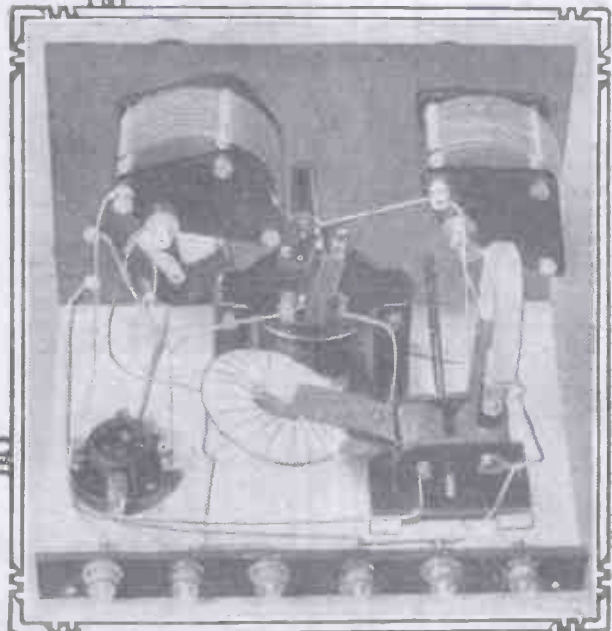

ALL stations of the B.B.C. are co-operating with local authorities to help some officially recognised civic charity over the Christmas season. It is understood that the London station will do its best for the Lady Mayor's Fund to provide toys for poor children.

BROADCAST NOTES.

FROM OUR BROADCASTING CORRESPONDENTS.

The B.B.C. and Christmas Charities—Broadcasting and Gramophones—The Time-Signal Storm—Artistes' Fees—Flotsam and Jetsam—Wave-length Anxieties—Bottled Radio Again—The New Theatre Agreement.

Broadcasting and Gramophones.

The good relations that have existed between the Gramophone industry and the B.B.C. for such a long time are now menaced. Recently there began to appear in a section of the Press a number of letters comparing gramophone reproduction with wireless broadcast reproduction, always to the advantage of the former. This spread until it was obvious that it was part of an inspired campaign against broadcasting. It then transpired that the campaign was in the hands of the publicity agents of one of the big gramophone groups. These agents had linked the letters with a general scheme of space-buying, and there was no chance, therefore, that broadcasting would have fair play. Simultaneously there was a change in attitude towards broadcasting on the part of individual members of the gramophone industry. The B.B.C. are fully alive to the possibilities of the position, and are considering reprisal measures. If the gramophone industry declare war on broadcasting they are likely to fare no better than the concert industry is now faring. If, on the other hand, the reasonable policy of the last two years is allowed to remain, then both industries should continue to flourish side by side. What may happen is that one of the gramophone groups will break away from the industry and make a special exclusive arrangement with the B.B.C. for a term of years. It is understood that negotiations to this end are already in hand.

The Time-Signal Storm.

For more than a year protests have been reaching the B.B.C. against the superimposing of the six-dot seconds from Greenwich on whatever transmission might be in progress at ten o'clock nightly. All music-lovers were naturally up in arms against such an atrocity. The general public likewise became restive. In the end the Savoy Hill people were forced to pay attention to the protests. After careful consideration, it was decided to put out the six-dot seconds always from 5 X X at four and ten; and from London at ten, when possible. This arrangement, taken in conjunction with the frequent transmission of Big Ben, was believed to be the best solution of the difficulty. When it was impossible to give the six-dot seconds from London, then the announcer was to transmit the time by the studio clock before beginning the news bulletin. The change has resulted in a new storm of protest, particularly in Glasgow;

but there is no doubt that the vast majority of listeners are in agreement with the B.B.C. There can be no excuse for superimposing a mechanical device on the last bars of an aria. On the other hand, it would probably have been wiser to have dropped the Greenwich signals from London at ten entirely. Their occasional transmission is not of much practical value.

Artistes' Fees.

Artistes are already demanding increased fees for broadcasting as a result of the



Mr. Rex Palmer, Director of the London station, before the microphone at Savoy Hill

prospective increase in B.B.C. revenue next year. Several well-known artistes have been dropped in consequence of these premature demands. But there is no doubt that the B.B.C. will have to pay a good deal more liberally next year, both to artistes and to authors. The Musicians' Union, too, is planning another big campaign against the B.B.C. and proposes a lightning strike of all broadcasting orchestras if its fresh demands are not met immediately. Altogether the troubles of the Corporation promise to be in no wise less than those of the Company.

Flotsam and Jetsam.

That these artistes were to broadcast was exclusively announced on this page. Their work was so well received that the B.B.C. are trying to arrange a return engage-

ment. More letters of appreciation reached Savoy Hill on account of this performance than in the case of any other programme feature in the past twelve months.

Challenge of the Critics

It is understood that the B.B.C. have accepted the challenge thrown down by the music critics to give a demonstration of broadcast reception before an independent group of their number. A controversy has been raging about whether music can be reproduced by wireless. The old school of criticism will not admit that wireless reproduction is more than a lamentable travesty of the original. On the other hand, the B.B.C. claim that they can demonstrate that it is almost identical with the original. Anyway, the challenge has been accepted, and if the test is conducted fairly on both sides, some extremely interesting results are promised.

Wave-length Anxieties.

The B.B.C. engineers have been passing through an extremely worrying time in re-adjusting the wave-lengths. The theory of the common British wave-lengths for the relays did not work because of geographical proximity. Then there was evasion and misunderstanding on the Continent. Germany was almost the only country apart from Great Britain where the Geneva plans were faithfully and intelligently applied. The position of broadcasting in France is so confused that no stable arrangements are possible. Some time will elapse before the new scheme settles down.

Bottled Radio Again.

There is a revival of interest at Savoy Hill in the possibility of effective sound recording. Authenticated news has reached the B.B.C. of a new sound recorder evolved on the Continent. This is stated to represent a great improvement on the Vox Haus machine brought out last year and investigated by B.B.C. engineers in Germany.

The New Theatre Agreement.

Mr. Walter Payne, for the Society of West End Theatre Managers, expresses himself as well pleased with the development of negotiations for a new agreement between the theatres and the B.B.C. It will be recalled that the present agreement which expires on December 31st, allowed the B.B.C. to take 26 excerpts of thirty minutes each during the year; excluded first-nights, and recommended that normally the excerpts should be taken on Friday or Saturday. This agreement seems to have satisfied both parties and is to be continued with some minor relaxations in favour of the B.B.C.

A TRANSFORMER WITHOUT A PRECEDENT—

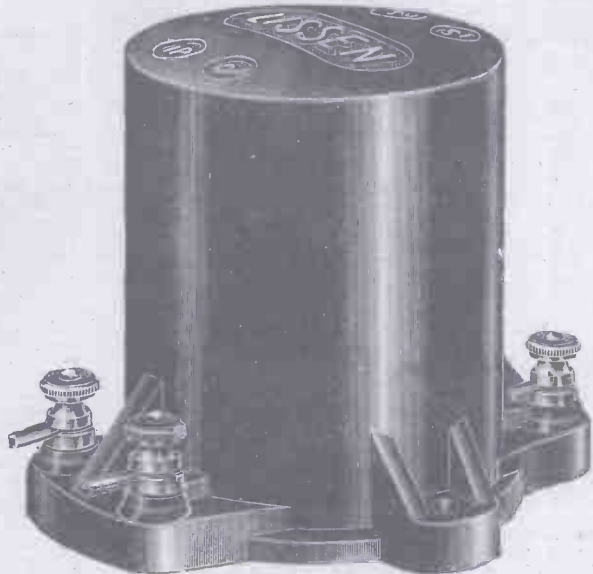

a GREAT CHOKE as well as a GREAT TRANSFORMER!

Transformer and Choke coupled amplifiers give greater and better volume per stage than resistance capacity coupled amplifiers (popularly referred to as r.c. sets). Less skill is also required in balancing an r.c. circuit to suit the valves used, an important point which requires careful watching in r.c. sets. No special high tension voltage is necessary for transformer and choke couplings, either. Transformers and Chokes are widely used, therefore, for excellent reasons. The advantage of being able to use a Transformer also as a Choke is obvious. And **NOT ONLY IS THE NEW LISSEN A GREAT TRANSFORMER, but by the simple act of connecting two of its four terminals together, we have found it to be A GREAT CHOKE, ALSO.**

LISSEN has therefore given you a radio part that saves you buying two parts—for a single LISSEN Transformer now enables you to make use of the two most used methods of low frequency amplification.

FOR USE AS A CHOKE:

All you have to do is to connect together the terminal marked O.P. to the terminal marked I.S. Then take a connection from the remaining two terminals, and you have a **HIGHLY EFFICIENT CHOKE**. Your dealer will show you how easily you can do this if you do not already know. Ask him.

Test this new Lissen as a Transformer against the most expensive Transformer you know of—test it as a Choke against the most expensive Choke you know of. If within seven days you find a better Transformer or a better Choke, no matter how high its price, then take the new LISSEN back to your dealer. It is significant that LISSEN has unhesitatingly withdrawn in favour of this new LISSEN all the previous expensive LISSEN transformers which have been on the market for several years.

USE IT AS A TRANSFORMER—USE IT AS A CHOKE, either way it AMPLIFIES FULLY EVERY NOTE, EVERY TONE, EVERY HARMONIC, EVERY OVERTONE. Never again pay a high price for a transformer—this new LISSEN will replace any transformer mentioned or used in any circuit. Choose your own transformer, and your own parts. Remember there are many advertising manufacturers, and that they expect a share of the use and mention of their products in any circuit published in periodicals. You can gain in performance and in economy if you choose your own transformer and other parts, for LISSEN now gives you keen prices as well as LISSEN quality.

8/6

GUARANTEED FOR 12 MONTHS

Turns ratio 3 to 1. Resistance ratio 4 to 1.
Use it for 1, 2, or 3 stages L.F.

It is suitable for all circuits and all valves you will want to use

USE LISSEN FIXED CONDENSERS, TOO, Mica & Mansbridge

Type

LISSEN Mica Type CONDENSERS

Small energy-conserving condensers—note the new case which enables the condenser to be used upright or flat. At present the new case is available only in the most used capacities, but will quickly become a LISSEN standard.



Capacities—

.0001 to .001 1/- each (much reduced).

.002 to .006 1/6 each (much reduced).

Accurate to 5%—they never leak—they never vary.

LISSEN Mansbridge Type CONDENSERS

To a fine LISSEN quality condenser is added the specially moulded case—the condenser cannot short circuit on to its case. The new LISSEN case protects you if the condenser is used in any circuit connected straight on to the electric light mains. And due to our new policy of direct-to-dealer distribution this LISSEN Condenser costs no more than the ordinary type.



.01 to .09	2/4
.1	2/6
.2	2/8
.25	3/-
.5	3/4
1.0	3/10
2.0	4/8

LISSEN FIXED GRID LEAKS

A case of these was left on our factory roof during the summer of 1925, soaked in rain, baked by sun, and the resistance value of these leaks never altered.

All capacities, previously 1/8. Now 1/- each.



Improve every circuit by using LISSEN parts wherever you can—save money, too—for now you get keen prices as well as fine quality.

LISSEN LIMITED,
8-16, FRIARS LANE,
RICHMOND, SURREY.

(Managing Director: Thos. N. Cole.)

AN ALL-WAVE SUPER-HET.

Designed by FRANK PHILLIPS, M.I.E.E.

EASILY CONSTRUCTED. DESIGNED TO WORK ON ALL WAVES, WITH A FRAME OR SHORT INDOOR AERIAL.

1. The Burndept "All-Wave" Super-Heterodyne Receiver has been designed for those who desire to construct a Broadcast Receiver of extreme selectivity and enormous range, giving absolutely faithful reproduction. The instrument is designed to receive on all waves from 50 to 3,000 metres, and can be used with a frame or ordinary aerial; in the latter case it need not be a large one, in fact twenty or thirty feet of wire, ten or twelve feet high, will bring in stations all over Europe, while a short length of wire stretched across a room, or around a picture rail will enable quite a number of stations to be received. Within ten miles of a broadcast station an aerial is not necessary at all.

2. As no doubt the construction of an instrument of this type will be undertaken by a great number of amateurs who already have components by them, the values for the various items are shown, but where possible it is recommended that similar types of components be used to those listed to enable results to be obtained equivalent to those obtained from instruments constructed and tested in our Research Department.

3. The Receiver is very easy to assemble and wire, as construction is proceeded with in the following manner:

1. Take a wooden base board, 19 1/2" x 8 1/2" x 3/4" upon which all valve holders, resistor holders, coil plugs, transformer and fixed condensers should be mounted and wired up.
2. Fit an ebonite strip 19 1/2" x 3 1/2" x 1/4" with terminals and screw to one edge of base board.
3. Assemble 3 variable condensers, 3 super-heterodyne transformers, potentiometer, etc., on the front panel of ebonite, 20" x 9" x 1/8" and wire up.
4. Screw front panel to other edge of base board and link up the two assemblies and terminals together.
5. The instrument is now complete and can be tested, if correct, it can be slipped straight into its cabinet, the front panel fitting flush and the terminals projecting through a slot provided at the back.

4. The finished appearance of the Receiver will be illustrated in the next issue but on this page is a complete theoretical diagram, in which every component is numbered, the numbers being repeated on a large lay-out and wiring diagram which can be supplied, No. 487/a.

5. The following comments concerning some of the components under their respective reference numbers will no doubt be of assistance to the constructor:

- Ref. Nos.
- 1-4 Burndept Flanged Valve Holders are recommended being fitted with soldering tags and terminals, to screw down on base board.
 - 5-7 Burndept Anti-Phonic Holders strongly recommended for last three valves, but of no advantage for others.
 - 14-19 Five different values of Fixed Resistors are required, being screwed into six adaptors (8 to 13), which can be changed at any time to try out new valves. It is essential for resistors to be inserted in the correct sockets as otherwise valves may be destroyed. Number 14 is 12 1/2 ohms, 15 and 17 are 7 1/2 ohms each, 16 is 4 ohms, 18 is 10 ohms, and 19 is 3 ohms. These values are correct for Burndept valves, type H.L. 512 in holders Nos. 1 and 2, type H. 512 in 3, 4, 5 and 6, and type LL. 525 (or L. 525) in No. 7.
 - 20-24 Burndept Universal Coil Plugs with side terminals and soldering tags which are fitted with a socket and a pin are shown in the wiring diagram, the plain circle representing the socket, and the circle with double lines across it, the pin. When screwing these components to base board, care should be taken not to reverse pin and socket and also to space plugs apart the correct amount.
 - 25-26 Variable Condensers .0005 mfd. should be of reliable make and fit in space allowed in lay-out. The type recommended is where moving plates are connected to metal end plates. Connections to fixed and moving plates should be exactly as shown in lay-out, one hole fixing condensers are not recommended, nor those with vernier incorporated. To obtain the necessary fine adjustment the condensers should be fitted with dials such as the Burndept Ethovernier or Super Vernier type.
 - 27 Variable Condenser .00006 mfd. Special type reaction condenser is supplied with pointer knob and aluminium scale.
 - 28-29-30 Burndept Super-Heterodyne Transformers, usually supplied as a kit of three, perfectly matched.

- Ref. Nos.
- 31 Low ratio, L.F. Transformer, recommend any good make of 2:7-1 ratio, for best results.
 - 32 Burndept Potentiometer of either 250 or 500 ohms fitted with knob and dial to match those fitted to reaction condenser.
 - 34-37 Grid Leaks should be mounted between clips on pieces of ebonite and those connected to the grid of first valve (oscillator) and sixth valve (first L.F.) must not be lower than 0.25 megohms or have a higher value than 0.5 megohms.
 - 38 Fixed Condenser .00005 mfd. is rather difficult to obtain, but two .0001 types can be connected in series as substitute.

6. The valves and the functions they perform will now be dealt with under the various reference numbers against each valve holder.

- Ref. Nos.
- 1 Takes oscillator valve, Burndept type H.L. 512, controlled by Resistor 14.
 - 2 Takes first Detector, Burndept type H.L. 512, controlled by resistor 15.
 - 3-4 Takes two intermediate Frequency Amplifiers, being two Burndept type H. 512, controlled by one Resistor 16.
 - 5 Takes second Detector, Burndept type H. 512, controlled by Resistor 17. This valve and the next are both high amplification valves because of the resistance-capacity coupling.
 - 6 Takes the resistance-coupled L.F. valve, type H. 512, controlled by Resistor 18, which has a negative bias impressed on the grid, arranged by the position of resistor.
 - 7 Takes a special power valve, type LL. 525 of very low impedance to suit up-to-date horn and cone type loud speakers. It is, of course, possible to use other makes of valves having same characteristics as above but unless the constructor has sufficient technical knowledge to define what exactly are required, it would be as well to keep to those mentioned.

7. Coming now to the coils to plug into the coil plugs, 20 to 24, to adjust the instrument to receive on various wave-length ranges, the reference numbers are again utilised for the plugs.

- Ref. Nos.
- 20 Takes the "Aerial Tuning Coil," which is removed when a frame aerial is used. It is tuned to required wave-lengths by condenser 25.
 - 21 Takes "Reaction Coil" for increasing strength of signals. The amount of energy fed to input circuit is controlled by Condenser 27, which can be varied so far as to cause the aerial circuit to oscillate. This should be avoided except on waves of about 60 metres or below, regarding which see Paragraph 9. On powerful nearby stations the reaction coil can be removed.
 - 22 Takes "Coupling Coil," which picks up energy from oscillator coils 23 and 24.
 - 23 Takes "Oscillator Grid Coil," tuned by condenser 26 to approximately 50 kilo-cycles above or below incoming wave.
 - 24 Takes "Oscillator Plate Coil," which has to be of such size to enable Coil 23 to oscillate.

8. The following table indicates the best Burndept coils to use in each position to receive on various wave-lengths:

Wave Range, Metres	Plug 20 Aerial	Plug 21 Reaction	Plug 22 Coupler	Plug 23 Osc. Grid	Plug 24 Osc. Plate
35-50	3	5	3	5	5
50-80	5	10	3	10	5 or 10
70-140	15	25	5	15	5 or 10
130-300	35	50	15	35	15 or 20
275-550	50	75	25	60	35 or 40
500-1000	100	150	35	100	75
900-1600	150	150	40	150	100
1200-2200	200	200	50	200	150
1800-3400	300	300	60	300	200

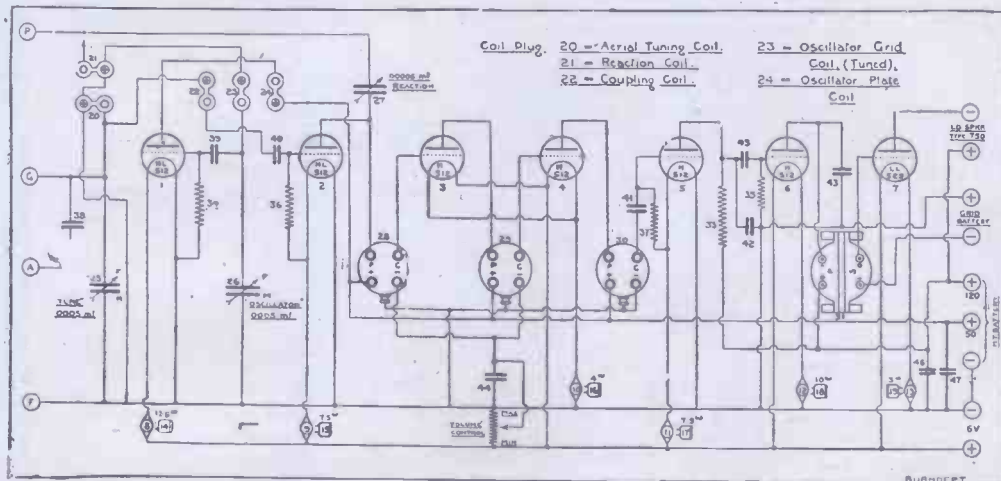

9. Coils are not required in plugs 23 and 24 when receiving waves below 60 metres, better results being obtained by using sufficient reaction (Condenser 27) to make input circuit oscillate, continuously giving autodyne reception.

AN ALL-WAVE SUPER-HET.

Designed by FRANK PHILLIPS, M.I.E.E.

II.

10. The method of connecting various types of aerial are as follows:

- (a) An ordinary aerial should be connected to the terminal A and the earth wire, if any, to F. If reception below 80 metres is taking place, however, it is better not to connect the aerial at all but place it about a foot away from the coils. This type of aerial necessitates the use of coils 20 and 21.
- (b) To get best results from a frame aerial it should be tapped a few turns from plate end, thus tapping going to F and ends of frame to P and G, no coils being required in 20 and 21 as reaction is obtained by means

that is, not to reverse any + and - connections. A standard 16-volt tapped grid battery should be used and the plugs inserted to give correct grid bias to last valve, depending of course, on the type used. At 120-volts H.T., if using an LL.525, the grid bias should be - 16-volts, or with an L.525 - 7½-volts.

13. The L.T. Battery must be an accumulator of 6-volts, being 50 or 60 ampere hours (actual) which should operate the set for about a fortnight without recharging. A small booklet can be supplied regarding suitable charging apparatus for these accumulators, W.P. 100. This supply, of course, should be connected to L.T. terminals on back of instrument.

14. The High Tension Battery for an instrument of this kind must be of ample size as the current consumption is rather high, and to obtain faithful reproduction it is necessary that the full voltage be always maintained on the anodes of the valves, especially those

on the low frequency side. Wherever possible use high-tension accumulators, as these alone will give a steady flow of current at a constant voltage. Details of apparatus for obtaining this supply direct from the mains will also be found in the booklet referred to above, W.P.100. This supply, of course, should be connected to the terminals marked H.T. on back of instrument. If two batteries or accumulators are used to make up required voltage, these should be connected in series. The remaining - terminal being connected to H.T. - a tapping taken at 50-volts on the battery to the + 50-volt terminal and the final 120-volt + terminal to be connected to the remaining + terminal on instrument.

15. The remaining pair of terminals marked "Loud Speaker 750" allow one or more Burndept type 750 Loud Speakers to be connected. 2,000 ohm type Loud Speakers

must be used, but the best results are not obtained if the LL.525 valve is used in the last stage of Receiver. Take great care to connect the + terminal of the set to the Loud Speaker + (those with cord connections usually have a red thread in + cord). Any Loud Speaker, providing the resistance does not exceed 800 ohms, may be used and faithful reproduction will be obtained.

16. It is possible to substitute for the last valve, LL.525 type L.525 which will reduce the consumption of high tension battery current by nearly one half, and is recommended if dry batteries have to be used. The use of the last mentioned valve, however, has one serious disadvantage, namely, owing to its higher amplification factor, the grid cannot be operated nearly so negative as the LL.525 and, therefore, at really full volume a certain amount of distortion occurs. The LL.525 type is recommended where the high tension battery is of sufficient capacity.

17. Presuming coils have been inserted in the five plugs, the receiver should be tuned to the nearest broadcasting station. The "Reaction and Volume Controls" should be set about half-way round. Turn the two tuning dials round more or less together, a slight "rushing" sound being heard in the Loud Speaker when they are synchronised. Once the required station has been picked up the "Volume Control" should be adjusted to secure the required strength, and the "Reaction Control" may also be adjusted to the same end. Too much "reaction" will make the first detector valve oscillate, and in that condition reception will be "mushy." If volume control is turned round too far some valves will oscillate and a continuous whistle will be heard. This must be avoided at all costs as reception will be spoilt.

In order to help further those who wish to construct this Receiver, BURNDDEPT WIRELESS Ltd. are prepared to supply, for a reasonable time, their Envelope containing Working Instructions, Wiring Diagram, and two 16-page booklets (usually sold at 2/6) at the reduced rate of 1/-. Fill in and post the coupon below, together with remittance, and you will receive the Envelope and contents. Alternatively, your Local BURNDDEPT dealer will supply the Envelope at the reduced rate on presentation of this coupon.

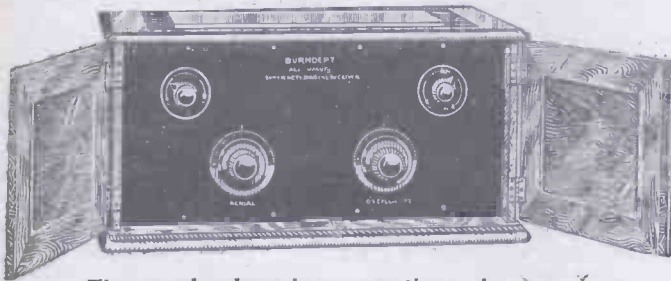

The completed receiver—note the main controls and absence of unnecessary components on panel.

of tap. Assuming a frame about 2 foot square, use ten or twelve turns of wire (tapped 4 or 5 turns from plate end) for 250-550 metres, while for 1,000 to 2,000 metres between 40 and 50 turns (tapped ten or twelve turns). Separate frames are recommended from the point of view of efficiency on the shorter waves.

CONSTRUCTION.

11. The lay-out and wiring diagram which can be supplied is so detailed as to make it unnecessary to give elaborate instructions regarding construction but the sequence of operations detailed in Paragraph 3 should be observed. It is recommended that all battery wire be run flat on base-board using insulated wire such as "Glazite" and all aerial, grid and plate wires be run as direct as possible, if convenient, using bare wire air spaced, soldering all joints unless a firm connection can be made under a screw.

OPERATION.

12. Take great care in connecting up batteries to terminals at the back of set,

To BURNDDEPT WIRELESS, LTD.,
EASTNOR HOUSE, BLACKHEATH, S.E.8

I accept your offer to supply a full-sized wiring diagram of the ALL-WAVE SUPER-HET. at the reduced rate and enclose postal order for 1/- to cover cost.

Name

Address

Name & Address of Local Dealer

Date



There'll be music o'nights in many a home this Christmas

FIRESIDES throughout the Country will, this Christmas, be brightened by music. Pure, mellow music, captured from the ether and realistically reproduced by **Brown Loud Speakers**. Your Christmas cannot possibly be dull if you have a good Wireless Set and a **Brown Loud Speaker**. For, with a **Brown** you are assured of a reproduction which is, indeed, remarkable for its fidelity.

If you want your gift to be appreciated, you cannot do better than give a **Brown Loud Speaker** or Headphone. See and hear any of the nine models at your Dealers.

There are nine types to choose from:

In addition to the two models shown here, there are seven other **Brown Loud Speakers**. From the little H.4 which costs but 30/- to the superfine Q type at £15 15s. you are assured of the same high standard of performance. Headphones too, from 20/- to 60/-



The Disc.
120 & 2000 ohms.
Black, Brown or
Cream and Gold
£7 7 0
Oxydised Steel
£8 8 0

Brown

The Hi.
120 ohms. £5 5 0
2000 ohms. £5 8 0
4000 ohms. £5 10 0



S. G. BROWN, LTD., Western Avenue, North Acton, W.1.

Retail Showrooms: 19, Mortimer Street, W.1; 15, Moorfields, Liverpool; 67, High Street, Southampton.
Wholesale Depots: 2, Landsdown Place West, Bath; 120, Wellington St., Glasgow; 5-7, Godwin Street, Bradford;
Cross House, Westgate Road, Newcastle; Howard S. Cooke & Co., 59, Caroline Street, Birmingham;
Robert Garmany, Union Chambers, 1, Union St., Belfast, N. Ireland.

Gilbert Ad. 6599

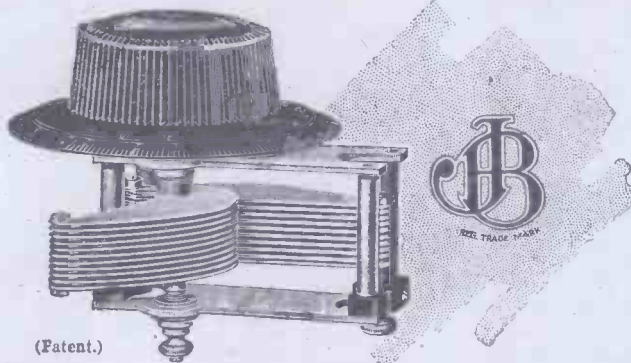

(Patent.)

Real Tuning at Last with the J.B. S.L.F. CONDENSER

What accuracy—what a wonderful "silky" touch! Yes! and the stations come in so evenly over the dial on all wavelengths that they can be quickly and easily tuned in or out, and accurately logged. It's all due to the precision and perfect workmanship which stamps the design and construction of the complete condenser. Accuracy in spacing is maintained by supporting the tips of the vanes; special bearings, eliminating springs, render side and end play impossible, and ensure a wonderfully smooth movement.

Finally you have the perfect finish of the condenser itself, adding that attractiveness in appearance which forms a perfect parallel to efficiency in tuning.

PRICES, complete with 4-inch Bakelite Dial | '0005 mfd. 11/6; '00035 mfd. 10/6;
| '00025 mfd. 10/-

The J.B. '0005 mfd. Dual Gang Control Condenser, complete with 4-inch Bakelite dial 33/-

JACKSON BROS
8, POLAND ST- OXFORD ST
LONDON - W.1
(First Floor) Telephone - GERRARD 7414

"EKCO" H.T. UNITS

SCRAP DRY BATTERIES!

By obtaining H.T. Current from Electric Supply Mains (D.C. & A.C.) by just attaching Adaptor to Electric Light Lampholder!

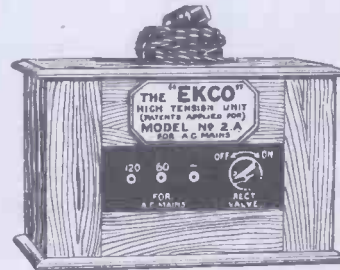

**SAFE!
SILENT!
SOUND!**

**BEST OBTAINABLE.
MOST POPULAR.
REASONABLY PRICED.**

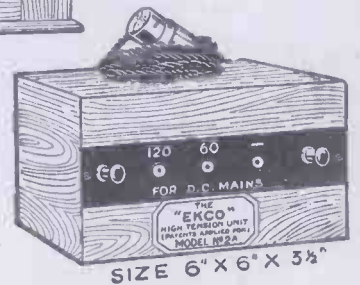

Illustrated Folder FREE!

UNITS TO SUIT } FROM **42/6**
ALL SETS - - -

Obtainable from all the leading Wireless Stores or direct from:—
E. K. COLE, Ltd., (Dept. A.), 513, London Road, WESTCLIFF - ON - SEA.

CURRENT TOPICS.

BY THE EDITOR.

The Wave-length Shuffle—Beam Interference—Cornish Amateurs Complain—All Wave-lengths Affected.

DURING the last few weeks it seems that the British Broadcasting Company have managed to collect sufficient data in connection with the recent alteration in wave-lengths, and now find it possible to consider what modifications are necessary as far as Great Britain is concerned.

It may be said that, on the whole, the results from the main stations have been satisfactory; but Belfast and Bournemouth will have to exchange wave-lengths in order to make it easier for listeners in certain districts in Ireland to separate the two stations from each other.

Relay stations sharing the wave-length of 288.5 metres have not been giving an uninterrupted reception over a sufficiently large area, and this is thought to be due largely to the fact that the two stations are not far enough apart. But when the wave-lengths were altered, our readers will remember, the B.B.C. had in mind only a *strictly local* reception for relay stations.

Common Wave-lengths.

The announcement that international common wave-lengths would be used caused a good deal of criticism a few weeks ago, and it was thought that interference would, if anything, be worse than before on these wave-lengths. But as a matter of fact, in practice it has been found that the interference on these international common waves has been less than was anticipated, although as a matter of necessity some of the relay stations are now remaining on the same wave-lengths of 288.5 metres. The revised wave-lengths for the British stations are now as follows:

	Metres
Daventry	1,600
Aberdeen	500
Birmingham	491.8
Glasgow	405.4
Manchester	384.6
London	361.4
Cardiff	353
Bournemouth	326.1
Newcastle	312.5
Belfast	306.1
Edinburgh	294.1
Liverpool	297
Bradford	254.2
Leeds	277.8
Nottingham	275.2
Sheffield	272.7
Plymouth	400
Hull	
Stoke	} 288.5
Dundee	
Swansea	

The B.B.C. state that they hope these modifications of the original wave-length plan will give an even better service to listeners, but in any case, reports will be warmly welcomed, and any other data regarding reception from the stations affected by the rearrangement.

It is interesting to note that since the opening of the beam wireless stations at Bodmin and Bridgwater many complaints of interference have been made by radio amateurs in the West Country.

In many cases they report that their contact with the various broadcasting stations has practically been cut off and they suggest this is due to the beam stations when in operation.

Trouble in Cornwall.

Interference is indeed particularly bad in Cornwall, and Mr. G. Pilcher, M.P., has been inundated with letters from Cornish amateurs bitterly complaining about the beam stations transmitting. Mr. Pilcher has asked the Postmaster-General whether he has any information regarding interference with ordinary wireless sets in Cornwall by the new beam system, and if he would approach the Marconi Company with a view to protecting the interests of owners of receiving sets in Cornwall and district.

The Postmaster-General has replied that the operation of the Post Office beam station at Bodmin did not interfere with broadcast reception in Cornwall providing suitable receiving apparatus was used by amateurs, although he agreed that some interference had been experienced by listeners in Cornwall who were using short-wave sets for experimental purposes. He considered this interference unavoidable.

This reply by the Postmaster-General has been strongly resented and criticised by many Cornish amateurs, who state that the official defence is absolutely incorrect and misleading. One reader writes to say that he has a first-class set, and declares that interference takes place practically all day long on any wave-length. Daventry, Paris, Eiffel Tower, Dublin and other low-wave stations, he states, are all the same. "The noise is awful, although my set is perfect," he writes. He wants to know if the Postmaster-General will explain how it is that on November 14th, when the beam station closed down in the

evening, his reception in Cornwall was perfect, adding that last winter no interference at all was noticed and it was considered that the beam station at Bodmin is causing all the trouble?

Another listener states that the engineers of the B.B.C. who made investigations in Cornwall recently were satisfied that there is some interference which justifies the complaints of Cornish listeners. The same writer has made many interesting tests, the results of which, he claims, prove conclusively that the interference is caused by the Bodmin station.

It seems here that the Postmaster-General's attitude in regard to this interference is not quite so strong as it should be, and we suggest that further investigation of affairs in Cornwall should immediately be made, as it would be distinctly unfair if thousands of listeners in that part of the country were to have their wireless reception ruined owing to the operation of a beam station.

We ourselves will welcome detailed reports from amateurs in the West Country who can show evidence that the interference is due to a beam station.

"THE WIRELESS CONSTRUCTOR"

(Special Xmas Double Number)

"THE SELECTIVE THREE"
A Christmas Set for the Amateur.

Order Your Copy Now.

Price 6d.

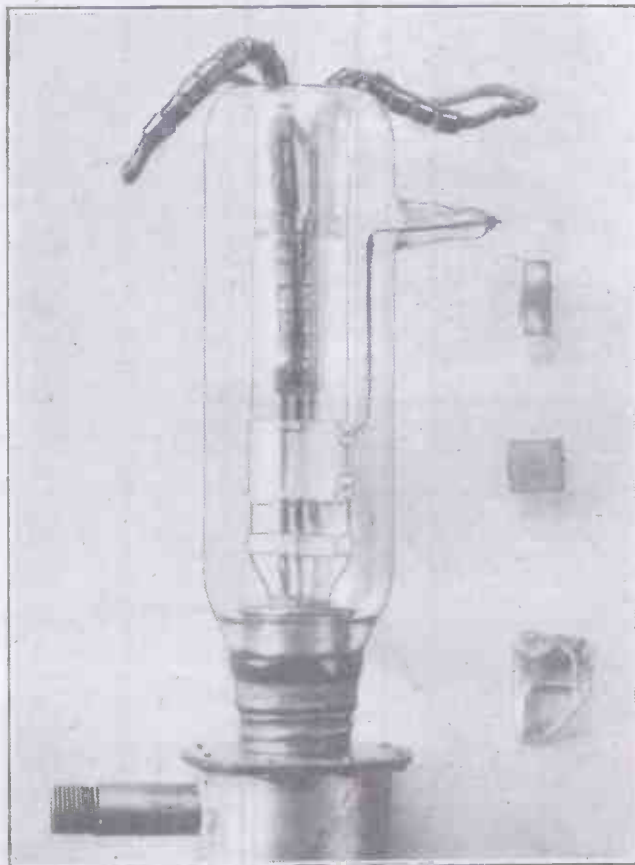

Specimens of quartz crystal used for frequency control compared with a modern transmitting valve.



The circuit described below is the result of a considerable amount of experiment made with a view to obtaining really fine loud-speaker reproduction.

By E. S. DUBRUCQ.

THE circuit to be described, while not possessing perhaps any strikingly original basic features, has been evolved by the writer after a considerable amount of experiment, as one giving the maximum purity of reproduction from a limited number of stations. It will give full loud-speaker results on two valves up to ten miles from a main station; with the third valve switched in, 30 miles is a conservative estimate. In London, full loud-speaker results are obtained on the three valves from

characteristic; the potentiometer permits of this adjustment. Furthermore, it allows for variations in the operating characteristics of the detector valve, should the latter at any time be changed.

Magnetic reaction is employed, but should be kept to a minimum as far as possible; the use of excessive reaction produces distortion in itself.

Between the detector and first L.F. valve, a combination of choke and resistance capacity coupling is employed; this comprises an 80,000 ohm anode resistance in series with an iron-cored choke of approximately 20 henries; this arrangement gives a practically even amplification over the whole range of vocal and musical frequencies. Grid condenser coupling, in conjunction with a grid leak of .5 megohm, is used, there being, however, three grid condensers.

Useful Tone Control.

From the plate side of the anode resistance to the H.T. negative lead is a fixed condenser .0005 mfd., this functioning as a by-pass condenser for the H.F. component of the plate current. Now, the greater the value of this condenser, the greater its impedance to the higher audio-frequencies, the lower-frequencies being accentuated. A switch is therefore incorporated, allowing two further condensers, each of .0005 mfd., to be paralleled in turn across the original; this device thereupon functions as an efficient tone control. Coming now to the three series grid coupling condensers, the principle just utilised again applies; the remaining studs on the switch are wired so that these condensers may be cut in or out, as desired, this varying their total capacity. In this way, the tone switch, as we may call it,

permits of a very flexible control over both the lower and higher audio-frequencies. A suitable value for each of the grid condensers is .125; two in series giving approximately .06, and all three .04 mfd.

Turning now to the valves, the detector should be of the high impedance type, working at an H.T. voltage of, say, 120. The first audio-frequency valve should be of low impedance—the D.E.5 type is quite suitable; its plate may be switched direct to the loud speaker, as shown, or, should the third valve be required in use, to the primary of a high-ratio transformer (4-1), the secondary of which is connected to the grid of the third valve (D.E.5).

A separate H.T. tap is supplied for the two L.F. valves, a suitable value being 150 volts, in conjunction with 9 volts negative grid bias. Separate grid batteries are shown in the diagram, but one tapped battery may be used instead if required. Blocking condensers, of 2 mfd. each, are shunted from each H.T. positive lead to the common negative.

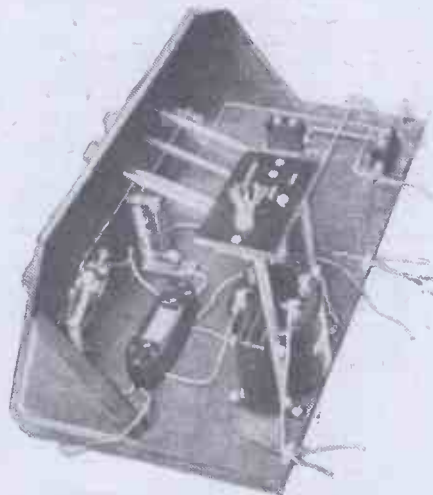

A set renowned for its pure reproduction—the Lodge "N" Receiver.

Daventry, Radio-Paris, Hilversum and Königswusterhausen.

The writer would emphasise the fact, however, that the primary object of this set is to give the best possible loud-speaker results; it is not a long-distance receiver. Three valves are employed—detector and two audio-frequency stages. The detector valve operates on the plate rectification principle; this ensures a distortionless output before amplification. A 250-ohm potentiometer, A, in conjunction with a 4½ volt grid battery adjusts the grid to the correct negative potential.

Circuit Details.

The potentiometer admittedly is a refinement, and may, if required, be dispensed with; its inclusion, however, is to be recommended for the following reason; plate rectification is not so sensitive as the grid condenser and leak method for reception of more distant stations, and it is essential therefore that the detector valve should function in these circumstances at exactly the correct point on the bottom bend of its

JOINTS IN D.C.C. WIRE

ALTHOUGH it is desirable, for the sake of neatness, to use one single length of D.C.C. or D.S.C. wire when winding a coil, a carefully soldered joint will not cause any loss of efficiency provided the bared portion of the wire is properly insulated from adjacent turns. A convenient method of doing this is to place a scrap of empire tape, or even paper, about 1 in. by ½ in., under the joint as this is laid on the former, and to double the tape over

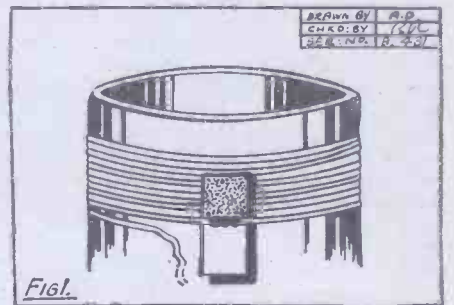

(see shaded portion in Fig. 1) so that further turns of wire cover the two thicknesses of tape.

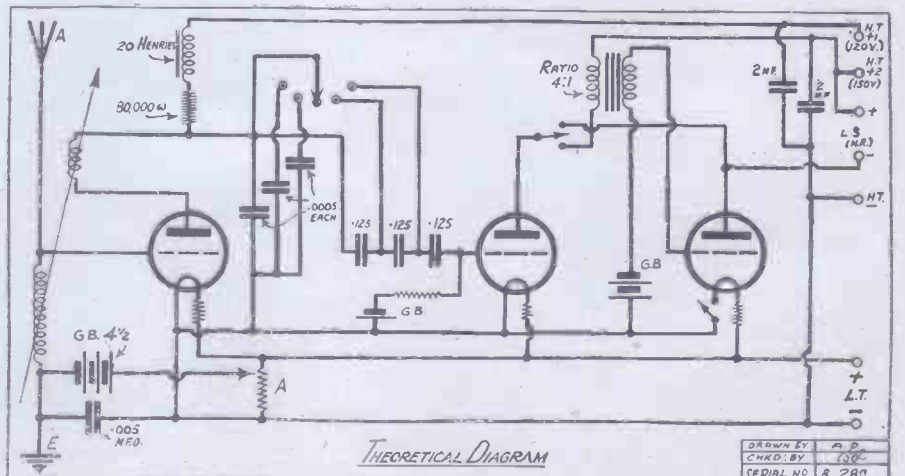

There's a "Cosmos" valve for every position in any set!



S.P. 18/B (BLUE SPOT)

Extra High Amplification
 Filament voltage 1.6-1.8 v.
 Filament current 0.09 amp.
 Amplification factor 35
 Mutual Conductance 0.5 mA p. v.
 Impedance 70,000 ohms

Price 14/-



S.P. 18/G (GREEN SPOT)

High Amplification
 Filament voltage 1.6-1.8 v.
 Filament current 0.3 amp.
 Amplification factor 15
 Mutual Conductance 0.85 mA p. v.
 Impedance 17,000 ohms

Price 14/-



S.P. 18/R (RED SPOT)

Last Stage L.F. Valve
 Filament voltage 1.6-1.8 v.
 Filament current 0.3 amp.
 Amplification factor 7
 Mutual Conductance 1.0 mA p. v.
 Impedance 8,000 ohms

Price 14/-



DE 55

Low Consumption G.P.
 Filament voltage 5.5 v.
 Filament current 0.09 amp.
 Amplification factor 9
 Mutual Conductance 0.5 mA p. v.
 Impedance 18,000 ohms

Price 18/6



S.P. 55/B (BLUE SPOT)

Extra High Amplification
 Filament voltage 5.5 v.
 Filament current 0.09 amp.
 Amplification factor 35
 Mutual Conductance 0.05 mA p. v.
 Impedance 55,000 ohms

Price 18/6



S.P. 55/R (RED SPOT)

Power Valve
 Filament voltage 5.5 v.
 Filament current 0.25 amp.
 Amplification factor 6
 Mutual Conductance 1.7 mA p. v.
 Impedance 3,500 ohms

Price 22/6

YOU try one valve after another in this or that stage, and listening critically you persuade yourself that the result is a little better or a little worse. Then perhaps by chance, or very likely on personal recommendation, you try a Cosmos S.P. Valve, and realize with delight that no straining of your ears or the exercise of supercritical faculties is required to recognize the immediate increase of pep and volume obtainable. How is it then that such a distinguishable difference, such a distinct improvement can be obtained?

The explanation lies in the unique Shortpath construction, which, without sacrificing anything in rigidity, reduces the path the electrons have to travel to a minimum impossible with other methods of construction, resulting in efficiencies and low impedances hitherto unobtainable. It is not overstating the case to say that this scientific construction marks the most notable advance in valve manufacture since their earliest development.

"Cosmos" Valves also have this distinction: they are designed to be most efficient for one particular purpose. They are not general purpose valves in the commonly accepted sense, and, whilst functioning admirably in many positions, there is always one particular application in which they will give the highest efficiency with a large factor of safety.

"Cosmos" Valves have been and always are tested dynamically.

Manchester Wireless Exhibition

"Sunday Chronicle" and "Evening Chronicle" £500 Wireless Research Competition.

In the 4-Valve Receiving Set Class:

First prize winner used 4 "Cosmos"

S.P. Valves.

Second prize winner used 3 "Cosmos"

S.P. Valves.

Third prize winner used 2 "Cosmos"

S.P. Valves.

Fourth prize winner used 1 "Cosmos"

S.P. Valve.

METRO-VICK SUPPLIES LTD.

(Proprietors: Metropolitan-Vickers Electrical Co. Ltd.)

Metro-Vick House, 155, Charing Cross Road,
 LONDON, W.C.2

For "The King of the Air"

As specified and used by Mr. P. W. Harris in this issue of "Popular Wireless."



17/6

with special five-pin base (not as illustrated).

EUREKA

Low Loss High Frequency Transformer.

Manufactured only by Portable Utilities Co., Ltd., 8, Fisher St., W.C.1.

Orphean

25/- PAID FOR OLD LOUDSPEAKERS

In order to popularise the Orphean Loudspeaker the manufacturers are willing to allow 25/- to the first 500 purchasers of either model who send to them their old loudspeakers, irrespective of make, together with a remittance of the balance.

The Orphean is well known to be equal to any make of Speaker regardless of price.

Send your old Loudspeaker before it is too late.

THE LONDON RADIO Manufacturing Co. Ltd.,
Loudspeaker Specialists,
Trafalgar Works, Merton Abbey, S.W.19.



MODEL NO. 12. Height 21 ins. Price 50/-.
MODEL DE LUXE. Height 24 ins. Price 90/-.



Price **7/6**

"Utility" Condenser
Price '0005 .. 15/-
Price '0003 .. 14/-
when fitted with this Micro Dial.

Fit "Utility" Guaranteed Components

THE "Utility" Micro Dial begins where other dials finish. The best adjustment with an ordinary dial is the preliminary movement of the "Utility" in which slow motion mechanism gives the finest possible tuning after the dial has provided coarse adjustment. Unlimited movement. No backlash. Can be fitted to all makes of Condensers.

Insist upon—"Utility" Micro Dial, No-Capacity Change-Over Switch, Low-Loss Condenser, Jack and Plug, Push-Pull Switch. All good dealers stock them.

WILKINS & WRIGHT LTD

KENYON ST.

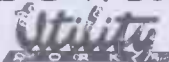

BIRMINGHAM

A SECTION

This diagram is a magnified section of the Watmel windings. Spotted area—interwoven cotton. Striped area—enamel insulation. Black area—wire. Expensive new machines have been installed to wind the WATMEL Auto Choke this way.

Watmel

AUTO-CHOKE

18/6

THE WATMEL WIRELESS CO. LTD., 352a, Goswell Road, London, E.C.1. Telephone: 474-4441; 2000. Lances, Yorks., and Cheshire Representative: Mr. J. B. Leves, 27, Hartley Street, Levenshulme, Manchester. Telephone: 475 Heaton Moor.

BECOL

Registered Trade Mark.

Makers of the ORIGINAL world-famous BECOL LOW LOSS FORMER

As used in sets that took the first four prizes at the 1926 "Manchester Evening Chronicle" Wireless Exhibition and the set that won the Gold Medal at the 1926 Amsterdam Exhibition.

Size: 3 inches diameter to outside of wings. Prices:
6 inch lengths. 3/- (Postage 9d.);
4 inch lengths. 2/- (Postage 6d.);
3 inch lengths. 1/6 (Postage 6d.);
Up to 36 in. lengths.

NOTICE:—Do not be put off with an imitation. Ask for BECOL and use the Former with a reputation.

Write for List "C."

THE BRITISH EBONITE Co., Ltd., Hanwell, London, W.7.

HOW TO READ CIRCUIT DIAGRAMS.

PART III.

This final article of the series shows how various well-known circuits are made up, and how the diagrams should be translated.

By **C. E. FIELD, B.Sc.**
(Staff Consultant)

ASSUMING that we are fairly familiar with the symbols employed in wireless work, let us take one or two circuit diagrams, and see what we can learn from them.

A diagram of connections for a simple receiver is shown in Fig. 1. We can see at once that the circuit contains one valve,

From this coil, signals pass through the telephones to the positive terminal of the H.T. battery, the negative terminal of which is joined to the negative of the filament battery. The positive terminal of the latter is connected to earth. The two ends of the valve filament are joined to the terminals of the L.T. battery, one lead passing through a variable resistance, which is the rheostat for controlling the brightness of the valve.

Construction.

A .002 mfd. condenser is connected between one telephone terminal and the H.T. negative.

If we desired to construct a set from this diagram, the first step would be to make a list of the components required. These would comprise two plug-in coils of 50 and 35 turns, two fixed condensers of .0003 and .002 mfd., a variable condenser of .0005 mfd., a 2-megohm grid leak, a filament rheostat, valve and telephones, and high and low tension batteries suitable for the valve.

In addition we should need fixed and movable holders for the two coils, a valve holder, ebonite panel, and terminals. When mounting the components on the panel, all leads connected with the aerial circuit and the valve grid should be kept as short as possible. We should, therefore, arrange for the aerial coil and condenser, and aerial and earth terminals, to be fairly close together and near to the valve grid, with space for the grid leak and condenser.

"Back of Panel" Diagram.

The valve plate pin should be in a convenient position for wiring direct to the moving coil, and H.T., L.T. and telephone terminals should be in a row, because the two batteries and telephones are all joined in series.

At the same time, we should naturally aim for a symmetrical appearance on the front of the panel, and convenience in operating the tuning condenser and reaction coil.

We might, for instance, arrange the set as shown in Fig. 2, which gives a view of the back of the panel.

Then we would wire up from the diagram, commencing by connecting the aerial terminal to the variable condenser, coil, grid leak, and grid condenser, and the earth terminal to the other side of the tuning coil and condenser. Then valve grid and plate connections could be made, all wiring being as short and direct as possible. Battery and telephone connections should be made last of all, because it is not of such great importance that these wires should be short, and they may be run wherever there is room for them under the panel.

Readers should check over the wiring diagram shown in Fig. 2, and make sure that they appreciate how it corresponds with the circuit diagram of Fig. 1.

In Fig. 3 is shown the diagram of another circuit. (Continued on next page.)

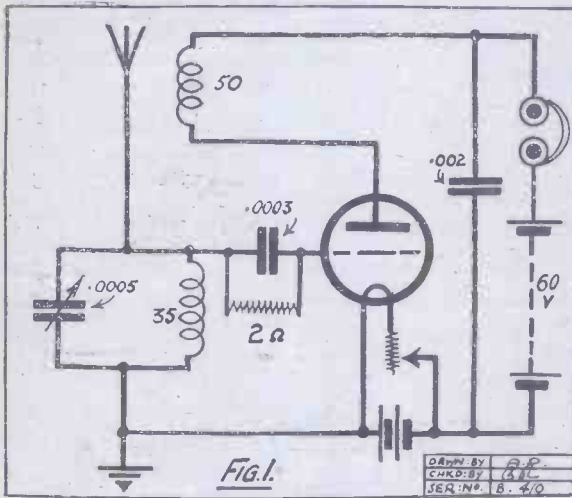

and no crystal detector, and so we may say that it represents a single detector-valve set.

At the left-hand side of the figure there is the aerial, which is connected to a coil marked 35, and also to a variable condenser marked .0005. The other ends of these are joined together, and to earth.

This arrangement we recognise as one of those mentioned in the previous article, being a straightforward aerial circuit consisting of a 35-turn coil in parallel with a .0005 mfd. variable tuning condenser.

These two constitute an oscillatory, or rejector circuit, which "rejects" the required signals along the lead to the valve grid. Inserted in this lead are a condenser of .0003 mfd. capacity in parallel with a high resistance of two megohms, which are respectively the grid condenser and grid leak, and which enable the valve to detect.

Path of the Signals.

Readers who understand the operation of a valve will know that when signals are applied to the grid they emerge in magnified form from the plate. We will, therefore, see what happens to the signals leaving this valve by the plate lead.

First of all they flow back through a 50-turn coil, which will be of the plug-in type, and which is invariably coupled to that in the aerial circuit.

As pointed out in the previous article, this is the reaction coil, which feeds back energy to the input circuit of the valve.

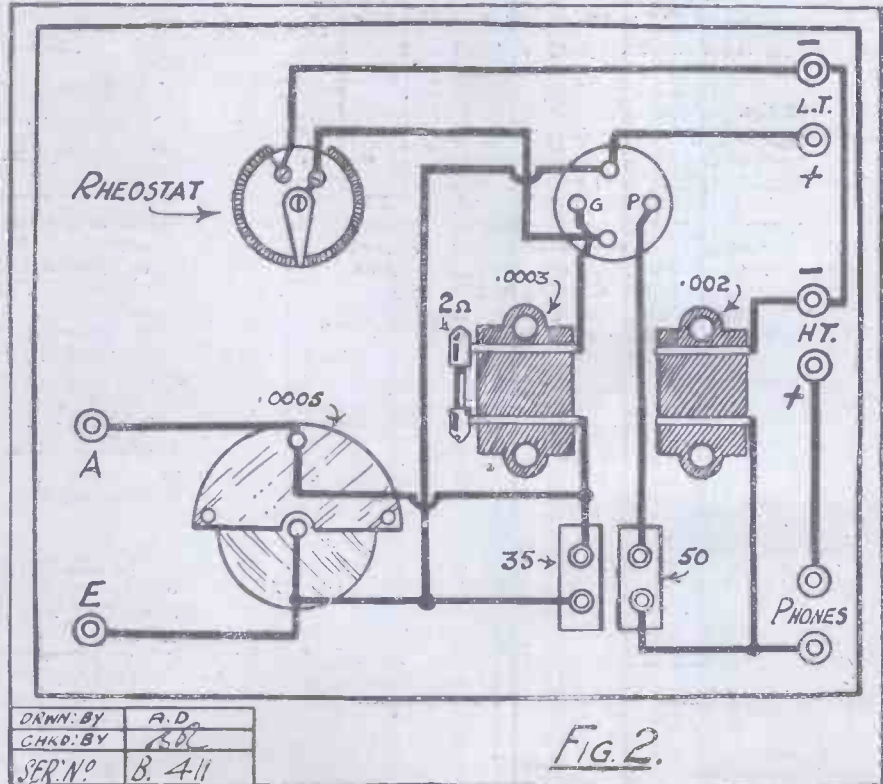

DRWN. BY A.D.
CHKD. BY S.D.
SER. NO. B. 411

FIG. 2.

HOW TO READ CIRCUIT DIAGRAMS.

(Continued from previous page.)

The first point to note is that it employs three valves, and since no crystal is used, one of these must function as a detector. Since the grid of the first valve is joined

The secondary winding of the transformer is connected between the grid of the last valve and the L.T. negative lead, the output from the valve plate passing through the telephones, which are shunted by a .002 mfd. condenser. A half-microfarad condenser is connected across the H.T. battery terminals.

A separate rheostat controls the brightness of each valve, and is connected in each case in the lead from the negative L.T. terminal.

battery, as this is present in practically all receivers, but is not an essential component.

Also, we may omit all wiring associated with the lighting of the valve filaments, for we can see from Fig. 4 that this is quite straightforward, the ends of each filament being joined to the terminals of the L.T. battery, with a rheostat in one lead in each case.

Reconstructing the Circuit.

A good plan now is to draw out first only that portion of the circuit which deals with H.F. impulses, as received by the aerial.

This is carried out in Fig. 5, which is obtained from Fig. 4 by sketching out the progress of H.F. signals, as follows:

Aerial impulses flow to earth via the tuned circuit A, which passes the required signals on to the grid of the first valve. They pass from the plate of this valve to the H.T. battery positive lead, through the primary winding of the transformer T.1, which is tuned by a variable condenser connected in parallel with it.

So far, then, we have an ordinary H.F. amplifying valve, passing on signals by means of transformer coupling. One end of the secondary winding of the transformer is connected directly to the grid of the next valve, which is therefore evidently another H.F. amplifier. The other end of the winding is joined to a condenser, which is connected in parallel with one winding of an L.F. transformer, T.2.

This may seem a little confusing at first.

Since the currents flowing in the wire are H.F. impulses, however, they will not pass

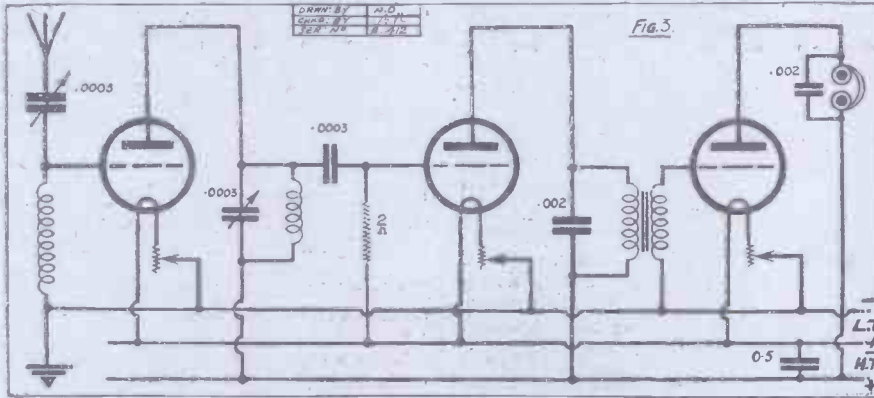

straight to the aerial coil without an intervening leak and condenser, this valve is evidently an H.F. amplifier.

As the second valve is followed by an L.F. transformer, it cannot be a second H.F. amplifier, and must, therefore, be detecting, the grid leak in this case being joined to the positive L.T. lead.

We can say, then, that the diagram represents a 3-valve set, comprising an H.F. amplifier, detector, and note-magnifier.

The aerial tuning condenser and inductance are connected in series, instead of in parallel as in the previous example.

Between the plate of the first valve and the positive H.T. lead is an oscillatory circuit, from the top of which is taken a connection to the detector valve grid, via the grid condenser. This we recognise as constituting *tuned-anode coupling* between the valves.

Final Examples.

In the plate lead from the detector valve is what may, at first sight, look like another oscillatory circuit, but it will be seen, first, that the condenser is of fixed value and, therefore, is not for tuning purposes, and secondly that the coil is only one winding of an L.F. transformer. The condenser across its terminals is not essential in this circuit, but will often improve the tone of an amplifier by preventing over-amplification of the higher notes.

The construction of a set from this diagram should present no difficulty, provided that the panel layout is carefully designed. Special care should be taken with the wiring of the H.F. portion of the circuit—i.e. all that which, in Fig. 3, lies to the left of the detector valve, and these connections should

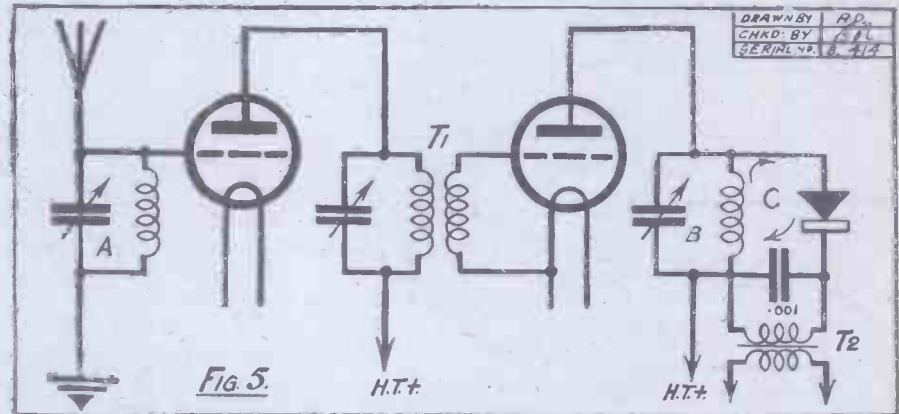

be carried out first, the wiring of the valve filaments being left to the last.

As a final example, let us suppose that we are confronted with the diagram shown in Fig. 4, which is reproduced from an old issue of "P.W." and represents a 2-valve reflex circuit, and we wish to "sort it out"

in order to find out how it works, and what duties are performed by the various components.

In a case like this the amateur should always make a new diagram for himself. Whether it is neater or clumsier than the original, he, at any rate, will be able to understand it.

First of all, we will simplify the circuit as far as possible.

We may omit the condenser which is joined in parallel with the H.T.

through the L.F. transformer winding, which we may therefore neglect for the moment, but will take the alternative path through the condenser, eventually arriving at the negative L.T. lead, which is connected to the valve filament. In short, the secondary winding of the H.F. transformer is connected to the grid and filament of the following valve in the ordinary way, the only unusual feature being the insertion

(Continued on page 1007.)

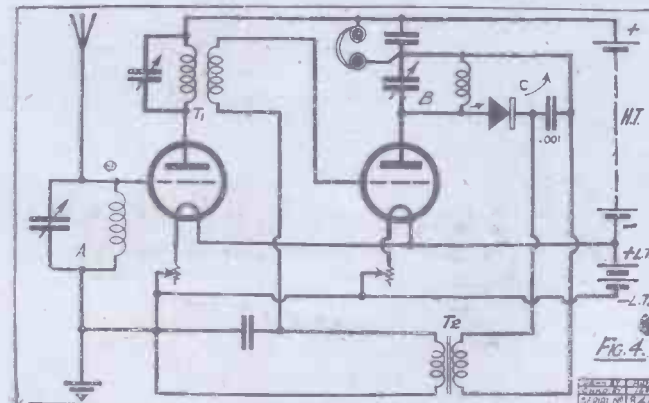

A corner of the generator-room at the Hilversum broadcasting station.

It is
not necessary
to use a .0005
mfd. condenser!



The new range of Lewcos Screened Coils and Transformers will tune from 350 to 600 metres with a .00025 Variable Condenser. This should prove a great advantage to constructors wishing to use existing condensers having a smaller capacity than the .0005 condenser usually specified with this type of coil.

**FULL WAVELENGTH RANGE
WITH .0005 CONDENSER
—350 TO 800 METRES.**

Complete Wavelength Table

No.	Type	Zero	Condenser	
			.00025	.0005
S.P.5	Split Primary Aerial Coils & Transformers	(220	400	550
S.P.8		350	600	800
S.P.20		800	1,400	2,000
S.F.5	Split Secondary Transformers	(220	400	550*
S.S.20		800	1,400	2,000*

* Note—SS type tuned with dual condensers.

THE
**LONDON ELECTRIC WIRE
COMPANY & SMITHS, LTD.**
Playhouse Yard, Golden Lane, London, E.C.1.

LEWCOS
Screened Coils

JUDD

**LATERAL ACTION
Conquers
the problem of
Selectivity**

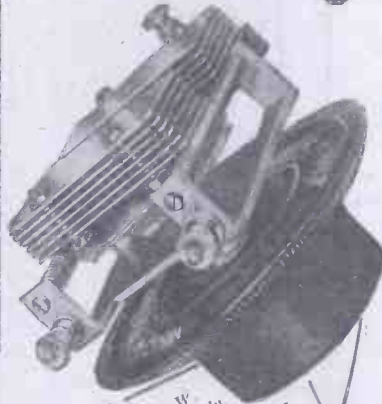

Reproduced are extracts from two of many tributes to Ripaults Lateral Action Condensers. LATERAL ACTION has given these users a considerable increase in the selectivity and general efficiency of their Receivers.

West Ealing, W.
"The L.A. Condenser duly came to hand, and was very pleasing on test, the movement being nice and smooth from minimum to max. Results, too, on low-wave work, were pleasing, and K D K A on 64, and another telephony Station on 44 metres were found fairly comfortably. This, without use of a verier movement, was, in my opinion, decidedly good. —R.F.D."

Coventry.
"...since I fitted the pair of Condensers received to my set the selectivity has been greatly enhanced; previously I was troubled by a powerful foreign Station jamming in on Birmingham, but I am now able to tune in or out either Station.
"The use of the Ripaults' Condensers has also entirely eliminated C.W. and spark interference, which spoiled reception from Cardiff Station."
—R.R.

Lateral Action means infinitely more efficient tuned circuits—more selective and much easier actually to tune. And the fact that both the "Selective Three" Receiver—a Radio Press Star Set published this month—and the Amateur Wireless "Lamp-Socket Three" rely upon Ripaults Lateral Action Condensers for efficient performance bears its own significance.

In up-to-date Sets *Lateral Action* is the secret of the skilfully-designed tuned-circuits that bring in stations "all round the Dial."

Ripaults
Patent Applied for
LATERAL ACTION CONDENSER

Manufactured & guaranteed by Ripaults Ltd., 1, King's Rd., London, N.W.1

Modern components for modern sets

Igranic-Pacent "PRESET" Resistors

Igranic - Pacent PRESET Resistors have all the uses of fixed resistors and yet are almost as easily variable as rheostats. Their use instead of rheostats lessens the cost of the receiver and prevents over-running the valves. Igranic - Pacent Resistors are suitable for all types of valves and the position of the contact finger is easily altered. Made with resistances of 6, 10, 20, 30 and 50 ohms.

Price 1/8 each.



Igranic - Pacent Plugs

The Igranic Universal Plug is efficient in operation and handsome in appearance. The method of connecting the necessary phone tags or wires is particularly simple and secure. There are several other types of Igranic-Pacent Plugs and Plug Adapters.

Price 1/6 each.

Write for the New Igranic Catalogue No. R 39.

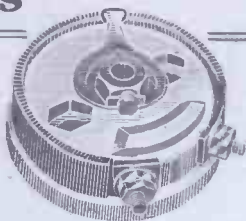

Igranic - Pacent Jacks

Modern receivers are fitted with Jacks. Igranic - Pacent Jacks are made in 10 types to suit every switching operation. Springs are of German silver with silver contacts riveted in.

Prices from 2/- each.



IGRANIC ELECTRIC CO. LTD.
149, QUEEN VICTORIA STREET, LONDON.
Works: BEDFORD.

PROTECT YOUR VALVES

BY USING W.B. ANTI-PHONIC

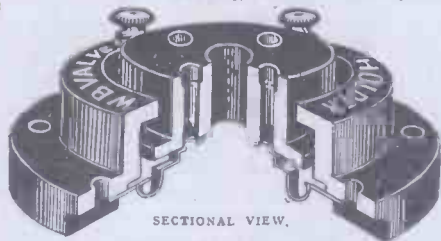

LOW LOSS VALVE HOLDERS

PRICE Complete with Terminals **2/3**

If unable to obtain from your dealer write direct.
Manufactured by **WHITELEY, BONEHAM & CO., LTD.**,
Duke Street, MANSFIELD, NOTTS.



ULTRA LOW-LOSS

Straight Line Frequency Condenser
Cone Bearings. Braced Vanes. Positive Collector. A real precision job.
Condenser only. 0003uF., 0005uF. .. 7/6
New Vernier Dial .. 6/-
Reduction Ratio 16-1. No Backlash.

THE FORMO COMPANY,
Crown Works, Cricklewood, N.W.2
Phone: Hampstead 1787.
Manchester: Mr. J. B. Levee,
23, Hartley St., Levenshulme,
Phone: Heaton Moor 476.

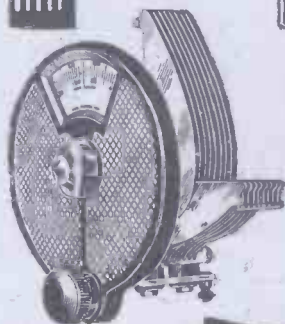

Special Christmas Number

The WIRELESS CONSTRUCTOR

Edited by
PERCY W. HARRIS, M.I.R.E.

Price **6^D** only

Every radio enthusiast should make sure of this fine issue of **The WIRELESS CONSTRUCTOR**. It is packed with good things. A particularly good feature is the description of a Set which you can easily make in time for Christmas—

The Selective Three

Designed by
J. H. REYNER, B.Sc., A.M.I.E.E.

The construction is simple, the coils you can make up yourself, the set is easy to operate and you can get excellent results from its up-to-date circuit and design. Numerous photographs and explanatory diagrams make everything very plain.

Other important articles include:—

- "How to Make Your Own Screened Coils,"
- "Making One of Your Own Supply Mains,"
- "Operating the All-British Six,"
- "Building the Economical Two,"
- "Are You Satisfied with Your Set?"
- "Loud Speaker and Receiver in One,"
- "Listen to America Direct,"
- "Things Every Operator Should Know,"
- "How to Use a Wave Meter,"
- "Workshop Hints for the Home Constructor,"
- etc., etc.

Don't miss this great issue of
The WIRELESS CONSTRUCTOR

On Sale **TO-DAY**
at all Newsagents,
etc.,

Price **6^D** only

WHEN THE SET WON'T OSCILLATE.

Some Valuable Hints Upon the Efficient Application of Reaction.
By HUMPHREY PURCELL.

IT sometimes happens that a regenerative receiver which ought to be capable of working at a point just short of actual oscillation refuses to approach that point and is consequently much less efficient than it should be.

The trouble may be due to one or more of several causes. It may be merely that the reaction coil is too small, or is connected the wrong way round; the H.T. or L.T. battery may be run down; there may be a defect in the grid leak, the grid condenser,

satisfactory as under normal conditions, and as a rule it should be possible to remedy the trouble by either inserting a .0001 fixed condenser in the aerial lead, or by changing the detector valve for one which oscillates more readily.

At the same time, if the set embodies swinging-coil reaction, and if it is possible to change the design without much difficulty, it is worth while adopting a circuit which gives a smoother control over reaction than is possible in the conventional

"straight" set. The circuit shown in Fig. 1 is a modification of the Reinartz circuit. The only additions required to a swinging-coil set are a .0005 variable condenser and an H.F. choke. Ordinary plug-in coils or basket coils are used, tightly coupled, in the same coil holder as before; for the broadcast band both coils may be of 50 turns, and for Daventry a 150 aerial

coil and 100 or 120 reaction coil are suitable. Reaction is obtained solely by varying the reading of the reaction condenser—a method of control which is much more accurate and easier to use than the more common method—and when it is necessary to force the set because of a poor earth, it will be found that better results can be obtained with less trouble than before.

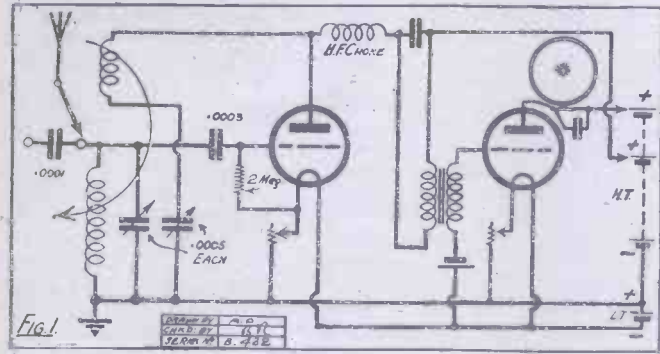

the valve holder, the coil holder, the tuning condenser, or the wiring of the set. If reaction is obtained by the Reinartz method, the reaction condenser may be faulty, or may be too small, or the H.F. choke may be inefficient. If the swinging-coil method of obtaining reaction is used, and there is no condenser across the telephones (in a one-valve set) or across the primary of the L.F. transformer following the detector valve, the addition of a .001 condenser may solve the problem.

A Peculiar "Fault."

If resistance-capacity or choke-capacity coupling is used instead of an L.F. transformer, a condenser of about .0002 across the resistance or choke may help matters.

But if the trouble is persistent, it is much more likely to be due to a poor "earth," particularly if it is most noticeable in dry weather. In a sandy neighbourhood a buried earth may be quite hopeless. The writer has known a set, consisting of a straight detector, followed by one L.F. stage, to refuse to oscillate for two or three weeks together (except when very drastic measures were taken), although the same set both before and after the troublesome period was as lively as could be desired.

In this case the earth was the only possible explanation, and yet it comprised a short and sound connection to the main water supply. The pipes ran away from the house, however, in the opposite direction from that in which the aerial was erected, and there had been an exceptionally prolonged drought. The drastic measures which restored to the set the power to oscillate were the insertion of a small condenser in the aerial lead, the use of an unusually large reaction coil (No. 100 on the broadcast band), and the application of 120 volts H.T. to the detector valve. Needless to say the results were not so

We now have a two-stage H.F. amplifier. The output of the second valve passes to a second oscillatory circuit B, and thence through the telephones or parallel condenser to the H.T. positive.

Here, again, since the impulses are still at H.F., they will not pass through the phones, and as the condenser will not affect them, it may be omitted, and we can show the connection as if it were made directly to the H.T. positive from the tuned circuit.

Signals which are selected by the latter are forced to flow round the circuit shown by the arrow C in Fig. 5. Here they enter a crystal, and are therefore rectified, and we are henceforth concerned with L.F. currents.

The L.F. Part.

Having passed the crystal, signals have the choice of passing through a .001 mfd. condenser, or down the branch lead to the L.F. transformer T2 at the bottom of the diagram. They will take the latter course on account of the opposition offered to L.F. currents by a condenser, so that the net result of the circuits B and C is impulses at voice-frequency in the transformer winding. Similar impulses are introduced in the secondary winding, ready for further amplification. Fig. 5 shows the circuit up to this point simplified, as already indicated, and re-arranged.

We can now see what part is played in the circuit by the L.F. transformer and condenser which we neglected in tracing the course of H.F. impulses.

One end of the secondary winding of the transformer is joined to the second valve grid (through an H.F. transformer winding which now does not concern us), and the other end is connected to the L.T. negative and the valve filament.

This transformer is therefore passing signals back into the valve for re-amplification at L.F. The magnified signals from the plate pass easily through the coil of the rejector circuit B, and so through the telephones to the H.T. battery, giving speech or music in the phones.

A simplified diagram of the complete circuit is shown in Fig. 6.

If the reader has been able to follow this analysis, he should try taking any other diagrams from "P.W." at random, re-drawing them, and finding out all he can from them.

He will be surprised how interesting—and how easy—it becomes, and will never think of reverting again to pictorial diagrams.

HOW TO READ CIRCUIT DIAGRAMS.

(Continued from page 1004.)

of a condenser in the filament lead. This will not affect the passage of H.F. impulses, and therefore for our present purposes may be disregarded, as in Fig. 5.

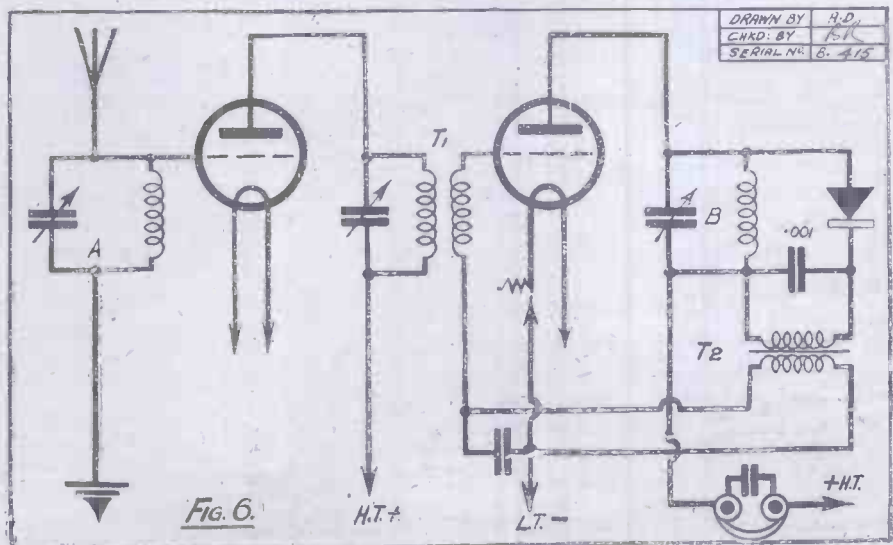



Apparatus Tested

Traders and manufacturers are invited to submit wireless sets and components to the "P.W." Technical Dept. for test. All tests are carried out with strict impartiality in the "P.W." Test room under the supervision of the Technical Editor, and the general reader is asked to note that this weekly article is also intended to provide a reliable and unbiased guide as to what to buy and what to avoid.—EDITOR.

S.T. VALVES.

AS we have had a large number of inquiries respecting S.T. valves from our readers, we would like to take this opportunity of announcing that we have a complete range of S.T. valves under observation and test.

In due course we will publish a detailed report; but we can, even at this juncture, state that without doubt this will be a favourable one.

Every one of those S.T.'s we have so far tested has proved to be highly efficient and to have characteristics as stated in advertisements.

* * *

THE BRETWOOD VARIABLE GRID LEAK:

The Bretwood variable grid leak has always held a high place in our estimation, but we have noticed that it tends to deteriorate somewhat with age—not necessarily usage. Nevertheless, it has been one

of the very few that could be trusted at all, and its deterioration does not evince itself in a matter of a few months.

But we now have the new and improved Bretwood "de-luxe," and although our sample has not yet stood the test of time, it should do so, and come through it with honours, according to the claims of its makers.

It is stated that a very hygroscopic substance is used, one that will remain practically unaffected for twenty-five years. It will be remembered that the Bretwood employs a small plunger which dips into a semi-liquid substance, the variation of resistance being obtained by varying the depth to which this plunger is forced by means of a fine screw adjustment. Obviously, if this liquid resistance element dries up, the device ceases to function; but there seems very little fear of this happening in the "de luxe" model.

A very fine, well-distributed resistance variation is given, ranging from below one-tenth up to approximately 10 megohms, and the settings remain constant over considerable periods.

The component is fitted with a very substantial knob, and is well-made throughout. The retail price is 3s. 6d.

SOME C.A.C. VALVES.

We recently received a complete range of C.A.C. valves for test from Messrs. The C.A.C. Valve Distributing Co., Ltd., 10, Rangoon Street, Crutched Friars, London, E.C.3. The characteristics of each valve are given, together with other details, and our comments subsequent to a series of practical tests.

Type B.E. H.F.; fil. volts, 3.5; fil. amps., .5; amplification factor, 18; impedance, 52,000 ohms. Price 7s. 6d.

This valve gave very good results in both H.F. amplifying and in detector positions. It is quite an economical bright emitter.

Type B.E. L.F.; fil. volts, 3.5; fil. amps., .5; amplification factor, 6; impedance, 12,000 ohms. Price 7s. 6d.

Although this valve does not operate exceptionally well when the L.F. stage in which it is used is the last stage in the receiver it is quite satisfactory when employed in a first L.F. stage preceding a power valve. We found it to be a good detector in a stage preceding a transformer coupled amplifier.

Type D.E.2 H.F.; fil. volts, 1.95; fil. amps., .25; amplification factor, 17; impedance, 58,000 ohms. Price 12s.

We found that this valve did not require.
(Continued on page 1010.)

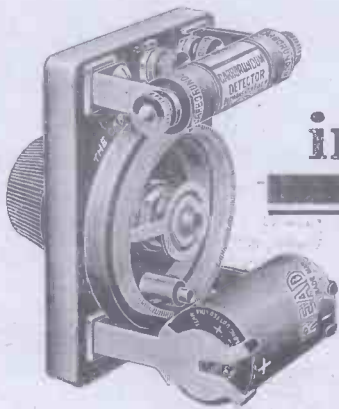

REVOLUTION!

in CRYSTAL detection

WE have revolutionised crystal detection by producing a unit from which perfect crystal reception is obtained, whether used in the form of a crystal set or a valve set in which crystal detection is used.

THE CARBORUNDUM STABILISING DETECTOR UNIT

is the only electrically governed crystal detector, and the most selective and stable of present-day detectors. The Detector Unit produces a more natural undistorted reproduction than any on the market, and abolishes the evils and inconsistencies of cat's-whiskers.

PRICES, POSTAGE PAID

- No. 32. Carborundum Stabilising Detector Unit .. 12/6
Ever Ready Dry Cell UW5, price extra 5d.
- No. 30. Carborundum Detector 5/-

THE CARBORUNDUM CO., LTD.,
TRAFFORD PARK, MANCHESTER

Write now for free pictorial diagram Book, W13, giving particulars of the

WONDERFUL NEW
CARBORUNDUM
"UNIFLEX" CIRCUIT



Will You Hear?

—the "Beco" Rose Bowl Hornless Loud Speaker? It reproduces faithfully, with a pure, clear tone, and—if desired—sufficient volume for dancing. Apart from its perfect performance the "Beco" Rose Bowl Model is of really beautiful appearance. Combining as it does, a perfect loud speaker with a useful and artistic flower bowl, the "Beco" Rose Bowl Model makes a cherished addition to the furnishing of the home. Whether the bowl is empty, or filled with water and flowers, the splendid tone remains unaltered. Obtainable in three varieties: Nickel Plate **£5 5 0**. Oxyd. Silver, **£5 17 6**. Antique Bronze, **£5 17 6**.

BECO

ROSE BOWL Hornless Loud Speaker

Deferred payments can be arranged on application to the address below.

Ask your dealer to demonstrate.

Other "Beco" Models from 52/6.

If your dealer cannot supply write to:

Dept. P.W., BRITISH ELECTRICAL SALES ORGANISATION,
623, Australia House, Strand, London, W.C.2
Telephone: City 7665. Telegrams: "Becospiker, Estrand, London."



Christmas Suggestions

SAFETY SWITCH and LIGHTNING ARRESTOR

Prov. Patent 20022/26.

Comprises Switch, Lightning Arrestor, Lead-in Tube and weather-proof cover. When off, the set is entirely disconnected from the Aerial and Lightning Conductance is attained Outside the house. Safety is ensured should you forget to switch off—by the Permanent Spark Gap provided.

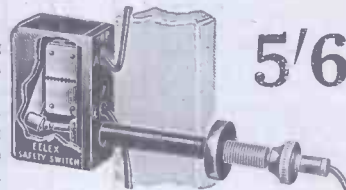

5/6

Price - 6-inch Tube - 5/6
 .. - 12-inch Tube - 6/6
 .. - 18-inch Tube - 7/6

MULTIPLE CONNECTOR **5/6**

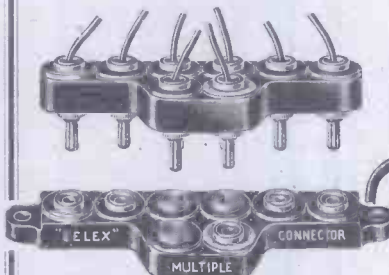

Non-reversible. Detachable name plates. Built with Eelex standardised Plugs and Sockets. All parts are standard, detachable and interchangeable. Coloured flexibles can be supplied in the following colours: red, blue, green, yellow, black, white and maroon at 1d. per yard. If at any time sets change so that multiple connectors are no longer required, then the parts can be put to other uses. It will pay you to adopt the Eelex Standardised system of Connections.

TREBLE DUTY TERMINAL

Price in nickel finish

4½d.

each



This terminal is used extensively in the specifications of the leading wireless Journals. There are 32 different directional tops now supplied. Polarity is clearly defined in Red and Black colouring.

EELEX LOW LOSS COIL HOLDER

(Reg. Design No. 718068.)

The Eelex low loss coil holders are designed to take coils of any diameter and up to a thickness of 1". The absence of solid dielectric between the plug and socket tends to greater efficiency in the mounted coil. The cross-slotted and waisted plugs ensure smooth and certain contact, even to loosely wound basket coils, a rigidity one would hardly think possible. Price complete, with side covers (no coil),

1/3

WRITE FOR NEW LIST P.W.7.
Now Published.



EELEX HOUSE, 118, BUNHILL ROW, E.C.

Phone: Clerkenwell 9252.

APPARATUS TESTED.

(Continued from page 1008.)

anything above about 1.85 volts, while at 2 volts its filament seemed rather hot as dull-emitter filaments go these days. It makes an excellent H.F. amplifier, and an equally good detector.

Type D.E.2 L.F.; fil. volts, 1.95; fil. amps., .25; amplification factor, 5.25; impedance, 18,500 ohms. Price 12s.

Well able to hold its own in first L.F. positions.

Type D.E.06 H.F.; fil. volts, 3.8; fil. amps., .06; amplification factor, 14; impedance, 45,000 ohms. Price 13s. 6d.

We had to give this a trifle above .06 before it would operate really well in both H.F. and detector positions, although fil. volts were well below 4. Using anode voltages between 45 and 90, it functioned as well as any other .06 valve we have tested.

Type D.E. .06 L.F.; fil. volts, 3.8; fil. amps., .06; amplification factor, 5; impedance, 14,000 ohms. Price 13s. 6d.

This L.F. amplifying .06 valve gave very good results, results that were almost exceptional for its class.

Type P.2; fil. volts, 2; fil. amps., .4; amplification factor, 5.75; impedance, 10,000 ohms. Price 20s.

This, in our opinion, is the outstanding valve in the C.A.C. range. As dull emitters go these days, it is not particularly economical, but it certainly is a sturdy little power amplifier. It handles quite large inputs in a very creditable manner. Using up to 108 volts H.T., with between

4 and 6 volts grid bias, it delivers full, "round" signals.

Type P.6; fil. volts, 5.5; fil. amps., .25; amplification factor, 5.5; impedance, 6,500 ohms. Price 20s.

The last of the C.A.C. range of eight, this valve is by no means the least efficient of the series. It is a 6-volter, well able to deal with considerable energy and can safely be "placed behind" a really large speaker.

In conclusion, we consider the C.A.C. range a good and fairly complete one. The valves are well made, although their bulbs are inclined to come loose if handled at all carelessly. A novel feature, and one that should appeal to all purchasers of valves, is that a stamped and addressed postcard is supplied with every C.A.C. valve, which forms part of a very generous three-months' guarantee system. No doubt the little trouble mentioned above would come under this, in which case it is one that need not be anticipated with trepidation.

"SLEKTON" PLUG-IN COILS.

These coils, which are products of the Automatic Coil Winder and Electrical Equipment Co., Ltd., are high class in every sense of the term. They are completely enclosed in neat cases of standard sizes, and are sufficiently robust to stand against the roughest of handling. They are efficient, too, and provide sharp tuning and have very low H.F. resistances.

The range available is very comprehensive, and extends from one of 25 turns, which costs 5s. 6d., up to one of 300 turns, which is priced at 9s. 6d. It will be noticed that they are not cheap, but they are excellent components produced by specialists in the particular line of coil winding.

LISSEN MANSBRIDGE CONDENSERS.

Messrs. Lissen can always be depended upon to turn out nice pieces of apparatus, and their new fixed condensers form no exception to this "Lissen rule." They—the condensers—are enclosed in nicely moulded insulating cases. The samples submitted to us were carefully tested, but no faults were traced.

Available capacities range from .01 mfd. (2s. 4d.) up to 2 mfd. (4s. 6d.).

DUBILIER DUVARILEAK.

Here we have a variable grid leak which is consistent in operation, handsome in appearance, and which is provided with a graduated dial. The sample sent us for test has already been used in several sets, and has not given anything but satisfaction.

The Dubilier Duvarileak is provided with a nice large knob which facilitates adjustments, and its action is smooth and free throughout the whole movement. It is a one-hole mounting component, and although it is priced at 7s. 6d. it should prove popular among those amateurs who require a really dependable article of this nature.

THE DUBILICON COMPETITION

The "Dubilicon" Condenser (Messrs. Dubilier) contains eight separate capacities, but entrants for the competition which the makers are running in connection with the accessory are required to forecast the possible capacities obtainable from the first FIVE only of these eight capacities.

It is thought that the advertisement in our December 4th issue did not make this quite clear.

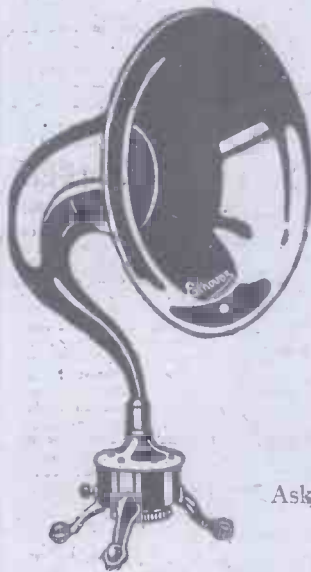

"ETHOVOX"
with
METAL HORN
£4. 10. 0

An Ethovox^{REGD}

LOUD SPEAKER

gets the utmost out of any set.
With a BURNDIPT RECEIVER

IT IS PERFECT

Try one this

CHRISTMAS

Ask your Local BURNDIPT DEALER for a DEMONSTRATION
or, if you prefer it, have one at our London showrooms.

BURNDIPT

WIRELESS LIMITED

BLACKHEATH, LONDON, S.E.3.

London Showrooms: 15, Bedford Street, Strand, W.C.2.

AGENTS AND BRANCHES EVERYWHERE

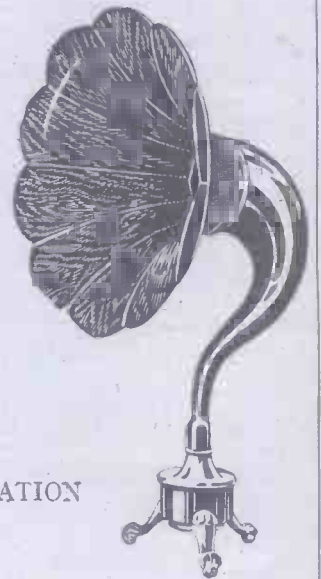

"ETHOVOX"
with
MAHOGANY
HORN
£5. 5. 0

4 reasons why you should use CYLDON Temprytes

FIRST—"TEMPRYTES" are guaranteed to function perfectly with any valve, providing they are chosen from our valve chart, or calculated from the formula we give with our folder.

SECOND—"TEMPRYTES" cannot overheat your filaments. They are scientifically designed to run the filament at the exact temperature, calculated from the valve maker's data.

THIRD—"TEMPRYTES" are WIRE WOUND, therefore noiseless, and are not carbon mixtures or other chemical combinations which pack. Each one is individually tested twice during manufacture and once after assembly. That is why "TEMPRYTES" are the perfect method of filament control.

FOURTH—"TEMPRYTES" are tested on the finest possible instruments and the careful testing of each "TEMPRYTE" enables us to guarantee their performance. The testing of "TEMPRYTES" in our laboratories takes considerable time, and is carried out by experts.

Do not be misled by the introduction of glorified filament Rheostats, called Variable Resistors, with which you can overheat your filament without knowing it. Buy "TEMPRYTES," the tested perfect control for all filaments.

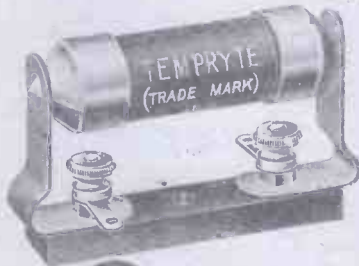

TEMPRYTES 2/6 Each
HOLDER MOUNTINGS 1/6 Each

Particulars of the other CYLDON Products will interest you.

The CYLDON Wavemeter identifies unknown stations and makes searching and testing out simplicity itself.

Then there is the complete range of CYLDON Condensers—S.L.F., Square Law, Dual, and the famous 2, 3 and 4 Gang models.

Every CYLDON product is the premier of its class—well designed, excellently finished and right up to the CYLDON standard.

If unable to obtain CYLDON products from your dealer, write direct to :—

SYDNEY S. BIRD & SONS, CYLDON WORKS, SARNSFIELD ROAD, ENFIELD TOWN, MIDDX. Telephone: Enfield 0672

THE HEART

of your Set is the Battery
and you can give your Set no better battery than the

PRIMUS AUTOCEL

The Battery with Many Lives

which has Rejuvenating Cells. Being made without Sal-Ammoniac or Acids, the cells recuperate instead of deteriorating when not in actual use

PRICES: 63-volt - 11/6. 103-volt - 17/3.
Pocket Lamp Type, 4.5-volt - 7d. each.

We take a personal interest in each Battery supplied. If not obtainable from your dealer, write to us direct. Batteries sent promptly, post free, or C.O.D. with a FREE XMAS PRESENT

THE PRIMUS MANUFACTURING CO.,
114-115, Great Saffron Hill, London, E.C.1.

HIGH & LOW TENSION ACCUMULATOR HIRE SERVICE

Here's a way of improving reception, saving money, time, and trouble for all valve set users who live within 12 miles of Charing Cross. Write now for particulars of the unique service.
RADIO SERVICE COMPANY,
105, Torriono Avenue, N. W. 5.
Phone North 0623. (3 lines).

Rotax High Tension Accumulators greatly improve Loud Speaker reception eliminating the uncanny noises caused by partly run down dry batteries and may be hired ready for use.



Our Low Tension Hire Service effects a considerable saving if you add the depreciation in value to the cost of having your own accumulator unskillfully recharged.

The latest product
FROM THE HOUSE OF RUSSELL

RUSSELL'S



HERTZITE

Guaranteed five years

LOW IN PRICE BUT HIGH IN QUALITY.
NONE GENUINE WITHOUT THIS SIGNATURE

L. G. Russell

SOLD COMPLETE WITH TWEEZERS AND SPECIAL METALOID CATWHISKER

GET ONE FROM YOUR LOCAL DEALER

THE L. G. RUSSELL LABORATORIES, HILL ST. BIRMINGHAM

RADIO TUTORIAL

All Editorial Communications to be addressed to The Editor, POPULAR WIRELESS, The Fleetway House, Farringdon Street, London, E.C.4.

Editor :
NORMAN EDWARDS, M.Inst.R.E., M.R.S.L.,
F.R.G.S.

Technical Editor :
G. V. DOWDING, Grad.I.E.E.

Assistant Technical Editors :
K. D. ROGERS. P. R. BIRD.

Scientific Adviser :
Sir OLIVER LODGE, F.R.S.

Staff Consultants :
Dr. J. H. T. ROBERTS, F.Inst.P.; J. F.
CORRIGAN, M.Sc., A.I.C.; C.E. FIELD, B.Sc.;
E. J. SIMMONDS, M.I.R.E., F.R.S.A.

Foreign Correspondents :
F. M. DELANO, Paris; Dr. ALFRED
GRADENWITZ, Berlin; L. W. CORBETT,
New York; P. F. MARTIN, Italy; W.
PEETERS, Holland.

The Editor will be pleased to consider articles and photographs dealing with all subjects appertaining to wireless work. The Editor cannot accept responsibility for manuscripts and photos. Every care will be taken to return MSS. not accepted for publication. A stamped and addressed envelope must be sent with every article. All inquiries concerning advertising rates, etc., to be addressed to the Sale Agents, Messrs. John H. Lilje, Ltd., 4, Ludgate Circus, London, E.C.4.

As much of the information given in the columns of this paper concerns the most recent developments in the Radio world, some of the arrangements and specialities described may be the subject of Letters Patent, and the amateur and the trader would be well advised to obtain permission of the patentees to use the patents before doing so.

Readers' letters dealing with patent questions, if sent to the Editor, will be forwarded to our own patent advisers, where every facility and help will be afforded to readers. The envelope should be clearly marked "Patent Advice."

TECHNICAL QUERIES.

Letters should be addressed to: Technical Query Dept., "Popular Wireless," The Fleetway House, Farringdon Street, London, E.C.4.

They should be written on one side of the paper only, and **MUST** be accompanied by a stamped addressed envelope.

Queries should be asked in the form of the numbered questions: (1), (2), (3), etc., but may be accompanied by a short letter giving any necessary additional particulars as briefly as possible.

For every question asked a fee of 6d. should be enclosed. A copy of the numbered questions should be kept, so that the replies may be given under the numbers. (It is not possible to reproduce the question in the answer.)

BACK OF PANEL DIAGRAMS can be specially drawn up to suit the requirements of individual readers at the following rates: Crystal Sets, 6d.;

One-Valve Sets, 6d.; One-Valve and Crystal (Reflex), 1s.; Two-Valve and Crystal (Reflex), 1s.; Two-Valve Sets, 1s.; Three-Valve Sets, 1s.; Three-Valve and Crystal (Reflex), 1s. 6d.; Four-Valve Sets, 1s. 6d.; Multi-Valve Sets (straight Circuits), 1s. 6d. Except SUPER-HETERODYNE DIAGRAMS, all of which, irrespective of number of Valves used, are 2s. 6d.

If a panel lay-out or list of point-to-point connections is required an additional fee of 1s. must be enclosed.

Wiring diagrams of commercial apparatus, such as sets of any particular manufacture, etc., cannot be supplied. (Such particulars can only be obtained from the makers.)

Readers may submit their own diagrams, etc., for correction or for criticism. The fee is 1s. per diagram and these should be large, and as clear as possible.

No questions can be answered by phone. Remittances should be in the form of Postal Orders.

Questions and Answers

THE "SPIDER."

W. E. F. (London, N.).—I have built the "Spider" 3-valve set, but it does not give good results. I have been using Mullard and S.T. valves, but quite recently was told that this set won't work unless a special detector valve is used. As I have not now got the copy of POPULAR WIRELESS describing this set, I would be glad of information on this point, and whether by some modification or slight addition I can use ordinary detector valves, such as the P.M.3 or S.T.21.

In the article describing the Spider, the point about the detector valve was made quite clear and a D.E.R. was advocated. Practically all other valves fail to operate in that position. By modifying the detector

(Continued on page 1014.)

XMAS

1926

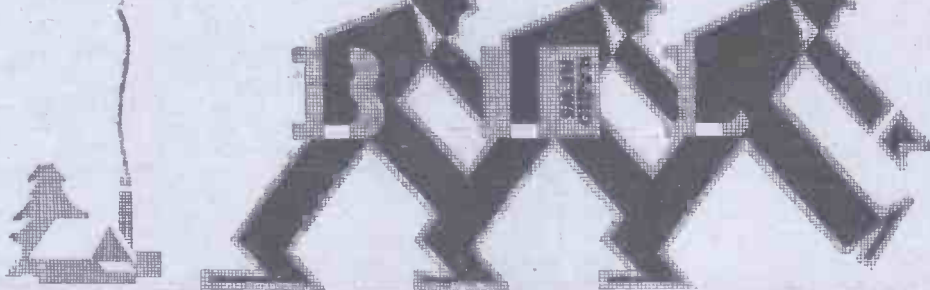

THE THREE WISE MEN AND THE STAR

Not unlike the three Wise Men of old, Bowyer-Lowe set out to prove, by performance, that components bearing their name would achieve Perfect Radio Reception. Ever since Bowyer-Lowe set out, with this star as guide, the proof has been manifest in the fact that sales are effected quicker than components are produced.

If you are not using Bowyer-Lowe Components—try them and you will understand why they are so popular. Put your trust in Bowyer-Lowe Components—they never let you down.

The Radio News will give you fuller details and illustrations—send 1½d. in stamps for your copy Now—and enjoy Perfect Radio Reception this Xmas.

Bowyer-Lowe Components
are Generously Guaranteed



From any reputable dealer
or direct from Radio Works

ANNOUNCEMENT BY THE BOWYER-LOWE

COMPANY LTD. LETCHWORTH HERTS

EDISON BELL RADIO

Christmas presents that charm away many an idle hour

THE EDISON BELL "GEM" 2-VALVE SET

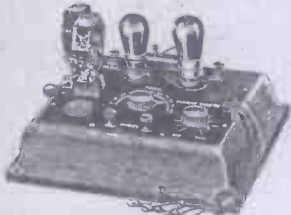

THE "GEM"

is so simple and reliable in action that even a child can use this instrument without incurring any risk of damage. A slight turn of the dials and you receive perfect broadcast music on a loud speaker—on headphones foreign stations can be tuned in.

Price £3 0 0

(Valves, Batteries and Marconi Licence extra.)

THE EDISON BELL "BIJOU" 2-VALVE SET



THE "BIJOU"

has the same circuit as the "Gem" set opposite, but is built into a more elaborate cabinet, which has a transparent oval front enabling it to be closed when desired.

Price £3 15 0

(Valves, Batteries and Marconi Licence extra.)



THE (NEW MODEL) SPEAKER

Charm is expressed both in the tone and design of the new model Edison Bell Speaker, the artistic appearance of which is second only to its perfect tonal reproduction.

Price 42/-

TESTED 500 VOLTS
FLAT TYPE



Ask your dealer for new illustrated catalogue containing many ideal Christmas presents. If unable to obtain write direct to the company.

EDISON BELL, LIMITED, London, S.E.15, and at Huntingdon

TESTED 500 VOLTS
UPRIGHT TYPE



INSIST ON EDISON BELL CONDENSERS

THEY ARE BRITISH MADE AND GUARANTEED BY A NAME WITH 30 YEARS REPUTATION BEHIND IT

The Bretwood S.L.F. CONDENSER!!!

Did you read the "P.W." Test Report on page 838 of December 4th issue?

Losses are disastrous in S.L.F. Condenser design.

The "Bretwood" is the only condenser made that has only TWO supports, and losses are therefore reduced to a greater minimum than that of any other design.

Lose nothing but rather gain greatly in selectivity and general reception results by fitting BRETWOOD S.L.F. Low-Loss Condensers.

PRICES: '0005 17/6 '0003 14/9
'0025 14/- '0015 13/6

THE BRETWOOD GRID-LEAK DE LUXE Constant-Silent-Efficient.

This improved type has a syphon container which prevents all possible leakage of resistance element and guarantees the even distribution of it.

For accuracy of readings (50,000 ohms to 10 megohms) it is on a par with those of our straight line frequency condenser.

If you desire to mount it on baseboard a special mount is now available. Price 3d.

Grid-Leak De-Luxe.. Price 3/6
Grid-Leak (with Condenser). Price 4/6
Anode Resistance. Price 3/6

OBTAINABLE FROM ALL DEALERS OR DIRECT FROM
Sole Manufacturers:

BRETWOOD LTD., 16, LONDON MEWS, MAPLE ST., LONDON, W.1.

PARRS Ad.



Throw away the headphones buy this loud Speaker

LET all the family enjoy the radio. Here is a Loud Speaker that was bound to come—it has long been needed. Matching in tone and volume any £5-5-0 instrument, it has been costed low so that thousands can buy and enjoy where before high prices prohibited. Profits are cut to a minimum, quality achieves a maximum and so great is our faith in the Allhall Speaker that we sell it to you with a

MONEY BACK GUARANTEE

Buy one, try it, and if you are not satisfied send it back within 7 days and your money is returned without any questions being asked.

Obtainable from all Radio Dealers.

27'6

L.Kremner

Radio Engineers
19a, Shudehill, Manchester.

READ THIS DESCRIPTION

The Allhall Loud Speaker stands 21 ins. high and has a depth of 14 ins. from back to front; the base is 6 1/2 ins. overall and is finished in ice black lacquer, relieved by a nickel plated diaphragm control, and supplied complete with long plug-in cords. The neck is of ice black lacquer, and 3 nickel screws secure the horn which is finished in matt black and has a flare of 14 ins., ensuring resonance and volume

RADIOTORIAL QUESTIONS & ANSWERS.

(Continued from page 1012.)

stage and introducing PLATE bias. Mr. English (well-known "P.W." contributor) claims that any ordinary valve can be used. Articles describing this and other Filadyne developments will appear in "P.W."

Of course, the Spider can quickly be converted into an ordinary H.F. Det., L.F., when it will take any normal arrangement of valves. In fact, should the Spider fail to give efficient results owing to the existence of an obscure fault, it should be tried out in this way, for it will no doubt be easier for the constructor to eliminate faulty components when he has a more familiar circuit to handle.

The alterations necessary are very few, and the whole operation will take but a few minutes. All that has to be done is to remove the present lead to the detector valve plate, move the lead which goes to the grid up to plate and the filament input lead up to the grid. A grid leak should be connected between the grid and L.T. plus. The filament chokes can then be shorted out of circuit. The set is then an ordinary H.F., det., L.F. with "ganged" tuning controls.

When the set is working properly in this form a reversion to filament input is just as simple as the above.

A HOWLING NUISANCE.

"HOWLING" (Pershore, Worcestershire).—Some weeks ago my set, which had been going perfectly, began to give trouble. This at first took the form of reduced volume, and the set seemed to need less H.T. than formerly, because it howled when full H.T. was plugged in. After about a week it started to howl all the time, though nothing has been touched except the H.T. wander-plugs, and a fresh accumulator connected up in place of the old one. What is wrong?

The trouble is undoubtedly caused by the deterioration of the H.T. battery, which generally shows itself by a howl of this kind. The only remedy of course, is a new battery.

COIL FOR A CRYSTAL SET.

If a crystal set coil is made "on air" by using wooden end pieces and ebonite rod, would it be more efficient than a similar coil wound on a cardboard tube?

Yes. Theoretically, the absence of a solid cardboard former is a decided advantage. A coil made in this way is illustrated above.

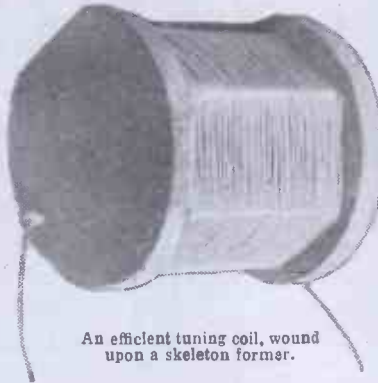

An efficient tuning coil, wound upon a skeleton former.

SIMPLE 3-VALVE SET.

"LOUD-SPEAKER SET" (Buckhurst Hill, Essex).—I am anxious to build up a good 3-valve loud-speaker set, easy to tune, and cheap to build. I should like simple switches for the different valves. What components do I need?

The following are the parts and accessories required:

- | | |
|----|---|
| | COMPONENTS. |
| 1 | panel 10 x 12 x 1/4 in. |
| 1 | box to fit, 4 1/2 in. deep. |
| 3 | filament resistances |
| 3 | valve holders |
| 1 | 2-way coil holder |
| 12 | terminals |
| 1 | '0005 variable condenser |
| 2 | S.P.D.T. switches |
| 1 | grid leak and condenser ('0002 mfd. and 2 meg.) |

- 1 L.F. transformer, 1st stage
- 1 L.F. transformer, 2nd stage
- 1 '001 fixed condenser
- 1 '002 fixed condenser
- 2 1-mfd. condensers (optional)
- Wire, screws, transfers, etc.

ACCESSORIES.

- 2 coils, 50 and 75 (150 and 200 for 5 X X)
 - 1 9-volt grid bias battery
 - 1 detector valve, 1 L.F. valve, 1 power valve
 - H.T. and L.T., according to valve maker's specifications
 - 1 pair of 'phones and/or loud speaker
- (A set of this kind is described in Blue Print form in the "P.W." 6d. Blue Print series, No. 20.)

BEST CIRCUIT TO USE.

B.O. (Dublin).—What is the best combination of valves to operate a loud speaker on distant stations? I understand that four valves should be employed, but am undecided as to using 2 H.F. or 1 L.F., or 1 H.F. and 2 L.F. with the detector.

Probably the best combination will be 1 H.F., Det., and 2 L.F. It is no easy matter to time two stages of H.F. and keep these in "step" with an aerial condenser, though the two variable condensers of the 1 H.F., Det., and 2 L.F. set can be handled effectively.

H.T. AND L.T. ACCUMULATORS.

R. L. (Lowestoft).—How can I estimate the charging rate of an accumulator?

You are advised to follow the accumulator maker's instructions on this point, though as a general rule the charging amperes in practice average one-tenth to one-eighth the actual capacity.

FILAMENT RESISTANCES.

"INTERESTED" (Portsmouth).—In which of the L.T. accumulator leads should the filament rheostats be joined?

It is the usual practice of valve manufacturers nowadays to recommend a rheostat in the positive lead of a valve when used as H.F., Det., or L.F. amplifier.

(Continued on page 1016.)

L OUD SPEAKERS are legion, their sponsors have been apt to write abundantly of qualities supreme. So-called mellowness, sweetness, clarity, wonderful depth, fidelity, etc., etc., are insufficient to truly describe the reception experienced by users of the Claritone.

It is sufficient for them to know that they can sit back and enjoy

Ashley Radio

Ashley Wireless Telephone Co. (1925), Ltd., 17, Finch Place, Falkland Street, Liverpool.

CLARITONE
LOUD SPEAKERS & HEAD PHONES

- W265 £5 0 0
- W267 £2 15 0
- W299 £12 10 0
- W287 £4 10 0
- W275 £6 0 0
- W277 £4 0 0

Described and illustrated in Booklet No. 71 obtainable from all dealers.

The Audio Frequency Transformer is the very heart of your set—FIT

FERRANTI TRANSFORMERS

and put "new heart" into your radio

A.F.3. 25/-		A.F.4. 17/6
IN IRISH FREE STATE		IN IRISH FREE STATE
32/6		23/-

"It's the heart, ay, that's the part, ay, that makes us recht or wrang."
Burns.



COME and SEE

for yourself how

BURNDIPT SUPER VALVES

ARE MADE IN OUR OWN FACTORY

YOU have had experience with many valves since you first installed a wireless set—now come and see them manufactured. Some afternoons during the next few weeks we are arranging to give a practical demonstration to 100 wireless enthusiasts of how Burndept Super Valves are made. If you would like to come fill in the coupon below and post it at once. One hundred will be selected each week, and the senders will receive invitation tickets giving full details. The following facts about Burndept Super Valves will interest you in any case.

FACTS ABOUT BURNDIPT Super VALVES

Filament efficiency is greater than any other valve. The current consumption is low. At no time during manufacture is the filament heated to a temperature higher than that when in actual use. The filament can be overrun, within reasonable limits, without damaging the valve. Only the latest and up-to-date appliances are used and include automatic vacuum pumps.

Every valve is tested twice before it reaches the user.

The factory limits, strictly imposed, ensure uniformity in characteristics and mechanical construction. Burndept Valves are good valves, honest valves and absolutely reliable—and we make them ourselves.

You will see the thoroughness with which every Valve is tested.

BURNDIPT SUPER POWER VALVE LL. 525.

Price 22/6

One of the famous BURNDIPT range.

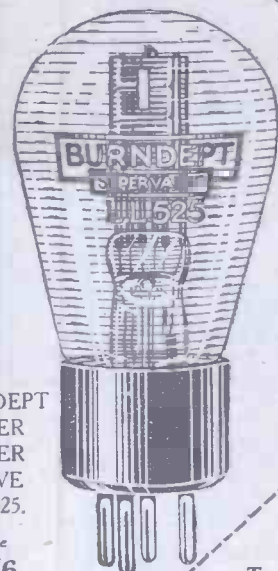

To BURNDIPT WIRELESS LTD.

I should like to be included in the party to visit your Valve Works. Please send me choice of dates.

NAME.....

ADDRESS.....

P.W.....



Head Offices and Factory: Blackheath, London, S.E.3.
London Showrooms: 15, Bedford Street, Strand, W.C.2.
AGENTS' AND BRANCHES EVERYWHERE.

<p>JACKS 4-POINT</p> <p>1-Hole Fixing 1/9</p>	<p>L.F. CONDENSER</p> <p>With 4-in. dial. .0005 7/8 .0005 7/3</p>	<p>RELIABILITY CONDENSERS</p> <p>Mansbridge Type. .25, 1/6 1 mfs., 2/6 .5, 1/9 2 mfs., 3/6</p>	<p>WIRELESS CABINETS</p> <p>For Panels 7 in. High Width 8 in. Hinged Lid .12, 1/7, 14 in., 17/6, 18 in. 18/6 Mahogany 1/- extra.</p>	<p>DEWAR SWITCH</p> <p>12-Contact 2/6</p>
--	--	---	---	--

READ THIS LIST AND SAVE MONEY ON COMPONENTS

RECENT REDUCTIONS.—Sterling .0005 Square Law Condensers with Vernier, 3/6; Geared 12/-; Miniloss, 15/-; .00025, 8/6; Geared, 10/6; Miniloss, 14/-; Marconi Automatic Detector, 2/6; Series Parallel Variometer, 10/6; Eddystone Absorbent Feet, set of 4, 2/3; Benjamin S.P. Switch, 1/3; N.P. Clix Plug & Insulator, 2/4; Adaptor, 1/4; Socket 2d. **LATEST COMPONENTS.**—5-Way Coil Stand, 2/9; Colvern Low Loss Inductance Former, 5/-; Formo Straight Line .0005 Condenser, 10/6; Success, 18/6; Eureka, 15/6; Cydon, 15/6; Lissen 50 v. H.T. New Process Battery, 10/6; Valve Vibrating Springs, 6d. set of 4. **TERMINALS & ACCESSORIES.**—Singlew. Office N.P. or Pol. Brass with nut and washer, 1/4; Phone and Cassio type, 1d.; Double Mark, 2d.; 4-way Phone Connector, 6d.; Pole-finding paper, 3d.; Fluxite, 8d.; Black Tape, 6d. coll.; 4 in. Empire Tape, 6d. dozen yards; Insulating tube, 3d. yard; Glazite, 1/2, 10 ft. coll.; Shellac Varnish, 6d.; Mica 2 in. x 1 1/2 in., 4d. dozen; Chattertons Compound, 9d.; Hand Drill, 3/6, Drills, 1/-.

EBONITE.—Any size cut; Clayton brand, 4 in. sq. in.; 9 in. by 6 2/2; 12 in. by 9, 4/6; 15 in. by 9, 5/6; 3/16 in. 25 per cent. less. Paragon and Radion, 1d. per sq. in.

CONDENSERS.—Low Loss, Square Law, with knob and dial, .0005, 5/-; .0003, 4/6; with Vernier Blade, 1/4 extra; Twin .0005, for Elstree Six, unequalled value, 9/6; Cydon Twin for ditto, 27/6; Ormond, J.B. Utility, Sterling, Polar, Formo, Igranite, G.E.O. Var. in all capacities. Neutrodyne types, Ormond, 2/-; Colvern, 3/6; Gambriel, 5/6.

FIXED CONDENSERS.—Dubilier, Edison Bell, Lissen, Watmel, Mallard, McMichael, at advertised prices. Special Reliability Fallon—,0003 mfd. 2 meg. Leak, 1/3; Cases only 3d.

BATTERIES.—Reliability, 90 v., 11/-; 60 v., 7/6; 36 v., 4/6; 15 v., 1/10; Ever Ready, Siemens, Hellesen, 100 v., 21/-; 66 v., 12/6; 36 v., 7/6; Flashlight Battery Cases for 14 Batts., 3/6; 4 v. Batts., 4d.; 60 v. Unequalled, 6/6; Wan. Plugs, 1/4; Clix Type, 2d.

ACCUMULATORS.—Exide, D.T.G., 4/6; D.F.G., 8/6; W.J., 20 v., H.T. type, 15/-; Oldham H.T. 10d. per volt, complete. Duros 20 v., 11/-; 10 v., 5/6; Repairing Outfit, 2/6.

L.F. TRANSFORMERS.—R.I. Model Range, 25/-; Marconi Ideal, 25/-; Junior, 18/6; Perant A.F.3, 25/-; A.F.4, 17/6; Formo, 10/6; H.T.C. Empire, 7/6; Croix 5 to 1, 6/-; Lissen new type, 8/6; Igranite, 18/-; Eureka Concert Grand, 25/-; No. 2 21/-; Baby Grand, 18/-; Ormond, 15/-; Royal, 20/-; Success, All Black, 21/-; Silvertown, 21/-; G.R.C., 15/-; Brandes, 17/6; Burndept, 16/6; Special Value, 7/6; Modulation, 7/6.

VALVES.—Radion— all types, Frelat 2 volt, 3 amp., 4/11. All advertised makes stocked.

VALVE HOLDERS.—Anti-Phonic Benjamin, 12/-; Lotus, 2/3; with terminals, 2/6; Burndept, 2/3; Harlie, 1/6; Reliability, unequalled, 2/-; all baseboard types, ord. ditto, 6d.; N.P. Valve Sockets, flush fitting, 1d.; Superior Panel Type, 6d.; All Ebonite, 10d.

HEADPHONES.—B.T.H., 15/-; Brown's "F" Type, 20/-; Reliability, 7/6; Adjustable, 8/-; Dr. Nesper, 12/11; T.M.G., 17/6; Western Electric, 20/-; all 4,000 ohms; Sullivan, 120 ohm Double, Ex-Govt., New, 4/-; 120 ohm Single Phone, 2/6; Long Phone Cord, 1/-.

AERIALS.—100 ft. 4 in. copper tape, 1/6; 7/22s Bright, 2/3; Enamelled, 3/3; Electron: 1/6; Superior, 2/6; Marx, 9/6; Ashton Spreaders, 12/- per pair; O.V., complete, 2/6.

INSULATORS.—Large Shell, 3d.; Reel or Egg, 1d.; Climax, 6d.; Ditto, with shock absorbers, 3/- pr.; Gal. Pulleys, 4d.; 100 ft. Gal. Straining Wire, 1/6; Straining Hooks, 6d.

EXPERIMENTERS' PARCELS.—Accessories of Various Types, worth 20/-, post paid, 5/6.

Send for New RELIABILITY WIRELESS GUIDE No. 9. Free on Request Trade Supplied.

J. H. TAYLOR & Co
4. RADIO HOUSE.
MACAULAY ST., HUDDESFIELD
Tel: 541. Grams: THOROUGH HUDDESFIELD

Orders 5/6 Value Carriage Paid. Under 5/6 2d. per lb. for Packing, etc.

Reliability of Service

ARE YOU BUILDING A WIRELESS RECEIVER ?

—then don't spoil it by using inferior components. Consult us. **GUARANTEED COMPONENT PARTS** for **ELSTREE SIX SOLODYNE**, or other Circuits can be supplied for **CASH** or **EXTENDED PAYMENTS. RECOMMENDED** Components supplied—**NOT SUBSTITUTES.** **ELSTREE SOLODYNE.**—Components including Bowyer-Lowe Condensers, Lewcos Coils and Screens, Peto-Scott Neutralising Condensers, Cydon Resistors, Lissen H.F. Chokes, Cabinet, Ebonite Panel, £20 Glazite Wire, etc.

Or Deposit £4 and the Balance payable over 6 or 12 months.

WIRELESS SPECIALISTS **Service Company Ltd** **SERVICE OUR NAME AND AIM**

Wireless Dept.,
273-274, HIGH HOLBORN, LONDON, W.C.1.

King of the Air Cabinets

(as used by Mr. P. W. Harris and illustrated on page (8) of last week's issue)

Complete Set of Parts - - 35/-
(Anyone with glue and polish can build his own in a short time).

Complete finished Cabinet - 52/6
(Carriage extra on either, 2/6).

UNICA CABINET COMPANY
72, Camden Street, London, N.W.1.

G.A. 6710.

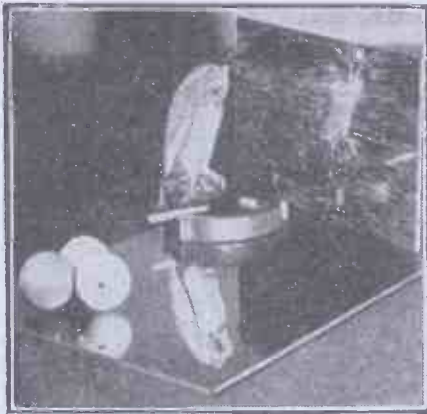

Panel Talks: No. 4

Why some Panels change colour

—and how you can be certain yours will not

MOST probably if, in the past, you have not chosen your panel wisely you have been disappointed, after a few months, to notice it has taken on a very unpleasant greenish shade. Almost as if it had gone mouldy!

For your new Receiver you will want to be sure that the colour of the panel is permanent. How can you be certain of this? Here is the answer. Cheap ebonite contains a large amount of sulphur. Sulphur, as you probably know, reacts to the action of the light. A panel, therefore, which contains sulphur, after being exposed to the light for a period, soon loses its black colour and becomes "mouldy" in appearance. How, though, can you be certain that in the Panel you buy, sulphur is entirely absent? The answer lies in the twin names, either of which is borne by every panel of the American Hard Rubber Co. [Britain] Ltd.—the names 'Radion' and 'Resiston'. Like the Hall-mark on gold, either of these names on a Wireless Panel is your safeguard. They are a veritable insurance against all panel ills. They mean that a panel bearing such a name is permanent in its colour—now and in the years to come. They mean that, in insulation, the panel is a hundred-per-cent perfect; that it is non-metallic, and its surface therefore is impervious to moisture and dirt, and lastly that 'Resiston' and 'Radion' Panels will not warp, nor will they split or break—they can be "worked" with absolute confidence.

For the sake, perhaps, of a few pence, will you court failure and disappoint by choosing an unnamed panel in preference to one bearing such a name as Radion or Resiston—names which give you positive assurance of lasting satisfaction?

Resiston comes in 17 stock sizes in Black or Mahogany-grained finish. Each panel is protected by its own stout manilla envelope—your safeguard.



American Hard Rubber Co., Ltd., 13a, Fore St., E.C.2. G.A.6609.

RADIOTORIAL QUESTIONS & ANSWERS.

(Continued from page 1014.)

AVOIDING HOWLING.

S. P. R. (London).—I possess a two-valve crystal reflex set which gives me excellent results from the local station and 5 X X. Recently, however, I wished to take the loud speaker in another room, but as soon as I joined up the long extension leads an unpleasant howl resulted. Separated leads were then tried and also various capacities of fixed condensers across the loud speaker, but the howl could not be stopped. Can you suggest how I might overcome the trouble?

The howling to which you refer is not uncommon with a reflex set, but fortunately it can often be cured by the use of a shunting device in the plate circuit of the last valve (i.e. in place of the loud-speaker connections).

A method usually employed is to place a large capacity fixed condenser in series with one extension lead and connect an L.F. choke directly across the output terminals.

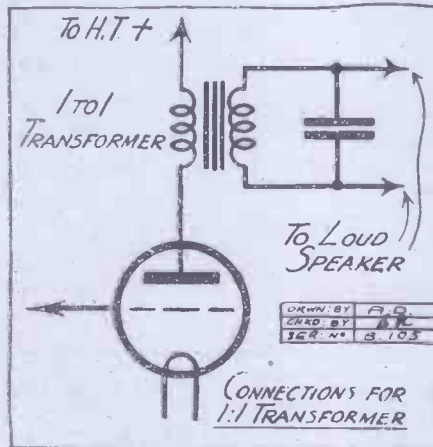

Another method (illustrated above) is to fit a telephone transformer of a 1 to 1 ratio to the "loud-speaker" terminals of the set. The long leads are then connected to the secondary of the transformer, and the usual fixed condenser placed across these if necessary.

LOUD-SPEAKER EXTENSIONS.

B. J. E. (Barrow-in-Furness).—I am going to "shunt" the loud-speaker output, from my set, so that H.T. does not wander about "upstairs, downstairs, and in my lady's chamber." But I am a little uncertain about the best way to run the wires and arrange the "points" in the different rooms, so as to be inconspicuous and at the same time efficient. What is a good method?

When the separate output has been obtained, the house can easily be wired so that the loud speaker can be plugged in where desired. Such wiring can be practically invisible if bell-wire or No. 16 D.C.C. wire is used. Do not use thin wire, or the resistance losses will be high, and do not run the "come" and "go" wires side by side, or leakage may occur between them. A good method is to run one wire to all the "points" via the picture-rail, tops of doors, etc. The return wire from all the points can be on the floor, skirting-boards, or under the carpets, linos, etc., where it, too, is quite invisible.

The "point" in each room need present no difficulty, for an ordinary coil holder may be used, the corresponding plug-and-socket being on the lead of the loud speaker.

If all the loud speakers or 'phones to be used are of the same resistance, the "points" can be wired in parallel, and any room can plug-in to the programme by simply inserting the loud-speaker lead. If, however, the resistances are different, the "points" must be in "series" and shorting-plugs must replace any loud speaker removed from the system.

If the coil-plugs are arranged on the skirting-board they may be so inconspicuous as to be practically invisible. Similarly the extension wire may descend from a picture-rail in a corner of the room, where it is unnoticeable, and, if the room is papered subsequently, the paper will cover, and protect the invisible wiring.

(Continued on next page.)

Britain's Best in Radio

LAMPLUGH GRID LEAK

Variable. 5 to 15 MEGOHMS. One hole fixing. An efficient and well made component, the resistance element is guaranteed constant and is impervious to moisture.



Price 4/- each.

S. A. LAMPLUGH LTD.

King's Road, Tyseley, BIRMINGHAM.

Sole Distributors for London and Southern Counties: The Empire Electric Co., 305, Euston Road, London, N.W.

Scottish Depot: 58, Montrose Street, Glasgow.

Send for RADIO Lists.



This mark is our Guarantee.

Obtainable from all Leading Wireless Dealers

WIRELESS.—Capable, trustworthy men with spare time who wish to substantially increase income, required where we are not fully represented. Applicants must have practical knowledge of installation of Set and Aerial, be a householder or live with parents, and be able to give references: state age and experience. Address: Dept. 10, General Radio Company, Limited, Radio House, Regent Street, London, W.1.

JARS, Waxed, ZINCS, SACS

1/6 DOZ. 1/- DOZ. 1/6 DOZ.
For making Wet H.T. Batteries, post free on 3 doz. or over. Packed in special carton with division for each cell. This can be used as a container for the battery when made up. Send 6d. for sample complete unit, particulars and instructions.

SPENCER'S STORES, LTD.,
4-5, Masons Avenue, Coleman Street, London, E.C.7.
'Phone: London Wall 2292. (Nr. Bank)

MEANS DOUBLE POWER
For use in both H.T. less and ordinary circuits, B.E., D.E. and '06, '10/5 to 14/-
Send card for Radio press reports and booklet. This valve can be used in any set without alteration and will give 50% to 150% increase in power.
ANELOY PRODUCTS,
Eton Works, East Dulwich London, S.E.22.
CALLERS: 4a, Forest Hill Road, East Dulwich

REPAIRS

Headphones, Loudspeakers, and Transformers re-wound & reconditioned equal to new.

AN UNSOLICITED TESTIMONIAL

"Thanks to the excellent manner in which it was reconditioned, the results achieved have been astounding. It is very gratifying to find a firm that really turns out a first-class job, as I have had very disappointing experiences with firms who have advertised as experts, and whose workmanship has been far from good."

Varley Magnet Co.,
Repairs Dept.,
Woolwich,
S.E.18.

Proprietors:
Oliver Peil
Control,
Ltd.



RADIOTORIAL QUESTIONS AND ANSWERS.

(Continued from previous page.)

GRID-BATTERY RENEWAL.

M. B (Portsmouth).—How often should a grid-bias battery be renewed? I expect a good many listeners have been puzzled as I have by the different length of time that batteries last. It is easy to see why the L.T. battery that heats the filament needs frequent recharging, but why does the grid-bias battery generally last so much longer than the H.T. battery?

The accompanying diagram will help to explain the different conditions.

The L.T. Battery obviously has a heavy drain upon it, for the filament circuit is connected right across the L.T. plus and L.T. neg. terminals (for simplicity's sake, no rheostat is shown in the diagram). A comparatively heavy current (measured in amps.) is flowing whenever the valve is alight, so the L.T. battery soon runs down.

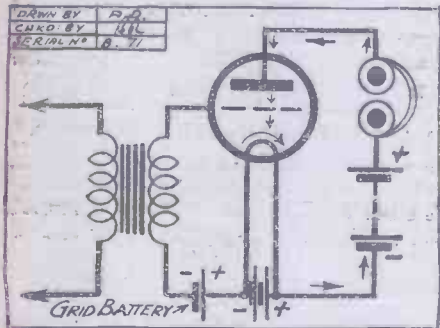

The H.T. Battery has a smaller—but, nevertheless, heavy—drain upon it. When the valve is alight, a steady H.T. current (measured in mill-amps.) can be imagined as passing from the + pole of the battery, through the phones, across the high-resistance of the valve, between plate and filament, and so back to the H.T. battery (neg.) terminal. As the loud speaker or phones are operated by this current, the battery supplying it runs down fairly quickly.

The Grid-Bias Battery provides no operating current, but is utilised merely to keep the grid's normal voltage negative, with respect to the filament.

Practically no current flows in the grid circuit, so this battery does not "run down," but simply deteriorates in the course of time. It should not require replacing oftener than twice a year.

CHOOSING A LOUD SPEAKER.

J. H. (Twyeross, near Atherstone, Warwickshire).—There are so many different kinds of loud speakers that I am very uncertain which type to buy. What is the difference between the various types, some of which cost much more than others, some being large and others small, etc.?

Loud speakers may be divided into three main sections—large, medium and small (irrespective of their design). The really large ones are unsuitable for ordinary use. They are designed for work in halls, at dances, etc., and need a considerable input.

TECHNICAL QUERIES.

Owing to very heavy pressure on the Technical Staff, there is a little delay in despatching answers to readers' queries.

At the moment every effort is being made to get replies posted within about 10 days of receipt, and it is hoped to reduce this period very shortly. Readers can help by making their questions as short and clear as possible.

The medium ones are best suited to cases where a large room is to be the home of the loud speaker, where perhaps occasionally dancing may be indulged in when dance bands are being broadcast. Such a loud speaker would be suitable on four and three valve sets, or on a two-valve set if a smaller room were used, and the set was fairly near a broadcasting station.

The small loud speaker is for use in a small room where a large volume of sound is not required, and is suitable for use on a two-valve set. This small loud speaker should not be expected to operate "loud enough to dance to," and it should also not

(Continued on next page.)

EXPERTS IN RADIO ACOUSTICS SINCE 1908

SEE FOR YOURSELF....

SEE and hear for yourself. Go to a Brandes Dealer and look over the Brandes range. Get him to demonstrate, and make your own comparisons. Not many instruments of such good class are so reasonably priced. Observe that the cost of the Brandola is considerably reduced.



THE BRANDOLA

Specially built to bring greater volume with minimum current input and exceptional clarity over the full frequency range. A large diaphragm gives, new rounded fulness to the low registers and

new clarified lightness to the high. Reproduction controlled by a thumb screw on the base. Polished walnut plinth with electro-plated fittings. Height 26 ins., bell 12 ins. **75/-**



THE TABLE-TALKER

The new goose-neck design is the result of research in radio acoustics, which definitely establishes its value in relation to the diaphragm fitted. Patent material used in the construction of the horn eliminates metallic harshness. Volume and

sensitivity controlled with small lever located at the rear of the base. Elegantly shaped, tasteful neutral brown finish, felt-padded base. Height 18 ins., bell 10 ins. **30/-**

Brandes

From any reputable Dealer.

BRANDES LIMITED • 296 REGENT ST. • W.1

The best British at Continental PRICES Jacks, Plug, and Resistances

Manufactured in the latest materials and design. Approved by the Elstree and other famous laboratories. Tested to withstand many times the conditions imposed in ordinary practice

JACKS

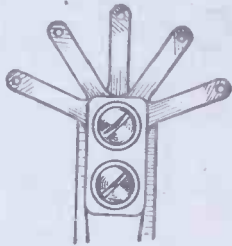

Tags are tinned and spread fan-wise for easy soldering. Nickel Silver springs, pure silver contacts. Insulated throughout with genuine Bakelite.

- No.1. Single Circuit open 1/3
- No.2. Single Cir. (closed) 1/6
- No.3. 1/9
- Double Circuit as illustrated.
- No.4. Fil. single Control 1/9
- No.5. Fil. Double Con. 2/3

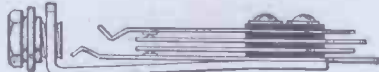

Plug

Actual size, conforms to spade tags, pin tags, flexible or rigid wire leads. Genuine Bakelite. Neatly finished.

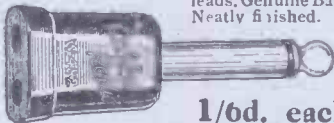

1/6d. each

ASHLEY-LEDWARD RESISTANCES (Anode and General Purpose).



Absolutely stable at ordinary temperatures & under high impressed voltages. Capacity free. Impervious to moisture. Each component is subjected to a 43 hour test, during which it is continuously under pressure at a mini-

2/6 d.
each

with clips.

mum of 230 volts. **Extract Radio Press remarks.** The uniform qualities of this component under adverse conditions (left out of doors several days) are worthy of notice and it can be recommended with confidence.

ASHLEY WIRELESS TELEPHONE CO., (1925) LTD., 17, FINCH PLACE, LONDON ROAD; LIVERPOOL.



RADIOTORIAL QUESTIONS AND ANSWERS.

(Continued from previous page.)

be expected to give good results if used with a four-valver. Such a set gives too heavy an output, and this would overload the loud speaker and give rise to distortion.

There are also two main classes of loud speaker—the hornless type and those with some form of sound conduit. As a rule the former are unsuited to small outputs and would not do for use with small sets. A four-valver should be capable of operating them, but they spread the sound so evenly that in most cases they do not sound so loud as would one of the horn type under the same conditions. For purity they are excellent, but the fact that signals may not be so loud should be taken into consideration when a decision between "with" or "without horn" has to be made.

For the Constructor

WHAT TO DO WITH SPARE APPARATUS.—CONDENSERS.

(a). Variable condensers if connected across the phones (of a 1-valve set) or across the primary of the first L.F. transformer, in place of an existing by-pass condenser, will often give perfect reaction control.

(b). Fixed condensers can be used across loud-speaker terminals to vary the tone and, to a certain extent, the volume.

(c). A fixed condenser (say .0005 mfd.) placed in series with the variable condenser controlling reaction in sets of the Reinartz-reaction type, will prevent shorting of the H.T. battery, due to the variable condensers touching.

(d). A small fixed condenser (.0002 or thereabouts) will tend to sharpen the flat tuning due to a screened aerial, especially if the present aerial tuning condenser is connected "in parallel." The small additional condenser should be connected between the aerial lead and the aerial terminal.

(e). A large fixed condenser in the earth lead often reduces "humming" interference. (It should be shorted when the aerial is not in use.)

REWINDING 'PHONE BOBBINS.

CONSTRUCTOR (Bournemouth).—As one of my 'phone windings has burnt out, I wish to rewire same. Can this be done?

We do not advise you to undertake the rewinding owing to the fragile nature of the wire and the difficulty of winding it on evenly.

It would be far better to get the job done by a firm specialising in this class of work, such as the Varley Magnet Co., Bloomfield Road, Woolwich.

EBONITE BUSHES

FOR MOUNTING ON WOOD. Orders under 1/- send 1/4d. postage. PERFECT INSULATION. Two required for each hole. NUMBER 0 1 2 3 4 5 6. Hole in Bush—.6BA. 4BA. 2BA. 1/4" 5/16" 3/8" 7/16" Price each: 1d. 1d. 1d. 1 1/4d. 2d. 2d. 2d. DAREX RADIO CO., Waldram Road, Forest Hill, London, S.E.23. TRADE SUPPLIED.

SUPREME

in the TWO VOLT class

H.F. ST.21(0-1A)-14/-
L.F. ST.22(0-1A)-14/-
POWER ST.23(0-15A)-18/6

POINT ONES WHICH GIVE THE HIGHEST EFFICIENCY ON THE LOWEST H.T. (60 VOLTS AMPLE)

BUILT LIKE THE PYRAMIDS—TO LAST

Give Him a multi-range one-meter THE DIXON ULTRA ONE-METER

Model de Luxe

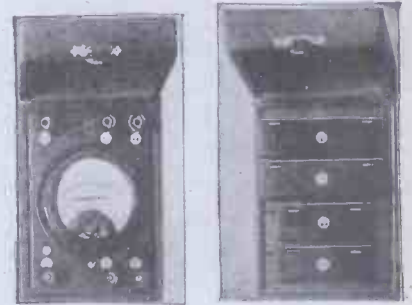

Mirror Double Scale. Moulded Base.

The finest Precision Multi Measuring instrument is the DIXON ONE-METER.

INSTRUMENT IN CASE 55/- MULTIPLIERS EACH 6/6

LESLIE DIXON & CO., 218, Upper Thames St, London, E.C.4.

TOUR THE CONTINENT AT XMAS with the MONOTUNE 3.

The greatest advance in receivers, designed by G. P. ALLINSON, A.M.I.R.E., late of Radio Press, Ltd. This three-valve receiver (detector and 2 L.F.) gives loud-speaker reception of stations all over Europe with only one tuning control. YOU CAN BUILD IT in one evening from detailed instructions and 15 diagrams, circuits and photos. NOTHING LEFT UNEXPLAINED.

SEND YOUR MONEY NOW for the Monotune Constructone No. 1. PRICE, post free, From The Constructor Publishing Co., 37, Drury Lane, Long Acre, W.C.2. 2/6

RADIO REGISTERED PANELS

Inches	Inches
7 x 5.1/2	6 x 6.1/2
7 x 6.1/3	8 x 5.1/2
8 x 6.1/4	9 x 6.1/7
10 x 8.2/1	11 x 8.2/3
10 x 9.2/4	12 x 8.2/6
12 x 10.3/4	12 x 9.2/10
14 x 12.4/4	14 x 10.3/5
	1/2 in. thick
	Post Free.

Money back guarantee that each and all Panels are free from surface leakage. Megger test Infinity. Callers cut any size. Quotations by post, or 'phone Clerkenwell 7853. Samples and prices post free to the Trade.

CROXSONIA CO., 10, South St., MOORGATE, E.C.2

Valves Repaired

AS GOOD AS NEW!!

HALF PRICE

(Except Weco, S.P.'s and low capacity types). Minimum D.E. Current 0-15 amps when repaired. ALL BRIGHT & DULL EMITTERS. Listed at less than 10/-. Minimum charge 5/-. VALCO LTD., Dept. r.w. Labor Grove, Wimbledon, S.

AERMONIC 1/9 DON'T PAY MORE

Anti-phonc. Lowest capacity. Lowest price—best value. The new design enables us to sell at less than other makes and puts Aermonic "miles in front." Aermonic Holder - 1/9 Other makes are not so fine. If 'can't obtain' drop us a line.



List of Aermonic Specialities Free.

JAMES CHRISTIE & SONS, LTD. 246, West Street, SHEFFIELD. London Agents: A. F. Bulkin & Co., 10, Cursitor Street, London, E.C.4.

"THE KING OF THE AIR."

(Continued from page 989.)

Owing to the wide wave-length band now required for broadcasting, it will be necessary to have two aerial coils, one to cover from just below 200 metres up to about 500, and the other from about 400 or 450 up to the highest wave-length of the shorter bands. You will also require a third coil in the aerial socket for the Daventry range. H.F. transformers for the three ranges are also obtainable.

The first point which will strike the reader when testing out this set is the very remarkable purity given, as well as the high selectivity. The selectivity of a set such as this is dependent upon several factors, and will not be the same in all cases. For example, one aerial may be much more selective than another, and the more the reaction amplification used the greater the selectivity from this source. Furthermore, as previously explained, the series condenser has a powerful bearing upon the subject, and the correct choice of this condenser is most important.

High Degree of Selectivity.

Generally speaking, one can say that if a person is resident within a couple of miles of a broadcasting station, the selectivity of this set is sufficient to receive a very large number of stations while the local broadcasting station is working, so as to give the reader a very wide choice of programmes.

As an example of the sensitivity and purity of the set, I may mention that during the first tests the Malmo broadcasting station was picked up one Sunday evening, and a complete church service was listened to on the loud speaker, the quality and strength being indistinguishable from that of the London station.

Admittedly the evening in question was particularly good, and as I have explained in a previous article on varying conditions, it would not always be possible to reproduce these good signals from that particular station, but on any given night you will find a large number of stations can be listened to sufficiently well to give genuine enjoyment to all who may be listening in a large room.

This, I think, is the most that can be claimed for any set using only one stage of H.F., for if better results than this were possible there would be no justification for building sets with five or six valves. Again, it is not claimed that a set with one stage of H.F. can give the sharpness of tuning possible with a well-designed set using two stages, but on the other hand I am convinced that the selectivity given by this set will be amply sufficient for many thousands of readers.

Twenty-five on the Loud Speaker.

On my own test aerial I have received twenty-five stations at loud-speaker strength, using the term in its correct sense and not to mean that one could just hear them when standing near the horn. These twenty-five stations have not all been heard at loud-speaker strength on one evening, but on the average evening one could rely on about a dozen.

In view of the fact that a large number of readers possess or desire to use screened coils in this set, I am now carrying out tests, and will describe very shortly the slight difference of wiring necessary.

JUST LISTEN!

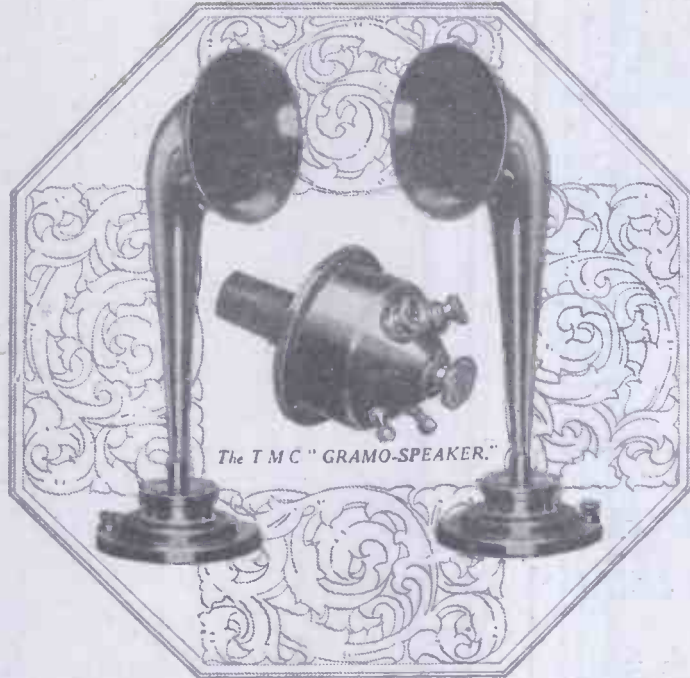

The T.M.C. "GRAMO-SPEAKER."

THE most critical test of any Loud-Speaker is to listen—not look.

The tone of the T.M.C. Junior will surprise you. The softest whisper is clear and audible—the full volume of a symphony Orchestra comes through without any blast or throatiness. So reasonably priced, too. Now only 30/-.

Another popular member of the T.M.C. Loud-Speaker family is the Minor. A fine little fellow with a rich, melodious voice. The T.M.C. Minor is inexpensive. Price 17/6.

Now comes the NEW T.M.C. Gramo-Speaker. This splendid unit will instantly transform your gramophone into a Loud-Speaker of highest merits. It costs but 13/6.



The T.M.C. "MINOR."

Any of these T.M.C. Loud-Speakers will make an enviable Christmas Gift.

Go to your dealer—ask to hear them, then take your choice.

We invite comparison.

Write for our latest Radio Catalogue.

T.M.C.

Telephone Manufacturing Co. Ltd.
HOLLINGSWORTH WORKS, WEST DULWICH, S.E. 21

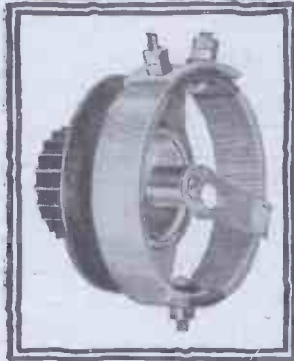
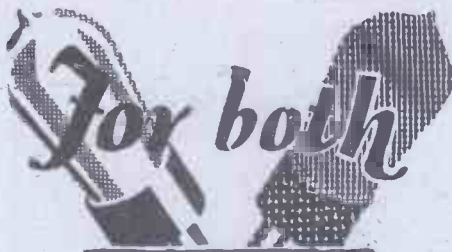

bright & dull emitter valves

There are two windings on this one Rheostat—one of a resistance of 6 ohms and a continuation of this on to a 30-ohm strip winding. This has been specially made to meet the demand for a thoroughly reliable Rheostat covering needs of both bright and dull emitter valves. The resistance wire is wound on hard fibre strip under great tension and is immune from damage. The popular one-hole fixing method is provided and the terminals are conveniently placed. Contact arm has a smooth silky action. All metal parts nickel-plated. Complete with ebonite combined knob and dial.

The 'PEERLESS' DUAL RHEOSTAT

PRICE 3/9 EACH

From all Dealers or direct from

The Bedford Electrical & Radio Co Ltd

-22, Campbell Road, Bedford.

CORRESPONDENCE.

Letters from readers discussing interesting and topical wireless events, or recording unusual experiences, are always welcomed; but it must be clearly understood that the publication of such does in no way indicate that we associate ourselves with the views expressed by our correspondents, and we cannot accept any responsibility for information given.—Editor.

CAN WIRELESS HELP THE FARMERS?

The Editor, POPULAR WIRELESS.
Dear Sir,—Your recent article on Radio Culture opens up a field of very great interest if not of great importance, and the more so since the article is written seriously and published in a serious paper. I am afraid, however, that I must class myself amongst those who have been "amused" at the suggestion that radio-activity can affect the growth of plants—there does not appear to be sufficient direct connection between plant life and ether waves. None the less, upon reading the account of the experiments described by the author, Mr. Corrigan, I began to wonder whether they could account for a phenomenal growth of a blue hydrangea which I have in the garden.

For eight years the plant had hardly ever borne a bloom; it was then transplanted into a large tub and given a favourable situation with more sunshine. Under these conditions it produced about a dozen small heads, and in the following year it did so badly that it was anything but an ornament. However, it was given one more chance, the usual top dressing was applied and the tub and plant were moved to a new position, this time vertically below the lead-in end of my aerial. The aerial is a high one, 75 ft. at the open end, and 50 ft. at the home end, and is permanently tuned in to 1,600 metres, so that it is oscillating for practically eleven hours every day, without cessation. The change of position of the plant took place last November. This spring the plant put out such abundance of growth from the ground that the whole of the existing branches had to be cut right out to make room for the new growth. By the middle of summer the plant had produced 35 enormous heads of bright blue blossom, the average diameters of which were over 10 inches, while the largest heads were 12½ in. in diameter. Being only an amateur gardener it was not until some experts had seen it that I realised that it was abnormal.

Whether the prodigious growth was due to the aerial or not, I am, since reading your article, somewhat in doubt. Naturally, one inquires as to whether other plants in a similar position had received any benefit. On looking back I find that a Wisteria, whose main trunk is only six feet from the hydrangea, last year put out a record bloom; this year it was below the average, apparently having temporarily exhausted itself. There is one other plant which might, from its position, be affected by the aerial; namely, a white jasmine. I am not sufficiently experienced as a gardener to know the propensities of this shrub, all I can say of it is that its prodigious growth of about 20 ft. every season in all directions has made it a perfect nuisance.

One other point which bears upon the same subject is the old-established belief amongst the county people that the crops require "summer lightning" to ripen them. Summer lightning is, I believe, identical with what is generally termed sheet lightning, and its effect upon a field of standing corn, I am told, produces a very strange phenomenon, the spikes on the heads of the corn acting like tiny lightning conductors and emitting a faint blue light. I have not, however, ever been privileged to witness it.

Yours faithfully,
GEO. C. SHERRIN.

Ingatestone, Essex.

THOSE PROGRAMMES.

The Editor, POPULAR WIRELESS.
Dear Sir,—Come programme and go programme, but the grouser still remains (to some) and rightly so, judging by the programmes served up by the B.B.C. of late.

Concerning the recent letters—"Too Many Talks" (by Mr. Yule), "B.B.C. Programmes," "Alternative Programmes," and "Another Four Years' Licence," respectively—I agree entirely with their views; but concerning the answer to the letter of "Ordinary Listener" by "Anti-Grouser," surely "Anti-Grouser" request in their last paragraph is a long and worn-out recommendation now. We have heard this before too often.

Getting down to brass tacks, as it were, we can confidently say that the programmes now are quite sixty per cent inferior to those "good old early days" of Marconi House in 1922-3 (Do "Anti-Grouser" recall these?) when the music—and programmes in particular—were a pleasure and delight to listen to—without even the "occasional" "soothing" symphony and chamber music so persistent in these days. Now, at the present time, with the greatly increased number of listeners (and dare we say revenue?) as compared with those "good old days," we are served with and fed on practically—a high-brow programme.

(Continued on next page.)

Bulgin
with
Good Things

Ask
your local
dealer to show
you some of the
following good
things for your set.

Slow Motion Control, Vernier dial, 4/6. Ruby Light Valve Reflector, 9d. Bracket Lamp Holders, 9d. Adjustable Panel Brackets, 1/6 pair. Radio Station Log (with Cards), 2/-. Dial Indicators, 9d. pair. Panel Dials, 2/6. Neutralising Condensers, 8 micro-mfcs., 3/-. 21 micro-mfcs., 4/3. Grid Bias Clips, 6d. pair. Vaseline Cups for Accumulator Terminals, 1/-. Push-Pull On-Off Battery Switches, 1/6 each. Panel Key Switches, 2/9 each.

DECKOREM
RADIO PRODUCTS (British Made).
WRITE FOR FREE ILLUSTRATED CATALOGUES.

A.F. BULGIN & CO
9-11, CURSITOR STREET
TEL. HOLBORN 2072 CHANCERY LANE E.C.6. WORKS CHISWICK

TRADE DECKO MARK Pairs Ad.

WET H.T. BATTERIES
BUY BRITISH Complete Units 3/6 per doz. All goods BRITISH MADE BY BRITISH LABOUR.
Jars 1/3, Zincs 1/-. Sacs 1/6 per doz. Carriage and Packing extra. Trade Inquiries invited.—**Demion Battery Co., 59, Badlis Rd., Walthamstow, E.17**

You can have that new Set for Christmas—and pay later.

How often have you wished for a multi-valve Set, but have been discouraged by the cost? Our Catalogue "P" tells how almost any well-known Receiver can be yours for a small initial payment. Everything is guaranteed. Let us know your requirements and we will advise you. Write to:

6619 New Times Sales Co.
77, City Road, E.C.1

REPAIRS

Headphones and loudspeakers re-wound and remagnetized, H.F. and L.F. Transformers re-wound and repaired **EQUAL TO NEW** by skilled mechanics on the latest automatic coil winding machines.

From 2/6

B. KIMBER, ALLEN & COY.,
39, Bargey Rd., Catford, London. S.E.6.
TRADE ENQUIRIES SOLICITED.

EASY PAYMENTS Finest 2-valve amplifier set, including loud speaker, 120 H.T., D.E. valves, £7 10s.; or 18" down and 11 instalments of 15/.

CASH BARGAINS

Amplifiers, 17/6 and 21/-. Phones, Telefunken type, 7/9; Fr. T. Houston, 11/- Good H.T. 60-volt 5/9, or 4½v. (laboratory test) 4/- doz. Famous Metal Valves (French) 2, 5, 7, 2, 5, 7, 06, 5/9; 2-v. 5. Power, 8/9; 4-v. 06, 5/6. Straight Line Condensers, 5/9; Ditto, 4' dial, 7/3. Transformers: Habana, 3/6; Radiolys, 3/8; Fr. T. Houston, 8/3; Brunet, 7/9. Also Ferranti, Eureka, Formo, etc. Postage extra. Everything in wireless, reliable and cheap. Satisfaction or cash refunded.
MUSIC ROLL EXCHANGE, 29 High St., Clapham, London, S.W.4.

EVERY LOUDSPEAKER

**DESERVES
MULLARD
MASTER
VALVES**

— Ask for —
Mullard P. M. Power Valves.

CORRESPONDENCE.

(Continued from previous page.)

If a ballot could be taken in regard to those "for" and "against" the average present-time evening concert, I am afraid the figures would astound a good many and reveal the true facts.

Perhaps "Anti-Grouchers" can explain the reason for the present "boom" in DX. I think I can find the correct explanation in the fact that the average evening programme—well, it is too terrible for words. One has only to scan the "Continentials" in one evening to find the great contrast in their meaning of "Variety" as compared with our own.

Regarding the De Groot abandonment and apropos the remarks of Mr. Wayman in "P.W." No. 232, this is the correct step to take—if licence-holders will only voice their views success will ultimately be assured. I have done my bit so far and have promptly sent in my postcard—in favour of Mr. Wayman's suggestion—a really excellent one, too. I would like to state that Mr. Wayman's idea deserves the support of thousands of licence-holders. This is the right programme wanted—not "wanted" only, but greatly desired, as has been proved in the past, and yet we are deprived of it.

Once again good luck to Mr. Wayman, may we all reach the goal for which we are fighting, and be successful in reviving one of the most delightful programmes ever broadcast. Now then, licence-holders, raise your "voices" and let them be heard at Savoy Hill.

Trusting you will find sufficient valuable space in one of your early numbers of "P.W." for publication of my letter.

Yours faithfully,

HERBERT W. TILLEY.

"Hazeldene," 100 Midway Road Midway Park, N.I.

TRANSATLANTIC RECEPTION.

The Editor, POPULAR WIRELESS.

Dear Sir,—I have pleasure in informing you that this morning from 12.30 a.m. to 2.30 a.m. I heard broadcast transmissions from nine U.S. or Canadian stations on the following wave-lengths: 375, 316, 332, 394, 407, 325, 300, 290, 350 metres, of which WGY and WBZ were strong and clear. The other stations were all audible, but I could not get their call letters owing to heavy statics, which forced me to give up at 2.30 a.m.

I used a straight detector and two L.F. circuit, with capacity reaction, using a D.E.5B as detector, and two D.E.5's as L.F., and Ideal Marconi-phone transformers, 45 volts on detector, and 120 H.T. on power side, and 9 volts grid bias and telephones.

I used a Burndept wave-meter to find their wave-lengths, and the meter is correct to 1 per cent., I am informed by Burndept. I have not previously listened in to the U.S. this year, but used to get WGY, WBZ, WOR, WTAM three and four years ago.

This reception may interest many of your readers, and spur them on to pick out many more on a good night and morning. My aerial is 82 ft. high one end and highly insulated, as is the earth until it gets to the 4 x 3 copper plate under the aerial.

Yours faithfully,

JOHN R. WORTLEY-TALEOT (Dr.).

Elmington, Chelston,
Torquay.

HOME MADE H.T.

The Editor, POPULAR WIRELESS.

Dear Sir,—We have read with interest the letter from your correspondent Mr. Whitby. The rapid eating away of the zinc and also creeping of Salammoniac can be greatly reduced by using a solution of 1 oz. of salammoniac to 1 pint of water. There is no need to use a stronger solution as the amount of current required is very small, and there is usually a fair amount of salammoniac used in the composition of the sac element. Further advantage of using a weak salammoniac solution is the elimination or at least a great reduction in "creeping."

It is, of course, in any case advisable to wax the jars (if this has not already been done) and also to wax the connections and brass caps on the sac elements after they are assembled. We trust this information will be of use to those who are adopting this method of H.T. supply.

Yours faithfully,

THE WET H.T. BATTERY CO.

23, Coldharbour Lane, London, S.E.5.

QUESTION OF IDENTIFY.

The Editor, POPULAR WIRELESS.

Dear Sir,—I should be glad to hear if any of our "short wave" experimenters could identify a station broadcasting a Roman Catholic Congress at Pittsburgh, U.S.A., on Sunday November 21st at 1 a.m. What was the actual wave-length?

The strength at which this was received and the absence of fading was extraordinary, the set used being a straight Det. and 2L.F. The coil was a home-made one of 10 turns D.G.C. tapped at 8th turn. The volume was sufficient to work two loud speakers at full strength. I am particularly anxious to know what the wave-length was.

Yours faithfully,

G. J. MANLY.

"St Nyth," St. Andrew's Road, Malvern.

New!—Radically Different

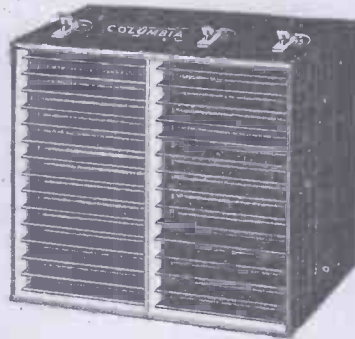

It's all battery. With every cubic inch packed to capacity, it contains about 30 per cent. more electricity producing material: All chance of loose or broken connections avoided by contact of full area of carbon plate against zinc plate. Price 25/-. No increase in price over old type.

"Layerbilt"

THE MOST IMPROVED H.T. BATTERY YET MADE

Absolutely new in construction—perfected through years of research in the greatest commercial laboratories known to science, the new COLUMBIA Layerbilt "B" Battery is as superior to the old type of "B" battery as a valve set is to a crystal.

Heretofore, all H.T. batteries have been made of cylindrical cells—no one knew how to make them any other way. The new COLUMBIA Layerbilt is made of flat layers of current-producing elements compressed one against another, so that every cubic inch inside the battery case is completely filled with electricity-producing material. Layer-building heightens the battery's efficiency by increasing the area of zinc plate and the quantity of active chemicals to which the plate is exposed.

After the most rigid laboratory test, more than 30,000 of these new COLUMBIA Layerbilt H.T. Batteries were manufactured and tested by use under actual home receiving conditions. These tests prove that on sets of four or more valves the life of this battery is 35 to 52 per cent. longer than the famous COLUMBIA extra Heavy-duty H.T. Battery No. 4770, which up to now has been recognised as the most powerful and longest-lived H.T. Battery manufactured.

The new Layerbilt principle is such an enormous stride forward in radio battery economy that the National Carbon Company will bring out other sizes and voltages in this Layerbilt form as quickly as new machinery is installed. For the present only the extra Heavy-duty 45 volts size will be available—READY JANUARY 1st, 1927.

Buy the new COLUMBIA Layerbilt No. 4486. It far exceeds the performance for which COLUMBIA Radio Batteries have always been famous. It is by far the most economical source of H.T. current obtainable.

Manufactured and guaranteed by
NATIONAL CARBON COMPANY.

J. R. MORRIS
IMPERIAL HOUSE, KINGSWAY, W.C.

Columbia

Radio Batteries

They last longer



THIS MAGNIFICENT 2-VALVE SET (D. and L.F.) as shown in Handsome American Type Cabinet, 12 x 8 Panel. ALL PARTS ENCLOSED. Complete with British D.E. Valves, Tandco latest Coils, British L.T. Super 100-v. H.T., Aerial Equipment, 4-way Leads, B.T.H. 4,000 ohm 'Phones, OR Lissenola, OR Loud Speaker. **£5 5 0**

Marconi Tax Paid. Carr. and Packing, 5/-.

KAY RAY

LOW LOSS SQUARE LAW

This variable Condenser is simply marvellous value. It cannot be equalled in price or quality.

By Post 5/11 '0003 or 4/11 '0005 or 1/- extra. With VERNIER 1/- extra.

S.L.F. CONDENSERS

LATEST MODEL NOW READY

6/11 POST 6d.



'0003 or '0005 **6/11** With knob and dial **7/11**

JACKSON BROS. (J.B.) S.L.F. '0005, 11/6. '0003, 10/6. Brass Vanes, 1-in. dial, Geared, CR. Law, Twin Gang stocked.

ALL CIRCUITS, PARTS, COILS & SETS STOCKED.

EVERYTHING in Demand Stocked for Wireless.

CALL HERE FOR LISSEN. BENJAMIN, DETEX, COSMOS, MULLARD, EDISWAN, MARCONI, COSSOR, OSRAM, JACKSON (J.B.), DUBILIER, MEMOCHAIL, SUGGESS, BEARD & FITCH, BOWEN-LOWE, LEWCOCK, KRANIC, EUREK, ORMOND, UTILITY, FORMO, EDISON BELL, FERRANTI, R.I., POLAR, NEWREY, P. & M., MAGNUM. We have the goods! Call and see us. All lines in demand stocked. Special terms to Radio Clubs, genuine experimenters.

LISSEN.—Lissenola, 13/6. L.F. Transformer, 8/6. 35 ohm Rheostat, 2/6. H.P. or L.F. Choke, 10/- Fieldless Coils, 13/6. GridLeaks, F. 1/-; Dito, variable, 2/6. All parts available.

EDISWAN R.C. THREESOME R.C.R.

2 Ediswan R.C. Units, 3 Valve Holders, 2 R.O.2 Valves, 1 P.V. do., 3 Fil. Rheostats, 3-wr. Grid Bias, '0005 Tuning Condenser. SET OF PARTS **67/6** Post Free.

All Accumulators, Panels L.T. Batteries stocked.

VALVES.—Cosmos S.F.18, Red or Green, 14/- New Blue Spot, 14/- All Mullard, Ediswan, Osram, Marconi, Cosor, Bright, D.E. and Fowler. 8/-, 14/-, 18/-, 22/6, 24/6, 30/-, 42/- Mullard PM 1. 2. 3. 4. 5. 6 stocked.

HEADPHONES.—114,000 ohms N. & K. Standard Pattern, 7/11 pair. N. & K. Genuine, new light weights, 11/6, 13/6. Dr. Nesper, 10/6 and 12/11 Telefunken, adjustable—'enuine '20' model 14/11 Brunet, 11/6, 12/11. BRIGGSON (Continental) E.V., 7/11 pr. (Post 6d.)

K. RAYMOND

27 & 28a, LISLE ST., LEICESTER SQ., W.C.2

Hours: 9.15 to 7.45 Back of Daily's Theatre
Saturday: 9 to 3.45 Nearest Tube Leicester Square
Sunday: 11 to 1 Phone: Gerard 4637

Open Xmas & Boxing Mornings 11 a.m. to 1 o'clock

You will have a **HAPPY XMAS** if you buy our **3-VALVE LOUD SPEAKER RECEIVER** (D. & L.F.)

Built in a fine **OAK AMERICAN CABINET**. ALL PARTS ENCLOSED. (Panel 16 x 8.) Marconi or Mullard D.E. Valves, Eveready L.T., Super Tandco Coils, 2 pairs of 100-v. H.T., 4-way Leads, B.T.H. 4,000 ohm 'Phones, OR Lissenola, OR Loud Speaker (please select), Aerial Equipment. Marconi Tax Paid.

THE LOT £8 8 0

NOTE THE QUALITY AND THINK IT OVER! Box and Carriage, 7/6.

CALLER'S COLUMN

NOT SENT BY POST.

Terminals with N. and W. 1d.; Nickel, 1 1/4d.; Spade Tags, 5 a doz. Soldering 3d. doz. E6 Bushes, 1d. Screw Winder Plugs, 2d., 3d., 4d. pair. Plug and Socket, R. or B., 3d. Staps, 4 a doz. Soldering 2 a doz. 4 or 2 B.A. Rods, 3d. ft. Earth Tubes—Copper, 2/3; Cllmax, 5/-; Fine 7/22 Aerial, 100 ft. 1/11; Special Heavy weight 2/3. Phosphor Bronze, 49 strands, 100 ft., 1/- (limited). Twin Flex, R. & B., 12 yds, 1/4, 1/6, 2/-; Miniature Suk Twin Flex, 6 yds., 6d. Maroon Light ng. Yds., 5 yds., 9d. Insulators, 2 for 1 1/4d. Tinned Copper, 1/16th sq., 1d. 2 ft. D.C.C. Wire, 1 lb. reel, 20s 9d., 22g, 10d., 23s, 1 1/4d., 26g, 1/-, 28g, 1 1/4d. Ebonite, Grade "A," cut while you wait, 3/16th is 1/4d. sq. inch; 1/8 in. is 1d. sq. in. Stock sizes cheaper. 8 x 3, 1/3 6 x 6, 1/3; 8 x 6, 1/9; 9 x 6, 1/11; 10 x 8, 3/-; 12 x 9, 4/- Also cheaper quality for crystal sets. Special offer in Crystal Sets, 6/11, 7/6, 8/11, 9/6, 12/6. Also in enclosed cabinet, wonderful value, 18/11. AMERICAN Type Oak Cabinet, with base, 10/6; 12 x 9, 11/9; 16 x 8, 16/11, 18/11. Handsome panel switches, DPDT, 1/6; SPDT, 1/- (highest quality). Lightning Arrestors, 1/- Wave-length Permanent Det., 6d. Red Diamond Perm. Detector, 2/-; Liberty, 3/6; Brownie, 3/-; R.I., 6/- Crystals: Shaw's Genuine Hertzite, sealed, 8d.; Neutron Wray, 1/6; Dayzite, 2/6; Splendid enclosed Crystal Detectors, on base, 1/5, 1/6. Micro-meter, 1/9; Service do, 2/9 (with crystal). P. & P. Switches, 1/- Non-micro-phonie V.H. 1/3. Solid Rod Eb. 1/11. Baseboard, 8d. 2-way Geared Coil Holders, 2/11, 3/11. Penton Lotus, Polar, Newer stocked. Back of panel, W.L.L. 4/11 Kay Ray, 3/11. Drills for 1-h. avg. 1/3, 1/3. 'Phone Cords, 1/-, 1/3. L.S., do., 1/6, 1/9. H.T. and L.T. Leads, 1/9, 1/11. Dr. Nesper old friends ADICO Batteries, 60-volt (not one in a 1,000 has to be returned. I will change any faulty). Price 6/11 Adico, Eveready, Siemens, Hellsena 60-v. and 100-v., all 1.5 Batteries here. (Columbia always stocked.) Dr. Nesper L.S. Unit, 14/11. Dr. Nesper De-Luxe Senior, 4,000 ohm Loud Speaker, 35/- Radio Micro "Safir," fine value, 22/6. STOP!—Adjustable 4,000 ohm Headphones (Nesper pattern), double leather headbands, 7/11 pr.

CALLERS: MAKE OUT YOUR LIST FOR A SPECIAL QUOTATION

World's Most Wonderful Crystal "WYRAY" 1/6

TECHNICAL NOTES

(Continued from page 978.)

been used for the silvering of mirrors, or by means of actual volatilisation of the metal in a vacuum with resultant deposit. The resistance value of the lead depends, of course, upon the thickness of the deposit and upon the length and diameter of the glass rod or glass filament which carries the deposit. In practice it is often found more convenient to keep to a standard method for the deposit, that is to say, to standardise the thickness of the deposit and to make leads of different values by using glass filaments of different diameters. Thus, for example, other things being equal, doubling the diameter of the filament will halve the resistance.

These leads, being metallic throughout, have the great advantage that it is comparatively easy to make the necessary contact at the ends and the resistance is in the resistance element and not in the end-contacts, as in so many other types of leak.

After completion, the resistance elements are coated with a protective varnish to exclude moisture and to prevent deterioration.

The Four-Electrode Valve.

There have been several types of multi-electrode valve developed lately, more particularly on the Continent, and it would seem that interest in this type of valve is reviving. It is curious how public interest is apt to get "into a groove," so to speak, and it is often very difficult indeed to move it. It is a well-known fact that a new invention or discovery, no matter how great its merit or usefulness, may be almost valueless commercially if it departs too radically from accepted design or practice. The only thing to do with such an invention is to wait until public opinion has gradually changed.

Sometimes the change in public opinion takes the form of a revival of interest in something which has previously passed out of favour: petrol lighters for cigarettes form an excellent example of this. Multi-electrode valves seem likely to furnish another example. The four-electrode valve has been with us for a long time, but until very recently was not used to any extent. Its great advantages, however, are in my opinion coming to be more and more recognised, and new circuits embodying its use are constantly being patented.

ALL MANUFACTURERS' GOODS ADVERTISED IN THIS PAPER

Can be obtained C.O.D. or Cash with Order, per return, from

YOUNG'S (GLASGOW) LIMITED,

40, STOCKWELL STREET, GLASGOW.

Write To-day for Big Free Catalogue.

LIFE LONG H.T.

Tromba units are constructed of the finest quality zinc, zines, jars, etc., and creeping of the electrolyte and other troubles usual to Leclanche cells eliminated. In units or any size battery to order in Mahogany Case with glass cover. Send-to-day for free descriptive folder, etc. Sample unit and sample jar capacity Sac. post free 1/-. Amalgamated zincs 6d. doz. extra.

TROMBA ELECTRICAL CO.

67 WHITE HART LANE, TOTTENHAM, N.17.

OF ALL DEALERS OR DIRECT FROM **6**

GRAVES

2-VALVE LOUD SPEAKER BARGAIN.

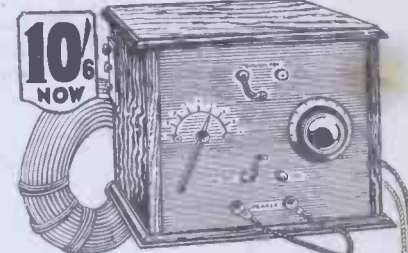

This highly efficient 2-Valve Loud-Speaker Set is the finest wireless value ever offered. It gives a volume and quality of tone unattained by any instrument of a similar price and is the essence of simplicity. Fitted with coils covering all the British wave-lengths, including Daventry.

THE CABINET is of beautifully polished Oak, & all components are of the highest quality. Full Emitter Valves with patent valve holders, 4c.; H.T. Battery, 2-volt accumulator and complete Aerial Outfit. **LOUD SPEAKER** of exclusive design with unique magnetic system and **£7:17:6** improved mica diaphragm. Price

TERMS: Our Bargain Price is for deferred payments. Send 10/6 now, & complete purchase in 14 monthly payments of 10/6. If you wish to pay cash, 5 per cent discount is allowed. Catalogue Post Free. Up-to-date Crystal & Valve sets at lowest prices. J. G. Graves Ltd. Sheffield

Of proved efficiency

Fullest Approval

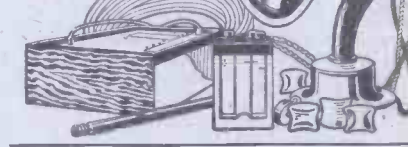

A.C. MAINS TRANSFORMERS.

As specified for Radio Constructor H.T. Battery Charger Unit, in "P.W." issue, Nov 6. 200/250 volts. A.C. current, 50 cycles, 1 amp. Satisfaction guaranteed, 9/6 each, post free.

STOREY BROS & CO., Radio Engineers,

2-4, Regent Street, BUNCOMB.

3/9 'PHONES 3/9

These 'phones are of British manufacture and were made specially for broadcast reception; they are 4,000 ohms, and are complete with 7 ft. cord and light aluminium adjustable headbands. These 'phones may be had on approval against cash, and if you are not satisfied your cash will be refunded if you return the 'phones.

Price 3/9 post free and immediate delivery from:

C. WILDE, WILLESBOROUGH, ASHFORD, KENT.

The High Tension System of the Future

WET H.T. BATTERIES

Due to the silent background and great economy of working, WET H.T. Batteries have almost everything to recommend them. They offer all the advantages of an H.T. accumulator, with none of the disadvantages such as the inconvenience of charging and the liability to sulphate if left run down. The cost is less than 3d. a volt, and upkeep 1/4d. per volt per annum.

Send 1/4d. for full details.

Jars 2 1/2" high, 1 1/2" dia. dozen 1/3
Sae Elements..... 1/6
Zincs..... 1/6

Carriage Extra.

WET H.T. BATTERY CO., 23, Coldharbour Lane, Camberwell Green, S.E.5.

'Phone: Bariston 2539.

BUILD A LOUDSPEAKER

WITH OUR NEW SEAMLESS MOULDED CONE

(Prov. Patent 25069/26.) You will obtain PERFECT RESULTS. Successful Construction for a minimum outlay is ensured with our Specialities. Illustrated Lists and full particulars for Stamp.

GOODMAN'S, 27, FARRINGDON ST., E.O.4.

TWO HINTS FOR CONSTRUCTORS.

A Useful Resistance Unit—An Easily-Made Shorting Switch.

A VERY convenient, although a rough and ready resistance unit can very easily be constructed from a suitable wooden panel, two pieces of sheet metal, and a few old Kodak film spools. Not only is the unit reasonably efficient in working practice, but the value of its resistance may be instantly changed.

The illustration will indicate to the amateur the constructional principle of the resistance unit. Two upright strips of brass or copper are attached to a suitable panel and connections from two terminals are taken to the brass strips. In ordinary cases, the supporting panel may be of wood,

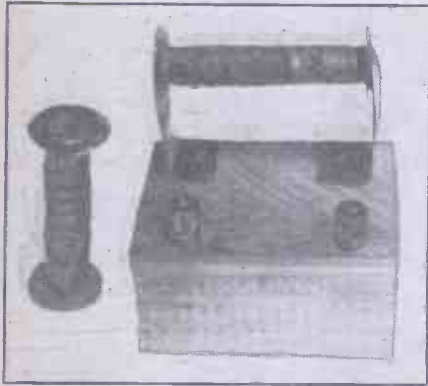

The Resistance Unit made by the writer.

but if very accurate results are required the panel must necessarily be of ebonite or some other high insulating material.

The resistance unit is complete when a Kodak or other film spool containing a quantity of resistance wire wound on it is wedged between the two upright brass strips on the panel. Thus, by having a number of film spools each wound with different lengths of resistance wire, rapid changes in the value of the resistance unit may readily be effected.

Wooden Spool Necessary.

The 3½ × 2½ in. film spool is the most convenient spool to use for this purpose. Care must be taken to see that the central portion of the spool is not made of metal, otherwise a direct short circuit between the two metal flanges of the spool would result, and the resistance unit would naturally be inoperative.

Choose a spool with a wooden central portion, and, having soldered one end of the resistance wire on to the inner side of the spool flange, wind the requisite quantity of wire neatly on to the spool. After the winding has been completed, solder the remaining end to the other inner flange of the spool. Finally, as a protection, cover up the winding with a layer of silk tape or insulating tape.

Tolerably accurate resistance units may thus be constructed, for most resistance

(Continued on next page.)

Radio Xmas Gifts

are the most acceptable

"Goltone" (Regd.) HIGH TENSION BATTERY ELIMINATOR

Entirely eliminates the troubles, worries and uncertainties associated with high tension dry batteries and accumulators. The constant voltage adds considerably to the volume and purity of reception. Saves its first cost in a short time. Connect to any convenient lampholder. Current consumed negligible.

Complete with Adaptor and Connecting Cords.

DIRECT CURRENT MODELS.
Type "D.J." Approx. tappings, 45 and 100 volts. Price 32/6.
Type "D." Approx. tappings, 30, 50, 75, 90, and 120 volts. £3.
Type "D.N." Possesses the latest refinements. Perfectly silent. Suitable for voltages from 200/250 volts. Voltage tappings as Model "D", £3/12/6.

ALTERNATING CURRENT MODEL.
Type "A." Approx. tappings, 30, 60, 90 and 130 volts. Dual tappings are taken from each voltage, thus providing eight separate tappings. £5/10/0, including valve.
State voltage and frequency of Lighting Mains when ordering.
See List No. R/116 for full particulars and also details of "Constructional Kits."

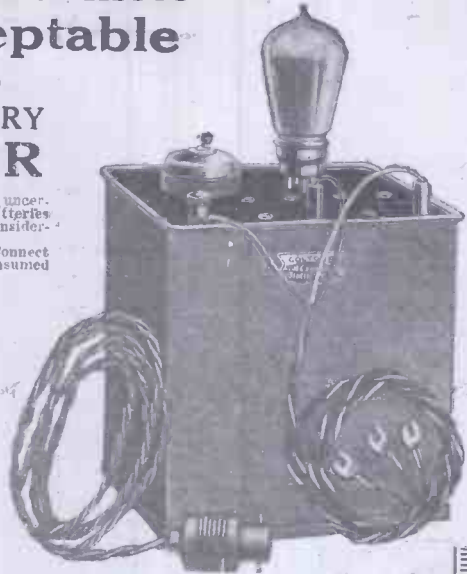

"Goltone" Pentlodyne VALVE RECEIVING SETS

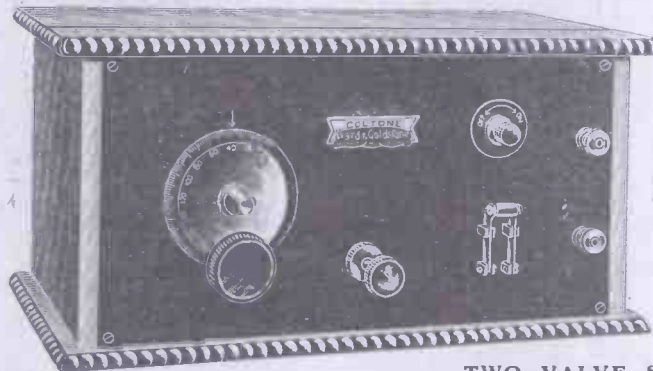

SIMPLICITY OF CONTROL

MAXIMUM VOLUME and PURITY

LONG DISTANCE RECEPTIVITY

JACOBEEAN OAK CABINET

The Valves and Tuning Coils are concealed inside the Cabinet, giving the "Outfit" a neat and refined appearance. The top of the Cabinet is hinged, permitting easy access to all the components.
Prices include Set of 5 Basket Coils covering all B.B.C. Wavelengths including Daventry.

TWO VALVE SET £5 10 0

Marconi Royalties 25/-

THREE VALVE SET £7 10 0

Marconi Royalties 37/6

FOUR VALVE SET £10 0 0

Marconi Royalties 50/-

See Catalogue No. R/116 for full details.

"Goltone" RADIO METERS

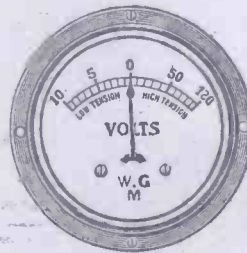

(British Made.)
Double reading 30 Volts and 120 Volts.
Panel Mounting, Flush Type.
As illustrated
Dia. of Dial 1½ ins.
Centre Zero reading.
Patent App.
Price 12/9

Panel Mounting Push Buttons, 1/6 pair.

POCKET TYPES

Side Reading, Price 8/6
Centre Zero Reading (Patent App.) 10/6
Strong Lined Cases 1/6 each.
See List No. R/116 for wide range.



EASIFIX

"COURT" RADIO ASSEMBLIES.
Overall size, 33 ins.
Eliminates ugly, loose wiring, and adds to the neatness of the Receiver. As a precaution against wrong connections, each conductor is distinctively coloured and enclosed within a strong outer braiding. Complete, fitted with Spade Terminals and Wander Plugs.
4-ways, 2/-
5-ways, 2/3
6-ways, 2/9
7-ways, 3/6
Refuse substitutes.

TO HIGH & LOW TENSION PANEL TERMINALS.

Large fully illustrated 48 page Catalogue on request. "Goltone" Products are stocked by the Leading Stores. Refuse Substitutes.

LONDON SHOWROOMS:

8a and 9, Gt. Chapel St., Oxford St., W.1.

Ward & Goldstone
PENDLETON, MANCHESTER LTD.
Frederick Road, Pendleton, Manchester.

BARGAINS—No. 211

DIXON ULTRA-ONEMETERS. De Luxe model, mirror scale, edge needle. The finest instrument with the widest range ever offered. Every B.C.L. needs one. Instrument, 55/-; Multipliers, 6/6.

SPARK SETS Sterling Coil, with Contacts. Spark Gap. Helix 25 to 600 metres. H.T. Mica Condenser and attachments on ebonite. These sets cost £15, and are given away at 15/6 each. Post 1s. 6d. Without Helix, with flat nose key, 15/-

700 G.P.O. 2-RANGE DETECTORS. Ediswan, G.E.C., etc. 250 m/a and 24 v. Brand new, 5s. 6d. each.

CELL CHARGERS OFF A.C. 220 volts 50 cycles to D.C. 6 volts, 6 amps. Fully guaranteed, 70s.

1,000 ACCUMULATOR FILLERS, suction bulb, acid chamber and nozzle, 1s. 6d.

WAVEMETER BARGAINS. Bought from the Admiralty, Gambrell and Het. Wavemeters; neat, need completion. Last few at 10s. each. Post 1s.

SHORT-WAVE HELIX. Copper strip on ebonite, with tapping clip, 5s. 25 to 200 metres.

MARCONI L.F. AMPLIFIERS, 2-valve in mahogany case, 32s. 6d.

PORTABLE FRAME AERIALS, 10/-. Indoor wire, 1s. 100 ft. Navy, 7/22 enam., 8/- 100 ft.

DUGONETTE, Plug-in indoor aerial 2s. 6d. Ducon, 10s.

110-v. ELECTRIC IMMERSION HEATERS, nickel-plated, flex and plug. Boils water, milk, etc. Two in series for 220 v. Sale, 5s.

220-v. ELECTRIC TOASTERS, nickelled, brand new, with flex and plug. List, 35s. Sale, 7s. 6d.

HOTPLATES, 100-v. LARGE, 200-v. SMALL SIZE. Aluminium frame. List, 35s. and 45s. Sale, 7s. 6d.

110-v. ELECTRIC MASSAGE VIBRATOR SETS. Work off 220 v. in series with lamp. Nickel finish with 5 applicators for muscular treatment. All in leatherette padded case. Brand new. List, 14 5s. Sale price, 21s. 6d. 110-v. or 220-v. Electric Irons. List, 21s. Sale, 10s. All the above guaranteed for A.C. or D.C., and brand new.

SURPLUS MARCONI 1-VALVE AND CRYSTAL DET. SETS, in closed case. Straight from the factory. Contain ebonite panel nickel fittings, detector, valve-holder, L. and S. wave switch, double spade tuning, two 200/4,000-metre H.F. chokes, T.C.C. condenser, Intervalve Transi. Terminal and plug sockets. All new and perfect with wiring diagrams and Ostram valve. List price, 17/. Sale, complete and tested on aerial, 27s. 6d.

MK. III CRYSTAL SET AND TUNER. Complete with Tapped Coils and Coupler, Perikon and Carborundum Detectors, Buzzer, Potentiometer, .001 and .0005 variable Condenser. Tune Stand-by, Crystal Valve Switch, in mahogany case. Price 45s. Complete, 50s.

SWITCHES. Lucas panel 3-lever flush, 1s. 3d., quarter price. Plugs and Jacks, 2s. 7d. pair; 4-pin plug and socket with switch, 4s. 6d. Earth Aerial, 1s. Arresters, 9d.

A.C. BOX PANELS. Contains A.C. Ammeter H.W. Quick-break Rotary Switch, 4-pin Plug, with four 6-ft. lengths of coloured H.T. flex. Cost 45s. Price to clear, 17s. 6d. each. Post, 9d.

EARTH MATS.—Galv. wave plate, with Electron wire rivetted on, 2s. 6d.; post 9d. Copper Mesh Earth for short waves, 5s. 6d. each. Earth spikes, 1s. 3d.

G.P.O. PORTABLE TELEPHONES. Mag. ringing, Hand Combination, Phone, Microphone, Receiver, Condenser, Magneto, Bell, Transformer, etc., leather case. Worth 14 each. Price to clear, 22s. 6d.

TWIN DOUGLAS PETROL ENGINES FOR ELECTRIC COUPLED GENERATION. In good running order. To clear, £12.

LAB. BRIDGE CONDENSERS, 3,000-volts, mica dielectric, contains 7 separate condensers. Any capacity can be plugged in and any combination capacity obtained to 3 mfd. £2 each.

M.III VALVE TRANSMITTERS, range 300-1,450 metres, containing Tuning Coil, with Stud Tapping, Double Vario Reaction and Variometer Tuning. Low Loss wound on tubular ebonite. Condenser .01. Wound Leak and Condenser, Multiple Switch, Lamp, Heavy Key, Aerial Ammeter, etc., on 1/2-in. Ebonite Panel. Cost £25. Price to clear, 30s. each.

SKINDER CRYSTAL SPEAKER TRANSFORMERS for Crystal Amplification. List price, 20s. To clear, 10s. each, post 6d. Small size, 8s. Micro. Insets, 1s. Buttons, 1s.

SALE CLEARANCE LOUD SPEAKERS, Violina, 6 gain. All wood model less receiver, 12s. 6d. complete with cord. Western Electric Table Talkers, 35s. model, 2,000 ohms, 17s. 6d.; T.M.C. Loud speakers, 2,000 ohms, 12s. 6d.; Fuller Sparta, 4-guinea models, 50s.; Texas Cone, bronzed, 40s.; Sterling Magnavox Concert Speaker, 55s.; Large Serenada, with Tone Control, 30s.

RELAYS, Weston, 20s.; G.P.O., 40s.; Magnetic Relays, 10s.; Telegraphic Filament Distant Control Switches, auto. on and off, in pol. case, 15s. Bronze, 17s. 6d.

RECEIVERS. 1, 2, 3, 4 and 6 valve sets Ex W.D. by Marconi, Sterling, West. Elec., etc., in stock at bargain prices.

WAVEMETER SALE. Reduced prices W.D. Service meters, calibrated to N.P.L. standard. Short Wave "Forward" cost £10, 40/100 metres, 35s.; Broadcast Townsend, 35s.; No. 67L "Townsend, 280/1,600 metres, 50s.; L.R. Townsend, 120/4,000 metres, £4; Long R. "Forward," 75/3,000 metres, £3 10s.; Pauls, 100/3,000, £4. Heterodynes, Brown, and Mark II, with calib. valve, 90/3,000 metres, £5, or 150/3,000 metres, £4 10s. Ondia Wavemeter prices reduced to £3 10s for 60/4,000 metres.

Our 43. Catalogue containing 600 unique illustrations will save you Pounds.

ELECTRADIX RADIOS.
218, Upper Thames St., E.C.
Blackfriars Stn., Met. Rly. Tel.: City 0191.

TWO HINTS FOR CONSTRUCTORS.

(Continued from previous page.)

wire is sent out by its makers with a statement as to the resistance per yard, and working on this basis, a simple calculation will enable the experimenter to calculate the exact length of wire which must be wound on a spool in order to attain a given resistance.

Naturally, resistance units of this type may be made very much neater than the ones illustrated. Nevertheless, the resistance unit in the illustration, despite its Heath Robinson appearance, has done some excellent experimental work and will doubtless continue to do so.

An Easily-Made Shorting Switch.

It is very often most useful to be able to employ a simple type of switch for the purpose of shorting two panel terminals. Not that such a switch may be required as a permanent fitting, but nevertheless there are periods during which the use of a suitable shorting switch of the above description is required for experimental work.

The illustration shown below depicts a very simple but none the less effective method of setting up a temporary shorting switch between two panel terminals. Short lengths of No. 18 bare copper wire are fashioned into the shapes illustrated, after which they are attached to their respective

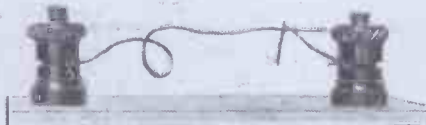

The simple nature of the switch can be seen from the above.

terminals. The loop on the longer piece of wire imparts to it a springiness and thus enables it to make firm contact with the shorter length of wire which is made into a sort of hook.

The principle of the whole arrangement is not unlike that of an ordinary safety-pin.

If it is desired to connect leads to the two terminals, this made-in-a-minute shorting switch can still be used efficiently, for the leads may be inserted around the terminal stem over the wires constituting the switch, and after the terminals have been screwed down tightly, the switch parts will be perfectly steady.

Convenient Aerial Switch.

The above arrangement makes a very convenient shorting switch for the purpose of connecting together the aerial and earth terminals of a crystal set employing a perikon or semi-permanent detector. For, under these conditions, the aerial and earth leads can remain permanently connected up to the set.

HOLROSE XMAS OFFER. For 7 days we are giving 4/- in the £1 discount off all list prices of Holrose Loud Speakers, Components, and Crystal Sets, etc. Now is your opportunity to buy your Xmas Radio goods at reduced prices. Send to-day for illustrated lists.—Holrose Mfg. Co., 43, Lonsdale Road, Kilburn, London, N.W.6.

ALUMINIUM COIL SCREENS !!!

Constructors save money and get perfect results by using our Screens. Suitable for Solotone, Mewflex, and all screened coil receivers. Beautifully made of heavy gauge metal.

COMPARE PRICES Polished 3/6 each Base Extra. Frosted 2/3 .. Special Prices for Quantities. Post Free.

SEND TO-DAY !!! R. SIMMONS & Co., 81, Gosta St., South Bank, YORKS.

THE MODERN WAY THE EFFICIENT WAY

THE "REGENTONE" Complete Battery Eliminator**5 AMP MODEL £6 10**

Supplying combined High-Tension, Low-Tension, and Grid Bias current for the operation of your receiver from your Household Electric Supply (D.C.) by simply attaching adaptor to electric light lamp holder.

Why use H.T. Batteries and Accumulators?

No Replacements Necessary.

No Attention Required.

H.T. MODEL (FIVE TAPPINGS) £2 10

A COMPLETE SET OF PARTS OF "REGENTONE ELIMINATORS" ARE SUPPLIED FOR HOME CONSTRUCTION.

Price List and Descriptive Leaflets FREE on Application.

150-page catalogue, 2,000 illustrations of components and accessories, post free 4d. stamps

Sole Manufacturers:

REGENT RADIO SUPPLY CO.,
45, FLEET STREET, E.C.4.

Phone: Central 9661

2-VALVE AMPLIFIER, 35/-
1-Valve Amplifier, 20/-; as new; Valves, D.E. 06 7/-; Headphones, 2/6 pair; new 4-Volt Accumulator, 13/-; new 60-Volt H.T. guaranteed, 7/-; 2-Valve All-Station Set, £4. Approval willingly. Write for free bargain list.

P. Taylor, 57, Studley Rd., Stockwell, London

EASY PAYMENTS

LOUD-SPEAKERS, HEADPHONES, H.T. ACCUMULATORS. Anything Wireless.

Send a list of the parts you are requiring, and we will send you a quotation on monthly payments.

H. W. HOLMES, 29, FOLEY STREET,
Phone Museum 1414. Gt. Portland St., W.1

HEADPHONES REPAIRED
Re-wound and re-magnetised 5/- per pair. Loud Speakers repaired 5/-. Transformers re-wound 5/- each. All work guaranteed and tested before delivery. Write for Trade Prices. Phone: Clerk, 1793. MASON & CO., 44, East Road, City Road, N.1.

Trelleborgs
GENUINE EBONITE
Experts choose it—
—its Choice!

STOCKED BY ALL THE BEST DEALERS
TRELLEBORGS EBONITE WORKS Ltd. Audrey House, E.C.4.

TRANSFORMERS REWOUND
Transformers, Phones, Loudspeakers. Rewound and Repaired to Maximum Efficiency. All One Price 4/- each. Don't discard if burnt out. All work guaranteed for 12 months. Write for trade terms. TRANSFORM CO., 115, LINKS RD., FOOTING, LONDON, S.W.17

ACCUMULATORS ON EASY PAYMENTS

High-Tension Accumulators built up from 20-volt sections (15/- each). Example: 60-Volt H.T. 45/- OASH or 12/6 DOWN and 6 monthly payments of 6/-. Carriage Paid. Satisfaction or money back. Write for List to DEPT. 11, COVENTRY DIRECT SUPPLIES LTD., 23, Warwick Row, COVENTRY. Any Wireless Goods supplied on easy payments.

SWING

FROM
175 METRES TO 4,000 METRES
IN AN INSTANT
WITHOUT THE
TROUBLE OF
COILS

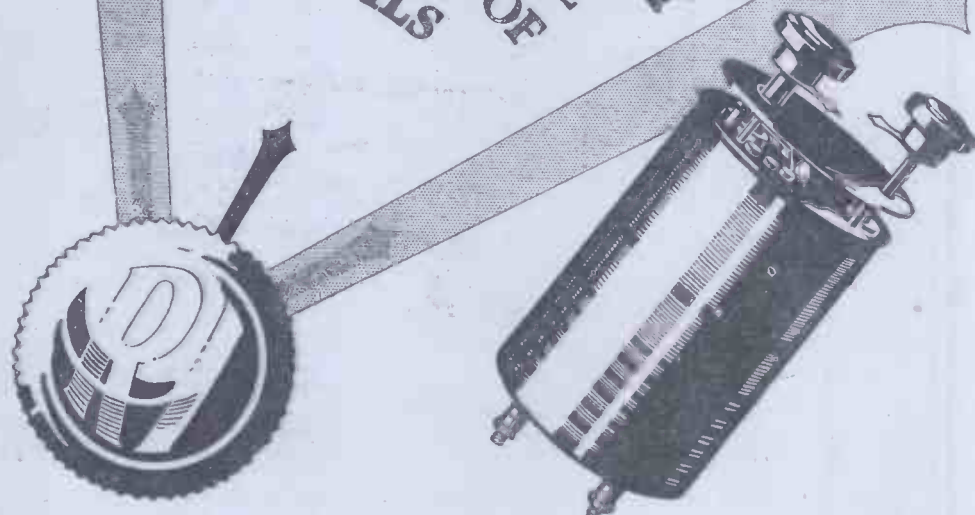

Get across from 175 to 4,000 metres with one twist of the dial. Tune in any station you want almost as quickly as you can think.

You only need the R.I. Retroactive Tuner to do this efficiently—even more efficiently than with a set of plug-in coils, for the R.I. Retroactive Tuner gives correct aerial reaction over the whole range of wavelengths covered—a modification almost impossible to obtain with the other method of aerial tuning. And remember this: the R.I. Retroactive Tuner costs appreciably less than a set of plug-in coils with coil holder to cover the same range.

Price 39/6

THE MARK OF  BETTER RADIO

Advt. R.I. Ltd., 12, Hyde St., New Oxford St., London, W.C.1.

**SOMETHING
WORTH
KNOWING**



Every valve user should get this book

In it is convincing National Physical Laboratory Test proof that Mullard P.M. Valves continue to give the finest results after a year's broadcasting service of a thousand hours' life. A complete and valuable valve guide to improve your radio reception is included. Do not lose this opportunity to secure the best from your receiver.

Write for your copy to-day, post free on request.

Mullard
THE MASTER VALVE

*For 4-volt accumulator
or 3 dry cells*

THE P.M. 3 (General Purpose) 0.1 amp. 14/-
THE P.M. 4 (Power) 0.1 amp. 18/6

*For 6-volt accumulator
or 4 dry cells*

THE P.M. 5 (General Purpose) 0.1 amp. 18/6
THE P.M. 6 (Power) 0.1 amp. 18/6

For 2-volt accumulator

THE P.M. 1 H.F. 0.1 amp. 14/-
THE P.M. 1 L.F. 0.1 amp. 14/-
THE P.M. 2 (Power) 0.15 amp. 18/6

*These prices do not apply in
Irish Free State.*

British Made
in a
British Factory

ADVT THE MULLARD WIRELESS SERVICE CO. LTD., MULLARD HOUSE, DENMARK STREET, LONDON, W.C.2

HOW TO BUILD THE "WHIPPET" (See Page 1051)

Popular Wireless

Every Thursday
PRICE
3d.

No. 238. Vol. X.

INCORPORATING "WIRELESS"

December 25th, 1926.



Special Features In This Issue

On the Short Waves The "P.W." Valve Guide That Oscillation Trouble
 A Prize-Winning Short-Wave Receiver
 Winter Aerial Tips Crystal Set Troubles Improving Detector Valve Efficiency
 From Daventry to Pittsburg—An "All-Wave" Receiver

No one in possession of a radio set need feel lonely this Xmas, not even those living in isolated dwellings in the Far North, like that one shown in our cover photograph.



MARCONI TYPE D.E.8L.F.

Dull Emitter for 6-volt Accumulators.

Recommended for L.F. amplification when a steady negative grid bias of 6-7 volts is required, when using an anode voltage of 100. The D.E.8L.F. may also be used as a general-purpose valve. Fil. volts 5.6-6. Fil. amps. 0.12. Amplification factor 7. Price 18/6

MARCONI TYPE D.E.8H.F.

Dull Emitter for 6-volt Accumulators.

A dull-emitter valve having filament characteristics similar to the D.E.8L.F., but suitable for H.F. amplification and rectification. May also be used for resistance-capacity coupled amplifiers. Fil. volts 5.6-6. Fil. amps. 0.12. Amplification Factor 16. Price 18/6

A FEW RECOMMENDED COMBINATIONS :

2-Valve Set.					
Type	Position	Fil. Amps.	Grid Bias Volts	H.T. Volts	
{ D.E.8H.F.	H.F.	0.12	0	60	
	Det.	0.12	+2	60	
3-Valve Set.					
{ D.E.8H.F.	H.F.	0.12	0	80	
	Det.	0.12	+2	80	
	D.E.8L.F.	L.F.	0.12	-6	100
4-Valve Set.					
{ D.E.8H.F.	H.F.	0.12	0	80	
	D.E.8H.F.	Det.	0.12	+2	80
	D.E.8L.F.	1 L.F.	0.12	-6	100
	D.E.5	2 L.F.	0.25	-7.5	120

Write for the Marconi Valve Literature giving comprehensive details concerning the D.E.8 and other types.



The Marconi International Marine Communication Co. Ltd., require 500 qualified Wireless Operators. Apply to Service Manager, Marconi House, Strand, London, W.C.2.

THE MARCONIPHONE COMPANY LTD.,
 Registered Office:—
 Marconi House, Strand, London, W.C.2.
 Head Office:—
 210-212, Tottenham Court Road, London, W.1.

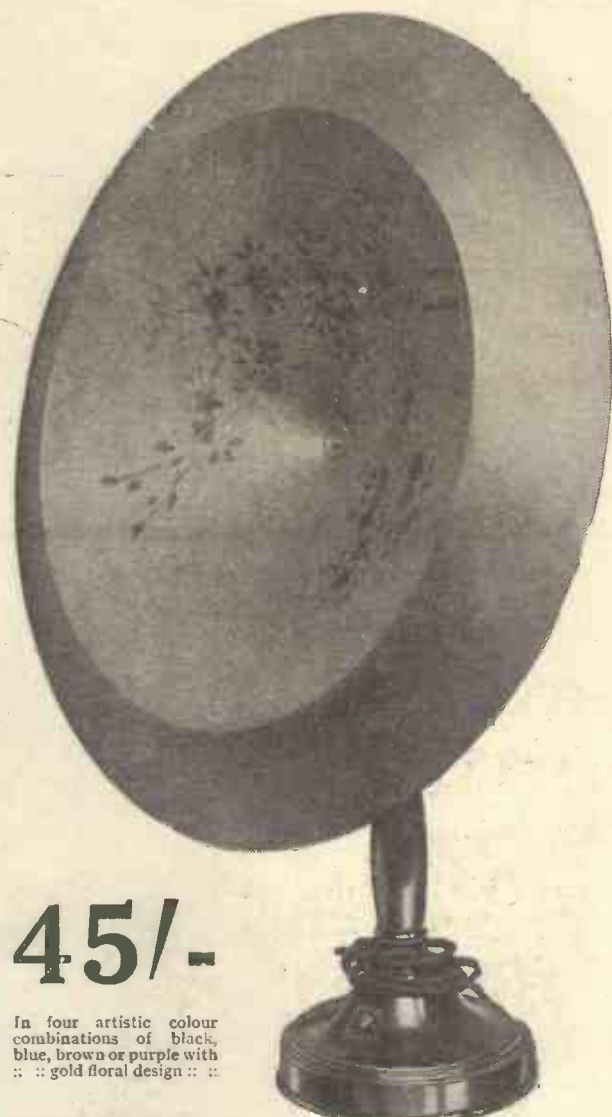

45/-

In four artistic colour combinations of black, blue, brown or purple with :: gold floral design ::

STERLING MELLOVOX Loud Speaker.

The beauty of the STERLING MELLOVOX lies not merely in its strikingly attractive appearance, but also



TYPE "33"
£5.5:0

in its remarkable purity and mellowness of reproduction.

Booklet 3649, describing the full range of Marconiphone and Sterling apparatus, sent on request.

THE MARCONIPHONE CO., LTD.
 (Sole Agents for Sterling Telephone & Electric Co. Ltd.)

STERLING "DINKIE"



"The little fellow with the big voice."

30/-



"LOUD SPEAKERS" ~ OLD AND NEW.

Announcement of Graham Amphion Limited, 25, Savile Row, London, W.1.

PLAYER'S "MEDIUM" NAVY CUT CIGARETTES WITH OR WITHOUT CORK TIPS

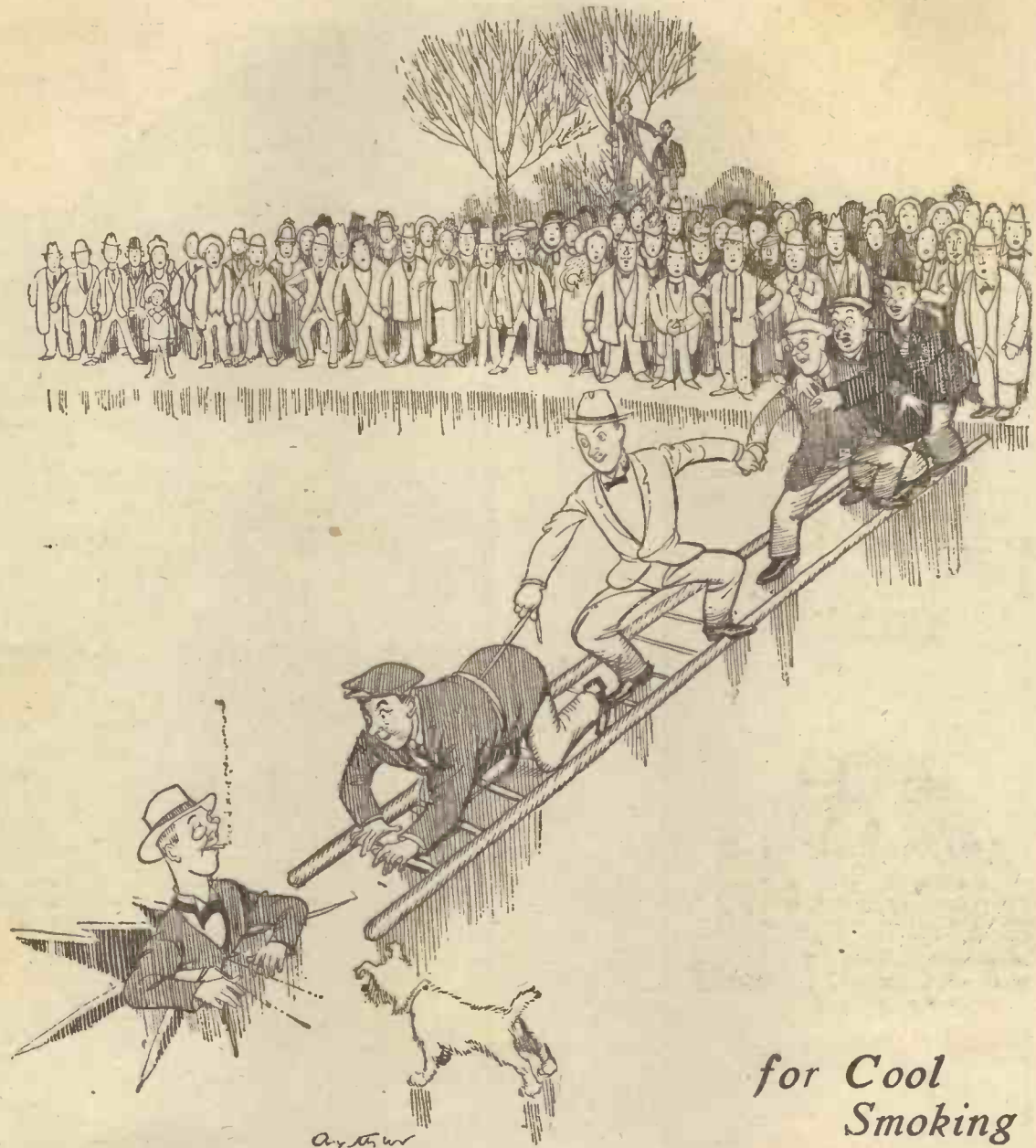

Arthur
Watts
26

for Cool
Smoking



REGD. NO. 15902A

PLAYER'S

Navy Cut

CIGARETTES

10 for 6d. 20 for 11½d.

50 for 2/5 100 for 4/8





The "Cosmos" Rheostat.



The "Cosmos" Permacon.



The "Cosmos" Coupling Unit and spring valve holder.



Ask your dealer for these attractive Folders on "Cosmos" Valves, Sets and Components.

Cosmos

(RADIO COMPONENTS)

ensure reliable sets.

Constructors who desire smooth working and efficient sets use "Cosmos" Precision components.

The "Cosmos" Rheostat. The principal features of the "Cosmos" Filament Rheostat are its sturdy construction and reliable, smooth movement. The contact arm cannot easily be damaged, having its movement on the inner side of a porcelain bobbin which carries the windings. Other pleasing features of this Precision Rheostat are the handsome knob and dial, ONE HOLE fixing, and the small space it occupies.

Made in four types, two of which are double-wound for BULL or BRIGHT Valves and one a Potentiometer.

Description	Ohms	Current	Price	
			s.	d.
Single Wound	6'0	1'0 amp.	4	8
Double "	20	" 4	5	0
"	34	" 2	5	0
Potentiometer	300	—	6	0

The "Cosmos" Permacon is an ideal fixed condenser, being light in weight, of guaranteed accurate capacity, and having the lowest possible losses.

The dielectric is mica, and each condenser is tested at 500 volts during inspection. Nickel-plated cases give them a particularly neat appearance.

.0001 mid.	1/8	.001 mid.	1/8
.0002 "	1/8	.002 "	1/10
.0005 "	1/8	.005 "	2/3
.0003 " (with clips for grid leak)	1/8	.01 "	3/9

The "Cosmos" Resistance Coupling Unit.—Real purity of reproduction can only be obtained with resistance capacity coupling. The "Cosmos" Coupling Unit with a suitable valve is as effective as an ordinary transformer-coupled stage. It avoids all distortion and effects considerable economies in first and operating costs. Designed primarily for use with the "Cosmos" S.P. Blue Spot Valves, it can be used successfully with any valve having an amplification factor of 30 or more. Special attention is directed to the following advantages of the "Cosmos" Coupling Unit:

- (1) It takes up little space in a set.
- (2) It is not liable to be broken.
- (3) It has permanent resistance values.
- (4) It allows for simplified wiring.
- (5) It is economical in L.T. current (S.P. Blue Spot Valves consume 0.09 amps.).
- (6) It is economical in H.T. Battery consumption (less than 1/20 normal).

And lastly its use results in purity of reproduction without loss in volume.

Type "O," the Unit alone 8/6
 Type "V," the Unit incorporating spring valve holder (as illustrated) 10/6
 Suitable valves for use with this unit are "Cosmos" S.P. 18/B at 14/- and "Cosmos" S.P. 55/B at 18/6.

METRO-VICK SUPPLIES LTD.

(Proprietors: Metropolitan-Vickers Electrical Co., Ltd.).

METRO-VICK HOUSE,
 155, CHARING CROSS ROAD, LONDON, W.C.2 R P6J

Louden Valves



"The two original valves have been working all the time."

Mr. P. Hearn, of Long Stratton, has had over 12 months satisfactory use from the two Loudspeaker Valves in his Little Giant Set.

Like all other Loudspeaker Valve users, Mr. Hearn is highly satisfied with the results, and he shows it by ordering two more Loudspeakers.

Read what he says—

Dear Sir
 "Enclosed please find P.O. for 9/6. Please forward, if possible by return, two Loudspeaker Valves (F1 at 4/6 each).
 My 'Little Giant' two valve set has now been in use for twelve months, and has given me every satisfaction. The two original valves have been working all the time.
 I feel that everything that bears the stamp of 'Fellows' is worthy of recommendation, and it gives me pleasure in being able to thus express my satisfaction.
 Yours truly,
 P. HEARN (Long Stratton)."

Louden Valves are made by British labour in a British factory with British capital and can be depended upon for the finest volume, range and silver clearness. They can only be offered at such low prices because of our well-known policy of selling direct to the public and cutting out the middleman's profit.

The list below gives prices and full particulars.

Order your Loudspeaker Valves from us by post.

<p>4/6</p> <p>Bright Emitters. L.F. Amplifier. F.1. H.F. Amplifier. F.2. Detector. F.3.</p> <p>5.5 volts 0.4 amps.</p>	<p>8/-</p> <p>Dull Emitters. L.F. Amplifier. L.E.R.1. H.F. Amplifier. L.E.R.2. Detector. L.E.R.3.</p> <p>2 volts 0.2 amps.</p>	<p>8/-</p> <p>Dull Emitters. L.F. Amplifier. F.E.R.1. H.F. Amplifier. F.E.R.2. Detector. F.E.R.3.</p> <p>4 volts 0.1 amps.</p>
<p>9/-</p> <p>Dull Emitters. L.F. Amplifier. F.E.R.1. H.F. Amplifier. F.E.R.2. Detector. F.E.R.3.</p> <p>6 volts 0.1 amps.</p>	<p>11/-</p> <p>D.E. Power Valves. Trans. Amplifiers P.E.R.1. Resist. Amplifiers P.E.R.2.</p> <p>4 volts 0.2 amps.</p>	<p>12/-</p> <p>D.E. Power Valves. Trans. Amplifiers P.E.R.1. Resist. Amplifiers P.E.R.2.</p> <p>6 volts 0.2 amps.</p>

Postage and packing: 1 Valve, 4d. 2 or 3 Valves, 6d. 4, 5 or 6 Valves, 9d.

FELLOWS, PARK ROYAL, N.W.10.

Branches:

- LONDON: 20, Store Street, Tottenham Court Rd., W.C. (Museum 9280)
- BIRMINGHAM: 248 Corporation Street (Central 435)
- BRIGHTON: 31, Queen's Road (Brighton 899)
- BRISTOL: 36, Narrow Wine Street (Bristol 7972)
- CARDIFF: Dominions Arcade, Queen St. (Cardiff 7685)
- LEEDS: 65, Park Lane (Leeds 21479)
- MANCHESTER: 33, John Dalton Street (Central 1164)
- NEWCASTLE: 36, Grey Street
- NOTTINGHAM: 30 Bridlesmith Gate (Nottingham 5551)
- TONBRIDGE: 34 Quarry Hill (Tonbridge 172)

BUY DIRECT AND SAVE MONEY

E.P.S. 97.

CAXTON 4-VALVE CABINET

Made for Sets, "As good as money can buy,"
 "Harmony Four Receiver," "The Melody Three"

Special Cabinets made to Customer's measurements. Prices quoted.

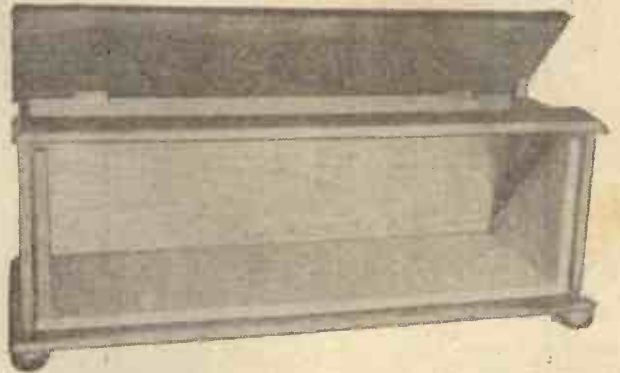

Cash with Order. Fumed Oak ... £1 5 0
 Dark or Jacobean Oak ... £1 10 0
 Real Mahogany ... £1 14 0

Detachable 7" deep Base Board to mount 21" by 7" panel to slide out of Cabinet front.
 Also supplied at 10/- extra with two beaded front doors placed 2 ins. in front of the enclosed panel.

Ebonite or Radion Panels Supplied and perfectly fitted at low extra cost.

All Polished with the new enamel that gives a glass hard surface that cannot be soiled or scratched. SENT FREE.—Catalogue of standard Wireless Cabinets in various sizes and woods.

Packed and delivered free in U.K.

No. C3

CAXTON WOOD TURNERY CO., Market Harborough



Throw away the headphones buy this loud Speaker

LET all the family enjoy the radio. Here is a Loud Speaker that was bound to come—it has long been needed. Matching in tone and volume any £5-5-0 instrument, it has been costed low so that thousands can buy and enjoy where before high prices prohibited. Profits are cut to a minimum, quality achieves a maximum and so great is our faith in the Allhall Speaker that we sell it to you with a **MONEY-BACK GUARANTEE**

Buy one, try it, and if you are not satisfied send it back within 7 days and your money is returned without any questions being asked.

Obtainable from all Radio Dealers.

276

L.Kremner

Radio Engineers
 49a, Shudehill, Manchester.

**“Ham-handed
Henry” at the
Garage down the
road can’t ruin
this Accumulator**

We have all had painful experiences with “Ham-handed Henry.” He is the man who takes our accumulators and puts them on charge without worrying overmuch about the charging rate. Sometimes they are charged too quickly, and sometimes they are taken off the mains before they are fully charged. In any case such rough and ready treatment is very bad for any Accumulator. That is to say, any accumulator *except* an Oldham O.V.D. This new Accumulator defies rough treatment. Although a slow discharge Accumulator it can be recharged rapidly. In fact, we ourselves have charged one fully within four hours and the cell was quite unharmed.

The ordinary slow discharge Accumulator however requires a slow charge of not less than 30 hours. It takes a long time for the electrolytic action to percolate through to the centre of its thick plates. In the Old-

ham O.V.D. however, all the advantages of the slow discharge—its freedom for sulphation and its ability to hold a charge over long periods—are obtained by the use of a special laminated plate (patent applied for). The acid can act upon its several surfaces immediately. And because a girder-like construction is employed buckling is quite impossible.

Here are some facts for valve users:

If you have a one valve Set fitted with a two volt 1 amp. Dull Emitter the O.V.D. will last 180 hours at a charge. Using two valves you will get 72 hours. With two 06 valves and two O.V.D. cells in series you will get 140 hours and with three valves 80 hours. An Oldham O.V.D. will save you money because it holds its charge longer than any other type of Accumulator. Call in for one this evening on your way home. Fill it up with acid and it is ready for immediate use.



5/6
Charged
ready for use
—merely add acid

Made only by
OLDHAM & SON, LTD.,
Denton, Manchester
London Office: 6, Eccleston Place, S.W. 1.
Glasgow Depot: 120, Wellington Street.

The new



O.V.D.

*—the slow discharge Accumulator
which can be fully charged in 8 hours*

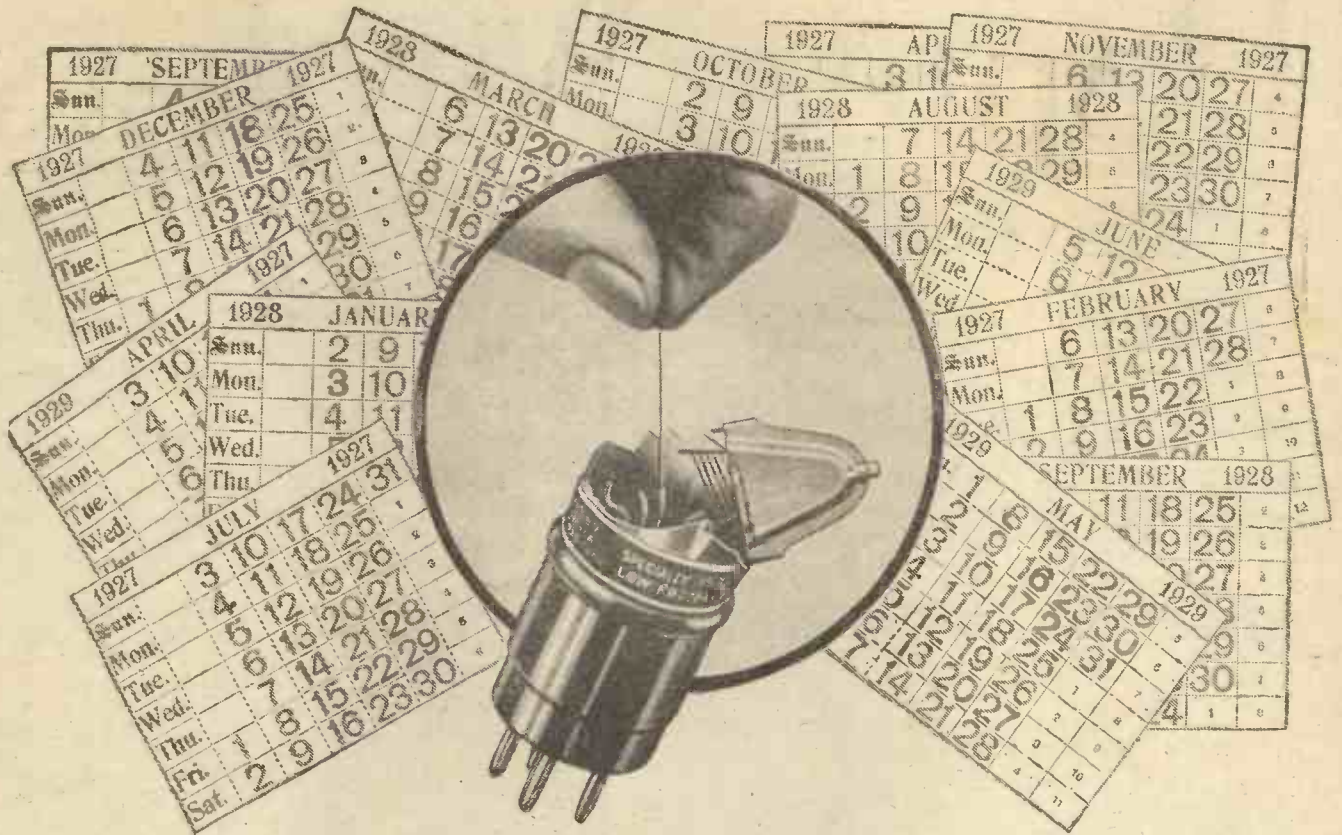

1927-1928-1929

—the Cossor Kalenised Filament sets new record for long life

AFTER an ordinary life test of 2,500 hours at 1.8 volts the Cossor Point One valve shown above was broken open and suspended by its filament. Even after this amazing test the Kalenised filament was still pliable and supple. There were no signs of brittleness. Indeed, the valve could have given satisfactory service for an even greater period. Based upon an average of 20 hours per week this is equivalent to 2½ years' regular use.

Never before in the history of valve making have such remarkable results been possible. Only the new Kalenised filament could have successfully withstood such a drastic test.

The reason is obvious. The Cossor Kalenised filament gives off a torrent of electrons practically without heat. Certainly no glow is visible when the valve is working. Heat is the destructive influence which sets up crystallisation in the ordinary filament. The molecules become displaced—a weak spot occurs—and, suddenly without warning, the filament fractures.

All this is now ended. The Cossor is the only valve to be fitted with the Kalenised filament. It is, indeed, the real long life valve. You, as a shrewd wireless enthusiast, will choose the valve which will last longest with the least consumption of current. That is why you will want the Cossor Point One—the 2-volt Dull Emitter taking only one-tenth of an ampere. 210D Detector and 210H H.F. Amplifier 14/- each. Stentor Two Power Valve 18/6. From all Dealers.

Cossor

—the Valve which serves you longest

Popular Wireless

Scientific Adviser:
 Sir OLIVER LODGE, F.R.S.
 Technical Editor:
 G. V. DOWDING,
 Grad. I.E.E.
 Assistant Technical
 Editors:
 K. D. ROGERS
 P. R. BIRD



Incorporating "Wireless."

Consultants:
 Dr. J. H. T. ROBERTS,
 F. Inst. P.
 J. F. CORRIGAN, M.Sc.,
 A.I.C.
 C. E. FIELD, B.Sc.
 E. J. SIMMONDS,
 M.I.R.E., F.R.S.A.

Editor: NORMAN EDWARDS, M.Inst.R.E., M.R.S.L., F.R.G.S.

RADIO NOTES AND NEWS.

A Radio Christmas—The "Beam" and Broadcasting—Turkish Delight—"Some" Condenser—St. Dunstan's and Wireless—Broadcast Advertising—Discontent in Scotland—Christmas Greetings.

A Fitting Coincidence.

DECEMBER 25th. Christmas Day. "P.W." day. What happier coincidence or more apt reminder that this is Radio Christmas? In that stilly hour after dinner, when the old folks are prone to slumber for a little and the younger ones are sluggish with good fare, don't forget your copy of "P.W."

A Radio Christmas.

YES, this will be the radioist radio Christmas since filaments and grids and plates got into valves, and I'm sorry that Dickens never had a chance to describe it. Talk about "The Cricket on the Hearth"! Why, that sturdy little soloist wouldn't stand an earthly nowadays, what with saxophones and ukuleles not only heard on the hearth but audible all over the house, not to mention next door.

That Glimpse.

IN my mind's eye I see the parcels being unwrapped, disgoring the new telephones or Tommy's first wireless set. ("Oh! why, oh! why, doesn't broadcasting begin at seven a.m.?" he cries.) I see the excited throngs round thousands of wonderful "valvers" with even more wonderful names, and I imagine the youngsters playing at "Hunt the Spanner" and "Inspector's Knock" while the apparatus is being connected up. I hear the elders, later in the evening, saying, "Whist," and see them dipping into the ethereal "Lucky Tub," while the proud manipulator enthalls himself with "The Mystery of Seven Dials." Am I right?

Have You Heard These?

THIS Week's Cheerful Ass. The man who took a season-ticket to Daventry and set up two homes, because the dealer told him his set would "only tune in London and Daventry"!

This Week's Exaggerator. The amateur (fisherman) who said he caught an "atmo-

spheric" so big that it broke the telephone cord, bit his grandmother and then jumped back into the ether!

This Week's Absent-minded Man.—The inveterate playgoer who listened-in at home to a broadcast "first night," tipped his

Standardised Condensers.

REAL, red-hot, scientific "fans" will be interested to know that the British Engineering Standard Association have drawn up specifications for wireless condensers. Condensers both in metal and insulating cases are dealt with, the specifications of the former types being for capacities of 0.1 mfd. to 2.0 mfd., and of the latter type for capacities of 0.01 mfd. and under. Both mica and paper dielectrics are covered by these specifications and condensers conforming to the standards laid down should bear the inscription "B.E.S.A."

The "Beam" and Broadcasting.

LISTENERS in Cornwall are complaining of interference which they allege is caused by the "beam" station at Bodmin. There is, perhaps, a natural tendency to pick on a new station, just as a new comet is blamed for low Bank Rates and abnormal rainfall. The fact remains, however, that the Post Office and the B.B.C. have independently investigated the matter, and, up to the time of writing, have failed to trace the cause of the interference.

Turkish Delight.

BROADCASTING is soon to spread over that land of mosques and mosquitoes, Turkey; but the Government is said to have made it a condition of every receiving licence, that the apparatus licensed must be at the disposal of the Government if so required. Perhaps when the Budget won't balance, or the latakia crop fails, the Government will call in all sets and auction them back again. What joy for the clever Abdul or Mohammed, who has just built the perfect set from a "P.W." design!

Two New Clubs.

STEPNEY and district readers please note that there is now in being the "Stepney and District Radio" (Continued on next page.)



Baby Peggy, the popular film "star," listens-in to a Christmas ghost story

wife a shilling and took a taxi to Victoria!

'The Latest.

FRUIT distribution in London is to be controlled by wireless. Yes, and then some radio-mad grower will produce a pipless pomegranate. It won't be worth a fig.

NOTES AND NEWS.

(Continued from previous page.)

Society." Meetings are held on Mondays from 7.30 p.m. to 9.30 p.m. at the Men's Institute, L.C.C. School, Ocean Street, Stepney, E.1. Hon sec., Mr. M. H. E. Abrahams, 129, Old Montague Street, E.1. Roll up, ye of Stepney and thereabouts, though the club's motto is "Don't oscillate."

Mr. A. Culyer asks me to say that as secretary of the newly-formed Grimsby and District Radio Society, 126, Rutland Street, Grimsby, he is prepared to wear his new fountain-pen to the bone in enrolling new members. Let the good work go on. I will present him with a pencil-sharpener when he has collected the first thousand subscriptions.

Two More Stations "on the Air."

MR. C. JORDAN, 45, Lower Park, Loughton, Essex, begs to announce that he will be transmitting any of these fine evenings on 90, and 150 to 200 metres; call-letters, 6 J D; and will be pleased to receive reports. New Zealand papers, please copy!

Leading Signalman W. Driver, writing from H.M.S. "Ceres," Malta, tells the world that on his return from foreign service he will worry the ether on 23 and 45 metres, using the call-letters 5 U D from 3, The Crescent, Walthamstow, London (C.W. and telephony). Mr. Driver does not say exactly when he proposes to return, but I hope it will be for Christmas. Good old Navy!

"Some" Condenser.

HERE is the latest "leg-pulling" yarn. An American visitor to Birmingham saw in a shop a very large model of a condenser. It was intended as an exhibit at a radio show, and was slightly larger than a house-pail. Said he, "Guess we build 'em mighty bigger way back in 'lil ole N'York."

"Possibly so, sir," replied the smart salesman. "I should hope so, too. This is for the Queen's Doll's House set."

St. Dunstan's and Wireless.

ONE of the most interesting facts given in the Eleventh Annual Report of St. Dunstan's for the year ending March 31st, 1926, which I have just received, is that the council decided to supply any officer or man with a crystal set, two pairs of telephones, aerial and "earth," or to those men already possessing sets but lacking accessories, up to 33s. worth of accessories. One of these days, when you clear up the wireless den, perhaps you may find a few unconsidered trifles. If so, Capt. Ian Fraser would no doubt welcome them. What about it?

N.P.L. Valve Tests.

I HAVE before me a most interesting booklet, issued by the Mullard Radio Valve Co., Ltd. I have never before seen any valve "literature" quite like it, for it contains facsimile reproductions of the report by the National Physical Laboratory of the tests applied to six samples of the Mullard P.M.5 valve and the results. Many makes of valve have been tested by the N.P.L., but in publishing their results in full Mullard's have publicly demonstrated

their confidence and courage, a step which is bound to create considerable interest.

The Test Conditions.

IT was stipulated that the valves were to be operated for 1,000 hours with 100 volts actual applied to the plates, which is some 20 volts more than is used in practice. For a test of total emission they were to be run under total emission conditions for a full ten seconds before any readings, during the 1,000 hours' life test were taken. The "total emission" curves show that the electron emission is more than sufficient to give 100 per cent operating efficiency after 1,000 hours' life, or say a year's ordinary use. The impartiality and reliability of the N.P.L. are beyond suspicion, and the published reports are, with the accompanying curves, a small treatise on the modern dull-emitter receiving valve.

Broadcast & Advertising.

IN a recent lecture at the Bath Rotary Club, Mr. E. R. Appleton, the director of the Cardiff B.B.C. station, told an amusing story concerning Mr. John Collinson and his experience of broadcasting at Barcelona, at which station broadcast advertisements are "put over" as a source of revenue. After Mr. Collinson's songs the announcer said, "You have just heard Mr. John Collinson singing a group of songs. If you feel run down, try Mother Seigel's Syrup." If, as I believe, the Spaniards have an acute sense of humour that one announcement alone was worth a round dozen of the "talks" I have heard from 2 L O.

The League and Radio.

A SUPER-STATION for the use of members of the League of Nations has been suggested by the Socialist

SHORT WAVES

The boy stood on the sinking wreck;
He didn't want to go.
He'd caught a new one on his set;
Its letters he must know.

His father called; he would not flee.
The water reached his ears,
And, as he sank, he cried with glee,
"By Heck, I had Algiers!"

"Wireless Finds Nurse." (Head-line,
"Manchester Evening News.")
We understand that "howling" will, of
course, be considerably reduced.

Columbus gambled and got America, but it
doesn't follow that the fellow who wins a
crystal set in a raffle will do the same.—"Sunday
Pictorial."

"I hear that many ladies in Sheffield who
are known to have pet subjects are to be asked
to broadcast on these during the coming week."
—"Sheffield Daily Telegraph."

We understand that special earphones are
being invented for the Pekes.

Radio waves don't care where they go,
so you may as well get your share.

"The Chairman then asked a question as
to whether the hospital should be supplied
with the necessary wireless set, loud speakers,
etc., for the local station to be received in the
main wards."

The answer in this case would certainly
seem to be in the infirmary.

The latest fashion in hairdressing reveals
one ear. This, of course, makes it possible
for the modern girl to listen-in with headphones.

So the end of the year will end B.B.C.;
The State will then "uncle" the licensee,
And all that remains of our 2 L O
Will just be a branch of the G.P.O.
But—we ask it in fear, as a goal of desires—
"Will a wireless State mean no pulling of
wires?"

(A writer in Daily Paper.)

French member of the League. Peace in their hearts but war in the ether, unless the wave-length allotted is well off the beaten tracks!

A Terrible Resolution.

THIS will have to be nipped in the bud or our beloved announcers will resign in a body. The Carnarvon County Association has passed a resolution pledging itself to press the Government to establish a Welsh broadcasting station. Not, mark you, just another station in Wales, but one which is to radiate in the Welsh language. If this comes off I forsee the B.B.C. Pronunciation Committee having the time of its life. Well, I ask you—look at the map of Wales, look you! Is there a microphone which will grin and bear Llandlwhaiairn?

A Debatable Point.

AN electrician at Grimsby was summoned under the Shops Act for selling batteries during the compulsory half-holiday. He argued that in replacing an exhausted battery by a "live" one he was not effecting a sale, but a repair of a wireless set, and the summons was dismissed. While I am glad that this good Samaritan was not sent to penal servitude, I really cannot agree with his argument, for he supplied power to a wireless receiving station, and every engineer knows that "power" is not a "repairs" item.

Discontent in Scotland.

IN spite of your simple tastes and thirst for knowledge, my friends beyond the Tweed, you are, I gather, muckle pit oot about the quality of your broadcast fare. The worst depression appears to be centred over Glesca, and the outlook is, as usual, unsettled. The 5 S C programmes are compared unfavourably with those of 2 L O, and I am confident that the southward drift of Scotsmen will be greater than ever after Hogmanay—whatever that may be! But cheer up, the Jocks! Remember the haggis that jumped out of the frying-pan into the fire. Millenium for broadcasting begins at midnight on Dec. 31st, 1926, a date which has a peculiar significance for Scots.

Making a Hash of It.

IS it the Aora Borealis that is making such a hash of reception lately?" asks a reader.

I should have thought that the Aora would have made a better pudding than a hash, wouldn't you?

Mr. A. J. Allan Again.

MY readers will be glad to learn that those fascinating talks by Mr. A. J. Allan to which we always look forward with such interest, are now being published in "The London Magazine." I shall certainly enjoy this reintroduction to some of his amazing experiences.

Christmas Greetings.

AND so, once more, a happy Christmas to all my readers, all listeners and radio men, at home and overseas, on the sea, under the sea, and in the air. A merry radio Christmas. May your bills not run up too high or your batteries run down too low.

And may your only "X's" be kisses.
ARIEL.

NEARLY everybody will admit that if the average individual suffered during his lifetime as few troubles and complaints as does the ordinary well-made crystal set, physicians and medical men in general would have a very sparse time of it. Given a good crystal set in the first place, there are a surprisingly small number of things that can go wrong with it, that is, of course, if we put aside the necessity for occasionally renewing the crystal when that indispensable article begins to show signs of old age.

Crystal set troubles, apart from accidental mishaps with the receiver, fall generally into three main classes. They may be due to:

1. Bad design and the use of faulty components and materials in the construction of the set.
2. Poor workmanship in the construction of the receiver.
3. The use of the set in conjunction with an inefficient aerial or earth, or at greater distances from the broadcasting station than the maximum sensitivity of the receiver as a whole will permit.

Inefficient Conditions.

A crystal set, however, which has been well constructed to an efficient design, and which is used with a reasonably efficient aerial-earth system within a distance of



Fig 1. The best method of securing good connection to the rotor of a variometer is by means of a pigtail.

ten miles from the local station, should never give any trouble whatsoever, except, as indicated in the first paragraph, the necessity occasionally arising for a change of crystal. In fact, such a receiver should go on functioning for an indefinite time.

Despite the above facts, however, it is a truism unfortunate to relate that quite twenty-five or thirty per cent of the crystal sets in general use are badly made or are constructed from poor materials. Further, another twenty per cent of the crystal receivers in operation in this country are used under thoroughly inefficient conditions. Low, short aeriels, parallel aerial and earth leads, bad aerial insulation, the use of diminutive indoor aeriels, and so on, cannot under any ordinary circumstances result in really good and efficient



The crystal set though not a complicated affair may occasionally go a little "off colour." In this article our Staff-Consultant discusses the ailments from which such receivers may suffer and points out the methods to adopt to cure them.

By J. F. CORRIGAN, M.Sc.,
A.I.C. (Staff Consultant).

reception being obtained with a crystal set, no matter how well the receiver may have been made in the first place.

It is not to be supposed that the regular reader of this journal will have experienced any of the above causes of trouble to any appreciable extent. Nevertheless, nearly every radio enthusiast and constructor receives urgent SOS messages from non-technical friends in distress, messages the gist of which is to the effect that So-and-so's crystal set will not work, and will he please come and see what is wrong with it.

Yes, I think we are all acquainted with that type of heartrending appeal, and therefore I have thought it advisable to devote an article to the subject of the rapid tracing of crystal set troubles for the benefit of the "P.W." reader who undertakes this sort of consulting work in his district, either on friendly or on professional terms.

Aerial Faults.

Confronted with a case of poor crystal reception within a reasonable distance from the local station, the best thing to do, I think, before examining the set itself, is to inspect the aerial and earth system of the receiver. By this means you will obtain a clear idea of the conditions under which the set has been in operation. For bad aerial and earth systems, the remedy is obvious. In any radio receiving installation it is vitally necessary that the aerial current must be led into the set with the minimum amount of leakage. And, of course, in the case of a crystal set, this necessity amounts to a matter of paramount and overwhelming importance.

Many good household folk have a knack of tacking loose lengths of aerial and earth leads to the wall in a mistaken endeavour to make the room look neat and tidy, and to prevent the loose wires from catching the curtains, and so forth. This running closely parallel of aerial and earth leads is quite a common cause of crystal set inefficiency. If such leads are run together for a distance of even a foot, the resulting reception will suffer very appreciably in strength owing to the capacity leakage to earth of the aerial current.

Then, again, there is that little question of the earthing of the set. If the receiver is used with a gaspipe earth, reception is very likely to suffer. Earth leads which

wander nearly all over the lower part of the house, up and down door frames, along yards of skirting boards, until eventually they reach a main waterpipe, are productive of continually poor results. All these facts are, of course, quite well known to the radio man, but nevertheless their recital may be of some use to the amateur who is called out to "have a look at" or "to see what is wrong with" his neighbour's crystal set.

The Crystal Itself.

The next part of the business of crystal set doctoring is to inspect the crystal. Most likely it will be found to have crumbled away into a mere speck of dirty-looking mineral, and, if this is the case, it will generally be held loosely in the crystal cup. Here, again, the remedial measures are obvious.

If the detector is of the perikon or semi-permanent type, carefully disassemble it and give it an examination. Generally, one of the crystals will be found to have broken,

(Continued on next page.)



Fig. 2. Both ends of the rotor winding should be soldered to the shaft of the spindle.

CRYSTAL SET TROUBLES.

(Continued from previous page.)

and the removal of the broken fragment, coupled with the sharpening up of the remaining part, will usually result in good rectification being once more obtained.

Some so-called permanent detectors contain an ordinary galena crystal with a cat's-whisker held in contact with the crystal surface by means of a small blob of sealing-wax or similar material. When such

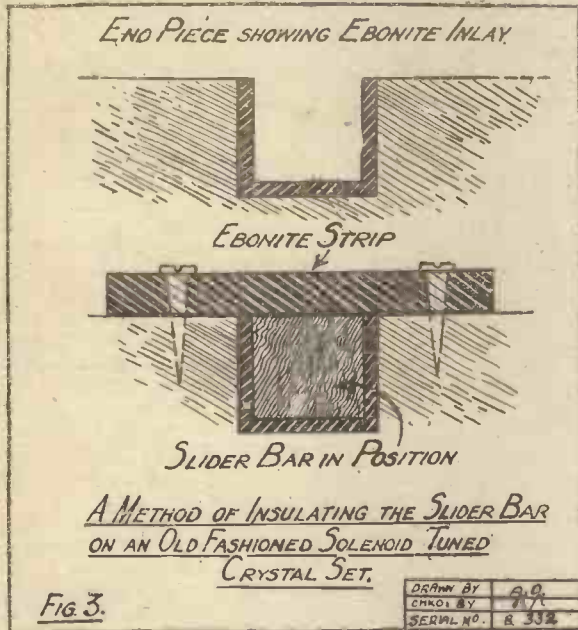

articles go wrong it is generally useless to try to resuscitate them. In the first place, the crystal itself may have gone dead (and the average galena crystal is a notorious offender in this respect); or even if the crystal is sensitive, it will be found a very delicate job to try to re-attach the cat's-whisker to the crystal surface in a satisfactory manner. In such cases the best thing to do, if possible, is to scrap the offending detector altogether, and substitute in its place a semi-permanent detector of the perikon type.

Variometer Failings.

The preliminary inspection of the detector completed, remove the panel of the set and examine the type of components used. Of course, if the set hasn't got a panel, this inspection will be carried out by the most obvious means. If the tuning coil of the set is a tapped one, see that the tappings are well soldered, and that the connecting wires do not touch one another. It is often a good idea to try the effect of making new tappings by the expedient method of pushing a hat-pin (scarce article nowadays!) through the insulative covering of the wire. Some crystal set tuning coils are hopelessly tapped, and a few simple trials of this nature may very well work wonders in improving the strength of the reception.

Variometer-tuned crystal sets often give trouble owing to rubbing contacts which have worn, and have thus set up poor

electrical contact between the stator and the rotor. The best method of connecting a variometer rotor and stator together is by means of a thin strip of copper foil made into a coil, one end of which is soldered to the main spindle shaft of the variometer, the other end being soldered to the extremity of the stator winding. Such detail of construction is shown in Fig. 1. Both ends of the rotor winding should be soldered on to the shaft of the variometer spindle in the manner indicated in Fig. 2.

Variable condensers sometimes give trouble in crystal sets, as in other radio instruments, owing to their vanes touching, and also through faulty rubbing contacts. Here, again, the remedy must be determined by the nature of the trouble.

One great cause of crystal set inefficiency is the loose joining of the various wire connections. Many cheap manufactured sets simply have the wires connecting the terminals loosely wrapped round the latter and secured by a nut. This sort of construction may be all very well when the set is new, but after a few months' working the joints tarnish, dirt creeps in between the wires, and thus areas of greater or less electrical resistance are set up. The cure, of course, is to see that every joint in the make-up of the set is well and truly soldered in position.

Another little point which very often escapes the notice of the crystal amateur is the difference in reception, especially in clarity, made by the inclusion of a small fixed condenser of a capacity of approximately .002 mfd. across the telephone terminals. Such a fact is well worthy of a trial.

Solenoid Coils.

Crystal sets containing large solenoid coils of the slider type are not often to be seen in regular use nowadays, but occasionally they do crop up here and there. With sets of this type there arises the necessity of seeing that the plunger makes efficient contact with the wire at all portions of its track, and also that two or more turns of the wire have not become short-circuited owing to the wearing effect of the plunger on the wire's insulation. The slider bar itself should be let into recesses in the wooden end-pieces, which have been inlaid with ebonite in the manner illustrated at Fig. 3. Slider bars which are merely screwed directly into the wood may set up quite an appreciable amount of current leakage.

And, finally, there is the matter of the set's general appearance to be taken into account. If the panel is found to be covered with the accumulated dust of ages, if the terminals have become tarnished or oxidised, and if apparently any contact studs in the set have not experienced the beneficial results of a little sandpaper rubbing since they were first put into position, it may be generally taken for granted that the owner of the set does not

know how to take care of his receiver, and to conserve its degree of efficiency. Clean up the set in this direction, and impress upon its owner the necessity of keeping the panel and the various external fittings in a reasonably clean condition.

Test the 'Phones.

Such, in brief, is the method of diagnosing the cause of poor reception with a crystal set of any ordinary design. Of course, troubles do now and again crop up which call for more specialised attention, but, at the most, they are not common.

Just another point. In this article I have assumed that the crystal set examiner will make use of his own 'phones in conjunction with his inspection of the receiver. Many crystal set complaints are due to faulty 'phones, and to broken or loosely connected 'phone leads. This, however, forms a subject in itself, and space does not permit the elaboration of the details which must be looked for in connection with the process of testing 'phone efficiency.

TWO USEFUL TIPS.

VERY fine wires are notoriously difficult to solder together, and even if plastic metal is used for this purpose there is always the danger that the metal may not hold and that the wires may come apart.

A very simple way out of the difficulty consists in carefully tying the bared ends of the wire together and, then in passing the tied ends of wire through the flame of a candle. The passage of the wire through the candle flame should occupy about three seconds, during which time the wires will become red-hot, will partially melt, and will fuse firmly together.

Satisfactory Results.

Care must be taken, of course, to see that the wires do not become too hot, otherwise they will melt away altogether.

The adoption of such a method will always give satisfactory and permanent results.



A good specimen of pyrites crystal found by a reader of "P.W." while on holiday.

Extension handles, if made from a strip of old gramophone record, which can be cut and bent quite easily when heated, can be made to clear any control or obstruction on the panel that might render the ordinary straight type useless.

The strip, about half an inch wide should be cut when the record is warm and soft, a hole made in one end enables the handle to be gripped between the nut and dial on the condenser spindle.

ON THE SHORT WAVES



An interesting description of a well-known British amateur station.
By C. S. BRADLEY.

I WRITE this short description of my station in the hope that it may prove of interest to readers of POPULAR WIRELESS, and also that some of the details described herein may prove useful to some other fellow experimenter into the mysteries of radio.

As will be seen from the photograph, the main feature is centred in the two receiving sets, so I will therefore start by describing these.

Firstly, the bigger of the two. This is a standard five-valve receiver consisting of

circuit. The circuit diagram is shown in Fig. 1.

I also give the values of the different components, as they are in my own set:

Secondary tuning condenser, .0001 mfd.; reaction condenser, .0001 mfd.; H.F. choke, 75 Edison Bell coil; grid condenser, .00025 mfd.; grid leak, 2 megohms (it is very often possible to dispense with this). Valve, Cosmos S.P.18, Red Spot.

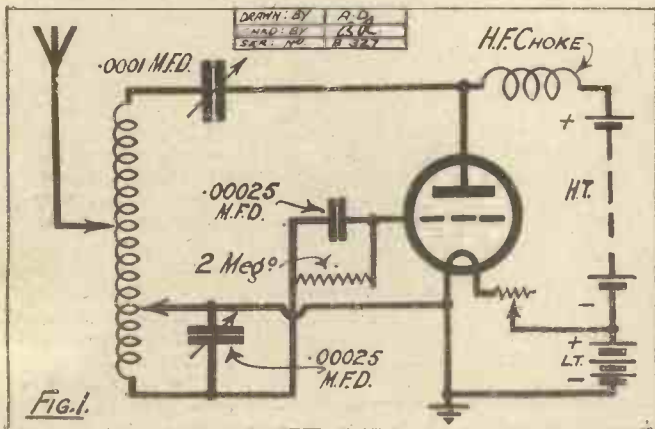

two H.F. valves, a detector, and two No. 6 magnifiers. The H.F. valves are coupled by the tuned anode method, and are neutrodyned. Any number of valves can be used, from one to five, and also, for the reception of the local station, in my case 2 L.O., a crystal detector can be used, followed by one or two stages of L.F.

The Short-Wave Receiver.

An Igranic "tone control" is placed across the secondary of the last L.F. transformer, and forms a very good method of controlling the volume without distorting the signals. The wave-length range of this receiver is from 200 metres up to about 20,000 or so.

When, however, I want to go down in wave-length and wander among the amateurs, the smaller set, which is in the window just above the big one, comes into use. This is a single-valve short-wave receiver, employing an adaptation of the well-known "Hartley"

one of the best of the various short-wave arrangements, inasmuch as it is very easy to control. Reaction is very finely adjustable, and by reason of interchangeable coils it can be used for any wave-length. Also it is possible, by varying the L.T. and aerial tapplings, to bring in a station lower down on the condenser scale, with a consequent increase of efficiency. This is particularly noticeable in the reception of short-wave "phone."

While I am on the subject of telephony, it may be interesting to some to know that on 45 metres this set is capable of reception over very long distances, and on most occasions when they are working it is possible to receive

speech as loudly as R 7 to 8 on O-V-I in London, from such stations as G X. 5 N J. and 2 IT of Belfast, and 5 SZ of Morecombe, to mention only three of the best, and, of course, should you be able to read Morse, the pleasure is more than doubled.

By the way, the L.F. amplifiers used with this set are the note magnifiers of the big set brought into circuit by plugs and jacks.

Coil Details.

No.	Turns	wave-length	
1	70	80-200	metres.
2	40	45-90	"
3	18	30-60	"
4	11	18-35	"
5	6	10-20	"

Power Supply.

The L.T. is derived from a 2-volt 240 ampere hour accumulator which, when not in use to light the valve filaments, is, by the turn of a switch, put on charge, so that the battery is always in good condition.

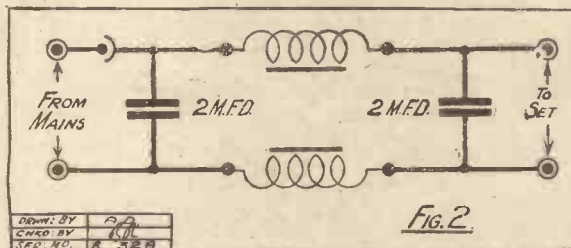

Coil Details: (See table in next column.)

These are, of course, only approximate as far as wave-length is concerned, but they will serve as a rough guide

to anyone who may be interested enough to try out the "Hartley." In my experience, this is

I would mention here that 2-volt valves are used exclusively at this station.

The H.T. current is taken from the borough power mains; these are D.C. at a pressure of 240 volts. This is broken down by resistances to the voltages required for

(Continued on next page.)

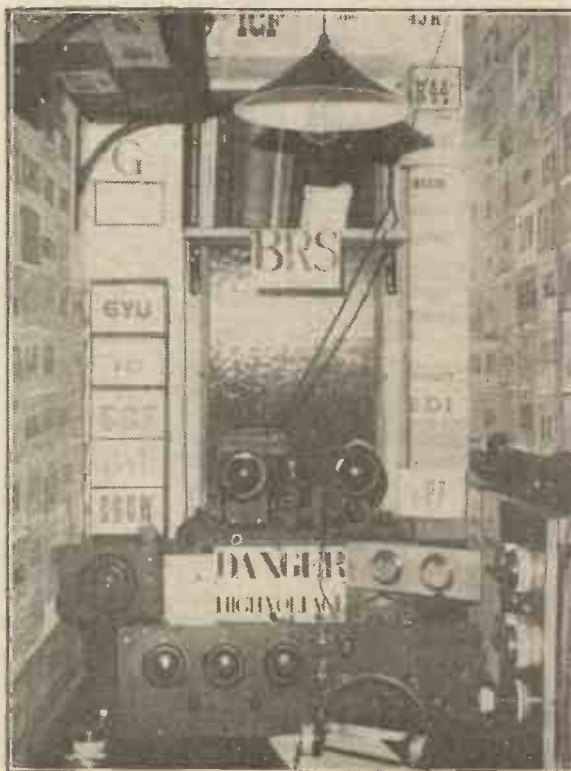

The operating-room of Mr. Bradley's station in North London.

BATTERY ELIMINATORS AND CHARGERS.

Some useful hints for those listeners contemplating the purchase or construction of battery eliminators.

By J. R. WHEATLEY.

"ALWAYS at your service" really describes battery eliminators and home-charging units in a nutshell. Those irksome journeys to and from the charging station on nights when you wanted your set to be at its best and the L.T. battery gave out could have been avoided. One thing is, however, necessary, and that is that some form of electric supply mains must be available, whether direct current (D.C.) or alternating (A.C.) matters not.

Both L.T. and H.T. units have passed the experimental stage and are now practical propositions. Units for both types of mains are available, and also for sets ranging from the seven-valve Super-heterodyne down to the ordinary two or three-valve set. Special types are also available for sets using one or more power valves.

The Output Voltage.

In the case of D.C. mains, the initial cost of a unit is fairly low, and this is due to the simplicity of the arrangement required to supply the necessary output. Such units have, unfortunately, one disadvantage: the highest voltage obtainable is approximately 15-20 volts less than that of the supply. As, however, to-day the usual D.C. mains are 150-200 volts, this is not a very important consideration, unless the set employs several stages of L.F., using resistance-capacity coupling. In the case of A.C. mains, the output voltage can be varied to suit all possible requirements.

Although with D.C. mains the output is limited, it is almost continuously variable from minimum to maximum, and the actual current obtainable is practically unlimited. With A.C. mains, using suitable transformers, the voltage is unlimited, but the current output is limited in certain cases. Owing to the totally different nature of A.C., more intricate apparatus is necessary, and naturally the cost is higher than that of the D.C. unit. Before obtaining an eliminator, the following should be ascertained:

Necessary Considerations.

Firstly, whether the mains are D.C. or A.C. (if of the latter type, the frequency), and the voltage. The simplest, surest, and safest way is to seek a reliable local electrician, or to inquire at the power station, from which the electricity is supplied.

Secondly, the number of valves used and

the type. This is important, especially if power valves are employed.

So far we have only dealt with the elimination of the H.T. battery. The elimination of the L.T. battery is a different problem. Although this has been successfully carried out, it is only applicable to certain sets using certain types of valves. Battery chargers are available which enable the amateur successfully and efficiently to charge his own batteries at home at a fraction of the cost and one-tenth the inconvenience of outside charging. With D.C. mains, the cost of such a unit is very low, but as with H.T. eliminators, the initial cost of charging units for A.C. mains is more expensive.

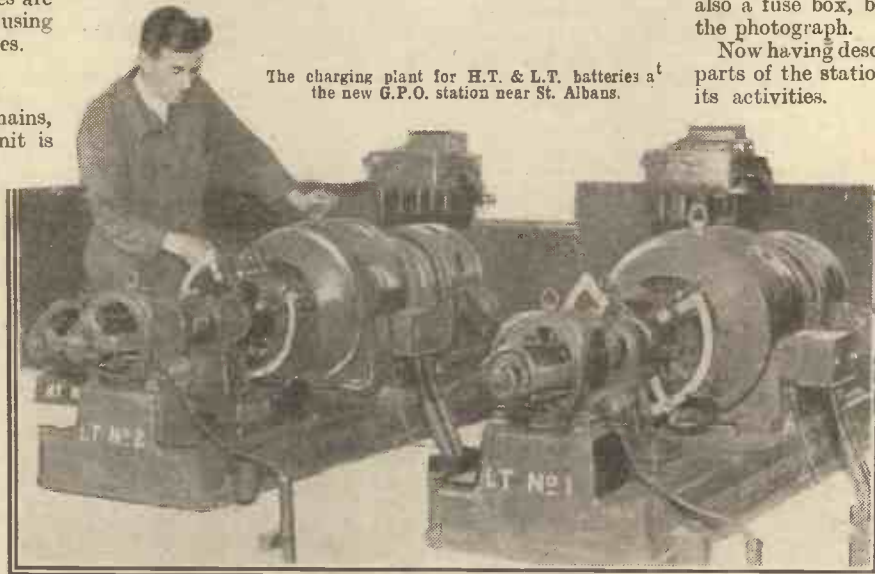

The charging plant for H.T. & L.T. batteries at the new G.P.O. station near St. Albans.

ON THE SHORT WAVES.

(Continued from previous page.)

reception, and the hum is smoothed out by the usual arrangements of chokes and condensers.

The basic circuit is shown in Fig. 2.

This, as it stands, makes a very good smoothing unit for use with D.C. mains, and by using a Neon tube in series as a resistance, two very useful voltages can be obtained. With the glow round the "Beehive" the H.T. voltage is about 70. Reverse the lamp on the holder, so that the glow is round the plate, and the voltage is about 50.

An added advantage of this method is, that should the H.T. accidentally be connected to the L.T. terminals, you cannot burn out the valve filaments, as the Neon

tube will not pass enough current. The maximum is, I think, about 30 milliamperes.

Leaving this, we will pass to a small panel just above the right-hand side of the big set. This contains two instruments, the left-hand one being the filament voltmeter, and the right-hand one is the plate milliammeter. This reads from zero to 25 milliamps.

At the bottom left-hand corner of the five-valver will be seen a switch; this is for cutting out the L.T., and just in front of this is the filament ammeter, reading to 3 amperes, thus giving an additional check on the accumulator.

Q. S. L. Cards.

It may be mentioned here that details as to current taken, time the valves are alight, number of valves in use, etc., are regularly noted in the station log book, thus providing me with a very good idea of how things are going on.

A switchboard, mounted on the wall on the left-hand side of the room, is used as a control board, containing an H.T. switch and plug, a switch for the electric light seen above, and a coupled switch, which completely isolates the main's current from the cabin. There is also a fuse box, but this cannot be seen in the photograph.

Now having described the various working parts of the station I will say a little about its activities.

As will be seen from the "wall-paper," the station leads a very active life, and, in fact, the wall contains cards from nearly every country on the earth.

For instance, there are cards from Australia, New Zealand, French Indo-China, Brazil, Porto Rico, South Africa, to mention only a few, but these will serve to give you some idea of the reception range of the station.

Now do not send a card worded, "UR sigs hrd ere OM at

04:15 G.M.T., Pse QSL," and expect that you are going to receive a card back from the "Ham" to whom it is sent—you are not.

"MODERN WIRELESS"

AND

"The Wireless Constructor"

Special Xmas Double Numbers of both of the above famous magazines are now on sale. If you have failed to obtain copies, write to:—

The Back Number Dept.,
The Amalgamated Press Ltd.,
Bear Alley, Farringdon Street,
London, E.C.4.

LEAVES FROM MY NOTEBOOK.

By PERCY W. HARRIS, M.I.R.E.

Although the eight-page supplement, "The Radio Constructor," has now ceased, owing to Mr. Harris taking over his old duties as editor of "The Wireless Constructor," he will continue to contribute articles to the pages of "P. W." Mr. Harris will also write articles of a constructional nature for "P. W." from time to time.—EDITOR.

RECENTLY I spoke of the changes in wave-length and how, at the time of writing, they had done little to improve conditions. A further period has elapsed and, as I write, my loud speaker is reproducing a Continental station badly heterodyned and interfered with, in just the same way as before the change. At least half a dozen other stations found within five minutes were equally badly "messed up," and the impression gained at the moment is that there is not much improvement. The British Broadcasting Company has rightly pointed out that listeners should not be too ready to criticise until all the stations have had time to settle down, and with this I agree, but it is at the moment disturbing to find that within the last week conditions have become worse instead of better.

One point, I think, already calls for some comment, and that is the new position of Bournemouth. It was rather surprising that in the rearrangement of station wave-lengths to the British Isles a wave-length of 306 metres should have been chosen for a seaboard station. I have received one or two bitter complaints from South coast readers regarding this. One listener who has been dependent upon Bournemouth and Daventry for his programmes wrote to say that the new position of Bournemouth, right in the middle of the 300-metre Morse interference, made it quite impossible to obtain any enjoyment from this station, although previous to the change he had found it the one station that was well free from the Morse interference so far as his position was concerned. The B.B.C. were very wise in making a further change to 326.1 metres.

The Morse Problem.

Newcastle, and Dublin too, are very close to Morse interference. Manchester, an inland station, on the other hand, has a wave-length which is remarkably free.

It is, of course, very easy to criticise a scheme of such a magnitude, and everybody cannot be satisfied, but the Morse interference is such a problem that I feel that changes will be made within a short time to obviate some of the trouble experienced by the sea-board stations. Because of possible changes, I would recommend readers who possess vernier dials to refrain from marking their dials for some little time yet. Later, when conditions have settled down, the dials can be marked, but for the present time leave the spaces blank!

On opening a package containing an ebonite panel the other day I came across a very good idea. On one piece of wrapping paper was printed an excellent chart of suitable size to paste inside the lid of a wireless cabinet. On this chart the various station readings could be recorded. The particular maker apparently does not do this consistently with all his wrappings, but the scheme is such a good one that I trust he will do so before long, and that the idea be adopted by others. In most cases a new panel means a new set, and a handy calibration chart of this kind forms a very welcome gift and incidentally costs the manufacturer very little.

Instructions for Fitting.

This reminds me that many of the firms making component parts still omit to provide fitting instructions with some of their apparatus. I have in mind at the moment a certain filament resistance which is sent out with one terminal only. Such a device obviously requires a second connecting point, and careful examination shows no obvious place to make it. Actually, it is necessary to unscrew a nut and fix a wire underneath it—not even a soldering tag is provided.

The loosening of this nut slackens other parts of the apparatus, which is then liable to fall to pieces in the hand. Although a template is printed upon the box no instructions are given, and if the experienced man has to examine the component carefully and reason out where the connection should go, what chance has the ordinary home constructor, just beginning to build sets, in making suitable use of the component?

I would also like to commend to the manufacturers the importance of plainly marking their templates to indicate whether they are to be used on the front or the back of the panel. Many are marked for the front of the panel without this being stated. In any case, even if stated, such a practice is not to be commended, as most home constructors mark on the back of the panel to save injury to the surface which will be exposed to view.

What the Constructor Needs.

A slip of the hand and the scriber may make a nasty scratch right across a panel, disfiguring it for the rest of its days. Such a slip on the back of the panel is harmless and will not be seen when the set is completed.

It is strange how many of the obvious needs of the home constructor are inefficiently met. For example, it requires no great mental effort to understand that centre-tapped coils are likely to be popular for some time in the conversion of old sets and the manufacture of new ones. One coil manufacturer already famous for his coils, has recently introduced a plug-in centre-tapped coil, otherwise excellently made, which requires a special base and cannot be used in the conventional two-coil holder, although the normal pin and socket is fitted.

Centre-Tapped Coils.

I only discovered this important fact when, in carrying out the experiments and tests on the modernised "Four-valve Family" set, I ordered centre-tapped coils from all those manufacturers who now market them. The particular

construction could not be used in the set in question.

An Aerial Query.

"Can you tell me something of the relative merits of insulated and uninsulated aerial wire?" is the question put to me by a South London reader. "On the strength of a recommendation, I made a new aerial of insulated wire, and find I get no better results. But my friend, who lives quite close to me, and has a very similar aerial, finds his results are very much better with an insulated aerial."

An ordinary copper or bronze aerial wire, after a time becomes discoloured, and will be found to be extremely dirty, with some amount of surface corrosion. This surface corrosion is neither a good conductor nor an insulator, and it may occasion quite appreciable losses. With enamelled aerial wire the good conductivity is preserved for a much longer period, so that in the case of your friend's aerial he probably had a badly corroded aerial to begin with, and in replacing it by new insulated wire obtained much better signals.

Had he replaced his old wire by any new wire, he would have obtained very much the same results, and as your aerial was presumably in much better condition than your neighbour's, you did not notice the difference on changing from one wire to another.

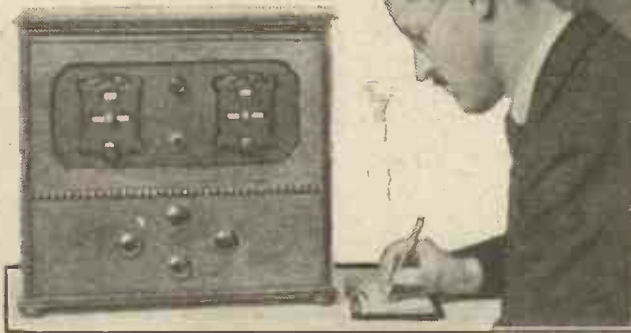

Calibrating the "King of the Air."

TECHNICAL NOTES.

A Weekly Feature Conducted by

Dr. J. H. T. ROBERTS, F.Inst.P.

(Staff Consultant.)

THE popular idea that a crystal detector should be handled with the utmost care and that, in particular, any form of greasy contamination should be avoided like the plague, would appear to be quite erroneous. I believe I have already mentioned in these Notes on one or two previous occasions that this idea with regard to crystal detectors was to be ranked in the same category with "low loss" and other boogies, and experiments have shown this to be the case. In some recent tests a piece of crystal was broken in two and the two clean fractured surfaces were tested and ascertained to be the same in performance. One was then kept as a standard, whilst the other was treated to all sorts of abuses, such as smearing it with vaseline, boiling it in water, heating it to about 300 degrees centigrade, and then plunging it into cold water, rubbing it with all kinds of dirt, and a number of other drastic forms of ill-treatment which I cannot remember. Although, of course, some differences were found in the signal strength, using portions of crystal treated in these various ways, these differences, even in the most extreme cases, did not amount to more than about 20 or 30 per cent; that is to say, the specimen which lost most of its detecting properties gave a signal strength, other things being equal, of not less than about 70 per cent of that given by the standard sample.

It seems from these tests that quite a popular myth has been exploded and that the meticulous handling of crystals with tongs is rather an elaborate farce.

Unfounded Myth.

The fact is with this, as with "low loss" and many other myths, that somebody starts an idea and most other amateur writers follow blindly and even go out of their way to lay stress on particular points, the validity of which they have never taken the trouble to ascertain. The wireless amateur is catered for very largely by amateur writers, and whilst there is something to be said against this, there is a great deal to be said in its favour (since the amateur experimenter as a writer is likely to write in popular and interesting style). Nevertheless, it is necessary to bear in mind that popular writers (in wireless as in other popular sciences) are usually not scientific investi-

gators and therefore they are apt to take statements on faith and then repeat them as facts.

Enclosed in Vacuum.

Whilst on the subject of crystal detectors, I should mention that I recently examined a type of "crystal valve" which resembled an ordinary wireless valve in that it comprised a glass bulb with the conventional pins at the base, but inside was a piece of galena crystal suitably mounted, with a special type of cat's-whisker which could be adjusted by mechanical means. The interior of the glass bulb was exhausted of air, exactly as in the case of a valve, and I was told that in use the crystal-in-vacuum was very much more stable and reliable than a crystal used in air in the ordinary way. A specimen crystal was broken in two portions,



Mr. L. Harvey, engineer-in-charge at the Leeds-Bradford station, in the control room.

one portion being introduced into a bulb as just mentioned, the bulb being subsequently evacuated, whilst the other portion was used in air in the ordinary way as a standard. It was found after some weeks that whilst the open-air specimen had deteriorated, the one in the glass bulb was giving perfectly consistent results.

This effect is not to be confused with the tests which I mentioned above. When a crystal detector deteriorates there may be several causes. Contamination may account for some degree of deterioration, whilst oxidation may also be an important factor. Inasmuch as the exact mechanism of crystal rectification is still not understood, or, at any rate, only imperfectly understood, it is difficult to say to what extent oxidation is likely to influence the rectifying property. But the fact remains that the crystal in the vacuum—which is evidently protected, not only from contamination, but also from oxidation—retains its rectifying power much better than the crystal in the atmosphere.

Apart from the practical advantages of a stable crystal rectifier, the fact that the crystal in vacuum still rectifies in the absence of oxygen, raises the interesting question as to whether oxygen plays any important part in crystal or contact rectification. It has been held by some experimenters that crystal rectification is, in fact, due to the alternate formation and breakdown of a film of oxide. The fact that the rectification still goes on in the vacuum may be explained in several ways without entirely contradicting the theory that oxides may play a part.

In the first place, the vacuum may not be a very high vacuum, and I am not aware that the tests have yet been carried out in the highest possible vacuum, so that there may still be a sufficient quantity of oxygen present; although if the effect itself depends upon oxygen it would seem very likely that a considerable reduction in the oxygen pressure, even if the oxygen were not entirely removed, would make a very marked difference in the effect.

In the second place, even if oxidation may play some part in the rectifier it is still possible, and, in fact, from many well-known experiments it seems particularly likely, that the formation or breakdown of other compounds than oxides may play a part in the rectifying action. In this connection it is well known that most of the best types of crystal rectifier are, in fact, metallic sulphides and that quite a good rectifier can be made by exposing a freshly cleaned metallic surface to a sulphur compound in conditions which favour the formation of a film of sulphide on the metal.

The Crystal's Future.

Thus, it is possible that the necessary elements may be contained in the crystal and the metal wire contact themselves. Before leaving this subject, I should like to remark—and I know that in this a very large number of readers will agree with

me—that in my opinion the crystal detector (and in that I include all such types of contact detectors) is by no means a thing of the past; in fact, I would go so far as to say that it is more a thing of the future. I believe that there is any amount of scope for further scientific investigation of the theory and mechanism of the contact detector, and it is a subject which is not only full of interest, but which is to a large extent within the experimental resources of the average wireless amateur. So don't despise the crystal; remember that its secret is still jealously guarded and its action is much more mysterious than that of the thermionic valve.

Rejuvenating the Valve.

"Tube" rejuvenators seem to be becoming very popular in the American field and are offered in forms suitable for home use. The rejuvenator, of course, or the re-activator as it is sometimes called, has for

(Continued on page 1076.)

From Daventry to Pittsburgh, Pa.

An "All-Wave" Receiver

By Percy W. Harris M.I.R.E.

This two-valve set, using ordinary plug-in coils, will receive American short-wave telephony regularly.



HAVE you yet had the thrill of hearing direct from America. "This is station K D K A, Westinghouse Electric Co., Pittsburgh, Pennsylvania"? Do you realise that with only a couple of valves these transmissions are available to you for perhaps seven nights out of ten?

Some while ago I designed a 2-valve short-wave receiver, using special coils, which met with a considerable measure of success, and among the letters I received was one reading as follows:

"Dear Sir,—I have built your special short-wave receiver, and although I have not previously tried on short-waves, I got every word of the Dempsey-Tunney fight broadcast direct from America. I find, however, that I cannot also receive transmission on the ordinary broadcast band. Is there any way of adapting the set?"

Between you and me I should think that if a short-wave receiver works satisfactorily on short waves there is not much left to grumble about, but at the same time, I fully realise that not everyone wishes to make up a set for short waves only. This led me to consider whether it would be possible to make a really universal 2-valver capable of

satisfactorily receiving all wavelengths from Daventry down to Pittsburgh, using plug-in coils of the conventional type. The receiver described this week is the result of recent tests, and I can assure you that results compare very favourably with any short-waver I have built or handled.

Inexpensive Set.

With the exception of the high-frequency choke about which I shall write a little later, all the parts are quite standard, and many of them you will have available from old sets, but assuming you buy everything new the total cost, excluding valves and batteries, should not exceed about five guineas. The set is not made up in any pretentious form, and, in fact, I have dispensed with an ebonite panel for the front panel

carries just two condensers, the frames of which are at earth potential and therefore do not require insulation.

You will notice upon examining the photographs that there are three plug-in coils, one for the aerial, one for the grid tuning circuit, and one for reaction. The aerial coil socket is made to swivel on a single screw so that variable coupling is obtainable between this and the next coil, but the grid and reaction coils are both in fixed sockets, variation of reaction being condenser controlled.

The form of reaction used is one which is becoming increasingly popular and has many advantages. It is commonly called "Reinartz reaction," but this is erroneously attributing to John L. Reinartz, the well-known American experimenter, something which he did not invent and does not claim to have invented. Reinartz, by the way, was the inventor of a particular circuit arrangement in which the Hartley transmitting circuit was adapted for reception and combined with a special form of aerial coupling. Many circuits which have made their appearance since the Reinartz circuit, and which are often called "modified Reinartz," should really be credited to Hartley or Wegant, and some indeed antedate the Reinartz arrangement in originality.

Easy Reaction Control.

However, that is by the way. Whatever we call it, this form of reaction has very distinct advantages, particularly on the short waves, as the reaction control is very delicate and, what is much more important, changes in reaction control do not seriously affect the tuning. Furthermore, it is possible to arrange both tuning condenser and reaction condenser with the moving plates at earth potential, so that hand-capacity effects, which can easily make short-wave receivers unworkable, are entirely eliminated.

The circuit is shown on the next page, and contains certain modifications introduced by Schnell the well-known American short-wave enthusiast. It works very well with plug-in coils on both long and short waves, provided the radio-frequency choke suits the wave-band it is to cover. On the ordinary broadcast band and on the Daventry band you can use the ordinary plug-in coils to which you are accustomed. For the 63-metre trans-

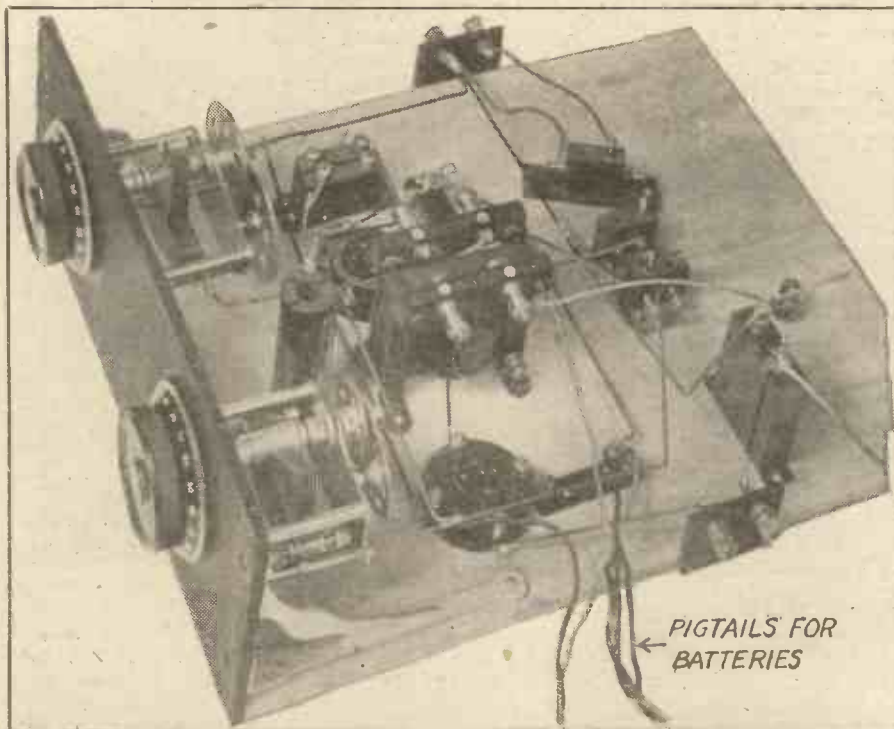

The front panel is of wood, as both condensers have their frames at earth potential and these do not need high insulation.

(Continued on next page.)

FROM DAVENTRY TO PITTSBURG, PA.

(Continued from previous page.)

mission from K D K A you can use either the new Igranic short-wave plug-in coils or other short-wave coils.

The small modification I have introduced into this set will be found very convenient, and add considerably to the efficiency. It consists in placing two fixed condensers, one of .0001 mfd., and the other of .0002 mfd., side by side in such a way that the value of the grid condenser can be .0001, .0002, or (combining both condensers) .0003 mfd.

The .0003 value will suit the ordinary broadcast band and the longer waves, while the .0001 will generally be found considerably better for the short waves. It will also be found preferable to use a higher value of grid leak on the short waves, and I suggest that you use two megohms in the ordinary band and four megohms for the short waves.

The practical wiring diagram makes clear the disposition of parts and the make-up, and the list of components shows you what is needed to build it.

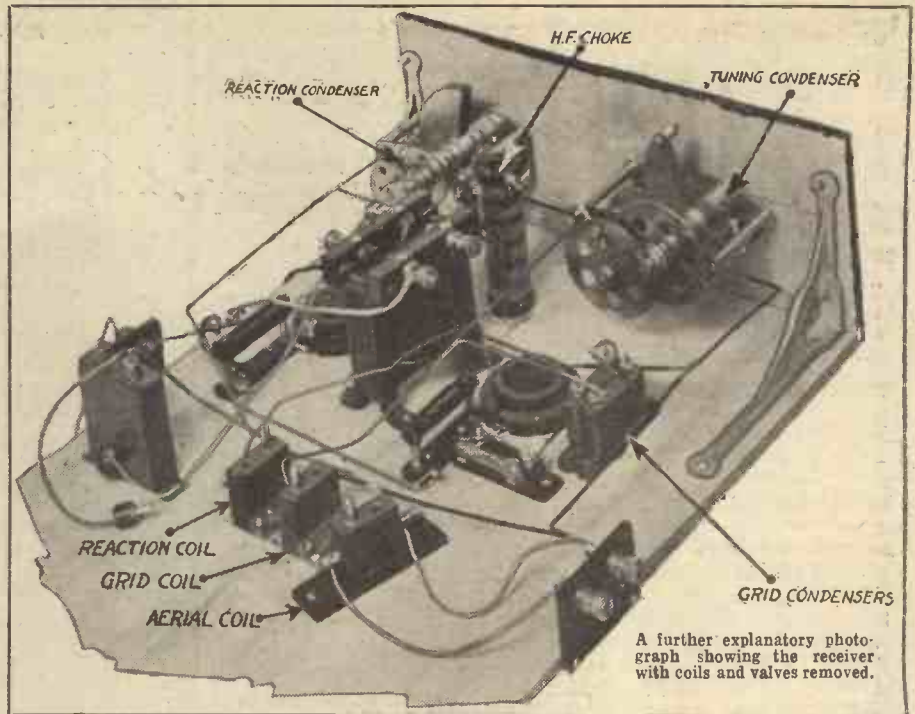

It is essential that the variable condensers should be of a good reliable make, and fitted with adequate vernier attachments. The G.E.C. condensers used have a built-in vernier arrangement, which has proved very satisfactory on short waves, as it is completely free from the slightest backlash and is remarkably smooth.

It is, however, possible to use any good make of low-loss variable condenser provided they have proper vernier dials. British-made vernier dials which I know from experience are quite satisfactory on these short waves, are the new type Igranic Indigraph, the new Formo and the Burndept. This should not be taken as a condemnation of other vernier dials which I have not tried, and I believe there are several others which are just as satisfactory.

The H.F. Choke.

A word about the radio-frequency choke. The one I have used is a special type known as the Varley Centre Tap choke, not because it is itself centre-tapped, but because it has been designed specially to go with centre-tapped neutrodyne circuits, which may develop certain peculiarities if one is not careful. Although this set is not neutrodyne, I find that the choke is

perfectly satisfactory on all wave-lengths for which this receiver will be required to work.

For the ordinary broadcastband the choice of the aerial coil will depend on some extent on your particular aerial. On my own I find a No. 30 suits excellently, and I would recommend that you try 25, 30, and 35 and 50 if you have them, to see which gives the best effect. In the grid tuning circuit a 50 and a 75 between them will cover the band, the former for the lower half and the latter for the upper half. In the reaction socket a 50 or a 75 should be used, depending upon the particular kind of valve, as some valves require a larger reaction coil than others to produce oscillation.

To check whether your reaction coil is of a correct value for the particular band proceed as follows. Place your aerial and grid coils in position (the aerial coil, by the way, should have its angular relation to the grid coil adjusted to give the best results, usually a slight angle between them, as shown in the photograph, will be about correct), now set your left-hand tuning condenser at zero position, and similarly set the reaction condenser.

Absence of Backlash Essential.

Now, leaving the grid condenser at zero; gradually turn the reaction condenser and see whether it takes the set in and out of oscillation (make these tests before or after broadcasting hours, to avoid interference with your neighbours).

Now set the condenser about half-way between minimum and maximum, and repeat the movement of the reaction condenser, finally setting the tuning condenser at maximum and again repeating the tests. With the correct coil you should be able to go in and out of reaction smoothly and without "backlash" at any position on the tuning condenser, although reaction reading will not be the same at every setting of the tuning dials.

Too small a reaction coil may enable you to obtain oscillation on the lower reading of (Continued on page 1043.)

- One variable condenser, .0003 mfd., General Electric straight-line frequency.
- One variable condenser, .0003 mfd., General Electric straight-line wave-length.
- One radio-frequency choke. Varley centre tap type.
- Two anti-vibratory valve sockets, Benjamin, Lotus, Burndept, W.B., etc.
- One fixed condenser, .0001 mfd. T.C.C.
- One fixed condenser, .0002 mfd. T.C.C.
- One low-frequency transformer (any good make).
- One Dumetohm holder for grid leak.
- One grid leak 2 megohms.
- One grid leak 4 megohms. (Dubilier, Mullard, Ediswan, or other good makes).
- Three coil sockets for baseboard mounting.
- Two fixed resistors to suit the valves employed. Magnum, Burndept, Bowyer-Lowe, etc.
- One Mansbridge condenser, T.C.C., Dubilier, Lissen, etc.
- Two small strips of ebonite, as shown.
- Four terminals.
- Grid bias battery.
- One pair of panel brackets.
- Plug-in coils to be described.

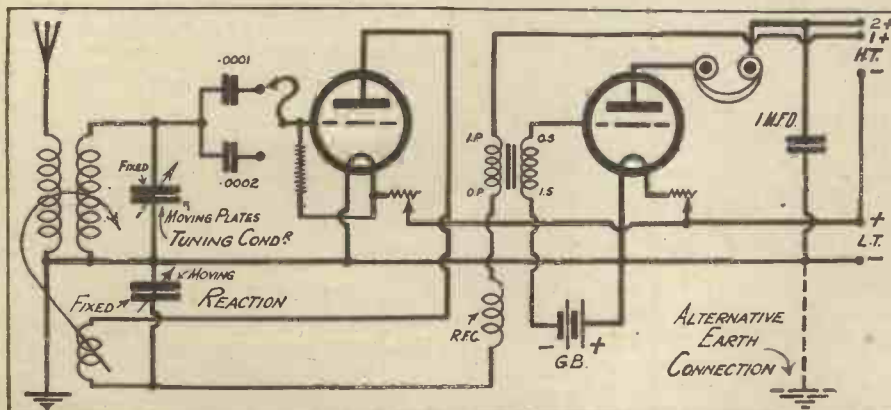

The Circuit. Notice the scheme for changing the grid condenser values.

CAN A USER SAY: "I DON'T CARE ABOUT PRICE," when LISSEN saves him so much?



Few people would pay a high price for a transformer just to say they were using an expensive part. There is much more satisfaction in saying, "Listen to this for tone and power. It's a LISSEN Transformer I've got working here, and I only paid 8s. 6d. for it." That is precisely why LISSEN withdrew all their own expensive transformers. They felt they could not go on selling expensive transformers when they had made this new LISSEN so good.

At last LISSEN has made a transformer which gives you amplification of the most complete and perfect kind, and at a new low price. Everybody can get a better enjoyment of radio in loud-speaker reception, and every crystal set user can now add a powerful amplifier to give strength for loud-speaker operation. Every valve set owner can make his amplification better by fitting this new LISSEN.

A GREAT CHOKE AS WELL AS A GREAT TRANSFORMER.

The new LISSEN Transformer can be used both as a Transformer and as a Choke. In a two-stage amplifier, for instance, you can make the first stage Transformer and the second stage Choke coupled, using the LISSEN Transformer in both stages. Your dealer will tell you how easily you can do this.

Never again pay a high price for a transformer. This new LISSEN will replace any transformer mentioned or used in any circuit. Use it for 1, 2, or 3 stages L.F. It is suitable for all valves and circuits you will want to use.

BIG POWERFUL AMPLIFIERS ARE NOW WITHIN THE REACH OF ALL WHO CARE TO BUILD THEM.

8/6

GUARANTEED FOR 12 MONTHS

Money refunded if within 7 days of purchase you return this LISSEN, having found a transformer to beat it at any price.

Turns ratio 3 to 1. Resistance ratio 4 to 1.

Use it for 1, 2, or 3 stages L.F.

It is suitable for all circuits and all valves you will want to use.

Everything we could employ has been used to make this new LISSEN Transformer, including a new LISSEN direct-to-dealer policy of distribution which cuts out all wholesale profits for your benefit.

USE LISSEN FIXED CONDENSERS, TOO, Mica & Mansbridge Type

LISSEN Mica Type CONDENSERS

Small energy-conserving condensers—note the new case which enables the condenser to be used upright or flat. At present the new case is available only in the most used capacities, but will quickly become a LISSEN standard.



Capacities—

.0001 to .001 1/- each (much reduced).

.002 to .006 1/6 each (much reduced).

Accurate to 5%—they never leak—they never vary.

LISSEN Mansbridge Type CONDENSERS

To a fine LISSEN quality condenser is added the specially moulded case—the condenser cannot short circuit on to its case. The new LISSEN case protects you if the condenser is used in any circuit connected straight on to the electric light mains. And due to our new policy of direct-to-dealer distribution this LISSEN Condenser costs no more than the ordinary type.



.01 to .09	2/4
.1	2/6
.2	2/8
.25	3/-
.5	3/4
1.0	3/10
2.0	4/8

LISSEN FIXED GRID LEAKS

A case of these was left on our factory roof during the summer of 1925, soaked in rain, baked by sun, and the resistance value of these leaks never altered.

All capacities, previously 1/8. Now 1/- each.



Improve every circuit by using LISSEN parts wherever you can—save money, too—for now you get keen prices as well as fine quality.

LISSEN LIMITED,
8-16, FRIARS LANE,
RICHMOND, SURREY.

(Managing Director: Thos. N. Cole.)

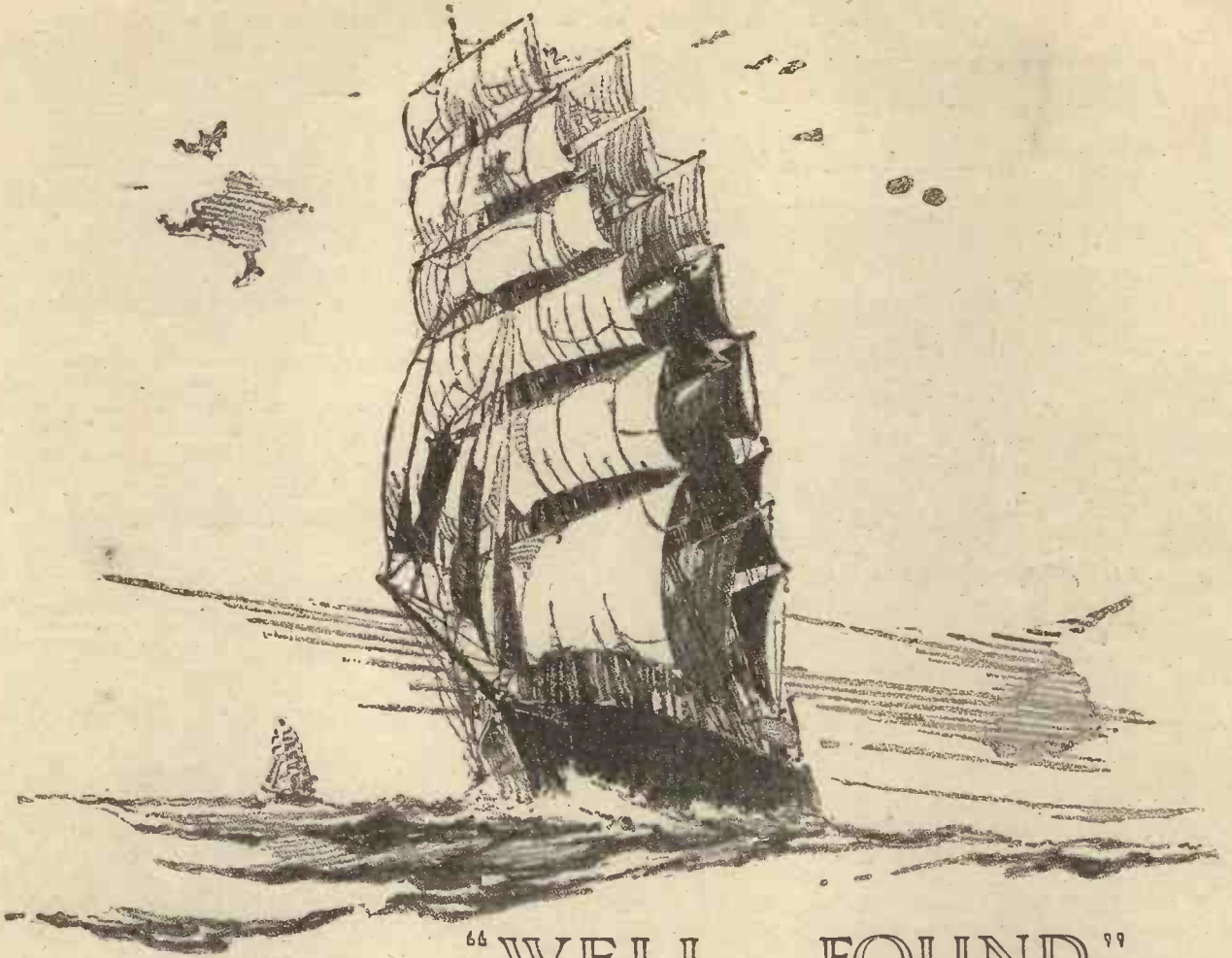

“WELL FOUND”

When the tall Clippers in all their pride raced for the wool and tea markets of the world, they had to be well found and seaworthy.

And being well found didn't end with having good “sticks, rigging, and running gear,” it implied a tip-top condition from the varnish on the truck down to a clean bottom.

It was attention to details more often than not which decided the issue of these stern chases—the details which, as far as one could see, “didn't matter.”

It is, perhaps, a far cry from Clippers to Condensers, but it is certainly a fact that many people regard Condensers as being a detail that “doesn't matter.”

And still more numerous are the people who say that cheap condensers seem to give just as good results as expensive ones.

The fact is that cheap condensers do *not* give as good results as expensive ones. If they did, we should not be interested from any point of view in making the more expensive variety.

And the second fact—namely that the Dubilier Condensers sold number more than all other makes put together—points to the fact that the great majority of people value a well-found wireless set and insist on seeing that it is equipped with Dubilier Condensers.

Do you?

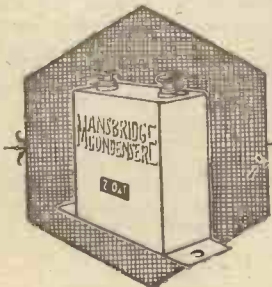

ADVT. OF THE DUBILIER CONDENSER CO. (1925) LTD.
DUCCN WORKS, VICTORIA ROAD, N. ACTON, W.3

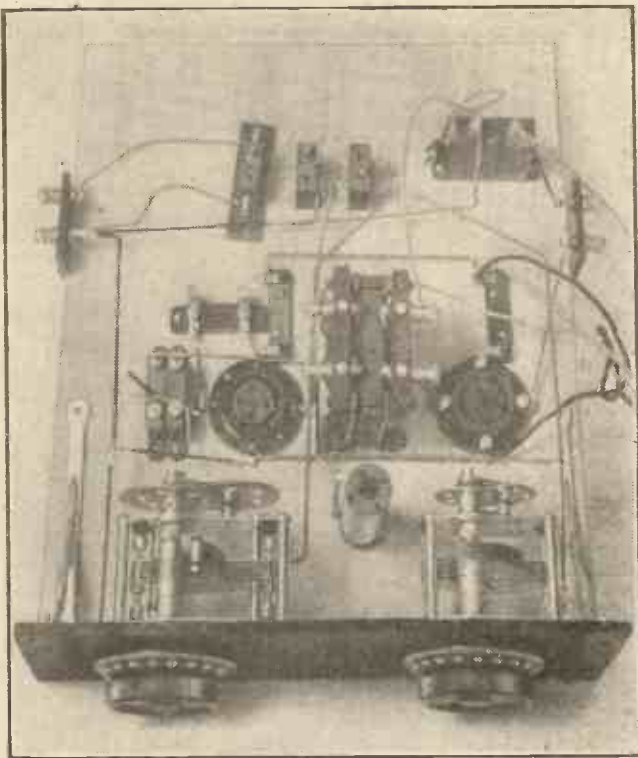

A low cost of construction has been attained without sacrificing efficiency.

in placing the reaction condenser at zero and then turning it until a reaction effect is noticed, but keeping the set below the oscillation-point.

The tuning dial is then turned and the reaction condenser simultaneously varied, for it will be found that more reaction is required on the upper region of the condenser than on the lower. For this reason, when you are tuning up the scale from a lower wave-length to a higher one, you will advance the reaction condenser slightly as you progress. When tuning in the reverse direction, be careful to maintain the reaction condenser well below the oscillation point to avoid interference with other listeners.

It is characteristic

A final note regarding valves. The set has been very thoroughly tested out with all the well-known makes of valves and is quite satisfactory with all types. In the note-magnifying socket any valve designed for note magnifying will do. In the first socket the best results are undoubtedly obtained with high-impedance valves of the type designed for H.F. magnification.

Satisfactory Valves:

Typical valves that I have found to work satisfactorily are the Marconi and the Osram D.E.2 H.F., and D.E.5 B., in two and six-volt varieties respectively. Cosmor, 1 H.F. two-volt valve; the H.F. valves in the Mullard P.M. series at various voltages; the 21, 41, and 61 of the new S.T. valves, and the S.P. 18 blue spot of Cosmos. I have also tested the Electron, Ediswan and Burndept valves of suitable types, so that you have a very wide range of choice with assurance of satisfaction. It is even possible to use the old-fashioned bright emitters and general-purpose valves, but if you want to get the best from the set see that the first socket has a valve recommended by the makers for H.F. magnification.

If there is anything you do not like in this issue of "Popular Wireless" please write and tell us about it.

**FROM DAVENTRY TO
PITTSBURG, PA.**
(Continued from page 1040.)

the tuning condenser, and too large a coil will give you a floppy reaction and "backlash." Be careful, too, that you have your reaction coil the right way round, or you may not obtain oscillation with coil.

For the Daventry range you will probably find a 75 in the aerial socket and a 250 in the grid tuning socket will suit, together with a No. 150 in the reaction socket. For the K D K A wave-length of 63 metres you will find a small *a* in the aerial circuit and *a/2* in the grid and another *a/2* in the reaction socket will suit. These are the Gambrell coils, and they cost 4s. 10d. each, so that the total cost of the coils for K D K A is about 14s. 6d. Of the Igranic short-wave coils you will require two of the nine-turns pattern for grid and reaction sockets, while for the aerial socket an ordinary No. 25 can be used.

The Igranic short-wave coils of the nine-turns variety cost 2s. 9d. each. The Burndept coils can also be used, of which you will require two No. 15 and one No. 25. The No. 15 cost 5s. each, and the 25 4s. 3d., so that you will see there is a choice of several makes.

Tuning Notes.

The operation of the receiver will be found extremely simple on all wave-lengths from Radio-Paris down to well below K D K A, and the complete freedom from hand-capacity effects on these short waves can only be appreciated by those who have handled some short-wave receivers which suffer from the defect mentioned. The method of tuning on all wave-lengths is extremely simple, and consists first of all

of this form of reaction that one can tune over a number of degrees on the condenser scale without touching the reaction control, and this enables close searching to be done when necessary.

On the short-wave adjustment for K D K A this station will be found on the Gambrell *a/2* coil at about 25 to 30° on the tuning dial, while with other makes of coils the tuning position will naturally differ slightly. You will generally find that K D K A becomes clearly audible soon after half-past eleven at night, and is generally heard at its best from that time onwards.

Finally, do not abuse the reaction control. It is quite practical to pick up K D K A on this set without making the receiver oscillate at all, simply by searching over the lower readings on the condenser with the reaction condenser a little way below oscillation-point. You can soon find where this point is during the hours when K D K A is not working.

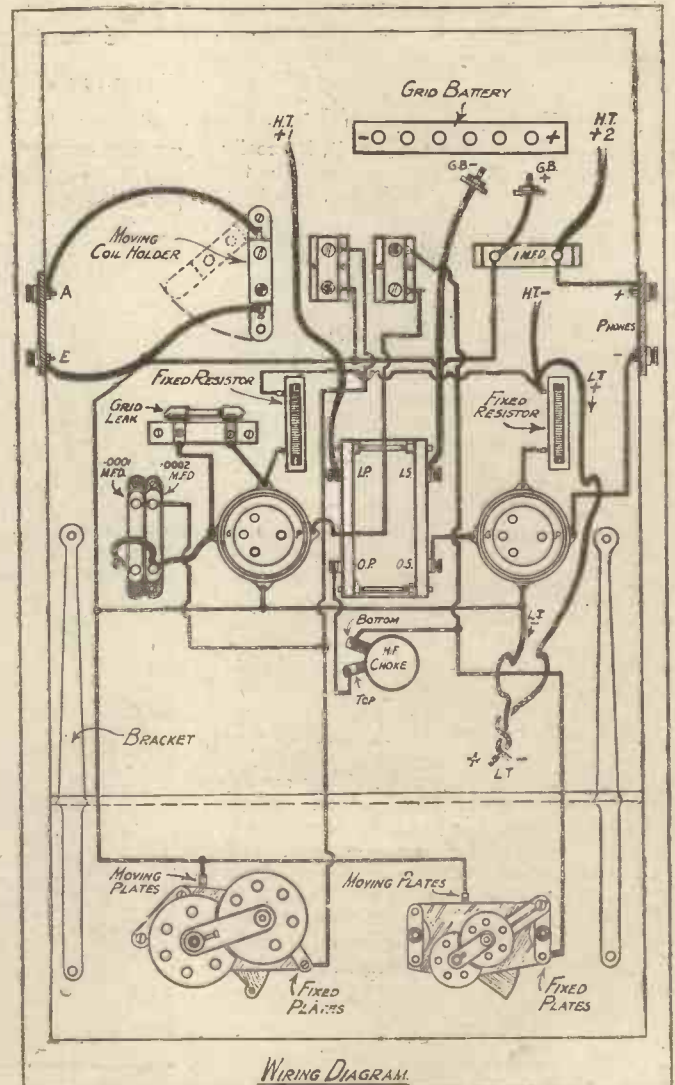

THAT OSCILLATION TROUBLE.

Remember others are listening besides you this Christmas, so watch that new set, and keep the ether as clear as possible.

By "ARIEL."

TO hoot, whistle, groan, shriek, moan, or yell in your neighbour's inoffensive ears—is this the way to spend Christmas?

To sit comfortably at home, with a fire and the 'phones, and to spoil other people's programmes—is that the Christmas spirit?

To twiddle a knob, that tickles a coil, that tunes a set, that tantalises the tympanic membrane of people many miles away—that's not the way to have a happy holiday, is it? For Christmas-tide is the home-festival. And not only should you be at home, but your wireless set should stay at home also.

Too Much on the Plate.

If you are lucky enough to have a brand-new wireless set this Christmas, and you haven't much idea yet of how to handle it, remember that we all share the programmes on the ether. And with all the good intentions in the world it is possible for an innocent listener with a valve set to push his way into other people's programmes, and to gargle, and splutter, and caterwaul for miles! For a valve set closely resembles a Christmas dinner, and it must not be tackled too eagerly. You must set about it knowingly and methodically, if you wish to get the most out of it.

When you come to think of it, it's really very simple, and very much like the Christmas dinner. The L.T. battery, lighting the filament, is like the oven. Get her the right temperature—hot, but not too hot—and all will be well. But turn her up too high, and you'll overdo things, burn something or other very likely, and spoil the flavour of the whole entertainment.

The H.T. battery, the one with all the spots on, is like the Christmas pudding. You've simply got to have it, of course, but you've also got to be just a little careful as to how much you can take. Though you can "plug in" more than once, it is possible to have too much on the first and second plates, so this is where moderation pays.

How to Handle Reaction.

The aerial lead is like the cook—if it is not in place the whole affair will be completely spoilt. Also, it should be clean, bright, and all that kind of thing, and must be kept as free from interference as possible, or results simply will not bear thinking about.

Then there are the coils. They are like your guests, aren't they? Must be of the same type, more or less, and they must be in the right relation to one another. It is important to keep them at the right distance apart, too, or they may start interacting unfavourably upon one another. That is, unless they are "coupled," in which case they will like to be placed fairly close together.

Variable condensers resemble the guests' appetites. They go by degrees. You will notice, too, that they vary from maximum to zero, as the plates pass up and down.

But most important of all is this reaction business—that is, the way you handle or control the whole affair. The wise man does not attempt the impossible. Trying to get loud-speaker strength from an earphone set is just like asking a guest with a weak and squeaky voice to fill the room with melody. He does his best, poor chap, but he should never have tried. You boosted him up too far, and everyone listening has to suffer for it!

"MODERN WIRELESS"

January Issue on Sale

NEXT WEEK

The "Bull Dog" Four
The "European" Five
The "Tranode" Two

and

The Beginner's Crystal Set

Four Fine Sets for Constructors.

The filament-control should be kept as low as is consistent with good results. The H.T. plug should be placed in the best position in the battery—not necessarily right at the maximum—and then left alone. The reaction coil itself should be far enough away from the aerial coil to prevent accidental oscillation.

Then you can sit back and enjoy the ether entertainment, with clear programmes and a clear conscience. And you and your neighbours will all, I hope, have a very Happy Radio Christmas.

THE TRAGEDY OF AN OSCILLATOR.

- | | |
|---|---|
| I.
MOMMA'S PET.
2-VALVE SET.
XMAS PRESENT.
VERY PLEASANT. | VI.
PET INDOORS
ONE DARK NIGHT.
UP GOES BRICK,
OUT OF SIGHT. |
| II.
EVERY NIGHT
VALVES ALIGHT.
HERE WE GO
2 L.O. | VII.
TERRIFIC BANG!
AERIAL WENT!
"PET" RUNS OUT.
ACCIDENT! |
| III.
PET TUNES IN.
FEARFUL DIN.
NEIGHBOURS
SWEAR.
TEAR THEIR HAIR. | VIII.
WHEN BRICK FELL,
UNDERNEATH
WAS MOMMA'S PET!
(SEND A WREATH). |
| IV.
FINALLY,
DESPERATION,
NEIGHBOURS HAVE
CONSULTATION. | IX.
MOMMA SHED
BITTER TEAR—
NEIGHBOURS SAID
"ETHER CLEAR!" |
| V.
THEY DECIDE,
IN THEIR IRE,
THROW UP WEIGHT.
BUST HIS WIRE! | MORAL.—The in-
judicious use of re-
action is the cause of
much unnecessary
bother! |



Dave Burnaby, in a Co-optimistic frame of mind, enjoying the London programmes.



WINTER AERIAL TIPS

By PERCY W. HARRIS, M.I.R.E.
(Editor of the "Wireless Constructor.")

THIS is the time of the year when many wireless aerials, erected light-heartedly during the summer months, are beginning to show signs of weakness, and, indeed, a complete collapse of the outdoor structure may follow after a heavy fall of snow.

One of the most frequent causes of breakage is overstrain of the wire, as the result of the shrinkage of rope halyards due to the wet—particularly with tall masts requiring long halyards shrinkage may be very considerable, and if the aerial is hauled tight when the rope is dry, tremendous strain is imposed on the wire, mast, and guys as soon as the rope gets wet. Frequently the aerial wire is stronger than the supporting ropes, and with the breakage of one guy, due to the strain, the whole structure collapses.

Wire Halyards.

The use of wire halyards to obviate this shrinkage trouble has been frequently recommended, but my own experience of them leads me to think that the disadvantages may outweigh the advantages. I woke the other morning to find my own aerial laying on the grass, and immediately suspected the breakage of the wire itself, but examination showed that the aerial wire was in perfect condition, and that the fall had been caused by the breakage of a galvanised wire halyard which had corroded right through to its hemp core.

My own mast carries four halyards, three to a pulley at the top of the mast and a fourth to a pulley half-way up, so that a low aerial can be hauled into position for experimental work whenever desired. Of the three long halyards one is a rope, and the other two galvanised wire specially sold for the purpose. The rope was found to be in excellent condition, but both the wire halyards were thoroughly bad, indeed, their condition was so rotten that I wondered that they had stood the strain for so long.

To overcome the shrinkage difficulty the counterweight can be used as described in one of my previous articles in POPULAR WIRELESS. Another alternative is to use the pair of insulators separated by a spring, sold by one of the firms advertising in these pages.

Self-Adjusting Aerial.

The spring can then take up the strain of the shrinking rope without overstraining the wire or the mast. Such a scheme, however, is not recommended for twin wire aerials when spreaders are used, since the

weight of such an aerial will normally stretch the spring quite enough if the aerial is pulled tight enough to have a good appearance.

For general receiving work I now advocate the single wire, as it seems to possess certain electrical advantages. Quite apart from the simplicity of the single-wire aerial and its comparatively light weight are many other points in its favour.

If during snowy weather your signals certainly "go off," look at your lead-in, as damage to an aerial system often occurs at this point. Many lead-in insulators project quite appreciably from a window or a wall, and in this position catch the full force of any snow or ice which happens to slide off the roof over the guttering. Dry snow will not be found to greatly reduce the strength of signals, for it is a fairly efficient insulator, but melting snow may give leakage trouble.

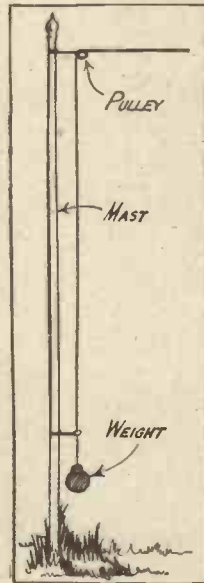

This arrangement will relieve the strain due to high winds.

Snow.

The chief trouble likely to be experienced with snow is the weight, particularly on twin or multi-wire aerials with fairly large spreaders.

The spreaders and insulators may accumulate a very considerable weight of snow, and, indeed, so may the aerial wire itself. A large land station such as Carnarvon, where enormous aerials are used—the weight of the snow on the aerial itself is a matter of considerable importance—may cause the whole aerial system to collapse. Most of these high-power stations now have a scheme by which a strong electric current from a generating machine can be passed through the aerial so as to warm it up.

The heat so generated in the wire melts the snow and ice and frees the aerial from its burden, but the method is not one which can be recommended to, or is likely to recommend itself to, the average member of the listening public.

When much experimental work is being performed with indoor aerials, obtain a reel of two or three hundred feet of single rubber-covered flexible wire through your local electricians. Such wire is very flexible

and yet well insulated can be run round a loft and threaded through holes in the woodwork without the need of special insulation.

Although I have seen a number of devices sold for the purpose of holding an indoor aerial wire well away from the walls I have not found any deleterious effects produced by running the insulated wire along the picture moulding, where it may be completely concealed. This applies to the ordinary broadcast wave-lengths, but, of course, on very short waves, such as the 6.3 metre transmission from KDKA (Pittsburg, Pennsylvania), much greater care must be taken.

Indoor Aerials.

Usually the most effective indoor aerial is that erected as high as possible above the instrument. Usually it is possible to take an unobtrusive lead from the room in which the instruments are used, up the staircase and into the loft.

Inside the loft, about 50 feet of this wire can be laid along the rafters, forming a circle or square, or, if greater height is obtainable thereby, it can be suspended from hooks screwed into the highest rafters that can be reached.

About forty or fifty feet of wire forming such a flat top often effects considerable improvement in signals, and indeed, I have known cases where an indoor aerial erected in this fashion has given better results than those yielded by a single wire taken to a twenty- or thirty-foot pole at the bottom of the garden.

In any case, even where a good outdoor aerial is available, the erection of an indoor aerial of this kind forms a very useful alternative. Indeed, the selectivity is usually higher on the indoor aerial, although the signal strength is generally reduced.

In cases where there is ample signal strength available, this additional selectivity may often prove very useful, while the availability of this aerial in emergencies is one of its good points.

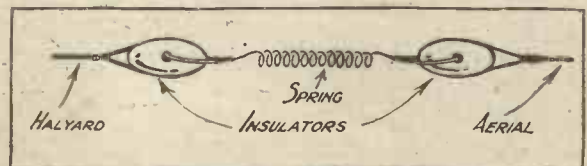

Another useful "anti-strain" idea.

It is often possible to work two sets on different wave-lengths (one on the outdoor and the other on the indoor aerial) without interference, although the wave-lengths must not be too close to one another. There is no reason, however, why Daventry should not be tuned in on one aerial and the local station on the other, so that the members of the family who desire to listen when you are doing your experimental work may not be deprived of that pleasure.



GEE BOYS
I'VE GOT THE
HICKADOOOLA
-- BLUES.

"ONE MAN'S MEAT"



THE HICK
A-DOOLA
OOLA-OOLA
BLU-OOS!

- IS ANOTHER MAN'S POISON! "

TEN SHAW

BROADCASTS BY 'TONE' & 'POWER'
The 'Boon' Companions of Osram Valves



'TONE' & 'POWER'
in the Family Circle

Father brought TONE and POWER home with him the other evening.

The kiddies simply loved POWER, they'd never heard jazz music so loudly. So did Brother Bert. He revelled in the range of distant stations. Mother and Father, in their more sedate way, appreciated TONE'S influence in the delicate musical phrases of the Symphony and the richness of the bass tones.

It will be a long time before our genial friends leave that family circle. They're indispensable to the evening's enjoyment every night. Bring POWER and TONE into your home by buying—

**Osram
Valves**

for **TONE & POWER**

The G. & C. - your guarantee



**BRITISH
MADE**

—
For
2-v., 4-v. & 6-v.
Accumulators
and Dry Cells

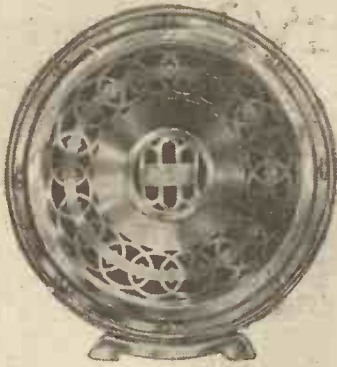

'Emas, 1926

The Makers of England's first Wireless Loud Speaker take this opportunity of extending to all Brown users (and users-to-be) the very best of wishes for a Christmas brightened by the purest music of the ether.

S. G. BROWN, LTD., Western Ave., N. Acton, W.3.

Retail Showrooms: 19, Mortimer Street, W.1.; 15, Moorfields, Liverpool; 67, High Street, Southampton. Wholesale Depots: 2, Landsdown Place West, Bath; 120, Wellington St., Glasgow; 5-7, Godwin Street, Bradford; Cross House, Westgate Road, Newcastle; Howard S. Cooke & Co., 59, Caroline Street, Birmingham; Robert Garmany, Union Chambers, 1, Union Street, N. Ireland.

Brown

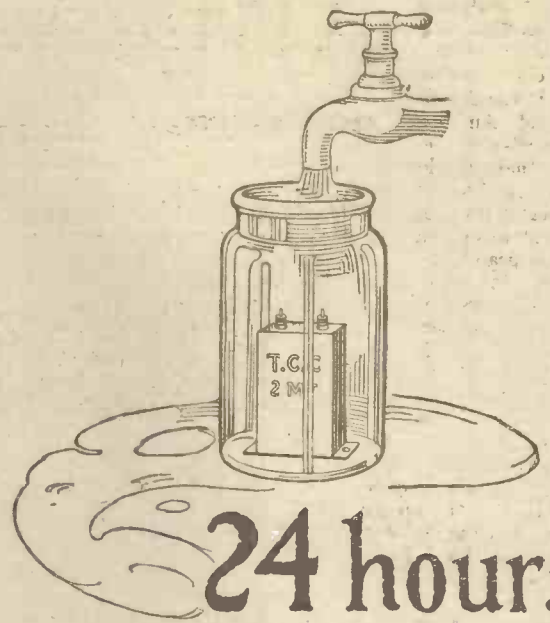
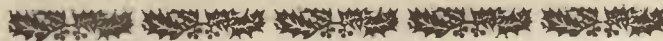

24 hours of this cannot harm the T.C.C.'s insulation

THAT'S some test, isn't it? Think of it. A whole day and night totally submerged in water! Even after this stringent experiment the insulation of the T.C.C. Mansbridge Condenser is unharmed. Thus, once more, our claim for 'metal for perfect insulation' is vindicated.

The metal case of the T.C.C. Mansbridge is impervious, not only to these conditions, but to every climatic change. Nothing can penetrate it; for insulation it is supreme. This is but one reason why you should choose T.C.C. There are others, numerous and convincing. The twenty years experience which is behind every T.C.C. is another. An experience which makes it possible to produce a Condenser which is guaranteed up to the hilt. To be dead accurate in its capacity. To be leak-proof. To be breakdown proof. In short, to be utterly reliable.

When you build your next Set, make sure that, at any rate, your Condensers are beyond fault. Even though they cost a little more, see that they have the letters 'T.C.C.' stamped on the side of their green metal cases. It may mean just the difference between success and failure. T.C.C. Mansbridge Condensers come in capacities from .009 to 2 mfd., priced 2/- to 4/8. From all Dealers.



T.C.C. Condensers

Adv. Telegraph Condenser Co., Ltd., Wales-Farm Rd., N. Acton, W.3.

SOME little time ago POPULAR WIRELESS announced a prize contest in collaboration with "Radio Broadcast" of America for a short-wave receiver that would not radiate. Despite the short period of time that was given for European contestants to enter their receivers, it was hoped that perhaps a British circuit would carry off the prize. Unfortunately, however, this was not the case.

Occasioned by many adverse factors, damage in transit being not the least of these, the decision of the judges was considerably delayed. Of the many receivers submitted, fifteen were chosen for consideration, and these were put to the first test (that of proving whether or not they radiated so as to cause interference). This test being the most important of all which had to be undergone, its procedure will here be outlined:

Located some 400 yards from the

A Prize Winning Short Wave Receiver



Details of the most successful short-wave set submitted in a recent American contest.
By L. W. CORBETT.
(Our New York Correspondent).

One at least was considerably better than the Reinartz, yet there is no gainsaying the

The two inductance arms of the Bridge are represented in Fig. 1 by the coil L2, centre tapped. C3 in Fig. 2 is shown also as C3 in the receiver diagram, this condenser being a small balancing one which must be made equal to C4. C4 is represented in the receiver by the grid-to-filament capacity of the detector valve plus various other capacities due to the placing of the wiring, etc. The

object in this receiver is to exactly balance the Bridge circuit, and thereby effectually prevent radiation from the antenna circuit.

When an incoming signal voltage is applied across points A and B in Fig. 2, there is, so our knowledge of the Wheatstone Bridge principle tells us, zero potential across points E and D. If our valve grid and filament legs were connected across these points, no signals would be heard in the 'phones. However, the grid and filament leads go to points E and B, so there will be a voltage across the valve.

Constructional Details.

The voltage caused by the incoming signal voltage drop across L3 is divided at A and B, half of it being lost through C3 and that half of L2 designated as A-D. This is of no importance, though, for it may easily be compensated. The fixed reaction coil, L1, is placed at the centre of L2, so that equal voltages are induced across both halves of L2. If care is taken in doing this, and in getting the tap on L2 exactly in the centre, it will minimise the handling of C3 when tuning.

This condenser just mentioned, the balancing condenser, has a capacity of 0.00003 mfd. maximum, and a low minimum value. The other condensers, C1 and C2 respectively, have maximum capacities of 0.0002 mfd. and 0.00015 mfd. C1, of course, controls regeneration. The grid condenser (fixed) should be of approximately 0.0001 mfd., while the leak should preferably be of the variable type.

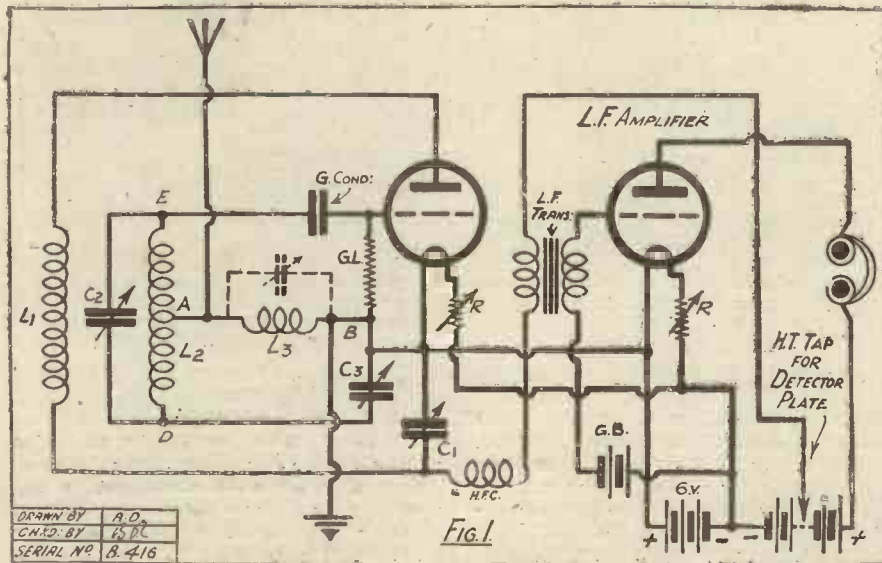

FIG. 1

DRAWN BY A.O.
 CHD. BY B.L.
 SERIAL NO. B. 416

laboratory and editorial offices of "Radio Broadcast," in Garden City, N.Y., is the transmitting station, 2 G Y, of that American magazine. By keying the plate circuit of a standard Reinartz receiver at 2 G Y, it was found possible to transmit quite intelligible signals to the laboratory 400 yards away, and, when a microphone was placed in the earth lead of the Reinartz, it was even possible to transmit speech to the laboratory. The contest receivers were put through a similar test. Those which radiated as badly were at once eliminated:

The Final Choice.

Of the fifteen receivers which were held for consideration, it soon became apparent that not one of them met the requirement relative to being non-radiating. Each one of them transmitted signals when tested in the same manner as the Reinartz. Some were better than the Reinartz, some worse.

fact that it did radiate more than was desirable.

As this receiver was better than the others, considerably so in fact, the judges decided to award it a consolation prize, despite the clause in the contest which made it clear that the set must positively not radiate to be considered. It was the design of an amateur hailing from Berkeley, California, who operates amateur station 6 A J F, and he was given a cheque for \$100 by the judges.

The circuit of this receiver is given in Fig. 1, reference to which will show that there is nothing startlingly new about it. In Fig. 2 is given a diagram of the Wheatstone Bridge, which principle is incorporated in the receiver described. Cross reference between the two diagrams, Fig. 1 and Fig. 2, will show how the Bridge principle is employed in the receiver. L3 in each diagram may be clearly discerned.

(Continued on next page).

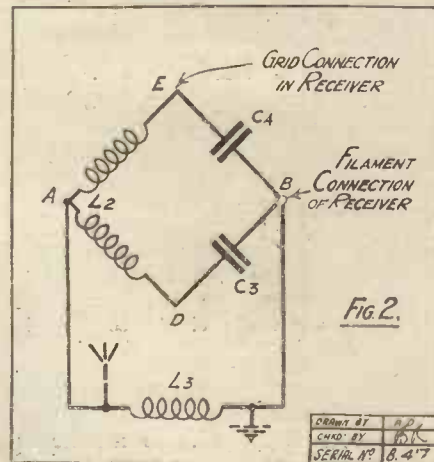

FIG. 2.

DRAWN BY A.O.
 CHD. BY B.L.
 SERIAL NO. B. 417

RECEPTION ON THE HIGH FREQUENCIES.

A few of the points that make for the successful operation of short-wave sets.

By "LAMBDA."

IT is difficult to discuss the operation of a short-wave set without touching to some extent on its design, for this is inextricably connected with the handling of the set, and neither can be treated properly without some reference to the other.

For example, it would be useless to try and describe the methods of tuning and reaction control from an operating point of view without taking into consideration the design of the set, type of reaction employed, and other little points which have a direct bearing upon the operation of the receiver.

Whatever circuit is employed—and there are a great many available—for the construction of the set, two main features must be borne in mind before the construction is commenced. The tuning controls must be of the vernier type, and reaction must be smooth and easily handled.

Vernier Control Essential.

In the first place, slow-motion condensers are a *sine qua non* and should preferably be of the straightline-frequency type, having a low gearing and definite connections to the moving plates. Rubbing contacts must be avoided like the plague and the motion of the condenser must be smooth and yet positive in action. Backlash or stickiness will spell failure when the set is being used to tune in distant signals, especially if the transmission it is hoped to receive is telephony.

The same remarks apply to the reaction control, for it is assumed that some form of Hartley or Reinartz reaction is employed—the older method of varying the coupling being quite inadequate for the higher frequencies. The reaction coil can be variably coupled, but the actual control should be carried out by means of a slow motion, variable condenser.

Another point that should be borne in mind is the possibility of capacity effects caused by the hand of the operator. If these are present the constructor should carefully

look over the set and make sure that his grid leads are not any longer than is absolutely necessary, and that his grid coil is not near the panel. Again, he should employ variable condensers having their moving plates taken to the frames, and these vanes should be connected to points at filament potential where possible. In the case of the grid coil the fixed vanes will go to the grid end and the moving to L.T., and possibly to earth.

The same holds good in the case of the reaction condenser, for in modern short-wave receiver design it is usually found that the reaction condenser has one connection to filament or a point at earth potential, as in the case of the popular Schnell circuit, and



Examining some of the short-wave receivers submitted in a recent competition held in North London.

in this case also the moving vanes must go to the earthed point. If this is impossible, the condensers will have to be screened and the screen earthed, or extension handles fixed on the dials. This latter, however, is an extremely clumsy method of avoiding hand capacity, or rather getting over its effect, and it is much better to alter the layout and design of the set if such effects are prominent. On a good short-wave set hand capacity should be nil, at least down to

20 metres or so, and its presence is a sign of inefficiency and will always be a source of trouble and annoyance.

The actual operation of a well-designed short-wave set is easy provided it is remembered that very high frequencies are being dealt with, and that the tuning must be systematically carried out, and the dials turned very slowly. In most sets the reaction coil should be set, and re-set every now and then as tuning goes on, as far away as possible, so that oscillation commences with the reaction condenser at about 120°. This usually results in far greater signal strength and easier reaction control.

A Common Fault.

The aerial coil—often aperiodic—should be loosely coupled to the secondary, and this latter should be as large as possible consistent with the frequency required. Thus the writer, on his own three-valve Schnell, uses a 9-turn secondary coil for 30 metres with an aerial coil of 4 turns and a reaction of 5. 2 X A F, the Schenectady station, comes in at 20° on the S.L.F. condenser, which has a maximum capacity of .00025 mfd., and the reaction con-

denser of similar capacity being set at 140° or thereabouts. The coupling between the aerial coil and the secondary is, as a rule, about 1½ in. for best results.

If the set howls just on the oscillation point a change of grid leak value, a series condenser in the aerial circuit, and a leak across the secondary of the L.F. transformer (if one is used) should be tried. This latter leak often cures the trouble if a leak of about .5 megohm is employed.

A PRIZE WINNING SHORT-WAVE RECEIVER.

(Continued from previous page.)

We shall now consider the winding of the necessary coils. We will take L3 first. This coil, when the set has been completed, should preferably be mounted on a separate stand about a foot or so away from the rest of the tuner, for best results. Across it is shown a dotted condenser which is employed for tuning the aerial circuit so that it will be practically in resonance to the incoming signal. Once determined, the setting of this condenser need not be changed. The size of L3 depends upon the size of aerial employed, the number of turns varying between 5 and 30 or so. The

number will not be critical. Its diameter should be about three inches, and it should be wound in low-loss fashion.

L2 is our next consideration. This coil (there are several, for the different ranges to be covered) is the centre-tapped one. That it should be of the low-loss type is important, as likewise that the centre tap is exactly in the centre. No. 16 D.C.C. was used for the smaller L2 coils, while No. 18 gauge is preferable for the larger ones. A 3-inch cardboard tube was used for the process, four narrow celluloid strips being tied lengthwise to the former before the winding is commenced.

The Reaction Coils.

Having wound on the requisite number of turns, the string which should be wound on at the same time as the wire to obtain spacing, is removed, and the coil should be

given a coat of acetone. This will cause the turns to adhere to the celluloid strips, and, when dry, the completed coil may be removed from the cardboard form.

The reaction coils are wound on 2-inch forms and therefore are small enough in diameter to be fastened within the coils L2 with thread. It is desirable to place these reaction coils as nearly concentrically with the L2 coils as is possible.

The choke coil in the primary lead of the L.F. transformer consists of 500 turns of 30 silk covered wire on a ¾-inch form.

Tuning Coil L2. No. of turns.	Reaction Coil L. No. of turns.	Wave-length Range, Meters:
4	5	17-30 (approx.)
8	7	29-55
13	9	41-92
24	11	75-130
43	13	80-170 (approx.)

The "Whippet"



THIS one-valve set embodies a recent Filadyne circuit and is particularly suitable for DX work. In the case of the local station it is possible to operate a medium-sized loud speaker under good conditions, although it is on distant stations that its sensitivity is more greatly in evidence. Although its panel looks somewhat crowded it is not a difficult set to control, for the majority of its adjustments are of a secondary nature, and are by way of being more refinements than absolute necessities.

Notwithstanding its high order of sensitivity the "Whippet" is by no means an unstable receiver; on the contrary, it is remarkably stable and does not evince

The Set Designed and Constructed by the "P.W." Experimental Staff.

A one-valver, incorporating a recent development of the Filadyne principle, which is particularly suitable for DX work. The receiver is exceedingly sensitive, and will, in cases, operate a loud speaker from the local station with surprising volume and clarity.

It is not a difficult set to build, and the circuit is not so critical that slight deviations from our specifications will cause failure or even losses in efficiency.

The Circuit Described.

The circuit has been described in previous articles, but a few further words concerning it may prove of interest. It employs the filament input system, of course, and the received signals are not taken to the grid of the valve, but are fed on to the filament in order to control the electron stream at its source. The grid is made highly positive in order to reduce the space charge, while the anode is used merely as a completing element in the input circuit.

An input bias system is introduced, and by means of a potentiometer the filament can be given just the correct negative potential to ensure

that the valve is operating at its most sensitive point. Reaction can be controlled by the potentiometer, and a very "vernier" control this is,

although with equally good results this biasing adjustment can be left "set" and the receiver handled only by its other adjustments.

LIST OF COMPONENTS.

1 Red Triangle panel, 13 in. x 6 1/2 in. x 1/4 in. (Peto-Scott), with cabinet and baseboard ..	1 6 0
1 Ormond .0005 geared variable condenser ..	15 0
1 Lotus two-way coil holder ..	7 0
1 Lissen H.F. choke ..	10 0
1 Cosmos H.F. choke ..	6 6
1 Lotus valve holder ..	2 6
1 Precision rheostat ..	3 0
1 Precision potentiometer ..	3 9
1 lb. 22 gauge D.C.C. wire ..	3 3
1 Watmel fixed condenser .002 ..	2 0
1 Watmel fixed condenser .0003 ..	2 0
1 Terminal strip, 8 in. x 2 in. complete ..	3 4
Wire screw, transfers, etc. ..	2 0

Once working satisfactorily the "Whippet" is as "graceful" in operation as a high-class racing motor-car, and is just as docile and just as full of potential energy. The filament control is not at all critical, and reaction is NOT controlled by this component. Constructors will discover that the "Whippet" has all the graces of an

(Continued on next page.)

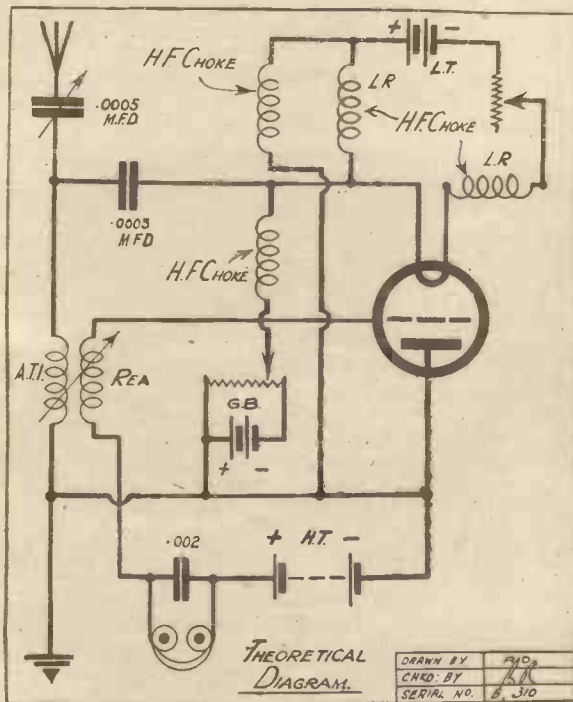

undue capacity and other such effects. On an average outdoor aerial and with fairly good local conditions the "Whippet" is capable of bringing in a surprising number of stations.

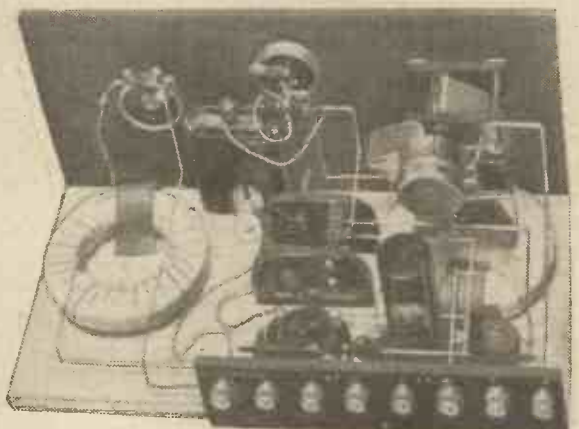

The components being carefully arranged compactness is achieved without undue "crowding."

THE "WHIPPET"

(Continued from previous page.)

ordinary straight one-valver and none of the vices of the super-criticaldyne, and is yet as sensitive a one-valver as they have ever known.

An Important Point.

It is very well worth while using good components in a set of this sort, for it is a receiver that, in our opinion, will satisfy the most ardent DX "lean" for a considerable time.

Anyway, none of the makes of components in our list of parts is a very expensive item, and although others can be used they are almost sure to be more expensive if they are as good or better. For instance, the Ormond variable is an excellent job and, at its price, as good value for money as it is possible to obtain. The Lotus two-way coil holder will be well known to "P.W." readers for its excellence of design, and the Precision rheostat and potentiometer are inexpensive, smooth-working little articles.



The panel lay-out is symmetrical and the controls are quite accessible.

Actually, of course, none of the parts is so critically inclined that a substitute cannot be used. This point is important, as it indicates that readers can use existing components and need not purchase a "this-or-that" or "his-or-their" make if another make of "this-or-that" is available.

But it should be noted that there is not overmuch room behind the panel of this little set, and if substitute parts are used care should be taken that undue overcrowding is not caused by the introduction of them. This applies especially to the H.F. chokes.

Before we proceed any further it may be as well if we point out there is only one valve which will work properly in this receiver, and that is the D.E.R. Either an Osram D.E.R. or a Marconi D.E.R. can be used, but they are not expensive valves and cost only 14s., the standard price for ordinary dull emitters.

Mounting the Components.

Having collected all the required components and parts together a commencement can be made on the actual construction of the set. First of all, the panel must be drilled, and this is a simple enough task, as everything is "one-hole mounting." Care must be taken that the hole for the coil holder handle is carefully centred, as otherwise it will require to be enlarged to enable the shaft to rotate easily, and this would look unsightly.

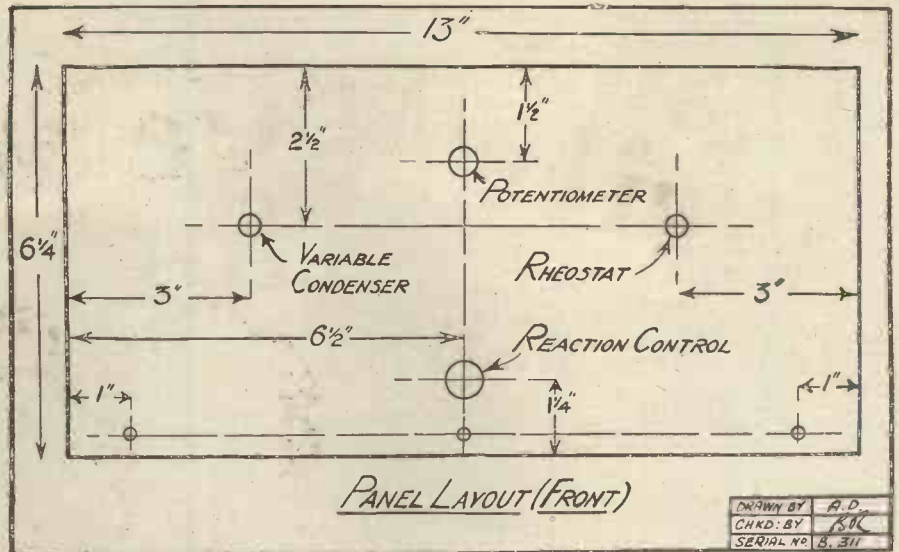

Having drilled the panel it can be screwed to the baseboard, but the components should not be mounted at this stage. Before proceeding with this work the terminal strip must be fixed. The terminal strip, measuring 8 in. x 2 in., holds eight terminals. It can be purchased complete and engraved from Messrs. Peto-Scott, or alternatively it is quite a simple matter to prepare one from $\frac{1}{4}$ in. or $\frac{3}{16}$ in. ebonite. A hole must be cut in the back of the cabinet to take this strip neatly in order to allow access to the terminals.

Now a start can be made in the task of mounting the various components. First of all, the coil holder. This requires to be placed carefully so that its handle lies at right angles with the baseboard, passes through the hole in the panel with just sufficient clearance to permit smooth operation, and projects just

far enough to take the ebonite knob. This position should be maintained, and the component securely screwed down.

Then the filament rheostat, potentiometer and variable condenser can be screwed on and, following this, the remainder of the components can be mounted.

Regarding the Wiring.

Now it will probably be noticed that in none of the photographs can the Cosmos H.F. choke be seen. As a matter of fact, it is tucked away behind the terminal strip just below the L.T. plus and earth terminals. The thick, bare wires at the ends of the choke were straightened out and soldered, one to the filament battery terminal and one to the earth terminal. The little H.F. component rests very snugly in that position.

One filament choke is held down by a strip of fibre screwed to the baseboard directly beneath the variable condenser, the other is similarly fixed down at the other end of the baseboard. The 'phone condenser is held by its own leads of thick

(Continued on page 1055.)

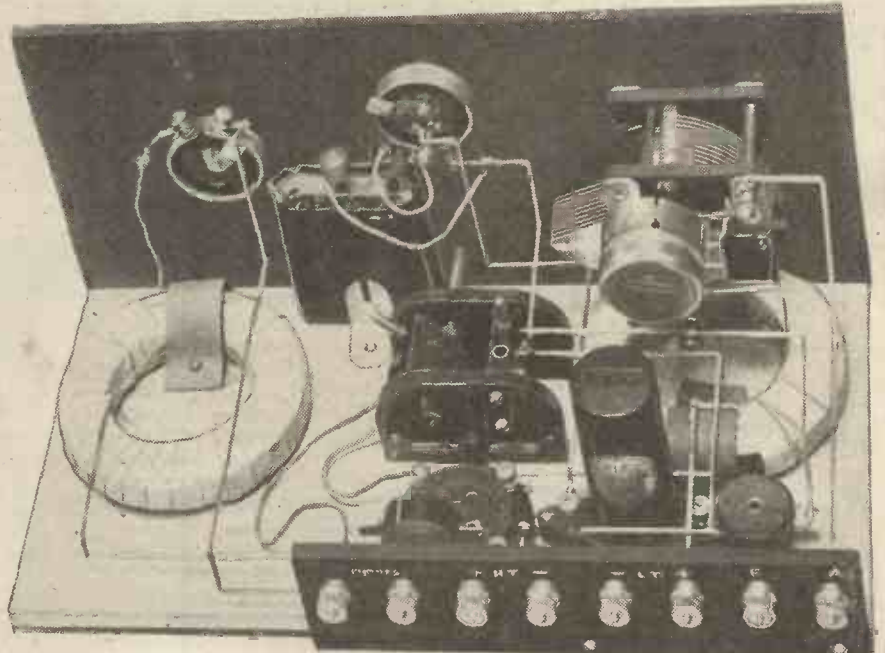

The only component that cannot be seen in this photograph is the Cosmos H.F. choke, which is tucked away behind the terminal strip.

Write Five words for £105

Nothing to buy — no entrance fee—no annoying rules. Just write a phrase of five words about EDISWAN Valves and comply with conditions given on the right.

ALL YOU HAVE TO DO.

Read the simple conditions. Fill in *Entry Form. Write on a sheet of paper the names and addresses of five friends who own wireless sets. Write a simple phrase of five words, which expresses the superiority of EDISWAN Valves. Your wireless dealer will tell you all about them and give you literature. Pin together the slogan, entry form, and list of five names; seal the envelope. Use 1½d. postage stamp. Post to Ediswan.



R.C. THREESOME.
If you have already received the R.C. Threesome Instruction Book strike out the "Threesome" paragraph in the Entry Form.

- First prize . . . £105
- Second prize . . . £55
- Third prize . . . £25
- Fourth prize . . . £15
- Fifth prize . . . £10
- Fifty prizes of . . . £5
- Fifty R.C. Threesome Receiving Sets with royalties paid.

RULES & CONDITIONS.

- 1.—Prizes will be awarded, in order of merit, for what in the opinion of the Judging Committee are the best slogans received.
- 2.—In order to qualify, the competitor must complete the accompanying Entry Form, and send with it the names and addresses of five wireless users.
- 3.—The Judging Committee's decision on any matter arising in connection with this competition must be accepted as final and legally binding in all respects, and acceptance of this rule is an express condition of entry.
- 4.—Proof of posting will not be accepted as proof of delivery.
- 5.—No correspondence can be entered into with regard to this competition.
- 6.—Employees of The Edison Swan Electric Co., Ltd., are not eligible to compete.
- 7.—All entries must bear a post-mark not later than Monday, January 10th, 1927.
- 8.—Results will be published in the "DAILY MAIL" on Monday, 31st January, 1927.

FILL IN ENTRY FORM — TEAR OUT and ENTER THIS SIMPLE COMPETITION TO-DAY!

EDISWAN

***ENTRY FORM.**

P.W. 25-12-1926.

To the EDISON SWAN ELECTRIC CO., LTD.
(Publicity), 123/5, Queen Victoria Street, E.C.4.

Name _____

I agree to enter this Competition in accordance with the conditions announced in this advertisement.

Address _____

Please send copy of R. C. Threesome Instruction Book and Blue-print.

Immediate supplies of **LEWCOS** Screened Coils now obtainable



The unprecedented demand for Lewcos Screened Coils caused delay at first. Production has now been greatly increased; and your Wireless dealer can supply Lewcos Screened Coils from stock, or can obtain them for you immediately.

Ref. No.	Description.	Wave-lengths in metres.			Price each.
		Tuned with Con. denser.			
		0	.00025 mfd.	.0005 mfd.	
SPA 5	SPLIT PRIMARY AERIAL COIL	220	400	550	6/-
SPA 8		350	600	800	6/-
SPA 20		800	1400	2000	6/-
SPT 5	SPLIT PRIMARY H.F. TRANSFORMER	220	400	550	10/-
SPT 8		350	600	800	10/-
SPT 20		800	1400	2000	10/-
SST 5	SPLIT SECONDARY H.F. TRANSFORMER	220	400	550	10/-
SST 20		800	1400	2000	14/-
RT 5	SPLIT SECONDARY REINARTZ COIL	220	400	550	10/-
RT 20		800	1400	2000	14/-
SCB	SCREEN COMPLETE WITH 6-PIN BASE				15/-

THE
LONDON ELECTRIC WIRE COMPANY & SMITHS, LTD.
Playhouse Yard, Golden Lane, London, E.C.1.

JACKS 4-POINT Hole Fixing 1/9	S.L.F. CONDENSER With 4-in. dial. .0003 .. 7/- .0005 .. 7/3	RELIABILITY CONDENSERS Transbridge A. 10g. Type. 2. 1/6 mfts., 2/6 3. 1/9 2 mfts., 3/6	WIRELESS CABINETS For Panels 7 in. high Width 5in. Hinged Lid Oak 12 in. 17/- 14 in. 17/6 18 in. 18/6 Mahogany 1/- extra.	DEWAR SWITCH 12-Contact 2/6
---	---	---	---	--

READ THIS LIST AND SAVE MONEY ON COMPONENTS

BATTERIES—Reliability, 90 v., 11/-; 60 v., 7/6; 36 v., 4/6; 15 v., 1/0; Ever Ready, Siemens, Hellesen, 100 v., 21/-; 60 v., 12/6; 36 v., 7/6; Flashlight Battery Cases for 14 Batts. 3/6; 4 v. Batts., 4d.; 60 v. Unequalled, 6/6; Wan. Plugs, 14d.; Clix Type, 2d.

ACCUMULATORS—Exide, D.T.G., 4/6; D.F.G., 8/6; W.J., 20 v. H.T. type, 15/-; Oldham H.T. 10d. per volt, complete; Duron 20 v., 11/-; 10 v., 5/6; Repairing Outfit, 1/6.

L.F. TRANSFORMERS—R.I. Multi-Ratio, 25/-; Marconi Ideal, 25/-; Junior, 18/6; Peranti A.F.3, 25/-; A.F.4, 17/6; Formo, 10/6; H.T.G. Empire, 7/6; Croix 5 to 1, 6/-; Lissen new type, 9/6; Igranic, 16/-; Eureka Concert Grand, 25/-; No. 2, 21/-; Baby Grand, 15/-; Ormond, 15/-; Royal, 20/-; Success, All Black, 21/-; Silvertone, 21/-; G.R.C., 15/-; Brandes, 17/6; Burndept, 16/6; Special Value, 7/6; Modulation, 7/6.

VALVES—"Radion" all types, Frelat 2 volt, 3 amp., 4/11. All advertised makes stocked.

VALVE HOLDERS—Anti-Phonic Benjamin, 2/9; Lotus, 2/3; with terminals, 2/8; Burndept, 2/9; Harile, 1/6; Reliability, unequalled, 2/-; all baseboard types, ord. ditto.

6d.; N.P. Valve Sockets, flush fitting, id.; Superior Panel Type, 6d.; All Ebonite, 10d.

HEADPHONES—E.T.H., 15/-; Brown's "F" Type, 20/-; Reliability, 7/6; adjustable, 8/-; Dr. Nesper, 12/11; T.M.C., 17/6; Western Electric, 20/-; all 4,000 ohms; Sullivan 120 ohm Double, Ex-Govt., New, 4/-; 120 ohm Single Phone, 2/6; Long Phone Cord, 1/-

AERIALS—100 ft. 1/4 in. copper tape, 1/6; 7/22's Bright, 2/3; Enamelled, 3/3; Electron 1/8; Superal, 2/6; Mars, 9/6; Ashton Spreaders, 12/- per pair; O.V., complete, 2/6.

INSULATORS—Large Shell, 3d.; Reel or Egg, 1d.; Olimax, 6d.; Ditto, with shock absorbers, 3/- pr.; Gal. Pulleys, 3d.; 100 ft. Gal. Straining Wire, 1/6; Straining Bolts, 6d.

EBONITE—Any size cut; Clayton brand, 1/4 in. id. sq. in.; 9 in. by 6, 2/2; 12 in. by 9, 4/6; 15 in. by 9, 5/6; 3/16 in. 25 per cent. less. Paragon and Radion, id. per sq. in.

CONDENSERS—Low Loss, Square Law, with knob and dial, .0005, 5/-; .0003, 4/6; with Vernier Blade, 1/- extra; Twin .0005, for Elstree Six, unequalled value, 9/6; Cydon Twin for ditto, 27/6; Ormond, J.B. Utility, Sterling, Polar, Formo, Igranic, G.E.C. Var. in all capacities, Neutrodyne type, Ormond, 2/-; Colvern, 3/6; Gambriel, 5/6.

FIXED CONDENSERS—Dubbler; Edison Bell, Lissen, Watmel, Mullard, McMichael, all advertised prices. Special Reliability Fallon—0003 mfd. 2 meg. Leak, 1/3; Cases only 4d.

RECENT REDUCTIONS—Sterling .0005 Square Law Condensers with Vernier, 9/6; Geared 12/-; Miniloss, 15/-; .00025, 8/6; Geared, 10/6; Miniloss, 14/-; Marconi Automatic Detector, 2/6; Series Parallel Variometer, 10/6; Eddystone Absorbos Feet, set of 4, 2/3; Benjamin S.P. Switch, 1/3; N.P. Clix Plug & Insulator, 2d.; Adaptor, 14d.; Socket, 2d.

LATEST COMPONENTS—6-Way Coil Stand, 2/9; Colvern Low Loss Inductance Farmer, 5/-; Formo Straight Line .0006 Condenser, 10/6; Success, 18/6; Eureka, 18/6; Cydon, 15/6; Lissen 60 v. H.T. New Process Battery, 10/6; Valve Vibrating Springs, 6d. set of 4

TERMINALS & ACCESSORIES—Single W. Office N.P. or Pol. Brass with nut and washer, 14d.; Phone and Castle type, id.; Double Mark, 3, 2d.; 4-way Phone Connector, 6d.; Pole-finding paper, 3d.; Fluxite, 8d.; Black Tape, 6d. coil; 1 in. Empire Tape, 6d. dozen yards; Insulating tube, 3d. yard; Glazite, 1/2, 10 ft. coil; Shellac Varnish, 6d.; Mica 2 in. x 1 1/2 in., 4d. dozen; Chatterton's Compound, 9d.; Hand Drill, 3/6; Drills, 1/-

EXPERIMENTERS' PARCELS. Accessories of Various Types worth 20/-, post paid, 5/6.

Send for New **RELIABILITY WIRELESS GUIDE No. 9**. Free on Request Trade Supplied.

J. H. TAYLOR & Co.
4, RADIO HOUSE, MACAULAY ST., HUDDERSFIELD

Orders 5/6 Value Carriage Paid. Under 5/- 2d. per 1/1 For Packing, etc.

LOUD SPEAKERS are legion, their sponsors have been apt to write abundantly of qualities supreme. So-called mellowness, sweetness, clarity, wonderful depth, fidelity, etc., etc., are insufficient to truly describe the reception experienced by users of the Claritone.

Ashley Radio

It is sufficient for them to know that they can sit back and enjoy

Ashley Wireless Telephone Co. (1925), Ltd., 17, Finch Place, Falkland Street, Liverpool.

W265 £5 0 0
W267 £2 15 0
W299 £12 10 0
W287 £4 10 0
W275 £6 0 0
W277 £4 0 0

Described and illustrated in Booklet No. 71 obtainable from all dealers.

CLARITONE
LOUD SPEAKERS & HEAD PHONES

THE "WHIPPET"

(Continued from page 1052.)

wire just above the 'phone terminals. One lug of the filament input fixed condenser can be directly screwed to one terminal of the Lissen H.F. choke. Before the wiring is commenced care should be taken that space is left for the free movement of the variable condenser vanes when the fixed coil is in position, and for the moving coil.

The wiring should be carried out with thick, bare wire, or with Glazite. The leads to the filament chokes should be spaced very carefully, although we do not want

B.5 is a high-resistance valve compared with the D.E.R.

Coils of ordinary sizes are needed—e.g. 50 or 75—for the A.T.I. and 75 or 50 for the reaction (moving coil), according to the wave-band. The 50 A.T.I. will probably be required for stations below 310 metres, and the 75 for those above and up to 550 or thereabouts.

Some 66 or so volts H.T. will be necessary—perhaps less, but not more. The bias tappings and potentiometer should be varied until satisfactory average settings are obtained.

Normal Adjustment.

There is little we need say about the handling of the "Whippet," for in respect of the variable condenser and coil holder controls it obeys normal tuning laws. The adjustment of the filament will not be found to be any more critical than in the

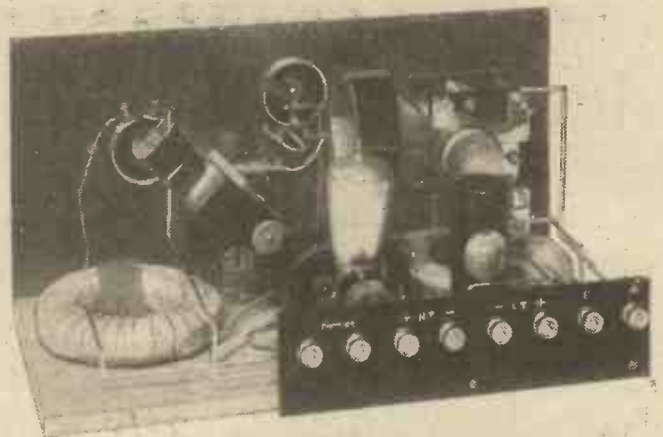

A further back of panel view of the "Whippet" showing the valve and wires in position.

case of an ordinary receiver. On DX the potentiometer forms a very useful secondary reaction control, while on local station work it enables the operator to work on just that part of the curve that will permit maximum amplification together with purity of tone.

By the way, amateurs must be careful that they connect up the L.T. battery the right way and also that they have the bias

(Continued on next page.)

POINT-TO-POINT CONNECTIONS

Aerial terminal to moving plates of the variable condenser. Fixed plates of condenser to plug of fixed coil holder and to one side of .0003 fixed condenser.

Earth terminal to socket of fixed coil holder, to plate socket of valve holder, to H.T. negative, to grid bias positive, and to one side of the Cosmos H.F. choke. Other side of Cosmos choke to L.T. positive, and to one side of No. 1 filament choke.

Other side of No. 1 choke to one filament socket of valve holder, to one side of Lissen H.F. choke, and to remaining side of .0003 fixed condenser.

Other filament socket of valve holder to one side of filament choke No. 2.

Other side of No. 2 choke to one side of rheostat. Other side of rheostat to L.T. negative.

Remaining side of Lissen choke to slider of potentiometer. The grid bias battery is connected across the two ends of the potentiometer.

Grid socket of valve holder to socket of moving coil holder. Plug of moving coil holder to one 'phone terminal and to one side of phone condenser. Other 'phone terminal to H.T. plus and to remaining side of the phone condenser.

to give the impression that success or failure depends on this. Not at all, but such points bear directly on the DX capabilities of the set.

Ready for Test.

A small clip should be screwed to the base-board to hold a 4½ volt grid bias battery against the back of the panel in a position between the filament rheostat and the potentiometer. One piece of springy brass 1½ to 2 in. by about ¼ in., bent at right angles, will serve the purpose.

Two small flex leads supplied with wander plugs should be provided, as per the wiring diagram. It is rather an intricate little one-valver to wire up, and it is advisable to check up each lead as it is cut and connected by both the wiring diagram and the point-to-point guide which is provided separately.

The wiring completed, there remains but to clean up everything and to affix panel transfers, and the "Whippet" is ready to place in commission.

A D.E.R. valve is necessary, as is also a four-volt accumulator. The extra two volts are required to overcome the resistance of the filament chokes. If a B.5 is used (and this valve will give quite excellent results) still only four volts are required, as the

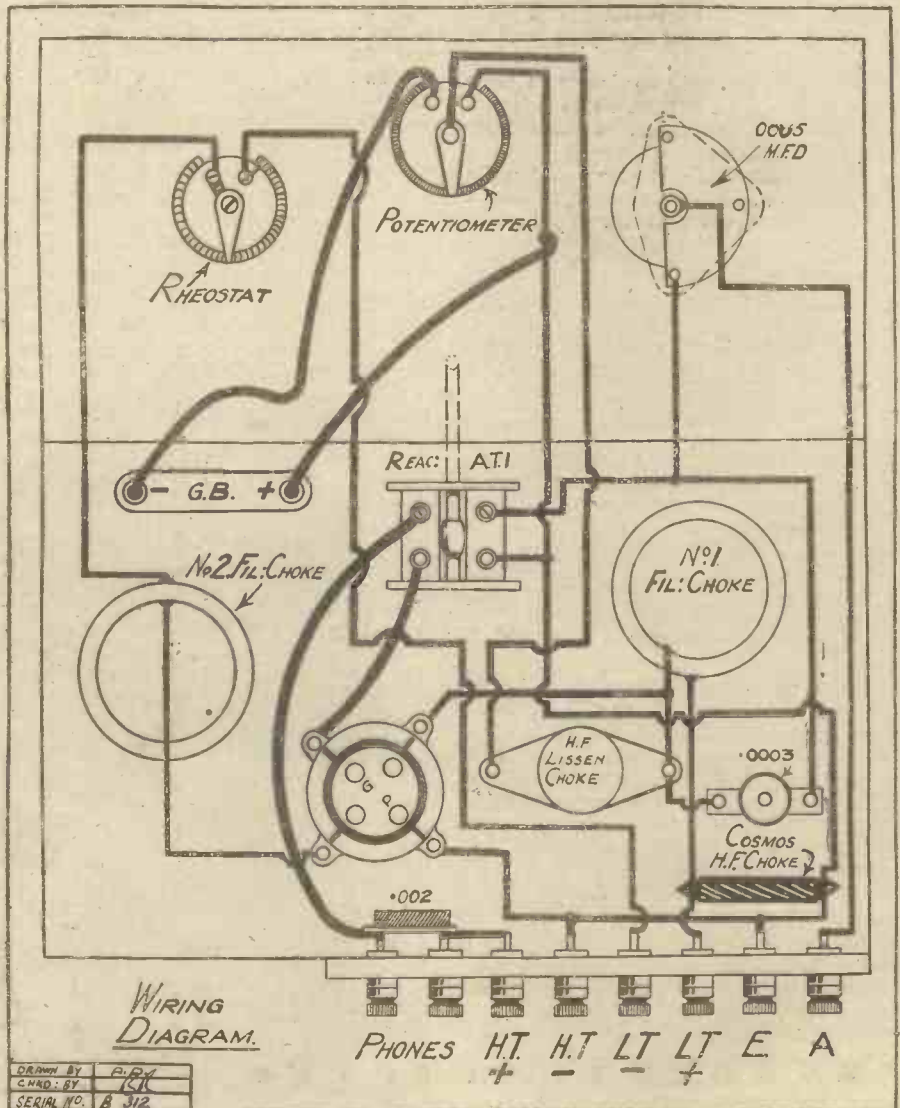

WIRING DIAGRAM.

DESIGN BY P.P.M.
 CHAS. BY K.L.
 SERIAL NO. 2 312

IMPROVING DETECTOR VALVE EFFICIENCY.

By B. H. TUBBS.

TO obtain the utmost efficiency from the detector valve may, I think, be taken as a cardinal necessity in the fitting up and operation of a valve receiver, and on this point the writer has been experimenting for some time past with the endeavour of seeing what were the best results obtainable from the detector valve alone.

The circuit used was the standard direct-coupled reaction, and after numerous tests and rejections of various combinations of components I at length arrived at what, I think, may be regarded as the desideratum spoken of in the first line of this article.

Some Important Additions.

The components that increased the detector-valve efficiency to a marked degree (that is on a comparison with the average receiver that has not these components) are:

(1) A 400-ohm potentiometer for operating the valve on the upper bend of its characteristic curve.

(2) A variable grid condenser in place of the usual fixed one. This is a Baty, two plate, 4 in. diameter, variable from .0003 to .00007 mfd.

(3) A .0002 variable condenser across the reaction coil, and to obtain very fine tuning of this coil a vernier condenser is put across this .0002.

(4) The aerial tuning condenser is .001, with a vernier condenser across it to give fine tuning.

(5) Three-point grid leak switch for putting the variable grid leak either across the grid condenser or connected to L.T. positive or negative.

(6) Filament resistance that gives fine control of current.

To deal with these points seriatim, firstly, the potentiometer is connected with the moving arm to the earth terminal, and one end of the resistance to the L.T. positive, the other end of the resistance being unconnected. Those who have not tried a potentiometer in this position will be surprised at the improvement that it brings about. Secondly, the variable grid condenser gives a very fine control of reaction, far superior to moving the reaction coil, and a very careful adjustment of this, together with the vernier condensers across the aerial and reaction condensers, makes all the difference in tuning in distant stations. These adjustments and that of the potentiometer for controlling the grid potential, are the secret of getting results that are unobtainable on sets lacking these components.

To continue dealing with the six points in question, thirdly, I find that even a slight movement of the vernier condenser

across the reaction condenser makes all the difference in the reception, and yet some text books speak of there being no need of having a condenser across the reaction. Fourthly, I fear that with many people too little attention is paid to the fine tuning of the aerial coil, which, if done, makes a lot of difference.

Fifthly, the grid leak switch is very necessary for testing different makes of valves, as some work better with the leak across the grid condenser, and others connected to L.T. positive or negative.

Sixthly, fine adjustment of the filament current helps considerably in getting good reception, a point that I note many people ignore as they switch on the current and never think of adjusting it.

Real DX Results.

As an instance of what can be done on a single valve (.06 dull emitter taking 4 volts L.T. and 40 volts H.T.) with the combination of components set forth above, and a single wire aerial 50 feet high, at this location (Southampton) I can get the London and Cardiff stations at good head-phone strength on a bright summer afternoon.

In winter and after dark all the main B.B.C. stations come in well on the headphones, and several relays such as Liverpool and Edinburgh, to mention two distant ones. As to the Continental stations, several German, Radio-Paris, Berne, San Sebastian, Radio-Toulouse, Rome, Madrid and Oslo come in well on the headphones. Fading there is, but one gets a lot of entertainment listening to the different stations.

I may say that these results were quite unobtainable without the grid potentiometer, using a fixed instead of a variable grid condenser, and not giving fine tuning to the reaction coil.

THE "WHIPPET."

(Continued from previous page.)

battery wander plugs in their correct sockets, as otherwise results will not be good.

What the Set Will Do.

In conclusion, we honestly believe those of our readers who construct the "Whippet" will join with us in claiming it to be absolutely the last word in one-valvers. Its flexibility will astonish hardened "fans." We will give a rough outline of the results we obtain on the original model. The local station, 2 L O, which is some six miles away, operates a medium-sized loud speaker quite comfortably and without "pushing" the set to its limits. Newcastle, Dublin, Cardiff and Bournemouth come in without a struggle, and Frankfurt frequently operates the speaker! Madrid, Hamburg and quite a number of continentals are received with ease. This is, of course, on an outdoor aerial. We ourselves have never operated a single valve set which we prefer, or which gives superior results to the "Whippet."

We anticipate a hefty correspondence as a result of publishing the constructional details of this receiver, and we will be bitterly disappointed—even surprised—if

the majority of the writers do not record exceptional performances. Already records have been assailed and broken by amateurs using Filadync sets, as such of the corre-

spondence received which we have published clearly shows, and there is no doubt whatever but that the "Whippet" will even go one better in every instance.

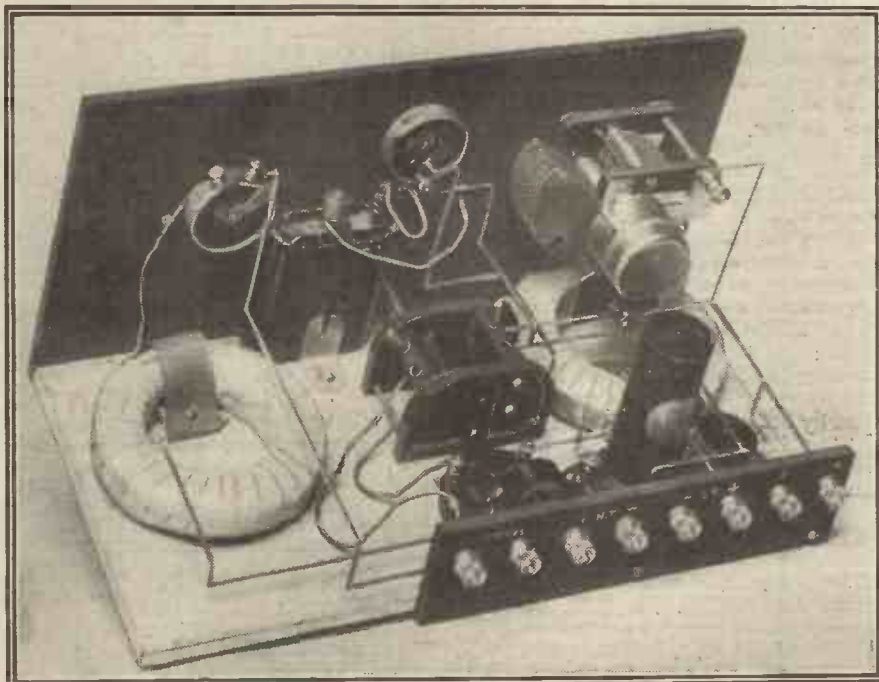

Another back-of-panel view of the "Whippet," clearly showing how the bias battery is held in position.

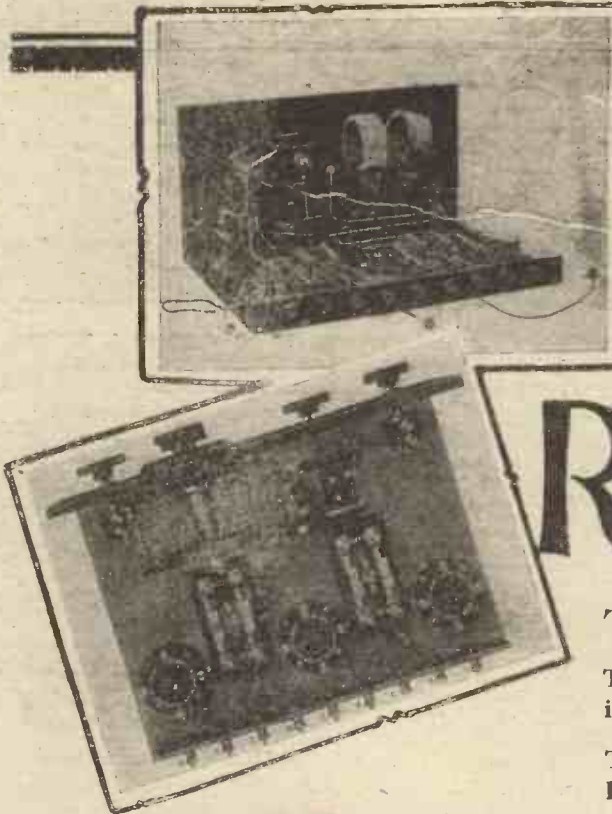

Are you making the famous R.C. Threesome?

TO get the wonderful results obtained with the original R.C. Threesome Set, you should use identical components.

The Coil Holder used is a "Lotus" Left-Hand Two-Way Coil Holder; the three Valve Holders are "Lotus" Buoyancy Valve Holders, with Terminals.

Wireless experts decided that these were best for a very important experiment; that they would get most out of the set on which depended the very high reputation of the famous Ediswan Valves.

They were not disappointed. YOU will be more than pleased with the R.C. Threesome's performance if you fit "Lotus" Valve Holders and Coil Holder.

From all Radio Dealers

LOTUS COMPONENTS

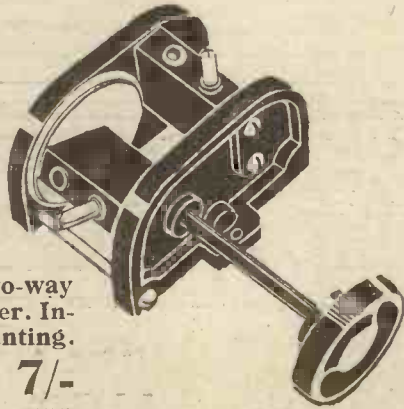

Lotus Two-way Coil Holder. Inside mounting. Left-hand. 7/-
Patent No. 244251.

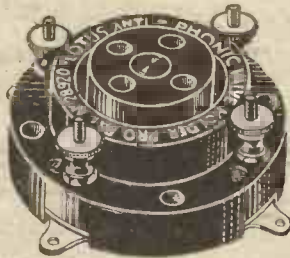

Lotus Buoyancy Valve Holder with Terminals. 2/6
Patent No. 256833.

A FASCINATING XMAS GIFT

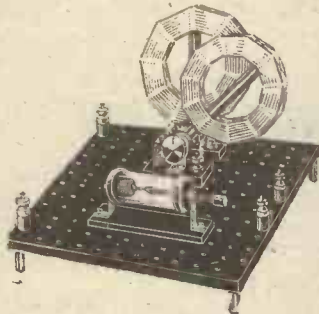

The above illustrates a simple yet most effective Crystal Receiver made from our parts. A splendid and instructive gift for boys. No technical skill required to construct.

A Blackadda set forms a delightful present for novice and expert alike. Owing to the advantages of this method, and the ease and quickness of operation, the initial feeling of novelty is ever present.

OF GREAT INTEREST.

We have pleasure in announcing the introduction of our new sub-panel system. Possessing all the advantages of the Blackadda method, which has already aroused enthusiasm, this latest product has farther advantages for the construction of modern sets, and is a great advance on anything yet devised. The layouts have been arranged by experts, and perfection assured in the resulting H.F. Receiver. The provision of a space under the sub-panel enables wiring to be laid both under and over the panel, thus allowing better spacing than usual. Write for particulars of sets for building the Monodial, the Solodyne, the All-British Six, etc.; also lists of new high-grade components.

BLACKADDA

RADIO BUILDING SYSTEM

PRICES: For complete components to build an ultra-efficient

Crystal Set	19 : 6
One valve Amplifier	£2 : 1 : 0
One valve Receiver	£2 : 12 : 6
Two valve Receiver	£4 : 12 : 0

Every part is well made, and the components are all of guaranteed quality.

Prices for more powerful sets and separate components are listed in an interesting publication we issue entitled "The Blackadda Way," (1/-). Parts can be bought singly if required. For instance the base or "table" is priced at 3/6 and is composed of first-class insulating material mounted on four brass feet. This "table" can be added to and extended in any direction to make up a multiple of 6 ins. and can be used as a base board with any cabinet set, with controls on panel.

Be up-to-date and adopt the Modern Method.

The BLACKADDA RADIO CO. LTD., Sadler Gate, DERBY.

'Phone: Derby 1820. 'Grams: "Blackadda, Derby." Agents wanted in London and Provinces.

If your local dealer cannot supply we shall be pleased to forward on receipt of remittance or C.O.D.

WHY PAY MORE THAN DOUBLE for other amplifiers or for a valve set, when you can get as good results with THE MAGNETIC MICROPHONE BAR AMPLIFIER

"NO CRYSTAL SET IS COMPLETE WITHOUT THIS WONDERFUL ATTACHMENT."

Not only will this marvellous device give really good LOUD-SPEAKER RESULTS from CRYSTAL RECEPTION of average strength, but it is absolutely the ONLY means of increasing the strength of weak signals in HEADPHONES without using valves.

Works perfectly on one or two dry cells.

A BOON TO DEAF PERSONS

EQUALLY EFFICIENT ON VALVE SETS

IF YOUR DEALER CANNOT SUPPLY ORDER DIRECT FROM SOLE MANUFACTURERS AND PATENTEES:



(Two-thirds actual size.)

NOT a Microphone Button.

NO Valves, Accumulators or H.T. Batteries. Fragile parts. Distortion.

Simple as A B C.

MICROPHONE AND OTHER PARTS OF AMPLIFIER SUPPLIED SEPARATELY

FULLY ILLUSTRATED LISTS FREE

COMPLETE AMPLIFIER as shown PRICE post free 38/- 3-volt DRY BATTERY lasting over three months 4/- extra. No other accessories required.

DELIVERY BY RETURN FROM STOCK EVERY AMPLIFIER GUARANTEED

NEW WILSON ELECTRICAL MANUFACTURING CO., LTD., 18, FITZROY STREET, EUSTON ROAD, LONDON, W.1. 'Phone: Museum 8974.

CURRENT TOPICS.

BY THE EDITOR.

A Critic's Views—Wireless and Music—The Trained Ear—Illogical Dogmatism—Marconi on the Future of Radio.

MR. ERNEST NEWMAN is a music critic, and in musical circles his articles in the Press are quite well-known. Recently Mr. Ernest Newman, probably inspired by Sir Thomas Beecham's outburst, "went" for wireless music and, with a pen long practised in the art of strong criticism, made a slashing attack on broadcasting music. His attitude towards the average listener is a very superior one, but in his article he betrayed an abysmal ignorance of wireless, both from the technical point of view and from the artistic point of view.

For that, of course, one cannot blame him. It is the habit of many people these days to criticise adversely subjects about which they know nothing. But it is a pity that Mr. Newman should have allowed himself to poke jibes at listeners who do not happen to have his technical knowledge of music, or his gift of appreciating good music. Mr. Newman would be well-advised to leave wireless alone when he writes about music, for he is talking arrant nonsense when he says: "The only people who have a right to be heard on the subject of wireless music are perfectly impartial and disinterested musicians." He also says: "In a matter of transmission of music by wireless, only the musicians' hearing, which is rather different from that of the scientist, is worth taking into consideration. What does the average scientist or wireless fan know about orchestral timbres?"

The Musician's Ear.

To talk of scientists and wireless fans in the same breath is a *faux pas*. Perhaps, also, Mr. Newman has never heard of Helmholtz and his colossal and famous work on Tone. Indeed, there are many scientists who probably know far more about the technicalities of music than Mr. Ernest Newman or his colleagues. And to suggest, as Mr. Newman does, that the trained musician is the only person whose opinion is worth having on wireless music is to suggest that the thousands and thousands of people who enjoy broadcasting music have no right to say anything about music because they have not the trained musician's ear. The trained musician's ear is, however, a *rara avis*, and it would be absurd to suppose that anything but a small percentage of the two million listeners in this country have that, and as well, say, perfect pitch, or even a satisfactory technical knowledge of music.

We should say, in reply to Mr. Newman, that the trained musician is the very last person on earth who should be asked to criticise broadcast music, or to in any way have a hand in the arranging of music programmes.

Perfection is all very well for those who have been trained to appreciate perfection, or who have been blessed with the gifts which allow them to differentiate

between perfection and the second-rate; but thousands and thousands and thousands of people in this country cannot listen to broadcast music with the excessively critical ear of the trained musician, and when Mr. Newman says that only the musician's hearing is worth taking into consideration in connection with broadcast music, he is, to put it colloquially, talking through his hat.

"Light Reading."

It appears that many critics of Mr. Newman have sent him extracts from

COMING SHORTLY.

"HOW I WOULD RUN THE B.B.C."

By A. CORBETT SMITH.

An answer to the Editor's Query.

various wireless papers. He has replied to these by saying: "I have no time for light reading."

This is very amusing—at least, as far as POPULAR WIRELESS is concerned—because, although we deal with a technical subject—i.e. wireless, it has always been our endeavour to present that subject in a fairly light way to our readers, and to avoid stodginess and excessive technicalities in our articles.

Perhaps we are taking a compliment where no compliment is intended, because we are not certain that Mr. Newman has received cuttings from POPULAR WIRELESS.

The only information we have is that he has received cuttings from wireless papers, but we do hope that when Mr. Newman says, "I have no time for light reading," it means he has seen a few cuttings from POPULAR WIRELESS. Anyway, we will presume the compliment, and thank him for it.

On December 12th, 1901, Senatore Marconi was sitting in a room of a disused barracks on Signal Hill, St. John's, Newfoundland. On a table stood some instruments connected by wire with a kite that was upheld at a height of about 400 feet. An Atlantic gale was blowing. To the instruments on the table there was connected a telephone, and, shortly after noon, Senatore Marconi heard sounds which corresponded to the letter "S" in the Morse code.

Those signals had been transmitted from the Poldhu wireless station in Cornwall, and were the first artificial wireless signals to be transmitted across the Atlantic Ocean.

Marconi's Prophecy.

Twenty-five years ago, that was; and every reader of POPULAR WIRELESS knows how wireless has grown out of that feat of Senatore Marconi's.

Talking about those early days, Senatore Marconi has recently been asked to give his views on the progress of wireless, and it is interesting to note that he thinks that during the next twenty-five years there will probably be almost as great a development in means of obtaining directional wireless transmission and reception as there has been in other directions during the last twenty-five years.

Apart from ordinary transmission and reception of wireless messages, Senatore Marconi thinks there is a possibility that the transmission of power over moderate distances may be developed, and that television will become an actuality. These prophecies seem fairly safe ones, for it is, indeed, difficult to refrain from any sort of prophecy when one reviews the progress made in wireless during the last twenty-five years.

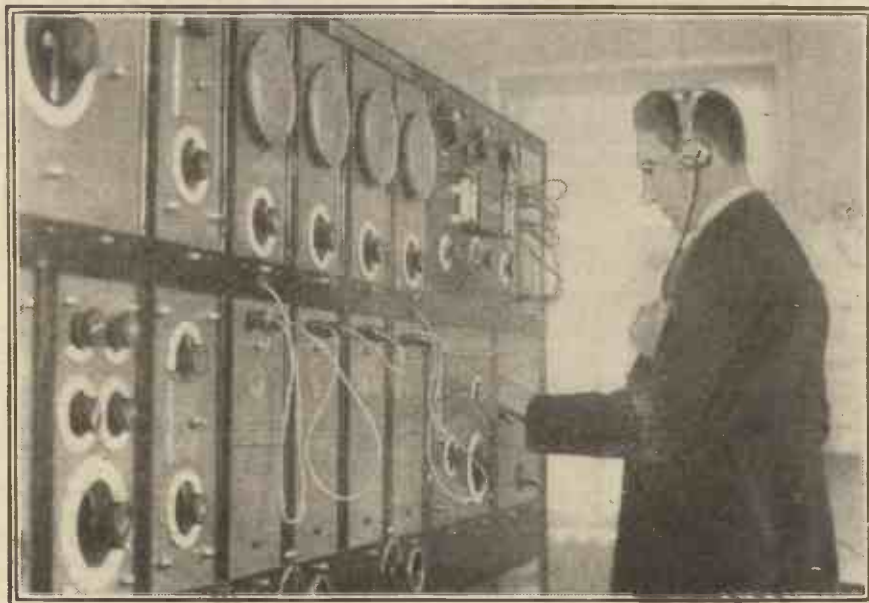

One of the control panels installed in the new G.P.O. wireless station near St. Albans.

BROADCAST NOTES.

FROM OUR BROADCASTING CORRESPONDENTS.

G. G.'s Triumph—A Policy of Concentration—More "My Programmes"—
Improving Dance Transmissions—Better Saturday Afternoons.

G. G.'s Triumph.

"MY Programme," by George Gros-smith, Broadcast from London, S.B., on Saturday, December 11th, was a complete triumph. Thousands of letters of congratulation have reached the B.B.C., and there is little doubt that in the minds of the vast majority of those who heard this programme it was acclaimed the brightest and best ever radiated from a B.B.C. station.

There have been just as good variety artistes before the microphone recently, but the distinctive success of this programme was in the way it was knit together. It went with consummate dash and élan. There was not a dull moment; the light and shade of burlesque, comedy, and pathos were interplayed. The B.B.C. will be expected to live up to this new standard in popular programmes.

A Policy of Concentration.

There is grave perturbation among listeners at Bournemouth and Newcastle. It has been announced that after the end of this year the station orchestras at these places will give way to octettes, and orchestral music will be relayed from London. This move does inflict hardship on the individuals concerned in the disbanded orchestras, but it is obviously a move in the direction of greater efficiency and better programmes all round. Land line relaying through the new repeater stations is now so highly developed that there are no longer any valid objections on the technical side to S.B. work.

To spend more money on programmes in London and distribute them efficiently will provide a better service for all listeners than to continue a policy of divided effort—a sort of inevitably subsidising of mediocrity. By a curious but quite justifiable paradox, the development of the new regional scheme of distribution which will give listeners a greater choice of programmes will involve greater concentration of programme building in London.

A Broadcast Arabian Night.

On Tuesday, December 28th, Cecil Lewis will put on a special "Arabian Nights" programme at London. This feature will be built up upon one of the better known

of the "Arabian Nights" stories. For the musical background, authentic Arabian instruments are to be used.

More Broadcast News.

The terms of the new agreement between the press interests and the Broadcasting Corporation will be announced about the end of the year. As forecast in this page, they represent a decided gain for broadcasting. All the chief sporting events of next year will be broadcast with running narratives.

There is in Fleet Street circles a general feeling of relief that the negotiations for the new Broadcasting Authority were left entirely in the hands of Mr. Reith. This fact alone precludes the possibility of the failure of the negotiations. The newspaper

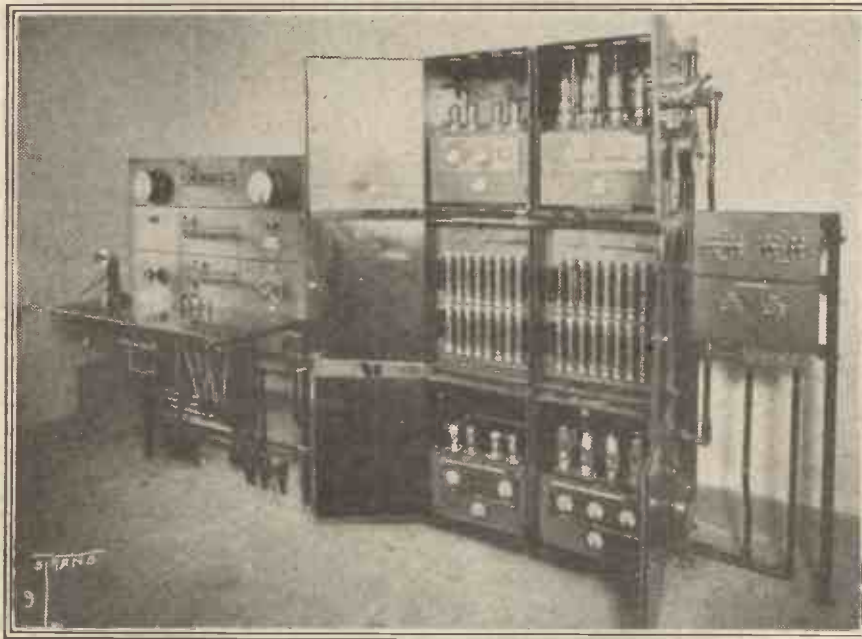

The 10 and 100 watt amplifiers and switchboard of the 50 kw. W J Z station at Boundbrook, New Jersey. This station transmits on 455 metres.

industry has incurred a considerable debt of gratitude to Mr. Reith personally for the patient tolerance with which he has steered broadcasting policy through the recent critical weeks.

The Beethoven Centenary.

Beginning on March 20th, there will be a week of special programmes to celebrate the Centenary of Beethoven.

Wireless Societies and the New B.B.C.

It looks as if the new B.B.C. is to be a good deal less tolerant of the wireless societies than was its predecessor. There used to be fairly frequent talks by spokesmen of the R.S.G.B., the Radio Association, the Wireless League, and the Wireless Association. For the future each of these societies is to be

allotted a bare five minutes every quarter in which to propound its views over the microphone. But there is this change, that whereas under the old regime self-advertisement was heavily censored, the new arrangement will permit the societies to sing their own praises as much as they please.

More "My Programmes."

Dame Madge Kendal will do the "My Programme" of January 12th. There is understood to be a division of opinion at Sayöy Hill on the merits of this series. The critics complain that most of the sponsors so far have had insufficient personality to convey. Listeners, however, appear to be well satisfied with the novelty, and take a keen interest in each of the series.

Improving Dance Transmissions.

The forthcoming disappearance of several outside dance bands from the programmes will signify an attempt to establish a better average standard of dance music. There has been a good deal to be desired in this respect, particularly with regard to the afternoon periods of dance music transmission.

Talks with Celebrities.

Beginning on Monday, January 10th, and continuing fortnightly on Mondays at 9.15 p.m., there is to be a special series of microphone interviews with celebrities in all walks of life. Mr. Bernard Shaw, Mr. Augustine Birrell, Mr. Eugene Tunney, and M. Poincaré are names mentioned in connection with this series.

Better Saturday Afternoons.

Beginning on Saturday, January 15th, the character and quality of the Saturday afternoon concerts at London will be greatly improved. More money is to be spent on this period, and it is to be developed as a regular feature.

The Classical Recitals.

The classical recital introduced early this year at 7.25 every week-night was an instant success. Many standard works were given, and a wide field of music efficiently covered. After some time there arose a keen demand to move it to a later programme period, the contention being that many music-lovers were unable to listen as early as 7.25, so it was moved to 9.45.

In the New Year, the wishes of both sections of listeners are to be met. There will be two distinct series of recitals each week-night.

The first will represent exclusively classical keyboard music, and will be put on at 7.15. At 8.15 the second series will be given. This will also be of high quality; but the entertainment aspect will figure more prominently than the educational.



“They tried to put me off—
but I wasn’t having any!”

“I WAS in town the other day and remembered I wanted one of the S.T. power valves. The assistant behind the counter hadn’t got one, and wanted me to buy another make. Said they were ‘just as good.’

“He argued a bit. Evidently thought I was fresh to wireless, and would buy a valve like I would a cake of soap, the actual make not mattering much.

“I got rather annoyed with him, but I remembered what you said about S.T.’s only selling through certain agents. I suppose he wasn’t one of their agents, or was trying to sell a valve giving him a greater profit. Anyway, I was so aggravated that I bought some other gear I wanted at a shop higher up the street where they *did* sell S.T.’s.

“I don’t suppose there are many dealers who insult the intelligence of their customers by ‘telling them the tale.’ My own local man wouldn’t do that kind of thing, anyway.

“At any rate, when I got home, my ruffled feelings soon wore off. There was a first-rate concert, and the new S.T. power-valve seemed to change the whole set. The music came in clear-cut and vivid, and the singing was absolutely life-like.”

2-VOLT.		4-VOLT.		6-VOLT.	
S.T.21 (H.F.) 0.1 amp.	14/-	S.T.41 (H.F. and Det.)	14/-	S.T.61 (H.F. and Det.)	18/6
S.T.22 (L.F. and Det.)	14/-	0.1 amp.	14/-	0.1 amp.	18/6
0.1 amp.	14/-	S.T.42 (Power) 0.1 amp.	18/6	S.T.62 (Power) 0.1 amp.	18/6
S.T.23 (Power) 0.15	18/6	S.T.43 (Super Power)	22/6	S.T.63 (Super Power)	22/6
amp.	18/6	0.25 amp.	22/6	0.25 amp.	22/6

If you are unable to obtain an S.T. valve from your local retailer, write direct to us, or call. All valves will be sent by post and insured by us against breakage. C.O.D. orders executed on receipt of post card.

S.T. LTD., 2, Melbourne Place, Aldwych, LONDON, W.C.2
(Next to Australia House)



Compiled by
K. D. ROGERS.

THE "POPULAR WIRELESS" VALVE GUIDE

2-VOLT H.F. VALVES

Make of Valve	Type	File Volts	File Amp.	Anode Volts	Grid Bias	Impedance	Amp. Fac.	Price	Remarks	Make of Valve	Type	File Volts	File Amp.	Anode Volts	Grid Bias	Impedance	Amp. Fac.	Price	Remarks
AMPLION— A. Graham & Co., 25, Savile Row, W.1.	A.M.R. 2/9 A.M.G. 2/25	1.0-1.8	0.00	120	—	70,000	35	14 0	High amp'n H.F. for res. coupling General purpose	LOUDEN— Fellows Mag. Co., Cum- berland Ave., Park Royal, W.	L.E.R.2	2.0	0.2	40-100	—	40,000	12	8 0	Also resist. L.F.
ARA— Stephens & Well, 55, St. Eastern St., E.C.2.	15 13	1.3-1.5 1.3-2	0.2 0.08	40-120 30-80	—	40,000 15,000	9 3	—	H.F. valve General purpose	LUSTROUX— Lustrotox Ltd., W. Bol- ington, nr. Maccles- field.	H.F.208 H.F.234	1.8-2.0 1.8-2.0	0.06- 0.08 0.34	30-80 40-100	—	50,000 50,000	12 10	9 0 9 0	H.F. valves
LESTER & MARQUIS, 15-16, Thames Valley, E.C.1.	D.E.2	1.8-2	0.12	20-90	—	—	—	9 0	General purpose	MARCONI— Marconi Co., Mar- coni Hse., Strand, W.C.2.	D.E.2 H.F.	1.8	0.12	40-120	—	45,000	12	14 0	Also det. and res. L.F.
BENJAMIN— Benjamin Electric Ltd., Brantwood Works, Tottenham, N.17.	S.P.18C. S.P.18B. S.P.18R.	1.6-1.8 1.6-1.8 1.6-1.8	0.3 0.09 0.3	20-80 80-120 20-80	—	17,000 70,000 7,000- 5,000	15.0 35.0 7.0	14 0 14 0 14 0	Tuned anode or trans. coupling. Tuned anode (neutralised) or res. coupling. Low imp. trans. or reflex	METAL— J. Haas Ltd., 60, Black- friars Rd., S.E.1.	C.L.62 C.L.152 C.L.202	1.8-2.0 1.8-2.0 1.8-2.0	0.06 0.15 0.2	20-60 20-80 20-100	—	25,000 30,000 25,000	4 9 7	10 6 — 8 0	General purpose General purpose General purpose
R.T.H.— The British Thomson- Houston Co., Crown Hse., Aldwych, W.C.2.	B.3	1.8	0.35	20-80	—	27,000	7.5	14 0	General purpose	MULLARD— Mullard Wireless Service Co., Ltd., Mullard Ho., Denmark St., W.C.2.	P.M.1 H.F. D.3 HF	1.8 1.8 1.8	0.1 0.3 0.3	50-125 50-125 50-80	—	28,000 60,000 32,000	13.5 17 9	14 0 14 0 11 0	Also det. and res. L.F. Also res. L.F. One fil. in use
B.S.A.— B.S.A. Radio Ltd., Small Heath, Birmingham.	H.125 H.125A G.125 G.125A G.225	0.85-1.1 0.85-1.1 0.85-1.1 0.85-1.1 1.7-2.2	0.25 0.25 0.25 0.25 0.28	60-90 60-90 30-60 30-60 60-120	—	50,000 40,000 50,000 25,000 15,000 -19,000	11-12 11-12 5-6.5 5-6.5 8.5	14 0 14 0 14 0 14 0 14 0	H.F. and det., 4-pin base H.F. and det., bayonet fixing G.F., 4-pin G.F., bayonet fixing G.F., 4-pin	NELSON— Nelson Electric Ltd., 138, Kingsland Rd., S.W.19	"Multi" D.3 HF G.220	1.8-2.0 1.8 2.0	0.35 0.2 0.2	50-80 50-80 20-80	—	32,000 20,000 20,000	9 7 11	11 0 11 0 12 6	Spec. non-phonetic Also det.
BURNDYPT— Burndypt Wireless Ltd., Bedford St., W.C.2.	H.L.213	2.0	0.13	30-45	—	23,000	6.5	14 0	General purpose	H. S. Electric Ltd., 32, Charlotte St., Bir- mingham.	H.R.210	1.8	0.10	30-80	—	50,000	18	12 6	Neutrodyne H.F., also res. L.F.
C.A.C.— C.A.C. Valve Distrib. Co., 10, Rangoon St., E.C.3.	D.E.2 H.F.	1.95	0.25	30-100	—	58,000	17.0	7 6	H.F. and det., also resist. L.F.	OSRAM— General Electric Co., Magnet Hse., Kings- way, W.C.2.	H.210 D.E.2 H.F.	1.8 1.8 1.8	0.10 0.12 0.35	30-80 40-120 30-80	—	25,000 45,000 32,000	11 12 9	12 6 14 0 22 6	Standard H.F. L.F. General purpose
CLEARTRON— Cleartron Radio Co., 1, Charing Cross, W.C.	C.T.15	1.8-2.0	0.15	30-100	—	18,000	7.5	14 0	General purpose	QUIKKO— J. W. Pickavant & Co., Ltd., Quikko Works, Lombard St., Bir- mingham.	D.E.25 P.2	2.0	0.25	40-100	1 1/2 max.	58,000	17	5 9	H.F. except for choke coupl., also det. res. L.F.
COSMOS— Metro-Vick Supplies Ltd., 165, Charing Cross Rd., W.C.2.	S.P.18G. S.P.18B.	1.6-1.8 1.6-1.8	0.3 0.09	20-80 80-120	—	17,000 70,000	15 35	14 0	Tuned anode or trans. coupling Anode (neut.) or res. field.	OSRAM— General Electric Co., Magnet Hse., Kings- way, W.C.2.	D.E.2 D.E.R. D.E.7	1.8 1.8 1.8	0.42 0.35 0.4	40-120 30-80 6-15	—	45,000 32,000 20,000	12 9 4.5	14 0 14 0 22 6	Also det. and res. L.F. General purpose Four-electrode valve
CUNNINGHAM U.S.A.— Rothermel Corp. Ltd., 24/25, Maddox St., W.	C.11 C.X.12 235	1.1 1.1 1.8-2.0	0.25 0.25 0.35	40-75	—	7,000- 8,000	7	14 0	Low imp. trans. or reflex	QUIKKO— J. W. Pickavant & Co., Ltd., Quikko Works, Lombard St., Bir- mingham.	D.E.25 P.2	2.0	0.25	40-100	—	58,000	17	5 9	H.F. except for choke coupl., also det. res. L.F.
DEXTAUDION— E. E. Co., Ltd., 10, Fitz- roy Sq., W.1.	W.2 W.R.2 Pt. 1 red	1.4-1.8 1.4-6 1.8	0.3 0.3 0.1	30-120 30-120 70-120	—	30,000 30,000 44,000	10 10 20	14 0 16 0 14 0	H.F. and reflex, also for super het. in intermediates or res. coupl. L.F.	RADIO MICRO— H. D. Zealander & Co., 124-127, Minorities, E.1.	Bi volt K. D.E.2V. H.F.	1.8 1.8-2.0 1.8-2.0	0.2 0.2 0.03	40-80 30-100 30-100	—	10,000 19,000 60,000	5.75 5.9 16.8	11 6 10 6 10 6	H.F. (choke coupl.), also det. and L.F. G.F. and L.F. H.F. and res. L.F.
EDISWAN— Electric Swan Co., Queen Victoria St., E.C.	A.R.D.E. H.F. G.P.2	1.8-2.0 1.8-2.0 1.8-2.0	0.3 0.1 0.15	20-100 60-120	—	40,000 16,500	10 10	11 0 14 0	I.F. General purpose special suit. as det.	RADVACO— Blitz Bros., 3, Lynton Rd., W.3.	S.B.6 S.B.6	1.0 1.0	0.05 0.15	30-100 30-100	—	22,500 40,000	9 10	4 3 4 6	General purpose General purpose
ELKA— L. Krenner, 49a, Shude- hill, Manchester.	C.	1.5-2.0	0.15	20-100	—	—	—	—	General purpose, high imped- ance	RATRACO— Blitz Bros., 3, Lynton Rd., W.3.	S.S.2 S.S.2 S.S.2	2.0 2.0 2.0	0.3 0.3 0.3	50-125 50-100 40-120	—	60,000 27,000 26,000	17 13.5 16	14 0 14 0 14 0	Also det. foll. by res. or choke L.F. and for L.F. res. coupl. Also det. the S.S.A. L.F. preferable H.F. valve
FRELAT— L. Krenner, 49a, Shude- hill, Manchester.	K. D.E.	1.8-2.0 1.8-2.0	0.3 0.06	20-30 30-100	—	—	—	4 11 8 6	G.P., suit. as det. G.F., suit. as det.	S.T.—S.T. Ltd., 2, Mel- bourne Place, W.C.2.	S.S.2 H.F. S.T.21	1.8 1.8	0.1 0.1	50-100 40-120	—	27,000 26,000	13.5 16	14 0 14 0	H.F. (4-pin base) H.F. (bayonet fixing)
LOTWE-AUDION— Audion Radio Co., 52, Dorset St., W.1.	L.A.77 L.A.75	1.3 2.0	0.13 0.17	60-200	—	—	—	10 6	General purpose	STANDARD— Standard Telephones Co., Connaught House, Aldwych, W.C.2.	D.E. D.E.	1.8-2.0 1.8-2.0	0.34 0.2	20-100	—	18,000	—	5 0	General purpose General purpose

(To be continued.)



Why don't you hear?

—the "Beco" Rose Bowl Hornless Loud Speaker? It reproduces faithfully, with a pure, clear tone, and—if desired—sufficient volume for dancing. Apart from its perfect performance the "Beco" Rose Bowl Model is of really beautiful appearance. Combining as it does, a perfect loud speaker with a useful and artistic flower bowl, the "Beco" Rose Bowl Model makes a cherished addition to the furnishing of the home. Whether the bowl is empty, or filled with water and flowers, the splendid tone remains unaltered. Obtainable in three varieties: Nickel Plate, £5 5 0. Oxyd. Silver, £5 17 6. Antique Bronze, £5 17 6.

BECO

**ROSE BOWL
Hornless Loud Speaker**

Deferred payments can be arranged on application to the address below.

Ask your dealer to demonstrate.

Other "Beco" Models from 52/6.

If your dealer cannot supply write to:

Dept. P.W., BRITISH ELECTRICAL SALES ORGANISATION.
625, Australia House, Strand, London, W.C.2
Telephone: City 7665. Telegrams: "Becospeker, Estrand, London."

Christmas!

Yes,
We'll give him
an

Ebonart
NON-METALLIC SURFACE

RADIO PANEL

for his
new set



Write for folder D262.

**REDFERN'S RUBBER WORKS, Ltd.,
HYDE CHESHIRE**

LONDON: 75, Newman Street, W.1. LEEDS: 7, Albion Street.
BRISTOL: 137, Victoria Street. GLASGOW: 93, Hope Street.
BELFAST: 2, Sandy Row.



Apparatus Tested

Traders and manufacturers are invited to submit wireless sets and components to the "P.W." Technical Dept. for test. All tests are carried out with strict impartiality in the "P.W." Test room under the supervision of the Technical Editor, and the general reader is asked to note that this weekly article is also intended to provide a reliable and unbiased guide as to what to buy and what to avoid.—EDITOR.

A NEW OLDHAM ACCUMULATOR.

IN order to cater for the requirements of amateurs who use low consumption two-volt valves, Messrs. Oldham have produced the O.V.D., a slow-discharge accumulator cell which is to be retailed at the very reasonable price of 5s. 6d. It is provided with a very stout glass case, and is fitted with special laminated plates. Therefore, it is a very robust assembly, and should stand up to very hard usage and even misuse. The O.V.D. is subjected to the "special activation process," and the sample submitted has so far proved most satisfactory in every respect.

THE T.M.C. GRAMO-SPEAKER.

The T.M.C. people recently sent us one of their new "Gramo-speakers." It is a loud-speaker unit which can either be fitted with a horn to form an ordinary

instrument, or it can be attached to a gramophone.

On test it gave excellent results. Tone was good, and plenty of volume could be obtained without loss of purity. It is quite sensitive (an adjusting screw is fitted), and is nicely made and finished. At its price of 13s. 6d. it forms excellent value for money.

TWO VARLEY COMPONENTS.

We recently received two interesting Varley components. The first is one of their new Bi-duplex Wire-Wound Anode Resistances, with a value of as much as 250,000 ohms. Without discussing the merits of an anode resistance of such a high value, we can say that we regard the construction of such a one in a really compact form as something of an achievement in itself. Wire-wound components of this nature are always preferable, as they are consistent and silent in operation. In

addition, this Varley resistance is damp-proof and is very neat in appearance. It costs 9s. 6d. complete with clips and a substantial base.

The other Varley component is an H.F. choke. It has a very low capacity, and sufficient inductance to "choke" up to the higher wave-lengths. It is wound in six sections, but is quite compact. Mounted vertically on a baseboard by means of one small screw, it occupies very little space indeed. It costs 12s. 6d., and is a thoroughly dependable component, and one we have no hesitation whatever in recommending to our readers.

AN ELECTRIC SOLDERING IRON.

Messrs. S. Wolf & Co., 115, Southwark Street, S.E.1, recently sent us one of their electric soldering irons. It has rather a small element, but as, of course, this is kept at a constant temperature, this is no real drawback, and from a radio constructor's point of view it is even an advantage in view of the awkward little pieces of work he has to face from time to time. The iron heats very rapidly and is in every way quite satisfactory. Since its arrival it has been in constant use in our workshop, where we find electric irons almost indispensable. The price of this useful accessory is 10s. post free.

THE "MIDGET" VERNIER KNOB.

An alternative to the more or less expensive "geared dial" is a vernier knob, such as the "Midget," a product of the Standard Insulator Co., Winsley House, Wells Street,

(Continued on page 1066.)

EDISON BELL RADIO

CHARM!

Charm is expressed both in the tone and design of the

NEW MODEL Edison Bell Speaker

the artistic appearance of which is second only to its tonal reproduction.

PRICE 42/.

(of all high-class dealers)

Ask your dealer for attractive new season's catalogue, or write direct to the company for same.

EDISON BELL, LIMITED,

LONDON, S. E. 15.

And at HUNTINGDON.



TESTED 500 VOLTS
FLAT TYPE



TESTED 500 VOLTS
UPRIGHT TYPE



INSIST ON EDISON BELL CONDENSERS

THEY ARE BRITISH MADE AND GUARANTEED BY A NAME WITH 30 YEARS REPUTATION BEHIND IT



Modern components
for modern circuits

IGRANIC GANG CONDENSERS
Igranic Gang Condensers are fitted with special equalising devices which enable the sections to be accurately matched without altering the relative settings. The square law characteristic is thus preserved and the full tuning range maintained, whilst the matching of different circuits is greatly simplified. Igranic Gang Condensers are built up from Igranic-Pacent '0005 mfd. Square Law Condensers. The whole construction is particularly rigid and the tuning movement extremely smooth.

Twin Gang £2/10
Condenser

Triple Gang £3/15
Condenser

IGRANIC-PACENT "PRE SET" RESISTORS
have all the uses of fixed resistors and yet are almost as easily variable as rheostats. Their use prevents over-running the valves and reduces the number of controls on a panel. Made with resistances of 6, 10, 20, 30 and 50 ohms. The position of the contact finger is easily variable over the whole range.

WRITE FOR THE NEW IGRANIC CATALOGUE LIST No. R/40.

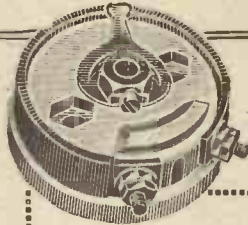

Price 1/8 each

IGRANIC ELECTRIC CO. LTD.

149, QUEEN VICTORIA STREET, LONDON

Works: BEDFORD

For D.X. results
this coming
Winter ~
resolder all
joints with

FLUXITE SOLDERING SET—complete 7/6

All Hardware and Ironmongery Stores sell FLUXITE in tins, price 8d., 1/4 and 2/6.

Another use for Fluxite—Hardening Tools and Case Hardening. Ask for leaflet on improved methods.

FLUXITE, Ltd.,
(Dept. 324),
Rotherhithe, S.E.16



FLUXITE

Why you should
use Siemens'
Radio Batteries!

FOR
STEADY
PERSISTENT
SERVICE



SEE THAT
THEY BEAR
THIS
TRADE MARK!

REG. TRADE MARK.

Primary Cells and Batteries, both fluid and dry, have formed an important and highly successful portion of our manufactures for over 40 years.

Only materials of the highest grade are used in their construction, and each battery is subject to the most stringent tests during the manufacturing stages and also before leaving the Works, in order to ensure that each battery is up to that high standard of quality which has always been associated with the name.

The experimental and research work which is continuously being carried out at our Woolwich Factory, combined with unrivalled manufacturing experience, enables us to offer the best dry battery suitable for any radio purpose.

It is sound economy, therefore, to purchase radio batteries which bear the name "Siemens" and the above trade mark.

We have recently issued a new Catalogue, No. 650, which contains a large amount of useful information on the care of radio batteries, also the correct size and type of battery to use. A copy of this Catalogue will be sent you, post free, on application.

SIEMENS BROTHERS & CO., Ltd., WOOLWICH, S.E.18

APPARATUS TESTED.

(Continued from page 1064.)

London, W.1. It is quite an efficient little device and, mounted by means of one small hole in the panel, it supplies a smooth vernier action by means of a direct friction drive on to the dial of the variable.

The "Midget" costs 9d.—and that is cheap enough!

THE "W.B." VALVE HOLDER.

There is nothing very original in the design of the "W.B." valve holder, which is made by Messrs. Whitely, Boneham & Co., Ltd., Duke Street, Mansfield, Notts; it is quite a straightforward component, but it embodies all those features that the discriminating amateur looks for when he is choosing such components. It is "anti-pong" and has positive connections to its sockets from terminals and soldering tags. It has sunk sockets and these have plenty of clearance at their bases. The holder is nicely made from apparently high-class materials. Finally, the "W.B." is retailed at the reasonable price of 2s. 3d.

USEFUL LITTLE ARTICLES.

No wireless amateur's or constructor's workshop is complete without a good stock of terminal soldering tags and spade terminals. Specialists in the production of these are Messrs. The S. H. Collett Manufacturing Co., of 60, Pentonville Road, London, N.1. who recently sent us a number of samples of these useful articles for examination. They

are sold in shilling packets containing two or three each of ten different types, types covering practically every requirement. Each packet is a most comprehensive little collection and the tags are cleanly stamped.

Messrs. Collett have recently produced a bracket pulley specially designed for fitting to the tops of wireless aerial masts. It is supplied complete with a 30-ft. endless halyard at 2s. 6d., and is, indeed, a useful fitting.

"RESISTON PANELS."

The American Hard Rubber Co. (Britain), Ltd., recently sent us a number of "Re-

siston" panels. "Resiston" is a high-grade ebonite which works easily without cracking and chipping and which has a very superior "finish." Its electrical efficiency is naturally of a very high order, too, and in our opinion it is in every way worthy of the producers of "Radion" panels. "Resiston" is slightly cheaper than "Radion," but is still miles ahead of much of the ebonite that is on the market. It can be obtained with either polished black or mahogany coloured surfaces.

SIMPLIFYING SOLDERING.

Soldering is so essential in the construction of wireless sets that anything that tends to simplify the process is of value. "Flusolda," a product of the Transport Supply Co., Ltd., of 62, Victoria Street, S.W.1, certainly does this, and therefore should appeal to the amateur who still finds soldering somewhat difficult. "Flusolda" is a fluid solder which contains a "flux" element. Thus, all that one has to do is to place a little of the material on a joint and heat it with an iron. We have used the 1s. 3d. tin sent us and it carried us through several sets large and small. Apart from a slightly noxious odour when heated, we discovered no "snags."

M.A.P. PLUG-IN COIL.

The M.A.P. Co. recently sent us one of their coils to test. Its winding is rather a novel one, a former being used which is divided by vertical slots. A fairly low self-capacity is thus achieved. A feature of the M.A.P. which appeals to us is the cut-away plug. The coil is carefully and rigidly assembled, and on test gave good results.



A very neat self-contained C.A.V. portable receiver.

THE AERIAL TUNER WITH AN INDUCTANCE EQUAL TO A WHOLE RANGE OF COILS

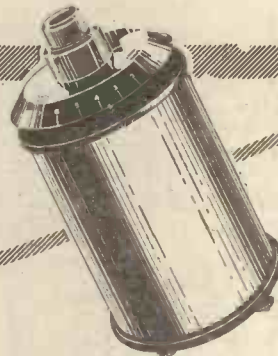

PRICE
35/-
COMPLETE

Ask your retailer, or write to-day for CATALOGUE 573/6 of EFESCA Components with diagrams illustrating their use in various circuits. It is more than a list—it is a fine 72-page book of great value, containing much technical information, which you will greatly appreciate.

FALK, STADELMANN & CO.,
LTD.,
83/83, Farringdon Rd, London, E.C.1

And at Glasgow, Manchester,
Birmingham, Newcastle,
and Dublin.

THE Efesca Regenerative Aerial Tuner is not a new gadget; but is a tried and tested component which has firmly established its superiority over conventional methods of tuning. It has an inductance equal to a whole range of Plug-in-type coils from 30 to 300. A turn of the switch covers both low and high wavelengths. The bother of choosing coil combinations is obviated. Losses are eliminated. Reaction is under perfect control. It is convenient to mount and simple to operate.

You cannot do better than use the

EFESCA

REGENERATIVE AERIAL TUNER



The name does not rotate

The head does not come off.

The slot and nut eliminate soldering.

The finish is perfect throughout.

Standard Large Insulated Model (polished black bakelite), Type B, 9d. each. Popular Model (non-insulated), Type M, 6d. each.

22 different engravings stocked. Catalogue free on request.

BELLING-LEE TERMINALS

Advt. of BELLING & LEE, Ltd., Queensway Works, Ponders End, Middlesex. E.P.8.14.



FELLOWS WIRELESS

60 Volts
8/9

FELLOPHONE
SUPER WIRELESS BATTERY
THE FELLOWS WIRELESS COMPANY LTD.

THIS H.T. BATTERY

- costs only 8/9,
- is made throughout in London,
- is sent post and packing free,
- reaches you, brim full of energy; within a few hours of manufacture owing to the enormous number we sell daily,
- maintains its voltage for the longest possible time owing to the extremely generous "elements" of which it is made,
- will give you a long life of loud, clear reception free from all crackling noises,
- is tapped every 3 volts enabling you to apply the exact voltage required by your valves for best results;
- is supplied complete with Red and Black wander plugs—no extras to buy,
- is, in short, the **FINEST IN THE WORLD** because no other H.T. Battery made (except other Fellophone batteries) can come anywhere near it in performance or value.

Other Fellophone Batteries are listed below. We can only offer you this astounding value because, by supplying you direct we can save all the middleman's profits and so give you a better battery for less money.

Order from us or from our Branches to-night.

- 54 Volt** (with 3 volt tap for grid bias). Post FREE **6/6**
- 60 Volt** (tapped every 3 volts and supplied complete with Red and Black wander plugs). Post FREE **8/9**
- 108 Volt** (tapped every 6 volts and supplied complete with Red and Black wander plugs). Post FREE **13/-**

FELLOWS, PARK ROYAL, N.W.10

Branches: [(Museum 9200).

- LONDON: 20, Store Street, Tottenham Court Road, W.C.
- BIRMINGHAM: 248, Corporation Street. (Central 435).
- BRIGHTON: 31, Queen's Road (Brighton 899).
- BRISTOL: 36, Narrow Wine Street. (Bristol 7972).
- CARDIFF: Dominions Arcade, Queen Street. (Cardiff 7685).
- LEEDS: 65, Park Lane. (Leeds 21479).
- MANCHESTER: 33, John Dalton Street. (Central 1164).
- NEWCASTLE: 36, Grey Street.
- NOTTINGHAM: 30, Bridlesmith Gate. (Nottingham 5551).
- TONBRIDGE: 34, Quarry Hill. (Tonbridge 172).

BUY DIRECT AND SAVE MONEY
E.P.S. 273



BECOL

Makers of the **ORIGINAL world-famous BECOL LOW LOSS FORMER**

As used in sets that took the first four prizes at the 1926 "Manchester Evening Chronicle" Wireless Exhibition and the set that won the Gold Medal at the 1926 Amsterdam Exhibition.

Size: 3 inches diameter to outside of wings. Prices:

- 6 inch lengths, 3/- (Postage 9d.);
- 4 inch lengths, 2/- (Postage 6d.);
- 3 inch lengths, 1/6 (Postage 6d.);
- Up to 36 in. lengths.

NOTICE:—Do not be put off with an imitation. Ask for BECOL and use the Former with a reputation.

Write for List "C."

Ebonite Rods, Tubes and Sheets. Panels guaranteed free from surface leakage.

THE BRITISH EBONITE Co., Ltd., Hanwell, London, W.7.

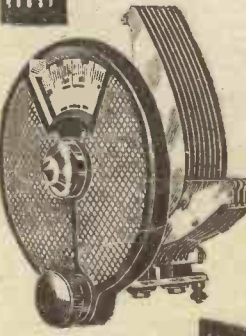

FORMO

ARTHUR POLLEN & CO. LTD.

ULTRA LOW-LOSS

Straight Line Frequency Condenser

Cone Bearings. Braced Vanes. Positive Collector. A real precision job. Condenser only. 0003uf., 0005uf. **7/6**

New Vernier Dial Reduction Ratio 16-1. No Backlash **6/-**

THE FORMO COMPANY,
Crown Works, Cricklewood, N.W.9

Phone: Hampstead 1787.
Manchester: Mr. J. E. Looze, 23, Hartley St., Levenshulme.
Phone: Heaton Moor 476

RADIOTORIAL

All Editorial Communications to be addressed to The Editor POPULAR WIRELESS, The Fleetway House, Farringdon Street, London, E.C.4.

Editor:
NORMAN EDWARDS, M.Inst.R.E., M.R.S.L.,
F.R.G.S.

Technical Editor:
G. V. DOWDING, Grad.I.E.E.

Assistant Technical Editors:
K. D. ROGERS. P. R. BIRD.

Scientific Adviser:
Sir OLIVER LODGE, F.R.S.

Staff Consultants:
Dr. J. H. T. ROBERTS, F.Inst.P.; J. F. CORRIGAN, M.Sc., A.I.C.; O. E. FIELD, B.Sc.,
E. J. SIMMONDS, M.I.R.E., F.R.S.A.

Foreign Correspondents:
F. M. DELANO, Paris; Dr. ALFRED GRADENWITZ, Berlin; L. W. CORBETT,
New York; P. F. MARTIN, Italy; W. PEETERS, Holland.

The Editor will be pleased to consider articles and photographs dealing with all subjects appertaining to wireless work. The Editor cannot accept responsibility for manuscripts and photos. Every care will be taken to return MSS. not accepted for publication. A stamped and addressed envelope must be sent with every article. All inquiries concerning advertising rates, etc. to be addressed to the Sole Agents, Messrs. John H. Lill, Ltd., 4, Ludgate Circus, London, E.C.4.

As much of the information given in the columns of this paper concerns the most recent developments in the Radio world, some of the arrangements and specialities described may be the subject of Letters Patent, and the amateur and the trader would be well advised to obtain permission of the patentees to use the patents before doing so.

Readers' letters dealing with patent questions, if sent to the Editor, will be forwarded to our own patent advisers, where every facility and help will be afforded to readers. The envelope should be clearly marked "Patent Advice."

TECHNICAL QUERIES.

Letters should be addressed to: Technical Query Dept., "Popular Wireless," The Fleetway House, Farringdon Street, London, E.C.4.

They should be written on one side of the paper only, and MUST be accompanied by a stamped addressed envelope.

Queries should be asked in the form of the numbered questions: (1), (2), (3), etc., but may be accompanied by a short letter giving any necessary additional particulars as briefly as possible.

For every question asked a fee of 6d. should be enclosed. A copy of the numbered questions should be kept, so that the replies may be given under the numbers. (It is not possible to reproduce the question in the answer.)

BACK OF PANEL DIAGRAMS can be specially drawn up to suit the requirements of individual readers at the following rates: Crystal Sets, 6d.;

One-Valve Sets, 6d.; One-Valve and Crystal (Reflex), 1s. Two-Valve and Crystal (Reflex), 1s.; Two-Valve Sets, 1s.; Three-Valve Sets, 1s.; Three-Valve and Crystal (Reflex), 1s. 6d.; Four-Valve Sets, 1s. 6d.; Multi-Valve Sets (straight Circuits), 1s. 6d. Except SUPER-HETERODYNE DIAGRAMS, all of which, irrespective of number of Valves used, are 2s. 6d.

If a panel lay-out or list of point-to-point connections is required an additional fee of 1s. must be enclosed.

Wiring diagrams of commercial apparatus, such as sets of any particular manufacture, etc., cannot be supplied. (Such particulars can only be obtained from the makers.)

Readers may submit their own diagrams, etc., for correction or for criticism. The fee is 1s. per diagram, and these should be large, and as clear as possible.

No questions can be answered by 'phone. Remittances should be in the form of Postal Orders.

Questions and Answers

HIGH-TENSION CONDENSERS.

P. M. R. (Weymouth).—What is the purpose of a fixed condenser across the H.T. battery and of what capacity should it be?

The current flow from a high-tension battery is very seldom perfectly smooth, especially if the battery is of the "dry" type. Consequently, if many stages of low-frequency amplification are in use, noises may be heard in the 'phone.

By the use of large fixed condensers, having capacities of .5 to 2 microfarads, the effective discharge of the battery will become much steadier and the extraneous noises reduced.

If several H.T.appings are employed in the set, a separate condenser must be used for each tapping.

(Continued on page 1070.)

Important Announcement by



A GREAT advance in short wave receiver design has been made by our engineers and full constructional details will shortly be available (probably by the time this announcement appears).

We are reserving a number of copies of the booklet and blue print describing this receiver for free presentation to short wave enthusiasts, and if you would not be disappointed apply at once for your copy to

The **BOWYER-LOWE CO LTD**
Radio Works,
LETCHWORTH
HERTS.

"EKCO" H.T. UNITS

SCRAP DRY BATTERIES!

By obtaining H.T. Current from Electric Supply Mains (D.C. & A.C.) by just attaching Adaptor to Electric Light Lampholder!



Model V2A-DC.



12" x 6" x 7"
Model V2A-AC.

SAFE!
SILENT!
SOUND!

"EKCO"

THE "QUALITY" UNIT AT THE LOWEST COMPATIBLE PRICE
READ WHAT THEY ALL SAY!

THE PRESS.

Amateur Wireless, 9/10/26.
"We have tested this Unit—no trace of 'hum' could be heard."

British Trade Journal, 1/10/26.
"We have tested the 'EKCO' H.T. Unit and found the instrument efficient in every way. It is one of the few exceptions that has reached the commercial stage."

Popular Wireless, 29/5/26.
"The 'EKCO' is the most satisfactory H.T. Unit we have yet had brought to our notice, and can be fully recommended to the attention of all readers."

Wireless World, 11/8/26.
"No 'hum' was discernible—The Unit is a good practical proposition and can be relied upon."

Wireless Magazine, 1/12/26.
"The 'EKCO' is extremely compact and very simple to use. Results obtained are excellent, the ripple being entirely eliminated."

Birmingham Mail, 2/6/26.
"PURE RECEPTION—with regard to the purity of reproduction obtained, I was rather surprised to find it so excellent as I have always been rather doubtful of taking H.T. Supply from the mains..."

Obtainable at all Dealers UNITS TO SUIT ALL SETS from **42/6** Illustrated Folder Free!

E.K. COLE LTD (DEPT. A), 513, LONDON RD., WESTCLIFF ON-SEA.



**a
new and better
valve holder!**

WHEN we introduced the C.E. PRECISION RHEOSTAT, we thought that in quality, in efficiency and in price, this Component could not be beaten. Now that we have added the C.E. PRECISION FLOATING VALVE HOLDER, we find it even excels the former in these respects to such an extent, that the demand has been amazing and we are working to maximum capacity to keep pace with the orders.

Before purchasing other makes, just ask your dealer to show you ours. We are confident that after comparison they will have the preference.

C.E. PRECISION FLOATING VALVE HOLDERS anti-capacity, non-microphonic,
2/3 each.

C.E. PRECISION RHEOSTATS, efficient and velvety,
50 and 30 ohms 3/- each,
7 and 15 ohms 2/9 each.

Dual Rheostats and Potentiometers, 3/9 each.

C.E. PRECISION GRID-LEAK, an entirely original and accurate component,
2/- each.

**FOR UTMOST
C.E. PRECISION
EFFICIENCY**

C. EDE & CO., LTD., BYFLEET, SURREY
Telephone: Byfleet 226. Telegrams: "Cebrecise, Byfleet."

**Cut out the
WORRY**

of uncertain High
Tension Batteries.

Install one of
"ATLAS"

"B" BATTERY ELIMINATORS
and lead the way to Brighter Radio



Models for A.C. & D.C. Current. Variable Voltages. Grid Bias. Full wave rectification.

Upkeep negligible. Silent and Efficient.

WE
GUARANTEE every instrument.

We make them good - Good judges make them famous

Manufacturers of the famous "Atlas" Plug-in Coils and Fixed and Variable Condensers; also sole manufacturers of the Super Selective Reactor Formers.

H. Clarke & Co. (Mer.) Ltd., 'Atlas' Works, Old Trafford, Manchester

Procurable at last!

An authoritative, popularly written book explaining the wonders of instantaneous vision by Wireless.

Do you know that actual living scenes are already being broadcast nightly?

Television is now here and is developing rapidly. As a wireless enthusiast, your friends will expect you to know about this latest wonder. Can you explain it, or how it is done? Get this book to-day. It explains lucidly, with illustrations, how Television is accomplished.

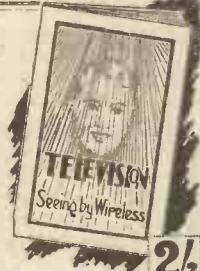

2/2
POST FREE

CONTENTS.—Introduction.—What TELEVISION is.—Various attempts to solve the problem.—The photo electric cell.—The Baird Televisor.—The problem solved.—True Television demonstrated at last.—2 TV, the World's first Television Broadcasting Station.—The development of TELEVISION.

Either order from your bookseller at 2/-, or send to us direct, enclosing postal order for 2/2, when the book will be sent you post free.

Sir Isaac Pitman & Sons Ltd. (Dept. P), 39, Parker St., Kingsway, London, W.C.2

—THE "HARTEL" BATTERY—

Revolution in Wet High Tension

WHAT IS THE "HARTEL" ???

It is a Wet Battery. It charges itself. All parts are replaceable. It is everlasting, as parts can be fitted at home.

It gives long, steady discharge, suitable for largest set. It is super-capacity.

It is ridiculously cheap. It is strongly recommended by "Popular Wireless."

Connections - cannot corrode.

Satisfied users are writing us daily. It is unique. GET A "HARTEL." No more charging. No more scrapped H.T.'s. No more expense, but satisfaction & perfect reception always.

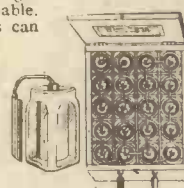

60 volts in Case 25/-
30 " " " 13/6
Carriage 1/3 and 1/-

SPARE PARTS:
Containers 2/- doz. Post
Elements 2/- " 1/-
Zincs 1/6 " doz.

Send P.O. to-day to the Sole Manufacturers:

**THE YORKSHIRE IGNITION CO., LTD., 1 & 3,
Broomhall Street, SHEFFIELD.**

**HIGH & LOW TENSION
ACCUMULATOR HIRE SERVICE**

Here's a way of improving reception, saving money, time, and trouble for all valve set users who live within 12 miles of Charing Cross. Write now for particulars of the unique service

**RADIO SERVICE COMPANY,
105, Torrington Avenue, N.W.5.
Phone North 0623 (3 lines).**

Our Low Tension Hire Service effects a considerable saving if you add the depreciation in value to the cost of having your own accumulator unskillfully recharged.



Forax High Tension Accumulators greatly improve Loud Speaker reception, eliminating the unrenny notes caused by partly run down dry batteries and may be hired ready for use.

**FOR BEST RESULTS
USE W.B.
ANTI-PHONIC
LOW LOSS
VALVE
HOLDERS**



**PRICE
Complete
with Terminals
2/3**

If unable to obtain from your dealer write direct.
Manufactured by **WHITELEY, BONEHAM & CO., LTD.,
Duke Street, MANSFIELD, NOTTS.**

RADIOTORIAL QUESTIONS AND ANSWERS

(Continued from page 1068.)

CONDENSER ACROSS 'PHONES ON CRYSTAL SET.

A. L. (London).—Can you tell me whether I can improve the volume from my crystal set by fitting a fixed condenser across the 'phone terminals?

Although theoretically a fixed condenser should slightly improve the volume if joined across the 'phones, yet in actual practice it makes very little difference, due to the natural capacity of the 'phone leads themselves acting as a fixed condenser.

In some cases, however, a fixed condenser will assist volume slightly, but the addition of this is a matter for personal experiment.

L.F. TRANSFORMERS AS CHOKES.

L. O. (Tunbridge Wells).—As I possess several rather old high ratio L.F. transformers, I was wondering whether these could be used successfully as L.F. chokes in L.F. amplifiers. Can you advise, please?

Your suggestion is quite practicable and, providing the windings on the transformer are still good, they should prove efficient in operation.

THE "HALE," WITH L.F. AMPLIFIER.

S. J. W. N. (Wavertree, Liverpool).—Seeing the glowing accounts of the results obtained with the Hale receiver, I made up my mind to build this set in the 2-valve style described in "P.W." No. 232 (Nov. 13th issue).

I tried to obtain a copy of this issue of "P.W." locally, but failing to get it I applied to your Back Number Dept., only to be informed that the number was "out of print."

Can you supply the diagram (theoretical will do) and details as to size, so as to enable me to go ahead with construction?

The theoretical diagram is given herewith, from which the connections will be clear. The coils are

of the standard plug-in type, 35 or 50 for aerial, and 50 or 60 for reaction.

Condenser values are shown on the diagram. In the original set (described under the title of "The Guaranteed Reflex") the coil-holder was mounted outside the case, and the panel carried only three controls—the tuning condenser, crystal, and rucostat. Any good L.F. transformers may be used, that shown in the first stage being an "R.I. Multi-ratio."

If a different type of L.F. transformer is to be used, its primary connections will correspond with P₁ and P₂, and its secondary connections with S₁ and S₂. P₃ and S₃ may be ignored, and as is usual with transformers in reflex sets, the primary and/or the secondary connections should be reversed when the set is tried out, to see which connection gives the best results. This applies also to the second L.F. transformer, the lettering on which refers to the connections upon the particular component used (C.A.V.).

The size of the panel was 10 by 7 by 1/4 in. Grid bias will depend upon the valves used, which should both be of the same type.

THE WAVE-LENGTH ALTERATIONS.

E. R. (Christchurch).—Since the change in the wave-length of Bournemouth, I have not managed to receive this station so well as I did previously. On the old wave-length my variable condenser was more than half-way in, but since the change it has to be all out and the volume is less.

Can you please inform me how I can remedy the trouble?

There is little doubt that your existing aerial coil does not "tune down" to the new wave-length and under the circumstances it will be advisable to try a smaller aerial coil.

Probably 35 turns instead of 50 will do the trick; but, should the tuning coils on the set be fixed so that they cannot be changed, then your best plan will be

(Continued on page 1072.)

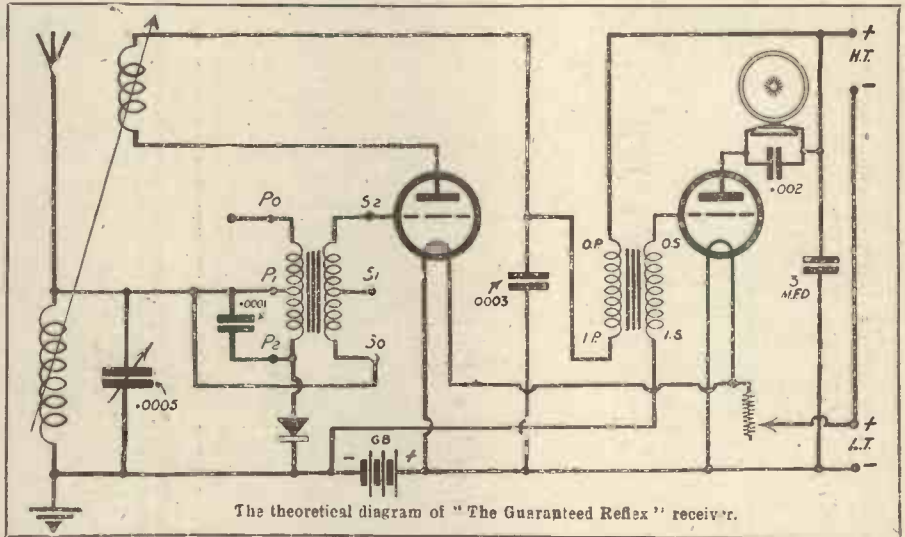

The theoretical diagram of "The Guaranteed Reflex" receiver.

£5 for a Limerick

CAN YOU BEAT THIS?

*There was a young man with a set,
Poor reception was all he could get,
So he re-did the wiring,
The result was inspiring,
Because he used "JUNIT"—you bet.*

—of course you can—

BUT YOU CAN'T BEAT

"JUNIT"

The Unique Self-Soldering Wire

(As used by Leading Radio Manufacturers.)

No. 17 S.W.G. } per coil 1/- Per 2 ft. 2D.
(Sq. section) } in Carton 1/- straight length 2D.

If unobtainable from your dealer send P.O. to us for
Coils 1/- each, post free.

It's BRITISH throughout.

We are offering £5 for the best Limerick submitted before February 8th, 1927, each attempt to be written on a separate carton of the 1/- coils. Write name and address clearly.

Patentees and Manufacturers:

REXO ENG. CO., 2, Ravenscourt Sq., London, W.6

'Phone: Riverside 0274.

FRELAT
D.E. VALVES

4/11 8/16

TYPE K.
Detector and
amplifier
2 volt '3 amp.

TYPE D.K.P.
1'8-2v. '3 amp.
New 2 volt power-valve.



MUCH MORE FOR MUCH LESS.

CUT out the high maintenance cost in Radio and use Frelat Dull Emitter Valves. For performance and long life they are unexcelled and yet the Type K. valve costs only 4/11. Next time put Frelat to the test and let this guaranteed valve prove that high prices are not necessarily the key to the best reception.—If your dealer cannot supply, send direct: For C.O.D. terms add 4d.—postage free.

CONTINENTAL RADIO IMPORT CO., LTD.,
8, SPITAL SQUARE, LONDON, E.C.1.

Frelat

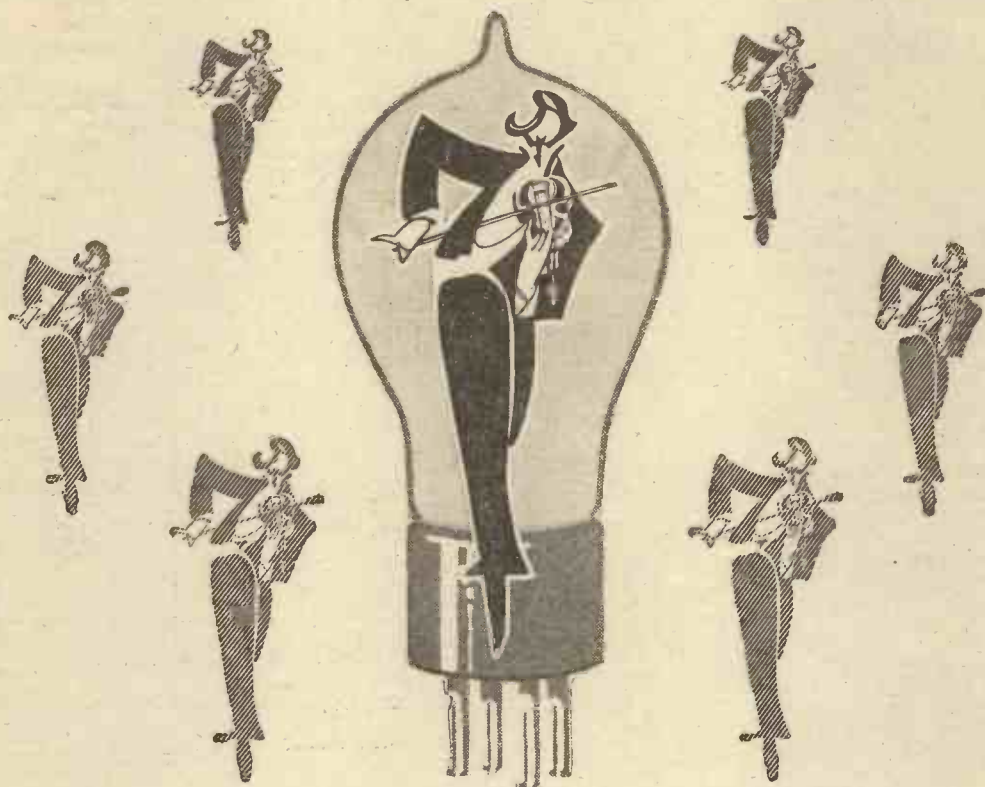

THEY BRING THE MUSIC NEARER

They make the Music Clearer

and yet they are no dearer than any other valves.

Cosmos Valves are valves of sheer musical virtuosity. Sure, exquisitely sensitive and sympathetic, they give your set a new soul. They are wonderful musicians, the Cosmos Valves, and keep their youth, knowing no fatigue!

Cosmos
SHORT PATH
RADIO VALVES
for all circuits

FROM WIRELESS DEALERS EVERYWHERE Wholesale only: METRO-VICK SUPPLIES LTD.
Metro-Vick House, 155 Charing Cross Rd., W.C.2. Proprietors: Metropolitan-Vickers Electrical Company Ltd.

PEERLESS FIXED RESISTOR

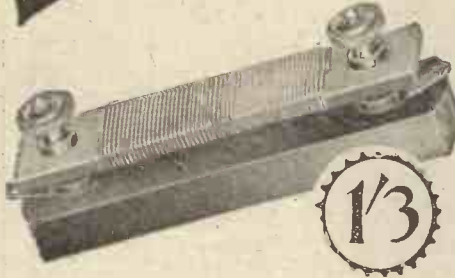

1/3

Efficient, Neat and Cheap

YOU can see from the illustration what a neat job this "Peerless" Fixed Resistor is. The Base is solid insulation and the former a strong impregnated material that atmospheric conditions will not affect. The wire is wound evenly and firmly and terminals and soldering tags are fitted. One hole fixing. A very thoroughly assembled and finely finished unit in all.

OTHER BEDFORD PRODUCTS:

- "Peerless" Dual Rheostat . . . 3/9
- "Peerless" Junior Rheostat . . . 2/6
(already over half a million sold)
- "Peerless" Resicon Variable Condenser, from . . . 15/- to 18/-
(Dial and Vernier 2/6 extra)
- "Peerless" Master Switch . . . 2/9
- "Peerless" Valve Switch . . . 3/-

From all good dealers or direct.

BEDFORD ELECTRICAL & RADIO CO. LTD.
22 CAMPBELL RD. BEDFORD

RADIOTORIAL QUESTIONS AND ANSWERS

(Continued from page 1070.)

to place a small fixed condenser in series with the aerial lead immediately before it gets to the aerial terminal. Either a .0002 or .0001 mfd. condenser would be found suitable.

OVERLAP.

"DX" (Chesterfield).—When I increase reaction I find that although the coils have to be close together to start the set oscillating, they can be loosened again for quite a long

TECHNICAL TERMS ILLUSTRATED. THE BATTERY.

He couldn't win PA by his flattery,
So one day, to finish the matter, he
Went up to her father,
Saying, "Which would you rather,
A wedding—or assault and —|||—?"

way before the oscillation stops. I am told this is "overlap," and a variable grid leak would help to cure it. Is that so?

Yes. The condition described is known as overlap, and it is a fatal fault if one hopes for long distance results. The variable grid leak will probably cure it completely.

TESTING FLASH LAMP BATTERIES.

"DEALER" (Blackpool).—What is the best method of testing for a faulty dry cell, by flash lamp or voltmeter?

The average flash lamp bulb takes far too much current to be good for the cell (10 milliamps, or more). Cheap voltmeters of the "moving-iron" type are also a heavy drain upon the cell, so a high-resistance voltmeter of the "moving-coil" type should be used.

Its resistance should be of 40 000 ohms, or so, and its scale a low one, reading up to, say, 10 volts.

MOUNTING A TAPPED SOLENOID COIL.

H. F. E. (Coventry).—Are bases of the plug-in variety advantageous when using home-made tapped coils, or can the wiring be taken straight to the coil? (The set is to operate upon the lower wave-band only—not for 5 X X.)

The bases are not necessary in such a case, and the wires to the tappings or ends should be connected directly to the coil, as shown in the photograph below.

The method of taking connections direct to a solenoid coil is shown by this photograph.

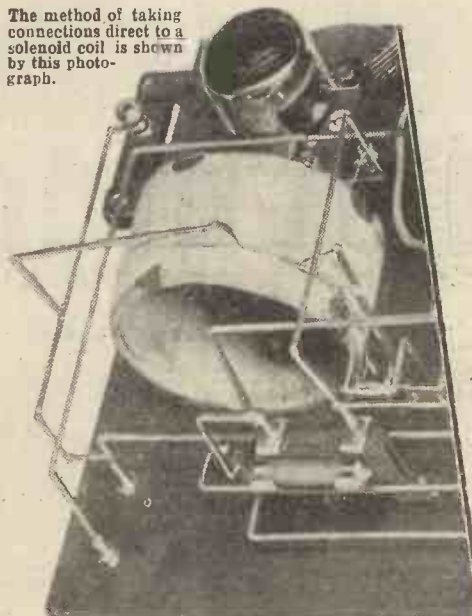

CONDENSERS ACROSS H.T. BATTERY.

F. J. (Nuneaton, Warwickshire).—My 3-valve set has separate H.T. for the H.F., Det., and L.F. stages, and I wish to add large fixed condensers to act as "by-pass" or reservoir condensers. How should they be connected?

The accompanying diagram shows how the large condensers should be connected to the H.T. neg. and H.T. plus leads.

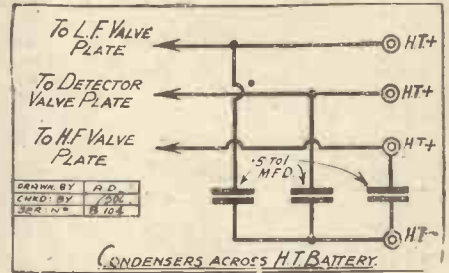

ADVANTAGES OF GRID BIAS.

"PREJUDICED" (S.S. "Grantully Castle").—What are the real practical advantages of grid bias?

Purity of tone for one thing, and economy in H.T. current for another. If, as your non-de-plume suggests, you have a prejudice against the use of grid bias, we advise you to throw it overboard. Failure to use the correct value of grid bias means loss of purity, and loss of money, too, for the amount of current taken from the H.T. battery largely depends upon the value of the bias applied to the grid.

In other words, one volt on the grid is often worth a dozen on the plate.

CAPACITY CONTROLLED REACTION.

"SEARCHER" (Pangbourne, near Reading).—I have an ordinary 1-valve set (2 coil holder, plenty of coils, etc.), but I would like to try "Capacity control" of reaction. Is it likely to improve the set, and if so what alterations are necessary?

The alterations are easily made, and we think you will improve results greatly.

Take leads from the reaction coil socket to a coil plug mounted away from the aerial coil (A. in accompanying diagram). Into this plug a large coil (150/200

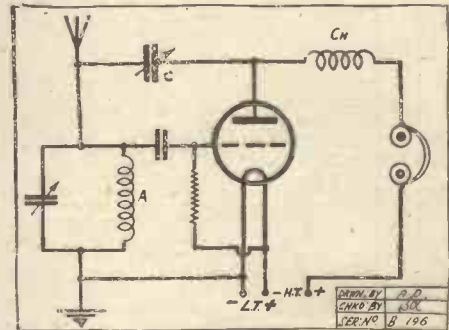

turns) to act as H.F. choke (Ch). Then the reaction condenser (.0002 or so) is joined between the plate and tuned grid circuit, as shown, and a fine variation of reaction is obtained by adjustment of this condenser.

JACK AND PLUG SWITCHING.

"ENQUIRER" (Burton-on-Trent, Staffs).—Why is it that jacks and plugs, which are now becoming so popular for low-frequency switching, are seldom employed in the high-frequency side of a receiver?

Jacks and plugs are liable to cause H.F. leakage due to their comparatively high self-capacity, and this has prevented their being used for H.F. switching. Self-capacity in a low-frequency switch is not a disadvantage, so after the detector stage full advantage can be taken of this handy form of switching.

CURE FOR A KNOCKING NOISE.

"2-VALVER" (Framlingham, Suffolk).—I have made up the 2-valve set as per "P.W." Sixpenny Blue Print (No 11), and obtained excellent results, so I assisted a friend to make a similar set. Although everything in his set

(Continued on next page.)

RADIOTORIAL QUESTIONS AND ANSWERS

(Continued from previous page.)

appears to be just as good as in mine, wiring similar, all joints O.K., etc., we cannot get rid of a regular knocking noise that starts as soon as the valves light. The thumps are regular ones, almost too fast to count, but very loud. What is the cause?

This is due to a fault in the detector valve's grid circuit, and in all probability you will find that the grid leak you are using is the cause of the whole trouble. To test this, try the effect of using your own grid leak in your friend's set. It is almost certain that the trouble will disappear instantly, proving that the leak at present in use is of the wrong value.

TUNING WITH D COILS.

"D" (Hampstead, N.W.).—How is a D coil wound, and what are its advantages?

D coils are wound upon specially slotted flat cardboard formers. (See illustration.) First one D is wound, and then the other, the direction of the winding being as shown by the arrows.



In the complete coil the flat faces of the D's are close together, and between them is the spindle-hole, for mounting the coil.

Two such coils, placed face to face, can be variably coupled by rotating one of the formers. In this way

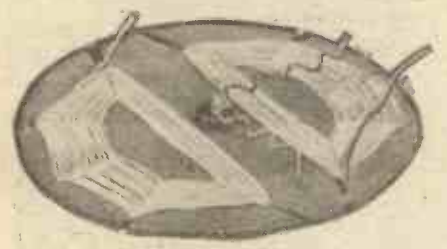

a flat variometer can easily be made, with the advantage of relatively sharp tuning and great compactness, as compared with "swinging-coils," or those coupled by the ordinary lateral movement.

H.F. AMPLIFICATION OF THE LOCAL STATION.

B. J. E. (Newcastle-on-Tyne).—My new H.F. and det. receiver (straight-tuned anode without neutralising) seems to be working fairly well, and I can get several Spanish, German and Swedish stations, as well as two Parisians, Brussels, Rome, Vienna and several unidentified foreigners. But I notice that on the 5 N O transmissions I can turn the H.F. valve filament right out, without making an atom of difference to the strength of reception. Why is this?

On the strong transmissions from the local station, there is little or nothing to be gained by H.F. amplification.

The reason that you hear these programmes when the rheostat is turned off is that the inter-electrode capacity of the valve acts as a by-pass condenser, passing the impulses along to the detector valve just like any other small condenser would.

(Continued on next page.)

STOP USING WASTEFUL and EXPENSIVE

HIGH TENSION BATTERIES!

The "Goltone" (Regd.)

HIGH TENSION BATTERY ELIMINATOR

operates your Wireless Receiving Set from the Lighting Mains at negligible cost.

~ Gives Increased Volume and Purity of Tone. ~

A Refinement and convenience beyond praise.

First Cost saved in a Short Time. Plug into any convenient Lampholder.

Complete with Adaptor, Connecting Cord and full instructions

DIRECT CURRENT MODELS.

Model "DJ." Approx. tappings 45 and 100 volts £2 6

Model "D." Approx. tappings 30, 50, 75, 90, and 120 volts £3 0 0

Model "DN." Possesses latest refinements. Perfectly silent. Tappings as Model "D." Suitable for voltages from 200/250 volts £3 12 6

State voltage and frequency of Lighting Mains when ordering.



ALTERNATING CURRENT MODEL.

Model "A." Approx. voltage tappings 30, 60, 90 and 130 volts. Dual tappings are taken from each voltage, thus providing 8 separate tappings. PRICE £5 10 0

What Users Say!

V. M., King's Rd., Rochdale.—It is ideal and there is not the slightest trace of hum. All my H.T. troubles are now done away with, thanks to you, and all my friends have been charmed with it, and NINE of them now possess units like mine.

J. T., The Cliff, Hr. Broughton, Manchester.—The Eliminator is working to my entire satisfaction.

J. W. G., Atkinson Rd., Fulwell, Sunderland.—I am delighted with the results. The increase of volume is great, and no trace of hum whatever.

L. M., Liverpool Rd., Gt. Crosby.—It is without doubt the best I have handled.

G. J., Church Rd., Acton, London.—The H. T. Eliminator is giving great satisfaction. The set is perfectly silent, there being not the slightest suspicion of hum.

G. A. J., Sheffield Rd., Glossop.—I am quite satisfied with the results and the Eliminator is working O.K.

E. J. G., Maulsecombe, Brighton.—After giving it a good trial I find it very satisfactory and have recommended it to several friends who are dissatisfied with H.T. batteries.

S. & Co., London.—I should like to say I find the Eliminator excellent—no hum whatever, and giving wonderful volume.

Fully illustrated 48 page Radio Catalogue on request.

"Goltone" Products are stocked by the Leading Stores. Refuse substitutes



Frederick Road, Pendleton, Manchester.

London Showrooms: 8a & 9, Gt. Chapel Street, Oxford Street, W.1

WIRELESS.—Capable, trustworthy men with spare time who wish to substantially increase income, required where we are not fully represented. Applicants must have practical knowledge of installation of Set and Aerial, be a householder or live with parents, and be able to give references: state age and experience. Address: Dept. 10, General Radio Company, Limited, Radio House, Regent Street, London, W.1.

EASY PAYMENTS Finest 2-valve amplifier set including loud speaker, 120 H.T., D.E. valves, £7 10s.; or 18/9 down and 11 instalments of 15/-.

CASH BARGAINS.

Amplifiers, 17/6 and 21/-; Phones, Telefunken type, 7/9; Fr. T. Houston, 11/-; Good H.T., 50-v., 5/9; Best 66-v., 6/9; or 4-v. (laboratory test), 4/- doz. Famous Metal Valves. (French), 2-v. 2. 5/-; 2-v. .06, 6/9; 2-v. .5, Power, 8/9; 4-v. .06, 5/6. Straight line Condensers, 5/9; Ditto, 4" dial, 7/3. Transformers: Habana, 3/6; Radiolye, 3/8; Fr. T. Houston, 2/3; Brunet, 2/9. Also Ferranti, Eureka, Formo, etc. Postage extra. Everything in Wireless reliable and cheap. Satisfaction or cash refunded.—Music Roll & Gramophone Records Exchange, 29, High St., Clapham, London, S.W.4.

ALUMINIUM COIL SCREENS!!!
ALUMINIUM COIL SCREENS!!!
Constructors save money and get perfect results by using our Screens. Suitable for Solodyne, Newflex, and all screened coil receivers.
Beautifully made of heavy gauge metal.
COMPARE Polished 3/6 each Base Extra.
PRICES Frosted 3/3 " Special Prices for Quantities.
Post Free.
SEND TO-DAY!!! R. SIMMO & Co., 51, Costa St., South Bank, YORKS.

TRANSFORMERS REWOUND
Transformers, Phones, Loudspeakers, Rewound and Repaired to Maximum Efficiency. All One Price 4/- each. Don't discard if burnt out. All work guaranteed for 12 months. Write for trade terms. TRANSFORM CO., 116, LINKS RD., Tooting, LONDON, S.W.17

AERMONIC
VALVE HOLDER.
Don't pay more. You can't buy more. New design eliminates losses. New springing system gives better results.
JAMES CHRISTIE & SONS, Ltd., 246, West Street, SHEFFIELD.
London Agents: A. F. BULGIN & Co., 10, Cursthorpe Street, London, E.O.4.

MOVING BLOCK CANNOT FALL

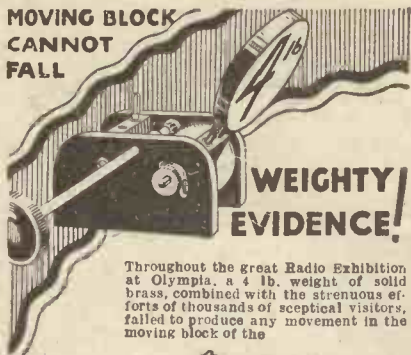

WEIGHTY EVIDENCE!

Throughout the great Radio Exhibition at Olympia, a 4 lb. weight of solid brass, combined with the strenuous efforts of thousands of sceptical visitors, failed to produce any movement in the moving block of the

Price **6/-**

Penton PAT. No. 193,150. **GEARED COIL HOLDER** GEAR RATIO 9:1.

The Only Perfect Coil Holder
The helical interlocking gears make it absolutely impossible for the moving block to fall, even with the heaviest coil made.

PENTON ENGINEERING CO.,
15, Cromer St., London, W.C.1.

Of all good Radio Dealers, or post free direct from the manufacturers.

44 STATIONS on SPEAKER

2 miles from 2LO. Great success of MONOTUNE 3, an advanced receiver designed by O. P. Allinson, A.M.I.R.E., late of Radio Press and Elstree Labs. Three-valve only (Det. and 2 L.F.) includes the highly efficient and powerful O.A.R. circuit, 15 diagrams, photographs, and 12 pages of detailed instructions enable you to duplicate this amazing performance. Order your copy of the MONOTUNE CONSTRUCTONE No. 1 NOW. PRICE 2/6 THE CONSTRUCTONE PUBLISHING CO., 37, Drury Lane, London, W.C.2. Post free.

"VIOLINA" LOUD SPEAKERS

are elegant furniture as delightful as a violin. Model-de-luxe, mahogany or walnut cabinet top type for lid of set or on wall. Liquidation stock of 5-guinea Violinas, fitted 2,000 ohm Brown's reed reproducer, 25/-, packing and carr. 5/-, Violina only 12/6.

ONEMETER buyers should remember that the only Onemeter is the DIXONEMETER a 55 Range Model-de-Luxe radio necessity with in the reach of all. Double Mirror scale, knife pointer, 500 ohms per volt. Dead accurate. Instrument only 55/-. Any Multiplier 6/6.

CONE LOUD SPEAKERS with the Golden Voice. 3-guinea Model, Bronze for 30/-, complete with cord. All the above and a thousand other Bargains at the showrooms of

ELECTRADIX RADIOS,
218, Upper Thames Street, London, E.C.4.

Britain's Best in Radio

LAMPLUGH RHEOSTAT AND POTENTIOMETER



Obtainable from all Leading Wireless Dealers.

RHEOSTAT, the choice of the expert. 3 ohm, 3/-; 15 ohm, 3/3; 50 ohm, 3/6 each. **POTENTIOMETER**, Using the famous Lamplugh Buffer Contact ensures absolutely silent operation. Resistance 500 ohms. 4/6 each.

S. A. LAMPLUGH, LTD.
King's Road, Tyseley, BIRMINGHAM.

Send for **RADIO** Lists.



This mark is our Guarantee.

RADIOTORIAL QUESTIONS AND ANSWERS

(Continued from previous page.)

Evidently the set is working well, as your "bag" of distant stations is a very good one, considering that you have not had the set long.

COUPLING THE REACTION COIL.

A. R. S. (Southend-on-Sea).—In a set having one or more stages of H.F. amplification, I understand that the reaction coil may be coupled either to the tuned anode coil of the H.F. valve, or to the A.T.I. (aerial tuning inductance).

Which method gives the loudest signals?

The loudest signals will be obtained when the reaction coil is coupled to the aerial coil, because the amplifying powers of the H.F. valve are employed to magnify the signals passed originally by the detector valve into the reaction coil.

If the latter coil is coupled to the tuned anode coil, the H.F. valve (first) is not made use of, except in its ordinary capacity as an H.F. amplifier.

POSTAL QUERIES.

It is necessary to remind our readers that only in cases where they wish to make suggestions for future articles, to raise points which can be dealt with in print, or to report results, should they write direct to Mr. Harris (or other authors).

No guarantee can be given of a reply to any letter addressed in this way, even when a stamped addressed envelope is enclosed, and it is pointed out that all questions of a technical nature must be sent to the Query Department, observing the usual rules. Under no circumstances whatever should remittances of any sort be sent direct to Mr. Harris or any other writer, since such remittances do not pass through our usual system of booking, and it is practically impossible to trace them in the event of any subsequent inquiry.

Should there be other receiving sets in the immediate vicinity, it is advisable to react on the tuned anode coil, as, though the reaction would be slightly more effective if coupled to the A.T.I., yet it is not so liable to set up oscillations in the aerial circuit, and thus spoil other listeners' enjoyment.

SHORT WAVE FLEWELLING.

J. G. (Boreham Wood).—Can the Flewelling, or modified Flewelling, be used successfully upon the short waves, round about 60 metres?

Yes. Excellent short-wave results are obtainable, using the circuit shown herewith.

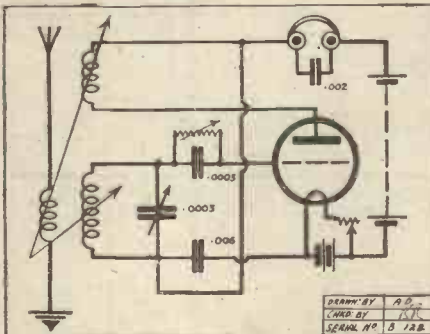

The primary is a 4-turn basket-coil, secondary 8 turns, and reaction up to 20 turns or so. (18 D.C.C. wire is O.K. for the coils).

With the .0003 variable tuning condenser the set is capable of bringing in WGY (40 metres), KDKA (63 metres), and other American stations.

He Wants a Model de Luxe

MULTI-RANGE DIX-ONEMETER

"The Rolls Royce of Radio"

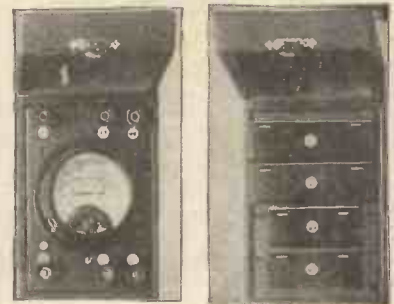

Latest Model.

Mirror Double Scale. Moulded Base.

The finest Precision Multi Measuring instrument is the DIX-ONEMETER. IMPORTANT.—If you are offered a Super-Substitute, ask if it has Mirror Scale, Knife-edge Pointer, 500 ohms per volt, and 55 Ranges.

DO NOT TAKE A FORD arrangement of a meter on a board, a clock hand pointer and a fuzzy scale substitute.

THE DIX-ONEMETER is worth owning.

INSTRUMENT IN CASE, 55/-
MULTIPLIERS, 6/6 EACH

Obtainable from:
Electradix Radios, 218, Upper Thames St. Radiax Ltd., Holloway Rd., N.7. Manchester Radios, 155 Oxford St., Manchester. Eagle Engineering Co., Warwick. Ballantynes, 103, Vincent St., Glasgow, or **LESLIE DIXON & CO., LONDON, E.C.4.**

JARS ZINGS SAGS

Waxed, 1/6 DOZ. Special, 1/- DOZ. High Capacity, 1/6 DOZ.

For making Wet H.T. Batteries, post free on 3 doz. and over. Packed in special carton with division for each cell. This can be used as a container for the battery when made up. Send 6d. for sample complete unit, particulars and instructions. Build a Loud Speaker of the latest type with the Seamless Moulded Cone for the most perfect reception. Easily assembled. All the necessary parts stocked. Call, inspect and hear.

SPENCER'S STORES, LTD.,
4-A, Mason's Avenue, Coleman street, London, E.C.2. Phone: London Wall 2292. (Nr. Bank.)

EVERY LOUDSPEAKER

DESERVES MULLARD MASTER VALVES

— Ask for —
Mullard P. M. Power Valves.

2-VALVE AMPLIFIER, 35/-
1-Valve Amplifier, 20/-, as new; Valves, D.E. .06, 7/-; Headphones, 8/6 pair; new 4-Volt Accumulators, 13/-; new 60-Volt H.T. guaranteed. 7/-; 2-Valve All-Station Set, £4. Approval willingly. Write for free bargain list. **P. Taylor, 57, Studley Rd., Stockwell, London.**

BUILD A LOUDSPEAKER

WITH OUR NEW SEAMLESS MOULDED CONE

(Prov. Patent 25069/26.)

and a BROWN A. or LISSENOA. You will obtain PERFECT RESULTS. Successful Construction for a minimum outlay is ensured with our Specialities. Illustrated Lists and full particulars for Stamp.

GOODMAN'S, 27, FARRINGTON ST., E.C.4.

CORRESPONDENCE.

Letters from readers discussing interesting and topical wireless events, or recording unusual experiences, are always welcomed; but it must be clearly understood that the publication of such does in no way indicate that we associate ourselves with the views expressed by our correspondents, and we cannot accept any responsibility for information given.—Editor.

BUY BRITISH GOODS.

The Editor, POPULAR WIRELESS.

Dear Sir,—May I be permitted to comment on Mr. Fullelove's letter in "P.W." No. 235 re prices and quality of British goods. I use a Flewelling 2-valve, and a neighbour, hearing same, asked me for copy of the circuit. Three-days later he told me he had burnt out both his valves. As everyone knows, there is a .006 fixed condenser between the filament-earth lead and the back-feed from re-action. Upon looking at his set, I saw a cheap fixed condenser marked D.R.G.M., which he stated cost him sixpence off a stall. My fixed condenser is a Dubilier, costing 2s.—but it has not cost me two valves also.

Again, I would like to record the very fair treatment I have received at the hands of the Ormond Co., and also Coscor's. I bought an Ormond S.L.F. Condenser which was slightly damaged upon opening the box. This was immediately replaced. A similar thing happened with a Coscor valve (Stentor Two); I returned same for examination and without quibble the Coscor people returned me a new valve.

In conclusion—I beg to offer the season's compliments to "P.W." and especially now—with such a formidable list of experts, it is far and above the outstanding radio paper.

Yours sincerely, S. GLEED.

5, Approach Road, Raynes Park, S.W.

"P.W." A.C. MAINS UNIT.

The Editor, POPULAR WIRELESS.

Dear Sir—Since you published "An A.C. Mains H.T. Unit" ("P.W." No. 227, 9/10/26), I have carefully perused all subsequent issues for a report on this unit, but without result.

As there may be many people "sitting on the fence," perhaps you would publish my experiences with this instrument.

First and foremost it is a roaring success—not literally!

I did not consider it possible to so completely cut out all hum, but your unit does it. With loud speaker on H.F., Det., 2 L.F., all on and no station working, there is positively *no sound* whatever. With same set am able to get continental stations as hitherto—no extra tuning difficulties.

Volume, using this unit, is increased, mainly, I think, because I am at last applying the full 120 volts to my D.E. O.

Construction is wonderfully simple compared with that of a receiver. For economy's sake I used a wooden panel with ebonite strip for the tappings. (Total cost of wood and strip 1/4.)

No second choke or screening necessary. (In this connection I suggest that where it is necessary to screen transformer, a lug should be left on the screen in such a position that it can be connected to the minus terminal of the transformer—but only when H.T. minus and L.T. minus in receiver are connected together.)

Thanking you very much for permanently solving my H.T. problem and giving me a use for my relegated bright Cossors. Yours faithfully,

W. D. RICHARDSON.

53, Cassio Road, Watford, Herts.

Internal Heat Kills Batteries Why?

ELECTROLYTE HEATED BEYOND THE LOW TEMPERATURE POINT OF 75° FAHRENHEIT.

which it quickly reaches, creates Chemical Heat. Everytime—short or long—that this low degree point is exceeded it then becomes a dangerous destroying Heat which permanently reduces the amperage capacity of each Plate, and eventually kills every Battery.

This is why present day Batteries require constant re-charges. Once damaged by Heat can never again hold a full rated re-charge. The modern Car Battery is also excellently assisted by the inseparable block of Wood and Plates. Celluloid Ebonite and other compound containers are all Heat retaining materials cemented into a solid block, and thereby the heat, fire and explosion risks are considerably increased and intensified. In another advertisement we give some facts on Gas in Batteries—the bye-product of excessive Heat.

Tungstone guarantees negligible internal resistance. How?

Tungstone is Entirely ALL Metal—WITHOUT WOOD and CELLULOID—which holds the heat.

METAL is the Ideal disseminator of Heat.

HEAT is dissipated as rapidly as made through the Tungstone patented Glass Valve Vent Plug.

BECAUSE Independent and Airy Plate Separation gives free and unfettered diffusion of the Electrolyte always at very low temperature rate and minimum rise.

FREE AIR is always freely circulating round the FOUR OUTSIDES of each 2-Volt metal container.

CONTINUOUS OVERCHARGING cannot create excessive heat.

TUNGSTONE High Tension 60 Volt Battery 3 a.h. is sold in the United Kingdom on monthly payments over extended period. Apply for particulars. Further interesting information on points of this advertisement are to be found on pages 58, 59, and 67 of the Illustrated Booklet "Photography tells the Story" which will be sent free on application to the— T.A.45 TUNGSTONE ACCUMULATOR CO., LTD., St. Bride's House, Salisbury Square, London, E.C.4



New Machinery

Expensive new machinery winds Waimel Chokes far better—each turn of wire exactly parallel with cotton between each layer. Remember Waimel Auto-Chokes have transformer volume with Choke purity.

Waimel

AUTO-CHOKER

The Waimel Wireless Co., Ltd.,
332a, Goswell Rd., London, E.C.1
Telephone: Clerkenwell 7990.
Representative for Lancs., Yorks., and Cheshire.
Mr. J. B. Levee, 25, Hartley St.,
Levenshulme, Manchester.

SPECIAL NOTE.

All communications concerning advertising in "Popular Wireless," "Modern Wireless," and "The Wireless Constructor," must be sent to

JOHN H. LILE, LIMITED,
4, Ludgate Circus,
London, E.C.4.
(Phone: CITY 7261.)
and NOT to the Editorial or Publishing Offices.

PICKETTS-CABINETS
For every Constructor.
Estimates to your OWN sizes and LISTS FREE.
Picketts Cabinet (P.W.) Works, Bexleyheath.

SUPREME
in the
ST **TWO VOLT**
class

H.F. S.T.21(0-1A)-14/-
L.F. S.T.22(0-1A)-14/-
POWER S.T.23(0-15A)-186

POINT ONES WHICH GIVE THE HIGHEST EFFICIENCY ON THE LOWEST H.T. (60 VOLTS AMPLE)

BUILT LIKE THE PYRAMIDS—TO LAST

BARGAINS—No. 211a

CRYSTAL SETS FOR B.B.C. 3/6. With Phones, 7/-
LOUD SPEAKER BOBBINS. Wound to 1,000 ohms,
4d. Unwound, 3d. pair. Loud Speaker Cords, 1/-.
LOW LOSS RECEIVER INDUCTANCES, 6 by 2½ ins.,
15 taps to plug sockets on ebonite panel, 200/2,000
metres, 5/-.

H.F. CHOKES ON EBONITE, 1/6, 2/6, 4/6. Cut-out
parasitic currents, 2-valve panels, with holders,
fitted 4 Antipong Springs, 3/6.

VARIOMETERS. B.B.C. 2/6. Polar 8/6.

WIRE. New 22 Gauge Cotton-enamel covered, 1/8
lb., cut price. Two tons all gauges in stock. Navy
7/23 Enam. Aerials. Superflex 3/- 100 ft.; Electro-
nic Aerial, 100 ft., 1/3; 500 ¼-oz. reels, 28 gauge
S.C.C. Wire, makes two Broadcast Coils, 4d. each.
Twin Flexible Cord, 2/6 doz. yds. 5/36 Silk-covered
Flex, 12 yds., 9d. Flex, rubbered, 1/- doz./yds., 100
yard coils, cheap, 6/6.

PHONE CORDS. Brown's Head, Double, new, 1/6;
Lightweight, 1/3. Single Cords, 6 ft., with solo
plug each end, 9d. Twin L.T. Battery Cords, with
spade ends, 1/- Single Phone Cords, 7d.

LOUD SPEAKER EXTENSION WIRE. 6/- 100 yds.
Transformer Coil-Wire, 1/3 lb. Stampings, 1/- doz.

NEW R.A.F. 4-WAY SWITCH-PLUG AND SOCKET
FOR L.T. AND H.T. 4-pin plug and socket with
cord, push switch for L.T. Neatest device for con-
necting to set. Cheap, 4/6 pair.

PLUGS AND JACKS, 2/6. Dewar's 1-way, 1/6; 3-
way, 2/6. 2-pin Lucas Plug and Sockets, 4d. pair.
Panel 2-pin Base and Plug, 8d. Adapters, 4d.

EARTH MATS. Mesh, Good Earth for short waves,
12/6 each. Earth Spikes, 1/3, Earth Clips, 6d.

AEROPLANE AERIALS. 110 ft. 7-strand hard-drawn
H.C. Copper Wire wound on bobbins to run out
freely. Sale price, 1/3; post 3d.

VALVES. D.E.C., 25 amps, 9/- Microslix Famous
06 valves, 7/6. Transmitting Valves, 17/6; 10
Watt, 15/- 250 Watt, Osram, Cossor, 40/-

INTERVALVE IRONCLAD TRANSFORMERS. Ratio
5 to 1, Type E, 3 to 1. Latest at reduced price of 7/6,
500 CHOKES FOR SMOOTHING. We have a few
hundred ex-W.D. Marconi 1,000 or 3,000 ohms, 4/-.
Small type 1/6. H.T. from Mains, 25/-.

2,000 MAGNETS FROM GOVERNMENT LAB. for
experimenters, 4 in. Bar Steel, 9d.; 10 in. ditto,
1/-; Horse Shoe, 1/-; Magnet Needles, Agate
centres, 9d., post extra. Pivot Pillars, 6d.

SLATE PANELS. Polished face, ½ in. thick, 5/8 per
sq. ft.; 1 in. thick, 6/6 per sq. ft. Plain Slate Bars
for Power Rheostats, 10d. each.

HEADPHONES. Ex-W.D. Brown's, 1,500 ohms.
A reed type, 30/- pair. 2,000 ohms single
receivers, "A" 12/6, Alumin. Headbands and
Swivels, 1/9. Pleated Parchment Paper for
Diaphragms, 2/6. MEL Headphones and Cords,
4,000 ohms, 8/- Single L.R. phones, 1/4 each, with
cord, 1/10. 4,000 ohm Ericsson with Headband
and Cords, fine tone, 9/6. Three days' trial.

SULLIVAN Double Headphones, L.R. type, new,
100 sets, 3/6 pair. B.T.H., 12/6; Marconiphones,
11/6; Magniphones, 11/-; Hezaphones, 10/-
All first-class English, new, with cords.

PRECISION INSTRUMENTS. Finest stock in London.
Mov. Coils to 500 m/a, etc., 20/-; 3-range Milliam-
meters, 37/6; 2-range Voltmeters, 6/120, 11/6;
0-30 volts, 10/-; 120 volts, 20/-; 600 volts, 55/-;
0-1,000 volts, 23; 1,500 volts, 24 10s.; 2,500
volts, 28; 50 Mov. Coil. Siemens Coil Testers,
15/-; 250 m/a or 500 m/a Thermo Meters, 15/-;
Megohmmeters, 500 volt. 50 megms., 28 10s.

SUNDRIES. Electric Bells, 1/6. Morse Sounders, 10/-
each. Morse Keys, with cover, 2/6. Aerial Erecting
Sets, 2/6.

Inductance Coil Blocks for Het., ebonite, enclosing
two basket coils, 4/6.

600 Potentiometers. 350 ohms, 2/6. Panel 600 ohms,
4/6. 3,500 ohms, 9/6.

Protractors. Engraved Double 0-180, in leather case.
Taylor, Hobson. Cost £2. Our price 8/-.

Switchboxes. Lucas 3-way Switches, in walnut case,
with flush metal cover, 3 levers, 1/3; 8-way, 4/6.

Grid Leaks. R.A.F. 2 and 4 megms., 1/-; 10 megms.,
1/9; Marconiphone Sterling, all ranges, 1/2.

Insulators. The R.A.F. Light Weight Aerial Insu-
lators, brass ring and screwed tension stem. Millions
in use, 10,000 in stock; 1/6 a dozen. Bell Porce-
lain, 1/3; Transmitting Insulators, 1/6.

Hanley Porcelain Lead-in Tubes. Straight or drip-
proof ends, 6d. and 9d. each. Egg or shell of China
reels, 1d. or 10d. per doz. Bullerdix Bell Aerial,
1/-; large, 1/3.

Mica Sheets. Best Ruby Mica for Condensers, .002,
2 by 2 by .002 thick, 1/- per doz.

Condensers. 2 mfd. ex-W.D., 2/6. New 1 mfd., 3/8;
2 mfd., 4/8; 4 mfd., 6/8.

Polar Surplus, All New. Precision Condensers, .0003
list, 12/6. Sale, 4/6. Polar Panel 2-way Coil Holders
Polar Varia H.F. Transformers 300/500, 3/6. L.F.
Intervalve, 7/6. Dubilier Anode Res., all sizes,
3/6. Holders on ebonite, 1/- Polar Semi-fixed
Detectors, 2/6. Polar Variometer on panel, scale
and dial. List, 21/- Sale 3/6.

The finest stock of perfect and accurate apparatus for
immediate delivery in the City. Please call.

4d. Catalogue, 600 illustrations. Saves you Pounds.

Have you bought your **DIXONEMETER** yet?
De Luxe Instrument 55/-, Multipliers 6/6 each.

ELECTRADIX RADIOS.
218, Upper Thames Street.
Blackfriars Stn., Met. Rly. Tel: City 0191.

TECHNICAL NOTES

(Continued from page 1038.)

its object the "gingering up" (so to speak) of dull-emitter filaments, particularly the plain thoriated-tungsten type. According to the manufacturers it is possible, by means of a reactor, to save nine out of ten valves which would otherwise be discarded for loss of emission.

As most of my readers know, the thoriated tungsten filament depends for its specially high emissive property (at any rate, according to prevailing theories) upon the presence on its surface of an extremely fine film of thorium which diffuses by some means, not at present properly understood, from the body of the filament and which gives at a dull red heat a much greater electronic emission than would be given by the plain tungsten not thoriated. There is a great liability for a dull emitter filament to be operated at a somewhat higher temperature than that specified by the makers, and if this is done it means that the thorium at the surface is dissipated more rapidly than it can diffuse out from the interior—without relying upon any particular theory as to how it gets there—more rapidly than it can be replaced.

The Cure.

The dissipation of the thorium on the surface of the filament is much accelerated by the application of a high potential difference between the filament and the anode, or, in general, by the application of a strong electric field which draws away the electronic emission from the filament. The basis of any reactivation process is usually the raising of the filament to a temperature considerably higher than its normal working temperature without the application of any electric field to draw away the emission.

In subjecting the filament to the high temperature and in carrying out the re-activation process generally, there is danger of burning out the filament or, if not that, of damaging it seriously, and some skill is called for to carry out the reactivation process safely and successfully. The re-activators or rejuvenators are really devices which take care of the filament and permit the reactivation process to be carried out with safety by the uninitiated.

HEADPHONES REPAIRED

Re-wound and re-magnetised 5/- per pair. Loud Speakers repaired 5/- Transformers re-wound 5/- each. All work guaranteed and tested before delivery. Write for Trade Prices. Phone Clerk 1790. MASON & CO., 44, East Road, City Road, N.1.

ALL MANUFACTURERS' GOODS ADVERTISED IN THIS PAPER

Can be obtained C.O.D. or Cash with Order, per return, from

YOUNG'S (GLASGOW) LIMITED.
40, STOCKWELL STREET, GLASGOW.
Write To-day for Big Free Catalogue.

LITTLE WIRELESS GADGETS



MAP

THE VERNOB Ltd
Prov. Pat. 27071 & 22489

MAP Co., 246, Gr. Lister St., Birmingham.

We regret that the photograph of Mr. De Groot which appeared in our Xmas number was published without his approval.

"COMET" TUMBLER SWITCH



Single hole fixing panel type.

The Switch you have been looking for .. each **1/9**

The LONDON COMMERCIAL ELECTRICAL STORES LTD., 13, Farringdon Ave., E.C.4

WET H.T. BATTERIES
BUY BRITISH Complete Units 3/6 per doz. All goods BRITISH MADE by BRITISH LABOUR. Jars 1/3. Zincs 1/6. Sacs 1/6 per doz. Carriage and Packing extra. Trade inquiries invited. — Devo on Battery Co., 59, Badiis Rd., Walthamstow, E.17

A Small Deposit Buys the Set you want!

How often have you wished for a multi-valve Set, but have been discouraged by the cost? Our Catalogue "P" tells how almost any well-known Receiver can be yours for a small initial payment. Everything is guaranteed. Let us know your requirements and we will advise you. Write to

6665

New Times Sales Co.
77, City Road, E.C.1



LIFE LONG H.T.

Tromba units are constructed of the finest quality sacs, zincs, jars, etc., and creeping of the electroflite and other troubles usual to Leclanche cells eliminated. In units or any size battery to order in Mahogany Case with glass cover. Amalgamated zincs 6d. doz. extra. Sample unit and sample large capacity Sac., post free 1/-. Send to-day for free descriptive folder, etc.

TROMBA ELECTRICAL CO.
17, WHITE HART LANE, TOTTENHAM, N.17.



The TANNOY

ALTERNATING CURRENT H.T. BATTERY ELIMINATOR

without smoothing choke and condenser **25/-**
COMPLETE with above (2 Tappings) **50/-**

H.T. Accumulator Chargers from 35/- L.T. " " " " 39/6

Negligible Consumption. Reliable and Efficient. COMPONENTS supplied for home construction.

Write for detailed price lists.

THE TULSEMERE MANUFACTURING CO.
TULSEMERE RD., WEST NORWOOD, S.E.27.
Phone: Streatham 2268.

Valves Repaired

AS GOOD AS NEW!!



(Except Weco, S.P.'s and low capacity types). Minimum D.E. Current 0.15 amps when repaired. ALL SIGHT & SOUND & ATTEN. Listed at less than 10/- Minimum charge 9/- VALCO Ltd., Dept. P.W. Tab. Grove, Wimbeldon, S.



Trelleborgs GENUINE EBONITE

Experts choose it — it's Choice!

STOCKED BY ALL THE BEST DEALERS
TRELLEBORGS EBONITE WORKS Ltd, Audrey House, E.C.1

4 - ELECTRODE VALVES



We are the suppliers of the genuine U.O. and Thorpe valves, as specially tested and recommended by the "Undyne" inventors and "Popular Wireless" U.C.5 and Thorpe K.4 (both 4-electrode 5-pin valves), each, post free. **10/6**

Order direct from—**LUDGATE RADIO CO.**
Cash with Order

56, LUDGATE HILL, LONDON, E.C.4

RADIO FOR THE MILLION



Perfect Radio—
Mullard brings it home to you

**FOUR WONDERFUL CIRCUITS
WITH FOUR BLUE PRINTS**

FREE

Every wireless amateur will welcome this great opportunity to build quickly and at little expense up-to-date receivers in keeping with the new high standard of modern valve design, made possible by the Mullard P.M. Series of Radio Valves with the wonderful P.M. Filament.

"Give us master circuits for your P.M. master valves," has been the demand from thousands of P.M. Valve users.

Here is your chance. Get this free book, "Radio for the Million." Gives you new radio outlook and endeavours for 1927.

The chapter "The Choice of a Receiver," alone, is a gold mine of lucid information.

Get your copy at once and make your existing components, with a few extras, bring greater zest to your radio pleasure.

Fill in the coupon to-day.

Mullard

THE • MASTER • VALVE

THE VALVE WITH A PUBLISHED
NATIONAL PHYSICAL
LABORATORY TEST

The
Mullard Wireless
Service Co., Ltd.
Mullard House, Denmark St.
London, W.C.2

Please let me have, free and at once, a
copy of "Radio for the Million," price 1/-,
either direct or through my nearest radio dealer.

(Your Name) M.....
Address.....

P.W.

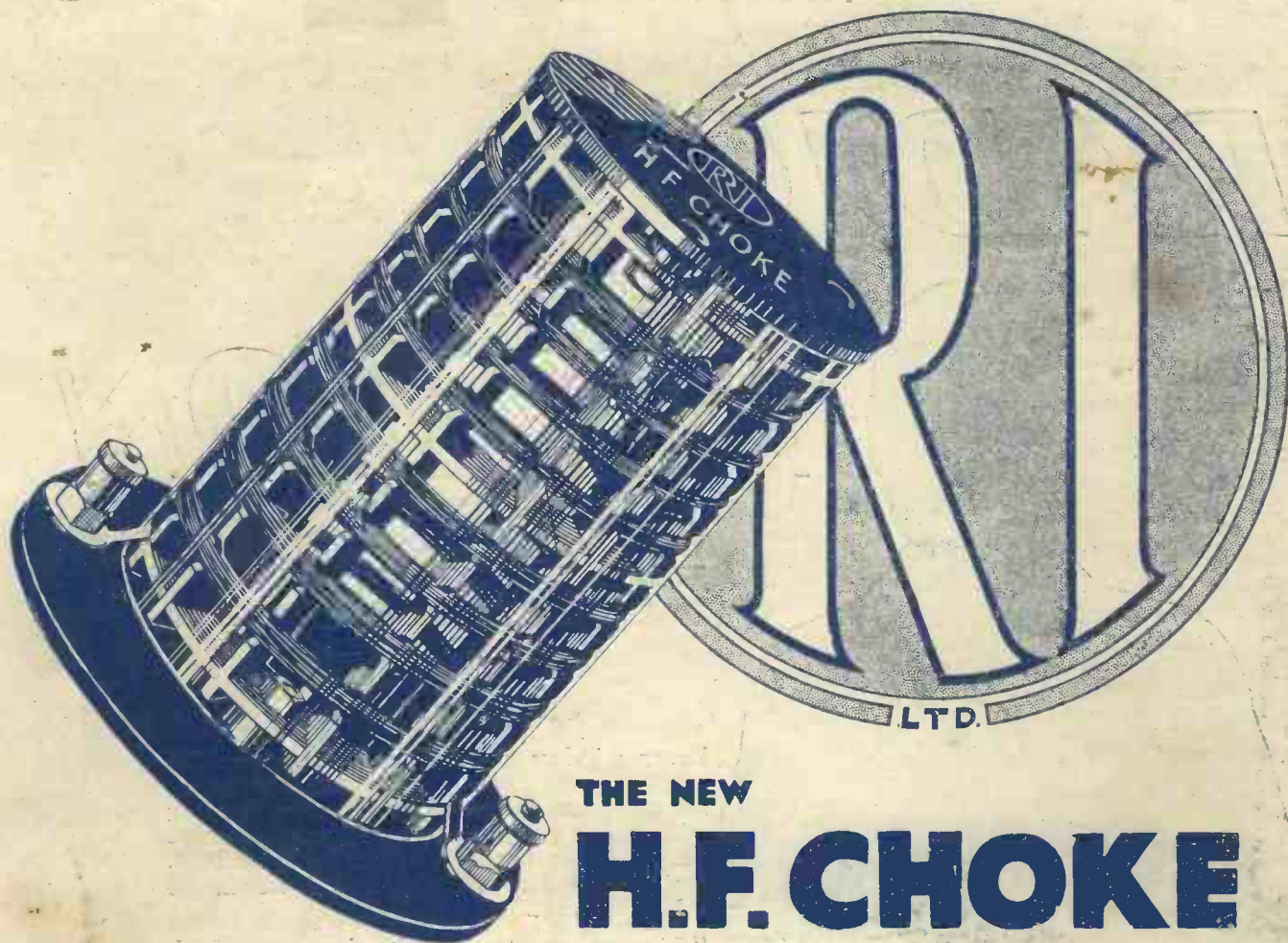

THE NEW

H.F. CHOKE

WILL BE THE BIGGEST FEATURE THIS YEAR

Here is another remarkable R.I. component designed for circuits where a tuned-grid circuit is employed.

Being an R.I. product it has all the features necessary to give improved working of this circuit, for, as it is used virtually in parallel with the tuned circuit it is important that the high-frequency resistance and self-capacity are negligible in order to maintain selectivity and efficiency.

Hence the New R.I. H.F. Choke possesses a high impedance value and is wound in well-spaced sections on a low-loss skeleton former. For wavelengths of from 50 to 4,000 metres it is quite suitable and no observable increase in the H.F. resistance of the parallel tuned circuit will result.

It is a precision instrument well in keeping with the sound engineering tradition of R.I. Ltd. Perfect in design and workmanship it is an outstanding example of the dominating influence of this progressive company in the wireless field

As
recommended
and used in
Mullard
P.M. Circuits

PRICE 12/6

Write for the R.I. Catalogue.

THE MARK OF



BETTER RADIO