

# The Post Office Electrical Engineers' Journal

R.A. Roe.  
PE21

---

VOL 72 PART 3 OCTOBER 1979



# THE POST OFFICE ELECTRICAL ENGINEERS' JOURNAL

VOL 72 PART 3 OCTOBER 1979

## Contents

<b>Editorial</b>	137
<b>Architecture of System X</b>	138
<b>Part 1—An Introduction to the System X Family</b> J. Tippler	
<b>The Formation of the New National Post Office Telecommunications Museum—J. M. Avis</b>	141
<b>Architecture of System X</b>	142
<b>Part 2—The Digital Trunk Exchange</b> N. J. Vanner	
<b>A Microprocessor-Controlled Teletraffic Logging Device</b> J. D. Smith	149
<b>Development of an 11 GHz Digital Radio-Relay System</b>	153
<b>Part 2—System Configuration and Parameters</b> E. G. Jarvis and R. P. I. Scott	
<b>A New Equipment Practice for Transmission and Other Applications: TEP-1(E)</b> N. G. Crump	160
<b>Continuous Power-Generation at the Goonhilly Satellite Communications Earth Station</b> C. Archer	166
<b>Viewdata Abroad—The Technical Aspects</b> K. E. Clarke	172
<b>DC Power Supplies to Telecommunications Equipment: Distribution, Earthing and Protection Against Induced Transient Voltages</b>	175
<b>Part 1—Past and Present Arrangements</b> P. C. Wilson	
<b>Digital Recording on Magnetic Tape and the Recorder Tape No. 3A</b> H. E. Westaway	180
<b>Plessey Pentex Installation in the UK Network</b> B. M. G. Brooks and A. M. Belenkin	186
<b>An Injection-Welded Joint Repair—R. Bundy</b>	190
<b>Developments in Frequency-Shift Voice-Frequency Telegraph Equipment</b> A. M. Brown	191
<b>Telecommunications Museum in the South-Eastern Telecommunications Region—J. M. Smith</b>	197
<b>Institution of Post Office Electrical Engineers</b>	198
<b>Notes and Comments</b>	200
<b>The Associate Section National Committee Report</b>	201
<b>Associate Section Notes</b>	201
<b>Forthcoming Conferences</b>	202
<b>Book Reviews</b>	152, 159, 179, 197

Published in April, July, October and January by *The Post Office Electrical Engineers' Journal*, 2-12 Gresham Street, London EC2V 7AG.

Price: 55p (80p including postage and packaging). Orders by post only.

Annual subscription (including postage and packaging): home and overseas £3.20.  
(Canada and the USA \$6.50.)

Price to British Post Office staff: 36p.

© 1979: The Institution of Post Office Electrical Engineers.

# Approved Components



Mullard is a leading supplier of components  
used by the Post Office



Mullard Limited, Mullard House,  
Torrington Place, London WC1E 7HD.  
Telephone: 01-580 6633  
Telex: 264341

# Mullard



Mullard manufacture and market electronic components under the Mullard, Philips and Signetics Brands.

# 'Protection'

A WORD THAT ENCAPSULATES WHAT M-OV DOES FOR TELEPHONE SYSTEMS.

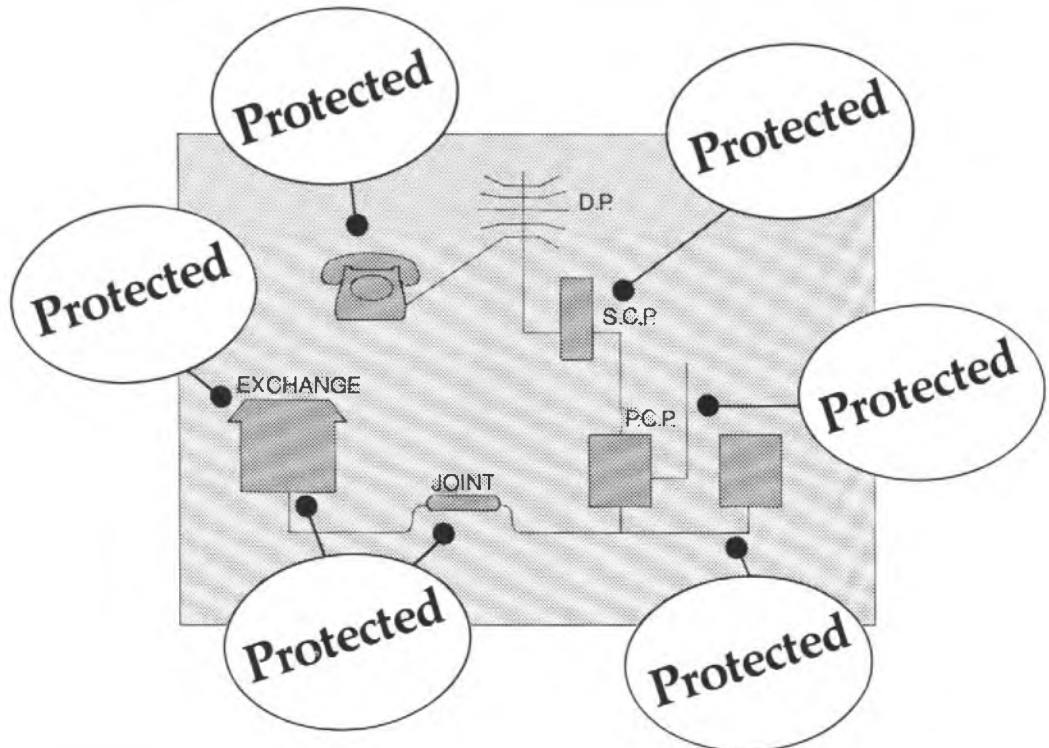

Necessity is the mother of invention!

A truism perhaps, but the depth of M-OV's experience and innovative ability can indeed be judged by the way we solve electronic protection problems.

For example, modern electronic telephone installations need protection at many points in the network from main distribution frames in telephone exchanges to the most exposed parts of the outside plant.

We have developed a range of 3-electrode gas-discharge arresters to cope with all these locations including a miniature encapsulated unit (type 50A) which completely resists the corrosive effects of salt water when installed in coastal regions, and remains ready to spring into action for years. Truly 'fit and forget'.

Again the miniature arrester with wire tails is eminently suitable for all forms of

cable joints. With grease-filled insulation displacement connectors, it is compatible with all PTT outside plant practices.

The same device can be used for subscriber terminals, or where 2-way protection is vital such as Post Office PRESTEL installations.

As well as looking at new installations, we have given a lot of thought to protecting existing equipment. Units have been designed for P.O. Jacks Test 33, 39, 40 and 41 and Fuse Mountings 10064/8064.

If you'd like to know more, contact us at Hammersmith.

SEE US ON  
STAND 110 AT  
ELECTRONICS '79,  
OLYMPIA, LONDON.  
NOV. 20-23,  
1979.

**M-OV**  
A MEMBER OF THE GEC GROUP



**S&C**

A Thorn Ericsson PABX can provide over twenty aids \* to efficient communications. Here is one of them

# Automatic Transfer

After an incoming call has been routed to an extension by the operator, the extension can transfer the call automatically to another extension by use of the service button on the instrument. To avoid a 'lost' call, special safeguards have been built into the system.



For optimum efficiency  
and maximum flexibility

A Thorn Ericsson PABX can be built up with extra lines, extensions or facilities as traffic needs increase.

Planning ahead with a Thorn Ericsson 561 or 562 PABX will give you that efficiency and flexibility that is a real investment.

Contact: PABX Division, Thorn Ericsson Telecommunications (Sales) Ltd., Viking House, Foundry Lane, Horsham, Sussex. Telephone Horsham 64166.

\* Other facilities available include:  
*Barred Extensions (stops unauthorised calls), Hold for Enquiry, Repeated Enquiry, Camp-on Busy, Call Announcing, Trunk Offering, Parking Incoming calls, Automatic Transfer, Night Service (Three methods), Inter PABX connexion (Private wires), Group Calling, Direct Dialling-in, Automatic Call Back and many more*

SAVE TIME. Simply clip this coupon to your letter heading and send to  
**Thorn Ericsson, Freepost, Horsham, Sussex.**

No stamp needed

Name \_\_\_\_\_

Please arrange for me to have:  
details of PABX's

A technical adviser (appointment )

A Demonstration of PABX

## THORN ERICSSON



# CALL LOGGING? InterScan are the experts

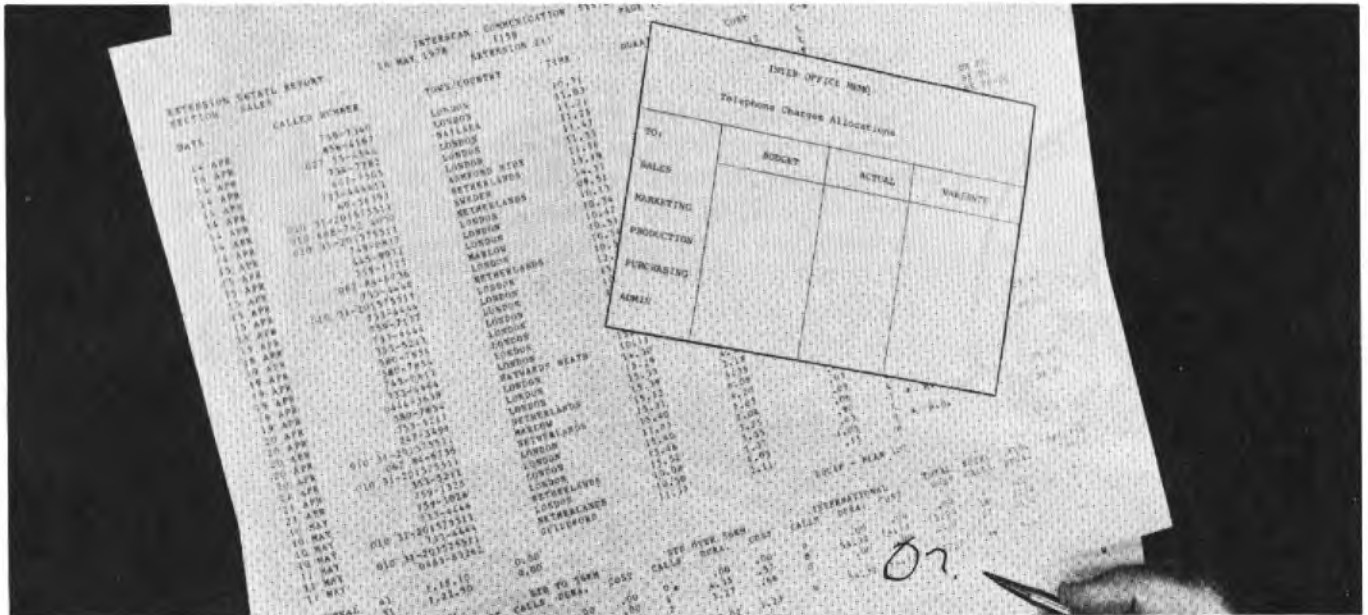

The cost of the telephone service is one of the hardest overhead expenses to control . . . and one of the highest.

The Post Office bill gives the customer the amount he has to pay. It cannot identify how it was spent or how much of it was really necessary.

By using our Call Information Logging Equipment, savings of up to 30% are being achieved by our customers, who range from small to multi-national businesses.

Results like these can only be achieved with equipment that produces comprehensive, easy to understand reports. What's more, an InterScan system enables users to accurately budget and allocate telephone costs, and is an effective aid to network planning.



**interscan**  
communication systems limited

39 Montrose Avenue  
Slough · SL1 6BS  
Telephone: Slough [0753] 70821  
Telex: 848952 · Facsimile Slough 37442

A world of expertise in Call Information Logging, Facsimile and Communicating Word Processing Systems.

*For more information, post the coupon or telephone Moira Pollard.*

Please tell me about InterScan's range of Call Information Logging Systems

NAME .....

TITLE .....

COMPANY .....

ADDRESS .....

.....

.....

TEL. No. .... TJ

# The Post Office Electrical Engineers' Journal

---

## EDITORIAL

### BOARD OF EDITORS

- J. F. P. Thomas, B.SC., C.ENG., M.I.E.E., Chairman  
A. J. Barnard, C.ENG., M.I.E.E.  
K. Chinner  
C. E. Clinch, B.SC.(ENG.), C.ENG., F.I.MECH.E., F.I.E.E., F.S.S.  
E. Davis, C.ENG., M.I.E.E.  
L. W. F. Vranck  
G. White, B.SC., PH.D., SEN.MEM.I.E.E.E.

### Managing Editor

D. J. Holmes

### Assistant Editor

A. R. Lawrence, C.ENG., M.I.E.E.E.

### Secretary-Treasurer

B. Farr

The application of evolving technology to the field of telecommunications engineering is evident: for example, the transistor replaced the thermionic tube; component miniaturization; and the use of integrated circuitry. For the future, large-scale integrated circuitry will, no doubt, find application to an increasing extent; in particular, to equipment designs oriented to the realization of an integrated digital transmission and switching network.

While equipment designers are anxious to incorporate the latest technology in their designs whenever possible, they have always to ensure that, at a defined interface, new designs are compatible with that of existing equipments. One area of constraint on equipment designers is that of equipment practice which, for economic and practical reasons, changes infrequently. For example, in the transmission field, one equipment practice, termed *OEP*, was used by the British Post Office (BPO) throughout the 1940s and earlier to house thermionic tube and large-component equipment designs; new equipment practices were introduced during the 1950s to house the smaller components then available and transistors.

During the 1960s the BPO adopted an equipment practice known as *62-type*, which is based on the use of printed-wiring boards and discrete-component technology. However, in consideration of many factors, including the continued advances in technology and the potential for exports to world-wide markets, the BPO, in consultation with the UK telecommunications industry, has adopted a new design of equipment practice for transmission equipment and other applications, known as *TEP-1(E)*. The equipment practice is described in an article on page 160 of this issue.

The *TEP-1(E)* equipment practice is similar, but not identical, to that used for the housing of System X exchange equipment. This latter equipment is known as *TEP-1(H)* and will be described in a later issue of this *Journal*. The similarity of the two equipment practices is yet another indication of how the traditional switching and transmission disciplines are converging by use of technology and techniques common to both.

# Architecture of System X

## Part 1 — An Introduction to the System X Family

J. TIPPLER†

UDC 621.395.34

*This article provides an introduction to the description of the architecture of the System X family of digital-switched telephone exchanges. Other articles in this series will describe the detail of particular types of exchanges and their subsystems, commencing with an article on p. 142 of this issue that describes the large traffic-carrying exchange (digital trunk exchange).*

### INTRODUCTION

Earlier articles<sup>1, 2</sup> published in this *Journal* have given brief descriptions of the basis of the System X family and of its relationship to the evolving UK telecommunications network. A description of the fundamental techniques and principles that characterize System X has also been given<sup>3</sup>.

This article introduces a set of related articles which will provide more detail, first of the architecture of the system comprising the family (trunk exchange, local exchange, etc.) and then of the subsystems of which they are composed. Further articles will deal with hardware and software technology, development support facilities, and services.

### THE FAMILY CONCEPT

A family is not simply a number of individuals. The individuals constitute a family only because of factors they share in common. Not only may they share physical characteristics, but they also share support systems by living together and learning together; but with all this, they are still individuals and have their differences. So it is with System X.

The parents of the System X family are a large traffic-capacity exchange system based on a large processor (computer), and a medium-size exchange system based on a mini-processor. These two systems are the basis for trunk and local exchanges of a wide range of traffic capacity and, by derivation and adaptation, for junction-tandem, international-gateway, and circuit-switched data exchanges. Special members of the family are the small local exchange, with microprocessor control, the local administration centre (LAC) system, and a new manual-switchboard system.

The first article in this series<sup>1</sup> explained how the members of the System X family share a standardized equipment practice, common technology and software standards, and common documentation and data-base control schemes. It also referred to the use of subsystems, and described in outline how they are used to form an exchange. It is the multiple use of these subsystems, or of their lower sub-divisions, such as functional entities, slide-in units and software modules, that provides the family physical-characteristic analogies for System X.

The subsystems are not invariable. The use of large and small processors has already been mentioned. The differences arise principally because of the wide range of exchange sizes that has to be provided for, and also to some extent because of the different applications; for example, trunk and local exchanges. It is not yet economically possible to meet the whole range of requirements with no variations at all in the design of subsystems. The design of System X aims, however, to minimize the variations and to maximize the use of common elements.

### THE FAMILY RANGE

The exchanges of the System X family are being developed to meet the operating objectives set out in Table 1, from which the wide range of capacity and the prime role of the large and medium systems is readily apparent. This range is designed not only to meet the needs of the British Post Office (BPO), but also to provide attractive ways of meeting the requirements of other telephone administrations. With the flexibility inherent in the System X architecture and designs, it will be possible to modify or enhance the range if necessary. For example, the addition of a large-sized combined local and trunk exchange would be relatively straightforward using the hardware subsystems and appropriate software configurations from the other family members shown.

The statistics given in Table 1 also serve to highlight two of the problems which face system designers in meeting operational needs. At the low end of the range, the small local exchange and the concentrator have to provide for low levels of exchange traffic, and for the relatively very-low occupancy of the switches, controls, and terminations of the customers' concentration stages. In common-control and digitally-switched exchanges, these are difficult requirements to meet economically, and result in special adaptation of the subsystems and special layouts of hardware on racks in order to achieve the desired economy and compactness. However, to a large extent, the actual slide-in units (SIUs) in these smaller exchanges, are drawn from the range of SIU designs developed for the larger exchanges.

At the high end of the exchange size range, the main problem is the achievement of the high level of throughput shown (500 000 busy-hour call attempts). For a common processor, this is a very high rate of call handling, and requires not only that processor operating speed is high, but also that the exchange software is efficient and does not require the execution of too great a number of processor instructions per call. Software efficiency depends not only on the skill of the programmers who produce it, but also on the effectiveness of the language in which it is written and of the compiler that converts it into machine code. From a system architecture point of view, software efficiency also depends on the structure of the software itself and the procedures by which the various parts of the software communicate with each other; the implications of software volume for exchange throughput depend on how much of the software is actually processed in the main processor of an exchange and how much is devolved to microprocessors located with the hardware of specific subsystems. In System X, many of the more routine, but time-consuming operations, are handled in this way by dispersed microprocessors; thus enabling the main processors to concentrate on the essential central functions, with the object of achieving the target capacities shown in Table 1.

† System X Development Department, Telecommunications Headquarters



**TABLE 1**  
**System X Operating Objectives**

	Termination Capacity	Switch Capacity (switched erlangs)	Processing Capacity (busy-hour call attempts)
Multiplexer	24 or 30	4 or 5	
Concentrator	2000	160	8000
Small local exchanges	2000	160	8000
Medium local exchanges	10 000	2000	80 000
Large local exchanges	60 000	10 000	500 000
Medium trunk exchanges	8000	2000	80 000
Large trunk exchanges	85 000	20 000	500 000
Medium international transit exchanges	8000	2000	50 000
Large international transit exchanges	85 000	20 000	400 000
Combined local and trunk exchanges	10 000 subscribers or 5000 trunks in combination	2000	80 000

### EFFECT OF EXCHANGE SIZE ON SUBSYSTEMS

Within a given size range, the amount of equipment installed at a particular exchange depends on the traffic and the number of lines and circuits at that exchange. For instance, in a "large-range" trunk or local exchange, the number of racks of signalling interworking subsystem (SIS) equipment may vary from only a few to several tens, according to the number of trunk and junction circuits served and the relative proportions of digital and analogue circuits. (Very little of this particular equipment is needed when circuits are digital, even for those to non-System X exchanges.) Similarly, the number of racks of digital switching subsystem (DSS) equipment required in a 1000-erlang large trunk exchange is obviously less than the number required in a 20 000-erlang unit. These differences are the natural provisioning differences familiar from the corresponding attributes of earlier systems. Of concern to us here are not these simple provisioning differences, but the differences which occur between different sectors of the size range. The effects in System X in this respect can be illustrated by the following examples, which refer to the medium and large traffic-capacity exchanges.

#### Processor Subsystems

The processor for the medium exchanges is a dual central processing unit (CPU). Each CPU has a number of main store modules reserved for its own use; it shares with the other CPU its access to the remaining main store modules and to the backing stores. The CPUs are operated in a worker-standby mode, the standby CPU and its storage being constantly updated with call information so that it can instantly take over if the working CPU fails. The backing store comprises magnetic-bubble memories.

The processor for the large exchanges is a multi-CPU arrangement, in which the CPUs are operated on a load-sharing basis with no designated standby. This enables both the CPUs and the modular main storage to be provided according to exchange traffic requirements to meet the large capacity ratio embraced in the "large" exchange range. The

provisioning rules make allowance for failure conditions and if a CPU or a store block fails, the remaining serviceable items simply carry on working. The backing store is on magnetic disc units.

These differences in the large and medium-size processors are necessary to enable the exchange-size range requirements to be met with economy. However, the main interfaces of the processors to the exchange are standardized, so that subsystem equipment can generally be connected to either without modification. (The large processor does have one additional interface—direct memory access (DMA)—which has a special use in the large exchanges, but the principle remains the same.) Within the processors, some hardware units, such as storage, are common to both and, perhaps most important, the machine facilities upon which programmers base their programs are largely common, those for the smaller machine being a sub-set of the larger. It is thus possible to produce software which is suitable for running on both machines, saving development effort, and simplifying operational use.

#### Digital Switching Subsystem

Basically, the main digital switching subsystem (DSS) has a time-space-time configuration. Each time-switch function provides for the connexion of 32 line systems with 32 time-slots (30 circuits) in each system. Alternatively, the 32 time-slot systems may be from customer concentration stages or from other within-exchange sources.

In the large-range exchanges, up to 96 such time-switches may be provided, the different time-switches being interconnected by a time-divided space-switch stage, which can grow modularly to the very large capacity implied.

In the medium-size exchanges, provision is made for only 4 of the time switches, which then require only a vestigial space-switch stage for interconnexion. The time-switches are identical to those used in the large exchanges, with the addition of 3 slide-in unit types required to meet the particular needs of the medium-size exchanges.

#### Signalling Interworking Subsystem

Apart from software, the main parts of the signalling interworking subsystem (SIS), are the analogue line signalling interfaces, the time-slot 16 pre-processing units, and the digital tone detectors and tone generators. The interfaces are completely standard for large and medium exchanges, while the other items are substantially so; thus, the majority of the equipment is common to both ranges, with only some differences in rack layout to meet the needs of the medium-size control-area configuration.

The above examples are illustrative of the System X principles of dealing with necessary differences, while retaining desirable consistencies between large and medium-size exchanges. The small local exchanges and the special applications, such as local administration centres (LACs), can make use of parts ranging from whole subsystems, such as the mini-processor, to individual slide-in units or software modules produced originally for the medium or large-size systems.

### EFFECT OF APPLICATION DIFFERENCES ON SUBSYSTEMS

The applications are trunk, local, international, etc., as mentioned previously. Each of these applications requires a core of equipment, consisting of processor, main digital switch, synchronization unit, signalling (interworking and common-channel), and various peripherals. A good deal of this equipment is suitable in its standard form for the various applications concerned. Apart from the existence of the customer concentration stages in the local exchanges, the main significant difference in system hardware is in the range

LEGEND

- Hardware Subsystems
- Software Subsystems (Processor only)

- AOCU Alarm Display and Control Unit
- ATS Alarm Termination Subsystem
- BDTS Bulk Data Transfer Subsystem
- CAS Call Accounting Subsystem (Local exchange only)
- MCS Maintenance Control Subsystem
- MMCS Mass Memory Control Subsystem
- MMIS Man/Machine Interface Subsystem
- MTS Message Transmission Subsystem
- OS Operating System
- TIS Terminal Interface Subsystem
- UPS User Process Subsystem
- VDT Video Display Terminal

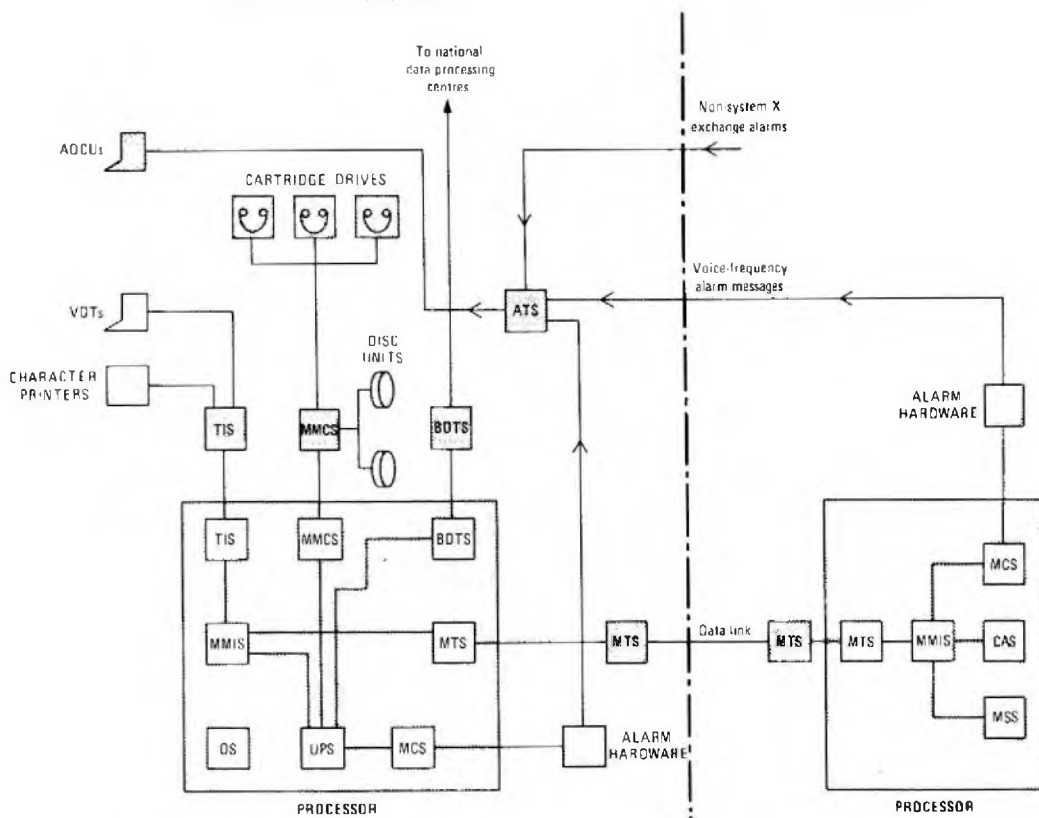

FIG. 1—Block diagram of local administration centre

of signalling interfaces required, especially in the international gateway exchanges, and even this will diminish as common-channel signalling becomes the norm.

Most of the differences arise from the different functions to be performed by the different applications and these are largely defined by the system software. Call handling differences which arise in the different exchange functions (trunk, local, etc.) are reflected mainly in the call processing subsystem (CPS), which consists entirely of software. Other software subsystems which are affected by the application differences are maintenance control, management statistics, and call accounting subsystems. However, in spite of differences occurring in the functional requirements of these subsystems, there are still many similarities from application to application, and many of the basic software modules can be re-used.

The overall picture is therefore of a system with some hardware differences arising from size-range requirements, signalling variety, and the presence or absence of a customer's concentration stage, but otherwise of a system in which different applications are mainly catered for by software variations applied to largely common hardware configurations.

**The Special Applications**

The local administration centre and the manual switchboard system differ in nature from the exchanges. The LAC hardware centres on one half of a standard mini-processor, as used in the medium exchanges; that is, it is an unsecured processor, which is calculated to provide adequate service availability for the purposes of the BPO. The remaining LAC hardware comprises mainly the alarm terminating subsystem (ATS), the modems provided as necessary to link the LAC via data links to the exchanges it supports, and the peripherals used for mass memory (disc units) and for man-

machine communication (visual-display terminals and hard-copy printers). The ATS provides for an independent alarm connexion from the exchange to the LAC to safeguard against data-link or LAC processor failure.

Apart from the ATS, the LAC hardware is therefore largely standard (processor) or proprietary equipment (visual-display terminals, modems), and its special nature is again a function of its software. Even here, there are parts, such as a maintenance control subsystem, a message transmission subsystem and a man-machine interface subsystem, which make significant use of the corresponding elements from the medium-sized exchanges. The composition of an LAC is shown in Fig. 1. The functions of an LAC and its location in the network were described in an earlier article<sup>2</sup>.

The manual switchboard system is currently in development. It will provide the capability for manual positions to be located remotely from the switching centres they serve, and will again make use of common hardware and software elements from earlier applications.

**The Initial Applications**

The System X family has been defined and designed with all the applications discussed above in mind. The early orders include the application of the "large" system to trunk and junction tandem exchanges, and of the medium system to local exchanges, with LACs ordered in support. Other orders now programmed call for concentrator units, large local exchanges, and combined local/trunk exchanges. Order dates for international units and manual switchboard units are under consideration.

**SUMMARY**

The System X family encompasses exchange applications as shown in Table 1, together with special applications such as

manual switchboards and local administration centres. Any of the exchanges listed in the table may be used independently within an existing network, though there are naturally advantages when the members of the family are used to complement each other in a network which makes use of the power of the System X features of common-channel signalling, processor control, and digital switching. Later articles in this series will explain the applications and subsystem in greater detail, beginning with the article on the "large" system as

applied to trunk exchanges, which appears on p. 142 of this issue.

#### References

- <sup>1</sup> MARTIN, J. System X. *POEEJ*, Vol. 71, p. 221, Jan. 1979.
- <sup>2</sup> HARRIS, L. R. F., and DAVIS, E. System X and the Evolving UK Telecommunications Network. *POEEJ*, Vol. 72, p. 2, Apr. 1979.
- <sup>3</sup> JONES, W. G. T., KIRKLAND, J. P., and MOORE, B. W. Principles of System X. *POEEJ*, Vol. 72, p. 75, July 1979.

## The Formation of the New National Post Office Telecommunications Museum

J. M. AVIS, M.Sc., D.I.C.†

In recent years there has been a steadily increasing interest in museums which has led to the establishment of many regional museums and equipment stores, largely as a result of the efforts and enthusiasm of Associate Section Members. One recently opened museum, in the SETR, is referred to elsewhere in this issue. This enthusiasm prompted the Associate Section National Committee to ask the IPOEE Council to consider ways of establishing and maintaining a national museum. Following discussions which took place between members of Council and the Post Office, the Managing Director (Telecommunications) has accepted the creation of a national telecommunications museum as an official commitment and has given the task to the London Telecommunications Region, which already holds the stock from the original Fleet Building Museum. Mr. Neil Johannessen has been appointed curator of the new museum.

It is the intention of Council to encourage the interest in museums and to assist where possible in the formation and running of the new museum. It is for this reason that the Council has appointed one of its members to liaise with the curator, and it is in this capacity that I am seeking your support, both in disseminating information about the new national Post Office Telecommunications Museum and in locating possible exhibits which might otherwise be lost.

The new museum will be housed in Baynard House, Queen Victoria Street, London. The accommodation comprises three floors: at street level there is an exhibition area of about 200 m<sup>2</sup> with a further area of some 80 m<sup>2</sup> intended to be used as an archive room for documents, with sufficient space available for visitors to use when consulting the archives; below street level there is a second exhibition area of about 200 m<sup>2</sup> and below this a tea room, a rest room, toilets and a workshop with storage area. There is also an adjacent area in which it may be possible to display a vintage vehicle. The new museum includes the Post Office Historic Vehicle Collection whose custodian is Mr. Vic Bignell. This consist of several

historic vehicles, some of which are undergoing restoration.

A museum designer has been engaged, but in broad outline the curator is considering including features on the history of telephones, manual boards, telegraph, radio and services such as STD. There may also be a small working exchange and part of the exhibition area will be reserved for temporary exhibitions. The museum is expected to open at about mid-1980. At present the building is only a shell and requires some interior construction work.

One of the curator's main tasks will be to catalogue the equipment and documents held not only by the new national Post Office Telecommunications Museum but also, where possible, by the many regional and local museums and stores around the country. This catalogue will give museums the opportunity of arranging inter-museum loans and exchanges. It is not intended to remove items from local ownership; indeed the curator is in favour of regional museums as he considers that it is better to display equipment than store it. To assist in this cataloguing, will any holders of museums or stores, however large or small, contact me on 01-357 2752.

The curator intends to visit most of the regional museums and to arrange a conference of museum holders to explain the position of the new national Post Office Telecommunications Museum, to find out in which fields the museum holders have particular experience, expertise or interest, and to discuss the problems experienced by museum holders. He is also considering setting up a travelling museum and is looking for City Festivals or similar events which may be suitable for the display of such a travelling museum. The curator has been working on a small display which can be seen on the 9th floor of 2-12 Gresham Street, London EC2.

Unlike the old Fleet Building Museum, the new museum will house documents as well as equipment. The curator is, therefore, looking for suitable material, and it may be that retiring members have old documents, textbooks or course notes which they would be willing to donate to the archive of the new museum. Anyone having equipment or documents which they are willing to contribute to the new museum collection should contact the curator, Neil Johannessen, on 01-622 2738 before sending them.

† Mr. Avis is with the Network Planning Department, Telecommunications Headquarters and is the Museum Liaison Officer, IPOEE Council

# Architecture of System X

## Part 2—The Digital Trunk Exchange

N. J. VANNER, B.SC.(ENG.)†

UDC 621.395.34: 621.395.722: 621.374

*The System X family of digital-switching exchanges includes a range of exchange designs that vary in their traffic-carrying capacities, from small to large. This article describes the architecture of the large-capacity design, which finds application in trunk, junction-tandem, international gateway and data exchanges.*

### INTRODUCTION

Description of the architecture of the "large" traffic-capacity exchange system is given in this article, which is one of a series to be published in this *Journal* describing the exchange systems within the System X family. The architecture of the large system forms the basis of the trunk exchange, the junction tandem exchange, the international gateway and the data exchange. With the addition of a concentration stage of switching, and software modification to provide customer facilities, the design may also be used in the large local exchange.

This article concentrates on the trunk exchange—the digital main-network switching system (DMNSS)—and is divided into 3 main sections: the first outlines the system in terms of its component subsystems; the second describes the functional operation of the switch, the call-handling subsystems and the processor; the third discusses aspects of exchange engineering and technology.

† System X Development Department, Telecommunications Headquarters

### OUTLINE DESCRIPTION OF SYSTEM

A DMNSS is a stored-program-controlled (SPC) digital-switching exchange for use in the main network. In the British Post Office (BPO) telephone network, it will replace the trunk-switching portion of a group switching centre and will handle incoming and outgoing main-network traffic and junction traffic between dependent local exchanges.

The principal elements of a DMNSS are a digital switch, which provides time and space switching, a processor on which application programs run under the control of an operating system, and a means for passing signalling between circuits and the call-handling software. The DMNSS terminates a variety of existing signalling systems for interworking with the present network and a Signalling System Common-Channel No. 1 (SSCC No. 1)\* for communicating with other-System X exchanges.

The DMNSS is highly modular in design and is built-up from subsystems which are rigidly defined in terms of functions and interfaces. The subsystems consist of hardware,

\* The BPO Signalling System Common-Channel No. 1 is based on the current specification<sup>2</sup> of CCITT Signalling System No. 7

SUMMARY OF ABBREVIATIONS USED IN THIS ARTICLE	
ALTS	Analogue line-terminating subsystem.
AMU	Alarm monitor unit.
ATBA	Automatic test break access.
CCU	Central control unit.
CODEC	Encoder/decoder.
CPS	Call-processing subsystem.
CPU	Central processing unit.
DDF	Digital distribution frame.
DIO	Direct input/output.
DLT	Digital line termination.
DMA	Direct memory access.
DMNSS	Digital main-network switching system.
DSS	Digital switching subsystem.
DTU	Data transfer unit.
LAC	Local administration centre.
MCS	Maintenance control subsystem.
MSS	Management statistics subsystem.
MSU	Management and status unit.
MTS	Message transmission subsystem.
MTU	Multi-terminal unit.
MUX	Multiplex.
NSS	Network synchronization subsystem.
OCS	Overload control subsystem.
OS	Operating System.
PROM	Programmable read-only memory.
RAM	Random access memory.
SCC	Signalling conversion circuit.
SCE	Signalling control electronics.
SCR	Signalling conversion relays.
SIS	Signalling interworking subsystem.
SMU	Super module unit.
SPC	Stored-program control.
STP	Signal transfer point.
TST	Time-space-time.
VDU	Visual display unit.

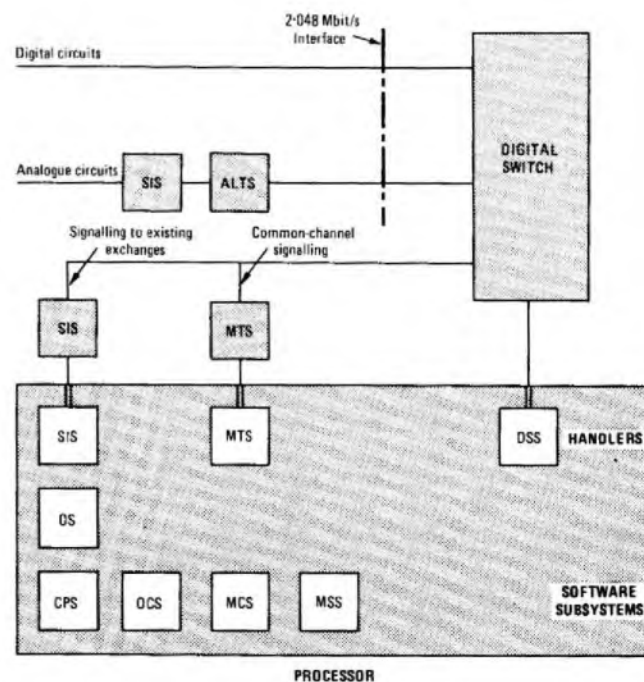

Note: Operating system includes man-machine interface (MMI) function

FIG. 1—Block diagram of the main subsystems used in a digital main-network switching system

software or a combination of both; in the latter case, the software part is termed the *handler* for the hardware. The main subsystems are shown in Fig. 1, with an indication of the division between hardware and software.

### Digital Switch

The digital switch has a standard internationally-agreed line interface, which is identical to that of the BPO 30-channel 2.048 Mbit/s pulse-code modulation (PCM) systems<sup>1</sup>. The switching process, which is in the 4-wire mode, operates in 3 stages in a time-space-time (TST) configuration which is virtually non-blocking. The TST switch path is duplicated and provides a highly secure 64 kbit/s slot-to-slot connexion capability. It can therefore be used to provide access to time-shared logic for handling common-channel signalling and interworking signalling from the present network. This logic comprises hardware of the message transmission subsystem (MTS) and time-slot (TS)16 units within the signalling interworking subsystem (SIS) respectively.

The signalling logic is connected to the digital switch by 2.048 Mbit/s highways, and paths are established through the switch to connect, on a semi-permanent basis, signalling time-slots from line systems to time-slots on highways feeding MTS and TS16 units. The hardware realization of the DMNSS is shown in Fig. 2. A similar technique is used to connect the speech time-slot to a multi-frequency (MF) unit for inter-register signalling, to provide access to tones and recorded announcements and to the multi-party connexion

bridge. This bridge provides a digital multi-way connexion facility, thereby avoiding the need for converting speech back to analogue for mixing purposes. For each of these accesses, the necessary switch paths are established only at the appropriate time during a call.

### Signalling

The MTS hardware performs the functions of error checking and correction of common-channel signals by retransmission; TS16 units provide analysis of interworking signalling. Information is assembled in the MTS/SIS handlers and formatted for passing to the call-processing subsystem (CPS). The MTS or the SIS handlers convert signalling information received from the hardware into a standard message form to communicate with the CPS. The standard interface enables the CPS to operate on calls using different signalling systems in a similar way. There are some minor exceptions, but these are kept to a minimum.

### Call Handling

The CPS is a software-only subsystem, which forms the heart of the system controlling all call-handling functions. Call information from the SIS or the MTS is received by the CPS and stored until sufficient information has been received to determine the outgoing route and circuit. The CPS then instructs the digital switch to connect a path between designated time-slots.

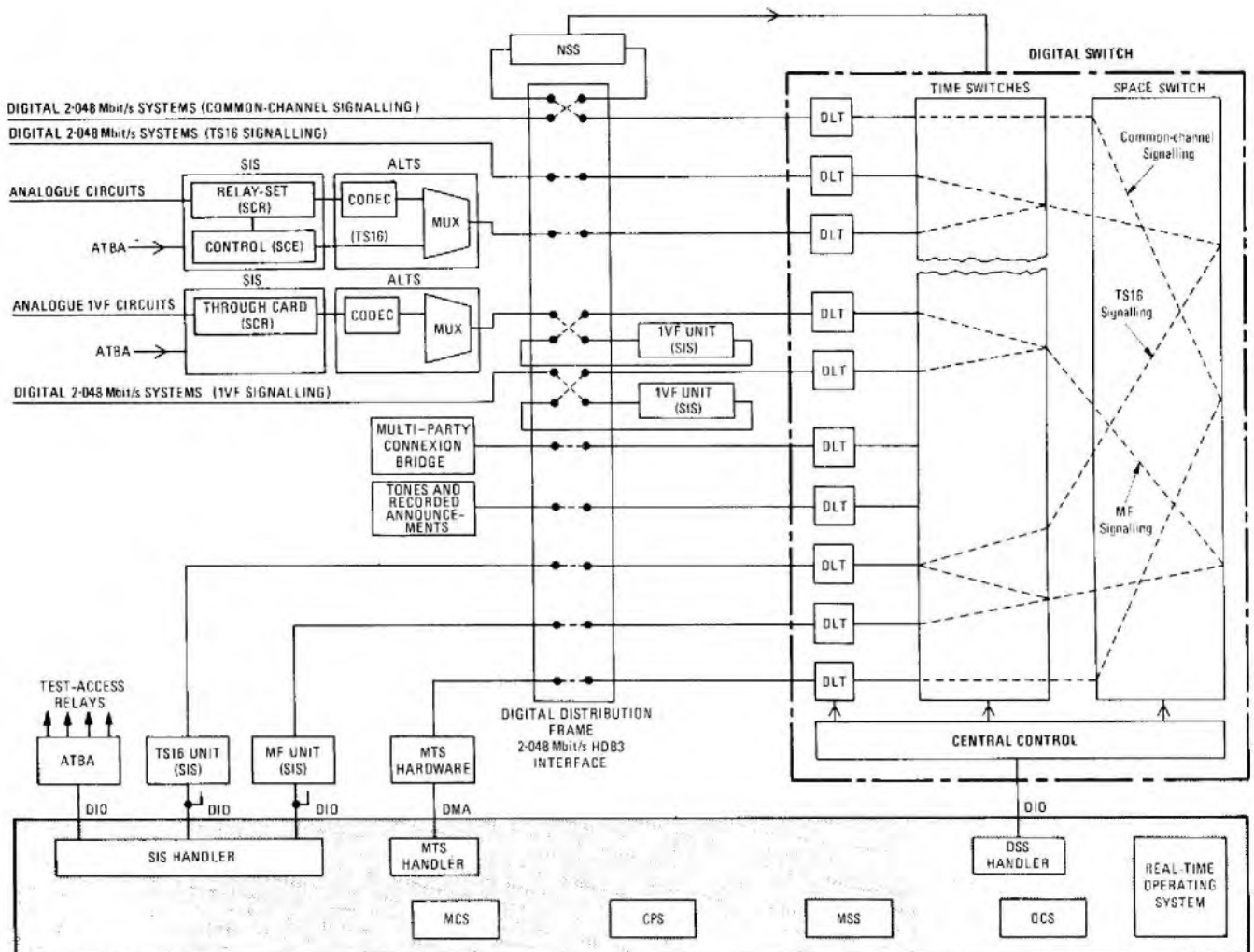

FIG. 2—Block diagram of a digital main-network switching system

## Analogue Circuits

In a fully digital network, signalling complexity will be much reduced but, prior to the realization of a fully digital network, 2-wire and 4-wire analogue interworking circuits will be terminated on the DMNSS with a range of signalling systems. Direct-current signalling is detected at the circuit termination (part of the SIS) and speech is encoded into PCM form by the analogue line-terminating subsystem (ALTS). The ALTS also multiplexes the signalling code into TS16 along with signalling from the other circuits in the 30-channel group. If single-voice-frequency (1VF) signalling is received over analogue circuits, the signal (2280 Hz) is not detected at the termination, but is encoded with the speech.

## 1VF Signalling

Digital tone-detection and generation techniques are used for 1VF signalling. The 2.048 Mbit/s highways containing digitally encoded 1VF tones are connected to 1VF units at the digital flexibility point (digital distribution frame (DDF)). Each unit converts between inband tones and TS16 code, giving a uniform method for handling all interworking signalling.

## Network Synchronization

The network synchronization subsystem (NSS) is connected to one or more designated 2.048 Mbit/s links carrying network synchronization information via the DDF. The NSS extracts this information and uses it to control the secured timing units of the exchange. The equipment was explained in detail in a previous article<sup>3</sup> in this *Journal*.

## Overload Control

At times of abnormally high traffic (for example, due to a fault in the surrounding cable network) SPC systems can experience system overload unless regulation is included in the system design. Overload of the system results in work queues building up and overflowing, information can be lost and attempts at recovery increase the workload, thus aggravating the overload problems.

An overload control subsystem (OCS) monitors the workload in the system to detect the onset of overload and exercises control by requesting subsystems to reduce work levels.

## Maintenance and Statistics

In addition to flexibility, a major advantage of SPC is that processing power can be made available for diagnostics and the measurement of detailed traffic statistics. These functions are handled by individual subsystems under the control of the maintenance control subsystem (MCS) and the management statistics subsystem (MSS) respectively.

Each subsystem is responsible for its own fault detection and location, and for the isolation of the faulty unit. Details of detected faults are passed to the MCS, which assembles fault information for transfer to the local maintenance point and/or to the remote local administration centre (LAC). The MCS also acts as the focal point for the update of data owned by subsystems; for example, modifications to route and circuit tables in the call-processing subsystem (CPS).

The measurement of statistics is controlled by the MSS, which initiates the gathering of information from subsystems and assembles the results for transmission to locations external to the exchange.

## Processor

Subsystem software consists of processes (programs) which run on the processor with their associated data. The processor is based on the GEC Mk2BL processor and operates in a multiprocessor configuration, in which the number of

central processing units (CPUs) provided depends primarily on traffic handled by the exchange.

Any process may run on any CPU, the allocation of work to CPUs being one of the functions of the operating system.

Two types of storage for software are provided in the processor: a fast-operating semiconductor store for immediate access and a slower-operating disc backing store for bulk storage. A CPU can only directly access programs and data held in the main store, but the store capacity is insufficient to hold all such information permanently. The virtual-storage concept employed in the processor is such that a process acts as if all its software is permanently in the main store, and the operating system deals with the transfer between the storage media as required.

The processor must also deal with transfers to exchange hardware. Two methods are used: the direct input/output (DIO) method and the direct memory access (DMA) method. The DIO method provides a simple means of transferring small amounts of data and is used by the digital switching subsystem (DSS) and the SIS. The DMA method, however, is more efficient for bulk data transfer and is used by the MTS.

## SWITCHING, CALL-HANDLING SUBSYSTEMS AND PROCESSOR

### Digital Switching Subsystem

#### Digital Line Termination

Digital line systems, after routing through the power feeding point, final regeneration and DDF, are terminated on digital line termination (DLT) units, which cater for both directions of transmission (see Fig. 3). In the receive direction, the DLT converts between line and exchange code (HDB3† to binary) and monitors the line error rate and the TS0 alarm bits and performs frame alignment. Delay is introduced to the incoming bit stream, to bring the line time-slot structure into synchronism with that of the exchange.

The TST switch is duplicated, and identical 4-wire paths are established in the two security planes for the duration of every connexion. The DLT transmits 8 bit speech samples with an additional parity bit to both receive time-switches, and receives information from both transmit time-switches; each plane is folded back on itself to associate receive and transmit time-switches together. The DLT is able to select from either plane; the choice of which sample is transmitted to line depends, primarily, on correct parity. At times of digital switching subsystem (DSS) growth, the DLT may be biased to one plane, thus allowing the other plane to be extended.

Up to 32 DLTs (a total of 1024 channels) can be connected to each receive and transmit time-switch although, if traffic is greater than approximately 0.95 erlangs per time-slot, then only 31 DLTs will be equipped, thus ensuring an adequate grade of service to those systems.

#### Time Switch

The function of a time switch involves receiving a speech sample, delaying it and forwarding it in an alternative time slot. This is achieved by writing the sample into a store and reading it out at a later time. The time switch consists of two stores: a speech store holding one frame of speech samples, and a control store which specifies the time-slot interconnections (see Fig. 4). The control store has one location for each time-slot of the multiplex which holds the address in the speech store to be accessed at that time. The time switch may be operated by writing-in sequentially and reading-out locations whose addresses are held in the control store, or

† HDB $n$  is one class of highly-redundant ternary codes, known as *high-density bipolar*, of the order  $n$ , where  $n$  is the maximum number of consecutive zeros in the HDB $n$  signal. In this case,  $n = 3$

by reading sequentially and writing as directed by the control store.

The receive and transmit time-switches each have a speech store comprising 1024 locations built up from four  $256 \times 9$  bit

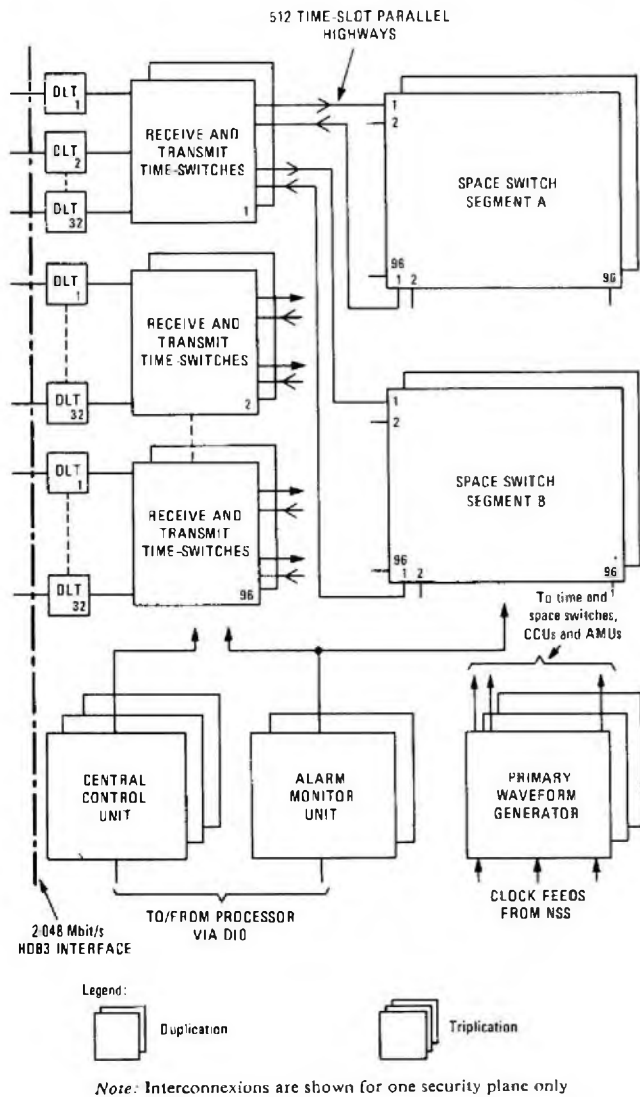

FIG. 3—Block diagram of digital switching subsystem

random access memories (RAMs). As shown in Fig. 5, speech samples are transferred sequentially between a DLT and the two speech stores; however, transfers between the speech stores and the space switch are directed by information held in a shared control-store.

There is one location in the control store for each time-slot of the space-switch multiplex. The location contains the address within the receive speech store to be transmitted to the row of cross points, the address of the crosspoint in the column to be closed, and the address in the transmit speech store where the received sample should be written. The control store is 32 bit wide including control and parity bits and is implemented with RAMs.

#### Space Switch

Two 9 bit parallel highways operating at  $8.192$  Mbit/s (1024 time slots every  $125 \mu\text{s}$ ) pass information to and from the time-divided space switch. To minimize problems of pulse distribution around racks, the 1024 time-slot highway is split into two highways of 512 time-slots (odd and even respectively). Hence, there are two segments of space switching in each security plane controlled on a column basis. The maximum size of the DSS is 96 combined receive and transmit time-switches per plane and, therefore, the maximum size of each segment is  $96 \times 96$ . However, growth is possible in multiples of  $8 \times 8$ .

#### Waveform Generation

The DSS receives triplicated clock feeds at  $2.048$  Mbit/s from the timing units in the NSS. The triplicated primary-waveform

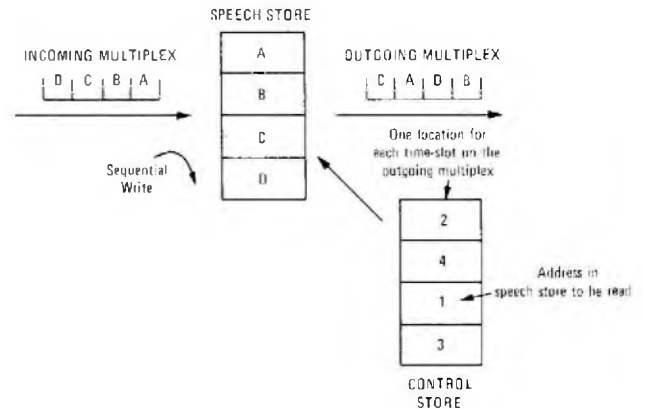

FIG. 4—Illustration of the operation of a time-switch speech store and control store

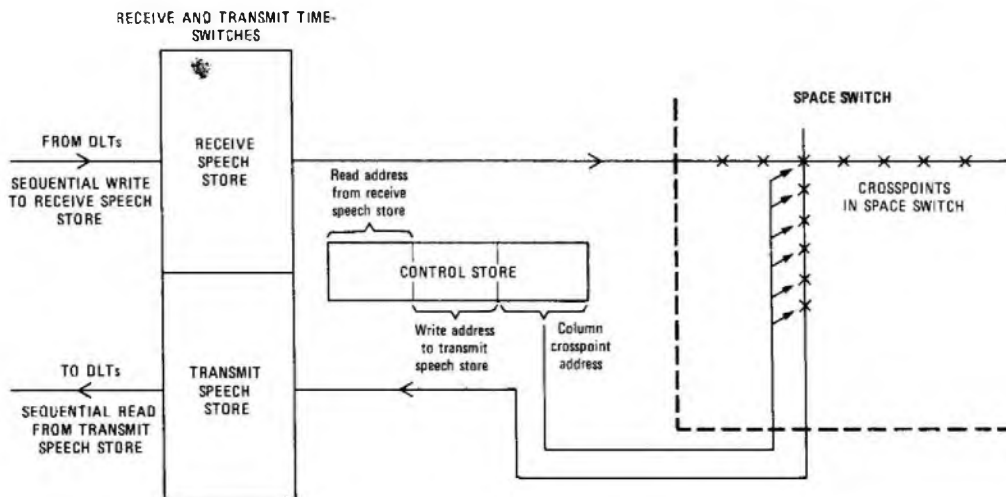

FIG. 5—Organization of the time-space-time digital switch

generator derives and distributes all clock signals required by the DSS.

#### *Control*

There are two hardware units—a triplicated central control unit (CCU) and a duplicated alarm monitor unit (AMU), both of which interface with the DSS handler process running on the processor. The CCU is primarily responsible for path control (for example, set-up and clear-down). The AMU is responsible for monitoring parity failure detectors in the digital switch and collecting line alarm conditions from DLTs. The handler receives requests from user subsystems, CPS, SIS, MTS, and MCS, over a common interface and controls the work given to the hardware. It also performs maintenance and statistics functions.

The DSS is responsible for its own interrogate and marking function, which is performed in hardware by the CCU and time switches together. The CCU receives the two termination identities (digital system and time-slot) and requests the busy/free status of time slots on the highways to and from the space switch. This information is obtainable direct from the two time-switch control stores. A common free time-slot outgoing from the receive time-switch and incoming to the transmit time-switch is chosen, and appropriate information is inserted in the control stores. As switching is 4-wire, a return direction of transmission is also established.

### **Signalling Interworking Subsystem**

#### *TS16 Unit*

A DMNSS will interwork with the signalling systems used in the present UK telephone network; for example, loop-disconnect signalling systems, SSDC, SSAC and SSMF.

With the exception of the MF systems, the signalling conditions of existing signalling systems are converted into equivalent TS16 formats for analysis by common TS16 units, which are terminated on the digital switch using the 2.048 Mbit/s interface (see Fig. 2). A maximum of 30 TS16 channels may be connected to each unit which, therefore, deals with signalling for 900 circuits. In theory, 930 circuits could be controlled (31 TS16 channels) but, in practice, the additional channel is used for test purposes.

The TS16 unit performs persistence checks, signal discrimination and protocol functions with hardware controlled by programmable read-only memories (PROMs) and interfaces with the SIS software using the DIO mechanism of the processor. It also includes, where necessary, duplicated metering-over-junction generators. The units are secured using *m-in-n* sparing and, under failure conditions of a TS16 unit, the TS16 paths affected are automatically re-established to a spare unit.

#### *Analogue Circuit Terminations*

Analogue circuits terminate on signalling conversion circuit (SCC) cards, whose design is dependent on the type and the variant of signalling used on the analogue circuit. For circuits employing DC signalling and SSAC8, the SCC comprises two parts: signalling conversion relays (SCR) and signalling control electronics (SCE), which drives the relays of the SCR (see Fig. 2). The interface to the SCE is via 4 bit TS16 codes which are passed to common SCEs, one transmit and one receive, for multiplexing into the TS16 slot by the ALTS. For circuits using inband 1VF signalling there is no SCE associated with the SCR because signalling information is not extracted; the SCR acts purely as a circuit termination point.

Test-access relays are included in all SCRs and are controlled from the SIS software via TS16. These relays divert the circuit to automatic test break access (ATBA) equipment which provides, under control of the processor, facilities for testing both into the DMNSS and out to line to locate circuit faults.

The number of designs of SCC is dependent on the types and variants of signalling systems which are encountered in the network. Systems which are rarely used will be phased out, but there are still many with which a DMNSS must interwork. There has been some rationalization with the local exchange signalling systems and, currently, 28 designs of SCC have been identified overall, excluding variants due to 600 and 1200  $\Omega$  working and 2-wire-to-4-wire terminations.

#### *1VF Unit*

The 1VF unit is patched into a 2.048 Mbit/s digital system prior to the DLT and, hence, performs line termination functions using circuit elements which are common to the DLT. On the receive side, a digital filter is used to detect the presence of 2280 Hz and the appropriate TS16 code is generated and inserted in the position within the multiframe corresponding to that circuit. On the transmit side, digitally-encoded tones are transmitted to line under control of TS16, these tone samples being permanently stored in the unit. The 1VF unit also performs the line-splitting and guarding functions of 1VF signalling systems. Not all 30 circuits on the unit need to use 1VF signalling; straps are provided on the cards which specify the circuits that should be analysed for a signal frequency of 2280 Hz. Other circuits using TS16 signalling are not affected.

#### *MF Unit*

The MF signalling units, each handling signalling from up to 30 circuits simultaneously, are terminated on the DSS in the same way as TS16 units. On receipt of a seizure over the line signalling system, handled by a TS16 unit, the SIS software allocates a free channel within the unit and instructs the DSS to connect a path between the speech circuit and that channel. The unit is time-shared and uses digital techniques for the detection and generation of the forward and backward frequencies; the low level signalling protocols are controlled by a microprocessor. The unit handles MF2, MF6 and R2 signalling in any combination, it is spared on an *m-in-n* basis and connects with the SIS software through a DIO interface.

#### *Signalling Interworking Subsystem Software*

The signalling interworking subsystem (SIS) software forms the interface between the hardware and call processing subsystem (CPS). In the receive direction, hardware units are polled for information every 10 ms and, in the transmit direction, the software is responsible for loading queues for hardware action. The majority of timings are performed in hardware and, hence, the software stores information and assembles call-protocol messages for passing to the CPS. The software consists of two types of process: the application (signalling) process and the common process, which performs maintenance and statistics functions in common with other subsystems. In exchanges where there is a large amount of interworking signalling, the application process is replicated, which results in additional copies being held in the processor. Therefore, these replications can run simultaneously on different CPUs handling separate simultaneous calls, thus ensuring a high throughput.

#### **Message Transmission Subsystem**

Common-channel signalling between exchanges is carried within signalling modules. The majority of modules will consist of 2 signalling links, although there may be up to 4 links, depending on signalling traffic. These links may be routed over digital plant using a spare time-slot within a digital system (normally TS16) or over analogue plant using 4.8 kbit/s modems. The MTS hardware is organized on a hierarchical basis and makes use of triplication in the majority of its units to provide the necessary security which is essential because of the large number of routes which are dependent on the MTS. A block diagram of the MTS hardware is shown in Fig. 6.



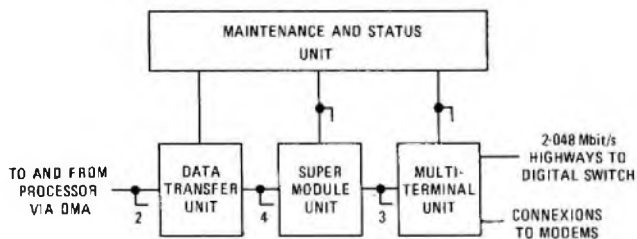

FIG. 6—Block diagram of the message transmission subsystem hardware

#### Multi-Terminal Unit

A multi-terminal unit (MTU), which acts as 31 independent signalling terminals, is connected to the DSS using the 2·048 Mbit/s interface, the digital switch providing access to signalling time-slots on digital systems. The main functions of the MTU are to perform error checking on each signalling link, to monitor the error rate and to control retransmission of messages which are not received correctly the first time they are sent. When no signalling units are available, the MTU transmits signals to preserve synchronization and to inform the distant end of equipment status. The MTS can also terminate common-channel signalling over analogue plant using 4·8 kbit/s modems by the use of low-speed adaptors, which may be used for any speed below 64 kbit/s. Up to 9 low-speed adaptors may be provided per MTU.

#### Super Module Unit

The super module unit (SMU) contains storage for the 3 MTUs which may be connected to it. This storage is used for queuing messages awaiting transmission and for those which have been received over the signalling links. It also acts as a retrieval and retransmission store in that messages can be recovered when a signalling link fails completely and retransmitted over an alternative link within the signalling module.

#### Data Transfer Unit

Up to 4 super module units may be connected to the data transfer unit (DTU), which controls the passing of signalling between the MTS hardware and software using DMA.

#### Management and Status Unit

There is a management and status unit (MSU) associated with each DTU. The MSU is responsible for monitoring the state of all hardware units and signalling modules and reports fault and other status information to the software through the DIO interface. The MSU also translates between destination labels (which accompany messages received by the MTS software from other software subsystems which are users of MTS) and the required signalling terminal, and vice versa.

#### Software

The software comprises 3 processes, an incoming, an outgoing and a management process. The incoming process receives messages from distant exchanges and routes them to the appropriate subsystems, the outgoing process operates in the opposite direction. At exchanges where there is a high percentage of common-channel signalling these processes are replicated to ensure a high message throughput. The incoming process also provides a signal transfer point (STP) facility which allows messages between two exchanges to be routed by the MTS at the third exchange. Such messages are routed by the STP to the appropriate outgoing signalling module via the outgoing process. The management process is responsible for the maintenance, statistical and management aspects of the MTS and works in conjunction with the MSU.

### Call Processing Subsystem

The call processing subsystem comprises 3 processes: call control, on-line update and replication synchronization. The call-control process is replicated to ensure a high throughput; replications are responsible for handling all incoming and outgoing calls over particular geographical routes. The call-control process is divided into an incoming and an outgoing module, the incoming module controls the set-up procedures and the outgoing module controls the call supervision.

The incoming module receives information relating to the call in the form of call-protocol messages from the SIS or the MTS. This information, including digits, is stored in an area of main store termed a *set-up record* and, when sufficient digits have been received, the module determines the outgoing route from a translation table.

A message is passed to the outgoing module of the process replication responsible for that route, which attempts to find a free circuit. If successful, the outgoing module passes back the identity to the incoming module and allocates a further area in main store for use as a *supervision record*. The incoming module then signals over the outgoing route or circuit, using the SIS or the MTS as appropriate.

In general, the incoming module waits until the entire number has been received before requesting the DSS to connect the incoming and outgoing circuits together. The set-up record is then discarded, although the smaller supervision record is retained until the call clears down. Information in both records may be passed to the management statistics subsystem so that detailed call statistics may be derived.

The other two processes are concerned with the management of the CPS, and are primarily used when the data of the call-control process replications is modified; for example, addition of circuits in a route.

### Processor

Main storage is provided in 64 Kword blocks in a structure where each block is accessible by all CPUs (see Fig. 7). To minimize the effect of store contention where 2 CPUs wish to access the same store block simultaneously, one store block is permanently associated with each CPU. Each of these private stores holds identical information, which comprise time-critical parts of the application programs and operating system.

The number of store blocks and CPUs provided may readily be increased as the exchange capacity grows. The amount of main storage required is dependent on program code and data and, although the code is virtually constant, the data increases primarily with the number of circuits terminated. The number of CPUs required, however, is dependent on the mix of traffic and signalling on the exchange, and up to 11 CPUs may be provided. An allowance is included in the provisioning of both store blocks and CPUs for security.

The processor is normally a task-driven machine, where a task transfers information between processes. During design, each process is allocated a priority and, when any CPU becomes free, the process allocation part of the operating system scans all processes with tasks in their input queue and causes that with the highest priority to be run and service its input queue of tasks. Interrupt signals can be handled when necessary. They are processed by the CPU handling the lowest designated priority process at that time; that process being suspended and continued later.

Ideally, when a process runs on a CPU, all the data to which it refers is in the main store. If it is not, then the process suspends operation until the storage allocation part of the operating system has transferred the necessary page of information from the backing store into the main store. In order that this operation does not significantly reduce throughput, frequently-accessed pages are locked in the main store.

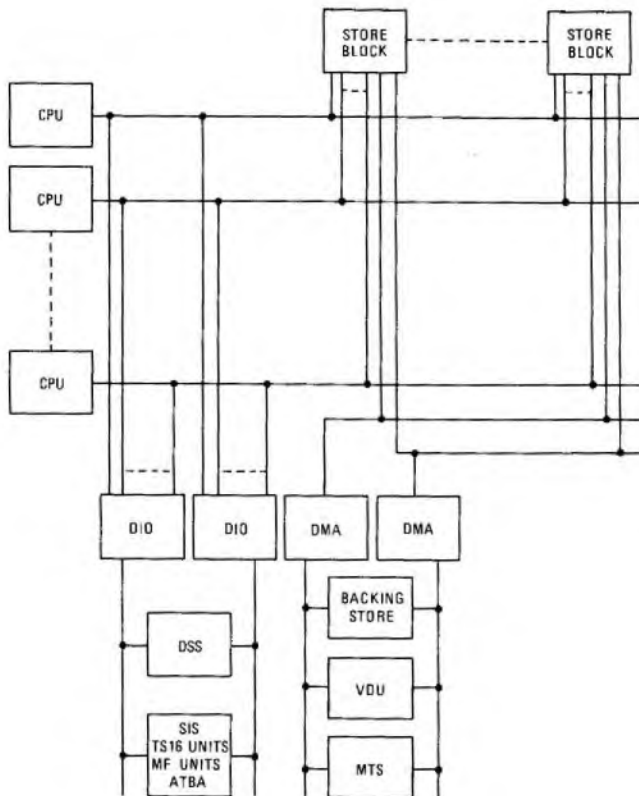

FIG. 7—Block diagram of processor

The two methods of input/output are also shown on Fig. 7. The DIO ports are within the processor's addressing range and therefore a CPU may read or write one word to that location. It is a simple operation, but it causes CPU work on every transfer. The DMA method, however, is a technique whereby data can be passed directly into the main memory without CPU involvement, except initially to set up the transfer. The DMA method requires more processing power to set up the transfer than the DIO method, but it is more efficient for bulk data transfers as the CPU can proceed with other work until notified that the transfer is complete. Both the DIO and DMA facilities are secured by duplication.

## EXCHANGE ENGINEERING AND TECHNOLOGY

### Equipment Practice

The DMNSS, along with the other system under development, will use a new equipment practice, designated TEP-1(H)<sup>†</sup>. Initially, the equipment will be mounted on racks which are 2164 mm high, 900 mm wide and 630 mm deep, although later a 520 mm deep variant will be used. TEP-1 equipment practice is built up using shelf units, which include a wired backplane where the shelf unit consists of 1-3 shelves. Wiring within a shelf unit is via a backplane; plug-ended cables link the shelf units within the system. Card positions at the ends of the shelves are reserved to accommodate plug-in cabling. Cabling between racks will be overhead, although an underfloor cabling option is available within the equipment practice.

<sup>†</sup> Equipment practice TEP-1 (H) will be described fully in an article to be published in this *Journal* as part of the series of articles on System X. The equipment practice is similar, but by no means identical, to TEP-1 (E), which is described in an article on p. 160 of this issue.

## Power Supply Distribution

Power will be distributed around a DMNSS at  $-50$  V, the lower voltages required by the logic being provided by a standard range of DC-DC converters which have been developed for System X. Busbars will supply a central power-distribution rack (or racks in large exchanges) from which cables will be used to feed the shelf units. Associated with each power cable there will be an earth return. A single earthing scheme will be used in which all earths are bonded together at the racks by a mesh over the equipment area. This earthing arrangement will overcome separation problems previously encountered with dual-earth schemes. (The power supply arrangements will be the subject of a later article to be published in this *Journal*.)

## Technology

The DMNSS uses the latest microelectronic devices, the choice of logic family being dependent on application. The low-power Schottky family within 74-series transistor-transistor logic (TTL) is the principle range of devices used, with ordinary Schottky TTL being used in time-critical areas. Normal TTL is used where required devices are not available in the low-power Schottky family.

Complementary metal-oxide semiconductor (CMOS) devices are used in the signalling card and ALTS areas of the system, where a maximum speed of 64 kbit/s only is required. Advantage is taken of the low power consumption of these devices and they are operated from  $-50$  V supply (via voltage-dropping resistors) rather than being powered from one of the standard range of DC-DC converters.

N-channel metal-oxide semiconductor (NMOS) is used in the microprocessors of the digital switch and MF unit and in high bit density RAMs, which are used extensively.

In those subsystems where a HDB3 line termination is required, custom-made large-scale integration (LSI) devices will be incorporated. However, in the interim period, these common functions are being implemented from uncommitted logic arrays (ULAs).

## CONCLUSION

The design of the DMNSS, along with that of the other systems within the System X family, is based on rigorously specified subsystems with precise and enduring interfaces. The definition of the system into subsystems with defined boundaries has led to highly modular software and hardware, and will also permit additions of new facilities and redesigns to take account of advances in technology within the system structure. Indeed, during the development it has been possible to update the technology used in the subsystems.

The design approach has enabled the DMNSS to be developed within a tight timescale whilst producing a cost-effective solution capable of meeting the trunk switching requirements of the BPO to the end of the century and beyond.

## ACKNOWLEDGEMENT

The author wishes to thank his colleagues in System X Development Department, Telecommunications Headquarters for their assistance in the preparation of this article.

## REFERENCES

- 1 VOGEL, E. C., and McLINTOCK, R. W. 30-Channel Pulse-Code Modulation System. Part 1—Multiplex Equipment. *POEEJ*, Vol. 71, p. 5, Apr. 1978.
- 2 JONES, W. G. T., KIRTLAND, J. P., and MOORE, B. W. Principles of System X. *POEEJ*, Vol. 72, p. 75, July 1979.
- 3 BOULTER, R. A., and BUNN, W. Network Synchronization. *POEEJ*, Vol. 70, p. 21, Apr. 1977.

# A Microprocessor-Controlled Teletraffic Logging Device

J. D. SMITH, and S. E. BARBER, B.SC. (HONS.), M.SC., C.ENG., M.I.E.E.†

UDC 621.395.31 : 681.31--181

*This article describes a multipurpose microprocessor-controlled logging system and the need for traffic measurements which led to its development. The ability of the equipment to fulfil many teletraffic requirements is shown and the high degree of flexibility in its hardware is illustrated.*

## INTRODUCTION

Recent articles<sup>1,2</sup> published in this *Journal* have described both the selection of microprocessors from the many available and also the automation of traffic-data collection. This article describes a practical application of microprocessors in the field of traffic-data collection.

The British Post Office (BPO) public switched telephone network is made up of nodes (telephone exchanges) and links (circuits). The nodes are switching points at which individual links are connected together to form connexions between calling and called customers. Given the grades of service\* to be used, it is necessary to plan the network in the most economical way. One example of the many problems which have to be resolved involves the routing of calls; a typical question that arises (illustrated in Fig. 1) is "should a call from exchange A to exchange C be routed via exchange B, or should the call be routed directly to exchange C?" The advantage of going via exchange B is that more efficient use of circuits can be made; that is, for a given grade of service, more calls can be carried per circuit because of the larger volume of traffic. In addition to the involvement of less switching, the advantage of going directly between exchanges A and C may be the use of cheaper circuits; for example, the physical distance from exchange A to exchange C may be significantly shorter than going via exchange B.

To make a judgement on the merits of the alternatives available, it is necessary to have call information for different classes of call under the headings of *time* (when the calls take place), *space* (the source and destination of calls), and *duration* (the time during which the calls are in progress.)

## SOURCE OF INFORMATION

For the day-to-day running of the network the obvious source of the required information is the network itself. Indeed, by

† Telecommunications Development Department, Telecommunication Headquarters

\* A grade of service is the limit, which it is planned should not be exceeded, for the proportion of calls which are unsuccessful (during the busy-hour) due to a shortage of capacity in the particular element of the network to which that limit applies

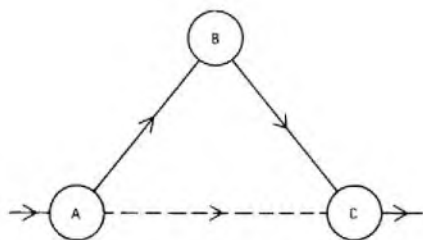

FIG. 1—Alternative routing of connexions between exchanges A and C

carrying out various forms of extrapolation, it is also the source of much of the data to be used for planning future requirements.

The device used to collect the majority of teletraffic information is the automatic traffic recorder, which has been used in telephone exchanges for many decades. The circuit-occupancy measurements gathered by the recorders give an indication of the volume of traffic, but they do not provide information on features such as call destination and duration, or even the number of calls made.

These additional features of traffic information have to be gathered by call-detail and destination measurements, and this is where microprocessor capability has been exploited to advantage.

## CALL-DETAIL AND DESTINATION MEASUREMENTS

One of the main problems associated with call-detail and destination measurements is the volume of information that has to be recognized and processed for each call. For normal traffic-usage measurements, the state of each input need not be sampled more than once every second and, in many cases, the frequency of sampling is as low as once in 3 min. For call-destination measurements however, where 10 pulses/s loop-disconnect dialling conditions are being monitored, each line needs to be sampled at least every 15 ms in order that the full range of dial speeds can be accepted. In addition, a variety of timing operations have to be performed simultaneously for each call so that the various stages of the call can be determined; for example, pre-dialling pause, inter-digital pause and end of dialling.

A further problem associated with call-detail and destination measurements is that, in most cases, speech wires have to be monitored and the state-of-line for the full range of line lengths (equivalent to 0–1200  $\Omega$  line resistance) has to be detected without unbalancing the line or presenting a load impedance of less than 1 M $\Omega$ .

## CHOICE OF SYSTEM

At present, there is a variety of proprietary call-detail measuring equipment available and a number of different approaches have been adopted in an attempt to solve the problems referred to above. In most of these cases, however, limitations have existed on each equipment which have restricted their use. The most common approach has been to use a system of dedicated logic to perform line sampling, counting of pulse trains, and formatting of data. This method has the advantage of being able to handle large numbers of inputs but, in general, there is very little flexibility, so that changes in timings or output format are very expensive to implement.

A second approach is an equipment having a simple front-end design which performs the basic scanning process only and records the state-of-line information on to magnetic tape, enabling full call details to be assembled at a later stage on a

main-frame computer. Although this approach offers higher flexibility than the first method, very large data volumes have to be handled and the main-frame computer costs can be high.

The third approach is to use a basic scanning arrangement linked to a local microprocessor in such a way that as much as possible of the logical signal processing is performed within the microprocessor area under the control of software.

It is the third approach that has been adopted for the equipment described in this article, equipment that has been given the acronym *EMPIRE* (Electronic Multipurpose Programmable Information Recording Equipment).

### REASONS FOR USING A MICROPROCESSOR

The main reason why the microprocessor approach was chosen is that it combines the advantages of the first two methods mentioned above: namely: low main-frame processing costs, low data volumes and a high degree of flexibility. In addition, the microprocessor approach offers a fast data turn-round time so that, if required, information can be made available locally in hard-copy form.

Of these advantages, it is the high degree of flexibility that makes this approach most attractive. This flexibility, if exploited fully, enables the same hardware to be used to perform data-logging functions, ranging from the basic erlang-type measurement of equipment occupancy to the more sophisticated call-detail logging measurements. In a similar way, output formats can be changed and timing parameters can be adjusted, if found necessary, for particular applications. To perform these changes using the microprocessor approach it is merely necessary to change memory modules holding the system software.

### DESCRIPTION OF HARDWARE

The hardware chosen for the implementation of the *EMPIRE* processor is the Intel 8080 microprocessor system, with the addition of a number of special-purpose interface cards.

The equipment has been designed so that a number of input channels are scanned sequentially, each input being sampled 100 times a second. The basic loop-disconnect condition found at each scan of each input is then transferred into the processor's memory with only limited pre-processing, consisting of buffering the serial scan data from a number of complete input scans and then transferring data associated with each input into the processor's memory at high speed. In this way, the processor is presented with blocks of information containing the conditions of a single input over a number

of scans rather than a number of inputs over a single scan.

The scan conversion, together with the high-speed transfer of data into the processor's memory, gives a considerable increase in the time available for processing of scan information compared with that for conventional scan methods, and was found to be essential for call-destination measurements.

A prototype of the *EMPIRE* equipment is shown in Fig. 2 and a block diagram of the equipment is given in Fig. 3.

### INPUT SCANNING

The number of inputs that can be monitored by this type of system is determined by the maximum amount of time required to process the information from one input channel. To monitor a maximum number of inputs it is therefore necessary to ensure that the software is efficient in terms of execution times, and that both input of scanning information and output of call-detail records occur at high speed. An initial examination of the proposed software and timing showed that, with the system clock running at 1 MHz, 64 inputs could be processed without the possibility of loss of data, even when dialling is occurring on all input channels.

Both the A-wire and B-wire of the telephone lines under test are examined for each of 64 inputs, and the condition on each wire of each input channel passes, via an attenuator and



Fig. 2—Prototype electronic multipurpose programmable information recording equipment (EMPIRE)

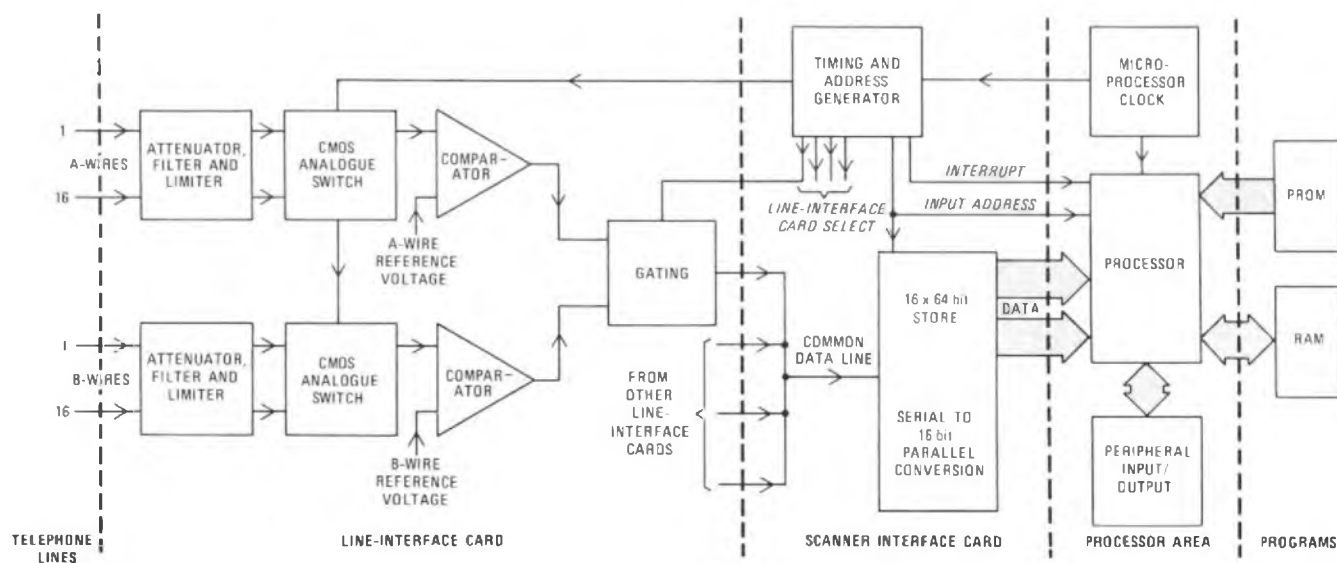

Fig. 3—Block diagram of EMPIRE unit

voltage protection circuit, to complementary metal-oxide semiconductor (CMOS) analogue switches. The CMOS analogue switches are switched sequentially using an external scan-address generator, and the outputs are fed to a set of common threshold detectors (comparators) so that the condition on each channel in turn is represented by the multiplexed condition on the threshold detectors. The input threshold can be set in range from  $-50\text{ V}$  to  $+50\text{ V}$ , with a voltage above the set threshold being considered as logic *one* and that below the set threshold as logic *zero*. The value of the threshold depends on the type of measurement required and the line conditions. In this way, a single data bit represents the state of a channel for one 10 ms sample period.

Scan data for 16 complete scans is stored external to the microprocessor, and then transferred at high speed into the processor's memory in such a way that each pair of 8 bit bytes represents the condition of a single channel over 16 complete scans. In this way, the processor sees a snapshot picture of each channel over 160 ms.

External hardware could have been reduced considerably by simply switching 8 inputs through to the processor in turn, but since individual bits in the data word would have represented different inputs, the amount of processing would have been much greater, with the consequence that the number of inputs available for collection of information would have been lower.

In order to transfer the complete block of scan data representing 16 complete scans, a single interrupt signal is generated by the external scan-address generator. This interrupt signal initiates the block transfer of information into the processor's working memory which, with the present system, takes 10 ms to complete and leaves 150 ms of each cycle for processing of input data.

### THE PROCESSING AREA

The basic system for recording individual call records on magnetic-tape cartridge requires a minimum of only 2 Kwords of programmable read-only memory (PROM) and 3 Kwords of random-access memory (RAM), but the modular system adopted allows both PROM and RAM to be easily increased. Individual boards can be equipped with up to 16 Kwords of PROM and 8 Kwords of static RAM.

A serial interface (to CCITT† Rec. V24) is available for system maintenance and a low-speed output, and a high-speed 8 bit parallel output is provided for a magnetic-tape cartridge recorder.

To provide a flexible man-machine interface, a 32-character alphanumeric display and a 16-position keyboard is used; thus enabling a range of values, for such input parameters as time of day, to be entered prior to use.

Facilities have also been provided to accept a PROM programmer card that will allow programs to be written, tested or changed in a live environment.

### SOFTWARE FEATURES

In an attempt to ensure efficiency of software in terms of execution times, software so far developed has been written in assembly language. Future versions of EMPIRE will have all software, with the exception of routines requiring precisely-controllable execution times, written in a high-level language termed *PL/M*. The use of this high-level language will simplify documentation and subsequent maintenance. To increase efficiency further, programs have been divided into foreground and background tasks.

Foreground tasks are concerned with high-priority data interpretation and, in these programs, the instruction execution times have to be minimized by analysing the timings for the various program paths. Techniques used to reduce

instruction times include the avoidance of sub-routine calls and the use of JUMP instructions.

Background tasks are concerned with system control, and here the priority is to reduce program size rather than execution time; consequently, for these tasks, sub-routine calls are used frequently.

Background tasks include keyboard monitor, display control and low-speed data-output control. Foreground tasks include scanner data input, real-time clock update, call-pattern recognition and, in the case of call-detail measurements, high-speed data output. Switching between background and foreground tasks occurs when an *interrupt* signal, indicating the end of 16 complete scan cycles, is received; reversion to the background mode occurs when all foreground tasks are complete.

### FACILITIES

The facilities offered by the EMPIRE equipment are summarized below:

#### Call-Destination Recording Program

The call-destination recording program produces a record of the number of calls and traffic to each of 1000 destinations. Destinations are determined by the first 3 digits dialled, which are examined and used to produce a traffic matrix. This will show the traffic and the number of calls to each number group (000-999) during a given period. The information recorded is printed-out after a period which can be pre-set by the user, and is typically 1 h.

Output can either be in hard copy form or to a magnetic-tape cartridge recorder. A typical output format produced on a teleprinter is shown in Fig. 4.

#### Call-Detail Recording Program

The call-detail recording program controls the following functions:

- (a) The simultaneous monitoring of all calls on 64 channels.
- (b) The recording of data for each call, including
  - (i) the input-channel number,
  - (ii) clear-down time,
  - (iii) the digits dialled (up to a maximum of 21),
  - (iv) an indication if more than 21 digits are dialled, and
  - (v) the duration of the call (in seconds) from seizure to release.

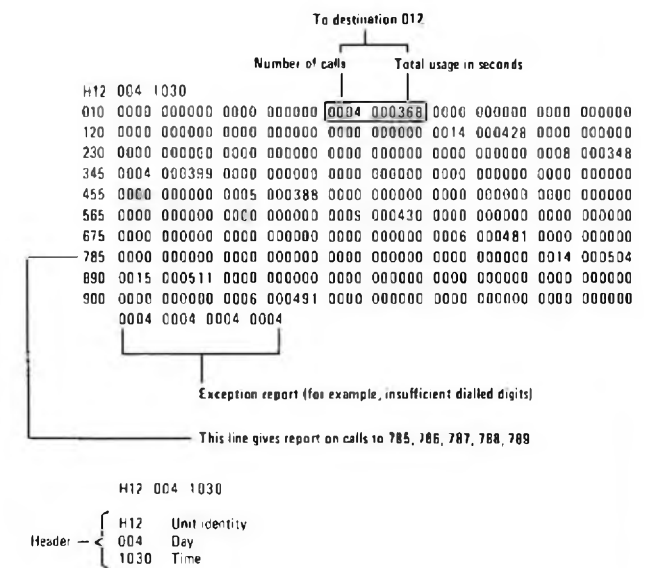

FIG. 4—A typical output of a call-destination analysis program (1000-destination matrix)

† CCITT—International Telegraph and Telephone Consultative Committee

(c) The production of a header at pre-set fixed time intervals, which includes the day of the year, the equipment identification and the time of day in hours and minutes.

(d) The outputting of data to a teleprinter or to a magnetic-tape cartridge recorder.

An example of a typical output format produced on a teleprinter is shown in Fig. 5.

### FUTURE DEVELOPMENTS

A version of the EMPIRE unit having 128 inputs is now being developed. This has been achieved by doubling the processor clock frequency to 2 MHz, giving a theoretical maximum of 198 channels. Any increase above this number of channels would, however, have necessitated a further increase in clock frequency, which would require a more advanced microprocessor system.

If more than 198 channels were read in at the 2 MHz clock frequency, then more time in each 160 ms (16 scans) period would have to be allowed for transferring data into the processor's memory. The effect of this would be that less time would be available to process the data, and processing could be incomplete at the end of a 160 ms period. In this case, the next interrupt would be ignored by the processor and data would be lost.

In preparation for future increases above 128 inputs, changes have been made to the scanner interface board which now includes two RAM blocks, the first of which stores the data collected during 16 scans and the second forms part of the processor's memory. Following an *interrupt* signal, which occurs every 160 ms, the functions of the two RAM blocks reverse and the data stored in the first is effectively transferred into the processor's memory. The second RAM prepares to store the data collected during the next 16 scans. The major advantage of this arrangement is that no time is needed for transferring data into the processor's memory and the full 160 ms is available for processing the information collected.

Future development work should result in equipment providing the following additional facilities:

- (a) data collection from more than 128 inputs,
- (b) recognition of called-subscriber answer condition,
- (c) differentiation between effective and ineffective calls,
- (d) ability to monitor meter pulses, and
- (e) tone detection capability.

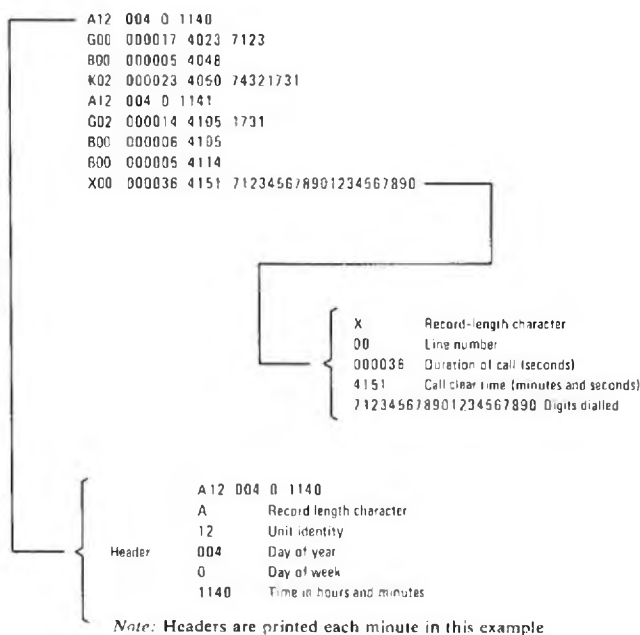

FIG. 5—A typical output of a call-detail recorder program

### CONCLUSION

This article has described a method of applying microprocessor techniques to teletraffic logging equipment which allows the equipment to be adapted to perform a variety of functions. The equipment described is now being produced on a limited basis and data obtained during field trials is being evaluated.

The ultimate object of the development work will be to produce a microprocessor-controlled device that will fulfil a wide range of teletraffic measuring requirements. The appropriate function will be selected by the use of software packages and, if required, special-purpose plug-in interface cards.

### References

- <sup>1</sup> ROWE, M. D. The Selection of Microprocessors. *POEJ*, Vol. 71, p. 101, July 1978.
- <sup>2</sup> BURVILLE, P. J., and DAWSON, W. Automation of Traffic-Data Collection. *POEJ*, Vol. 71, p. 164, Oct. 1978.

## Book Review

*Communications Systems*. S. Haykin. John Wiley & Sons Ltd. xvi + 620 pp. 349 ills. £15.15.

This book essentially aims at giving, at graduate level, the basic theory of the mechanisms of modulation and demodulation. It is one of a number of similar books which have emerged from across the Atlantic in the last year or so. It broadly consists of three parts: signal analysis and probability, continuous-wave modulation systems (amplitude and angle), and pulse-modulation systems. The treatment is theoretical and mathematical with minimal references to practical operational systems. The title of the book is misleading as although it contains the word "Communications" (which it must be admitted is a vogue word), the book reveals

little on information theory, very little on transmission-media characteristics and nothing on switching. However, it does contain the formal lecture room type of derivation and mathematical treatment of classical modulation mechanisms. No mention is made of partial response systems, but this is perhaps not surprising given the scheme of the book. However, it could be a useful companion reference volume for the student or a lecturer preparing the theoretical components of a more fuller explanatory treatment of modulation systems. Each chapter contains a set of problems of which ideal solutions can be made available in a separate volume obtainable from the publishers.

G. D. ALLERY

# Development of an 11 GHz Digital Radio-Relay System

## Part 2—System Configuration and Parameters

E. G. JARVIS, C.G.I.A., C.ENG., M.I.E.R.E., F.I.T.E., and R. P. I. SCOTT, B.SC.(ENG.), C.ENG., M.I.E.E.†

UDC 621.371 : 621.37.029.6 : 621.376.4

*Part 1 of this article described the technical considerations involved in choosing the characteristics of an 11 GHz digital radio-relay system. Part 2 describes the configuration and parameters of the required system which will carry trunk traffic at 140 Mbit/s per radio frequency channel and will use the sites and structures of the existing analogue 4 and 6 GHz radio-relay network. A later article will describe the final system, which is being developed for the British Post Office by GEC Telecommunications Ltd.*

### INTRODUCTION

The possibility of using the existing sites and structures of the analogue line-of-sight radio network and overlaying the 4 GHz and 6 GHz radio network with an 11 GHz digital network will provide a cost-effective and rapid method of providing some of the total digital overlay network. Since 1972, the objective of the British Post Office (BPO) Research Department has been to develop and field-evaluate 2-level and 4-level 11 GHz phase-shift-keyed (PSK) systems and develop equipment to combat propagation problems.

The 11 GHz digital line-of-sight radio-relay system described in this article provides 6 GO and 6 RETURN channels, each operating at 140 Mbit/s and capable of transmitting 1920 telephone channels, or at least 2 television channels, in the band 10.7 GHz to 11.7 GHz.

The input data is processed prior to transmission to ensure that the system is capable of correctly transmitting any 140 Mbit/s signal presented at its input, and to provide error-monitoring facilities; this increases the transmitted symbol rate by a small amount. The 4-level PSK modulation

is carried out directly at the radio frequency (RF) to be transmitted.

Where it becomes necessary to reduce the effect of multipath fading, a phase-control height-diversity system can be provided. An adaptive linear amplitude-distortion equalizer may also reduce the effects of multipath fading.

This article compares the different methods that have been considered for achieving various functions, and describes the method chosen.

### SYSTEM CONFIGURATION

Fig. 8 shows a block diagram of a channel of an 11 GHz radio system from the 140 Mbit/s input at a terminal transmitter to the output at a terminal receiver. The alternative arrangements at repeaters are shown by dashed lines.

### THE TRANSMITTER

A 4-level PSK modulated signal is obtained by dividing the input signal into 2 streams, which are applied to the 2 sections of the modulator. The output of the modulator is a carrier modulated at half the original signal rate; that is, at the symbol rate.

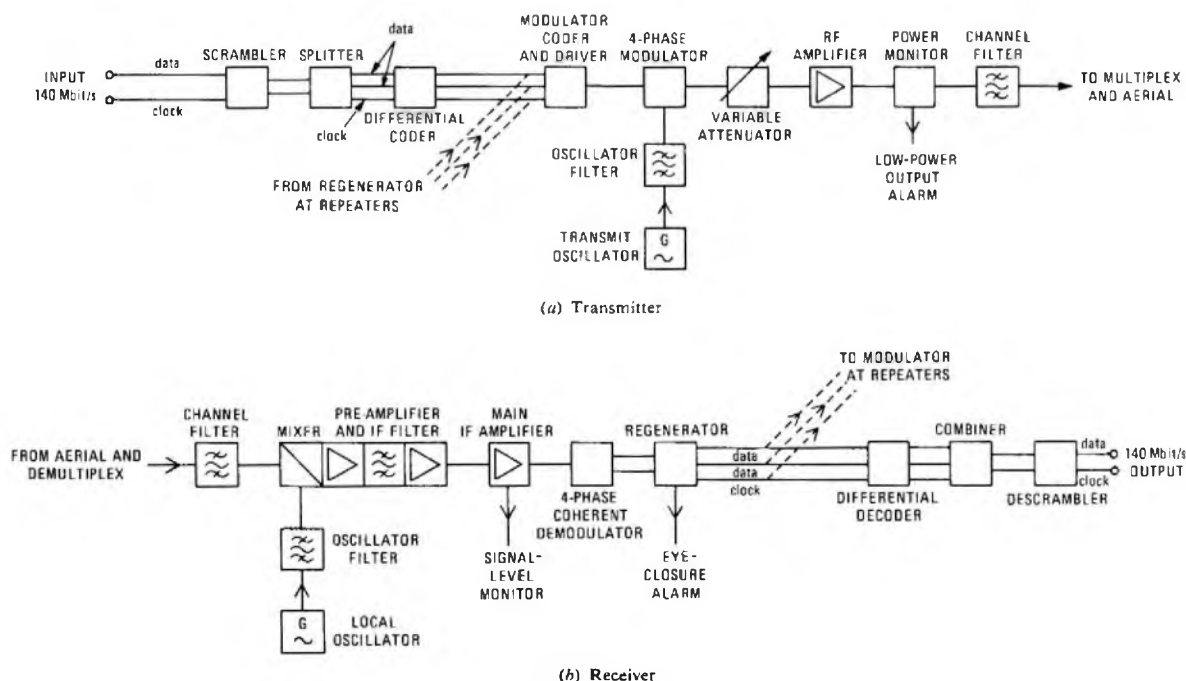

FIG. 8—Block diagram of a channel of the 140 Mbit/s, 11 GHz system

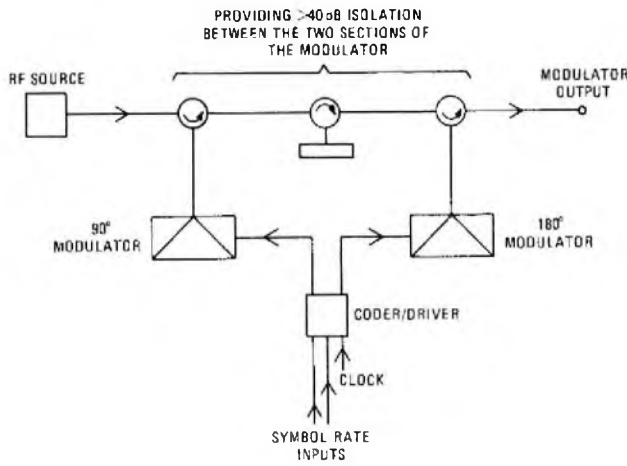

FIG. 9—Block diagram of an RF modulator

Two 180° modulators can be used in parallel, and the 2 outputs combined in quadrature<sup>6</sup>; alternatively, a 90° modulator can be cascaded with a 180° modulator to produce the 4 phase states. The parallel form comes closer to the ideal: the series form requires the 180° modulator to switch for 2 of the four 90° transitions, and these 2 transitions may not be ideal in that they do not pass through the centre of the phasor diagram. Crosstalk is therefore produced between data channels. This is not important if the transition is shorter than 0.1 of a digit period.

Several modulation methods have been investigated. Modulation has been applied at intermediate frequency (IF), using both serial and parallel modulation, and direct modulation has been used at RF<sup>6</sup>.

Modulation at IF is followed by up-conversion to the RF channel frequency and amplification using a travelling-wave amplifier (TWA). Back-to-back testing at IF between modulators and demodulators is possible, and a standard modulator can be provided for all channels. However, the provision of an IF oscillator and up-converter RF drive power and sideband filtering increases the cost of the system, both in terms of component cost, and line-up and testing costs. Back-to-back testing does not have the same importance as with analogue systems, particularly if a unit-replacement maintenance philosophy is adopted, because demodulation and regeneration occurs at each repeater.

Parallel modulation is difficult when providing an RF modulator to cover a number of channels at 11 GHz because phase accuracy and amplitude balance cannot easily be maintained over the band. When RF modulation is used a test modulator is needed at maintenance centres for testing IF demodulators.

However, the large cost advantage makes series RF modulation a preferred method. Switching times of 1 ns at 11 GHz are achievable, and synchronization of the switching of the separate modulators to better than 0.1 ns is possible. Since a symbol period is approximately 14 ns, these parameters are adequate for RF serial modulation and this form of modulation is adopted for 11 GHz systems. Fig. 9 shows a block diagram of an RF modulator.

TWAs provide the output power at this time, but progress is being made towards an all solid-state transmitter. A 10 W amplifier using high-efficiency IMPATT diodes has been proved feasible at the BPO Research Centre and will be described in a later issue of this *Journal*.

A good RF modulator permits a better eye amplitude in a system than a good IF modulator, because there are fewer transmitter stages where spectrum distortion and crosstalk can be introduced, and there is no possibility of distortion due to the foldover effect. The phase inaccuracy<sup>7</sup> and ampli-

tude imbalance of the modulator is specified to close tolerances.

The transmitter RF power source consists of a 1 GHz oscillator, phase-locked to a crystal reference, and a single multiplier stage to provide the 11 GHz signal. This type of source has proved less liable to produce spurious emissions than the crystal oscillator and multiplier chains used in many analogue systems. They are also more easily tunable, and can be frequency modulated at low deviation with audio frequencies to provide auxiliary circuits.

## THE RECEIVER

The receiver uses a balanced mixer for down-conversion, realized in microwave integrated circuit form, using gallium arsenide Schottky-barrier diodes. The noise factor at the input to a channel filter is 8 dB.

The RF oscillator is the same type as used in the transmitter. Using an IF of 140 MHz allows all IF units to use standard components on printed wiring boards at low cost; it is also a standard CCIR† frequency. Since high power radar signals lie below 10.7 GHz, and there is an astronomy band above 11.7 GHz, it is an advantage that all local-oscillator and receiver image frequencies lie in-band.

### The IF Pre-Amplifier

The IF pre-amplifier must have a noise factor of 2 dB and a gain of 25 dB to prevent significant noise contribution from following stages. Signals up to levels of -35 dBW must be accepted at the receiver input during exceptional multipath enhancement conditions; this can be achieved by providing an automatic gain control (AGC) system for the pre-amplifier to attenuate signals exceeding the normal input signal level by up to 15 dB. The IF filtering can be provided by the pre-amplifier.

### The Main IF Amplifier

The main IF amplifier must have a gain of approximately 60 dB, with an AGC range of 55 dB. The dynamic range of the main IF amplifier is -50 dBW to -105 dBW, measured at the input to the down-converter. An input signal level indicator is provided from the AGC loop.

### The Demodulator

Four-level differentially-coherent demodulators, using a 1 symbol-period delay line for simultaneous comparison of the existing carrier phase with that one symbol delayed, have a carrier-to-noise penalty. This type of demodulator is no longer considered.

Coherent demodulators of 3 types have been developed.

#### IF Remodulation Demodulators

The IF remodulation-type demodulator feeds back the output data to a modulator (see Fig. 10). The modulator cancels the modulation on the carrier output in the reference path. A phase comparison can then be made with the voltage-controlled oscillator (VCO) output. However, the receive-end modulator does not produce a signal identical to the distorted received signal, so that adequate cancellation of the data on the incoming carrier is difficult. The circuitry is complex and the unit large. It is also critical to align and difficult to maintain in alignment.

#### Baseband Remodulation Demodulators

In the baseband remodulation-type demodulator (see Fig. 11), the phase-locked-loop is controlled by the sum of a signal from each channel, these comprising the product of the baseband output from the phase detectors and a hard-limited baseband output from the other channel. If the reference carrier and the incoming carrier are out of phase, a change of

† CCIR—International Radio Consultative Committee



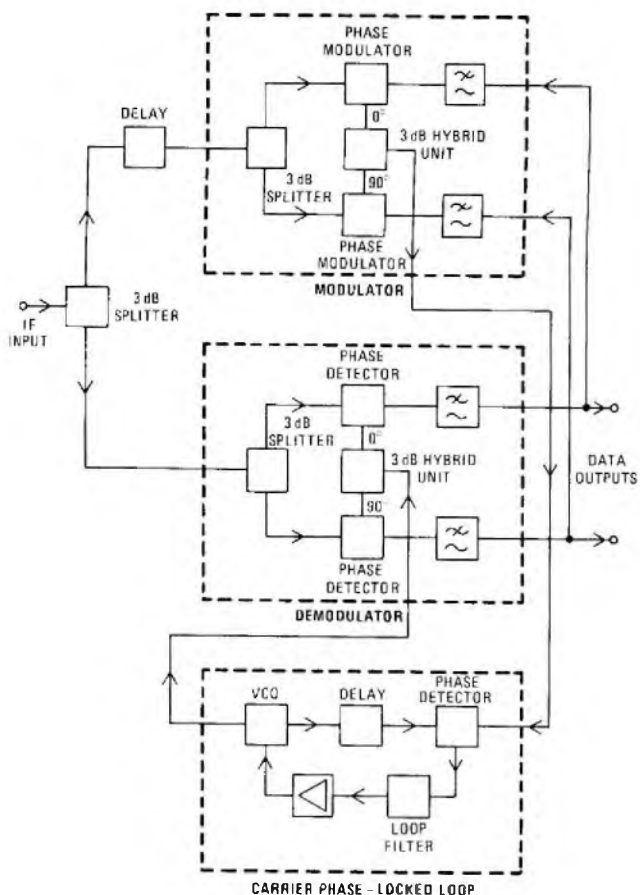

Fig. 10—Block diagram of an IF remodulation-type demodulator

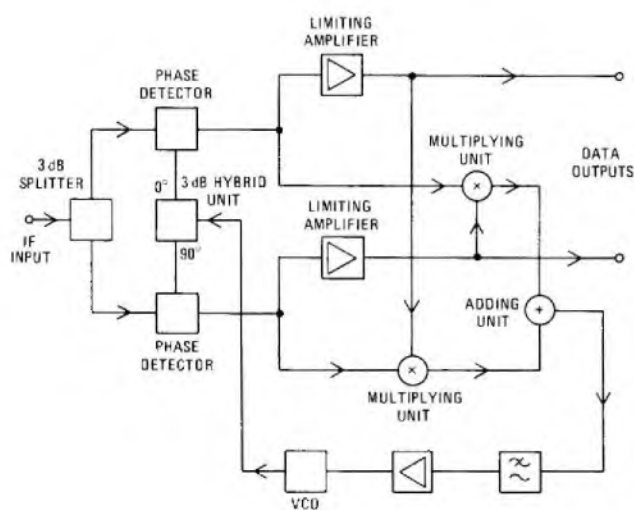

Fig. 11—Block diagram of a baseband remodulation-type demodulator

relative level results in a voltage change at the VCO input. In the absence of digital modulation, this type of demodulator loses lock, whereas other types remain locked. It also loses lock at higher carrier-to-noise (C/N) ratios than do other types, and DC drifts in the baseband detectors degrade the eye amplitude.

#### The Multiplier-Type Demodulator

The reference carrier for demodulation is recovered by removing the modulation from the IF received signal by multiplying the modulated carrier signal at IF by 4 (see Fig. 12); ideally all modulation components are then reduced

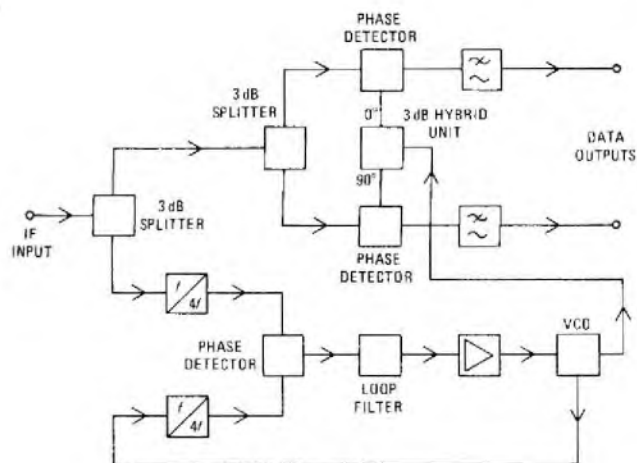

Fig. 12—Block diagram of a multiplier-type demodulator

to the same phase. An unmodulated carrier is thus produced at 4 times the IF. A VCO is phase-locked to this carrier at 4 times the IF using a second multiplier, a phase detector and an amplifier; this provides the carrier for demodulation. The narrow bandwidth of the phase-locked loop provides filtering that removes unwanted residual modulation components from the recovered carrier.

The signal recovery circuits can be DC coupled, thus making the demodulator independent of signals transmitted. The design is rugged and stable.

This type is used in 11 GHz systems.

#### Phase-Locked Loop Parameters

All 3 types of coherent demodulator described use phase-locked loops containing a VCO that provides the recovered carrier for demodulation. The capture range of the phase-locked loop must be large enough to lock-in over the full frequency tolerance of the received carrier and the VCO. The small frequency variation of the recovered carrier at the demodulator is predominantly due to frequency changes of the RF sources and the VCO with temperature.

The maximum phase error in the loop is reduced if the phase-locked loop operates only over the central portion of its frequency error tracking range, because the phase error is proportional to the tracking range of the loop. Thus, it is advantageous for the loop to have a larger capture range than is required purely for the frequency tolerance of the recovered carrier.

The frequency variation of the recovered carrier over a temperature range of 2–40°C, using crystal-controlled RF sources and a 140 MHz demodulator VCO, is about  $\pm 1.4$  MHz. To keep the phase error of the recovered carrier to less than 1°, the loop must have high gain and a capture range of about  $\pm 3$  MHz. The loop noise bandwidth should be kept as small as possible to minimize the probability of the VCO slipping to one of 3 other phase-locked states in the presence of noise. A loop natural frequency of about 300 kHz meets these objectives.

The onset of phase slipping prior to loss of lock by the phase-locked loop at low C/N ratios is sudden<sup>8</sup>. For a loop natural frequency of 300 kHz and a receiver noise bandwidth of 80 MHz, one slip per second occurs when the C/N ratio is about 5 dB. The interval between slips reduces by four orders for about a 1 dB reduction in C/N ratio. Thus, the phase-locked loop loses lock at about 5 dB C/N ratio. Only a slight increase in C/N ratio is needed for the loop to regain lock.

There is a large margin between the minimum working C/N ratio of about 18 dB and the 5 dB region at which loss and regaining of lock and associated unacceptable phase slipping

occurs. The loop thus regains lock well before the threshold C/N ratio is reached as the received signal increases after a fade, and permits baseband circuits to re-establish synchronism well before the working range is reached.

Phase slips at normal receive level (that is, at high C/N ratios) should be extremely rare, but might occur if the loop is disturbed by external interference. For the parameters described, a typical phase slip would result in a block of 200 bits unrelated to the transmitted data.

### Adaptive Techniques

The phase inaccuracies of a demodulator can be reduced by an adaptive technique that optimizes the recovered carrier phase to the phase detectors<sup>9</sup>. This technique could also reduce the effects of any long-term phase drifts in a demodulator.

### The Regenerator

The output from the demodulator is band-limited and can be noisy. To regenerate an undistorted signal, free from noise, it is necessary to reshape and retime the pulses. The pulses are regenerated by sampling the baseband signal for a very short period at the centre of each bit and making a decision as to whether the level is above or below a threshold, thereby deciding whether a *one* or a *zero* has been received. One method used to recover the timing is to sense the transitions between bits of opposite polarity and to lock a VCO to these transitions<sup>10</sup>. The timing information is retained by the oscillator for a limited period to permit satisfactory operation during periods when a succession of the same digits occur and there are no zero crossings.

## BASEBAND PROCESSING

### Scramblers

A scrambler modulates the incoming digital signal to the transmitter with a pseudo-random sequence, and a descrambler at the receive terminal restores the original information. There are considerable advantages in making a scrambler a standard item in digital radio systems: it improves the transparency of the system; it tends to stabilize the spectral and power distribution of the system; it reduces systematic jitter<sup>11</sup>; it provides timing information, particularly when no data transitions are occurring; and it can provide a means of out-of-service error-rate measurement.

The transparency of a radio transmitter and receiver is its ability to reproduce at the output of the receiver the information fed into the transmitter. In general, this means that the carrier recovery system and the bit-timing recovery system must be capable of dealing with any sequence of digits at the input to the radio system, including supervisory information if present in binary form. The addition of a scrambler ensures that the carrier recovery system and bit-timing recovery system are operative continuously, except under fade conditions, and that, after a fade, control is reestablished as quickly as possible.

Some bit sequences will cause continuous phase cycling of the modulated carrier and produce specific spectral lines. A carrier recovery system could lock onto one of these spectral lines due to either long-term drift in the VCO or the VCO drifting through the frequency of one of these spectral lines during warm-up. The scrambler reduces the probability of this occurring.

A typical scrambler and descrambler are shown in Fig. 13. The proposed scramblers and descramblers are self-synchronizing and consist of shift-register and logic-feedback circuits very similar to those used to generate, and detect errors in, pseudo-random sequences<sup>12</sup>. Scrambling is a simple effective way of eliminating the dominant factors generating pattern-dependent jitter, leaving only a low-level random jitter component, which can be removed using jitter reducers. The 11 GHz systems will use scrambling.

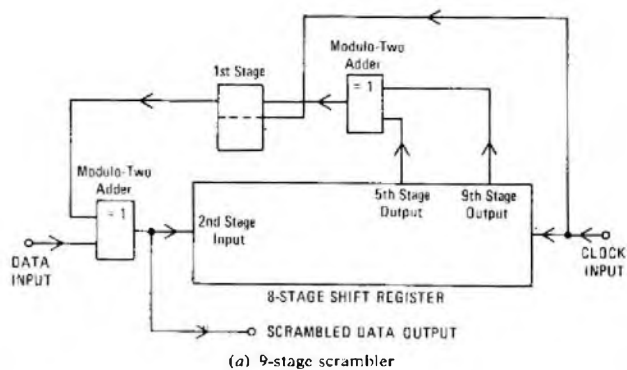

(a) 9-stage scrambler

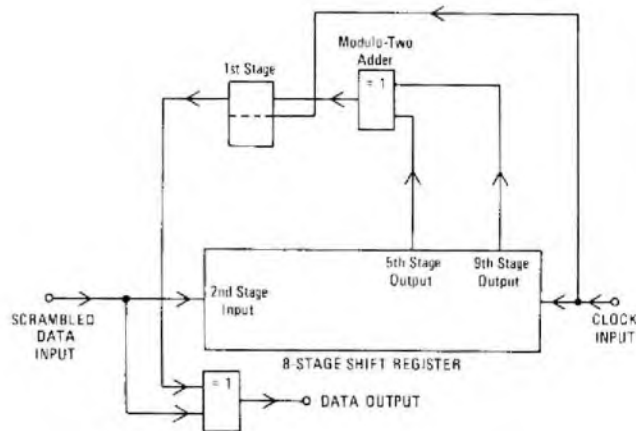

(b) 9-stage descrambler

FIG. 13—Block diagram of scrambler and descrambler

### Differential Coding

The modulation and demodulation scheme described results in 4 possible permutations of the 2 output channels of the demodulator, and only one of these 4 states is the same as the input to the modulator. This ambiguity occurs due to the phase-locked loop of the carrier recovery circuit having 4 possible phase-locked states, separated by 90°, resulting from the 4-phase modulation.

To overcome this effect, the input to the modulator is differentially encoded. The data is encoded such that transmitted symbols represent changes of phase and, at the receiver, a differential decoder restores the original data.

### Error Monitoring

To monitor errors, it is desirable to be able to check the error rate over a maximum number of sequential bits of data, while introducing the minimum redundancy. The scrambled sequence could be used during periods of no data input, but this would not give continuous error monitoring.

The channel plan allows for up to 10% redundancy, but satisfactory error monitoring can be achieved with lower redundancy. A common method of monitoring errors is to use a circuit that counts errors up to a specified number and then resets. Another counter gives a measure of the time between error count resets. This time indicates the error rate. Suitable error counts are counts from 8 to 64<sup>13, 14</sup>.

Further details of the error monitoring will be described in a later article.

## SUPERVISORY SYSTEMS

There are 2 accepted methods of providing supervisory signals. The first is by added-bit insertion and the second is by amplitude modulation or frequency modulation (FM). The second method is called *supermodulation*.

The bit insertion method is versatile, but adds redundancy to the data rate and therefore requires a greater bandwidth per channel, or has a penalty in increased degradation. Base-band processing equipment must be provided at the repeaters as well as at the terminals, and this equipment is complex and expensive. For engineering circuits and for tone transmission, analogue-to-digital converters must be provided at the transmitter and digital-to-analogue converters at the receiver.

The preferred method, however, is that using super-modulation due to the lower cost involved; further details will be given in a later article.

### AERIAL SYSTEM

Aerials with a gain of at least 48.5 dB will be required to achieve adequate fade margins, particularly for longer sections.

When using existing sites and structures, losses in the feeders can be high. In some cases, the section of feeder from the equipment room to the tower is the biggest problem because several changes of direction have to be made. The semi-rigid elliptical waveguide used in this situation has a loss of about 11.5 dB/100 m. The loss of the section of feeder up a tower can be minimized by the use of circular waveguide having a transmission loss of about 4.6 dB/100 m using the TE<sub>11</sub> mode. When only one feeder is used, the feeder, the aerial or the ground profile can cause static depolarization effects. Commissioning can be a very costly exercise where combinations of these effects are concerned. Thus, separate feeders will be used, which greatly simplifies commissioning.

The gravitational and wind loading of structures by aerials, and the available space for them, is of concern in some cases. A dual-band aerial, for the U6 GHz and 11 GHz bands, will be used where it is necessary to maintain the present loading on the aerial-support structure. Where diversity is necessary, one diversity aerial can be used to feed all receiver channels, a channel dropping network being used.

### PHASE-CONTROL HEIGHT DIVERSITY

Phase-control height diversity<sup>15</sup> can be provided to reduce the effects of multipath fading. A low-frequency low-deviation phase modulation, which does not affect the information carried, is applied to the signal received from the diversity aerial, which is separated vertically by typically 10 m from the main aerial. An error signal is extracted from the main IF amplifier AGC loop; this is used to drive a phase-shifter in the input from the diversity aerial to the combiner, which is typically a 3 dB hybrid coupler, until the 2 inputs to the combiner are in phase. During deep multipath fading, the combined signal fades less than the individual signals and so the outage time of the system is reduced.

### PROPAGATION CHARACTERISTICS AFFECTING 11 GHz SYSTEMS

#### Rain

During 5 years of experimental work at 11 GHz in East Anglia and the Midlands, no fade due to rain has exceeded 37 dB. Since rain causes a flat fade over the whole 6-channel band, and the occurrence of such deep fades is about once a year for 5-6 min, rain is unlikely to cause problems provided the system is designed to have a 40 dB fade margin. The Appendix shows how a 40 dB fade margin could be obtained for a 50 km section.

#### Multipath Fading

Multipath fading has a significant effect on bit error rate in digital radio systems because it results in reduced received signal level and in intersymbol interference. To ensure the robustness of 11 GHz systems, phase-control height diversity<sup>15,16</sup> must be installed on the longer sections, and on those

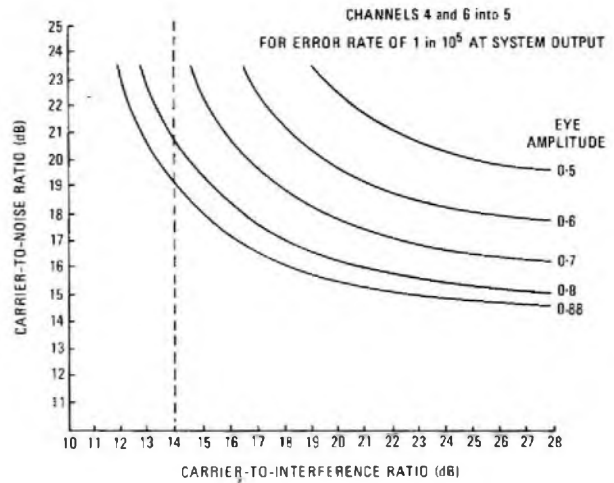

FIG. 14—Effect of adjacent-channel interference

sections that are particularly subject to multipath fading, however short. This reduces susceptibility to the effects of frequency-selective fading. Further benefit may result from providing an adaptive amplitude equalizer, which samples the received IF signal at the 2 band edges and corrects the distortion across the band, assuming it to be linear.

### Cross-Polar Discrimination

Because so little work has been carried out on depolarization, the effects are largely unknown.

The BPO 11 GHz system interleaves the polarizations and, as indicated in Fig. 14, a 14 dB carrier-to-interference (C/I) ratio, for an eye amplitude of 0.7, results in an error rate of 1 in 10<sup>5</sup> being reached at high C/N ratios. A deterioration of the cross-polar discrimination from 30 dB to 9.5 dB is required to reduce the C/I ratio from 2 adjacent cross-polar channels from 34.5 dB to 14 dB C/I ratio.

Diversity partially restores cross-polar discrimination so that, if the level of cross-polar adjacent channel interference is the cause of excessive outage time, diversity can be used to improve the system performance.

Experience, cost, and aerial-support structure capacity and loading will dictate policy as to whether phase-control height diversity and adaptive distortion-correcting techniques are used.

### MONITORING AND MEASUREMENTS EXCLUSIVE TO DIGITAL SYSTEMS

Monitoring arrangements the same as those adopted for analogue systems will be used, together with the addition of some arrangements specifically required for digital radio systems, these being described below.

#### Eye-Amplitude Monitor

The eye amplitude is monitored by a circuit that gives an alarm when the system eye amplitude begins to degrade<sup>17</sup>.

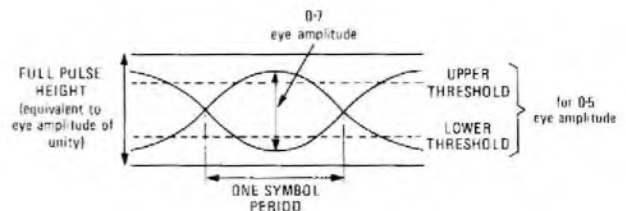

FIG. 15—Basic eye diagram for an eye amplitude of 0.7

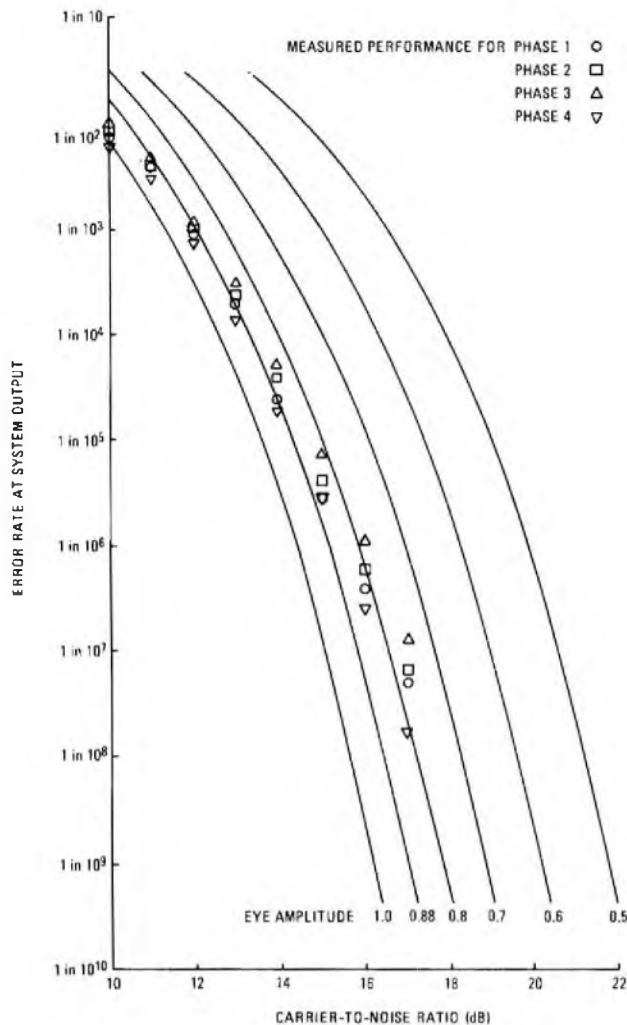

FIG. 16—Error rate against carrier-to-noise ratio

This is achieved by detecting when pulse amplitudes out of the demodulator fall between upper and lower thresholds of the eye diagram formed by pulses of opposite polarity (that is, *ones* and *zeros*), as shown in Fig. 15. The degree of degradation detection is adjustable. This is a valuable provision, ensuring that an indication of reduced fade margin is given even in the absence of fading. Servicing can be carried out before any failure is experienced.

A suitable setting for operation of the alarm is a 30% eye closure, which corresponds to about 3 dB reduction in fade margin, assuming an initial eye amplitude of 0.7.

#### Carrier-to-Noise Ratio/Error-Rate Characteristics

A most important characteristic is that of C/N against error rate. A typical example is shown in Fig. 16. The ideal characteristic of an eye amplitude of 1.0 is shown, together with the characteristic for the channel filters alone which degrade the eye to 0.88.

Typical measured C/N against error-rate characteristics are also shown for a channel without interference. There are 4 characteristics associated with each transmitter and receiver pair; one for each of the 4 possible phase-locked states of the demodulator. These 4 characteristics should ideally be identical, but phase inaccuracies in the modulator and demodulator do not permit this. The spread in C/N ratios between the 4 characteristics should be less than 1 dB at an error rate of 1 in 10<sup>6</sup>. A useful addition to the characteristics is a background graticule of eye amplitudes between 1.0 and 0.5, as shown in Fig. 16.

#### Phase-State Indicator

A phase-state indicator<sup>18</sup> is provided so that each of the 4 phase-locked states can be identified and maintained (the phase is liable to slip at low C/N ratios) to allow the C/N against error-rate characteristics to be measured. The phase state can be changed by disconnecting and reconnecting the input to the demodulator, which slips the phase-locked state of the carrier recovery circuit.

#### CONCLUSIONS

Using the design procedures described in this article, an 11 GHz digital radio-relay system can be established that will provide a significant proportion of a digital overlay network. The effects of multipath fading can be reduced by the use of phase-control height diversity and by adaptive distortion correction, to ensure a low percentage outage time on 11 GHz digital radio sections.

A field evaluation system will shortly be installed between Birmingham and Charlwellton, and a subsequent article will describe this system after information becomes available from its evaluation.

#### ACKNOWLEDGEMENT

The authors wish to acknowledge the contribution to this work of their colleagues in Research Department (R6) and Telecommunication Development Department (TD6) and, in particular, the contribution of Dr. M. C. Davies.

#### References

- JARVIS, E. G. An Experimental 11 GHz, 25 Mbit/s Digital Radio-Relay System. Research Department Report No. 323, 1972.
- DAVIES, M. C. The Effect of Phase Error on 2 and 4-level Phase-Shift-Keyed Digital Radio-Relay Systems. Research Department Report No. 377, 1973.
- PALMER, L., and KLEIN, S. Phase Slipping in Phase-Locked Loop Configurations that Track Biphasic or Quadruphasic Modulated Carriers. IEEE Transactions on Communications, Oct. 1972.
- SCOTT, R. P., and GILLILAND, J. D. Improvements in Phase-Shift Keyed Systems (An Adaptive Demodulator). UK Patent Application 2001218A.
- BALL, J. R. A 120 Mbit/s Digital Regenerator Employing a Phase-Locked-Loop for Timing Recovery. Research Department Report No. 413, 1973.
- MULLER, H. Bit Sequence Independence Through Scramblers in Digital Communications Systems. NTZ Heft 12, p. 475.
- DIECKMANN, D. J., and GRAVES, F. A. Pseudo-Random-Sequence Binary-Digit Generators and Error Detectors. POEEJ, Vol. 64, p. 245, Jan. 1972.
- SWAIN, R. S. Detection of an Interleaved Sequence Used for Monitoring Radio-Relay System Performance. Research Department Report No. 592, 1977.
- SPRIGGS, H. Bit-Error Probability Threshold Alarm Systems. Research Department Report No. 704, 1978.
- JARVIS, E. G. The Use of Phase-Control Height Diversity for 11 GHz Digital Radio Systems. Radio and Electronic Engineer, Vol. 47, No. 3, p. 101, Mar. 1977.
- MARTIN-ROYLE, R. D., DUDLEY, L. W., and FEVIN, R. J. A Review of the British Post Office Microwave Radio-Relay Network. POEEJ, Vol. 70, p. 45, Apr. 1977.
- GILLILAND, J. D. Eye Amplitude Monitor. UK Patent Application 10743/78.
- LIU, H. T. A Phase-State Indicator for PSK Systems. UK Patent Application 20053/77.
- CCIR Study Group V Report No. 233-3 (rev. 1976).

#### APPENDIX

##### 11 GHz Radio System Receive-Level and Fade Margin

The normal receive level  $P_R$  is given by

$$P_R = [P_T - L_O] \text{ dBW},$$

where  $P_T$  is the transmitted carrier level (dBW) and  $L_O$  is the overall loss (dB).

The overall loss is given by

$$L_O = L + A + S_T + S_R + F_T + F_R - G_T - G_R$$

where  $L$  is the equivalent free-space path loss (dB),

$A$  is the path absorption due to water vapour and oxygen (dB),

$S_T$  is the transmit filter and branching unit losses (dB),  
 $S_R$  is the receive filter and branching unit losses (dB),  
 $F_T$  is the transmit feeder loss (dB),  
 $F_R$  is the receive feeder loss (dB),  
 $G_T$  is the transmit aerial gain (dB), and  
 $G_R$  is the receiver aerial gain (dB).

( $S_T$  and  $S_R$  can include any remaining fixed losses).

Therefore

$$P_R = P_T - [L + A + S_T + S_R + F_T + F_R - G_T - G_R] \text{ dBW.}$$

The equivalent free-space path loss is given by

$$L = 10 \log_{10} \left( \frac{4\pi d}{\lambda} \right)^2 = 20 \log_{10} \left( \frac{4\pi d}{\lambda} \right) \text{ dB,}$$

where  $d$  = distance between aerials (m), and

$\lambda$  = free space wavelength (m).

$$\text{But } \lambda = \frac{c}{f} \text{ metres,}$$

where  $c$  is the velocity of light (m/s), and

$f$  is the frequency (Hz).

$$\text{Thus, } L = 20 \log_{10} \left( \frac{4\pi d f}{c} \right) \text{ dB.}$$

For  $d = 50 \text{ km}$  and  $f = 11.2 \text{ GHz}$ ,

$$L = 20 \log_{10} \left( \frac{4\pi \times 50 \times 10^3 \times 11.2 \times 10^9}{3 \times 10^8} \right) \text{ dB,}$$

$$= 147.4 \text{ dB.}$$

*Calculation of Fade Margin for a Typical Section of 50 km*

Fade Margin = normal receive C/N ratio - C/N ratio at threshold error rate.

Assuming  $S_T = 2.8 \text{ dB}$ ,

$$S_R = 2.2 \text{ dB,}$$

$$F_T = F_R = 6.5 \text{ dB (for tall towers),}$$

$$G_T = G_R = 48.5 \text{ dB,}$$

$$A = 1 \text{ dB (from reference 19),}$$

$$L = 147.4 \text{ dB,}$$

then  $L_O = 147.4 + 1 + 2.8 + 2.2 + 6.5 + 6.5$

$$= -48.5 - 48.5 \text{ dB,}$$

$$= 69.4 \text{ dB}$$

For the normal transmit level of 10 W,

$$P_T = +10 \text{ dBW.}$$

$$\therefore P_R = +10 - 69.4 \text{ dBW,}$$

$$= -59.4 \text{ dBW.}$$

Normal receive C/N ratio =  $P_R$  - equivalent noise input (ENI).

$$\text{ENI} = kTB \times \text{noise factor,}$$

where  $k$  is Boltzmann's constant =  $1.38 \times 10^{-23} \text{ J/K}$ ,

$T$  is the absolute temperature (K), and

$B$  is the noise bandwidth (Hz).

$$kT = -204 \text{ dBW/Hz at room temperature (20°C).}$$

Therefore, for an 80 MHz noise bandwidth and a 7 dB noise factor,

$$\text{ENI} = -204 + 10 \log_{10} (8 \times 10^7) + 7 \text{ dBW,}$$

$$= -118 \text{ dBW.}$$

Normal receive C/N ratio =  $-59.4 - (-118) \text{ dB}$ ,

$$= +58.6 \text{ dB.}$$

This gives a fade margin of  $58.6 - 18 = 40.6 \text{ dB}$ , for a 1 in  $10^5$  error rate threshold at 18 dB C/N ratio.

## Book Review

*Semiconductor Circuit Design* (Third Edition). J. Watson, B.Sc., S.M., Ph.D., F.I.E.E. Adam Hilger Ltd. xi + 536 pp. 393 ill. £7.50 (cloth).

Apart from some outstanding exceptions, there is not generally a great deal to choose between textbooks devoted to electronics for students, which is what this book really is. The author has taken care, in this edition, to give some emphasis to microelectronics, and the book could be said to be more comprehensive than some. It is also, perhaps, a little purer in its coverage, in that it confines itself to analogue (linear) electronics.

In common with many introductory works on electronics, the mathematics used is straightforward and well presented, and the book is suitable for undergraduate and equivalent courses. The treatment of transistors retains the familiar pattern: physical principles, characteristics, equivalent circuits and parameters, and small-signal and feedback amplifiers. The discussion is thorough, and the section on feedback includes an introduction to operational and DC amplifiers. A later chapter brings together these 2 topics in a more detailed discussion of what the author describes as, "arguably the most useful and versatile (configuration) in the entire field of circuit design". Descriptions of a wide range of devices are illustrated by typical applications, carefully explained.

Noise, frequency-selective amplifiers and oscillators, power

amplifiers, field-effect transistors and power supplies each have a chapter to themselves. One 46-page chapter deals with semiconductor transducers, ranging from thermistors, through photo-electric effects (including light-emitting diodes), to pressure transducers and gas sensors.

The book ends with a very brief summary of the major characteristics of a typical electronic "system", but this is only an illustrative example, not a lecture on system synthesis. This final chapter appears complementary to the first, in which the capabilities of various semiconductor devices are listed. The intention is to show that practically any circuit function can be realized by suitable combinations of devices—a novel and instructive beginning which defines electronics in an uncluttered manner.

Although the book is subtitled "for Audio-Frequency and DC Amplification and Switching", the author has deliberately made no attempt to cover the vast subject of digital electronics and logic applications. The one chapter dealing with the transistor as a switch confines itself to the mechanism of switching in a bipolar transistor, and to applications not strictly associated with digital technology.

I found this book readable and explicit, and the author's efforts to keep it up to date are reassuring. One gets the impression that the author has taken pains to consider what to include, and how the information should be presented so as to be most useful to students.

B. STAGG

# A New Equipment Practice for Transmission and other Applications: TEP-1(E)

N. G. CRUMPT†

UDC 621.395.461

*The British Post Office is to introduce a new equipment practice to house future designs of transmission and other electronic equipment. The equipment practice recognizes the increasing application of integrated circuit technology to the latest designs of telecommunications equipment; in particular, that of digital equipment. The equipment practice described in this article has been developed in co-operation with the British telecommunications industry and with regard to its export potential.*

## INTRODUCTION

For the last 15 years, transmission equipment in the UK telephone network has been housed in 62-type equipment practice\*. This equipment practice was designed when transistors were beginning to be incorporated in transmission equipment, which at that time operated only in the analogue mode. The size of the printed-wiring boards (PWBs) suited the discrete-component technology that then predominated, and the circuit requirements of the day were met by the use of manually-wired rear-of-shelf connexions, which were economical to provide with the labour rates then applicable.

A few years ago it became increasingly apparent that 62-type practice would not continue to fulfil all of the technical and commercial requirements of modern equipment. This was particularly true for new digital equipment which makes extensive use of integrated circuitry, and it was recognized that the expected future use of large-scale integrated circuitry would aggravate the problem.

About this time, the UK economic climate changed and equipment manufacturers began to look increasingly towards exports to maintain production levels. This move was hampered by the age and format of the existing equipment practice. Thus, a new equipment practice was considered to be needed urgently by both the British Post Office (BPO) and industry, and a joint working party was set up to determine the requirements. The working party took account of

- (a) the need to accommodate a wide range of transmission and allied equipment, with particular emphasis being placed on digital equipment,
- (b) the need to achieve as much commonality as possible with the installation requirements of switching equipment, thus enabling common transmission and switching installations to be rationalized,
- (c) the possibility that some future designs of switching equipment could be housed in the new racks,
- (d) the emerging requirements of CEPT‡ recommendations leading towards European equipment harmonization, and
- (e) export considerations,

It was inevitable that some compromises had to be reached but, nevertheless, the working party agreed a basic specification which catered for most of the above requirements and the BPO placed a contract with industry for the development of a new rack and ancillary equipment.

The equipment practice has been given the title *TEP-1(E)*,

† Telecommunications Development Department, Telecommunications Headquarters

\* WALKDEN, M.R. Construction Practice for Transmission Equipment. *POEEJ*, Vol. 66, p. 25, Apr. 1973.

‡ CEPT—European Conference of Posts and Telecommunications Administrations

where the designation (*E*) is used to differentiate from the title *TEP-1(H)*, which has been assigned to the equipment practice to be used for the System X project and which will be described in a later issue of this *Journal*. The '*E*' practice houses electronic equipment only. The '*H*' practice houses both electronic and electromechanical equipment.

## DIMENSIONS

The nominal overall dimensions of the TEP-1(E) equipment rack are:

depth	260 mm,
width	600 mm, and
height	2600 mm (maximum).

The dimensions accord with the emerging CEPT agreements and yield convenient PWB sizes. The maximum rack height is 2600 mm; and a range of shorter racks will be made available to meet particular installation requirements.

The modular relationship between racks used for transmission, switching and radio equipment is shown in Fig. 1, which also shows a hypothetical suite layout for mixed usage installations.

The main function of the new equipment practice is to house integrated circuits, the overwhelming majority of which have a pin spacing of 2.54 mm (0.1 inch). This pin spacing dictated the use of a 2.54 mm PWB grid, which led to the use of a 2.54 mm PWB-to-shelf connector, a 2.54 mm shelf backplane grid and a 2.54 mm backplane-to-cable connector.

The integrity of the backplane grid has to be preserved between shelves which are coupled together to form multi-shelf equipments to enable wiring of multishelf backplanes to be achieved automatically. Thus, shelf dimensions and spacing are all based on a fundamental module of 2.54 mm.

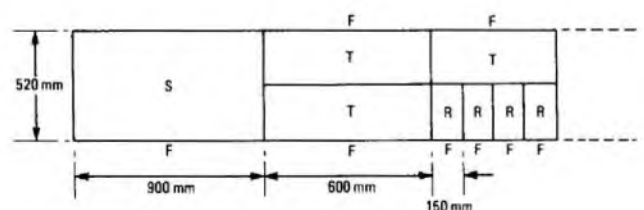

Legend  
 S : Switching equipment (TEP-1(H))  
 T : Transmission equipment (TEP-1(E))  
 R : Radio equipment  
 F : Front face of equipment

FIG. 1—Hypothetical suite layout for mixed equipment



(a) Front view, showing cabling and fuses

(b) Rear view

FIG. 2—Skeleton rack

## MATERIALS

Traditionally, the material used for telecommunications equipment practices is mild steel with a passivated-zinc or painted finish. The relevance of this material to modern transmission equipment needs was examined and it was concluded that

(a) the labour cost associated with the finishing processes was high,

(b) the specification and inspection of the finishing processes were difficult to achieve, and acceptance standards were somewhat arbitrary, and,

(c) corrosion problems could not always be prevented on export equipment.

Although mild steel is relatively cheap, it was decided that overall savings could be achieved by using more sophisticated materials which were self-finished, or finished at source under controlled conditions. Therefore, bearing in mind the relatively small amount of steel involved, chrome steel to British Standards Institute specification BS1449 430 S15 was selected for all rack and shelf parts which required mechanical strength. This is a low-grade, self-finished stainless steel which is also finding application in some foreign equipment practices.

Plastics-coated aluminium was chosen for the rack cladding and shelf covers. This is delivered from the supplier in its finished state and can be cut and formed without causing surface damage. The cladding controls the rack colour, and this can easily be selected to suit different marketing requirements.

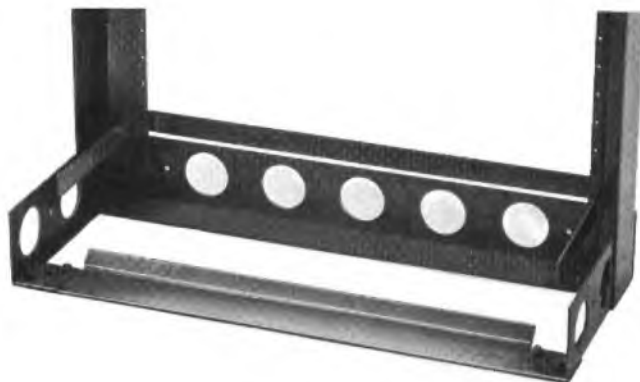

FIG. 3—Rack base

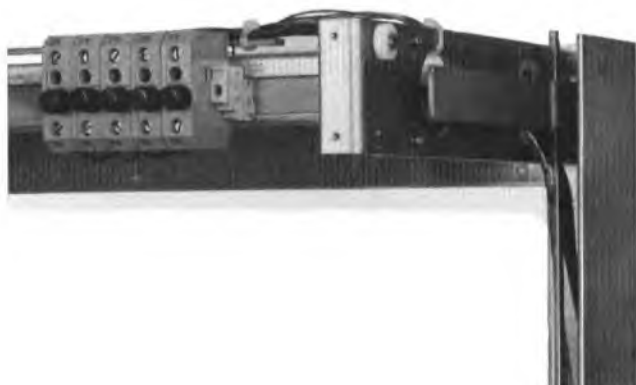

FIG. 4—Rack-top fuse mounting

## RACK

The main strength-giving members of the equipment rack are 2 vertical sections of L-shaped cross-section, as shown in Figs. 2(a) and (b). These upright sections have a thickness of 3.0 mm, and are drilled and tapped with a metric M4 thread at 30.48 mm intervals in the vertical plane. The uprights are held at a precisely-controlled distance from each other by the rack top, base and intermediate horizontal tie bars. The forward-facing surfaces and the 2 rows of tapped holes form the defined interface between the rack and the equipment shelves.

A base is formed from parts which are bolted together and bolted to the main uprights (see Fig. 3). Holes are positioned at strategic points at the back and sides of the base to enable power cables to be fed from rack to rack. A front panel is fitted which forms a *kicking plate* for the rack. This plate incorporates ventilation holes, and a facility for mounting a mains socket outlet.

The rack-top assembly is similarly fabricated and provides facilities for mounting the alarm unit and fuses, (see Fig. 4). A removable front-cover is fitted which carries the rack labelling.

Cabling compartments are partitioned off on each side of the rack by means of fittings which are screwed to the uprights (see Fig. 5). The vertical compartments thus formed each have a cross-sectional area of 4600 mm<sup>2</sup>. This gives a cable-volume to equipment-volume ratio of 1 : 17, which was considered to be the optimum for the range of equipments to be housed. A copper earth-bar can be situated in either cable compartment, although, normally, only one bar is fitted in the right-hand compartment. Entry to the cabling areas is from both the top and base of the rack.

The rack can be used in its skeleton state but, normally, cladding is fitted to enable control to be exercised over the

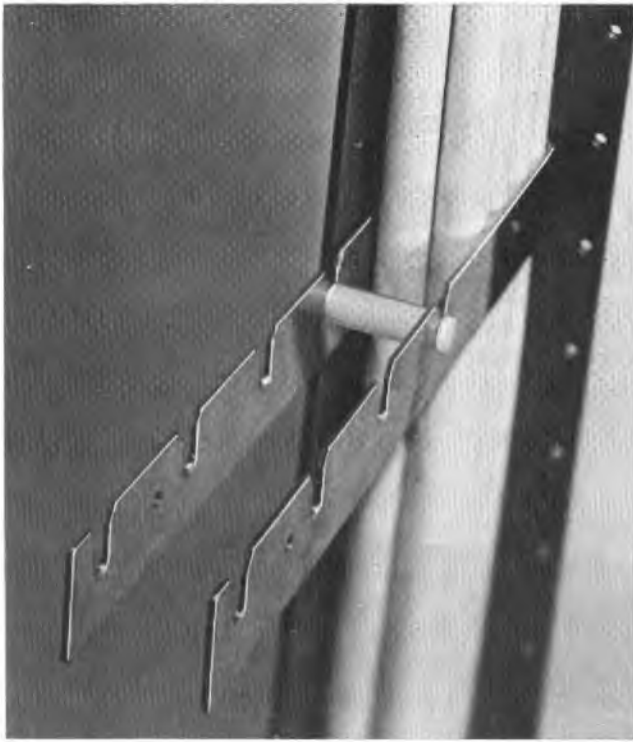

FIG. 5—Cable-compartment fitting

thermal and radiation characteristics to protect the equipment and to enable a good appearance to be achieved. Cladding is available for the rack sides and back and is screwed to the main uprights. In addition, easily-removable cable covers are provided which fit on the front of the rack to hide the cabling compartments. Thus, when fully clad and fitted with equipment, a conventional box-like appearance is presented, see Fig. 6.

### SHELVES

The spacing (30·48 mm) of the drillings in the rack uprights is taken as the module upon which the vertical dimensions of the shelves are based. Four-unit and 8-unit shelves have been selected as standard provisioning units, although the use of other sizes is not ruled out. The following description applies to either 4-unit or 8-unit shelves, any differences being indicated at appropriate points in the text.

Four sections are bolted together to form a rectangular frame which surrounds the backplane. The 2 horizontal sections contain holes which provide location and fixing for the connectors, and for the location of the plug-in-unit (PIU) guides. The holes are spaced at 5·08 mm and this spacing provides the horizontal module for the positioning of the PIUs within the shelf. Side cheeks are mounted on the sides of the rear frame. They provide the mounting arrangements for securing the shelf to the rack and enable the front horizontal members and front covers to be held in position. Holes are incorporated which allow cables to pass from the rack cabling compartments to the shelf connectors. The front horizontal members also contain holes spaced at 5·08 mm intervals at positions corresponding with those in the rear frame. Plastics guides are snap-fitted into these holes as required to guide and partially secure the PIUs into position. The section of the members is shown in Fig. 7, from which it can be seen that a cavity is formed which is used to provide PIU locking facilities.

The 8-unit shelf can be partially sub-divided into 4-unit shelves by adding additional component parts; a sub-divided 8-unit shelf is shown in Fig. 8. A 4-unit shelf is shown in



FIG. 6—Fully-equipped and clad rack

Fig. 9. When required, stiffeners can be provided on the 8-unit shelf to decrease flexion of the backplane during PIU insertion and withdrawal (see Fig. 10.) Multishelf equipment can be formed by making the rear-frame vertical members common to a number of shelves.

An insulated backplane is fitted within the rear frame. The



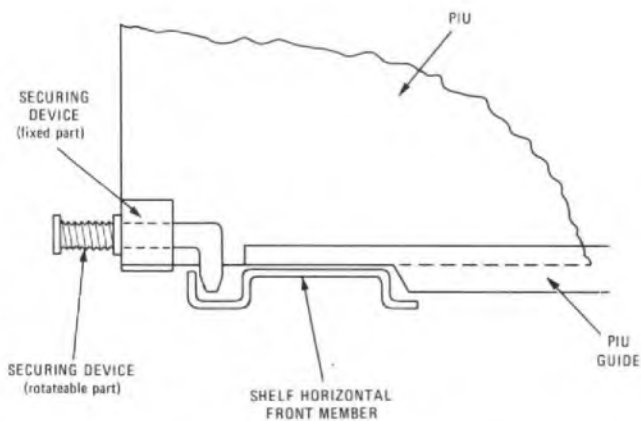

FIG. 7—Plug-in-unit locking facility

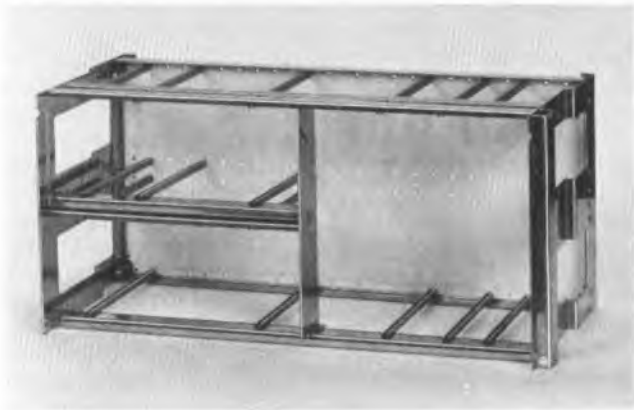

FIG. 8—Eight-unit shelf fitted with backplane, plug-in-unit guides and partial-division facility



FIG. 9—Four-unit shelf

backplane can be a simple 1.6 mm glass-epoxy board, drilled as required to position connector wire-wrapping posts in those situations where wire-wrapping is considered to be the most appropriate form of interconnexion. Alternatively, a PWB can be fitted, the connector tags being soldered to the backplane (see Fig. 11). Combinations of these 2 techniques can be used if required. For development work, connectors can be fitted to the rear frame without the backplane.

The connector chosen for the shelf is the International Electro-Technical Commission (IEC) 130/14 style, as shown in Fig. 12. This connector can house up to 96 contacts, arranged on a 2.54 mm grid. It is available in other forms having a lesser number of contacts. One variant of particular interest is that shown in Fig. 13. This connector has cavities which can be fitted with coaxial contacts, high-current or high-voltage contacts, first-make/last-break contacts, switching contacts or

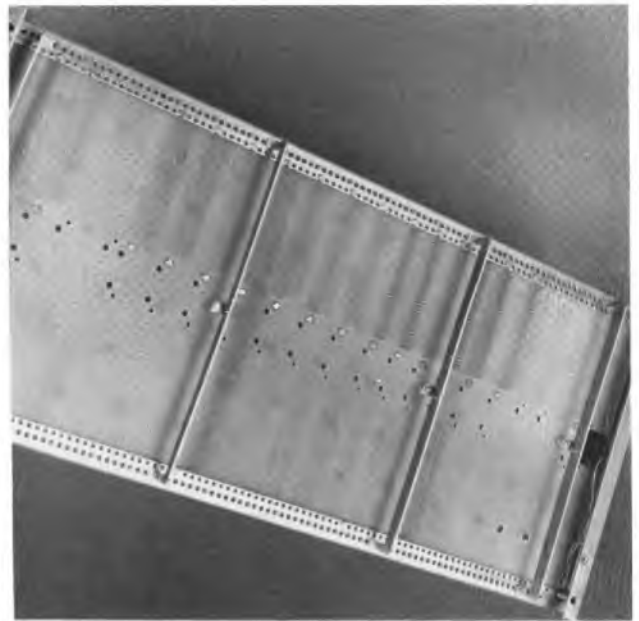

FIG. 10—Rear view of 8-unit shelf showing backplane and stiffeners

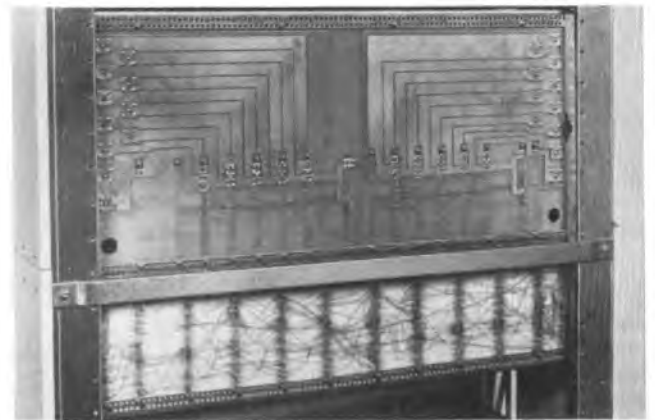

FIG. 11—Rear view of rack-mounted shelves (rack covers removed) showing printed-wiring and wire-wrap backplanes

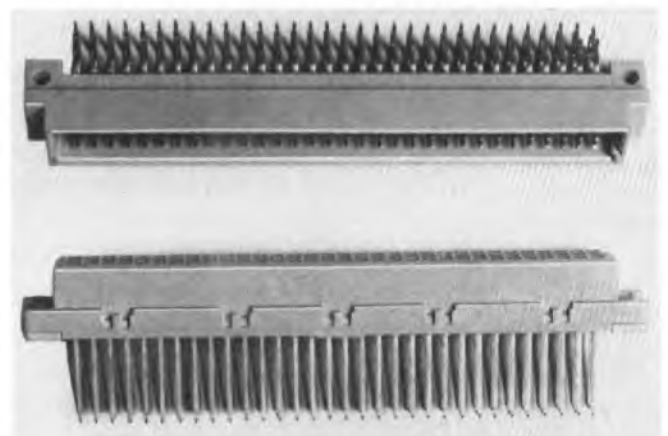

FIG. 12—A 96-way connector

optical-fibre connectors. The range of connectors is used to interconnect the PIU and the shelf, and also to connect the shelf to pair-type station wiring. A different style of connector is used to interconnect the shelf and coaxial station wiring,



FIG. 13—Connector fitted with 2 coaxial contacts

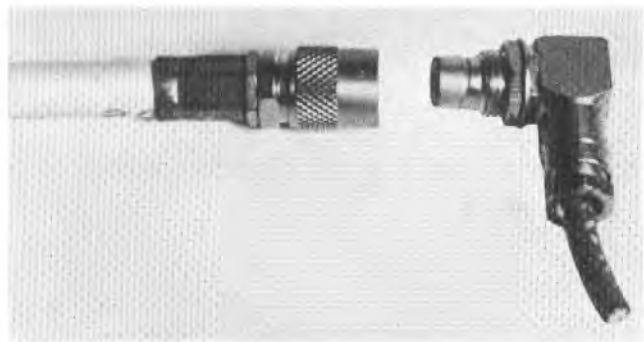

FIG. 14—Coaxial shelf-to-cable connector

based on a proprietary range, and is shown in Fig. 14.

Normally, the front of the shelf is fitted with a cover that is secured by rudimentary bottom hinges and top-mounted fasteners, and is easily removed by releasing the finger-operated fastener catches.

### PLUG-IN UNIT

The majority of PIUs consist of PWBs fitted with connectors as shown in Figs. 15 and 16. For the 2 standard shelf sizes, the corresponding PIU sizes are 100 mm × 195 mm (4-unit shelf) and 222 mm × 195 mm (8-unit shelf). The larger card can be fitted with either one or two connectors as required.

At the front edges of an equipment card, a securing device is fitted which locates to the lower front horizontal shelf member. The securing device can also be fitted to the top of the card if required. Manipulation of the rotatable part of the securing device provides either a locking facility when operated against the rear face of the horizontal shelf member, or an extraction facility when operated against the front face.

Test points, both symmetrical and coaxial, can be affixed to the front edge of an equipment card; typical connectors are shown in Fig. 15.

PIU cards can be either unscreened or screened. The screens are constructed from 0.45 mm chrome steel and form an integral part of the PIU.

Various alternative mechanical configurations can be used for PIUs, but all of them will be located in the shelf by one or more pairs of card guides.

### EQUIPMENT CONFIGURATION

The basic unit of equipment provision is the shelf, or a combination of shelves. A shelf can contain equipment to

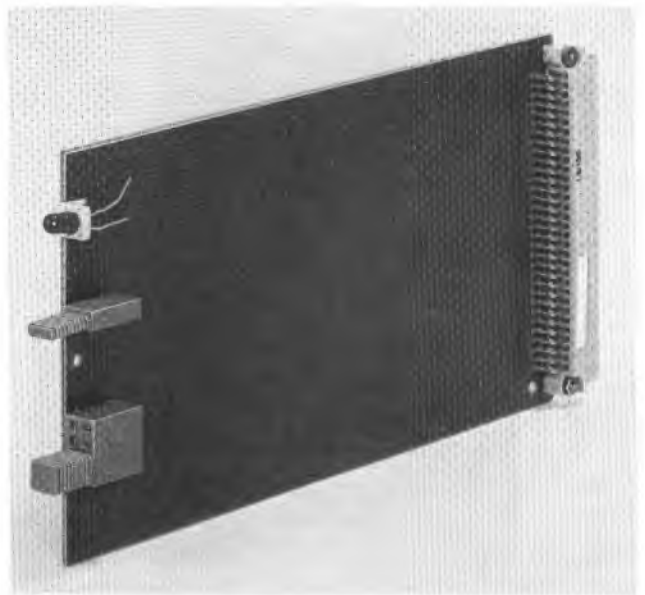

FIG. 15—Four-unit plug-in-unit showing typical front-edge component



FIG. 16—Eight-unit plug-in-unit showing card locks

provide more than one discrete electrical function, but the shelf must be dedicated to a particular equipment type from the outset of its manufacture. Future development might allow partially-equipped shelves to be provided.

Equipment (or equipments) forming a shelf incorporates alarm facilities on a per-shelf basis, as described later.

Connexions to and from the equipment ports are made by means of connectors which, normally, are situated at one or both ends of the shelf backplane, although other positions might be chosen to meet particular circuit requirements. In addition to the signal connexions, power and alarm connexions are made by means of connectors situated at either or both of the extreme sides of the backplane, with preference being given to use of the right-hand side only. The connectors facilitate factory and on-site testing, and enable the equipment to be removed from the rack for maintenance.

## POWER SUPPLIES

Power supplies are connected via fuses situated in the rack top. The terminating fuses are strapped to distribution fuses; these can be provided during initial installation or added as equipment is fitted to the rack. The fused supplies are connected to the equipment backplanes by 1 mm<sup>2</sup> wires situated usually in the right-hand rack cable compartment.

## ALARM FACILITIES

An alarm unit is normally provided for equipment containing active components; it is situated at the left-hand side of the rack top and provides the interface between the rack-mounted equipment and the station alarm systems. The alarm unit incorporates 4 lamps, which are visible from the front of the rack. When illuminated, the functional indication given by the lamps are as shown in Table 1. In addition, the alarm unit provides an alarm-lamp test-switch and 2 test-trunk terminations. The former enables all the rack alarm lamps to be tested, including those mounted on the shelf sides.

Each shelf containing active components is equipped with a shelf alarm unit which is mounted on the right-hand side cheek. The unit is protected by a metal cover which has apertures for 2 lamps and a push-button switch; the functions of the unit are given in Table 2. Further alarm-lamps may be provided on the shelf PIUs, but these are normally hidden by the shelf cover.

Connexion between the shelves and the rack-top alarm unit is provided by means of a 10-wire bus housed in the right-hand cable compartment. The bus design is based on ribbon cable and associated connectors.

An equipment fault will cause the red shelf-lamp to light, and a signal is sent to the rack-top alarm unit. This extends a signal to operate the appropriate station alarm and the appropriate rack-top red lamp. The station alarm is silenced by pressing the RECEIVE-ATTENTION button on any shelf. This extinguishes both shelf and rack-top red lamps, and causes the shelf and rack-top green lamps to operate. Further fault-location is then achieved after removal of the shelf cover. After fault clearance, the lower rack-top red lamp, rack-top green lamp, shelf green-lamp and the station alarm will operate. These indications are restored by pressing the RECEIVE-ATTENTION button on any shelf.

**TABLE 1**  
**Alarm-Unit Lamp Indication**

Lamp Colour	Functional Indication
WHITE	Power on
RED	Prompt or deferred alarm
GREEN	Receiving attention
RED	In-station alarm and alarm clear

**TABLE 2**  
**Shelf Alarm-Unit Indications**

Component	Functional Indication
RED lamp	Alarm
GREEN lamp	Receiving attention
SWITCH	Receiving attention or alarm cancel

## HEAT DISPERSION

Air enters the bottom of the rack through the rack-base ventilation holes and passes through all the equipment housed

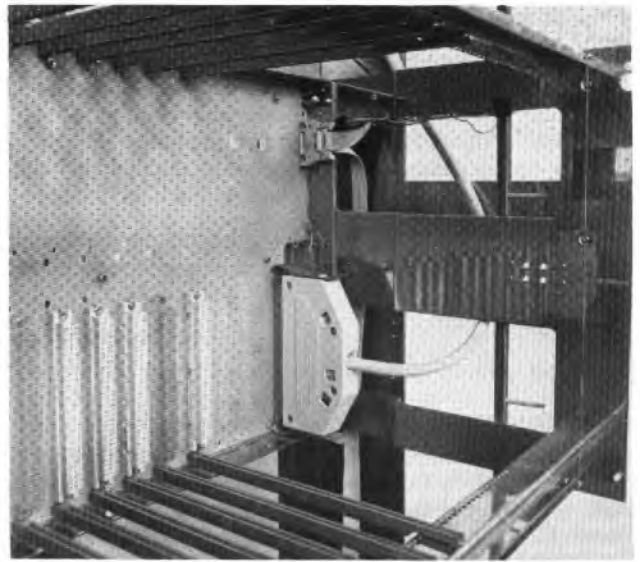

FIG. 17—Mounted 8-unit shelf showing cable connector

on the rack, to exhaust at the rack top. In addition, air enters the gap between the bottom shelf and its cover, and flows upwards through a similar gap between all the other shelves and their covers.

If thermal coupling between equipment cannot be tolerated, or high-dissipation equipment is to be housed, then ventilation shelves can be fitted as required.

A good degree of thermal isolation between adjacent racks is provided by the rack cable channels, and by a 25 mm gap which exists between the shelf backplanes and the rack rear cladding. Total permitted rack dissipation is 400 W.

## CABLING

Station cables are installed by first removing the rack side cable covers to expose the cabling compartment. The cables are then pushed from the front into the cable securing devices, which are adjustable to accommodate various sizes and quantities of cables; finally, the cables are threaded through the holes in the shelf side cheeks, see Fig. 17. Cable termination can be carried out immediately before this latter operation, or pre-terminated cables can be used.

Symmetrical-pair cables are terminated on a standard IEC130/14 connector housed in a purpose-designed shroud. Either soldered or wire-wrapped methods can be used, although insulation-displacement terminating techniques are being studied for future use. Coaxial cables are terminated using a soldered inner joint and a crimped outer.

## CONCLUSION

A new equipment practice has been described which will house new designs of transmission and other electronic equipments, and which is expected to provide an economical means of packaging such equipment over at least the next 5, and hopefully 10, years.

Transmission-type equipment associated with System X could be housed in the new practice in addition to more conventional transmission equipment. It is hoped that the new format will assist exports by enabling a readily-marketable equipment package to be designed.

## ACKNOWLEDGEMENT

The author acknowledges the assistance of his colleagues and GEC personnel in the preparation of this article.

# Continuous Power-Generation at the Goonhilly Satellite Communications Earth Station

C. ARCHER †

UDC 621.311.6 : 621.396.946

*This article describes the continuously-running base-load power generation installation at the British Post Office satellite communication earth station at Goonhilly Downs.*

## INTRODUCTION

The British Post Office (BPO) satellite communication earth station at Goonhilly Downs was originally brought into service using the national electrical-supply network as the prime source of electrical power. Distribution around the site was by radial feeders at 11 kV, with local sub-stations providing a medium-voltage supply at 415 V to the aerials and the main building complex. At each site, standard power plants provided a medium-voltage 415 V standby facility.

This system, however, proved to have several disadvantages, the most serious coming from the local mains-supply network which, being at the end of a long distribution line subject to interference from lightning ionization conditions and switching operations, caused large voltage transients to be reflected into the distribution system. To reduce the transients produced during local storm periods, a pre-arranged run-up system for the standby generating sets was introduced, but had the disadvantage of producing supply interruptions during the starting and stopping of the sets.

Other disadvantages were found to be

(a) the inflexibility of the standby generating plant, which inhibited any spare generating set capacity at one part of the site being used at another part of the site, and

(b) the site maintenance commitment was increased because the standby generating plant was dedicated to individual accommodation.

The effect of the voltage transients and supply interruptions produced a relatively-high aerial outage time, which resulted in the loss of transmission revenue and customer confidence. Aerial maintenance costs also increased in proportion to the number of aerial outages; thus, in an effort to reduce these operational problems to a minimum, studies were undertaken of an alternative type of supply arrangement which could provide a more stable source of voltage supply.

From these studies, it was revealed that a base-load system, comprising a number of continuously-running generating sets operating in a parallel concept and controlled within close limits, could best meet the station's operating requirements at the lowest capital and maintenance costs.

Although the prime object in selecting this form of plant was to achieve a secure and stable electrical supply, considerations also had to be given to the operating costs. At that time, energy tariffs were not of a volatile nature and comparative studies between the base-load plant and the existing electrical charges, coupled with the standby generating plant operating costs, showed that the base-load system was economically viable. To effect further cost savings and to conserve energy, it was decided that heat recovered from the engine exhausts would replace the existing oil-fired boilers as the prime source of heating for the station.

The installation of a continuously-operated base-load plant at Goonhilly commenced in 1973. However, by 1975, the economic climate forced a cut back in the scope of the plant

and only a partial system has been installed. The reduced installation was put into operational service in a base-load mode and confirmed the original concept to be sound. This article describes the generation system.

## OPERATIONAL CRITERIA

To prevent aerial transmission interruption, operational requirements demanded that the power supply be controlled under all load and switching conditions within the limits given in Table 1. In addition, a high degree of flexibility and reliability was attained to enable the future power supply needs of the station to be met and for maintenance routines to be implemented without interruption of the plant.

Projected electrical load forecasts dictated that 4 continuously-running sets, each with a capacity of 1 MW, would ultimately be required to provide correct load matching, but that 3 sets would meet the initial demand. To provide high reliability standards, two further engines were installed, one to act as standby at all times to the running sets, and the other to enable maintenance routines to be carried out on any set without reducing the standards of security.

The generating sets were required to operate in parallel to provide maximum utilization of capacity and flexibility, and a redundancy form of running was adopted to allow the station load to be met by the remaining sets in the event of any one operational set failing; the standby set automatically replaces the set which has failed.

The prime source of power for the generating sets had to be relatively inexpensive and, at the same time, provide a high degree of reliability. To achieve this, diesel engines, of which the BPO has considerable operating experience, were chosen as being the most reliable form of motive power at the lowest overall cost. Heat exchangers on the engine exhaust outlets provide exhaust-heat recovery and the generators operate at 11 kV to ensure compatibility with the existing distribution, switchgear and transformers. The use of natural gas as an alternative source of fuel was ruled out on the grounds of excessive connexion costs.

To provide extra security it was decided to retain the local mains-supply feeders from the national network. By this means, the diesel-oil main-storage capacity, which was originally planned to have had a 90 d reserve, was reduced to a 30 d

**TABLE 1**  
Operating Limits

Parameter	Limits
Voltage	$\pm 1\%$ of nominal under stable conditions $\pm 4\%$ of nominal under transient conditions
Frequency	50 Hz $\pm 2\%$ under stable conditions 50 Hz $\pm 10\%$ under transient conditions
Frequency-controlled time check	$\pm 3$ min of standard time

† Operational Programming Department, Telecommunications Headquarters

reserve, which is the normal BPO standard for this type of station. Maximum electrical distribution flexibility was achieved by converting the existing high-voltage radial distribution into a ring distribution, linking all outdoor substation sites and connecting to the generating plant. To prevent untried sets being connected directly into the system after periods of repair or maintenance, a permanent test-load facility has been incorporated in the electrical-distribution system, enabling sets to be tested singly or in pairs.

## BUILDING DESIGN

A purpose-built building of single-storey design and concrete block construction was selected as the most economical form of building to meet the requirements of the plant. A low-building profile was needed to meet local planning requirements, and the design allows the generating plant to continue operating normally, as far as is possible, should a fire break out. There are two generator halls, each capable of housing 3 generating sets; a control room is placed centrally between the two generator halls.

The extract ventilation fans and exhaust heat boilers associated with each set are housed separately adjacent to the generator halls. Engine radiators and exhaust stillages are installed within compounds external to the main building.

To obtain the lowest height possible for the buildings, the engines are erected on isolated concrete foundation blocks sunk into the floor of the generator halls.

Other rooms included in the central section are the medium and high-voltage switchrooms, a store room, workshop, staff locker room, toilets and washroom. Direct access from each generating hall into the workshop is available.

Fuel and lubricating-oil storage areas are external to the main buildings and are enclosed by bunded areas of sufficient capacity to contain all contents of the tanks in the event of a rupture.

Fire protection for the buildings is afforded by fire extinguishing systems installed within the high-voltage switchrooms, and a general alarm system is installed in the remaining accommodation. In each high-voltage switchroom a separate carbon dioxide (CO<sub>2</sub>) plant has been installed which is designed to half flood the cell with CO<sub>2</sub>. Operation is by fusible link and restraining wire.

Smoke and temperature-rise detectors are mounted in strategic positions around the accommodation to give advance warning of a fire hazard. A central alarm panel provides visual and audible alarm facilities which are also extended into the main station fire-alarm system.

Pipework and cabling services installed within floor trenches provide unobstructed working space within the accommodation. An overhead, remotely-controlled, 1 t gantry within each generator hall facilitates ease of maintenance on the generating sets.

## GENERATING SETS

Each prime mover is a pressure charged, intercooled in-line 6 cylinder, 4-stroke diesel engine producing 1248 BHP at 600 RPM, the speed being closely controlled by a hydraulic governor.

Temperature and pressure switches monitor the engine, and activate alarm and shutdown systems if normal operating conditions vary outside operational limits; indications are given at a central console of the temperature and pressure conditions at critical points on the engine. Access for maintenance is facilitated by a free-standing platform extending the full length of the set.

Each engine is directly coupled via a pedestal bearing to an 11 kV salient pole, brushless alternator with an overhung exciter, having an output of 1010 kVA at a power factor of 0.9. Anti-condensation heaters, which come into operation when the associated high-voltage circuit breaker is open, are

provided in both the alternator and exciter stator to prevent moisture damage to the winding insulation.

Field-suppression contactors and discharge resistors are provided in each exciter field to accelerate the decay of the alternator magnetic field under alternator-fault conditions.

During normal operations, the alternators operate in parallel and control transients due to load changes to within  $\pm 4\%$  of the nominal voltage. Voltage control is provided by a thyristor divert automatic regulator, operating within  $\pm 1\%$  of nominal under stable conditions.

## ENGINE SERVICES

### Engine Starting

Engine starting is by air obtained at a working pressure of 2.07 MPa† from a compressed-air system (see Fig. 1) installed in each generator hall. Each set of 3 engines has an electrically-driven reciprocating compressor supplying compressed air to 4 vertically-mounted steel receivers, one serving each engine set with one acting as a standby. Interconnecting pipework provides flexibility between the receivers by allowing any receiver to serve any engine. A diesel-driven compressor set provides a standby unit for emergency use.

The admission of air to start the engine is by a solenoid valve activated from the control desk, the air first passing through a 3-way valve which, by manual operation, can release the air pressure from the engine when maintenance work is to be carried out. An engine starting sequence of 25 s duration can be achieved twice from each receiver before the engine minimum-operating pressure of approximately 827 kPa (120 PSI) is reached, recharging of the receivers is normally achieved within 20 min.

All valves, pressure switches and gauges associated with each receiver are mounted on a framework adjacent to the receiver, a control panel enables electrical isolation of the various pressure switches during maintenance periods and provides indication for any alarm or maintenance condition.

† Equivalent to 300 pounds per square inch (PSI)

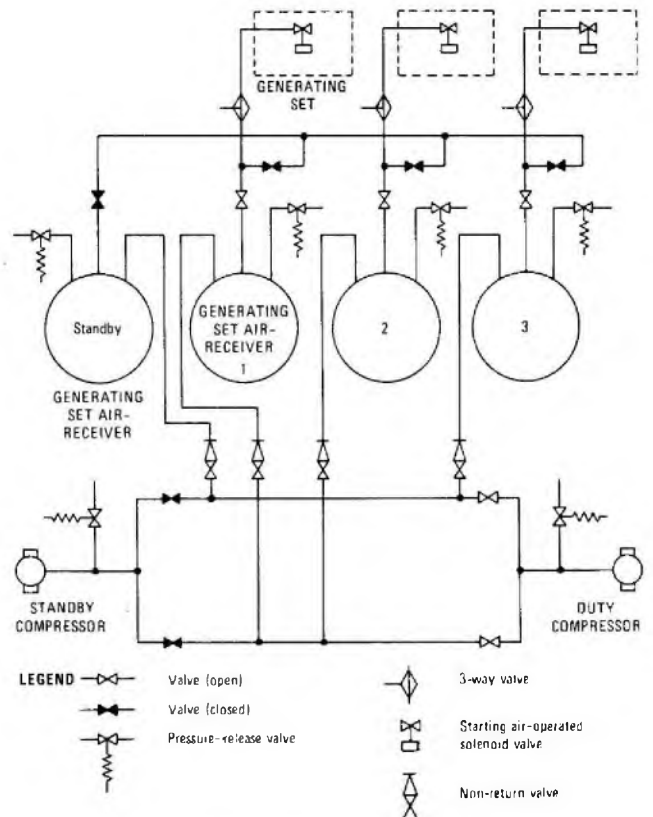

Fig. 1—Block diagram of compressed-air system

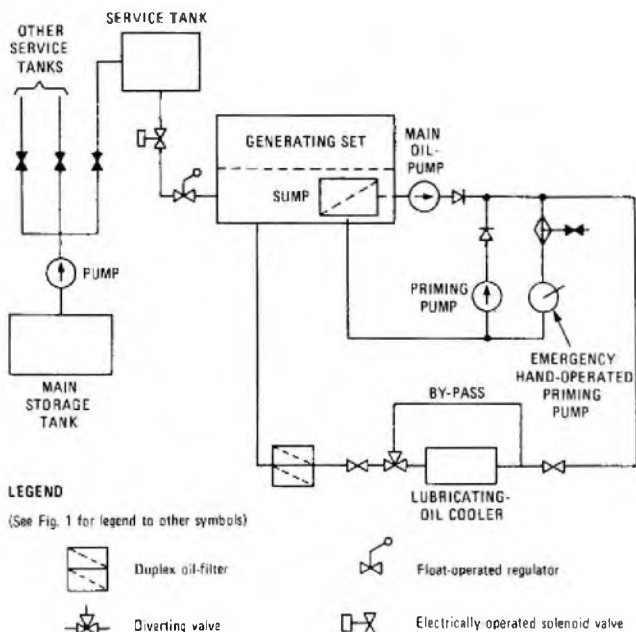

FIG. 2—Block diagram of lubricating-oil supply system

All alarms and indications are extended to the main control desk.

### Lubrication

Engine lubrication is by a gear-type pump driven from the free-end of the engine crankshaft drawing oil from the sump and discharging it via a filter and shell and a tube water-cooled heat exchanger into the engine distribution main. The oil circulation pipework to the cooler is provided with a wax-operated diverting valve which allows a proportion of the oil to by-pass the cooler, thus ensuring that the oil flow to the engine is kept at the required temperature automatically.

When stationary, the engine is continuously primed at a minimum pressure of 34.5 kPa (5 PSI) by a motor-driven priming pump installed in parallel with an emergency manually-operated semi-rotary pump. If the priming pressure falls below 34.5 kPa (5 PSI), the engine is prevented from starting. When the engine has been started, the priming system is stopped automatically when the oil pressure reaches 138 kPa (20 PSI), however, should the engine oil pressure fall below 117 kPa (17 PSI) during normal operation the engine shuts down automatically.

The oil in each engine sump is maintained at the correct level by a regulator of needle-valve construction which controls the flow of oil from a 455 litre (100 gallon) service tank adjacent to the engine. The service tank which provides the daily oil requirements of the engine has a capacity which can allow the engine to run unattended for approximately 10 h.

A 3410 litre (750 gallons) main storage tank mounted beneath the fuel day-service tanks provides a 30 d supply of lubricating oil for each engine hall. Oil is drawn from the storage tank and delivered to the service tanks by a push-button operated pump. A block diagram of the lubricating-oil supply system is given in Fig. 2.

### Fuel

The engines are designed to operate on diesel-oil fuel to Class A of British Standard Institute specification BS2869. Fuel is stored within two 227 000 litre (50 000 gallon) cylindrical vertically-mounted main storage tanks located in individual external bunded areas and is gravity fed to the engines from service tanks, which provide the daily fuel requirements for the engines. The service tanks, of which there are two for each

set of three engines, are supported on a stillage to the rear of each generator hall and each tank contains sufficient fuel to provide a minimum operating time of 12 h for the three engines operating on full load.

Fuel is transferred automatically from the main storage tank into the service tanks by an electrically-operated pump, controlled by magnetically-operated switches. The switches also operate alarms at the control desk if the fuel supply is not maintained at the correct level under all operating conditions.

To ensure security of fuel, the supply lines to the engines are taken from a common main connecting both service tanks; valves which can be closed from a remote position external to the engine hall are installed on each supply line to ensure that the fuel can be shut off from an engine in the event of fire.

A block diagram of the fuel-supply system is shown in Fig. 3.

### Engine Cooling

Once in operation, cooling for each engine is obtained by passing water through two separate systems, one serving the engine jacket, the other the engine auxiliaries. Engine-driven pumps circulate water in each system to a horizontally-mounted forced-draught radiator sited in the external compound, where heat from the water is rejected to the atmosphere. The operation of the 3-way by-pass valves, which allows full water by-pass of the radiator when the engine is started, ensures that the water in each circuit is maintained at the required temperature. A block diagram of the engine cooling system is shown in Fig. 4.

Each engine-cooling system contains 20% anti-freeze to prevent radiator freezing when not in operation.

Cooling and aspiration air for each engine is drawn through high-level fixed louvres mounted on the inside wall of an air intake chamber built above the central accommodation area. Thermostatically-controlled axial-flow extract fans, mounted within separate rooms adjacent to the free-end of the generating sets, limit the air temperature rise within the engine halls to 9°C above ambient. Two fans are provided for each engine. The air intake chambers each contain 3 motorized external air-intake louvred units, one being provided for each generating set. The louvres are opened automatically from their associated engine-control circuits, with alarm facilities provided in the event of the louvres not opening. Noise attenuators have been installed within the air-intake chambers and at the outlet of each extract fan to limit the noise to 48 dBA at the boundary of the site.

Exhaust gases are discharged to the atmosphere through mild-steel pipework terminating in the external plant compound, where the primary and terminal silencers are located on a floor-mounted stillage; before entering the silencers, the exhaust gases pass through exhaust-heat recovery boilers. Provision is made for expansion within the exhaust system by stainless-steel expansion bellows and roller-type supports and guides installed under the silencers.

### CONTROL

The monitoring and protection circuits required to control and safeguard the operation of the generating sets are housed within a single desk located in the control room. Indication is given on the status of the ring main, bus-sections and auxiliary transformer circuit breakers and generating sets. A centre section contains all alarms, controls and indications common to the plant. A graphic mimic, the top section of which is devoted to the ring main, is provided on the control desk to indicate the status of all circuit breakers and switches.

Under normal operating conditions, a minimum of 3 generating sets operate in parallel to provide the necessary security of supply, but any number of generating sets can be selected depending on their availability. The control circuit logic, which is operated at 50 V DC, stops and starts the sets automatically at the dictates of the plant, and provides

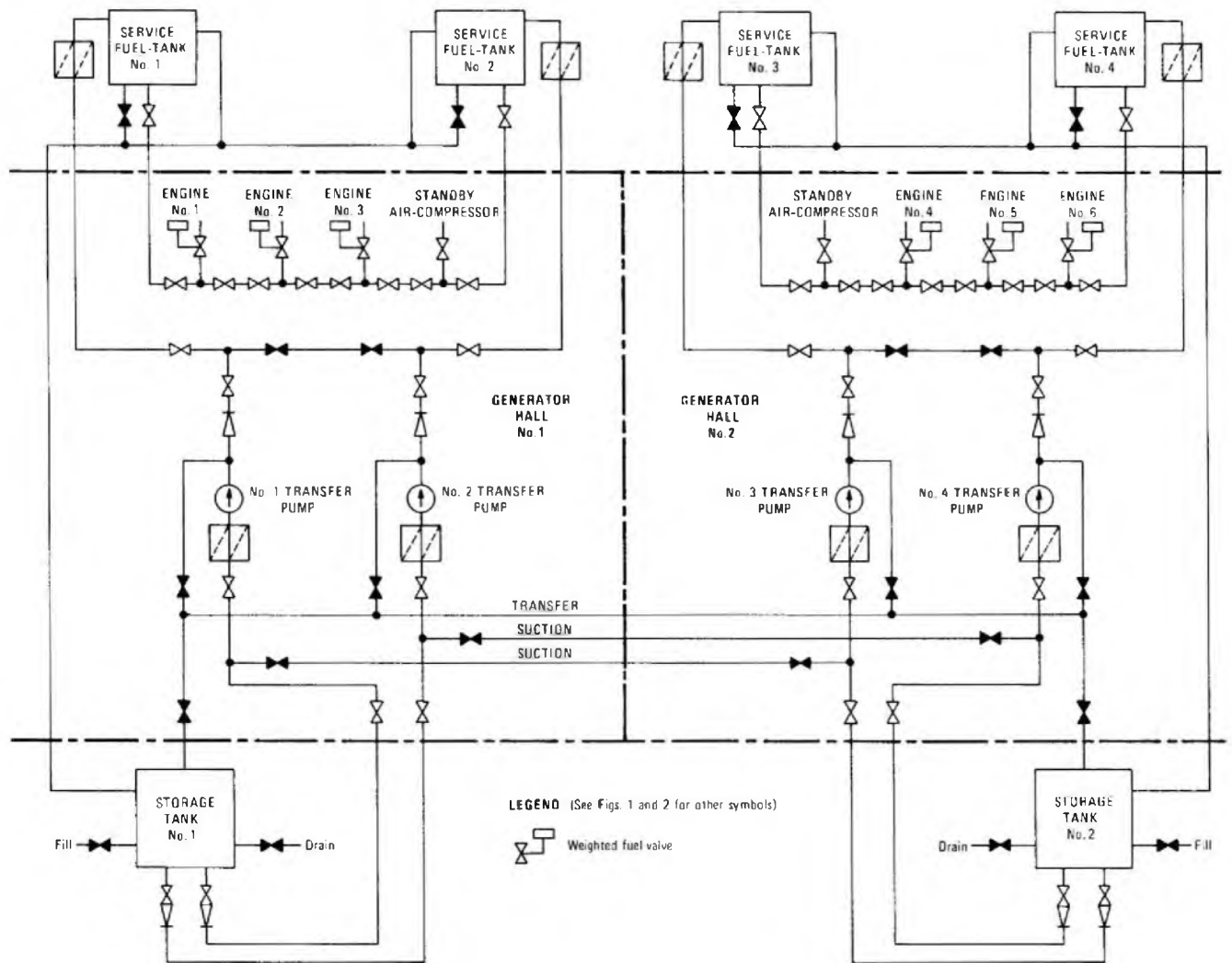
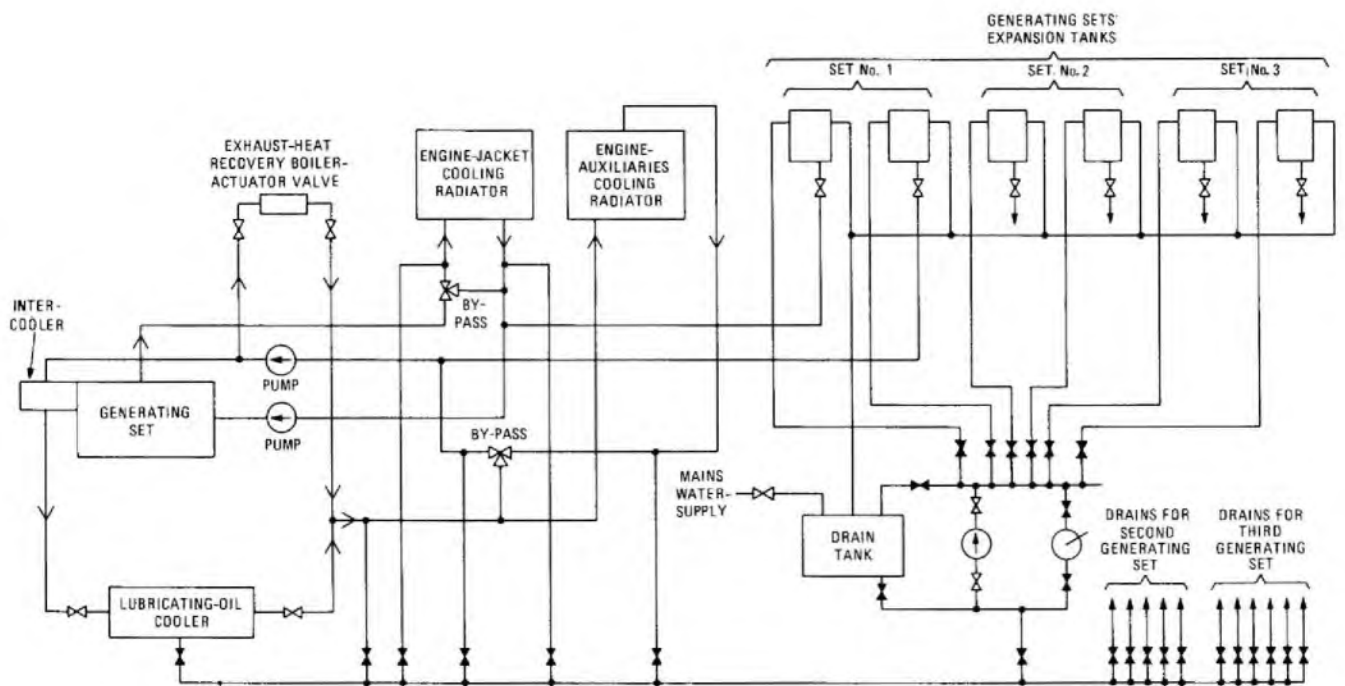

FIG. 3—Block diagram of the fuel supply system



Note: See legends of Figs. 1-3 for symbol definition

FIG. 4—Water-cooling system

synchronization of the generators to the load when operating in parallel. Once connected, the load of the station is shared equally between the generating sets, with the voltage and frequency being closely controlled within the required operating limits. Should these limits be exceeded, alarm circuits and, if required, engine shutdown circuits, are called into operation by the control logic. In the event of the automatic control being faulty, full manual facilities are provided to enable the station to continue functioning under operator surveillance.

Malfunctions likely to affect the performance of the plant or station equipment initiate visual and audible alarms. In the event of several malfunctions being present a *priority-first* system identifies the first fault by a fast-flashing indicator, all subsequent faults are identified by slow-flashing indicators. Acknowledgement of the alarm condition changes the light indication to a steady state and mutes the audible alarm, after which the alarm can be reset only when the fault conditions causing the alarm have been corrected. A separate module, which provides individual exhaust-cylinder indication, initiates an alarm when any cylinder temperature deviates from the average by  $\pm 25^\circ\text{C}$ .

A slave mimic, mounted within the operational control area of the main building complex, indicates the status of all circuit breakers and switches and contains an alarm system which operates in response to any fault condition existing on the control desk.

If a set which is operating at two thirds or more of its capacity is shutdown under fault conditions, the voltage transient condition without regulation would exceed 4% of nominal. To prevent this, a system is employed whereby an alarm from the set will first cause the voltage regulator to shed the reactive portion of the generated load from the alternator before the alternator breaker is opened. Opening of the alternator breaker sheds the remaining active portion.

Under normal operating conditions the high-voltage ring main is in a closed condition but, in the event of the high-voltage switchboard having one section isolated and the ring being broken by a fault, the control system will divide automatically into two independent systems. Push-button control also provides a manual facility to divide the control system should it be anticipated that the ring will be sectionalized.

A digital differential-clock system ensures that the time shown by the station clocks, whose reference is taken from the generated frequency, compares with that of standard time. The system comprises two sets of 6-digit displays and quartz-crystal-operated clocks, one operating as a master clock set to standard time and the other operated from the generated 50 Hz supply. A differential unit continuously computes the difference between the two time circuits and, in the event of the local time indication deviating from standard time by more than  $\pm 3$  s, the generating frequency-control system is called into operation to vary the frequency of the generators until such time as the difference is reduced to zero. Should this time extend to  $\pm 3$  min, an alarm is operated. A comparator circuit compares the oscillator outputs of both clocks and operates the same alarm in the event of the two frequencies deviating from each other by more than a preset tolerance.

### EXHAUST-HEAT RECOVERY SYSTEM

Heat recovered from the exhaust gases is designed to provide the prime source of hot water for the station. Extraction of heat from the gases is obtained by passing the exhausts from each engine through a shell-and-tube type heat-exchanger; a maximum extraction rate of approximately  $1.5 \times 10^6$  BTU/h can be achieved when cooling the gases from  $371^\circ\text{C}$  to  $177^\circ\text{C}$ .

An hydraulically-controlled deflector plate controls the water temperature within the heat exchanger to a maximum of  $121^\circ\text{C}$  by diverting the gases past the heating tubes and out to atmosphere via the exhaust. A nitrogen unit maintains the water pressure at a constant 350 kPa (50 PSI) under varying water-temperature conditions. A block diagram of the exhaust-

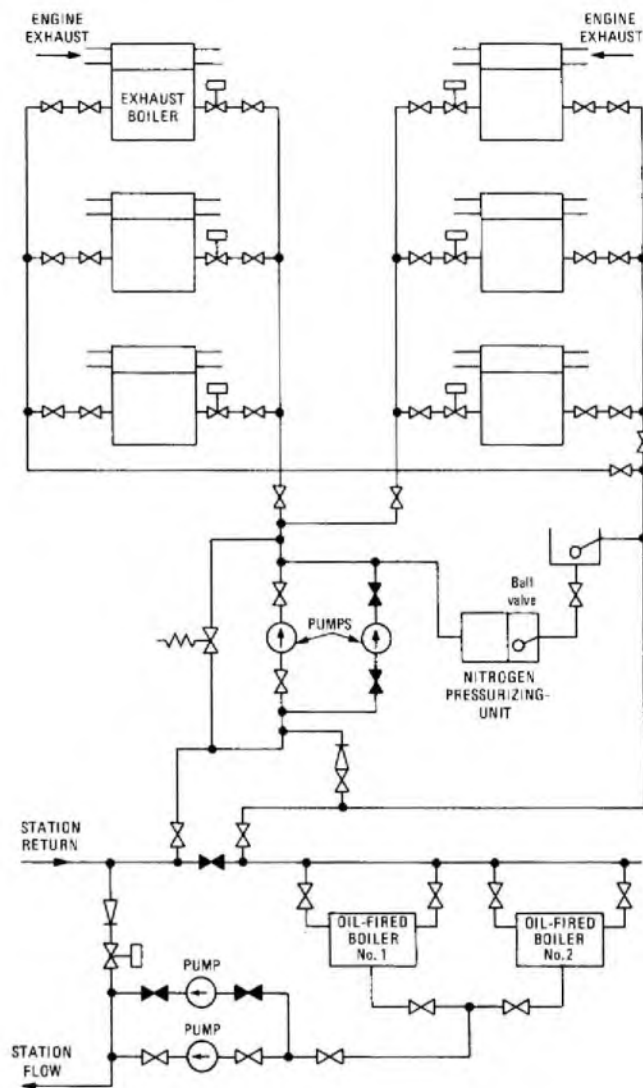

Note: See legends of Figs. 1-3 for symbol definition

FIG. 5—Exhaust-heat recovery system

heat recovery system is given in Fig. 5.

Hot water from the heat exchangers flows into a common main connecting to the existing oil-fired heating boilers. Extra heat can be supplied by the boilers if the output from the heat exchangers is not sufficient to meet the station heating demand.

### ELECTRICAL DISTRIBUTION

The station's high-voltage ring-main distribution is connected to the output of the generators by the front bars of a duplicate bus bar high-voltage switchboard (see Fig. 6). The switchboard has a short-circuit capacity of 250 MVA at 11 kV and incorporates 14 independent cubicles containing free-standing oil-filled circuit breakers. A rear set of bus-bars provide connexion from the alternators to the system test load. The switchboard is divided into 3 sections, each section is connected to two alternators, and is housed within a separate brick compartment. Switches provide isolation for the sections in the event of a fire within any compartment.

Protection of the generators from excessive current, short-circuit faults and reverse power flow is achieved by relays mounted on the upper front section of the cubicles which disconnect the generators from the distribution should any of these fault conditions prevail.

The oil-filled circuit breakers, with the exception of the bus-



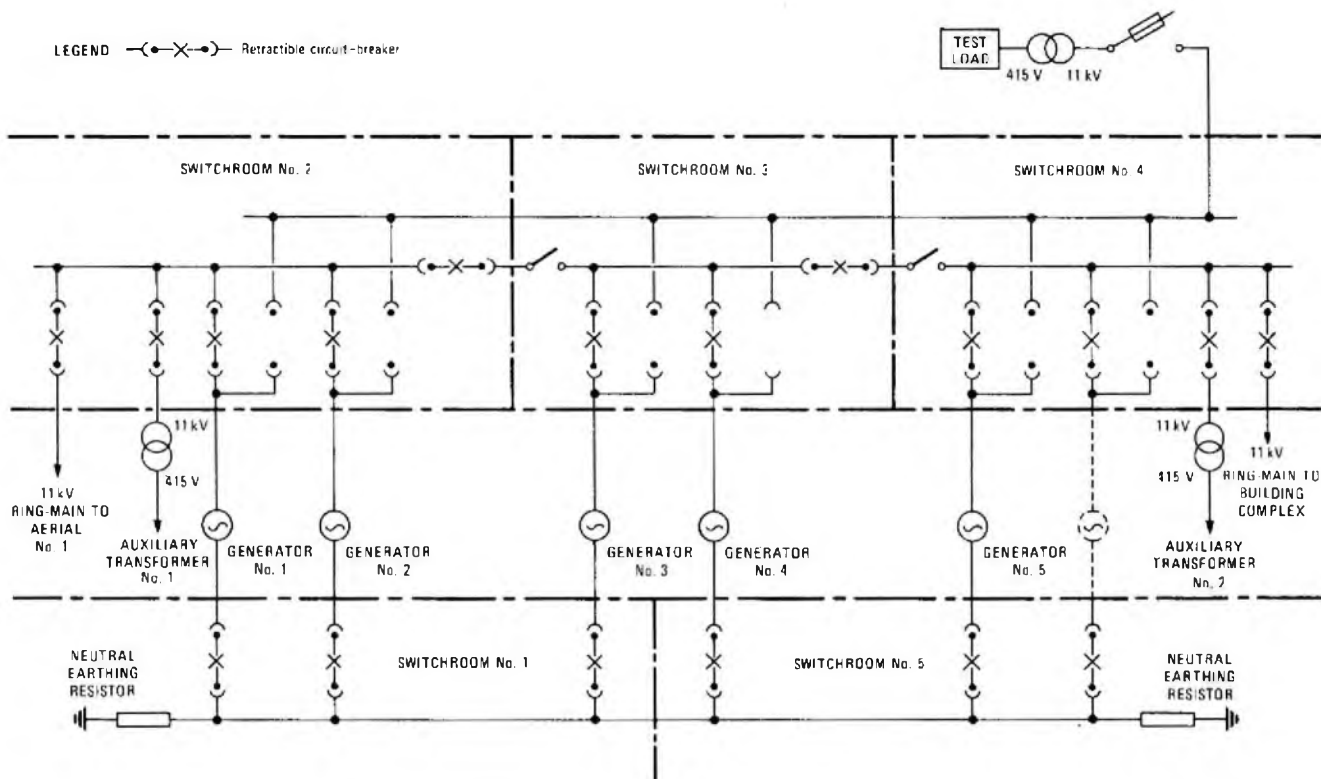

FIG. 6—High-voltage switchboard

section and test-load switches which are manually operated, are normally operated remotely from the control desk. The generator circuit-breakers have the added facility of being able to operate on either the front bars for load connexion, or on the rear bars during test. Interlocks ensure that a circuit breaker cannot be raised in other than the selected positions.

The neutral side of each generator is connected to earth via a single common-resistor bank which limits a system fault current to that value which would satisfactorily operate the protective relays. To prevent circulating currents flowing between the generators when operating in parallel, the control system allows only one generator neutral to be connected to earth at any one time.

Voltage supplies to the generator complex are derived from a 415 V triple pole-and-neutral switchboard fed from a 500 kVA transformer. In general, main and sub-main cables internal to the building are run in trenches, all others being run at high level on cable trays or trunking. Cables considered to be at risk from fire are of mineral-insulated-sheath construction and any cables not installed within conduit or trunking have an armoured protection.

## CONCLUSIONS

The trial period of the plant as a continuously-running base-load system covered a 2-year span. Over this period, a high degree of voltage stability and reliability was achieved, resulting in a dramatic reduction in aerial outage time and maintenance commitment. Although it is not possible to place a definitive financial value on these improvements there is no doubt that, in the terms of maintenance costs and customer satisfaction,

this form of power supply arrangement has met its design objectives.

Other advantages gained over the previous scheme emanate mainly from the flexibility of the system, which provides a central point of control over the station's power supply and enables the output capacity from the generators to be utilized to a maximum. Fewer generating sets are required to meet the station load, thereby increasing generating efficiencies and decreasing fuel consumption per electrical-unit generated.

Although the technical objectives of the plant have been realized, because of the volatile nature of fuel costs since the oil crisis of 1974, the economic case for a continuous-generating base-load system has not been fully established, even taking into account the savings in boiler fuel costs which could be gained from the exhaust-heat recovery system. Future price increases in energy tariffs may however change the balance significantly.

Because of the maintenance problems experienced in operating only 3 generating sets and the inherent insecurity to the supply should any one set fail, the plant is at present being restored to a standby unit having the facility to synchronize with the national mains network, thereby providing a no-break supply except in the event of a mains failure.

## ACKNOWLEDGEMENT

The author wishes to acknowledge the assistance of colleagues in the External Telecommunications Executive and the Operational Programming Department of Telecommunications Headquarters in the preparation of this article.

# Viewdata Abroad—The Technical Aspects

K. E. CLARKE, B.TECH., D.I.C., M.PHIL., C.ENG., M.I.E.E., M.B.C.S.†

UDC 025.3 : 681.31

*The success of Prestel, the British Post Office viewdata service, has aroused considerable interest in many countries. As a consequence, systems similar to Prestel are now appearing or are under development. Inevitably, the question of operational standards arises; this article comments on the technical aspects of such discussions.*

## INTRODUCTION

Since the first public announcement<sup>1</sup> of viewdata by the British Post Office (BPO) in 1975 there has been immense technical and commercial activity in Britain centred on Prestel, the BPO viewdata service. Some 150 "information providers" have written 130 000 frames of information on the data base, and a total of 180 000 frames have been sold. Twelve terminal suppliers, including all the major British television receiver manufacturers, have supplied receivers for the market trial and three integrated circuit modules have been produced. Some 26 GEC 4082 computers have been installed or ordered to provide service, and the first receivers available to the general public were offered for sale in March 1979.

Impressive though the UK Prestel activity is, it is matched by interest and activity abroad. This takes several forms. As a result of strenuous efforts by the Prestel International Division of the BPO, a number of foreign administrations have purchased complete viewdata installations from the BPO (who provide the software) and from GEC computers. Such sales have been made to Germany, Holland, Switzerland and Hong Kong. The marketing rights in the USA and certain other marketing rights have been sold by the BPO to INSAC\*, who have also sold a further private system to a publisher in Holland. Some 20 overseas organizations pay to use the Prestel service for demonstrations and evaluation. Inspired by viewdata, a number of nations have developed their own systems, similar but not always identical to Prestel. Finally, a major debate on technical standards, thought by veterans to match the PAL/SECAM/NTSC television colour standards debate of the 1960s in its intensity, has arisen. Comment on the technical aspects of these viewdata activities is given below.

## TECHNICAL SUPPORT TO PRESTEL INTERNATIONAL SALES ACTIVITY

It says much for the simplicity and universality of Prestel that it transplants abroad readily without major technical change. However, in order to achieve the sales, it has been necessary for engineers from the BPO Telecommunications Headquarters Network Planning and Research Departments to make some 40 trips to 20 countries during the last three years to mount demonstrations, often at short notice and with minimum preparation. The first trips were made by BPO Research Department staff travelling by road, since the viewdata sets of those days were rather cumbersome and some test equipment was also taken. Darel Modems No. 1 were carried because, although other modems were usually made available, clear instructions for their connexion and use were often difficult to obtain. Moreover, because they were more widely used, 1200/1200 bit/s half-duplex modems were often provided instead of the required 1200/75 bit/s asymmetric full-duplex modem.

As far as transmission requirements are concerned, the international public switched telephone network usually sufficed, but private circuits were often used, either to ensure quick access to the computer at the required time, or because local regulations prohibited the use of the switched network for data. Other technical points requiring attention were the voltage, frequency and plug standard of the local power supply, and possible interference from metering pulses on the subscriber's local line. Echo-suppression disabling equipment has been required on some occasions.

Points of organization include allowances for time zone changes in the demonstration computer schedules and, most important, attention to the complex and strictly enforced system of carnets required for the transportation of scientific equipment across international boundaries.

The first viewdata demonstration given abroad was in 1976 to the German Communications Technical Centre (FTZ) at Darmstadt. The overland trips reached their zenith in late 1976 and early 1977 with visits to Berne, Florence and Venice. The visit to Berne required a vehicle equipped by the BPO Research services for a winter crossing of the Alps; for the visit to Venice, local negotiations for the hire of a barge were necessary. The Venice trip was complicated further by the fact that a colour projection television receiver, fully converted to receive viewdata, was used to ensure that the large audience could see the demonstration.

A growing confidence in the ability of viewdata to work abroad reduced the requirement for test equipment, and the demonstration teams began to transport television receivers by air cargo. The main problem then was the disturbingly high rate of damage to television receivers while in transit. Demonstration locations in 1978/79 included Moscow, Hong Kong, Jerusalem, Bahrain, Hawaii, Orlando and Mexico. Russian, Arabic and Japanese character generators were produced for use on these trips, and specimen texts in these languages were incorporated into the computer software at Martlesham. Equipment to generate PAL, SECAM or NTSC composite video signals from a viewdata decoder was also developed.

The latest phase in the programme of overseas demonstrations began in September 1978, when a demonstration in Madrid was given by an engineer who used a portable aerial input adaptor that he carried as passenger's luggage. This device is capable of driving up to 10 additional display monitors.

## VIEWDATA-TYPE SYSTEMS DEVELOPED OVERSEAS

The viewdata-type systems developed overseas are summarized in Table 1. The information given is the latest available at March 1979, and may not fully represent the publicly-announced capabilities of the systems concerned at the time of publication. Any technical synopsis of a subject as complex as viewdata must depend on a degree of simplification, but the author has endeavoured to maintain a balanced picture.

† Research Department, Telecommunications Headquarters  
\* INSAC—A company sponsored by the UK National Enterprise Board

**TABLE 1**  
**Viewdata-Type Systems Developed Overseas**

Country	Organization	Name of System	Main Technical Features
Canada	Department of Communications	TELIDON <sup>2</sup>	Graphics capability of terminal greatly enhanced by considerably increasing the memory store (and thus costs) at the terminal
Canada	Bell Northern	VISTA	Described as a <i>modified viewdata system</i>
Japan	NTT and Ministry of Posts	CAPTAINS	A more complicated terminal is used to produce Katakana characters. Transmission time is also increased
Japan	NTT	Video Reference System	Not strictly a viewdata system, since it assumes a broad bandwidth facility to the subscriber, but often quoted as such. Greatly enhanced facilities for the limited number of customers who use broadband transmission
France	CCETT	ANTIOPE <sup>3</sup>	Most influential competitor to viewdata. It uses asynchronous free-format transmission for television data (that is, for its Teletext equivalent) and thus gains flexibility at the expense of transmission security
Finland	PTT	TELSET	A small system compatible with viewdata, based on the use of a PDP11 computer
Sweden	Televerket		Viewdata-type system being developed with strong emphasis on social rather than commercial requirements
USA	Bell		Bell have expressed interest in the development of a viewdata-type system with emphasis on communications for the deaf
USA and Canada	(various)	Cable Television Information System	The wider penetration of cable in North America has resulted in a number of cable-based information systems which tend to resemble UK broadcast teletext in that the information is not tailored to the requests of the individual

### THE INTERNATIONAL DEBATE ON CHARACTER SETS AND CODING TECHNIQUES

The debate relates to the choice of a coding system for *Videotex*, which is the CCITT† committee term for services like viewdata. The debate centres on transmission codes, because most of the bodies concerned with international standards make the assumption that one code table should be applied throughout a communications or information system, and that the same codes should be used within the computer central processing unit, for transmission, and in the terminals. There is no fundamental reason why this should be the case, indeed there are quite strong arguments for a greater degree of separation of coding schemes but, at present, there is a general acceptance of the unified approach.

There are two major points of contention. One is the choice of basic character set (that is, the allocation of graphics symbols, including letters and numbers) to the 96 codes that are available before any shift (or escape) techniques are used. (Only 96 of the 128 codes produced by 7 bit encoding are available because 32 are reserved for control purposes.) In the jargon of international standards, the basic set is referred to as a *GO* (G nought) set. Once this has been defined, a method of extending this to provide the wider range of special characters (letters with accents and diacritical signs, etc.) required for continental languages is needed. The choice of method is the second point of contention. The number of special characters required is much larger than many people realize. Most are familiar with the *accents*, *circumflex* and *cedilla* of France, with the German *umlaut*, and are also aware that the Scandinavian and Mediterranean countries have special letters. Few realize that, when minority languages such as Icelandic, Friesian, Welsh and Maltese are considered, the total number of special characters required for

western Europe alone is about 120. The inclusion of the languages of eastern Europe extends the range further before one considers Russian, Greek, Arabic, Chinese, Japanese or Hebrew. The additional character sets are created using various shift escape techniques, and are called *G1*, *G2*, sets etc. There is a slight technical difference between the way that *G1* sets are created and the way that subsequent *G* sets are created, so one of the methods described below has its second character set referred to as *G2* rather than *G1*.

#### The GO Set

Considering the choice of a *GO* set, and limiting the scope to western Europe, there is general agreement that standard 646 of the International Standards Organization (ISO) is the correct starting point. British Standard No. 4730 is the relevant UK document. However, the ISO standard offers several options, and this could be said to be a weakness. There is a basic code table, which has a further option regarding the position of the crucial £ and \$ signs. There is provision for a range of registered national variants which may differ in the use that they make of certain designated positions in the table. For special applications, *application-oriented* sets are described. There is an international reference version (IRV) available for use when there is no requirement to use a national or an application-oriented version. Despite this range of options, the American standard code for information interchange (ASCII), the national variant of the USA, has been a *de facto* international code for many applications because components and terminals working to this standard are widely available.

When the BPO, the British Broadcasting Corporation (BBC), and the Independent Broadcasting Authority (IBA) and the British Radio Equipment Manufacturers Association allocated the codes for viewdata and teletext, an application-oriented set was chosen after careful reading of the standard. It is now being suggested by other nations that the IRV should

† CCITT—International Telegraph and Telephone Consultative Committee

be used. Britain is opposed to this because, apart from the major investment that has now been made in the application-oriented set, the characters offered by the IRV are of less use for terminals aimed at the domestic market. The £ and the \$ are not offered in the IRV, instead there is a peculiar symbol called the *international currency symbol*. Some IRV characters, which rely on backspace and overstrike techniques, cannot be implemented easily on television receivers. In addition, three versions of curly brackets are offered instead of fractions, and market research information from the Prestel test service indicates that "1/2" sign is particularly important to customers.

### CODE EXTENSION TECHNIQUES

There are three major proposals being considered internationally. These can be summarized (again with some simplification) as follows.

#### *The Composition Code Method*

The composition code method is favoured by the French. In this method, an accented character is created by the transmission of the character without its accent, followed by a backspace, then the accent. (In some versions of the method the backspace is implicit rather than explicit.) This method gives compatibility with the older type of mechanical printer, which uses a carriage and can backspace and overstrike, but it has several disadvantages for use in viewdata systems. It is not the best method for use in television receivers or visual display terminals (VDTs), where the electron beam cannot be taken back in the space of one character and the decoding techniques necessary to simulate this effect are expensive. The method is not very suitable for use by computers used for word processing because the identification of a particular character is difficult when it is represented by a number of codes rather than by a unique code. Most important of all, however, is its unsuitability for use by synchronous broadcast teletext systems. The UK teletext system, which has now been tested in thousands of locations in Europe, uses synchronous transmission with one television line allocated to one line of displayed text. This method offers greatly increased security in conditions of noise and of multiple-path propagation, but it precludes the use of composition coding since a blank space would occur in the display when a coding sequence was contracted to form the character required. Composition coding also gives rise to about 1500 possible characters, most of which are not used and it is not liked by semiconductor manufacturers, who wish to have the set of possible characters pre-defined for insertion into a read-only memory.

If the British arguments in favour of a synchronous teletext transmission system are accepted, and if compatibility between viewdata and broadcast teletext is required, as it is for eventual penetration of the domestic market, the points above become crucial.

#### *Direct-Coding Method*

Britain has proposed a direct-coding method in which escape techniques are used to give access to a pre-defined G2 set. By using an eighth bit to discriminate between the two graphics sets, this technique can be used with a synchronous broadcast teletext system without incurring the difficulties mentioned above. Its main disadvantage is that compatibility with the older type of mechanical printer is not achieved, but this is not regarded as serious because a new generation of stylus printers is emerging for use by broadcast teletext and viewdata customers.

Care must be taken in the selection of characters for insertion in the G2 set, but the method can readily cope with the requirements of the languages of Western Europe; also, a G3 set can be provided to deal with East European languages if these are required.

#### *The German Proposal*

This recent proposal, still under discussion and subject to modification, is compatible with UK Teletext and viewdata. It provides a full range of special characters, including metric symbols not considered by previous schemes. It assumes that a British-style synchronous broadcast television system is essential and that the penalty of a blank space, caused by a shift character when a change between GO and GI sets is made, must be accepted. To minimize the effect of this on the display, two completely new character sets have been defined. The GO set contains all the letters (accented and non-accented) and varies from region to region. The GI set contains numbers, special symbols and mathematical signs; thus, shifts occur only at places where a space would normally occur in the text. It is the separation of the numbers from the letters that is a radical departure from previous coding practice. The languages of Western Europe are accommodated in about 5 regional GO sets, and the existing UK GO set is included.

### STANDARDIZATION PROCEDURES

All of the above are technical comments; the author would like to make one point of a non-technical nature. As the field of information display expands to encompass word processing, electronic mail and electronic publishing, so standards assume increasing importance. However, because the field is becoming so wide, the number of organizations properly concerned in the definition of standards is increasing. The present viewdata/teletext debate is taking place in the European Broadcasting Union (EBU), CCITT, CCIR†, ECMA\*, European Economic Community, ISO and CEPT‡. Since these organizations can only meet every few months and work through up to 4 levels of subcommittee, progress can be fairly slow at a time when commercial decision making requires a rapid response. It may be that, in some areas, it is desirable to go for slightly limited standards, in order to achieve them quickly and make them effective. Another paper by the author<sup>4</sup> gives further consideration to these issues.

### ACKNOWLEDGEMENTS

The author acknowledges the value of conversations with Mr. D. J. Sargent, BPO Research Department, when preparing the sections of the article relating to international standards.

Sections of this article were presented at the Institution of Electrical Engineers colloquium entitled *User terminals for communications systems*. The author thanks the Institution for permission to reproduce them.

The success of the international viewdata demonstrations described in this article was due to the efforts of many BPO staff, including those in the Viewdata Division and the Motor Transport Division of the BPO Research Department, Network Planning Department of Telecommunication Headquarters, Colchester Telephone Area staff, Administrative Services Department (foreign travel), and Prestel International.

### References

- 1 FEDIDA, S. Viewdata—An Interactive Information Service for the General Public. Proc. European Computing Conference on Communications Networks, p. 261, 1975.
- 2 BROWN, H. G. *et al.* A General Description of TELIDON—A Canadian proposal for Videotex systems. Canadian Department of Communications Technical Note No. 697-E, Dec. 1978.
- 3 *Specification Du System de Teletexte Antiope*. Centre Commun d'Etudes de Television et Telecommunications, 1977.
- 4 CLARKE, K. E. The Post Office Viewdata Service. International Broadcasting Convention, London 1978. (Also reproduced in the Journal of the Royal Television Society, Vol. 17, No. 5 p. 49.)

† CCIR—International Radio Consultative Committee

\* ECMA—European Computer Manufacturers Association

‡ CEPT—Conference of European Posts and Telecommunications Administrations

# DC Power Supplies to Telecommunication Equipment: Distribution, Earthing and Protection Against Induced Transient Voltages

## Part 1—Past and Present Methods

P. C. WILSON †

UDC 621.311.6 : 621.3.024 : 621.39

*Part 1 of this article describes past and present methods of power distribution and earthing for DC power supplies to telecommunications equipment. The electrical, mechanical and economic advantages and shortcomings of the different methods are examined. Explanation is given why changes are necessary to the power distribution arrangements for the new generation of equipment provided for System X.*

*Part 2 will describe the philosophy of the new radial cable-distribution and single-earthing system to be used for System X.*

### INTRODUCTION

The purpose of a telecommunications power-distribution system is to transport power from where it is produced or converted, to where it is required. The distribution should fulfil this function in as cost-effective a manner as possible, consistent with electrical safety, a high degree of security, and ease of extension, so that, ideally, only that required at a particular time need be provided.

Within an installation, the earthing system ensures a safe return path to the supply source for fault currents. It also provides a common return path for signalling and some supervisory functions and sometimes, increasingly so with new equipment designs, for transmission of intelligence.

Externally, the earthing system provides a return path for signalling between exchanges, party-line and telegraph operation and for the signalling of alarm conditions between exchanges. For these functions, the return circuit to the equipment uses the earthed pole of the power-distribution system. Hence, in this article, earthing is considered only as part of that system; the means employed to achieve the actual earth connexion are outside the scope of this article, as is the earthing technique used with mains-operated equipment.

### BAR DISTRIBUTION

Traditionally, in the British Post Office (BPO), power plant has been located in areas (such as basements) which would not be usable for telecommunications apparatus. Moreover, the design concept of the older power plants did not facilitate deployment of their units around a building; all rectifiers, batteries and switching facilities had to be grouped together.

Considerable amounts of power had to be supplied via large conductors, termed *risers*, from basements to apparatus floors. Copper bar was used for the earlier installations but, with the advent of reliable jointing and testing methods, copper gave place to aluminium in the late 1950s. Copper is nowadays used only where there is a need to do so; for example, to overcome space limitations. Comparisons of construction, size and cost between aluminium and copper-bar conductors are given in Fig. 1.

The extra space occupied by aluminium bar as compared with copper bar has hitherto been generally tolerable because bar runs are usually placed above rack-top level, in otherwise unused space. However, the advent of modern equipment designs, with their high heat output, has resulted in increased competition for this space from ventilation ducting, especially

where buildings designed for Strowger equipment have been used to house TXE4 exchanges. At some such exchanges where ventilation ducts have been provided as an extension to the original building design, gangways are extremely congested.

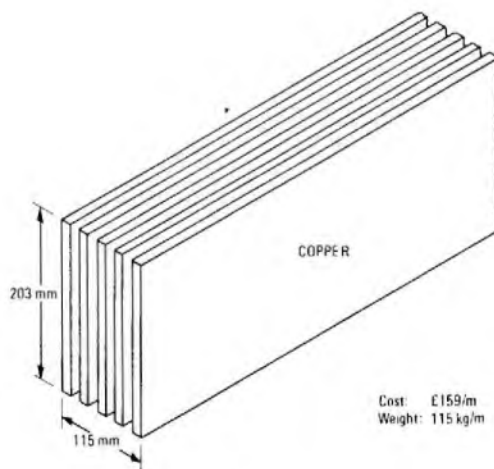
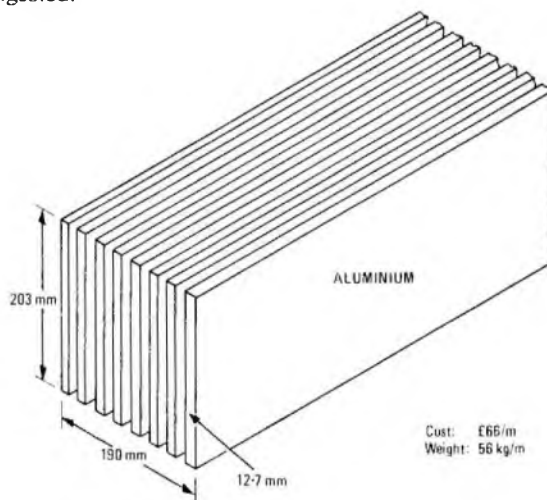

Note: Only one pole of the power-distribution is shown in each case

FIG. 1—Size, weight and cost comparison of aluminium and copper power-distribution bars for the same given voltage drop

† Operational Programming Department (Power Division), Telecommunications Headquarters

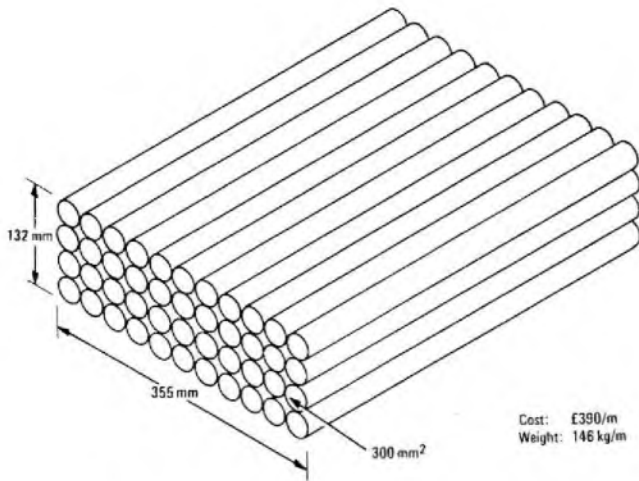

Note: Size, weight and cost values can be compared directly with those given in Fig. 1

Fig. 2—Copper power-distribution cable having performance equivalent to that of distribution bars shown in Fig. 1

### CABLE DISTRIBUTION

Up to the present, the BPO has not made great use of cable conductors for DC power distribution. The constraint of having all power plant in one location dictates that the power distribution conductors from that location are routed, initially, in one direction only. The use of large, heavy, rigid and very costly cable conductors (see Fig. 2) offers no real overall advantage over the use of aluminium bar. Moreover, it is difficult to electrically protect large stacks of paralleled cables, or to safely add further cables. Accordingly, aluminium bar has hitherto been the preferred method of distributing power. Nevertheless, the relative merits of cable and bar are kept under regular review.

The use of cable conductors is becoming more feasible with the increasing penetration of modern plant, the units of which can be dispersed around buildings near the load centres. From such centres, power can be dispersed radially to the equipment, an application obviously more suited to cable since, in the smaller sizes of cable, the better flexibility and reduced planning and installation costs help to offset the high cost of the cable. The use of cable conductors for DC power distribution will be dealt with more fully in Part 2 of this article.

Another development at present in hand within the BPO is the use of self-supported solid-core aluminium cable for distribution in small exchanges. Some trials in the Southampton area have shown this to be a very simple and cost-effective technique, provided that reliable terminations can be assured.

### ECONOMICS

Optimum cost-effectiveness can only be obtained in a power distribution system if there is full facility for deferring additional provision until it is actually required.

In the case of a bar distribution rising from, say, a basement to upper floors (known as a *tree-type* distribution), economic provision could only be achieved by either adding bars to existing stacks, or running a second feed parallel to the first with cross-connexions being made at suitable intervals. Both practices proved to be dangerous and extremely hazardous to service and are now prohibited. Full ultimate capacity has therefore to be provided on main bar runs from the outset, thus accepting the probability of over-provision and the inevitable cost penalty in favour of safety and service security.

It is often suggested that power distribution costs could be reduced by increasing the present voltage-drop allowance of 1 V (that is, the voltage drop along the distribution), since

the cost of providing a distribution system is, approximately, inversely proportional to the square root of the designed voltage drop along the conductor. At first sight, the savings available by changing to, say, a voltage-drop limit of 2 V, appear attractive. However, this is not a complete solution because account must be made for the true cost of a power distribution system, which includes the cost of the power losses attributable to the distribution system. These losses are directly proportional to the voltage drop, as described below.

(a) Firstly, if equipment is supplied at a reduced voltage, then, to satisfy its minimum power requirement, the equipment has to draw additional current. Constant-power equipment, such as a DC-DC converter, only draws the additional current when actually receiving the lower voltage, but the position is much worse with a constant-resistance load, such as electromechanical switching equipment. This equipment can be designed to work at the minimum voltage ( $-44$  V for a 2 V drop system, under battery discharge conditions). However, when supplied at higher voltage, as will be the case when located near the plant, and under normal plant operation, the equipment draws continually a higher than necessary current.

(b) Secondly, power is lost in the distribution system in direct proportion to the voltage drop obtaining at the time in question.

Both the above conditions result in the need for higher output from the power plant, which results in the provision of larger power plant with higher energy consumption, together with the cost of removing the additional heat generated.

A typical relationship between the cost of distribution and the cost of lost power, both as a function of distribution voltage drop, is given in Fig. 3. The true cost of the distribution is the sum of the two costs. Study has revealed that the historic standard of a 1 V drop between battery and equipment is very near the optimum, and this value will thus remain as the general standard for traditional distribution systems. Nevertheless, it is operationally convenient to have equipment which will work at  $-44$  V. This enables unforeseen new loads to be supplied, existing bar stacks to be re-used where suitable, and new distribution systems to be developed where the power loss costs can be traded off against other savings, which is the case with the new distribution system to be described in Part 2 of this article. Hence, all new designs of telecommunications equipment are now required to work at  $-44$  V.

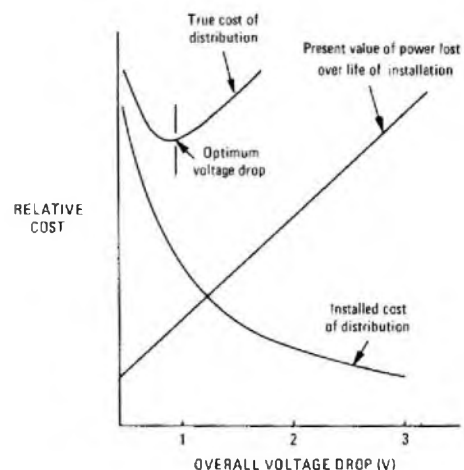

Note: Actual costs vary with each installation and are therefore omitted

Fig. 3—Cost elements of a power-distribution system

## PROTECTION

Earlier bar-distribution systems were usually protected by fuses or circuit breakers at batteries and rectifiers, then by 125 A fuses to the apparatus suites. In small exchanges, the 125 A suite fuses were usually dispensed with, protection being provided solely by the battery fuses. Larger power plants, usually exceeding 5000 A capacity, had no protection at source. Instead, power was distributed to the apparatus floors and there fused off in 1000 A or 1200 A units. Supplies were then taken to the apparatus via 125 A suite fuses.

Protection of a DC distribution by fuses or circuit breakers presents several problems, as explained below.

(a) The voltage drop introduced by the devices (typically 0.1 V across a fully-loaded fuse) has to be compensated for by an increase in conductor size.

(b) Ratings and characteristics of protection devices connected in series have to be carefully chosen to ensure that, in the event of a fault, only the device protecting that part of the distribution operates. For example, if a 150 A battery fuse fed 100 A suite fuses, then a suite fault would probably rupture both fuses and isolate the entire exchange.

(c) Experience has shown that large circuit breakers and fuses of 500 A and above rarely, if ever, operated even to severe faults; the faults apparently burned themselves clear before the devices had time to operate.

(d) Security requirements for new equipment demand that no one fuse shall, on operation, cause an exchange (or equivalent unit) isolation. This precludes fusing of large units of equipment.

(e) When protective devices operate, the inevitable voltage disturbances interfere with equipment operation and cause damage to semiconductor devices. These disturbances are examined more fully later in this article.

## THE MODERN HIGH-SECURITY MAIN DISTRIBUTION

In the late 1960s, the decision was taken by the BPO to abandon electrical protection of main distribution conductors in favour of improvements to their mechanical protection. In this way, not only is the chance of fault contact reduced but, because of the improved insulation, such contacts are inevitably of very small cross-sectional area because, unless insulation is removed, only a sharp edge or point can penetrate the insulation.

Provided that the conductor area is large compared with that of the fault contact, such small contacts can be expected to burn themselves clear without too much conductor or insulation damage, or disturbance to the supply. This is reasonably certain with bars, but additional protection is given to the smaller cables by means of a polyvinyl chloride (PVC) sheath over the insulation. For bars, a single PVC sleeve of 1 mm minimum thickness is normally sufficient, but in some hazardous situations the bars are given further mechanical protection.

The elimination of most of the bare areas of live conductor (consequent with the abolition of large fuses), careful attention to the planning of extension points and, where possible, deployment of plant modules around buildings to suit the load growth, has resulted in a very reliable distribution system.

To ensure safe extension of a distribution, equipment is made up into load sections of up to 300 A nominal load and, if bar distribution is employed, each such load section is connected to the main distribution by cable links. Otherwise, the load sections are cabled to the nearest plant module. Use of a cable connexion in either case ensures that the final connexion to a working distribution can be made with the minimum of risk. A final connexion using a bar conductor could be difficult; for example, the conductor might have to be bent into position or fixing holes adjusted—all with the main distribution live and supplying working equipment.

When new equipment racks are added, these are made up into a new load section or, depending on the type of equipment, taken from spare fuse-ways in an existing load section.

In this way, extension of bar distribution, known from experience to be the chief fault liability, has been virtually eliminated except at purpose-designed extension points. To finally minimize risk, the BPO has made itself responsible for making all final connexions to a main distribution serving working equipment. This exercises control over the timing of operations, safety measures, and the skills involved in performing this critical operation.

## POWER SUPPLY DISTURBANCES

Faults on power distribution systems cause disturbances to the supply voltage, whether such faults result in the rupture of a fuse, trip a circuit breaker, or the faults burn themselves clear.

Apart from liability to misoperation, electromechanical equipment is fairly tolerant of supply-voltage disturbance, but electronic circuit elements are not only more liable to misoperation, but are very vulnerable to damage by over-voltages.

The disturbances vary considerably in duration and amplitude, but the following sequence is common to all.

(a) The onset of a fault severely overloads the distribution system for the brief time taken to either melt a fuse element, to trip a circuit breaker, or for the time taken for a fault to burn itself clear. During this *pre-arcing* time, as it is termed, a magnetic field is built up around the distribution conductors and the voltage supply to all loads is depressed by the combined effect of these resistive and inductive losses in the source and distribution. This depression can cause equipment misoperation.

(b) Interruption of the fault current takes place over a very short and, except by fuse design, uncontrollable time interval. Consequently, the rapid collapse of the magnetic field around the distribution conductors generates a transient potential in those conductors; this potential appears across the poles of the power supply to all loads and across the arcing fuse-element or fault arc. For this reason, it is referred to as the *arc voltage*, and it is this voltage which causes damage to equipment.

The kind of disturbance observed across poles of a supply when a 125 A fuse is ruptured is illustrated in Fig. 4.

Generally, the pre-arcing time increases with the rating of a fuse. Due to the distribution and source inductance, the fault current rises exponentially and therefore a low-rated fuse, in the same circuit, will interrupt the fault current at a lower value and in a shorter time, as shown by Figs. 5(a) and 5(b). Thus, use of low-rated fuses gives the advantages of smaller and shorter duration disturbances, and greatly reduced likelihood of conductor and insulation damage.

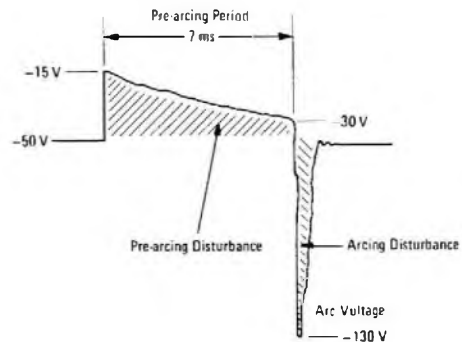

FIG. 4—Oscilloscope trace of a typical disturbance detected across a power supply when a Strowger group-fuse (BPO Type 59A/125) ruptures

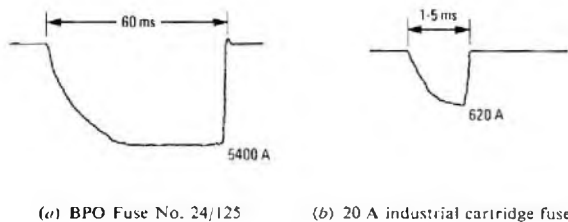

FIG. 5—Current traces of the rupture of two different types of fuse in the same circuit

Physically-small, low-rated fuses used to protect individual circuits cannot be relied upon to interrupt the large fault current which a power distribution can deliver. Therefore, supply fuses cannot be eliminated entirely from a power distribution, but they can be placed as near as possible to the equipment they are intended to protect. The consequent use of low-rated fuses not only minimizes disturbance to other loads, but the fusing can be arranged to satisfy the requirement that no one fuse shall cause a service isolation.

### CONTROL OF DISTURBANCES IN OLDER EQUIPMENT

The distribution of existing systems, notably Strowger, cannot be easily rearranged in the way described in the previous section, but control can be exercised over disturbances where a distribution is shared with an electronic exchange.

The first approach is to fit special fuses which control the problems at source. These fuses have an element which melts quickly, thus minimizing the duration of the pre-arcing disturbance. The element design is also such that the reduction of current to zero during arcing is more gradual than with conventional fuses. This reduces the arc voltage to an acceptable level.

The second approach is to connect a bank of large Zener diodes across the  $-50\text{ V}$  supply: these deal with disturbances which do not blow a fuse. The diodes clamp disturbances to about  $-70\text{ V}$ ; that is,  $-20\text{ V}$  superimposed upon  $-50\text{ V}$ .

Both of the above measures are at present being adopted in exchanges where a Strowger and an electronic unit share the same power supply. As a further precaution, where possible, the electronic unit is connected direct to the power plant.

### THE PROBLEM OF EARTHED-POLE DISTURBANCES

This article has, so far, summarized the principal features of a power distribution of up-to-date design. Such a distribution is quite capable of supplying power to present-day and new-generation electronic systems. However, it is on the matter of earthing that the real difficulties arise and which have necessitated a new approach which is to be described in Part 2.

Potential disturbances generated in the distribution conductors by a rapid current change arise mainly in the live (negative) pole, because the earthed pole is electrically damped by its multiplicity of connexions to the rack frames. Nevertheless, when faults occur, potential disturbances of the order of  $10\text{--}15\text{ V}$  can, and do, arise between one end of an equipment area and the other, along the earthed pole of a bar distribution.

Referring to Fig. 6, it can be seen that a power distribution fault at point Y will cause a disturbance between that point and point X, and hence between the earthed connexion points of circuits A and B. If the signalling potential is high compared with that of the disturbance and/or if the disturbance time is short compared with that of the signals, as is usually the case with electromechanical equipment, the information signals between A and B are unlikely to be impaired. However, discrete-component electronic circuits usually convey

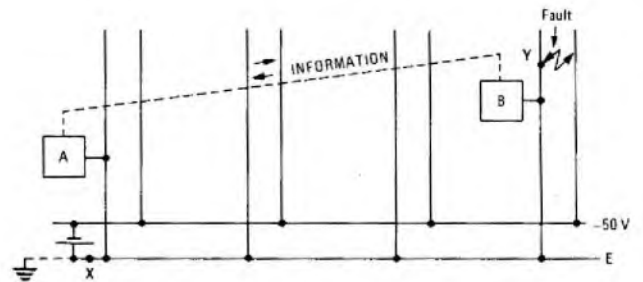

FIG. 6—Voltage-potential disturbance mechanism

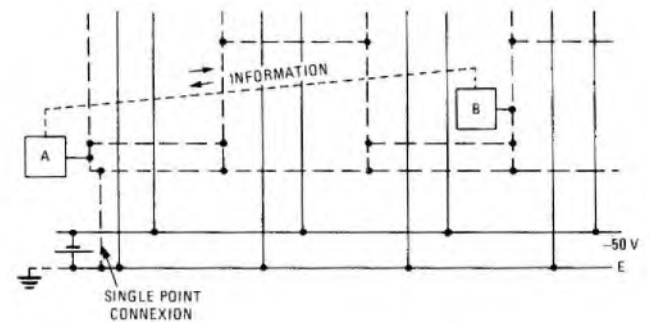

FIG. 7—Electronic-earth circuit configuration

high-speed digital signals at  $\pm 12\text{ V}$ , and therefore are much more liable to signal corruption, notably because the signal voltage is comparable with the likely disturbances and, additionally, because much more information is passed during the time interval of the disturbance.

It is obvious that integrated-circuit elements, signalling at  $\pm 5\text{ V}$  and at pulse-repetition frequencies of  $5\text{ MHz}$ , could not use a common earth return with the conventional forms of bar distribution. Vulnerability to disturbance was reduced in some of the present designs of electronic exchange systems by introducing a separate earthing system for the electronic circuitry. This system, known as an *electronic earth*, can be separated easily from the  $50\text{ V}$  power-supply return path because the circuit elements, operating at  $\pm 12\text{ V}$  or  $\pm 5\text{ V}$ , have to be supplied via DC-DC converters. The principle of an electronic earth is illustrated in Fig. 7, where it can be seen that information in transit between A and B will be immune to corruption by earthed-pole disturbances—always provided that the electronic-earth network does not come into contact with either the earthed pole of the  $50\text{ V}$  supply or the rack frames, or that power contacts to the electronic-earth network do not occur.

The electronic-earth principle is used in the TXE4 and TXE4A electronic exchange designs. The mechanical arrangement comprises a network of insulated single cables joining all racks and suites, laid on a grid mesh. The network is connected at each rack to a terminal insulated from the rack frame. Each circuit requiring the electronic-earth connexion is wired to the rack terminal. The electronic-earth system is earthed at one point only, at present to the power-plant earth terminal, but this practice is under review.

Sound though the theory may be, electronic-earthing systems have proved vulnerable to disturbance by inductive and capacitive pick-up from the main distribution. However, their real fault liability lies in the risk of contact with rack-frame earths, mains earths and  $50\text{ V}$  power circuits.

It is not difficult to envisage that the liability to such faults increases with the physical size of an electronic-earth conductor system, especially if its conductors are exposed. Real though these risks are in a TXE4 exchange, the risk in



System X would have been many times higher because, to cope with the very-high bit rates at which intelligence is passed and processed, each shelf employs a perforated sheet-metal back-plane as an earth common for all circuits. Up to 6 shelves can be installed on a standard TEP-1(H) rack†. Therefore, including the metal shelf sides, the electronic-earth medium of the rack comprises some 3 m<sup>2</sup> of bare metalwork. A prototype TEP-1 rack for System X is shown in Fig. 8.

The original intention was to create a separated electronic-earthing system by linking together all back-planes in an exchange by an insulated bond network, but it soon became clear that

(a) the risk of frame or power contact over such a large total area of bare metal could not be accepted, and

(b) since the system would still have to be tied to the earthed pole of the supply at one point, there would be no means of detecting a stray frame-contact until it caused trouble with the occurrence of a distribution fault.

### A NEW SYSTEM OF DC DISTRIBUTION

Since it was thus apparent that the needs of System X could not be met using conventional bar distribution, the BPO decided to embark on the development of a system of power supply and earthing that would meet not only the System X requirements but which would also have other future applications.

The concept and development of the new system will be the subject of Part 2 of this article.

† Equipment practice TEP-1(H) will be described in a later issue of this *Journal*

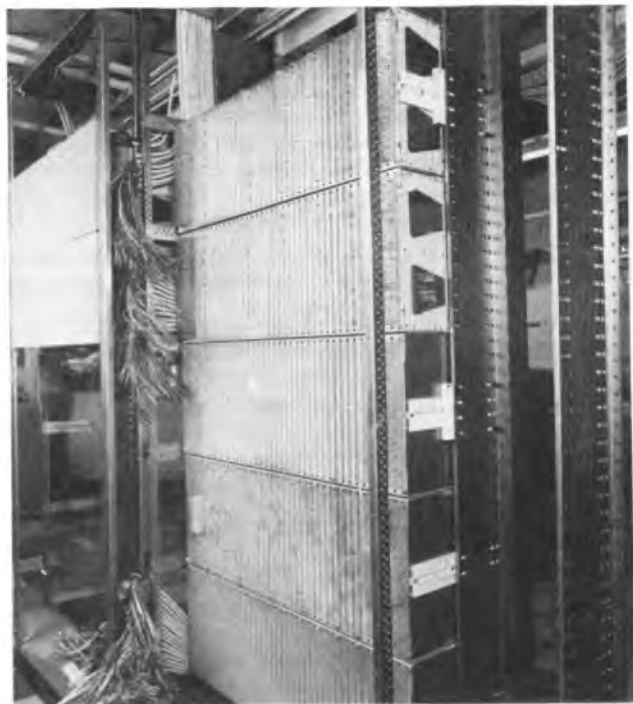

FIG. 8—Prototype System-X equipment rack

## Book Review

*Electrical Principles for Technicians 2*. S. A. Knight. Newnes-Butterworth, 128 pp. 139 ills. £3.75.

Those who have seen recent books on telecommunications engineering for technical colleges will be familiar already with the author's previous publications on electrical principles, including his two-volume work, "Telecommunications Principles for Final Certificate". In order to meet the newly published syllabus of the Technician Education Council (TEC) unit U75 019, he has rewritten the first volume of the earlier books using the second-person singular and many step-by-step diagrams following in close sequence.

The scope of the book, for those not familiar with the new, highly-detailed TEC syllabi, is roughly that of the City and Guilds of London Institute's subject "Principles B" with some of the "Principles A" material intermingled. The emphasis on the presentation is simplification for the student. Implicit instructions are given for each step in a worked problem, which may lead to more confidence in the less mature student, and will certainly help those who find some of the ideas in elementary telecommunications analysis difficult to grasp.

The chapter on magnetism and magnetization is usually one of the most difficult to write well in this type of book, which may be related to the fact that most examining bodies in electrical engineering find this part of the syllabus is always poorly answered. Mr. Knight must know this, because he has taken much care with this chapter and has dealt clearly with descriptions of magnetic permeability, hysteresis and hysteresis loss. In accordance with the new TEC syllabi, the treatment is largely descriptive, based on the shape of the  $B/H$  loop without scales or quantities. A thorough graphically-based chapter on sine waves with relation to alternating currents and voltages has been included with phasor equivalents explained. The simple trigonometry of the sine wave is introduced as if the student had already taken a parallel course in mathematics. The author is to be applauded for making such a strong case to support the need for additional mathematics, without which studying telecommunications or electrical engineering principles tends to be a waste of time.

This book is well written and excellently produced. However, I feel that the previous books by the same author provide a sounder coverage of the basics of the electrical principles that are needed by present-day technicians.

C. F. FLOYD

# Digital Recording on Magnetic Tape and the Recorder Tape No. 3A

H. E. WESTAWAY†

UDC 534.862.3: 621.374: 621.395.31

*This article outlines the basic principles of recording digital data on magnetic tape, considers the operation of the digital-data tape cartridge and looks at the facilities offered by the British Post Office Recorder Tape No. 3A.*

## INTRODUCTION

The decision taken by the British Post Office (BPO) to supersede punched paper-tape by magnetic tape as the recording medium for data from the TXE4 electronic exchange traffic recorder has led to the development of the Recorder Tape No. 3A.

The practice of recording electrical signals by magnetizing the coating on a plastics tape has developed over the last 30 years to a point where tape recorders can be found in widespread use, ranging from the cheap domestic cassette recorder to the highly sophisticated and costly back-up stores of large computer complexes. The tape recorder offers an inexpensive method of storing information indefinitely in a compact form and, furthermore, provides the opportunity to re-use the recording medium when the information recorded has been processed or has otherwise ceased to be required<sup>1</sup>

Magnetic tape is at present available in a number of forms; it can be obtained on single spools of 12.5 or 6.3 mm width, or in a packaged form, referred to as a *cassette* or *cartridge*. For the Recorder Tape No. 3A, the BPO has decided to use 6.3 mm wide tape housed in a cartridge developed by the 3M Company of the USA<sup>2</sup>; the 6.3 mm tape cartridge has been standardized by the International Organization for Standardization (ISO) and the European Computer Manufacturers Association (ECMA).

There are a number of suitable tape recorders available which use this type of cartridge. Most of them are used as computer peripherals, are highly sophisticated in their operation and are expensive. The object of the Recorder Tape No. 3A development project was to provide a tape recorder which would record digital data with an acceptable level of accuracy at a price which would make it attractive in the telecommunications field.

## RECORDING ON MAGNETIC TAPE

There are 2 basic systems of recording electrical signals on magnetic tape:

(a) analogue, in which the variation of signal amplitude and the signal polarity with respect to time must be faithfully reproduced; and

(b) digital, in which the polarity and duration of binary signals are the only parameters of interest.

One way of recording binary signals is to record an analogue signal tone (or the absence of signal tone) to represent the binary signal. This method could make use of one of the many commercially available analogue recorders. If this course of action were adopted, it would be necessary to record several cycles of signal tone to represent each binary digit recorded, which would make inefficient use of the

storage capacity available and, furthermore, recognition of the precise number of bits represented by long runs of one sense would be difficult.

Recording on magnetic tape is normally achieved by drawing the tape across 2 ferromagnetic pole pieces, which may be magnetized to either polarity by passing current through windings on one or both of the pole pieces. The pole pieces are so arranged that the gap between them, across which the magnetic flux will be developed, is at right angles to the plane in which the tape is moved. The normal practice is to record across only a portion of the tape width, thus allowing several recording tracks to be formed. In this way, the storage capacity of the tape is increased. It is not proposed here to deal further with the recording of analogue signals on magnetic tape.

Several systems of recording binary signals on magnetic tape have been proposed. One of the principal problems to be overcome is that of recording the precise number of bits forming a sequence of one polarity or the other; some systems use more than one tape track for the purpose.

The system described in this article is referred to as a *phase encoding* (PE) system, and has been adopted by the ECMA and the ISO. In this system, the data bits, presented on 8 parallel paths, are scanned, coded and written in sequence on tape. A flux reversal in the recording head in one direction is used to record a logic *zero* bit and a flux reversal in the other direction records a logic *one* bit. It is not possible to record 2 successive flux reversals in the same direction; therefore, where the data to be encoded would require this, a flux reversal in the opposite direction is inserted midway between the flux reversals recording adjacent bits of the same polarity. The reversals that carry information are known as *data transitions*; the reversals inserted to permit the writing of adjacent bits of the same polarity are known as *phase transitions*. The flux reversals recorded on the tape will vary from one per data bit (when each data bit differs from its predecessor) to 2 per bit (when all data bits are of the same polarity), see Figs. 1 and 2.

The number of flux reversals that can be recorded on a given length of magnetic tape depends on the quality of the tape, the contact achieved between the head pole-pieces and the coated surface of the tape (ECMA: Standard No. 46) and the gap between the 2 pole faces. The ECMA specifies a flux reversal density of 126 per millimetre, which gives a maximum data bit density of 63 per millimetre of tape. This permits the recording of nearly eight, 8 bit data bytes/mm. The recording could be performed by moving the tape by a given amount and then recording a data or phase inversion as required. However, this method would not be practicable because it would be necessary to accelerate and decelerate the tape 126 times per millimetre (that is, the tape would be moved by only 80  $\mu\text{m}$  at each step). Therefore, it is the practice to collect data in an electronic buffer store until a block of data has been assembled and then, after accelerating

† Telecommunications Development Department, Telecommunications Headquarters

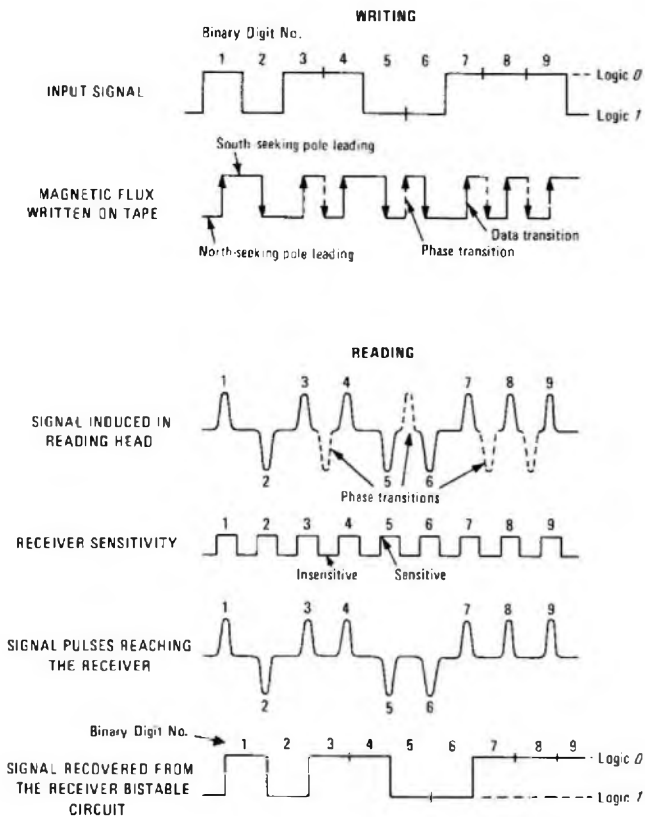
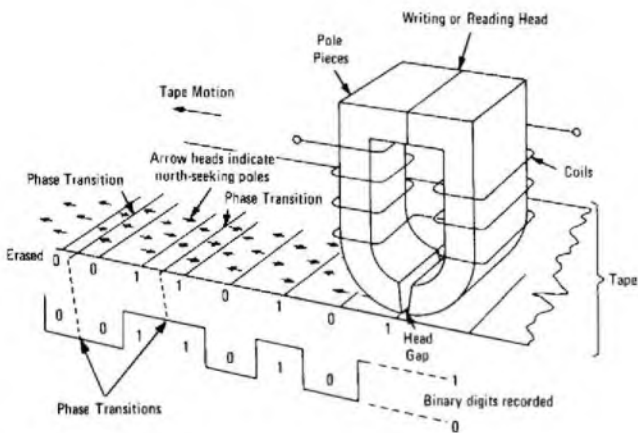

FIG. 1—Phase-encoding format



Note: The Recorder Tape No. 3A writes 4 tracks on 6.3 mm wide tape

FIG. 2—Phase-encoded digital writing on magnetic tape

the tape to a linear speed of 762 mm/s, the contents of the store are fed to the recording head to write at a density of 63 bit/mm.

### THE RECOVERY OF THE DATA FROM TAPE

Unlike paper-tape perforations, magnetic recordings can only be sensed by moving the tape past the reading-head gap; flux reversals recorded on the tape will induce potentials in the reading-head coils only during the fleeting instant that a reversal passes the reading-head gap. It is therefore necessary to hold the output data temporarily in an electronic store until it can be translated into a form suitable for passing to a teleprinter, a visual display terminal (VDT) or some other

device that requires a data input.

The reading head is of similar structure to the writing head and the same head may be used for both purposes. However, the established practice in digital recording is to use a separate read head situated close to the writing head so that the data written on the tape may be checked soon after writing. It is usual for the track written to be of greater width than the read track so that variations at the edges of the recorded track do not impair the reading capability.

### TAPE HANDLING

As mentioned, the tape may be housed on separate reels or in some form of container that eliminates delicate tape-threading procedures. The tape drive may be applied by friction between the tape surfaces and a motor-driven capstan or by driving the spool to which the tape is to be wound. The former method tends to damage the magnetic coating of the tape; the latter method results in an increase in tape velocity because the effective diameter of the driven spool increases as it gathers tape.

### The Data Cartridge

An ingenious method of overcoming the problems of damage to the tape magnetic coating and variation of tape velocity has been embodied in the tape cartridge defined by the ECMA and the ISO. The device contains not only the hubs on which the tapes are wound but all the propelling and guiding mechanism, leaving only the recording heads and the driving motor to be provided on the recorder. The drive is provided in the cartridge by a wheel that makes contact with a rubber-tyred driving roller, which is powered by the motor on the recorder. Inserting the cartridge in the recorder causes contact to be made between the tyre of the driving roller mounted on the motor shaft and the wheel projecting from the cartridge. An elastic belt within the cartridge passes over a pulley coupled to the drive wheel and 2 internal guide rollers (see Fig. 3). The pulley and guide rollers are so positioned that the belt bears on the outer turn of the tape on both spools. The tape is propelled at the same speed as the belt is driven, regardless of variations in tape spool diameter and without the use of a surface-damaging capstan in contact with the tape coating.

The insertion of the cartridge causes the tape to be deflected by contact with the tape heads intersecting the straight line between the tape guides. No pressure pad is used and thus the tension of the tape is important.

The method adopted in achieving correct tension of the tape is based on the well known fact that when equal-sized pulleys are connected by an elastic belt and a drive is applied to one pulley and a frictional load to the other, the driven pulley will make less revolutions than the driver. When a non-elastic tape is coupled between these pulleys, the drive

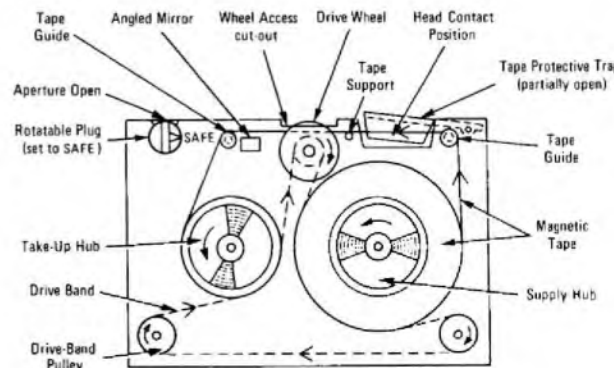

FIG. 3—Data tape-cartridge

tension is transferred to the non-elastic tape. Thus, if a non-elastic tape is connected initially with some slack, the take-up pulley advances on the paying-out pulley until the slack has been taken up and the tension had been transferred to the tape.

The drive belt used in the cartridge is, of course, no ordinary rubber band, but is a highly developed piece of elastomeric engineering, with constant and reproducible characteristics and a long life expectancy.

The construction of the cartridge is based on a flat metal base-plate of considerable section. On this plate are mounted the tape guides, and the pillars on which the tape spools and belt pulleys rotate. The whole assembly is then enclosed by a transparent moulded-plastics cover which is screwed to the metal base-plate. A small cut-out gives access to the drive wheel. A spring-loaded trap opens automatically when the cartridge is inserted to allow the heads to make contact with the tape. Also formed within the plastics cover is an angled mirror and a rotatable plug. The function of the mirror is to deflect light directed at the upper surface of the cover on to the tape and thence, if punchings in the tape are present, on to photo-electric cells in the recorder. The plug functions as a safety catch and, when rotated with a coin or screwdriver, points to a SAFE marking. The operation of the plug opens an aperture which enables a sensor on the recorder to disable the recording facility, thereby safeguarding data recorded on the tape from being overwritten.

The location of the cartridge in the recorder is maintained by spring-loading the base plate against 3 reference points on the recorder. The location of the cartridge is precise and reproducible on other recorders.

### Control of the Tape

Holes are punched in the magnetic tape which are sensed photo-electrically. Light directed on to the upper surface of the cartridge is deflected on to the tape by an angled mirror (see Fig. 4). On the other side of the tape, 2 photo-electric cells are positioned on the recorder to be illuminated by light passing through holes punched in defined positions in the tape. Three combinations of photo-electric cell activation are used to indicate *beginning of tape*, *end of tape* and *load point* or *early warning*, the latter alternatives being recognized by their proximity to the beginning or end of the tape. The tape is driven by friction between the rubber-tyred roller on the motor shaft and the wheel in the cartridge that drives the elastic band when reading or writing. The tape must be driven at a speed of 762 mm/s within defined tolerances ( $\pm 3\%$  in the long term and  $\pm 7\%$  in the short term). The most arduous requirement is that the tape must be decelerated from the nominal speed to a stationary position and re-accelerated to the nominal speed within 80 ms and 30.5 mm of tape movement. During this operation, the speed of the tape must not exceed the nominal speed.

When a cartridge is loaded into a recorder the tape is wound back at 2290 mm/s until a *beginning-of-tape* punching is detected; the tape is then fed forward at 762 mm/s until a *load-point* punching is detected, at which point the tape is halted. When the received data has filled an electronic buffer the tape will be accelerated to 762 mm/s, the data from the buffer is written on the tape and it is then decelerated to rest. Transfer of filled buffers will continue until the *early warning* punching is detected, whereupon the block undergoing transfer will be completed before rewinding. If the *end-of-tape* punching is detected, recording is stopped automatically and the tape is rewound at 2290 mm/s. It is important to realize that punchings are detected only while the tape is in motion; that is, during data transfer or winding.

When a tape has not been used for a period of several days or has been subject to considerable temperature change, it is recommended that the tape should be wound from the supply

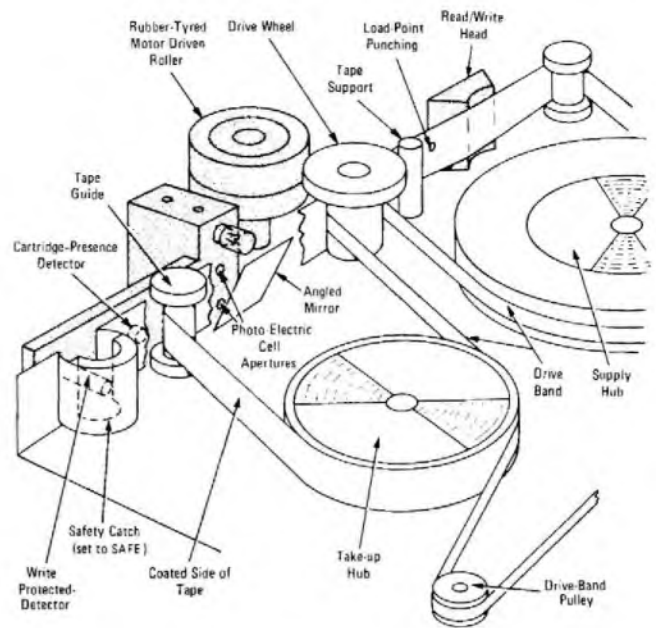

FIG. 4—Cartridge and Recorder Tape No. 3A interface

to the take-up hub and back again before recording commences. This action evens tape tension and reduces the tendency to inter-tape layer adhesion. Re-spooling may be performed automatically on the insertion of a cartridge into the recorder or, optionally, omitted if found to be unnecessary.

## RECORDING PRACTICE

### Principles

Recording of data is performed on up to 4 tracks on the 6.3 mm tape housed in the cartridge, in a manner described in the ECMA specification. During recording, the head windings are fully energized in one direction or the other. They are de-energized only during fast winding, reverse winding, when reading data recorded on the tape or if a cartridge set to SAFE is encountered. During tape acceleration and deceleration between data blocks the head will write an *erase* polarity. Tape in a new or freshly erased cartridge will be magnetized with a north-seeking pole leading in the reading direction; that is, an erase polarity. If the first bit is a logic zero, a flux inversion from erase polarity will be recorded. If the first bit is a logic one, a phase inversion of the erase flux followed by an inversion back to the erase polarity will be recorded. As the reading equipment would be unable to distinguish between an initial data transition and an initial phase transition, writing always starts with a logic zero.

When a sequence of dissimilar data bits, often referred to as *reversals*, is recorded, a simple flux reversal will be written for each data bit. However, if the sequence is of one polarity or the other, there will be 2 flux reversals written for each data bit: one *phase* reversal and one *data* reversal. Therefore, except where the tape has been erased, at least one flux reversal will be written for every data bit recorded; that is, between 63 and 126 per millimetre of tape.

### Recording Quality Assurance

As a data bit is represented by a magnetized zone no longer than 0.016 mm, it will be realized that a very small defect in the tape surface could result in failure to record a flux reversal. Therefore, it is necessary to take some steps to ensure that the data written on the tape is correct. The accepted method

of doing this is to pass the tape over a reading head as soon as possible after writing. It might be considered possible to compare the flux reversals read off the tape with a delayed version of the data fed to the recording head but, because of tape velocity variations and the manufacturing tolerances of the head assembly, this is not practicable.

The practice adopted is to consider each block of data transferred from the buffer store to the tape as a binary number, to divide it by a fixed binary number and to record the remainder as a 16 bit number spread over two 8 bit cyclic-redundancy-check bytes. The deduction of this remainder from that obtained by performing the same function at the reading counter should, if the data is correctly recorded and read back, provide a zero result. If the counters do not agree, an error will be registered. The fixed binary divisor has been chosen to detect most errors likely to occur.

When an error is detected the tape is halted, it is reversed back to the beginning of the recorded block and a further attempt is made to write. If this is not successful, the writing will be erased, the tape will be fed on for a short distance and an attempt to re-write will be made at another point on the tape. The number of re-write attempts to be made and the number of points used on the tape may vary, but are usually between 3 and 6 attempts at 2 or 3 points on the tape, depending on how much hold-up of the data recording process can be tolerated.

### Assembling Data for Recording

It is not feasible to accept data directly on to tape. It is therefore collected in an electronic buffer store until a pre-arranged block of between 6 and 2048 bytes has been gathered. The buffer having been filled, the tape is accelerated to speed and the data in the buffer is transferred to tape after 6 extra bytes have been added to the block for control purposes. These are, in order:

(a) 2 bytes known as the *preamble*, the first of which is of all *zero* polarity and the second is of 7 *zeros* followed by a logic *one* bit, these bytes are followed by a block of data from the buffer store;

(b) 2 bytes forming the cyclic redundancy check; and

(c) 2 bytes known as the *postamble*, the first of which consists of a logic *one* bit followed by 7 *zero* bits and the second of all *zero* bits. (The postamble reads as a preamble if the tape direction is reversed. Reversed reading is often performed at data processing centres.)

The size of the buffer store is governed by several considerations. The larger the store capacity, the more expensive it will be and the longer it will take to transfer the data to tape. Irrespective of its size, each data block requires the tape to be accelerated to speed, for the control bytes to be written and the tape to be brought to rest after the transfer. This takes up to 50 mm of tape, on which no data can be written. To record 400 bytes also requires about 50 mm of tape. Therefore, with blocks less than that size, less than 50% of the tape will be used to record data. In general, a compromise is reached by using blocks of 500-1000 bytes. With 1000-byte blocks, over 70% of the tape length is used for recording data which, with 4 tracks in use, will allow over 2 million bytes of data to be recorded on the tape in a single cartridge.

Some data sources can present a continuous flow of bytes and could not tolerate the delay incurred when each data block is transferred to tape. In this case, it is normal practice to provide dual buffers, one of which will start to accept data as soon as the other is filled and during its transfer to tape. The size of the tape buffers will also be affected by the 50 s (approximately) taken to rewind the tape after one track has been filled, before recording on the next track can be commenced. To avoid data delay, each buffer must be capable of holding the data presented over a period of at least 25 s.

Data may be presented to the buffer store for recording in

a serial or parallel form. If in serial form, the data may be presented as a telegraph signal with *START* and *STOP* elements, which can be stripped off before recording, or in a continuous stream. In parallel form, each bit of the presented byte is on a separate input path. Bytes can normally be received into the buffer stores at a higher rate than that at which transfer to tape can take place. From this it follows that some means must be available to restrain the presentation when congestion threatens. Continuous flow presentation can be accepted only if it is never possible to exceed the long-term acceptance rate or to overflow the storage capacity of the tape in a cartridge. Serial and parallel presentation must be capable of being held up by the return of a *busy* signal to the data source when congestion is about to occur. In the case of parallel bit presentation, it is normal to send a *ready* signal from the recorder to the data source and for the data source to send a *strobe* signal to the recorder on a separate path when the 8 bit of the byte to be recorded are established on the data paths. As soon as the *strobe* signal has been received the data presented will be accepted into store, and the signal sent back to the data source will be changed to *busy* and be so maintained until the recorder is able to accept a further byte. Similarly, recording may be held up until a further byte is available from the data source, by delaying the presentation of the *strobe* signal from the data source. The presentation of each byte will require the operation of a *ready-strobe-busy* cycle and no byte must be written more than once.

### Summary of Operations for Recording Data

A summary of the operations for the recording of binary data is given below.

(a) The *ready* signal is sent from the recorder to the data source.

(b) The data is presented to the recorder in serial or parallel form, as arranged.

(c) The data is admitted on the presentation of a *strobe* signal from the data source to the recorder.

(d) The recorder replaces the *ready* signal sent back to the data source by a *busy* signal.

(e) When the presented data byte has been absorbed, the *busy* signal will be replaced by *ready* signal and the cycle will repeat as soon as a fresh data byte is available.

(f) The data bytes will be collected in the buffer store until it is full. Unless dual buffers are provided, the *busy* signal sent back after the last accepted byte will be extended until the data has been transferred to tape and the buffer cleared to accept further data from the source.

(g) The transfer of a data block to tape requires

(i) the tape to be accelerated to working speed, normally 762 mm/s, during which time the writing head will be energized to record an erase polarity on the tape,

(ii) the writing of preamble bytes,

(iii) the phase encoding of data bytes from the buffer,

(iv) the transfer of the encoded data to tape,

(v) the writing of the cyclic-redundancy-check bytes,

(vi) the writing of the postamble bytes, and

(vii) the deceleration of the tape to rest. (Again, the head will be energized to record an erase polarity.)

(h) The recording cycle will continue for as long as data is presented and tape capacity is available.

### RECOVERY OF DATA

To recover data, it is necessary to provide an output device, such as a data printer or VDT, that can display graphic characters. The write head must be de-energized to avoid destroying data recorded on the tape.

The relevant operations and processes for the recovery of binary data from tape are as follows.

(a) The tape must be accelerated to 762 mm/s within

15 mm of tape.

(b) Flux reversals on the tape will, on passing the read-head gap, induce potentials in the coils. As the head will have started from erased tape in an inter-block gap, the first flux transition will induce a pulse potential in the coil to represent a logic zero condition.

(c) The preamble starts with 15 consecutive zero bits. There will therefore be 15 pulses induced, indicating 15 zero bits, interleaved with 14 pulses of the opposite polarity, indicating 14 phase transitions.

(d) The reading equipment will synchronize with these pulses, enabling data and phase transitions to be distinguished.

(e) The phase-transition pulses will be suppressed and the data-transition pulses will be used to set or reset a bistable circuit, depending on polarity. The signal thus constructed will be identical to that originally presented for recording.

(f) After suppression of the bytes forming the preamble, the cyclic redundancy check and the postamble, the data block is fed into buffer storage.

(g) When the buffer is filled, the tape will then be brought to rest, unless a second buffer is provided.

(h) The data in the first buffer will, after suitable signal processing, be fed out to a printer, VDT, computer or other device requiring a digital data input.

(i) As soon as a buffer has been read out, the tape will again be accelerated and it will be refilled, ready to be read out again. In the meantime, the second buffer, if fitted, will provide an uninterrupted output.

(j) The process will continue until all the data on the tape has been read out or the reading is manually terminated.

The output data will be a continuous stream and will contain no reference to the blocks into which it was divided for recording.

### THE RECORDER TAPE NO. 3A

The function of the Recorder Tape No. 3A is to accept data output from the TXE4 electronic exchange traffic-recorder rack and to record the data on magnetic tape housed in a cartridge. Periodically, the cartridge will be replaced and dispatched to a computer centre for reading and data processing. Under the operating conditions envisaged, a single data cartridge will have ample capacity to store a full week's traffic data from the busiest of TXE4 exchanges. The data is presented to the Recorder Tape No. 3A on 8 parallel paths at transistor-transistor-logic level, each combination of bits from the 8 paths is accepted by the recorder following an exchange of appropriate signals; that is, *ready*, *strobe* and *busy* signals. The flow of data bytes may be irregular, but no 2 consecutive bytes will be presented at less than 30 ms intervals.

To ensure compatibility with the equipment at the data processing centres, recording complies with standards set by the ECMA and the ISO (ECMA 46 and ISO/DIS 4057). The tape labelling is in accordance with the standards of ECMA 41 or ISO/DIS 4341 (basic system) and all recording is deemed to be of the same file.

Because the tape is normally dispatched to a computer centre for reading, a write-only recorder could have met the basic requirement. However, this would have been very difficult to set up and maintain, especially as confirmation of correct functioning would have to be obtained via the computer centre and could take several days.

A read head is provided to perform a read-after-write check on the quality of writing. A comparatively minor extension enables a test read-out to a data printer to be provided. The printer normally used is a Teleprinter No. 30A (read only facility). Because this print out is a test facility, no re-read attempts will be made; the data will be printed out as read, complete with any errors. A prototype of the Recorder Tape No. 3A is shown in Fig. 5.



FIG. 5—Recorder Tape No. 3A and cartridge

### Controls

The operational controls have been kept as simple as possible and consist of one switch and 2 push buttons. The switch, which is located in a prominent position on the control panel, switches the AC mains supply ON and OFF; the ON condition is signalled by a lamp housed within the switch. This switch is provided mainly for safety reasons because it is considered essential that, in a telephone exchange environment where earthed metalwork abounds, the power supply should be able to be disconnected promptly in case of an emergency.

The 2 push buttons are marked CONTROL and UNLOAD. The CONTROL button performs a sequential function to render the equipment active or passive, the normal state being the latter. The UNLOAD button functions only when the equipment is in the passive state.

### Indicators

Indicators are provided within the 2 push buttons, one is illuminated to indicate the active state and the other to indicate that the cartridge retaining latch has been released and that the cartridge is available for withdrawal.

In addition to the indicators associated with the controls, light-emitting diode indicators are provided to indicate

- (a) TRACK IN USE,
- (b) ERROR, and
- (c) PROTECTED.

A more prominent (red) track indication is provided when the last track on the tape is in use. This is intended to warn that less than 25% of the recording capacity remains and that a fresh cartridge may soon be necessary to avoid the risk of losing data.

### Automatic Actions

When inserting a cartridge into the recorder it will first be examined to see if the safety catch has been set to SAFE. If it has been, the write PROTECTED indicator will glow and the operation of the CONTROL button will be ineffective. The only operational command that the recorder will obey is *unload*.

The insertion of a cartridge will, unless the option has been negated, cause the tape to be re-spooled; that is, wound on to the take-up spool and back on to the supply spool at a

speed of 2290mm/s. Following this action the tape will be moved forward at recording speed to the load point.

Operation of the control button will cause a *tape mark* to be written on the tape and will enable data to be accepted from the TXE4 equipment as and when offered. (A tape mark comprises 6 bytes, 2 preamble bytes, followed by 2 logic zero and 2 postamble bytes.) Alternatively, operation of the UNLOAD control will cause the tape in the cartridge to be rewound to the beginning of the tape and to be discharged. This action is provided to allow a cartridge that has been loaded in error to be removed without defacing any data on the tape.

When recording is under way, data will be received into one of the buffer stores until it is full, whereupon the succeeding data will be directed into the other buffer while that in the first is transferred to tape. When the second buffer is filled, the cleared first buffer will be substituted while the content of the second is transferred to tape. This action will continue until the *early warning* punching is detected on the tape. At this point, which will normally arise during the transfer of a data block to tape, the transfer of that data block will be completed. Thereafter, a tape mark will be written on the tape, the tape on that track will be erased to the *end of tape* punching, and the tape will be re-wound at 2290 mm/s to the beginning of the tape and moved forward to load point. The recording will be transferred to the next higher track head and, after writing a track opening tape mark, data will be transferred from the buffers as soon as one is full. The tape rewind action takes approximately 50 s so that, with buffers each having a capacity of 800 bytes, no restriction of the flow of data from the TXE4 equipment should be necessary.

The data written on the tape is read almost immediately after it is written, and each block is examined against the cyclic-redundancy-check bytes following the data. If an error is registered, the tape will be moved back to the start of that block and a fresh attempt to write will be made. If this also fails, the block will again be erased and writing will be attempted further along the tape. If this attempt also fails, the tape track will be erased for 2 m or to the end of the tape, signifying end of data on that track. Rewind to the beginning of the tape will then be implemented, the attempt to write that block will be abandoned and, after rewind, writing of the following block will be attempted on the next track. The block presumed to be in error will be left on the tape because there is an even chance that the cyclic-redundancy-check error was caused by the failure to read correctly rather than by incorrect writing. The failure to pass the cyclic redundancy check after 3 attempts will cause the ERROR indicator to light and to remain alight until the cartridge is withdrawn from the recorder.

If recording continues to a point where the *early warning* punching is detected on the final track, any data beyond that remaining in the buffer in course of being transferred to tape will be lost on unload. A double tape-mark will be written on the tape, the recorder will be switched to the passive state and the tape will be rewound on to the supply hub. The cartridge will then be unlatched, the WITHDRAW CARTRIDGE indicator will light and alarm contacts will close to call attention if so desired. It is stressed that this condition should not normally be allowed to happen in service; the condition would indicate either that faulty writing is causing loss of recording capacity, or that cartridges are being overfilled and that they should be replaced more often.

### Test Facilities

A number of controls for use by installation and maintenance staff are mounted under a cover at the back of the equipment. The controls and facilities provided are as follows.

### Track Select (1, 2, 3, 4 or Automatic)

The track-select facility enables the functioning of the heads on a selected track to be examined. For normal operation, the track select control is set to the AUTOMATIC position.

### Re-wind

Use of the re-wind facility enables the tape to be rewound for further tests on the same track, or on another selected track, without discharging the tape cartridge.

### Self Test

This facility provides a limited performance check by writing and reading a simple pattern on each track. No external attachments are required. If a fault is detected, the test is halted and the ERROR lamp is lit.

### Read Last Block Written

This facility enables the last block written to be read out to the printer, in most cases without delaying the acceptance of traffic data from the TXE4 equipment.

### Read from Beginning of Track

This facility is available only with cartridges set to SAFE. Normally, reading will be of selected tracks, and termination will be by pressing the REWIND control.

With the exception of the read-last-block-written control and the track-select switch, the test controls operate only when the equipment is in the passive state.

## FUTURE DEVELOPMENTS

The Recorder Tape No. 3A has been designed specifically to meet the TXE4 traffic-recording requirements. The equipment is compact and, because it incorporates a microprocessor, is highly versatile. It is expected that future requirements will be met by minor changes to the Recorder Tape No. 3A, which will then be designated Recorder Tape No. 3B, C, etc. This will enable a wide range of facilities to be provided, while keeping spare part holdings and maintenance training to a minimum. The equipment is capable of accepting data at up to 1000 bytes/s although, in the case of the Recorder Tape No. 3A, 30 bytes/s is about the maximum presentation rate that will be experienced.

## CONCLUSIONS

The Recorder Tape No. 3A provides almost 15 times the data-storage capacity per loading of the previously used punched paper-tape equipment and should provide ample capability to store a week's traffic data output from even the largest TXE4 installation. It is accepted that the ability to inspect the data visually is lost, but this facility is not often required and is more than compensated for by the reduction of manual effort from that needed to service the punched paper-tape equipment.

The magnetic-tape cartridge is claimed by its manufacturers to be capable of at least 5000 recording/reading cycles before replacement is necessary. To date, the experience of the BPO suggests this may even be an understatement. If this is borne out in use, the life of a tape should exceed the expected life of exchanges by a considerable factor.

## ACKNOWLEDGEMENT

The author acknowledges advice received from colleagues in Telecommunications Headquarters; in particular, those in Telecommunications Development Department (TD 9). Also, Feedback Data Ltd. and 3Ms Company Ltd.

## References

- 1 LOOMES, E. A. A Review of Magnetic Storage Devices. *POEEJ*, Vol. 68, p. 96, July 1975.
- 2 VON BEHREN, R. A. USA Patent No. 3692 255, Sept. 1972.

# Plessey Pentex Installation in the UK Network

B. M. G. BROOKS† and A. M. BELENKIN, C.ENG., M.I.E.R.E.\*

UDC 621.395.722

*This article describes the Plessey Pentex electronic telephone exchange system and the arrangements made by the British Post Office and Plessey Telecommunications Ltd. to introduce this system into public service at Werrington in the Peterborough Telephone Area.*

## INTRODUCTION

A Plessey Pentex telephone exchange was recently introduced into public service at Werrington in the Peterborough Telephone Area. The installation of this type of equipment arose from a request by Plessey Telecommunications Ltd. (PTL) for operational facilities for their Pentex system. The objective being to demonstrate the system in a public service environment, in order to support and enhance export prospects. The British Post Office (BPO) has, on a number of occasions, supported UK manufacturers in their export activities, especially in the spheres of operational management and network planning, and the question of support in this form, although novel, was considered favourably.

Preliminary discussions between Telecommunications Headquarters (THQ) of the BPO and PTL verified that the proposed system would meet BPO facility and quality-of-service requirements and that documentation and the availability of spares would allow the BPO to maintain the exchange satisfactorily. The long-term availability of equipment for extension purposes was also verified; this latter point being particularly important since a large installation was proposed which, of necessity, would have a life of more than 20 years. The PTL proposals for system configuration were explored to enable the BPO to select a suitable site. Factors which influenced site selection were exchange size (subscribers to be served and traffic to be switched, both at the outset and the 20-year date), suitability of accommodation, order timing and finally, ease of access to the PTL factory at Nottingham to facilitate viewing by potential overseas customers. With the co-operation of the Midland Telecommunications Region (MTR) and Peterborough Telephone Area, the Werrington exchange site was chosen, since it was ideal in most respects, with the existing Strowger equipment already planned for replacement by a TXK1 exchange, which PTL were to supply.

This new exchange was planned to serve some 6000 subscribers at the outset, growing to 14 000 at the 20-year date. Total bothway traffic to be switched was 270 erlangs and 642 erlangs respectively, with further growth to serve ultimately 20 000 subscribers.

## PENTEX SWITCHING SYSTEMS

*Pentex* is the Plessey trade name for a range of electronic exchange systems designed specifically to meet the requirements of overseas administrations. These systems have evolved from the TXE2 exchange system, adopted in the mid-1960s by the BPO for all new small-to-medium local terminal exchanges. Exchanges in the Pentex series are identified as follows:

- ERM series—main exchanges for 500–20 000-plus subscribers' lines;
- ERT series—2 or 4-wire tandem/transit switching units;
- ERU series—unit type exchanges for up to 2400 subscribers' lines;
- ERC series—container exchanges for up to 2400 subscribers' lines;
- ERS series—rural or end exchanges for 50–500 subscribers' lines.

Pentex exchanges have now been supplied to over 26 overseas administrations and, in recognition of its export achievement, PTL received the Queen's Award to Industry in 1978.

The type of equipment installed at Werrington is in the Pentex ERM series and a brief description of this system and how it differs from the TXE2 system is given in this article.

The TXE2 system has been described in previous articles in this *Journal*<sup>1, 2</sup>.

## The Pentex ERM System

The Pentex ERM system is an electronically controlled system with wired-program flexibility and uses reed-relay switching to provide discrete physical paths for each established speech connexion. Fig. 1 shows the main functional blocks of the system, and its TXE2 parentage is self evident. Calls through the switching network are directed by the electronic call-control, which comprises a combination of magnetic cores, discrete semiconductor devices and, progressively, integrated circuits.

Each call-control is fully duplicated and operate in on-line and standby modes. The on-line control is continuously monitored and, if a fault is detected, changeover to the standby takes place automatically; a maintenance data printer operating in an on-line mode records the state of the system, equipment in use, calling line identity, digits dialled, control status, etc. at that time. The registers store the information relating to the call, including calling and called directory numbers, classes of service, and digits dialled. They are also equipped, where necessary, with tone-detector circuits for push-button telephone working and with add-on units for multi-frequency inter-exchange signalling systems. The register access switch is a single or 3-stage fully-available switch for providing the connexion between junctors (supervisory circuits) and the registers. The 3-stage register access switch is used in large exchanges to economize on crosspoints. The junctors provide the transmission bridge, supervise the call after set-up, control the metering of calls, their clear-down and the release of circuits. Junctors are available to interwork with a wide range of exchange system and signalling variations encountered overseas.

Changes from TXE2 are the incorporation of more up-to-date technology in the call-control, register and junctor areas with reed-relay logic elements replaced by semiconductor devices. In the call-control, the use of standard complementary

† Plessey Telecommunications Ltd., Nottingham

\* Operational Programming Department, Telecommunications Headquarters



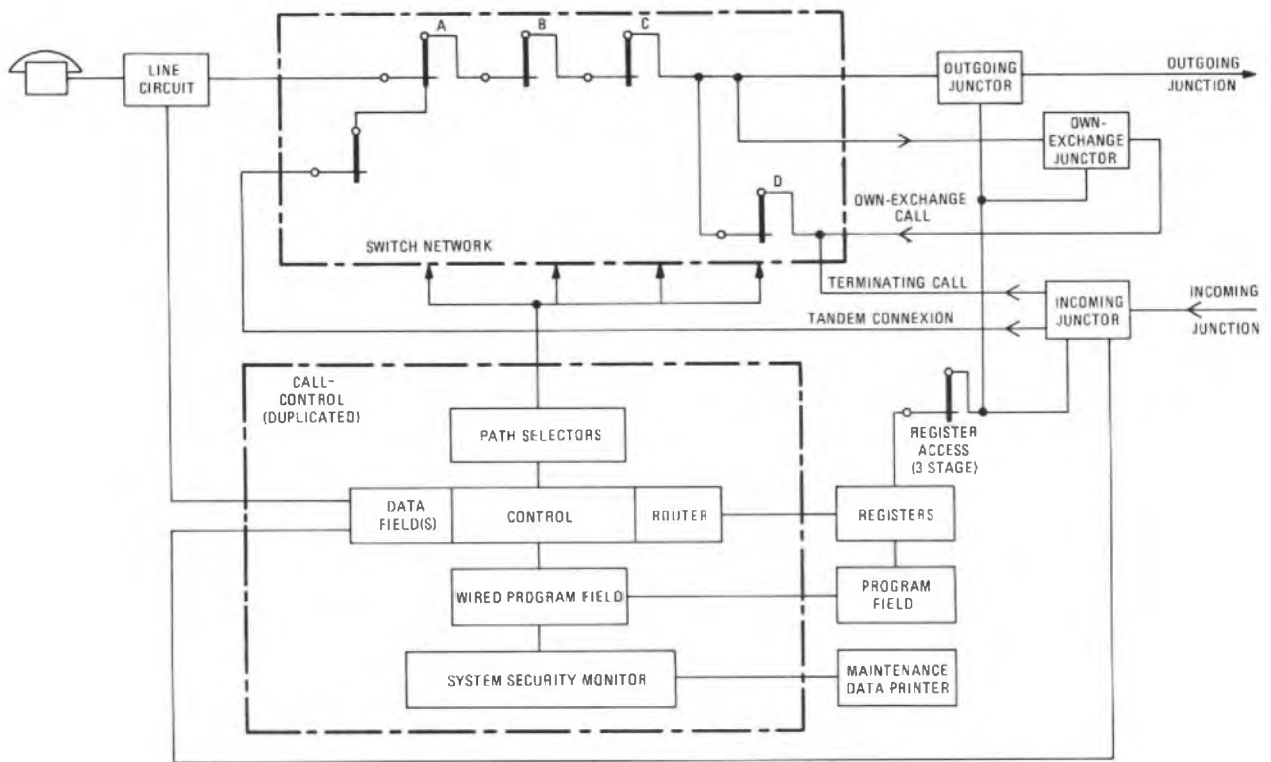

FIG. 1—A block diagram of the Pentex system

metal-oxide semiconductor (CMOS) medium-scale integrated (MSI) circuits has improved reliability, increased the speed of operation and hence increased traffic-handling capacity. The registers (see Fig. 2) and junctors make use of custom-designed P-type metal-oxide semiconductor (PMOS) large-scale integrated (LSI) circuits to improve reliability, lower the power requirements and permit a higher packing density. Microprocessors are used in the call-control for applications where network-routing (translation) and variable-metering facilities are required; for example, at group switching centres.

The custom-designed PMOS LSI circuits have been developed by PTL engineers. The production method, developed at the Nottingham site, is largely based on software techniques with much cross-checking in the preparation of the integrated-circuit masks. This has virtually eliminated the possibility of human error in chip fabrication from the original logic design. In total, 16 custom-designed circuits have been introduced,

using 110 mil (2.8 mm) silicon chips in a 40-pin assembly and are manufactured at the PTL semiconductor plant at Plymouth.

The switching network consists of reed-relay matrices, which provide the speech and signalling paths through the exchange. Flat-4 reed relays with "B" specification reeds are used (see Fig. 3). The switching network is made up of several stages, as shown in Fig. 1; the main operational features are:

- (a) originating calls are switched to junctors via 3 stages—A, B and C,
- (b) terminating calls (incoming and own exchange) are routed via a fourth switching stage (D), and then pass to the same switching stages as for the originating calls but in the order C, B and A, and
- (c) for tandem working, incoming junctors are switched through the A, B and C stages to outgoing junctors.

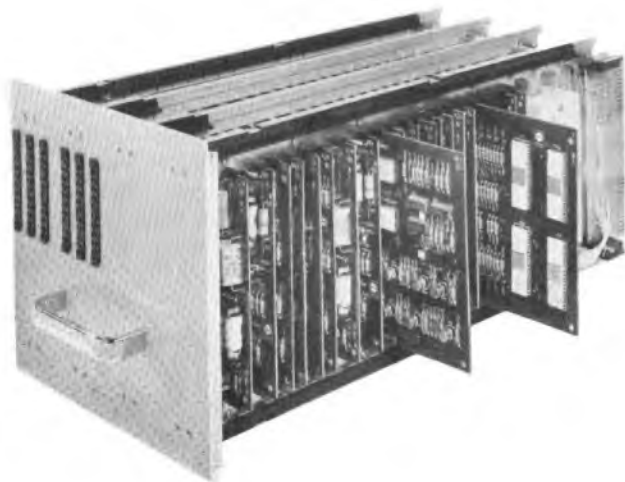

FIG. 2—Register unit

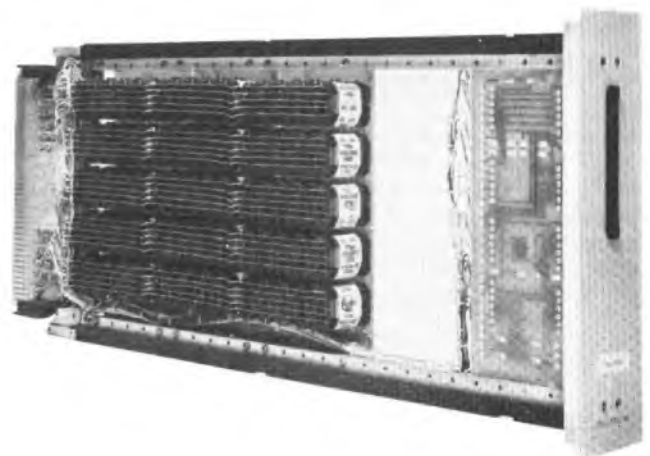

FIG. 3—5 x 15 C-switch unit showing the use of flat-4 reed relay

The switchblock structure is substantially that as used in the TXE2 system, except that, for larger exchanges, up to 5 A-switches (instead of 3) can be combined to form a *major*. The B-stage still comprises 5 B-switches but the C-stage can comprise 10 (as in TXE2), 15 or 20 C-switches. Fig. 4 shows a 2-major, 20 C-switch, switch section. Such switch trunking has been developed to maintain switching efficiency (measured in crosspoints per erlang) over the complete Pentex application range. In particular, the square-law growth characteristics of the C-stage can be largely overcome by dividing the network into a number of parallel switch sections, suitably interconnected to provide the required connexion availability.

### Multi-Call-Control Working

As described, a large and economic switchblock can be provided by paralleling identical switch sections. To provide a matching control capacity, extra call-controls can be provided.

In effect the exchange is segregated into subscribers' units, each with their own call-control, but with the switchblocks linked at the D-stage. If further control capacity is required, a separate incoming call-control can be provided; this being the equipment arrangement employed at Werrington and is as depicted in Fig. 5. Providing a dedicated incoming call-control to off-load the most onerous call-connect requirement

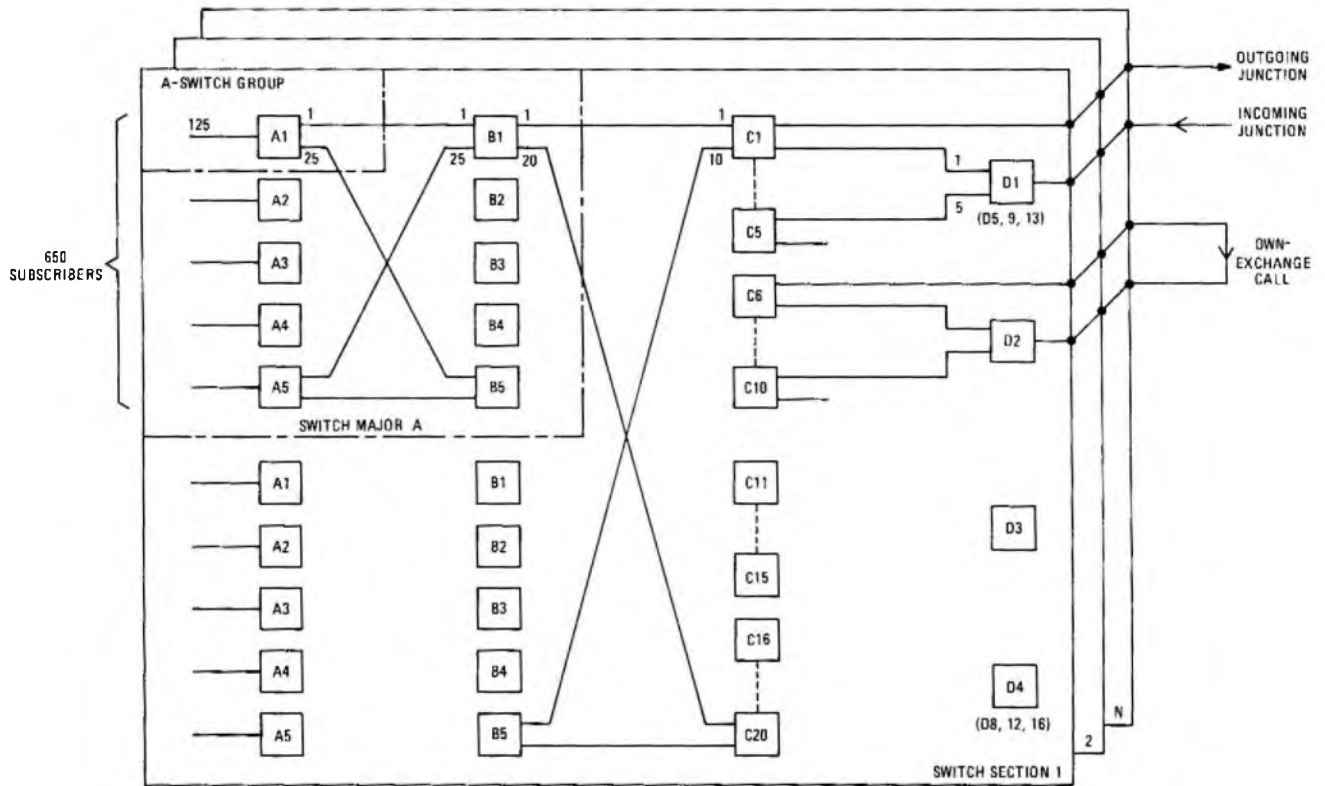

FIG. 4—Switch network, comprising 1-N switch sections (as employed at Werrington, where  $N = 6$ )

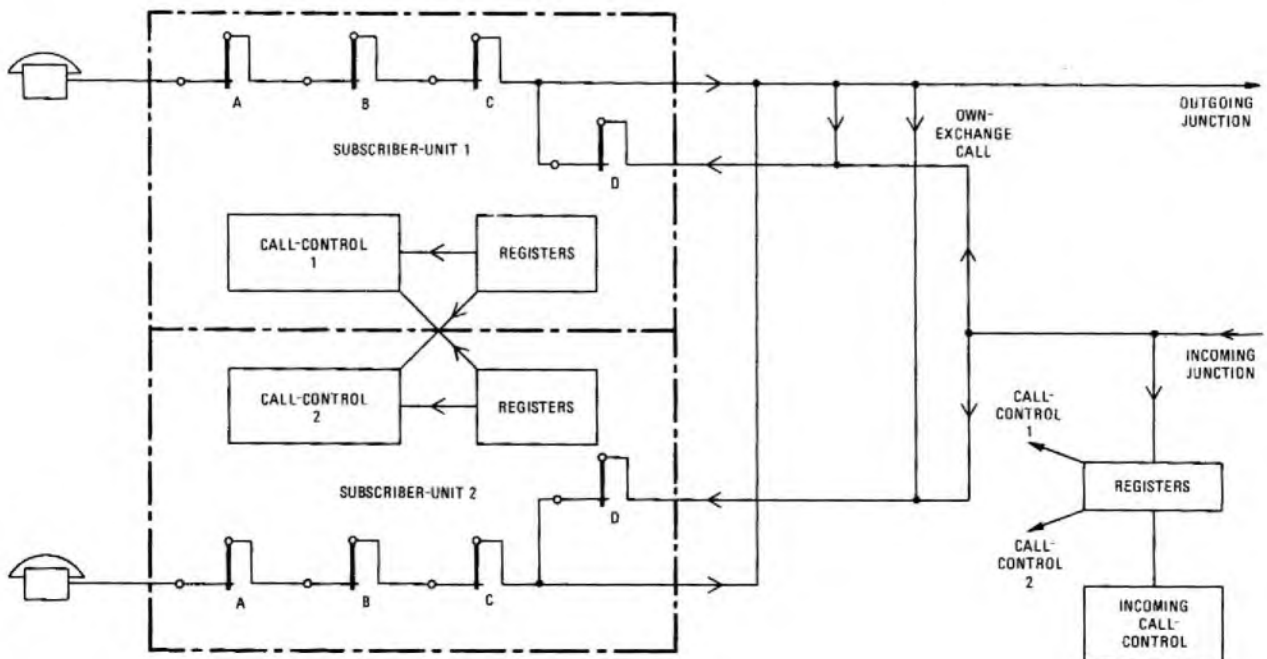

FIG. 5—D-linked double unit with separate incoming call-control (as used at Werrington)

(connecting incoming junctors to registers), allows the remaining call-controls to deal with more subscriber-originated traffic. Setting of the final speech path for incoming calls is still under the control of the main call-controls, requiring a connexion between them and incoming registers. Such a configuration can handle some 94 000–112 000 busy-hour call attempts and, in general terms, is referred to as a D-linked double unit with separate incoming call-control. This arrangement can meet the full range of subscribers' traffic and facilities, line and inter-exchange signalling and metering requirements encountered overseas. Maintenance enhancements include an updated maintenance data recorder with standard teletype output, programmable routiners to test those parts of the exchange not included in the self-checking program and the ability to make calls on an out-of-service security block for fault checking. An Alston-type traffic recorder with a programmable high-speed scanning capability is provided; this enables simultaneous recording of all traffic-carrying groups in the exchange. Detailed analysis of individual groups is also possible.



Fig. 6—The Werrington Pentex ERM installation

## THE WERRINGTON INSTALLATION

### Planning and Execution

While a single-unit exchange as depicted in Fig. 1 would have met the initial Werrington requirements, it was proposed by PTL that, in order to adequately demonstrate the Pentex ERM system, a multi-call-control configuration as depicted in Fig. 5 would be provided. Subscribers' traffic being split roughly equally over the 2 subscribers' units.

The method of integrating the system into the network was discussed with the MTR and it was decided that the existing satellite scheme should continue; Werrington telephone numbers being within the Peterborough linked-numbering scheme. Interconnexion via junction routes was such that normal TXE2-type discriminator working could be employed but, to avoid false traffic at the main exchange, the own-exchange route was made first choice.

Dimensioning of the exchange was carried out by PTL using design rules agreed by THQ and the MTR; a contract specification was placed by the MTR in the normal way. A commercial agreement was entered into to give safeguards to both the BPO and PTL. Equipment was manufactured and supplied to current TXE2 quality assurance standards. Installation and commissioning was undertaken by PTL with normal BPO clerk-of-works staff in attendance. An exception was the use of the PTL commissioning manual in lieu of normal BPO commissioning specifications, with special test equipment being supplied by PTL. Training of Peterborough Telephone Area installation and maintenance staff was carried out at the PTL Technical Training Centre in Nottingham. Finally, the installation was subjected to a multi-call-sample test of 54 in 20 000 and proved to be acceptable. The exchange was brought into service on 5 December 1978. The installation is shown in Fig. 6.

### In-Service Experience

Since being brought into service, the exchange has typically handled over 150 000 calls per week and has quickly settled down to a low fault rate. The number of calls failing due to the exchange has dropped from 0.3% to a steady 0.04% during the first few months. An analysis of fault dockets has revealed that many of the early faults were due to problems in the on-site wiring areas; for example, pieces of wire or solder splashes. Being of an intermittent nature they took some time to locate and contributed to more than one fault report. To date, the performance of the equipment has been most encouraging.

The first extension to increase capacity by 2000 lines is planned, and this extension equipment should be ready for service in the first quarter of 1980.

### CONCLUSION

The successful introduction of this system variant into the BPO network owes much to the close co-operation of THQ, MTR, Peterborough Telephone Area and PTL staff. The capability PTL now have to demonstrate an operational system in the UK network should support and enhance export prospects. The BPO has been pleased to make such facilities available to assist PTL, and all concerned hope the desired objectives are achieved.

### References

- <sup>1</sup> LONG, R. C., and GORRINGE, G. E. Electronic Telephone Exchanges: TXE2—A Small Electronic Exchange System. *POEEJ*, Vol. 62, p. 12, Apr. 1969.
- <sup>2</sup> MOON, R. J., TARRY, D. G., and BEALE, G. A. TXE2 Electronic Exchange System—The Evolution from Mark 1 to Mark 3. *POEEJ*, Vol. 69, p. 210, Jan. 1977.

# An Injection-Welded Joint Repair

R. BUNDY †

As part of the development of injection-welding equipment to be used for polyethylene sheath closures in the British Post Office (BPO) cable network, prototype equipment was used to repair a failed sheath closure at a cable joint in the London Telecommunications Region/NorthWest (LTR/NW) Area. It was found that the moulded adaptor between sleeves and sheath had cracked, producing an air-leak. A general view of the original joint arrangement within the manhole is shown in Fig. 1. The fault was at the single-cable-entry end of the closure and was not visible, but air could be heard escaping at that point.

The problem presented by such a failure is that replacement of the moulded adapter is practical only if the joint is broken down to thread the new adaptor into place. The new BPO method of injection welding avoids this expensive and undesirable service interruption by moulding the equivalent of the adaptor *in situ*, using moulds that are clamped around the cable and sleeve-end during the welding operation.

To effect a repair of the greatest reliability in this particular case, a completely new sheath closure was thought to be desirable: which required the complete removal of the old closure. This, however, may not always be necessary. To avoid rewelding on the previously welded area, an extra-long (760 mm) split jointing sleeve was used which, after being placed around the joint, was sealed longitudinally with the new compression-welding technique. This method had, on many previous occasions, been proved to be highly efficient. Thus, the new joint enclosed the previously welded area, and fusion was achieved on an unmarred region of cable sheath. After preparation of the cable sheaths and sleeve, the mould, with the particular cable-entry assemblies required, was positioned. In this instance, the cables involved were all polyethylene-sheathed 1040-pair, 0.63 mm paper core quad trunk, with one twin and one single cable entry into the joint.

The repaired closure is shown in Fig. 2, in which a comparison can be made with traditional methods of sheath closure; Fig. 3 gives a view of the twin-cable-entry end of the closure and shows the neat appearance of the completed joint closure.

Almost immediately on completion of welding, the joint closure was pressure tested in the normal way, without awaiting the long setting times associated with the putty closure, and

found to be satisfactory. Welded sheath closures of this type are showing considerable field reliability.

The only problems apparent at the time were due to cabling conditions within the non-standard manhole. Although the welding equipment could be set up and readily used, it was apparent that some of the cable had been kinked severely where it had been bent beyond its minimum bending radius. This could raise a risk of stress-crack problems at some future date. Constructing and maintaining the minimum bending radii of polyethylene-sheathed cables, in a manhole environment, is a problem, especially on routes where congested manholes are prevalent. Planning new cable schemes will require increasing vigilance to ensure that the incidence of cable-sheath kinking is minimized.

The work described here was carried out at the invitation of, and with the able and willing assistance of, staff of the LTR/NW Area.



FIG. 1—The original sheath closure



FIG. 2—The renewed closure showing the single-cable-entry end



FIG. 3—The renewed closure showing the twin-cable-entry end

† Operational Programming Department, Telecommunications Headquarters

# Developments in Frequency-Shift Voice-Frequency Telegraph Equipment

A. M. BROWN, B.Sc.†

UDC 621.394.441

*This article briefly describes the systems used at present to multiplex telegraph channels onto an audio bearer and the methods by which this has previously been achieved. A fuller description of the latest designs of frequency-shift multiplex equipment is given, leading to a conclusion which indicates the direction that future developments might take.*

## INTRODUCTION

Frequency-division multiplexing has long been the established method of multiplexing a number of telegraph channels onto an audio bearer, the technique being known as *multi-channel voice-frequency telegraphy* (MCVFT, or simply VFT). Initially, amplitude modulation (AMVFT) was employed with electro-mechanical generation of the necessary tones; electronic equipment was subsequently employed. With the growth of international services, particularly those on radio bearers, the need arose to develop frequency-shift (FSVFT) systems, with their inherently greater noise immunity and insensitivity to level variations. The earliest forms of MCVFT equipment used a group-modulation process to derive the necessary channel frequencies<sup>1</sup>. This was done primarily to ease the stability problems of channels at each end of the frequency range. The development of more stable equipment led to the introduction of directly-derived systems which use separate oscillators for each channel, this equipment forms the bulk of that now in use in the UK. The latest equipment, now being introduced, derives all channels from a common crystal-controlled oscillator. This leads to a further improvement in stability and further potential cost savings by the use of digital circuitry.

## THE SYSTEM HIERARCHY

The system used is that described in CCITT\* Recommendations R35 to R38A. The basic arrangement consists of 24 channels, each suitable for a nominal modulation rate of 50 bauds. The channel spacing used is 120 Hz and the 2 binary

states are represented by shifts of  $\pm 30$  Hz on the nominal channel mean frequency. For modulation rates of nominally 100 or 200 bauds, wider channel spacing and shifts are used with a corresponding reduction in the number of channels. To obtain mixtures of channel rates, 2 adjacent channels may be replaced by one at the next higher rate. Table 1 shows the nominal mean frequencies for 50, 100 and 200 baud channels and also gives an example of a mixed system. Table 2 shows the channel spacing and frequency shift employed for the various modulation rates.

A pilot tone of 300 Hz or 3300 Hz may be added for monitoring the performance of the bearer, the most appropriate frequency for the particular system being selected; for example, a 300 Hz pilot is used when the bearer includes a submarine cable system having 3 kHz channel spacing, but cannot be used on inland high-frequency systems because of the sharp cut-off at the lower end of the audio band.

## GROUP-MODULATED AND DIRECTLY-DERIVED SYSTEMS

These systems derive their channel frequencies by means of a carrier generator, modulator and band-pass filter individual to each channel. As already mentioned, frequency stability

**TABLE 2**  
Channel spacing and frequency shift for 50, 100 and 200 baud channels

Modulation rate (baud)	50	100	200
Channel spacing (Hz)	120	240	480
Frequency shift (Hz)	30	60	120

**TABLE 1**  
Allocation of frequencies for 50, 100 and 200 baud channels and a mixed system

50 baud channels	Channel number	101	102	103	104	105	106	107	108	109-120	121	122	123	124
	Mean frequency (Hz)	420	540	660	780	900	1020	1140	1260		2820	2940	3060	3180
100 baud channels	Channel number	201		202		203		204		205-210	211		212	
	Mean frequency (Hz)	480		720		960		1200			2880		3120	
200 baud channels	Channel number	401				402				403-405	406			
	Mean frequency (Hz)	600				1080					3000			
Example of a mixed system	Channel number	101	102	103	104	402				...	121	122	212	
	Mean frequency (Hz)	420	540	660	780	1080				...	2820	2940	3120	

† Telecommunications Development Department, Telecommunications Headquarters

\* CCITT—International Telegraph and Telephone Consultative Committee

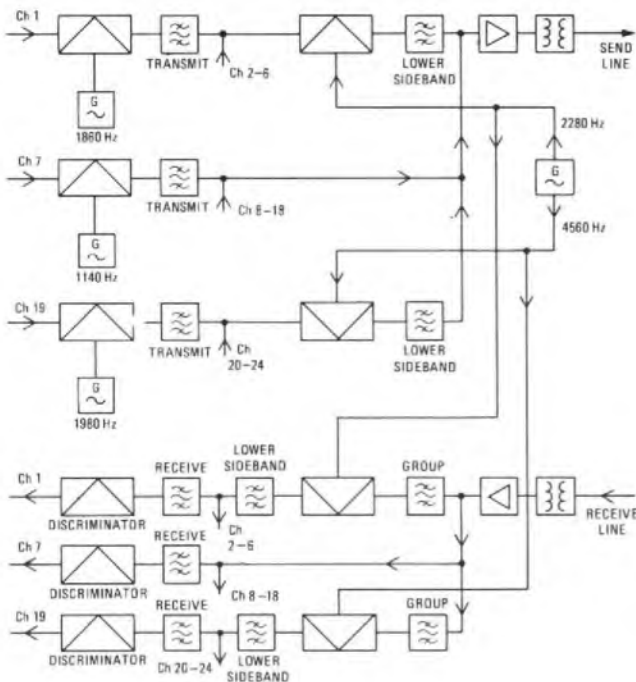

FIG. 1—Block diagram of group-modulated FSVFT system

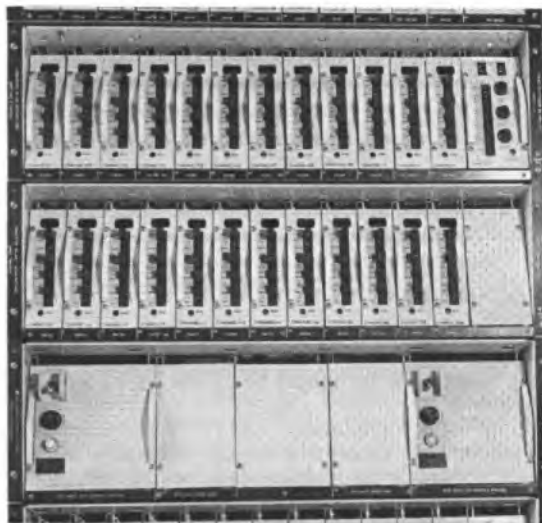

FIG. 3—Pye-TMC Ltd. 24-channel, 50 baud FSVFT equipment

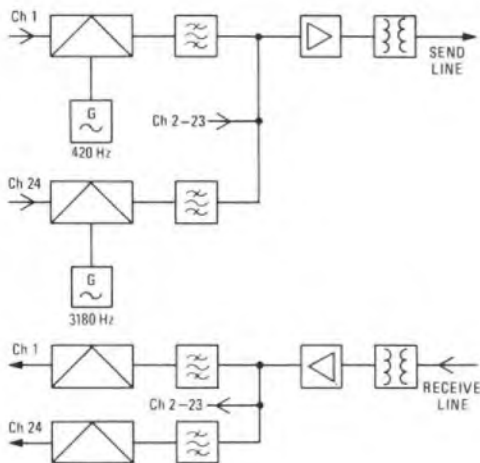

FIG. 2—Block diagram of a directly-derived FSVFT system

problems in early FSVFT systems were overcome using a group-modulation process, in which the first and last 6 channels were modulated with carrier frequencies in the middle of the range (see Fig. 1). A second stage of modulation, followed by a filter passing the lower sideband, translated these signals into the required frequency ranges. The precise choice of first and second stage carrier frequencies varied between types of equipment. Fig. 1 shows, for channel 1, first and second stage carrier frequencies of 1860 Hz and 2280 Hz which give rise to a lower sideband at the required frequency of 420 Hz. Channels in the centre of the frequency range were modulated directly. Demodulation was performed using the reverse process.

The development of more stable equipment enabled all channels to be directly derived, with the carrier generator and modulator operated at the nominal frequency of each channel. (See Fig. 2.)

### THE LATEST DESIGNS OF SYSTEMS

The system hierarchy and the basic principles are as previously described, but the method of deriving the channel frequencies

is very different. All channel frequencies are indirectly derived, by digital means, from a common master-oscillator. However, the method of doing this differs radically between the 2 systems currently in use by the British Post Office (BPO). The equipment designed by Pye-TMC Ltd. (see Fig. 3) is based on 3 different custom-designed large-scale integrated (LSI) circuits, while the equipment designed by GEC Telecommunications Ltd. is based on low-power transistor-transistor logic (TTL).

Both systems use 62-type equipment practice and may be powered by DC-DC converters connected to the station 24 V or 50 V power supply. An AC mains power unit, which is a switched-mode type, is available for use in locations where DC battery supplies are not present. The channel interface may be operated at nominally  $\pm 6$  V or  $\pm 80$  V. Pilot monitoring facilities are provided, but aggregate monitoring may be used in cases where a pilot signal is not available from the remote end. A noise detector can distinguish a noisy bearer when pilot operation is employed, and can be used to take the channels out of service if required.

### FREQUENCY DERIVATION

The 2 designs of equipment employ different means of frequency derivation. In the Pye-TMC approach, DC signals, incoming to a channel card, produce upper and lower intermediate-frequency shifts ( $IF_A$  and  $IF_Z$ ) about a notional mean intermediate frequency ( $IF_O$ ) which is common to all cards of the same nominal modulation rate and is derived from a master clock on the line unit. The signals are then passed through a band-pass filter to the channel modulator. The channel modulator translates  $IF_A$  and  $IF_Z$  into the required channel frequencies by amplitude modulating a carrier frequency derived from a local crystal-oscillator individual to that channel.

In the GEC design, a master oscillator and pulse-derivation circuit on the line unit provide 7 basic non-coincident pulse rates, which are fed in parallel to all 24 channel cards. By suitable selection and logical addition and subtraction of these signals on each channel card, multiples of the required upper and lower characteristic frequencies are derived, according to the polarity existing on the DC channel input. The multiples are then divided down to the basic channel frequencies and converted to sinusoidal form by the channel transmit filter.

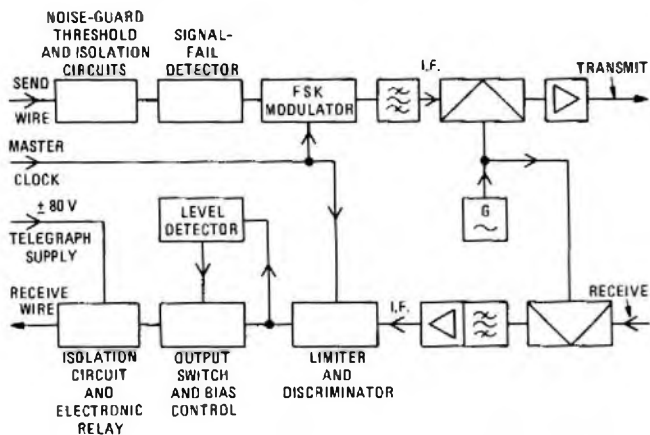

FIG. 4—Block diagram of the Pye-TMC Ltd. channel card

## DETAILS OF OPERATION

### Pye-TMC Design

#### Input Circuit

Incoming telegraph signals enter the channel card on the SEND wire (see Fig. 4). These signals are applied to a pair of opto-isolators via a network which determines the threshold of operation and the nominal input impedance. The isolators drive a bistable latch circuit which in turn drives a frequency-shift-keying (FSK) modulator. The latch circuit holds the preset polarity for the duration of the threshold transit time or for momentary line breaks, but longer periods of disconnection are timed-out and the latch forced to one or other preselected polarity.

#### FSK Modulator

The function of the FSK modulator is to produce the intermediate frequencies  $IF_A$  and  $IF_Z$  corresponding to the DC conditions placed on the input. The intermediate frequencies are the same for all channel cards of the same nominal modulation rate, thereby allowing a common design of transmit band-pass filter. The modulation process is achieved by the generation of a pulse train, the rate of which varies with the input polarity. Depending on whether an A or Z polarity exists on the DC channel input, the master-clock frequency of 3 088 800 Hz, provided by the line card, is divided by a factor of 66 or 65 respectively. Further divisions by 3 and 2 then follow, depending on the channel card nominal modulation rate, as given below:

- (a) For nominal 50 baud channels,

$$IF_Z = \frac{3\ 088\ 800}{65 \times 3 \times 2 \times 2} = 3960\ \text{Hz},$$

$$IF_A = \frac{3\ 088\ 800}{66 \times 3 \times 2 \times 2} = 3900\ \text{Hz}, \text{ and}$$

$$IF_O = 3930\ \text{Hz}.$$

- (b) For nominal 100 baud channels,

$$IF_Z = \frac{3\ 088\ 800}{65 \times 3 \times 2} = 7920\ \text{Hz},$$

$$IF_A = \frac{3\ 088\ 800}{66 \times 3 \times 2} = 7800\ \text{Hz}, \text{ and}$$

$$IF_O = 7860\ \text{Hz}.$$

- (c) For nominal 200 baud channels,

$$IF_Z = \frac{3\ 088\ 800}{65 \times 3} = 15840\ \text{Hz},$$

$$IF_A = \frac{3\ 088\ 800}{66 \times 3} = 15600\ \text{Hz}, \text{ and}$$

$$IF_O = 15720\ \text{Hz}.$$

#### Transmit Band-Pass Filter

The transmit band-pass filter is centred about  $IF_O$  and is designed to remove the dominant third harmonic and other modulation products from the signals generated by the FSK modulator, before they enter the channel modulator.

#### Channel Modulator and Carrier Generation

The channel modulator translates the common frequencies  $IF_A$  and  $IF_Z$  into the specific channel frequencies required. This is achieved by amplitude modulating a carrier wave generated by a local crystal-oscillator, the frequency of which is individual to each channel.

The channel carrier frequency is obtained by dividing the crystal-oscillator frequency by 1024, 512 or 256, depending on the channel-modulation rate of 50, 100 or 200 bauds respectively. The crystal frequencies are given by

$$1024(3930 + f_0)\ \text{Hz for 50 baud channels,}$$

$$512(7860 + f_0)\ \text{Hz for 100 baud channels, and}$$

$$256(15720 + f_0)\ \text{Hz for 200 baud channels,}$$

where  $f_0$  is the nominal mean channel frequency.

#### Channel Card Voice-Frequency Output

Both the wanted lower sideband and the unwanted upper sideband from the modulator are amplified before being passed through an attenuator, where the output level is set to  $-31$ ,  $-28$  or  $-25$  dBm† for nominal modulation rates of 50, 100 and 200 bauds respectively.

Selective level measurements can be made directly or, alternatively, wideband measurements may be made via a measurement filter on the line unit, which suppresses the unwanted upper sideband of modulation, leaving the wanted channel signals.

#### Summing Amplifier

The signals from all the channels are commoned on the shelf wiring, and enter the line unit at the summing amplifier (see Fig. 5). The summing amplifier is designed to present a very low impedance to the channel cards, such that the input level remains relatively constant irrespective of the number of channels equipped and mutual interaction between channels is prevented.

#### Filtration and Transmit-Line Output

The output of the summing amplifier still contains the unwanted upper sidebands generated by the channel modulators. These are suppressed by a low-pass filter. The signals then pass through a further amplifier to provide the required level (set by an attenuator) before being sent to the transmit pair of the 4-wire bearer circuit via an isolating transformer.

#### Pilot Generation

Frequencies of 300 Hz and 3300 Hz are derived from the master clock by dividers in the line unit, the required frequency being selected by means of a wired strap.

The signal is then filtered (the cut-off frequency being set to suit the frequency used), before being attenuated to obtain the required level. The pilot frequency is combined with the channel frequencies at the input of the summing amplifier.

#### Master Clock Generator

The master clock generator is located on the line unit and provides a frequency of 3 088 800 Hz from a 6 177 600 Hz oscillator. This clock is used by all channels to form the basis for the frequency generation and as a reference for the discriminators.

A level detector is provided to operate an alarm should the master clock fail.

#### Receive Path

Voice-frequency telegraph signals enter the line unit from the receive pair of the 4-wire bearer circuit, via a line isolating transformer.

† dBm— Decibels relative to one milliwatt

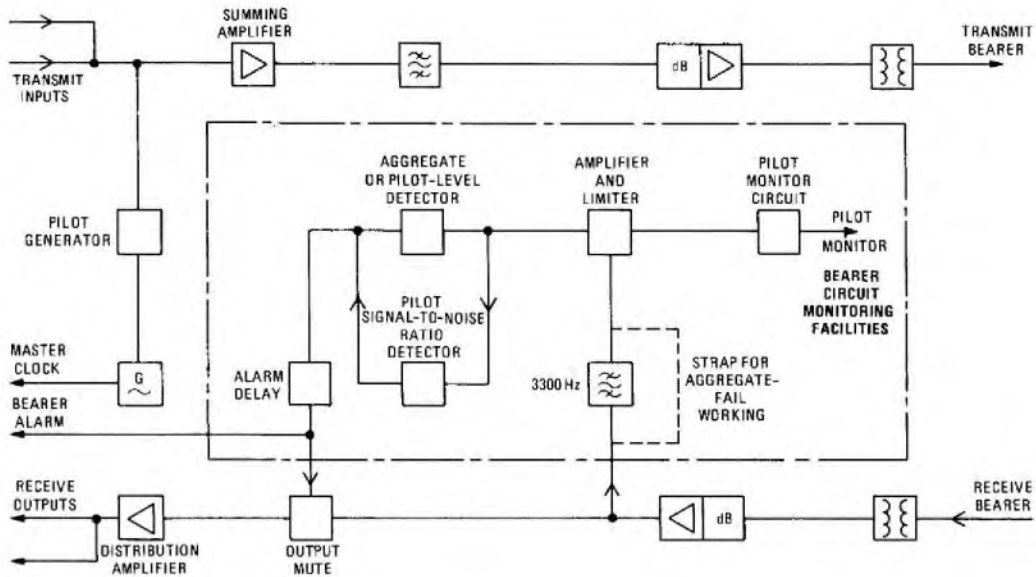

FIG. 5—Block diagram of the Pye-TMC Ltd. line unit

### Filtration and Distribution

An attenuator is provided to cater for a range of nominal receive levels. The signal is then passed through a low-pass filter to remove signals over 3400 Hz. The signals then pass through two stages of amplification: the first stage provides the main receive-path gain and the signal for the level and noise detectors; the second stage is essentially an active impedance-converter, which provides a very low output impedance for the distribution of signals to the channel cards.

A gate is inserted between the 2 stages of amplification which suppresses the signals to the channel cards when the level detector or noise detector indicates an alarm condition. If the suppression facility is not required, it may be disabled.

### Channel Demodulation and Pre-Filtering

The output from the distribution amplifier in the line unit is fed to each channel card and is applied to the channel demodulator. The channel demodulator is similar in operation to the modulator in the transmit path and, being fed with the same channel carrier frequency, the original intermediate frequencies are produced as components of the lower sideband. The unwanted upper sideband is removed by a band-pass filter.

### Intermediate-Frequency Amplifier

This consists of 2 amplifiers and a band-pass filter, centred on  $IF_0$ , which selects the original intermediate frequency from the demodulator and amplifies the signal for the channel limiter and level detector. The gain of the amplifier is made adjustable so that the following threshold detector operates at the correct level.

### Limiter and Discriminator

The limiter absorbs the amplitude variations in the received signal and provides a reasonably constant amplitude signal to the discriminator. The discriminator is of a period-measuring type, whereby the difference between the  $IF_A$  and  $IF_Z$  frequencies is detected by comparing their periods with a common timing-reference from the master clock. A high-frequency waveform is therefore generated which contains a low DC component when  $IF_A$  is received, and a high DC component when  $IF_Z$  is received. The high frequency component is suppressed by a post-discriminator filter, leaving the wanted DC signal.

### GEC Design

#### Input Circuit

The input circuit of the equipment is essentially the same as the Pye-TMC equipment and is shown in Fig. 6.

### FSK Modulator

The channel frequencies are synthesized in the following manner. The characteristic frequencies of all 24 channels have a common factor of 30. Removal of this factor gives the following sequence

$$30 \times (13, 15; 17, 19; 21, 23; \dots \dots \dots 105, 107)$$

$$F_Z, F_A; F_Z, F_A; F_Z, F_A; \quad F_Z, F_A$$

$$\text{Ch 1; Ch 2; Ch 3; Ch 24}$$

For example,  $F_Z$  for channel 1 is  $30 \times 13 = 390$  Hz.

The figures 13, 15; 17, 19 etc. may be described as the channel frequency equivalents.

Seven basic clock rates are derived on the line unit and fed to all channels. These 7 rates have the relationship 1, 2, 4, 8, 16, 32 and 64 (normalized to the lowest rate). By suitably adding and subtracting the appropriate pulse rates, any channel frequency-equivalent may be derived. For example, for channel 1, the frequency equivalent of  $F_Z$  is 13, which is derived from  $16 - 2 - 1$ , and the frequency equivalent of  $F_A$  is 15, which is derived from  $16 - 1$ ; for channel 24, the frequency equivalent of  $F_Z$  is 105, which is derived from  $64 + 32 + 8 + 4 - 2 - 1$  and the frequency equivalent of  $F_A$  is 107, which is derived from  $64 + 32 + 8 + 4 - 1$ . For each channel, the difference between  $F_Z$  and  $F_A$  is the subtraction or non-subtraction of the pulse rate 2. The channel frequencies for nominal 100 and 200 baud modulation rates are synthesized in a similar manner, although the frequency equivalents are, naturally, different for each modulation rate. For 100 baud channels, the difference between  $F_Z$  and  $F_A$  is the subtraction or non-subtraction of the pulse rate 4; for 200 baud channels, the difference is the subtraction or non-subtraction of the pulse rate 8.

### Channel Card Voice-Frequency Output

The output from the modulator is passed through a low-pass filter and an attenuator which is adjustable in steps of 0.5 dB and enables the channel-card output to be set to the required level. The harmonics of the square-wave signals are suppressed by a channel band-pass filter to provide sine-wave outputs. The output impedance of the filter is matched to 600  $\Omega$  before leaving the channel card. A test point is provided on the front plate of the channel card to enable 600  $\Omega$  terminated level measurements of the output signal to be made. A channel card and line unit are shown in Figs 7 and 8 respectively.

### Summing Amplifier

The operation of the summing amplifier is essentially the same as that described for the Pye-TMC equipment.



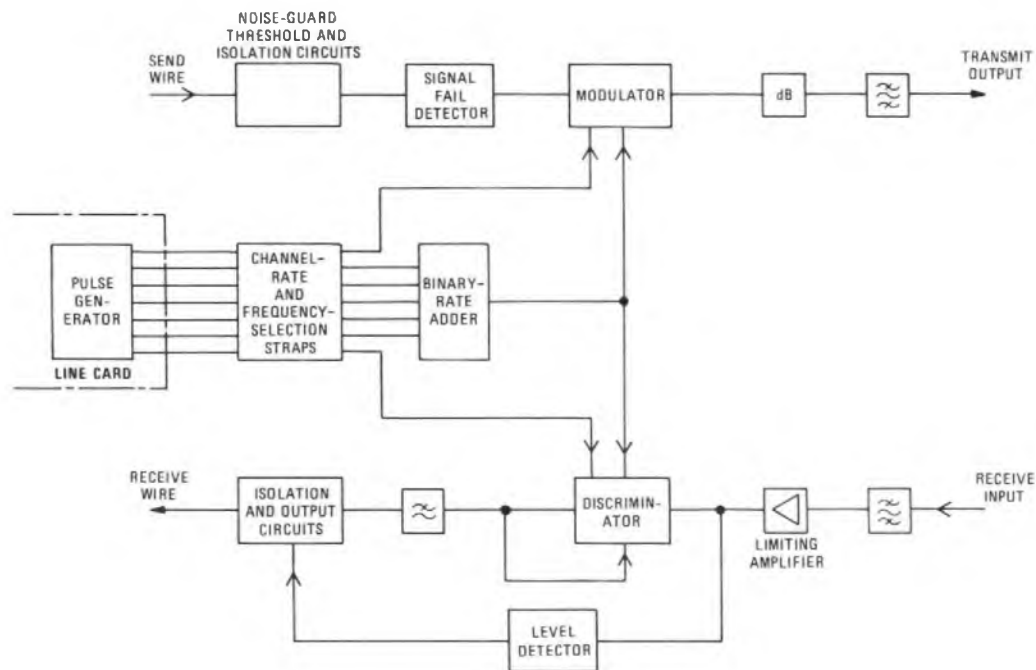

FIG. 6—Block diagram of the GEC Telecommunications Ltd. channel card

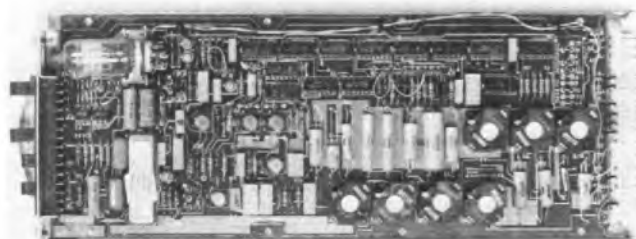

FIG. 7—A GEC Telecommunications Ltd. FSVFT channel card

#### Filtration and Transmit-Line Output

The output of the summing amplifier is filtered before being passed through a variable attenuator used to set the output level. The signals are further amplified before transmission to line via a line transformer. An auxiliary winding on the line transformer is provided to enable a through-level measurement of the line output level to be taken.

#### Receive Path

Signals enter the line unit via a line transformer, variations in nominal receive level being adjusted by means of a variable attenuator. The signals pass to the channel cards via a low output-impedance distribution amplifier. The signal level at the output of the attenuator is monitored continuously and, should it fall below a preset level, the input to the distribution amplifier may, optionally, be connected to earth potential, thus inhibiting the output of the channel cards which in turn clamp to the SPACE condition.

#### Channel Filtering and Demodulation

The output from the distribution amplifier is fed to all channels simultaneously. Each channel card contains a filter which selects the frequencies individual to that channel, and the appropriate signal passes to the limiter circuit. The limiter consists of an amplifier which, with normal signal levels, is overdriven to provide a substantially square wave to the demodulator. If the signal level falls, the amplifier ceases to limit, at which point the threshold clamp circuit operates to hold the DC output in a steady state and switching to noise is prevented.

The discriminator consists of a phase-locked loop whose frequency is derived from the appropriate digital pulse rates

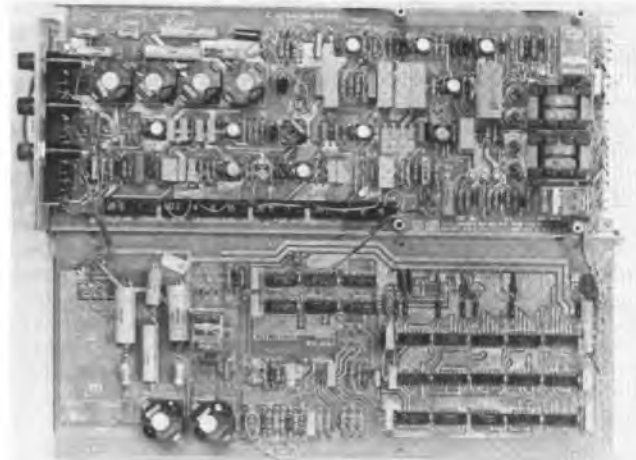

FIG. 8—A GEC Telecommunications Ltd. FSVFT line unit

as described for the modulator. A phase comparator is fed with the output from the frequency generator, together with the filtered and limited signals, to produce an output whose average DC content varies with the frequency of the incoming signal. The signal is then filtered to produce a smooth DC voltage which is used to drive the output circuit.

#### Pilot Generation

Frequencies of 300 Hz and 3300 Hz are generated on the line unit by addition of the relevant clock rates, selected by means of straps. The signal is then passed through a variable attenuator to set the level before being filtered (the filter being strapped for the appropriate pass band) and then added to the channel frequencies.

#### Master Oscillator and Pulse Rate Derivation

The sequence of 7 basic pulse rates is derived from the master oscillator, which is situated in the line unit and is crystal controlled at a frequency of 7.86432 MHz. This crystal frequency is divided by 8 to produce a pulse rate of 983 040 pulses/s, which is the actual rate of the normalized pulse rate 64. Pulse rates 32 to 1 are successive divisions of the pulse rate 64 by 2.

Pulse rate 1 is monitored by a master-oscillator-fail-alarm

circuit, thereby checking the operation of the master oscillator and the divider chain.

### BEARER-CIRCUIT MONITORING

A bearer-circuit monitoring facility is provided on both designs of equipment to monitor the performance of the bearer in terms of the received 3300 Hz pilot signal or, where a pilot is not used, the aggregate signal level.

The pilot-monitoring circuit consists of a narrow band-pass filter which selects the 3300 Hz pilot frequency. The signal is then amplified and fed to 3 different circuits (see Fig. 5):

#### (a) Level-detector circuit.

The level detector circuit is normally set to operate an alarm if the pilot signal level falls to 15 dB below the nominal received signal level. The alarm restores if the signal level rises to less than 12 dB below the nominal received signal level.

#### (b) The pilot-monitor output circuit.

The filtered and amplified signal is rectified and smoothed to provide a DC output which is directly proportional to the level of the incoming pilot signal. A pen recorder, or similar meter, may be plugged into a test point on the line unit to obtain a continuous record of the incoming pilot signal level.

#### (c) Signal-to-noise-ratio detector circuit.

Noise on the bearer will cause phase jitter on the 3300 Hz pilot signal and it will give rise to distortion on the channel outputs. The noise detector measures the degree of phase modulation on the 3300 Hz pilot by means of a discriminator, which produces an amplitude component proportional to the depth of the phase modulation. This is used to instigate an alarm condition when the noise generates a depth of phase modulation equivalent to an 8% increase in channel output distortion. The alarm condition is removed when the noise falls to an equivalent channel distortion increase of 5%.

For bearers on which a pilot is not employed, the above monitors cannot be used. Instead an aggregate level detector is employed to operate an alarm when the bearer signal level behaves as described in the pilot signal-level detector circuit.

All alarms are delayed such that the alarm condition must exist for a minimum of 10 s before the alarm is given. The fault must be removed for at least 5 s before the alarm is restored to normal. This prevents transient conditions affecting the state of the alarm.

### FREQUENCY-CORRECTION UNIT

A frequency-correction unit can be employed and is placed between the incoming bearer circuit and the receive section of the line unit. The unit corrects for any frequency shift on the channels and the pilot signal caused by the bearer. The correction function is controlled by the error on the incoming nominal 300 Hz or 3300 Hz pilot signal. Since frequency shift on bearers is not usually a problem, this unit is fitted only when required.

The signal from the bearer circuit is filtered and then modulated by a locally-generated 9900 Hz carrier (see Fig. 9). The modulated signals are then filtered to obtain the upper sideband, before being further modulated by a carrier of  $9900 + \Delta$  Hz where  $\Delta$  Hz is the error frequency. The lower sideband of the second stage of modulation, when filtered, leaves the corrected signal ready for processing by the line unit.

The  $9900 + \Delta$  Hz signal is obtained by filtering the input signal to obtain the  $3300 + \Delta$  Hz pilot and modulating by a locally-generated 6600 Hz carrier.

For 300 Hz pilot working, the  $300 + \Delta$  Hz pilot is selected and modulated by a 3000 Hz carrier to obtain  $3300 + \Delta$  Hz signal, which is processed as described above. This derived  $3300 + \Delta$  Hz signal, having been corrected, can then be processed in the line unit as if it were a 3300 Hz pilot signal.

As a result of the above processes, input frequency errors of up to  $\pm 10$  Hz can be corrected to within  $\pm 0.33$  Hz of nominal.

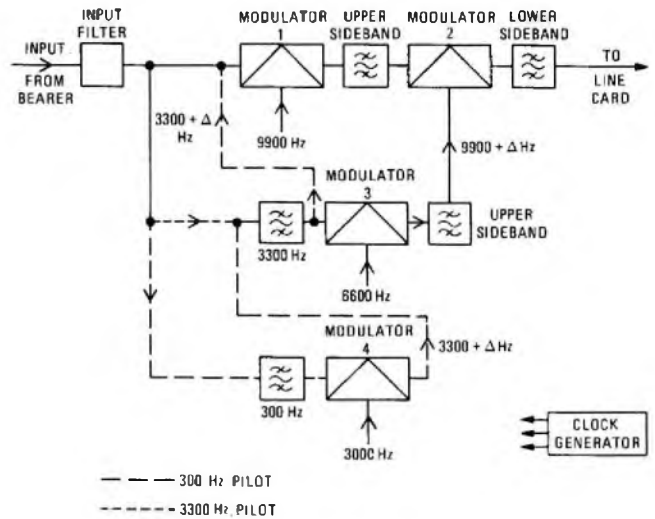

FIG. 9—Block diagram of the GEC Telecommunications Ltd. frequency correction unit

### BEARER SIGNAL-LEVEL REDUCTION

By the early 1970s, the growth of telegraph and other non-speech services on the high-frequency network had reached the stage where the power-loading restrictions were causing planning difficulties. There was less audio plant available and the much higher mean transmit level of VFT equipment at  $-8.7$  dBmO, compared with the mean power level of a speech circuit at  $-15$  dBmO was restricting the number of VFT bearers on high-frequency systems to one main and one reserve bearer per supergroup.

Following extensive field trials, the recommended transmit level was reduced to  $-13$  dBmO†. This eased the problem to the extent that service considerations dictated the planning limits rather than the power loading. The limit was increased to 20 main and 20 reserve bearers per supergroup, with an overriding maximum of 6 main and 6 reserve bearers per group. At the same time, new standards were introduced for the bearer-circuit performance, which were applied not only to new circuits but also to all existing inland and some international circuits.

### CONCLUSION

With the widespread availability of low-cost digital integrated circuits, it became possible to develop a new generation of FSVFT equipment in which much of the signal processing formerly performed by analogue circuitry could be performed by digital means. At the same time, the opportunity was taken to introduce extra bearer-performance monitoring facilities.

However, this new generation FSVFT equipment is itself being superseded by time-division multiplex (TDM) equipment in many applications and TDM equipment designed for use on BPO Telex customers' lines has already been described in this *Journal*<sup>2</sup>. International standards have now been agreed by the CCITT for 2 types of telegraph TDM equipment and these will be described in a later article.

### ACKNOWLEDGEMENTS

The author wishes to thank Pye-TMC Ltd. and GEC Telecommunications Ltd. for their permission to publish the design information contained in this article, parts of which are covered by patents.

### References

- SALLIS, R. T. G. A Multi-Channel Voice-Frequency Telegraph System Using Transistors. *POEEJ*, Vol. 57, p. 95, July 1964.
- SKINGLE, G. D. Time-Division Multiplex for Telex Customers' Lines. *POEEJ*, Vol. 68, p. 84, July 1975.

† dBmO—indicates the actual level measured at, or referred to, a point of zero relative level.

# Telecommunications Museum in the South-Eastern Telecommunications Region

J. M. SMITH†

A party of 50 members of the Institution, Associate Section members and guests attended the opening of the South-Eastern Telecommunications Region (SETR) Museum on Monday 5 March 1979.

The Director, SETR, Mr. A. J. Barker, in opening the museum, said that, as a result of rapid developments in the field of technology, many items of historic interest had been withdrawn from service during the past 15 years or so. Many people who had been involved in the business over the years were anxious to see that those items still in existence are located and preserved before they are scrapped and lost forever. Mr. Barker welcomed Mr. Rose, who was representing the Brighton and Hove Engineerium, a local museum which houses and preserves beam engines and industrial items, and said that they hoped a close liaison would develop between the two projects.

The new museum was named the *John Morgan Room* in recognition of the previous Chairman of the South Eastern Centre of the IPOEE, and recently-retired Planning Controller, SETR, who had encouraged and helped to bring the museum project into being and was present at its opening.

The museum accommodation at 14 Bavant Road, Preston, Brighton, housed a Siemens No. 16 Automatic Exchange from 1927 until 1970. Since then, the building had been used as a Regional Data Repair Workshop and Test Equipment Design Centre. Due to expansion, these have needed larger premises, thus leaving space for the new museum, which opened with 174 items, dating from the late nineteenth century to the present time, exhibited in specially-designed display cabinets.

The curator is Mr. E. Hall, Assistant Executive Engineer in charge of the Test Equipment Design Centre, who may be contacted on Brighton 500766 (STD 0273) for further details of the museum.

† South-Eastern Telecommunications Region

## Book Reviews

*Trends in Communication Satellites*. Edited by D. J. Curtin, Pergamon Press Ltd. vi + 342 pp. 169 ills. £40.00.

This book has been produced by inviting specialists from organizations involved in satellite communications to supply articles on various topics which have then been assembled to form a book. The method of reproduction makes economies by using the contributors' original texts for the tables and diagrams, but this does not detract unduly from the convenience in reading the book.

Most of the articles simply describe particular communication satellites and there are only four articles which have a more general coverage. The satellites described in detail, each with its own chapter, are INTELSAT V, Hughes Aircraft Corporation domestic satellites, the RCA domestic satellite, the MARISAT system, the NASA Applications Technology satellites, the Symphonic satellite, the Canadian Technology Satellite (2 articles), the Italian Sirio satellite, the European OTS satellite and the Japanese Broadcasting Satellite. Because all of these articles are written by engineers who are intimately involved in the satellite programmes concerned, they contain comprehensive and authoritative accounts, many of them going into considerable detail of the satellite design. Some of the authors make an attempt to go beyond a description of the satellites themselves and give the background to the technical choices adopted and an account of the system into which the satellite is intended to fit. The article on the Hughes domestic satellites is probably the most successful in this respect.

Of the four remaining articles, one serves as introduction and historical background and includes some theory which is so basic as to be quite out of key with the rest of the book. The second article is supposed to give an account of the in-orbit experience with the INTELSAT system, but spends the first 15 of its 20 pages giving a necessary description of the satellites themselves. Another article attempts to cover economic aspects but succeeds only in presenting financial data pertaining to some existing systems and one example of an economic optimization study. The last of these four articles describes future trends in communication satellite technology and is a

useful forward projection of techniques in launching, satellite design, signal processing, overall system trends and orbit utilization.

The problem with any book on satellite communications is that the material becomes so rapidly dated. The comment applies particularly to this book, which is mainly describing current satellite designs rather than fundamentals. In fact, probably half its useful life has passed in the 2 years or more between the submission date of its articles and the publication date of the book. It may be of some value to professional workers in the field as a compendium of the design features of the principal operational and experimental communication satellites of the 1970s. However, it would be only the very keen non-specialist who would plough through the 11 chapters giving detailed descriptions of satellites and systems—it is not exactly bedtime reading.

A. K. JEFFERIS

*Telecommunications Switching Principles*. M. T. Hills. George Allen & Unwin. xii + 327 pp. 171 ills. £11.95.

In this book, which is based on courses given at post graduate level in the University of Essex, the author describes the basic elements of exchange design with the aim of developing a coherent set of principles. The topics covered include switching and signalling techniques, the economics of design, traffic theory, network organization, the design of switching networks and control units, and circuit techniques. Several practical switching systems are briefly reviewed. With this breadth of subject matter the treatment throughout is inevitably superficial and the importance of digital systems is not reflected in the one brief chapter devoted to the subject. Although not a handbook for practising designers, and falling some way short of the author's ambitious objective, the book provides a wide ranging introduction to exchange design. It will be valuable to newcomers to the switching field, especially if full use is made of the extensive references provided.

T. E. LONGDEN

# Institution of Post Office Electrical Engineers

General Secretary: Mr. R. Farr, THQ/NP9.5.4, Room S 04, River Plate House, Finsbury Circus, London EC2M 7LY; Tel: 01-432 1954

## ASSOCIATE SECTION PAPER AWARDS 1977-78

Although the Institution offers prizes for the best papers presented by members of the Associate Section each session, no papers were submitted for the 1977-78 session awards.

## THE FEDERATION OF TELECOMMUNICATIONS ENGINEERS OF THE EUROPEAN COMMUNITY (FITCE)

Since the last report, almost 3000 members have responded to my letter, including over 500 who were not asked to vote; for example, Assistant Executive Engineers. Some 300 members indicated a definite wish to join FITCE and a further 1250 wanted more details before committing themselves; less than 600 members indicated that they were not interested. A meeting with the President and Secretary-General of FITCE has established that final approval to the IPOEE terms of entry must await a vote at the General Assembly in September or October 1980. No other country has FITCE members without a university or equivalent (professional institution) qualification, hence it has been found necessary to modify our proposals by the inclusion of a "cut-off" date, beyond which any IPOEE members wishing to join FITCE would also need to be fully qualified. Our proposals have also been extended to include members below Executive Engineer level and affiliated members who have the requisite qualifications. A period of negotiation now follows, meanwhile Local Centre Secretaries will be kept fully informed of progress.

## ESSAY COMPETITION 1979-80

To further interest in the performance of telecommunications engineering work and to encourage the expression of thought given to day-to-day engineering activities, the Council of the Institution offers cash prizes totalling £100 and up to 5 certificates of merit in each of the following categories:

**SECTION 1.** The most meritorious essays submitted by members of the Institution in BPO grades below the Senior Salary Structure and above the grades in Section 2, and including BPO engineering staff of the rank of Inspector.

**SECTION 2.** The most meritorious essays submitted by BPO engineering staff below the rank of Inspector.

The Council reserves the right to limit the amount of prizes and numbers of certificates awarded if, in its opinion, the essays submitted do not attain a sufficiently high standard.

In judging the merits of an essay, consideration will be given to clarity of expression, the correct use of words and to presentation and neatness. Although technical accuracy is important, a high technical standard is not essential. Marks will be awarded for originality.

Competitors may choose any subject relevant to engineering activities in the BPO. Manuscript entries are acceptable. A4 size paper should be used and the essay should contain 2000-5000 words. A 25 mm margin should be ruled on the left-hand side of each page for marking purposes. Competitors are required to certify their entry, at the end of the essay, in the following terms:

*"In forwarding the foregoing essay of . . . . . words, I certify that the work is my own unaided effort, both in regard to composition and drawing.*

Name (block capitals) . . . . .  
Grade . . . . .  
Signature . . . . .  
Official Address . . . . ."

The essays must reach

The Secretary,  
The Institution of Post Office Electrical Engineers,  
2-12 Gresham Street,  
London EC2V 7AG  
by 15 January 1980.

Prospective competitors may wish to note that awards of prizes and certificates are entered on the staff records of recipients, and that copies of prize-winning essays are retained in the central library of the Institution.

## MEETING OF LOCAL-CENTRE SECRETARIES

Local-centre secretaries meet annually under the chairmanship of the General Secretary, together with other members of the Secretariat, the Librarian and the Managing Editor of this *Journal*, to discuss organizational and other problems. This year's meeting was held at the Technical Training College, Stone on 4-5 July. A wide range of topics was discussed and the Chairman thanked all local-centre secretaries on behalf of Council for their continuing work for the Institution.

## CONSTITUTION OF THE COUNCIL 1979-80

Council for 1979-80 is constituted as follows:

- Mr. J. F. P. Thomas, Chairman
- Mr. D. Wray, Vice-Chairman
- Mr. C. E. Clinch, Vice-Chairman
- Mr. A. V. Knight, Honorary Treasurer
- Mr. A. G. Leighton, representing Group 1 (members in the Headquarters Departments and the London Regions holding posts in bands 1-8 of the Senior Salary Structure).
- Mr. W. N. Lang, representing Group 2 (members in the provincial Regions holding posts in bands 3-8 of the Senior Salary Structure).
- Mr. R. D. Edwards, representing Group 3 (members in the Headquarters Departments (London) holding posts in bands 9-10 of the Senior Salary Structure).
- Mr. F. K. Marshall, representing Group 4 (members in the London Regions holding posts in bands 9-10 of the Senior Salary Structure).
- Mr. D. G. Rossiter, representing Group 5 (members in the provincial Regions and in Headquarters Departments (provinces) holding posts in bands 9-10 of the Senior Salary Structure).
- Mr. J. M. Avis, representing Group 6 (members in the Headquarters Departments (London) listed in Rule 5(a), with the exception of those in Group 14).
- Mr. J. W. Turnbull, representing Group 7 (members in the London Regions listed in Rule 5(a), with the exception of those in Group 14).
- Mr. L. W. F. Vranich, representing Group 8 (members in the provincial Regions and in Headquarters Departments (provinces) listed in Rule 5(a), with the exception of those in Group 15).
- Mr. M. E. Barnes, representing Group 9 (members in the Headquarters Departments (London) listed in Rule 5(b), with the exception of those in Group 14).
- Mr. J. D. Overall, representing Group 10 (members in the London Regions listed in Rule 5(b), with the exception of those in Group 14).
- Mr. D. F. Ashmore, representing Group 11 (members in the provincial Regions and in Headquarters Departments (provinces) listed in Rule 5(b), with the exception of those in Group 15).

Mr. C. Stanger, representing Group 12 (Inspectors in the London Regions).

Mr. G. A. Gallagher, representing Group 13 (Inspectors in the provincial Regions).

Mr. R. O. G. Clarke, representing Group 14 (Draughtsmen, Illustrators and above, but below the Senior Salary Structure, in Headquarters Departments (London) and London Regions).

Mr. K. Chinner, representing Group 15 (Draughtsmen, Illustrators and above, but below the Senior Salary Structure in provincial Regions and Headquarters Departments (provinces)).

Mr. P. M. Annett, representing Group 16 (all affiliated members).

Representation for Groups 2, 10 and 11 was contested. The unsuccessful candidates, in descending order of votes cast where appropriate, were:

Group 2 Mr. Ness, Mr. Godfrey.

Group 10 Mr. Jewitt.

Group 11 Mr. Larkin, Mr. Sharman, Mr. Cholerton.

## CENTRE PROGRAMMES 1979-80

### Eastern (Colchester)

Meetings will be held at the University of Essex commencing at 14.00 hours unless otherwise stated.

17 October: *Generating Electricity from Solar Energy* by P. Howell. To be held at the Youth House Lecture Hall, South-end.

14 November: *U.F.O.s—The Mysteries that Refuse to go Away* by A. Watts.

5 December: *International Telecommunications Union—Worldwide Communications* by Prof. K. W. Cattermole.

16 January: *System X—Local Exchanges* by G. Oliver.

13 February: *Tariff Policies Within the Telecommunications Business* by G. J. Jones.

19 March: *Research—The Door to Tomorrow?* by C. A. May. This is a joint meeting with the Bletchley Centre and will be held at 14.00 hours in the Guildhall, Cambridge.

23 April: *Time for Network Planning* by J. W. Young.

### Martlesham Heath

17 October: *Life in the London Telecommunications Region* by K. H. Ford.

31 October: *Devices for Optical Communications* by I. Garrett

14 November: *Prestel: Progress and Prospects* by A. A. L. Reid.

12 December: *Introduction of Digital Transmission into the UK Network* by J. F. Boag.

16 January: *Recent Developments in European Data Networks* by P. T. F. Kelly.

13 February: *Software Development for Microprocessors* by K. F. Clements and others.

12 March: *Submarine Cable Systems* by S. A. Taylor.

16 April: *Future Satellite Communication Systems* by E. C. Johnston.

7 May: *System X: How the Project is Managed—and the Latest Developments* by W. G. T. Jones and P. J. Burville.

### Stone/Stoke

Meetings will be held at the Staffordshire Fire Brigade, Bethesda Street, Hanley, Stoke-on-Trent, or at the Post Office Technical Training College (POTTC), Stone at 13.45 hours with the exception of the Joint meetings on 10 December and 21 February which will commence at 19.00 hours, with tea at 18.30 hours.

15 October (Stoke): *The Importance and Influence of Engineers in General Management* by A. P. Parsons.

12 November (Stone): *The European Satellite* by J. D. Golding.

10 December (Stoke): *Radio Paging* by N. W. Brown.

10 December (Stone): *Computer-Aided Design* by Dr. R. E. Massara (Joint meeting with the Institution of Electrical Engineers and the Institution of Electronic and Radio Engineers).

14 January (Stone): *Total Energy* by N. G. Johnson and P. W. Faulkner.

11 February (Stone): *Industrial Robots and Their Future* by D. C. Hall.

21 February (Stone): *Semiconductor Sources in Optical-Fibre Transmission* by Dr. D. H. Newman (Joint meeting with the Institution of Electrical Engineers and the Institution of Electronic and Radio Engineers).

11 March (Stoke): *Environmental Aspects of Telecommunications Buildings* by E. V. Pearce.

## Wales and the Marches

### South Wales Area

Meetings will be held at the venues shown commencing at 14.00 hours.

17 October (University College, Swansea): *'Blow Me, I've Tripped'* by R. L. Howie.

14 November (Pontypridd Polytechnic): *Technology in the Modernization of Mail Handling* by C. E. Clinch.

12 December (University College, Swansea): *The Microprocessor—A Look at Its Origins, Potential and Social Impact* by D. Hornsby.

16 January (Pontypridd Polytechnic): *CDSSI—A New Digital PABX System for the Post Office Rental Range* by R. C. Gibbs.

13 February (University College, Swansea): *Generating Electricity from Solar Energy* by P. Howell.

12 March (Pontypridd Polytechnic): *Madley Earth Station* by A. G. Reed.

16 April (Lord Hill Hotel, Shrewsbury) *Overseas Liaison and Consultancy* by J. F. P. Thomas (Combined centre annual meeting followed by the annual dinner).

### Shrewsbury Sub-Centre

Unless otherwise stated, meetings will be held at Shrewsbury Technical College commencing at 14.00 hours.

17 October: *Nuclear Power* by C. Freezer.

14 November: *Generating Electricity from Solar Energy* by P. Howell.

16 January: *Method of Introduction of Digital Operation in the Local Network* by J. M. Griffiths.

19 March (at Chester Technical College): *The Microprocessor—A Look at Its Origins, Potential and Social Impact* by D. Hornsby (combined meeting with Chester Sub-Centre).

16 April (Lord Hill Hotel, Shrewsbury): *Overseas Liaison and Consultancy* by J. F. P. Thomas (combined centre annual meeting followed by the annual dinner).

## IPOEE CENTRAL LIBRARY

The following books have been added to the IPOEE Library since the publication of the 1974 Library Catalogue. Any member who does not have a copy of the catalogue can obtain one on loan from the Librarian, IPOEE, 2-12 Gresham Street, London EC2V 7AG. Library requisition forms are also available from the Librarian, from honorary local secretaries, and from Associate Section local-centre secretaries and representatives.

5277 *Fundamentals of Electric Circuits*. D. A. Bell (U.S.A., 1978).

This book is a basic introduction to AC and DC circuits clearly presented in an easy-to-read form.

5278 *How to Buy Solar Heating . . . Without getting Burnt!* M. Wells and I. Spetgang (U.S.A., 1978).

This is a lively, well-illustrated guide to house insulation and solar heating. Although written for an American readership, it is still packed with useful and relevant information.

5279 *The Sports Car*. C. Campbell (1978)

This is the fourth edition of this standard work on sports car design and performance.

5280 *The Building Regulations Explained and Illustrated*. W. S. Whyte and V. Powell-Smith (1978).

This book is a straightforward guide to the complex subject of building regulations. This edition incorporates the consolidated 1976 regulations and also the effects of Part III of the Health and Safety at Work Act, 1974.

5281 *Microelectronics*. Scientific American (U.S.A., 1977).

This a reprint, in book form, of the much sought-after September 1977 issue of the magazine Scientific American. It is a good basic summary of the development, production and applications of silicon chips and associated microcircuitry.

5282 *Digital Processing of Speech Signals*. L. R. Rabiner and R. W. Schafer (U.S.A., 1978).

This is a comprehensive introduction to this increasingly important field.

5283 *Radio and Television Servicing, 1977-78 Models*. R. N. Wainwright (1978).

The 1977-78 edition of this series features plans and servicing information for all new and modified models introduced.

5384 *Ravensbourne Guide to Do-It-Yourself Central Heating*. Ravensbourne Heating Limited (1979).

This is a commercial guide to do-it-yourself central heating which is more explanatory than many books written on the subject.

R. CROSS  
Librarian

### Local-Centre Secretaries

The following is a list of local-centre secretaries, to whom enquiries about the Institution should be addressed. It would be helpful if members would notify any change in their own address to the appropriate secretary.

Centre	Local Secretary	Address and Telephone Number
Birmingham	Mr. D. F. Ashmore	General Manager's Office, ED3.7, 84 Newhall Street, Birmingham B3 1EA 021-262 4831
Eastern (Bletchley)	Mr. D. R. Norman	General Manager's Office, ED9.3, Telephone House, 25-27 St. John's Street, Bedford MK42 0BA (0234) 55860
Eastern (Colchester)	Mr. P. M. Cholerton	Eastern Telecommunications Region, PLG1.3.3, St. Peter's House, St. Peter's Street, Colchester CO1 1ET (0260) 89458
East Midlands	Mr. D. W. Sharman	General Manager's Office, ES3.3, 200 Charles Street, Leicester LE1 1BB (0533) 534409
London	Mr. M. S. Armitage	London Telecommunications Region Special Studies, 11th floor, Keybridge House, 80 South Lambeth Road, London SW8 1RG 01-622 9736
Martlesham	Mr. A. F. Hare	PO Research Centre, ResD/R2.1.2, Martlesham Heath, Ipswich IP5 7RE (0473) 643487
North Eastern	Mr. D. Spencer	North East Telecommunications Region, S133, Darley House, 79 St. Paul's Street, Leeds LS1 4LW (0532) 37529
Northern	Mr. L. G. P. Farmer	General Manager's Office, U1 28, Swan House, Pilgrim Street, Newcastle-upon-Tyne NE1 1BA (0632) 27212
Northern Ireland	Mr. W. H. Tolerton	General Manager's Office, EC1, Dial House, 3 Upper Queen Street, Belfast BT1 6LS (0232) 24777
North Western (Manchester and Liverpool)	Mr. W. Edwards	North West Telecommunications Board, PLG 112, Bridgewater House, 6 Whitworth Street, Manchester M60 1DP 061-863 7267
North Western (Preston)	Mr. R. L. Osborn	General Manager's Office, PS, Telephone House, Fenton Street, Lancaster LA1 1BA (0524) 88400
Scotland East	Mr. S. Walker	Scottish Telecommunications Board Headquarters, P312, Canning House, 19 Canning Street, Edinburgh EH3 8TH 031-222-2361
Scotland West	Mr. G. A. Dobbie	General Manager's Office, EX14, India House, 6-10 India Street, Glasgow G2 4PU 041-220 2697
South Eastern	Mr. J. M. Smith	South East Telecommunications Region, PL/LT1.2, 52 Churchill Square, Brighton BN1 2ER (0273) 201318
South Western	Mr. D. P. Cook	South Western Telecommunications Board Headquarters, SV2.3.1. Mercury House, Bond Street, Bristol BS1 3TD (0272) 295578
Stone/Stoke	Mr. J. Coulson	Post Office Technical Training College, TP7.2.9B, Stone ST15 0NQ (078 583) 3671 Extn. 571
Wales and the Marches	Mr. D. A. Randles	Wales and the Marches Telecommunications Board, W3.1.22, 25 Pendwyallt Road, Coryton, Cardiff CF4 7YR (0222) 391370

## Notes and Comments

### INCREASE IN THE PRICE OF THE POEEJ

The Board of Editors regrets that the price of the *Journal* will increase from the January 1980 issue. The new price will be 70p (£1.05 including postage and packaging); annual subscription: £4.20 (including postage and packaging) (Canada and USA \$10.00). The special price to BPO employees will be 48p per copy. The increase in price has been necessitated by continued increases in the costs of printing and paper. All possible economies are looked at very carefully, but it would

not be possible to maintain the present price without serious loss of quality, which we are sure readers would not want.

Members of the Institution of Post Office Electrical Engineers will not, for the present, have their subscriptions increased above the level applicable at October 1979.

### CONTRIBUTIONS TO THE JOURNAL

Contributions to the *POEEJ* are always welcome. In particular,

the Board of Editors would like to reaffirm its desire to continue to receive contributions from Regions and Areas, and from those Headquarters departments that are traditionally modest about their work.

Anyone who feels that he or she could contribute an article (short or long) of technical, managerial or general interest to engineers in the Post Office is invited to contact the Managing Editor at the address given below. The editors will always be pleased to give advice and try to arrange for help with the preparation of an article, if needed.

## PUBLICATION OF CORRESPONDENCE

The Board of Editors would like to publish correspondence on engineering, technical or other aspects of articles published in the *Journal*, or on related topics. Letters of sufficient interest will be published under Notes and Comments.

Letters intended for publication should be sent to the Managing Editor, *The Post Office Electrical Engineers' Journal*, NP 10.1.4, Room S 08, River Plate House, Finsbury Circus, London EC2M 7LY.

# The Associate Section National Committee Report

## ANNUAL CONFERENCE 1979

The Annual Conference for 1979 took place at the Technical Training College, Stone, on Saturday 19 May, with most regions represented, plus two observers. The National Executive Committee for 1979-80 consists of the following officers.

*Chairman:* B. W. Headley.

*Vice-Chairman:* E. W. H. Philcox.

*Secretary:* M. E. Dibden.

*Assistant Secretary:* R. V. Parton.

*Treasurer:* C. J. Webb.

*Editor:* B. Harlow.

*Quiz Organizer:* M. Haynes.

*Projects Organizer/Visits Secretary:* J. J. F. Anning.

## AMATEUR RADIO STATIONS

The Secretary has sent a letter, via delegates and officers, to all centres in the United Kingdom asking for information about amateur radio stations within the Associate Section.

It is proposed that an article on this subject be prepared for publication in a later issue of this *Journal*, and therefore the secretary is hoping for a big response to the request. The sort of information required is:

(a) location of radio station/club,

(b) station call sign,

(c) mode of operation; for example, HF bands, VHF, RTTY, Facsimile, Slow Scan TV, and

(d) primary interests; for example, general QSO's, propagation studies, equipment design and construction, field days, etc.

## NATIONAL NEWS SHEET

May I on behalf of the National Committee Editor appeal for more articles for the News Sheet as the magazine is largely dependent on articles that are received from regional reporters. To quote the Editor, the News Sheet is the shop window of the National Committee and the Associate Section, so be proud of it and display it to the full effect.

If you have a useful article please contact Bryon Harlow (0742) 732787.

## NATIONAL TECHNICAL QUIZ 1979-80

The dates for the rounds of the 1979-80 Technical Quiz are as follows:

First round to be played by 28 November 1979.

Second round to be played by 15 February 1980.

Third round to be played by 7 March 1980.

Final to be played at the Institution of Electrical Engineers, London on 25 April 1980.

## THE COTSWOLD TROPHY

Some guide-lines agreed at the Annual Conference for future Cotswold Trophy Competitions are:

(a) The Trophy shall be presented on an annual basis to that Region Board Centre deemed to have best furthered the aims and interests of the Associate Section of the Institution.

(b) The Centres entering for the trophy shall be affiliated to the National Committee.

(c) Entries to be with the National Committee Secretary by 31 January.

(d) The judging panel will consist of the National Executive Committee and the President.

(e) The winning entrant will be presented with the trophy at the National Technical Quiz Final following the closing date.

## PROJECT COMPETITION

In future the Project Competition will be of the following format: centres are invited to enter any project completed by their members, the project will be judged on its merits within the aims and interests of the Institution and the winning entry will be awarded the E. W. Fudge Trophy.

## ASSOCIATE SECTION DIARY

All centres have been sent a letter about an Associate Section Diary in which they were asked to give an estimate of the number they would require for 1980. On the strength of this, the Treasurer has ordered 3 000 copies initially, any centre that has not ordered yet and would like to do so should contact the Treasurer, C. J. Webb (0409) 253687.

M. E. DIBDEN  
*Secretary*

# Associate Section Notes

## AYR CENTRE

The activities of the 1978/79 session started with a visiting speaker from the National Trust for Scotland who delivered a lecture with particular emphasis on the restoration of Culzean Castle.

At the following meeting, Mr. Murray, head of the area maintenance division, gave an engrossing history of under-

ground maintenance activities and, suitably assisted by Messrs McFarlane and Love, he displayed samples of cable and various items of test equipment.

The final meeting of the session was an evening to be remembered, when 6 films, supplied by Scottish Telecommunications Board Headquarters, Public Relations Office, were presented. This proved to be a suitable finale to an interesting year of activities.

R. GLEN

## DUNDEE CENTRE

November saw the reintroduction of the day visit when 20 members visited Chryslers Linwood car plant in the morning and Buchanan's bottling plant in the afternoon. The morning's frenzied activities were smoothly compensated by the relaxing atmosphere of the afternoon.

Mr. N. J. Vanner of Telecommunication Headquarters braved the Scottish winter to come and lecture on System X. This was an unusual exercise, put in motion by the Scottish Regional Committee, as all Centres participated. The lecture was given in three Centres: Perth (for Dundee, Aberdeen and Edinburgh centres), Inverness and Glasgow. The Dundee Centre, who hosted the first meeting, would like to thank all those who attended, for making an interesting lecture a success.

Local centre members' talks started the year for us. A. J. Millar of Cupar told us about *Mountain Rescue*, and J. C. Howe of Montrose spoke on *Hang-gliding*—one of the reasons for mountain rescue.

G. K. DUNCAN

## EXETER CENTRE

If the success of a Centre's programme can be determined by higher than average attendance at meetings, then Exeter had an excellent winter session in 1978-79. The largest audiences were for the obviously popular lectures; for example, *Wildlife Behind the Camera* by Maurice Tibble and *All You Will Ever Know About Micro-processors* by Don Greig. However, those who braved the winter's elements in February to attend *An American Evening*, though few in number, were greatly entertained by three of our members presenting their various observations on living and touring in that vast country.

The Centre's summer programme included a round of the Regional Quiz versus Swindon; the Exeter team winning by an extremely narrow margin. The winners will now go on to play Southampton in the Semi-Final. In July a family outing to the Pumping Station at Crofton, Wilts, was arranged; the visit included a two-hour trip on the Kennett and Avon Canal. The venue of later visits will be announced, as will the winter programme, when plans are completed.

MRS. G. J. HARDING

## GLOUCESTER CENTRE

The winter series of meetings began with a talk and films on the activities of the Royal National Lifeboat Institution which, apart from helping to increase our admiration for these brave volunteers, also helped to swell their funds by member's donations. We were fortunate enough to win through to the Regional final of the National Technical Quiz, beating Bath, and also Swindon in close contests. The Regional final against Plymouth was held at Exeter, but Gloucester lost to our friends from the south-west in a closely fought contest.

Another very popular quiz is the annual general-knowledge contest held between Bristol, Cardiff, Newport and Gloucester, now known as the *Four Rivers Quiz*. This year the hosts were Cardiff and, as now seems a regular occurrence, Gloucester came third!

Three visits have already taken place this year, one to the Kodak photographic factory which proved very interesting but not too well attended. The visit to Bagworth Colliery again proved very popular, although a restriction of 15 was placed on the number of members able to see the coal face and mine workings. On 10 May 1979, a party of 20 members visited BBC Broadcasting House at Cardiff during the morning and Sony UK at Bridgend in the afternoon. We were privileged to see several programmes being made including a new opera to be transmitted sometime in the future. It came as somewhat of a surprise to learn that the orchestra was situated at Broadcasting House, but the opera itself was recorded simultaneously at a theatre some five miles away, the two venues being linked by BPO landlines. Following lunch at the BBC canteen, we were treated to an extensive tour of the Sony colour television factory. We were extremely impressed at the lengths to which the company go to ensure perfect quality of their products—perhaps an example of the legendary Japanese efficiency.

At the Annual General Meeting on 26 April, the President, Chairman, Secretary, Treasurer and Visits Secretary were re-elected en bloc, although two new members were elected on to the Committee.

J. R. SMITH

## Forthcoming Conferences

Further details can be obtained from the conference department of the organizing body.

*Institution of Mechanical Engineers*, 1 Birdcage Walk, London SW1H 9JJ. Telephone: 01-839 1211

### International Progress in Postal Mechanization

6-8 November 1979

The Institution of Mechanical Engineers, London

*Institution of Electrical Engineers*, Savoy Place, London WC2R 0BL. Telephone: 01-240 1871

### Submarine Telecommunications Systems

26-29 February 1980

The Institution of Electrical Engineers, London

### Communications 80: Communications Equipment and Systems

15-18 April 1980

National Exhibition Centre, Birmingham

*Secretariat 1980 International Zurich Seminar*, Miss D. Hugg, Dept. ENF, BBC Brown, Boveri and Co. Ltd., CH-5401 Baden, Switzerland. Telephone: +41-56-299038.

### International Zurich Seminar on Digital Communications (Digital Transmission in Wireless Systems)

4-6 March 1980

Swiss Federal Institute of Technology



## POEEJ: SUBSCRIPTION ORDER FORM

Those wishing to subscribe to *The Post Office Electrical Engineers' Journal* can do so by completing the relevant section of the order form below. British Post Office (BPO) staff should complete the upper section and send it to their local *POEEJ* agent or, in case of doubt, to the address shown; non-BPO staff should complete the lower section. A photocopy of this form is acceptable.

### SUBSCRIPTION ORDER (BPO STAFF)

To: The Local Agent (*POEEJ*), or  
*The Post Office Electrical Engineers' Journal* (Sales),  
2-12 Gresham Street, London EC2V 7AG.

**The Post Office Electrical Engineers' Journal:**  
**Authority for Deduction from Pay**

Please arrange for me to receive *The Post Office Electrical Engineers' Journal*. I have completed the form opposite authorizing deductions from pay to cover the special annual subscription of £1.44.

Date ..... Signature .....

Name and initials (in block capitals) ..... Rank .....

Official address .....

.....

.....

I, .....  
(name in full, surname first in block capitals), authorize the deduction from my salary or wages, until further notice, of the sum of 12p per month/3p per week for 48 weeks for payment to the Managing Editor, *The Post Office Electrical Engineers' Journal*, on my behalf.

Date ..... Signature .....

Official address .....

.....

Rank ..... Pay No. ....

Area/Dept. ....

### YEARLY SUBSCRIPTION ORDER (NON-BPO STAFF)

To: *The Post Office Electrical Engineers' Journal* (Sales),  
2-12 Gresham Street, London EC2V 7AG.

Please supply 4 quarterly issues of *The Post Office Electrical Engineers' Journal*. I enclose a cheque/postal order for the sum of £3.20 (Canada and the USA: \$6.50) to cover the yearly subscription.

(Cheques and postal orders, payable to "*The POEE Journal*", should be crossed "& Co." and enclosed with the order. Cash should not be sent through the post.)

Name .....

Address .....

.....

.....

Please state with which issue you wish your subscription to commence (April, July, October or January) .....

# The Post Office Electrical Engineers' Journal

## Copyright

The entire contents of this *Journal* are covered by general copyright, and special permission is necessary for reprinting long extracts, but editors are welcome to use not more than one-third of any article, provided that credit is given at the beginning or end, thus: "From *The Post Office Electrical Engineers' Journal*".

The Board of Editors is not responsible for the statements made nor the opinions expressed in any of the articles or correspondence in this *Journal*, unless any such statement is made specifically by the Board.

## Subscriptions and Back Numbers

The *Journal* is published quarterly in April, July, October and January, at 55p per copy (80p per copy including postage and packaging); annual subscription: £3.20; Canada and the USA: \$6.50.

The price to British Post Office staff is 36p per copy. Back numbers will be supplied if available, price 55p (80p including postage and packaging). At present, copies are available of all issues from April 1974 to date with the exception of the April and October 1975 issues; copies of the July 1970 and April and October 1973 issues are also still available.

Orders, by post only, should be addressed to *The Post Office Electrical Engineers' Journal*, 2-12 Gresham Street, London EC2V 7AG.

Employees of the British Post Office can obtain the *Journal* through local agents.

## Binding

Readers can have their copies bound at a cost of £5.25, including return postage, by sending the complete set of parts, with a remittance, to Press Binders Ltd., 4 Hiffe Yard, London SE17 3QA.

## Remittances

Remittances for all items (except binding) should be made payable to "*The POEE Journal*" and should be crossed "& Co."

## Advertisements

All enquiries relating to advertisement space reservations should be addressed to The Advertising Manager, *Post Office Electrical Engineers' Journal*, Kemps Publications Ltd., Federation House, 2309 Coventry Road, Sheldon, Birmingham, B26 3PG, (Telephone: 021-742 4471).

Advertisement copy should be addressed to the Managing Editor, *The Post Office Electrical Engineers' Journal*, NP 10.1.4, Room S 08, River Plate House, Finsbury Circus, London EC2M 7LY.

## Distribution and Sales

Correspondence relating to the distribution and sale of the *Journal* should be addressed to *The Post Office Electrical Engineers' Journal* (Sales), 2-12 Gresham Street, London EC2V 7AG.

## Communications

With the exceptions indicated above, all communications should be addressed to the Managing Editor, *The Post Office Electrical Engineers' Journal*, NP 10.1.4, Room S 08, River Plate House, Finsbury Circus, London EC2M 7LY (telephone 01-432 4840).

## Model-Answer Books

Books of model answers to certain of the City and Guilds of London Institute examinations in telecommunications are published by the Board of Editors. Copies of the syllabi and question papers are not sold by *The Post Office Electrical Engineers' Journal*, but may be purchased from the Department of Technology, City and Guilds of London Institute, 76 Portland Place, London W1N 4AA.

## INDEX TO ADVERTISERS

### Advertisements

Communications, advertisement copy, etc., should be addressed as shown on p. 202.

*No responsibility is accepted by the Journal for any of the private or trade advertisements included in this publication.*

E.I.C. Electronics Ltd. . . . .	5	Mullard Ltd. . . . .	1
GEC Telecommunications Ltd. . . . .	7	North London Polytechnic . . . . .	5
Herman Smith Ltd. . . . .	6	R.F. Components Ltd. . . . .	5
Interscan Ltd. . . . .	4	Thorn Ericsson . . . . .	3
M-O Valve Co. Ltd. (GEC) . . . . .	2		

### Relays & Switches

2—30 way  
XY Matrix  
0—18 GHz

Remote  
or  
Manual

### R. F. COMPONENTS

*Trading as*

**HERCOAX LTD.,  
PLUMPTON HOUSE,  
PLUMPTON ROAD,  
HODDESDON,  
HERTS, EN11 0EB  
ENGLAND**

Tel: HODDESDON 63603

Telex: HERCO 265849

# R. F. COMPONENTS

## Full Technological Certificate

The following evening classes leading to Pt. III of the City and Guilds Courses 271 and 272 will be available from October at the Polytechnic.

271: Advanced Electronic Switching Principles.  
Advanced Microwave Principles.  
Advanced Telecommunications Principles.  
Radar and Radio Navigational Aids.  
Sound Studios and Recording.  
Television Studios and Recording.

272: Colour Television.  
FM and Multiplex Stereo.  
Microelectronic and Semiconductor  
Technology.

Write to the Department of Electronic and Communications Engineering, Holloway Rd., London N7 8DB, for details and application forms.

The Polytechnic  
of North London

# LOGITEK

## Keyphone Tester solves a touchy problem



The Logitek Keyphone Tester can cope with PABX systems and SA4258 telephones. This reliable, robust, time-saving portable unit more than satisfies P.O. standards.

For detailed information please contact

E.I.C. Electronics Ltd, 30 Kelvin Ave,  
Hillington Industrial Estate, Glasgow.

Tel: 041-882 1661/1662, 1166 Telex 777255

# The Post Office approves, so will you!



Cabinet systems for  
Switching Equipment

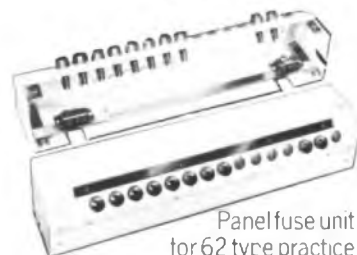

Panel fuse unit  
for 62 type practice

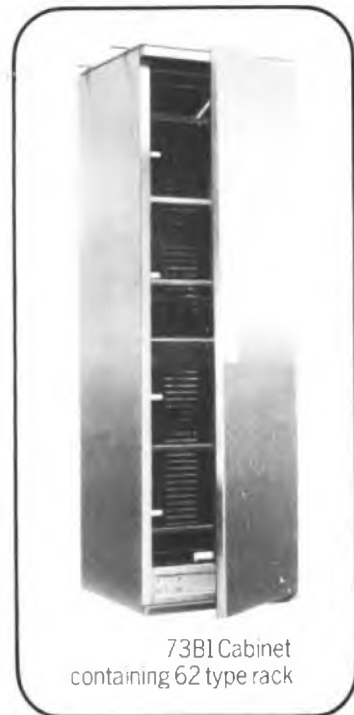

73B1 Cabinet  
containing 62 type rack

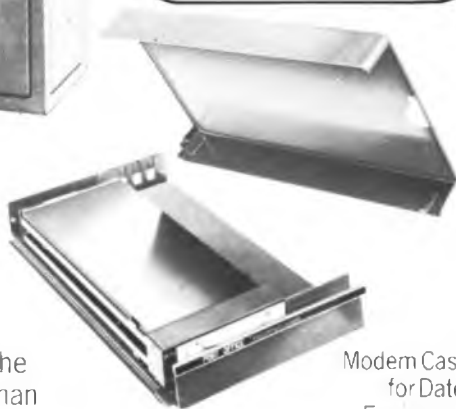

Modern Case  
for Datel  
Equipment

Herman Smith have long held full approval from the Post Office for the production of 62 type equipment. But that's only half the story. Wherever precision electro-mechanical work is involved Herman Smith have all the facilities and all the experience.

From simple sheet pressings to sophisticated cabinets and wired assemblies, we maintain the highest standards, our fully trained QA personnel—ensure your approval to any specification.



Contact Peter Bowen **HERMAN SMITH LIMITED**, Cinder Bank Works, Netherton, Dudley,  
West Midlands. DY2 9AH Telephone Dudley 52791

# Good Morning

It's the dawn of the digital 80's from GEC Telecommunications. Now with a total network capability in digital transmission systems up to 140 Mbit/s; microwave radio systems, coaxial-cable and optical-fibre line systems and a complete range of digital multiplex.

Versatile business communications systems, including P.A.B.X.'s from 4 to over 5,000 lines using digital switching and stored programme control.

The dawn of digital technology from GEC Telecommunications...make an early start.

## **GEC**

Telecommunications

GEC Telecommunications Limited,  
P.O. Box 53, Coventry CV3 1HJ England.

A Management Company of  
The General Electric Company Limited of England.