

The Post Office Electrical Engineers' Journal

R.A. ROE
PE12

VOL 68 PART 4 / JANUARY 1976



THE POST OFFICE ELECTRICAL ENGINEERS' JOURNAL

VOL 68 PART 4 JANUARY 1976

Contents

	<i>page</i>
Editorial	194
The Royal Opening of the Martlesham Research Centre	195
TXE4 Electronic Exchange System—Part 1—Overall Description and General Operation—J. V. Goodman and J. L. Phillips	169
Local Distribution—An Assessment for Future System Development Part 1—Short and Medium-Term Development—A. G. Hare	204
Selecting an Earth-Station Site—P. S. J. Duffy, M. A. Streete and R. T. E. Wing	211
Frequency Co-ordination for the SPADE Satellite-Communication System M. H. Mallett	222
A New International Telegram Retransmission Centre for the External Telecommunications Executive—L. Veale	226
Experimental Packet-Switched Service: Routing of Packets—A. J. Gardner and K. N. Sandum	235
Designing Low-Loss Polymer Dielectrics for New Transmission Systems—J. Haigh	240
Developments in Digital Transmission—G. H. Bennett	243
Programmable Automatic Testers in the British Post Office Factories Division W. H. Sambrook	249
Regional Notes	255
Associate Section Notes	260
The Associate Section National Committee Report	261
Institution of Post Office Electrical Engineers	262
Notes and Comments	264
Post Office Press Notice	265
Book Reviews	210, 239

Published in April, July, October and January by *The Post Office Electrical Engineers' Journal*,
2-12 Gresham Street, London EC2V 7AG.

Price: 35p (60p including postage and packaging). Orders by post only.

Annual subscription (including postage and packaging): home and overseas £2.40.
(Canada and the USA \$6.00.)

Price to British Post Office staff: 27p.

Get more for your money with the ITT 2300.

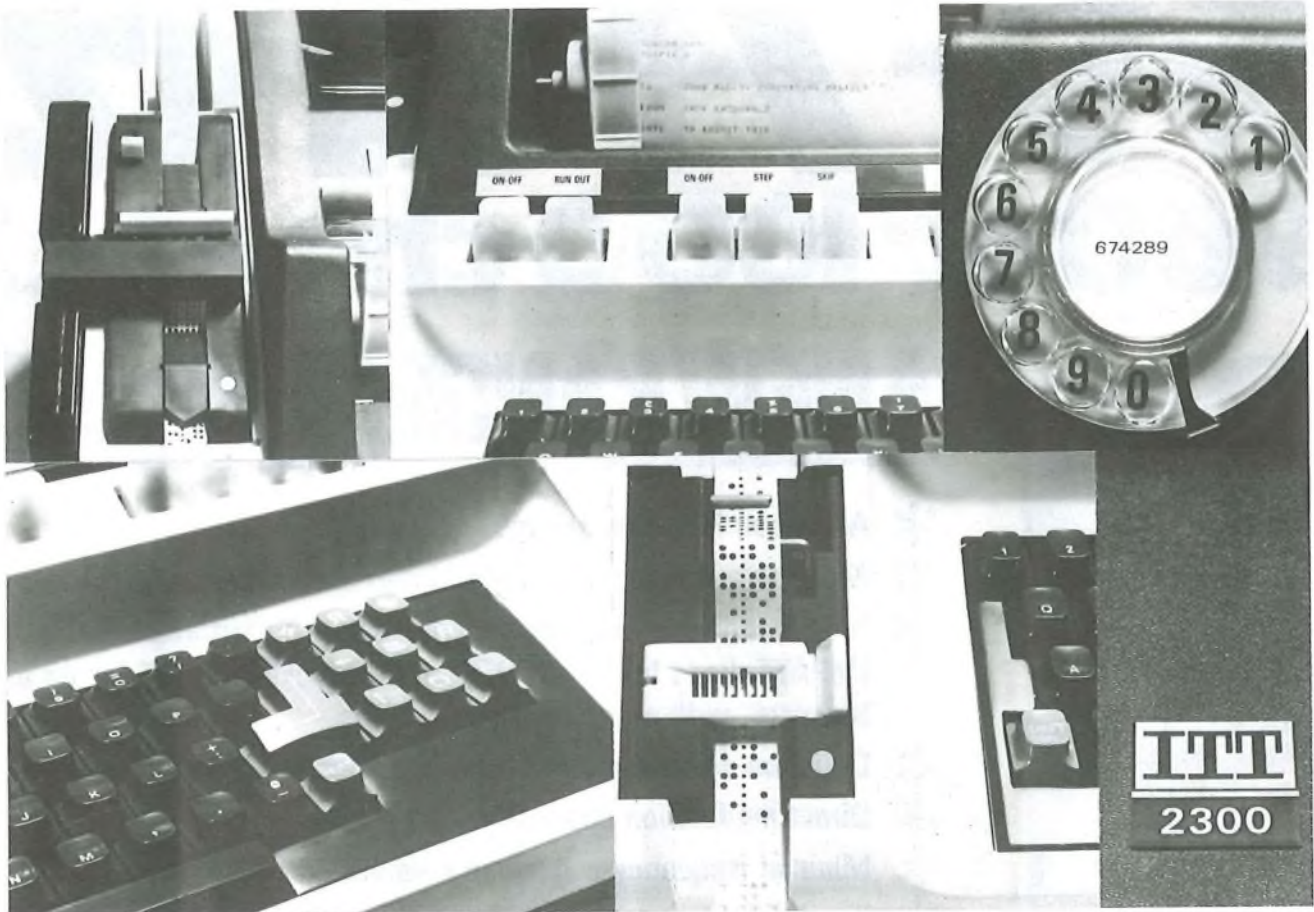

The teleprinter that's years ahead in design and performance.

The semi-electronic ITT 2300 cuts costs down to size.

It costs less to run because maintenance is simplified, reliability increased, expensive spares holdings minimised and storage space saved. (The number of its mechanical parts has been reduced by two thirds over the previous ITT Creed model.)

All in all, the ITT 2300 offers a speedy return on capital invested.

The ITT 2300 has integrated telex and private wire facilities. It works on all telex systems throughout the world and satisfies technical and safety standards worldwide. All signal processing is electronic.

The ITT 2300 is designed to have many more

operating features than the usual modes. It is adaptable, with built in features that can be adapted to suit individual requirements.

Any typist can operate the ITT 2300, after minimal training. Changing the paper reel and tape roll is easy, and replacing the ink roller cartridge is a clean simple job – so no dirty hands.

The ITT 2300 takes up little more space than a typewriter, making it quite at home anywhere in a modern office.

The ITT 2300.
Tomorrow's teleprinter – today.

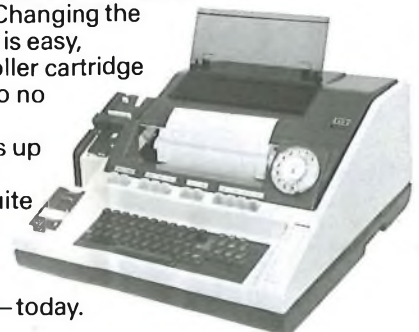

ITT Creed Limited **ITT**

BROADBAND RADIO LINKS

5.9-7.1 GHz

960 or 1800 channel

A NEW RANGE FROM GEC

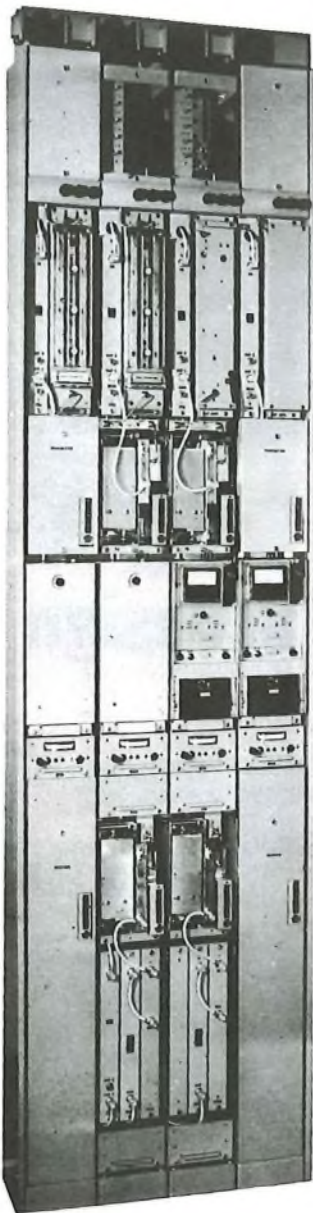

- * Advanced MIC technology.
- * Modular construction—plug-in interchangeable units.
- * Interchangeable modules for transmitter output amplifier.
IMPATT diode for 1 watt OR long-life packaged TWT for up to 10 watts—with associated power units.
- * Optimum commonality of other modules throughout the range.
- * Direct modulation capability.
- * Minimal frequency-conscious modules.
- * Flexibility of system design — choice of frequency and transmitter output power within system configuration using the same basic equipment.
- * Interchangeability without compensating adjustments.
- * Reduced spare-unit requirements.
- * Simplified maintenance routines.
- * Ready expansion above 960 channels with interchangeable modules.



Four 6.8 GHz equipment racks.

Left to right:

1 watt, 960 channel rack, covers on.				
1 watt, " " " " off.				
10 watt, 1800 " " " " off.				
10 watt, " " " " on.				

MICROWAVE AND LINE TRANSMISSION · MULTIPLEX · V.F. TELEGRAPHY
DATA MODEMS · TELEPHONE SWITCHING SYSTEMS · PRIVATE
TELEPHONE SYSTEMS · TELEPHONES · TOTAL SYSTEMS CAPABILITY

GEC TELECOMMUNICATIONS LIMITED of Coventry, England.

A Management Company of The General Electric Co. Ltd. of England.

CB1

GEC DIGITAL TRANSMISSION SYSTEMS

FOR LOCAL JUNCTIONS AND TRUNK ROUTES

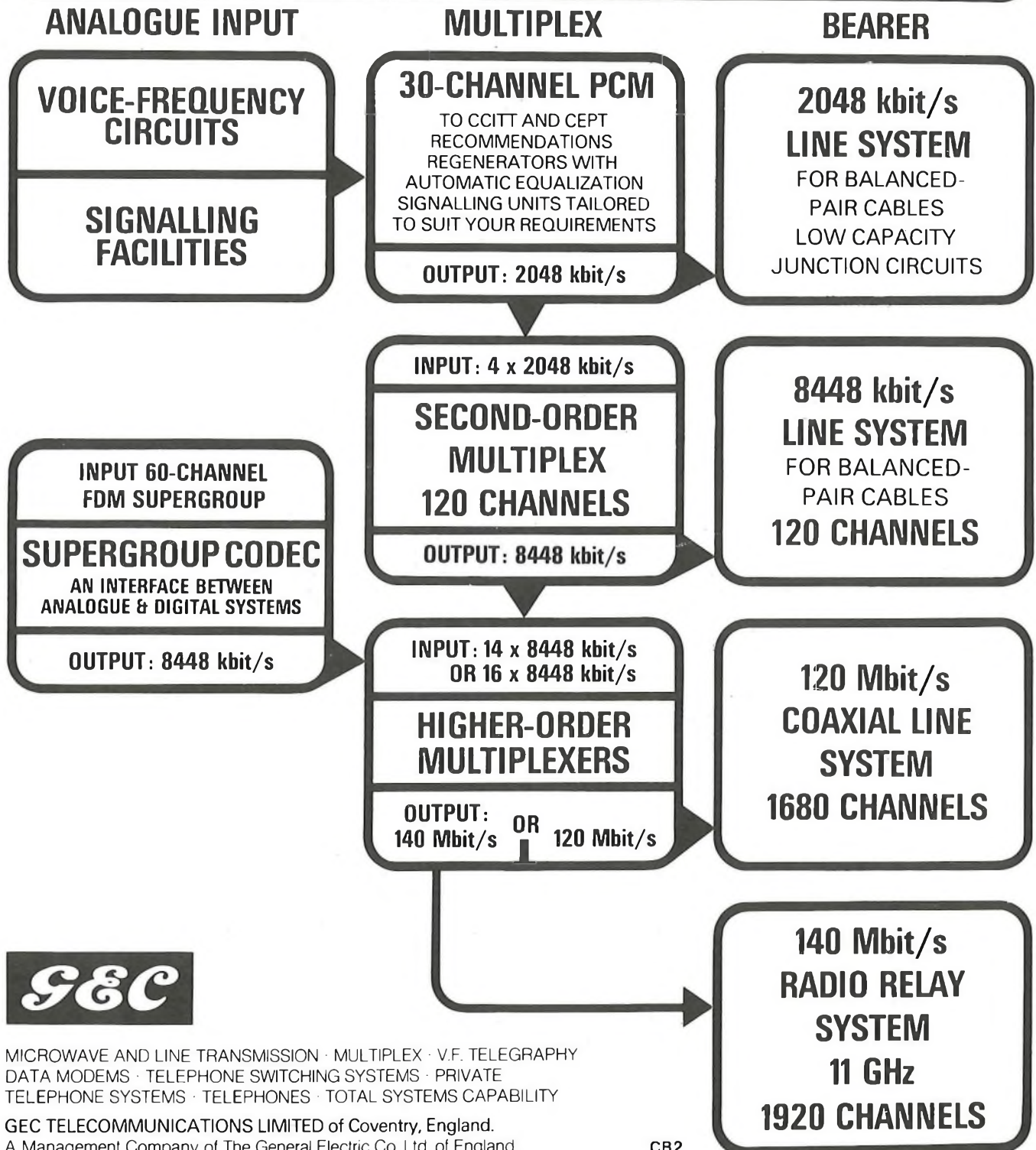

MICROWAVE AND LINE TRANSMISSION · MULTIPLEX · V.F. TELEGRAPHY
DATA MODEMS · TELEPHONE SWITCHING SYSTEMS · PRIVATE
TELEPHONE SYSTEMS · TELEPHONES · TOTAL SYSTEMS CAPABILITY

GEC TELECOMMUNICATIONS LIMITED of Coventry, England.
A Management Company of The General Electric Co. Ltd. of England.

CB2

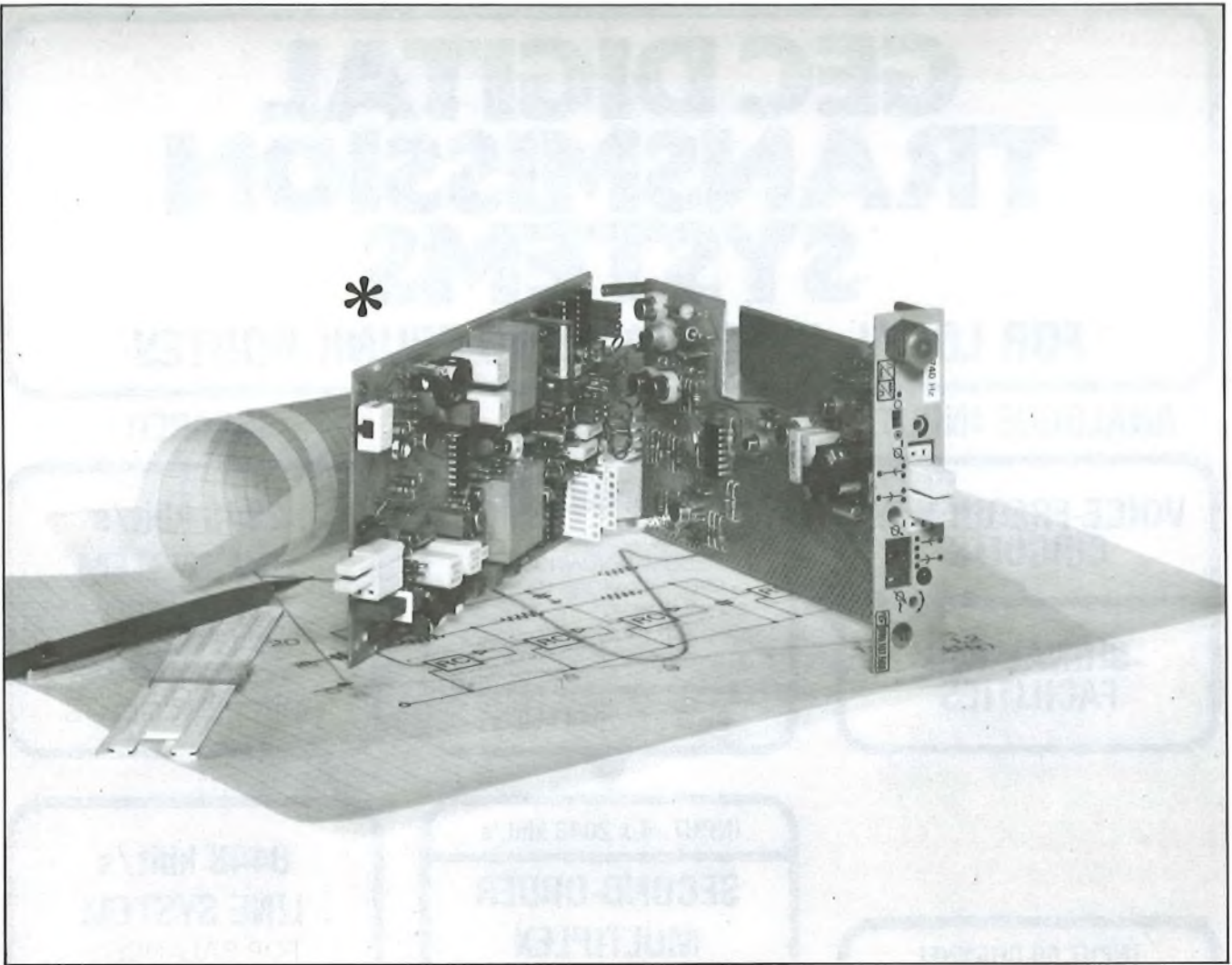

TG48

new generation voice frequency FSK multiplex equipment

Reduced size

Two complete 24-channel systems in a slim rack of dimensions 2600 H x 120 W x 225 D mm

Extensive use of advanced technologies

Digital frequency modulator and discriminator with complementary MOS integrated circuits - Active RC filters with Tantalum thin-film and beam-lead operational amplifiers

Low power consumption

32 W per 24-channel system, with typical 1 kohm/±20 mA local circuit

Simplified maintenance and reduced spare parts

Invariant channel units at equal modulation rate, except for a replaceable crystal for line frequency allocation of the channel

Excellent frequency stability with temperature and time

Line frequencies within ±0.1 Hz over the 0-50°C temperature range

Modulation rates of 50-100-200 bauds with performance according to, or better than, CCITT recommendations

* FSK voice frequency channel developed by Telettra's FDM Laboratories.

Telettra

S.p.A. LABORATORI DI TELEFONIA ELETTRONICA E RADIO - VIMERCATE MILANO ITALY

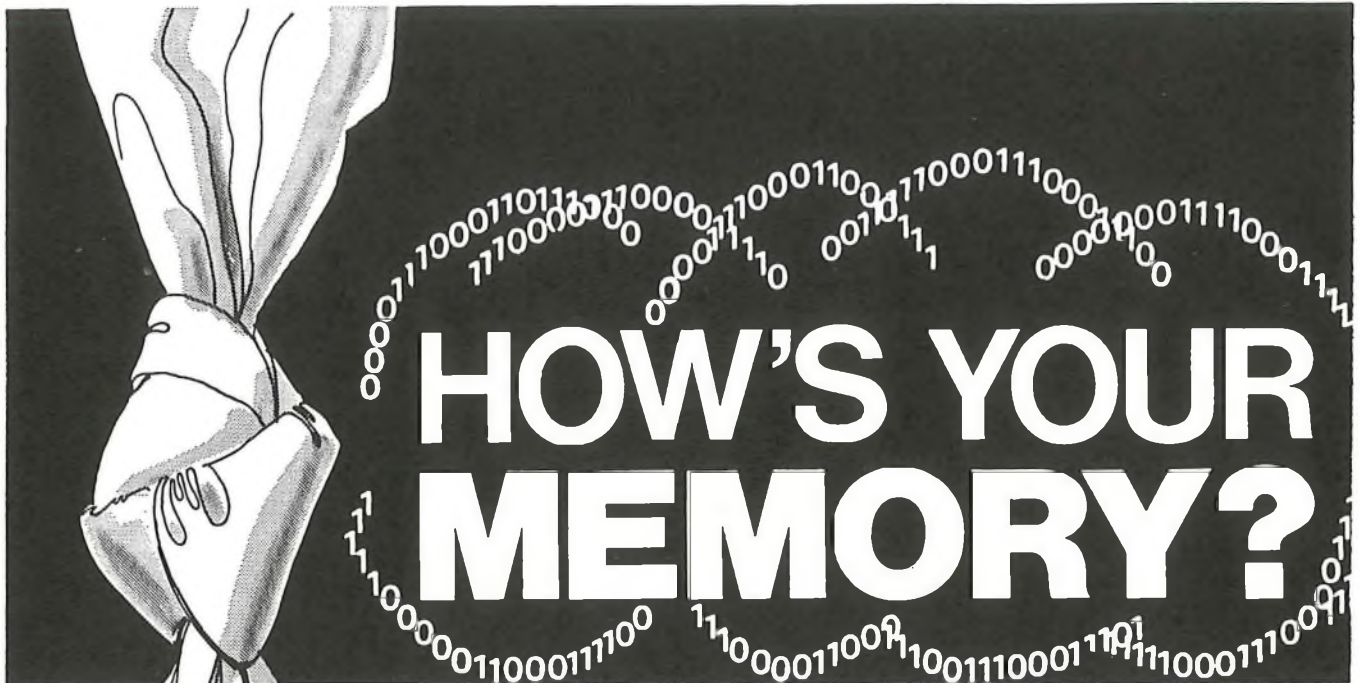

Our's is all right. It's been working hard for the Post Office and Government for more than fifteen years.

Sperry drum memory systems are available for all fast back-up store applications and have a proven reliability. Early models supplied to the British Post Office more than fifteen years ago continue to give excellent service. Current models incorporate the latest storage techniques and provide bulk data storage for computers and message switching, telecommunications and similar data processing systems. For example, Sperry memory stores together with our 1412 mini-computers are the principal modules in the SCAMP (Sperry Computer Aided Message Processor) System.

*For more information about Sperry memory systems contact David McNaught.
Bracknell 3222.*

SPERRY
GYROSCOPE

BRACKNELL BERKSHIRE ENGLAND RG12 1QL
TELEPHONE 0344-3222 TELEX 848129

The Post Office Electrical Engineers' Journal

EDITORIAL

The first TXE4 electronic exchange, Birmingham Rectory, is due to open this year. This exchange will serve over 4000 telephone lines in the Sutton Coldfield district of Birmingham, and the British Post Office (BPO) currently has more than 50 TXE4 exchanges on order. The *Journal* has, over the past 3 years included articles describing the history and development of the TXE4 system, the special project control arrangements associated with the contract and the teletraffic characteristics of TXE4 exchanges. This issue includes the first part of a 3-part article that will describe the TXE4 electronic exchange system: the first part gives an overall description of the system and its operation; the 2 subsequent parts, to be published in later issues of the *Journal*, will describe the design of the switching and control equipment in detail, and will discuss the very important aspects of system security and maintenance features.

In November last year, the BPO announced a contract valued at over £1M for the first phase of the new satellite earth station to be developed on a 0.32 km² site near the village of Madley in Herefordshire. The earth station could ultimately have up to 6 ariels, but initially construction will be limited to 3 single-storey buildings and other site development work for up to 3 earth terminals, each equipped with one parabolic aerial. Initially one aerial will be built; this will be the subject of a separate contract and it is expected to be in service in early 1978. This issue contains a detailed description of the wide-ranging and lengthy search for a site that would be a suitable location for the second UK earth station. This article highlights the difficulties in finding a site to satisfy the many conflicting requirements, describes in detail the major problem of finding a site having a tolerable level of radio interference, and discusses the possible development of the site chosen.

This issue also marks the opening by Her Majesty the Queen of the new BPO Research Centre at Martlesham described opposite.

BOARD OF EDITORS

J. F. P. Thomas, B.SC., C.ENG., M.I.E.E., Chairman

E. W. Ayers, B.SC.(ENG.), C.ENG., F.I.E.E.

A. J. Barker, C.ENG., F.I.E.E.

A. J. Barnard, C.ENG., M.I.E.E.

C. E. Clinch, B.SC.(ENG.), C.ENG., F.I.MECH.E., F.I.E.E., F.S.S.

J. Martin, B.SC.(ENG.), C.ENG., M.I.E.E.

A. Ness, C.ENG., M.I.E.E.

Managing Editor

D. Millington, C.ENG., M.I.E.E.

Assistant Editor

B. Stagg

Secretary-Treasurer

B. Farr

Advertisement Manager

R. G. Rothery

The Royal Opening of the Martlesham Research Centre

UDC 061.6 : 621.39.001.5 : 654.07



On Friday, 21 November 1975, Her Majesty the Queen graciously opened the new British Post Office (BPO) Research Centre at Martlesham Heath, Suffolk. The ceremony, which consisted of unveiling a commemorative plaque in etched glass, was attended by approximately 400 staff and guests in the new lecture theatre. Because it was not possible to invite all of the 1200 staff now on site to the ceremony itself, live closed-circuit television coverage was provided by the London Telecommunications Region Outside Broadcast Television Unit at 2 other locations on site and to the 500 staff who have not yet moved from Dollis Hill. Afterwards, Her Majesty toured the library, laboratory and workshop areas to inspect the new facilities and see some of the latest developments in communications.

The opening of the Centre marks the beginning of a new era in scientific and engineering research in the BPO. Since before 1930, the home of research has been at Dollis Hill whence many of the famous developments described in this *Journal* have emanated, but now, after nearly half a century, the activities are being transferred to provide proper facilities for complex modern studies. Against the background of miniaturization in electronics, modern systems studies require extensive outdoor areas for field work; long underground waveguide installations and studies of multi-channel cable systems require access to open spaces that are not to

be found in suburban London. The new Centre is the foremost telecommunications research laboratory in the UK and has as its aim to improve techniques and reduce costs in telecommunications, so improving the range of services offered and enhancing the profitability of the BPO in its service to the community.

Approximately 0.7% of the BPO's income is spent on research activities which range over all the needs of the Telecommunications Business. Fundamental work on the physics and chemistry of materials is making possible the production of highly reliable devices from a proper understanding of the various failure mechanisms. Greatly improved materials are resulting; for instance, new low-loss optical fibres. New systems developments are under active study: high-speed digital transmission systems have been brought to the stage of engineering trials, much activity centres around the application of software-controlled electronics to exchange control, work continues to improve telephone performance standards, and human-factors studies enable the BPO's customers to be more efficient in their use of the system.

Close links will continue to be maintained between the Centre, industry, and the universities such that, in combination, a substantial impact upon world telecommunications will be made from the UK.

A. H. I.

TXE4 Electronic Exchange System

Part 1—Overall Description and General Operation

J. V. GOODMAN, B.SC.(ENG.), A.C.G.I., C.ENG., M.I.E.E., and J. L. PHILLIPS, C.ENG., M.I.E.E.†

UDC 621.395.345

This first part of a 3-part article gives a general introduction to the TXE4 electronic exchange system by outlining the design philosophy adopted, describing the modular design concept used, and demonstrating the way some facilities are provided. Subsequent parts will describe the design of the switching and control equipment, and examine the important aspects of security and maintenance.

INTRODUCTION

This is the first part of a 3-part article that describes the TXE4 electronic exchange system and marks the opening of the first TXE4 local director exchange. The first of this new series of exchanges is Birmingham Rectory, serving over 4000 lines in the Sutton Coldfield district of Birmingham. More than 50 TXE4 exchanges are currently on order; Fig. 1 shows one of these in the course of installation. They are being manufactured and installed by Standard Telephones and Cables Limited (STC), the Plessey Company Limited and the General Electric Company Limited (GEC).

Equipment in Plessey and GEC TXE4 exchanges will use the same circuit designs and layouts as are used in TXE4 exchanges manufactured by STC, and all the equipment will be fully interchangeable between exchanges made by any of the companies. The first GEC and Plessey TXE4 exchanges are planned to open about 2½ years after the opening of Rectory.

The TXE4 exchange system represents the culmination of a series of developments that started in 1963 with laboratory trials on telephone exchange designs based on electronically-controlled reed-relay switching networks. At that time, electronic exchange development took place under the guidance of a Joint Electronic Research Committee (JERC), comprising representatives of the British Post Office (BPO) and its, then, 5 major suppliers of telephone equipment. These suppliers became, in due course, the 3 companies mentioned above. A full description of the steps leading to the TXE4 exchange system was given recently in this *Journal*.¹

The most significant steps were the opening of the TXE1 exchange at Leighton Buzzard (Bedfordshire) in 1969,² the field trial of a model TXE3 exchange at the BPO circuit laboratory in London from 1968–70,³ and a similar field trial of a model TXE4 exchange at Tudor (Muswell Hill) exchange, London, from 1969–72.

The basic aspects of the TXE4 exchange design, which is now in bulk production, are, therefore, the result of extensive studies carried out in collaboration between the BPO and all its major telephone-exchange suppliers. In June 1971, a contract was placed with STC to complete a production-engineered version of the TXE4 model that had been tested at Tudor exchange. This contract called also for the provision of an initial series of exchanges, of which that at Rectory is the first. An article on the special project control arrangements associated with this contract has already appeared in this *Journal*.⁴

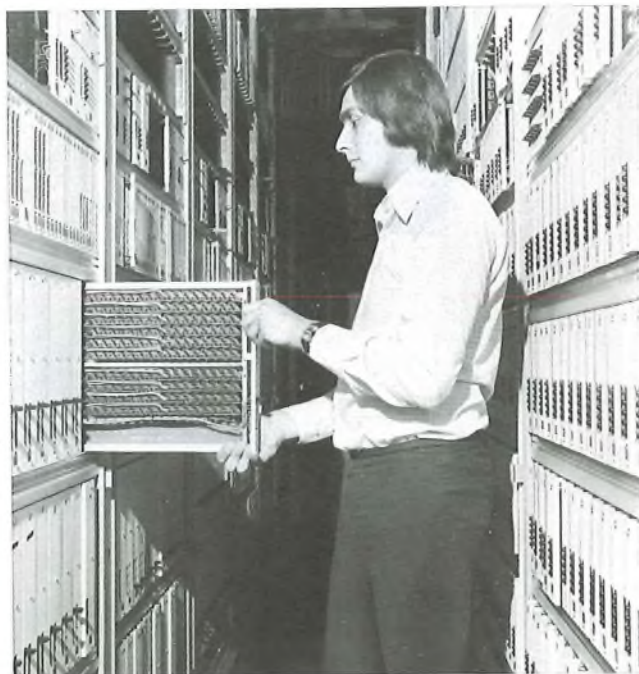

FIG. 1—Shepherds Bush TXE4 exchange in course of installation

TXE4 SYSTEM

The TXE4 system is designed to meet economically the requirements of large local exchanges in the BPO network, and is complementary to the TXE2 system,⁵ which is used in smaller local exchanges. The range of exchange sizes over which the TXE4 system is suitable can be expressed in several different ways. In terms of connexion capacity, a TXE4 exchange can handle from about 2000–40 000 lines. The upper limit is set by the maximum number of racks containing line terminations that can be used in a single exchange; the lower limit represents a TXE4 exchange having the minimum of equipment that will provide acceptable security while still being used efficiently. The TXE2 system, on the other hand, while being originally designed for exchanges of below 2000 lines, has now been developed so that in suitable cases installations up to 7000 lines are possible (up to 14 000 lines for double TXE2 exchanges). There is thus a useful area of overlap between the TXE2 and the TXE4 systems, within which other factors such as traffic capacity and planned growth pattern are decisive.

Turning to traffic-carrying characteristics, an exchange system suitable for general use in large local exchanges in

† Telecommunications Development Department, Telecommunications Headquarters.

the UK must be able to handle economically a very wide range of customer calling rates. The TXE4 system is designed to accommodate calling rates from 0.02-0.35 erlangs; that is, a bothway rate of 0.04-0.7 erlangs. Thus, at the upper end of the range, customer's lines having traffic characteristics similar to junction circuits can be efficiently accommodated. The maximum switching capacity of a TXE4 exchange as a whole is, for call-holding times usually encountered in the UK (about 2 min), set by the maximum number of registers that can be connected and the average register-holding time. The present design of TXE4 exchange allows for the connexion of up to 700 registers, and register-holding time is conditioned by use of signalling systems which, for some years to come, are expected to be predominantly 10 pulses/s on both customer and junction circuits. The consequence is a design maximum switching capacity of 5000 bothway erlangs.

It is important to realize that, in any one exchange, either the connexion capacity (40 000 lines) or the switching capacity (5000 erlangs) will be the crucial limit, whichever is reached first. There is a crossover point at a calling rate of about 0.06 erlangs, below which the connexion capacity will be limiting, and above which the switching capacity will be limiting. Extensive traffic studies, described in earlier articles,^{6,7} have been performed on the TXE4 design. The studies included computer simulation of the switching network, and comprehensive traffic design rules for the TXE4 system have been established.

The TXE4 system is the latest in a series of evolutionary system designs. The major system concepts that have moulded the present detailed design were identified from an economic and technical study of the TXE1 system as Leighton Buzzard exchange was being installed. The changes introduced into the TXE3 design at this time were aimed at improving system simplicity, flexibility and security. A modular design was adopted which provided for growth in simple stages and gave potential for further development. The basic system concepts introduced then are important to a full understanding of the present TXE4 system design and it is worth examining each of them further.

BASIC SYSTEM CONCEPTS

Modularity

The design and manufacture of a telephone exchange can be simplified if it is possible to standardize the configuration of the equipment. For the smallest exchanges, such as small UAXs and PABXs, it is possible to take standardization to considerable lengths without incurring unacceptable cost penalties from provision of unnecessary equipment. As exchanges grow larger in size, it becomes more important to cater accurately for the wider variety of applications; extensive standardization becomes more and more difficult to achieve. In the TXE4 system, a considerable degree of standardization has been achieved; yet the ability to tailor each exchange to the local circumstances has been retained. This is achieved by splitting TXE4 equipment into modules.

The grouping of the parts of the TXE4 system into each module takes account of the 3 major variables that occur in exchange design. Thus, equipment that must be provided according to the designed traffic level is grouped into the switching area. Equipment whose provision rate depends upon the rate of setting-up of calls is grouped into the control area and equipment provided in proportion to the number of connexions served is grouped into an area known as the *cyclic store*. There is, of course, also some equipment whose provision rate does not vary significantly with exchange size.

Each module consists of one or more standard racks. A brief description of the equipment in each of these areas is given later, and a more thorough explanation of their design is the subject of a subsequent part of this article.

Exchange Design and Growth

A crucial effect of the modularity of the TXE4 system is that exchange design commences simply by deciding how many equipment modules are to be provided in the switching, control and cyclic-store areas. TXE4 exchanges are engineered on an equipment practice now made familiar by TXE2 and other electronic equipment; that is, the majority of the circuits are in the form either of printed-circuit-board units or of assemblies mounted on standard-sized unit frameworks. These, in turn, plug into racks. It is therefore possible to provide individual circuits, such as switches and junction relay-sets, exactly to suit the particular exchange. However, to take standardization further, all TXE4 equipment racks are always provided fully wired. Growth can, therefore, be achieved very simply. On the one hand, individual circuits can be added by plugging standard units into prewired racks and, on the other hand, extensions of basic capacity can be added by the addition of further standard modules.

Security

Security is the ability of a telephone exchange to maintain continuous service in the presence of occasional equipment faults. Advantage has been taken of the modularity of the TXE4 system to make each module independent of each similar module. This yields a high degree of security through substantial immunity to component failure and accidental damage. Where possible, fault detection within each module is made the responsibility of that module, so that there is no requirement for infallible fault-detection or change-over equipment. Furthermore, repair can be speedily accomplished in most cases by the replacement of faulty plug-in units. Security and maintenance will be explored in a later part of this article.

Simplicity and Flexibility

Although individual circuits within the modules are relatively complex, care has been taken in the design to keep the basic functions of each module simple and well defined. Interconnexions between different types of module are mostly made with plug-ended signal highways, which lend themselves to easy extension when additional modules are called for. Where possible, the design has been made general-purpose, rather than tailored to a particular set of facilities. For example, the main control units, which form an important part of the control area, are programmed; different facilities can often be included by programme changes rather than by circuit variations.

Potential for Further Development

A large proportion of the circuit design for the TXE4 system began to take shape in the second half of the 1960s, and the decision was taken then to restrict the designers, wherever possible, to well-tried circuit techniques and freely-available components that were well established. This had the advantage of concentrating all the designers' attention on the problems of achieving a sound, flexible and economic system design. Most circuits designed then were, therefore, based on discrete-component silicon-transistor technology. Since then, however, advantage has been taken of the modular nature of the TXE4 system by using a more up-to-date, but still well-proved, technology, whenever a major module redesign has become necessary. Thus, some transistor-transistor-logic silicon integrated circuits have already been introduced into parts of the TXE4 system.

At present, a major exercise is under way to introduce integrated circuits, large-scale integration and other up-to-date technology into the control and cyclic-store areas of the TXE4 system. The main purpose of this work is cost reduction, and the new equipment being designed is designated

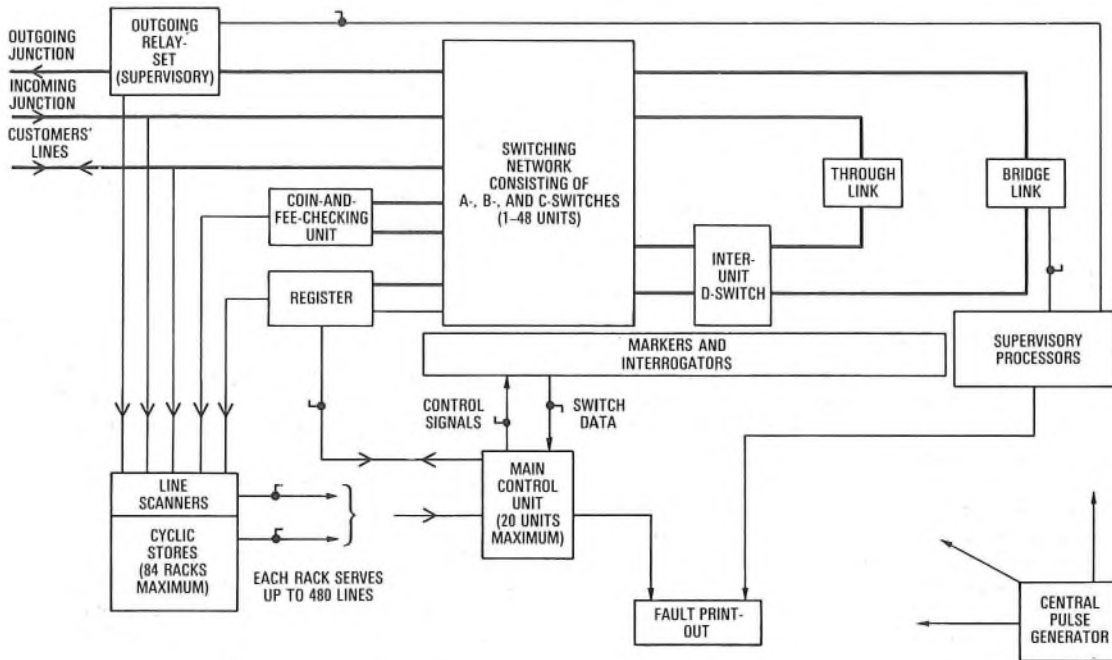

FIG. 2—Block diagram of the TXE4 exchange system

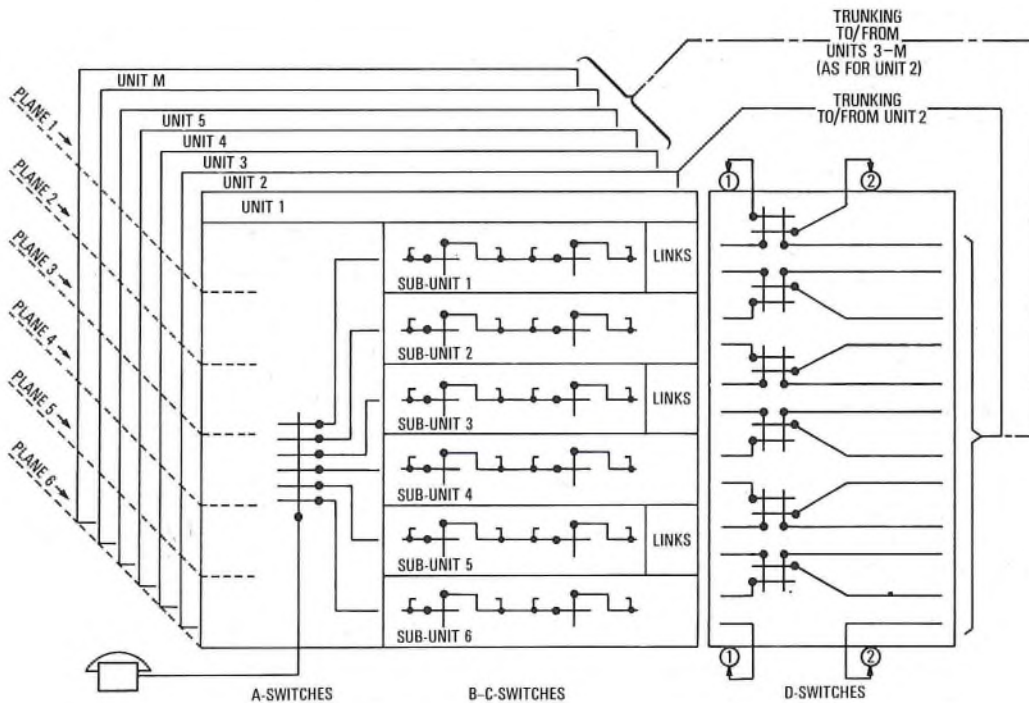

FIG. 3—TXE4 switching area configuration

TXE4A. However, the module boundaries are being retained, so that when TXE4A equipment is available, it will be suitable for extension of the present generation of TXE4 exchanges, as well as being used for new exchanges. The potential for further development and the ability to incorporate new technologies were key concepts introduced at the start of the TXE3 design and retained in the TXE4 and TXE4A systems.

OUTLINE OF THE TXE4 EXCHANGE SYSTEM

The main items of equipment that make up a TXE4 exchange are depicted in Fig. 2, and are briefly described below.

Switching Area

The switching area consists of a number of identical switching networks, called *units*. The various customer and service terminations required on the exchange are distributed over the units. Each unit is sub-divided into 6 or 8 sections according to the size and growth pattern of the exchange during its life. These sections are called *sub-units*, and each group of like-numbered sub-units (one per unit) across the exchange is referred to as a *plane* (see Fig. 3). Every termination has one connexion to each plane in the particular switching unit concerned.

The purpose of division into units is to simplify exchange extension, and of division into planes to ensure security.

If a sub-unit fails, no termination suffers loss of service. Instead, the traffic capacity and grade of service are slightly reduced.

Each sub-unit consists of a number of reed-relay cross-point matrices arranged in 3 stages, designated *A*, *B* and *C*. *C*-switches in even-numbered sub-units are connected to *D*-switches; those in odd-numbered sub-units to link circuits. Each link circuit is connected on the one side to a *D*-switch, and on the other to an odd-numbered sub-unit *C*-switch. The *D*-switches serve to interconnect units; the *D*-switches and link circuits together provide connexions between adjacent planes.

All customer and junction lines are terminated at the variable-concentration *A*-stage of the switching network, along with all other types of circuit requiring interconnexion. Any 2 terminations can be interconnected by the operation of switches to connect one side of a free link circuit to one termination, and the other side of the link circuit to the other termination. Four wires are carried through the switching network: 2 wires form the speech path, one provides the signalling and metering wire (equivalent to a Strowger *P*-wire), and the fourth provides the holding circuit for the crosspoint relays. The method of operation of the switching network will be described in a later part of this article. Link circuits are of 2 types; either

- (a) a *through link*, providing a metallic speech path or
- (b) a *bridge link*, having a transmission bridge and circuits for call supervision.

The switching networks are controlled by wired-logic markers and interrogators. The former can control from 1-5 sub-units (in different units, but on the same plane); the latter are provided once per sub-unit. Simplification and size reduction of bridge links, and of certain other call-supervision equipment (such as outgoing junction circuits), are achieved by providing common serial processors called *supervisory processing units*. These are associated with the odd-plane markers, through which they receive the data needed to control the call.

Cyclic Stores

The purpose of the cyclic stores is to hold the semi-permanent data that defines customers' numbers and the trunking and routing arrangements at the particular exchange. This data must be altered from time to time, and this constrains the physical arrangement of the cyclic store which, in the current design, consists of a read-only, threaded-ring transformer store. An impression of this can be gained from Fig. 4, which shows unwired threading fields of a pair of cyclic-store racks. Up to 84 cyclic-store racks can be provided in a TXE4 exchange. A single wire threaded through the store is, in most cases, sufficient to record the information needed for a customer's line. Further threadings are required for each junction circuit and for routing instructions associated with dialled codes.

Closely associated with the cyclic store is line-scanning and state-of-line equipment. These inspect customers' lines and junctions regularly, and provide instantaneous busy/free information for each termination in conjunction with the threaded semi-permanent data. All this data is broadcast in a constantly cycling stream, and selected information can be read from the stream as required by main control units. This arrangement safeguards the cyclic store against faults in main control units. A further security feature is the extensive use of duplicated, and in some cases quadruplicated, circuitry throughout the cyclic store.

Main Control Units

Main control units are special-purpose processors that use programme control techniques to correlate cyclic-store data and register information. According to rules set by the stored programme, main control units establish the required

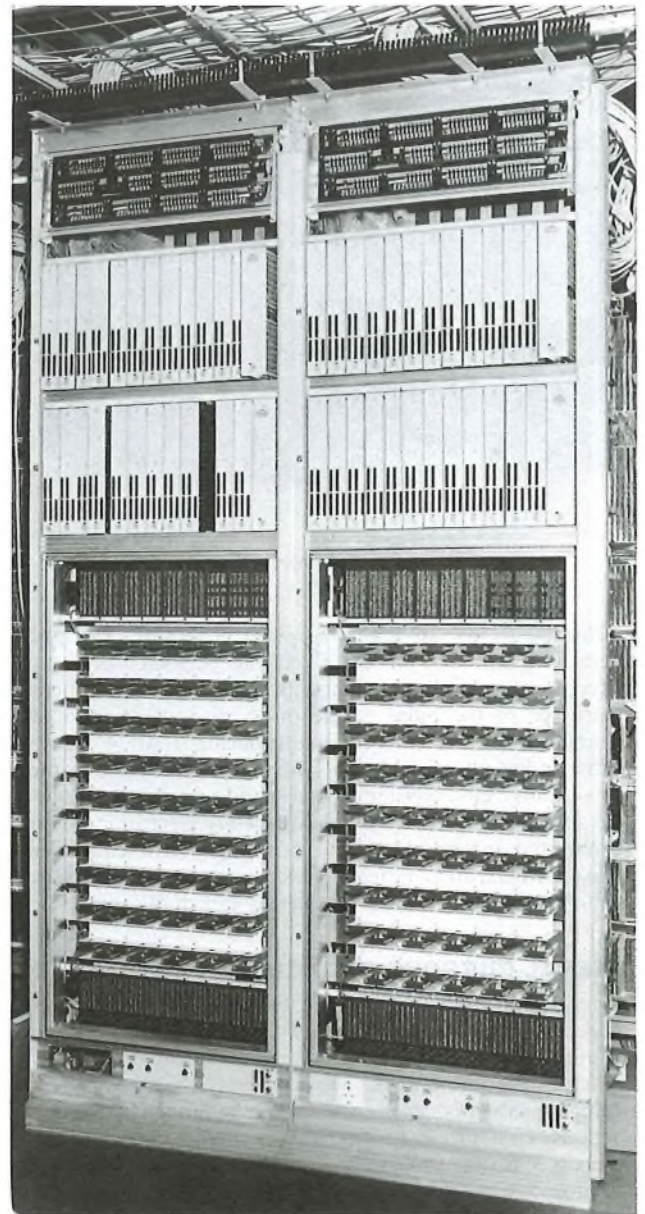

FIG. 4—TXE4 cyclic-store racks

connexions through the switching area. From 3-20 main control units are provided according to the amount of register traffic. Registers are arranged in groups of up to 36, each group being associated with, and controlled by, one specific main control unit.

Each main control unit is connected by highways to all markers so that it can control path selection and connexion. Access to these highways is restricted to one main control unit at a time to simplify the path-selection process. Failure of an individual main control unit will not deny service to customers, since any connexion can be established by any main control unit.

The programme for each main control unit is stored on a read-only, threaded-core store, similar in principle to the cyclic-store field, although it is not cyclically addressed. The programme is mounted on a series of plug-in units (see Fig. 5), giving a capacity of up to 5000 words. Each word is defined by a wire threading 8 rows of cores.

Pulse Generator and Fixed Equipment

The interrelated functions of the various items of equipment in a TXE4 exchange need to be synchronized in time, and this

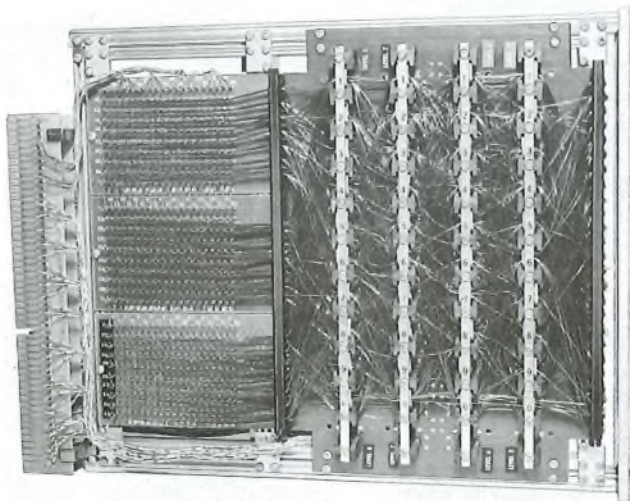

FIG. 5—Main-control-unit programme unit

is achieved by use of a central pulse generator. The pulse generator distributes pulses of varying periodicities to suit the requirements of the exchange. Because of the fundamental importance of the pulse generator to the operation of the exchange, most circuits are quadruplicated. All 4 sections operate independently, but in synchronism with each other, their outputs being constantly compared and checked.

In addition, a variety of miscellaneous electronic circuits are required in the exchange, including alarm equipment, traffic recorders, and routiners. These are provided as required and non-essential circuits are generally not duplicated.

GENERAL-PURPOSE SWITCHING NETWORK

Before going on to examine the method of operation of a TXE4 exchange, it is necessary to look in more detail at an important feature of the switching network; namely, that it is a general-purpose network. Most other systems have several switching networks, each performing a limited number of functions. In addition to the network used to set up speech connexions between telephones and junctions, it is usual to find auxiliary networks providing such facilities as register and/or sender access, routiner access, test access, trunk offering and telephone service observation. In exchanges other than TXE4, each of these networks involves some form of special switch control and, when the exchange is extended, extensions to some or all of these networks are necessary. This is true, for example, of Strowger exchanges.

TXE4 has a single general-purpose switching network. All circuits and terminations, whether provided for traffic or service purposes, are connected to the network A-stage. All paths, without exception, involve 2 terminations and a pair of *half-paths* on adjacent planes. Seven crosspoints and one link circuit are always involved. This arrangement gives a uniformly high level of security to all interconnexion operations and contributes to the ability of TXE4 to provide a wide range of facilities. Clearly, some of the more-complex facilities involve many more than 2 circuits; these facilities require a further feature of TXE4 called *serial trunking*.

SERIAL TRUNKING

Serial trunking is the use, on one call, of 2 or more 7-crosspoint paths, each connecting a pair of A-switch terminations. Each path-setting operation follows a standard setting-up sequence, involving a main control unit and a pair of markers. The order in which paths are set up for the call, and the particular busy/free tests performed, are selected by the main-control-unit programme. The programme can take

account of a wide range of class-of-service (also known as service-marking) indications recorded in the cyclic store. The introduction of a new facility involving a novel circuit type can be achieved in the TXE4 system by programme modification, the special circuit being connected by serial trunking on appropriate calls. Some types of circuit, such as the coin-and-fee-checking unit, have 2 separate terminations on A-switches. This enables them to be connected in between, for example, a coin-box and an ordinary customer's line, to monitor coin insertion and control the call. Serial trunking enters into many of the facilities offered by TXE4 exchanges, and the concept will be encountered several times in the following descriptions of system operation and of a selection of special facilities.

GENERAL OPERATION OF SYSTEM

Connexion of Register

All customers' terminations are scanned regularly about 6 times/s to determine whether they are free, busy or calling. At any time, one of the main control units is nominated to deal with the next call, and this unit continuously observes the cyclic store-main control unit highways (see Fig. 2) for a new calling condition. When a new call is detected, the main control unit stores the class of service and the equipment number of the line concerned; the equipment number is a 6-digit number that locates the termination on the switching area by defining the switching unit and the outlet from the switching unit. The main control unit makes further reference to the cyclic store-main control unit highways to establish the equipment number of a free register in the group of registers controlled by the main control unit. It is then necessary to set a path through the switching area between the calling line and the register. This is done by signalling the pair of equipment numbers concerned to the interrogators, to determine which paths and through links are available to establish the connexion. One free path combination is chosen. The main control unit then instructs the markers that control the sub-units concerned to set up the chosen path. The customer-register connexion involves 7 crosspoints and a through-link circuit, and is identified on Fig. 6 as half-paths 1 and 2; that is, path 1/2. When the path is proved, dial tone is sent to the customer from the register.

The Own-Exchange Call

Digits dialled by the calling customer are received in the register and stored in the main control unit. The main-control-unit programme analyses these digits to determine how the call should be routed. If an own-exchange call is recognized, the main control unit observes the cyclic store-main control unit highways to locate the called customer. When the called customer is recognized, the main control unit stores the relevant equipment-number and class-of-service data, and notes whether the called customer is free. Further main-control-unit programme analysis is required to determine whether special treatment of the call is necessary. For example, if the called line is barred service, the call is connected to number-unobtainable tone; if the called line has PBX class of service, further action is necessary to ensure that the call is directed to the first free line. If, however, the call is to proceed, the 2 equipment numbers defining the calling and called customers are signalled to all interrogators and a free path through the switching area is selected, marked and set up in the same way as was path 1/2 described earlier. This time, however, the path includes a bridge link, and the path is identified as half-paths 3 and 4 (path 3/4) on Fig. 6. When the path is proved by the register, the original path 1/2 and the register are released. The called line is then rung and, in due course, conversation can take place. Initial and periodic metering is controlled from the bridge link, using positive-battery pulses signalled through the switching area

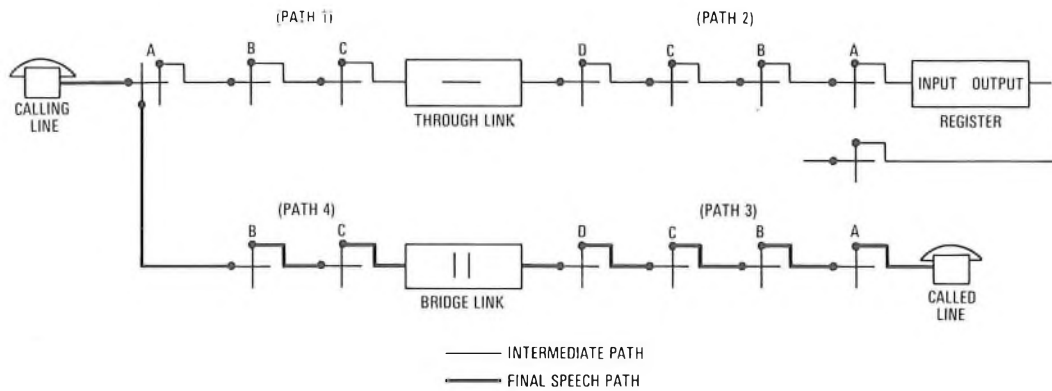

FIG. 6—Serial trunking sequence: own-exchange call

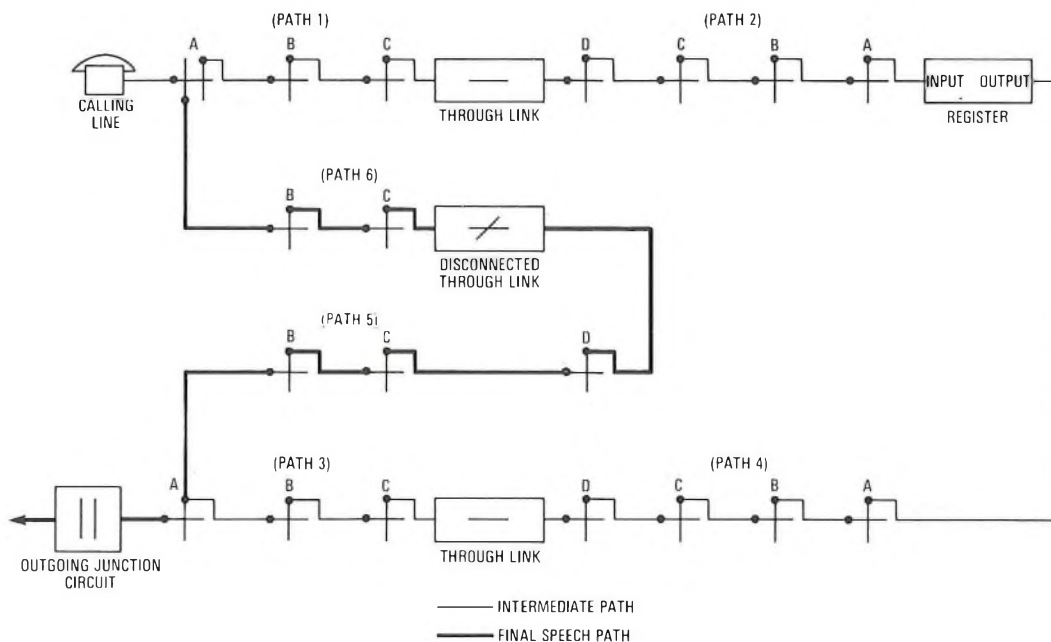

FIG. 7—Serial trunking sequence: outgoing junction call

to the calling-customer's meter. The call is supervised by the bridge link and all equipment is released immediately the calling party clears, or after a delay if only the called party clears.

Incoming Junction Calls

Calls from incoming junctions are dealt with in the same way as calls from customers' terminations. A significant difference is, however, that each incoming junction is scanned much more frequently (once every 12 ms), to ensure that register association is fast enough to avoid losing or mutilating the received information. A register is typically associated with an incoming junction in about 50 ms, and provision is made to transmit the first break of the first digit via the cyclic store-main control unit highways in case the incoming junction-register path through the switching area is not established in time.

Outgoing Junction Calls

If, after connexion of a customer to a register, analysis of the dialled information indicates that the call must be routed to another exchange, a different serial trunking sequence is used. The main control unit normally determines the call routing by locating the first few dialled digits in the cyclic-store data

and storing the routing instruction associated with it. These instructions normally indicate an outgoing junction route number, and further observation of the cyclic store-main control unit highways allows the main control unit to store the equipment number of a free outgoing junction circuit on the required route.

Because it is usually necessary for the register to signal forward to the next exchange some or all of the dialled digits, possibly preceded by additional routing digits, each register is provided with a second termination on the switching area for digit sending. The pair of equipment numbers, defining respectively this second register terminal and the chosen outgoing junction circuit, are next signalled to all interrogators to establish a free path including a through link. This path is then marked and set up. Fig. 7 shows the initial customer-register connexion path 1/2 and the register-outgoing junction connexion; path 3/4.

Before the commencement of signalling to the next exchange, it is necessary to set up a third path directly from the calling customer to the outgoing junction circuit. This is the path that will be retained after the call has been set up for the conversation to take place. Because call supervision will be provided by the outgoing junction circuit, a through link is used, but to avoid mutual interference between customer signalling on path 1/2 and register signalling on path 3/4, it

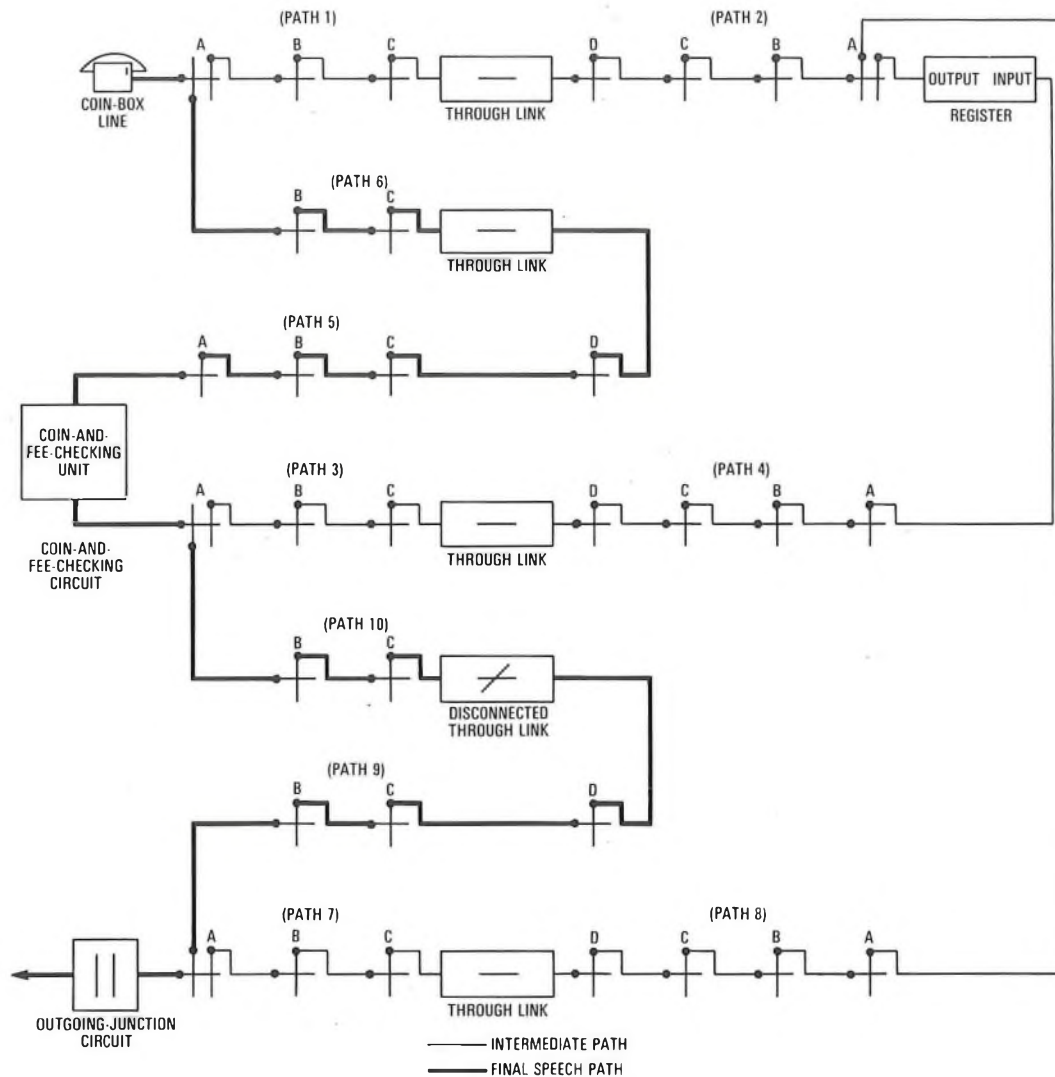

FIG. 8—Connexion of a coin-box call to an outgoing junction

is necessary to have the 2 speech wires disconnected at the through link during the setting-up of the call. This third path is selected, marked and set up in the normal way and becomes half-paths 5 and 6 (path 5/6) on Fig. 7.

The register then signals all necessary information to the next exchange. When the call is fully set up, the register sends a signal to the through link on path 5/6 to reconnect the speech wires and then releases, allowing paths 1/2 and 3/4 to release also. The outgoing junction circuit, in turn, detects the release of the register and switches the transmission bridge into the speech wires so that conversation can take place. Metering is controlled by the outgoing junction; for calls via the STD network; metering-over-junction signals are detected on the junction and passed on to the calling-customer's meter. As for the own-exchange call, all equipment is released immediately the calling party clears, or after a delay if only the called party clears.

SPECIAL FACILITIES

Non-Direct-Dialling-In PBX Calls

Customers' lines having PBX facilities are identified on TXE4 exchanges by the class-of-service indication in the cyclic store. Unidirectional lines have an additional class-of-service indication for outgoing or incoming only service, as appropriate. On terminating calls, the main control unit establishes

that the directory number has PBX facilities; it then searches for the first line of the PBX and commences sequential hunting for the earliest free line. If blocking or a path failure is encountered, one or more repeat attempts are made to later lines on the PBX. Because there is no restriction on the distribution of directory numbers over the cyclic store, it follows that individual lines of a PBX group can be located anywhere on the switching network.

Direct-Dialling-In PABX Calls

The facility of direct dialling-in to PABX extensions is provided by reserving blocks of directory numbers and translating these to a selected outgoing junction route. A wide variety of numbering arrangements can be adopted according to the number of directory-number digits that must be signalled to the PABX to select the extension. If required, in director areas, all-figure-numbering codes can be allocated to one or a group of direct-dialling-in PABXs, as an alternative to reserving a block of directory numbers in the main-exchange numbering scheme. The path-setting arrangements are those used for the outgoing junction call already described. For calls originating from an incoming junction, a tandem call must be set up. Particularly in director areas, direct-dialling-in traffic can be a significant proportion of tandem traffic and special account of this is taken in designing the particular exchange.

Coin-Box Calls

Coin-box calls make use of a coin-and-fee-checking unit that is based on the corresponding Strowger design. Coin-box lines are identified by the class-of-service indication. The path-setting sequence involves up to 5 separate paths (see Fig. 8). When the coin-box telephone receiver is picked up, the first path (path 1/2) connects the line termination to a free register. This busies the calling line while a coin-and-fee-checking unit is being found. Next, path 3/4 is connected from the selected coin-and-fee-checking unit to the register (incoming side), followed by path 5/6 from the coin-box line to the second terminal of the coin-and-fee-checking unit. When the continuity of these last 2 paths has been checked, path 1/2 (now redundant) is released, and the register connects dial tone.

Later, when the caller has sent sufficient digits to identify the outgoing route or line, a fourth path (path 7/8) is connected from the register (outgoing side) to, for example, a junction on the outgoing route concerned. The register signals to the next exchange over this connexion. At the same time, a fifth and final path (path 9/10) is selected to connect the coin-and-fee-checking unit to the outgoing junction. When the call is set up to the distant customer, paths 3/4 and 7/8 are released together with the register. This leaves the coin-box line connected to an outgoing junction through the coin-and-fee-checking unit via paths 5/6 and 9/10, and conversation can take place.

Local Numbering Schemes

Call routing is controlled by the main-control-unit programme and the capacity of the cyclic store to store routing/translation data. Both linked and self-contained numbering schemes with local directory numbers from 4-8 digits can be accommodated. The facilities provided allow the TXE4 system to be used in any UK local-exchange application. The programme can include digit-absorption and digit-insertion facilities and this, combined with class-of-service indications on incoming junctions as well as customers' lines, means that the TXE4 system can be used as an integrated extension of a Strowger exchange. Calls can be accepted from, or sent into, a wide variety of selector levels in the Strowger exchange, as necessary. This feature permits staged replacement or extension of Strowger exchanges, and is an important contribution to the UK exchange modernization programme. Integrated Strowger/TXE4 exchanges are designated *hybrid exchanges*.

Subscriber Trunk Dialling

The initial digit 0 dialled on a trunk call normally routes the call to the nearest group switching centre (GSC). However, the comprehensive digit-analysis/call-routing capability of the TXE4 exchange programme allows flexible examination of STD and ISD codes and can, if required, switch selected calls directly to other GSCs or local exchanges. This feature can be used to reduce the traffic that must be circulated via the GSC STD equipment.

Automatic Alternative Routing

In common with most modern systems, TXE4 makes provision for an alternative and a basic translation against selected dialling codes. The alternative translation can be used whenever route busy conditions are encountered outgoing from the TXE4 exchange. This facility has complex network traffic implications and is not being used in early TXE4 exchanges.

Telephone Service Observations

This facility is another interesting example of serial trunking. The telephone-service-observations circuit is connected by a highway to all main control units and can signal to them when observation is required, identifying the type or types of call to be observed. When the signal is given, the first main control unit to encounter the required call type sets up one path in addition to the normal serial trunking sequence for the call concerned. The additional path connects, for example, the calling-customer's line to the observation circuit, and a high-impedance tapping circuit prevents transmission degradation. The extra telephone-service-observation path can be released without affecting the progress of the observed call. Thus, telephone-service-observation facilities are given without either auxiliary switching or special jumpering. In addition, since the entire exchange contributes to the observed sample, the arrangement ensures minimum delay between the presentation of successive calls to the observation equipment.

CONCLUSIONS

This first part has given a general introduction to the TXE4 electronic exchange system. Some of the philosophies adopted in the design have been described and the modular areas into which the exchange is divided have been explained. The TXE4 system owes much of its flexibility to the use of a general-purpose network allied to a programmed control, and the way in which some of the facilities have been provided has been demonstrated. Later parts of this article will explore, in greater depth, the design of the TXE4 exchange equipment, and will go into the important aspects of system security and maintenance.

References

- ¹ MAY, C. A. Electronic Exchanges: The Steps Leading to TXE4. *POEEJ*, Vol. 65, p. 134, Oct. 1972.
- ² SHEPPARD, S. H. The Leighton Buzzard Electronic Telephone Exchange. *POEEJ*, Vol. 59, p. 255, Jan. 1967.
- ³ VOGAN, D. H., and PRICE, C. D. E. The TXE3 Experimental Electronic Exchange System. *POEEJ*, Vol. 62, p. 142, Oct. 1969.
- ⁴ DAVIS, E. Management of the TXE4 Electronic Exchange Project. *POEEJ*, Vol. 65, p. 247, Jan. 1973.
- ⁵ LONG, R. C., and GORRINGE, G. E. Electronic Telephone Exchanges: TXE2—A Small Electronic Exchange System. *POEEJ*, Vol. 62, p. 12, Apr. 1969.
- ⁶ BEASTALL, H., and POVEY, J. A. Teletraffic Studies of TXE4. *POEEJ*, Vol. 65, p. 251, Jan. 1973.
- ⁷ PAIS, A. F. Traffic Characteristics of the TXE4 Electronic Exchange. *POEEJ*, Vol. 68, p. 163, Oct. 1975.

Local Distribution—An Assessment for Future System Development

Part 1—Short and Medium-Term Development

A. G. HARE, B.SC.(ENG.), C.ENG., F.I.E.E.†

UDC 621.395.743: 654.15

The British Post Office is currently implementing programmes that will involve increasing penetration of electronic, digital and software technologies into the main switched network. In local distribution, however, there has so far been little change either in line plant or in associated terminal equipment.

In this first part of a 2-part article, the evolving pattern of service demand is briefly reviewed, together with network implications and the relevant development of technology in the UK system. The prospects for future changes in local distribution are studied and alternative local-line options discussed, aimed at meeting both shorter-term and medium-term needs. In the second part, longer-term aspects will be considered.

It is noted that the future evolution of the local-line network will be significantly influenced by policy decisions in the provision of wideband services.

INTRODUCTION

As the British Post Office (BPO) deploys its resources to meet the demands for growth and expansion of the UK telecommunications system, it is also noting a quickening movement of interest towards new services and facilities. This interest is consistent with marked changes in patterns of communication occurring in society. These changes arise from factors ranging from developments in the way we live to a greater public awareness of the capabilities and potential uses of modern technology, and a desire to exploit such technology to the full.

The business of telecommunications is concerned with the transfer of information. The rate at which this can be done is largely conditioned by the capabilities of the network; capabilities that are expressed in terms of parameters such as the frequency bandwidth of the media. To meet adequately some of the service requirements now being seriously considered, however, would result in heavy demands on such capabilities. The repercussions on established systems in areas of transmission and switching and in the organization of traffic are, therefore, likely to be fundamental and far reaching. Clearly, there must be co-ordination in the development of the overall telecommunications system to meet new demands. The dangers inherent in permitting haphazard and piecemeal growth of projects, which satisfy only limited situation needs and which may constrain wider system evolution, must be recognized. It is logical to aim for a rationalized development toward the objective of an integrated system; integrated both in the way customer services and facilities are provided, and in the manner of realization of the essential transmission, switching and signalling media. The scenario for this development must be flexible and realistic; flexible in its capability of dealing with variations from predicted patterns and realistic in the economics of implementation.

FACTORS INFLUENCING LOCAL-SYSTEM DEVELOPMENT

The foregoing general comments are particularly relevant when applied to that part of the telecommunications system described as the local network and, within this, the local-line

network (see Appendix 1). The problems here for system planners are compounded by:

(a) the difficulty of predicting, both in the short term, and, perhaps more so, in the long term, the nature and pattern of service demand; factors such as the range and scope of possible new vision services and the likely effect on the system of varying degrees of their implementation become markedly significant,

(b) the uncertainty of making the right choice of technological strategy from the expanding variety of options which are increasingly available for planning consideration, and

(c) the problem of variation within the local network of the type of territorial environment; that is, the geographical situation, the density and type of premises and the methods already in use and which could be adopted both now and in the future for the provision of the various services.

In addition to these uncertainties, there is the necessity for development of the local system to remain complementary to, and entirely compatible with, evolutionary progress in the main part of the telecommunications system. The size of the UK inland network is not without significance here; the consequences of making even small and apparently isolated local changes can be widespread and repercussive. In short, there are a large number of constraints.

Before any attempt is made to decide whether any radical local-system changes are necessary, or even desirable, a clear assessment is required to establish the likely needs of the customer; that is, to identify the broad pattern of his probable requirements, both in the shorter-term and longer-term future. This is because even the most successful of technologies applied to the provision of some new service would not be able to avoid unfortunate business repercussions if the service were to be of little practical use or interest to potential customers. But the further into the future that predictions for specific services are taken, the greater is the probability of error in the assessment of their demand patterns.

THE BROAD PATTERN OF CUSTOMER SERVICE REQUIREMENTS

In making an assessment of the likely future pattern of requirements, there are some services which can be readily identified and for which demand can be predicted with an

† Telecommunications Systems Strategy Department, Telecommunications Headquarters.

TABLE 1
List of Future Services

Bandwidth	Switched or Non-Switched	Main Services	Other Services		Remarks
			2-Way	1-Way	
Narrow-Band (up to 10 kHz)	Switched	Telephony (PSTN) PSDDS Telex	Datel Viewdata Facsimile Telegraphy	Telemetry (alarms) Telecommand	Up to 4 kHz bandwidth or 64 kbit/s PCM equivalent
	Non-switched	Private circuits (Speech)	Datel Facsimile Telegraphy	Music Telemetry (alarms)	Typically up to 4 kHz, but could require up to 10 kHz
Medium-Band (10 kHz to 1 MHz)	Switched	Viewphone PSDDS	Facsimile Viewdata Data	Surveillance Telemail Home newspaper	Up to 1 MHz or equivalent 6 Mbit/s
	Non-switched	Private circuits	Data Facsimile CCTV	Surveillance Telemail Music††	††Includes stereophonic broad- casts at 55 kHz/channel
Wideband (Over 1 MHz)	Switched	Viewphone*	Facsimile Viewdata Data	Telemail Home newspaper Surveillance	*5.5 MHz/channel
	Non-switched	Broadcast Entertainment television*‡	CCTV* Confravision* Facsimile	Business television* Educational television* Pay television*† Telemail Surveillance	†Selected service ‡Includes FM radio.

PSTN—public switched telephone network
PSDDS—public switched digital data service
CCTV—closed-circuit television
PCM—pulse-code modulation
FM—frequency modulation

acceptable level of confidence. Examples include telephony (both business and residential components), Telex, (the teleprinter service) and Datel (the variants of the data service).

However, there are new services which may be required, particularly of a video or audio-video type, for which demand and pattern of future growth is completely unknown at the moment; for these, any attempt at predictive assessment must be quite speculative. Such services would include

- (a) person-person visual communication; for example, Viewphone and Confravision,
- (b) man-machine interaction, such as iterative services, programmed information and learning, and
- (c) machine-machine communication; for example, computer-computer dialogue.

All these services could involve fast information transfer and the need for this capability could significantly influence system development, particularly in the implications for the network of the channel bandwidth and switching requirements.

Also, there are other services of a broadcast type, audio and video (for example, entertainment, educational and community), which set their own characteristic network requirements in terms of transmission, switching and control, and influence network topology.

Table 1 sets down a range of services likely to be required within the foreseeable future, and classifies the services in terms of the probable bandwidth needed and on whether or not they will require to be switched. The table is not intended as a complete catalogue, but serves to demonstrate the diversity of the likely demands on system capability.

In interpreting these services into system hardware, the growth rates and penetrations are highly significant factors. An important study aspect must, therefore, be the acquisition of socio-economic/service information, enabling credible predictions to be made of likely demand patterns. As part of

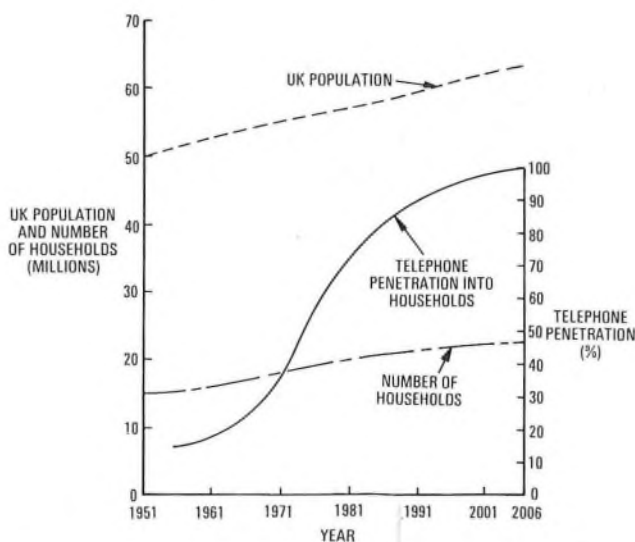
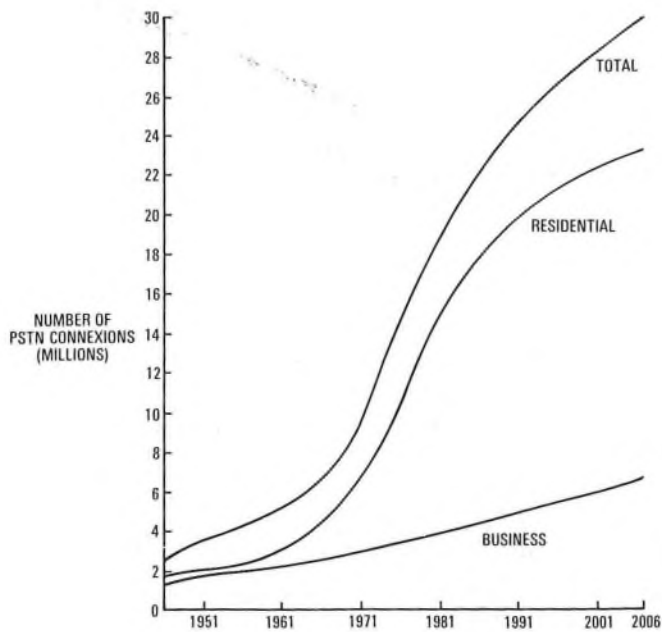

FIG. 1—UK population, households and residential telephone penetration forecasts

a current study in the BPO Telecommunications Headquarters (THQ) Telecommunications Systems Strategy Department (TSSD),¹ groups of 30-year forecasts for several services based on this approach have been assembled. Examples are illustrated in Figs. 1-5.

Residential telephone penetration is shown against growth of households and UK population in Fig. 1. The forecast breakdown of public switched telephone network connexions is shown in Fig. 2; the forecast for data and Telex connexions is shown in Fig. 3. Entertainment television forecasts are given in Fig. 4, related to households and television licence issues;



PSTN—public switched telephone network

FIG. 2—Public switched telephone network connexions forecast

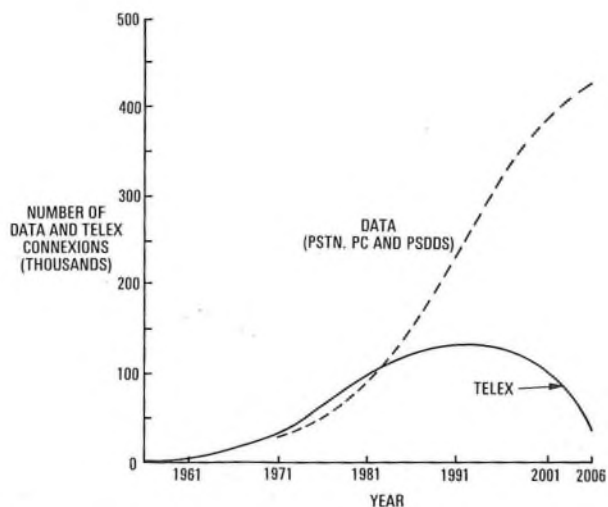

PC—private circuits

FIG. 3—Data and Telex connexions forecast

they are based on one of a specific range of cable television growth projections which allows approximately 50% overall service penetration by the year 2006. Finally, in Fig. 5, educational, pay and business television, and Viewphone forecasts have been assembled. All the figures illustrate mean-value curves, derived from demand projections used in the THQ/TSSD work.

The forecast information has been summarized in Table 2 to provide one of a family of "telecommunication futures", giving a quantifiable base on which to develop a range of technological options for the local-line network. The table describes a demand pattern midway within the projected limits set in the THQ/TSSD study.

Allowing for the uncertainty of such predictions, it is nevertheless apparent that the future UK network will be required to carry and switch a wider range of services than at present, and that some of these will require channels having frequency bandwidths considerably greater than are currently

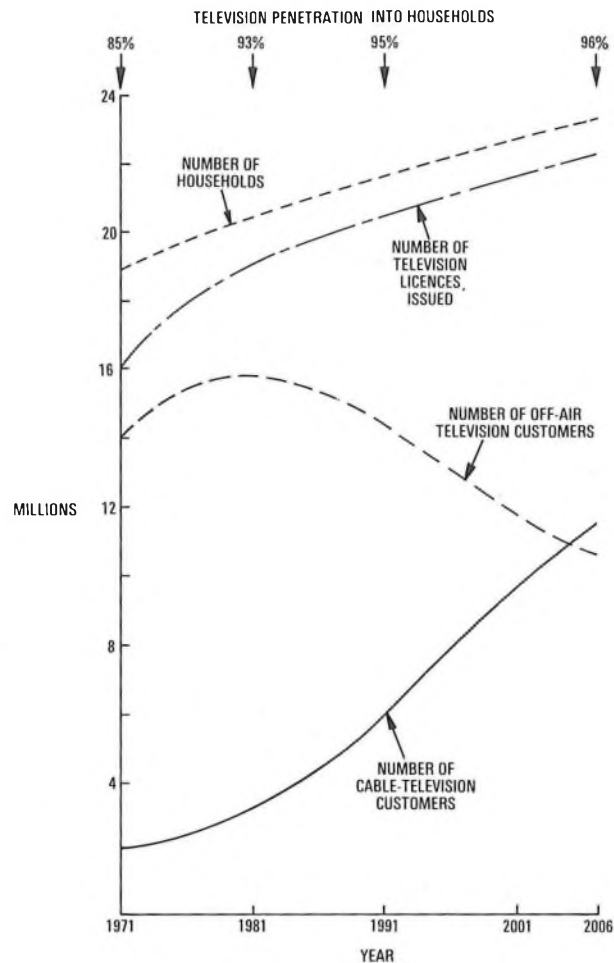

FIG. 4—Entertainment television forecasts

available. Provision will be needed in the local-line network for customer access to this system, access which will also be on a wideband basis.

SYSTEM TECHNOLOGY

UK Main (Trunk) Network Trends

Any authoritative study of systems principles and techniques of potential application in the evolution of local telecommunication, must take into consideration advances in technology being made over a broader area of interest. There are, for example, lessons to be learned from developments in the main network, where relevant trends in systems philosophy can be identified.

Here, for many years, in the transmission field, development of the long-haul or trunk system has been based on the application of analogue principles and frequency-division-multiplexing (FDM) techniques, which have been successfully refined as development proceeded. But, for some time, pressures for more fundamental changes have been growing.

The United Kingdom Trunk Task Force (UKTTF) was set up to study the situation and, in its final report in October 1971, made a number of recommendations.² One of these was that high-capacity digital transmission systems should be developed and introduced into the trunk network as early as possible as part of the planned move to digital working.

In the switching area, hitherto dominated by electro-mechanical systems using space-division switching methods, the need for far-reaching changes has also been demonstrated.

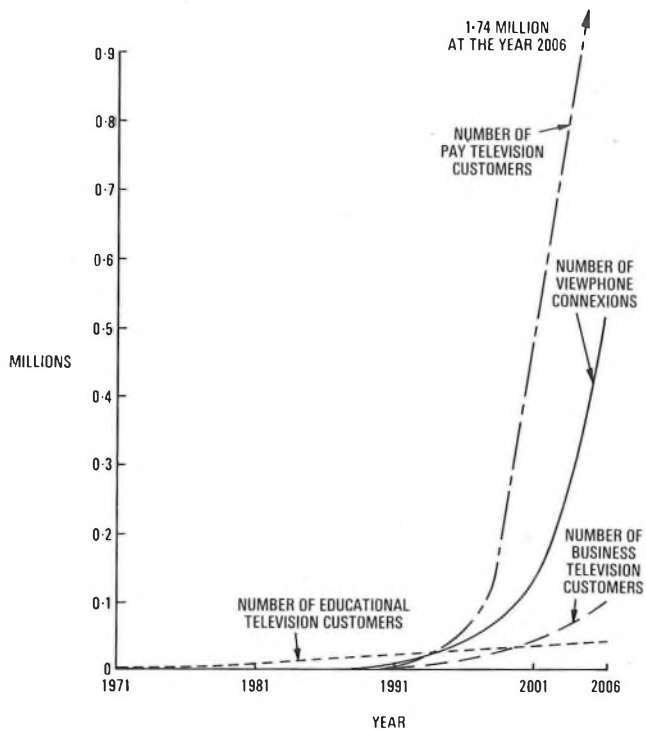

FIG. 5—Educational, pay and business television and Viewphone forecasts

A further recommendation arising from the UKTTF study was that digital switching should be introduced into the trunk portion of group switching centres, in conjunction with the planned introduction of digital line plant.

A long-term objective was identified as the introduction of an overall digital transmission and switching capability, local exchange to local exchange.

The reasons for the trend to digital system technology have been discussed elsewhere³, and include flexibility and compatibility with modern component technology. Also, there is evidence that integrated digital transmission and switching offers economic advantages over analogue transmission and space-division switching. System flexibility is a particularly important factor as the number of different services increases.

In the light of the trends mentioned above, it is possible to envisage in the trunk and junction system, within the next decade, the progressive introduction of high-capacity time-division-multiplex hierarchies which will augment, and ultimately replace, present audio and FDM traffic assemblies. The backbone of an all-digital network will develop; fast digital methods of setting-up, routing and management of traffic will be established.

Hitherto, broadly, system advances and reduced network costs have come from fuller exploitation of the available transmission media and more intensive development of existing technologies. But, more recently, and certainly in the future, much more will be gained by the utilization of new wideband transmission media and the availability of new component technologies, coupled with greater realization of the economies of scale.

The Local-Network Situation

Progress in technological innovation, trends such as those increasingly apparent in the main part of the system, require to be carefully noted when studying the local-network situation and assessing options for the future. However, before discussion of these options, comment on the existing situation is relevant.

TABLE 2

Forecasts of Existing and Future Services

Service	Band-width	Forecast in Millions at			
		1975	1981	1991	2006
Data Connexions Datel (PSTN) Datel (PC)	Narrow Narrow and medium	0.045	0.093	0.237	0.425
PSDDS					
Facsimile Terminals	Narrow, medium or wide	0.01	0.08	0.5	0.92
Telemetry Terminals	Narrow	?	?	?	?
Telephony Connexions	Narrow	13.6	19.2	24.8	29.8
Telex Connexions	Narrow	0.05	0.10	0.132	0.03
Viewdata Terminals	Narrow, medium or wide	?	?	?	?
Viewphone Connexions	Medium or wide	0	0	0.01	0.52
Cable Television Customers:	Wide	0	0	0.005	0.10
Business Television					
Educational Television					
Entertainment Television (Plus FM Radio)					
Pay Television	2.3	3.3	6.0	11.6	
CCTV Circuits	Wide	0	0	0.01	1.74
Confravision	Wide	?	?	?	?

The network serving the UK has been developed essentially to provide switched links between customers' equipment; links able to carry telephonic speech of an acceptable quality, together with any necessary routing and signalling information. The aim has been to do this efficiently, reliably and economically; an aim which, in no small measure, has been achieved, aided by steady and progressive development.

Within the inland local-distribution system, which is defined here broadly as the plant, cabling and terminal equipment connecting customers to the near-by main or group switching centre, large capital sums are now committed. These sums, in terms of plant and equipment, account for something like 59% of the working assets of the telecommunication system. Specifically, estimates of local-line plant show a 1975 book value of the order of £859M. The situation is summarized in Appendix 2.

With the present plant arrangement, the routing of calls from customers' premises is normally over separate pairs of wires to the local exchange, where access is gained to the junction and trunk hierarchy. Whereas progressive development has, in the past, enabled more intensive exploitation and efficient use of equipment in the higher echelons of the system, there has been relatively little corresponding change in the local-network plant and equipment. The mode of

Local-exchange switching is still very largely dependent on relatively slow electromechanical devices, whilst transmission uses small-gauge pairs in multi-pair cables. Seen in terms of the capabilities of modern technology and the pressures for new services, the resulting constraints and limitations are becoming increasingly embarrassing to system progress; particularly so when the need for compatibility with existing plant is accepted as implicit in assessing the feasibility of providing any radically new facility.

The BPO is currently implementing a comprehensive modernization programme of capital plant in the exchange switching area.⁴ It is now possible to contemplate a progressive evolution through fast electronic control systems associated with hard-contact switches, to solid-state device technology utilizing time-division methods of switching and transmission. Future main-network strategy is currently the subject of intensive study and policy implementation work that will determine the arrival of a new generation of exchanges, generically termed *System X*. But implementation of the more advanced system principles at local-exchange level still remains some way off.

Meanwhile, the problem of achieving improvement in the capability of the local system has not yet been solved. It is a problem compounded by a number of factors. There is the reality of heavy plant commitment; plant with long useful life. There is serious under-utilization of local-line plant, both on a circuit-time and frequency-spectrum basis; the low telephone calling-rates in residential areas typifies this aspect. But then there is the increasing likelihood of a demand for service bandwidths that are quite possibly outside the existing network capability.

In the local-line network, the problem is being approached broadly on 3 fronts. There is, firstly, the immediate aim to exploit more fully the plant and equipment that already exists, to improve the services currently being provided and to carry new ones whenever possible. Secondly, there is a requirement to consider the medium term, in which the limited capabilities of the existing system are acknowledged and where the aim is to make suitable provision for the wider range of facilities, including wideband services, that are likely to arise over the next 20 years or so. Thirdly, there is the objective of providing for the longer-term system evolution; developing a network with the flexibility and capacity to carry adequately a total service requirement as yet not fully defined, and to do so in an advanced system environment.

Overall is the need to avoid making specific planning decisions that close options for future system development.

SHORT-TERM SYSTEM PROVISION

In the short term, the clear objective is to maximize the potential of the very large capital assets existing in the local-line network. Cables already in use are known to be capable of carrying traffic at signal frequencies considerably greater than are needed for the conveyance of speech signals, which occupy, for practical purposes, a frequency spectrum less than 4 kHz wide. A number of services are being planned or implemented to take advantage of this capability. One example is the subscribers' carrier system,⁵ in which a second 2-way speech circuit is assembled, using double-sideband signals on 40 kHz and 64 kHz carrier frequencies, on the single local-line pair carrying a normal audio circuit. Another is concerned with improvements in modulation and transmission systems that enable digital data services to be provided at higher information rates, typical objectives here being 9.6 kbit/s and 48 kbit/s.

There is a further area where it is possible to improve the transmission capabilities for existing services by the use of electronic add-on devices, such as loop extenders, in which some measure of bi-directional gain and/or correction is provided. Care is inevitably necessary in the application of

such devices for they are invariably frequency conscious and, although effecting improvements in one service aspect, might well preclude more intensive line exploitation for another type of service.

Although local telephone pair-type cables are in most cases adequate for speech without using electronic aids, if exploitation at higher frequencies is attempted, such characteristics as insertion loss and crosstalk, which are frequency dependent, set limits to system tolerance. Generally, impulsive noise, interfering carriers and similar hazards will always present difficulty, particularly as traffic loading increases.

It is when consideration is given to the possibilities of using existing local distribution for medium-frequency and wide-band services that these limitations become most apparent. The question arises of just how much can be achieved. It may be possible, under favourable network conditions and appropriate planning rules, to exploit the medium, for example, to carry a monochrome Viewphone system, transmitting, in an analogue mode, signals limited to a spectrum below 1 MHz; but much more relevant measurement information needs to be acquired before this could be recommended with confidence. However, the present small-gauge conventional pairs are not suitable for, say, a 625-line colour-television service, except under very special conditions; for example, where a temporary single vision channel set-up is required. Clearly, although it is imperative to exploit fully the existing pair medium, its limitations must lead ultimately to use of new media, if wideband services are to be implemented at any acceptable levels of penetration.

The problems associated with the provision of wideband facilities in new cabling situations (for example, new-town developments) are likely to be far less severe than those met in the progressive implementation of such facilities within existing area networks. The solutions to be applied may well differ as a consequence.

SYSTEM DEVELOPMENT IN THE MEDIUM TERM

For transmission purposes, media of potential use in the medium-term and longer-term development of the local-line network include

- (a) balanced-pair cables of superior performance,
- (b) coaxial-pair cables,
- (c) radio links carrying millimetric systems, and
- (d) guided-wave systems on, for example, optical fibres.

Assessment of these options must be conditioned by the state of development of the media concerned, and the availability of plant and equipment within the time scales of interest. For the medium-term system requirements, the first 2 of the above categories, taken singly or in some combination, must merit first consideration. The study, therefore, becomes one of potential application of appropriate cable systems.

The local-line network, as described in Appendix 1, consists of a number of main cable feeds between exchange and primary cross-connexion points (PCCPs), then primary and, sometimes, via other flexibility points, secondary connexions to the distribution points (DPs), which finally serve the individual customers.

One seemingly obvious method of making suitable wide-band provision would be to replace progressively this entire system by one having the same type of topology, but with superior cables; distribution throughout would continue on a separate-pair basis between exchange and customer. Of the 2 groups of cables available, high-quality balanced-pair and coaxial, the former appears to offer some short-term advantages. It would allow the existing telephone system to continue in its present form and make as much use of existing line plant as possible. There would be no new demands on exchange equipment for present-type telephony services. Introduction of some wideband services could be made on a

small scale, plant being provided only as required. The resulting capital outlay would, thereby, be minimized.

However, a number of disadvantages are apparent, these largely arising from the inherent bandwidth limitation of the balanced-pair media.

To achieve sufficiently low attenuation, heavy-gauge conductors would be necessary, and considerable care would need to be directed toward factors determining the cable characteristics, such as insulation, spacing and lay. It would be extremely difficult to produce cable of sufficient homogeneity to maintain good balanced properties at frequencies higher than about 15 MHz, although claims have been made for a high-frequency polyethylene-insulated cable usable up to frequencies of about 20 MHz.

But a significant factor is crosstalk. For a typical video channel, acceptable performance requires an r.m.s. signal-to-noise ratio better than around 50 dB. Signal impairment arises from a number of causes, including crosstalk (cross-view), cross modulation and intermodulation, all of which require some safety margins in the system. It is apparent, however, from a consideration of available crosstalk figures that even for relatively short-distance use in the distribution side of the local-line network, the cable frequency spectrum would be limited to the baseband of about 10 MHz. Furthermore, unless well-separated paths were chosen for separate high-frequency pairs, even for this limited part of the network, crosstalk difficulties could still be expected; penetration of wideband service would remain limited and careful planning rules would need to be adopted. Methods such as use of screened pairs would produce further loss effects and raise cost objections.

Whilst it is clearly feasible to use high-quality balanced pairs for video transmission over part of the network, to provide a full 625-line standard colour-television transmission, one pair would be required for each direction of transmission. If, in addition, a number of broadcast channels were to be made available to the customer, very severe restrictions on cable length and planning parameters would ensue.

The alternative choice for a single-pair replacement cable would be a coaxial type. This has a transmission bandwidth capacity at least an order of magnitude greater than high-quality balanced-pair cable, and the cost and overall size is comparable. Severe crosstalk problems would not arise and systems would not need to be engineered at the limits of their capability. An adequate number of services could be carried on each coaxial cable, with scope for further exploitation as required.

However, if a single coaxial cable were to be used as a replacement for an existing pair, modifications to the existing telephone system would be necessary, arising in part from the need to avoid the baseband. Nevertheless, studies have shown⁶ that an individual coaxial-cable distribution system of modified form is technically feasible, although its economic viability is dependent on the extent of wideband service requirement and costs of multiplexing.

The previous comments, whilst serving to highlight some of the differences between the 2 cable types, deal with a situation which, for the medium term, at least, is largely hypothetical; that is, the entire replacement of local distribution on an individual-feed basis. It must be clear that such organizationally simple solutions would not solve the problem of under-utilization of local plant. Customers could not share the media on a traffic/demand basis; for a common distribution service such as broadcast television, plant would be seriously over provided. Such factors as this weigh heavily against individual cable schemes. Finally, the economic implications of entire replacement on a large scale of individual connexions between exchange and customer are sufficient to deter any such proposals.

Nevertheless, the inherently greater bandwidth capability of the coaxial medium, with its possibilities for the multiplexing of several services, offers opportunities for applying

sharing techniques where economic advantages could accrue; particularly in the more heavily loaded sections of the local-line network. In this context, the PCCPs become significant, partly because of their key position in the network and partly because they are served by ducted routes which facilitate cable replacement. A number of possible options can then be considered, largely dependent on the ability to effect system changes at these flexibility points. Several such schemes have been proposed, offering various degrees of capacity for penetration of wideband services. They are generally aimed at avoiding disruption of existing telephone provision and applying principles of progressive implementation with some degree of overlay.

In the second part of this article, 2 examples of such schemes will be discussed briefly, together with several aspects of the longer-term development of the local system.

References

- 1 THQ Local Lines Task Force, Progress Report—Stage 1, Feb. 1974.
- 2 THQ United Kingdom Trunk Task Force Report, Oct. 1971.
- 3 BRAY, W. J. The Expanding Role and Integration of Telecommunications. EUROCON 74, Amsterdam, Apr. 1974.
- 4 BENSON, D. L. Local-Exchange Renewal Strategy: Formulating a Strategy. *POEEJ*, Vol. 67, p. 130, Oct. 1974.
- 5 KINGSWELL, L. W., and TOUSSAINT, G. C. A Subscribers' Carrier System for the Local Network. *POEEJ*, Vol. 64, p. 213, Jan. 1972.
- 6 THQ Local Lines Task Force Stage 1 Study—Supplementary Report, Aug. 1974.

APPENDIX 1

The Local Network

The local network is the part of the BPO telecommunications network that is located between the primary centre and the customer. It may contain several local exchanges linked by junctions and includes all the associated line plant. The primary centre, currently known as the *group switching centre* and later to become known as a *main network switching centre*, is the point at which traffic enters or leaves the trunk network.

The Local-Line Network

The local-line network (Fig. 6) lies wholly within the local-exchange area and consists of the external plant required to connect customers' telecommunications terminal apparatus to the local exchange. There are 2 major sub-divisions of this network divided by a PCCP. On the exchange side of the PCCP, the network of cables is termed the *main network*, while from the PCCP to the DP, the plant is classed as the *distribution network*. A secondary cross-connexion point (SCCP) may be interposed between the PCCP and the DP. (Cross-connexion points are often referred to as *cabinets* or *pillars*, the latter now regarded as obsolete, but these terms are not synonymous with PCCP and SCCP, since they refer to the physical shapes of the devices rather than their function. In practice, either a cabinet or a pillar could be a PCCP or an SCCP.)

There are also cables which connect the exchange main distribu-

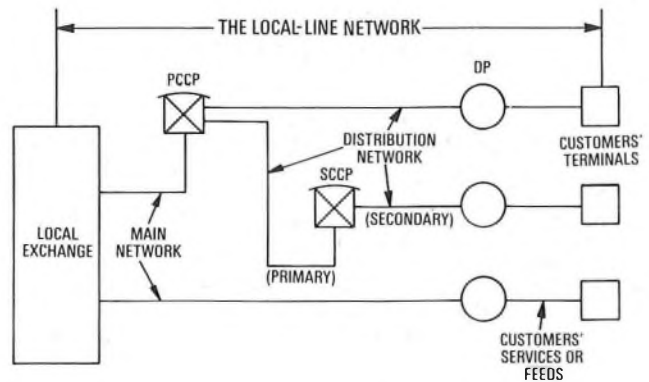

PCCP—primary cross-connexion point
SCCP—secondary cross-connexion point

FIG. 6—The local-line network

TABLE 3
Breakdown of Route Lengths

Distribution Mode	Percentage of Total Customers	Average Lengths (m)					
		Exchange to Cabinet	Exchange to Pillar	Exchange to DP	Cabinet to Pillar	Cabinet to DP	Pillar to DP
MDF-DP (direct)	15	-	-	1570	-	-	-
MDF-Pillar-DP	2	-	1160	-	-	-	436
MDF-Cabinet-DP	68	1540	-	-	-	373	-
MDF-Cabinet-Pillar-DP	15	1340	-	-	467	-	242

tion frame (MDF) with a DP directly; these are included in the main network.

The plant between the DP and the customers' terminal equipment is termed the *customers' service* (or feed).

APPENDIX 2

The Local-Line Network—A Background Note

Line Plant

Local-line plant is currently an assembled network of individual pairs of wires, connecting customers' equipment to local exchanges. To take advantage of the economic savings which can be made by providing pairs in suitable instalments, intermediate access to the network is afforded at suitably-sited cross-connexion points (CCPs). Customers' services are distributed from DPs which, generally, are designed to permit a connexion of pair multiples, collected together inside a single cable sheath, to individual leads-in. Between the exchange and the DPs, the pairs are provided in cables that taper in size (that is, number of pairs) as they progress away from the exchange. The cables are normally provided below ground level, usually in previously laid ducts and accessible at underground joint boxes. Between the DP and the customer, several methods of plant provision are in use; these fall broadly into 2 categories.

(a) *Overhead* The DP is mounted at the top of a pole, and a span of wire or cable is suspended between this point and the customer's premises.

(b) *Underground* The customer's service feed is provided below ground level and becomes in effect an extension of the underground cable network as a whole. It can be ducted or directly buried.

The UK network consists of about 19.5-million main-network

pairs (exchange-PCCP), and about 21-million distribution-network pairs (PCCP-DP) with approximately 2-million DPs.

Route Lengths

The average exchange-line route length is approximately 1.925 km; 1.875 km exchange-DP and 50 m DP-customer. A breakdown of the route is shown Table 3.

Table 3 shows that 83% of customers are fed via a cabinet. For these, the exchange-PCCP distance is 78% of the exchange-customer distance.

Plant Value

The net book value of local-line plant (at 31 March 1975) has been estimated to be £709M (excluding customers' service feeds), of which about 52% is duct and jointing points (including cabinets and pillars), 33% underground cable, and 15% overhead plant. During 1974-75, the net asset value increased by £71M. The net book value of customers' feeds is estimated to be of the order of £150M, making a total line-plant figure of around £859M.

Commitment to the Present Style of Network

Telephony penetration into households is, at present, rising rapidly; for example, it is forecast that over 80% of residential tenancies will have a telephone in 10 years' time compared with only 50% at present. To meet this demand, pairs are being added to the local network at the present net rate of about 1.5-million/annum, in both main and distribution networks. Assuming that this rate of growth continues, the penetration of pairs to households in the distribution network will reach 100% around 1977-78 and saturation (that is, beyond which growth is confined to new residential development) at about 1981-82.

Book Review

IEEE Recommended Practice for Emergency and Stand-by Power Systems. John Wiley & Sons Ltd. 111 pp. 45 ills. £5.40.

An attempt is made, in about 100 pages, to identify the factors justifying the provision of emergency and stand-by power systems, and to give a brief description of some of the more common types of hardware available.

The publication is aimed at commercial and industrial users who do not have the services of professional power engineers at their disposal. USA practice, legislation and costs are quoted throughout, but the systems described could be applied universally.

The book falls broadly into 2 parts, a little over half being devoted to users' needs and possible motivating factors for providing emergency stand-by power, and the remainder covering the systems available on the market.

Although the section covering users' needs could be said to be little more than common sense, it does give reasoned

arguments covering most needs for any potential purchaser who has not carried out a formal justification exercise. In the main, the arguments are all qualitative, leading towards cost-justification, but in the few cases where a quantitative approach is attempted, the mathematics are questionable.

The section on hardware attempts to cover a large subject in too few pages and, in doing so, is in danger of misleading the potential purchaser. The technical content of the section is substantially correct, but the space devoted to the various subjects is not consistent with their relative importance. It is unfortunate that at no point is a realistic comparison of different systems offering similar facilities attempted. In addition, little emphasis is placed on the cost of ownership once the equipment is purchased—a subject of great importance to the owner.

The book ends with a short chapter on case histories, which is rather dramatic and statistically meaningless. Finally, there is an extensive list of useful references. This is not a book for the power engineer, but may form a useful reference for the potential purchaser of emergency or stand-by power equipment.

R. E. E. C.

B. W. B.

Selecting an Earth-Station Site

P. S. J. DUFFY, C.ENG., M.I.E.E., M. A. STREETE, B.SC., C.ENG., M.I.E.E., and R. T. E. WING†

UDC 621.396.743: 629.783

This article describes the factors involved in the selection of a new satellite-communication earth-station site in the UK, and the layout of aerials and other buildings on the site, with particular reference to the new British Post Office earth station to be built at Madley in Herefordshire.

INTRODUCTION

The choice of location of any new earth-station site in the UK must take into account

- (a) the possible operational aerial azimuth and elevation angles,
- (b) the avoidance or reduction of radio interference from or to inland and overseas radio and radar systems, both existing and planned,
- (c) its relationship to the areas in which the international communications traffic is generated or received,
- (d) the availability of power and water supplies,
- (e) road access, and
- (f) availability of amenities for staff and their families.

The study must also cover the methods of connecting the earth station into the national terrestrial trunk network. It is important to assess the impact that the earth station will have on an area, together with the likely reaction of the public and district planning authorities. Satellite systems are still in a state of evolution, expansion and change. New satellite systems have been proposed. Possible changes to earth-station aerial designs and sizes can be foreseen, although it is not possible to determine if, or when, such design changes will be implemented, or their extent. Consequently, the layout of aerials and other structures on the selected site, and where appropriate, their order of construction, must be such as to give some flexibility to cater for changes to the initial plans.

† Telecommunications Development Department, Telecommunications Headquarters.

POSSIBLE SITE LOCATION

Aerial Angles of Operation to Satellites

The earth-station aerial pointing azimuth and elevation angles, required for operation to geographically-stationary (geostationary) satellites, depend on the latitude of the earth station and the longitude of the satellite relative to that of the earth station. Fig. 1 shows a graph of the operational azimuth and elevation angles for a typical UK earth-station aerial at a latitude of around 52°, when working to a satellite in a geostationary equatorial orbit. If a satellite is maintained in a truly synchronous orbit parallel to the equator, the aerial operates at one point on the full curve. If, as is usually the case, the satellite orbit is slightly inclined to the equator, the aerial pointing direction daily follows a figure-of-eight pattern centred on the nominal direction and confined within elevation-angle limits determined by the angular amount of the orbit inclination (see the dotted curves on Fig. 1); the maximum orbit inclination will not normally be allowed to exceed 5° and, in practice, INTELSAT satellites are usually maintained within a 0.5° orbit inclination. Nevertheless, in planning the layout of aerials and other structures on any given site, allowances have to be made for the 5° maximum orbit inclination.

Radio interference from terrestrial radio-relay systems and the noise picked up by an aerial from the earth and sky is greatest at the lowest elevation angles. Moreover, at the lowest elevation angles, signals have the longest path length through the troposphere and, therefore, suffer the greatest variation in propagation-path conditions and attenuation. Hence, it is

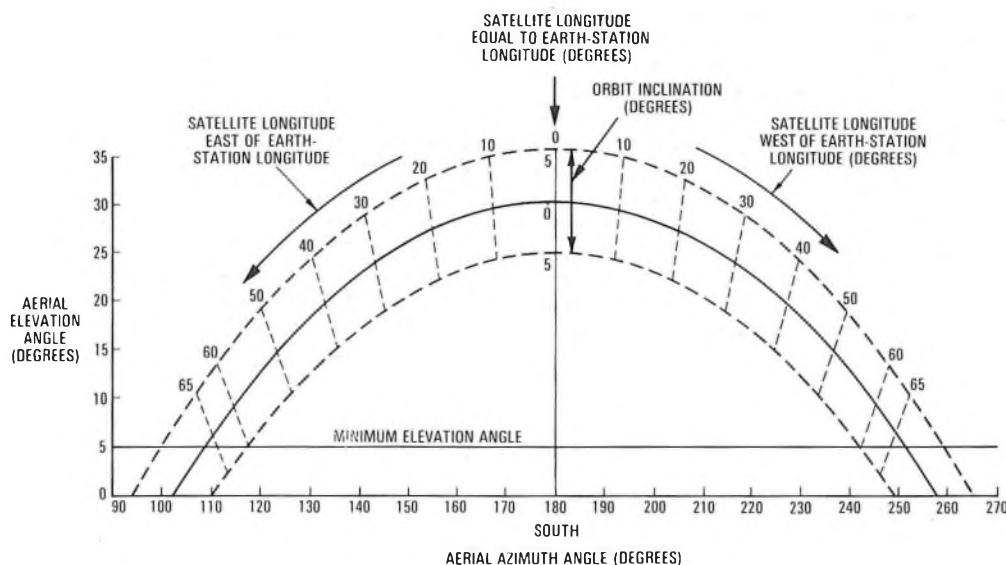

FIG. 1—Aerial azimuth and elevation angles for a latitude of around 52° when operating to geostationary satellites

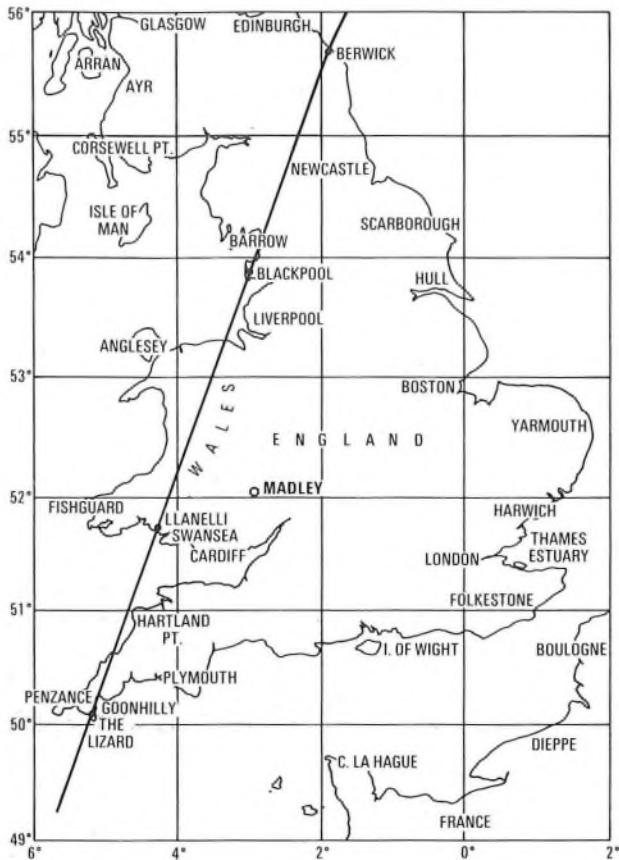

FIG. 2—Contour for 5° elevation angle of aerial operating to an Indian Ocean satellite at longitude 63° 15' east

a mandatory requirement that the minimum operational elevation angle be limited to 5°. Some UK aerials will work to a satellite stationed over the Indian Ocean and will be operating at, or near, the 5° minimum elevation angle. This factor limits the site location to the area of the UK to the east of the arc shown in Fig. 2; it is preferable that the site be in the east of the UK to raise the operational elevation angle.

Terrestrial Link Economy

The areas of the UK in which the international traffic terminates, and the length, capacity and cost of the terrestrial links between these areas and the earth station, are important factors in the selection of an earth-station site. At present, most of the international traffic is terminated in, or passes through, London. The distribution of traffic and its routing over the terrestrial network will eventually be altered to a certain extent by the establishment of international switching centres throughout the UK and, perhaps, the dispersal of businesses from London. But, for at least the next decade, it is unlikely that the distribution of traffic sources will be radically changed. Thus, it is preferable to have the earth-station site as near to London as practicable to minimize the length and cost of the terrestrial links.

Avoidance of Interference

There is an extensive line-of-sight microwave radio-relay network in the UK, and it shares common frequency bands with the satellite services. This radio-relay network is being continually expanded and extended. Any new earth-station site must be kept away from these terrestrial radio-relay systems, and far enough away from their directions of propagation to avoid the possibility of interference from signal overshoot. This is a most stringent restriction that greatly

reduces the area within which an earth-station site could be located.

Other civil and military authorities operate radio and radar services in the UK. These, too, are in a continual state of expansion and change. Although they do not necessarily share the same frequency bands as the satellite services, they may generate harmonic or spurious frequencies that fall within the satellite bands. It takes time to locate and identify such sources of interference, and arrange for their owners to take corrective action. Hence, it is prudent to select earth-station sites that are unlikely to suffer unduly from such spurious interference. These interference mechanisms were described in an earlier article.²

During certain weather conditions, usually following a period of fine settled weather, the existing Goonhilly earth station has suffered intermittent interference from the French microwave terrestrial radio-relay systems, owing to abnormal propagation conditions over the sea. Goonhilly is situated on a high exposed plateau on the Lizard peninsula, Cornwall; this site was specifically chosen to be as far west and south as possible to meet the requirements of an experimental satellite system linking the USA and UK via low-altitude satellites (*TELSTAR* and *RELAY*) in elliptical orbits, to establish the feasibility of satellite-communication systems. The interference from France has been detected only during the last few years, and the levels are substantially higher than those predicted by the propagation data available at the time Goonhilly was selected. This interference could be prevented only by costly, time-consuming, continuous and tedious planning of the co-ordination of the use of particular frequencies in the terrestrial and satellite systems involved, but this could lead to unwelcome restrictions on the growth and expansion of both systems. The use of current co-ordination procedures has not eliminated this interference. Further, the continental terrestrial microwave radio-relay systems are being expanded at a rapid pace. Thus, to reduce the likelihood of interference from Europe, it is more practicable to keep the earth-station site away from the east and south coasts, to take advantage of the longer propagation-path distance and the higher attenuation over land.

Some shielding against interference can be provided by low hills surrounding a site. Thus, a site in a natural bowl or valley is preferred. However, the aerials may be required to point in any direction, from east through south to the west. Their operational elevation angles will range from 5° near the east or west to about 30° in the south; consequently, the surrounding hills must be low enough to allow the aerial beam to pass without obstruction, but high enough to give reasonable shielding from radio interference. This is discussed in greater detail later in this article.

Very low levels of microwave-frequency noise can be generated from high-voltage (35 kV/132 kV) power-line equipment when insulators become contaminated badly enough for tracking to occur. Usually, the levels of noise are too low to affect earth-station systems, but as a precaution, no aerial system should be within about 100 m of such high-voltage power-line equipment. Another source of interference is the possible obstruction or reflection of an aerial beam by aircraft flying through it and, to reduce risks, a spacing of 1.6 km is recommended between the earth station and airports or air traffic lanes. There are many sources of man-made interference noise, such as industrial equipment and vehicle ignition systems, and interference from these sources can normally be detected only by making measurements at the earth-station site.

Site Geology

The ground at the site must be strong enough to provide stable foundations for large aerial structures without the need for expensive and extensive deep piling. Many valleys and natural bowls were once river or lake beds, and their ground

strata often contain alluvium which is weak and unsuitable for aerial foundations.

Proximity to Roads, Services and Amenities

The earth-station site should preferably be close to a road, and power and water supplies to minimize the cost of providing these facilities. Staff and their families will require housing within reasonable daily travelling distance of the site and conveniently situated with regard to shops, schools and other amenities.

Impact of Earth Station on an Area

An important and critical factor is the assessment of the impact that the construction of an earth station will have on an area. In the UK, there are a number of influential organizations who safeguard flora and fauna or those special areas where rare insects, birds and other wild life are known to breed. District planning authorities, as well as the general public, are usually quick to reject any proposals that, in their opinion, could spoil an area of outstanding natural beauty. The planned development or preservation of an area could be seriously affected by the construction of an earth station. It could place restrictions on the size and use of other near-by structures. It will generate an increase in the amount of road traffic from earth-station staff and suppliers, as well as sight-seers. The influx of earth-station staff and their families will result in an increased demand for housing, a growth in local trade and employment, and possibly an expansion in schools. It is essential to win local support for any proposal for the establishment of any new earth station, otherwise planning consent might be refused or there could be long delays in obtaining planning consent.

In general, standards, opinions and beliefs are as varied as are the number of people, and are very often inconsistent. False rumours spread like wildfire, and it is essential to present the facts publicly and openly as early as practicable.

Summary of Site-Selection Factors

Summarizing, the general objectives of a search for an earth-station site in the UK are that the site should be

- (a) near London, but not too close to the east or south coasts,
- (b) remote from terrestrial radio-relay and other radio systems,
- (c) surrounded by low hills,
- (d) near to a road,
- (e) near power and water supplies,
- (f) reasonably close to a small town,
- (g) away from areas of outstanding natural beauty,
- (h) at least 1.6 km from airports or air traffic lanes, and
- (i) composed of adequately strong ground strata.

London is a terminal for many terrestrial radio-relay systems whose routes emanate from all around London; thus, there is a conflict between the need for the site to be near London and yet away from terrestrial radio-systems. Further, the site should be large enough to carry a specified minimum number of aerial systems. An important point is the cost of a site; any site in a town or suburb, or in an area scheduled for industrial or housing development, will be very much more expensive than agricultural land. Therefore, careful comparison of overall costs, not just site costs, would be necessary to find the cheapest suitable site, if there were more than one. The major difficulty is the need to avoid or reduce radio interference; the remaining factors are not too restrictive.

METHOD OF SEARCHING FOR SITES

The search for earth-station sites commences with a map search for prospective sites that appear to meet the technical

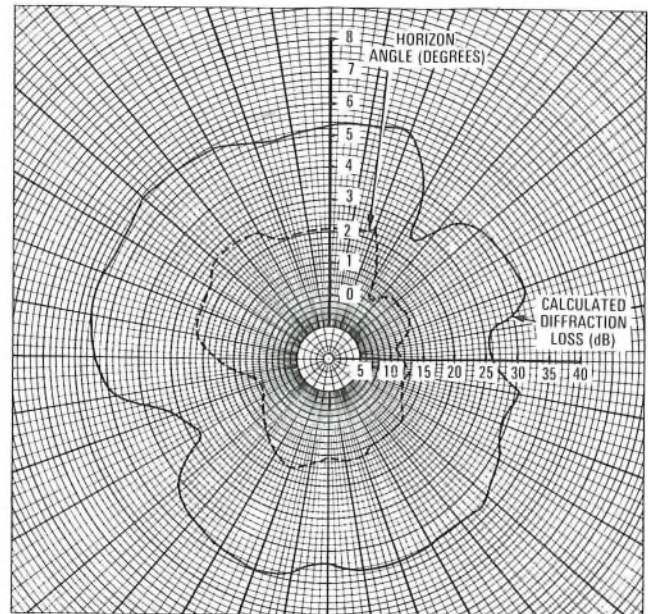
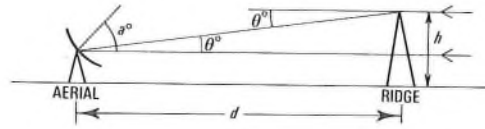

FIG. 3—Plots of horizon angles and diffraction loss

criteria discussed previously. Each prospective site is then considered in more detail. The distances to the horizon and the heights of the horizon relative to the height of the aerial centre are found from the map contours for all directions, and a drawing of the horizon angles is produced (shown by the dotted curve in Fig. 3). This information is subsequently used to determine the diffraction loss; that is, the extent of the shielding from interference. Next, the interference levels at each site from all known sources are calculated, taking into account all shielding factors, and compared with predetermined tolerable interference levels. If all likely interference levels are considered tolerable, the geology of the site is studied using existing data obtained from the Geological Museum in London and other sources. If the ground strata appear satisfactory, measurements of interference levels are made, both at the site and on near-by high ground, to enable the amount of site shielding to be assessed. Assuming that the level of any likely interference is tolerable, the final stage is to carry out a site inspection and land-level survey, together with drilling geological test bores and making ground-loading tests. Simultaneously, the local planning authorities are consulted about the prospects of obtaining planning consent for the construction of an earth station and the current plans or proposals for the development of the site and surrounding area. If the response is favourable, preliminary negotiations are started for the purchase of the site and the obtaining of formal outline planning consent based on a provisional layout of aerials and other buildings on the proposed site.

PRINCIPLES OF SITE SHIELDING FROM RADIO INTERFERENCE

The need to reduce interference from national and continental sources led to studies of various forms of site shielding to reduce significantly the flux densities of interfering signals. Artificial screens in the form of a pit³ and fence⁴ had already been proposed for specific applications. However, these proposals appeared unattractive both economically and aesthetically. The logical alternative, therefore, was to investigate the possibility of using natural topographical shielding by siting an earth station so that a ridge of high ground existed between the earth-station site and source of interference. Where many sources of interference exist around any site, the ideal site would be in a shallow bowl. Provided that



(a)

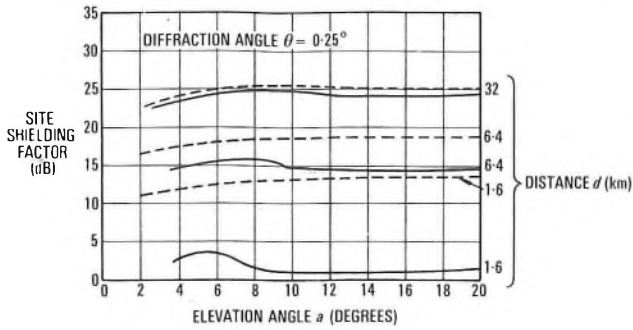

(b)

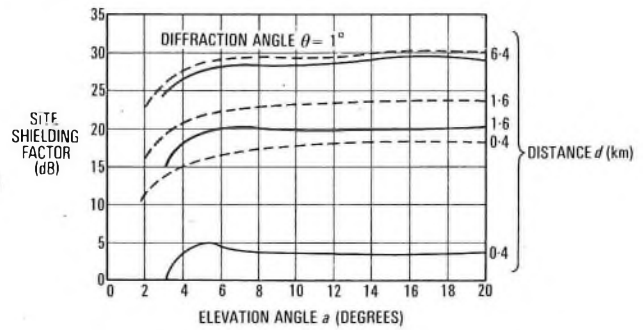

(c)

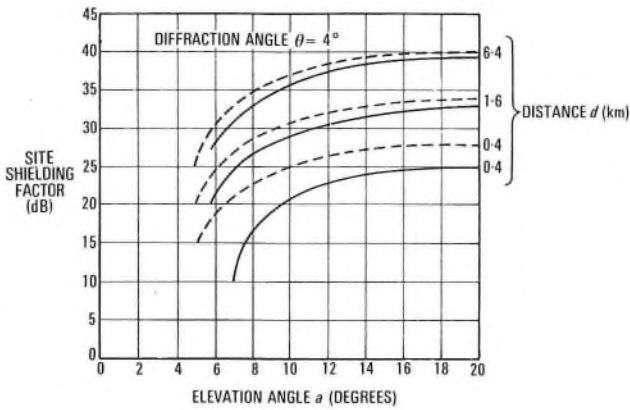

(d)

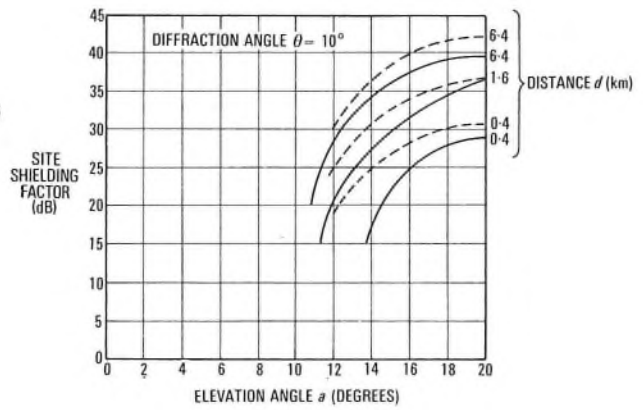

(e)

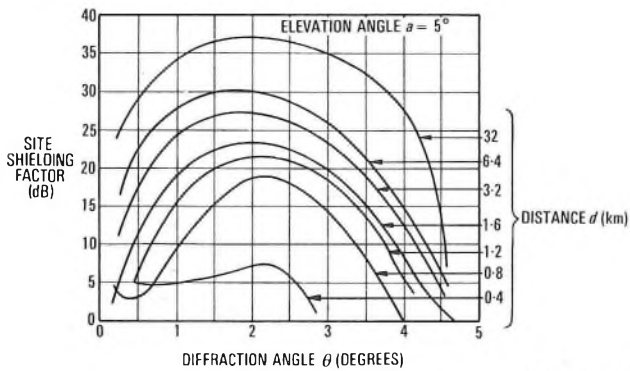

(f)

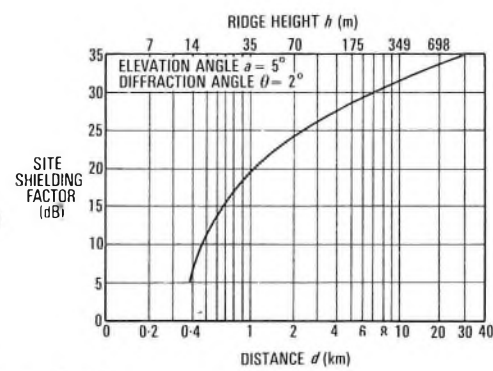

(g)

$$\begin{aligned}
 & \text{---} 20 \log_{10} \left\{ \frac{\pi^2 \theta}{90} \sqrt{\frac{d}{\lambda}} \right\} + 25 \log_{10} \left(1 - \frac{\theta}{\alpha} \right) \\
 & \text{---} \text{RESULTS OF COMPUTER PROGRAMME}
 \end{aligned}$$

FIG. 4—Site shielding factors for a 30 m aerial at 4 GHz

at any operational azimuth angle the main beam of the aerial clears the horizon, there will be no reduction in the power of wanted signals at the earth station; by the same token, the topography will not give significant shielding against interference arriving at low angles above the horizon angle; for example, from tropospheric scatter.

The ratio of the interfering signal power that would be received at the earth-station aerial from a specified azimuthal direction in the absence of topographical obstruction, to the interfering signal power actually received from that direction is known as the *site shielding factor*. For most sites, the site shielding factor can be calculated approximately by using

diffraction theory⁵. However, there are 2 factors that can significantly reduce the site shielding factor from that predicted by this simple approach. Firstly, consider interfering radiation arriving horizontally at an earth-station aerial working at a fairly low angle of elevation. If an obstruction is introduced (see Fig. 4(a)), the gain of the aerial in the direction of the top of the ridge, at an angle $(\alpha - \theta)^\circ$ from the main beam, may be significantly more than the gain of the aerial in the horizontal direction, that is, at an angle of α° from the direction of the main beam. Secondly, the site shielding factor will be reduced if the obstruction is within the near field of the aerial.

In considering the field in front of a large aerial, an important parameter is the *Rayleigh distance* R , which is defined as $R = D^2/2\lambda$, where D is the diameter of the main aerial reflector or aperture and λ is the wavelength. The space in front of an aerial can be considered as consisting of 3 regions: the near-field region (distance from the aerial, $d \leq R$), the intermediate region ($R < d \leq 4R$), and the far-field region ($d > 4R$). In the near-field region, the aerial radiation from the main reflector is nearly all contained within a cylinder of diameter D . In the intermediate region, the radiation spreads out from this cylinder, and in the far-field region, it spreads out sufficiently to form the far-field radiation pattern.

It had been suggested⁶ that, if an obstacle is placed at a distance less than R from the aerial, in such a position that the main cylinder of radiation clears it, then this obstacle causes no change in the radiation pattern formed by the main radiation, although it might obstruct radiation due to spill-over and scattering. Little quantitative evidence on this topic had been published and, in consequence, there were considerable doubts about its validity. In particular, it was necessary to establish whether diffraction theory applies where the shielding (assumed to be a knife-edge ridge) is located within the near-field distance of the aerial aperture. Hence, the British Post Office (BPO) placed a study contract aimed at eradicating these doubts.

A summary of this study has been published⁷ and, in essence, is as follows. A computer model was developed for the prediction of the radiation pattern of a Cassegrain aerial, the alteration of this pattern in the presence of a knife-edge ridge and, hence, the evaluation of the site shielding factor. A comparison of the shielding predicted by this model was made with measurements obtained from a 3 m diameter Cassegrain aerial operating at 9 GHz. These measurements were made on a disused airfield using a hangar with a sliding door as the knife-edge, and included a number of tests where this obstruction was in the near-field of the aerial.

There was fairly close correlation between the predicted and measured site shielding factors. These results were used to derive the conditions for a 30 m aerial at 4 GHz. A flat-earth profile was assumed, and the effects of rounding of the diffraction edge and of vegetation were excluded. The computed results are shown by the solid-line curves in Figs. 4(b)–(e). The broken-line curves of site shielding factors in Figs. 4(b)–(e) were calculated using a formula derived as follows.

(a) The diffraction loss, S , due to a knife-edge ridge is given by

$$S = 20 \log_{10} \left\{ \frac{\pi^2 \theta}{90} \sqrt{\left(\frac{d}{\lambda}\right)} \right\} \text{ decibels,}$$

where d is the distance between the shielding ridge and the aerial⁵. For a frequency of 4 GHz, this reduces to

$$S = 22 + 20 \log_{10} \theta + 10 \log_{10} d \text{ decibels.}$$

(b) The earth-station far-field aerial gain, G , relative to an isotropic aerial, is approximately

$$G = 32 - 25 \log_{10} \phi \text{ decibels (see Fig. 5),}$$

where ϕ is the angle (degrees) between the axis of the radiated beam and the direction of interest⁸.

The power received at the input to the earth-station receiver in the presence of the shielding ridge is, therefore, given by

$$\begin{aligned} \text{EIRP} - \text{path loss} - 20 \log_{10} \left\{ \frac{\pi^2 \theta}{90} \sqrt{\left(\frac{d}{\lambda}\right)} \right\} \\ + 32 - 25 \log_{10} (a - \theta) \text{ dBW,} \end{aligned} \quad \dots (1)$$

where EIRP is the effective isotropic radiated power (dBW), and is given by the product of the transmitted power and aerial gain at the interfering station in the direction of the earth station.

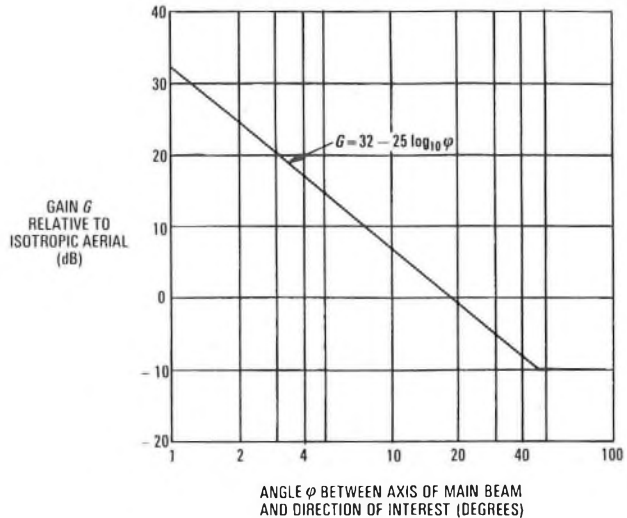

FIG. 5—Earth-station aerial radiation pattern

The power received at the input to the earth-station receiver in the absence of the shielding ridge is given by

$$\text{EIRP} - \text{path loss} + 32 - 25 \log_{10} a \text{ dBW.} \quad \dots (2)$$

Thus, the site shielding factor, SSF , is given by the difference between the receive levels in equations (1) and (2); that is

$$SSF = 20 \log_{10} \left\{ \frac{\pi^2 \theta}{90} \sqrt{\left(\frac{d}{\lambda}\right)} \right\} + 25 \log_{10} \left(1 - \frac{\theta}{a} \right) \text{ decibels.}$$

To ensure that this approximation yields an accuracy within 3 dB of the site shielding factors obtained by computer, the variables used in the formula are subject to the following constraints, referring to Fig. 4(a).

(a) The angle $(a - \theta)$ must be greater than 2° .

(b) The distance, d , must be greater than the Rayleigh distance (approximately 6 km at 4 GHz for a 30 m diameter aerial).

(c) The diffraction angle, θ , must lie between $0.5 - 10^\circ$.

(d) The interference source must be in the far-field zone of the aerial (that is, 4 Rayleigh distances from the aerial), or at least $3d$ from the aerial, whichever distance is greater.

An earth station is particularly vulnerable to interference when operating at low angles of elevation. Fig. 4(f) shows the site shielding factor at an elevation angle of 5° for various distances between the aerial and the ridge. Note that the maximum site shielding occurs when the ridge elevation is approximately half the aerial elevation angle; that is, about 2° . Fig. 4(g) shows the site shielding factor for a ridge elevation of 2° , as a function of ridge height and the separation distance between the aerial and ridge.

TECHNICAL EVALUATION OF POSSIBLE SITES

Interference from Terrestrial Radio-Relay Links

The levels of interfering signals likely to be received at the earth-station site from radio-relay stations, situated both in the UK and on the continent, were calculated using the following assumptions.

(a) All radio-relay stations either were, or would in the future be, transmitting in the frequency bands used for earth-station reception.

(b) The maximum EIRP of each radio-relay station is +55 dBW⁹.

(c) The earth-station aerial radiation pattern is represented by $G = 32 - 25 \log_{10} \phi$ decibels.

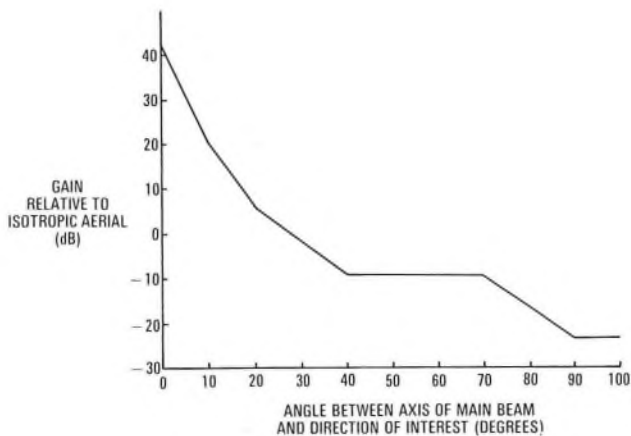

FIG. 6—A radio-relay-station aerial radiation pattern

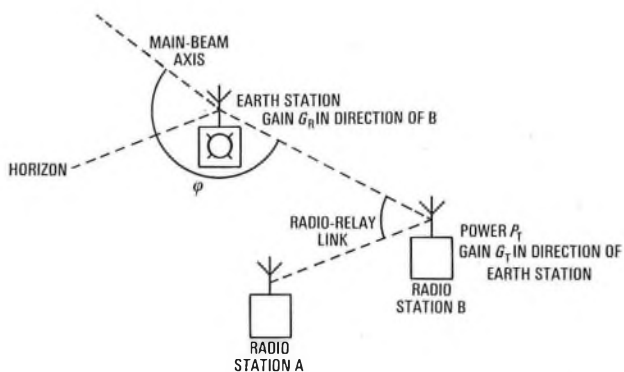

FIG. 7—Simplified diagram of line-of-sight interference from a radio-relay link

(d) The radio-relay-station radiation patterns are those used by the Network Planning Department of the BPO, and by the continental administrations, as shown in Fig. 6.

The level of the interfering signal received from a radio-relay station depends on the prevailing atmospheric conditions which, in turn, affect the propagation conditions and the mechanism whereby the interference is propagated. Usually, one mechanism predominates for a particular set of conditions. The propagation paths can be broadly considered as either surface mechanisms where the radio wave travels near the surface of the earth, or volume mechanisms where radio waves from satellites to the earth station and from an interfering station to the earth station interact in a common volume in the atmosphere.

Surface Propagation Mechanisms

Surface propagation mechanisms are affected by the nature of the terrain between the radio-relay station and earth station, and by the refractive index of the atmosphere. Normally, the refractive index decreases with increasing altitude because of the decreasing temperature, pressure and humidity. This variation in refractive index causes a microwave beam to curve slightly towards the earth's surface and to be received beyond the horizon seen from the transmitting-station aerial centre. The surface propagation path may be free space where, after allowing for the curvature of the beam, there is a line of sight between the 2 aerials. Alternatively, the beam may be diffracted over the earth at the distant horizon, or over a single or a number of obstacles between the 2 stations.

Assuming a line-of-sight path, the interfering signal level, I_S , is given by

$$I_S = P_T + G_T - L + G_R \text{ dBW,}$$

where P_T = power fed to the transmit aerial (dBW),

G_T = gain of the transmit aerial (dB) in the direction of the earth station as obtained from a radiation pattern,

G_R = gain of the earth-station aerial (dB) in the direction of the terrestrial station, and

L = free-space path loss (dB), see Fig. 7.

When high ground surrounds an earth station, the received interference level, I_S , is reduced by additional losses resulting from diffraction over the horizon ridge, or over a number of successive ridges, lying between the terrestrial-link transmitting station and the earth station.

As previously discussed, the additional diffraction loss does not necessarily apply if the earth-station aerial beam passes over a ridge situated in the near field of the aerial. When assessing the diffraction loss over successive ridges, the extent to which the radio wave bends towards the surface of the earth under different meteorological conditions must be taken into account, because the relative positions of hill tops and radio wave change as the conditions vary. The long-term condition (level of interference not to be exceeded for more than 20% of the time) for a site in the UK is assumed to be when the radius of curvature of the radio wave is 4 times the radius of the earth.* For small percentages of the time, under abnormal meteorological conditions, the refractive index can decrease with height more rapidly than normal and the radio wave then has a smaller radius of curvature; under these conditions, the summits of hills effectively become less prominent to the beam and the diffraction loss is reduced. For very small percentages of the time, a duct can be formed in which the radio wave is trapped, propagated over greater distances than normal, and gives rise to interference far beyond the horizon of the transmitting station.

The change in propagation-path attenuation, A , caused by super-refraction and ducting relative to free-space attenuation, and exceeded for all but small percentages of time¹⁰, is approximately given by

$$A = -10 \log_{10} d + 10 \log_{10} 2d_0 + d(C_a + C_s) \text{ decibels,}$$

where d = path length (km),

d_0 = minimum coupling distance (km) into the duct and is dependent on the propagation conditions and percentage of time,

C_a = leakage coefficient dependent on the atmosphere (dB/km), and

C_s = leakage coefficient dependent on the nature of the earth's surface (dB/km). Path profiles between the transmitting and receiving points are drawn to determine the terrain roughness; if the path is entirely over the sea, C_s is zero.

C_a , C_s and $10 \log_{10} 2d_0$ are obtained from International Radio Consultative Committee (CCIR) curves¹⁰.

The total path attenuation for all but these small percentages of time (for example, 0.01% and 0.001%) would exceed $A + \text{free-space attenuation} + \text{shielding from horizon ridge}$.

Volume Propagation Mechanisms

Volume propagation mechanisms include tropospheric forward scatter, precipitation scatter and scatter caused by the presence of a solid object (for example, an aeroplane) in the volume where the wanted and interfering beams intersect. Turbulence in the atmosphere produces local fluctuations in refractive index. Microwave transmissions passing through a

* To allow for this, the effective radius of the earth is taken as 4/3 times the actual radius

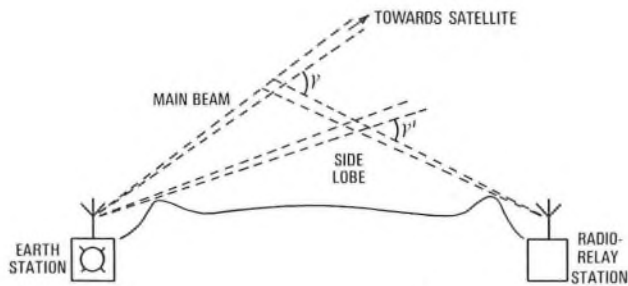

FIG. 8—Tropospheric forward scatter

medium subject to such fluctuations tend to be scattered in a forward direction away from the transmitter. Tropospheric propagation is always present and, for paths extending well beyond the horizon, may be the mechanism producing the highest level of interference. Except for the limiting of the extent of radiation by local horizons, the nature of the terrain over which the beams pass does not directly affect the scatter path.

The long-term median (50% of time value) transmission loss caused by tropospheric scatter is approximately given by

$$L_{50} = 30 \log_{10} f - 20 \log_{10} d + F_{\gamma'd} - G_P - V_{de} \text{ decibels}^{11},$$

where γ' = angle (rad) between radio horizon rays in the great-circle plane* containing the aerials for median atmospheric conditions (see Fig. 8),

d = distance between the aerials (km),

V_{de} = correction factor for various types of climate,

G_P = total effective gain of the transmitting and receiving aerials,

f = frequency of transmission (MHz), and

$F_{\gamma'd}$ = an attenuation factor related to $\gamma'd$, and is derived from published curves¹¹.

The loss caused by tropospheric scatter, exceeded for all but 20% and 0.01% of the time, can be obtained by adding appropriate time variability factors to the long-term median loss L_{50} .

When the earth station is pointed at a satellite, its gain in the direction of the horizon and towards a transmitting terrestrial radio-relay station could be quite low, and result in a relatively low interference level being received. Interference along the great-circle path can be via the main beam of the earth-station aerial and, because of the high aerial gain in this direction, a higher interference level could result. The transmission loss for various percentages of the time can be derived from the above formula, but with γ' replaced by the angle of intersection between the main beam of the earth-station aerial and the tangential ray from the terrestrial station along the great-circle path, γ (see Fig. 8).

The received interference level caused by tropospheric forward scatter will be $I_S = P_T - L_P$ dBW,

where L_P = transmission loss not exceeded for percentage of time P .

Whereas interference caused by tropospheric scatter is assumed to occur in the forward direction in the great-circle plane, interference caused by precipitation scatter occurs when radio beams intersect in a common volume experiencing rainfall and the emergent energy is scattered isotropically. Interference can be caused when the aerial beams intersect outside the great-circle path, the most serious occurring when main beams intersect in storm-type rain.¹⁰ Interference produced by scatter from an aeroplane exists only for the short period when the aeroplane is in the common volume where the 2 beams intersect. Such interference could have a high relative intensity; hence, the location of an earth station should

* The shortest distance between the aerials

be chosen to avoid the intersection of beams in the vicinity of air traffic lanes.

The interference discussed so far is assumed to have originated from terrestrial radio-relay systems allocated transmit frequencies in the earth-station receive-frequency bands. Interference generated by harmonic or spurious emissions from civil or military radio or radar systems can be similarly assessed for the various propagation mechanisms, although, in some instances, it will be necessary to use assumed values of EIRP for the emissions from these transmitting sources.

Tolerable Interference Levels

Having calculated the possible interference levels, it is then necessary to compare them with specified acceptable interference levels to establish whether the prospective site is satisfactory. Maximum allowable values of interference from terrestrial radio-relay systems in a telephone channel of a communication-satellite system using frequency modulation (FM) have been agreed¹². At a point of zero relative level in any telephone channel of a hypothetical reference circuit of a communication-satellite system, the interference noise power caused by the aggregate of the transmitters at terrestrial radio-relay stations should not exceed

(a) 1000 pW psophometrically-weighted mean power in any hour,

(b) 1000 pW psophometrically-weighted 1 min mean power for more than 20% of any month, and

(c) 50 000 pW psophometrically-weighted 1 min mean power for more than 0.03% of any month.

The corresponding interference levels at the input of the first-stage receiver in an earth-station aerial system have been calculated for the most sensitive condition, namely for the reception of an INTELSAT IV 24-channel frequency-division-multiplex (FDM) global-beam carrier, which has the narrowest deviation, smallest spread factor and hence the lowest spectral energy density. These levels are

(a) -141 dBW for 0.01% of the time, and

(b) -158 dBW for 20% of the time.

Future INTELSAT and regional satellite systems could use time-division multiple access (TDMA). Pending international agreement on objectives for error rates in digital satellite systems, it has been necessary to assume similar quality objectives derived from an equivalent basis to those recommended by the CCIR for FDM/FM systems. Provisionally, the interference receive levels taken for an 11/14 GHz regional satellite TDMA system using pulse-code modulation/phase-shift keying (PCM/PSK) are as shown in Table 1.

TABLE 1
Interference Receive Levels for TDMA Systems

Tolerable Level (dBW)	Percentage of Worst Month	Bit Error Probability PCM/PSK
-145	20	10^{-6}
-138	0.01	10^{-4}
-128	0.001	10^{-2}

Measurement of Interference

If the calculated interference levels appear to be tolerable, it is essential to confirm that a prospective earth-station site is free from intolerable interference by making measurements at or near the site. It would be uneconomic to provide sufficient equipment and manpower to search for the very-short-term interference; that is, 0.01% and 0.001% of the time, or 52 min and 5.2 min a year. To do this, the 500 MHz bandwidths at 4 GHz and 11 GHz used by the satellite services

must be scanned in increments of 1 MHz, each increment for a period of at least 12 s to pick up those radar signals that could scan at a rate as low as 5 rev/min. Each scan of 500 MHz bandwidth would take 100 min and, because of the narrow beamwidth of the aeriels used, detect interference at or near the tolerable levels in only a very limited azimuthal arc. Thus, without multiple sets of equipment and staff to operate them, it would be easy to miss short-term interference. The interference measurements are, therefore, aimed at picking-up the more permanent or long-term interference, to confirm the calculated levels of long-term interference and site shielding factors, and to ensure as far as practicable that interference does not occur from features ignored in the theoretical studies; for example, because of the reflection and scattering of signals from large areas of hills and buildings.

Measurements are made at very-high frequency (VHF) using a vertically-polarized dipole aerial connected to a VHF receiver, and at super-high frequency using a horn aerial connected via low-loss coaxial cable to a travelling-wave-tube pre-amplifier and microwave receiver. The measurements are initially made on high ground near the prospective earth-station site to establish a reference where the interference levels would be higher than those expected on the site. Owing to its narrow beamwidth, the horn aerial has to be turned in small steps in azimuth and the frequency bands examined at each step. These measurements are then repeated at the prospective site on the same day if practicable. A comparison of the levels measured on site and on near-by high ground gives an indication of the values of site shielding factor, if the interference levels are high enough to be measured at both places.

THE SEARCH FOR THE SECOND UK EARTH-STATION SITE

All existing BPO radio stations and available Government-owned land were considered, but proved unsuitable. This was not surprising because the site requirements for high-frequency radio stations and satellite earth stations are different and incompatible. A search was then made for sites in the vicinity of London, and extended in all directions from London as the various sites were rejected because they did not comply with the main technical requirements. In many instances, the radio interference was intolerable and, in others, strong resistance was met from local planning officers. Eventually, after nearly 3 years' work covering hundreds of map locations, detailed investigations into 65 prospective sites and some 550 potential sources of radio interference from the national and continental terrestrial microwave radio-relay networks and numerous radar systems, 5 sites near Hereford were found acceptable.

The disused Madley airfield was chosen because it was judged to pose the least difficulties in obtaining planning permission for the construction of an earth station. Compared with the other sites, it had poorer agricultural land, and had been despoiled by the construction of aircraft hangars, runways, large poultry houses and a sewage farm. There was a large amount of scrap iron, rubble and other rubbish on the land and it was adjacent to an area scheduled for development of light industry.

Measurements of interference made on high ground near the site did not reveal any intolerable interference. Nevertheless, a number of potential sources of interference were located and discussions held with the administrations concerned to agree on courses of action that could be taken if ever interference was experienced from these sources in the future; for example, insertion of spurious or harmonic frequency rejection filters.

Following satisfactory discussions with the District Planning Authorities, the Madley site was purchased at a public auction in September 1973. A public meeting was immediately organized by the BPO and produced a favourable

response to the BPO proposals. Since then, outline planning consent has been granted and the detailed planning advanced to the stage where the construction work on site can start.

SITE LAYOUTS

General Principles

The planning of the layout of aeriels and buildings on any new earth-station site has to

- (a) cater for a growth in the number of aeriels,
- (b) allow sufficient flexibility to cater for future changes in aerial sizes or type,
- (c) make provision for the later extension of buildings,
- (d) make the maximum use of the land available, and
- (e) minimize costs.

Future generations of satellites or new satellite systems might require a different size of aerial. Other future satellite systems might use earth-station aeriels with fixed reflectors and multiple steerable feeds for operation to several satellites simultaneously, but there is great uncertainty about the timing of the introduction of such changes or their extent. The connexion of the earth station into the terrestrial trunk network might introduce further complications into the site planning if it involves the location of tall microwave-radio aerial masts on the site, whereas these complications will be avoided if underground cables are used. Finally, the development of the site will have to conform to the restrictions imposed by District and County Planning Authorities.

As a prelude to the evaluation of prospective sites, comprehensive studies of the layout of aeriels on straight lines and arcs were made for mixtures of aerial sizes to provide general information. The complex calculations involving many variables were carried out using computer programmes, which could be used to make a quick assessment of typical layouts for any site irrespective of its size or shape. These studies assumed that 2 nominal aerial sizes would be used, namely 33 m and 15 m diameter, all aeriels being steerable and fully flexible in their use with geostationary satellites. Existing proprietary aerial designs were studied to assess the extent of the arcs described in space by movement of the main reflector in azimuth and elevation. The one considered to be the worst-case from an aerial-layout point of view was used as a model in the studies.

The power radiated by the main reflector of a paraboloidal aerial in the near field close to the aerial is contained in a cylindrical beam having approximately the same diameter as the main reflector. Referring to Fig. 1, the beam may be required to point to any part of the geostationary satellite orbit visible from the earth-station aerial, but not below 5° elevation. In azimuth, the maximum range of movement is $\pm 71^\circ$ relative to south. Towards the south, the lowest elevation angle could be between 25–30°, depending on the satellite orbit inclination. Thus, Fig. 1 can be used to derive the operational elevation angle for each azimuthal position and, hence, the position in space of the cylindrical aerial beam.

All the aeriels and other structures on an earth-station site must be arranged such that no aerial beam is obstructed. Allowances have to be made for possible use of cranes and other elevated or wider support structures such as scaffolding and temporary access towers during construction work, small variations from nominal aerial sizes or building dimensions and, where appropriate, the presence of staff and vehicles. These unknowns are catered for by setting a minimum clearance distance between each aerial beam and other structures. If this clearance distance is made too large, it would require wider spacings between aeriels and buildings, thus resulting in a wasteful use of the land and an increase in the length and cost of intersite roads, cables and waveguides. If the clearance is too small, it could impose severe restrictions on future construction work and flexibility in the future use of the

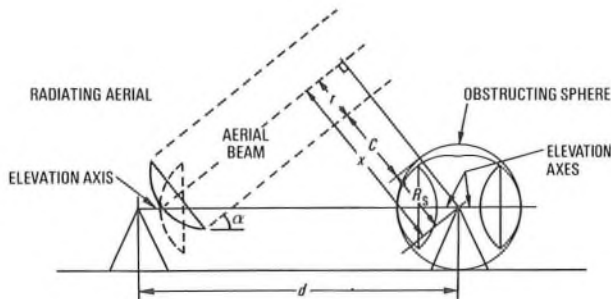

FIG. 9—Aerial spacing and beam clearance

site and the type and size of aerials, particularly if the later satellite systems demand slightly larger aerials than the nominal sizes used for current site-planning purposes. For the new BPO earth-station site at Madley, a nominal clearance distance of 12 m was adopted.

Fig. 9 shows a steerable aerial at an elevation angle α radiating a cylindrical beam over another steerable aerial at a distance, d , away. An obstructing aerial reflector can move in azimuth and elevation; hence it is assumed that a sphere of obstruction surrounds the obstructing reflector. The radius of this obstructing sphere depends on the geometry of the reflector and the relative positions of the azimuth and elevation axes. Referring to Fig. 9, the clearance distance, C , between the nearest parts of the beam and sphere is given by $C = x - R_s - r$, where x is the distance between the beam axis and centre of the obstructing sphere, and R_s and r are the radii of the obstructing sphere and beam respectively.

Although Fig. 9 shows the centre of the obstructing sphere and the effective centre of rotation of the radiating aerial at the same height, in practice this might not be so; it depends on the relative ground levels and respective aerial designs. For instance, it is quite likely that a small aerial might be required to radiate over a larger aerial standing on higher ground. The geometry used for calculating clearances and aerial spacings can be readily modified to suit the particular circumstances.

If an aerial radiates to a satellite due south and another aerial is to be sited due south of the first aerial, the spacing between them must be such that the beam passes over the top of the second aerial. If the direction of radiation is varied

about south, the operational elevation angle decreases from the maximum obtained towards south, as shown in Fig. 1. Hence, the beam clearance around the obstructing aerial sphere changes from an over-the-top condition to around-the-side. Similarly, if the 2 aerials are progressively rearranged from a north-south line to an east-west line, then for each aerial line, the effects of varying the azimuthal pointing direction of the radiating aerial about each line can be assessed by reference to Fig. 1. For a given aerial spacing, the minimum beam clearance distance is obtained in a direction between the over-the-top and around-the-side directions. The minimum spacing between aerials is obtained when they are on a north-south line, because they would have the highest operational elevation angles to the south. As the aerial line is changed from north-south towards east-west, their spacing would have to be progressively increased to maintain the specified minimum beam clearance. The maximum aerial spacing is required when the aerials are on a line at 109° or 251° east of north, because the operational elevation angle is then the minimum permissible at 5° , assuming zero satellite orbit inclination. Aerials on an east-west line can be spaced more closely together than those on 109° or 251° lines, because the aerials will not have to operate in a due east or west direction, but some 19° south of east or west at the extremes of the azimuthal range.

Any pattern of aerials laid out on a site can be analysed as a series of straight-line arrangements to determine the spacings necessary to give specified clearances. Each site layout must include all the buildings for housing equipment, offices, canteen and other structures required. One of the most important factors is the need to connect each aerial to a main central building by a road and cable/waveguide trough. To minimize intersite cable and waveguide losses, it is necessary to use the shortest and most direct route between each aerial and main building. In consequence, some site layout patterns would require excessive roads, and complicated arrangements of intersite troughs that would create major difficulties in routing the intersite cables and waveguides to their destinations in the main building.

Madley Site Layout

In practice, the site layout depends on the size and shape of the land available. The BPO land at Madley is split into two by a narrow country road (see Fig. 10), each part being large enough for an earth station having 5 or 6 aerials. That part

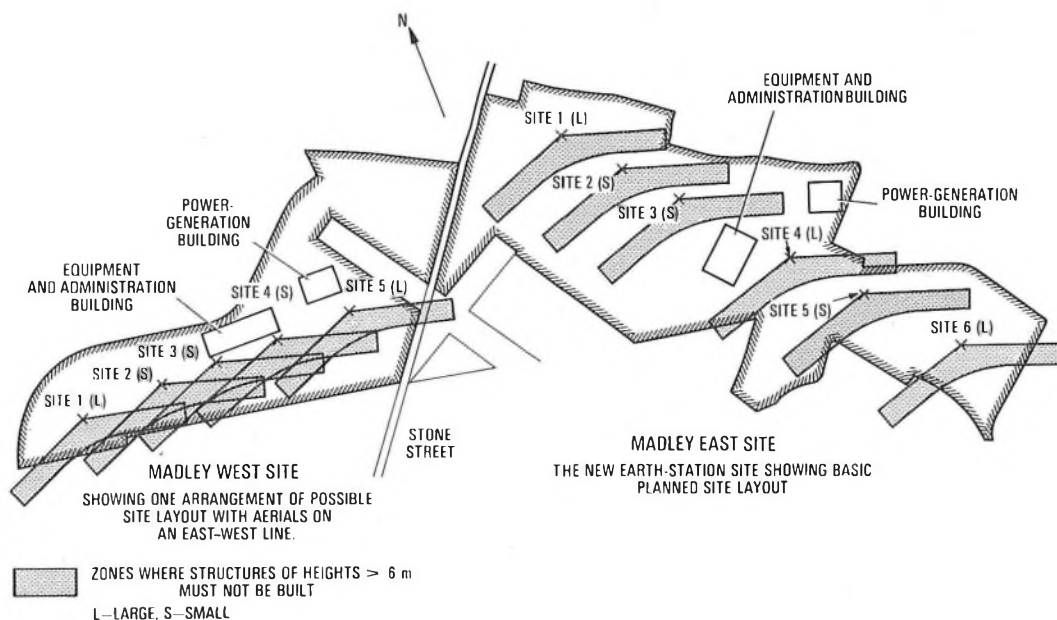
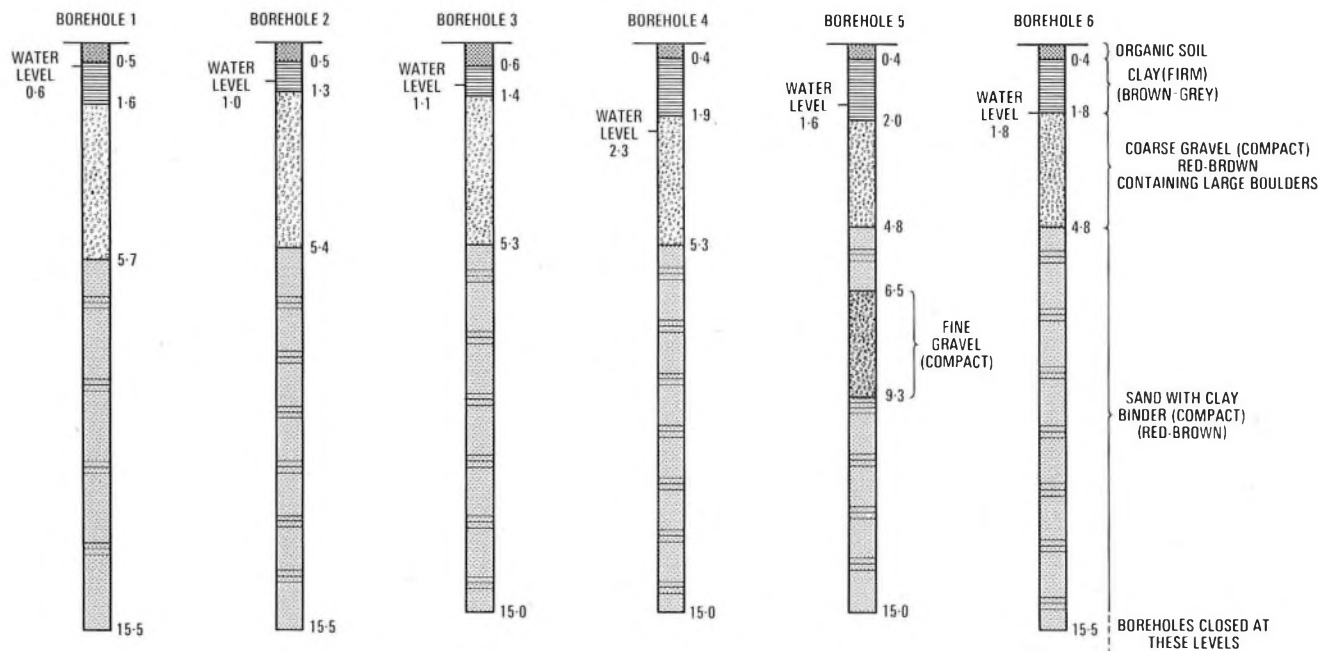

FIG. 10—Madley earth-station site layout



All depths in metres
 FIG. 11—Ground strata in trial boreholes

on the west has a shape that lends itself to an east-west line arrangement of 2 large and 3 small aerials, with all other buildings situated to the north of the aerials. Other combinations of numbers and sizes of aerials were considered, as were other layout patterns. Several site layouts were also devised for the eastern site. That shown in Fig. 10 is the one finally selected; 3 large and 3 small aerials are located on a straight baseline running very roughly north-west-south-east, with the main equipment and office buildings in the centre and the power-generation buildings to the north-east of the main buildings. It meets the critical conditions for operation to satellites stationed over the Indian Ocean and poses no problems for operation to Atlantic Ocean satellites.

To assist in the location of buildings and other structures on the site, it is convenient to plot a family of zones within which structures above specified heights must not be built if the required beam clearances over the structures are to be achieved taking into account the respective differences in ground level. Typical zones for structures not exceeding 6 m in height are also shown in Fig. 10 for each aerial.

It was finally decided to develop the eastern site as an earth station because it would accommodate more aerials than the western site. Further, it provided more scope to cater for future changes in aerial designs and sizes, because the order of use of the nominal aerial locations could be selected to allow some flexibility for later alterations by working out from the main building either to the south-east or the north-west. The first aerial will be a large one (30-33 m diameter) on site No. 4. The second aerial could be large or small, but its size will be known before a decision needs to be made on the choice of aerial site. Thus, if the second aerial is small, it could be placed on either site No. 3 or 5; probably, the latter would be chosen. If it is large, site No. 6 would probably be selected to leave room for changes to plans on the north-western part of the aerial base-line. For example, if later forward planning showed that 4 large aerials would be required on the earth station, a large aerial could be put on site No. 3. This would prevent a small aerial on site No. 2 from being fully flexible in its directions of operation, even if site Nos. 1 and 2 were pushed as far to the north-west of the baseline as is practicable. Nevertheless, it is possible that some small limitation on its azimuthal direction of operation might

be quite acceptable at the time of provision, thus permitting the use of all the nominated aerial sites. Other possible variations have been foreseen to cater for certain contingencies.

Separate intersite troughs will be used for each aerial. Their routings have been designed to avoid troughs crossing or running into each other. At the main building, all the intersite cables and waveguides will be brought to a common area containing termination racks. Normally, these racks will be associated with equipment connected to a particular aerial, but facilities will be provided to permit the equipment housed in the main building to be manually patched to a different aerial if required.

Madley will be connected into the UK trunk network by underground cables to a new terrestrial microwave radio-relay terminal to be built about a mile away near Coldwell and, also, by underground cables routed via Hereford and Gloucester. Hence, there will be no terrestrial radio-relay aerial masts on the earth-station site, but the planning authorities have asked for the site to be extensively landscaped with flowers, shrubs and trees, and for a public car park to be provided within the site. The selection of types of tree and their location on the site will be the most onerous task because they must not be allowed to grow where they will eventually obstruct the aerial beams.

INVESTIGATIONS OF SITE GEOLOGY

Initially, the geology of prospective sites is studied from existing data, geological maps, well bores and any published reports that are available in the Geological Museum and other sources. A site visit is essential. If any excavations exist, either on the site or near-by land, they are studied to gain further geological information. While these preliminary studies can be valuable, particularly in the saving of manpower and money where sites are obviously unsuitable geologically, they are insufficient for a proper assessment of the suitability of the site for the provision of strong, stable foundations for aerials and buildings. Consequently, it is essential for a thorough geotechnical investigation of the site to be carried out by expert civil-engineering geological surveyors.

At the Madley site, BPO engineers located underground

pipes, culverts and cables, with the aid of detectors and a local construction team who dug down into the ground to trace pipe routes. Earth electrical resistivity surveys were made. A land-level survey was carried out to enable the provisional site-layout plans to be completed so that the aerial-site centres and the main-building positions could be marked by wooden pegs. Then, the Foundation and Ground Engineering Branch of the Department of the Environment (DOE) Property Services Agency carried out a geotechnical investigation of the site. This comprised the drilling of one borehole on each of the 6 aerial sites using the shell-and-auger method, the digging of 5 test pits on the main building sites by machine, and 2 *in-situ* plate-loading tests. Samples of soil and groundwater were sent to the DOE Civil Engineering Laboratory for measurements of shear strength, consolidation properties and sulphate (SO₃) content. Fig. 11 shows the ground strata in the 6 trial boreholes and reveals that the ground strata is fairly homogeneous over the whole site. The site is not truly level, but has level variations of up to 2–3 m.

Standard penetration tests were made during the drilling of the boreholes. These tests are used in geological survey work to measure indirectly the density of the ground at any selected depth at the bottom of a cased borehole. This measured density is then used to calculate the approximate strength, or load-carrying capacity of the ground at the selected depth. The standard penetration test is an empirical test and its results are used in empirical formulae. Unless great care is taken when making the tests, and a comparison of the test results is made with the examination of core samples extracted from the borehole, it is easy for large errors to occur. The method used is to drive a specially designed steel tube into the ground at the bottom of a borehole with blows from a 65 kg hammer dropped through a distance of 760 mm. The number of blows required for each 76 mm of penetration is recorded until a total penetration of 450 mm has been achieved. The number of blows required for the first 150 mm of penetration is ignored, in case the ground has been disturbed by the boring operation. Then, the number of blows for the remaining 300 mm of penetration are summed, and their total is called the penetration resistance, *N*. Depending on the type of soil, and possibly the measured value of *N*, it may be necessary to modify the *N* value according to an empirical rule, before using it in the formula for calculating density. The *N* values for the Madley site ranged from 13–77 blows/300 mm penetration, indicating that all the soils existed in a medium dense or dense state with a load-carrying strength roughly equivalent to that of a weak rock.

For the *in-situ* plate-loading tests, a pit was dug to a depth of about 1.05 m, and a 381 mm diameter circular plate placed at the bottom of the pit. Incremental loads were applied to the plate by a hydraulic jack acting against a frame loaded with heavy ballast (called *kentledge*). At each increment of the load, the settlement was measured on 3 dial gauges spaced around the perimeter of the plate, and a graph of the settlement was plotted against applied pressure. The

final load was maintained for a period of some 6 h and the further settlement recorded. A similar loading test was carried out in a second pit.

Analysis of the results of the standard penetration tests and the plate-loading tests, together with the results of the laboratory tests, showed the permissible static ground loading to be 150 kN/m² for normal spread foundations, and 200 kN/m² for deeper foundations taken onto the gravel after allowing for the presence of water. The gravel will safely accept dynamic loads up to 400 kN/m². Thus, the ground is quite suitable for carrying large aerials and other buildings. The sulphate content of the soil and groundwater proved to be too low for there to be any risk of any sulphate attack on buried concrete foundations. Where the water level is above the level of the gravel, it will be necessary to pump out the water during the construction of aerial foundations, but this is not expected to present any serious problems.

CONCLUSIONS

Exhaustive theoretical planning, many site investigations and measurements of radio interference led to the conclusion that the hostile environment of terrestrial radio-relay links and radar emissions embraces the whole of the UK, and that no area exists that is entirely free from radio interference. The Madley site is one of the few where the calculated and measured interference is below the tolerable levels, and some shielding from interference is provided by the low hills that surround the site. It provides an acceptable compromise between all the technical, economical and other factors, and should cater for the BPO's future requirements for at least the next decade.

References

- 1 DALGLEISH, D. I. The Influence of Interference on the Siting of Earth Stations. International Conference on Satellite Communication Systems Technology, 7–10 Apr. 1975. IEE Conference Publication No. 126, p. 21.
- 2 BEDFORD, R. A., and PURDY, J. E. Interference and Frequency Co-ordination at Earth Stations. *POEEJ*, Vol. 65, p. 85, July 1972.
- 3 LUCIA, E. F. Artificial Site Shielding for Communications Satellite Earth Stations. *IEEE Transactions on Aerospace and Electronic Systems*, Vol. AES-6, No. 5, Sept. 1970.
- 4 RUZE, J., SHEFTMAN, F. I., and CAHLANDER, D. A. Radar Ground-Clutter Shields. *Proc. IEEE*, Vol. 54, No. 9, Sept. 1966.
- 5 CCIR Report No. 427, 1970.
- 6 NAGELBERG, E. R. Limitations of Fence and Pit Shielding for Satellite Earth Stations. 70-CP-338-COM Bell Telephone Laboratories Inc., Whippany, New Jersey.
- 7 STREETE, M. A., and SHINN, D. H. Site Shielding for Earth Station Antennas. *Electronics Letters*, Vol. 10, No. 8, Apr. 1974.
- 8 CCIR Report No. 319, 1970.
- 9 Radio Regulations, Section VII, Terrestrial Services Sharing Frequency Bands with Space Services between 1 GHz and 10 GHz, 1968.
- 10 CCIR Document 5/1048E.
- 11 CCIR Document 5/1032-E.
- 12 CCIR Recommendation 356-2.

Frequency Co-ordination for the SPADE Satellite-Communication System

M. H. MALLETT, B.Sc.†

UDC 621.396.946:621.391.82:341.226

The introduction of a new radio service requires consideration of the effects of interference. Sharing of the radio-frequency spectrum has to take place, and is governed by international agreement. The SPADE satellite communication system introduced some special problems and required a study of the effects of interference from radio-relay systems on its operation. This study has produced values of parameters applicable to the SPADE system which, it is suggested, could be used to extend the Radio Regulations dealing with frequency co-ordination.*

INTRODUCTION

Frequency co-ordination is a procedure that accompanies the introduction of new terrestrial and space radio services, and forms the technical basis for international negotiation to prevent harmful interference occurring between new and existing services. This is particularly important in the 4 and 6 GHz frequency bands, as both satellite and terrestrial radio-relay systems share the available bandwidths.

Although the attenuation of the atmosphere and the restriction of line-of-sight operation normally limit the propagation of microwave frequencies to short distances around the earth, under certain atmospheric conditions, propagation over abnormally long distances is possible. In co-ordination exercises, these conditions are considered with a view to preventing interference that is sufficient to cause degradation of services, except for very small percentages of time.

The procedure used for co-ordination calculations is agreed internationally, and is laid down in the *Radio Regulations* published by the International Telecommunications Union (ITU).¹ The way in which co-ordination is applied to satellite earth-stations has been described in detail in a previous article.² Earth-station receivers are extremely sensitive to amplify the minute signal power received from a satellite. Consequently, the earth-station receiver is rather vulnerable to interference falling within the bandwidth allocated to the satellite carriers, and the resultant co-ordination area for a receiving earth-station covers a much wider area than that for a transmitting earth-station. This article is concerned with the special case of the receiver co-ordination contour for an earth-station operating in the SPADE* system, since the parameters currently agreed internationally for use in co-ordination do not allow for the peculiarities of SPADE. The features special to SPADE are that

(a) the radio-frequency carriers are assigned on demand to telephone channels,

(b) each 4 kHz telephone channel modulates a separate carrier; that is, single-channel-per-carrier (SCPC) operation,

(c) signalling information is carried separately by a common signalling channel (CSC), and

(d) the reference SPADE station transmits a standard-frequency pilot via the satellite to all the other stations, for frequency-synthesis purposes.

Additionally, SPADE presents new problems, being the first digital satellite system needing to be frequency co-ordinated by the British Post Office.

The operation of the SPADE system has been described in detail in a previous article³, but a brief explanation of the system is given below for completeness.

SPADE

Demand Assignment

The control of the SPADE terminal is achieved by a demand-assigned signalling and switching (DASS) unit. DASS units in all the SPADE terminals in the system are linked by the SPADE CSC, which acts as an omnibus control channel between all the terminals.

When a country initiates a telephone call via SPADE, the DASS unit at the local SPADE terminal assigns a channel frequency to the call from a record it holds of the free channels in the system. This record is continually updated via the CSC. As a result, the selection of channels is virtually a random process. If interference occurs to a SPADE channel and the call proves to be unacceptable in quality, then it is likely that, on redialling the call, an interference-free channel will be obtained. Consequently, demand assignment permits interference to degrade individual channels of the SPADE system for a greater percentage of time than would otherwise be acceptable.

It can be shown that, if interference affects n frequencies out of the total of 794 actually available to the SPADE system, the probability of selecting a channel suffering from interference is $n/794$. Referring to Fig. 1, it can be seen that, of the frequencies currently allocated to SPADE and terrestrial microwave radio-relay systems, a total of 3 terrestrial frequencies, recommended by the International Radio Consultative Committee (CCIR) and designated 3P, 3PA and 4PA, lie within (and share) the bandwidth demand-assignable to SPADE. The distribution of power within the spectrum radiated by terrestrial microwave systems is such that the

† Telecommunications Development Department, Telecommunications Headquarters.

* SPADE: Single-channel-per-carrier, pulse-code-modulation, multiple-access demand-assignment equipment

highest spectral-energy density radiated falls within a bandwidth narrower than, or comparable with, the bandwidth of a SPADE channel. Assuming that severe interference occurs only for small percentages of time, then, in practice, each terrestrial interfering carrier will severely degrade only one SPADE channel when it arises.

Under operational conditions, instructions can be stored in the computer-controlled DASS units in all the SPADE terminals to prevent these particular channels from being used for transmissions to stations likely to be affected. However, for the purposes of co-ordination, it is necessary to produce interference limits based on the normal operation of the system to be co-ordinated. This results in a value for n of 3, giving a value for the probability of selection of a channel susceptible to interference of 0.00378.

Single-Channel-per-Carrier Operation

SCPC systems are favoured for their flexibility, since they permit the assignment (either by demand, or by pre-assignment) of satellite telephone channels according to the actual needs of the traffic path. However, to maintain the capacity of the satellite, the power used to transmit SCPC channels is lower than that used for equivalent frequency-division-multiplex (FDM) channels. This means that SCPC channels are slightly more prone to interference. Additionally, when interference is co-channel (that is, at the same frequency) the performance of that one channel is liable to be severely degraded. In the FDM carrier case, the degradation tends to be spread over a number of channels.

The demand-assigned speech channels are digitally modulated (pulse-code modulated and 4-phase phase-shift keyed), which means that, when interference degrades a channel, the degradation increases sharply as the interference level increases. This results in a limit on the bit-error probability of 1×10^{-3} for only 0.001%, or less, of the time. Note that this percentage of time applies to calls that are made through the SPADE system and, because of demand assignment, the percentage of time applicable to the radio-frequency channels is determined also by the selection probability.

Common Signalling Channel

The SPADE CSC uses 2-phase phase-shift keying to transmit the digital signalling information required within the SPADE system. When a call is to be set up, messages are passed via the CSC from the originating earth-station, and these must be received correctly by the distant earth-station. To ensure that errors do not seriously affect the system, error-detecting codes are used in the CSC, enabling the receiving SPADE station to request retransmission of any messages likely to be in error. However, retransmission of messages is allowed only

once per message and, if errors occur in the retransmission, the call is lost.

Error-detecting codes are restricted in the number of incorrect digits they can detect. The SPADE CSC error-detecting mechanism is restricted to detecting up to 4 incorrect digits in a burst of data 48 bit in length. This is accomplished by the addition of 6 parity bits to each data burst. The data transmitted by the CSC includes the frequency of the channel on which the call is to be transmitted (this automatically assigns the frequency for the return channel) and, should this be in error, the possibility arises of calls being set up on channels already in use by other earth-stations. If more than 4 errors occur in a data burst, the error-detecting mechanism fails to operate, and an incorrect frequency allocation could result. Because the effect of this on the system could be disastrous, it is considered necessary to protect the CSC to a high degree from the effects of interference.

To obtain this degree of protection, it is proposed to allow the bit-error probability in the CSC to reach 2×10^{-7} for only 0.001%, or less, of the time. This is in contrast to the bit-error probability of 1×10^{-3} at which it is considered that the communication channels become inoperative. With the normal operating thermal-noise level, the bit-error probability of 2×10^{-7} corresponds to a carrier-to-interference-level ratio of 16.5 dB for a 2-phase phase-shift-keyed channel.⁴

Standard-Frequency Pilot

Timing signals and a frequency reference for all the terminals in the SPADE system are transmitted by the master, or reference, station. This role can be assigned to any one of the terminals in the system, to allow for possible failures. The reference frequency is transmitted to the satellite in the form of an unmodulated pilot tone, which is retransmitted and received by all the other stations in the SPADE system. The pilot is detected by a phase-locked-loop receiver, and provides a frequency standard for the frequency synthesizers within the SPADE terminal. This ensures the correct registration of the frequencies used for transmitting and receiving at the terminals at both ends of the 2-way link. The pilot tone, being unmodulated, occupies only a narrow bandwidth, and a filter bandwidth of 1 kHz is, therefore, adequate for the receiver's phase-locked condition. However, initially to lock-on to the pilot tone requires a wider filter bandwidth, so the pilot-receiver noise-limiting filter is made to switch automatically between noise bandwidths of 32 kHz and 1 kHz after acquisition of the pilot.

The pilot receiver must cause no degradation to any of the communication channels when the pilot receiver carrier-to-noise ratio is 10 dB in a bandwidth of 32 kHz.⁵ This may also be taken as the limit for carrier-to-interference-level ratio for the pilot channel, where it is assumed that the interference is distributed evenly over the 32 kHz receiver bandwidth.

DETERMINATION OF PARAMETERS FOR CO-ORDINATION

In the method laid down in the *Radio Regulations*, the amount of interference considered permissible is related to the level of thermal-noise power normally allowed by design in the satellite system. This is related to the thermal-noise temperature and reference bandwidth for the satellite system by the expression

$$P = kTB \text{ watts,}$$

where P is the thermal-noise power (W), k is Boltzmann's constant and is equal to 1.38×10^{-23} J/K, T is the thermal-noise temperature (K), and B is the reference bandwidth (Hz).

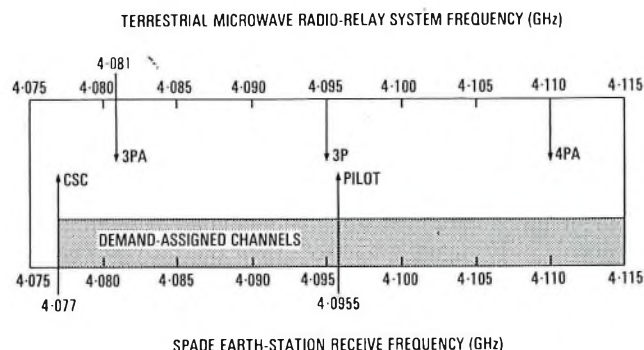

FIG. 1—Frequency allocations for SPADE system, and those recommended by the CCIR for terrestrial radio-relay links

In general, for SCPC systems, the reference bandwidth is the noise bandwidth of the carrier. The thermal-noise temperature actually used in the calculation is the receiver, or down-path, noise temperature, which includes the noise contributed both by atmospheric attenuation and the receiving earth-station.

The value of P is then modified by 2 factors: J and $M(p)$. Factor J relates the down-path thermal-noise contribution to the amount of interference power permissible in the long term; that is, up to 20% of the time. Factor $M(p)$ relates the permissible short-term ($p\%$ of the time) level of interference to the long-term permissible level.

In the *Radio Regulations*, this is expressed as

$$Pr(p) = 10 \log_{10} (kTB) + J + M(p) - W \text{ decibels,}$$

where $Pr(p)$ is the permissible interference power for $p\%$, or less, of the time (dB relative to 1 W),

J is the relationship between permissible interference power in the long term and the down-path thermal noise in a satellite system (dB); this is normally assumed to be zero for digital systems,

$M(p)$ is the relationship between permissible interference power in the long term and that for $p\%$ of the time (dB),

p is the percentage of time for which interference is considered to be tolerable (0.001% of the time for digital systems), and

W is the relationship between the thermal-noise power required to produce the same amount of degradation as the interference and the interference power (dB); this is usually assumed to be zero for digital systems.

The parameters remaining to be derived for the SPADE system are, therefore, $M(p)$ and p .

Relationship Between Permissible Interference Power in the Long Term and that for $p\%$ of the Time

The value of $M(p)$ is obtained by considering the condition under which SPADE operates. For the demand-assigned channels, the normal operating carrier-to-noise ratio is 15.5 dB.⁶ To obtain a bit-error probability of 1×10^{-3} requires an addition of interference corresponding to a carrier-to-interference ratio of 8.75 dB.⁴ In a satellite system, the normal operating noise is made up of 3 major components: up-path noise, satellite intermodulation noise and down-path noise. For the particular case of SPADE, these 3 sources respectively produce 10%, 33% and 57% of the total noise.⁷ The relationship between down-path thermal noise, N_D watts, and total noise, N_T watts, is therefore given by

$$\frac{N_D}{N_T} = 0.57.$$

Consequently, the down-path carrier-to-noise ratio, C/N_D , is given by

$$\frac{C}{N_D} = \frac{C}{0.57N_T},$$

and, since $(C/N_T) = 15.5$ dB, then

$$\left(\frac{C}{N_D}\right) = 17.94 \text{ dB,}$$

where the ratios shown in brackets are expressed in decibels, the others being expressed as power ratios. The value of $M(p)$ is defined as the difference, in decibels, between the permissible long-term and short-term interference levels. Assuming that $J = 0$, that is, that the long-term permissible interference level is equal to the long-term down-path noise,

$$M(p) = \left(\frac{C}{I}\right) - \left(\frac{C}{N_D}\right) \text{ decibels,}$$

TABLE 1

Values of $M(p)$ for Communications, Common Signalling and Pilot Channels

Parameter	Carrier		
	Communications (Demand Assigned)	CSC	Pilot
Noise Bandwidth (kHz)	38	148	32
Operating C/N_T ratio (dB)	15.5	17.1	16.25
N_D/N_T ratio (dB)	-2.44	-2.44	-2.44
Down-path C/N_D ratio (dB)	17.94	19.54	18.69
Permissible short-term C/I ratio (dB)	8.75	16.5	10
$M(p)$ (dB)	9.2	3	8.7

where (C/I) is the carrier-to-interference ratio (dB) and, since $(C/I) = 8.75$ dB,

$$M(p) = 9.2 \text{ dB.}$$

Similar calculations were made for the CSC and pilot channel, and the results are all given in Table 1.

Percentage of Time for which Interference can be Allowed

Because the communication channels are demand-assigned, the percentage of time for which interference can be permitted to occur to individual channels is greater than it would be for pre-assigned channels. The probability of selecting a channel susceptible to interference was shown earlier to be 0.00378.

Interference from a single terrestrial radio-relay source is allowed to degrade a digital satellite system severely for 0.001% of the time. This applies to channels that are actually in use by the satellite system at that particular moment in time. Therefore, the percentage of time for which interference may arise at any particular frequency is given by

$$p = \frac{0.001}{0.00378} \% \text{ of time,}$$

$$= 0.265 \% \text{ of time.}$$

This gives the appropriate percentage of time for the determination of the propagation loss required, and is the value for p quoted in the summary.

SPADE DATA CHANNELS

A system has been devised for the transmission of digital data in an SCPC mode in spare SPADE channels, using the SPADE terminal equipment. The data channels are pre-assigned and have a data rate of 48 kbit/s. The 48 kbit/s bit stream is convolutionally encoded, improving the error performance and increasing the actual bit rate. Further bits are introduced to obtain a bit rate of 64 kbit/s, matching the normal transmission rate in a SPADE channel. The convolutional encoding improves the error probability such that the bit-error probability in the decoded 48 kbit/s data stream is between 1×10^{-5} and 1×10^{-6} when the SPADE-channel bit-error-probability is 1×10^{-3} . This means that the requirements for the pre-assigned data channels can be met adequately by meeting the requirements of the SPADE demand-assigned channels. Therefore, the value of $M(p)$ appropriate to the data channels is the same as for the demand-assigned channels. The percentage of time for which interference may occur is smaller however, since there is no moderating probability factor for the selection of channels.

SUMMARY

The co-ordination parameters derived for the 3 different types of carrier used in the SPADE system are summarized in Table 2, together with parameters currently used for 4 GHz frequency-modulated FDM satellite systems. Using these parameters and the method of calculation laid down in the current *Radio Regulations*, some examples of receive co-ordination contours have been plotted in Fig. 2, to illustrate the extent of the co-ordination area.

These contours relate to the simple case of an earth-station operating at an elevation angle of 30° in the direction of an Atlantic-Ocean satellite. The horizon elevation angle is assumed to be zero at all bearings from the earth-station site. The value taken for the terrestrial radio-relay maximum equivalent isotropic radiated power is $+55$ dB relative to 1 W. The further simplifying assumption is made that the surrounding area is all sea, so that the relevant propagation zone is that defined in the *Radio Regulations* as zone B. It is, generally, more appropriate in the UK to consider propagation zone B, since it is assumed in the *Radio Regulations* that zone B extends 100 km inland to account for the special atmospheric conditions arising near the coastline.

The 2 inner contours are drawn for the SPADE demand-assigned communication channels and for a 24-channel frequency-modulated FDM INTELSAT IV carrier, which is shown for comparison. The outer contour, for the CSC, encompasses a much larger area than the demand-assigned contour. This illustrates the magnitude of the co-ordination problem, since the number of radio-relay links to be co-ordinated increases with the co-ordination area. The co-ordination area for the CSC is roughly 4.5 times that for the demand-assigned channels.

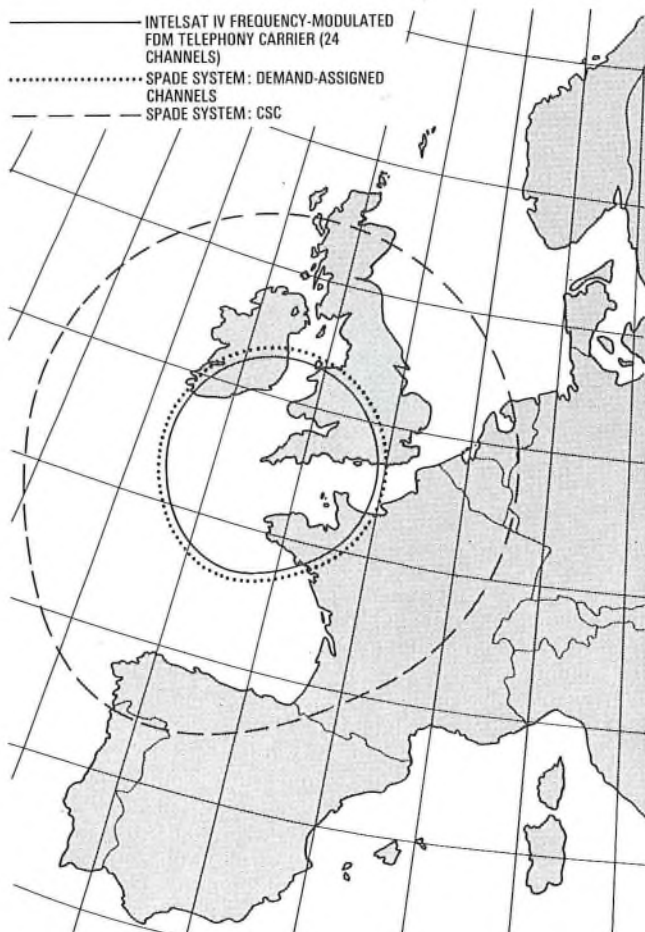

FIG. 2—Receive co-ordination contours centred on Goonhilly earth-station

TABLE 2

Summary of Co-ordination Parameters

Parameter	Carrier				
	Communications (Demand-Assigned)	CSC	Pilot	Data Channels (Pre-Assigned)	Frequency-Modulated FDM
p (%)	0.265	0.001	0.001	0.001	0.01
J (dB)	0	0	0	0	-8
$M(p)$ (dB)	9.2	3	8.7	9.2	17
W (dB)	0	0	0	0	4
B (Hz)	38×10^3	148×10^3	32×10^3	38×10^3	10^6

The problem can be reduced somewhat by considering the actual frequencies to be used; the CSC and pilot frequencies have been agreed internationally through INTELSAT. Although the pilot frequency is near to the recommended terrestrial carrier designated 3P (see Fig. 1), only those terrestrial stations actually using carrier 3P are potential sources of interference to the SPADE system. The pre-assigned data channels can be protected by the careful choice of the actual frequencies to be used, avoiding those frequencies that are normally assigned to radio-relay carriers.

After the co-ordination contour has been decided, and possible interference sources identified, most of these can be rapidly eliminated by examining the alignment of the radio-relay links with respect to the earth-station. Following this, the remaining sources are examined further, using actual parameters for the radio-relay stations involved, such as transmitted power, aerial gain, polarization angle or sense, and site shielding factor. Any further problems then require mutual agreement between the administrations concerned, and adjustments to be made to ensure that harmful interference will not occur, and that all services operate satisfactorily.

CONCLUSIONS

The novel features of the SPADE system raised a number of problems for co-ordination with terrestrial microwave-radio links. Satisfactory solutions to these problems appear to be possible. The solutions do, however, require the use of system concepts not previously invoked in co-ordination procedures. The use of the parameters derived for the co-ordination of SPADE should result in a realistic determination of the protection from interference necessary for satisfactory operation of the SPADE system, but modification of the existing *Radio Regulations* will be needed, using the information given in Table 2, for the procedure to become internationally effective.

References

- 1 International Telecommunications Union. Final Acts of the World Administrative Radio Conference for Space Telecommunications, Geneva, 1971.
- 2 BEDFORD, R. A., and PURDY, J. E. Interference and Frequency Co-ordination at Earth-Stations. *POEEJ*, Vol. 65, p. 85, July 1972.
- 3 HALL, G. C. Single-Channel-per-Carrier, Pulse-Code-Modulation, Multiple-Access, Demand Assignment Equipment—SPADE—for Satellite Communications. *POEEJ*, Vol. 67, p. 42, Apr. 1974.
- 4 PRABHU, V. K. Error-rate considerations for coherent PSK systems with co-channel interference. *BSTJ*, Vol. 48, Mar. 1969.
- 5 Board of Governors, INTELSAT. SPADE technical report. INTELSAT reference BG/T-9-30E.
- 6 Board of Governors, INTELSAT. Performance characteristics for earth-stations in the INTELSAT IV system. INTELSAT reference ICSC-45-13E.
- 7 Board of Governors, INTELSAT. INTELSAT IV channel capacity versus earth-station G/T. INTELSAT reference ICSC/T-36-13E.

A New International Telegram Retransmission Centre for the External Telecommunications Executive

L. VEALE, C.ENG., M.I.E.E., M.I.E.R.E.†

UDC 621.394.34: 654: 621.39

This article describes a stored-programme-controlled telegram switching system with ancillary facilities, which has recently been brought into service for the international telegraph service. It replaces a combination of automatic, semi-automatic and manual systems used hitherto. The system uses purpose-built telecommunications computers, with facilities for on-line retrieval of up to 750 000 telegrams and editing with the aid of visual display units. It provides an interface between the Gentex network and direct UK and overseas public telegraph circuits. Suitable provision has been made to maintain high system serviceability under equipment-failure conditions.



FIG. 1—General view of TRC computer area

INTRODUCTION

The new Telegram Retransmission Centre (TRC), shown in Fig. 1, is designed to switch international telegrams between telegraph offices in the UK and points overseas; it replaces a combination of automatic, semi-automatic and manual systems used hitherto.^{1,2} A world-wide network of point-to-point circuits terminates at the TRC; it also has direct connexions to all International Telegraph Offices (ITOs) in the UK, interfaces with the circuit-switched international Gentex network, and is connected to the UK Telex network for telegram delivery purposes (see Fig. 2). It is one of the

first adaptations for public service of a system hitherto used for large private telegraph networks. The External Telecommunications Executive (ETE) of the British Post Office (BPO) has made an appreciable contribution to the software development and testing of the system.

The TRC uses store-and-forward principles, telegrams being passed via multiplexers to and from the on-line processor where routing and analysis functions are carried out. Magnetic drums act as back-up stores for the on-line-processor core storage; moving-head discs store telegrams for on-line retrieval and deferred delivery, in addition to carrying certain file information. Magnetic-tape units record the history of transactions within the system, and off-line retrieval and accounting information; they also permit telegrams to be removed from and entered into the system.

† System Planning Division, External Telecommunications Executive.

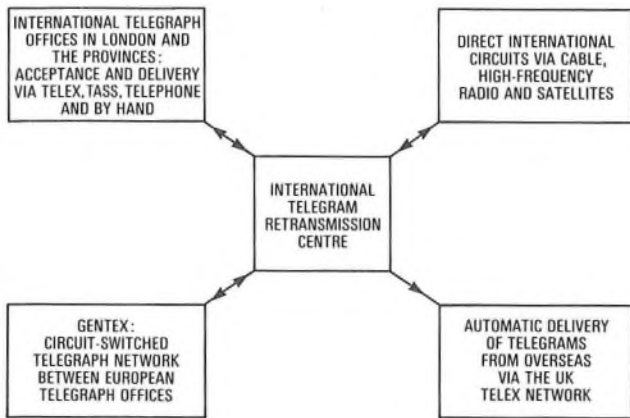

FIG. 2—Block diagram of connexions terminating at the TRC

Most telegrams will be automatically switched, but those needing manual attention are presented at visual display units for correction and subsequent routing. Manual handling of telegrams and transmission delays are further reduced by providing, as an automatic facility, the decoding of up to 100 000 registered telegraph addresses to obtain delivery instructions, and automatic clearance of telegrams via the UK Telex network.

The system has a designed busy-hour capacity of 12 500 telegrams, each of 54 s average duration. It is equipped with 500 bothway circuit terminations and can be expanded to 1250 terminations. Extensive duplication of equipment, a software-controlled configuration switch to deploy equipment, and automatic switch-over facilities in the event of equipment failure, all ensure that the international telegraph service is maintained to a high standard of reliability.

TELEGRAM FORMAT

The TRC has been designed to accept telegrams primarily using the internationally-agreed F31 telegram format (see Fig. 3), which facilitates automatic routing, accounting, and checking.

Reception of the *start-of-message* signal ZCZC alerts the TRC to receive the telegram. This is followed by a channel-identification and sequence-number group. There may be several such groups present, depending upon the telegram routing from its origin. The number line is terminated by a telegram identification group, which is an acceptance office reference.

In the pilot line, the destination indicator (sometimes in conjunction with the origin indicator) determines the international routing, and the priority indicator controls the order of transmission. This information, together with the tariff indicator, number of chargeable words, and customer identification group, facilitates automatic international accounting and customer billing. The customer identification group is deleted before transmission and is not, therefore, shown as part of the pilot line.

The preamble line gives the office of origin, chargeable and actual words, and a date/time group; the paid service indications identify the type of message. In the address line, an example is given of a registered telegraph address (MID-BANK), from which the TRC can derive the full address and delivery instructions. Following the text and signature is the collation, which repeats any figure groups or unusual words for checking purposes at the receiving end. The telegram is terminated by 10 line-feeds, and NNNN which is the *end-of-message* signal.

The TRC can cope with other international telegram formats with the aid of operator-inserted additions or corrections at the edit-assist position. By automatically providing re-alignment functions, the TRC can convert from continuous tape to page format and correct for over-long

Item	Start of Message Signal	Channel Sequence Numbers					Telegram Identification Group	End of Line
		Channel Indicator	Sequence Number	Channel Indicator	Sequence Number	Channel Indicator		
Number Line	Z C Z C	→ G E B	↑ 0 9 9	↓ → A F A	↑ 1 3 5	↓ → L X → 7 4	< ≡	
Item	Destination Indicator		Priority and Tariff	Origin Indicator		Number of Chargeable Words	End of Line	
	Country	Office		Country	Office			
Pilot Line	↓ G B	L O →	H L →	U R	W A →	↑ 0 1 3	< ≡	
Preamble Line	↓ W A S H I N G T O N	→	↑ 1 3 / 1 2	→	1 3 →	1 2 0 5	< ≡ ≡ ≡	
Paid Service Indications	↓ L T	< ≡						
Address Line	↓ M I D B A N K	< ≡	↓ L O N D O N	< ≡ ≡ ≡				
Text	↓ F O R W A R D → S O O N E S T → P R E S E N T → A C C O U N T < ≡							
	↓ B A L A N C E → J O N E S → N U M B E R → ↑ 7 8 ↓ A ↑ 7 6 5 < ≡							
Signature	↓ → → → → J O H N S O N < ≡ ≡ ≡							
Collation	↓ C O L → L T → ↑ 7 8 ↓ A ↑ 7 6 5 < ≡ ≡ ≡ ≡ ≡ ≡ ≡ ≡ ≡							
End-of-Message Signal	↓ N N N N ↓ ↓ ↓ ↓ ↓ ↓ ↓ ↓ ↓ ↓ ↓ ↓							

Key to symbols representing functional combinations:
 → = Space
 ↑ = Figure Shift
 ↓ = Letter Shift
 < = Carriage Return
 ≡ = Line Feed

FIG. 3—Example of F31 telegram message format

lines in page format. It can also automatically correct, tolerate or suppress a number of minor format aberrations and redundant functional characters.

OUTLINE OF OPERATION

Of the 3 processors available, one is active in the on-line mode and one in the hot-stand-by mode, the third being the cold stand-by. Circuits terminated on multiplexers paralleled to the on-line and hot-stand-by processors permit switch-over to the latter without loss of data.

Detection circuits in the multiplexers identify the start-of-message signal and initiate the transfer of the telegram to discrete blocks of core memory, these being dynamically assigned from a common group of blocks dedicated to input and output functions. As each block becomes full, a new one is linked until detection of the end-of-message signal terminates assignment. The incoming prefix/serial number is checked, the format validated, the routing analysis performed, and an outgoing queue entry assigned according to telegram priority and order of reception into the system. For telegrams accepted at ITOs, the destination indicator is automatically inserted after consulting the overseas town name file. An internal cross-system check number is given to the telegram, which is recorded on the history magnetic tape unit. Each block of data is then transferred in duplicated mode to the magnetic drums forming part of the on-line system, until the complete telegram is assembled on each drum in an area known as *in-transit storage*.

Telegrams destined for the UK undergo a further routing process, in which the UK town name file is accessed and, where appropriate, the registered telegraph address is expanded to a full address with accompanying delivery instructions. If Telex delivery is indicated, the collation is automatically verified against the telegram. In the case of deferred delivery, the telegram is held on disc file until needed.

When the outgoing circuit is free, the telegram is read from the drum into core blocks, and thence via a multiplexer to line. Writing operations to the on-line retrieval disc file, and to the accounting and retrieval magnetic tape units, are also carried out. Before transmission on an outgoing channel, the appropriate identification prefix and sequence number are added to the telegram, and the internal cross-system check number is crossed off. If the telegram is destined for transmission over the Gentex or UK Telex networks, up to 4 call attempts are made automatically. Should all of these be unsuccessful, the telegram is alternatively routed; in the UK delivery case, it is routed to the local ITO for manual transmission via the Telex network.

SYSTEM DESCRIPTION

Fig. 4 shows the general equipment assignments for the on-line, hot-stand-by and cold-stand-by elements of the TRC. Sufficient equipment redundancy has been provided to achieve, with the aid of the configuration switch, a designed system availability of 0.999975; that is, 2.5 h total system out-of-service time owing to equipment failure in approximately 11.5 years. The processors, multiplexers, and peripheral equipment are connected to the configuration switch for flexibility of allocation. Under certain failure conditions, an automatic switch-over from the on-line to the hot-stand-by processor occurs, all on-line peripheral equipment being transferred to the latter. The hot-stand-by processor aborts any off-line programmes currently running when on-line status is assumed. The cold-stand-by processor is then normally upgraded to the hot-stand-by role manually.

Processor

The processor is designed primarily for data and telegraph switching and handling, having features tailored to real-time operation, particularly in the areas of priority control and

data transfer. An assembler language is used, which has a 59-instruction repertoire, oriented towards data manipulation rather than calculation.

Processor Core Memory

The processor core memory allows a complete word of 36 bit, consisting of 4 characters (or bytes) each of 8 data bit plus 1 parity bit, to be read out and rewritten in a cycle time of $2.2 \mu\text{s}$. The memory is word or character addressable but, in the latter case, the complete word is first read out from the core store.

A memory module has a capacity of 16 384 words or 2^{16} characters. Direct addressing is possible over 2^8 characters or 4 modules, which is termed a *bank*. By switching over 4 banks, it is possible to address $2^{20} = 1\,048\,576$ characters. Currently, the 3 TRC processors are each equipped with 2 banks of memory.

A reserved area covering the lowest addresses in the memory is devoted to registers storing status information on interrupted programmes, start addresses of interrupting programmes, and registers concerned with data transfers over input/output channels. The remainder of the memory is used for storing tables, programmes and data.

Processor Priority Control

A priority control unit regulates the operation of programmes and has 8 levels of priority. Each level has 16 entry points, thus providing a total of 128 conditions under which jumps from the running programme to another programme can be executed.

The higher priority levels are reserved for interrupt programmes that have a relatively small number of instructions for initiating autonomous data transfer between the processor memory and peripheral devices, such as multiplexers, or magnetic drums, discs, and tape units. This is a transfer independent of programme control, once parameters such as memory address and block length have been set. Autonomous transfer of data frees the priority control unit to activate other interrupt requests, and allows programmes to run concurrently with the data transfer. The lowest priority level is used for programmes dealing with system housekeeping functions* and the processing of telegrams. These are activated in a cyclic manner by a base sequencer programme which also calls for data transfers to store the results of processing, or to provide data on which these programmes can operate.

A memory-access control unit works in conjunction with the priority control unit to schedule core memory usage in accordance with the instant-by-instant demands of data transfer and running of programmes.

Processor Input/Output Channels

The processor has 3 types of input/output channels.

(a) *Buffer Channels*. A processor has 4 buffer channels, each serving a maximum of 7 subsystems. A subsystem is defined as a magnetic drum, tape unit, line printer, inter-processor connexion, or group of magnetic discs. Buffer channels handle the highest speed autonomous data transfers between the processor and peripheral equipment.

(b) *Multiplex Input/Output Channels*. Two multiplex input/output channels are provided per processor, each being assigned to 2 communications multiplexers. A maximum of 7 multiplexers can be concentrated on one input/output channel. Data between circuits connected to multiplexers and the processor core memory, are transmitted autonomously over the multiplexer-multiplex-input/output-channel path.

(c) *Direct Channel*. The direct channel, connected between the processor and each multiplexer, is the controlling link enabling data to be transferred over the multiplexer-multi-

* Maintaining and monitoring system viability

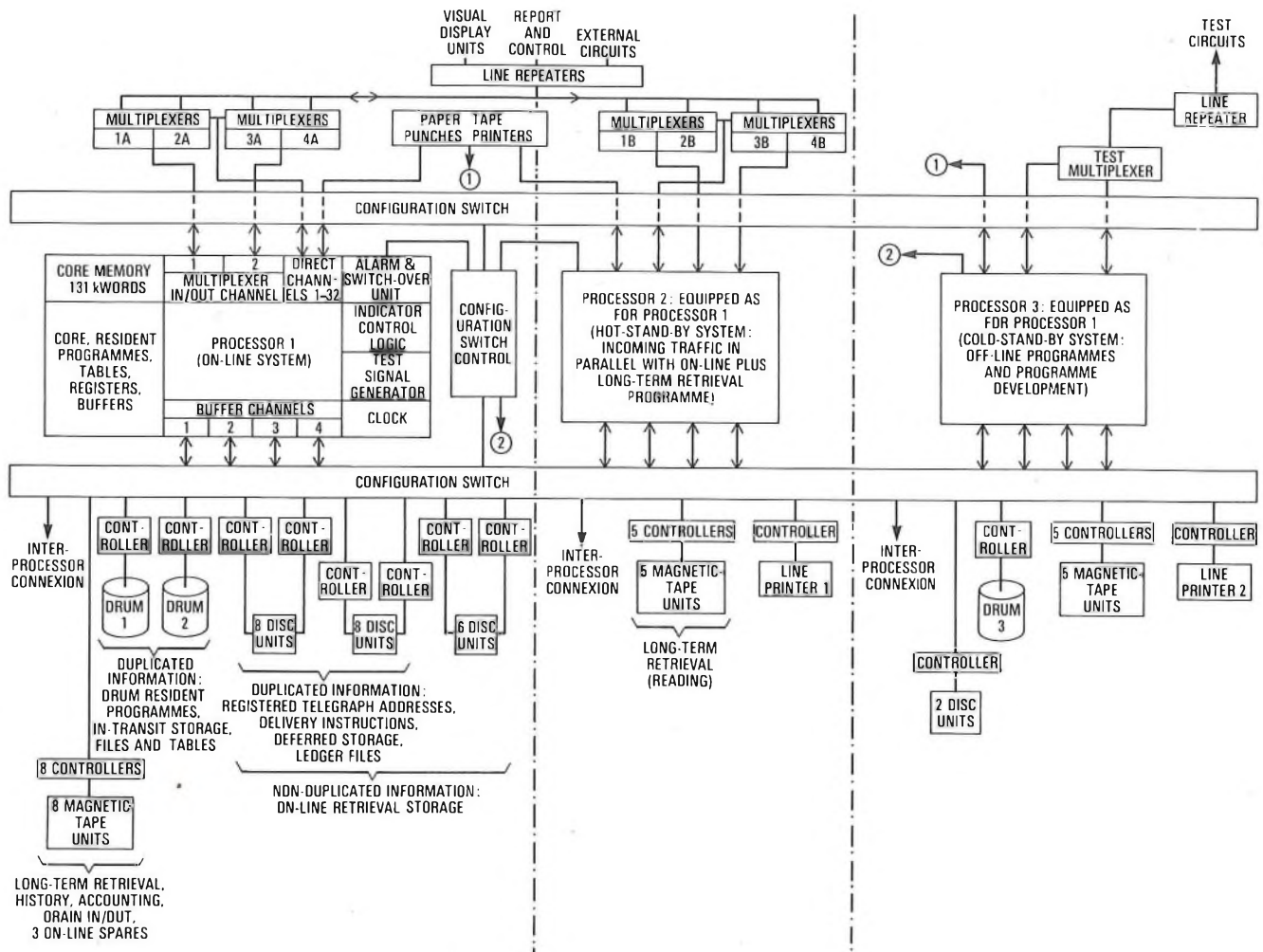

FIG. 4—Block diagram of TRC equipment

plex-input/output-channel path. The direct channel is also the input/output channel for low-speed peripheral equipment such as paper-tape punches, readers, control and display devices. In this case, the data transfer is not autonomous, but under programme control throughout. There are 32 direct channels per processor.

Alarm and Switch-Over Unit

Each processor has an alarm and switch-over unit, these being interconnected for the 2 processors forming the in-service system. All data transfers within the system are parity checked. Certain subsystem responses and programme elements are guarded by time-out and fault-detection circuits. These safeguards are supported by special test signals and on-line test routines that periodically check the operation of system units and transmission paths within and outside the processor. Detection of any malfunction causes the alarm and switch-over unit to take action; for example, initiating a change to the hot-stand-by processor.

Processor Construction

The processor uses mainly discrete-component technology, with considerable derating to ensure the good reliability essential for continuous operation of a public telecommunications service. The components are assembled on small boards, printed on both sides, and having a front panel carrying numerous test points. Up to 36 boards can be mounted on a shelf. A cabinet can contain a maximum of 33 shelves, mounted on one fixed and 2 hinged frames. Wiring is mainly in the form of twisted pairs to minimize crosstalk.

Configuration Switch

The configuration switch is a programme-controlled reed-relay matrix, to which processors, peripheral equipment and communications multiplexers are connected. It permits flexibility in system equipment allocation and minimizes the effect of equipment failure on the system as a whole. Where possible, duplicated paths are provided to system elements connected to the configuration switch.

Detection of certain faulty equipment on the on-line system causes the configuration switch to change automatically to the hot-stand-by mode. Recognition of a malfunctioning magnetic-tape unit causes it to be replaced automatically by a previously nominated spare. In other cases, the configuration switch can be commanded to change from faulty to serviceable equipment.

Communications Multiplexers

The TRC has 4 pairs of communications multiplexers, each pair being common to a group of 125 outgoing and incoming line repeaters. One multiplexer of each pair is connected to the on-line processor, the other to the hot stand-by. Multiplexers each have a nominal 128-circuit capacity, but 3 of these are reserved for on-line loop tests and control purposes, leaving 125 available for traffic circuits.

Integrated-circuit technology is used, with emphasis on low dissipation and derated components. Metal-oxide-semiconductor shift registers are also used. Incoming repeaters are purely electronic; outgoing repeaters are semi-electronic, using mercury-wetted relays for the line interface.

Twelve transmission speeds are available, ranging from 45·45–200 bauds. The multiplexer can, with the appropriate software conversion, handle a variety of codes, including International Telegraph and Telephone Consultative Committee (CCITT) Nos. 2 and 5, American Standard Code for Information Interchange (ASCII), and extended binary-coded decimal interchange. Line speeds and code levels are independently controllable for incoming and outgoing lines. A line pair can be used as a full or half-duplex circuit. Incoming and outgoing lines can be operated independently. Telex or Gentex signalling and automatic dial-pulse generation can also be handled. Other features of the multiplexer are parity detection and generation, and control-character or character-pair detection. For 5-level codes, automatic-shift detection is used on inputs and automatic-shift generation is used on outputs. The 5 bits are padded out to 8, plus one parity bit; bit 6 is set to one for figure shift and to zero for letters.

Each multiplexer is connected to the direct channel for the reception of processor commands and transmission of status information to the processor. The latter are typically programme-interrupt requests on the detection of character pairs comprising the start-of-message and end-of-message signals. Having thus prepared the conditions for data transfer, this takes place autonomously via the multiplexer and the multiplex input/output channel, to and from the core memory. Serial-to-parallel bit conversion is carried out on reception, or conversely for transmission, a 1-character buffer store is provided for each incoming or outgoing line. Incoming signals are scanned at a rate that typically achieves a margin of 47·2% for 50-baud working.

Peripheral Magnetic Storage Equipment

Magnetic Drums

Of the 3 magnetic drums used in the TRC, 2 are assigned to the on-line system carrying duplicated information and one to the cold-stand-by processor. The drums each have a capacity of 2·4 Mcharacters. The method of recording is by phase modulation and the average access time is 20 ms. The scheduling of data transfers to the drum is optimized to reduce latency time.

A major part of the 2 on-line drums is devoted to in-transit storage of telegrams awaiting analysis and routing, or being queued for outgoing routes. Other parts of each drum hold housekeeping programmes, such as those for supervisory command, system-performance monitoring, telegram security and recovery. Also stored on the drums are various indexes and routing files, together with the basic programme and table package. The latter is read into the hot-stand-by processor, when the drums and other peripherals are switched over on failure of the on-line processor. Because the drums contain duplicated information, the system can still be maintained with one drum failed.

Magnetic-Disc Units

The moving-head disc-drive units each have disc packs of 20 effective surfaces, providing a working storage of approximately 25·7 Mcharacters. A double-frequency method of recording³ is used and hydraulic actuators position the recording heads. The on-line disc-storage system comprises 22 disc units, divided into 2 groups of 8 units and one of 6 units. Each group has dual controller access facilities to increase reliability.

On-line storage for the retrieval of telegrams requiring further attention is spread over the 3 groups in a non-duplicated mode, the back-up storage for this being on retrieval magnetic tape. The 2 groups of 8 disc units also contain duplicated storage for deferred-delivery telegrams, retrieval and registered-telegraph-address indexes, delivery instructions, message-security data and ledger. Information entered into the ledger provides a datum line from which the

hot-stand-by processor can start to process telegrams after a switch-over. Two disc units are also available to associate with the cold-stand-by processor for off-line programme running and development.

Magnetic-Tape Units

The TRC has 18 magnetic-tape units. Of these, 15 can be configured to the on-line system, although only 8 can be so connected at any one time. The units operate at a packing density of 32 characters/mm and use the non-return-to-zero method of recording.³ Each magnetic-tape unit is connected to the buffer channels via its own controller. The 8 on-line tape units are used

- (a) for recording information for international accounting and customer billing,
- (b) for recording transmitted telegrams for off-line retrieval,
- (c) as history tape, giving a record of all transactions through the system,
- (d) to enable telegrams to be removed from, or re-entered into, the system, and
- (e) for on-line spares.

The remaining magnetic-tape units can be associated with the hot-stand-by or cold-stand-by processors for retrieval, statistical or programme-development purposes. A special recording format is used, but to allow the accounting and billing information to be read on ICL System 4 computers, 2 of the magnetic-tape units have special controllers to convert, as an off-line process, into extended-binary-coded-decimal-interchange code and to provide cyclic-redundancy-check information at the end of each tape block.

Visual Display Units

In the TRC, 26 visual display units are used for the routing and format correction of telegrams. Others are used for inputting service messages or for the display of selected telegrams.

The character display uses a 9 × 7 dot matrix, with 80 characters/line, the screen being capable of accommodating 27 lines. By using the roll-up/roll-down facility, in conjunction with the unit's independent memory, a telegram with a number of lines in excess of the nominal screen capacity can be displayed for analysis without processor intervention. For edit-assist positions, a 2000-character memory is used, and a 3000-character memory is used on miscellaneous-services positions. Information is packed contiguously in the memory, a varying portion being allocated to each line according to the data contained. The keyboard has been adapted to resemble that of the Teleprinter No. 15 to simplify operating and training procedures. A special finish applied to the screen reduces reflections liable to impair viewing, and safeguards against tube implosion. The unit operates to the communications multiplexers at a speed of 200 bauds using ASCII. It can be selected to transmit in the character-by-character mode or alternatively the character-block mode. An audible alarm sounds when the character reaches the fifty-sixth position on any line, or when the limits of roll-up/roll-down are reached. Other facilities are available, such as blink display on selected characters and the display of a pre-established format.

Other Peripheral Equipment

A variety of equipment using ASCII 8-level code, is available to produce printed copy or read paper tape for systems management purposes. This includes 2 line printers capable of producing outputs of 600 lines/min at 120 characters/line, and paper-tape punches operating at 110 characters/s. Also available are teleprinters and paper-tape readers that step characters at a rate of 250/s. Teleprinters No. 15 are used at certain report and control positions.

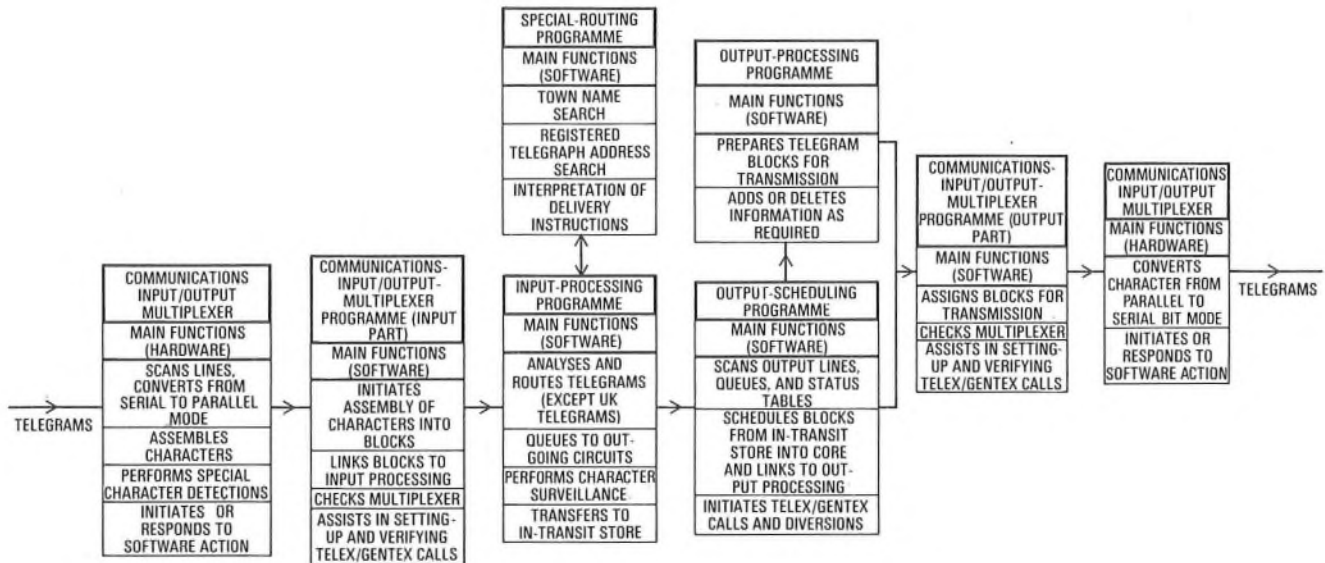

FIG. 5—Sequence of telegram handling in the TRC

OUTLINE OF SYSTEM PROGRAMMES

The system software consists basically of the following groups of programmes, their functions in the sequence of telegram handling being shown in Fig. 5.

Interrupt-Driven Programmes

Each peripheral storage device or communications multiplexer can originate an interrupt request to initiate its related service programme, which is concerned with setting-up the conditions for data transfer to or from that device. The programmes are assigned to the higher priority levels in such a way that the peripherals or subsystems performing the most urgent functions are serviced first. The priority structure ensures that the programmes in the highest priority level are the shortest. The most important interrupt-driven programmes are described below.

Communications-Input/Output-Multiplexer Programme

This programme is responsible for recognizing certain line conditions, and for the assignment of core memory blocks into which incoming telegrams are assembled as they are received by the communications multiplexers. It operates in both the on-line and hot-stand-by processors to deal with telegrams fed in parallel to these processors by the twin sets of multiplexers. For outputting, this programme performs a similar function, except that in this case, the in-transit drum storage is the source from which telegrams are assembled into core blocks before transmission.

Magnetic Drum, Disc, and Tape Interrupt Programmes

These programmes are responsible for the initiation and termination of data transfer to and from these peripheral storage devices.

Clock-Interrupt Programme

This programme governs the internal function timing for the system software, and activates certain system surveillance elements on a periodic basis.

Base-Sequencer Programme

The base-sequencer programme operates in a cyclic mode to

control and co-ordinate, in a fixed sequence, the telegram-processing and system housekeeping programmes. With the aid of the interrupt-driven service programmes, the base-sequencer programme also controls, in a manner related to this sequence, the transfer of data to and from the magnetic drums, discs, and tapes. An important transfer is the writing operation from the ledger to a disc, which records the state of transactions at the end of each base-sequencer cycle to facilitate system recovery in the event of a switch-over to the hot-stand-by processor.

The cyclic operation of the base-sequencer programme permits efficient co-ordination between the accesses to files and data required during telegram processing and the related programmes. Various stages of processing in a number of telegrams are handled by different programmes during the same cycle. Intermediate processing results are stored in system tables and administrative parts of data blocks containing telegrams.

Each programme has a number of time slots allocated during the cycle. As the load increases, the time slots can lengthen up to certain limits, and hence the overall cycle time increases.

The programmes controlled by the base-sequencer programme are shown in Table 1.

TABLE 1

Programmes Controlled by Base-Sequencer Programme

Telegram-Processing and Related Programmes		System Housekeeping Programmes
Input-processing Special-routing Output-scheduling	Supervisory-command Retrieval Output-processing	Initiation Miscellaneous System-monitor

Telegram-Processing Programmes

Input-Processing Programme

The chain of core memory blocks containing a telegram is scanned by the input-processing programme, and the telegram is assigned an internal system number. The format is analysed and validated, each telegram being queued according to routing and priority. Character-by-character surveillance is

performed, eliminating redundant functional characters and taking corrective action where necessary. Excessively long lines are detected and re-alignment functions inserted at the appropriate points. Telegrams over 309 words in length are assembled in a special output position for manual attention. Tape format is converted to page format. Repeated character (stuck tape), intertelegram garble, and abnormal start-of-message/end-of-message conditions are all recognized. Pauses over a specified length, in mid-telegram, are detected, and the telegram terminated artificially. Data transfers to the drum in-transit store and to the history tape are scheduled. Missing and duplicated incoming serial numbers are reported.

Special-Routing Programme

This program is especially concerned with telegrams for UK delivery. According to the town name, and the presence or absence of a registered telegraph address and relevant service indicator, telegrams are routed to UK international telegraph offices or automatically delivered by Telex from the TRC. In the latter case, collation and word-count checks are carried out automatically. If clearance is not successful via a Telex circuit, the telegram is routed to the ITO nearest to the address.

Output-Scheduling Programme

The output-scheduling programme scans the outgoing lines and, if a telegram is available for a free line, it initiates transfer from the in-transit store to the core memory, as required, for processing and transmission. If a transmission failure is detected on a point-to-point, Telex or Gentex circuit, any interrupted telegram is queued for retransmission and marked as a possible duplicate message. The output-scheduling programme controls the diversion of traffic from one destination to another by transferring the queue entries.

If an output channel is idle for more than 30 min, a last-sent message is transmitted, and also last-received message if there is a corresponding incoming channel. Outward calls on Telex and Gentex circuits are initiated and their progress monitored. After 4 unsuccessful attempts to establish a call, one further attempt is made to an alternative number if this is available. If this is unsuccessful, a Gentex telegram is routed to an edit-assist position or, for Telex deliveries, the telegram is routed to an ITO.

Output-Processing Programme

The output-processing programme takes the core memory blocks from the chain created by the output-scheduling programme and prepares telegrams for transmission according to the type of circuit; for example point-to-point, Telex, Gentex, and edit assist. A new header is prepared including the start-of-message pattern and the outgoing prefix/serial number. Repeat transmissions at the request of the distant end do not have a new number assigned. In accordance with the control information associated with the telegram, prepared texts are attached at specified points. Typical examples are CORRECTION TO FOLLOW, CHECK COLL, and POSSIBLE DUPLICATE MESSAGE. The output-processing programme also extracts telegrams from the deferred store at the appropriate time, and schedules the transfer of data to retrieval discs and tape, and history and accounting tapes.

Supervisory-Command Programme

Commands entered from the technical and operational control positions are serviced once per base-sequencer cycle, and the appropriate responses generated.

Retrieval Programme

Any data read from the disc-based retrieval data or retrieval index files during the current base-sequencer cycle are processed

for transmission to destinations that have made a telegram retrieval request.

System Housekeeping Programme

Initiation Programme

The initiation programme updates the clock, calendar, and system cycle number. It is also the starting point for bringing newly assigned equipment into service.

Miscellaneous Programme

The miscellaneous programme returns to a common pool those core memory blocks whose release has been delayed until data transfers to peripheral storage equipment have been accomplished. Reports on the condition of this equipment are generated at this point.

System-Monitor Programme

The system-monitor programme maintains quality control of the TRC on-line system by keeping a constant surveillance of

- (a) the technical status of the peripheral equipment,
- (b) the condition of the input/output communication lines, and
- (c) the critical limits of the system's capability, such as availability of buffer storage, in-transit and deferred storage, and queue entries.

For item (c), if critical limits are reached, the appropriate overload reports are generated. The system-monitor programme also provides the status material for system condition reports requested by supervisory command.

Off-Line Programmes

Long-Term-Retrieval Programme

Telegrams can be retrieved, for example, to clarify accounting queries from a 7-months' store of retrieval tape. The long-term-retrieval programme is run daily.

Hardware-Test Programmes

Hardware-test programmes are available for testing peripherals and individual parts of the processor to locate faulty equipment functions. From this information, faults can be traced to a particular printed-circuit board. A test programme is also available to exercise and co-ordinate the various system hardware functions.

Statistical Programmes

An accumulated statistics tape is derived from the history tape and is used as a base from which can be obtained

- (a) table access counts for assessing any redundant entries or new entries required,
- (b) analysis of traffic by origin and destination for establishing general routing patterns,
- (c) error analysis for assessing the quality of message preparation, and identifying troublesome circuits and those requiring excessive reruns,
- (d) Telex/Gentex abnormalities for verifying Telex/Gentex circuit performance,
- (e) random samples, parameters from which are punched on cards for subsequent analysis of particular characteristics, and
- (f) transmission verification used as an off-line check of system performance.

SYSTEM SWITCH-OVER AND RECOVERY

The 3 main methods of system recovery are described below.

Switch-Over

Switch-over to the hot-stand-by processor occurs automatically if

- (a) the on-line (master) processor or multiplexer fails,
- (b) both drums fail, or
- (c) a software fault is detected.

On receiving a main alarm condition from the on-line processor, the hot-stand-by processor is connected to the configuration switch controllers, the drums, discs and magnetic tapes. The recovery programme, permanent tables and on-line programmes are read in to the hot-stand-by processor. The telegram core blocks that were not recorded on in-transit storage before switch-over are processed by the new master processor. Output traffic in progress at the time of switch-over is annulled and retransmitted by the new master processor. Inter-processor transfers from the master to the hot stand-by before switch-over provide the hot-stand-by processor with information on peripherals in service and data from the ledger. This information is used to restore the magnetic tapes, dynamic tables, and buffers of core memory to the *status quo* existing at the end of the last complete base-sequencer cycle.

Restart

If hardware or certain software faults occur when the system is operating in a single-processor mode, restart can be carried out automatically or manually. For restart, incoming-message data is lost, but the system conditions at the time of failure are re-established, the processor being restored by loading the on-line programme from the drum and using the available dynamic data. The number of consecutive automatic restart attempts can be preset.

Start-Up

Start-up of the on-line processor is achieved by reading the system object programme library tape from magnetic tape into core memory. Old data on drums is cleared and the complete operating system and recovery programme re-initiated and loaded on a drum. Peripherals and multiplexers are reconnected according to the start-up configuration, and spare magnetic-tape units are assigned. During the start-up operation, the last sent and received telegram serial numbers are lost. These are recovered from history tape and written on a drum. The disc and retrieval index is also recovered to regain access to on-line retrieval storage.

SYSTEM CONTROL

The complexity of the TRC has made it necessary to split control of the system into technical and operational functions. The operational control, sited in an area remote from the computer equipment, controls the flow of telegrams through the system, and deals with telegram abnormalities and the opening and closing of circuits. The technical control, situated in the computer equipment area, deals with system malfunctions, and configuring and operating the equipment to the best advantage.

Operational Control

Operational commands and report requests can be given using a push-button device or, alternatively, through a command/echo teleprinter. A visual display unit is available to give rapid access to selected reports. Abnormal conditions relating to telegrams and circuits and system loading are reported automatically or by command. Control telegrams can be initiated to start or stop transmission on individual, or a number of, direct circuits. A graduated series of reports gives the load state on the common group of telegram core blocks, queue entries, and the in-transit and deferred area

storage. If system overload is approached, it is possible to stop immediately transmission from ITOs into the TRC, and also to remove traffic from the system.

Telegram routing and format abnormalities are dealt with in the edit-assist area, where 26 visual display units can be fed cyclically in groups dealing with particular classes of discrepancy. The command method of amending telegrams is used, an operator instructing the processor via the visual-display-unit keyboard to amend, delete or add a line in a telegram. The original version of a telegram can be recalled if necessary. On some positions, a hard-copy print-out of the display can be obtained.

Other parts of the operational control area deal with missing or duplicated telegrams, or queries arising that require corrective information from the telegram source. The operational area has been designed to an external consultant's specification, using custom-built furniture, air-conditioning and double glazing. It is carpeted throughout.

Technical Control

The technical control is part of the main computer complex. Each processor has a control panel which provides access to the key registers, priority control circuits, and to the memory for data-entry purposes. Individual programme steps can be executed, and instructions entered and looped. The contents of all significant registers are displayed and the conditions indicated, allowing processor status to be rapidly analysed.

On system start-up, programmes are usually loaded via magnetic tape, although paper-tape entry is possible. High-speed paper-tape and line-printer outputs are available for such functions as listings and core dumps. A configuration-switch display gives the relative disposition of processors, peripheral equipment and multiplexers. Also displayed is the status of processors and the condition of the various system power supplies. Technical commands are entered via an echo printer. Facilities are provided for originating test telegrams over any channel. Automatic reports are given on all system technical aspects, including equipment malfunction and re-configuration. An illuminated mimic diagram indicates whether the computer system is being supplied from the mains, from the no-break diesel sets, or normal automatic-start diesel sets. It also indicates whether primary or stand-by feeders are being used.

AIR CONDITIONING AND POWER SUPPLIES

Air-Conditioning Plant

Seven air-handling units are provided, having individual condensing units situated immediately above on the roof. Any 6 units can maintain the desired environment under full-load conditions. Temperature is regulated to within $21.1 \pm 1.1^\circ\text{C}$ and relative humidity to within $50 \pm 5\%$. Dust filtration of particle sizes down to $5 \mu\text{m}$ is achieved in the air-handling units. A fire-detection and alarm system is incorporated in the installation.

Power Supplies

The required d.c. logic levels are derived from individual a.c. fed power packs within the TRC equipment, or from a 48 V d.c. supply. The power packs are duplicated where vital areas are being served. All voltages are monitored by power guarding units, which activate either alarms or automatic equipment transfer facilities when deviations outside tolerance occur. Rotating magnetic storage equipment is fed from the 415 V 3-phase supply. On mains failure, the first-line back-up for both operating and engineering areas is the no-break generator system, but normal automatic-start diesel generators are also available if required. A diesel fuel switching facility permits the no-break and the normal automatic-start diesels to be fed from any of 3 storage tanks.

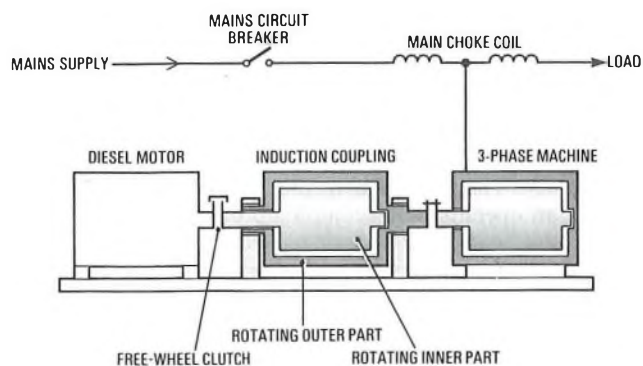

FIG. 6—TRC no-break supply stand-by generator sets

No-Break Power Supply

The TRC has a no-break a.c. supply comprising two 200 kVA diesel generator sets with two 6-cylinder, 4-stroke diesel engines as prime movers.

The no-break system is unusual in that it forms a stabilizing filter across the mains supply (see Fig. 6), thereby eliminating mains-borne high-frequency transients and reducing supply fluctuations. It consists of a choke, to which is connected a rotating synchronous machine operating in parallel with the mains supply. The machine is connected to the hollow outer rotor of an induction coupling. The inner rotor drives one part of a free-wheel clutch, the other part being connected to the diesel engine. The hollow outer rotor electrically drives the inner rotor at 3000 rev/min. On failure of the mains supply, the 2 rotors are inductively coupled so that the kinetic energy of the fast rotating inner rotor is transferred to the shaft of the synchronous machine through the outer rotor running at 1500 rev/min. The transferred energy enables the synchronous machine to provide the a.c. supply whilst the diesel engine runs up to speed. At the instant that the increasing speed of the diesel engine equals the decreasing speed of the inner rotor, the 2 are mechanically coupled by a free-wheel clutch and the diesel engine becomes the energy source. The degree of slip between the 2 rotors is governed by the frequency control, which regulates the torque supplied from the diesel engine to the generator such that the supply frequency is constant and independent of diesel engine speed variation.

To ensure system security, the 2 no-break sets run continuously, in parallel, but a single set can meet the total TRC load.

SYSTEM TESTING

TRC hardware testing, both at the factory and on site, was carried out jointly by BPO staff from the Telecommunications Development Department and the ETE. In addition to seconding BPO personnel to the manufacturer to participate in programme writing, the ETE provided a team to test intensively these programmes during their development and acceptance-test stages. Over 60 000 test telegrams were devised to exercise the TRC to the limits of its tolerance and telegram-handling capability. In addition, the team tested all other aspects such as recovery procedures, supervisory commands and reports, and interfaces with external networks. A simulated load test using magnetic tape input was formulated and used to test the designed peak system throughput capacity of 5.4 telegrams/s.

MAINTENANCE AND TEST EQUIPMENT

The TRC is maintained by BPO staff on a 24 h rota basis. A technical operations manual has been produced by the ETE to cover system technical management and those engineering aspects not dealt with in the Contractor's manuals.

Besides the usual electronic test equipment, the following 3 items were specially purchased.

(a) *Magnetic-Tape Cleaner/Evaluator*. This services the 3000 magnetic tapes used in the system. Lint-free spools of material, turning slowly, clean the tape twice on each side during one pass, any particles embedded in the oxide surface of the tape being scraped off by a ceramic or sapphire blade. In the evaluation mode, the device cleans the tape on the forward pass and writes a test band across the tape at 32 characters/mm. This is checked by 9 read heads, and drop-outs recorded.

(b) *Printed-Circuit-Board Tester*. A total of some 33 000 printed-circuit boards, of 308 different types, and 8 different types of edge connector are used in the TRC. Although maintenance exchange of printed-circuit boards with the manufacturer is possible, about 80% of printed-circuit-board faults are expected to be located using transition redundancy check equipment on site. This compares faulty printed-circuit boards with previously-assessed good ones of the same type when stimulated at the logic input, and discrepancies are used to locate the fault.

(c) *Printed-Circuit-Board Repair Station*. A special soldering technique, used in conjunction with small mechanically-driven cleaning, drilling and polishing tools, enables printed-circuit boards to be repaired to high standards. Unsoldering of components is carried out with an air-flow background, thereby preventing excessive temperature rise which is liable to cause lifting of printed circuits from the base material.

CONCLUSION

The TRC incorporates all major features found in stored-programme telegram switching systems throughout the world. In addition to providing the telegram-switching function, the TRC facilities replace associated activities that were tedious and manually intensive. The store-and-forward concept permits the interfacing of circuits operating at different codes, speeds and transmission conditions. It is possible to expand the facilities to include, for example, acceptance of telegrams by Telex, and the connexion of data circuits operating at speeds up to 9.6 kbit/s.

ACKNOWLEDGEMENTS

The author wishes to thank colleagues in the BPO for their assistance, and Pye TMC Ltd., Philips' Telecommunicatie Industrie BV, and Heemaf BV for the use of certain material.

References

- ¹ MARSH, H., and LEE, E. W. A Push-Button Torn-Tape Relay System for Electra House, London. *POEEJ*, Vol. 57, p. 175, Oct. 1964.
- ² AUSTIN, D. N., and HUCK, J. F. J. A New Message-Relay System for the Overseas Telegraph Service. *POEEJ*, Vol. 62, p. 44, Apr. 1969.
- ³ LOOMES, E. A. A Review of Magnetic Storage Devices. *POEEJ*, Vol. 68, p. 96, July 1975.

Experimental Packet-Switched Service: Routing of Packets

A. J. GARDNER, B.SC., M.TECH., C.ENG., M.I.E.E., M.B.C.S., and K. N. SANDUM, B.A.(ENG.)†

UDC 681.327.8: 621.394.4

This article describes the routing aspects and strategy used in determining the paths of packets in the British Post Office Experimental Packet-Switched Service, and explains why an alternative-routing strategy was chosen. Other possible routing strategies are then described, and their performance is compared with that of fixed routing in terms of average packet delay and adaptability.

INTRODUCTION

In any communications network, the transmission of data has to be controlled. The determination of the path by which data traverses the network is one component of this control. This path, which is called the *routing*, is defined by the routing strategy used in the network.

In a packet-switching network, blocks of data, called *packets*, can travel across the network by many different paths; thus, the choice of routing strategy is critical. The routing aspects and strategy used for determining the paths of packets in the British Post Office (BPO) Experimental Packet-Switched Service (EPSS) are described in the first section of this article.

Many routing strategies exist, apart from that used by the EPSS. The second section of this article examines a number of these strategies and concludes with an overall comparison of their characteristics.

ROUTING OF PACKETS IN THE EPSS

The EPSS

The BPO EPSS is currently being implemented, and will consist of 3 packet-switching exchanges (PSEs) situated in London, Manchester and Glasgow, interconnected by 48 kbit/s circuits. The basic function of the network is to switch packets of digitized information, having a maximum data-field content of 2.04 kbit/packet, between 2 participating customers as quickly as possible. A fuller description of packets and how they are used by the customer, is given in previous articles in the *Journal*.^{1, 2, 3}

Customers use packet terminals to assemble, transmit and receive packets. Each packet terminal has a unique EPSS number and PSE access circuit, over which packets can be multiplexed using a logical channel number called a *label*;³ this provides, for example, a 200 simultaneous call capability for a customer using a 48 kbit/s local PSE access circuit. When an exchange of packets is required between 2 packet terminals, the network connects the 2 participants by a *virtual call*. The setting-up and clearing-down phases of a virtual call are analogous to the corresponding phases of a telephone call. It is a virtual rather than a physical call because transmission resources at the PSE(s), local to the packet terminal(s) associated with the call, are not dedicated

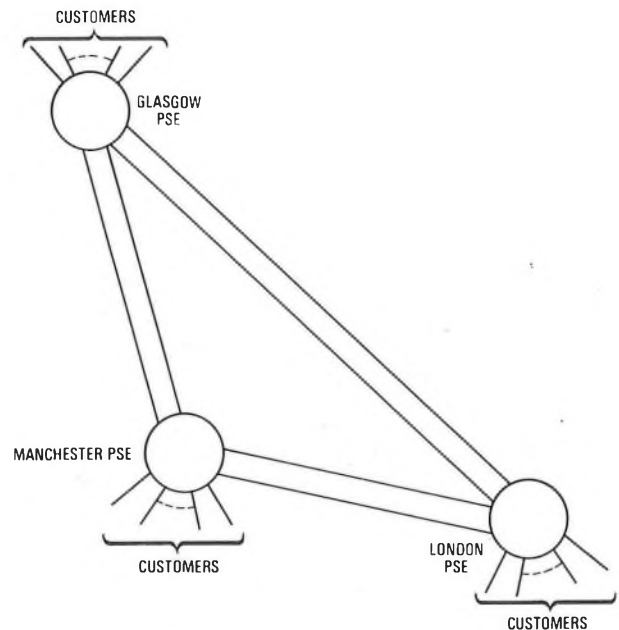

FIG. 1—Location and interconnexion of PSEs

and transit PSE(s), if any, are completely unaware of calls as such. The routing algorithm also allows consecutive packets within a call to travel through the network by entirely different paths.

Topology of the EPSS Network

The geographic location and interconnexion of exchanges are as shown in Fig. 1. The network is not as simple as shown because of the architecture of the PSEs. Each PSE is constructed of sub-systems called *packet-switching units* (PSUs), which are fully interconnected within each PSE and are configured so that each PSU handles an equal proportion of customer ports. Each PSU has to be capable of performing all the functions of a PSE for the traffic presented to it, and hence, for routing purposes, they can be thought of as separate switching nodes. By using the PSUs in this fashion,

† Telecommunications Development Department, Telecommunications Headquarters.

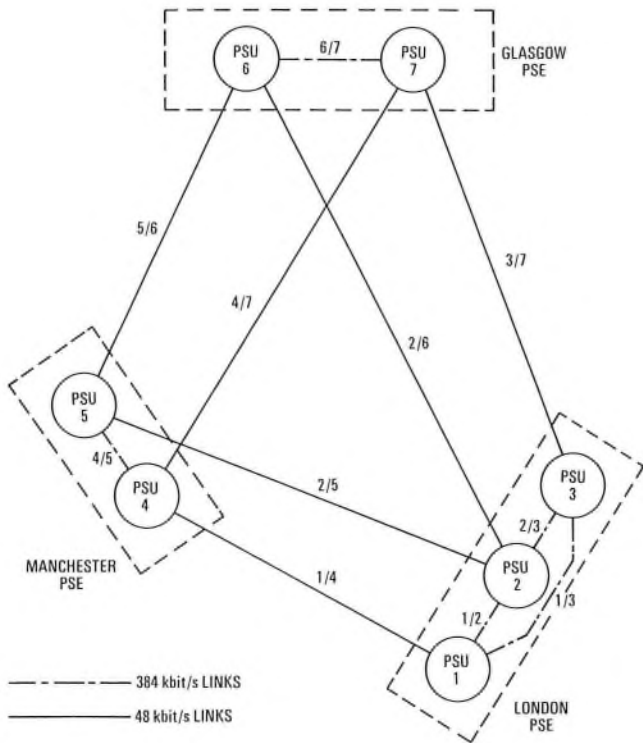

FIG. 2—Interconnexion of PSUs

a single-level network is produced and, unlike the telephone network, no hierarchy exists. The main reason for this is the small size of the network and it is likely that, if the EPSS were to be enlarged, a hierarchical organization of PSUs would need to be introduced.

The Glasgow and Manchester exchanges will initially consist of 2 PSUs, whereas the London exchange will consist of 3. In effect, the network has 7 nodes, which are interconnected by 48 kbit/s Datel circuits and 384 kbit/s short inter-computer links. Therefore, the network, for routing purposes, will be as shown in Fig. 2.

Routing Considerations

In Fig. 2, consider how a packet could be routed from node 1 to node 7. There are many possible routings such as 1-2-3-7, 1-3-7, 1-2-6-7, or 1-4-7, to name but a few. Generally, in packet switching, all routes are theoretically possible because routing decisions are taken on behalf of each packet at each node through which it passes, as opposed to the single routing decision taken with a telephone call. At this point, the question that arises is "What criteria should be used to determine the next route to be taken at any node?" The criteria and how they are used are called the *routing strategy*.

Routing Strategy

A routing strategy is a set of rules that determines the path taken by packets through a network in their journey from a source to a destination terminal.

The effect that the choice of routing strategy has on the network performance is dependent upon many factors, some of the more important being network topology, trunk capacity, protocols, traffic intensity and the variation of the traffic distribution from the associated design premise. The complicated interdependence of these factors makes analytical performance predictions of a routing strategy difficult and, in practice, the designer must resort to experimentation on a live network or to simulation.

Routing Strategy for the EPSS

The design aims of the EPSS that affect the routing strategy are

- (a) packets should be switched between participants as quickly as possible, and
- (b) alternative routes should be used to try to bypass links that have failed or are heavily congested.

To attempt to meet these aims a packet should travel via the path containing the least number of nodes and links whenever possible; this is generally known as a *minimum-hop philosophy*. Failing this, an alternative path should be found.

Alternative-Routing Strategy

To meet the EPSS routing design aims, an alternative-routing strategy is used. In this strategy, a number of priority-ordered choices are maintained in a routing table at each node. A routing table is a form of decision table, with the dimensions dependent upon the number of criteria used to access it. In packet switching, the routing table generally is 2-dimensional, with the ultimate destination node and level of choice being used as the access criteria. An example of a routing table for node 5 of Fig. 2 is shown in Table 1. The table entries indicating the route to attempt have been determined using a minimum-hop philosophy.

TABLE 1

Example of a Routing Table

Ultimate Destination Node		1	2	3	4	5	6	7
Outgoing Route	First Choice	2/5	2/5	2/5	4/5	—	5/6	5/6
	Second Choice	4/5	5/6	4/5	2/5	—	2/5	4/5

To demonstrate how Table 1 is used, consider a packet that has arrived at node 5 and is ultimately destined for node 3. The column associated with node 3 is selected and can be considered to be a route vector whose elements represent outgoing-route identities. The order of choice is determined by the position of the route identity in the vector, which is generally indexed sequentially. In this example, the first element imparts route 2/5, which is then examined; if found to be congested, other elements are considered in turn, route 4/5 in this case, until a route is found or all the elements are exhausted. In the latter case, failure routines are invoked on behalf of the packet in question. When a suitable route is found, the packet is placed in the queue of packets awaiting transmission for that route. (In packet switching, queues can form because the amount of data required to be transmitted on a route for short periods of time can be greater than the peak capacity of the route. These periods are complemented by instances of no packets arriving for transmission and the queueing technique smoothes out these peak variations.)

A route that is not in working order can, for the purpose of routing, be represented by infinite congestion. One way of detecting congestion or failure is to monitor, against a preset threshold, the number of packets queueing for transmission on a route; this is referred to as *queue length* in this article.

Alternative routing is often used in switching networks, but can perform poorly under transmission-path failures or when there are large variations from the traffic distribution anticipated during the design.

Routing Algorithm for the EPSS

The routing algorithm is a set of instructions that performs the routing function using the routing table as data. In the EPSS, the algorithm and table are constructed for each node to produce an alternative-routing strategy with a maximum of 2 choices per ultimate destination node. The choices are called *primary* and *secondary* routes. The contents of the routing tables are static while a node is operational, being altered only by the manual intervention of the network administrators.

As currently proposed, each PSU on the EPSS will be aware of the state of only the links it is directly serving and its own internal state. Therefore, the information available to the routing algorithm used to determine the routing of each packet is restricted to

- (a) the node for which the packet is finally destined, indicated in the packet header,
- (b) the node from which the packet has just been received,
- (c) the current queue length for each route,
- (d) which of the routes are the faster intercomputer routes,
- (e) the node from which the packet originated initially, this being indicated in the packet header.

The information listed above is used in the following ways. When the routing tables are being constructed, cognizance is taken of (a) and (d). The routing algorithm uses (a) to determine the appropriate routing vector from the routing table, and (b), (c) and (e) to determine which element, if any, of this vector is suitable.

The general form of alternative routing gives rise to 2 phenomena that need to be suppressed to meet the EPSS design aims; these are *circulation* and *ping-pong* of packets.

There are 2 types of packet circulation, temporary and indefinite, caused by 2 different mechanisms. Temporary circulation is the result of fluctuations in traffic producing primary and secondary route selections that result in one or more packets travelling in a loop. In alternative routing, this type of circulation cannot be prevented, but the probability of its occurrence can be reduced by the careful design of routing tables. Indefinite circulation occurs when a failure in the network results in the looping of all packets being sent between particular source and destination nodes. These packets will loop continually until the routing tables are changed or the failure in the network is corrected. In the EPSS, the tables are changed manually from a centralized monitor and control point. Such manual methods are operationally viable only for small networks, as the complexity of the problem increases sharply with the number of nodes forming the network.

In the EPSS network, circulation cannot be fully prevented in a fault situation because no packet carries information about the history of the route taken so far, or the time it has spent within the network. Also, each node keeps only a minimum amount of information concerning individual packet transactions and cannot, therefore, check for circulation from its records. However, in the EPSS network, a circulatory path that includes the source PSU is trapped because the address of the source PSU is carried in the packet header.

Ping-pong effect occurs when packets are sent backwards and forwards over the same link. To prevent this in the EPSS, the simple rule is used that packets cannot be transmitted on the route on which they were received. This rule can, however, under certain network fault conditions, produce unidirectional routing failures.

The above effects have been analysed for the current EPSS topology and, for a single route or node failure, indefinite circulation is completely eliminated, and unidirectional routing failures can be limited to only a few instances, by careful routing-table design.

The routing algorithm used by the EPSS can be described precisely as a flow chart, and this is illustrated in Fig. 3.

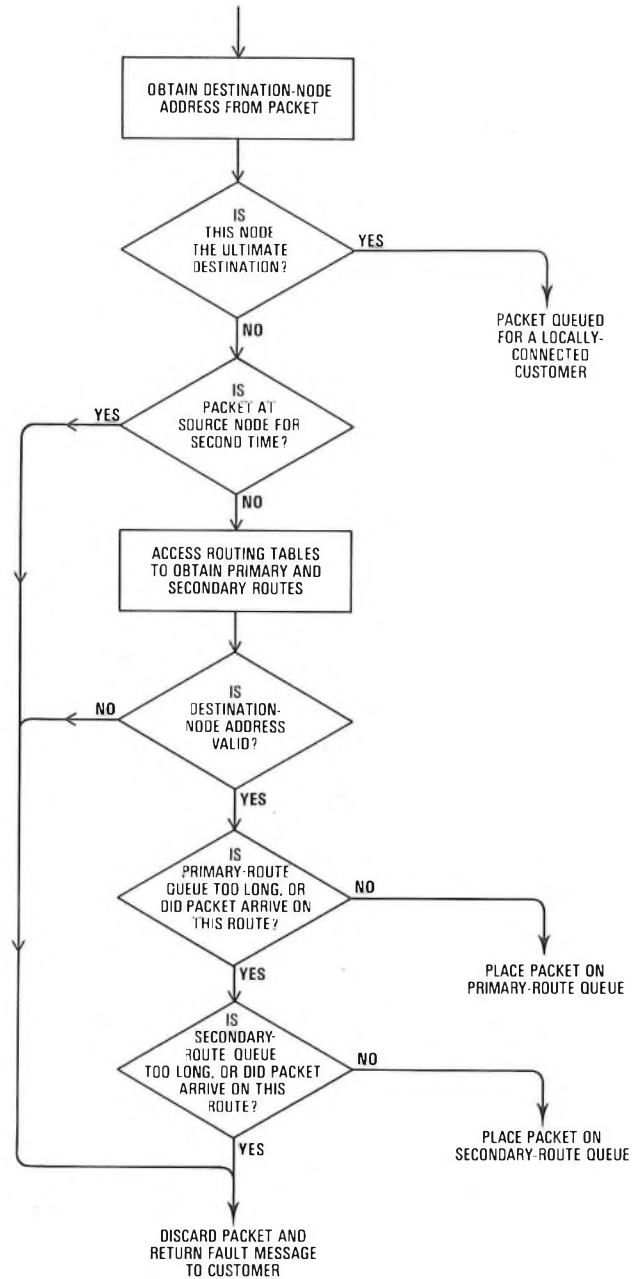

FIG. 3—Flow chart describing the routing algorithm used by the EPSS

PERFORMANCE COMPARISONS OF SOME ROUTING STRATEGIES

The first section of this article has described the need for a routing strategy and the one that was adopted for the EPSS. Other routing strategies are now considered and performance comparisons made.

Performance Measures

A number of performance parameters can be chosen to compare the relative merit of routing strategies. The choice of these parameters should be dependent on the application of the network; however, the following 2 parameters give an insight into the properties of various routing strategies and are important in packet-switching networks.

(a) Average Packet Delay [Weighted]

This parameter quantifies the network performance in terms

of packet delay, and assumes all the routes and nodes in the network are operational. Packet delay is defined as the time interval between the start of the transmission of a packet at a source terminal and its complete reception at the destination terminal. The average packet delay [weighted] is the average of the packet delays for all combinations of source and destination terminals, weighted by the traffic intensity between the terminals; a linear weighting function is usual.

(b) *Adaptability [Weighted]*

This parameter is a measure of how well the network performs, in terms of packet delay, under failure conditions. Adaptability is defined as the ratio of average packet delay to the mean of the average packet delays of each of the sub-networks created by all possible single failures in routes and nodes.

These 2 performance measures will now be considered for some well-known routing strategies, using fixed routing as the reference for comparison.

Deterministic Routing

In general, deterministic routing strategies apply constant criteria in selecting a routing for a packet, and give little or no significance to existing network traffic or performance. For low traffic intensities, or traffic distributions that vary insignificantly from those anticipated during the design, these strategies give low average packet delays. However, the average packet delay increases sharply with changes in the traffic distribution; also, adaptability is very poor.

Alternative routing, which is used in the EPSS and is described above, is generally included in this category because it acts on traffic information only when route queues exceed a preset threshold.

Fixed Routing

Fixed routing, which is a form of deterministic routing, is a system in which all packets exchanged between a given source and destination terminal pair are forced to take the same path or routing through the network.

Fixed routing has poor adaptability and this is often overcome, in practice, by increasing the reliability of the routes by the provision of more than one transmission path per route; such a route is called a *multi-link* route, and the routing algorithm is unaware of the multiplicity. This is a strategy similar to that used in the current UK public switched telephone network. CYCLADES⁴ is an example of a packet-switching network currently using fixed routing, although feedback routing will be tried in the near future.

Feedback Routing

Feedback strategies take account of the traffic present in the network and use this information in deciding the route that packets shall take. There are 2 categories of feedback strategies:

(a) internal-feedback strategies, which use information about traffic distribution obtained by monitoring internal events in the node, such as packet queue lengths and response delays, and

(b) external-feedback strategies, which use internal indicators as in (a), and also interchange information regarding topology failures and traffic flow between nodes.

For the optimum traffic distribution, these strategies give longer average packet delay than deterministic routing. This is because the inherent delay in the feedback of routing information produces a finite probability that packets take a longer path through the network than is necessary to minimize their delay. These strategies have, however, the ability to direct traffic away from locally congested areas, and are much less sensitive to changes in the traffic distributions. This is of extreme importance in practice, as the traffic

distribution is often not known to any high degree of confidence before the network is operational and providing a service.

In external-feedback strategies, packets can be used to carry the control information for the routing processes at each node and, in the case of extreme global congestion, the average packet delay can be reduced by removing the feedback.

Three examples of feedback routing are queue-length routing, also called dynamic balancing, queue-length-plus-bias routing, and queue-length-plus-bias routing with periodic updating, all of which have good adaptability.

Queue-Length Routing

With queue-length routing, packets are transmitted on the route with the shortest queue, regardless of the ultimate destination node specified in the packet header. This system gives extremely long average packet delays compared with fixed routing and consequently is little used.

Queue-Length-Plus-Bias Routing

Queue-length-plus-bias routing represents a compromise between the property of short average packet delay inherent in fixed routing and the good adaptability of queue-length routing.

In this system, the route selection is determined by the evaluation of a function of queue length and bias for each available route. The bias terms are preset constants, obtained from a bias table, and have values selected to impart a gross traffic-flow pattern. The queue-length term provides for local disturbances such as variation in traffic or topological failures. An example of such a function, f , is

$$f[(\text{bias term for route}) - K(\text{queue length for route})],$$

where K is a constant; the route selected is the one whose function, f , has the largest numerical value.

Under low-traffic conditions, the system reverts to a fixed-routing strategy, but as traffic builds up, so the system adapts to equalize the imbalance of route usage. The adaptability of this strategy is worse than queue-length routing, owing to the influence of the fixed bias terms.

Periodic Updating (External Feedback)

This can be used to increase the adaptability of fixed, alternative and queue-length-plus-bias routing by periodically updating the tables held at each exchange to reflect any changes in network topology. The benefits of this approach must be balanced against the transmission and exchange overheads in maintaining and updating the routing tables. This strategy has been used successfully in the Advanced Research Projects Agency (ARPA) network in the USA.⁵

Random Routing

In random routing, the route selection is made by random choice, no account being taken of the ultimate destination node, topology, or traffic distribution. Such strategies are theoretically interesting, but give extremely long average packet delays and are not used if the choice of routing algorithm has packet delay as a significant factor. The advantage of such systems is their excellent adaptability.

The Feedback Diagram

Each routing strategy that has been considered can be represented by a point or locus of points on a graph with axes corresponding to average packet delay and adaptability. Random routing, with its very good adaptability and long average packet delay, and fixed routing, with poor adaptability and short average packet delay, form the 2 extremes of the routing-strategy spectrum.

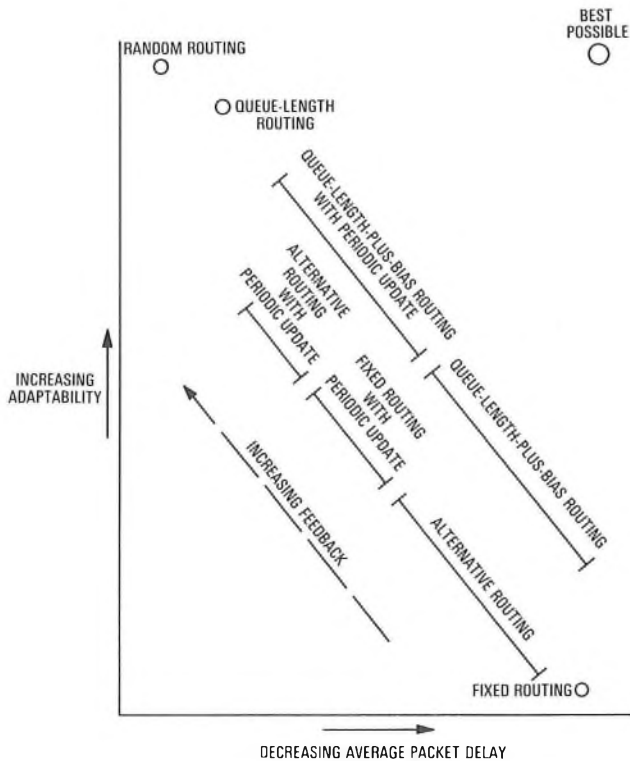

FIG. 4—The feedback diagram

Adaptability and average packet delay are dependent upon factors other than the routing strategy, such as topology and protocols, and therefore the feedback diagram (see Fig. 4)

shows only trends and does not represent a particular network. Most of the strategies achieve their adaptability by the use of feedback; the greater the feedback, the more adaptable the routing. The diagram has been completed for the routing strategies discussed in this article, and illustrates that, generally, adaptability is inversely related to efficiency.

CONCLUSION

This article has described many routing strategies which exhibit a wide range of properties. A number of these strategies meet the design requirements for the EPSS and, of these, alternative routing was selected and has been described in detail. The properties of alternative routing are short average packet delay with a correspondingly low adaptability. The latter property is less critical for small networks, where it is feasible manually to update the routing tables in the event of failure or overload.

In the EPSS, the customer interface is unaffected by the routing strategy adopted; consequently, should it be necessary to change the routing strategy to cater for growth, then this can be done without affecting the customer.

References

- ¹ BELTON, R. C., and SMITH, M. A. Introduction to the British Post Office Experimental Packet-Switching Service (EPSS). *POEEJ*, Vol. 66, p. 216, Jan. 1974.
- ² HADLEY, D. E., and MEDCRAFT, D. W. F. Experimental Packet-Switched Data-Transmission Service: Network Design and Implementation. *POEEJ*, Vol. 67, p. 88, July 1974.
- ³ NEIL, W., SPOONER, M. J., and WILSON, E. J. Experimental Packet-Switched Service: Procedures and Protocols, Parts 1, 2 and 3. *POEEJ*, Vol. 67, p. 232, Jan. 1975, and Vol. 68, pp. 22 and 110, Apr. 1975 and July 1975.
- ⁴ POUZIN, L. Presentation and Major Design Aspects of the CYCLADES Computer Network. Proceedings Third Data Communications Symposium, Tampa, Nov. 1973.
- ⁵ ROBERTS, L. G. ARPA/Information Processing Techniques Computer Network Concepts. Proceedings of Invitational Workshop on Networks of Computers, National Security Agency, Oct. 1968.

Book Review

Computer Communications. Editors: P. E. Green and R. W. Lucky. John Wiley & Sons Ltd. vii + 615 pp. 332 ills. Cloth £9.70, paper £4.85.

This is a volume in the IEEE Press Selected-Reprint series. The introduction claims that this collection of republished papers provides a state-of-the-art report on the exploitation of digital telecommunications as a means of geographically extending and enhancing electronic data-processing, and that it represents an updating and expansion of the November 1972 *Proceedings of the IEEE* special issue on computer communications. This source alone provides 19 of the 60 papers selected by the editors, and a further 10 are drawn from other IEEE publications; Bell and IBM journals, the American Federation of Information-Processing Societies' conference proceedings and *Datamation* provide the remainder.

The papers are arranged in 18 sections under 4 main headings, entitled "The Computer Communications Environment", "System Elements", "Digital Transmission Media", and "Total Systems". Each section is introduced by a single-page summary and a few additional references.

The sections on terminals, modems, multiplexers, concentrators and communications processors all include papers giving a basic introduction to the principles and functional

requirements; and equipment surveys which deal exclusively with the American market. The papers in other sections, on tariffs, regulations, common-carrier facilities, reliability and growth predictions, are similarly restricted.

The Advanced Research Projects Agency network is well represented, with papers on the interface message processor (IMP), the terminal IMP, the new multiprocessor IMP, and the Aloha system of packet switching via satellites; it also appears in a further 4 papers which constitute the entire section on computer networks.

Topical issues, on the use of synchronous data-link control procedures, the versatility of programmable terminals, and the problems of data-base security and privacy, appear in the 3 most recent papers, first published early in 1974. The concepts and facilities of the telecommunications-access-method (TCAM) software for the system 360 are described in an extract from an IBM manual, but a notable omission is any paper or reference to IBM system network architecture, which extends the concepts of TCAM.

This book is little more than a bound set of photocopies of papers, the majority of which have been readily available for several years. Even for the American reader, for whom this book is intended, a bibliography would have sufficed.

J. R. T.

Designing Low-Loss Polymer Dielectrics for New Transmission Systems

J. HAIGH, M.A., D.PHIL., M.INST.P.†

UDC 537.226: 678: 621.372

The part of the signal attenuation in cable and other transmission systems that is due to polymer dielectric loss is becoming important as transmission frequencies rise. Some of this absorption is due to the polymer molecular structure. This contribution is being studied, with the promise of a reduction without abandoning the useful practical properties of polymers.

INTRODUCTION

Transmission systems in telephony use insulating materials (dielectrics) in 3 ways:

(a) in capacitors, where the material should have high permittivity and low loss,

(b) to provide mechanical support for a component (for example, the inner conductor of a coaxial cable); here the material should be of low permittivity and loss, and

(c) to provide contrasting permittivity conditions that will guide an electromagnetic wave, examples being the optical fibre, and the dielectric rod;¹ in this case, the material should have very low loss.

In both the second and third types of application, the equations of propagation show that the contribution to the total system attenuation by the dielectric absorption always increases as the frequency rises. In dielectric-only systems, this contribution is dominant. But even in more familiar technology, such as the standard design of submarine cable, demands to create new systems at ever-rising frequencies are now focusing attention on the loss, or radiation absorption, of the dielectric, and leading to demands for an improved dielectrics technology. This article shows, in general terms, how dielectric absorptions arise, and how they can be reduced.

MEASURING LOW ABSORPTION (0.1 THz)

Measurements of dielectric loss are often needed to an accuracy of about $1 \mu\text{rad}$; that is, $\tan \delta$ or $G/\omega C$ to within 10^{-6} , where δ is the dielectric loss angle, G is the dielectric conductance, C is the dielectric capacitance and ω is the angular velocity. Ability to measure the low absorptions found in telecommunications dielectrics has improved greatly in recent years. Measurement is fairly easy at frequencies below 1 MHz, using electrode sets and improved bridge networks. Between 1–100 MHz, absorptions can be measured by means of the Q -factor of dielectric-loaded cavities.² No reliable technique exists between 0.1–10 GHz. Between 10–100 GHz, precise measurements are made with dielectric-loaded microwave resonators, each of which has a limited frequency range and gives essentially a spot measurement.³ Waveguide bridges can also be used,⁴ with the same limitations. Between 0.1–10 THz,* precision Fourier interferometric spectrometry can now be used, and is a broadband technique.⁵

Thus, there is a weakness in the 0.1–100 GHz region, and a reliable broadband technique is urgently needed, especially in the important 0.1–1 GHz region; fortunately, as is shown below, the loss peaks above 1 GHz are so broad that they span several decades, so that measurements at 0.1–10 THz often give indirect information about losses in the 1–100 GHz

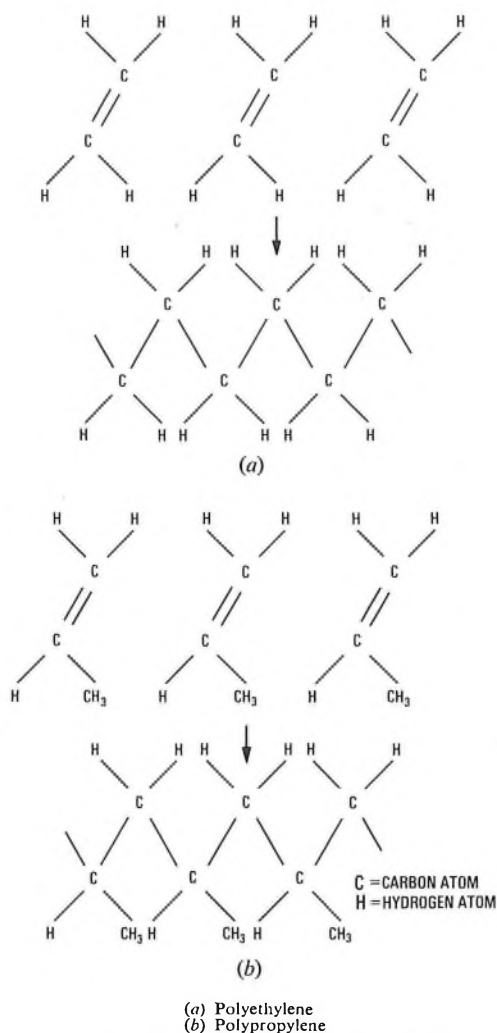

FIG. 1—The structure of polyolefin molecules

interval. Various techniques are under investigation in the British Post Office (BPO) Research Department and elsewhere.

CAUSES OF LOSS IN POPULAR DIELECTRIC MATERIALS

Since 1939, the most widely used cable dielectric has been polyethylene. There are some simple reasons: it is cheap and easy to process, and has the right mechanical properties. There is also a more fundamental reason which is connected with the molecular structure of polyethylene or, in other words, the way in which atoms are joined together to make the polyethylene molecule.

† Research Department, Telecommunications Headquarters.

* THz = 10^{12} Hz.

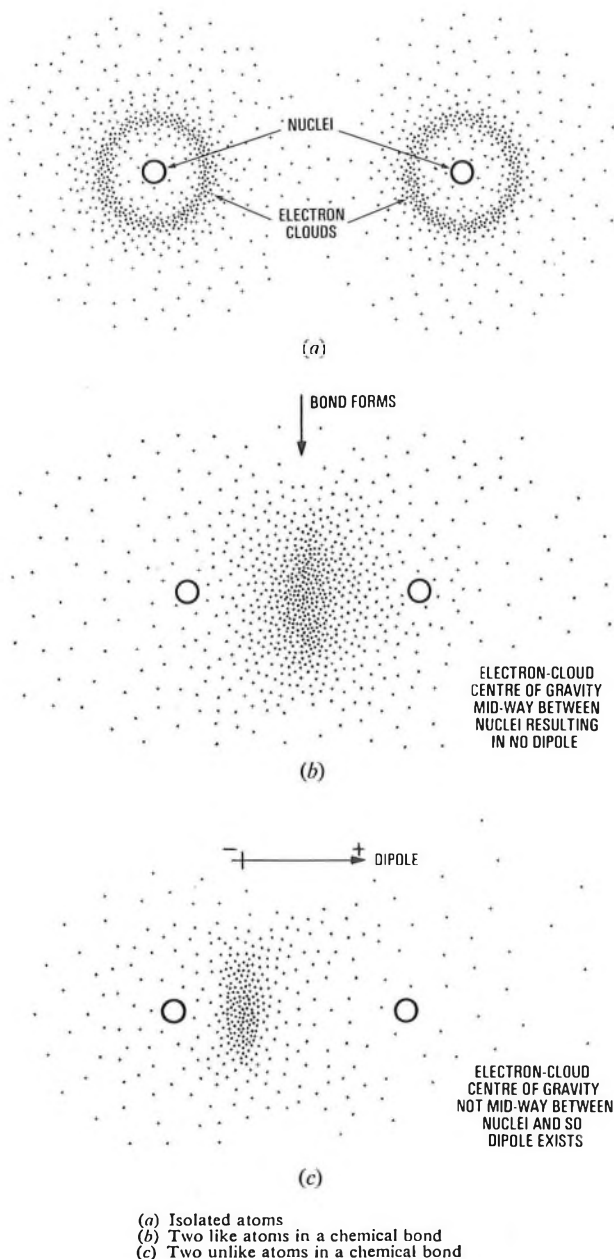
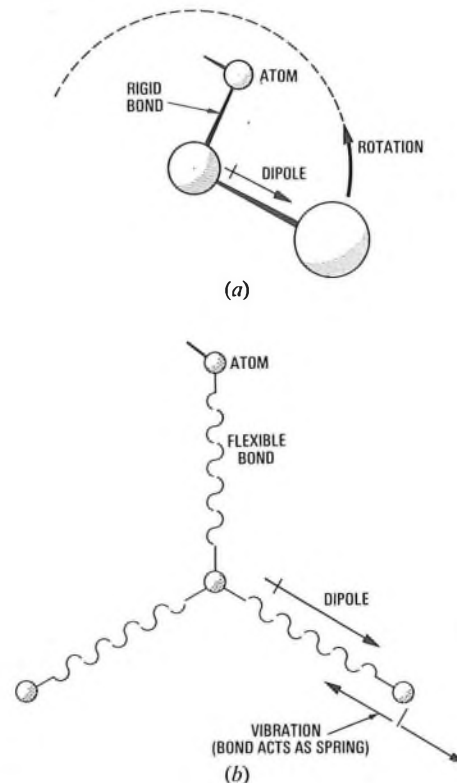

FIG. 2—The nature of the dipole due to chemical bond

Each polyethylene molecule is formed by joining together large numbers of molecules of ethylene (a gas generally made from petroleum), head-to-tail as shown in Fig. 1(a). In a typical sample, the average molecule can contain 2000 ethylene units. Polyethylene is therefore a polymer, and belongs to a class of polymers which contains only carbon and hydrogen atoms joined together by single bonds. Polypropylene is another polyolefin; it is formed from propylene, as shown in Fig. 1(b). To understand the dielectric properties of these polyolefins, it is necessary to look briefly at the nature of the bonds that hold their molecules together.

Each atom consists of a positively-charged nucleus, surrounded by a cloud of negatively-charged electrons. This cloud is of complex shape, but when the atom is isolated in space, its centre of gravity coincides with that of the nucleus (see Fig. 2(a)). Because of this, the atom has no dipole moment. However, when atoms form chemical bonds to each other, as part of the process of building a molecule, the cloud of electrons is distorted, and its centre of gravity moves away from the nucleus under the attraction of the atom to which bonding is taking place. If the 2 atoms in the bond are identical (for example, 2 carbon atoms), equal and opposite



(a) Dipole of fixed magnitude which rotates with the molecule
 (b) Dipole which vibrates as the molecule vibrates, so that its magnitude oscillates

FIG. 3—The 2 main classes of dipole activity below 100 THz

distortions occur, so that the 2-atom system still has no dipole moment (see Fig. 2(b)). If they are different, however, the distortions are not equal and a dipole is generated, as shown in Fig. 2(c).

Different atom pairs, on combining, produce dipoles of different magnitudes. The dipole moment of a carbon-oxygen bond, for example, is high, whereas that of a carbon-hydrogen bond is low. Polyolefin molecules, with their carbon-carbon and carbon-hydrogen bonds, are thus very depleted in dipoles.

When an oscillating electromagnetic field propagates through a dielectric, it can couple with any electric dipoles that are present, on condition that these can be made to oscillate at the field frequency. If this condition holds, energy is transferred from the field to the dipole, which subsequently loses it by degradation into heat.

Because polyolefins contain only weak dipoles, their oscillations (which are described below) cause only a low level of energy transfer from the field, and hence the materials have low absorption and are good dielectrics. Their absorptions are, however, still high enough to be technologically important and worthy of investigation.

Such an investigation reduces to determining the pattern of oscillatory motions that a long polymer chain molecule can undergo and, more particularly, those that cause oscillation of the dipoles carried by the molecule. It has been found that the dipoles that oscillate fall roughly into the following 2 types, depending on their location in the molecule.

(a) Generally below 10 GHz, the dipoles that oscillate are built into the molecule, are of fixed magnitude and rotate when the molecule, or part of it, rotates (see Fig. 3(a)).

(b) Generally above 10 GHz, the dipoles that oscillate are those whose magnitude oscillates as the molecule vibrates; that is, as the bonds between atoms expand and contract, or the angles between bonds open and close (see Fig. 3(b)).

This is true of all polymers, but the pattern of motion in the polyolefins is complicated by the fact that they are

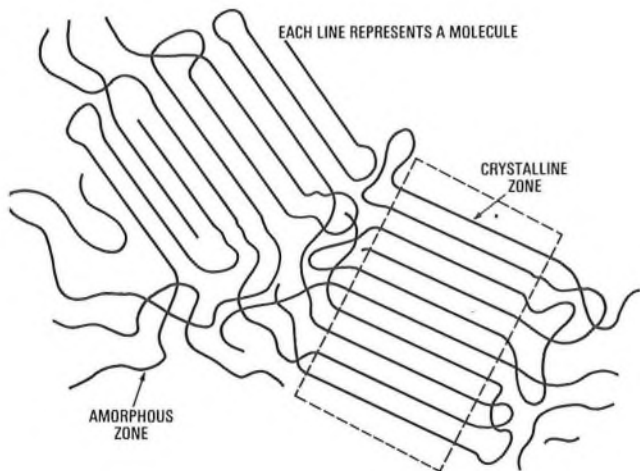

FIG. 4—Polyolefin microstructure, showing crystals dispersed in and interlinked with, an amorphous matrix

2-phase systems. A block of polyethylene contains an intimate mixture of amorphous and crystalline zones. In the amorphous part, the molecules are tangled randomly; in the crystalline part, they are arranged in regular folds, with molecules passing between, and linking, the 2 phases, as shown in Fig. 4. The frequencies of dipole rotations are influenced by the forces exerted on a molecule by its neighbours, and these forces have a different pattern in the amorphous regions from that in the crystalline regions. Thus, the spectrum of the molecular motions can be vastly different in the 2 phases.

Fig. 5 shows the loss-angle/frequency spectra of polyethylene and polypropylene. These spectra were obtained using materials of higher purity than the normal commercially-available samples. It has been found that normal samples show an enhanced absorption, which is due to dipolar impurities, degradation products and additives. A process for preventing much of the degradation, and removing the impurities, was recently developed in the BPO Research Department;⁶ it is primarily a laboratory tool, but might have some manufacturing applications. Indications are that the absorptions shown in Fig. 5 are intrinsic to the polymers; further purification would not reduce them significantly.

Work at the BPO Research Department (and elsewhere) has had the aim of identifying the patterns, or modes, of molecular motion that cause features in the absorption spectrum, and of determining whether these modes occur in the amorphous regions, or the crystalline regions, or both. Fig. 6 summarizes, in simplified form, what has been achieved with part of the polypropylene spectrum. This tentative assignment shows that, in this frequency range, dipoles in the amorphous regions give rise to a broad featureless absorption, whereas those in crystalline regions produce a more structured spectrum, with possibly a weaker, featureless, additional contribution. The rationalization of this is that molecular motions in the amorphous regions are spread over broad frequency ranges, since the forces between molecules vary greatly in strength; in the crystalline regions, however, forces are more uniform from molecule to molecule and the motions become resonant.

A more detailed analysis of the spectrum yields information about the exact nature of the molecular motions. Using this knowledge, it has been found that the crystalline-motion components can be sharpened and shifted upward in frequency, thereby lowering the microwave dielectric loss, by making the crystals rather larger, or more perfect, or both.⁷ A similar analysis is being attempted with polyethylene, with emphasis on the important 10 MHz–10 GHz region; as a starting-point, it is known that the feature centred at 1 GHz (see Fig. 5) has an intensity dependent on the crystalline–amorphous balance.

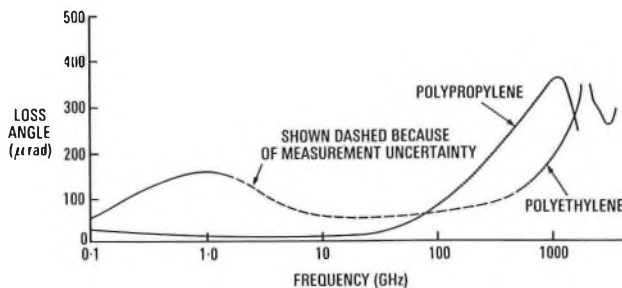

FIG. 5—Dielectric-loss-angle/frequency spectra of polyethylene and polypropylene

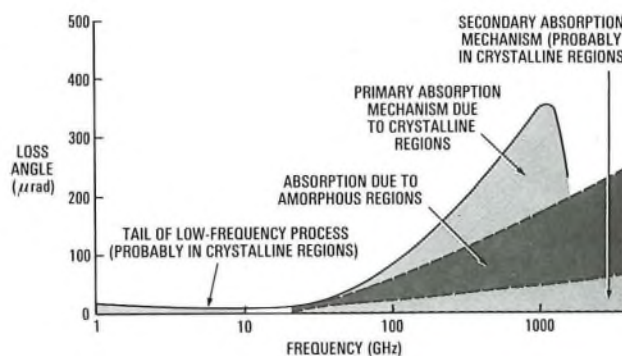

FIG. 6—Analysis of the polypropylene structure

CONCLUSION

The most noteworthy point emerging from the studies described in this article is that the dielectric properties of polyolefins at frequencies below 1 THz are sensitive to the detailed structure of these complex materials to an extent which has been overlooked in the past, and a whole battery of physical and chemical methods for analysing this detailed structure can profitably be brought to bear.

This work would be of little importance to telecommunications if it were found to be impossible to bring about changes in the loss spectra in practice, or if changes proved too expensive to be economical, or if they spoiled the good mechanical or physical properties of the polymer. These cautions must be remembered, but so far, there is every hope that a thorough understanding of dielectric losses in polyolefins will, indeed, bring with it new materials for telecommunications technology.

References

- 1 RAVENSCROFT, I. A., and JACKSON, L. A. Proposal for a Dielectric Rod Transmission System. Proceedings of the 1973 European Microwave Conference, Brussels, Sept. 1973.
- 2 REDDISH, W., BISHOP, A., BUCKINGHAM, K. A., and HYDE, P. J. Precise Measurement of Dielectric Properties at Radio Frequencies. *Proc. IEE*, Vol. 118, p. 255, 1971.
- 3 COOK, R. J., JONES, R. G., and ROSENBERG, C. B. Comparison of Cavity and Open-Resonator Measurements of Permittivity and Loss Angle at 35 GHz. *IEEE Transactions on Instrumentation and Measurement*, 1M-23, p. 438, 1974.
- 4 LYNCH, A. C., and AYERS, S. Measurement of Small Dielectric Loss at Microwave Frequencies. *Proc. IEE*, Vol. 119, p. 770, 1972.
- 5 FLEMING, J. W., and CHANTRY, G. W. Accurate Radiometric Measurements on Low-Loss Polymers at Submillimetre Wavelengths. *IEEE Transactions on Instrumentation and Measurement*, 1M-23, p. 473, 1974.
- 6 AYERS, S., DAVIES, G. J., HAIGH, J., MARR, D., and PARKER, A. E. Low-Loss Dielectrics for 10–3000 GHz. Research Department Report No. 422.
- 7 DAVIES, G. J., HAIGH, J., and ALI, A. S. M. Structural Effects in the Submillimetre Wave Spectrum of Isotactic Polypropylene. *Polymer*. (To be published.)

Developments in Digital Transmission

G. H. BENNETT†

UDC 621.394.49: 681.327.8: 621.391

Digital methods of providing communication are showing a marked tendency to take the place of traditional analogue methods. This article reviews the present state of the art and examines the development of digital transmission systems in the British Post Office.

INTRODUCTION

Pulse-code modulation (PCM) has been in use by the British Post Office (BPO) since 1968, when the first 24-channel systems were installed. There are now well over 4000 of these in revenue-earning service and present ordering is running at nearly 1000 systems/annum. During 1976, it is intended to commence ordering the International Telephone and Telegraph Consultative Committee (CCITT) recommended 30-channel system, which is being widely adopted by European administrations, particularly those who are members of the European Conference of Posts and Telecommunications (CEPT). The 30-channel system will not only supersede the 24-channel system in the junction network, but will also provide the basic building block for the planned digitalization of the trunk network.

In addition to the provision of PCM systems and low-digit-rate (that is, 1.5–2 Mbit/s) digital line sections on symmetrical-pair cables, there will be a need to provide higher-digit-rate sections on both coaxial cables and microwave radio-relay systems. Further in the future, optical-fibre and circular-waveguide systems might also be used to complement these media, but as these are adequately described elsewhere,^{1,2} it is not proposed to deal with them here.

To assemble the digital outputs from PCM systems, and other sources such as data and encoded wideband analogue signals, digital multiplexing equipment is required in association with the digital transmission systems.

It is proposed to review and describe in summary the developments that are either current or may be planned for the future. It is intended that a later series of articles will describe in detail the equipments for which development work has been substantially completed.

PCM SYSTEMS

The technique of PCM has been dealt with in many articles, and the BPO 24-channel system has been described in detail in this *Journal*.³ Following lengthy international discussions, a CCITT Recommendation⁴ now specifies, in some considerable detail, the characteristics of a 30-channel PCM system.

The important difference between the 2 systems, besides the number of voice channels, is that the 30-channel system uses 8 bit for each character representing an encoded signal sample, instead of 7 bit. This improves the signal-to-quantizing-distortion ratio by up to 6 dB and offers the possibility of interconnecting, at audio frequencies, up to 13 systems in tandem with acceptable overall speech performance. Although

this need is likely to diminish when digital switching is introduced, it can be important in the early stages of the introduction of PCM.

The other differences are of system configuration rather than performance, and these are summarized in Table 1.

TABLE 1
Essential Differences between 24-Channel and 30-Channel Primary Multiplex and Line Equipment

Parameter	24-Channel Equipment	30-Channel Equipment
Number of 8 bit channel time slots	24	32
Bit rate (Number of time slots × 8 bit × 8000 samples/s)	1.536 Mbit/s	2.048 Mbit/s
Frame-alignment signal	16 bit distributed between time slots 9–24	7 bit bunched in time slot 0
Signalling	1 bit/channel time slot every other frame	Bunched in time slot 16, 4 bit/channel every 16 frames
Codec† monitoring	2 kHz test tone end-to-end in channel 12	In-station during time slot 0
Number of encoding bits	7	8
Number of systems in tandem for satisfactory signal-to-quantizing-distortion ratio	4	16
Line code	Alternate mark inversion	HDB3*
Error detection	Bipolar violations in line signal	Binary errors in frame-alignment signal
Number of regenerators per repeater case	24	36
Cable equalization	Discrete equalizers	Automatic

* HDB_n is one class of highly-redundant ternary codes, known as *high-density bipolar*, of the order *n*, where *n* is the maximum number of consecutive zeros in the HDB_n signal. In this case, *n* = 3.

† Codec—an assembly comprising an encoder and a decoder in the same equipment

† Telecommunications Development Department, Telecommunications Headquarters.

System Design

In terms of system design, there have been few major changes. A common codec, shared between a number of channels, is still used, although single-channel codecs have been the subject of investigation; a system incorporating this method has not yet been fully developed.

One important difference, however, is that signalling units are now made to a single design, rather than only to a performance specification. This approach means that all signalling units of any one type will be identical, irrespective of the source of manufacture. This should represent a substantial advantage in provision and in the stocking of spares, since complete interchangeability and interworking should be possible. Moreover, maintenance staff and repair centres will now have to deal with only one single design instead of the several variants manufactured for 24-channel systems.

So far, 12 types of signalling unit have been developed, and these provide all the facilities available on 24-channel PCM signalling units. A further development of 11 types is envisaged; this will provide additional facilities such as metering over junctions, conversion of AC No. 8 type signalling to loop-disconnect signalling, signalling for use on private circuits, traffic-recorder output and further operator facilities. Hence, the range of facilities available should permit the provision of circuits by PCM in a high percentage of cases. Fig. 1 shows a typical signalling unit.

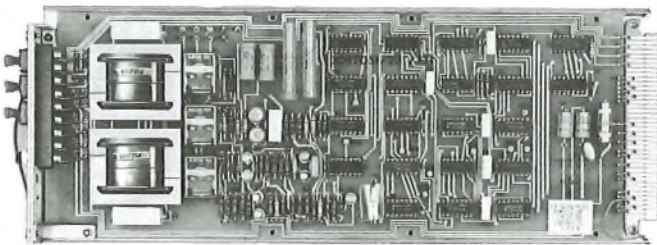

FIG. 1—Typical signalling unit

2·048 Mbit/s Digital Line Sections

The gross digit rate generated by the 30-channel system is 2·048 Mbit/s, and this represents an increase of approximately 500 kbit/s compared with the 24-channel system. On 0·63 mm cables, this can be equated to an increase of 7 dB in the attenuation of a 1·8 km regenerator section at the centre frequency of the line signal spectrum. However, studies have shown that it should be practicable to apply the same planning rules and cable-utilization factors as were applied to the 1·536 Mbit/s digital line sections, since these rules were devised with substantial margins.

The most significant differences between the new regenerators and those used to provide 1·536 Mbit/s digital line sections are that automatic equalization is provided over a range of more than 30 dB and that the size has been reduced to allow the installation of 36 regenerator units in one repeater case; an increase of 50%.

The advantage of automatic equalization is that it will no longer be necessary to select and fit equalizers prior to installation of regenerators; this should substantially reduce the time required to prepare regenerators, and also avoid the possibility of inadvertently fitting an incorrect equalizer.

A further feature is the provision of a range of regenerators and line terminal equipments with in-built lightning protection for use in areas known to be prone to lightning strikes. Although this protection cannot avoid the momentary disruption of the digital signals being transmitted when a lightning strike occurs, it should substantially reduce the probability of damage to equipment from this cause. A 2·048 Mbit/s regenerator unit comprises 2 regenerators,

together with the required power-feeding and fault-location facilities which are the same as those used for the 1·536 Mbit/s regenerators. Indeed, both types can be mixed in the same repeater case and share the same fault-location circuit.

Field Trials

The Telecommunications Development Department and the Network Planning Department of the BPO are collaborating in the field trials of 30-channel PCM systems and associated 2·048 Mbit/s digital line sections from the UK manufacturers. Following the evaluation of each route, the equipments will then be re-installed on an "intermix" basis to ensure that full compatibility has been achieved between systems from all manufacturers.

DIGITALIZATION OF THE TRUNK NETWORK

In parallel with the provision of PCM equipment in the junction network, digital transmission equipment for the trunk network has reached an advanced stage of development.

The provision of digital transmission systems, by any medium, requires digital multiplexing equipment to assemble lower-rate sources up to the rate corresponding to the capability of any particular transmission system, and to separate the composite signal into its corresponding components by demultiplexing. (The term *mudex* has been proposed to represent the composite equipment performing both functions at one location.) This leads to the concept of a digital hierarchy that is analogous to the frequency-division-multiplex (FDM) groups, supergroups and hypergroups. CEPT has adopted, and CCITT is expected to recommend, the following hierarchies based on 2·048 Mbit/s, the rate generated by a 30-channel PCM multiplex.

First (Primary) Order:	2·048 Mbit/s ×4	2·048 Mbit/s ×4
Second Order:	8·448 Mbit/s ×4	or as an alternative 8·448 Mbit/s ×16
Third Order:	34·368 Mbit/s ×4	
Fourth Order:	139·264 Mbit/s	139·264 Mbit/s

The fourth-order frame structure at 139·264 Mbit/s is identical for both alternatives.

For initial use in the UK network, the BPO has developed a 120 Mbit/s line system, based on 14 × 8·448 Mbit/s. This will allow international interconnexion at the agreed first-order and second-order rates, but future digital transmission systems for cable, radio and waveguide will be based on 139·264 Mbit/s or its multiples.

Digital Multiplexing Equipment

The digital multiplexing equipment produces a gross digit rate at each order of the hierarchy that is greater than 4 times the tributary rate. This arises for 2 reasons: firstly, it is necessary to insert frame-alignment signals into the composite output signal to enable this signal to be correctly demultiplexed; secondly, to avoid loss of information in the multiplexing, it is necessary to provide enough time slots in the output signal to accommodate tributaries that are operating faster than their nominal rate, although still within their permitted tolerances. This latter process is known as *justification*.*

The process of justification can be realized in digital

* Justification—a process of changing the rate of a digital signal in a controlled manner so that it can accord with a rate different from its own inherent rate, usually without loss of information

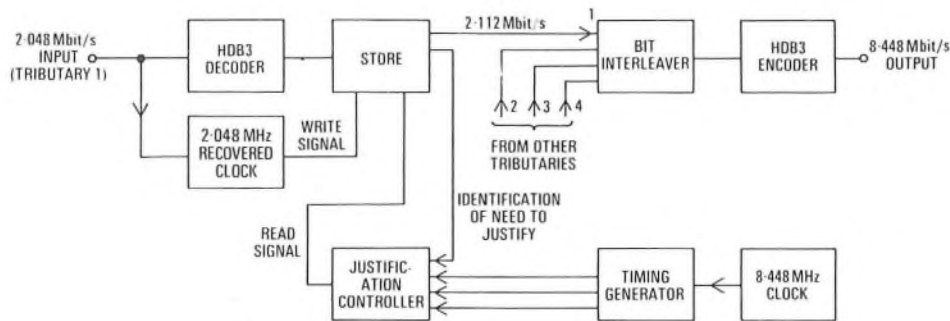

FIG. 2—Block diagram of 2.048 Mbit/s-8.448 Mbit/s digital multiplexing equipment

multiplexing equipment by the following means, taking the 2.048 Mbit/s-8.448 Mbit/s digital multiplex as an example (see Fig. 2).

Each input tributary is written into its own separate store at a rate corresponding to the rate of the timing signal recovered from that tributary. The stores are read at a rate derived from the 8.448 Mbit/s multiplex clock rate divided by the number of tributaries; that is, $8.448/4 = 2.112$ Mbit/s. The difference between the input-signal write rate, which is nominally 2.048 Mbit/s, and the store read rate of 2.112 Mbit/s creates additional digit time slots. Some of these are used to provide a frame-alignment signal and alarm and monitoring indications; the remaining additional digit time slots are used for justification control and the justifiable digit time slots. The justifiable digit time slots may, or may not, contain information from the tributary, depending on the fill of the tributary input store. This can be detected in respect of each separate input signal; if, at the justification decision instant, the store fill is below a predetermined threshold, the read clock is inhibited at the next justifiable digit time slot and no information is read out of the store for that digit period. Conversely, if the store fill is above the threshold, 1 bit of information is read out of the store into the justifiable digit time slot. By this means, it is possible to absorb differences in the relative rates of the plesiochronous† input signals and the multiplex-equipment clock rate.

It is necessary for the remote demultiplexing equipment to know whether or not a useful signal is contained in each justifiable digit time slot. This information is transmitted from the multiplex equipment by means of justification

† Plesiochronous—2 signals are plesiochronous if their corresponding significant instants occur at nominally the same rate, any variation in rate being constrained within specified limits.

control digits; these are triplicated for each tributary to provide greater immunity from errors.

Using the frame-alignment signal as a reference, the demultiplex equipment (see Fig. 3) separates the composite 8.448 Mbit/s signal into four 2.112 Mbit/s signals, and routes them to the correct output stores. Each set of justification control digits is individually examined and the relevant justifiable digit time slot is either read into the output store or ignored, determined by a majority decision of the 3 relevant control digits.

The removal of the frame-alignment signal, service digits, justification control digits and those justifiable digit time slots that have not been used, leaves gaps in the digit stream which must be smoothed out. This is achieved by reading each output store at a constant rate derived from a voltage-controlled oscillator incorporated in a phase-locked loop with a narrow-bandwidth low-pass filter. The loop reference signal is obtained from the output store write pulses, which are derived from the demultiplex clock with gaps corresponding to those in the information digit stream. The average rate of this reference signal is, therefore, the same as that of the corresponding nominal 2.048 Mbit/s input signal and, in consequence, no information is lost by this justification process. An impairment that is introduced is a small amount of low-frequency timing jitter, but the complexities of this subject are beyond the scope of this article.

8.448 Mbit/s Digital Line Systems

Proposals have been made for the development of a digital line system at 8.448 Mbit/s, using the existing network of 24-pair/40 lb paper-core quad carrier cables as bearers. These cables, which were laid from 1937 onwards, interconnect most important towns in the UK and offer some 5800 route

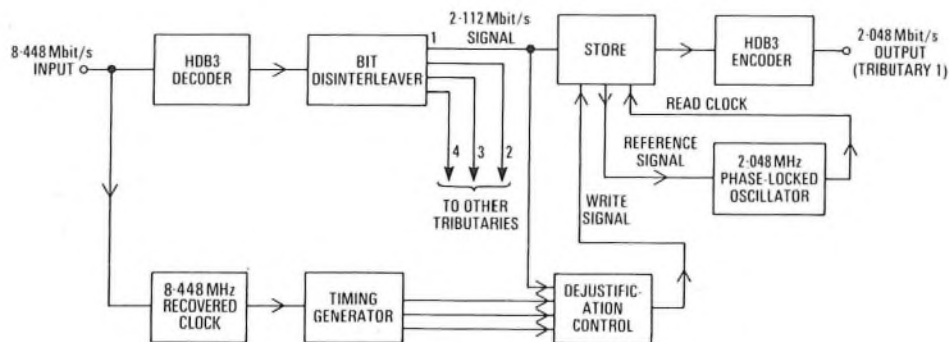

FIG. 3—Block diagram of 8.448 Mbit/s-2.048 Mbit/s demultiplexing equipment

kilometres. The existing 24-channel FDM carrier equipment is now reaching the end of its useful life and, as the cables represent a valuable capital asset, consideration is being given to re-equipping them with digital line systems at 8.448 Mbit/s.

A limited number of cable measurements have been made and these show that it should be possible to equip 20 pairs, with regenerators spaced at up to 3 km intervals. The present intermediate carrier repeater stations could be retained as power-feeding stations.

The existing cables are laid in pairs, one for the GO direction and one for the RETURN direction of transmission, and this same arrangement could be retained for the new digital systems, with a separate repeater case jointed into each cable to house the regenerators. Those pairs not being equipped with digital line sections are available to provide engineering-speaker and regenerator fault-location facilities.

120 Mbit/s Digital Line System

Studies made by the BPO and by Industry under study contracts during 1970 showed that, if the existing repeater spacing currently used for 12 MHz analogue systems (for example, CEL 4000) on 1.2/4.4 mm coaxial pairs were to be retained, it would not be possible to design a system having a gross digit rate significantly greater than 120 Mbit/s. This conclusion was reached in the light of 2 important factors:

(a) the need to retain the existing power-feeding limits of 250–0–250 V with a maximum current of 50 mA, and

(b) that it should be possible to accommodate regenerator spacings of at least 2.1 km and preferably 2.2 km; although this latter was necessary for only a small number of situations.

A further fundamental concept was that regenerators should be readily installed on existing cable routes laid out for 12 MHz working without any modifications to cable plant or cable terminations, and that the same repeater cases could be shared on a mixed digital/analogue systems basis.

Contracts for the development of systems were placed in 1972 with one company for a field-trial system between Guildford and Portsmouth (Portsdown Repeater Station), and jointly between 2 other companies for a second field-trial system between Portsmouth and Southampton. The first of these 2 systems has been under field trial for some 8 months, and the second system is now being evaluated. The principal parameters of both are similar in concept, although there are significant differences in the designs.

To reduce the symbol* rate, both systems use a ternary line signal which is derived from a binary signal by code conversion. There are several possible arrangements for carrying out this conversion, but those used are of the class known as 4B3T, in which words of 4 binary digits are converted into a word of 3 ternary digits. Two typical sets of conversion tables are given in Tables 2 and 3. It can be seen that the most significant difference is that the basic 4B3T uses only 2 sets of ternary words, whereas the variant known as MS43 uses 3 sets of ternary words.

An important feature of this class of code is that the running digital sum† is constrained within certain limits. For basic 4B3T, at the end of each ternary word, the running digital sum can have a value only between -2 and +3; for MS43, the running digital sum at the end of each ternary word must be between -1 and +2. (It can be seen from Tables 2 and 3 that the set chosen to encode a binary word depends on the running digital sum at the end of the preceding ternary word.) The running digital sum of these codes is significant for 2 reasons. Firstly, the amount of low-frequency energy contained in the line signal is dependent on the range of possible values of the running digital sum. It is desirable to restrict the low-frequency energy in the signal so that extraction of the direct power-feeding current from the line does not distort the signal. Secondly, the finite bound of the running digital sum can be exploited to detect errors that occur in the digital line; the introduction of erroneous ternary words will violate this bound, thereby permitting the error rate to be detected at the power-feeding and terminal stations by monitoring the line signal in the presence of traffic.

Detection of error rate at a regenerator can be achieved either by monitoring the number of times that the running digital sum bound is exceeded, or by examining the spectral null of a known digital signal. In the latter case, errors in the line cause energy to occur at the spectral null which can be detected through an appropriate band-pass filter.

With both methods, the output of the regenerator error detectors, and also the status of the power-feeding stations,

* Symbol—a unit interval in which the signal can assume one of a set of *n* states

† Running digital sum—the difference between the number of positive and negative polarity pulses that have been transmitted

TABLE 2
Basic 4B3T Binary to Ternary Code Conversion Table

Binary Input	Ternary Output Signal					
	Running digital sum at end of preceding word equal to					
	-2, -1 or 0			1, 2, or 3		
0000	+	0	-	+	0	-
0001	-	+	0	-	+	0
0010	0	-	+	0	-	+
0011	+	-	0	+	-	0
0100	0	+	-	0	+	-
0101	-	0	+	-	0	+
0110	0	0	+	0	0	-
0111	0	+	0	0	-	0
1000	+	0	0	-	0	0
1001	+	+	-	-	-	+
1010	+	-	+	-	+	-
1011	-	+	+	+	-	-
1100	0	+	+	0	-	-
1101	+	0	+	-	0	-
1110	+	+	0	-	-	0
1111	+	+	+	-	-	-

+, 0, and - represent the 3 states of the ternary word

TABLE 3
MS43 Binary to Ternary Code Conversion Table

Binary Input	Ternary Output Signal								
	Running digital sum at end of preceding word equal to								
	-1			0 or 1			2		
0000	+	+	+	-	+	-	-	+	-
0001	+	+	0	0	0	-	0	0	-
0010	+	0	+	0	-	0	0	0	0
0011	0	+	+	-	0	0	-	0	0
0100	+	-	+	+	-	+	-	-	-
0101	0	-	+	0	-	+	0	-	+
0110	-	0	+	-	0	+	-	0	+
0111	0	0	+	0	0	+	-	-	0
1000	0	+	0	0	+	0	-	0	-
1001	+	0	0	+	0	0	0	-	-
1010	-	+	0	-	+	0	-	+	0
1011	+	-	0	+	-	0	+	-	0
1100	+	0	-	+	0	-	+	0	-
1101	0	+	-	0	+	-	0	+	-
1110	-	+	+	-	+	+	-	-	+
1111	+	+	-	+	-	-	+	-	-

+, 0, and - represent the 3 states of the ternary word

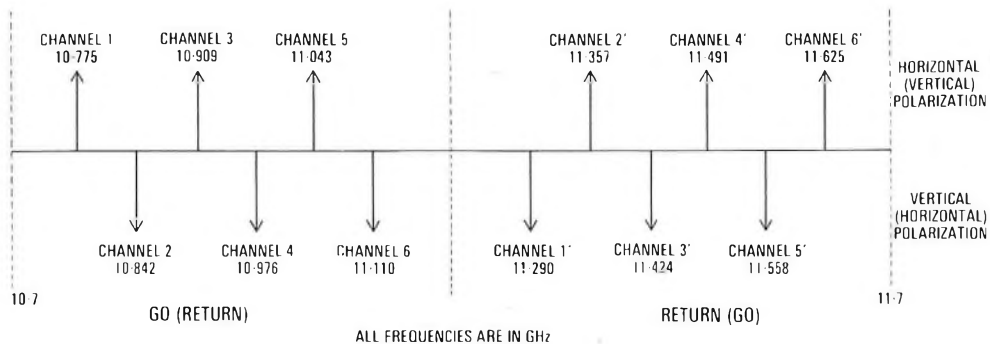

FIG. 4—Frequency plan of proposed 11 GHz digital radio-relay system

can be transmitted to the terminal stations by a telemetry system using the same coaxial pairs in the part of the available spectrum below that required for the digital signal.

Higher-Rate Digital Line Systems

Following the completion of the development of the 120 Mbit/s line system, consideration is now being given to further exploiting the existing coaxial cable network, particularly 1.2/4.4 mm coaxial pairs, although use of 2.6/9.5 mm coaxial pairs is also envisaged.

Studies have shown that, although the transmission impairments due to systematic cable impedance irregularities are unlikely to cause problems with 120 Mbit/s systems, their effect on systems in the vicinity of 500 Mbit/s may prove to be the limiting factor. Nevertheless, measurements made so far indicate that there is a reasonable likelihood that most of the existing plant could, with some updating of cable terminations and the elimination of back-joints,* be suitable for higher-rate systems.

Studies with Industry are proposed, to identify which of the following configurations is most likely to form the basis of a practical system having adequate operational margins:

- (a) 3×140 Mbit/s (424 Mbit/s) at a nominal regenerator spacing of 1.1 km,
- (b) 4×140 Mbit/s (565 Mbit/s) at a nominal regenerator spacing of 0.8–0.9 km, or
- (c) 4×140 Mbit/s (565 Mbit/s) at a nominal regenerator spacing of 1.1 km.

Of these 3 possibilities, configuration (c) is the most attractive from a planning viewpoint, but presents the greatest technical problems of realization.

Digital Transmission by Microwave Radio-Relay Systems

A low-capacity digital radio-relay system, operating in the 5.85–5.925 GHz band, has already been described.⁵

Recent development activity has been concentrated on the 11 GHz band (10.7–11.7 GHz), which has hitherto been exploited only for a small number of analogue systems. A research contract, which has provided equipment for the evaluation of potential system designs, has recently been completed by the provision of a hop between Birmingham and Charwelton. The results of field tests, together with studies made by the BPO Research Department, have confirmed the feasibility of providing digital transmission in the 11 GHz band using existing radio-relay stations provided for the 2 GHz, 4 GHz and 6 GHz bands.

It is expected that the principal parameters of the system could be as shown in Table 4.

* Back-joint—a joint in which the coaxial pair is turned through 180°

TABLE 4
Principal Parameters of Proposed 11 GHz Digital Radio-Relay System

Digit rate per channel	140 Mbit/s
Number of channels	6 bothway
Utilization	5 + 1 service spare
Modulation	Quaternary phase-shift keying
Demodulation	Coherent
Intermediate frequency	To be determined
Frequency plan	As shown in Fig. 4

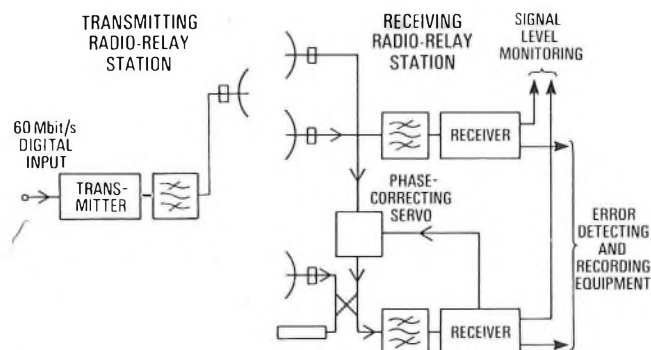

FIG. 5—Block diagram of aerial-height diversity arrangement

Experimental work carried out by the BPO Research Department has shown that a substantial improvement in performance during multipath propagation conditions can be achieved by the provision of aerial-height diversity. This is outlined in Fig. 5.

A consequent penalty of this configuration is that it necessitates the provision of additional aerials on the existing mast or tower and, in a number of installations, particularly on lattice masts, the wind loading and available space make this impossible. To overcome this problem, it is possible to develop a dual-band aerial to cover both the upper 6 GHz and 11 GHz bands. This is a practicable solution to the difficulty; it avoids substantially strengthening or completely replacing some existing masts, which involves considerable expenditure on civil-engineering work as well as disruption to existing services.

If the system were designed for 140 Mbit/s working on each carrier, conforming to the digital hierarchy proposed by CEPT, it would also be necessary to provide digital line sections on coaxial pairs at the same digit rate to interconnect outlying terminal radio stations with repeater stations in city centres. Interworking with the 120 Mbit/s line systems will, when necessary, be provided at the 8·448 Mbit/s order of the digital hierarchy.

Wideband Codex

In the transitional years, when digital transmission systems are being introduced but have not achieved a substantial penetration, it will be necessary to provide a measure of interworking between the existing analogue and the new digital networks.

A particular example of this is where a digital line section (for example, at 120 Mbit/s) has been provided, but there is as yet insufficient digital traffic to provide adequate usage. At the same time, there may be a shortage of analogue transmission capacity. This situation could be alleviated by encoding FDM assemblies, such as groups, supergroups and hypergroups, into digital signals for transmission over the digital line section. It is not intended to develop a group encoder, but development of a supergroup encoder and, at a later date, a hypergroup encoder is envisaged. The digit rates required and other parameters are given in Table 5.

TABLE 5
Wideband Encoders

Type of Encoder	Bandwidth (kHz)	Sampling Frequency (MHz)	Approximate Gross Digit Rate (Mbit/s)	Noise/Channel (pW0p)*
Supergroup	312-552	0·576	7	158
Hypergroup (15 or 16 supergroups)	60-4028	8·432	94	Approximately 250
Hypergroup (14 or 15 supergroups)	60-3780	Approximately 7·6	69	Approximately 500

* Psophometrically-weighted power in picowatts at the 0 dBm point

In the case of the supergroup encoder, an 8·448 Mbit/s path offers rather more capacity than is actually needed, and the signal needs to be "filled" to bring it up to the required rate. For the hypergroup encoder, the gap between the digit rate required and either 120 Mbit/s or 140 Mbit/s is substantial, and is too large to be discarded. Fitting in several 8·448 Mbit/s paths for digital traffic would be possible, but could lead to problems in utilization. Consequently, it has been decided as a possible development objective to aim at encoding 2 hypergroups, each within about 69 Mbit/s, and then combining them digitally onto a 140 Mbit/s path. This may necessitate reducing the number of supergroups in the hypergroup to 14 or less, to achieve the required noise objectives.

An important aspect in considering noise objectives is that the noise contribution into each voice channel is largely independent of distance for digital systems, whereas in the FDM case, the noise is proportional to distance, plus a constant for the FDM translating equipment. This being so, where a long analogue hypergroup is replaced by an encoded hypergroup, there might be an improvement in the channel noise, whereas the converse is likely to be true for short hypergroups. Thus, to avoid worsening the total noise in a circuit by the introduction of either supergroup or hypergroup encoders, the shortest analogue case should be considered, although practical and economic considerations could make it necessary to base the design on the median length.

Television Encoders

A further consideration in choosing to allocate about 69 Mbit/s to an encoded hypergroup is that present studies being made by both the BPO and the broadcasting organizations indicate that this digit rate should be adequate for encoding a colour television signal.

This takes into account that, in the UK, the required broadcast standards need to be maintained whilst allowing for up to 4 or 5 links to be interconnected in tandem at video frequencies. The important advantage of digital transmission is that it should be possible to transmit a television signal over comparatively long distances without incurring the attenuation and phase distortion that are characteristic of analogue transmission. Nevertheless, error rate and jitter play an important part in the transmission requirements of a digital path and will need to be contained within acceptable limits.

CONCLUSION

This article has surveyed a number of development projects in digital transmission that are either in being or are envisaged, and all of which have their part to play in future digital communications networks.

Within the scope available, it has been possible to give only a superficial appraisal of digital transmission, but it is intended that, at a later date, further articles will provide a detailed description of each of the systems being considered.

ACKNOWLEDGEMENT

The author wishes to acknowledge the help given by colleagues in the Telecommunications Development Department in the preparation of this article and GEC Telecommunications Ltd. for permission to publish Fig. 1.

References

- 1 RAVESCROFT, I. A., and RITCHIE, W. K. Some Considerations in the Optimization of Waveguide Systems for Operational Use. IEE Conference on Telecommunications Transmission, 9-11 Sept. 1975.
- 2 TURNER, R. J. Preliminary Engineering Design of Digital Transmission Systems Using Optical Fibre. *POEEJ*, Vol. 68, p. 7, Apr. 1975.
- 3 BOLTON, L. J., and BENNETT, G. H. Design Features and Applications of the British Post Office 24-Channel Pulse-Code-Modulation System. *POEEJ*, Vol. 61, p. 95, July 1968.
- 4 CCITT Green Book, Vol. III. Recommendations G712 and G713.
- 5 DOE, E. S. A Digital Radio-Relay System. *POEEJ*, Vol. 65, p. 160, Oct. 1972.

Programmable Automatic Testers in the British Post Office Factories Division

W. H. SAMBROOK†

UDC 621.317: 537.74

The technical and economic advantages obtained from the use of automatic test equipment are attracting increasing interest and attention. This article describes the programmable automatic test equipment developed and introduced in the British Post Office Factories Division to realize these advantages to the benefit of the Telecommunications Business.

INTRODUCTION

The types of equipment repaired by the British Post Office (BPO) Factories Division are many and various. When all the technical and economic factors concerned with testing are considered, including the increasing complexity of apparatus, the need to test to more-stringent tolerance limits with greater reliability, and the needs of quality-assurance operations, a viable and economically-justified case exists for the design of programmable automatic testers (PATs) for use within the Factories Division.

Items to be tested can be classified within 3 areas of technology: electromechanical apparatus, analogue electronic equipment and digital electronic equipment, with some items having a combination of these technologies. To meet the testing needs, a family of PATs has been developed. PATs 1 and 2 cater for analogue printed-circuit boards (PCBs), and PATs 3 and 4 cater for electromechanical apparatus. A programmable jig for analogue PCBs, known as a *programmable automatic unit locator*, and a stored-programme digital PCB tester, known as a *stored-programme automatic logic-circuit analyser*, have also been developed. A general description of PATs has been given in a previous article.*

The basic requirements of all types of PAT are that they should provide

- (a) an interface or access unit,
- (b) a test unit,
- (c) a programmable control unit, and
- (d) a means of connexion to the unit under test.

PAT 1

PAT 1 was the first PAT of the range to be developed. It is designed to test unenergized analogue PCBs diagnostically, is inexpensive and uses simple techniques. Most of the principles used in the design of PAT 1 have been extended, improved and included in the development of PAT 2. For this reason, PAT 1 is not discussed further, a detailed description of PAT 2 being given below.

PAT 2

PAT 2 is a punched-tape-controlled tester designed to carry out diagnostic, functional or alignment testing of analogue PCBs. Fig. 1(a) shows a general view of PAT 2.

† Purchasing and Supply Department, Telecommunications Headquarters.

* SPANTON, J. C. A Survey of Recent Test-Equipment Development in the British Post Office Factories Division. *POEEJ*, Vol. 68, p. 175, Oct. 1975.

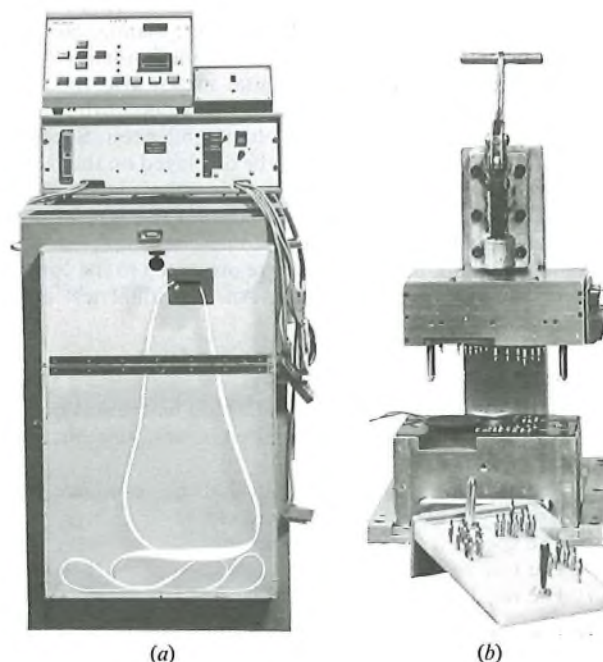

(a) PAT 2
(b) Bed-of-nails jig, showing interchangeable probe-assembly inserts

FIG. 1—PAT 2 and a typical bed-of-nails jig for diagnostic testing

Diagnostic testing requires some form of probe connexion to the PCB track, and jigs using spring-loaded plungers in a “bed-of-nails” formation are in common use on repair flowlines. Functional and alignment tests can usually be carried out via the PCB’s edge-connector. Fig. 1(b) shows a bed-of-nails jig.

The design specification of PAT 2 requires that

- (a) it be capable of carrying out functional, diagnostic and alignment tests, or a combination of these, on all types of analogue PCBs,
- (b) it be controlled by means of a punched-paper-tape programme using a standard data code,
- (c) it makes use of a simple basic instruction language,
- (d) its construction be entirely modular and such that the tester is easily transportable,
- (e) it has a short test-cycle time, giving 120 tests/min, and
- (f) it has simple controls, making it suitable for operation by semi-skilled labour.

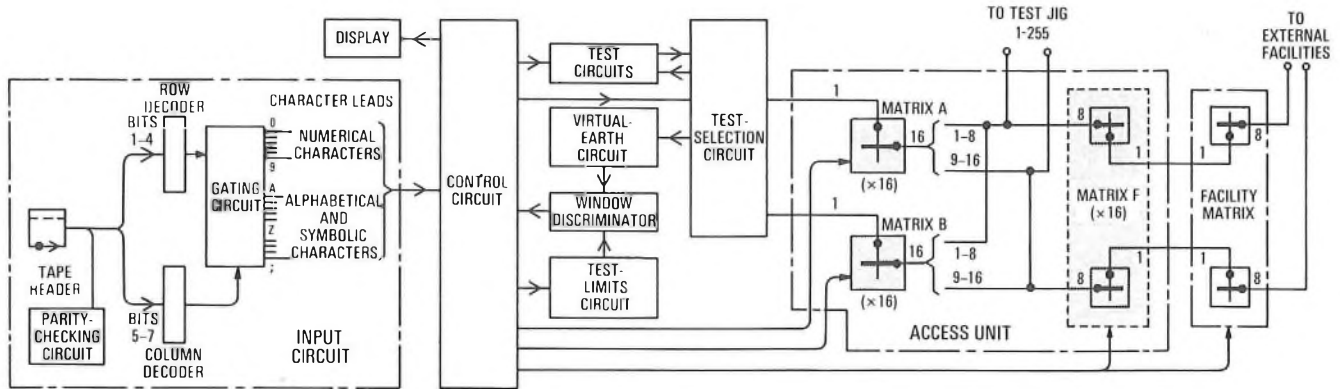

Note: The numerals adjacent to the inlets and outlets of each matrix indicate the number of wires

FIG. 2—Block diagram of PAT 2

A block diagram of PAT 2 is shown in Fig. 2. The access, test, input and control modules are housed in a metal cabinet (see Fig. 1(a)) approximately 840 mm high; manual controls and the display are mounted on a slant-fronted cabinet approximately 200 mm high. A digital meter, also mounted on the slant-fronted cabinet, indicates the value of the resistance, capacitance, or a.c. or d.c. voltage under test. Specified upper and lower test limits can also be displayed on the meter, under test-failure conditions, to ascertain the magnitude of the error. Lamp displays include test-failure, fail-high, fail-low, parity-error and test-number indications.

Test instructions, in serial form, are presented to the control unit using a punched-tape reader. An individual test is set up in the following order.

- (a) The test-number display is set or updated.
- (b) All unwanted facilities are reset.
- (c) The required test points are set up via matrices A and B.
- (d) Any external test facility required is set up via matrix F and the facility matrix.
- (e) The type of test is selected; that is, resistance test, capacitance test, voltage measurement etc.
- (f) The specified test limits are set up.
- (g) The test is applied.
- (h) The result is monitored and displayed.

The sequence is repeated for each individual test. The complete test programme is so arranged that diagnostic tests are carried out first on the unenergized PCB; further diagnostic tests, and functional and alignment tests, are then conducted with the PCB energized. Variable time delays can be programmed to be inserted between the setting-up of a test and its execution, to allow the circuit to stabilize before a measurement is made.

Basic Instruction Language

A simple 8 bit instruction language, derived from the American standard code for information interchange (ASCII), controls the access and test functions of PAT 2. The ASCII consists of 64 numerical, alphabetical and symbolic characters, arrayed as a matrix of 16 rows and 4 columns. A particular character is identified by its row and column co-ordinates, and is expressed in 7 bit binary form, bits 1-4 selecting the row, and bits 5-7 the column. Bit 8 is introduced to provide an even-parity check.

The programme can be written on a teleprinter or computer-terminal teletype to give both an 8 bit programme tape and a hard-copy verification of the programme's content. The programme consists of a series of test instructions presented in serial form via the tape reader to the tester's control circuit. Each test instruction has a setting-up command

specific to the test being carried out, and an executive instruction to the control circuit. The test sequence, or series of test sequences, is followed by *carriage-return* and *line-feed* characters to enable a printed copy of the programme to be obtained if required. The test information is read by the tape reader at a speed of 100 characters/s.

Input Circuit

The input circuit is shown in block form in Fig. 2. An even-parity-checking circuit is connected across the output of the tape reader; if a parity error is sensed, the tape-reader drive is disconnected.

Bits 1-4 of each character read from the tape are fed to the input of a decoder to select the required row, while a second decoder responds to bits 5-7 to select the particular column. The decoders control a gating circuit to give an output on the appropriate character lead. The character leads are at 0 V in their normal state, and rise to 5 V when enabled by the appropriate code. They are hard-wired to the various sections of the control and test circuits.

Access Unit

The access unit consists of a number of standard matrix PCBs assembled to form switching matrices, designated *matrix A*, *matrix B* and *matrix F*, which are used to make the connexions between the required test-jig leads and the appropriate test facility. The complete access unit is illustrated in Fig. 2.

An explanatory diagram of matrix A is given in Fig. 3, showing one of the standard matrix PCBs in detail, together with the control circuitry that decodes the switching instruction. An example of a switching instruction to set matrix A to outlet 015 is also shown.

Each standard matrix PCB consists of 16 miniature reed relays with single *make* contacts forming a 1-inlet-to-16-outlets switch. Sixteen such cards, designated A1-A16, have their inlets commoned together to form matrix A, a 1-inlet-to-255-outlets switch, the two-hundred-and-fifty-sixth outlet not being used since binary zero cannot be a selection code. A switching instruction to set up matrix A to, say, outlet 015 consists of the character elements $MA,015$; presented serially on their respective character leads. The 3 numerals are decoded in turn at decoder 1 and stored on latching circuits 1-3 respectively in 4 bit binary-coded-decimal (BCD) form. The BCD-binary converter then presents the complete 3-digit number, in binary form, to decoders 2 and 3. The programme combination MA ; causes the NAND gate to enable decoder 3 which, from the information on leads 2⁴-2⁷, selects and enables the decoder of one of the 16

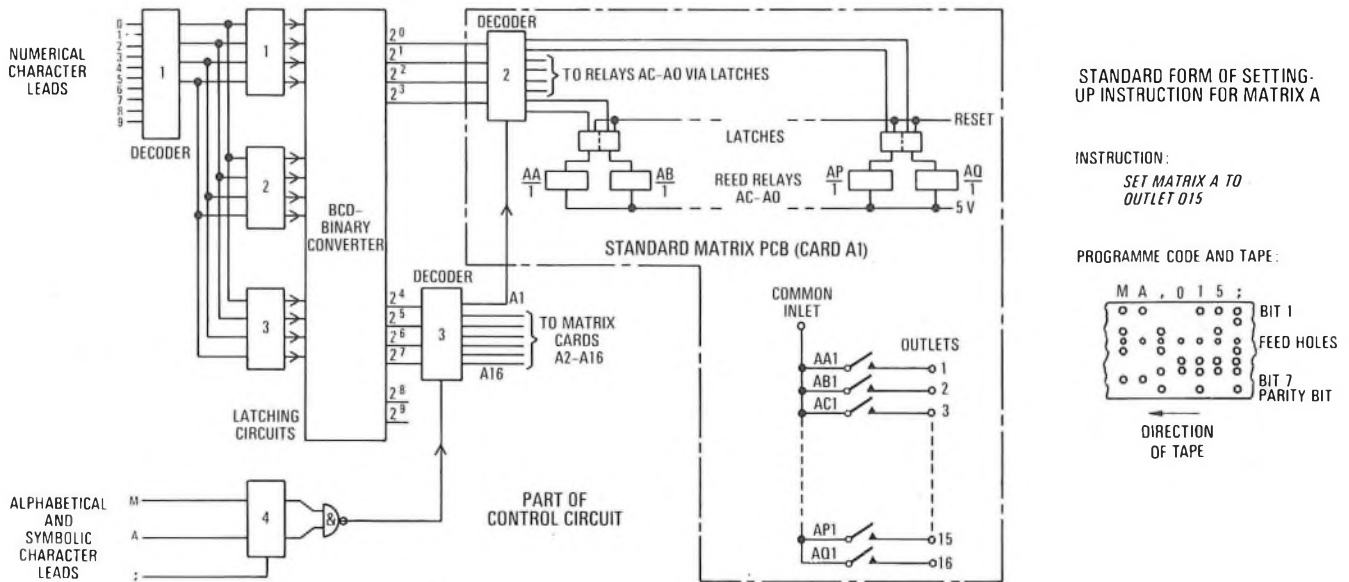

FIG. 3—Explanatory diagram of matrix A, showing standard matrix PCB and setting-up instruction

standard matrix PCBs. In the case illustrated, decoder 2 in card A1 is enabled. From the information on leads 2^0 – 2^3 , decoder 2 selects and operates one of the 16 relays on card A1, the operating information being stored on the appropriate latch until reset. Thus, matrix A connects one of its 255 outlets to its inlet. (To obtain the correct logic conditions, inverted outputs from decoder 2 are used.)

Most diagnostic tests on PCBs require only a 2-wire test circuit. Matrix A provides one of the test wires, and an exactly similar matrix, matrix B, provides the other. To give full flexibility of access to the test jig, the like-numbered outlets of matrices A and B are connected together to form a 2-inlets-to-255-outlets access unit as shown in Fig. 2. Functional and alignment tests are carried out using matrix F, which is similar in principle to matrices A and B, and has its outlets wired to those of matrices A and B. Matrix-F inlets are wired to a relay-crosspoint facility matrix to allow up to 16 single-wire or eight 2-wire external test facilities to be connected to the unit under test.

Test Units

Operational-amplifier techniques are used in the test units. Three basic testing elements, using well-established principles, form the diagnostic-testing circuit. These are

- the window-discriminator circuit,
- the digital-analogue convertor, and
- the virtual-earth circuit.

The basic test circuits are shown in Fig. 4.

Window Discriminator

The window discriminator is used to determine whether a voltage or pulse amplitude is within prescribed limits, on a GO/NO-GO basis. Two operational amplifiers are connected in the differential mode. A lower test-limit voltage, V_1 , is applied to the non-phase-inverting terminal of one amplifier, and an upper test-limit voltage, V_2 , is applied to the phase-inverting terminal of the other. The remaining input terminals are connected together to form a junction to which the test voltage, V_{IN} , is applied. Provided V_{IN} is within the tolerance "window" set by V_1 and V_2 , a pass signal is transmitted back

to the control circuit, and the test programme continues. A test voltage outside the tolerance window causes the control circuit to stop the test programme and light either a FAIL-HIGH or a FAIL-LOW lamp, as appropriate.

Test-Limits Circuit

The lower and upper test-limit voltages, V_1 and V_2 respectively, for the window discriminator, and other reference voltages, are derived using digital-analogue converters, as shown in Fig. 4. The circuit can provide test-limit or reference voltages within the range 0.01–9.99 V, summed in increments of 0.01 V, of either polarity. A signal on the negative symbolic character lead operates and holds relay A via bistable circuit 1 and the NOR gate. Contact A1 reverses the polarity of the voltage supply to the digital-analogue converters and, hence, the polarity of V_1 and V_2 .

An instruction to set up upper and lower test-limit voltages of 5.3 V and 4.7 V, respectively, consists of the character elements +, 530, 470; presented serially on their respective character leads. The initial sign character (positive, in this example) ensures that contact A1 connects the correct polarity to the digital-analogue converters, and prepares registers 1 and 2 for the reception of the numerical information via bistable circuit 1, the OR gate and leads E1. The first comma sets bistable circuit 2 to enable register 2, via lead E2, to receive the upper test-limit value. The 3 numerals, 530, are decoded in a manner similar to that described for the access unit and presented to register 2 in binary form for storage. The second comma resets bistable 2 to enable register 1, via lead E3, to receive the lower test-limit information, 470. Digital-analogue converters 1 and 2 then perform the conversions to produce the test-limit voltages.

Virtual-Earth Circuit

The problems associated with testing resistive components mounted on unenergized PCBs can be overcome if the component under test forms part of the feedback loop of an operational amplifier. In Fig. 4, the component selected via the access unit, with contacts T operated and contacts M normal, forms such a feedback loop in conjunction with a

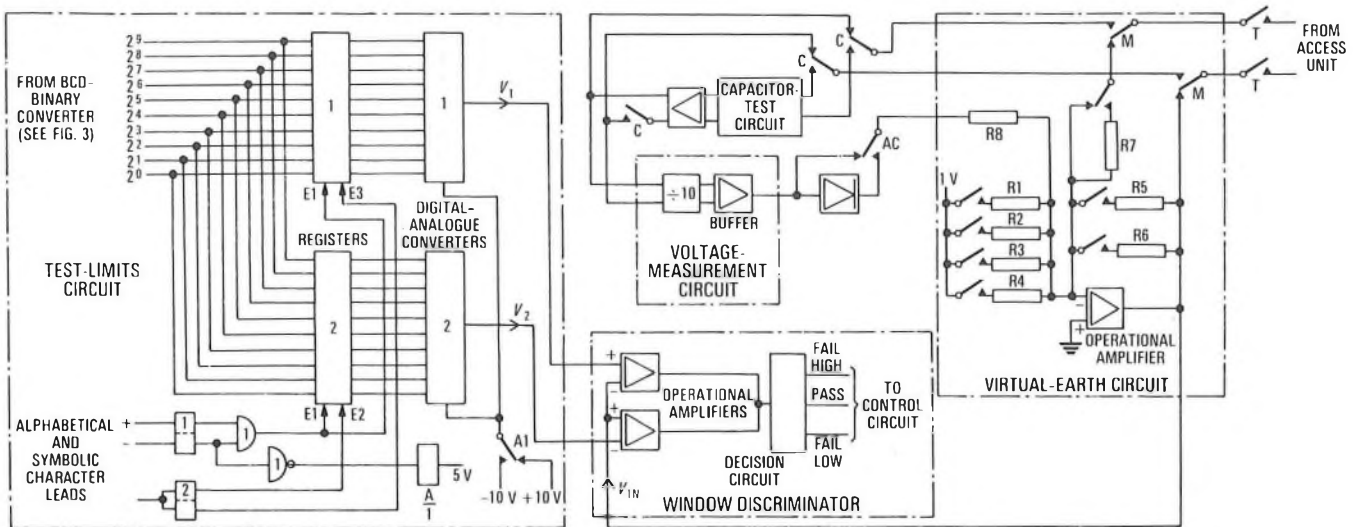

FIG. 4—Basic test circuits

resistor selected from resistors R1–R4. (For short-circuits and low-resistance components, resistor R7 is used as the feedback element.) The voltage at the negative terminal of the operational amplifier is prevented from changing by feedback, and the terminal acts as a virtual earth. Other points on the PCB can be artificially earthed using matrix F to obtain the degree of isolation required for the test. An output is obtained in terms of voltage, and this is fed to the window discriminator for comparison with the test-limit voltages.

Voltage-Measurement Circuit

A 0–100 V measurement facility is provided. With contacts M operated and contacts C normal, the voltage to be measured is fed into a high-impedance buffered-output divide-by-ten stage. For alternating voltages, a rectifier is switched in by contact AC. The voltage is then fed to the virtual-earth circuit, acting as a range amplifier, via resistor R8. Two ranges are available: unity gain or times 10, selected by switching either resistor R5 or R6 into the feedback path. The output voltage is compared with reference voltages using the window discriminator.

Capacitance-Measurement Circuit

Facilities are provided to measure capacitances between 0.0001–1000 μF in 7 decadal ranges (0.0001–0.001 μF , 0.001–0.01 μF , 0.01–0.1 μF etc.). The capacitance to be measured is connected to the capacitor-test circuit via contacts C operated. An alternating source voltage of only 1.2 V enables aluminium and most solid tantalum capacitors to be measured without regard to their polarity. For each range, the capacitor-test circuit produces an output voltage between 1–10 V, directly related to the value of the capacitance under test. This voltage is compared with upper and lower test-limit voltages, selected to suit the capacitance tolerances, using the voltage-measurement circuit, the virtual-earth circuit and the window discriminator.

Programmable Sine-Wave Oscillator

A fixed-frequency 2.28 kHz sine-wave oscillator (not shown), with programmable output-voltage facilities, is available for test purposes, enabling loss measurements to be made on the unit under test.

PROGRAMMABLE AUTOMATIC UNIT LOCATOR

It is not always economic to produce a bed-of-nails jig for a small quantity of a particular type of PCB and, to meet such situations, a programmable automatic jig has been developed to work in conjunction with PAT 2. The jig is programmed using the basic instruction language, and works to the normal testing procedure used by PAT 2.

Two digital stepping motors are used to drive each of 2 probe carriages along sets of steel runners aligned with the X-axis of the PCB, one set along each long edge of the PCB. Two further motors, one mounted on each probe carriage, drive the probes themselves in the Y-axis direction along runners mounted on the carriages at right-angles to the X-axis runners. Thus, by using suitable control equipment, movement of both probes in the X and Y directions is obtained. Using cartesian co-ordinates, the programme can exactly define the required position of each probe for a particular test. When the probes are positioned, an electromagnetic device is actuated to make contact with the PCB at the chosen points. Because only 2 probes are used, the unit is generally more reliable and easier to maintain than a bed-of-nails jig. It is, however, more expensive, and its use increases the length of the overall test-cycle time.

The digital stepping motors are geared to give 18° steps at 300 steps/s. A lead screw with 200 threads/m is used, giving a movement to each probe of 0.25 mm/step.

The control circuit uses a microprocessor and programmable read-only memories. When used in conjunction with PAT 2, the jig-movement information is presented to the jig's control unit from the programme tape prior to each complete test cycle.

The jig can accommodate PCBs of up to 400 mm × 300 mm. Limited test conditions can also be applied and monitored via the PCB's edge-connector and matrix F of PAT 2. Most voltage tests can be conducted using one probe only, with an earth-return circuit via the edge-connector.

PAT 3

PAT 3 is designed to test electromechanical apparatus; in particular, BPO Strowger-type selectors and relay-sets. The tester can be programmed to carry out, on most types of BPO selectors and relay-sets: functional and diagnostic tests, checks of alignment and adjustment, figure-of-merit tests

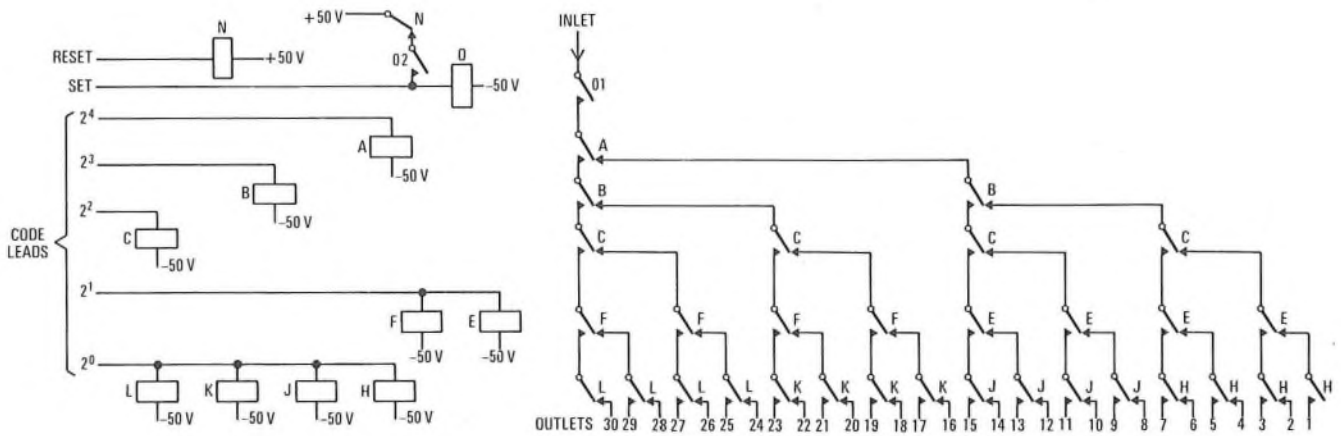

FIG. 5—Explanatory diagram of standard interface card

(for high-speed relays and relays requiring special adjustments and current tests, known as *red-label* relays), leaky, non-leaky and other types of pulsing tests, and transmission tests.

PAT 3 test-programmes have been written for a total of 34 items including, for example, local-call-timing and auto-auto relay-sets, 200-outlet group selectors, ordinary and PBX final selectors, and PABX connecting circuits. Also, programmes to test TXE2 slide-in apparatus are currently being prepared. A complete test cycle for a fairly complex selector or relay-set takes, on average, about 90 s, and the programme tapes and schedules take about 120 man-hours to prepare.

Access Units

A different type of access unit to that of PAT 2 is required to test selectors and relay-sets, since testing can be carried out only via the U-points and test-jack sockets. Also, numerous test conditions are often required to be connected simultaneously to obtain a satisfactory test. A number of standard interface cards are combined to form the access units.

An explanatory diagram, illustrating the principle of a standard interface card, is shown in Fig. 5. Nine relays, each with a maximum of 4 contact units, are assembled on a PCB to form a relay tree, giving a 1-inlet-to-30-outlets switching matrix. Two control relays, relays O and N, are also provided, and various other relays (not shown) perform holding functions for the selection relays.

Signals, in binary code, are presented to the code leads from the tester's control circuit. The outlet selected exactly corresponds to the binary-code input. For example, binary code 00101 (denary 5) operates relays C, H, J, K and L to connect the inlet to outlet 5; similarly, binary code 11100 (denary 28) operates relays A, B and C to connect the inlet to outlet 28. The input information is present only for a short time and holding circuits (not shown) are provided for the selection relays in a similar manner to that shown for relay O. The inlet is switched through to the selected outlet by an instruction on the SET lead, which operates relay O; contact O1 then makes the required connexion. The connexion remains held until a signal is received on the RESET lead to operate relay N. Contact N then removes the holding conditions, and the selection relays and relay O release.

A total of 45 standard interface cards are used to form the access units. Fifteen of the cards have their outlets multiplied together to form access-unit 1, a 15-inlets-to-30-outlets matrix. Access-units 2 and 3 are formed in a similar manner. Connexion to the unit under test is made through the U-points and test-jack sockets using a standard Strowger test stand, the stand being connected to PAT 3 by a flexible cable and plug.

Control Units

Fig. 6 shows a block diagram of PAT 3. A simple 8 bit binary language, in machine-code form, is used to control the

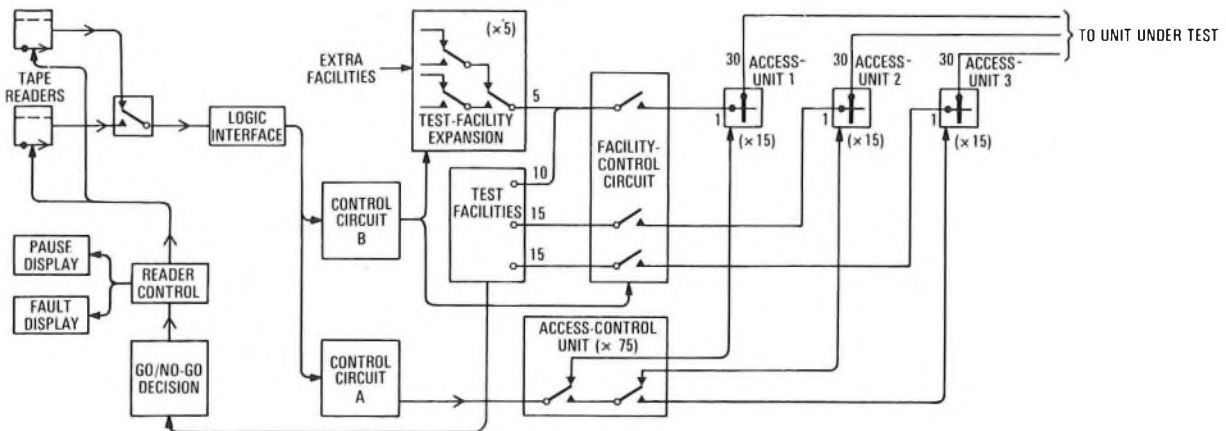

Note: The numerals adjacent to each path indicate the number of wires in that path

FIG. 6—Block diagram of PAT 3

test and access functions of PAT 3. The output information from a paper-tape reader is directed either into control circuit A or control circuit B. It is convenient to provide PAT 3 with 2 tape readers; a change in the test programme can then be easily effected. The information presented to control circuit A is used to set up the access units. Altogether, 75 codes are required to select outlets 1-30 in access-unit 1, and the same codes are also used to select outlets 1-30 in access-units 2 and 3. A steering code, to operate the contacts in the access-control unit, precedes the selection information in the case of access-units 2 and 3.

Control circuit B connects the required test facilities on commands from the test programme. It also monitors the progress of each test, and stops the test cycle under fault conditions. It is often necessary, when testing selectors or relay-sets, to stop the test sequence to allow mechanical operations to be performed; for example, the adjustment, under controlled conditions, of a high-speed relay when particular spring-set contacts may need to be isolated to disconnect one side of a parallel-path circuit. A simple and inexpensive visual display unit with a pause facility is fitted to the tester's control panel to indicate when these, and similar functions, are to be carried out during a test sequence. Test results are signalled to the GO/NO-GO decision circuit from the test-facilities unit.

PAT 3 has a self-routine-test facility; routine-test tapes have been developed to test every module *in situ*. Once a faulty module has been identified, it can be withdrawn from the tester for diagnostic testing, using an outrigger and the appropriate test-programme tape.

Test Facilities

Because of the nature of the units tested by PAT 3, most of the testing elements required are elementary. Simple battery-connected and earth-connected search-relay circuits, resistive-battery and earth-testing elements, and short-circuited and resistive loops are all that are required for most of the tests. More sophisticated testing circuits, using both analogue and digital techniques, are required to carry out figure-of-merit, pulsing and transmission tests. The test facilities are mounted on PCBs and allocated to a particular inlet or inlets of the access unit. An expansion facility is available from the first 5 inlets of access-unit 1 to give a total availability for that unit of 30 individual test-facility leads. Hence, a total of 60 test-facility leads are available to the access units.

PAT 4

PAT 4 is designed to carry out continuity and resistance measurements on various types of racks and frames. The tester uses most of the test and control modules developed for PATs 1 and 3. Nine uniselectors are used to form the

access unit, their outlets being connected to the unit under test through a hard-wired translation field and special-purpose jigs.

PAT 4 has the capacity to carry out a maximum of 1800 tests, 4 tests being conducted simultaneously at any one time. Switching and selection of the test facilities are controlled by an 8 bit machine code, similar to that used to programme PAT 3, on punched paper tapes.

CONCLUSIONS

The advantages arising from the application of automatic testing methods, on a basis of return of capital invested, are self-evident when large quantities of a particular item are to be tested. It is sensible, if a diversity of items needs to be tested, to design an automatic testing system capable of being applied without the need either for modification to dedicated special-purpose test gear or new development work. Experience has shown that the introduction of PAT techniques has been beneficial, and has resulted in increased productivity due to faster test-cycle and turn-round times. Provided the equipment is correctly utilized, the initial development costs are recovered in a short space of time. The introduction of PAT 3 to the testing of relay-sets and selectors brought about a saving of £0.70, on average, per unit tested; the test-cycle time was reduced to about 90 s, compared with 15 min using dedicated test gear.

Finally, the cost of not having PATs has to be assessed. It is difficult to place a monetary value on advantages other than the time and cost reduction offered by the system. Improved quality-monitoring techniques, simpler methods of fault diagnosis, the impartiality of the tester when making decisions, the repeatability of the test cycle to known and agreed standards, and the fact that programming costs only are incurred for new work, instead of the cost of developing special-purpose test gear, are some of the benefits obtained from using PATs.

Looking to the future, second-generation PAT development will include the use of microprocessor techniques to form a central processor unit for the control functions. Inexpensive and occupying a minimum of space, a micro-processor has the ability to carry out programmes by executing a series of its own micro-instructions, and hence to control all data transfers and test functions by computed results, thus producing a tester design less costly, more reliable and easier to adapt than the current series. Development work is proceeding along these lines at present within the Factories Division.

ACKNOWLEDGEMENT

The author gratefully acknowledges helpful discussions with many colleagues; in particular, with Messrs. J. C. Spanton, R. N. Stevens and L. S. Auld.

Regional Notes

SOUTH WESTERN REGION

Tunnelling in Taunton

The existing Taunton telephone exchange is situated in the main shopping centre of the town. It houses a group switching centre (GSC) serving 3 charge groups, an auto-manual centre (AMC) which also serves a remote GSC, and the local exchange. The building has been extended and equipped to saturation point, and attempts had been made to obtain an adjacent site for expansion, but without success. It was decided, therefore, to replace the GSC equipment by a new TXK1 unit on a remote site already owned by the British Post Office (BPO). This would allow the AMC and local exchange to expand into the space vacated by the GSC equipment. Fig. 1 shows the relative locations of the existing exchange and the new GSC.

The river Tone flows through the centre of Taunton, and the new GSC is on the opposite side of the river to the existing exchange. All main and junction cables had to be diverted to the new GSC, and several large tie cables were needed between the 2 exchanges. It was easy to reroute a few cables feeding North Devon, but most had to cross the river. The Tone Bridge was incapable of taking any more ducts since the existing ductways were already very congested. A river-side park had recently been constructed in the area of the castle, and to lay ducts through this area and erect a service bridge over the river was not permissible. Because of transmission and signalling limitations, the route had to be the shortest possible.

The route finally considered most feasible is shown in Fig. 1. From a suitable interception point near the exchange, conventional duct would be laid to Castle Way and linked to a tunnel under the bus station and river to the GSC site.

It was agreed with the River Authority that the tunnel would be at least 3 m below the river bed. Test bore-holes were driven in the line of the route (but not in the river). Pipe-jacking was rejected, as the ground was a rock-type marl at the required depth and the resistance would have been too great. Also, there were doubts about the accuracy of the method.

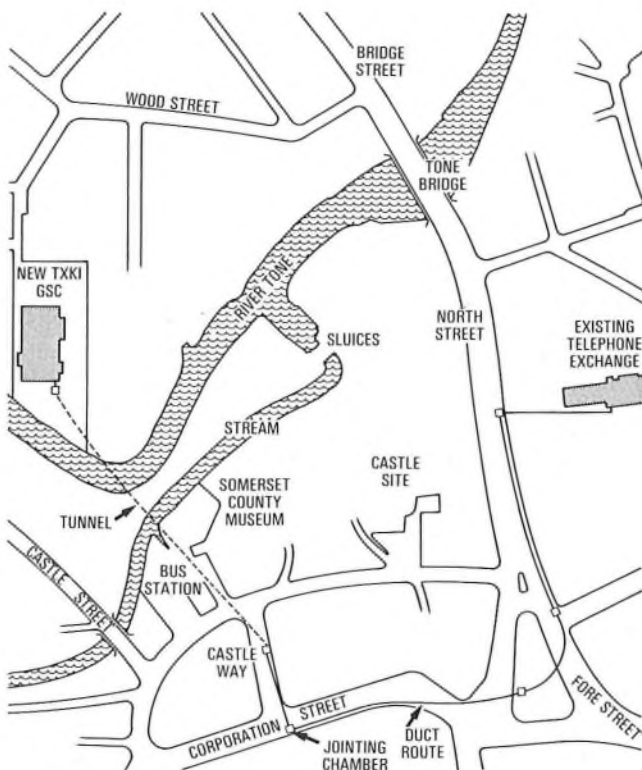

FIG. 1—Part of Taunton town centre showing the existing exchange and new GSC

A tunnelling system called *Seerflex Minitunnel*, a miniaturized version of traditional tunnelling techniques, was the method chosen. The tunnel lining is consecutively built up in sections, each section consisting of 3 identical 120° concrete segments. Each section is assembled within the rear of a tunnelling shield. The shield incorporates 6 hydraulic rams mounted on a mobile rig with front and rear thrust-rings. When the miner is working at the tunnel face, the rig is moved to the rear with the rear thrust-ring bearing against the last section built. When the rams are operated, the shield is moved forward, away from the last section of lining. The tunnel has an internal diameter of 1 m and contains 48 ducts. It has a length of 197 m and is laid at a depth of 8–10 m, with a 1° fall towards the GSC. Fig. 2 shows a section along the line of the tunnel.

The tunnel was built in 2 stages: the first from a construction pit approximately 7 m from the river bank on the GSC site to a construction pit in the bus station, and the second from the bus-station pit to the end of the tunnel in Castle Way.

Ducts were laid from both ends towards the central construction pit in the bus station. Fig. 3 shows the duct formation in the tunnel. Wooden separators were used to maintain alignment, the spaces being filled with a sulphate-resisting cement-mortar. The ducts were butt-joined at the central pit and secured with a sleeve. The first level of ducts was laid on a concrete base and bedded in cement-mortar. Concrete blocks were used to wedge the ducts, and subsequent layers were also bedded in cement-mortar. Reinforced concrete was laid on top of the ducts to form a solid block.

At Castle Way, a 3-tier manhole, with the upper level doubled in length, was built. Cables could then be tacked throughout the 3 tiers and the joints made horizontally near surface level. The GSC had been designed to have a cable trench and, so, a large jointing chamber with a turning

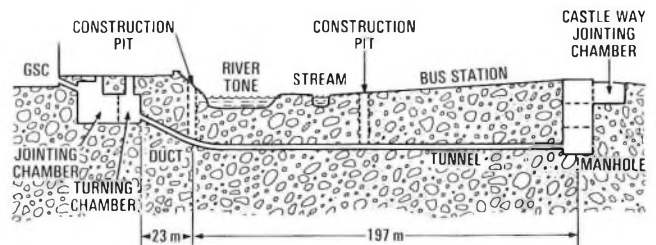

FIG. 2—Section along the line of the tunnel

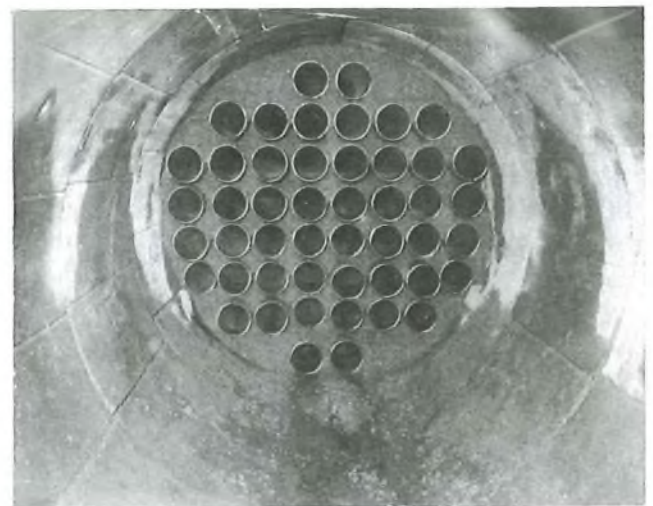

FIG. 3—Duct formation in the tunnel

section was built to accommodate the cables and joints and allow the cables to be aligned with the exchange's duct entry. The 23 m of duct between the end of the tunnel and the turning chamber were laid by the open-cut method.

It was initially envisaged that the work would be completed within 9 months, but it took over 18 months. There were a number of difficulties to be overcome, and some staffing problems.

Originally, it was intended that the river crossing would be carried out concurrently with a public-works sewerage scheme that necessitated draining the river over this particular section, but the BPO contract was late starting and the opportunity was missed.

Progress varied according to the conditions encountered. At the start, the weather was appallingly wet and an old test-bore caused water to pour into the tunnel. Work had to be abandoned until remedial action had been taken. Towards the middle of the river, the tunnel was driven into a strata of gypsum (hydrated calcium sulphate), apparently washed down over the years into the sedimentary basin. Samples were taken, and informed opinion intimated that the sulphates would cause serious damage to the tunnel within a few years. The precaution was taken, therefore, of filling the spaces between the ducts with a sulphate-resisting concrete.

Excavations for the open-cut section were soon abandoned in favour of a tunnel because of the instability of the ground; however, after a few metres, this also collapsed. Consulting engineers advised using steel-sheet piling over the deeper section, and it was found that this permitted the open-cut excavation to be completed.

Although the scheme has had its full share of difficulties, the cables are now being drawn-in with ease, and the jointing arrangements are proving adequate.

The help given by the contractors, Taunton Deane Council and the National Bus Company is acknowledged, and thanks are extended to all who co-operated in Telecommunications Headquarters, Regional Headquarters and Taunton Telephone Area.

C. BLAGG

Discovery at Cheltenham

Whilst excavating for a new 8-way duct route in High Street, Cheltenham, at a very busy road junction, it was discovered that a derelict Midland Electricity Board (MEB) underground sub-station lay directly in the path of the duct route and occupied the whole of the road space on that side of the road. The sub-station was in very good condition and contained lighting from a 200 W bulb and heating from a tubular heater. A 5.5 m long tunnel connected the sub-station chamber to its access manhole in the footpath. Fresh air was circulated through a duct in one side of the chamber to a ventilator in the footpath approximately 6 m away, and through a ventilator connected to the tunnel near the manhole.

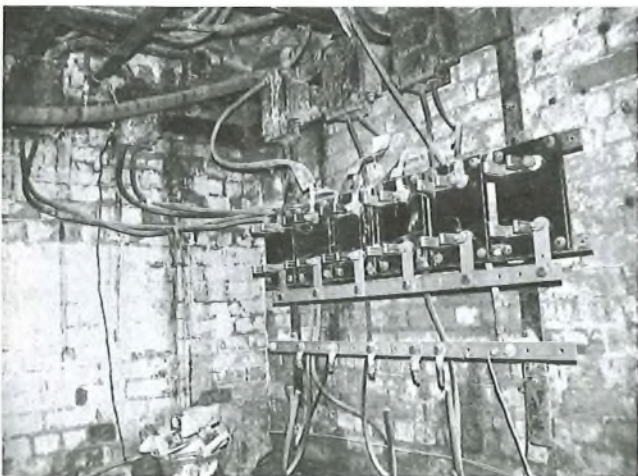

Part of the switchgear inside the derelict sub-station

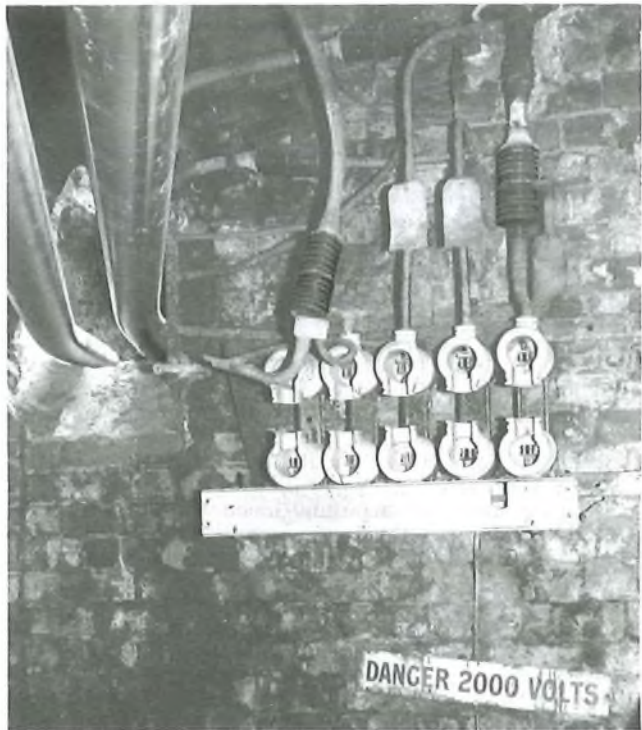

Two of the British Post Office's steel ducts entering the chamber from the duct trench
(Photographs by courtesy of D. Grant)

The MEB had overlooked the existence of the sub-station, which was last entered over 20 years ago. It still contained all the switchgear for a 2 kV mains system that formerly served the area and was later converted to power a street-lighting system.

Permission was readily given by the MEB for the new duct route to be laid through the walls of the chamber. A diversion to the main duct line at this point would have been a very costly operation.

R. L. ADAMS

LONDON TELECOMMUNICATIONS REGION

Inspection of Tunnel-Proving Bores by Closed-Circuit Television

Until recently, there was no British Post Office (BPO) specification for the construction of timber-lined tunnels, or *headings*, as they are sometimes called. The standard of construction was decided by the contractor, taking into account the nature of the ground penetrated, and was carried out in a form established over many years of experience. The final standards achieved depended on the integrity of the contractor and the amount of on-site supervision given by the BPO.

Experience of road collapses, with their consequent high repair costs to the BPO, indicated that this type of work should be closely regulated and supervised. Two stages of tunnel construction are critical. They are

(a) the excavation of the ground and the placing of timber of adequate strength and quantity, avoiding loss of ground and the consequent creation of voids outside the tunnel, and

(b) the infilling of the space around the ducts with concrete so that there are no voids inside the tunnel into which the ground-supporting timber can later collapse.

The first requirement can be regulated to some extent by close supervision and regular inspection of both work and timber, coupled with an assessment of the integrity and skill of the miner. The second requirement, the avoidance of voids, is more difficult to achieve because it would be uneconomic to make the tunnel wide enough to give space where a supervisor could stand to one side and watch the

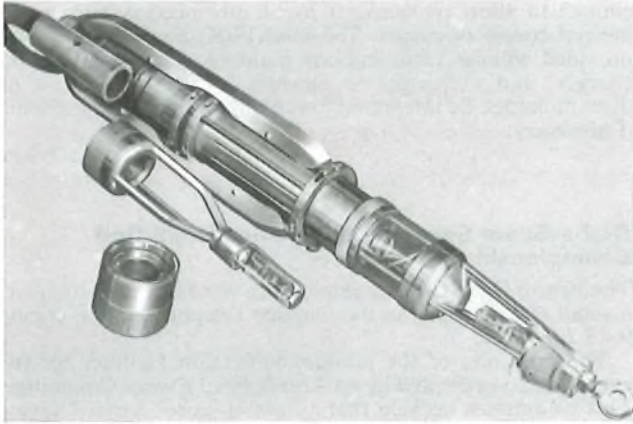

The camera fitted with a rotatable radial viewing head, and showing 2 alternative forward-viewing heads

whole operation. The required volume of concrete can, however, be calculated, and the supervisor can check that this amount is actually placed in the heading, provided he can eliminate the problem of checking the volume of ingredients in a situation where there is continuous delivery of material to a stockpile. There is no inspection window through which the activity of the operatives below ground can be observed to see if the tunnel is completely packed and without voids. All the supervisor can do is stop the work while he tests the infill with a steel rod, and even this will not locate all voids.

A BPO specification has now been written that gives guidance on producing work of a high standard. The problem of proving that a well-packed concrete infill has been achieved is solved by casting an examination bore, or proving bore, in the concrete just under the tunnel's head trees. This is done by means of a mould formed by an inflated rubber tube of approximately 100 mm diameter, which is progressively moved forward as each batch of infilling sets. A continuous bore is thus produced that can then be inspected by means of closed-circuit-television equipment. Any attempt to skimp the concrete packing will produce voids that are obvious, and must be filled at the contractor's expense. The television equipment is operated by Regional Headquarters staff, and has enabled them to retain close control of the quality of work, and has also eliminated the delay to contractors awaiting inspection of a concrete infill.

The closed-circuit-television equipment has proved very effective. The many headings inspected to date have shown both a high quality of concrete used and full packing of the headings, even in the spaces just behind the head trees, the most difficult parts to pack because they are out of sight of the miner. Very few small voids are shown up by the inspections, indicating that special efforts are being made fully to fill the tunnels.

The definition obtained on the television picture is remarkable. There is a small magnification effect that reveals fine detail of the proving bore and permits the examination of the concrete's texture. The camera consists of a waterproof stainless-steel cylindrical body, 44 mm in diameter and 330 mm in length, containing a camera unit with a 6.5 mm diameter lens, together with a focus control and lighting unit. The camera has 300 scanning lines and can be remotely focused from infinity down to objects immediately in front of the lens assembly. The camera is connected to its associated control equipment by a flexible PVC-sheathed cable, 136 m long. The equipment operates from a 110 V a.c. supply. Control units for the camera and lighting, a monitor and a video tape-recorder are mounted in a general-purpose vehicle, which also has ample room to carry the drum of cable, the 110 V generator, a power-distribution board and any other necessary equipment.

The equipment has been developed and adapted to meet fully BPO needs regarding the fixing of rods and pulling attachments, and there are robust protective sleeves both to centralize the camera in the bore and protect it from the very

abrasive environment in the bore. The viewing heads can be changed to allow both forward and radial viewing, and can be rotated to give a full circumferential investigation of the bore. Lighting is provided by quartz-halogen bulbs that will operate effectively under water.

The television equipment has also been used to examine blocked or obstructed duct lines with good results. All investigations can be recorded on video tape which can conveniently be used to illustrate the situations in subsequent discussions. The London Telecommunications Region's experience, since November 1974 when the equipment was brought into use, has shown its value both as an aid to duct-work investigation and as a means of obtaining good-quality tunnel-works that meet BPO specifications.

W. D. PRIESTLEY

A Portable Dam for River-Crossings

The route of the ductwork for the 60 MHz cable in West Telephone Area included a crossing of the river Brent at Hanwell. The Brent is an outlet of the Welsh Harp at Hendon, and flows into the Thames at Brentford. Its level varies considerably during rainy periods, and it is subject to occasional flooding.

Consideration was given to the use of a coffer-dam technique for the crossing, requiring sheet piling to be driven into the river bed to enable work to be carried out in one half of the river at a time, the water flow being maintained in the other half. However, about that time, the television programme "Tomorrow's World" demonstrated the use of a system known as *Portadam*, and the opportunity was taken to obtain details from the BBC.

Portadam comprises a self-locking steel framework, erected across a river to provide a rigid support for plastics-coated fabric sheeting. A large plastics bypass tube is welded to the sheeting. The sheeting is placed over the steel framework and rolled down onto the river bed, so that the water pressure provides a seal and the flow of water is diverted through the bypass tube. Fig. 1 illustrates the construction and principle of the portable dam.

After a visit to the site, the manufacturer's agents confirmed that the situation was suitable, the hiring costs economic, and that the firm would give technical advice and assistance on site. They also advised a lower dam to be constructed of sandbags, downstream of the main dam, to prevent water flowing back to the dry side of the portable dam.

The work was carried out during June 1975, and completed within 10 d. The work site remained dry during this period, and a 35-way duct route, including ducts for the 60 MHz cable, was laid by conventional methods. The river bed and banks were restored using the excavated materials, with bags of cement-mortar included to prevent subsequent erosion of the banks.

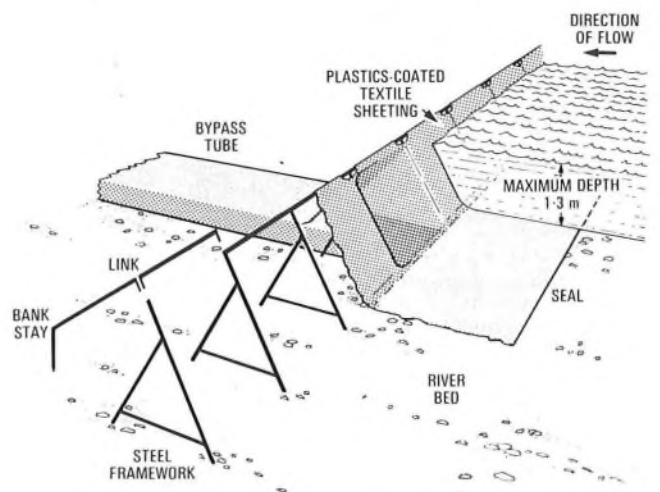

FIG. 1—Principle of the portable dam

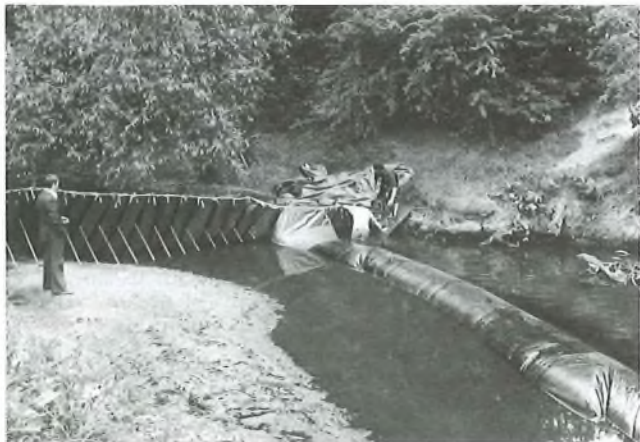

FIG. 2—Erection of the portable dam

The work went smoothly, few problems arose, and an overall cost saving of 30% over conventional damming techniques was achieved. The other advantages were an unbroken duct line in the river bed, the ease of transporting the dam materials, and the speed of erection: 1 d. Fig. 2 shows the dam in the course of erection. A regional specification was prepared for the provision of the dam, the erection work being carried out by John Hudson (Birmingham) Ltd., Flexible Structure Division.

R. C. HOGBEN

SCOTLAND

The Unit Automatic Exchange No. 13 (Restricted)

In Scotland West Telephone Area, service to the many small communities has, for several decades, been provided by unit automatic exchanges (UAXs) No. 12. As growth in the majority of these exchange areas is minimal, the STD facility was, in most cases, provided in the existing UAX12 using the pre-2000-type switching equipment, much of which is more than 30 years old.

The recent policy decisions on modernization have been restricted to exchanges with over 400 connexions, and there is, at present, no replacement policy for UAX12s. In the circumstances, efforts have been directed locally to convert to the next best thing; that is, 2000-type Strowger equipment. The UAX13 is the natural choice.

The larger UAX12s that exhaust in normal course, or require replacement on service grounds, will be converted to UAX13s in the usual way.

Elsewhere, however, where sufficient space exists, investigations have shown that UAX13 subscriber units (units No. 13A) can be used to replace UAX12 subscriber units (units Nos. 12A and 12B) with only minor changes to the UAX12 STD equipment, giving a restricted form of UAX13 known as a UAX13(R). As the UAX12 STD equipment is less than 6 years old, it is capable of giving adequate service for many years yet.

Almost all the UAX12s in the Area are provided in extended type-A buildings, either of timber or brick construction. Those with not more than 3 subscriber units (that is, 2 units No. 12A and one unit No. 12B) are more suitable for conversion to UAX13(R)s, due to the restricted floor area available. Two units No. 13A can be installed, giving a multiple capacity of 100. Sufficient space is available to provide discriminator facilities, if required. Two UAX13(R)s have been brought into service, one using loop-disconnect signalling to the group switching centre, and the other using Signalling System DC No. 2. It is planned to bring 10 more into service by March 1976.

There are about 60 UAX12s in Scotland West Area that will have less than 100 connexions by the early 1990s. In these cases, the UAX13(R) offers an economic method of providing more modern equipment with a greater traffic-carrying capacity than the UAX12, and with a life span long

enough to allow replacement by an advanced system in the normal course of events. The UAX13(R) equipment can be provided without incurring any building or external-cabling charges, and exchanges so converted can, by the use of discriminators, be integrated into a linked-numbering scheme if necessary.

S. A. WATT

Dial-a-Score Service at the British Open Golf Championship, Carnoustie

The British Open Golf Championship was held at Carnoustie, a small seaside resort in the Dundee Telephone Area, during 9–13 July 1975.

The provision of the telecommunication facilities for the event was co-ordinated by an Area Special Events Committee. This Committee decided that a "dial-a-score" service, giving up-to-the-minute information on the progress of play, would be an attractive revenue-earning proposition.

The technically-sophisticated facilities available from announcement levels had not yet been installed in this part of the country, so that the provision of a makeshift service seemed at first to pose a problem.

Obviously, tape-recording facilities, with scope for updating, was a basic requirement, and Answering Sets No. 2A were found to be readily available. With these sets, an associated 700-type telephone is used as the means of recording. An answering set was, therefore, chosen in preference to the hire of a proprietary tape-recorder. This left the problem of modifying the answering set to give a continuous-running facility, since its normal function is to stop after one cycle of the tape. Tape control is effected by a light beam focused on a photo-electric cell through a hole punched in the tape. Experiments showed that blanking off the light beam gave the desired continuous-running facility. Removal of the lamp altogether affected the erase circuitry.

However, while setting up the recording studio, it was observed that the answering set tended to run fast because of overheating when run continuously. Therefore, 4 machines were installed with the facility to select one from the 4 as the transmitting machine at any particular time. This arrangement also satisfied the information-updating requirement, at least one machine always being available for making a fresh recording.

The design of the signal-distribution network evolved from 3 main considerations: the number of outlets required, the equipment readily available for use in the announcement network, and the desire to minimize the amount of construction work involved. Twenty outputs were called for initially, and an interconnexion scheme for spare 4-wire terminations, used in the manner of splitting networks, evolved to meet all the considerations. The diagram shows

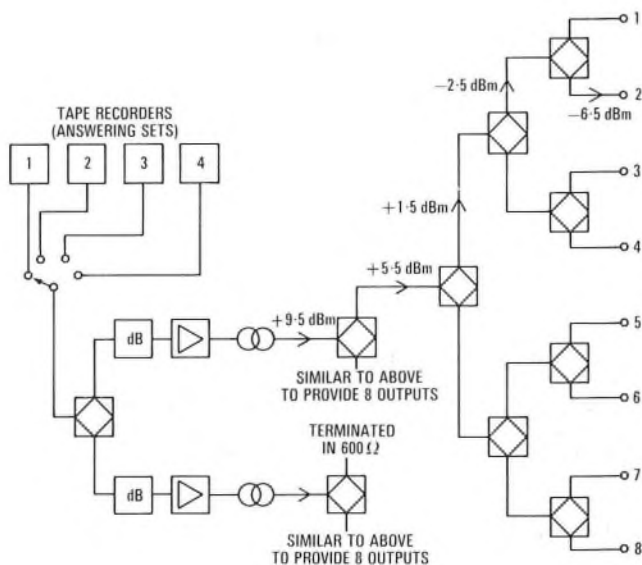

Block diagram of the announcement network

how the network was established and the signal levels sent to line.

Twenty outputs were connected to a spare group of 11-and-over PBX final selectors. Overflow meters were connected, and a hastily-contrived use-meter circuit associated with each output. The equipment was tested and handed over to the Traffic Division to organize the staffing arrangements. A private circuit to the studio from the Score Control Centre on the golf course was installed, to be staffed by golf enthusiasts from the Traffic Division, and telephonists rehearsed recording techniques. A tape length of 85 s was decided on for the opening day of the event.

The service was publicized in various ways: by local newspaper advertisements, hand-outs to national newspapers and commercial radio stations, and letters and placards to Scottish golf clubs.

It soon became evident, on the first day of the championship, that the service was under-provided, with nearly 6000 successful calls and 5000 overflows recorded. Steps were taken to increase the outputs to a total of 40. Two spare groups of 2-10 PBX final selectors were taken into use, and the additional numbers on which the service was then available were given publicity. Only 4 spare outputs of the signal-distribution network were readily available. These were connected to the first 2 choices of each of the 2-10 PBX final selectors. The remaining 16 outlets were served by multiple teeing to 16 of the original outputs. This had the effect of coupling 2 callers together, but degradation of the signal was not excessive. Also, the tape length was reduced to 45 s.

More than 26 000 calls were successfully handled by the service, with an indeterminate proportion of these being incoming STD calls. The exercise was, therefore, felt to have been well worth while.

E. RUSE

EXTERNAL TELECOMMUNICATIONS

Niton Coast-Radio Station

September 22 1975 saw the formal opening of the new Niton coast-radio station on the Isle of Wight by His Excellency Admiral of the Fleet the Earl Mountbatten of Burma, K.G., O.M., Governor and Lord Lieutenant of the Isle of Wight, himself a qualified expert in radio communication. The opening ceremony was relayed to shipping by Niton's transmitters, and Earl Mountbatten spoke with the liner *Queen Elizabeth II (QE2)*, the warship *Kent* and the Yarmouth lifeboat, each of which paid tribute to the coast-radio service.

Niton radio station provides the following communication facilities for Channel shipping: Morse telegraphy, or wireless telegraphy (WT), in the frequency band 405-535 kHz over a range of 800 km; radio telephony (RT) in the marine-frequency band 1.605-3.800 MHz over a range of 400 km; and RT in the very-high-frequency (VHF) band 156-174 MHz over a range of about 80 km. In common with the other UK coast stations, Niton maintains a continuous WT and RT distress watch, and is equipped to alert ships fitted with selective-calling facilities using the sequential single-frequency-code system. Niton is also a link in the 100 baud data system used to enable the publication of a special edition of the *Daily Telegraph* on board the liner *QE2* at sea.

One of 11 short-range stations providing communications to shipping in our coastal waters, Niton radio station has been in existence since the early years of this century. At that time, wireless communication between ships and the UK was in the hands of Lloyds and the Marconi International Marine Communication Company. Following the formation, in 1908, of the Post Office Wireless Telegraph Section, the coast stations passed into British Post Office (BPO) ownership in 1909. They are now under the control of the Maritime Radio Services Division of the External Telecommunications Executive (ETE).

Niton radio station was formerly situated at Niton Undercliffe, east of St. Catherine's Point. The station grew to provide marine-frequency WT and marine-frequency and VHF RT services and, for many years, offered single-sideband facilities for those ships equipped to take advantage of that type of emission. The marine-frequency transmitting aerials



Earl Mountbatten talks with a radio officer in the new Niton radio station, watched by Capt. C. B. H. Wake-Walker, Head of Maritime Radio Services Division (right) and Mr. S. R. Abram, Officer-in-Charge, Niton radio station (left)

(Photograph by courtesy of Joy Warren, Bembridge, Isle of Wight)

were located on the station site, while the receiving aerials were about 800 m away at a site known as Rill Farm. In 1961, a landslip occurred below the station, and a geological survey revealed the prospect of further ground instability under exceptionally wet weather conditions. Room for further development within the station building was becoming inadequate, and the decision was eventually taken to abandon the site in favour of a more stable location.

In seeking an alternative location, the opportunity was taken to plan for accommodation of the transmitting complex on a separate unattended site, to be remotely controlled from a staffed receiving station some distance away. This would afford relief from the problems attending the operation of receivers and the associated audio-frequency equipment within the ambient high-level radio-frequency fields of co-sited transmitters and aerial systems. At St. Lawrence, about 3 km east of the old station, there was a disused Ministry of Defence site having buildings admirably suited to adaptation to BPO requirements. The site was acquired and the premises converted to accommodate staff and equipment. New receiving aerials were built on the site. The new operating room is provided with 4 consoles: 3 of these are equipped for the simultaneous handling of marine-frequency and VHF RT traffic, while the fourth deals with WT traffic and maintains a continuous watch on the WT distress frequency of 500 kHz and the RT distress frequencies of 2.182 MHz and 156.8 MHz. Ship-shore RT calls are linked to the UK telephone network and, to improve transmission standards, Niton radio station has been provided with 4-wire circuits to Ryde. Facilities are also provided for direct international dialling. A crossbar switch is used to connect the land lines to the radio systems, and stand-by power facilities are provided.

A remote transmitting station has been built on the old Rill Farm receiving-aerial site, which has been extended to accommodate a new transmitting aerial system comprising 3 broadband aerials, a mast radiator and a WT aerial. The building houses 2 WT transmitters, each of 2 kW peak envelope power (PEP), 7 single-frequency RT transmitters of 1 kW PEP, and a multi-frequency reserve RT transmitter of

1 kW PEP. The single-frequency transmitters are coupled in groups by 3 combining equipments, each of which feeds a broadband aerial covering the range 1.6–3.8 MHz. The multi-frequency reserve transmitter feeds the mast radiator via a remote multi-frequency matching unit. A control console enables local command of the transmitters. Remote control is achieved via a multiple-pair tie-cable back to the receiving station. A crossbar switch provides the operators with instant push-button control of any RT transmitter from any RT console, accompanied by revertive signalling facilities and various safeguards. Control of the WT transmitters is achieved directly from the WT console and, also, from an adjacent RT console having a reserve WT capability. A stand-by power plant is installed, with remote control and alarm systems connected to the staffed station.

The VHF RT transmitters and receivers remain at their previous site at St. Boniface Down, under remote control

from the St. Lawrence site.

The new Niton radio station was planned by the Maritime Radio Services Division in conjunction with the ETE's Radio Engineering Services Division, who undertook the design, construction and installation of all the local and remote control equipment, 4-wire-terminal and miscellaneous equipment, transmitter-combining and aerial-matching units and aerial systems, together with the installation of all the transmitters. All power and alarm installations were undertaken by the Power Group of the ETE's Project Design and Implementation Division. Maintenance of the station remains the responsibility of the appropriate field units within the ETE.

With a very minor interruption to services, the new Niton radio station became operational on 13 March 1975.

S. J. CLARK

Associate Section Notes

Bedford Centre

The programme of the Bedford Centre for 1974–75 came to an end in July. The session commenced in November 1974 when Brian Pearce, Eastern Telecommunications Region Headquarters, presented a paper on *International Subscriber Dialling* which proved to be most informative.

In January, a party of 10 members visited the BBC studios in Wood Lane, London. Despite the strict security precautions in force at the time, the party enjoyed a very interesting visit. There have been many requests to repeat this outing.

Submarine Cables was the subject of a talk given in March by Dr. P. R. Bray, former principal of the British Post Office (BPO) Technical Training College, Stone. What started as an evening lecture turned into a most enjoyable social gathering, with the Centre buying a round of drinks.

The long-awaited Prestige Lecture was held at the County Hotel, Bedford, during April. An audience of 250 gathered to hear Professor J. H. H. Merriman, Post Office Board Member for Technology and Senior Director (Development), present extracts from his Presidential address to the Institution of Electrical Engineers. This was the outstanding event of the year for the 4 centres in Bedford Telephone Area which worked together to promote this lecture—one that will be long remembered.

To complete the year's programme, 24 members visited the BPO's Central Marine Depot at Southampton, where they toured both the depot and a cable ship.

D. B. B. WHITMORE

Dundee Centre

Our 1975–76 session got under way on 20 September with the long-awaited visit to CS *Monarch* at Robb Caledon's shipyard, Dundee. After much thought and searching for new ideas, the following visits were arranged for the latter part of 1975.

29 October: Visit to Comrie Colliery, Saline, Fife.

19 November: Visit to Dundee University's meteorological-satellite ground-station.

The programme for the rest of the session is as follows. A day visit has yet to be arranged.

22 January: *Computerized PABXs* by A. M. Scott, IBM (UK) Ltd.

12 February: *Pulse-Code Modulation—Basic Principles* by W. More.

20 April: Annual general meeting.

Currently, there are 219 members taking the *POEEJ* in Dundee Telephone Area. If you are one of them and read this, why not attend at least one meeting this session?

R. T. LUMSDEN

Edinburgh Centre

Our 1975–76 session opened on 20 September 1975, when 7 members visited the new British Post Office (BPO) cable ship at Robb Caledon's shipyard in Dundee. The visit was part of an open day for BPO personnel and, by means of an arrowed one-way system, we were able to view all parts of the ship. The visit was a most enlightening one and, by answering each other's questions, we found it occasionally very entertaining.

On 22 September, 14 members visited the Southern Scotland Electricity Board's grid-control centre at Kirkintilloch. We were shown the main control room, where graphs of electricity consumption are recorded to allow the controlling officers to determine just how much electricity should be generated. We were surprised to hear that surplus generated electricity can be sold to other electricity boards. Some of the equipment used was similar to our own BPO equipment. This visit was extremely well received, and questions were asked throughout. It was felt that, because of the level of interest shown by the members, the visit could have lasted longer than the 2 h allocated.

J. L. M. ALEXANDER

Glasgow Centre

The 1974–75 session began in October 1974 with a lecture by Mr. D. Soutar, Deputy General Manager, Glasgow Telephone Area, entitled *Manpower—The Asset*. In November, Mr. R. S. McDougal, Executive Engineer, Glasgow Telephone Area, gave a talk entitled *The Effects on Maintenance of the Latest Maintenance Aids*. December saw our first visit, and this was to the Standard Telephones and Cables Ltd. factory at East Kilbride. This was followed, in January 1975, by another visit, this time to the planetarium of the Glasgow College of Nautical Studies. In February, Mr. W. Skinner, of Insurance Services (Glasgow) Ltd., spoke on general insurance.

Our last meeting of the session, in March, was a talk entitled *Video Cassette Recording and High-Fidelity Equipment*, given by Mr. J. Wilson of Philips Electrical Ltd. A visit that had been arranged to the Glasgow Telephone Area (North) tunnel for April had to be postponed, as conditions in the tunnel were not suitable for visiting parties.

Some of the events arranged so far for the 1975-76 session are as follows.

- The Experimental Packet-Switched Service* by D. E. Hadley.
- The Work of Erskine Hospital* by the hospital's commandant.
- Visit to William Teacher and Sons' bottling plant.
- Visit to the Glasgow Corporation Cleansing Department's incinerator at Dawesholm.
- Visit to Glasgow Airport's air-traffic-control centre.
- Visit to the Glasgow Telephone Area (North) tunnel.
- Organizations* by J. E. Dadswell.

R. I. TOMLINSON

Leicester Centre

The Leicester Centre was recently resurrected at a rather poorly-attended annual general meeting. The officers and committee elected were as follows.

- Chairman*: J. A. Chamberlain, EM 3.3.
- Vice-Chairman*: J. H. Clarke, EM 2.6.
- Treasurer*: E. E. Periam, EM 2.6.
- Secretary*: S. K. Wittering, EM 2.5.
- Committee*: R. A. Bettles, EM 2.5; M. Colyer, EI 7.5; A. J. Davies, EM 2.5; and P. J. Timms, EI 7.5.

A programme of events is being planned at the time of writing.

S. K. WITTERING

Norwich Centre

The 1975-76 session opened on 16 September with a visit to IBM's computerized PABX installed at Blandy Payne Ltd., the international insurance brokers.

The remainder of the programme for 1975 featured talks on gliding, and sailing and navigation, and a selection of films from the British Insulated Calender Cables Ltd. library.

On 21 January 1976, we have a lecture on scene-of-the-crime investigations. The annual general meeting will be held on 17 February and, on 17 March, Mr. R. Bower will give a talk entitled *The Development of the Pipe Organ*. We also plan to visit a coal mine and the atomic energy research establishment at Harwell.

D. PAYNE

The Associate Section National Committee Report

J. P. McDonald, Ballymena Centre

It is with deep regret that I have to announce the sudden death of "Seamus" McDonald on 29 September 1975, aged 29 years. He leaves a young wife. Seamus was, until this year, Assistant Secretary of the National Committee, and had been a member since its inception. He relinquished the post to devote more of his time to the organization of centres into a collective voice for Northern Ireland. He was a very well-liked and respected member of the Committee, both at business and socially, and his loss will be felt by all who knew him. The National Committee was represented at the funeral by the Chairman, John Hannah.

National Technical Quiz Competition

At the National Committee meeting at Stone on 4 October 1975, the draw for this year's quiz was made, and is shown in the table.

The final will be held at the Institution of Electrical Engineers, Savoy Place, London WC2, on Friday 26 March 1976.

Associate Section Ties and Lapel Badges

The Associate Section has its own design of tie and lapel badge. The tie is dark green with red and silver stripes, and costs £1.00. The lapel badge is 16 mm in diameter and has an enamelled design on a silver background; it costs 25p. Supplies are available from the secretary of the National Committee (telephone 01-462 1843).

National News

Owing to the extended negotiations regarding the restyling of *National News*, we have been unable to produce further issues this year. Members will be brought up to date with the latest news by the issue of news-sheets until these negotiations are completed. The editor, Colin Newton, requires items for

Preliminary Round	Quarter-Final
Wales and The Marches versus South Eastern Region	Wales and The Marches or South Eastern Region versus South Western Region
London Region versus North East Region	London Region or North East Region versus Eastern Region
—	Midland Region versus Northern Ireland
—	Scotland versus North West Region

inclusion; if you have anything for publication, please contact him (telephone 094 34 2361).

National Quiz Electronic Timer-and-Scoreboard Competition

The response to the timer-and-scoreboard competition has been very encouraging; 9 centres have submitted entries. It is expected that the final judging, early this year, will be a very lively affair. Most centres are well advanced with their design and production work for this project, and the winning entry will eventually be used in national quiz competitions. A prize of £25 will be awarded for the winning entry.

C. WEBB
Secretary

Institution of Post Office Electrical Engineers

Officers and Members of Council, 1975-76

The constitution of the Council of the Institution of Post Office Electrical Engineers for the year 1975-76 is as follows.

Chairman: Mr. J. F. P. Thomas, Director of Network Planning.

Vice-Chairmen: Mr. D. Wray, Deputy Director, External Telecommunications Executive (ETE), and Mr. T. Pilling, Deputy Director, Postal Mechanization and Buildings Department, Postal Headquarters.

Honorary Treasurer: Mr. R. T. Mayne, Head of ET7, ETE.

Secretary: Mr. A. B. Wherry, Controller of Trunk Planning, London Telecommunications Region.

Members: Messrs. T. Austin, A. J. Barker, D. A. Barry,

F. Bateson, F. L. Brooks-Johnson, J. Farrand, E. W. Fudge, D. V. Gasson, M. G. Grace, R. Hall, K. B. Hinchliffe, A. Ness, K. J. B. Potter, C. W. Read, D. W. Sharman, G. Warner and B. A. B. Wood.

South Eastern Centre Programme, 1976

21 January: *External Contracts—Can We Reduce the Costs?* by D. Shore.

18 February: *Traffic Dimensioning of Telephone Systems* by D. L. Dransfield and C. R. Warren.

24 March: *New Cable-Repair Ships* by D. N. Dick.

5 May: *Second-Generation Letter-Mail Coding and Sorting Equipment* by E. G. Hills.

Local-Centre Secretaries

The following is a list of local-centre secretaries, to whom inquiries about the Institution may be addressed. It would be particularly useful if members would notify any change in their own address to the appropriate secretary.

<i>Centre</i>	<i>Local Secretary</i>	<i>Address</i>
Birmingham	Mr. D. F. Ashmore	General Manager's Office, ED3/7, 84 Newhall Street, Birmingham B3 1EA.
Eastern (Bletchley)	Mr. R. A. Hughes	General Manager's Office, 16 Paradise Street, Oxford OX1 1BA.
Eastern (Colchester)	Mr. B. J. Miller	Eastern Telecommunications Region, Planning Division, St. Peter's House, St. Peter's Street, Colchester CO1 1ET.
East Midland	Mr. D. W. Sharman	General Manager's Office, Room 1301, 200 Charles Street, Leicester LE1 1BB.
London	Mr. J. M. Avis	NP 7.1.3, Room 311, Lutyens House, Finsbury Circus, London EC2M 7LY.
North Eastern	Mr. D. Spencer	North East Telecommunications Region, Service Division, Darley House, 79 St. Paul's Street, Leeds LS1 4LW.
Northern	Mr. L. G. Farmer	General Manager's Office, Newcastle Telephone Area, Hadrian Telecommunications Centre, Melbourne Street, Newcastle-upon-Tyne NE1 2JQ.
Northern Ireland	Mr. F. G. Cole	General Manager's Office, Churchill House, Victoria Square, Belfast BT1 4BA.
North Western (Manchester and Liverpool)	Mr. W. Edwards	North West Telecommunications Board, Planning Division, Bridgewater House, 60 Whitworth Street, Manchester M60 1DP.
North Western (Preston)	Mr. J. W. Allison	Post Office Telephones, Clifton Road Depot, Marton, Blackpool FX4 4QD.
Scotland East	Mr. W. L. Smith	Scottish Telecommunications Board, Planning Division, Canning House, 19 Canning Street, Edinburgh EH3 8TH.
Scotland West	Mr. D. M. Dickson	Telephone House, Pitt Street, Glasgow G2 7AH.
South Eastern	Mr. J. M. Smith	South Eastern Telecommunications Region, Planning Division, Grenville House, 52 Churchill Square, Brighton BN1 2ER.
South Western	Mr. R. G. Willis	South Western Telecommunications Region, Planning Division, Mercury House, Bond Street, Bristol BS1 3TD.
Stone/Stoke	Mr. G. G. Owen	TP 7.2.3D, Post Office Technical Training College, Stone ST15 0NQ.
Wales and the Marches	Mr. R. E. Jones	Wales and the Marches Telecommunications Board, Planning and Works Division, 25 Pendwyallt Road, Coryton, Cardiff CF4 7YR.

A. B. WHERRY
Secretary

IPOEE Central Library

Members are reminded that prize-winning essays, Associate Section prize-winning papers and various unpublished papers are held in the Library for loan, and that a list will be sent on request. Field Medal award-winning papers are also held for loan, and are listed in the Library Catalogue.

Printed Papers of the Institution are available on loan, or can be purchased from the Library. A list of papers will be sent on request.

The following books have been added to the IPOEE Library since the publication of the 1974 Library Catalogue. Any member who does not have a copy of the catalogue can obtain one from the Librarian, IPOEE, 2-12 Gresham Street, London EC2V 7AG. Library requisition forms are also available from the Librarian, from honorary local secretaries, and from Associate Section local-centre secretaries and representatives.

- 5181 *Radio and Television Servicing, 1967-68 Models.*
- 5182 *Radio and Television Servicing, 1968-69 Models.*
- 5183 *Radio and Television Servicing, 1969-70 Models.*
- 5184 *Radio and Television Servicing, 1970-71 Models.*
- 5185 *Radio and Television Servicing, 1971-72 Models.*
- 5186 *Radio and Television Servicing, 1972-73 Models.*

5187 *Linear Micro-electronic Systems.* A. G. Martin and F. W. Stephenson. (1973).

Presents the undergraduate student of electrical and electronic engineering with detailed instruction in the analysis of linear active systems.

5188 *An Introduction to the Analysis and Processing of Signals.* P. A. Lynn. (1973).

Presents, in a concise and readable form, the basic concepts of signal theory as applied to both continuous and discrete (digital) signals.

5189 *Business Planning and Forecasting.* D. Cooper-Jones. (1974).

Covers the whole spectrum of business planning, and is intended for all levels of management in industry and Government organizations.

5190 *Logical Design of Switching Circuits.* D. Lewin. (1974).

Describes those methods of designing logic circuits that have emerged as useful techniques from the vast amount of published work on switching theory. An engineering approach, rather than the more usual mathematical treatment, has been chosen.

E. DOHERTY
Librarian

POEEJ: Subscription Order Form

Those wishing to subscribe to *The Post Office Electrical Engineers' Journal* can do so by completing the relevant section of the order form below. British Post Office (BPO) staff should complete the right-hand section and send it to their local POEEJ agent or, in cases of doubt, to the address shown; non-BPO staff should complete the left-hand section.

Yearly Subscription Order (Non-BPO Staff)

To: *The Post Office Electrical Engineers' Journal* (Sales),
2-12 Gresham Street,
London EC2V 7AG.

Please supply 4 quarterly issues of *The Post Office Electrical Engineers' Journal*. I enclose a cheque/postal order for the sum of £2.40 (Canada and the USA: \$6.00) to cover the yearly subscription.

Name

Address

Please state with which issue you wish your subscription to commence (April, July, October or January).....

Cheques and postal orders, payable to "*The POEE Journal*", should be crossed "& Co.", and enclosed with the order. Cash should not be sent through the post.

The POEE Journal is a non-profit-making publication, established for nearly 70 years. A regular subscription will help you to keep up to date with the frequent changes in plant and techniques used in communication engineering.

A Supplement is issued with each *Journal*, containing model answers to examinations of the City and Guilds of London Institute Telecommunication Technicians' Course.

Reviews of a wide range of new books on telecommunications and related subjects are published.

Note: A photocopy of this form is acceptable.

Subscription Order (BPO Staff)

To: The Local Agent (POEEJ), or
The Post Office Electrical Engineers' Journal (Sales),
2-12 Gresham Street, London EC2V 7AG.

Please arrange for me to receive *The Post Office Electrical Engineers' Journal*. I have completed the form below authorizing deductions from pay to cover the special annual subscription of £1.08.

Date Signature

Name and
initials (in
block capitals) Rank

Official address

The Post Office Electrical Engineers' Journal: Authority for Deduction from Pay

I,
(name in full, surname first in block capitals), authorize the deduction from my salary or wages, until further notice, of the sum of 9p per month/2p per week for payment to the Managing Editor, *The Post Office Electrical Engineers' Journal*, on my behalf.

Date Signature

Official address

Rank Pay No.

Area/Dept.

Notes and Comments

Correspondence

Rediffusion International Limited,
Carlton House,
Lower Regent Street,
London.

Dear Sir,

I refer to the letter from Dr. A. P. Bolle published in the July 1975 issue of the *Journal*, in which he explains the decision of the Netherlands Postal and Telecommunications Service to adopt an entirely separate network for cable television services, with outward transmission of only a limited number of channels, and having a trunk-and-branch distribution formation. He explains that an alternative type of network, enabling a subscriber to obtain his personal-request programme on the screen in his home, would be unduly expensive.

I believe that this conclusion is open to question. It happens that studies have been carried out in Holland by a firm that is anxious to secure the permission of the Dutch Government to install a star-type wideband network with individual connexions from each subscriber's home to central exchanges. This firm, with which my company is associated, has shown that the cost of such a network, with an initial capacity of 12 channels in an area with an average density of 4000 homes/km², would be broadly comparable with that of the conventional communal-aerial type of network preferred by the Netherlands service, with the difference that, in areas with very high densities (up to 8000 homes/km²), the cost of the conventional branched system drops by about 25%. This is because less equipment is necessary per home, while the equipment required in the hub network stays the same. However, it is very widely agreed that the hub formation will be adopted for broadband networks at some time in the future because of its greater flexibility in providing additional programmes and other services, and this justifies a longer amortization period. The annual costs per subscriber will thus be the same as, or lower than, for conventional branched systems.

About 12 alternative programmes could be made available at the head-end of the cable system from broadcasting stations in Holland and neighbouring countries, and the multi-lingual population would be able to appreciate them. It seems probable, therefore, that such a star network would be commercially viable on the basis of distributing these programmes alone, and additional services could be offered in response to demand against special payment on a pay-television basis, facilities for which are very easily provided on a star network in comparison with the scrambling and other complications necessary on tree-structured networks. Subscribers would then be in a position to dial an additional choice of programmes on a similar basis to the very successful dial-up information services operated by the British Post Office. The Dial-a-Disc service, for example, in spite of the poor quality of sound reproduction available over the ordinary telephone, attracted no less than 71-million calls last year. Admittedly, the exchanges and the primary network serving them would need to be expanded before many subscribers could be offered their individual choice of programme at the time they wanted it, and such a service would no doubt be rather expensive in its early days. It should, however, represent a very attractive alternative to the individual ownership of video-tape or disc machines, the initial cost of which is, at the present time, around £450 retail. Also, the operating costs for a library service to provide programmes for such machines would be high because of the large number of video-tape or disc copies that would be required of the more popular programmes, and the ever-increasing cost of the postal service.

A comparison of the total annual costs of a dial-access cable-television network with the alternative of the individually-owned video-tape or disc machines (with a postal library service) is obviously not an easy one to make, and must be dependent on a good many assumptions. Our own studies, however, indicate that the break-even point occurs at around 10%, so that when more than that percentage of

homes require the service, the overall economics favour the dial-access cable system. However, if the basic costs of the dial-access system can be supported by the offer of a wide choice of programmes from broadcasting stations, as there is good reason to believe they can be in Holland, then the case for a dial-access system seems quite overwhelming.

Yours faithfully,
R. P. Gabriel,
Chairman.

Network Planning Department,
Telecommunications Headquarters.

Dear Sir,

In his letter to you in the July 1975 issue of the *Journal*, Mr. H. G. Gange refers to recent articles dealing with long-term forecasting in telecommunications. As one of the people concerned with the long-term study of the UK trunk network, perhaps I may be permitted to comment on that particular study.

Mr. Gange refers to 2 factors affecting long-term forecasts: the rate of economic growth and the pattern of sociological change. There are, of course, many other factors and, if one is attempting to produce a highly-refined forecast, all such factors must be taken into account. The trouble is, however, that many of these contributory factors are highly volatile and their changes with time, especially in the longer term, are virtually unpredictable. In any case, their influence on future levels of telecommunications services can be judged only by reference to history and by guesses (however scientifically arrived at) about the future. The forecaster is rarely certain that he has taken all factors into account, that he has interpreted the statistics available to him correctly and, more particularly, that no unforeseen factors will emerge. The production of highly-refined forecasts, therefore, requires study in great depth, and it is often questionable whether such effort is worthwhile for the particular study in mind.

The object of the UK trunk-network study was primarily to ascertain what technology would best meet the demands for telecommunications services in the longer term, say up to the end of the century, and what the network and other consequences would be. This question introduced 2 quite important factors. Firstly, there was a need to consider what new services are likely to be provided (for example, video telephones) and, secondly, there was the need to consider what effect the new technology itself could have on demand. We have already seen the considerable impetus given to trunk calls by the introduction of STD in the 1960s, and there was an earlier impetus when demand working was introduced in the 1930s. What impetus could we expect from a new technology that offered perhaps a notable improvement in quality of service and the potential for a reduction, in real terms, in tariffs?

Obviously, for any network study, a reliable forecast is highly desirable, but for the study under discussion, there were many imponderables quite apart from those of predicting future changes in the rate of economic growth etc. In the circumstances, the time and effort available had to be balanced against the marginal increase, if any, in the accuracy of the study's conclusions resulting from greater sophistication in forecasting. In the event, a very high degree of sophistication was not considered appropriate, it being much more important to recognize the inevitable limitations of forecasting and to test the sensitivity of the conclusions to realistic variations about "best-possible" forecasts.

It may interest your readers to note that the estimates of effective trunk calls, prepared in 1967, exceeded the achievement for 1973-74 by about 2%. This does not, of course, guarantee the remainder of the forecast until the end of the century.

Yours sincerely,
J. R. McCubbin

Publication of Correspondence

The Board of Editors would like to publish correspondence on engineering, technical or other aspects of articles published in the *Journal*, or on related topics.

Letters of sufficient interest will be published under "Notes and Comments". Correspondents should note that, as it is necessary to send copy to the printer well before publication date, it will be possible to consider letters for publication in the April issue only if they are received before 14 February 1976.

Letters intended for publication should be sent to the Managing Editor, *The POEE Journal*, NP 9.3.4, Room S 08, River Plate House, Finsbury Circus, London EC2M 7LY.

Regional Notes and Short Articles

The Board of Editors would like to encourage contributions suitable for publication under "Regional Notes", and short articles dealing with current topics related to engineering, or of general interest to engineers in the British Post Office (BPO).

The "Regional Notes" section is intended for engineers in Telecommunications and Postal Regions and Telephone Areas briefly to report items of technical or management content, and to describe the solutions adopted to solve specific problems that may be of interest to other Regions, Areas and departments. Also, items of general interest to engineers in the BPO are welcomed.

Authors should obtain approval for publication of their contributions at General Manager or Regional Controller level.

As a guide, there are about 750 words to a page, allowing for diagrams; Regional Notes are generally up to about 500 words in length. Articles and Regional Notes should preferably be illustrated, where possible, by photographs or sketches. Contributions should be sent to the Managing Editor, *The POEE Journal*, NP 9.3.4, Room S 08, River Plate House, Finsbury Circus, London EC2M 7LY.

Guidance for Authors

Some guiding notes are available to authors to help them prepare manuscripts of *Journal* articles in a way that will assist in securing uniformity of presentation, simplify the work of the *Journal's* printer and illustrators, and help ensure that authors' wishes are easily interpreted. Any author preparing an article for the *Journal*, who is not already in possession of the notes, is asked to write to the Managing Editor to obtain a copy.

It is emphasized that all contributions to the *Journal*, including those for Regional Notes and Associate Section Notes, must be typed, with double spacing between lines, on one side only of each sheet of paper. Articles, and contributions for Regional Notes, must be approved for publication at General Manager/Head of Division (Regional Controller) level.

Each circuit diagram or sketch should be drawn on a separate sheet of paper; neat sketches are all that are required. Photographs should be clear and sharply focused. Prints should preferably be glossy and should be unmounted, any notes or captions being written on a separate sheet of paper. Good colour prints can be accepted for black-and-white reproduction. Negatives are not required.

Special Issues and Back Numbers

Copies of the April 1974 issue covering sector switching centres, and the October 1973 special issue on the 60 MHz transmission system, are still available.

Back numbers can be purchased, price 60p each (including postage and packaging), for all issues from July 1970 to date, with the exceptions of April, July and October 1971.

A few copies of the October 1966 issue are also still available. This issue contains articles dealing with telephone-circuit characteristics in relation to data transmission, the Lincompex system for protecting high-frequency radio-telephone circuits, the trunking and facilities of the 5005 crossbar system, 12 MHz submerged repeaters, and the sheath-jointing of plastic-sheathed cables.

Orders, by post only, should be addressed to *The Post Office Electrical Engineers' Journal* (Sales), 2-12 Gresham Street, London EC2V 7AG. Cheques and postal orders, payable to "The POEE Journal", should be crossed "& Co.", and enclosed with the order. Cash should not be sent through the post.

Model Answer Books

Students of the City and Guilds of London Institute Telecommunication Technicians' Course are reminded that books of model answers are available in certain subjects. Details of the books available are given at the end of the Supplement. Copies of the syllabi and question papers are not sold by *The Post Office Electrical Engineers' Journal*, but can be purchased from the Department of Technology, City and Guilds of London Institute, 76 Portland Place, London W1N 4AA.

Post Office Press Notice

Electrically-Powered Vehicles on Field Trial

New electrically-powered vans are soon to be introduced by the British Post Office (BPO) on a trial basis.

The vans, developed in Birmingham by Lucas Industries, will be used both by postal and telecommunications staff. The postal vehicles will first be tried out in London for about 6 months, and then in different parts of the country. The telecommunications vans will be operating in the Stevenage area.

The purpose of the 3-year trial, with 10 electric vehicles, is to determine their performance in everyday conditions. So far, the vans have been driven only in test situations by Lucas development engineers. The BPO wants to find out how their performance efficiency and running and maintenance costs compare with those of conventional vehicles, and to obtain the reaction of BPO drivers.

The new vans are far removed from the "milk-float" image of electric vehicles. They have a 0-48 km/h (0-30 miles/h) acceleration-time of about 10 s, and top speeds in excess of 80 km/h (50 miles/h).

The vehicles being used for the BPO trial are standard 1 t Bedford vans, with the engine replaced by traction motors, sophisticated control gear and light-weight lead-acid batteries. The vans have no gearbox or clutch. Two push-buttons on the fascia panel control forward or reverse movement. All the driver has to do is turn the ignition key, press the appropriate button, and depress the accelerator. The van then moves off.

The BPO, as operator of one of the biggest road-transport fleets in the country, has an obvious interest in the development of new vehicles that might improve the efficiency and general operating aspects of its fleet.

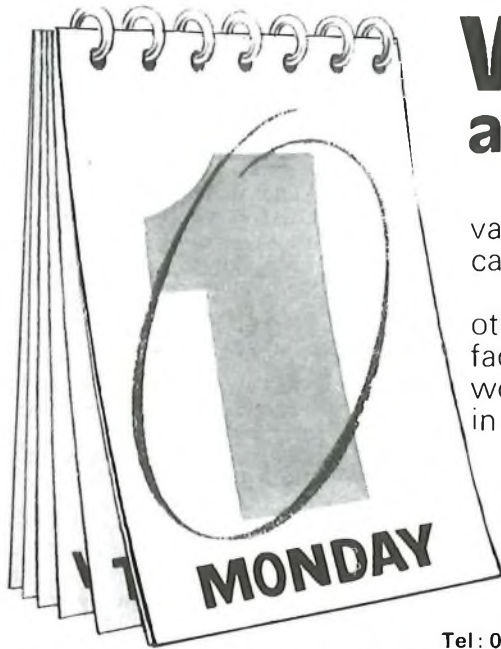

Working Day any day

From Monday through to Friday, you'll find TCL's vast plant producing more and more telecommunications cable to meet the world's increasing demands.

Typical is the laying-up machine. This and other modern plant are constantly at work in our Dagenham factory, speeding out much of the cable that goes to work for The Post Office, British Rail and similar authorities in countries throughout the world.

But, TCL service stretches beyond the manufacture. You'll also find our Technical Advisory Staff ready to help at the Planning Stage – ready to supply a working brief any day of the week you want it.

Telephone Cables Limited, Dagenham, England.
Tel: 01-592 6611. Cables: Drycore, Dagenham. Telex: 896216



The Data Printer

that's more than a data printer

How the ENM 4850 meets the data logging requirements of a number of different users.

Fire Alarm Systems

4850 is used for multipoint monitoring of processes or establishments to provide continuous visual and electrical confirmation of a safe condition. In an alarm condition, the electrical readout can trigger an audible or visual warning and the printout records the fault and location in red. On alarm clearance, a similar printout is provided in black.



Police and Security Alarm Systems

Sensor conditions at up to 16 locations can be printed simultaneously by a single printer. An observer can view a whole bank of printers and thus monitor continuously many different alarm locations. As with Fire Alarm Systems, an audible or visual alarm can automatically be triggered, together with the 2 colour printout.



Effluent Control in sewage treatment plants or industrial effluent outlets:

With the optional time and date unit fitted, a 4850 can give a printed record of effluent output relating it to time and date for the periodic metering, which in many cases is now a legal requirement.



Monitoring at Remote Stations

In many installations, the cost prohibits regular visits to remote locations such as flow monitoring points for oil and gas pipelines or automatic weather and telecommunications stations. The installation cost of a 4850 with its programmed printout in this application is soon justified, particularly in locations where only a 24Vd.c. supply is available.

Video Editing

Video editing requires accurate synchronization of sound to vision from a host of different inputs. The 4850 is extensively used to monitor these inputs, typically frame numbers, tape input references etc., to provide a complete record of the make-up of the finished tape.



Self-Service Petrol Stations

With the increasing popularity of self-service petrol filling stations, 4850's can be used to provide a record of fuel dispensed by grade, pump number, time and date and most important - cash value. A printed record prevents arguments after the pump readings have

been reset to zero, and provides an automatic check on fuel stocks and cash intake.

Ships' Automatic Logs

Used in Ships' Automatic Logs, 4850's record bridge to engine room instructions and responses, logging them in chronological order with a time and date reference.



Telecommunications

With its 16 digit capacity, the dialled number from a telephone system for calls to anywhere in the world can be monitored, checked and recorded by a system incorporating a 4850. The Post Office currently use hundreds in various systems in their exchanges.

Bingo Control

Printers are used to monitor and record the time of each game played, showing the number of players participating. The 4850 with its date and time mechanism provides an automatic security control on the cash system.

The flexible Data Printer

The design of the ENM 4850 offers great flexibility. Standard modules are assembled in the form required to give you precisely the facilities you need - printing, counting and controlling. And, what is more, you can buy the printer complete or you can buy the head alone, the case and head, or whatever combination of parts you require for building into your own equipment.



The ENM 4850 can cost more than a standard drum printer, but it offers so much more. If you want a Printer that does exactly the job you need at a very sensible cost, ask for further information now.

Some of the options offered with the ENM 4850

- Up to 16 digits, format to your requirements, with space, decimal points and colons as required
- Purple or purple/red printout as required
- Automatic zero reset of selected decades after each print action
- Alpha, numeric or special characters
- Serial, parallel, serial with parallel access, or parallel BCD inputs
- Data output by printed record, visual indication and electrical readout or whatever combination of these you need
- Counting and printing at fixed intervals
- Date and time assembly to record time at one minute intervals



ENGLISH NUMBERING MACHINES LIMITED
Queensway, Enfield, Middlesex EN3 4SB
Tel: 01-804 8121

A Trade Mark of English Numbering Machines Ltd.

The Post Office Electrical Engineers' Journal

Copyright

The entire contents of this *Journal* are covered by general copyright, and special permission is necessary for reprinting long extracts, but editors are welcome to use not more than one-third of any article, provided that credit is given at the beginning or end, thus: "From *The Post Office Electrical Engineers' Journal*."

The Board of Editors is not responsible for the statements made or the opinions expressed in any of the articles or correspondence in this *Journal*, unless such statement is made specifically by the Board.

Subscriptions and Back Numbers

The *Journal* is published quarterly in April, July, October and January, at 35p per copy, 60p per copy including postage and packaging (annual subscription: £2.40; Canada and the USA: \$6.00).

The price to British Post Office staff is 27p per copy.

Back numbers will be supplied if available, price 35p (60p including postage and packaging). At present, copies are available of all issues from July 1970 to date, with the exceptions of April, July and October 1971 which are now sold out. Copies of the October 1966 issue are also still available.

Orders, by post only, should be addressed to *The Post Office Electrical Engineers' Journal*, 2-12 Gresham Street, London EC2V 7AG.

Employees of the British Post Office can obtain the *Journal* through local agents.

Binding

Readers can have their copies bound at a cost of £3.00 including return postage by sending the complete set of parts, with a remittance, to Press Binders Ltd., 4 Iliffe Yard, London, SE17.

Remittances

Remittances for all items (except binding) should be made payable to "*The POEE Journal*" and should be crossed "& Co."

Advertisements

All correspondence relating to advertisement space reservations, copy, proofs etc., should be addressed to the Advertisement Manager, *The Post Office Electrical Engineers' Journal*, 2-12 Gresham Street, London EC2V 7AG.

Distribution and Sales

Correspondence relating to the distribution and sale of the *Journal* should be addressed to *The Post Office Electrical Engineers' Journal* (Sales), 2-12 Gresham Street, London EC2V 7AG.

Communications

With the exceptions indicated above, all communications should be addressed to the Managing Editor, *The Post Office Electrical Engineers' Journal*, NP 9.3.4, Room S 08, River Plate House, Finsbury Circus, London EC2M 7LY.

Model Answers Books

Books of model answers to certain of the City and Guilds of London Institute examinations in telecommunications are published by the Board of Editors. Details of the books available are given at the end of the Supplement to the *Journal*. Copies of the syllabi and question papers are not sold by *The Post Office Electrical Engineers' Journal*, but may be purchased from the Department of Technology, City and Guilds of London Institute, 76 Portland Place, London W1N 4AA.

MODEL ANSWER BOOKS

CITY AND GUILDS OF LONDON INSTITUTE EXAMINATIONS FOR THE TELECOMMUNICATION TECHNICIANS' COURSE

Six model answer books are available, each covering one of the following subjects:

TELECOMMUNICATION PRINCIPLES A LINE PLANT PRACTICE A ELEMENTARY TELECOMMUNICATION PRACTICE

Price 50p each (post paid)

RADIO AND LINE TRANSMISSION A TELEPHONY AND TELEGRAPHY A TELECOMMUNICATION PRINCIPLES B

New, completely rewritten editions: price 85p each (post paid)

Orders may be sent by post only, to
The Post Office Electrical Engineers' Journal,
2-12 Gresham Street, London EC2V 7AG

INDEX TO ADVERTISERS

English Numbering Machines Ltd.	7
GEC Telecommunications Ltd.	2, 3
Herman Smith Ltd.	10
ITT Creed Ltd.	1
Plessey Telecommunications Ltd.	9
Sperry Gyroscope Ltd.	5
Telephone Cables Ltd.	6
Telettra SpA, Milan	4

Plessey Pentex electronic telephone exchanges

Plessey Telecommunications has been developing and manufacturing exchange systems and subscriber equipment for nearly 70 years. The Company's policy of continual development has resulted in a new generation of exchanges – the PENTEX family – designed to meet the complete requirements of telephone administrations. PENTEX has been in production since 1966 and the performance, flexibility and reliability of this advanced system has been fully proved in service – in more than 500 installations, large and small, in many parts of the world.

**Whatever your future requirements,
Pentex meets them**

Although Pentex provides new services and facilities, together with the enhanced reliability and versatility provided by the latest solid-state control circuitry and reed-switching, it is also completely compatible with all types of existing electromechanical exchanges and, more importantly, with any foreseeable form of exchange development. Thus, Pentex is making an important contribution to the modernisation and the extension of national networks in many parts of the world.

The Pentex range provides efficient, cost-effective answers to almost any exchange requirement – from the smallest end exchange to main exchanges with 20,000 lines or more. The family also includes 2-wire and 4-wire tandem exchanges, containerised



exchanges designed for fast installation and fast extension when additional capacity is needed, and small exchanges from 50 to 500 lines. This versatility and flexibility is due, in large part, to modular design and common technology and construction practice. Pentex exchanges are available at short delivery – meeting specific traffic and facility requirements. Additional facilities can be quickly and economically installed at any time with little or no interruption to traffic.

Pentex exchanges are operating throughout the world with maintenance costs far lower than those of electro-mechanical systems and with a figure of reliability setting new standards for telephone administrations.

 **PLESSEY**

One of the world's great telephone enterprises

Plessey Telecommunications Limited, Edge Lane, Liverpool, England L7 9NW. Telephone: Liverpool 228 4830 Telex: 62267

Do you know what else Herman Smith can do?

"62" type equipment is the aspect of our output you probably already know about. It's worth remembering however, that we produce many other types of presswork and sheet metal assemblies which may be of use to you.

We are acutely aware of the needs of the electrical and electronics industries and our experience in these spheres is comprehensive.

We are prepared for any challenge, complex or simple, large or small. Try us.

We produce the range of "62" type equipment, including the racks themselves, shelf assemblies, card locks, card guides, slide brackets, dummy front plates, etc. We also undertake electrical and electronic assemblies.



Contact Peter Bowen
Herman Smith Limited Cinderbank Works Netherton Dudley
Worcestershire Telephone Dudley 52791

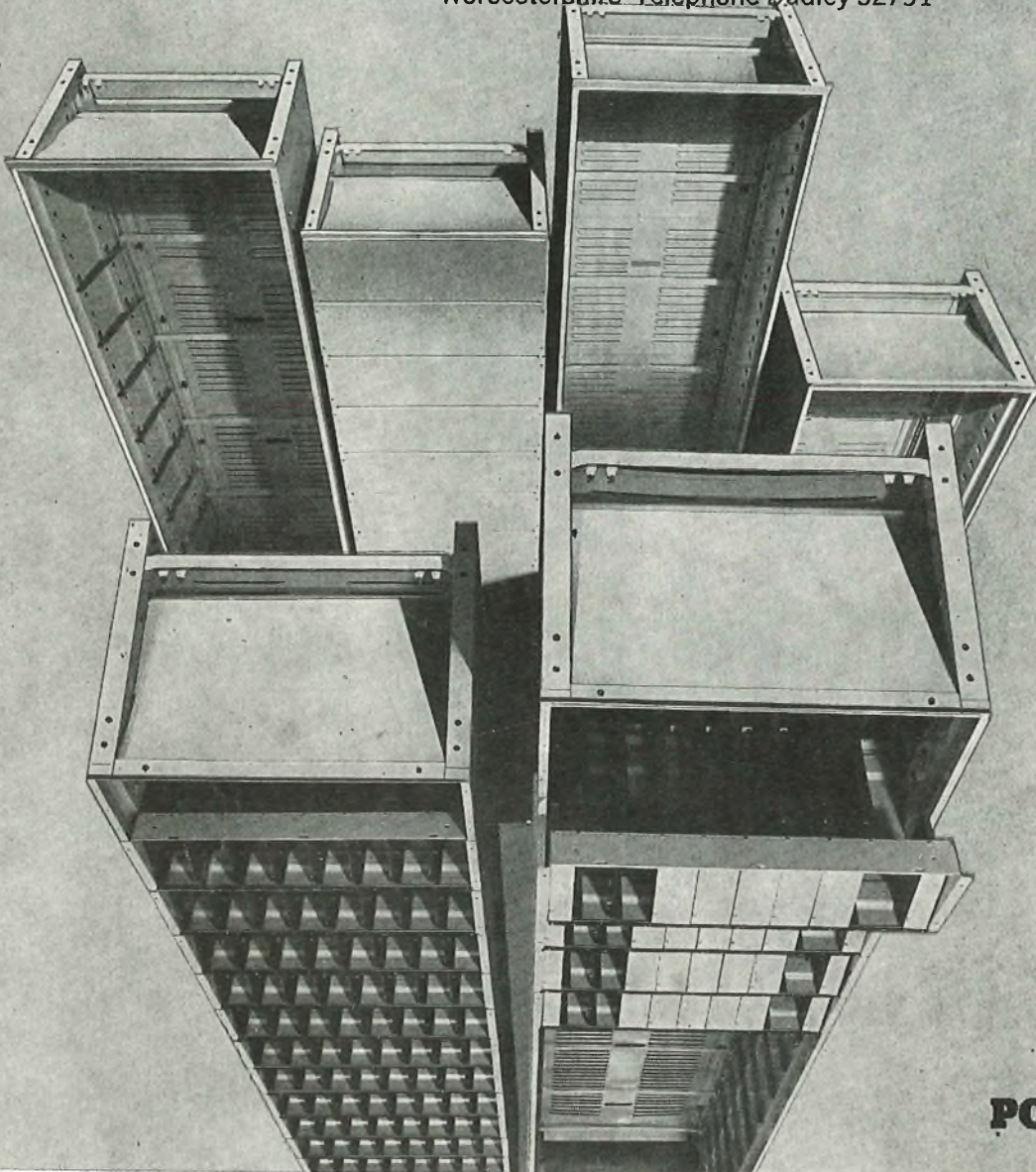

PO approved