

# THE POST OFFICE ELECTRICAL ENGINEERS' JOURNAL

**VOL. 37**

**OCTOBER, 1944**

**PART 3**

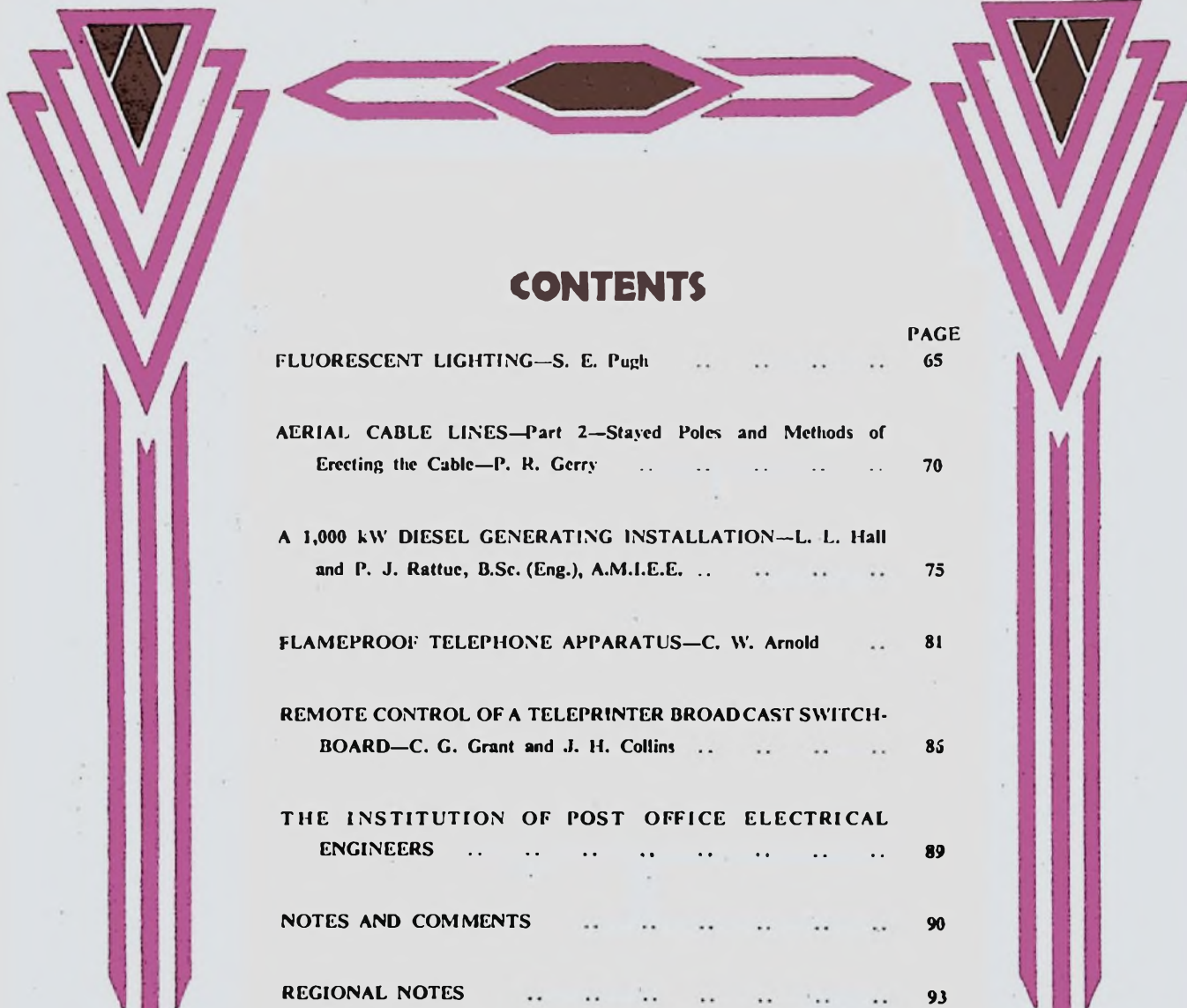

## CONTENTS

	PAGE
FLUORESCENT LIGHTING—S. E. Pugh .. .. .	65
AERIAL CABLE LINES—Part 2—Stayed Poles and Methods of Erecting the Cable—P. R. Gerry .. .. .	70
A 1,000 kW DIESEL GENERATING INSTALLATION—L. L. Hall and P. J. Rattue, B.Sc. (Eng.), A.M.I.E.E. .. .. .	75
FLAMEPROOF TELEPHONE APPARATUS—C. W. Arnold ..	81
REMOTE CONTROL OF A TELEPRINTER BROADCAST SWITCHBOARD—C. G. Grant and J. H. Collins .. .. .	85
THE INSTITUTION OF POST OFFICE ELECTRICAL ENGINEERS .. .. .	89
NOTES AND COMMENTS .. .. .	90
REGIONAL NOTES .. .. .	93
STAFF CHANGES .. .. .	95

Price 1/- net

**THE INSTITUTION OF POST OFFICE ELECTRICAL ENGINEERS**



# GE CALLOY

## RADIO TUNERS

### MAIN ADVANTAGES

- Great magnification
- High selectivity
- Small size
- Reduced costs.
- Robust construction
- Simple adjustment.
- Non-rusting.

**SALFORD ELECTRICAL INSTRUMENTS LTD.**  
 PEEL WORKS, SALFORD, 3. Telephones : BLAckfriars 6689 (6 lines). Telegrams and Cables : "Sparkless, Manchester"  
 PROPRIETORS: THE GENERAL ELECTRIC Co. Ltd., OF ENGLAND

# EDISWAN

## TELEPHONE LINE PROTECTOR PANELS

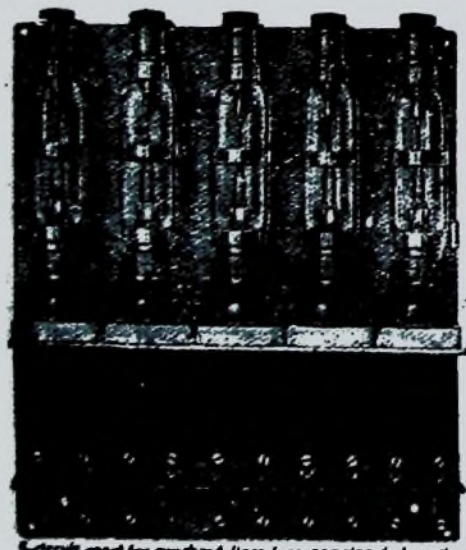

5-drain panel for overhead lines incorporating choke coils, spark gaps, etc.

EDISWAN-SHOTTER-GREETHAM PATENT (British Patent No. 353724)

for the protection of telephone systems against surges induced by faults on neighbouring power lines

Of the difficulties attendant upon the employment of overhead systems one of the most serious is to ensure uninterrupted working of the telephone system, by providing adequate protection against induced surges caused by switching or line faults in adjacent power lines or by lightning.

The Ediswan Patent Protectors provide the solution. They are inert at the normal working pressure of the telephone line, they keep the voltage on the line down to a pre-determined figure by providing a path of low resistance to earth whereby the surge is cleared and they again become inert immediately the surge is cleared.

They ensure simultaneous discharge of both lines and are capable of clearing heavy discharges without detriment to the system or the protector.

Ediswan Telephone Line Protectors have now been in use by Supply Companies for many years.

THE EDISON SWAN ELECTRIC CO. LTD., 155 CHARING CROSS ROAD, LONDON, W.C.2

# THE POST OFFICE ELECTRICAL ENGINEERS' JOURNAL

Vol. XXXVII

October, 1944

Part 3

## Fluorescent Lighting

S. E. PUGH

U.D.C. 621.327.43

This article describes some of the constructional and operating features of the fluorescent tube and its associated control gear, and gives some suggestions for the installation and maintenance of fluorescent lighting fittings.

### Introduction.

FOLLOWING the introduction of the electric discharge lamp when light produced by the electrical excitation of a gas began, in some fields, to displace that produced by the incandescence of a filament, research went on in lamp laboratories both in this country and in the U.S.A. with a view to developing a source of discharge lighting suitable for industrial purposes and operating on mains voltage. The now well-known fluorescent tube operating on voltages of 200-250 V was the outcome, and followed the high pressure fluorescent tube which was developed a few years earlier. In this country, due to the wartime conditions and the restrictions on supplies, only one size of tube, viz. 80 W, has been made, but in the U.S.A. a range of tubes varying from 6 W to 100 W, and operating at voltages of from 64-250, has been in use.

The fluorescent tube is essentially a mercury discharge lamp in which the energy radiated by the mercury vapour in the ultra-violet region of the spectrum is absorbed by the fluorescent powder coating on the inside of the tube and converted to energy in the visual range. Minute particles of some substances have the property of acting as frequency changers, and by a careful selection of substances

radiations in the 2,000 Å to 3,000 Å range may be converted to visible light radiations extending over the 5,000 Å to 7,000 Å range. A large number of powders will respond very effectively to radiations of approximately 2,537 Å, and according to the characteristics of each will convert to a certain wavelength, and hence a particular colour in the visual spectrum. Thus by the production of 2,537 Å energy within the tube and the use of a combination of powders which can transform the energy to produce a near-daylight effect, the fluorescent tube has been developed.

The generation of the 2,537 Å energy within the tube is made possible by using mercury vapour at a very low pressure. At this determined pressure (a fraction of a millimeter) about 60 per cent. of the input power can be radiated at 2,537 Å and is available for changing to visual energy. The energy actually radiated in the ultra-violet range under this condition is more than twenty times that radiated in the visual range. (Fig. 1.) By using in the correct ratios a combination of powders which individually would produce yellow, red and blue lighting, a light approximating to north daylight has been produced. (Fig. 2.) The particles of the powders used are so

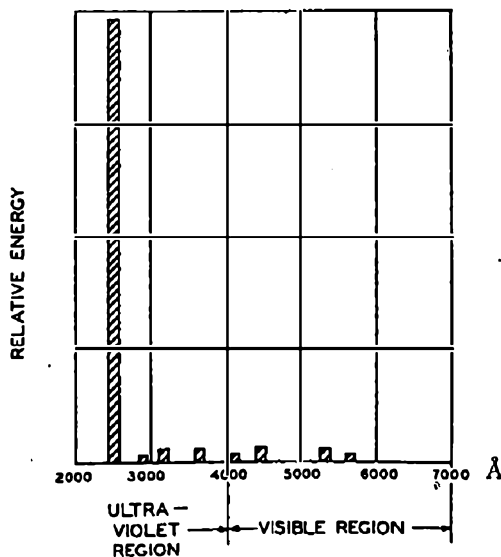

FIG. 1.—RELATIVE ENERGY RADIATION IN ULTRA-VIOLET AND VISIBLE REGIONS.

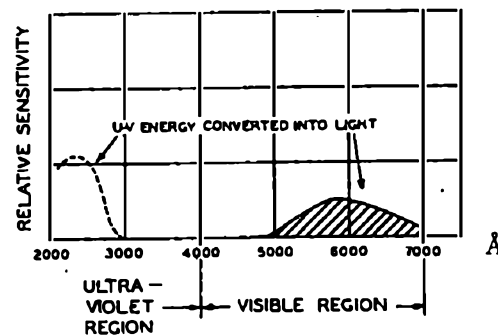

FIG. 2.—GRAPH ILLUSTRATING CONVERSION OF RADIANT ENERGY INTO LIGHT.

small that the unaided eye cannot distinguish the separate colours, but under suitable conditions a rainbow effect is observed when the tube coating is viewed under a microscope.

The 80 W fluorescent tube consists of a glass tube about 5 ft. long and about 1½ ins. in diameter, coated on the inside with a layer of fluorescent powders and containing argon at a pressure of about 1/200 of an atmosphere, and mercury vapour produced

from a small amount of mercury inserted into the tube. The electrodes are sealed one at each end of the tube and are terminated on normal bayonet caps.

The other general data regarding the lamp are as follows:—

Nominal lamp operating current	0.8 A
Choke consumption	10 W
Lamp operating volts	$115 \pm 10$
Initial efficiency	35 lumens per watt
Surface brightness	3 candles per sq. in. (approx.)

#### Operation of Tube.

The elementary lamp circuit diagram is shown in Fig. 3. In common with all mercury discharge lamps it is necessary to have a current limiting device in the line, and due to the length of the tube, and to the fact that it is designed to work on mains voltage, an automatic starting switch is incorporated, the essential function of which is to assist in the production of a high voltage impulse to start the discharge.

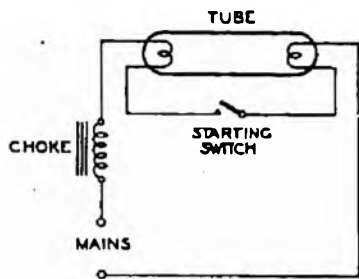

FIG. 3.—ELEMENTARY LAMP OPERATING CIRCUIT.

It will be seen from the diagram that the choke, electrodes and starting switch are all in series, the starting switch being between the electrodes. When the circuit is closed the electrodes are heated and ionisation begins. After about two seconds, by which time the electrodes are sufficiently heated, the starting switch opens sharply and due to the inductance of the choke a voltage surge is produced across the lamp which, assisted by the ionised gas at each end, operates the lamp by causing discharge between the electrodes. The argon in the tube facilitates starting because of the relatively low voltage at which this gas conducts current. The initial discharge is through the argon gas, the arc produced quickly vaporises the mercury, and the current is then carried entirely by the mercury vapour.

The complete lamp circuit is illustrated in Fig. 4, the arrangements (a and b) being slightly different according to the type of automatic starting switch used.

#### Control Gear.

The control gear associated with the fluorescent tube consists of the following items: (a) choke, (b) automatic starting switch, (c) radio suppressor condenser, and (d) power factor correction condenser.

**Choke.**—The essential functions of the choke are:—

- (1) To produce the voltage surge to start the discharge.
- (2) Due to the negative resistance characteristics of the fluorescent tubes, to provide good regulation so that the current is limited during the line voltage variations.

- (3) To limit the current to prevent overheating of the electrodes before the starting switch opens. It is essential that the choke should have a low noise level and a reasonably low wattage loss.

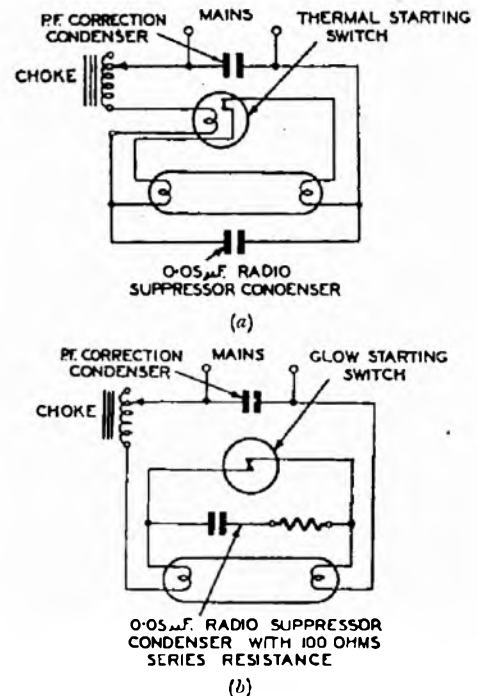

FIG. 4.—TYPICAL LAMP OPERATING CIRCUITS.

An important constructional feature is that the insulation of the wiring must be able to withstand the surge voltage which may be as high as 1,000 V. Chokes are usually supplied in two ranges and have various tappings, and it is essential to see that the correct choke and the correct tappings are used when installing.

**Starting Switch.**—The functions of the starting switch are:—

- (1) To close the circuit to enable the electrodes to heat up.
- (2) To break the circuit producing with the choke the voltage kick sufficient to ignite the tubes when the electrodes are hot.
- (3) To remain open to disconnect the heating current from the electrodes.
- (4) To reclose again quickly when the current is switched off and thus prepare the circuit for restarting.

There are three types of starting switches, viz., the thermal switch, the thermal glow switch and the magnetic switch, but only the two first mentioned are commercially used at present, and only those two are described here.

The circuit for the thermal switch is shown in Fig. 4 (a). The switch consists essentially of a short heating coil and bimetal strip carrying a contact which is normally making with a fixed contact also mounted on a bimetal strip to compensate for ambient temperature changes. When the circuit is

closed at the main switch, current flows through the electrodes of the lamp via the heating coil and the contacts of the starting switch until the heating coil generates sufficient heat to cause the contact-carrying strip to expand and break the contact. During this time the electrodes have been heated sufficiently to start ionisation and the switch contacts opening produce the inductive kick which causes the tube to light. When the lamp circuit is broken, the starting switch contacts remake and the circuit is set up for restarting.

The circuit for the thermal glow switch is shown in Fig. 4 (b). In this type of switch a bimetal element carries a contact which is normally broken from a fixed contact, the whole being enclosed in a glass bulb filled with low pressure helium or other suitable gas. When the main switch is made, mains pressure across the starting switch contacts produces a glow discharge sufficient to cause the bimetal element to heat up and close the contacts. When this happens the glow and, therefore, the heating effect ceases, and the contacts break, causing the inductive kick which starts the tube. The voltage across the contacts is now only the same as that across the tube, viz., about 115 V, and this is insufficient to operate the starting switch and the contacts remain open. With this type of switch a 100  $\Omega$  resistance is placed in series with the radio suppressor condenser across the terminals of the switch to prevent the condenser discharging across the contacts of the switch and welding them together.

*Radio Suppressor Condensers.*—A small condenser of 0.05  $\mu$ F capacitance is connected across each tube to suppress any radio interference which might be caused by the discharge of the tube or by the breaking of the starting switch.

*Power Factor Condensers.*—The power factor of the tube itself is about 0.9, but with the control gear the overall power factor is in the region of 0.5-0.6. The sole function of the power factor condenser is to raise this to approximately 0.85, and for this purpose a condenser with a capacitance of 7.5-8  $\mu$ F is generally used.

*The Performance of the Lamp.*

At 35 lumens per watt the initial light output of the fluorescent tube should be about 2,800 lumens, but in practice it has been found that this figure is exceeded when the lamp is first switched on, and that it falls to this figure after 6-10 hours. Thereafter there is an appreciable drop in light output for 150-200 hours, after which the drop is more gradual until the figure

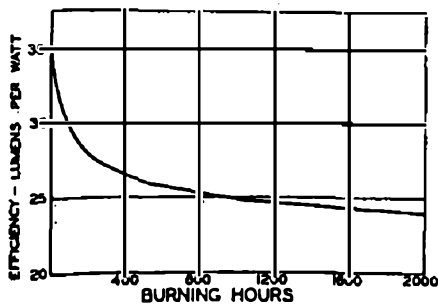

FIG. 5.—TYPICAL EFFICIENCY/LIFE CURVE.

of approximately 2,000 lumens is reached, after about 2,000 hours, at which point the useful life of the tube is usually spent. An approximate life curve is given in Fig. 5.

In common with all types of lamps working on A.C. mains there is a stroboscopic flicker with fluorescent tubes. The effect, however, is not so pronounced as with ordinary mercury vapour lamps due to the slight phosphorescent effect of the fluorescent powders, although it is greater than with the ordinary filament lamp. This flicker is not usually objectionable, but where it is essential to reduce it to a minimum this may be done by wiring adjacent fittings on different phases of a three-phase system, so that the tubes are 120° out of phase with their neighbours, and the periods of minimum light outputs do not coincide. In two-lamp fittings a suitable power factor condenser used across one tube only will produce a leading current in that tube, and the other tube with only a choke in circuit will have a lagging current, and again the minimum light outputs will not coincide and the flicker will be less noticeable.

The fluorescent tube is designed to give maximum light output at a running temperature of about 100°-110°, and at a normal room temperature of 70°-80°F. The lamp is relatively cold when switched on, and while warming up the light output increases until the temperature of 100°F is reached, during which time the current first carried by the argon ions heats the tube and assists in the production of mercury ions until the running current reaches a maximum coinciding with maximum light output. Higher or lower bulb temperatures result in lower efficiency, and the efficiency falls more with decrease than with increase of temperature, as shown in Fig. 6.

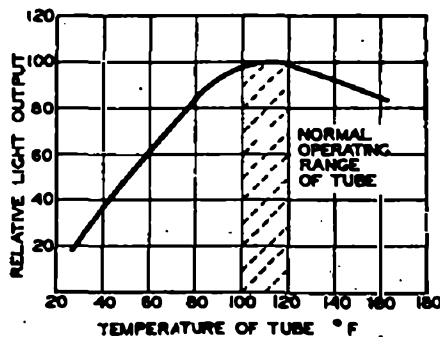

FIG. 6.—GRAPH ILLUSTRATING EFFECT OF TUBE TEMPERATURE ON EFFICIENCY.

At lower temperatures some of the mercury vapour condenses and consequently less of the ultra violet radiation is produced to activate the fluorescent powders. At higher temperatures the mercury vapour pressure increases, and some of the ultra violet radiation is shifted from the 2,537 Å to longer wavelengths, which are less efficiently converted to the visual range. The lamp temperature will be affected by the temperature of the surrounding air, and for maximum efficiency the lamp should be in a warm still air. Hence, it is advisable wherever practicable to arrange fluorescent fittings to avoid cold draughts, especially from high velocity discharge

outlets on ventilating systems. At very low temperatures there is difficulty in starting the lamp, and in consequence this type of lighting is not recommended for outdoor use.

The effect of mains voltage variations is shown in Fig. 7. A change in voltage of  $\pm 5$  per cent. produces

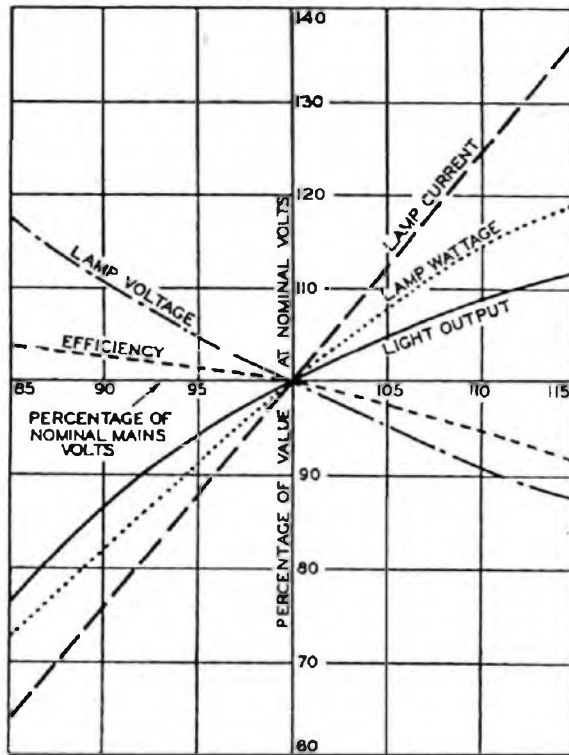

FIG. 7.—GRAPH ILLUSTRATING EFFECT OF SUPPLY VOLTAGE VARIATIONS.

a change only of approximately  $\pm 5$  per cent. in lumen output, comparing very favourably with the  $\pm 4$  per cent. variation in output with a 1 per cent. change in voltage experienced with filament lamps. The figure also shows the effect of mains voltage variations on other characteristics of the lamp.

*D.C. Operation.*

- The fluorescent tube is designed for operation on A.C. supplies, but it is possible, though not economical, to work it on D.C. When used on D.C. a series resistance is necessary to limit the current, and the functions of the choke are to produce the inductive starting kick and to limit the cathode preheating necessary for starting the lamp. In D.C. operation the power loss in the control gear is about equal to that taken by the lamp, whereas in A.C. operation only about 10 W are lost in the control gear. Furthermore, on D.C. operation the life of the tube is less than on A.C., and special starting facilities have to be provided. The unidirectional flow of the current produces a dark end

effect at one end of the tube, which can be overcome only by reversing the polarity regularly. The quality of the light compares favourably with that produced on A.C. working and, of course, there is no stroboscopic effect.

*Installation Design.*

Due to the initial high cost of the fittings, and to the wartime restrictions placed on the use of this type of lighting, fluorescent lighting has not yet been widely used in the Post Office, but by arrangement between Headquarters and various staff associations it has been adopted for use under certain agreed conditions. Usually these are found in strengthened telegraph and telephone operating rooms, which are

TABLE I.

Height above working plane	Approximate Area	Foot-Candles		
		Max.	Min.	Mean
2 ft.	Ellipse 5 ft. x 3 ft.	60	30	45
3 ft.	Ellipse 6 ft. x 5 ft.	30	15	25
4 ft.	Circle 6 ft. diam.	20	10	15
5 ft.	Circle 7 ft. diam.	15	7	10

TABLE II.  
SINGLE ROW OF FITTINGS.

Height above working plane	Spacing (Centres)	Foot-Candles			Distance between rows
		Max.	Min.	Mean	
3 ft.	6 ft.	34	18	26	10 ft.
4 ft.	6 ft.	24	16	20	12 ft.
4 ft.	8 ft.	20	12	16	11 ft.
5 ft.	6 ft.	18	14	16	13 ft.
5 ft.	8 ft.	14	10	12	12 ft.
5 ft.	10 ft.	13	7	10	11 ft.

\* This column gives the maximum distance apart, at which the rows of fittings should be mounted in order to comply with the statutory minimum requirement of 6 ft. candles in working areas.



FIG. 8.—TYPICAL FLUORESCENT LIGHTING INSTALLATION.

devoid of natural light and where work goes on continuously. In these rooms, most of which are in basements, it is usual to find that due to the existence of strengthening girders, cable racks, pipes and ventilation ducts the height for installing fluorescent fittings is greatly restricted. This usually precludes the planning of a general lighting scheme, and it has been found that suites of positions or even individual positions must be treated individually. A typical installation illustrating how the rows of fittings have followed the table positions in a protected basement telegraph operating room is shown in Fig. 8.

For general lighting with open type trough reflectors where such schemes are possible, the usually accepted

formula for general lighting holds good, using the coefficient of utilisation for industrial dispersive reflectors and a depreciation factor of 1.43. In all cases, however, due allowance must be made for the drop in light output with age of the lamp, and it is recommended that a figure of 2,400 lumens instead of the initial higher figure of 2,800 lumens should be used when designing installations. With the unequal ageing and the irregular replacing of the lamps this figure of 2,400 lumens gives good average results.

For low mounting heights for individual positions and rows Tables I and II give approximate figures of the illumination that may be expected. It will be seen from Table I that at heights above 4 ft. from the working plane the tube behaves as a point source.

With most of the Post Office fluorescent lighting installations, especially in rooms where the height is restricted, it has not been possible to keep the illumination to within the usual Post Office standards for ordinary non-blacked-out conditions for the class of work concerned, and still obtain even illumination over the working positions. In general it has been the aim to limit the illumination so that a minimum of about 8 ft.-candle are obtained at the end of the life of the tube.

#### Maintenance.

The end of the useful life of a tube is not so obvious as with filament lamps and any of the following signs may indicate that the tube is nearly finished.

- (1) A tendency to flash excessively before striking when the circuit is made.
- (2) A low light output accompanied by a blackening of the tube, most noticeable at the ends, and becoming less intense towards the centre.
- (3) A slow and very noticeable flicker.

In each of these conditions the tube should be replaced, and in condition (1) without delay, as otherwise the starting switch may be damaged.

The most likely items to fail are the tube itself and the starting switch. Table III gives some of the more probable causes of trouble and the steps to be taken to overcome them.

TABLE III.

Behaviour of the Lamp	Cause	Remedy
Lamp flickers on or off.	(1) Lamp has run useful life. (2) Low line voltage, cold draughts or low ambient temperature. (3) Faulty switch tending to switch on and off. (4) Faulty lamp.	(1) Renew lamp. (2) Check voltage, protect lamp from cold draught. (3) Renew switch. (4) Renew lamp.
The whole column of light appears to be moving in the lamp, usually in the form of a spiral.	This usually occurs only when the lamp is new and disappears after a short period of use.	Switch off lamp and restart after a few seconds. If the effect persists for a long period renew lamp.
A slow pronounced flicker.	Lamp has probably run its useful life.	Renew lamp.
The lamp does not light when switched on, but both filaments glow.	(1) Switch contacts have welded together or short-circuited. (2) Radio suppressor unit short-circuited.	(1) Renew switch. (2) Renew radio suppressor unit.
The lamp does not light when switched on and only one filament glows.	(1) Earth in wiring of starter switch or radio suppressor unit. (2) Faulty thermal switch.	(1) If no earth detectable replace suppressor unit. (2) Renew switch.
The lamp appears quite dead when switched on.	(1) Broken lamp filament. (2) Switch fails to operate.  (3) Break in the circuit or failure of supply.	(1) Replace lamp. (2) Renew switch. If new switch also fails to operate, try circuit with a test lamp. (3) Examine circuit with a test lamp, test lampholder plungers.
Behaviour of the Switch	Cause	Remedy
Too rapid operation of switch. This will result in the lamp attempting to start repeatedly as the filaments have insufficient time in which to heat up.	Faulty switch.	Renew switch.
Electrodes loose in bulb.	This may be caused by an earth or short circuit in the switch leads, or by mechanical damage.	Check wiring and replace switch.
Heater coil of thermal switch burned out.	May be due to broken lamp filament.	Change lamp if defective and renew switch.
Glow switch glows while lamp is running.	Faulty switch.	Renew switch. If glow persists with new switch, fault probably in the lamp. Renew lamp.

*Conclusion.*

It is, as yet, too early to say to what extent fluorescent lighting will be adopted as the Post Office standard for general lighting when the war is over and the supply position is easier, but where it is adopted it would seem that the present standards of illumination will have to be modified, for at intensities below about 8 foot-candles fluorescent lighting is very "thin" and tends towards a cheerless moonlight effect. The extent to which fluorescent lighting will be adopted for offices will probably depend upon the sizes in which the tubes will be available, and upon the comparative costs with filament lighting. For such positions where lighting is required for a few hours each day only in the winter months, it is possible that no changes from the filament lighting will be made. Great care must be exercised in the mixing of filament and fluorescent lighting, owing to the great disparity between the colour charac-

teristics of the two. Some complaints have been made that a certain monotony is experienced when working continuously under fluorescent lighting, and this effect is supported by the following extract from a journal describing an American factory installation:—"The cafeteria has windows and is equipped with incandescent lights, both being designed to rest the workers after being under the fluorescents." Without doubt, however, fluorescent lighting will be widely used in industry and in shops and stores where natural light is restricted, and in such places the cool daylight effect of the tubes will be greatly appreciated. There will also be many applications for display purposes, especially when the tubes are made available in various colours.

This article has been prepared from information made available by E.L.M.A., and from papers and lectures given by representatives of various lamp manufacturers.

## Aerial Cable Lines

P. R. GERRY

### Part 2: Stayed Poles and Methods of Erecting the Cable

U.D.C 621.315.24.

This article deals with the computation of the forces to which stayed poles may be subjected, the determination of the size of pole required, and some new methods of erecting cables of all sizes. Part I, which was published in the July, 1944, issue, covered straight sections of route.

*General.*

STAYS are provided to relieve a pole of the bending stresses caused by the pull of the line and suspension wires and, in certain cases, by the wind. Although a stay prevents the pole from bending, its tension, acting in conjunction with the pull of the wires, will impart a downward thrust to the pole; in fact, by fitting a stay, a pole is changed from a cantilever into a strut. As the thrust may be sufficient to cause the pole to buckle, it is necessary to ascertain its value to ensure that a pole of adequate strength is used.

The actual weight of the wires and cable increase the downward thrust, but their effect, though appreciable, may be ignored in comparison with the thrust caused by the tension in the stay and in the wires.

Referring to the stayed pole in Fig. 1,  $T_s$  represents

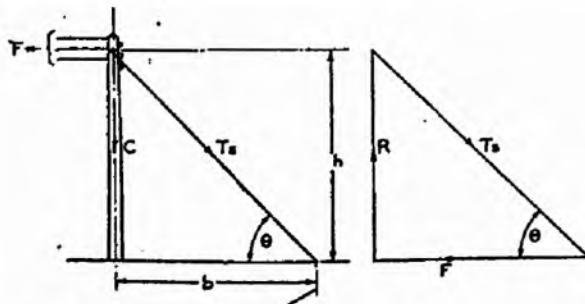

FIG. 1.—FORCES ACTING ON STAYED POLE.

the tension in the stay,  $F$  the pull of the line wires and  $C$  the downward thrust on the pole. To keep the forces in a state of equilibrium, it is necessary for the pole to resist force  $C$  by an equal and opposite force  $R$ . By constructing a triangle of forces of  $T_s$ ,  $F$  and  $R$ , as shown in Fig. 1, it will be seen that  $R = F \tan \theta$ , but as  $\tan \theta$  is also equal to  $h/b$ ,  $R$  can be expressed as  $Fh/b$ . This expression applies for all types of stayed poles in use, but as the value of  $F$  will not be the same for each type, a brief description of the principles on which the value is based is given in the following paragraphs.

*Terminal Poles.*

The stays fitted to a terminal pole, where wires exist on only one side of the pole, should be strong enough to keep the pole vertical when the maximum tension to be allowed for is applied to the wires.

Where open wires exist, falling trees or even branches of trees may cause breakage, and as the number of such wires on an aerial cable line will generally be small they are all likely to break simultaneously. It is assumed, therefore, that the maximum tension to be allowed for on open wires will be equal to their combined breaking weights.

The specified breaking weights of aerial cable suspension wires vary from 5,700 lbs. to 22,000 lbs. according to size, and they are capable of resisting most of the forces which cause open wires to break. It is not necessary, therefore, to allow for the full breaking weight of such wires and it is assumed that



the maximum tension to be allowed for is the value they will attain under working, as distinct from breakdown, conditions. As suspension wire loadings are calculated to allow for a minimum factor of safety of two when severe storm conditions prevail, the maximum working tension can be regarded as half the specified breaking weight of the wire.

The value of F for a terminal pole should, therefore, be the full breaking weight of the open wires plus half the breaking weight of the suspension wire.

#### Angle Poles.

The value of F for an angle pole will be the resultant of the tension in the line wires, and will depend on the deviation of the route. In practice line deviations are expressed in terms of "pull-on-pole," which is measured as shown in Fig. 2. A distance of 100 ft.

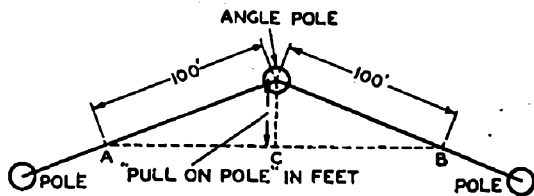

FIG. 2.—"PULL-ON-POLE" MEASUREMENT.

is measured in both directions of the line from the angle pole to points A and B, and the distance in feet from C to the angle pole is the "pull-on-pole" measurement. Utilising this value, it will be seen that the resultant pull of the line wires on the stayed pole can be expressed as  $2PT/100$ , where P is the "pull-on-pole" measurement, and T is the maximum tension to be allowed for in the wires.

The maximum tension to be allowed for in both open and suspension wires will be the maximum working tension, i.e. half the breaking weight of the wires, as stays fitted to angle poles are intended only to keep the pole vertical under working conditions. It is the practice, except on sharp angles where the pole is stayed against the pull of the wires in both directions so as to form a double terminal pole, to fit the stay in a direction that bisects the angle. As will be seen from Fig. 2 a stay in this position would not keep the pole from being deflected or even breaking if a fracture occurred in the wires on one side of the pole. The value of F for an angle pole can therefore be expressed as  $PW/100$  where P is the pull on pole and W is the combined breaking weight of all the wires.

#### Transverse Stayed Poles.

Transverse stays are fitted at intervals along straight sections of a line to restrict the lateral movement of the heads of the poles during periods of high wind. The value of F for such poles will be the wind pressure on the wires, cables and poles in half the distance from the transverse stayed pole to the next transverse stayed pole on each side. The buckling load imposed on the pole is, however, so small that it can be ignored provided the transverse stayed pole is of the same class as is used in the unstayed sections of the line.

#### Longitudinal or In-line Stayed Poles.

The fitting of in-line stays in straight sections of aerial cable lines is regarded as unnecessary. To be effective in limiting the extent of a pole line breakdown each in-line stay would have to function as a terminal stay, and the expenditure involved cannot be justified in view of the remote possibility of the suspension wire breaking. Should a break occur, only a limited number of poles would be seriously affected.

#### Buckling Loads.

It will be seen from the foregoing that, for aerial cable lines, the risk of buckling needs to be considered for terminal and angle poles only, and that the buckling loads can be found from formulæ derived from the expression  $Fh/b$ . When constructing aerial cable lines, however, it is the practice, except when the cable is small and the wires are few, to fit separate stays for the aerial cable and for the open wires; so that the different values of the factors concerned may be taken into account the formulæ used in the field are as follows:—

$$\text{Terminal Poles. Buckling load} = \frac{W_1 h_1}{b_1} + \frac{W_2 h_2}{2b_2}$$

$$\text{Angle Poles. Buckling load} = \frac{P}{100} \left( \frac{W_1 h_1}{b_1} + \frac{W_2 h_2}{b_2} \right)$$

Where  $W_1$  = Breaking weight of open wires.

$W_2$  = Breaking weight of suspension wire.

$h_1$  = Height of stay provided for open wires.

$h_2$  = Height of stay provided for suspension wire.

$b_1$  = Spread of stay provided for open wires.

$b_2$  = Spread of stay provided for suspension wire.

P = Pull-on-pole.

#### Buckling Resistance of Poles.

The buckling resistance of a pole is calculated from the formula (*vide* Rankine-Gordon) for the failing load of a column having incomplete fixity at one end and no fixity at the other.

$$\text{The formula used is } c = \frac{fA}{1 + a \left( \frac{K}{L} \right)^2}$$

Where c = the failing load in lbs.

f = the fibre strength of the pole in lbs. per sq. in.

A = area in sq. ins. of the pole at the point where the load is applied.

a = a constant whose value is dependent on the fixity of the column and the elasticity of the material.

L = the length of the pole subject to buckling or crushing in inches.

K = least radius of gyration.

The values for each class and length of pole in general use and for various heights of stay have been calculated, assuming poles of minimum permissible diameter and a factor of safety of two, and are published in table form. The values for light poles are quoted as an example in Table 1.

TABLE 1.  
BUCKLING RESISTANCE OF LIGHT POLES.

Length of pole (in ft.)	Safe loads at different heights above ground (in thousands of pounds)															
	Height (in ft.) of Aerial-cable Stay															
	12	14	16	18	20	22	24	26	28	30	32	34	36	38	40	42
20	15	11														
22	17	13	9.5													
24	20	14	11	8												
26	22	16	12	9	7											
28	24	18	13	10	7.5	6										
30	27	20	15	11	8.5	6.5	5									
32	28	21	16	12	9	7	5.5									
34	32	24	18	14	10	8	6.5	5								
36	35	26	20	15	12	9	7	5.5	4.5	3.5						
40	39	29	23	17	13	10	8.5	6.5	5.5	4.5	3.5					
45	53	40	31	24	19	15	12	9.5	8	6.5	5	4	3.5			
50	69	54	42	33	26	21	17	13	11	9	7	6	5	4	3.5	3

When the buckling load imposed on a pole has been found, the table will provide a ready means of determining whether a pole on an existing line is strong enough, or for a new line, what type of pole will be suitable.

When considering the suitability of an existing pole line for an aerial cable, the form shown in Fig. 3

ERECTION OF AERIAL CABLES.

The standard method of erecting aerial cables in the Post Office is first to run out the stranded steel suspension wire along the line, support it temporarily on the poles, tension it to a predetermined value and then secure it to each pole. Steel cable rings are then attached to the suspended wire at regular intervals,

DETAILS OF POLE LINE TO BE USED FOR AN AERIAL CABLE - STAYED POLES															
TITLE OF SCHEME.....										LOCALITY..... TO.....					
POLE		PULL ON POLE	OPEN WIRES				STAYS				SUSPN. WIRE		BUCKLING LOAD ON POLE :-		BUCKLING RESISTANCE OF EXISTING POLE
No.	SIZE & TYPE TERMINAL TO ANGLE (A)		SIZE	No.	BREAKING WEIGHT OF WIRE	BREAKING WEIGHT OF EACH GROUP OF WIRES COL. 5 X COL. 6	TOTAL BREAKING WEIGHT OF ALL GROUPS	EXISTING FOR OPEN WIRES	PROPOSED FOR SUSPN. WIRE	SIZE	BREAKING WEIGHT	TERMINAL POLE = $\frac{W_1 h_1}{b_1} + \frac{W_2 h_2}{2 b_2}$	ANGLE POLE = $\frac{P}{100} \left( \frac{W_1 h_1}{b_1} + \frac{W_2 h_2}{b_2} \right)$		
1	2	3	4	5	6	7	8	9	10	11	12	13	14	15	16
X	X	X	X	X				X	X	X	X				

FIG. 3.—FORM FOR POLE LINE DETAILS.

has been found useful in determining the buckling load imposed on the stayed poles in the line. The details required in the columns marked X are recorded during a survey of the line and the remaining columns are completed at a later stage as convenient. When the form has been completed, a comparison between columns 15 and 16 will indicate whether the existing pole is strong enough and if not, reference to the table of buckling resistance values will indicate the type of pole required.

usually 20 ins., by a man riding along the wire in a specially designed chair. The cable draw-rope is enclosed in the rings as they are attached. When the rings have been attached, the cable is drawn through them with the aid of a motor vehicle or winch. When the cable has reached its final position, and before the pulling-in tension is released, the cable, at selected points, is anchored to the suspension wire by cable clamps.

This method has been selected from the many

different methods that have been employed in the past because:—

(1) It is the only method which can be used under every condition likely to arise;

(2) It has been found to be the cheapest, even when an equivalent man-hour allowance is made for the risk allowance payable to the man riding in the ringing chair; and

(3) It ensures that the cable, when in position, will be reasonably taut and free from any slackness which is liable to introduce maintenance troubles.

The method of attaching the suspension wire to the poles by a bracket fixed under the nut of a bolt was satisfactory for the lighter cables erected in the past, but this support has had to be strengthened for the heavier cables now being erected. This has been done by reversing the bolt through the pole so that the weight of the cable is taken by the full diameter of the bolt instead of the threaded portion and also by the use of a brace support between the head of the bolt and the pole, as shown in Fig. 4.

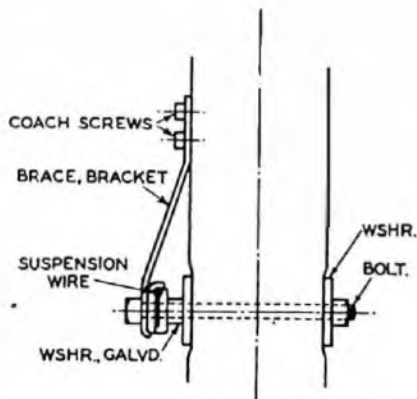

FIG. 4.—METHOD OF ATTACHMENT FOR SUSPENSION WIRE.

One of the problems which arise in pole-line work is due to the incidence of road junctions, gateways and other obstructions which prevent poles being placed in the positions which are theoretically most suitable, and cases often occur where a considerable distance between adjacent poles is unavoidable. When an aerial cable has to be erected in these long spans, it becomes necessary to use special construction to restrict the tension in the suspension wire to a reasonable value. For the lighter cables erected in the past, the excessive tension in the long span was reduced by an auxiliary wire which was erected between the poles at the ends of the long span and above the main suspension wire. The auxiliary wire was attached to the mid-point of the main wire and tensioned so as to lift the mid-point to the same level as the supporting brackets on the poles. This in effect, converted the long span into two shorter ones with a corresponding reduction in the tension. The tension in the auxiliary wire, however, depended on the vertical distance between the two wires at the poles as well as upon the weight of the main wire and cable to be supported.

For light cables, it was generally possible to provide sufficient space between the main and auxiliary wires to keep the tension in the latter within a safe value, but with heavier cables the distance between the two wires was required to be greater than could be provided on the pole. A new method of reducing the tension in the suspension wire which is suitable for both heavy and light cables has therefore been introduced. In this method the suspension wire of suitable size for the normal spans in the line is continued through the long span, but when ringing is carried out a second wire of suitable size is enclosed in the rings as they are attached to the main wire in the long span. The second wire is terminated on the first pole beyond the long span on either side, so as to cover three spans. The auxiliary wire is only passed through the rings in the long span. The wire is tensioned until it just touches the top of the rings, when it is secured by a true termination immediately above the brackets supporting the main suspension wire.

On the poles at the ends of long spans and on intermediate poles where the auxiliary suspension is continued over more than one span, the wire is fixed in separate brackets which are attached to the poles by the same bolts as are used for the brackets holding the main wire. The auxiliary wire is clamped to the main wire at both ends of each long span by U-bolt clamps, and in such a manner that it is directly below the main wire. In this manner the tension imposed by the cable is suitably distributed between the two wires, and subject to the correct size of auxiliary wire being used, the tension in both wires will be within their respective safe limits. Back stays



FIG. 5.—CABLE SUPPORTED BY MAIN AND AUXILIARY SUSPENSION WIRES.

will, of course, be required to resist the tension in the auxiliary wire. The relative position of the main wire, the auxiliary wire and the cable in the rings are shown in Fig. 5, which also shows the fittings at the intermediate poles.

Another change has been in connection with the mounting of heavy loading-coil cases on poles. When the first large-sized loaded aerial cables were erected it was the practice to provide jointing chambers near the foot of convenient poles to accommodate the loading-coil cases for the cable. Difficulty was experienced, however, in wartime, in obtaining labour for building the jointing chamber, and it was found that the leading of large cables down the pole and into the jointing chamber was a tedious and costly business. It was also found that when allowance was made for the lengths of the leading-in cables, the spacing between loading manholes would not be suitable for subsequent underground cables laid on the same route. It was decided, therefore, that loading-coil cases for aerial cables should, wherever practicable, be installed on poles.

The normal method of mounting by steel strip brackets with securing bands encircling the case and fixed to the pole is not suitable for cases weighing more than 320 lb., and, as cases up to 1,000 lb. have to be installed, a more substantial structure has been designed. To obviate the difficulty of obtaining special fittings, use has been made of existing items, and the type of structure illustrated in Fig. 6 is now used when the loading-coil case weighs more than 320 lb. The structure consists of a short auxiliary pole erected at a specified distance from an existing line pole and on the same side of the pole as the cable. The two poles are held together by two lengths of wood arms, which form the platform on which the case rests, and also by a tie-bolt near the top. Where obstructions prevent the auxiliary pole being erected in the position shown, the structure is modified

slightly to allow the auxiliary pole to be erected in a position clear of the obstructions.

The stress imposed on the poles by the weight of the loading-coil case is negligible so long as the two poles remain vertical. Should the structure move out of the vertical, bending stresses would be introduced and the weight of the case would increase the tendency to overturn. To prevent this occurring, the structure should be stayed in four directions.

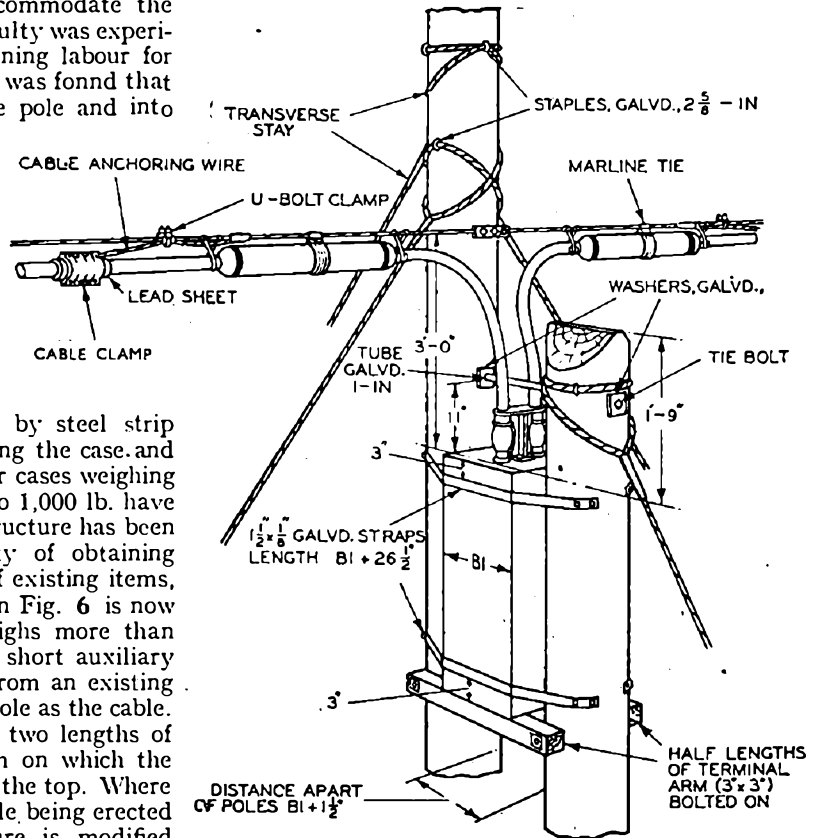

FIG. 6.—MOUNTING OF LOADING COIL CASE.

TELEPHONE AND TELEGRAPH STATISTICS—SINGLE WIRE MILEAGES AS AT JUNE, 1944  
THE PROPERTY OF, AND MAINTAINED BY, THE POST OFFICE

REGION	OVERHEAD			UNDERGROUND		
	Trunks and Telegraphs	Junctions	Subscribers *	Trunks and Telegraphs †	Junctions ‡	Subscribers †
Home Counties .. .. .	10,100	48,923	321,148	1,477,405	323,440	1,342,132
South Western .. .. .	7,040	41,545	244,048	754,800	137,300	730,712
Midland .. .. .	8,404	30,806	190,503	900,136	207,073	1,027,105
Welsh and Border Counties ..	8,800	25,077	121,816	438,100	72,901	307,210
North Eastern .. .. .	12,480	25,140	160,230	783,082	232,120	972,123
North Western .. .. .	1,471	0,160	107,117	580,193	350,450	1,223,720
Northern Ireland .. .. .	0,707	0,055	32,671	105,810	41,410	131,732
Scottish .. .. .	24,257	33,520	180,444	604,250	242,721	803,740
Provinces .. .. .	80,030	230,728	1,370,786	5,730,911	1,700,448	6,547,408
London .. .. .	600	1,040	73,222	803,808	1,072,815	3,752,135
United Kingdom .. .. .	80,090	232,308	1,444,008	6,543,770	3,370,203	10,200,033

\* Includes all spare wires.

† All wires (including spares) in M.U. Cables.

‡ All wires (including spares) in wholly Junction Cables.

§ All wires (including spares) in Subs. mixed Junctions and Subs. Cables.

# A 1,000 kW Diesel Generating Installation

U.D.C. 621.313.3—84

L. L. HALL and  
P. J. RATTUE, B.Sc. (Eng.), A.M.I.E.E.

This article describes the provisions made for safeguarding a large radio station against failure of power supply. Some details of the Fullagar engine principle have been included as this is not often met in Post Office work. Attention is drawn to the more unusual features of the installation as determined by special site, load and wartime conditions.

## Introduction.

CONTINUITY of the power supply is a very essential factor in the operation of a large radio station, and some time after the outbreak of the present war arrangements were put in hand for prime movers to be made available. At one such station the maximum demand was estimated at about 1,000 kW with instantaneous peaks of 1,500 kW. The engine provided was an English Electric 1,470 B.H.P. 6-cylinder Fullagar Diesel, directly coupled to an English Electric 1,290 kVA alternator. The total weight of the set is 80 tons and the overall dimensions are 30 ft. × 11 ft. approximately in plan by 16 ft. in height.

## Planning of Accommodation.

The engine room was designed to accommodate the single large engine generator set, together with cooling water pumps, lubricating oil purifiers and coolers, and electrical switchgear, the layout being such that the controls for the engine and alternator are within easy reach of a single operator. The arrangement of plant in the engine room is shown in Fig. 1.

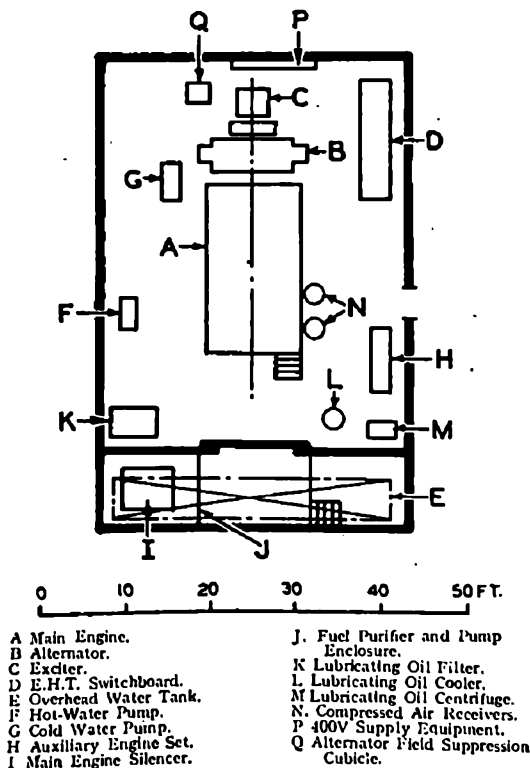

FIG. 1. GENERAL PLAN OF LAYOUT.

Mention may be made of the special design of the foundation block for the engine generator set. The subsoil consists of a crust of fairly firm clay overlying an indefinite depth of soft clay, and accordingly it was most desirable that the foundation block should not penetrate the crust, and that the bearing pressure imposed by the block should be as small as possible. Also, as the site is liable to flooding, the floor level of the engine room had to be 3 ft. above general site level. The normal depth of foundation block, viz., 10 ft., was reduced to 6 ft. so that penetration into the silt crust was limited to 3 ft., and the width was increased to preserve the required mass of 300 tons which had been found by experience to be desirable to limit vibration. As the block was thus made relatively wide and shallow, it was heavily reinforced to preserve a high degree of rigidity. The block was insulated from the floor of the engine room by fibre-board to prevent transmission of vibration.

A large doorway at one end of the room was obviously necessary for entry of the plant and the doors, when louvred, provided in a very convenient manner a sufficiently large and light-tight air intake to the engine room to limit the pressure drop to a negligible amount. (The total air intake to the engine room when the engine and ventilating fans are working is 22,000 cu. ft. per minute.) Such doors are vulnerable to blast, and so a large blast wall outside the doorway was essential. However, in view of the facts that (a) the water cooling arrangements for the new engine necessitated the provision of a 3,500-gallon overhead water tank, (b) a 3-ton silencer had to be supported at a height of about 12 ft. above engine room floor level, and (c) a fuel purifier and various changeover valves had to be accommodated adjacent to but outside the engine room, the blast wall was enlarged and the space between it and the engine room proper completely enclosed to form an annexe, so that the water tank could be supported on the engine room and annexe walls, the silencer could be supported between them at the appropriate height, and floor space was provided for fuel oil equipment and housing a spare transformer. The elevated water tank was enclosed as a protection against freezing and enemy action. For the ultimate cooling of the circulating water, to which is rejected approximately 44,000 B.T.U. per minute on full load, a cooling pond 40 ft. square and equipped with spraying plant was provided adjacent to the power house.

## Engine Details.

In the Fullagar type Diesel engine there are in each cylinder two opposed oil cooled pistons rigidly connected to cross-heads. The cylinders are cast in pairs, and the cross-head of the upper piston in each

cylinder is connected by oblique tension rods to the cross-head of the lower piston in the other cylinder. This arrangement, which is indicated pictorially in Fig. 2, is the special feature of the Fullagar engine,

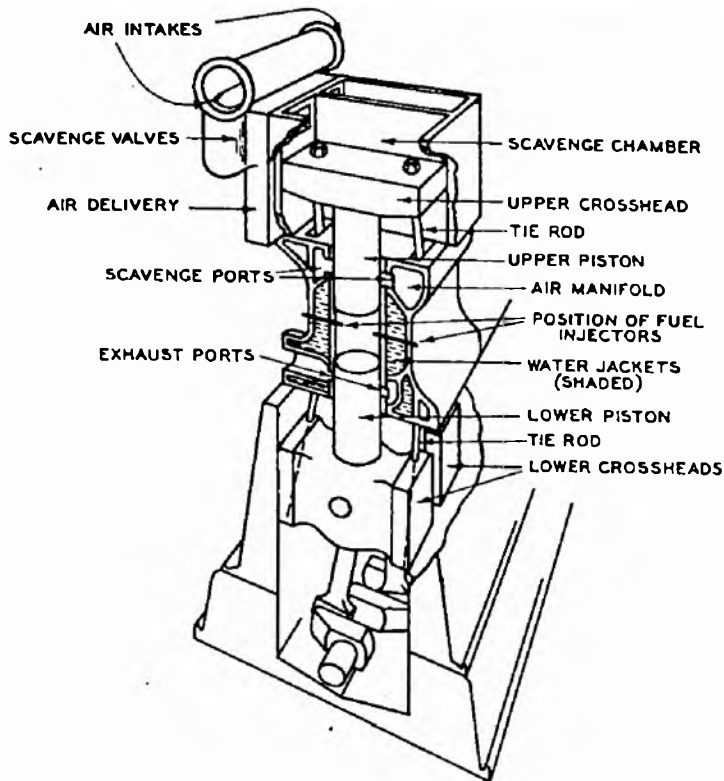

FIG. 2. SECTIONAL VIEW OF TWO CYLINDER UNIT OF FULLAGAR ENGINE.

which enables the number of cranks per cylinder to be limited to one. The engine works on the 2-stroke cycle, fuel being "solidly" injected into the centre of each cylinder, i.e. between the pistons when near their inner dead centres, and the products of combustion scavenged by air entering the top of the cylinder through ports, sweeping right through the cylinder and out of the exhaust ports at the bottom of the cylinder when the pistons are near their outer dead centres. The engine gives two impulses per crank per revolution, resulting in a very uniform turning moment, and the arrangement of pistons, tie rods and cranks results in very low framework and main bearing stresses. Incidentally, the power required for compressing the air in one cylinder is derived via the oblique rods from the pistons in the adjacent cylinder instead of being transmitted through the crankshaft.

The upper cross-heads take the form of rectangular pistons or displacers operating in rectangular chambers to provide air at 2 to 3 lbs. per sq. in. for scavenging purposes. The air is inspired through cylindrical silencers mounted on top of the rectangular chambers and amounts in this case to 6,000 cu. ft. per minute. The products of combustion are released and swept out of the exhaust ports at the bottom of the cylinder when the lower piston uncovers the ports, the scaven-

ging being so complete that approximately 20 per cent. of the scavenge air passes through the cylinder into the exhaust pipe. Apart from scavenging, the air flow exerts a very considerable cooling effect on the piston crowns, the difference between the heat rejected to the cooling oil by the upper piston and that rejected by the lower piston being very noticeable on test. An indication of the exhaust temperature is given by electrical pyrometers mounted on the exhaust pipes from the cylinders to the manifold. An interesting fact concerning these pyrometers is that they all give lower readings than that given by a thermometer placed in the exhaust pipe a foot or two beyond the end of the manifold. This is due to the fact that each pyrometer is acted upon by hot exhaust gas for a small fraction of a revolution followed by cooler scavenge air for a further small fraction of a revolution, after which it is not acted upon by any gas for a period corresponding to the greater part of the revolution. Therefore to assess the heat lost in the exhaust gases from each cylinder, it is necessary to obtain from the thermometer reading a correction for each pyrometer reading.

Each cylinder is equipped in the middle with two diametrically opposed fuel injectors, and a relief valve. The relief valve is set to lift at 650 lbs. per sq. in., and provides the pressure connection for indicator gear, the motion for which is derived from levers which may be placed in contact with the oblique rods by a cam. A point of interest in taking indicator diagrams from this type of engine arises from the fact that the motions of the two pistons in each cylinder are not simultaneously identical and, therefore, if the I.H.P. of a cylinder is required accurately, two indicator diagrams must be taken simultaneously, one instrument being operated from one set of oblique rods and the second instrument from the other set. Normally, however, to overcome this difficulty, a factor of 0.909 is applied to one diagram obtained by using the motion of the lower piston.

The fuel injection pumps which are of the C.A.V. Bosch type are mounted in pairs at platform level, on the front of the engine, and are driven from a horizontal camshaft. This type of pump, which operates at a pressure of 4,000 lbs. per sq. in., gives constant timing for the beginning of the injection, but the quantity of fuel delivered is controlled by the governor. The governor is remotely controlled from the alternator control panel.

In this particular engine the cylinders are of 14 in. bore, the piston stroke is 16 ins., and the speed 300 r.p.m. A general view of the engine and E.H.T. switchboard is given in Fig. 3.

#### Water Cooling System.

The engine cylinder jackets, exhaust outlets and manifold, the sides of the scavenging chambers (which also act as the bearing plates for the upper

cross heads) and the lubricating oil, are water-cooled. For this purpose water flows by gravity from the 3,500 gallon elevated tank (which provides a reserve of water for starting and after cooling, and covers a half-hour failure of water supply) fitted with a level indicator and low water alarm, through a lubricating oil cooler seen in the centre background of Fig. 3, and thence to the engine, in which it divides through the different cylinder and exhaust jackets and the

the M.V. supplies. To cater for quick warming up of the engine on light load and under abnormally cold weather conditions, arrangements were made to enable the overhead tank and lubricating oil cooler to be by-passed.

The cooling pond is brick built and cement-rendered, and provided with a central dividing wall. For cleaning purposes either half can be isolated by valves in the water pipework, all of which is bifurcated

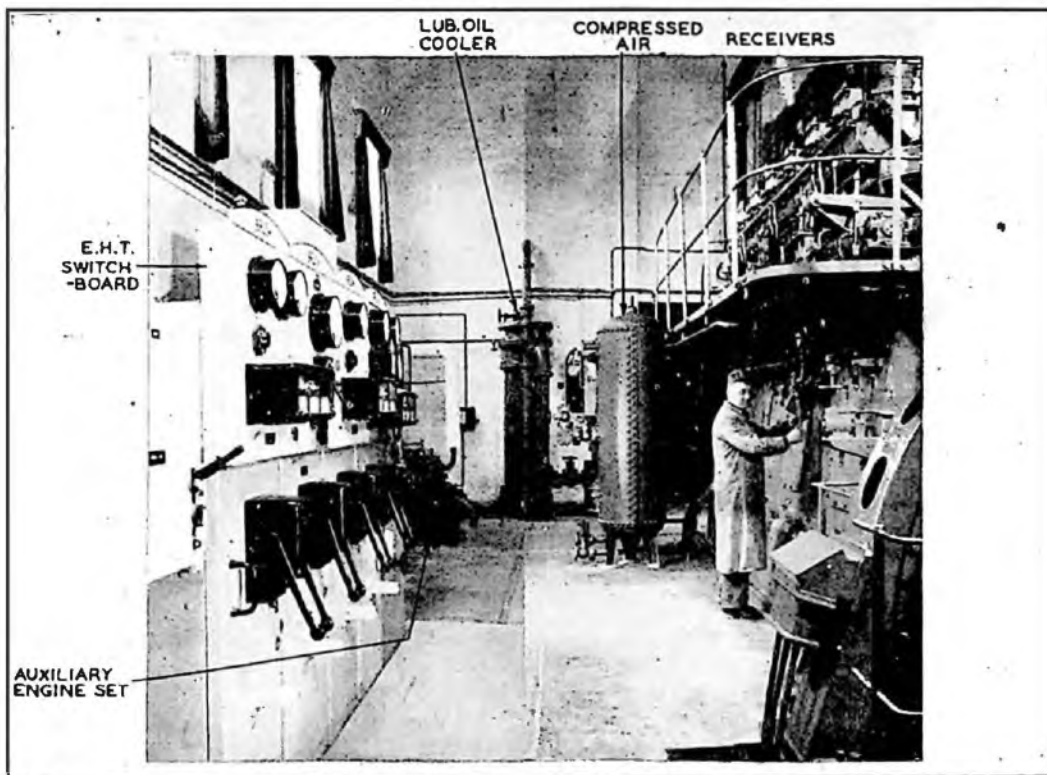

FIG. 3. GENERAL VIEW OF ENGINE AND E.H.T. SWITCHBOARD.

hollow upper cross head bearing plates. From these jackets and bearing plates the water discharges via throttle valves into tundishes fitted with thermometers, from which it flows to an outdoor hot water sump, whence it can be pumped back to the overhead tank directly, or via the cooling pond (to which the hot sump is connected by balance pipes) or by both routes, according to the degree of cooling necessitated by the load and duration of run. Maximum cooling is obtained by drawing all water for the overhead tank from the pond, and at the same time pumping the returning hot water from the sump via spray nozzles into the pond using a separate pump for this purpose. The motor-driven water circulating pumps were fixed at engine room floor level, and the height of the cooling pond was arranged to be such that the pumps were always "drowned" to avoid priming difficulties. A special feature in connection with the pumps is that although both are fitted with motor drives, it was arranged that the pump supplying the overhead tank should normally be belt-driven from the engine, to obviate shutdown due to failure of

for this purpose, leaving the other half of the pond available for emergency use of the engine. To inhibit scale formation or corrosion of the water jackets and pipe work, D.M. boiler enamel was injected into the cooling water. On a long full load run in summer, it was estimated that the evaporation of water from the pond would amount to 390 gallons per hour. This, combined with the fact that the cooling pond was also required to function as a static water tank for fire fighting purposes, necessitated special precautions being taken to ensure an adequate supply of make-up water from the general water system of the station.

#### Fuel System.

Three outdoor 6,600 gallon bulk fuel storage tanks were each equipped with a manhole, filling and breather pipes, dip rod, suction pipe, sludge and emergency disposal cocks and an immersion heater. The suction pipes were carefully laid on a continuous slope into the end of the annexe where a 2,000 g.p.h. fuel transfer pump and an oil purification plant were

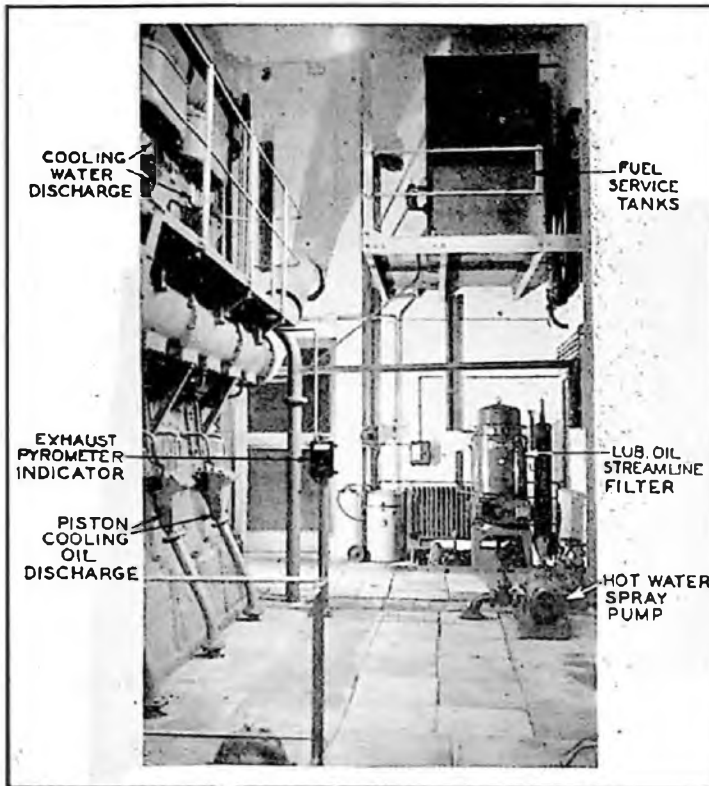

FIG. 4. VIEW OF ENGINE ROOM SHOWING POSITION OF ELEVATED STORAGE TANKS.

located. Changeover valves and pipework were arranged to permit of fuel being drawn from any bulk storage tank and pumped into any other, or to the elevated ready-use tanks in the engine room directly, or via the purifier. The possibility of deterioration of available fuel, with the consequent increase in viscosity and sludge, was catered for by the immersion heaters, arrangements for drainage of suction pipe lines, and by the purification plant, which is of the Alfa Laval centrifugal type equipped with fuel pre-heaters. The elevated ready-use tanks installed in one corner of the engine room, as shown in the top right-hand corner of Fig. 4, were arranged so that one could supply the other via a ball-cock to maintain a constant head of fuel to the engine. Both tanks are fitted with overflow and drainage pipes, and special arrangements were made to enable valves in the latter to be controlled from outside the engine room in case of fire.

#### Lubricating Oil System.

A lubricating oil reservoir tank is located below engine room floor level at the end of the engine room remote from the alternator. Oil may be drawn from the tank by either the main lubricating oil pump, which is mounted

on the end of the main engine crankshaft, or by a priming lubricating oil pump clutch-driven from one side of a 7 H.P. auxiliary Diesel engine, shown in Fig. 5. Before starting the main engine, the auxiliary Diesel must be started and the priming pump clutch engaged, so that oil is circulated to all bearings and pistons of the main engine. After starting the main engine, the lubricating oil priming pump may be declutched. The main pump delivers oil via a coarse strainer to the oil cooler previously referred to (a further view of which can be seen in Fig. 5) whence it is delivered to the engine bearings and pistons, the latter being fed through telescopic tubes. From the pistons the oil is delivered into tundishes (at which thermometers indicate the oil temperature) and thence back to the oil reservoir tank, in the top of which is a wire mesh strainer. For the removal of fine sludge and water from the lubricating oil, a centrifugal purifier and a streamline filter are provided, both of which draw oil from the reservoir tank and return it thereto after purifying. These auxiliaries are usually operated while the main engine is running to economise in the power required for the pre-heaters and to draw oil from the tank while it is in a turbulent state. The streamline filter is shown on the right hand side of Fig. 4.

#### Compressed Air System.

The main engine is started by air at a pressure of 300-350 lbs. per sq. in., which is automatically delivered at the correct time to cylinders 1 and 6 on operation of a hand-controlled master valve. The air is stored in two steel receivers mounted on the floor in front of the engine, as shown in Fig. 3, these

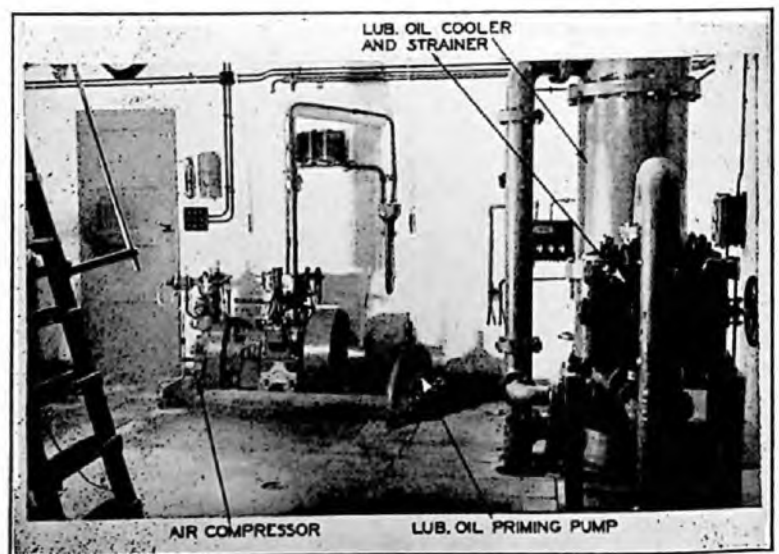

FIG. 5. AUXILIARY EQUIPMENT.



receivers being recharged by an air compressor, clutch-driven from the auxiliary Diesel engine (Fig. 5). The priming lubricating oil pump and the air compressor could not be motor-driven since a failure of the normal power supply to the station would render both items of equipment useless.

#### *Ventilation.*

The heat dissipated in the engine room from the engine and alternator when on full load is approximately 5,000 B.T.U. per minute, and to keep the room reasonably cool under midsummer and black-out conditions two 30 in. 900 r.p.m. fans, extracting 8,000 cu. ft. per minute, were installed.

#### *Electrical Plant.*

The generator is direct-coupled to the engine and consists of a 6 kV 1,290 kVA A.C. protected type machine, with a single pedestal bearing and direct driven exciter. Special features consist of interpolar links between pole face damping grids (which help to reduce the subtransient and transient reactances the significance of which is mentioned later, reduce the machine impedance to harmonic currents produced by rectifier loads and assist the stability of the machine when supplying a fluctuating load in parallel with the public supply) and side terminal boxes, one of which is seen on the right hand side of Fig. 3, which replace the usual terminals in the alternator pit, as a result of the limited permissible depth of pit in the special foundation block.

The alternator is solidly connected to a 1,300 kVA 6/11 kV transformer required to step up the voltage to that of the station distribution system, and both alternator and transformer secondary neutral points are earthed solidly. The alternator and transformer windings and cable connections are protected against phase or earth faults by Merz Price circulating current gear, consisting of a pair of balanced current transformers in each phase (one connected in the neutral end of the alternator winding and the other in the output side of the transformer), and an instantaneous relay in each phase arranged to respond to any difference in the secondary currents of these current transformers in excess of a chosen fault setting. Operation of the relays causes tripping of the oil circuit breaker controlling the transformer output and of a field suppression switch in the D.C. circuit between the alternator and exciter. The field suppression switch is provided with a large discharge resistance since very rapid "open-circuit" suppression is not practicable when the alternator has laminated field poles, as in this case.

Automatic control of voltage is effected by a Brown Boveri regulator. The load imposed by the station is subject to a wide fluctuation, but although the alternator has the rather high leakage and synchronous reactances standard for this type of machine and the regulator does not possess a particularly rapid response, the variation in voltage is not excessive owing to the rapid nature of the load changes which prevents armature reaction from becoming effective. The regulation under these conditions is dependent only on the transient and subtransient reactances of

the alternator (the former being determined by stator flux leakage and low decrement damping currents in the poles, and the latter additionally by high decrement damping currents in the pole faces) since, irrespective of the speed of response of the regulator and its capacity for "overshooting," it would be impossible to vary the alternator magnetic field to any appreciable extent at the frequency with which the load is varied.

#### *Switchgear.*

It was desirable for purposes of engine maintenance and limitation of maximum demand charges to be able to supply one transmitter building from the station alternator while the rest of the station continued to take its supply from the local power company, and interlocks were provided to prevent unintentional paralleling of the alternator and public supply.

All circuit-breaker equipments are of the metal-clad, air-insulated type arranged for vertical isolation and horizontal withdrawal of the oil circuit breakers, and battery tripping was adopted. The alternator panel is equipped with a voltmeter, an ammeter, phase selector switches for both these instruments, frequency meter, power factor meter, integrating kilowatt hour meter, overcurrent relays of the induction type with "definite minimum" time-delays, the instantaneous circulating current protective relays referred to previously, potential transformer for metering and voltage regulator supply purposes, and the necessary protective and metering current transformers. The over-current relays are set to protect against busbar faults or a sustained 30 per cent. current overload on the alternator. Discrimination of the latter against feeder or load faults (which should trip the local circuit breakers) is obtained by a long definite minimum time setting and a close current setting of the relays. The exciter control panel is equipped with output ammeter and voltmeter, automatic and hand voltage regulators, regulator controls and a governor control switch.

It is proposed to add facilities to enable the public supply to be paralleled with the alternator to avoid shutting down the transmitters when the former supply is restored after a failure involving running the Diesel set, and also to enable the load to be transferred to the Diesel without traffic interruption for maintenance run purposes.

An auxiliary 400 V 3-phase power supply for water and fuel pump motors, governor motor, fuel and lubricating oil purifiers, fuel heaters, exhaust fans, plug points and lighting is obtained via a high rupturing capacity switch fuse directly connected to the 500 kVA transformer which supplies another building. A 24 V 50 Ah battery is installed to supply emergency lighting (relay operated on failure of the 400 V supply), engine water and lubricating oil failure alarms and circuit breaker tripping. The loads are individually fused and standard Post Office signalling lamps are fitted to each of the circuit breaker panels, and connected across protective relay trip contacts to indicate that the tripping supply is in order, and that the trip circuits are intact throughout the trip coils, auxiliary contacts, etc.

### Acceptance Tests on Site.

A few of the more unusual aspects of the site tests may be of interest, and are mentioned below.

To carry out acceptance tests of the equipment on site it was necessary to provide an 11 kV 3-phase load which would dissipate up to 1,000 kW plus 10 per cent. overload, and could be easily adjusted to provide  $\frac{1}{4}$ ,  $\frac{1}{2}$  and  $\frac{3}{4}$  loads. A resistance load was therefore made up from 36 asbestos-wire woven mats, each of 1,500  $\Omega$  resistance, and nominally rated at 24 kW, 6 kV, connected in star formation with 12 mats in parallel per phase. The mats were suspended out of doors and each phase divided into four sections by insulators which could be short-circuited as necessary by simple bolted wire connections. The 11 kV alternator circuit breaker panel was disconnected from the main busbars, which were in normal service, and connected by temporary cables to the artificial load.

An 11 hour run at full load, followed by a one-hour run at 10 per cent. overload, was successfully carried out, fine adjustment of the load being effected by varying the alternator voltage. Rates of flow and temperature rises of the individual cooling water and lubricating oil circuits, and of exhaust gases and engine room air were measured and fuel consumption per cylinder was determined. Voltage and current were measured at the alternator terminals, and from the known efficiency of the machine the engine B.H.P. was obtained.

From the results a heat account was obtained indicating that at full load 35 per cent. of the input heat (corresponding to the lower calorific value of the fuel) was converted into brake horse-power; 20 per cent. was rejected to the lubricating oil and cooling water, 42 per cent. was carried away by the exhaust (of which 5 per cent. was transferred to the exhaust manifold water jacket), and 3 per cent. lost by radiation. The brake thermal efficiency is expected to improve slightly after the set has run for a few hundred hours. On the second day of the tests  $\frac{1}{4}$ ,  $\frac{1}{2}$ ,  $\frac{3}{4}$  and full loads were applied in turn, the corresponding fuel consumptions measured, and the speed and voltage regulation observed when each load was suddenly removed and reapplied by operation of the alternator circuit breaker. The full load voltage regulation figures were + 11.5 per cent. instantaneous, + 0.4 per cent. steady, and -13.7 per cent. instantaneous, and the corresponding figures for speed were + 7.7 per cent., + 3.7 per cent. and -2.7 per cent.

With regard to the determination of the mechanical efficiency of the engine the engine makers were unwilling to place any reliance on indicator diagrams for the purpose of obtaining the indicated horse-power. Accordingly the frictional losses in each cylinder were determined by running the engine at 300 r.p.m. on  $\frac{3}{4}$  load under fixed hand fuel control (i.e. with the governor adjusted for, say, 310 r.p.m.), cutting out each cylinder in turn and adjusting the load by hand voltage control so that the speed

returned to 300 r.p.m. The reduction in B.H.P. in each case represented the indicated horse-power of the cylinder cut out (subject to a small error due to heat loss in compressing and re-expanding the air in the cylinder.) The difference between the total I.H.P. thus obtained, and the original total B.H.P. gave the total frictional loss as 415 H.P., which would be practically independent of load. Thus the mechanical efficiency at any load is given by 
$$\frac{\text{B.H.P.}}{\text{B.H.P.} + 415}$$

which at full load becomes 78 per cent.

In a final test on the station load it was not possible to interrupt all radio transmissions, but as the transmitter in one building involved the greatest available load fluctuation (100-300 kVA approximately at that time) this load gave a fair indication of the voltage regulation expected when the station is fully developed. The variation in voltage under such conditions was  $\pm 200$  V, indicating that if, as is anticipated, the load ultimately fluctuates from 900 to 1,300 kVA the corresponding variation in voltage will be approximately  $\pm 4$  per cent., which is permissible.

The Merz Price "circulating current" protective gear was tested by short-circuiting the alternator, thus simulating a 3-phase fault, and gradually increasing the excitation until the relays operated. The relay current being then approximately 2 A as compared with the measured full load relay current of 0.18 A (which is largely due to magnetising current of the 6/11 kV transformer) a sufficient degree of stability against through faults was indicated, and at the same time the 2-A setting corresponding to a fault current of 40 per cent. of full load current, gives sufficient earth fault sensitivity in this case where alternator and transformer are solidly earthed.

In view of the nature of the subsoil, special steps were taken to record crankshaft web spacings, and also the levels of a number of steel pads which were sunk into the surface of the foundation block relative to a pad in the outer engine room floor, so that checks may be made from time to time against the possibility of subsidence.

### Conclusion.

Although a large proportion of this article relates to standard practice as far as power generating plants are concerned, it is hoped that the somewhat unusual application of plant of this size to Post Office work (the engine generator being the largest single unit so far installed in Post Office premises) and other special aspects of the work have warranted the inclusion of a certain amount of detailed description.

The planning and installation of the plant was carried out in co-operation with the English Electric Company, who supplied the engine, generator, transformer and engine auxiliary gear, and the Brush Electrical Engineering Company, who supplied the EHT switchgear, protective equipment and cabling.

# Flameproof Telephone Apparatus

C. W. ARNOLD

U.D.C. 614.841 : 621.395.6

The author discusses briefly some general features of the above subject with a reference to the Department's policy, and then describes the various types of apparatus available with details of its installation and maintenance.

## Introduction.

IT has always been the policy of the Post Office to discourage the use of any telephone apparatus or the provision of telephone circuits in any situation where there is likely to be a risk of explosion. Nevertheless the Post Office will agree to supply certain flameproof apparatus, provided it is installed in positions where the risk is not continuous (i.e. in positions where a concentration of explosive vapours would be present only occasionally), and on condition that the subscriber will accept the full responsibility for any consequences. This article describes the special types of telephone apparatus which the Post Office has available for this purpose.

## General.

It is well known that telephone apparatus (such as the dial, gravity switch and trembler bell contacts), like other electrical apparatus which has to break reactive circuits, will produce sparks during its normal operation. The amount of energy dissipated in such a discharge is dependent upon the voltage employed, the electrical characteristics of the apparatus, and the mechanical frequency of the circuit interruptions. It has been established by the Ministry of Fuel and Power (Coal Division) that the sparks caused by telephone apparatus using the standard telephone voltages would cause an explosion if allowed to occur in certain concentrations of explosive vapours (such as petroleum and acetone fumes) hence the need for some form of protection on such apparatus. It should perhaps be mentioned that when using telephone apparatus in ordinary premises and under normal conditions the sparks produced by this apparatus do not constitute a hazard.

To facilitate the design and subsequent testing of flameproof apparatus, the explosive gases generally encountered in industry are classified into three groups:

Group I.—Methane (fire damp).

Group II.—Acetone, benzene, pentane, etc.

Group III.—Coal gas, coke-oven gas, etc.

Some of the Post Office apparatus is suitable for all three groups, but others are suitable for only Groups I and II. The apparatus is not suitable for use in premises where explosive powders are handled.

Before detailing the various pieces of flameproof apparatus it will, no doubt, be of interest to mention that there are two distinct and different principles employed to make telephone apparatus and circuits safe, and it is essential to recognise that the two systems are not interchangeable. These two methods of obtaining safety are known as

(a) Flameproof protection.

(b) Intrinsic safety.

Flameproof protection consists of enclosing all parts of the circuit and apparatus where sparks would normally occur during operation, so that

any resulting flame is so cooled in its passage to the outside atmosphere that it is incapable of igniting the most sensitive mixture of the gases within the group for which the apparatus is to be used.

Intrinsic safety consists of the limitation of the energy which can be liberated in any spark to below that required for ignition of the most sensitive gases.

The apparatus described here is all of flameproof design, and Tele. No. 153 is, in addition, designed for intrinsic safety. Intrinsically safe apparatus cannot be used effectively on the standard Post Office systems because the voltage and circuit conditions of these systems are outside the limits allowed for intrinsic safety.

The types of flameproof apparatus at present available for use in premises where some protection is desirable are very limited, and consist of:—

- (a) A telephone suitable for use in auto and C.B. areas (Coded Telephone No. 149). This telephone can also be used in C.B.S. areas by fitting an auxiliary unit (Unit Auxiliary C.B.S. 536) at the exchange to provide a battery feed and signalling facilities.
- (b) A telephone suitable for use in magneto areas (Coded Telephone No. 153).
- (c) A flameproof relay—suitable for connection in the extension bell position of the above two telephones and used for controlling devices operated by the electric supply mains such as bells, hooters, etc. (Coded Relay-Unit C.D. 393.)
- (d) A flameproof box to house a Protector and Fuse No. 1 2/2 when the latter is fitted in the danger area. (Coded Box Protector C.D. 408.)
- (e) A flameproof switch plug purchased specially as required for certain ship-to-shore terminations.

An effort is also being made to obtain a flameproof magneto loud-sounding extension bell of which none is available at the moment. The availability of a bell of this type will reduce the demands for the flameproof relay.

Items (a)-(d) above are covered individually by flameproof certificates as issued by the Ministry of Fuel and Power (Coal Division). This Government Department undertakes to test all flameproof apparatus, and if satisfactory in design issues what is called a flameproof certificate. Each piece of apparatus is required to bear a distinguishing mark followed by the certificate number.

Although the switch plug is of flameproof design, it has not been certified by the Ministry of Fuel and Power. This is because its design permits the use of a flexible lead which has never been regarded as satisfactory from a flameproof point of view.

*Telephones.*

Fig. 1 (Tele. 149) and Fig. 2 (Tele. 153) illustrate the appearance of both telephones with access doors open. They are identical in external appearance and are of very robust construction, being

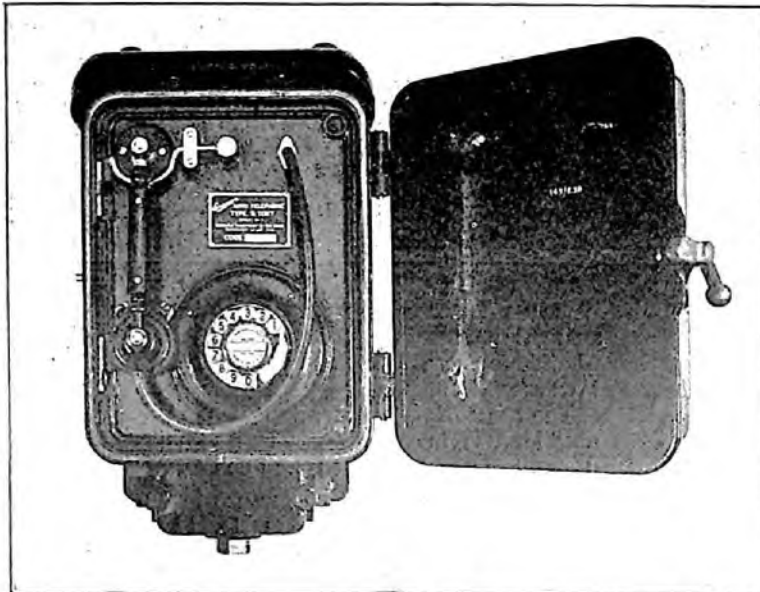

FIG. 1.—TELEPHONE No. 149—ACCESS DOOR OPEN.

completely enclosed in a substantial iron case. The weight of each telephone is approximately 85 lbs. The front portion or cover of the telephone, which is in fact an access door, is normally kept closed for protection from weather, dirt, etc., and has to be opened to gain access to the receiver, transmitter, etc.

Both telephones were originally designed for use in coal mines, and therefore, in addition to their flameproof properties, they were required to withstand fairly rough usage. They are also made weatherproof.

Although designated as being of flameproof design the flameproof properties are confined to those parts of the telephone such as the gravity switch, dial contacts, and generator contacts where sparking occurs during normal operation. These parts of the telephone circuit (A and B on Figs. 3 and 4) are completely enclosed in small separate enclosures designed for flameproof protection in accordance with B.S.S. 229, and known as flameproof enclosures. The terminal chamber C located at the base of the telephone housing is also a flameproof enclosure.

It will, of course, be appreciated that it is impossible to make the telephone completely flameproof due to the fact that all working parts cannot be completely enclosed.

**Flameproof Enclosure.**—All flameproof enclosures are distinguishable by

the wide, machine flat, flange on their periphery. The width of the flange is  $\frac{1}{2}$  in. as specified in B.S.S. 229 "for bells and accessories and parts of telephones." Larger enclosures have  $\frac{3}{4}$  in. or 1 in. flanges, depending on whether they are less than 100 cu. in. or not.

The definition of a flameproof enclosure per B.S.S. 229 is as follows:—

"A flameproof enclosure for electrical apparatus is one that will withstand, without injury, any explosion of prescribed inflammable gas that may occur within it under practical conditions of operation within the rating of the apparatus (and recognised overloads, if any, associated therewith), and will prevent the transmission of flame such as will ignite the prescribed inflammable gas which may be present in the surrounding atmosphere."

The following essential points of manufacture are also worth mentioning: all the joints of the flameproof enclosure shall be either flanged joints, spigoted joints or screwed joints, or a combination of such joints without the intervention of any loose or perishable packing; all such joints shall fit as closely as the methods of manufacture permit, and in no case shall the gap

between joints exceed certain limits; the maximum permissible gap allowed will depend upon the gas in which the flameproof enclosure is required to work, and these limits vary from 0.046 in. for methane to 0.001 in. for acetylene.

Referring again to Figs. 3 and 4, it will be seen that some of the internal wiring for the telephone components, also certain terminals, are not within

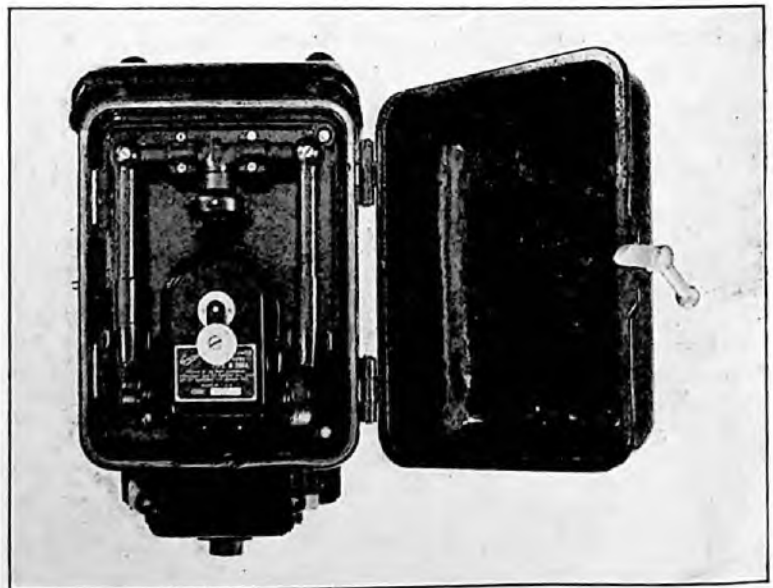

FIG. 2.—TELEPHONE No. 153—ACCESS DOOR OPEN.

the special enclosures. This in itself constitutes a hazard, and should one of the wires become disconnected during a conversation or while the bell is being rung a spark might occur, and an explosion might be caused. It is for this reason the two telephones are not 100 per cent. safe.

The electrical circuit for the Telephone No. 149 is similar to the standard astic circuit, and that for the Telephone No. 153 similar to the old local battery circuit, and neither calls for any special comment. There are, however, one or two mechanical features not normally found on ordinary telephones, and these will now be dealt with in greater detail.

The main physical difference between the Telephone No. 149 and the No. 153 is that the former incorporates a hand microphone, whereas the latter has twin receivers fixed to rigid arms with the transmitter located centrally between these arms. The striker for the magneto bell on both telephones passes through a watertight gland on the top of the casing.

There is a special attachment to the dial mechanism on the Telephone No. 149, which is commonly known as a "slipping clutch device," and is fitted to prevent the mis-operation of the dial, which might otherwise produce a condition for which the telephone had not been tested. This provides that when the dial has been engaged and drawn round to the finger stop, the finger plate, when released, is disengaged from the dial mechanism and returned to its normal position very quickly under the control of a coil spring.

Referring to Fig. 5, A is the normal finger plate

which is directly coupled to detail B. Detail C is directly coupled to the dial mechanism. Detail B engages with C when the dial is being operated and drawn round to the finger stop. Immediately the finger plate is released it will be returned to normal,

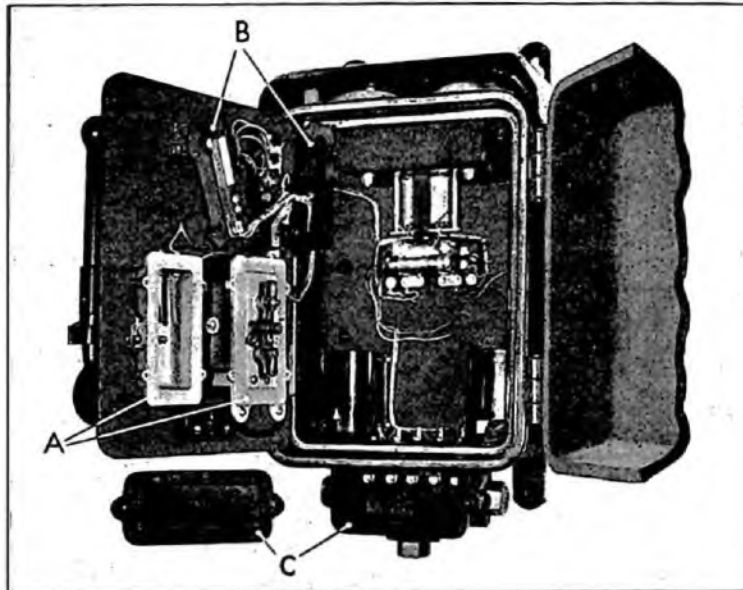

FIG. 4.—TELEPHONE No. 153—INTERNAL LAYOUT.

in advance of the dial mechanism, by the spring D. A locking arrangement E is provided so that B is locked on its return to normal and cannot be operated again until the dial mechanism is returned to zero and the lock on B removed by C.

A metallic gauze cover is fitted over the front of the dial mechanism as an additional safeguard against flame being transmitted from the dial direct to the outer atmosphere via a worn finger plate spindle and bearing.

Telephone No. 153 incorporates a hand generator in place of the dial in the Telephone No. 149. The generator is a special 3-magnet type of rather more robust construction than the standard No. 4C. It has a flameproof cover over the generator contacts.

This telephone, in addition to having a flameproof certificate, is certified as intrinsically safe. This latter feature is maintained only when the telephone is used on an intrinsically safe circuit—i.e., a circuit in which the energy is controlled below the incandive limit.

Briefly, the difference between a piece of apparatus designed for intrinsic safety is the incorporation of shunts across such items as generators to limit the voltage and condensers connected in shunt with inductive coils such as the magneto bell, to absorb the back E.M.F.

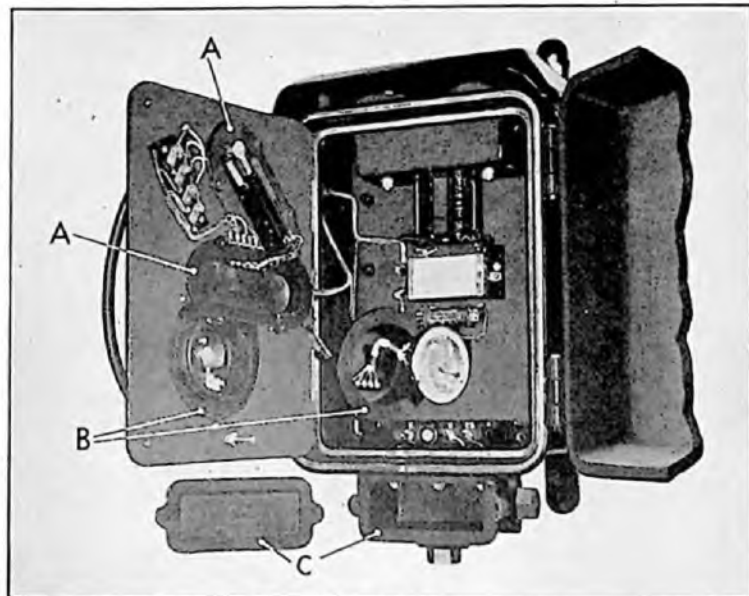

FIG. 3.—TELEPHONE No. 149—INTERNAL LAYOUT.

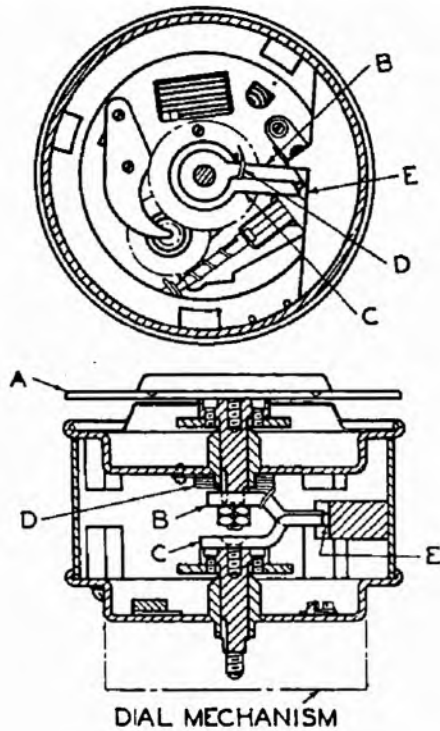
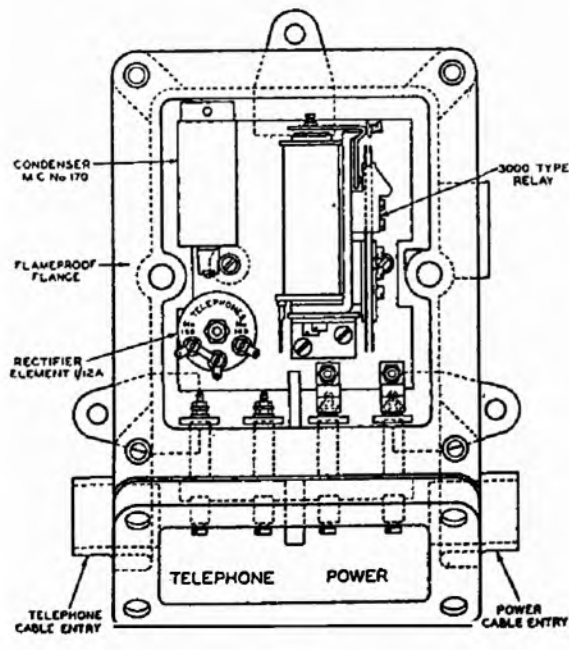

FIG. 5.—DIAL MECHANISM FITTED WITH SLIPPING CLUTCH DEVICE.

*Flameproof Relay (P.O. Code Relay Unit C.D. 393).*

This item (Fig. 6) has been designed for the purpose of relaying calling signals (such as magneto ringing current) to devices operated by electric supply mains. The reason for its introduction was the demand for a suitable loud sounding flameproof bell or visual device for use in particularly noisy situations where



COVERS REMOVED  
FIG. 6.—RELAY UNIT.

flameproof apparatus was desirable. As mentioned previously, no satisfactory flameproof loud sounding bell, suitable for operation on the standard telephone circuit, and by the normal ringing current, was available, and the only alternative was to provide some device similar to a relay switch which could be used to operate an electric supply mains device, of which several were available.

The relay unit comprises a 3,000 type relay with heavy duty contacts, a rectifier element 1/12A, and a Condenser MC No. 170 ; a strap is provided on the top of the rectifier element to facilitate disconnecting the condenser when the relay unit is used with Telephone No. 149. The condenser is required only when the unit is used with Telephone No. 153.

All the components are housed in a substantial metal casting which, together with a terminal chamber, comprises a complete flameproof unit. The wide flanges called for per B.S.S. 229 are easily recognised from the illustration.

*Protector and Fuse.*

The flameproof enclosure to house the Protector and Fuse No. 1 2/2 as illustrated in Fig. 7 requires no special comment. The complete unit is a properly designed flameproof enclosure with a separate input

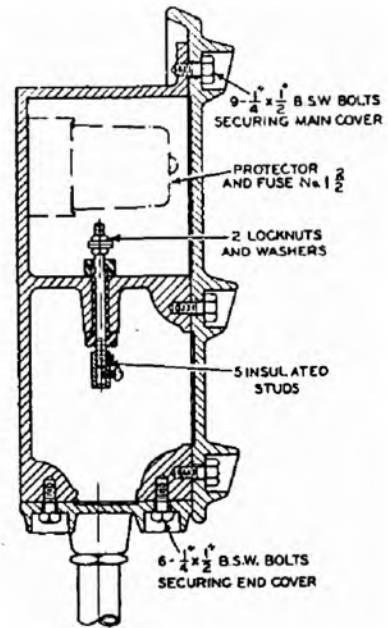

FIG. 7. PROTECTOR AND FUSE UNIT.

terminal chamber. Five terminals, insulated from the metal case, are provided, one of which is to facilitate bringing out the earth connection which may have to be separated from the conduit earth.

*Switch Plug and Socket.*

The flameproof switch plug and socket is of special design. In addition to being of flameproof design, a locking device is provided in association with the switch so that the plug cannot be withdrawn with the switch in the "on" position.

### INSTALLATION.

To provide a reasonably safe installation in a danger area where the use of flameproof apparatus is considered necessary, special precautions have to be taken to prevent damage to the cabling. This is achieved by using (1) armoured cable, (2) pyrotenax cable, or (3) enclosing the wiring in solid-drawn or seamless conduit. System (3) is the one used by the Post Office.

The type of conduit used for this purpose should be either solid-drawn or seamless-welded in accordance with B.S.S. No. 31. The conduit must be screwed to the telephone or other apparatus, and run to a point outside the danger area, where it is coupled up by the normal methods of construction employed for that installation. Where the circuit is being led into the premises from an O.H. line, the conduit would be terminated in a Box Weatherproof CD 364, which is provided to house the protectors. (Certain slight departures from this method are, however, being allowed for the duration of the war.) The ends of the conduit must be effectively sealed where it leaves the danger area, or at its termination, whichever is the more convenient, to prevent the travel of gas.

Alternatively to the effective sealing by the compound, a proper flameproof barrier between the wiring in the danger area and the safe area can be provided. This method has not, up to the present, been adopted for use on Post Office circuits.

All conduit bends must be of the solid type; inspection elbows and tee pieces must not be used. Where access to the conduit is required for drawing in or testing it should be provided by properly designed flameproof junction boxes or inspection bends. Lock nuts are usually provided at the points where the conduit enters each piece of apparatus, but for telephone installations these are considered unnecessary.

#### *Earthing of the Conduit.*

To avoid the possibility of sparking between the conduit and other earthed subjects, and between the conduit and the internal circuits due to the presence of a high potential induced on the conduit from the effects of lightning, special attention has to be paid to the efficient earthing of the conduit. The earth lead connecting the conduit to the earth electrode should be as short as possible—not more than five yards in length. The protector earth should, if possible, be separated from the conduit earth by a distance of at least 10 ft.

#### *Lead-In.*

The lead-in for the telephone circuit to a danger building should normally be run underground, employing standard methods of construction, as determined by the circumstances of the particular site. Certain firms and large undertakings may insist upon the provision of special construction and in some cases offer the use of their own cables.

In certain classes of premises handling petroleum products the use of insulated overhead wires is being permitted as a war-time departure.

In areas where overhead distribution is employed,

the protectors for each circuit would normally be fitted outside the danger area in a Box Weatherproof CD 364. Where, however, the overhead wires are permitted to be run in the danger area the protector also has to be fitted in the danger area, and is then located in a Box Protector CD 408. The provision of these boxes has been insisted upon by one of the larger groups of subscribers, who agreed to the use of the overhead wires in the danger area.

Although there is no authoritative specification for a flameproof installation at present, it is understood that consideration is being given to the issue of a code of practice for electrical installations (including telecommunications in dangerous premises), early in the post-war period. It is expected that both flameproof and intrinsic safety protection will be considered

### MAINTENANCE.

The efficacy of a flameproof installation in preventing an explosion lies not only in its correct installation to the recognised standards, but also in providing regular and efficient maintenance. Periodic and regular inspections of all flameproof installations should be made as a matter of routine, all flameproof apparatus being examined for loose parts, frayed or damaged cords, loose material on the flat surface of the flameproof enclosures, etc. The conduit should be inspected for loose connections, damage by rust or corrosion, efficiency of the earth, connections, etc.

The necessity for the prompt reporting of all faults should be impressed upon the subscriber, otherwise faulty parts, not given immediate attention, may create an undesirable hazard.

All Post Office staff whose duties involve their working in dangerous premises must comply with the regulations appropriate to the type of premises concerned, as issued by the owner of the premises. It is the duty of the officer concerned, when visiting this type of premises, to first contact a responsible representative of the firm and inform them of the type of work proposed to be undertaken, the tools, etc., it will be necessary to use, and the apparatus to be fitted.

#### *Conclusion.*

An endeavour has been made to give readers an insight into the main features of flameproof protection and the associated apparatus which the Post Office is able to supply for telephone purposes.

The subject of flameproof protection is so wide in scope that it is quite impossible to give but the briefest reference to many aspects of this important subject. Questions such as the "design and testing of electrical apparatus," "types of gases, materials, and premises involved," and "intrinsic safety" would each in themselves provide material for lengthy articles.

The author acknowledges the very informative discussions which have taken place with both Messrs. Ericsson of Beeston, and Mr. J. A. B. Horsley of the Ministry of Fuel and Power (Coal Division), and which have proved extremely valuable in the preparation of this article. Thanks are due to Mr. E. S. Ritter for some helpful suggestions.

# Remote Control of a Teleprinter Broadcast Switchboard

C. G. GRANT and  
J. H. COLLINS

U.D.C. 621.394

This article describes a means of remotely controlling a teleprinter broadcast board which was constructed and installed at short notice to meet the special requirements of a renter. The equipment was designed so that use could be made of standard automatic telephone apparatus, and the circuit design incorporates an interesting example of the application of reverberate signalling.

## Introduction.

THE installation described in this article consisted originally of a 40 line manually operated broadcast switchboard with upwards of 30 outstations and two internal extensions from which the material to be broadcast was transmitted. The switchboard was located in central London and only short physical lines were required to connect it with the outstations. Two separate broadcasts could be given simultaneously, a three position key on the switchboard associated with each outstation extension allowing it to receive either broadcast or neither as desired. Standard broadcast acknowledgment facilities were available, i.e. at the end of each broadcast message the teleprinter operator at each outstation receiving the message could indicate that she had received it by depressing an acknowledgment key for 5 seconds, thus lighting a lamp on the switchboard. Inter-communication between outstations was also catered for, although not used except for testing purposes.

The material to be broadcast was collected at premises in the country some distance from London, sent to the switchboard over teleprinter lines and retransmitted to the various outstations. This retransmission introduced several undesirable features which it was considered necessary to eliminate, viz.:-

- (a) the reception of the broadcasts was delayed, a point to which considerable importance was attached in view of the nature of the intelligence transmitted ;
- (b) the retransmission was an additional source of error.
- (c) unnecessary employment of teleprinter operators, particularly since a 24 hour a day service was given.

As a temporary measure the two lines from the country headquarters were terminated as extensions on the switchboard and connected by cords, in the normal manner, to the input jacks of the broadcast relays. The teleprinter operators at the country premises were thus able to broadcast direct to any group of outstations desired, provided the keys on the switchboard were operated appropriately. The switchboard was not continuously staffed, any changes in the selection of the outstations receiving the broadcasts being made by such of the renter's staff as were on duty at the London H.Q.

There were, however, objections to this scheme since delay inevitably occurred each time it became necessary to change the selection of outstations and the renter accordingly pressed for the provision of some means whereby the selection of outstations

could be made by the staff at the country premises. The possibility of locating the switchboard at the premises in the country could not be entertained, since quite apart from considerations of cost, the line plant was not available. A remotely controlled equipment was therefore developed which could be actuated by signals passed over VF channels. The equipment consists of a control panel situated at the country premises and a switching unit situated in London. This equipment was installed in addition to the existing manually operated broadcast board which was left *in situ*, the switching equipment being arranged so that on the operation of manual changeover keys at each end of the circuit the manual board can be used in place of the automatic equipment.

## Method of Operation.

The control panel is shown in Fig. 1 and is arranged

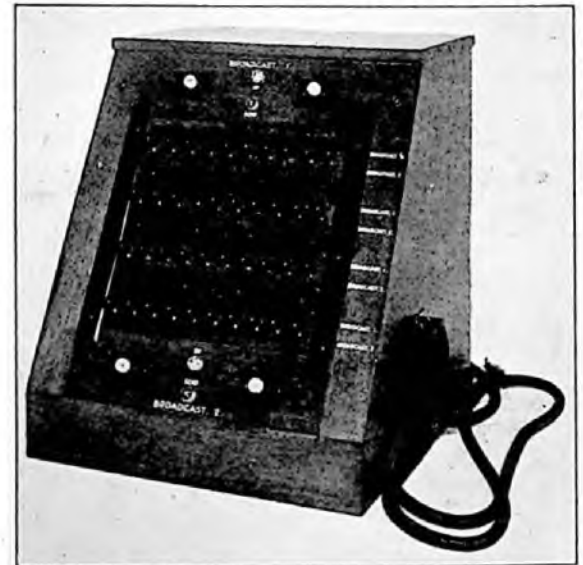

FIG. 1.—CONTROL PANEL.

so that two broadcasts can be controlled independently. Connections to the panel are made via a multi-way cord and plug of the type used on teleprinters and the panel is stood on a teleprinter table situated between the two teleprinters used for the broadcasts 1 & 2 transmissions. This panel is similar to the existing manual board in that it has 40 double throw keys, each key representing an extension from the broadcast switchboard. On moving one of these keys upward the appropriate extension can be selected for connection to Broadcast 1 circuit. Alter-



natively, on moving the key downwards the extension can be selected for connection to Broadcast 2 circuit.

For controlling the setting up and clearing down of connections each of the two broadcast circuits is provided with Start and Cancel keys and On and Send lamps. The keys and lamps associated with Broadcast 1 are situated at the top of the control panel and those for Broadcast 2 at the bottom.

Assuming a broadcast is required on Broadcast 1 circuit, the method of operation will be as follows. The keys corresponding to the extensions to be connected to Broadcast 1 circuit will be operated upwards and the remaining keys will be left normal. When all the required keys have been set the Start key of Broadcast 1 circuit will be momentarily depressed. This will cause the On lamp (Red) to glow and the switching unit will commence to connect the selected lines to the Broadcast 1 outlet. On completion of selection the Send lamp (Green) will glow, indicating that all lines are switched and that teleprinting can commence, and this lamp, together with the On lamp will continue to glow until the set-up is cancelled.

A front view of the switching unit is shown in Fig. 2. The connecting blocks and uniselectors are

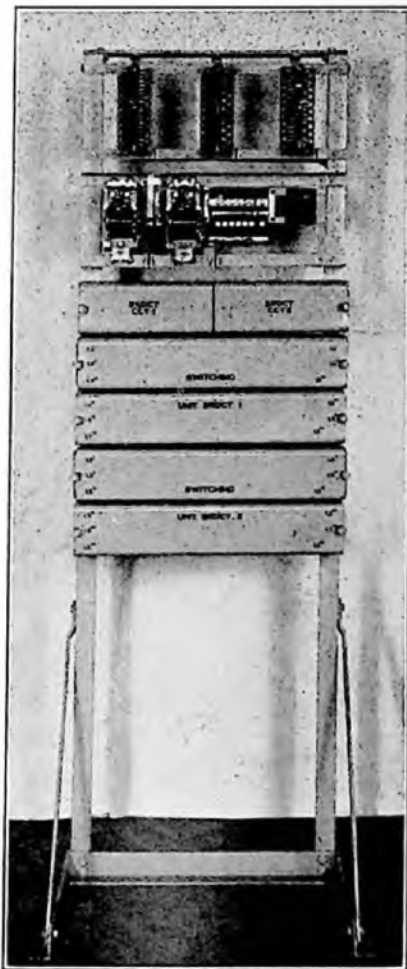

FIG. 2.—SWITCHING UNIT.

mounted at the top of the rack with the switching control relays mounted immediately below. The lowest four relay plates house the 80 line switching (LS) relays. Two line switching relays being provided for each outstation to enable connection to be made to either Broadcast 1 or Broadcast 2.

To enable the operation of the line switching relays to be checked lamp display panels are provided over the existing manual board. Eighty lamps are used, each lamp being controlled by one of the line switching relays and arranged to light when that relay is operated. Master switches are provided so that the lamps need only be switched on when required.

On completion of a broadcast the equipment can be restored to normal by the momentary depression of the Cancel key. When the equipment is normal the On lamp will be extinguished and the equipment is then ready for further action.

When a broadcast has been set up and the Send lamp is glowing, further movement of the selecting keys is ineffective. Should it be required, therefore, either to add an extension to or subtract an extension from the set-up the Cancel key must be depressed to clear down the existing set up. The Start key should then be re-depressed after the new set-up of extension keys has been arranged.

When a broadcast is required on Broadcast 2 the method of setting up is the same except that the required extension keys are operated downwards. It should be noted that a key already operated in the upward direction indicates that this extension is in use on Broadcast 1 and cannot be connected to Broadcast 2.

The time taken to set up a typical broadcast is of the order of 15 seconds, much of this time being taken up by the time lags of the signalling channels. With ordinary methods of signalling the slow response of the channels would not affect the speed of the circuit, but as it will be seen later with the revertive method of signalling employed the channel lags are additive. In practice the time taken for selection is not all wasted as some of it is used by the operators for arranging their copy.

A schematic diagram showing the connections between the various pieces of apparatus is given in Fig. 3.

The primary consideration in the design of this remotely controlled switching scheme was that the equipment should be made reasonably immune from incorrect set-ups. That is to say, only the stations selected by the operator should be connected to the broadcast. In order to check that each selected station has been connected a revertive system of signalling has been used in which all signals sent from the control panel are received back on that equipment after they have caused the appropriate functions to take place at the switching unit.

As a further precaution against misoperation a separate send channel shown in Fig. 3 as Send (Control) VF Channel has been used to control the setting up and clearing down operations. This VF channel has been arranged so that in the normal condition there is no tone on the line. The selecting signals therefore consist of pulses of tone.

For the reverteive signals sent back from the switching unit to the control panel the normal teleprinter receive channels have been used. In Fig. 3 these channels are designated Receive (Control

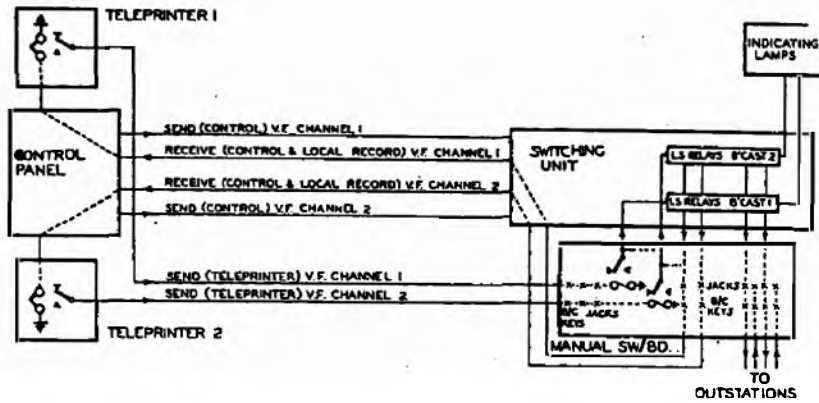

FIG. 3.—SCHEMATIC DIAGRAM OF TELEPRINTER BROADCAST SYSTEM.

and Local Record) VF Channel and during the setting up of the switching unit the signalling conditions are reversed so that signals consist of pulses of tone.

The local copy on the sending teleprinter is obtained from the output of the broadcast board over the receive channel, which is selected and switched in the same manner as the other outstations. Correct functioning of the switching equipment is checked by arranging that connection of the local copy is the last switching action to be performed.

These arrangements have been adopted to make the equipment more immune from incorrect operation due to interruption on the VF channels.

#### Circuit Description.

The elements of the circuit are given in Fig. 4,

which for simplicity shows only the controlling and switching equipment associated with Broadcast 1.

When the selecting keys of the required stations have been operated the momentary depression of the Start key causes relay ST to operate. ST3 connects  $-50V$  to arcs 5 and 6. This D.C. signal is used to control a Send (Control) VF Channel and the application of  $-50V$  at the sending end causes the VF to be applied to the channel.

At the receiving end the receipt of the signal causes an earth to be extended to the switching unit. This signal operates relays AS, CA, ON and ONR and causes the unselector R to take one step. The movement of wiper R5 from contact one to contact two changes the potential on the Receive (Control and Local Record) VF Channel from  $+80V$  to  $-80V$  and as this is a standard type of signalling channel it causes a corresponding change of D.C. conditions at the output of the VF receiver at the controlling end which operates relay AR. Contact AR1 causes the S unselector to take one step and this will cause wiper S5 to remove the signal from the send channel, thus causing relay AS to release. The release of relay AS disconnects relay CA and causes relays CB, CD and CE to operate. It also causes the R unselector to take a further step, which restores  $+80V$  to the receive channel and relay AR is released.

When the wiper of arc S3 reaches a contact corresponding to a selected outstation relay SW is operated and SW1 disconnects the S unselector and connects relays PS and RS to AR1. These relays are arranged

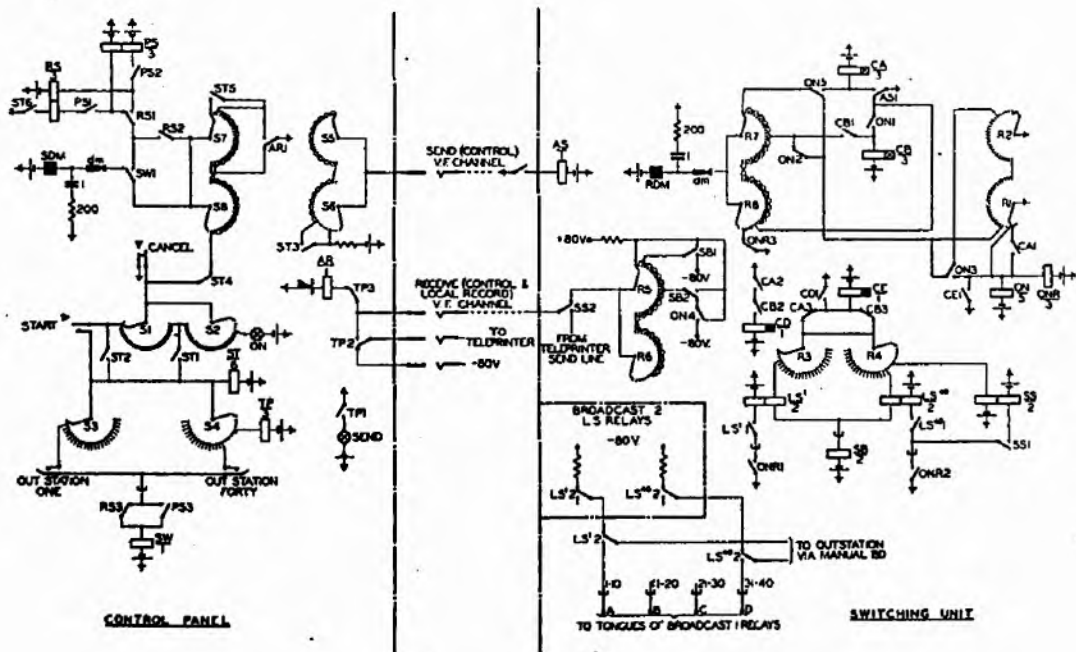

FIG. 4.—CIRCUIT ELEMENTS ASSOCIATED WITH BROADCAST 1.

to count the additional signals that are returned when the LS relays are operated and to reconnect the S uniselector driving magnet when conditions are ready for the next outlet on arc S3 to be tested. To achieve this the coils of relay PS are connected differentially so that on the first pulse relay PS operates and on the second pulse it releases. If, for example, outstation one has been selected, relay SW will have operated when the S uniselector moved from contact one to two. With SW1 operated the release of relay AR will not operate the S uniselector but will cause relay PS to operate. Owing to the S uniselector not having moved, no further signal has been sent to the switching equipment, therefore relay AS will remain released and relay CA will release after a lag. Contact CA3 will operate the appropriate line switching (LS) relay in series with relay SB. CA2 will disconnect relay CD, which will release after a lag and disconnect the operating circuit of relays LS and SB. Relay SB will release, but the LS relay will be held operated by its locking winding. The momentary operation of relay SB will send a signal back over the receive channel, which will cause relay AR to operate momentarily. The operation and release of relay AR will cause the operation of relay RS and the release of relay SW. Contact SW1 will reconnect the S uniselector magnet to AR1 and the switch will take a further step sending a signal to the selecting equipment which reoperates relays AS, CA and CD, and causes the R uniselector to take a further step. Stepping thus continues until another marked line is found, whereupon the line switching action just described is repeated.

When the R uniselector reaches the 45 contact

relay SS is operated in a similar manner to a line switching relay. The operation of SS2 switches the Receive (Control and Local Record) VF Channel to the output of the broadcast board. This changes the potential on this channel from +80V to -80V and thus restores to normal the signalling conditions ready for teleprinting.

At the control panel relay AR is operated by the -ve potential on the receive channel and AR1 causes the S uniselector to step to contact 46, thus operating relay TP. Contact TP1 lights the Send lamp and TP2 and 3 connect the teleprinter to the receive channel and release relay AR. The release of relay AR causes the S uniselector to take one more step. The lighting of the Send lamp indicates that the operator can commence to broadcast.

At the completion of sending, the set up can be cleared down by a momentary depression of the Cancel key, which releases relays ST and TP and steps the S uniselector one step. This sends a signal to the switching unit momentarily operating relay AS. Contact AS1 causes the R uniselector to take a further step and this causes relays ON and ONR to release and complete the homing circuit of the switch. The opening of contacts ONR1 and 2 releases all operated line switching relays. On restoration of the Cancel key the S uniselector restores to its home contact and both On and Send lamps are extinguished.

Both control panel and switching unit have been designed to operate from 50V D.C. and in each case this supply has been obtained from the A.C. mains by the use of metal rectifiers. The display panel lamps are fed from a 6V A.C. supply.

## The Institution of Post Office Electrical Engineers

### ELECTION OF COUNCIL. NOTICE TO MEMBERSHIP.

It is necessary to arrange for the election of representatives to the following grades for the year 1944-5 :—

Assistant Engineers, M.T.O. Class III, Chemists and Physicists (E. in C.O.) (*vice* Mr. F. C. Haliburton, promoted).

Inspectors and Assistant Chemists and Physicists (Provinces) (*vice* Mr. J. McEachan, mobilised).

Draughtsmen Class I and II (Provinces) (*vice* Capt. T. Martin, mobilised).

Nominations are accordingly invited from the membership concerned and should reach the Acting Secretary, Institute of P.O. Electrical Engineers, G.P.O., Alder House, London, E.C.1, by not later than 30th November, 1944.

The elections are governed by the provisions of Rules 16 and 24. Members should obtain the consent of any member they wish to nominate. Nominations should be made in the following manner :—

I desire to nominate Mr.....of  
.....to represent the.....  
(headquarters)  
on the Council for the year 1944-5.

Signature .....

Rank.....

H.Qrs. ....

Date .....

N.B.—The usual method of forwarding nomination forms to the membership concerned (Rule 23) is not being followed in this instance, to conserve paper supply. Ballot papers, however, will be issued in due course.

The co-operation of the membership is invited to ensure that members of the grades concerned are made aware of this change in procedure.

H. L. DUNSTER,

*Acting Secretary.*

# Notes and Comments

## Roll of Honour

The Board of Editors deeply regrets to have to record the deaths of the following members of the Engineering Department :—

*While serving with the Armed Forces or on Post Office Duty.*

Bedford Telephone Area ..	Trinder, T. H. ..	Unestablished Skilled Workman	Sergeant, Royal Air Force
Belfast Telephone Area ..	Sargent, W. L. ..	Skilled Workman, Class I ..	Sergeant Observer, Royal Air Force
Birmingham Telephone Area	Jordan, G. W. ..	Skilled Workman, Class II ..	Signalman, Royal Signals
Birmingham Telephone Area	Matthews, D. G.	Skilled Workman, Class II ..	Flight Sergeant, Royal Air Force
Birmingham Telephone Area	Moyniham, F. H.	Unestablished Skilled Workman	Flying Officer, Royal Air Force
Birmingham Telephone Area	Selwyn, H. ..	Unestablished Skilled Workman	Signalman, Royal Signals
Bournemouth Telephone Area	Wright, A. E. ..	Skilled Workman, Class II ..	Pilot Officer, Royal Air Force
Bradford Telephone Area ..	Pullan, H. ..	Unestablished Skilled Workman	Flying Officer, Royal Air Force
Brighton Telephone Area ..	Bowley, A. C. ..	Skilled Workman, Class II ..	Gunner, Royal Artillery
Brighton Telephone Area ..	Hogwood, A. R.	Unestablished Skilled Workman	Flight Sergeant, Royal Air Force
Canterbury Telephone Area	Tye, A. ..	Unestablished Skilled Workman	Corporal, Royal Signals
Edinburgh Telephone Area..	Simmonds, F. T.	Skilled Workman, Class II. ..	Regimental Q.M.S., Royal Signals
Edinburgh Telephone Area..	Simpson, R. ..	Skilled Workman, Class II ..	A.C., Class II., Royal Air Force
Engineering Department ..	Brewer, B. M. ..	Clerical Officer .. ..	Lieutenant, Duke of Wellington's Regiment
Engineering Department ..	Cumming, J. A.	Quartermaster .. ..	On Post Office Duty
Engineering Department ..	Hicks, K. A. ..	Skilled Workman, Class I ..	Sergeant, Royal Air Force
Engineering Department ..	Ovens, A. ..	Seaman .. ..	On Post Office Duty
Engineering Department ..	Parr, J. W. ..	Boatswain .. ..	On Post Office Duty
Engineering Department ..	Troops, A. E. ..	Commander .. ..	On Post Office Duty
Engineering Department ..	Wood, R. ..	Chief Officer .. ..	On Post Office Duty
Exeter Telephone Area ..	Vicary, R. G. T.	Unestablished Skilled Workman	Private, Devonshire Regiment
Glasgow Telephone Area ..	Beviridge, H. ..	Skilled Workman, Class II ..	Sergeant, Army Air Corps
Glasgow Telephone Area ..	Lindsay, D. S. ..	Skilled Workman, Class II ..	Sergeant, Royal Air Force
Glasgow Telephone Area ..	Mooney, R. L. ..	Unestablished Skilled Workman	Flying Officer, Royal Air Force
	(D.F.M.)		
Lancaster Telephone Area ..	Beattie, W. H. T.	Skilled Workman, Class II ..	Flight Sergeant, Royal Air Force
Lincoln Telephone Area ..	Harris, J. ..	Unestablished Skilled Workman	Sergeant, Royal Air Force
Liverpool Telephone Area	Corson, L. ..	Skilled Workman, Class II ..	Ordinary Telegraphist, Royal Navy
Liverpool Telephone Area ..	Hardy, L. T. ..	Unestablished Skilled Workman	Sub-Lieutenant, Fleet Air Arm
London Postal Region ..	Hawke, A. J. ..	Skilled Workman, Class I ..	On Post Office Duty
London Postal Region ..	Smith, C. W. ..	Labourer.. ..	On Post Office Duty
London Telecommunications Region	Apps, D. W. ..	Skilled Workman, Class II ..	Signalman, Royal Signals
London Telecommunications Region	Baldry, J. J. ..	Unestablished Skilled Workman	Signalman, Royal Signals
London Telecommunications Region	Cooper, J. W. E.	Unestablished Skilled Workman	Sergeant, Royal Air Force
London Telecommunications Region	Craig, A. V. ..	Unestablished Skilled Workman	On Post Office duty
London Telecommunications Region	Ellis, P. H. ..	Unestablished Skilled Workman	Signalman, Royal Signals
London Telecommunications Region	Kennedy, W. E.	Skilled Workman, Class II ..	2nd Lieutenant, Royal Fusiliers
London Telecommunications Region	Lansley, G. F. ..	Labourer.. ..	Private, Royal Fusiliers

London Telecommunications Region	Mair, A.	..	Unestablished Skilled Workman	Pilot Officer, Royal Air Force
London Telecommunications Region	Morgan, F. P.	..	Skilled Workman, Class II	Signalman, Royal Signals
London Telecommunications Region	Newton, E. C. W.		Unestablished Skilled Workman	Flight Sergeant, Royal Air Force
London Telecommunications Region	Phillips, C. E.	..	Skilled Workman, Class II	Signalman, Royal Signals
London Telecommunications Region	Phillips, C. J.	..	Labourer	Private, Border Regiment
London Telecommunications Region	Porter, K. L.	..	Youth-in-Training	Pilot Officer, Royal Air Force
London Telecommunications Region	Roberts, J.	..	Skilled Workman, Class II	Driver, Royal Army Service Corps
London Telecommunications Region	Saile, E. G. W.		Unestablished Skilled Workman	Signalman, Royal Signals
London Telecommunications Region	Shimeild, E. H.	..	Unestablished Skilled Workman	Sergeant, Royal Air Force
London Telecommunications Region	Smeaton, D. G.	..	Unestablished Skilled Workman	Private, Argyll and Sutherland Highlanders
London Telecommunications Region	Spearman, A. F. L.	..	Labourer	Sapper, Royal Engineers
London Telecommunications Region	Taylor, W. H.	..	Labourer	Private, Dorsetshire Regiment
London Telecommunications Region	Vaughan, K. R.	..	Unestablished Skilled Workman	Sergeant, Dragoon Guards
London Telecommunications Region	Wheeler, R. W.		Unestablished Skilled Workman	Flying Officer, Royal Air Force
Middlesbrough Telephone Area	Hornsby, J. S.	..	Labourer	Sergeant, Royal Air Force
Newcastle - on - Tyne Telephone Area	Peel, P. H.	..	Unestablished Draughtsman	Lance Corporal, Royal Engineers
Nottingham Telephone Area	Edmonds, C. R.	..	Unestablished Skilled Workman	Sub-Lieutenant, Fleet Air Arm
Nottingham Telephone Area	Morrell, G. C. R.		Unestablished Skilled Workman	Sub-Lieutenant, Royal Navy
Nottingham Telephone Area	Stalvies, B. W. H.		Unestablished Skilled Workman	Pilot Officer, Royal Air Force
Reading Telephone Area	Raggett, A. E.	..	Unestablished Skilled Workman	Trooper, Nottinghamshire Yeomanry
Scotland West Telephone Area	Couser, A. C.	..	Skilled Workman, Class II	3rd Officer, Air Transport Auxiliary
Sheffield Telephone Area	Stafford, W. A.	..	Unestablished Skilled Workman	Signalman, Royal Signals
Tunbridge Wells Telephone Area	Scott, A. J.	..	Unestablished Skilled Workman	Pilot Officer, Royal Air Force

### Recent Awards

The Board of Editors has learnt with great pleasure of the honours recently conferred on the following members of the Engineering Department:—

#### *While serving with the Armed Forces, including Home Guard*

Aberdeen Telephone Area	..	Smith, R.	..	Skilled Workman, Class I	Petty Officer, Royal Navy	British Empire Medal
Engineering Department	..	Hickox, A. J. L.	..	Unestablished Skilled Workman	Flying Officer, Royal Air Force†	Distinguished Flying Cross
Leicester Telephone Area	..	Kersey, A. G.	..	Skilled Workman, Class I	Sergeant, Royal Artillery	Mentioned in Despatches
London Telecommunications Region		Boys, C. E.	..	Inspector	.. Major, Royal Signals	Military Cross
London Telecommunications Region		Bull, W. T.	..	Labourer	.. Chief Petty Officer, Royal Navy	George Medal
London Telecommunications Region		Cox, K. R.	..	Unestablished Skilled Workman	Flying Officer, Royal Air Force	Distinguished Flying Cross

London Telecommunications Region	Hogg, N. V.	..	Skilled Workman, Class II	Sergeant, Royal Signals	Mentioned in Despatches
Manchester Telephone Area	Guy, W.	..	Skilled Workman, Class II	Signalman, Royal Signals	Mentioned in Despatches
Manchester Telephone Area	Mackie, G. L.	..	Skilled Workman, Class II	Corporal, Royal Signals	Mentioned in Despatches
Manchester Telephone Area	Mycoe, F.	..	Skilled Workman, Class II	Flight Sergeant, Royal Air Force	Distinguished Flying Medal
Manchester Telephone Area	Yates, A. E. H.	..	Skilled Workman, Class I	Corporal, Royal Signals	Mentioned in Despatches
Nottingham Telephone Area	Howard, G.*	..	Unestablished Skilled Workman	Lance Corporal, Royal Signals	Military Medal
Portsmouth Telephone Area	Collins, G. H.	..	Skilled Workman, Class I	Company Q.M.S., Home Guard	British Empire Medal
Stoke-on-Trent Telephone Area	Davenport, W.	..	Skilled Workman, Class II	Pilot Officer, Royal Air Force	Distinguished Flying Cross
Tunbridge Wells Telephone Area	Lloyd, T. A.	..	Unestablished Skilled Workman	Sergeant Pilot, Royal Air Force	Distinguished Flying Medal
Tunbridge Wells Telephone Area	Upchurch, S.W.J.	..	Inspector	Flight Lieutenant, Royal Air Force	Distinguished Flying Cross

\* Awarded posthumously.

† Now Flight Lieutenant.

### Birthday Honours

The Board of Editors offers its sincere congratulations to the following members of the Engineering Staff who have been honoured by H.M. the King in the Birthday Honours List :—

Bristol Telephone Area	..	Winckworth, S. E.	..	Inspector	..	British Empire Medal
Engineering Department	..	Reid, Col. F., M.C., T.D.	..	Staff Engineer	..	Commander of the Order of the British Empire
Engineering Department	..	Blackhall, W. A. C.	..	Inspector	..	British Empire Medal
Gloucester Telephone Area	..	Sceats, F. W.	..	..	..	Chief Inspector
					..	Member of the Order of the British Empire
Hull Telephone Area	..	Taylor, W. E.	..	..	..	Inspector
London Telecommunications Region	..	Conner, C. H.	..	..	..	Inspector
					..	British Empire Medal
Nottingham Telephone Area	..	Lane, V. E.	..	..	..	Inspector
					..	British Empire Medal

### Recent Appointments

We are pleased to note the following appointments of engineering personnel to the higher engineering and administrative posts :—Dr. W. G. Radley, who becomes Controller of Research, a new post ; Mr. J. Morgan and Mr. E. A. Speight, who in addition to holding the posts of Chief Regional Engineer in the Welsh and Border Counties Region and Midland Region respectively are appointed

as Deputies to the Regional Directors of these regions ; Mr. A. C. Warren, who succeeds Mr. J. Morgan as Chief Regional Engineer of the South-Western Region.

Paper restrictions prevent us from publishing personal paragraphs as was our custom in pre-war days, but our congratulations are none the less sincere.

## Regional Notes

### Home Counties Region

#### FLYING-BOMB VISITS A U.A.X.

One of the considered requirements for the efficient working of a U.A.X. is that it should be housed in a reasonably substantial and weatherproof building, but the recent experience at a village "somewhere in Southern England" must surely be unique in the history of this type of telephone exchange, though not recommended as an alternative to a well constructed building.

At 5.55 p.m. on July 11th, 1944, news was received that a flying-bomb had fallen near a U.A.X. and that the exchange was isolated.

The U.A.X. has seven outlets to its parent auto exchange, two to a manual exchange some four miles to the north, and four to another manual exchange some five miles to the south. As no route was operative and the only spot where all three routes ran together was either in the U.A.X. itself or in a short length of cable route from the adjoining road through the garden of the U.A.X. it was quite apparent that the damage was at the site of the U.A.X. itself.

Immediate arrangements were made for staff and certain essential stores to be conveyed to the scene and a speedy journey made in advance of staff, to ascertain extent of damage. The sight which greeted the eye as one approached the building, or all that was left of it, banished at first any hope one might have entertained of salvaging anything, much less restoring the "service" with the existing plant. Two walls had completely disappeared and what little was left of the other two was more of a danger to life and limb than any value as part of an exchange building.



The roof, completely bereft of its tiles and some of its timbers, was resting not on the walls but on top of the units themselves and these units were leaning over some 15 degrees from the upright and gradually slipping over carrying the roof with them. In fact the local policeman and the warden in charge of the rescue squad who were on the scene strongly urged that the Department's engineers should keep well away, as there was no hope of saving a complete collapse of roof, units and everything else. The desire to restore 'essential' circuits and save what one could of the apparatus was, however, too strong to heed these warnings, and observing that the tie bar normally fixed to the wall to stabilise the units in an upright position was still bolted to the units—the emergency gang arriving at that moment—several ropes were made fast to the

tie bar and fixed to crowbars driven into the field adjoining. Then, in spite of ominous creaks and loud cracks from the roof, the units were gently hauled back to an upright position and rescue squad instructed to prop up the roof on the side away from the units to prevent it slipping again.

While that was being done, the main frame unit was cleared of the surrounding rubble and access to subscribers' circuits gained. It was decided that as many as possible of the essential subscribers should be given service via distant exchanges and staff was hurriedly despatched to these exchanges to convert the junctions to subscribers' ends and the 'essential' subscribers were joined through on the main frame of the damaged exchange. The first of these was working at approximately 10 p.m. and the remainder, i.e. some twelve subscribers, including a "Bureau" telephone, installed at the same time in the village school-house about a mile away in the following hour.

In the meantime, it was discovered that a good number of the secondary cells had been smashed and acid had flooded the floor. The local village grocer was roused from his sleep with a request for all the washing soda he could spare. His total stock of 20 lb. was obtained and a supply of water procured from a mansion some mile away. This was used to neutralise the acid to enable staff to work.

When the building was struck the overhead power line, from which the U.A.X. is served, was also severed, and the power feed, meters, and switches were discovered in the adjoining field. After an examination it was found that the power board and charging panel could be made to work and sufficient cells were rescued to form a complete single battery to serve the exchange, if the apparatus could be made to work.

Prior to this, advice had been given to headquarters of the occurrence and a tentative request made for the supply of a mobile U.A.X.

A portable charging set was obtained from Area Headquarters and battery put on charge on its arrival. When the acid was cleared away and units were in an upright position the latter were examined and at first survey looked hopeless. The cases were dented and covers wrenched away and buckled, switches and relay sets in many cases hanging on by wiring and giving the impression that they were destined for the scrap heap only. However, with the aid of several hand torches the switches and relay sets were carefully restored to position, and by the splendid efforts of three good auto men, were adjusted to work again.

By 4 a.m. the next morning, i.e. 10 hours after building was wrecked, every subscriber whose external circuit was intact, a total of 127 subscribers, was working as well as junctions working normally on the restored apparatus, in fact, only a very small percentage of the subscribers to the exchange were aware that the service had been interrupted.

The exchange was working with only a roof overhead protected by tarpaulins and one or two tarpaulin covers draping two sides.

Prior to the rescue squad—a local builder and his men—leaving that night, they were instructed to procure several good timber struts and lifting jacks and to proceed early next morning to lift the roof and secure it above the units with a view to enclosing the sides with some material, wood, or even temporary brick walls, to enable the exchange to continue to function.

Next morning the scene was visited by an architect from Headquarters and his advice sought as to stability of roof and the possibility of rebuilding the walls under

the roof. After a thorough examination he decided that with replacement of missing roof timbers and the immediate rebuilding of walls the structure could be



reinstated and the local builder proceeded with the work that same hour. Being unable to obtain Moler blocks for inside walls a local absorbent "white" brick was used and one window aperture bricked up pending cessation of the war. To obtain ventilation and occasional natural light it was also decided to dispense with glazing in the other window and fix wooden "panes" instead.

Continuous engineering attendance was maintained at the exchange until July 27th, but except for one or two minor faults, common to any exchange, the apparatus has continued to function correctly. Every portion of apparatus and wiring has been examined and many broken parts discovered, for instance, most of the tag blocks are broken or cracked, but still work; bolts holding the mountings to cabinets have sheared off, but the mountings remained in position, fuse mountings had become detached, but kept in service until refixed.

Power was restored to the exchange on July 14th, a short pole being erected outside the building and a rough but weatherproof box affixed to take the meters and switches, temporary leads being run from this into the exchange.

By July 14th two of the new walls had been erected and door frame was in position, and by July 26th the whole of the walls had been rebuilt, and the roof lowered to its normal position. On removal of the tarpaulins from the roof it was found that considerable additional damage and displacement to the timbers had occurred. These were replaced or refitted, the full restoration of the building except for painting, being effected by August 2nd, three weeks from the date of the unwelcome visit of the flying bomb.

Unfortunately, it was not possible to get a photograph of the building when the damage was first seen, but the associated photographs taken on the 12th give some idea of the state of the building.

The account would not be complete without a word of tribute to the builder who tackled the raising of the roof with great skill and determination and made the building weatherproof pending permanent repairs under very difficult circumstances, and despite the many calls for his services in the locality, restored the building so expeditiously.

## North Eastern Region

### DARLINGTON EXCHANGE TRANSFER.

Darlington Exchange was transferred on June 10th, 1944, from the Old Western Electric Rotary system to a standard Strowger non-director system manufactured by G.E.C. and installed in a new building devoted solely to telecommunications. The erection of the building, begun in 1939, was delayed as a consequence of the war necessitating, in 1942, the extension of a relief suite of C.B.10 switchboards installed in 1938, while at the same time the manual switchroom had to be enlarged to cater for more trunk sections. Installation of the new auto equipment commenced in December, 1942, and proceeded steadily throughout 1943, but various associated works were delayed from time to time due to the withdrawal of skilled labour to other more urgent works. Apart from cable diversion and modifications at out-exchanges it was necessary to fit new dials at all subscribers' dialling points, as the impinging ratio of the dials used on the standard Strowger system is different from that on the Western Rotary. Lack of sufficient operators to staff the new manual board necessitated deferring conversion of coin box stations—all of which were connected to the C.B. 10 relief suite—to the last two pre-transfer weeks. They were then permanently connected to their uniselectors at the new exchange and the coin box "0" level junctions temporarily extended via change-over keys to the old manual switchboard.

At the time of the transfer more than 1,500 lines were connected to the rotary plant and more than 800 to the C.B.10 relief suite. The new exchange is cabled to serve 4,000 subscribers' lines and there are 27 operators' positions in the manual switchroom. The transfer gave 13 manual exchanges and 10 U.A.X.'s facilities for dialling into Darlington, and Darlington subscribers who previously had no dialling-out facilities were enabled to dial two manual exchanges and one U.A.X.

In the final stages there was evidence that ties of affection do develop between men and machines and that the gain of a new and modern exchange does not immediately relieve the regrets at parting from an old, though very troublesome, mechanical colleague.

F. W. A.

## Welsh and Border Counties Region.

### RETIREMENT OF MR. J. H. WATKINS, M.C.

The retirement of Mr. J. H. Watkins, M.C., on 30th September, 1944, at the age of 61, marks the departure of one more of the few remaining stalwarts who came to the Post Office from the National Telephone Company at the transfer. As his connection with telecommunications dates back to the beginning of the century, Mr. Watkins has seen some remarkable developments in the art during his career. After service in France during the Great War he gained a wide experience in various phases of telephone work in London and in 1929 was promoted to be Sectional Engineer, Bangor. Advancement to the rank of Assistant Superintending Engineer, North Wales District followed in 1935 and to Chief Regional Engineer, Welsh and Border Counties Region, in 1943. All grades of the staff wish him a long and happy retirement.



# Staff Changes

## Promotions

Name	Region	Date	Name	Region	Date
<u>Area Engr. to T.M.</u>			<u>Insp. to Chief Insp.—contd.</u>		
Lister, B.	H.C.R. to Cardiff	10.8.44	Baker, H.	E.-in-C.O.	14.6.44
<u>Asst. Engr. to Exec. Engr.</u>			Maynard, R. R. J.	S.W. Reg.	16.7.44
Burton, J. P.	N.W. Reg.	6.6.44	Jones, C. W.	N.W. Reg.	30.7.44
Combridge, J. H.	E.-in-C.O.	14.7.44	Heenan, J. P.**	N.E. Reg.	13.8.44
Maddison, W. H.**	E.-in-C.O.	14.7.44	Finney, P.	N.W. Reg.	13.8.44
Parker, J. D., M.B.E.**	E.-in-C.O.	14.7.44	Welburn, R.	H.C. Reg.	16.7.44
Smith, P. E. C.**	E.-in-C.O.	14.7.44	Soar, W. D.	E.-in-C.O.	9.8.44
Mabe, W. S.	L.T.R. to E.-in-C.O.	14.7.44	Pollard, A. J.	E.-in-C.O.	28.7.44
Haliburton, F. C.	E.-in-C.O.	18.7.44	Bronsdon, E. G.	E.-in-C.O.	8.8.44
<u>Chief Insp. to Asst. Engr.</u>			Cranston, W. D.	E.-in-C.O.	6.3.44
Sinstead, H. A.	L.T.R.	6.6.44	Bentley, W. C. B.	E.-in-C.O.	29.8.44
Dickenson, C. R.	S.W. Reg.	5.6.44	Green, D.	N.E. Reg.	9.7.44
Barratt, J. W.**	N.E. Reg.	23.7.44	<u>S.W.1 to Insp.</u>		
Wardrop, C. G.**	N.E. Reg.	30.7.44	Williamson, C. C.	E.-in-C.O.	1.6.44
Taylor, I.	N.W. Reg.	30.7.44	Stanley, E. R.	Mid. Reg. to E.-in-C.O.	12.6.44
Conn, C. A.	E.-in-C.O.	12.7.44	Owens, J. J.	N. Ire. Reg. to E.-in-C.O.	18.6.44
Smart, J. H. C.	N.W. Reg. to Mid. Reg.	23.7.44	Ilett, N. J.	H.C. Reg. to E.-in-C.O.	18.6.44
Williams, L. A.	E.-in-C.O.	14.7.44	McNab, A. M.	Sc. Reg. to E.-in-C.O.	1.7.44
Manners, W.**	W. & B.C. Reg.	13.8.44	Hammersley, D. E.	Mid. Reg. to E.-in-C.O.	11.6.44
Tuck, R. O.	N.W. Reg. to W. & B. Reg.	13.8.44	Smith, T. E.	Mid. Reg. to E.-in-C.O.	16.7.44
Williams, W.	E.-in-C.O.	28.7.44	Hart, G. B. G.	N.E. Reg. to E.-in-C.O.	25.6.44
Abel, G. P.	W. & B.C. Reg.	2.8.44	French, J. A. T.	E.-in-C.O.	30.7.44
Atkinson, J.	H.C. Reg. to L.T.R.	6.8.44	<u>Chief Officer to Commander</u>		
Fleetwood, C. H. J.	E.-in-C.O.	5.6.44	Betson, J. P. F.	H.M.C.S.	14.6.44
<u>Insp. to Chief Insp.</u>			<u>Second Officer to Chief Officer</u>		
Bunn, C. G.	S.W. Reg.	25.5.44	Finlayson, I. R.	H.M.C.S.	1.5.44
Chisnall, W. E.**	E.-in-C.O.	1.4.44	<u>Draughtsman, Class I, to Senior Draughtsman</u>		
Donaldson, A. L.**	E.-in-C.O.	1.4.44	Downard, F.	N.E. Reg.	1.7.44
Lucas, V. F.	H.C. Reg.	7.6.44	<u>Draughtsman, Class II, to Draughtsman, Class I</u>		
Callon, E.	N.E. Reg.	8.4.44	Sweeney, E. J. S.	N.W. Reg. to Mid. Reg.	1.6.44
Winckworth, S. E.	S.W. Reg.	5.6.44	Clement, N. C.	Mid. Reg. to S.W. Reg.	6.6.44
Pearce, H. S.	L.T.R.	13.6.44	Lewis, L. W.	H.C. Reg. to N.E. Reg.	12.6.44
Williamson, F. R.	Scot. Reg.	18.6.44	Guthrie, D. E.	L.T.R. to H.C. Reg.	3.7.44
Manning, G. A.	E.-in-C.O.	1.4.44	Whitaker, F. H.	N.E. Reg.	1.7.44
Peters, B.	E.-in-C.O.	4.2.44			
Walton, J. M.	E.-in-C.O. to Scot. Reg.	11.6.44			

## Retirements

Name	Region	Date	Name	Region	Date
<u>Exec. Engr.</u>			<u>Insp.</u>		
Powell, H. W.	N.W. Reg.	31.5.44	Robbins, E. H.	L.T.R.	30.6.44
Mobbs, H. J.	E.-in-C.O.	15.6.44	Wise, J. W.	L.T.R.	6.7.44
Stollard, A. E.	Mid. Reg.	14.7.44	Mansfield, A. H.	S.W. Reg.	6.7.44
<u>Asst. Engr.</u>			Bowden, H. J. B.	S.W. Reg.	3.7.44
Bothwell, A. D.	E.-in-C.O.	30.6.44	Beresford, T. W.	Mid. Reg.	9.8.44
Miller, A.	L.T. Reg.	31.7.44	Corner, W. H.	N.E. Reg.	30.6.44
<u>Chief Insp.</u>			Gadd, P. E.	L.T.R.	21.6.44
Robertson, J.	Scot. Reg.	30.4.44	McNamara, W. H.	S.W. Reg.	30.6.44
Bellet, F. W.	Scot. Reg.	30.6.44	McDonald, J. W.	S.W. Reg.	30.6.44
Slocombe, A. E.	L.T.R.	29.6.44	Bridgman, B. B.	S.W. Reg.	24.6.44
Lockie, R. A.	L.T.R.	31.8.44	<u>Senior Draughtsman</u>		
			Warrant, H. T.	N.E. Reg.	5.6.44

### Transfers

Name	Region	Date	Name	Region	Date
<i>Exec. Engr.</i>			<i>Insp.</i>		
Evans, G. ..	E.-in-C.O. to Mid. Reg.	15.7.44	Barron, H. ..	E.-in-C.O. to N.W. Reg.	4.6.44
Chapman, R. H. ..	E.-in-C.O. to H.C. Reg.	15.8.44	Worts, W. G. ..	E.-in-C.O. to L.T.R.	2.7.44
<i>Asst. Engr.</i>			<i>Chief Insp.</i>		
Smith, R. ..	Mid. Reg. to N.E. Reg.	12.6.44	Dean, J. E. ..	E.-in-C.O. to H.C. Reg.	20.8.44
Thompson, J. O. ..	Scot. Reg. to E.-in-C.O.	25.6.44	Prichard, E. J. ..	E.-in-C.O. seconded to Palestine Service	17.5.41
<i>Chief Insp.</i>			<i>Insp.</i>		
Barrass, J. A. ..	Scot. Reg. to N.W. Reg.	18.6.44	Freshwater, R. A. A.	E.-in-C.O. to L.T.R.	6.9.44
Jago, R. T. ..	H.C. Reg. to L.T.R.	30.6.44	Neill, T. B. M. ..	L.T.R. to E.-in-C.O.	3.9.44
Kirkham, W. D. ..	E.-in-C.O. to H.C. Reg.	1.8.44	Nesbitt, W. R. ..	E.-in-C.O. to S.W. Reg.	25.6.44
Philipson, W. ..	Scot. Reg. to N.W. Reg.	31.7.44	Brough, R. ..	E.-in-C.O. to Scot. Reg.	16.7.44

### Deaths

Name	Region	Date	Name	Region	Date
<i>Commander</i>			<i>Boatswain</i>		
Troops, A. E. ..	H.M.C.S. ..	13.6.44	Parr, T. W. ..	H.M.C.S. ..	14.6.44
<i>Chief Officer</i>			<i>Chief Insp.</i>		
Wood R. ..	H.M.C.S. ..	13.6.44	Spice, W. H. J. ..	L.T.R. ..	21.7.44
<i>Quartermaster</i>			<i>Insp.</i>		
Cumming, J. A. ..	H.M.C.S. ..	19.6.44	Yates, A. W. J. J. ..	E.-in-C.O. ..	3.7.44
<i>Seaman</i>			<i>Insp.</i>		
Ovens, A. ..	H.M.C.S. ..	13.6.44	Parr, F. T. ..	L.T.R. ..	7.7.44
			Harris, F. ..	L.T.R. ..	20.7.44

### CLERICAL GRADES

#### Promotions

Name	Region	Date	Name	Region	Date
<i>C.O. to E.O.</i>			<i>C.O. to E.O. (continued)</i>		
Dinsmore, L. ..	E.-in-C.O. ..	7.6.44	Coe, G. M. M. (Miss) ..	E.-in-C.O. ..	7.6.44
John, B.** ..	E.-in-C.O. ..	7.6.44	Howe, W. G. J. ..	W. & B.C. Reg. ..	14.6.44
Attrill, R. A.** ..	E.-in-C.O. ..	7.6.44	Peak, H. C. H. ..	E.-in-C.O. ..	6.7.44

\*\* Mobilised (promoted in absentia).

#### BOARD OF EDITORS

A. J. GILL, B.Sc., M.I.E.E., F.I.R.E., Chairman.  
 F. E. NANCARROW, O.B.E., A.R.C.Sc., M.I.E.E.  
 P. B. FROST, B.Sc., M.I.E.E.  
 A. H. MUMFORD, B.Sc.(ENG.), M.I.E.E.  
 C. W. BROWN, A.M.I.E.E.  
 G. H. S. COOPER.  
 H. LEIGH, B.Sc.(ENG.), A.M.I.E.E., Acting Managing Editor.  
 G. E. STYLES, A.M.I.E.E., Acting Assistant Editor.  
 A. J. BAKER, Secretary-Treasurer.

#### Copyright

The entire contents of this JOURNAL are covered by general copyright, and special permission is necessary for reprinting long extracts, but Editors are welcome to use not more than one-third of any article, provided credit is given at the beginning or end thus: "From the *Post Office Electrical Engineers' Journal*."

The Board of Editors is not responsible for the statements made or the opinions expressed in any of the articles in this JOURNAL, unless such statement is made specifically by the Board.

#### Communications

All Communications should be addressed to the Managing Editor, *P.O.E.E. Journal*, Engineer-in-Chief's Office, Alder House, Aldersgate Street, London, E.C.1. Telephone: HEADquarters 1234. Remittances should be made payable to "*The P.O.E.E. Journal*" and should be crossed " & Co."

#### Back Numbers

The price of the JOURNAL, which is published quarterly, is 1s. (1s. 3d. post free) per copy, or 6s. per annum post free. Back numbers can be supplied, subject to availability of stocks, at 1s. each (1s. 3d. post free). Orders for back numbers may be sent to the Local Agents or to the Publishers.

#### Advertisements

All communications relating to space reservations should be addressed to the Advertisement Editor, *P.O.E.E. Journal*, Alder House, Aldersgate Street, London, E.C.1. Communications regarding advertisement copy, proofs, etc., should be addressed to the Publishers, Messrs. Birch & Whittington (Prop. Dorling & Co. [Epsom], Ltd.), 49 Upper High Street, Epsom, Surrey.

*So much depends on them*



"AVO" Electrical Testing Instruments are actively engaged on the fighting and factory fronts, sharing a great responsibility with a proud sense of duty and high confidence in the future.

*It will therefore be appreciated by our numerous trade friends that we can now only accept orders which bear a Government Contract Number and Priority Rating.*



Sole Proprietors and Manufacturers  
THE AUTOMATIC COIL WINDER AND ELECTRICAL EQUIPMENT CO. LTD.  
Winder House, Douglas Street, London, S.W.1  
Phone: VICToria 3404-8

## These dials will interest you:—

DIALS & DRIVES: TYPES D-115-A & D-206-A.

TYPE D-115-A employs a 20:1 worm reduction gear providing a right-angle drive for two components. TYPE D-206-A employs a 20:1 spur reduction gear providing a single in-line drive.

### OUTSTANDING FEATURES:—

- High reading and setting accuracy by means of a dial embodying an adding mechanism—effective scale length over 12 ft. with 500 divisions.
- Gears spring-loaded to reduce backlash.
- Rugged die-cast construction and substantial bearings for long and continuous service.
- Shafts:  $\frac{1}{4}$  in. diameter and  $\frac{9}{16}$  in. projection.
- Finish: gunmetal with engraving filled white.
- Weight: 2 $\frac{1}{2}$  lb.

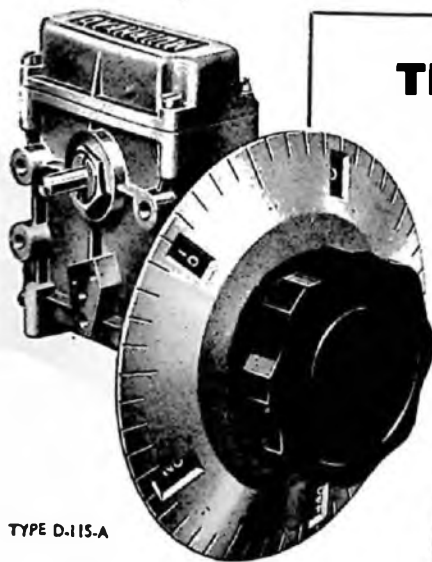

TYPE D-115-A

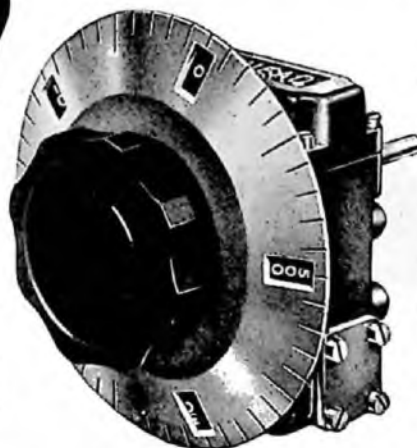

TYPE D-206-A

# MUIRHEAD

MUIRHEAD & COMPANY, LTD., ELMERS END  
BECKENHAM, KENT · BECKENHAM 0011-2

FOR OVER 60 YEARS DESIGNERS AND MAKERS OF PRECISION INSTRUMENTS

C.B.C. 51

*Clip-on*

# FOR EASY CURRENT MEASUREMENTS

in Busbars, Fuses and Cables up to 2½" diam.

- DUAL RANGE WITH SELECTOR SWITCH
- FULLY INSULATED CORE AND HANDLE

# FERRANTI

DUAL RANGE

## *Clip-on* AMMETER

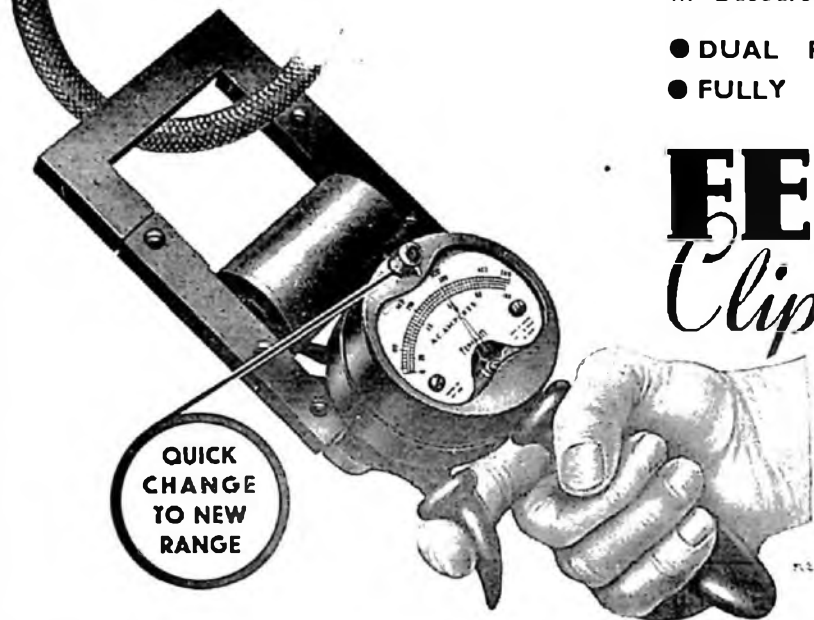

### RANGES

- 0— 10— 50 Amps.
- 0— 20— 100 Amps.
- 0— 50— 250 Amps.
- 0— 100— 500 Amps.
- 0— 200— 1000 Amps.

11 50a

FERRANTI LIMITED, Hollinwood, Lancs.

London Office : Kern House, Kingsway, W.C.2

## TURNER DIFFERENTIAL MILLIAMMETERS G.P.O. No. 17 & No. 18

Meet the most exacting demands for balancing currents in multiplex telegraph circuits.

— A quality product of outstanding merit —

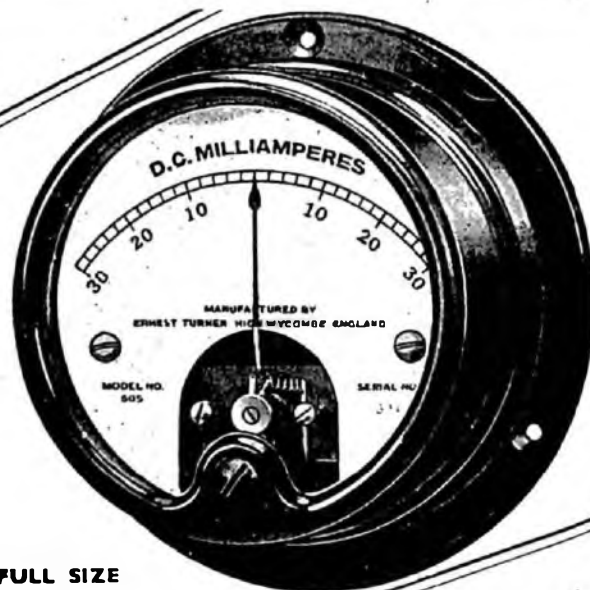

FULL SIZE

Also manufacturers of G.P.O. Detector No. 4, and a comprehensive line of instruments for precision electrical measurements.

### ERNEST TURNER ELECTRICAL INSTRUMENTS, Ltd.

CHILTERN WORKS,  
49-73 TOTTERIDGE AVENUE,  
HIGH WYCOMBE,  
BUCKS, ENGLAND.

Telephone : High Wycombe 1301, 1302.  
Telegrams : Gorseous High Wycombe.

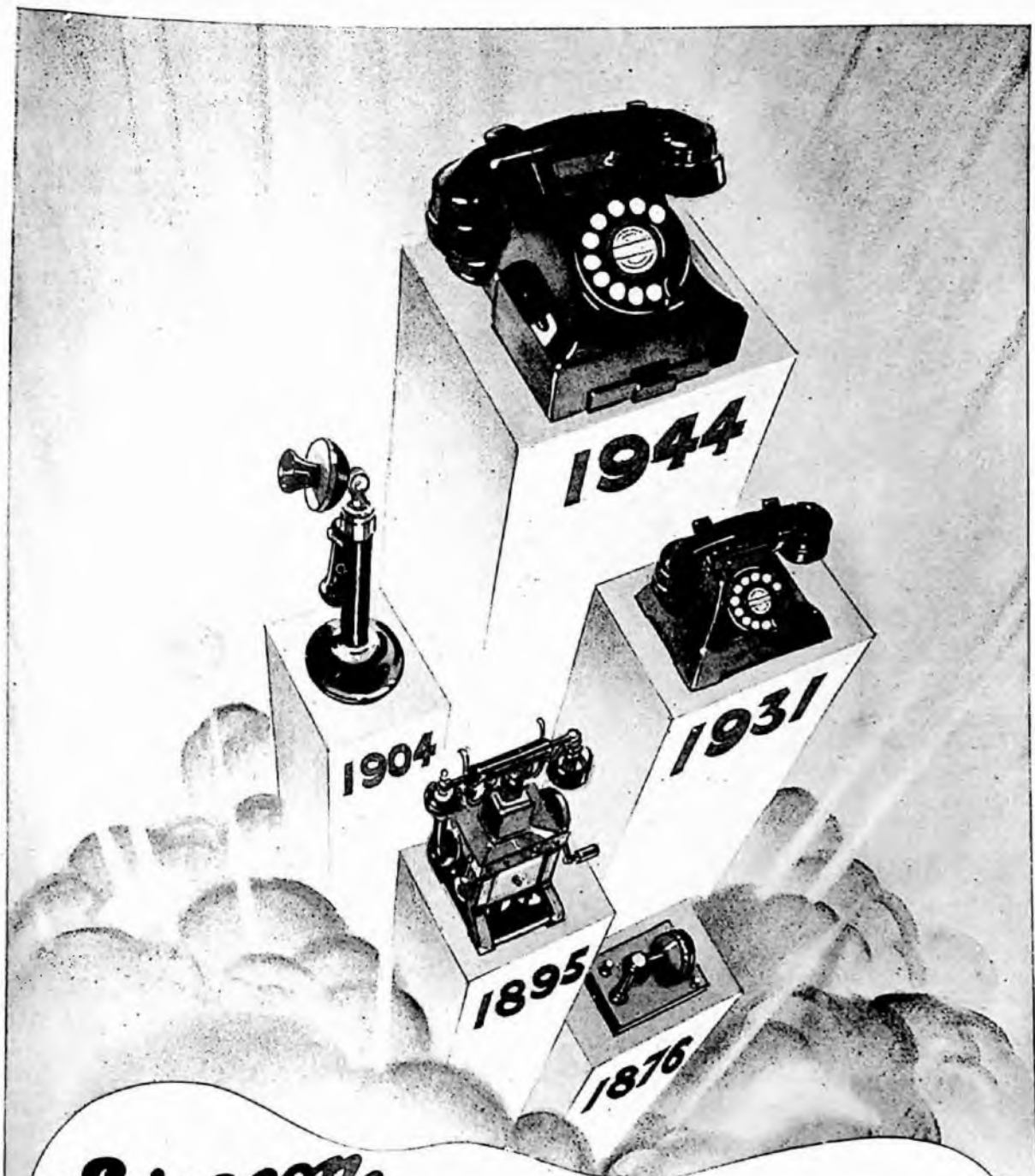

# *Ericsson*

66 years of steady progress in telephony and its applications sees Ericssons in their extensive plant to-day utilising Modern Plastics for the improvement of telephone design and efficiency. Ericssons have unrivalled experience in

the production of telephone equipment required to function under tropical and similar extreme conditions—taking full advantage of the application of Plastics in this connection. Enquiries welcomed.

ERICSSON TELEPHONES LTD., Head Office: 56, Kingsway, London, W.C.2. Tel.:—HOL. 6936. Works Beeston, Notts.

WAVE METERS

OSCILLATORS

CONDENSERS

INDUCTANCES

RESISTANCES

**H. W. SULLIVAN**  
— LIMITED —

London, S.E.15

Tel. New Cross 3225 (Private Branch Exchange)

## Electrical Standards for Research and Industry

Testing and Measuring Apparatus  
for Communication Engineering

BRIDGES — Capacitance  
Inductance  
Resistance

ALL TYPES — ALL FREQUENCIES — ALL ACCURACIES

## Hall Telephone Accessories (1928) Limited

Contractors to H.M. Post Office, Admiralty, War  
Office, Air Ministry, and Colonial and Foreign  
Administrations.

*Precision Engineers & Instrument Makers*

Manufacturers of Prepayment Telephone Multi-  
Coin Collectors, Gas Leak Indicators, Automatic  
Stamp Selling and Ticket Selling Machines,  
Automatic Slot Machines and Fire Alarm  
Apparatus.

*Enquiries Invited.*

*Registered Office and Works:—*

**DUDDEN HILL LANE, WILLESDEN,  
LONDON, N.W.10**

Tel. WILLESDEN 5141, etc. Also DOWLAIS, GLAM.

## RELAYS



The illustration shows mechanism of Time Delay Relay PRL driven by synchronous motor (without base plate and cover). Six types cover between them a range from 2 seconds to 28 days. All types reset instantaneously.

Wide range of other relays for A.C. and D.C.

Ask for leaflet 97/PO.

## PROCESS TIMERS

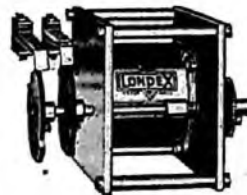

The illustration shows mechanism of Process Timer PR/S driven by synchronous motor (without base plate and cover). This type as well as a wide range of others are fitted with easily interchangeable gearing. Up to 20 circuits can be controlled, each circuit with different time characteristics.

Ask for leaflet 92 B/PO.

**LONDEX LTD**

*Electrical Remote Control  
Engineers & Manufacturers*  
Anerley Wks. 207 Anerley Rd. London S.E.7  
Phone 5701 (4 lines) 6258 9

# SIEMENS PRODUCTS

*backed by over 80 years' Electrical Experience*

Contractors for the manufacture, laying and maintenance of Submarine and Land Cables for Telegraphy, Telephony and the Electric Transmission of Power, for the erection and maintenance of Overland Telegraph, Telephone and Power Transmission Lines, Marine Wireless Telegraph and Telephone Installations, Public and Private Telephone Exchanges and Carrier Equipment for Telephone Lines.

### Manufacturers of

Electric Lamps of all types for Domestic, Industrial and Street Lighting, including "Sieray" Electric Discharge Lamps, Fluorescent Tubes, Motor Car Lamps, Projectors, etc.



**ELECTRIC  
WIRES & CABLES**

**CABLE  
JOINT BOXES**

**TELEPHONE CABLES**  
Aerial, Underground, Submarine

**OVERHEAD  
LINE MATERIAL**

**CELLS & BATTERIES**  
Dry, Fluid & Inert

**ELECTRICAL  
MARINE APPARATUS**

**ELECTRIC  
LAMPS**

**PRIVATE  
TELEPHONE SYSTEMS**

**PUBLIC  
TELEPHONE EXCHANGES**

**CARRIER-CURRENT  
EQUIPMENT**

**WIRELESS EQUIPMENT  
FOR SHIPS**

**"ZED" FUSES  
L.T. SWITCH & FUSE GE**

**SIEMENS BROTHERS & CO., LTD.**  
**WOOLWICH, LONDON, S.E. 18**

SIEMENS ELECTRIC LAMPS & SUPPLIES LTD., 38-39 UPPER THAMES STREET, LONDON

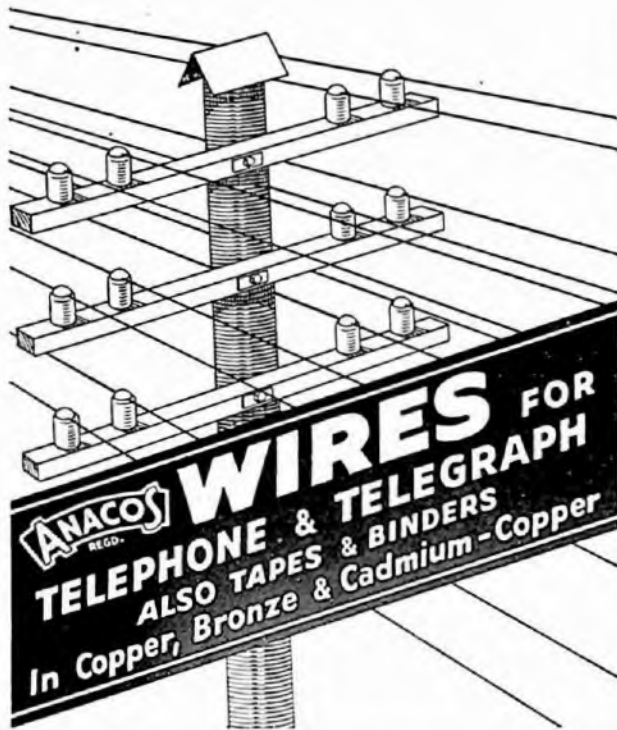

**FREDERICK SMITH & CO. LTD.** (Incorporated in The London Electric Wire Company and Smiths, Lim. ter.)  
 ANACONDA WORKS, SALFORD, 3, LANCS.  
 Telephone : BLACKFRIARS 8701 (8 lines)      Telegrams : "ANACONDA" MANCHESTER



**5 mmf/ft**

NEW LOW LEVELS in capacity and attenuation of CO-AX Cables mean new possibilities in electronic equipment design both for the war effort and for the post-war electronic age.

**BASICALLY BETTER AIR-SPACED**

**CO-AX LOW LOSS CABLES**

**TRANSRADIO LTD. 16 THE HIGHWAY BEACONSFIELD - B. BUCKS.**

**design for reliability & efficiency**

Westinghouse Metal Rectifiers more than meet G.P.O. standards of reliability and efficiency. Every unit, including the latest "Westalite" selenium-compound rectifier, has behind it the experience of eighteen years' rectifier technique and development and is built up to a standard and not down to a price.

Illustrated is a Mobile Power Unit for V.F. Telegraph Equipment, 24 and 130 volt output, incorporating "Westat" Constant Potential System.

Descriptive pamphlet No. 11 H describes the principles of many circuits employed in communication engineering in which Westinghouse Metal Rectifiers play a prominent part. We shall be pleased to send a copy to any interested Post Office Engineer

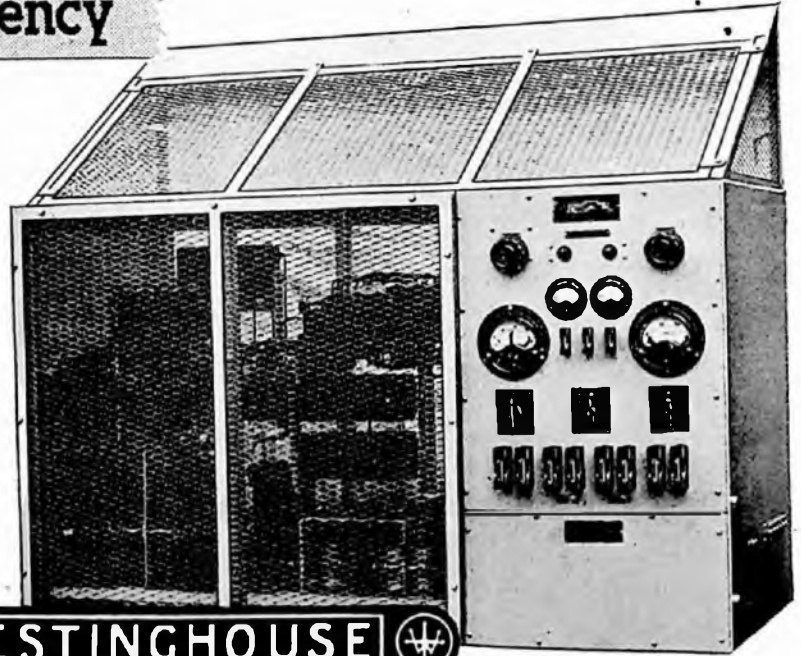

**METAL RECTIFIERS**

**WESTINGHOUSE BRAKE & SIGNAL CO. LTD.,**  
 Pew Hill House, Chippenham, Wilts.





**AND LIGHT-CURRENT SIGNALLING  
SYSTEMS AND EQUIPMENT...**

including Strowger Automatic Telephone Equipment—standard almost the world over—for networks of all sizes or for isolated exchanges, Manual Telephones and Exchange Equipment, Single and Multi-Channel (Carrier) Transmission Systems and Associated Apparatus, Supervisory Remote Control Equipment, Colliery Telephone and Signalling Equipment, Electro-matic Street Traffic Signals and other products. Fully descriptive literature, catalogues, etc., are available and will be sent upon application, whilst expert technical knowledge and advice are always at the service of those interested.

**AUTOMATIC TELEPHONE & ELECTRIC COMPANY LTD**

LONDON AND



LIVERPOOL

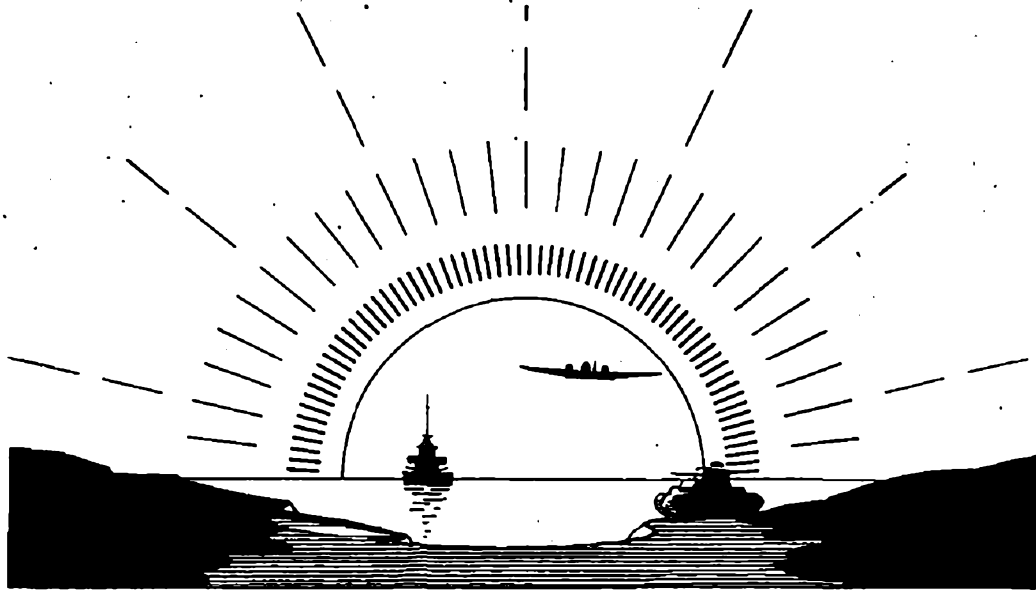

## ON LAND - AT SEA - IN THE AIR

Peace will bring telephones for all, new and better telephones incorporating ideas forged in the heat of war and worthy of carrying the Voice of the New Civilisation. G.E.C. engineers are eager to plan them. G.E.C. production is ready to make them, but until the day when the Nazi is destroyed and the last Jap is beaten to his knees, G.E.C. Telephone Communication Equipment has a sterner task, carrying those messages so vital to the man in battle, so essential to the smooth flow of production at home, the messages that are winning the war.

**G.E.C.**

**THE GENERAL ELECTRIC CO. LTD.**  
**TELEPHONE WORKS, COVENTRY, ENGLAND.**  
*Head Office Magnet House, Kingsway, London, W.C.2.*



*A midget  
in size  
but a  
giant in  
performance*



**CERAMIC  
PEARL TYPE  
CONDENSERS**

**TYPE APPROVED**

A mighty important little fellow for maintaining vital radio communications is this U.I.C. Pearl Type Ceramic Condenser.

*Diameter 7 mm. max. Length 9 mm. max. Capacity range 0.5pF—5pF. Capacity Tolerance Plus/minus 20%. Test Voltage 1500v D.C.*

Suitable for tropical and arctic conditions.

**UNITED INSULATOR CO. LTD.**

**12-22, LAYSTALL STREET, LONDON, E.C.1**

Tel.: TELminus 7383 (5 lines) Grams.: Colanel, Smith, London

**THE PIONEERS OF LOW LOSS CERAMICS**

★  
**TELEGRAPH APPARATUS**  
*for*  
**MORSE SYSTEMS**

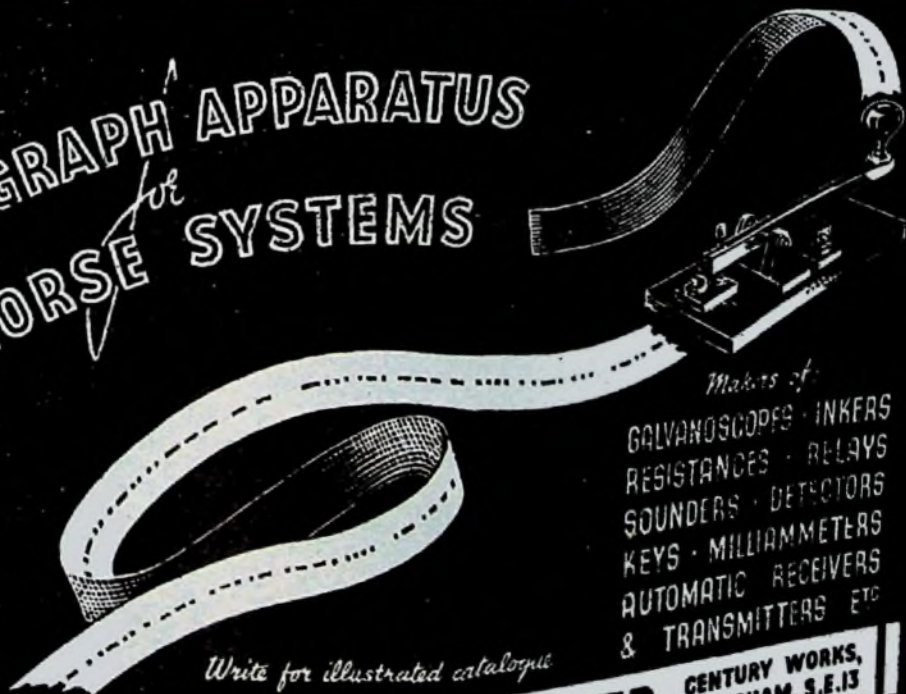

*Makers of*  
GALVANOSCOPES · INKERS  
RESISTANCES · RELAYS  
SOUNDERS · DETECTORS  
KEYS · MILLIAMMETERS  
AUTOMATIC RECEIVERS  
& TRANSMITTERS ETC

*Write for illustrated catalogue*

**ELLIOTT BROTHERS (LONDON) LTD.** CENTURY WORKS, LEWISHAM, S.E.13

# MAINTAINING EFFICIENCY

THE HIGH STANDARD OF EFFICIENCY  
OF PIRELLI - GENERAL TELEPHONE  
CABLES IS MAINTAINED BY THE  
CONTINUOUS RESEARCH WORK OF  
AN EXPERIENCED TECHNICAL STAFF.

TELEPHONE:  
SOUTHAMPTON  
2141 (5 lines)

**PIRELLI-GENERAL**  
CABLE WORKS, Ltd., SOUTHAMPTON.

TELEGRAMS  
"PIREKAYBEL"  
SOUTHAMPTON

60/40  
45/55

### WHAT'S THE DIFFERENCE ANYWAY?

Government reduction of tin content of alloys often means the increase of soldering temperatures if satisfactory soldering processes are to be achieved. But what increases are necessary? How will the components be affected by increased heat? These and other technical queries are answered in "Technical Notes on Soldering," issued by the manufacturers of Ersin Multicore the A.I.D. and G.P.O. approved three core Solder Wire. Firms engaged on government contracts are invited to write for a copy of this reference sheet and samples of Ersin Multicore Solder Wire.



## ERSIN MULTICORE

THE SOLDER WIRE WITH 3-CORES OF NON-CORROSIVE ERSIN FLUX

**MULTICORE SOLDERS LIMITED, BUSH HOUSE, W.C.2. 'Phone Temp.Bar 5583/4**