

# THE POST OFFICE ELECTRICAL ENGINEERS' JOURNAL

**VOL. 36**

**JANUARY, 1944**

*RA Pac*  
*Peterfield*  
*NOT -> 100 Hms Pa*  
**PART 4**

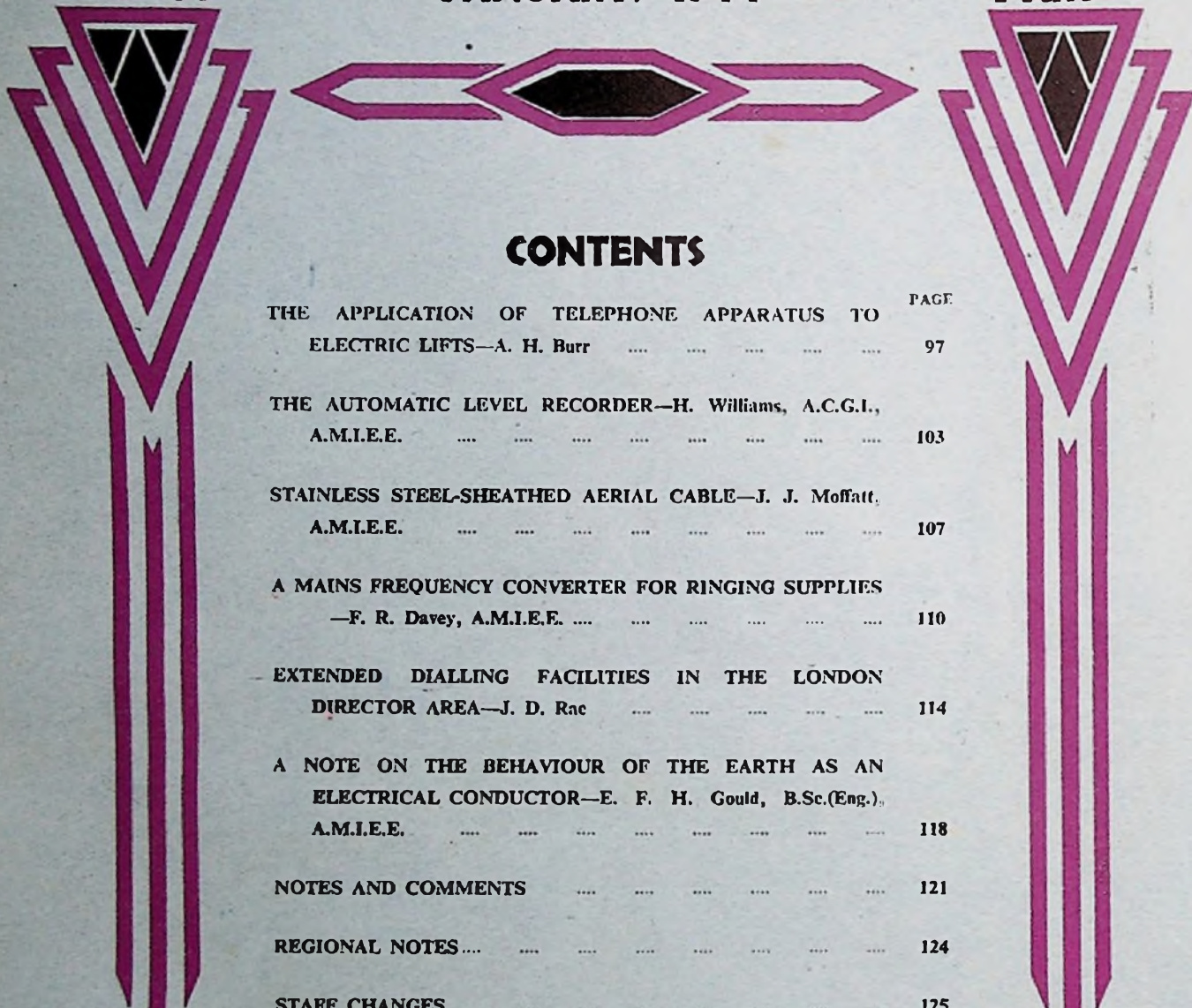

## CONTENTS

	PAGE
THE APPLICATION OF TELEPHONE APPARATUS TO ELECTRIC LIFTS—A. H. Burr .....	97
THE AUTOMATIC LEVEL RECORDER—H. Williams, A.C.G.I., A.M.I.E.E. ....	103
STAINLESS STEEL-SHEATHED AERIAL CABLE—J. J. Moffatt, A.M.I.E.E. ....	107
A MAINS FREQUENCY CONVERTER FOR RINGING SUPPLIES —F. R. Davey, A.M.I.E.E. ....	110
EXTENDED DIALLING FACILITIES IN THE LONDON DIRECTOR AREA—J. D. Rac .....	114
A NOTE ON THE BEHAVIOUR OF THE EARTH AS AN ELECTRICAL CONDUCTOR—E. F. H. Gould, B.Sc.(Eng.), A.M.I.E.E. ....	118
NOTES AND COMMENTS .....	121
REGIONAL NOTES .....	124
STAFF CHANGES .....	125
INDEX TO VOLUME 36 .....	127

Price 1/- net

**THE INSTITUTION OF POST OFFICE ELECTRICAL ENGINEERS**



# GE CALLOY

## RADIO CORES

### MAIN ADVANTAGES

- Greater magnification.
- Higher selectivity.
- Small size.
- Reduced costs.
- Robust construction.
- Simple adjustment.
- Non-rusting.

**SALFORD ELECTRICAL INSTRUMENTS LTD.**

PEEL WORKS, SALFORD, 3. Telephones: BLAckfriars 6688 (6 lines). Telegrams and Cables: "Sparkless, Manchester"  
 PROPRIETORS: THE GENERAL ELECTRIC Co. Ltd., OF ENGLAND

*A midget  
 in size  
 but a  
 giant in  
 performance*



## CERAMIC PEARL TYPE CONDENSERS

TYPE APPROVED

A mighty important little fellow for maintaining vital radio communications is this U.I.C. Pearl Type Ceramic Condenser.

Diameter 7 mm. max. Length 9 mm. max.  
 Capacity range 0.5pF—5pF. Capacity Tolerance  
 Plus/minus 20%. Test Voltage 1500v D.C.

Suitable for tropical and arctic conditions.

**UNITED INSULATOR CO. LTD.**  
 12-22, LAYSTALL STREET, LONDON, E.C.1

Tel: TERminus 7383 (5 lines) Grams: Colonel, Smith, London

THE PIONEERS OF LOW LOSS CERAMICS

# THE POST OFFICE ELECTRICAL ENGINEERS' JOURNAL

Vol. XXXVI

January, 1944

Part 4

## The Application of Telephone Apparatus to Electric Lifts

A. H. BURR

U.D.C. 621.318.5 : 621.876

The author describes, with the aid of typical skeleton circuit diagrams, how telephone exchange type relays and uniselectors have been adapted to the control of automatic lifts, using for purpose of illustration an installation of three passenger lifts in Lancaster House, Liverpool.

### Introduction.

THE application, in other fields, of specialised apparatus developed primarily for telecommunication purposes has become well known, i.e., race track totalisators, traffic signals, etc. The use of such apparatus for electric lift control has also been developed with success by the Express Lift Company in collaboration with the General Electric Company. A contribution appeared in the January, 1937, issue of this journal describing generally the passenger lift installation at Telephone House, Birmingham, on which "3,000" type relays were used. It is the purpose of this article to give some details of the circuits employed in similar installations, with particular reference to the three high speed lifts installed at Lancaster House, Liverpool, in 1940.

### General.

The lifts are dual controlled, i.e. by automatic push button or attendant-operated car switch, and travel at 300 ft. per minute, serving seven floors. The car and landing doors on two of the lifts are power operated by small geared motor units, one of which is provided for each door. The gates of the third

lift are of the "Bostwick" type, and are opened and closed manually. The control equipment for each lift comprises some 90 relays and contactors, three uniselectors and a 4-valve amplifier. For the sake of clarity the diagrams included in this article are in skeleton form, many auxiliary relays and contacts having been omitted. The diagrams follow as far as possible the conventional detached contact system, and the symbols used for the "3,000" type relays will be familiar to most readers.

Other relays are of special types designed to handle heavier currents such as are involved in brake and door motor operation, etc. These are denoted by small squares with diagonals, their associated contacts being shown as heavy lines with curved extremities. Other items such as mechanically operated switches, governor contacts and main contactor contacts for which no standard symbols are available have been shown as far as possible in pictorial form, and the lettering of diagrams should assist in identification. It should also be explained that some relays are numbered whereas others are lettered. No special significance is attached to either series, and the number or letter code often bears no relation to the function or sequence of operation. For

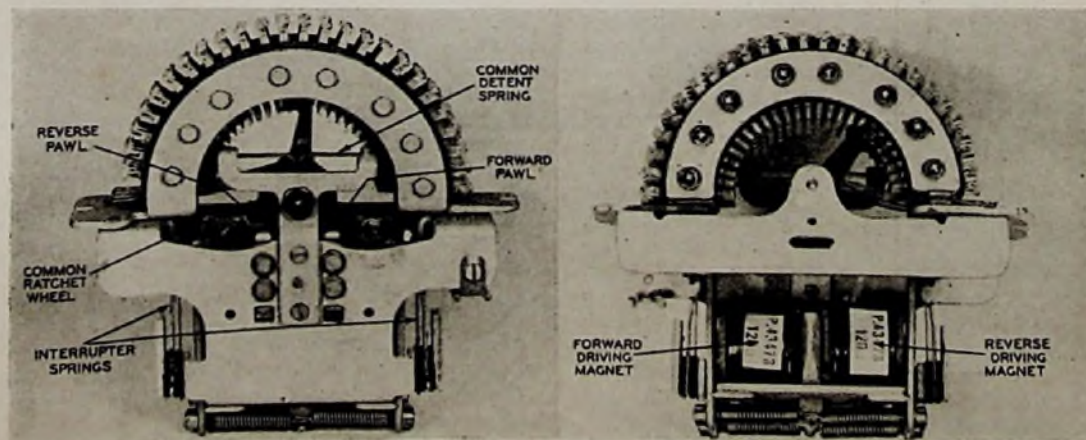

FIG. 1.—26-POINT BOTHWAY UNISELECTOR. (FRONT AND REAR VIEWS).

instance, the order of operation may be: 103, 49, 49A, 83, 38, CT, 67 and so on, which may prove slightly bewildering to those accustomed to the more orderly sequences of telephone switching.

The supplies of direct current for the control circuits are either 230 volts from the exciter or 50 volts obtained via transformers and metal rectifiers. Other supplies are as follows:—

Main driving motor of M.G. set, 400 volts 3-phase A.C.

Lifting motor (from main generator), 230 volts D.C.

Door motors: 110 volts 3-phase A.C.

Amplifier and inducers: 230 volts single-phase A.C.

### Floor Selection.

The floor selector on most lifts takes the form of a rotating shaft carrying a number of fingers which operate a series of switch contacts corresponding to the floors served by the lift, the function being to provide for slowing and stopping at the selected floor. This selector is normally driven by a steel tape or wire rope from the lift car through a small reduction gear. On the lifts described this is replaced by a specially designed 25-point uniselector, known as the bothway selector. As the name implies this switch can step in either direction, being provided with forward and reverse driving magnets as shown in Fig. 1. It has not been used in this country for telephone switching, although other uses have been found for it.

When the bothway selector is employed, the travel of the lift is divided into "zones" by a number of iron inductor plates fixed to the wall of the lift well. The schematic arrangement of the zone and slowing inductor plates is given in Fig. 2.

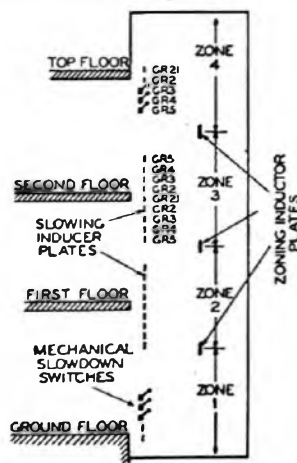

FIG. 2.—TYPICAL LAYOUT OF ZONE AND INDUCER PLATES.

It will thus be seen that the position of the bothway selector corresponds to the

position of the lift at any instant. Should the selector fail to remain in register with the position of the lift automatic resetting is provided at terminal floors.

The selector has four banks of contacts which provide the facilities necessary for the control of the lift, the main features being described in the following paragraphs. In addition, one bank has an extra wiper working over spare contacts which is arranged to operate a series of relays which provide illuminated signals on position indicators fixed at each landing.

### Call Relays and Non-Interference Facility.

The floor or call relay circuits are shown in Fig. 3,

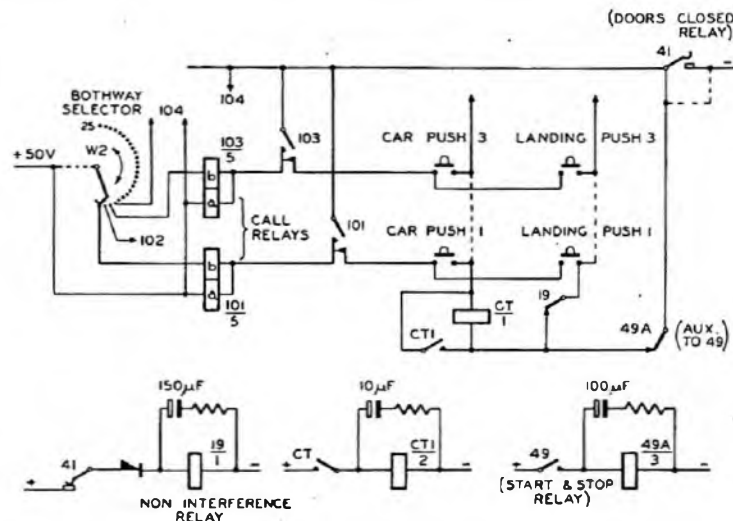

FIG. 3.—CALL RELAY CIRCUITS SHOWING NON-INTERFERENCE FACILITY.

the relays being numbered in the series 101, 102, 103, etc., to correspond with ground, 1st, 2nd and higher floors as required. Assume that the lift is stationary at the lower terminal floor as indicated by the position of W2, and that a push button in the car is pressed to enable a passenger to travel to the second floor. The call relay 103 operates on the "a" coil, and holds over make-before-break contacts to negative. During the initial pick-up of 103, CT is energised in series with a normal contact of 49A; 49 and its auxiliary 49A operate every time a call is made, 49 being known as the "start and stop" relay. The operating circuit for 49 is not shown. CT, when operated as described, completes the circuit of CT1 which operates immediately to short-circuit CT, thus de-energising CT1. This relay, however, is held for about half a second by the 10 µF condenser associated with it. The reason for this operation will be seen later in the appropriate section.

The operation of 103, 49 and 49A in other circuits that have not been included initiates a series of operations culminating in the connection of the driving motor to the generator, and the release of the electro-mechanical brake, and the lift travels to the second floor.

On arrival at this floor the doors are automatically opened by the relative door motors, the "door

closed" relay 41, in releasing, being arranged to open the call relay holding circuit and thus cancel the call. The neutralising "b" winding of the call relays and the W2 selector bank are not in use on the lifts having power door operation. On the lift with manually operated gates, however, the stopping of the lift at floor level, combined with the arrival of the wiper W2 on the corresponding segment, energises the neutralising winding and thus cancels the call.

Now assume that a person has called the lift to a landing by the landing push button. The lift arrives and the doors commence to open automatically. The doors closed relay 41 is released and a normal contact energises the non-interference relay 19, which operates to isolate all landing pushes. The automatic re-closing of the doors after a passenger has entered the car re-operates 41, but 19 does not release for about 5 seconds owing to the discharge of its 150  $\mu$ F condenser. This period is usually sufficient to enable the passenger to select and press the correct car push button and so gain precedence. The normal condition of the lift when on automatic control is "doors closed." Landing callers can thus call the lift to their landing, in the absence of a passenger, after 19 has "timed" out. It will also be observed that a normal contact on the auxiliary start and stop relay 49A is included in the initial call relay circuit for both landing and car push buttons. This relay is shunted by a 100  $\mu$ F condenser. Once a call has been established, all car and landing push buttons are isolated to ensure that no other calls can be originated while the lift is in motion. The lag in release (about 3 seconds) ensures that a call cannot be made before the doors have opened, or, on the lift with hand operated gates, before the passenger has time to open the car gate to leave the car.

#### Direction.

It is necessary for the control circuits to distinguish between UP and DOWN calls. This function is carried out by the first bank of the bothway selector and wiper W1 in conjunction with the direction relay 83 and further contacts on the call relays. The circuits are shown in Fig. 4. 83 normal corresponds

"a" winding of 83 via normal contacts on 101 and 58 (down relay), the circuit being completed by resistances YA and YB in parallel. A positive feed from W1 also exists through the chain of call relay break contacts, 38 (up relay) normal, and the make-before-break contacts of 83 to the negative side of the "a" winding, which is thus short-circuited. Operation of call relay 103, as described, breaks the chain of normal contacts and allows 83 to operate and hold on the "b" winding via resistance YA. Meanwhile the operation of 103 having energised 49, 49A also operates and applies a positive feed to the "a" winding of 83, so that should the hold circuit release the relay remains operated and guarded against premature reversals. On completion of the call 103 is released, but 83 remains operated, set for the up direction, since with the release of 103 and the up relay 38, the initial pick-up circuit, now originating from segment 3, via the chain of normal call relay contacts, is restored and the "a" winding is again energised and holds the relay. If the next call is in the down direction, say on 102, the operation of this relay breaks the feed to the "a" coil and the short-circuit on the "b" coil becomes effective to restore 83 to normal for down direction.

#### Slowing and Door Control.

Slowing for the selected floor is also initiated in the circuit associated with wiper W1. When the selector arrives in the calling zone a circuit is completed through the changeover contact of the call relay concerned to energise the slowing relay 27. This relay operates and a make contact connects the two 150  $\mu$ F condensers in series with resistances to the supply, when they commence to charge. Other contacts operate a series of relays which, in conjunction with the slowing selector described later, prepare the slowing and stopping circuits. Further contacts on 27 also prepare the door opening circuits in readiness for completion of the call. When this occurs the call relay is released, the doors commence to open, and the operating circuit of 27 is broken. This relay holds for approximately 9 seconds, however, on the discharge of the condensers. The opening of the doors occupies from 3-4 seconds, the doors then remaining open for about 6 seconds to allow for entry or exit of passengers. When 27 eventually "times out," normal contacts complete the door closing relay circuits and the doors re-close.

Assume now that an intending passenger calls the lift to his floor and the lift arrives and the doors open. For a single passenger to enter the car and press the desired button the time taken is but

a second or so and it is undesirable for him to be compelled to wait for the release of 27. The momentary operation of CT1, already described, when the car push is pressed opens the local discharge circuit holding 27, and this relay releases to close

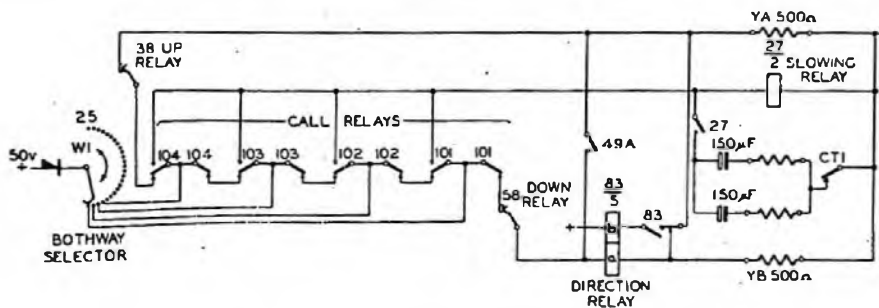

FIG. 4.—DIRECTION AND SLOWING RELAY CIRCUIT.

to the down direction. When a call is originated from the lower terminal floor to the second floor as described, an up journey is involved. Reference to the diagram will show that W1, standing on segment 1, extends a positive feed to the operating

the car and landing doors. The metal rectifier element in the feed to W1 ensures that the discharge of the condensers is localised and that other relays are not energised or neutralised out of sequence.

#### Speed Control of Lift Motor.

Speed control of the lifting motor is on the "Ward-Leonard" or variable voltage principle. A motor generator set with combined exciter is provided and

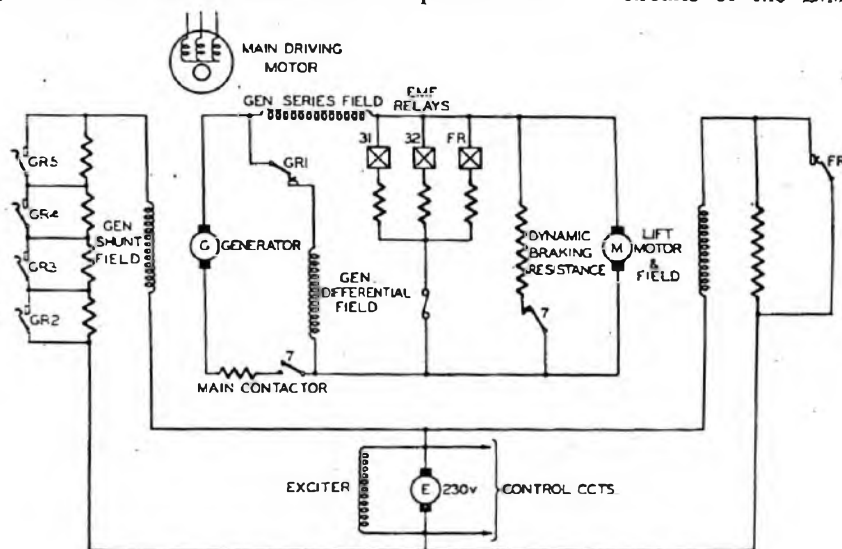

FIG. 5.—MOTOR, GENERATOR AND E.M.F. RELAY CIRCUITS.

runs continuously on the main 3-phase supply to the building. The exciter provides 230 V. D.C. for operation of the brake, the motor and generator field windings and for certain of the control circuits, as shown in Fig 5. The generator output is connected direct to the motor armature by a specially designed contactor 7 capable of handling the heavy currents flowing in this circuit. When normal this contactor connects a dynamic braking resistance across the motor armature. In normal circumstances the contactor closes and opens under zero current conditions. A special winding is provided to give a lag between opening of the make contacts and connection of the dynamic resistance so that should the lift stop push be operated at full speed the speed of the lift and motor is reduced by the mechanical brake before the dynamic resistance is brought into use. This is necessary to ensure that braking and the ensuing regenerated currents shall not be too severe.

Control of the lifting motor speed is effected in two ways: (a) variation of generator shunt field strength and (b) variation of motor field strength.

When the starting circuit has been completed, resulting in the operation of either 1 or 2, the generator field reversing relays (see Fig. 6), and 7, the main

contactor, GR1, GR2, GR21 and GR3 are energised simultaneously. GR1 operates to disconnect the generator differential field (used for rapid demagnetisation on stopping). GR2 and GR3 short-circuit sections of the generator shunt field series resistance and the lifting motor starts and accelerates. At predetermined values of generator output voltage the E.M.F. relays 31 and 32 operate in that order. The circuits of the E.M.F. relays and generator field relays GR2, GR3, etc., are shown in Fig 6. GR4 and GR5 then close to cut further resistance out of the generator field and finally E.M.F. relay FR operates to weaken the motor field when full speed is rapidly attained.

Deceleration cannot be carried out in the same manner, since the E.M.F. relays will hold at a much lower voltage than that required to operate them. Consequently a further 25 point uniselector is employed, the connections also being shown in Fig 6.

The principle of slowing is similar to that used for "zoning" of the bothway selector. Slowing inducer plates are fixed in the lift well above and below intermediate floors, as shown in Fig 2. An inducer box mounted on the lift car contains five adjacent coils, two of which are known as dissipator coils, being connected to a 230 V. A.C. supply. Under normal conditions an E.M.F. is induced in the remaining "inducer" coils, which is applied to a four-valve amplifier in such a manner that the final anode current is zero. Passage of an inducer

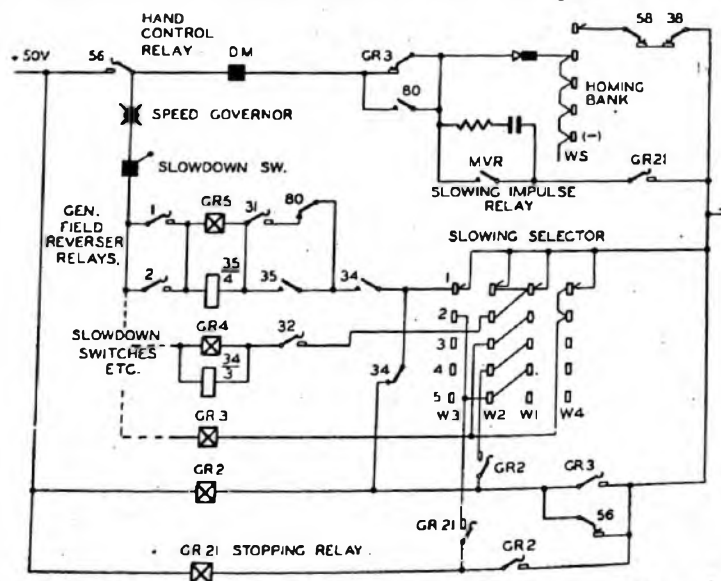

FIG. 6.—SLOWING SELECTOR, GENERATOR FIELD RELAYS, ETC.

plate through the air gap between adjacent coils intercepts the flux and the induced E.M.F. falls accordingly. The effect on the amplifier is to increase the anode current momentarily to operate the slowing impulse relay MVR. Immediately before arrival at a floor, therefore, the effect of the inducer plates is a rapid series of impulses on MVR, which is applied to step the slowing selector as follows. Slowing having been initiated on 27 as described previously, this relay operates in turn an auxiliary slowing relay 80. The hand control relay 56 being energised, the first impulse of MVR energises the driving magnet and the selector steps to segment 2 to drop out GR5 and its auxiliary 35. GR5 in releasing reinserts the relative section of generator field resistance and also releases FR (circuit not shown), to strengthen the motor field and the lift slows down to about 55 per cent. full speed. The next impulse releases GR4 and 34 and speed falls a further 20 per cent. The remaining impulses cause GR3, GR2 and GR21 to release in turn, reducing speed to 16 per cent., 8 per cent. and finally zero, when the electro mechanical brake is applied to stop the lift at floor level. It will be observed that during the stepping of this selector the hold circuits for the lower speed relays are transferred from one segment to the next by the interconnections of the banks. Immediately the lift has stopped or 58 releases, and via GR3 normal the homing circuit is completed and the wipers return to segment 1.

For intermediate floors the whole of the slowing sequence is carried out by the inducer plates. At terminal floors, as shown in Fig. 2, however, GR5, GR4 and GR3 are released by mechanical slow-down switches actuated by the movement of the car, inducer plates being provided for GR2 and GR21 only. This ensures that in the event of failure of the amplifier or inducer system the lift cannot run through terminal positions at a speed greater than about 70 feet per minute.

The hand control relay 56 is provided for maintenance purposes, i.e., guide cleaning and greasing, when a steady slow speed is required. On hand control, 56 is released and the lift can only run at GR2 speed under the direct control of the car switch.

On car switch or attendant control what is known as the "straight to floor" system is employed. The doors are normally open on this control and operation of the car switch to either "UP" or "DOWN" positions closes the doors and starts the lift. The car switch is released immediately after passing the floor preceding that at which it is desired to stop, when the lift slows and levels automatically. This system obviates the necessity for attendants to judge the position at which the car switch should be released, and consequently much better floor levelling is obtained, as the operations of slowing and stopping are carried out in the same manner as for automatic control once the car switch has been released.

Should the speed of the lift exceed the normal maximum by as much as 10 per cent. a centrifugal speed governor, driven by a steel wire rope connected to the car and counterweight, operates a contact which releases GR5 and GR4 and the lift

slows down to GR3 speed. In the event of an even greater increase above normal speed, i.e., 20 per cent. or over, the speed governor operates to grip the "safety" rope and to apply the gradual screw type safety gear to car or counterweight guides, thus stopping the lift. Simultaneously a contact on the safety gear opens the main power and control circuits.

#### Automatic Shut-Down of M.G. Set.

On automatic control, particularly during periods of light traffic, it is uneconomical for the main motor generator set to run continuously. An automatic facility is therefore provided to switch off the main motor a predetermined time after the lift has stopped. The circuits are given in Fig 7. On completion of a

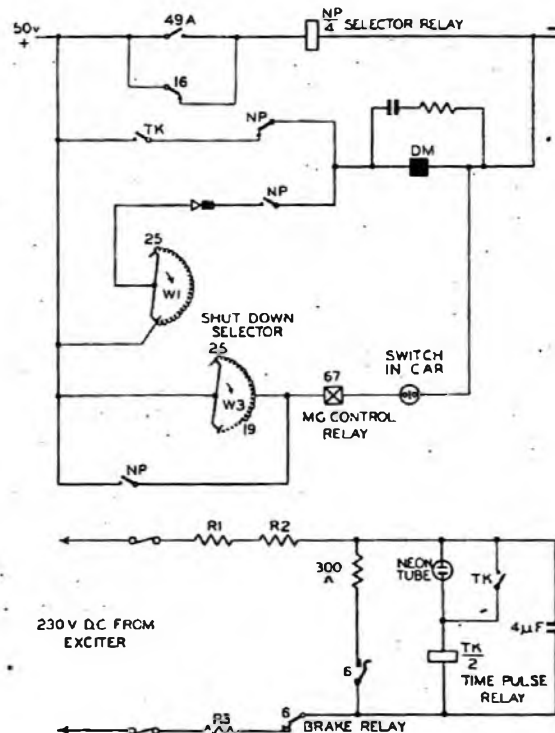

FIG. 7.—M.G. IMPULSE AND SHUT-DOWN SELECTOR CIRCUITS.

journey the brake relay 6 is released and completes a circuit on 230 V. D.C. to a 4  $\mu$ F condenser, which commences to charge, the rate being dependent on the series resistances. When the condenser terminal voltage reaches the "striking" voltage of the neon tube the momentary current operates TK, the time pulse relay, which self-holds until the condenser has discharged. On release of TK the procedure is repeated. The impulses of TK are applied to operate a 25 point uniselector as shown. Relay 16 being operated on automatic control, the release of 49A on completion of a call drops out NP, shut down selector relay, which is energised during the progress of a call. The impulses of TK every 5-10 seconds then step the selector until the wiper W3 reaches segment 19, when 67, the M.G. set control relay, is released and the set stops.

At the next operation of a call relay, 49A is ener-

gised to re-operate NP, which completes the homing circuit, the selector then returning to normal. Relay 67 is thus re-operated by wiper W3 and the motor-generator is started. If a call is set up before the cycle has been completed 6 operates to discharge the condenser through a 300  $\Omega$  resistance and to open the charging circuit, and the selector homes from any intermediate position. On car switch control, which is only used during periods of heavy traffic, 16 is normal and NP remains operated, the M.G. set running continuously.

#### *Protective Features.*

A rather similar feature is provided to open the control and power circuits in the event of a fault which, though insufficient to trip the main over-current circuit breaker immediately, might result in damage to the lift motor or other apparatus in time. A charging circuit and neon tube here operate to open the control circuits after a period usually set at from one and a half to twice the time occupied by a full UP or DOWN journey of the lift car.

The door operating motors are also protected by local relays and condensers from damage due to obstruction during the opening or closing operations.

#### *Relay Sets.*

The relays are mounted and enclosed in the same way as telephone relays in standard "sets." Where the lifts are maintained by the manufacturers, relay faults are not usually cleared on site, the procedure being to remove the set complete and jack in a spare set, the faulty one then being attended to by specialists.

As the sets are standard, it is quite usual for additional relays and wiring to be provided although not in use on a particular lift. On the lifts described

- (a) Bank W4 of the bothway selector is wired to further contacts of the call relays. These circuits are used for speeds above 350 feet per minute where slowing is initiated in the zone preceding that for which a call has been set up.
- (b) Bank W1 on the slowing selector is also wired to additional relays (not shown) in order to give speed selection. For very high speed lifts it is impracticable to attain maximum speed during floor to floor or two floor journeys. Discriminating circuits are therefore provided to select low speeds for short journeys and vice versa.

Although the relays are of the 3,000 type the codes do not correspond with Post Office telephone relay codes. One of the reasons is that the relays, manufactured by the G.E.C., are in "tropical" finish, which entails different methods of coil winding and

spring set insulation, many lifts of the type described having been installed abroad in tropical or sub-tropical climates.

#### *Advantages.*

Some of the advantages of the system as a whole will be dealt with briefly.

To commence, the 3,000 type relay, of which the reliability is well known, is very flexible in application. The use of special contact materials, such as silver and tungsten alloys, have enabled the relays to be used for high voltage and relatively high current circuits, such as are employed on the lifts described. In addition the small space required makes it possible to instal a complicated control system in a comparatively small space. The same remarks apply to the uniselectors. The bothway selector, for example, is capable of being used for a far greater number of floors than is usual in this country, and the wear and maintenance required is probably less than that experienced in telephone switching owing to the comparatively slow stepping speed.

These advantages are partly counteracted by the fact that lift motor rooms and lift wells are seldom free from dust, or air conditioned, as in the modern telephone exchange. As a result a small amount of dust, combined with the low operating voltage, may give a fairly high percentage of high resistance contacts, with consequent faults. This is less noticeable in standard lifts with a control circuit voltage of, say, 200 and where a relatively high contact resistance can be tolerated.

The system of acceleration, inducer slowing and stopping, gives very smooth travel and accurate floor hitting, it being possible to maintain floor levelling within  $\pm \frac{1}{8}$ ". It is also remarkable for the almost complete absence of mechanical noise which is a feature of most lifts employing the usual type of floor selection and mechanical switching.

The advantages of the Ward-Leonard system, which do not, of course, apply only to the lifts described, are principally in smooth and rapid speed control, which is not otherwise easily available for modern high speed lifts, and ease of control. The currents handled by the field resistance relays are quite small and the necessity for making and breaking "main" currents does not normally arise. As a result, much of the wear and tear associated with the more usual type of controllers and switch-gear does not occur.

#### *Acknowledgments.*

Thanks are due to the Express Lift Co., Ltd., for certain information and for permission to reproduce diagrams of patented features.



# The Automatic Level Recorder

U.D.C. 621.317.726

H. WILLIAMS, A.C.G.I., A.M.I.E.E.

A description of the apparatus employed for making automatic transmission measurements is preceded by details of the considerations which led to the adoption of the various facilities provided.

## Introduction

BEFORE proceeding with the description of the automatic level recorder it will be of interest to the general reader to give a short résumé of the events which led to its design. The reasons for some of the facilities provided too may not appear obvious, and it is proposed, therefore, to revive some of the discussions which were taking place at the same time.

### REASON FOR THE USE OF THE EQUIPMENT

One of the properties of a telephone circuit which helps to determine its quality is its "frequency response." This is really the insertion loss of the circuit measured between specified impedances (usually 600  $\Omega$ ) over a range of frequencies. The limits allowable are generally stated in two parts—

- (1) The loss at 800 c/s.
- (2) The relative loss at other frequencies.

(1) is, of course, the circuit equivalent.

The C.C.I.F. were debating these matters before the war, and agreement had been reached on limits to be applied to international circuits. For instance,

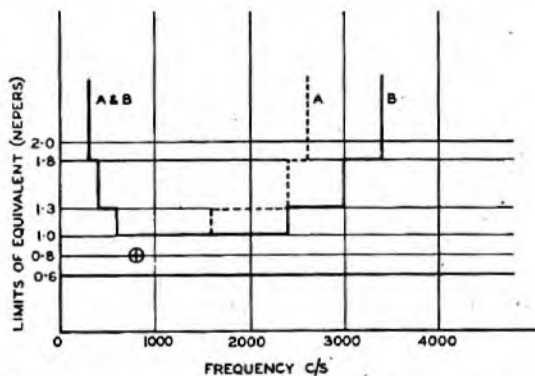

FIG. 1. LIMITS OF EQUIVALENT FOR A 4-WIRE CIRCUIT.

Fig. 1(A) shows the limits applicable to a 4-wire speech circuit.<sup>1</sup> In 1938<sup>2</sup> it was suggested that where a 4 kc/s band was agreed to be transmitted, for instance on wide band systems, new limits should be fixed, and the limits of Fig. 1(B) were agreed by the sub-commission held in London in December, 1938,<sup>3</sup> but the agreements have never been ratified. New circuits in this country provided on wide band systems conform to these limits and to other agreements reached at that meeting. Fig. 2 shows the limits fixed for the output levels of amplifiers on international music circuits.<sup>4</sup>

It will be apparent that any instrument which will automatically and quickly draw the overall frequency response of a circuit, or indeed any section

of a circuit, will be useful. For this purpose the C.C.I.F. suggested certain necessary facilities for such

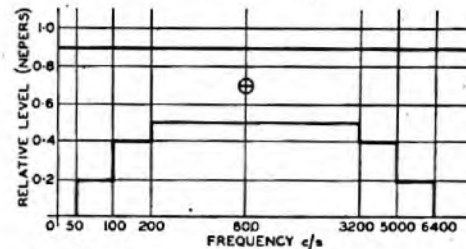

FIG. 2. BROADCAST CIRCUIT—RELATIVE LEVEL AT A NON-FRONTIER STATION.

an equipment<sup>5</sup> as it is essential that an instrument in one country should work to another instrument in another country.

### METHODS OF SETTING-UP CIRCUITS

The frequency response of a music circuit is of the greatest importance since the circuit is a link in a radio broadcast and quality is immediately observable. The check of this characteristic is therefore of particular interest. The setting-up and equalisation of such a circuit is deserving of great pains, and on this subject much thought and discussion was expended on the C.C.I.F. The problem is made more complicated by the fact that music circuits, being of wide band, are often provided on unloaded circuits, the impedance of which varies considerably over the frequency range. For international circuits it was recommended<sup>6</sup> that music amplifiers having low impedance outputs should be used. As shown later, this results in the voltage applied at the line input being practically independent of the line impedance. The sponsors of low output impedance also claim other advantages such as lower harmonic content and easier bunching of lines. The low impedance output amplifier, however, does not appear to have found favour everywhere,<sup>7</sup> and indeed has never been adopted for Post Office circuits in this country although the method was in extensive use on the Continent.

Although the setting-up of a trunk circuit is a common enough occurrence it is by no means a simple operation. This is particularly so on unloaded or other equalised circuits, and it is necessary to have a very clear idea of the operations, which are based on the assumption that the induced E.M.F. from the output of an amplifier bears a linear relation to the voltage across the input terminals. The first operation is to "send a milliwatt." This consists of setting the sending oscillator to send 1 mW (or other convenient unit) of power at the desired frequency into 600  $\Omega$ . The impedance of the source

<sup>1</sup> Reunions D'Oslo, p. 41. Tome 1 ter.

<sup>2</sup> Reunions D'Oslo, p. 43 and p. 157. Tome 1 ter.

<sup>3</sup> C.C.I.F. 1939-1940 Transmission document No. 24.

<sup>4</sup> Budapest Tome III, p. 172.

<sup>5</sup> Budapest Tome IV, p. 241 et seq.

<sup>6</sup> Budapest Tome III, p. 199.

<sup>7</sup> Electrical Communications, January, 1932, p. 131, "Lining up Broadcasting Circuits," E. K. Sandeman.

in the normal case is also arranged to be  $600 \Omega$ . The  $600 \Omega$  load is then disconnected and the send element connected to the line. The power received in  $600 \Omega$  at the other end of the line, usually at the output of a repeater, is then measured. This gives the insertion loss, or equivalent of the circuit. The frequency of the sending source may then be varied and other readings taken. The first necessity is evidently that the oscillator E.M.F. should not change as the frequency is altered. It will also be obvious that if the line impedance changes with frequency, the current taken from the  $600 \Omega$  source will vary with frequency and the voltage applied to the line will not be constant. This voltage (or "level") is a reading therefore to be used with discretion. The C.C.I.F. suggestion of the low output impedance amplifier for music circuits (where this difficulty is more apparent) is an attempt to obviate this and enable a known level to be sent independent of frequency or line impedance. It therefore came about that another of the facilities to be provided by the recorder was that it should have a number of low impedance outputs.

The instrument besides being capable of automatic recording operations also incorporates a normal transmission measuring set of first quality together with a number of other very useful facilities.

#### DESCRIPTION OF THE APPARATUS

Many features of the automatic recorder are similar to those provided in normal types of transmission measuring equipment, and it is proposed to deal in detail only with the automatic part of the instrument. The main items necessary are a sending oscillator the frequency of which can be easily controlled, and a flat receiving amplifier which can be made to control a recording millimeter calibrated as a transmission receiving set.

#### 'Sending' Circuit.

The source of voice frequency power is a heterodyne oscillator, the frequency of which is controlled by a variable condenser. The condenser may be operated by hand or by an electric motor located on the back of the panel. A mechanical clutch sets up the conditions for hand or motor operation. The latter is used for automatic measurements.

The output of the oscillator is fed through a relay circuit into the transmission measuring set. Here it passes through a sending network by which it may be controlled and the required power level selected.

The oscillator in the set being described has a maximum output of  $0.3 \text{ W}$  with a harmonic content when working into  $600 \Omega$  less than  $1.5$  per cent. at any frequency. The accuracy is  $\pm 2$  per

cent.  $\pm 2$  c/s. The unit consists of two high frequency oscillators, the frequency of one of which is constant at  $100 \text{ kc/s}$  and the other variable from  $90$  to  $100 \text{ kc/s}$ . The outputs from these are connected to a balanced modulator and the desired modulation product (the difference between the two frequencies) is used to obtain the main output. Filters are used to suppress harmonics and, to obtain the constant output at any frequency, equalising circuits are employed.

Fig. 3 is a rear view of the oscillator panel. The electric driving motor  $M$  is connected through its reduction gear  $R$  to the main driving shaft  $A$ , which connects the motor to the main oscillator tuning condenser  $N$ . On the motor armature spindle is fitted the governor  $G$ , which controls the speed of the motor. The governor is fitted with a free wheel device so that it couples with the motor shaft when it is rotating in one direction only. This prevents the governor operating when the motor is reversing at full speed to return the condenser to the zero position.

Coupling the reduction gear box to the main shaft  $A$  is the differential gear  $D$ . This is so arranged that when the brake  $B$  is clamped the motor will drive the shaft  $A$ . If, on the other hand, the brake  $B$  is free, the differential case  $D$  is free to rotate, and the shaft  $A$  may be rotated without being locked by the

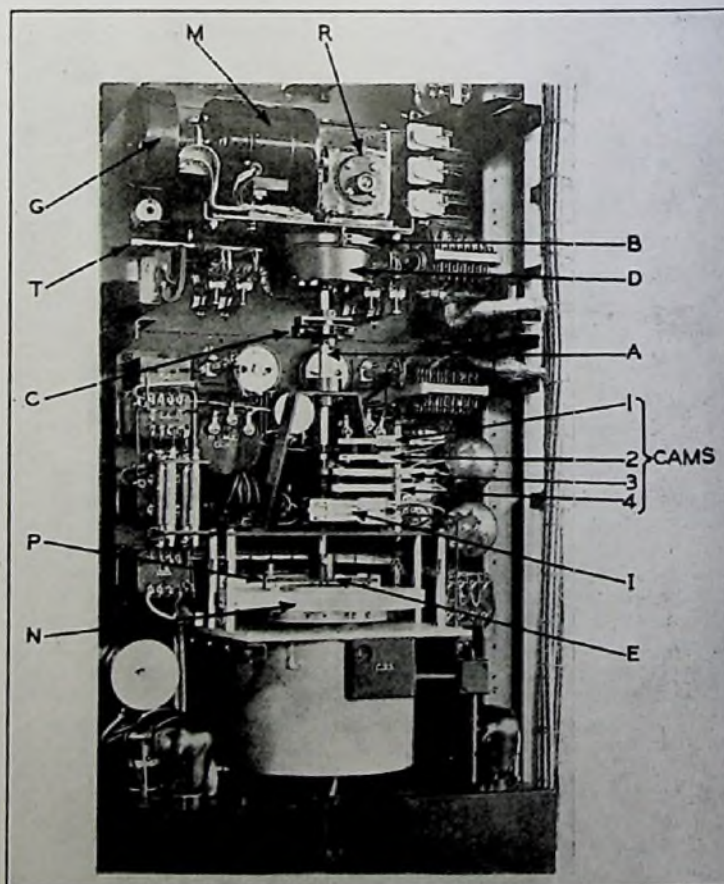

FIG. 3.—REAR VIEW OF OSCILLATOR PANEL.

motor gear box, and therefore the condenser N may be rotated by hand. The brake is connected to and is operated by the manual-automatic changeover key shown in Fig. 4.

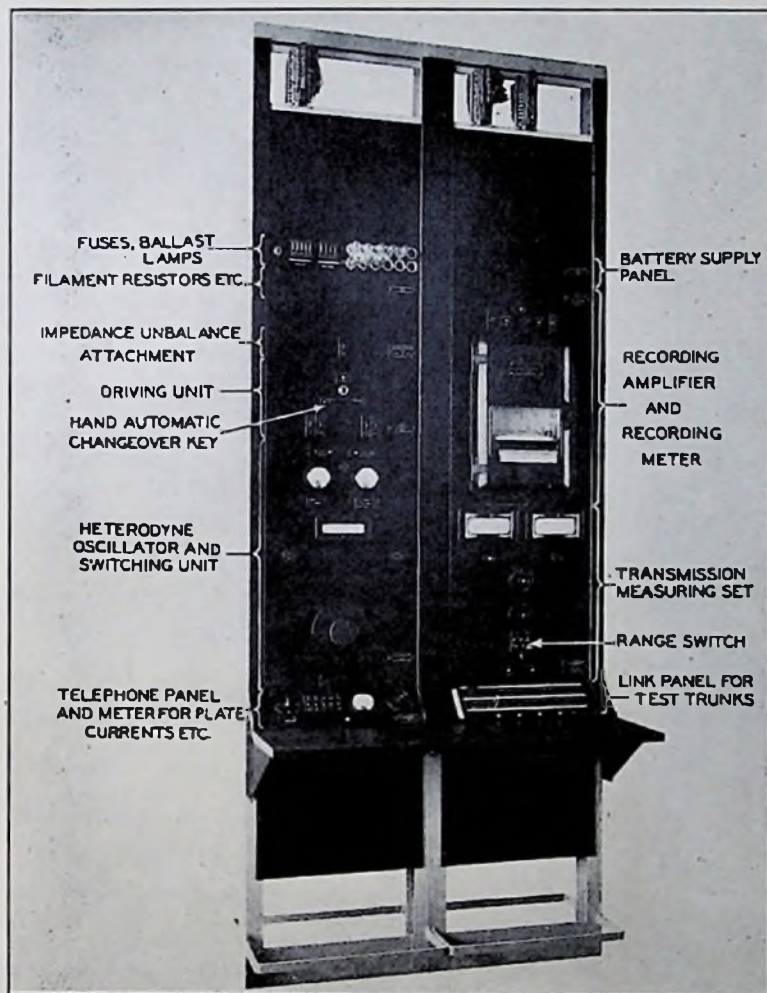

FIG. 4.—AUTOMATIC LEVEL RECORDER EQUIPMENT.

The main shaft is coupled to the main tuning condenser by the coupling E. This is not rigid and operates on the rubber spring pillars P so that a steady drive is applied to the condenser without fear of damage.

#### Receiving Circuit.

The receiving circuit comprises a normal type of transmission measuring set and a recording meter with an associated amplifier for use under automatic recording conditions. To make a recording, part of the normal transmission measuring set is used, followed by the recording amplifier (see Fig. 4); on the same panel as the latter is fitted also the recording meter. The transmission measuring set consists essentially of a valve voltmeter which may present either a high impedance, greater than 100,000  $\Omega$  or a 600  $\Omega$  termination to the circuit under test. It is fitted with a range switch engraved 0, -1, -2, -3, -4, and -5

nepers, in conjunction with which the readings on the valve voltmeter or the chart of the recording meter should be read. The "receive" sockets to which the line is connected are taken via a 1,300 c/s band-pass filter in the recording amplifier panel to the input of the T.M.S. The function of this filter is to pass a starting signal as described later, and also to protect the starting circuit against line noise or surges. The filter is switched out of circuit when measurements are being made. For recording purposes the input of the recording amplifier is connected across a resistance in the last valve stage of the T.M.S., and this serves to convert the input voltage into sufficient current to operate the recording milliammeter. This is a moving coil instrument of 1,000  $\Omega$  resistance requiring approximately 8 mA D.C. for a full-scale deflection. The chart is driven by a clockwork motor governed to within 0.5 per cent. of the speed of the condenser. The frequency characteristic of the receiving circuit is sensibly flat from 30 c/s to 10,000 c/s.

The apparatus may be used (in a similar manner to an ordinary transmission measuring set) for the delineation of a circuit between two points, or for a loop measurement to a distant station or a loop measurement in the sending station itself.

#### Automatic Production of Line Characteristic.

The instrument is first set up under manual conditions, say, at 1,000 c/s and a rough check made by rotating the condenser dial by hand to see that the range switch gives the most favourable conditions on the chart.

The apparatus is so arranged that the whole of the control when making automatic measurements is from the sending end. The motor on the driving unit is so designed that it will sweep the frequency control condenser of the heterodyne oscillator through the frequency range (0-10,000 c/s) in 121.2 seconds. It is started by the momentary depression of a key. This starts the whole cycle of operations for taking a record and it is not necessary to attend to the apparatus again until the record is complete—a period of three minutes. The apparatus is then automatically reset for the next record.

At the receiving end it is necessary to ensure that:

- (1) The starting of the recorder should take place at exactly the same time as the oscillator condenser passes through the zero frequency point, and
- (2) The speed of the recorder and the time lines on the chart should synchronise with the speed of rotation of the oscillator condenser.

The first requirement is met by making the sending

circuit responsible for starting the recorder clockwork. This is achieved, when the sending and receiving elements are at different ends of a line, in the following manner. As the oscillator tuning condenser passes the zero frequency mark a cam on the motor shaft (see Fig. 3) operates a relay, which by putting a condenser in parallel with the main tuning condenser, causes a frequency of 1,300 c/s to be sent over the circuit under test for 1.5 seconds. At the receiving end this is accepted by the band-pass filter and causes a relay to operate in the recording amplifier panel. The operation of this relay starts the recording millimeter clockwork motor and switches the filter out of circuit.

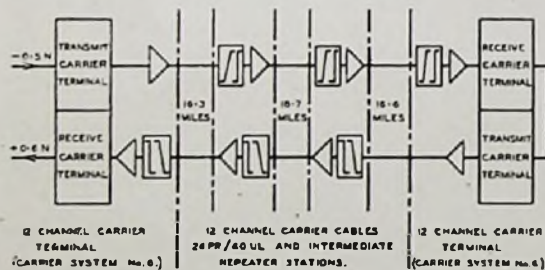
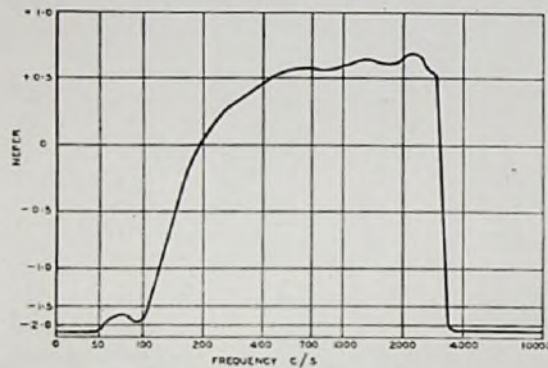

FIG. 5.—TYPICAL RECORDING AND SCHEMATIC OF THE CIRCUIT UNDER TEST.

The second requirement is met by the accuracy of the clockwork recorder mechanism, which, by an escapement, is held to within 0.5 per cent. of the speed of the oscillator condenser. The motor is wound by hand by means of a lever, operated by opening the cover of the recorder.

After the recording meter has been started the chart paper continues to run past the pen and the characteristic chart is drawn. When the zero frequency line of the next chart coincides with the pen, relay circuits automatically stop the recorder clock. At the sending end the driving motor automatically reverses and restores the main oscillator condenser to zero frequency and then stops. The correct level at any frequency is the sum of the chart and range switch readings.

The frequency scale as specified by the C.C.I.F. is as follows:—Linear from 0-100 c/s. Logarithmic from 100 c/s to 10,000 c/s. The band 30 c/s to 100 c/s is sent in 15 seconds, and each octave of the logarithmic range takes 15 seconds to transmit.

This is obtained in the instrument described entirely by the design of the main tuning condenser in the sending element and is thus independent of ageing effects liable to occur in any electrical method of accomplishing this.

#### Facilities.

The apparatus is mounted upon two standard repeater station bays (Fig. 4) and will provide the following facilities:—

- (1) Frequency-level characteristics over the range + 3 nepers to - 6 nepers referred to 0.775 V.
- (2) Frequency-loss characteristics over the range + 3 nepers to - 6 nepers referred to 1 mW.
- (3) Gain-frequency characteristics of amplifiers up to 6 nepers.
- (4) Frequency-singing point characteristics over the range 0-6 nepers.

This is accomplished by measuring the loss across a 3-winding transformer or hybrid when the line and balance are connected to the appropriate terminals.

- (5) Frequency-impedance characteristics up to 5,000  $\Omega$  impedance by means of level measurements.

The above may be made either manually or automatically on a chart.

- (6) Provision is made for the sending of all frequencies between 30 c/s and 10,000 c/s at any of the following levels:—

- (a) 1 mW into 600  $\Omega$  from an internal impedance of 600  $\Omega$ .
- (b) -1, -2, -3, -4 or -5 nepers referred to 1 mW into 600  $\Omega$  from an internal impedance of 600  $\Omega$ .
- (c) 0.775 V into 600  $\Omega$  from an internal impedance not exceeding 4  $\Omega$ .
- (d) 1.55 V into 600  $\Omega$  from an internal impedance not exceeding 8  $\Omega$ .
- (e) 2.1 V into 600  $\Omega$  from an internal impedance not exceeding 12  $\Omega$ .
- (f) 4.0 V into 600  $\Omega$  from an internal impedance not exceeding 40  $\Omega$ .

- (7) Numerous monitoring facilities.

Fig. 5 shows a typical recording and schematic of the circuit under test. The chart is so arranged that it is open at the important parts of the scale and is calibrated in nepers referred to 0.775 V.

#### Conclusions.

A number of these instruments have been installed in repeater stations in this country, and have been found to be of great range and use.

The thanks of the author are due to Standard Telephones and Cables for photographs and permission to publish the information in this article, and also to the staff of the firm who have designed the apparatus and given freely of their knowledge.

# Stainless Steel-Sheathed Aerial Cable

J. J. MOFFATT, A.M.I.E.E.

U.D.C. 621.315.22

The construction and erection of stainless steel-sheathed aerial cables is described and comparison drawn with the normal lead-sheathed type.

## Introduction.

THE majority of aerial cables at present in use have lead-antimony sheaths and are supported on separate stranded high-tensile steel wires by means of spring-steel cable-rings clipped to the suspension wire at frequent intervals. A cable which is self supporting, and thus enables the suspension wire and rings to be dispensed with, has now been developed and a few miles have been obtained and erected as a field trial. It is the purpose of this article briefly to describe the salient aspects of the manufacture and erection of this experimental type of cable.

## Construction of the Cable.

The core of the cable consists of paper-covered conductors formed in quads in the normal manner but with a final wrapping of paper metallised on the outside to dissipate the heat developed in the sheathing process.

The sheath is formed from stainless steel strip, 0.031 ins. thick, having a tensile strength of 40 tons per sq. in., by a process similar to that employed in the manufacture of split conduit. The strip is passed through a series of four pairs of power-driven rollers, the pre-assembled core being introduced between the second and third pairs, as shown diagrammatically in Fig. 1. The first three pairs of

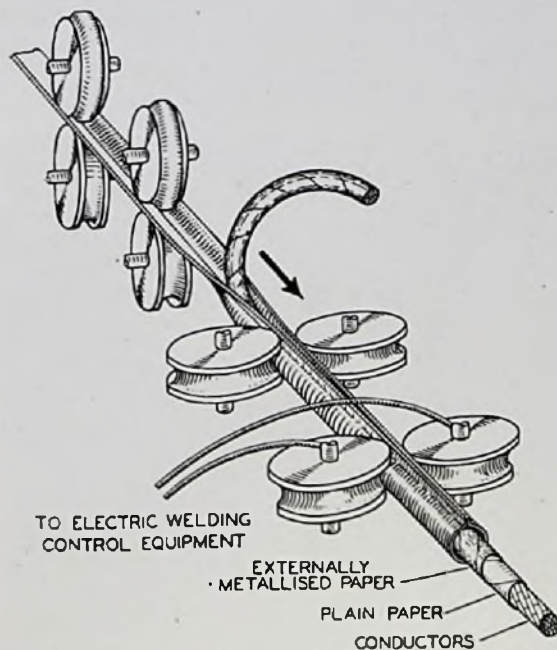

FIG. 1.—FORMATION OF STEEL SHEATH.

rollers convert the flat strip into an unsealed oval tube having flanges located longitudinally on the tube. As the sheath, containing the core, passes

through the last pair of rollers it is compressed into a round section, the flanges pressed together and electrically spot welded at approximately 1/16 in. intervals. The last pair of rollers are made of copper and utilised as the welding electrodes.

The frequency of the welding spots is under thyatron control and is selected to ensure that there is sufficient fusion of the two flanges to produce a continuous weld and thus provide an air-tight seal without the addition of further metal. The photomicrographs (magnification by 11) shown in Fig. 2



illustrate the degree of fusion between the two flanges when examined as a transverse cross-section and as a longitudinal cross-section half-way down the flanges. It will also be seen how the areas of fusion overlap to produce an efficient seal.

The temperature of the steel at the time of welding is raised to between 500 and 900°C. and this is sufficient to cause the carbon content of many ordinary stainless steels to be thrown out of solution and to migrate to the grain boundaries, an action which causes the material to become brittle and susceptible to corrosion. This condition, which is known as "weld-decay," is avoided by adding a small amount (0.4 to 1.0 per cent.) of titanium.

columbium, molybdenum or vanadium to the normal austenitic steel alloy, thus producing a "non-weld-decay stainless steel." Before leaving the manufacturer's works the trial lengths of cable were subjected to an internal air pressure of 75 lb. per sq. in. and immersed in water for several hours to ensure that the sealing of the sheath was satisfactory.

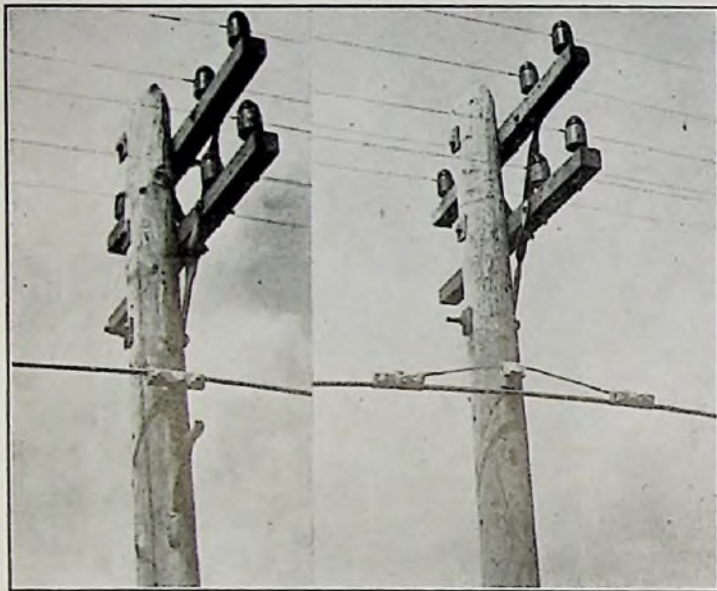

FIG. 3.—RIGID AND FLEXIBLE CABLE SUPPORTS.

The electrical characteristics of the completed cable were the same as those of a lead-covered cable of similar make-up.

#### *Erection of the Cable.*

The fittings used to support the cable at the poles were assembled from items used in normal P.O. practice, and typical assemblies are shown in Fig. 3. The rigid and flexible assemblies were designed for use in sheltered and exposed localities respectively. The bracket holding the supporting wire of the flexible assembly is spaced away from the pole by a tubular distance washer to prevent the cable striking the pole in a high wind. The use of a flexible support at an angle pole is illustrated in Fig. 4.

The cable was drawn out from drums mounted upon jacks either in a lorry or at the roadside to suit local circumstances. The cable was then secured at one end in its supporting bracket on the pole, raised to the level of the supporting brackets at intermediate poles and then tensioned at the distant end, or at an intervening angle pole if the deviation of the line was considerable. The cable was secured with the fin protruding through the space between the two plates forming the clamp. Tensioning was performed by one man operating slightly-modified ratchets and tongs of the type used for regulating open line wires. The tension applied to the cable sheath was small in comparison with the tensions applied to normal aerial cable suspension wires, and

ranged from 630 to 450 lb. according to the temperature prevailing on the site. The application of tensions within this range resulted in sags in the cable similar to those in normal type aerial cables, i.e. approximately 20, 30, 40 or 50 ins. for span lengths of 40, 50, 60 or 70 yds. respectively, when measured in still air at 20°F. After being tensioned the cable was secured in the supports at each pole.

Although the experimental cables were small, approximately  $\frac{3}{8}$  in. diameter for the 20 pr./6 $\frac{1}{2}$  lb. and  $\frac{1}{2}$  in. diameter for the 20 pr./20 lb. and 38 pr./10 lb. cables, their stiffness was considerable. A nine inch length was the shortest length that could be bent in the hands of a normal man. Longer lengths could, however, be bent with comparative ease into the required position.

The stiffness of these sizes of cable required the use of cable drums having a barrel diameter of not less than 4 ft.

#### *Jointing.*

Vertical plug-type joints as shown in Fig. 5 were employed, both between adjacent lengths of steel-sheathed cable and between lead and steel-sheathed cables, the mixed joints being required where connection was made with other aerial or underground cables or where distribution points were to be served.

After bending the cables into the required position and shape, each cable was tinned for approximately 1 in. near the point where the surplus length of sheath was later to be cut away prior to jointing. This precaution ensured that the corrosive flux did not come into contact with the

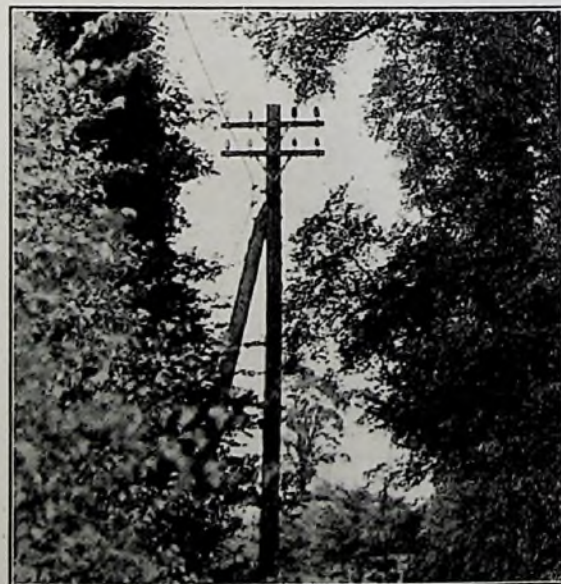

FIG. 4.—USE OF FLEXIBLE SUPPORT AT ANGLE POLE.

core of the cable. The tinning operation presented no serious difficulty provided that reasonable care, clean tools and a hot soldering iron were used. Although various fluxes suitable for soldering stainless steel are available, the flux used for the tinning operation was that recommended by the Research Laboratory which consisted of zincchloride in dilute hydrochloric acid.

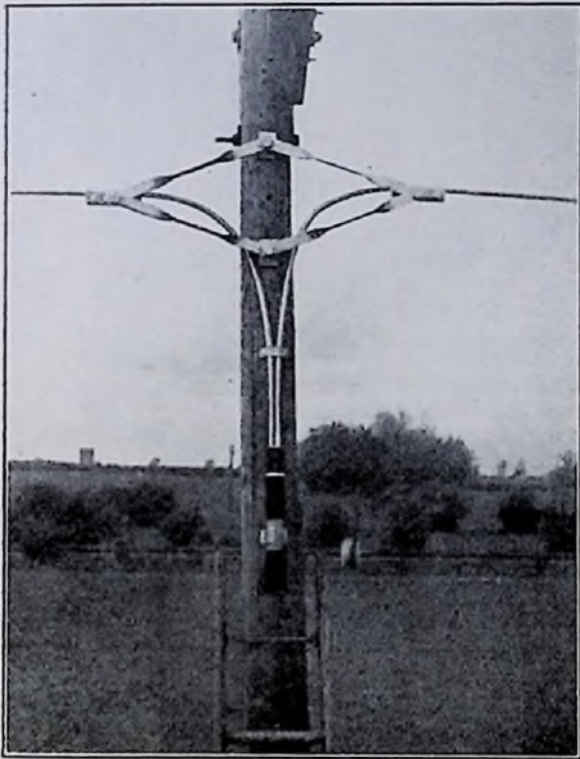

FIG. 5.—SUPPORT FOR VERTICAL PLUG-TYPE JOINT.

The cable sheath was then partly cut through with a hacksaw or file and the surplus portion broken off by bending in several directions. Plug-type joints were then made, using a lead collar and sleeve, by the normal lead-to-lead technique. This type of joint was employed to permit any subsequent removal and replacement of the sleeves to be carried out by ordinary plumbing methods and so obviate the need for maintenance staff to carry supplies of the special soldering flux. It is not anticipated that this method of jointing will suffer from electrolytic or corrosive effects.

On completion of the jointing operations the cable was satisfactorily subjected to a 24-hr.—20 lb. per sq. in. gas (carbon dioxide) pressure test.

#### *Economic Aspects.*

Comparing the initial costs of the steel-sheathed cable with those for lead-covered aerial cables of similar size, the saving on the subsidiary stores and the considerable saving of labour for erection were not sufficiently great to offset the higher initial cost of the experimental steel-sheathed cable. In this connection it must be borne in mind that the

high cost of the cable may be due to the present absence of competition in the manufacturing stage and also to the small quantity of cable that was obtained. The overall economic aspect may, however, be considerably affected by the life of the cable and by the maintenance costs when these can be estimated from the present trials.

The life of the cable under the widely varying and complex conditions encountered in the field is at present problematical, but it has been shown by tests made in the Research Laboratory that the sheath is less liable to failure from fatigue, resulting from vibrational stresses, than a lead-antimony sheath. One such test showed that a tensioned length of steel-sheathed cable remained intact after ten million vibrations, whereas vibrations of the same amplitude applied to a lead-antimony sheathed cable caused failure of the sheath at approximately one million vibrations. Other tests, carried out to obtain information regarding the vulnerability of the cable to gunshot and similar damage, showed that although a direct centre-line-hit with a rifle bullet caused a considerable dent, it did not puncture the sheath. Bullets not making such centre-line-hits caused only a small dent before ricocheting. Attempts to crush a piece of empty steel sheath by over-tightening the bolts of a clamping bracket proved abortive, the only result being the failure of the two  $\frac{1}{2}$ -in. B.S.W. bolts.

The continuous support given to the core of the cable, and hence the elimination of the liability of ring-cutting troubles, is another factor tending towards lower maintenance costs.

#### *Conclusions.*

The principal advantages offered by this type of cable are that it:—

- (a) eliminates the possibility of ring-cutting to which lead-sheathed cables are susceptible;
- (b) effects economies in:—
  - (i) the total labour and materials required for manufacturing the components forming the suspension system,
  - (ii) the labour required for the subsequent erection of the cables (a saving amounting to approximately 300 manhours per mile);
- (c) effects reductions in:—
  - (i) the total load on the pole-line,
  - (ii) the area subjected to wind pressure,
  - (iii) the labour and materials required for pole line construction, or strengthening, consequent upon (c) (i) and (ii);

whereas the disadvantages lie in the high initial cost and the stiffness of the cable. The stiffness would tend to limit the extensive use of this type of cable to the smaller sizes, such as those used for distribution purposes, unless very large-diameter cable-drums and pipe bending tools were employed.

In conclusion, it is desired to acknowledge the valuable assistance so willingly given by the staff of the Pirelli-General Cable Works, Ltd., during the manufacture of the cable and also for supplying the photo-micrographs reproduced in Fig. 2 of this article.

# A Mains Frequency Converter for Ringing Supplies

F. R. DAVEY, A.M.I.E.E.

U.D.C. 621.395.631.

The author describes the basic operating features of a static device which generates  $16\frac{2}{3}$  c/s ringing current from 50 c/s supply mains. Two patterns of the converter are available, the principal difference between them being the method of initiating the  $16\frac{2}{3}$  c/s oscillation.

## Introduction.

IN the past a number of methods have been employed for generating ringing current for telecommunication purposes, and these have usually taken the form of mains driven motor generators, battery driven dynamotors, vibrators or hand generators. Although such machines have, in general, met telephone signalling requirements, a need has long been felt for a cheap static device which would operate from the commercial supply mains and reduce maintenance attention, particularly at small unattended stations. Such a device was marketed in America before the war, and two models operating on the same principles are now available in this country. These have been coded by the British Post Office "Converters Ringing Nos. 1 and 2."

## RINGING CONVERTER No. 2

### Basic Circuit.

The basic circuit elements are shown in Fig. 1. It will be seen that the components consist of a tank

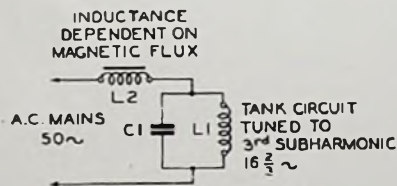

FIG. 1.—ELEMENTS OF BASIC CIRCUIT.

circuit L1 C1 fed from the supply mains via a saturable choke L2. An exact description of the manner of operation of the circuit is somewhat complicated, particularly on "no load." A simple explanation applicable to full load conditions is as follows: The constants of the tank circuit are so proportioned as to have a natural frequency of oscillation approximately equal to the third sub-harmonic of the input power frequency, i.e.  $16\frac{2}{3}$  c/s. When the tank circuit is oscillating freely, at every third half cycle of the supply mains, the voltages of the 50 c/s supply and the  $16\frac{2}{3}$  c/s oscillations will be in phase as shown in Fig. 2. At such instants the current drawn from the

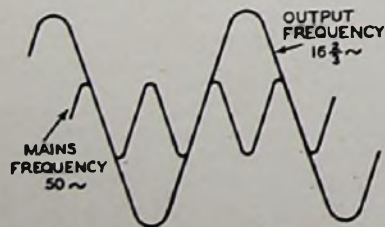

FIG. 2.

mains is a maximum, and saturation of the choke L2 occurs. Thus, when the two voltages are out of phase the inductance of L2 is high and the current drawn from the mains is very small owing to the reduction of the coupling between the tank circuit and the mains. When, however, the voltages are in phase the saturation of L2 causes its inductance to be considerably reduced. The value to which it falls is in fact lower than L1 and the circuit constants are so proportioned that a series resonant circuit at the main supply frequency is formed between L2 and C1, for one half cycle of the input wave. For every two out of three half cycles this series circuit is non-resonant at mains frequency, but at each third half cycle when the series circuit becomes resonant, energy is drawn from the mains by an amount which is not only sufficient to maintain the oscillations of L1 C1 during the other two half cycles, but also enables power at the sub-harmonic frequency to be delivered from the tank circuit to a load.

### Circuit Operation.

A complete circuit diagram of the ringer is shown in Fig. 3. Since the operation of the circuit is dependent upon the existence of low frequency

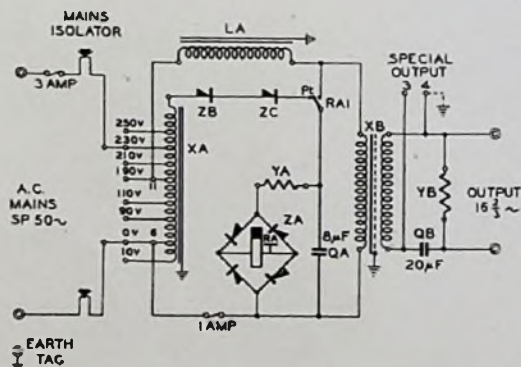

FIG. 3.—SCHEMATIC DIAGRAM OF RINGING CONVERTER No. 2.

oscillations in the tank circuit, it is necessary for the tank circuit to be given an initial current impulse sufficient to saturate the choke L2. Further, it is necessary that the oscillation started by the impulse shall be approximately in phase with the input voltage wave, otherwise oscillations in the tank circuit will die out. There are many methods by which the necessary impulse to the tank circuit can be produced, and the method adopted in this converter has been found to be most desirable in many ways since the method is

(a) entirely automatic and



(b) avoids sparking at the contact springs of relay RA owing to the fact that the oscillations are initiated on the closure of the relay springs and not the opening.

When the A.C. mains are first switched on, a steady voltage via rectifiers ZB and ZC is applied to QA, which is connected in shunt with relay coil RA via the dropping resistance YA. The relay thereupon operates and the condenser is given a charge. RA completes the tank circuit and the  $16\frac{2}{3}$  c/s oscillations are initiated by the discharge of the condenser. Should the phase relationship between the oscillations of the tank circuit and those of the 50 c/s supply be correct, the relay remains operated by the rectified current via ZA. The slug on the relay fulfils two important functions, firstly it ensures that the relay does not operate until sufficient time has elapsed for the condenser to become charged, and secondly, it allows oscillations in the tank circuit to die away before the relay contacts open on switching off the mains supply, or if the oscillations are not maintained when the relay operates initially due to phase opposition between the mains and the tank circuit. Should the latter condition obtain when the mains are switched on, the relay will be de-energised, and when the contacts open, the condenser will acquire a new charge. The relay will then re-operate and, if necessary, will repeat the cycle of operations until the required phase relationship is established. In service it has been found that the relay rarely makes a double operation before the oscillatory conditions are maintained.

It is necessary that the condenser QA shall be charged to a higher voltage than that applied to the converter circuit, and this is accomplished by the auto transformer XA, the direct current being furnished by rectifiers ZB and ZC. It will be appreciated that since the mains supply maintains a reactive system, the alternating voltage across the individual components may exceed that applied to the converter, which it will be seen is 190 volts. The auto-transformer is suitably tapped to provide this voltage with the ringer connected to any A.C. 50 c/s supply between 90 and 260V.

Resistor YB is provided to permit the dissipation of a possible charge being held by QB in the event of the output being disconnected while on load. The function of condenser QB is primarily to provide a measure of stability in the performance of the ringer over its load range. In the circuit shown in Fig. 1, due to the damping effect of the load on the resonant circuit, the current drawn from the mains tends to decrease as the load increases, and so weaken the oscillations which would, if the load were sufficiently heavy, cease altogether.

Another useful function of condenser QB is that it places a limitation on the amount of power which can be taken from the ringer, and so prevents any heavy damping of the tank circuit through possible overloading. In fact, no damage is caused to the ringer by overheating of the components or other reasons, even

if a continuous short-circuit is connected across the output terminals. Under these conditions the oscillations will still be maintained. Relay RA is of the standard 3000 type with platinum contacts, but it is very important that a minimum contact clearance of 20 mils be maintained between the relay springs due to the extremely high voltages developed between them. For this purpose special spring assemblies are employed. In its application for most telecommunication purposes, it is usual for the ringer to be continuously connected to the mains, so that the relay is normally required to operate or release only on such rare occasions as mains failure.

Output terminals 3 and 4 are provided for use on very light loads where a full output voltage of 100 is required.

#### Performance.

The output wave form of the ringer on "no load" and "full load" is shown in Fig. 4. It should be

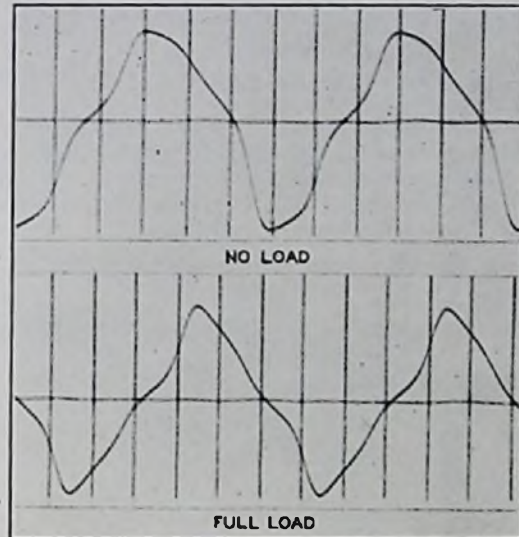

FIG. 4.—OUTPUT WAVE FORM OF RINGING CONVERTER No. 2.

mentioned that these were obtained with the load at unity power factor. It will be observed that the

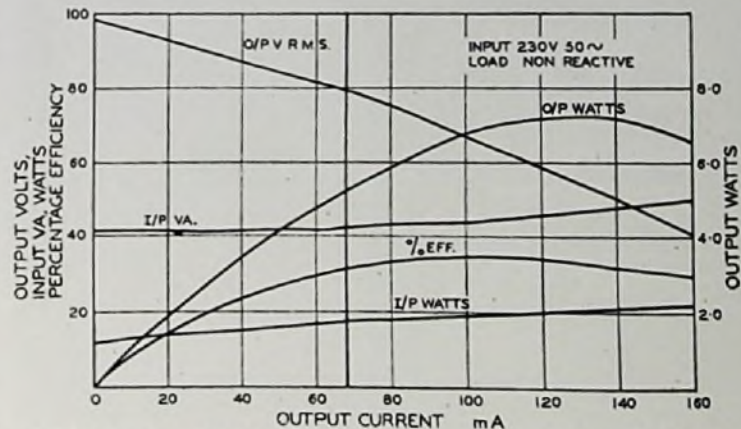

FIG. 5.—OVERALL PERFORMANCE CURVES—RINGING CONVERTER No. 2.

wave shape changes from approximately the sinusoidal form at "no load" to a more peaky form on "full load." The ringer described is capable of delivering a continuous rated power output of 5 watts, and tests have shown that 15 to 20 magneto bells can be rung simultaneously under average line conditions. Ringers operating on the same principle and having a larger power output can be made available if required. The overall performance curves shown in Fig. 5 were obtained using a load having unity power factor. It will be seen that the output voltage ranges from 88 volts at "no load" to approximately 75 at "full load," a performance comparable to that of ringing machines of the rotary type. It will also be noticed that the input watts and volt amps. are both of the same shape, which indicates that the power factor is reasonably constant over its load range.

Two models of the Converter No. 2 have been standardised, viz. Nos. 2A and 2B, the former being suitable for rack mounting and the latter for wall mounting; both models are provided with a substantial metal cover and can easily be installed. Due to the high voltages which are developed on certain of the components, each type of converter is provided with a locking device, which

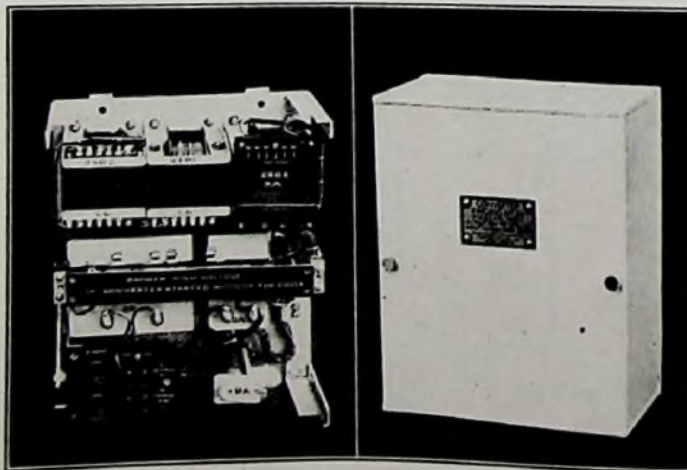
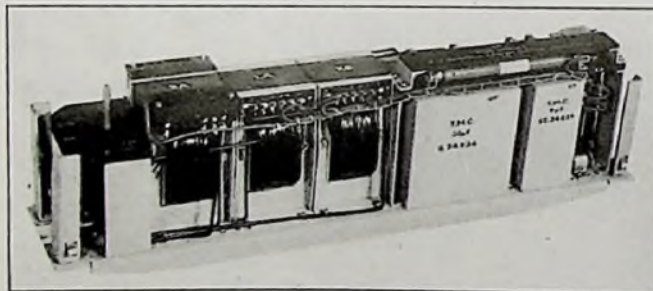

FIG. 6.—RINGING CONVERTERS NOS. 2A AND 2B.

ensures that the mains supply is disconnected when the cover is removed. Both items are shown in Fig. 6.

#### CONVERTER RINGING NO. 1

In normal operation the converter functions in much the same way as that previously described for Converter Ringing No. 2, but the chief differences are as follows:—

- (a) An alternative method is employed for initiation of the  $16\frac{2}{3}$  c/s oscillations.
- (b) The connections of the tank circuit differ slightly.

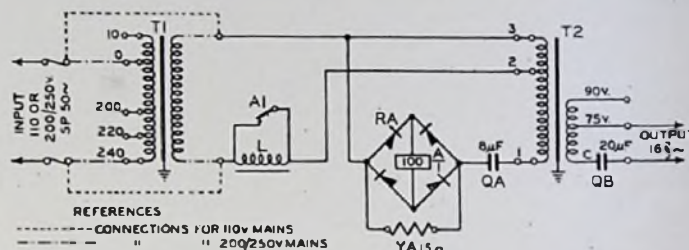

FIG. 7.—SCHEMATIC DIAGRAM OF RINGING CONVERTER NO. 1.

- (c) The converter is suitable for connection to 110 and 200/250 volt, 50 c/s, single phase mains only.
- (d) The converter has a larger continuous rated power output.
- (e) The model is suitable for wall mounting only.

#### Circuit Operation.

A circuit diagram of the converter is shown in Fig. 7. The input transformer is suitably tapped so that 110 volts are always applied to the converter circuit. With relay A1 contact in the resting position the input power is connected to terminals 2 and 3 of transformer T2. This voltage is then stepped up to approximately 450 volts R.M.S. across terminals 1 and 3. The voltage is applied to condenser QA through the  $15\ \Omega$  resistance YA, which is connected in shunt with relay A, via the bridge-connected rectifier RA. The charging current causes the relay A to operate, its operate time being arranged to coincide with the time taken for QA to be charged to its peak value. When the relay operates a short-circuit is removed across choke L at A1 and the oscillatory circuit is coupled through the choke to the input supply. The first oscillations are established by shock excitation which is accomplished by the condenser QA discharging through the primary winding of T2, so causing a starting current to flow through choke L. Once the oscillations in the tank circuit have been started they are maintained by the impression of the mains voltage by the coupling of the tank to the mains via the saturable choke. It will be seen that

the operation of Converter No. 1 is substantially the same as that of Converter No. 2.

One disadvantage which was found on test is sparking of contact A1 during the starting or restarting of the converter. When the relay contacts open at the commencement of oscillation, a heavy spark is drawn out momentarily with a tendency to burn the contacts. This is due to the P.D. across the contacts rising as they open. The circuit of the Converter Ringing No. 2 is superior in this respect. The relay used is

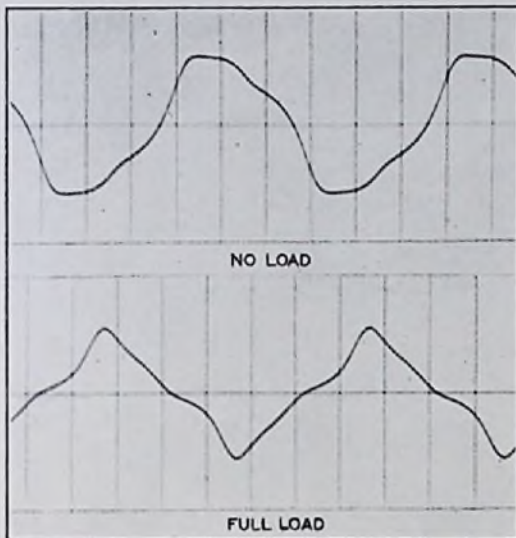

FIG. 8.—OUTPUT WAVE FORM OF RINGING CONVERTER NO. 1.

of the 3000 type, and as with the relay on the Converter Ringing No. 2, it is necessary to specify minimum contact clearance due to development of high voltage.

#### Performance.

The output waveform at "no load" and "full load" is given in Fig. 8, from which it will be seen that the characteristics are continuously uniform and are quite suitable for ringing magneto bells. Overall performance curves are given in Fig. 9 which it will be noticed are similar in shape to those in Fig. 5 for Converter Ringing No. 2. The rated output of Converter No. 1 is 75 or 90 volts, at 6 and 8 watts respectively, which output has been found sufficient to ring approximately 40 bells in parallel simultaneously under average line conditions. This power can be approximately doubled if the output condenser QB is increased to 40  $\mu$ F.

The converter is provided with an open mesh cover to facilitate ventilation and is easy to instal. It may be conveniently mounted either on the front or rear of any power panel or

on the wall. Owing to the excessive voltages that are developed on certain of the components a

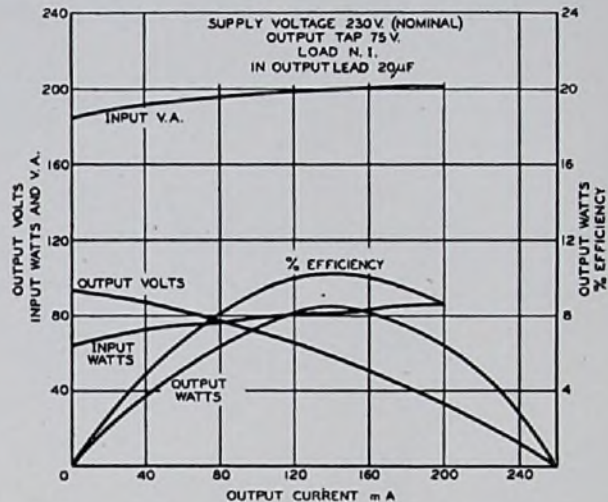

FIG. 9.—OVERALL PERFORMANCE CURVES—RINGING CONVERTER NO. 1.

cautionary notice is affixed to the cover to draw attention to the vital necessity of ensuring that the mains are switched off before the cover is removed. The complete converter is shown in Fig. 10.

#### Conclusion.

In the many applications for which the converters described in this article have already been used the performance has proved quite satisfactory, and as far as can be seen they should have a trouble-free life for a considerable number of years.

In conclusion, the author would like to thank the Telephone Manufacturing Company for their kind co-operation in supplying information and illustrations.

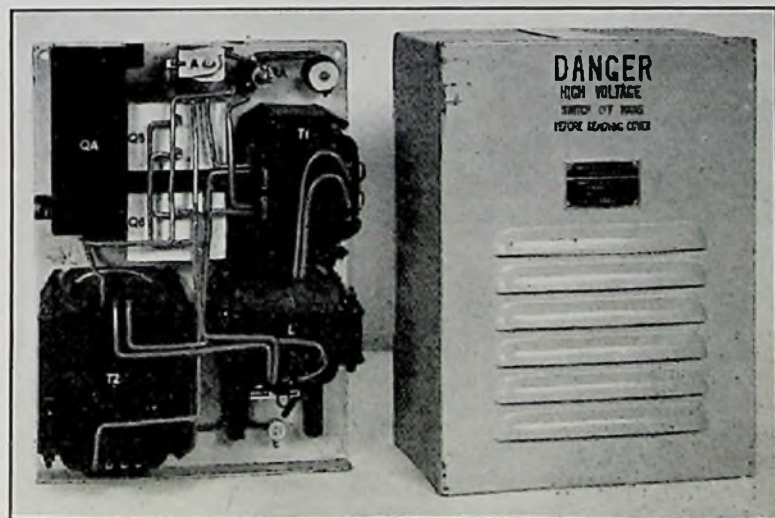

FIG. 10.—RINGING CONVERTER, NO. 1.

# Extended Dialling Facilities in the London Director Area

J. D. RAE.

U.D.C. 621.395.342

The recent introduction of multi-metering in the London 5-mile circle to enable calls to be dialled to exchanges within  $12\frac{1}{2}$  miles of Oxford Circus, together with the additional dialling facilities in the remainder of the Director area, are described.

## Introduction.

**H**OLBORN, the first automatic exchange in London, was opened in November 1927, and subscribers were enabled to dial direct to any exchange within a radius of 10 miles from Oxford Circus. To complete the calls without challenge by an operator, each manual exchange within this area was equipped with the Coded Call Indicator system. The London Director Area was virtually increased to a  $12\frac{1}{2}$  mile radius when Director type exchanges were installed in the 10/12 $\frac{1}{2}$  mile belt. Subscribers connected to these exchanges were able to dial direct to any exchange in the 10 mile circle. Multi-metering facilities were not in force at exchanges within 5 miles of Oxford Circus, and dialling access from these exchanges to the 10/12 $\frac{1}{2}$  mile belt could not be given as the charge for such a call is two unit fees. It was therefore considered uneconomical to equip the manual exchanges in the 10/12 $\frac{1}{2}$  mile belt with C.C.I. facilities. Automatic metering on calls up to 3 unit fees has been in force at exchanges in the 5/10 mile belt since 1930, and in 1936 subscribers connected to these exchanges were given dialling access to all automatic exchanges in the 10/12 $\frac{1}{2}$  mile belt.

## Call Fee Areas.

Before describing the new dialling facilities it is proposed to explain how a charge for an untimed call is determined. The amount charged is dependent on

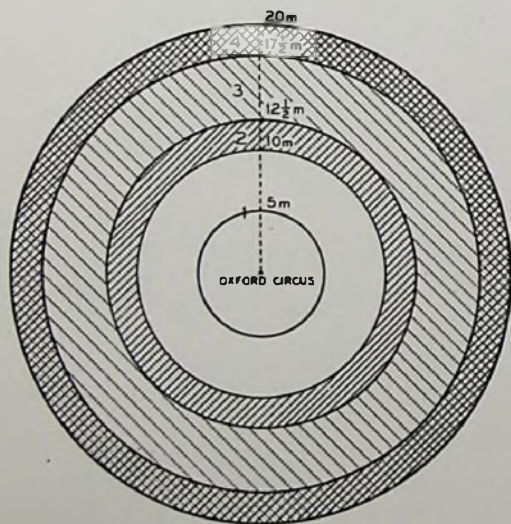

FIG. 1.—FEE AREA MAP FOR LONDON EXCHANGES WITHIN 5 MILES OF OXFORD CIRCUS.

the radial distance between the originating and objective exchanges. The rates are as follows:—

Chargeable Distance	Fee	Chargeable Distance	Fee
0-5 miles	1 unit	7 $\frac{1}{2}$ -12 $\frac{1}{2}$ miles	3 units
5-7 $\frac{1}{2}$ miles	2 units	12 $\frac{1}{2}$ -15 miles	4 units

In London, however, all exchanges within 5 miles radius of Oxford Circus have been grouped together and treated as a point when determining call fees. (See Fig. 1.)

Each exchange in the 5-10 mile belt, as distinct from those in the 5 mile circle, has its own fee areas.

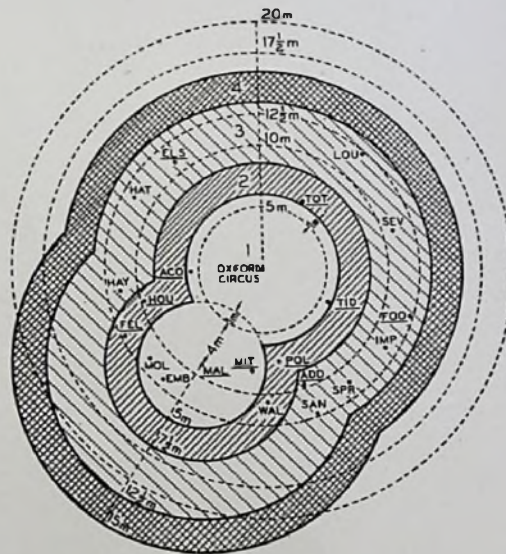

FIG. 2.—FEE AREA MAP FOR MALDEN EXCHANGE IN 5/10 MILE BELT. (SHOWS TYPICAL EXCHANGES ONLY. UNDERLINE INDICATES AUTOMATIC.)

Reference to Fig. 2 shows that the Malden 5 mile circle overlaps the London 5 mile circle by approximately 1 mile, and that a Malden subscriber obtains a call to any exchange in the London 5 mile circle, or in a ring 1 mile wide outside that circle, for one unit. Thus the unit fee area for Malden and other 5/10 mile exchanges is roughly in the form of a figure 8. The proportions of the figure vary with the distance between the exchange and the 5 mile circle. The 2, 3 and 4 unit fee areas are bands round the 1 unit fee area respectively  $2\frac{1}{2}$ , 5 and  $2\frac{1}{2}$  miles wide. Malden subscribers can obtain access to any exchange

in the 10/12½ mile belt for a maximum of 3 unit fees. This is true also for any other exchange in the 5/10 mile belt.

A typical fee area map for an exchange (Elstree) in the 10/12½ mile belt is shown in Fig. 3. The

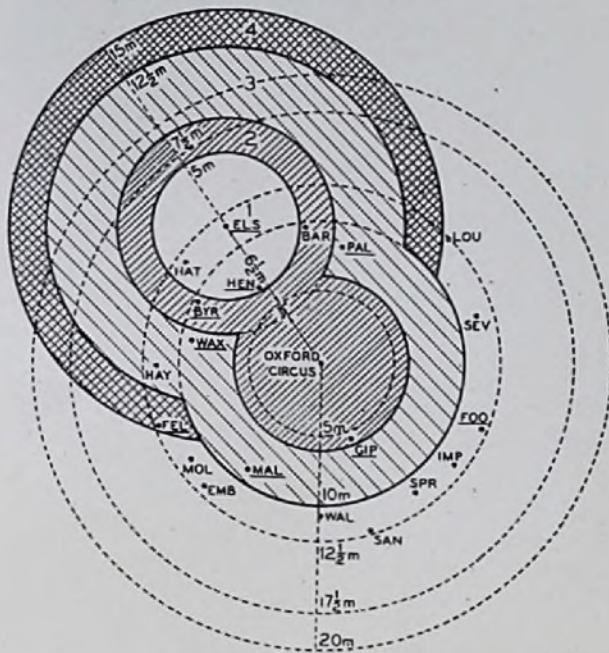

FIG. 3.—FEE AREA MAP FOR ELSTREE IN 10/12½ MILE BELT. (SHOWS TYPICAL EXCHANGES ONLY. UNDERLINE INDICATES AUTOMATIC.)

1 unit fee area is a circle of 5 miles radius, but the 2 unit fee ring overlaps the London 5 mile circle by approximately 1 mile. An Elstree subscriber obtains a call to any exchange in the London 5 mile circle, or in a ring 1 mile outside that circle, for 2 unit fees. The 3 unit fee area for Elstree is nominally the 7½/12½ mile belt round that exchange, but as subscribers in the London 5/10 mile belt obtain calls to Elstree for a maximum of 3 unit fees, the reciprocal also applies. Thus that portion of the London 5/10 mile belt which is outside Elstree's 1 or 2 unit fee area, is included in the 3 unit fee area. The 4 unit fee area for Elstree is the 12½/15 mile belt round that exchange, except for that portion which coincides with the London 10 mile circle. The chargeable distance for a call from an exchange in the 10/12½ mile belt to any exchange outside the London 10 mile circle is the direct distance between the two exchanges.

#### The Necessity for Extended Dialling Facilities.

As the war progressed, the difficulty of obtaining operating staff became acute, and consideration was given to the problem of allowing subscribers connected to exchanges in the 10 mile circle to dial direct to all exchanges in the 10/12½ mile belt. All calls from the 5 mile circle, and the majority from the 5/10 mile belt were obtained via the toll operators

at the originating exchanges. A considerable saving of operators' time would be effected if the calls could be dialled direct. The problem was two-fold in that (a) there was no C.C.I. equipment at the manual exchanges in the 10/12½ mile belt, and (b) there were no multi-metering facilities at the automatic exchanges in the 5 mile circle.

The majority of the traffic from the 10 mile circle to exchanges in the 10/12½ mile belt was routed via tandem. At the 17 manual exchanges the junctions were terminated on straight forward junction (S.F.J.) or jack-ended junction (J.E.J.) positions. Dialling-out from automatic exchanges to J.E.J. positions was already an agreed facility. No circuit development work, therefore, was necessary at the four exchanges employing J.E.J. terminations. S.F.J. working was originally designed for operators' use only and was unsuitable, in its existing form, for subscribers' use.

#### Modifications to Manual Exchanges in the 10/12½ Mile Belt.

In order that the modifications to the manual exchanges in the 10/12½ mile belt may be understood it is proposed first to give a brief description of normal S.F.J. working. Fig. 4 shows a simplified version of the S.F.J. cord circuit, with a part of the position circuit for explanatory purposes. Ignoring the modifications shown by the chain lines, the progress of a call is as follows:—

The calling signal received from the distant exchange is a battery on the negative wire, which operates L relay. L operates LL, and LL1 earths the start wire to the position circuit. LL2 disconnects the private wire so that the junction finder will find the correct junction. Immediately the junction is found,

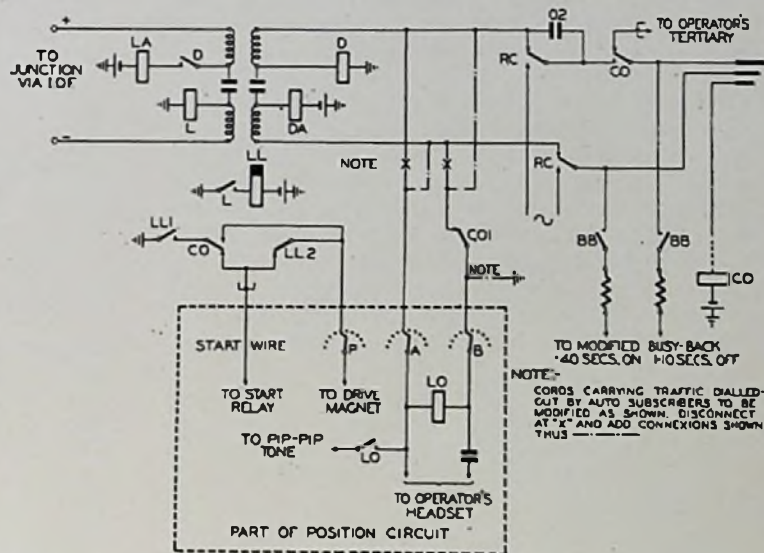

FIG. 4.—SIMPLIFIED SCHEMATIC OF S.F.J. CORD CIRCUIT SHOWING WIRING MODIFICATIONS TO PREVENT PREMATURE METERING.

LO relay, in the position circuit, operates the "pip-pip" tone is transmitted over the A wire, and the S.F.J. operator connected to the "A" operator. D relay in the cord circuit operates simultaneously with LO and connects battery to the positive wire of

the junction, providing the calling operator with supervision.

On receipt of the pip-pip signal the calling operator announces the number required, the S.F.J. operator acknowledges, and picks up the cord which is now marked by a flashing supervisory signal. The called subscriber's line being free, the operator inserts the plug, operating CO relay by the earth on the sleeve of the jack. RC operates and connects ringing current to the called subscriber's line, and CO steps the junction finder, disconnecting the S.F.J. operator from the cord circuit. Ringing tone is transmitted to the calling operator via the 0.02  $\mu$ F condenser connected across the RC contact in the A line, and D relay restores to normal, causing the calling supervisory lamp to glow. When the called subscriber answers, the ringing trip relay releases RC, and D reoperates via the subscriber's loop, thus giving normal supervision to the calling operator.

Should the called subscriber's line be busy, the S.F.J. operator depresses the busy key fitted on the position key shelf, and BB relay in the cord circuit is operated. This relay operates CO and connects busy back to the A and B lines. Standard busy tone and flash is 0.75 seconds on and 0.75 seconds off, and D relay flashes at this periodicity, transmitting busy flash to the calling operator.

The conditions necessary for supervision and metering on junctions to C.B. exchanges are identical. From the above description it will be seen that a call from an automatic exchange subscriber would be metered immediately the pip-pip tone was transmitted from the S.F.J. position.

The initial problem was to prevent D relay operating until the called subscriber answered. This could have been accomplished satisfactorily by a modification to the position circuit, but would have caused all calls arriving at the position to receive non-standard supervision when the operator answered. As toll and other operator-controlled calls are dealt with on these positions, it was decided to modify each cord circuit associated with a tandem junction. The A and B lines to the position circuit were reversed, and an earth connected to the position side of CO1 contact. This earth provides a short-circuit for D relay until the plug is inserted in a jack, when CO relay operates, leaving D relay under control of the called subscriber's loop. After a suitable field trial these modifications were approved as a war emergency measure.

The second problem was to prevent metering taking place when busy back was returned to the calling subscriber. Metering in a modern automatic exchange is controlled by S and Z pulses. The S pulse, lasting 250 milliseconds, prepares the circuit for metering. The Z pulse follows 550 milliseconds later, and lasts for 2.1 seconds, during which the required number of pulses are transmitted to operate the subscriber's meter. Providing the D relay in the 1st code selector is held operated during the 550 millisecond gap between the S and Z pulses, metering will take place. Busy tone and flash (750 mS on and 750 mS off) received from a distant manual exchange flashes the D relay. It is probable, there-

fore, that the subscriber's meter would be operated on a busy call.

As the junction routes were still to be used by operators as well as by subscribers, it was desirable to suppress metering without, at the same time, suppressing busy flash. A circuit was developed which reduced the tone period to 400 mS and increased the silent period to 1,100 mS. The busy flash circuit was correspondingly modified, the darkened period coinciding with the tone. On an operator-controlled call the supervisory would therefore be darkened for 400 mS and would glow for 1,100 mS, and a subscriber's call from an automatic exchange would not be metered because the D relay in the 1st code selector would restore during the 550 mS pause between the S and Z pulses. The modified tone was clearly recognisable as a busy signal.

In addition to the busy key, each S.F.J. position is fitted with busy-back and guard-flash jacks, for use under special conditions. These also were supplied with the modified tone and flash.

Each S.F.J. position is equipped with an "emergency speak jack," which is wired directly to the operator's telephone circuit. To avoid metering, a duplicate jack, giving non-metering facilities, was fitted on each S.F.J. position.

Calls with which the S.F.J. operator is unable to deal in the normal manner are usually extended to the information desk. The circuit used by the I.D. operator gives supervision, and would therefore cause metering to occur on a call from a subscriber on an automatic exchange. Duplicate answering jacks, designed to give non-metering conditions, were fitted on the I.D. for answering calls from automatic exchanges.

On J.E.J. terminations, the work involved was the changing of the existing circuits for press-button metering type relay sets, which have been designed for answering calls from automatic exchange subscribers.

#### *Multi-metering at Exchanges in the 5 mile Circle.*

Details of the 2nd fee metering equipment existing at exchanges in the 5 mile circle were ascertained. It was found that each exchange fell into one of three categories.

Category "A" comprised 19 exchanges at which multi-metering equipment was already in existence but not in use. These exchanges were the ones most recently installed, the equipment having been fitted in anticipation of multi-metering requirements. The bulk of the work necessary to introduce the facility at these exchanges was the grading of a 2nd code selector level, from which to route the 2nd fee traffic, and the regrading of the appropriate 1st code selector level for 10 availability, which is necessary in order that the negative wire of the odd outlets may be used to extend the meter wire to the 2nd code selectors.

Category "B" consisted of 20 exchanges at which it was necessary to fit vertical marking banks before multi-metering could be introduced. The remainder of the work involved at these exchanges is similar to that described above for Category "A." This work is now proceeding and is expected to be completed early in 1944.

For both category "A" and category "B" exchanges the 2nd fee traffic will be routed from a 2nd code selector level and thence via tandem.

Category "C" comprised the remaining 22 exchanges requiring major modifications. These exchanges are mainly of the older type equipped with double-sided selector boards, and employing metering circuits which preclude the ready provision of 2nd fee registration. Such provision has therefore been left till a more opportune time.

#### *Additional Facilities in the 5/12½ mile Belt.*

As a result of the modifications to the manual exchanges in the 10/12½ mile belt, it became possible to extend the multi-metering facilities already available at the automatic exchanges in the 5/10 mile belt. It was found that dialling-out facilities to manual exchanges in the 10/12½ mile belt could be given to all automatic exchange subscribers in the 5/10 mile belt, except those connected to Hendon. This exchange is a satellite on Gladstone, which is situated in the 5 mile circle, and falls in category "C."

A number of direct routes from exchanges in the 5/10 mile belt to manual exchanges in the 10/12½ mile belt were already working via code selector levels, the subscriber dialling an arbitrary numerical code. In these cases the junctions terminated on press-button metering equipment at the manual exchanges and it was merely necessary to instruct the subscribers to dial the first three letters of the exchange name instead of the arbitrary code, and to translate the directors accordingly.

To give subscribers access to the remainder of the manual exchanges, it was necessary to translate the directors to route the calls via the tandem level carrying the appropriate fee. Reference to Fig. 2 will show that calls from exchanges in the 5/10 mile belt to the 10/12½ mile belt may cost 1, 2 or 3-unit fees.

The seven automatic exchanges situated in the 10/12½ mile belt were already equipped with multi-metering for calls up to 3 unit fees, and it therefore entailed a very small amount of work to give access to the manual exchanges within this range. The amount of traffic from any one of these automatic exchanges to other exchanges in the 10/12½ mile belt beyond the 3 unit fee range is very small. To simplify dialling instructions, such calls are routed to the manual board and dealt with by an operator.

#### *Publicity.*

The main object of the additional dialling facilities in London was to effect a saving of operating staff dealing with toll traffic, and it was therefore necessary that the subscribers should use the new service to its fullest extent. A new issue of the "A to K" portion of the directory for limited circulation was due to be distributed in May, 1943, and it was decided to print the names of the seven automatic exchanges in the 10/12½ mile belt in a manner similar to exchanges in the 10 mile circle, i.e., the first three letters of the exchange name in heavy capitals. This indicated to a subscriber that he should dial the first three letters of the exchange name followed by the four numerical

digits. To show the names of the 17 manual exchanges in a distinctive manner the system authorised for Glasgow was adopted, in which the first three letters of the exchange name were printed in thin capitals. This indicated that the subscriber should dial these letters only, and listen for pip-pip tone or the distant operator's challenge. On the receipt of either of these indications that the operator was waiting on the line, the subscriber should pass his number verbally. Typical examples of directory entries are shown below.

Crofts K, 4 Oak av Shirley Croydon .....	SPRingpk 2975	(a)
Crofts L. C, 40 Grove cres N.W.9 .....	COLindale 5123	(b)
Crofts Leslie T, 25 Squires rd Shepperton gn ..	Chertsey 3135	(c)
Crofts P. W, 2 Whitehorn av Coulsdon.....	UPLands 5284	(d)

Entry (a) shows a manual exchange in the 10/12½ mile belt.

Entry (b) shows an exchange in the 10 mile circle.

Entry (c) shows an exchange outside the 12½ mile circle, calls to which are obtained via toll.

Entry (d) shows an automatic exchange in the 10/12½ mile belt.

The alterations to the directory made it desirable that some provision should be made for the subscribers who would not receive the extended dialling facilities initially, but who attempted to dial direct to exchanges in the 10/12½ mile belt. These are the subscribers connected to exchanges in categories "B" and "C". Arrangements were made for such calls to be routed to the manual board via a code selector level and a new group of circuits designated "excess fee interception circuits."

Each subscriber to receive the additional facilities was advised by a postcard which was so worded that, together with the directory preface, the subscriber had all the information necessary to make calls. On the postcard was printed a list of the additional exchanges that could be obtained by dialling, together with an explanation of the heavy and light capitals. Cards to be despatched to subscribers on exchanges having numerical dialling-out codes to exchanges outside the 12½ mile circle, were specially printed to show these codes in addition. All the cards were so arranged that they could be cut to fit in the drawer attached to the base of some telephones.

In addition to the above arrangements suitably worded announcements appeared in the local press, and also in the London evening papers, at about the time the facilities were introduced.

The new dialling facilities were brought into use on Monday, 28th June, 1943, and the postcards were despatched from the Telephone Managers' Offices so as to arrive at their destinations on the morning of that day. The new dialling facilities will be extended to subscribers connected to exchanges in category "B" immediately the work is completed at those exchanges.

#### *Conclusion.*

It is interesting to see that one effect of the war has been to hasten the introduction of multi-metering to the centre of London, and no doubt when peace returns an early attempt will be made to extend the new dialling facilities to the remainder of the exchanges in the 5 mile circle.

# A Note on the Behaviour of the Earth as an Electrical Conductor

E. F. H. GOULD,  
B.Sc. (Eng.), A.M.I.E.E

U.D.C. 621.396.993

Examples are given of instances where earth leakage current from power and tramway systems may cause the potential of the surrounding earth to be raised appreciably above its normal value, with consequent risk of damage to adjacent telecommunications or other plant.

## Introduction.

IN the past it was commonly believed that the potential of the earth could not be altered by the discharge into it of any current of practicable magnitude. Upon this general assumption is founded the widespread practice of earthing electrical apparatus in order to ensure the safety of users against the effects of an electrical fault. Unfortunately it is not always possible to secure such low resistance connections with earth as to prevent the existence of considerable difference of potential between bodies nominally at earth potential. The potential of the earth immediately surrounding an earth connection, or electrode, carrying current is raised, or lowered, depending upon the direction of current flow, with respect to the value when no current is flowing and only regains this value some distance away from the earth connection.

## Typical A.C. Conditions.

Consider the circuit shown in Fig. 1. If the resistance of the fault between the phase conductor and the earthed casing of the apparatus is

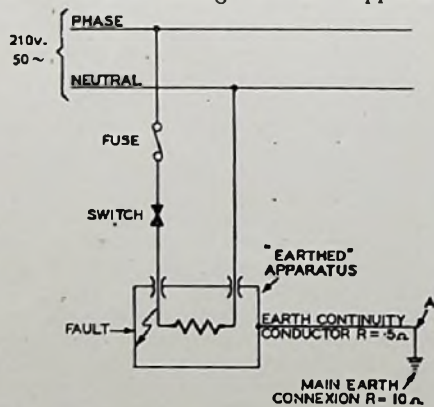

FIG. 1.—TYPICAL A.C. FAULT CONDITION.

assumed to be zero, then the current which would flow into the earth connection is  $210/10 \cdot 5 = 20$  A, assuming the resistance of the earth connection on the neutral at the point of supply is zero. The point A on the conductor would be raised to 200 V above the normal earth potential, and the earth in contact with the earth electrode would be raised to the same potential. A few yards from the surface of the earth electrode, the earth potential would approach its normal value again, and anyone bridging this distance would have 200 V impressed upon him. Although it is impossible for a person to span 10 or 15 ft. with his body, he might reasonably span 3 ft. and, if he does this in the close vicinity of the earth electrode,

he would experience a large part of the 200 V. In passing, it is worth observing that voltages of less than 60 volts in unfavourable circumstances have proved fatal. All metalwork in contact with earth may not be at the same potential and to avoid electrical accidents from such differences of potential it is advisable, in most cases, to bond together all "earthed" metalwork associated with or adjacent to an electrical installation.

An interesting case of damage due to rise of earth potential occurred recently in a U.A.X. The neutral point of the L.V. system and the metalwork associated with the H.V. feeding the L.V. system were bonded to separate earth systems only 5 ft. apart. A leakage on an insulator on the transformer pole caused fault current to flow through the H.V. earth connection, thereby raising its potential. The neutral earth connection, being situated too close to the H.V. earth connection, was raised in voltage and, as a consequence, the voltage of the whole L.V. network was raised with respect to earth. This increase in voltage broke down the insulation on the L.V. system at several points and damaged various pieces of apparatus in the exchange. Other consumers on the L.V. system also suffered damage to their apparatus. It will be seen that the primary cause of the damage was the juxtaposition of the two earth electrode systems. Nowadays the practice is growing of separating them by at least one span in the overhead system and, in some circumstances, a special requirement to this effect is made by the Electricity Commissioners in their Regulations concerning L.V. Electricity Supply.

## Leakage from D.C. Systems.

The foregoing examples of the risks arising from rise of earth potential refer only to A.C. systems, but the variations of earth potential are, none the less, important in cases of leakage from D.C. mains.

Recently an interesting set of tests was carried out to confirm some unusual results obtained in an investigation of a case of severe damage to several cable sheaths attributed to leakage from a nearby negative D.C. main. In normal circumstances it is usual to find that the cable sheath is markedly positive to earth in the vicinity of such a fault but, in the case under consideration, it was reported that the cable was negative to earth. The test results were as shown in Fig. 2 (a).

The explanation of the negative voltage was not apparent until it came to light that for special reasons the continuity of the cable sheaths had, for the purposes of test, been interrupted as shown in the diagram. The explanation advanced to account for the negative voltage was that the potential of the isolated length of cable sheath was made negative by



passing through the earth which was depressed in voltage due to the fault on the negative D.C. main and that, whereas the potential of the earth rose to a value approximating to its normal earth potential at a short distance from the fault, the potential of the cable sheath remained sensibly constant and was, therefore, negative to earth at the end remote from the fault and positive to the earth close to the fault as shown in Fig. 2 (b). To verify that this explanation

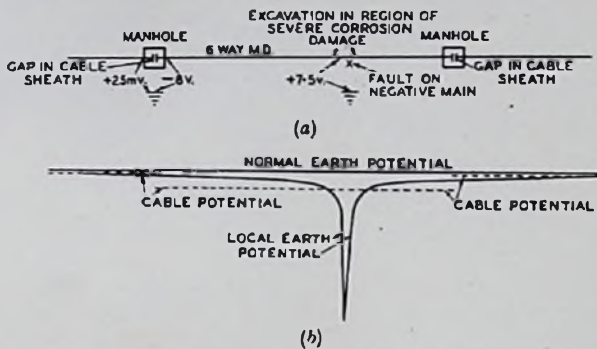

FIG. 2.—TYPICAL LEAKAGE CONDITION FROM D.C. SYSTEM.

was sound, tests were made in a locality free from extraneous D.C. leakages under conditions simulating those in the case referred to above. The potential across the earth connection representing the fault on the negative D.C. remained steady, as far as conditions would permit, at a value of 106 V. The potentials of the telephone cable sheath and of the adjacent earth were measured with respect to a reference earth electrode placed at a distance of 650 yds. from the earth connection representing the fault on the D.C. main. The reference earth was sufficiently remote from the earth electrodes carrying current as to be unaffected by the voltage gradient around them. The potential distribution was first determined with the cable sheath continuous, and later on discontinuities in the cable sheath were progressively introduced. The results obtained are shown graphically in Fig. 3 and fully support the

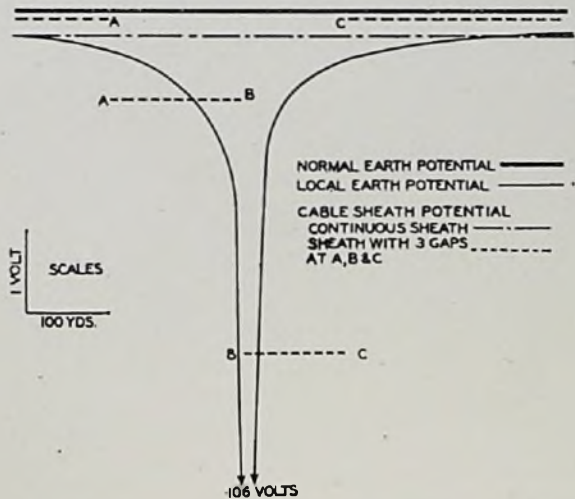

FIG. 3.—POTENTIAL DISTRIBUTION RESULTING FROM FAULT INDICATED IN FIG. 2.

explanation put forward in the actual case of damage under investigation.

#### Leakage from Tramway Systems.

Although the potential differences are much smaller in the case of damage to underground cables by leakage currents from traction systems, the changes in earth potential come about in just the same way as that described above. Tramway systems in this country are worked with uninsulated return and, due to the ohmic drop in the rails caused by the load currents, there is a P.D. (which fluctuates with the tramway load) between various points on the rails, and this causes current to leave the rails for the earth. It is a requirement of the existing Ministry of Transport Regulations that the rails shall be bonded to an earth connection of not more than  $2\Omega$  resistance at the substation supplying the system, the intention being that this earth connection would maintain that point of the rails to which it is connected at normal earth potential. Far from this being the case, the rails are usually connected with the general mass of earth so much more effectively than the earth connection provided at the substation that the latter is depressed with respect to normal earth potential. To make this clear, assume that there is a P.D. of 7 V (the maximum permitted by the Ministry of Transport Regulations) between the point on the rail outside the substation and the end of the track. If the rails were perfectly insulated from earth, there would be no leakage current; the earth at the substation would, therefore, carry no current and accordingly remain at normal earth potential. The potential distribution along the track would be as indicated by curve A in Fig. 4,

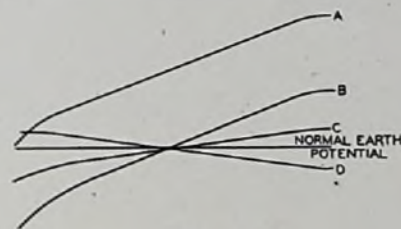

FIG. 4.

which shows a theoretical potential distribution for a branch line from an urban to a suburban area. If, however, the track is not perfectly insulated from earth, then current will leave the track at points remote from the substation and return at others close to it, and also by way of the substation earth connection. As the resistance of this earth connection is high compared with that between rails and earth, it does not appreciably influence the potential distribution along the track with respect to earth, which would be of the form indicated by Curve B in Fig. 4. So far we have not considered what happens to the earth close to the track. It was assumed for many years that this would remain at normal earth potential and that any buried conductors paralleling but not connected to the rails—as for example the sheath of telephone cables laid in the ground—took up a potential as indicated by Curve C of Fig. 4. Although this position for the potential curve of the cable

sheath would satisfy the observed values of P.D. between cable sheath and rails, it would not agree with the P.D. between cable sheath and local earth. It is apparent at once that, if current leaks on to the cable sheaths near the terminus and leaks off in the vicinity of the substation, the cable must be negative to earth at the former point and positive to earth at the latter. A potential distribution as indicated by Curve D of Fig. 4 would satisfy the observed values of P.D. between cable and local earth, but would conflict with the observed values of P.D. between cable and rail. Furthermore, for both the suggested potential distributions (Curves C and D in Fig. 4), the P.D. between the ends of the cable sheath would have to be such that it would require a very large current indeed to account for this drop—a current much larger in fact than would leak away from the tramway track. This confusion arises from the fact that the earth potential is assumed to remain fixed at its normal value, an assumption which would imply the earth to be a perfect conductor, whereas it is the cable sheath, by virtue of its low resistance to earth in those parts outside the influence of the voltage gradient around the rails, which approximates to normal earth potential throughout its length and of is the earth adjacent to the rails which, by virtue of its resistance, is displaced in potential. A simplified representation of the relative distribution on this basis is shown in Fig. 5.

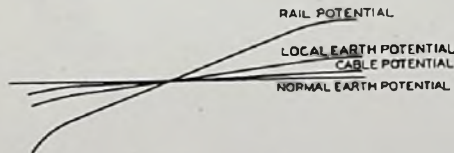

FIG. 5.—SIMPLIFIED REPRESENTATION OF POTENTIAL DISTRIBUTION IN TRAMWAY SYSTEM.

Some actual results from tests made on a route in Liverpool, which were undertaken to determine the position for insulating gaps in the cable sheaths, are

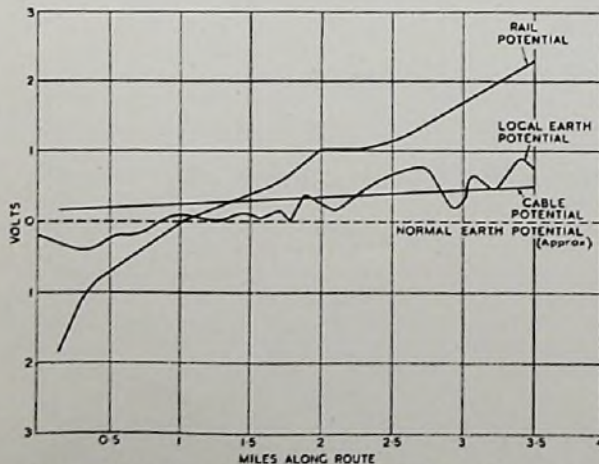

FIG. 6.—TEST RESULTS ON TRAMWAY ROUTE IN LIVERPOOL.

shown in Fig. 6. An accurate determination of the normal earth potential was not made as it was unnecessary for the purpose of the tests at the time. The approximate potential, therefore, has been shown dotted in the diagram. The cable potential approximates to a straight line on the scale of Fig. 6, but actually small variations were observed. The marked variation in the local earth potential is a point worth noting. This is due largely to the fact

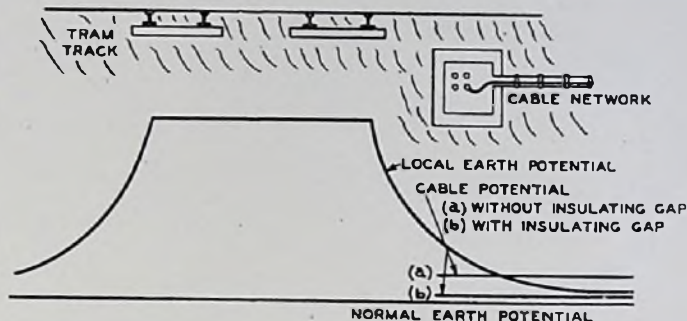

FIG. 7.—DECREASE OF EARTH POTENTIAL IN DIRECTION TRANSVERSE TO TRAM TRACK.

that the earth potentials were measured in the manholes of the cable route all of which were not at the same distance from the tramway rails. In a homogeneous earth the decrease in the earth potential as the distance from the rails in a transverse direction increases is similar to that experienced with other earth electrodes, and is shown diagrammatically in Fig. 7. Thus, if the earth potential at various points along the track at a constant distance from the rail were measured, it would be the same proportion of the local potential of the rail wherever the test was made, and the earth potential curve would, therefore, have the same shape as the rail potential curve. If, however, the earth potential is measured at varying distances from the rail, the shape of the earth potential curve bears no fixed relation to the rail potential curve. The decrease in earth potential as the distance from the rail increases has an important effect upon cables branching from a main cable paralleling the tramway rail. The potential of the branch cable sheath is practically uniform throughout its length and is equal to that of the sheath of the main cable. For this reason, the branch cable sheath will in one place be negative to the surrounding earth and at a point remote from the rail it may be positive to the surrounding earth, which conditions are conducive to current leaking on and off the cable and causing corrosion. To avoid damage due to this cause, it is now the practice to fit insulating gaps in the sheaths of all cables branching from a route paralleling a tramway track.

#### Conclusion.

It is hoped that this simple presentation of some typical cases of the behaviour of the earth as an indifferent electrical conductor will stimulate interest in a subject which is often more obscure than may be commonly supposed.

# Notes and Comments

## Roll of Honour.

The Board of Editors deeply regrets to have to record the deaths of the following members of the Engineering Department :—

*While serving with the Armed Forces, including Home Guard.*

Birmingham Telephone Area	Collins, A. W.	..	Labourer..	..	..	Gunner, Royal Artillery
Birmingham Telephone Area	Evans, D. J. P.	..	Unestablished Skilled Workman			Signalman, Royal Corps of Signals
Birmingham Telephone Area	McCann, R.	..	Skilled Workman, Class II	..		Lance Corporal, Royal Corps of Signals
Blackburn Telephone Area	Pennell, L. S.	..	Unestablished Skilled Workman			Sergeant Pilot, Royal Air Force
Bradford Telephone Area ..	Wolff, H. J.	..	Unestablished Skilled Workman			Sergeant Pilot, Royal Air Force
Cambridge Telephone Area	Colls, P. R.	..	Unestablished Skilled Workman			Pilot Officer, Royal Air Force
Cardiff Telephone Area ..	Booker, H. W.	..	Youth-in-Training	..	..	Leading Aircraftman, Royal Air Force
Chester Telephone Area ..	Humphreys, J. R.		Unestablished Skilled Workman			Sergeant, Royal Corps of Signals
Colchester Telephone Area	Ruffle, A. J.	..	Unestablished Skilled Workman			Sergeant Pilot, Royal Air Force.
Dundee Telephone Area ..	Conacher, P.	..	Skilled Workman, Class II	..		Lance Corporal, Royal Corps of Signals
Engineering Department ..	Meads, J. ..	..	Motor Cleaner	..	..	Sergeant, Royal Army Service Corps
Engineering Department ..	Proud, R. D.	..	Inspector..	..	..	Company Quarter Master Sergeant, Royal Corps of Signals
Exeter Telephone Area ..	Gibbings, A. J. V.		Labourer..	..	..	Trooper, Royal Armoured Corps
Exeter Telephone Area ..	Hayman, F. E.	..	Unestablished Skilled Workman			Sergeant Pilot, Royal Air Force
Glasgow Telephone Area ..	McNamara, J.	..	Skilled Workman, Class II	..		Lance Corporal, Royal Corps of Signals.
Gloucester Telephone Area	Jennings, R. E.	..	Skilled Workman, Class II	..		Signalman, Royal Corps of Signals
Leeds Telephone Area ..	Pratt, A. H.	..	Skilled Workman, Class II	..		Signalman, Royal Corps of Signals
Liverpool Telephone Area..	Bradley, J.	..	Unestablished Skilled Workman, Class II			Signalman, Royal Corps of Signals
Liverpool Telephone Area..	Corcoran, J.	..	Unestablished Skilled Workman			Aircraftman Class II, Royal Air Force
Liverpool Telephone Area..	Malley, D. G.	..	Unestablished Skilled Workman			Sergeant Air Gunner, Royal Air Force
Liverpool Telephone Area..	Williams, H. S.	..	Inspector	..	..	Sergeant, Royal Corps of Signals
London Postal Region ..	Allen, W. ..	..	Skilled Workman, Class II	..		Stoker, First Class, Royal Navy
London Telecommunications Region	Colsell, R. E.	..	Unestablished Skilled Workman			Signalman, Royal Corps of Signals
London Telecommunications Region	Evenett, A. G.	..	Unestablished Skilled Workman			Signalman, Royal Corps of Signals
London Telecommunications Region	Higman, W. G.	..	Unestablished Skilled Workman			Corporal, Royal Corps of Signals
London Telecommunications Region	Leader, W. W.	..	Labourer..	..	..	Sergeant, Royal Fusiliers
London Telecommunications Region	Miller, L. T.	..	Unestablished Skilled Workman			Signalman, Royal Corps of Signals
London Telecommunications Region	Sinclair, P. G.	..	Unestablished Skilled Workman			Signalman, Royal Corps of Signals
London Telecommunications Region	Smith, G. A. B.	..	Unestablished Skilled Workman			Signalman, Royal Corps of Signals

London Telecommunications Region	Tucker, W. J. H...	Skilled Workman, Class I	..	Wing Commander, Royal Air Force
London Telecommunications Region	Walker, A. P. L...	Unestablished Skilled Workman		Sergeant, Royal Air Force
Manchester Telephone Area	Brook, G. ..	Unestablished Skilled Workman		Lance Corporal, Royal Corps of Signals
Newcastle-on-Tyne Telephone Area	Sheedy, J. R. ..	Skilled Workman, Class II	..	Lieutenant, Royal Corps of Signals
Nottingham Telephone Area	Howard, G. ..	Unestablished Skilled Workman		Lance Corporal, Royal Corps of Signals
Oxford Telephone Area ..	Ford, E. G. M. ..	Skilled Workman, Class II	..	Private, Hampshire Regiment
Oxford Telephone Area ..	Willis, S. W. ..	Youth-in-Training	.. ..	Guardsman, Coldstream Guards
Portsmouth Telephone Area	Ball, W. A. H. ..	Unestablished Skilled Workman		Sergeant Flight Engineer, Royal Air Force
Scotland West Telephone Area	Grierson, J. A. ..	Unestablished Skilled Workman, Class II		Signalman, Royal Corps of Signals
Southend Telephone Area..	McCreeth, P. ..	Skilled Workman, Class II	..	Lieutenant, Royal Corps of Signals
York Telephone Area ..	Burks, J. W. ..	Labourer.. ..	.. ..	Sergeant, Durham Light Infantry

#### Recent Awards

The Board of Editors has learnt with great pleasure of the honours recently conferred on the following members of the Engineering Department :—

*While serving with the Armed Forces, including Home Guard.*

Dundee Telephone Area ..	McHardy, Geo. L. S.	Unestablished Draughtsman	Pilot Officer, Royal Air Force	Distinguished Flying Cross
Edinburgh Telephone Area..	Gillie, I. G. ..	Skilled Workman, Class II	Lance Corporal, Royal Corps of Signals	Mentioned in Despatches
Engineering Department ..	Parker, J. D...	Assistant Engineer	Major, Royal Corps of Signals	Member of the Order of the British Empire
Engineering Department ..	Reading, J. ..	Assistant Staff Engineer	Major,* Royal Corps of Signals	Member of the Order of the British Empire
Engineering Department ..	Reading, J. ..	Assistant Staff Engineer	Major,* Royal Corps of Signals	Mentioned in Despatches
London Telecommunications Region	Lee, A. W. ..	Skilled Workman, Class II	Flt. Sergeant, Royal Air Force	British Empire Medal
Norwich Telephone Area ..	Aldridge, D. R.	Unestablished Skilled Workman	Pilot Officer, Royal Air Force	Distinguished Flying Cross
Sheffield Telephone Area ..	Price, D. ..	Skilled Workman, Class II	Lance Corporal, Royal Corps of Signals	Mentioned in Despatches

*While serving with the Civil Defence Forces or on Post Office duty.*

Engineering Department†	Child, A. J. ..	Staff Officer	..	Member of the Order of the British Empire
H.M.T.S. .. ..	Baldwin, F. S. B.	Seaman Cable Hand		British Empire Medal
H.M.T.S. .. ..	Evans, C. M. G.	Chief Officer	..	Member of the Order of the British Empire
H.M.T.S. .. ..	Prince, E. ..	Third Engineer	..	Member of the Order of the British Empire

\* Now Lieutenant-Colonel.

† Seconded to the Ministry of Home Security.

### **Sir Stanley Angwin's I.E.E. Presidential Address**

Our readers will have noted with gratification that the Engineer-in-Chief, Col. Sir Stanley Angwin, D.S.O., M.C., has been elected President of the Institution of Electrical Engineers for the current session, 1943-44. Sir Stanley is the sixth Engineer-in-Chief of the Post Office to be elected to this post, which is acknowledged to be the highest form of technical recognition which can be accorded to an electrical engineer.

Sir Stanley delivered his Presidential Address to the Institution on October 7th, 1943, and chose as his subject "Electrical Communications."

In view of the difficulties attending, at the present time, any attempt at a review of current practice, Sir Stanley developed his subject in the form of a survey of the possibilities of development of telecommunications in the international field, dealing in particular with the subject of International Control and Regulation and its repercussions on post-war developments in this country.

Pointing out that telecommunications more than any other branch of engineering demanded an ever-increasing measure of international regulation and standardisation, Sir Stanley emphasised the work of British engineers in the framing of these regulations and standards, and the necessity of their playing a full part in work of this kind in the future. He also emphasised the need for this country to keep in advance in technique and to take a lead in research in the field of international communication in the future, if the interests of British trade are to be safeguarded.

After outlining the development of international regulation in telecommunications commencing with the first International Telegraph Convention of Paris, 1865, down to the present day, and the gradual increase in scope to cover the developments of telephony and radio, Sir Stanley made special reference to the difficult subject of radio frequency allocations—a matter on which he is an acknowledged expert of world wide reputation. Special reference was made to the need for dealing with this problem on a rational and engineering basis unhampered by political considerations if the mistakes of the past are to be eliminated or reduced in the future.

The address then proceeded to outline some possible developments in the future. In connection with possible developments in submarine cable telephony, the normal conception of the continents of America and Australia being separated from Europe by vast stretches of ocean is not necessarily correct, and routes exist whereby the longest submarine cable link could be reduced to about 200 miles in each case. In the case of America, this would involve traversing Russia, the Aleutian Islands and Alaska. It is pertinent to note in this connection that a telephone route from the United States to Alaska is now being built by the United States Army and 2,000 miles of this, from Edmonton to Fairbanks has already been opened. The possibilities of the submarine repeater were next discussed and after mention of the proposals contained in Dr. Buckley's Kelvin Lecture before the Institution for deep sea repeaters, Sir Stanley described briefly the work carried out by the Post Office in the design, manufacture and laying of a

submarine repeater in the Irish Sea. The repeater consists of a three stage amplifier having an overall gain of 70 db. at 504 kc/s and is provided with three alternative valves at each stage which can be changed either automatically on a valve failure or deliberately by switching from a distant end of the cable. Power of 0.63 A at 200 V is supplied along the cable from the end remote from that from which switching is effected. The repeater is housed in a cylindrical steel case with a cast steel end cover containing glands for the "in" and "out" cables. The repeater case has been tested to a pressure of 800 lbs. per sq. in. corresponding to a depth of 270 fathoms; the actual depth at which the repeater is lying is 32 fathoms. The results of this experiment are awaited with a good deal of interest and it is anticipated that with further improvements it should go far to meet the requirement of providing long distance telephone circuits by submarine cable where it has not been possible to do so before.

Passing to the subject of telegraphy the work of standardisation which has already been carried out by the C.C.I.T. was outlined and the standardisation of methods which has been achieved in connection with the transmission of photographs over the public services between European countries was cited as an example of such successful international collaboration.

We regret that it is not possible to give a fuller abstract of this interesting address, but no abstract could do it full justice, and readers who were unable to be present at its delivery are recommended to study it in full from the printed proceedings of the I.E.E.

The fact that the address did not deal to any great extent specifically with the work of the Post Office Engineering Department but with matters of a much wider scope in which Post Office engineers have to play their part, endows it with an importance which a more restricted treatment would have lacked, and at the same time will enhance its interest to telecommunications engineers generally as well as to Post Office readers.

### **Recent Appointments**

We offer our sincere congratulations to Mr. A. J. Gill on his appointment as Deputy Engineer-in-Chief in succession to Mr. P. J. Ridd, who retired from the service on 31st December, 1943; to Mr. Ridd we express the hope that he may enjoy a long and well-earned retirement. We welcome back to the Engineering Department Mr. H. Faulkner, who succeeds Mr. Gill as Assistant Engineer-in-Chief.

Another appointment which we are pleased to note is that of Mr. L. G. Semple as Deputy Regional Director, North Eastern Region. We offer Mr. Semple our best wishes for continued success in his new sphere.

### **Sir William Noble**

We regret to have to record the death, at the age of 82, of Sir William Noble, who, during the difficult years following the last war, held the post of Engineer-in-Chief to the Post Office. On retiring in 1922, Sir William became a director of the General Electric Company, a post which he held until his death.

# Regional Notes

## Midland Region

### RETIREMENT OF MR. W. S. COX, A.M.I.E.E.

Mr. W. S. Cox, Regional Engineer, Midland Region, retired from the service on September 30th, 1943. He entered the National Telephone Company in 1900, at Birmingham, and was transferred to the Sectional Engineer's office at Nottingham in 1909. He took up duty in the Technical Section of the North Midland District in 1925, as Assistant Engineer, and was appointed Executive Engineer in 1934. During this period Mr. Cox was closely associated with the Nottingham Exchange Area change-over to automatic working, and was the first Departmental Instructor in Auto Telephony in that area. For a short period he served as Assistant Superintending Engineer in the North Wales District, returning to the Midland Region, as Regional Engineer, in 1940.

In all these appointments Mr. Cox secured the respect and affection of his staff and colleagues, and his retirement is regretted by a wide circle of friends, who wish him many years of health and happiness.

Mr. Cox was a recipient of the King George VI Coronation Medal in 1937. At the farewell party given to Mr. and Mrs. Cox at Regional Headquarters on September 30th, 1943, a remarkable coincidence was revealed. It appeared that both he and his wife commenced and also severed their Post Office career in the same building. It is surely unique for an officer to commence and finish his career in the same building, especially after a period of 43 years.

### LOCALISATION OF HIGH CROSSTALK IN LONG TRUNK CABLE.

High crosstalk in a long cable is not one of the easiest faults to locate, and the following notes on a recent case in the Midland Region may be of general interest.

During tests after repairs to the L-BM-LV cable high S/S crosstalk was observed on pairs 331/2 at Birmingham. This was proved to originate south of Dunchurch interception hut and further tests were made from that point to Fenny Stratford. Normally an isolated source of high crosstalk in a long cable is located by crosstalk frequency measurements. A tuned amplifier-rectifier-galvanometer type of measuring set is required if the results are to be reliable and this apparatus was not available.

It was found, however, that impedance-frequency measurements on either of the faulty pairs, when compared with those on a good pair, gave a difference curve having the characteristic "wave" produced by an impedance irregularity in the line. The average frequency of this wave in the difference curve was 1,070 c/s, whereas the "frequency" on a good pair with an artificial fault (disconnection at Fenny instead of Z<sub>0</sub> termination) was 255 c/s. Hence a localisation of  $x = 255 \times 37.5 \div 1070 = 8.9$  miles from Dunchurch was obtained. The pairs were opened and found to be split at the loading point 8.5 miles from Dunchurch. A ballistic test over the L.C.S. located the rectifying split at 770 yards from this L.P. and the joint at 680 yards was opened and the trouble found and corrected.

The capacity unbalance (p-q) of 680 yards of split pairs is about 20,000  $\mu\mu\text{F}$ , giving a calculated crosstalk value of 13,000 C.T.U. at the fault, or, allowing for  $2 \times 3\frac{1}{2}$  db. line loss, 6,000 C.T.U. at Dunchurch. This compares with the measured value which was recorded as 5,000 C.T.U. at 1,000 c/s.

It is of interest to note that 680 yards of split pairs

in star-quad cable have a mutual capacity approximately 0.004  $\mu\text{F}$  higher than the normal and that this was sufficient to give a successful localisation on a cable length of 37.5 miles.

G. J.

## Home Counties Region

### SOME CABLING DIFFICULTIES

In the Cambridge Area it has recently been necessary to draw a 4/40 + 384/20 PCQT cable over a 28/40 PCQT cable in a 4-in. S.A. duct for a distance of about five miles. It was realised that the risk of damage by such a large cable to such a small one was appreciable, but the expense and labour involved in any alternative scheme would be such that the risk was well worth while. It was found that the larger cable drew along with it the smaller one, with consequent damage to the smaller cable, including "snaking" within the duct and movement of joints. Trials were then made with the small cable anchored, but anchoring by rope did not prove sufficient to prevent some movement. Finally a stranded steel wire and a vice draw No. 2 were used between the split cable grip and the crowbars or other anchorage, some initial tension being applied by the ratchet. This proved very successful, and of the remaining 42 lengths, faults were caused to only two of them, one due probably to some fault in the duct line and the other to the extra wear involved in renewing a faulty length of the larger cable.

On this same work the Couplings C.I. No. 8 proved too small in internal diameter to accommodate the existing and new joints, but as an alternative to building buried boxes the coupling halves have been separated along each side by arms wood (creosoted oak) and the ends packed with tarred yarn and Mixture No. 2, the couplings being bound together by copper wire. The utilisation of the existing couplings in this way, though not ideal, appears to be quite a satisfactory war-time expedient.

## W. and B. C. Region

### ANCHORING OF SUBMARINE CABLES

A submarine cable has recently been laid across a tidal waterway in this Region. The tidal currents are strong and the sea bed rocky. The cable, being an important link in a trunk cable route, had to be anchored and kept clear of jagged rocks on the bed. This was done by concrete cushions. These cushions were set in place by a diver. While the work was in progress it was inspected by certain members of the Regional Engineering and Telephone Managers staffs. The descent to the sea bed was made in a diving suit, and it is thought that a description of this experience may be of interest.

Before being fitted into the diving suit one is dressed in two woollen suits. A woollen cap is also placed on the head covering the ears and back of the neck. The purpose of these coverings is to distribute, as evenly as possible, the pressure over the body. Unevenness of pressure results from the folds and creases in the diving suit. Eight copper studs project from the suit around the lower neck, and to these a copper corsage is fixed and secured by wing nuts. The corsage is fashioned to receive the helmet. Before the helmet is put in place, two 40-lb. lead weights are placed in position, one on the back, and one on the chest. These are securely tied in position. The boots are lead-soled and each weighs 20 lbs. A rope, referred to as a life line, is made off around the waist, and also secured to the helmet. After starting the air pumps and making sure that air is passing into the helmet, the windows are screwed into place and aural communication with the outside ceases.

Secured to the outside of the boat is a ladder, the bottom of this is about 6-7 ft. under water. With the assistance of the boat's crew, the diver is placed on the outside of the ladder. Secured to the gunwale is a rope which is made off to the cable on the sea bed. The descent is made whilst grasping the rope in one hand and the ladder in the other. The main sensation at this stage is the increasing grip of the water over the whole body. After becoming accustomed to the gripping and the weird sense of being shut in, there is little discomfort. When on the sea bed, which in this case was 30 ft. down, the two most noticeable features were: (a) the difficulty of moving the limbs, due to the gripping of the water, and (b) the lack of weight on the feet, even though the release air valve was kept fully open. These handicaps combined to make progress in any direction difficult and slow. Visibility at 30 ft. depth and the sky clear at noon and summer time, was about 0-12 ft. To examine objects on the sea bed, the cable for instance, one must bring the windows of the helmet comparatively near to the object. In doing this it is well to remember the mass of metal situated around the chest and head. If this mass is brought forward by bending in the normal manner, the result is that one topples over and the air in the suit lifts the legs upwards. This results in a complete inversion, and it is impossible to right oneself.

The sea bed presented an uneven and rocky surface over the course followed by the cable. Wherever a pillar was built, the cable was anchored to the top of it by placing a further bag of concrete on top of the cable. Ropes made off to the cable enabled the boat's crew to lift the cable. Bags of concrete were lowered in a dry state by ropes and guided into position by the diver. The cable was then lowered on to the pillars so built. In this case our examination showed that the cable had been anchored and secured in such a manner that no damage due to chaffing against sharp rocks is to be expected. S. J. M.

#### GROUND WATER LOWERING

In connection with the notes on this subject, published in the last issue of the JOURNAL, it should, perhaps, be added that one of the main features of the ring valve arrangement in the Moretrench Wellpoint is the gravity assisted return of the valve. In the modified design the 1-oz. valve has to be held open by the pump suction, and this offsets, to a certain extent, the advantage gained by the "straight through" flow of water. Access to the valve for cleaning purposes, as provided in the modified design, is necessary to ensure ready action of the valve in the absence of a more positive return action. Further experience will show which arrangement presents the greater advantage.

## Staff Changes

### Promotions

Name	Region	Date	Name	Region	Date
<i>Regl. Engr. to T.M.</i>			<i>Insp. to Chief Insp.</i>		
Milton, G.P.	L.T.R.	16.8.43	Allan, A. F. G.	E.-in-C.O.	5.7.43
<i>Exec. Engr. to A.S.E.</i>			Nightingale, W. H.	L.T.R.	12.7.43
Ellson, F. A.	Test Section (Ldn.) to Mid. Reg.	1.10.43	Deal, F. C.	L.T.R.	3.8.43
Scantlebury, L. F.	Scot. Reg. to E.-in-C.O.	17.10.43	Knight, A. R.	L.T.R.	18.7.43
Flowers, T. H. (M.B.E.)	E.-in-C.O.	15.11.43	Missen, L. A.	E.-in-C.O.	5.9.43
<i>Asst. Engr. to Exec. Engr.</i>			McClements, J. S.	E.-in-C.O.	17.10.43
Keeble, A. G.	Test Section (Ldn.)	1.10.43	Watt, G. D.	E.-in-C.O.	28.10.43
Winch, B.	E.-in-C.O.	2.11.43	Rivis, J. W.	E.-in-C.O.	19.9.43
Coombs, A. W. M.	E.-in-C.O.	15.11.43	Dutton, E. S.	L.T.R.	2.10.43
<i>Chief Insp. to Asst. Engr.</i>			McEwan, A.	Scot. Reg.	3.8.43
Seymour, E. H.	L.T.R. to E.-in-C.O.	20.9.43	Wadeson, D. E.	Scot. Reg.	22.11.42
Burrows, C. T.	H.C.R.	20.9.43	Christopher, F. J.	H.C. Reg.	5.7.42
Trussler, H.	S.W. Reg. to Scot. Reg.	3.10.43	<i>5th Engr. to 4th Engr.</i>		
Cottrell, H. E.*	Test Section (B'ham) to Test Section (Ldn.)	1.10.43	Robinson, R. A.	H.M.T.S.	8.9.43
Blower, G. A.	Test Section (Ldn.)	1.10.43	<i>S.W.1 to Insp.</i>		
Powning, S. H.†	L.T.R.	16.11.43	Davis, J. A.	Test Section (B'ham) to Test Section (Leicester)	5.9.43
Pocock, D. G.†	L.T.R.	16.11.43	Humphrey, E. A.	L.T.R. to E.-in-C.O.	25.9.43
James, L. R.†	L.T.R.	16.11.43	Wilks, H. G.	L.T.R. to E.-in-C.O.	7.5.43
Plumpton, F. E.	E.-in-C.O. to L.T.R.	16.11.43	Hatton, G.	E.-in-C.O.	27.5.42
Donovan, J. G.	L.T.R. to E.-in-C.O.	16.11.43	Walker, J. D.†	E.-in-C.O.	27.5.42
Fudge, G. A. E.*	E.-in-C.O.	3.9.43	Boxhall, T. R.	E.-in-C.O.	27.5.42

\* On loan to another Government Department.

† Promoted in absentia.

### Appointments

Name	Region	Date	Name	Region	Date
<i>Asst. Tfc. Supt.</i>					
Dean, L.	Mid. Reg.	27.7.43	Paramor, S. R. V.	S.W. Reg.	27.7.43
			Samson, G. S.	E.-in-C.O.	26.8.43

### Retirements

Name	Region	Date	Name	Region	Date
<i>Asst Engr.</i>			<i>Insp.</i>		
Blake, E. C.	E.-in-C.O.	12.10.43	Taylor, C. E.	L.P.R.	25.7.43
James, F. G. H.	H.C. Reg.	22.11.43	Phillips, M. W.	E.-in-C.O.	16.9.43
<i>Chief Insp.</i>			<i>4th Engr.</i>		
Collins, T. J.	H.C. Reg.	10.8.43	Sharp, J. F.	H.M.T.S. (resigned)	21.9.43
Wilson, G.	E.-in-C.O.	13.8.43	<i>D-aught'sman Class II.</i>		
Blewett, G. M.	S.W. Reg.	14.11.43	Shepherd	E.-in-C.O.	16.9.43

### Transfers

Name	Region	Date	Name	Region	Date
<i>Exec. Engr.</i>			<i>Insp.</i>		
Harnston, A. T.	E.-in-C.O. to L.T.R.	18.10.43	Atherton, W. S.	L.T.R. to E.-in-C.O.	7.11.43
<i>Asst. Engr.</i>			<i>4th Engr.</i>		
Robertson, C. D. S. G.	W. & B.C.R. to E.-in-C.O.	12.9.43	Lewis, H.	N.W. Reg. to E.-in-C.O.	6.9.43
			Kelly, F.	N.W. Reg. to E.-in-C.O.	26.9.43
			Stollard, A. F.	Mid. Reg. to E.-in-C.O.	10.10.43

### Deaths

Name	Region	Date	Name	Region	Date
<i>A.S.E.</i>			<i>Insp.</i>		
Gregory, H. J.	E.-in-C.O.	5.11.43	Proud, R. D.	E.-in-C.O. (on Active Service)	7.12.42
<i>Asst. Engr.</i>			<i>4th Engr.</i>		
Wheeler, W.	E.-in-C.O.	16.11.43	Jackson, J. T. H.	N.W. Reg.	2.8.43
<i>Asst. Chemist</i>			<i>4th Engr.</i>		
Prior, G. L. W.	Test Section (Ldn.)	29.8.43	Hewitt, W.	L.T.R.	7.9.43
			Kain, J. S.	N. Ire. Reg.	5.11.43
			Stowell, A. C. St. John	L.T.R.	5.11.43

### BOARD OF EDITORS

A. J. GILL, B.Sc., M.I.E.E., F.I.R.E., Chairman.  
 F. E. NANCARROW, A.R.C.Sc., M.I.E.E.  
 P. B. FROST, B.Sc., M.I.E.E.  
 A. H. MUMFORD, B.Sc.(ENG.), M.I.E.E.  
 C. W. BROWN, A.M.I.E.E.  
 G. H. S. COOPER.  
 H. LEIGH, B.Sc.(ENG.), A.M.I.E.E., Acting Managing Editor.  
 G. E. STYLES, A.M.I.E.E., Acting Assistant Editor.  
 A. J. BAKER, Secretary-Treasurer.

#### Copyright

The entire contents of this JOURNAL are covered by general copyright, and special permission is necessary for reprinting long extracts, but Editors are welcome to use not more than one-third of any article, provided credit is given at the beginning or end thus: "From the *Post Office Electrical Engineers' Journal*."

The Board of Editors is not responsible for the statements made or the opinions expressed in any of the articles in this JOURNAL, unless such statement is made specifically by the Board.

#### Communications

All Communications should be addressed to the Managing Editor, *P.O.E.E. Journal*, Engineer-in-Chief's Office, Alder House, Aldersgate Street, London, E.C.1. Telephone: HEADquarters 1234. Remittances should be made payable to "The *P.O.E.E. Journal*" and should be crossed "& Co."

#### Binding Cases

Cases for binding are available, and may be obtained from the Local Agents for 1s. 9d. Subscribers can have their copies of Volumes bound, at a cost of 3s., by sending the complete set of parts to the Local Agents or to the *P.O.E.E. Journal*, Engineer-in-Chief's Office, Alder House, Aldersgate Street, London, E.C.1. Orders for binding for Vols. 1-19 should indicate whether the original binding case with black lettering, or the later pattern with gold, is required. Cases with gold lettering are the only type stocked from Vol. 20 onwards.

#### Back Numbers

The price of the JOURNAL, which is published quarterly, is 1s. (1s. 3d. post free) per copy, or 5s. per annum post free. Back numbers can be supplied, subject to availability of stocks, at 1s. each (1s. 3d. post free). Orders for back numbers may be sent to the Local Agents or to the Publishers.

#### Advertisements

All communications relating to space reservations should be addressed to the Advertisement Editor, *P.O.E.E. Journal*, Alder House, Aldersgate Street, London, E.C.1. Communications regarding advertisement copy, proofs, etc., should be addressed to the Publishers, Messrs. Birch & Whittington (Prop. Dorling & Co. [Epsom], Ltd.), 49 Upper High Street, Epsom, Surrey.



*NOTE.—The fact that goods made of raw material in short supply owing to war conditions are advertised in this Journal should not be taken as an indication that they are necessarily available for export.*

50-range Model 7  
Universal AvoMeter



**'AVO'**  
Regd. Trade Mark

*Meters that Matter*

THE world-wide use of "AVO" Instruments is striking testimony to their outstanding versatility, precision and reliability. In every sphere of electrical test work, on active service and in industry, they are appreciated for their dependable accuracy, which is often used as a standard by which other instruments are judged.

Orders can now only be accepted which bear a Government Contract Number and Priority Rating.

Sole Proprietors and Manufacturers

THE AUTOMATIC COIL WINDER & ELECTRICAL EQUIPMENT Co. Ltd.  
Winder House, Douglas Street, London, S.W.1

Phone: VICtoria 3404-7

## POWER LEVEL INDICATORS

POWER LEVEL INDICATORS—TYPES D-152-A and D-152-B

Embodying a simple resistance bridge, self-balancing at a pre-determined power level—Robust—Accurate—Inexpensive.

Type D-152-A indicates a fixed power level; D-152-B is variable over a limited range.

Equally accurate on D.C. or A.C. Accuracy is independent of wave form and frequency up to 50 Kc/s.

With A.C., telephones will indicate balance to better than 0.1 db; a reasonably sensitive galvanometer (e.g. 100-0-100 $\mu$ A) gives equivalent discrimination with D.C.

Cannot be damaged by overloads up to 1,000 %.

Indispensable to Transmission Engineers, Meter Manufacturers and others requiring a standard power level.

### STANDARD TYPES

TYPE NUMBER	POWER INDICATION Ref. 1 mW	INPUT RESISTANCES	DIMENSIONS	WEIGHT
D-152-A	+20 db $\pm$ 0.1 db	600 $\mu$ $\pm$ 1%	6" $\times$ 5" $\times$ 5 1/2"	3 lbs.
D-152-B	+10 to +22 db $\pm$ 0.2 db	600 $\mu$ $\pm$ 5%	8" $\times$ 5" $\times$ 5 1/2"	4 lbs.

Full particulars are given in Bulletin B 540-A a copy of which will gladly be sent on request.

MUIRHEAD & CO. LTD., ELMERS END, BECKENHAM, KENT  
Beckenham 0041-0042.  
FOR OVER 60 YEARS DESIGNERS & MAKERS OF PRECISION INSTRUMENTS.

**MUIRHEAD**



PRINTING  
TELEGRAPH  
APPARATUS

TELEPRINTERS  
HIGH SPEED MORSE INSTRUMENTS  
RELAYS  
AND REPEATERS

**CREED** AND CO. LTD  
CROYDON

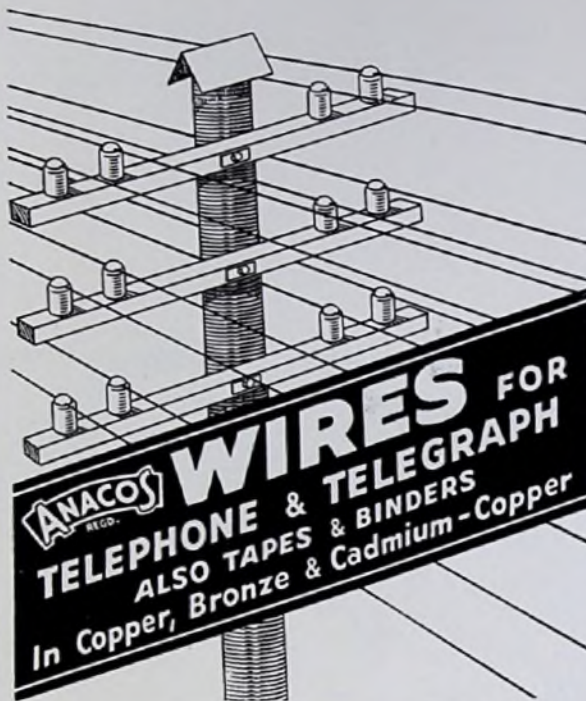

**ANACOS** WIRE FOR  
TELEPHONE & TELEGRAPH  
ALSO TAPES & BINDERS  
In Copper, Bronze & Cadmium-Copper

FREDERICK SMITH & CO. LTD. (*Incorporated in The London Electric Wire Company and Smiths, Limited.*)  
ANACONDA WORKS, SALFORD, 3, LANCS.  
Telephone : BLACKFRIARS 8701 (8 lines)      Telegrams : "ANACONDA" MANCHESTER

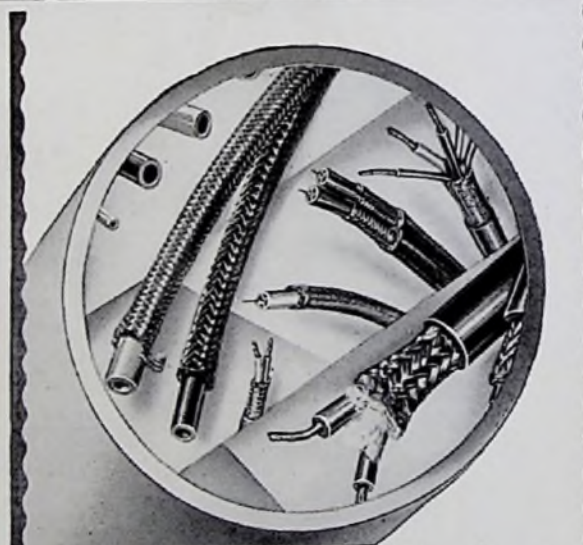

For electrical and chemical insulation the mechanical, physical and chemical properties of Tenaplas extruded plastics offer notable advantages over existing materials.

**TENAPLAS**  
ELECTRICAL  
INSULATION

TENAPLAS LTD., Head Office, 7 PARK LANE, LONDON, W.1



**FOR TELE-COMMUNICATION**

**AND LIGHT-CURRENT SIGNALLING  
SYSTEMS AND EQUIPMENT...**

including Strowger Automatic Telephone Equipment—standard almost the world over—for networks of all sizes or for isolated exchanges; Manual Telephones and Exchange Equipment; Single and Multi-Channel (Carrier) Transmission Systems and Associated Apparatus; Supervisory Remote Control Equipment; Colliery Telephone and Signalling Equipment; Electro-matic Street Traffic Signals and other products. Fully descriptive literature, catalogues, etc., are available and will be sent upon application, whilst expert technical knowledge and advice are always at the service of those interested.

**AUTOMATIC TELEPHONE & ELECTRIC COMPANY LTD**

LONDON AND



LIVERPOOL

*Trusted by those  
carrying great  
responsibility*



The engineers responsible for equipping 500 of Britain's Power Stations pinned their faith to Tudor Accumulators. This confidence was justified by the Tudor record of unsurpassed efficiency and reliability. Many of the largest battery installations in the country are Tudor, and some of these have been functioning without

pause or hitch for over 30 years. You should specify Tudor for important jobs.

SAFETYLYTE (Patent No. 313248) the Tudor Emergency Lighting System is automatic and instantaneous in operation. It is installed in thousands of schools, hospitals, factories and other large buildings.



**TUDOR ACCUMULATORS**

THE TUDOR ACCUMULATOR CO. LTD  
50 GROSVENOR GARDENS, LONDON, S.W. 1

W-25122

## ELECTRIC VEHICLE



**BATTERY  
CHARGING**

Group of Metrovick electrics for Postal Services (published by courtesy of H.M. Postmaster-General) and Westinghouse vehicle charger type VR.30/45 with MJV battery charge timing relay.

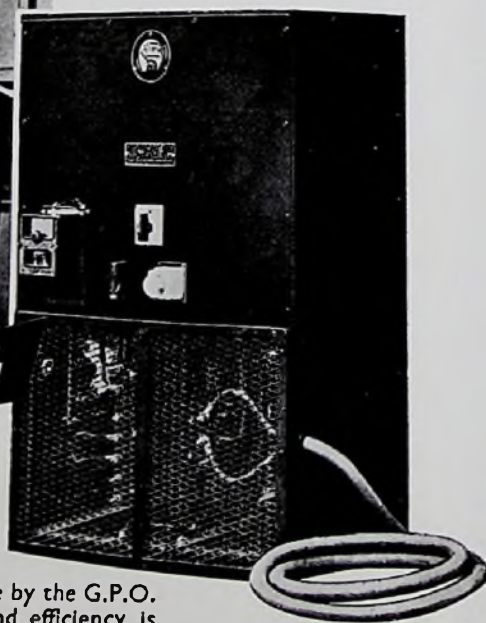

Thousands of Westinghouse Metal Rectifiers are in use by the G.P.O. in telephony and telegraphy. Now their reliability and efficiency is being made use of by the Postal Services to provide a convenient and economical delivery service.

WESTINGHOUSE BRAKE & SIGNAL CO., LTD., PEW HILL HOUSE, CHIPPENHAM, WILTS.

# SIEMENS PRODUCTS

*backed by over 80 years' Electrical Experience*

Contractors for  
the manufacture, laying and main-  
tenance of Submarine and Land  
Cables for Telegraphy, Telephony  
and the Electric Transmission of  
Power, for the erection and main-  
tenance of Overland Telegraph,  
Telephone and Power Transmission  
Lines, Marine Wireless Telegraph  
and Telephone Installations, Public  
and Private Telephone Exchanges  
and Carrier Equipment for  
Telephone Lines.

## Manufacturers of

Electric Lamps of all types for  
Domestic, Industrial and Street  
Lighting, including "Sieray" Electric  
Discharge Lamps, Fluorescent Tubes,  
Motor Car Lamps, Projectors, etc.



**ELECTRIC  
WIRES & CABLES**

**CABLE  
JOINT BOXES**

**TELEPHONE CABLES**  
Aerial, Underground, Submarine

**OVERHEAD  
LINE MATERIAL**

**CELLS & BATTERIES**  
Dry, Fluid & Inert

**ELECTRICAL  
MARINE APPARATUS**

**ELECTRIC  
LAMPS**

**PRIVATE  
TELEPHONE SYSTEMS**

**PUBLIC  
TELEPHONE EXCHANGES**

**CARRIER-CURRENT  
EQUIPMENT**

**WIRELESS EQUIPMENT  
FOR SHIPS**

**"ZED" FUSES  
L.T. SWITCH & FUSE GEAR**

## SIEMENS BROTHERS & CO., LTD.

WOOLWICH, LONDON, S.E. 18

SIEMENS ELECTRIC LAMPS & SUPPLIES LTD., 38-39 UPPER THAMES STREET, LONDON, E.C. 4



The War has not been allowed to interfere with Ericsson quality . . . our telephone apparatus remains at that peerless efficiency that ensures trouble-free service. ERICSSON TELEPHONES LIMITED, 56, KINGSWAY, LONDON, W.C.2. (Tel.: HOLborn 6936.)



**capco**

REGISTERED TRADE MARK

# QUARTZ CUTTING MACHINE

LIGHT & HEAVY DUTY MACHINES  
HAVE BEEN RE-DESIGNED & IMPROVED  
LATEST DEVELOPMENT, HAND AND  
AUTOMATIC NOTCHING MACHINES  
· · · DETAILS ARE NOW AVAILABLE

**CAPLIN ENGINEERING CO. LTD.**

**1918 · · · 1943**

**SILVER JUBILEE YEAR**

25 years of service to the engineering  
and allied trades.

Well over one thousand "CAPCO"  
machines in use to-day, including hun-  
dreds of special machines and apparatus.  
"CAPCO" is synonymous with accuracy.

*Designers and manufacturers of Capco Sound-on-Film  
recorders and equipment. Capco built recorders are in use  
at Elstree, Pathe News and Universal Talking News, etc.  
Patentees and manufacturers of Capco Enamelled Wire  
Cleaning machines.*

**BEACONSFIELD RD WILLESDEN, LONDON, N.W.10**

Sole Agents : CAPCO (Sales) LTD.

Telephone : WILLESden 0067-8

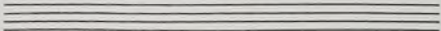

x

# STANDARD WITH THE BRITISH POST OFFICE

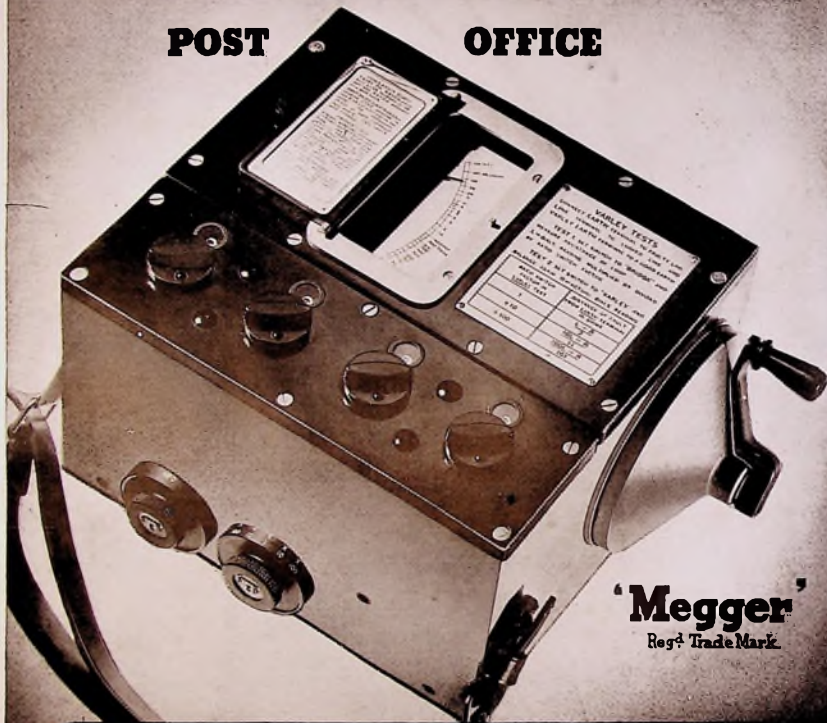

**'Megger'**  
Reg<sup>d</sup> Trade Mark

THE BRIDGE-MEG TESTING SET used by the British Post Office is a portable, self-contained instrument combining the functions of an Insulation Tester and a Wheatstone Bridge; it can be used for fault location by the Varley Loop method. Facilities can also be provided whereby, with the use of an external galvanometer and resistance box, the instrument may be used for making Murray Loop tests. Insulation range 100 megohms at 500 volts. Bridge range 0.01 to 999,900 ohms. Size 7 x 8 $\frac{1}{2}$  x 12 ins. Weight 12 $\frac{3}{4}$  lbs. Mains operated instruments are also supplied to the British Post Office. Ask for list X 267.

**EVERSHED & VIGNOLES LTD., CHISWICK, LONDON, W.4**  
TELEPHONE: CHISWICK 1370 \* TELEGRAMS: "MEGGER" CHISK, LONDON

WR 5-14





“**T**he roads of the present  
lie deep in the past”

FOR every purpose demanding a dependable high standard of performance, Alton stationary batteries are installed. Behind them is a tradition of craftsmanship in battery design and manufacture and of efficient and reliable performance in service.

The established traditions associated with the name of Alton define the standard of the future and point to the choice of Alton batteries for services of vital importance.

# ALTON

## BATTERIES OF MERIT

THE ALTON BATTERY COMPANY LIMITED  
(Sole Suppliers of FULLER Stationary Batteries)  
ALTON, HANTS

Telephone: Alton 2267 and 2268  
Telegrams: 'Battery, Alton'

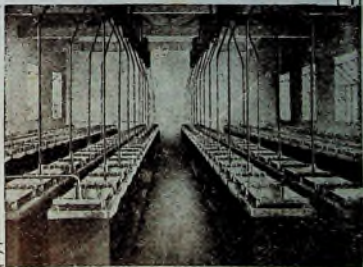

# MAINTAINING EFFICIENCY

THE HIGH STANDARD OF EFFICIENCY  
OF PIRELLI - GENERAL TELEPHONE  
CABLES IS MAINTAINED BY THE  
CONTINUOUS RESEARCH WORK OF  
AN EXPERIENCED TECHNICAL STAFF.

TELEPHONE  
SOUTHAMPTON  
2141 (5 Lines)

**PIRELLI-GENERAL**  
CABLE WORKS, Ltd., SOUTHAMPTON.

TELEGRAMS  
"PIGEKAYBEL"  
SOUTHAMPTON.

**lbs AND £s**

... **4,416 Good Joints**  
**TO THE LB. - THEREFORE**  
**MORE TO THE £.**

Of course, Ersin Multicore 3-Core Solder is not as cheap as ordinary solder—but it costs less in the end. The three cores of Ersin flux being continuous, there is no waste of either labour or material, and no dry joints even with the majority of highly oxidised components. One pound of sixteen S.W.G. Ersin Multicore Solder will give as many as 4,416 sound joints which can be trusted to remain sound, both electrically and mechanically. Firms engaged on government contracts are invited to write for reference sheet and samples of Ersin Multicore Solder Wire—approved by the A.I.D. and G.P.O. for all purposes where resin is specified.

**ERSIN MULTICORE**

THE SOLDER WIRE WITH 3-CORES OF NON-CORROSIVE ERSIN FLUX



**MULTICORE SOLDERS LTD. COMMONWEALTH HOUSE, NEW OXFORD ST. LONDON, W.C.1. Tel: CHAncery 5171/2**