

THE POST OFFICE ELECTRICAL ENGINEERS' JOURNAL

VOL. 36

OCTOBER, 1943

PART 3

CONTENTS

	PAGE
THE PRODUCTION OF MAGNETIC LAMINATIONS—F. C. Carter, B.Sc.(Eng.), A.M.I.E.E.	65
SOME NOTES ON THE ENGINEER-IN-CHIEF'S LIBRARY— J. E. Wright	71
MEASUREMENTS ON HIGH-FREQUENCY CABLES AND FEEDERS: Part II. Impedance, Transmission and Crosstalk Attenuation Measurements—R. F. J. Jarvis, Ph.D., and J. C. Simmonds, Ph.D.	76
SIMPLIFICATION OF CABLE CAPACITANCE NETWORKS— V. R. Pettitt, D.C.M., B.Sc.(Eng.)	82
AN AIR CONDITIONING PLANT—K. O. Bawtree, B.Sc.(Eng.), A.M.I.E.E.	85
AN IMPROVISED OSCILLATOR FOR PIP-TONE SUPPLY— N. W. Lewis, Ph.D.(Eng.), M.I.E.E.	90
NOTES AND COMMENTS	91
REGIONAL NOTES	93
STAFF CHANGES	95
BOOK REVIEWS	96

Price 1/- net

THE INSTITUTION OF POST OFFICE ELECTRICAL ENGINEERS

GE CALLOY

RADIO CORES

MAIN ADVANTAGES

- Greater magnification.
- Higher selectivity.
- Small size.
- Reduced costs.
- Robust construction.
- Simple adjustment.
- Non-rusting.

SALFORD ELECTRICAL INSTRUMENTS LTD.

PEEL WORKS, SALFORD, 3. Telephones: BLAckfriars 6688 (6 lines). Telegrams and Cables: "Sparkless, Manchester"
 PROPRIETORS: THE GENERAL ELECTRIC Co. Ltd., OF ENGLAND

EDISWAN

TELEPHONE LINE PROTECTOR PANELS

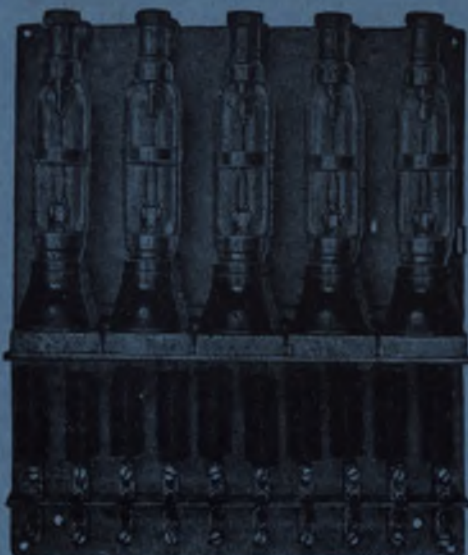

5-circuit panel for overhead lines incorporating choke coils, spark gaps, etc.

EDISWAN-SHOTTER-GREETHAM PATENT

(British Patent No. 353924)

for the protection of telephone systems against surges induced by faults on neighbouring power lines

Of the difficulties attendant upon the employment of overhead systems one of the most serious is to ensure uninterrupted working of the telephone system, by providing adequate protection against induced surges caused by switching or line faults in adjacent power lines or by lightning.

The Ediswan Patent Protectors provide the solution. They are inert at the normal working pressure of the telephone line, they keep the voltage on the line down to a pre-determined figure by providing a path of low resistance to earth whereby the surge is cleared and they again become inert immediately the surge is cleared.

They ensure simultaneous discharge of both lines and are capable of clearing heavy discharges without detriment to the system or the protector.

Ediswan Telephone Line Protectors have now been in use by Supply Companies for many years.

THE EDISON SWAN ELECTRIC CO. LTD., 155 CHARING CROSS ROAD, LONDON, W.C.2

THE POST OFFICE ELECTRICAL ENGINEERS' JOURNAL

Vol. XXXVI

October, 1943

Part 3

The Production of Magnetic Laminations

F. C. CARTER, B.Sc. (Eng.), A.M.I.E.E.

U.D.C. 621.318.322

The article describes some of the principal processes involved in the production of nickel iron and silicon steel laminations for transformers and inductors, etc., particularly those used in the telecommunications industry.

Introduction.

THE question of the design of transformers and chokes has been the subject of many articles in the technical press, and the basic principles applying to the particular requirements of telecommunications engineering are very ably summarised by Dr. Glazier in I.P.O.E.E. printed paper No. 176, and Messrs. R. O. Carter and D. L. Richards in *P.O.E.E. Journal*, October, 1941. It is evident that even when the overall performance requirements of a coil have been specified, and the preliminary design determined, there are an infinite variety of designs all differing slightly in detail which meet the requirement. The design engineer's function is to decide which of these is the most suitable and economic design. The choice of the most suitable lamination offers perhaps the greatest problem owing to the many interdependent variables that have to be considered simultaneously, i.e. size, shape, thickness, window area, flux density, permeability, frequency spectrum and hysteresis and eddy current losses. In practice the final choice of the type of lamination to be utilised depends largely upon the availability of certain stock sizes, shapes, thicknesses and materials which have been developed over a period of years and which are now produced by bulk production processes, and it has recently been agreed by the interested Service Departments that the bulk of the requirements for radio and telecommunications purposes can be met from about 32 standard types.

Materials.

The two principal types of materials now in use for the production of these laminations are :

- (1) Nickel Iron Alloys containing up to 80% nickel.
- (2) Silicon Steel Alloys containing up to 4½% silicon.

Some nickel iron alloys also contain small proportions of molybdenum, chromium, copper and manganese.

The magnetic properties of the alloys vary with the chemical composition and there are a number of proprietary alloys of definite compositions which are the optimum for certain specific magnetic characteristics. The principal properties of certain of these alloys and of mild steel are shown in Table I. It will be evident from this that the silicon steels are most suitable for use at high flux densities, i.e. output and power transformers, whereas the nickel irons, having very high permeabilities at low flux densities, are suitable for low power level transformers and filter coils where the losses must be the minimum.

The processes involved in the production of these materials fall into four broad divisions :

- (1) The production of the alloy in the form of billets or bars.
- (2) Rolling the billet into strips or sheets.
- (3) The stamping of the laminations from the strip.
- (4) Heat-treatment of the laminations.

A fundamental point to note in the production processes of the nickel iron group is the fact that the required magnetic characteristics are strongly influenced by cold working.

TABLE I

Material	Approx. Composition	Permeability		Saturation Flux (Gauss)	Total Loss (Watt per lb. at 50 c/s.)			Resistivity (Microhm cm ²)	Nominal Thickness (in.)	Comparative Price
		Initial	Max.		100 Gauss	1,000 Gauss	10,000 Gauss			
Mild Steel	—	250	5,000	21,000	—	—	1.5	10	.014	1
Silicon Steel	Si/Fe. 2/98	300	6000	18,000	—	.1	.63	55	.014	2
Nickel Iron	Ni/Fe 50/50	1800/2400	10000/20000	16,000	.00007	.005	.32	55	.015	10
"	80/20	10000/30000	50000/100000	8,000	.000016	.0022	—	60	.015	16
"	36/64	1500/2000	6000/8000	13,000	.00005	.009	—	90	.015	

NICKEL IRON

The Billet.

The first stage in the production of the billet is to ensure the satisfactory alloying of the various metals. This can be achieved only by bringing them into intimate contact with one another at an elevated temperature, i.e. of the order of 1500°C. A convenient means for this operation is a H.F. induction furnace (Fig. 1) capable of holding $\frac{1}{4}$ to $\frac{1}{2}$ ton of material.



FIG. 1.—HIGH FREQUENCY INDUCTION FURNACE.

The frequency of operation is of the order of 2,000 c/s. The furnace requires a power of about 200 kW, applied for 1 to 2 hours to heat the charge to the required temperature and this power is usually supplied by a motor-alternator set. The energising coils of the furnace are copper tubes cooled by internal circulating water.

Each charge consists of certain proportions of raw materials and of remelted alloy of the same composition as that to be produced. The principal raw materials are iron, which must be in a pure state and is fed in the form of billets weighing about 1 cwt., and nickel in the form of pellets $\frac{1}{8}$ to $\frac{1}{4}$ " diameter. As the charge is heated and becomes molten so the ingredients are mixed automatically by a swirling action set up by eddy current effects, and slag also collects on the top of the melt. The mixing process can be seen very clearly by viewing the furnace through dark blue glasses, when the slag appears as dark oily patches floating on the surface of the mix. The majority of the slag can be collected and removed by steel spoons.

The design of the furnace is such that the charge is run off by tilting the whole furnace, the charge being collected in a number of iron moulds each holding about 1 cwt. The moulds are split longitudinally in two sections to facilitate

the removal of the billet after cooling. To facilitate the emptying of the furnace a sufficient number of moulds to contain the whole of the charge are mounted either on a rotating table or fixed to a rotating wheel located in such a position in front of the furnace that each mould in turn can be brought up to the furnace mouth for filling. The whole charge is poured off quickly into the moulds at a predetermined temperature. To eliminate the possibility of slag being poured into the billets, the whole charge is sometimes run off into a pre-heated ladle which is then suspended above the moulds and the alloy run off from the bottom of the ladle.

It will be appreciated that only one composition of alloy can be produced in such a furnace at a time and to maintain the desired high degree of accuracy in the composition of the alloy it is essential to scavenge the furnace between melts.

After cooling down the mould is opened and the top end of the billet, known as the crop and containing a small amount of slag and other impurities, removed. The billet is then tested for composition by drilling out a small test piece and subjecting it to chemical analysis.

Production of Strip.

The first operation in the production of the strip is to heat the billets in a pre-heating furnace in preparation for hot rolling. The temperature of the furnace is kept as high as possible consistent with the non-liquification of the billet. A plant suitable for the hot rolling operation is a "three high" mill (Fig 2), the billet being passed forward between the upper and middle rollers and backward between the middle and lower rollers. It is usual to cool the rollers to avoid damage to the bearings. During

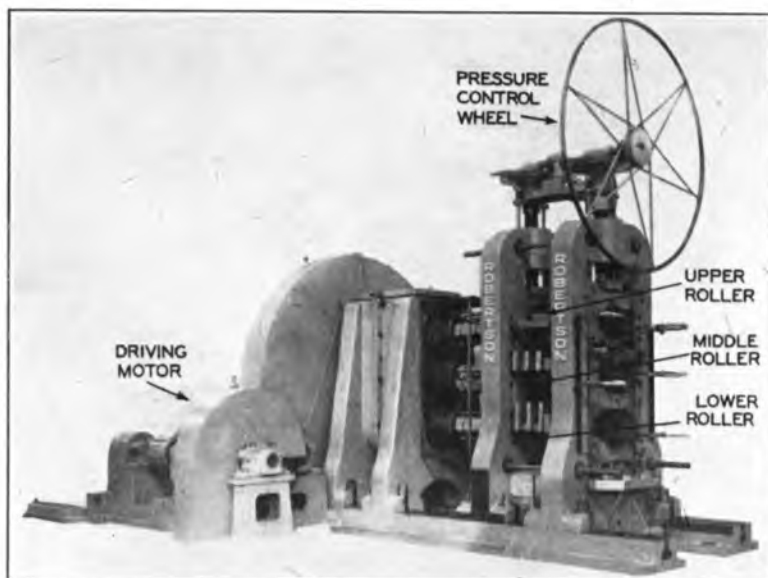

FIG. 2.—"THREE-HIGH" MILL.

this process the pressure is carefully controlled in relation to the temperature of the billet and each forward and backward movement constitutes a separate rolling operation and is usually referred to as a "pass." In about 12 passes a billet $24 \times 8 \times 2.0$ ins. thick is rolled into a strip about 30 ft. long and 0.125 ins. thick, the width of the strip being but little changed. The edges of the strip are then trimmed by passing the strip through a rotating cutter and, after softening, the strip is ready for cold working.

The principle of the cold working process is to pass the cold strip repeatedly through a rolling mill under great pressure which is carefully controlled. Since nickel iron alloy is extremely tough, for the satisfactory cold rolling of the type of strip in question, it is necessary to use a special type of mill (Fig. 3) capable

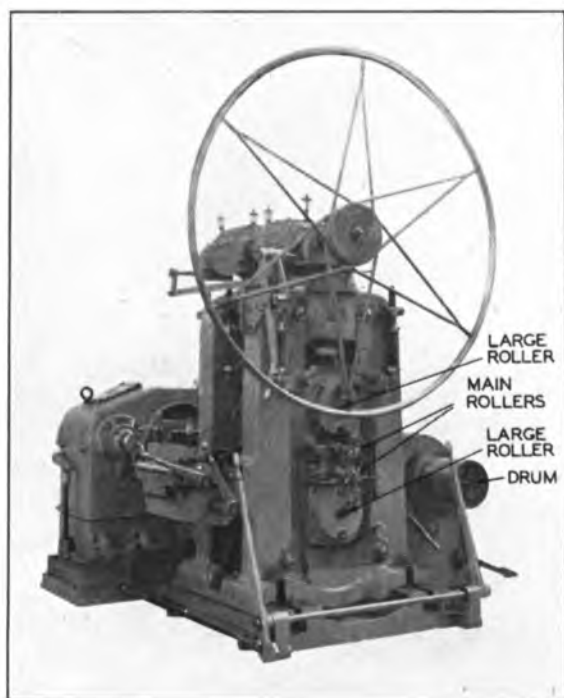

FIG. 3.—"FOUR-HIGH" MILL.

of exerting a pressure of the order of 200 tons. The mill illustrated is known as a "four-high" mill, the principal feature of which is the use of small diameter main rollers in contact with the strip and which are supported mechanically by the large rollers. The use of small diameter rollers permits the rolling pressure to be concentrated upon a small area of the strip. After each pass through the mill the strip is automatically coiled upon a drum which is driven through a friction clutch, and by maintaining a tension in the strip avoids buckling and twisting which would otherwise occur in this operation.

The required magnetic characteristics are obtained by passing the strip repeatedly through the mill in a predetermined manner and under carefully controlled pressures until the required thickness is obtained. This repeated rolling causes the strip to become extremely hard, and to keep it in a workable state and incidentally to avoid overstraining the mill, it is

necessary to anneal the strip at intermediate stages. The final rolling operation is usually made in a finishing mill after which the strip is cut to the width required on a rotating slitting machine.

Strip that is wound direct into toroidal cores is always heat-treated after forming. Strip used for laminations is stamped in the hard condition and subsequently annealed.

For the intermediate annealing the strip is usually wound into coils about 18 ins. diameter and heated to a temperature between 900° and $1,100^\circ\text{C.}$, depending on the particular alloy, in a controlled atmosphere to minimize oxidization. This operation is usually carried out either by stacking the strip in sealed containers and heating in an ordinary furnace or by straight annealing in a "bell" or "box" furnace described later.

It would be convenient at this stage to consider for a moment the nature of the changes that occur in the material during the cold rolling processes. This matter has been the subject of extensive study and it is now generally agreed that although the changes are of a complex nature, they are distinctly related to the orientation of the crystal axes. It is known that the magnetic properties of a crystal vary with the direction of the flux carried by it, so that a strip having the greatest number of crystals aligned in the optimum direction will have the best magnetic properties. It is important to note also that although this increase in magnetic properties occurs principally along the rolling direction, an overall improvement but to a lesser extent also occurs across the strip.

This alignment of the crystals could be achieved by other methods than cold working, but at present cold rolling is most convenient for economic bulk production. The heat-treatment of the strip in the annealing furnace mentioned does not substantially alter this alignment of the crystals but it does release the internal strains in the material set up by the cold working.

The strip is normally worked down to a finished thickness of 0.015 inch, but thicknesses of 0.008 in., 0.005 in. and 0.002 in. are available commercially for special applications. For the high nickel content alloys used at power frequencies there is an optimum thickness for the best magnetic properties which is, about 0.01 in. At these frequencies, however, 0.015 in. material meets most applications.

It is of interest to note that the physical appearance of all the alloys, whether in billet form or as hot rolled strip, is similar, due to the oxide formation on the surface, but under cold working the surface of the strip gradually acquires a bright polished finish. Also that under cold working treatment any normal means of marking for identification purposes would become obliterated, and particular care is necessary in handling different batches to avoid confusion during processing.

After cold rolling, a careful check is made upon the magnetic properties of every strip. The measurements can be made upon either a short test piece or a number of small standard size laminations stamped from each strip. These laminations are placed in a standard test set in such a position that they comprise the core of a small transformer. Routine A.C. and

D.C. tests conditions are then applied so that the permeability and flux density are quickly checked. The performance of these test pieces is used as a control of the heat treatment.

Stamping.

The finished hard strip is now ready for stamping into laminations. This operation is usually performed in a high speed power press with automatic feed. As the monetary value of strip is considerable it is important to avoid undue wastage, and considerable economies in material can be effected by choosing certain geometrical arrangements of laminations for stamping purposes, although the scope of these is limited by the shape and proportions of the individual designs. Typical geometrical arrangements for stamping are shown in Fig. 4. It will be noticed

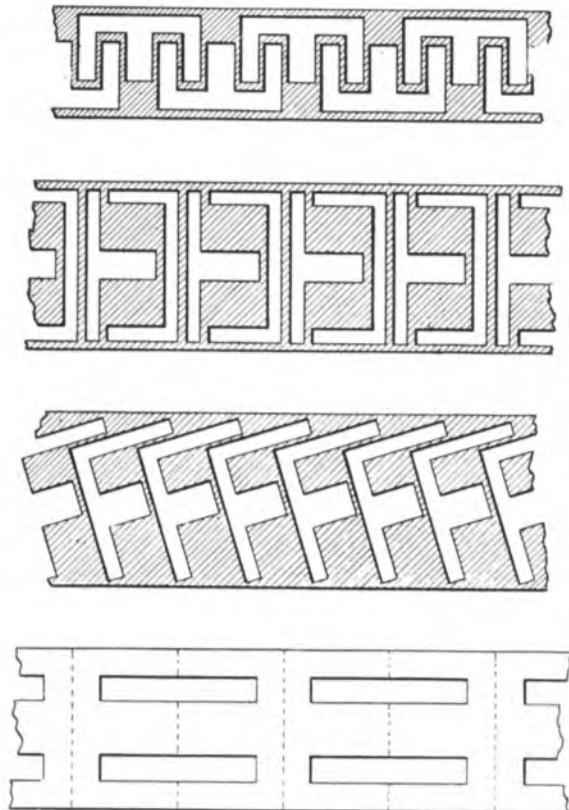

FIG. 4.—GEOMETRICAL ARRANGEMENTS FOR STAMPING STRIP.

that E's are generally arranged in pairs face to face, the corresponding I's being cut all in a row, T's and U's interlinked, and F's in echelon; the width of the strip being different in each case. An interesting arrangement of E's and I's, which is very popular in N. America and has the advantage of being absolutely waste free, is also shown. In this arrangement the strip is cut to the exact width required, the I's are stamped out and the strip sheared across the dotted lines to form the E's. The restricted winding space increases the relative copper losses and designs based upon this type usually operate at higher temperatures than those based upon A type. The normal wastage at this stage is 20% to 25% of the gross weight of the strip, but it can amount to 40% in the case of F's.

Thinner strips, i.e. .002in. to .010in., can of course be stamped on smaller and lighter presses than .015in. strip, the lighter presses having the advantage of a greater number of strokes per minute. Different tools must be used for different thicknesses of the material, e.g. for the P.O. No. 10 lamination three sets of tools cover the ranges .010in. to .015in., .005in. to .010in. and .002in. to .005in. Bearing in mind the speed of the presses it is not normally economical to set up a production unit for less than 50,000 identical laminations. The amount of burr on the edges of the laminations is controlled by periodical grinding of the tools. The life of a tool may vary considerably and may be between 300,000 and a million operations.

Final Heat-Treatment.

The magnetic properties of nickel iron laminations in their hard condition are inferior to those of low grade commercial electrical steel, and it is essential therefore to develop these properties by suitable heat-treatment. This treatment is applied after stamping, since otherwise localised strains would be present in the laminations after this operation and the magnetic characteristics degraded.

The heat-treatment can be carried out conveniently in the type of furnace illustrated in Fig. 5, and usually

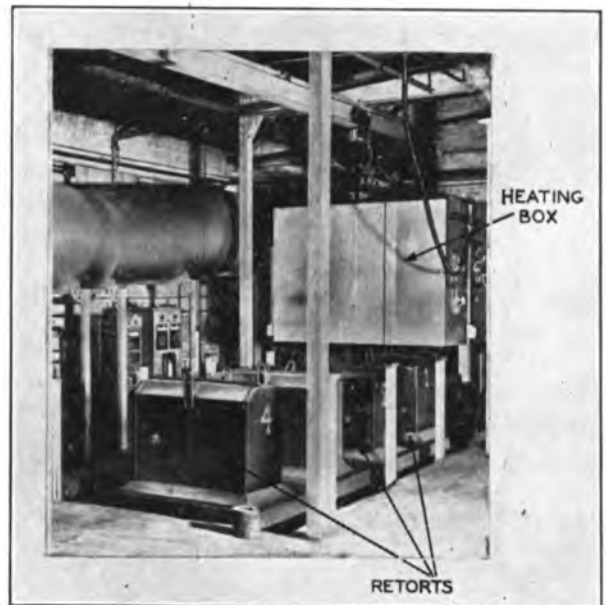

FIG. 5.—BOX FURNACE.

known as a box furnace. In this process the items to be annealed are built up to form a compact core upon a firebrick base. A retort is then lowered over this core, sealed round the base and filled with a suitable gas. The "box" or dome of the furnace containing the heating elements is then lowered over the whole assembly, the furnace heated and allowed to cool off slowly under controlled conditions. A complete cycle of operations occupies about 12 hours. A supply of hydrogen or an inert gas is passed through the furnace to minimise oxidation.

To facilitate handling in this operation the laminations are usually stacked in nichrome annealing pots.

Insulation.

The last process is to insulate one side of each of the laminations, the principal methods being as follows :—

- (1) *Lacquering.* One side is spray-painted with a thin coat of a suitable cellulose paint. The colour of the paint is used to indicate certain proprietary alloys and Table II shows a colour scheme which has recently been agreed.

TABLE II.

Material	Colour Code.
Permalloy B	Orange
Radio metal	Grey
Permalloy C	Magenta
Mu metal	Blue
2129 alloy	Green
Rho metal	Chocolate
Permalloy D	White

- (2) *Oxidisation.* The laminations are stacked and heated in a suitable furnace under carefully controlled conditions.

The laminations are now ready for assembly into transformers or chokes, but care must still be exercised in this operation since undue hammering will appreciably degrade the magnetic characteristics, and this degradation can be remedied only by re-annealing which destroys the paint insulation.

Strip type cores.

As these cores are in great demand it may be mentioned that the process of production up to the cold worked stage is similar to that of strip used for laminations, but at this stage the strip is cut to the required width, wound into coil form and held in position either by spot welding the last turn or by enclosure in a single turn hoop of the same material. The coils are then inspected to see that all convolutions move freely over one another to prevent sticking during heat-treatment and thus avoid undesirable strains on cooling. The complete coils are then annealed either in annealing pots or in a box furnace.

SILICON STEEL

As silicon steel alloys have a wide range of application in branches of electrical engineering other than telecommunications, i.e. power transformers, motors, generators, etc., production is generally on a much larger scale and the plant employed much heavier than that used for the production of the nickel irons. The technique is, in fact, similar to that employed in the production of ordinary steel, but additional processing is necessary due to the fact that the higher percentage silicon content steels are very brittle,

prone to oxidation and workable only at comparatively high temperatures, i.e. 1,100°C., and this special processing affects the magnetic characteristics of the finished product. Nevertheless the fabrication processes can be sub-divided into three broad divisions, i.e. the production of ingots and slabs, the production of sheet and the production of finished laminations.

The Production of Ingots and Slabs.

It is not possible in this article to describe in detail all the processes employed in the production of steel. A brief description of one process, known as the basic open hearth process, is included for comparison with those used in the production of nickel iron. In this process the raw materials which usually comprise pig iron, lime and scrap are heated in a gas-fired open hearth furnace having a capacity of about 50 tons. Silicon in the form of ferro-silicon is added whilst the molten steel is being run off into a pre-heated ladle since otherwise silicon, being an acid forming base, would corrode the linings of the furnace.

The ladle (Fig. 6) which holds about 60 tons is filled and slag allowed to spill over the mouth. The molten silicon steel is then run off from the bottom of the ladle into one-piece moulds, each holding about 7 tons. Immediately a solid skin has formed the ingots, which are about 40in. × 20in. × 20in. are lifted out and placed in a hot container known as a soaking pit, while the centre core solidifies and the



FIG. 6.—FILLING THE MOULDS FROM THE LADLE.

temperature of the whole ingot becomes uniform. When at a uniform high temperature the ingots are rolled out into slabs about 38in. wide × 4½in. thick in a "slabbing mill" under carefully controlled pressures. A mill suitable for this process is a remotely controlled heavy duty "two-high" reversible mill with adjustable gap and automatic conveyor mechanism with facilities for rolling the slab on edge as well as flat so that the required section is obtained. The remote control feature lessens considerably the discomfort which is otherwise caused by the operator

being in close proximity to the large mass of hot material.

Samples are taken for chemical analysis at intervals during the above processes and the results of the analysis used for the control of the process.

The Production of Sheet.

The hot slabs are then cut into three lengths to facilitate handling, and after samples have been taken for chemical analysis the slabs are heated in a gas-fired furnace in preparation for hot rolling. The slabs are then hot rolled down to a thickness of .078 in. (12 S.G.), trimmed and cut into rough plates about 10 ft. x 3 ft. A suitable plant for this hot rolling is a "four-high" mill similar to that shown in Fig. 3, but of more robust construction.

The rough plates are then heated in a controlled atmosphere to limit oxidation and hot rolled again down to a nominal thickness of .014 in. when, after the edges have been trimmed, they are cut into sheets approximately 8 ft. x 3 ft. or 6 ft. x 3 ft. Thinner sheets are made by a further reheating and hot rolling, the nominal thickness of thinner sheet being 0.007 in.

At this stage it is customary to pickle the sheets in a sulphuric or other acid bath to remove loose oxide scale. This process is particularly necessary with high silicon content materials which are so prone to oxidation, since although a certain amount of oxide firmly fixed to the sheet has a beneficial effect upon the insulating properties, loose oxide which will flake off and carry with it any other insulating medium which has been applied subsequently would be most undesirable.

The sheets are usually given a cold roll to standardise thickness and then annealed in a box type furnace similar to that described earlier. In the present application, however, the furnace is usually of larger and of more robust construction and capable of dealing with 10 tons of sheet at a time. Different gases are employed for controlling oxidation, and a complete cycle of treatment occupies about a week, the temperature of the furnace being carefully controlled throughout.

After annealing, test sheets are taken from different positions in the stack, i.e. top, middle and bottom, cut into standard size test pieces and tested for magnetic characteristics and particularly permeability, watts loss, and resistivity, the last serving as a ready check upon the percentage silicon content. Periodic checks are made also upon the space factor, i.e. the percentage volume of material in a given stack of sheets, as uneven material will waste core space in the finished transformer.

Every sheet is then inspected for irregularities, flatness and surface correctness, all unsatisfactory material being used again as scrap.

It is of interest to note that despite the robust proportions of the mills and rolls, the rolls may be 18 in. diameter and made of chilled steel), a slight

bending of the rolls occurs during rolling, with the result that sheets are rolled thinner at the edges than the centre, the difference being however less than .001 in. The maximum allowable variations in thickness are covered by B.S.S. No. 601 and are defined in terms of limits of weight variations of standard size test pieces taken from the centre and edge of the strip. To maintain a high standard of finish to the sheets it is necessary to grind down the face of the rolls fairly frequently, with the result that their life is limited.

The Production of Laminations.

The first operation is to cut the sheets into strips between 3 feet and 9 feet long in a guillotine machine, the width of the strip depending upon the size of the laminations required. Sometimes the strips are insulated before stamping and sometimes stampings are insulated as a final operation. The most popular forms of insulation are:—

- (1) To bake on to the strip a wet mixture of starch and clay; normally the application is made only to one side of the strip.
- (2) To bake on to one side or both sides of the strips a suitable insulating varnish.
- (3) To oxidise the strips.

The strips are then stamped out into laminations as already described, the size and shape again controlling the geometrical arrangement for stamping purposes. It is of interest to note that the iron losses in silicon steel laminations can be reduced by about 10% by annealing after stamping, the annealing being performed at a temperature of about 700°C. In this case the laminations are of course insulated after annealing.

Conclusion.

It will be evident from the foregoing that manufacturers are exercising considerable care at all stages of the production of these materials so that uniformity of both the physical properties and magnetic characteristics is ensured, and that the fundamental production processes are intimately bound up with the technique of hot and cold rolling. It is evident also that in the course of time a number of lamination sizes and thicknesses have become, for production purposes, recognised in effect as standards, and the engineers designing transformers and coils can effect appreciable economies both in labour effort and materials and at the same time ease some of the difficulties of the production engineer by using these standards as far as possible.

In conclusion the author would like to express his thanks to various companies, including Magnetic & Electric Alloys, Ltd., Standard Telephones & Cables, Ltd., G.W.B. Electric Furnaces, Ltd., the Electric Furnace Co., Ltd., and Telegraph Construction & Maintenance Co., for information in the preparation of this article.

Some Notes on the Engineer-in-Chief's Library

U.D.C. 025.5

J. E. WRIGHT

After discussing the advantages of special technical libraries in general the article describes the library at the Engineer-in-Chief's Office in greater detail. This library is available to members of the Post Office staff, and for such the article makes suggestions for obtaining full advantages of its service.

Introduction.

LIBRARIANS and others concerned with the dissemination of knowledge through books have realised for some time now that to make the most effective use of libraries it is necessary to know something of the principles which govern their arrangement. As a result experiments are being undertaken in certain schools for including in the time-table visits to the school library to encourage the library habit, both for private reading and as a supplement to the ordinary study period. In certain universities, particularly in America, the librarians arrange for conducted tours of their libraries, and informal lectures are given on how to use the library facilities. Quite a number of text-books on how to use libraries have been written¹ and books such as *The Library Guide for the Chemist*² are appearing for the benefit of those who use a particular library or a limited number of special libraries.

The value and importance of libraries is not due to the fact that they are collections of books, but that they are organised arrangements of books from which any required work can be easily located and quickly obtained. The extent, therefore, of their usefulness is primarily dependent on the arrangement of the books, etc., and the adequacy of the catalogues. Although, in theory at any rate, it might be said that the best libraries are the largest libraries, since they only can be expected to contain books giving information on any topic which a user may wish to read about, it has been found in practice that a number of very specialised libraries, each catering very thoroughly for a narrow field of knowledge, is more satisfactory in many respects. It is generally agreed, that before any new fundamental investigation or industrial project is undertaken as much knowledge as possible of the experience of others should be obtained. For this purpose the relevant articles scattered through a large amount of literature must be scrutinised. That this can be done fairly quickly is due to the existence of these special libraries, and although no figures are available to show what subsequent saving in time and cost result from searches of this nature it is reasonable to assume that a not inconsiderable sum is involved annually. As proof of this it may be pointed out that practically every large firm and industrial organisation in the country has a library.

Technical Literature.

In collecting as much information as possible on special subjects many kinds of publications besides books and periodicals must be considered, namely, pamphlets, brochures, reprints, papers, theses, speci-

cations, patent specifications, catalogues, in fact anything and everything. Most scientific workers realise that there is a great amount of literature available to them, but few realise how great this amount really is or how fast it is accumulating. It has been estimated that three quarters of a million scientific articles appear annually and that 14,000 technical books and monographs are published every year.³ Of these, for example, some 40,000 articles and 1,500 books are of chemical interest. With such a large amount of literature available it is useful to be able to discriminate between the relative merits of different works.

A good knowledge of books can be acquired only by constantly using them. Most people get to know a certain number of books through using them at school or college and particularly during their subsequent studies. Unfortunately this excellent beginning is not always continued, with the consequence that when the book they know is not available for them they are at a loss for an alternative, although there may be several equally good books on the same subject. It is therefore well worth while getting to know something of as many books as possible. It is probably true to say that very few technical books are read through from beginning to end. They are mostly used as sources of information on some subject or other, and this is undoubtedly the reason why a technical book invariably has an index. Nevertheless these indexes are not used as habitually as they should be; more often than not they are turned to only after a certain amount of general dipping into the books has been tried first. The list of chapters or contents gives a general idea of the scope of a book, but the index gives the page reference for each mention of a subject and so indicates information which the chapter headings of a book would be no clue to. Bibliographical references may be found as footnotes, at the end of each chapter, or as an appendix to the book.

Periodical literature may be divided into three groups as follows:—

- (1) The publications of societies, institutions, etc.
- (2) House journals, i.e., the publications of organisations and firms.
- (3) Independent journals produced by publishing houses.

¹ *Libraries for Scientific Research.* H. P. Spratt. 1936.
Facts and how to find them. W. A. Bagley (2nd). 1938.
The uses of libraries. E. A. Baker. 1927.
How to use a large library. E. J. Dingwall. 1933.

² *Library Guide for the Chemist.* B. A. Soule. 1938.

³ *Records and Research in Engineering.* J. Edwin Holmstrom. 1940.

The first class publish the papers read before meetings of the members of their societies. The second class are of two kinds, those which are essentially a medium for disseminating matter of a trade and advertising nature and those which describe the technical developments of an industry. Some of the journals in the third class are also specialised and contain much fundamental work, but the majority may be regarded as scientific newspapers since they review current conditions and developments, particularly from the industrial and commercial management standpoint. An understanding of the category to which a periodical belongs is often of guidance in assessing the value of an article in it, and the ability to discriminate in this way between references in a long bibliography can save a considerable amount of time when searching for information. Once again the volume indexes, both author and subject, should be used habitually and the cumulative, i.e., five or ten year, indexes issued with some journals should not be forgotten.

It is scarcely necessary to draw the attention of Post Office readers of this JOURNAL to the reports issued by the Research and Radio Branches of the Engineer-in-Chief's Office, but a very similar and equally important class of literature which is not so well known is that issued by the various sections of the Department of Scientific and Industrial Research. The following list of some of the Research Boards of the D.S. & I.R. and some of the Research Associations gives an indication of the wide field of research covered by these organisations.

- Building Research Board.
- Chemistry Research Board.
- Forest Products Research Board.
- Fuel Research Board.
- Metallurgy Research Board.
- Radio Research Board.
- Water Pollution Research Board.
- British Scientific Instrument Research Association.
- Wool Industries Research Association.
- British Cotton Industry Research Association.
- Research Association of British Rubber Manufacturers.
- British Non-ferrous Metals Research Association.
- British Refractories Research Association.
- British Electrical and Allied Industries Research Association.
- British Cast Iron Research Association.
- Research Association of British Paint, Colour and Varnish Manufacturers.

Another important section of the Engineer-in-Chief's Library is its files of specifications. These consist of a selection of British Standards Institution specifications, P.O. specifications and Government specifications and the publications of the American Society for Testing Materials.

Libraries may be divided into two main classes, general libraries and special libraries. The term

special technical library is usually interpreted as meaning a library catering for a special branch or branches of pure or applied science. These libraries specialise in collecting all the information they can on the particular subjects which interest the parent organisation.

Historical.

The Engineer-in-Chief's Office library was originally located in the city but in 1925 an attempt was made to set up a branch library at Dollis Hill. The accommodation consisted of one room round the walls of which were arranged a few shelves, some chairs, and two fairly large tables on which a few current periodicals were displayed. A handful of text-books, perhaps twenty in all, had been obtained on extended loan from the Engineer-in-Chief's library. As time went on this little library grew slowly larger and more useful. An abstracting scheme was started and a very small library circular was introduced. The plans for the main building at Dollis Hill allowed for the present library accommodation as shown in Fig. 1, and although the Engineer-in-Chief's library was transferred there when the new premises were taken over in 1933 the shelves of the new library for a time seemed very empty. Now there is only room in the library reading room for about half of the total stock; the other half has to be kept in a library annexe. So it will be seen that



FIG. 1.—ENGINEER-IN-CHIEF'S LIBRARY, DOLLIS HILL.

in the last seventeen years the library has grown in a very marked manner.⁴ Although still intended primarily for the use of engineering staff it supplies technical information on occasion to other P.O. Departments.

⁴ The special Library and Information Service of the Post Office Engineering Department. Proc. Brit. Soc. Int. Biblio. Vol. I. No. 1 1940, p. 1.

Arrangement of the library.

The literature in the library is restricted in the main to subjects relevant to the work of the Engineering Department. At present it consists of rather more than seventeen hundred text-books, over two thousand bound volumes, a very considerable number of reports, many monographs and pamphlets, and files of specifications and translations. Over 100 current periodicals are still received.

The text-books are divided into two sections, the reference section and the loan section. Copies of many of the books are allocated to each section. It is hoped as time goes on to duplicate all those which are much in demand. Meanwhile books which are only in the reference section are indicated in the catalogue by a prefix R to the book number. The fact that the only copy of a book is in the loan section is not indicated in the published catalogue but in such cases other works covering the same field are in the reference section. The periodicals which are accommodated in the reading room have been chosen as representative of the periodical holdings of the library. Longer runs of those which are in most demand are kept in the reading room than is the case for the lesser used journals, but in many instances earlier volumes are stored in the annexe and will be supplied upon request. Direct reference to the shelves is permitted and, except for the reference books section and the bound volumes of abstract journals, books and periodicals are available for loan.

Rules.

The normal loan period is 14 days. Reference books may in special circumstances, and at the discretion of the librarian, be borrowed overnight but they must be returned first thing the following day. Books, etc., should not be left at home during the day or locked up while on detached duty or leave. Many of the books and periodicals are so much in demand that satisfactory library service is dependent on the close observance of these rules and in particular on the prompt return of loans. All loans returned through the post should be adequately packed and wrapped and, if received by registered post, returned by the same means.

Catalogues.

There is a classified subject catalogue of the text-books, a name index of authors which lists also, under the name of the issuing body, the publications of various organisations and firms, an alphabetical shelf-location index to periodicals, and the author and subject indexes of the 800 translations which have been made. When the issuing body such as the British Standards Institution supplies indexes these are filed with the publications to which they refer. A classified abstract file is kept in the library office.

Facilities of other Libraries.

As may be imagined many requests can be met only by borrowing from other libraries, and this is at present being done at least twice every day. The

libraries from which most loans are obtained include:

- Lewis's
- Science Museum
- Standard Telephones and Cables, Ltd.
- British Non-ferrous Metals Research Association
- Institution of Electrical Engineers (on behalf of members)
- Imperial Chemical Industries
- Mullard Valve Co.

Other sources from which material may be obtained include the Department of Scientific and Industrial Research with its large number of out-station libraries, the Association of Special Libraries and Information Bureaux and the National Central Library through which the help of almost any library in the country can be obtained. It has been computed that through the N.C.L. anyone in this country can take his choice from over 21 million books. Not all of these are scientific works, but the figure gives an indication of the excellent way libraries are linked together for the benefit of their users.

Microphotography.

Librarians are giving considerable attention to microphotography. The scheme has already been used in the Engineering Chief's Library, but until better and cheaper viewing devices become available the wider adoption of this new library tool is likely to be slow.

Policy.

The planning of the library to meet best the requirements of the majority of users, the choice of books to be bought with the money available, etc., is assisted by a small informal committee. This Committee consists of three engineers drawn from the Research and Radio Branches of the Engineer-in-Chief's Office who, between them, combine specialist knowledge of most of the telecommunications field. They are thus able to advise regarding the probable usefulness of any book which is recommended for purchase. There are many arguments for and against the various arrangements that are possible in such a library, and a useful purpose may be served if the pros and cons of some of the more controversial points are outlined so that users, having a better appreciation of these problems, will realise the difficulties which face the committee. It is fully appreciated that the facility of borrowing is of great help to users of the library. It enables them to have articles, data, diagrams, etc., beside them whilst working on the job. The argument that a man cannot spare time to read in the library may be justified. Nevertheless the demand for some works is so great that if the borrowing of every copy were permitted those works would never be available in the library for reference. It is for this reason that it was recently decided to build up separate reference and loan sections for the text-books. For a time the loan section may suffer in consequence, although actually the number of books in that section is being added to all the time. But when the reference section has been built up a little more it will be possible

to obtain more copies of books for the loan section. It is thought by some that the bound volumes of periodicals should be considered as reference works. Some such scheme may be possible if an adequate collection of duplicate unbound journals, reprints and photo-copies, can be built up to form an alternative lending section. Actually some of the difficulty at present experienced would not arise if loans were returned as promptly as possible. If the library only had to serve members of the staff at Dollis Hill other alternatives might be practicable, but since the requirements of officers in all parts of the E.-in-C.'s Office as well as in the Regions are catered for lending facilities must be continued. The committee's efforts have so far been concentrated on the text-books section of the Library. A number of out-of-date books have been withdrawn and many of them have been replaced by new editions or alternative works. The books which are being obtained include the standard works on many subjects, a certain number of the recognised students' text-books, and some selected books describing progress in other scientific fields. The circulation of periodicals is another bone of contention. The chief argument put forward in favour of the library circulating periodicals to the staff employed at Dollis Hill is that the staff have no time to use the reading room. As against this it must be realised that the present number of copies of journals which are taken would have to be considerably increased so that circulation lists could be kept reasonably short, otherwise periodicals would never be available for loan before they were three or more months old.

Quoting References.

To discuss logically the procedure to be adopted when using a library it may be helpful at this stage to assume that users of libraries can be divided into two classes, namely,

- (1) those who want a specific publication such as a book or periodical, and
- (2) those who want to obtain information on some subject or other.

Generally speaking, those in the first category will only need to consult the catalogues to see if the work they require is held by the library. The author index to the text-books, or the library list of periodical holdings, may be sufficient for this purpose. If the required publication is not in its place the library staff should be informed, and if, as is most probable, it is already on loan arrangements can be made for it to be reserved on its return. If the required publication is not held by the library it can nearly always be obtained quite quickly from another library. When requests are made of other libraries full and accurate details should be supplied. For books these include, author, title, edition, date, and even the publisher and price, besides the last date when the supply of the book will still be useful. The full and correct references to periodicals are, if anything, even more important. The last edition of the "World List of Scientific Periodicals," published in 1934⁵, listed over 36,000, but the number has greatly increased since then. The Research Branch Library has only about 150 periodicals, but the

Handlist of Periodicals in the Science Library⁶ refers to over 9,000 titles of current periodicals. It is therefore absolutely necessary for readers to ascertain the correct and full title of the periodical which they wish to consult, and cryptic abbreviations should at all times be avoided as they lead to endless confusion and delay. A good rule is "never abbreviate a title beyond a point where the original words can be identified."⁷

Searching.

The requirements of the second category of users, i.e., information on some specific subject or other, or the exact references to an article which is known to exist, although sufficient details are not known, are not so quickly dealt with. Prolonged or difficult searches are best handed over to the Information Officer but it is generally agreed that the more straightforward ones should be tackled by the users, at any rate in the first instance.

The problem of ascertaining the exact references to an article can usually be solved by resolving the few known facts into clues as outlined below.

<i>Clue.</i>	<i>Procedure.</i>
1. Name of the author who writes or who has written on the subject.	Refer to author indexes of published abstracts.
2. Title of periodical is known but not the volume, year, etc.	Consult the cumulative index of the periodical if there is one.
3. Likely date for the required information to have been published. (It is worth remembering here that time passes quickly and references one has in mind are often several years older than memory at first suggests.)	If some years ago information may be in a text-book covering the subject. Bibliographical references in a text-book may be useful. If information published less than two years ago it is not likely to be in a book, so periodical literature must be relied on.
4. The type of journal in which information was probably published.	This may be a guide to the type of abstract journal to consult.
5. Subject matter only known.	The classified subject indexes of the appropriate abstract journal must be consulted.

The abstracts available include the file of over 20,000 references compiled by the library since 1935 which are subject classified by the U.D.C.⁸ and the abstract journals listed in Table 1.

The problem of finding specific information can be dealt with along the same lines, but sometimes a different approach may be advantageous or even necessary. For instance, information on the physical,

⁵ A World List of Scientific Periodicals (2nd). 1934.

⁶ Handlist of Short Titles of Current Periodicals in the Science Library. 1938.

⁷ International Code of Abbreviation for Titles of Periodicals 1930.

⁸ Classification for Works on Pure and Applied Science in the Science Museum Library.

The Universal Decimal Classification of Information P.O.E.E.J., Vol. 32, p. 56.

The Application of the Universal Decimal System of Classification to the Indexing of Literature and Information Relevant to the Work of the P.O.E.D. Research Report 10040.

TABLE I.
Published Abstracts received by the Engineer-in-Chief's Library.

Publication	Subjects covered	Frequency of Issue	Form of Reference	Kind of Index
Science Abstracts A	Physics	Monthly	Abstracts	Author + Classified U.D.C., annually
" " B	Electrical Engineering	"	"	" " " "
Wireless Engineer (Radio Research Board Abstracts)	Acoustics, radio, television, valves	"	"	Subject Classes alphabetically subdivided, annually
Proceeding of the Physical Soc.	Physics	Two months	References (Suitable for cards)	Classified U.D.C. index slips
Bolletino del Centro Volpi di Electrologia*	Physics, Electrical Engineering	"	"	Subject classified abstracts, U.D.C. and L. of C.
Engineering Abstracts (Inst. of Civil Engineers)*	Mechanical, mining, marine engineering	Two months	"	Author + Alphabetical subject, each issue
British Chemical Abstracts A	Pure and physiological chemistry	Monthly	Abstracts of journals and patents	Author + Alphabetical subject, annually
" " " B	Applied chemistry	"	"	" " " "
Metallurgical Abstracts (Inst. of Metals)	General and non-ferrous	"	Abstracts	" " " "
Building Science Abstracts (D.S. & I.R.)	Materials, construction, industrial organisation	"	"	" " " "
Water Pollution Abstracts (D.S. & I.R.)	Water supplies, pollution, corrosion	"	"	" " " "
Monthly Summary of Reports (D.S. & I.R.)	Work of Government experimental establishments and Research Associations	"	"	Grouped under names of departments
Research Association of British Rubber Manufacturers Abstracts	Raw materials, machinery, processes, products	"	Abstracts of journals and British and Foreign Patents	Name index and Patents list. Classified division of subjects, annually
British Non-Ferrous Metals Research Association Bulletin	Non-Ferrous metals developments in research and industry	"	Abstracts	Author + Alphabetical subject, annually
Kodak Abstracts	Photography	"	"	Classified U.D.C. abstracts
Metropolitan Vickers Bulletin	Electrical Engineering	Weekly	"	Classified U.D.C. abstracts
The Nickel Bulletin (Mond Nickel Co.)	Nickel in industry	Monthly	"	Author + Alphabetical subject, annually

* Discontinued since the war.

chemical or mechanical properties of substances will more often than not be available in one of the reference books in the library.

Information Bureaux.

It will be appreciated from the section on technical literature that it is no exaggeration to say that no one person can see, let alone read, even a tenth of the published matter which may refer to his work. Realising this most large organisations have built up information bureaux which methodically sift this tremendous amount of technical literature so as to collate as much information as possible relevant to certain branches of science and industry. Many organisations issue bulletins giving abstracts of selected articles in current periodicals, but over and above this they prepare bibliographies and supply information for the benefit of those engaged on particular problems. The Engineer-in-Chief's Library Circular is issued monthly. It consists of classified references and abstracts of articles in current periodical literature and an Accessions List of specifications, reports issued by other bodies, pamphlets, etc., as well as text-books. Classified abstracts of new Research and Radio Branch Reports are given in the Quarterly Bulletin of Research. Bibliographies are supplied upon request. In addition the information officer can obtain help from other information services. No matter, therefore, how remote the nature of an enquiry may be from

the normal interests of the Post Office it should be possible to provide an answer to it. In order that the best service can be given, however, it is most necessary for the question to be framed as clearly as possible. This includes indicating what is already known of the subject, what sources have already been tried, whether or not the subject is confidential or secret—so that the information officer may decide what, if any, outside sources he may contact—and the urgency of the enquiry.

Conclusion.

It is to be hoped that this paper will materially assist users of the Engineer-in-Chief's Library not only to use the library to better advantage, but through it the resources of the large number of libraries with which it has contacts. The suggestion that users should to a certain extent be able to search for and find material themselves is not intended to imply that the library staff and the information officer should not be asked for help. Such help should be more frequently asked for in connection with problems which may previously have been thought to be beyond the resources of the library. Although the particular features of the Engineer-in-Chief's Library have been chiefly considered it is hoped that this description will also be of value to those who may have occasion to use other libraries particularly libraries specialising in scientific and engineering subjects.

Measurements on High-Frequency Cables and Feeders

Part II. Impedance, Transmission and Crosstalk Attenuation Measurements

R. F. J. JARVIS, Ph.D., and
J. C. SIMMONDS, Ph.D.

U.D.C. 621.317.33 : 621.315.2

Methods of measuring open and closed circuit impedance are discussed further and methods of making transmission and crosstalk attenuation measurements on cables are considered.

HYBRID TRANSFORMER METHOD OF MEASURING IMPEDANCE

HYBRID or differential transformers have been used for measurement purposes at low frequencies for many years. They have now been developed sufficiently to operate satisfactorily at frequencies as high as 5 Mc/s.¹ Their use in the Post Office was primarily intended for comparison of balanced impedances with unbalanced standards, without having to resort to complicated double screened bridges. However, a very much wider use has been found for them, and they have been used extensively for measurements of balanced and unbalanced impedances. Among these have been measurements

¹ P.O.E.D. Radio Report No. 565.



(a)



(b)

FIG. 1.—(a) DECADE H.F. RESISTANCE BOX. (b) HYBRID TRANSFORMER UNIT

on balanced and unbalanced cables over the frequency range 100 c/s-5,000 kc/s, on aerial systems, inductors, condensers (capacitance and power-factor), resistors, two terminal impedances of transformers, and input and output impedance measurements on feed-back repeaters. In Fig. 1 a hybrid transformer unit is shown, together with a high value decade resistance box used in conjunction with the transformers and described below. A circuit diagram of the transformer system adopted is shown in Fig. 2, where it

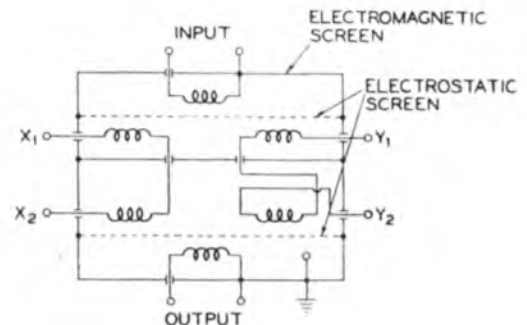

FIG. 2.—CIRCUIT DIAGRAM OF HYBRID TRANSFORMER

will be seen that two transformers are used in each unit. Each transformer has two secondary windings, screened electrostatically from the primary, and made as nearly identical as possible by forming the windings from the individual wires of a twisted pair. To reduce the leakage inductance, and to obtain as large a frequency band-width as possible, the transformers are wound on small toroidal cores of very thin rhometal tape. The range 50c/s-5 Mc/s can be covered with three units.

If the windings are assumed to have no stray capacitance and to be correctly balanced magnetically, then it is obvious that when equal impedances are connected between the pairs of terminals X_1 , X_2 and Y_1 , Y_2 , no voltage will appear across the output terminals when a signal is applied to the input terminals. It will be observed that this holds even when one of the impedances is balanced and the other unbalanced. Unfortunately, it is not possible to avoid stray capacitances between the windings, since to obtain a good magnetic balance the secondary windings on each transformer must be twisted together, but it can be shown that no errors are introduced when two unbalanced impedances are compared. When a balanced impedance is compared with an unbalanced one some error is unavoidably introduced by the stray capacitances, but by careful design of the transformers the errors can be kept negligible at frequencies up to 5 Mc/s, providing the

impedances being compared have not too high a value.

Very widely different types of standard impedances have been used with the hybrid transformers, but it is not possible to give full details in the limited space available. Attention will accordingly be restricted to those standards usually employed for cable measurements at high frequencies. When the hybrid transformers were first developed the standard used for high-frequency cable measurements was invariably a standard variable condenser connected in parallel with a resistance box. Since that date the position has been changed, because balanced standards have become available. However, if unbalanced condensers and resistance boxes only are available it is possible to compare both unbalanced and balanced impedances with the standards by connecting the standards to one side of the transformer and the unknown impedance to the other. Assuming the resistance box described below is available, the error on both the resistive and capacitive components of the impedance can be made less than about $\pm 1\%$. More accurate measurements can be made on unbalanced impedances by making a preliminary balance against any available suitable impedance and then connecting the unknown impedance directly across the standard. From the change in the standards required to restore the balance, the components of the unknown impedance can be calculated. This method gives a true substitution measurement, and the errors inherent in the transformers do not appear in the result. A balanced standard variable condenser and balanced resistance box are now used in conjunction with the transformers so that the substitution method of measurement can also be used for measurement on balanced impedances. When measurements on balanced cables are made in this way, an error may arise due to slight unbalance of the voltage applied to the cable. However, by making the impedance used for the preliminary balance sufficiently low the amount of the unbalance can be made negligible.

Measurements on resonant and non-resonant lengths of cable can be made on the transformers, but for the reasons given previously the resonant length method is used whenever possible. The most difficult part of this type of measurement is the determination of the resonance frequency. Consider first a case such that the input resistance of the cable will be a maximum value. The procedure is first to balance the arrangement at approximately the correct frequency without the cable connected. Then the cable is connected and if the frequency is the exact resonance frequency, the balance can be re-established simply by adjustment of the resistance box.

If the frequency is not the exact resonance frequency then the balance can be re-established by adjustment of both the frequency and the resistance box. Actually the detector used for this type of measurement is a heterodyne receiver, and by altering the signal frequency and, at the same time, following the alteration with the receiver, it is possible to find the resonance frequency quite quickly, but a considerable amount of skill is required to perform the operation satisfactorily. When the resonance frequency has

been almost found it is advisable to balance the arrangement again with the cable disconnected, and then make final adjustments with the cable connected to find the exact resonance frequency.

The minimum values of the input resistance can be measured in a similar manner, but it is then necessary to connect a solid carbon composition type resistor of about $100\ \Omega$ in series with the cable. This is necessary because at low settings of the resistance box the reactive component of the input impedance changes rapidly with setting. In general, it is desirable that sufficient length of cable to give a minimum attenuation of about 1 db. is available, since this prevents the values of input resistance being both too high and too low for accurate measurement.

Input impedance measurements can be made on cables quite easily using the hybrid transformers, but if the characteristic impedance is below about $100\ \Omega$ it is necessary to connect the cable in series with a resistor sufficiently large to bring the total resistance to a value greater than $100\ \Omega$.

Reference has been made above to high frequency resistance boxes.² These boxes merit a brief description, as they are not of the usual pattern. Five decades are employed to cover the range 0–11,111 Ω in steps of 0.1 Ω . Each decade consists of a turret which rotates the resistance elements and brings each one in turn between the fixed contact arms, thus keeping the inductance and capacitance of the decade units constant. By providing one element for each position of the decade, connecting wires between elements are also avoided. The resistance elements are of the solid carbon composition type with the exception of the 0.1 Ω decade whose elements are made of straight lengths of eureka wire. The elements are adjusted to be within 1% of the nominal value. If the value of the resistance in the box is required to a greater degree of accuracy than 1% the D.C. resistance of the box can be measured; in any case this should be done periodically because the resistance of the elements is likely to vary with time. An unbalanced and a balanced box have been constructed on the above principle and the unbalanced type is available commercially. The unbalanced box can be used for measurements of parallel resistance components of value between 300 and 5,000 Ω with an error less than 0.5% up to 5 Mc/s. (It will be noted that parallel resistance components are measured by the methods described above.) At low settings of the box the error increases but by applying simple corrections the error can be reduced to less than 1% even at 5 Mc/s. The effective parallel capacitance of the box is nearly independent of frequency for resistance values greater than $100\ \Omega$, and is independent of setting for resistance values above 1,000 Ω . Actually the variation of capacitance with setting for values below 1,000 Ω is small but can be allowed for by reference to a graph showing input capacitance against box setting. The characteristics of the balanced box are very similar but the resistance errors are slightly greater due to the greater inductance.

² P.O.E.D. Radio Report No. 568.

MEASUREMENT OF CHARACTERISTIC IMPEDANCE

The characteristic impedance of cables can be found from the open- and closed-circuit impedances (or resistances at resonance frequencies) and methods of measuring these quantities have already been described. If a long length of cable is available it is sufficient to measure the input impedance with the far end terminated in approximately the correct value. In this connection it is useful to remember that the input impedance of a uniform cable, the attenuation of which is 20 db., differs from the characteristic impedance by only 1% with the extreme terminations of open- or closed-circuit. Another possible method is to terminate the cable in approximately the correct value and then to measure the input impedance at different frequencies. The characteristic impedance is then the geometric mean of the maximum and minimum impedance values. Alternatively, the termination can be varied until the input impedance is equal to the impedance of the termination. In fact, a method has been described¹ in which the termination is automatically made equal to the impedance used to balance the cable input impedance. When a balance is obtained the input impedance is obviously also the characteristic impedance. It is also possible to measure the capacitance of a very short length of cable at a low frequency and the inductance at any convenient frequency sufficiently high to ensure that the skin effect is fully established. From these values the characteristic impedance can be calculated, for it is simply the square root of the quotient, inductance divided by capacitance.

Since the magnitude of the characteristic impedance is given by the square root of the product of the magnitudes of the open- and closed-circuit impedances, it could be found by measuring these magnitudes directly by the simple voltmeter and ammeter method. Some difficulty would in general be experienced because of the extreme values of the impedances. If, however, the measurement is made at a frequency such that the electrical length of the cable is equal to some odd multiple of one-eighth of a wavelength, then the magnitudes of the open- and closed-circuit impedances can be shown to be equal to the characteristic impedance. Thus the measurement can be made by feeding the cable with a known current and measuring the voltage across it. The correct frequency is found by adjusting the frequency until the same voltage is obtained with the cable far end open- or close-circuited. Actually it is not necessary to obtain exact equality since the arithmetical mean of the two voltages, providing they are approximately equal, is very closely equal to the required value.

METHODS OF MEASURING INSERTION LOSS

Referring to Fig. 3, the insertion loss, in nepers, of the network shown between resistances R , is given by the logarithm of the ratio $\frac{V_o}{V_i}$. In the simple case illustrated it is seen, therefore, that the only requirements for an insertion loss measurement are a source

of constant voltage E and a means of measuring the received voltage V_i or V_o . Unfortunately the case is not quite so simple when a cable is measured, as the two ends may be separated by several miles.

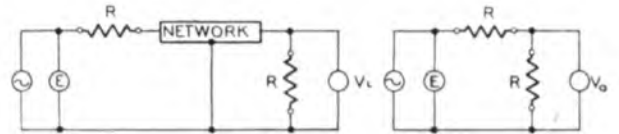

FIG. 3.—PRINCIPLE OF INSERTION LOSS MEASUREMENTS

A method of measurement which has been used very considerably at frequencies up to 3 Mc/s is illustrated in Fig. 4. A known signal is transmitted to the cable through a thermo-junction send element and the signal received across a suitable terminating

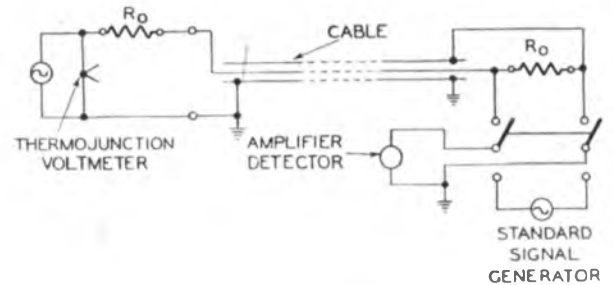

FIG. 4.—ARRANGEMENT OF APPARATUS FOR INSERTION LOSS MEASUREMENTS

resistance at the far-end is taken to a wide-range amplifier detector. It is also possible to connect a standard signal generator to the input of the detector. The signal received across the terminating resistance can therefore be determined by comparison with the standard signal generator and, since the voltage at the transmitting end is known, the insertion loss can be found. This method, as described, leaves a good deal to be desired, but with care results accurate to about ± 0.5 db. can be obtained. Some of the chief objections to the method are:—

- (1) The thermo-junction meter is sluggish and error may be introduced by incorrect adjustment.
- (2) As the detector is not a square-law device considerable errors will be introduced by impure waveform of the sending oscillator or the calibrating standard signal generator.
- (3) Reliance is placed upon the accuracy of the signal generator attenuator.
- (4) The amount of insertion loss that can be measured is limited by the noise level at the detector, which is considerable since a wide frequency band is covered.

To avoid errors due to (2) an oscillator and standard signal generator with very good waveform must be used. The waveform of the usual type of simple oscillator is not sufficiently good for accurate measurements, but the waveform of the input to the send element can be improved by means of a low-pass filter connected between the oscillator and the send element. The output waveform of the usual type of standard signal generator is also generally poor, but in this case a filter cannot be connected between the generator and the wide-band amplifier detector.

¹ *Electrical Communications*, 1941, p. 7 and p. 30.

Accurate $75\ \Omega$ attenuators have now been designed, however, and the standard signal generator can be replaced by an oscillator, filters, send element and attenuator.

The method as described above is only suitable for unbalanced measurements. It has been modified for balanced measurements by using similar balanced send elements for transmitting and for calibrating. The method may be more clearly understood by reference to Fig. 5. An unbalanced to balanced

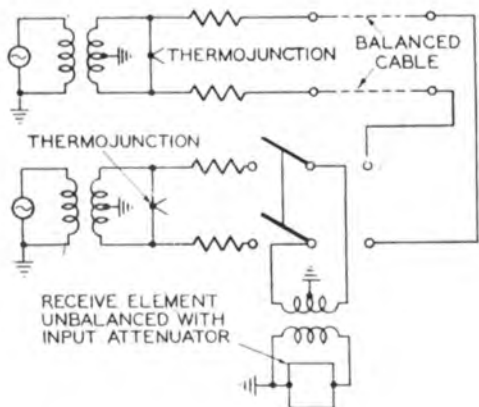

FIG. 5—METHOD OF MEASURING INSERTION LOSS OF BALANCED CABLES

transformer is connected between the balanced send element and the oscillator at the transmitting end of the cable. At the receiving end the cable is connected to an unbalanced receive element by means of a balanced to unbalanced transformer. The received signal is measured by connecting a send element, transformer, and oscillator, identical with those at the transmitting end, to the receive element, through the transformer, and then adjusting the receive element attenuator until the standard deflection is obtained on the output meter. The change in the attenuator readings is then the insertion loss of the cable.

A more accurate method of measuring insertion loss is indicated in Fig. 6. The receive element,

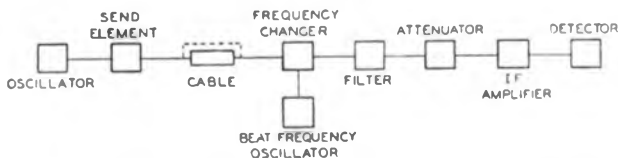

FIG. 6—DIAGRAMMATIC ARRANGEMENT OF APPARATUS IN FREQUENCY CHANGE METHOD OF INSERTION LOSS MEASUREMENT

which is shown in Fig. 7, consists of a frequency-changer stage, which translates the received signal to the intermediate frequency of 110 kc/s, followed by a filter, an attenuator, an I.F. amplifier and a detector. Providing the signal input to the frequency-changer is low enough, the intermediate frequency output is proportional to the signal frequency input, and the effect, on the final output of the receive element, of inserting a given amount of attenuation in the intermediate frequency attenuator is exactly the same as the effect of inserting the same amount of attenuation in front of the frequency-changer. The advantage of using the

frequency change lies in the fact that the lower the frequency the more nearly will the attenuation in a given type of attenuator approach the D.C. value.

When this receive element was designed, experience with attenuators indicated that they could be made with errors less than 0.1 db., possibly of the order of 0.01 db., at 1 Mc/s on 80 db. This was later confirmed by measurements made by the apparatus now being

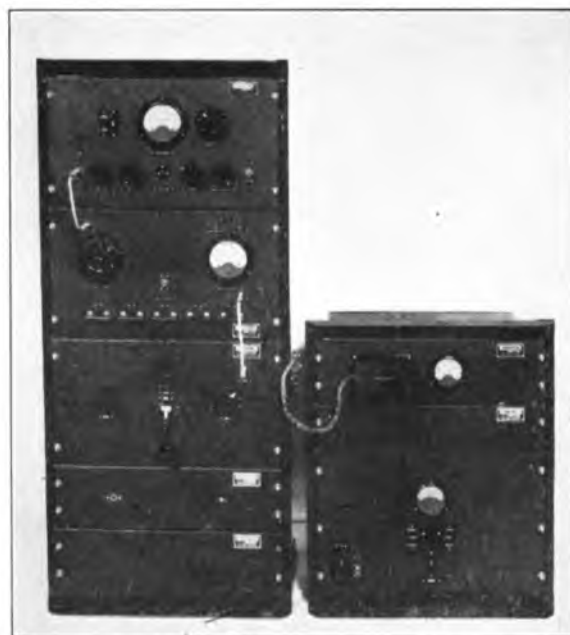

FIG. 7—APPARATUS FOR THE MEASUREMENT OF INSERTION LOSS (FREQUENCY CHANGE METHOD)

described. Thus at the low frequency of 110 kc/s there was no doubt that the errors in an attenuator could be made much less than 0.1 db.

The attenuator is variable in steps of 1 db. and a fine calibrated attenuator control covering the range 0.1-2 db. is incorporated in the I.F. amplifier. This amplifier also has uncalibrated gain controls by means of which the gain may be adjusted so that only the minimum amount of attenuation need be introduced in the I.F. attenuator. The final meter may be either a thermo-junction meter or a slide-back valve voltmeter, the latter enabling a high sensitivity to be obtained and small attenuation changes to be accurately measured.

Frequency error does not arise in this apparatus and the highest frequency at which it can be used depends upon the stability of the oscillators. Although it was designed for use at frequencies up to 5 Mc/s, it has been used satisfactorily up to 10 Mc/s and measurements have been made at 20 Mc/s, but operation was very difficult above 10 Mc/s.

In the previous method noise voltage does not have a direct effect upon the errors. In the present method, however, this is not so since the contribution to the total noise at the detector from the frequency-changer varies with the amount of attenuation, whereas the contribution from the intermediate circuits does not vary.

The input voltage to the frequency-changer is limited to less than 0.2 volt for the required degree of linearity of conversion conductance. Because of this limitation of input voltage the amount of insertion loss which can be measured for a given error due to noise is restricted. It is estimated that insertion loss up to 80 db. can be measured with an error due to noise not exceeding 0.05 db. For insertion loss measurements on very long cables these values have been extended by a further 40 db. by using a high power send element to transmit about 20 volts to line. The receive element, in this case, is calibrated with the same send element followed by a 40 db. attenuator, or by a separate low power send element. It is, of course, possible to eliminate the errors due to noise by using a linear detector with a long time constant. This scheme was not incorporated in the apparatus, however, as it was considered that errors might arise due to faulty adjustment of the operating conditions of the detector.

The highest accuracy is obtained when both ends of the network are available at the same point. Coaxial cables almost always have at least two cores so that two ends can be made available at the same point by joining the far ends of the cores. When this can be done the insertion loss is measured simply by first sending a given signal to the cable and receiving on the receive element, then applying the signal directly to the receive element and introducing attenuation into the standard attenuator so that the detector indicator reads the same as before. The amount of attenuation inserted is obviously the insertion loss of the cable. When insertion losses of the order of 120 db. are being measured, cross-talk between the sending and receiving apparatus or even between the cores of the cable may cause appreciable errors, and great care is necessary to ensure that the result obtained is the true insertion loss. If only one core is available, or if the insertion loss of the looped cable is too great, then the loss may be measured by sending a known signal to line and calibrating the receive element against a known signal. To avoid waveform errors it is advisable to use thermo-junction send elements to provide these signals, but a further error is introduced by setting inaccuracies and even with very careful adjustment the additional error due to these causes is probably of the order of ± 0.1 db.

Since the apparatus has been available it has been possible to develop variable attenuators of 80 db. accurate to ± 0.1 db. at frequencies up to 10 Mc/s, and employing these it is possible to use the first method of insertion loss measurement described above. However, the frequency-changing apparatus is still very useful, particularly when the permissible errors may not exceed, say, ± 0.1 db., and when large losses are to be measured. It is also, of course, the standard against which the attenuators are checked.

Table I shows the results of measurements made on a section of cable of a total length of 5,100 yards. With this length the attenuation is such that the open- and closed-circuit impedances at the resonance frequencies can be determined very accurately, and from these impedances the attenuation can be calculated

as previously described. The table also shows the results of measurements made, using the resonance frequency method previously described by independent operators.

TABLE I

Frequency Mc/s	ATTENUATION MEASURED BY	
	Insertion Loss Method db/ml.	Resonance Frequency Method db/ml.
0.50	2.73	2.73
1.00	3.87	3.88
1.50	4.78	—
1.51	—	4.77
2.00	5.55	—
2.05	—	5.57
2.20	5.84	—
2.21	—	5.81
2.49	—	6.23
2.50	6.24	—

THE MEASUREMENT OF CROSSTALK ATTENUATION

The frequency changing apparatus described in the previous section is always used for the measurement of crosstalk attenuation. As previously explained, it is possible to measure losses as high as 120 db. quite accurately by using a high power send element. This value is not sufficiently great to allow the cross-talk attenuation of the types of cable now in use to be measured, even when lengths of seven miles are available. Flexible feeders usually have poorer screening properties, but when measurements are made on such feeders only comparatively short lengths are available, say from 10 to 50 yards of double feeder. However, by allowing the error due to noise to rise to about 1 db. and by employing a wide-band step-up transformer between the receive end of the cable and the receive element, it is possible to measure losses as high as 160 db. with an error less than 2 db.

It is usual to measure both near-end and far-end crosstalk attenuation on long lengths of cable. Of these the far-end crosstalk attenuation is the easier to measure, firstly because there is then no possibility of direct coupling between the sending and receiving apparatus and secondly because the characteristic is a smooth curve so that quite a small number of measurements suffice to determine it. High near-end crosstalk attenuations are extremely difficult to measure accurately. As in most measurement work, the main difficulty is in ensuring that the quantity measured is the quantity it is desired to measure. The difficulty can be better visualised by considering the magnitudes of the quantities involved. A signal of 20 volts is impressed across the end of one cable and a voltage of 0.2 microvolts is produced across the end of another cable, usually only a few inches distant. The problem is to determine the ratio of these voltages with an error less than about 20%. It is obvious, therefore, that the screening of the apparatus must be very good, and also that the

connecting feeders to the cables and the connections to the cable must not introduce additional crosstalk. A further important point, which is satisfied if the screening is good, is to ensure that no current is sent along the outside of the cable used for transmitting the power and that no current on the outside of the cable used for receiving the power can be transferred to the receive element. It has been found essential to use interconnecting feeders constructed from copper pipe throughout, and to make connections from the feeder to the cable with rather elaborate devices which screw on to the cable end and grip the copper pipe feeder by a long close-fitting bush. However, by taking the utmost precautions it is believed that the actual cable crosstalk attenuation can be measured with an error not exceeding 2 or 3 db.

A further difficulty in measuring near-end crosstalk attenuation arises from the nature of the characteristic. The elementary contributions to the crosstalk all travel different distances along the cables, and therefore the phase relations of the contributions are random at the near-end of the cable. This fact causes the crosstalk attenuation at the near-end to have peaks and crevasses, and on long lengths of cable these occur every 10 or 20 kc/s. Thus, very many measurements are necessary to determine the true shape of the characteristic and the frequency must also be measured accurately.

Using the frequency changing apparatus a very large amount of work has been carried out on cable crosstalk attenuation, and the screening properties of various types of cable termination boxes have been examined in detail. The results obtained require far too much space to allow inclusion here, but Fig. 8

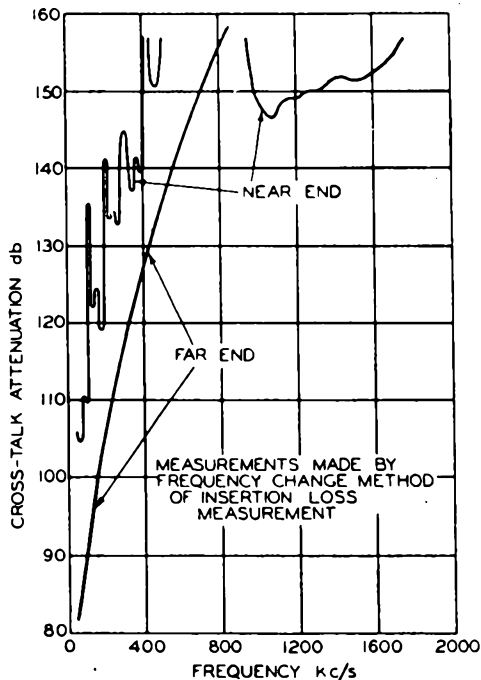

FIG. 8.—CROSSTALK ATTENUATION ON LONDON-BIRMINGHAM COAXIAL CABLE

shows the type of near- and far-end crosstalk attenuation characteristics associated with a well screened four-core coaxial cable.

USE OF THERMO-JUNCTIONS AT HIGH FREQUENCIES

Thermo-junctions have been used for measuring current at very high frequencies, and much has been written on the subject. Their use in the Post Office for cable measurements has been restricted to frequencies below about 30 Mc/s; the reason for this being that more suitable methods were available whenever measurements have had to be made at higher frequencies. Thermo-junctions are fundamentally current measuring devices, but can, of course, be modified to measure voltage. Thus, when impedances are to be measured the voltmeter and ammeter method must be used, and this only gives the magnitude of the impedances. Modifications of this simple method are available, which allow the angle of the impedance to be found also, but they have not been used because it is considered that the accuracy obtainable would be poor. Fig. 9 shows an arrange-

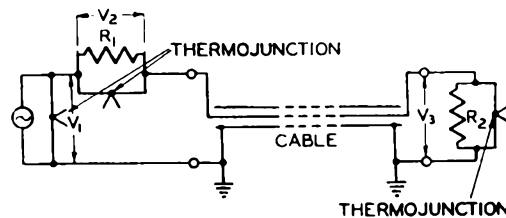

FIG. 9.—ARRANGEMENT OF APPARATUS FOR INSERTION LOSS MEASUREMENTS USING THERMO-JUNCTIONS

ment which has been used satisfactorily for the measurement of input impedance and insertion loss of cable at frequencies up to 30 Mc/s. The resistances R_1 and R_2 when shunted by their respective junctions are adjusted to have values equal to the characteristic impedance of the cable. From the voltages V_1 and V_2 the input impedance can be obtained and the additional voltage V_3 enables the insertion loss to be calculated. This method has many disadvantages, some of which are:—

- (1) The meters are sluggish and setting errors are considerable.
- (2) The resistance of the junction changes with the current through it.
- (3) The amount of attenuation which can be measured is limited to less than about 6 db., and if it is too small it cannot be measured with any degree of accuracy.

Apart from any special advantages of the method which may occur in particular cases the only advantages of the method would appear to be that it is simple to use and measurements can be made quickly; waveform errors are not important. It can, of course, easily be applied to balanced cables.

THE LOCALISATION OF CABLE FAULTS AND MEASUREMENT OF INPUT IMPEDANCE IRREGULARITIES.

Faults on high frequency cables are not easy to locate by usual methods, and it is often necessary to use high-frequency methods. If the attenuation between the end of the cable and the fault is not too great, say less than 10 db., the position of the fault

can be found by measuring the input impedance of the cable over a range of frequency. From the period of the variation of the input impedance with frequency the distance to the fault can be calculated, for the period of the variation of the input impedance is a function of the distance to the fault. Alternatively, the frequencies at which the input impedance is non-reactive can be found because the difference between such frequencies is also a function of the distance to the fault. The hybrid transformers are particularly suited to measurements of this type. On one occasion the apparatus described under "Reactance-variation method" was used to check the joints on a length of low-loss feeder which was being built up from short lengths. Measurements of characteristic impedance were made periodically at frequencies from 10-25 Mc/s. The results of the first set of measurements indicated a fault on the cable at 34 ft. from the sending end. This was 1 ft. from the nearest joint, and when the cable was opened at this joint the fin insulator was found to be cracked, covered with flux, and solder was nearly short-circuiting the cable.

A greatly superior method has now been developed. In this a sharp pulse of energy is transmitted to the cable and the time measured between this pulse and the arrival, at the sending end, of the pulse reflected from the fault. A cathode-ray tube is used to give the time between the transmitted and reflected pulses so that more than one partial fault can be located at the same time. Thus the apparatus can

also be used to investigate impedance irregularities in cables.

FUTURE TRENDS AND DEVELOPMENTS.

Already, when at all possible, impedance measuring apparatus is made direct reading in terms of resistance and reactance or conductance and susceptance. No doubt in the future further developments in this direction will be made, and the use of "corrections" will be avoided. Although most of the methods described above could be made direct reading, it appears that bridge methods of measurement are particularly suited to developments of this type. Bridge methods have not been used extensively in the Post Office for high frequency measurements on cables, and have now been replaced almost entirely by the hybrid transformers. In this connection the bridges described by D. B. Sinclair^{4, 5} are worthy of note since they are direct reading.

ACKNOWLEDGMENTS.

In conclusion the authors would like to express their thanks to their colleagues in the Post Office Engineering Department who have assisted in the development of some of the apparatus described, and in particular to Messrs. E. F. S. Clarke, K. D. Bamford, and R. C. Looser. Mr. Looser also gave valuable assistance in the preparation of this paper for publication.

⁴ *Proc. I.R.E.*, 1940, p. 310.

⁵ *Proc. I.R.E.*, 1940, p. 497.

Simplification of Cable Capacitance Networks

V. R. PETTITT, D.C.M., B.Sc.Eng.

U.D.C. 621.391

The author derives the well-known formulæ for converting a star to a mesh capacitance network by a simple method which avoids the use of determinants.

Introduction.

THE simplification dealt with here involves the transformation of a "star" capacitance network into a "mesh" capacitance network.

It is well known that a star network of n ray capacitances $a_1, a_2, a_3, \text{etc.}$, can be transformed to a mesh network of $\frac{n}{2}(n-1)$ capacitances each equal to $\frac{a_1 a_2}{\Delta}, \frac{a_2 a_3}{\Delta}, \text{etc.}$, where a_1 and a_2 are the ray capacitances forming the triangle with the mesh capacitance $\frac{a_1 a_2}{\Delta}$ and where Δ equals the sum of the ray capacitances $a_1 + a_2 + a_3 + \text{etc.}$

In most articles on this subject the reader is referred to other literature for the proof which usually takes the form of solving simultaneous equations by means of determinants.¹ This is a laborious process. As an example of the simplification which can be effected in this calculation relatively simple telephone cable capacitance networks

are resolved, first by the method using determinants, followed by the method evolved by the author.

Method using Determinants.

A star network of n rays each having capacitance $a_1, a_2, \text{etc.}$, the ends of the rays being $A_1, A_2, \text{etc.}$, respectively, can be represented, as regards the effects at its terminals $A_1, A_2, \text{etc.}$, by a network of capacitances joining the terminals, the capacitance joining the terminals A_1 and A_2 being b_{12} and the capacitance joining the terminals A_2 and A_3 being

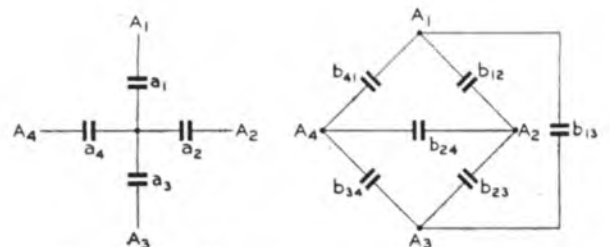

FIG. 1.—STAR NETWORK AND EQUIVALENT MESH.

¹ *Bell System Technical Journal*, Vol. 1, No. 1, July, 1922.

b_{23} , etc. Fig. 1 shows a star network of four rays and its equivalent mesh form. To obtain the values of b_{12} , b_{23} , etc., in terms of the ray capacitances a_1 , a_2 , etc., it is necessary to consider the condition when all terminals except one are connected together. Thus if terminals A_2 , A_3 and A_4 are bunched the effective capacitances are as shown in Fig. 2 (a), the equivalent of which is shown in Fig. 2 (b).

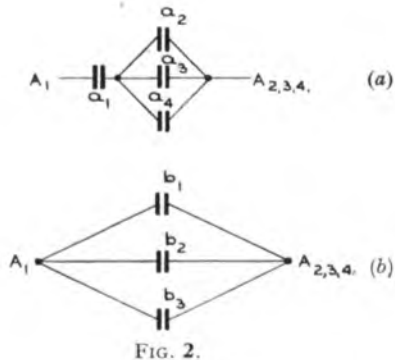

FIG. 2.

By equating the capacitances in these two Figs. the following equation is obtained :

$$b_{12} + b_{13} + b_{14} = \frac{a_1 (\Delta - a_1)}{\Delta}$$

where $\Delta = a_1 + a_2 + a_3 + a_4$

Similarly, by short-circuiting all terminals but A_2 , A_3 and A_4 in turn, the following equations are derived :—

$$b_{21} + b_{23} + b_{24} = \frac{a_2 (\Delta - a_2)}{\Delta}$$

$$b_{31} + b_{32} + b_{34} = \frac{a_3 (\Delta - a_3)}{\Delta}$$

$$b_{41} + b_{42} + b_{43} = \frac{a_4 (\Delta - a_4)}{\Delta}$$

Since there are six unknowns two more equations are required. These are obtained as follows :

Short-circuit terminals A_1 , A_2 and A_3 , A_4 . Fig. 3

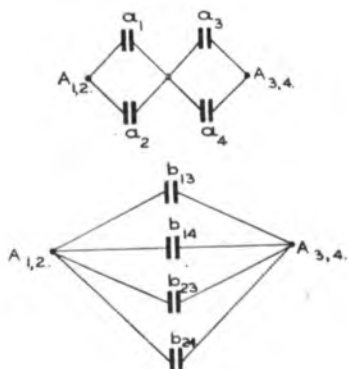

FIG. 3.

shows the effective capacitances remaining. and equating capacitances

$$b_{13} + b_{14} + b_{23} + b_{24} = \frac{(a_1 + a_2)(a_3 + a_4)}{\Delta}$$

Short-circuit terminals $A_1 A_3$ and $A_2 A_4$. Fig. 4 gives the effective capacities remaining. and equating as before

$$b_{12} + b_{14} + b_{23} + b_{34} = \frac{(a_1 + a_3)(a_2 + a_4)}{\Delta}$$

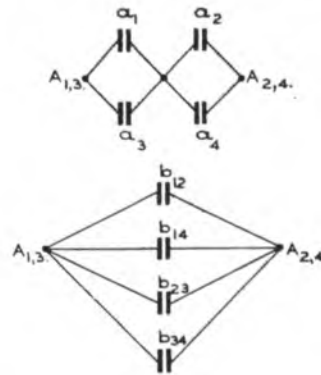

FIG. 4.

The six equations are now arranged as follows :

$$b_{12} + b_{13} + b_{14} + 0 + 0 + 0 \quad \frac{-A_1}{\Delta} = 0$$

$$b_{12} + 0 + 0 + b_{23} + b_{24} + 0 \quad \frac{-A_2}{\Delta} = 0$$

$$0 + b_{13} + 0 + b_{23} + 0 + b_{34} \quad \frac{-A_3}{\Delta} = 0$$

$$0 + 0 + b_{14} + 0 + b_{24} + b_{34} \quad \frac{-A_4}{\Delta} = 0$$

$$b_{12} + 0 + b_{14} + b_{23} + 0 + b_{34} \quad \frac{-R}{\Delta} = 0$$

$$0 + b_{13} + b_{14} + b_{23} + b_{24} + 0 \quad \frac{-S}{\Delta} = 0$$

where $A_1 = a_1 (\Delta - a_1)$, $A_2 = a_2 (\Delta - a_2)$,

$A_3 = a_3 (\Delta - a_3)$, $A_4 = a_4 (\Delta - a_4)$,

$R = (a_1 + a_3)(a_2 + a_4)$, $S = (a_1 + a_2)(a_3 + a_4)$

and by determinants :

$$b_{12} = \frac{-1}{\Delta} \begin{vmatrix} 1 & 1 & 0 & 0 & 0 & -A_1 \\ 0 & 0 & 1 & 1 & 0 & -A_2 \\ 1 & 0 & 1 & 0 & 1 & -A_3 \\ 0 & 1 & 0 & 1 & 1 & -A_4 \\ 0 & 1 & 1 & 0 & 1 & -R \\ 1 & 1 & 1 & 1 & 0 & -S \end{vmatrix}$$

$$\begin{vmatrix} 1 & 1 & 1 & 0 & 0 & 0 \\ 1 & 0 & 0 & 1 & 1 & 0 \\ 0 & 1 & 0 & 1 & 0 & 1 \\ 0 & 0 & 1 & 0 & 1 & 1 \\ 1 & 0 & 1 & 1 & 0 & 1 \\ 0 & 1 & 1 & 1 & 1 & 0 \end{vmatrix}$$

$$\begin{aligned}
& \begin{vmatrix} 0 & 1 & -1 & 0 & -1 & (-A_1 + A_3) \\ 0 & 0 & 1 & 1 & 0 & -A_2 \\ 0 & -1 & 0 & -1 & 1 & (+A_3 + S) \\ 0 & 1 & 0 & 1 & 1 & -A_4 \\ 0 & 1 & 1 & 0 & 1 & -R \\ 1 & 1 & 1 & 1 & 0 & -S \end{vmatrix} \\
&= \frac{-1}{\Delta} \begin{vmatrix} 1 & 1 & 1 & 0 & 0 & 0 \\ 0 & -1 & -1 & 1 & 1 & 0 \\ 0 & 1 & 0 & 1 & 0 & 1 \\ 0 & 0 & 1 & 0 & 1 & 1 \\ 0 & 0 & 1 & 0 & -1 & 1 \\ 0 & 1 & 1 & 1 & 1 & 0 \end{vmatrix} \\
&= \frac{-1}{\Delta} \begin{vmatrix} 0 & -1 & -1 & -2 & (-A_1 + A_3 + A_4) \\ 0 & 1 & 1 & 0 & -A_2 \\ 0 & 0 & 0 & 2 & (-A_3 + S - A_4) \\ 0 & -1 & 1 & 0 & (-A_4 + R) \\ 1 & 1 & 0 & 1 & -R \end{vmatrix} \\
&= \frac{-1}{\Delta} \begin{vmatrix} 0 & -1 & 2 & 1 & 1 \\ 0 & -1 & 0 & -1 & 1 \\ 0 & 1 & 0 & 1 & 1 \\ 0 & 1 & 0 & -1 & 1 \\ 1 & 1 & 1 & 1 & 0 \end{vmatrix} \\
&= \frac{-1}{\Delta} \begin{vmatrix} 0 & 0 & -2 & (-A_1 - A_2 + A_3 + A_4) \\ 0 & 2 & 0 & (-A_2 - A_4 + R) \\ 0 & 0 & 2 & (-A_3 + S - A_4) \\ -1 & 1 & 0 & (-A_4 + R) \end{vmatrix} \\
&= \frac{-1}{\Delta} \begin{vmatrix} 0 & 2 & 2 & 2 \\ 0 & 0 & 0 & 2 \\ 0 & 0 & 2 & 0 \\ 1 & 0 & -1 & 1 \end{vmatrix} \\
&= \frac{2}{8\Delta} \begin{vmatrix} 2 & (-A_3 + S - A_4) \\ -2 & (-A_1 - A_2 + A_3 + A_4) \end{vmatrix}
\end{aligned}$$

$$\therefore b_{12} = \frac{1}{2\Delta} (-A_1 - A_2 + S - A_4) = \frac{1}{2\Delta} 2 (a_1 a_2) = \frac{a_1 a_2}{\Delta}$$

Similarly it can be shown that $b_{23} = \frac{a_2 a_3}{\Delta}$, and so on.

Using the normal notation the transformation is shown by Fig. 5.

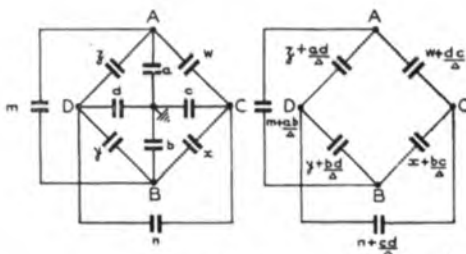

FIG. 5.

Alternative Method.

To avoid this tedious working the following proof is considered adequate, and has the merit of being direct, simple and easily understood.

To illustrate this method consider a network of five rays. Fig. 6 shows the transformation using the notation described above.

By successively short-circuiting all terminals except one, five similar equations are obtained, as with the previous method, i.e. :

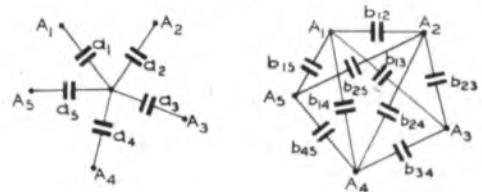

FIG. 6.

$$\begin{aligned}
b_{12} + b_{13} + b_{14} + b_{15} &= \frac{a_1 (\Delta - a_1)}{\Delta} \\
b_{21} + b_{23} + b_{24} + b_{25} &= \frac{a_2 (\Delta - a_2)}{\Delta} \\
b_{31} + b_{32} + b_{34} + b_{35} &= \frac{a_3 (\Delta - a_3)}{\Delta} \\
b_{41} + b_{42} + b_{43} + b_{45} &= \frac{a_4 (\Delta - a_4)}{\Delta} \\
b_{51} + b_{52} + b_{53} + b_{54} &= \frac{a_5 (\Delta - a_5)}{\Delta}
\end{aligned}$$

adding these five equations

$$\begin{aligned}
& b_{12} + b_{13} + b_{14} + b_{15} + b_{23} + b_{24} + b_{25} + b_{34} + b_{35} + b_{45} \\
&= \frac{a_1 a_2}{\Delta} + \frac{a_1 a_3}{\Delta} + \frac{a_1 a_4}{\Delta} + \frac{a_1 a_5}{\Delta} + \frac{a_2 a_3}{\Delta} + \frac{a_2 a_4}{\Delta} + \frac{a_2 a_5}{\Delta} \\
&\quad + \frac{a_3 a_4}{\Delta} + \frac{a_3 a_5}{\Delta} + \frac{a_4 a_5}{\Delta}
\end{aligned}$$

In this equation there are the same number of terms on each side and each term on the right-hand side consists of the product of two ray capacitances divided by the sum of all the ray capacitances and is symmetrical to one pair of terminals. On the left-hand side there is a simple summation of the mesh capacitances, each of which is symmetrical to one pair of terminals. Therefore the terms on the left-hand side can be equated to those on the right-hand side which are symmetrical to the same pair of terminals, i.e., $b_{12} = \frac{a_1 a_2}{\Delta}$, $b_{13} = \frac{a_1 a_3}{\Delta}$, etc.

A star of n ray capacitances will always lead to an equation of this kind with $n/2 (n-1)$ terms on the right-hand and left-hand sides.

Conclusion.

For another method of proof of this important transformation theorem, the reader is referred to "A New Network Theorem," by A. Rosen, *J.I.E.E.*, Vol. 62, November, 1924.

An Air Conditioning Plant

K. O. BAWTREE, B.Sc.(Eng.), A.M.I.E.E.

U.D.C. 697.93

The article describes an air conditioning plant installed in a special protected building. Control of temperature and humidity is provided, and additional plant deals with war gases.

Introduction

THE building in which the plant described in this article is installed was designed to be reasonably immune from the effects of aerial attack either by bombardment or war gas. Any ventilation by natural means was therefore, of necessity, precluded and a complete air conditioning plant had to be provided, together with means of filtering war gas from the incoming air if necessary.

The building houses telecommunications equipment with associated power plant and emergency diesel engines, and provides staff accommodation, including kitchens and dormitories, etc., all of which have to be furnished with clean air at the right temperature and humidity. A feature of the installation is the refrigerating plant employed to maintain an equable air temperature during the summer period. The air conditioning plant to serve the building was designed by and installed under the supervision of the Ministry of Works.

It is impossible in a comparatively short article to enter into much detail, and several minor but nevertheless interesting features of the plant have had to be omitted from the present description. Those familiar with the plant will also notice that mention of certain other features has had to be left out for security reasons.

Main Plenum System.

Fig. 1 is a diagrammatic layout of the ventilating plant, showing the main items of the plant described. Views of the plant are shown in Figs. 2 and 3.

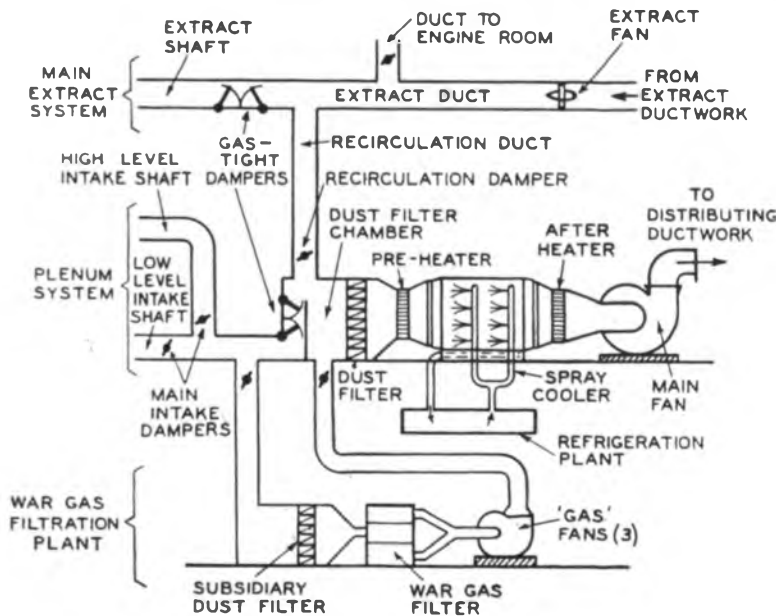

FIG. 1.—LAYOUT OF VENTILATING PLANT.

There are two air intake shafts provided in the structure of the building, one at high level and one at low level, whence air is drawn into the dust filter chamber. The air may be drawn into the building through either of the intake shafts by an appropriate setting of the main intake dampers in the plant room. Air may be fed also into the dust filter chamber from the extract duct via the recirculation duct and by regulation of the recirculation and main intake dampers, the proportion of "fresh" to "recirculated" air can be varied at will.

The dust filter itself, which forms the whole of one end of the dust filter chamber, comprises 100 sections each 18 ins. \times 24 ins., fitted slantwise into a supporting framework. Each section consists of a metal mesh frame, which holds the cotton-wool filter medium in position, and can be detached from the supporting framework when the filter requires renewal.

The pre-heater, which follows immediately after the dust filter, consists of a single bank of gilled tubes heated by hot water. The heater is controlled automatically by a thermostat fitted in the duct work between the spray cooler and the after-heater. When the temperature of the air leaving the spray cooler falls below the setting of the thermostat, the motorised valve on the supply line to the pre-heater opens, the extent to which it opens depending on whether the temperature of the air leaving the spray cooler is much, or little, below the required value. A switch is provided in the supply to the motor of the motorised valve to enable the motor to be stopped during periods when the pre-heater is not required, e.g. during the summer season.

The object of the pre-heater is to raise the temperature of the air before entering the spray cooler, so as to increase its moisture carrying capacity. This is normally necessary only during the winter season on days when both the temperature and relative humidity of the incoming air are low. For example, should the temperature of the air leaving the spray cooler (which of course in such circumstances is not being used as a cooler, but merely as a humidifier) be 36°F., the quantity of moisture contained in the air passing into the building—irrespective of its temperature—cannot exceed 31.4 grains per pound. This is the amount of water in air at 36°F., 100% relative humidity. At a temperature of 63°F. this moisture content represents a relative humidity of 36%, which is too low. The pre-heater supplies the remedy by raising the temperature of the air so that it leaves the spray

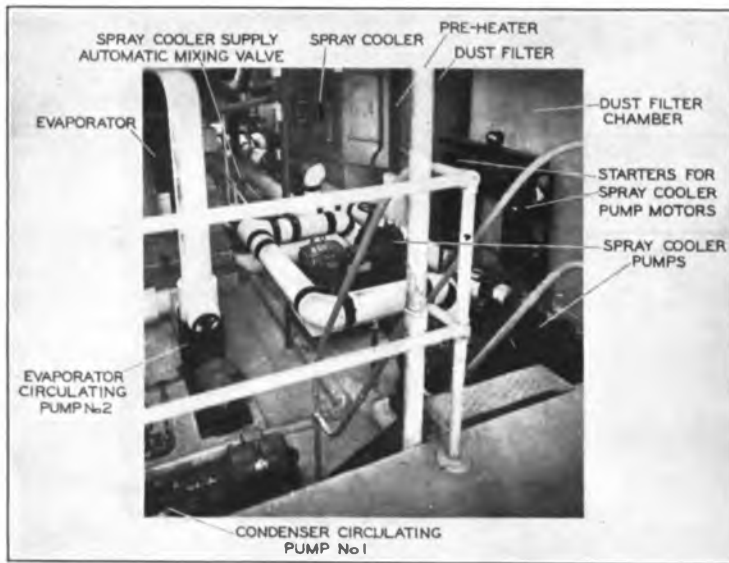

FIG. 2.—VENTILATING PLANT.

cooler, say, 5°F. higher, i.e. at 41°F. The air now contains 38.3 grains per pound, which at 63°F. represents a relative humidity of 44%.

After leaving the pre-heater, the air enters the spray cooler. The spray cooler is so called because its main use is for cooling the air, in conjunction with the refrigerating plant, during the summer season. As intimated above, the spray cooler can be used on occasions during the winter season as a humidifier, but this is not its main purpose, and such occasions are not frequent. The spray cooler comprises two banks, each consisting of eight vertical pipes, spaced evenly across the air stream. On each side of each vertical pipe there are a number of nozzles through which, when water is passed under pressure, a fine spray is ejected into the air stream, thus ensuring intimate contact between the water and the air. Both before and after the spray cooler, the air passes through an eliminator, which consists of a number of zig-zag vertical metal plates, to prevent, as far as possible, the passage of droplets of moisture into other parts of the system. The water from the spray collects at the bottom of the cooler, whence the overflow passes into the refrigerating plant for cooling prior to re-use.

The after-heater, which stands between the spray cooler and the main fan, is of similar construction to the pre-heater, but the control is not automatic. A manually controlled valve is situated in the hot water supply line to the heater.

The main fan, manufactured by Messrs. Matthews and Yates, is a centrifugal fan capable of delivering 45,000 cu. ft. of air per minute

with a total fan head of 3 ins. water gauge at 262 r.p.m. The fan is driven through a multiple V rope drive by a 40 h.p. motor. A spare motor is fixed in position on the opposite side of the pulley so as to reduce delay in bringing the fan back into commission in the event of a breakdown of the normal motor.

From the main fan the air is carried to all parts of the building through sheet metal duct work. The main riser ducts are felt-lined to reduce noise and heat transference.

With a few exceptions, a thermostatically controlled heater is installed in the air duct supplying each room. The thermostats, which are of the Q type, made by The Rheostatic Company Ltd., are mounted on the walls of the rooms. When the temperature of the air in the room drops below the setting of the thermostat, a motorised valve on the hot water supply line to the heater is operated automatically

and the hot water continues to flow through the heater until the room temperature has been restored to normal.

The duct outlets are of various types to meet the individual requirements of the rooms concerned. Generally speaking, conical distributors of a diffusing type are employed in switch rooms and dormitories, revolving punkah louvres in the apparatus rooms, and in the kitchen and canteens punkah louvres of the non-revolving type are mounted direct on the side of the duct work. In the battery and engine rooms plain adjustable grilles are provided in the ductwork and high velocity nozzle outlets are employed in the air conditioning plant and compressor rooms. All the duct outlets are at high level.

Extract Systems.

The main extract system, as distinct from the subsidiary systems described later, carries the used

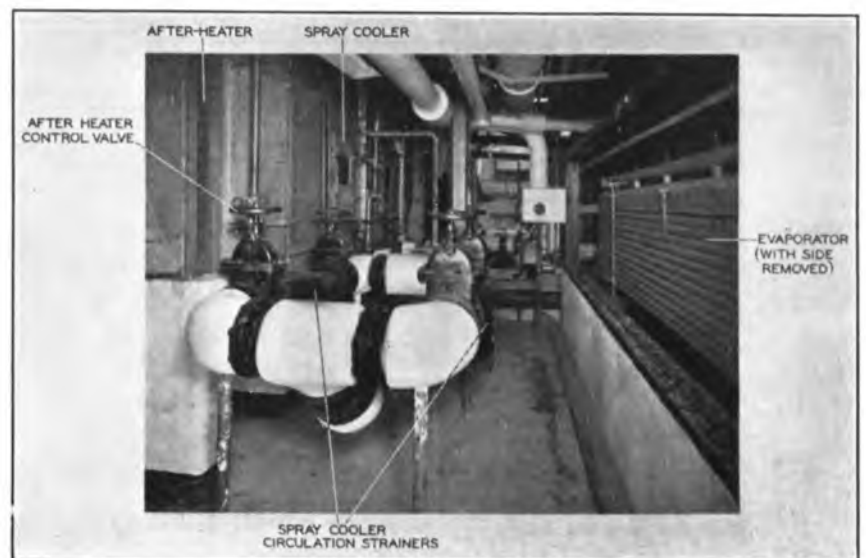

FIG. 3.—VENTILATING PLANT.

air from the various parts of the building to the air conditioning plant room in the basement, whence it passes either into the extract shaft and so out to atmosphere, or back into the dust filter chamber to effect partial or complete recirculation as required. In the majority of cases the branch ducts of the extract system are fitted immediately under the floor of the room from which they extract and connections are made at intervals through the floor, to metal grid-protected openings at low level against the wall. A Thermotank axial flow fan with impeller diameter of $47\frac{1}{2}$ ins. and speed of 955 r.p.m., capable of passing 34,750 cu. ft. per minute at 1.2 ins. fan static head, is situated in the extract duct near the point where the ducts from the various floors converge, and just beyond the fan a short branch leads from the extract duct into the engine room adjoining. This branch is normally closed by a damper, but whenever one or more of the oil engine sets is started up, the damper is opened automatically. An adequate supply of air to meet the requirements of the engines and their coolers is thus ensured. Near this point the recirculation duct connects the extract duct to the dust filter chamber.

In addition to the main extract system there are other subsidiary systems for the removal of used air from (i) the battery room, and (ii) the lavatories and kitchen. The air from the former is discharged directly into the extract shaft, while that of the latter is discharged into the boiler room to supply the air required by the steam boilers for combustion. For disposal of this air when the boilers are not in service, a propeller fan is provided in the wall between the boiler room and the extract shaft.

War Gas Filtration Plant.

To prevent the ingress of gas-contaminated air through the ventilating plant under war gas con-

ditions, two gas-tight dampers are provided, one in the intake and the other in the extract. The gas-tight damper in the intake is situated at the entrance to the dust filter chamber, and that in the extract at a point adjacent to where the extract duct joins the extract shaft rising up through the building. When these gas-tight dampers are closed, air can be drawn into the building only through the war gas filtration plant which by-passes the intake gas-tight damper.

The war gas filtration plant comprises a subsidiary dust filter of similar construction to the main dust filter, but of smaller capacity, a bank of war gas filters, two large "gas" fans capable of passing 25,000 cu. ft. of air per minute at 6.05 in. w.g. total fan head and one small gas fan capable of passing 9,000 cu. ft. of air per minute at 1.25 in. w.g. total fan head, all the fans being in parallel. All the gas fans were manufactured by Messrs. Matthews and Yates. After passing through the gas filtration plant, the air is discharged into the dust filter chamber of the main system. With the small gas fan in operation, sufficient air is drawn into the building to make up for that expelled by the battery room and lavatory and kitchen extract systems, together with a little extra to ensure the maintenance of a slight pressure, above atmospheric, within the building. With either of the large gas fans in operation, sufficient extra air is drawn into the building to meet the needs of all the emergency oil engine sets and their coolers. Only one of the gas fans is intended to be run at a time; the second large gas fan is provided as a spare.

Refrigerating Plant.

A schematic drawing of the refrigerating plant is shown in Fig. 4. There are two separate circuits for the refrigerant, carbon dioxide, one associ-

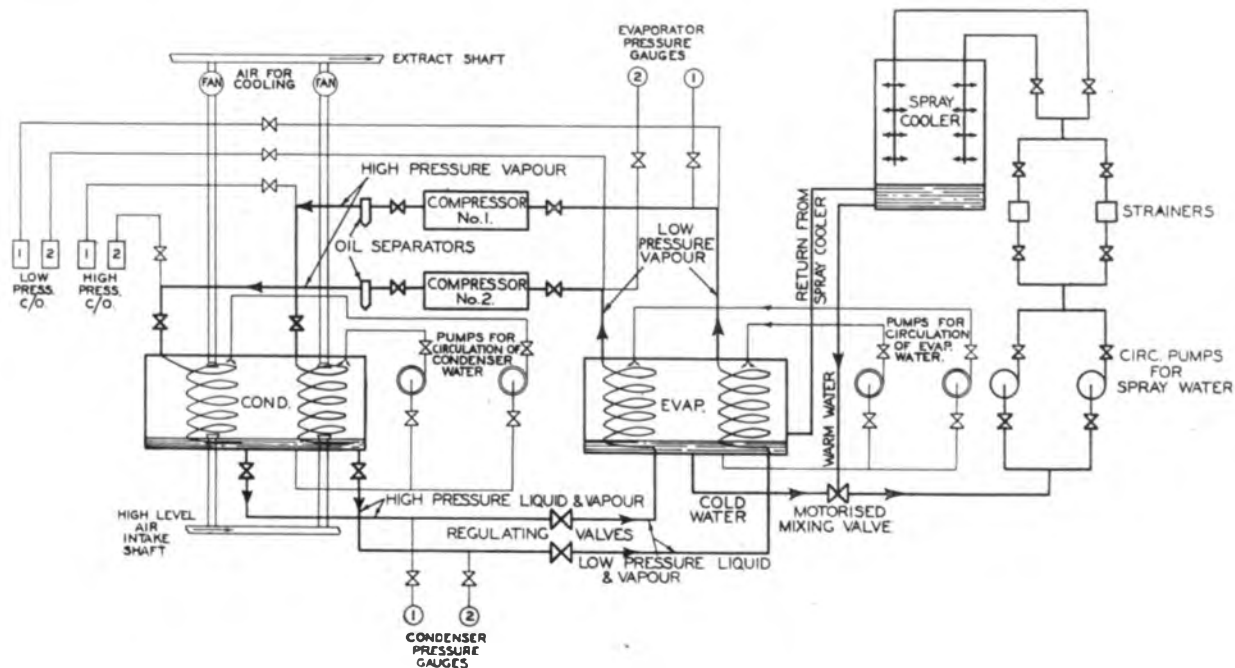

FIG. 4.—SCHEMATIC OF THE REFRIGERATING PLANT.

ated with each of the two compressors, and the plant can be run with either or both of the compressors as required. The compressors, as illustrated in Fig. 5, are horizontal, twin cylinder, single acting, single stage machines running at a speed of 270 r.p.m., and each is driven by a 170 h.p. motor through a "Tex-ropc" drive of 15 belts.

The plant, which was manufactured and installed by Messrs J. and E. Hall Ltd., of Dartford, was designed to remove 1,050,000 B.T.U./hour when used for cooling water from 48°F. to 42°F. and with air fed to the condensers at 80°F. and 70% relative humidity.

The condensers are of the induced draught evaporative type and consist of two banks of coils formed from solid drawn steel tubing and galvanised after fabrication. Each bank of coils is surrounded by a galvanised sheet steel casing. Air ducts connect the high level intake shaft to the lower side of the casing. An axial flow fan, capable of passing 19,000 cu. ft. per minute with 1½ in. w.g. fan static head, is provided in each of the two extract ducts leading from the top of the condenser casing. A water-tight steel tray is fitted under each bank of coils, and pipe-work from these trays carries the water to two centrifugal pumps and so back to the top of the condenser.

The regulating valve is essentially an adjustable restriction of the circuit which enables a high pressure to be built up on the outlet side of the compressor. By partially closing or opening the regulating valve, this pressure can be raised or lowered, so increasing or reducing the output of the plant.

The evaporator (see Fig. 3) comprises two banks of coils for the refrigerant, of similar construction to those in the condenser, the whole being enclosed in a casing of wood and cork for heat insulation purposes. Water troughs, arranged over each stack of coils, distribute the circulating water over the surface of the coils, and a water-tight tray forms the bottom of the evaporator. Two centrifugal pumps in parallel circulate the chilled water from the base of the evaporator back to the top.

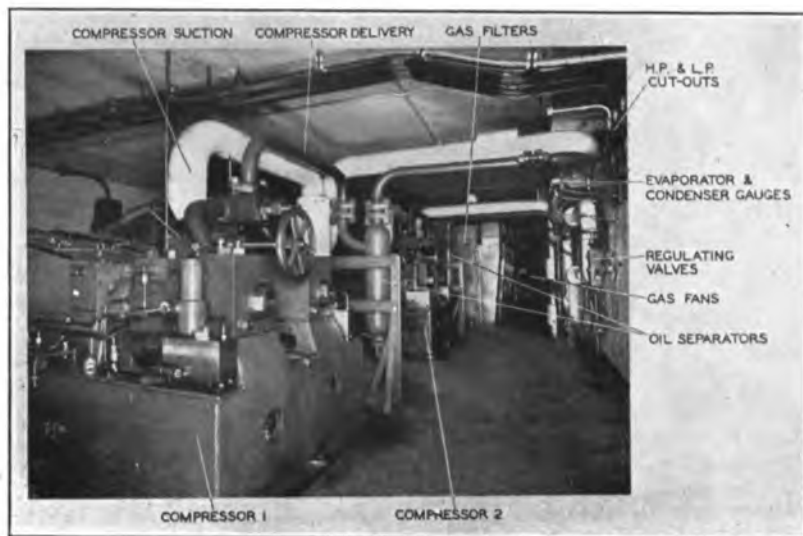

FIG. 5.—REFRIGERATOR COMPRESSORS AND WAR GAS PLANT.

It is from the base of the evaporator that the chilled water for the spray cooler is drawn. This chilled water, mixed with warmer water from the base of the spray cooler, is supplied under pressure to the spray cooler by a centrifugal pump. A fine mesh copper strainer is included in the water circuit to prevent particles of solid matter, washed from the air, getting into the spray nozzles and blocking them. A spare circulating pump and a spare strainer are included in the installation.

The mixing of the chilled water and the warmer water from the spray cooler, in the correct proportion to produce the desired degree of cooling of the air, is performed by an automatic mixing valve. The mixing valve is controlled by a thermostat in the main air duct, between the spray cooler and the

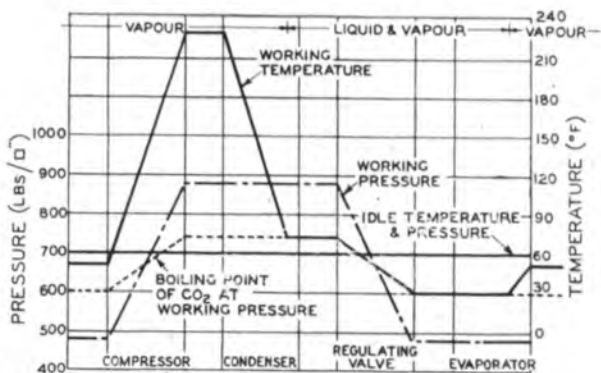

FIG. 6.—PRESSURE AND TEMPERATURE VARIATIONS IN TYPICAL CYCLE OF REFRIGERATION.

after-heater. According to the setting of the adjustment on the mixing valve, when the temperature of the air leaving the spray cooler drops to a certain level, the opening of the mixing valve is altered automatically so that the water, instead of coming entirely from the evaporator, is drawn partly from the bottom of the spray cooler. The mixing valve was manufactured by the British Thermostat Co. Ltd.

The changes of state which the refrigerant undergoes as it passes through the system are illustrated in Fig. 6, which shows the variations of temperature and pressure in a typical cycle. In the compressor, work is done on the vapour raising both its pressure and its temperature. The pressure of the vapour from the compressor to the regulating valves remains more or less constant, but across the regulating valve it falls to the pressure on the inlet side of the compressor. The changes in temperature, on the other hand, are more varied. On leaving the compressor, the temperature drops slightly, due to loss of heat through the unlagged pipework between the compressor and the condenser, but in the condenser the temperature of the vapour falls rapidly until the boiling point is reached, and then remains

constant while part of the vapour changes into a liquid. In passing through the regulating valve, there is a further fall in temperature due to the expansion of the mixture of vapour and liquid carbon dioxide. It is this cold refrigerant which passes through the coils of the evaporator and gives the required cooling effect. The temperature of the refrigerant remains steady until all the liquid carbon dioxide has been evaporated in the coils of the evaporator and then rises once more as the vapour is superheated prior to return to the compressor.

Air Flow Measurement.

Before the air conditioning plant could be operated intelligently it was essential that means should be provided for measuring the quantities of both fresh and recirculated air being passed into the system at any given time. Various methods are available for the measurement of air flow in ventilating ducts, but the most satisfactory method is probably that in which the velocity head is measured directly.

Where extreme accuracy is required it is necessary to take velocity head readings at a number of points over the cross section of the duct and then, after converting the velocity head figures so obtained into velocities, their average is multiplied by the cross sectional area of the duct at the point of measurement. The resulting product gives the total quantity of air passing. However, provided a fair length of straight duct work with uniform cross sections exists where the measurement is required, it is possible to find some point in the cross section where, for all practical purposes, the velocity corresponds to average velocity. By fixing a Pitot tube (combined facing and side tube) in the duct at this point, the inclined tube gauge to which the pitot tube is connected can be calibrated to register directly in cubic ft./min.

There are several limitations in this method, two of which are as follows. The first, which has been mentioned already, is that it is essential that measurements be taken at a point where the duct work is straight and the cross section uniform for some distance prior to the test point and a shorter distance after, travelling in the direction of the air stream. In many installations, the number of bends in the ductwork renders accurate measurement impossible. The second limitation is that velocities below about 5 ft./sec. do not provide sufficient velocity head to enable the inclined tube gauge to be read with any degree of accuracy. For example:—

$$V = 4000 \sqrt{h} \text{ (where } V = \text{velocity in ft./min. and } h = \text{velocity head in inches water gauge).}$$

$$\begin{aligned} \therefore \text{ At 5 ft. sec., } 5 \times 60 &= 4000 \sqrt{h} \\ \therefore \sqrt{h} &= .075 \\ \therefore h &= .005625 \end{aligned}$$

Thus, using an inclined tube gauge with 20 to 1 magnification, the largest magnification that can be obtained for practical use, a reading of just over 1/10th inch is obtained. Although readings of less than 1/10th inch can of course be taken, small inaccuracies of measurements are subject to quite large errors when converted into terms of quantity.

The measurement of the quantity of recirculated air was comparatively simple, as a suitable straight length of ductwork was present in the recirculation duct where the section was uniform, and the velocity sufficiently high to permit the adoption of the method outlined above.

The measurement of the quantity of fresh air was not so simple however. Access to either of the main intake shafts for measurement of air flow was precluded for structural reasons, so the only alternative was to measure the total quantity passing through the main fan and by subtracting the recirculated air quantity, the volume of fresh air passing could be found. The problem then arose as to where the measurement should be taken. The ductwork on the discharge side of the fan was subject to the first limitation mentioned above, and that on the input side subject to the second. The calculation of air flow by the measurement of velocity head had therefore to be abandoned.

The method finally decided upon was to make use of the fact that there is a definite loss of total head across the air conditioning plant when air is passing (due mainly to the resistance of the pre-heater and after-heater and the eliminators on either side of the spray cooler), and that this loss varies approximately as the square of the quantity passing. On measurement, it was found that when the full quantity of air was passing through the main fan, a loss of about 1/2 in. w.g. was incurred. This, on an inclined gauge with ratio 20:1 would give a 10 in. reading and so enable any measurement over the range required to be obtained quite accurately. Owing to the small increase of resistance introduced when the sprays of the spray cooler were used, two scales had to be prepared, one showing the quantity of air passing with the sprays in operation and the other showing the quantity without the sprays in operation.

Conclusion.

In conclusion, the author desires to acknowledge his indebtedness to Mr. R. T. Pocock, of the London Telecommunications Region, and to his colleagues in the Engineer-in-Chief's office for assistance given in the preparation of this article.

An Improved Oscillator for Pip-Tone Supply

N. W. LEWIS, Ph.D.(Eng.), M.I.E.E.

U.D.C. 621.396.615

An expedient means of generating a 900 c/s pip-tone supply, using a line repeater, an equaliser, and a pair of rectifiers.

Introduction

FOR a recently-developed special service employing pip-tone signals similar to those of the trunk chargeable-time indicator, it was necessary to provide sources of tone at a large number of stations. The requirement at each station was merely a few milliwatts of tone of any frequency between 900 and 1,000 c/s. Among the expedients adopted to obviate the provision of special oscillators is one that may be of general interest, and find other uses. This is termed the "oscillating amplifier," and is a practical though somewhat unusual application of well-known principles.

The arrangement may be set up at any repeater station without modification of either equipment or permanent wiring, and consists of a spare audio 4-wire repeater (or pair of amplifiers) of any type, an equaliser or any other device that can be arranged to provide a resonant circuit of the desired frequency, and a pair of small metal rectifiers.

Principle

The principle of the arrangement is shown schematically in Fig. 1. The U/D amplifier, having its input and output terminals connected together, "sings" at a frequency determined by the resonant circuit L, C. The rectifier-combination MR acts as a voltage-limiter, preventing the oscillation from reaching a level likely to cause crosstalk into neighbouring circuits. The tone supply is available at the output of the D/U amplifier, which may be adjusted to give any suitable output level.

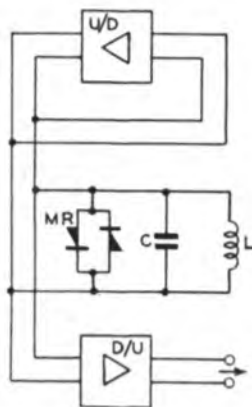

FIG. 1.—SCHEMATIC DIAGRAM SHOWING PRINCIPLE OF OPERATION.

Practical Arrangement

Fig. 2 shows a typical practical arrangement, consisting of a Unit Amplifying No. 20A, Equaliser No. 8A and Rectifier-element No. 2/2A. The equaliser conveniently provides an inductance of 37 mH and capacitance of 0.74 μ F, giving a nominal resonant frequency of 960 c/s. The rectifier-element is of the double type used in operators' telephone circuits for the prevention of acoustic shock, and its effect is to reduce the level of the oscillation generated by the U/D amplifier from about +20 to -10 db. relative to 1 milliwatt. The input circuit of this type of amplifier being unbalanced, a transformer (No. 48), which may be of any ratio, is provided for

each input circuit to prevent possible crosstalk trouble. Another transformer (No. 48J) with line windings paralleled is used at the output of the

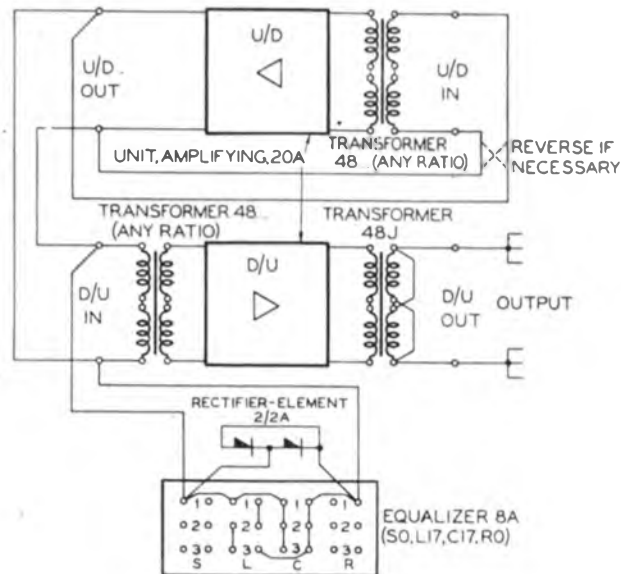

FIG. 2.—TYPICAL ARRANGEMENT FOR IMPROVED OSCILLATOR.

D/U amplifier to give a nominal output impedance of 75 ohms.

The method of setting up is as follows:—

- (1) Set the U/D amplifier to minimum gain, and the D/U amplifier to about 20 db. gain.
- (2) Listening with a telephone receiver connected to D/U OUT, increase the gain of the U/D amplifier in 1½ db. steps until oscillation commences. If tone is not heard before a gain of about 10 db. is reached, or if only a very high frequency "sing" is heard, reverse the U/D IN connections as indicated in Fig. 2.
- (3) Increase the gain of the U/D amplifier 3 steps (4½ db.) beyond the step at which oscillation commenced.
- (4) Adjust the gain of the D/U amplifier to give +5 db. on 1 milliwatt in a 600 Ω decibelmeter connected to the output terminals, i.e. +5 db. "terminated level" at the line side of the output transformer. With this adjustment, the arrangement is approximately equivalent to a source having 1½ V internal E.M.F. and 80 Ω impedance.

Although it has not been possible to carry out a comprehensive series of tests, it may be taken that the harmonic content and stability of frequency and amplitude of the output under normal working conditions are entirely satisfactory for such a purpose as pip-tone supply.

Notes and Comments

Roll of Honour.

The Board of Editors deeply regrets to have to record the deaths of the following members of the Engineering Department :—

While serving with the Armed Forces, including Home Guard

Birmingham Telephone Area	Harrison, C. R.	..	Skilled Workman, Class II	..	Leading Aircraftman, Royal Air Force
Birmingham Telephone Area	Salt, R. J. P.	..	Draughtsman, Class II..	..	Sergeant, Royal Air Force
Bradford Telephone Area ..	Pinkney, W. R.	..	Skilled Workman, Class II	..	Trooper, Royal Armoured Corps
Brighton Telephone Area..	Green, G. L.	..	Skilled Workman, Class II	..	Signalman, Royal Corps of Signals
Colchester Telephone Area	Ellwood, D. F.	..	Unestablished Skilled Workman		Temporary Sub-Lieutenant, R.N.V.R.
Dundee Telephone Area ..	Wilson, N. S.	..	Unestablished Skilled Workman		Flying Officer, Royal Air Force
Edinburgh Telephone Area	Parrott, J. G. J.	..	Unestablished Skilled Workman		Sergeant Air Gunner, Royal Air Force
Engineering Department ..	Carter, W. S. T.	..	Skilled Workman, Class I	..	Sergeant, Royal Air Force
Engineering Department ..	Ceeney, G. E. H.	..	Unestablished Draughtsman	..	Sergeant, Royal Air Force
Engineering Department ..	King, J. F.	..	Labourer..	Sergeant, Royal Army Service Corps
Engineering Department ..	Meredith, E. C.	..	Unestablished Skilled Workman		Sergeant Navigator, Royal Air Force
Exeter Telephone Area ..	Ayling, A. J.	..	Skilled Workman, Class II	..	Lieutenant, Royal Electrical and Mechanical Engineers
Lincoln Telephone Area ..	Leakey, K. W.	..	Unestablished Skilled Workman		Flying Officer, Royal Air Force
Liverpool Telephone Area..	Bull, G. D.	..	Unestablished Skilled Workman		Lance Sergeant, Royal Tank Regiment
London Telecommunications Region	Brodie, C. C.	..	Unestablished Skilled Workman		Signalman, Royal Corps of Signals
London Telecommunications Region	Burden, R. E.	..	Unestablished Skilled Workman		Driver, Royal Army Service Corps
London Telecommunications Region	Cornish, C. H.	..	Unestablished Skilled Workman		Sergeant, Royal Air Force
London Telecommunications Region	Dalton, T.	Unestablished Skilled Workman		Signalman, Royal Corps of Signals
London Telecommunications Region	Davy, H.	..	Skilled Workman, Class II	..	Sergeant, Royal Corps of Signals
London Telecommunications Region	Dutton, R. E.	..	Skilled Workman, Class II	..	Sergeant Observer, Royal Air Force
London Telecommunications Region	Fransham, A. J.	..	Labourer..	Lieutenant, Reconnaissance Corps
London Telecommunications Region	Harris, F.	Labourer..	Sergeant, Reconnaissance Regiment
London Telecommunications Region	Hunt, H. J.	..	Unestablished Skilled Workman		Signalman, Royal Corps of Signals
London Telecommunications Region	Joel, D. C.	..	Unestablished Skilled Workman		Sergeant, Royal Air Force
London Telecommunications Region	Kelly, P.	Labourer..	Lance Corporal, East Surrey Regiment
London Telecommunications Region	Mason, D. C.	..	Skilled Workman, Class II	..	Corporal, Royal Corps of Signals
London Telecommunications Region	Melhuish, J. W.	..	Unestablished Skilled Workman		Sergeant, Royal Air Force
London Telecommunications Region	Morrison, D.	..	Labourer..	Rifleman, Rifle Brigade
London Telecommunications Region	Mundy, H. A.	..	Skilled Workman, Class II	..	Lance Corporal, Home Guard
London Telecommunications Region	Russell, F. J.	..	Skilled Workman, Class II	..	Able Seaman, Royal Navy

Newcastle Telephone Area	Johnson, J.	..	Unestablished Skilled Workman	Sergeant, Royal Air Force
Newcastle-on-Tyne Telephone Area	Eades, A. B.	..	Unestablished Skilled Workman	Flying Officer, Royal Air Force
Nottingham Telephone Area	Rawson, L. V.	..	Skilled Workman, Class II	Lance Corporal, Royal Corps of Signals
Oxford Telephone Area	Haynes, H.	..	Skilled Workman, Class II	Warrant Officer, Class II, Royal Armoured Corps
Oxford Telephone Area	Simmons, P. W.	..	Unestablished Skilled Workman	Sergeant, Royal Artillery
Scotland West Telephone Area	Fotheringham, R.	..	Unestablished Skilled Workman	Signalman, Royal Corps of Signals
Scotland West Telephone Area	Mackay, A. H.	..	Unestablished Skilled Workman	Signalman, Royal Corps of Signals
Shrewsbury Telephone Area	Allport, P. A.	..	Unestablished Draughtsman	Sergeant Observer, Royal Air Force
Southampton Telephone Area	Harris, D. L.	..	Draughtsman, Class II	Sergeant, Liaison Regiment
Southend Telephone Area	Potts, G. H.	..	Skilled Workman, Class II	Lance Bombardier, Royal Artillery
Tunbridge Wells Telephone Area	Ellis, R. W.	..	Unestablished Skilled Workman	Driver, Royal Corps of Signals
Tunbridge Wells Telephone Area	Vincent, D. R.	..	Skilled Workman, Class II	Signalman, Royal Corps of Signals

While serving with the Civil Defence Forces or on Post Office duty

Brighton Telephone Area	Ockenden, L. A.	Skilled Workman, Class II
Post Office (London) Railway	Everett, C. W.	Skilled Workman, Class I

Recent Awards.

The Board of Editors has learnt with great pleasure of the honours recently conferred on the following members of the Engineering Department :—

While serving with the Armed Forces, including Home Guard

London Telecommunications Region	Allaway, S. D.	..	Unestablished Skilled Workman	Sergeant, Royal Corps of Signals	Military Medal
London Telecommunications Region	Taylor, W. J.	..	Skilled Workman, Class II	Chief Petty Officer, Royal Navy	British Empire Medal
London Telecommunications Region	Willis, R. H.	..	Unestablished Skilled Workman	Pilot Officer, Royal Air Force	Distinguished Flying Medal
London Telecommunications Region	Yeats, H. J.	..	Skilled Workman, Class II	Able Seaman, Royal Navy	Distinguished Service Medal

Mr. A. O. GIBBON

It is with very great regret that we record the death of Mr. Andrew O. Gibbon which occurred with tragic suddenness at Scale, Farnham, on June 19th, 1943, in his sixty-ninth year. Our regret will be shared not only by Mr. Gibbon's former colleagues in the Post Office Engineering Department whom he served so well and so long, but by many other officers in the Post Office and in other Departments of State. He gave many years of able and devoted service to the Society of Post Office Engineers and as the Society representative on Committees of the Institution of Professional Civil Servants. This work was widely known and appreciated but his buoyant and even helpful personality secured for him an even wider circle of friends.

Gibbon was interested also in educational subjects, and was a member of the Formation Committee of the I.P.O.E.E. to which he gave valuable assistance. He was sometime Assistant Editor of this JOURNAL.

In recognition of his services to the Institution he was elected Honorary Member in 1934.

The possessor of a fine voice, Gibbon was an ardent lover of music, particularly of choral music, and was for some years Chairman of the Oriana Madrigal Society and of the Whitsuntide Singers and Players founded by Gustav Holst.

Mr. Gibbon leaves a widow and three daughters, to whom our deepest sympathy is extended.—P. J. R.

NEW APPOINTMENTS

We offer our congratulations to Mr. J. H. Watkins, M.C., who succeeds Mr. Harvey Smith as Chief Regional Engineer of the Welsh and Border Counties Region. Mr. Watkins needs no introduction to his staff as he has been Regional Engineer at Shrewsbury since the inception of the Region, and was previously Assistant Superintending Engineer in the old North Wales District.

Mr. Harvey Smith, who reached the age of 60 on 30th June, has been retained at Headquarters to advise on local line plant matters.

Regional Notes

Welsh and Border Counties Region

RETIREMENT OF MR. HARVEY SMITH

The retirement of Mr. Harvey Smith from the position of Chief Regional Engineer at the end of June last was suitably recognised by a presentation from his many friends in the Region. Representative speakers paid tribute to his many excellent qualities and our regret that the time for parting had arrived.

It is understood that Mr. Harvey Smith's services are being retained by Headquarters in connection with post-war planning, with particular reference to methods of underground cable distribution—a subject upon which he is an acknowledged expert. We wish him every success in this return to familiar scenes.

J. H. W.

GROUND WATER LOWERING.

The Moretrench method of ground water lowering has been described in Vol. XXXV, part 1, April, 1942, of this JOURNAL and a similar appliance, the property of Millars Machine Co., Ltd., in Welsh and Border Counties notes, Vol. XXXV, part 3, October, 1942. On account of the difficulties associated with the hire of these appliances complete with pump and operator it was decided to make up a well-point of modified design and use a $1\frac{1}{2}$ H.P. Homelite pump to operate it.

Tests indicated that the $1\frac{1}{2}$ H.P. Homelite pump would deal adequately with one and probably two well-points; because of this it was decided to make or purchase further well-points for use with such pumps. The Engineer-in-Chief finally obtained a set of ten Moretrench well-points for use in connection with construction or maintenance works in water-logged areas. These have been tried out with Homelite pumps with satisfactory results.

Four Moretrench well-points were sunk at the corners of a rectangle 8 ft. 6 in. by 6 ft. 3 in. and these were coupled to two $1\frac{1}{2}$ H.P. Homelite pumps. The water within the rectangle was lowered to the top of the screens, which were 9 ft. below the surface of the ground in $5\frac{1}{2}$ hours, even though trouble was experienced with the pump motor. The water before the commencement of operations was 3 ft. below the surface of the ground. The combined output of the pumps varied between 3,000 gals./hr. and 4,100 gals./hr.

The main difference between the modified design of well-point and the Moretrench well-point is that the ring valve is located at the top of the composite tube instead of at the base, as in the Moretrench. This avoids the complete reversal in the direction of flow of the water after it has passed through the screen. When this modified design was compared in operation with a Moretrench both well-points passed water at the same rate. This is probably accounted for by the fact that in the former it had been found necessary in order not to pass sand to use a screen having 70 meshes to the inch, whereas in the latter a screen having only 36 meshes to the inch was used. It is concluded that the 36-mesh screen did not pass sand because it was separated from the perforated tube by means of a coarse gauze of 10 meshes to the inch. This results in a much greater area of the screen being available to pass water. In the modified design the 70-mesh screen was in direct contact with the perforated tube, the perforations occupy only 30% of the area and consequently only 30% of the screen is available to pass water. The screen in modified design is therefore subject to a much greater pressure than in the Moretrench and this is apparently sufficient to force the sand

through a screen having less than 70 meshes to the inch.

S. J. M.

North-Eastern Region

DIVERSION OF THE MANCHESTER-SHEFFIELD CABLES

An extensive and unusual cable diversion, necessitated by the construction of a large reservoir, has just been completed in the Sheffield Telephone Area of the North-Eastern Region.

The reservoir was planned to collect water from three valleys by the construction of a dam commenced in 1935 and the demolition of two villages to clear the bed of the reservoir. A length of 3,890 yds. of formerly existing road was replaced by 3,840 yds. of new road, this reduction making possible the use in the new road of the existing cables and so avoiding special manufacture.

The cutting of the road along a hillside presented a problem as to which side of the road the Post Office should select for the laying of its ducts. The Region, supported by the County Council, decided on the cutting side with its consolidated undisturbed ground; the Civil Engineers to the Water Board recommended the embanked side with its easy excavation. Consulting Engineers called in to give their advice on the issue supported the Region and their advice was accepted and the ducts laid on the cutting side.

This choice produced a further problem—the draining of the manholes at points along the road where the slope of the land and the camber of the road would result in the surface water draining into the manholes. The road itself was drained in these sections by drains too shallow to take water from the Post Office manholes. The consulting civil engineer's recommendation was the provision of drain pipes from the duct outside the manholes across the road to the embankment sloping down to the reservoir. Several of the manholes have been so provided. The adequate draining of the Post Office duct was necessary not only for the safety of the Post Office plant, but also to prevent erosion of the foundations of the road by water conducted along the Post Office duct to weak places in the road, where the force and volume of water draining off the very steep hillsides might otherwise cause serious damage to the main trunk road, for which the Post Office would be held responsible.

The cost of the excavation was reduced where possible by laying the duct with only 9 in. cover in the narrow grass margin, in order to avoid rock. This could safely be done, as there is no prospect of the road being widened at any time.

When the ductwork was ready, an interruption cable PCQL 200/20 was drawn into the duct and jointed. The working circuits in the Manchester-Sheffield No. 2 cable were transferred to the interruption cable by simultaneous jointing operations at both junctions of the new and old roads. The length of 3,840 yards of the MR-SF No. 2 cable was drawn out in sections of about 170 yards, drawn in and jointed in the track of the new road. The cabling operations required careful planning, as the excess cable allowed only 3 yards jointing allowance per section length. The working circuits were then transferred back to the permanent cable and the interruption cable was then set free for use in the transfer of the No. 1 cable to the new road by a repetition of the process described. The two cables had been laid in 1925 and 1938 respectively and they were withdrawn intact by careful handling, using a motor winch. No new cabling stores, except subsidiary

items, were required, and the three loading coil pots on the two cables were transferred to the new loading manholes. The interruption cable was not loaded. Each joint on both cables was scheduled carefully and restored precisely as it had been. No rebalancing was necessary and only overall tests on the whole length were taken at the finish, which showed the electrical condition of the cables to be satisfactory.

In addition to the diversion of the M.U. route there were also the diversion of local overhead and underground plant and the recovery of part of the former Manchester-Sheffield overhead trunk route—an H pole line built many years ago. These works required co-operation with the Water Board's contractors and engineers, but presented no problems of unusual interest.

The Post Office contractors for the duct work and manholes were Messrs. Moulson of Bradford and the cabling and jointing work was done by the engineering staff of the Sheffield Area. The whole work was completed in less than the scheduled time required by the Water Board, and a saving on the estimated cost of the work was effected.

R. H. H.

North-Western Region

The article on air raid damage to overhead plant in Volume 36, Part 2, brings to mind a case in this area which may now be mentioned and should prove of interest to telecommunication engineers.

As is indicated in the article, barrage balloons sometimes come adrift and in one case in the Liverpool Area the trailing cable of a drifting balloon fouled at the same time a H.T. supply line and an adjacent Post Office telephone route.

The Post Office open route, an old trunk line, was connected to underground wires at various D.P.'s in three adjacent exchange areas and the discharge currents from the power line caused as many as a dozen underground faults over a wide area, the nearest to the scene of the incident being the adjacent P.O. underground power crossing and the most distant a junction cable some four miles away; in some cases the whole cable was fused and in others odd wires fused and the cable sheath punctured.

Home Counties Region

EXPERIENCES WITH THE DEKALIN SPRAY CLEANING APPARATUS

Damage to two exchanges has been experienced during the past few months, one a uniselector and the other a line finder type of exchange. Damage in the first exchange was limited to the effect of dust, whereas in the other considerable damage was also done to switches and cabling.

The dekalin spray outfits were ordered and promptly delivered and were put into use as soon as the exchanges had been made reasonably clean. At the uniselector exchange it was unfortunate that the fire risk when using dekalin was over-emphasised, perhaps due to

the rather frightening notice which accompanies the plant, since this led to an attempt to clean the banks with the equipment rendered inoperative by removal of the fuses. This was not a success, a deposit being left on the bank. The fuses were then replaced and carbon tetrachloride substituted for dekalin. Very satisfactory results were then obtained and 3,600 uniselectors were restored to use in 12 hours using a single spray. It was possible to restore unrestricted service 16 hours after the damage had occurred, although restricted service had to be reintroduced during the busy period while faulty switches were cleaned and overhauled. It was not appreciated locally that any danger to health might result from the use of carbon tetrachloride, but fortunately no one suffered. The switches responded very well to spray cleaning, though it was found desirable to remove them from the banks for cleaning and overhaul.

At the line finder exchange the automatic plant was completely out of service due to damage to common equipment wiring as well as to the effect of dirt and a considerable amount of preliminary work had to be done before the spray outfit was brought into use. When spraying was commenced first reactions were favourable, but as the liquid dried off, faults reappeared which affected various outlets and caused repeated dropping out of switches in the middle of impulse trains. This was proved to be due to poor wiper to bank connections, although the banks appeared to be fairly clean. The faults were put down to the fact that further dust can collect on the banks during the rather long time the dekalin takes to dry off. The banks were cleaned again and finally the trouble was removed by a thorough clean of the banks, using the standard bank contact cleaner. Subscribers were receiving service, if not a very good service, while this cleaning was in progress.

There were some unusual features regarding the way in which the damage was caused by the bomb in this exchange which may have a bearing on the apparent only partial success of the dekalin. The bomb or mine must have been very large and exploded on the roof of an outbuilding only 30 or 40 ft. from the automatic switchroom windows and the dust, which was pulverised bricks and glass, was driven in a downwards direction into the banks as distinct from settling afterwards; also it is quite possible that the gases from the explosion would affect the equipment at this short range and it may have been corrosion products which defied the spray. Doors having been blown off, it was very difficult to seal the apparatus room effectively to stop further dirt getting in and the removal of the debris and dust inside the exchange was a very real problem. There is no doubt, however, that as a means of cleaning filth out of inaccessible places, such as switch banks, the spray is very useful and the fact that it is necessary under certain circumstances to give further cleaning afterwards does not detract from this usefulness.

Staff Changes.

Promotions

Name	Region	Date	Name	Region	Date
<u>Regl. Engr. to C.R.E.</u>			<u>S.W.1 to Insp.</u>		
Watkins, J. H.	.. W. & B.C.Reg...	1.7.43	Dearing, J. E.	.. Cable Test Section ..	7.4.43
<u>Asst. Engr. to Exec. Engr.</u>			Franklin, L. E.	.. Test Section (L'pool) to Cable Test Section ..	3.7.43
Jago, W. B.	.. E.-in-C.O. ..	5.7.43	Allum, F. H.	.. Radio Stn. ..	31.3.43
Wright, C...	.. N. Ire. Reg. ..	14.7.43	Pavey, F. Radio Stn. ..	3.8.42
<u>Chief Insp. to Asst. Engr.</u>			Healey, J. A.	.. Radio Stn. ..	15.3.43
Thomas, H. C.	.. E.-in-C.O. ..	2.6.43	Johnston, M.	.. Radio Stn. ..	30.8.43
Padgham, F. V.	.. E.-in-C.O. ..	23.7.43	Imray, T. D.	.. Radio Stn. ..	6.9.43
Moody, W. R. N.	.. E.-in-C.O. ..	30.7.43	Parker, W. R.	.. Radio Stn. ..	6.9.43
<u>Chief Insp. to Chief Insp. with Allce.</u>			Foster, H. W.	.. Radio Stn. ..	16.11.42
Sharp, J. L.T.R. ..	5.5.43	Campbell, A.	.. Radio Stn. ..	28.8.43
Diggle, A. N.E. Reg. ..	25.7.43	Miles, B. T. W.	.. Radio Stn. ..	22.2.43
<u>Insp. to Chief Insp.</u>			Sharp, H. S.	.. Radio Stn. ..	9.11.42
Humphreys, L. W...	E.-in-C.O. ..	18.4.43	MacQueen, R. S.	.. Radio Stn. ..	22.2.43
Choldcroft, E. W. ...	E.-in-C.O. ..	18.8.43	Ridgway, H.	.. Radio Stn. ..	8.2.43
			Cross, H. Radio Stn. ..	6.9.43
			Hope, S.* Radio Stn. ..	1.3.43
			Tuppier, F. J.	.. Radio Stn. ..	1.3.43
			Durman, M. R.	.. Radio Stn. ..	5.4.43

* Promoted in absentia. All promotions "acting."

Retirements

Name	Region	Date	Name	Region	Date
<u>Asst. Engr.</u>			<u>Insp.</u>		
Beaumont, G. W.	.. H.C. Reg. ..	20.7.43	McLeod, T. N.W. Reg. ..	13.6.43
<u>Chief Insp.</u>			Pratt, C. R...	.. Cable Test Section ..	2.7.43
Jones, H. L.T.R. ..	28.6.43	Plummer, E. S.	.. S.W. Reg. ..	4.7.43
Blewden, S. A.	.. S.W. Reg. ..	31.7.43	Annible, E. E.-in-C.O. ..	31.7.43
			<u>Second Officer</u>		
			Ramshaw, A.	.. H.M.C.S. ..	28.8.43

Transfers

Name	Region	Date	Name	Region	Date
<u>Regl. Engr.</u>			<u>Chief Insp.</u>		
Hodge, G. W.	.. N. Ire. Reg. to W. & B.C. Reg. ..	18.7.43	Lettsome, E. W.	.. N.W. Reg. to Mid. Reg.	1.6.43
<u>Exec. Engr.</u>			Hale, C. S. N.W. Reg. to S.W. Reg.	22.8.43
Charles, F. N.	.. H.C. Reg. to N.E. Reg.	1.7.43	<u>Insp.</u>		
<u>Asst. Engr.</u>			Everett, A. A. F.	.. E.-in C.O. to Cable Test Section ..	26.7.43
Swain, E. C.	.. Scot. Reg. to E.-in-C.O.	1.6.43	Snow, H. F.	.. Cable Test Section to E.-in-C.O. ..	26.7.43
Naylor, S. E.	.. E.-in-C.O. to H.C. Reg.	25.7.43			
Shearing, M. R.	.. E.-in-C.O. to H.C. Reg.	16.8.43			

CLERICAL GRADES

Promotions

Name	Region	Date
<u>S.O. to P.C.</u>		
Hamilton, C. J.	.. E.-in-C.O. ..	6.7.43

Book Reviews

"Applied Mechanics." A. Morley, O.B.E., D.Sc., M.I.Mech.E. 360 pp. 162 illustrations. Longmans, Green & Co. 7s. 6d.

Dr. Morley has added another textbook to his already impressive list of works dealing with mechanics and allied subjects. The book under review is intended as a third year textbook covering the syllabus of the Ordinary Grade National Certificate in Mechanical Engineering. It follows the author's earlier works, written in conjunction with Dr. Hughes, entitled "Elementary Engineering Science" and "Mechanical Engineering Science," which form the first and second year groundwork.

The ground covered includes statics, dynamics, hydro-statics, hydraulics, materials and structures, the main principles of which are clearly enunciated.

The book can be thoroughly recommended to ordinary National Certificate and Inter-B.Sc.(Eng.) students.—H. L.

"Calculation and Design of Electrical Apparatus."

W. Wilson, D.Sc., B.E., M.I.E.E., M.Amer.I.F.E. 240 pp. Published by Chapman & Hall, Ltd.

This book by W. Wilson, now in its third edition, deals broadly with the principles of design of electrical power apparatus, with the exception of rotating electrical machines and transformers, which are already catered for very thoroughly in a number of text books and have therefore purposely been excluded.

The first chapter is devoted to fundamental principles, including D.C. and A.C. theory, resistivities of solid and liquid conductors and temperature co-efficients, following which, each chapter deals in a specialised way with such matters as rheostats, mechanical forces due to electric currents, electro-magnets, calculations of windings and solenoids, heavy busbars, insulating

materials and practice, condensers, chokes and corona effects.

The chapters on temperature rise in conductors under continuous and short time ratings and on the calculation of short-circuit capacities and circuit-breaker performance are especially valuable and cover the subject in a very comprehensive manner.

The most striking feature of the book is the wealth of data in the form of tables and curves giving information such as emissivities of surfaces, skin co-efficients and proximity co-efficients for conductors and so on, which should prove most useful both for students and designers and much of which it would ordinarily be impossible to obtain without laborious searching.

The inclusion of a large number of worked-out examples inserted at appropriate points throughout the text is an admirable feature and has enabled the explanatory matter to be made more concise. In addition, answers are provided for the examples appended to each chapter, a large number of them being taken from I.E.E. and other examination papers of similar standing.

The diagrams and tables are well arranged in relation to the text and the irritation of having to refer to other pages is almost entirely avoided. It would have been an improvement from a student's point of view if more diagrams had been introduced to augment the descriptions of certain types of apparatus, particularly in the chapters dealing with oil switches and electro-magnets.

Throughout the book a careful balance has been maintained between purely theoretical and practical considerations and, apart from being invaluable for reference, it should make interesting and stimulating reading for all concerned with electrical matters.

G. M. M.

BOARD OF EDITORS

A. J. GILL, B.Sc., M.I.E.E., F.I.R.E., Chairman.
F. E. NANCARROW, A.R.C.Sc., M.I.E.E.
P. B. FROST, B.Sc., M.I.E.E.
A. H. MUMFORD, B.Sc.(ENG.), M.I.E.E.
C. W. BROWN, A.M.I.E.E.
G. H. S. COOPER.
H. LEIGH, B.Sc.(ENG.), A.M.I.E.E., Acting Managing Editor.
G. E. STYLES, A.M.I.E.E., Acting Assistant Editor.
A. J. BAKER, Secretary-Treasurer.

Copyright

The entire contents of this JOURNAL are covered by general copyright, and special permission is necessary for reprinting long extracts, but Editors are welcome to use not more than one-third of any article, provided credit is given at the beginning or end thus: "From the *Post Office Electrical Engineers' Journal*."

The Board of Editors is not responsible for the statements made or the opinions expressed in any of the articles in this JOURNAL, unless such statement is made specifically by the Board.

Communications

All Communications should be addressed to the Managing Editor, *P.O.E.E. Journal*, Engineer-in-Chief's Office, Alder House, Aldersgate Street, London, E.C.1. Telephone: HEADquarters 1234. Remittances should be made payable to "*The P.O.E.E. Journal*" and should be crossed "& Co."

Binding Cases

Cases for binding are available, and may be obtained from the Local Agents for 1s. 9d. Subscribers can have their copies of Volumes bound, at a cost of 3s., by sending the complete set of parts to the Local Agents or to the *P.O.E.E. Journal*, Engineer-in-Chief's Office, Alder House, Aldersgate Street, London, E.C.1. Orders for binding for Vols. 1-19 should indicate whether the original binding case with black lettering, or the later pattern with gold, is required. Cases with gold lettering are the only type stocked from Vol. 20 onwards.

Back Numbers

The price of the JOURNAL, which is published quarterly, is 1s. (1s. 3d. post free) per copy, or 5s. per annum post free. Back numbers can be supplied, subject to availability of stocks, at 1s. each (1s. 3d. post free). Orders for back numbers may be sent to the Local Agents or to the Publishers.

Advertisements

All communications relating to space reservations should be addressed to the Advertisement Editor, *P.O.E.E. Journal*, Alder House, Aldersgate Street, London, E.C.1. Communications regarding advertisement copy, proofs, etc., should be addressed to the Publishers, Messrs. Birch & Whittington (Prop. Dorling & Co. [Epsom], Ltd.), 49 Upper High Street, Epsom, Surrey.



THE demand for "AVO" Electrical Testing Instruments for H.M. Forces is now such that we regret we can no longer accept orders for ordinary Trade or private purposes. Orders already accepted will be despatched as soon as possible.

Orders from Government Contractors or Essential Works can be accepted, but they must bear a Contract Number and Priority Rating, and even these orders will necessarily be subject to delayed delivery.

We take this opportunity of expressing to the Electrical and Radio Trades our appreciation of their co-operation and patience during the considerable and unavoidable delays that have occurred in executing their orders. We feel confident that our customers will appreciate that we, in common with other manufacturers, are prompted by the universal desire to assist towards a speedy and satisfactory termination of hostilities.

THE AUTOMATIC COIL WINDER & ELECTRICAL EQUIPMENT CO. LTD.
WINDER HOUSE, DOUGLAS ST, LONDON. S.W.1. Phone-VICTORIA 3404-7

A Standard of Zero Loss Angle

VARIABLE AIR CONDENSER TYPE D-14-A

This three-terminal double-screened condenser is provided with a guard circuit which ensures that the dielectric of the plate-to-plate capacitance is composed entirely of air. This, together with the special surface treatment of the plates reduces the plate-to-plate power loss to a quantity which can be disregarded even when measuring the smallest power factors.

MUIRHEAD

BRIEF SPECIFICATION

CAPACITANCE. 50 μ F min. 1,250 μ F max.
LOSS ANGLE. Approximately 1 micro-radian in a dry atmosphere: 7 micro-radians in 75% relative humidity, for the frequency range 50 c.p.s. to 10,000 c.p.s.
DRIVE. Worm reduction gear, 50 : 1 ratio.
SCALE READING. To 1 part in 5,000 direct reading; To 1 part in 20,000 by interpolation.
BACKLASH. Not exceeding 1 part in 20,000.
DIMENSIONS. 12 $\frac{1}{2}$ x 10 x 13 $\frac{1}{2}$.

Write for Bulletin B-537-A giving further particulars.

MUIRHEAD AND COMPANY LIMITED, ELMERS END,
BECKENHAM, KENT. TELEPHONE: BECKENHAM 0041-0042

FOR OVER 60 YEARS DESIGNERS AND MAKERS OF PRECISION INSTRUMENTS

*Clip-on***FOR EASY CURRENT MEASUREMENTS**

in Busbars, Fuses and Cables up to 2½" diam.

- DUAL RANGE WITH SELECTOR SWITCH
- FULLY INSULATED CORE AND HANDLE

FERRANTI
DUAL RANGE
Clip-on **AMMETER**

**QUICK
CHANGE
TO NEW
RANGE**

RANGES

0—10—50 Amps.
0—20—100 Amps.
0—50—250 Amps.
0—100—500 Amps.
0—200—1000 Amps.

FERRANTI LIMITED, Hollinwood, Lancs.

London Office : Bush House, Aldwych, London, W.C.2

TURNER DIFFERENTIAL MILLIAMMETERS G.P.O. No. 17 & No. 18

Meet the most exacting demands for balancing currents in multiplex telegraph circuits.

—A quality product of outstanding merit—

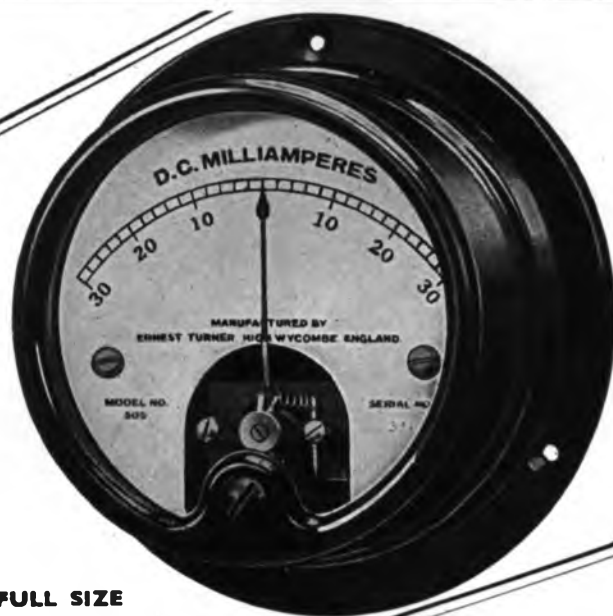

FULL SIZE

Also manufacturers of G.P.O. Detector No. 4, and a comprehensive line of instruments for precision electrical measurements.

ERNEST TURNER ELECTRICAL INSTRUMENTS, Ltd.

**CHILTERN WORKS,
49-73 TOTTERIDGE AVENUE,
HIGH WYCOMBE,
BUCKS, ENGLAND**

Telephone : High Wycombe 1301, 1302.
Telegrams : Gorgoous High Wycombe.



MODERN TELEPHONE APPARATUS

by

Ericsson

The War has not been allowed to interfere with Ericsson quality . . . our telephone apparatus remains at that peerless efficiency that ensures trouble-free service. ERICSSON TELEPHONES LIMITED, 56, KINGSWAY, LONDON, W.C.2. (Tel.: HOLborn 6936.)

Electrical Standards for Research and Industry

Testing and Measuring Apparatus
for Communication Engineering

BRIDGES — Capacitance
Inductance
Resistance

RESISTANCES

INDUCTANCES

CONDENSERS

OSCILLATORS

WAVEMETERS

H. W. SULLIVAN
— LIMITED —

ALL TYPES — ALL FREQUENCIES — ALL ACCURACIES

London, S.E.15

Tel. New Cross 3225 (Private Branch Exchange)

Hall Telephone Accessories (1928) Limited

Suppliers to the British Post Office, Air Ministry,
Admiralty, War Office and Foreign Government
Departments.

Manufacturers of prepayment telephone
multi-coin collectors, gas leak
indicators, precision instruments,
automatic stamp selling and ticket
selling machines, automatic slot
machines and fire alarm apparatus.

Registered Office:

**70, DUDDEN HILL LANE, WILLESDEN,
LONDON, N.W. 10**

Tel. WILLESDEN 5141/2/3.

Also SOUTH WALES

LONDEX REMOTE FLOW INDICATOR

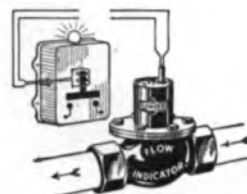

If Flow ceases :

- (1) Motor or other circuit tripped automatically.
- (2) Alarm lamp illuminated or alternatively extinguished.

Ask for leaflet 102/PO.

FLOATLESS LIQUID LEVEL CONTROL

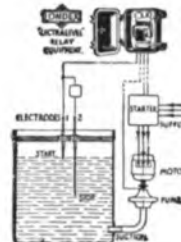

for

- Pumps
- Valves
- Signalling
- Recording
- Drainage
- Storage

"LECTRALEVEL" SYSTEM

Ask for leaflet 94/PO

RELAYS

G.P.O. approved types.
Ask for leaflet SPN/PO

LONDEX LTD

Electrical Remote Control,
Engineers & Manufacturers.
Anerley Wks, 207 Anerley Rd, London, S.E.20
Phone: SYDENHAM 6258-9

SIEMENS PRODUCTS

backed by over 80 years' Electrical Experience

Contractors for
the manufacture, laying and maintenance of Submarine and Land Cables for Telegraphy, Telephony and the Electric Transmission of Power, for the erection and maintenance of Overland Telegraph, Telephone and Power Transmission Lines, Marine Wireless Telegraph and Telephone Installations, Public and Private Telephone Exchanges and Carrier Equipment for Telephone Lines.

Manufacturers of

Electric Lamps of all types for Domestic, Industrial and Street Lighting, including "Sieray" Electric Discharge Lamps, Fluorescent Tubes, Motor Car Lamps, Projectors, etc.



**ELECTRIC
WIRES & CABLES**

**CABLE
JOINT BOXES**

TELEPHONE CABLES
Aerial, Underground, Submarine

**OVERHEAD
LINE MATERIAL**

CELLS & BATTERIES
Dry, Fluid & Inert

**ELECTRICAL
MARINE APPARATUS**

**ELECTRIC
LAMPS**

**PRIVATE
TELEPHONE SYSTEMS**

**PUBLIC
TELEPHONE EXCHANGES**

**CARRIER-CURRENT
EQUIPMENT**

**WIRELESS EQUIPMENT
FOR SHIPS**

"ZED" FUSES
L.T. SWITCH & FUSE GEAR

SIEMENS BROTHERS & CO., LTD.
WOOLWICH, LONDON, S.E. 18

SIEMENS ELECTRIC LAMPS & SUPPLIES LTD., 38-39 UPPER THAMES STREET, LONDON, E.C. 4

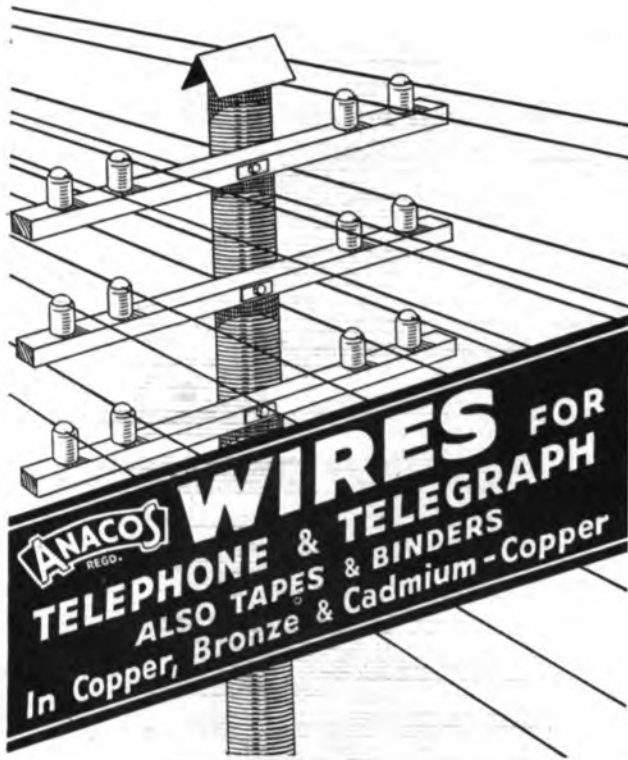

FREDERICK SMITH & CO. LTD. (Incorporated in The London Electric Wire Company and Smiths, Limited.)
ANACONDA WORKS, SALFORD, 3, LANCs.
 Telephone : BLACKFRIARS 8701 (8 lines) Telegrams : 'ANACONDA' MANCHESTER

BASICALLY BETTER..

FROM THE COMPLETE RANGE MAY BE QUOTED.	
Char Imped. ohms	75Ω 43 24
Capacity mmF/ft	70 714
Attenuation dB/100 ft	16.3 5.2
Dielectric constant	0.21 1.27 1.25

Air Insulation...
 is the basic principle of
CO-AX LOW LOSS CABLES
Unequaled
H. F. PROPERTIES
There is a CO-AX Cable for all H.F. purposes.

TRANSRADIO LTD. Inc TELEQUIPMENT CO. 16 HIGHWAY-BEACONSFIELD

ELECTRIC VEHICLE



BATTERY CHARGING

Group of Metrovick electrics for Postal Services (published by courtesy of H.M. Postmaster-General) and Westinghouse vehicle charger type VR.30/45 with MJV battery charge timing relay.



Thousands of Westinghouse Metal Rectifiers are in use by the G.P.O. in telephony and telegraphy. Now their reliability and efficiency is being made use of by the Postal Services to provide a convenient and economical delivery service.

WESTINGHOUSE BRAKE & SIGNAL CO., LTD., PEW HILL HOUSE. CHIPPENHAM. WILT.

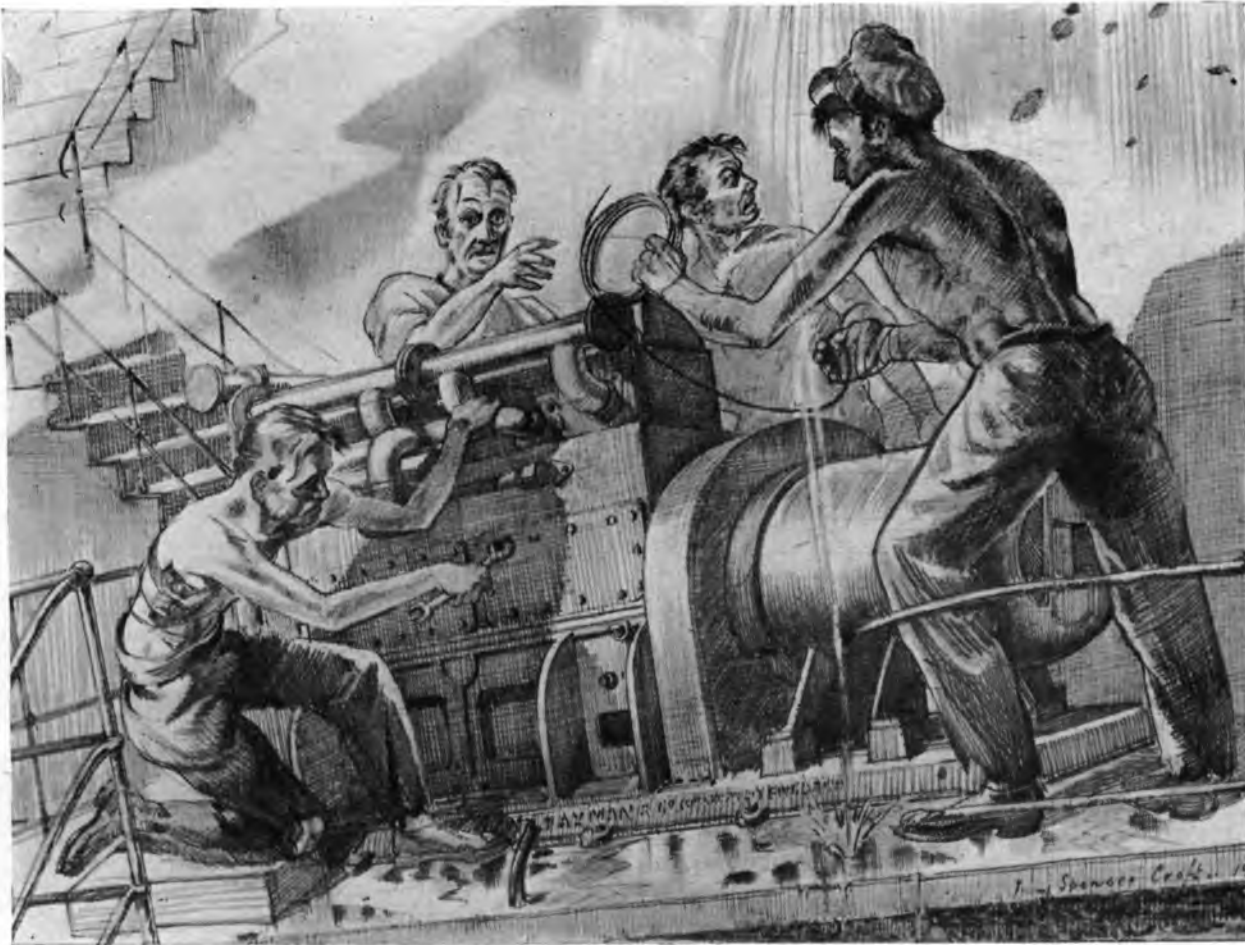

M.V. "San Demetrio"—heroically salvaged November, 1940.

Shells from a German battleship turned the British tanker "San Demetrio" into a blazing torch. Abandoned by her crew, she drifted into the path of one boat 36 hours later, still burning furiously. She might have exploded at any moment, but her cargo was precious, so these heroic few, some injured, reboarded her. They determined to bring her to port. But the will alone was not enough . . . they had to extinguish the fire, plug the decks and reassemble the generator to start her engines. Devoid of navigational instruments, "by guess and by God," the "San Demetrio" sailed home.

This announcement is a tribute to the bravery of these and many other gallant souls whose stories of battling against adversity with inadequate equipment will never be told.



The Will alone is not enough—

Need is ever the yardstick of values. To destroy Hitlerism and Fascism free men need guns, aeroplanes and tanks—to the production of which their utmost energies are now devoted. But will victory over the Axis powers bring peace? Assuredly not, while evils which nurtured aggression remain in the world. To banish them the will alone is not enough. Another and greater war must be fought—the war to secure President Roosevelt's "four freedoms," which include "freedom from want." In this other war, when the constructive—moral and material—will supersede the destructive, telecommunications will play a vital part. Telephone Carrier and Radio equipment will be urgently needed to convey speedily the plans for the remoulding of both mind and matter.

Those concerned with telecommunication problems in national reorganisation should consult—



Automatic Telephone & Electric Co. Ltd.

L O N D O N & L I V E R P O O L

Manufacturers of · Strowger Automatic Telephone Equipment · Carrier Current and Transmission Equipment · Street Traffic Signals · Street Fire Alarm Apparatus · Supervisory Remote Control Equipment for Power Networks · Mine Telephones and Signalling Apparatus, etc



*manufacturers
of High Grade
telephone
communication
equipment . . .*

G.E.C.

TELEPHONE • WORKS
THE GENERAL ELECTRIC CO., LTD.,
Head Office • MAGNET HOUSE • KINGSWAY • LONDON • W.C.2.



SILVERED MICA CONDENSERS

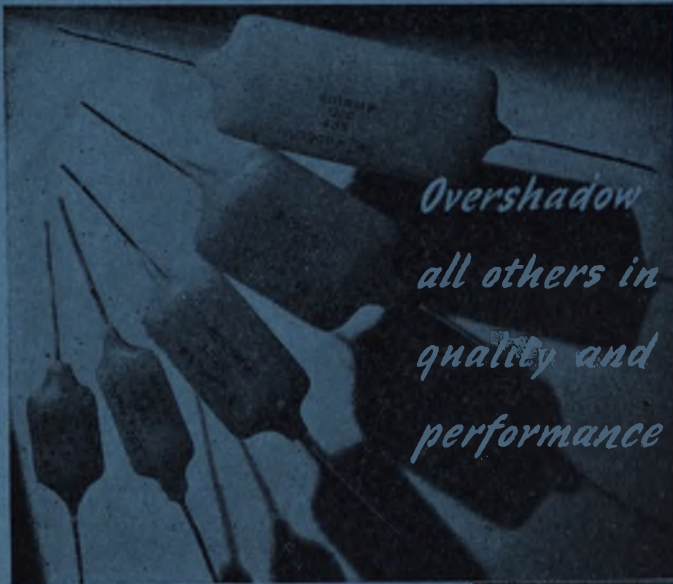

*Overshadow
all others in
quality and
performance*

Incessant progress in methods of manufacture and research linked with the most thorough mechanical and electrical inspection, are reasons for the outstanding superiority of U.I.C. Silvered Mica Condensers. Available in all standardized sizes. Suitable for tropical and arctic conditions. Type approved.

UNITED INSULATOR CO. LTD

12-22, LAVSTALL STREET, LONDON, E.C.1

Tel: TERminus 7383 (5 lines)
Grams: Calanel. Smith, London

THE PIONEERS OF LOW LOSS CERAMICS

★
TELEGRAPH APPARATUS
for
MORSE SYSTEMS

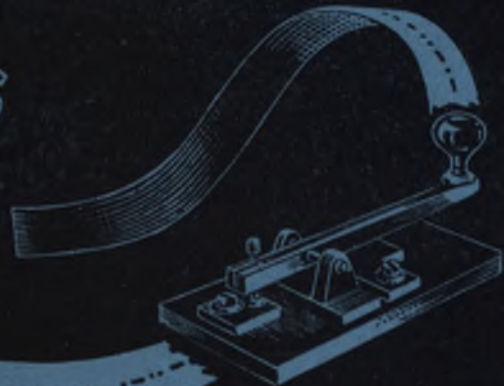

Write for illustrated catalogue

Makers of:

GALVANOSCOPES · INKERS
RESISTANCES · RELAYS
SOUNDERS · DETECTORS
KEYS · MILLIAMMETERS
AUTOMATIC RECEIVERS
& TRANSMITTERS ETC

ELLIOTT BROTHERS (LONDON) LTD. CENTURY WORKS,
LEWISHAM, S.E.13

MAINTAINING EFFICIENCY

THE HIGH STANDARD OF EFFICIENCY
OF PIRELLI - GENERAL TELEPHONE
CABLES IS MAINTAINED BY THE
CONTINUOUS RESEARCH WORK OF
AN EXPERIENCED TECHNICAL STAFF.

TELEPHONE
SOUTHAMPTON
2141 (5 lines)

PIRELLI-GENERAL
CABLE WORKS, Ltd., SOUTHAMPTON.

TELEGRAMS
"PIRELLI-KAYBEL"
SOUTHAMPTON."

60/40
45/55

WHAT'S THE DIFFERENCE ANYWAY?

Government reduction of tin content of alloys often means the increase of soldering temperatures if satisfactory soldering processes are to be achieved. But what increases are necessary? How will the components be affected by increased heat? These and other technical queries are answered in "Technical Notes on Soldering," issued by the manufacturers of Ersin Multicore the A.I.D. and G.P.O. approved three core Solder Wire. Firms engaged on government contracts are invited to write for a copy of this reference sheet and samples of Ersin Multicore Solder Wire.



ERSIN MULTICORE

THE SOLDER WIRE WITH 3-CORES OF NON-CORROSIVE ERSIN FLUX

MULTICORE SOLDERS LIMITED, BUSH HOUSE, W.C.2. 'Phone Temp.Bar5583/4