

CONTENTS

Vol. XIX. No. 76. MODERN WIRELESS APRIL, 1933.

	Page		Page
Editorial	295	On the Test Bench	355
Measuring Studio Echo	296	Trouble Tracking	357
Guarding Against Interference	298	Underground Wireless on Top of the World!	358
The O.P.P. Radiogram	299	Questions Answered	361
Practical Suggestions for Practical Men	308	Round the Turntable	362
Those H.F. Chokes	309	Spotlights on the Programmes	363
Faults I Have Found	333	In Passing	365
The "Three-Range" Two	335	The B.B.C.'s New Organ	368
My Broadcasting Diary	341	Improving the Family Set	369
Special Section:		At Your Service	372
HOW TO OBTAIN BETTER RADIO	343	Recent Record Releases	374
" M.W." Tests the H.M.V. Superhet		Testing Tips	376
Radiogram Seven	346	A Short-Wave Aerial	378
Presenting the Programmes	347	Keeping H.F. in Its Place	379
On the Short Waves	351	Notes and News of the Month	380
For the Constructor	354		

SPECIAL SECTION, "THE WORLD'S PROGRAMMES," PAGES 311-332
(See page 311 for Contents).

As some of the arrangements and specialties described in this Journal may be the subject of Letters Patent the amateur and trader would be well advised to obtain permission of the patentees to use the patents before doing so.

Edited by NORMAN EDWARDS
 Technical Editor: G. V. DOWDING, Associate I.E.E.
 Radio Consultant-in-Chief: Capt. P. P. ECKERSLEY, M.I.E.E.
 Scientific Advisor: J. H. T. ROBERTS, D.Sc., F.Inst.P.

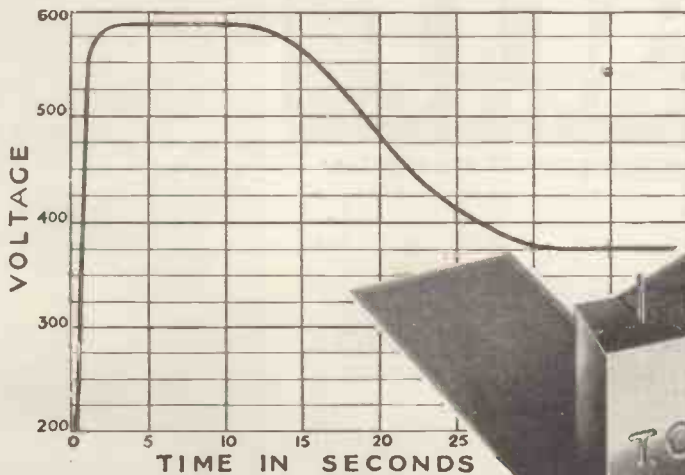

The above graph, an actual example, shows what happens when an A.C. Set is switched on—an immediate rise to 595 volts, then 30 seconds before normal conditions are reached. For half a minute smoothing condensers are subjected to this overload! Again to the fore in condenser practice, T.C.C. have produced a new condenser—the type 87—definitely built to withstand these dangerous surges—up to 650 volts. Play for safety! Ask for the surge voltage figure of your condensers, be sure they are T.C.C.—the condensers in the green case.

Capacity Mfds.	Dimensions			Price s. d.
	Height	Width	Thickness	
0.1	1 1/2"	1 1/2"	8"	2 2
0.25	2 1/2"	1 1/2"	8"	2 4
0.5	2 1/2"	1 1/2"	8"	2 6
1.0	2 1/2"	2"	12"	3 0 0
2.0	2 1/2"	2"	12"	4 7
4.0	2 1/2"	2"	22"	7 3

YOUR CONDENSERS MUST STAND UP TO THESE HIGH SURGE VOLTAGES



THE TYPE 87
 Tested to 1,500 v. D.C. Normal working voltage 450. To withstand surges of 650 volts.

T.C.C.

TYPE 87
 ALL-BRITISH
 CONDENSERS

THE TELEGRAPH CONDENSER CO. LTD., WALES FARM ROAD, N. ACTON, LONDON, W.3

© 2536



Graham Farish

says:

My NEW OHMITES
are **PILLARS OF STRENGTH**

Reliability, safety, consistency, accuracy characterise my NEW OHMITES. Put them in your set, and whatever else may go wrong, depend upon it, you will find the OHMITES standing up to their job—veritable pillars of strength, dependable to a degree. That's why the Technical Editor of "MODERN WIRELESS" so frequently specifies them.

The "Q.P.P." Radiogram requires Ohmites as follows:

- 1 100,000 ohm. 1 25,000 ohm.
- 1 2 megohm. 1 50,000 ohm.

The "THREE-RANGE" TWO requires Ohmites as follows:

- 1 2 meg.

1'6

Graham Farish
OHMITE
RESISTANCES

SAFE MAXIMUM CURRENT CARRYING CAPACITY OF "OHMITES."
100° F. Temperature rise.

Ohms	Milliamps	Ohms	Milliamps	Ohms	Milliamps
1,000	40	5,000	20.25	40,000	6
2,000	35	10,000	12	50,000	5.5
3,000	29	20,000	8	60,000	5
4,000	24	30,000	6.75	80,000	4.24
				100,000	3.5

Heavy Duty type approximately double the above ratings. Price 2/3.
Every wireless enthusiast should have a copy of the Graham Farish "Component Book" and also a free copy of the "Instant Station Tuning Chart." Send a Postcard request for these by return.

BETTER THAN WIRE WOUND

A very carefully constructed instrument, compact in size and efficient in design, with accurately gauged bakelite dielectrics and solid brass pigtail connection to moving vanes. Made in all capacities up to .0005-mfd. in Tuning, Reaction and Differential types. Used by many leading manufacturers and specified in sets by famous designers. One-hole fixing; supplied complete with terminals.

2!

The "Q.P.P." Radiogram requires 1 .0003-mfd. Differential reaction.
The "Three-Range" Two requires 1 .0003-mfd. Differential.

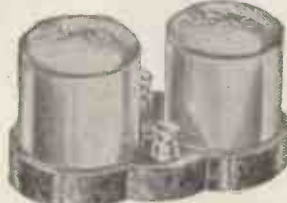
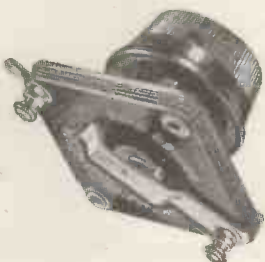

L.M.S. H.F. CHOKE.

The L.M.S. is silk wound and has a consistent high inductance on all wave-lengths, whilst its capacity is negligible. Particularly suitable for H.F. Circuit where high efficiency is the first consideration.

4'6

GRAHAM FARISH COMPONENTS

GRAHAM FARISH, LTD., MASON'S HILL, BROMLEY, KENT.
Export Office: 11/12, Fenchurch Street, E.C.3.

Modern Wireless

Vol. XIX. No. 76.

BRITAIN'S LEADING RADIO MAGAZINE

APRIL, 1933

A Q.P.P. Radiogram—Three-band Reception—B.B.C. Holiday Talks

DESPITE the burst of unprecedented Spring weather which we have been enjoying lately, interest in home construction seems to show no signs of flagging, and the recent revival of interest in Quiescent Push-Pull circuits is an indication of the great hold radio as a hobby still exercises over hundreds of thousands of amateurs.

It is pretty certain that the "Q.P.P. Radiogram" in this issue of MODERN WIRELESS will arouse so much interest that not even a miniature heat-wave will put off constructors. Anyway, there always was a bit of a fallacy in the saying that radio is a seasonal hobby, and we rather feel it would be a safe bet to say that, for example, the new Westector cold valve will be figuring in hundreds and thousands of sets built during the next three or four months, despite so-called summer time.

Extremely Economical in Upkeep

BUT, to revert to the "Q.P.P. Radiogram," readers will notice that this is really an up-to-date battery radiogramophone employing quiescent push-pull pentode valves. It is an exceptionally economical set as regards running costs, and gives maximum power with a minimum of H.T. consumption.

A good deal has been said about Q.P.P., but not enough stress has been laid on the fact that it is one of the most economical, if not the most economical, method of radio reception to-day—at least, as regards the output stage.

The "Three-Range" Two is another interesting receiver—simple but ingenious. It is a three-band set which covers all the important wavelengths between 20 and 2,000 metres. We recommend it as an excellent set for the man who likes to pick his programmes from the corners of the earth. A particularly interesting method of waveband change-over is employed, thus reducing the need of switching to a very low minimum.

A Forthcoming Talks Series

THE B.B.C. announce that, following the usual practice, there will be fewer talks in the summer programmes. What talks are arranged will be lighter in character than those we are accustomed to listen to in the winter.

One interesting new series has been arranged for the coming session, April–June, and will deal with holidays. Various talkers will give descriptions of unusual and enterprising holidays which they have undertaken. They will emphasise the joy of getting a holiday which has a spice of adventure in it without, perhaps, too much risk—and, of course, without too much expense.

"Got to Sound Convincing"

WE hope these talks will live up to the advance publicity which has been given to them. Holiday advertisements, as a rule, are rather stereotyped, advising you to go to so-and-so watering place. They tell you there is a good pier (the usual collection of slot machines), good bathing facilities (a pebbly beach and no sand), and give the usual platitudinous descriptive matter more worthy of a railway time-table than a serious piece of propaganda designed to enhance one's interest in how to spend a holiday.

There is no doubt the B.B.C. can do a lot of good with these talks if they bear in mind that they have got to sound convincing and that the speakers ought to give practical details, whenever possible, as regards what it is going to cost the listener who decides to take the broadcaster's advice and try an unusual type of holiday.

Vernon Bartlett on Foreign Affairs

WE don't suppose many readers of MODERN WIRELESS will be interested in the series, "The International Housewife," but, anyway, it is fixed for the summer session. These talks will be given by women of various nationalities, and they will describe the problems that arise with a growing family in their respective countries.

A more lively series for our readers will be given by Mr. Vernon Bartlett, who will give two talks on foreign affairs.

Being foreign correspondent for the B.B.C. is no easy task, and Vernon Bartlett must have had some difficulty at times to avoid being led "up the garden" by enthusiastic political partisans in other countries. Probably, too, he has not forgotten how twelve good men and true watched him through the studio window when he spoke in one foreign city!



MEASURING

Some interesting details of recent progress in acoustics and present-day broadcasting technique from rooms and halls where an echo effect either is desirable, or must be eliminated.

There is a special reason why a pure tone whistle should not be used, and why the queer howl is emitted by the speaker and picked up by the "mike." The rest of the apparatus is not seen, it is in the studio waiting-room, or in some adjoining room as close as possible to the studio, but not where the studio howl can leak back to it.

Particularly Nasty Noise

Some parts of the gear are rather difficult to understand. "The rough idea," said one of the echo-measuring experts, "is that we put out this howl from the loudspeaker, pick it up by the microphone on the other side of the room, suddenly switch off and note how long it takes for the echo to die away—not entirely, but to a certain proportion of the original sound."

"Why don't you have a more agreeable noise tested?" I inquired. "Is there any special reason for that particularly nasty noise?"

"There is," he said. "In any room where there are echoes backwards and forwards from one part to another, you get standing waves; these are waves which do not move along through the air but which resist the movement of direct sound waves and so upset our measurements. We find that if we break up the noise causing the echo we get rid of these standing waves. I think you will clearly see the reason for this."

"How do you get the howl?" I asked.

"An ordinary L.F. oscillator in the next room is modulated by another valve so that the frequency of the tone is varied a very small percentage of its value, about ten times a second. That is what gives it a humming sound."

"That is not a Reisz microphone, is it?" I inquired.

"No, that's one of the new condenser microphones," he replied. "Generally we work it behind a baffle, so that the pick-up is directional. When we want to check the echo from one wall of a studio, we simply face the microphone in that direction and put the loudspeaker giving out the howl in a suitable position. Come with me into the ante-room and see the gear."

Intricate Measuring Apparatus

Apart from the ordinary wireless type apparatus used in connection with the L.F. oscillator for the loudspeaker and the L.F. amplifier for the condenser microphone, there were two or three other special gadgets.

The echo is measured by a reverberation meter. It is more than a meter. It is a very complicated low-frequency amplifier, coupled up to a delicate relay and a chronograph. I asked what was inside the amplifier box of the reverberation meter, and was told that there were two R.C. stages and an ordinary valve acting as a two-electrode rectifier. In the plate circuit of this valve is a

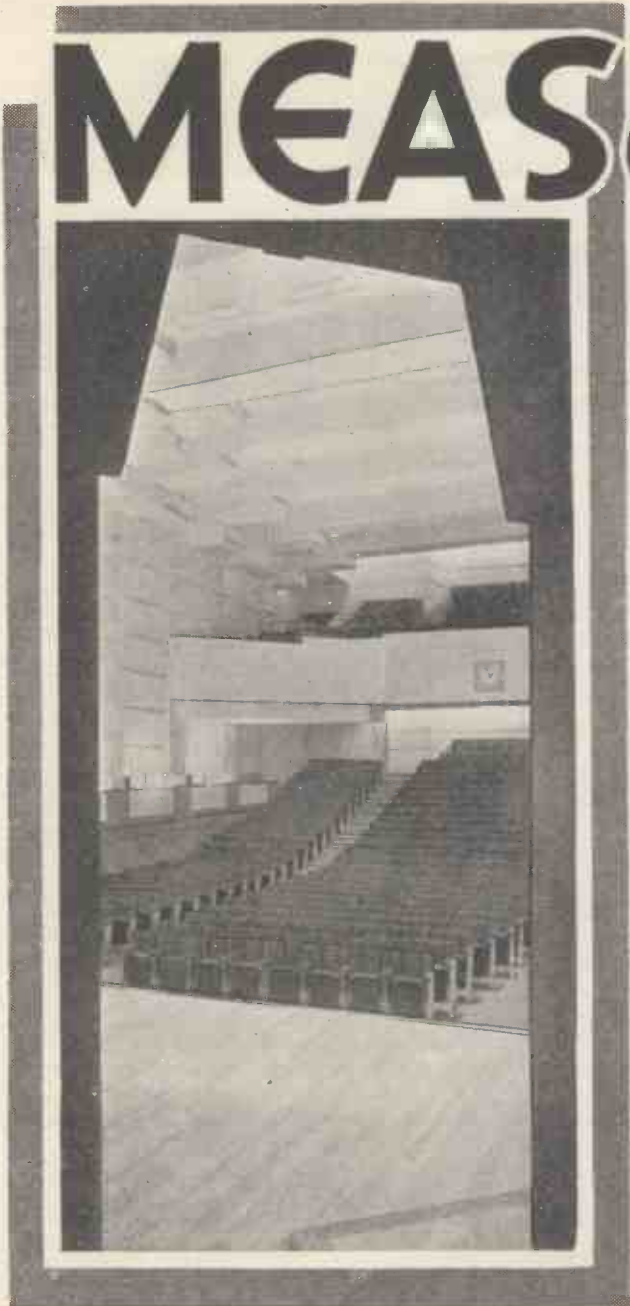

About 750 can be seated in this the B.B.C. Concert Hall, at Broadcasting House, and owing to skilful design the presence of an audience does not markedly affect the room's acoustic properties.

IN descriptions of the new studios at Broadcasting House reference has been made from time to time to the special echo-testing apparatus which the engineers use when they are determining just how much sound damping curtaining they can have in any studio and just which is the best place to put the microphone.

Once or twice I have actually seen the measurer at work. It is only within the last week or so, though, that I have obtained permission to see the "works" in detail.

Little to See

All you see when an echo is being measured in a studio is a microphone moved about on a stand, with a long length of flex and a moving-coil loudspeaker with a baffle at the other end of the room. All that you hear is a most disagreeable whining noise.

STUDIO ECHO

From a Special Correspondent.

milliammeter which is specially calibrated to give an idea of the A.C. voltage coming in to the amplifier.

After the two-electrode rectifier comes another stage of amplification connected to a relay. The idea is that the chain of amplifiers can be set to break the relay contacts at any given value of input to the amplifier.

Automatic Control

Here, as this was explained to me, light began to dawn!

You see that, by connecting the relay in this way, there is a simple means of switching on or off when the condenser microphone, picking up the echo, drops to any selected value of input.

All that the engineers have to do is to switch on the low-frequency oscillator so that the moving-coil speaker starts to howl and to pick up the echo via the microphone. The sound is interrupted and when the volume falls to the previously selected value (and when the anode current of the last valve in the amplifier drops

In the circle—an engineer keeping a check on quality in the programme being reproduced by the loud-speaker shown.



Below—the tangle of wiring which confronts the engineers at the back of the amplifiers at Broadcasting House.

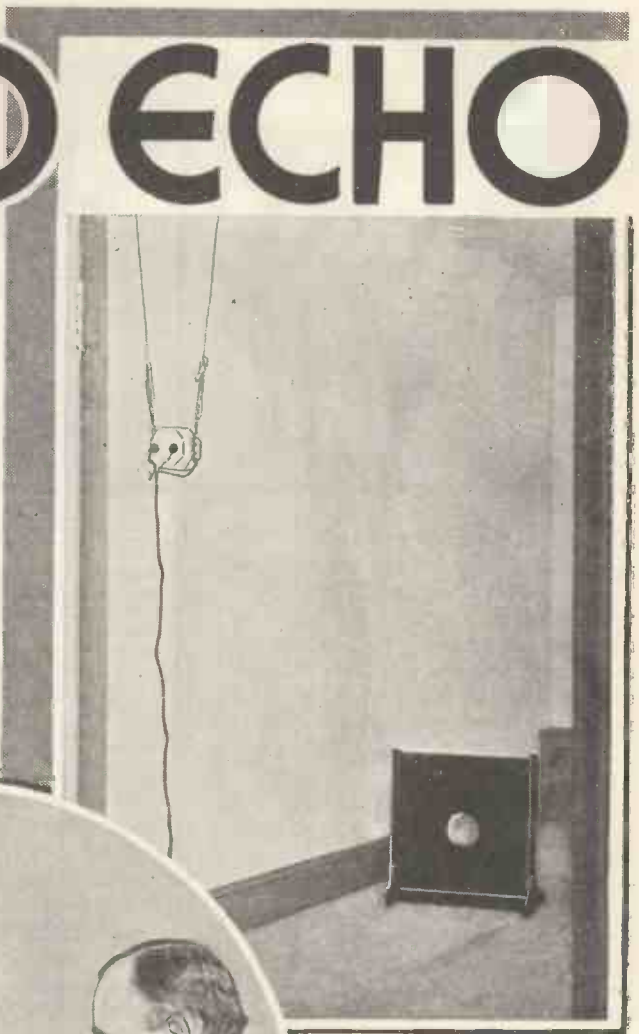

By arranging to reproduce the studio programme in a bare and "echoey" room, and adding the effects obtained to the original sounds, the B.B.C. can, in effect, modify the acoustic properties of any studio. The amount of echo added is under the easy control of the B.B.C. engineer in charge of the broadcast.

accordingly) the relay comes into action.

The relay contacts are connected up to the operating key of the L.F. oscillator. The chronograph is in circuit with this set of contacts and, by means of this, the engineers get a visual record of the time taken for the sound to die away to the value they have selected.

Photographic Record

A Duddell ray oscillograph projected on to a moving strip of cinema film is used to give the photographic record of the echo. The film is moved along in front of the oscillograph beam at a regular speed, and a tuning fork, vibrating at the side, is also photographed on to the film strip. This gives the standard of time in comparison with

(Continued on page 384)



GUARDING AGAINST INTERFERENCE



ONE of the difficulties which confront the new-comer to wireless is the possibility of electrical interference with reception. In districts congested with electrical machinery a certain amount of disturbance is inevitable, but in most cases it is possible to effect a cure.

The Causes

Among the causes of interference is the small motor working such contrivances as vacuum cleaners, refrigerators, neon lights and flashing signs. It is a singular fact that larger types of electrical motors rarely cause interference. This may be on account of the greater care taken by owners and maintenance engineers in seeing that the machines are periodically overhauled, the brushes and contacts being carefully cleaned to prevent sparking.

With the increase in sales of multi-valve sets it follows that there will be more complaints of electrical disturbance due to the greater sensitivity of the sets. Before installing a new set the purchaser should insist that the set is first tested in his home and under working conditions.

Test It First

He should ask that the set be allowed to remain at least forty-eight hours in order that the results may be observed. Thus, if any motors likely to set up radiation were working, the disturbance would be detected. The purchaser would then know of the trouble which might mar the excellence of reception.

When a listener becomes aware of disturbance he should first overhaul his set for loose connections, valve seatings, etc., and make sure that the battery or eliminator is functioning satisfactorily.

Many people make complaints of

Sometimes what is suspected to be outside interference is really "inside." But when it is not, the best way to tackle the trouble is to get at its source, if this is possible, as explained

By W. J. WILSON.

outside interference and the trouble is later traced to a fault in the set. If the source of the trouble is thought to be an electrical motor, ascertain from the neighbours if they experience the same trouble.

Should this be the case, a visit to the owner of the offending plant will be necessary. In all probability he

ONE EXTERNAL SOURCE OF NOISES



Piccadilly Circus has an unusually large collection of flashing signs which cause listeners in the locality a lot of trouble. Even one or two such devices can produce enough interference to keep any listener busy.

will do what he can to eliminate the disturbance.

In most cases a double condenser of two microfarads capacity with the centre point earthed, placed across the supply leads, will definitely overcome

the trouble. It may be necessary to use larger capacity, but this is unlikely.

The condensers should be tested to at least three times the voltage of the supply. If the supply is A.C. the voltage test of the condensers should be higher.

A Safety Measure

Frequently it happens that the owners of motors which are causing disturbance are insured against possible breakdown, and the permission of the insurance company has to be obtained before any apparatus can be fitted. Should it be necessary to install condensers, an electrical engineer will supply and fit these for a few shillings.

Do not forget to see that the condensers are properly "fused," otherwise there is grave risk of the apparatus being burnt.

Aerial and Earth

Aerials being the medium for picking up signals, and the power of motor radiation being low, it is often easy to alter the run of the aerial with satisfactory results. See whether the interference decreases when a counterpoise earth is fitted.

Altering the position of the set in a room sometimes effects a cure. If you have an inside aerial do not let it run parallel with the lighting mains, as induction may occur. Endeavour to place the set so that ample space is between the offending motor and the set.

Time It

If troubled by motor radiation, first be sure that your set is not at fault. Then by a process of elimination, logging the time of the disturbance and the time the motors are started and stopped, the offending plant can usually be discovered.

Should you be unable to deal with the matter yourself, place the matter before the B.B.C., who are only too willing to assist.

There is an arrangement with the General Post Office whereby a qualified staff is available to deal with problems of electrical interference.

The Q.P.P. RADIOGRAM

THE electrical method of reproducing gramophone records has long proved its worth. The advantages it has over the earlier acoustic system are almost incalculable, and for some years now the electric gramophone has been superseding the acoustic model.

When one considers that the amplifying system of an electric gramophone is the same as that of a radio receiver, it is not surprising that practically all electric record reproducers (excepting those for cinema and dance hall use) include radio as well. Thus it is true to say that the acoustic gramophone has been replaced (with certain exceptions) by the radiogramophone.

Two Exceptions

Those exceptions are mainly two. One is the portable type of gramophone which has become exceedingly popular for picnics and what might be called inter-house light entertainment. People carry these compact machines hither and thither, complete with records.

The other main exception is the house which has no electric light or power supply. There are battery driven radiogramophones, but these are not (or have not been up to now) nearly so effective as the all-mains type. They give comparatively poor volume, are expensive to run, and so have not been really popular. Thus it is not uncommon to find in what may be termed "all-battery" houses, just the radio receiver and an acoustic-type of gramophone.

Economy and Volume

But the resurrection of quiescent push-pull, with the availability of satisfactorily designed components, has changed all this. It is now possible to get the punch from a battery radiogramophone that one can get from the average small all-mains type.

It would be absurd to give the impression that the giant all-mains radiogram, has been equalled in output by quiescent push-pull sets—that

Featuring
QUIESCENT PUSH-PULL
Pre-Detector Control of Volume
One Dial Tuning
Low Running-Costs

would not be true; but it is true to say that the ordinary all-mains three-valver or four-valver, with its 1 to 2 watts output, has been emulated by the new battery-radio development.

That is not all the story, of course, for we could get the same volume from battery valves as from the normal types of mains valves before Q.P.P. came along. The whole pith of the thing lies in the fact that this power can be gained with a moderate supply of H.T.

SELF-CONTAINED



Great compactness has been achieved without sacrificing accessibility. The method of loudspeaker mounting and arrangement of the set above it is evident from this illustration.



There is no longer the need for ruinous anode currents of the order of 17 to 25 milliamps. We can get sufficient power (about 1 to 2 watts) with an average anode current of 12 milliamps.

Dealing with "Peaks"

It must be remembered that the maximum power output of any set is only required on peak passages, when the loudest points of the programme are reached. The average output wattage is probably about .25 watt.

Now, with quiescent push-pull (as those who read the February MODERN WIRELESS will realise), we only use what current we require to give any degree of loudness.

Unlike normal amplification where there is a steady current flowing through the output valves (and unlike normal push-pull for that matter), we only draw current to any extent when music or speech is to be reproduced.

Thus when nothing is being received on radio, or no record is being played, the anode current taken by the two output valves is about 4-5 milliamps. On the receipt of music or speech this goes up, and it fluctuates in accordance with the strength of the programme.

Low Average Current

In this way the average current consumption is remarkably low. Also it must be remembered that in radio and record "reception" there is an amazing amount of interval (a soft speech which does not take much current) between items and while records are being changed. You will

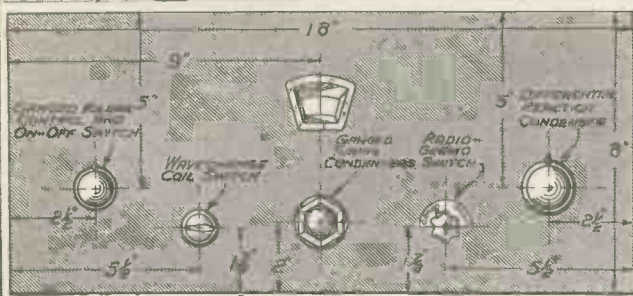

PANEL LAYOUT

QUIESCENT PUSH-PULL

The newly popular system of highly biased output valves is employed, with its great saving in running costs. This method makes practicable the use of H.T. batteries for obtaining results such as were previously considered possible only with mains.

PENTODES FOR OUTPUT

The two valve holders for the pentodes are arranged as shown, close to the push-pull intervalve transformer secondary, short leads from which go to the adjacent grid terminals. A protective fuse is incorporated in the common high-tension negative lead, and this is shown to the right, near the pentode valve holders and the 100,000-ohm resistance which is connected in the G.B. - 2 lead.

SIMPLE SWITCHING

The control knob on the panel alters both the coil units' connections for wavechanging, and the units are completely screened by their "cans" when the set is in use. The circuit is on the H.F. transformer principle, and is extremely selective.

CONTROLLING THE VOLUME

The great sensitivity of the set calls for very efficient volume control, and this is provided by the potentiometer, to the centre of which the aerial terminal is directly connected. Beside it stands the valve holder for the S.G. valve, which is mounted horizontally.

Doubling the Power Output

probably find during the playing of gramophone records, if you time yourself, that between one-quarter and one-third of the time the set is switched on is used for changing the records, needles, and getting the motor wound up.

With a normal set about 15 or more milliamps. would be going "down the drain" all this time for the output valve alone. With Q.P.P. it is only 4-5 milliamps.

Halving Current Consumption

We have not stressed the point that in addition to the saving of H.T. (which works out at about 50 per cent) there is a doubling of output power over that which would normally be obtained with one of the same types of output valves used in a normal set.

Thus, if you have a Mazda Pen. 220A valve for your output in a normal set, and you use 150 volts H.T. (don't think of the current taken!), you will get about 1,000 milliwatts of A.C. output power.

Use two of the same valves as quiescent push-pull amplifiers, the same H.T. voltage, and less current and you will get 2,000 milliwatts

output power. As a matter of fact, you can afford to cut the H.T. voltage down a bit and use only 120 or so volts, for even then your output power will be about 1,250 milliwatts or so.

Efficient Volume Control

In the Q.P.P. Radiogram we have made use of this economical system of output valve operation, and have harnessed two push-pull pentodes to a normal high-efficiency screened-grid and detector circuit.

No variable-mu valve has been used because, although this gives excellent volume control, it is rather costly on H.T. when operating in its most sensitive condition (for the reception of distant stations). We have arranged the well-known aerial resistance type of volume control in the radiogram, and used a straightforward S.G. stage. Thus the H.T. consumption throughout the set is kept down to a minimum consistent with good results.

Trying Triodes

It is of importance, in our opinion, that the output of a radiogramophone be something of the order of 500 milliwatts or more. Less than this somehow does not "get over" con-

vincingly unless one has a sensitive speaker and a small room to "fill."

But it may be of interest to readers who are of an experimental turn of mind to try this set, using triodes of the L.P.2 variety for output. These valves give an output of some 300 milliwatts between them and, though this is not great, it is obtained with the ridiculously low quiescent anode current of 2 milliamps, or less for the two output valves, the whole set taking only 7 milliamps.

For Super Economy

With the valves fully loaded the increase is not great, and for less than 10 milliamps. average the full use of the valves can be made. The output is not great, of course, and we only mention it because for the man who requires almost drastic economy with regard to his anode current consumption the triode offers an exceptionally easy way.

In such a case it would be necessary to use a different output transformer or choke ratio, the matching of the valves being a most important feature which should be carried out in accordance with the instructions of the choke or transformer makers.

Probably it would be of advantage,

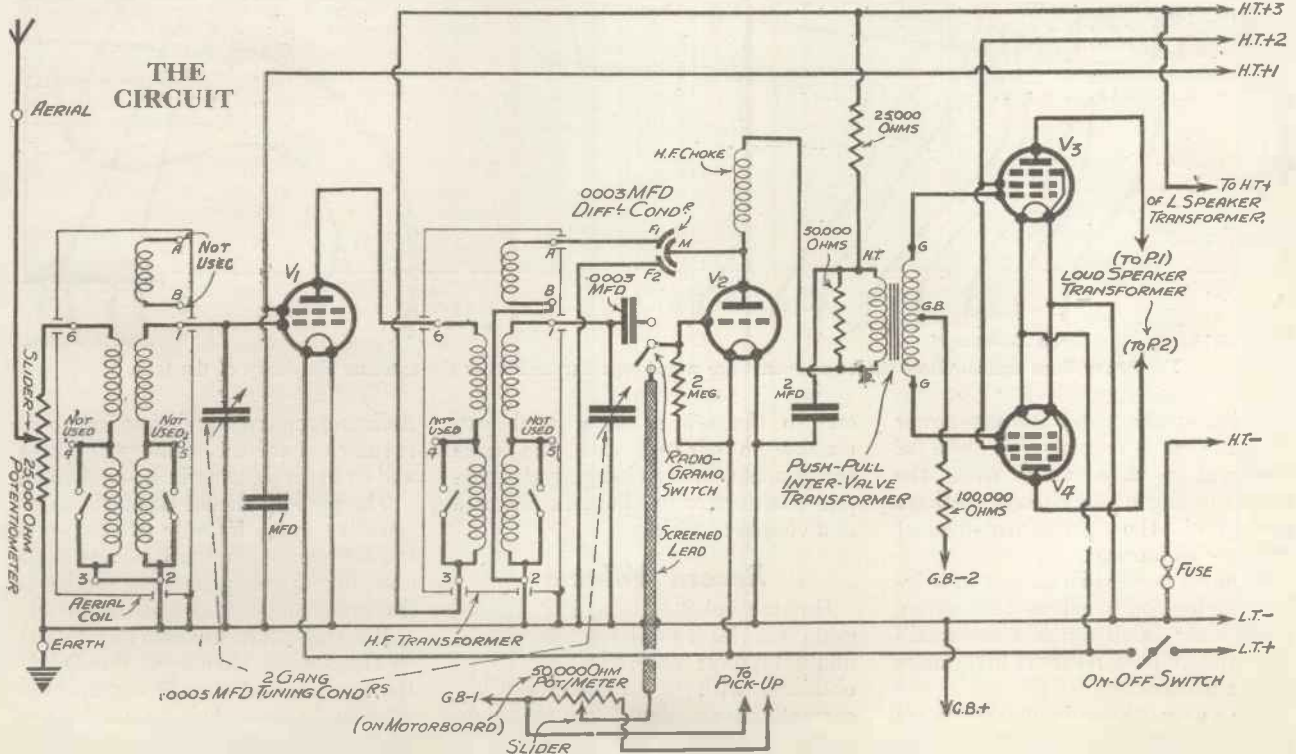

Among the noteworthy points are ganged switches for wavechanging, simple radiogram change-over, adequate decoupling, and, of course, the quiescent push-pull pentode output, with its economy in running costs

ONE TUNING DIAL

FULLY-SCREENED COILS

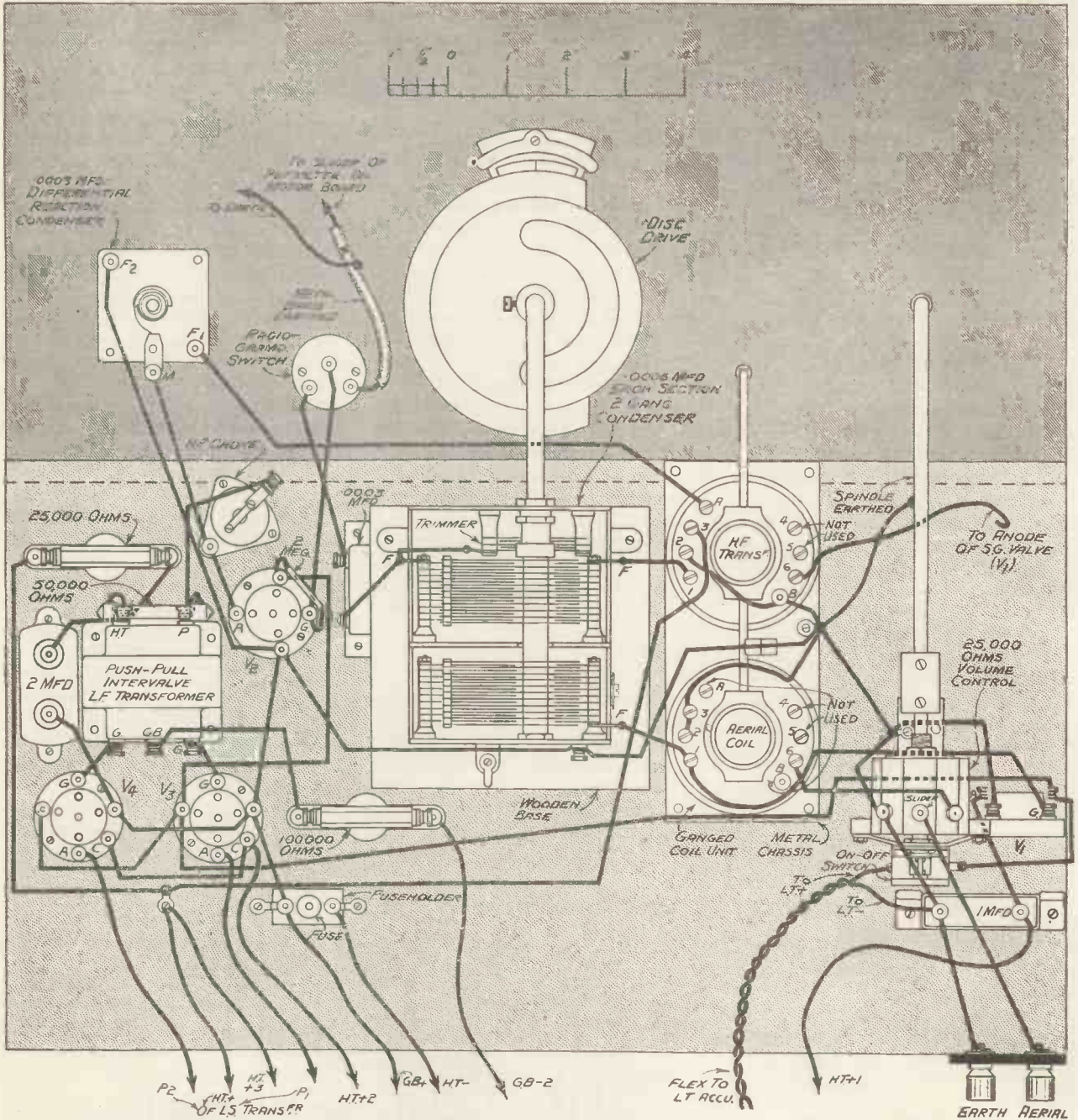

The heavy lines indicate how the components are wired together and show the extreme simplicity of the task.

considering the small output power available, if a moving-iron type of loudspeaker were used with the triodes failing a particularly sensitive model of the permanent-magnet moving-coil variety.

So much power can be lost in driving moving-coil speakers that often, where only small outputs are available, the audible result is little more than a whisper.

The easy interchangeability of quiescent push-pull between triode and pentode output valves is one of its useful features for conversion from

one to the other as a trial can usually be effected with the same components, or by changing the output transformer or choke in the case of a couple of makes.

Record Volume

On gramophone the Q.P.P. Radiogram enables record reproduction of unusual power and brilliance to be obtained with a remarkably low current consumption from the high-tension battery.

In respect of power output it resembles the all-mains-driven type of

radiogramophone, and thus its power is sufficient for all ordinary purposes, and even for dancing in a small room.

The pick-up should be of the fairly sensitive type, for only two stages of low-frequency amplification are available, but this is gone into further in the succeeding sections of this article.

But you will be anxious to get down to the specific details of the Q.P.P. Radiogram, and we will say no more of general aspects, leaving the choice of triode or pentode and speaker question to the reader to decide. It is merely a matter of output power and economy.

ABOUT THE COMPONENTS

SOME ADVICE ON IMPORTANT QUESTIONS OF CHOICE.



BEFORE we can discuss the components in any receiver we must perforce consider the circuit. This is specially important in the case of the Q.P.P. Radiogram, which is not exactly conventional, though it is quite straightforward in design.

It consists of a screened-grid amplifier stage which is transformer- (not tuned anode) fed into the leaky-grid detector stage. This is supplied as usual with reaction, and is tuned, together with the aerial secondary circuit, by means of a double gang condenser.

High-Efficiency Coils

To render unnecessary any great accuracy in trimming, one of the gang condensers that has a separate concentrically driven trimming vane is used, so that the two circuits can be kept perfectly in step all the way up the frequency scale.

The coils, too, have been chosen exceedingly carefully, and while they are not of the new high efficiency, but difficult to gang, Ferrocart variety, they represent very efficient design, and are new additions to the large range of Colvern coils.

The efficiency of the coils enables us to use them for S.G. transformer coupling, thereby increasing the selectivity of the tuning system without impairing its amplification. Incidentally, such a step is cheaper, for it does away with an S.G. H.F. choke and its associated coupling condenser.

As was indicated in the previous section, the volume control for radio is the well-known aerial resistance method, for the set is designed for the use of an ordinary S.G. valve and not the variable- μ variety,

Output Connections

Ordinary differential reaction is employed in the detector, which is transformer-coupled to the two output valves. This transformer is a special quiescent push-pull type, with

a high step-up ratio feeding into two pentode output valves.

The output from these valves has to be fed through either a centre-tapped choke or a transformer to the loudspeaker, but in the set, as shown in the photographs and diagrams, we have used a special quiescent push-pull model of loudspeaker which incorporates the required transformer.

Including a Choke

In case constructors may like to use their present loudspeaker, which will have its own transformer already on board, we have left room in the design for the inclusion of an output choke, which should be of the quiescent output type. Such chokes or transformers are made by R.I., Sound Sales, Ferranti, Varley and Multitone, and are used in addition to the transformer on the loudspeaker.

A word should also be said about the variable condenser concerning the fitting on the baseboard and the possibility of using another make. It

is possible to use a Polar Uniknob instead of the Utility condenser shown, but it must be remembered that substitution entails alteration of the panel diagram, for the size of the escutcheon is different, and the distance between the escutcheon and the control knob changes.

Also, it must not be forgotten that the piece of wood that is used under the condenser on the baseboard will probably have to be of different thickness in order to retain the symmetry of the panel layout.

Employing Alternatives

The question of using alternatives to the specified parts in a radio set will always be one that must be carefully considered, for it is not possible to change without due care any and every component and expect the same good results that were given by the original receiver.

Coils are specially difficult things to change, for in most cases, although there are suitable alternatives as

PRE-DETECTOR CONTROL OF VOLUME

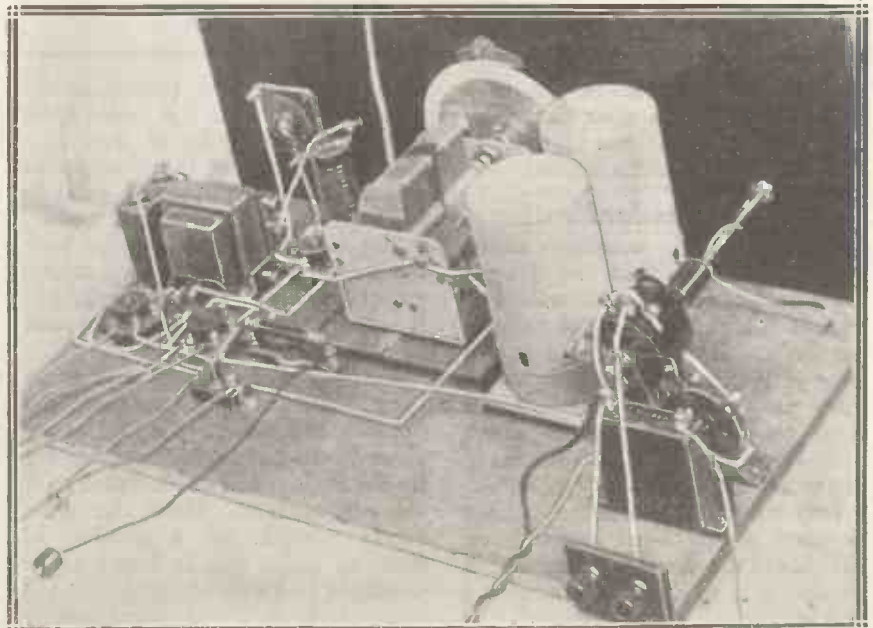

The aerial terminal (right) is connected to the slider of the 25,000-ohm potentiometer, which is operated by a rod with control knob on the panel.

regards the efficiency and the types of windings, the terminal positions are by no means standard, and in every case it requires very great care to avoid any slip-up in the changing process.

Alternative Coils

This is why in our set designs we do not nowadays give alternative coil mention, for although in the case of the Colvern coils used in this set there is the alternative of Telsen, as regards the actual electrical characteristics of the coils the terminal arrangements are quite different and the wiring diagram would be seriously thrown out. Those who know what they are doing, and feel sure that they can make the substitution without any fault occurring, can alter these coils to the Telsen canned variety if they so desire. They will get per-

fectly satisfactory results, but they must be prepared to alter the wiring considerably, and to wire-up to quite different terminal arrangements.

It would not make a bit of difference to the valve holder makers, other than the requiring of new moulds in certain cases. The vertical mounting (for valve horizontal mounting) valve holder for S.G. valves is another case that the makers might take into consideration, for here the positions of the grid and anode terminals and sockets vary, some having the former at the top and the others at the foot of the moulding. Can we not have some standardisation here, please ?

Output Matching

In choosing the output transformer or choke for your loudspeaker, assuming that you are not going to take advantage of the special type of speaker now available for quiescent push-pull, it is advisable that you get in touch with the makers of the output

Note the extension arm and the ebonite or other insulator coupling that is used for the volume control. This is essential as the extension rod has to be earthed, and this would upset the action of the volume control were this latter to have no insulation between the control spindle and the earthing lead.

Avoiding Shorts

The slider of the volume control is connected to aerial, and so it would obviously be disastrous if this were shorted to earth. Also, it must be noticed that the volume control is provided by the makers with an ebonite bush, and this has to be used to insulate the potentiometer from the metal bracket on which it is supported. This bracket is earthed.

On the motor board there are the motor itself, which is a single (or

THE PARTS YOU NEED, AND THE MAKES WE RECOMMEND

PANEL AND CABINET

- 1 Panel 18 × 7 in. (Goltone, Peto-Scott, Pernicol, Becol, Direct Radio, Wearite).
- 1 Baseboard 18 × 10 in.
- 1 Cabinet (Peto-Scott "Adaptogram").

VARIABLE CONDENSERS

- 1 Two-gang .0095-mfd. (Utility W.312).
- 1 .0003-mfd. differential reaction (Graham Farish, Telsen, Polar, Lotus, Ready Radio, J.B., Ormond, Keystone).

FIXED CONDENSERS

- 1 2-mfd. (Dubilier type BB, T.C.C., Telsen, Ferranti, Igranic, Lissen, Formo, Goltone).
- 1 1-mfd. (Telsen W.227, or see above).
- 1 .0003-mfd. (Graham Farish, Telsen W.242, Dubilier, T.C.C., Goltone, Ferranti, Sovereign, Lissen, Ready Radio, Watmel, Peto-Scott).

RESISTANCES

- 1 Combined 25,000-ohm potentiometer and rotary on-off switch (Wearite Q.V.O. 25,000 ohms and G.40).
- 1 100,000-ohm fixed, with holder if required (Graham Farish "Ohmite," with horizontal holder, Telsen, Watmel, Sovereign, Wearite, Colvern Strip, Ferranti).
- 1 25,000-ohm fixed, with holder if required

(Graham Farish "Ohmite," with horizontal holder, or see above).

- 1 2-meg. grid leak with wire ends or terminals (Graham Farish "Ohmite," Tunewell, Dubilier 1-watt type, Ready Radio, Igranic, Goltone).
- 1 50,000-ohm fixed, with wire ends or terminals (Graham Farish "Ohmite," Dubilier 1-watt).

COILS AND CHOKES

- 1 Two-gang coil unit with metal base (Colvern K.5).
- 1 H.F. choke (Goltone Super, Telsen, Lewcos, R.I., Ready Radio, Varley, Lissen, Bulgin, Tunewell, Slektun, Igranic).

SWITCH

- 1 Rotary three-point change-over (Bulgin S.86, Tunewell, Ready Radio).

VALVE HOLDERS

- 1 Four-pin (W.B., Telsen, Lotus, Lissen, Clix, Tunewell, Ferranti, Benjamin, Goltone, Wearite).
- 1 S.G. for horizontal mounting (W.B., Telsen, Goltone, Lissen, Wearite).
- 2 Five-pin (W.B., Telsen, Ready Radio, Benjamin, Clix, Wearite, Lotus, Tunewell, Goltone).

TRANSFORMER

- 1 Quiescent push-pull input (Sound Sales, Multitone PU L.S, R.I.).

MISCELLANEOUS

- 1 Fuse holder (Goltone, Belling-Lee, Telsen Bulgin).
- 1 Terminal strip 2 × 1½ in.
- 2 Indicating terminals (Belling-Lee type R, Bulgin, Igranic, Felex, Clix).
- 8 Wander plugs (Belex, or see above).
- 2 Accumulator spade terminals (Clix, or see above).
- 5 Yards of insulating sleeving and 8 yards of 18-gauge tinned copper wire (Goltone, Wearite).
- 1 Fuse (Belling-Lee 150-millamp. "Scru-fuse," Bulgin, Goltone, Telsen).
- 1 Switch bracket for aerial volume control, 3¼ × ¼ in. (Wearite).
- 1 Spindle for same, ¼ × ¼ in. (Wearite).
- 1 Insulated coupling link, 1 × ¼ in. (Wearite).
- 1 Bush to take ¼-in. spindle.
- 1 Pair of bias battery clips (Bulgin No. 1).
- 1 13-in. length of screened sleeving for pick-up connection (Goltone).
- 1 Wooden block, 4¼ × 4¼ × ¼ in. Screws, flex, etc.

fectly satisfactory results, but they must be prepared to alter the wiring considerably, and to wire-up to quite different terminal arrangements.

Plea for Standardisation

A point that is sometimes raised by constructors is that the five-pin valve holders are not standardised as regards the positions of the cathode terminals. This is true, and it is a great pity that the manufacturers of these parts do not get together and come to some arrangement about this seemingly small, but really important, point.

It is true that even if the cathode terminal of one valve holder is on one side of the anode terminal and in another it is on the other, the wiring of a set is not seriously affected; but it would simplify constructors' tasks if standardisation were effected, and

transformer or choke (except in the case of the R.I. and the Sound Sales and Multitone products), and give them full details of the loudspeaker and the valves that you are going to use.

The makers will then let you have the correct component and will inform you of the best connections to make to it in order that the correct ratio shall be obtained.

In the case of those three firms we have mentioned in the brackets, the full details of the coupling ratios are given on the leaflets that are provided by the makers and are included with the components. These should be carefully read, for a number of different ratios will be found to be available, and it is essential that the correct ratio for the valves and speaker you are going to use should be employed.

double, if you wish) spring Garrard, the pick-up and the volume control that is used for record work. This latter is easily fitted on because the motor board is only ¾ in. thick, and so the usual single-hole fixing of the standard potentiometer can be used.

Controlling Volume

The potentiometer should be about 50,000 ohms in resistance value, which suits most pick-ups. Occasionally, one comes across pick-ups that the makers say require a larger or a smaller resistance than that, and in such a case one should go by the manufacturers' recommendations. We have found, however, that even in cases where higher values have been specified, the 50,000 ohms acts perfectly well, and, in fact, we prefer it as a general rule.

BUILDING *the* RADIOGRAM

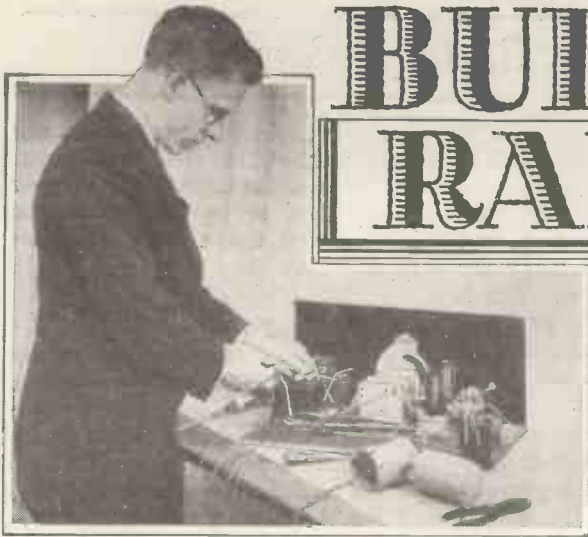

Such a powerful receiver as the Q.P.P. Radiogram might be expected to entail somewhat laborious constructional work, but as a matter of fact the set is quite an easy one to make. Even comparatively inexperienced set-builders need have no fear of the task being beyond them.

THE actual construction of the Q.P.P. Radiogram is quite an easy task. It is little more than the assembling of the necessary parts for an ordinary radio receiver, the extra work entailed in the building of the gramophone side being very slight.

An Important Feature

A good deal that directly bears on the construction of the set has been said in the previous section of the description of the receiver, though in one or two cases extra and valuable emphasis can be added by bringing the points up again here.

One of the most important features is the mounting and insulation of the aerial potentiometer volume control. This, as you will see from the theoretical diagram, is connected between the top and bottom of the primary winding of the aerial coil, the slider of the potentiometer being connected to the aerial.

In the design of the potentiometer the slider is connected to the spindle controlling it, so therefore this spindle is at an H.F. potential to earth.

That would not matter at all if the component were mounted on the panel. But it is not convenient to fix it there, it being better to

situate it near the aerial terminal and the aerial coil.

This necessitates a long rod to the panel so that the potentiometer can be controlled, and also a bracket on which the potentiometer can be raised to the required level above the base-board.

Preventing Instability

If we were to let the spindle and the extension rod, to say nothing of the bracket, come in contact with each other, the whole of that mass of metal, passing the tuned grid coil of the detector and its associated wiring, would be "alive" just as if the aerial had been taken along to the panel.

A BEHIND-THE-PANEL ARRANGEMENT

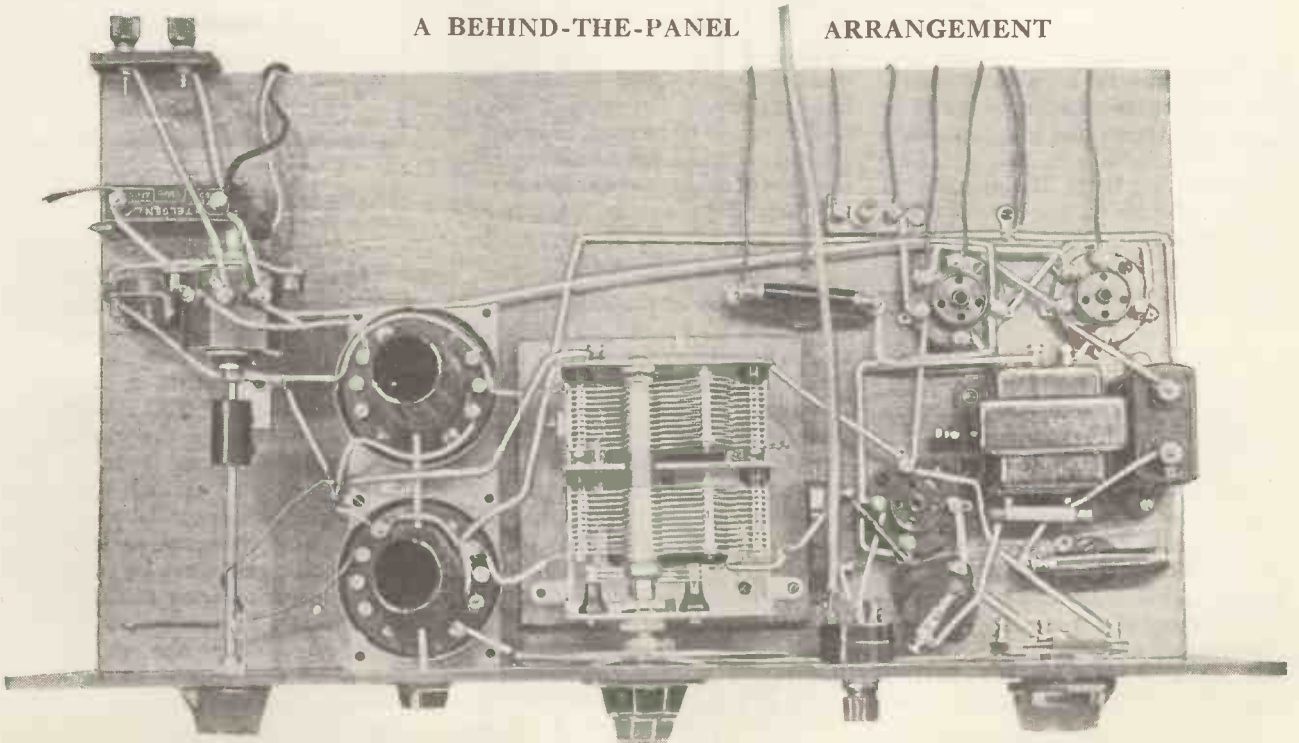

The components are arranged close to the panel and all the important leads are short and direct—a point of considerable importance in obviating feed-back, and one which makes for straightforward construction.

Mains Set Volume with Battery Power

This would cause grave danger of instability, and so it is important to isolate the spindle from both the extension rod and the supporting bracket. This latter is accomplished in the latter case by the insulating bush that is supplied with the potentiometer; but to isolate the long rod it is necessary to make use of an ebonite or fibre insulating junction piece, or collar, which is interposed between the extension rod and the spindle.

Further, to prevent coupling due

This has been done for a reason. It will not affect all constructors, but it may affect quite a lot. You will notice that no output choke or transformer has been included in the design—that has been left to the transformer on the speaker. This is unusual in a quiescent push-pull layout, for some form of output choke or transformer is essential to the operation of the scheme.

In the Q.P.P. Radiogram we have used one of the special Q.P.P. loudspeaker models, on which is provided

the ratio advised by the makers, will be connected to the usual input terminals of the transformer on your loudspeaker, or to the loudspeaker itself if you use a high resistance type.

Fitting the Speaker

The speaker is fitted to a secondary baffle board, which itself is screwed to the front of the cabinet. This is essential, because the fret of the cabinet is not circular, while the hole required in the baffle by the speaker is so.

The bias battery should be placed, preferably in clips, along the back of

YOUR GUIDE TO VALVE TYPES

Make	S.G.	Det.	Pair of Push-pull.
Mazda	S.G.215	H.L.2	Pen.220 or Pen.220A
Mullard .. .	P.M.12	P.M.1.H.L. ..	P.M.22A or P.M.22
Cossor	220 S.G.	210 H.L.	220 H.P.T., 230 P.T., or 220 P.T.
Marconi .. .	S.22	H.L.2	P.T.2
Osram	S.22	H.L.2	P.T.2
Tungram .. .	S.210	H.L.2	P.P.230
Micromesh ..	—	H.L.B.1	Pen.B.1

WHAT WE RECOMMEND

LOUDSPEAKER
Celestion C.T.1715. (Note: See text.)

BATTERIES
L.T.—Ediswan, Oldham, Block, Pertrix, Exide, Lissen, G.E.C.
H.T.—120-volt, or special Q.P.P. type (Siemens, Pertrix, Lissen, Ever Ready, "Silver Knight," Drydex).
G.B.—1 16-volt (Drydex, or see above).

PICK-UP
Radiophone, Bulgin, Celestion, B.T.H., Marconiphone, Audak, Bowyer-Lowe, Telsen.

GRAMOPHONE MOTOR
Garrard single spring, Collaro.

NEEDLE CUPS
Bulgin N.C.2 and N.C.3.

VOLUME CONTROL ON MOTOR BOARD
1 50,000-ohm (Lewco, Wearite, Watmel, Sovereign, Igranic, Graham Farish, Magnum, Colvern, Varley, Ready Radio).

AERIAL AND EARTH EQUIPMENT
Electron "Superial," Graham Farish "Filt" earthing device.

to static induction between the live spindle and the extension rod and the supporting bracket, both these are earthed by means of a piece of flex soldered to the rod, and taken to the foot of the bracket, which latter is joined to the earth circuit of the set. (See wiring diagram.)

Those constructors who are keen on securing an attractive panel appearance may like to have their attention drawn to the selection of knobs of different patterns and standard sizes that are available from Bulgin & Co., Ltd., of Abbey Road, Barking, Essex. These knobs are for use on sets where the components chosen provide a diversity of knob design, and thus upset the general appearance of the panel.

Matching Knobs

They are not expensive, and when used to replace the motley selection that so often occurs they enable a most satisfactory uniformity of panel appearance to be obtained. It is a point worth remembering—if you do not like your panel knobs, try Bulgin.

Now many of our readers will have taken a look at the baseboard layout, and realising that no bias battery could possibly take up all the space we have left at the back, they will have begun to criticise the "waste" of space.

the necessary input transformer. Many, however, will prefer not to scrap or alter their present loudspeakers, and for their benefit we have left on the baseboard space for the output choke or transformer that they will require.

These can be obtained from Sound Sales, R.I., Ferranti, Multitone, or Varley, and in each case if the constructor will let the manufacturers know details of the speaker and the output valves to be used, they will be pleased to furnish full details regarding the type of choke (or transformer) and the ratio tappings to use.

Output Connections

In the event of the inclusion on the baseboard of an output device the connections from the set to the loudspeaker would be modified somewhat, like this. Instead of the two anode leads of the pentodes being taken to the transformer of the speaker, as at present, they will be taken to the two points on the output component as directed by the manufacturers thereof.

The resistance and condenser impedance equalising scheme that now goes across the loudspeaker transformer will be connected instead from anode to anode of the output valves—that is, the connection will be across the output choke or transformer.

Finally, the output terminals, giving

the set, between the aerial input and the L.F. end.

Preventing Interaction

We must emphasise the importance of using screened wires between the pick-up and the set, or between the pick-up volume control on the motor-board and the set. This is to prevent interaction between the loudspeaker leads and the pick-up leads, for with Q.P.P. we are dealing with high stage gain, and so special precautions against any tendency to instability at the L.F. end must be taken.

The metal covering of the pick-up leads should be earthed to the L.T. negative circuit at the set end, and the other end should be connected to both the frame of the pick-up and the gramophone motor. This is easily done with a short length of flex.



Practical Hints on Getting the Best Results.

LITTLE need be said concerning the actual handling of the Q.P.P. radiogram—it is perfectly straightforward. The ganging is carried out in the usual way, the trimmer of the aerial side being adjusted with the variable condenser placed in the mid-way position.

This trimming vane is extremely useful, for it enables the two circuits to be kept in tune over the full wavelength range without any difficulty at all.

Grid-Bias Voltages

Flex leads from the set to the batteries and the loudspeaker are used, the batteries and speaker being housed below the receiver. Above this latter is the motor board with its pick-up, motor and volume control, the two leads from the volume control going to grid bias—1.5 volts, and to the pick-up switch. Make sure it is the lead from the slider of the potentiometer that is connected to the pick-up switch. We have already

pointed out the advisability for screened wire.

The grid-bias battery is situated along the back of the baseboard and, in addition to the 1.5 volts required for the pick-up tap, we need some 13.5 to 16.5 volts for the push-pull valves.

Adjusting Output Valves

There are two ways of getting at the bias required for this stage. One is to write to the makers or to look up a list of valves and find out what bias is required for 120 or 150 volts H.T., when the valves are used in quiescent form; the other is to use the trial and error method.

We prefer the latter, for valves differ in their characteristics, and so it is impossible to give exact bias figures. Apart from exceptional cases, you will not require more than 16.5 volts, even if you use 150 volts H.T., and so it is best to start with the full bias voltage applied, and reduce it little by little until you have the

maximum value consistent with good quality.

In most cases we find there is no audible difference between different tappings until you get round about the correct figure, then even one tap below will cause bad distortion, showing you have gone too far with your bias voltage and must decrease it.

It is important that the set be switched off every time the bias is adjusted or the emission of the valves will soon be ruined.

Using a Meter

The voltage applied to H.T.2 should be about 9–12 volts less than that applied to H.T.3. Many will say that the valves should be properly matched. Theoretically that is so, but unless the valves are very badly “out” there is no real “audible need” for this rather cumbersome procedure.

If you write to the valve manufacturers you will be able to get two matched pentodes straight away, if you tell them you need them for quiescent push-pull, and that will put all doubt aside.

Alternatively, if you have a milliammeter reading to 10 or more milliamps. you can match the two valves yourself. First of all try the set unmatched. Get the bias approximately right and then switch off. Insert the meter between H.T.— and the H.T.— tap of the battery, and pull out all valves except one of the pentodes.

Taking Readings

Keep the bias fixed as it was and switch on. You should find that the current is some 2–3 milliamps., depending on the valve and the anode potential and bias. If it is more than 3 milliamps., increase the bias by 1.5 volts and test again.

Now switch off and disconnect the second pentode valve holder “C” terminal from the “C” terminal of the other, and take, instead, a flex lead from the terminal to a wander plug. This will give you separate taps for the screens of the pentodes.

(Continued on page 384)

READY FOR THE VALVES

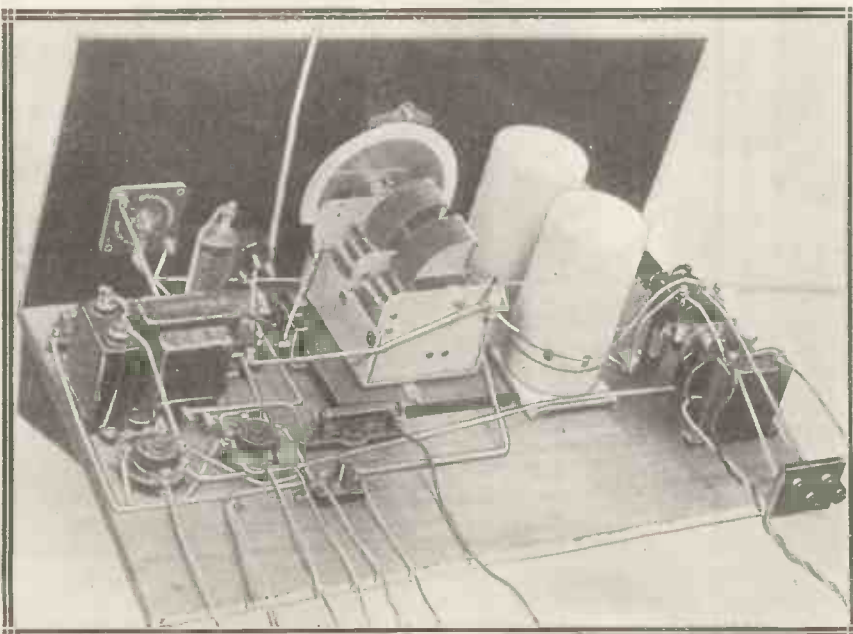

In this picture we show the coils with their “cans” in place. Be sure to put these on carefully, as if unnecessary force is used it is possible to cut the connections that pass through the slots.

PRACTICAL SUGGESTIONS for PRACTICAL MEN

Some selected hints which give you ideas for the improvement of your radio installation—both indoors and out.

Oiling the Pulley

EVERY careful wireless enthusiast equips his aerial mast with a "running halyard" so that the aerial may be lowered at any time.

In addition to making the aerial always easily get-at-able the "running halyard" confers the advantage of making it easily possible to keep the pulley at the mast-head free by oiling it.

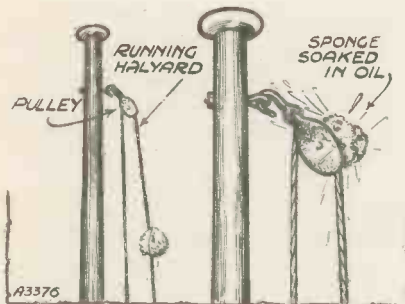

You mustn't expect the sponge to go through the pulley, but it will do its work.

A small piece of sponge is filled with oil and tied to the halyard and then "sent aloft."

It will not, of course, go through the pulley, but your efforts to make it do so will result in the sponge discharging its cargo of oil, a fair proportion of which, besides anointing your head, will certainly find its way into the "works" of the pulley.

Biassing Screened Grid Valves

Although grid bias is not by any means an essential factor in the operation of an S.G. valve, there are occasions when the application of a small negative voltage to the grid definitely improves the results.

Take, for instance, the case of a set which is being used in the vicinity of a powerful Regional transmitter. In the absence of a pre-H.F. volume control, the S.G. valve is quite likely to be overloaded, with a detrimental effect upon selectivity.

This is liable to occur with any loud transmission, and apart from considerations of selectivity, the application of a little grid bias does save a milliamp. or so of H.T.

With some sets the insertion of a grid biasing cell in the grid circuit of the S.G. valve is not so simple as it may appear, but a safe scheme is the one shown in the pictorial diagram.

The Connections

The lead which goes from the grid of the S.G. valve to the grid side of the detector tuning coil and fixed vanes of the tuning condenser is "broken," and a .0003-mfd. fixed condenser inserted. One end of a 1-meg. grid leak is then joined to the grid terminal of the S.G. valve holder, and the other end is connected to the negative terminal or tag of a .9 or 1.5 volt dry cell. The positive terminal of the cell is joined to L.T.—

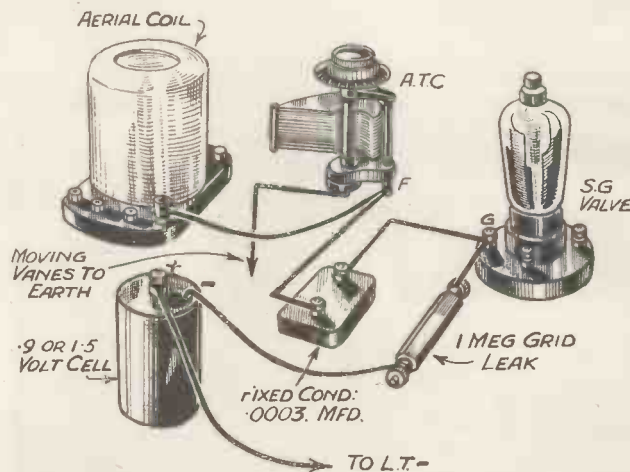

A Filter Unit

An output filter has several advantages, among these being its stabilising effect on the L.F. portion of the set, and the fact that it isolates the loudspeaker from the steady H.T. current flowing in the anode circuit of the power valve.

In many cases, however, the inclusion of a filter feed necessitates lengthening the baseboard, a pro-

cedure which is not always acceptable to the constructor.

Separate from the Set

But there is no reason why the filter should not take the form of a separate unit with the necessary terminals for wiring it up to the receiver.

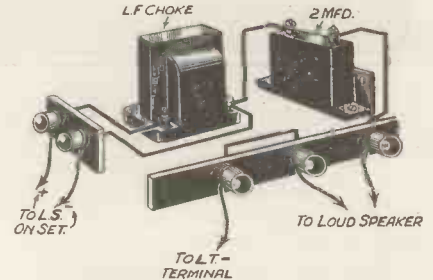

The L.F. choke and the condenser can easily be placed in a box with connections to five terminals as this pictorial representation explains.

The L.F. choke (20 henries suits most power valves) and 2-mfd. condenser are placed in a small box, the connections being taken to five terminals, as shown in the pictorial diagram.

Two of these terminals go to the existing speaker terminals on the set, L.S.+ being the one joined to the H.T. supply, and L.S.— that which is connected to the anode of the output valve.

Of the remaining terminals on the unit, two are joined to the loudspeaker, and the other goes to the

HOW IT'S DONE

This practical diagram shows a safe and satisfactory method of inserting a biasing cell in the grid circuit of your S.G.

L.T.— terminal on the terminal strip, or alternatively to H.T.—

If a D.C. eliminator is employed, it is sometimes advisable completely to isolate the speaker from the set. This may be done by connecting another condenser in the unit between the terminal marked "to loudspeaker" and that marked "to L.T.— terminal." Both condensers should then be 4 mfd.

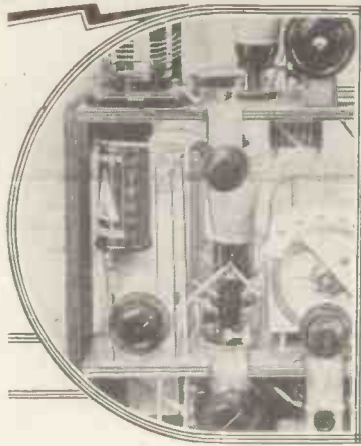

Those H.F. CHOKES

By Marcus G. Scroggie

A GOOD H.F. choke is one which in action is equivalent to a very high resistance—1 megohm or more, for choice.

If the choke consists simply of a bobbin of wire wound anyhow, the self-capacity is unreasonably high. A high capacity generally means a low parallel resistance, so both evils exist in combination. To reduce the capacity the coil is made very narrow. This is in itself a very sound move, but in order to wind the necessary number of turns without using an excessively fine gauge the diameter of the coil must be large. This again results in large capacity, so the difficulty is overcome by dividing the winding into a number of sections, each narrow and small in diameter.

End-Section Design

A very great improvement is effected in this way. Sometimes the end sections are made smaller, as it is these that chiefly determine the capacity at short wavelengths. It is possible to obtain a choke with a capacity of less than 1 mmfd. (0.000001 mfd.) by careful adoption of this method, but thorough tests of dozens of different types have shown that a choke consisting of a number of unequal sections is likely to have

The selection of a suitable H.F. choke is not such an easy matter as it might seem, and our contributor continues below the valuable guidance he gave last month to constructors who wish to get maximum efficiency.

several sub-resonances, at which the effective resistance drops to a very low value and the capacity fluctuates madly. Whereas, if the sections are all made equal, there is generally only one such dead-spot.

Another Aspect

This usually contrives to find its way into a vital part of the medium waveband, but by careful design it is possible to banish it to the no-man's land between 150 and 200 metres.

The most satisfactory type of choke is almost invariably one with a fairly large number of small equal sections.

There is another aspect that has to be taken into consideration, and that is the possibility of coupling between the choke and other components. It may couple to other chokes or tuning coils, and thus cause H.F. troubles, possibly even instability. It may couple to L.F. transformers. Or it may couple to power

transformers and smoothing chokes. These last are particularly troublesome, because they introduce hum, the cause of which may give the constructor a very weary time locating it.

There are several ways in which attempts have been made to guard against this. One is to put the choke in a pot; a pocket edition of those used for tuning coils. This is effective up to a point against H.F. coupling, but it is almost entirely ineffective against hum. And as a screen may have the effect of making the choke itself thoroughly bad, by increasing its capacity and lowering its resistance, this remedy is not always ideal.

Another method that has long been familiar is to mount two chokes side by side but wound in opposite directions, so that whatever is picked up—or sent out—by one is exactly opposed by the other half. The success of this—the binocular coil—depends on both halves being an equal distance from anything to which coupling is probable.

Binocular Types

Obviously, if one half of the choke is close up to another coil and the other half is on the far side the opposition will be very far from equal. Generally, it is not very difficult to mount the binocular choke, so that all is well in this respect.

But if it is necessary to assemble many inductive components rather

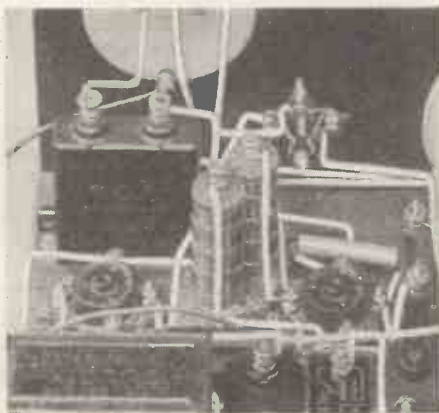

CONTRASTS IN CONSTRUCTION

To the left is a binocular type of H.F. choke; and to the right, between the two valve holders, stands one in which the sections are shielded by cans, in the manner so often employed for coil units.

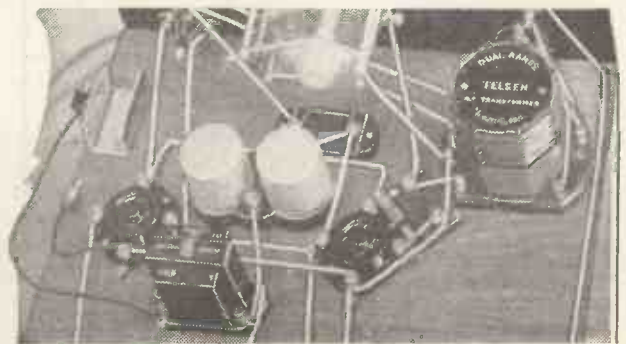

For Good Results on All the Wavebands

compactly, there is a good deal to be said in favour of a choke in which the two halves are in the same line, so that in effect it consists of one sectionalised coil with half of the sections wound one way and half in the reverse direction.

It may be rather difficult to wind such a choke to a high enough inductance without using very fine wire, with consequent high D.C. resistance.

Using Iron Cores

The closer the two halves are together the more they destroy each other's inductance, and more turns must be used to make good the loss. Perhaps it is hardly correct to say "must be used," because if a suitable type of iron core is employed the inductance is thereby raised so much that quite a reasonable gauge of wire suffices. It is popularly supposed that an iron core in an H.F. coil gives rise to large losses, but if the core is properly contrived this belief is incorrect. It is thus possible to arrive at an H.F. choke which is small in diameter, has small equal sections, and is practically free from external coupling. To show how such a design compares with others of unsuitable construction, curves are shown giving the equivalent resistance and capacity across a tuned circuit.

As a matter of fact, that is precisely how they were measured, by connecting the choke across a tuned circuit and comparing its effect with that

of a small variable condenser and known non-inductive resistors. Short, medium and long wavebands are covered, and curves A refer to a choke consisting of a single coil $\frac{1}{4}$ in. wide by about $1\frac{1}{8}$ in. in diameter. It

C shows the performance of a field-less choke designed in the way recommended. Except for a tendency to lapse at the extreme lower end of the medium waveband, its resistance is generally about a megohm or more

STRAY CAPACITY AND LEAKAGE RESISTANCE

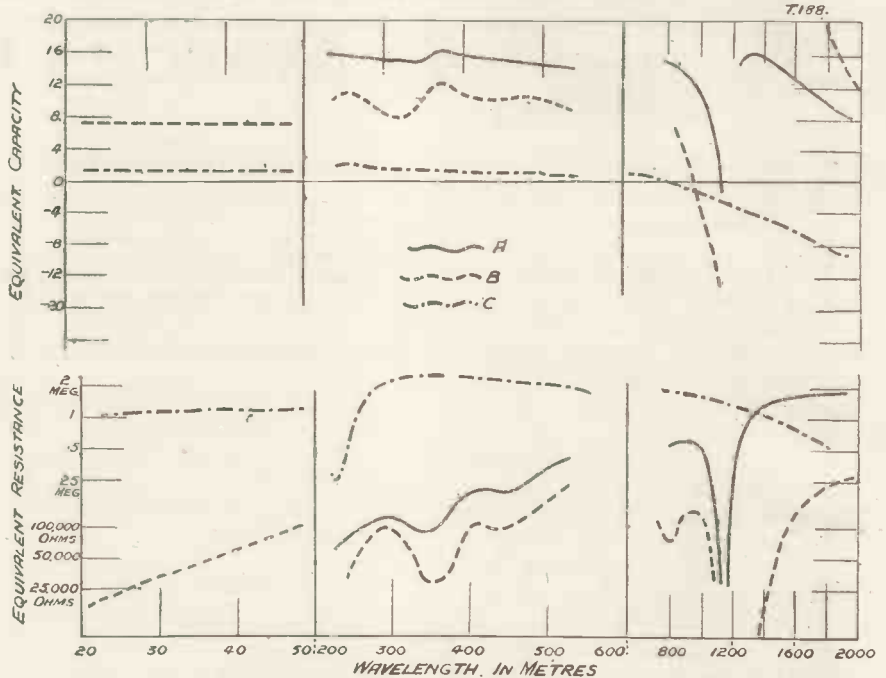

The effective stray capacity and leakage resistance of three types of H.F. chokes over three broadcasting wavebands. A is a choke wound in a single slot $\frac{1}{4}$ in. wide. It was too bad to measure on short waves. B is a multi-section choke in an aluminium screening pot, with the screen earthed. Both A and B go outside the range of measurement on long waves. C is a multi-section choke of small diameter and equal sections arranged in two opposing groups to avoid coupling. Each group has a special iron core.

puts up a perfectly appalling show in the middle of the long waveband. By the way, a *negative* capacity means that the coil is *inductive*. Capacity and inductance work in opposite directions.

On Short Waves

On the short waveband the resistance was so low—less than 15,000 ohms—that it was impossible to take measurements. That may safely be taken to mean that in practice it would be impossible to get good results, or in fact any results.

B is the record of a choke consisting of a number of *unequal* sections screened by an aluminium pot. Apart from the fact that the pot served no useful purpose so far as low frequencies are concerned, note the severe loss caused at several wavelengths due to sectional resonances, and the high capacity due largely to the screen (which was connected to the low-potential end of the choke).

and, therefore, not likely to impose a severe strain on even a highly efficient tuning system. And the capacity is very small and steady. A negative capacity of not more than about 10 mmfd. is rather an advantage, for it helps to neutralise the stray circuit capacities.

These results are confirmed by reception tests which, though rougher, are of more direct appeal.

Choke A connected to any circuit tuned to about 1,200 metres reduced reception almost to zero and shifted the tuning by about 30 divisions on a 100-line scale. Truly terrible! B was more extensive in its evil influence; whereas C had no noticeable effect in most cases, beyond a very tiny shift in the tuning, only perceptible in an ultra-selective receiver.

Measurements of many other types are not shown; those given represent extreme contrasts. They indicate what may be expected from chokes of various designs.

SEPARATE SECTIONS

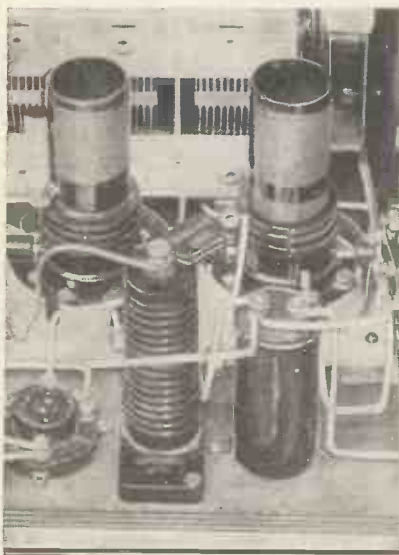

The sectional winding of an H.F. choke is well illustrated by the popular type shown here.

The WORLD'S PROGRAMMES

HOW WHEN AND WHERE TO HEAR THOSE FOREIGNERS—

LA MARSEILLAISE
 Written and composed by Claude Joseph Rouget de Lisle 1792.
 Con anima
 Arr. for male voices by [illegible]

GOD SAVE THE KING
 Attributed to Henry Carey 1745
 Moderato
 1 God save our Lord the King
 2 O Lord our God the King
 3 Thy right hand O Lord is raised
 4 Long live our Lord the King
 5 O Lord our God the King
 6 On him be placed our trust
 7 O Lord our God the King
 8 Long live our Lord the King

Austrian Hymn
 (Joseph Haydn 1755-1806)
 Andante (♩ = 100)

The Belgian National Song

The Polish Hymn
 Allegretto (♩ = 110)

THE STAR-SPANGLED BANNER
 National Song of the United States
 With spirit
 Arr. by J. K. L.

SONNER AF NORGE
 Den Norske Nationalsang
 Norwegian National Song
 Allegro con spirito

THE MAPLE LEAF FOR EVER
 Words and Music by [illegible]
 Con spirito

Dutch National Hymn
 Maanloos (♩ = 100)



SHOWING THEM HOW it's done in Britain! George Allison, the B.B.C.'s leading football commentator, giving his impressions of an American Rugby Football match to the N.B.C. microphone.

CONTENTS OF THIS SPECIAL SUPPLEMENT

- Listening on the Long Waves.
- Medium-Wave Results.
- On Board the "Elettra."
- "Shorts" from the Stations.
- The Announcers of Leipzig.
- What They are Doing.
- Programmes of Distinction.
- The Month in Europe.
- Modern Wireless for Modern Women.
- New Station for Capetown.
- Other People's Programmes—Hungary.
- How to Dial.
- Brno Grows Up.
- Britain's New Long-Waver.
- The Voice of Kansas State.
- Affairs Overseas.
- Distant Stations and How to Hear Them.

LISTENING ON THE LONG WAVES



THE long-distance enthusiast has every right to hope for good radio conditions during the coming summer, for all the preliminary signs have been favourable.

Between the best and the worst reception times of the year—midwinter and midsummer respectively—there is usually a fairly smooth retrogression of conditions, but in previous years early March has been a specially critical period. The transition from perfect to imperfect conditions occurs about then, and even on long waves many hitherto reliable programmes are apt to become a little uncertain and disappointing as the spring advances. This year there have been remarkably few casualties.

A close watch on Radio Paris, in fact, seems to indicate that this particular station provides for the South of England listener just as reliably as it did three months ago. Eiffel Tower, too, is good.

His wavelength neighbour, Warsaw, on 1,411 metres, shows distinct signs of fall-off, but is nevertheless still capable of putting over a good account of himself. (The distance between this country and the Polish capital is some 900 miles, as against the mere 200 or so from London to Paris.)

We heard so much about the great advertising long-wave station at Luxembourg before it commenced transmitting that its present tests round about 1,200 metres have been something of an anticlimax. Perhaps when it settles down officially to a certain wavelength and certain programme value, this will become a popular station in Britain, for it is undoubtedly well situated from a geographical point of view.

Several correspondents who have apparently been interested in the political situation in Germany have remarked that Königs Wusterhausen "Deutschlandsender" occasionally sounds much louder on 1,635 metres than at other times. They have wondered

whether increased power is being used, as for some of the lower wavelength Germans.

No confirmation of that is obtainable, so it seems likely that the variation noticed is due to the approach of summer conditions. For here again the distance is very considerable—Königs Wusterhausen is 588 miles from London—and it is asking a lot to look for reliability at such a range.

The Scandinavian stations have been good, and even in daylight plenty of listeners can get Kalundborg and Motala satisfactorily. Oslo is not quite up to the same standard on my own aerial, but in the evenings 1,083 metres is always worth a visit.

In accordance with the usual "double-Dutch" custom, we must expect a change-over between Huizen and Hilversum on April 1st (an appropriate date for this unique system of transmitter exchange).

At present the Huizen station, on 1,875 metres, is linked by land-line to the Hilversum studio, so the present announcement, on 1,875 metres, is "Hier Hilversum." (And vice-versa, on the medium waves, the Hilversum aerial radiates the message "Hier Huizen," on 296.1 metres.) But from April to June each station is linked to its own studio, so Huizen will announce himself on long waves as "Huizen" for the next three months.

It is now definite that a good site for Britain's long-waver, to supplant 5 X X, has been selected at Wychbold, near Droitwich. The B.B.C. is carrying out the preliminary work necessary to place this country once more into possession of a really first-class long-wave broadcaster. It is said that the new 5 X X will easily be the best long-waver ever designed.





MEDIUM-WAVE RESULTS

American stations which still come over—Making the acquaintance of Athlone—Testing a new transmitter—Notable stations

THE most surprising feature of medium-wave reception is the way in which the American stations have continued to come over, despite the advance of spring.

It seems remarkable enough in mid-winter to be able to go to an ordinary three-valve set, after Europe has gone to bed, and to hear perhaps Philadelphia or New York at good, easy-to-understand strength. But one does not expect to find such transatlantic triumphs in March; and yet a great many zealous searchers have had the experience this year.

It is even said that there is a chance of such freak reception continuing—atmospherics permitting—right through the summer months. But generally summer atmospherics are *continuous*, and not even an American programme would seem to have much chance against that sort of barrage!

Most of our readers must by now have made full acquaintance with Athlone, relaying Dublin's programme on 413 metres. His tuning position is usually somewhere about three degrees on the tuning dial above Midland Regional, and the strength and quality now place this as a really excellent alternative programme for those with selective sets.

At about the same tuning distance as Athlone from Midland Regional (but lower on the dial instead of higher) is Toulouse, who has been testing his new transmitter. At the time of writing the official "Go" for this has not been given, but no doubt when it occurs there will be

still more attention paid to this very interesting section of the medium waveband.

Incidentally, the Polish station Katowice (just immediately below Athlone, and pronounced "Katto-veecha") has been an uncommonly consistent turn on this section of the dial, which is fortunate for the many British members of its famous "circle."

Do not, on any account, miss the next "World's Programmes" Supplement

It will be included in the May issue of "MODERN WIRELESS"

On sale everywhere April 29th

A list of the other notable medium-wave stations would be too long to be interesting, but mention should be made here of the prevalent seasonal variations which are apt to lead listeners to wrong conclusions. The trouble is this:

Suppose a distant station hitherto well received proves to be "missing," it may be assumed that he has gone till next winter. And if he is not watched for he will have done so, in effect, and the listener is the loser.

But often after a temporary lapse such a station will stage a "come-back" that is all the more pleasing because of its unexpectedness.

Talking of "come-back," has anyone been surprised by the breakfast-time capers of Lille? Soon after I mentioned this station last month it perversely "went off." For a few days there was nothing, and then a faint carrier-wave was heard on his dial reading at about 8.30 a.m.

And it was then noticed that overnight the aerial had been disconnected, so Lille's carrier was coming over in daylight on no aerial!

When the aerial was switched on there was no doubt about it—Lille, on 265.4 metres, quiet clear in broad daylight. And yet his power is supposed to be only a matter of 1.3 kw.

Most important of all, we have the public reception tests of our new B.B.C. West Regional station to look forward to during April. These will all take place on the Cardiff wavelength of 309.9 metres, and though they may be erratic and of queer quality at first, there will be few listeners who will not welcome this, the last of the great Regional stations to be erected under the scheme so brilliantly evolved by Capt. Eckersley, "M.W.'s" chief radio consultant.

D. X.



MEMORIES OF YESTERDAY

Listeners who enjoy the fine quality transmissions of many foreign stations may be amused at this photograph, taken in 1923, of the first official German broadcasting concerts. Note the microphone tied to the violin!



ON BOARD the "ELETTRA"

THE S.Y. *Elettra* was anchored off Civitavecchia Harbour.

A radio friend connected with the

Marconi interests in Italy arranged for me to visit the world-famous yacht to see the very latest in short-wave apparatus. And so one very sunny morning I found myself being carried out in the launch to the mid-stream of the harbour, where the yacht was lying idle for a few days after having come up from radio tests being made with Rocca di Papa.

An Unusual Arrangement

As the *Elettra* swayed gently in the wash of other boats entering and leaving, and as the launch slowly came alongside, I did not at first see anything unusual in her appearance, but as we came near the stern I noticed a rather unusual aerial arrangement looking like a direction-finder. The ordinary 600-metre aerials between the masts are the conventional parallel cages of four wires each.

We clambered up the ladder, arrived on the main deck and were then shown round by a specially-appointed guide. No work was being done, as the Marchese was filling in business appointments

It is not often that you get the chance to look over Marchese Marconi's world-famous yacht. Let us seize an opportunity while the owner is ashore on business, and slip aboard S.Y. "Elettra" for an inspection of this floating radio station.

Down we went into what in a normal steam yacht would be the state-room. In the *Elettra* the living quarters have been

moved farther forward, and the main cabin is filled with a C.W. commercial transmitter, direction-finding receivers, and a standard shipping receiver.

Separate Power Supply

Some of the largest air-cooled valves are used in the main transmitter, the power being taken from a separate generator in the engine-room. This is quite separate from the lighting power supply of the yacht.

The main transmitter has a universal wavechange arrangement, so that not only can it work on the 400-600 metre shipping band, but in an emergency it can go up to longer wavelengths such as are used by Rugby.

The *Elettra* is fitted with one of those clever automatic S O S listeners which work continuously night and day, and which will only respond to a repeated—three dots, three dashes, three dots, the dramatic S O S call.

I saw the delicate relay which responds to the call. The signal



FOR EXPERIMENTS

The *Elettra* is fully equipped for experimental work. Above are the main aerial and part of the direction-finding apparatus.

ashore until the weather improved and he could then go on to Sardinia. We therefore had a wonderful chance of seeing all the new short-wave apparatus without interrupting experiments and being pushed out of the Radio Department in consequence!

operates one set of relays which pull up a plunger. The plunger is, however, retarded by a dashpot, and takes about four seconds to rise. There are several of these relays interconnected so that the signals will cause the main contacts to touch on any ordinary SOS call.

Then we went aft to see the star-piece of the *Elettra*, the ultra-short-wave beam aerial receiver.

A Beam Receiver

"*Si accomodi,*" said the guide, "and I will explain it to you."

"This is the beam receiver which we used to see just how far we could reach out with ultra-short-waves after the Vatican authorities had had a beam transmitter fitted up for the Pope at his Castel Gandolfo palace, near Rome. This works on less than one metre.

"These very short wavelengths aren't supposed to travel farther than optical range. The Vatican City is less than eighteen miles away from Castel Gandolfo, but there is no optical line between the two, owing to the trees in the Vatican gardens. This made us realise that perhaps the short waves could be used for more than optical range, so the Marchese had this receiver fitted on the stern of his yacht."

The Aerial

We examined it.

Probably you know what these "wavelet" receivers are like. There is a roughly U-shaped metal strut carrying a number of short reflector wires at right-angles. At the focus-

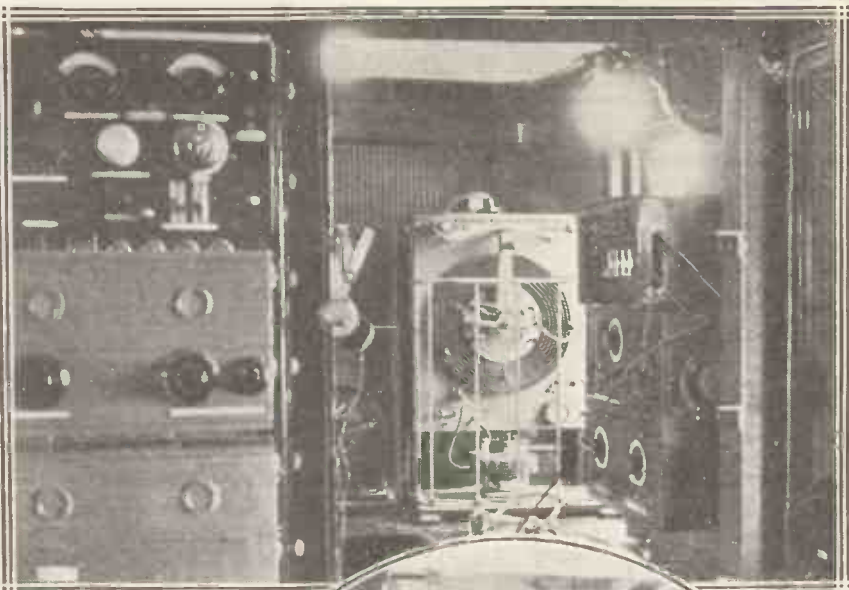

COMPACT AND ACCESSIBLE

Above, on the right of the picture, is the coil of the spark transmitter, while the switchboards seen in the circle are used for the short-wave apparatus. Below is a general view of the radio room, with its specially designed apparatus, mostly of British manufacture.

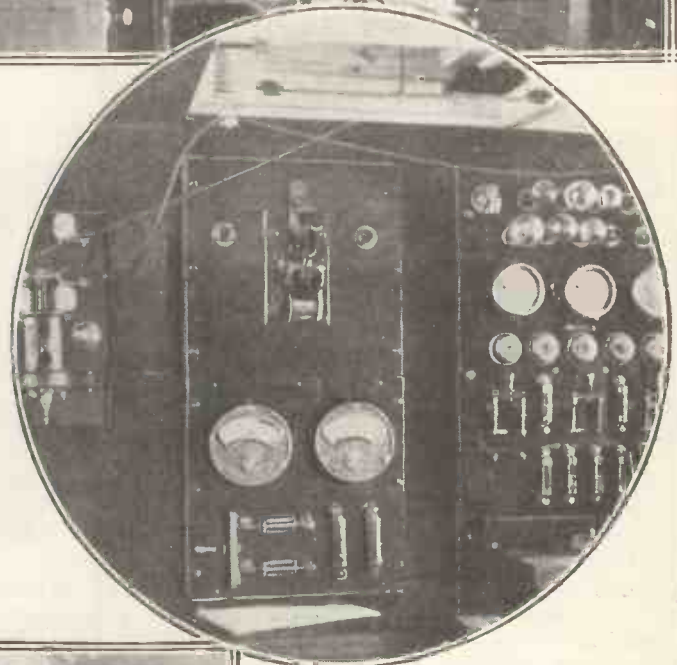

ing point (where the bulb is in a car headlamp) is a pair of parallel feeder wires with little discs on the end.

That's the aerial!

The U-shaped affair is the beam reflector. The feeder wires run back a foot or so behind the U, and disappear into a metal-covered box which houses the oscillator and other equipment.

On Wooden Supports

On the *Elettra* the back of this box comes off to allow new valves to be plugged-in. There are two groups of bunched rubber cables running off to the power supply and listening cabin. The whole beam arrangement is fixed on wooden supports astern of the main deck.

The World's Most Famous Floating Laboratory

"We have been working with a very special beam transmitter at Santa Margherita," continued the guide. "This is built with four beam reflectors and aerials in parallel!"

"And the wavelength is——"

"Micro-Ray" Tests

"Fifty-seven centimetres, as a rule. The *Elettra* replies on 26 metres. We have managed to cover a distance of 28 miles with this transmitter, in spite of the curvature of the earth cutting out any possibility of an optical range!"

"Then, last July, the land station gear was transferred to a disused observatory at Rocca di Papa, which is just over 10 miles from Rome and some 15 miles inland. We anchored off Ostia, and with the *Elettra's* stern turned towards the observatory we found we had reliable 57-centimetre reception."

Both on the ultra-short wave and on the *Elettra's* normal short wave of 26 metres speech was used. On the yacht there is a carbon microphone and the necessary speech amplifier.

I noticed that although the *Elettra's* staff is normally more closely in touch with the Marconi interests in Italy than it is anywhere else, the gear on board (with the exception of the 57-centimetre plant) is mainly British made

Bad weather was encountered before the *Elettra* came into Civitavecchia Harbour, and the beam tests have been made in the worst of shipping weather, and even in fog.

No Reflection

"We thought there might be a reflection owing to the moisture in sea fog," explained the guide, "but it didn't happen."

"This confused some of the technical folk, especially those who said we on the *Elettra* were wasting time with the micro-rays."

"Last month the Marchese Marconi was entertaining a guest on board who couldn't see how the 57-centimetre waves could possibly travel round the earth's surface. The Marchese reminded him that, way back in 1901, when the historic 'S' signals were sent across the Atlantic there were critics who tried to prove to him that it would be absolutely impossible to send wireless waves

farther than 165 miles owing to the earth's curvature! And some of those critics were distinguished mathematicians!

"Before this receiver was fitted on the *Elettra* the Marchese had tested a similar receiver on the balcony of a private villa at Levanto, and signals had been picked up from Santa Margherita—the station we first tested with when the set was transferred to the yacht."

Tuned Filaments!

The guide showed me the inside of the ultra-short-wave outfit.

Two valves in a kind of push-pull



SHORT WAVES WITH A VENGEANCE!

Marchese Marconi photographed with the ultra-short-wave equipment by means of which he has arranged to maintain 2-way working between his yacht and the shore at a distance of 80 miles on a wavelength of only 57 centimetres! The wavelength of our own Daventry National transmitter is 2,726 times as long!

circuit are used. Even the filament circuits of the valves are tuned so that there is no stray H.F. The grid and anode circuits are tuned by pushing metal tubes up or down the feeder wires. The little discs in the beam aerial, in fact, are on the ends of the tuning tubes.

One of the First

We went back to the main radio cabin to chat about the ultra-short waves and to see the rest of the testing gear, which comprises tape printers and calibrated wavemeters. The 26-metre transmitter was

actually one of the first short-wavers to be fitted on a boat. The present ship-to-shore telephony on Atlantic liners is only possible owing to the *Elettra* tests with the 26-metre plant.

Frequently Visited England

The guide told me that the yacht had made trips over all European waters in the course of radio tests. It has been frequently to England, and generally anchors off Southampton.

We talked of the old days when spark-transmitters tests were made with the *Elettra* (and until recently the yacht had an ordinary quenched-spark outfit), and of the time when I had known Mr. Romano as the chief officer on board.

Our conversation had been carried out in English (a creditable effort on the part of the guide), and when it came for *addio*, I felt it time to exchange the compliment.

The best I could muster was "*Mi piace tanto questo battello*" (simply "I like this boat very much indeed"), which didn't really express the way in which we were astonished at the radio gear on board!

KEEP A LOG

When To Expect the most Favourable Long Distance Reception.

WHAT exactly is the connection between weather and wireless is not yet certain, though some interesting data has been obtained. Atmospheric, for instance, are most likely to occur if the barometer is unsteady or if large and rapid changes in the temperature are taking place. But why is it that on some nights the set seems positively alive, stations coming in with immense volume at almost every division of the tuning dials; whilst on others only the biggest stations can be received without working dangerously close to the oscillation point.

I have kept a radio log for many years, and if I were asked to choose the ideal night for long-distance wireless I would select a thoroughly dirty one. By far the greatest number of dates when columns of the log are filled with "V.G.s," signifying first-rate loudspeaker reception, are those when the record reads "Pelting rain and blowing hard,"

H. S. M.



"SHORTS" FROM THE STATIONS

For your greater enjoyment and better understanding of long-distance listening, we offer each month the latest available information about the broadcasting stations of the world.

PHILIPPINE ISLANDS. The station at Kavite (N P O) sends out time signals at 03.00 and 14.00 (3 a.m. and 2 p.m.) on a wavelength of 33.8 metres.

PÉCS (HUNGARY). This, the third Hungarian relay station to come on the air, has been testing on 210 metres in the evenings, using low power.

THE ANTARCTIC. Commander Larsen, the Norwegian airman who is exploring in the Antarctic, intends to keep in touch with civilisation by means of a short-wave transmitter.

POSTE PARISIEN (FRANCE). It is intended to give a three-act play every Wednesday and a one-act play every Saturday when the newly-formed repertory company gets into its swing.

ROME (ITALY). The recently introduced gymnastic exercises by radio have met with a quite enthusiastic reception.

RADIO PARIS (FRANCE). As this station often changes its announced programmes at the last minute, listeners may like to know that a summary of projected broadcasts is given daily at 07.45, 12.30 and 22.30 (i.e. 7.45 a.m., 12.30 p.m. and 10.30 p.m.).

NEW ZEALAND. The good results from South American stations received in Britain on medium waves pale into insignificance besides the New Zealand reception this winter.

Many listeners there have picked up European stations, but curiously enough it has generally been the German, French, Swiss and Polish programmes that have given best results.

MARSEILLES (FRANCE). This station appears to be using considerably increased power on tests on 315 metres

RADIO AGEN (FRANCE). Replacing the original Agen Station that was destroyed in the great French floods of 1930, the new Radio Agen has been going strong on about 453 metres.

Its hours of working are usually 12.30-13.30 and 19.30-20.30 (i.e. 12.30 p.m. to 1.30 p.m. and 7.30 p.m. to 8.30 p.m.)

BRUSSELS (BELGIUM). Both the Brussels stations recently extended their hours of working. (509 and 338.2 metres.) Their week-end programmes now continue until midnight, and they are on the air at 10 a.m. on Sundays, instead of beginning at midday.

MADONA (LATVIA). This station, relaying Riga, has been heard in this country on about 450 metres at fair strength.

STUTT GART (GERMANY). Owing to the cutting of the cable with an axe, and the consequent interruption of a speech by Chancellor Hitler, the technical staff at Stuttgart were suspended from duty whilst an investigation into the matter was being made.

"THE COMET." The Irish lightship "The Comet" is to be fitted with a Marconi automatic wireless beacon, which will work in conjunction with a submarine signalling device, as an aid to navigation.

MOUNT EVEREST (INDIA). The special portable radio transmitter used at the advance radio camp was constructed by the two well-known amateurs, G 6 R L and G 6 U S.

It operates on waves between 60 and 120 metres, and can be transported by one man.

TRIER (GERMANY). This new relay of Frankfurt works on 259.3 metres.

It is a town of great historical interest—it was called "Treves" in the

history books—and it is now the centre of the Moselle wine industry.

G 2 Z Q (GREAT BRITAIN). The amateur station, G 2 Z Q (operated by Mr J. Hunter, of Blackheath) was the first of the British competitors in the recent accuracy contest promoted by the Ragchewers' Club in the interests of amateur transmission.

The contest was won by the German station D 4 U A N.

OSLO (NORWAY). The beginning of July will see the end of the present Norwegian privately-controlled broadcasting, the State taking over control on the first of that month. The licence fee will be reduced to about ten crowns per annum.

BISAMBERG (AUSTRIA). The new Vienna station at Bisamberg is to radiate not from a wire aerial, but from a steel mast, in conjunction with a reflector aerial to concentrate the transmissions in a westerly direction.

AMSTERDAM (HOLLAND). The Dutch radio concern known as "Avro" is dismantling an Amsterdam mansion, brick by brick, to make its new headquarters. The intention is to restore the building when the necessary internal structure and installation is completed.

BUCHAREST (ROUMANIA). The new transmitter at Blaj, on the Roumanian-Hungarian frontier, has been testing on about 1,900 metres.



"MODERN WIRELESS" introduces

THE ANNOUNCERS OF LEIPZIG

There is probably no one in broadcasting who impresses his personality upon listeners so strongly as the announcer. Our special travelling correspondent affords you the opportunity of meeting the personalities behind the voices of Leipzig.



Now that Leipzig booms out its "Hier ist der Mitteldeutsche Rundfunk, Leipzig und Dresden," with 120 kw. in the aerial, there is hardly a set owner who is not familiar with two voices: that of a girl and that of a man.

An Early Riser

Little Miss Leipzig, as I have christened her, gets up very early in the morning at 6 a.m., or even earlier, as she takes over shortly after the morning exercises that start at 6.15 a.m.—or, rather, at 5.15 G.M.T.—and stays on duty until 4 or 5 p.m. Sometimes she takes the gym. in the morning too, sometimes she only comes on at 9.40 a.m. with the first news, but she is Leipzig by day. Her name? Elisabeth Teetzmann. She has been on the staff of the Mitteldeutscher Rundfunk some three years, and about two and a half years ago she—then typist in the Press department—and a budding actress were first in a big contest for the post of lady announcer at Leipzig. Miss Teetzmann won the day, and there she is at her post every day from morning till late afternoon.



ERICH WÖTZEL

Announcer at Leipzig since 1929—is confident that no woman can fill any post as well as a man!

She is well on the right side of thirty and on the wrong side of twenty, but only slightly so, and is still unmarried.

She likes the microphone, but distinctly does not like the old ladies who write in and say that she did not pronounce correctly the "r" in orchestra yesterday, during the lunch-time concert.

Her colleague, Mr. Erich Wötzel, left business to become a Press stenographer, and he has been the "voice of Leipzig" since 1929. He is a firm believer in the fact that no woman could ever fill a post as well as a man, and that is actually the main reason for his becoming a member of the Mirag staff. They had advertised for a good stenographer to take down the daily press bulletins which came in via telephone, and had mentioned that a woman would fill the post adequately. Mr. Wötzel wrote in and said that it was a man's job.

The "Evening Voice"

Well, they tried a woman and she had a nervous breakdown, and so Mr. Wötzel was asked if he would like to try his hand at it. He refused twice, and the third time he said yes. But he soon left the stenographer's block behind him and did announcing, as well as a certain amount of acting in radio plays, and he has now become the actual voice of Leipzig, the "evening voice," as Miss Teetzmann is the "day-time" voice. Although they are the best of friends, I know that Mr. Wötzel considers Miss Teetzmann as a person out of her sphere. I am sure he would prefer to see a man and the father of many children in her place, just on principle. But, luckily, those are his subconscious thoughts, and his waking mind greets

Miss Teetzmann as a good comrade of the microphone, though, of course, she is "only" the day voice. Next to these two there are a number of other men who occasionally take over some of the announcements. But let us return to Erich Wötzel.

Offer of Marriage

He is proud to be announcer at Germany's most punctual station. He once got an offer of marriage from a widow, aged 59, with four grown-up children, but this was not sent to him, but to the station director. He was requested only to pass on the letter if he could give Wötzel a good character. It must have been a blow to the good lady to hear that the man of her dreams was already married and was a good twenty years younger than she.

One of Wötzel's most amusing stories is about the young girl who sent him a glass jar of pickled herrings on New Year's Day to help stave off a bad head, as she was sure he had sounded thirsty the night before, and she had been sorry for him, who had first to close down the station before he could indulge in a belated last "deoch-an-doris" of the old year.

Don't Forget

The next time you hear the hollow sound of Leipzig's metronome and the voice of Mr. Wötzel, the man who believes in a woman being a good housewife, and Miss Teetzmann the lady who is a good announcer and an indifferent cook, you will know all about them.

"Achtung, hier ist der Mitteldeutsche Rundfunk, Leipzig und Dresden, wir beschliessen unsere heutige Sendung und wünschen Ihnen eine recht gute Nacht!" And don't forget to earth your aerial.

If you are interested in distant stations, the "World's Programmes" foreign news service will keep you fully informed and up to date as to the most recent changes and additions.

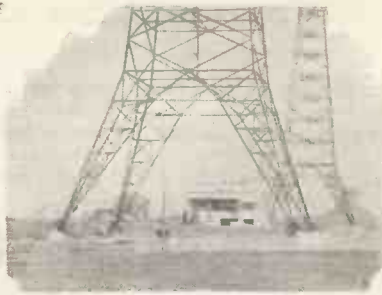

If you only indulge in occasional "foreign listening" you will still be interested in these news paragraphs from all over the world. They make absorbing reading and place you in touch with developments abroad.

WHAT THEY ARE DOING

LJUBLJANA, YUGOSLAVIA. Listeners who have succeeded in picking up the English music series broadcast on Wednesdays at 5.30 p.m. from Ljubljana, on 574.7 metres, are invited to report to the station director there.

ATHLONE, IRISH FREE STATE. The Athlone station (on 413 metres) employs twin masts, each 330 ft. high. They are erected 730 ft. apart, and support an aerial of the T type.

FINMARK, NORWAY. A new station is to be erected in this, the farthest-north province of Norway. Its power will probably be 20 kilowatts or more, and it is hoped that it will be working before next Christmas.

CARDIFF, WALES. The Cardiff transmitter will be withdrawn from service when the new West Regional station has successfully taken over the whole-time programmes on 309.9 metres.

MOSCOW (TRADES UNION), RUSSIA. The 1,304-metres English talks at 8 p.m. on Sunday, Monday, Wednesday, and Friday are regularly relayed on 50 metres.

WELLINGTON, NEW ZEALAND. The 49.5-metre Wellington station, Z L 2 Z X now broadcasts a four-hour afternoon programme from 2.15 onwards, on Monday, Wednesday, Thursday, and Saturday.

WEST REGIONAL, GREAT BRITAIN. This new B.B.C. station, at Watchet, Somersetshire, should be heard testing on 309.9 metres (Cardiff's wavelength) by about the time these words appear in print.

HAUGESUND, NORWAY. The present Bergen station is to be erected as a relay at Haugesund when the 20-kilowatt Bergen transmitter which is now planned is in working order.

EINDHOVEN, HOLLAND. This popular station, which for a long time was "off

But it is probable that this Italian-speaking station will be in operation within the next two months.

BISAMBERG, AUSTRIA. The tests of the new Vienna station, at Bisamberg, will probably be heard well in this country during April.

VIENNA, AUSTRIA. Aircraft using the Vienna aerodrome at night are to be protected from accidental collision with the masts of the great new station (at Bisamberg) by a powerful lighthouse.

CASTEL GANDOLFO, ITALY. After their successful inauguration, the ultra-short-wave stations at Castel Gandolfo and at the Vatican City were presented to the Pope by Marchese Marconi.

BELGRADE, YUGOSLAVIA. The present low-powered station (2.8 kilowatts) which works on 430.4 metres, and announces as "Radio-Beograd," is to be replaced by a high-power station, probably of 50 kilowatts, before 1934.

CANTERBURY, NEW ZEALAND. A five-fold increase of power for the Canterbury station is one of the projects to be put into operation before the end of the year by the N.Z. Broadcasting Board.

LUXEMBOURG. The wavelength of 1,190.5 metres has recently been semi-officially named as that which will be fixed on for the regular Luxembourg transmissions.

YOUR FRIEND ABROAD

Why not send him "Modern Wireless" every month to keep him in touch with all the latest radio news and developments? Post his name and address with 17s. to the Subscription Department, Amalgamated Press Ltd., The Fleetway House, Farringdon Street, E.C.4, and "M.W." will be sent every month for a year.

the air," has adopted the wavelengths of 25.57 metres and 16.88 metres.

REYKJAVIK, ICELAND. This station has recently been keeping very late hours at the week-ends, so Saturday and Sunday nights are good times to try for him on 1,200 metres.

TESSIN, SWITZERLAND. At the time of writing the date of opening of the new Swiss Regional at Tessin is uncertain.

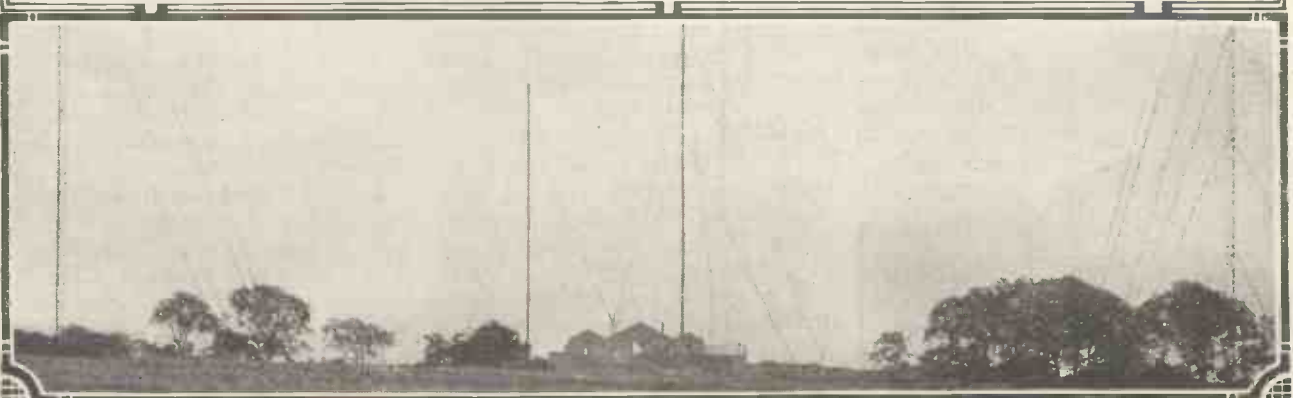

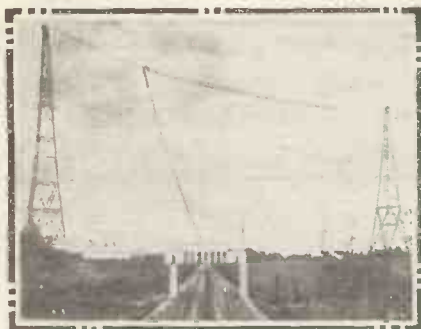

"All the World's a Stage" was never more true than to-day, when entertainment from all the world is at your command at the turn of a dial.



PROGRAMMES OF DISTINCTION

THERE are still many listeners who confine their foreign-station listening to making a log of transmissions received, and they would not think of listening to a programme longer than is necessary to identify a particular station.

But regular listening to foreign programmes provides a great deal of delight for those who realise that such programmes make real alternative entertainment to British stations.

In these notes on foreign programmes I have tried to pick out a number of representative items heard during the past month as an encouragement for listening more seriously in the future.

Let us see, then, the kind of thing that foreign stations have to offer.

Belgium

The Brussels stations seemed to have a particular partiality for musical comedy, for among the light musical programmes were included performances of both "The Land of Smiles" and "The Vagabond King." The music of these two shows must have revived pleasant memories for many an English listener.

Denmark

Copenhagen was well up to date with a programme entitled "From The Stage Coach to the Aeroplane," which mixed literary and musical



Foreign station programmes which have been outstanding events of the month.

compositions into a delightfully pleasing whole. And in order that the older generation should be properly catered for, there was also an "Old Folks Ball" devoted to polkas, and two-steps, and lancers and the like. A very jolly affair it was.

Germany

German broadcasting has been very upset by the recent political situation, and there was never any guarantee that the advertised programmes would take place!

I tuned-in early in the month to hear a relay of dance music from the B.B.C. only to find that the burning of the Reichstag had upset all arrangements.

Incidentally, although I did not hear it myself, I hear that Berlin, on the morning after the fire, provided a broadcast of the actual scenes, recorded the night before on gramophone records. A very enterprising effort.

Längenbergh has been very practical in his talks, providing a regular shorthand lesson as well as a talk on "What Everyone should know about the Telephone Book"!

Holland

The Hilversum programmes included an exciting running commentary on the football match between Holland and Hungary, arranged by the enterprising AVRO, and a special performance, in two parts, of Bernard Shaw's "The Doctor's Dilemma."

Another Hilversum programme which I enjoyed was a talk on "Hot Jazz," illustrated by some extraordinary gramophone records.

Hungary

Budapest was in the news for arranging that the English Prime Minister's daughter, Joan, in Austria with her husband, should broadcast for the first time.

Shakespeare also appears popular here, for a special adaptation of "Coriolanus," which ran for over two hours, was produced from Budapest.

Poland

Warsaw was another enthusiastic supporter of Shakespeare with a broadcast of "Romeo and Juliet," but one of the most interesting items in the Polish programmes is a national lesson in "Anti-Gas Drill." This is a more or less regular feature in the Warsaw programme, and usually accompanies the aviation reports.

Sweden

I was interested to hear a radio version of "The White-Headed Boy" from Stockholm. This play is by Lennox Robinson, who has done quite a lot of work for the B.B.C.

* * *

From a month's listening it would appear that radio plays consist almost entirely of comedies in almost every European country. Tragedy is very rare.

Lehar's "Gold and Silver" has appeared in the programmes almost as many times as "The Blue Danube," which shows that light musical tastes are the same the world over!

COSMOPOLITE.

THE MONTH IN EUROPE

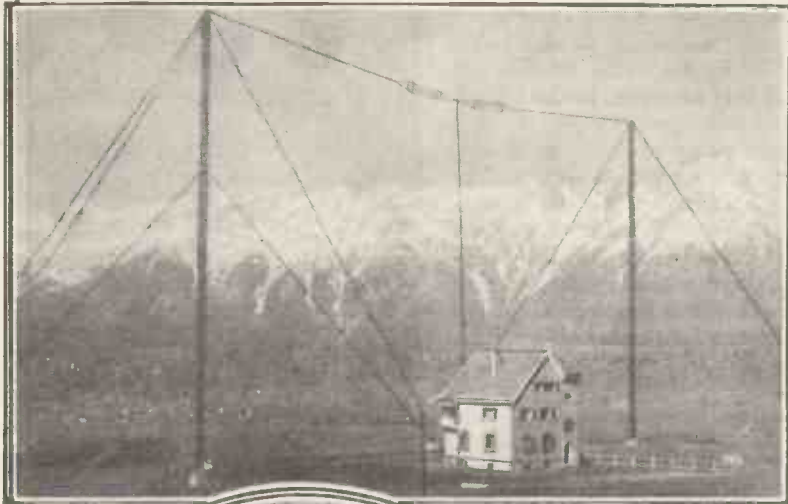

INNSBRÜCK, Austria

One of the many practical and topical talks which this station relayed from Vienna was "First Aid at the Winter Sports."

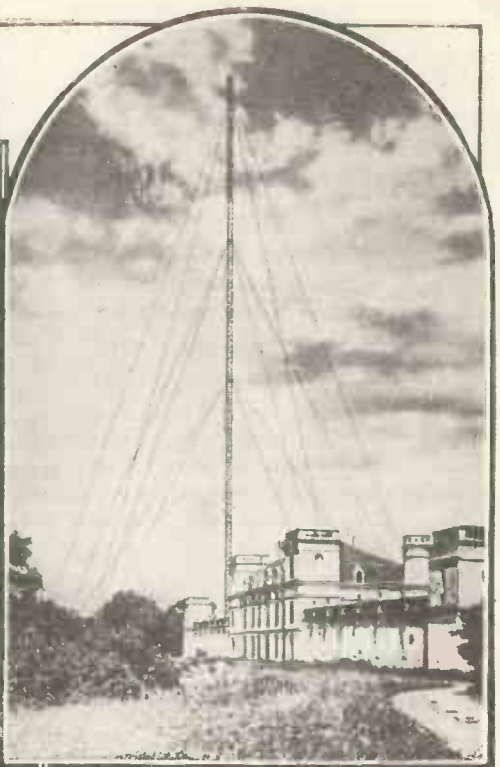

RADIO TOULOUSE, France

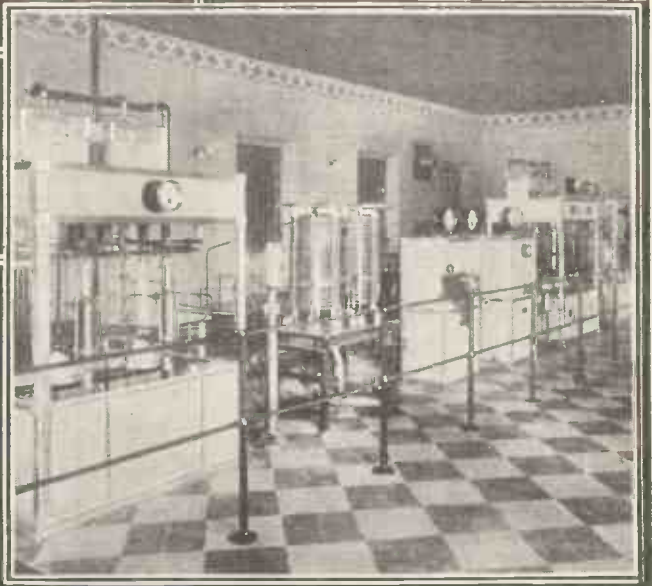
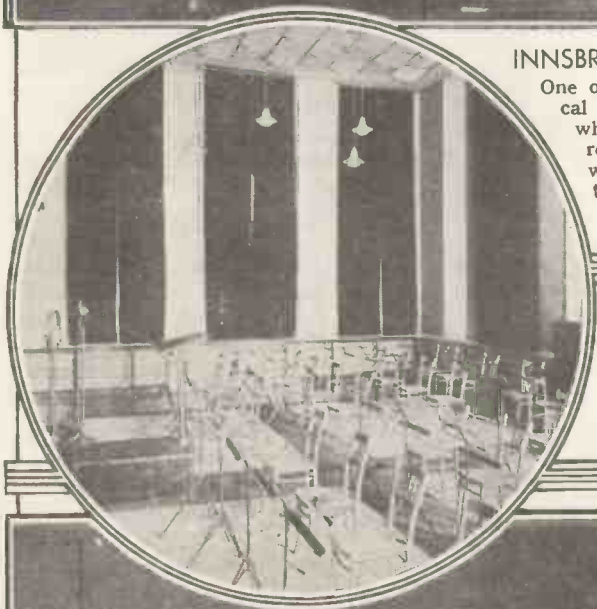

RADIO MILAN, Italy

MILAN presented a new radio revue under the title, "One Hour With You," which contained much tuneful music. A performance of Strauss' "Last Waltz" was also given.

PRAGUE (on the left) chose a scene from Shakespeare's "Julius Caesar" for one of its German transmissions. A performance of "Macbeth" was also part of Prague's programmes last month.

TOULOUSE continues to make a daily feature of extracts from the latest "talkie" films, and the evening programmes contain a special transmission for listeners in Morocco.

TRIESTE (Italy), a view of which station is shown in the circle, takes most of its programme material from Turin or Rome.



MODERN WIRELESS FOR MODERN WOMEN

An answer to those who maintain that radio transmission is too technical a hobby for the fairer sex!

Most people take it for granted that amateur radio transmission is much too technical a hobby to appeal to women.

In reality, however, this idea is far from correct. A search through the published lists of private experimental stations reveals the surprising fact that there are over 230 lady amateurs, in various parts of the world, who hold transmitting licences at the present time.

Nearly 200 in U.S.A.

The majority of these fair amateurs are to be found in the United States. Quite a casual glance through the formidable list of U.S. private experimental stations (which now total something like 30,000) reveals about a hundred call-signs allotted to operators rejoicing in manifestly

feminine names; and in addition, of course, there are others who are listed under initials and surname only, giving no obvious clue to their sex.

Actually, according to the latest available figures, the number of licensed lady amateurs in the United States is 190.

A good many of these, no doubt, are female telegraphists employed in Post Office services, who turn their business accomplishments to good account during leisure hours by taking a busman's holiday transmitting radio messages in Morse or telephony from their own experimental stations.

Call-Sign Clues

Only two feminine names appear in the list of British amateur stations. This is due, of course, to the much greater difficulty in qualifying for a transmitting licence in Great Britain. One of these lady transmitters, Miss Barbara Dunn, has been allotted the call-sign G6YL as her "radio telephone number."

Evidently the letters "YL" are intended to stand for "young lady," as they occur in the call-signs used by a good many other feminine wireless enthusiasts in different parts of the world. For instance, there is VK3YL, the call-sign used by Miss Marshall, of Murrumbena,



SHE TALKS WITH 'PLANES

Edythe Clemons, America's only air service operator, demonstrating from the landing ground.

Victoria; OK2YL, that of a Czechoslovakian young lady, Miss Jarmila Hermanova of Brno; and SP3KYL, the call-sign allotted to Miss H. Malinovska's station at Poznan, Poland.

THE new high-power broadcasting station to be erected near Cape Town is to replace the existing low-power transmitter which is situated in the heart of the city. Work on the new apparatus is now proceeding in the Chelmsford works of the Marconi Company.

Bigger and Better

To be erected at Milnerton, about 15 miles north of Cape Town, the new station is expected to cover a

NEW STATION FOR CAPE TOWN

Details of the new high-power transmitter

much larger service area than the old transmitter, and will thus give new impetus to broadcasting in the African peninsula.

In its plans will be incorporated the latest developments in broadcasting technique, placing it amongst the most advanced in design and quality of reproduction in the world.

The unmodulated aerial energy of the transmitter is 10

UNDER TEST

The Marconi transmitter undergoing preliminary tests at Chelmsford.

kilowatts. Modulation can be effected up to 100 per cent, and a substantially flat frequency response curve between 30 and 10,000 cycles is arranged.

This feature and the extreme care taken in the design of the valves and their associated circuits will ensure faithful transmission of every type of musical and vocal programme. The transmitter is built in the form of a switchboard on which all measuring instruments are mounted, the valve circuits being assembled at the back of the board.

Latest Design

This form of construction is now adopted in many of the most modern broadcasting stations. It allows for ease of maintenance and supervision.

Access to the valves and their circuits is gained through expanding safety gates on the side of the switchboard. A control desk facing the transmitter provides an efficient means of supervising the installation.

The transmitter can be adjusted to work on any wavelength between 200 and 545 metres.

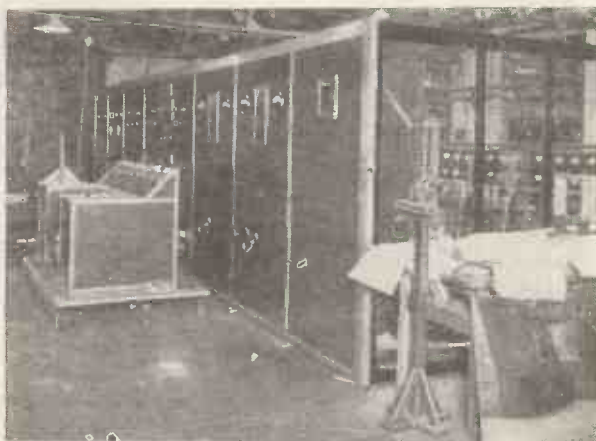



OTHER PEOPLE'S PROGRAMMES

No. 5—HUNGARY

The more we listen to other people's programmes the more we realise what a wealth of fine entertainment is provided by the broadcasters of Europe.

This month we investigate Budapest—for Hungary means Budapest—and we find the Hungarian programmes, studios and announcers of exceptional interest.

RIGHT in the centre of the town of Budapest, which is picturesquely situated on both banks of the Danube, you will come upon a quiet little street—the Rue Sandor—where stands the building that holds the broadcasting destiny of the Hungarian listener.

The Hungarian H.Q.

No palatial and modernistic building greets the visitor to No. 7, Rue Sandor. Just a pleasant town house, faced by a courtyard through the arch of which can be seen circular flower beds and little green box hedges. An unassuming enough headquarters for an organisation which claims nearly one out of every sixteen of the country's inhabitants as a licensed listener.

The Rue Sandor building is self-contained. On the ground floor you will find the control engineers; higher up are the studios; and the second floor houses the director and the programme officials.

Studio Tours

But do not think that because there is no outward sign of grandeur Hungary's broadcasting system can be lightly regarded. On the contrary, the programme people at Budapest are among the most enterprising in Europe and they take pride in showing you some refinements in their studios which are unique.

Shall we go up to the studios and take a look round? The three smaller ones first. Do you see the heavy drapings which hang round the walls? Decoration is not their chief use, for they can be adjusted in height, drawn backwards or forwards, and so on as programme requirements demand.

No Moving Walls

And the Hungarian programme people will tell you that the effects they can obtain in this way are comparable with the most modern



A VERSATILE TRIO

Lili Filorás, Arpád Rado and Koloman Rosner, announcers at Budapest, who have to deal with the programmes in three languages—Hungarian, German and French.

moving walls and acoustic roofs of other countries.

In one of these studios there is a talk going on—one of those practical or entertaining science talks in which the Balkan countries specialise. A talk on the splitting of the atom will be followed by advice for the unemployed, perhaps, or a foreign language lesson, or a course in dress-making. All very practical and useful.

A rehearsal of a radio play is going on in the next studio. It is a bright comedy—for they take their pleasures more gladly than we do in England, with radio plays at any rate—and the producer has the cast roaring with laughter over his demonstration of how a particular part should be played.

There is no elaborate effects department here, but the apparent informality of the whole production seems to the listener to give just that air of spontaneity to radio drama which is sometimes sadly lacking in more mechanised systems of broadcasting.

On 550 Metres

In the third of the small studios we find a quintet, under the direction of Wilhelm Komor, preparing for a broadcast of light music. You won't be surprised to find "The Blue Danube" among the items on the programme, for it seems to be a general favourite all over Europe.

But you may be surprised to hear how remarkably well this small orchestra plays it. Hungarians must be born with the sound of music in their ears—for they certainly play as though their tunes were part of their lives.

Hungarian music, of course, plays no small part in the orchestral and vocal programmes. And the national tunes of Hungary are really worth listening to. At any rate, I should imagine that they form part of the reason why so many British listeners tune their sets whenever they can to 550 metres, and why the relay from Budapest during the B.B.C.'s "Birthday Week" drew so many appreciative letters.

A Source of Pride

It is in the large studio, however, that we see the arrangement of which Hungarian broadcasters are so proud. This studio is used whenever the

Hungary's "Silent Loudspeaker"!

full orchestra plays, and also for the more elaborate radio dramas, musical comedies and operas.

At the end of the studio you will be intrigued to see a large plate-glass panel, stretching almost the full length of the room, behind which is a rostrum, a loudspeaker and a table. In front of the partition is a desk which carries a number of coloured lights.

Seen But Not Heard

What is it all for? The musical director of Budapest was surprised, one day, to notice how different his orchestra sounded when he was conducting it in the studio from when he listened to it through the loudspeaker of his own receiver.

So, as a result, this special conductor's rostrum was built, and now the musical director, though he can see his orchestra and conduct them in the usual way, can only hear them through a loudspeaker—just as the listener does.

Other countries arrange for a control engineer to maintain a proper balance of musical items before they are sent on to the transmitter. In Budapest the conductor can do all the balancing before the transmission reaches the engineers. A very sound system and one which has received universal approbation.

An English Comment

Actually the conductor is not cut off from his orchestra. During rehearsals he can make all the remarks he wants through a microphone, and at the actual performance he can supplement his ordinary conducting by means of a series of coloured lights and signals—"Stop," "Interval," "Too loud," and the like.

The musicians have had a great deal of amusement out of the fact that an English journalist once described this signalling method as a "silent loudspeaker."

Modern "Mixing"

There is no doubt that a great deal of the quality of musical transmissions from Budapest depends upon this method of conducting and upon the other unique features of the studio—the programme meter, which is fixed on the wall in full view, and which shows the slightest distortion in the transmission.

Outside broadcasts, of course, have their place in the day's programme. Private landlines are permanently connected to different parts of the

which are used to produce that well-known musical-box interval signal and to work the chiming clock.

It was only last month that Budapest staged a real radio "scoop" which was of interest to English listeners. They persuaded Mr. Ramsay Macdonald's daughter, Joan, and her husband to come to the microphone for the very first time while they were holidaying in Hungary!

The Announcers

But we are forgetting those most interesting people, the announcers of Budapest. Five of them there are altogether—Frau Elisabeth Gecső and the Fraulein Lili Filotás and Lydia Beöthy uphold the honour of the fair sex, and do their utmost to out rival the men of the party, Herren Arpad Rado and Koloman Rosner.

All of them are young and all are jolly—can you doubt it when you see the photograph on the previous page, especially that of Fraulein Filotás! See if you can recognise her voice when next you listen to Budapest. And remember, too, that the Hungarian programmes are announced not only in the national language, but in French and German as well.

It's not all honey being an announcer at Budapest.

The more you listen to other people's programmes the more you realise how much you are missing by "staying at home" with your receiver, and once you have heard the programmes from Budapest you will be certain to come back for more.

That, at least, is the opinion of the 332,693 Hungarian listeners who are confident that their broadcasting is the best in the world.



THE MAN BEHIND THE SCREEN

A photograph of the orchestral studio at Budapest which shows the special features of which Hungarian broadcasters are so proud. In the top left-hand corner is the "programme meter" which indicates any overloading. At the back is the glass soundproof screen behind which the conductor controls his instrumentalists while listening to their efforts through a loudspeaker. In front of the screen are the electric signals for controlling the orchestra.

town, to cafés, theatres, churches, etc., and with typical thoroughness all this apparatus is in duplicate. You will have to listen for a long time to find a breakdown on the lines of Budapest.

Elaborate broadcasts, involving the use of all four studios as well as the outside lines, are undertaken with the greatest nonchalance owing to the use of a really modern "mixing" panel.

And we mustn't forget to have a look at the two electrical machines

HOW TO DIAL

An article of outstanding and practical interest to all who listen to foreign stations—proving that accurate tuning, while essential to successful listening, is not impossible to obtain!

WITH stations coming in as they do these days, all round the dial (sometimes two or three to a degree) accurate dial readings are difficult to obtain. But obtained they must be, if a log is to form more than just a rough guide.

Listeners do not usually realise how much there is in correctly noting a station's tuning point. And a wrong "degree-number" is highly prone to cause mis-identification of the station.

Ensuring Satisfactory Calibration

The following is a good example of the pitfalls to be met, and concerns an ordinary plain dial. A pointer that overlaps the edge of the dial is employed.

Looked at from slightly towards the right, a station might tune in at 78 degrees; while looked at from the left, the same station could easily appear at 79 degrees.

The true reading in such a case would be about 78½ degrees. How, then, can one ensure the same reading each time?

One good way is to take a leaf out of the instrument maker's book.

On high-grade meters a piece of mirror is placed behind the needle to ensure that readings are taken only when looking exactly above the needle. Any slight divergence to either side causes the image of the needle in the mirror to become visible.

Application of the scheme to dial reading is quite simple. Immediately adjacent to the edge of the dial, and at the point where the indicator is to come, a small piece of mirror is attached to the panel. (If desired, it may be let into the panel.)

Useful for Wavemeters

The pointer is made from a piece of copper wire, hammered flat, and fixed edgewise to the mirror. It passes first over the glass, and then over the edge of the dial. If it is always dead in line with its reflection, one is sure of taking all readings from the same view-point.

Apart from the above use, this

scheme is worthy of consideration by all who employ wavemeters. The necessary accurate readings with these instruments if they are to be of full use are made certain with this mirror dial-indicator.

With Plain Dials

While dealing with plain dials—here is another point.

The bigger their diameter, the easier it is to log accurate readings for all stations. An 8-in. dial, for instance, would provide accurate settings for two or three stations, which, crowded into one degree on a small dial, appear to defy all attempts to separate them.

When two tuning dials are used adjust them simultaneously.



An interesting suggestion in this connection is to fix a large cardboard disc, carefully marked in degrees, to the back of a plain dial and arrange the dial-indicator at its edge. If the card is large enough in diameter it makes a log unnecessary, as stations can be printed against their dial readings on the cardboard itself.

Reference to logs brings us to an item which puzzles many people. Why do stations sometimes appear to vary in their tuning positions from night to night, making a carefully prepared list seem useless?

Of the many causes, some are more easily overcome than others. It might

be that the wavelengths of several stations had altered. Luckily, this is unlikely, since there would be no remedy in this case.

Much more likely is the possibility of the dial slipping on its spindle, a common cause of readings varying from time to time. As a result all dial settings shift up or down a little.

Usually this trouble is traceable to the grub screw holding the dial being insufficiently tight. Difficulty in securing may be overcome by filing a flat on the spindle.

Another prolific cause of dial readings varying from one night to another is the amount of reaction employed. Simple sets of the det. and L.F. type are most likely to suffer in this way, for their reaction is often pushed almost to the oscillation point to bring in very distant transmissions.

The Effect of Reaction

The more reaction employed the lower the point at which a certain station tunes in. So if you use less reaction one night because conditions are good, the dial reading may be higher than on another night when reception is poor and you need much more reaction.

With differential reaction condensers the effect is not much in evidence; but on sets with plain reaction it may make several degrees difference. The best remedy is to set reaction at zero when logging loud stations, and always to use the set just off oscillation

when dealing with weak ones. Readings will then hardly vary at all, and reaction can be slackened back when a station is found.

Other Causes

Differential couplers to tuned circuits, taps on coils, series aerial condensers and similar variables also cause changes in readings.

When possible, mark the best average positions for these items and calibrate at that point. Returning to these settings will enable the duplication of dial readings at any time. As with reaction, final adjustments can be made after a station is found.

Marking the positions of preset

The Milliammeter's Aid to Easy Tuning

condensers with any accuracy is impossible, so leave these permanently set at their best average values. Otherwise your log will be of little assistance to you.

Which Dial?

These effects of reaction and variable controls lead to the question of which dial to calibrate when there are two or three to a set. The one least affected by varying factors is naturally the best, and that immediately rules out the one coupled to the reaction coil.

If a choice is still left, choose the one least affected.

Usually, alternative aerial tapings made on the tuned coil itself produce definite tuning variations.

On the other hand, taps on a separate aerial primary, or condenser in series with it, produce much less effect. The amount depends upon the closeness of the coupling between primary and tuned windings, a factor that varies with the type and make of coil.

But suppose the set is ganged, then there is naturally no choice of circuit for calibration. And with this type of design another snag arises.

Quite often the tuning of ganged receivers, especially when band-pass coils are used, is broad; and difficulty exists in deciding just where a station is properly tuned in. The application of reaction in these circumstances, even when stations are loud, will tend to reveal the correct readings.

Using a Meter

Incorrect ganging can cause broad tuning, and if the circuits are very badly balanced two distinct maximum points. In such cases a little care given to trimming may work wonders—both sharpening up the tuning and increasing the set's sensitivity.

And now for one of the biggest

aids to correct dial reading—the milliammeter. This ubiquitous instrument has so many uses there is a danger of them obscuring this one.

The current in the detector's anode circuit varies according to the strength of the station tuned-in. With leaky-grid rectification the current decreases as reception strengthens, and the opposite applies with anode-bend rectification.

KEEPING THEM APART

So powerful are the stations to-day that two or three may be covered by one degree on the dial. Thus, on inselective sets, Gleiwitz might easily be mistaken for Frankfurt, since they are only three channels apart.

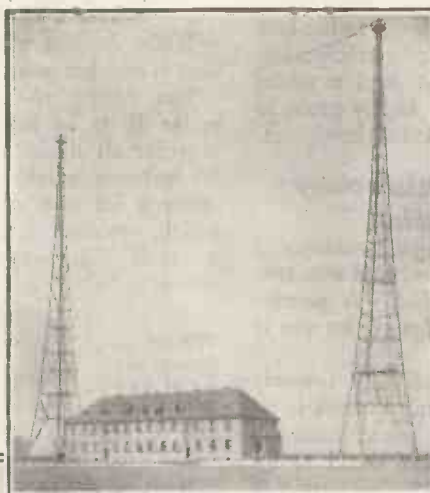

GLEIWITZ
which relays Breslau on a wavelength of 253 metres, with a power of 5 kilowatts.

FRANKFURT
(below) uses 17 kilowatts to put over his programmes on 259.3 metres.



Thus, a milliammeter in the detector's H.T. supply enables tuning to be watched as well as heard. And the visual check is far more accurate than the aural.

Let us suppose for a moment we use leaky-grid rectification, and are about to tune to the local station. Watch the meter!

Watch the Needle

As we approach the station's tuning-point, and almost before we can hear anything, the needle begins to fall back gradually. The current has begun to decrease. This de-

crease becomes more and more rapid as we approach the fully-tuned-in position.

Continuing to turn the dial in the same direction, we note an increase in current now begins to take place. This increase shows up before we can detect a weakening of the volume.

A Warning Note

The increase goes on as the dial is turned until, as the station fades

out, the reading returns to its old value.

The meter will react in just the same way, but to a lesser degree, to weak and distant transmissions.

For the final hint a note of warning must be sounded. A warning in connection with the making of alterations to the set or the changing of components.

Nothing Like It

Anything that causes variations (no matter how slight) in the capacity permanently across a coil, will upset the readings of the condenser tuning that coil.

The changing of the detector valve, for instance, is likely to produce some alteration. Changing a grid condenser, putting in a new tuning condenser, rewiring, or the insertion of a new coil are items that make the recalibration of a receiver necessary.

But what of it? There is nothing like twisting the dials to certain settings and saying, "That's Heilsberg," or "You're listening to Rome." But one has to pay heed to accurate dialling to do it.

A. S. C.

THE guiding spirit at Brno is Vladimir Konupka, who is nominally the chief announcer and who is a very dynamic personality who plays an important part in the programme arrangement and station direction. When at "Brunn" (to give it its local pronunciation), recently, I took the opportunity of dropping round to gain Konupka's permission to visit the new high-power transmitter.

I had not seen the station since the days when it was simply a 3-kilowatt relay of the central Prague transmitter. From time to time, while touring Austria, I had heard the new Brno transmitter, and I wanted to see how it suffered from Moravska-Ostrava, which is also a high-power station connected with the Prague programme line.

Made in England!

A guide was arranged. We went out to the new transmitter—a pleasant, two-storey building, quite small and standing between the twin aerial masts. I have been seeing some other giants recently, and it was a change to come to Brunn and walk beneath masts only 150 feet high!

But that was not the only surprise. We went inside the station building, through the tiny office and into the room in which are the transmitter panels.

Lo and behold, a British transmitter!

A small type of Marconi transmitter has been chosen, and the station bears a strong resemblance to the old-type B.B.C. transmitters. The racks are of the open type, as were popular in the 2 L O days, and the big glass valves are encased in safety boxes of glass, metal-edged. Brunn is bigger than was 2 L O, of course.



Czechoslovakia is a far cry from Britain, but radio brings the two countries so closely together that it becomes a really interesting business to visit Brno, one of the principal transmitters in Central Europe.

The actual power taken is 96 kilowatts—the aerial output being 35 kilowatts.

Neat Layout

I have generally found, in connection with Prague broadcasting, that the engineers take a great pride in the arrangement of their gear, no matter whether it is British made (as at the main Prague station, and, of course, here at Brunn), or by a local firm under contract.

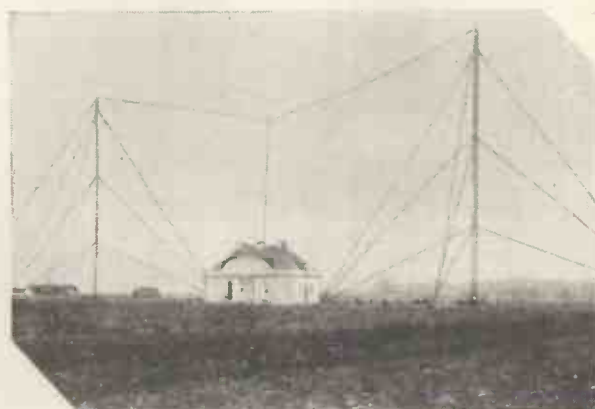

NO LONGER A BABY

The aerial system of Czechoslovakia's 35-kilowatt transmitter which can be heard on 342 metres.

An engineer at Brunn told me with pride that the transmitter panels were ordered by cable from the Chelmsford factory of the concern building the plant, and that they were erected on arrival in accordance

with the local engineers' own ideas. I must say that the station is exceptionally neat. It is much smaller than quite a number of other broadcasters of the same power I have visited. Hardly an inch of space is wasted. My guide didn't hesitate to point out to me how they managed to squeeze in everything.

"It's crystal-controlled, I suppose?" I inquired, knowing that the Prague station itself has quartz crystals. The engineer smiled.

"No, we have valve drive here," he said. "We have keen competition with our fellow engineers at Prague who pin their faith to the crystal drive. As you can tell, we must have absolute stability. Prague, Brunn, Bratislava, Moravska-Ostrava and so on have all, at times, to relay the same programme.

Stabilising Wavelength

"It is just the same as your B.B.C. relay stations. If they were not all frequency-controlled, it would be impossible for them to transmit on the same wavelength. For many of the listeners Brunn, Bratislava and other Czech stations are well in the field strength of Prague. Frequency control is, therefore, vital. But enough of technicalities."

He explained the station layout to me. It is absolutely straightforward: power control on one side, H.T. panels on the other, valve drive at the end. Channels in the stone floor, covered with wooden slats, carry the cables from one side of the gear to the other.

Bigger parts such as the power condensers—large steel tanks filled with oil for the dielectric—are stood out separately on the floor.

A small receiver-type power valve

Effecting Valve Replacements in a Few Seconds

is the drive. It is fed from batteries, of course. Strangely enough, it is no bigger than the average oscillator of a superhet. It is an oscillator. It drives a number of circuits tuned to harmonics of the original frequency. The output valve of the drive panel is a 250-watter—a big air-cooled glass valve which is a real transmitting valve, and is the first valve of the Brunn plant to look like a transmitter!

This output valve is connected to the modulator. The rest of the modulation side is ordinary, and, in fact, is like a big public-address speech amplifier.

A Matter of Appearance

It is connected through an intricate switchboard to the landline circuit running through Czechoslovakia and carrying the broadcast programmes.

Brunn is now planned to cover a big area. A breakdown would be infinitely more serious than was the case when the old relay station was working in the town. Therefore all the air-cooled valves are fitted with quick-action contacts so that if a valve flashes over, a new one can be plugged-in with only a few seconds delay. Strictly speaking, Brunn is not so up to date as the latest 60-kilowatt broadcasters of the same make (as at our Regional stations, for example), but it is largely a matter of appearance and the fact that the panel layout reminds a British visitor of the 2 L O days!

Anyway, there is no discredit to Brunn. It is giving a fine local signal, and it is making a huge difference to listeners in this part of Europe who previously weren't satisfied with Prague alone.

Studio Arrangements

Brunn's studio arrangements justify the new plant. Reisz "mikes" are used as we have in B.B.C. studios; there are the familiar wall drapings, indicator lights and stand-by electric gramophone arrangements. There is a station orchestra of twenty, and the keenness of Vladimir Konupka results in such good local-talent programmes that Brunn is often the source of programmes which are given through all the Czech stations.

Konupka tells me that although Brunn broadcasts from 9 o'clock onwards, the morning transmissions are

almost invariably relays of Prague. It is in the evening period from 6 o'clock onwards that Brunn, Bratislava and the rest take a hand in the national programmes, and each local studio each gives its share. It is rather as though all B.B.C. stations gave the same programme, but that part came from London, part from Manchester, part from Edinburgh, and so on—not a bad scheme.

Air of Enthusiasm

I was invited into the studio during the news bulletin broadcast from Brunn. Konupka read it. I thought of Hibbard, Snagge and the other London announcers, over 750 miles away! There is a general air of keenness and enthusiasm at Brunn which grips you. It is the same enthusiasm which has given Czechoslovakia one of the world's biggest stations.

FOR THE NEW "5 X X"



The new 5 X X will use valves capable of delivering an unmodulated carrier energy of 50 kilowatts. Their filaments operate at about 32 volts at 460 amperes.

BRITAIN'S NEW LONG - WAVE

An advance description of the transmitter which will replace the present Daventry 5 X X.

Now that the site for the B.B.C.'s super-power long-wave station, which is to supersede 5 X X, has been selected, the following

details of the equipment ordered for it will be of interest.

As stated elsewhere in "The World's Programmes," the new site is at Wychbold, near Droitwich.

The transmitter has been designed by the Marconi Company, in close co-operation with the engineers of the B.B.C., and will incorporate some interesting new features and high-power valves capable of dealing with very large inputs.

The power rating of the station will be 100 kilowatts unmodulated carrier energy, and modulation up to 90 per cent is arranged. (The power of the present Daventry National station is only 30 kilowatts.)

Modern Modulation Methods

Faithful and life-like reproduction of vocal and musical programmes will be assured by a frequency characteristic which will be straight between 30 and 10,000 cycles.

By the application of the modern principle of series modulation, it is possible to effect a very considerable simplification in high-power station design, and the new B.B.C. transmitter will consist of a drive with only two power stages, the first of which will be modulated, while the main oscillatory circuit will complete the wireless transmitting equipment.

With this method, modulating the plate voltage of the radio-frequency valves is accomplished without the need for any iron core choke or transformer. In consequence, there is no difficulty in applying the method to a transmitter with valves of considerable power, while maintaining a high degree of linearity and wide range of frequency response.

By this means the stages of modulated amplification required can be reduced to only one, with a reduction in harmonic distortion.

A Valve in Reserve

The final power stage consists of two units, and each contains three Marconi water-cooled valves of the C.A.T.14 type, operating at 18,000 to 20,000 volts on the anodes. Two valves in each of the units are in use, while the third valve is a spare which can immediately be placed into circuit.

The water-cooled valve type C.A.T.14 is one of the latest Marconi high-power transmitting valves.



The VOICE of KANSAS STATE

Readers of "The World's Programmes" have been introduced to several interesting "out-of-the-way" stations in the past. To-day we visit the Kansas Agricultural College station, K S A C, which transmits with a power of 1,000 watts.

THE Voice of Kansas State," they call it, this American broadcaster, K S A C, and seeing that the station has recently taken unto itself an entirely new Western Electric 1,000-watt transmitter, the "voice" is one which intends to make itself heard.

Station K S A C has been on the air for a number of years, beginning, as many of the medium-powered American broadcasters did, as a small experimental "laboratory" transmitting installation.

That, however, was back in the wilds—the radio wilds—of 1923 or 1924. At the present time, by virtue of an evolutionary process, station K S A C has thrust itself into the foremost ranks of American radio.

Advertising Unnecessary

The station is run under the supervision of the Kansas State College of Agriculture and Applied Science, which has a special department of Radio attached to it. A state grant supplies the needful for the running of the station and its maintenance, so that, unlike many of the American broadcasters, Station K S A C is not compelled to rely upon advertising, commercial or otherwise, as a bread-and-butter source.

Located at Manhattan, Kansas, Station K S A C functions, as I have

said, on a power of a thousand watts (1 kw.). Its wavelength is 516.9 metres. Make a note of these figures for reference on the next occasion you are out to bag American stations. It is just possible that you may be successful in "landing" this particular broadcaster.

The Manhattan station, K S A C, is very favourably situated for radio transmission. Hence, there is no striving for huge power-ratings by the station authorities. If you refer to an American map you will see that the State of Kansas is situated pretty well in the middle of the various States. Also—assuming that your map is a detailed one—you will note that Kansas is a very tranquil sort of State, a State which contains no hills of any great height. It is all fairly well a level or a gently undulating surface. The land is agricultural. There are no large industrial towns; no smoky cities.

Hence, only a medium-powered station is required to do the work of

K S A C, for the transmitting conditions are exceptionally favourable for good and effective transmission and reception within the service area of the station.

A Novel Microphone

Manhattan's microphone, however, is an interesting one. To look at it, it appears to consist of a long narrow rectangular box perched upon a suitable support. In appearance it is nothing like the orthodox type of "mike." Actually, the instrument is a condenser-microphone. The idea is old, of course, consisting as it does of a condenser device which varies its capacity in sympathy with the sound-waves falling upon it, but the people at Manhattan have their own ideas upon the subject, and they have worked out a special adaptation of the condenser-microphone idea, which, so far as one can see, serves them admirably.

Station K S A C does outside broadcasts. Hence it is fully equipped with relay and outside control boards, and apparatus for out-door events.

The station's programmes are more or less like the programmes of any other rural or semi-rural station in America, or in any other country for that matter. Only, perhaps, the Kansas station's programmes last longer. At all events, the broadcasting people at K S A C bestir themselves every morning at 8 o'clock



AN UP-TO-DATE STUDIO

This view of the K S A C studio, with the control room at the back, shows the condenser microphone, of the type favoured by the B.B.C.

to transmit a "Housewives' Musical Programme," which is followed at 8.40 a.m. by a "Health Period," and at 10 a.m. by a "Housewives' Half-Hour."

But then, you see, agricultural work was ever an early-morning job. Therefore the day begins very early in most parts of Kansas.

Changes in the power of transmitters, in their hours of working, and other matters of moment to the long-distance enthusiast are tersely recorded below.

AFFAIRS OVERSEAS

Authentic and last-minute broadcasting news.

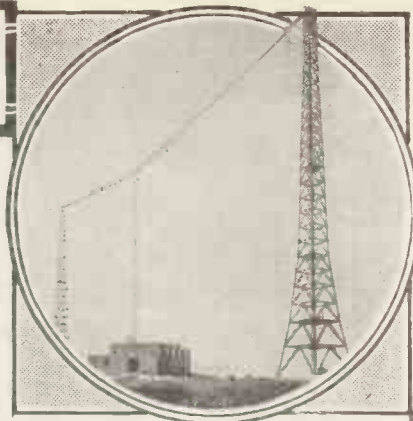

NEW YORK, U.S.A. Although the American broadcasting stations usually give the call-signs every fifteen minutes (at the exact quarters), this is not now compulsory, as it was at one time. If, however, no call is heard at the end of one fifteen-minute period, it is almost certain to be given at the end of the next one.

RADIO VITUS, PARIS. The authorities decided to allow their radio audience to vote for who should be their new announcer, after an eliminating competition had reduced the original 270 competitors to six.

AUCKLAND, NEW ZEALAND. It is planned to modernise the Auckland transmitter and re-erect it nearer the coast before the end of this year.

RADIO CITY, NEW YORK. This giant venture has been hard hit by present financial conditions in the U.S.A., as it was courageously planned to take advantage of a boom period which has not yet materialised.

DETROIT, U.S.A. It is reported that the Ford and other great financial interests have been considering the launching of a new radio-station network, to compete with the National Broadcasting Co. and the Columbia Chains.

GRACUINELU, ROUMANIA. This new Roumanian station has been testing on 1,935 metres.

453 METRES. The jam around this wavelength has recently been worsened by the reappearance of Radio-Agen, the French station, and by the new Latvian relay at Madona.

CINCINNATI, OHIO. It is still uncertain whether the new 500-kilowatt super-station planned to be operating this summer at Cincinnati will be delayed much by the present economic crisis in the U.S.A.

MOSCOW, RUSSIA. There are now nine broadcasting stations in action at Moscow, on the following wavelengths: 1,304 metres, 1,101 metres, 1,000 metres, 720 metres, 424.3 metres, 378 metres, 50 metres, and 46.6 metres.

BROOMFIELD, ESSEX. The recent highly successful "split-echo" experiments of Mr. T. L. Eckersley (brother of Capt. P. P. Eckersley, "M.W.'s" Chief Radio Consultant) were conducted at Broomfield, Essex, the test transmissions being sent out from the Writtle experimental station, which is about three miles away from Broomfield.

TRONDHEIM, NORWAY. The power of this Oslo relay station (which works on 495.8 metres) is to be increased from 1.2 to about 20 kilowatts.

WEST NATIONAL, GREAT BRITAIN. The test transmissions of this, the "twin" of the new West Regional station, may possibly be heard by listeners before the end of April. The wavelength will probably be 261.6 metres, but it is not likely to intrude much on public notice till the West Regional has settled down to a regular service on 309.9 metres in May.

LILLE, FRANCE. The P.T.T. programme on 265.4 metres, is still sometimes clearly receivable in the mornings between 8 and 9 a.m. on sensitive sets which fail to get this station clear of its neighbours after darkness has fallen.

VIIPURI, FINLAND. It is proposed to increase the power of Viipuri, on 291 metres, from about 13.2 to 40 kilowatts.

PLYMOUTH, GREAT BRITAIN. The new Plymouth transmitter, on 218.5 metres, is generally conceded to be much better than its predecessor, which operated on the common wavelength, 288.5 metres.

RADIO SALONIKA, GREECE. This, the first Grecian station, is now operating experimentally on low power on a wavelength a little above that of the London National programme.

LUCERNE, SWITZERLAND. This is to be the site of the next European Conference on wavelengths. The conference is due to open on June 1st.

KIEV, RUSSIA. This Soviet station uses a wavelength of 1,034.5 metres, and as much power as the Leningrad and Moscow transmitters.

RADIO NATIONS, SWITZERLAND. The League of Nations station on 40.3 metres now broadcasts on Sundays from 10 p.m. onwards.

WYCHBOLD, GREAT BRITAIN. The new B.B.C. long-wave station—to be the finest in the world—is to be erected on a site about three miles north-east of Droitwich, and preparations for building have already commenced.

ROME, ITALY. This station has recently been getting over well in the early mornings and evenings, although it is sometimes comparatively difficult to pick up late at night.

BERGEN, NORWAY. Bergen is to increase its power to 20 kilowatts under a new scheme now approved by the Norwegian Government.

KEMIKAWOA - CHO - CHIBA - KEN, JAPAN. Short-wave enthusiasts who have ambitions to log a Japanese station should be able to recognise the name "Kemikawoa-Cho-Chiba-Ken," which broadcasts daily from 10 a.m., for two hours, on a wavelength of 19.36 metres.

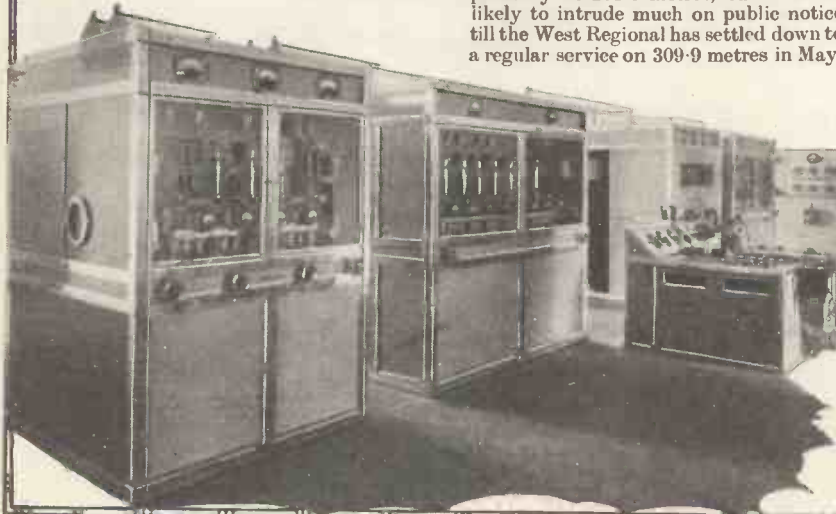

DISTANT STATIONS AND HOW TO HEAR THEM

Reports and advice by our special correspondents on various aspects of broadcast reception.

Q.P.P. AND DX

To the long-distance man who uses a battery-operated set quiescent push-pull amplification is of the greatest value, for it enables him to obtain good quality and fine volume from distant stations with a marked saving in high-tension current.

To obtain a watt of output with a single power valve used in the ordinary way about 35 milliamps. of high-tension current at 150 volts are required. With Q.P.P. you can obtain the best part of a watt with an average consumption of about 6-8 milliamps. at 120 volts.

For long-distance work there is much in favour of the combination of Q.P.P. and tone control.

There are two reasons why tone control is desirable in the DX set. The first is that its sensitiveness and selectivity make correction advisable if quality is not to suffer; the second is that not every foreign broadcasting station has the same degree of tone balance in the transmissions.

You will find, for instance, that even if your set is not selective enough to be accused of sideband cutting, some stations are apt to be bass-heavy. Others, again, are rather too "toppy" for most people's liking.

With tone control plus Q.P.P. the set can rise superior to individual variations in station tone.

NOT THE SET'S FAULT

Every long-distance enthusiast must have had personal experience of that most unpleasant phenomenon—"sideband

splash." Two high-power stations are working on adjacent wavelengths; the set is selective enough to separate them so well that neither transmission can be heard intelligibly as a background of the other.

But from time to time a hateful break-through occurs, the unwanted station's transmission causing spluttering sounds—which are very far from being in the background.

The trouble is caused by the heterodyning of the wanted station's carrier wave by the unwanted station's sidebands. It is not the fault of the receiving set, and no increase in its selectivity will effect a cure.

Sideband splash is one of the biggest problems produced by the all-round increase in output power rating that has taken place in Europe, and it is to be hoped that it will be dealt with successfully at the Lucerne Conference of the U.I.R.

SHORT-WAVE NEWS

By the time these words appear in print we shall be almost within sight of the summer, and the time seems opportune to give another list of "best times" for short-wave

stations. The chief characteristics of the lighter evenings and longer days are an improvement in the general standard of the stations below 30 metres (good) and an increase in atmospherics (bad)!

Anything below 25 metres used to be regarded as a daylight wave. We know now that this was wrong—for have we not heard W2XAD on 19.56 metres long after dark?—but it certainly is correct to say that these shorter waves are more useful in summer than in winter.

THE BEST TIMES

The best times, for the next month or so, for most of the stations on 25 metres and below, will be from 4 to 5 p.m. until nearly midnight. This appears to hold good, irrespective of the direction or locality of the station. For 20-metre amateur signals, we may expect the Antipodes in the early mornings—6 till 8 a.m.—and again in the afternoons—2 till 4 p.m. The Americans will be in evidence from noon till nearly midnight, with the exception of the West Coast stations, who generally make a good show between 5 p.m. and 9 a.m. only.

South Africa comes in during the early evening, and South America last of all, the latter not usually being audible until 9 or 10 p.m. and continuing for quite a long time.

Broadcast stations on the 31-metre band do not change very much throughout the year. We may, as usual, expect to find W2XAF and W1XAZ during the latter part of the evenings, and Sydney at his usual erratic times, both morning and evening.

Europeans don't worry us much, except that some of us would like to know at what time they don't come in, so that we could listen then!

The 49-metre stations usually show rather a great falling-off during April, May and June. They don't

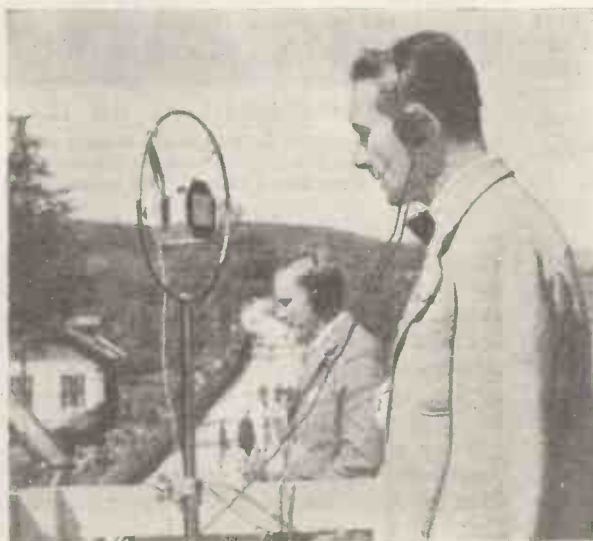

A POPULAR FEATURE

Listeners to German and Austrian stations will have noticed the prominence given to running commentaries. Here a radio reporter is dealing with the Austrian Automobile "Grand Prix" from the roof of the judges' stand.

NOTES AND NEWS FOR THE "DX" MAN

commence to reach a reasonable strength until very late, and they are only fair game for the man that doesn't mind being up at three in the morning. That is if *reliable* reception is wanted. On the other hand, Nairobi and Johannesburg may be expected to be good between 7 p.m. and 10 p.m., if they continue on the air so late.

ALWAYS SOMETHING OF INTEREST

The 40-metre amateur band, in many ways the most interesting of them all during the winter, usually loses its pride of place to "20," about this time of year. "Yanks" are there in plenty, but only in the small hours, and the hours of daylight are usually rendered rather painful by the host of nasty noises from the Continent! Anyone who has listened there much on a Sunday evening will know just what is meant by that!

Even through the summer it is safe to say that there is something of interest going on at all hours of the day, if we only choose our wavelength intelligently. It is obviously no use looking for DX on 40 metres in the morning, or on 20 metres after the nightly "fade-out." This latter, naturally, becomes later and later as we approach the longest day, but during April it will probably occur well before midnight. It is rather erratic, since it varies with local conditions as well as with the distribution of light and shade over the earth.

On the whole, the best motto is, as always: "Listen till you find something!"

LATIN-AMERICAN STATIONS

Within the last few months many listeners have inquired as to the whereabouts of the "Spanish station" upon 303 metres. There being no Spanish station upon (or near) that wavelength, they had concluded that it was either an unauthorised or unlisted Spanish station. Few of the many listeners who hear this station guess its locality, which is Buenos Aires and not Spain, the station being L R 4 (Radio Splendide).

There are many similar instances of South American stations being

mistaken for Spanish stations. L R 3, (Radio Nacional, 316 metres) and L R 2 (Radio Prieto) are two excellent examples. The reason for this apparently ridiculous state of affairs is largely due to the volume with which these stations "come over" and also because they are heard so early in the evening (frequently as early as 10.30 p.m.).

A number of these stations announce in both the English and Spanish tongues, and are therefore readily verified. Unfortunately, the large percentage announce in Spanish only, and difficulty is consequently experienced (by the majority of listeners) in verifying them.

Although the Buenos Aires stations

the "Yanks," and many new stations may be added to the log.

IMPROVING LONG-DISTANCE QUALITY

In long-distance work the receiving set must be very selective, more selective, in fact, than is consistent with first-rate quality in reproduction unless steps are taken to set matters right. The trouble is that the set which is naturally highly selective, or the set, normally rather flatly tuned, which is brought to its most selective condition by means of reaction, gives undue emphasis to low-pitched notes in both speech and music owing to the process known as sideband cutting. For this reason

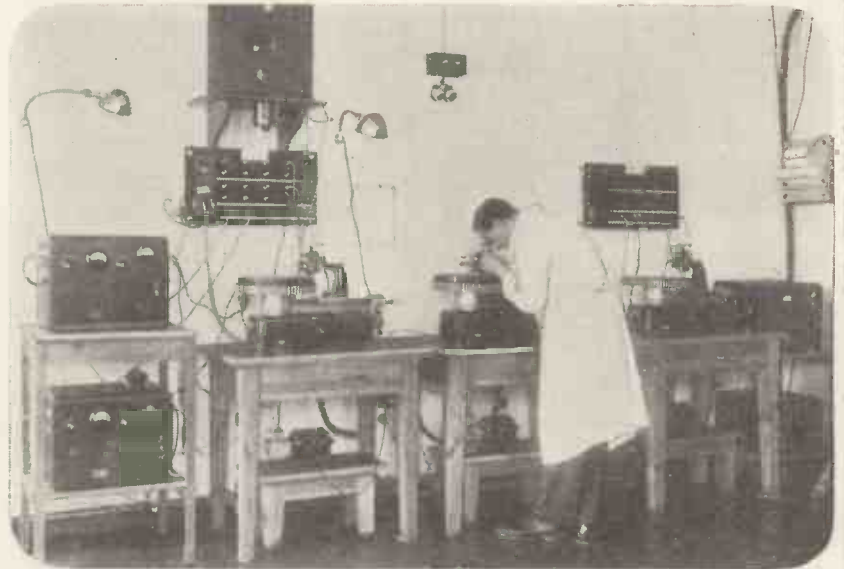

EXPERIMENTS AT THE TRANSMITTING END

Long-distance reception depends nearly as much upon the transmitter as upon the listener's receiver. The German technical experts are constantly at work upon experiments, and you can see here a corner of the experimental laboratories at Berlin.

are received far more readily than other Latin-American stations, it is not infrequent for Mexican broadcasters to be received in this country.

Probably the most frequently received is X E R (Villa Acuna). This station operates upon 408 metres, with a power of 75 kw.

Many listeners "skip" the Latin-American stations when out on the hunt for American stations. I agree that it is tempting (the Latin-American stations being comparatively difficult to verify), but, even so, it is well worth while paying a certain amount of attention to them, for they provide quite a change to

there were at one time many who scoffed at long-distance listening, maintaining that nothing really worth hearing could be brought in by the receiving set. This is no longer true, for the tone-balance upset by high selectivity can be restored by the use of a tone-correcting device. Several firms make these; they are quite inexpensive, and they *work*! I can testify from personal experience that a tone-correcting low-frequency transformer makes all the difference in the world. With one of these devices in use fine quality can be obtained in combination with real knife-edge tuning.

FAULTS I HAVE FOUND

by a
SERVICE ENGINEER



JUST as words of wisdom issue from the mouths of babes and sucklings, so do many of the most interesting and instructive wireless problems emerge from the experiences of the ordinary listener, for this reason: a service engineer's notebook, whilst affording interesting and often amusing reading, throws new light on old snags and reveals unforeseen pitfalls into which the most experienced amateur may fall.

Many a receiver which has fulfilled expectations on the test bench fails lamentably when transferred to its position of intended permanency, and the reasons range from steel-framed buildings to hungry domestic pets with a taste for rubber-covered flex; so the reader must expect an "infinite variety" in the following notes.

In offering these extracts I do not propose to confine myself solely to technical points, for the "slings and arrows" of outraged customers, directed at the technical representative of a large manufacturing concern, are often too pointed to be disregarded!

After Two Hours

Follow me, then, through the pages of my notebook and prepare to meet the unexpected.

I came across a curious case of distortion the other day: When the symptoms were explained to me I confess I was a little sceptical, for, on the face of it, the impossible had occurred!

The facts, as recited, were that the receiver operated perfectly well for exactly two hours' constant use; after

this period a distinct echo was heard in the speaker, and—most curious of all—the *less the volume of reproduction the louder* the echo appeared to become.

Can You Guess?

Obviously it was not possible to put my finger on the fault from this description, and the only means of

accurately fulfilled in practice. After one hour and fifty-five minutes by my watch, there appeared a curious "scratchy" sort of echo, particularly noticeable on speech, whilst the normal reproduction was unimpaired. On reducing the volume to a whisper the "echo" lost all semblance to the reproduction, however, and became a mere intermittent irritating scratch.

All sound disappeared with the volume control at zero.

Can you guess the trouble?

It was some time before I hit on it, and when I

did the symptoms were so acute that location was easy.

The fault was in the loudspeaker. The coil was out of centre and almost fouling the sides of the gap when cold; after running for two hours, however, the heat from the field winding was sufficient to expand the centre pole slightly and thus cause the coil to rub very lightly during its normal motion. Hence the "scratchy" echo!

attacking the trouble was to switch on and wait for the stipulated two hours. The receiver was an A.C. radiogram of more or less conventional design, employing three valves, S.G., detector and pentode output, with a small field excited moving-coil loudspeaker.

Well, the description of the case was

IT CAUSED AN ECHO!



If the coil of the loudspeaker gets a little out of centre it can cause some surprising effects, and a very curious one is described on this page.

HIS EXPERIENCE AT YOUR SERVICE

This new series of really practical articles by a radio fault-finding expert will prove of the utmost value to our readers. In the course of his duties our contributor meets the most difficult and unexpected problems, and his solutions and experiences are remarkably enlightening.

Concerning Speakers

Look out for this trouble with speakers which have very small gaps. In some cases it may be necessary to file about a thousandth of an inch off the centre pole to ensure clearance, but do not be heavy-handed or your speaker will be very insensitive.

Here is another note concerning speakers which I have found invaluable during test work.

Moving-coil speakers will handle such generous outputs that it is often forgotten that they all have a definite overload point. Usually, the volume of sound reproduced at this

point is so great that it is difficult to note any distortion simply by listening.

Assuming you have made certain there is no overloading in your amplifier, you can test your speaker at full volume for rattle or overload quite

HARD TO FIND



"Dry" joints in valve legs are not unknown, so try digging the solder out of the valve leg with a penknife.

simply—but, if you are quite satisfied with results at present, my advice is to skip my next suggestion, for it almost always reveals noises that only the slovenly and careless "ham" could tolerate (in spite of the fact that they are not noticeable under normal conditions!).

Can You Solder?

Turn on full volume on a really loud orchestral broadcast, put your fingers in your ears and place your head close to the speaker.

(Note to Wives.—I disclaim all responsibility for homes broken up due to harassed husbands pulling apparently perfect sets to pieces as the result of this suggestion.)

(Note to Harassed Husbands.—Don't make this test on a gramophone record, or you will mistake needle resonance for distortion.)

Remark passed to me last week: "Regional's all right, but we don't get London Natural."

Can you make good soldered joints? My experience is that a very small percentage of amateurs pay sufficient attention to soldering.

A golden rule should be that if you can't solder well, don't solder at all!

Bad joints, especially those known as "dry," can cause most extraordinary faults.

Difficult to Locate

Actually, a "dry" joint may be defined as one which, although it may be mechanically strong, has a high electrical resistance and consequently it is not always easy to locate.

The most usual fault produced by a "dry" joint in the H.F. end of a set

is a periodic fading of signals; this fading will occur even on the local station, and usually the signal cannot be restored without producing a comparatively heavy surge of current through the receiver, either by switching off and on rapidly or removing a valve and re-inserting same after a short pause. Turning on a lighting switch in the house often does the trick, too.

A Certain Method

The location of a fault of this type certainly is difficult; after a great deal of experience I have come to the conclusion that the quickest and surest method is to run over all the joints in the H.F. stages (paying particular attention to coil connections) with a hot iron and watch the solder run in each case.

You may save yourself this rather tedious job, however, by examining the valves before suspecting the receiver. "Dry" joints in valve legs are not unheard of. Try digging the solder out of the valve leg with the point of your penknife; if the solder flakes or chips, apply fluxite and a hot iron.

I always appreciate true effort and determination. A case of this came my way when in Huddersfield a month ago.

A man had bought a very excellent three-valve set comprising one screened-grid and pentode output. The masts of Slaithwaite transmitters were visible from his window; obviously his chances of satisfactory reception were poor.

Superhet Troubles

But the dealer who had sold him the set was an opportunist and had supplied him with three wave-traps, all of the "acceptor" type, and these were all connected in series with his aerial lead-in. The effect was remarkable inasmuch as a definite silent space was obtainable between the two locals, but, of course, "cross-modulation" still prevented reception of less than two programmes at once.

By reducing the aerial to about 15 feet of wire indoors, and reducing the number of wave-traps to one, I was able to obtain the desired effect. For foreign reception, of course, the original aerial remained and was connected when the B.B.C.'s near-by dissipator of kilowatts had closed down.

Here is a useful hint when endeavouring to locate a fault on a superhet.

If the set is completely "dead," connect the aerial lead on to the grid of the first intermediate-frequency

valve; if all is well with the circuit from that point to the loudspeaker, a certain liveliness should be noticeable and probably some Morse signals.

The usual "inter" frequency is in the neighbourhood of 170 kcs., which is equivalent to a wavelength of 1,750 metres; hence the "dot and carry one"!

And if a superhet is dead and this test is successful, it is ten chances to one the fault is in the oscillator circuit. As in the bad old days of swinging reaction coils, test for oscillation with a wet finger, or a moistened digit, on the anode of the oscillator valve.

It is not often when one is in normal health and is not given to late nights that one meets with a radiogram that dances! Yet that was my experience the other day.

The Jumping Radiogram

Working off A.C. mains, the turntables was driven by an induction motor of first-class make.

With the earth connection broken all was well, but when the earth was connected—as I say, the whole outfit danced about the parquet floor accompanied by a noise like ten thousand pneumatic drills!

FOR QUICK TEST



If the set is completely dead, connect the aerial lead on to the grid of the first intermediate-frequency valve.

The cause of this performance was that one of the coils in the motor was shorting to the frame—which was, of course, earthed—so completing the mains circuit via about half the normal amount of winding. This produced sufficient flux to make the motor laminations jump at 50 times per second. A truly awesome spectacle. Imagine the effect on the household if the fault developed during one of the B.B.C.'s best thrillers!

The THREE-RANGE TWO



I AM fond of music, and of broadcasting in general. I don't mean that I stand in front of the microphone and give the ether the benefit (?) of my tongue; I enjoy the reception of radio programmes.

There is nothing new in that—all my readers will express the same sentiments, or they would not take MODERN WIRELESS. But, in common with a large number of set owners, I get tired of the B.B.C. programmes sometimes, in spite of their admitted excellence.

Farther Afield

At such times I either switch off or go farther afield in search of diversion among the denizens of Europe. This is not always to the liking of the others at home, and so I keep two sets.

One is used for loudspeaker entertainment only; it picks up the main British and Continental programmes and relays them to whosoever of the household wants them. The other is the one I want to describe to you here.

It is a two-valver, capable of working a loudspeaker very nicely for the local and a few more powerful stations, but its main virtue is that it not only allows me, with phones (or speaker if conditions are good), to search the British and European stations for programmes, but to scour the whole world in search of radio fare. You see, it covers a wide band of the short waves as well as the medium and long.

Without Any Plugging

I am by nature a comfort-loving fellow, and though I like to be able to search the world at will, I hate doing more than I can possibly help in the way of adjustments, coil-changing, and so forth.

I could have used an adaptor with my other set, but apart from disorganising the reception of that

Described by K. D. ROGERS

An entirely new three-band circuit is employed for this set, which is highly efficient on all the important wavelengths between 20 and 2,000 metres.

By means of its self-contained short-wave section the range is extended to cover the whole world!

section of my family that is not of an exploring nature, I should have to plug the adaptor into the set and remove it every time I wished to change from medium and long to short waves, and vice versa.

No, I must say I like the three-band set; one that will enable me to search all and sundry of the interesting wavebands without any plugging or alterations to do. I keep the set hooked to a second aerial, and it is ready for use when I require it.

Others may like to attach it to their main aerials as required, but, as I said before, I am lazy.

Though it is only a two-valver, it will get quite a lot of broadcast stations on the medium and long waves, and the tuning coil was chosen with a view to making the set as sensitive and selective as feasible. Also, as I often use headphones on European broadcasters, it had to be pretty free from break-through of the medium waves on the long waveband.

A New Coil

This is asking no mean thing of a two-valver, with its one tuned circuit, especially when it is remembered that this circuit must be selective and sensitive. But the "Three-Range" Two is remarkably free in that respect, and though I have tried it in

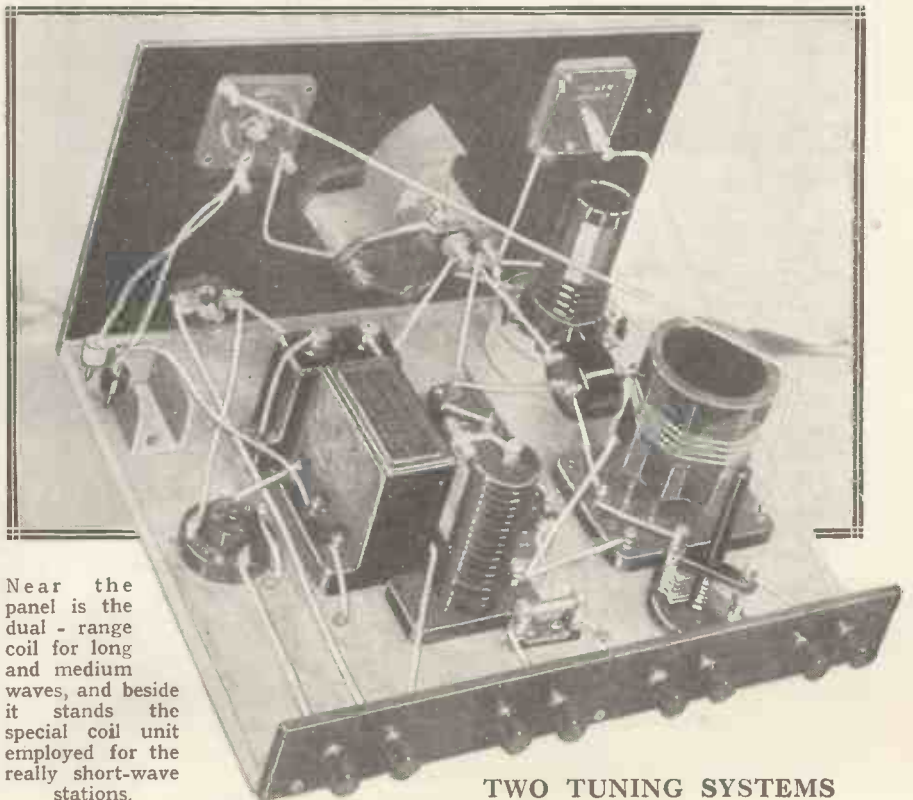

Near the panel is the dual-range coil for long and medium waves, and beside it stands the special coil unit employed for the really short-wave stations.

TWO TUNING SYSTEMS

NOTHING DIFFICULT IN THE CONSTRUCTION

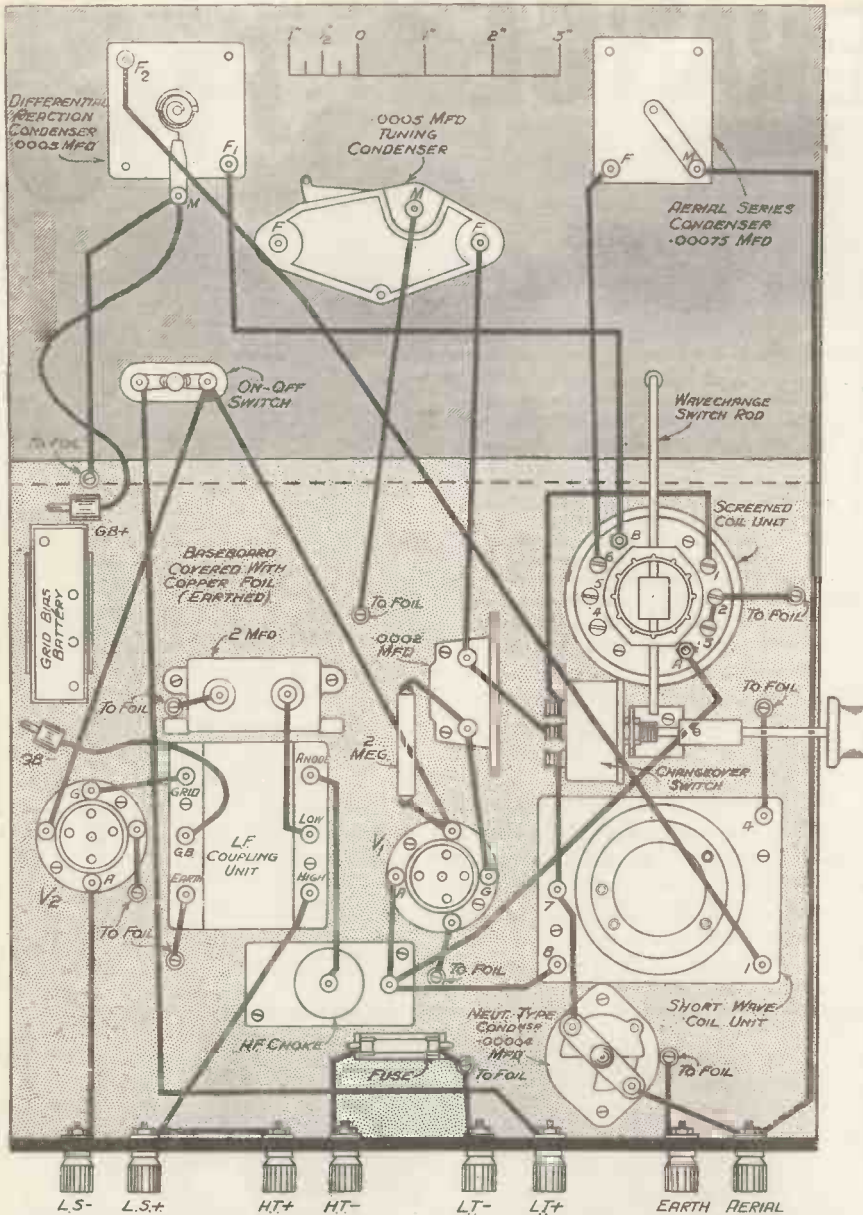

Although its range is extended to include the short waves, there is nothing tricky about the wiring, which is indicated by the heavy lines. Note that some of the connections go to the metal foil covering the whole baseboard.

several districts near a powerful station, I have never had trouble from break-through above 1,000 metres—not even on headphones.

As I say, I chose the coil with some care, and my choice fell on the Colvern K5. It is a new coil, recently produced, and is very efficient indeed.

Eminently Suitable

True, it is of the "canned" variety, but although there is no need for screening in the set, this is no drawback, and the coil is eminently suitable for the task it has to perform.

The K5 coil, therefore, gave me all I required between 200 and 2,000 metres. What about 20-50 or so?

Obviously, I had to have another coil here; and I did not want to have to use plug-in coils, nor did I wish to go in for wavechange switching down there.

You see, I had already got two essential switches besides the on-off switch; the medium-long wavechange control, and a necessary grid change-over switch to take me down to the short waves.

So I picked a coil that would tune over the required range in one go—with the .0005-mfd. condenser I was going to use for the normal wavelengths.

"How inefficient!" I hear you say. But it is not nearly so bad as it

sounds, for the set is wanted as a "recreation receiver," and with a good condenser and a good vernier drive, it is not at all difficult to tune in the short waves.

A Gem for the Job

One thing had to be certain about that condenser—it had to be silent in operation, and in spite of its plain metal bearing (perhaps because of it), it is absolutely dead quiet, a perfect gem for the job!

The coil I chose had to be slightly modified, to the extent of disconnecting the reaction winding from the pin that is common to the bottom of the grid winding, and connecting it instead to the free pin (No. 1). This gave a reaction winding free at each end, and this is essential to the design of the set, as you will see.

If I switched on my grid from one coil unit to the other, how was I to avoid a complicated (and therefore inefficient) switching arrangement to take over the aerial and also the reaction? In other words, how could I avoid completely switching the coils, or shorting the canned coil when the other was in use? That was my next problem, and it caused quite a bit of thinking.

With Perfect Satisfaction

Short waves are funny things. They are not nearly so hard to deal with as many people imagine, and you will find that very often one can operate a short-wave receiver with perfect satisfaction on the same aerial as a medium-wave set, and at the same time. The presence of the medium-wave receiver does not upset the short-waver a bit.

The reason is probably that the aerial system of the medium-wave set acts as a choke to short waves, thereby taking none of the ultra high-frequency energy, while the high reactance of the tuning series condenser used in the aerial circuits of most short-wavers prevents the latter upsetting the other receiver.

Common Aerial Feed

So I decided to try the scheme in the "Three-Range" Two. Thus you will see that the aerial feed to both the canned coil and the short-wave inductance is common, branching off through two suitably sized condensers to the respective coils.

The condenser in series with the short-wave coil is of the neutralising type, and is mounted on the baseboard. It is seldom touched, and though it has a maximum capacity

Why Limit Your "Alternatives" to Europe?

of about .00004-mfd. it is normally set at something below half this figure.

Thus we have the parallel of the case mentioned above taking place in one receiver. The large coil acts as a short-wave choke, and the short-wave circuit will act as a high reactance path to the lower frequencies.

Naturally, the tuning circuits had to be kept separate, hence the grid switching, the tuning condenser being permanently connected to the grid

So there is no need to use a differential condenser on the short waves. But this does not hold on medium and long waves. There the capacity is required, for often no reaction is used, and reduction of reaction means (unless a differential or a shunt condenser is used) reduction in this necessary capacity.

With a three-range set the permanent shunt is out of the question unless another switch is used, for on

short waves it would prevent reaction being obtained.

That meant that we should have to try to use a differential condenser on the medium, and an ordinary condenser on short waves. Two condensers! Incidentally, to prevent hand capacity on short waves, the moving vanes of the condenser would have to be at earth potential.

The case seemed hopeless until it was realised that in reaction, as well as aerial feed, the large coil (comparatively speaking) of the medium-wave reaction would act as an H.F. choke to short waves, and that to the medium and long-wave frequencies the mere two or three turns of the short-wave reaction coil would be as a dead short.

It Solved Itself

Then the problem solved itself as shown in the diagram. The moving vanes of a .0003-mfd. differential reaction condenser (suitable in size for all wavebands) were joined to earth, and then the two fixed sets of vanes were joined in one case to one

Near the terminal strip is a "neutralising" type of baseboard-mounting condenser for controlling aerial coupling when the set is employed as a short-waver.

ONE TUNING DIAL FOR THREE WAVEBANDS

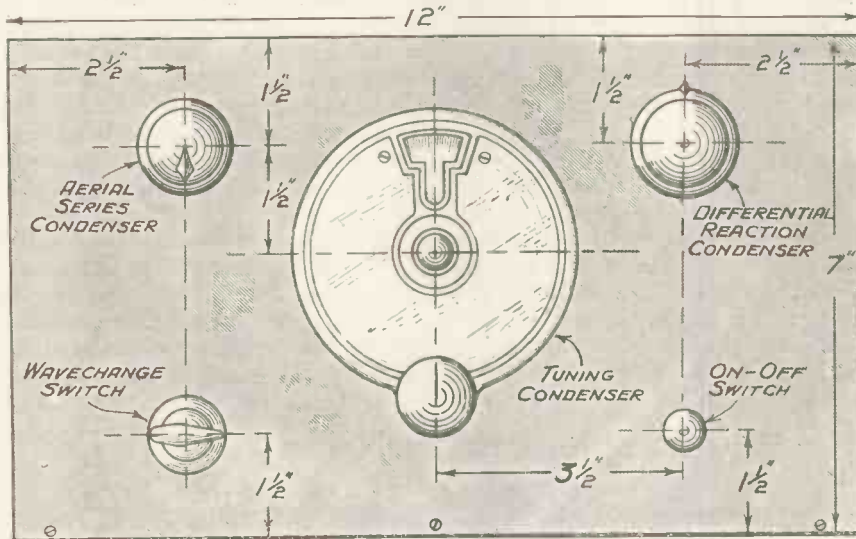

PANEL LAYOUT

The "aerial series condenser" above the wave-change switch governs the selectivity on the medium and long wavelengths.

input lead. The earthed ends of the two coil units and the earthed end of the variable condenser remain joined to earth and L.T.

So far so good. What about reaction? Here again the wide difference in frequency came to my rescue. For short-wave reception one always (except in a superhet) uses reaction on the detector. So there is no need for a capacity between anode and filament of the detector—that is supplied by the capacity of the reaction condenser.

Providing Capacity

As you know, some capacity is always needed between the rectifier anode and filament to provide efficient rectification, and the differential reaction condenser is a convenient way of providing this, as well as other advantages.

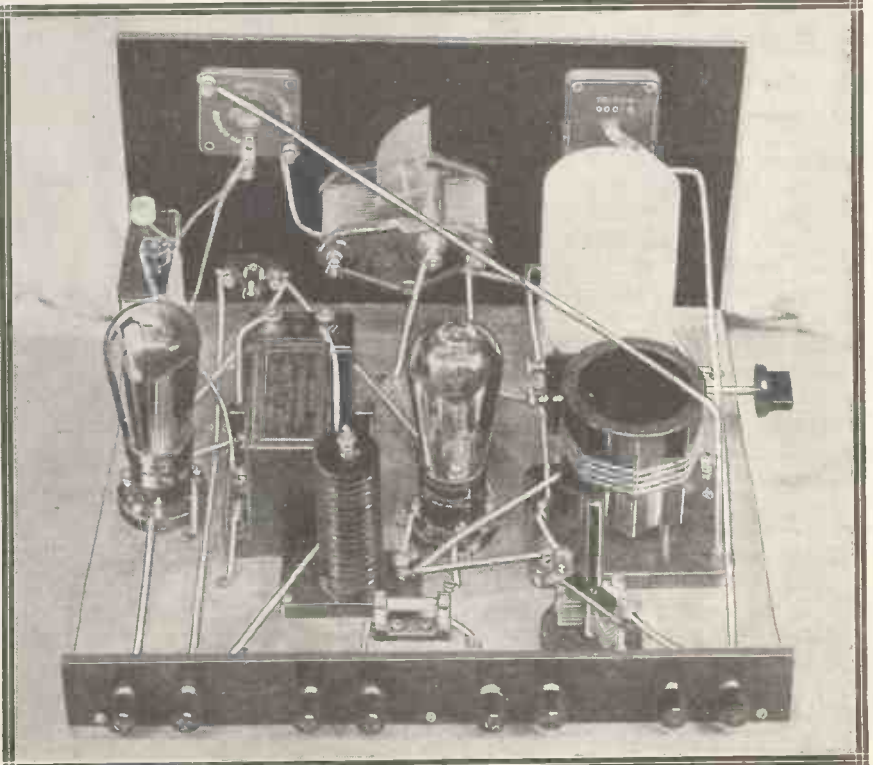

Tunes Down to 20 and Up to 2,000 Metres

end of the medium and long-wave reaction coil and to the short-wave, reaction coil, in the other.

That is why the short-wave reaction coil had to be freed from the earthed end of the grid coil as explained earlier.

VALVE TYPES AND MAKES.

Make	Det.	L.F.
Mazda ..	H.L.2	P.220
Mullard ..	P.M.1H.L.	P.M.2A.
Cossor ..	210 H.L.	220 P.A.
Osram ..	H.L.2	L.P.2
Marconi ..	H.L.2	L.P.2
Tungsram ..	H.210	P.220
Eta ..	B.Y.1815	B.W.604
Micromesh ..	H.L.B.1	P.B.1
Clarion ..	H.2	P.2

The "top" ends of the coils were then taken together to the anode of the valve, in which circuit was placed an all-wave H.F. choke, operating efficiently from 20-2,000 metres.

Choke to Short Waves

Now what happens? When the set is switched to short waves we have the aerial connected as already explained, while the reaction condenser is moved so that the moving vanes are meshing with the F2 fixed vanes. This increases the reaction effect, and the coil AB acts as a choke to short waves, thus having no deleterious effect on reaction control.

With the set ready for medium or long waves we have the reaction condenser fully meshed with F2 while local stations are being heard, and this acts then as a .0003-mfd. condenser from anode to filament of the detector—exactly what is required, for the reaction coil of the short-wave unit has no effect at that "low" frequency.

For distant stations reaction is turned so that the moving vanes gradually mesh with F1, and then normal reaction takes place through coil AB, the capacity through F2 decreasing as that through F1 increases. Perfectly normal differential reaction.

Difficulties Solved

Thus were the difficulties solved by just the one grid change-over switch, the unusual use of the differential condenser and the slight alteration of the reaction coil on the short-wave unit.

The detector is shunt-fed into a transformer to prevent any tendency

to threshold howl when reaction is applied on the short waves, a "trans-coupler" being used as L.F. coupling to the output valve. Incidentally, the anode circuit of the detector is decoupled—a further guard against that annoying howl on the verge of oscillation that ruins so many short-wave sets.

The whole set is built in the usual baseboard form, copper foil being used over the full length of the baseboard. It is surprising how effective copper foil is in reducing stray capacity effects on short waves, especially hand or body capacity, while its value as an earthing medium for many parts of the circuit is very noticeable when one comes to wire up the set.

A High Maximum

An ordinary solid dielectric aerial series condenser is used for selectivity and volume adjustment on medium and long waves, the condenser being placed between the aerial and the primary winding of the K5 coil.

It has a high maximum capacity, for it is felt that, having no H.F. amplification, as much as possible of

the received energy must be used, and the large capacity is very valuable when one is listening to long-wave stations that are some distance away.

This condenser could, if desired, be substituted by a smaller one having a self-shorting device, but this is not essential as I find that the .00075-mfd. condenser gives a more progressive control, avoiding the sudden increase in received strength when the short circuit takes place; and it is quite large enough for the long waves.

Sorting Foreigners

This condenser, acting as it does as a volume and selectivity control, must obviously be placed on the panel. It is wanted nearly every time the set is used, and is invaluable in helping to sort out one foreigner from another, the reaction control being its greatest ally.

It is not yet sufficiently realised by many set owners how very important a part the reaction control plays in providing selectivity. One is apt to forget that not only does reaction increase the strength of reception, thereby nullifying the weakening

THE LAYOUT OF THE COMPONENTS

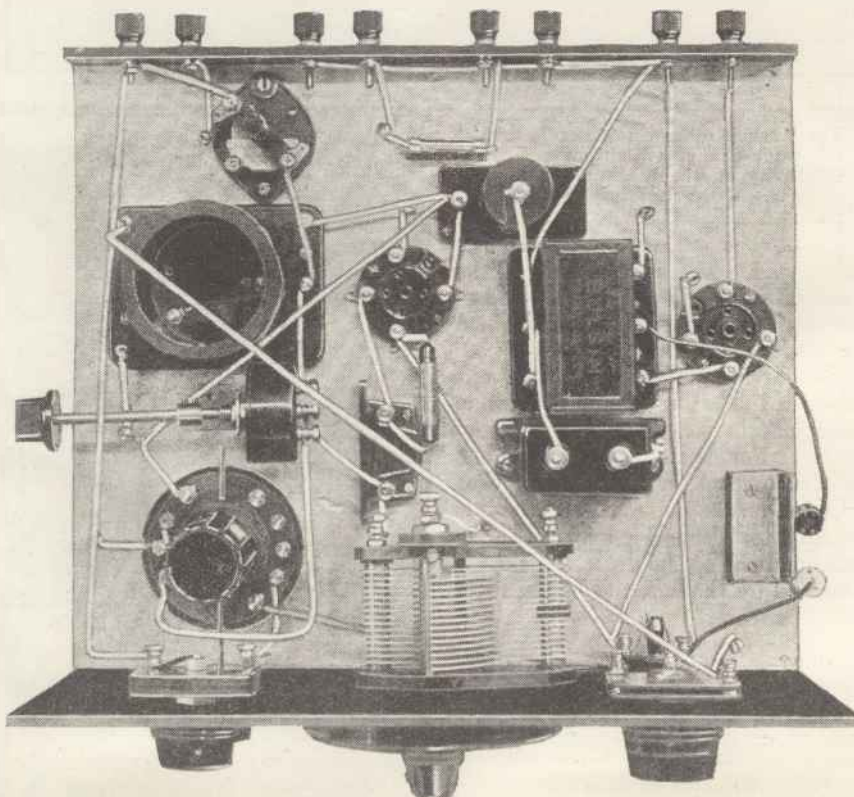

A bird's-eye view, showing the run of all the wiring to the various components and exactly how they are placed relative to one another. The grid-bias battery goes in the clip to the right.

effects of increased selectivity, but it does in itself increase selectivity for the same reason that it increases sensitivity—it decreases the damping of the detector grid circuit.

So when you are bothered by an interfering station, try the effect of reducing your aerial coupling, by the series aerial condenser, and bringing back the reception strength with increased reaction.

This Quality Business

Some will immediately mutter, "exit quality." But of what use is "quality" if it is accompanied by whistles and "monkey chatter"? I would rather lose some of those precious high notes and get rid of that interference than keep the high notes and be unable to understand what was said or to enjoy the music that is being broadcast.

I would rather ride in a Ford that is going well than in a Rolls that is missing on a couple of cylinders, or that has a flat tyre.

Some people are very pig-headed about this quality business. If they think they have lost some of those notes above 5,000, or you suggest cutting down to about 3,000 to avoid

SWITCHING OVER TO SHORT WAVES

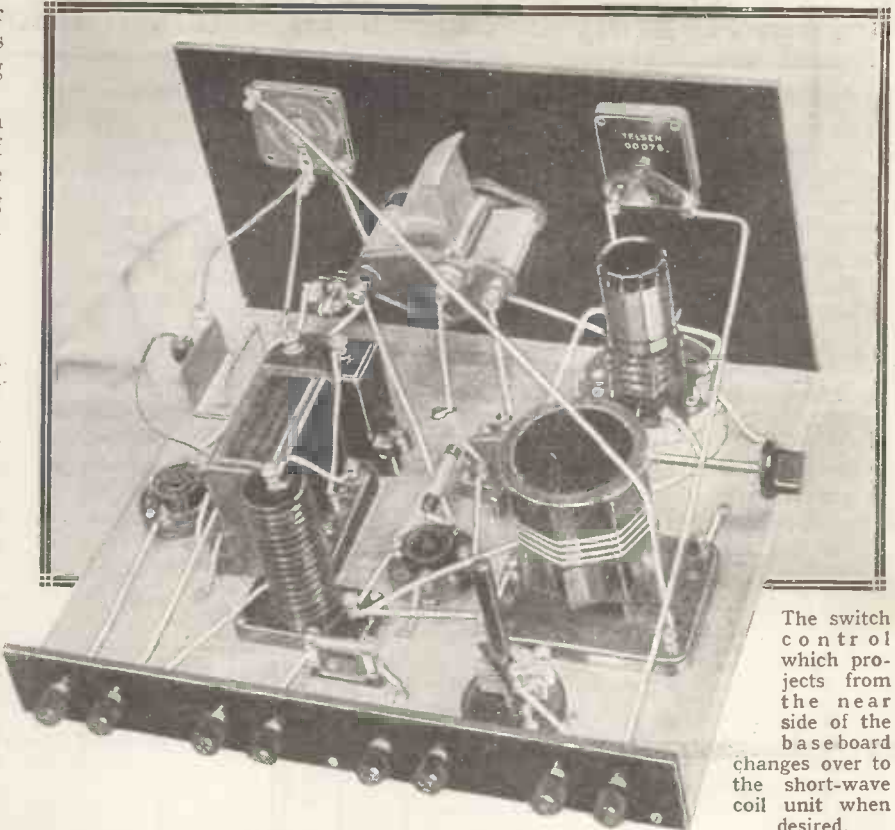

The switch control which projects from the near side of the baseboard changes over to the short-wave coil unit when desired.

THE "THREE-RANGE" TWO IN DETAIL

PANEL

12 x 7 in. (Goltone, Permeol, Peto-Scott, Direct Radio, Lissen, Wearite, Becol).

BASEBOARD

12 x 10 in.

CABINET

To fit panel 12 x 7 in., and baseboard 12 x 10 in. (Osborne, Gilbert, Camco, Direct Radio, Peto-Scott).

VARIABLE CONDENSERS

- 1 .0005-mfd. (Telsen W.132, Lotus, Polar No. 3).
- 1 .00075-mfd. solid dielectric (Telsen W.101, Ready Radio, Polar).
- 1 .0003-mfd. differential (Graham Farish, Telsen, Ormond, J.B., Polar, Ready Radio).
- 1 .00004 to .00005-mfd. max. baseboard mounting "neut" type (Igranic, Bulgin).

FIXED CONDENSERS

- 1 .0002-mfd. (Graham Farish, Telsen W.241, T.C.C., Dubilier, Ferranti, Lissen, Ready Radio, Goltone).
- 1 2-mfd. (T.C.C. type 50, Dubilier, Telsen, Igranic, Goltone, Ferranti, Lissen).

FIXED RESISTANCE

- 1 2-meg. grid leak with wire ends or terminals (Graham Farish "Olmite" Ready Radio, Igranic, Goltone, Dubilier 1-watt type).

COILS AND BASES

- 1 Screened dual-wave coil (Colvern K.5).
- 1 Short-wave coil and base (Ready Radio).

H.F. CHOKE

- 1 All-wave type (Lewcos Super, Slektun, Bulgin H.F.2, Goltone Super, Telsen W.74, Graham Farish H.M.S.).

SWITCHES

- 1 Two-point on-off (Lissen LN5070, Goltone, Telsen, Ready Radio, Bulgin, W.B., Lotus, Benjamin, Tunewell, Keystone, Wearite).
- 1 Rotary change-over (Ready Radio, Tunewell, Bulgin).

VALVE HOLDERS

- 2 Four-pin (W.B. small type, Telsen, Benjamin, Clix, Ready Radio, Wearite, Lotus, Igranic, Ferranti, Peto-Scott).

I.F. COUPLING UNIT

- 1 Bulgin transcoupler.

MISCELLANEOUS

- 1 Fuse holder (Belling-Lec type 1034, Telsen, Goltone, Bulgin).
- 1 Terminal strip, 12 x 1 1/2 in. (Goltone, etc.).
- 8 Indicating terminals (Belling-Lec, Bulgin, Igranic, Goltone).
- 4 Wander plugs (Goltone, Eclax, Belling-Lec, Clix, Bulgin, Igranic).
- 2 Accumulator spades (Eclax, or see above).
- 3 yds. of insulating sleeving and 5 yds. of 18-gauge tinned copper wire (Goltone, Wearite).
- 1 Fuse (Belling-Lec 150 m/a type 1056, Goltone, Bulgin, Telsen).
- 1 Piece of .004 in. copper foil, 12 x 10 in.
- 1 Slow-motion dial (Igranic catalogue reference "Vinn").
- 1 Coupling link to take 3/8-in. spindle (Wearite).
- 1 Switch bracket, 2 x 1/2 in. (Wearite).
- 1 Spindle 2 1/2 x 3/8 in. (Wearite).
- 1 Bias battery clip (Bulgin No. 2).
- Screws, flex, etc.

heterodynes, they go about as if the world were coming to an end. "Give us the high notes," they say, "even if we have mush with them."

Well, if they like it, let them have it. I am going to listen to what is said and done on my sets. If interference arrives I am going to cut it out as far as possible, even if I lose high notes. They are not real "notes" after the heterodyne has done with them, anyway.

How It Works

But to get back to the "Three-Range" Two. I have explained the whys and wherefores of the design,

and it will be clear to you now how the circuit was evolved, and how it works.

The actual construction is extremely simple. There are no knotty points to overcome; no snags that you are likely to meet except one. That is the old one that is constantly liable to recur while valve holders permit the valve pins to go right through them, and where the holders are of the comparatively squat type.

I refer to a danger I have often pointed out as being present where metal chassis or foil-covered baseboard is used—that of the valve pins protruding sufficiently through the sockets to touch the foil.

Such a happening, of course, is ruinous to the L.T. battery, if not to the valve itself and to other components.

Sure to Suffer

The fuse would prevent any valve blowing, but a nice little fix might be started in the set through the L.T. leads becoming red hot, and the battery would be sure to suffer.

But such a danger can easily be avoided by the simple expedient that I always adopt when I use a metal baseboard—placing a disc of thin card beneath the valve holder. It is

A Simple Set—with Extraordinary Range

simple, cheap, and perfectly effective.

I ought here to say a word or two about the change-over switch for medium, long and short waves. It will be seen that the switch is the normal rotary single-pole change-over type, and it performs its function by taking the grid of the detector valve and the "top" of the tuning condenser either to the "top" of the medium-long coil secondary, or the short-wave winding.

Extension Control

Obviously, then, this switch must be conveniently placed so that it does not demand long leads from the grid of the valve or the coils. The best place is where I have put it.

set in a cabinet, so that it is the easiest thing for me to alter the switch by the knob and spindle provided.

Many who build the set will prefer to have a cabinet, and to them the switching can be just as easy. The extension rod disconnects at the metal collar which connects it to the spindle of the switch. So it is an easy task to drill a hole in the cabinet side to take the extension rod, and then, when the set is placed in the cabinet, the rod can be run through the hole into the collar, the grub screw on the latter effectively keeping it in position.

The extension can be as long as you like, but I would not advise extending it more than is required to give clearance of the knob on

Note how the lead from the aerial terminal to the series condenser on the panel is run, and also the reaction lead to the No. 1 terminal of the short-wave coil. This lead comes along high up, just clearing the coil as it passes over the top and down to the required terminal. The coil does not have to be pulled out for changing, so the wire is in no wise in the way, and it is conveniently clear and untrammelled by the other leads.

Increasing Reaction

The operation of the receiver is very easy indeed. Turning the grid switch clockwise places the set in order for the reception of medium or long waves, the usual wavechange switch on the K5 coil unit being employed to change over on these two wavebands.

In this case reaction is increased by rotating the reaction condenser knob in an anti-clockwise direction provided the same make of reaction condenser is used as I employed. Other makes may result in the control being in the opposite direction. This does not matter, for it is easily found out which way reaction is increased.

I used a P.220 valve as output, with some 3 to 4.5 volts for grid bias, and about 100 in H.T. + terminal. This gives good smooth reaction. Selectivity and volume are controlled by the aerial series condenser.

To receive short waves the grid switch is turned in the other direction and reaction is increased by rotating the condenser knob clockwise.

For smooth reaction it is best that the neutralising type condenser on
(Continued on page 383.)

AN UNUSUALLY INTERESTING CIRCUIT

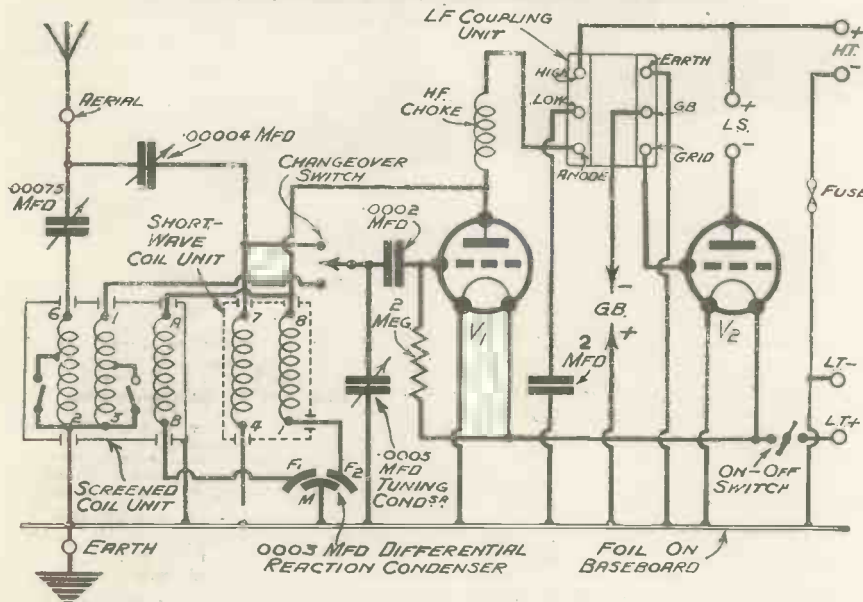

The circuit of the "Three-Range" Two is particularly interesting, as it incorporates a very ingenious method of obviating elaborate three-band switching. The reaction condenser is so arranged that it operates differentially on the broadcast band, and is a normal reaction condenser on the short waves, due to the H.F. choking effect of the medium-wave reaction coil. Similarly, the effects of coil impedance and condenser reactance are used to simplify the aerial-grid wavechange switching.

The leads are all reasonably short, especially the ones to the short-wave coil and to the grid condenser, and the switch is easily mounted on a bracket.

The question of controlling the switch comes up, of course, but as it is not in constant use, like tuning and reaction, there is hardly any need for the control to be on the panel. I do not like more knobs on the panel than I am going to use pretty frequently.

So the switch has been so arranged that by an extension rod the control can be made to protrude to the left-hand side of the set. I do not use the

side of the cabinet, for a long rod will mean unsteady operation of the switch unless you fit a bush for the rod in the side of the cabinet—an unnecessary complication.

Keep to the Layout

In building copies of the "Three Range" Two, care should be taken that the layout of the original set is adhered to as closely as possible. Especially is this important round about the tuning coils, for any careless jumbling of wires here may materially affect the operation of the receiver on the short waves.

THE "THREE-RANGE" TWO ACCESSORIES

Loudspeakers

R. & A., Celestion, Marconiphone, H.M.V., B.T.H., G.E.C., Baker's Selhurst, Blue Spot, Igranic, Lanchester, Ormond, Atlas, Epoch.

H.T. Battery

120-volts (Ediswan, Drydex, Siemens, Pertrix, Magnet, "Silver Knight," Marconiphone, Ever Ready).

G.B. Battery

To suit output valve (Ever Ready, or see above).

L.T. Battery

(Exide, Ediswan, Pertrix, Oldham, Block, G.E.C.).

Aerial and Earth Equipment

Electron "Superial," Goltone "Akrite," Graham Farish "Filt" earthing device.

MY BROADCASTING DIARY



B.B.C. Organisation

As I expected, the Parliamentary storm, although so well weathered by the B.B.C., had repercussions at Broadcasting House, where there were heart-searchings by the Director-General and the Governors to devise new organisation safeguards.

I have not heard what is happening, but there are indications that the organisation will be made more complex and involved. If so, nothing will be gained.

What is needed is simpler organisation, and a more clearly defined lead, accompanied by more effective discipline.

By simpler organisation I mean the concentration of the programme work with the elimination of all unnecessary red tape. By a more clearly defined lead I mean the definite laying down and the equally definite acceptance of the policy that in all its activities the B.B.C. works in its own best interests, and not for some political, ethical, or extraneous ideal.

As for more effective discipline, I mean discipline directed more towards reality and less to appearances. To my mind it would be better to have all the responsible members of the staff working harmoniously for the established policy in a spirit of loyal collegueship and friendly respect for authority than to carry on a kind of personal interpretation of policy.

Undoubtedly Sir John Reith can clear up the situation, and there may be something in the suggestion that he can reform the service to suit his plans. On the other hand, it is to be hoped that any clearance that may be decided upon will not denude the defences.

Washford Cross

The B.B.C. reports exceptionally rapid progress in the completion of the West Regional Station at Washford Cross. The public tests have already been arranged, and it is anticipated that the full alternative service will be working by the middle of June. According to present plans the West Regional National Programme will be distributed on the London National frequency of 261.6 metres, another experiment in shared wavelength working.

Money Problems

The financing of the "New Daventry" station near Droitwich may well cause some anxiety to the B.B.C. This will be easily the biggest engineering job so far undertaken.

Our Own Broadcasting Correspondent keeps a critical eye on the affairs of the B.B.C., and each month, for the benefit of listeners, comments frankly and impartially on the policies and personalities controlling British broadcasting.

Wychbold, as the new station will be called, will be the last word in design and efficiency, and should indeed be the outstanding high power transmitter, certainly in Europe, if not in the world.

The Empire Broadcasting Service also puts a strain on the finances of the B.B.C. There is, however, no public support for the criticism of the B.B.C. on the ground that it is not entitled to spend money on programmes designed primarily for the Empire overseas.

FAMOUS RADIO AND STAGE COMEDIAN ON HIS HONEYMOON



Popular entertainment stars do not always have an easy time. Mr. John Tilley is here seen at Saltdean on his honeymoon which had to be put off because of pressure of engagements.

This expenditure will go on for some years before any substantial contribution can be expected from the Dominions and Colonies. No sensible person, however, would query the wisdom of the initiative of the B.B.C.

Future of Broadcast Education

The future of Broadcast Education on the Schools side is receiving the earnest attention of the Board of Education, which is taking this part of broadcasting very

The Possibilities of a "Tinned" Service

seriously. The policy of the B.B.C. has been to encourage the Board of Education ultimately to take over responsibility for school broadcasting, and it seems that this view is about to be accepted in official quarters.

This does not mean that the B.B.C. would abdicate responsibility for any part of its transmissions; it does mean, however, that the organisation at the listening end would be no longer part of B.B.C. responsibility.

Mechanical Reproduction

The necessarily considerable proportion of mechanically produced programmes in the Empire Service has called attention more definitely than at any time in the past to the future possibilities of a "tinned" broadcasting service. Only trained ears could detect some of the Blattnerphoned reproductions, were it not for the acknowledgement.

The snag, however, is that the acknowledgement of the process tends to disappoint the listener. There is a feeling overseas that it would be better for the B.B.C. to give shorter, simpler programmes and avoid mechanical reproduction.

What the outcome will be it is impossible to predict; but it is perhaps worth noting that no less an authority than Mr. David Sarnoff, Vice-President of the Radio Corporation of America, is quoted as prophesying that the future of broadcasting lies entirely in the field of mechanical reproduction.

AT THE VATICAN STATION

A special ultra-short-wave transmitter has been installed at the Vatican station. The parabolic reflector can be seen to the left of the main mast.

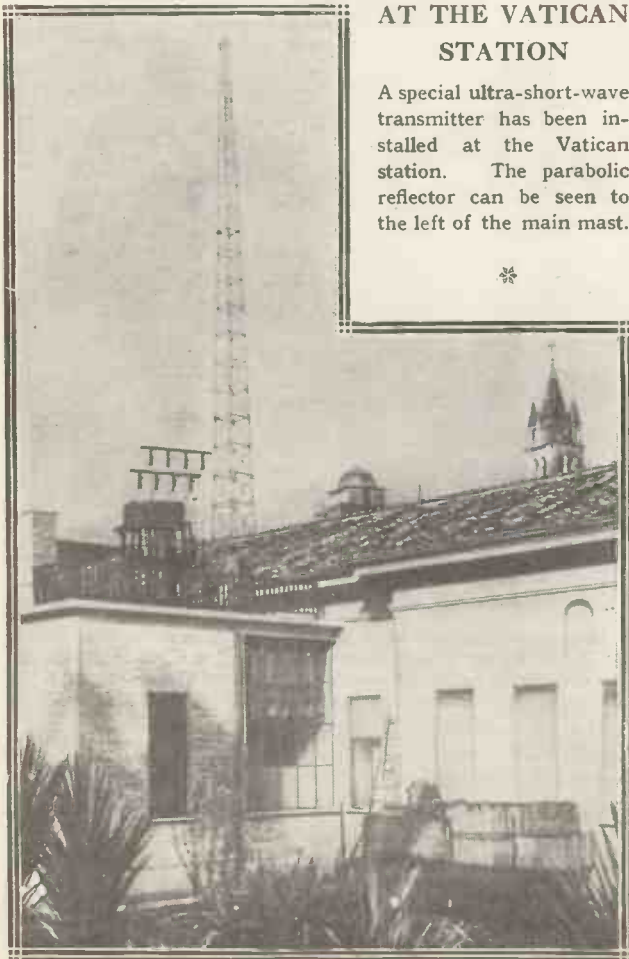

That Sponsoring Problem

It is estimated that at least £2,000 a week is transferred from Great Britain to Continental Stations on account of sponsored programmes radiated from abroad for the purpose of selling to the British public. This does not count the money spent by foreigners for the same purpose.



B.B.C. ROMANCE

Mr. Gerald C. Beadle, assistant director of programmes of the B.B.C., with Miss Jocelyn Rose on the occasion of their wedding at Marylebone.

The new station at Athlone has also begun to accept sponsored programmes, and British money is flowing in that direction also.

One school of thought which deplores the transfer of such large sums to other countries is urging the B.B.C. to set up a station which would be avowedly run on sponsored programme lines. The Island of Sark is mentioned as providing a likely site. It is improbable that the B.B.C. will accept this proposal.

Future of the Broadcasting Union

Although the February meeting in Brussels of the International Union of Broadcasting was by no means smooth, it is an exaggeration to suggest that the Union is in danger of breaking up. The self-interests of broadcasters would prevent this in the last resort.

There will be another meeting in May, when a further attempt will be made to devise a successor to the Prague plan. That is, a new scheme of distribution of broadcasting channels, based on the results of the Madrid Conference of last year. Great Britain need not expect any new facilities.

On the other hand, the B.B.C. delegation can be counted on to defend the facilities already enjoyed.

Wales and the B.B.C.

The prolonged estrangement of Wales from the B.B.C. promises to be healed. Two main factors have intervened.

First of all, Mr. Lloyd George's influence has been an important conciliatory factor. Secondly, the B.B.C. has agreed to radiate the Welsh Children's Message of Peace to the Children of the World.

For several years the B.B.C. has rejected the proposal to broadcast this message, and Welsh opinion was seriously irritated. This cause of trouble has now been happily removed.

HOW TO OBTAIN BETTER RADIO

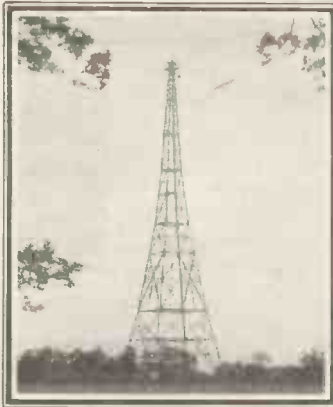

Whether you build your sets or buy them ready-made, you'll always find some query cropping up regarding maintenance, installation or modification. This special monthly feature solves all such problems for you in an attractive and entertaining manner.

MAKING THE MOST OF H.T. BATTERIES

THIS looks a good title for an article about Q.P.P., but we realise that though many listeners would like to adopt this latest development, their pockets prevent them from taking the step. However, we can point the way to appreciable economies in the use of H.T. with ordinary sets.

In the first place, brief reference must be made to grid bias. We have covered this point before, but no article about H.T. economy would be complete without at least a brief recapitulation.

Negative grid bias limits H.T.

SECTIONAL REPLACEMENTS

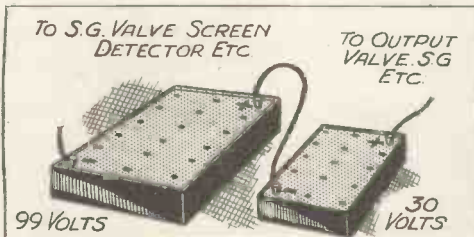

An economical method of supplying the different H.T. voltages required. There is a smaller current drain on the 30-volt unit than on the 99-volt one.

flow. Obviously, it must not be limited excessively or the performance of the set will be interfered with.

Nevertheless, we believe it is the rule rather than the exception to apply less G.B. than is necessary. It is better to err on the side of generosity with G.B. And don't forget that G.B. has its applications on the H.F. side of a set. It can both save H.T. and improve results.

Many modern receivers use variable-mu valves, and G.B. is part and parcel of their working. But G.B. can be applied to ordinary S.G. valves with benefit.

One and a half volts is ample, and special cells for the purpose can be bought. Don't try to use the same battery that supplies the L.F. valves with G.B. (We hope to give full details of G.B. for S.G.'s in a future issue.)

Try More G.B.

On the L.F. side, remember that valve makers give grid-bias voltages for maximum outputs. You might not want the full output of your power valve.

In such a case it would be waste of H.T. current not to increase the G.B. a little.

Finally, keep as close a watch on the condition of your grid-bias battery as you do on that of your L.T. or H.T. And now we come to the H.T. supply itself.

When the H.T. consumption is rather heavy (more than ten milliamperes, say), it is decidedly worth while buying double or treble capacity batteries.

There is a great deal to be said for breaking the supply into sections: purchasing a 99-volt and a 30-volt unit instead of one battery, for example, because the drain over the whole is not often even.

Take a set having two H.T. terminals, one feeding the anodes of an S.G. valve and a power valve, and one the S.G. screen and the detector anode.

The latter will require 90 volts at the most, while the former will need

a full 120 or more. The cells lying between negative and 90 volts have to supply the total current of the set, although those from 90 to 120 serve only the S.G. and power valve anodes. Obviously, these will, or should, last longer.

If the battery comprises two sections, two batteries joined in series, as illustrated in the sketch, one may be giving good service for some time after the other has been replaced.

The actual saving largely depends upon the exact disposition of the H.T. feeds and the currents they have to supply. But it will be clear that "sectionised" H.T. may save some listeners quite a lot of money in the course of years.

Nevertheless, it is not a principle to be acted upon without a very careful weighing of the pros and cons—or costs, we should say, to be more exact!

And the matter needs consideration in the light of individual conditions and requirements.

There would be much less of a problem if the prices of H.T. batteries were standardised on a so-much-per-volt basis.

But this is not the case, and you do not necessarily have to pay twice as much for a battery of twice a given voltage.

At one time you could build up an H.T. battery from flash-lamp cells, and spend no more than if you purchased a complete H.T. battery.

And this was a sectionising of the supply which made for a definite economising.

But the procedure is no longer a money-saving one. However, the use of two H.T. batteries in the manner described above definitely may be very well worth while.

THOSE SELECTIVITY CONDENSERS

WE meet the necessity for compromise at almost every turn in radio. Because of the wide frequency difference between "long" and "medium" wavelengths, it is often difficult to arrange an aerial series condenser satisfactorily.

A Simple Remedy

Even if a "preset" is used, the setting necessary to give the required selectivity on medium waves is likely to be such that there is loss of strength on long waves.

Well, here is an idea for over-

NO LONG WAVE LOSSES

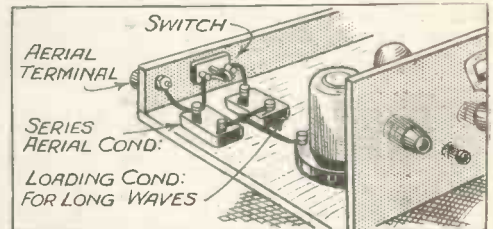

The correct aerial series capacity for both long and medium waves is given by this simple arrangement which necessitates the use of only a switch and an extra fixed condenser.

coming this snag. It is shown very clearly in the accompanying sketch. In addition to the normal series condenser, there is an extra one which is switched into parallel with it when you go over to long waves, so that the capacity is right for both wavebands.

The capacity values of these condensers will depend upon the coil and aerial used. .0002 mfd. is usually about right for the medium

WHERE TO LOOK FOR HOWLS AND HUM IN YOUR SET

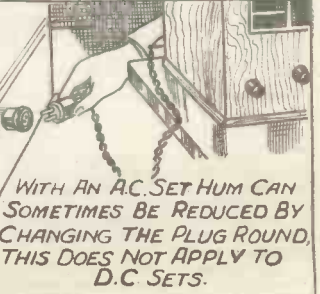
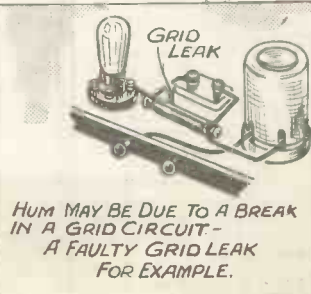
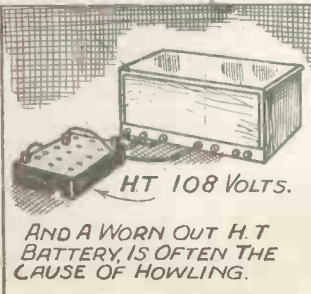
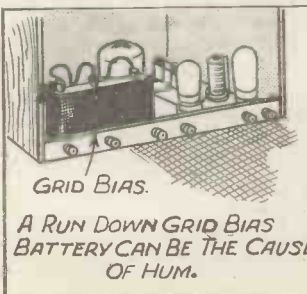

Receiving Short Waves on an Ordinary Set

waves and .0003 mfd. for the long waves when an S.G. valve is used.

In such a case a .0002-mfd. and a .0001-mfd. should be employed, the latter being the one to be "switched in." Alternatively, two presets could be used the most suitable adjustments being found by trial.

LOST EMISSION

It is unfortunate but true that the life of a valve is limited. Anyway, its useful life. However, modern dull-emitter valves last a very long time if carefully operated.

The battery types are mostly capable of many thousands of hours of work. It is the opinion of some that mains valves do good service if they run for one thousand hours before losing their efficiency.

But we have a dozen mains valves which have all exceeded the two-

VISUALLY INDICATED

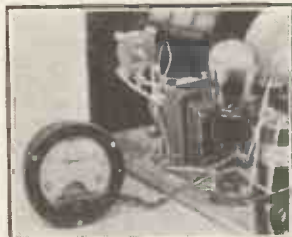

Providing the H.T., L.T. and G.B. are in good order a falling anode current indicates an ageing valve.

thousand-hour mark and are still in good condition!

Sometimes the life of a valve is accidentally curtailed by its filament being burnt out. Given careful use, it is generally a gradual wearing out that marks the end of a valve's life.

When the Current Falls

The filament loses its power to emit electrons in the original quantity. In short, the "emission" falls off.

This is at once shown by a milliammeter. As we all know, with a given H.T. and G.B. a certain anode current should flow: the valve-maker's leaflets provide the information.

With loss of emission the current drops and, of course, the valve tends to become inefficient.

There is nothing to be done about it except buy a new valve! So if your set begins to grow less sensitive or, despite correct H.T. and G.B. voltages, there is distortion, suspect that one or other of the valves is losing its emission.

Most dealers will test valves free of charge.

PROS AND CONS OF SOLDERING

At one time soldering was considered to be an absolutely essential operation in assembling a wireless set, and "screwed" connections were regarded as mere expedients.

Nowadays, however, soldering has gone out of favour and is the exception rather than the rule.

The reason is that the average constructor does not take kindly to soldering, and there is nothing

worse in radio than a badly soldered joint.

It is a most obscure fault to trace at times and its effects can be very marked.

That soldering is not as easy as some would have us believe is proved by the fact that "dry joints" are often to be found in commercial apparatus. And if soldering cannot always be properly done in factories, it is obvious that constructors cannot be expected to make a one hundred per cent success of it on all occasions.

Terminals Often Preferable

On the other hand, "screwed" connections have an uncanny habit of working loose. This is probably due to both vibration effects and to atmospheric changes causing expansion and contraction of the metal concerned.

But although a first-class soldered joint is superior in point of permanency, the soldering must be first class or it will certainly not be comparable with the "screw" method. And as first-class soldering is beyond the powers of many designers are right in adopting the screw terminal wherever possible.

SHORT WAVES ON ORDINARY SETS

When the long and medium waves begin to pall on one, the short waves provide a very refreshing diversion.

Nevertheless, you must not look to the short waves for an entertainment service comparable with that to be found on the higher wavebands.

Fading and atmospherics, particularly fading, are nearly always present although, now and then, one can listen to a whole programme without being seriously interfered with in that way.

QUICK CONNECTIONS

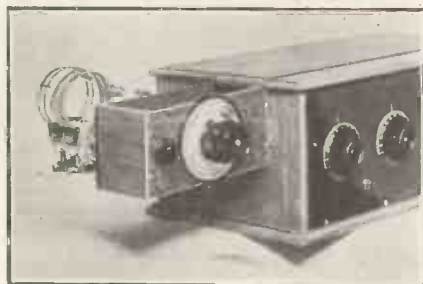

A short-wave adaptor transforms an ordinary set into a short-waver.

And, in any case, you will be indeed a hardened listener if you cannot get a really big thrill from hearing even only scraps of concerts, talks and sports broadcasts from the far distant corners of the globe.

It is not now considered essential that a special set should be used for short-waves.

Three-band sets capable of tuning them in as well as ordinary broadcasting are now almost a commonplace. It is pleasing to recall that "M.W." was one of the very first journals to introduce the public to this interesting form of receiver.

Tuning Condenser Size

It is often said that efficiency on one or other of the bands must be sacrificed in order to achieve such versatility.

This need not be the case if the design is carried out carefully.

Where many designers are apt to

stumble slightly is in trying to make the one variable condenser of the conventional .0005 mfd. capacity tune the short waves as well.

This can only be done with entire success if the condenser is chosen with great care and a very efficient slow-motion dial used with it.

TRI-BAND COILS

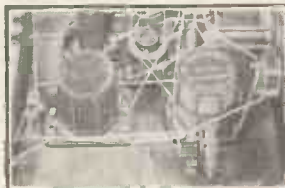

Coils designed to cover short, medium, and long waves.

Practically any existing receiver, battery or mains, can be adapted for short-wave reception by using a short-wave adaptor.

This usually comprises a short-wave detector circuit built up as a compact unit. It is connected to the receiver by means of a plug which is inserted into the detector valve socket.

The detector valve is employed in the adaptor. Thus the L.F. stages of the set are used in conjunction with the special detector stage and an efficient short-wave outfit results.

In another form of short-wave adaptor there are two valves arranged to function in conjunction with an S.G. set as a superheterodyne.

This more elaborate method is capable of giving extremely fine results, though the simple single-valve adaptor has set up astonishing performances and is almost invariably successful.

By the way, it is interesting to recall that the short-wave adaptor idea was invented by Mr. G. T. Kelsey, who is on the staff of this journal.

And so successful did this invention prove to be that within a year or two of its inception short-wave adaptors were being made and used in practically every country in the world.

WORTH NOTING

A large number of different makes of wireless sets and kits of parts are being "sold off" at temptingly low prices. But listeners should note

that these "bargains" seldom carry their manufacturer's guarantees, and that "after sales service" is denied to purchasers of cut-price apparatus.

WHAT ABOUT TELEVISION?

This is a question that we have not been eager to deal with, but our kindly correspondents, or many of them, have been getting, very pressing on the subject lately.

They want us to give them our opinion as to whether or not television has yet reached that stage of development where its introduction into the home makes for "better radio" enjoyment.

Well, in view of the fact that

television occupies only an odd half an hour here and there in the programmes, it would seem doubtful that it has value as a provider of regular entertainment quite apart from its technical aspects.

And those odd half hours appear to occur when most listeners are thinking about going to bed.

If there were television broadcasts of all the important programme features, then it would be more difficult for us to frame an opinion.

Progress Still to be Made

But, personally, we do not regard the present transmissions as being more than opportunities for enthusiastic experimenters to exercise their wits, or as novelties for those who are prepared to expend considerable time and money to be in at what may be the beginning of a new radio development.

Anyway, our experience is that it is by no means easy to tune in pictures, and that when the pictures are tuned in they are very, very crude.

One day, perhaps in the not very distant future, television may "arrive," but it is our considered opinion that at its best it is not yet good enough to warrant the attention of seekers of consistent and worthwhile entertainment.

But, mind you, that is only our opinion. There are others who would appear to think that television is already a proposition all listeners should consider.

YOUR AERIAL EQUIPMENT

We have said in a previous issue that we believe listeners should use "lightning protectors," not because lightning ever has caused serious damage owing to the presence of a wireless aerial, but because an "earthed" aerial is a fine protection against the ten million to one chance of lightning striking a house.

Must be "Weather-proof"

But an aerial earthing switch is not an unmixed blessing. To be effective it needs to be fixed up outside, and unless specially designed and made it won't "stand the weather." Curiously enough, many lightning protector devices are constructed as though they were intended for use indoors, no attempt at "weathering" being introduced!

If you do use one of these it ought to be encased within a weather-proof box and not left to corrode away in the open.

A MIXED BLESSING



An aerial-earthing switch may be a mixed blessing as is shown in the accompanying article.

It seems very amateurish to us to expose a flimsy little brass switch to the elements.

However, if it is recognised that to do so implies the necessity for fairly frequent cleaning and, perhaps, yearly replacement, why should we pursue the matter further?

On the other hand, be prepared

Interesting and Helpful Notes For All Listeners

for more or less regular "break-downs" in reception if you install a flimsy and unprotected switch and "hope-for-the best."

Those of you who erect poles for your aerials ought to make sure that you use ropes treated to withstand the weather.

Also, the pole itself needs to be treated for dry rot, especially at the point level with the surface of the ground and for a foot or so above and below.

Ordinary paint does not provide good protection, and spreading tar on the surface is not much better.

The best method is to have the wood "treated" in the same way as are telephone poles and railway sleepers. But that must be done by the suppliers of the wood. It is impossible to apply such treatment after the pole is erected.

If you use ropes for supporting a mast it should be remembered that they are liable to stretch quite a bit when they get wet.

Therefore, it is wise to arrange either to slack them off when it rains or to devise some system of spring compensation.

and may even break off. If this happens the cell goes right out of action, owing to the impossibility of connecting it in circuit.

If the terminals are always kept clean and a thin film of vaseline applied after each charge, they should never be attacked by corrosion.

"EARTH" POINTS IN SETS

THE word "common" implies a sharing of one point in a circuit. For example, if two wires, A and B, join to the one terminal, the condition is described in this way: this terminal is common to wires A and B.

A "common" L.T. lead is an L.T. lead shared by two or more valves. The "earth" terminal carries the greatest grouping of this nature. Many of the connections

A FEW OF THEM!

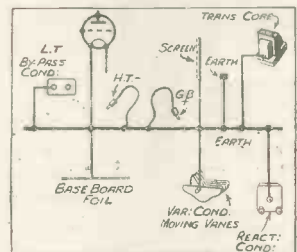

Illustrating some of the points in a set which will be at "earth" potential.

But it rapidly attenuates. It is the indirect ray which makes spectacular long-distance results possible. However, the indirect ray reaches your aerial after reflection from the Heaviside Layer—a belt of conduction gas some scores of miles above the earth.

When this layer is in a state of flux, the wireless waves are not reflected at the same steady angle all the time. And, therefore, fading occurs.

Automatic Volume Control

There have recently been developed methods of automatic volume control designed to maintain a steady volume from the loudspeaker despite irregularities of the above nature.

We have not yet encountered entirely successful methods, but have hopes of at least two new systems. As soon as we are able to report definitely concerning them we shall give readers the benefits of our experiments.

But we must add in neither case can the method easily be applied to existing sets.

CONCERNING SCREENING

DURING the past few years there has been a move away from "interstage" screening, in which whole sections of the set were shielded, towards the adoption of screened components.

Indeed, practically all sets using H.F. stages now employ "canned" coils.

The use of individually screened components must not lead constructors to imagine that the problems of unrequired feedback are solved.

Coupling Effects

You cannot jumble together a collection of even these so-called shielded components without taking very stringent precautions against it.

Owing to the fact that modern valves give greater amplification, the coupling effects which can and always did, tend to occur between leads are magnified.

Then, again, the screening of many coils is not by any means complete.

For perfect screening the component must be totally enclosed in metal. Apertures constitute opportunities of leakage.

ONLY PARTIAL



A vertical screen of this type provides only partial shielding, although this is, of course, often quite sufficient.

It may be argued that the simple vertical screen (see photo), which has often been the alternative to the use of screened coils, is only a partial shield.

Very true, but such a screen was always backed up by careful component disposition designed to supplement its effect.

While we are on the subject of screening we must not forget to place it on record that we view with concern the almost indiscriminate

manner in which component screening is being carried out by some firms.

Particularly does this apply to coils. Screening causes losses. And the losses can be considerable. To wind a coil smaller than usual and place it in a "can" without regard to certain fundamental laws is simply throwing energy away.

To be comparatively efficient a screened coil needs to be very scientifically designed.

We were testing a det.-L.F. set a week or two ago. It had a screened coil and the results it gave can only be described as poor.

But when a quite ordinary un-screened coil was wired in instead, the performance was improved in a remarkable way.

Candidly, we cannot see the advantage of using, even a good "canned" coil in a "det." type of set having no H.F. stage. But we are open to correction on this point!

When there is efficient H.F. amplification the use of screens of some kind or other becomes imperative.

And with every additional H.F. stage the need for screening is vastly greater.

Two H.F. stages sometimes necessitate the shielding of leads in addition to component screening and the introduction of baseboard foil.

The losses occasioned by screening are accepted, one might almost say gladly, by American set designers.

The average American set will have as many as four or five S.G. stages of H.F., and, to our way of thinking, the shielding is almost savagely applied!

But it is all part and parcel of a definite system of design which is almost diametrically opposed to that adopted in this country.

However, we are now anticipating, for that is a subject which we have ear-marked for discussion in a future issue.

TRANSFORMER TROUBLES

TWO things are primarily required of an L.F. transformer if it is to give good results. Firstly, that it should have a high primary inductance and, secondly, that the capacity of its secondary winding should be low.

The high primary inductance can be achieved by winding on a great quantity of wire. But for every turn of wire in the primary there must be three or four in the secondary in a 1:3 and 1:4 ratio transformer respectively.

Special Alloys

And the larger the secondary the higher its capacity unless very special steps are taken.

An alternative is to use a core of special nickel alloy. But here again there is a snag because these alloys tend to saturate easily. A current of but a few milliamperes will throw them right off their characteristic.

Lately there have been developed special alloys which are more stable, but, in general, the only method of using "nickel" transformers so that their functioning is free from saturation limitations, is to "parallel-feed" them—i.e. by "shunting" their primaries with condensers and resistances.

But this tends to cause some loss of amplification, although, against this, can be credited the fact that a much better response in point of quality is obtainable.

Indeed, with "parallel-feed" a "curve" can be achieved that is unbeatable except by a very expensive transformer employed in the "direct connection" manner.

In addition, the auto-transformer method of connection can be used.

THAT SULPHATION

SULPHATION is a common complaint in accumulators used for wireless. It is caused by neglect. If an accumulator is carefully maintained it will function for years without any sign of it.

Exhaustion is the primary cause. A cell is allowed to run down and stand a time before re-charging; sulphation is the almost inevitable consequence of such neglect.

WHAT IT DOES



A striking example of the amount of corrosion that can occur on a neglected accumulator terminal.

Sulphate crystals form on the surfaces of the plates and reduce their effective area. The capacity of the cell is therefore reduced.

So instead of giving, say, eighty hours of use, in a case of bad sulphation a cell may only operate for a few hours per charge.

Tackle It At Once

In the early stages sulphation can be dealt with by special charging methods. Long, slow charges and a good cleaning out may bring the cell back to good condition.

If the sulphation is advanced, only the drastic step of having new plates fitted might be able to cope with the trouble, and that is seldom worth while with small accumulators.

There is another and more easily avoidable form of sulphation. This affects the terminals. Perhaps we should call this corrosion?

But this can be bad enough if allowed to go too far. A badly corroded terminal will be unusable

"common" to the earth terminal do not go direct to it.

They are connected to the most convenient wires that run to that terminal.

The accompanying illustration shows a number of the points in a set which are "earthed." These are extremely important connections, and not only do many of them complete vital circuits, but all contribute in one way or another to the stability of the set.

The one terminal of each of the batteries joins to this "earth line," so, obviously, it is necessary to keep all the other connections of the batteries and their leads well separated from points in direct contact with it.

DEALING WITH FADING

IN this article we are concerned only with that fading which is due to atmospheric conditions. This never occurs with powerful "local" stations.

If you get a fading effect from a transmitter like one of the B.B.C. National or Regionals, and it is only ten or twenty miles away, then you can be fairly certain that your own receiving installation is at fault. But we should add that another listener mishandling his set on an aerial very close to your own can cause your reception to fluctuate in a marked manner.

The Indirect Ray

"Natural" fading is due to variations in the transmission of the indirect ray from a station. Wireless waves are sent off in two forms. The one, the direct ray, keeps to the earth and maintains a moderate evenness of strength.

"A THING of beauty is a joy for ever."

The quotation is an old one. It dates back to long before broadcasting was even dreamed of in this or any other country, yet, curiously enough, it is only now, after a decade of wireless entertainment, that its full significance in the radio sense can be appreciated.

For the past eight or ten years in retrospect, it is clear that in all but a few cases, the question of cabinet work, if not exactly an afterthought, was at least a consideration of quite secondary importance. Those years, in a sense, were "novelty" years—years when results were of far greater importance than appearance.

Studying Appearances

But the psychology of the 1933 buying public is very different. Today, the "thing of beauty" is as vital a selling point as the performance of the set itself. That is why the Gramophone Company is one of the most successful organisations in the whole of the industry.

They understand this modern psychology which

attaches as much, if not more, importance to appearance as to results, and they cater for it in a way which does them credit. H.M.V. cabinet work could be distinguished the proverbial mile away. It is nothing short of magnificent.

The Superhet Radiogram Seven which was recently submitted to us for test and report is no exception. It is made from the finest walnut, and the impressiveness of its appearance baffles description.

"M.W." TESTS

THE H.M.V. SUPERHET RADIOGRAM SEVEN

THE LAST WORD IN RADIO AND

GRAMO-PHONE PRACTICE



Nothing short of "magnificent" fitly describes the superb cabinet which worthily houses an outstanding receiver.

Again to refer to the language of the sages, it is true that one should not judge a book by its cover. But following our tests of this magnificent

cabinet that is worthy of such a remarkable set, or whether it is the set that is worthy of such a superb cabinet. At least both combine to place the instrument in a class of its own—a class that is representative of the finest in modern

radio and gramophone practice.

There are many things which warrant early reference in describing our impressions of the Superhet Radiogram Seven. Selectivity, sensitivity, quality of reproduction, ease of operation, all are sufficiently outstanding to be placed right at the top of the list. But we must make a start somewhere, and so perhaps we had better adopt the logical course, and deal first of all with the circuit.

Circuit Details

The six valves which constitute the receiving and amplifying chain are arranged in the circuit sequence of H.F. amplifier, oscillator, first detector, intermediate frequency amplifier, second detector and output valve. The seventh valve, which is the rectifier, is a U.12.

Magnetically-coupled band-pass circuits provide a degree

of selectivity more than adequate for the most exacting of modern requirements, and distortionless control of volume is effected by a potentiometer which is connected between the common cathodes of the first H.F. amplifier and the intermediate frequency amplifying valve.

Exactly as it should be, this is the only control that can be operated without opening the cabinet lid. It is located centrally at the front of the instrument.

(Continued on page 379)

A MAGNIFICENT ALL-ELECTRIC RADIOGRAM

H.M.V. instrument we are unable to definitely decide whether it is the

of selectivity more than adequate for the most exacting of modern requirements, and distortionless control of volume is effected by a potentiometer which is connected between the common cathodes of the first H.F. amplifier and the intermediate frequency amplifying valve.

THE CHASSIS IS MOUNTED ON END

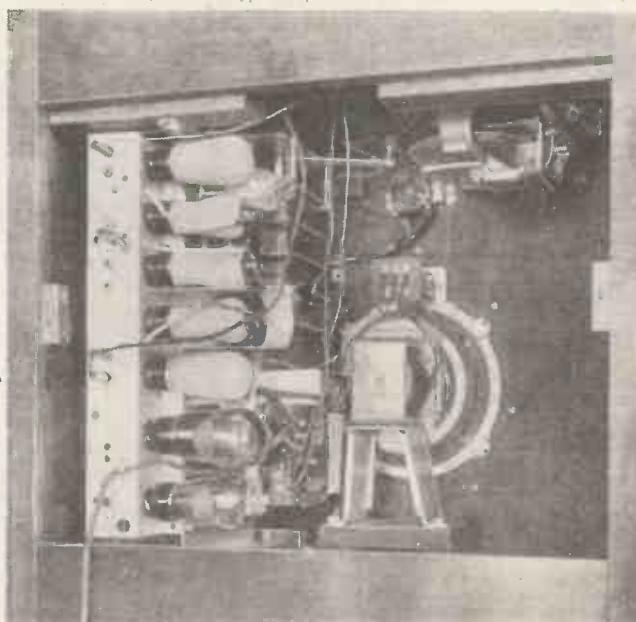

To simplify valve insertion the chassis is mounted on end. The induction disc turntable and the high-power moving-coil speaker can be clearly seen in this view.

TECHNICAL

GENERAL DESCRIPTION: All-electric seven-valve superheterodyne radio gramophone, for A.C. mains.

CIRCUIT DETAILS: Seven valves are arranged in following circuit sequence: H.F. amplifier, oscillator, first detector, I.F. amplifier, second detector, and output (seventh valve is mains rectifier).

CONTROL ARRANGEMENTS: Volume control on front of instrument is only control visible. Main tuning control, tone regulator and four position "wave-change-gramophone-off" switch are all conveniently mounted on

SPECIFICATION

motor board. Turntable is actuated by automatic stop working on eccentric groove of minimum diameter record principles.

SPECIAL FEATURES: (1) High degree of selectivity consequent upon inclusion of band-pass tuning principles; (2) Great sensitivity; (3) Realistic reproduction; (4) Simplicity of operation; (5) Cabinet craftsmanship; (6) Wavelength calibrated dial; (7) Illumination of only the appropriate wavelength scale (depending upon position of wavechange switch).

Presenting the Programmes

Last month we showed you something of the work which goes on behind the scenes while preparing the programmes. This month the curtain is up—On with the Show!



In the Vaudeville studio Jack Hulbert spends his time between stage and listening-room. The proceedings are not very formal. In fact, Jack Hulbert is shown frantically waving instructions to his principals.



Earlier in the evening the Children's Hour has been enlivened by Mario de Pietro, who is seen with the Uncles and Aunts (though they mustn't be called that now) as they read the birthdays. While, on an alternative wavelength, Henry Hall and the B.B.C. Dance Orchestra (left) have delighted more sophisticated folk with song and dance.



The Talks studio this evening is occupied by Mr. Gerald Heard, whom you see engrossed in his manuscript. Meanwhile, members of the Wireless Singers (above) await their turn to "go on."



TEAM WORK

The Wireless Singers have not had long to wait for their call, and on the left you will see Edward Clark conducting the Singers and the B.B.C. Orchestra in Studio 8A. These "team-work" concerts, which Edward Clark and Joseph Lewis produce at frequent intervals from the studios, are among the most popular staff contributions to radio entertainment.



As a contrast, we show you below a glimpse of Marion Harris, the famous American cabaret star, on one of her many popular visits to the B.B.C.'s microphone.



The control point, where an engineer is engaged upon checking quality "over the air" against the transmitter lines.

Below is an unusual view of studio BA, as seen from the stage entrance. Readers who have not helped to compose a studio audience now know what the singers look like.



UNDER THE CLOCK

This photograph was taken during a broadcast by Jack Hulbert and his Follies, and shows the artistes what *they* look like! Note the studio clock, the style of which is typically "Broadcasting House."



THE MEN BEHIND THE SCENES

And what of that silent band of enthusiasts whose names you never hear but whose work is essential to the success of the programmes?

Up on the eighth floor the men at the dramatic control panel are gathering speech and music and "effects" from several studios throughout Broadcasting House and mixing them to make one intelligible programme.

The circle photograph shows one of these studios, seen through the listening-room window, where members of a cast are taking part in a radio-play—heard but not seen by the producer.

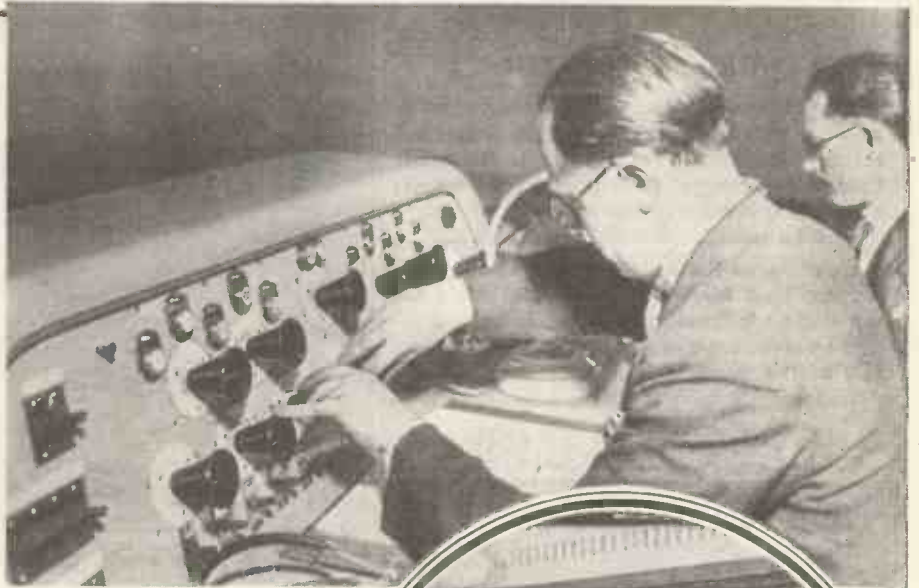

You will notice above how different a radio "stage" is from the usual variety.

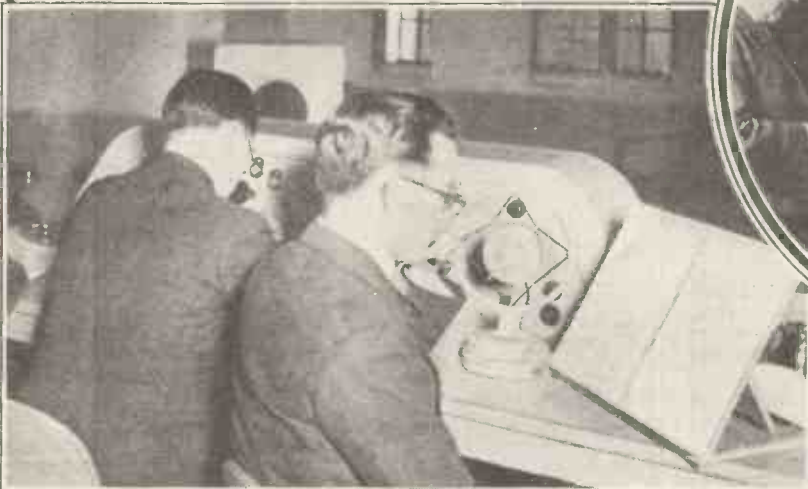

The man at the dramatic control panel above (with his back to you) is known as the operator. His duty is to control the studios at the direction of the producer and he is the radio counterpart of the stage manager. The producer is studying the script.



Above and on the left the "effects" engineers are busy adding "local colour" to the production. The water tank and its accessories are used for wind and sea effects, and other noises are made on a specially treated table with several different surfaces.

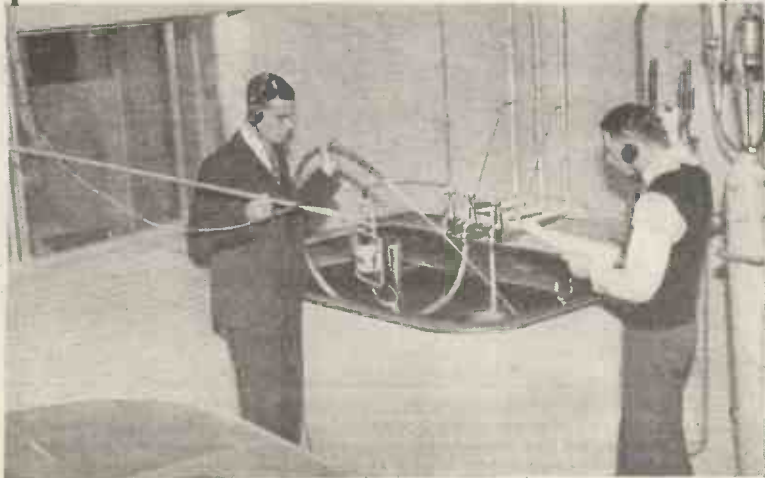

AND SO TO BED!

During the whole course of the evening's broadcast the transmission control engineer has not relaxed his attention for an instant. His hands hold all the strings of the night's entertainment; if he made a mistake the transmission might be ruined. But he never does.

Meanwhile, in the smaller of the two debates studios, Holt Marvell and S. P. B. Mais are working up to the climax of a vehement discussion on some topic of the day. This is the last talk of the evening, and literally millions of listeners will be following it with interest.

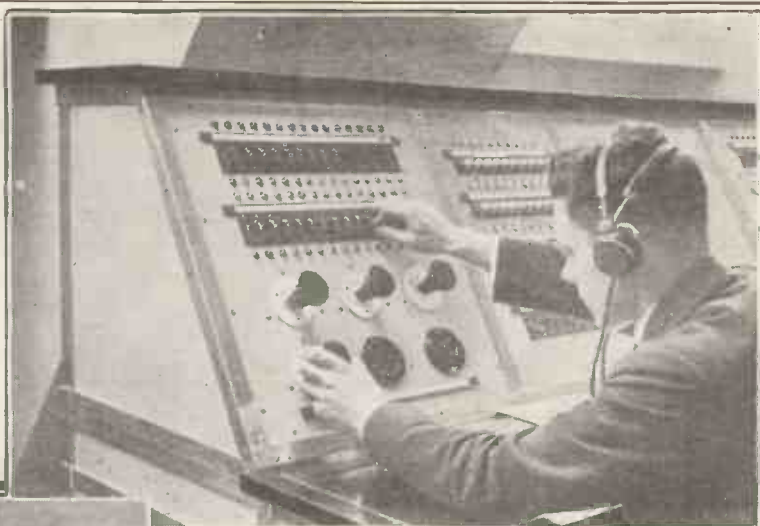

In one of the news cubicles, seen below, our friend Mr. Hibberd, the Senior Announcer, is reading the "last news," while the news editor keeps coming in from his office next door with "an item of news that has just arrived."



Now the dance music from some outside hotel is well under way and the studio programmes are over. No, not quite over, for there is still the television transmitter from the studio in the basement—the one with the check floor!

Below you can see an artiste dancing in front of the television apparatus.



And if there have been spare minutes between programmes, the operator at the bank of gramophone turntables steps in and ensures complete continuity from the morning service to the announcer's "Good-night, everyone, good-night," and the midnight chimes of Big Ben.

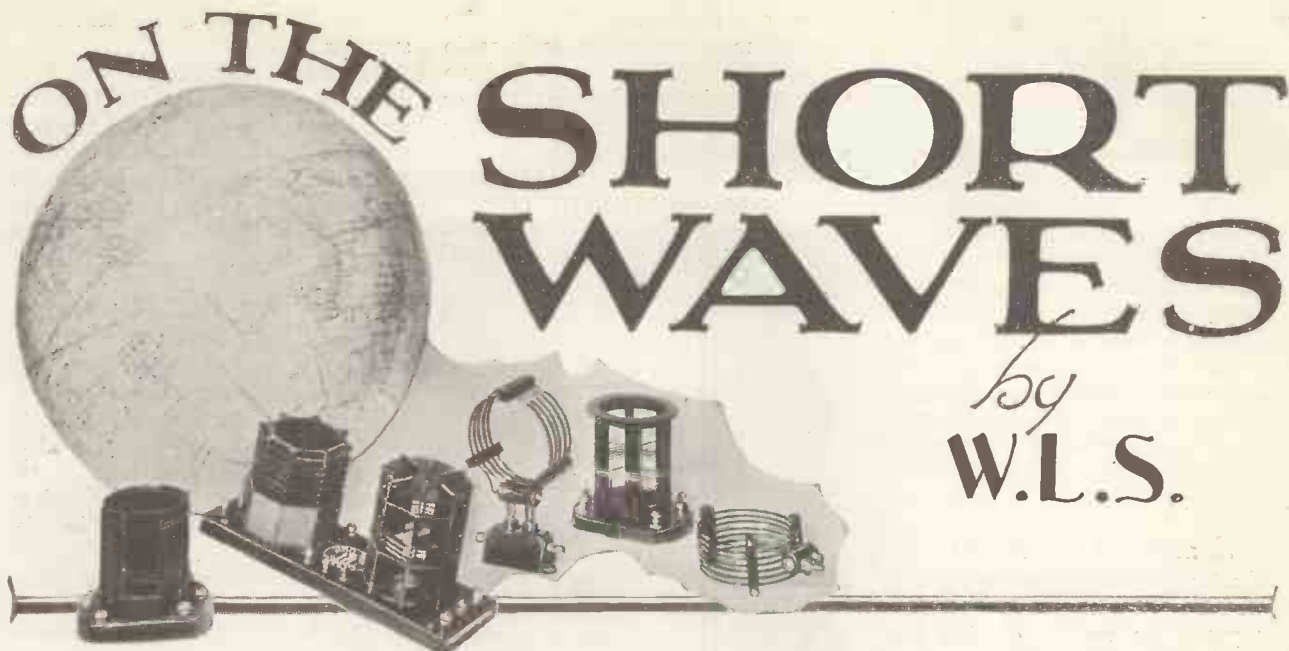

IT is a curious thing that only about one person in a thousand ever seems to be able to see the other man's point of view. Of the remaining nine hundred and ninety-nine, seven or eight hundred seem to descend to mere abuse when anyone else puts up a suggestion that does not agree with their own theories.

The Set Controversy

I have been much amused by my correspondence this month, the bright spot of which has been the "large-versus-small set" controversy. Mr. A says he has a superhet which is *IT*; therefore Mr. B, with a single-valver, is either a nincompoop or a perverter of the truth.

Mr. B, with the single-valver, says that Mr. A must be a person of deficient intellect to use a superhet. More rarely, Mr. C, with any old set, is perfectly happy with it, sits tight and "says nuffin." Mr. C, I salute you; would that there were more of you.

I wonder whether Mr. A and Mr. B will ever realise that the man who uses some particular type of set generally has a jolly good reason for doing so, and would be merely silly if he changed it on the recommendation of one single person who happens to prefer something else?

Each Has Its Advantages

And, may I ask, what would happen to me if I blossomed out with a single-valve set in print and suggested that owners of superhets should scrap them forthwith? Or, for that matter, with the "Empire Super" or something similar, suggest-

No matter what branch of short-wave reception claims your special interest, you will find these pages by our popular contributor make uncommonly good reading.

"W. L. S." combines a ripe experience and knowledge of his subject with a special aptitude for clear writing on the really interesting short-wave topics of the moment.

it is hardly a set on which to impress visitors with the loud and clear reception of distant broadcasting.

Hence the need for a superhet. I should like to have a third set in between the two, but one can't rig up three sets in a row these days.

A Compromise Necessary

Everyone who dabbles in short waves would like to have more than one set, but one has to compromise. The most effective compromise is to build the type of set that is most suitable for the purpose that one is most keen on.

If you spend six days a week listening to feeble transmissions from distant amateurs and the other day listening to W2XAD, obviously you ought to build a set that suits the first job best. Sufficiently obvious, perhaps, but not to people like our peculiar Messrs. A and B.

I hope this learned discourse of mine will clear the air a bit. Please, everybody, assume that your friend with a set that differs radically from yours has a reason for his apparent madness; and, above all things, don't write to me, as someone has done this month, asking me to "use my influence to make old So-and-So rebuild his set like mine." I'm not a Universal Aunt.

Most Popular Type

Some time back, in the columns of "Popular Wireless," we had a kind of competition to see which type of short-wave receiver reached the highest peak of popularity. As one would expect, the "straight" O-V-1 topped the list by a substantial

ing meanwhile that anyone who didn't make it was mentally deficient?

Readers cannot fail to know by now that I have a very soft corner in my heart for the very small, simple set, such as a straight single-valver. But I should hate to have to do everything with one valve.

I use it, it is true, for DX work on the amateur bands, mostly on Morse, and I wouldn't exchange it for anything. On the other hand,

IN THE AIR

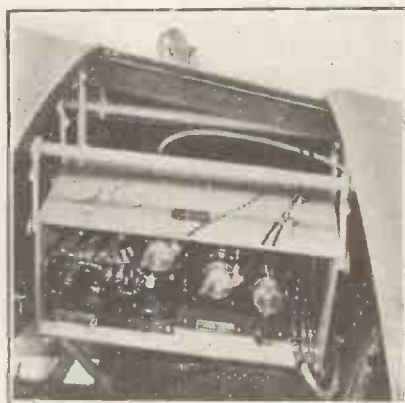

This is one of the light-weight radio telephone equipments developed by Marconi's Wireless Telegraph Co., Ltd., for short-wave communication from aeroplanes.

majority. I should imagine that there are at least six O-V-1 short-wavers in use for one of any other type of receiver.

S.G. Stage Desirable

Certainly the dear old "det. and L.F." is a very nice general-purpose-set, but I have a feeling at the back of my head that it won't do all that one expects from a short-waver in a year or so. With the increasing number of stations on the air, and the increasing number of listeners who let their sets oscillate violently, I think a stage of S.G. is going to be an absolute necessity before long. I will elaborate on this later.

Summer Conditions

Short waves used to be looked upon as summer waves. For the last few years the reverse of that has been the case, chiefly because our periods of bad conditions have generally coincided with the summer. The long days have really had nothing to do with it.

If I am not mistaken, we are due for a bout of good conditions this summer, and possibly next as well, although that's a long way ahead.

Naturally the outstanding feature of the summer is the improvement in the general standard of stations below 25 metres. In this case the long days are responsible.

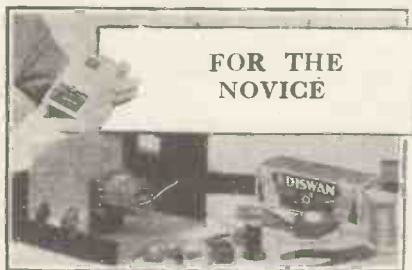

I often try to imagine the feelings of a novice to short-wave work—a real novice, that is. He finds all his ideas about radio turned upside-down for the first few days, if he is lucky enough to get his set to work at all at such an early stage! "Sharp tuning," he finds, previously meant absolutely nothing to him. Now he knows all about it.

Well Worth While

"Threshold howl" and "hand-capacity" are somewhat depressing topics on which we need not touch. But the thrills that are the novice's almost for the asking make the whole business a hundred times worth while.

I only wish that some of us old

hands could recapture some of the exciting moments of our early radio experiences. The nearest I have been to it during the past two or three years was when I heard my first American signal on 10 metres,

RADIO v. MOSQUITOS



R. L. Knowles, the American inventor, with an ingenious oscillator which he has designed. It produces musical notes which he claims will attract mosquitos, and enable them to be exterminated.

After days of listening to nothing at all, a loud and clear C.W. signal announced W 2 J N of New Jersey. Again, in a smaller degree, I have produced the feeling of starting radio all over again by taking up 5-metre work, but I soon found myself becoming blasé even over that. (There was once a celebrated gentleman named Alexander . . .)

An Interesting Letter

My recent remark to the effect that the world was still waiting for a set that operated with equal ease and efficiency on all wavebands has produced a long letter from Mr. W. Zietsman (Z S 5 N), of South Africa. He gives me details of a commercial receiver (American, unfortunately!) which really comes in this category.

Mr. Zietsman says that he got hold of an absolute novice and explained the set to him for ten minutes. Switching off after that, and leaving the other man to go ahead for himself, he says that Davenport was produced within a few minutes. Soon after this Johannesburg was tuned-in, first on the short and then on the medium waves.

Unfortunately the set does not quite cover my point, as it has no long-wave side. "W.Z." says that, as an un-biassed observer, he considers that the American sets outshine the British for power, but he makes no comparison from the point of view of quality. On the other hand, he says that the

British components are immeasurably superior.

The whole business probably boils down to the fact that the American sets are six- or seven-valve (I beg your pardon—"toob") superhets, whereas the British are three- or four-valve straight receivers. There is not much wrong with British circuits which valve for valve cannot be surpassed.

Empire Reception

"W.Z." by the way, is a real old stager. He remembers the days when he and his girl-friend had to put off their Sunday afternoon ride because the "flivver" had been deprived of one of its spark coils to provide the watts for the transmitter. He wonders, too, whether we were not all happier then.

A cutting from the "African Radio Announcer" confirms my prophesy that the South Africans sometimes get better reception of the transmissions intended for the West African zones than of their own. The 49.6 metre station certainly seems to be the best all-round man at present.

The Amateur Tests

February and March, the months of tests in amateur radio, are behind us once more, and we are all waiting for the publication of the results with rather a similar feeling to that which haunts one after a big exam.! B.E.R.U. Tests this year were split in two—half for the high-power fiends and half for the 25-watters.

In the high-power tests some British stations had over 50 contacts with the Antipodes; not bad going for two week-ends.

The two "low-power" week-ends were not blessed with nearly such good

HEARD FROM W 2 X A D



The recent political addresses relayed by W 2 X A D and other U.S. short-wave stations were picked up by the parabolic type of microphone shown towards the left of the picture.

How We Can Improve Our Sets

conditions, but, nevertheless, contacts between Great Britain and Australia and New Zealand were quite numerous.

It is nice to see the British Empire Radio Union becoming such a live concern. Practically every part of the Empire now has its representatives, and the R.S.G.B. is the "Home Office." Splendid co-operation between the different zones is made pos-

air" that keeps it going so well. Is there *any* other hobby quite like amateur radio?

Selectivity is going to be a problem that must be faced in a much more serious manner by short-wave people than has been the case up till now. Increasing numbers of high-powered commercials, not to mention the filling up of the short-wave broadcast bands,

—and doesn't it need it, sometimes? Capacity-coupled aerials can only be used when the capacity is kept very, very small, and often it is found, then, that inductive coupling gives better results. The aerial coupling coil, if untuned and of the right number of turns, can generally be coupled pretty tightly without causing troubles.

AT A RECENT INTERNATIONAL RUGBY MATCH — WE WERE REMINDED OF QUITE A NUMBER OF WIRELESS TERMS —



SUCH AS: — "BAND-PASS"



"PUSH-PULL" AND "RESISTANCE"



"IN STEP" AND "HAND CAPACITY"

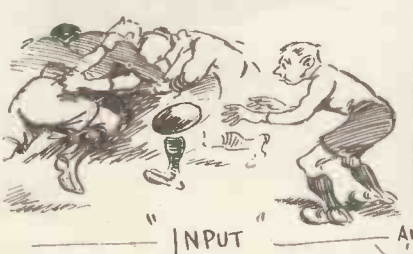

"INPUT"

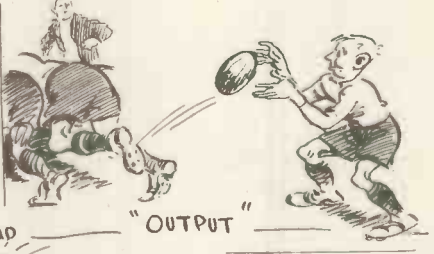

"OUTPUT"

AND

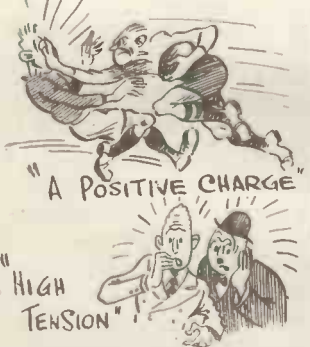

"A POSITIVE CHARGE"



PRODUCING "NOISE EFFECTS"



"VOLUME — CONTROL!"

— ERN SHAW —

sible by the existence of a world-wide society of this kind.

I should like to see the establishment of something similar for short-wave listeners, although it is the mere fact that members of the B.E.R.U. can converse with each other "on the

are beginning now (one might almost say for the first time) to put the owner of a flatly-tuned receiver at a disadvantage.

How can we improve our existing sets? The one obvious method is to improve our method of aerial coupling

Changes in Calibration

One of the greatest advantages of this system is that the coupling can be altered to meet varying conditions without having a very great effect upon the calibration of the set. If one has a capacity-coupled aerial and indulges in much "twiddling" of the condenser, it is often found that 48 metres appears where 36 metres was before! Such big changes naturally upset all one's ideas about dial readings.

If you are in a really bad location for interference—I mean from *stations*, not man-made static—it is well worth while to install a screened-grid stage before the detector. In an emergency I made up a little unit of this kind in just over an hour, and it worked splendidly.

By coupling the aerial very loosely to the S.G. valve, and also by coupling that valve very loosely to the detector, one can obtain a signal-strength about equal to what it was before the unit was added. But what a difference in selectivity.

Even our old friend H A T can be made to disappear in a degree or so with careful adjustment of the screened-grid stage. With a capacity-coupled detector only you will probably hear him from 60 to 20metres without a stop.

A Small Aerial Helpful

The use of a small aerial, too, is another obvious but useful way of helping matters. In the B.E.R.U. Tests I was trying to read some really weak DX signals through the usual dog-fight of European stations on 40 metres, and I did it eventually—but not before I had put up a little aerial eight feet long across the "shack."

Even such a short aerial as this seems to show directional properties, and I had great fun running round the place with it until I found the best orientation. We have very efficient noise-filters nowadays, but I wish someone would invent one that would cut out all signals from less than 1,000 miles for occasions like this.

FOR THE CONSTRUCTOR

Connecting To Earth—Stopping Humming—Emergency Connectors—A Fuse Hint—Switch Conversion.

Down to Earth

An efficient method of earthing an aerial, and one which removes most of the usual snags associated with switches due to faulty contacts, is illustrated in the arrangement below. An ordinary lead-in tube is fitted in the normal manner, but the usual nut under which the aerial is clamped is removed, and instead a socket is fixed either by soldering, or by drilling and tapping same.

The set side of the lead-in tube is connected to the set in the normal manner. To the end of the aerial lead proper is connected a plug, which will fit into the socket already attached to the lead-in tube.

PLUG IT IN

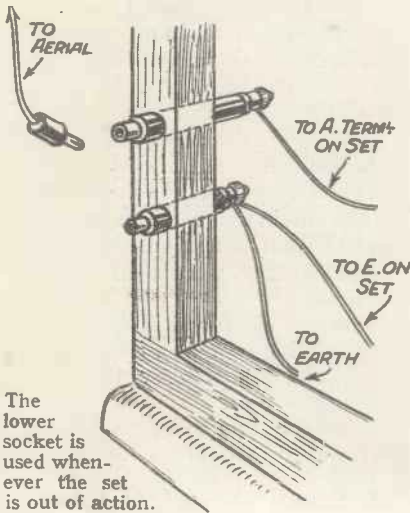

The lower socket is used whenever the set is out of action.

A further socket is now arranged in such a position that the aerial can either be plugged into the first socket or into the second. The second socket may be fixed to the window ledge or to the side of the door.

This second socket must be permanently connected to earth, the set E. terminal may either be joined to this earth or to a separate one.

Preventing Pick-Up

It often happens that the leads between a pick-up and a radiogram receiver are the cause of introducing hum induced from the electric light supply mains. This is especially the

case where an all-mains set is being used.

The prevention is best carried out by the use of metal screened wire for

USE FLEX

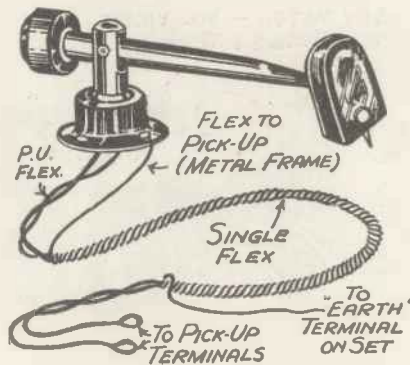

This adaptation is very efficient and easily carried out.

the pick-up connections, the metal covering of the wire being earthed.

If this type of wire is not available, the cure can often be effected by winding a length of single flex round the twin pick-up leads and earthing this length of flex.

The end of this flex not connected to the earth terminal of the set should be joined to the metal frame of the pick-up.

Connecting Flashlamp Cells

There must be quite a number of people who still use flashlamp batteries in series for their H.T. supply, and quite a cheap and reliable unit can be made up from such cells.

The chief drawback lies in the fact that the cells have to be connected up in some manner.

A very effective and cheap method, however, is to use ordinary paper

VERY SIMPLE

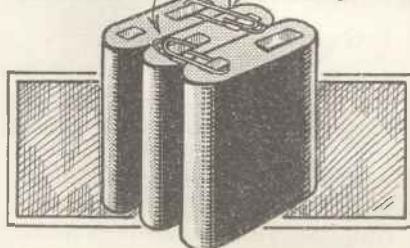

Ordinary clips make excellent and easily-fitted battery connectors.

clips. Such clips are, fortunately, just of the right length if the batteries are held close together by a strap, or by being placed in a box.

The clips, however, should be used in a slightly different manner than usual, and the tip of the middle shorter spring, which is slightly turned up, should be pushed through the outer spring and the metal strip clipped between the two springs on the opposite side of the long one to normal. This ensures that both strips of metal are firmly clasped.

Fitting a Fuse

Nobody wants to burn out a set of valves, but accidents will happen. If one is wise, precautions will be taken against this unpleasant occurrence by fitting a fuse to the receiver concerned.

That is, of course, if it does not already possess such a fitment.

The fuseholder should be connected between the H.T. — and L.T. — terminals on the receiver as shown in the drawing, the short wire which normally connects these two terminals together being removed first of all.

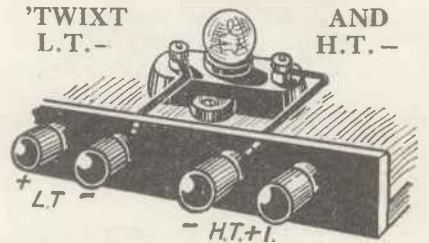

The correct method of connecting.

Regarding the actual fuse, this should be rated so that it "blows" at about 100 milliamperes for the average set.

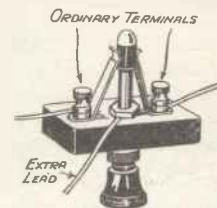

Converting a Two-Point Switch

In the interests of modern wireless conditions a large number of dual-range coils are provided with primary and secondary windings which, for the purpose of wavechanging, require a three-point switch.

Should a coil of the above type be incorporated, and a three-point switch is not immediately available, one can be easily improvised by using the spindle of a two-point switch as the third contact (see diagram).



On the TEST BENCH

Our comments regarding some interesting new components.

R. & A. Reproducers

WE have recently had the opportunity of testing an R. & A. "Challenger" reproducer. It is a moving-coil unit having a cadmium-plated permanent magnet of new design.

There is a three-ratio transformer permanently fixed on the chassis, and with this, matching for both power and pentode valves is possible.

It is a well-designed and well-built unit and, as our observations proved, it provides a performance of a definitely high order.

In regard to sensitivity it compares favourably with any instrument we have recently examined, and it can deal with both light and moderately heavy inputs with equal effectiveness.

There are no marked peaks in its response. The retail price of the R. & A. "Challenger" is 35s.

Another R. & A. reproducer which we have tested, and which is equally worthy of note, is the R. & A. "Victor," a larger instrument capable of doing full justice to the outputs of the biggest of sets.

Of special interest regarding this model is the fact that it is very fully protected against accidents in handling before



The two R. & A. Reproducers, "Victor" (left) and the "Challenger."

it is fixed into a cabinet or on a baffle. The back is covered by two shells having "staggered" apertures, so that resonances cannot occur.

And a substantial grille is built over the front of the diaphragm.

There is a transformer having no less than six ratios with which extremely close matching can be obtained with practically any existing power valve.

Very full reproduction is given by the "Victor," both in the bass and the treble register, while its sensitivity is above the average. The price is 70s. complete.

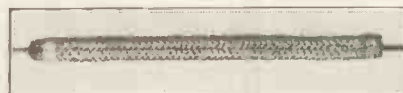

A short length of Goltone screened lead-in.

The R. & A. "Victor" is a unit we would advise "M.W." readers to hear before finally deciding upon the purchase of a new one.

Stopping Interference

It has been found that interference is often picked up by the aerial down lead and lead-in.

But the use of ordinary shielded wire is not possible without adding undesirable capacity and creating losses.

However, Messrs. Ward and Goldstone are now manufacturing a lead-in arrangement which possesses the necessary shielding without the hitherto inevitable drawbacks.

It comprises a series of insulating sections, which can be built up to any desired length, covered by a strong metal braided sleeving. The lead-in wire passes through the centre and is

well spaced from the metal so that there is negligible capacity.

This Goltone screened lead-in is certainly very welcome and should assist many listeners in the elimination of interference.

A W.B. Knife Switch

Whiteley Electrical Radio have produced an excellent knife switch which will commend itself to all constructors.

It is made on most robust lines, and its contacts are positive and firm. They are also, of course, self-cleaning.

A double lever is fitted so that the action of the switch is easy, despite the "firmness" of the contacts.

It is primarily intended for use as an aerial-earthing switch, and lightning arresters are provided to give protection while the set is in use.

But it is possible to use the switch as a double-throw, two-pole type merely by unscrewing a removable shorting bar.

The retail price of this W.B. knife switch is only one shilling.

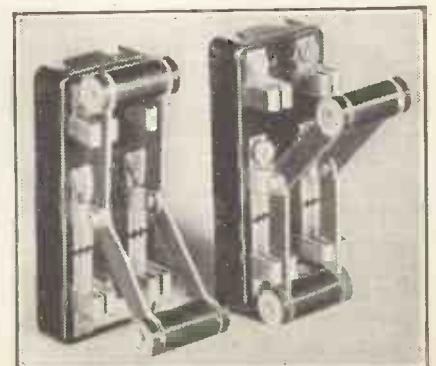

An easy-to-operate aerial earthing switch made by W.B.

Some Interesting New Radio Productions

The Blue Spot 66KC Unit

Two or three years ago "M.W." struck a note of warning regarding the great moving-coil boom which was then just beginning and is now at its height.

We said then, and time has proved we were right, that the inexpensive electro-magnetic type of speaker would not easily be displaced by the M.C., for the simple reason that the flood of cheap moving-coils would not comprise more than a percentage of instruments capable of beating a good electro-magnetic on all-round results.

To call a loudspeaker a "moving-coil" does not invest it automatically with superiority over other types.

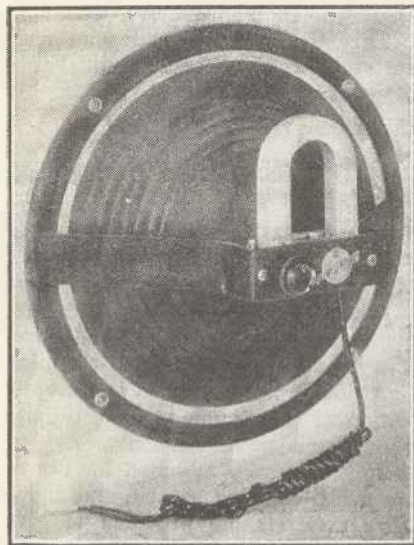

The Blue Spot 66KC loudspeaker unit.

We are pointedly reminded of this by the Blue Spot 66KC unit, which we have recently subjected to tests.

This is a first-class speaker, and one which on its merits can hold its own against many of the so-called moving-coils.

(There are, of course, exceptions—some of the latest M.C.'s. are worthy of the highest praise.)

The sensitivity and absence of slurring in the Blue Spot 66KC are decidedly refreshing, and its bass is clean.

For averaged-sized home-radio outfits we strongly recommend this electro-magnetic. We are convinced it will give greater satisfaction to listeners than many of the small moving-coils, although it costs only about half the price of one of these.

Well-Designed Chokes

There are four new Bulgin L.F. chokes. L.F.16 has an inductance of 20 henries at 20 milliamperes; L.F.20, 32 henries at 15 milliamperes (these two retail at 7s. 6d. each). L.F.14, 20 henries at 50 milliamperes; L.F.15, 32 henries at 30 milliamperes.

The last two list at 10s. 6d. each.

It should be noted that the above details are informatively related. Instead of maximum inductances and maximum current-carrying capacities, Messrs. Bulgin rate their chokes at certain inductances and give the maximum currents which can be handled without the rated inductances falling.

A very sound scheme and one that all constructors will no doubt appreciate.

These new Bulgin chokes are all metal shielded and are built into neat and distinctive cases. They are unusually compact, too, and by virtue of skilfully introduced air gaps they maintain excellent constancy under varying currents.

We have already used them in various receivers with complete success.

A New Spade Terminal

The new Clix spade terminal incorporates several attractive features. It is non-corrosive, and it has a special collar to prevent acid creeping. This collar is anchored so that it cannot fall away from the spade portion. So is the siding piece with which firm metal-to-metal connection can be made.

You will also note from the photo that the spade itself is shaped for

easy fitting and good contact with terminals of differing sizes.

The terminal is available in small and large models at 1½d. and 2d. each respectively.

The "Block" Accumulator

One of the most interesting of all innovations, and far from the least important, is the new "Block" accumulator.

Its construction differs entirely from the conventional, for it possesses no interleaving plates.

There is an electrode centrally disposed, which consists almost entirely of active positive material instead of the usual team of plates in which this is more or less sparsely distributed.

In this way a much greater capacity is achieved; in fact, twice the capacity per pound of the total weight of the cell.

Also, as will be obvious, there is less local action.

With these advantages added to the absence of plates to buckle, it is seen that the "Block" must be a very efficient and robust accessory.

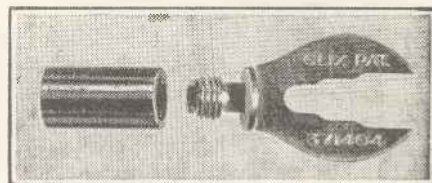

This is the new Clix spade terminal.

Further, it is provided with a handsome bakelite case, which is also practically unbreakable. And this alone is sufficient to give it distinction.

Accumulators often have to be accommodated externally to the set, and for that reason it is a pity that greater attention has not hitherto been paid to appearance.

In that the "Block" is attractive in appearance and only half the size and weight of other types we feel certain that it will appeal most strongly to constructors; for these are features which can at once be heartily appreciated by all.

We have had a "Block" on test for some months now, and it has proved to be highly satisfactory from every point of view.

Despite calculated and serious mishandling, it shows no signs of wear and tear whatever, and is apparently in as good condition as when it was first received from the manufacturers.

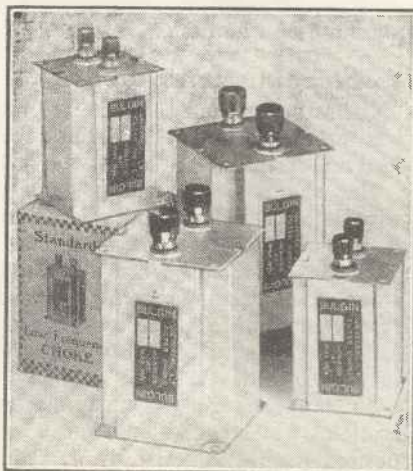

The new Bulgin chokes are metal-shielded, in distinctive cases.

TROUBLE TRACKING



THE number of complaints I get about instability both on the H.F. and L.F. side is amazing. I wonder why constructors fail to appreciate to the full the value of decoupling. If they refer to any of our published designs they will find that these are invariably decoupled "up to the hilt."

Those who have changed over to mains units for their H.T. supply often find that when they connect up the unit in place of the battery the set starts to "motor-boat" or howl at low-frequency.

Now, true "motor-boating" is recognisable by its slow periodicity. When the set is switched on there is a pop-pop-popping rather like that of a single-cylinder motor-cycle engine, or the motors used in outboard boats.

Cutting Down Bass

If the amplifier functions down to below 50 cycles, motor-boating in the true sense will occur, but by cutting down the bass amplification, this risk is obviated.

The modern parallel-fed L.F. transformer, with its high inductance primary winding, or a good R.C. stage, amplifies the bass down to a very low figure, and every L.F. amplifier incorporating stages of this type should be adequately decoupled.

The point to bear in mind is that the L.F. impulses in the anode circuit of the detector valve have an essential function to fulfil. The designer's job

DON'T FORGET THIS!

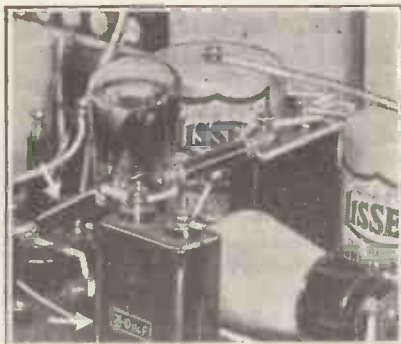

Adequate decoupling is an essential factor of any sensitive receiver. It is advisable to use decoupling both in the H.F. and L.F. stages.

is to see that they do useful work, and from this standpoint we are only concerned with the work they do in creating voltages across the grid and filament of an R.C. stage, or across the secondary windings of the L.F. transformer.

Decoupling Condenser

We do not want these L.F. impulses to pass into the common H.T. circuit, and so produce varying potentials across the common impedance, namely, the H.T. supply.

Decoupling is a method of overcoming this by returning the "waste"

Every month the Chief of the "M.W." Query Department discusses some of the common difficulties which can often be so troublesome. This time he deals with the value of adequate decoupling.

L.F. impulses back to the earth-line via a by-passing capacity which we call a decoupling condenser.

The question is how are we to choose suitable values for the decoupling resistance and condenser?

By Rule of Thumb

Normally we work on the rule of thumb principle and choose a resistance having a value roughly ten times that of the impedance of the by-passing condenser at the lowest frequency the set is designed to handle.

Suppose the receiver amplifies all frequencies down to 50 cycles, and that we have a 2-mfd. condenser for decoupling. The impedance of a 2-mfd. condenser at 50 cycles is approximately 1,600 ohms. Working on the rule of thumb principle, we find that 16,000 ohms is a suitable value for the decoupling resistance. This will give us a good chance of keeping 50-cycle impulses out of the H.T. circuit, since the impedance of the condenser path back to the earth-line is only one-tenth that of the path into the H.T. circuit.

These values usually give satisfactory decoupling, but the risk of

instability would be lessened by increasing the value of the decoupling condenser to 4 mfd., its impedance at 50 cycles then being 8,000 ohms.

Voltage Drop

On the other hand, we could make the value of the decoupling resistance higher and still retain the 2-mfd. condenser, but the disadvantage of this is the voltage drop across the decoupling resistance, which in some cases may prevent the valve from functioning properly, unless very high H.T. values are available.

For instance, suppose that we wish to apply 80 volts to the anode of the detector valve, and that at this figure its current consumption is 2 milliamps; if the value of the decoupling resistance was 30,000 ohms, and neglecting all other resistances, such as the D.C. resistance of the primary of the transformer or the R.C.C. anode resistance, we find that by Ohm's Law the voltage drop across the 30,000-ohm decoupler is 60 volts. Hence, in order to get 80 volts on the anode of the valve we should have to apply 140 volts to the detector H.T. + terminal.

Different in Practice

These figures, of course, have merely been taken to illustrate the principle, and might be widely different in practice. It is, however, a sound policy to make the decoupling condenser very big, and to keep the decoupling resistance at a reasonably low value.

The detector decoupling is of first importance, and if there are two L.F. stages it is advisable to insert a resistance and decoupling condenser in series with the anode of the 1st L.F. valve. Treated in this way, a well-laid out set ought not to give any trouble from instability.



BIG BEN struck midnight. It was six o'clock in the afternoon.

"I can get Paris if you like—and you'll hear all about Monsieur Doumergue's funeral—or New York, they're still fussing about the Lindbergh baby. Once I got Australia—"

The pale young man involved himself with what looked like an untidy attempt at Heath Robinson architecture. He turned a number of handles, knobs or dials. The air spat at us. From three loudspeakers came the most extraordinary sounds. "I believe it's Japan," said the pale young man in an ecstasy.

And all this happened a mile or so underground. For we were visiting the copper mines at Teniente, one of the few in the world, surely, which runs *up* instead of *down*. At Santiago we heard of this underground republic—for it is self-supporting and self-sufficient—which when working full strength employs 7,000 men and produces a million pounds of copper a day.

Suitably Attired

We were told it was one of the highest mines in the world—not *the* highest, for there are some in Chile and Bolivia which work at an altitude of 14 and 16 thousand feet—and that "the camp" would be several feet in snow. So we dressed ourselves in what we thought would be suitable clothes for the Arctic wilderness. In our thickest riding breeches and boots, with our oldest coats worn one on top of another, we slunk to the station, for Santiago is a fashionable metropolis where the women are as chic as any in the Rue de la Paix.



The description of a visit by the famous woman explorer to the copper mines of Teniente, near Sewell, where experiments in underground radio have resulted in remarkable reception.

If anyone looked surprised at the sight of our nether limbs, we reminded ourselves of the snowdrifts awaiting us 9,000 feet up in the Andes. And from the windows of the excellent State Railway we watched the proud advance of the snow giants.

It was still summer at Rancagua, or perhaps the very beginning of autumn, for the trees were turning. Willows were showering gold into the stream, and a row of women in white overalls were selling apples and shiny purple alligator pears.

Climbing to Winter

Some charming Americans met us, gave us coffee and honey out of a beer bottle, told us we should require rubber shoes "up there," and hurried us into an "auto-carril," which is a

sort of motor-car on a narrow gauge line. In this and in the course of about 2½ miles we climbed from the early autumn of trees turning scarlet, and the tropical suggestiveness of cactus standing prickly and inhospitable on barren hillsides, to mid-winter.

Just below the snow-line the huge smelting-plant sprawled across a ridge, its solitary but gargantuan chimney belching forth clouds of sulphuric acid. Round the plant were banks and hillocks of grey, faintly sparkling weed—the concentrate as it comes from the mine in buckets slung from an aerial railway.

"We've got a million and a half dollars' worth of stuff lying round here," explained an engineer, pointing to the quite unspectacular weed. This is roasted, smelted, and refined until after the last process it pours out of the great drum-like furnaces in a bluish red molten stream of copper, and is hardened under sprays of ice-cold water into 25 lb. bars.

Treacherously Deep

But we were hurried on and up. The snow balled on the rails and the car skidded. There was generally a drop of undimensional extent on the right side or a drift treacherously deep, blandly smooth, and so evenly white that it looked like the very best Christmas cake icing.

I was glad when, high above us, clinging to the side of a conical peak, there appeared a geometrical cluster of molluscs, all about the same size, all so thickly snow-coated like an architectural experiment with heavy umbrellas.

WIRELESS ON TOP OF THE WORLD! BY ROSITA FORBES



Below is a railway engineer's hut with its newly erected aerial, while to the right are typical colonists of South America.

"Just about here's where we often stick," said the driver. "I can't tell you the number of times I've had to be dug out." But on this occasion the auto-carril made a great effort and drew up with a snort at Sewell.

Sewell is an aerial phantasy. I don't know how it "stays put." The houses are like swallows' nests wadded not in inches, but in feet and sometimes yards of snow. They are plastered upon such a precipitous slope that the average gradient in the "camp" is one in three.

Fringe of Icicles

Each fragment of level ground has a hummock of snow on it, with the front wall, or sometimes only the windows of a house, peering out of it. The real roofs, the only ones you see, are of snow. A fringe of icicles, some of them four or five feet long, hangs from every porch. Ladder-like flights of

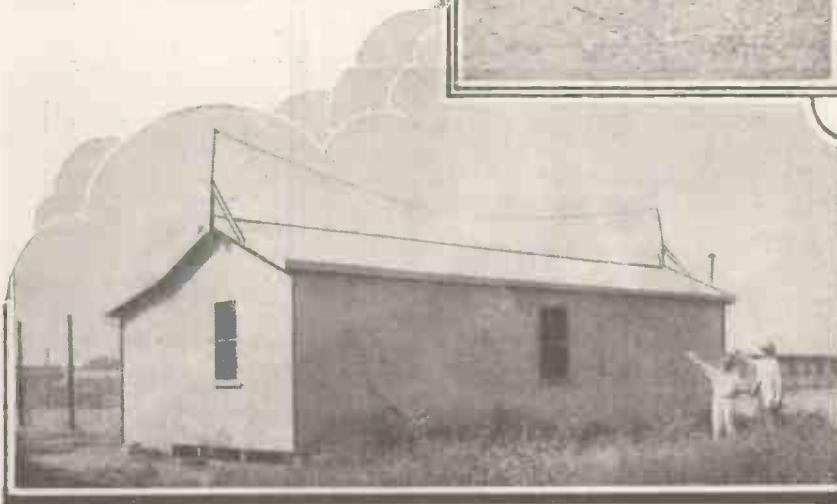

The houses of the mining town are built in tiers one above the other on the slopes of the hills. The house to the left of the people in this photograph is where Rosita Forbes stayed during her visit which she describes in this article.



A Cinema Which Gets the Newest Films

steps connect the various levels. The few paths, slippery as the Cresta run, have to be dug out each time there is a snowfall, until they are little more than tunnels between blind white mounds in which the houses are smothered.

It was carefully explained to me why no avalanche could detach this gallant little colony from its precarious position; but I never understood the reason, except that the houses, so concentrated that they look as if they were built one on top of another, overhang a ravine. Down this roar the snow-slides, taking deadly toll of everything or anyone in the way.

Buried Alive

"We daren't venture out of the shelter of the camp," said the doctor, and he told us how while he and some companions had been trying to dig out three men buried by an avalanche

agricultural south, where they are not faced with such dangers, but somebody noticed a hand feebly waving above unbroken snow. They dug out its half-suffocated owner, who ironically adjured them to rescue one Johnson or Davidson—I forget the name.

Satisfactorily Civilised

"Where is he?" they said. "He was right under my feet." "How do you know?" "I was talking to him." So they dug still deeper and pulled out a black-faced Johnson or Davidson, but left eleven dead in the unplumbable depths of the great snow torrent.

Yet Sewell is one of the most satisfactorily civilised places I've ever met. Only America could have achieved it. England, at that altitude, would be living in huts and on tinned foods. It would never change

The oblong growths are rows and rows of three-roomed workmen's flats with electricity laid on and wire-netted balconies wherein the children can play at a giddy altitude above the next tier of roofs.

In an atmosphere of central heating, thin silk frocks, grape-fruit cocktails, high-heeled shoes, and caviare, we had a perfect lunch.

When we started for the Teniente mine perched high above the larger "camp" of Sewell, the snow came up to our knees, the snow glittered on icicles as large as walrus tusks.

Under the River

We climbed the steep ascent—well, if not through "peril, toil and pain," at least by way of an infinity of precipitate and slippery steps, with much puffing and panting and some falls. And when we reached the top of Sewell "camp," there was another miniature railway.

Before packing ourselves into another auto-carril, which was this time a sort of platform on wheels, we put on short black coats, made in Yarmouth of sail cloth treated with fish oil. They were as stiff as boards and precluded any abandoned movement. This was perhaps as well for the auto-carril plunged suddenly into the mountainside. "Now we're going under the river bed," said the manager. The tunnel darkened and narrowed. Icicles dripped over our heads. For two kilometres we trundled farther and farther into the earth.

Then, having been shown a compressor room 285 feet by 35 feet, which was either the highest or longest underground room in the world—the manager and the engineer differed on this question—we got into a lift.

Underground Town

It was a completely dark wooden box which seemed to be unpleasantly like a coffin, and—surprisingly—it went *up not down*. In fact, we went up 1,800 feet in three and a half minutes, which made our ears orchestral and our hearts unsteady. Then we walked out on to the second level of the great Teniente copper mine, and a whole underground town spread around us.

Some idea of its size may be gathered from the fact that it contains seven canteens, where the miners pay 21 pesos a week—at the present rate

(Continued on page 381)

THE MINING TOWN OF SEWELL AT NIGHT



In spite of its precarious situation on the side of a ravine, the mining town of Sewell is fully civilised, and has its cinema, hospital, library, indoor sports accommodation, etc.

a vast snow torrent slid down the ravine, tossed the rescuers off the rope to which they'd been clinging, and buried half a dozen of them a layer above their companions.

"I can tell you we were scared," he said, but a score of volunteers joined the battered party and they managed to unearth some of the more recently entombed. A third avalanche interrupted the work.

"Save the living," shouted the miners, most of whom came from the

out of its severely practical clothes, and it would adopt a stern and Spartan attitude towards the complete lack of amusement with which it would feel itself obliged to put up.

But America does none of these unpleasant things. One of the snow hummocks is a splendidly equipped hospital with 70 beds. Others are a cinema which gets the newest films from Santiago, a library with 6,000 books, a gymnasium with indoor bowling-green and golf practice course.



Frame Aerials

A. S. R. (Croydon).—"I am troubled with lack of selectivity, my set being of the S.G., det. and pentode type. Could I use a frame aerial with a receiver such as this and so increase my selectivity?"

A frame aerial, although possessing definite selective properties, cannot be fitted to every type of set.

The frame itself takes the place of the aerial coil and is tuned by the aerial condenser. In consequence it would scarcely be suitable for a "ganged" receiver owing to the difficulty of matching the frame winding with the detector tuning coil.

Moreover, a frame has a large magnetic field and must necessarily be used in conjunction with a properly screened circuit.

There is another point, and that is, an aerial of this type cuts down the range of a receiver and therefore does not readily lend itself to designs other than those with more than one stage of high-frequency amplification.

Given the required sensitivity, however, a directional frame is an excellent selectivity device.

R.C. Coupling

H. L. (Croydon).—"Will you please tell me how the value of the coupling condenser for a resistance-capacity-coupled low-frequency stage is chosen? I am aiming at practically straight-line amplification down to 50 cycles."

The value of the coupling condenser is chosen in relation to the grid resistance, which is joined between the grid of the valve and grid-bias negative. In the ideal amplifier the voltages across the anode resistance are applied between the grid filament of the following valve—i.e. across the grid resistance, without loss.

An R.C.C. amplifier would be independent of frequency but for (a) the fact that the coupling condenser impedance varies with frequency, and (b) the effect of small unavoidable capacities across the anode resistance. The result of (a) is a loss of bass response, and (b) produces a loss of amplification of the higher frequencies.

TECHNICAL QUERIES DEPARTMENT

Are You in Trouble With Your Set?

The MODERN WIRELESS Technical Queries Department is in a position to give an unrivalled service. The aim of the department is to furnish really helpful advice in connection with any radio problem, theoretical or practical.

Full details, including the revised scale of charges, can be obtained direct from the Technical Queries Department, MODERN WIRELESS, Fleetway House, Farringdon Street, London, E.C.4.

A postcard will do. On receipt of this all the necessary literature will be sent to you, free and post free, immediately. This application will place you under no obligation whatever. Every reader of MODERN WIRELESS should have these details by heart. An application form is included which will enable you to ask your questions so that we can deal with them expeditiously and with the minimum of delay. Having this form you will know exactly what information we require to have before us in order to solve your problem.

London Readers, Please Note: Inquiries should not be made in person at Fleetway House or Tallis House.

Consequently the amplifier can only be "straight-line" within certain limits. The grid condenser is considered as an impedance in series with the grid resistance, the condenser having an impedance of $\frac{1}{2\pi fC}$ at any given frequency f .

The L.F. voltages are therefore applied across the condenser and grid resistance in series, the actual voltage at the grid of the valve being the fraction developed across the grid resistance.

In general, a condenser of .01 mfd. and a grid resistance of .5 megohm give about 90 per cent of the total

available amplification at 50 cycles. The same percentage amplification at this frequency is obtained with a 1-megohm grid resistance and a coupling condenser of .0065 mfd.

Which Type of Moving Coil?

G. F. (Barking).—"I wish to purchase a moving-coil loudspeaker, but at present I am undecided whether to obtain a permanent-magnet or mains-energised type. Will you please advise me on this point?"

If you already possess a radio set and you merely want to replace your existing speaker with a moving coil, we would suggest one of the permanent-magnet type.

All that you would have to do would be to connect up the new speaker in place of your present one, using for preference a valve of the super-power class in the output stage.

If, on the other hand, you are building an "all-mains" receiver, you could use a moving coil having a mains-energised field winding, thereby gaining a little extra sensitivity.

The permanent-magnet models are, however, very sensitive, and you need have no fears on this score.

Variable-mu Bias

M.C. (Upton Park).—"I have just installed a variable-mu valve in my set and I find that I am unable to adequately control the strength of the local station. Can you tell me why this should be so?"

This sometimes occurs through using too small a grid-bias voltage across the potentiometer. Your total voltage may be only $7\frac{1}{2}$ or 9 volts, in which case you cannot apply more than this figure to the grid of the valve. Try replacing the existing biasing battery with a larger one giving, say, 15 volts.



ROUND the TURNTABLE

*Q.P.P. and the Pick-up—Plenty of Volume—Saving of H.T.—
The Impedance Equaliser.*

By "TONE ARM."

QUIESCENT push-pull has given a great filip to the electrical reproduction of gramophone records with battery sets. Before its advent the battery receiver owner was rather up against it as to how to get good punch from his records without (1) badly overloading his valves, or (2) running into enormous expense due to H.T. battery renewals.

At Low Cost

Q.P.P. has solved this problem to a certain extent. And "Class B" amplification (as we call it, though Q.P.P. is really a branch of Class B) should do still more in the way of providing power. But this type of amplifier is not yet ready. The valves are not available in quantity at the time of writing, for a special output double valve is required, and so I cannot say much on the subject yet.

But the quiescent push-pull method of using pentodes (it is especially satisfactory if steep-slope valves are used, such as the Mazda Pen.220A) *does* give excellent power at remarkably small cost. The H.T. consumption for given power-peak output can be reckoned at 50 per cent less than that required for the same output with a similar valve used normally.

Very Economical

Thus, a gramophone amplifier giving 1,000 milliwatts output with Q.P.P. would take an H.T. current of only about half that normally required to give the same output.

Actually with the Pen.220A valves and 150 volts H.T. we can get about 2,000 milliwatts, with an *average* anode current of some 12-14 milliamps.

It should be realised by the gramophone user who takes up Q.P.P. that

the power supplied from the H.T. battery is only proportional to the strength of reproduction. On soft passages very much less current is taken than on loud ones, while during the time when records and needles are being changed and the gramophone motor wound up, only the mere quiescent current of some 4-6 milliamps. for the whole amplifier is being consumed.

Thus, one-third of the time the set is on (which is the time taken on an

"SIGN, PLEASE!"



Miss Gracie Fields autographing one of the "record" tables used at the recent lunch given by The Gramophone Co. to celebrate the pressing of Gracie's four-millionth record.

average for record changing, etc.), only 4-6 milliamps. are being consumed. Much more economical than the normal battery amplifier, is it not?

Concerning Components

There is the large power output, too, which holds great value for the battery radiogram user, and Q.P.P. honestly does hold out new vistas in

reproduction for the non-mains users of pick-ups.

Where's the snag? Someone is sure to ask that. Well, theoretically, there is no snag. Practically the only snag occurs through one of two things—the use of inferior components and wrong matching either of valves or speaker.

The Best to Buy

So much has been written lately concerning the latter two points—how valves are anode-current equalised, how speakers are matched, and so on—that I am not going into all that now. *But* I do want to stress the importance of attending to the circuit properly and using the best components you can afford.

The question of primary inductance of the input transformer is a vital one. If it is somewhat low in the model you decide to use, you should shunt-feed it, so that you can get it as high as possible. You can get transformers with inductances of 16 henries at 2 milliamps. or of something over 40, at the same current.

It does not mean that the former is the result of poor workmanship, though it is obviously not so good a component. But the price has also to be considered, and at over twice the cost one expects to get some more

henries. Thus, as in everything, it boils down to the financial side. If you can afford it, get the 40-henry transformer; if you cannot, then get the other and shunt-feed it so that you do not decrease its inductance by the steady current. Shunt-fed, you will be nearer the 30-henry mark.

High Notes

The impedance equaliser, high-note loss, or whatever you like

to call it, across the output choke or transformer is very necessary with pentode push-pull. Without it, especially with many pick-ups, the high notes are particularly shrill and distorted.

But I have had a Q.P.P. amplifier going experimentally for some time, and as the next best thing to mains-driven amplification it is excellent. It certainly gives punch!

SPOTLIGHTS



PROGRAMMES

Those Six Pips!

THOSE of you who make a habit of setting your clocks and watches by the six pips which the B.B.C. sends out at 9 o'clock every day must have had a shock when a newspaper divulged the sad truth of the time signal.

It was stated that the main responsibility for the accurate timing of the pips rests on the shoulders of a porter at Greenwich Observatory, whose duty it is, in all weathers, to poke his head out of the lodge and shout down a telephone to the B.B.C. as the seconds hand of the Observatory clock creeps round to the hour.

This method seems to have proved satisfactory to unsuspecting listeners for ten years, but I dread to think what might happen if some future porter should suddenly develop a stammer, or feel an irresistible urge to sneeze at the crucial moment.

The clocks of five million homes depending on a porter at the Observatory. Well, well!

Let's Be Fair

Whatever I may have said or thought about the B.B.C., I have never had occasion to accuse its officials of misleading listeners.

I was sorry, therefore, to notice that the radio critic of a morning newspaper (which has a circulation of more than a million) made a recent story by A. J. Alan the occasion for an attack on the publicity staff at Broadcasting House.

This critic suggested that the statement that "A. J." would stay on at Broadcasting House until the early hours of the morning so as to repeat his delightful "Joy Ride" to the Empire was all nonsense, and that

the talk would be repeated via the Blattnerphone.

I can't think why the luckless A. J. Alan should be so set upon—because in actual fact he did stay on in the studio until 1.45 a.m. the next morning.

And I hope the Empire enjoyed his story as much as I did.

In the Soup

Poor John Watt was very definitely put in the soup recently by a South Wales paper which, boasting of the success of a local singer, announced that she had been engaged for the next "Soup from the Shows"!

Although the songs which John Watt has collected from the shows continue to make very pleasant

ingredients for a musical soup tureen, I am inclined to think that the original title for this production is at least more explicit!

Where the Programmes Fail

Those critics who dislike a certain variety show and make that the excuse for demanding the complete abolition of vaudeville in favour of plays which they like are just running their heads against a brick wall. They might as well go to one of Mr. Cochran's revues, complain because they had not seen a play by Bernard Shaw, and then expect "C.B." to take off the revue and present "The Apple Cart."

Criticism of that kind gets nobody anywhere. The things that need criticism are those which affect every listener's convenience whether he be "intellectual" or "lowbrow."

Which is why I maintain that the programmes fail, not in the variety of the interests which they represent, but in the way the daily time-table is arranged.

Too Early—or Too Late

It's all very fine to produce a "star" show for two evenings in one week on alternative wavelengths, but it does listeners precious little good when the first performance starts too early and the repeat production finishes too late.

The principal item of the evening should be put on between the end of the last meal of the day and bedtime—which means, in the great majority of homes, between 8.30 and 10.30.

The present system seems to be to arrange the chief item either to start at 8 o'clock, when most of us have not had time to finish eating and settle down, or to finish at 11 o'clock, when

IN SERIOUS MOOD



Mr. Gillie Potter, the famous wireless comedian, deserts Hogsnotton for an evening to lecture at Church House, Westminster. Mr. Potter is an authority on Church affairs.

The Best of the Month's Light Fare

those who have early trains to catch want to be in bed.

I hope this suggestion will provide those responsible for the programmes with food for thought.

Where are The Comedies?

The idea of a radio play festival to be spread over several weeks and to contain the principal dramatic productions of the last few years is an excellent one.

But the Productions Director is going to find himself pretty badly handicapped by the fact that, so far as I can remember, there has not been one good, full-length comedy broadcast either from Broadcasting House or Savoy Hill.

On many occasions critics have

dental music, some of the sound effects were almost comic, and the whole affair failed to combine the supernatural and the practical. I cannot imagine that even those nervous invalids who were warned against listening lost a minute's sleep as a result of this "gruesome" play.

This Applause Business

I can think of no better argument in favour of those who demand the complete abolition of the studio audience during vaudeville shows than that offered by the gramophone studios.

I have yet to hear of any studio which goes to the trouble of providing a large audience for those variety artistes who record. And if they can

Advice to Holt-Marvell

As everyone else seems to be rushing in to give good advice to Holt Marvell (alias Eric Maschwitz), who takes up his duties shortly as the B.B.C.'s new Master of Revels, I will refrain from adding my quota.

But I do hope we may have more and more of John Tilley and Hugh E. Wright (you haven't heard him?—believe me you should), of Davy Burnaby and the Hulbert Brothers, of Flotsam and Jetsam and Jeanne de Casalis. The first two have made a reputation through broadcasting—the others, though all stage favourites, have never failed to provide material which is really suitable for the microphone.

In the Programmes

DULCIMA GLASBY

Although Miss Glasby resigned her position as the B.B.C.'s official "play doctor" last month, her seven years of adapting radio plays make it impossible to exclude her from this page.

Originally on the stage—she played with Matheson Lang in "The Wandering Jew," among other things—Dulcima Glasby decided to devote herself entirely to writing. But in 1925 an advertisement for "someone with literary and stage experience" proved too tempting, and she became a member of the B.B.C. staff.

To have "doctored" more than 200 plays in seven years is not a bad record, but Miss Glasby found time to write a radio play of her own—"Obsession"—which



has twice been produced, and is undoubtedly one of the best ever written.

Of all the plays which have passed through her hands she prefers those of Galsworthy. Shakespeare is her ideal of a radio playwright and "The Taming of the Shrew" his best play for broadcasting.

Thinks that radio plays should be short and sweet and without long intervals.

Dulcima Glasby is now going to devote herself to writing stage plays, short stories, and films; she has already had one book published.

Her hobby is collecting horse brasses; she lives in Putney with her father, who designs stained glass, and her mother, who writes; she hates vermicelli pudding, and her dog came from the Battersea Dogs' Home.

pointed out this fact, but so far nothing has been done to remedy it. I cannot believe that comedies have not been submitted to the B.B.C. Why not let us hear one, even if, at the first reading, it does not seem to come up to the standard of radio drama. A good cast can put over a moderately good play with a lot of success.

Not a Good Example

I am afraid that "The Fall of the House of Usher," one of last month's principal dramatic affairs, will not be a candidate for inclusion in the radio festival.

Poe's original short story was good as a short story, but it did not justify being dragged out to a full-length play.

There was much too much inci-

do it in front of a gramophone microphone, why in heaven's name do they make such a fuss in the broadcasting studio?

Other People's Troubles

Our own B.B.C. are not the only people who find themselves in trouble with the programmes.

The Austrian broadcasting authorities were anxious recently to conclude all their programmes with the Austrian national anthem. The fact that the tune is the same as the German anthem was not considered an insuperable difficulty, but the words presented a problem.

The original anthem started with the words "God guard the Emperor." But Austria has no Emperor—and nobody seems to know the new words which have been written!

And may we have less and less of those stage "stars" who imagine that what is good enough for the theatre must be good enough for the B.B.C.

Praise Is Due

Our congratulations for the best performances of the past month go to A. J. Alan (of course!) for "Joy Ride"; and to Haver and Lee, who made an otherwise deathly vaudeville programme quite bearable.

And a very special "thank you" to J. C. Cannell and Martin Webster for inventing a pretty little murder and devising a new way of presenting cabaret all at the same time. Definitely the best of the light entertainments last month.

PATRICK CAMPBELL.



IN PASSING

Assorted Jottings on Radio Themes

BE it observed, in passing, that although the poet Browning said in one of his outbreaks, "Oh, to be in England now that April's here" (quotation unverified), he took jolly good care to live in Italy.

Let me, however, be charitable, and assume that Italy suited Mrs. B. better than Wimpole Street, London, and that Pa B. was merely expressing his hunger for winter sports.

Now, on referring to my notebook, I find that I am booked to discourse about our good old B.B.C. again, though I badly wanted to give it a rest this month, and enlarge on other matters. *But really!*

Many of the B.B.C.'s ideas are quite good—Chamber Music, Foundations of Music, Everlasting Bach, Egg-sucking Lessons for Grannies; Thrillers such as "How Iron Foundries make Angle Irons and

IN ENGLAND, NOW



"Browning said in one of his outbreaks, 'Oh, to be in England now that April's here'."

Knee Pieces"; advertisements of B.B.C. publications; Gramophone Records, etc., and alternative programmes which give some listeners no alternative other than to switch

off or go a-hunting foreign stations. Yes, those are quite good! Pure B.B.C., one might say.

But now and then someone who has a "say" goes wool-gathering and produces an idea which makes me think that there must be a crack in the sturdy common sense at the back of that great organisation which gives the Empire its supplies of throat-whistling, saw-solos and quintets.

Firstly, no doubt arguing on the basis of the well-known fact of natural history that all the jam in a roly-poly pudding is concentrated in

About Debates—Enamoured of the Blattnerphone—Dobson Hoists the Aerial—"Stop me if you've heard it."

the middle, some genius has hit upon the idea of broadcasting only the middle of the debates. Having mustered all my mental powers, I am utterly unable to discern the object of such a mutilation.

Are we to suppose that the beginning and the end of the debates are not worth hearing, or is the notion underlying this departure that we are to be mere eavesdroppers suddenly hustled from the keyhole, having enjoyed stolen sweets?

But there is more in this yet. When, in hopes of discovering the head and tail of a debate, one refers to "The Listener," one finds that there is no head or tail, that the pudding had no ends at all; for the middle of the debate was *all* the debate—and the B.B.C.'s little fiction about the beginning and the end is nothing but an infants' trick after all.

Secondly, we have as a variant of that "topping and tailing" operation the simpler but far more effective Death at One Stroke, colloquially called the "Middle Cut."

It is relished as a huge joke at

Broadcasting House, and I am told that Henry Ainley is so tickled about it that he is likely to go into straight comedy.

To perform this pleasantry the B.B.C. selects a special favourite, like the play "Hassan," with a strong cast, including Ainley and Quartermain, plus music by Delius, basket and fountain "effects," and an excellent orchestra. The whole is then accurately bisected by two Polish professors of Euclid and a meat-axe.

One lump is fed to the microphone
AN EMERGENCY MEASURE



"It gives him time to saunter round to his locker and take any necessary refreshment."

on Wednesday and the remainder of the carcass is dished up cold on Friday. An art-form which is just a bad imitation of the Chinese technique.

* * *

Somewhat *blasé* in the matter of radio, I have become enamoured of the Blattnerphone. The thought that the descendant of the amocba has succeeded in mixing up a Ridgeway Parade with the molecules of a steel tape bids me hope that future generations may learn how to prevent common colds or may invent a sauce-bottle that will deliver tomato catsup and keep a clean neck.

There is, however, an element of danger involved in this instrument. We may be Blattnerised unawares. We may already have been Blatt-

The Artisan and the Aerial

nerised many times and have known it not.

The dice are loaded in the B.B.C.'s favour by its possession of this cannery, and in instances of emergency, instead of giving us an artiste brought by force from his subterranean wine den, the announcer will complacently measure off a couple of yards of Blattner and let fly. It gives him time to saunter round to his locker and take any necessary refreshment.

Domestic Difficulties

Here follows an imaginary conversation. Husband: "I say, m'dear, old Charlie has done a perfectly ripping turn in the vaudeville programme to-night." Wife: "Oh, has he? Well, I can tell you that for the past two hours Charlie and his wife have been strolling round Quorn Square. I could see 'em from the Club windows. You've either been asleep or at the brandy—or both." Husband: "But—hang it all, m'dear, I *did* hear him. Here! Look here! He's down on the programme. See for yourself!"

Wife: "I don't care. He must have cancelled his 'turn.' I saw him going round and round the Square. D'ye think I could mistake his shamble?" And so on, etcetera.

Next day. Husband (to Charlie): "Fine turn you gave last night, old boy." Charlie: "Yeah, not so bad. I recorded it on the Blattnerphone last week."

THOSE PRICKLY TREES



"My own aerial is lashed to a branch of a very prickly sort of tree!"

"Then you *were* with your wife in Quorn Square for two hours last night? My wife saw you."

"The dickens she did! Look here, old man, that wasn't my wife. Now, mind you, I don't want this to go any further, but——" And so on, confidentially.

Charlie's professional pride was evidently not so highly developed as that of the artisan who put up my aerial last week. I am not incapable of hoisting aeriels. I once put up a four-wire "umbrella," two hundred feet high at the ferrule, on a windy day, and except that I couldn't think of any new adjectives, I was as cold at the finish as I was when—most ill-advisedly—I began.

But my own aerial hangs at its open end from a long stake which is lashed to a branch of a very prickly sort of tree. The stake flopped during a gale and so I gave Dobson the job—and he shamed me.

Seeing that he had reached an awkward stage of the work, I suggested some makeshift or temporary expedient, for he was purple with cold. Through the swaying branches thereupon came this rebuke.

Nothing Doing!

"No, sir. Not me! *Why*, serpose one o' yore gennelman friends sees *that*. *Why*, he'll say, 'Who done that?' And wattle you say, sir? *Why*, you'll say, 'Dobson done that,' you'll say. And then me name's mud, sir."

I am not feeling quite happy about the possible outcome of the B.B.C.'s little difference with the music-hall people. So long as the vaudeville programmes contain a healthy sprinkling of "stars," one has no special objection to advance if the B.B.C. occasionally tries to manufacture a "star" from a street performer. But the B.B.C.'s suggestion that it will go out amongst the highways, by-ways and hedges, calling a penny-whistler here and a raconteur there, gives me a vague sense of bad days to come.

Getting More Variety

After the theatre queues have been robbed of their choicest entertainers and every whistling office-boy has been given an audition; after the coffee-rooms of "commercial" hotels have been dredged for "drummers" who address one as "Laddie" and begin, "Stop me if you've heard this one"; after B.B.C. sleuths disguised as window-cleaners have eavesdropped on us as we sing in our very baths—what sort of vaudeville shall we get?

1. Tom Trott, the curious fish-curer of Bermondsey, will sing a few scales.

2. The jazz-band of the South Euston Piano-tuners' League.
3. Albert Hy. Scoggins, in "How I didn't half tick the foreman off" (*twice nightly*).
4. Mrs. Driver, the clear-starcher, who creaks in her boots.
5. Agatha Shadbolt, pianist, from the Only Cinema, Hutton's Ambo, Yorks.
6. Percy Cutbush, the Sniffing Boy Wonder.

* * *

The great debate in the House of Commons about the B.B.C. turned out to be a bouquet-tossing competition. The Director-General, who is reported by his office bath-attendant to have

THE B.B.C. SLEUTHS



"Disguised as window cleaners, they have eavesdropped on us as we sing in our baths."

put on an asbestos collar for the occasion, was observed to turn as pink as some of his talks on Russia and to mutter, "Nay, I cannae thole it!"

A Magnetic Eye

As a matter of fact, several members who went to thunder have since told me that directly they rose, a Large Electro-Magnetic Eye, situated in the Distinguished Strangers' Gallery and the property of a Scottish gentleman, reduced their tongues to impotence and their kneebones to pulp. As one of them remarked, "I'd 'ate to be an Hannoncer on the carpet for dropping a Haitch."

* * *

Stop Press News: Just as this article was going into print we received a cable from Jardine stating that he is bringing back a few barrackers as souvenirs. Here's a chance for the B.B.C.! They can either be trained to bark for use as "effects" in hunting plays, or introduced into the studio clagues as an Official Opposition. The B.B.C. is nothing if it is not strictly constitutional!

B.I.

ENAMELLED WIRES

8 SPECIAL FEATURES

1. High dielectric strength and free from pinholes.
2. It is tough and will withstand severe handling.
3. Enamel is highly elastic and will not readily fracture.
4. Will resist temperatures which would char any fibrous insulation other than asbestos.
5. Under ordinary conditions, retains all its qualities year after year.
6. The enamel is non-hygroscopic, thus avoiding short circuits where damp occurs.
7. The gauge of the wire, both under and over the enamel, is accurately constant, making it ideal for coil winding.
8. Entirely British made.



The B.I. have been manufacturing enamelled wire since it first came into use, and long experience, constant research and the use of the finest machinery available have led to the production of B.I. enamelled wires of a consistently high standard of quality. For all fine windings where economy of space is essential, there is nothing to compare with the perfect insulation of B.I. Enamelled Wires, which are made in all usual sizes down to 0.002-in. diameter. Write for full particulars.

BRITISH INSULATED CABLES LTD.

CABLEMAKERS AND ELECTRICAL ENGINEERS

PRESCOT—LANCS

Telephone No. : Prescott 6571.

London Office : **Surrey House, Embankment, W.C.2**

Telephone Nos. : Temple Bar 4793, 4, 5 & 6.

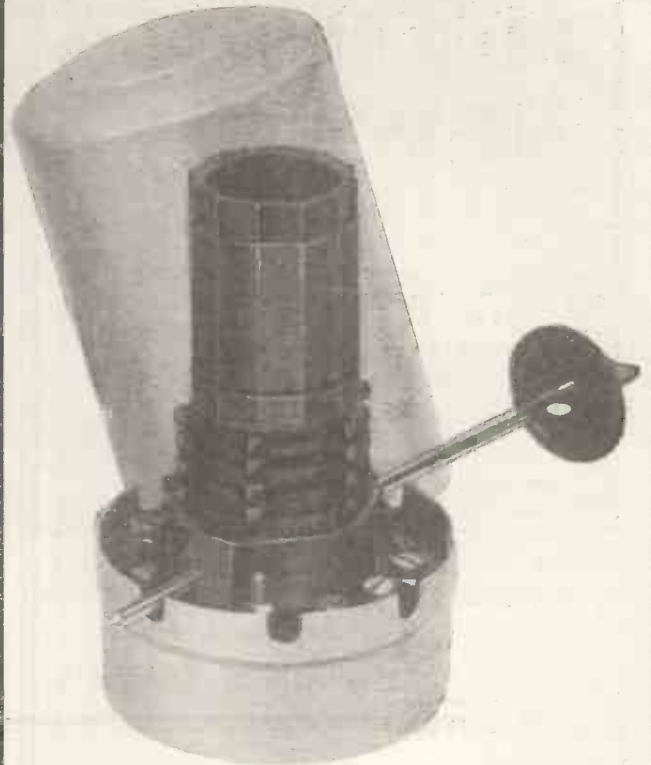

Whichever you choose—

THE THREE-RANGE TWO

or

THE Q.P.P. RADIOGRAM

you will need

COLVERN K.5 COILS

THE constructor who builds for efficiency reliability maximum performance, always insists on COLVERN COILS . . . they are his guarantee that his receiver will give maximum performance.

TYPE K.5 - - - 9/6 each

ALL COLVERN "K" TYPE COILS are accurately matched and fitted with gold-silver switch contacts.

Send for the COLVERN CIRCUIT BOOKLET R.L.10

COLVERN

MAWNEYS ROAD ROMFORD, ESSEX

London Wholesale Depot, 150, King's Cross Road, W.C.1



The new British organ, now being installed in the Concert Hall of Broadcasting House at the cost of £10,000, is described for the ordinary listener by

PATRICK CAMPBELL.

“**W**HAT does the B.B.C. want with an organ?” I hear you say. “Surely this really is one of the occasions where outside broadcasts would score over studio work?”

But you must realise that with organ music, as with every other branch of radio entertainment, broadcasting technique is an entirely separate art to be met with its own separate methods.

Designed for Broadcasting

When you hear a fine church organ echoing round the roof of a cathedral, it is that very echo and reverberation of the deep pedal notes which you admire. But these same deep notes cannot be broadcast as they would sound in a cathedral, and the B.B.C. with such knowledge in mind has set out to install an organ which will be designed and played entirely for broadcasting.

The builders are the John Compton Organ Company of London, and many organ enthusiasts will doubtless feel that the task could not be entrusted to more capable hands, for this famous firm are pioneers of the modern system of organ building.

No “Effects”

In spite of many statements to the effect that the new B.B.C. organ will be arranged after the cinema type—you may even have seen photographs of bells and tambourines and storm

machines designed for it—no “effects” of any kind will be built into the instrument. The B.B.C. organ will be a concert organ pure and simple.

The Concert Hall in Broadcasting House has ideal acoustics for organ playing—acoustics which are to be found in very few churches or halls in the world. It is in the Concert Hall that the new Compton organ will be installed, and a perfect balance of tone between the high and low registers will be secured after the



FOR REMOTE CONTROL

Engineers testing the remote control key-board which manages the 2,362 pipes of the new organ.

installation by very severe microphone tests.

There is much in the B.B.C. organ which is of interest to the expert, but even the ordinary layman, whose knowledge of organs is confined probably to his local church and cinema, will be interested to hear something of the construction.

The organist will have in front of him four rows of keys and an imposing and complicated looking collection of stops. One hundred and forty-nine of them there are altogether, to say nothing of eighty thumb and toe pistons!

Entirely Electric

Anyone watching the organist at work will notice that instead of pulling and pushing these stops, he will just give them the gentlest of touches with a finger when a light in the transparent head of the stop will come on and another section of the organ be brought into action. Another flick of the finger and the light and the stop are “off.”

The entire action of the organ is electric, and the console is really nothing more than a glorified switch-board which is connected to the organ chamber by a cable containing hundreds of insulated wires.

You would be surprised at the difference in size between the various pipes. There is a giant of thirty-two feet, and a midget of only three-quarters of an inch.

Listeners who expect that the B.B.C. organ will sound anything like the relays from cinemas will be disappointed. Those who look for an exact replica of a church organ are not likely to have their hopes realised. The B.B.C. organ will be something quite new—the first organ in this country to be designed especially for broadcasting.

Music at its Best

Doubtless the cinema relays will continue—probably you will still hear the organs of our big churches and cathedrals. But, when you listen to the organ from the Concert Hall at Broadcasting House you will be hearing organ music at its best so far as the wireless is concerned.

The fact that the B.B.C. has appointed Dr. Alcock in an advisory capacity, and has entrusted the work of building to a firm of such standing and reputation as John Compton, is, I think, sufficient justification for hoping that when the B.B.C. organ recitals commence we shall hear something really fine.

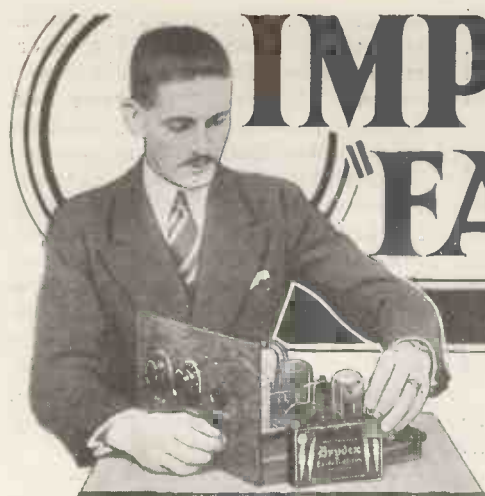

IMPROVING THE "FAMILY" SET

by W.L.S.

Every DX enthusiast should, in the opinion of our popular short-wave expert, provide his family with a receiver so devoid of knobs that they can use it without difficulty. A set of this type which has given satisfactory "family" service for some time is described below in the inimitable W.L.S. style.

LEST anyone should think that I am deserting my own particular sphere—that of short-wave reception, let me say that the remarks I am about to make are, in a way, the direct outcome of being a short-wave "fan."

Short-wave people have a habit of wanting to listen at all sorts of queer times, much to the annoyance of the "family," who generally find that their favourite artist is "on the air" at the local station at that very moment. Thus it usually happens that, sooner or later, the "family" is given its own broadcast receiver.

Very often this is made and then completely disowned; that all depends on the ferocity of the particular "short-wave bug" that has bitten the patient. In my own case the "family" set is a very straightforward affair, using a detector and two L.F. stages, all run from the mains, and equipped with a small indoor aerial. (The nice big pole outside serves to carry my wire!)

Simplicity Essential

It is most desirable that a "family" set—particularly when the radio handyman about the house does not operate it—should be a good one. Most essential of all, it should be simple, and, if possible, absolutely fool-proof. In my own case I find that those who use it do not care a rap for foreign programmes.

Their idea of an ideal set is one that gets the National and Regional with the minimum of trouble and with fairly decent quality. Heterodyne whistles in this particular case don't

matter, because, as is usually the case with elderly or even middle-aged people, they aren't heard, however painful they may seem to the youngsters.

Surrounded With Mystery

So my radiogram cabinet houses a not-too-selective three-valver with one switch "to make it go" and another "to choose the programme." No knobs or dials grace the front of the cabinet; no "station charts" hang on the wall above it. The entire set is surrounded with mystery except for the fact that the neat little switch gives "National" on the right and "Regional" on the left.

The detector circuit is shown in the accompanying diagram. The L.F. magnifiers, being perfectly straight-

forward transformer-coupled stages, don't need drawing.

The principle of changing programmes by a switch is perfectly easy. It is best explained by taking a normal set and tuning it to, say, the London National programme; in any case, choose the lower, in wavelength, of your two locals. Now put another variable condenser across the existing tuning control, and set that one (leaving the other where it was) so that London Regional (or the upper of whichever two stations you want) appears. Just put a switch in series with that condenser, and you will have "Nat." one way and "Reg." the other.

I know there is nothing the least bit original about this idea; but it is a good one that seems to be made very little use of, and I make no apology for reminding readers of it. Ingenious-minded folk can elaborate it in a very neat way.

FOR WORLD-WIDE RECEPTION

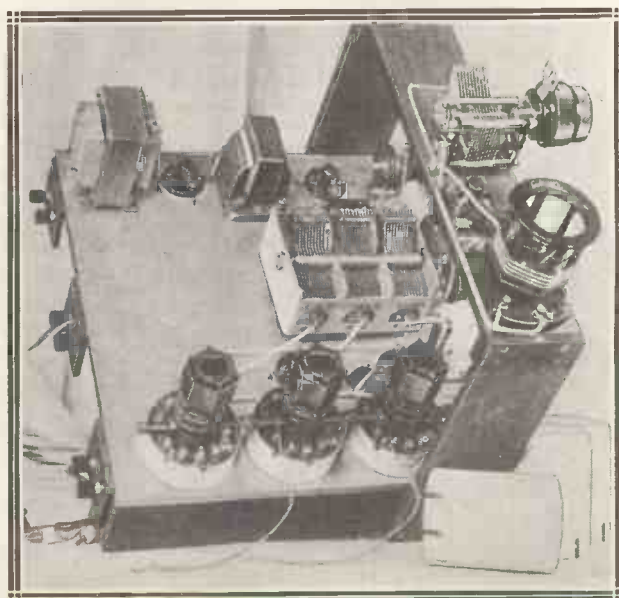

Where the provision of a separate "family" receiver is, for any reason, an impracticable proposition, it is not a bad idea to install an "all-purpose" set—such as, for instance, the "Whole-World Five," a "Modern Wireless" design which cover severe worthwhile waveband.

Adding Refinements

For instance, I thought of doing the station-changing with a double-pole switch, the spare contacts being arranged to light a green bulb for one station and a red one for the other. Another plan would be to use two bulbs which would illuminate the words "National" or "Regional."

I should not advise the combination of the station-changing switch with the main on-off switch, particularly in the case of a mains-driven set. When one tries to simplify a thing too much one often ends up by making it more complicated.

Readers may argue that there is no fun in having a

IMPROVING THE "FAMILY" SET

—continued from previous page

set on which there is nothing to twiddle; but remember that I am only talking about real "family" sets. Those that are operated and generally fiddled about with by the man who designed and made them hardly come into that category.

A "family" set seems to me to be one that is left for the "old folks" when the wireless expert is only home at week-ends, or if he is a short-wave fiend with a room and a set of his own for that purpose.

A Reaction Tip

There are some other small points that should not be overlooked when one simplifies a set, whether in the manner I have described, or any other. For one, the reaction control. It should be of a type that will not need re-setting when one goes from one local programme to the other.

On my own set, at first, I was "up against it." When the "Regional" was tuned-in at reasonable volume, I found that the set was oscillating and the tuning was taken down to the "National." This proved to be due to the damping effect, higher up, of the capacity-coupled aerial.

A loosely-coupled aerial, by means of a small untuned coil, provided quite

enough "pick-up" for the locals, and at the same time increased selectivity, while overcoming the difficulty of varying reaction. This arrangement has been running ever since quite satisfactorily.

The second variable condenser need not be large. A small air-dielectric .0001 reaction condenser seems the ideal thing for the purpose. I don't trust the average solid-dielectric condenser to keep its capacity quite constant enough for this particular job, particularly in our own unrivalled climate!

A convenient way of arranging the parts is to have a conventional panel

TUNING BY SWITCH

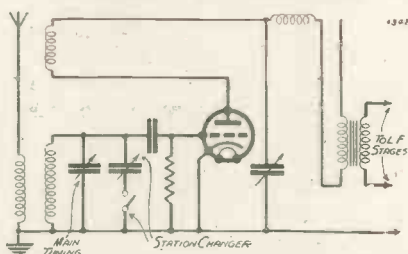

The station-selecting method advocated by W. L. S. for "family" use.

and baseboard set, with an extra panel out in front. The two condensers can then both be mounted on the back panel, the front one carrying nothing but the switches.

When tuning the set in the first place, the "station-changing" condenser is cut out of circuit by the switch, and the lower station ("National" for Londoners) tuned-in

on the main dial. This dial is then left severely alone while the other condenser is switched in. The upper station ("Regional," of course, for Londoners) is then tuned-in carefully on the second dial.

Naturally, no slow-motion dials are needed, and a plain knob is sufficient for the second condenser. A full-sized dial is an advantage on the main condenser in case the set should have to be tuned to any other station at some time. All being well, after the above sequence of operations, the switch should do the necessary work of choosing either programme for quite a long time.

As a matter of fact, any ordinary receiver (provided it hasn't too many controls!) can be equipped in this way, and the change-over switch may be mounted on the front panel without interfering with the other controls at all.

Sometimes Baffling

Looking back at what I have written, it occurs to me that I may have given the impression that I don't think "families" can be trusted to do anything more than pushing buttons. Please don't think that, but I do know that the most ordinary combination of two knobs will completely baffle some folk who don't know anything about radio and don't particularly want to. A friend of mine once used to talk about "parent-proof" sets for the old people, and it is this type of set that I have been thinking of.

ALL home constructors who make their own cabinets will, at one time or another, have faced the problem of decorating them satisfactorily.

Here is a method whereby the veriest amateur can impart to his woodwork that professional touch with a minimum of trouble and expense.

How to Start

The few simple materials required for this process are:

A tin of oil scumble (of the required shade).

A small quantity of pure turpentine.

A small quantity of gold size.

Some eggshell varnish.

A good soft varnish brush.

First make a mixture of the turpentine and gold size, in the proportion of 6 parts of turps to 1 part of gold size.

Now thin as much of the scumble as will do the required work. To do this it should be thoroughly mixed (an

FINISHING OFF THE WOODWORK

Some hints for getting the professional touch.

ordinary jam jar is useful for this) with some of the turps and gold size until it becomes about the consistency of cream. Take care to have no lumps or "skins" left in it.

The next job is to coat the surface to be decorated. The scumble should be brushed on quickly and fairly evenly all over. Now, after two or three minutes, take a small piece of soft cloth (of material which is not hairy) and with a circular motion rub the scumble evenly all over the surface and well into the grain.

Almost any depth of shade can be obtained according to the pressure used, and the length of time used in rubbing. For an extra strong depth of colour, a second rubbing may be required. In this case the first should

be allowed to dry thoroughly (not merely surface dry) and the process then repeated exactly as before.

When the final rubbing is quite dry and hard, you may then treat it with the eggshell varnish. The same brush you used to apply the scumble may be used for varnishing, provided you first wash it out well in turpentine. The varnish must be applied quickly and evenly.

An Attractive Finish

When dry, this type of varnish has an extremely attractive semi-gloss finish, which it is almost impossible to imitate by any other method. As wax is one of its components, it is an ideal varnish for subsequent polishing, and a simple application of any good wax furniture polish will give a very high and permanent finish. When you see the finished work, however, you will in all probability decide to leave it without further treatment, as it really is a most decorative and artistic finish.

W. A. C. W.

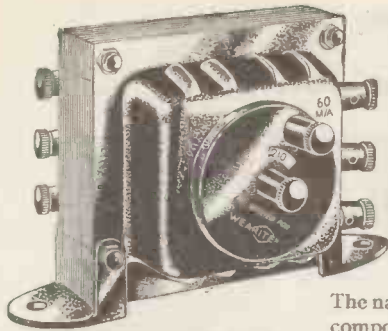

The Wearite T.21A Mains Transformer

Reg. Design, Pat. app. for.
The latest addition to the Wearite range—a truly efficient transformer to give 250v.-0-250v. at 60 milliamps, 2v-0-2v. at 1 amp. and 2v.-0-2v. at 4 amps. Complete with exclusive fool-proof voltage selector. Price **25/-**

H.F. CHOKES.—The Wearite range covers every possible need and full details and technical data are contained in special leaflet on request.

The H.F.P. is remarkably efficient, operating from 15 to 2,500 metres and was the first of its type in this country. Price **3/6**

The H.F.P.A. is similar but fitted with screened pigtail. Price **4/-**

WEARITE CONTRIBUTIONS TO RADIO DEVELOPMENT
The name Wearite has always meant components of highest quality and efficiency, but even more, "Wearite" means development. Whenever a receiver design calls for a special or exclusive component Wearite laboratories are the first to produce it. Whatever your need consult Wearite. Send for Book No. O.I.

The H.F.O. covers a range of 10 to 2,000 metres without marked resonances. Price **6/6**



H.F.O. Choke

WEARITE COMPONENTS

WRIGHT & WEAIRE, LIMITED

740, HIGH ROAD, TOTTENHAM, N.17. Tel. Tottenham 3847/8/9

♥ 2539



"ATLAS" GIVES MORE POWER FOR LESS THAN 1/- A YEAR

JUST imagine unlimited and infinitely better reception for less than one shilling a year—the price of a packet of cigarettes! Power from the mains with an "ATLAS" Unit is fifty times cheaper than batteries.

There's an "ATLAS" Unit for your battery set whether portable, table or radio-gram, from 39/6 or 10/- down. Abolish batteries now and save 50/- every year.

Ask for a demonstration to-day, and be sure to insist on "ATLAS," the only Units to win the Olympia Ballots for two years in succession. No other is so silent, safe and sure. Guaranteed 12 months. Westinghouse Rectifiers.

If your dealer cannot supply, write to:
H. CLARKE & CO. (M/CR.), LTD.,
PATRICROFT, MANCHESTER.
London: Bush House, W.C.2.
Glasgow: The G.E.S. Co., Ltd.,
38, Oswald Street.

★ Ask for details of the new "ATLAS Q.P." Units, specially designed for "Q.P.P." Sets.

The Paper for the Boy of To-day!

Such is MODERN BOY. Its every issue is brimful of thrilling stories and articles on the very latest Invention, Adventure, Hobbies, etc. It is the paper for the youth of to-day. Buy it regularly.

MODERN BOY

Every Saturday - - 2D.

MODEL T.S.H.

Enjoy SHORT-WAVE Reception—

With the Magnum Short-Wave Adaptor. Models are now available for A.C. Mains and Battery Sets using British valves, American valves, British S.G. Detector valves, and American S.G. Detector valves. Price, complete with 40/80-m. coil, 39/6. 18/40-m. coil 3/- extra.

SUPER-HET. ADAPTOR (Model T.S.H.) for all British and American A.C. Mains and Battery Sets employing a tuned high-frequency stage. Price, with 2 coils, 45/- Complete with valve and batteries. 63/- Full particulars, with a list of short-wave stations and free trial offer on request.

BURNE-JONES & CO. LTD.

"MAGNUM" HOUSE,
298, BOROUGH HIGH STREET,
LONDON, S.E.1

Telephone: HOP 6257 & 6258.



"CLARKE'S" ATLAS MAINS UNITS

Messrs. H. Clarke & Co. (M/cr.) Ltd.,
George Street, Patricroft, Manchester.
Please send me full details of "ATLAS" Mains Units, etc.

Name

(in capitals)

Address

34/4

POST NOW

AT YOUR SERVICE



by
**OUR TRADE
COMMISSIONER**

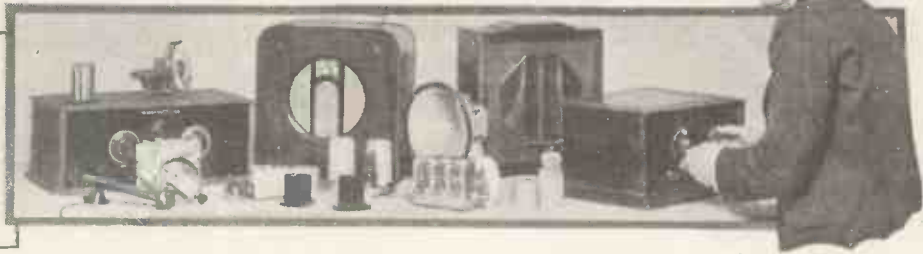

MESSRS. E. K. Cole may well have taken our monthly heading as their motto, for they have developed a system of set servicing that can be second to none in this country.

As a result of an elaborately organised array of mobile service depots, Ekco set owners in any part of the country can get service at a moment's notice.

These depots take the form of well-equipped test laboratories on wheels, and they can undertake any fault finding and repair that may come their way.

Accompanying each van is a specially trained engineer who will give advice and help on not only set faults, but general topics of radio interest, such as local conditions and how to combat them, installation problems, and so forth.

Radio sets have been developed on wonderfully fault-proof lines, but things go wrong occasionally in the best regulated circles, and if the receiver that has failed happens to be an Ekco, then the firm's flying squad of technicians will very soon be on the spot.

Cheaper H.T. Batteries

Reliability is a word that has long been the most treasured of British trade terms. To be reliable in workmanship has been the British reputation for many years. And so it is not surprising to find that this most valuable term is greatly treasured by Britain's still young industry—Radio.

And it is a reputation that Ediswan are determined to keep in connection with their H.T. batteries, in spite of the fact that substantial reductions in prices have been made.

As you probably realise, there are Ediswan dry batteries for practically every purpose—radio, electric bells, torches and so forth, incorporating the experience of many years of dry battery manufacture.

A definite guarantee of full voltage and capacity is issued with every one

Some trade news and views that will prove of interest to readers, whether or not they are connected with the radio industry. Members of the trade are invited to send items of interest or photographs, to be included under this heading.

and it is the aim of the makers to deal with any complaint within twenty-four hours.

The H.T. battery price reductions will be of interest to every battery-set user, the drop in prices being really considerable. The 60-volt battery has come down from 6s. 9d. to 5s. 6d., while all the other types have been reduced by two shillings.

New Blue Spot Speakers

I have just received a letter from the British Blue Spot Co., Ltd, saying that they will this month be releasing some new moving-coil speakers.

The speakers will consist, first, of the 29PM, a chassis design obtainable

for 32s. 6d., and the same speaker chassis in an oak cabinet to be sold at 45s. (Model 22PM).

In addition, there is to be the 45PM, a speaker for those who "demand that little extra," and sold for 45s. in chassis form and 67s. 6d. in a walnut or mahogany cabinet (Model 62PM).

Then we have the 99PM at 59s. 6d., and with the same chassis in a walnut cabinet (32PM) at 87s. 6d. All the above are of the permanent-magnet type, but in addition Blue Spot are bringing out two mains-energised models for D.C. 100-110 and 200-240 volt supply. These are to retail at very keen prices.

Incidentally, all these loudspeakers can be supplied with Q.P.P. transformers on board at an extra cost of 2s. 6d.

In this connection readers should note that the letters Q.P.P. must be quoted after the usual model numbers when ordering.

"BROADCASTING" FOR A FILM

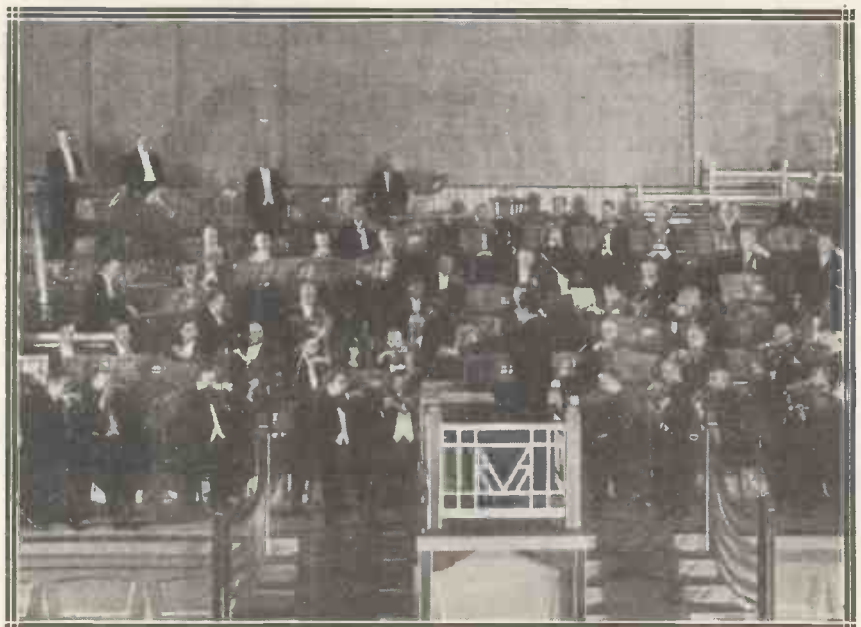

Here is a still from a concert hall. Dr. Malcolm Sargent conducting the London Symphony Orchestra during the making of an H.M.V. talkie.

The Advent of "Class B" Amplification

An H.M.V. Test Case

For a long time the manufacturers of gramophone records have been worried about the application of the Copyright Act of 1911. They argue that, though a public concern like a restaurant may use one of the gramophone company's own machines and records, these should not be played to provide public entertainment without permission of the gramophone company.

To test this, a writ has recently been issued by H.M.V. (The Gramophone Co., Ltd.) against Messrs. Stephen Carwardine and Co., Ltd., well-known caterers of London and Bristol, for "performing in public without authorisation at their restaurant in Bristol a His Master's Voice record, of which the copyright is vested in The Gramophone Co., Ltd."

When the case will come off (it may be heard before you read this) I cannot say, but it is stated that it will act as a test case for all the gramophone record manufacturers to define their rights under the 1911 Copyright Act. The case is down for hearing in the High Court of Justice in London.

Automatic Record-Changing

Like many others, I hate record-changing, and it was with unmingled joy that I learnt of the introduction of the Garrard Automatic Record-changing unit in "Universal" form. Thus D.C. as well as A.C. users will be able to make use of this most valuable device at a cost of only £10 17s. 6d., a price that is really moderate considering what you get for the money.

This step has been taken to encourage the conversion of existing radio sets to radiogramophones; and a further inducement is the production of two Garrard Radiogramophone units. These are either spring-motored, or contain an electric motor of either "Universal" or induction type, and they also incorporate the standard Garrard pick-up, which is mounted on the bronzed and lacquered unit plate, together with the automatic stopping and starting switch and two needle cups.

Everything is therefore being made as easy as possible for a set owner to convert to a radiogramophone, and the prices run from 63s. for a double-spring model to 128s. 6d. for the "Universal" type. There are three intermediate types available.

Finally, it should be noted that the Garrard pick-up is now available separately, with or without volume control, at 37s. 6d. and 32s. 6d. respectively.

"Class B" Sets

We shall shortly be in the midst of a certain amount of excitement due to the introduction to the public of "Class B" amplification. I cannot go into the full theory of it here, but it is in a form of Q.P.P. which uses a special double output valve instead of two separate valves, this valve being so designed that it requires no bias on its grid, the latter

A MAGNIFICENT GIFT

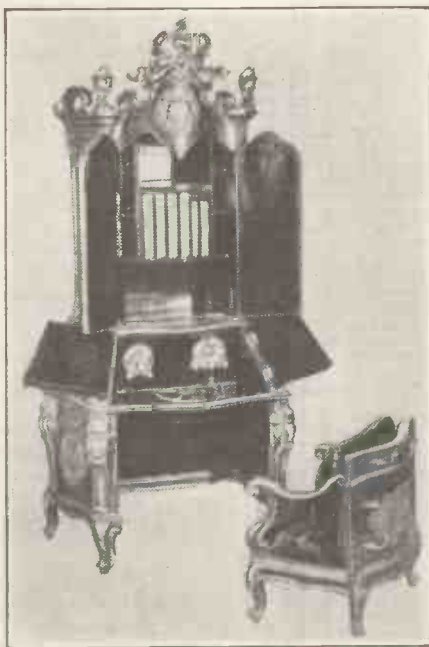

The City of Milan has presented this magnificent radiogram to His Holiness the Pope, together with a chair to match it. The set is shown open and ready for use.

operating at a positive potential when reception is being carried out.

At the moment of writing I have only heard this type of amplification with experimental valves, the valve pundits not having decided how to place the necessary six pins (or terminals) from the valve.

They will no doubt have come to some decision by the time this is published, and the various valve holder manufacturers will be hard at it getting valve holders on the market.

The Class B valve will affect quite a number of firms, besides the manufacturers who decide to use it in their next season's sets. Transformer

manufacturers are affected, a new input transformer being required, while the normal Q.P.P. output coupling can be used in many instances.

The power one can get from small battery H.T. voltage is certainly surprising, and the system should have quite a popular appeal. It is a pity though that some confusion between normal Q.P.P. and Class B is likely to arise in the public mind.

This is bound to occur, and the possibility of a diversity of valve types, each requiring its own special input transformer, seems also (if true) to show a lack of co-operation on the part of the B.V.M.A.

But, as a famous politician once said, we must "wait and see." All these little points *may* get straightened out by the time you see this, though, as things are now, it does not look as if there is much hope.

Sensible Standardisation

The whole of the component trade is in sore need of sensible standardisation. When we consider the number of different coil designs with their multitudinous terminal arrangements and the glorious conglomeration of valve types and characteristics, to say nothing of the non-standardisation of L.F. transformer and "Parafeedacoupler" terminal placing and labelling, and of the varieties of gang condensers with their diversities of terminal and trimming arrangements—when we consider all this (or these), we begin to realise that our radio industry is well and truly British.

No other country could mix up the radio trade in such a successful manner. Shall we ever get out of the wilderness and reach some sane order of things?

"What's to do about it?" Let's tackle it, *not* "turn out the lights and go to sleep." What a chance for the newly-formed component makers' association—or whatever this somewhat reticent body is called!

The "Westector"

The use of metal rectifiers for the detection of radio signals has been "in the news" quite a lot lately.

The Westinghouse Brake & Saxby Signal Company, who are responsible for the development of the new device, are marketing four models.

There are two half-wave types (W.4 and W.6) costing 7s. 6d., and two full-wave types (W.M.24 and W.M.26) at 10s.



A brief review of a typical selection of the latest gramophone records.

BROADCAST

I STILL think that the Broadcast "Four-tune" record is the best value in the "inexpensive section" of canned music on the market, for the variety provided is good, though, of course, only dance numbers have been recorded so far. The recording itself is of a remarkably high standard. I would suggest that light orchestral and, perhaps, cinema-organ items be included in some of these discs, for by mixing the style as well as the actual tunes still further programme value could be obtained from these records.

This month the four-tune record I have picked out for your attention is No. 507, on which we have Pretending You Care and On The Air doubled with Play, Fiddle, Play! and Butterflies In The Rain. Could there be a more tuneful selection of four different-style but up-to-date tunes? And all for one and sixpence!

Tom Burke is still hailed as "England's greatest tenor," and is recorded on Broadcast 3291, whereon he sings Her Name Is Mary and Play, Fiddle, Play! His voice is worthy of better recording, but the record manufacturer's opinion of him, as expressed on the disc, is not mine.

Sandy is In Hospital and tells you about his experiences on 945. Flu seems to be a favourite ailment for comedian recorders, though there is always a lot of fun to be obtained from it (except in real life). You should hear this record; it will give you a merry five or six minutes.

The famous choir of canaries is at it again on 949; while Sue, Sue, Sue will recall old memories on 946. Another "memories" record is that of Reginald New playing on the cinema organ. He covers some of the popular classics, such as Chopin's Polonaise and Liszt's Liebestraume, forming a pleasant "Super Twelve." (No. 3297.)

I am not sure that I like the Sanctuary of the Heart, one of Ketelbey's popular compositions as a vocal solo. But Arthur Vivian turns out a good record of it on 3295, coupled with Salut d'Amour.

Said to be America's latest radio sensation, The Wandering Boy sings some treacly "rolling-stone" sentiment in When The Wandering Boy Comes Home and Go Home To Your Best Pal, Go Home.

COLUMBIA

One of the best light entertainments that have appeared this month in the Columbia list is Halfway House, a complete incident that might have been taken from a musical play. It is sung by Harry Welchman and Company and is well worth hearing. The second side is particularly good, with its haunting melody of "Drifting On"; you should not miss DX446.

I am willing to acknowledge the excellency of Debroy Somers and His Band, but I feel that it is wasted in such things as Tantalising Trovatore and Rigoletto Ramblings, which are hotch-potches from famous operas played to strict dance time and rendered almost unrecognisable in parts. If they were only completely unrecognisable it would not be so bad, but they are sufficiently true to the composer's script to make one realise what a big departure Somers had made from the famous arias musically.

In their monthly bulletin Columbia foresee criticism of this record (DX447), and quote other of his "jazzing the classics" series as excuse, or even reason, for this latest perpetration. I agree that such old songs as "Little Brown Jug," "There's a Tavern," and so on, make a very rousing and enjoyable pot-pourri on these lines, but to take a couple of operatic tragedies and jazz them thus is a tragedy in itself.

Anona Winn, one of our most popular broadcasting stars, singing Play, Fiddle, Play! and Irving Berlin's latest I'm Playing With Fire is recorded on DB1043, and both songs are thoroughly enjoy-

able. I like particularly the first, which suits Anona Winn's wonderfully clear voice better than the latter, which is incidentally just as tuneful as Berlin's compositions usually are. The record is a good one, and will be sure to be popular.

Flanagan and Allen have been forced by the public demand to sing. They are not singers, and their "Underneath The Arches" was composed as a sort of signature tune; but the public demand has been so great that these clever comedians have bowed to the request for a couple of dance numbers, which they sing on DB1052.

The tunes themselves are good, and with the B.B.C. Dance Orchestra ("directed by Henry Hall") they make a very pleasant disc. The titles are Can't We Meet Again? and Do You Recall?

A second Flanagan and Allen record this month is a backchat one called The Cl-O-I-sters. It is well up to the true Flanagan and Allen style, and should be a successful follow-up of "O-I" and "The Sport of Kings." (DB1042.)

You will like Raymond Newell on DB1040, whereon he sings The Song of the Tramp and Devil-May-Care with his usual smooth and clear vocalisation: while Cinema Memories, by Quentin Maclean, will revive some old favourites that were seen on the screen in pre-talkie days. The items are taken from those films that had characteristic and sometimes specially composed accompanying music, such as "Orphans of the Storm," "The Four Horsemen," and so on, and ends up

ONE OF THE MOST POPULAR BROADCASTERS



Roy Fox (conducting) and his dance band, whose recording of "Wheezy Anna" is one of the best yet published.

with the first of the true talkies, "The Singing Fool." It is a most pleasant record and one that will find a home among many lovers of cinema-organ recordings. (DX382.)

I have had a number of good dance numbers sent to me this month, among which must be mentioned the B.B.C. Dance Orchestra playing It's Winter Again (a bit belatedly, I think) and I'm Sure of Everything But You on CB553, and The Savoy Orpheans dealing with Poor Me, Poor You and Ich Liebe Dich, My Dear, with vocal refrains by (I think) Maurice Elwin. These two items are very well done indeed, and are a pleasure to listen to from every point of view. (CB571.)

Finally, in pursuance of the present-day custom of resurrection of old favourites, we have Percival Mackey and His Band—who, it will be remembered, first recorded for Columbia many years ago—popping up with two old numbers from "The One Girl," namely, I'm Glad I Waited and Time On My Hands.

The vocal chorus is carried out by an American lady with a style not unlike that of a less powerful Sophie Tucker, so you know what to expect. I think you will like it, however. (CB557.)

H.M.V.

A £360 record! Not for public sale, but as a presentation to the world's greatest basso. That is the rough worth, in cold cash, of the gold master that has been presented to Chaliapin to mark the thirtieth anniversary of his recording for H.M.V. Naturally, the disc was of "The Song of the Volga Boatmen," and Chaliapin, in merry mood, tested its quality by the time-honoured method of dental application to the metal.

Another historic record is the re-recording of two more items from Caruso's vast repertoire, and H.M.V. have released this, the second of the revival discs that have been brought out by the new process I discussed a short time ago. The items this time are La Donna e Mobile and O Sole Mio. (DA1303.)

Records seem to be affected in the same way as pictures, for they are more appreciated after the artist's death than during his life. I understand that the number of re-recorded Caruso records sold since "Vesti La Giubba" was issued in December last has exceeded the figures over the same period of any record released during the artist's lifetime.

Naturally one has to take into account the greater popularity of the gramophone and the radiogramophone, but the number of the revived records that has been sold is astonishing.

A second historical disc is that of the late Vladimir de Pachmann, playing Chopin's Etude in G Flat Major (for the black notes only). This recording was not thought to be good enough because the famous maestro not only makes a false start, but carries on a sort of intermittent running commentary on the music he is playing throughout the record.

It is, however, one of the most typical recordings that could be made of the artist, and as such it is of more than usual interest and value. The record was made in 1927 when Pachmann was in London, and all the others made at that time have been issued.

It was because the H.M.V. officials thought that this was spoiled that it was not published, but now that the artist is dead, and there is no possibility that the same pieces can be recorded again by him, the record was brought up for discussion again, and it was realised that what had seemed a failure was really a great success.

Pachmann died a few weeks ago at the age of

85, and I should think that this record, among those above-mentioned made in 1927, stands alone as that of the oldest artiste ever recorded in a normal way—that is, playing the instrument for which he was famous. (DA1302.)

Butterflies in The Rain is excellently recorded by Ray Noble and His Orchestra on B6310, together with that delicious comedy number, Wheezy Anna.

I wish Ray had brought out the asthmatical character of this excellent lady a little more strongly. I like Roy Fox's method of dealing with this better, but he has certainly done justice to the former number. It is delightfully played.

new

29 PM
MOVING
COIL
SPEAKER
32/6



Yes, it's another triumph for Blue Spot. A moving coil speaker really worthy of the name—a performance and reliability that is truly astonishing.

SPECIAL FEATURES

Scientifically designed and well-made output transformer ● Terminals in place of solder tags for easy valve matching ● Suitable for Power, Super Power, Pentode and Q.P.P. (Triode) output. Special Q.P.P. Pentode model 2/6 extra ● New process cone and speech coil ● Copper-plated chassis ● Felt surround ● Undistorted output 3 watts ● Only by the most careful attention to every detail of design and construction is it possible to produce a speaker of this quality for so moderate a price.

You must hear 29 PM moving coil at your dealers. Catalogue M.W.24.S about other new Blue Spot Moving Coil Speakers post free on request.

CABINET MODEL. This speaker is also obtainable in a cabinet of fine quality oak (22 PM) 45/-.

THE BRITISH BLUE SPOT CO., LTD.

BLUE SPOT HOUSE, 94/96 ROSOMAN ST., ROSEBERY AVE., LONDON, E.C.1.

Telephone: Clerkenwell 3570.

Telegrams: "Bluspot, Isling, London." Distributors for Northern England, Scotland and Wales: H. O. RAWSON (Sheffield and London), Ltd., 100, London Road, Sheffield; 22, St. Mary's Parsonage, Manchester; 177, Westgate Road, Newcastle-on-Tyne; 37, 38, 39, Clyde Place, Glasgow.



BLUE SPOT

FOR THE "EMPIRE SUPER"

USE PREH POTENTIOMETERS

50,000 ohms. Retail price 5/9

The new range of variable resistances has been designed to meet the demand for a component with a particularly silent and smooth movement.

The curve of the potentiometer is arranged "straight line," which gives a straight-line ratio between angular movement and resistance variation.

The resistances can be supplied with "straight line" or logarithmic curves according to requirements.

These components are also supplied with a combined switch, making an extremely neat and robust unit. The switch has a quick make-and-break movement and will handle 1.2 amperes at 250 volts without arcing.

Preh

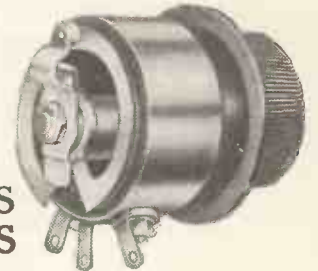

POTENTIOMETERS
AND RHEOSTATS

Prices for your special requirements on application.

PREH MANUFACTURING CO. LTD.,

Broadwater Road, Welwyn Garden City, MANUFACTURERS AND WHOLESALERS ONLY SUPPLIED.

Sole Sales Organisation: Harwell Ltd., The Sessions House, Clerkenwell Green, E.C.1. Phone: Clerkenwell 6905-6.

HOME CHARGING!



Charge your Radio and Car Accumulators at Home. Simply connect one side of the Heayberd Charger to the mains—the other to the Accumulator. Better, quicker, cheaper and your battery will last much longer this way. Two models available:

MODEL A02 CHARGER: Charging 2, 4, or 6 volts at 1 amp. Price 35/-

MODEL A03 CHARGER: Charging 2, 6 or 12 volts at 1 amp. Price 42/6

Including Westinghouse Rectifier and Transformer complete in neat steel case and Guaranteed.

10, FINSBURY STREET, LONDON, E.C.2.

POST COUPON

I enclose 3d. stamps for 36 paged Illustrated Handbook containing hints, tips and diagrams.

Name.....

Address.....

M.W.



PUT YOUR SET IN THIS CAMCO CABINET



"The Popular"—a very attractive but inexpensive Radio-Gram Cabinet with room for set, batteries and speaker, etc. Automatic stay and baffleboard. Finished shaded walnut 75/-. See it at our showrooms, open 9.15 to 5.45 (Sat. 12.50). Send coupon for FREE Camco Cabinet Catalogue.

This cabinet will take the Garrard Automatic Record Changer without alteration.

GARRINGTON MFG. CO. LTD.,

Showrooms: 24, Hatton Garden, London, E.C.1

Phone: Holborn 8202

Works: S. Croydon.



Post in 3d. envelope.

Name.....

Address.....

8M.W.....

TESTING TIPS

A Voltmeter Hint—S.G. Potentials—Loudspeakers—Large Condensers.

Double Range Voltmeter

THE range of a voltmeter can easily be doubled by joining a resistance in series with it, but, of course, the resistance must bear a certain definite relationship in value to the resistance of the voltmeter. It is frequently difficult to calculate the correct size of resistance mathematically, but the correct value can very simply be arrived at practically.

A variable resistance should be used for the purpose having a maximum value of 100,000 ohms. This is wired in series with the voltmeter, and should have a switch connected across it, so that the resistance can in effect be cut out when necessary.

Then a battery, preferably new, should be joined up to the voltmeter and its series resistance, and in the first instance the resistance should be shorted by the switch. A convenient voltage for the required purpose would be 50 volts, and this value should, of course, be shown on the voltmeter.

Switch in the resistance, and then turn the knob so that the voltage shown on the meter drops to 25 volts. Thus the reading in this case being halved, it follows that any reading now obtained on the meter is half the actual voltage. The range of the voltmeter is thus doubled.

When the resistance is shorted it will give normal scale readings, of course.

By taking 60 volts in the first place and adjusting the resistance until the reading is 20, the range will be trebled. Any reading obtained in this case has to be multiplied by three.

HALVE THE READING

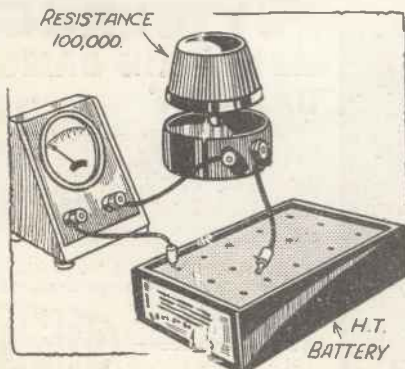

The variable resistance is adjusted until the voltmeter reading is halved.

Measuring Screen Voltage

A very common way of adjusting the voltage on the screening electrode of an S.G. valve is to employ a potentiometer consisting of two fixed resistances connected in series across the H.T. supply. The screening electrode is connected to the junction of the two resistances.

A good value for the "bottom" resistance is 50,000 ohms, and this happens to be the total resistance of many good voltmeters. To find the correct value of the "top" resistance the voltmeter may be connected in place of the "bottom" resistance. A reading will be given on the meter which will rise as the value of the "top" resistance is lowered.

If a "top" resistance is chosen so that the meter reads the voltage required by the particular screen-grid valve under consideration, it is then

MATCHING THE VALUES

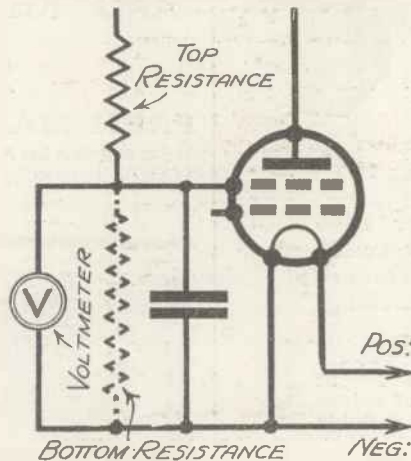

Connected as shown, the voltmeter may be considered as forming a potentiometer in conjunction with the top resistance.

only necessary to replace the meter by a "bottom" resistance of 50,000 ohms.

The screen will then be known to be receiving its correct voltage.

Of course, a meter having a total resistance of any reasonable value may be used. All that is required is for the "bottom" resistance to be equal to the resistance of the meter which is used.

Testing a Speaker

Many people still use the original home-constructed moving-coil loudspeakers. Very often these have no centring device, so that occasional adjustment of the coil and diaphragm is called for.

When making such adjustments it is always easiest to detect whether or not the coil is clear of the magnet if the diaphragm is actually being actuated by signal currents.

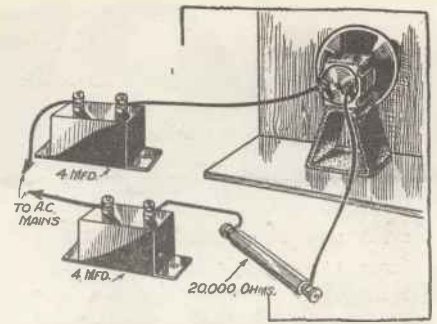

Quality condensers of high test voltage are used in this loudspeaker test.

What is wanted is a steady low-frequency applied to the speaker terminals. This will produce a low hum, against which the scratching noise of a rubbing coil is easily discerned.

Where A.C. mains are available it is easy to actuate the speaker at a frequency generally of 50 cycles by connecting the speaker to the mains.

Of course, direct connection should not be made, but two condensers and a resistance connected as shown will ensure safety.

Is the Condenser Leaky?

When building a radio receiver it is always advisable to test all large-capacity condensers before installing them in the set. This can be done very easily in the following manner.

Take the condenser to be tested and connect it directly between the positive and negative sockets of a 100-volt H.T. battery, or if you have a mains unit it will do just as well. After leaving the condenser connected for a few seconds, disconnect it and lay it aside for half an hour or so.

A good-class condenser should hold a charge for a considerable time—twenty-four hours is not beyond the capabilities of one in really good condition.

The actual test is to short the two terminals with a screwdriver after the allotted period, and note if there is a good, fat spark.

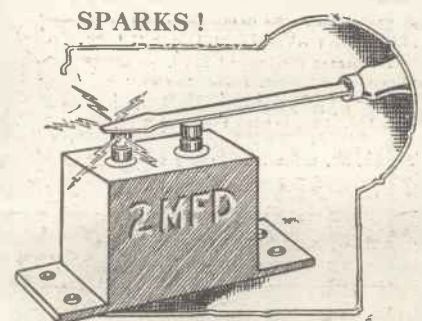

A good condenser will spark vigorously many hours after it has been charged.

DELIVERED TO YOUR HOME IMMEDIATELY



A BOOK FOR EVERY HOME AND OFFICE

HARDLY a day goes by that you are not confronted by some problem that needs a knowledge of law. With this masterly, authoritative and simply-written Guide to English and Scots Law you will be armed on all points concerning your domestic and business life.

MY OWN LAWYER will protect and guide you against many pitfalls and save many a bill of costs for those who consult its pages when in difficulties.

The Editor of MODERN WIRELESS has been able to secure a number of these volumes on specially advantageous terms and is offering them this week to all regular readers at reduced prices, which cannot be repeated. If you want to take advantage of this marvellous offer you must act now.

The standard edition is bound in stout covers of blue cloth, with gold lettering on the spine, and is both serviceable and attractive. Price 5/-, plus 1/- for carriage, packing, insurance, etc.

The de luxe edition, illustrated here (reduced), is in British leather cloth (blue), with full gilt back. A masterpiece of bookbinding; beautiful, yet of great durability. Price is 7/6, plus 1/- for carriage, packing, insurance, etc.

Edited by Mr. R. Storry Deans, Recorder of Newcastle-on-Tyne, MY OWN LAWYER is stamped with unquestioned authority. The learned Editor has had the assistance of many famous legal experts in compiling this valuable work which should save its cost many times over in any home or business.

This fine volume embodies all recent legal changes and a very special feature of the work is the amount of attention given to Scots Law, a subject that is often neglected entirely in publications of this kind.

Make sure of a copy by filling in the Order Form to-day. To-morrow may be too late.

SPECIAL BARGAIN

OFFER *Open for a*

Short While Only

STANDARD EDITION 5/-
DE LUXE as illustrated 7/6

Carriage, packing, insurance, etc., 1/- extra in each case.

(M.W.)

ORDER FORM

To A.P. Presentation Book Dept.
 (G.P.O. Box 184a),
 Cobb's Court, Broadway, London, E.C.4.

I am a regular reader of MODERN WIRELESS, and wish to take advantage of your offer. Please send me immediately the Special Edition of MY OWN LAWYER as specified below.

STANDARD EDITION.
 I enclose Postal Order value 6/-, i.e. 5/- for Volume plus 1/- to cover carriage, packing, insurance, etc. Please send me the Standard edition.

DE LUXE EDITION.
 I enclose Postal Order value 8/6, i.e. 7/6 for Volume plus 1/- to cover carriage, packing, insurance, etc. Please send me the De Luxe edition.

Please cross out section NOT required.

PLEASE WRITE CLEARLY.

SIGNATURE

NAME
 (Block Letters)

FULL ADDRESS

Date P.O. No.

Cross P.O. & Co. and make payable to "Amalgamated Press Limited."

IMPORTANT.—This Order Form, together with remittance, must be enclosed in a sealed envelope bearing 1½d. stamp.

Irish Free State readers not eligible.

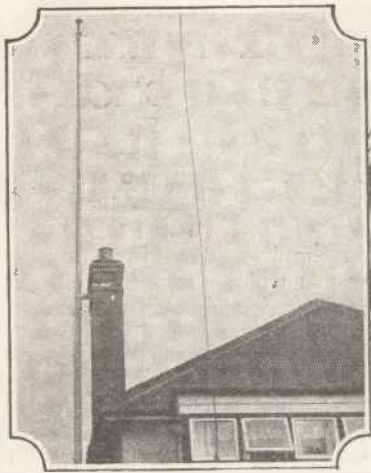

A SHORT-WAVE AERIAL

from elementary mathematics that the relative lengths of AB and AC will depend upon the angle ABC. If ABC is less than 45 degrees, for example, AB will be greater than AC. If ABC is about thirty degrees, AB will be about twice AC.

What Happens in Practice

Now—ignoring the fact that a wireless wave won't look like that at all, for the diagram is not meant to depict one in detail—what happens when we receive the signal BC, when the angle ABC is thirty degrees?

Receiving it vertically, with the ordinary aerial, we get roughly the signal strength represented by the perpendicular AC. With an aerial designed to do so, we could make our set responsive to the signal strength represented by the horizontal line AB—which would be twice as great.

As the majority of short-wave transmissions arrive tilted over in greater or lesser degree, it follows that a good proportion of them will have a bigger signal strength received horizontally than they will have when received on the vertical system. This is what actually happens in practice.

Before we go on to constructional details, I just want to make it quite clear that the diagram no more shows a wireless wave in action than would a map of the L.M.S. Railway; it is merely intended to illustrate the ratio of the two components, horizontal and vertical, when a wave is tilted at the particular angle shown.

In order to explain why this aerial gives, at times, vastly better results on the short waves than does the conventional system, it will be necessary to go into a little theory.

This aerial will definitely produce results from a DX station when the ordinary one won't, it is no more trouble to put up, and with a single touch of a switch it can be converted into the usual system for purposes of comparison.

Improved Results

Facts are better than words. During the last few months the "horizontal" aerial, as it is called, has been in use at the writer's station, and during this period he has been consistently able to hear W 2 X A D, for example, at times when that gentleman is normally inaudible.

As regards cost and trouble of putting up, my own aerial consists of 50 ft. of wire, three insulators, and one 20-ft. pole.

Now, then, let's get the spot of theory over. The whole point is that while waves of the order of 400 metres arrive at a distant receiving station more or less as they left the transmitting aerial, short waves—less than about 80 metres—become tilted over in transit at an angle to the perpendicular.

Vertical Aerials

Our ordinary aerials—T, inverted L, frame, indoor—when used with an earth are designed to give best results from a wave which arrives more or less vertically. When a wave turns up which is inclined at an angle of less than forty-five degrees to the earth, we are getting poorer results from our "vertical" aerial than we should with one designed to receive "horizontally."

Bear in mind that I am speaking electrically here. It doesn't matter

Listeners on short-waves should try this aerial scheme as it often brings in stations otherwise unavailable. Quick comparison with your ordinary aerial is possible.

By F. N. BASKERVILLE.

how the aerial is built; the greater part of it may be in the lead-in, or it may be nearly all parallel with the ground. The average broadcast aerial, whatever it looks like, is—electrically—vertical.

Now, then, glance at the diagram. AB represents the plane of the earth, and BC is a wireless wave in transit. AC is the perpendicular. It follows

THEORY AND PRACTICE

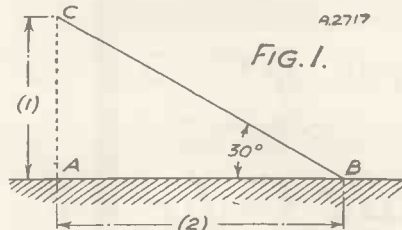

With the help of this diagram the author explains why the horizontal-type aerial works well on short waves.

FIG. 2.

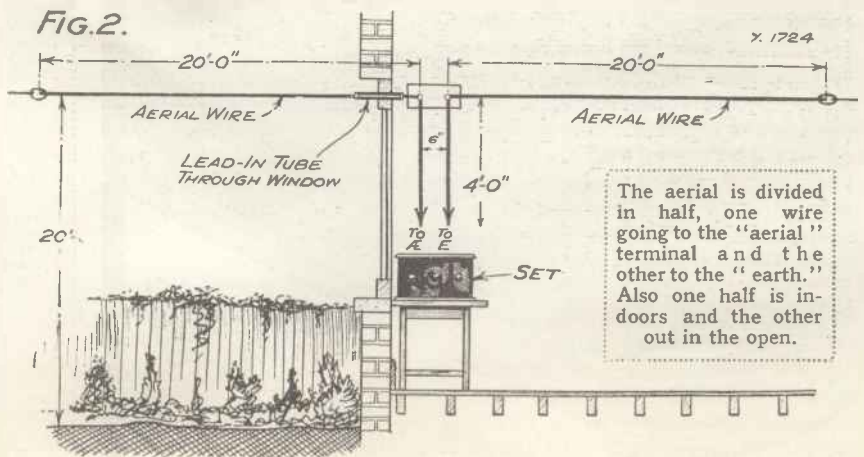

The aerial is divided in half, one wire going to the "aerial" terminal and the other to the "earth." Also one half is indoors and the other out in the open.

(Continued on page 383)

KEEPING H.F. IN ITS PLACE

How to avoid bad quality due to H.F. getting into the L.F. stages.
By A. W. YOUNGMAN.

BAD quality in a wireless receiver is not always due to faulty components or overloading of the valves, but where high-frequency amplification is incorporated it can often be traced to the presence of H.F. currents in the low-frequency

TO DETECTOR COUPLING

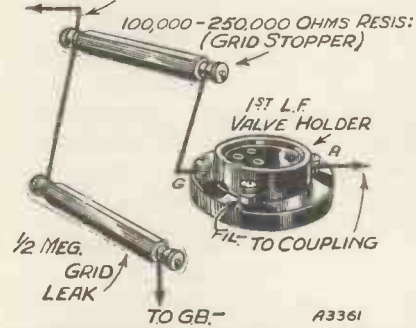

A grid-stopper effectively keeps H.F. out of an L.F. valve, and the connections are very simple.

circuit. The effect of this does not only result in bad quality, but sometimes a continuous and undesirable high-pitched whistle is audible in the loudspeaker—making the possibility of good reception very remote.

The output from the second detector is shunt-fed to a 7:1 ratio shielded L.F. transformer, the secondary of which is connected across the grid circuit of the output valve, which is a PX.4. The undistorted output rating is approximately 2½ watts.

Convenient Controls

All the other controls, with the exception of the one for volume adjustment, are conveniently situated on the motor board. They consist of a single tuning control, a tone regulator and a four-position switch giving "medium waves," "long waves," "gram" and "off."

The tuning scale is calibrated in wavelengths, and it is ingeniously arranged so that only the appropriate readings are illuminated depending upon the position of the wavechange switch.

The gramophone turntable, which is driven by an induction disc motor, is actuated by a new type of automatic stop which operates on either the eccentric groove or minimum diameter record principles. The

The fact that the majority of receivers are fitted for radiogram working offers a convenient method of ascertaining whether the leaking of H.F. into the amplifier circuit is responsible for such quality. This test is effected by simply switching over to gramophone operation and comparing the difference in reproduction with that of radio, although in view of the possible risk of stray currents, it is advisable to disconnect the H.F. stage or stages, as the case may be when testing on gramophone.

Recommended Cures

If a marked improvement is audible, then the cause of bad quality is very probably the above, and the following methods should be adopted to remedy it.

The first necessary step, of course, is to make sure that the H.F. choke in the anode circuit of the detector valve is thoroughly efficient, and such a choke to be effective should have a comparatively high inductance to act as an obstruction and impede the passage of the H.F. currents. Should it happen that this barrier is inadequate, then a small by-pass condenser must be included between the anode side of the choke and L.T. negative of the detector valve. See Diagram.

This condenser should have a value of between .0001 mfd. and .0003 mfd.

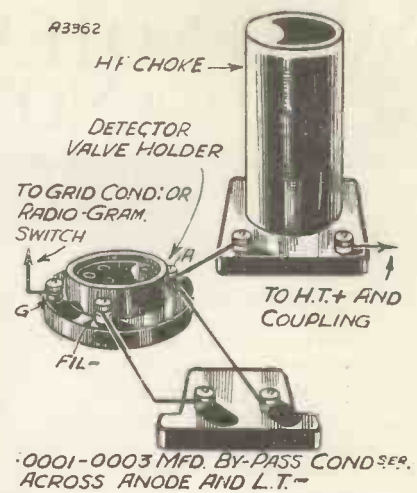

The connection of a fixed condenser across anode and filament of the detector valve is an easily-applied cure for wandering H.F. currents.

If, in spite of the foregoing, H.F. is still present, a grid stopper with a resistance between 100,000 and 250,000 ohms should be connected in the grid lead of the first L.F. valve. See other Diagram.

Should the coupling between the detector and first L.F. be resistance, then care should be exercised to include this grid stopper in the correct position. The ½-megohm grid leak must be joined as shown in the Diagram and not from the grid side. If connected in the latter method the amplification is reduced.

THE H.M.V. SUPERHET RADIOGRAM SEVEN

(Continued from page 346)

pick-up is the standard H.M.V. No. 15 with rotatable head.

Provision is made for the use of a mains or external aerial, and in the latter case a preset compensating condenser, which is set when the set is installed, ensures perfect ganging under widely varying aerial conditions.

Our aerial tests of the Superhet Radiogram Seven were conducted in a locality approximately 12 miles south-west of Brookmans Park, and under these conditions, when using an outside aerial of rather small dimensions, the performance was little short of amazing.

Reference to the number of stations we received is hardly a distinctive testimonial these days, because the same is true of any really modern superhet. We should have no option but to criticise the instrument if it

did not provide at real programme value the bulk of the European broadcasters.

The H.M.V. Superhet Radiogram Seven is definitely an "all stations" set, but its distinctive characteristics are (1) the amazing ease with which any one of what must surely be nearly a hundred stations can be received; and (2) the superb quality of reproduction on local and distant stations alike.

Lifelike Reproduction

On the gramophone side the results bear comparison with the living artists themselves. A darkened room, a bit of imagination, and the illusion would be complete. What more can we say?

Thus, to sum up, if you want a set that represents the very last word in modern radio practice, a set that will re-create the living artist from your wax discs, an instrument that is of domestic utility both from the points of view of operation and appearance, then you need not look farther than this one. In a word, it's just magnificent.

RADIO NOTES and NEWS of the MONTH

By G.B.



Surprising Growth

THESE are at present 250 licensed relay exchanges in operation in this country, with subscribers amounting to about 80,000. This works out about 320 subscribers per relay station. There has been a surprising growth of relays, as the following figures indicate:

In March, 1930, there were 10,913 subscribers.

In March, 1931, there were 26,219 subscribers.

In March, 1932, there were 51,740 subscribers. While in December, 1932 the figures had reached 82,690.

Diplomacy!

When the representatives of Japan and China visited Broadcasting House a few days ago to broadcast their respective views on the Manchurian War, the B.B.C. displayed an elaborate appreciation of diplomatic tact. A lift was reserved to take the ministers to the studios for their broadcasts, but, for diplomatic reasons, they were not allowed to meet, nor were they even allowed to see each other until the broadcast was over. In fact, the Japanese representative broadcast from one studio, and the Chinese representative from another.

Did the B.B.C. expect that hostilities would break out unless these precautions were taken?

SOS Appeals

A big increase was shown in the number of SOS and similar messages broadcast from B.B.C. stations during 1932. The figure for the year was 1,007; which compares with 833 and 842 in 1931 and 1930 respectively.

Apparently messages were slightly more successful last year than during the previous year, the percentage of successes being 40.91 in 1932 and 40.21 in 1931, an increase of .7.

Mr. Churchill and India

Mr. Churchill has renewed his request to be allowed to broadcast at an early date on the Indian constitutional question. The B.B.C. has replied that it is proposed to have three factual statements explanatory of the White Paper on India shortly after Easter. In the autumn it is

proposed to have a series of talks on India, representative of the different points of view in connection with which it is hoped to communicate with Mr. Churchill, probably in June.

Mr. Churchill has replied that he is very astonished to hear that the B.B.C. have made arrangements to have explanatory statements of the Government's forthcoming White Paper and not to allow a reply to the statements of fact contained therein until many months have passed.

"Fair and Free"

Consequently, the war is again on between Mr. Winston Churchill and the B.B.C. Copies of letters between the Corporation and Mr. Churchill have been sent to the newspapers, and Mr. Churchill states in one of his replies to the B.B.C. that he "does not see how such conduct can be reconciled with fair and free discussion of public matters. It partakes of the nature of an intrigue to force a particular line of policy on the country without the public being able to form a judgment on the merits."

He Is Enjoying It!

Somehow we have a feeling that Mr. Churchill is rather enjoying this argument with the B.B.C.; but, all the same, it will be surprising if the B.B.C. is swayed by Mr. Churchill's arguments.

Vienna's Latest

Very shortly now listeners will be hearing experiments from the new 120 kw. Vienna station. This new station will cost 18,000,000 francs, and the new programmes will include certain exclusive gramophone records which are the property of the Vienna Institute of Sciences. This Institute possesses records of extraordinary interest in 400 different languages.

B.B.C. Official for Canada

Major Gladstone Murray, who is Sir John Reith's right-hand man, has left London for Canada especially at the request of Mr. Bennett, the Prime

Minister. He is going to reorganise Canadian broadcasting.

Major Murray will probably be away for two or three months. It is understood that Sir John Reith has loaned Major Murray for a limited period at the desire of Downing Street, to whom Mr. Bennett first addressed his request.

Nearly 5½ Millions

No fewer than 61,200 new licences were issued during February, bringing the national total up to nearly 5½ millions. Just under one million are now in force in the London district.

Apparently London is divided into ten regions; the eastern region contains most licences, with 180,000; while there are 179,000 in the South-Eastern region. The lowest district is the West Central, with only 8,000; while East Central ranks next with 8,100 licensed listeners.

France's Programme

It is reported that France will shortly open eight new broadcasting stations, two of which—Toulouse and Rennes—will have a power of 120 kw. as against the power of 50 kw. for the most powerful British station.

The other stations are at Lyons la Doua, Limoges, Bordeaux, Nice, Marseilles, and Lille. With the exception of Lyons, all these stations will have a power of 60 kw.

U.S.A. Giant

If all goes well, listeners in this country at the end of the year will be able to receive direct transmissions from a proposed new transmitter which is to be built at Cincinnati, Ohio. This station has been authorised by the Federal Radio Board to work on a wavelength of 428.3 metres, with a power of 500 kw.—that is, a power five times as great as the new British transmitter at Droitwich.

It is expected that the station will cost £100,000, and that the average service area of the station will be 2,500 miles.

Song-Plugging

Song-plugging has always been a sore topic where broadcasting is concerned, and there is no doubt that some music publishers have been paying dance bands to play and announce their dance tunes.

The whole trouble is, of course, that the bands want more and the publishers want to pay less.

It is alleged that some conductors have been paid as much as £5 a tune, and a new arrangement has just been circularised to dance bands

RADIO NOTES AND NEWS OF THE MONTH
—continued from page 380

announcing a cut to £1. According to a representative of the evening newspaper, the "Star," who interviewed Jack Payne on this question some days ago, Mr. Payne said, "If I had been dishonest I could have made £30,000 or £40,000 out of publishers during the last five years; but I have never accepted one farthing, and I have kicked song publishers' representatives out of my office for daring to suggest that I should accept consideration."

B.B.C.'s Gift

This year the B.B.C. was entitled to about one and three-quarter million pounds, but it is now announced that the Corporation has decided to surrender a quarter of a million to the Treasury.

We Want to Know

Were listeners consulted about this? No.
Was it understood when broadcasting began and a licence fee of 10s. imposed that the fees should be raided? No.
Are listeners entitled to have a thorough legal inquiry into this arrangement? Very decidedly, yes.
Will such an inquiry be held? Very unlikely.

Income for Broadcasting

All the same, although the B.B.C. is making a gift of £250,000 to the Exchequer, it is actually receiving £152,000 more than it did last year. The figures show that the amount due to the B.B.C. is £1,768,000. This sum is reduced to £1,518,000 because of the gift to the Exchequer. In 1932 the Corporation received £1,366,000.

"Anaesthetics"

It is reported in one of the newspapers that for the first time in medical history hospital patients have been listening to broadcast dance music, songs and jokes, etc., while undergoing serious operations.

Dr. Basil Hughes, the well-known surgeon, has explained that instead of a general anaesthetic being used, the patients were treated with a serum which renders them insensible to pain but at the same time allows them to retain consciousness. Headphones were worn by the patients.

UNDERGROUND WIRELESS ON TOP OF THE WORLD!
—continued from page 360

of exchange about 6s. 8d.—for the right to eat a 6.30 a.m. breakfast of beefsteak, porridge, coffee and bread, two other square meals and a good solid tea for six consecutive days. And they eat it to the sound of music from Santiago, or speeches from Berlin and Paris.

Conflicting Radio

Each canteen has its wireless. On a lower level there is a cinema, a dance hall, and a school where reading, writing and arithmetic are taught. The miners watch the succulent embraces of Greta Garbo, or dance with each other, under notices which request the removal of all hats, to conflicting radio. In fact, the only places underground where the loud-speakers were silent seemed to me to be the first-aid post, which had a room with half a dozen beds attached to it, the jewellery store which sold cheap watches and copper bracelets guaranteed to cure rheumatism, and the general store where, amidst a plethora of German goods, clothing, cutlery, and hairwash, the only English things I could find were braces and Sunlight soap.

The kitchens were sibilant with wireless. Print-aproned women cooked in rag-time. "They are wives or daughters of miners," explained the manager. "We're about the only place in Chile that insists on marriage certificates."

A Wide Choice

"Why?" I asked, surprised, for all over South America marriage in what is called "the camp" is something of a polite fiction.

"There is a commercial reason," said the manager. "The company's responsible in case of accident for any woman living with a miner, and we want to be sure she has a legal right. It's not always so easy. When we asked one chap for a marriage certificate he produced fifteen, and said, 'Take yer choice, boss.'"

We walked along endless passages. The outer ones had windows cut out of the surface of the mountain, but during the winter months they are completely blocked up by snow. We saw several underground billiard rooms, where pale, boneless men chalked their cues to the sound of

(Continued on page 382)

The Easy Way TO PERFECT RADIO

CASH—C.O.D. or H.P. PILOT AUTHOR KITS

Q.P.P. RADIOGRAM
(Described this month.)

KIT "A"
Author's Kit of First Specified Components including ready-drilled panel, but less valves, cabinet, gram. parts and speaker.

Cash or C.O.D. £5 - 0 - 0
Carriage Paid.

or 12 monthly payments of 9/3

KIT "B." As Kit "A" with valves only. Cash or C.O.D. Carriage Paid, £7 - 18 - 6 or 12 monthly payments of 14/6.	KIT "C." As Kit "A" but with valves and Peto-Scott Model "B" Adaptor-gram less speaker. Cash or C.O.D. Carriage Paid, £14-4-6 or 12 monthly payments of 26/-
---	--

SPECIALLY RECOMMENDED PETO-SCOTT GUARDIAN Q.P.P. MOVING-COIL SPEAKER

A permanent-magnet moving-coil unit, specially designed for Q.P.P. output. Extremely sensitive. Perfect quality. Cash or C.O.D. Carriage Paid. With Q.P.P. Radiogram Pilot Author Kit Or add 2/4 to If ordered separately, Cash above 12 monthly or C.O.D., carriage paid, 29/6 payments.

25/-

KIT-BITS Selected C.O.D. Items for Q.P.P. Radiogram. You pay the postman. We pay post charges over 10/-

1 Colvern Two-Gang Coil Unit, K5	19/-
1 Sound Sales Q.P.P. Input Transformer	15/-
1 Utility Two-Gang Condenser (W.312)	19/6
1 Set of Valves	£2 - 18 - 6

Exact to Specification SPECIFIED EXCLUSIVELY! 1933 WALNUT ADAPTIAGRAM

Constructed in Walnut with inlaid Walnut Veneers.

MODEL A comes to you with vignotted front as illustrated and motor-board, ready to take your Q.P.P. Radiogram Set Gramophone, Motor and Pick-up. No skill or expensive tools are required to transform your Radio into a combination instrument, presenting a professionally finished appearance.

Carriage and Packing 2/6 extra, Eng. and Wales.

63/- Or Deposit 2/3 and 11 monthly payments of 5/9. Carr. paid. Baffle-board 3/6 extra.

MODEL B with Garrard Double Spring Motor. 12in. Turntable. Automatic Stop. B.T.H. Tone-Arm with Pick-up, and Volume Control Complete. Automatic Needle Cup. Cash or C.O.D. or 12 monthly payments of 12/-.

MODEL C with Collaro Induction Electric Motor with Tone-Arm, Pick-up and Volume Control in one Unit. 12in. Turntable. Automatic Stop. Automatic Needle Cup. Cash or C.O.D. or 12 monthly payments of 13/6.

6 7 8

PETO-SCOTT CO. LTD.
77, CITY ROAD, LONDON, E.C.1
Telephone: Clerkenwell, 9406/7
West End Showrooms: 62 High Holborn, London. W.C.1

GRIP



NEW BOWSPRING WANDERPLUG

Strong spring and wide self-adjustment. Side entry with Belling-Lee patent grip for flex. 12 indications and 6 plain colours.

The "BOWSPRING" gives strong pressure over a far wider range of distances than any plug we have so far tested.

Write for list of radio connections.

BELLING-LEE
FOR EVERY RADIO CONNECTION

Cambridge Arterial Road, Enfield, Mdx.

UNDERGROUND WIRELESS ON TOP OF THE WORLD!

—continued from page 381

Buenos Aires advertising face-cream, or Santiago reciting the President's address.

A pale young man asked us if we'd like to hear London. We went into a room with a bar at one end—soft drinks only; Teniente and Sewell, balanced half on the top of the world, half inside one of its steepest mountains, are bone dry.

It was then that Big Ben struck midnight, and the sunset was still a fiery red somewhere far away, outside the underground world where night and day are the same.

While the pale young man experimented with outraged air-waves, we talked about bootleggers. Sometimes they come secretly over the mountains, and such miners as could afford it had an orgy which usually ended with murder.

The Cook's Quarters

Of that amazing underground settlement, I remember, of course, the long ride on a motor trolley to the nearest working—I think it was a mile and a half straight into the mountain—and the engineer's casual, "Don't touch that wire"—my hat had been within an inch of it—"it's high tension—you might get bumped off, but I dare say it wouldn't do more than give you a powerful shock."

But I remember more vividly than the green and faintly shining stairs of copper on the rock or the thunder of the underground trains—the "passenger" ones consisted of sheet metal boxes "so that the men can't go and knock themselves about"—the couple of rooms where one of the cooks lived with her family.

There were frilly muslin curtains at the windows which looked into an underground corridor, and several statues of the Madonna surrounded with artificial flowers. There was a brass bedstead with a brocade quilt. A sophisticated celluloid doll sat astride the loudspeaker which also served the canteen next door, and there was a mug with a picture of Margate on it. How it got there, its owner did not know.

A Question of Clothes

From the cushions and the fripperies, the oleographic photographs and the illustrations torn out of the weekly magazines that trimmed these rooms, we went over more and more

stairs cut out of the earth till we reached the level where the miners had their quarters.

The manager led us down the subterranean corridor, and we looked into a cave-like chamber where several men and a dog were listening to a radio speech about the new taxation destined to relieve unemployment by increasing road construction.

"Where do they keep their clothes?" I asked.

"Wear 'em," said the manager. "They put on their best suit underneath and their working clothes on top. When they've finished their shift, they strip off the old suit and lock it in the bunk; and then they're already dressed to go out." He laughed. "Saves time and prevents stealing."

Keeping In Touch

"What about baths?"

"There's every kind down here—hot, cold, and shower. Like to see 'em?"

I shook my head. A blast of orchestral music was issuing from an open door—there was a counter inside piled with trousers. The thought of baths to the accompaniment—even if distant—of political propaganda or syncopated ragtime was too much for me.

We returned to Sewell, to hot baths and iced water, to contract bridge and "Thousand-island-salad" made from a Long Island recipe. After dinner our hostess turned on the wireless.

"It's nice to keep in touch," she said. "We can get most anywhere, though the hours are a bit difficult."

Her husband said: "Well, Mrs. Forbes, you like local colour, so I'll tell you—if you go down a mine in Bolivia, like as not the miners'll want to kill a llama and sprinkle its blood in the shaft. They're superstitious about priests or women going down a mine."

Certainly Unlucky

"Oh, miners are always superstitious," said the doctor, or perhaps it was the engineer. "Sometimes they get it into their heads one of a shift's bringing them bad luck. So they stand round in a circle on the nearest cancha (piece of ground) and pass a lighted stick of dynamite from hand to hand. The man in who's hold it goes off—well, he's the unlucky one."

"He sure is unlucky," said the engineer, or perhaps it was the doctor.

"I've got New York," said our hostess, delighted.

TAYLOR WET H.T. BATTERIES.
Give long service, improved volume and tone; very economical.

Replacements for Taylor or Standard batteries at low prices; details post free; also Bargain List. Radio Kits and parts at lowest prices.

M. TAYLOR, 57, Studley Rd., Stockwell, London.

Famous Maker's Offer! **PIANO-TONE CABINETS**
7 DAYS' FREE TRIAL
(or 10/- Monthly)

Piano built (Pat. 8123). The acoustic Tone brings a fine thrill.

(Radio-Press, B.B.C., 3,000 clients).

MAKER'S PRICES 35/- to £15
Photographs and List FREE

PICKETTS Piano-Tone Cabinets, (M.W.) Albion Rd., Bexleyheath

LIST FREE

PLEASE be sure to mention "Modern Wireless" when communicating with Advertisers. THANKS!

THE BATTERY SET COMES INTO ITS OWN

This is the title of Varley's new illustrated brochure on Q.P.P. In simple language, with stage-by-stage diagrams, it shows you how easy and inexpensive it is to install Q.P.P. in any existing battery set—to get the quality and volume previously associate with Mains apparatus only. Don't fail to get your copy of the above interesting brochure—see coupon below.

Varley Q.P.P.

To Messrs. VARLEY, 103, Kingsway, W.C.2
Please send me, post free, your new brochure, 'THE BATTERY SET COMES INTO ITS OWN.'

Name.....
Address.....

M.W.1

FREE COUPON

A SHORT-WAVE AERIAL

—continued from page 378

set, across the room, and out along the landing.

At the centre of the wire, just over the set, make a break, and insert an insulator. Take leads, one from each side of the insulator, to the aerial and earth terminals on the receiver—having first removed the earth lead.

It is advisable to keep the gap between the two halves of the aerial not less than six inches, to cut down capacity between them; and to make the leads to the set as short as possible.

When you make your first test—depending on the time of day, you will find a host of stations that would be otherwise inaudible; and in proportion many of your “regulars” will have slumped in strength. Or you may, according to conditions at the moment, find just the reverse.

For the First Time

As a general rule, it will be found that stations just on the point of fading out will come in at good strength on the “horizontal” aerial; moreover, the skip distance will have shifted, and the nearer Europeans may be audible for the first time.

A large field exists for comparison of results between the two systems, and many interesting experiments can be made. The swiftest method of changing over is to connect both down leads to the “aerial” terminal, and bring an earth lead into action. You have then the equivalent of an ordinary “T” aerial.

The “horizontal” aerial will not give you increased signal strength and range all round; but it will, definitely, give you vastly better results from many stations at certain times of day, and also bring in DX signals inaudible on the ordinary system.

THE “THREE-RANGE” TWO

—continued from page 349

the baseboard be adjusted so that it is not more than one quarter of the way “in.” It may even be less when dealing with wavelengths that are tuned at the bottom of the range of the short-wave coil. Should you come up against places in tuning on the short-waves where reaction is unobtainable—it occasionally happens on some

aerial systems—a slight adjustment of the neutralising type condenser setting will remedy matters.

I may, perhaps, be excused for going back at this juncture to a purely constructional matter. It will be noted that several leads are joined to the metal foil, and that screws are shown as the method of making contact. This is actually the case.

It is difficult to solder on to a large area of foil owing to the conduction by the foil of the heat from the iron. It is simpler, and just as effective, if brass (or steel) screws are used, with washers, to fix the wires to the foil.

Below 25 Metres

Loops are made in the wire and then, with washer above, the screw is driven through the loop and the foil into the baseboard below. It is better for this purpose to use round-headed screws rather than the countersinking type.

Slow turning of the tuning control is, of course, essential when searching for short-wave stations, and in this use of the set I employ a simple device to enable me to get down below the 22-25 metres that is the normal minimum of the coil. I use an ordinary crocodile clip and short-circuit a couple of turns at the earth end of the coil, by the simple expedient of clipping the crocodile across the turns. It is quite effective and worth trying.

LOW-TENSION FUSES

A little used, but very necessary, safety device for your accumulator

ALTHOUGH fuses are in common use in high-tension circuits of receivers, it is very seldom that low-tension fuses are incorporated.

There is always the possibility that a short-circuit may occur between the leads from the accumulator. If this is not soon discovered, the accumulator may be badly damaged, or even completely ruined.

The fuse should be placed as close to the accumulator terminal as possible. That in the accompanying sketch actually takes the place of the usual spade connector.

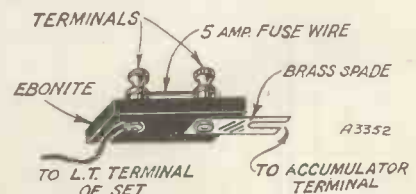

Ordinary 5-amp. fuse wire, as used in house lighting circuits, is perfectly satisfactory.

1 INSTANTANEOUS FUSING ACTION

The high vacuum exclusive to genuine “Competa” Radio Fuse bulbs ensures immediate fusing on 50% overload and safeguards the emission. No limitations can give you this assurance. The safety of your Valves depends on their use.

Ask for “Competa” **6** in the little orange box. Send for Competa Folder “M.”

From all Dealers.
Large stocks always available.

INSIST ON GENUINE
COMPETA
RADIO FUSE BULBS

REGISTERED TRADE MARK

A. F. BULGIN & CO., LTD., ABBEY ROAD, BARKING.
Telephone: Grange Wood 3266/7.

Fit “SOUND SALES” and be Safe !!

Follow the lead and specification of the designer of

The O.P.P. RADIOGRAM INTERVAL TRANSFORMER
Type S.S./P.P.9.

15/-

0.1 Ratio, 30 Henry Primary Inductance at 2 m/a.

UNIVERSAL OUTPUT CHOKE
Type O.P.Q. 10/6

SOUND SALES

SOUND SALES LTD.
Phone: Archway 1661-2

Tremlett Grove, Highgate, London, N.19

RADIO SUPPLIES

Send your list of Radio needs for our quotation—Kits, Parts, Sets, etc. Everything in Radio stocked; prompt delivery. 7 days’ approval. Catalogue from Taylor and standard Wet H.T. replacements stocked.

M. TAYLOR, 57, Studley Rd., Stockwell, London.

The Magazine for the MANLY BOY!

CHUMS has been famous for many years and is now more popular than ever. Every month it is crowded with splendid yarns of School, Sport, and Adventures. There are also articles on interesting hobbies, copious illustrations, and eight pages in photogravure.

CHUMS

Monthly
At all Newsagents

1/-

MEASURING STUDIO ECHO

—continued from page 297

which the volume of the echo as it diminishes can easily be checked.

I asked how the whole gear works in practice and was told that after spending an hour or so in setting up the amplifiers and the oscillograph, the engineers usually took half a dozen measurements in each studio, with the speaker and microphone facing in various positions each time. From several studios tested back at Savoy Hill, they know how each kind of material used in studio decoration absorbs the sound.

Free from Harmonics

They know, too, that certain proportions of height, length, and breadth must be maintained. I was told that the experts of the National Broadcasting Corporation (America) advise ratios of 2 for the height, 3 for the width and 5 for the length. The B.B.C. does not adhere rigidly to this, and from the Broadcasting House studios it is fairly obvious that a greater ratio has been followed for the height.

The echo-measuring gear is normally kept at the Clapham Testing Depot, along with the pure-tone whistle which is used in checking up the bigger studios, such as the Broadcasting House Concert Hall and Studio No. 1 at Edinburgh. I am not quite clear how the engineers get over the trouble of standing waves with their whistler.

It is a special kind of organ pipe designed by one of the best known organ builders in the country, and is claimed to be as nearly as possible

free from harmonics. It is automatically blown so that no unlucky engineer gets winded while they are testing the echo!

The pure-tone whistle was used in the early stages of Broadcasting House when they were trying to discover whether or not the big gallery at the Portland Place end would cause an écho.

"Dead Spot" Troubles

It was the pure-tone whistle which convinced them that they might be troubled with a "dead spot," and that is why, when you go as a visitor to the concert hall, you will find a large U-shaped portion cut out from the front of the gallery—sufficient for seating room for some thirty people.

The programme staff did not like this reducing of audience accommodation, but the echo-testers, sticking firmly to their pure-tone whistle, pointed out the necessity!

THE Q.P.P.'S PROGRAMMES

—continued from page 307

We should state here that if you are going to match these valves you should get one of the special close-tapped quiescent type H.T. batteries.

Now place pentode No. 2 in the holder and withdraw No. 1. Place the new flex lead tap into a voltage similar to that used for No. 1. Switch on and read the meter. If it reads the same as with No. 1 you are O.K. If not, adjust the screen voltage of No. 2 (not the bias, for this must not be touched) until the milliammeter reads the same as it did for No. 1.

Four-pin Pentodes

When that has been achieved the valves have been "matched," and with the milliammeter removed from the circuit and the other valves put back, you are ready to operate the set.

It is possible that you may use pentodes that have only four pins, having the screen-grid connection on the side of the base.

In this case you can neglect terminal "C" on the valve holders, and take your screen-grid voltage tap direct from the side terminal of the valve in each case.

Don't Forget

The on-off switch is ganged with the volume control on the panel of the set, and so it must not be forgotten that on gramophone as well as radio this control must be operated, in so far as the switch must be manipulated, by a slight turn of the volume-control knob in one direction or the other.

NEXT MONTH

Another splendid number for constructors includes the

"DIO-Q"

A further addition to the famous "Diodion" series, incorporating the diode detector and Q.P.P.

On sale 29th April Price One Shilling

INDEX TO ADVERTISERS

	PAGE
Belling & Lee, Ltd.	382
Br lgin, A. F. & Co., Ltd.	383
British Insulated Cables, Ltd.	367
Burne-Jones & Co., Ltd.	371
British Blue Spot Co., Ltd.	375
"Chums"	383
Clarke, H. & Co. (M/cr.), Ltd.	371
Colvern, Ltd.	367
Carrington Mfg. Co., Ltd.	375

	PAGE
Edison-Swan Electric Co., Ltd.	Cover iv
"Family Doctor"	Cover iii
Graham Farish, Ltd.	294
Heyberd, F. C. & Co., Ltd.	375
Jackson Bros. (London, Ltd.)	Cover ii
London Electric Wire Co. & Smiths, Ltd.	Cover ii
"Modern Boy"	371
"My-Own Lawyer"	377
Pickett's Cabinets	382
Peto-Scott Co., Ltd.	381

	PAGE
Preh Manufacturing Co., Ltd.	375
Pifco, Ltd.	Cover ii
Sound Sales, Ltd.	383
Telegraph Condenser Co., Ltd.	293
Taylor, M.	382 & 383
Varley Products	382
Wright & Wearite, Ltd.	371

All communications concerning advertising in "Modern Wireless" must be made to John H. Lile, Ltd., 4, Ludgate Circus, London, E.C.4. Telephone: City 7261.