

PREPARING FOR THE NEW 2LO

MODERN WIRELESS

1¹/₄
MONTHLY

Vol. XII. No. 33.

*The Leading
Radio Magazine.*

SEPTEMBER, 1929.

THE "BROOKMAN'S" THREE



FULL DETAILS
INSIDE

As British

as Britannia!



Price

25/-

with Cords

Chassis (with 12" Cone) - - 15/-

Overloading impossible

* * *

Cannot chatter or distort

* * *

Instantly fixed to Brown Chassis—a complete loud speaker in 2 mins.

* * *

Widest frequency range of any Unit

* * *

Utilises entirely new principles

* * *

Ask your Dealer to demonstrate



The Sensational

NEW

Brown

"VEE" UNIT

"Re-creates the Living Artistes"

CONTENTS

VOL. XII. No. 33. MODERN WIRELESS. SEPTEMBER, 1929.

	Page		Page
Editorial	203	Power or Pentode?	237
The "Brookman's" Three	204	Wales and the B.B.C.	239
On the Short Waves	210	The "Reactohm" Two	240
Using S.G. Valves	211	Broken Waves	245
Interference Via Mains	213	An L.T. D.C. Unit	248
One-Way Electron Traffic	214	Concerts of Europe	251
Your L.T. Battery	217	"Safety First" Aerials	253
Measuring Millamps	219	The Mystery of Radio Waves	254
Radio and World Peace	220	Radio Abroad	257
Why Volume Varies	223	G.H. Mains Units	258
This Year's Exhibition at Olympia	225	Is It Resistance?	262
The "Change-Range" One	226	Short-Wave Aerials	264
My Broadcasting Diary	231	H.T. Battery Resistance	269
Crowded Current Carriers	233	In Our Test Boom	272
Wireless at Sea	234	Radio Notes and News of the Month	287
Questions Answered	236	In Passing	290

SPECIAL SUPPLEMENT, "RADIO AND THE GRAMOPHONE," PAGES 275-286

As some of the arrangements and specialities described in this Journal may be the subject of Letters Patent the amateur and trader would be well advised to obtain permission of the patentee to use the patents before doing so.

Edited by NORMAN EDWARDS.

Technical Editor: G. V. DOWDING, Grad.I.E.E.

Scientific Adviser: J. H. T. ROBERTS, D.Sc., F.Inst.P.

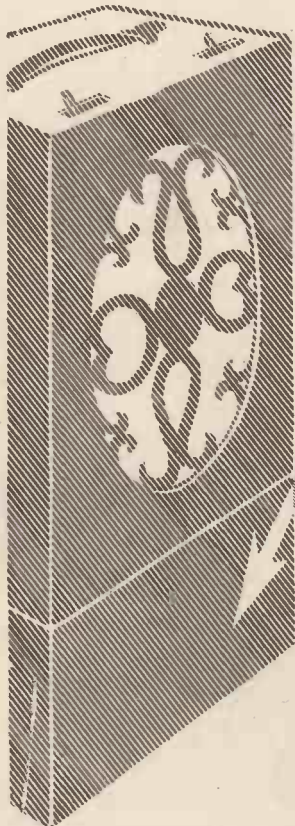

To get the best out of your
Portable Set-put the best into it!

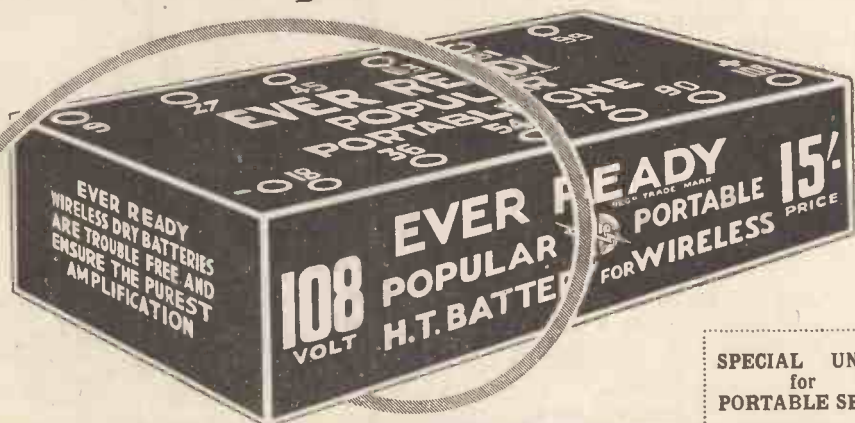

EVER READY
BRITAIN'S BEST BATTERIES

SPECIAL UNITS
for
PORTABLE SETS.

PORTABLE 1.
63 volts . . . 8/6
Size 6" x 5" x 3"

PORTABLE 2.
99 volts . . . 13/6
Size 9" x 5" x 3"

PORTABLE 3.
108 volts . . . 15/-
Size 10" x 5" x 3"

ADVERT. OF THE EVER READY CO. (G.B.), LTD., HERCULES PLACE, HOLLOWAY, N.7.

**RIGID
AS A BRIDGE!**

**FIRM
AS A ROCK!**

**INTERLOCKED
CONSTRUCTION
MAKES COSSOR
THE STRONGEST
AND MOST
DEPENDABLE SCREENED
GRID VALVE EVER
PRODUCED**

This wonderful new Cossor development—Interlocked Construction—eliminates all the inherent weaknesses of valve design. In the Cossor Screened Grid Valve the elements are rigidly locked in position. All through their abnormally long life they retain their perfect alignment. Even the hardest blow cannot upset the performance of this wonderful valve. Use Cossor in your Screened Grid Receiver—no other Screened Grid Valve has such strength or dependability.



Get full details of this wonderful Cossor Valve—write for leaflet L.10.

Made in three voltages for use with 2, 4 or 6 volt accumulators.

Technical Data.

Cossor 220 S.G. (2 volts, .2 amp.)
410 S.G. (4 volts, .1 amp.)
and 610 S.G. (6 volts, .1 amp.)
Max Anode Volts 150, Impedance
200,000, Amplification Factor 200
Grid Bias 1.5 volts at max anode
volts. Price (any type) **22/6**

COSSOR
Screened Grid
Valve



MODERN WIRELESS



Vol. XII. No. 33.

September, 1929.

Four Special Sets—An Important Broadcasting Step—The Marconi Royalties.

This Month's "M.W." Receivers

THESE are four special sets in this issue of MODERN WIRELESS, all of which deserve the close attention of amateur constructors. The first of these sets, the "Brookman's Three," is a product of the MODERN WIRELESS Research Department. The use of a screened-grid valve gives this set great sensitivity, while the special circuit developed by the Research Department brings the selectivity of the receiver up to a remarkable degree of efficiency.

Readers should note, however, that this is without sacrificing the general quality of the set or in any way compromising the general design. On test we found it to be very efficient and a really excellent long-distance loud-speaker receiver.

The "Reactohm" Two has been designed and described by A. S. Clark, of the MODERN WIRELESS Technical Department. This set employs a special reaction control which makes it very effective and easy to handle. With this receiver DX enthusiasts will find little difficulty in bringing in distant stations.

The "Change-Range" One has been designed and described by G. T. Kelsey, also of the MODERN WIRELESS Technical staff. This is a wave-change receiver using only ordinary plug-in coils. It is as easy to build as it is easy to handle, and may be recommended as a good long-distance telephone receiving unit.

The "L.T. D.C." Unit has been designed and described by G. V. Dowding, Grad.I.E.E., and, as will be seen from the photographs, is a very attractive-looking piece of apparatus. It offers an excellent solution to the L.T. problem for those who have D.C. mains, and, furthermore, it can be connected to any set without the set being altered in any way.

A glance at the components required will show that the unit is attractively inexpensive and, for the benefit of those readers who still have doubts about using electric light mains, it may be guaranteed as safe and simple to install and operate.

An Important Broadcasting Step

IT is interesting to note that an agreement has been made between the German Broadcasting Company and the organisers of the famous Bayreuth Festival. Every reader who is interested in Wagner's music will know that the Bayreuth Festival is the great yearly Wagnerian season, where the finest performances in the world of Wagner's operas are given.

The theatre at Bayreuth is of almost unique design; the orchestra, for instance, not being in front of the stage, as is usual in the ordinary theatre, but hidden away behind and underneath the stage.

The fact that the German Broadcasting Company has come to an "arrangement" means that the Broadcasting Company has undertaken the financial guarantee for the 1930 Festival and obtains the right to broadcast the performances.

For listeners with sets capable of picking up German broadcasting stations, this arrangement foreshadows many future opera treats. The 1930 programme for the Bayreuth Festival includes two cycles of *Der Ring*, five performances each of *Tannhäuser* and *Parsifal*, and three of *Tristan and Isolde*.

This arrangement is a pleasant sequel to the recent arrangements made in Italy for the broadcasting of operas from the famous Milan Scala Opera House.

Incidentally, as we have had many requests from listeners asking us to recommend Russian stations worth picking up, it might be mentioned here that Leningrad, on 351 metres; Kharkov, on 427; Moscow, on 825; Leningrad, again, on 1,000; Kharkov, on 1,304; and Moscow, on 1,481 metres, are all worth listening to these days.

The Marconi Royalties

THE Radio Manufacturers' Association and Marconi's Wireless Telegraph Co., Ltd., have come to terms with regard to the payment of royalties owned by the Marconi Company. The arrangement is that for five years the members of the R.M.A. will pay royalties on all sets, whether under patent or not, to the Marconi Company. Also, the R.M.A. gives the use of all patents to the Marconi Company and the Gramophone Company, and in return they get the use of all patents, present and future, controlled by the Marconi Company or H.M.V. Gramophone Co., including all the patents of the Radio Corporation of America and the General Electric Company of America, and their German and French associated companies, plus the use of the Eliminator Patent thrown in.

But the main point of this agreement is that the royalty is reduced to 5s. per valve holder.

The fact that the Marconi Co. and the leading representatives of the trade have got together and have reached this tentative agreement is all to the good, and is bound to make things happier and more settled in the radio industry.



The

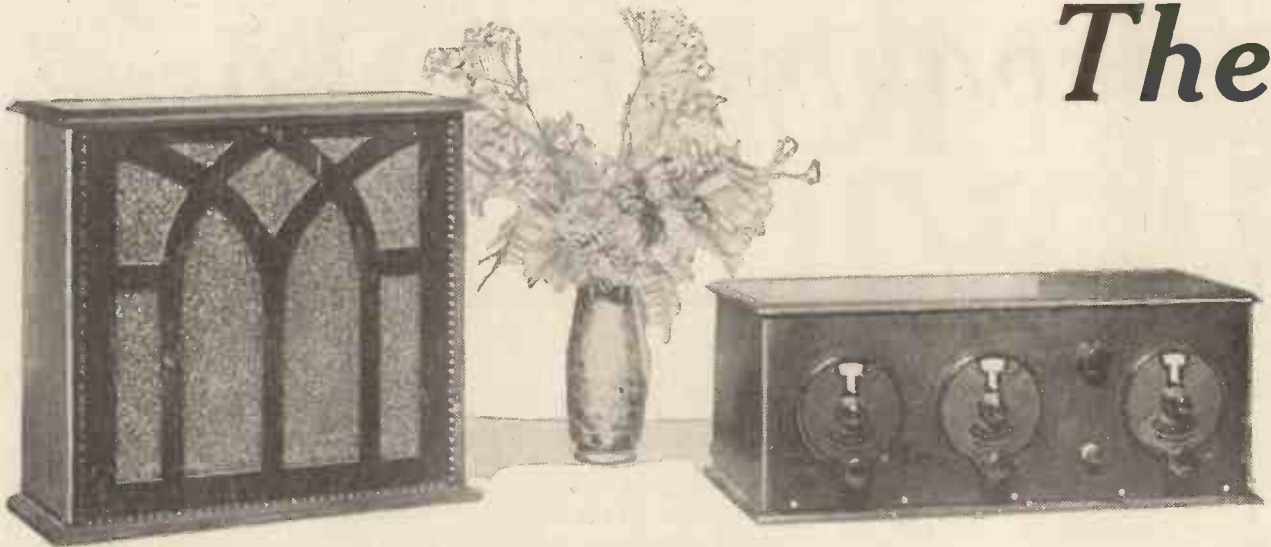

COMPONENTS REQUIRED

- 1 Panel, 18 in. × 7 in. (Beol, Resiston, Ripault, Trelleborg, Ebonart, "Kay-Ray," etc.).
- 1 Cabinet, with baseboard 10 in. deep (Raymond, Cameco, Lock, Gilbert, Pickett, Bond, Caxton, Artercraft, etc.).
- 3 ·0005-mfd. variable condensers (Lotus, J.B., Lissen, Gecophone, Pye, Burton, Raymond, Utility, Bowyer-Lowe, Formo, Cyldon, Ormond, or other good make of moderate dimensions).
- 3 Slow-motion dials, if condensers not of slow-motion type (Igranic, Formo, J.B., Utility, Brownie, Lissen, Lotus, Ormond, etc.).
- 1 ·0001-mfd. or ·00015-mfd. reaction condenser (Bowyer-Lowe, J.B., Lotus, Lissen, Formo, Ormond, Magnum, Burton, Dubilier, Raymond, Cyldon, Polar, Utility, etc.).
- 1 On-off switch (Lotus, Lissen, Benjamin, Wearite, Bulgin, Magnum, Raymond, Burton, Igranic, etc.).
- 3 Single-coil sockets (Wearite, Magnum, Lotus, Raymond, Igranic, etc.).
- 2 1-mfd. condensers (T.C.C., Lissen, Dubilier, Ferranti, Hydra, etc.).
- 1 ·01-mfd. fixed condenser (T.C.C., Dubilier, Goltone, Lissen, Clarke, Igranic, Magnum, etc.).
- 1 ·001-mfd. fixed condenser (Lissen, etc.).
- 1 ·0003-mfd. fixed condenser (Dubilier, etc.).
- 1 Neutralising Condenser (Magnum, Peto Scott, Bulgin, etc.).
- 1 H.F. choke (Varley, Dubilier, Lissen, Cosmos, Igranic, Raymond, Climax, Bowyer-Lowe, Magnum, Wearite, Precision, Ormond, Colvern, R.I., Leweos, etc.).
- 1 2-meg. grid leak and holder (Lissen, Dubilier, Ediswan, Igranic, Cosmos, Pye, Loewe, etc.).
- 1 100,000-ohm resistance and holder (Cosmos, R.I., Lissen, Igranic, Ediswan, Dubilier, Ferranti, Varley, Precision, etc.).
- 1 Low-ratio L.F. transformer ("Hypermu," Lissen, Brown, Ferranti, Varley, Cossor, Marconiphone, Igranic, Philips, etc.).
- 1 ·0001-mfd. or ·0003-mfd. compression-type adjustable condenser (Formo or similar type).
- 1 Special screening box (Magnum, Paroussi, Ready Radio, Wearite, etc.).
- 3 Sprung valve holders (Precision, Lotus, Benjamin, W.B., Redfern, B.T.H., Igranic, Wearite, Formo, Burton, Marconiphone, Magnum, etc.).
- 1 Terminal strip, 16 in. × 2 in.
- 10 Terminals (Eelex, Burton, Belling and Lee, Igranic, Clix, etc.).
- Flex wire, G.B. plugs (Clix, Lisenin, Eelex, Burton, etc.).
- Screws, etc.

performance, giving almost anywhere the fullest loud speaking on the local station, 5 X X and 5 G B, and quite a number of foreigners at adequate strength on the speaker likewise. On anything like a decent aerial it will bring in a string of stations on the speaker which a year or so ago would have done credit to a good four-valver.

Pentode Can Be Used

True, the fact that it has only one low-frequency stage means that one must be careful to use a really good low-frequency transformer, and even then quite a few stations will only be heard at quite moderate loud-speaker strength unless an exceptionally good aerial is available. If one is ambitious, however, and wants to get everything which is worth hearing at really full volume, one can always use a pentode in the low-frequency stage. When that is done you have something rather more than half a valve extra, but not quite a whole L.F. valve. This, together with the higher mag. of a good S.G. stage, means that pretty nearly everything worth hearing will come in on the speaker.

WHAT is the ideal general-purpose set? "Beauty is in the eye of the beholder," and what one person would regard as the perfect all-round set another would consider far too small, but there is one type which very many people have discovered during the past six months or so to possess some special claims to the title. That type is the three-valver consisting of a screened-grid H.F. valve, detector and one low-frequency stage.

Such a set of good design and construction will put up a really excellent

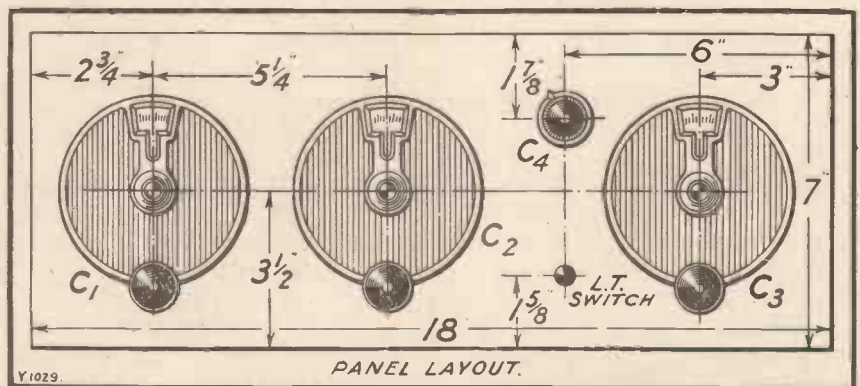

Y1029.

PANEL LAYOUT.

“Brookman’s” Three

One of the best general-purpose three-valvers — the “S.G.-Det.-L.F.” combination — usually gives selectivity below the level of its high amplification. This fine, new design maintains a high standard of amplification from the S.G. valve, yet gives at the same time really remarkable selectivity by virtue of a special circuit based on the “Kuttemout” Three, and developed

By the “M.W.” Research Department.

Even using an ordinary power valve such a set has a very fine performance as a distance-getting outfit, and it is usually open to criticism on one score only — selectivity. As a rule, this is scarcely proportionate to the

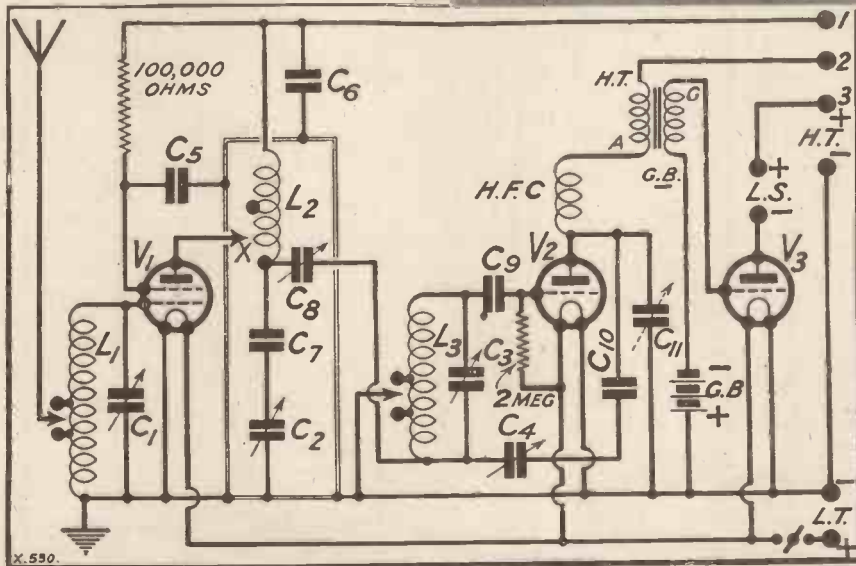
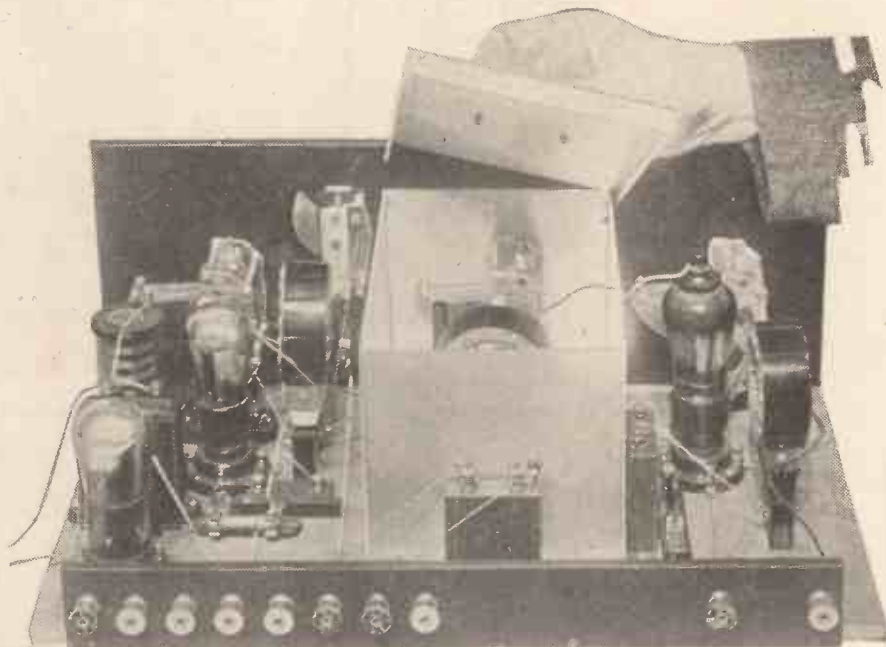

The special screening box has a detachable lid for coil changing.

the other hand, is no easy matter by this method, unless one is prepared to face a very considerable drop of signal strength, or to use very special and rather expensive coils. Working within the usual

very high magnification given, and this factor has been one of the difficulties in the way of the satisfactory use of a single stage of screened-grid H.F. amplification. The difficulty really is that the usual method of improving selectivity has been to weaken the H.F. intervalve coupling, that is to say, the coupling on the output side of the screened-grid valve, and this cannot be carried very far before amplification begins to fall off somewhat seriously. One can take it to a useful point, of course, and such sets can be extremely useful for general purposes.

To get really high selectivity, on



The “aerial end” of the set is extremely simple. Note the use of entirely standard coils.

"M.W." limits of "standard components as far as possible," the problem is not a very easy one, but it is one which we have had to face seriously within the past few months in order that sets could be produced fully capable of coping with the situations which may arise when the regional scheme really gets going.

Exceptionally High Selectivity

We have already tackled the problem in so far as it concerns the detector and low-frequency type of receiver, and regular readers will no doubt remember the "Kuttemout" Three, in which a special system of two tuned circuits very loosely coupled capacitatively was used to

give the necessary degree of selectivity. We turned next to the problem of the three-valve combination, consisting of a screened-grid stage, detector and one low-frequency; this being, as we have just seen, one of the best of general-purpose receivers and hence one calling for immediate attention in the interests of those readers who will be affected by the coming of the regional scheme. The objective at which we have aimed is this: a set of exceptionally high selectivity, fully equal to the demands of the most adverse regional conditions, yet maintaining a really effective degree of high-frequency amplification,

The degree of selectivity obtainable merely by loosening the coupling between the anode circuit of the screened-

grid valve and the grid circuit of the succeeding detector was not found adequate unless one was prepared to face a serious drop in signal strength. Remembering that it is always our effort to avoid the creation of new and special types of coils, it will be realised that we quickly came to the conclusion that a radical modification of the circuit would be needed to obtain the desired results.

A Question of Position

We soon decided that it would be necessary to incorporate an extra tuned circuit in addition to the two normally present in an ordinary screened-grid receiver, and a good deal of work has been done on the best methods of introducing this

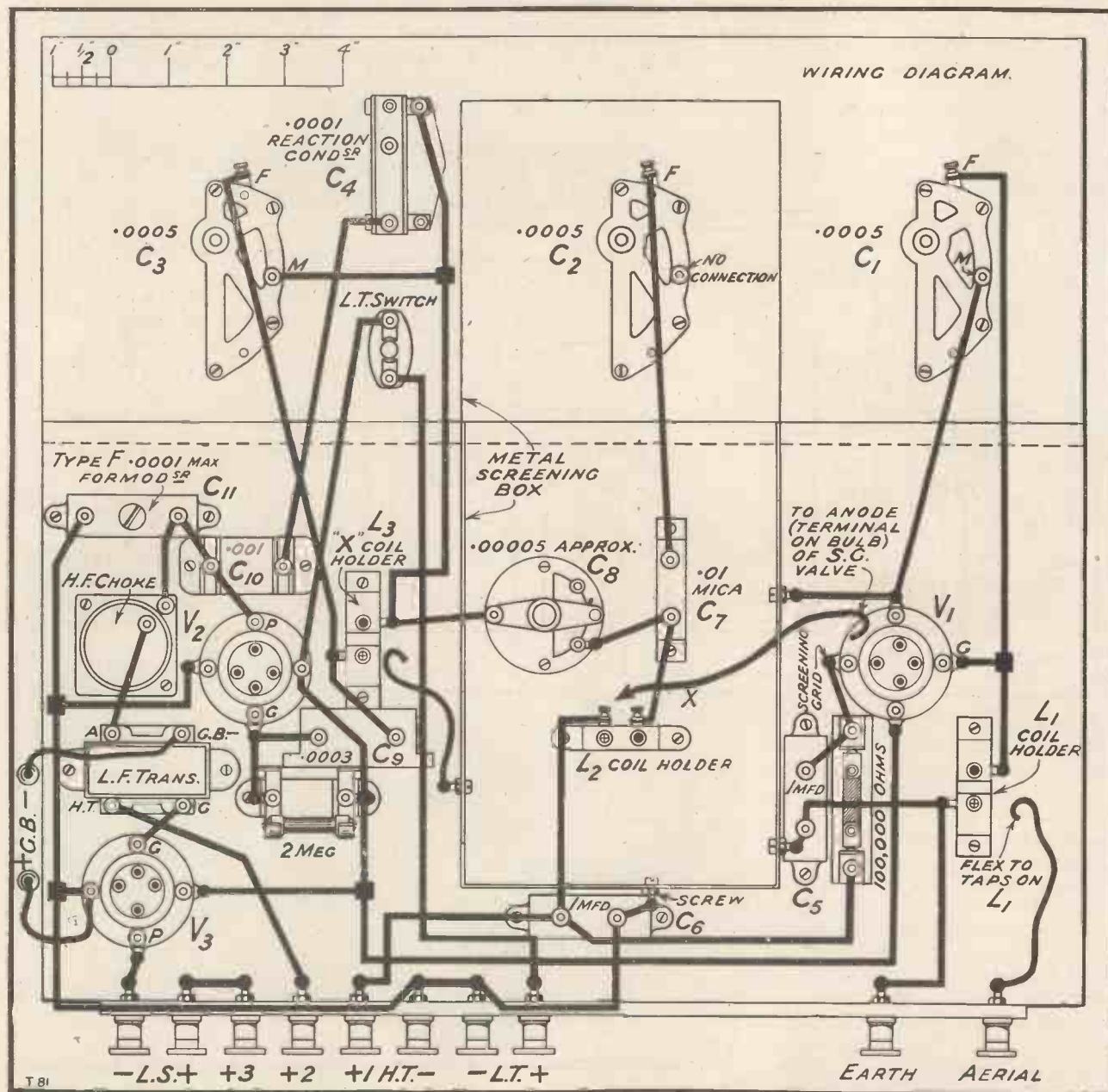

An Ideal Set for "Difficult" Localities

extra circuit. The preliminary investigations quickly showed that it was not desirable to follow exactly the "Kuttemout" Three method of introducing the extra circuit in front of the first valve; very considerably better results being obtained by placing it after the screened-grid valve, and between that stage and the detector.

The Better Method

Eventually we produced a scheme which you see incorporated in the "Brookman's" Three, in which we

obtainable in this way, in spite of the necessarily rather weak coupling between the anode and the succeeding grid circuit, than by the ordinary method of weakened coupling between the primary and secondary of an H.F. transformer.

Easy Tuning

The results given on test by various forms of this circuit have been exceedingly good, the degree of selectivity obtainable being most exceptional. For example, at a distance of only one mile from 2 L O,

learn to work the three dials more or less in synchronism, the procedure being to get them in step on a single station and then to work upwards or downwards from that point, keeping them in step as one goes. This is not so difficult as it sounds, because there is the usual indication of resonance in the form of a slight sound of crackling and general liveliness when all three dials are in step, and, moreover, the first and third dials tune very similarly, while the middle one is less critical.

We issue this little warning about

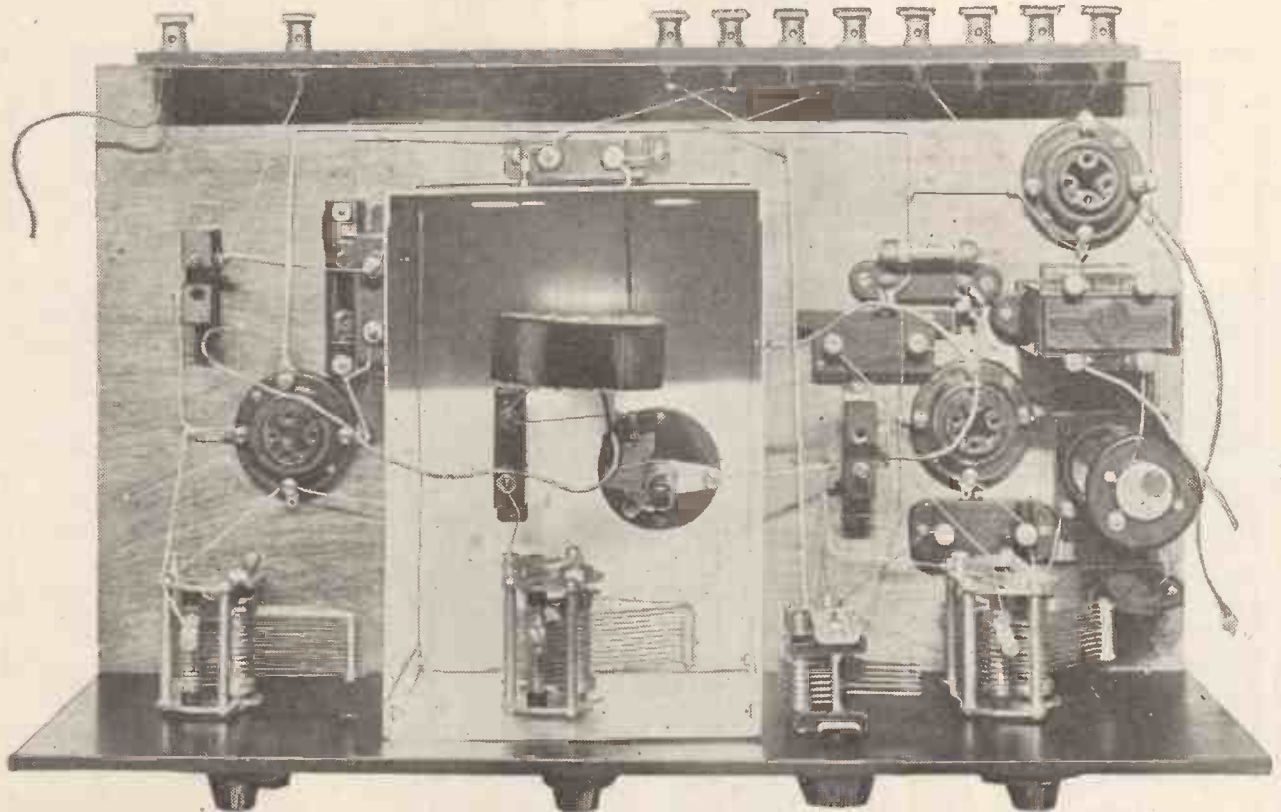

No wooden dummy baseboard is used inside the screening box. It contains so few parts that it is easy to drill holes in the metal and put screws right through into the main baseboard. There is plenty of room in this box, but when coil-changing it is advisable to disconnect the H.T. - plug from the battery to prevent the possibility of a slight shock.

have quite an ordinary scheme of an auto-coupled aerial and tuned-grid circuit for the screened-grid valve, then, following this, a tuned-anode circuit coupled by means of a very small capacity condenser to a third tuned circuit which forms the grid circuit of the detector valve.

The fact that the screened-grid valve is provided with a tuned-anode circuit instead of the customary H.F. transformer means that a very full degree of amplification is obtainable, and it has been found that very considerably better magnification is

and on a full-sized outside aerial, that station disappeared completely from about 380 metres upwards. Nevertheless, the amplification given is extremely good, and distant stations come in at excellent volume once one has got the knack of handling the three dials.

This latter point should perhaps be emphasised a trifle, because prospective constructors should realise that any three-circuit set requires just a little practice before one gets the best from it. It is not really a difficult matter, but it takes a little time to

the need for realising that all three dials must be in step lest you have the same upsetting experience that we did when this set was first finished: we attempted to tune in the local station, and could not find it! It took some moments to find the correct "in step" setting for the dials, but, of course, once it was found searching became a comparatively simple process.

Ordinary Plug-In Coils Used

The reader will by now have a general idea of the arrangement of the circuit, and we can proceed to go into

the circuit diagram of the receiver, and see how it is all worked out in practice. First of all, note that quite ordinary plug-in coils are used throughout, and by making efficient use of the various types available, only one coil is needed in each circuit, making three in all. Coil changing, when going over from long to short waves, and vice versa, is thereby considerably simplified (you will realise, of course, that wave-change switching in a circuit which is so relatively complicated as this one is scarcely a practical proposition).

The Tapping Points

Standard "X" coils are used for the first and third circuits, and in the first the "X" tapping is used for aerial coupling purposes in just the normal manner. In the third circuit the "X" portion of the winding is used for coupling between the H.F. anode circuit and the detector grid circuit, and also to provide a small reaction winding. Actually, you will see that it is a form of Hartley circuit, in

which the tuning condenser is connected across the whole coil, and a filament lead taken to one or other of the tapping points on the coil. (Always try both these taps and see which is the best one for your particular conditions.)

A Safety Scheme

In the anode circuit of the screened-grid H.F. valve we have another standard plug-in coil, and there is here a choice of two types of coil and two systems of connection. The simplest thing to do is to use a perfectly plain tuned-anode and an ordinary standard coil, and this usually gives the maximum degree of amplification. The anode coil, you will observe, is tuned by a variable condenser connected between one end of the anode circuit and the filament circuit, that is to say, actually to the metal of the screening box. In order to avoid a short-circuit of the H.T. battery in the event of the fixed and moving plates coming into contact by accident, a fixed condenser of large

size is placed in series between the variable condenser and the actual anode circuit, as a safety precaution. This does not, of course, affect the tuning of the circuit in any appreciable way.

This scheme is suitable in many cases, but you may find that if you are using particularly low-resistance tuning coils there is a tendency to oscillation, since it is well known that if the coil resistances are below a certain point and the general damping is very low, even a screened-grid valve will tend to oscillate, and it is as well to be prepared for this fact.

Using Centre-Tap Coil

We have found that an excellent procedure in such cases is to take the lead from the anode of the valve to a centre-tapping on this coil, a standard centre-tapped variety being then required. This gives slightly greater selectivity than was given before. To obtain this arrangement the flex lead from the anode of the valve (marked X in the wiring diagram) is taken to the centre-tap terminal on the coil, all other connections remaining exactly as before. It is advised that this scheme be tried out first of all.

To obtain the first scheme, namely, a plain tuned-anode, the lead X should be joined to that terminal of the anode coil holder which is remote from the H.T. positive lead, this connection being quite clear on an inspection of the wiring diagram. Which ever method is used the coil size remains the same, namely, a No. 60 for the ordinary broadcast wave-band, the same size being also required for the other two sockets of the set; X coils being needed in these positions. Since the same size of coil is needed in each circuit they tune very similarly, and if you care to shift your condenser dials round before locking them up so that they all read exactly the same on any one station you will find that they keep in step fairly well over the greater part of the tuning range. For the long waves you will require coils of size 250 in each of the three circuits.

Improving Reaction Results

Just one other point about the general details of the circuit. We have provided at the detector stage our usual sensitivity-improving device which we introduced recently for use in all capacity-controlled reaction circuits, namely, a small adjustable bypass condenser from plate to filament of the detector valve. This is just the usual compression type of adjustable condenser with a maximum

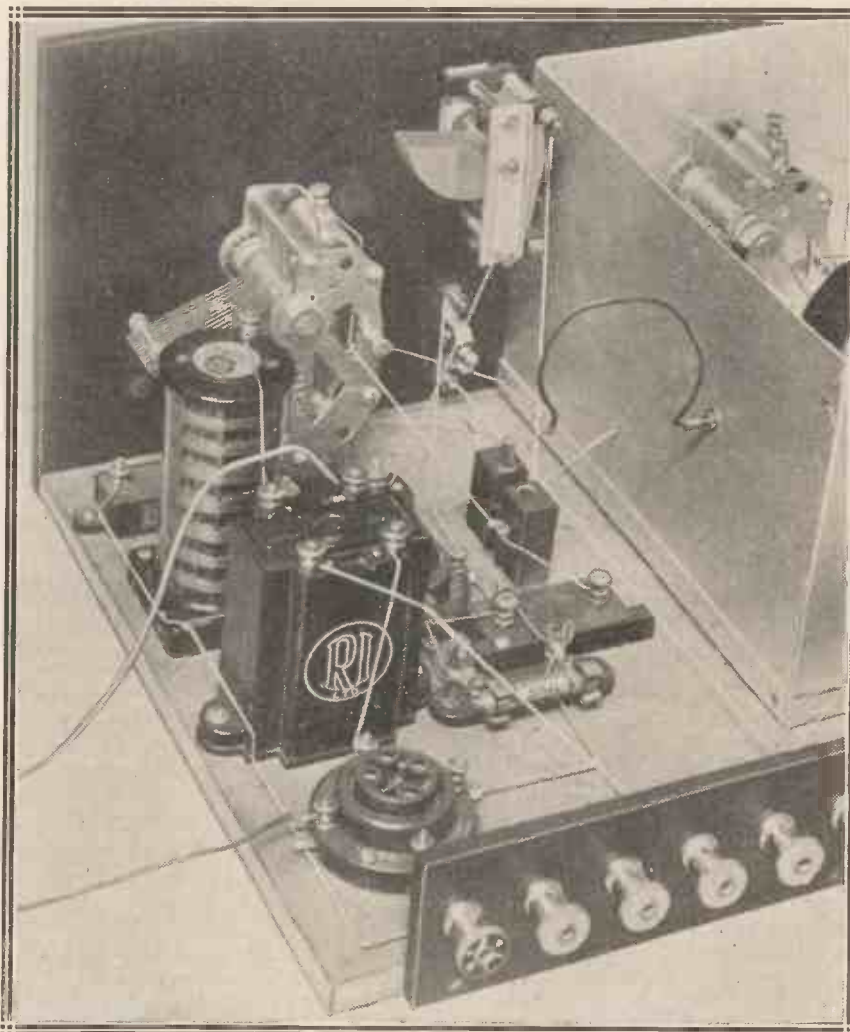

The detector and L.F. circuits. Note the flex lead for the tapping points on the coil.

Real Selectivity with the Screened-Grid Valve!

capacity of either .0001 or .0003 mfd. (either will serve), and it is adjusted so that starting at minimum the capacity is brought up to that value which only just permits you to get reaction over the whole tuning scale when the reaction condenser is nearly at its maximum.

rotary-vane types of neutralising condensers being quite suitable. This is normally kept set to maximum.

While you are laying out the parts, mark out a suitable position for the adjustable bypass condenser at the detector stage. The position shown only clears the moving vanes of the

are quite straightforward, being the standard recommendations for the detector, screened-grid, and L.F. stage. The screened-grid valve to give anything like its best must, of course, be provided with the full 120 volts permissible, and this should be applied to the terminal H.T. +1, which feeds the screened-grid valve.

The valves should be as follow: The first socket needs a screened-grid valve of the newer upright type with the anode terminal on top, two-, four-, and six-volters being all suitable for this receiver. The detector should be of the H.F. type with an impedance of about 20,000 ohms; and the third valve, a power or super-power, according to the current-supplying capacity of your H.T. supply. The choice here will naturally depend to some extent upon whether your main interest is in long-distance reception or in high-quality results from the stronger stations.

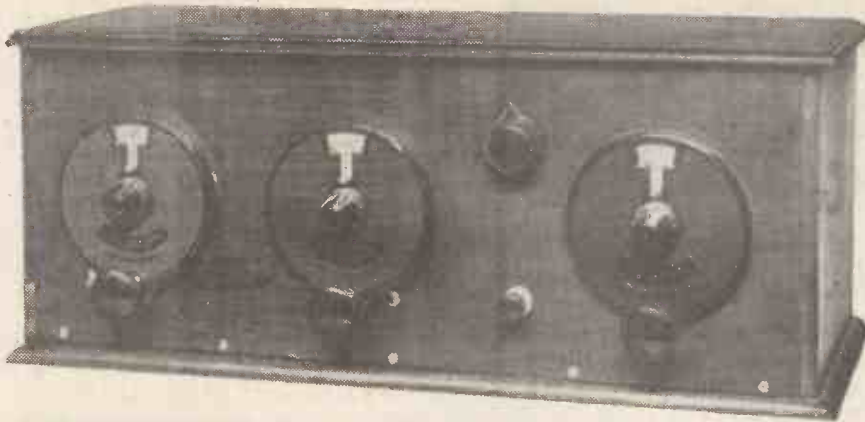

The two left-hand dials control the tuning of the grid and anode circuits of the S.G. valve, while the right-hand one tunes the grid circuit of the detector valve.

The rest of the set is quite straightforward and calls for no particular explanation, although it should just be mentioned in passing that no separate H.T. tapping is provided for the screening electrode of the H.F. valve, this electrode being fed through a voltage-dropping resistance off the same positive terminal as the anode of the valve.

The Screening Box

Turning to constructional matters, there are several details which may, perhaps, be mentioned with advantage. The screening box is very similar to the ones employed in the "Summertime" Five, and is actually exactly the same except that the rear extension pieces are omitted. Since this box is of limited depth, and since, moreover, it contains only three components, it was not considered worth while to fit the usual dummy baseboard, the parts being actually screwed down direct to the baseboard of the set through suitable holes in the metal. (The metal is quite soft and thin, and you will not find it difficult.) While dealing with the contents of this box, we should just mention that the neutralising type condenser you will see therein is actually the coupling condenser between the anode circuit and the tuned-grid circuit which follows, and this should have a maximum capacity of about .00005 mfd., one of the

third variable condenser by rather a small margin, and with some types of variable condenser you may find it necessary to turn the third one round a bit so that the vanes do not foul the knob of the bypass condenser, or in some cases to move the bypass a little so that there is rather more space for the variable. Naturally, this will depend upon the particular components used, and a slight re-adjustment of the layout is very easily made if you find it necessary.

The operating voltages for the set

"6-Pin" Possibilities

Our general impressions of this new type of circuit are so favourable that we intend to develop it considerably, and the reader who has a certain number of components on hand and is considering a new set may be interested to learn that we propose in the next issue of MODERN WIRELESS to include a variation of this design in which 6-pin coils are used for the first and third circuits, the types being the split-primary aerial coil and split-primary H.F. transformer.

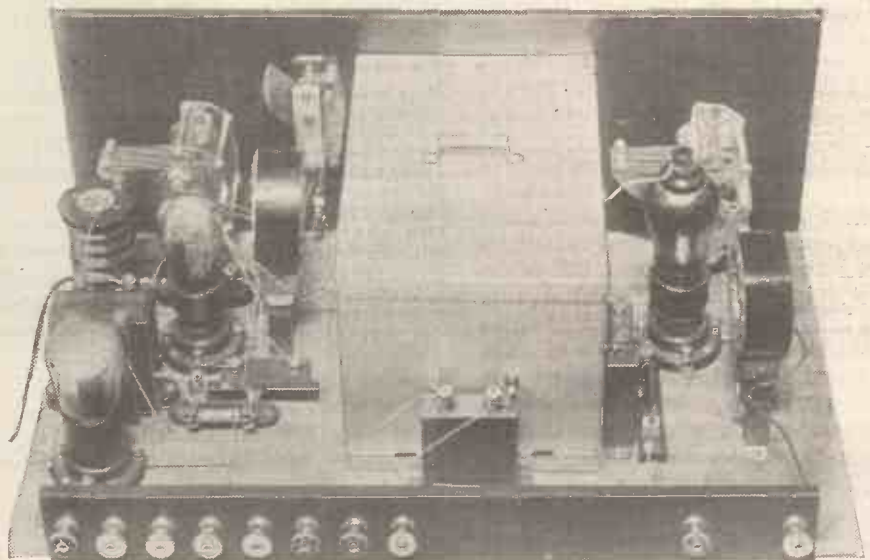

With valves and coils inserted ready for work. Both the coils visible here are of the standard "X" type.

ON THE SHORT WAVES

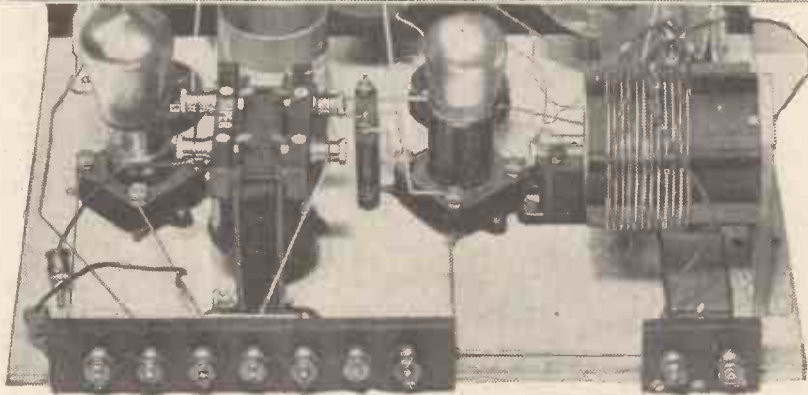

Notes of Interest on Short-Wave Receivers and Reception. By W.L.S.

I SEEM to have had recently a large crop of inquiries after suitable layouts, rather than circuits, for short-wave work. It is rather difficult to describe layouts in detail without the help of a diagram, and space this month does not permit that luxury.

I must say that the most sensible layout I have ever come across for an out-and-out short-waver is that used by a friend of mine, who has a "dummy" panel with the two dials and the L.T. switch on; behind this (about six inches away) is the proper panel with the two condensers linked up to the dials by extension rods.

No Hand-Capacity

The detector portion of the set is behind this panel, and the L.F. section is accommodated between the two panels. Thus there is no risk whatever of hand-capacity effects, the set is reasonably compact, and wooden panels may quite well be used if desired.

Since I myself never seem to have the same receiver going for two consecutive sets of notes, it is not of much use describing the present set; it is interesting, however, inasmuch as the circuit is an Ultraudion, which appears to behave very nicely right down to ultra-short wave-lengths of the "freakish" order, and it is a great advantage only to have to use one coil in place of two, where rapid changes in wave-length are desirable.

There is no denying the fact that we have now reached the dull period of the year for short-wave work, and I strongly advise those who are thinking of giving themselves the luxury of a

"rebuild" to do so now, and to take their time over it, so that they have a really good outfit going by the time conditions liven up again.

A General "Rebuild"

I have completely dismantled my transmitter and the usual receiver that works with it (as opposed to the set covering the whole of the short-wave range), and although the temptation to get them together again in a couple of days is sometimes very strong, I am doing the rebuilding thoroughly.

Of course, the trouble about re-



Famous radio engineers visit the American Bureau of Standards at Washington. Left to right are: Prof. Kennelly, of Harvard, Dr. Dellinger and Dr. Alexander Meissner, of the Berlin Telefunken Co. Dr. Dellinger is explaining the operation of the gear in the portable observation station.

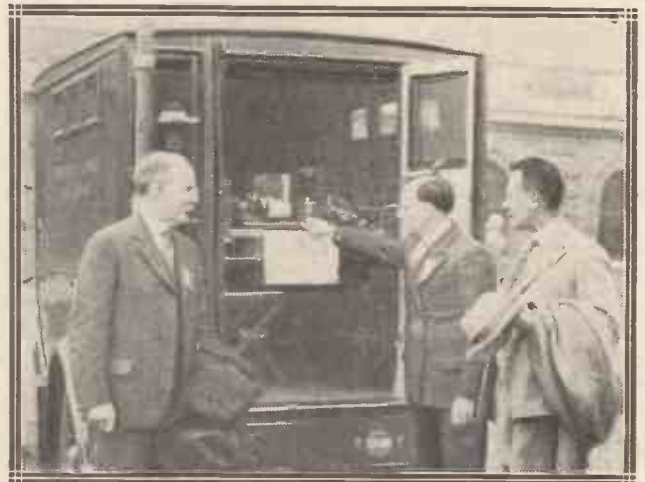

building at this dull period of the year is that when one *does* get going again it is very difficult to tell whether everything is going as efficiently as it might. You can hardly tell right away whether you have struck an extraordinarily bad night for the first test or whether the set is not all that it might be. Here again patience is

required, and if you resolve not to worry for the first three or four days you will soon find out what is happening.

Problem of 5 S W

5 S W is rather a problem nowadays. I receive quite a crop of letters now and then from India which refer to the B.B.C. in no uncertain terms, and obviously the writers regard 5 S W as a "Heath Robinson station."

On the other hand, if I say a word against him a whole host of people write from South Africa and fairly demolish me on the spot! In South Africa reception of 5 S W (in some parts at least) appears to be faultless, and the thrill that the homesick ones experience on hearing the London announcer (*and*, of course, Big Ben) is quite unequalled by anything that other short-wave stations can give them.

I don't profess to know a great deal about the aerial systems that they use at Chelmsford, but none of them appears to have given the Indian listeners a very high degree of satisfaction as yet. Surely the B.B.C. realise by now that they were wrong in their first ideas about the popularity of the steps they took with regard to Empire broadcasting.

Resistance Reaction Control

How many readers of these notes have tried resistance control of regeneration on their short-wave receivers? It is well worth trying,

at all events, and for those interested there is a very excellent article in the August "QST," by one of the technical editors, on the subject.

The relative merits and demerits of some ten different systems are summed up in a very concise and interesting manner and the article is well worth reading.



An Article for the Experimenter.

By C. P. ALLINSON, A.M.I.E.E., F.Inst.P.Inc.

I WONDER how many experimenters realise the extreme susceptibility of the screen-grid valve to added external capacity, and the resulting effect on the selectivity, amplification and stability of the receiver.

This was borne on me very forcibly recently when called in by a friend to see if I could diagnose the trouble in his receiver.

He had made up a four-valve set (H.F., Det., and 2 L.F.), using wave-change coils and a S.G. H.F. valve. This had worked very well, gave excellent H.F. amplification, and was quite stable.

Two Similar Sets

An acquaintance of his who had heard the set was so pleased with the performance that he asked him to make up a set for him, to go in an old Sheraton cabinet that he had. My friend accordingly built up a copy of the set to fit in this cabinet, and arranged the receiver so as to have a sloping, almost horizontal, control panel, and with this exception the two sets were identical.

I have drawn a rough sketch of each set, the original set being shown in Fig. 1 at A, and the duplicate in Fig. 1 at B, while Fig. 2 shows the skeleton theoretical diagram of the H.F. side of the receiver, omitting the wave-change switching arrangements, as these merely serve to complicate the circuit.

Very Different Results

I hooked up the set and proceeded to test it out on the aerial. Compared with the original set, the results were

four other stations all came in on top of Hilversum.

It was quite obvious that something was wrong in the set, for the other receiver was perfectly stable on the long waves. I carefully checked the connections, all were O.K. Components were examined and tested, valves tested and different ones tried out, different aerial lead arrangements tested, for it was possible that coupling between the aerial lead and the plate circuit of the S.G. valve might have been present in one set and not the other.

The Mystery Explained

All to no purpose, however, and I was about to give the set up as one of those mysteries that occur occasionally in wireless, when I chanced to take one more look at the two sets. I then noticed that in the case of the set built with the horizontal panel, the valve was so placed that the lead from the grid went up almost vertically to the tuning condenser, so that the lead was close and parallel to the valve itself. A thought struck me, was this lead close enough to introduce extra capacity coupling between

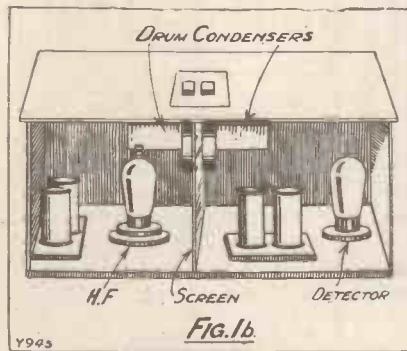

quite good, though not, in my opinion, quite up to the standard of the other set on the broadcast wave-band. When, however, I switched over on to the long wave, not only did I find the set unselective, but exceedingly unstable from about 1,300 metres downwards. Hilversum, for instance, could not be got without the set oscillating violently. Or if stability were obtained by detuning the two circuits, then about three or

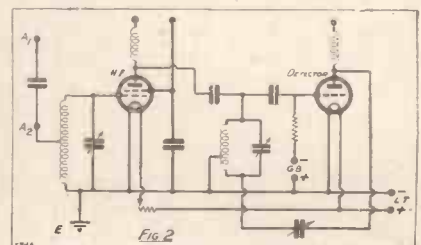
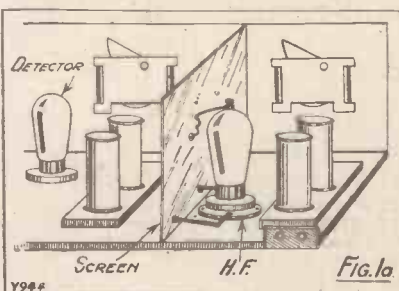

The Interesting Effects of Neutralisation

grid and anode? Also, the anode terminal was close to the fixed vanes of the tuning condenser.

The other set was connected up, a piece of wire connected in the same position in the set—and, lo and behold, this receiver then became unstable on the lower end of the long-wave coil!

Now, the slight variation in layout and the position of that one lead

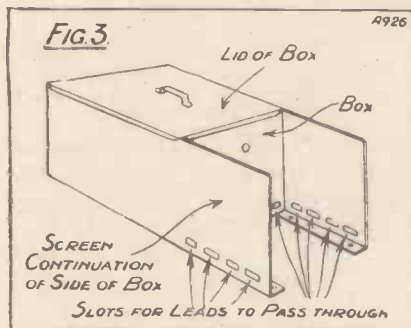

cannot have introduced more than an added fraction of a micro-microfarad, yet it was sufficient to produce instability on the long-wave coil.

This sensitivity of the S.G. valve to added capacity, and the ease with which such capacity can be added, has further been brought home to me during some experiments I have been carrying out with neutralised screen-grid H.F. amplifiers.

An Interesting Experiment

In the test set the H.F. valve is mounted fairly close to the coil, which is a vertical six-pin coil, with the grid connected to the end of the winding. The plate of the S.G. valve is, of course, also at the top, so that the proximity of these two parts of the circuit resulted in a certain additional capacity being present. I suspected this to be so, and a re-arrangement of the layout proved it.

In the original set I found that I had to use seven turns for the neutralising winding, a number greatly in excess of what I had expected. With the new layout, the number of turns

was reduced to three, but, even so, this was still more than I had reckoned would be correct on theoretical grounds. So I determined to take the matter a step further, and by entirely re-designing the screen in I thought I should be able to get to the root of the matter.

Special Screens Devised

I therefore had some special screens made up on the lines of the drawing in Fig. 3. It was my intention by using this type of screen to put all tuning coils, condensers, H.F. chokes, neutralising condensers, etc., inside the box. The valve filament resistances and screen shunting condenser would be placed in the bay at the back. By this means no extra capacity could possibly be added between plate and grid, for the wiring was so arranged that no leads in input and output circuits came near each other.

That my conclusions were correct was shown by the fact that I now had to reduce my neutralising winding to one turn, the correct number according to the theoretical aspect of the matter.

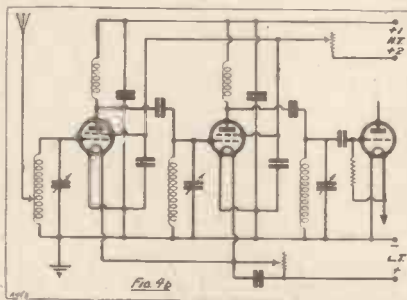

When working with two S.G. stages, the precautions to be taken become greater in number and greater care is required. It is possible to get coupling in filament circuits, in common H.T. leads, and in all kinds of odd ways that have to be considered.

A Fixed Plan

When working with an H.F. amplifier of this description I always work according to fixed plan, which has for its object the elimination of coupling of this description, and Fig. 4 shows in theoretical form what I do.

At A you will see what is an ordinary straightforward scheme of wiring. H.T. and L.T. busbars supply the two H.F. valves, a variable resistance is used to control the potential of the screens, while a

filament resistance for the two H.F. valves forms a convenient volume control. Were you to make a set like this, it is exceedingly probable that even with inefficient coils it would be quite unstable. Fig. 4B shows the wiring revised so as to give freedom

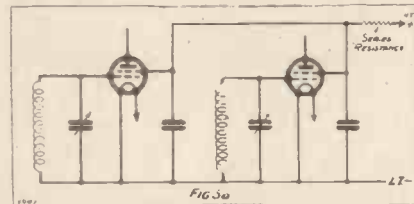

from coupling through common leads, without carrying the scheme to extremes.

First of all, separate leads from the filament resistance have been used, while this resistance is shunted with a large fixed condenser, between .1 and 1 mfd. will serve. The two screen leads have also been separated, as also the H.T. leads, the shunting condensers being connected as close as possible to the point where they are to be effective.

S.G. Voltage Control!

As regards L.T.—, I have assumed that screening boxes are being used, and that they are serving as a common L.T.— return and earth lead for all circuits. In any case, the resistance of the copper boxes is negligible, and I doubt if it would be possible for any coupling to be introduced when they are all well bonded and earthed.

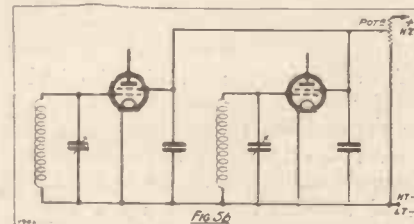

We now come to another point that I have noticed in my experiments with S.G. valves, and this concerns the control of the screening-grid potential. Although I have used the series variable resistance with a certain amount of success, I have not really been satisfied with it since a high value of resistance is often needed.

I therefore came to the conclusion that I would try the potentiometer method instead. The two arrangements are shown in Fig. 5 at A and B. The B method I found to be far superior, the control of the voltage was much more accurate and positive.

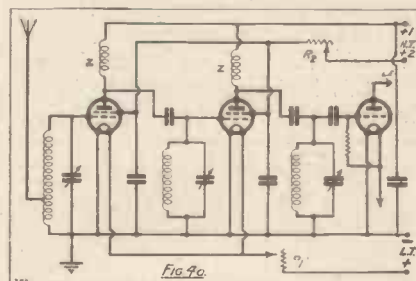

lising winding, a number greatly in excess of what I had expected. With the new layout, the number of turns



THEORETICALLY current supplied by A.C. power mains should be much purer than that from the D.C. variety. An A.C. generator has no commutator to generate subsidiary ripple. Also it is generally much easier to keep the slip rings that figure in A.C. generators free from sparking. Not that there should be sparking in the case of a D.C. generator if this is kept in good order, but, unhappily, it is only too frequently known to occur.

However, it is not likely that you are going to have a network of power distributing lines all over a city without these picking up parasitics. Thus we are apt to find H.F. on even A.C. mains. But having eliminated this by means of series H.F. chokes, there are still plenty of interference possibilities in the alternations of the supply itself.

Loud-speaker Limitations

At one time ordinary A.C. hum did not worry us, for our outfits could not deal with frequencies below about 100 cycles, but now we have stepped-down not only to the 50 of the average A.C. supply, but in cases lower. Obviously then, among other things, we must not have too much wire near the set carrying raw A.C., for this can be caught up by induction and slipped through to our very efficient loud speakers.

It is a modern practice to feed certain types of valves with unrectified A.C. The "indirectly heated" valve utilises this "juice" for operating a heater element not in any way connected metallically to the cathode, which is, in this case, the "filament" of the valve. In another type of mains valve this raw A.C. current is passed direct through a thick, short, low-resistance filament.

The average resistance of the filament of this type of valve is 1 ohm, and the potential difference across it is something less than 1 volt. And

Some practical information and useful tips for amateurs who use mains units.

By H. A. R. BAXTER.

operated properly these mains valves give wonderful results, but in order to eliminate any possibility of hum arriving with the music at the output end of the set, the grid returns of the valves should be taken to the electrical centre of the filament circuit.

Filament Circuit Balance

This centre can be more or less positioned by means of a centre-tapped transformer, but perfect balance cannot be achieved by this means for the reason that the connecting wires in different sets will vary in resistance.

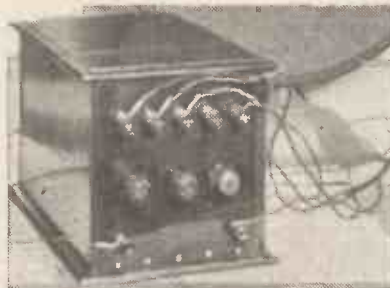

Untidy wiring where mains units are concerned may be dangerous and possibly cause "hum" in the loud speaker.

But a potentiometer can be brought into service in order to achieve perfection. The two ends of the winding of the potentiometer should be connected across the filament input, and the grid return or returns taken to the contact terminal. The potentiometer is then adjusted until the hum disappears. But even without the use of such a device it may, of course, be found that the hum is of a minor character and only audible when there is a pause in the transmission.

In the case of a multi-valver it is obviously desirable, if not essential, to employ shielded wire for the filament circuits when raw A.C. is being fed through them. Suitable lead-covered wire is very easily obtainable from any electrician's store. The covering of every separate length used should be connected by means of a soldered lead to the nearest earth point.

A Restricted Field

It should be noted that the field surrounding a conductor carrying an alternating current of such low frequency as 50 cycles or so is not likely to be a particularly extensive one. It cannot be compared, for instance, with the field generated by H.F. Nevertheless, if you would be thoroughly free from hum then you should adopt the precautions I have indicated.

While we are on the subject of mains, it might prove useful to say something in regard to earth currents. You might adopt all the precautions laid down in regard to shielding, filament circuit balancing, and so forth, and still hear a noise in your loud speaker that sounds very much like noisy mains. This may be due to earth currents.

Earth Currents

There are frequently quite heavy electrical demonstrations caused in the earth by leakage from power mains, especially near electric tramways and railways. I have myself quite recently experienced this. A counterpoised earth would have stopped the trouble, but I was unable to arrange one.

However, I completely cured the disturbance by placing a mains L.F. choke in series with the earth lead.

Of course, it would not prove a barrier to parasitic impulses of an H.F. nature, but only to interference of purely L.F. character.

One-Way Electron

THE placing on the British market of a further "dry rectifier"—the Elkon—which the Igranic Electric Co. are now marketing, draws attention once again to what is really a remarkable series of devices of the greatest utility in a number of branches of radio and electrical engineering.

It is strange, too, that so many experimenters and the general public should have settled down to call them "dry rectifiers," because their dryness is a characteristic by no means confined to this type of rectifier—nothing, for example, can be drier than a rectifying valve—and the number of liquid rectifiers in use is so small as to be negligible, at least so far as radio is concerned.

How They Work

However, the name seems to have stuck, although the Westinghouse Company have always referred to their type as a "permanent all-metal rectifier." Purists might equally object to the term "all-metal," for an essential part of this rectifier is the oxide between the metal plates.

But as we all know what is intended by "dry rectifier" let us consider the various types, their modifications, and how they work. Although all dry rectifiers superficially resemble one another closely, actually they can be divided into two main groups—the copper oxide rectifiers and the sulphide rectifiers.

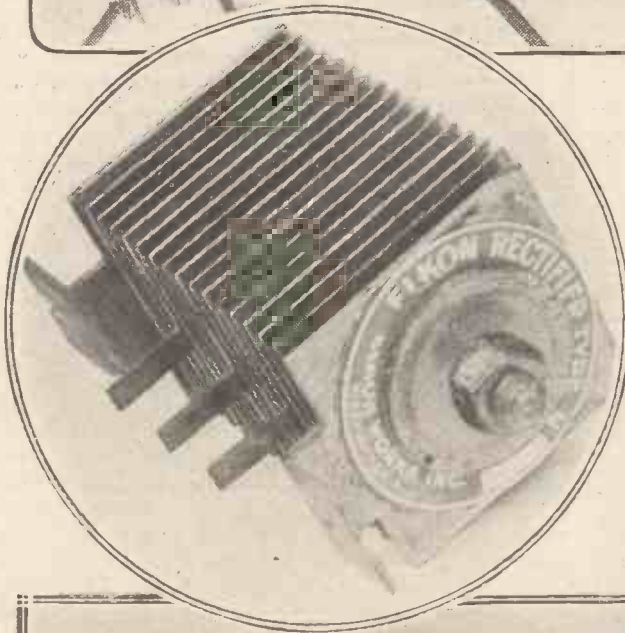
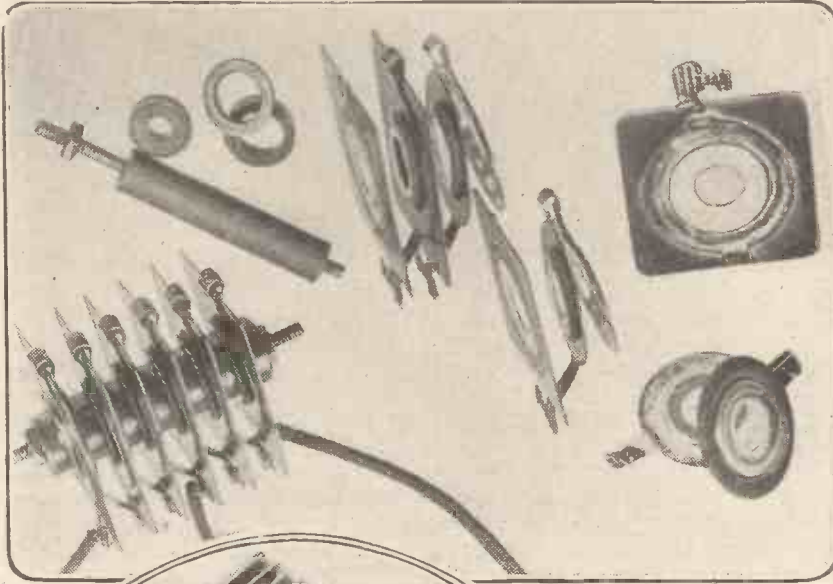

Above is a disassembled Kuprox unit showing the oxidised plate and circular contact discs. The small rings are insulators. Each side of the square plate is oxidised. To the left is the Elkon L.T. unit, which rectifies A.C. for the operation of valve filaments.

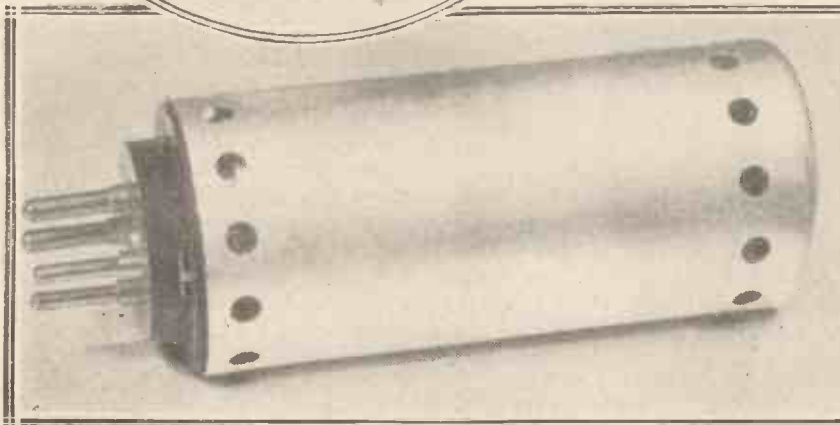

A typical sulphide dry rectifier is shown to the right. The two back lugs are connected to the A.C. supply. The central lug (with terminal) and the right-hand bolt are the D.C. connections. On the left is the Elkon H.T. unit.

Traffic

By
**PERCY W.
HARRIS**
M. I. R. E.

A fascinating chat about dry rectifiers. How they work, and what they do in mains units of various kinds.

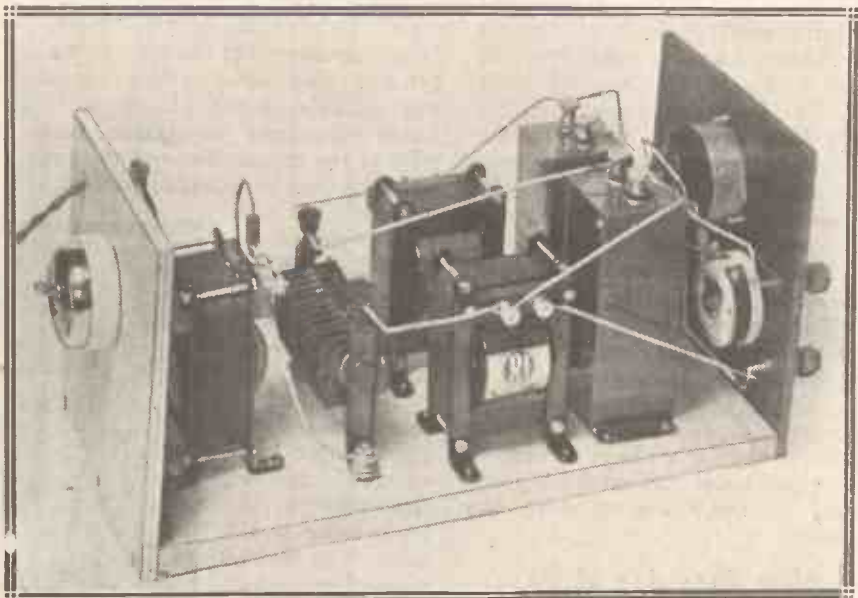

The "Stedipower" unit, showing the Kuprox Rectifying unit in use.

Both types are made up of an assemblage of units according to the purpose for which they are designed. Thus a simple single-wave rectifier may be made up with a single series of units, while a full-wave rectifier may consist of four sets of units, arranged "bridge fashion."

The Individual Units

The size and number of the individual units will depend respectively upon the current the rectifier is designed to pass, and the voltage applied to it. Thus a low-voltage high-current rectifier for accumulator charging or running filaments from the mains will have a comparatively small number of large units, while high-voltage low-current rectifiers, for charging high-tension accumulators or providing high-tension power from the mains, will have a large number of discs of relatively small area.

Thus in the design of a dry rectifier we have to consider carefully the purpose for which it is required.

Each rectifying unit has a certain resistance (the resistance differs in different types), therefore there is a certain power dissipation, in the rectifier which shows itself as heat.

For this reason practically all dry rectifiers—and particularly those used for continuous running—have carefully arranged radiating fins to assist in the dissipation of the heat, and for this reason, too, it is inadvisable to build a dry rectifier into a confined space where there is no adequate ventilation. The amount of permissible heat in a rectifier depends upon the particular type; some can be, and in fact are, run very hot without any deleterious effect.

Four volts per unit is about the general allowance, and, as most of the units are made up in disc form, a high voltage rectifier consists of a pile of discs generally assembled and bolted on a central insulated rod.

Copper Oxide Type

Dealing first with the copper oxide rectifiers, two forms are on the British market—the Westinghouse and the Kuprox. The peculiar rectifying

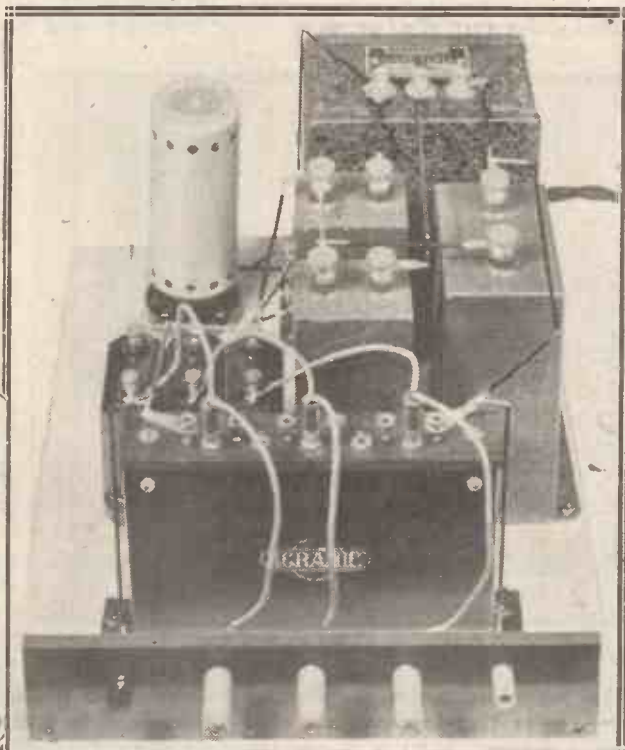
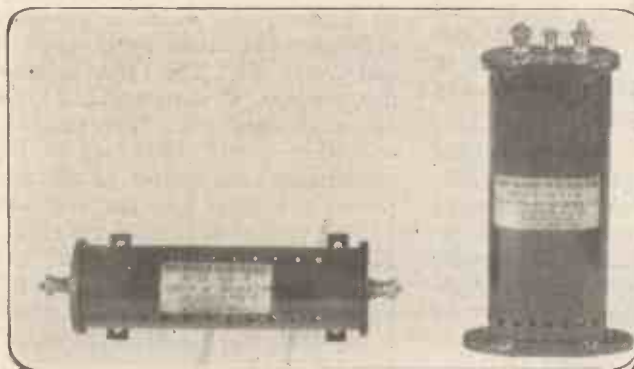

On the left are the new Westinghouse H.T. Rectifier units referred to in the text of this article. On the right is an apparatus designed by the author for testing out the Elkon H.T. unit.

properties of the copper oxide film has been known for many years, but it is only comparatively recently that practical forms of oxide rectifiers have been evolved, owing to the difficulty of establishing proper contact with the oxide film.

Briefly considered, it may be said that when a sheet of copper is oxidised, two oxides are formed upon the surface, the oxide in contact with the copper being "cuprous" and the outer layer "cupric." The rectifying action takes place between the surface of the copper and the cuprous oxide, and in order to make a practical rectifier we have to remove the cupric oxide and establish good, sound electrical contact with the cuprous.

How They Are Made

Great care is necessary in the preparation of the oxide film and considerable knowledge and experience is necessary in order to do this properly.

The method of establishing electrical contact with the cuprous oxide differs in the cases of the Kuprox and the Westinghouse. In the latter rectifier, after the oxide has been formed on the surface of the copper the outer layer of cupric oxide is removed by a special process and intimate contact established with the underlying layer of cuprous oxide by means of a lead disc, this contact being formed under very great pressure.

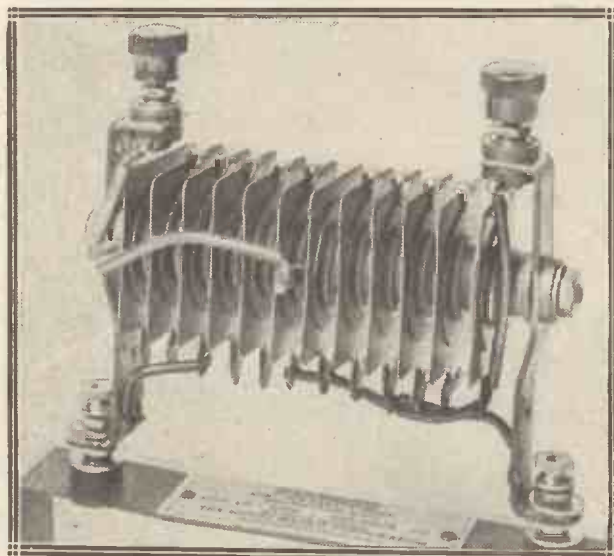

A close-up of the Kuprox unit.

An assembled series of Westinghouse units therefore consists of a disc of copper, a layer of cuprous oxide, a thin disc of lead, and a radiating fin much larger than the copper

disc, with as many of these groups as are necessary for the voltage and current. This radiating fin can be of any suitable metal. It is sometimes convenient to oxidise both sides of the copper disc and the two sides can then be joined in parallel.

In the Kuprox process the copper disc is first oxidised, as in the case of the Westinghouse, and then the cupric oxide layer, which is not wanted, is reconverted into pure copper by a chemical process, this pure copper layer being in the most intimate molecular contact with the underlying cuprous oxide.

The surface layer of copper being in every way an excellent conductor, contact can be established with it without any very high pressure such as is necessary in the Westinghouse type. The general assembly of the unit with radiating fins, series-parallel, etc., for the different purposes is similar in both the Westinghouse and the Kuprox rectifiers.

I have no figures by me with regard to the current density allowed in the Westinghouse rectifiers, but the Kuprox people state that where no means of artificial cooling is employed, and using the standard commercial spacing of $\frac{3}{8}$ of an inch, it has been found that a current density of 200 milliamperes per square inch (rectifying area) will ensure continuous operation with not more than 20 degrees Fahr. rise in temperature in the surrounding air.

With the help of additional radiating space, forced ventilation, oil immersion, and wider spacing, or a combination of these, the figure may be increased to many times this value. My own experience with both types of rectifiers has shown me that the Kuprox runs considerably hotter

than the Westinghouse, and an examination of the individual rectifiers shows that the Westinghouse rectifiers are designed to work with a very much lower current density, which would appear to be all to the good.

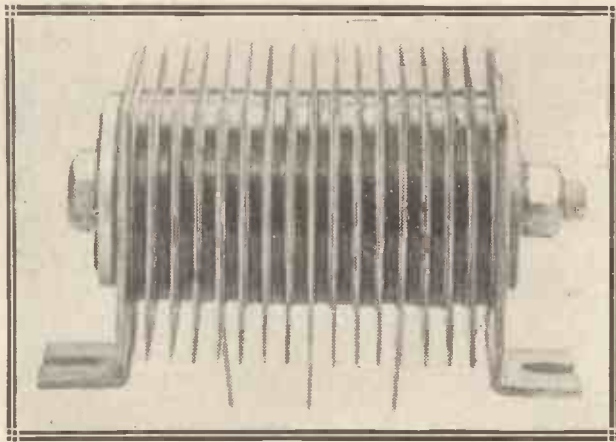

The Elkon L.T. supply unit.

I have used both types of rectifiers for over a year for many hours each day, and frequently for twenty-four hours on end, and I cannot find any deterioration in either of them, so that both appear to be quite practical propositions.

Comparatively Little Used

On the high voltage side, that is to say for the provision of rectified current for high-tension, the dry rectifier has been comparatively little used among home constructors owing to the almost prohibitive cost of the necessary units. Good modern rectifying valves have a very long life (I have, for example, a U.5 rectifying valve which has been in use on the average five hours a day for over a year without the slightest apparent deterioration, and I have friends who have used them similarly for over two years), and their cost is not unreasonable.

The U.5 will give a D.C. output of 60 milliamperes, which is considerably more than most people require, and costs £1. The Westinghouse dry rectifier, of corresponding type, cost until recently four times as much, and while it will deliver up to 100 milliamperes, as against 60 milliamperes, on the other hand the maximum voltage applied to it must not exceed 250, whereas the U.5 will stand 400.

The Westinghouse rectifier has the advantage that no filament current is required, and therefore the overall efficiency is higher (there is also less voltage drop in the rectifier), but on

(Continued on page 293.)



A practical article on an often maltreated part of the wireless set—the low-tension accumulator.

By G. W. EVANS.

ONE of the most valuable accessories to the listener is usually unconcernedly referred to as "the L.T. battery." This, in contrast to the H.T. battery, is usually of the accumulator type, and because it is so robust and faithful in service it is often greatly misunderstood and very badly treated.

Too Often Neglected

Generally purchased when the set is first built, it is usually charged up and left to get on as best it can, without any further attention, save an occasional charging when "run down" or topping-up when the acid level has dropped too low.

It is constantly maltreated and overworked, but continues to give good service for a long time until it begins to fail to "hold its charge" and to sulphate badly.

Like most things, however, especially where wireless is concerned, there is a right and wrong way to treat an L.T. battery, for the internal action of the accumulator is by no means a simple one. The idea that it "holds" electric power which is "packed" into it by the charging station and gives it out again when the set is attached to it is only a half truth.

"Holding" a Charge

Actually the passage of the electric current through it at the charging station causes a very important and fundamental change to occur in the composition of the plates of which the accumulator is built up, and it is

only when the accumulator is asked to give up its "charge" by being connected to the valves of a wireless operating device, that this change which has taken place in its various plates is reversed and they return to their former condition, an electric current being supplied at the same time.

The capacity of an accumulator to "hold a charge," as it were, is dependent upon the size and number of its plates, and also on the condition of those plates. When the manufacturers turn out the accumulator it is in first-class condition. It is usually properly charged and will hold pretty well its maximum charge. After one or two recharges it reaches the zenith of its "capacity," which

is known and referred to as so many *ampere hours*.

If you treat the battery properly it will remain at this zenith for a considerable time, but if you treat it badly then its charge-holding properties will rapidly be reduced and before very long it will be giving comparatively poor service.

The ampere-hour capacity of an accumulator gives you the number of hours which the battery will supply at one ampere of current. For instance, if the battery is rated at a capacity of 30-ampere hours it will supply one ampere for thirty hours, or two amperes for 15 hours, or half an ampere for 60 hours, and so on.

An Important Rule

But in order to keep the battery in good condition it is advisable never to discharge it at a rate greater than one-tenth of its maximum capacity, that is, in the case of the 30-amp. type, never take more than three amps.

Preferably never discharge it at a greater rate than two amps., but any rate greater than three amps. is liable to damage the battery or, at least, considerably shorten its life.

Similarly the average accumulator should never be charged at a rate greater than one-tenth of its ampere-hour capacity. Always top it up with distilled water—never use tap water—and for long life it is best to have it cleaned right out at least every eight or nine months and filled with fresh acid of proper specific gravity, and afterwards carefully recharged



Topping-up the accumulator must always be done with distilled water.

with a long, slow charge by a reliable service station.

The voltage of the battery should be tested when it is on discharge and not lying around idle, and a further check should be given by means of a hydrometer. The specific gravity of a fully-charged battery should be somewhere about 1.2, while the voltage should be about 2.1 volts, the specific gravity dropping to about 1.18 and the voltage to 1.82 when the battery requires recharging.

The "Safety" Limit

Any drop below these figures means that the battery is below its "safe discharge" figure, and should be recharged at once. Running a battery below its safe limit will shorten its life and in the end is an expensive procedure.

The terminals should always be kept well greased, free from corrosion and verdigris, which eat into the terminals and cause bad contacts, while regular charging and careful but regular discharging is one of the main points to consider in the correct treatment of the average low-tension battery.

Special slow-discharge batteries can be treated somewhat differently, but the average L.T. battery should be cared for as indicated if full service is desired.

Trickle Charging

If you have a trickle charger it is easy to keep the battery "up to scratch," but even with a trickle charger it does the battery good to be discharged to its safety limit

gassing which will occur if the battery is charged right up to its fullest capacity each time will cause the level to drop rather more rapidly than you may expect.

It is always advisable to keep a bottle of distilled water on hand, so that you can add a little every now and then before the battery is charged. This water should always be added while the battery is either charging or before it is charged, and certainly not just after it has been charged.

When a battery is fully charged and is on charge the electrolyte takes on a slightly milky appearance, gassing also occurring. After this milky appearance has shown itself and the cells are gassing freely they should be left on for an hour or two to charge completely.

Preventing Spraying

Do not forget that during the charging operations, when gassing is occurring, the battery should not be near any parts of the set, such as the cabinet or close to the speaker, as a certain amount of spraying may take place, which is likely to cause corrosion of metallic parts in a very short time.

To stop excessive spraying, a thin layer of mineral oil of about an eighth of an inch thick on the top of the electrolyte will do a lot of good. Such oils as Price's "Blancol" are very good for this purpose, but on no account should Hudson's Soap be employed, as is sometimes recommended, in order to stop frothing.

Bad frothing is usually due to

AN ANTI-SPLASH FUNNEL

By J. F. C.

RADIO workers who have experienced the filling-up of fairly large accumulators with acid will know pretty well, I expect, the trouble which occurs when the acid enters the accumulator too quickly, with the result that the escape of air from the accumulator causes a miniature acid spray to take place around the neck of the funnel.

It struck me, however, that if a piece of wire could be coiled round

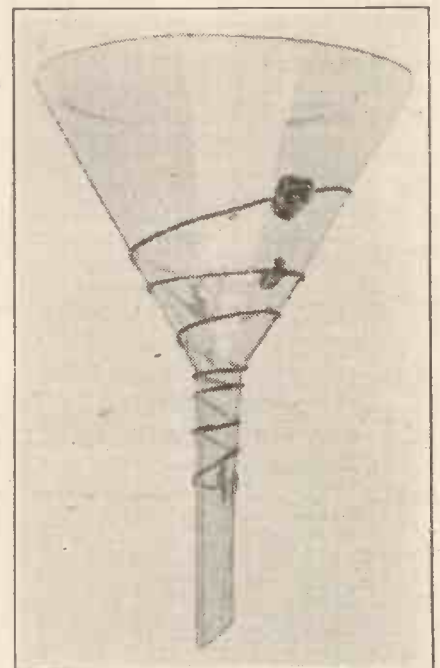

Showing how a spiral of wire is attached to the glass funnel.

the neck and a portion of the way up the sides of the funnel, a clear air space would be provided when the funnel was inserted through the accumulator vent. The difficulty about carrying out the idea, however, was to find some material which would stick the wire to a glass or celluloid funnel. I found after a time that the best cement for this purpose was at hand in the form of that friend of the radio man, Chatterton's Compound. Such a material, if applied hot, will stick the spiral of cotton-covered wire down to the sides of a glass or celluloid funnel quite effectively, and, unlike sealing wax, it will not chip off when cold.

The result of my trials in the above direction is the funnel photographed at Fig. 1.

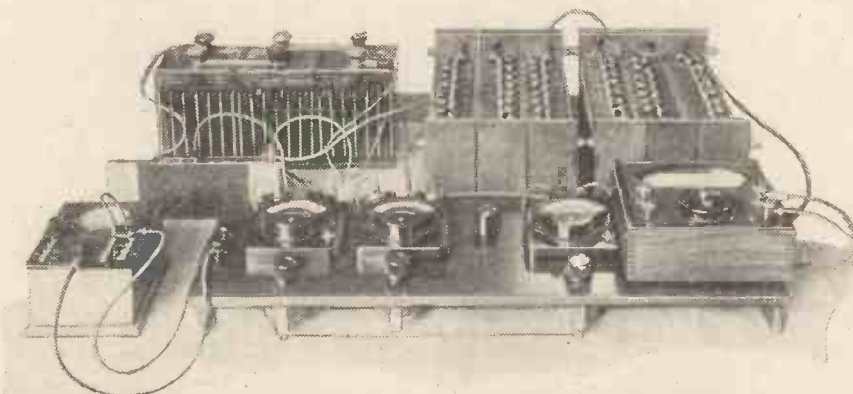

The H.T. accumulator needs the same attention as the L.T. battery and should be carefully checked as to voltage and specific gravity. Neglect of this type of battery, with its small plates, will rapidly ruin it, and its charge-holding powers will quickly decrease.

occasionally and then recharged properly.

If you use a trickle-charger you must keep an eye upon the acid level in your battery, because constant use of a trickle-charger and the constant

impurity in the containing case of the battery, which in such instances is usually of celluloid, and the purchase of a battery with a glass container will obviate any possible trouble in this respect.

MEASURING MILLIAMPS

An easy way of making one meter do two duties is described in this article.

By a Correspondent.



THE majority of experimenters who take a real interest in obtaining the best reproduction possible from their set have invested, at some time or another, in a milliammeter, both in order to guard against overloading and also to satisfy themselves that the valves, etc., are functioning correctly. It frequently happens that a good moving-coil meter has been purchased, perhaps a couple of years ago. At that time the owner of the set, knowing that the total high-tension consumption did not exceed, let us say, 15 milliamps, chose therefore a meter with a full-scale reading of perhaps 20 milliamps, the result being that on substituting one of the modern valves it is found that this reading is quite inadequate.

At first it would appear that the only thing is to buy a new meter with a higher maximum reading in order to meet the changed conditions, but it may not be generally known that this difficulty can quite easily be avoided by the very simple alternative of attaching a suitable resistance in shunt or parallel with the existing meter, thereby increasing its range to cover the new reading demanded of it.

Few Tools Required

There must be very few experimenters whose collection of discarded components does not include at least one filament rheostat, and with the aid of one of these and a few tools we have all that is necessary to make the required alteration.

The best method of doing the job is probably as follows: For the sake of example let us suppose that the milliammeter in question has a full-scale reading of 20 milliamps, and

that in order adequately to meet present conditions it is required to increase this figure to 40 milliamps.

The first step is to adjust the high-tension and grid-bias voltages so that an exact reading may be taken on the meter; for example, let us suppose that 16 milliamps is found to be a convenient figure. Having done this, the next operation is to attach two short lengths of wire to the two terminals on the rheostat and then to fasten the other ends of the wires under the two terminals of the milliammeter, leaving the original leads still under the same terminals also,

Halving the Reading

The slider of the rheostat should now be turned to the off position and then gradually revolved so as to include less and less resistance wire in shunt with the milliammeter. As this is done it will be seen that as the resistance is decreased, so the reading of the milliammeter decreases, until at a certain position of the slider the needle, instead of reading 16 milliamps, reads half that figure—i.e. 8 milliamps.

A note should now be made of the approximate amount of wire included between the slider and the end fastened to the other terminal, and having made a small allowance for connecting up afterwards, the rheostat may be disconnected from the milliammeter.

The next thing to be done is to dismantle the rheostat. This is generally a very simple process, being only a matter of removing a few bolts and screws to take it completely apart.

Fixing the Shunt Resistance

In many cases the resistance wire will be found wound round a strip of fibre, in which case it is only necessary to unwind the surplus wire which was not included between the slider and the terminal.

The two ends of the resistance wire now left on the former should again

be fastened under the milliammeter terminals and another reading taken, when it will probably be found that the meter reads perhaps 9 milliamps, owing to the allowance which was previously made, and short lengths of the wire should now be clipped off, frequent readings at the same time being taken, until the reading is reduced to exactly 8 milliamps.

The two ends of the wire should now be permanently fastened (soldering is preferable) to two terminals or bolts mounted at either end of the fibre strip, and the whole arranged so as to be connected in parallel with the milliammeter, either permanently or brought into circuit by means of a switch or jack.

Easily Applied Method

By now it will be seen that when the shunt, which has been described, is in operation, in order to obtain the correct reading the figure shown by the meter must be doubled; that is, if under normal working conditions a reading of 11.5 milliamps is obtained, the actual current flowing will be 23 milliamps. Thus where we previously had a meter reading only to 20 milliamps, we have now one reading to 40.

Obviously this method is not limited to doubling the range of a meter only; if necessary, the same system may be used to treble or quadruple the scale, while, should a low reading on a more open scale be required, such as the consumption of one of the earlier stage valves, it is only a matter of removing the shunt in use to have the meter with its original scale reading.

In the writer's case a moving-coil meter of well-known make was in use, and it was found that the resistance wire from a 6-ohm rheostat suited the purpose admirably, the wire not having a very high value of resistance; the amount to be removed was, therefore, not very critical.

Radio and



ALWAYS it is the unknown which men fear—the distant place which is uncharted and legendary, the noise in the silence of the night which may be anything or nothing, and, on a wider plane, the man in another country whose language, customs and ideas are strange. Ignorance is invariably at the root of fear and distrust.

Behind most of the suspicion with which foreigners were formerly

regarded lay a lack of the realisation that they are ordinary human beings like ourselves; their remoteness, owing to crudity of communications between one country and another, sometimes gave them an unreal quality which for some people held a terror which would readily vent itself in war.

International Entertainment

To the Englishman, a Frenchman was not just another human being like himself, but almost a mythical sort of caricature of a human being—a name, not a reality; someone of whom every Englishman was just a little suspicious. The same was true of the German and the Italian, the Dane and the Spaniard, and so on. Until wireless came on the scene.

The one great element which was necessary to break down the barrier of mistrust which existed, through ignorance, between the ordinary people of one country and the ordinary people of another was some daily means of communication with each other. Wireless, as if by a miracle, provided that daily communication, that mutual interchange of entertainment and opinion, and that free contact of one national mind on another which may do more to assure the future peace of the world than all the schemings of the politicians and diplomats.

Mr. Baldwin Tunes-In Berlin

For wireless makes the whole world kin because it brings to every man an intense realisation, perhaps for the

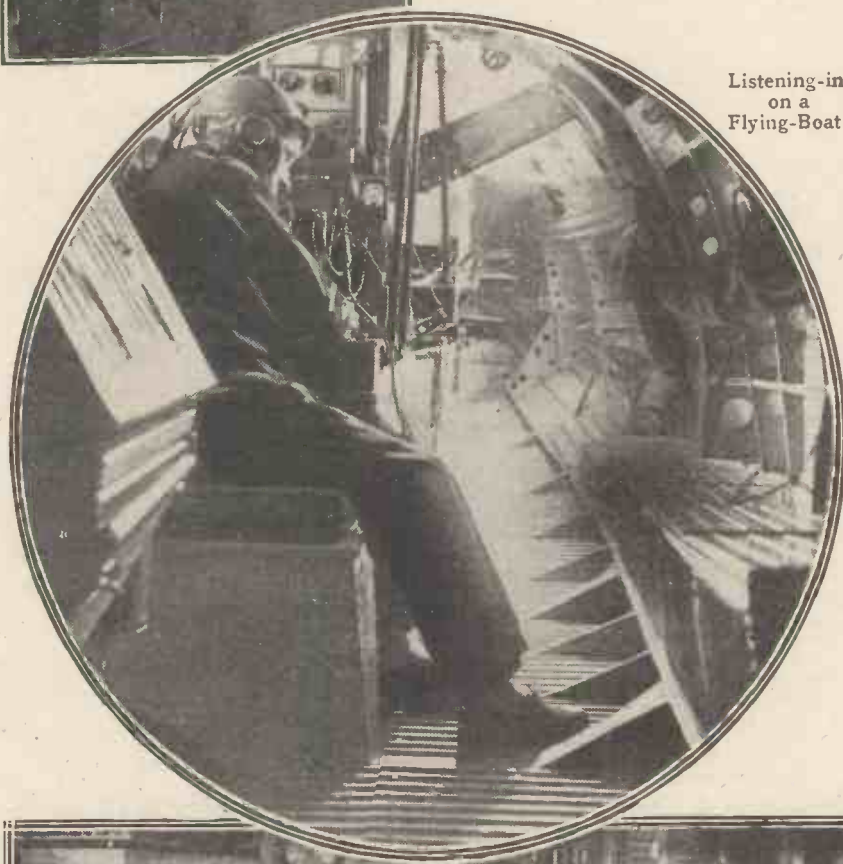

Listening-in on a Flying-Boat.



Striking differences in the uses of radio are disclosed by these three photographs, showing respectively the Voxhaus (Berlin) orchestra broadcasting, a super-flying boat in touch with land, and the microphone at the signing of a Paris Peace Pact.

World Peace

By Brig.-Gen. CROZIER,
C.B., C.M.G., D.S.O.

first time, of the essential humanity of other men the world over in spite of a hundred and one superficial differences.

I remember a very striking statement made by Mr. Stanley Baldwin, when Prime Minister, at an Albert Hall gathering of the League of Nations' Union. Dealing with wireless and world peace, he described very realistically how, coming down to breakfast one morning, and having to wait, he tuned-in his wireless set to Berlin! Now this is really immensely significant.

Breaking Down Boundaries.

There was a time not long since when, except to the travelled minority, Berlin was but a name learned by heart at school during a somewhat dull geography lesson, or casually mentioned now and again in the Press. People knew that men called Germans existed, but their reality and their humanity had never been forced on to the consciousness of the majority. Probably they had never heard a German voice.

To-day there must be thousands upon thousands of listeners who tune-in Berlin day after day—for whom Berlin has become, not a name, but a vivid reality.

It is the same with Paris, Rome, and any great capital you care to mention. People are dancing to music made by men and women in these places which before they may hardly have realised as having a concrete existence. They will go on dancing to this music

The portrait to the right is of the author, and the picture below it shows a German high-school class listening to a broadcast lesson from France.



The soldiers above are talking to a tank, by-radio. To the right is shown a modern battleship's aerial.

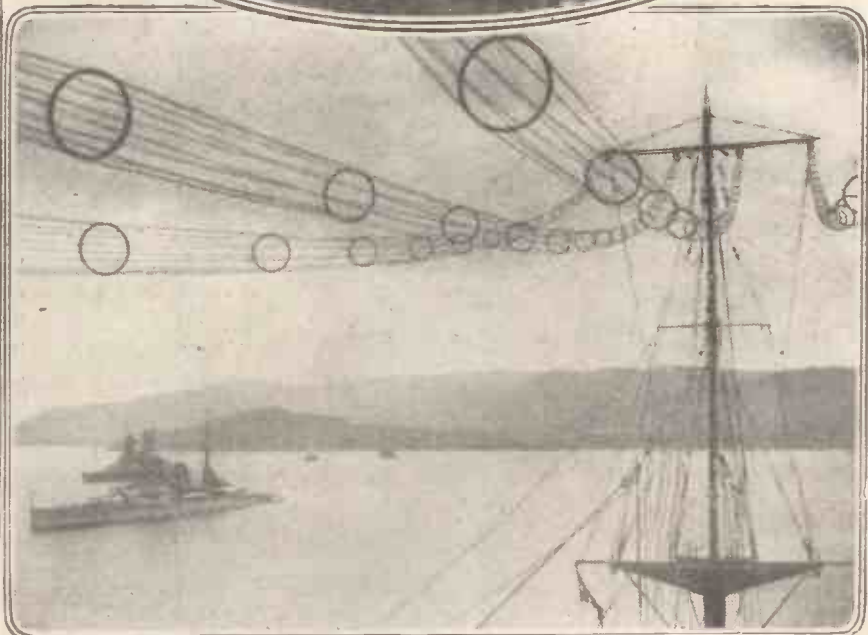

Radio a Potent Force for Peace

for twenty, fifty, a hundred years—who can tell how long? Is it remotely likely that after a century or so of such listening they will ever want to fight the people in Paris, or Rome, or any other more distant place?

Educational Broadcasting

Obviously not. And wireless is doing more than entertaining people and making them conscious of foreign people as living realities. It is educating them. There is sometimes an outcry in certain quarters against the educational side of broadcasting. People say they do not want to be educated by wireless; they want entertainment, and there is much justice in this point of view. But in any broadcast programme there is almost always some shred of wisdom to be picked up, perhaps almost unconsciously.

Many a war comes about because the science of life, of which we are now dimly perceiving the rules, is not acted upon, or is misunderstood. The educational element in wireless cannot help but give men and women a wider and more sympathetic understanding of this science, and incidentally help to avoid those things which lead to breaches of the peace between nations.

Even from the severely practical point of view the introduction of wireless into the machinery of war has made war itself more futile than ever.

The growing efficiency of methods of destruction is bad enough in itself. The danger of every civilian in every country in any war being as liable to sudden death as the soldier at the front is sufficiently appalling. But because both sides in a conflict use wireless, their wireless power is cancelled out.

This is all to the good, for as men realise the utter futility of war they will become more and more ardent in the cause of peace.

You may say that ships and aeroplanes can be guided by wireless in their voyages of destruction and death. The same ships and aeroplanes may be located by wireless before they reach their destination. Even with the faintest possibility of cities being blotted out in a few hours by wireless by both sides within a short time of the declaration of war, the whole thing becomes so absurd that surely no nation with any instinct for self-preservation would venture such a step.

Quiet But Steady Influence

Wireless has, in fact, already proved its worth in the cause of peace, for it has been found very useful to the Secretariat of the League of Nations at Geneva, in cases of emergency if the Council has to be assembled at a moment's notice when war between two states appears to be inevitable.

There was the conflict a few years

ago between Greece and Bulgaria, which was settled amicably owing to the intervention of the League. In this instance wireless played a very important part in assembling the delegates quickly.

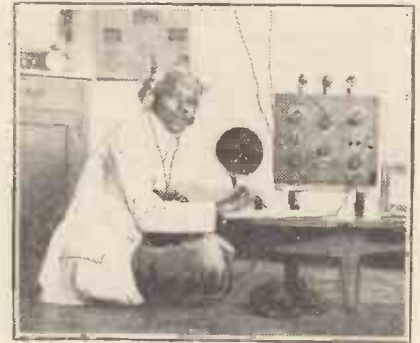

An enthusiastic listener of Penang.

But it is in its rôle of unofficial propagandist for peace that wireless will do its most useful work.

Into the remotest hamlets in the loneliest places, into the homes of men and women who never during a lifetime move more than a few miles away, it is bringing a new conception of the world as a place where men may differ externally, but where they are moved by similar needs, hopes and desires. Only time can show the quiet but steady influence which it will have on the hearts of men in setting their feet in the paths of peace.

RADIO INVENTIONS

IT is a common fallacy that the lodging of an application for provisional patent protection entitles an inventor to take action at law against "infringement" of his idea. The fact is, of course, that a provisional application is merely the staking of a claim. If anybody comes along later and endeavours to take out a patent for the same thing, priority is proved by the lodging of that provisional application.

The patent, as a patent, is of no value until the full specification has been filed, passed by the patent office examiners, and Letters Patent bearing the official Royal Seal are granted. The issuing of a number in connection with a provisional application does not signify that the Patent Office considers the patent is a good and valid one.



The Signals section keeping an Army Division in touch with G.H.Q.

WHY VOLUME VARIES



MOST listeners know that at every B.B.C. station there is a control room, with an engineer on duty all the time that broadcasting is in progress. His duty is to control the volume, toning down the too loud passages or giving extra amplification when the sounds which reach the microphone appear to be too weak.

So skilfully is the work of the control engineer done that seldom is it realised how carefully he must be on the watch against underloading and overloading. If you doubt this, you can easily make a test for yourself. The next time a strange speaker is announced to give a talk, listen to his opening words and probably you will hear the control engineer at work.

An Easy Experiment

After the pleasant voice of the announcer introducing him ceases, ten to one the opening words of the new speaker are spoken either too softly or too loudly. But before half a dozen words have been uttered he has been toned up or toned down to about the same strength as the announcer's voice, and at that strength the control engineer will hold him to the end of his talk, neither too soft nor too loud.

It is not often realised that many other varying forces are at work beside the control engineer, and that all day and all night the broadcasting which comes to your set is being carried across channels that are constantly tending to vary the volume of the reproduction.

Night and Day Differences

The words "all day and all night" were used advisedly, for here we have a very important volume control which affects all broadcasting. If you live quite close to a B.B.C. station you may not realise the

Everyone has noticed that sometimes the local station's programme sounds louder than at other times for no apparent reason. This article outlines some of the causes which play their part in modifying signal strength.

By P. R. BIRD.

difference between day and night transmission heard on the same apparatus, but every country listener knows that when the sun is up the volume goes down, daylight reducing the range of every transmitting station to about half its night strength.

It is only during the hours of darkness that the distant stations start to climb in on a small receiver, and many a long-distance enthusiast sits up till two or three in the morning because

he has found that the later the hour the better is his range of reception. This day-and-night effect operates in the general as well as in the particular sense, so during the dark and cloudy winter days reception is far superior to that obtainable in the bright summer weather.

Darkness Increases Range

Although the effect of better range during darkness is now so well known, it escaped notice for years after wireless was introduced, and was first appreciated by Marconi in a long-distance test voyage on his yacht the "Elettra." This voyage was undertaken after his successful attempt to span the Atlantic by wireless from Poldhu to Newfoundland, and it is a remarkable fact that this astounding Transatlantic feat was carried out during daylight, because

A BROADCASTING CONTROL ROOM

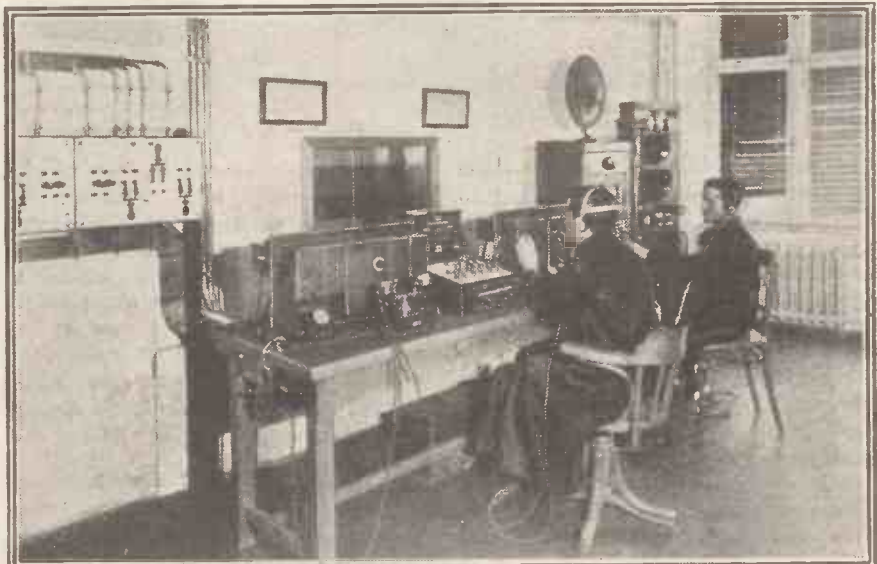

All the time that broadcasting is in progress engineers are operating volume controls to strengthen weak passages and to tone down when the voice or music is too loud. This photograph shows the control room at the Prague station, which works upon a wavelength of 487 metres.

How Batteries Affect Signal Strength

those responsible were not aware of the far greater likelihood of success after the sun had set! (The real cause of day and night variations is the Heaviside Layer, but that is a story in itself.)

The Effect of Rain

Many listeners have noticed that their strength of reception seems to fall off during *wet* weather, but this is not a true volume variation in the same class as light and darkness. Generally when signals fall off in wet weather it will be found that the insulators are either inadequate in size or number, and that the rain is forming a conductive path across them to earth. The effect would be

telephones. The reason for this is that although broadcasting will always reach your aerial (provided that it is within range), the effect of it will only be at a maximum when your tuned circuits are adjusted to exactly the same frequency as the distant station's.

Many Other Factors

At short distances there is a breakthrough effect which may lead the listener there to suppose that tuning is not very important, but all listeners who live a long way from the nearest station will have noticed how greatly the results improve when the tuning is set exactly right.

In every valve set there are many

extra voltage will ruin it. But not every listener realises that his "2-volt" accumulator does not remain steadily at 2 volts, being more than this figure when newly charged and considerably less before it is taken to be re-charged again.

A good voltmeter will show that the voltage when a newly-charged cell is first in use is 2.1, or a little more, and this falls slowly all the time that the accumulator is supplying current until it drops to 1.8, when results fall off quickly, and it becomes incapable of supplying the current demanded of it. We are accustomed to think of accumulator voltages as being very steady, but these figures show a drop of something like 14 per cent between the newly-charged and the run-down accumulator. As the results from many valves vary appreciably with the low-tension supply, it is obvious that here we have an important reason for volume variations. Fortunately modern valves are less critical than their predecessors.

Magnified Alterations

Advantage is often taken of this very fact that filament voltage affects output by connecting a variable rheostat in the filament circuit of an H.F. valve, for the specific purpose of controlling the volume of the output. Here the slightest touch of the rheostat will affect volume to a surprising degree, one reason for this being that the volume control in this case is followed by amplifying valves which magnify the effect of any input variations.

A powerful receiver amplifies the input many thousands of times, so that any changes in volume which take place in the earlier stages of the input are enormously magnified before they are reproduced by the loudspeaker.

H.T., Too

Variations in high-tension voltage supplied to the receiver affect volume in the same way as variations in low-tension voltage, but generally not to the same degree.

It will thus be seen that there are many factors working simultaneously to vary volume, and the marvel is not that the strength of the programme is sometimes better than at others, but that the cumulative effects of these variations is not too great to spoil our enjoyment of the fare provided by the B.B.C.

EUROPE'S HIGHEST AND OLDEST "MAST"



The Eiffel Tower broadcasting station is housed underground, and is famous because it has the highest "mast" in Europe from which to suspend its aerial.

to leak a certain proportion of the signals away, so it is hardly fair to class this among nature's volume variations, as the provision of insulators which remain dry will completely remove these symptoms.

Out of Tune

All the foregoing affect the signal before it reaches the set. But in the set itself we have many volume controls in addition to the particular components which are so labelled. Most of these apply particularly to the valve sets, but even the crystal types have the effect of detuning.

Everyone has noticed that throwing the set out of tune results in a marked drop in the power supply at the

other factors besides tuning which affect the strength of reproduction.

The basis of the operation of every valve set is the provision of suitable low-tension voltage and high-tension voltage from batteries or some other source. Everything that goes on in the receiver depends upon these, and obviously the ideal plan for even output would be an absolutely *steady* source of supply.

The Voltage Drop

In practice both the low- and the high-tension voltages vary, and to a surprising degree in both cases. Everybody knows that if you have a 2-volt valve you must not supply it direct from a 4-volt accumulator or the

THIS YEAR'S EXHIBITION AT OLYMPIA

We have less than a month to go before the 1929 Wireless Exhibition opens—and there is no doubt that this year's show is going to be the "best ever."

From a Correspondent.

OUR next issue will see the opening of the Wireless Exhibition at Olympia.

It may be regarded as a trite saying, but this year's Exhibition will be better than last. That is, perhaps, a statement which is often overdone when talking about yearly events such as the Wireless Exhibition at Olympia. But, as a matter of fact, in this particular instance such a remark is quite true; and any reader who remembers the Exhibitions in the past, and especially the first Radio Exhibition held at Olympia—and even before that, when the Exhibition was held at the White City—will realise that as year follows year the Radio Exhibition improves, not only in size, in variety of appeal and quality, but in every conceivable way.

No Saturation Yet

This year's Exhibition at Olympia simply cannot help being better than last year's Exhibition, for the simple reason that radio is very far from having reached saturation point in this country, and very far indeed from having reached the limits of ingenuity, research and general progress.

Each succeeding year seems to bring forth something, if not fundamentally new, at least radically better than the last. Last year saw the screened-grid valve take its proper place in the repertory of radio, and its popularity has grown steadily since, until no amateur building himself a really first-class, up-to-date, modern receiver would dream of designing a set without considering a screened-grid valve.

"Portable" Progress

Not for one instant do we wish to suggest that a screened-grid valve is essential in every kind of receiver, but for the modern, up-to-date multi-valve set, capable of bringing in twenty or thirty stations, the screened-grid valve naturally is incorporated.

Another development during the past twelve months has been in connection with the portable set. Great improvements in design have been obvious, and with reductions in price the portable set has at last claimed its rightful popularity. At the Exhibition some first-class examples of portable sets will be on view, and those readers who have hesitated this year in either building themselves one or buying one will be amazed at the extraordinary strides which have been made in the general design—their compactness and efficiency in particular will strike the critical visitor.

Loud-speaker Improvements

Moving-coil loud speakers—in fact, loud speakers of all types—will make a brave show at Olympia this year, and although it is practically impossible for the organisers to allow

loud speakers to be demonstrated in turn, it is a pity that some arrangement cannot be made for a special auditorium to be hired where loud speakers can be switched, one after another, to a regular programme, so that visitors can really have an opportunity of judging their respective merits.

Pay Us a Visit

From the point of view of appearance, loud speakers have, at any rate, definitely improved, and the visitor to the Exhibition should be given some sort of an opportunity of realising that not only appearance but quality has been improved almost beyond belief.

Of complete sets, mains units, and general accessories there will be, as usual, a bewildering variety. In fact, it is doubtful whether the average visitor to the Exhibition this year will be able to take in all that Olympia offers in one visit. But considering the low price of admission, and the great number of exhibitors who will be displaying their goods, it is a safe recommendation to urge our readers to pay more than one visit.

And, in particular, we would urge them to pay a visit to the MODERN WIRELESS stall in the gallery (Nos. 246 and 249), where the latest "M.W." receiving sets, as well as examples of the sets which have been described in our contemporaries, "Popular Wireless" and the "Wireless Constructor," will be on view.

Times and Prices

There will also be a special expert staff in attendance to answer queries, and we cordially invite our readers to take advantage of the service which we are glad to offer them at the Radio Exhibition.

The Exhibition this year is to be opened on September 23rd, and will remain in full swing until October 3rd. (Hours 11 a.m.—10 p.m.). The price of admission is 1s. 6d., except on Tuesdays, when it will be 2s. 6d. up to 5 p.m.

THE LATEST



One of the latest "fashions" in radio in America is the fitting of receivers in the fascia boards of cars, the loud speakers being in the roofs of the vehicles.

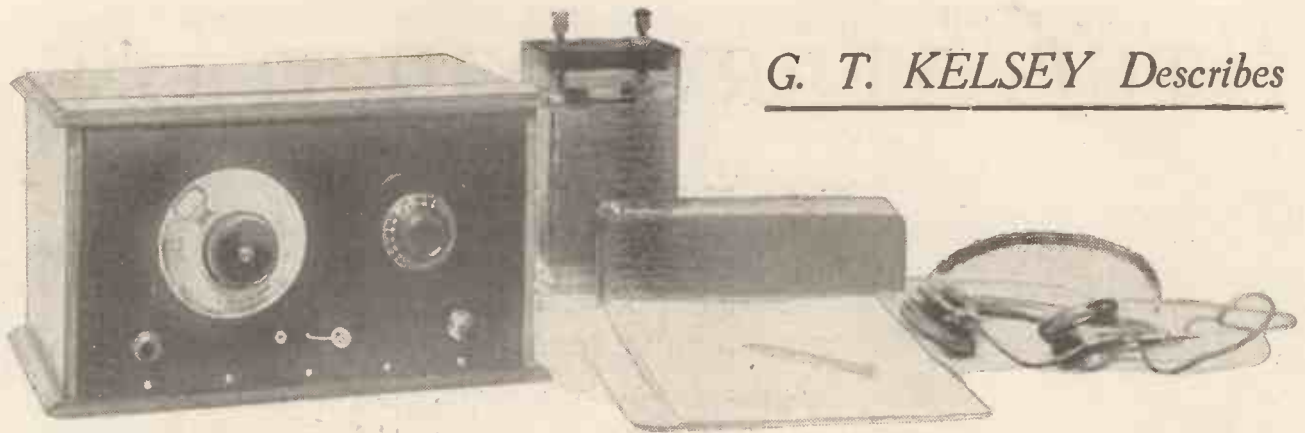

G. T. KELSEY Describes

SINCE the introduction of the first set with a really efficient wave-change scheme, many interesting "change-over" arrangements have been produced, and the present tendency in set design seems to be all in favour of this feature.

Whether it is that the interior of the set offers a better "parking place" than the mantelshelf for the coils not in use, or whether, purely from the convenience point of view, it is considered an advantage to be able to change over from one wave-band to the other merely by the movement of a switch, is possibly a doubtful question.

One Coil Less

But the "switch-it-bug" has, without a doubt, extended to the ever-popular single-valve detector set, and in point of fact this particular type of set offers considerably wider scope for interesting wave-change schemes than a circuit with H.F., since there is only one dual set of coils with which to be concerned.

The necessity for only one dual set of coils renders it possible to arrive at quite a number of interesting and, what is of more importance, efficient change-over schemes, and the particular development around which the present receiver is based is one enabling use to be made of the standard plug-in coil.

What is more, the scheme is one in which use is made of only three plug-in coils, instead of the customary four, and in this connection perhaps a few words in explanation of the theoretical considerations would be of interest.

Circuit Explained

The three single-coil sockets are arranged in such a way that the long-wave secondary coil comes on one side and the short-wave secondary on the other. The coil which is inserted in the centre of the two secondary coils is of the centre-tapped variety,

and by means of a very simple switching arrangement it functions as a combined aerial and reaction coil on whichever wave-band the set is working.

When the wave-change switch is in the short-wave position, the two secondary coils are placed in parallel, and one-half of the combined aerial and reaction coil is cut out of circuit. On long waves the long-wave coil is used alone and the whole of the centre-tapped coil is brought into circuit.

In the preliminary experiments it was hoped to be able to effect the complete change-over with an ordinary push-pull wave-change switch, but with these conditions, in which it was necessary to short-circuit one-half of the combined aerial and reaction coil, it was found impossible to

obtain a normal reaction effect on both wave-bands.

A small plug-and-socket shorting arrangement had therefore to be used, in addition to the ordinary wave-change switch.

What to Buy

The novelty of the set is in the wave-change circuit employed, and following the above brief explanation it remains only to describe the construction and operation of what I consider, after considerable experimenting, to be an ideal set for the 'phone reception of quite a number of stations.

A complete list of the parts required for the construction of the set is given on a following page for the convenience of readers, and although in each case the name of the component

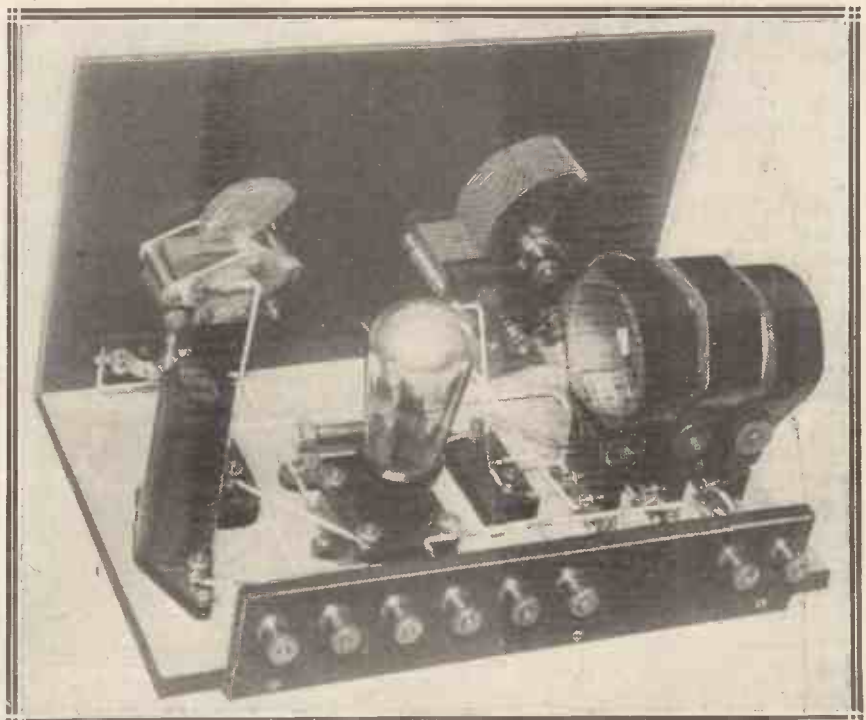

One great advantage of the set is that once the coils are in they remain in position, the wave-changing being done by means of the switches.

The "Change-Range" One

High and low waves covered without coil-changing.

used in the original set is given first, it should clearly be understood that any parts of reliable manufacture can be used satisfactorily in this design.

The positions for the components on the panel are clearly shown on the front-of-panel drawing, and since there is no heavy weight to support on the panel, there is no necessity for panel brackets.

Accessories Required

When the panel has been fixed to the baseboard, which latter, incidentally, can be given a distinctive appearance by painting it with a mixture of permanganate of potash and water, the two variable con-

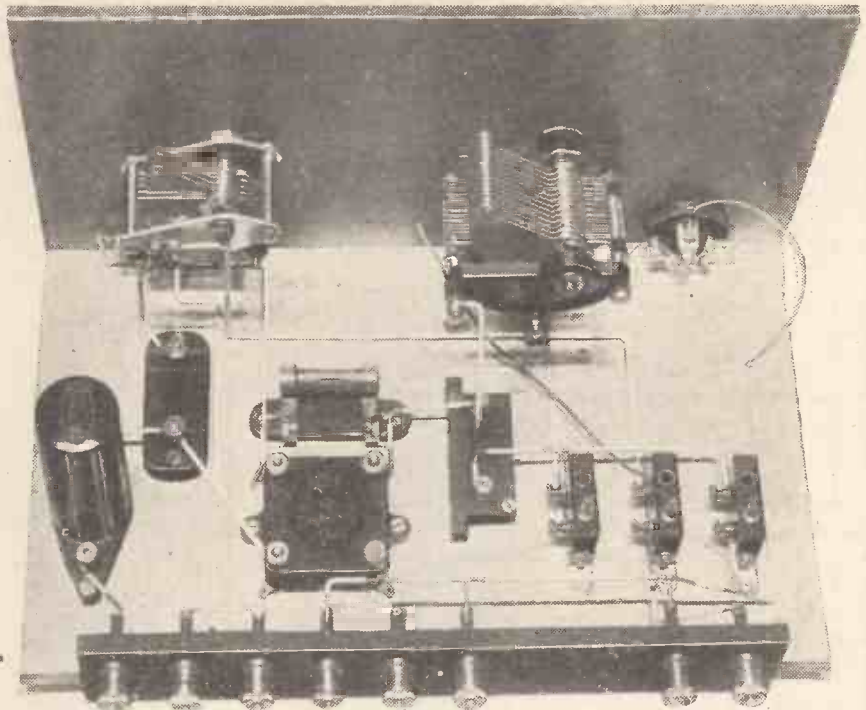

All the wiring and spacing will be clear from this photograph, the layout being exceptionally simple and straightforward.

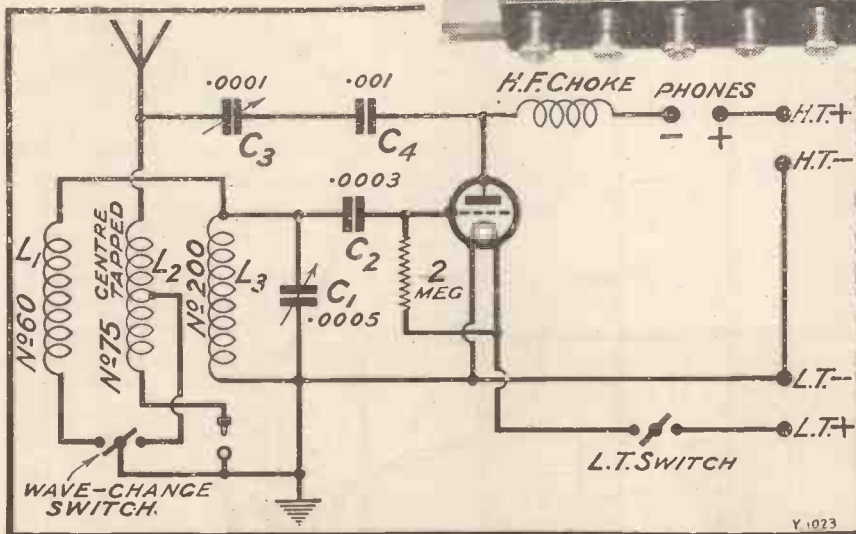

Here is the circuit, showing the coil numbers and connections.

densers and the switches can be fitted.

In the laying-out of the components, again, there is no operation which can be called difficult, and it is merely necessary to follow the arrangement shown in the back-of-panel drawing, in which is also shown the wiring connections.

Having completed the wiring, insert a valve of the H.F. type in the detector valve socket, and join up the usual batteries. In this connection perhaps it would be opportune to mention that a 60- or 66-volt H.T. battery will be ample for the successful running of this set, and it is quite

immaterial whether you decide to use 2-, 4- or 6-volt valves so long as you use an accumulator of a voltage to suit the valve chosen.

In the matter of coils, the following sizes were found to give the most satisfactory results in the original receiver, although it is quite possible that used under different aerial conditions the coil sizes will require to be modified slightly.

The Right Coils

The long-wave secondary coil should consist of a No. 200 standard plug-in coil, and it should be placed in the socket nearest the side edge of the

baseboard. For the short-wave secondary a No. 60 will, in most cases, be entirely satisfactory, and this coil should be inserted in the holder nearest the valve.

This leaves the centre socket to fill, and in this position a No. 75 centre-tapped coil will probably enable you to obtain reaction on each of the two wave-bands. The flex lead from the wave-change switch should be joined to the terminal on the centre-tapped coil.

With the aerial, earth and 'phones joined up to the correct terminals, all is now ready for use, and the first thing is to determine whether the set will oscillate smoothly over each wave-band.

Testing for Oscillation

Commence by placing the push-pull switch at the out, or shorted, position (short wave), and the plug in the hole to the right of the flex lead looking at the set from the front. It would perhaps be as well to mention that this hole is drilled in the panel, and is simply used as a place in which to insert the plug when the set is being used on the short-wave band.

Turn the reaction condenser to the minimum capacity position (plates

all out) and rotate the tuning condenser until the exact setting is found for the local station.

In the oscillation tests which are to follow, the tuning condenser must on no account be turned through this setting with the set in an oscillating condition, otherwise you will be liable to cause considerable annoyance to neighbours.

Starting, then, with the tuning condenser at zero, gently increase the capacity of the reaction condenser until the set commences to oscillate, and turn the tuning condenser throughout its scale, noting whether an oscillation effect is obtainable over the whole range.

Of course, you have not forgotten what was said a little earlier about

oscillation on the local station? Well, may I go further by interposing a remark to the effect that precisely the same rule holds good when passing through the setting of the Daventry experimental station. If you hear a squeal on either of these two stations, the capacity of the reaction condenser should be reduced immediately.

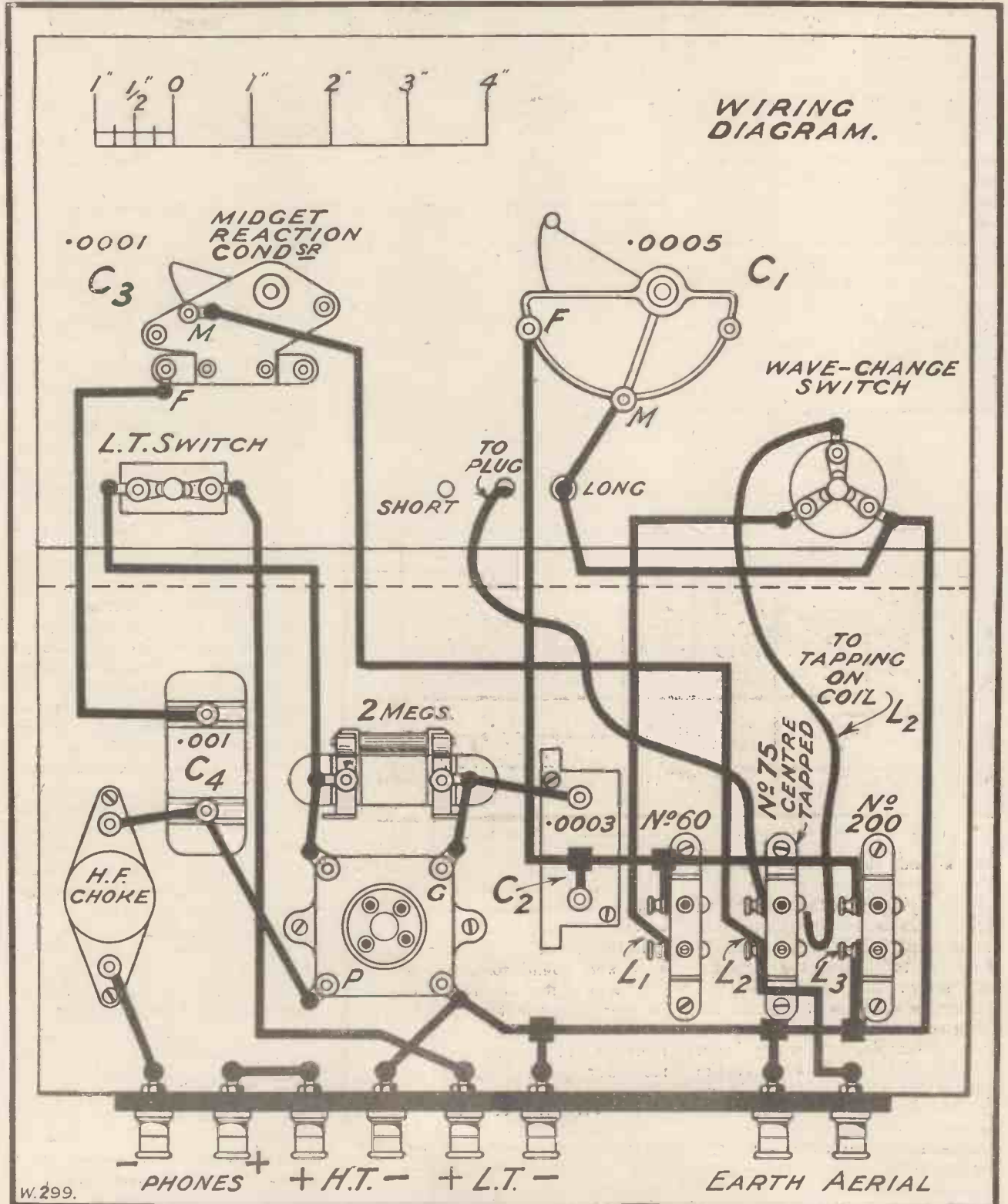

Having tested the set on the short-wave band, transfer the plug into the metal socket on the panel, push the switch in (long-wave position) and test in exactly the same way on this range.

Station Hunting

The most satisfactory and sensitive position for the reaction condenser is that which enables the set to be just on the verge although not actually oscillating. Unfortunately the setting for this condenser will not remain constant over the whole range of the tuning condenser, and readjustment will therefore be necessary.

If reaction should be at all ploppy or sudden, the thing to try is reducing the voltage on the detector valve until reaction becomes quite smooth. On the other hand, if reaction is difficult to obtain over the whole range, the H.T. voltage should be increased, and with some aeriels it may even be found an advantage in this respect to use a .0002 fixed condenser in series with the aerial lead. This condenser will also have the effect of sharpening tuning slightly.

The question of receiving distant stations on this set is rather more a matter for practice than explanation. However, when you have obtained the "feel" of the set you should not have any difficulty in receiving quite a number of stations other than the

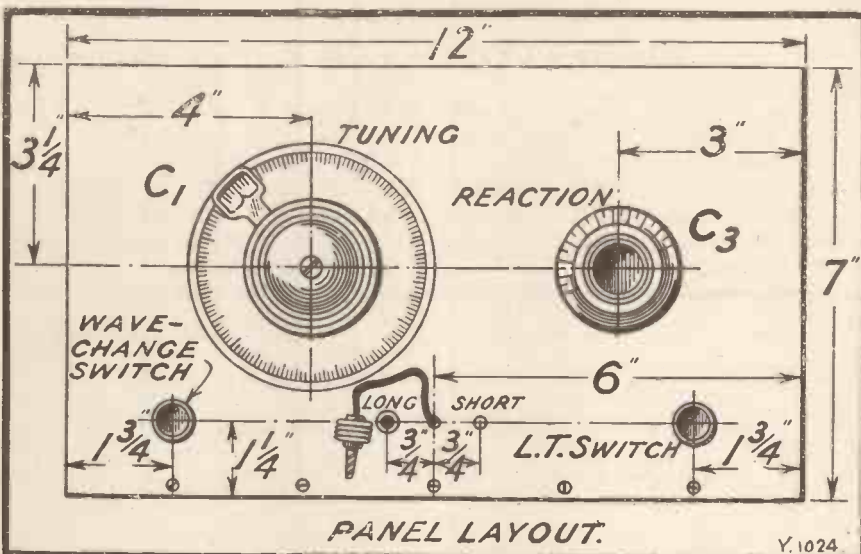

local and 5 G B. But do please bear in mind what has been said about reaction and the local station, and in those now famous words, "Please don't do it!"

Aerial Importance

After dark is, of course, the best time to listen for distant stations, and under favourable conditions it should be possible to receive upwards of twenty stations on the 'phones with this receiver.

The above remark is based on the assumption that you are using the

set in conjunction with a reasonably good outdoor aerial, and in this connection perhaps it would be opportune to emphasise the importance of using a good aerial when receiving with only one valve.

The aerial should be from 25 ft. to 30 ft. in height (higher, of course, if possible), and not less than 50 ft. in length. As far as circumstances will allow, the wire forming the aerial should be erected as far away from trees, buildings, etc., as possible, and particular care should be taken to see that the lead-in is brought to the lead-in insulator well clear of walls or any metal pipes.

Reaction Control

With an aerial on these lines it should be quite a simple matter to hear many stations other than the local, but only when you have mastered the operation of the set, and providing reaction is perfectly smooth.

In the preliminary operating notes reference was made to "ploppy" reaction, and a suggestion was made as to the usual method of curing such troubles. There may be some readers, however, who are not at all clear as to what is meant by the term "ploppy" reaction, and for the benefit of these it would probably be helpful to have a brief explanation.

Assume for the purposes of explanation that you are operating the receiver and are endeavouring to receive distant stations. The reaction condenser would—or shall I say should—be adjusted to the point just before the receiver definitely commences to oscillate, and under these conditions you find it possible by slow rotation of the tuning dial to locate a distant transmission.

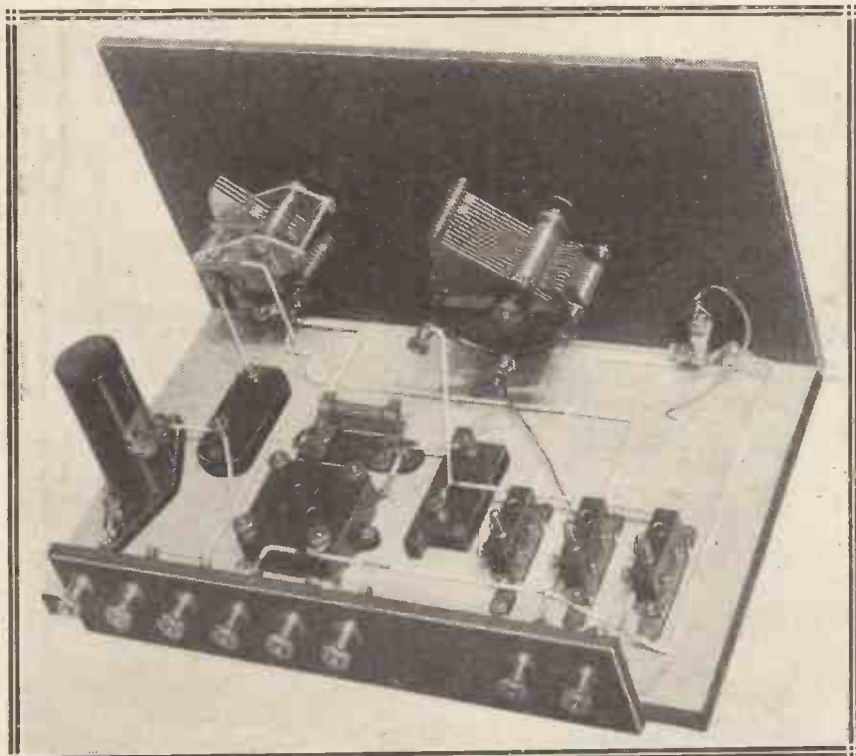

The flexible lead on the wave-change switch is for connection to the centre-tap on the middle plug-in coil.

Use Your Old Coils in this New Set

You may so far have found the station rather weak, and so in order to obtain louder results you try to increase the capacity of the reaction condenser, with the result that instead of the signals becoming louder the set "spills over" into the oscillating condition with something of a violent "plop."

If you experience anything of this

five-turn plug-in short-wave coil will be required in the socket marked L_3 , and a three- or four-turn coil will in most cases be suitable in the L_2 socket. The holder L_1 should in this case be left without a coil in it.

With regard to the switching, it is important to note that the plug at the front of panel must be placed in the "long-wave" position, and the

Having proceeded thus far, it now only remains to carry out slight modifications to the aerial arrangements, and all will then be ready.

The normal aerial terminal should be ignored, and instead the aerial lead-in should be joined to one side of a neutralising condenser placed in some convenient position at the rear of the set.

The remaining side of the neutralising condenser should be joined to the terminal on C_2 , which goes to L_1, L_3 , etc.

Getting Good Reaction

Short-wave reception should now be possible, but you can consider yourself very lucky if you succeed from the moment you switch the set on.

Without being unduly pessimistic, it requires considerable practice if you have not previously handled a short-wave receiver before satisfactory results are possible.

One of the difficulties with which you may have to contend is that of obtaining a reaction effect. In this connection perhaps I should mention that not all standard chokes are suitable for ultra-short-wave reception, however efficient they may be on normal broadcast waves.

Therefore, if you fail completely to get reaction, obtain a former of roughly $1\frac{1}{2}$ in. diameter, and on it wind 80 or 90 turns of No. 30 D.S.C. in a single layer, using this on the short waves instead of the existing choke.

YOUR SHOPPING LIST

- | | |
|--------------------------------------------------------------------------------------------------------------------------------------------------------------------------------------------------------------------------------------------------------------------------------------------------------------------------------------------------------------------------------------------------------------------------------------------------------------------------------------------------------------------------------------------------------------------------------------------------------------------------------------------------------------------------------------------------------------------------------------------------------------------------------------------------------------------------------------------------------------------------------------------------------------------------------------------------------------------------------------|------------------------------------------------------------------------------------------------------------------------------------------------------------------------------------------------------------------------------------------------------------------------------------------------------------------------------------------------------------------------------------------------------------------------------------------------------------------------------------------------------------------------------------------------------------------------------------------------------------------------------------------------------------------------------------------------------------------------------------------------------------------------------------------------------------------------------------------------------------------------------------------------------------------------|
| <ul style="list-style-type: none"> 1 Ebonite panel, 12 in. \times 7 in. (Becol, Ripault, Trelleborg, "Kay Ray," Resiston, etc.). 1 Cabinet for the above with baseboard 7 in. deep (Raymond, Cameo, Ready Radio, Lock, Gilbert, Pickett, Bond, Arterraft, Caxton, etc.). 1 '0005 variable condenser (Burton, J.B., Lissen, Igranic, Utility, Formo, Dubilier, Raymond, Ormond, Lotus, Pye, Gecophone, Cylidon, Colvern, Bowyer-Lowe, etc.). 1 '0001 midget reaction condenser (Cylidon, Lissen, J.B., Bowyer-Lowe, Raymond, Ormond, Dubilier, Utility, Burton, etc.). 3 Single-coil mounts, baseboard type (Lotus, Ready Radio, etc.). 1 Sprung valve holder (Benjamin, Lotus, W.B., Igranic, Pye, Marconiphone, Wearite, B.T.H., Precision, Bowyer-Lowe, Magnum, Ashley, Formo, etc.). 1 Fixed condenser, '0003 mfd. (Lissen, Clarke, Goltone, Dubilier, Igranic, Magnum, Mullard, T.C.C., etc.). | <ul style="list-style-type: none"> 1 Grid leak, 2 megohms, and holder (Lissen, Igranic, Pye, Dubilier, Ediswan, Loewe, Mullard). 1 Fixed condenser, '001 (Dubilier, Mullard, T.C.C., Lissen, Magnum, Igranic, Goltone, Clarke, etc.). 1 H.F. choke (Lissen, Varley, Cosmos, Lewcos, R.I., Raymond, Dubilier, Igranic, Ready Radio, Climax, Wearite, Magnum, Bowyer-Lowe, Peto-Scott, etc.). 1 L.T. "on-off" switch (Pioneer, Lotus, Benjamin, Magnum, Ready Radio, Lissen, Bulgin, Igranic, Ormond, Raymond, Burton, etc.). 1 Push-pull switch, three-spring wave-change type (Pioneer, Wearite, Bulgin, Ormond, etc.). 1 Slow-motion dial (Utility, Igranic, J.B., Lotus, Lissen, Brownie, Formo, etc.). 1 Clix plug and socket; Glazite for wiring; flex, screws, and 1 terminal strip, 10 in. \times 2 in., with eight terminals. |
|--------------------------------------------------------------------------------------------------------------------------------------------------------------------------------------------------------------------------------------------------------------------------------------------------------------------------------------------------------------------------------------------------------------------------------------------------------------------------------------------------------------------------------------------------------------------------------------------------------------------------------------------------------------------------------------------------------------------------------------------------------------------------------------------------------------------------------------------------------------------------------------------------------------------------------------------------------------------------------------|------------------------------------------------------------------------------------------------------------------------------------------------------------------------------------------------------------------------------------------------------------------------------------------------------------------------------------------------------------------------------------------------------------------------------------------------------------------------------------------------------------------------------------------------------------------------------------------------------------------------------------------------------------------------------------------------------------------------------------------------------------------------------------------------------------------------------------------------------------------------------------------------------------------------|

nature you need not entertain any doubts as to your inability to receive distant stations. You can rest assured that your trouble is due to the "plop," and if variation of the H.T. voltage fails to effect a complete cure, try another valve, if possible, in the detector position.

For Short Waves

It will probably be of interest to most readers to learn that the set can, with one or two small modifications, be used for the reception of short-wave stations. By short-wave I mean, of course, stations between 20 and 40 metres.

But before detailing the modifications necessary it should clearly be understood that successful short-wave reception calls for rather more operating skill than is required for ordinary broadcast reception, and readers are therefore strongly advised to acquaint themselves with the set on ordinary broadcasting before attempting anything on short waves.

For reception on short waves, a

actual wave-change switch pushed in; in other words, also in the "long-wave" position. The flex lead from one of the terminals at the back of the switch should be ignored.

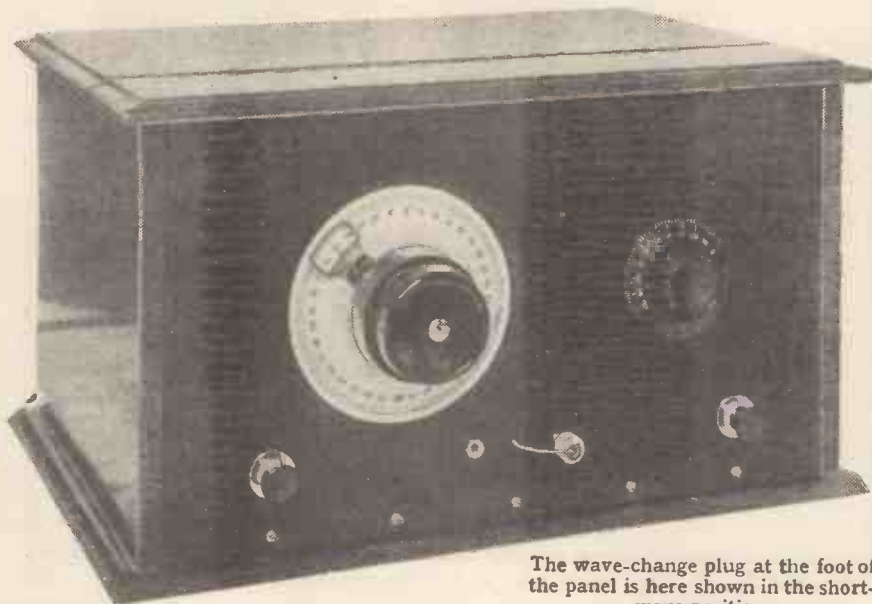

The wave-change plug at the foot of the panel is here shown in the short-wave position.

MY BROADCASTING DIARY



Under this heading month by month our Broadcasting Correspondent will record the news of the progress of the British Broadcasting Corporation, and will comment on the policies in force at B.B.C. headquarters.

Flutters at Savoy Hill

I DISCOVER that some quite innocent and friendly observations of mine create great stir at Savoy Hill. It is my business as a responsible journalist to serve my Editor to the best of my ability and opportunities. The policy propounded in this page since the feature began some time ago is definitely friendly to and sympathetic with the B.B.C.

Nevertheless, the tradition of honest journalism must be upheld; there are occasions when the duty of the candid friend is to condemn and deplore. Then, on the side of news, it is part of my job to keep *au fait* with all that goes on in the broadcasting world.

I find the publicity staff at Savoy Hill most helpful and courteous; but naturally I cannot rely on them for "inside news," by which I mean policy and constitutional matters, relations between the executive and the Board, etc.

I make no apology for the public discussion of such subjects. They are of vital interest to the bulk of the general public, which, through the apathy of Parliament, is kept in almost complete ignorance of the inner politics of the Broadcasting Corporation.

I find it necessary every twelve months to make a statement of policy and intentions, because it is at about these intervals that the customary urbanity of friends at Savoy Hill gets ruffled. "Pressure" is brought to bear, presumably because my remarks are uncomfortably close to the absolute truth. It is accordingly my duty to state publicly for the fourth time that I can be persuaded, but not frightened or coerced.

The Gold Rush and After

The number of staff lost by the B.B.C. to the talkies this year is still below fifty, of which some forty are comparatively junior engineers. This defection in relation to the total number of staff, 1,100, is not serious. But there are rumours of a much larger defection in the offing, and it is not surprising that the Governors have bestirred themselves about the matter.

It is understood that, largely through the initiative of Mrs. Philip Snowden, there is to be a general upward

revision of engineers' salaries at the B.B.C. It remains to be seen whether this increase will be substantial enough to stop the leak at the technical end. But simultaneously there are fresh staff troubles to be reckoned with.

Changes in the Talks' Department of the programme branch, which have already been announced by me, are shaping a first-class staff crisis which may involve the early resignation of Miss Matheson and four members of her staff. There seems to be a good deal of fluctuation in all aspects of B.B.C. policy and organisation these days.



Mr. Noel Ashbridge, successor to Captain P. P. Eckersley in the onerous position of Chief Engineer to the British Broadcasting Corporation.

The sooner things are straightened out and a little more "humanity" imparted to the spirit of the place, the better for broadcasting, which is apt to get neglected.

The Television "War"

With the suspension of the armistice between the B.B.C. and the Baird companies in June, hostilities were resumed on a wider front than ever before. The direct appeal of the Baird interests to the new Postmaster-General did not bear the expected fruit.

Then a big attempt was made to get Parliament to institute a public inquiry into the B.B.C. and its affairs.

All the Latest News for Listeners

in the hope of capitalising the recent crop of internal troubles at Savoy Hill. But Parliament rose for the summer before this attack could be properly developed. The summer interval is being utilised by the Baird interests in a diligent endeavour to prepare the way for fresh methods of obtaining the concessions they require.

All the elements actually and potentially hostile to the B.B.C. are being mobilised for a big combined offensive

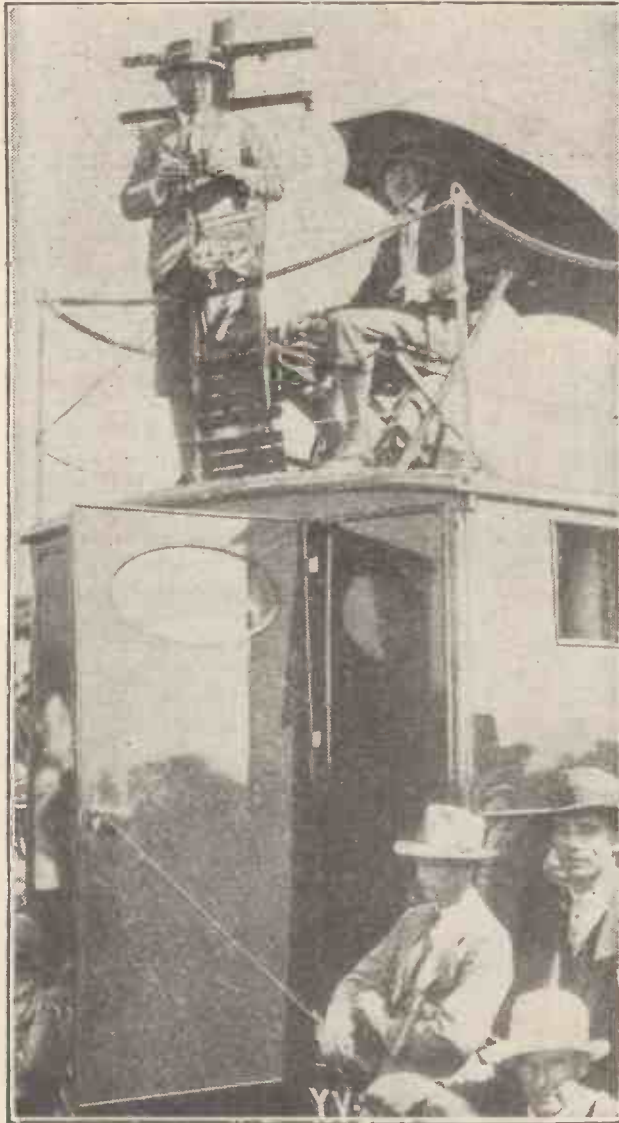

A scene at the broadcasting of a Bisley commentary on the shooting for the King's Prize.

on the eve of the reassembly of Parliament. War to the bitter end, with no quarter on either side, is the order of the day.

The National Orchestra

It looked at one time as if this proposal were to die a natural death, pre-natal. But apparently one more desperate endeavour is to be made to get the scheme under way. The chief difficulty now is that by linking up with one of the big gramophone companies for exclusive recording rights the B.B.C. will be so effectively boycotted

by the others that a large proportion of the best artistes will be withdrawn from the programmes.

Here is a situation which will require just that superlative handling which made for Sir John Reith his great reputation in the early days of broadcasting. The danger is that he will leave the job to others.

A Vaudeville Change

The autumn is likely to see a change in the method of presenting the vaudeville features that are taken from music-halls. Last season it was the custom to insert these in the ordinary B.B.C. vaudeville programmes, but this was never quite satisfactory. For one thing, the contrast was terrific both in the quality of performance and in the atmosphere.

So the matter has been reconsidered, with the result that during the Promenade season, and probably thereafter, relays from outside variety theatres will be divorced from the ordinary broadcast variety programmes and left to stand on their own feet supported by Jack Payne and his B.B.C. Dance Orchestra. This seems to me a very sensible move. Incidentally, it is good showmanship.

General Dawes to Broadcast

General Dawes, the new United States Ambassador in London, will be heard by listeners to all British stations at 9.40 p.m. on October 15th. The occasion will be a function in connection with a Civic Week at Hull. The only other speech to be included will be that of the Lord Mayor of Hull.

A Repeat Poe Horror

"The Tell-Tale Heart," a horror monologue by Edgar Allan Poe, is to be repeated S.B. by the B.B.C. in October.

Another Festival Broadcast

The success of the Thanksgiving Festival broadcast from the Abbey has suggested a similar broadcast late in November from the Albert Hall under the auspices of the "Daily Mail." The proceeds of the Albert Hall show will be divided between certain national charities.

Mr. R. H. Eckersley to Stay

I am told authoritatively that there is no foundation whatever for the rumour that Mr. R. H. Eckersley contemplates joining his brother in business outside the B.B.C. "Roger" does not share "Peter's" views about how broadcasting should be done, and declares himself satisfied with things as they are at Savoy Hill.

As events are developing, I would not be at all surprised to see Captain Eckersley going all out for more than one broadcasting authority when the present licence expires in 1936. While in his rôle of "the Warwick of Broadcasting" Captain Eckersley made and unmade numerous programme directors, culminating with the elevation of his brother to the coveted place.

In the event of several authorities replacing the B.B.C. in seven years' time, it may well turn out that Captain Eckersley and his brother will be in the most vigorous opposition. But the whole future of broadcasting in this country is so obscure that he would be rash indeed who committed himself to any definite prophecy.

Crowded Current Carriers



A RADIO set is a maze of electrical circuits. Some deal with radio-frequency currents, some with audio-frequency currents, and others with direct current. Every valve will have a grid circuit, an anode circuit and a filament circuit, while there will be an aerial tuning circuit and, in the case of a mains set, various smoothing and rectifying circuits.

And it is the aim of a radio set designer to get every one of these individual circuits connected to earth as effectively as possible. In doing this he aims at a maximum degree of stability. Any circuit that is not so treated is reckoned to be "up in the air" and a possible source of instability.

You will notice in any radio receiver that there are more things connected to the earth terminal directly by wires than to anything else. And there are other earthing connections which are not metallic, these being via fixed condensers.

In the case of a set employing screening, these are naturally grounded and thus form convenient points to which earthing connections for various parts of the set can be taken.

Branch Connections

Branch connections simplify wiring and make for tidiness. If you are told to connect one terminal of a certain component to the earth terminal of the set you can join the wire to the nearest lead that goes to this point. This is, of course, a common practice, as you will see by referring to any wiring diagram.

The result is that it frequently happens that through one piece of wire all kinds of current flow. The accompanying diagram shows a very small section of a possible series of connections.

One of those knotty points that confuse many amateurs interestingly explained.

By D. GLOVER.

The L.T. minus terminal has been placed close to the earth terminal and a short length of wire joins them together. Another lead goes to the earth terminal from a large fixed condenser that happens to be placed in series with the loud speaker in accordance with the familiar choke-capacity shunt scheme.

Shortening the Wiring

One terminal of an H.F. transformer has had to be taken to earth, and, to shorten the necessary wiring, the lead has been joined to that L.F. shunt condenser wire which happens to be passing close by. And the same thing applies to the L.T. minus terminal of a valve holder.

Therefore, through one short length of wire pass L.F. impulses that have negotiated and operated the loud speaker; H.F. impulses that have

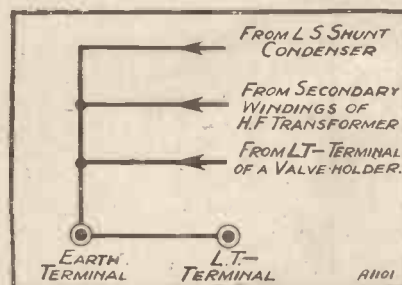

been generated in the secondary winding of the H.F. transformer, and a steady uni-directional current which flows from the battery through the filaments of the valve.

There is no confusion whatever and the H.F. does not interfere with the L.F., the L.F. with the D.C., or the D.C. with either of the others. In actual fact they are not three different kinds of energy. It would be more correct to refer to them as variations of the same energy.

You can think of the direct current as a steadily flowing stream to which is added a further current of an alternating nature, either high- or low-frequency, or both. A heavy buoy in a river or sea will bob up and down as waves pass it, but only the size of the waves will determine the movement of that buoy, and it does not matter whether the water is 10 ft. or 100 ft. deep, the buoy will bob up and down to the same extent.

Now you see, if you have D.C. current flowing through a device that needs alternating energy to operate it, such as the loud speaker, it is only the wave motion, which may be accompanied by D.C., which will directly determine the actuation of the device.

No Confusion At All

The total current, including the D.C., may be large or small; that does not matter, it is only the alternations, the L.F. impulses, that have to be taken into consideration in this particular case.

Similarly, you could pass a mixture of D.C., L.F. and H.F. through the primary winding of an H.F. transformer, but it would only be the H.F. ripples that would do any work in that component. You certainly need not worry about one wire having to carry D.C., H.F. and L.F. Providing the set connections are in order each current will complete its own circuit or circuits without worrying about either of the others.

WIRELESS AT SEA

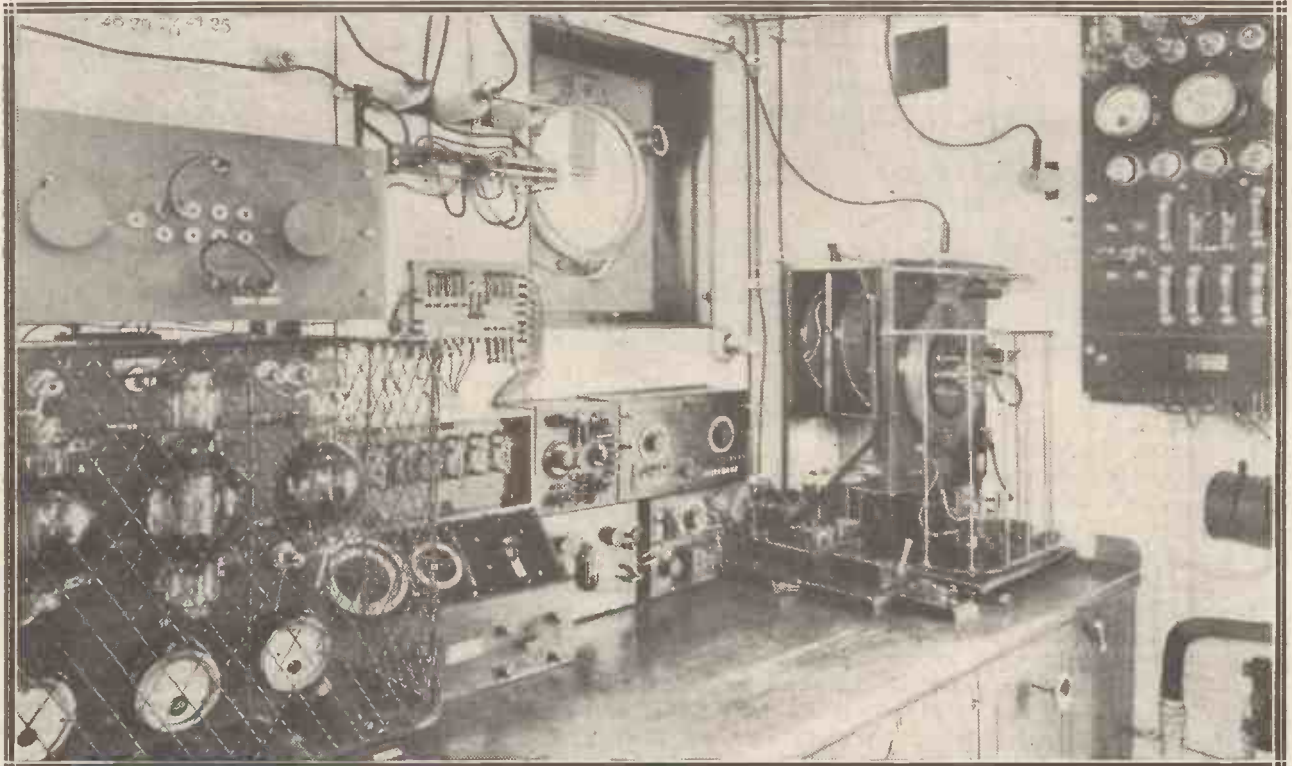

News of many a stirring drama of the Atlantic has been borne to and from this wireless cabin on the S.S. "Minnetonka." This vessel has figured directly in more than one exciting radio incident during her regular voyages between this country and America. The transmitting inductances will be seen on the right, with the transmitting key screwed to the operating table beside the protective "cage." On the bulkhead to the right is the control board, with its indicating lamps, switches, fuses and meters. The main transmitting valves are shown to the left of the picture.

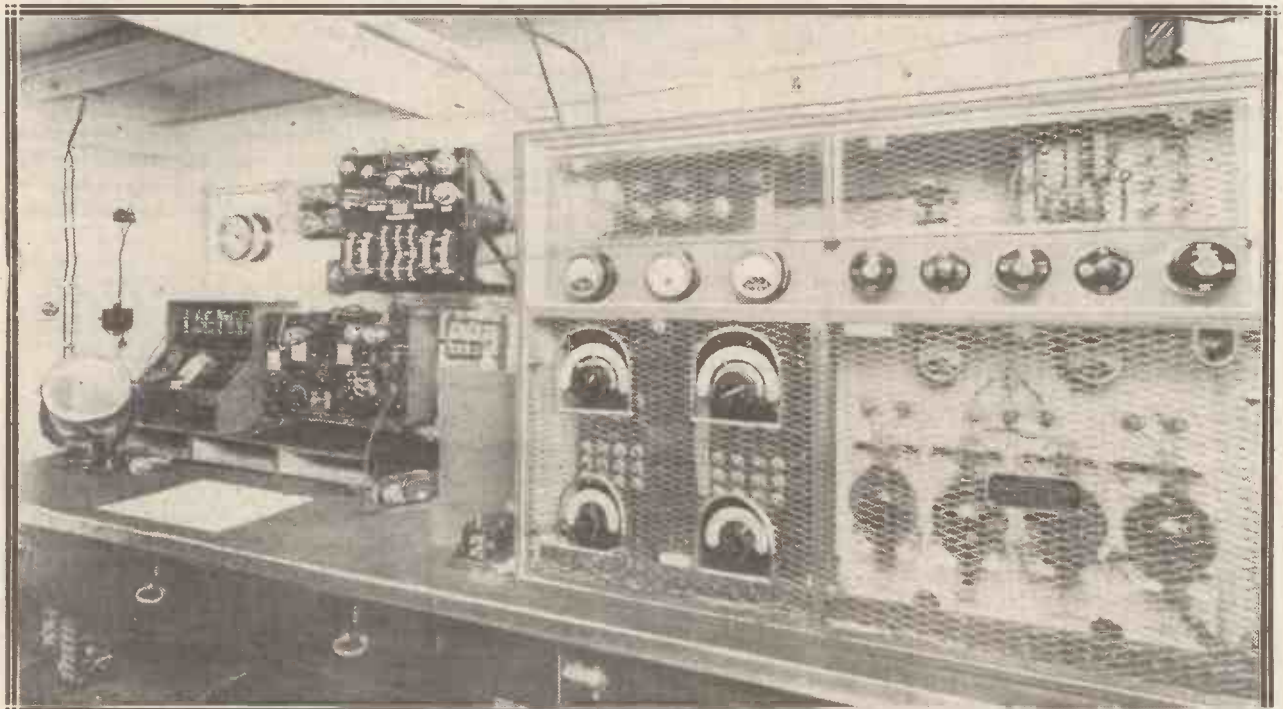

Here is the up-to-date apparatus fitted on board the S.S. "Duchess of Bedford." Note how wire screens are placed to prevent accidental contact with the transmitting apparatus, such as might all too easily result from a sudden lurch in a heavy sea. An interesting feature of the installation is the Marconi direction-finder on the extreme left, under the clock. Next to this and screwed to the bulkhead is the standard Marconi Marine receiver.

SOME FAMOUS SHIP SETS

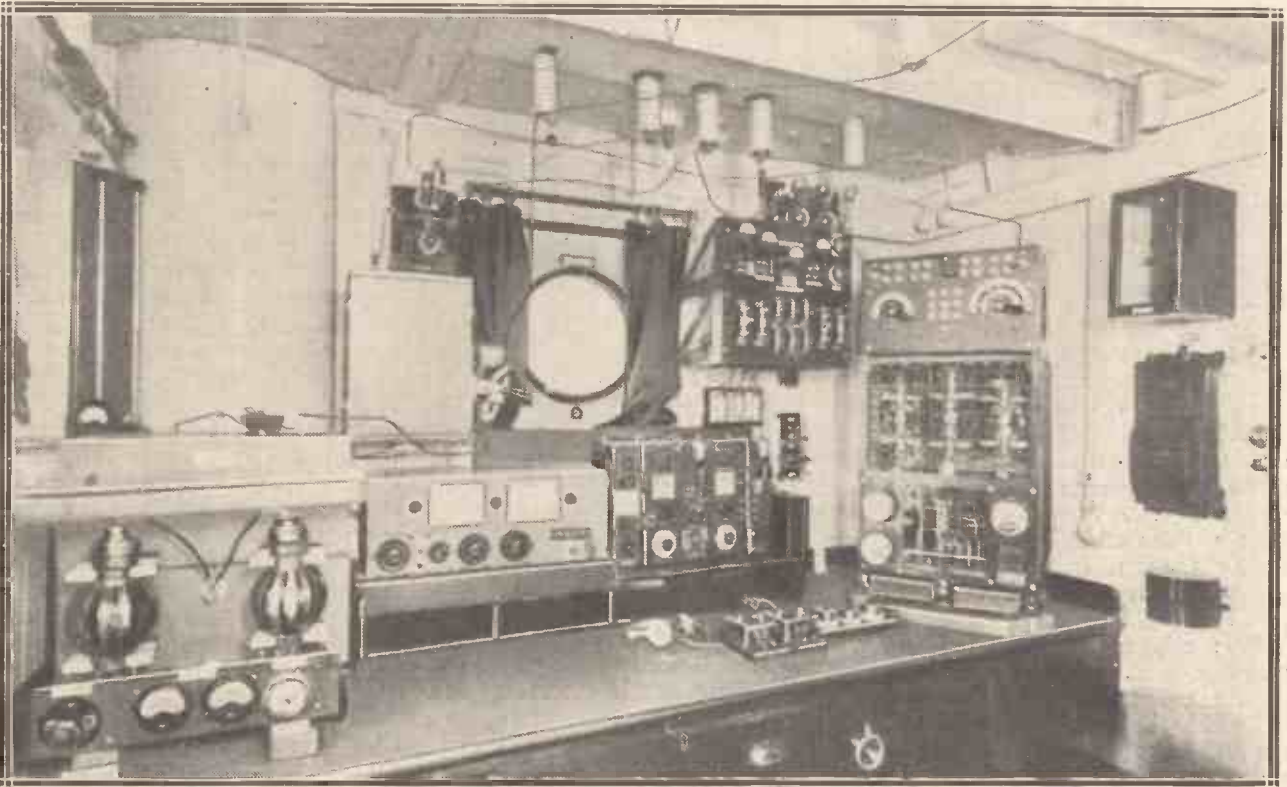

The radio gear of the "Staffordshire" includes an experimental short-wave transmitter (to the left), with next to it a short-wave receiver. On the bench will be seen the telephones and transmitting keys, and to the right of these is a 1½-kilowatt valve transmitter. The motor-starter and regulator are fitted under the bench (just below the transmitting keys), where they are easily within instant reach of the operator on watch.

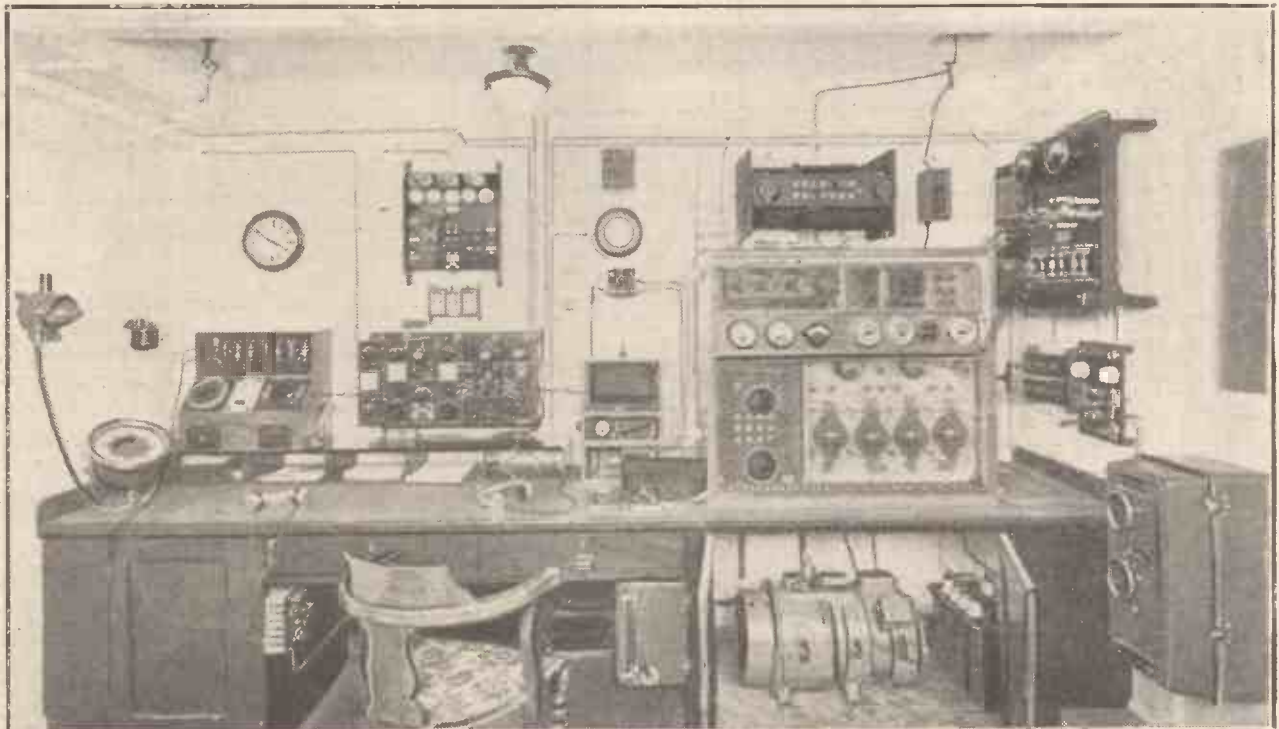

There is an air of comfort and spaciousness about the radio room of the motor liner "Bermuda." On the extreme left is the gyro-compass repeater, with a Marconi direction-finder mounted below the clock. The receiver (in front of the operator's chair) tunes to all wave-lengths between 300 and 28,000 metres. This vessel can transmit on the long wave-lengths (2,000-2,750 metres) or on the ordinary ship wave-lengths between 600 and 850 metres.

QUESTIONS ANSWERED

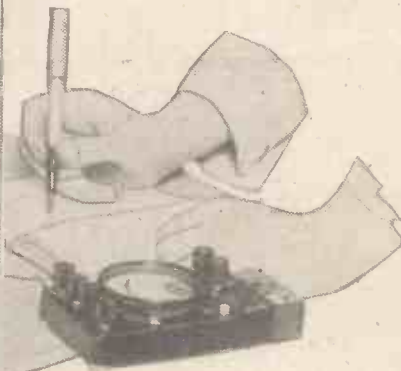

H.F. Chokes

B. C. N. (Chatham).—"I have a number of plug-in coils of large size which I find are no longer used in modern sets. A friend suggests that some of them could be employed in place of the usual H.F. choke. Can I use any of my coils for this purpose?"

Yes; a large plug-in coil makes a perfectly satisfactory H.F. choke. For the medium broadcast wave-band a No. 250 or 300 coil is adequate. For 5 XX and similar long-wave stations, however, you will need a much larger coil. Usually a No. 400 or 500 is advisable. On the other hand, on the very short waves a No. 40 or 50 coil is quite large enough.

Distortion in a Portable

C. E. V. (Northampton) asks a question concerning a portable set which distorts badly on both 5 GB and his local station.

The answer, C. E. V., depends upon the location of the distortion. For instance, the use of too much reaction or a tendency to oscillate on the part of the H.F. valve would cause the trouble. On the other hand, your L.F. side may be unstable, since there is no earth to assist in holding it down. Try reducing the H.T. voltage on the H.F. valve, and decreasing the amount of reaction.

On the L.F. side it would be a good plan if you were to connect a .25-meg. resistance across the secondary terminals of your transformer.

Erecting an Aerial

A. P. C. (Lowestoft).—"I am in a position where it is impossible for me to erect an outside aerial. I shall therefore have to choose between an indoor aerial round the picture railing, or a frame. Which of these is likely to give the better results in my case?"

From the point of view of reception generally, the indoor aerial is the better. The pick-up of a frame is small and in consequence an extra H.F. valve is usually needed in order to obtain equal results. An indoor aerial, on the other hand, whilst not possessing the sensitivity of the outdoor arrangement, is nevertheless capable of giving good results.

It is as well to carry out experiments with indoor aerials of various types,

THE TECHNICAL QUERIES DEPARTMENT

Are you in trouble with your set?

The MODERN WIRELESS Technical Queries Department is now in a position to give an unrivalled service. The aim of the department is to furnish really helpful advice in connection with any radio problem, theoretical or practical. Full details, including the revised and, in cases, considerably reduced scale of charges, can be obtained direct from the Technical Queries Department, MODERN WIRELESS, Fleetway House, Farringdon Street, London, E.C.4.

A postcard will do: on receipt of this all the necessary literature will be sent to you, free and post free, immediately. This application will place you under no obligation whatever. Every reader of MODERN WIRELESS should have these details by him. An application form is included which will enable you to ask your questions so that we can deal with them expeditiously and with the minimum of delay. Having this form you will know exactly what information we require to have before us in order to solve your problems.

London readers, please note: Inquiries should not be made in person at Fleetway House or Tallis House.

since the disposition of the wires frequently has a marked effect upon signal strength. Possibly it will be best for you to erect the aerial just below the roof, running the lead-in down the side of the house and as far away from the wall as you can manage.

A frame aerial is very often a great help in reducing the Morse interference from shipping, but, as previously stated, one must be prepared to build a larger set to make up for the loss in sensitiveness.

Crackling Noises

S. R. (Rochester) is troubled with crackling noises in his three-valve receiver. He has had the set thoroughly tested and pronounced O.K. He is of the opinion that the interference is coming in from the outside, because when he removes his aerial and earth wires from the terminals on the receiver the trouble ceases.

It is always difficult to diagnose a trouble such as this, S. R. Since the noises are persistent it is improbable that atmospheric disturbances, as, for instance, lightning, etc., are responsible.

The noises are quite probably due to some nearby electrical machinery, and perhaps if you make enquiries you will be able to discover the source. Local overhead tramway systems are often to blame for trouble of this nature.

In most cases it is difficult to effect a cure, but you could try a counterpoise instead of the earth, and a smaller aerial.

Using a Milliammeter

T. Q. (Birkenhead).—"I have been told that a milliammeter is a valuable aid from the point of view of checking distortion. Is this so?"

Yes, a milliammeter is extremely useful and is invaluable to all those whose aim it is to secure distortionless reproduction. The meter is inserted in circuit between the H.T. + lead to the last valve and the loud speaker or choke terminal to which this lead goes. The object is to obtain an adjustment of signal strength which does not produce needle "kicks."

It is usual to permit not more than a variation of 10 per cent of the anode current in the form of "kicks." If the needle fluctuates more than this amount the H.T. and grid bias should be increased or a more suitable power valve inserted in the last socket. A suitable milliammeter for most purposes is one having a reading of 0-25 m.a.

The 1928 "Solodyne"

L. N. (Torquay) asks whether it is possible to use a pentode valve in the last stage of the 1928 "Solodyne."

Well, L. N., it is certainly possible to do this, but it is not desirable. The 1928 "Solodyne" is capable of enormous magnification and it is most probable that the introduction of a pentode would produce L.F. troubles and overloading. The only thing to do would be to cut out the R.C. stage and use only one L.F. valve.

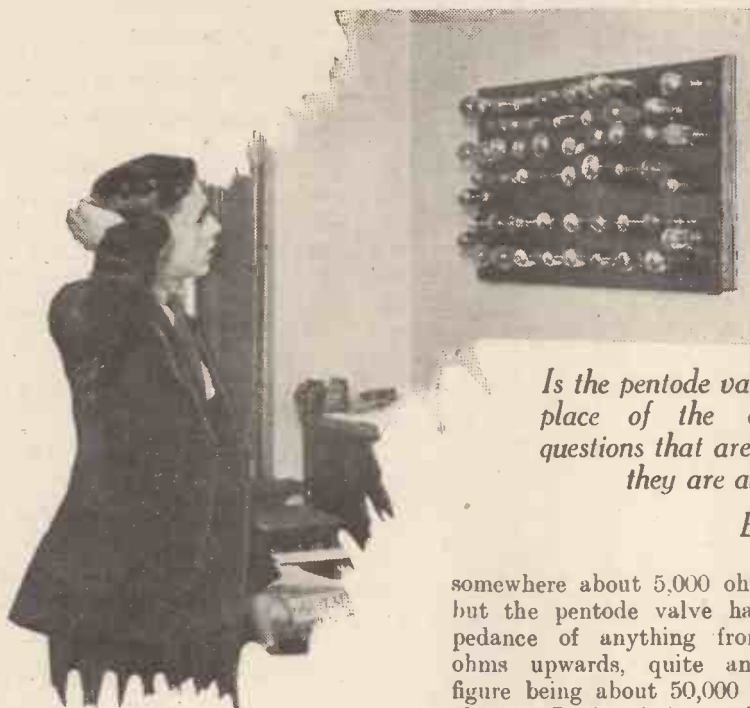

POWER OR PENTODE?

Is the pentode valve worth while? Does it really take the place of the ordinary output valve? These are two questions that are always cropping up among constructors, and they are answered in this straightforward article.

By KEITH D. ROGERS.

A GREAT deal has been said and written about the new five-electrode valve commonly known as the pentode, but there still seems to exist a considerable amount of doubt as to the true usefulness of that valve.

The trouble is that it is quite

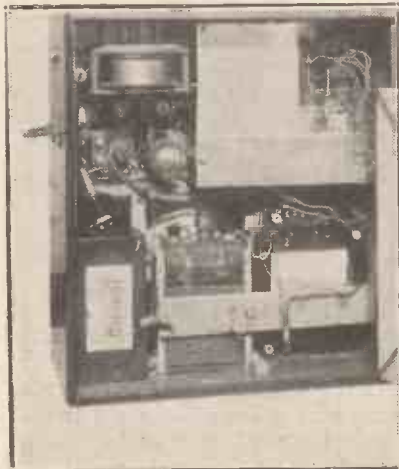

One of the many portable sets that employ pentode output valves—the Dubilier Westminster.

unlike any other valve that we have ever had before, and so there is no precedent to guide the average constructor. He cannot judge things from his experiences of the use of the ordinary super-power output valve.

The whole problem is wrapped up in the extraordinarily high impedance of the pentode compared with that of the usual output valve. The average output valve has an impedance of

somewhere about 5,000 ohms or so, but the pentode valve has an impedance of anything from 20,000 ohms upwards, quite an average figure being about 50,000 or 60,000 ohms. It is obvious, then, that when using a pentode the electrical properties of the output circuit of the receiver are going to be very different from those when one is using an ordinary output valve

Different Response Curve

For instance, if you take an ordinary super-power valve having an impedance of somewhere about 3,000 ohms, and use it with any particular loud speaker, you get certain results; a certain response curve which gives you a certain character of reproduction. You may like it or you may not like it, dependent upon your taste and the loud speaker employed; but insert a pentode valve in the place of that ordinary valve, and the results are likely to be very different.

In the first place, you are most likely completely robbed of the bass (not due to the valve itself, mind you), and with the average speaker it is not unlikely that the treble will predominate to a rather unpleasant degree. We are assuming, of course, that the pentode valve is being used directly in the place of the ordinary valve, and without any alteration to the output circuit.

The "Peak" Problem

If an output transformer is employed, it is more than probable that the amplification of the pentode will be made use of to a fuller extent, and that greater signal strength will be obtained; also more or less the same type of reproduction as with

the power valve will be experienced.

There is a difference, however, in that the pentode will not take the same grid swing as the power valve, and so overloading troubles at once become very apparent.

The whole trouble in using a pentode is this: that the impedance of the valve is so high that unless it is used with an output transformer the power transference from the valve to the speaker is decidedly lower than would be expected from the valve's magnification powers. On the other hand, this power transference is liable, of course, to increase with the higher notes, and so if your loud speaker has a peak, or tendency to peak at the higher notes, then, with the tendency of the valve to transfer greater power at these high



Two well-known super-power valves—the Ediswan P.V.610 and the Marconi P.625.

frequencies, this will give you very badly pronounced treble and a lack of bass.

It is a well-known rule that the maximum power transference is

Sacrificing Grid-Swing For Magnification

obtained when the impedance of the valve equals that of the impedance of the loud-speaker circuit at any given frequency. Now to all intents and purposes the impedance of the valve does not vary with frequency, but the impedance of the loud speaker *does* vary; and so, in the case of the pentode valve, we may start off on a low note with the impedance of the valve being very high and the impedance of the loud speaker low, and therefore a low transference of energy. But as the notes get higher and higher, the impedance of the loud speaker increases, while the impedance of the valve remains where it was, and so we gradually get more and more transference of energy as the notes go higher.

What Actually Happens

Eventually, when the impedance of the loud speaker is somewhere about that of the valve, we get the maximum transference of energy, and therefore the maximum signal strength.

That would be all very well if, like in some loud speakers, especially the M.C. types, there were a tendency for the response to fall off at the high frequencies; but when reed-driven speakers are employed there

transference being obtained on the low notes, when the loud-speaker impedance is usually somewhere about equal to that of the valve, while as the high notes come along so the impedance of the loud speaker gets farther away from that of the valve, and the power output transference is reduced.

So we get an inclination to get bass and to cut off the high notes.

That is how the matter stands with the valves when used with an ordinary speaker. When used with a

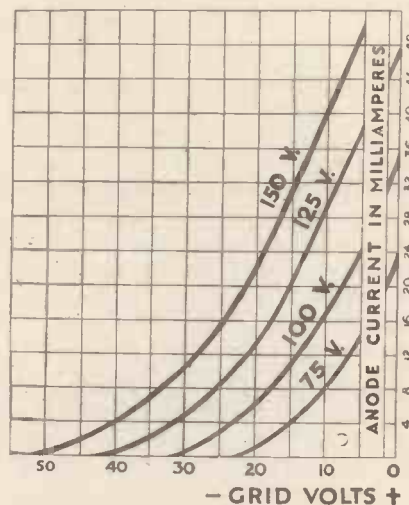

The curves of the Cossor 230 XP. valve—of the super-power class. Note the grid swing available.

moving-coil speaker things are somewhat different, and the pentode can be made to counteract the tendency of some moving-coil speakers to emphasise bass and cut off the treble until we get a certain approximation to straight-line response.

Unless the loud speaker is of the type which tends to over-emphasise the bass at the expense of the treble, it is certainly not advisable to use a pentode valve unless an output transformer is employed.

Special Power Pentodes

If used with an output transformer you will counteract this tendency to over-emphasise the treble and you get back more or less to where you started as regards the response curve. You get a certain amount of extra amplification due to the amplification powers of the pentode, but at the same time you get an inability to carry a large grid swing, which somewhat counteracts the maximum signal

strength available with the combination.

There are special power pentodes coming on the market which will be able to deal with heavier grid swings than those at present on the market,



The super-power valve has the advantage of large grid swing, while the ordinary pentode "has it" on magnification, losing on the grid swing very considerably.

but it is indeed a moot point as to whether a pentode or a power valve is preferable with the average loud speaker.

It is not easy for the ordinary listener to decide which valve to use, but I think it will help him if he considers the few points I have brought out and also the following.

If the set is of such a type that there is no danger of the pentode being overloaded, and if you have a reasonably good loud speaker and use an output transformer, then the pentode may give you quite a good increase in volume and good tonal quality.

If, however, your set provides so much power at present that you need a super-power valve to handle the output, then the pentode is almost sure to be a waste of money and trouble unless you have a loud speaker which really needs correcting, i.e. is too boomy and is deficient in the treble register. Certain boomy loud speakers which have no resonant points in the treble are often improved by being used with a pentode valve, and the moving-coil speaker, of course, is often very greatly improved by use with such a valve.

Short-Wave Sets

In these cases, however, it must not be forgotten that the output transformer should *not* be employed and that the valve should be used in the ordinary filter circuit as in the case of the super-power valve.

(Continued on page 300.)

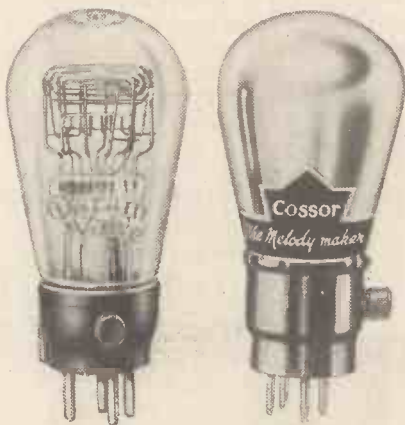

Two modern pentodes—the Osram and Cossor two-volters.

is often a tendency to resonate at these high frequencies, so this, together with the increased output from the valve, gives a nasty peaky effect which makes the treble altogether too prominent.

In the case of the ordinary super-power, of course, we have low impedance, the maximum power

WALES AND THE B.B.C.

The question of special Welsh programmes is a very delicate one, and, due to the B.B.C.'s latest move, the situation is becoming very strained. The position as it is to-day is reviewed and discussed in this article.

By The EDITOR.

THE latest news in the controversy between the B.B.C. and the Welsh Nationalists is that the B.B.C. has refused definitely to extend the scope of the Welsh programmes from the Cardiff broadcasting station.

In view of the importance of this decision, we feel that some comment upon the B.B.C.'s action must have place in this issue of MODERN WIRELESS, for there is no doubt that the B.B.C.'s refusal has caused widespread resentment in Wales.

Strong Protests

At a recent meeting of the Welsh University Court at Cardiff, there was a strong protest against the B.B.C.'s attitude to broadcasting in Wales, and it now seems that various societies in the Principality are going to make a determined effort to get the B.B.C. to withdraw what is regarded in Wales as a slight upon the Welsh people.

We feel, however, that this attitude is a little strong, for our personal knowledge of the heads of the B.B.C. makes us feel confident in stating that no slight upon the Welsh people was intended at all. The B.B.C.'s decision, of course, is simply one of policy, and is based purely upon what it considers to be its best policy.

However, there are some justifiable reasons for Welsh resentment, for up to eighteen months ago the Swansea relay station catered extensively for Welsh listeners—there were musical, literary and dramatic programmes of specific interest to Welsh people. But eventually Swansea's policy seems to have undergone a change, for it has decidedly lost what the "Western Mail" calls its "separate entity," and is now completely subordinate to the main station at Cardiff.

Lost Individuality

Occasionally, about once a fortnight, the B.B.C. provides a more or less Welsh programme, but the specific Welsh features have practically disappeared from the programmes.

Another reason for the protest in Wales is that the broadcasts to Welsh

schools are, in future, to be part of the London programme. This, we feel, is a very unwise step on the B.B.C.'s part, for how can these programmes maintain their distinctly Welsh character? In particular, the B.B.C. should realise that broadcasts from Wales, when they are bona fide Welsh programmes, have an individual character and personality which cannot be imitated at the London station.

Already, representatives of the Welsh University Colleges have called at B.B.C. headquarters with a view to emphasising the importance of giving the Principality its fair share of the broadcasting service; it appears, however, that they have received but little sympathy. The B.B.C.'s view is that the Cardiff station caters for a large English-speaking community in South Wales and across the River Severn, and that the B.B.C. has

are emphatic on this point; and there has even been the suggestion that because Sir John Reith is a Scotsman himself, Scotland gets more consideration.

No Separate Entity

But that, we venture to say, is a very childish point of view; and we feel sure is not borne by responsible people in Wales. Sir John Reith is the very embodiment of impartiality and fairness. In fact, sometimes his impartiality is a little too strict, for there are occasions when one's sympathies should be swayed, if not completely captured, and the Welsh broadcasting question is one which requires very, very tactful handling and sympathetic consideration.

The situation, in fact, is becoming strained, and there is now a movement on foot to organise Welsh listeners

ADJUSTING THE SIGNAL STRENGTH



The control room of the Leeds-Bradford relay station, one of the most important sub-stations in Britain.

given the highest possible margin for Welsh programmes relative to other demands made on the B.B.C.'s Welsh service.

But Welsh listeners still maintain that they are not being fairly treated and that they are not receiving the same treatment as Scotland, for example. Some of the Welsh societies

into a body for the purpose of refusing to pay the licence fee!

The "Welsh Outlook" puts this point of view: "Wales is merged in England. As a separate entity, with a national life of its own, Wales does not exist for the B.B.C. That is what it amounts to, and this is particularly

(Continued on page 300.)

The "Reactohm"



Only four controls are employed. From left to right: these are tuning condenser, wave-change switch, resistance reaction control, and the on-off L.T. switch.

NORMAL methods of controlling reaction, whether by a moving coil or a variable condenser, all have one drawback.

The drawback is an alteration in the tuning every time the reaction is increased or decreased.

This makes it necessary to readjust the tuning condenser every time an alteration of reaction is made. The amount of retuning necessary depends upon the particular scheme employed to provide feed-back.

It is greater in the case of swinging coil reaction than when capacity control is utilised; however, it is quite sufficient in the latter case to complicate tuning considerably.

Really Smooth Action

The reader will gather from the foregoing that a means of controlling reaction without affecting tuning is a very desirable feature, particularly in the case of distant reception.

In the receiver to be described, the desired conditions just outlined are very satisfactorily obtained by controlling the reaction by means of a variable resistance. So well does it work that it is possible to change the power of the whistle produced by a heterodyned carrier-wave without altering its pitch at all.

Incidentally the control of oscillation is so smooth that it is difficult to tell exactly when the receiver commences to oscillate.

Apart from the advantages of the

set as regards reaction control, one of the simplest possible forms of wave-change switching, using ordinary plug-in coils, is provided. No special components are required, and the set is extremely simple to build.

Before describing the construction it will be interesting to consider the circuit employed. A diagram of it is given which will enable you to follow the special arrangement. There are two sets of plug-in coils, one for the lower wave-band, in series with which the others are connected for long waves. The two loading coils for the long waves are both shorted when the set is being used on the lower wave-band.

The coils which provide the aerial coupling are used also to give the

necessary feed-back of H.F. for reaction purposes.

This is done by connecting the plate to the aerial terminal via a semi-fixed condenser. It is desirable that this condenser be adjustable, so that coils may be chosen for aerial coupling which, whilst giving suitable reaction, enable the set to be sufficiently selective. The actual wave-change switch is of the usual three-connection type.

Most readers will be familiar with the fact that a valve can be made to stop oscillating (with a given reaction setting) by simply lowering the H.T. voltage on it. It is this fact of which use is made in controlling the reaction of the set. A high resistance of 50,000 ohms is connected across the positive and negative of the H.T. battery.

Easy to Operate

This resistance takes the form of a potentiometer, and it has a slider which will make contact with any point along the resistance. Since H.T. is supplied to the detector valve via this slider, it will immediately be apparent that any voltage from zero to the maximum of the H.T. battery can be applied to the detector valve.

The slider makes it possible to vary the voltage gradually and continually over the whole range. It thus provides a very good control of reaction, and the controlling knob of the high-resistance potentiometer takes the place of the usual reaction condenser.

The name given to the receiver, the "Reactohm" Two, is a descriptive

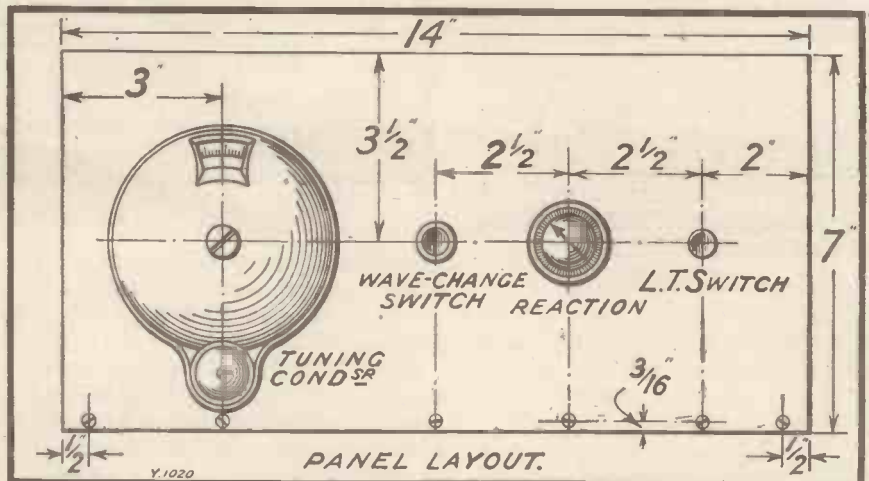

Two

Designed and Described
By A. S. CLARK.

An efficient two-valver which has exceptionally smooth reaction due to a novel method of control.

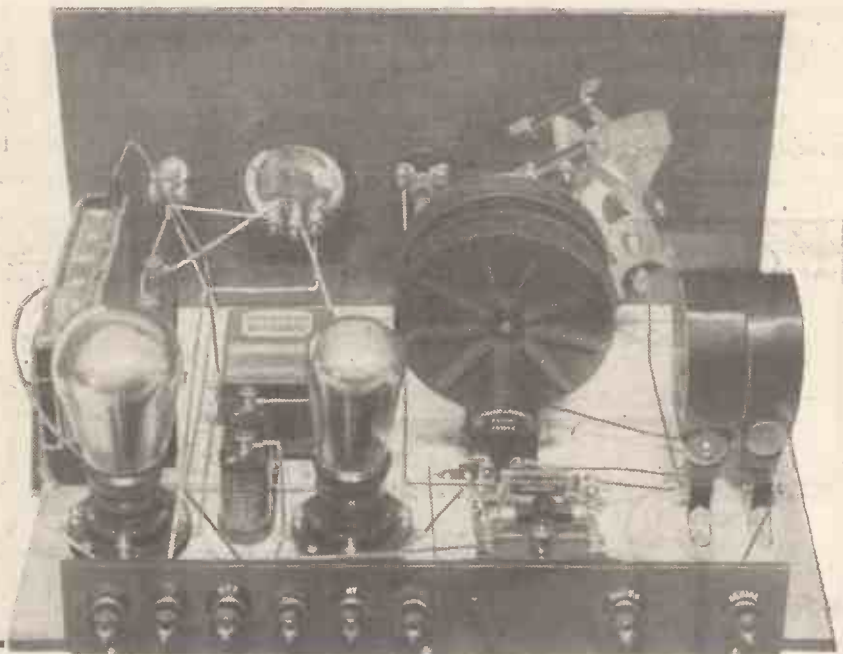

A general view of the receiver, showing how the coils are placed—a very important feature of the design.

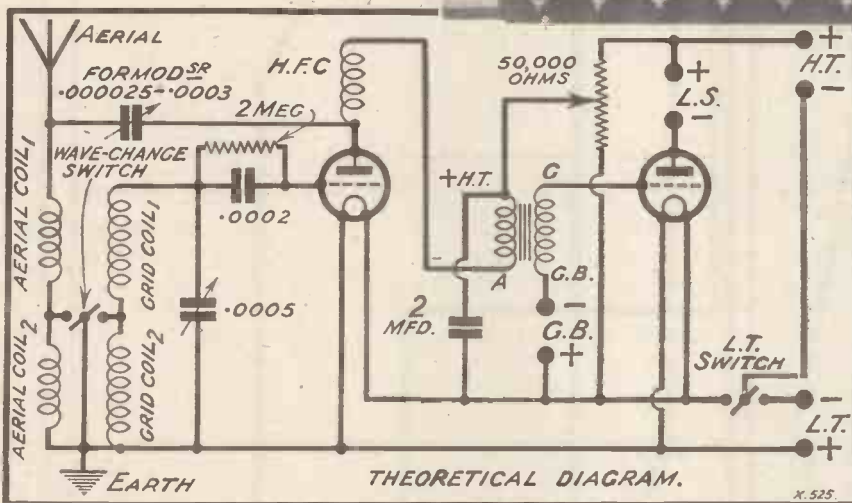

three-quarters of an inch from the top of the terminal strip. The correct markings for the terminals will be found on the wiring diagram.

Little need be said about the mounting of the components. Those which go on the panel should be fixed in place before the panel is screwed to the baseboard. The positions of the coil mounts should be noticed carefully. It is as well to place coils in them before they are permanently fixed, to make sure that the coils will not touch one another.

one. It is a combination of the two words "reaction" and "ohm," and it thus forms a convenient title, since the reaction is resistance controlled.

The L.F. stage is transformer coupled to the first valve in the usual manner. A large fixed condenser is shunted across the section of the potentiometer in the plate circuit of the first valve.

The Panel Drilling

This prevents any possibility that the resistance might cause L.F. instability and consequent distortion. Only one H.T. positive terminal is required, as the potentiometer is shunted across the whole of the H.T. battery.

A list of the components required to build the set is given, and names of suitable makes of components are indicated. Although the value of the potentiometer used in the original

set was 50,000 ohms, as previously mentioned, its value is not critical.

Within a few thousand ohms it does not matter what its resistance is. However, the value must not be too low or an undesirably large current will be taken from the H.T. battery.

The drilling of the panel is quite simple, the dimensions and positions of the holes being given on the front-of-panel drilling diagram. The necessary details for drilling the terminal strip are as follow: The piece of ebonite is 12 in. by 2 in., and is screwed to the baseboard so as to leave a clear inch at either end.

Terminal Strip Spacing

The outside terminals are three-quarters of an inch from the ends, and there is a distance of two inches between the aerial and earth terminals. The other terminals are spaced one inch apart. All the terminals are

The two sets are arranged at right angles to avoid all possibility of trouble due to coupling. Room must be allowed at the left-hand end of the baseboard (looking at the set from the back) for a 9-volt grid-bias battery.

The set has to be wired in accordance with the wiring diagram. The photographs of the back of the set will be helpful, and the spacing should be arranged as nearly as possible to agree with the photographs.

Coil Connections

The set may be wired with bare or covered tinned-copper wire. In the original fairly thin wire was employed and covered with Systoflex.

It is very important that the leads to the coil mounts should be arranged exactly as indicated in the wiring diagram. If they are not, it may be impossible to make the set oscillate and consequently no reaction will be obtainable.

Suitable valves for the receiver are as follows: In the first position use an H.F. If, however, you have an R.C. valve on hand, this will probably work equally well.

Assuming the set is to be used for

running a loud speaker, the second valve must be a small power valve. Should it only be desired to use the set with telephones, then an ordinary L.F. valve may be employed in the second position.

Any voltage valves, providing they are of suitable type, may be employed. An accumulator of voltage to suit the valves is required, also a standard 9-volt grid-bias battery. H.T. batteries with a total voltage of 120 are

WIRING DIAGRAM.

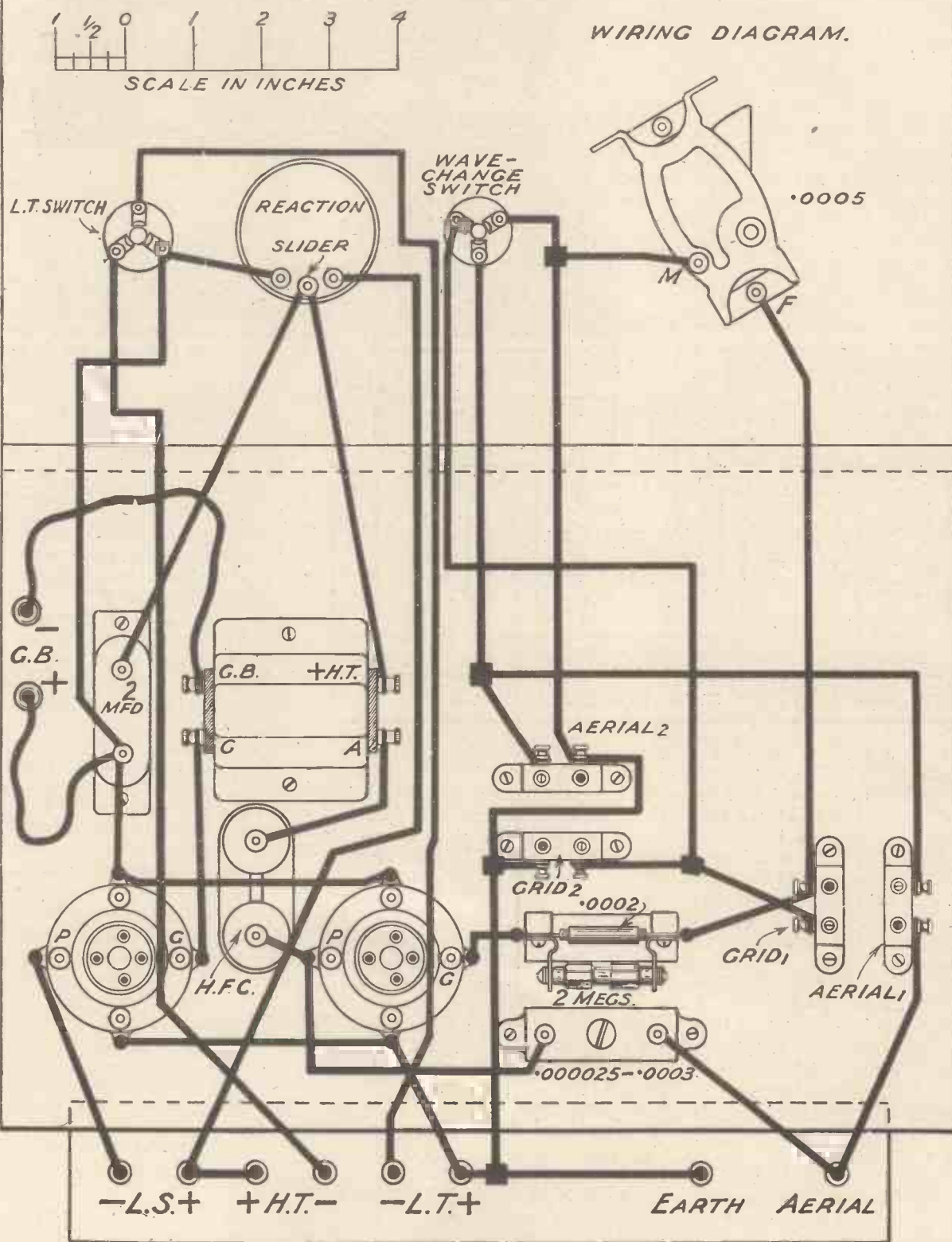

desirable, although the set will give fairly good loud-speaker results on a little less. For telephone work, of course, 60 volts should be sufficient.

When a loud speaker is employed, and H.T. is obtained from dry batteries, it is desirable that they should be of double or triple capacity. The receiver should work quite satisfactorily with a mains H.T. unit.

The first grid coil should be a No. 60, and the second a No. 200. Since the two grid coils are in series for long waves, they are approximately equal to the usual No. 250 employed for a closed circuit on the upper broadcast band.

Setting the Condenser

The sizes of the aerial or reaction coils have to be found by trial. The first will be a No. 25, 30 or 35, and the second a No. 50, 75, or perhaps a No. 100.

When the set is completely connected up and ready for working, except for the coils, you should proceed as follows: Insert the No. 60 in the first grid mount, namely, the mount which has one side directly connected to the grid leak and condenser, and the No. 200 in the other grid coil mount. Now pull out the knob of the wave-change switch—this is its position for short waves—and place the slider of the potentiometer about half-way round.

Next place a No. 25 coil in the first aerial coil mount, and increase the capacity of the Formodensor until the

set is too selective with it, a No. 30 should be tried.

Generally speaking, the larger the

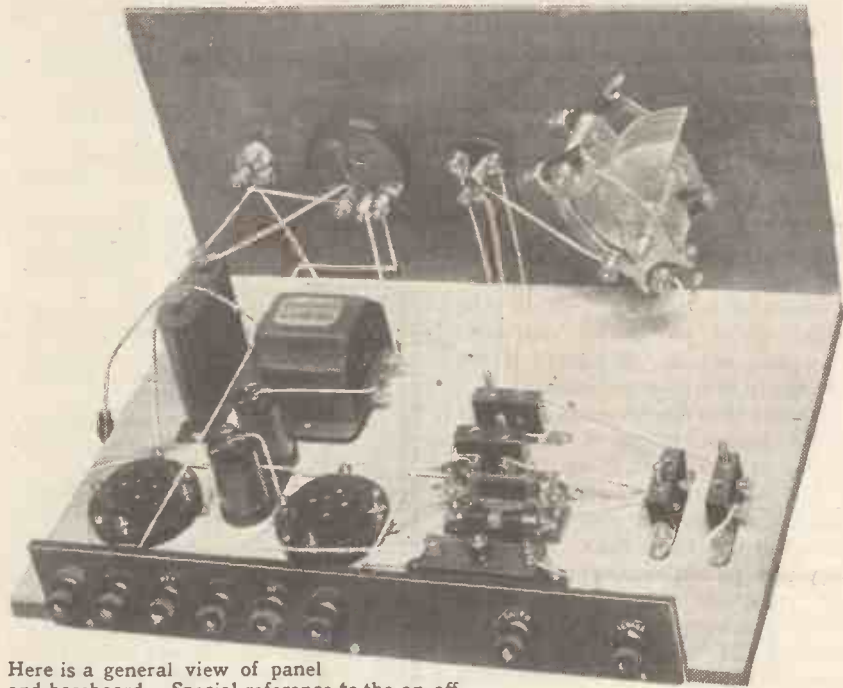

Here is a general view of panel and baseboard. Special reference to the on-off switch connections will be found on the next page.

set starts to oscillate with the tuning condenser at its maximum. Should it not be possible to make the set oscillate with the 25 coil, or if the

capacity of the first aerial coil, the smaller the setting of the Formodensor should be. It will be found, however, that a little experiment by trial and error with the aerial coil, Formodensor and potentiometer will be well repaid in results obtained.

When you feel satisfied that the lower wave coils and adjustments are approximately correct, you may change over to the higher waves. This is done by merely pushing in the knob of the wave-change switch.

The size of the aerial coil No. 2 should be chosen, if possible, so that the set will oscillate over the whole of the movement of the tuning condenser, without any alteration being made to the Formodensor. However, it may be found necessary to alter it a little, but do not change its capacity sufficiently to upset the adjustments arrived at for the lower wave-band.

Reaction Hints

Since the adjustments of this set are a little different from usual, a little patience is required in getting used to it if the best results are to be obtained. Do not, however, imagine that this is a hint that the set is difficult to handle, because it is not.

It is merely given here because the set is capable of results slightly above the average, and it is certainly worth

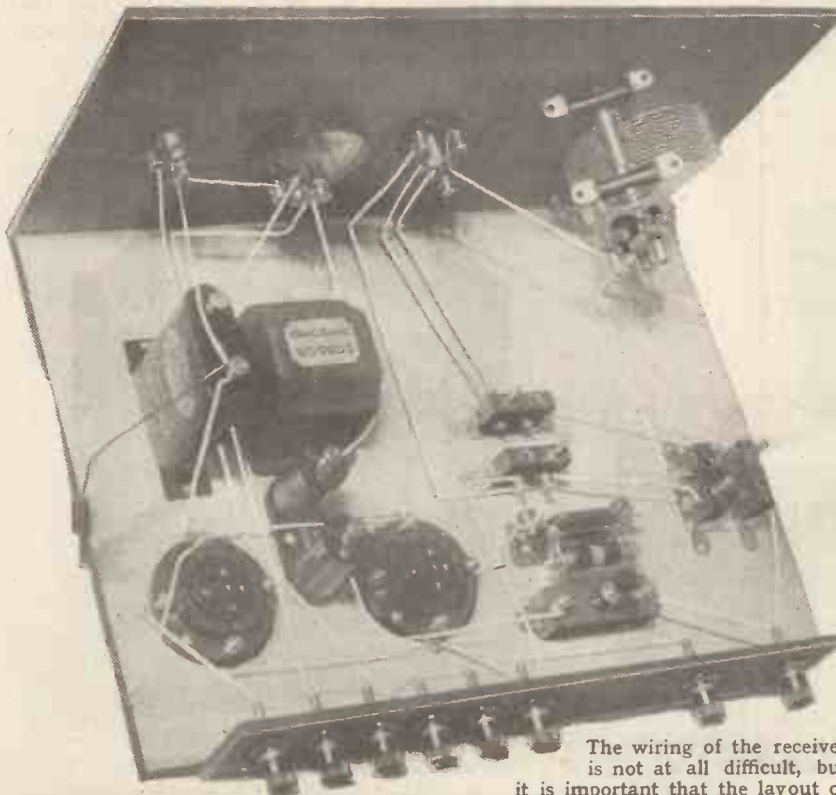

The wiring of the receiver is not at all difficult, but it is important that the layout of components be followed closely when building the set.

while obtaining the maximum from a set once you have gone to the trouble of building it.

Should you find that the set goes into oscillation before the reaction seems to have built up signal strength as it should, this may be taken as an indication that the reaction coil is too large, and a smaller one must be used with a consequent adjustment of the Formodensor and potentiometer.

Potentiometer Current

If the trouble is experienced on the short waves, adjust the size of the first aerial coil, and if on the long waves, use a smaller coil in the second aerial position. The foregoing only applies, of course, if the H.F choke is above suspicion.

The fact that the resistance element of the potentiometer is connected directly across the H.T. battery may at first appear a drawback to the reader, since current will be flowing through it the whole time. However, since the potentiometer is of very high resistance, the current taken by it will be very small. For instance, assuming the voltage in use is the highest it is likely to be—namely, 120—the current taken by the potentiometer will be less than 2½ milliamps.

The On-Off Switch

The current taken may easily be worked out by means of Ohm's law for any voltage. All that has to be done is to divide the voltage by 50. Thus if 100 volts is used the potentiometer will take exactly 2 milliamps. It will be noted that the connections to the potentiometer are arranged in such a way that the current from the H.T. battery to the resistance is cut off when the set is out of action.

It was originally intended to use a 2-contact switch and remove the H.T.—plug from the battery, so that H.T. current could not flow round the potentiometer via the valve filaments.

so overcome the expense of the extra 2 milliamps. or so. The objection to a series resistance is that since the current of the detector valve is very small, a large value resistance would

COMPONENTS REQUIRED

- Panel, 14 in. x 7 in. (Resiston, Becol, "Kay-Ray," Trelleborg, Ripault, etc.).
- Cabinet for above, with 10 in. deep baseboard (Pickett, Raymond, Aircraft, Caxton, Camco, Bond, Gilbert, Lock, Ready Radio, etc.).
- 0005 variable condenser (Lissen, J.B., Cyldon, Lotus, Raymond, Igranic, Utility, Formo, Pye, Gecophone, Bowyer-Lowe, Colvern, Ormond, Dubilier, Burton, etc.).
- Slow-motion dial for above (Lissen, Lotus, Utility, Igranic, Formo, Brownie, etc.).
- 2 Three - contact "wave - change" switches (Bulgin, Wearite, Ormond, etc.).
- 50,000-ohm Centralab potentiometer (Rothermel).
- 4 Single-coil mounts (Lotus, Ready Radio, Raymond, Wearite, etc.).
- Grid condenser and leak with mounts (·0002 and 2 megohm). (Igranic, Lissen, T.C.C., Mullard, Goltone, Clarke, Dubilier, etc.).
- 000025-·0003 Formodensor (Formo Co.).
- 2 Anti-vibration valve holders (Lotus, Igranic, Benjamin, W.B., Pye, Ashley, Magnum, Bowyer-Lowe, Precision, B.T.H., Wearite, Marconiphone, etc.).
- 2-mfd. fixed condenser (Ferranti, Lissen, Hydra, Mullard, T.C.C., Dubilier, etc.).
- H.F. choke (Raymond, Bowyer-Lowe, Magnum, Wearite, Climax, Ready Radio, Igranic, Dubilier, R.I., Leweos, Cosmos, Varley, Lissen, Peto-Scott, etc.).
- L.F. transformer (Cossor, Ferranti, R.I., Brown, Lissen, Mullard, Igranic, Marconiphone, Philips).
- Terminal strip, 12 in. x 2 in.
- 8 Indicating terminals with necessary marking (Igranic, Belling & Lee, Burton, Ealex, etc.).
- 2 Wander plugs, screws, wire, etc.

However, it was so easy to forget the H.T.—plug that even the author found himself leaving it in place!

Consequently a 3-contact switch was substituted as shown in the diagrams, and this automatically disconnects H.T.—(This, of course explains why L.T.—is joined direct to H.T.—in the back of panel photographs.)

You may wonder why a series resistance cannot be employed, and

be required to give an appreciable variation of H.T. voltage. There are certain reasons why a large series resistance is not desirable in a set of the type described, as it would tend to cause "ploppy" reaction control if the set were worked in an efficient manner.

Although an output filter is desirable with the set when a loud speaker is employed, it has been omitted for the sake of simplicity and cheapness.

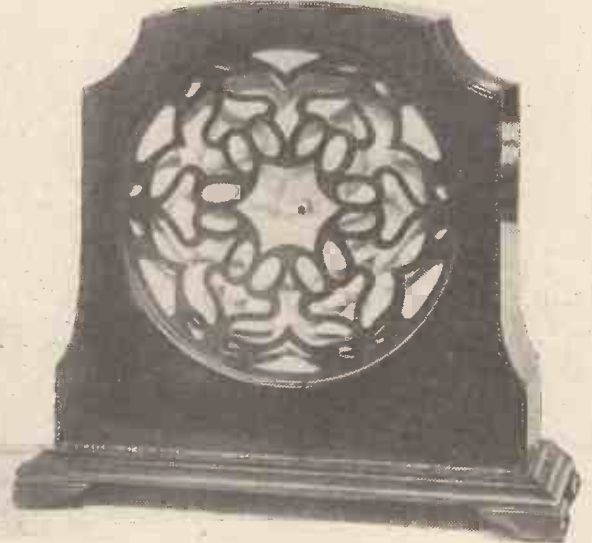

The "Reactohm" Two is quite capable of working a loud speaker from several stations and gives the listener a varied choice of programmes.

BROKEN WAVES

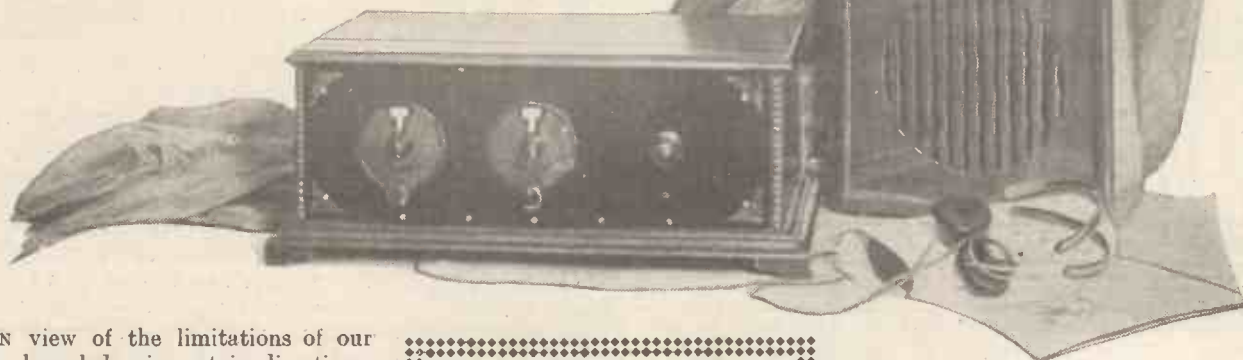

IN view of the limitations of our knowledge in certain directions, it is rather remarkable that radio has made such vast progress. It would appear to be advancing on well-ordered lines despite the fact that much of our knowledge of the art is still superficial. During but a few years the radio receiver has grown from something that sounded like an early type of gramophone to a musical instrument that is really worth listening to.

Far From Perfect

Nevertheless, we are far from having reached perfection—farther than some radio enthusiasts would have us believe. In a way, perhaps, this is all to the good, because it leaves something to the future, a moderately distant goal for experimenters to aim at. One of these days radio is going to be taken really seriously by physicists and scientists. That is inevitable, and when we get a genius of the calibre of Sir E. Rutherford, or Prof. Bragg, or Sir Oliver Lodge, devoting a life-study to, for instance, the valve, we may perhaps begin to have a foundation laid for us for really definite advancement.

At the present moment the valve is an enigma. We know it statically, but dynamically its characteristics are

An interesting chat about valves, transformers and loud speakers and their shortcomings in regard to the reproduction of speech and music.

By B. MEDLICOTT.

still vague. From the static characteristic curve of a valve we can obtain some guidance as to its use, but that static curve does not tell us what is happening while the valve is in operation, and at present there is no means of obtaining that knowledge.

The operation of the valve is bound up with the electron theory, and it is only by minute researches into its interaction with the phenomenon of H.F. and L.F. wave-form that a true picture of the inner workings will be revealed.

An L.F. transformer can have a very full specification in regard to primary

and secondary winding inductances, ratio, current-carrying capacity, together with an N.P.L. curve, but may still leave a lot to the imagination. As a standard of comparison you can accept these things with every confidence, for practice has proved that it is safe to do this.

Working in the Dark

Nevertheless, only a superficial knowledge of the true working of the component is gained. For instance, the curve of an L.F. transformer is taken by running through a series of calibrated frequencies. The result might be a moderately straight line, very creditable to the designer and manufacturer, and indicative of high efficiency. However, the low-frequency transformer has to deal with the complexities of varying frequencies and the true effects of these cannot yet be determined.

There must be a certain amount of wave-form distortion due to hysteresis in every L.F. transformer, but to what extent in certain circumstances it is impossible to say. Hysteresis is the lagging of the magnetisation of the core, behind the magnetising force. It is my impression that hysteresis is greater with the

(Contd. on page 301)

THE BIRTHPLACE OF MARITIME RADIO

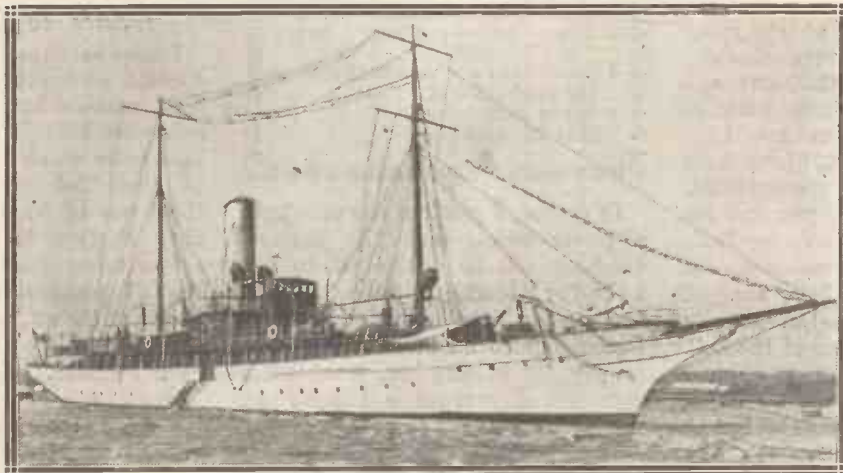

Marquis Marconi's famous steam yacht "Elettra." It is equipped with a magnificent radio laboratory and has figured in some of the most important research work that the Marquis has carried out during the past ten or so years.

An L.T.

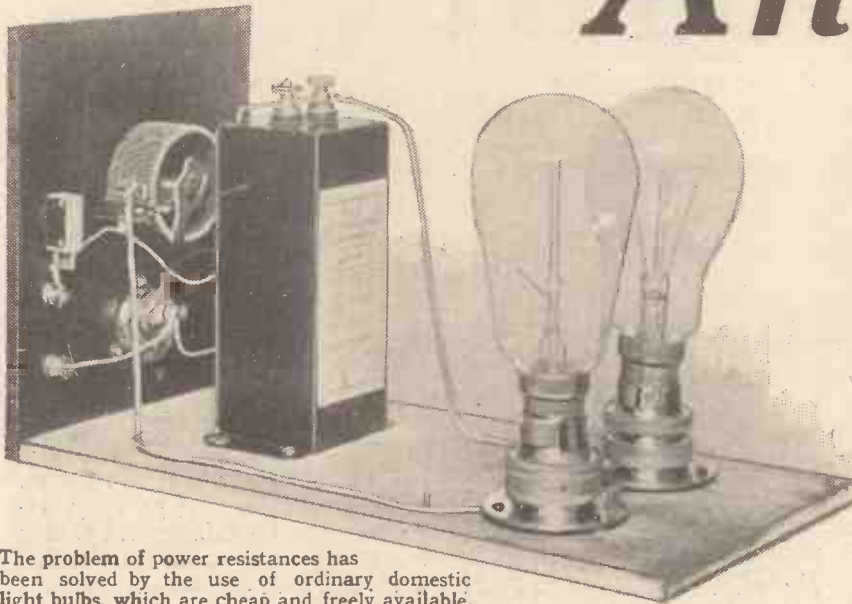

The problem of power resistances has been solved by the use of ordinary domestic light bulbs, which are cheap and freely available.

ACCUMULATORS are at best nasty, messy things to have around the house, although in many instances they form the only solution to the problem of L.T. But if you have the electric light supply mains laid on there is no reason why you should use batteries. You have a wonderfully constant source of power brought right into your own living-rooms. Why, in such circumstances, should you pay periodic visits to a shop to buy small stocks of electricity in the form of accumulator charging?

Inexpensive to Run

But, you might say, what if I have D.C. mains? If you do ask that question you are contributing to a common fallacy, and that is that the D.C. mains stop short at supplying H.T. very easily and very cheaply. It is a curious fact that although there are more D.C. mains users in this country than there are A.C., it is the latter class upon which radio scientists seem to have concentrated.

Everywhere you look you can see A.C. power packs for H.T., for L.T., for L.T. and H.T. combined, for L.T., H.T., and grid bias, etc. A good many H.T. units and an absurdly few L.T. units are the lot of the D.C. user. And yet it is easier, cheaper and, I think, safer to make an L.T. unit for D.C. mains than for A.C. And the only point where the A.C. unit scores is that it is cheaper to run.

The D.C.-L.T. unit I am going to describe costs about as much to run

as one ordinary electric light bulb used in the ordinary way—that is, in the case of the average three- or four-valve set; but with a multi-valver, using high consumption filament valves, the cost might rise to that of one 200-watt electric light bulb.

COMPONENTS REQUIRED.

- * 1 Panel, 7 in. x 6 in. (see text).
- * 1 Baseboard, 12 in. x 6 in. (teak or 5-ply).
- * 1 Cabinet (if desired) to fit (Camco, Raymond, Lock, Pickett, Arterraft, Gilbert, Caxton, etc.).
- * Note.—This is a size often used for H.T. units.
- * 1 Electrolytic condenser, 2,000 mfd. (T.C.C., Dubilier, etc.).
- * 1 30-ohm power rheostat (Centralab, or similar type). (Claude Lyons).
- * 1 Power switch (Claude Lyons, "B.A.T." type).
- * 4 Power plugs and sockets (Belling & Lee insulated type).
- * 2 Batten lamp holders.
- * Glazite for wiring-up.

Of course, if you run the unit from a power point, then the financial outgoing will be equivalent to but a third or a fourth the cost of running one electric light bulb. Anyway, a farthing or so an hour as the price to pay for battery-less, trouble-free operation of your set is, I think you will agree, a small one.

No Complications

It has often struck me as curious that a radio enthusiast having D.C.

mains will go to the trouble of running a battery charger, while at less cost he could do away with the battery. But perhaps it is because he has not met a unit like the one I am about to describe. Perhaps for that matter nobody has!

This L.T. unit is no more complicated than a very straightforward low-current accumulator charger.

You will see how simple the whole thing is if you refer to the diagrams accompanying this article. By means of ordinary electric light bulbs, supplemented by one small rheostat, the current is dropped to that required by the valves.

Quite Silent

The valves used must be of the one-voltage rating, but any requisite current can be catered for. There is a simple on-off switch and a cheap moving-iron voltmeter to show the voltage across the L.T. terminals. The only smoothing required is a large fixed condenser; one of the electrolytic type.

My mains have a name for being very rough, but not a scrap of hum gets through when my unit is in use. In order to make the theoretical diagram look a bit more complicated and the instrument slightly more elaborate, I could have included L.F. chokes and several bypass condensers, but I hope that nobody will find these necessary even to achieve complete silence.

Safe to Operate

I have said that the unit is safe to operate, and you will no doubt see good reasons for this. Your main resistance takes the form of electric light bulbs which will not be operating at their full pressure. Therefore there can be no serious temperature rise. Further, the lamps themselves act as safety fuses, and if you short the L.T. terminals or their equivalent points in the set, nothing will happen except that the lamps will glow a trifle brighter.

Should one of the lamps burn out, far from there being any serious voltage rise, there will be a current drop; and should both lamps burn out, then it is just the same as if you had switched the unit off.

D.C. Unit

Designed and Described by G. V. DOWDING, Grad.I.E.E.

A simple and effective "accumulator eliminator" that is safe and inexpensive both to install and operate.

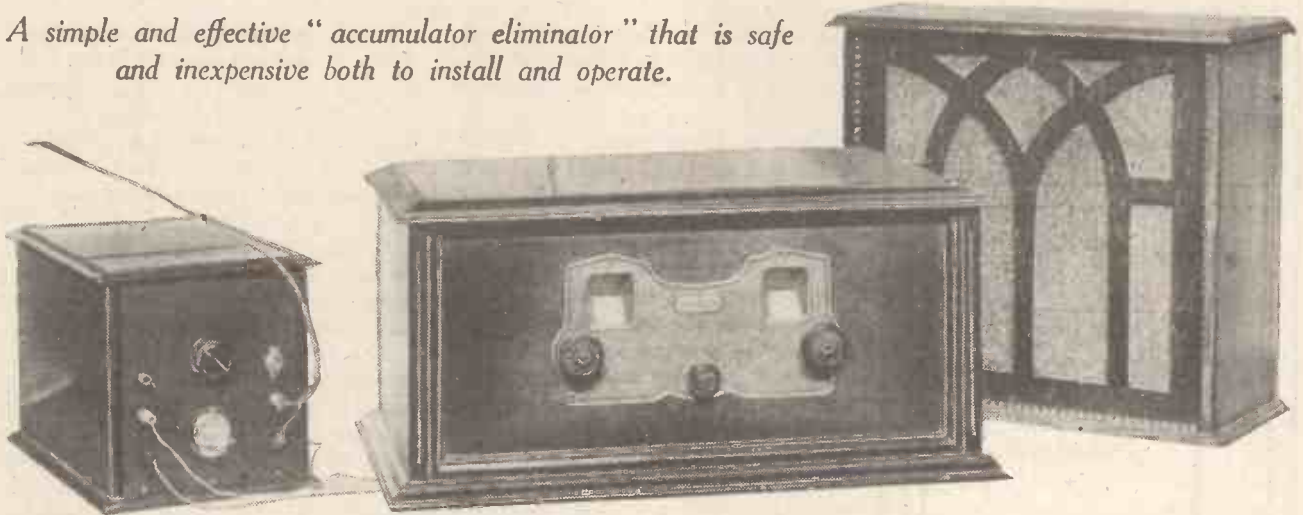

There are, however, one or two points you must note in regard to the working of this device, if you would avoid any possibility of trouble, but they are of a commonsense nature, and deal mainly with the initial installation of the unit.

Once the unit has been installed, you switch the whole set on and off by the one simple switch, and as there are no running or maintenance adjustments to be made, absolutely nothing of an untoward nature can happen except that after many hundreds or thousands of hours—perhaps tens of thousands of hours—one of the lamps might "give up the ghost," in which case it would have to be replaced. As the lamps will be working at

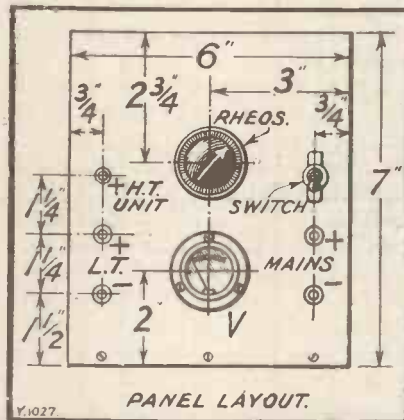

that you are giving the valves their right current, but in view of its position in the circuit it can be of the cheapest panel-mounting moving-iron variety and of low resistance. A high-resistance voltmeter would be just as suitable, if not better, but is not needed.

The Large Panel Hole

The two or three lampholders of the batten type you can purchase at any electrical store. I say two or three because, in the cases of some mains and some sets, three may be required, but of this, too, more anon. Anyway, there is plenty of room for a third holder on the baseboard, and it is a very simple job to put it in circuit with the other valve holders.

A bakelite panel is to be recommended, as this material is not inclined to warp at the slight warmth which there must of necessity be generated in the unit in view of the bulbs that

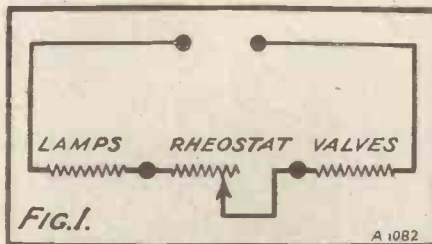

something under their ordinary voltage they might last thirty or forty years!

Notes on Components

The accompanying list of components will give you a good idea of what you have to buy. Do not buy ordinary electric light bulbs; I will deal with these items in detail later

on. Also, do not buy an ordinary valve-set rheostat; one of the power variety is needed in order to carry the current that is going to be dealt with.

If the total consumption of all your valves is 4 ampere, get a rheostat rated to carry safely 5 ampere. Always have a margin. The on-off switch decidedly must be of the power type. The ordinary push-pull filament switch as used on most sets would arc at mains voltage. This is not a serious phenomenon, although an annoying one. You would try to switch the set off by this unsuitable device only to find that you were unable so to do.

The 2,000-mfd. electrolytic condenser is a necessity without which you may have to put up with fairly considerable hum. The voltmeter, too, is rather vital, because it ensures

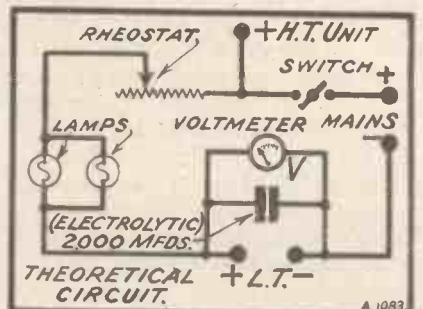

The simple switch also controls an H.T. unit if this is used.

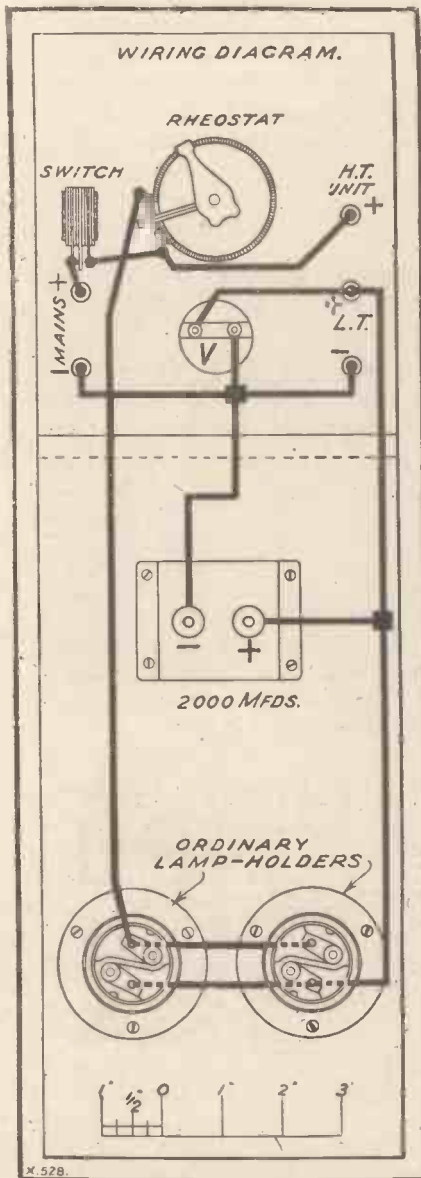

are at work. The panel drilling is quite straightforward with the exception of the making of a hole for the panel-mounting voltmeter.

Unless you have a proper tool for this you will have to drill a ring of little holes, cut the barriers between them and then file the resultant aperture smooth. For a very few pence a local garage would undertake the job.

The Safety Plugs

In order to leave room for the connecting wires to come away from the batten holders underneath, I placed nuts between the holder and the baseboard at each point through which a screw passed.

You will have noticed that I have used Belling-Lee safety-plugs and sockets for this unit. I consider the employment of these very desirable for they banish all possibility of

Volts and Amperes

shock through exposed terminals, or shorts in the unit when it is disconnected. For a similar sort of reason I strongly advise you to use Glazite or other well-protected wire for the connecting up.

The cabinet or box in which you place the unit should have one or two holes of half an inch or so in diameter bored in the back and along the side for ventilation purposes. It is very doubtful if anything would happen if you did not do this, but "safety first" is a good motto!

Check Your Wiring

In view of the fact that this is a mains device the wiring should very carefully be checked, and every point examined to see that soldered or screw joints are robust and reliable. No more need be said about the construction of the unit, which is the task of but an hour or so. On the front panel there are five sockets, and two of these are for connection to a power or light point. Strong flex should be used for this.

Two of the other sockets represent the L.T. connections to the set, which are taken in the usual way, as with an accumulator. The remaining terminal socket is for an H.T. unit, if such be employed, and here is something I want you to note carefully.

The H.T. unit can be left connected to the set as usual, but instead of having two wires joined to it from the mains it now has only one, and this is taken from the H.T. unit socket on

the panel of this L.T. unit. The minus input terminal of the H.T. unit is then disconnected and can quite well be removed. The H.T. system finds its negative connection in the set via the L.T. unit.

It is important that you should not switch on the L.T. unit when the L.T. terminals are disconnected. If you do the whole of the voltage of the mains will be impressed on the electrolytic condenser and the voltmeter, with the result that either or both of these might be damaged. Short the L.T. points by all means, this can do no harm at all, but do not leave them open. And that is all there need be said about the connections of the unit.

The choice of the lamps is quite straightforward, although you will have to do a little calculation. I cannot very well give you a table with which to work as conditions will vary so much with individual mains and sets. Your object is to drop the current in the whole of the circuit down to the figure representing the consumption of the valves, and this figure is found when the resistance of the lamps and valves plus a portion of the resistance of the rheostat is divided into the voltage of the mains.

Current Calculations

Supposing the total filament consumption of all the valves in the set is .5 ampere. You might, for instance, be using five .1 valves. These will naturally all be of the same

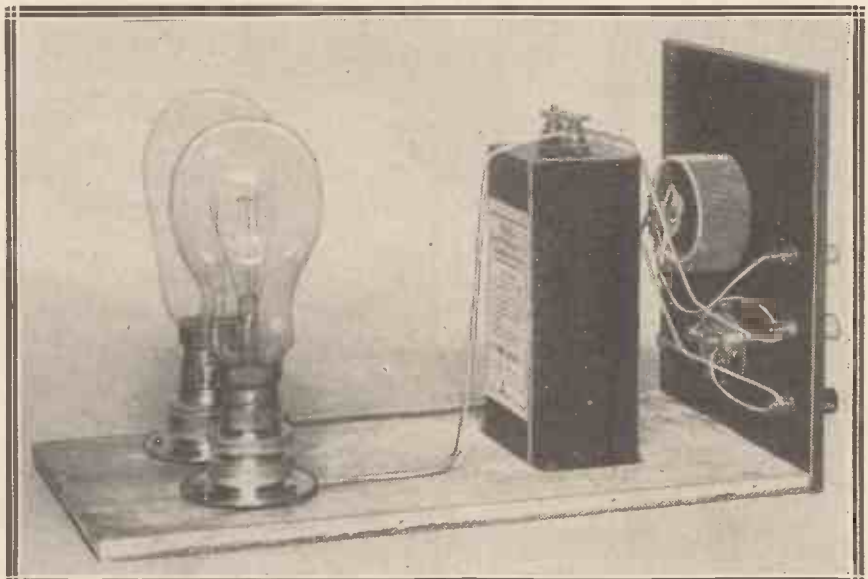

The lamps are placed well back and have plenty of space in which to dissipate the slight warmth generated. Gas-filled bulbs run hotly and are not advised.

Arranged to Suit Your Own Requirements

voltage rating. Supposing they are six-volt valves, then Ohm's law, which is $R = \frac{V}{C}$, where R =resistance, V =voltage, and C =current, says that the combined resistance of the valves is 12 ohms. (You divide the voltage rating of the valves by their total filament consumption.)

Now supposing you have the awkward D.C. voltage of 150. In order to reduce the current flowing in the circuit to .5 ampere, you have got to have 300 ohms resistance, for $R = \frac{V}{C}$, remember!

You have got 12 ohms in the valves and another 20 or 25 in the rheostat. (I am not including the full 30 ohms

225. We can add 40 ohms for rheostat and valves and approximate the whole job with one bulb.

One holder only in this case need be occupied. You put this lamp in, switch on and adjust the rheostat until exactly 6 volts is shown on the voltmeter. You must not switch on and off by the filament switch on your set, as this would be the same as leaving the L.T. terminals of the unit open, and this, as I have said, you must not do. I would advise you to solder together the two leads going to the switch on the set so that this mistake cannot occur.

Another Practical Example

Let me give you another example. Supposing you were using three

more than three or four before the exact voltage of 2 is registered on the voltmeter.

So far, I have dealt with the use of only one bulb, and in many, if not the majority of cases, only one will be wanted, as the consumption of bulbs seems to line up very nicely with our requirements. However, where the problem is not quite so easy of solution, two bulb results will have to be tried.

If they are of exactly the same wattage their resistances will also be the same and two in parallel will give you just half the resistance of the one. In order to obtain awkward resistances you can place bulbs of different wattages in parallel, such as, for instance, a 30 and a 60.

The simple formula for finding the resultant resistance of two resistances placed in parallel is the same as for



The L.T. unit coupled to a set that already draws its H.T. from the small H.T. mains unit that can be seen. Special mention is made in the accompanying article of the coupling of both H.T. and L.T. units to sets.

in this case, because you want a margin for adjustment purposes.) Say you have a total of 40 ohms adding together the resistance of the rheostat and valves, and you will thus leave 270 ohms which have got to be contributed by lamps.

Working with Wattages

The wattage and voltage of any electric light bulb is plainly marked on it. Now you find the watts of anything by multiplying its volts by its current. Therefore, it is very easy to discover the current consumed by any lamp by dividing the wattage figures by the voltage figures.

In the case of our 150-volt supply we find that a 100-watt lamp consumes two-thirds of an ampere, for our formula demands that 150 be divided into 100. Dividing the voltage by this new current figure, that is, two-thirds into 150, we get 225 as the resistance of the lamps. We wanted 270 ohms and here we have

2-volt valves, each taking .1 amp., the total consumption being .3 ampere. Dividing 2 by .3 you find that the resistance of the valves will be approximately 7 ohms. Add 13 from the rheostat, making it that you have 20 ohms resistance. Now supposing your mains are 210 volts. These have got to deliver .3 ampere. Dividing .3 in to 210 we find that the resistance required will be 700 ohms.

You have 20, so that you should have 680 to find. Let us see what a 60-watt lamp will give us. Dividing 60 watts by the 210 volts we get the current consumption for that bulb, $\frac{2}{7}$ amp. Dividing the $\frac{2}{7}$ into 210 volts, the resistance of the lamp is found to be 735 ohms. Not close enough by 55 ohms!

But a slight discrepancy in the voltage supply or the characteristics of the lamps will bring it to the desired figure. If you are using 60-watt lamps in the house for the lighting, you will not have to try

condensers in series. That is to say, you divide each of the resistances into one, add together, and divide the result into one.

Supplying a Multi-Valve

In other words, the reciprocals of the individual values added together equals the reciprocal of the resultant resistance. Let me give you an instance.

Suppose you find that the resistances of two bulbs are 400 and 500 ohms. Then you have got to add $\frac{1}{400}$ to $\frac{1}{500}$. Reducing these to common denominators, that is, $\frac{5}{2,000} + \frac{4}{2,000}$ you get $\frac{6}{2,000}$. Turn this result upside down and the amount is $\frac{2,000}{6}$, or 333 ohms approximately.

I will give you a practical example before we go any further.

Minor Miscalculations Will Not Matter

Supposing your set is a five-valver having three valves of the awkward filament currents of .075 ampere each and two of the .1 rating. This would give you a total of .425 amperes. We will presume that your D.C. mains are of 210 volts.

Right away I would say that a 60- and a 30-watt bulb in parallel would fill the bill. But let us see what resistance we want. Your total

about 490 ohms and we have got them by connecting the 30- and the 60-watt bulbs in parallel.

For very great filament consumptions we can have three bulbs connected in parallel, while to get at a very awkward result we can connect two in parallel and, in a third socket, have another bulb in series. Remember, when you have resistances in series you simply add together.

Again, supposing your valves take .3 ampere and your mains are 200 volts. Multiplying the .3 by 200 we arrive at 60 as the watts that are needed, and you would no doubt find that one 60-watt bulb would do the work. The resistance of the valves themselves is low in comparison with the rest of the circuit and need not worry you if you only desire an approximation. The rheostat will cope with slight discrepancies and, as I have already said, you can take in quite comfortable errors.

Now it is obvious that you can use bulbs suitable for mains of greater voltage than those serving your house, and in this way the most awkward resistances can be attained, but you must not use bulbs specified for lower voltage mains.

A "Rule-of-Thumb"

The whole thing, although it might seem complicated the way I have explained it in detail, is really remarkably simple. Providing you know how to deal with resistances in parallel and series, a few moments with pencil and paper will soon put you on the right road.

But here is a simple rule-of-thumb way of getting at least an approximation; the voltmeter will show you how close you are in practice. Take the total filament consumption of your valves and multiply this figure in amperes by the voltage of your mains. Supposing your valves take .5 ampere and your mains are 210 volts. You multiply these figures together and get 105, and this is the watts that you have got to dissipate in your filament circuit. Obviously a 100-watt lamp will get you close enough to the condition required.

Gas-filled Bulbs Unsuitable

Also I would advise you to employ lamps of the ordinary vacuum type and not gas-filled. Gas-filled lamps run very hotly even on slightly lower voltages than they are rated at. On the other hand, the ordinary vacuum type get only a little warm, and if you want to have your unit in a case great heat must be avoided. There are one or two other points in regard to this L.T. unit which I had hoped to cover but I shall have to leave them until next month.

```

*****
*           SIMPLE FORMULAE.           *
* To find resistance of electric-light *
* bulb:                                *
*           R = V ÷  $\frac{W}{V}$  ohms.          *
* To find watts rating of bulb needed *
* to give certain known resistance:    *
*           W =  $\frac{V^2}{R}$                     *
* R = Resistance; V = Voltage          *
* (mains); W = Watts Rating.          *
*****
    
```

current consumption is .425, and in order to find out how much resistance is needed to drop down to this, divide the .425 into 210 volts. This gives you approximately 495 ohms that is needed.

If the valves are two-volters these themselves will have a resistance of .425 divided by 2, and that is, near enough for our purpose, 4. We have therefore got to find an additional 490 or so ohms, although we have a little up our sleeve in the way of the rheostat.

Three Bulbs in Parallel

Now the current consumption of a 60-watt lamp on 210 volts will be 210 divided by 60 amperes, and that is $\frac{7}{2}$. Dividing the $\frac{7}{2}$ into 210 we see that the resistance of the lamp is 735 ohms.

The 30-watt bulb having half the power on the same mains must obviously have twice the resistance, and that is 1470 ohms. We have got these two bulbs in parallel. What is the total resistance? We have to add the reciprocals of these two resistances

together, that is $\frac{1}{1470} + \frac{1}{735}$. Reducing them to common denominators we get $\frac{1}{1470} + \frac{2}{1470}$ and that equals $\frac{3}{1470}$. Reversing this fraction, we get $\frac{1470}{3}$, and this is 490. We wanted

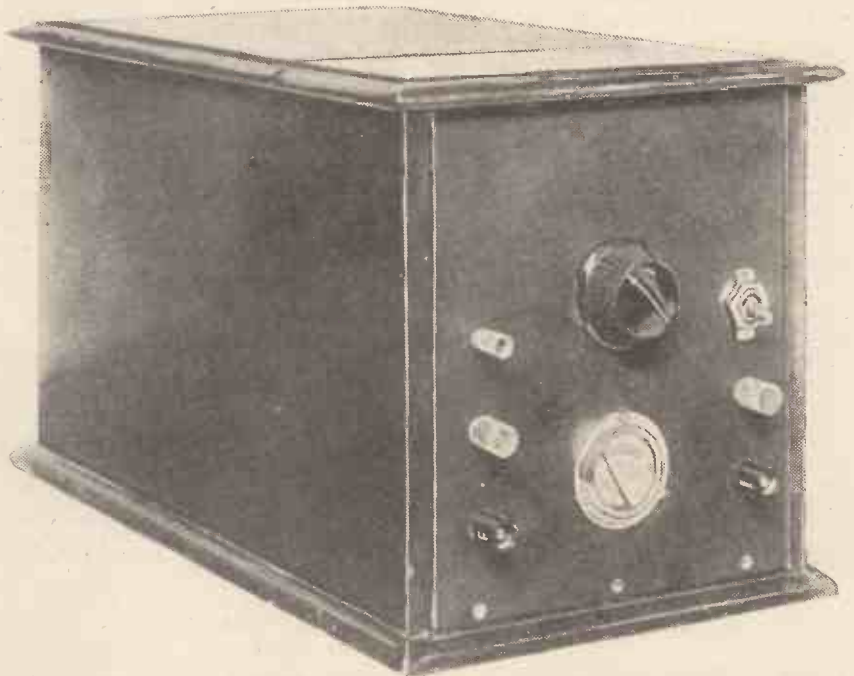

And here is the unit complete in a cabinet. The input sockets are on the right, and it is to these that the mains are connected. The top terminal on the left is for the only connection that an H.T. unit needs to its input when the L.T. unit is used.

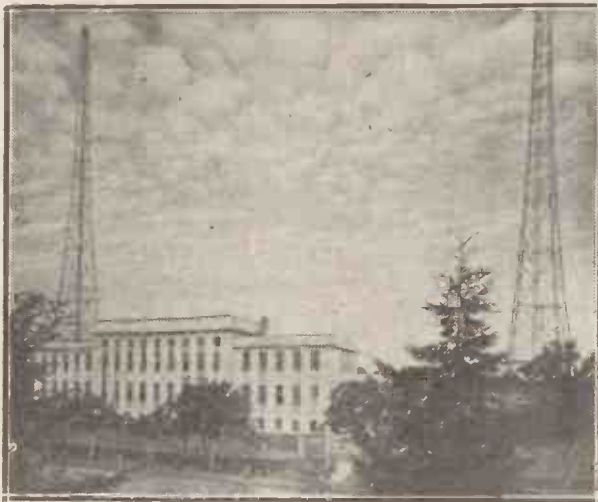

CONCERTS OF EUROPE

The shorter days mean improved reception from Continental stations, and never since broadcasting commenced have so many fine programmes been "on the air" as at the present time. The list below shows the main stations on the lower wave-lengths which are received under good conditions with sufficient strength to provide alternative programmes.

STATIONS WORKING ON WAVE-LENGTHS BETWEEN 190 AND 250 METRES.

Wave-length in Metres.	Name of Station.	Remarks.	Wave-length in Metres.	Name of Station.	Remarks.
196	Karlskrona, Sweden	Relays Stockholm. Power .25 kw.	231	Umea, Sweden	Power .2 kw.
200	LEEDS (2 L S)	Relay station. Power .13 kw.	231	Malmö, Sweden	Power .6 kw.
202	Jonkoping, Sweden	Relays Stockholm. .25 kw.	231	Helsingborg, Sweden	Power .2 kw.
203	Kristinehamn, Sweden	Power .25 kw.	234	MUNSTER, GERMANY	Relays Langenberg. Power .5 kw.
214	Uleaborg, Finland	Relays Helsingfors. Power .6 kw.	237	Orebro, Sweden	Relays Stockholm. Power .2 kw.
218	Bjorneborg, Finland	.8 kw. Relays Helsingfors	237	Juan-les-Pins, France	Irregular
218	Ornskoldsvik, Sweden	Relays Sundsvall. Power .2 kw.	238	Bordeaux-Sud-Ouest, France	Irregular.
218	Flensburg, Germany	Relays Hamburg. Power .5 kw.	239	NURNBERG, GERMANY	Relays Munich. Power 2 kw.
218	Karlstadt, Sweden	Relays Stockholm. Power .25 kw.	239	Nimes, France	Power 1 kw.
221	Helsingfors, Finland	Power .9 kw.	242	BELFAST, IRELAND	Call-sign, 2 B E. Power 1 kw.
225	CORK, IRISH FREE STATE	Call-sign 6 C K. Power 1 kw. Evening programmes usually from Dublin.	246	Cassel, Germany	Relays Frankfurt. Power .25 kw.
227	COLOGNE, GERMANY	Power of 2 kw. Langenberg programmes.	246	Kiel, Germany	Relays Hamburg. Power .35 kw.
228	Biarritz, France	Power of 1.5 kw.	246	Linz, Austria	Power .5 kw.
231	Boras, Sweden	Relays Goteborg. Power .15 kw.	246	Jakobstad, Finland	Power .25 kw.
				Note.—This wave-length is shared also by Kalmar, Saffie, Eskilstuna, and Kiruna (Swedish relay stations), and by Cartagena, Spain.	

NOTES.—The Prague Wave-length Plan, on which the present wave-lengths are based, and which was introduced on June 30th to relieve ether congestion and prevent interference between stations, is generally acknowledged to be more successful than any previous arrangement of European wave-lengths.

The more powerful and popular stations are shown in heavier type. Certain comparatively unimportant stations are omitted altogether owing to lack of space. British stations have been shown prominently for the benefit of listeners who have no wave-meter, and who rely upon the dial positions of British stations to act as "finger-posts" indicating the approximate dial positions of foreign stations.

STATIONS WORKING ON WAVE-LENGTHS BETWEEN 250 AND 310 METRES.

Wave-length in Metres.	Name of Station.	Remarks.	Wave-length in Metres.	Name of Station.	Remarks.
251	Schaerbeck, Brussels (Belgium).	"Radio Schaerbeck."	270	Trollhatten, Sweden	} Wave-length shared by four relay stations.
251	Almeria, Spain	Call-sign E A J 18. Power 1 kw.	270	Hudiksvall, Sweden	
253	BRESLAU, GERMANY	Power 2 kw. Usually commences 6 a.m., and transmits all day at intervals.	270	Norrköping, Sweden	
255	TOULOUSE, FRANCE	Power 1.5 kw.	270	Kaiserslautern, Germany	
257	HORBY, SWEDEN	Relays Stockholm. Power 10 kw.	274	TURIN, ITALY	"Radio Torino." Power 7 kw.
259	LEIPZIG, GERMANY	Power 2 kw.	276	KONIGSBERG, GERMANY	Power of 2.5 kw. Transmits all day, at intervals.
261	NEWCASTLE (5 N O)	Power 1 kw.	279	BRATISLAVA, CZECHO-SLOVAKIA.	Power of 12.5 kw.
263	BARCELONA, SPAIN	"Radio Catalana." Call E A J 13; Power 10 kw.	281	Copenhagen, Denmark	Power of .75 kw.
263	MORAVSKA-OSTRAVA (CZECHO-SLOVAKIA).	Power 10 kw.	283	Magdeburg, Germany	Power of .5 kw.
265	LILLE, FRANCE	Power .7 kw.	283	Stettin, Germany	Power of .5 kw.
			283	Berlin (Relay), Germany	Power .5 kw.
				NOTE.—This wave-length is shared also by Notodden (Norway), Innsbruck (Austria), and two Swedish relay stations.	

(Continued on next page.)

STATIONS WORKING ON WAVE-LENGTHS BETWEEN 250 AND 310 METRES—*continued.*

Wave-length in Metres.	Name of Station.	Remarks.	Wave-length in Metres.	Name of Station.	Remarks.
288.5	BOURNEMOUTH (6 B M) ..	1 kw.	293	Košice, Czecho-Slovakia ..	Power of 2 kw.
288.5	BRADFORD (2 L S) ..	13 kw.			
288.5	DUNDEE (2 D E) ..	13 kw.			
288.5	EDINBURGH (2 E H) ..	35 kw.			
288.5	HULL (6 K H) ..	13 kw.			
288.5	LIVERPOOL (6 L V) ..	13 kw.			
288.4	PLYMOUTH (5 P Y) ..	13 kw.			
288.4	SHEFFIELD (6 F L) ..	13 kw.			
288.4	STOKE-ON-TRENT (6 S T) ..	13 kw.			
288.4	SWANSEA (5 S X) ..	13 kw.			
		Exclusive wave-length for British relay stations.	301	ABERDEEN (2 B D) ..	Power of 1 kw.
			304	Bordeaux, France ..	"Bordeaux - Lafayette" (P T T). Power 1 kw.
			308	Radio Vitus, France ..	Was closed during August.
			310	CARDIFF (5 W A) ..	Power of 1 kw.

NOTES.—British stations (except Daventry 5 X X) are not usually received easily in this country, except in or very near their own service areas, though they are picked up at great strength on the Continent.

The most interesting newcomer on this part of the wave-band is the Czecho-Slovakian station at Moravska-Ostrava (263 metres). The German stations are well received and are remarkably consistent, and the Swedish station at Horby is another exceptionally good programme provider. Turin also comes over at very great strength.

The Lille transmissions have been received very powerfully in many areas, despite the fact that the power used is only 7 kw. Gleiwitz, relying the Breslau programme, is generally receivable at far greater strength than the latter station, which uses less power than its "relay" at Gleiwitz. (The Breslau station, building and masts are shown in the photograph on the previous page.)

STATIONS WORKING ON WAVE-LENGTHS BETWEEN 312 AND 550 METRES.

Wave-length in Metres.	Name of Station.	Remarks.	Wave-length in Metres.	Name of Station.	Remarks.
313	Cracow, Poland ..	Power 5 kw.	399	GLASGOW (5 S C) ..	Power of 1 kw.
319	Dresden, Germany ..	Power 25 kw.	403	San Sebastian, Spain ..	Power of 3 kw. Call-signs E A J 8.
322	GOTEBORG, SWEDEN ..	Power 10 kw.	408	KATOWICE, POLAND ..	Power of 10 kw.
325	GLEIWITZ, GERMANY ..	Power 5 kw. Relays Breslau.	412	RABAT, MOROCCO ..	Power of 10 kw. (Announces in French.)
332	Naples, Italy ..	Call-sign 1 N A. Power 1.5 kw.	413	DUBLIN, IRISH FREE STATE.	Call-sign 2 R N. Power 1 kw.
335	Posen, Poland ..	Power 1.2 kw.	418	BERLIN, GERMANY ..	"Witzleben." Power 1.5 kw. On at intervals all day from about 6 a.m.
335	Cadiz, Spain ..	Power 5 kw.	424	MADRID, SPAIN ..	"Union Radio." Power 2 kw. Call-sign E A J 7.
336	PARIS, FRANCE ..	Petit Parisien (5 kw.)	436	Stockholm, Sweden ..	Power 1 kw. Programmes relayed by Motala on 1,348-metre wave-length.
339	Bremen, Germany ..	Relays Hamburg. Power 2 kw.	441	Roma, Italy (1 R O) ..	Power 3 kw.
342	Brunn, Czecho-Slovakia ..	Power 2.4 kw.	447	PARIS, FRANCE ..	Ecole Supérieure (P T T). Power 8 kw.
349	BARCELONA, SPAIN ..	Call-sign E A J 1. "Radio Barcelona." Power 8 kw. Announces in French	459	ZURICH, SWITZERLAND ..	63 kw.
351	Algiers, N. Africa ..	Power 2 kw.	466	LYONS, FRANCE ..	"La Doua," 5 kw. Relays Ecole Supérieure.
352	Graz, Austria ..	Power of 7 kw. Relays Vienna's programme.	473	LANGENBERG, GERMANY ..	13 kw.
356	LONDON (2 L O) ..	Power 2 kw. On all day at intervals from 10.30 a.m.	479	DAVENTRY EXPERIMENTAL, 5 G B.	25 kw.
360	STUTTART, GERMANY ..	Power 2 kw.	487	PRAGUE, CZECHO-SLOVAKIA ..	5 kw.
364	Bergen, Norway ..	Power of 1 kw.	493	OSLO, NORWAY ..	1.2 kw.
368	Seville, Spain ..	Power of 1.5 kw. Call-sign E A J 5.	501	MILAN, ITALY ..	7 kw.
368	Paris, France ..	"Radio L L"	509	BRUSSELS, BELGIUM ..	"No. 1 Station," 1 kw.
372	HAMBURG, GERMANY ..	Power 2 kw. Usually commences about 6 a.m. and on at intervals all day.	517	VIENNA, AUSTRIA ..	"Rosenhugel," 15 kw.
377	MANCHESTER (2 Z Y) ..	Power 1 kw.	533	MUNICH, GERMANY ..	1.5 kw.
381	TOULOUSE, FRANCE ..	Power 8 kw. "Radio du Midi"	550	BUDAPEST, HUNGARY ..	20 kw.
385	Wilno, Poland ..	Power 5 kw.			
385	Genoa, Italy (1 G E) ..	Power 1 kw.			
390	FRANKFURT, GERMANY ..	Power 2 kw. Usually commences 6.30 a.m.; on all day at intervals.			

Compared with the position early this year, nearly all the stations in this section of the wave-band have been improved as a result of the Prague Wave-length Plan. Heterodyning still exists, however, though to a small degree in the majority of cases.

The wave-lengths given in this list are the latest available from official sources at the time of going to press, and though small variations are to be noticed, most of the stations now seem to be settled at the wave-lengths indicated.

Barcelona is one of the best foreign stations for British listeners, and Toulouse is another great favourite owing to the strength and consistency of its programmes. Hamburg can be identified by the Morse signal H A (- . . . - . -). Many other stations are sufficiently strong to be worth listening for almost every night, particularly on the upper part of the wave-band.

THE instal-
lation of
aerial and
earth wires for
listening may not
appear to be a
very momentous
step for a house-
holder to take,
but nowadays we
are so far removed
from the simple
life that it may
be a great deal
more important
than appears at
first sight. This
is particularly
true if the house

is wired for electric supply, for in all such wiring insulation is of first-class importance, and the erection or careless placing of aerial and earth wires may affect this considerably.

Avoid Other Wires

In America fire insurance companies are notoriously particular about the way in which aerials are installed, and it is possible that the rules regarding such installations may be tightened up in this country when the present scheme for further electrification gets well under way.

One important safety precaution for the householder is that aerial wires must be so placed that there is no chance of their coming into contact with any electric power or light wires, even if the mast supporting the aerial is accidentally overthrown. In mining and manufacturing districts one frequently finds such wires overhead, carrying high voltages, and the listener who lives in the neighbourhood of such a wire would do well to make it impossible for his aerial wire to come into contact with it.

Other points to which the American fire underwriters pay particular attention are the following: All aerial joints should be soldered and where the lead-in travels along the outside of a building it must not come closer than four inches to any electric light or power wires, unless there is, besides the regular insulation of the wires, an additional insulating covering.

Switching Off

Every lead-in should be provided with a lightning arrester of approved pattern, which is placed near the point of entry between the lead-in and the set, and where an earth connection may be made easily. An earthing switch may be used, if desired, but this must be in addition to the lightning arrester, which should be fitted



Other satisfactory earth connections are those to plates or metal rods, well buried in the ground; or to the building framework of a steel building. Outside the receiver all the wires to and from the set should be installed in accordance with the approved methods of light and power wiring.

The wires attached to accumulators must be rubber covered, and near the battery fuses should be fitted.

An Extra Protection

Finally it is recommended that none of the wires outside the receiver should be allowed to come closer than two inches to any light or power wire that is not enclosed in a conduit, unless the wires from the receiver are themselves enclosed in porcelain tubes or in some flexible insulator besides the wire insulation.

In this country the fire insurance companies do not take such a critical view of the aerial-earth installation, but if you have not already done so, it is a good plan to inform them of the fact that you have an aerial and earth for wireless reception installed, and to ascertain if this in any way affects the conditions of your policy.

Some useful hints to householders upon points that are apt to be overlooked.
By M. L. CROSS.

in all cases. (The underwriters favour the use of an earthing switch, and also the practice of disconnecting the receiver from the lead-in when it is not in use.)

The Question of Earthing

The earth wire recommended should be at least as large as the aerial wire, and the connection from the earthing switch and lightning arrester to the earth must be as short and direct as possible. If the earth connection is made to a water pipe, some approved form of clip should be used for the purpose of attachment.

Where an aerial wire runs along the outside of a building it should not be placed close to any electric light or power wires unless special provision is made to prevent accidental contact.

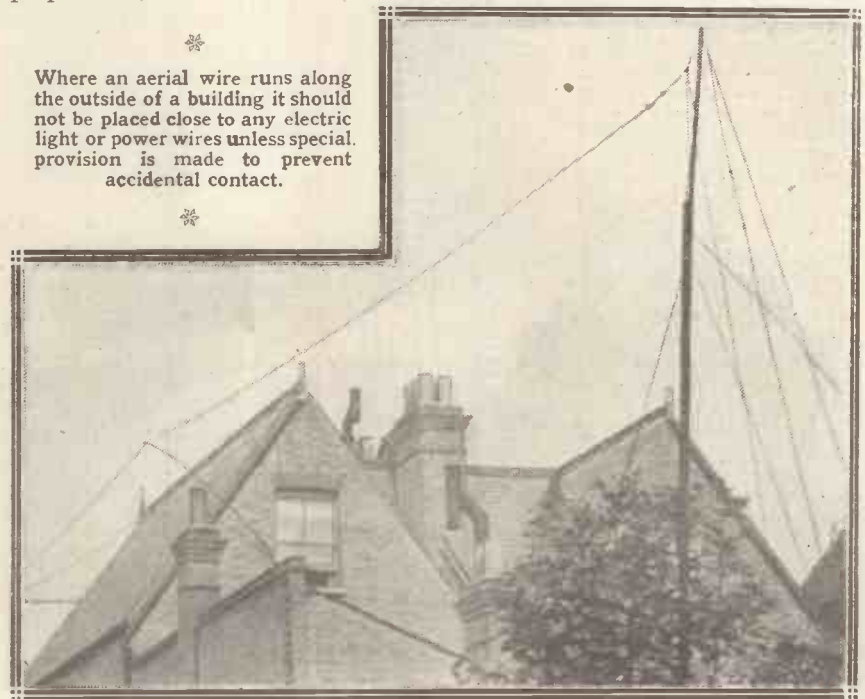

The Mystery of Radio Waves

Now although it is easily possible for wave velocity to vary with some power of the wave-length, if it varies at all, it is not by any means necessary that a simple power law like λ^n is the correct mode of expression in any given case. Another law of variation of a simple kind can be suggested.

Wave velocity might be represented as the hypotenuse of a right-angled triangle, of which one side represented the ordinary velocity of light, while the other side represented the wave-length combined with some peculiarity in the medium conveying it. This would seem rather an odd mode of variation, because the hypotenuse of a triangle must be longer than either of the sides, and therefore it would mean that the waves might travel sometimes quicker than light.

Odd or not, that is the result which appears to be true when wireless waves travel through electrified or ionised air, according to the investigations both of the radio expert, Dr. Eccles, and of the exceptionally learned mathematician, Sir Joseph Larmor.

Travelling Faster than Light

The right-angled triangle spoken of must be depicted, or thought of, as one with a very long horizontal side

* In this article, the third of a fascinating and instructive series by *
* the most popular of all scientific writers and broadcasters, Sir Oliver *
* deals with waves which travel faster than light, and with the *
* Heaviside Layer. *

representing the velocity of light, and a short vertical side representing some condition of the ionised medium. In that case the hypotenuse or slant side of the triangle is very little longer than the base, but it is a little longer, and accordingly the wave velocity does depend to some extent on the wave-length and on some peculiarity in the medium, and is a little quicker than light, especially for long waves.

Matter is a Form of Energy

Now since that kind of geometrical law of dispersion applies in the wireless case, the resulting expression for group velocity becomes of interest; and I propose to draw a geometrical diagram appealing to the eye, and indicating clearly the relation between these three velocities, namely, the velocity of light in free space c , the velocity of wave transmission in ionised air, like the Heaviside layer, v , and the observed or observable group velocity or energy velocity u .

The diagram is a very simple one. You draw a right-angled triangle with base c , and with vertical side $b\lambda$ to represent the properties of the medium in association with the wave-length, you draw the slant side representing wave velocity; and then on the base you draw a semi-circle. The big portion which it cuts off from the slant side represents the group velocity.

Here is the very simple diagram that illustrates an interesting and important aspect of radio radiation.

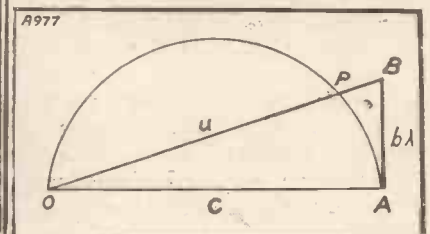

The author broadcasting one of his popular talks on the ether, from the London studio.

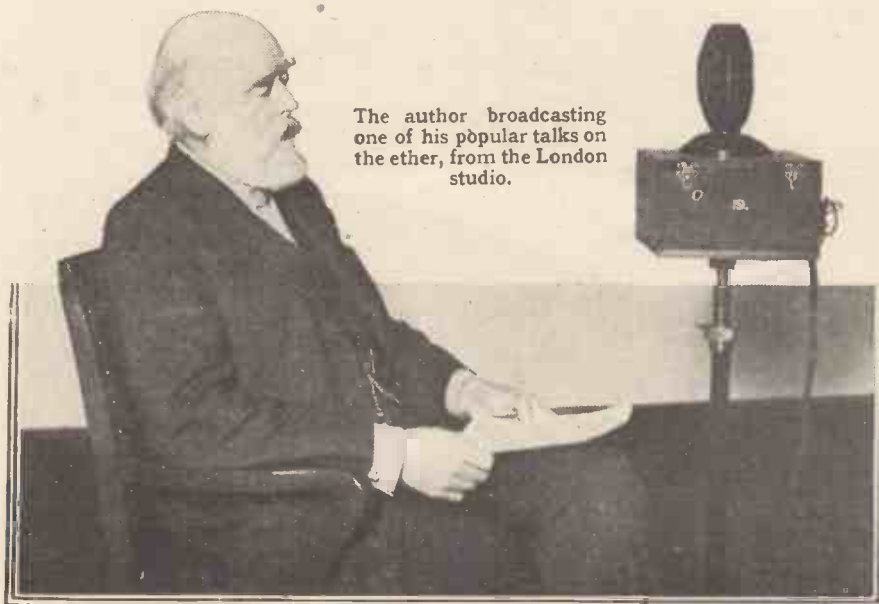

By Sir Oliver Lodge, F.R.S.

From this you see at once that the wave velocity must be bigger than c , and the group velocity less, but that if the slope is slight the three are nearly equal. Whereas a considerable slope means that the wave velocity is great and the group velocity small, so that ultimately when the wave velocity becomes infinite the group velocity sinks to nothing, in which case the energy would hardly move at all, and might be what we call stationary, as most of our terrestrial energy is.

But you may well say: What has ordinary terrestrial energy to do with group waves? Modern physicists tell us that matter is a form of energy. Do you mean to say that a particle of matter has any association or kinship with waves? Well, that is a long story, but that is just what modern physics is beginning to maintain, that particles and waves are universally associated with each other, and that in some cases they merge into each other.

The Structure of the Ether

This is the most recent addition to modern physics, and must have a deep meaning in connection with the structure of the ether. Anyone interested and wanting to know more about it should get hold of Sir J. J. Thomson's Girton Lecture called "Beyond the Electron" (published for 2s. 6d. by the Cambridge University Press), and read that. If they can understand it all, they will have made some progress into the intricacies of modern ideas, so far as they can be expounded without mathematics.

Let OA be drawn to represent the velocity of light c and let AB be drawn to represent $b\lambda$, a quantity proportional to wave-length. Then OB represents the wave velocity v , always a little greater than c . And then, if a semi-circle be drawn on OA so as to cut OB at P, OP represents the group or energy velocity u , always a little less than c .

The relation $uv=c^2$ is expressed by the diagram geometrically.

The discrepancy between the three velocities u , c and v increases as $b\lambda$ increases. It increases with length of wave transmitted, and also with the number of electric charges per unit volume of the medium.

If there are no electric charges, then the slant of the line OB is shut up; it coincides with OA, and u , c and v are all equal.

We shall find that if the diagram is drawn so as to represent conditions which enable radio waves to curl round the earth, the vertical side AB must be $\frac{1}{10}$ of the horizontal side OA; in other words, that the necessary angle of AOB is just about ten degrees.

The Heaviside Layer

Now let us assume, as the result of mathematical investigation by experts, that in a medium or atmosphere containing free ions, or at least electrons that are temporarily free, that ether waves, especially long ether waves, do travel at a speed slightly greater than their normal velocity, and see what the result will be in connection with the Heaviside Layer.

The term "layer" rather suggests a sort of parapet or boundary, which might act like a whispering-gallery; and indeed that phrase may be used as a sort of popular



exposition of what happens. But, I see no reason to suppose that the layer is at all a sharp one, such as would have a reflecting power on the waves. What we call the Heaviside Layer is probably a region in the upper atmosphere where the air has been ionised by sunlight.

What is called photo-electricity has been known now for some years. Ether vibrations of extremely high frequency, such as constitute the very short waves of light, are liable to affect and temporarily decompose the atoms they encounter, the said atoms being a nucleus surrounded by planetary electrons, so that one or other of the planetary electrons is jerked up either into a higher orbit or jerked out altogether.

Radiation Causes Chemical Action

To do this requires a certain amount of energy; but radiation contains quanta of energy, greater in proportion to its frequency, which are quite competent to eject electrons from some atoms. Even the ordinary luminous radiation is able to do that under some conditions, and hence it is that radiation is able to cause chemical action.

Chemical action is a sign that the photo-electric effect has occurred, so that fresh chemical compounds are formed. This action undoubtedly goes on in the leaves of vegetation; and in that way the carbonic acid and water with which the plant is fed are changed into starch and sugar and the other ingredients necessary for the elaborated sap in the formation of woody tissue. It is indeed the photo-electric or photo-chemical power of light which makes vegetation possible.

Investigating the Heaviseide Layer

The same power enables salts in photographic films to be affected and the silver molecules rearranged, so that they are amenable to the action of the developer, and are then no longer soluble in the fixing solution. It is probable also that it is by the photo-electric action on certain ingredients of the retina that the nerves are stimulated, and vision produced.

Not all radiation is able to do this. The quanta must contain sufficient energy, that is, they must carry with them a frequency of vibration above a minimum in order to produce the effect. Infra-red rays have no such power on the eye, though there are salts that can be affected even by them. The most efficient agents in producing chemical action are the waves of higher frequency or much shorter wave-length.

Stopped by a Smoke Screen

Ordinary visible light is not able to ionise the air through which it passes, but X-rays can. Ultra-violet light can ionise the substances in photographic plates, but X-rays can ionise the air and make it conducting, so that an electroscope is discharged in their neighbourhood.

WIRELESS IN THE ANTARCTIC



Many important investigations have been carried out by expeditions to polar regions, and this photograph shows the wireless headquarters of the Wilkins-Hearst Antarctic Expedition.

No ordinary source of radiation can do this. The temperature has to be very high in order to emit waves of excessive frequency. I am not aware that even the electric arc can emit anything beyond ordinary ultra-violet. But the sun is at a far higher temperature, and accordingly some of its radiation is of excessive frequency, so that it ionises the first portions of atmosphere which it encounters; the rays thus expend their energy, and do not come down to us in any appreciable quantity.

Even ultra-violet light is partly cut off by the atmosphere; by the thinnest pall of smoke it is cut off completely, only the visible rays managing to get through. But if we ascend a mountain, so as to get above the lower strata of the atmosphere, a residue of rather high ultra-violet light does reach us, and accordingly chemical action goes on in the skin, so that we are bronzed or blistered.

Protected by the Atmosphere

If we could ascend higher still, say 20 miles into the atmosphere, we should find the rays actually damaging; their chemical activity would be too strong, not only for the human skin, but for vegetation too; and leaves exposed to such rays would wither.

The atmosphere, therefore, acts as a beneficent screen, protecting us from the extremest rays of the sun, and the air in those upper regions is pretty thoroughly ionised. The atmosphere of the earth has no definite sharp limit as an ocean has. It fades away into emptiness in a highly rarefied condition.

The presence of this highly rarefied upper air makes itself perceptible when bodies are flying through it at tremendous speed, like the meteors we sometimes encounter revolving in very elliptical orbits round the sun, and having at the distance of the earth a speed of 26 miles a second; for these small bodies, even by air so rarefied that we should ordinarily call it vacuum, are raised to incandescence by the friction, and become visible as shooting stars or meteors. Their height has been estimated by comparing the results of observers in different positions, and it is understood that they are sometimes at a height of as much as 80 miles.

When the Wave-Front Curves

Let us realise then that the upper regions of the earth's atmosphere are strongly ionised, and see what happens to radio waves emitted by a central station. Such waves consist of polarised electro-magnetic radiation, with the electric oscillation vertical, ready to be picked up by a vertical aerial, and magnetic oscillation horizontal, ready to be picked up by a coil or portable receiving set. The one produces electric currents in the aerial wire direct, the other produces currents in the coil by magnetic induction, the coil being so placed that it is threaded by the lines of magnetic force.

If there were no atmosphere the advancing waves would start in a horizontal direction and go off tangentially into space. But the waves are of great extent, they reach up from the earth's surface into the upper air and beyond it, and the part of the wave which finds itself in the ionised region would be travelling a little faster than the lower portion. Accordingly, the vertical oscillation will not remain vertical, but will be tilted slightly forward, so that the whole wave front moves in a somewhat curved path.

A Sound-Wave Analogy

The same sort of action occurs in sound when a wind is blowing, though not for the same reason. Sound is really carried by the air. Hence if the air is moving, its velocity is added to that of the sound if it is blowing the same way, or subtracted if it is blowing against the sound wave.

Accordingly, sound travelling with the wind is curved down towards the earth and quenched, so that it is not

(Continued on page 302.)

RADIO ABROAD



*Notes and News of Wireless in Other Lands.
By Our Special Correspondents.*

The "Monophone"

THE completion of a form of radio transmitted over telephone wires, and called the "Monophone," was announced a little while ago to the National Academy of Sciences, U.S.A., by General G. O. Squier, the well-known U.S. radio engineer.

Calling attention to the crowding of the radio "lanes," General Squier advocated the application of high-frequency currents to the millions of ordinary telephones in use in the United States. Without interfering with the present point-to-point service, and without changing equipment, the telephone wires could be made to work sixteen hours a day, bringing all kinds of programmes into the home.

The low power used in the transmitting is another advantage claimed for the system; fifty watts, for instance, will supply 5,000 telephone subscribers with the broadcast over their telephone lines.

No Tuning

No tuning is required when operating the telephone-connected set, as the mere turn of a switch gives a different programme. Static effects and other kinds of interference are eliminated. Furthermore, it is claimed that television will enter the home by this system.

"Wired wireless," which was the early name for what is now called the "Monophone," was patented by General Squier in 1910. The principle is the same as that used for the sending of multiple telephone or telegraph messages over one line at the same time.

Developments in Sweden

We referred recently to the rapid development of broadcasting in Sweden. The famous station of Motala heads a list of some thirty-one broadcasting stations which also supply a large number of relays through Europe. According to recent figures, the total number of licensed listeners in Sweden is now close upon half a million, and the percentage works out at about 6.6 per 100, or 66 receiving sets per 1,000 inhabitants.

Messages En Route

Telegraph receiving apparatus has now been installed in some of the express trains of the Paris-Lyon-Mediterranée Railway Company, by means of which passengers in these long-distance trains can receive messages on the journey.

Radio Schaerbeek

Radio Schaerbeek, which was originally a very low-power station operating in a private house outside Brussels, has now been moved to much more commodious premises within the precincts of the Belgian capital, and a well-known concert hall has been taken over as a studio.

The programmes have recently been largely taken from the Moulin Rouge, The Gambrinus, Coliseum, Hotel Cosmopolite, and the Ten O'Clock Theatre. There is a friendly rivalry between this station and Radio Belgique, and the standard of transmissions from Radio Schaerbeek has been greatly improved during recent weeks. The wave-length is roughly 250 metres, but this appears to be somewhat variable.

Bratislava

The new Marion broadcasting station at Bratislava, Czecho-Slovakia, has shown during early transmissions that this station may be relied upon as a good source of programmes of interest to listeners in this country.

When the tests were made British listeners from various parts of the country received the broadcast at good strength.

Broadcast Studios

The proposed new headquarters of the B.B.C. reminds me that in the United States the Columbia Broadcasting Company, which now includes about 50 stations throughout the States, has taken unto itself a new twenty-storey building in New York City. The upper floors of this building will be equipped as studios, and the largest will accommodate an orchestra of between 200 and 300.

THE DANZIG BROADCASTER

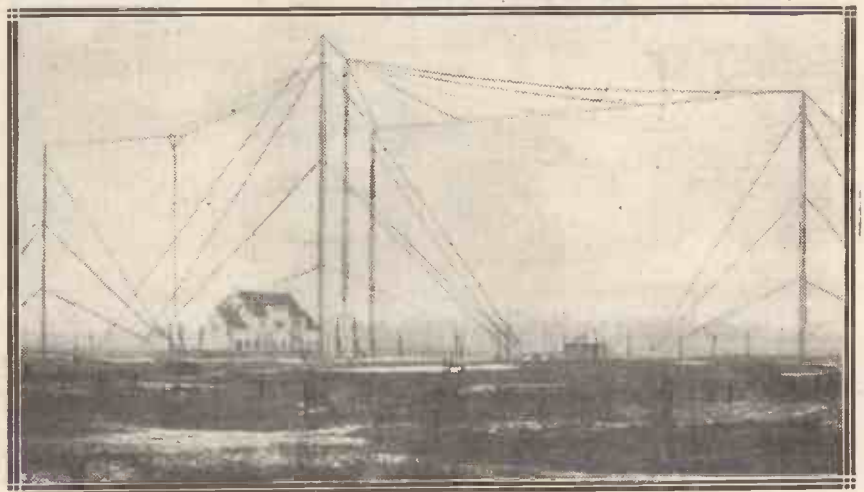

The Danzig station transmits with a power of 0.25 k.w. and relays the Königsberg programmes. It shares with other relay stations the "common" wave of 453 metres.

G.B.



THE little affair that you see illustrated in the accompanying photographs is a complete mains unit. It enables you to eliminate a battery. But although I call it complete, it is something in the nature of a parasite. You can use it only if you are already employing an H.T. eliminator. Coupled to this, it enables you to obtain grid bias without a battery. All you have to do is to disconnect the lead which runs from the minus output terminal of the H.T. eliminator to the H.T. negative terminal of your set, and connect two of the terminals of the device at these points. From a third and remaining terminal of the grid-bias unit a lead is run direct as a grid-bias connection.

Only Two Components

You do not have to worry about the G.B. plus, as in the case of a battery, for this is automatically arranged for in your circuit.

In the G.B. unit there is nothing besides a fixed condenser and a variable resistance. As you will see from Fig. 1, the variable resistance is in series with the H.T. unit and the set. The fixed condenser bypasses the resistance. I am going to deal with the construction of the unit right away, for the theory of its operation is really interesting and I want to leave adequate room to deal with it.

You can mount the components constituting this little unit in the set itself or in the mains unit, should this be one of your own construction. Alternately, the components can be built into a small unit of its own on the lines of the one illustrated.

In this instance there are two small ebonite panels mounted on a small baseboard. The higher panel takes the variable resistance, while three terminals are mounted on the remaining panel. This particular assembly was designed to go into the battery

 * The full description of useful and *
 * novel mains devices. Readers *
 * will find the theoretical explanations *
 * of the way these units operate *
 * very fascinatingly described. *
 * By F. A. TURNBULL. *

compartment of a cabinet set, so that the need for a separate case did not arise.

The variable resistance used is actually a power potentiometer having a maximum resistance of 5,000 ohms; 2,000 ohms would have been adequate to cope with any G.B. demand, but I happened to have this 5,000-ohm type on hand.

The Condenser Bypass

Only the two terminals of the potentiometer are used, the one connected to the slider and the one joined to one end of the winding. The fixed condenser, which should perhaps be of 4 mfd., although 2 mfd. appears to be adequate, is of the medium voltage variety. That is, it is rated at being safe at 100 volts.

As the voltage across this condenser will be merely that of the grid bias, this is adequate.

This unit gives only one grid-bias "tapping." If another or others are required these can easily be arranged for, but the unit becomes slightly more complicated. However,

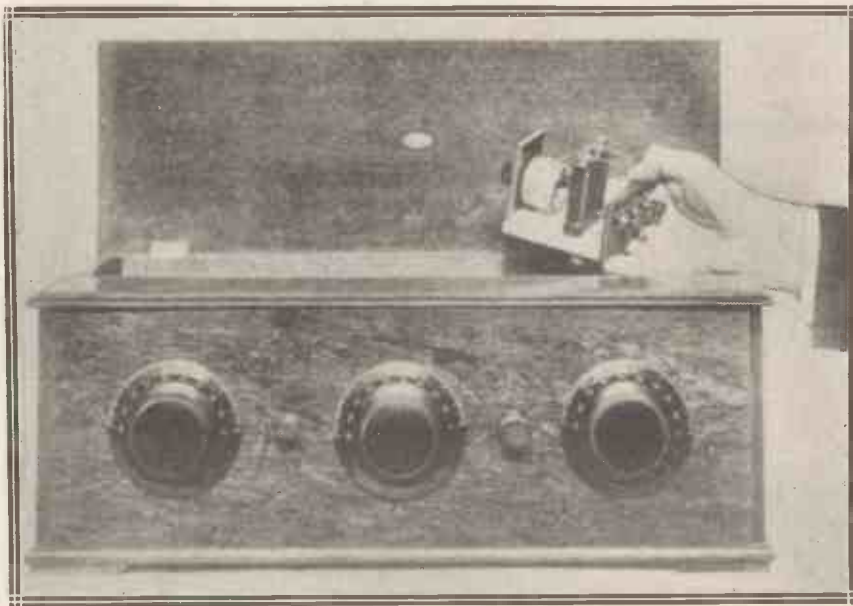

The little G.B. mains device can be fixed in the back of a set in the same way as a G.B. battery.

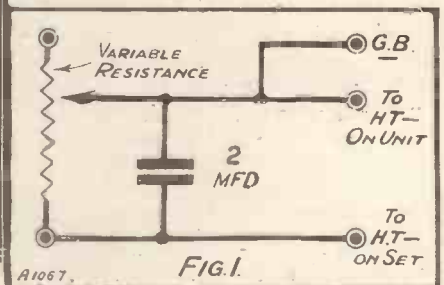

Mains Units

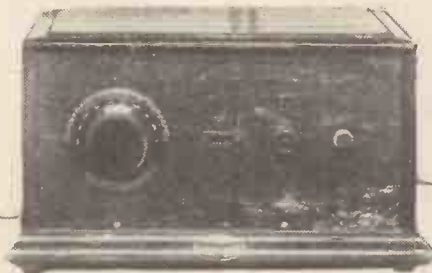

having got a grid bias sufficient to deal with the power valve, you may consider that the other four or five volts that are probably needed could quite well be applied by a small battery.

Why it is a "Parasite"

You will have done away with the need for a young H.T. battery. Nevertheless, later on, or in some future article, I hope to tackle the question of a G.B. unit for several tappings.

I have called this unit a "parasite" for two reasons. In the first place, it derives its smoothing from the H.T.

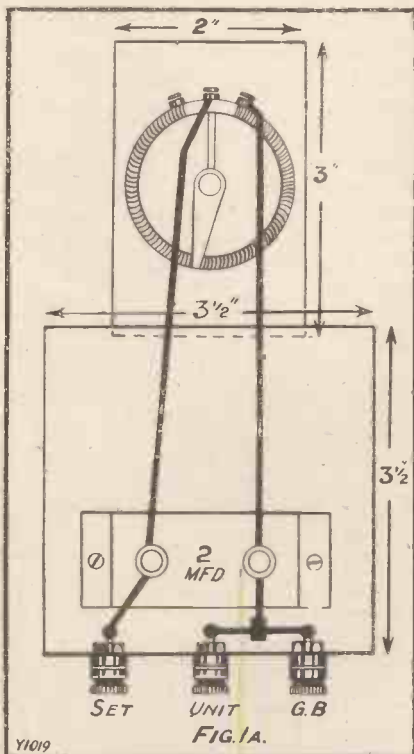
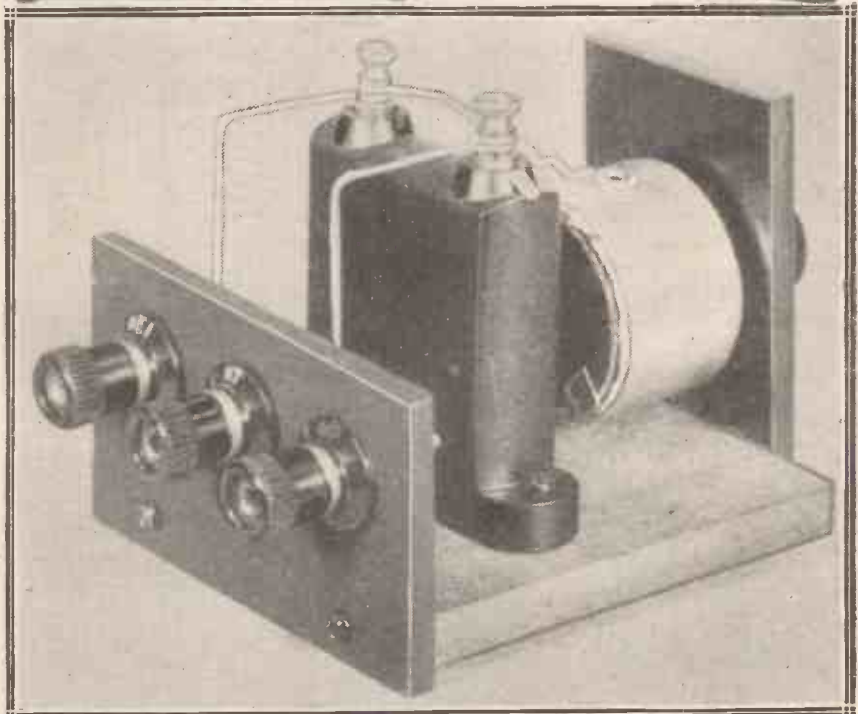

The extreme simplicity of the unit is shown by this photograph, which is a practically full-size reproduction.

If the output of your H.T. mains unit is already barely adequate, you cannot afford to use this unit, as every volt of grid bias so taken off is a volt away from the high-tension. If the output of your high-tension battery eliminator is greater than you need, as is often the case, then the unit is going to give you so much sheer profit.

For instance, it may so happen that your unit output is 220 volts or so, and that the power valve you are employing asks for only 150 of these. Of the remaining 70 volts you surely can afford 20 or 30 for grid bias; in fact, this will be so much clear gain.

Fine Variations Possible

A distinct point in favour of this grid-bias unit is that it provides an infinitely variable bias voltage. This

a battery decidedly does not do. At the best you can vary conditions only by steps of $1\frac{1}{2}$ volts. With the unit you can go up or down in fractions of volts.

For H.F. Valves

This swings the little affair away from the low-frequency end to the H.F. and det., and finds a use for it here if you cannot spare the voltage from the eliminator for biasing a power valve. You can safely subtract two or three volts from even the most inadequate H.T. eliminator.

In fact, I am not too sure whether the real purpose of this G.B. mains unit does not lie in the higher end of the receiver. True, here you can get very fine variation by using a potentiometer connected across the L.T. to supplement a battery. With

battery eliminator; further, it derives its voltage from this source and that is more serious.

A Fascinating Account of What the Device Does

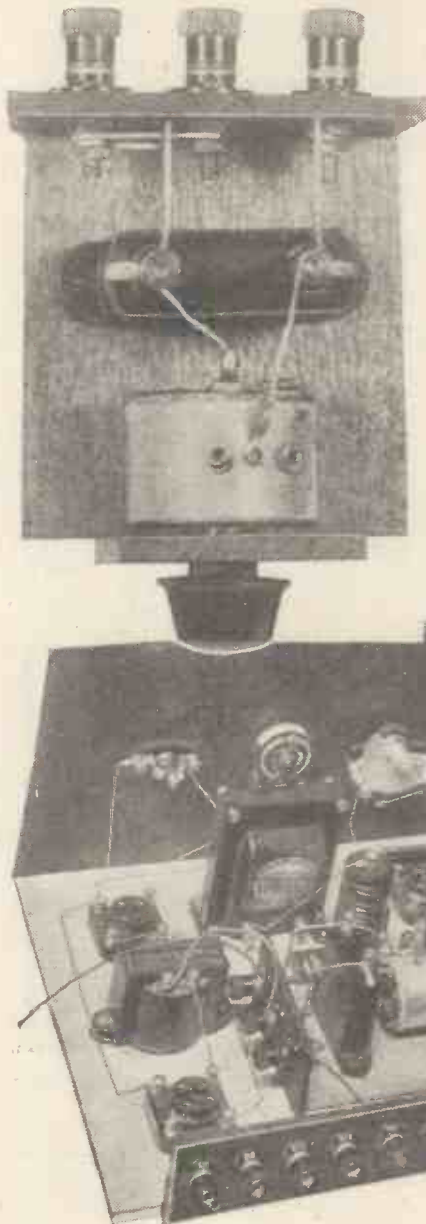

and you will have carefully to follow the circuit descriptions I am going to outline.

Fig. 1 shows the grid-bias unit in theoretical form. At Fig. 2 you see the bare elements of a mains H.T. unit. I have included an L.F. choke and a fixed condenser as representing the smoothing section, and a voltage controlling resistance. There may be other chokes, fixed condensers and resistances, but if there are they need not concern us. The fixed condensers decidedly do not, for the simple reason that they have nothing to do with our voltage variations,

* * *

(Left) A plan view of the device and, below, showing how in many cases it may prove possible to mount it on the baseboard of a set in place of the G.B. battery.

need not worry about the fixed condensers, so that we might as well get rid of these right away. Fig. 4 is Fig. 3 with the fixed condensers omitted and the resistance of the L.F. choke (ohmic resistance, remember!) lumped with the voltage controlling resistance under R_1 . R_2 is the variable resistance figuring in the grid-bias unit.

The Valve Set

Now let us couple this circuit with a simple valve arrangement. I say simple valve arrangement, although Fig. 5 can represent for our purposes (simple as it is) all the elements of the most complicated valve outfit.

The resistance of a loud-speaker winding, transformer, or anything else figuring in the circuit of the valve can be lumped with R_3 as in Fig. 6.

You will note that I have included an H.T. battery in diagrammatical form instead of the mains. I do not want you to look upon it simply as a battery, but as a voltage. My purpose in giving you the battery symbol is so that you can easily visualise the potential applied across the points in question.

A Circuit of Resistances

In Fig. 6 you have the whole thing boiled down to a complete circuit of resistances. Let me just run through them, so that you can grasp the situation. The H.T. battery symbol indicates the input to the mains unit, and the voltage of this will be the voltage of the mains themselves in the case of a D.C. supply, and the voltage developed across the secondary of a transformer in the case of A.C.

R_1 represents the total internal ohmic resistance of the H.T. unit. R_2 is the plate to filament resistance of the valve, and you can lump with this the resistance of the rest of the anode circuit, with, of course, the exception of R_3 , which comes in the

the G.B. unit, however, you can do the whole thing much more simply and without having to have a battery at all. If the volts you need are few the resistance in the G.B. unit will have to be small—I will tell you later on how to work out exactly the value required for different purposes.

Very Confusing!

Now for the theory I have referred to. At first sight, many of you will think that I have made a mistake and that this unit gives you a positive bias to a grid point instead of a negative bias. It is very confusing,

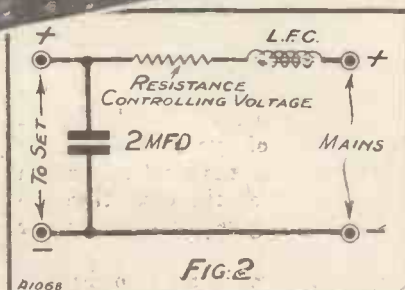

and nor does the L.F. choke except from the point of view of its ohmic resistance, and this we are going to lump with the internal resistance of the unit, as I will show you.

A Skeleton Circuit

Fig. 3 is the theoretical form of the G.B. unit coupled up to the H.T. unit. I have already said that you

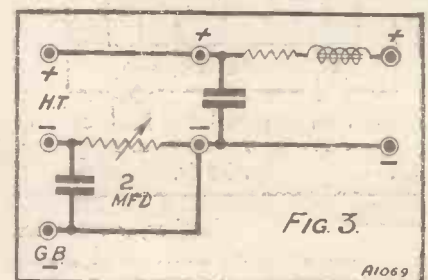

and How the Unit Derives Its Voltage

anode circuit, although it is the resistance of the G.B. unit. It is, anyway, external to the receiver.

The letters indicate: P the plate of the valve, F the filament, and G the grid, this last corresponding to the grid-bias point on the G.B. unit. Placing all the resistances in line directly across the source of energy we get Fig. 7, and the whole thing begins to become clear. The G.B. resistance lies between G and F.

A "Potentiometer Effect"

You can regard the three resistances as a sort of potentiometer winding connected across a battery. If you connect two wires to a point G there would be no potential difference between them, but if you connect one to G and one to F there would be a decided potential drop. F would obviously be positive in relation to G, and this is the same as saying that G is negative in relation to F.

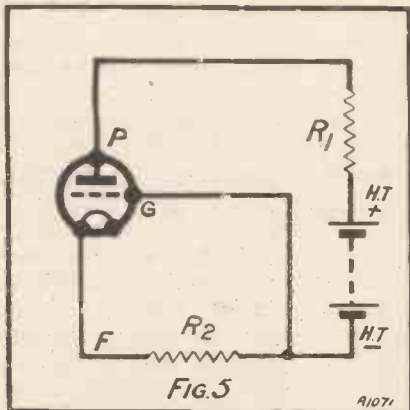

And the nearer F is taken to the point marked H.T. plus, or the farther away in ohms it is separated from G, the greater will be the potential difference between them.

The greater the resistance between F and G in comparison with the resistance of the rest of the circuit, the greater the potential difference

between those points. Now you will begin to see how the G.B. unit robs H.T. from the eliminator. As you take F farther away in ohms from G (and this is the same as increasing the resistance of R_2), so in effect you take F closer to P and drop the volts across the valve.

The Other H.T. Tappings

There is another rather serious aspect of this point, that is, with every adjustment of the G.B. the voltage of all the H.T. tappings on the H.T. mains unit may be upset.

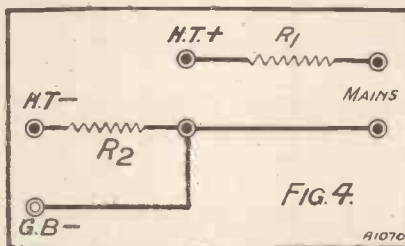

Compensation can quickly be made by new adjustments providing you have some volts to play with.

Again, if the G.B. you are taking is only a matter of a volt or two, then it is hardly likely that anything will be upset.

The Deciding Factors

I think I have made it clear that the G.B. you get from the unit depends primarily upon three things, viz., the input voltage of the H.T. unit, the internal resistance in ohms of this article, and the internal resistance of the receiving set between the set's H.T. terminals. The fourth and obvious factor is the resistance of the G.B. unit.

The grid bias voltage available when

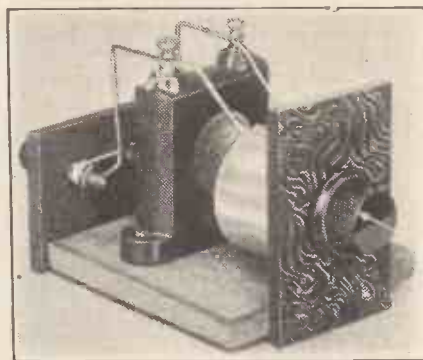

A further view of the unit.

the unit is connected up will be $\frac{R_2 V}{R_1 + R_2 + R_3 + \text{volts}}$ where V equals eliminator volts, R_2 the G.B. unit resistance, R_1 the H.T. unit resistance and R_3 the receiving set resistance.

A Simple Calculation

If you want to find out the resistance needed to give you a certain G.B. voltage the simple formula is

$$R = \frac{VR_1}{V_1} \text{ ohms.}$$

V is the G.B. voltage required and V_1 the eliminator input, while R_1 is the total of the resistances of the set and H.T. unit.

It is hardly probable that these formulae will be particularly useful in the majority of cases, as many of the resistances I have been referring to will be unknown to most people. Besides, most eliminators have several taps providing H.T. to different stages of the set, while in the set itself there will be the several valves and various transformers and so on to provide a complex network of paralleled and seriesed resistances.

(Continued on page 298.)

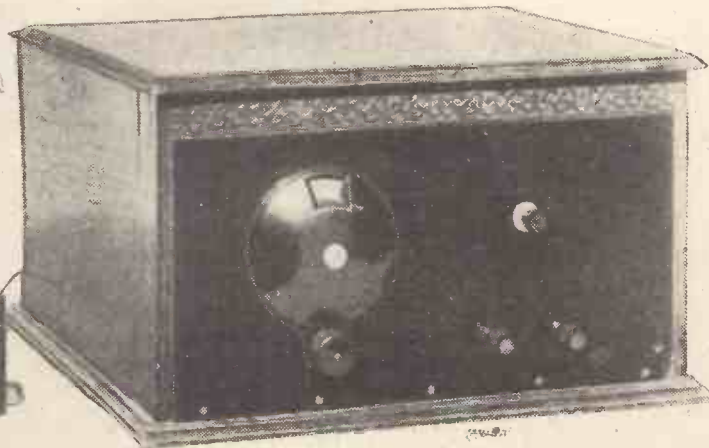

The G.B. unit is connected between the H.T. unit and the set and derives its voltage and smoothing from the H.T. outfit.

IS IT RESISTANCE?

BROADCASTING, or any kind of radio, for that matter, must set up electrical vibrations in all sorts of things besides ordinary wireless aerials.

This is proved by the fact that you can use practically any electrically conductive body as an aerial to collect radio energy from the ether. An iron bedstead, a wire fence, even a tree will make quite an efficient antenna.

When Fireplaces "Oscillate!"

But the radio vibrations are not likely to be set up to any great extent in every article of this nature during its ordinary existence. Thus you need not fear that because you are close to a broadcasting station the wire mattresses of your beds are palpitating with electrical oscillations, or that your mangles, sewing machines, fireplaces, baths, and what not, are all in a state of electrical activity.

A metallic conductor will only develop an oscillating sympathy with a radio station if it is moderately in electrical sympathy with it. That is, it has got

Following upon the requests of a large number of appreciative correspondents, the author has written another article dealing further with unconventional aeriads and the curious effects that follow certain simple set experiments. Some really practical information on set testing is also given.

By G. YOUNG.

to be tuned in the same way as you tune an ordinary aerial.

A slight activity can be caused if the tuning is fairly close and the station is near without there being a radio set in circuit. Even so the

energy so developed will be very minute and not likely to cause any kind of trouble.

Shock Excitation

It may be remembered that a crane that was in use near 2 L O's Oxford Street transmitter exhibited indications of liveliness. Sparks were seen and mild shocks were experienced by the workmen using the machinery.

It should be noted, however, that only a few yards separated the transmitting aerial and the crane, and that the crane must have had a natural "tune" close to that of 2 L O's wave-length. This is quite certain,

because there is a large number of metal objects in the great store right under the aerial which never show signs of electrical life.

Right inside the engine-room of a radio station nearly all the metal can be made to "oscillate" by the sheer proximity of powerful H.F. generators. Careful earthing can, however, prevent this causing discomfort to the engineers or danger to the building.

It is interesting to note the remarks of Messrs. Barfield and

MIGHTY MARCONI MAGNIFIER

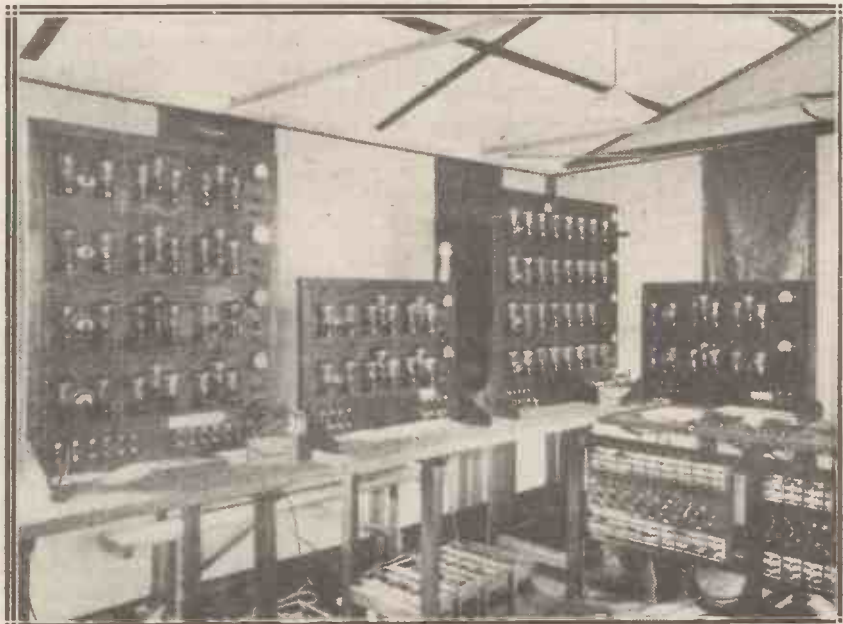

This is the Marconi amplifying apparatus used at the recent Air Pageant. The anodes of the valves took 6,000 milliamperes at 350 volts!

A Loud Speaker that Altered in Pitch!

Munro in a paper entitled "Attenuation of wireless waves over towns" (Journal of the Institution of Electrical Engineers, Vol. 67, No. 386). This is what they say:

"The attenuation of waves over a large town is different from the attenuation of waves over the country. There appear to be two distinct effects, according to the nature of the surface which the waves traverse. Over the town itself the attenuation is determined by the absorption of energy in the vertical metal conductors, such as pipes of all kinds, electric wiring, steel frames, etc., and possibly by the dielectric losses in the bricks, cement, stone, and woodwork. The particular feature of the attenuation is that it increases very rapidly with the frequency of the waves. Thus, when the amount of town traversed is of

the energy they absorb being negligible compared with that absorbed by the masses of other conductors. This is no doubt due to the fact that such aeriels are usually very inefficient and heavily screened.

Over the Suburbs

"Over the suburbs, however, the extra rapid rate of change of attenuation with wave-length disappears, but if there are aeriels tuned to the same wave-length these play an important part."

You will particularly note the "masses of other conductors" in view of my earlier remarks.

People are conductors and make quite good aeriels, as I pointed out in an article which I wrote for "M.W." two or three months ago.

As a matter of fact, so many letters

Unit and Selector W.T. in front. What seemed to me odd was this.

"The set being switched on to 5 G B, I found on removing the flex lead connecting the wave-trap to the unit and set (the aerial lead being still attached to the W.T.) that signals still came through as long as I held the metal pin of the wander plug between my finger and thumb. I then removed the W.T. out of the way, leaving the aerial lead (an undesirably long one) unconnected, lying along the stand at the back of the set, and found that by slightly adjusting the tuning dials and applying more reaction I could get 5 G B at full loud-speaker strength.

Human Aeriels

"I fancy there must have been some inductance between the set and the disconnected aerial lead in this case. However, I next removed the aerial lead-in from the tube at the window, throwing it to the other side of the room, and still obtained much the same result.

"With both A. and E. disconnected I still obtained signals as long as I kept my finger on the aerial terminal of the S.G. unit.

"The length of the human aerial, if such it is, did not seem to matter, as a tiny child seemed to give quite as good results as a six-foot man.

"Anyway, I can get the news bulletin free from atmospherics on a bad night."

Among others, I have had another very interesting letter from a reader who says he can alter the pitch of his loud speaker merely by placing his finger on the detector valve.

He does not think that the effect is due to any of the things I mentioned in my first article.

A Volume Variation?

It is, of course, very difficult to say much about a case like this without having the opportunity to examine the phenomenon at close quarters. But I am inclined to think that it is more of a volume variation than a pitch variation that occurs.

If the set is being worked fairly close to an oscillating condition, the placing of the finger near a certain point in the set (without even touching anything) might quite conceivably run the set into a distorting increase in output. Thus the loud speaker might tend to resonate at a particular higher or lower frequency and give the impression of a pitch variation.



A wire fence makes quite a good aerial. The metal stake is stuck into the ground in order to obtain the necessary earth connection.

the order of three miles or more, the signal strength decreases as the fifth power of the wave-length over the range dealt with in these experiments (roughly the broadcast range).

"It appears that tuned aeriels occurring in the dense part of the town do not affect the attenuation,

were received about that article that I was invited by the Editor to write another on the same subject. One of the most interesting letters was from a Mr. D. J. Godfrey, of Grantham. He says:

"I had been playing about with 'Everybody's 3,' with 'Titan' S.G.

SHORT WAVE AERIALS



Some invaluable information, derived from experiments conducted between the Grenfell Mission base and a point in Labrador, is embodied in the following most interesting article.

By F. DEARLOVE.

IN the upper regions of the earth's atmosphere, sometimes called the Stratosphere or Isothermal layer, there is believed to exist a band of ionised air, maintained constantly, it is said, partly by high-velocity electron streams from the sun, and partly by "penetrating radiation of cosmic origin."

The height of this ionisation level varies with the time of day, and year. And it is this variation, coupled with the fact that radio waves which reach this level are bent and reflected or refracted back to the earth's surface at some distant point, which is said to account for the difference in the night and day range of a transmitting station, and the peculiar behaviour of the short waves!

Radiating at Angles

In view of this theory, it would appear to be advantageous to employ a radiating system which would propagate maximum energy at an angle suitable for refraction at the ionisation level. In general, the radiator should project maximum energy in the horizontal plane or tangent to the earth's surface at the transmitter, for communication at long distances, whilst for shorter distances, the strong

component of radiation should be at greater and greater angles with the horizontal as the distance to the distant receiving point is decreased.

In the days of short-wave transmission employing frequencies of

insuperable difficulties from a practical standpoint. Now that transmission using frequencies of the order of 28,000 k.c. and higher (10 metres and lower) is of everyday occurrence, because of the much smaller dimensions of the aerial system, no practical difficulties of a serious nature are involved.

Applicable to Reception

It is therefore expedient when erecting an aerial for operation on these extremely high frequencies to consider not only electrical efficiency, but also the radiating characteristics controlling the direction of energy distribution and the angle of propagation of the waves. It is the object of this article to make a comparison of various aerial systems from this viewpoint and, though the following remarks, which are mainly conclusions drawn from experiments, refer chiefly to transmitting aerials, they may in many cases apply equally well to receiving systems.

Because the ordinary vertical grounded aerial is a quarter-wave system when working at its fundamental, it is of no great length, even when operating on the lower frequencies. It cannot therefore be

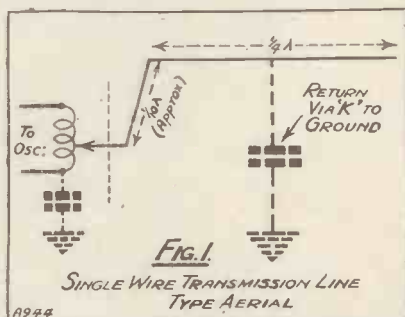

The aerial is fed by a short single wire and the capacity of the system to earth. If the feeder is long compared with the wavelength, the whole arrangement functions as an aerial, though series capacity may be used. The system is difficult to adjust correctly and its use is to be deprecated, because it is impossible to prevent radiation from this type of feeder.

3,500 and 7,000 kilocycles, an efficient aerial system was always to be desired. Any arrangement for propagating the waves at an angle suitable for refraction or reflection from the ionisation level usually presented

raised sufficiently high to prevent absorption by surrounding structures such as would be present on board ship, for example; and moreover, except perhaps in this latter case, it is usually a matter of extreme difficulty to obtain a low-resistance earth connection.

Aerial Counterpoise System

It is, however, when installed in an ideal location an exceptionally low-angle radiator, and is consequently fairly efficient in transmission at long distances. The ideal location is a matter of some rarity, however, and the disadvantages attendant on employing the grounded aerial nearly always outweigh this one good point,

and it has therefore become the almost universal practice to employ some form of ungrounded or Hertzian aerial.

A very common type of aerial in this class is the usual "Aerial-Counterpoise" system so extensively used by amateurs. This consists of two wires approximately each one-quarter wave-length long, one above the other, and separated by a distance of 20 ft. or more.

This system, though fairly effective, has two great disadvantages; the first is that serious losses occur where the wires enter the station because of their proximity to the walls of the building; whilst the second, common to the grounded aerial, is the impossi-

bility of elevating it appreciably above surrounding objects, because its dimensions would then become too

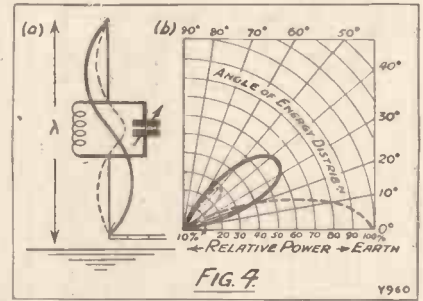
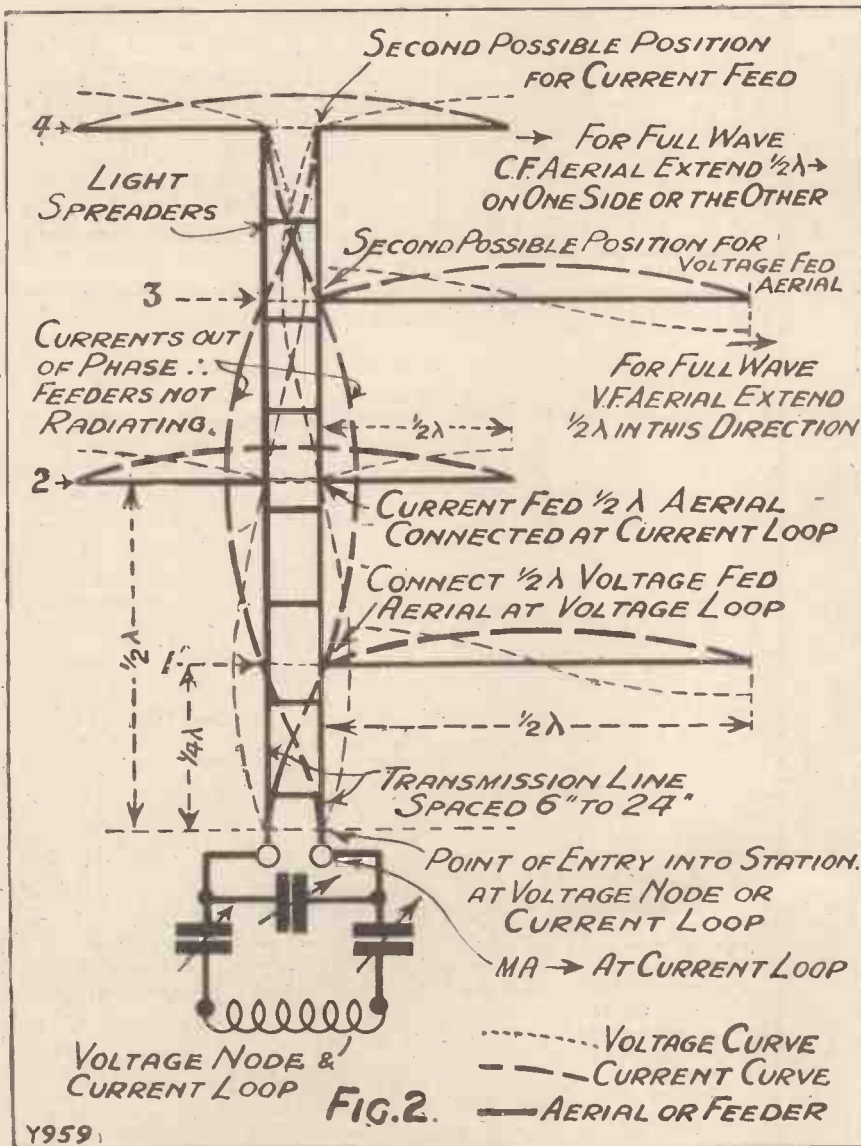

Fig. 4a shows a $\frac{3}{2} \lambda$ system, $\frac{1}{2} \lambda$ of which consists of a coil (or coil and condenser) tuned almost to the working wave. The current distribution is shown by the dotted line. When the phasing coil is short-circuited the system becomes a full-wave radiator and the current curve is indicated by the thick line. The former arrangement produces a very low-angle radiator, and the latter a mainly high-angle system, as shown by the curves for each in Fig. 4b



Showing voltage and current distribution in feeders and aerials with different possible feeder lengths. The different combinations are: 1. $\frac{1}{4} \lambda$ feeder-half-wave V.F. aerial. 2. $\frac{3}{4} \lambda$ feeder-half-wave C.F. aerial. 3. $\frac{1}{4} \lambda$ feeder-half-wave V.F. aerial. 4. λ feeder-half-wave C.F. aerial. N.B.—There is, of course, no reason why any of the aerials should not be full-wave systems (2nd harmonic), the V.F. aerials would be extended a further $\frac{1}{2} \lambda$ and the C.F. aerials would be extended $\frac{1}{4} \lambda$ at one side only.

great for satisfactory operation at the desired wave-length. A step in the right direction is the use of the single-wire feeder to a quarter-wave aerial, as shown in Fig. 1. But it is invariably found that the whole system is being employed as an aerial, whilst even if adjusted correctly it is impossible to prevent the feeder wire radiating, a state of affairs still far from desirable.

A vast improvement over the last-mentioned type of aerial is the horizontal or vertical Hertzian aerial, fed by a two-wire transmission line. All the disadvantages of the aerials previously mentioned now disappear, whilst all their good points are retained. The feeder line may be connected to the system at either a voltage or current loop, the important point being that the feeder must bear a definite relation to the designed operating wave-length of the aerial:

Transmission Line Factors

This is at once apparent on glancing at the voltage and current distribution curves given in Fig. 2, for we see that, in the case of the voltage-fed aerial, the transmission line MUST be either one quarter-wave or any odd number of quarter wave-lengths long, whilst in the case of the current-fed aerial it MUST be either one half-wave or any number of half-wave-lengths long. Voltage and current loops will then appear in their correct positions, and the currents in the transmission line will be exactly 180 degrees out of phase, thus ensuring radiation from it is practically zero. (It has been proved experimentally that at least 85 per cent of the energy

Aerials that Radiate Beams

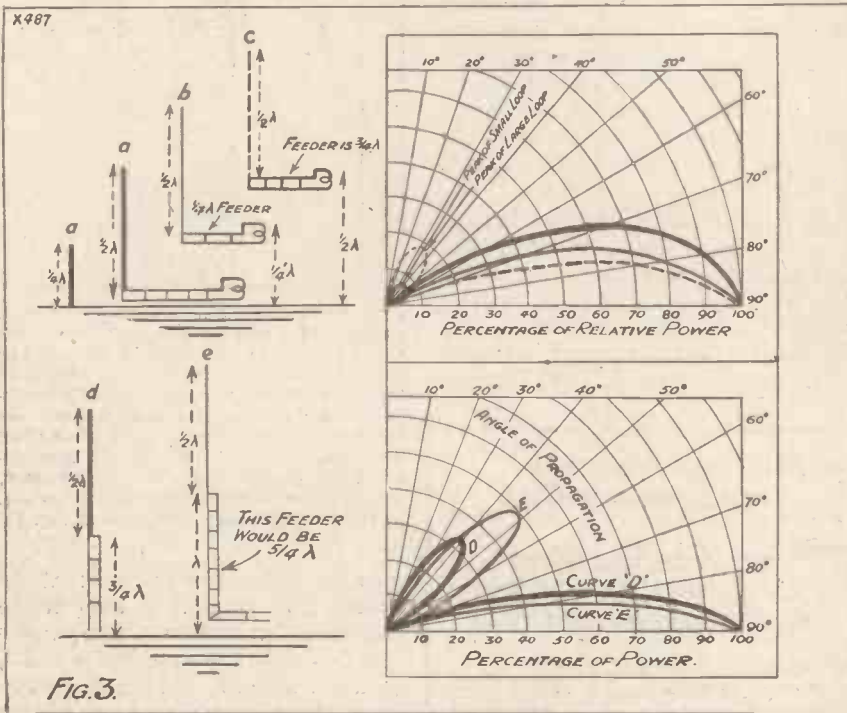

Fig. 3.

Note the feeder length must be an odd number of $\frac{1}{4}\lambda$ in all cases. For example: with aerial at height of $\frac{1}{4}\lambda$ feeder would have to be at least $\frac{3}{4}\lambda$.

is confined about the wires within a circle whose diameter is equal to four times the separation of the wires).

Attempting to determine whether or no attenuation was taking place due to excessive feeder length, actual current measurements were taken at the current loops of the various aerials, with their several possible feeder lengths as indicated in Fig. 2. The results showed that very little difference existed for any of the arrangements, when at their optimum adjustments, thereby indicating that the feeders (providing always they are the requisite number of half or quarter wave-lengths long) could be as long as might be necessary to clear local objects and obtain the height desired.

Many Advantages

The advantages of the foregoing system are many. The aerial and its feeders may be cut to exact measurements determined by the wave-length desired; no empirical or "cut-and-try" methods need be used, and since the feeder does not radiate, it may be brought around corners, placed in an upright or an horizontal position, fastened down to stand-off insulators, or, in fact, arranged in any

way desired, provided that the wires do not swing relative to one another, though the entire feeder may swing as a whole.

Reduced Losses

Losses are reduced to a minimum, since a voltage node exists at the point where the wires enter the station, whilst the aerial itself may

be raised well clear of nearby structures. (In practice, two variable condensers are placed in the feeder, one in each wire, whose function is to compensate for discrepancies in feeder length, and ensure the nodal points are in their correct position.) But, finally, perhaps the greatest advantage of all is the ease with which the angle of propagation may be changed, by varying the height of the aerial and its position relative to the earth (i.e. from a horizontal to a vertical plane).

Effective at Long Distances

The energy distribution round a vertical ungrounded or Hertzian aerial is symmetrical for a given angle of propagation, depending on the length of the wire, character of the earth and the height above the earth. (That is, it radiates equally well in all directions in a given plane in the absence of disturbing factors such as metal masts, etc., which may distort the field.) In the case of a half-wave vertical aerial, with its lower end as near the earth as possible, the radiating characteristics are identical with those of the grounded quarter-wave aerial, namely, maximum energy is distributed in the horizontal plane with very little vertical radiation.

Hence it is very effective in transmission at long distances. Fig. 3 shows the energy distribution for various heights of the vertical aerial. If the aerial is raised one quarter

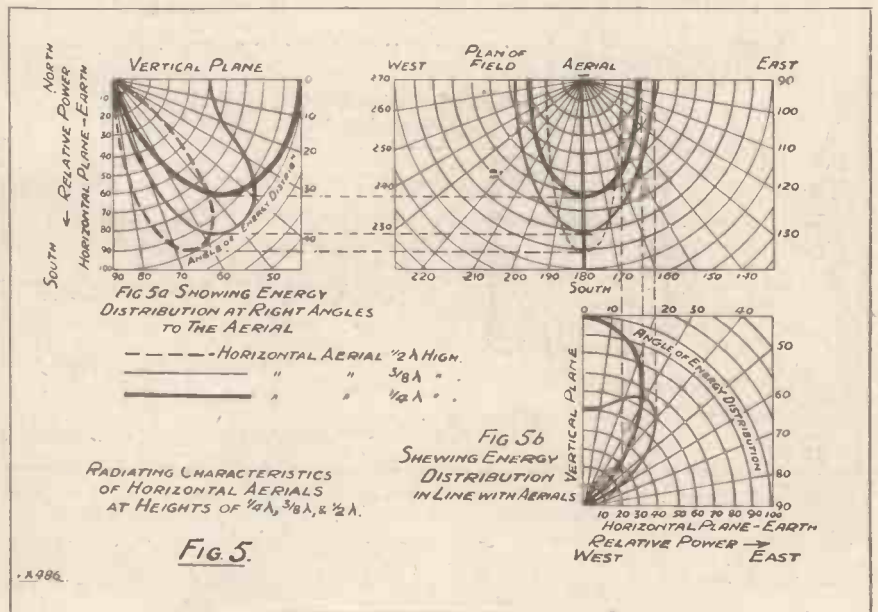

FIG. 5. RADIATING CHARACTERISTICS OF HORIZONTAL AERIALS AT HEIGHTS OF $\frac{1}{4}\lambda$, $\frac{3}{8}\lambda$, & $\frac{1}{2}\lambda$.

Fig. 5.

SILENT POWER

FROM BIG CELLS



MADE IN ENGLAND

PRICES:

60-volt (reads 66)	7/11
100-volt (reads 108)	12/11
36-volt	4/6
120-volt (standard cells)	15/10
60 (super power)	13/6
9 volt Grid Bias	1/6
4½ volt Pocket Battery (4/6 a doz.)	each 5d.
Single Cell To. Battery	4½d.

The power of a Lissen Battery flows steadily, smoothly. The big cells are packed with energy. The secret process keeps it pure and sustained. The quality lasts throughout the longest programme—there is never a sign of ripple in the current, never a trace of hum.

Hear how well your own loudspeaker will reproduce a heavy orchestral item when you have the power of a Lissen Secret Process Battery flowing through your set—test it on opera, vaudeville, speech, song or sports event. Hear how natural and true everything sounds.

Obtainable at every good radio dealer's—ask for Lissen New Process Battery and be sure to take no other.

LISSEN LIMITED, 20-24, Friars Lane, Richmond, Surrey.

Managing Director: THOS. N. COLE.

wave-length above the earth, a small percentage of high-angle radiation results (see Fig. 3b), and if the aerial is carried still farther above the ground, say to a height of one half wave-length, the percentage of higher-

standpoint, is shown in Figs. 4 (a and b), for it has the advantage of being quickly converted from a very low-angle radiator to a high-angle radiator or vice versa.

The energy distribution from a

for any height of the vertical aerial, we see that no position of the horizontal aerial results in radiation in the horizontal plane.

Fig. 5a shows a section of the field cut at right angles to the line of the the

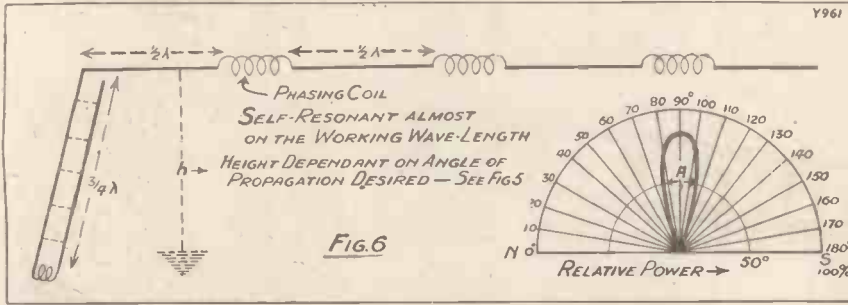

Fig. 6 gives plan of half field showing resulting beam. The other half is symmetrical. The angle "A" depends on the number of $\frac{1}{2}\lambda$ sections employed (see text), in this instance 32° . The aerial is lying North and South and the beam is at right-angles to the line of the aerial, and on both sides of it. Fig. 7a shows arrangement of aerials for operation in or out of phase. The wires are shown as they would be seen from above. The dotted circles represent the addition of a second row of aerials. Fig. 7b gives curves showing energy distribution when operating: "A," one row, currents in adjacent wires being in phase—fairly sharp beam at right angles to the line of the aerial. "B," one row, currents being out of phase—fairly broad beam in line with the aerials. "C," two rows, currents being out of phase within the rows, but both rows being in phase with each other—sharper beam but not so good as "A." (Note: Addition of second row "all in phase" makes no difference to Curve "A.") * Unilateral radiation takes place when second row is placed $\frac{1}{4}$ wave-length distant. The currents being in phase within the rows, and the rows out of phase with each other. (Rad. as per half of Curve "A.") Bilateral radiation, as at "C," takes place when "d" = $\frac{1}{4}$ wave-length.

angle radiation increases, with a corresponding decrease in the amount of purely horizontal radiation, but it is found that the higher-angle radiation has rotated towards the horizontal, from an angle of about 30° degrees from the vertical at a height of one quarter wave-length to one of about 40° degrees at an elevation of one half wave-length (Fig. 3c).

horizontal aerial is not symmetrical, as in the case of the vertical aerial, a greater percentage of radiation taking place in a direction at right

aerial, whilst Fig. 5b shows a section cut on the line of the aerial. When operated at a height of one quarter wave-length, the energy distribution

Conveniently Practical Form

As the aerial is raised still farther, the percentage of higher-angle radiation increases, with a corresponding decrease in purely horizontal radiation, but at the same time the angle of the former continues to rotate towards the horizontal, from the 40° degrees noted at a height of one half wave-length to about 45° degrees at three-quarters of a wave-length, and 48° degrees when its elevation is one full wave-length (Figs. 3d and e). An aerial, convenient from a practical

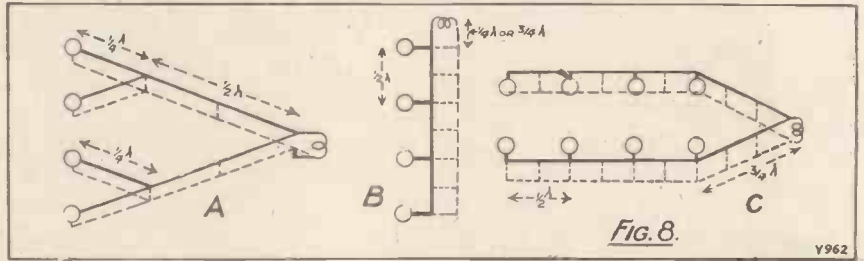

Dotted line indicates second feeder wire in each case. *Note: For Unilateral radiation the two rows shown at "C" should be one quarter wave-length apart, but the feeder lengths must remain the same. Some difficulty has been experienced in getting this arrangement to function correctly, and for this type of radiation the parabola shown in Fig. 10 is recommended.

angles to the line of the aerial and on both sides of it (see Fig. 5 for plan of the field). In contrast to the comparatively large percentage of purely low-angle radiation obtained

is almost entirely in a vertical direction, but when elevated to heights between one-quarter and one-half wave-length, the radiation progresses (Continued on page 303.)

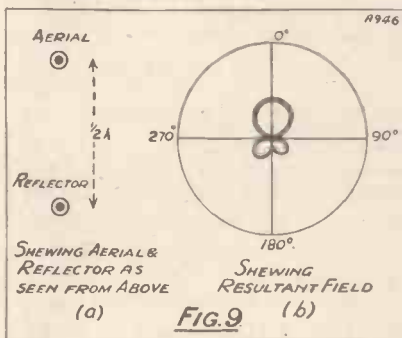

A fundamental characteristic of any parabola is that the distance from the focal axis "A" to any reflector "R" plus the distance from that reflector to the point of emergence of the resultant ray "E" must be equal to twice the distance from the aerial to the reflector immediately behind it. These distances are shown by the dotted lines, which measure 1λ in each case.

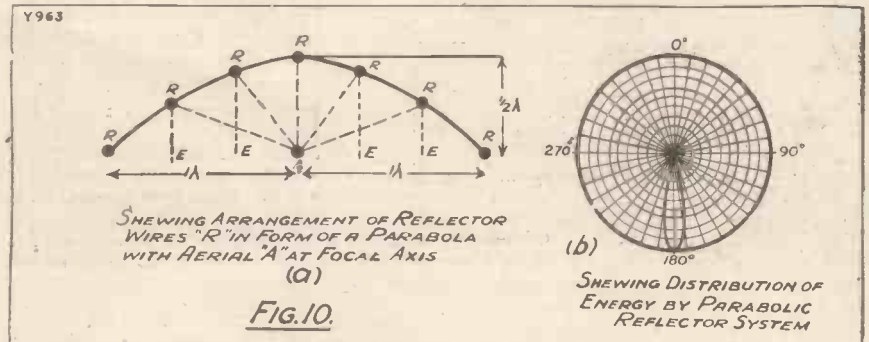

These distances are shown by the dotted lines, which measure 1λ in each case.

H. T. BATTERY RESISTANCE



THERE are at least three methods of measuring battery resistance in use at the present time. That employed by the famous American Bureau of Standards is as follows: The open-circuit voltage of the battery is measured with an accurate high-resistance voltmeter. The battery is then connected to a large rheostat whose approximate total resistance is 1.5 ohm for each cell of the battery under test.

Not So Straightforward

The rheostat is now adjusted until the current flowing is exactly one ampere. Then the closed-circuit voltage of the battery is taken. The formula used is:

$$\frac{OCV - CCV}{I} = R.$$

Where OCV is the open-circuit E.M.F. in volts; CCV the closed-circuit E.M.F.; and I the current in amperes.

Since $I = 1$, the resistance is equal to the difference between the two voltages. At first sight this might seem a simple method, but actually it is not quite so straightforward as it looks, and it has a good many drawbacks.

If your H.T. battery has a high internal resistance it will cause trouble or perhaps howling and very high-pitched noises, or, at best, faulty reproduction.

In this article several methods of arriving at a very close approximation of a battery's true condition is described

*By
R. W. HALLOWS,
M.A.*

Another serious drawback is that a high-tension battery that has seen a certain amount of service is often incapable of passing an ampere of current even for a fraction of a second.

The High-Tension Battery

This method may, however, be modified and used with success by anyone who possesses a high-resistance voltmeter (it is desirable that the resistance of the instrument should be not less than 500 ohms per volt) and a milliammeter reading up to 25. Here is the way in which it is done. Use a fixed resistance with a value of 50 ohms for each volt of the battery's nominal E.M.F.

Thus if you wish to examine the internal resistance of a 60-volt battery your fixed resistance will have a value of 3,000 ohms. Take the open-circuit voltage, then put the milliammeter and the fixed resistance into circuit, measure the current flowing and take the closed-circuit voltage quickly. The current will be somewhere in the neighbourhood of 20 milliamperes. Use the formula given above and divide the answer by two.

Open-Circuit Voltage

Thus suppose that on open circuit the battery measures 65 volts, and that with the resistance in action the voltage is 63 and the current 21 milliamperes, then by the formula we have:

$$\frac{65 - 63}{.021} = \frac{2}{.021} = 95.2$$

and this divided by 2 gives 47.6. Since such a battery will probably contain forty-four cells we know that the internal resistance is just over 1 ohm per cell.



Meters enable you to discover exactly any particular part of a wireless set, are working properly or whether or not up to scratch. In this latter regard the H.T. is generally harder to "sound" than the L.T. battery simple way of doing it, as Mr Hallows describes.

what is going on in whether the valves the batteries are battery is gen- but there is a

Test Your Own H.T. Batteries

When it is in new condition the internal resistance of a standard capacity battery should not exceed more than about .25 ohm per cell, and the figure should be rather smaller for double- and treble-capacity batteries, going as low as about .15 ohm in quadruples of the very best quality. With use the resistance rises considerably, and when it has reached a figure of 1 ohm per cell it may be sufficient to give rise to big back-coupling effects in certain delicate circuits.

As a rule, though, a battery may be fit for service until its resistance has reached two or three ohms per cell. The resistance that batteries

previous reading, or 25 milliamperes. It is clear that this result will be produced only when the total resistance in circuit, including the original resistance, the resistance of the battery itself and that of the milliammeter windings, has been doubled.

From the amount of the total external resistance in circuit we subtract twice the amount of the original resistance required to produce the 50 m.a. deflection added to the resistance of the milliammeter. Thus if 1,305 ohms are needed in the first instance, if the milliammeter has a resistance of 20 ohms, and if the

as flashing the battery and measuring the current passed.

The negative terminal of the ammeter is connected to the zero socket of the battery, and to the positive terminal of the instrument is fixed a lead with a bared end. Whilst one's eyes are glued to the dial of

 * "A high-tension battery that *
 * has seen a certain amount of *
 * service often can't pass one *
 * amp. of current for a fraction *
 * of a second." *

the instrument, the bared end of the lead attached to its positive terminal is touched for a fraction of a second on to the extreme positive socket of the battery. Don't try to wait for the needle to steady itself.

If the instrument is of a well-damped type, take the extreme point of its swing; if it is not quite so dead-beat, take a point half-way between the extreme swings. With a little practice it becomes quite easy to take reasonably accurate readings whilst flashing. No harm whatever is done to the battery so long as it is not allowed to be under load for more than a fraction of a second.

A Sure Test of Quality

All that is necessary now is to divide the voltage of the battery by the amperage, in order to obtain a pretty good idea of its internal resistance. It will serve as a useful guide to readers to know that a standard capacity battery in fresh condition should flash at least 4 amperes, a double 6, a treble 8, and a quadruple 10. When a newly purchased battery shows lower figures than these, you may be fairly sure either that it is of poor quality or that it has long lain in stock.

Should the receiving set become unstable for some mysterious reason,

 * "When in new condition the *
 * internal resistance of a stan- *
 * dard capacity battery should *
 * not exceed .25 ohm per cell." *

the flash test applied to the high-tension battery will often disclose the source of the trouble in the form of enormously high internal resistance.

MAKING AN AMMETER "FLASH" TEST

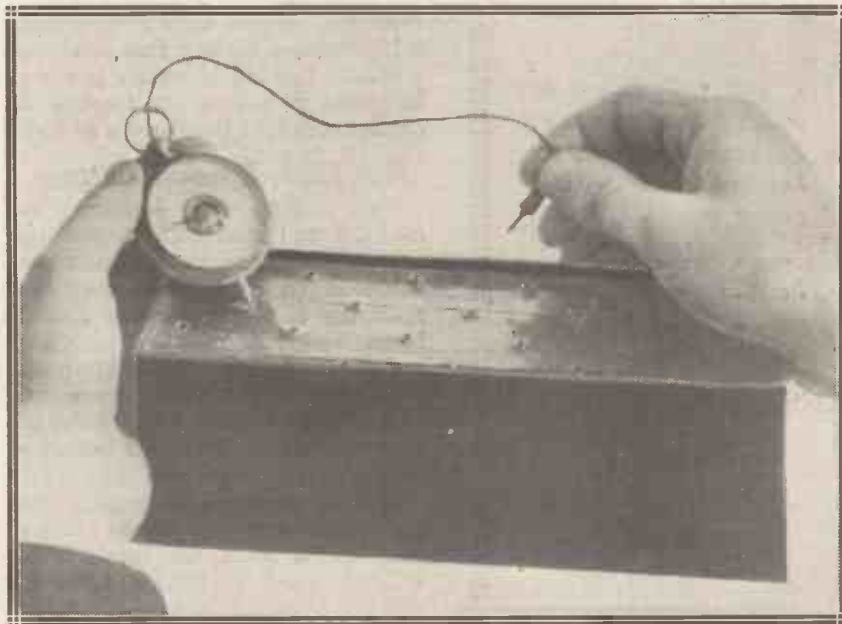

One of the simplest ways of measuring the internal resistance of an H.T. battery is to use an ammeter in the manner suggested in the accompanying article.

of poor quality can attain in a very short time after they have been brought into use is nothing short of astonishing. The writer had a batch of half a dozen under test recently whose resistance after only twenty-five hours of service life amounted to more than 200 ohms per cell!

A Better Method

The next method is probably the most commonly used in laboratories and the most accurate of all. By means of an adjustable resistance and a milliammeter the current taken from a battery under test is adjusted to, say, 50 milliamperes. Further resistance is now added until the milliammeter shows exactly half its

total external resistance to produce a 25 m.a. reading is 2,660 ohms, the calculation is:

$$\begin{aligned} \text{Battery resistance} &= 2,660 - (1,305 \times 2 + 20) \\ &= 2,660 - (2,610 + 20) \\ &= 2,660 - 2,630 \\ &= 30 \text{ ohms.} \end{aligned}$$

This method can be employed by anyone who possesses a Wheatstone bridge and the necessary instruments. It is, however, more accurate and less rough and ready than we need for ordinary wireless purposes.

The third method is the simplest of all. It takes only a moment or two to put into practice, and no instrument is required but an ammeter. It consists simply in what is known

VARLEY

FOR L.F. CHOKES



The man who has a real knowledge of the technical side of radio will be quick to appreciate the value of our many years of experience in the winding of chokes for ordinary electrical purposes. This past experience has been of incalculable help in tackling the more difficult problem of producing L.F. Chokes for radio receivers. The relationship between iron and copper, the positioning of the different elements, etc., right down to the actual coil-winding itself—all these problems have been successfully solved in the light of our past experience.

We are now able to market a range of L.F. Chokes which is second to none in the British Isles—in fact, the new Varley Constant Inductance L.F. Choke (20 henries over the whole range of from 0-100 m.a.) can lay claim to advantages unknown to any other L.F. Choke of the present day.

Full particulars of any of these L.F. Chokes on application:—

Standard L.F. Choke, 20 henries	£1 0 0
Constant Inductance L.F. Choke, 20 henries over the whole range 0-100 m/a	£1 1 0
Dual L.F. Choke, 75 Henries, series resistance 700 ohms	£1 1 0
Pentode Output Choke, 2 ratios for high resistance speakers	£1 1 0
Low Tension L.F. Choke, for 3 amperes	£1 0 0
Push-Pull Output Choke, for high and low resistance speakers	£1 1 0



STANDS 154 & 159 Olympia

Advertisement of Oliver Pell Control Ltd., Kingsway House, 103, Kingsway, London, W.C.2. Telephone: Holborn 5303.



IN OUR TEST ROOM

The Brown "Vee" Unit—Magnum Reaction Condenser—The R.I. H.F. Choke—New Plugs and Sockets—"Blue Spot" Productions—The Brown Budget—Important Price Reductions.

The Brown "Vee" Unit

THESE are sure to be a vast number of people buying the new Brown "Vee" unit during the coming radio season, and to such of those who should happen to read these paragraphs we would tender this advice. Spend another fifteen shillings and buy the Brown "Vee" chassis as well. Then, for a modest sum of two pounds, a complete loud speaker is acquired that makes really excellent value for money.

It gives good results in its original form, but to hear what it really can do it should be fitted to a simple baffle board, or a little more can be spent and one of those loud-speaker cabinets bought.

The reason for the name "Vee" is to be found in the special construction of the unit. The poles of the electro-magnet which figures in the unit are concentrated into a "V" shape, and the armature closely fits

into this. Of course, there is a reasonable gap enabling considerable power to be developed.

The result of the ingenious design is first to be found in the uniform sensitivity of the unit. We presume that it is for this reason that the Brown "Vee" unit retains bass on smaller inputs than do the majority

Manufacturers and Traders are invited to submit for test purposes radio sets, components and accessories to the "Modern Wireless" Test Room at Tallis House, Tallis Street, London, E.C.4. Under the personal supervision of the Technical Editor all tests and examinations are carried out with the strictest impartiality. Readers can accept the Test Room reports published monthly under the above heading as reliable guides as to the merits and demerits of the various modern productions of the radio industry.

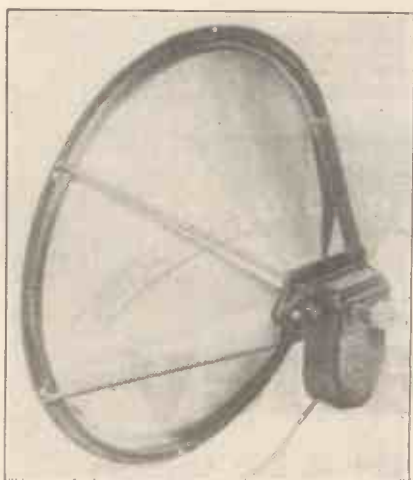

This is the Brown "Vee" unit and chassis.

of loud-speaking devices. Readers will no doubt have noticed how so many loud speakers run into distortion when volume is cut down below a certain level.

From the foregoing it will be gathered that the "Vee" unit is a versatile accessory, and certainly it seems to be as satisfactory with a small two-valve set as with a large multi-valver.

While no doubt many purchasers of these units will, as we have advised, also acquire the cone chassis, others will prefer to employ the semi-free-edged type of diaphragm which is so popular among home-constructors at the present time. They will find that the "Vee" unit operates with these with remarkable satisfaction.

Magnum Reaction Condenser

It is rather a mystery to us why definite stop positions are not fitted to all reaction condensers. Surely most constructors would find it comforting to feel a definite minimum and maximum setting of reaction? However, the new Magnum reaction condenser has a large knob for adjustment purposes, so that the indicating pointer can traverse a fairly large circle. This enables simple panel-marking to be made. And for those who require stops, it is an easy matter to fit small screws in the panel to impede the travel of the pointer.

The new Magnum reaction condenser costs 4s., and Burne-Jones and Co., Ltd., will lose none of their reputation for high-class radio components on its account. It is a very nicely-made piece of apparatus, and it is pleasing to note that the slotted terminal nuts' idea is retained. By making it possible to tighten the nuts with either pliers or screw-driver, the task of the constructor is considerably facilitated. On this



Messrs. Burne-Jones' new reaction condenser.

**"AS BRITISH AS
BRITANNIA"**



Registered
design.



OF all the many Brown triumphs, this is the greatest . . . a range of loud speakers which, by means of entirely new principles of design, lift Radio reproduction on to a new and higher plane. Brown Duplex Loud Speakers re-create the living artiste. Their tone is purer, sweeter and more mellow than any you have ever heard. Their volume, too, is fuller and richer —yet without any trace of distortion. Every note is faithfully reproduced. Every instrument is true-to-life. See and hear these wonderful new Brown instruments at your dealer's. You'll agree, too, that never before has such beautiful cabinet-work been seen in a loud speaker. In appearance and performance, Brown Duplex Loud Speakers are years ahead.

NATIONAL RADIO EXHIBITION,
OLYMPIA,
September 23rd to October 3rd,
Stands Nos. 213 - 214 - 215

**THE
WONDERFUL
NEW**

IN THREE MODELS:

Mahogany or Oak.

Design as illustrated.

Model V15 - £12 10s. 0d.

Model V12 - £7 10s. 0d.

Model V10 - £5 10s. 0d.

Also obtainable by easy payments, ask your Dealer for particulars.

Brown

DUPLEX LOUD SPEAKER

(Incorporating the new "Vee" Movement)

reaction condenser also there are two terminal nuts for the fixed vanes, a feature of some real practical value.

The R.I. H.F. Choke

The A.C. impedances of screened-grid valves are of a very high order, consequently it is imperative that the total effective impedance of the H.F. choke, virtually in parallel with the second tuned-grid circuit, should be of a correspondingly high value in order that the S.G. valve shall give reasonably high voltage amplification.

It should be clear, therefore, that if an H.F. choke gives an appreciable damping on the tuned-grid circuit, the arrangement will be inferior to tuned-anode and that reception of certain transmissions may be quite impossible.

The foregoing is an extract from a leaflet describing the new Dual Astatic H.F. choke, one of the latest productions of that well-known firm, R.I., Ltd. Up to not so very long ago there were more H.F. chokes used in capacity-reaction detector circuits than for anything else. And for that particular purpose an H.F. choke need not have a very high order of efficiency.

Probably for this reason the H.F. choke has tended to be the "cinderella" of components; but, in modern circuits, more particularly those employing screened-grid valves, it often happens that an H.F. choke is very much of a key component, and that upon it depends very largely the efficiency of the complete hook-up.

This is quite particularly the case where choke coupling is employed with S.G. valves. One of those H.F. chokes just good enough for reaction purposes could drop the whole performance of the set to a depressing level if used in that position.

On the other hand, the new Dual Astatic R.I. H.F. choke undoubtedly would give absorption-free service at all broadcasting frequencies. This is



The new R.I. choke.

very clearly shown in the curves of the component that are the main illustrations of the descriptive leaflet.

The Dual Astatic is certainly worthy of the famous monogram it bears. Our research department has tested it in critically key positions and has not found it wanting in any way. We have indicated that for one particular purpose an H.F. choke need not possess the highest degree of efficiency, but that must not be interpreted as suggesting that there is no such thing as a quite inefficient H.F. choke, for there are one or two still available that should be avoided for any work in any set.

Good results can only be ensured by seeing that every component used is of the best quality, and, where an H.F. choke is specified, constructors can insert this new R.I. product and know that at least one item is above suspicion.

New Plugs and Sockets

Messrs. Belling Lee, Ltd., are now making an interesting new line in plugs and sockets. The plugs and sockets are specially designed to prevent short-circuits through the insertion of the wrong socket in a [plug, or through stray leads, etc. Certain of the devices have their socket portion at the panel end, while others have the plugs there.

The division is made between plugs

and sockets for those points to which the H.T. positive is usually connected, and other points of H.T., and those which are not. And as you cannot insert one plug into another plug security is ensured by these means. An ingenious shielding of the plug and socket metal parts is arranged, as you will see in the accompanying photograph. Lettering is brightly engraved on these plugs and sockets.

Blue Spot Productions

F. A. Hughes & Co., Ltd., have now completed their programme for the coming season. One of the most important features is that the only Blue Spot unit to be retained is the 66K, and it is stated that the demand for this extremely popular model has rendered the other types superfluous. There are four loud speakers, ranging in price from two guineas to six guineas. Only one model gramophone pick-up is to be featured and this is the standard model with volume control at two guineas.

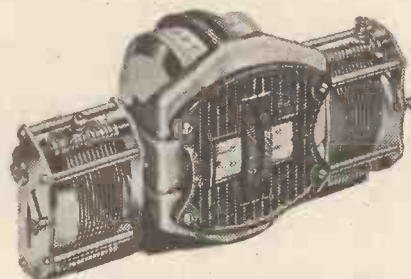

A new "Lotus" product. A dual drum-drive control complete with two variable condensers.

The Brown Budget

A recent issue of the Brown Budget is the annual catalogue number, and, as well as all the well-known Brown loud speakers, we notice that Brown screened-grid receivers are described and illustrated.

Important Price Reductions

Owing to the fact that the new Celestion factory is now well under way, and is considerably larger and more up to date in its plant than its predecessor, and owing to increased demand, it has been possible substantially to reduce the price of all Celestion loud speakers. The very popular C.12 model has been reduced from £7 5s. Od. to £5 12s. 6d.

"Peer-point" Soldering Iron

This is the correct name of the Junit soldering iron, and not "Peerless" as stated recently in these pages.

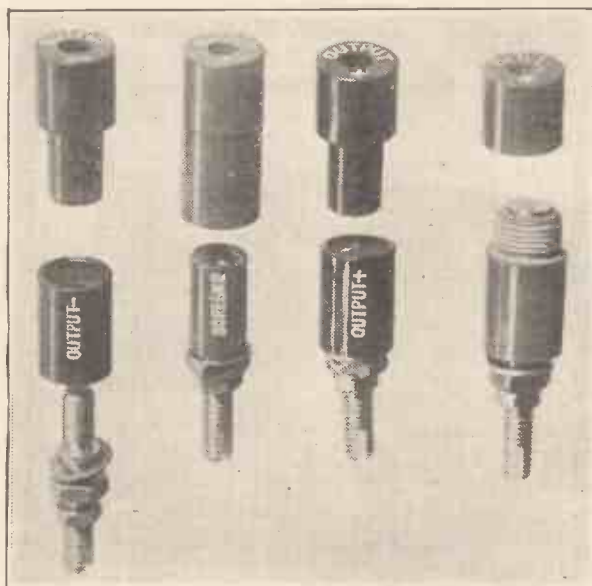

The two types of Belling and Lee plugs and sockets are shown in this photo.

Radio and the Gramophone

In this section of MODERN WIRELESS each month will be discussed both technical and other data of interest to the set owner who is also interested in gramophones.

Besides articles of a practical nature, a brief survey and critique of the latest gramophone records is included, making the section of vital interest to all music-lovers.

Conducted by **KEITH D. ROGERS.**

CONTENTS

	Page		Page
Round the Turntable	2	Making Solid Sound	6
A page of notes of interest and value to all radio and gramophone enthusiasts.		A brief description of a visit to one of the most famous record factories, showing how the modern gramophone record is made.	
This Month's Pick-up Programme ..	2		
A collection of records of particular interest and suitability for pick-up reproduction.		Recent Record Releases	8
More About the "M.W." Electric Gramophone	3	Our regular review of some of the records published during the month, written from the point of view of their suitability, or otherwise, for electrical reproduction in the home.	
Further details of the construction of the up-to-date radio-gram receiver first described last month.			

A Radio-Gram Exhibition

IN this issue we publish further details of the "M.W." Electric Gramophone, giving the wiring of the power unit which supplies H.T., L.T. and grid bias. In addition, a brief description of a visit to one of the leading gramophone record factories will be of interest to readers.

It gives an idea of how complicated the gramophone record really is, and serves as a reminder of the wonderful advances that have been made in that industry since the early days of the Edison Bell soft wax cylindrical record.

Don't Miss Olympia

In three weeks' time we shall once more have the annual Wireless Exhibition with us, and a large number of the sets will cater for the radio-gram enthusiast, and of pick-ups there promises to be a bewildering display.

This year also an interesting and valuable innovation is to take place at Olympia in the addition of demonstration salons. Prospective purchasers of sets and radio-gram outfits will have a chance to hear as well as see the apparatus, and thereby to make their choice more easily.

Cutting Down Running Costs

Many readers have written to ask if pentode valves can be used in push-pull to give good gramophone reproduction with moving-coil and

other large speakers, the idea being to cut down the H.T. current to a minimum without serious loss of volume due to restricted grid swing. Accordingly experiments have been made into the subject, and next month a special article describing the results of the tests that have been made will be published in this section.

Using Dry Batteries

The problem of providing suitable volume for moving-coil or large cone-speaker reproduction with moderately low (140 or so volts) H.T. voltages and H.T. current, so that the set can be successfully operated from dry H.T. batteries, has long been awaiting solution, and while not cheap in the initial outlay, the push-pull pentode appears to "have it" when it comes to running costs. But more of this next month, when readers will be able to judge for themselves.

Personal Attention

Finally we should like to emphasise the fact that the Wireless Exhibition this year is to be chock-full of interest to the radio-gram listener, and that readers of this section will be able to obtain personal attention and advice concerning any of their radio problems at the MODERN WIRELESS stands. So don't forget to pay us a visit between September 23rd and October 3rd.



Interesting Odds and Ends—by "Tone Arm."

Fibre Needles

I WONDER how many of my readers favour the fibre type of needle? Personally, I have tried a large number of these and have never been able to get really satisfactory results when using them with a pick-up. They seem to flatten down very rapidly, and become very dull in reproduction

* * *

Recently there has come upon the market a type of needle which, I believe, is made from the prickly pear, and which is being sold at rather a high price under the name of the Burmese Colour Needle. This certainly sounds excellent in the ordinary gramophone, and in some cases with a pick-up can prove very valuable, but on the whole I must say it has not come anywhere near the ordinary oud-tone or medium-tone steel needle

"Permanent" Types

The main trouble, in my opinion, is that these fibre types of needles do not fit the grooves into which they have to run, nor for that matter do the various permanent needles, such as the tungstyle, so for really first-class reproduction I must award the palm to the ordinary steel needle which has to grind itself in at the beginning of every record, and which has to be changed after ever side.

* * *

Changing is a nuisance, and the permanent needle is certainly not without merit, but I am afraid I cannot support the claims of some of these patent needles that they are practically permanent, and make the tone of reproduction more "life-like." In my opinion, no fibre needle, or anything purporting to be of the fibre needle variety, has any tendency to make the sound more "life-like."

Loss of Higher Frequencies

There may be a slight reduction of scratch, but in reducing this they also cut off a large number of the higher

frequencies, thereby reducing the brilliance of the reproduction by a rather serious amount. In addition, this type of needle does seem to make the reproduction "fibrous," if I may use that expression. It becomes woolly in tone, and the definition on a first-class recording is seriously impaired.

Question of Long Life

Like most people, I like the idea of the fibre needle because of the longer

going to stick to my steel needles, to change them after every side, and buy a new record when the old one wears out. After all, this is not a very hard business, because with a properly set pick-up and one of good design a record will last quite as long as one's liking for it.

* * *

The Edison Bell "Sympathetic" chromic needles often do a great deal to improve reproduction if the pick-up is inclined to chatter on deep bass notes.

Over Twenty Years Ago

It is interesting to recall that Dame Nellie Melba, then Madame Melba, laid the corner stone of the record factory which was being built by the Gramophone Company at Hayes in 1907.

* * *

The first pressings of gramophone records for issue to the public were made in July, 1908, and "His Master's Voice" recently celebrated the twenty-first anniversary of an outstanding event in the history of the gramophone.

Sixty Acres Covered

The factories now cover sixty acres, and land has been acquired for important factory extensions which, when finished, will mean 75 acres of buildings.

* * *

In 1908 the output was some 700 records a week, and now nearly half a million records a week are produced under normal conditions, with nearly twice this number at busy times.

Up-to-date Mechanical Arrangements

For labour-saving purposes automatic conveyors travel over 200 miles a day carrying records from one department to another.

Four hundred tons of raw material are used weekly to meet the demands made on the Company by the public.

This Month's Pick-Up Programme

- ORCHESTRAL.
 - German Dances (Mozart) . . . H.M.V. D1624
 - Berlin State Opera Orchestra.
 - Echoes of the Valley . . . Col. 9821
 - Bournemouth Municipal Orchestra.
 - Goliwog's Cakewalk (Debussy) Parlo. R.386
 - Opera Comique Orchestra.
- INSTRUMENTAL.
 - La Capriciosa (Ries) . . . H.M.V. DA1003
 - Master Yehudi Menuhin (violin).
 - Shepherd's Hey (Grainier) . . . Col. D1604
 - Percy Grainger (pianoforte).
- OPERATIC.
 - Pilgrims' Chorus—Tannhauser (Wagner) . . . Col. 9826
 - B.B.C. Choir and Wireless Symphony Orchestra.
 - Miserere—Il Trovatore (Verdi) . . . H.M.V. C1692
 - Mavis Bennett and John Turner.
- VOCAL.
 - Nichavo! . . . Bruns. 10276
 - John Charles Thomas (Baritone).
 - Macushila . . . H.M.V. B3068
 - Derek Oldham.
- LIGHT ORCHESTRAL.
 - Wakc Up and Dream Selection . . . Parlo. E.13869
 - Leslie Hutchinson and Concert Orchestra.
 - Valse Triste (Sibelius) . . . H.M.V. C.1578
 - Victor Olof Sextet.
- DANCE.
 - Dance of the Paper Dolls . . . H.M.V. B3075
 - Victor Arden and Phil Ohman.
 - Wait Till You See "Ma Cherie" Parlo. R.398
 - Frankie Trumbauer's Orchestra.
 - A. G. McD.

life that it gives the record, but if the reproduction is going to suffer, the advantage of long life is immediately overruled.

* * *

If anyone knows of a good fibre type of needle that really gives life-like reproduction I should be very glad to hear of it, but for the present I am

In the September CASSELL'S:

The Ecstatic Thief

by

G. K. Chesterton

In a new, long complete novel of romantic adventure this famous writer introduces in Alan Nadoway, a new and charming Chestertonian hero. Have you ever read a story by the versatile "G.K." and not enjoyed every word of it? You won't leave "The Ecstatic Thief" until the very end.

In this bumper issue of CASSELL'S MAGAZINE there are also complete stories by such popular authors as

H. A. VACHELL VINGIE E. ROE

H. de VERE STACPOOLE

GUY FLETCHER ELIZABETH MARC

and also lively, entertaining articles including "THE SQUADRON OF DEATH," a thrilling and authentic article—one of the most remarkable ever published. It is written by a member of the aptly-described "Squadron of Death" which provides the comfortable Cinema with unbelievable thrills. Don't miss this great issue.

CASSELL'S

MAGAZINE

1/-

Buy the September Issue TO-DAY.

MORE ABOUT THE "M.W." Electric Gramophone

By G. V. COLLE.

The concluding section of an article describing the details of an up-to-date radio-gram receiver.

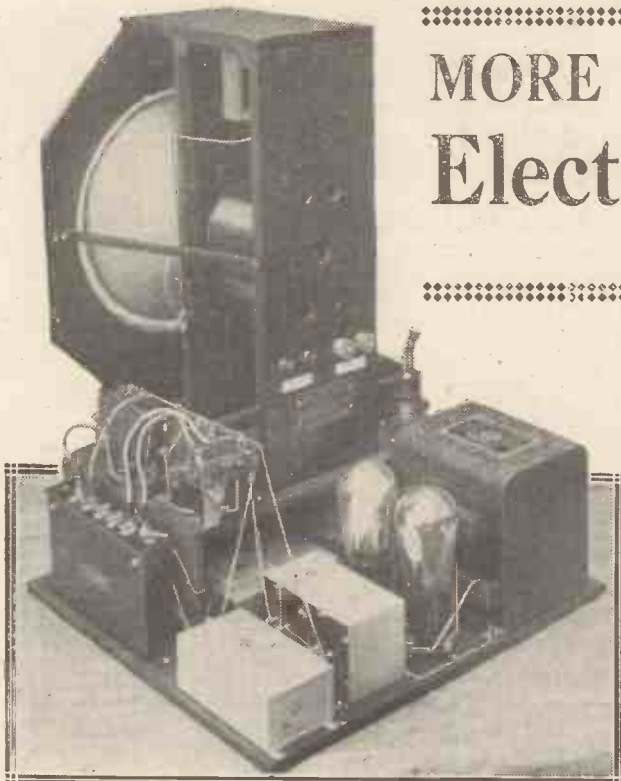

This view clearly illustrates the layout of the A.C. rectifying equipment as arranged under and behind the M.C. loud-speaker platform.

THOSE readers employing the Marconiphonic M.C. type of speaker should experience no difficulties in fitting it, as full dimensions and sketches are provided, but other readers wishing to utilise different makes of M.C. speakers will have to adapt the mounting to suit their particular speakers.

If the reader can arrange to have the speaker attached to the battery eliminator, the writer would recommend this in preference to the direct "baffle" attachment scheme, as provided the bottom baseboard of the eliminator is made slightly shallower than the depth of the cabinet (say 1 in.), the loud speaker can be removed some 1/4 to 1 in. from the "baffle," sometimes resulting in an improvement in the frequency register, by preventing a predominance of bass notes.

The Power Unit

Don't forget that if this suggestion is adopted, the baseboard of the receiver must be of a depth sufficient to leave a space of approximately 1 in. between its back edge and the back of the loud speaker.

Next fit the motor, when the remaining constructional work will be found quite straightforward, and is confined to the mounting and wiring

seen as dotted outlines, which also serves as a support for other chokes, etc., in addition to the loud speaker.

Mounting the Components

The writer made a point of wiring the components situated under the top platform first, thus simplifying what would otherwise be an involved job. To do this the platform was removed temporarily and replaced

of components on the receiver and the mains unit.

The wiring diagram of the set itself was published last month. Regarding the wiring diagram of the eliminator, the positions and leads to the 28/14-henry L.F. chokes, the two 8-mfd. and one 4-mfd. condensers can be

immediately after, to allow the remaining components to be wired.

Readers should note the extra and perhaps rather peculiar earthing leads that run from point to point on the wiring diagram, and follow the connections carefully, because the inclusion of these may provide against mishaps in the case of a breakdown in the insulation of any of the components.

Wiring-Up

No. 19 or 20 S.W.G. tinned copper wire and 2 m/m Systoflex is a combination that can be confidently recommended as being suitable for wiring both the eliminator and the three-valve receiver. Of course, the leads to the heaters of the A.C. valves must consist of twisted flex, to confine the A.C. field within a small area, otherwise there is a risk of "hum" being introduced, which will prove difficult to cure.

Initial tests are best commenced with the battery eliminator and trickle charger, the former for output and the latter for noting the amount of "hum" which may be heard when

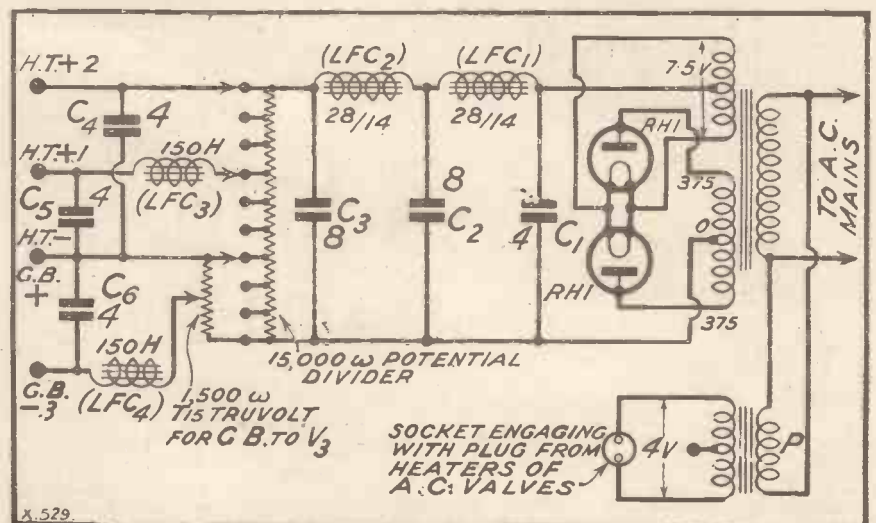

The theoretical diagram of the power unit.

LEWCOS

REGD.

CENTRE TAPPED & "X" COILS



Lewcos Centre Tapped Coils and Lewcos "X" Coils have now firmly established themselves as a necessity with discriminating users of Radio Sets.

Their Maximum Inductance, Minimum Self-Capacity and Circuit Adaptability make Lewcos coils extremely selective, securing the best results for any circuit.

CENTRE TAPPED COIL
No. 25-75 **3/6** ea.
No. 100-300 **4/6** ea.

LEWCOS H.F. CHOKE

The Lewcos H.F. Choke is absolutely reliable for an efficient performance on all wave-lengths from 2,000 down to 20 metres.

Though there is the minimum amount of H.F. leakage through self-capacity, the terminals of the Lewcos H.F. Choke are arranged one at the top of the coil and the other at the base, so as to eliminate the risk of additional self-capacity in the wiring of a receiver.



H.F. CHOKE
Reduced Price
7/9

LEWCOS

REGD.

WE ARE EXHIBITING AT

THE NATIONAL RADIO EXHIBITION
OLYMPIA (NEW)
SEPT. 25-OCT. 5. 11 AM-4.30 PM
ADMISSION 1/6 DAILY
100 DAY SEP. 24 & OCT. 10 2 PM 2/6

RADIO PRODUCTS

THE
LONDON ELECTRIC WIRE
COMPANY AND SMITHS
LIMITED

CHURCH ROAD, LEYTON, LONDON, E10
Telephone: Walthamstow 2531. Telegrams: "Lewcos," Phone, London."
Trade Counter and Cable Sales:
7, PLAYHOUSE YARD, GOLDEN LANE, E.C.1

AGE 16 TO 45.

I WANT YOU.

LET
ME BE



YOUR
FATHER.

J.B. Bennett

I want you to realise that I have helped thousands of people to qualify for and obtain good positions. Our gigantic connection brings us in touch with all the big employers, therefore, although we do not undertake the work of an employment agency, we certainly do know where the demand exceeds the supply. If you think you are in a rut, or if advancement seems slow, write to me, telling me your age, past experience, present employment, and anything else that may help, and I will tell you what chances there are; if they are suitable for you, and if so, how you may attain your objective.

IT COSTS NOTHING TO ENQUIRE

We have full particulars in connection with any of the following courses, or special courses can be combined to meet all requirements. We specialise in preparation for all examinations; most moderate fees, payable monthly.

COMMERCIAL

Accountancy
Advert. Writing
Salesmanship
Army Certifct. Courses
Auctioneering and Estate Agency
Auditing
Banking
Book-keeping
Civil Service
College of Preceptors
Commercial Arithmetic
Commercial Law
Company Law
Costing
Economics
English and French
Executorship Law
Foreign Exchange
General Education
Modern Business Methods
Police Entrance and Promotion Courses
Secretaryship
Workshop Organisation

INSURANCE.

Exams. for Agents and Officials, F.C.I.I.
Motor, Fire, Life, Marine,

INSURANCE.—Con.

Employers' Liability
Auctioneers F.A.L.P.A.

TECHNICAL.

Teacher of Handicrafts
Applied Mechanics
Architectural Drawing
Building Construction
Clerk of Works' Duties
Boiler Engineering
Boiler Making
Chemistry
Civil Engineering
Concrete and Steel
Draughtsmanship
Electrical Engineering
Practical Mechanical Engineering
Engineering Costing, Quantities and Specifications
Foundry Work
Heat Engines
Heating, Ventilating and Lighting
Internal Combustion Engines
Marine Eng., B.O.T.
Mathematics
Matriculation
Metallurgy
Motor Engineering

TECHNICAL—Con.

Naval Architecture
Pattern Making
Post Office Examinations
Costing and Estimating
Builders' Quantities
Road Making and Maintenance
Sanitation
Shipbuilding
Structural Engineering
Surveying and Levelling
Surveyors of Works, R.E.
Telegraphy and Telephony
Town Planning
Transport A.M.Inst.T.
Wireless Telegraphy
Works Managers' Course

MINING

Fireman's Exam.
2nd Class Mine Mangr.
1st Class Mine Mangr.
H.M. Inspector
Mining Elect. Engineer
A.M.E.E.
Mining Mech. Engineer
Mine Surveyor

WE TEACH BY POST IN ALL PARTS OF THE WORLD.

Also Ask for Our New Book FREE OF CHARGE.

THE HUMAN MACHINE.

Secrets of Success.

Note Address Carefully :
THE BENNETT COLLEGE, LTD.,
Dept. 134, SHEFFIELD.



Easy to Operate, Perfect in Quality

it is joined to the L.T. field winding of the M.C. loud speaker.

A fairly accurate high-resistance voltmeter will prove of service for testing the voltages set up across the potential divider tapplings, readings also being taken for grid bias (across H.T.— G.B.+ and G.B.—3) from the two-socket holder.

If the voltmeter reads high enough, it can also be employed to measure the voltage set up between H.T.— and H.T.+1, and also between H.T.— and H.T.+2, tested from the two-socket bases. Do not forget that grid bias can be varied over wide limits without affecting the H.T. voltages, and therefore adjust the T.15 Truvolt

to give a G.B. voltage suitable for the H.T. applied to V_3 ; figures for grid bias at various H.T. values are available from the leaflet supplied with Cosmos AC/P2 valves (which by the way, are not yet on the market, but should be available by the time this appears in print).

Avoid Too Much H.T.

The H.T.+1 tapping must never exceed 180 volts, so that if the voltmeter readings from two adjacent sockets on the potential divider read slightly under and over this voltage, choose the lower value of the two, increasing to the higher value if it is found the voltage drops appreciably

under 180 under load, that is, with the valves in action.

Although slightly excessive H.T. voltages do not spoil the emissions, yet it always pays to respect the valve-maker's warnings, as over-running must eventually reduce the lives of the valves.

The plugs in the "0" and "10" sockets on the potential divider should be left permanently in position, only the H.T.— G.B.+ plug and H.T.+1 being varied and not left necessarily as shown on the wiring diagram.

Adjust the H.T.— first and the H.T.+1 last, as the latter is dependent on the position of the former, with makes other than the Igranic

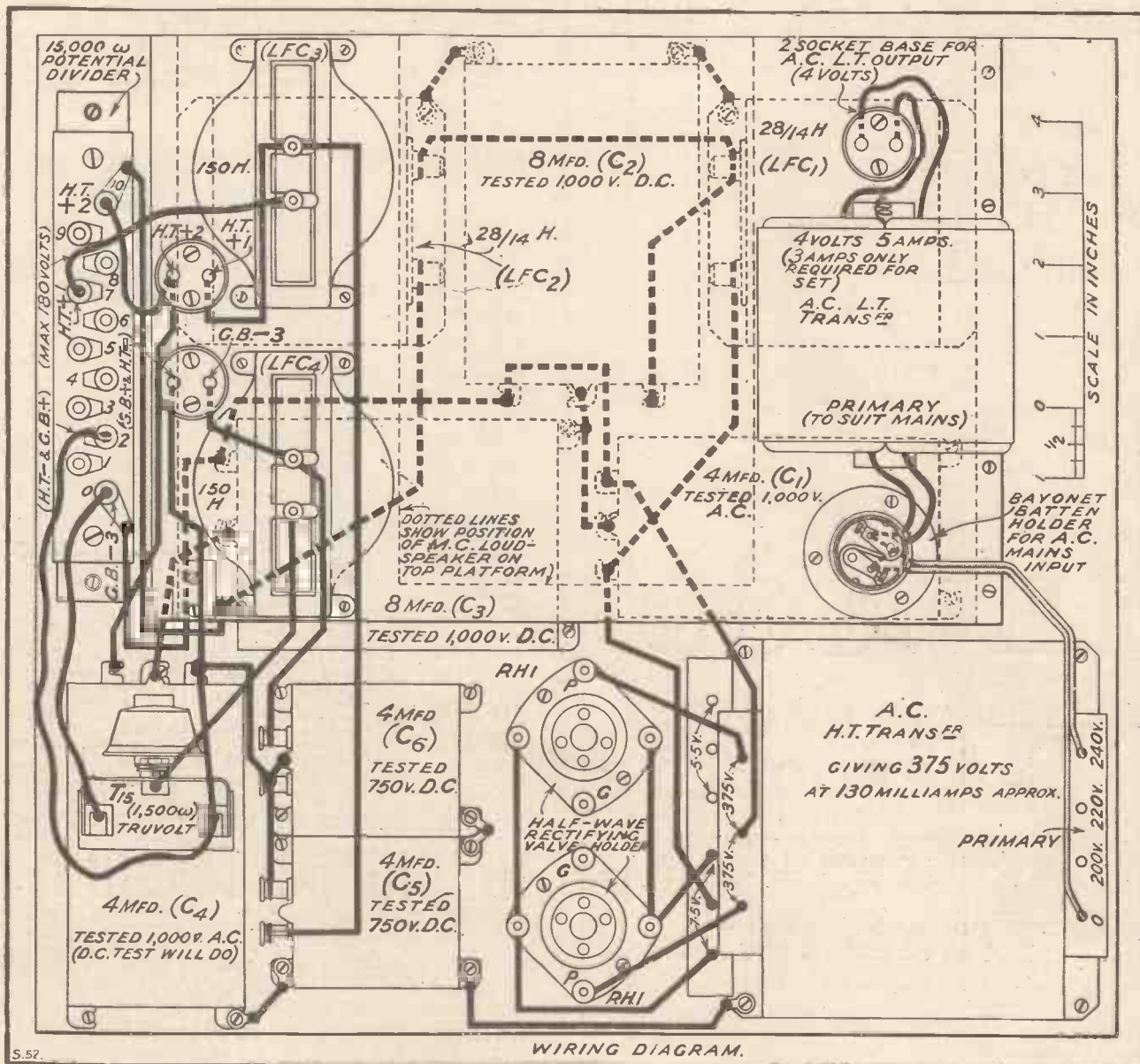

DO YOU REMEMBER?

*Hullo!
Hullo!! this is
Wrrr--ittle*

If you're a real "old stager" in radio you will remember "Wrrittle"—"Two Emma Toc," Capt. P. P. Eckersley's station. How his "Wrrr-ittle" used to thrill us! Those were the days! The B.B.C. first official transmission—via 2LO—was in 1922—"Wrrittle" days were pre-B.B.C. days—days when we knew only "R" valves—long, cumbersome sliding tuners, and hefty .001 variables. In those days transmitting and receiving gear depended largely on T.C.C. Condensers for their efficiency.

It's the same to-day—the choice of serious experimenter and amateur alike is T.C.C. Be guided by them—ask for T.C.C. always.

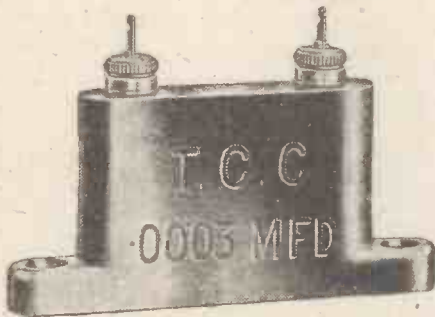
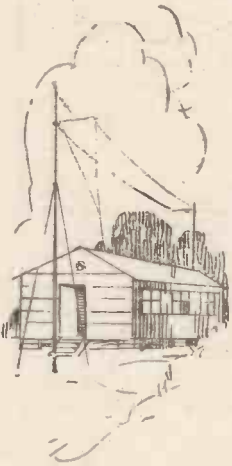

There is a T.C.C. Condenser for every purpose. This is the .0005 mf. Upright Type Mica Condenser, price 1s. 10d. Other capacities from .0001 mf. to .25 mf. Prices 1s. 10d. to 18s. 0d.

**T.C.C.
CONDENSERS
WERE USED THEN**

Advt. Telegraph Condenser Co., Ltd., Wales Farm Rd., N. Acton. London. W.3

CA 9713

IGRANIC

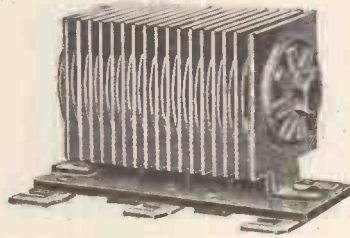

**IGRANIC-ELKON
METAL RECTIFIERS**

FOR

L.T. and H.T. SUPPLY UNITS

These rectifiers definitely supersede valve rectifiers in performance and length of life. There is nothing to go wrong or deteriorate. Many thousands of hours after the normal life of a valve rectifier, the Igranic-Elkon Metal Rectifier will continue to give the same high performance as at first.

There are the further advantages of compactness and a special self-healing feature which prevents any damage resulting from a temporary overload.

Send now for full details and prices to Dept. J.920.



Works: BEDFORD

the procedure will be much the same.

Having ascertained these points, the reader can then insert the plugs from the receiver into the sockets on the eliminator, taking great care that (1) the plugs are inserted in their correct holders, and (2) that they are inserted the right way round. Failure to do this may have disastrous results, so if the reader can possibly find plugs possessing dissimilar sockets the likelihood of incorrect connections is minimised.

Final Adjustments

Plugs with similar-sized sockets can be marked in different colours, and also scratched with identification marks. Once they are in position they will not be removed for perhaps months.

Now, before finally completing the external connections adjust the G.B. values to the receiver as derived from the 15- or 16½-volt G.B. battery.

Complete the fitting of the leads to the loud speaker and pick-up and insert the A.C. valves, at the same time fitting the R.H.1. rectifying valves in the A.C. battery eliminator. The volume control for the pick-up consists of a .5-meg. potentiometer of the graphite variety.

Everything being ready, the mains plug can be inserted and the mains switched on. If all is correct, the receiver will sound "lively," but will not oscillate or howl, unless the radio-pick-up switch is set for radio, with the reaction condenser at maximum.

If so, turn the dial to "O" and switch over to pick-up, turning the volume control on the set to nearly maximum. A record can be placed on the turntable, the spring motor wound up, a loud-tone steel needle inserted in

the 'chuck on the pick-up and the motor started, the needle being placed in the first groove on the record.

With the grid bias correct, the output should be pure and undis-

The use of a good quality voltmeter for measuring the various output voltages should prove of inestimable value in "balancing" the grid-bias voltages against the H.T. potential for

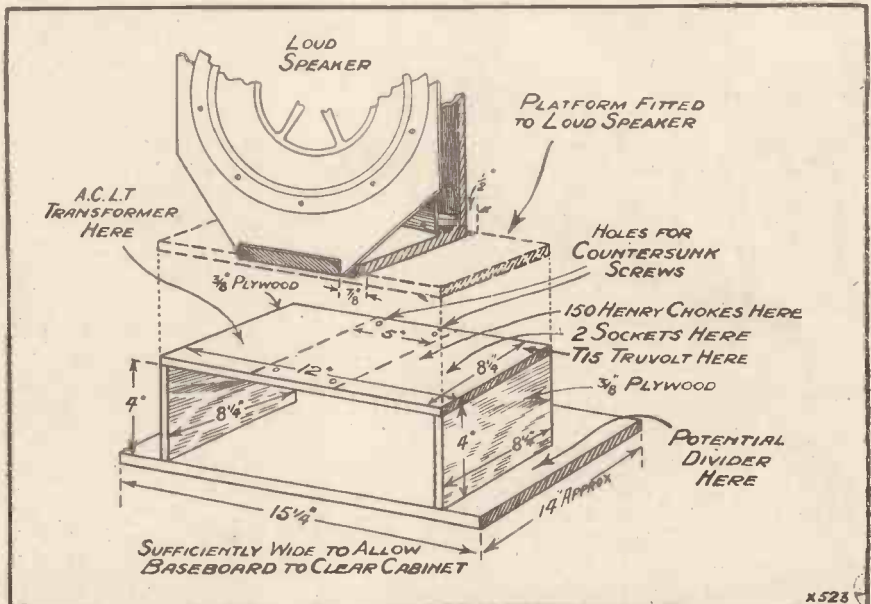

Showing how the speaker is mounted in position.

torted, assuming the volume controls are adjusted to prevent overloading of the last valve. On the other hand, if the G.B. voltages require further regulation, switch off the motor and mains and readjust on the G.B. battery, repeating on the eliminator with G.B.—3 if necessary.

A Necessary Precaution

Under no circumstances should the operator attempt the readjustment of voltages while the mains are switched on, as it is possible to receive a nasty shock if the full output of the A.C. transformer is accidentally encountered

the particular valves chosen. This will remove all doubt as to the ultimate performances of the A.C. valves. Guessing the values of the voltages according to the positions of the tappings on the potential divider incurs grave risks of overrunning.

A few hours spent on adjusting and mastering the various controls will more than repay the constructor, and he can then be sure of possessing not only a splendid source of amusement, but an instrument that can more than hold its own with the very best on the market.

COMPONENTS REQUIRED

- 1 A.C. H.T. transformer, to give 375 + 375 volts output and 7.5 volts L.T. for the filaments of the R.H.1 rectifying valves. Primary winding to suit the mains voltage and frequency (R.I. shown, Heayberd, etc.).
- 1 A.C. L.T. transformer, to give 4 volts 3 amps. (or preferably more). One shown gives 4 volts 5 amps. with primary winding of 250 volts used on 240 supply (Heayberd).
- 2 28/14-henry L.F. chokes (R.I.).
- 2 150-henry L.F. chokes (Pye, Wearite).
- 1 15,000-ohm. potential divider (Igranic, Pearl).
- 2 Spring valve holders (Benjamin).
- 2 8-mfd. condensers, tested 1,000 volts D.C. (Hydra).
- 2 4-mfd. condensers, tested 1,000 volts A.C. (one of which can be tested 1,000 D.C. if necessary). (Hydra.)

- 2 4-mfd. condensers, tested 750 volts D.C. (Hydra).
- 1 1,500 variable resistance, having potentiometer connections. (T.15 Truvolt shown). (Rothermel, Hamley, Claude Lyons.)
- 1 Batten lamp holder of bayonet type, complete with plug for A.C. mains input (Pearl, Ready Radio, or any electrical stores).
- 2 Red and 2 black wander-plugs to fit potential divider (Clix).
- 1 Plywood baseboard 15½ in. × 14 in. × ½ in. or ⅝ in. thick.
- 1 Plywood platform 12 in. × 8½ in. × ⅝ in. thick.
- 2 Plywood supports 8½ in. × 4 in. × ⅝ in. thick.
- Quantity of No. 19 or 20 S.W.G. tinned copper wire and 2 m/m Systoflex, and also a few yards of

red and black single flex (or twisted flex unrolled).

ACCESSORIES.

- 1 Moving-coil loud speaker, low-resistance moving-coil winding and complete with step-down transformer (Marconiphone as shown, or existing one). Six-volt field.
- 2 Half-wave rectifying valves, R.H.1's (B.T.H.).
- 1 Trickle charger, giving .5 amp. at 6 volts (Ferranti).
- 3 A.C. valves, as follows:
 - 1 AC/G for V₁ position.
 - 1 AC/R (or AC/G if found necessary with insensitive pick-up) for V₂ position.
- 1 AC/P2 for V₃ position. An AC/P1 may be employed in certain cases where a lower output will suffice.

Making Solid Sound

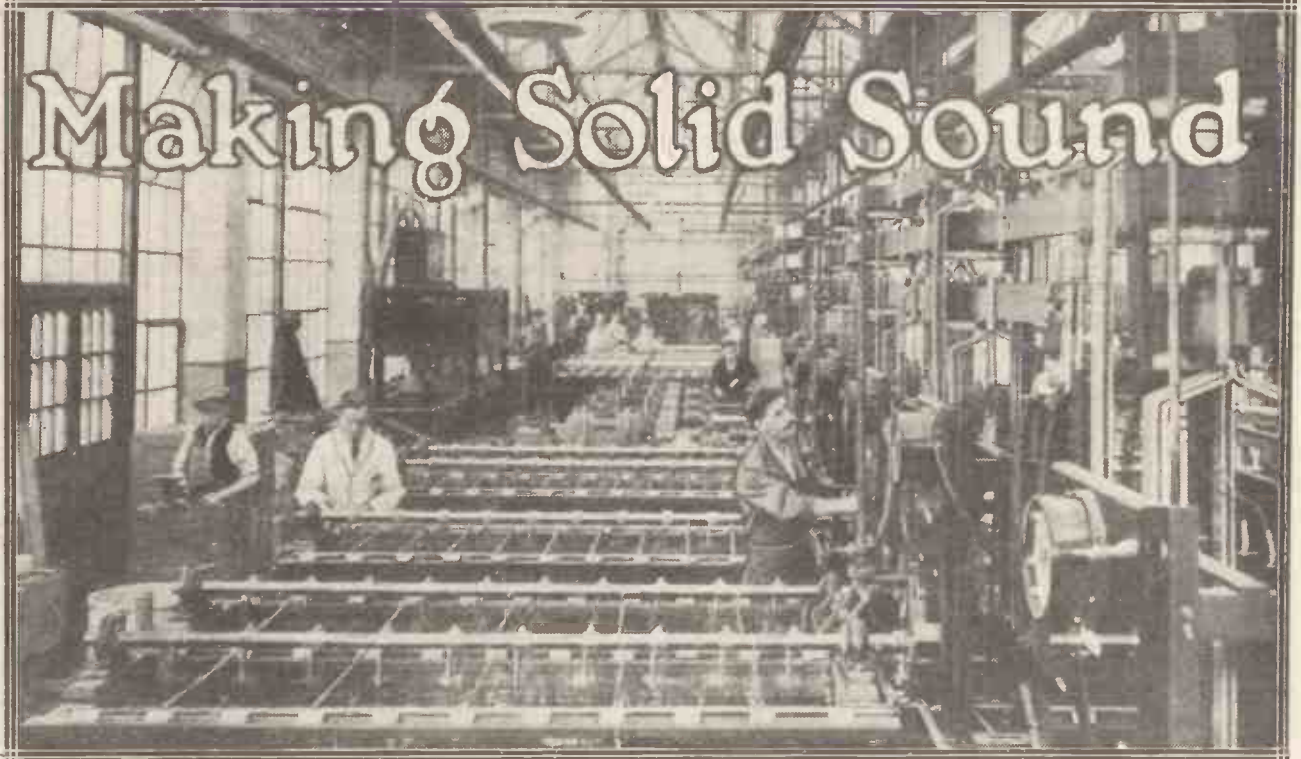

IN introducing this brief account of a recent visit to the Columbia Record factory, I cannot do better than quote a paragraph from the illustrated booklet with which all visitors are provided when making a tour of the works at Wandsworth.

Emphasising what a wonderful thing the gramophone record really is, it says:

"It is, indeed, one of the world's mysteries, and although it is produced by purely mechanical and electrical processes, yet no scientist or musician could take that gramophone record and read the multitudinous indentations on the disc as they stand. Not even by a microscopic examination could the scientist determine whether it was Schubert's Unfinished Symphony or passages from the latest jazz tune. Only by traversing those engraved sound waves by a needle point can we discover it."

Involved Processes

If you were to take an ordinary record and examine it closely, it may appear to you to be a wonderful piece of work, but however much you looked at it, without a visit to the factory you would have no idea how involved are the processes which the sound waves which are uttered by the speaker or singer have to go through before they are finally put on the market as black, flat discs of "solid sound."

You probably know that the origin of the gramophone record is based

A brief description of a visit to a well-known record factory.

By L. ROBINS.

upon the vibrations of the air from the singer's voice or the orchestral instruments, causing by means of a diaphragm a tiny cutting point of sapphire to vibrate upon a rotating



Trimming and polishing the wax "blank" before it is sent to the recording studio.

disc of wax, making various indentations and wavy lines which are replicas in wax of the various com-

plicated sound waves which have come from the source of the music.

Nowadays, these sound waves are made to impinge upon a microphone, similar to the microphone used in broadcasting, and then electrical currents, which are the electrical counterparts of the sound waves, are made to operate the cutting stylus upon the wax disc.

All this seems extremely simple, but it is really quite involved, and requires the highest technique in order that pure recording shall be obtained.

How It Begins

But what of that wax disc? Obviously the wax is soft and is cut easily by the sapphire, but it has to go through many processes before it is ready to be put upon the market in the hard, black form which we know so well.

The wax disc is made in the usual mouldings, but before it is sent to the recording studio it has to be very carefully examined and carefully polished by a special sapphire and a special polisher so that the surface is absolutely without fault, for it must be remembered that any flaw on that wax disc, or the "blank" as it is called, will completely ruin the record.

When it comes back from the studio it bears on it the indentations caused by the stylus, in the form of wavy lines round and round the disc, and has then to be made into some permanent form so that records can be

One Record Made Every Minute

sent out in their thousands. All have to come from this one disc.

After recording, therefore, the wax record is specially treated in a dust-proof laboratory with very fine graphite, which is dusted on to it, and polished so as to give it a conductive surface. After this the "blank" (which is no longer blank, but is really a master record) is placed in an electrolytic bath for about sixteen hours, and a deposit of copper is formed upon the graphite-covered wax. This copper is deposited in a completely even form, and when it is finally removed from the face of the disc it bears on the underside the indentations and variations of the wax disc completely and faithfully portrayed.

The Next Step

The only difference is that whereas grooves occurred in the wax disc, so ridges will occur in the copper, or, in other words, the copper is a negative of the positive wax disc.

This new copper disc is exceedingly soft, and would be quite useless as a stamper for stamping out commercial records.

It is, indeed, the copper master, and once it has been removed from the wax disc it has to be carefully



Dusting the "filled blank" with fine graphite to prepare it for copper plating.

preserved in order that it shall not be damaged, for it is now the only record of that particular number of music that the gramophone company possesses; the wax disc usually being quite spoiled when the copper is removed.

The next process is to make a number of "mothers," as they are called, from this copper, so that the master may be locked away and kept as the permanent record in a fireproof safe, while the mothers may be used for making the special stampers to form the commercial records.

These "mothers" are made by carefully plating the copper with further copper; but in order that this further copper shall come off and not adhere permanently to the original copper master, the copper master is first nickel-plated and then thoroughly cleaned and copper-plated once more.

This copper plating is taken off when thick enough, and here on the face of the copper we now have a positive once more of the original record. In other words, if this record were placed on a turntable, and the gramophone needle placed on it, then the sound would come out as originally heard in the studio.

A number of these copper mothers are made, and from these positive records the final stampers, which, of course, are negatives, are constructed.

Stamping Records

These are formed in a similar way by a further process of copper-plating, only this time quite a thin copper sheet is formed, nickel-plated, and finally soldered to a thick backing sheet. We now have a negative of the original record in a form ready to be placed in the stamping presses to make the commercial records.

These latter are made of a mixture of various materials, including shellac and a black colouring matter, and, in the case of the Columbia records, are of what might be termed the three-ply variety. In other words, there is a centre portion (called the "biscuit") of fibrous strong material, and on either side of this on the record face is a thin paper disc covered over with a thin layer of special surface material, and it is into this surface material that the indentations of the recording are impressed.

After various processes of mixing and formation, the "biscuit" is placed in a steam-heated press between two sheets of the specially prepared paper, and above and below are the two faces of the stamping records, i.e. the two "sides" of the final record. The two items, complete with labels, are now ready to be impressed upon the two sides of the disc.

The press is closed, steam is passed in, and then as quickly again the press is cooled off by water, and on release we find a black disc bearing all the requisite sound tracks and the labels on the two sides.

This is now taken away, examined, and passed on to be trimmed and polished, the special polishing machines being operated by girls at an amazingly rapid rate. After this the records are again examined and placed in their covers ready to be packed and exported to the markets.



Polishing the edges of Columbia records after they come from the steam presses.

I believe the paper facing of these records is a Columbia patent which has a great deal to do with the lack of surface noise noticed in this make of record. About 700 records can be made by one man in ten hours on the presses, which run day and night in the busy months of the year.

All Languages

This account, of course, is quite a short, brief outline of a process which takes some days before a record reaches the stamping stage, but once the stampers are made the finished records can be turned out with amazing speed.

These records undergo stringent tests as to their strength and wearing qualities, for records are made in the factory for countries all over the world and are made to withstand all climates. During my visit there quite a number of Turkish records, bearing Turkish songs in the Turkish language, were turned out for export to Constantinople.

INSTANT RESPONSE

No fiddling about with nuts and connections once you've built your set with Lotus Components—easy to fix, quick to assemble, neat, compact and utterly reliable, Lotus Components work together in perfect harmony and ensure instant response and fulfilment of your highest hopes.

Every Lotus unit is faultlessly accurate—every one is compact, practical and of the latest and best pattern. All good circuits recommend Lotus Components; they are the best and safest choice for every set.

Use
LOTUS COMPONENTS
for the
MULLARD AND OTHER
ADVERTISED CIRCUITS.

From all radio dealers.

LOTUS COMPONENTS

The Lotus range includes L.F. and Power Transformers; Variable, Reaction and Differential Condensers; Valve Holders; Drum Dials; Flat Vernier Dials; Dual Wave Coils; H.F. Chokes; Coil Holders; Jacks; Switches; Plugs, etc. Send for literature.
Garnett, Whiteley & Co., Ltd.,
Lotus Works, Liverpool.

Caution

NEW YORK

AMERICA-SPAIN FLYERS,
KEEP IN TOUCH WITH DARIO



(On left) The wireless receiving and transmitting set on the airplane "Yellow Bird" showing the "Dario" Valves.

THE Yellow Bird's and its heroic occupants' flight from New York to Santander, Spain, is already well known. All the time on this journey wireless communication was maintained with Dario Valves. Why not use Dario Valves yourself—they've proved themselves in a matter of life and death—they will improve your set beyond all expectations. Dario prices are little short of marvellous—they are due to one of the biggest and most modern valve outputs in the World. Ask your dealer or write direct for full particulars.

5/6 G.P. & R.C.C.

POWER 7/6

TWO VOLTS	
General Purpose ..	5/6
R.C.C. ..	5/8
Super Power ..	7/6
Super H.F. & R.C.C. ..	7/6
Pentodion ..	21/-

FOUR VOLTS	
General Purpose ..	5/6
R.C.C. ..	5/6
Super Power ..	7/6
Super H.F. & R.C.C. ..	7/6
Pentodion ..	21/-

DARIO VALVES

WRITE FOR
DARIO
FOLDER!

IMPEX ELECTRICAL, LTD.,
DEPT. H, 538, HIGH ROAD, LEYTONSTONE, LONDON, E. 11

RECENT RECORD RELEASES



Our monthly review of Gramophone records.

Broadcast "Twelves"

SOME of the most interesting news this month comes from the Vocalion Gramophone Co., for these enterprising people have gone one further with their Broadcast "Twelve" records and produced what is known as the Broadcast "Twelve" Super Dance record.

This is a special series (orange label) of specially picked dance tunes made by quite a new series of bands, the records running for a time comparable to that of the ordinary twelve-inch record.

We will deal with the main dance items of the Broadcast Super "Twelve" first. The most successful in our opinion is *Mean to Me*, a slow fox-trot by the Manhattan Melody Makers (though it is a pity the record starts after the band has commenced playing, giving no leader groove), the reverse side of which is *Am I Blue?* by the same band (2506). "Mean to Me" is pleasing, the orchestration is good, and the whole thing goes with a crispness and swing which is rather reminiscent of Jack Payne and the B.B.C. Dance Orchestra. The next best is *Glad Rag Doll* by the same band, on 2505, the reverse being *The Wedding of the Painted Doll*. These two items have xylophone solos by Teddy Brown, and should certainly be heard by every collector of dance records. Al Benny's Broadway Boys play *My Sin* and *Who Knows?* on 2502, another pair of excellently recorded numbers.

The ordinary Broadcast "Twelve" records continue with various numbers, one of the most pleasurable being of the *Hungarian Fantasia*, on two complete discs, recorded by Maurice Cole (pianoforte) and the Metropolitan Symphony Orchestra.

These are recorded on 5087 and 5088.

Sibelius' *Valse Triste*, by the Stoll orchestra and organ, and *Minuet*, by Botcherini, form an interesting record on 5093, while the *March Militaire*, by Schubert, and *Pomp and Circumstance*, played by the band of H.M. Life Guards, with the Stoll Theatre organ, are well worth hearing on 5092.

Broadcast "Ten" Records

Amongst the smaller Broadcast records this month we must mention several notable dance tunes and an interesting Stoll organ recording of the *Broken Melody* and *Annie Laurie*, on 431.

Amongst the dance tunes there are one or two from recent talkie films, *Louise* and *On Top of the World Alone*, from "The Innocents of Paris," sung by Billy Desmond with a dance band accompaniment, on 426, and a number from *On With The Show*, played by Bidgood's Broadcasters, on the reverse side of which is the *Dance of the Painted Doll*.

H.M.V.

We have also received for experimental work a batch of the H.M.V. constant-frequency records. These are very valuable indeed to the experimenter who wants to take curves of pick-ups and amplifiers, especially of the pick-up, and though the records are 8s. 6d. each, and there are fifteen of them to the complete set, the money is well spent.

The majority of experimenters will probably be very disappointed with their pick-ups when they first try them, as we have found very few which will go down below 120 cycles per second without a very heavy extra

weight for holding the pick-up down.

Some of the best pick-ups used in the "M.W." laboratory for test standards have proved very inadequate to deal with cycles of lower frequencies than 150 per second, although on ordinary music and speech they bring out the bass very well indeed. These records range from about 25 cycles per second right up to above 8,000, and form a very interesting and valuable collection indeed.

Parlophone

The Parlophone constant frequency and howling and gliding tone records have also been received, neatly bound in a little album. These form another useful method of testing pick-ups, giving as they do more of the musical beat-notes than the ordinary sine-wave form will provide, and these enable one to test apparatus more under working conditions.

As an aural test of what a pick-up and amplifier can do the "gliding howling tones" are extremely valuable, and give a good idea of what is happening from about 6,000 cycles per second right down to about 100.

Zonophone

The Zonophone list is a very comprehensive one this month, including some very tuneful light orchestra recordings that are sure to be popular.

Sir Harry Lauder again delights his listeners with *Rising Early in the Morning* and *She Is Ma Daisy* (G.O. 89), while the London Orchestra gives us an interesting "selection" record from *Wake Up and Dream*, on 5349.

Of the light orchestral numbers we like the Zonophone Salon Orchestra playing *Mighty Lak' a Rose* and *Love's Garden of Roses* (5357), and *Narcissus* and *Simple Aveu* (5370), two most exquisitely played records.

Foster Richardson gives his *All Through the Night* and *Savoureen Delish*, which bring out his fine bass voice to perfection on 5357, and Clarkson Rose is "at it again" with *Ee, By Gum* and *Feminine Company*, on 5359.

Of the dance tunes we must mention the Rhythmic Eight in *My Flame of Love* (5362), on the reverse side of which is *In the Heart of the Sunset*, by the Arcadians Dance Orchestra. *The Dance of the Paper Dolls* and *The Wedding of the Painted Doll* are also worth hearing, played by the last-named orchestra, on 5360 and 5361 respectively.

RADIO NOTES AND NEWS OF THE MONTH

A feature in which our Contributor brings to your notice some of the more interesting and important Radio news items.

Conducted by "G.B."

At Last!

AMATEURS will be glad to hear that the transmitting station at Boulogne (FFB) is to be altered from the spark system to the interrupted continuous-wave system. For years now there have been regular complaints of the interference caused by the Boulogne station, and people, especially on the South Coast, have experienced considerable difficulty in receiving 5 GB because of the Morse interference from FFB.

"Discovery's" Radio

The "Discovery," which has left for a new voyage of Antarctic exploration, was fitted with the latest Marconi apparatus before sailing. The gear has been specially designed so that the ship will be able to maintain constant communication with the outside world when it reaches the Antarctic regions.

The expedition is under the leadership of Sir Douglas Mawson, the Australian explorer, and has been organised in order to carry out scientific and survey work in the Antarctic. It is reckoned that the wireless gear will play an important part in keeping the party in touch with the scientific world, and, in case of a forced landing, the aeroplane which is carried by the ship can rig up an emergency aerial on the aeroplane and send messages direct to the ship.

Fancy Tuning This In!

The broadcasting stations in Japan make a regular habit of sending out matrimonial announcements. These announcements give Japanese girls an opportunity of boasting in flowery language of the charms of their figures and faces. One of these announcements by a Japanese girl reads as follows: "I am a very pretty girl. My hair is wavy like the clouds and my complexion has the brilliance and the bloom of a flower. My brown eyes are like two moon crescents."

This seems a novel way of using broadcasting, and the least we can

do is to wish the Japanese girls good luck!

Wireless Mind-Reading

There is a man in New York by the name of Dunninger who is a professional mind-reader. In short, he claims to be able to achieve thought transference by radio, and he is attempting to introduce telepathy into the weekly programmes from WJZ. So far he has not been particularly successful.

A sealed envelope, with a note of three thoughts which Dunninger tried to transmit, was placed in the hands of one of the judges on the committee selected to keep an eye on the experiment. When the chairman of the committee opened the envelope it was found that out of over 2,000 replies sent in from listeners only 2½ per cent. were accurate in every particular, although in 45 per cent. there was partial accuracy.

This is, of course, a repetition of the telepathy test made from 2 LO in October, 1927.

The Music Habit

Dr. Adrian Boult, the conductor of the Incorporated Society of Musicians, who recently accepted an appointment as B.B.C. Musical Director, was speaking a few nights ago at the opening dinner at New College, Oxford.

"I think," said Dr. Boult, "we are rather apt to take our music too seriously." And he went on to say that broadcasting and the gramophone wielded a tremendously powerful force, but they had to be watched. "Many people," he said, "turn on the wireless the moment they enter the house, and then proceed to dress or cook or do anything like that, only turning their attention to the music occasionally. This is the very worst way of teaching people, particularly children, not to concentrate."

I wonder whether our readers will bear out Dr. Boult's theory that wireless is turned on more as a habit than as a pleasure.

5 SW Again

A correspondent in the "Daily News," criticising the B.B.C.'s policy in connection with the Chelmsford experimental short-wave transmitter, 5 SW, points out that the United States' short-wave stations show transmissions each day for a total of 48½ hours weekly, as against 29 hours weekly from Chelmsford, 5 SW. He complains of the shutting down on 5 SW every week-end.

Help from Holland

This New Zealand correspondent states that he has to rely on Holland and the United States of America; particularly the Philips station, PCJ, which gets to work early each Saturday morning broadcasting special programmes for the benefit of Australia and New Zealand.

Criticisms about short-wave policy have been growing for some time past, and there seems to be some real resentment among Colonial listeners at the way in which the B.B.C. handles the transmissions from 5 SW.

A New Use for the Fultograph

An enormous amount of research into the origin and nature of atmospheric has been done in recent years at the Radio Research station at Slough. The station is now to make use of an entirely novel method of recording atmospheric. The Royal Meteorological Society has arranged with the B.B.C. for special Fultograph transmissions after the normal picture programmes and these will be picked up by Fultograph receivers installed for the purpose at recording stations in various parts of Europe.

Investigating Individual X's

The transmissions will not take the form of pictures; instead there will be sent out a series of straight lines, both horizontal and vertical, forming a grid or network. When an atmospheric occurs deformations of the straight lines will take place to an extent depending upon the intensity of the interference. It is hoped by this means that it may be possible to make records giving the most valuable data for research into the intensity, duration and origin of individual atmospheric.

Fixing Fultograph Pictures

For a long time past scientists in many countries have been conducting experiments and research with a view to discovering some means of rendering permanent the pictures received by the "Fultograph" on paper treated with starch and potassium iodide. It is well-known that

Radio Notes and News of the Month—continued

such pictures may last for several months if the paper is dried out quickly as soon as it has been removed from the cylinder and is afterwards not unduly exposed to strong light; but until a short time ago no means could be found of making them as permanent as photographic prints.

Add Alum

The credit for the discovery of a method of fixing "Fultograph" prints goes to an amateur, Dr. Alfred J. H. Iles, of Taunton, who has owned a "Fultograph" for some months and has taken the keenest interest in the electrical and chemical problems bound up with still-picture reception. After a great deal of experimental work he discovered that the key to the problem was to be found in that very common and inexpensive substance alum. After reception the picture is laid face downwards in a dish containing a solution of alum and ordinary tap water. One teaspoonful of alum to a pint of water is a satisfactory mixture. The picture then becomes as permanent as a photographic plate or print after fixing. It is astonishing that so simple a process should have eluded discovery for so long, and it is a great feather in Dr. Iles' cap that he has beaten the research chemists at their own game.

Roumania's Radio

The First International Exhibition of radio and electrical household apparatus in Roumania will be held in Bucharest from the 1st to 20th September, 1929.

At this Exhibition will participate almost all the Roumanian radio merchants and also the most important constructors of radio apparatus in the world. The Exhibition has established in the chief hall a stand where specimens of radio reviews of the country and from abroad may be exposed and distributed to visitors to the Exhibition.

"Bremen's" Big Set

The "Bremen" is certainly not only the latest liner to serve on the Atlantic route and to beat the "Mauretania's" record, but she also possesses the finest and most up-to-date wireless equipment ever fitted to any ship.

The "Bremen" carries six wireless operators, and the wireless department is quite an integral part of the

organisation of the ship. The main installation consists of a 3-kw. c.w. and i.c.w. transmitter. It can be operated on waves from 500 to 3,000 metres. A smaller transmitter operates on i.c.w. on waves of 175 metres and between 600 and 800 metres, and a third transmitter uses c.w. or i.c.w. for working either with telegraphy on waves between 13 and 105 metres, or telephony. There is also a special short-range telephone transmitter for communication direct between the ship and the ship-owners' offices.

Watch on Wave-Lengths

In addition, there is a 1½-kw. spark transmitter for emergency

Canada and Australia of the Abbey Thanksgiving Service.

Letters from all parts of the Dominion have poured into the offices of the Canadian Marconi Company congratulating the Company on the success of the re-broadcast and expressing gratitude for the opportunity of listening to such a programme.

The comments on the quality of the transmission show that in the opinion of the listening public this broadcast was far better than any previous overseas re-broadcast hitherto attempted on the American Continent.

The Best Ever

The Thanksgiving Service was heard as clearly in all parts of Canada as a first-class local broadcast, having been transmitted from England over the Beam circuit by means of the new Marconi-Mathieu multiplex apparatus which enables telephone and telegraph services to be conducted simultaneously over a single Beam circuit.

That the excellence of this transmission, which far exceeded public expectation, was entirely due to the Beam link is demonstrated by the fact that listeners who attempted to pick up the transmission direct found that conditions were poor. Reception on the Beam circuit was, however, so good that the programme was passed on to Australia over the Canada-Australia Beam and was successfully re-broadcast in Australia.

An Important Amalgamation

On and from August 12th, 1929, as the result of arrangements made between The Edison Swan Electric Company, Ltd., and the British Thomson-Houston Company, Ltd., the Wiring Supplies, Lighting Engineering, Electric Refrigeration and Radio business of the British Thomson-Houston Company, Ltd., will be taken over by The Edison Swan Electric Company, Ltd., who will market the British Thomson-Houston Company's products in these lines.

Mazda radio valves will also be marketed by The Edison Swan Electric Company, Ltd., for the British Thomson-Houston Company, Ltd.

(Mazda lamps will NOT be included under this arrangement, but will continue to be marketed by the Lamp Sales Department of the British Thomson-Houston Company, Ltd.)

NEXT MONTH

Be sure not to miss the

SPECIAL

EXHIBITION NUMBER

of

MODERN WIRELESS

containing a full description of
the RADIO EXHIBITION at
OLYMPIA

besides constructional details of
SEVERAL SPECIAL SETS.

USUAL PRICE. ORDER YOUR COPY NOW.

purposes. Each transmitter is provided with a separate receiver, and the whole of the apparatus is connected up to a switchboard so that each set can work independently or otherwise as desired. Duplex working can be carried out by two operators working at the same time on the main set, while a third operator can receive press, weather and time-signal reports; and a further operator can keep constant watch on the distress wave of 600 metres.

Beam Broadcasts

Canadian listeners have commenced an active agitation for more inter-Empire broadcast programmes by Beam following the remarkable success of the re-broadcasting in



P.G.5. Non-Indicating 20 a.h., 2-v., 9/-

P.G.7. Non-Indicating 30 a.h., 2-v., 11/-

P.G.9. Non-Indicating 40 a.h., 2-v., 13/-

P.G.F.5. Indicating 20 a.h., 2-v., 11/9

P.G.F.7. Indicating 30 a.h., 2-v., 13/9

Guaranteed— but costs less

Although we guarantee it for six months the Peto & Radford Accumulator costs no more than the ordinary battery.

Just think of this for 9/- A 2-volt 20 ampere hour (actual capacity) accumulator; with sturdy plates: interlocking grids to hold paste: terminals with acid-proof glands: glass key-ways in the box to hold the plates: a crack-proof, hermetically sealed Dagenite lid: non-reversible terminals: a screwed, splash-and-spray-proof vent: ample acid space, all, as we say, for 9/-, and guaranteed for six months.

This same accumulator can be supplied with our patent indicating floats—they tell you at a glance whether the cell is charged, half-charged or run down—for 2/9 extra.

Send for particulars of these and other P. & R. Batteries (including H.T.) to

Peto & Radford, 50, Grosvenor Gardens, London, S.W.1.

Telephone: Victoria 3667 (5 lines)

P. & R.

PETO & RADFORD

ACCUMULATORS

The beginning and the end in

POWER.

W.T.5.

Glasgow Depot: 45, Clyde Place.

London Sales and Repair Depot: 107a, Fimlico Road, S.W.1.

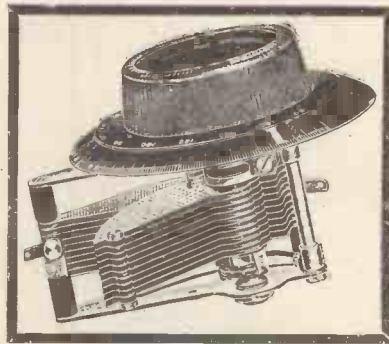

WATCH J. B.

Watch them for big developments. See them on

STAND No. 97

at the Radio Exhibition, at Olympia, Sept. 23rd—Oct. 3rd. See the latest in condenser design—condensers that make tuning simpler and results so much better. These new components will arrest attention by reason of their originality and advanced design.



PRECISION INSTRUMENTS

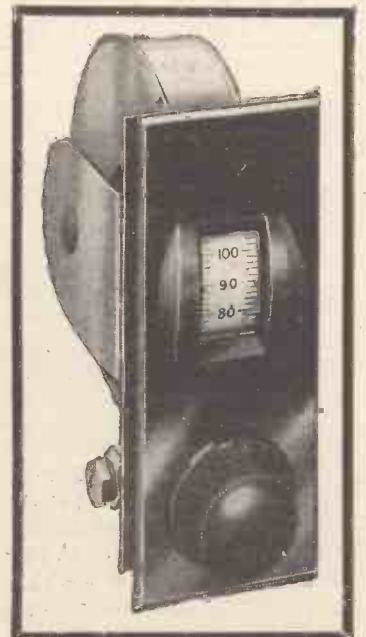



IN PASSING

GLANCING idly at the elegant calendar on my desk (Gift of A. Higgs, Gen. Dealer, Xmas, 1928), I observe with horror that my article on this occasion, must be Septemberish, something sad, as of the dying summer and the leaves reddening to the fall, something with a hint of tragedy at the approach of Michaelmas Day, and the consciousness of unpaid bills as numerous as the strewn leaves in Vallambrossa.

Drearily drag the dripping—no! Hold on! *Hurray-ee!* Here's my



Stiff's passion was conjuring.

subject all cut and dried, and there's nothing dreary about it. (*Song and dance. Fol-de-rol-lol.*)

Old "Dried Blood"

Michaelmas Day! Reminds me of dear old Stiff Gore, as proper an aristocrat as ever put on a boiled shirt before mangling garbage. He was born on Michaelmas Day—but that was pure coincidence. He spells his name Styffe Gore-Gore (of Styffenitte Park, Berks.), but at school we used to call him "Dried Blood." The Styffe G-G's came over with William of Orange and cut the blighter dead in the Park the next day. That'll show you! And old Stiff G. inherited their strain of exclusiveness. In fact, I may as well confess that our acquaintance began, and continued,

only on the strength of my having lent him a pair of bags for "prep." after he had sat, by accident, on a newly-tarred road.

A bit wildish, perhaps, Stiff was, but he escaped the tobacconist's daughter at Oxford and settled down as the perfect eligible bachelor. His one accomplishment was conjuring, a passion which old Sir Goff Gore-Gore, his father, declared publicly was a blot on the county. But to see Stiff take a frog from the left ear of a marchioness—well, *beautiful!* And at his sister's wedding affair he drew a rabbit from the cake and three hundred feet of pink paper tape out of Dean Glug's pocket.

The "Tatoo" Six

At the age of thirty he was left a lonely orphan, as well as the mansion, estate, and income of £17,000 per annum. By dint of judicious dealings with the Kings of Finance he managed to reduce his income by £7,000 per. He then retired to Styffenitte Park in a huff and began to be bored in the grand manner. Here and then I found him and made him buy a radio set for the good of his soul.

Some months later he asked me down for a week-end. The radio set—it was an ornate lump of furniture as big as a console gramophone—seemed to wear an air of neglect and I asked questions.

"Oh, that? Well, Jonesy, old f'lah, the thing was pernicious. Quate tew poisonous. First day it came I put the chauffeur on to the job. 'Stand by this, Fittle,' I said, 'and if anything transpires, note same!' Then I buzzed along to look at Elsie's foal. Elsie's that cock-eyed bay you saw. Very good! Coming in round by the garage, believe me,

Jonesy, if I didn't see three of the maids dancin'! And this awful hand-organ wireless affair was givin' out some filthy one-step. I can tell you I gave Fittle hot cockles."

"What you ought to do is to make a receiver for yourself, Stiff. Horrid fun! What?"

He let his jaw drop and fixed upon me a stony stare. "You—well, dash my tibia! Would you mind repeating that? Something about *makin'* a receiver. Fearful word—receiver! Learnt about 'em in the City. Assets and things. But—what would I be doing with a spanner and a gluepot, Jonesy?"

"Make a darned rotten job, I expect, but you would find the time passing rapidly, Dried Blood."

"And what about this white elephant?" asked Stiff, pointing to the de-luxe, all-in, "Tatoo Six." "Why make anything of the same breed? I think I'd rather enamel the bath or make mats."

We Commence Operations

"Forget it," I replied. "It is Stiffs' Stupid Stunt."

"Jonesy," he said, as I left, "I believe you are going to be poisonous to me. I want to warn the butler not to admit you and teach the dogs to regard you as a piece of warm liver. But I cannot overlook those trousers of yesteryear. They saved me from having to dye my pyjamas in ink."

So on the following Saturday I landed on to Stiff with a suitcase full of choice components, a couple of blueprints and a simple kit of tools. Stiff looked as though I were about to uncase a python as I threw back the lid and displayed the collection.

"Rummy-looking lot of old iron, Jonesy," he commented, picking up a three-noughts five variable. "What

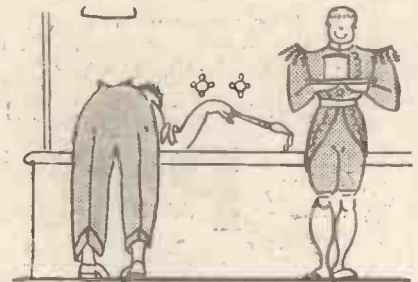

I'd rather enamel the bath.

d'ye call this? A spud slicer? And what's this map thing? Looks like a plan of the new lunatic asylum at Leeming Abbot. Haw, haw!"

"Don't be too ribald, Dried Blood, or I'm blown if I won't skelp you like I used to when you talked in your sleep at school. Sit down and

Note!
the
Dates

Sept. 23rd
to
Oct. 3rd

THE NATIONAL RADIO
EXHIBITION
OLYMPIA (NEW HALL)
★ SEPT. 23-OCT 3 11AM to 10 PM
ADMISSION 1/6 DAILY
TUESDAY SEPT. 24 & OCT. 1 UP TO 5 P.M. 2/6

2H. ORGANISED BY THE RADIO
MANUFACTURERS' ASSOCIATION

**DUBILIER FOR
STAUNCH
RESISTANCES**

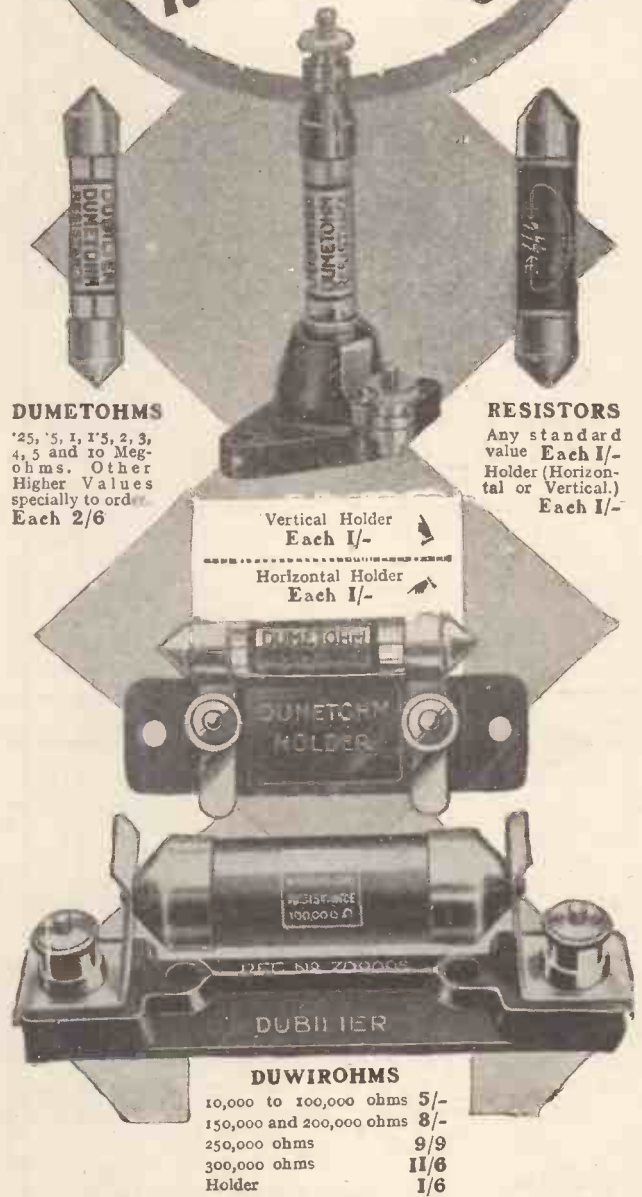

DUMETOHMS
25, 5, 1, 15, 2, 3,
4, 5 and 10 Meg-
ohms. Other
Higher Values
specially to order.
Each 2/6

RESISTORS
Any standard
value Each 1/-
Holder (Horizontal
or Vertical.)
Each 1/-

Vertical Holder
Each 1/-

Horizontal Holder
Each 1/-

DUBILIER DUWIROHMS
10,000 to 100,000 ohms 5/-
150,000 and 200,000 ohms 8/-
250,000 ohms 9/9
300,000 ohms 11/6
Holder 1/6

WE ARE EXHIBITING AT STANDS
NOS. 181 and 182, RADIO EXHIBITION.

**DUBILIER
RESISTANCES**

If unobtainable from your
dealer, write direct to us
giving his name and address.



Dubilier Condenser Co. (1925),
Ltd., Ducon Works, Victoria
Road, N., Acton, London, W. 3.

©250/R

IN PASSING

—continued from page 290

light one of those smoke cartridges you call cheroots, and listen to your Uncle Stalky."

Thereupon I spake winged words and cunning withal, toying the while with the pretties, which one by one I took from the case and laid out in battle array. I led him over the "map," from "Æ" to "E," showed him where the juice went in and where it came out, and made him arrange the bits as on a baseboard. Interested, he drew his chair nearer, and as in a reverie took from my hair 5 megohms which I thought I must have left at home. Then he produced a piece of Systoflex from my hip pocket and the screwdriver from his butler's collar.

"Wired" Wireless

"Avaunt!" I cried. "Low juggler! Thimble-rigger! Professor of magic! Is this the heir of the Gore-Gores? What about your duty to the County?"

"Sorry, Jonesy! Shows I'm interested, that's all. How did you

say you connect the condenser to the thingummy? And what's that you said about positive low-down tension?"

By Sunday evening he knew his way about that blueprint as he knew his own broad acres, and I left him "heating" the soldering iron over an electric fire which he had forgotten to switch on.



Mrs. Loops fancies her voice.

Thereafter on and off for two weeks our local telegraph operator had the time of her life, for she had to wrestle with trifles like:

"Jones, The Glebe, Hixton. Sorry but if put B2 and Z3 where you said no room for T1 besides P4 is blue which means XPN missing please explain and say if I conjured choke into top left pocket your waistcoat as unable find.—Gore."

"Jones, The Glebe, Hixton. Sorry but what is milliammeter could I borrow

one from vet? You forgot bring wave-length send express or shall I get blacksmith make temporary? About how long? And where does it fit in?—Gore."

"Traces" of Life

I answered these and a dozen more and had another week-end with him. Then I fled, but did not escape his importunities. He reported that the set seemed to have traces of life in it, but that on his near approach to it it whistled like Chevalier. Believe me, Jonesy, when that thing pipes up, all the kites in the parish flock round the window and exchange back-chat with us. Makes me feel like that Pied Piper johnny in Shakespeare."

Fearing Post Office wrath, I hastened to the scene. It was very bad indeed; I blushed to think that I, President of the Hixton Radio, Television, Philately and Pigeon-breeding Club, should be even remotely responsible for such anti-Eckersley biz.

"Yes," I said sarcastically, "I think that without being guilty of piling it on I may venture to say that I suspect you of howling."

"Pardon, Jonesy! Wouldn't do such a thing. Not got hydrophobia in the family. Never make any uncouth sound. Nothing more than (Continued on page 294)

**Build the
"BROOKMAN'S"
THREE**

as described in this
issue

Complete kit as described, including
cabinet,

£7 15s. Od.

OR

Ready wired and tested, including
cabinet, valves and royalty

£12 0s. Od.

**DO NOT FAIL TO VISIT
STAND No. 125
OLYMPIA RADIO
EXHIBITION**

**Introducing MAGNUM
A.C. MAINS RECEIVER**



This receiver is not supplied as a constructional kit.

Operates direct from A.C.
supply.

Wave-length range 250 to 550 and 1,000
to 2,000 metres. No coil changing is
required.

The output of this receiver is sufficient
to operate a Moving Coil Speaker, giving
great volume free from all distortion.

Provision is made for Gramophone
reproduction by means of an Electrical
Pick-up.

Price, complete with valves and all
Royalties
Paid **£16 10s. Od.**

**BURNE-JONES
& CO. LTD.,
MAGNUM HOUSE**

Telephone: Hop 9257.

296, BOROUGH HIGH STREET, LONDON, S.E.1.

A 3-valve model incorporating
Screened Grid H.F. will be
available shortly.

SEND FOR LISTS

Centralab



*For Want
of a
Nail . . .*

Everybody remembers the verse about the courier in the battle of Waterloo speeding to get reinforcements for Napoleon. His horse faltered and fell . . . For want of a nail a shoe was lost . . . and the battle lost.

A radio receiver is very much the same. You may have the "reinforcements" in the form of fine workmanship, good condensers, good transformers, and yet there may be a "nail" that causes trouble. Look to the volume control for a great amount of the grief—mechanical and electrical noise . . . inadequate and uneven control. Are those the symptoms?

Then turn to Centralab controls whose quality is vouched for by this fact: the great majority of radio manufacturers include them in standard equipment.

Centralab specialises in Modulators, Potentiometers, Power Rheostats and Power Potentiometers. Write for full lists—they're free.

ROTHERMEL CORPORATION Ltd.,
24, Maddox Street, London, W.1.

'Phone : Mayfair 0578/9.

TELSEN

TRANSFORMERS



12/6

**BRITISH
MADE**

The **RADIOGRAND**, as shown above, is a component of outstanding merit and remarkable value.

Used by all the high-class set manufacturers and sold everywhere.

TELSEN ELECTRIC CO., LTD.
Head Offices:
MILLER STREET, BIRMINGHAM.

WEARITE

COMPONENTS

FOR

"MODERN WIRELESS" CIRCUITS

WEARITE "TITAN" COILS

Wearite "Titan" Coils are made strictly to specification and are manufactured with highest grade materials throughout. Make sure of best possible results from your "Titan" Set by using a Wearite Coil

Price 15/-

Wearite Heavy Duty H.F. Choke (for Eliminators).

Range 30-2,000 metres; self-cap. 10 mmf.; inductance 100,000 mh., D.C. Res. 60 ohms; current carrying cap. 250 ma.

Constantly recommended by the Technical Press.

Price 10/6

Other Wearite H.F. Chokes . . . from 4/6

Write for New List.

WRIGHT & WEIRE, LTD.,

740, HIGH RD., TOTTENHAM, N.17.

Phones: Tottenham 3847-3848.

NOW ON SALE

Full constructional details of
The "Radiano" Three
and

The "Concert" Four
are obtainable in Envelope form in

**THE WIRELESS CONSTRUCTOR
ENVELOPE SERIES, Price 1/6
ON SALE EVERYWHERE**

By post, 1/6, from Wireless Constructor Envelopes, The Amalgamated Press, Ltd., Bear Alley, Farringdon St., London, E.C.4

CUT THIS OUT

for your copy of our new season's catalogue which will be sent to you FREE on Sept. 14th.

NAME

ADDRESS



(Write in block letters, please).

CARRINGTON Mfg. Co., Ltd.,
Camco Works,
Sanderstead Road, South Croydon
Telephone: Croydon 0623 (2 lines).

IN PASSING

—continued from page 292

a slight trill in the bath, y'know. Quite likely that overbearing chauffeur has concealed a mongrel in his quarters. Or possibly Mrs. Loops, my housekeeper, is practising for the bazaar. She fancies her voice, Jonesy, but between you and me I think she must have resided for some long time in the vicinity of a dogs' home. There she is again! Hark! Feeding-time in the hyena's cage!"

More Telegrams

Well, I put his beastly set right and slunk home. I had indeed started something. Presently more telegrams arrived, mainly about coils. He wanted to tie a "75" to a "25" in order to get a "100," etc. And was there a remedy for "condenser poisoning." When I queried this last trouble the reply was, "Glue in the vanes!" Finally he wrote, "I say, Jones, a most peculiar thing has happened. I left my man, as usual, to do the radio and went along to judge pigs at the show. On returning, my man reported that the wretched thing had been

speaking through its nose. Really, a vile Yankee accent! Have you been giving me American volts or something? I suppose they are cheaper, but can I have some naturalised ones? Better still, send me a map of a set with a Balliol accent."

During my next visit to Styffenitte I rammed him into a chair and put him and the set through their paces! He had the makings of a fair manipulator, though afflicted with spasms of mental vacancy during which he would amuse himself by idly flicking the L.T. on and off. He became enormously excited when he heard Dolly Dolbox in a short sketch, and



Socialist M.P. for Long Wigsby.

regaled me with some secret history of his wild youth, finally telling me to "brace up the volt bottles and search for Gertie Figgs." He said I ought to find her "working" at the Har-

monic Music-hall. I failed to locate Gertie in any of the programmes, but I got him a talk on "Diseases of the Hog" which made him restless and argumentative, especially the section on "worm in the hoof."

How It Ended

Now mark the end of Percival Wentworth Goff Styffe Gore-Gore! By the end of two years he and the chauffeur had a short-wave transmitter in the Blue and Gold Music-room, alongside of the harp which had been played before A Certain Personage and Her Dear Prince Consort. To hear him and Fittle talking radio "shop" was worth a long journey, especially as Fittle had not the Balliol manner. ("You gits 'old of the hend of thisyer woyer—so! See?") But old Dried Blood stood with his head mixed up with inductances and never batted an eye. His aunt, Lady Kinchumber-Poote-french, cut him out of her will and he retaliated by marrying the daughter of a gas-fitter who never used more than Det.-L.F. for 3 L O. He is now the Socialist M.P. for Long Wigsby—and is expected to become Assistant P.M.G. all in good time.

Now, isn't *that* a pretty story? All because I remembered that old Dried Blood is a Michaelmas Goosie.

New "All Metal" Rectifiers

for high-tension battery eliminators

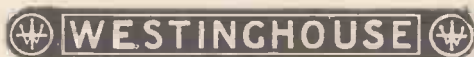

ALL-METAL RECTIFIERS

TYPES H.T.3 & H.T.4



Type H.T.3.
D.C. output
120 volts. 20 m.a.
Price: **21/-**



Type H.T.4.
D.C. output
180 volts. 30 m.a.
Price: **37/6**

No moving parts; No valves

The action of the Westinghouse "All Metal" Rectifier is purely electronic, and its life is not limited by chemical action such as occurs in rectifiers, wet or dry, which depend upon electrolytic action.

There is a Westinghouse "All Metal" rectifier unit for any size of charger or eliminator from 6 volts to 350 volts.

Westinghouse "All Metal" Rectifiers are British made throughout and are manufactured by

The Westinghouse Brake & Saxby Signal Co., Ltd.
82, York Road, King's Cross, London, N.1.

One or More **FORMO** Components

ARTHUR PREEN & CO LTD

SPECIFIED

In every NOTABLE CIRCUIT PUBLISHED during past year.

“1930” CONDENSERS

For COMPACTNESS, EFFICIENCY and RELIABILITY UNEQUALLED.

“1930” LOG (mid-line) CONDENSER

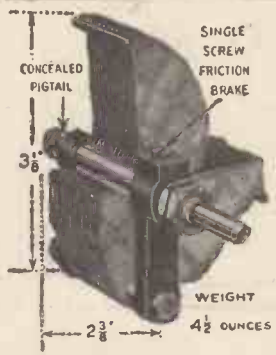

‘0005
‘00035
‘00025
‘00015

4/6

NOTE.
‘00015
Double spacing for Ultra Short Wave

WEIGHT 4½ OUNCES

“MIDGET” REACTION CONDENSER

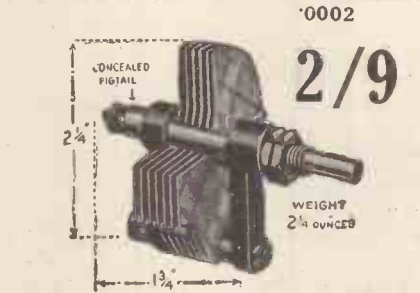

‘0002

2/9

WEIGHT 2¼ OUNCES

Can be supplied with Insulated Spindle
Price 3/-

“1930” DUAL GANG CONDENSER

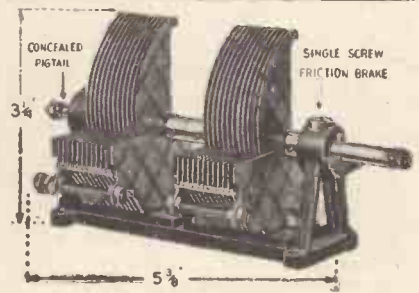

‘0005

15/6

FORMO Patented INTERNAL NOISELESS “PIGTAIL” is incorporated in ALL FORMO CONDENSERS.

As mechanically and electrically perfect as the Formo Condensers of the last season of which we had to treble anticipated production to meet demand.
The patented features are obtainable only in FORMO CONDENSERS. The method of construction is such that the amount of solid dielectric is reduced to negligible quantity.
The “Pigtail” passes through a central hole practically the full length of the spindle, and is securely fastened to the end bearing, which is integral with the Rotor Terminal. The means employed completely overcomes the noises associated with the generally used clock spring and similar loose external devices.
The terminals are placed conveniently accessible. All brass parts are plated.
Small, elegant, but robust condensers of perfect design and workmanship and of highest efficiency.

The patented constructional features of this Gang Condenser (obtainable only in Formo Condensers) permit individual adjustment of each condenser, thus enabling us to perfectly balance one condenser with another at all positions of the condenser movement, without destroying the logarithmic curve. The usually-employed method of balancing condensers is by a small auxiliary condenser. This method, however, corrects errors in one position of the condenser only, and as a result the curve of the condenser is destroyed. By the Formo method, the gang when balanced in any one position remains correctly balanced over the whole scale.

The Finest VERNIER DIAL obtainable.

BLACK, BROWN, 3/- MAHOGANY, WALNUT.

MECHANICALLY PERFECT. POSITIVE BRASS CONTACT drive on SOLID BRASS SCALE ensuring smooth movement, with absolutely NO BACKLASH, NO SLIP, ROBUST in Construction and Trouble Free.
SMALL. EXTREMELY ELEGANT. EFFICIENT.



TUNING WITHOUT IRRITATING, UNCOMFORTABLE CROUCH OR STOOP.

As depicted here, the scale and aperture are inclined at an angle of 30° from perpendicular, thereby permitting convenient unobstructed view of scale without need to crouch or stoop.



Black, Brown, Mahogany, Walnut (Black supplied unless otherwise stipulated).
(Centre knob nickel plated).

Price 3/-

Anti-Microphonic VALVE HOLDER

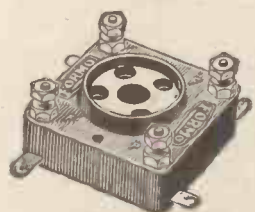

First-Grade BAKELITE including BASE PLATE Practically DUSTPROOF

Price 1/3

FORMO-DENSOR



The finest article of its kind on the market.

Ref.	Max.	to Min.	Price.
F	‘0001	‘000005	2/-
J	‘0003	‘000025	2/-
G	‘001	‘0002	2/-
H	‘002	‘001	3/-

TWO-RANGE TUNER



Price 10/6
Six-Pin Base - 2/-

COMBINATION L.F. UNIT.

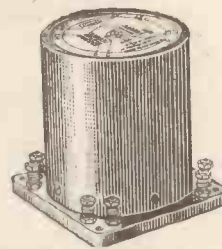

“TRUE SCALE” - 25/-
“TRANSFORMER CHOKE” - 25/-
“TWO STAGE” - 30/-
(Send for full details).

SHROUDED L.F. TRANSFORMER



The First Shrouded Transformer on the market
Ratio 1-3 1-5 Price 8/6

SEND FOR CATALOGUE.

THE FORMO CO., CROWN WORKS, CRICKLEWOOD LANE, LONDON, N.W.2

ONE-WAY ELECTRON TRAFFIC
 —continued from page 216

the other hand as the filament of a rectifying valve is fed from A.C. by a special winding on the same transformer which supplies the necessary high voltage current, that advantage is more apparent than real.

It is significant that in the United States, where practically all the sets are sold A.C. operated, valves and not metal rectifiers are incorporated in every case, and I can only assume that it is the high cost of the metal rectifier which prevents its use in such circumstances.

Until recently, all Westinghouse metal rectifiers available, with the exception of a grid-bias model, were of the full-wave bridge-connected type. In a number of cases the units have been larger than the home constructor required, and to meet the demand for units with output ratings suitable for modern three- and four-valve receivers, the Westinghouse people have introduced two new and very interesting types of great utility.

The two new units have the following ratings:

H.T.3.—Input voltage, 135 to 140 max. Output, 20 milliamperes at 120 volts. This is a half-wave rectifier.

H.T.4.—Input voltage, 135 to 140 max. Output, 30 milliamperes at 180 volts. This is a full-wave rectifier used with a special circuit.

The H.T.3 is suitable for the popular range of three-valve sets requiring from 12 to 20 milliamperes. The H.T.4 rectifier has several special features. Many receivers using pentodes or super-power valves in the last stage require more current than that obtainable from the H.T.3, and they may also require a higher voltage.

Peak Voltages

A rectifier to give this higher voltage may seem to require a transformer providing a higher input voltage, but by using the special circuit recommended by the makers for the H.T.4 it is possible to use the same voltage transformer as that required for the H.T.3. The voltage doubling circuit recommended is a development of the well-known bridge network, but two arms of the bridge which normally consist of metal rectifiers are now formed of two condensers.

This circuit will deliver to the smoothing filter rectified current with a ripple of twice the supply frequency, just as happens with the ordinary bridge network. The condensers recommended have a value of 4 mfd. each, and it is important to note that they must stand the full peak voltage, applied by the transformer, or approximately 200 volts (191 volts to be exact, if the R.M.S. voltage of the transformer is 135 volts). The ordinary small receiving condensers of the Mansbridge or paper type must not be used, the correct condensers being those designed for use with mains H.T. units.

It should also be noted that this circuit should not be applied to a metal rectifier not designed for it, as the rectifier units have to carry double load at each half cycle, one portion of this load going to the output circuit and the other to charge the condenser ready for the next half cycle. The voltage doubling effect is due to the voltage in the already charged condensers being added to that of the transformer secondary at each half cycle.

We now come to what are generally called the "Sulphide" rectifiers, a very interesting type of which the

(Continued on page 298.)

WE'RE IN ON THE GROUND FLOOR

AT **OLYMPIA** ON

STAND No. 7
 RADIO EXHIBITION

Do not fail to pay us a visit and see the wonderful "Musikon" Electric Gramophone as used in Cinemas, Talking Pictures and Dance Halls. Inspect the "Mogen" generator for High and Low Frequency currents. Electrical Gramophone Motors and all the leading components and accessories.

For Everything in Radio

WILL DAY LTD.
 (THE BEST IN THE WEST)
 119 LISLE STREET, LEICESTER SQUARE, LONDON, W.C.2.
 Telephone: (2 lines) Regent 0921 and 0922. Telegrams: Willday, London.

EXACTLY RIGHT—every one tested



EDISWAN GLASS-ENCLOSED VACUUM RESISTANCES.
 (Grid Leak or Anode)
 Ediswan are the only British made resistances of this type on the market. All resistances are thoroughly tested before leaving our works, and are absolutely accurate and noiseless in operation. Obtainable in values from 5,000 ohms to 5 megohms. Overall length, 45 mm.

CARTRIDGE CONDENSERS.
 These condensers are ideal for the man who likes to experiment. In a second, you can pull one out of the clips and put in another of a different value. They are made in values from .0001 mfd. to .001 mfd. Overall length, 45 mm.

For the best results.

EDISWAN

W.S.
 Made only by The Edison Swan Electric Co. Ltd., 12315, Queen Victoria Street, London, E.C.4.



ARE YOU GOING TO BUILD A SET?



If so, you must not miss the latest

"BESTWAY" WIRELESS BOOKS

Four Fine Sets in Each!

"Bestway" No. 328 tells you how to build

A Wave-Change One-Valver

A Two-Valve Amplifier

The "Bestway" Wave-Change Three

The Home-Circle Four

"Bestway" No. 329 contains full details of

A "Regional" Crystal Set

A One-Valve Amplifier, and

An All-Wave Two-Valver

The S.G. & Pentode Three

PRICE

6d.

NOW
on
SALE



**THE
MOST FAMOUS
OF ALL
LOUD SPEAKERS**

CELESTION
The Very Soul of Music

*Now
obtainable at
big
price reductions*

MODEL	OLD PRICE.			NEW PRICE.		
	£	s.	d.	£	s.	d.
C.10	5	10	0	3	15	0
C.12	7	5	0	5	12	6
C.14	13	10	0	11	0	0
C.24	24	0	0	20	0	0

These substantial reductions are made possible only by reason of the greatly improved production facilities made available in the new and extensive Celestion factory.

Obtainable from any high-class Radio Dealer.

Write for free Booklet to:
**CELESTION, LTD., DEPT. H,
KINGSTON-ON-THAMES.**

**ONE-WAY ELECTRON
TRAFFIC**
 —continued from page 296

Elkon is the first to be placed on the British market. Superficially, as previously mentioned, they resemble the copper oxide rectifiers, but actually they differ considerable.

The Elkon Rectifier

Our illustrations show both high- and low-voltage Elkon sulphide rectifiers. The high-voltage rectifier is enclosed in a ventilated metal case with four legs, designed to take the place of a Raytheon type of gas-filled rectifier, while the low-voltage type is suitable for units such as the Harris "Stedipower" or for accumulator charging.

Here again we have the central bolt and the copper radiating fin, but whereas in the rectifiers previously mentioned we had to consider a rectifying surface which exists between a copper plate and a surface of cuprous oxide, in the present rectifiers we have an entirely different arrangement.

It has been found that when relatively high electro-positive and electro-negative bodies are brought into proper contact and current passed so that an electro-chemical action takes place at their junction, a film is formed at the junction which permits a passage of current in one direction only.

In the Elkon rectifier a disc of magnesium is used as the electro-positive body, and a fairly thick disc of cupric sulphide is used as the electro-negative body.

The disc of cupric sulphide is held under considerable pressure in contact with the magnesium—the pressure being approximately 200 lb. a square inch—and it is claimed that there is a relatively high resistance for the passage of current from the magnesium to the cupric sulphide, and a relatively low resistance in the other direction, measurements showing the ratio of these resistances to be of the order of 75 to 1.

Self-Healing

It is further claimed that should the film break down under overload conditions, it is self-healing as soon as the overload is removed. Here, again, about 4 volts per junction is allowed, and the designers have worked out their rectifiers for a normal operation of approximately 3.6 per

junction, so as to give a sufficient factor of safety for general use.

There seems to be a fairly considerable voltage drop in the Elkon rectifiers, and they work very hot; in fact, it is intended that they should do so. The high-voltage rectifier designed to deliver 60 milliamperes at 250 volts at the output of the rectifier works with an input voltage of approximately 350, and the current of a 100 milliamperes. One photograph shows a high-tension mains unit of my own design, in which I have given a number of fairly prolonged tests to the Elkon high-voltage rectifier, illustrated separately. This seems to stand up to its load quite well with no appreciable variation on very long runs, and although it runs quite hot it does not get any hotter than the average rectifying valve in such conditions. The Elkon people state that their rectifier under normal load conditions operates at a temperature of approximately 90 degrees centigrade (194 degrees Fahr.), and will operate at a temperature as high as 150 degrees centigrade without deleterious effect.

For Moving-Coil Speakers

Dry rectifiers of both general types are coming into considerable use for the provision of rectified current for operating the field of moving-coil speakers, and in the United States the sulphide type of rectifier is very widely used for this purpose. Originally the sulphide type of rectifier was used mainly for battery-charging, and other purposes where a steady output was not needed, but an improvement in this type of rectifier has enabled the makers to produce types suitable for both high- and low-tension mains units.

G.B. MAINS UNITS
 —continued from page 261

But providing you know the H.T. eliminator input, which in the case of the D.C. variety will be the voltage of the mains, and have a milliammeter, there is a simple way of getting at the required value.

The milliammeter should be of reasonably low resistance. Place the milliammeter in series with the minus connections of the eliminator and the set at that point where you will insert the G.B. unit. Note the current flow with the set turned on and working in the ordinary way. If you divide this figure reduced to amperes (that

(Continued on page 299.)

**CONDENSERS
COME AND
CONDENSERS
GO**

but

**HYDRA
stays on
for ever !**

PRICES :

Test Voltage 500
D.C. Working
Voltage 240 D.C.
or 160 A.C.

- *001-1 MFD. 1/6
- 25 MFD. .. 1/9
- 5 " .. 2/-
- 1 " .. 2/2
- 2 " .. 3/-
- 3 " .. 4/-
- 4 " .. 5/-

You can count the makers of condensers by the dozen—but the only condenser that counts is HYDRA. Because HYDRA have been making condensers all the time—HYDRA have never made anything but condensers—HYDRA therefore know more about the making of condensers than the rest.

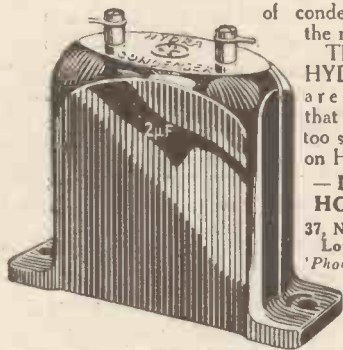

That is why HYDRA sales are growing—that is why you too should insist on HYDRA.

— LOUIS —
HOLZMAN
37, Newman St.,
London, W.I.
Phone: Museum
—2641

G.B. MAINS UNITS
—continued from page 208

is to say, when the reading is in milliamps divide it by a thousand) into the voltage supply, you have the resistance of the complete eliminator-set circuit in its normal operating condition. In fact, you have R_1 in the second simple formula above.

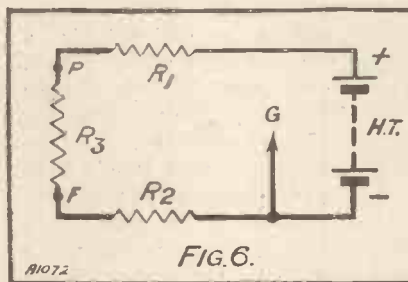

And you have, in effect, the sum of the R_1 and R_3 figures in the first formula, but there are several things which will contribute to a certain degree of error so do not work out a resistance value by this means and very closely adhere to it.

Allow a Margin

If your figures say 50 ohms is required for a certain job, then I would advise you to use a variable resistance with a maximum of 100. If 2,000 ohms appears to be preferred,

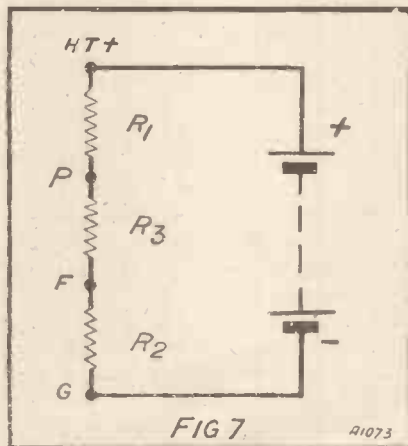

put the maximum of your variable resistance up to half as much again. Do not be too careful and use a resistance of many more thousand ohms than are needed, for the closer you can work to the real value the finer will be your control.

There are one or two other interesting little points concerning the G.B. unit with which I would like to deal, but I am afraid I shall have to leave them for a future occasion.



**MAKE
THESE and
MAKE MONEY!**

**At Home!
At Once!!**

MEN!—Here is the chance of a lifetime! A GOLDEN Opportunity in every sense of the word. It is an opportunity for you to participate in the BIG PROFITS now being made in the Electrical and Wireless Industry—a business which has enlarged enormously of late years, but which has not yet reached a tenth of the size to which it will eventually attain. My new and improved Patents are in increasing demand everywhere because they are such an improvement upon all others, THIS I can prove to you by Certified Tests.

**A Genuine
Spare Time
Business!**

The work is so easy that the whole family—including the children—can help. Even though you have no knowledge of Wireless or Electricity you can commence at once to turn your spare time into CASH and earn anything up to

£300 a Year!

No expensive "plant" or machinery, and no special skill is required. I will supply you with all details Entirely Free of charge. Your Kitchen or any small Outbuilding can be your workroom. Nobody can encroach upon your business; it is protected under Royal Letters Patent.

WE GUARANTEE

Your Profits.—Only a limited number are allowed to Manufacture, so your Market can never be overcrowded. If necessary I arrange to purchase all your stocks. Thus you are positively certain of profit!



This is not a dying industry but a rapidly growing one which is competing successfully against big Combines. It has been established a decade and offers a tremendous opportunity now. Send at once for Full Free Particulars. Don't hesitate—this is a Straightforward, Genuine, Honest Proposition. Commence to earn easy EXTRA £££'s NOW and become an independent Master Man.

SEND THIS FORM NOW

"MODERN WIRELESS" COUPON

To Mr. V. ENGLAND-RICHARDS,
The England-Richards Co., Ltd.,
1011, King's Lynn, Norfolk.

Sir,—Please send me at once, and FREE, full details as to how I can Make Money at Home in my spare time. I enclose 2d. stamp for postage.

Print your name and address boldly in capital letters on a plain sheet of paper and pin this Coupon to it.
"Modern Wireless," September, 1929.

**STARTLING
DEVELOPMENT**

in Electrical Reproduction of Gramophone Records shortly to be announced by the firm known as the "Pioneers of All-electric Sets."

Make
The DAILY SKETCH
YOUR Picture Paper

Ready Radio

SELECTIVITY UNIT (PATENT PENDING)

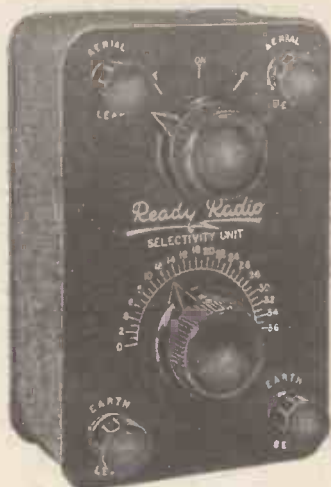

The Cold Shoulder

By using the Ready Radio Selectivity Unit you can give the "cold shoulder" to all unwanted stations. It employs a new principle which incorporates a variable capacity between astatic coils and an H.F. by-pass, on account of which it is immeasurably superior to all forms of apparatus which have endeavoured to overcome the interference problem.

PRICE 20/-

READY RADIO,
159, Borough High Street,
London Bridge, S.E.1.

Telephone: Hop 5555

CLAROSTAT

OVER 500,000

IN USE IN THE U.K. ALONE!

"Clarostat" variable resistances solve every resistance problem met in radio. Why continue to use guesswork fixed values?

Use "Clarostats" for "Anode-feed"; for "Eliminators"; for Volume and/or Tone Controls; for 1,001 other radio purposes. A large Instructional Book FREE; gives scale drawings, circuits, useful hints; from your Dealer, or post free from:

CLAUDE LYONS LTD.
76, OLDHALL STREET, LIVERPOOL

POWER OR PENTODE?

—continued from page 238

Where short-wave sets are concerned the pentode may prove a valuable ally following a detector valve, when good amplification with quietness of background is required, and very good results can be obtained by using the valve here with its ordinary output transformer.

The pentode is, undoubtedly, a wonderful valve, and properly used can be exceedingly valuable, but, as will have been seen from the foregoing, it requires very careful use if the maximum results are to be obtained from it. The idea of getting the maximum amplification from this valve should be dismissed from the user's mind, because if amplification is the only reason for the use of the pentode, I am afraid that the quality may suffer very badly indeed.

Not a Power Valve

It is far better to use the pentode in an inefficient way, somewhat cutting down the amplification and to get the tonal quality and "correcting" effects, about which special use I believe Mr. Kendall is going to have something to say in the near future.

As a "correcting" valve on certain speakers where a tendency to cut off the high notes and to lack of brilliance generally is noticed, the pentode valve is excellent, but as a substitute for the ordinary super-power valve it requires very careful handling indeed, and it is doubtful whether many constructors will benefit from the change from the "power" to the pentode under those circumstances.

Lest it be thought that I am decrying the pentode unnecessarily, I should like to point out that the makers never intended it to oust the power valve under every circumstance. It was intended as an output valve with special peculiarities and properties, which would make it valuable to a great number of people and especially to those who have small sets.

For the man with detector and one L.F. the pentode can be a real boon, and in such a case I think it is perfectly safe to say that used with its proper transformer (unless wanted as a correcting factor) the pentode will give a very real advantage over the ordinary power valve; but for multi-valve sets the pentode should be used with circumspection if real satisfaction is to be obtained.

I remember, when it first came out, that I got hold of one of the early models and plugged it into a set using a cone speaker. The results were truly horrible, and I was inclined to mark it down as a "dud."

But after a little experiment in several valve sets, I found that used properly and with due consideration of its characteristics and the speaker with which it is to be used, the pentode valve can be a great help and an advantage over the power valve.

But the pentode cannot be said to be a *general-purpose* output valve, and it is because it has a more limited application that the pentode valve and the power valve can hardly be said to work in opposition in any way. Both have their uses, but in my opinion those uses are different, and under few conditions can you use either a power valve or a pentode valve indiscriminately.

WALES AND THE B.B.C.

—continued from page 239

true of the school broadcasts. Swansea and Cardiff, which used to broadcast to schools, are now forbidden to do so. Welsh children must take the Davenport programme. Scotland, on the other hand (and as one might expect!), has a school syllabus of its own and four stations from which to broadcast.

"Admitting the technical difficulties caused by the peculiar lie of our Welsh mountains, admitting also that we must wait some time before these difficulties are overcome and we can have a high-power station of our own, why cannot the Cardiff and Swansea broadcasts to schools go on?"

Need for Revision

With this we are in agreement, and we trust the B.B.C. will revert to its old policy and allow the continuation of the characteristic Welsh programmes from Swansea and Cardiff to be resumed.

Professor Ernest Hughes quotes to some effect the official B.B.C. Handbook in connection with this point. In it the reader will find this passage: "that each country has a national character of its own, a character which should be preserved and developed, and broadcasting can thus perform important work."

If the B.B.C. really believes this, then it will realise that the Welsh Nationalists certainly have a case

(Continued on page 301.)

WORTH THEIR WEIGHT IN GOLD

HEAYBERD POWER TRANSFORMERS

The undermentioned transformers are used in the "ELECTRO-GramO" THREE Unit as described in this issue.

Type E4. 375+375 volts, 120 ma. . . 57/6
+4 volts, 2½ amps.

No. 723. 2+2 volts, 3 amps. 9/-

No. 727. 2+2 volts, 5 amps. 12/6

The following transformers are for use with the latest Westinghouse Metal Rectifiers:

No. W10 for use with Rectifier H.T.3 . . 15/-

No. W10 " " " " H.T.4 . . 15/-

No. W5 " " " " A.3 . . 15/-

No. W9 " " " " A.4 . . 20/-

Write, 'phone or call for new List No. 936, giving diagrams and full list of components necessary for building L.T. Chargers, and H.T. and L.T. Battery Eliminators using Heayberd Transformers and Westinghouse Rectifiers.

F.C. HEAYBERD & CO
10, FINSBURY ST EC2
One Minute From Moorgate Station.

WALES AND THE B.B.C.

—continued from page 300

which deserves immediate and sympathetic attention.

We do not disagree with the B.B.C. in refusing to erect a station purely for Wales. The technical difficulties are, in this case, severe.

There was talk at one time that the Cardiff station would be speedily converted into a high-power Regional station with a transmitter so erected as to cover the whole of the Principality. But we understand that, on technical grounds, this scheme had eventually to be turned down.

However, that does not prevent the B.B.C. from again reconsidering the plea of Welsh Nationalists for the revival of the old policy of the Swansea and Cardiff stations, plus more sympathetic consideration of school broadcasts for Welsh children.

BROKEN WAVES

—continued from page 245

closed-core type of design (which seems to be universal these days), but then the complete magnetic circuit of the greatest possible permeability is one of the essentials of successful L.F. transformer design.

Perhaps it has been found necessary to make a compromise, but, even so, permeability can be varied by the steady uni-directional current which may be flowing through the transformer or by the varying current components, and here, again, we find something which may cause the L.F. transformer in practice to do something a little different from that which its curve would lead one to expect.

Much To Be Learnt

But there is very active research going on in regard to L.F. transformer design, and the sum total of our knowledge is being increased almost every day. Nevertheless, specialists in this branch of the art would be the first to admit that there is yet much to be learnt. The magnetic behaviour of iron, let alone those complicated alloys of nickel and iron, silicon and steel, and so on, which are being adopted, is a vast complication of varying phenomena about which numberless volumes have been written.

(Continued on page 302.)

CLIX

The Cure for Clicks!

Bad contacts account for unwanted noises. Get rid of them by using "Clix."



CLIX HOOK TERMINAL.

Ideal for speedy connection and sure contact. Lead coated for L.T., Nickel plated for H.T. Red and Black. 2d.

CLIX RING TERMINALS.

An ideal fitment for permanent contact. Red and Black. 2d.

CLIX-LOX WANDER PLUG.

Adjustable to fit any socket. A turn of the insulator locks it. Special short insulator. Red, Black and Green. 2½d.

CLIX 21 VARIETIES

of perfect aids to contact are illustrated in our New Folder "M.W."

LECTRO LINX, LTD.

254, Vauxhall Bridge Road, London, S.W.1

OH BOY!

KESTER ROSIN CORE

RADIO SOLDER

IS NOW AVAILABLE.

Kester Radio Solder is the one safe combination of solder and flux. The pure rosin inside of this genuine solder makes wiring of radio sets a pleasure. Kester Solder is recommended and used by leading engineers and manufacturers.

REQUIRES ONLY HEAT.

In handy tins from all wireless and hardware dealers.

1/6 per tin.

Also in 1-lb. spools and 18-in. sticks for manufacturers.

If you have difficulty, write to the exclusive distributors:

ROTHERMEL CORPORATION LTD.

24, MADDOX STREET, LONDON, W.1

Telephone: MAYFAIR 6578-9.



"REQUIRES ONLY HEAT"

FLUX, IN POCKETS



SCREENS **PAREX** SCREENS

BROOKMAN'S THREE

SPECIAL SCREENING BOX as specified—
HIGHLY POLISHED and MOTTLED 7/6
ALUMINIUM
COPPER 12/6

SCREENS & COILS FOR ALL CIRCUITS.

E. PAROUSSI. 10, Featherstone Bldgs., HIGH HOLBORN, W.C.1.

SOLVE ALL H.T. TROUBLES



Per doz.	No. 1.	No. 2.
	s. d. s. d.	s. d. s. d.
Jars (waxed)	- 1 3 1 6	- 1 2 1 9
Sacs	- 1 2 1 9	- 1 2 1 9
Zincs	- 10 11	- 10 11
Rubber Bands (24)	4 4	4 4
Terminals	8 10	8 10

Special sizes for Pentodes.



LONG LIFE : SILENT : ECONOMICAL

Sample doz. (18 volts), complete with bands and electrolyte, No. 1, 41; No. 2, 5/-; post 9d. terminals extra. No. 3, with terminals, 7/6 (10,000 milli-amps), sample unit 6d. Orders 10/- carr. paid. New illustrated catalogue post free.

FREE Bargain List of Receivers, Amplifiers and Components.

M. TAYLOR, 57, Studley Road, Stockwell, London.

PLEASE be sure to mention
"Modern Wireless"
when communicating with
Advertisers. THANKS!

ARE YOU

"IN TUNE"

with all the recent radio developments?

Keep yourself right up to date by reading

POPULAR

WIRELESS

¶ This fine three-penny-worth is well worth the small weekly subscription because it gives the brightest and best radio reading every week.

¶ But there is more in it than that! Full of hints, tips, and practical how-to-make articles, "Popular Wireless" is

A SOUND RADIO

INVESTMENT

Scores of readers have testified that one 3d. copy of "Popular Wireless" has saved them *Pounds!*

So now they always ask for

POPULAR WIRELESS

Every Thursday. Price 3d.

BROKEN WAVES

—continued from page 301

The average modern loud speaker is almost behind the times from a power point of view; it is a most inefficient converter, while its performance gives much hope to experimenters and inventors. It provides a definite link between the allied sciences of radio and acoustics, both of which are equally complicated. But I think I can safely say that we know more about the purely acoustic aspects of the loud speaker than we do in regard to its electrical side.

Thus we know that, in the case of a cone loud speaker, whereas the higher frequencies are thrown more or less directionally from the diaphragm, the low frequencies tend to spread around the side and to the back. And this may cause you to wonder why some loud speakers are arranged with their diaphragms convexly pointed to the front. This would appear to make for a less efficient projection of the higher frequencies, and may be a deliberate contrivance in order to compensate for unit deficiencies.

One cannot hope to get a true representation of what is happening in a broadcasting studio without arranging the loud speaker in a room with special acoustic qualities; but this would appear to be striving for the impossible, since it might be said that one could never devote or arrange a room in a house suitable for a symphony orchestra or brass band!

The foregoing would seem to be a fairly depressing criticism of the modern radio installation. It is not intended to be that, rather a tribute to what has been done towards solving incredibly difficult problems; and any radio set, whatever its circuit or its accessories, constitutes a monument to real scientific achievement.

THE MYSTERY OF RADIO WAVES

—continued from page 256

audible at a great distance. When sound is travelling against the wind the waves are tilted backwards, so that they tend to rise above the surface of the earth, and again are lost to a listener at a distance. Hence in stagnant air, as during a fog or anti-cyclone, sounds are heard much farther

than they would be in windy weather; and even in a wind they can be heard better across the wind than either with it or against it.

That radiation should behave in this way is peculiar, and would not have been suspected. The ionised air which causes the tilt forward is always in the upper regions, and accordingly radiation is never tilted upwards but always down, just as the surface of the ocean is curved downwards by reason of the gravitational shape of the earth.

Curving Round the Earth

The increased speed of radiation in the upper layers is not great, and the curvature therefore is quite moderate; and there may be conditions in which the curvature of the radiation would correspond with the curvature of the earth. In that case the waves would curve right round the earth, so as not only to reach America, but even the Antipodes.

We could hardly have expected such a favourable condition, but we know by experience that it does exist, though not always and under all circumstances. Still, the Antipodes is rather favourably situated, for when we are trying to reach the Antipodes every direction is equally good, and the chances are that a favourable direction, in which the curvature is of the right magnitude, might be automatically found by the waves, so that at any rate some portion might travel right round the earth.

A little arithmetic would tell us how much extra speed is necessary at a given height for the right curvature to occur. The upper portions of the waves have farther to go than the lower portions, so that to keep pace with the lower portion it has to travel a little quicker.

A Homely Example

When you are walking or driving round the bend of a road, especially a wide road, you naturally take the inner portion of the curve so as to shorten the distance. If a file of soldiers were walking round the bend, the outer ones would have to walk quicker than the inner ones to preserve their formation. The extra distance which an outside circus performer would have to go round a complete circle would be 2π times the width of the course.

Therefore, in going round a 90° bend in a road the extra distance would be a quarter of that, that is, one and a half times the width of the road. And so on in proportion

(Continued on page 303.)

THE MYSTERY OF RADIO WAVES

—continued from page 302

The waves travelling to the Antipodes are going round a 180° bend, and accordingly the upper portion has an extra distance to travel, π times the height above the earth. Suppose this height were 60 miles, that would mean an extra distance of 180 miles in the whole journey of 12,000 miles. Hence the speed of the upper portion compared with the speed of the lower portion would be roughly 12,180:12,000. This then gives the ratio of speeds required.

Thus we find that to produce the desired effect on radio waves 1 kilometre long, the number of free electrons at a height of 60 miles in the earth's atmosphere ought to be of the order ten or a dozen per cubic centimetre; which is a modest sort of estimate, when we remember that the number of atmospheric atoms per c.c., at that height, would be comparable to a million million.

SHORT-WAVE AERIALS

—continued from page 268

from the vertical towards the horizontal plane, maximum radiation taking place at an angle of 48 degrees from the vertical for a height of three-eighths of a wave-length, to about 60 degrees for a height of one-half wave-length.

It would seem from the foregoing that the horizontal aerial could not compare with the vertical for low-angle radiation such as would be utilised for long-distance transmission, but for high-angle radiation it is unsurpassed, hence it is particularly useful in communication at comparatively short distances.

Beam Radiation

It is often a decided advantage not only to propagate maximum radiation at an angle suitable for refraction at the ionisation level, but to cause the greater percentage of energy to be radiated in the general direction of the distant receiving station. Quite a number of aerial systems have been evolved whose resultant radiation will take the form of a beam, unilaterally or bilaterally, and the basic principle of them all seems to be that of employing a

(Continued on page 304.)

RAYMOND'S

27 & 28a, LISLE ST., LONDON, W.C.2

Come to LEICESTER SQUARE TUBE

This address is at the back of Daly's Theatre
Phones: Gerrard 4637 and 2821

HOURS OF BUSINESS EVERY DAY 9 to 8
SATURDAY 9 to 9
SUN. MORN 11 to 1

SENSATIONAL OFFER IN LOUDSPEAKER SETS (NOT PARTS)

READY TO USE

In-Handsome Cabinet.

Receives London, 5GB, 8XX, and many Continental Stations.

Straight 3 Circuit NO COILS TO CHANGE



JUST SWITCH ON—THAT'S ALL.

Complete with 3 Dull Emitter Valves, S.M. Dial. All parts on Baseboard. Hinged Lid. Various Panel Designs. Packing and Carriage, 6/6. Tax paid. Net Cash OR supplied complete, as shown, with Valves, 120 v. H.T. Battery, Cone Loud Speaker, and 2 L.T. Batteries, Battery Cords, Aerial Equipment (not post). Nothing more to buy. Ready to use. 16/6 first payment, 11 monthly payments of 12/6

MULLARD MASTER 3*

This new and wonderful set must appeal to Young and Old, amateur or experimenter—in fact EVERYBODY! The above circuit in Handsome American Type Cabinet, with Tunewell Dual Coil, 3 Mullard Valves and Battery Leads. READY TO USE. Tax Paid. Pack. and Carr. 3/6. Net Cash. 84/-

OR complete with 120-v. H.T., 2 L.T. Batteries, Cone Loud Speaker, Battery Cords, Aerial Equipment, with Set, Coil and Valves, ready to use. First payment of 19/6 and 11 monthly payments of 14/9

"TITAN" THREE

"P.W." 2/2/29. Kit of parts approved by Editor. 0005 Variable S.M. Dial, Metro 0005 Lenses L.F. 8/8 (add balance other), 2 Switches, TITAN COIL UNIT, R.I. H.F. Choke, 0002 and 2 of 0003 fixed, 2 meg. Leak, Holder, 2 Mansbridge Condensers, P.W. Standard Screen, 2 H.T. Panels, 11 Engraved Terminals, Strip, Screws, Wire, Flex, Plugs, Baseboard, 14 x 7 in. Above usually 72/6. Reduced until August 30th. Net Cash Post 1/ U.K. £6:10:0

With Cabinet, 3 Valves (Mullard) L.T. 2 v. 30 amps., H.T. 120 v. Pack. and Carr 3/6. Net Cash. The "Titan" is a Kit of Parts, and is NOT assembled ready to use.

H.T. BATTERIES

Packing, etc., U.K., 1/- each (20/- worth free).
SIEMENS
60-v., 8/; 100-v., 13/-
Power, 60-v., 13/6;
100-v., 22/6.
PETRIX
60-v., 8/; 100-v., 13/-
120-v., 15/6; G.B., 1/6.
Special Portable
Size, 100-v., 15/6.
Very highly recommended.
CARMALITE
60-v., 5/9; 100-v., 9/4.
Fully guaranteed.
HELLSEN
60-v., 10/6; 99-v., 18/-.

DARIO RADIO MICRO VALVES

10/6 each.
Cossor 210RC, HF, LF, Mullard PM1A, HF, LF, Six-Sixty RC, HF, LF, Marconi DEH210, HL, DEL, Osram DEH210, HL, DEL, Ediswan RC, HF, LF.
12/6 each.
Cossor 220F, Mullard P22, Six-Sixty, P215F, Marconi DEP215 (Osram same), Ediswan PV215.
15/- each.
Cossor 230P, Mullard 252, Six-Sixty 230SP, Marconi 240 (Osram same), Ediswan P225, Screened Grid, 25/- Pentodes, 22/6.

TRIOTRON VALVES

H.F., Det., E.C., 5/2 each; Power, 5/9, 2 v. or 4 v. Post 4d. (3 post free).

MASTER THREE STAR

3 Spring V. holders, Combined wave coil, Permacore L.F., Climax L.F., H.F. Choke, Battery Switch, J.B. 0005, J.B. 00055, Mullard 0005 and 2 meg., holder, 0001 fixed; panel brackets, spades, 8 plugs, Flex, Links, 4 engraved terminals, Baseboard, all screws, Aluminium panel ready drilled (or obsolete, if preferred), Grid Bias, Handsome American Type Cabinet, hinged lid, 3 Mullard valves.
FIRST PAYMENT 15/- and 11 MONTHLY payments of 16/11.

SUNDRY COMPONENTS

UNITS.
Brown's "Vee" Unit 25/-
Chassis & Cone 15/-
Ormond 4-pole Unit 12/6
Walnet ditto 17/6
Blue Spot 66k disto 25/-
Triotron 4-pole 17/6
Lissen Super Unit 15/-
Do. Gramophone Unit 13/-
Raymond Bal. Arm. B.T.H. Pick-up Arm 10/11
..... 45/-

Postage under 10/-, please.
Burne-Jones Magna-Ricon 12/6
(Station separator).
Panel Brackets 2/6
Small do. 1/6
Std. Loading Coil 7/6
Titan Coil Unit 13/-
Wave-Trap 15/-
Screens, 10 x 6 2/6
Reaction, B.B. and P.M. 5/-
Vol. Control 7/6

L.F. TRANSFORMERS
R.I. Hypermu 21/-
R.I. G.P. 15/-
Lotus 12/6
Igranic "J" 17/6
Igranic "P" 14/-
Cossor 21/-
Permacore 25/-
Climax L.F.A. 25/-
Brown 30/-
Ferranti A.F.3 25/-
Do. A.P.4 17/6
Lissen Super 19/-
Lissen L.F. 8/6
"Stahl" Log 6/6
"Elite" (powerful) 7/6

Postage under 10/-, please.
Bulgin All-wave Tuner 15/-
Wetzel Tuner 15/-
British General Tuner 18/6
Kay Tuner All-wave Tuner Dual 6-pin Tunewell S.G.P. Anode and Aerial 6-pin 7/10
Colvern S.G. Coils, B.B.C. pr. 9/6; L-wave 10/6
Ultra Short wave Coils for 1929 Cossor S.G.3 7/6
B.H.C. do., 12/6; L-wave 13/11
Colvern 3-Star Dual Lotus QA. 15/-; QSP 21/-

SPEAKERS
Amplion Guinea Cone 2 1/2" B.T.H. Cone Speaker 6 1/2" B.T.H. C2 Horn Type 4 1/2" Celestion 11 1/2" model, now 72/- Brown's H.3, now 63/- Blue Spot 66k. in hand some Oak Cabinet, ready to use 35/-

H.F. CHOKES
Postage under 10/-, please
R.I. 7/6; Dubilier, 4/6; McMichael (for S.G.), 4/6; Wearite, 6/6; Lewcos, 8/; Climax 7/6; Climax Kit of 2 M.5, 15/-; Bowyer-Lowe Long Range, 7/6; Raymond Binocular, 4/3 (for Low & 5X); Screened Grid, 5/-, etc., etc.

REACTION CONDENSERS
"P.W." Recommended
0001 4/-
Igranic Micro Panel 5/6
Ditto, B.B. 4/-
Cydson Hebe 0003 8/-
Dubilier 0001-0002 5/6
Polar 0006-00015 5/9
J.B. Baseboard 3/6
Peto Scott 0001 4/6

LEWCOS
Lewcos C.A.G.5, 10/6; C.A.C.20, 12/6; C.S.P.5 10/6; O.S.P.20, 12/6; P4 to 14, 3/- each; P16 to 22 4/- each. Touchstone Coils, 30/-; G.T. Coils, 3/6, 5/3, Q Coils, 5/-; 15/-; Q.S.P., 21/-; Q.A.R., 21/-; Q.A.A., 16/-; Q.S.G., 21/-; A.M.S.4, 7/6; A.M.S.9, 7/6; A.M.5, 10/-; A.M.20, 10/-; All Binocular Coils, Split Primary H.F.F. etc.

Postage under 10/-, please
VARIABLE CONDENSERS
Lotus 0005, 00035 5/9
Polar 0005 5/9
Ormond Log 0005, 6/- 00035, 5/6; 00025 5/3
Ormond Short-wave, 7/6
Friction Dials (Cansel, 5/- Small (Silver or Black) 3/6
KayRay 0005, 0003 each 3/11
(Complete with 4in. Dial.)
J.B. 0005, 11/6; 00035 10/6
J.B. Vernier Dials 5/9
J.B. 40-0005, 14/-; 4/6; 0003, 14/-
J.B. Condensers and Drum Dials for S.G.P. set of 2 40/-
Geophone 0003, 16/6
Ultra 12/6
K.C. Dubilier 12/-
Thumb Control 15/6
Formo 5/- & 6/-
Pye 0005 geared 12/-
Igranic Lokvane 10/-

Postage under 10/-, please.
VOL. CONTROLS
Rotor, 5/6; H.T. 6/6; Volveteria, 6/6; Magnum, 7/6; Charostat, 8/6; Do. Standard, 10/6; Centralab, 10/6.

CLEARTRON SCREEN GRID.

2-v., 12/6; usual types, 4/-; R.C. or Power, 6/-; Post 3d.

C.O.D. OVER 10/- (U.K.). SEND ORDER PAY POSTMAN. IF RAIL, NEAREST STATION. PLEASE WRITE PLAINLY.

ALL PARTS ADVERTISED IN THIS JOURNAL CAN BE SUPPLIED CASH OR EASY TERMS—PLEASE SEND YOUR LIST.

KITS OF PARTS FOR ALL CIRCUITS
PLEASE SEND DETAILED LIST OF REQUIREMENTS

CASH OR EASY TERMS
PARTS, SETS, PORTABLES, H.T. UNITS, SPEAKERS, ETC.

SPECIAL INCLUSIVE PRICE 25/- Please send list. FOR CASH ORDERS OVER 25/-

MULLARD S.G.P.
(Screened Grid. Detector, Pentode).
Aluminium Panel, ready to use, 5/6; Junit Board, 2/-; J.B. pair of Condensers, fixed Drum Dials, 40/-; Benl 0003, 8/-; Rheostat, 2/8; Benl. Bati. Switch, 1/3; 2 6-pin Bases, 4/-; aerial and Anode Coils, B.H.C., 9/6; 2 H.V. Valve Holders, 3/6 pr.; 1 Valve Holder, 2/-; Mullard Combined Base, 0005, and Leak 7/6; Climax H.F. Choke, 7/6; Permacore L.F., 25/-; 2 Junit Mounts, 1/3; 4 Terminals, B.L., 2/-; Magnum Brackets, 2/6; Metal Screen, 10/6; 0/1 Fixed, 3/-; 25 Mansbridge, 2/3; J.B. Clips, Plugs and Spades, Links, Flex and Screws, 3/8 the lot. (Coins for 5X, 10/6 pr.)
Table Cabinets 25/-, 27/6, 29/6, 35/-, 3 specified Valves, £2/18/0. Let me quote you. Easy Terms.

LATEST VARY VARY LINES

20 Henry Choke 20/- Pentode Output Choke 21/-
C.I. LF Choke 21/- LT. LF Choke (5amps.) 20/-
Dual LF Choke 21/- PP. Output Choke 21/-

ALL FERRANTI PARTS

SHORT-WAVE AERIALS
 —continued from page 303

number of aerials at distances of a definite number of quarter wave-lengths from each other, and operating them in such a manner that their respective currents are either in or out of phase, thus obtaining an addition of their separate effects in certain directions and an annulment of their effects in others.

We have seen that, in the case of the horizontal aerial, a much greater percentage of energy is distributed at right angles to the aerial than in any other direction. This is probably the very simplest form of directional system, though the radiation from it cannot, however, be termed a beam.

Aerials in Series

By utilising a number of horizontal aerials in series, having at their junction a tuned circuit, similar to that previously shown in Fig. 4, which acts as a phase reverser, an addition of the separate effects of each aerial will be obtained, since the currents in the radiating portion are in phase, and a radiating system having a very sharp directional characteristic, at right angles to the aerials, will result. The width of this beam of bilateral radiation will depend on the number of aerials in series, being, according to Meissner, about 72 degrees for one aerial, 42 for two, 32 for four, and 14 degrees for 8 aerials so connected.

Fig. 6 shows the arrangement of such a system, though it has the disadvantage of all horizontal aerials, radiation cannot be obtained in a purely horizontal plane, whilst the dimensions of the system may also be a disadvantage in certain cases, for we see that, in the case of a

directional aerial of this type producing a beam 14 degrees in width, and working on a wave-length of 40 metres, it would be at least 525 ft. in length.

If we operate an aerial system consisting of a number of half-wave vertical aerials in line and spaced one-half wave-length apart, the feeder arrangements being such as will cause the currents in adjacent wires to be in phase, radiation will be obtained which is sharply directional at right angles to the line; whilst if the feeders are so arranged that the

obtained by placing one of the rows of a two-row system one-quarter wave-length behind the other, both rows having the currents in adjacent wires in phase, but the two rows being out of phase with each other. It is a matter of some difficulty in practice to get this arrangement functioning correctly. (See Figs. 7 and 8.)

Complicated Feeders

It is apparent that with all the foregoing arrangements of vertical aerials, to produce anything like a narrow beam of unilateral radiation whose angle of propagation can be easily varied, the feeder systems will be fairly complicated.

In the absence of disturbing factors a single half-wave vertical aerial gives symmetrical distribution of energy in all directions around the aerial at an angle of propagation depending on its height from the ground, character of the earth and the current distribution in the aerial itself.

If a second aerial, identical with the first and parallel to it, is placed at a distance of one-half wave-length, then it will act as a reflector and will re-radiate energy picked up from the aerial proper in such phase relation as to augment the distribution of energy in the direction of a line drawn from the reflector towards the aerial, whilst the energy distributed in other directions will be correspondingly diminished. Fig. 9 shows this arrangement and, as will be seen, the system does not produce anything like a beam.

If we accurately arrange a number of reflector wires in the form of a parabola, with the radiator at the focal axis, the energy distribution will be in the form of a very narrow beam of unilateral radiation.

Fig. 10 is a schematic diagram of the parabolic reflector which is fairly simple both in operation and construction.

KEEP IN TUNE

WITH RADIO WEEK BY WEEK

- Get good how-to-make articles
- Get dependable designs
- Get red-hot news
- Get hints and tips
- Get busy and

GET
POPULAR WIRELESS

Every Thursday. Threepence.

currents in adjacent wires are out of phase, maximum radiation will take place along the line of the aerials.

Beam Too Wide

Although this latter arrangement offers many advantages from a practical standpoint, it has the disadvantage of producing a relatively wide beam. Even if two rows of aerials are employed and properly excited, the beam, though much narrower, will not be nearly so sharp as that obtained at right angles to the aerial, when the currents in the wires were all in phase. Unilateral radiation may be

INDEX TO ADVERTISERS

	PAGE
Bennett College, Ltd.	279
Brown, S. G., Ltd.	Cover ii, 273
Burne-Jones & Co., Ltd.	292
'Best Way' Wireless Books	297
Carrington Manfg. Co., Ltd.	293
Cassell's Magazine	277
Celestion, Ltd.	298
Centralab (Rothermel)	293
Cossor, A. C., Ltd.	202
Day, Will, Ltd.	296
Dubilier Condenser Co. (1925), Ltd.	291
Ever-Ready Batteries	201
Edison Swan Electric Co., Ltd.	296
England Richards Co., Ltd.	299

	PAGE
Fornio Company	295
Garnett, Whiteley & Co., Ltd.	285
Gambrell Radio, Ltd.	299
Hayberd, F. C., & Co.	301
Holzman, Louis	299
Hughes, F. A., & Co., Ltd.	Cover iii
Igranic Electric Co., Ltd.	281
Impex Electrical, Ltd.	285
Jackson Bros.	289
Lectro Linx, Ltd.	301
Lissen, Ltd.	267
London Elec. Wire Co. & Smiths, Ltd.	279
Lyons, Claude	300
Paroussi, E.	301
Peto & Radford	289
Pickett's Cabinet Works	299
'Popular Wireless'	302

	PAGE
Ready Radio	300
Raymond, K.	303
Radio Instruments, Ltd.	Cover iv
Rothermel Corp'n., Ltd.	293, 301
Radio Exhibition (Olympia)	291
Taylor, M.	301
Telegraph Condenser Co., Ltd.	281
Telsen Electric Co., Ltd.	293
Varley Products	271
Westinghouse Brake & Signal Co., Ltd.	294
Wright & Weaire, Ltd.	293
'Wireless Constructor' Envelopes	293

All communications concerning advertising in "Modern Wireless" must be made to John H. Lile, Ltd., 4, Ludgate Circus, London, E.C.4. Telephone: City 7261.



FOR YOUR PROTECTION

The amazing popularity of the Blue Spot Unit has resulted in certain unscrupulous persons taking advantage of the great demand for these units by passing off certain units in plain boxes as Blue Spot units.

Genuine Blue Spot units are retailed in specially designed cartons, which

are clearly marked with the price 25/- and the famous Blue Spot trade mark. Every genuine carton contains a 12 months' guarantee and for your own protection insist on the guaranteed and genuine Blue Spot Unit—the unit that has revolutionised loud-speaker reception.

F. A. HUGHES & CO. LIMITED, 204-6, Gt. Portland St., London, W.1 (Tel.: Museum 8630. 4 lines.)

Distributors for Northern England, Scotland, and North Wales: H. C. Rawson (Sheffield and London), Ltd., 100, London Road, Sheffield (Tel.: Sheffield 26006), and 185, Princess Street, Manchester (Tel.: Manchester City 3329).

THE NEW SEASON'S GREATEST SUCCESSES



The All-Electric Screened Grid TRANSPORTABLE '3' for A.C. and D.C.

A wonderful receiver operated from the mains, giving wide choice of programmes without an aerial. It has only one stage of L.F. amplification, and reproduces speech and music with fidelity hitherto thought unattainable.

NOT DIRECTIONAL
No frame aerial is used

Price complete, including valves and all royalties. For A.C. or D.C. **£30**



"DUAL ASTATIC" CHOKE

The first H.F. Choke free from absorption, and the most efficient Choke for modern valves (including screened grid) and modern circuits using parallel choke feed. **7/6**

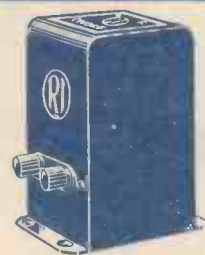

L.F. CHOKE

28/14 Henries, 100 M.A., D.C. Resistance 260 ohms. The Choke adopted as the standard for modern smoothing and output filter circuits. Universally employed and recommended by the technical experts. **21/-**



THE "HYPERMU"

The remarkable modern nickel alloy transformer, giving the highest and most uniform amplification from 25 to 6,000 cycles. It is the first metal screened transformer encased in Bakelite. Weight 14 ozs. Size 3" x 1 1/2" x 3". A midget in size—a giant in performance. **21/-**



THE "PENTAMU"

A new output transformer specially designed for use with pentode valves. It has four ratios—2:1, 3:1, 6:1 and 25:1 Suitable for any type of loud speaker. **21/-**

The Specialists in



Sound Reproduction

RADIO INSTRUMENTS, LTD.

'Phone : Regent 6214-5.

Sole Address : 12, Hyde St., London, W.C.1

Offices, Works and Showrooms.

STANDS 122, 123, 124 AT OLYMPIA FOR THE LATEST IN RADIO

Printed and published by the Amalgamated Press, Ltd., Fleetway House, Farringdon St., London, E.C.4, on the 1st of each month. Address for advertisements only: John H. Lile, Ltd., 4, Ludgate Circus, E.C.4. Telephone: City 7261. Registered for transmission by Canadian Magazine Post. Subscription rates: Inland and Abroad, 17/- per annum; 8/6 for six months. Sole Agents—Australasia: Gordon & Gotch (Australasia), Ltd.; South Africa: Central News Agency, Ltd. —September, 1929.