

MODERN WIRELESS



January.

1/-

Vol. 2. No. 4.

Edited by JOHN SCOTT-TAGGART, F.Inst.P., Member I.R.E.

January, 1924.

SPECIAL
"Long Distance"
Number.



Vol. II.

No. 4

HOW TO RECEIVE AMERICA.

AN "ALL-CIRCUIT" RECEIVER *By John Scott-Taggart, F.Inst.P.*

CONTINENTAL BROADCASTING—What to Listen For.

A SIMPLE REFLEX RECEIVER—Working from Dry Cells. *By Percy W. Harris,*

THE COWPER CIRCUIT EXPLAINED. *By A. D. Cowper, M.Sc.*

CHOKE CIRCUITS FOR AMPLIFICATION. *By John Scott-Taggart, F.Inst.P.*

BRINGING HOME THE BROADCAST RECEIVER.

How to Make Two Crystal Sets—Notes on the New Dull-Emitter Valves—Practical Notes—A New Aid to Experimenters

FREE WITH THIS ISSUE—"JUNIOR WIRELESS," A MAGAZINE FOR BOYS.

RADIOBRIX

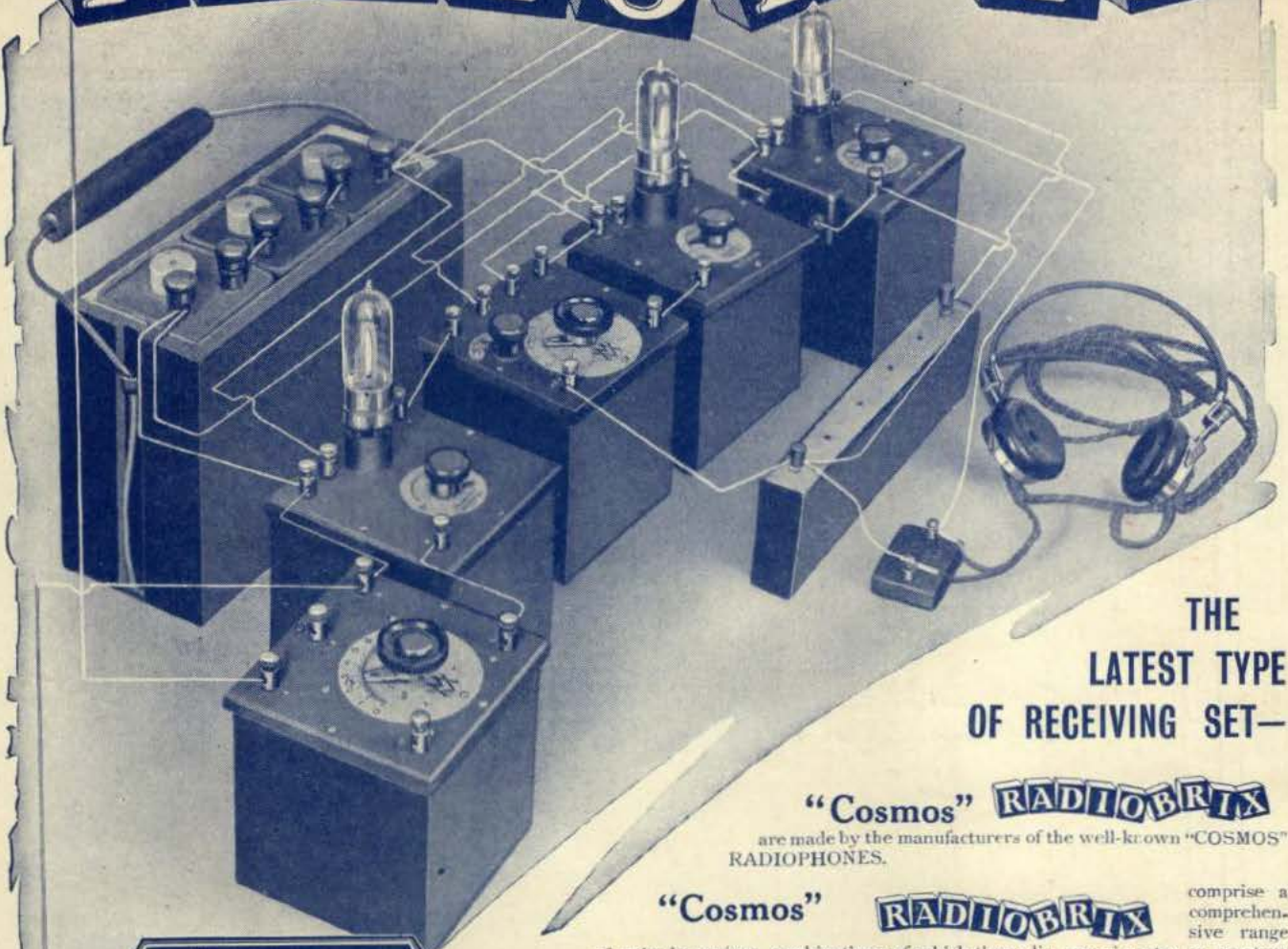

THE
LATEST TYPE
OF RECEIVING SET—

“Cosmos” **RADIOBRIX**
are made by the manufacturers of the well-known “COSMOS”
RADIOPHONES.

“Cosmos” **RADIOBRIX** comprise a comprehensive range of units by various combinations of which the radio experimenter or amateur can build up any type of receiving set or circuit.

“Cosmos” **RADIOBRIX** have been designed to secure the utmost flexibility. They enable the “listener” to build up his set gradually as his means allow, yet the bricks obtained at first never become useless, but can be utilized as part of a more elaborate set.

“Cosmos” **RADIOBRIX** are thoroughly well made and moderate in price.

Ask your regular Wireless dealer to show you

“Cosmos” **RADIOBRIX** If he has not yet obtained his stock, write, sending his name to the manufacturers:—

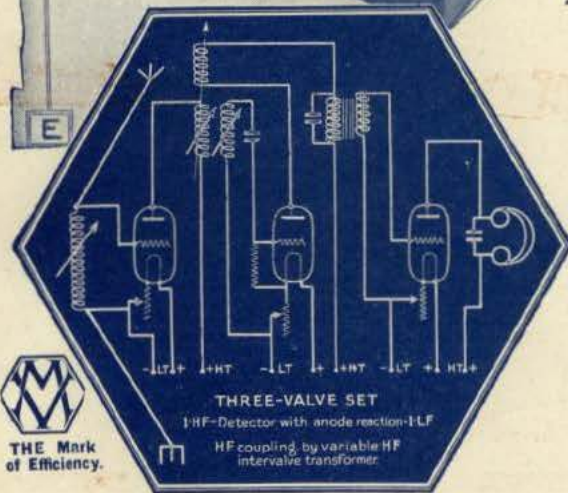

The above illustration and diagram shows a three-valve set made up with RADIOBRIX. Get a copy of the new book “BUILDING WITH RADIOBRIX,” full of useful circuits with theoretical and wiring diagrams, obtainable everywhere, 1/-, or post free, 1/5.

METROPOLITAN Vickers
ELECTRICAL CO. LTD
Works: TRAFFORD PARK, MANCHESTER.

Amateurs reminded. Their co-operation invited in relaying experiment American transmission commencing New Year's Eve. See notices Radio Press.



Contents

	Page
Editorial	184
The Problem of Local Interference	185
"Wireless Weekly" Omni-Circuit Receiver	186
By JOHN SCOTT-TAGGART, F.Inst.P.	
In Passing	191
The New Low-Filament Current Valves	193
Continental Broadcasting: What to Listen For	195
By A. MORIZOT.	
From Our Readers	198
A "Series-Tuned-Anode" Two-Valve Broadcast Receiver	198
By A. D. COWPER, M.Sc.	
Some Notes on Long Distance Reception	4
A Simple Reflex Set	209
By PERCY W. HARRIS.	
"Modern Wireless" Choke Circuits	216
By JOHN SCOTT-TAGGART, F.Inst.P.	
Above and Below Broadcast Wavelengths	226
A Crystal Receiver for Broadcasting and Paris Time Signals	231
By A. J. RODGMAN.	
Catalogues We Have Received	232
High-Frequency Amplification	233
By R. W. HALLOWS, M.A.	
Wireless, Lines and Cables	238
By LT.-COL. CHETWODE CRAWLEY, R.M.A., M.I.E.E.	
Amateur Transmissions	242
"Modern Wireless" Directory of Amateur Call Signs	244
Some Notes on Low-Frequency Amplification	259
By G. P. KENDALL, B.Sc.	
Some Hints on the Selection and Design of Wireless Receiving Apparatus	264
By W. A. JACKSON.	
Other Ether Waves	265
By C. J. COZENS, M.C., B.Sc.	
"Tested by Ourselves"	269
Practical Notes	270, 271
Bringing Home the Broadcast Receiver	273
By E. L. R.	
An Improved Aerial Insulator	283
A New Aid for the Home Constructor: The "Radio Press" Envelopes	284
JUNIOR WIRELESS.	

Editor:
JOHN SCOTT-TAGGART,
F.Inst.P.

Joint Assistant Editors:
PERCY W. HARRIS,
E. REDPATH.

Staff Editors:
E. H. CHAPMAN,
M.A., D.Sc.
A. D. COWPER, M.Sc.
G. P. KENDALL, B.Sc.
R. W. HALLOWS, M.A.
S. G. RATTEE.

Scientific Adviser:
Prof. G. W. O. HOWE,
D.Sc., M.I.E.E.

Advisory Editors:
Prof. R. WHIDDINGTON,
M.A., D.Sc.
Prof. C. L. FORTESCUE,
M.A., M.I.E.E.

Advertisement Managers:
SCHEFF PUBLICITY
ORGANISATION, LTD.,
1-5, Pall Mall, London,
S.W.1.
Tel.—Regent 2440.

MODERN WIRELESS

All correspondence relating to contributions is to be addressed to the Editor of "Modern Wireless."

Radio Press Ltd
PUBLISHERS OF WIRELESS WEEKLY
DEVEREUX COURT.
• STRAND, W.C.2 •
1 tel.—Central 3703.

Nothing contained herein is to be regarded as permission or encouragement to infringe any patent rights.



THE year 1924 begins with great promise for the future of radio. During the past year we have witnessed steady progress in both the technique of the art and its adoption by the non-scientific public. The man who twelve months ago looked upon radio as a thing of mystery—a wonderful invention without doubt, but of little personal interest to him—is now found glancing down the daily broadcast programme and discussing from his corner seat in the “smoker” the achievements of the previous night. In a phrase, radio is now established as the most popular home amusement.

Not the least interesting aspect of radio telephony is the remarkable success with which the reception of broadcast concerts from the other side of the Atlantic has been accomplished. As has happened in so many branches of the art, amateurs have here led the way, and if keen experimenters had not sat up night after night with no other purpose than endeavouring to snatch a few words from across the 3,000 mile expanse of ocean, most of the “experts” would not have thought it possible.

In this, our special “long distance” number, the reader will find several articles having an important bearing upon such reception. In “Some Notes on Long Distance Reception” a full explanation is given of the peculiarities which surround the Transatlantic reception, whilst in the article “Continental Broadcasting and what to Listen for” the talented Editor of our French contemporary, “*T.S.F. Moderne*,” gives fullest details as a guide to the reception of broadcasting from across the Channel.

High-frequency amplification, the secret of long distance work, is ably explained in a special article, and the principles of the now

famous “Cowper circuit”—a form of receiver eminently suitable for long distance work—is fully described by the inventor.

In presenting these special features, the general requirements of our readers have not been forgotten, so that they will find the usual practical descriptions of efficient yet simple receivers of several types. A very large number of readers will welcome the section of this issue in which we publish the most complete and up-to-date list of amateur call signs and addresses yet given.

Many readers have written to say that it is one of the attractions of MODERN WIRELESS that it so frequently presents something entirely new. Living up to our reputation, we present in this issue the description of a remarkable “All-Circuit” instrument which combines the appearance, efficiency and convenience of a finished cabinet set with the flexibility of a set of units. The man whose tastes lean towards experimenting with the new circuits will find much to interest him in the article “Some Choke Coil Circuits,” an article which may well start a “boom” in choke circuits, just as we have had a boom in tuned anode receivers. Of general articles, too, we can present a large variety, extending from notes designed entirely for the beginner up to practical descriptions and workshop wrinkles for the man who makes all his own apparatus.

It is appropriate in a special long distance number that we should offer the hearty congratulations of MODERN WIRELESS to Mr. Partridge, 2KF, of Wimbledon, who in the middle of last month succeeded in effecting two-way communication for considerable periods with Mr. K. B. Warner, Secretary of the American Radio Relay League and

Editor of our interesting American contemporary "Q S T." A year or two ago we considered it wonderful that we could hear signals from the other side of the Atlantic on the small powers used by our Transatlantic confrères, and last winter, although careful preparations were made, only occasional signals from this side were heard in the States. We understand Mr. Partridge has been using a wave-length considerably shorter than usually adopted by amateurs and has succeeded in getting in touch with Mr. Warner for sometimes two hours at a time. Another London

experimenter, Mr. Hogg (2SH) has also effected two-way communication with Canada, so that we have not the slightest doubt that before another few months have passed British experimenters will be able to communicate with their colleagues in Australia with the intervention of only one or two relays in the States. It must not be forgotten that trans-Pacific communications from the Pacific seaboard of the United States to Australia and New Zealand have now become quite a regular feature, although this distance is considerably greater than that across the Atlantic.

THE PROBLEM OF LOCAL INTERFERENCE

QUITE apart from orthodox jamming by transmitting stations and the squealing of inexperienced or unscrupulous listeners-in, the possessor of a sensitive receiver may have to contend with troublesome interference arising from sources in no way connected with wireless, sources which are not always easy to identify and locate and which, in some cases, give rise to interference so serious that effective reception may become practically impossible. An adjacent electric railway or tramway, a motor with sparking commutator, the ignition of a nearby internal-combustion engine, a partial fault on the electric light circuit, an overhead trunk telegraph line carrying high-speed "auto," an electro-therapeutical and X-ray practitioner with a 12-in. spark coil or even a small boy with his Rhumkhorf coil and Geissler tubes, may be at the bottom of it, or it may be something more subtle; such as the intermittent leakage of atmospheric electricity from a partially insulated conductor or even the variable contact of two conductors such as a loose wire dangling against a water-pipe. Frequently these things are by no means easy to trace, and it is often impossible to deal with the trouble at its source.

The writer has had a number of experiences connected with local interference, and in one case came near to closing down an important receiving station, during the war, solely because faulty overhead A.C. mains were making reception unreliable. The trouble was intermittent and varied in intensity,

coming through in the phones as long grinding and scratching noises capable, sometimes, of wiping out whole Morse groups. Fortunately it was found possible sufficiently to reduce the interference by bringing the mains to the station and keeping them earthed there, so that the necessity for shutting down the station was avoided. Drastic remedies of this kind are, however, out of the question in ordinary circumstances, and in such cases it is possible only to minimise the trouble by the introduction of such devices as screening, trap circuits, astatic arrangements and directional reception.

A sensitive unshielded receiver

in the writer's laboratory picks up all sorts of extraneous noises, such as the ignition of passing motor-cars and cycles, and it will register as a distinct and unmistakable click the gentle removal or replacement of a spanner from the lathe bed at the far end of the "lab." An equally sensitive receiver, efficiently screened with metal sheet, is practically immune from direct influence, though it responds to sparks from a distant electric tram system, the resulting H.F. being sufficiently powerful to impulse the aerial. Such an untuned impulse cannot be cut out by a trap circuit, and the only remedy lies in the use of directional reception.

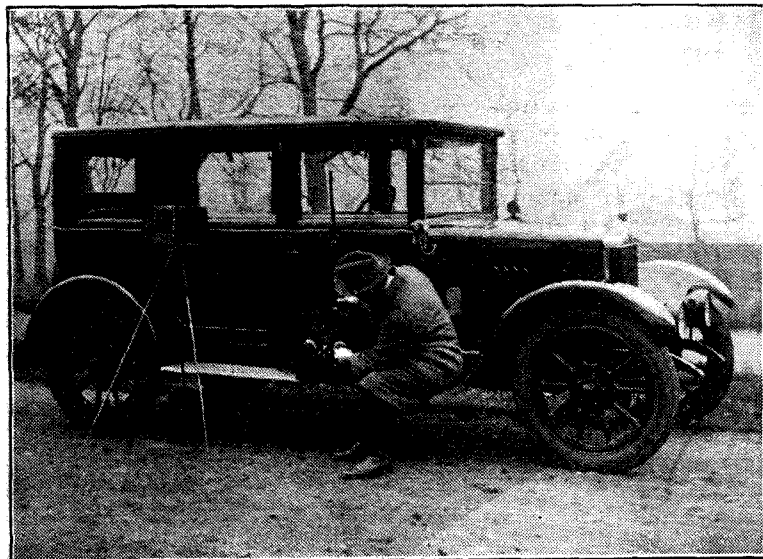

A frame aerial car set used with a portable Amplion loud-speaker.

THE "WIRELESS WEEKLY" OMNI-CIRCUIT RECEIVER

A new Receiver with which practically any Circuit may be tried

By JOHN SCOTT-TAGGART, F.Inst.P. (Editor of "Wireless Weekly" and of "Modern Wireless").

FOR a long time I have been trying to devise some scheme which would enable the experimenter to try out, with a minimum of effort, the numerous circuits which appear from time to time, and the 151 circuits in my two books "Practical Wireless Valve Circuits," and "More Practical Valve Circuits." I have at last found a solution, and a description of it has just appeared in *Wireless Weekly*. It is known as the *Wireless Weekly* "Omni-Circuit" Receiver, and readers of MODERN WIRELESS will, I feel sure, be interested in what marks an entirely new departure from existing practice in wireless sets.

The trouble about an ordinary wireless receiver is that it is more or less designed for a specific purpose, and that its flexibility is, in most cases, negligible. There are, of course, some highly expensive receivers with which one can obtain a variety of effects—for

example, cutting out high-frequency or low-frequency amplifying valves—but there has been no solution to the problem of providing a set which, while remaining a *real* set mounted in a cabinet, affords the experimenter facilities for modifying the circuit.

We have had sets which, by means of switches, provide for two or three different circuits; we have had unit sets which, while they have many advantages, do not lend themselves to a rapid change of circuits; we have had several types of sets which consist of boards on which different components are mounted, the wiring being all visible and on top.

These attempts have in no case resulted in a finished-looking set which enables the experimenter to wire up any circuit he likes in a few minutes and yet be able to present an instrument which remains entirely unchanged in its appearance.

I would like my readers to glance

at Fig. 1—a photograph of the *Wireless Weekly* Omni-Circuit Receiver. No one, to look at it, would imagine that it was anything else but a nicely finished three-valve set; nevertheless, this perhaps rather elaborate-looking three-valve receiver could keep any experimenter busy for months trying out thousands of different circuits, and deriving experience of the most valuable kind.

Moreover, whenever the set has been rewired, its appearance will always resemble that of Fig. 1. No matter how complicated the wiring may be, or how many components are used, the set is fit to place on the drawing-room table, and the experiments may be carried out on the same table without any waste of time, straggling wires or disturbance.

In reality, the set shown in Fig. 1 is not so innocent as it looks. If you took hold of the front edge of the top of the cabinet and lifted it up you would find that the top

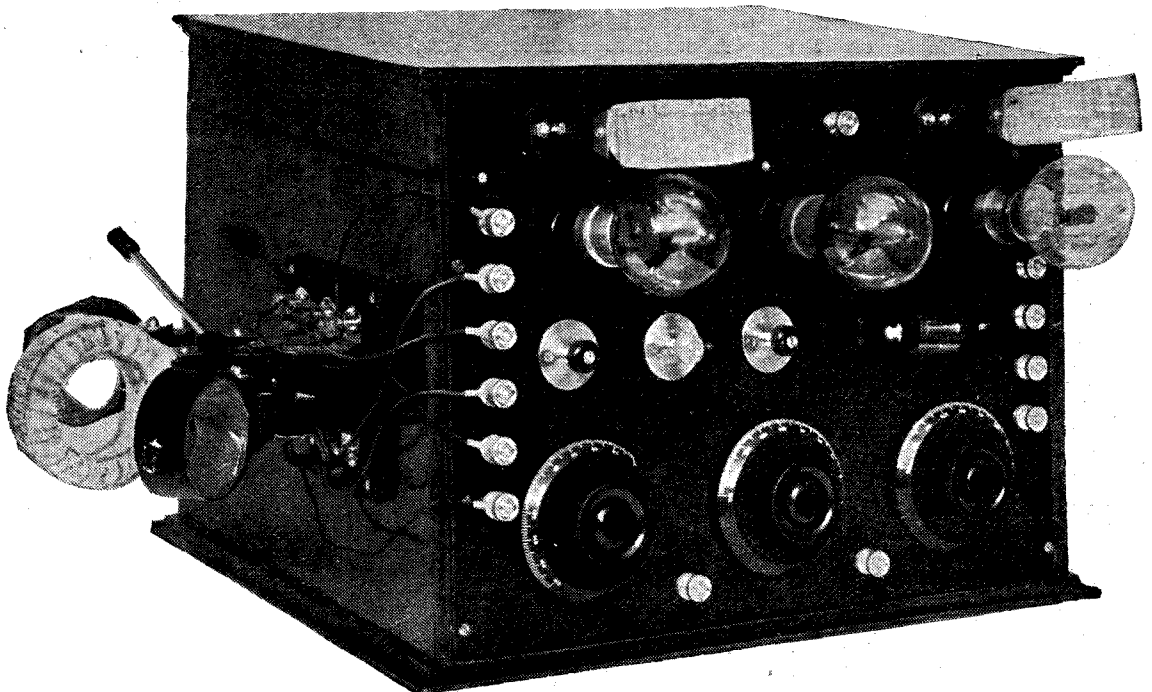

Fig. 1.—The Omni-Circuit Receiver ready for work.

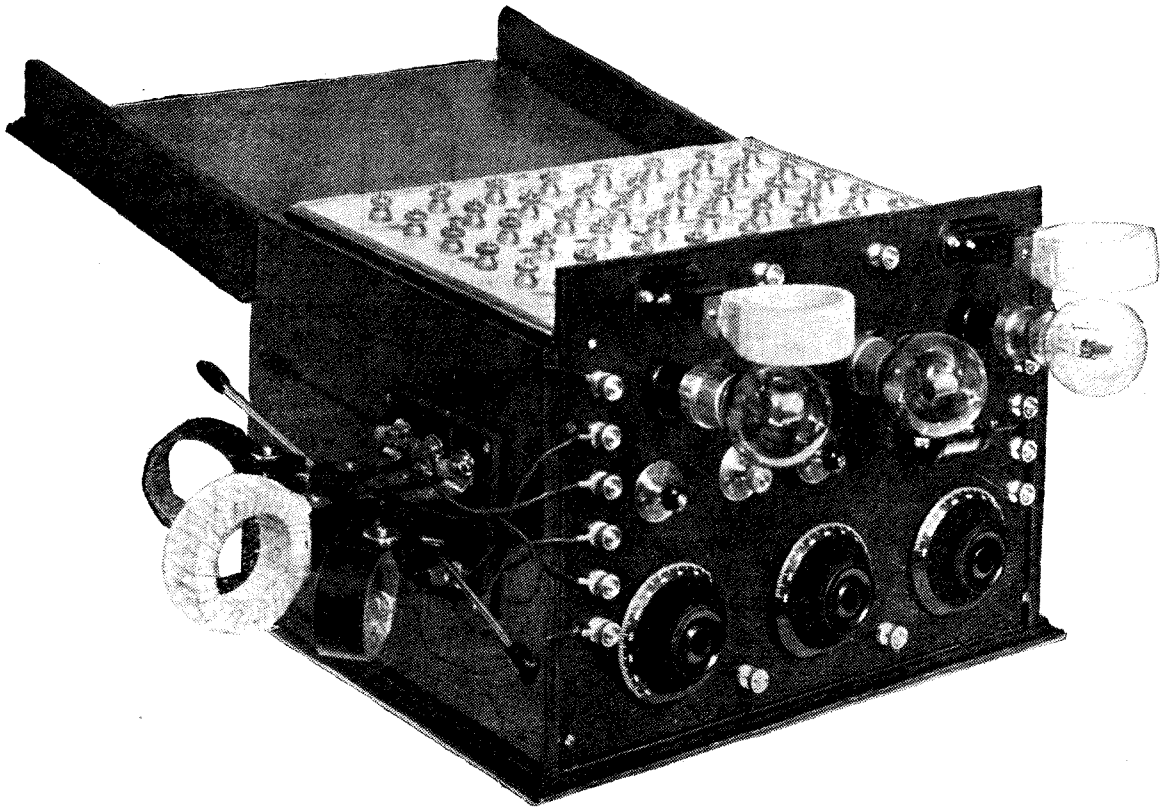

Fig. 2.—The secret is revealed as soon as the lid is lifted.

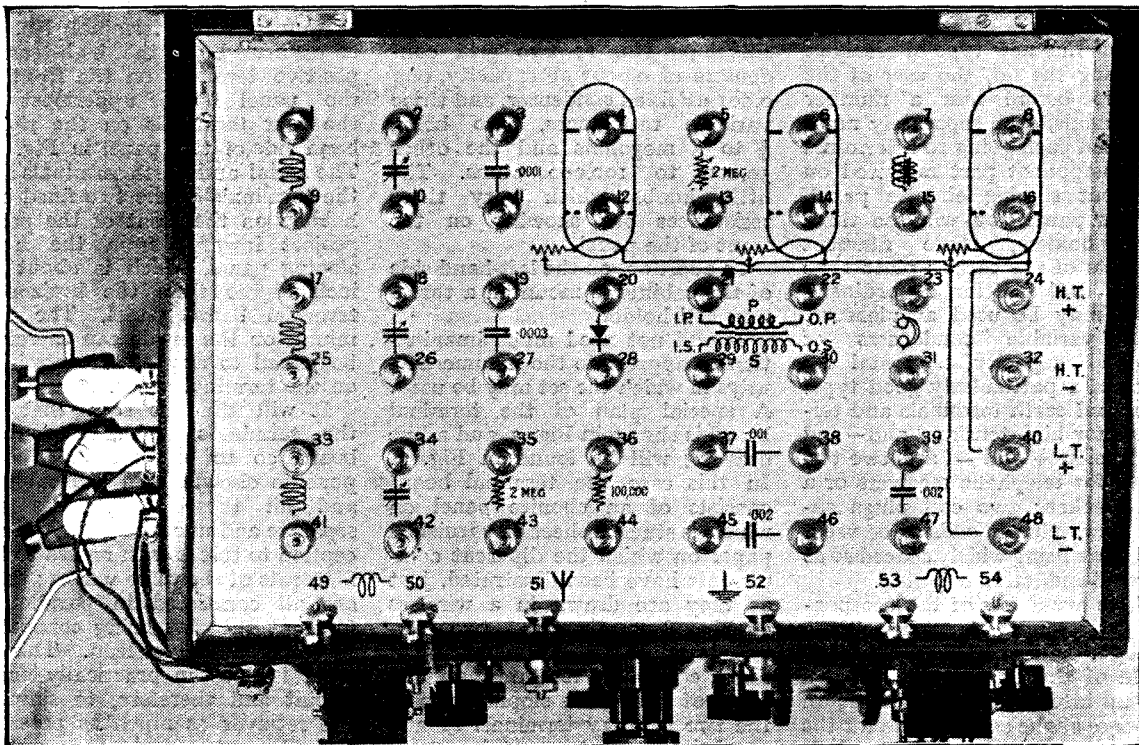

Fig. 3.—A "close-up" of the terminal board in position.

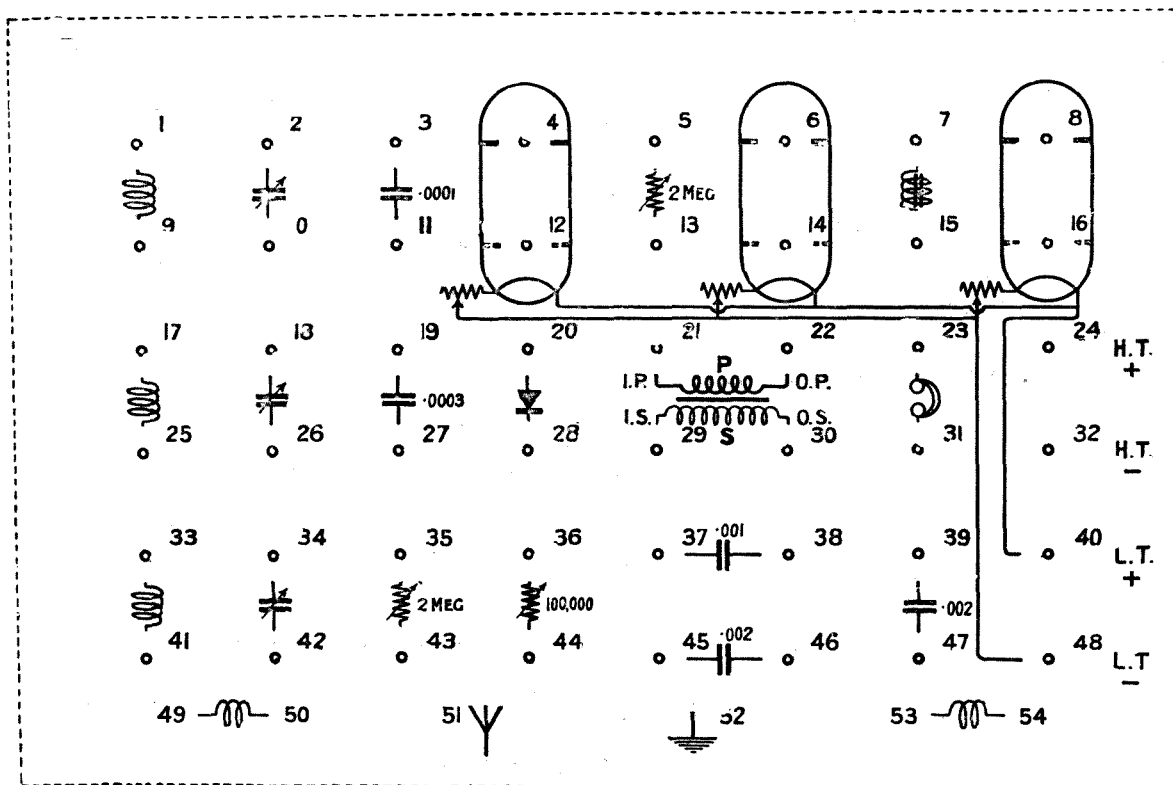

Fig. 4.—Details of the terminal board markings.

of the cabinet was a lid and that immediately beneath the lid was a neatly arranged terminal board having about 50 terminals arranged in rows, each terminal being numbered. Fig. 2 shows the secret of this new type of receiver. On lifting the lid, the user of the set sees before him a number of terminals, each separately numbered and each going to a terminal of a component part mounted on the front sloping ebonite panel. On this panel you will see three valve holders, three filament rheostats of the carbon plate type so that dull emitter or ordinary valves may be used at pleasure, three variable condensers of $0.0005 \mu\text{F}$ capacity, a crystal detector of a particularly good type, aerial and earth terminals and terminals for high-tension + and - and low-tension + and -, and two terminals for telephone receivers or a loud-speaker; two coil plugs enabling two plug-in coils to be used, these coils being widely spaced so as to avoid inductive coupling.

These are a few of the components which, as it were, show through. An examination of the inside of the box would reveal a step-up intervalve transformer; an iron-core choke coil suitable for the choke circuits of different kinds which may be devised, a few of which are given in this issue of

MODERN WIRELESS for the first time; a couple of $0.002 \mu\text{F}$ capacity fixed condensers; a fixed condenser of $0.0001 \mu\text{F}$ capacity, particularly useful for the constant aerial tuning system described in my Radio Press Envelope No. 1; two grid condensers of $0.0003 \mu\text{F}$ capacity, one $0.001 \mu\text{F}$ fixed condenser, and three variable resistances, two being $\frac{1}{2}$ to 5 megohms and the other 50,000 to 100,000 ohms. The little knobs which vary these resistances are showing on the front of the panel.

In addition, on the left-hand side of the cabinet is mounted a three-way coil holder.

It will not need much imagination to appreciate the innumerable ways in which the set may be used. A special plan of the terminal board is shown in Fig. 3, and a line drawing will be found in Fig. 4. In this case the terminal board consists of an ebonite panel on which is stuck a sheet of varnished paper on which the different components have been illustrated, just as they are drawn in a wireless circuit. For example, two terminals go to two terminals on a fixed condenser mounted on the back of the front sloping panel; the two primary terminals 21 and 22 of the intervalve transformer go to the two primary terminals on the transformer itself which is

mounted on the back of the sloping panel. Similarly, the two secondary terminals 29 and 30 go to the two secondary terminals on the actual transformer; the high-tension positive terminal No. 24 is connected to the high-tension positive terminal on the front of the panel (the uppermost of the four terminals on the right-hand side of the panel in Fig. 1). The aerial and earth terminals and the terminals of the two fixed coil holders on the front of the panel project inwards from the front sloping panel, which is about an inch higher than the horizontal terminal board panel. The terminals on the inside can therefore be joined to any of the terminals on the terminal panel.

It will thus be seen that all the terminals on the terminal board go to corresponding components elsewhere in the cabinet, and all these components are separate and unconnected. An exception to this is with regard to the filaments of the three valves; these are all connected in parallel, a filament rheostat being connected in each negative lead. This is what is done in practically every circuit and therefore, to simplify the receiver as much as possible, the filaments were connected in parallel.

When designing a set of this

description, one is continually torn between the desire to put in every component likely to be used and the wish to avoid making the receiver too large and unmanageable and too costly. Moreover, it is desirable to avoid unnecessary wiring, and for this reason the filaments were connected up in parallel. Otherwise, any of the components may be connected up in any way desired. The way this is done is simplicity itself.

A number of rubber-covered flexible leads of two or three different lengths are made up by using bare rubber-covered stranded wire and soldering at each end fish-tail bits of brass usually known as spade terminals. All you now do if you wish to connect up a new circuit is to open the lid of the receiver and proceed to wire up the components from a wiring diagram, the different connecting leads being used; two or three of these spade terminals will easily go under any one of the terminals if it is desired. Having wired all the terminals by means of the

leads, a process which may be carried out in five minutes without any trouble whatever, the lid is simply lowered back into place and to all intents and purposes the set is unchanged. Nevertheless, hundreds and even thousands of different circuits may be tried with this receiver.

Ideal for the Beginner

It must not be imagined that this receiver is only suitable for the circuit enthusiast. Some people who desire to listen in to broadcasting, for example, may only desire to change the circuit six times in a year when they hear of some particularly good arrangement being evolved.

It is proposed shortly to give every week in *Wireless Weekly* a new arrangement of connections to conform to new circuits. Each terminal is numbered, and every week a list of numbers will be given, somewhat resembling a chess problem. Even a person who knew nothing whatever about wireless could derive great interest from

rewiring the set to different circuits. To some the receiver might be something almost in the nature of a plaything, while to the really serious investigator the set affords the greatest possibilities. Anyone could wire up the set by giving them the numbers, but the experimenter of experience will prefer to wire up the terminals without bothering about the numbers, the conventional signs on the panel telling him all he wants to know. These conventional signs, of course, will be engraved on the black ebonite panel, but at present a varnished sheet of paper has been employed.

Any addition or connection may be made in a few seconds. For example, if it is desired to try the effect of a fixed condenser across the transformer winding, the experiment may be carried out and finished within half a minute; there is no question of parts straggling about on a table.

Of course, it is not possible for everything to go inside the box, although it would be a simple

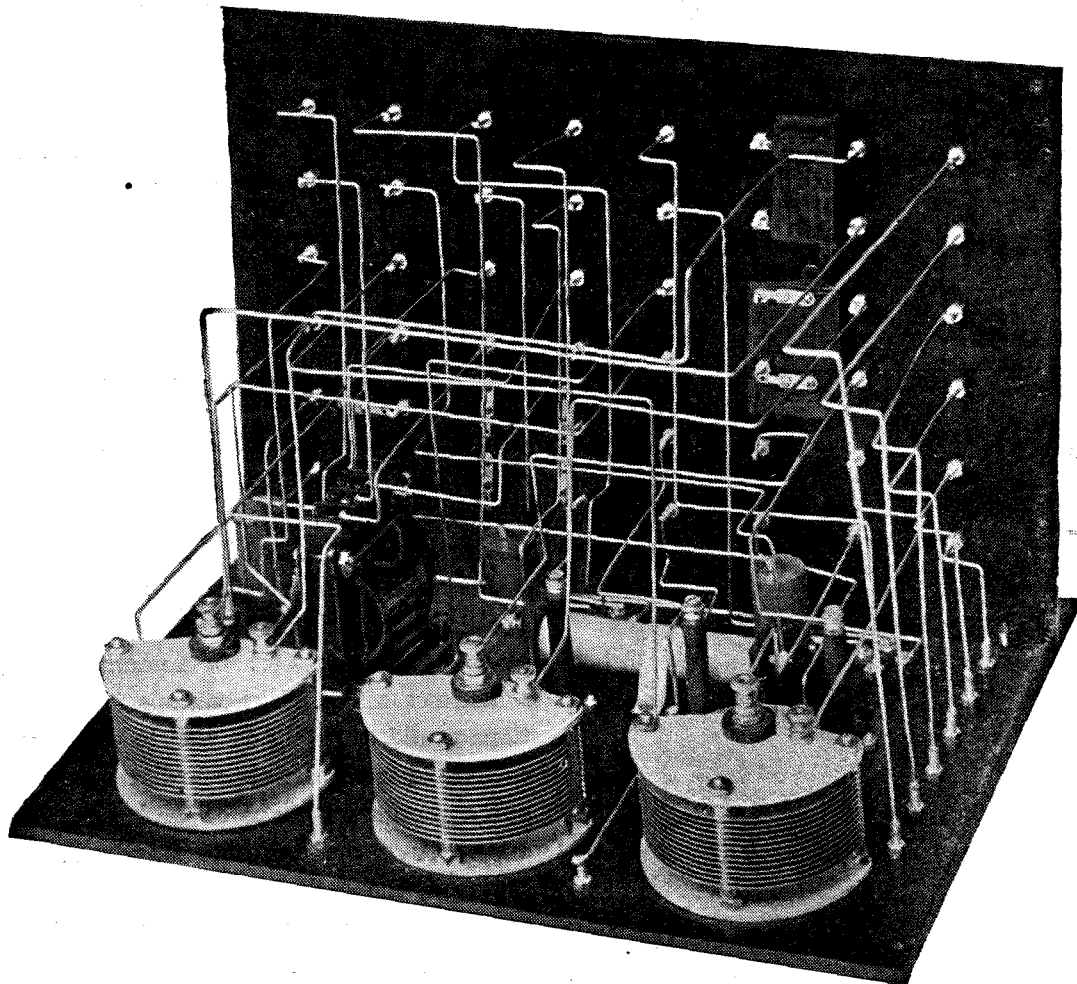

Fig. 5.—A peep behind the scenes.

matter to have a larger set containing more components. It has, however, been decided to fix on this present design. Although the idea was conceived some time back, it has only been, after making several models, considered a suitable time to publish the invention. A three-valve set was found to be practically as cheap as a one-valve set, and yet it is by no means necessary that the beginner should start with three valves. He will be able to carry out innumerable experiments with only one valve. Later I propose describing a second cabinet containing additional parts and dry batteries for use with dull emitters, and this cabinet set will stand next to the one just described, the adjoining sides of the respective lids having a number of grooves in them to enable leads to pass from one terminal board to the other.

The only technical objection that could be raised would be with regard to the crossing of leads.

Examples of Circuits

The following terminal connections would be made to wire up the set to the circuit employed. These are given merely as examples of the thousands of possible combinations.

Single Valve Dual, 24 connections:—

51—11	3—2	1—2	3—12	52—9
9—10	10—30	29—52	29—37	38—30
52—48	44—52	36—12	4—17	17—18
25—26	26—31	23—24	32—40	31—39
23—47	18—20	28—22	21—31	

ST150 2-Valve Receiver, 20 connections:—

51—10	1—2	2—12	9—30	29—52
29—37	30—38	52—48	4—23	31—17
17—18	25—26	26—24	32—40	18—19
27—14	14—5	13—40	6—22	2—24

3 valve ST45 Circuit (1 H.F. tuned anode with reaction, 1 valve detector and 1 L.F. amplifier), 23 connections:—

51—10	2—1	2—12	9—52	52—48
4—17	17—18	25—26	26—24	32—40
4—19	27—14	14—5	13—32	6—33
41—22	21—24	21—45	22—46	30—16
29—48	8—23	31—24		

Conclusion

It is, of course, not possible to give in this issue all the constructional details. More information regarding the construction and uses of the *Wireless Weekly* Omni-Circuit Receiver will appear in *Wireless Weekly* from time to time, and it is proposed, when a sufficient number of readers have these sets, to devote a certain amount of space to experiments with the set every week. Readers will be able to exchange their opinions and a vast club of users will thus be formed.

Next month I propose to give further constructional details, and Radio Press, Ltd., the publishers of *Wireless Weekly* and MODERN WIRELESS, will very shortly issue a Radio Press Envelope giving blue prints, sheets of working instructions, sheets of working drawings and sheets of photographs printed on special art paper, list of components, etc., for making the *Wireless Weekly* Omni-Circuit Receiver. When ready this will be duly advertised.

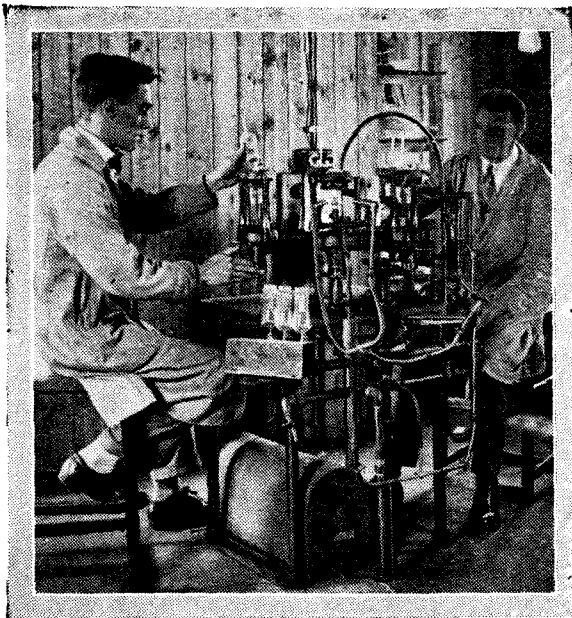

In a valve factory. Note the elaborate apparatus necessary.

A CRYSTAL NOTE.

In order that the public should be able to obtain full benefit from the purchase of ready mounted crystals, it is, of course, essential that the sizes and threads of these cups should be standardised. At present a great variety of sizes is in use, and the threads of the mounting screws are sometimes 6, sometimes 4 and sometimes 2 B.A. The various trade associations would certainly do well to call a conference to discuss the standardisation of parts, and a good start might be made upon crystal cups. Once the desirable standardisation is achieved, the exchange of a crystal for a new one will occupy only a moment or two, and the careful user can keep two or three spare crystals on hand for immediate interchange.



In passing

A Warning

THIS, they tell me, is to be a special long distance number. On other pages able and serious-minded writers will no doubt tell you how to hear New York, or Honolulu, or Hong Kong, as you list. They will explain that here you place a coil of so many mics, there a condenser of such and such a fraction of a microfarad, here a valve, there a transformer, and the thing is to all intents and purposes done. All that remains is for you to sit yawning and shivering into the small hours, a process that appeals but little to those that are fat, sleek-headed men, and such as sleep o' nights. Pay no heed, reader, as you value your health, your sunny temper, and your bank balance to those who seek to delude you. Listen to my words, and mine only. I will give you the whole secret of perfectly painless long-distance reception.

The only outfit really needed for its successful accomplishment is a large and showy aerial and a conscience that has been thoroughly well trained to speak only when spoken to. It is not even necessary for you to possess a wireless set; you can always refer darkly to some epoch-making experiments that are in progress, explaining that it would be a breach of confidence to let anyone see your apparatus. A guarded mention of the War Office or the Admiralty usually suffices to make your hearers wag their heads knowingly

and say: "Ah, I see." Even though you have said nothing about the alleged experiments, always pledge them to secrecy; this will ensure that all kinds of wondrous rumours regarding your prowess are published abroad.

Some Helpful Hints

The subsequent procedure is perfectly simple. Wait until an important transatlantic test has been arranged for three o'clock in the morning, and retire comfortably to your bed on that night as usual. The next morning in the train going up to business, remark casually to your next-door neighbour: "I thought WHAZee's modulation was rather poor, didn't you?" Always say *zee*, not *zed*; this is one of the most important points in long-distance reception. An awed silence will descend upon the carriage. Little Bloggsby, whose dark-ringed eyes show that he really has been fool enough to wake and shiver, will hazard a remark about WGY.

"Oh, WGY," you riposte, "I never bother with him; he's so easy to pick up." Brownson, who also bears the tell-tale marks, will then join in saying that he thought WHAZee's transmission of "Tell me; I'm feeling sloppy," approached perfection. You inform him gently that this item was sent not by an American station, but by Aberdeen. "Difficult, of course," you add, "to tell which is which if you are working with a small set." That finishes Brownson.

The Need for Tact

Consolidate your position by criticising the transmission of "Kitten on the Keys," "At the Bamboo Babies' Ball," and "The Star-Spangled Banner." You are on safe ground here, for these items form part of any transatlantic test. Keep this up until you have reached your destination, and you are safe.

On the way home things are easy. You will already have perused the evening paper in which are full details of what took place. You are thus prepared to discuss things more widely, making scathing references to local oscillators (here you should glare fiercely at Bloggsby, who is too small to be formidable), and to the unsuitable weather conditions which prevented those with *ordinary* sets from hearing much. In a few minutes the whole carriage-full will be hanging on your lips thirsting for hints that will help them to achieve something like the noble results that always fall to your happy lot. Here, of course, you smile, shake your head in the kindest possible way, saying that you only wish you might tell them, and that no doubt they will know before long, for the work that you and a certain Great Personage are undertaking in collaboration is very nearly complete.

An Alternative

An alternative method, almost equally successful, is to lie low and

say nothing until you have heard from the burners of the midnight oil exactly how things went. Then you can chip in with a few patronising remarks, saying how creditable it is to the great body of amateur enthusiasts that such wonderful results are achieved with simple and often home-made apparatus. Once you know what those who sacrificed sleep have heard, it is easy to improve upon it if you have any skill in the use of words. Let the others talk, what time you smile indulgently; and then when they have finished, speak modestly about your own achievements.

One thing is important. Never be drawn into any really technical discussion. If the waters seem to be getting beyond your depth, a wave of the hand and an airy "Well, I'm afraid that I mustn't go into that question, much as I'd like to," invariably suffices to save you from impalement from the horns of any passing dilemma. Follow these simple hints and they will increase the range of your set more than the addition of three stages of high-frequency amplification. It is by sheer tact coupled with a little quickness of mind that half the long-distance reception is done.

Insult to Injury

Those on the other side of the Herring Pond are, of course, luckier than we as regards the hours they have to keep for receiving transatlantic broadcasting. When our stations are closing down at 11 p.m., it is but six o'clock with them. Hence, they can recline luxuriously in their arm-chairs after tea and invent their taradiddles in complete comfort. In one respect, however, we score. We can always obtain the nourishment that is essential for lubricating the imagination, whilst they must do their inventing upon lime juice or lemcnade, or some equally ineffectual mental fertiliser.

In this connection I thought it was a little tactless on the part of whoever was conducting the English end of the test at 2 LO during the early days of December to beg those at WGY to pull themselves together by taking a good drink ere letting the control valves rip. That surely was rubbing it in quite unnecessarily.

At Last

Talking of the States, I see that what I have been expecting for so long has at last come to pass over

there. I am not referring to a strike against the tyranny of English lecturers—any of our writers who is temporarily out of a job of work takes the first boat to New York and passes his time in telling Yanks (who pay to hear him!) precisely what he thinks of them, their manners and their customs. Nor am I thinking of the anti-nicotine campaign or of the crusade to obtain perfectly proper theatrical performances.

I mean the wireless divorce. No one in America ever gets married in the ordinary hum-drum way. When your time comes for committing matrimony, you do it in an aeroplane, or a lion's den, or a submarine. Should these have become rather common, you cudgel your brains to think of some place of a kind that no one else has ever thought of. Marriage is a difficult business over there, and to compensate for this, divorce has been made correspondingly easy.

A Sad Story

Strangely enough, until the last few weeks no one had ever thought of citing wireless as a cause. But now one brave woman has come forward to champion the cause of her oppressed sisters. Hundreds, nay, thousands of them have been suffering in silence, but she alone has had the courage to stand boldly forward and to claim divorce as her right on the ground that her husband is an incorrigible and incurable wireless maniac.

Did she wish to converse sweetly with him, he sat with the 'phones upon his head, vouchsafing her never a grunt. If she moved, his looks and his bitter words enjoined instant and complete silence. And now for the most brutal part of this sad tale. When after performing prodigies of tuning he failed to get distant stations, he lifted up his voice and filled the air with naughty words.

Deliverance

Think upon this, you who nightly strive after the far corners of the earth. Are you not silent when you should be telling your wives the gossip that you have heard during the day? Do you not repulse their offers of sweet companionship by intimating that the click of scissors and the gentle ripple of polite conversation are out of place in the wireless den? Do you not keep terrible hours, crawling into bed when the dawn is about to break? You cannot

deny that you do all these things, and more also.

So far our poor wives have suffered meekly, but one of these fine days there will arise in this country a woman who will liberate her fellow sufferers by bringing in a Bill to make acute radio-mania a sufficient cause for divorce. Then our wives will cast us off, leaving us to our own unhalloved devices, and we . . . well, we shall really be able to get some serious work done.

Bootlesby's Terrible Plight

There is, of course, the other side of the question. My friend Bootlesby, who knows nothing at all of wireless and does not want to do so, has a wife who is one of the most acute cases of radio-mania that has ever been recorded. On one occasion when the baby was yelling for its bottle she absert-mindedly thrust into its gaping mouth a valuable condenser, over whose loss she was inconsolable for many a day. You will see her sallying forth wearing a length of 4 B.A. rod as a hatpin, and her shoes as often as not are laced with odds and ends of flex.

Poor Bootlesby is desperate, especially now that she has developed what Americans call the long-distance itch. 'Tis he who must rise from his warm couch to persuade the baby to switch off, for she, instead of being in her place, is seated downstairs at her wireless set, hearing nothing of her offspring's vocal efforts owing to the fact that telephones are clamped firmly about her ears. So far as I can see there is but one course for him. He, too, must take up wireless. Then they can decide by the simple expedient of spinning a coin who is to be on duty with the baby. But the thought of two radio maniacs beneath one roof is a rather appalling one when you come to think of it, and what the baby's ultimate condition will be I cannot imagine, for it will doubtless catch the disease in an acute form at a very early age

A Happy New Year

May I wish all my readers, long-distance enthusiasts, and imitators of the late George Washington alike, A Happy and A Prosperous New Year? That your good resolutions may not become paving stones, and that your sets may behave themselves as they should in all respects, is the heartfelt wish of—

THE LISTENER-IN.

THE NEW LOW-FILAMENT CURRENT VALVES

By A. D. COWPER, M.Sc., Staff Editor.

Readers of MODERN WIRELESS will be interested in our report on the new dull-emitter valves. It is the result of independent tests conducted by our own staff.

A GREAT step forward in rendering possible the universal enjoyment of radio telephony at more than suburban crystal range, has been made with the development of the dull-emitter and low-consumption type of valve. The earlier types of dull emitters were really not a dry-cell proposition at all, except as a temporary expedient, as few but the largest dry-cells could maintain the necessary current for any length

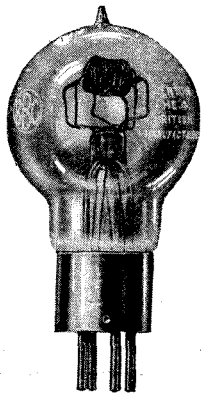

The Penton valve.

of time, although they represented a very appreciable economy of demand on the accumulator. The "Peanut" type of valve, with its demand for some $\frac{1}{4}$ ampere at around 1 volt, is more reasonable, as but one dry cell (or large wet cell of the Leclanché type) is required, and that can well be of the monster variety which can stand the strain. Actually it is often operated successfully (for brief and intermittent use) with quite small dry cells.

The other types, the DE 3, AR 06, and B 5 valves, take the extraordinarily small current of .06 ampere, so can be run even off a pocket flash-lamp battery if desired; but the voltage required is a somewhat awkward figure: 2.4 to 3 volts. This suits admirably the powers of two dry cells in series, when fresh, but when approaching the end of their available life, and giving little over 1 volt in action as a consequence, a third cell must be added. Thus the utilisation of the L.T. battery cells is not very economical—the manufacturers specify usually three

dry cells in series to make sure—and an exceptionally high filament resistance has to be used to control them when the batteries are new. In the tests referred to here, two large dry cells, or Le Carbone wet cells, fairly new, were used, and proved completely adequate for the purpose. Still, it is a pity that these excellent valves were not made so as to be practically useable with two dry cells throughout their effective life. The ordinary filament resistance can be used, all in, with two cells on these valves, when the former are in good condition.

The Penton low-consumption valve has an exceedingly slender bright emitter filament, which in the present type needs about $4\frac{1}{2}$ volts and .15 ampere. Thus the current demand is not too high for use with large dry cells; but the voltage again is a little awkward in value, being, in fact, adjusted for use with small 6-volt accumulators. Three dry cells hardly suffice; whilst four are somewhat wasteful during part of their effective life, besides being actually more cumbersome than the small accumulator they replace. We understand that new types are being experimented with to overcome this difficulty.

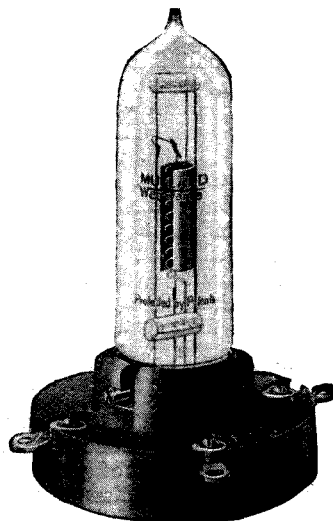

A Wecovalve (Peanut) in the first type of base. It is now supplied in a four-pin base.

The Peanut.

The characteristic curve, as determined by the writer, shows a liberal filament emission at low plate voltage; but a modest amplifying factor. The characteristic for around 40 volts H.T. is excellently straight, and nearly symmetrical about the zero-grid-volts line, indicating the conditions for favourable L.F. amplification. In actual reception, it was noticeable that the plate voltage had to be kept quite low, rectification



The B.T.-H. "B5" valve.

being best between 17 and 22 volts, as indicated by the makers. It proved wonderfully effective in single-valve reception, reaction and oscillation being delicately controllable by adjustment of filament current. It was worth all of an ordinary stage of H.F. amplification in long-distance reception, sliding imperceptibly in and out of oscillation in the most delightfully smooth manner, particularly in an "Ultra-Audion" circuit.

In L.F. amplification, with about 40 volts H.T. and no grid-bias, good build-up was obtained, with little distortion; though, of course, it is hardly a power-valve.

In simultaneous amplification, as in the S.T.100, it operated well. For H.F. amplification, however, the trouble of self-oscillation was so prominent that comparatively poor results were obtained, as much as 3 volts positive grid-bias having to be applied to hold it down. The elaborate precautions

taken in one commercial type of receiver to neutralise effects of valve-capacity are an illustration of this.

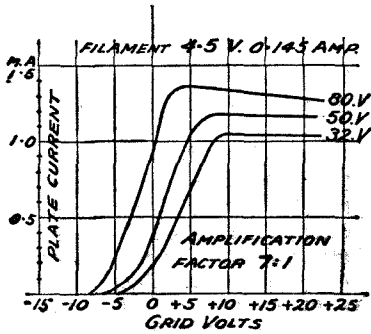

Characteristic curves of the Penton valve.

In various types of "super" circuits it operated well on low plate voltage; but with less stability, of course, than with valves that handle high plate voltages.

In general, the Peanut is an excellent rectifying valve, and can be used for a moderate stage of L.F. amplification with every success.

The General Electric Company's DE 3 valve shows ample plate current, and a good amplification-factor; the characteristic on 80 volts H.T. gives good promise of effective L.F. amplification, which was borne out in practice when proper grid-bias was used. It gave, on trial, excellent rectification and H.F. amplification: thus the writer picked up W.G.Y. Schenectady, U.S.A., extremely clearly when trying out a new two-valve circuit (one H.F. valve) using two of these DE 3's. Good loud-speaking resulted on local transmissions with a dual-amplification circuit; and on super circuits quite low plate voltage sufficed, some measure of audibility on the L.S. being possible with the Armstrong fliver circuit on 8 volts.

While distinctly microphonic, this is a good all-round valve, and does not require any special mode of handling.

The Edison AR 06 showed, in the single specimen available for test, rather a low saturation current, though an excellent amplifying factor of about 11:1. As a rectifier, and in H.F. amplification, it

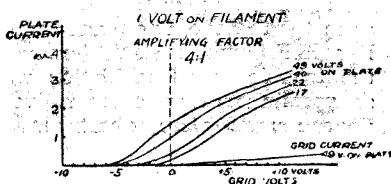

Peanut characteristics.

operated well; for L.F. work the comparatively small plate current (with .06 amperes in the filament) rather operated against loud results, with whatever H.T. and grid-bias that were tried. It performed satisfactorily in simultaneous and super circuits. A special feature is the "fool-proof" arrangement of the valve-pins, two of which are cut much shorter than the others, thus making it impossible to

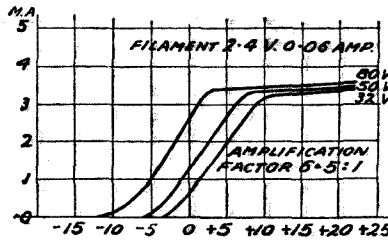

Characteristic curves of the DE 3 valve.

insert the valve in such a manner that the H.T. is short-circuited through the filament.

The B.T.-H. B5 valve gave a very satisfactory filament emission in both of those tested, and straight characteristics on 50 and 80 volts. The amplification factor was around 6:1. In every test applied in actual reception most excellent results were obtained. An unidentified American transmission (two musical items) was heard with an efficient two-valve receiver (one H.F., one D.) when tried in the small hours of the morning. In simultaneous amplification, and on different types of supers, the results were very encouraging, audible reception being obtained of local broadcasting on the loud-speaker on the outside aerial without any H.T. at all, and on a small frame aerial with the writer's version of the Armstrong fliver circuit with one flash-lamp battery as H.T. and one as L.T. supply. The valve is distinctly microphonic.

The Penton valves showed quite a reasonable value of saturation current, considering the economy of L.T. demands—which incidentally is balanced by a similar economy in first cost. The factor of amplification was also satisfactorily high: 7:1. A straight characteristic was observed on moderately high H.T. In general, the performance in actual reception fell just a little short of a first-class French K valve consuming four times the current, whilst excellent loud-speaking resulted on local transmissions with two valves; it was not so noisy as with the latter. In simultaneous amplification the

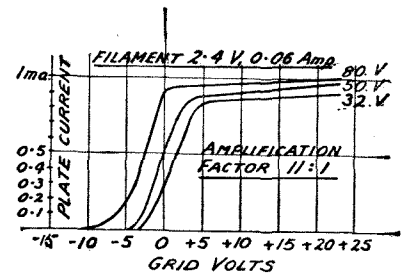

Curves obtained with the AR 06 type valve.

valves worked well; also on various forms of supers. Thus Glasgow was heard extremely clearly on a two-foot frame in London, with 28 volts H.T., with the Armstrong single-valve circuit; and London was just audible, at 13 miles, without any H.T. at all, showing good filament emission combined with close grid control. There was but slight microphonic effect noticed.

"PICTORIAL WIRELESS CIRCUITS"

Will our readers kindly note that as a result of the unexpectedly large demand for "PICTORIAL WIRELESS CIRCUITS," by Oswald J. Rankin, the first edition is now out of print, and as a result of the intervention of the Christmas holidays, there will be some delay in the preparation of a second edition.

Prospective purchasers are therefore requested to withhold their orders until January 14th.

A CRYSTAL HINT

A large number of excellent crystals are either partially or completely spoiled in regard to their sensitivity by the method of mounting. The best of all methods is to fix the crystal into the cup with that compound known as "Wood's metal," but unless this is done very carefully you will overheat the crystal and destroy its sensitivity.

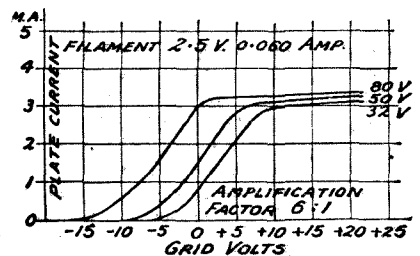

Curves given by the B 5 type valve.

CONTINENTAL BROADCASTING—WHAT TO LISTEN FOR

By A. MORIZOT, Editor of "La T.S.F. Moderne."

Readers of this magazine will find M. Morizot's article of immense value when trying to pick up the more distant broadcasting. This commentary on the transmissions is also of considerable interest.

CONTINENTAL broadcasting? Truly for those who have the good fortune to possess a telephone headpiece, two ears and practically any kind of sensitive apparatus, there is always something to be heard. Nowadays we find voices on all wave-lengths at all hours. Let us pass the stations in review and indicate the peculiarities by which readers of this magazine can recognise them.

France (Eiffel Tower).

Our old friend the Eiffel Tower—in point of date one of the first radio telephone stations—continues its work faithfully, and several times a day breaks the hertzian silence with its powerful voice. Its normal power is 5 kilowatts. Incidentally it is the most powerful of the Continental broadcasting stations.

One of the most peculiar characteristics of this station is that the transmitter has but a single valve (type Holweck). This valve is detachable and one can change the filament in the twinkling of an eye.

Generally the modulation of the Eiffel Tower transmissions is excellent, although at times it is irregular owing to the tests which are frequently occurring. The radio concerts at this station take place from 6.10 p.m. until 7 p.m. Several times during the day the Tower broadcast market reports and meteorological information. The wave-length is 2,600 mètres.

Here is the daily time table:

- 6.40 a.m... Forecast.
- 10.50 a.m... Fish prices in the Paris markets.
- 11.14 a.m... Announcement of the time.
- 11.15 a.m... Regional forecast.
- 12. 0 a.m... Livestock prices (Tuesdays and Thursdays).
- 3.40 p.m... Financial news.
- 5.30 p.m... Closing prices. (Saturdays excepted).
- 6.10 p.m... Radio concerts.
- 7. 0 p.m... General forecast.
- 10.10 p.m... General forecast. On Sundays the radio concerts and forecasts are given at 7 o'clock.

Ecole Superieure de Postes de Telegraphes.

With this station we return to the true "broadcasting" wave-length of 450 mètres. This wave-length falls between Cardiff and Birmingham. The power used is only 400 to 500 watts, yet in spite of this it is clearly heard in Scotland, Norway and Morocco. This plain statement of results is worth more than the most flattering compliments. Furthermore the modulation is perfect and very regular. The concerts take place generally on Tuesday and Thursday of each week, beginning at 9 p.m. Quite frequently the station of the Ecole Superieure transmits a concert from one of the large halls in Paris, such as the Salle Gaveau, Salle Pleyel, etc.

Radiola Transmissions.

It is most regrettable that the station which could give the most interesting transmissions in France has a deplorable modulation. Very often—too often—the speech is incomprehensible, even to French people! The power of Radiola is 2 kilowatts, but we strongly suspect that it is not constant. The actual station is installed at Levallois (near Paris) in a factory; the wave-length is 1,780 mètres.

The times of the concerts are 12.30 p.m., 4.30 p.m. and 8.30 p.m. These are preceded by news items.

We learn that the Radiola people are building at the present time another station at Clichy destined to replace that at Levallois. We are promised marvels from all points of view—we shall see!

Belgium.

Up to quite recently the Belgium broadcasting was represented by one station near Brussels which gave wireless concerts at 6 p.m. The wave-length was 1,100 mètres and the power 1½ kilowatts. Just recently a new station constructed by La Société Belge Radioelectrique has begun its transmissions. This station is situated right in the middle of Brussels in the Rue Stassard, and has two towers about 60 feet high on the roof of a building of the same height. The wave-length is round about 400 mètres, and the installation is of the Marconi type identical with that at London, 2 LO. The actual energy in the aerial is 1½ kilowatts, but can be increased to 4 kilowatts. This new station is apparently provided with a highly perfected modulation system. The studio in particular has been carefully studied, and there is no doubt

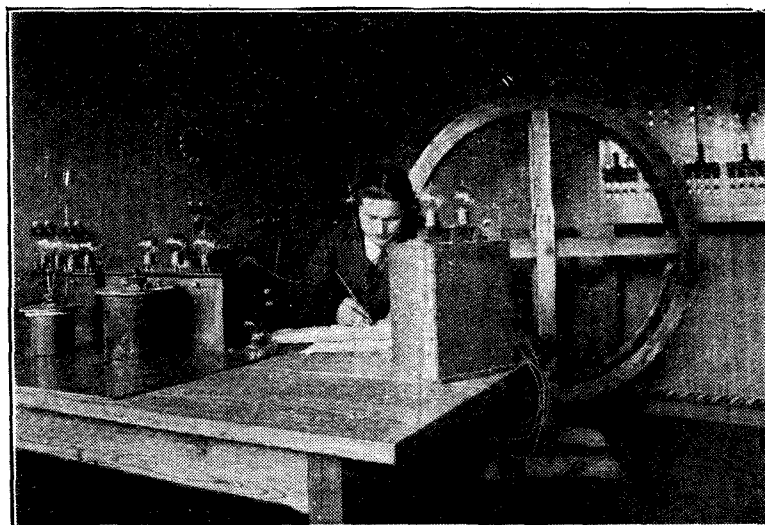

An interesting circular frame aerial in use at the Lafayette station (Bordeaux).

whatever that in these conditions the Belgian people, who are great lovers of music, will give us excellent concerts. Already this new station has been heard very well at considerable distances.

The new hours of transmission from this station at Brussels are 5.30, 6.0 and 8.30 p.m., on a wave-length of 405 metres, intensity strong and modulation excellent.

Holland

PCGG made itself known a long time ago by its announcements of the "Daily Mail concerts." Although they have changed their title, the Sunday afternoon concerts still continue from 3 to 6 o'clock, on a wave-length of 1,050 metres. PCGG is a fantastic station, its power varying from one transmission to another. Its wave-length jumps all over the place and drives to distraction amateurs who are using tuned high-frequency sets.

Other Dutch stations work very irregularly at the following hours:

PCVW (The Hague, Heussen), Thursdays from 7.45 to 10.0, and Sundays from 9.40 to 10.40 a.m.

PCKK (The Hague, Velthysen), Fridays from 8.40 to 9.40.

PCMM (The Hague, Ijmuiden), Saturdays from 8.40 to 9.40.

Spain

Spanish broadcasting for a long time was represented by a single military radio telephone station at Madrid. Then the day broke when a new station raised its voice. This new transmitter had a wave-length of 450 metres, good modulation, and gave concerts from 5 to 7 p.m. This continued for about eleven days when silence reigned once more. We understand that this station will shortly resume its transmissions.

The Military station at Madrid carries out its trials, and is easy to hear in the mornings from 10 to 12 noon, on a wave-length of 2,100 metres.

Switzerland

In spite of its territorial limitations, Switzerland has a regularly organised broadcasting service. The transmissions are given by a station at Lausanne. The wave-length is 1,100 metres; the power from 300 to 500 watts. Modulation is excellent.

The regular time-table is as follows:

- 8.5 a.m...Meteorological forecast for Lausanne.
- 10.50 a.m...Meteorological forecast for Geneva and Dubendal.
- 1 p.m...Meteorological report for Switzerland.

6.55 p.m...Meteorological report for Switzerland.

4 p.m...Tuesdays, Thursdays and Saturdays, wireless concert.

7 p.m...Mondays, Wednesdays, Fridays and Sundays, wireless concert.

Italy

Still another country has availed itself of broadcasting. For some little time the station installed at Rome has given concerts on a wave-length of 540 metres. The apparatus is similar to that used at the Ecole Supérieure des Postes

de Telegraphes de Paris. The transmissions take place on weekdays from 5 o'clock to 6 o'clock in the evening.

Czecho-Slovakia

KBELY, near Prague, is the one station of Czecho-Slovakia. It is an aircraft station designed normally to transmit meteorological information to aviators. Under an arrangement KBELY transmit concerts organised by the technical review *Radio Journal*. The power is 1 kilowatt, and the wave-length at the present time 1,150 metres. Concerts take place from 6.20 to 7.20.

CONTINENTAL BROADCASTING.

COILS REQUIRED.

	Aerial Tuning.	Anode Tuning.	Reaction.
Eiffel Tower (2,600)	.. 300	400	500
Ecole Sup de P. T. (450)	35	75	100
Radiola (1,780)	.. 200	300	400
Brussels (405)	.. 35	75	100
Dutch stations (1,050)	.. 100	200	250
Spain (450)	.. 35	75	100
" (2,100)	.. 300	400	500
Switzerland (1,100)	.. 100	200	250
Italy (540)	.. 50	100	150
Czecho-Slovakia (1,150)	.. 100	200	250

FROM OUR READERS

SIR,—Seeing the particulars in "WIRELESS WEEKLY" of the WGY Station, I tried at 11 o'clock on Friday night and succeeded in getting them, although only very weak—this was from 11 to 12 o'clock. On Saturday night, or rather Sunday morning, from 1.15 to 2.15, I heard a station on 400 metres very plainly, a number of orchestra selections, an organ, as far as I could judge, and also songs from a gentleman and lady. I did not get the call sign, so do not know what it was. (I did not sit up any later.)

On Monday night I again heard WGY on 380 metres, at 11 o'clock, and it was remarkably good. After reading a list of prices on the stock market, he gave the price of barrels of apples, etc., and then some news. I heard him say that a deputation of 200 women for the League of Equal Rights for Women had waited on President Coolidge, also other items. All this was so plain that had I been a shorthand writer I could have taken practically every word down (apart from short spells of fading). Mine is a four-valve set, but I only had three valves on, one H.F.

Detector and L.F. (ordinary tuned anode with reaction).

I have taken in "MODERN WIRELESS" and the WEEKLY from the onset, and this set was made up from "MODERN WIRELESS" information.

Yours, etc.,

H. J. V.

Walsall, 19th Nov.

A Useful Instrument.

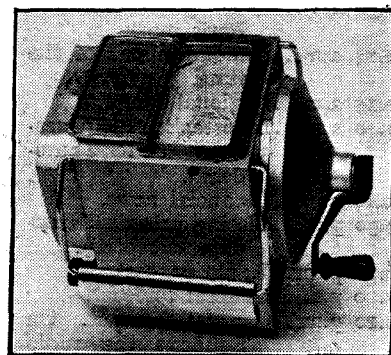

The portable "Megger" described in last month's "Modern Wireless."

All you need to know

About your valves is
that they bear the name

MARCONI VALVES

MADE AT THE OSRAM LAMP WORKS

First produced in the Osram Lamp Works during the war, enormous numbers of these valves were used by all branches of H.M. Forces.

Their great dependability became a by-word amongst the thousands of men in the Services to whom wireless meant so much.

They are still made at the Osram Works, and the invaluable experience gained during those four years of arduous valve-operating conditions is now reflected in all types of the highly efficient MARCONI VALVES available for Broadcast Reception.

YOU CAN OBTAIN MAXIMUM SATISFACTION FROM
YOUR SET BY INSISTING
ON

MARCONI VALVES

MADE AT THE OSRAM LAMP WORKS

SOLD BY ALL WIRELESS DEALERS, ELECTRICAL CONTRACTORS, STORES, ETC.

(Manufacturers)

THE GENERAL ELECTRIC Co., Ltd., Magnet House, Kingsway, London, W.C.2.

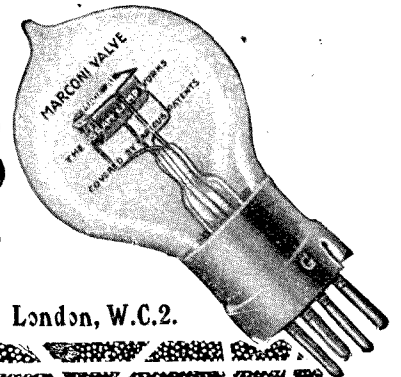
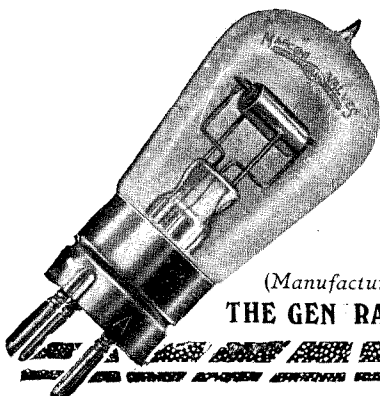

A "SERIES-TUNED-ANODE" TWO-VALVE BROADCAST RECEIVER

By A. D. COWPER, M.Sc. (Staff Editor).

This article explains the Cowper circuit—a new method of obtaining stable high frequency amplification.

THE stable series-tuned-anode method of H.F. coupling (for short waves) described by the writer in *Wireless Weekly*, Vol. 2, No. 19 (Nov. 21st), p. 643, has marked advantages for use in broadcast reception; in particular, on account of its inherent stability—when properly carried out inductances of extremely low-resistance can be used, without any damping devices to give a dearly-paid-for temporary stability; and the sharpest of tuning. As a result, both the build-up of signals, and the selective power, are distinctly higher than with the conventional parallel-tuned-anode or low-resistance H.F. transformer, at least in the way the latter have actually to be used, i.e., with a heavily-damped circuit, to avoid persistent self-oscillation. An almost ideally sharp and high-peaked resonance curve can be obtained with this series-tuned arrangement, the only damping necessary being that inherent in the valves, and the very low H.F. resistance of a

properly-designed intervalve tuning inductance wound with thick wire and with a minimum distributed capacity.

It must be understood, though, that the greatest care must be taken to avoid casual couplings, both magnetic and capacitive, if this stable state of affairs is to be retained. The margin of safety is narrow, particularly when a loose-coupled circuit, or a very small series aerial tuning condenser are used.

Once that the need for external damping is removed, one can break away from that old vicious mode of regarding a H.F. coupling device as necessarily something analogous to an ordinary alternating-current transformer, with its extremely tightly-coupled coils and definite step-up ratio. The ordinary type of small plug-in H.F. transformer, with its tiny coils of many turns of fine wire, offering hundreds of ohms H.F. resistance to the oscillation it is attempted to hand on, with primary and secondary

coupled so tightly as to be electrically practically one wire, tuneable as such with a single condenser, is an excellent demonstration of this analogy. No one, except perhaps the designer of some child's match-box crystal-set, would propose to wind his A.T.I. with No. 40 wire in a groove in a 1 in. ebonite bobbin—yet this is how the A.T.I. of the valve following an ordinary H.F. transformer-coupled amplifying valve is constituted! As is well-known, such transformers give a certain measure of amplification, and the desired stability and ease of operation; but the degree of amplification falls absurdly below the theoretical amplification ratio of the valve used; and the tuning is extremely flat and unselective.

An instructive analogy is the following: a H.F. amplifying circuit of several valves in cascade should behave like a series of swings arranged in order, so that each one, when set in oscillation, can give the next a slight kick or

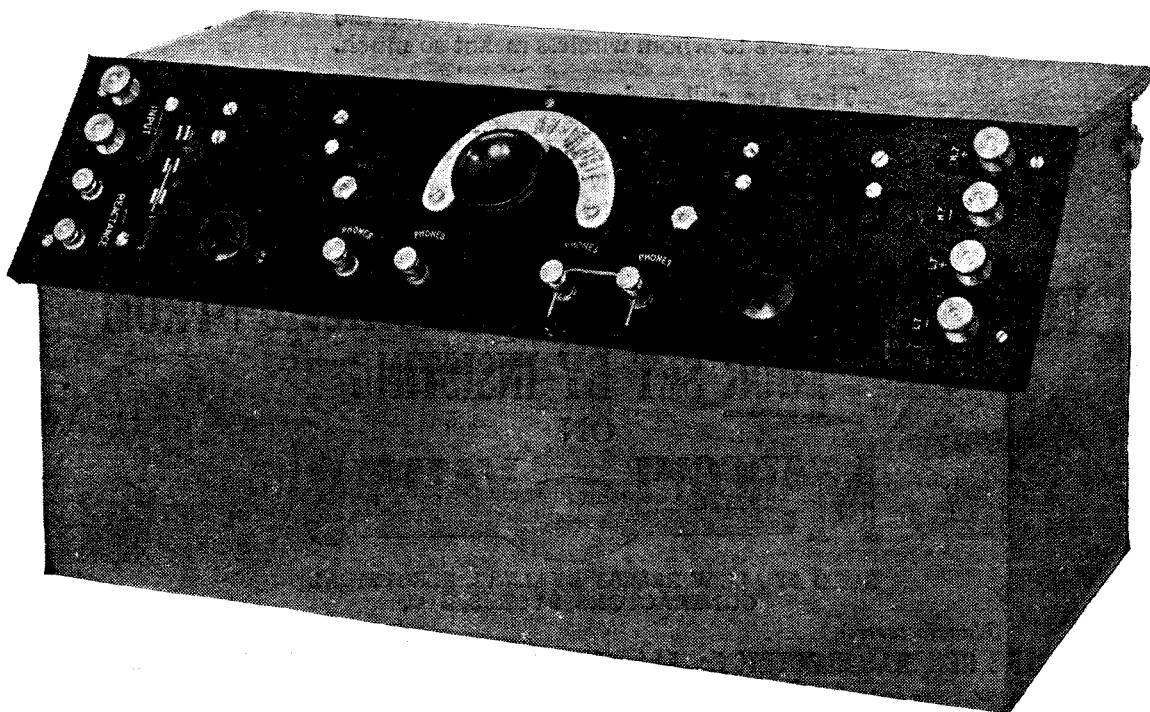

The instrument described in this article. It is possible to mark the dial with positions for the different broadcasting stations, instead of the usual arbitrary degrees.

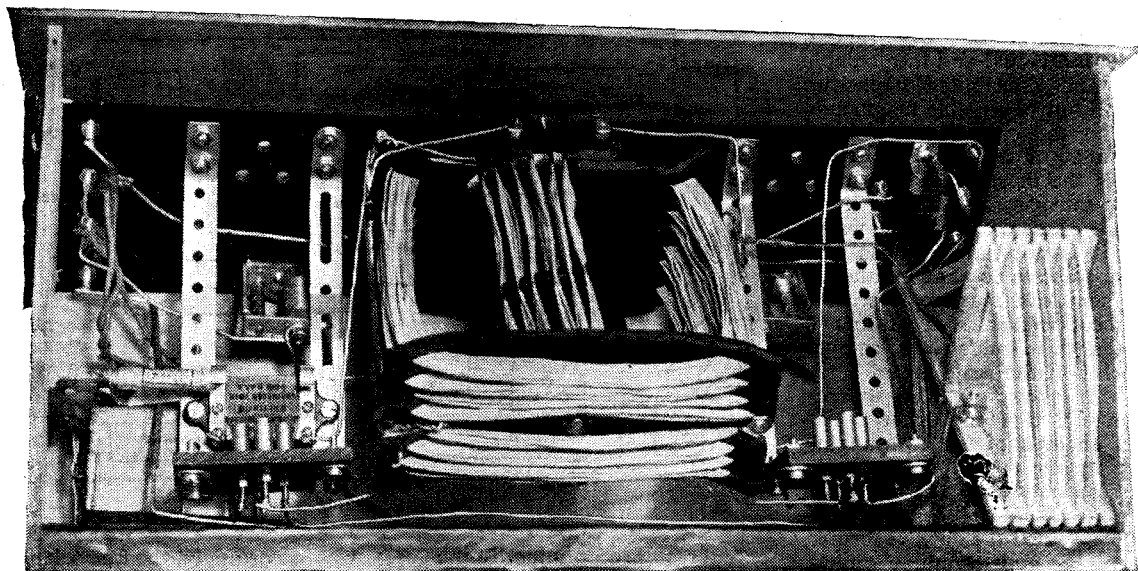

Interior of the instrument. The unconventional appearance is largely due to the peculiar variometers and inductances used.

impetus, at the right times, so setting that in motion in turn, and ultimately handing on the motion to the end one. If each swing had a vigorous occupant who would respond to the slight kick by strenuous personal efforts, there would be possible a build-up of activity along the series, as with H.F. valves. If when the motive—the slight repeated kick—is no longer present, the occupants of the swings ceased their efforts, and the swings rapidly came to rest, we would have a close analogy of how a H.F. amplifying circuit ought to work. Now if the swings are all bound up by a tangle of tarred ropes, we have a picture of what is happening in an ordinary close-coupled and heavily-damped H.F. circuit. There will be some movement handed on; but little amplification.

Accordingly, in order to get high amplification, both theory and practice show that each stage of a H.F. amplifier should have a freely-oscillating, lightly damped circuit, sharply tuned to the desired wave, and extremely lightly coupled both with the preceding and succeeding circuit—in place of being tied up inextricably with these, and even crowded, several of them, together in a small cabinet, like chickens in a market coop!

It must be realised that with the series-tuned circuit—it will be seen on close examination of the circuit diagram—the available tuning capacities are minute, being in fact the anode-to-filament capacity of the first valve (roughly), the grid-condenser of the second

valve, and the grid-to-filament capacity of the second valve, all arranged in series, together with distributed and stray capacities of coil and wiring. Thus, unless some additional capacity is added across the tuning-coil (experience shows that this must not exceed $.0001 \mu\text{F}$) a relatively enormous tuning-inductance is required to reach a broadcast wave-length. Actually, on this account alone the method is not suggested for longer wave-lengths. Since the circuit was published, from correspondents and others who have experimented with it, the writer has learnt that, as expected, the principal difficulty met with in connection with it, is that of tuning to the desired range: both the minute capacities and the large inductances required and involved are outside the usual experience of tuned-anode work. A coil which will tune from 300 to 500 metres with less than $.0001 \mu\text{F}$ variable condenser across it is not commonly required in radio practice; nor a low-resistance variometer covering the broadcast belt when in parallel with less than that capacity. What is probably an important factor in the intrinsic stability of the circuit, is the fact that the main capacities in this oscillating circuit are oppositely-arranged Fleming-valve rectifying devices, as will be seen on a moment's consideration of the circuit diagram. Adding large capacities in parallel with those, as an alternative oscillating path, will upset the conditions. Incidentally it may be noticed that successive grids are approximately in the

same phase, in this circuit, instead of reversing in phase at each valve. This makes possible an exceedingly convenient mode of electrostatic reaction, when needed, by a three-plate variable condenser across the grids of the two valves.

In *Wireless Weekly*, Vol. 2, No. 21, the writer described suitable forms of inductance for use in this circuit, and as an alternative to the three-pile-wound variometer, with total of 1800 turns of No. 22 S.W.G. d.c.c. wire mentioned in the original article. The variometer with coils in the form of miniature frame aerials (originally described as a convenient form of fixed inductance by Mr. P. W. Harris in *Wireless Weekly*, No. 16, p. 553, and mentioned in the article in No. 19) is used in the receiver to be described here, slightly modified for greater convenience and signal-strength by being wound with No. 20 S.W.G., d.c.c. wire, a total of 80 turns of mean size about 5 in. square on the stator and 66 turns on the rotor about 3 in. square in size. The formers are built up of bent, slotted ebonite and 2 B.A. screwed rod. The only alteration needed from the original design is the deepening of the six slots on the rotor to nearly $\frac{3}{4}$ in. in order to accommodate the 11 turns of wire per slot. It is readily mounted behind the panel by means of the side rods of 2 B.A. screwed rod, and will tune over the broadcast range required with very little more than the valve capacities indicated. A tiny adjustable condenser is used across it to bring up the

range of wave-lengths with the particular receiver constructed, with its individual and incalculable casual and distributed capacities (of small but of sensible magnitude in this connection). The permanent adjustment of this tiny condenser presents the most formidable difficulty in constructing the set. With the aid of some form of wave-meter it is not hard; those who have not access to that invaluable instrument can manage it with a loud local transmission of known wave-length to guide them as once one point in the scale is right the rest will follow. In the writer's instrument, this condenser represented an area of foil overlapping about 13 by 6 millimetres with thin mica between. An otherwise worthless "cheap" fixed condenser provided the ebonite former, cover-plate and terminal screws,

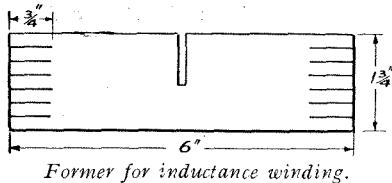

the size being adjusted by trial and error. This was equivalent to less than 90 degrees on a three-plate "vernier" condenser; and pulled the maximum up from 380 to over 500 metres wave-length!

The radio-choke coil indicated in the circuit was made as suggested in the original article quoted as a small frame-aerial coil, on a plywood former of two half-notched diagonal strips each 6 inches by 1 3/4 inches with six notches each 3/4 inch deep, wound with about 1/4 lb. No. 26 S.W.G. d.c.c. wire, well varnished and dried after completion. The distributed capacity in this choke must be kept low. An ordinary plug-in coil, or several basket-coils in series, of about 250 total turns of ordinary size, can be substituted if desired. It must be mounted well away from and if possible at right angles to other inductances.

Actually, a large type of commercial variometer of say 160 turns or more in all, and of large size (4 inches diam.), such as the large Igranic, can be substituted for the special type described but the amplification obtained will be sensibly less, as direct comparison will show on account of the thin wire generally used offering considerable H.F. resistance and not negligible distributed capacity. Though a whole pound of No. 20 wire seems rather extraordinary for a single intervalve inductance the

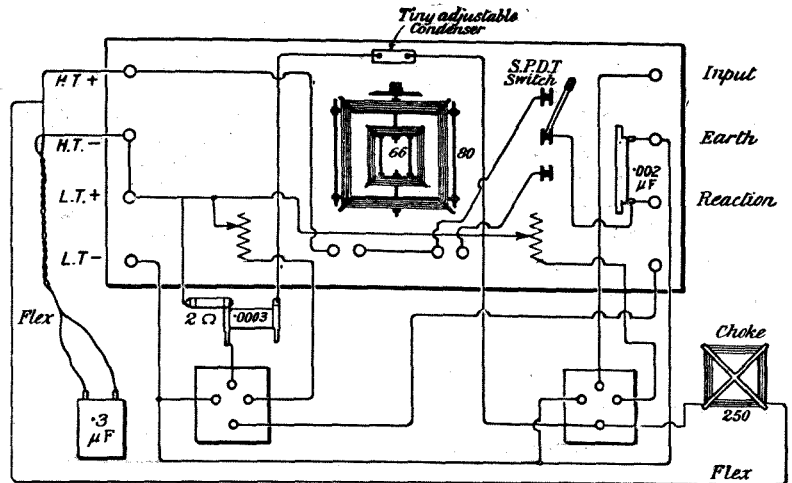

The wiring diagram.

actual results amply justify the use. Few would begrudge this wire on an A.T.I. if found necessary.

Performance

The receiver shown in the photograph was actually finished in the small hours of Sunday morning. It was tried forthwith on the aerial (twin 40 foot P.M.G., of low resistance but neither high nor remarkably well situated) in a N.W. London suburb with two General Electric Co.'s D.E.3 valves run from two Le Carbone wet cells, and about 50 volts H.T., using a low-resistance Bowyer-Lowe variometer and series condenser of fairly small value, and an anode variometer for reaction (with .0001 μ F fixed condenser across it to sharpen tuning).

On tuning in to 380 metres the usual mush from Northolt was found, but with a persistent carrier-wave in the middle of it: when Mr. e ceased from troubling for a spell a lively jazz band was heard at excellent strength—query 2LO's well-known jazz orchestra trying to get over to the States on an unfamiliar wave-length from one of the distant stations at that hour? Then the measured tones of the announcer solved the mystery: "W.G.Y., Schenectady." This

was accordingly, the first telephony heard on the receiver. Another jazz selection was enjoyed on two pairs of phones at comfortable strength, and the station call heard again by two observers. A rush was made for the loud-speaker—it should have been quite audible on it—when Northolt started again, and the chance for a record was lost. More than one carrier-wave was heard during the next hour, as well as some snatches of music; but conditions were not favourable after that.

London at 13 miles comes in, of course at excellent moderate loud-speaker strength; Birmingham in daylight quite readable on the loud-speaker; all other stations in reasonably favourable circumstances being comfortably readable in London, except perhaps the elusive Manchester station whose wave is hard to resolve. Aberdeen is received at night as loudly and clearly (without any evil reaction-effects) as the local broadcast station on a crystal. The two Continental short-wave stations come in similarly well, and half-a-dozen local amateurs at loud-speaker strength. Selectivity is excellent, even with direct-coupled aerial.

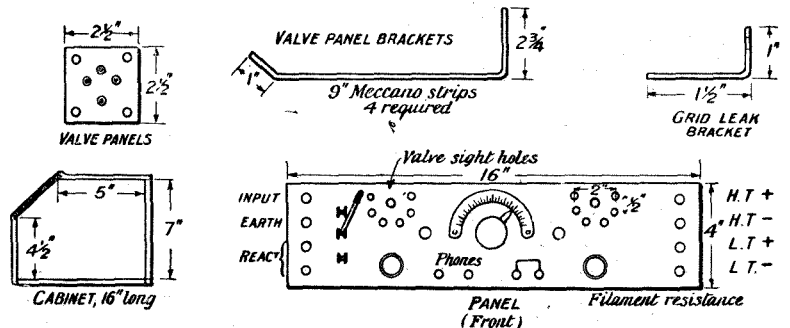

Constructional details.

Silvertown

WIRELESS ACCESSORIES.

Quality guaranteed by over 50 years' electrical manufacturing experience

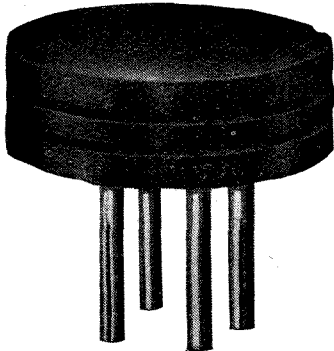

EBONITE TRANSFORMER FORMERS
No. 2. Complete with metal legs, 1/3 each. Made in other sizes.

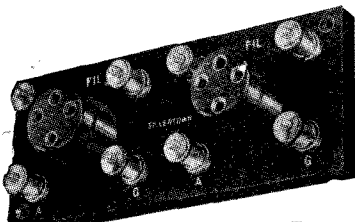

MOUNTED VALVE SOCKETS
2-Valve Type.
Single, double and triple. Suitably engraved for use with valves or for plug-in type high-frequency transformers. 5/6, 9/- and 13/6 each.

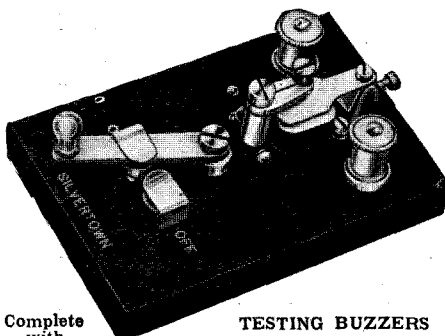

Complete with Switch.

TESTING BUZZERS

Mounted on ebonite base with terminals and shunt or mounted with terminals, shunt and switch. Supplied unmounted, 3/6, 7/- and 8/- each.

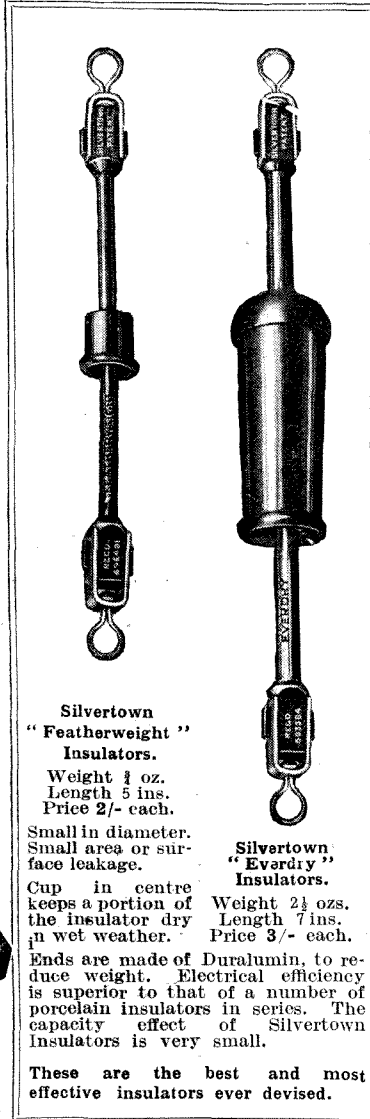

Silvertown "Featherweight" Insulators.

Weight 1/2 oz.
Length 5 ins.
Price 2/- each.

Small in diameter. Small area or surface leakage.

Cup in centre keeps a portion of the insulator dry in wet weather.

Ends are made of Duralumin, to reduce weight. Electrical efficiency is superior to that of a number of porcelain insulators in series. The capacity effect of Silvertown Insulators is very small.

These are the best and most effective insulators ever devised.

Silvertown "Everdry" Insulators.

Weight 2 1/2 ozs.
Length 7 ins.
Price 3/- each.

Silvertown Ebonite Sheet, Rod & Tube — British and Best. Silvertown Accessories are obtainable of all dealers.

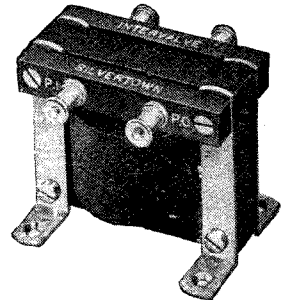

SILVERTOWN INTERVALVE TRANSFORMERS

Tested 1,000 volts between windings and 2,000 volts between winding and frame. 2 1/4 in. high by 3 1/2 in. wide by 2 1/2 in. deep overall. Weighs 1 lb. 3 1/2 ozs. Price 21/- each.

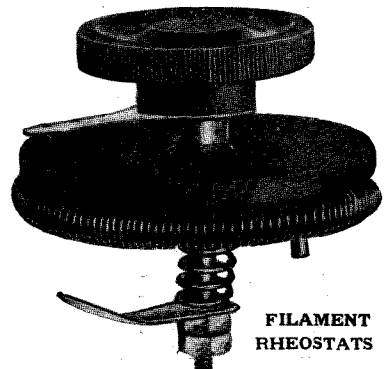

FILAMENT RHEOSTATS

With finished and lacquered brass bush for panel mounting. Resistance wire wound on insulating rod, thereby giving perfectly smooth adjustment. Each supplied with diagram giving drilling dimensions. 3/6 each.

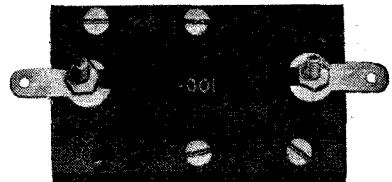

FIXED MICA CONDENSERS

Built up with copper foil and best ruby mica dielectric. High insulation and capacity adjusted to within 5 per cent. Stocked in capacities from 0.0001 to 0.01 mfd. 2/- to 3/6 e ach.

Makers : The Silvertown Company, 106, Cannon Street, London, E.C. 4. Works : Silvertown, London, E. 16, and Burton-on-Trent

BRANCHES:

BELFAST : 75, Ann Street.
BIRMINGHAM : 15, Martineau Street.
BRISTOL : 4, Victoria Street.
CARDIFF : Pier Head Chambers, Bute Docks.

DUBLIN : 15, St. Andrew Street.
GLASGOW : 2, Royal Exchange Square.
LEEDS : 1, New York Road.
LIVERPOOL : 54, Castle Street.
LONDON : 100 & 102, Cannon Street.

MANCHESTER : 16, John Dalton Street.
NEWCASTLE-ON-TYNE : 59, Westgate Road.
PORTSMOUTH : 49, High Street.
SHEFFIELD : 88/90, Queen Street.

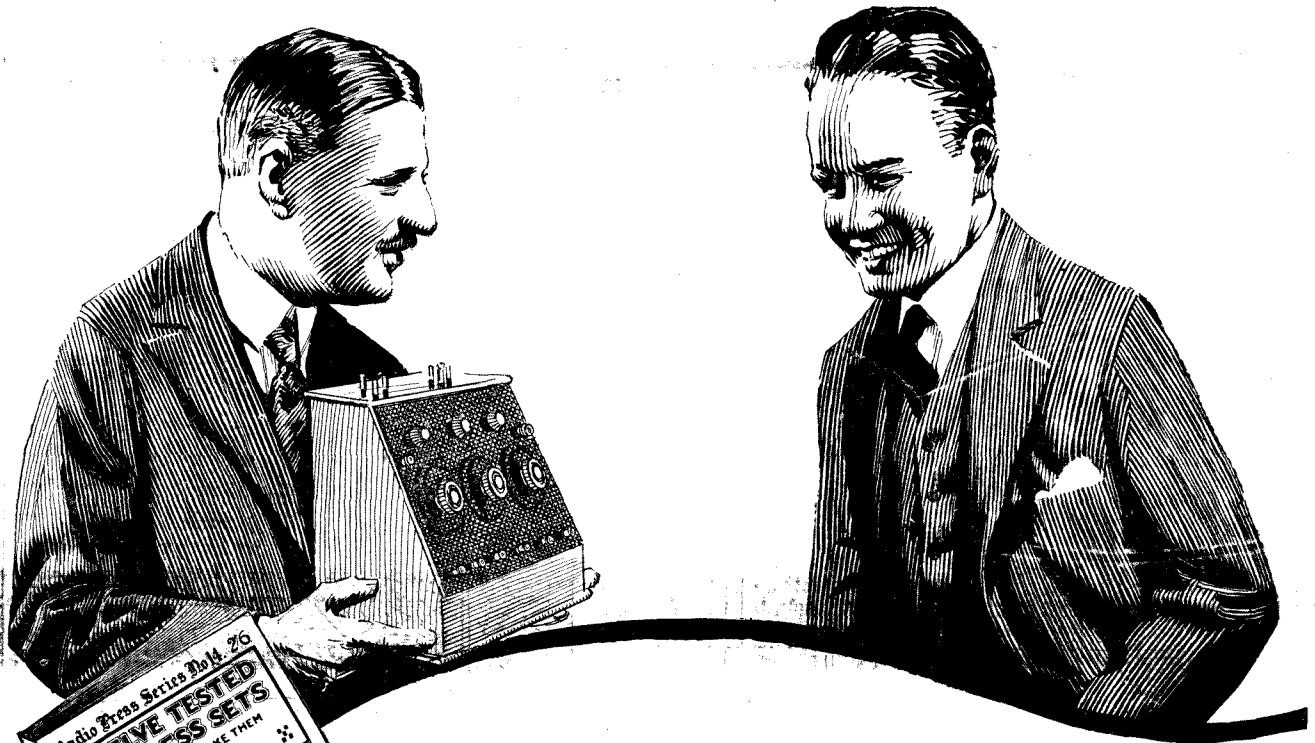

That's pretty smart of you, Williams!

"WELL, I must admit it's not too bad for a first attempt. I'm getting excellent results from it, too."

"Tell me, how did you obtain your knowledge and skill? I suppose you have had some sort of engineering training?"

"Oh, no. My job is in the insurance line—I've never been in any works in my life. As a matter of fact, it was Garnett who put me up to it. He told me how simple it was to build up a really good Set from ready-made components."

"It is a very creditable piece of work—I must congratulate you. I suppose Garnett showed you how to make it?"

"Not a bit of it. He merely advised me to get a copy of a book called *Twelve Tested Wireless Sets* and to follow the instructions. By the way, your boy is coming home from school next week, why not spend a couple of evenings or so with him making up a good Set?"

"That's not a bad idea. He'll sure to be at a bit of a loose end. Let me make a note of the book and I'll call in at the bookshop on the way home for a copy."

Twelve Tested Wireless Sets.

By Percy W. Harris.

Assistant Editor of "Modern Wireless" and "Wireless Weekly."

One of the most practicable constructional books yet published. Mr. Harris' reputation as a bright and informative writer of constructional books is well known and his latest book is easily the best he has written.

Every Set described in this book is well within the capabilities of any enthusiast, and provided the very clear instructions are followed perfect results will be obtained at the first attempt.

The following instruments are fully described:

- 1 A 2/6 Crystal Set.
- 2 A Crystal Set on a New Principle.
- 3 A Single Valve Magnifier.
- 4 A 2-Valve Magnifier.
- 5 A Simple 2-Valve Receiver.
- 6 A 2-Valve Cabinet Set.
- 7 An "Old Folks" Receiver.
- 8 A 3-Valve "All Concert" Receiver.
- 9 A "Transatlantic" Receiver.
- 10 A 3-Valve Reinartz Set.
- 11 An S.T. 100 Set for the Beginner.
- 12 Wave Traps in Various Forms.

2/6

post free
2/8

From all Booksellers or direct from
RADIO PRESS LTD., Devereux Court, Strand, W.C. 2.

Operation

The writer does not recommend the form of tuned-plate reaction for those without experience with this circuit, as it is quite tricky in use, though extremely selective in its action. The tuned anode occasionally takes charge; and a "grid-leak howl" is easily produced. An easier type of operate is provided by the conventional two-coil tuner with plug-in coils. An exceedingly convenient form tried by the writer is what might be termed the "anti-aircraft-gun-mounting" type, recently produced by the Radio Communication Co., which gives admirable control over reaction. A No. 50 coil is generally sufficient for reaction over the broadcast belt, fairly loosely coupled. A No. 50 for London, and No. 75 for higher stations, with a .0005 μ F series variable condenser, will be required for A.T.I. It is inadvisable to mount the coil-holder right on the set, as is frequently done, for unwanted reaction-couplings may be introduced. The stability of this circuit has already suffered to some extent from these by boxing it up in a cabinet, as usually happens; so reasonable care must be taken as to too high H.T. or too low series tuning-condenser, if stability is to be preserved. It is strongly advised that anyone constructing this form of receiver for the first time experiment with the components spread out loose on a board, and well isolated as to casual magnetic couplings, etc., before starting on an ebonite panel. The tiny adjustable condenser must be fixed after everything else has been completed. Once put together, the variometer scale can be marked directly in stations, with the aid of the broadcast stations' carrier waves and or a wavemeter, in the place of meaningless degrees or wave-lengths which convey nothing to the uninitiated; as the tuning is not greatly affected by external alterations. The plain back of an ivory condenser scale, roughened with glass-paper, and a pen with Indian ink serve for this purpose.

Constructive Details

The receiver takes the form of a sloping-desk type of cabinet, with reasonably-small expense of ebonite. (Actually it is uniform, in size and appearance, with a very selective tuner described by the writer in *Wireless Weekly*, to which it is adapted to be linked by four short straps.)

The valves are placed where they should be, in a receiver which

is likely to have some domestic use—inside, on small panels mounted on brackets made of the convenient "Meccano" strip.

Those who prefer to purchase components ready-made, as far as possible, will be interested to learn that the small square valve-socket fitting for board-mounting marketed by Messrs. Peto-Scott is just the right size for these tiny panels, and carries terminal-screws already, whilst the holes for screws at the edges are spaced right for the Meccano strip. These brackets are also spaced correctly for carrying the Dubilier grid-condenser by two small No. 4 B.A. bolts through the flanges. The 'phones blocking-condenser of .002 μ F is the Grafton Electric Co.'s clip-in form, the clips being mounted on the back of the panel by No. 4 B.A. countersunk screws; the same firm supplied the switch, which cuts out the head-phones when the loud-speaker or a note-magnifier is in use. The second pair of 'phone terminals is bridged by a short wire when using the first alone. The 2 megohm Dubilier grid-leak is mounted at one end in the usual clip, the other end supported by a small bracket of bent Meccano strip, the latter connected to the L.T. plus.

All fittings, except the 3 μ F Mansbridge blocking-condenser for H.T. (connected by flex and fixed in the case by a brass strip at the back), and choke-coil (screwed by with aid of Peto-Scott board-mounting clips to end of cabinet) are mounted on the panel by No. 4 B.A. countersunk screws, etc. The panel should, accordingly, be made of not less than $\frac{1}{4}$ in. good ebonite, cleaned as usual with fine emery, and finished with say, "Vim" and oil on a soft rag. Wiring is done with No. 16 bare copper wire, preferably ready tinned; some care has to be taken to avoid crowding these wires, and to clear the variometer. The filament resistances are the handy small type of T.C. Ball.

The cabinet was made of fret-wood, about $\frac{1}{4}$ in. thick, with stouter base-board, and hinged

back (giving access for replacement of valves, etc.), and finished with shellac varnish, sand-papering after the first coat, and applying others (of thick shellac varnish) with a light touch by a rag pad, so as to produce a result comparable with french-polishing.

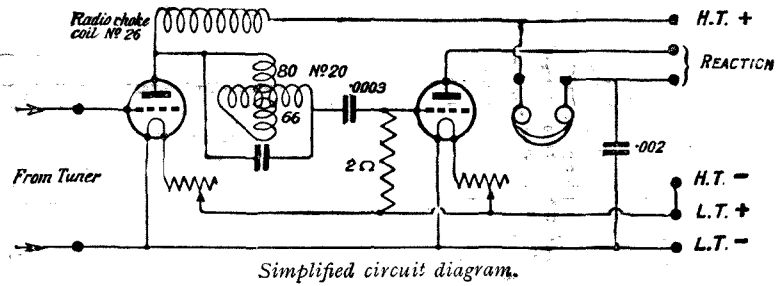

Simplified circuit diagram.

**RADIO PRESS
INFORMATION
DEPARTMENT**

Owing to a tremendous increase in the number of queries, and the policy of the Radio Press to give expert advice and not merely "paper circuits," it has been found necessary to enlarge our staff dealing with such matters. The slight delay in answering letters will shortly cease. In view of the expense incurred we are reluctantly compelled to increase our charge for replies to 2s. 6d., according to the rules below.

If readers will comply with the conditions laid down they may be assured of more prompt attention.

All queries are replied to by post, and therefore the following regulations must be complied with:—

- (1) A postal order to the value of 2s. 6d. for each question must be enclosed, together with the coupon from the current issue and a stamped addressed envelope.
- (2) Not more than three questions will be answered at once.
- (3) Complete designs for sets and complicated wiring diagrams are outside the scope of the department and cannot be supplied.
- (4) Queries should be addressed to Information Department, Radio Press, Ltd., Devereux Court, Strand, London, W.C.2, marking the envelope "Query."

THE FEBRUARY ISSUE
 of
"MODERN WIRELESS"
 will be a Special Birthday
 Number.

SOME NOTES ON LONG-DISTANCE RECEPTION

Do you want to hear America? This article will give you many valuable hints.

NOT long ago when lecturing before a wireless society the writer of these notes was asked, "What is the minimum number of valves required to receive American broadcasting with certainty?" The only answer that could be given was that in the present state of the art we cannot guarantee to get American broadcasting with certainty with *any* number of valves. If, on the other

East Coast United States time, which means that it is not much use listening before about 11 at night, corresponding with 6 p.m. in America).

- (2) Atmospheric conditions on the Atlantic suitable for the transmission on the short waves used. (We have only a vague idea what these conditions are.)
- (3) Apparatus accurately tuned to the wavelengths on which the

should be large, high and very efficient, but experience goes to show that quite successful reception is often possible on an aerial which would be condemned by any expert. Let us now consider the above factors in detail.

Time of Listening

Analysis of a large number of reports sent in by successful listeners shows that transatlantic concerts have been received as early as 11 o'clock—only rarely, however—frequently around midnight, and best of all between 3 and 4 o'clock in the morning. At first it might appear from these figures that the reception across the Atlantic is best after 3 o'clock, but one must not jump at conclusions, for the reception by many listeners is interfered with by the harmonics and "mush" from high power stations such as Leafield and Northolt. In the

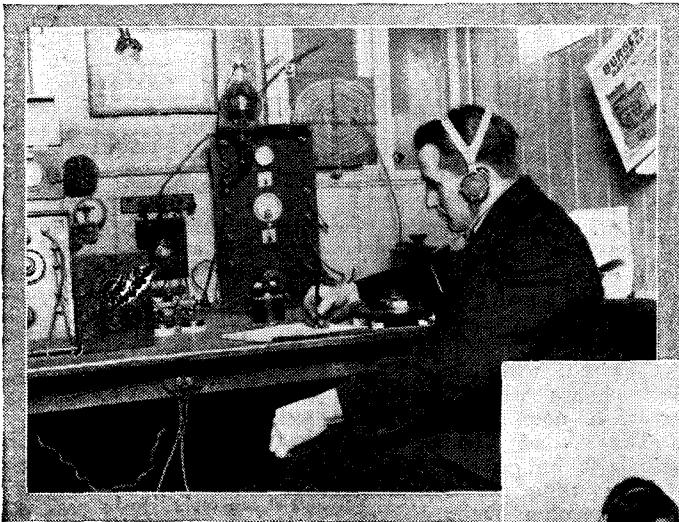

Mr. J. A. Partridge (2 KF), of Merton, who, in December, succeeded in maintaining two-way communication with Mr. K. Warner, the Secretary of the American Radio Relay League at Hartford, Connecticut.

hand, the question had been, "What is the minimum number of valves with which we can receive this broadcasting when conditions are extremely favourable?" the answer is: *one*, for there are many well-authenticated instances of reception of such broadcasting with single valve apparatus. As there seems to be considerable misapprehension as to the true state of affairs, a few notes on the subject of how to receive distant broadcasting may be helpful.

First of all, what do we mean when we say "conditions are favourable for the reception of transatlantic concerts"? These are the chief factors governing reception:

- (1) Correct time of listening (British time is five hours later than the



Mr. Frederic L. Hogg, of Highgate, who in the small hours of a December morning set up an amateur record by "talking" with an amateur station at Toronto. Working on a comparatively low wavelength he kept up communication by Morse code from about four until six a.m. This was the first time that amateurs have been successful in linking England with Canada.

broadcasting is taking place. (These are similar to those used for British broadcasting.)

- (4) Suitable receiving apparatus. Some readers might think that we should continue this list and add one or two numbers relating to the aerial, which they imagine

writer's case such interference makes it virtually impossible to listen for America on concert wavelengths before 3 a.m., when the ether is comparatively free from such transmissions. Interference from ship and coast stations will trouble a good number of listeners, particularly

those who are situated either on the seaboard or close to it. Residents in Margate and the vicinity, for example, experience a great deal of interference from the coast station at North Foreland, whilst Isle of Wight listeners and those in the West of Cornwall (to quote two other districts blessed with busy coast stations) are similarly troubled. 600-metre interference only arises where the listener is comparatively close to the station working on this wave, but the 450-metre transmissions used by ship and coast stations for directional work falls very close to the waves used by the transatlantic stations. This kind of work is probably at a minimum about 3 o'clock in the morning, and for this reason, as well as the absence of harmonics at that hour, the number of successful receptions is bound to be higher at such times.

Suitable Atmospheric Conditions

This is the most uncertain factor of all. If we cannot state definitely what are the best conditions we do at least know those which appear generally to be unfavourable. For example, if the night is clear, with stars glittering brightly and no wind, it will generally be impossible to receive distant signals. If, however, there should be a high wind, rain, fog or mist and generally "dirty" weather, there is a high probability of something coming through. On nights when atmospheric disturbances are conspicuous by their absence, it is almost always impossible to receive long distances satisfactorily. Particularly good nights are generally accompanied by considerable atmospheric disturbance.

Almost without exception the reception of American broadcasting has taken place in those hours which are dark on both sides of the Atlantic. The sun sets in England five hours earlier than in the Eastern States of America, which means in effect that for a certain portion of the time Great Britain is in darkness, whilst America is bathed in sunlight. If we were able to detach ourselves from the world, so that we could look down upon it from hundreds of miles above the earth, we should see the darkness creeping across the Atlantic at the rate of 600 miles an hour, taking 5 hours to complete the crossing. As it is apparently necessary that both sides should be in darkness if the transmissions are to succeed, it is easy to understand that very little successful reception will take place during the summer months. Experience in the last year or two shows

us that the most favourable times of the year are the autumn and winter months, December being perhaps the best.

Once picked up, the American signals rarely maintain a uniform strength—the sounds will rise and fade away sometimes rapidly, sometimes slowly. Occasionally it will be possible to listen to a whole lecture without a break, but in most cases the intensity of sound will vary several hundreds per cent. within a minute. Only on one occasion has the present writer succeeded in "keeping" an American transmission for a whole hour without losing anything, this being in the early hours of December 3rd last. The station heard, WHAZ, was picked up at 3 o'clock, a lecture on rainfall and such matters being delivered at the time. For 10 or 15 minutes the strength was just comfortable in the telephones and then fading occurred quite rapidly for another 10 minutes, the weakest signals, however, still being audible. Shortly after this the strength rose quite considerably and on adding two note magnifying valves it was possible to hear everything on the loud-speaker. Most of the programme for the remaining half-hour was heard on a loud-speaker.

Apparatus Accurately Tuned

It is well, if the listener intends to sit up for American broadcasting, to calibrate the set beforehand either with a wavemeter or by noting the positions of the broadcasting stations generally heard.

At one time all American broadcasting was done on 360 metres, and this naturally occasioned a good deal of interference. With the growth of popular broadcasting in U.S.A. it soon became apparent that hardly anyone could listen-in with a sensitive set without picking up several broadcasting stations simultaneously. At the present time several wavelengths have been reserved for broadcasting, so that it is possible to hear stations on 360, 380, 385, 400, 405 metres and so on, some wavelengths being as long as 469 and 492, whilst numerous broadcasting stations worked on wavelengths as short as 229 and 231. The majority of the stations in the United States, however, still work on 360 metres.

The station which has been heard more often than any other in this country is WGY, the studio of the General Electric Co., at Schenectady, New York. The wavelength of this station is 380 metres. Next on the list is WHAZ, the Rensselaer Polytechnic Institute at Troy, New York. Troy is some distance inland

from the coast, as is Schenectady. WJZ, another station quite frequently heard and one of the first stations to be picked up on this side, works on 360 metres. Occasionally broadcasting stations from such distant States as Nebraska are heard.

If you have not a wavemeter, the best thing to do in preparing for the reception of American broadcasting is carefully to note the positions on your tuning apparatus for each one of the British broadcasting stations. Take a piece of squared paper and mark along a horizontal line equal divisions for the degrees of your condenser or variometer scale, and on a vertical line wavelengths from 300 to 500 metres. Now place dots at the intersection of the horizontal line from the particular wavelength of a station and the vertical line from the reading in degrees. When you have plotted all the stations in this way, you will be able to join the dots with a curve, from which you will be able to find any wavelength with reasonable accuracy. Pick out the broadcasting station you want to receive (and at first it is well to try for WGY on 380 metres) and set your tuning apparatus accordingly. The position for WGY will be approximately the same as Bournemouth, so that it is not a bad plan to tune accurately to Bournemouth on the evening previous to listening and leave the set adjusted. The beginner is strongly advised not to attempt to listen for American broadcasting on a single valve set, for it is only when using such a set with highly critical adjustment of reaction and mostly skilfully handled that it is possible to receive America even in the best of conditions. The unskilled user will quite likely cause his set to oscillate, thus radiating waves in the surrounding ether, causing serious interference to more advanced workers who are listening at the same time.

A good all-round set which can generally be relied upon to get American broadcasting on nights which are at all favourable is one using three valves, the first being a high-frequency valve, the second a detector and the third a note magnifier. On those nights when conditions are exceedingly favourable, it is possible to hear American broadcasting on a loud-speaker, but for this four or five valves are nearly always required.

Many listeners who have kept their apparatus handy with a switch so that extra magnifying valves could be switched in for loud-speaker operation, have frequently been disappointed in not being able to receive American broadcasting on

a loud-speaker when it has been quite clear in the 'phones. The reason for this is that the additional load thrown on the accumulator by switching on further note-magnifying valves has caused a drop in voltage which has upset the critical reaction setting or high-frequency adjustment of the apparatus. The best plan is to use a separate accumulator for any note-magnifying valves that may be switched into circuit for loud-speaker operation. Switching them in will then not alter the brightness of the filaments of those valves which are already in use.

Suitable Apparatus

As just indicated, a three-valve instrument is a good all-round set for use when listening to American broadcasting, provided the first valve is a high-frequency magnifier. It is practically impossible to receive such broadcasting on a three-valve set consisting of a detector and two note magnifiers, as such apparatus is very inefficient for distant reception and will magnify up the slightest disturbance into a most distressing crash in the telephones. The use of more than one note magnifier is not recommended in any case, for the results on weak signals are most disappointing. The best of all sets for lengthy "sitting in" is one with two or three stages of high-frequency and detector valve without any note-magnifying valves whatever. Such apparatus, whilst exceedingly sensitive, does not greatly magnify atmospherics, and

one is thus saved much nervous irritation.

The aerial used should be as good as possible, but too much should not be expected from the aerial part of the equipment. One 30 feet high and 50 feet long running over grass and having either one or two wires

should serve admirably. If the aerial is made much higher, the apparatus will be more sensitive in some respects, but will be far more prone to interference from mush, harmonics, jamming, etc. Save with the most elaborate multi-valve set in skilled hands, a frame aerial is quite useless and is not to be recommended for such work.

That such excellent results are so regularly obtained in the reception of transatlantic broadcasting is all the more remarkable when we consider that the power used by our transatlantic friends rarely exceeds one kilowatt, whereas similar stations in this country use 1½ kilowatts and sometimes more.

A final note. Whatever you do, take every possible precaution to avoid radiation and consequent interference with other listeners. Do not be selfish just for the sake of hearing American concerts. If you must make your set oscillate so as to pick up a carrier wave see that the oscillation is confined to a circuit not directly connected to the aerial. A good-tuned anode set with the first grid connected to the positive and not to the negative leg of the filament is quite suitable and will not radiate even when the anode circuit oscillates strongly.

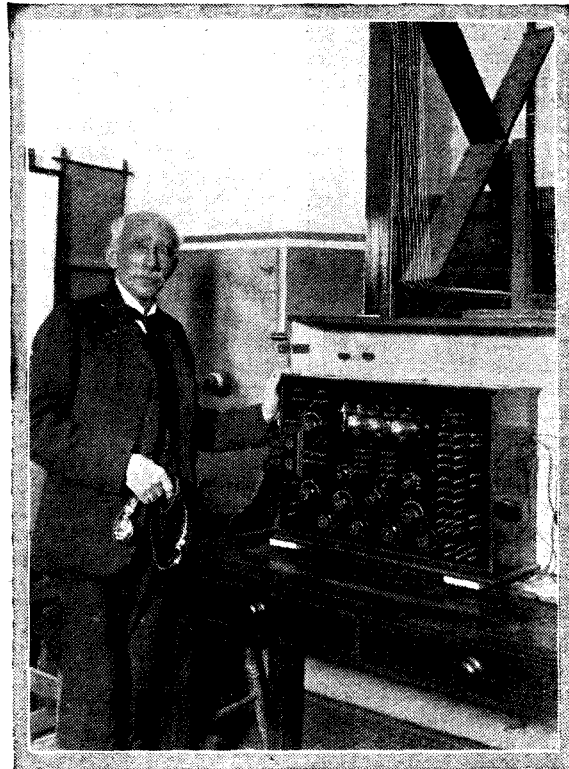

A recent photograph of Dr. J. A. Fleming, F.R.S., the famous inventor of the thermionic valve.

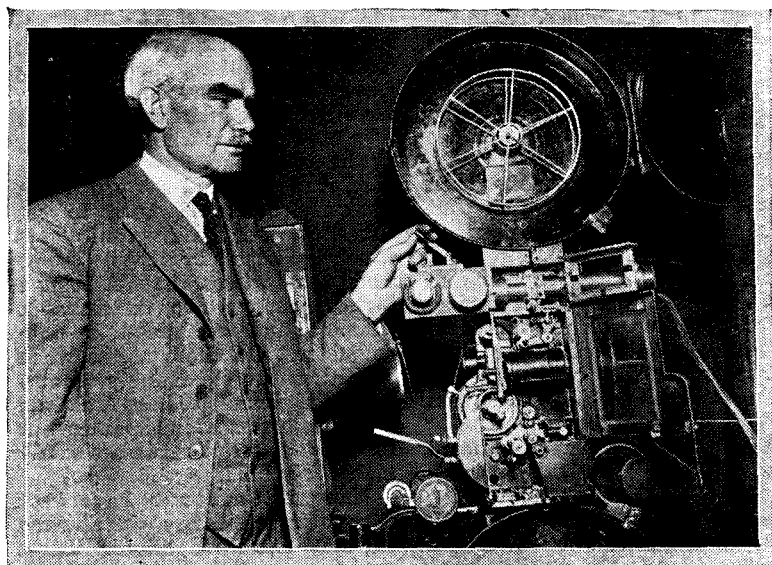

Dr. Lee de Forest, who by adding a grid to the original Fleming valve, converted it into a much more sensitive device.

For Dependability use "IGRANIC" RADIO DEVICES

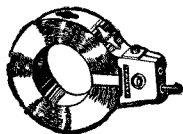

IGRANIC HONEYCOMB COILS. (De Forest Pat. No. 141344.)

These world-famous coils are renowned for their high efficiency, low self-capacity, small absorption factor and minimum high-frequency resistance. No dead-end losses. Each turn surrounded by air pocket. Made in two types, gimbal and plug mounted. Wavelengths approximately 100 to 25,000 metres. The only coils that uphold their claim for negligible losses. Prices vary with sizes.

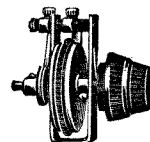
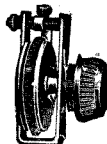

FILAMENT RHEOSTATS. (Patent No. 195903.)

A splendid instrument for filament control under all conditions. Novel method of construction ensures smooth and silent operation. Designed for individual valve control. Adjustable contact fingers. Permits of resistance values from zero to 4 ohms by fine variation. Supplied in two types, plain and vernier.

PRICES : Plain, 4/6 Vernier, 7/-

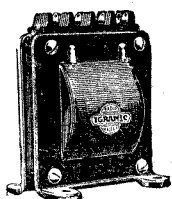

INTERVAL TRANSFORMERS. (Patent No. 205013.)

Designed for the distortionless reproduction of speech and music. The steel shroud effectively shields from external interference. Recent improvements in design render it the finest amplifying transformer obtainable.

PRICE : Shrouded 21/-, Open 20/-



VERNIER FRICTION PENCIL. (Regd. No. 696394.)

Fine tuning easily accomplished. Positive friction drive. Hand interference minimised. No radio set complete without it. Each pencil complete with three bushes and one spare rubber ring. To convert into an anti-capacity adjuster, slip the clip attachment down and insert the brass pin and ball into two holes drilled in the knob.

PRICE 7/-

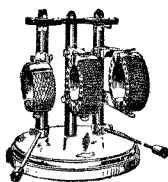

GIMBOLDER TUNING STAND. (Patent No. 206899.)

This coil holder has been designed and produced for accommodating gimbal-mounted Honeycomb Coils, which enable extremely fine settings to be obtained. In addition to the angular relation of the coils being varied, they can also be rotated about their own axis, thus giving extremely fine and critical adjustment when used on selective and regenerative circuits.

BATTERY POTENTIOMETER. (Pat. Applied for.)

An Igranic Potentiometer is a necessity where one or more stages of high-frequency amplification is used. Stabilises grid and eliminates noises and self-oscillation. Resistance 300 ohms. Current consumption negligible. Nickelled finish, complete with fixing screws, knob and pointer.

PRICE 7/-

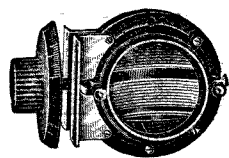
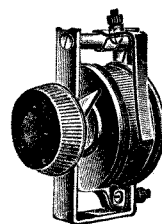

TYPE "H" VARIOMETER.

Recommended for use in the aerial circuit of crystal and valve sets. Wavelengths range approximately 150-600 metres with P.M.G. standard aerial. Stator and rotor best quality mouldings, windings self-supporting and impregnated solid.

PRICE, with Knob, Dial and Fixing Bracket, 15/-

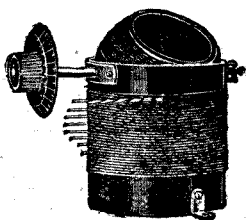

TYPE "H.R." VARIOCOUPLER.

Stator and rotor of hard moulded insulation, and windings impregnated solid. Tappings on primary enable fine tuning to be obtained, thus eliminating condenser. Coupling continuously variable over wide range.

PRICE, with Knob, Dial and Fixing Brackets, 19/-

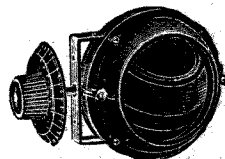

TYPE "S.R." VARIOMETER.

Designed for secondary and tuned anode circuits. Wavelengths 150 to 600 metres approximately. Similar to Type "H," but with larger winding. Moulded insulation and windings impregnated solid.

PRICE 18/-

STOCKED BY ALL HIGH-CLASS DEALERS :—: :—: :—: :—: :—: WRITE FOR LEAFLETS Z122.

Manchester : 30, Cross Street.
Birmingham : 73/4, Exchange Buildings,
New Street.
Glasgow : 50, Wellington Street.
149, Queen Victoria Street,
LONDON.



Cardiff : Western Mail Chambers.
Bradford : 18, Woodview Terrace, Manning-
ham.
Newcastle : 90, Pilgrim Street.
Works :
Elstow Road, BEDFORD.

MARK OF MERIT
The MARK OF MERIT on any Wireless Set or component is a guarantee of efficiency reasonable price and sound British manufacture.

We are exhibiting in the Electrical and Allied Engineering Section British Empire Exhibition, 1924

Complete Catalogue Post Free, 1s. 8d.

H.F. TRANSFORMERS

Plug-in.

Can be obtained matched for operation in the TRANS-ATLANTIC and similar sets.

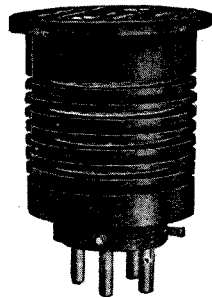

- No. 0. 150 to 300 metres 7/-
- No. 1. 300 to 600 metres 7/-
- No. 2. 550 to 1200 metres 7/-
- No. 3. 1100 to 3000 metres 7/-
- No. 4. 2000 metres and upwards .. 7/-
- Complete Set 32/6

We have a large stock of brand new Sullivan low resistance head telephones (no cords) which we are disposing of at exceedingly low rates, namely, 8/- per pair. Send at once to avoid disappointment.

FLAT MOUNTING COMPONENTS

A series of components for flat mounting on to wooden baseboards enabling great economy to be effected in ebonite for panels with absolute security.

FILAMENT RESISTANCE

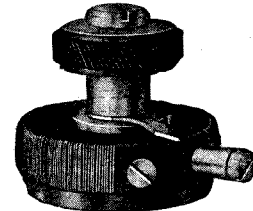

Velvety smooth motion, certain contact.

As illustrated, 4/6.

L.M. MICHAEL LTD
IN CONJUNCTION WITH B. HESKETH LTD

SHOWROOMS: RADIO CORNER, 179, STRAND, LONDON, W.C. 2.

All correspondence to Head Office—

HASTINGS HOUSE, NORFOLK STREET, STRAND, LONDON, W.C. 2.

Fourmoumouth Depot, 5, Yelverton Road.

“Efficiency” Inductances

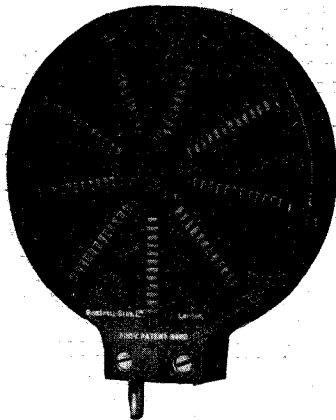

Supplied with either double plug or standard plug and socket fittings.

Insure your set against losses

High frequency losses are not always apparent but are nevertheless responsible for poor signal strength to a degree not often realised. A coil which has a D.C. resistance of a few ohms may be several hundred ohms resistance at radio frequencies. The “Efficiency” Inductance has been so designed that the losses are reduced to an almost negligible figure. Consequently the signal strength is improved, less reaction is required, selectivity is increased and each coil covers a far greater range of wavelength on a given condenser than less efficient coils. The proof of this is in the table below.

Coil.	Wavelength range shunted with .001 capacity condenser.	Self capacity in Microfarads.	Price.
a	75 .. 325	.000004	5/9
A	120 .. 525	.000004	5/9
B	200 .. 855	.000005	6/-
C	285 .. 1200	.000006	6/9
D	400 .. 1700	.000006	8/-
E	690 .. 2875	.000008	9/6
F	1040 .. 4350	.000009	10/3
G	1575 .. 6800	.000011	12/-
H	2250 .. 9500	.000014	14/-
I	4300 .. 18000	.000017	16/-
J	6400 .. 27000	.000021	19/-

If your dealer does not stock these coils please send us his name and address.

Write for full particulars or call at our London Office:

76, Victoria Street, S.W. 1. (Entrance in Palace Street.)

Phone: Victoria 9938.

WORKS: MERTON ROAD, SOUTHFIELDS, S.W. 18.

Gambrell Bros., Ltd.

A SIMPLE REFLEX SET

Working from Dry Cells

By **PERCY W. HARRIS** (Assistant Editor).

This set has been designed to fill the need for a simple receiver, running off dry cells entirely, which will operate a loud-speaker within six to eight miles of a broadcasting station. Its "telephone" range is considerably greater.

THE introduction of several makes of valves using only .06 of an ampere—just a tenth of the current taken by the older type of bright emitter valve—has at last brought us to the stage where we can run a single valve set economically and efficiently from dry cells. I say economically and efficiently for it has been possible to run the older type of dull emitter from large dry cells, but these have been bulky and very expensive and could not be recommended for use by any reader who has reasonable facilities for getting accumulators charged. The small current taken by the new valves can easily be provided by the average dry cells, such as are used for ringing electric bells and even from the smaller square cells used in general electrical work.

If we want to get the maximum efficiency from one valve, we naturally turn to reflex amplification—that is to say, we think of a circuit in which the valve can act first of all as a high-frequency magnifier, thus providing amplified signals which can be rectified or detected by a crystal detector and then once more taken to the valve, which now acts as a low-frequency or note magnifier. In this way we shall get results somewhat comparable with those given by the ordinary "straight" three valve sets, in which there is a high-frequency valve, detector and a note magnifier. Such a three valve set will give louder signals than a single valve reflex, but only because the detector (a valve in this case) will amplify as well as detect, whereas in a reflex set the detector, a crystal, will only serve to rectify the currents, but will not amplify them in any way. Single valve reflex circuits are very easy to make, require few parts and generally give little trouble compared with the two and three valve reflex receivers, which require certain precautions to be taken if they are to be satisfactorily operated and prevented from howling. The present receiver was designed and built with the idea of making a compact cabinet set of such a size

that the dry cells necessary to light the filament, as well as the high-tension battery to provide the plate current, could all be packed away in the cabinet out of sight, thus avoiding trailing wires

this will be seen a small knob operating the filament resistance. On the top of the cabinet are three sockets, the two outside being for the aerial and anode coils respectively, the central socket taking

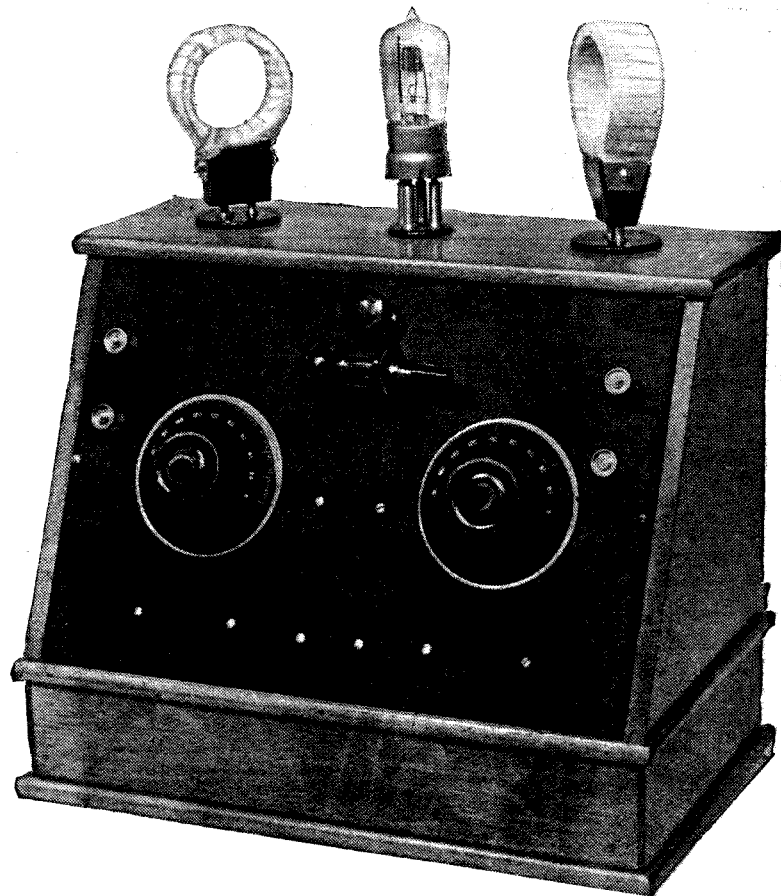

Two variable condensers, a crystal detector and a filament resistance knob are the only controls needing adjustment.

and messy accumulators. As will be seen from the above photograph, there are four terminals on the front, the two on the left being for aerial and earth and the pair on the right for telephones or loud-speaker. Two dials are provided, that on the left being for aerial tuning and that on the right for tuning the anode. The crystal detector, which is of the enclosed type, is mounted on the panel immediately above the condensers, and just higher than

the valve itself. Plug-in coils are used, as in this way it is possible to obtain a wide range of wavelength, and the many readers who already possess sets of plug-in coils will be able to use them in this receiver equally as well as in any other.

The circuit used has been known for several years. It will be found, for example, in Mr. Scott-Taggart's book, "Thermionic Tubes in Radio Telegraphy and Telephony," published more than two years ago.

More recently it has appeared in MODERN WIRELESS (July issue of this year) in a portable broadcast receiver designed and described by Mr. G. P. Kendall, B.Sc. The main interest in the present instrument lies in its arrangement of parts and general make-up, which will suit the convenience of readers who like their instruments to be as simple to make and to handle as possible.

Although it is possible in a set such as this to use a limited amount of reaction to intensify the signals, no reaction has been introduced in the present set, and for this reason the anode and aerial coils are fixed in position so that they stand at right-angles to one another. This elimination of one variable in the circuit makes for greater simplicity of handling, and the loss of signal strength is very small—perhaps 10 per cent. The stability of the set has been further enhanced by placing the intervalve transformer

in the aerial circuit in the manner recently described by Mr. Scott-Taggart in his useful improvement to the ST100 circuit. The set is thus fully as stable as an ordinary "straight" circuit and is no more difficult to handle than the common tuned anode sets.

With regard to the capabilities of this instrument when used with an average outdoor aerial, it will give loud-speaker reproduction for an average living-room six to eight miles from a broadcasting station. When conditions are favourable this distance may be increased. When substituting it temporarily for my ST100 set I found that the strength was exactly that to which I usually detune the ST100 for comfortable audition. Two or three of the other broadcasting stations can be heard in the phones quite easily when London is not working, but it should be stated clearly that the selectivity of this set is not high. Rating it con-

servatively, we can say that it will give good telephone strength at any part of the country from one broadcasting station at least, and probably in many districts from several, if not all.

Components Needed

The following is a complete list of parts:—

- (1) Suitable cabinet to take an ebonite panel, 12 in. by 8 in. by $\frac{1}{4}$ in. thick.
- (2) Two variable condensers, one of .0005 μ F and the other of .0003 μ F (.0005 for both if it is intended to use this set for Continental wavelengths as well).
- (3) One crystal detector for panel mounting (preferably glass-enclosed).
- (4) One filament resistance suitable for a .06 ampere valve (any dealer will supply this).
- (5) One valve socket for panel mounting.
- (6) Two single coil holders for panel mounting.
- (7) Four terminals.
- (8) Two fixed condensers, .002 μ F.
- (9) One fixed condenser, .0003 μ F.
- (10) One intervalve transformer of good make.
- (11) Three dry cells.
- (12) One H.T. battery, 45 to 50 volts.
- (13) No. 22 tinned copper wire for wiring up.
- (14) Lengths of Systoflex or other tubing for insulation.
- (15) One of the new valves taking .06 of an ampere. (Marconi-Osram, B.T.H. or Ediswan.)

So far as the cabinet is concerned, this, in my case, is identical with those described for the Transatlantic receiver, the Transatlantic note-magnifier and the three-valve Reinartz set described in my book "Twelve Tested Wireless Sets." In the present set it could with advantage be somewhat deeper (not so far as the panel size is concerned, but in the woodwork). The present cabinet will contain the necessary batteries, but they are a rather tight fit, and I would suggest that those readers who are having cabinets made should have them two or three inches deeper to accommodate larger cells if required.

It will be seen on examination of the photographs and diagrams that all the component parts, with the exception of the valve socket and the two coil sockets and one fixed condenser, are carried on the ebonite panel. This last fixed condenser could also quite conveniently be placed on the panel, there being plenty of space for it.

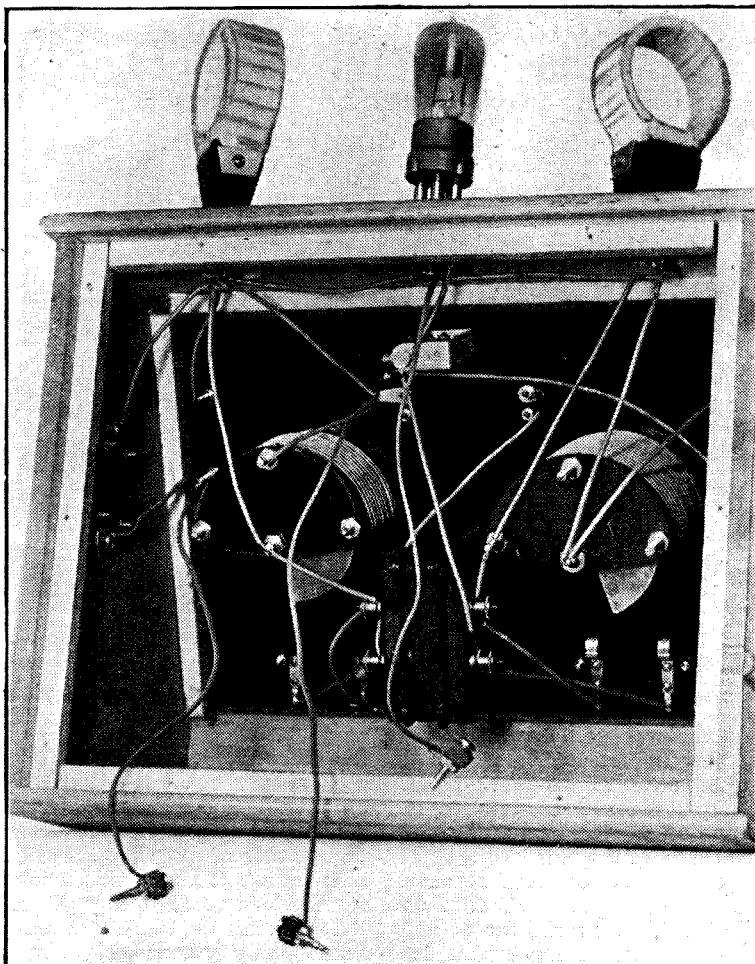

The receiver with back removed. The flexible leads are connected to the dry cells for filament lighting and to the high tension battery. These cells can be stored within the cabinet, and are not shown in the picture.

HONEYCOMB COILS

De Forest Patent
No. 141344.

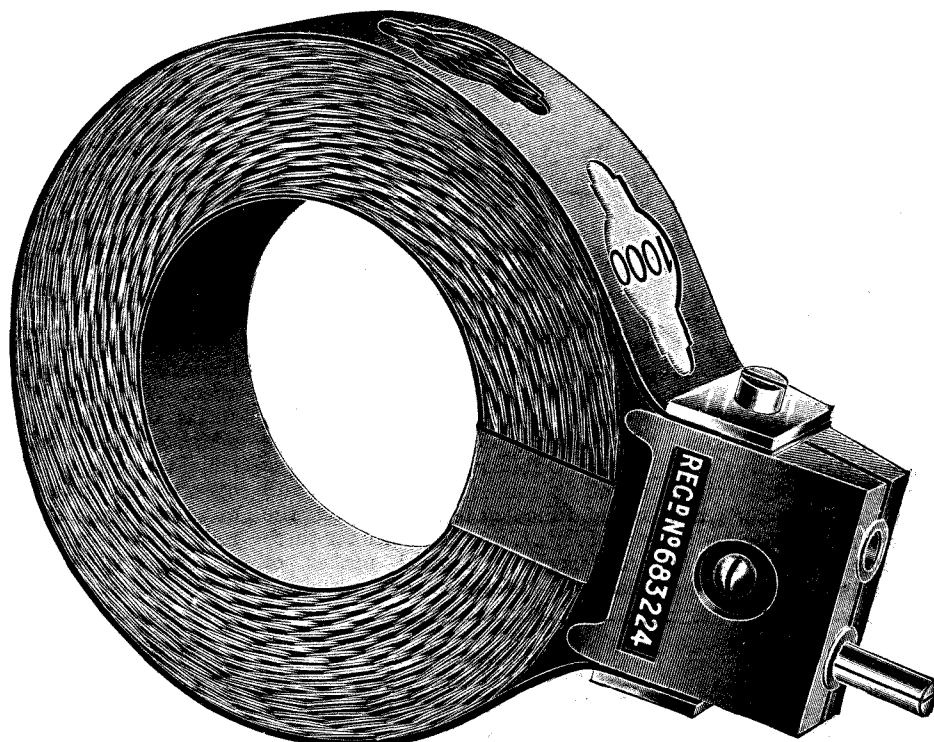

MERITS.

A honeycomb coil is not a mere reel of wire. It is a scientifically designed article, very carefully made, every turn of wire being accurately and securely placed to the best advantage and all its air spaces evenly distributed. Among its salient merits are the following:—

*Low distributed self capacity. Maximum Inductance.
Small Absorb. on Factor.*

*Sharp Tuning at any frequency. Absence of Dead-end Losses.
Minimum High-frequency Resistance.*

It is easy to mount, flexible in use, and mechanically strong.

INFRINGEMENTS.

WARNING. LETTERS PATENT No. 141344.

The Trade and the public are warned that Inductance Coils having a cellular structure and generally sold as Honeycomb Coils, are protected by Letters Patent as above, under which the Igranic Electric Company, Limited, are the sole Licensees in this Country.

There are on the market imitations of our coils which, we are advised, infringe the Letters Patent as above, and action has been commenced against the manufacturers to restrain these infringements, but dealers and others should remember that in selling these infringing coils they render themselves liable to action. As these infringing coils are quite often boldly described as "Honeycomb Coils," both dealers and purchasers would be well advised to satisfy themselves that the coils they purchase are genuine Honeycomb coils of IGRANIC Manufacture.

WESTERN ELECTRIC COMPANY, LIMITED.

OWNERS OF PATENT

Western Electric Company Limited.

CONNAUGHT HOUSE, ALDWYCH, LONDON, W.C.2

SOLE LICENSEES AND MANUFACTURERS

IGRANIC ELECTRIC CO. LTD.

149, Queen Victoria Street, LONDON.

Works: Elstow Road, BEDFORD

The reason for its present position is that it was not included in the design when it was first made up and was introduced as the result of experiment, the side of the box then being the most convenient place to put it.

The construction of the set is extremely easy; it is only necessary to mark out the panel on the back with a scribe, using a steel rule and a little care, then to drill holes of such a size that they will take the various parts. It is quite unnecessary to make tapped holes. Most of the variable condensers on the market are secured to the panel by a couple of metal screws of 4 B.A. thread. Therefore, if we drill a central hole to take the spindle of the variable condenser and two holes of such a size that the 4 B.A. screws will pass through them, we can hold the condensers to the panel by passing the screws through the front and tightening them up. A countersink bit will be useful for recessing the upper portions of the holes so that the metal-screw heads may lie level with the panel. Some little care is necessary in locating the positions

for the holes. Perhaps the best way is to take a sheet of thin paper and lay it over the top plate of the condenser, pressing it down firmly on to the top plate so that markings will show where the holes come for the securing screws. The paper template so made can then be placed on the top of the panel, the positions of the holes marked with a centre punch or some sharp instrument and the holes drilled. The intervalve transformer is secured to the panel in a very simple manner, by passing 6 B.A. screws through the panel and through the holes in the supports of the transformer, the latter being held in place by four nuts on these screws. Similarly the Dubilier fixed condensers are held to the panel by 6 B.A. screws passed through clearance holes and secured with nuts.

It is interesting to note that the distance between the two holes of the Dubilier fixed condenser is exactly 2 inches, so that there will be no difficulty in marking out the panel for drilling the holes for these condensers. Several makes of filament resistance are provided

with paper templates to show where to drill the securing holes. In the present receiver I used a T.C.B. potentiometer, which, having a resistance of 300 ohms, is quite suitable for use with these valves. Of course, when using a potentiometer as a filament resistance it is only necessary to connect the slider and one end of the coil. However, it is better to use one of the special filament resistances designed for these valves. The Lissenstat of Lissen, Ltd., and the Microstat, the latter obtainable from Messrs. McMichael, Ltd., are both excellent for use with these valves. They have the advantage that if you want to try the set with a bright emitter, the same filament resistance will do.

The crystal detector holder and the crystal itself should both be good. That used on the present set is the new Burndept pattern which has the advantage of a very delicate screw adjustment of the cat-whisker, making adjustment of this important detail easy, reliable and stable. I can also recommend the Edison Bell double crystal detector. This consists of

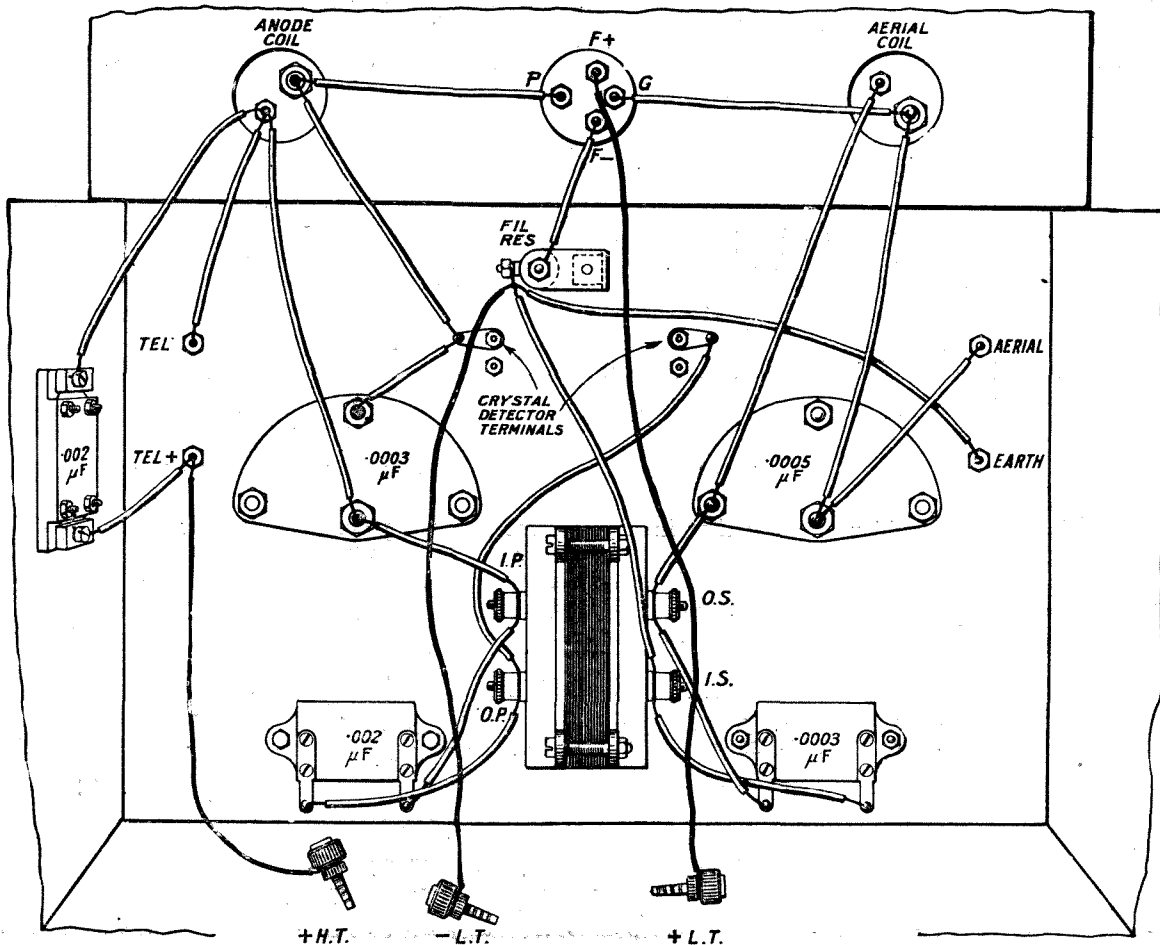

The wiring, as will be seen, is quite simple. For clearness, the top of the cabinet has been drawn as if lifted up.

B.B.C.

**WIRELESS
DRY
BATTERIES**

For
B.B.C.
Sets

No. 1 W.

Standard Pocket Lamp Size—4½ volt with patent spiral wire terminals and plug sockets to take Wander Plugs.

Note — 1 doz. = 54 volts.

Used units replaced easily.

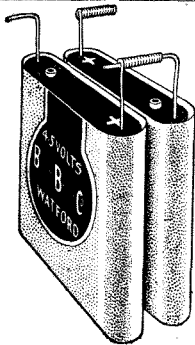

To connect in Series insert straight Terminal in Spiral of next battery. Bend spiral and thus ensure permanent electrical connection without soldering.

BRITISH MADE.

Patent applied for.

Connect as illustrated.

PRICE CARRIAGE PAID, 7/- PER DOZEN, WITH PLUG.

Standard Sizes :

- | | |
|--|----------------|
| No. 2 W. Slab, 16½ volts, 3-volt tappings. Size approx. 9 x 1 x 3 ins. ... | Price 3/- each |
| No. 4 W. Slab, 36 volts, 3-volt tappings. Size approx. 10 x 1½ x 3 ins. ... | " 6/6 " |
| No. 5 W. Block, 60 volts, 3-volt tappings. Size approx. 9½ x 3¼ x 3¼ ins. ... | " 12/- " |

Prices include Wander Plug. Carriage Paid.

Manufactured by

Telephone: Watford 617.

The BRITISH BATTERY CO. LTD.
CLARENDON RD., WATFORD, HERTS.

You need this Book

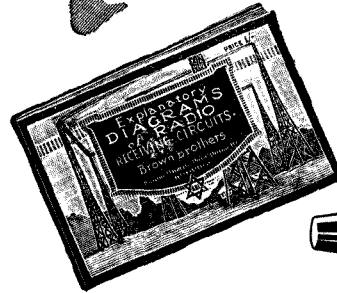

The "B.B.C." Booklet of Wiring Diagrams shows all the Components required in their relative positions for wiring up. Get a copy from your Dealer ... PRICE 1/-



"LISSEN" VARIABLE GRID LEAK

"Lissen" one hole fixing.

To obtain clear signals and the correct grid potential providing maximum signal strength, this variable grid leak is specially recommended. Occupying very little space, it can be fitted in any odd space on the panel. List No. 15741 ... each 2/6

INTERVALVE TRANSFORMERS

(Patent No. 255013) Correctly designed for minimum distributed capacity. Low core losses. Coil wound by patent cotton interweave process. Maximum amplification without distortion.

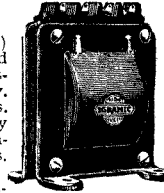

Price

- | | |
|--------------------------------|------|
| List No. 17182A Shrouded Type, | 22/6 |
| " 17182B Open Type | 21/- |



"WOODHALL" BASKET COIL PLUG.

Adaptable for any size Basket Coil to enable fitting to standard plug-in type Coil Holder.

List No. 15272 ... each 2/6

Brown Brothers LIMITED

with which is amalgamated Thomson & Brown Brothers, Ltd.
Wholesale only. Head Offices & Warehouses
Gt. Eastern St., London, E.C.2,
118, George St., Edinburgh, and Branches

Trade only supplied. Please order from your usual dealer.

"WIRELESS VALVES."

OUR works are the largest in the Country solely adapted for the repair of Wireless Valves and this, combined with up-to-date machinery and an expert staff, results in first-class work. Send through your Local Wireless Dealer or direct to—

**RADIONS LIMITED, BOLLINGTON,
NEAR MACCLESFIELD.**

Tele; 71, Bollington.

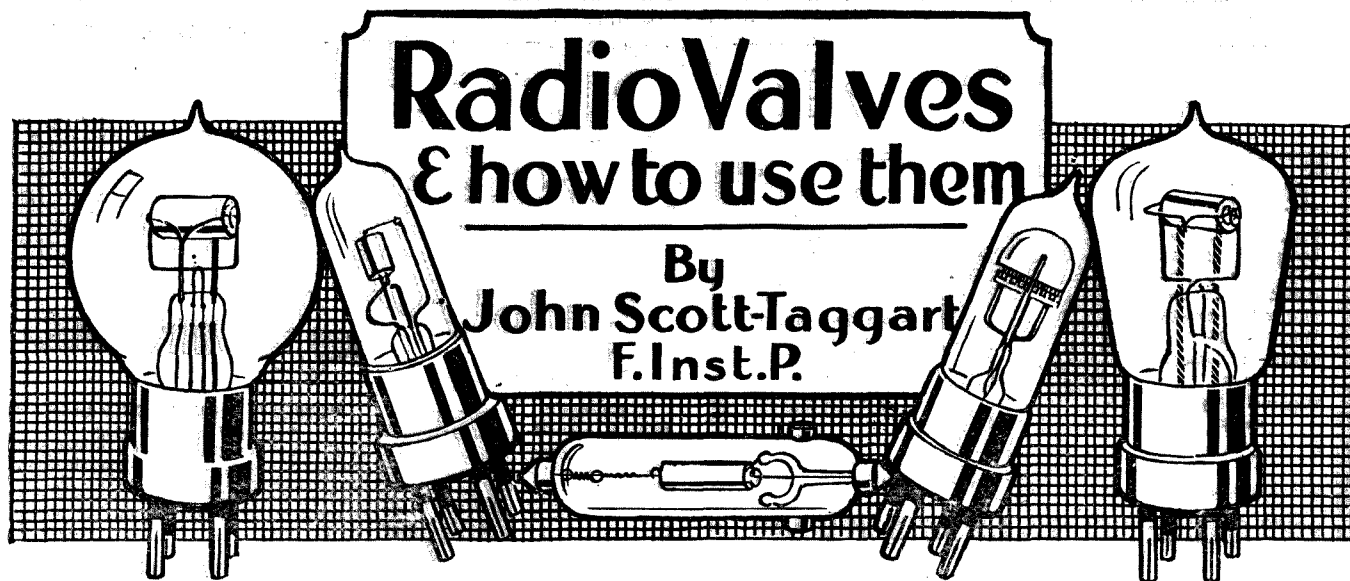

JUST
PUBLISHED!

—a complete course of
instruction on the Valve

Can you answer
these questions fully?

What is meant by Reactance-capacity coupling?

Which is more selective—“Tuned Anode” or “Reactance capacity” for H.F. use?

What is Reaction?

What is meant by “Dual Amplification”?

How is self-oscillation caused?

What is an aperiodic transformer and its advantages?

2/6

from all Booksellers, or
2/8 post free direct from
publishers.

RADIO PRESS, LTD.,
Devereux Court, Strand,
W.C. 2.

TO make real progress in Wireless you must be able to understand the principles of the Radio Valve. The importance of this cannot be emphasised too strongly.

While there are several Books on the Valve by the same author, none of them covers quite the same field as “*Radio Valves and how to use them.*”

This Book is rather more elementary in its appeal and should be extremely useful to those who are beginning to take a more serious interest in Wireless.

Its explanations are most lucid and graphically illustrated by a very large number of diagrams. It is a Book which, although dealing with a difficult subject, is most fascinating and intriguing in its appeal. A Book which ought, in fact, to be on every wireless enthusiast's book-shelf.

It is written from the point of view of the man who is going to **use** valves.

Radio Press Series No. 12.

two complete glass-enclosed detectors on one base with a rapid change-over switch. It is very useful in all dual circuits to be able

bending the wires at right-angles in the manner described in my article on the Transatlantic receiver in the November issue.

CORRESPONDENCE

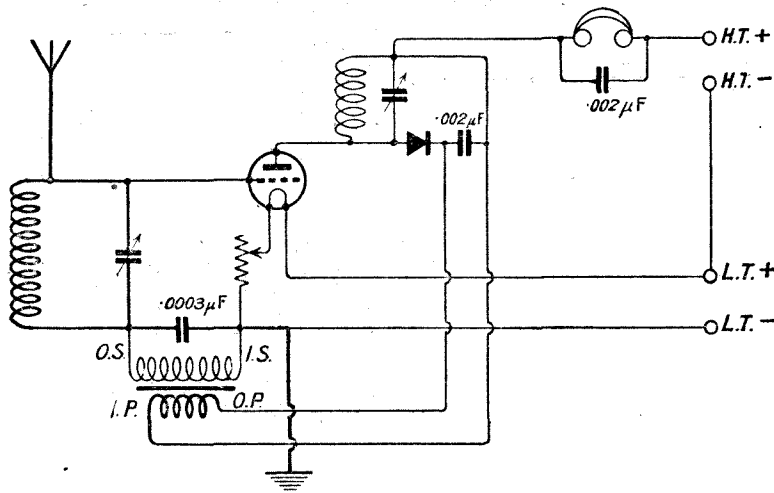

The theoretical circuit diagram.

to change rapidly from one crystal to the other. This particular instrument is ready fitted with two good crystals, so that it is not necessary to buy them in addition. The Burndept is also fitted with a crystal ready for use.

If you make up this set I would strongly advise you to adhere as closely as possible to the disposition of the parts. This remark applies to all the designs published in this journal. Those of us who do the experimental work necessary to make efficient instruments spend many hours and often remake a set half a dozen times from the same circuit diagram, but with a different disposition of parts, before we achieve the results at which we aim. If you think that you can introduce a number of improvements in this design I would suggest that you first of all make up the instrument and get it working on exactly the lines described here. When you have obtained good results in this way you can try the modifications, and you will then be able to judge whether or not they are better than those of the designer. A very large number of questions received by the Radio Press Information Dept. relate to sets which will not work for no other reason than a departure by the constructor from the general lay-out described.

Wiring up should be carried out exactly as shown, making the connections as short as possible and using insulating tubing if thin wire is used. A better but more difficult arrangement is to use stiff wire,

Operation of the Set

Tuning the set will be found a comparatively simple matter, and if the builder has experience in an ordinary tuned anode set, he will be able to adjust the receiver at once. The best way is first of all to set the cat-whisker on the crystal,

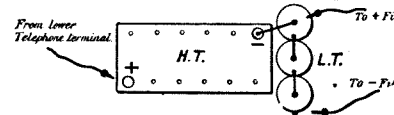

How to join up the H.T. and L.T. batteries. + Filament lead goes to the positive of the three cells, which, in turn, is connected to the - H.T. battery.

and then to tune simultaneously on both aerial and anode tuning condensers. When signals are brought in to tune, readjust the crystal detector to give best results and once more try the tuning adjustment. The tuning of the anode will be found quite flat compared with the usual tuned anode, as the crystal will introduce considerable damping into this circuit. The filament of the valve should only be burned as bright as is necessary to give good signals. The high-tension voltage should be about 50; lower voltages will work the set, but the signal strength will not be so great.

The set will be just as efficient (probably a little more efficient) when used with bright emitters. If external batteries are used, the leads which are now shown as flexible can be taken to terminals on the panel or at the rear. Many readers may prefer this arrangement.

SIR,—It may interest you to know that I was successful in tuning in between 2.45 a.m. and 4.5 a.m. on the 16th December two American broadcasting stations, the first at 2.47 a.m., but the announcer omitted to give his call sign. The part of the programme I received consisted of orchestral selections and vocal items by a baritone. Atmospheric were rather bad. Eventually I lost the station at 3.5. At 3.40 I tuned in WGY when a dance band was playing and I listened to three dances until 3.55. The announcer of this station spoke very clearly and repeated the call sign twice; at times the band could be heard with the phones off quite clearly. I lost this station after having rearranged the valves, and was unable to tune in anything else. The set used was the "3 Valve All Concert Receiver" as described in the September issue of MODERN WIRELESS, using 4-volt filament current and 54 volts H.T.

I regularly receive FL Paris on an Amplion loud-speaker, the strength being practically equal to that of 2 LO; Radiola comes in fairly strong. The new Belgian station and Ecole Supérieure PTT can also be tuned in with 2 LO working, at full strength. I am able to receive with this fine circuit all the B.B.C. stations with the exception of 2 ZY. My aerial is a 50 ft. twin on a 40 ft. mast.

I am, etc.,

W. A. F.

Forest Gate, E. 7.

NOTE.—We have received numerous requests from readers for a method of adding a fourth valve to the all concert receiver without the use of a separate unit. Probably the best way to do this is to lengthen the box and panel of the set about 6 inches, and add the components specified in the article on p. 80 of the November issue, wiring them up by the aid of the diagram on p. 86. The extra terminals shown will be found convenient for cutting out the fourth valve.

“MODERN WIRELESS” CHOKE CIRCUITS

By JOHN SCOTT-TAGGART, F.Inst.P., Editor.

This type of circuit, although of great value to the experimenter, has been strangely neglected in the past. This article gives full practical details so that readers may try out the methods for themselves.

A TYPE of circuit which has received little or no attention in the technical Press is what I propose to call a choke circuit. Several of these circuits are described below, but further circuits will be published from time to time, and many readers will be able to adapt their receivers so as to use this principle.

Choke coils have, of course, been frequently used before for coupling valves but, as in several other cases, the experimenter has not taken advantage of this useful method. Dual amplification was invented more than ten years ago,

and yet only when a thoroughly practical circuit is produced does it achieve the very wide popularity it deserves. Tuned anode coupling also suddenly became popular as a means of coupling valves, although in more restricted circles it was well known. So it may be in the case of choke coupling.

Chokes may be divided into two classes: high-frequency chokes,

and low-frequency chokes. A high-frequency choke in most cases is an air-core choke, that is to say, it consists of a large number of turns of insulated wire wound in the form of an inductance which offers a high impedance to high-frequency currents. A low-frequency choke is also intended to offer a high impedance to low-frequency currents, but since the

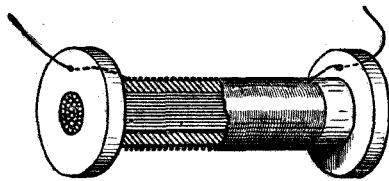

Fig. 1. A simple choke coil.

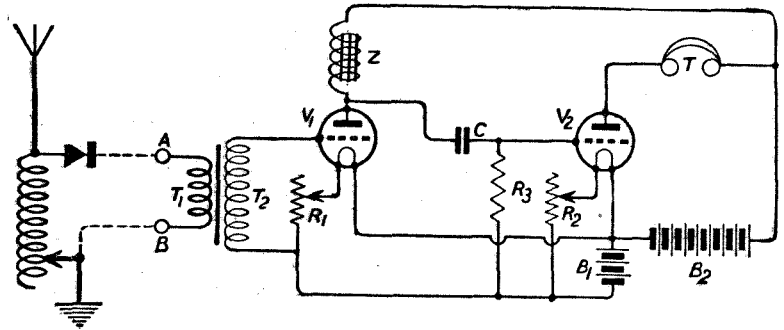

Fig. 2. A simple choke amplifier connected to a crystal receiver.

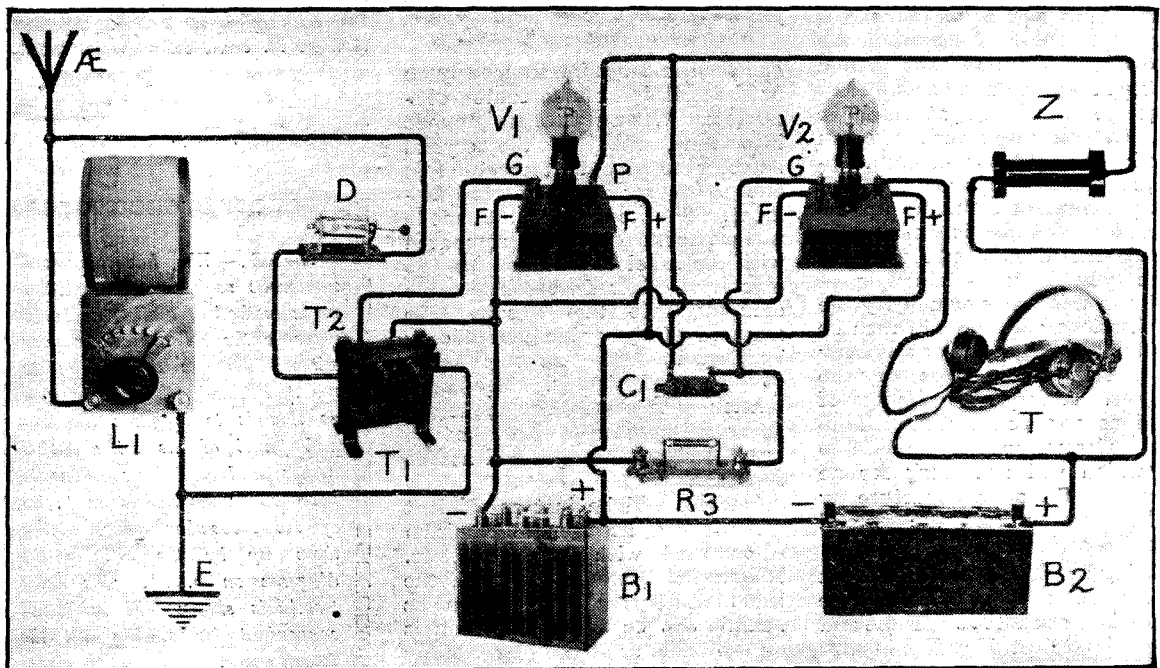

Fig. 3. The above circuit shown pictorially.

impedance of an inductance decreases as the frequency of the current passing through the choke decreases, we have to make up for this, in the case of low-frequency chokes, by increasing the inductance. This we do in two ways; more turns are used and the inductance is wound on an iron core.

The choke with which experiments have been carried out consists of a simple core consisting of a bundle of iron wires 4 in. long and about 7-16th in. diameter, on which a bobbin is slipped, the bobbin having, of course, end pieces or cheeks. The space on the bobbin for winding is 3 in. long and 14,000 turns of No. 44 gauge single or double silk covered wire is wound on the bobbin, stouter wires being connected to the ends. Several different kinds of open and closed core choke coils were tried, but the simple one illustrated in Fig. 1 was found to be as good as any. Those who are desirous of carrying out experiments should try using the secondary of a step-up intervalve transformer, the primary being left free. The secondary windings of induction coils, such as Ford coils, may also be tried, but my experience of these for this purpose is *nil*.

Object of the Choke.

The object of the iron-core choke is to serve as a means of coupling two valves and passing on low-frequency potentials to the grid

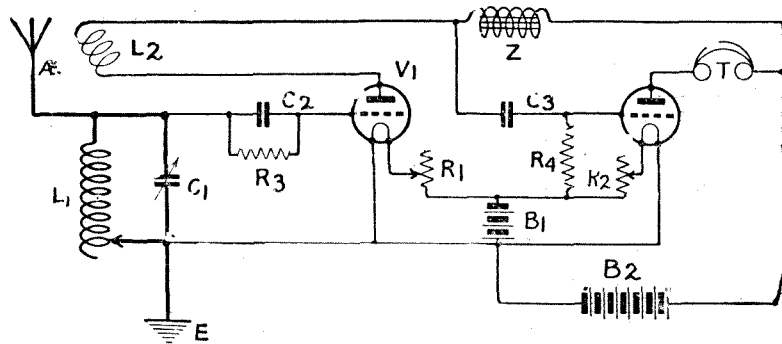

Fig. 4. A choke circuit using valve detector with reaction.

of the second valve. The choke is included in the anode circuit of the first low-frequency amplifier, and the anode of this amplifier is connected through a grid condenser to the grid of the next valve, a gridleak being provided between the grid and the negative terminal of the filament battery.

A circuit which shows the use of a choke for low-frequency amplification is given in Fig. 2. It will be seen that on the left there is the ordinary crystal receiver, and the rectified currents are passed through the primary T_1 of the step-up transformer $T_1 T_2$, the secondary T_2 of which is connected across the grid and filament of the first valve. The dotted lines are thus shown to indicate that the terminals A B of the two-valve amplifier of special design shown in this figure might be connected to other circuits. In the anode circuit of the first valve

V_1 , we have the choke coil Z, while the anode itself is connected through the condenser C to the grid of the second valve V_2 . The condenser C has a value of $0.002 \mu F$ (microfarad). Different sizes of condensers have been tried for this purpose, but it was found that no noticeable advantage was gained by using a larger condenser than this. The gridleak R_3 has a value of 2 megohms, but it was found that the actual value of this was quite immaterial, and therefore a variable gridleak is quite unnecessary.

In the anode circuit of the second valve we have the telephones T, or loud-speaker, as the case may be.

The operation of this circuit is briefly as follows:—The rectified currents pass through T_1 and set up varying currents in the secondary T_2 which communicates the potentials to the grid of the first valve; the variation in grid

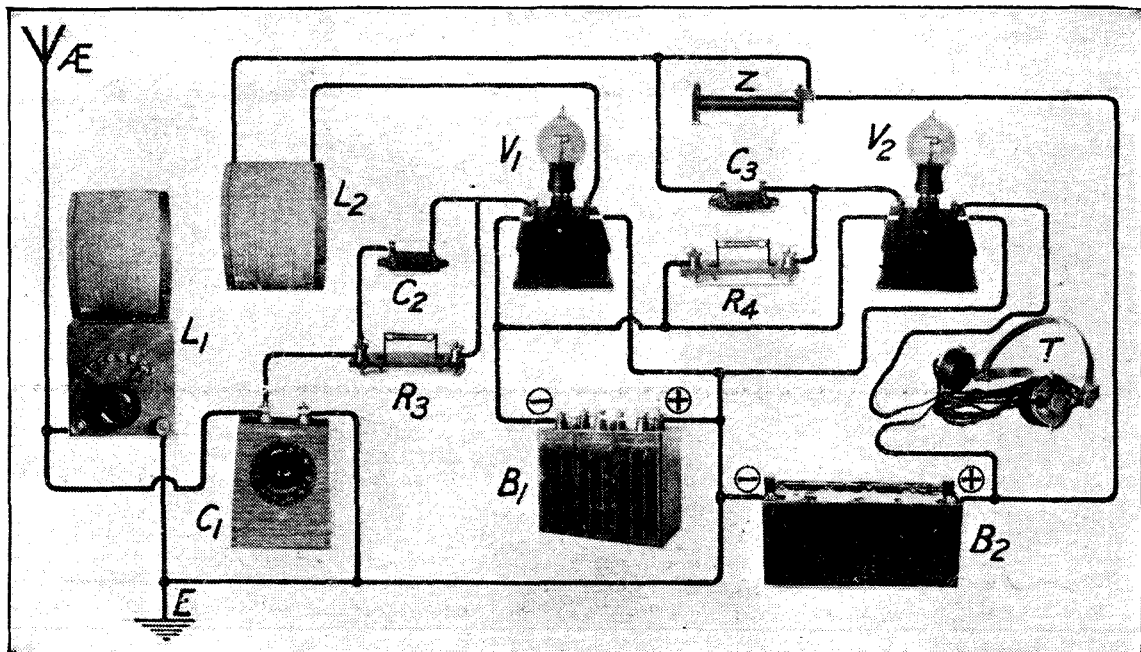

Fig. 5. The above circuit depicted in photographs. In this and Fig. 10 the terminals of choke are both at one end.

potential of the first valve alters the number of electrons flowing between the filament and anode of this valve, and therefore the anode current flowing through the choke Z, the anode circuit of the first valve consisting of filament A_1ZB_2 and so back to filament. When a steady current is flowing through the inductance, no potential difference is set up across it, but if a steady current passes through a resistance, there is a voltage drop across the resistance, and if the current fluctuates the potential difference across the ends of the resistance will also fluctuate. If, instead of passing a direct current through the choke coil, we pass a varying current, there will be varying potential differences set up across the inductance. So it

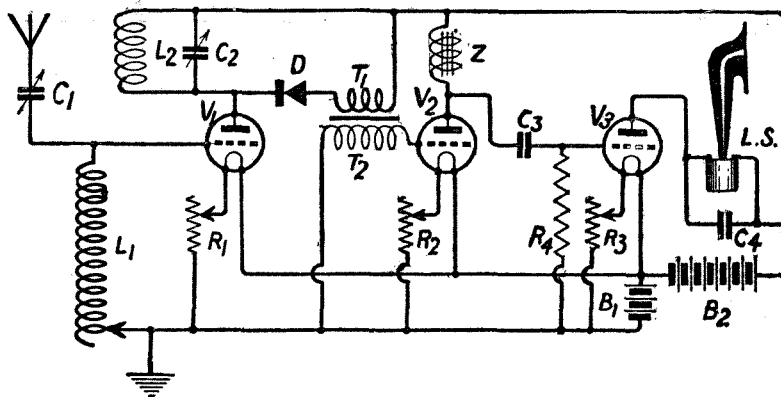

Fig. 6. An excellent three valve circuit using a choke.

is in this case. The steady anode current of the first valve, when no signals are being received, does not

set up any potential difference across the choke coil Z.

There may be a small E.M.F. across the choke because of its resistance, but this may be neglected in this explanation.

When signals arrive, however, the current flowing through the choke coil Z varies at low frequency, and this varying current, passing through the high inductance of the choke, causes potential differences to be set up across it; these potential differences are communicated to the grid of the second valve through the condenser C. The top end of the choke Z is connected through the high-tension battery B_2 to the filament of the second valve, and since the battery B_2 has practically no inductance or resistance, the low-

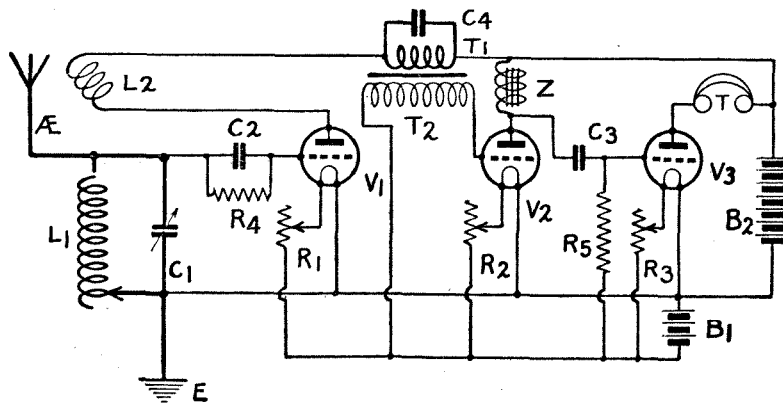

Fig. 7. A three valve circuit without crystal detector.

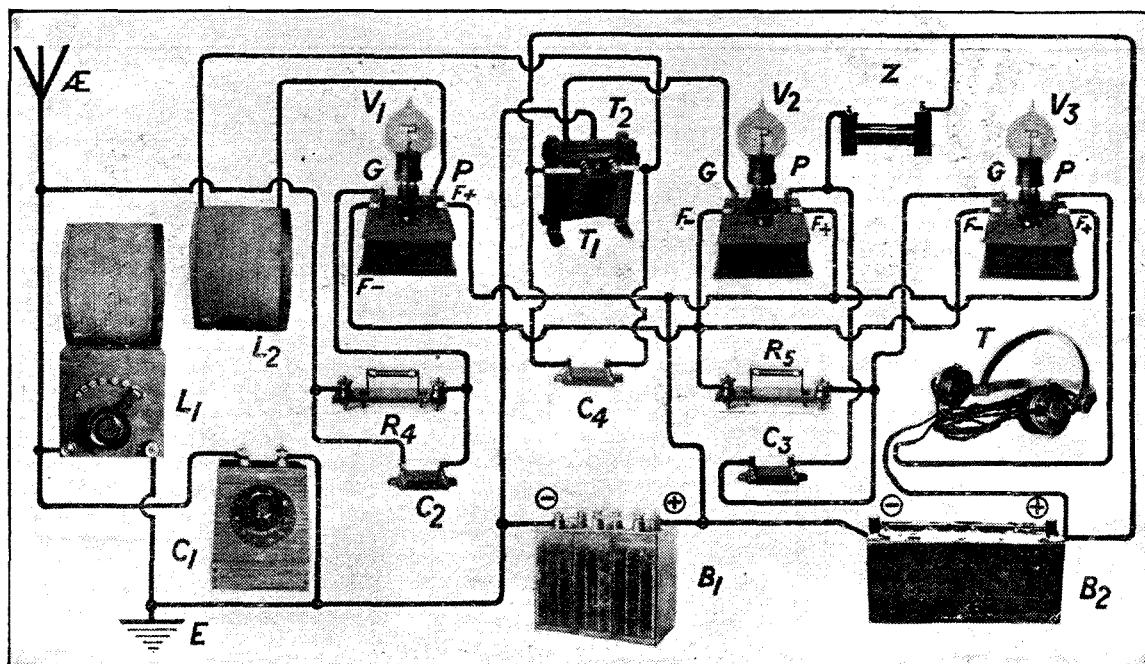

Fig. 8. The last circuit shown in photographic form.

NEW YORK on a TWO-VALVE SET

These Letters tell their own story.

*Sutton Paradales
Chesterfield
Nov 7th 1923*

GENERAL ELECTRIC COMPANY
GENERAL OFFICE
SCHENECTADY, N. Y.

In Reply Refer to

October 24, 1923.

*Dear Mr. Bacon,
Near The Floods Electrical
Storage Co Ltd*

Mr. H. Bacon,
Cavendish Motors, Ltd.,
Holywell St.,
Chesterfield, England.

Dear Mr. Bacon,

We were pleased to receive your letters of September 22nd and 24th, enclosing a printed account of your reception of our program of September 21st.

In checking over our station log, we find that it corresponds in nearly every particular with your report of reception. The exceptions are noted on the sheet which you sent us and is being returned herewith.

If it is your practice to issue similar reports on all WGY receptions, we would be pleased to have you send us an extra copy for our files.

Trusting that you may continue to receive and enjoy our programs, and assuring you of our desire to hear from you whenever you are successful in tuning us in, we are

Very truly yours,
GENERAL ELECTRIC COMPANY
BROADCASTING STATION WGY

By *P. H. Humph*

Dear Sir
You will see by the enclosed letter of my success in receiving full programmes of American wireless transmissions, which thanks to the Exide Batteries is received by me quite clearly using D.E.R. valves 1HF 1D 50 Volts Plate Voltage 2000s Filament I have tested the results with Dry batteries there is not the clearness or sharp tuning that I can get with your batteries. You are quite at liberty to publish this if you care
Yours faithfully
H. Bacon

P.S. You will see there were only 4 phones used in the program enclosed & corrected by the S & S of America

PH:umpf:HAYB
Enclosure

Note particularly that Mr. Bacon could only get this result with

Exide

The long life battery.

THE Chloride ELECTRICAL STORAGE COMPANY LIMITED.

HEAD OFFICE AND WORKS:
CLIFTON JUNCTION, Nr. MANCHESTER.
LONDON: 219-229, Shaftesbury Avenue, W.C.2.
BIRMINGHAM: 57-58, Dale End.
MANCHESTER: 1, Bridge Street.

USE CHLORIDE BATTERIES FOR HOUSE LIGHTING.

In replying to advertisers, use COUPON on last page

DUBILIER CONDENSERS

Constructional Chats

By PHILLIP R. COURSEY, B.Sc.
No. 2.

SOME USES OF CONDENSERS IN A RADIO RECEIVER.

IN the modern wireless receiver employing valves several condensers are needed, each having a separate and possibly a different function, and careful selection is necessary in order to ensure that each condenser is best suited to the particular duty which it is expected to perform. We will deal here with the condensers employed in the tuning or oscillatory circuits. These are usually (1) Variable Condensers in conjunction with inductances which are either fixed or variable in steps only, and (2) fixed condensers employed in conjunction with a variometer and giving the necessary wavelength ranges. In case (1) the variable condenser should have an air dielectric, and it should be rigidly constructed so that it will retain its adjustment and calibration indefinitely. Generally speaking a variable condenser used in tuning the aerial circuit should have a maximum capacity of 0.0007 to 0.001 microfarad; similarly one for tuning the secondary circuit should have a maximum capacity of 0.0005 to 0.0007 microfarad, the values chosen depending upon the wavelength range or ranges on which it is desired to work. For tuning the anode circuit of a valve amplifier, values of 0.0001 to 0.0003 microfarad should be chosen depending upon the type of intervalve coupling in use.

In case (2) the fixed condensers must usually have solid dielectrics, and in consequence their efficiency becomes a matter of great importance. Their construction and design must be such that all energy losses have been reduced to the minimum. The usual values of a fixed condenser used in series with a variometer for tuning the aerial circuit on the ordinary broadcast wavelengths is from 0.0002 to 0.0005 microfarad, while similar condensers arranged so that they can be included in parallel with the variometer will serve to increase the tuning range. Care should be taken, however, not to include too large a condenser in parallel with the inductance in the receiving aerial circuit.

DO NOT MISS No. 3 OF THIS SERIES.

THE DUBILIER CONDENSER CO. (1921), LTD.,
DEPT. D.

Ducon Works, Goldhawk Road, LONDON, W. 12.

Telegrams: "Hivoltcon, 'Phone, London." Telephone: Hammersmith. 1084.

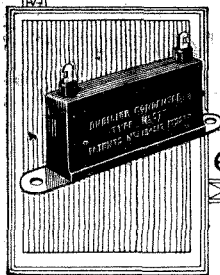

CP 38

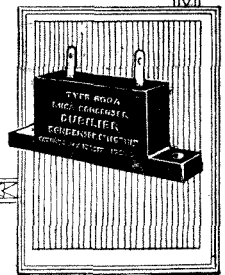
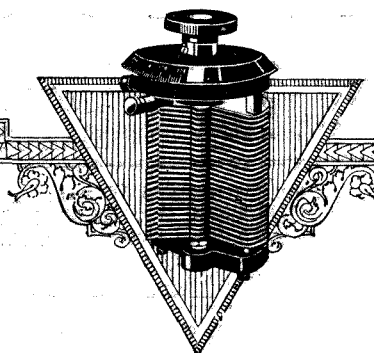

frequency current through it will not in any way set up varying potentials across it. We can therefore consider the top end of the choke coil Z as being at the same potential as the filament of the second valve, and if, say, there is a potential difference at a given instant of 1 volt across the choke coil Z, when signals are being received, this will be applied through the condenser C to the grid of the valve V₂. It is to be noted that only changing potentials across Z are communicated to the grid of the second valve; the positive potential of the high-tension battery is not communicated to the grid of the second valve because the condenser C acts as an insulator towards direct currents, whereas it readily allows low-frequency potentials to be communicated through it to the grid.

The gridleak R₃ is merely for the purpose of preventing an accumulation of electrons on the grid of the second valve. If this leak were not provided, the variations in grid potential would cause electrons to be drawn up to the grid, and they would then have nowhere to go, but would charge up the right-hand side of the condenser C and the grid itself. After a time, these electrons would accumulate to such an extent that the grid would acquire a considerable negative potential which would interfere with the correct operation of the second valve. In order to keep

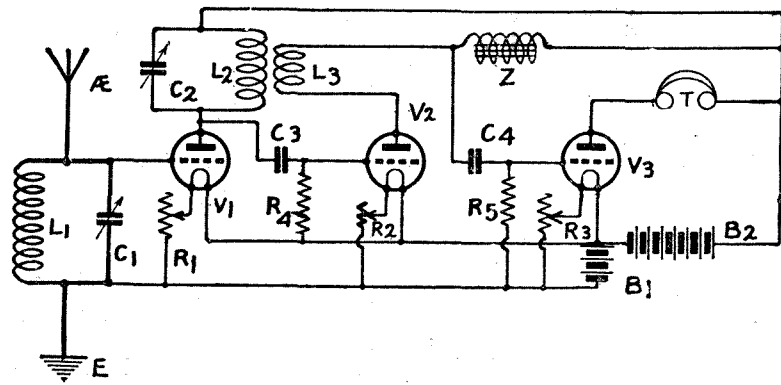

Fig. 9. An interesting modification of the ST34 circuit.

the grid at a suitable normal potential, the gridleak is provided, and the excessive electrons flow through the resistance R₃.

It must not, therefore, be imagined that the second valve acts in any way as a rectifier. The value of the gridleak R₃ is almost immaterial; a resistance of, say, 100 ohms would act virtually as a short circuit, but 1 or 2 megohms would in no wise affect the strength of the applied potentials, but would prevent the undesirable accumulation of electrons on the grid of the second valve.

The low-frequency changes of potential of the second grid cause amplified current variations to affect the telephones T in the anode circuit of this second valve.

The whole arrangement works

excellently as a low-frequency amplifier, and there are certain technical merits, from the point of view of purity of reproduction, which cannot be disregarded. It is found, for example, in the case of a transformer, that some of the higher frequencies are not properly reproduced, whereas in this arrangement the potential changes due to the higher "low-frequency" currents due to the incoming signals are communicated to the grid of the second valve.

Fig. 3 is a pictorial representation of the Fig. 2 circuit.

The following values will be found useful in connection with the Fig. 2 circuit.

The inductance L₁ for the broadcasting wavelength = cardboard tube 4½ in. long, 3 in. diameter wound with

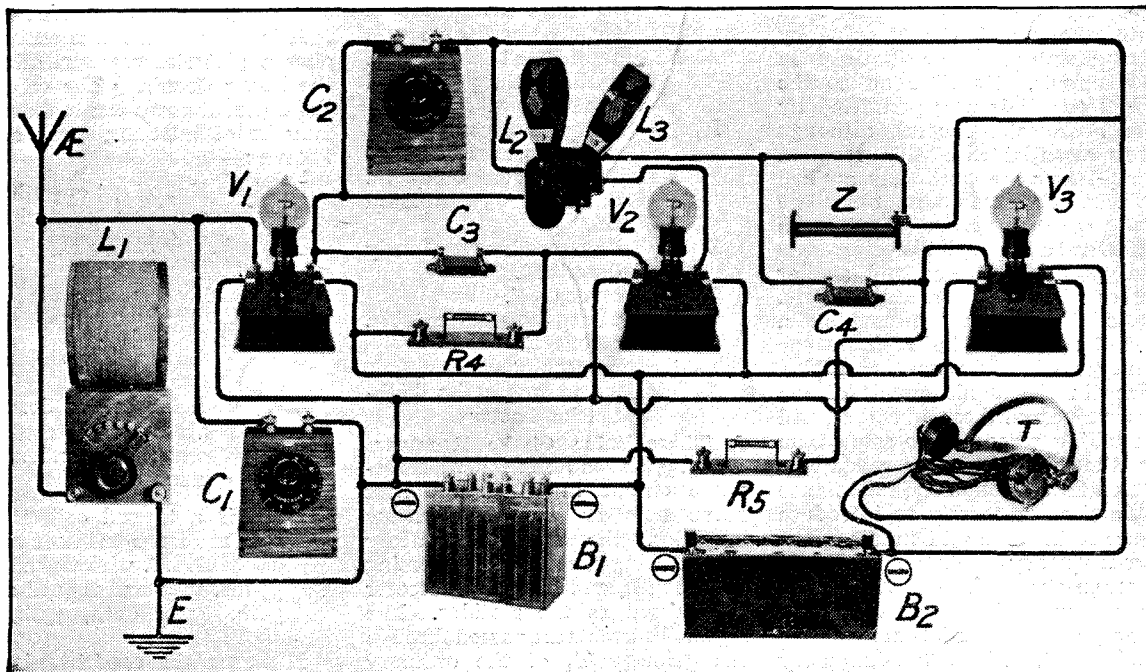

Fig. 10. How to connect up the Fig. 9 circuit.

- No. 26 gauge enamelled wire ; slider provided.
- T_1T_2 = ordinary step-up transformer.
- Z = choke coil, as shown in Fig. 1.
- C = 0.002 μ F (microfarad).
- R_3 = 2 megohm gridleak.
- B_2 = High-tension battery 60 to 100 volts, according to valves used.

Another Circuit.

Another interesting choke circuit is that illustrated in Fig. 4. In this case the first valve acts as a detector with reaction, the inductance L_2 in the anode circuit being coupled to L_1 in such a way as to introduce reaction into the aerial circuit which is tuned by means of the variable condenser C_1 which might, of course, be tried in series with the aerial. The usual grid condenser C_2 and gridleak R_3 are provided and in the anode circuit of the first valve we have the choke coil Z, of the kind previously described in connection with Fig. 1. The left-hand side of the choke Z, i.e., the side nearest the anode of the first valve, is connected through the condenser C_3 of 0.002 μ F to the grid of the second valve, a gridleak R_4 being connected across this secondary and the negative terminal of the filament accumulator B_1 . The telephones T are included in the anode circuit of the second valve.

The operation of this circuit is briefly as follows: The valve V_1 acts as a detector and also serves as a means of introducing reaction into the aerial circuit, thereby strengthening the oscillations in this circuit. Reaction on to the aerial circuit is now permitted by the Postmaster-General, although it is essential that this reaction should be very cautiously applied so that the valve does not oscillate and radiate waves which will interfere with neighbouring sets and produce howling and similar undesirable noises in their receivers.

As the first valve acts as a detector there will be low-frequency changes of anode current taking place in the anode circuit of the first valve and these, of course, will be taking place at the same time as the high-frequency variations which flow through the inductance L_2 and serve merely to introduce reaction into the grid circuit. The low-frequency currents pass through the choke coil Z, and we consequently have low-frequency changes of potential across this choke coil. These low-frequency potential changes across Z will be communicated to the grid of the second valve through the condenser

C_3 , and we have therefore a simple low-frequency amplifier circuit. Such an arrangement, however, will not be found to be as good as one in which a transformer is used. Experiments seem to show that the first stage of low-frequency amplification needs a transformer, while the second and third stages, if employed, may be effectively carried out by the aid of a choke. The use of the choke in such circuits as that shown in Fig. 4 will, however, lead to interesting results being obtained.

The low-frequency potential variations across Z, being communicated to the grid of the second valve, will cause amplified low-frequency current variations to flow through the telephones T and actuate them. As regards the high-frequency currents in the anode circuit of the first valve, these will pass through the self-capacity of the choke coil Z; the connecting of a small condenser of, say, 0.0003 μ F capacity across the choke coil Z may be tried experimentally.

Fig. 3 shows the Fig. 2 circuit pictorially represented.

As regards values for the Fig. 3 circuit, the following data may prove of interest.

- L_1 = No. 25, 35 or 50 honeycomb coil, according to aerial, or 3½ in. diameter tube wound with 50 turns No. 26 D.C.C. wire tapped at 10th, 15th, 20th, 25th, 30th, 35th, 40th, and 50th; or if the variable condenser is in series with the coil, then a 100 turn coil tapped at the 30th, 45th, 60th, 75th, and 100th turns.
- L_2 = No. 75 honeycomb coil or 35 turns of No. 26 D.C.C. wound on a 3 in. diameter cardboard tube.
- Z = Choke coil as previously described.
- C_3 = 0.0003 μ F.
- R_3 = 2 megohms or variable.
- C_2 = 0.002 μ F.
- R_4 = 2 megohms.
- B_2 = 60 to 100 volts high-tension battery.

A Three-Valve Choke Receiver.

Fig. 5 shows an excellent three-valve circuit in which the first valve acts as a high-frequency amplifier, the anode oscillatory circuit being tuned to the incoming wavelength, and a crystal detector being used as the rectifier. The rectified currents are passed through the primary T_1 of the ordinary intervalve transformer T_1T_2 , the secondary T_2 of which is in the grid circuit of the second valve.

In the anode circuit of this valve we have the choke coil Z, which is of a similar pattern to that initially described in this article. The anode of the second valve is connected to the grid of the third valve through the condenser C_3 of 0.002 μ F capacity, while a gridleak of 2 megohms is connected across the grid and filament of the last valve. In the anode circuit of this valve we have a loud-speaker which is shunted by the condenser C_4 , which may have a value from 0.002 μ F to 0.05 μ F, according to the type of loud-speaker used.

This circuit will be found very effective in practice, and good loud-speaker results should be obtained up to about 20 miles from a broadcasting station.

The circuit L_2C_2 has, of course, to be accurately tuned every time the reaction between L_2 and L_1 is varied; the condenser C_1 will also require accurate adjustment. It is important to try connecting the leads to L_2 in a reverse direction to see which way gives the best results, because a reaction effect is obtainable on a circuit of this kind even when the reaction coil is the wrong way round, but the results obtainable are not as good as when the coil is the right way round. The apparently inexplicable phenomenon is due to capacity coupling between the anode circuit and the grid circuit, and this overcomes the reverse reaction.

Both the second and third valves act as high-frequency amplifiers, and it will be found that the choke coil Z will give good results.

It is not considered necessary to give a pictorial representation of the Fig. 5 circuit. The values of the different components, however, may be of interest; they are as follows:—

- L_1 = No. 25, 35 or 50 honeycomb coil or equivalent coil.
- C_1 = 0.0005 μ F variable condenser.
- L_2 = No. 50 or No. 75 honeycomb coil.
- C_2 = 0.0005 μ F variable condenser.
- Z = choke coil as described above.
- C_3 = 0.002 μ F condenser.
- R_4 = 2 megohms.

If L_1 is a tapped coil, it may consist of 100 turns of No. 26 gauge D.C.C. wire wound on a 3½ ins. tube and tapped at the 30th, 45th, 60th, 75th, and 100th turns.

If the variable condenser is to be connected across L_1 , then the values given in connection with Fig. 4 should be adopted.

*No more
Wireless Masts*

UTILITY ENDORSED
BY THE EDITOR OF
"WIRELESS WEEKLY"



**CHEAPEST AERIAL
AND THE BEST
IN THE WORLD.**

WIRELESS experts are enthusiastic with regard to the uses of our wire for indoor and or outdoor aerials, and report wonderfully clear results with either crystal, valve or tube sets. Bare copper wire exposed to the weather soon corrodes, weakening the incoming signals, and necessitates renewals. Our covered wire will not corrode, saves renewals, reduces interference and holds all the strength of the incoming signals. The ether wave penetrates the coverings and provides an unexpected clearness of reproduction. Obviously, insulated wire is better protected from storms than wire uncovered. Use it as an aerial and wireless masts are entirely done away with. Troublesome insulators are abolished.

10) ft. **1/8** Carriage Paid,

It is a simple matter to make a portable aerial or frame aerial from this wire. Suspend it where you will (it is vulcanized) lead in, and the result is there.

We will send 100 ft. of the finest insulated aerial (VULCANIZED) carriage paid for 1/8.

READ THIS ONE OF MANY UNSOLICITED TESTIMONIALS

<p>300 ft. 4/3</p> <p>500 ft. 6/3</p>	<p>16, Duncay Road, Manchester.</p> <p>Dear Sirs, The 100 ft. of your excellent cable arrived quite safely, for which many thanks. I might add that I removed my original aerial of 7/22 hard copper, and re-erected it with your cable and the results are much better and more stable. Will you please forward me a further 100 ft. of the same, for which I enclose P.O. for 1/8 as before.</p> <p>Yours faithfully, (Signed) R. W. EVANS.</p> <p>[Originals can be seen at our offices.]</p>	<p>1000 ft. 10/3</p> <p>1/2 mile 17/6</p>
---------------------------------------	--	---

Money Refunded if not entirely satisfactory.
Prices for larger quantities upon application.

NEW LONDON ELECTRON WORKS, LTD.,
99, Regent's Dock, London, E.14.
TELEPHONE : EAST 1821. TELEGRAMS : "STANNUM, LONDON."



Fit Your Headphones with
CLIX
Build Your Components with
CLIX
Fit ALL Your Leads with
CLIX

Prov. Patent 13950/23.

CLIX	3d. each
"	LOCKNUTS...	1/2d. each
"	INSULATORS	1d. each
"	Complete with Locknut and Insulator	4d. each
"	BUSHES	1 1/2d. pair
"	Complete with Locknut and one pair Bushes	4 1/2d. each



Of all high-class dealers, or direct from the Patentees and Manufacturers. Send cash with order and 2d. per doz. or 6d. per gross for packing and postage.

AUTOVEYORS Ltd.
Radio Engine rs and Contractors
84, VICTORIA STREET, WESTMINSTER,
LONDON, S.W.1

Published November 8th.

500
Wireless Questions
Answered

By E. REDPATH and G. P. KENDALL, B.Sc.

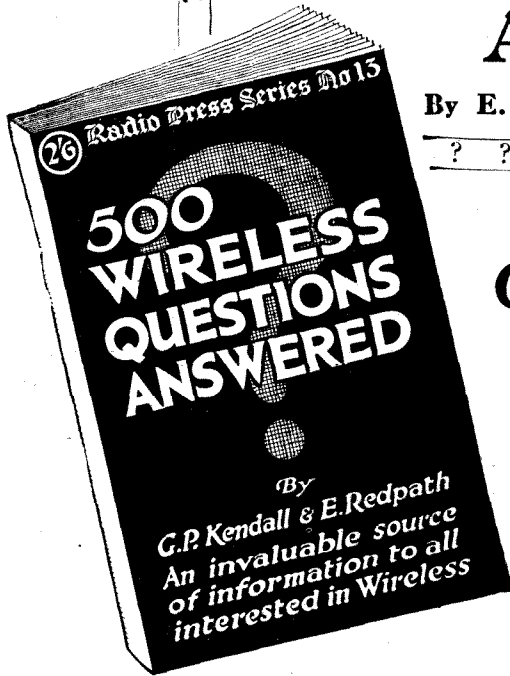

*Get the right information
quickly!*

THIS Book is going to be one of the most useful and popular Radio Books ever published. No matter how much or how little you know, there will often arise little difficulties and queries which need explanation.

Instead of having to wade through pages of text-book matter to obtain the information you need, all that you have to do is to refer to **500 Wireless Questions Answered** and in a moment you have the information accurately and concisely.

If you are in difficulties with the Set you are building—if the Set you are using is not working to your complete satisfaction, it is probably due to your lack of knowledge of some fundamental Wireless principle. Get the facts from this real "Wireless Encyclopædia"; it will save its cost to you time and again.

**Questions
about :**

- Aerials.
- Frame Aerials.
- Earths.
- Waves.
- Wave-Lengths.
- Tuning Coils.
- Tuning Condensers.
- Valves.
- Reaction.
- Primary Batteries.
- Secondary Batteries.
- Crystal Sets.
- Amplifiers.
- Grid Leaks and Condensers
- Loud-speakers.
- Wire.
- Range (transmitting and receiving).
- Interference.
- Morse Signals.
- Sounds and Signals heard.
- Telephone Receivers.

Published by

RADIO PRESS LTD.,
Devereux Court, STRAND,
W.C.2.

*From all Booksellers
and Newsagents or
2/8 post free.*

2/6

Radio Press Series No. 13.

If L_2 is to be a tapped coil, it should consist of 70 turns of No. 26 gauge D.C.C. wire wound on a 3 in. tube, tapings being taken at the 30th, 50th, and 70th turns.

Another Three-Valve Choke Circuit.

A three-valve circuit employing a choke coil, but not a crystal detector, is illustrated in Fig. 7.

In this figure, the first valve acts as a detector, and a reaction effect is obtained by coupling the anode inductance L_2 to L_1 . The anode circuit of the first valve contains the primary T_1 of a step-up intervalve transformer T_1T_2 . This primary is shunted by a condenser C_4 of 0.002 μ F capacity; the secondary T_2 is connected across the grid and filament of the second valve in the anode circuit of which is the iron core choke coil Z . The anode of the second valve is connected to the grid of the third valve through the condenser C_3 of 0.002 μ F capacity, while a grid leak R_5 is connected across the grid and filament of the third valve. The telephones, or loud-speaker, are connected in the anode circuit of the last valve.

This circuit is very simple to operate because the only variables are the reaction adjustments and the variable condenser C_1 .

Suitable values of components for this circuit are as follows:—

L_1 = No. 25, 35 or 50 honeycomb or equivalent coil, or a cardboard tube $3\frac{1}{2}$ in. diameter round with 50 turns of No. 26 gauge D.C.C. wire tapped at the 10th, 15th, 20th, 25th, 30th, 35th, 40th, and 50th turns.

C_1 = 0.0005 μ F variable condenser.

L_2 = No. 75 honeycomb coil or 35 turns of No. 26 D.C.C. wound on a 3 in. diameter cardboard tube.

A Three-Valve Circuit Using High-Frequency Amplification.

A three-valve circuit using high-frequency amplification is illustrated in Fig. 9. In this case we have the now well-known tuned-anode, with reaction circuit (ST 34), followed by a stage of low-frequency amplification which, instead of being effected by means of a step-up intervalve transformer, is obtained by the use of a choke in the manner illustrated in Fig. 8. The aerial circuit is tuned by means of L_1 and C_1 , while in the anode circuit of the first valve we have the inductance L_2 tuned by means of the condenser C_2 . The usual grid condenser C_3 is provided to enable the high-frequency potentials of the anode of the first valve to be communicated to the grid of the second, the usual grid-leak R_4 being also connected in the position shown.

The second valve acts as a detector, and reaction is introduced into the circuit L_2C_2 by the reaction coil L_3 . In series with this reaction coil, and included in the anode circuit of the second valve, is the choke coil Z . The left-hand side of this choke coil, that is to say, the side next to the anode of the second valve, is connected through the condenser C_4 of 0.002 μ F capacity to the grid of the third valve, a gridleak R_5 being connected across grid and filament. In the anode circuit of the third valve we have the telephones, or the loud-speaker, as the case may be.

This circuit will not in general give quite as good results as if a step-up intervalve transformer were used in place of the choke Z . Quite effective results, however, may be obtained.

As regards the different components for this circuit, the following particulars may be of interest.

L_1 = No. 25, 35 or 50 honeycomb or equivalent coil, or 50 turns of No. 26, D.C.C. wire wound on a $3\frac{1}{2}$ in. tube tapped at the 10th, 15th, 20th, 25th, 30th, 35th, 40th and 50th turns.

C_1 = 0.0005 μ F variable condenser.

L_2 = No. 50 or No. 75 honeycomb or similar coil, or 70 turns of No. 26 D.C.C. wire wound on a 3 in. tube and tapped at the 30th, 50th, and 70th turns.

C_2 = 0.0005 μ F variable condenser.

L_3 = No. 75 honeycomb coil or 35 turns of No. 26 D.C.C. wire wound on a $3\frac{1}{2}$ in. tube.

C_3 = 0.0003 μ F condenser.

R_4 = 2 megohms or variable.

Z = Choke coil as previously described.

C_4 = 0.002 μ F condenser.

R_{55} = 2 megohms resistance.

B_2 = Usual high-tension battery of 60 to 100 volts.

Conclusion.

The above particulars will give some indication of the usefulness of the choke method of low-frequency amplification, and the experiences of readers will prove of considerable interest.

The general conclusions to be drawn are that after an initial stage of low-frequency amplification, the use of a choke is certain to give excellent results. Without the initial stage of low-frequency amplification, effected by means of an intervalve transformer, results are not quite as good, but on the other hand great purity of reproduction is obtained and the choke is, of course, simple to make or cheap to buy.

Those who desire to purchase the choke will no doubt find what they require in the advertisement pages of this journal.

“ WIRELESS WEEKLY ”

IS BOTH SOUND AND INTERESTING.

All the latest Circuits and Novelties are
: : described as they appear : :

“ AS GOOD AS ‘ MODERN WIRELESS. ’ ”



Above & below the Broadcast Wavelengths

Transatlantic Telephony

THOUGH these are strictly speaking neither above nor below the broadcast wavelengths, since our own authorised band now extends from 300 to 500 mètres, I feel that a few hints upon the reception of American broadcast programmes may not be out of

fiction is all that is in general use for the purpose. American broadcasting has been received on very many occasions with a single valve set, though this demands a great deal of patience coupled with no small skill in fine tuning, and it usually is liable to lead to a considerable amount of interference

during the recent test carried out by the B.B.C. when an attempt was made to establish telephonic communication by means of alternative five-minute transmissions with eight of the American stations. Almost every owner of a valve set appeared to be at work and great numbers of them were oscillating so badly that anything like respectable reception in and around London was impossible. Though weather conditions were not good the test was undoubtedly ruined not by this fact but by interference caused through reradiation. In proof of this let me say that though nothing was heard officially except one remark from WGY at 3.16, I was able to hear this station on two other occasions during the test, thanks to my living in the country, and not being bothered on this occasion by local oscillation.

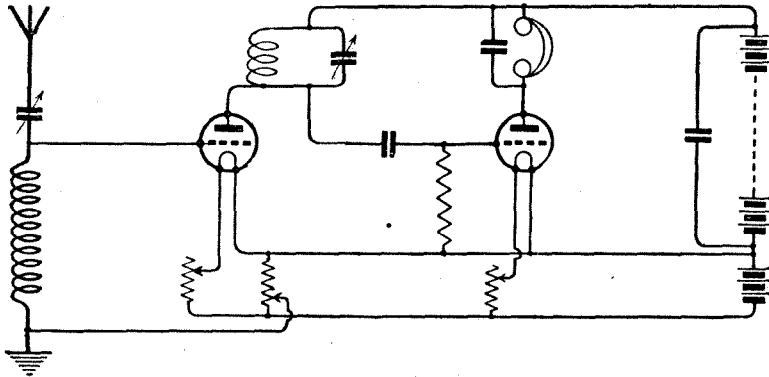

Fig. 1.—A seemingly innocent circuit that often radiates badly.

place, for listening in to the United States has become one of the most popular pastimes among wireless men. It should be said at once that there is nothing very difficult about the feat provided that one has a good unscreened aerial and that weather conditions are favourable. These latter have an immense influence upon one's chance of success. Generally speaking, it is of very little use to sit up on still bright nights. What one wants is, at any rate, an overcast sky, and my experience has been that a really dirty night with a gale of wind and rain falling in torrents is the nearest possible approach to ideal conditions. On such a night one can switch on the set with almost a feeling of certainty that one or more stations will be picked up.

A large set is not, as a rule, necessary, in fact a reference to the lists of those who report American receptions will usually show that one stage of high-frequency ampli-

with others owing to misuse of the reaction circuit.

Reaction Abused

Though the Postmaster-General's regulations regarding the use of reaction have recently been relaxed, the experimenter should endeavour to play the game by causing as little interference as possible at all times. A glaring example of the way in which the abuse of reaction can ruin reception far and wide occurred

Those who were conducting the test at 2 LO broadcast pathetic appeals to people who were oscillating to close down so as to give them at any rate a fair chance. These appeals fell apparently upon deaf ears for the noisiness continued unmitigated. However, I cannot believe that anyone who was knowingly oscillating would be so unsporting as to continue to do so in face of such a request. The trouble I think is that a very large number of amateur users of receiving sets do not know when oscillation is present.

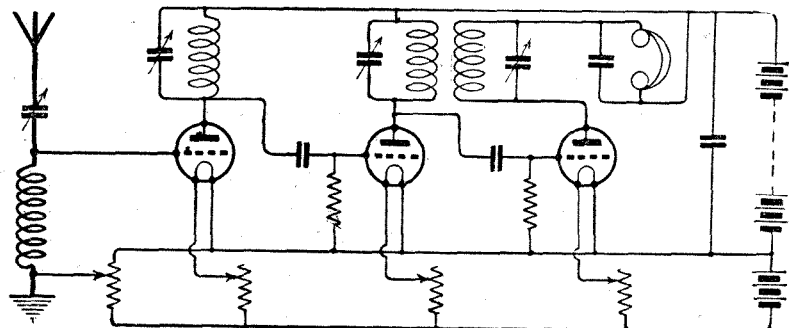

Fig. 2.—Another apparently innocent circuit.

Testing for Oscillation

Many people believe that no interference can be caused unless howls and squeaks are audible in the headset or the loudspeaker. It should be realised that howling is an *audio-frequency* noise due to oscillation of the most violent type. Interference can be, and in

makes and breaks contact. This click is certain proof that the set is in oscillation and that it is radiating. Interference produced when the set is in this condition will not, of course, be so bad as that which occurs when it actually howls, still its effects are fairly powerful, and they affect other

stations or from those in the States, should make this test frequently, and should do everything in their power to avoid giving rise to interference by allowing their sets to oscillate even mildly.

Another misconception which is fairly widespread is that interference cannot be caused unless reaction is used. Nothing could be further from the truth. A set employing tuned anode or tuned transformer coupling oscillates very readily unless the grid potentials are properly controlled and is capable of reradiating even though the reaction terminals are short circuited and the coil removed altogether. Those who use circuits of this type therefore should be particularly on the look out for oscillation, and should not allow themselves to be lulled into a false feeling of security.

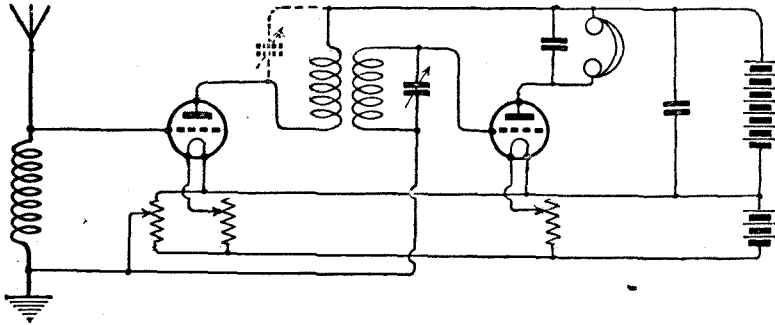

Fig. 3.—A third set which can radiate powerfully.

most cases is, caused long before the set reaches this stage. When even mild oscillation is present energy is transferred from the set to the aerial; the receiver thus becomes for the time being a weak transmitter sending out waves of small amplitude. As these have usually a frequency very near to that of the transmission being received they heterodyne it and may set up in other receivers in the neighbourhood a low continuous note which utterly spoils reception. If the heterodyne produces a beat that is either above or below audio frequency no note will be heard, but receiving sets in the vicinity will be affected. Often there will be a tendency on their part to oscillate and certainly reception will be blurred and distorted. The unmistakable signs of oscillation in one's own set are these: As adjustments are made, the received signal grows very loud, and is accompanied by rushing or rustling noises; C.W. signals may be heard faintly if any are in progress on the same wave-length; any tendency that the set naturally has to noisiness becomes exaggerated—thus if faint cracklings are heard normally they will become very loud and may assume proportions of atmospherics when oscillation is present.

But there is one absolutely certain test for the presence of oscillation. This consists in touching the aerial terminal of the set with a wet finger. If there is no oscillation the result will be to cause signals to fall off, since by touching the terminal the aerial is earthed to some extent; but there will not be anything like a sharp click in the receivers as the finger

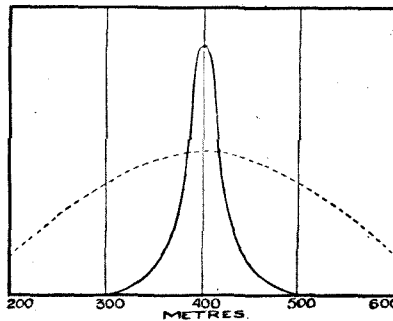

Fig. 4.—Comparative efficiency curves of tuned transformer (solid line) and a periodic transformer, the former being tuned to 400 metres, and the latter designed with an optional wavelength of that figure.

receivers at a considerable distance. During some experiments, carried out some time ago in conjunction with a friend who is also an enthusiast, it was found that if a microphone was inserted into the earth lead of a set oscillating just sufficiently to cause the clicks referred to telephonic transmissions could be made to a distance of at least half a mile. All amateurs then who are engaged upon broadcast reception whether from home

Circuits that Appear Harmless

Potentiometer control of the grid potential of high-frequency valves will do a great deal towards cutting down the tendency to oscillate, and accounts of other circuits by means of which full high-frequency amplification can be secured without oscillation have appeared recently in both *MODERN WIRELESS* and *Wireless Weekly*. In any case, it is undesirable to use sets for the purpose mentioned in which reaction is coupled directly to the aerial tuning inductance. This type of receiving apparatus can hardly help causing interference, occasionally at any rate, no matter how carefully and how skilfully it is handled.

Figs. 1, 2 and 3, show circuits which, though they look perfectly innocent, may yet produce very bad interference in the hands of an unskilled or unscrupulous user. Any of them would be to some extent improved by fitting a double circuit tuner, but here again careful use is necessary, for if the closed circuit is in oscillation energy will be transferred from it to the aerial. Also when a set of this type is so finely tuned that it is close to the oscillation point it can often be thrown

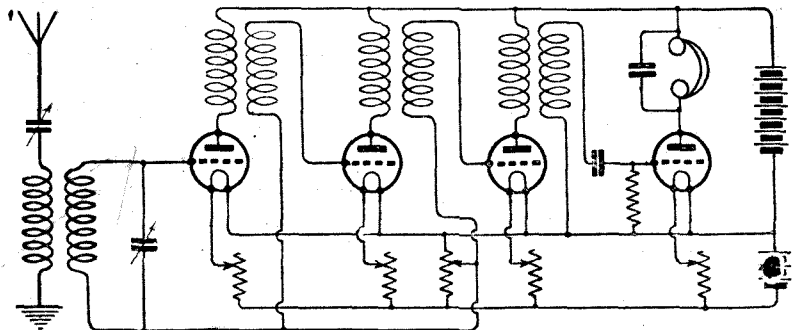

Fig. 5.—A good layout for long-distance work.

into oscillation by varying the coupling between the closed circuit inductance and aerial tuning inductance. All of these circuits should always be used with extreme care, and no ordinary high-frequency amplification circuit should ever be employed unless the grid

fairly good over a comparatively broad band of wave-lengths. It does not reach the same level as the peak of the tuned transformer curve, but for some distance on each side it does not fall off markedly below it. The fact that the plate circuit cannot be tuned to quite the same

Hence three aperiodic transformer coupled valves will be found almost as good as two tuned anodes so far as amplification is concerned, and they will be infinitely easier to handle. It should be remembered that the finer is the wire with which they are wound the greater is the total resistance, and therefore the lower of both the amplification factor and the tendency to oscillate. The experimenter who cares to set himself the task of trying out aperiodic transformers wound with various kinds of resistance wire will find he has a most interesting field before him. No. 40 S.W.G. Eureka gives quite respectable results, but probably a stouter gauge could be used, thereby increasing the amplification of the transformer without making the circuit unstable. On the other hand this would make the transformer less aperiodic, and it would cover effectively a much narrower band of wave-lengths.

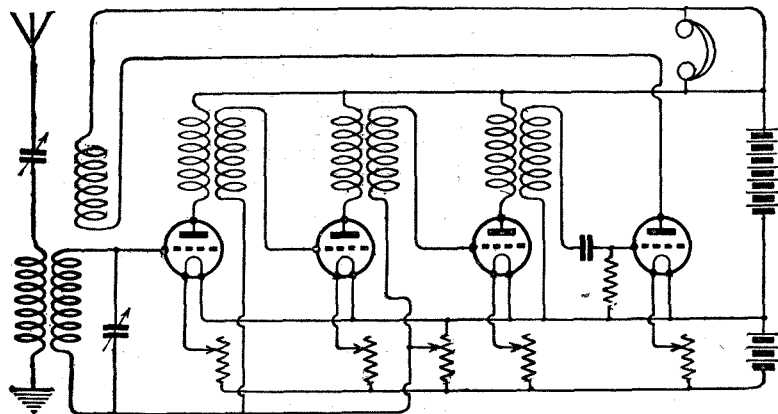

Fig. 6.—Reaction added to Fig. 5.

potentials are controlled by a potentiometer or some other form of damping is provided so that it may have a fair measure of stability.

Safe Circuits

Is there any form of circuit not too complicated in character which can be relied upon not to cause interference by radiation? It is a little difficult to give a direct answer to this question, for so much depends upon the operator. A circuit which in one man's hands would be as stable as could be desired; will play all kinds of pranks when worked by another who does not exercise the same amount of care. To design a circuit which is perfectly stable and yet at the same time ultra-sensitive is not an easy task. The more finely a set can be tuned the more liable, speaking generally, is it to be capable of oscillating. Probably the best way out of the difficulty is to resort to a compromise, thus living up to our national reputation.

In an article which appears in this issue of MODERN WIRELESS reference is made to the aperiodic high-frequency transformer wound with resistance wire. The chief difference between these and transformers of the ordinary type is shown diagrammatically in Fig. 4. The tuned transformer gives its best only when its condenser is adjusted so that the circuit is in perfect resonance with the received wave-length; that is to say there is a very marked peak effect. The aperiodic transformer on the other hand has a very flat efficiency curve. It cannot be sharply tuned by a condenser, but at the same time, its efficiency is

degree of sharpness as the grid circuit reduces the tendency to oscillation almost to zero. Though this is very satisfactory, we must set against it the fact that with the aperiodic transformer we cannot hope to obtain the same degree of amplification as with the tuned anode or tuned transformer. We can, however, make use of quite a number of untuned transformers in series without producing instability in the receiving set. I often employ three of them, and on many occasions have used as many as five working

With these transformers it is important to obtain exactly the right plate potential. Owing to the resistance of the windings which may range from 5,000 to 50,000 ohms, there is a considerable potential drop across the primary which must be compensated for by an increase in the number of cells used in the high-tension battery. A further point to which the constructor might direct his attention is in the construction of a secondary of this type of transformer. In all commercial patterns it is also wound with resistance wire, but

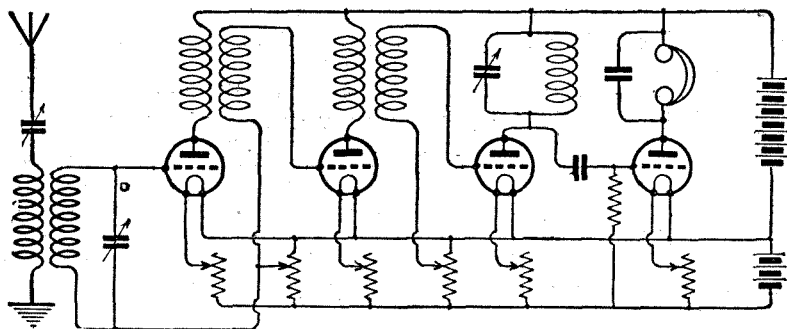

Fig. 7.—A composite circuit

together without experiencing any tendency to oscillate on the part of a set controlled simply by the potentiometer.

A Comparison of Efficiency

On their optimum wave-length the efficiency of these transformers is about 70 per cent. of that of the tuned plate of the tuned transformer coupling, and we may take it for a band extending over about 160 metres on each side of the optimum point as about 60 per cent.

there appears to be no reason why it should not be made with copper wire of the same gauge as the Eureka used for the primary. It might be possible to obtain something of a step-up effect by placing more turns on the secondary than on the primary.

Reaction

Since these transformers are untuned the reaction coil cannot be coupled to them with any great success, for as the Editor has frequently pointed out, reaction is not

effective unless the circuit to which it is coupled is sharply tuned. The layout shown in Fig. 5 will be found quite good for the reception of distant signals. If it is carefully handled no interference will be caused by the addition of reaction coupled to the closed circuit as

best to keep them well apart and to arrange them so that the degree of coupling between them is as near zero as possible. All wires in the set must be kept short; no two carrying currents at different potentials should be allowed to run parallel or close to each other; connections

As regards the arrangement it is always better for long-distance reception to use what the Americans call a "bench hook-up." One can thus keep them well separated and can try the effect of moving them about. If it is intended subsequently to make up the various components into a cabinet set, the positions which they should occupy when mounted can be ascertained pretty well by placing them on a board of about the same size as the intended panel and seeing whether interaction effects are noticeable when they are arranged in different ways. By means of a little experimenting in this way one can discover the best method of laying out the panel. It is well worth while to take this trouble, for often if the apparatus which has worked perfectly well upon the bench is bundled hastily into a cabinet the results are found to be anything but pleasing.

LAMBDA.

REMINISCENCES.

DEAR SIR,

Modern experimenters do not appreciate how good and reliable are the modern crystal detectors.

I well remember the little visits I used to pay to a small wireless shop near Broadway, run by Mr. Gernsback (now editor of your American contemporary *Radio News*). I particularly remember purchasing a little electrolytic detector with a small phial of nitric acid, and carefully carrying this on board ship to my cabin. As soon as I was through with my ordinary work (we wireless operators had rather a quiet time then) I fixed up to the new apparatus and listened in. The results were a revelation, as the detector was vastly more sensitive than the old, but much more stable, magnetic detector. But every strong "atmospheric" that came along put the detector right out of action and it had to be carefully reset. Of course, we were supposed to work our apparatus just as it was provided, and not to alter it in any way, but most operators were keen experimentalists and took every opportunity they could of trying out new gadgets and stunts. I remember Jack Binns of C.Q.D. fame proudly showing me a rotary gap he had fixed up on his transmitter, consisting of a large disc of wood (I think it was the top of a barrel) fitted with old brass terminals!

Yours etc.,

R. S. Y.

Fenchley Road, N.W.

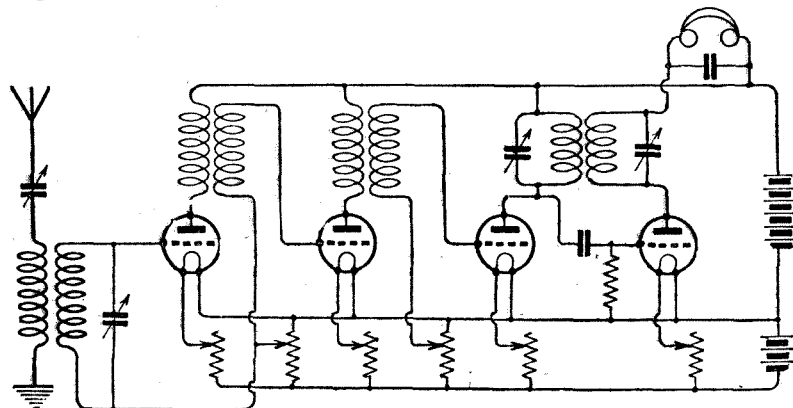

Fig. 8.—The same circuit with reaction added.

shown in Fig. 6. A further development is seen in the next diagrams which show a set with a composite high-frequency side. Two aperiodic transformers are used between valves 1 and 2, and 2 and 3. Valve 3 is coupled to the rectifier by means of a tuned anode circuit to whose inductance the reaction coil is coupled. This again is a sensitive and satisfactory apparatus to work with, and it is very unlikely to cause interference by radiation.

Making Up Long-distance Circuits

The best of circuits on paper may be a very disappointing thing if

must be soldered. Valves on the high-frequency side must be dead hard if they are to be efficient, and it is desirable that their interelectrode capacity should be very low in order to furnish the smallest possible amount of coupling between plate and grid circuits. For high-frequency purposes there are none to beat the specially designed V 24 and QX, or their dull emitter counterparts D.E.V. and D.E.Q. Of the last two, D.E.Q. is very much better, for it gives a higher degree of amplification and stands up more satisfactorily to its work. For some reason the filament suspension in the D.E.V. valve is not too good.

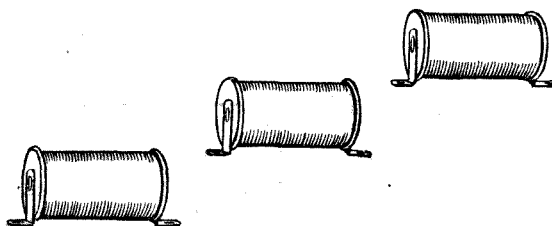
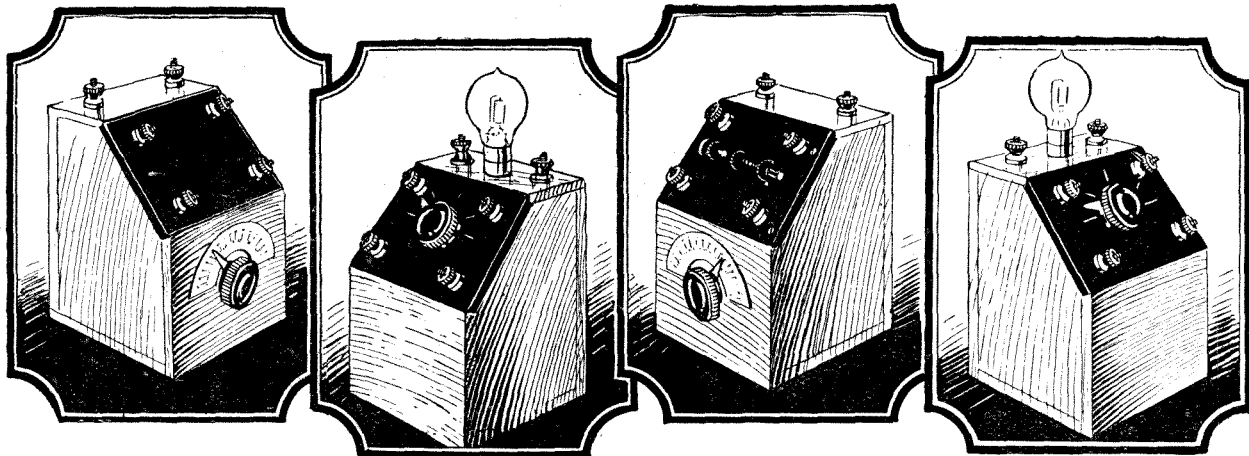

Fig. 9.—Transformers mounted in staggered formation.

badly made up. So much depends upon the quality of the wiring, the position of the various parts of the apparatus, the valves and other detail. When transformers are used they should never be crowded together, otherwise interaction is sure to take place with unpleasant results. If space is limited for any reason, aperiodic transformers may be mounted beneath the panels in the staggered method which was popularised by the inventor of the neutrodyne circuit. This is shown in Fig. 9. In general, however, it is

I have had one or two whose filaments became so slack that they could be seen swinging, slowing towards and away from the grid, probably under the influence of static pull from the plate. When this happens the results are extraordinary and not a little mystifying until the cause is spotted. At one moment signals are of normal strength, then gradually fade until they are quite weak, coming back in a second or two to their proper power once more and then repeating the process.



Efficiency plus Economy

The principles of the "Unit" System

The principle of this "Unit" Receiver is more or less along the lines of the well-known sectional Bookcase. From the first Unit—like the first section of the bookcase—it is ready for immediate service.

The first Unit to be constructed (No. 3 in the illustration) as a complete Crystal Receiving Unit. The design of this Unit is so efficient that Broadcasting has been received regularly at over 40 miles distance from the Station. The second Unit to be added is a Low Frequency Amplifier which greatly increases the volume of sound. If you live close to a Broadcasting Station these low Units should work a small loud Speaker. If you wish to increase its range, you can add the High Frequency Amplifier. These four Units give almost the range, sensitivity and volume of a three Valve Set with only the small upkeep costs of 2 valves. Full instructions are given for building absolutely every part in a particularly economical manner. Even if you already possess a Set you ought to get this Book—there are quite a number of new ideas sure to interest you.

THIS book, by Mr. E. Redpath, assistant editor of *Wireless Weekly*, should be purchased by every wireless enthusiast who is keen on simple constructional work for two reasons. First, because it describes a new idea in Wireless—a highly sensitive Receiving Set which, starting from a self-contained Crystal Set, can be added to, and made more efficient at any future time at small cost. Secondly, because not only are the elementary principles of Wireless soundly and simply explained, but every step in the actual constructional work is carefully shown by clear diagrams and well-written text. Even the beginner in Wireless can safely start on this Receiving Set and know that his efforts will be crowned with success.

How to make a "Unit" Wireless Receiver

By E. Redpath.

Contents

- Chapter 1.—The Essential Principles Involved.
- Chapter 2.—The Aerial—Earth System at the Receiving Station.
- Chapter 3.—Unit No. 1. The Variometer Tuner with Crystal Detector.
- Chapter 4.—Unit No. 2. The Low-Frequency Amplifier with self-contained H.T. Battery.
- Chapter 5.—Units Nos. 3 and 4. Aerial Tuning Variometer and High-Frequency Valve Unit.
- Chapter 6.—The Completed Set and How it Works.
- Chapter 7.—The Construction and Erection of an Efficient Aerial.

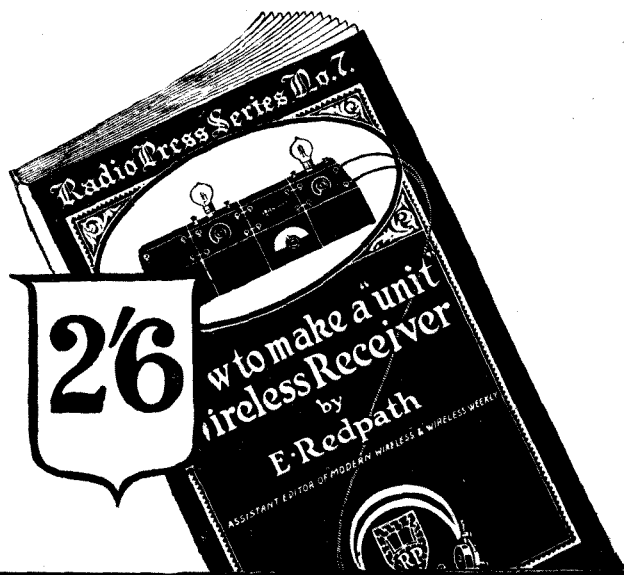

Sold by all Booksellers and Newsagents, or 2/8 post free direct from Publishers.

Radio Press, Ltd.,
Publishers of Authoritative Wireless Literature
DEVEREUX COURT, STRAND W.C.2

A CRYSTAL RECEIVER FOR BROADCASTING AND PARIS TIME SIGNALS

By A. J. RODGMAN.

This set, being somewhat different from the usual crystal receivers, may be welcomed by many readers.

THE accompanying photograph (Fig. 1) shows a type of receiver which is equally efficient on comparatively high and low wavelengths, and which is particularly suitable for the constructor who, while broadcasting is his chief point of interest, is also interested in the reception of morse, such as the Paris Time Signals, ships and other stations.

From the photograph and sketches the constructional details can be gathered. It is seen that a cylindrical coil is fitted beneath the panel. This coil has four tapplings taken to four valve legs placed in an arc on the panel. Tuning between the tapplings is accomplished by a small basket coil mounted on a spindle, which is free to rotate 90 degrees. A plug is provided to take loading coils for wavelengths above 600 metres, and is seen on the panel between the A and E terminals.

Construction.

The inductance can be first wound. Obtain a cardboard tube 3 in. diameter and 4½ in. long and saturate with paraffin wax. Then wind with No. 22 S.W.G. D.C.C. wire (about 3 oz. will be required) in the following sections. At ½ in. from the end wind ten turns, leave a space of ⅓ in. and wind another ten turns. At this point the first tapping is taken, after which three further tapplings, at intervals of twenty turns each, are taken. The coil will then have eighty turns when completed. The coil may be given a thin coat of shellac varnish.

The basket coil, which is joined in series with the main inductance, is shown in Fig. 2 and sectionally in Fig. 3. The former measures, 2 in. the outer diameter, and ¾ in. the inner diameter, and has nine segments. It is wound with No. 28 S.W.G. D.C.C. wire, and this coil also can be given a coat of varnish. The method of securing the coil to the spindle and the manner in which the spindle and cylindrical coil are fitted to the panel are clearly shown in Fig. 3. The ebonite piece A, measuring ¾ in. by ¼ in. by ¼ in., is secured to the centre of the coil by two screws. The spindle passes through the hole at the side, and the

coil locked in the desired position by screw B. The spindle is 4½ in. long and with ½ in. of thread at one end. The action of the washer C

access for connections to detector and valve legs.

The panel can be cut from ⅜ in. ebonite and all the required holes drilled in the positions given in Fig. 2. When the surfaces have been polished the various parts can be mounted. They consist of the A and E and the two 'phone terminals, the crystal detector, which is purchased, the two valve legs acting as the socket for loading coils, and the five valve legs for varying the inductance. The protruding thread of the valve legs will have to be cut off so as not to interfere with the inductance.

The coil is placed on the panel and the exact positions of the holes for the securing screws marked and then bored, and the coil fixed. Adjustments are then made to the spindle, washer, etc., to give smooth working.

The circuit diagram is shown in Fig. 3, and also the actual connections, where the dotted lines indicate the connections beneath the coil. A little difficulty may be experienced in making connections with flexible wire to the basket coil. A convenient way is to use the two securing screws F in Fig. 3 as terminals for the ends of the coil, soldering them with the ends of the

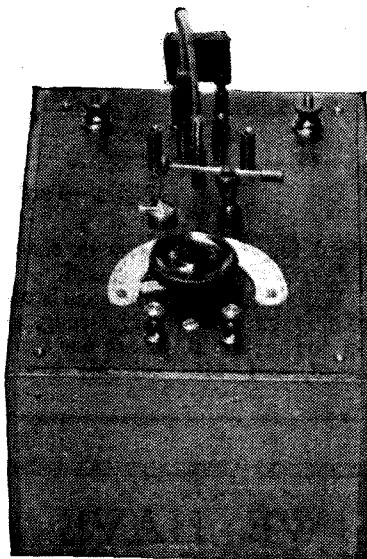

Fig. 1.—The finished instrument.

is to prevent the pulling out of the spindle. The cylindrical coil is raised ¼ in. from the panel by a wooden block E, in order to have

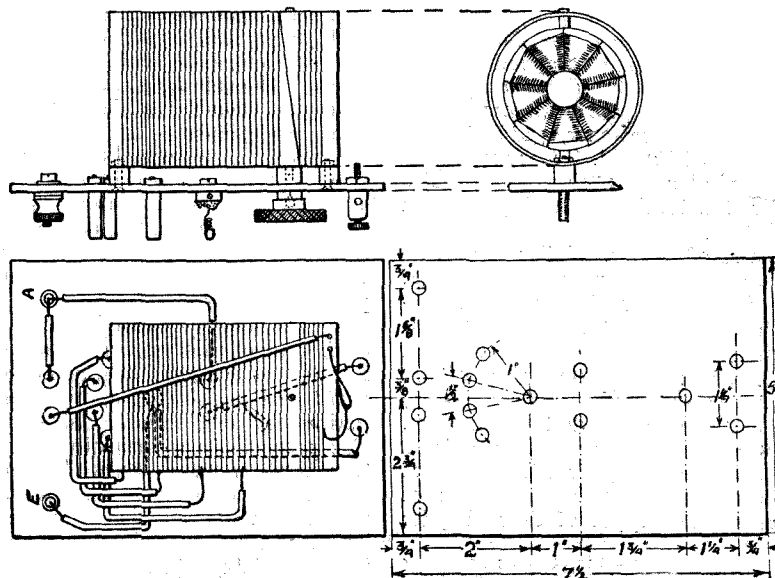

Fig. 2.—Some constructional details.

flexible wire to the screws. This would be more effective and not so liable to break with the continual turning of the basket coil.

A short-circuiting plug must be made to insert when no loading coil is used. It consists simply of two valve pins fitted $\frac{1}{4}$ in. apart to a small piece of ebonite, and a piece of wire connecting the pins together.

A wandering lead must also be made by joining two valve pins together with flexible wire. One pin is fixed stationary in the centre leg, and the other is free to be plugged in any desired leg.

The containing box for the complete instrument could be made from $\frac{1}{4}$ in. fretwork wood. The pieces required would be two side pieces 8 in. by 4 in., the front and back $5\frac{1}{2}$ in. by 4 in., and the base 8 in. by 6 in.

A suitable loading coil to receive Paris would be a coil consisting of 260 turns of No. 36 S.W.G. D.C.C. wire wound on a former sketched in Fig. 3. This is made of two disks of cardboard $2\frac{1}{2}$ in. diameter and a centre disk $1\frac{1}{4}$ in., and the three

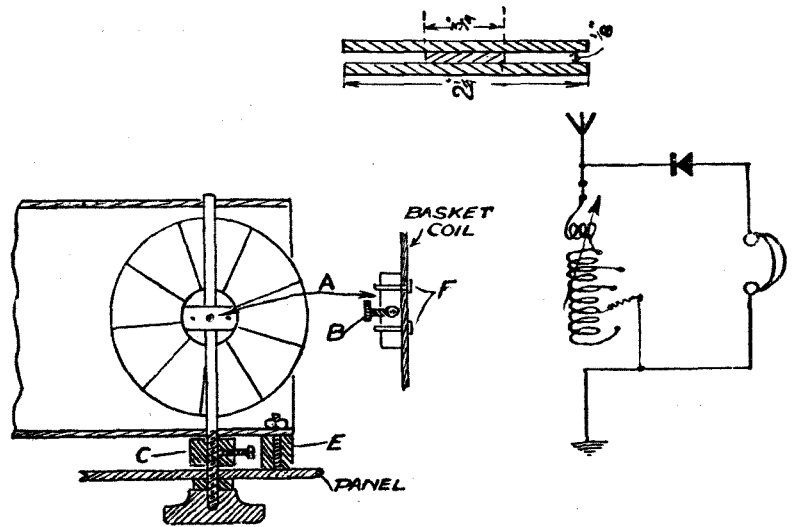

Fig. 3.—Further constructional details.

glued together. Of course, a suitable coil could be purchased.

With this receiver the local broadcasting station is very strong, and on 600 metres ships are constantly heard, and, with suitable loading

coils, many commercial stations employing spark transmission have also been heard. For these latter stations careful adjustment of crystal is essential, and this is best made with the aid of a buzzer.

CATALOGUES WE HAVE RECEIVED

MESSRS. HUNT, of Croydon, send us their latest catalogue of dry batteries and accessories. Their well-known Hellen dry batteries are listed in all sizes, tapped and untapped, and are also supplied for filament lighting. The H.A.H. accumulators, loud-speakers, telephones, grid leak, etc., are also described. Other accessories include a combined voltmeter for low-tension and high-tension testing.

From Messrs. Fuller we have received their new catalogue of accumulators and accessories. Instruments of note are their "Iron-clad" transformers, which are metal screened; their "tone selector" for improving loud-speaker results; fixed condensers and coil-holders. Included in the catalogue is a description of their wide range of accumulators, with particulars of their latest types of cells in glass cases.

From Messrs. Pye and Co., of Cambridge, we have received a leaflet describing their tuning coils and coil-holders. These are an

improved form of basket coil. The coils for the shorter waves are wound with Litrendraht wire.

Messrs. Edison Swan Electric Co., Ltd., have just issued a catalogue of complete sets and component parts. The sets range from crystal sets to four-valve instruments. The components include the Ediswan loud-speakers and valves (A.R., R., and low-temperature types), accumulators, high-tension batteries and a collapsible frame aerial. A novel variometer which plugs into the standard coil plug is also described.

Messrs. Abbey Industries send us catalogues of their broadcast receiving sets and accessories, including parts and accessories for the experimenter and home constructor. These are in two separate books. The first includes their "Abbi-phon" sets, with a crystal set which can be enveloped in the hand, and the "Abbindaerial," an indoor aerial which can be fixed up in five minutes. The second consists of a complete range of accessories, including a special variable con-

denser which only takes up one-third the bulk of the plate type, and a neat wavemeter.

Messrs. Sterling Telephone and Electric Co., Ltd., of London, send us two new publications, the first of which illustrates the elaborate finish of their sets, the booklet being illustrated in colours. The sets, which range from crystal to four-valve, are mounted in handsome cabinets, and can be had, if desired, in Chinese lacquer designs. Messrs. Sterling also supply loud-speakers finished in Chinese style. The other publication received from this firm is a comprehensive catalogue of their radio manufactures, including their new Threelflex receiver, which needs no outdoor aerial or earth. Among the accessories is apparatus for charging accumulators from both direct and alternating current; in the latter, rectification is performed by means of a valve filled with argon. This firm also sends particulars of their new unit system.

Messrs. L. McMichael, Ltd., have available their latest list in the form of a loose-leaf catalogue. It is published with the object of acting not only as a catalogue, but also as a guide to the uninitiated in buying wireless apparatus. It caters fully for amateur needs, from complete multi-valve sets to contact studs, and includes complete sets of parts for home construction.

HIGH-FREQUENCY AMPLIFICATION and its problems.

By R. W. HALLOWS, M.A., Staff Editor

For long-distance reception high-frequency amplification is essential. In this article many valuable hints are given.

NEARLY everyone who takes up wireless, beginning with a single valve or a crystal, soon becomes fired with the desire to obtain a greater volume of sound in his telephones. He adds a note magnifier with the help of which his local broadcasting station comes in at good strength. For a time he is satisfied, though not for long. There succeeds a second form of ambition, which is to increase the range of his apparatus so that he

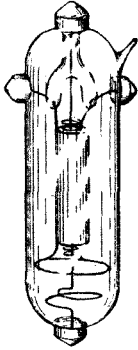

Fig. 1.—A low-capacity valve.

may be able to hear not one set of transmissions only, but those from several other stations. He thus has to tackle the problem of high-frequency amplification, which is really one of the most difficult in the whole realm of wireless.

The function of the high-frequency amplifier is to receive impulses brought in by the aerial and to magnify them. It is essential that the oscillations in its plate circuit should be of precisely the same form as those which reach its grid, the difference between the two being that the amplitude of the former is several times greater than that of the latter. If there is any kind of rectification or any deformation of the waves distortion will result.

Let us consider for a moment a view of the problems which occur in the case of the high-frequency amplifying valves but are not present with a note magnifier. The greater the frequency the more easily will oscillations pass through a small condenser of given capacity. If we examine a valve of the

4-pin type we shall see that there are several points at which condensers are formed both inside the bulb and outside it. There is, for example, capacity between the grid and plate as well as between the leads where they pass through the glass pinch. Capacity again exists between the leads inside the cap, and outside the valve there are the pins which provide a further capacity. The sockets of the holder again, especially if they are embedded in moulded ebonite, have quite a considerable capacity. Beyond this we have the capacities existing between terminals and between the leads that run under the surface of the panel.

Each of these capacities may in itself be tiny, but the sum total of them comes to an appreciable amount varying between $0.000005 \mu\text{F}$ and $0.00005 \mu\text{F}$. This capacity provides a coupling between grid and plate circuits, the result being that on short wave-lengths the high-frequency valve is very liable to fall into self oscillation, thereby ruining the quality of the reception and probably causing interference with others through reradiation from the aerial.

For short wave work, then, it is essential to keep what we may term parasitic capacities as low as possible upon the high-frequency

side of the set. We can do this in several ways. If 4-pin valves are used the holder should consist of separate short legs mounted upon the panel and not encased in an ebonite mould. It is better, however, to employ special anti-capacity valves such as the V 24,

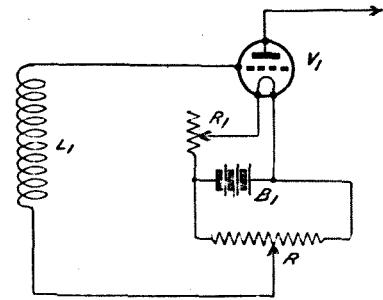

Fig. 2.—The use of a potentiometer.

in which there is no pinch. The design of this valve is shown diagrammatically in Fig. 1. The filament runs from end to end of the glass tube, grid and plate being held by supports sealed into opposite sides at right angles to the filament. Next we must keep all leads of grid and plate circuits as short as possible, we must see that they do not run parallel or close together and we shall find it advisable to use well-spaced bare wires rather than those covered

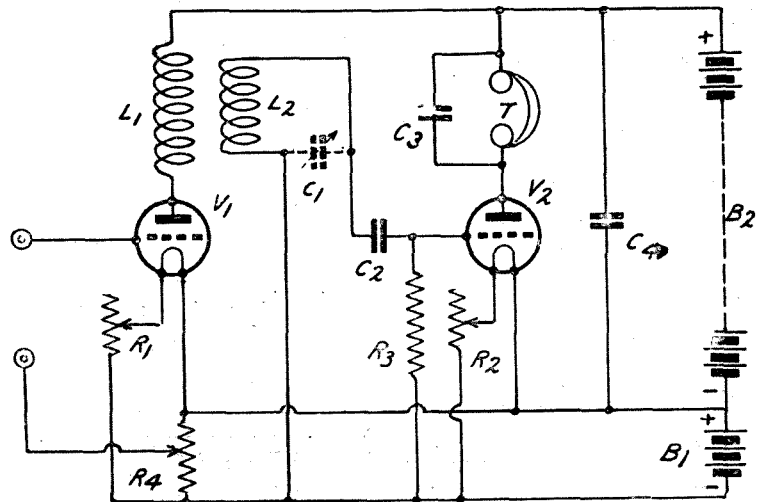

Fig. 3.—Transformer coupling.

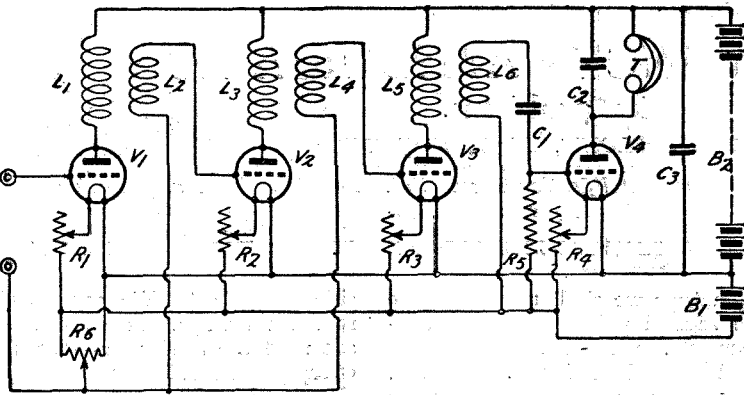

Fig. 4.—Controlling three grids with common potentiometer.

with insulating material, whose dielectric constant is much greater than that of air.

In theory the best working point for amplifying valves is rather below the middle of the straight portion of their curves with a grid potential in the neighbourhood of zero volts. At this point the flow of grid current is very small indeed and the valve will function as an almost perfect relay. Actually, however, a high-frequency valve, particularly if it is one of a series, can very seldom be made to work at such a point owing to its liability to oscillate. This tendency we can reduce by applying a positive potential to the grid, which increases the flow of grid current with a consequent damping effect. With the high-frequency valve, then, we shall have to steer a mid-course between two undesirables: on the one hand oscillation awaits us; on the other an excessive positive potential produces both extensive damping and distortion of signals. Probably the best means of obtaining the most satisfactory working point is to use a potentiometer wired as shown in Fig. 2. With its help we can adjust the grid potential until oscillation is

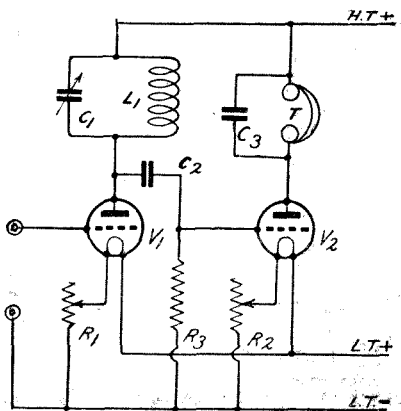

Fig. 6.—The tuned anode method.

with copper wire. Either its primary or its secondary or both may be tuned by means of small condensers of, say, $0.0003 \mu\text{F}$ capacity (Fig. 5). If both primary and secondary are loosely coupled and so tuned the device becomes extremely selective, though the tendency to oscillation is increased since both grid and plate circuits are brought into resonance. In most cases it is usual to tune either primary or secondary only. A single transformer with both primary and secondary tuned is not too difficult to operate, but with two or three stages of high-frequency amplification such a coupling becomes unworkable, owing to the great number of adjust-

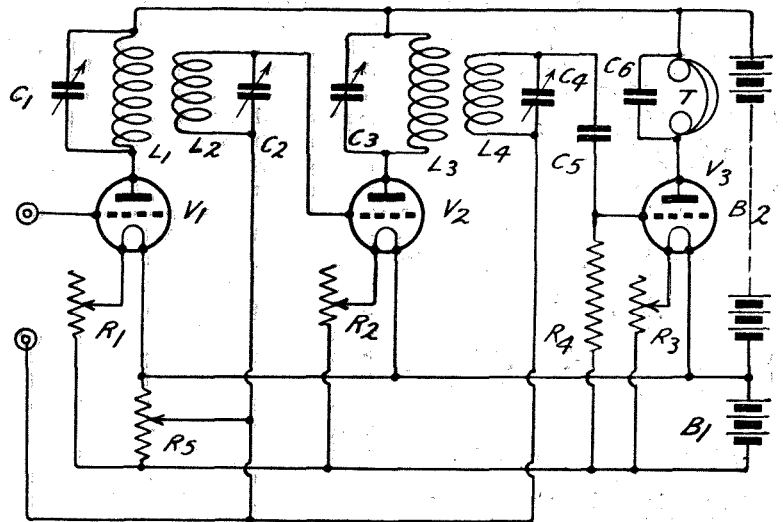

Fig. 5.—Transformers with both primary and secondary tuned.

killed by the introduction of the minimum amount of damping. This damping we can compensate for by the judicious use of reaction.

There are three methods of high-frequency coupling in general use, the transformer, the tuned anode and the resistance capacity. Each of these has its own particular merits and demerits of which we will endeavour to see something. The simplest and probably the most widely used is that which employs some kind of transformer (Fig. 3). Here currents flowing in the plate circuit of the first valve pass through the primary of the transformer, inducing in the secondary varying potentials which are applied to the grid of the second valve. With transformer coupling we can use the potentiometer for adjusting the grid potential of each valve as shown in Fig. 4. The most usual type of high frequency transformer is one wound

ments that must be made practically simultaneously.

For all-round efficiency there is, I think, nothing to beat the semi-a-periodic or untuned transformer. Its only drawback is that it covers only a limited band of wave-lengths. This disadvantage is

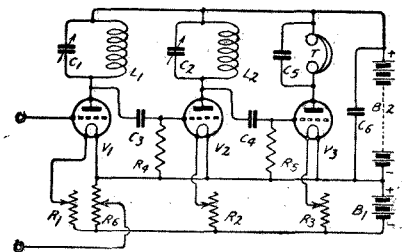
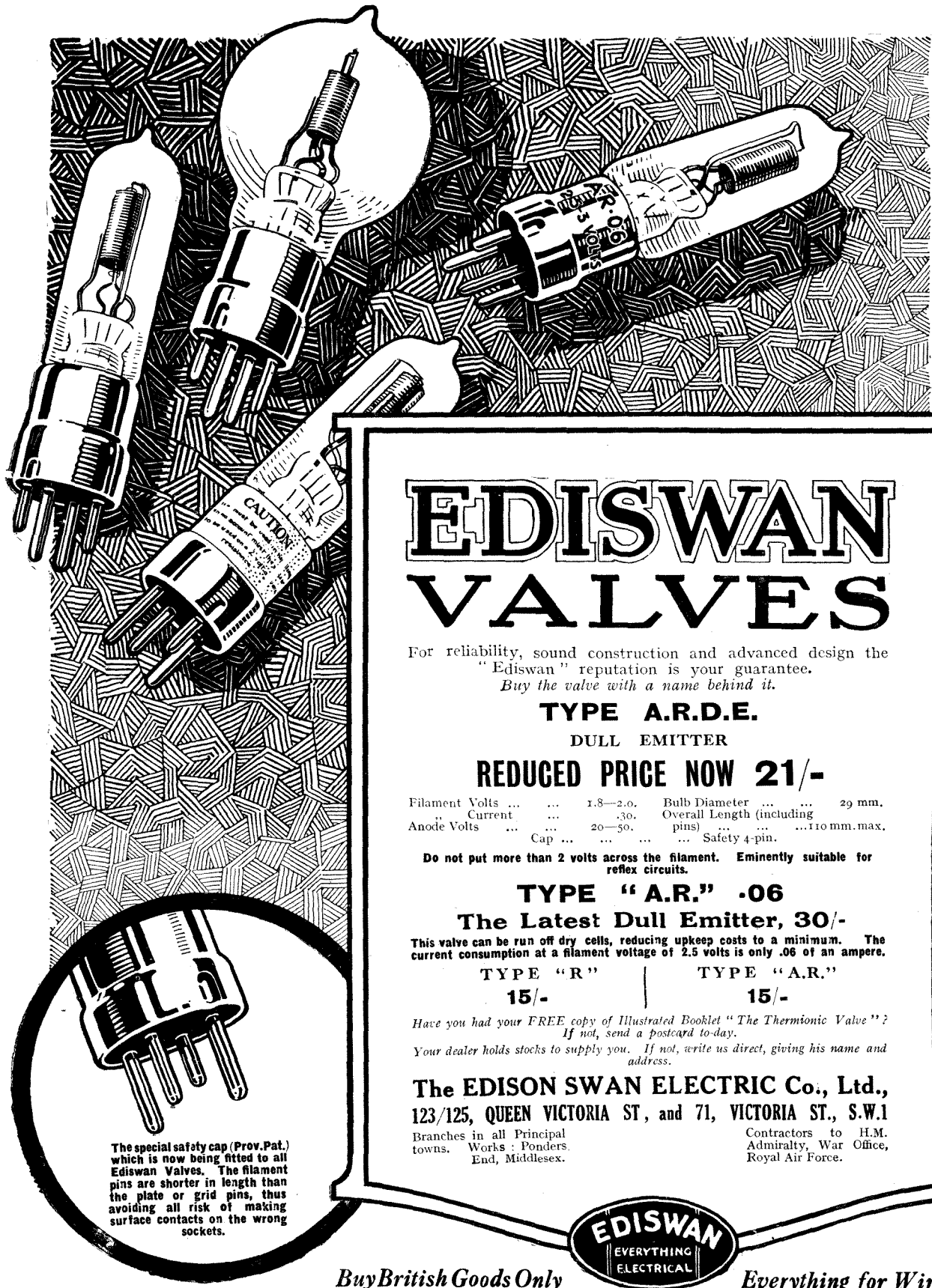

Fig. 7.—How to connect two tuned anodes.

not a serious one since a set of transformers suitable for various wave-lengths can be made up with clip fittings so as to be easily and



EDISWAN VALVES

For reliability, sound construction and advanced design the "Ediswan" reputation is your guarantee.
Buy the valve with a name behind it.

TYPE A.R.D.E.

DULL EMITTER

REDUCED PRICE NOW 21/-

Filament Volts	1.8—2.0.	Bulb Diameter	29 mm.
Current30.	Overall Length (including pins)	110 mm. max.
Anode Volts	20—50.	Cap	Safety 4-pin.

Do not put more than 2 volts across the filament. Eminently suitable for reflex circuits.

TYPE "A.R." -06

The Latest Dull Emitter, 30/-

This valve can be run off dry cells, reducing upkeep costs to a minimum. The current consumption at a filament voltage of 2.5 volts is only .06 of an ampere.

TYPE "R"

TYPE "A.R."

15/-

15/-

Have you had your FREE copy of Illustrated Booklet "The Thermionic Valve"?
If not, send a postcard to-day.

Your dealer holds stocks to supply you. If not, write us direct, giving his name and address.

The EDISON SWAN ELECTRIC Co., Ltd.,
123/125, QUEEN VICTORIA ST, and 71, VICTORIA ST., S.W.1

Branches in all Principal towns. Works: Ponders. End, Middlesex.

Contractors to H.M. Admiralty, War Office, Royal Air Force.

The special safety cap (Prov. Pat.) which is now being fitted to all Ediswan Valves. The filament pins are shorter in length than the plate or grid pins, thus avoiding all risk of making surface contacts on the wrong sockets.



Buy British Goods Only

Everything for Wireless



The new Book of S. T. Circuits

By JOHN SCOTT-TAGGART, F.Inst.P.

EVERYONE needs this handsome volume of new S.T. Circuits. The fame of S.T. 100, the dual amplification Circuit using but two Valves yet giving the signal strength of at least four, has spread throughout the country. Many thousands of Wireless enthusiasts are using this Circuit with every success.

Other S.T. Circuits equally as useful and likely to become quite as well known are given for the first time in "More Practical Valve Circuits," by the Editor of MODERN WIRELESS.

"More Practical Valve Circuits" contains the fullest data for over 80 different types of Circuits, including all recent discoveries, such as the Armstrong and the Flewelling. Not merely are Circuit diagrams given with the greatest exactitude, but sufficient details as to condenser and resistance values, etc., as will enable the experimenter to build up any Receiving Set without further help.

3/6

Bound in full cloth.

No matter how much or how little experience you may have had in Wireless, the moment you decide to build your own Set you should buy a copy of this book and make quite sure that you are starting with a good practicable and efficient Circuit. Its cost will be saved many times over in time and materials.

RADIO PRESS, Ltd., Devereux Court, STRAND, W.C. 2.

Gilbert Ad.

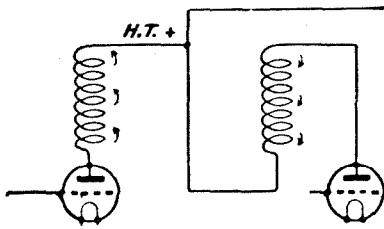

Fig. 8.—Best arrangement of inductances.

quickly interchangeable. The great point about the aperiodic transformer is that it so much reduces the tendency of the valves to oscillate that the set becomes quite stable even when three or four stages are in use. These transformers are very easily made. If the former is a length of ebonite rod with a diameter of 1 inch, and the wire used is No. 40 Eureka, the winding formula is: one turn per metre plus ten per cent. Thus, to wind a transformer for 360 metres both primary and secondary would consist of 360 plus 36 = 396, or, say, 400 turns. It will be found that a transformer of these dimensions will give quite good results between 200 and 600 metres, though signal strength will of course be greater on wave-lengths from 40 to 80 metres on either side of the optimum wave-length for which it is designed.

I have been hoping for some time, though the opportunity has not yet been found, to try out an idea for increasing the range of these resistance wound transformers. The suggestion is simply to wind them upon tubular instead of solid formers and to introduce a sliding iron core in much the same way as they are used in one of the R.A.F. patterns of high-frequency transformer.

From the point of view of amplification the tuned anode method is by far the most efficient of all on wave-lengths up to 1,500 metres, and I have used it with success up to 4,000 metres. With this circuit, which is seen in Fig. 6, a tuned oscillatory circuit is placed between the anode and the high tension supply. When this circuit is correctly tuned it acts as a rejector to oscillations of the desired frequency. These are therefore transferred to the grid of the following valve, whilst unwanted oscillations are absorbed to a very great extent. The tuned anode coupling is, therefore, extremely selective. Its great drawback is that it is not at all easy to handle since it makes the set liable to oscillate. One tuned anode can be operated successfully if reasonable care is exercised, but

when a second is added, matters become extremely difficult unless certain precautions are taken. It is very important that the first valve should be potentiometer controlled and that the second should have its gridleak (Fig. 7) connected directly to L.T. plus. A further point which is often overlooked is that the two inductances should be so arranged that there is a minimum possibility of interaction between them. The simplest way of accomplishing this is to wire them so that the current flow is as shown in Fig. 8.

The reaction coil with tuned anodes may be coupled conveniently to one of the anode inductances as shown in Fig. 9.

The man who contemplates adding one stage of high frequency amplification to either a single valve or to a crystal cannot do better than make use of the tuned anode coupling. The way in which it is wired in the case of a valve set will be plain from foregoing

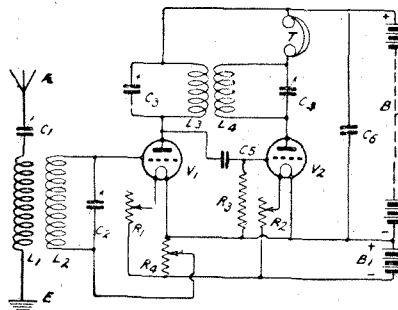

Fig. 9.—Reaction coupling with two tuned anodes.

diagrams; Fig. 10 shows how it is connected to a crystal rectifier.

The last method of high-frequency coupling is that known as the resistance capacity. It is very similar in appearance to the tuned anode system, as a glance at Fig. 11 will show. In place of the tuned oscillatory circuit we now have a non-inductive resistance of 50,000 to 100,000 ohms between the anode and the high-tension battery. The working of resistance capacity is, however, quite different from that of the tuned plate.

In Fig. 12 we have a circuit containing two resistances, one of which A is variable, whilst the other B is fixed. If we reduce the value of A more current will flow through B and the voltage across it will consequently be higher. This is precisely what happens in such a circuit as that shown in Fig. 11. The valve itself is the variable resistance, the fixed being, of course, that inserted in the anode circuit. When the grid is

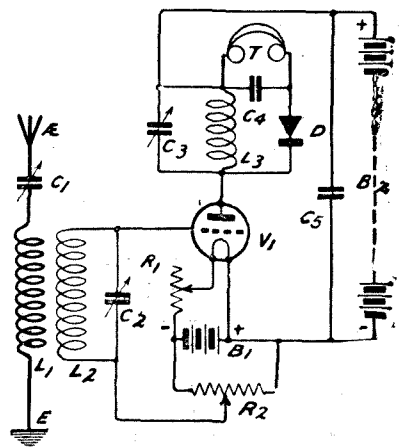

Fig. 10.—Crystal rectification following high-frequency valve.

made positive by an incoming impulse the internal resistance of the valve is decreased so that the current and therefore the voltage across the fixed non-inductive resistance is increased. A negative impulse will produce precisely the opposite effect, increasing the resistance of the valve and decreasing current and voltage across the fixed resistance. These potential variations are transferred to the grid of the following valve by way of the grid condenser.

Resistance capacity coupling is excellent on wave-lengths from 1,000 metres upwards. It can therefore be used as a substitute for the tuned anode employed on the lower wave-lengths. It is quite a simple matter to have a pair of sockets for the anode coils and to arrange a fixed resistance in such a way that either form of coupling can be thrown in or out of action by means of a double-pole change-over switch.

It is usually stated that resistance capacity amplification is of very

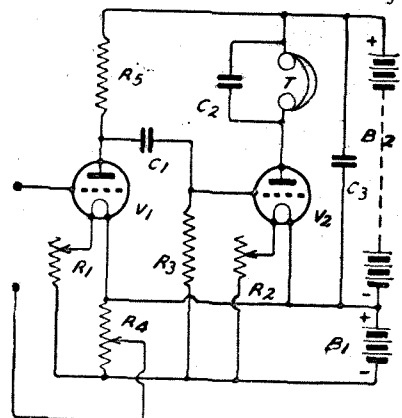

Fig. 11.—A resistance coupled amplifier. little use below 1,000 metres. This is, however, rather an exaggeration. I have seen sets on which it was

(Continued on page 278).

WIRELESS, LINES AND CABLES

By Lt.-Col. CHETWODE CRAWLEY, R.M.A., M.I.E.E.,

Deputy Inspector of Wireless Telegraphy, G.P.O.

A suggestive article on a much discussed topic.

BROADCASTING by wireless telephony has so suddenly taken hold of the public imagination that many "listeners-in" are even now asking themselves whether line telegraphy and telephony are likely to give way to their wireless counterparts; if so when, and if not why not, are the natural questions they would like to have answered. Such questions are as easy to ask as they are difficult to answer, and it is not to be hoped that this short article will do more than point out a few of the sign-posts on a road of many turnings.

In considering this subject, the first important fact to be noted is that line signalling has been firmly established on a commercial basis for about eighty years, and wireless signalling for only about twenty years. This has a distinct bearing on any comparison between the two systems, but there are considerations which must be taken into account in assessing even this seemingly simple fact at its true value. For instance, line signalling started on its career comparatively quietly in days when newspapers

were sold by the thousand, whereas wireless signalling was introduced to the public at a time when newspapers were being sold by the million, thus producing from the start a popular interest in wireless which has never been allowed to slacken, and was never accorded to the older system. Not that this popular interest in wireless has been an unmixed blessing; indeed, it tended to nurture in the early stages financial hopes which would not otherwise have arisen, and these, when shown in practice to be ill founded, threw over the commercial aspect of the science a cloak of uncertainty and distrust. In other respects, however, the public notice accorded to wireless signalling has, on the whole, assisted in its development, especially in its most important applications, namely, for ships and aircraft, and latterly for broadcasting by telephony. For these purposes there is, of course, no question of a comparison between line and wireless, as the former cannot be used.

For point-to-point working, line signalling has the great initial

advantage of having been already in the field, and highly developed at a huge expenditure of money years before wireless was even thought of. On the other hand, wireless starts off with the advantage of being able to make use of all the costly experience gained by line working, and much of this experience is as useful to the one system as to the other. But this is a minor advantage compared with the fact that line working is already established between all places where connections are of value from the financial point of view. If, therefore, wireless is to supplant line signalling between any given places, it has to provide a service so superior to the service already provided that it will attract so much of the available traffic as to cause the line system to collapse economically.

Generally speaking, for short distance communications already served by land lines or cables wireless can only hope to become profitable by creating a demand for new traffic, and by attracting to itself some small proportion of the existing traffic, but it cannot

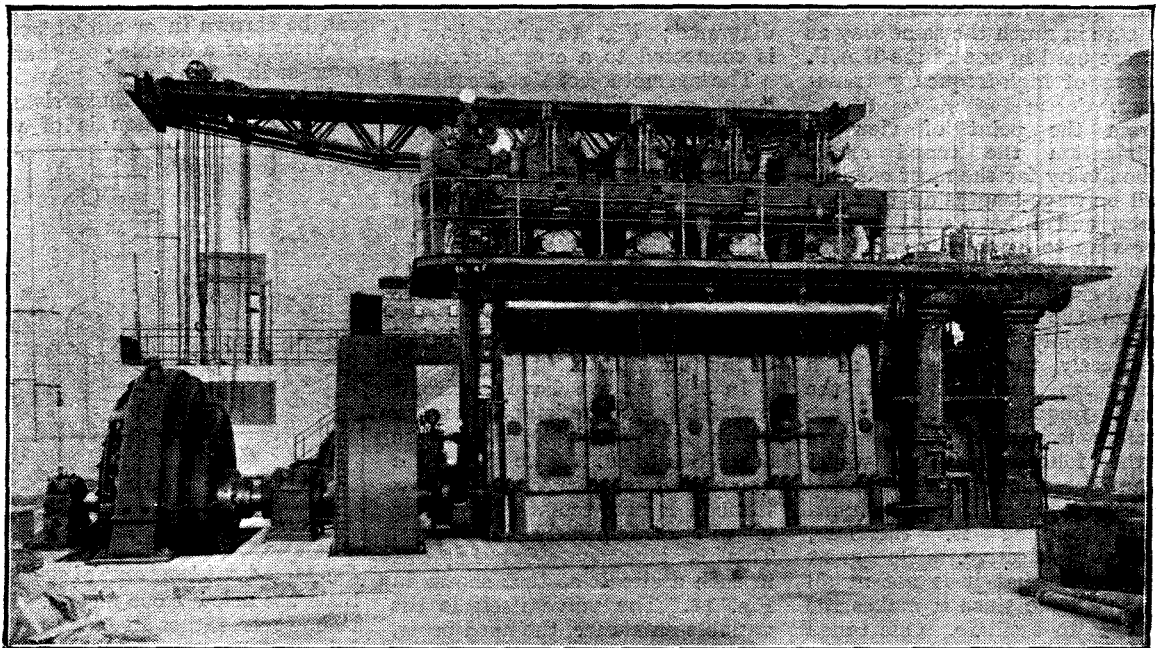

Few people realise the size of the power plant necessary at a large trans-Atlantic wireless station. This photograph shows a part of the generating machinery at St. Assise, near Paris, a station working regularly with America.

All Wave-Lengths Covered.

P.P. No. 2250/23.

COME WHAT COME MAY THE "ATLAS" COILS

Once Tried

NOW LEAD THE WAY

Always Used.

MAXIMUM
INDUCTANCE

OPTIMUM
WAVE-LENGTH
RANGE



MINIMUM
SELF-CAPACITY

INCREASED
SIGNAL
STRENGTH

Radio Components Catalogue on Request.

Trade Terms on Application.

SALIENT FEATURES are :

The TWIN-WIRE WINDING is so effected as to enable MORE THAN 95 p.c. of each strand to be SURROUNDED BY AIR. EACH TURN and EACH LAYER being AIR-SPACED REDUCES CAPACITY TO UTMOST LIMIT.

WOUND IN TRUE CONCENTRIC CIRCLES, the Coils give FINE TUNING, so ESSENTIAL TO CUTTING OUT UNWANTED SIGNALS.

Agency applications considered for districts where not already represented.

"ATLAS" PATENT PLUG-IN COILS

Coil No.	Wave-length in metres with .001 Variable Condenser in shunt.		Price s. d.
	Min.	Max.	
25	120	375	5 0
35	175	515	5 0
40	180	650	5 2
50	230	780	5 2
65	280	1000	5 6
75	325	1120	5 6
100	410	1520	7 0
150	660	2300	7 10
200	850	3100	8 8

Manufactured only by—
H. CLARKE & Co.
(MANCHESTER), LTD.,
Radio Engineers,
Atlas Works, Old Trafford,
:: MANCHESTER. ::

Tel. Nos.: 683 & 793 Telegrams:
Trafford Park. Pirtoid, Manchester.

Coil No.	Wave-length in metres with .001 Variable Condenser in shunt.		Price s. d.
	Min.	Max.	
250	1280	4150	9 0
300	1550	4940	9 5
400	2045	6380	10 3
500	2980	8900	10 6
600	4000	12100	11 0
750	4970	15000	11 10
1000	6100	20000	12 8
1250	7000	22000	14 0
1500	8200	26000	15 0

2/6

Homebuilt Wireless Components

THERE are often quite a number of Components which the average Experimenter can make tolerably well if he is only shown how to make them. Although every issue of MODERN WIRELESS AND WIRELESS WEEKLY contains a number of useful constructional articles dealing with small components, it will be obviously more useful to have all the information in one book.

Every Component necessary for an up-to-date Receiving Set is fully described and illustrated with diagrams and working drawings.

This book shows you how to make, using the ordinary simple household tools, rheostats, condensers — fixed and variable, resistances, low frequency transformers, high frequency transformers, tuning coils of every description, potentiometers, switches of every form, crystal detectors, grid leaks, valve panels, etc.

Why not exercise your own ingenuity? The crystal detector, grid leak, interchangeable fixed condenser and rotary series-parallel switch shown here could easily be made up by you at the cost of a few pence. Further, you will have the added satisfaction of using apparatus which is entirely home-made.

133 pages and 184 illustrations — can you afford to be without a Book like this? The first component you make will save the cost of the whole book. Call in and examine it at your Bookseller—he has 17 other Radio Press Books on sale, or send 2s. 8d. for a copy (post free) to the Publishers, Radio Press, Ltd. Devereux Court, Strand, W.C.2.

expect to attract sufficient of this traffic to put the older systems out of court.

Indeed, for inland communications wireless has not yet reached a stage where it has any chance whatever of competing with line working, except in places far removed from centres of civilisation and in cases where the communications have to pass through various

local arrangements, and there is the trouble of transit charges; whereas in the case of wireless the only arrangements to be made are those at the terminal stations, and the ether over all countries is available for the use of wireless, free of charge. From the technical point of view, however, wireless, in this latter case, is not able to reap so much advantage as might

but it must be remembered that land lines and short distance cables are also rapidly increasing their traffic carrying capacities. A land line, for example, with four wires may now provide for twenty-seven telegraph and telephone circuits by making use of wired wireless, and a submarine cable, up to a distance of about three hundred miles, can be constructed with four cores to deal with a total of sixteen telegrams simultaneously.

But we must now turn to the remaining comparison, namely, wireless with long distance cables, and here we find that wireless is in a very much stronger position than when compared with direct land lines or short distance cables.

To start with, wireless has the great advantage of utilising the

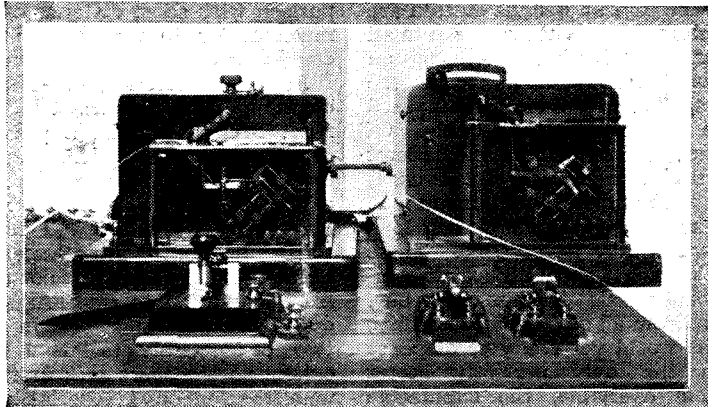

Automatic apparatus is largely used for transmission in high-power wireless stations. The automatic transmitter at Lafayette Station, Bordeaux.

countries. This is largely due to the fact that wireless is hopelessly unselective compared with line working, and it is surely too much to expect that such an essentially efficient broadcaster as wireless can ever be brought into

be expected, because, owing to interference troubles, it cannot yet make use of anything like such efficient high speed signalling arrangements as are possible in line



Above: The Kleinschmidt perforator, an ingenious apparatus which punches paper tape by the aid of a typewriter keyboard.

Left: The perforated tape which actuates the transmitter, thus replacing hand telegraphy.

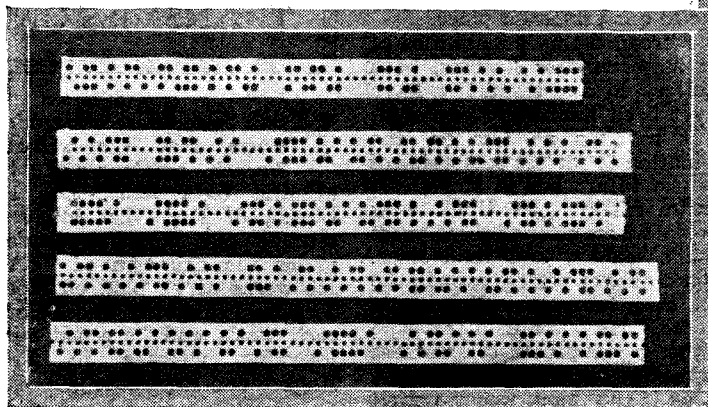

the same class for selectivity as line signalling, which is perfectly selective.

As regards places far removed from civilisation, the erection and maintenance of lines may make line signalling economically impossible where wireless would be profitable. Again, in the case of line communications having to pass through a number of countries, there is often much delay due to

working. This disability of wireless is very marked when comparing the traffic carrying capacity of wireless with direct land lines, or even short distance cables, and such comparisons show clearly how far wireless lags behind in this particular respect. The position of wireless, from this point of view, is, of course, improving rapidly with the advances being made in selective circuits and directive arrangements,

shortest route between any two places, whereas the length of cable required is often very much longer than this distance, with a resulting heavy expenditure in capital cost; but cables, on the other hand, are firmly established all over the world, and have been giving an excellent service for many years.

From the technical point of view it is a fact that for long range communication there are fewer difficulties to be overcome in developing high speed working by wireless, when conditions are

favourable, than by cables. It is true that long range wireless circuits cannot, at present, deal with traffic so rapidly as cable circuits, but then long range wireless is only on the threshold of its commercial development. The great difficulty with wireless is interference, but much is being done to reduce this trouble, and each step made means another step towards commercial high speed working. It must not be thought, however, that cable speeds have reached their limit; in fact, possibilities for increasing present speeds are now being worked out. The steady, continuous operation of cable circuits is what eats up the traffic, and is what makes the wireless enthusiast so jealous. Wireless is differently constituted and requires different treatment—a fact which is now fully realised, and acted upon, by traffic managers. There is no use trying to deal with wireless traffic in the ding-dong manner of cables. "Make hay while the sun shines" is the motto for the wireless traffic manager, though it may not sound very apt, as the best time for wireless "hay" is usually when the sun is not shining. The point is to get rid of the traffic at the highest possible speed when conditions are favourable, for they will not long remain so. It sounds so simple, but it is really very difficult, and the difference in time between widely separated places on the globe increases the complication, though it often helps to solve the difficulty. To add to one's troubles is the knowledge that, all the time, the cables are working away steadily and serenely, without caring whether it is Christmas or Easter.

There were many wireless enthusiasts in 1910 who thought that the cable laid across the Atlantic in that year would be the last trans-Atlantic cable, but by now they are not surprised to learn that a new one is to be laid this year, with twice the capacity of any existing cable from the United States.

All important countries are embarking on long range commercial wireless schemes, but at the same time are developing their submarine cable communications. Even Germany, which during the war was cut off from all cable communication, and had thus a special incentive to develop long range wireless, will soon have a cable connection with America, and has recently been joined to Sweden by a new combined telegraph and telephone cable.

We have already noted the two great assets of wireless which are

quite outside the possibilities of land lines or cables, namely, communications with mobile stations, and broadcasting. It is this facility for broadcasting that gives wireless the possibility of becoming a serious competitor with cables, and at the same time gives cables one of their chief advantages over wireless.

To deal with the latter point first. The fact that messages sent by wireless to a distant station are simultaneously sent broadcast in all directions over the earth is an obvious disadvantage, from the point of view of secrecy, compared with messages sent by cable. Of course, secret codes and secret forms of transmission can be used, and, in the future, a certain amount of directive transmission over long distances may be possible. These arrangements should meet all commercial needs for secrecy, but, apart from all other considerations, is the world yet ready to dispense with the only perfectly secret system available, the submarine cable?

Now for the other side of the question. Broadcasting gives wireless, compared with cables, an elasticity of action, which is its greatest asset. At one moment, a single wireless transmitter may be sending traffic to Australia, and at the next moment to Canada, and so on to all parts of the world in succession, or, if desired, it may send the same traffic to all parts of the world simultaneously; whereas a cable transmitter can only send traffic to one particular place.

The broadcasting possibilities of these large wireless stations, both for telegraphy and telephony, have not yet been practically explored, but it requires no tax on the imagination to foresee something of what the future has in store. It is extraordinary to think how parochial we are after all these years of mails, cables, and land lines. Our ignorance of what goes on in the world, even in our own Empire, is immense. Here is a field just ripe for the possibilities of wireless broadcasting, and it really looks, now, as if the long, weary period of waiting were drawing to a close.

In this short comparison of wireless with land lines and cables, we have had in mind, chiefly, the present position and future possibilities of telegraphy; but, for the most part, what has been said applies also to telephony. For short distance telephone working on land, apart from wireless broadcasting, which has unique and unchallenged possibilities, wireless cannot at present compete with

land lines, where these are practicable, owing to interference troubles, which are even more serious than in the case of wireless telegraphy. Much is being done with directive arrangements, and high hopes are entertained by many, but point-to-point wireless telephony has a very long way to go before it can even be compared with land lines. It is fortunately in a much better position for comparison with short distance cables, much better, in fact, than in the corresponding case of telegraphy.

For trans-ocean point-to-point communication wireless telephony may, before long, be a practical commercial proposition, unchallenged, as in broadcasting, by cables, and its possibilities for this long range work can well be left to the imagination of an Esperanto enthusiast. But he must not allow his imagination to ride roughshod over facts. He must bear in mind two disagreeable technical difficulties, not yet overcome: first, that wireless telephony is especially open to interference from wireless communications and from atmospheric; and, secondly, that the power required, which means cost, is far greater than in the case of wireless telegraphy.

AMATEUR TRANSMISSIONS

IT will be of interest to readers to know that the well-known French amateur of transatlantic tests fame, Dr. Pierre Corret, of Paris, has lately been sending out Morse transmissions under the call sign of "8AE2." He works at 11 p.m. on Monday, Tuesday, Thursday and Friday of each week, and he sends out the following message in French, English and Esperanto:—

"Wireless amateurs who hear these signals are requested to be good enough to report to Dr. Corret, 97, Rue Royale, at Versailles, Paris, how these signals have been received."

Dr. Corret first gives the general call "CQ de 8AE2," then the call in French, English and Esperanto. Wavelength 200 metres.

We trust that this little experiment will meet with the success it deserves.

HULLO EVERYBODY!!

CALLERS' COLUMN

Buy Best Goods at Low Prices.

No Post Orders at these Prices

Terminals (comp. with Nuts), Telephone, doz.	1/-
Large W.O. 4 for 5id., doz.	1/3
W.O. Pillar 4 for 5d., doz.	1/3
Small Pillar 1d. each, doz.	9d.
Switch Arm, 12 Studs and Nuts	1/-
Small Variometers, 250/650, with knob and bush	3/-, 2/8, 2/4
Larger Variometers, 250/650	4/9, 3/9, 2/11
Igranic Variometers, Ebonite, 350/650	15/-
2-Way Coil Holders, for Duolateral Coils, 5/6, 4/6	5/6, 4/6
3-Way Coil Holders, for Duolateral Coils, 6/11, 5/11	6/11, 5/11
Phillips R. type Valves	8/-
Stop Pins, with shoulder 2 a 1d., doz.	5d.
Fixed Condensers to .001	10d.
Fixed Condensers to .005	1/3
Fixed Condensers .006 up to .01	1/6
Valve Pins	6d.
Valve Sockets	9d.
2, 4, 5, B.A. Nuts	3 doz. 6d.
Basket Coils	Set of 2 2/-
Spade Terminals	4d.
Vario Coupler, with Knob, Wound D.C.C.	4/11
Glass Enclosed Whisker Detector	2/6
High-Class Whisker Detector (large), enclosed	2/6
Fine Perikon, 2 Crystals, enclosed	3/-
Small Perikon, 2 Crystals	2/-
Bell Wire, D.C.C., 1.C. 2 og.	10 yds. 6d.
Twin Flex	12 yds. 1/7, 4 yds. 7d.
Plug Coils, Ebonite	9d.
Extra Quality, ditto on base	1/-
Pillar Terminals, Nut and Washer, 2 B.A., large	6d.
Switch Arms	8d., 9d., 10d., 1/3
Filament Resistances	1/8, 1/10, 2/-
Igranic Resistances	4/6
Igranic Vernier	4d.
4 Cats'-Whiskers, one gold	1/4d.
Single Basket Coil Holders	1/5
Variable Grid Leaks	3/-
Bretwood Variable Grid Leaks, guaranteed 3 years	3/-
Pin Terminals, screw pattern, 1/3 doz., 2 for	3d.
Spade Terminals, screw pattern, 1/3 doz., 2 for	3d.
Shaw's Genuine Hertzite	9d.
Grid Leaks and Condensers, .0003	3/-, 2/3
Valve Sockets, with shoulder	1/-
Basket Coils, Duplex Waxless, set of 5 for	2/-
100,000 ohm Resistance	1/6
Variometer on Ebonite, ball rotor, wound, D.C.C.	8/11, 7/11, 6/11
D.C.C. Wound Tapped Coils	2/-, 1/9, 1/6
Double Phone Cords	9d.
Wound Coils, 12 X 4, best quality	2/6
Wound Coils, 6 X 3, best quality	1/9
D.P.S.T. Switches, special	1/3
S.P.D.T. on Ebonite	1/8 to 2/3
D.P.D.T. on Ebonite	1/11 to 2/9
2 B.A. Rod, 12 in.	2 for 5d.
Basket Coil Holders, for 3 coils	5/6
Plug and Socket, brass	13d.
Fixed Condensers .01	1/6
Pocket Lamp Batteries (best)	2/3
Special Filament Resistance, very fine value	6 for 2/3
D.P.D.T., Nickel Switches for panel mounting	2/-
File Res. Dials, 0-10	7d.
Real Ebonite Slider Knob and Plunger	6d.
Set of Names (12), engraved black or white	6d.
Insulated Hooks	1d.
Copper Foil	per foot 4d.
Best Zincite and Bornite	6d. each, pair 1/-
Xtraudion Valves (E.E.C.)	15/-
Ebonite Turned Valve-Holder and Nuts	1/-
Shellac	5 1/2
Tinned Copper, 16, 18, 20 gauge in stock.	
Formo Fil Resistances, best	2/6
Accumulator (Relax), 6 v. 80 amp.	33/-
" " 4 v. 40 amp.	17/6
" " 4 v. 60 amp.	21/-
Rubber Lead-in Wire, 10 yards.	1/6

RAYMOND VARIABLE CONDENSERS

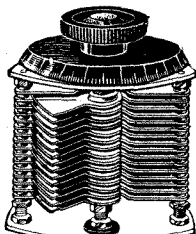

Without Dial.

'0016/6
'000755/6
'00054/9
'00034/2
'00023/-
'00012/8

Fully assembled with knob, pointer, bush, screws and connections, aluminium end plates.

Reg. Post and Packing 6d. set. Foreign post 2/- set

HEADPHONES.

4,000 ohms "Sidg" genuine	Post, 1/- pair. 14/6
Sterling, 4,000 ohms, latest mod l. B.B.C.	25/-
N. & K. Standard, latest model	15/11
Raymond, 4,000 ohms, high class	16/11
4,000 "Brunet"	17/6
4,000 "N. & K."	14/9
4,000 "Fellows' Lightweight B.B.C."	18/6
Premier B.B.C. 4,000 ohms, very fine value	16/11

ERICSSON "EV" TYPE PHONES

4,000 ohms. Thousands sold last season. Lovely tone. 13/9 per pair. Post. 1/- pair.

VALVES

MARCONI D.E.R.	post 1/- each. 21/-
EDISWAN A.R.D.E.	21/-
EDISWAN COSSOR P.I.	15/-
MULLARD ORA	12/6
MARCONI R	15/-

L.F. Intervalve Transformers.

5-1 Radio Instruments, Ltd. (1)	25/-
5-1 Igranic (shrouded) (2)	21/-
5-1 Formo (shrouded 18/-) (3) plain	15/-
5-1 Raymond	12/6

On Transformers (1), (2) and (3) goods to the value of 1d. in the 1/- given free to callers.

H.T. Batteries (very best only) — No post orders
 60 v. with plugs ... 9/6, 10/6, & 12/6
 36 v. ... 5/- & 5/6

CRYSTAL SETS

B.B.C. "Entophone," very compact, 8 by 6 crystal set, wonderfully effective, 25/-
 Or with phones, etc., ready to fix up, 39/11.

THE SIMPLEX BROADCAST CRYSTAL SET

The most efficient, simple and inexpensive crystal set made, range 200-600 metres. Will receive all broadcasting stations within a radius of 40 miles, using telephones of average sensitivity with a standard P.M.G. aerial. Very fine tuning obtainable using basket coils of very low self-capacity. Every set sold has been tested, and is guaranteed.

Simple, Cheap and Efficient, 12/6 per set. Post 1/-

POST ORDER COLUMN

NO POST ORDERS except for goods in this column, and at prices marked, which include all post, rail and packing charges, U.K. only.

ALL ORDERS EXECUTED AT THE EARLIEST POSSIBLE MOMENT, IN STRICT ROTATION.

Accumulators, high-class goods, 4v. 40 amps.	20/-
Fixed Condensers, .003 to .001	1/4
Fixed Condensers, .002 to .005	1/8
Fixed Condensers, .006	2/-
Ebonite Valve Holders, 8 nuts. Each 1/6, 3 for	4/-
Ebonite Dials and Knob, turned ebonite	2/-
D.P.D.T. Switches, small size, on ebonite base	3/3
S.P.D.T. Switches, small size, on ebonite base	2/9
Variable Grid Leak (Bretwood), guar. 3 years.	3/6
Variable Grid Leak, pencil pattern	2/6
Two-way Coil Holders, 3 qualities, all good value	5/6, 6/6, 7/6
Three-way ditto, as above	6/9, 7/6, 8/9
Twin Flex for Extension Leads 12 yds.	2/3
Grid Leak and Condenser, .0002, .0003, .0005	2/9
Grid Leak, 2 megohms	1/4
Fellows' Lightweight Phones, 4,000 ohms, (similar to Brown's) B.B.C.	19/6
Pin Terminals, screw pattern, for phone leads	6 for 1/-
Spade Terminals, screw pattern, for phone leads	6 for 1/-
Ebonite Coil Plugs, high-class article, each 1/3,	6 for 6/9
4 Cats'-whiskers (gold, silver, etc.)	6d.
Bell Wire, D.C.C., I.R.C.	10 yds. 1/-
100,000 ohms Resistance	2/-, 2/6
Switch Arms, very good quality, complete with 12 studs	2/-
Valve Sockets, polished, with shoulder and nuts	doz. 1/6; 3 doz. 4/-
Shaw's Genuine Hertzite Crystal	1/6
Double Phone Cords, with screw terminals	1/6
Basket Coil Holders, for 3 coils, on stand	6/-
Basket Coil Holders, single, with coil plug	2/9
Filament Resistances (not cheap rubbish)	2/6, 2/8, 3/-
Very Special ditto (limited number)	2/9
Terminals, Telephone, with nut, doz. 1/9; 3 doz.	4/-
Terminals, Large W.O. pattern, with nut	doz. 1/9 3 doz. 4/-
Terminals, Extra Large 2 B.A., with nut	6 for 2/6; doz. 4/6
Variometers and knob, 250/650	4/6
Basket Coils up to 3,500 metres	set of 6 2/6
Spring Washers	3 doz. 2/-
Crystal Detectors, all best quality, not Junk. Enclosed, large whisker	3/3
Crystal Detectors, enclosed smaller whisker	2/9
Crystal Detectors, enclosed, large, Perikon, 2 crystals	3/9
Crystal Detectors, enclosed, slightly smaller ditto	3/3
Many Other Detectors, open type	2/-, 2/6, 2/9, 3/-
L.F. Intervalve Transformers, Radio Instruments, Ltd.	25/-
L.F. Intervalve Transformers, Igranic (shrouded)	21/-
L.F. Intervalve Transformers, Formo, 18/- and 15/-	15/-
L.F. Intervalve Transformers, Raymond	13/9
Variometer on Ebonite Ball Rotor	10/-
Igranic Variometers, Inside Winding	15/-
Sets of 12 name tabs, black or white	1/-
2 B.A. Nuts	per gross 1/10
Real Ebonite Slider Knob and Plunger	1/-
Insulating Sleeving, all colours	6 yds. 2/9
Amplion Junior Loud-speaker	42/6
Best Knobs, Bushed 2 B.A.	4 for 1/6
Brunet Phones, 4,000 ohms	18/6
N. and K. Standard, 4,000 ohms.	15/9
B.B.C. Best Phones, 4,000 ohms	17/11
D.P.D.T. Nickel Switches for panel mounting	2/6

TRADE AND RADIO CLUBS SUPPLIED. I advertise what I sell, and sell what I advertise. HONEST GOODS AT THE RIGHT PRICE. Right Reserved to Return Cash. SEND FOR POST LIST.

RIGHT OPPOSITE
DALY'S
 GALLERY DOOR

K. RAYMOND

27, LISLE STREET, W.C.2

HOURS
 OF BUSINESS:
 DAILY - 9 to 7.45
 SUND, 10.30 to 1

PHONE GERRARD 4637.

2 FU E. T. MANLEY 49a, Arthur Road, Wimbledon Park.
 2 FW REV. D. THOMAS St. Paul's B.P. Scouts, Bourne-
 mouth.
 2 FX H. C. BINDEN 32, Oxford Road, Bourne-
 mouth.
 2 FZ MANCHESTER WIRELESS SOCIETY. The Albion Hotel, Piccadilly, Manchester.

2 IH TECHNICAL COLLEGE ... Cardiff.
 2 II SOUTHPORT WIRELESS SOCIETY. Queen's Hotel, Promenade, Southport.
 2 IJ COUNTY SCHOOL FOR BOYS Altrincham.
 2 IK H. R. GOODALL Fernlea, Winchester Road, Basset, Southampton.
 2 IL J. F. FISH Thornleigh, Station Road, Thornton-le-Fylde, near Blackpool.
 2 IN W. A. WARD... .. 26, Marlborough Road, Sheffield
 2 IO REV. H. W. DOUDNEY ... St. Luke's Vicarage, Bath.
 2 IS REV. H. W. DOUDNEY ... St. Luke's Vicarage, Bath.
 2 IT G. A. E. ROBERTS ... Twyford, near Winchester.
 2 IU L. F. WHITE Priory Road, Bristol.
 2 IV G. R. MARSH Mallard's Close, Twyford, Win-
 chester.
 2 IX S. G. TAYLOR Fressingfield, Littleover, Derby.

2 GA REV. J. A. GIBSON 18, Daniel Street, Bath.
 2 GD BIRMINGHAM WIRELESS SOCIETY. Birmingham.
 2 GF J. V. NEWSON 130, Ormside Street, S.E. 15.
 2 GG R. H. KIDD Marlborough House, Newbury.
 2 GI MR. JOHNSON Park View, Hind House Lane, Pitsmoor, Sheffield.
 2 GL W. J. HENDERSON 2, Hollywood Avenue, South Kensington.
 2 GN HALIFAX WIRELESS CLUB ... Clare Hall, Halifax.
 2 GO L. BLAND FLAGG 61, Burlington Road, Bays-
 water, W. 2.
 2 GP W. GARTLAND 14, Baalbec Road, Highbury, N. 5.
 2 GQ 1ST TAUNTON SCOUTS 11, Park Street, Taunton.
 2 GR F. FORSYTH Ashington.
 2 GS F. FORSYTH Ashington.
 2 GT G. IRVINE 12, Treborth Street, Liverpool.
 2 GU HALIFAX WIRELESS CLUB ... Clare Hall, Halifax.
 2 GV REV. W. P. RIGBY St. Lawrence Viarage, Bris-
 tol.
 2 GW A. CASH Foxley Mount, Lymm, Cheshire.
 2 GZ A. L. MEGSON Cambridge Street, Manchester.

2 JA A. S. ATRINS St. Malo, Beauchamp Road, Norwood.
 2 JB MESSRS. DORTE & LINDSAY Downside School, Stratton-on-the-Fosse.
 2 JC I. H. STOREY Escowbeck, Lancaster.
 2 JD I. H. STOREY White Cross Mills, Lancaster.
 2 JF C. G. WILLIAMS 22, Scholar Street, Sefton Park, Liverpool.
 2 JG W. A. SEED Crigglestone, Wakefield, Yorks.
 2 JH C. BURRAND STEFANO ... Wellington Street, Slough.
 2 JJ C. WORTH 4, Riverside Road, Egremont, Wallasey, Cheshire.
 2 JK P. R. COURSEY 138, Muswell Hill Road, N. 10.
 2 JL G. G. BAILEY The Beeches, Cowley, Middlx.
 2 JM G. G. BLAKE 10, Onslow Road, Richmond.
 2 JN H. B. BURDIN Bilton, Rugby.
 2 JO J. W. WHITESIDE 30, Castle Street, Clitheroe, Lancs.
 2 JP M. C. ELLISON Huttons Ambo Hall, Yorks.
 2 JQ M. C. ELLISON Huttons Ambo Hall, Yorks.
 2 JU E. J. PEARCEY 115, Woodland Road, Hand-
 worth, Birmingham.
 2 JV A. G. BOBINS Station Road, Epping.
 2 JW J. R. BARRAST Westgate Court, Canterbury.
 2 JX L. L. VIZARD 12, Seymour Gardens, Ilford.
 2 JZ R. D. SPENCE Craighead House, Huntly, Aberdeenshire.

2 HA A. L. MEGSON Cambridge Street, Manchester.
 2 HB L. H. LOMAS Highfield, Somerset, near Man-
 chester.
 2 HC F. M. J. WHITE, B.S. ... Winchcombe Lodge, Buckle-
 bury.
 2 HF W. G. GOLD Rosedale, Belwell Lane, Four
 Oaks, near Birmingham.
 2 HG T. BOUTLAND (SENR.) ... Ashington.
 2 HH T. BOUTLAND Ashington.
 2 HK A. A. CAMPBELL SWINTON ... 66, Victoria Street, S.W. 1.
 2 HL A. A. CAMPBELL SWINTON ... 40, Chester Square, S.W. 1.
 2 HP H. C. WOODHALL 10, Holborn House, E.C. 1.
 2 HQ A. W. FAWCETT 11, Leigh Road, Bristol.
 2 HR F. O. READ & Co. 13/4, Great Queen Street, W.C.
 2 HS C. W. HALE 30, Dagnall Park, S. Norwood,
 S.E.
 2 HT R. H. KLEIN, M.I.R.E. ... 18, Crediton Hill, W. Hamp-
 stead, N.W. 6.
 2 HV BERESFORD BROS. Bull Street, Birmingham.
 2 HW }
 2 HX } F. A. LOVE 26, Guildford Park Road,
 Guildford, Surrey.
 2 HZ P. W. NORTHEY 12, Pelham Crescent, S.W. 7.

2 KA BRIGHTON AND HOVE R.S. Buckingham Road, Brighton.
 2 KB W. E. EARP 675, Moore Road, Mapperley,
 Nottingham.
 2 KC H. T. LONGUEHAYE 96, Barnacod Road, Ecken-
 ham.
 2 KD DENISON BROS. Wainhouse Tower, Halifax.
 2 KE J. A. PARTRIDGE 22, Park Road, Colliers Wood,
 Ye'ton, S.W. 10.
 2 KF A. E. HAY Glendale, Abernant, Aberdare.
 2 KG ASHLEY WIRELESS TELE- 60, Renshaw Street, Liverpool.
 PHONE CO., LTD.
 2 KH HUTCHINSON & Co. 101, Dartmouth Road, S.E.
 2 KL F. PINKERTON 50, Peak Hill, Sydenham.
 2 KM C. STAINTON 155, Estcourt Street, Hull.
 2 KN A. B. DAY Finchley.
 2 KO C. S. BAYNTON 48, Russell Road, Moseley,
 Birmingham.
 2 KP F. A. BIRD 13, Henrietta Road, Bath.
 2 KQ H. TAYLOR The Lodge, Tottenham Wood,
 near Wolverhampton.
 2 KR E. EDMONDS 2, Yew Tree Road, Edgbaston,
 Birmingham.
 2 KS C. CLAYTON-BREAKELL ... Mill Bank, Church Street,
 Preston.
 2 KT J. E. NICKLESS 83, Wellington Road, Snares-
 brook, E. 11.
 2 KU A. J. SELBY 66, Edward Street, Burton-
 on Trent.
 2 KV W. J. CRAMPTON Huntingdon House, St. George's
 Hill, Weybridge.

also 5DT

2 IA L. F. OSTLER 10, Windsor Terrace, Penarth.
 2 IB W. BEMROSE Littleover Hill, Derby.
 2 IC CAPT. A. L. STILES Heron's Ghyll, South Harrow.
 2 ID E. S. FIRTH Thames Ditton.
 2 IF S. W. BLIGH 2, North Lane, Canterbury.

2 KW	W. R. BURNE	Springfield, Sale, Cheshire.	2 NA	H. FROST	Longwood, Barr Common, Walsall.
2 KX	W. STANWORTH	Fern Bank, Blackburn.	2 NB	J. W. BARNABY	Sylvan House, Broad Road Sale, Manchester.
2 KY	L. FOLLARD	209, Cunliffe Road, Blackpool.	2 NC	J. GOODWIN	Crown Street, Duffield, Derby.
2 KZ	B. CLAPP	Meadmoor, Brighton Road, Purley.	2 ND	E. H. PICKFORD	6, Wilson Road, Sheffield.
			2 NF	JORDAN S. WHALE	Whale's Wireless Works, Colwyn Bay.
			2 NH	O. R. C. SHERWOOD	41, Queen's Gate Gardens, S.W. Dartford and District W.S.
			2 NI	P. H. LYNE	London, S.E.12.
			2 NJ	J. JOSEPHS	174, Woodside Road, Lockwood, Huddersfield.
			2 NK	P. PRIEST	Ashdene, 129, Wells Road, Bath.
			2 NL	F. J. HUGHES, A.M.I.E.E.	Coombe Dingle, Queen's Park, Caterham, Surrey
			2 NM	G. MARCUSE	Epping.
			2 NN	BRIG.-GEN. PALMER	Crescent Cabinet Factory, Sutton Road, Walsall.
			2 NO	H. R. ADAMS	Middleton Cheney, Banbury.
			2 NP	H. G. TREADWELL	14, Woodside Road, Kingston-on-Thames.
			2 NQ	R. J. T. MORTON	Mount Pleasant Works, Wooden Box, nr. Burton-on-Trent.
			2 NR	J. KNOWLES HASSALL	39, Leighton Road, Southville, Bristol.
			2 NS	M. BURCHILL	
			2 NV	H. LITTLE	15, Lodge Road, W. Bromwich.
			2 NW	J. N. C. BRADSHAW	Ambrose House, Bilsborough, near Preston.
			2 NY		
			2 NZ		
2 LA	H. F. YARDLEY	121, Victoria Road, Leeds.	2 OA	F. TOWNSEND	46, Grove Lane, Ipswich.
2 LB	H. F. YARDLEY	6, Blenheim Terrace, Leeds.	2 OD	E. J. SIMMONDS	Meadowlea, Queensway, Gerard's Cross, Bucks.
2 LD	J. COTTIS	4, Crondace Road, Fulham, S.W. 6.	2 OF	H. C. TRENT	Secondary School, Lowestoft.
2 LF	P. HARRIS	Wilts.	2 OG	A. COOPER	16, Wentworth Road, York.
2 LG	H. H. WHITFIELD	The Glen, Primrose Lane, Hall Green, Birmingham.	2 OI	C. BAIN	51, Grainger Street, Newcastle-on-Tyne.
2 LI	C. H. WILKINSON	14, Kingswood Avenue, Brondesbury, N.W. 6.	2 OJ	E. A. HOUGHTON	52, First Avenue, Hove, Sussex.
2 LJ	WORCESTER CADET SIG. COY.	Junior Technical Sch., Worcs.	2 OK	H. D. BUTLER	222, Gt. Dover Street, W.
2 LK	S. KNIVETON	22, Broadway, Kirkstall, Leeds.	2 OL	H. D. BUTLER	Trebarwith, South Watfield.
2 LL	MARCONI CO.	Marconi House, Strand, W.C. 2.	2 OM	H. S. WALKER, A.M.I.R.E.	Park Lodge, Brentford, Middlesex.
2 LO	A. W. KNIGHT	26, Stanbury Road, Peckham, S.E. 15.	2 ON	MAJOR PARKER	Walthamstow, 56, Stern-Hall Street.
2 LP	J. A. HENDERSON	Elm Hall Drive, Mossley Hill, Liverpool.	2 OP	G. COURTENAY PRICE	8, Lansdown Terrace, Cheltenham.
2 LQ	J. SCOTT-TAGGART	6, Beattyville Gardens, Ilford.	2 OQ	D. P. BAKER	Cleveland Road, Wolverhampton.
2 LR	A. F. BARTIE	5, Ulandi Road, Westcombe Park, S.E.	2 OT	ILFORD RADIO SOCIETY	Ilford.
2 LT	W. A. APPLETON	Wembley Park.	2 OU	F. W. WOODWARD	5, Portland Gardens, Harringay, N.4.
2 LU	W. R. H. TINGEY	22, Leinster Gardens, W.	2 OV	J. R. RADCLIFFE (DR.)	Birmingham.
2 LV	W. R. H. TINGEY	92, Queen Street, Hammer-smith.	2 OX	CAPT. E. J. HOBBS, M.C., A.M.I.R.E.	4th Tank Battalion, Wareham, Dorset.
2 LW	S. SKEET	120, Highcross Street, Leicester	2 OY	WORCESTER CADET SIG. CO.	R.C. of Sigs. Junior Tech. School, Sansome Walk, Worcester.
2 LX	H. H. THOMPSON	59, Redlands Road, Penarth, Glamorgan.			
2 LY	F. A. MAYER	Stileman's, Wickford, Essex.	2 PA	G. Z. AUCLAND & SON	395, St. John Street, E.C.
2 LZ			2 PB	D. E. O. NICHOLSON	41, Upper Kennington Park Lane, Lambeth, S.E.11.
			2 PC	A. G. DAVIES	Reico, Park Road, Timperley, Cheshire.
2 MA	P. S. SAVAGE	Norwich Road, Lowestoft.	2 PD	W. H. MARSTON	The Manor, Willenhall, Staffs.
2 MB	E. H. JEYNES	67, St. Paul's Road, Gloucester.	2 PE	F. FOULGER	London, S.E.14.
2 MC	H. B. DENT	Fleetwood Avenue, Westcliff-on-Sea.	2 PF	B. HESKETH	High Street, Chalvey, Slough.
2 MD	C. CHIPPERFIELD	Victoria Road, Oulton Broad.	2 PG	L. DORE	139, Milcote Road, Bearwood, Smethwick, Staffs.
2 ME	MARCONI SCIENTIFIC INSTRUMENT CO.	Dean Street, Soho.	2 PH		
2 MF	C. CREED MILLAR	Arndene, Bearsden, near Glasgow.	2 PI	LOUGHBOROUGH COLLEGE	Leicester.
2 MG	A. LAWTON	Brown Edge Vicarage, Stoke-on-Trent.	2 PJ	MAJOR L. N. STEPHENS, R.A.	Haddon House, Bridport.
2 MH	L. McMICHAEL, LTD.	Stag Works, Providence Place, Kilburn, N.W. 6.	2 PK	N. C. HARDWAN	"Magfield," Cloughfold, Nr. Manchester.
2 MI	A. W. HANBLING, A.M.I.R.E.	23, Winchester Avenue, Brondesbury, N.W. 6.	2 PL	J. S. KNIGHT	Clark's Hill, Nursery, Prestwich.
2 MJ	R. C. CLINKER	Tryfan, Bilton, Rugby.	2 PM	G. E. MORTLEY & Co	Nelson Road, Tunbridge Wells
2 MK	C. C. A. HINES	Watley, Twyford, Winchester, Hants.	2 PN	A. E. WHITEHEAD	Hollingwood, King's Ride, Camberley, Surrey.
2 ML	BURNDIPT, LTD.	Chiswick.	2 PS	J. H. GILL	18, Fourth Avenue, Sherwood Rise, Nottingham.
2 MM	R. H. REECE	62, Addison Gardens, W. 14.	2 PT	J. JARDINE	Crosby, Blundellsands.
2 MN	R. H. REECE	Baskets, Birchington, Kent.	2 PU	C. W. R. CHAPMAN	Nirvana, 44, Chaplin Road, Wembley.
2 MO	MARCONI WIRELESS TELEGRAPH CO.	Writtle, near Chelmsford.	2 PV	CAPT. G. T. SMITH-CLARKE	Waverley Road, Kenilworth.
2 MP	R. WALLIS	Denh de Lion, Westgate-on-Sea.	2 PW	MR. MATTHEWSON	35, Capel Road Forest Gate.
2 MQ	H. M. HODGSON	Clifton House, Hartford, Mid-Cheshire.			
2 MR	J. MAYALL, A.M.I.E.E., M.Soc.C.E. (FRANCE).	Burfield, St. Paul's Road.			

T. O. BUSS, Scientific Instrument Maker,

77, CLERKENWELL ROAD, LONDON, E.C.1.

Established 1850.

Exhibition Awards—London 1862. Sydney 1879. Melbourne 1880.

HEADPHONES 12/9

Genuine French Telephones, most sensitive obtainable, 4,000 ohms with cords (Double Receivers) ... post free
 "BRUNET" Headphones, 4,000 ohms. .. 17/6 post 9d. extra

Side, 4,000 ohms. .. 14/11
 Side, 8,000 ohms. .. 17/11

N & K (The Genuine Article) 12/9

4,000 ohms, all guaranteed per pair
MARCONI D.E.R. TYPE
EDISWAN, COSSOR, MARCONI R.
MULLARD "ORA"

VALVES

CONDENSERS. Complete Sets of Parts.			Assembled Complete for Cabinet Mounting.	
Approx. Capacity Microf'ds.	No. of Plates.	Price.	Approx. Capacity Microf'ds.	Price.
.001	57	6/6	.001	7/6
.00075	43	5/9	.0005	5/11
.0005	29	4/11	.0003	5/2
.0003	19	4/2	.0002	4/6
.0002	13	3/6	.0001	4/-
.0001	7	3/-		

FIXED CONDENSERS. .0003, .0005, .002, .003, 10d. and 1/- each. .004, 1/6 each. Post, 3d.
VARIABLE GRID LEAK, 2, each and 6/- each.
GRID LEAK AND CONDENSER. .0003, 2/3 each. 100,000 ohms Resistance, 2/- each. Postage on above, 3d. each.

WIRELESS PARTS AND ACCESSORIES.

Aerial Wire, 7/22 bare copper, stranded. Price per 100 ft., 2/6 and 2/4. By Post, 3/6.
Aluminium Vanes, 1 doz., 5d. By Post, 8d.
Basket Coils, 7 in. set, 3/- set. By Post, 3/4.
Brass Washers, 2, 3, 4 or 5 B.A. .. dozen 2d.
 " Nuts, 2 B.A. .. dozen 2 1/2d.
 " Nuts, 3, 4 or 5 B.A. .. dozen 2d.
 " Rod (screwed)—
 2 B.A., in 12-in. lengths .. each 3d.
 3 B.A., in 12-in. lengths .. each 3d.
 4 B.A., in 12-in. lengths .. each 2 1/2d.
Contact Studs, 1/2 in. by 1/4 in., complete with nut and washer, 5d. doz.
Copper Foil Sheets, uniform thickness, 12 in. by 3 in. 3d. each.
Crystal Detectors on Ebonite, 1/6 each.
Crystal Detector, cup enclosed with glass cover, dust proof, 3/6. By Post, 4/-.
Coil Holders, Ebonite, 3-way, 5/6, 6/6, 7/6; 2-way, 4/8 and 5/6. Post any one, 6d. extra.
Ebonite Dials, with engraved scale 0-180, 1/- each. By post, 1/6.
Engraved Iverine Scales, 0-180 round ends, 4d. ea.
Filament Resistance, 1/6, 2/6 each. By Post, 1/10 and 2/10.
Inductance Coils Wound Enamel Wire, 12 by 4, 3/- By post, 5/-.
1 1/2 Insulating Sleeving, 4d. yd. By post 4/- doz. yds.
Insulators, Egg, 4 for 11d., 2/6 per doz. By post, 3/6 doz.
Insulators, Reel, 1 1/2d. each. By post, 6d. doz. extra.
Knobs, with brass nut (2 B.A.), 3d. each. By post, 3d.
Large Spacer Washers, 3 doz., 9d. By post, 1/-.
Lead-in Tubes, ebonite with brass terminals, 9 in., 1/- By post, 1/4, 12 in., 1/4. By post, 1/8.
Slider and Plunger, 4d. By post, 6d.
Slider Knob, Plunger and 13 in. rod, 8d. the set. Cannot be sent by post.
Small Spacer Washers 6 doz. 1/- By post, 1/4.
Spade Terminals, 4d. doz. Post 1 1/2d.
Switch Arms, with polished knob, bushed 2 B.A. nut, laminated blade, spring coil washer, nuts and bush, 1/- and 1/6 each. By post, 1/3 and 1/9.
Tin Foil, free from lead. Sheets, 17 in. by 11 in., 4d. each.
Valve Legs, with nuts and washers, 1d. each, 9d. doz.
Valve Holders ebonite, complete with nuts, 1/-.
Valve Pins, split, 7d. doz.

Terminals.

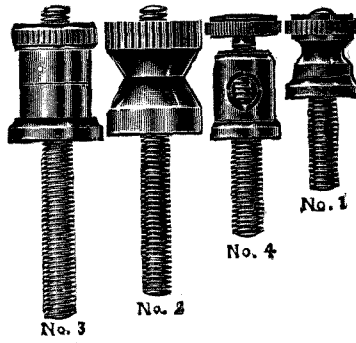

No. 3 Terminals, 2 B.A., with nut and washer, 2/- doz. By post, 2/6.
No. 2 Terminals, War Office Pattern, with nut and washer, 1/3 doz. Post, 1/9.
No. 4 Terminals, Telephone, with nut and washer, 1/3 doz. By post, 1/9.
No. 1 Terminals, with nut and washer, 1/- doz. By post, 1/6.
Terminals (large), aerial and earth, complete with 2 nuts and 2 washers (2 B.A.), 2 for 8d. By post, 1/-.

"Ebonite"

POSTAGE FREE. ANY SIZE CUT.

	s. d.		£ s. d.
8 x 1 x 1/2 ..	- 7	12 x 10 x 1/2	- 7 6
4 x 4 x 1/2 ..	1 3	17 x 8 x 1/2	- 8 9
7 x 6 x 1/2 ..	2 8		
10 x 6 x 1/2 ..	3 9	18 x 18 x 1/2	- 15 9
17 x 5 x 1/2 ..	5 3	36 x 18 x 1/2	1 7 6

Post free.

Instrument Wires

BRITISH MADE COPPER WIRES.

Prices per lb.

Other sizes in stock. A charge of 3d. extra is made for reeling off in small quantities. Postage extra.

S.W.G.	per lb.	yds. ohms 1/2	S.C.C.	D.C.C.	S.S.C.	D.S.C.	Enmld.
22	140	39	2/9	3/-	4/-	5/-	2/7
24	230	63	3/-	3/6	4/6	6/-	2/8
26	340	95	3/7	4/1	5/-	8/-	3/2
28	530	140	4/4	4/8	6/-	9/-	3/6
30	716	200	5/-	5/6	7/-	10/-	3/10
32	950	262	6/-	7/3	8/-	12/6	4/2
34	1,300	362	7/-	8/3	9/-	13/6	4/4
36	2,000	530	8/8	10/-	12/-	15/6	4/8

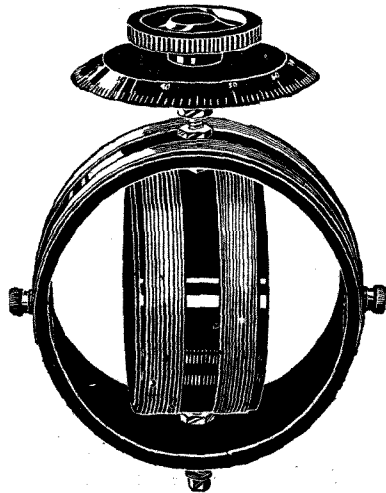

VARIOMETERS.

Bushed Bearings, Ebonite Dial 0-100; and Knobs. Metal Parts Plated. Wave-length 250 to 560 metres.
 Possessing high insulating properties, and the finish of the instrument throughout is excellent.
 Adequate provision is made for mounting on a panel, and the dial is neatly and clearly engraved.
 A variable condenser of .0005 microfarad capacity in series of parallel for the short and longer wavelengths respectively.

Marvellous Value **4s. 6d.**
 Post 6d. extra.

L.F. INTERVALVE TRANSFORMERS

5-1	Radio Instruments, Ltd.	25/-
5-1	Igranic Shrouded	21/-
5-1	Formo Shrouded 18/-	Plain 15/-
5-1	Buss	14/6

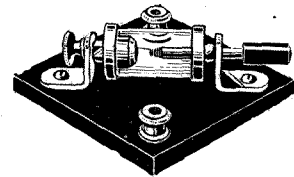

Crystal Detector

Enclosed Type with Glass Dust Shield, as illustrated. Price .. 2/3.
PERIKON TYPE with Glass Dust Shield. Price 3/9

H.T. Batteries

60 v.	8/6, 10/6 & 12/6
36 v.	5/- & 5/6

Inductance Tubes

Cardboard.

12 x 2 1/2, 4d., Post 2 1/2d.	12 x 3 1/2, 6d., Post 4d.
12 x 3, 5d., Post 3 1/2d.	12 x 4, 8d., Post 5 1/2d.

Mahogany Boxes

Polished.

	Post.
4 1/2 x 4 1/2 x 3 1/2 in. ..	2/9 3d.
4 1/2 x 4 1/2 x 5 in. ..	3/3 6d.
6 1/2 x 6 1/2 x 4 in. ..	4/6 1/-
13 x 6 1/2 x 4 in. ..	7/- 1/-

Any size and shape to order. Price on application.

TRADE SUPPLIED.

Terms on Application.

2 PX	H. H. LASSMAN	429, Barking Road, East Ham, E.6.	2 SK	K. G. STYLES	52, Jerningham Road, New Cross, S.E.14.
2 PY	H. CARTER BOWLES	51, Gunterstone Road, West Kensington.	2 SL	A. G. STYLES	Kitscot, 57, Bower Mount Road, Maidstone.
2 PZ	A. SYMONDS	Addison Avenue, Holland Park.	2 SM	R. J. BATES	Abbeygate Street, Bury St. Edmunds.
					2 SO	T. GEESON	Alder Cottage, Peel Street, Macclesfield.
					2 SP	L. MANSFIELD	Cregneish, Ley Hey Park, Marple, Cheshire.
					2 SQ	A. J. SPEARS	25, Rawlings Road, Birmingham.
					2 SS	MR. EVANS	Bradford Technical College.
					2 ST	L. LAMBERT	46, Clarendon Road, Holland Park, W.11.
					2 SU	MR. ESKDALE	230, Manchester Road, Bradford
					2 SX	F. B. BAGGS	24, Westhorpe Street, Putney, S.W.15.
					2 SY	H. STEVENS	25, Oaklands Road, Wolverhampton.
					2 SZ	W. H. BROWN	Mill Hill School, N.W.7.
2 QA	H. W. TAYLOR	Cambridge.	2 TA	H. ANDREWS	8, North Grove, Highgate, N.6.
2 QD	J. AYERS	18, Seaford Avenue, New Malden, Surrey.	2 TB	H. W. SELLERS	Caresbrooke, Langley Avenue, Bingley, Yorks.
2 QG	J. S. ALDERTON	1542, Stratford Road, Hall Green, Birmingham.	2 TC	H. W. SELLERS	
2 QH	C. HEWINS	42, St. Augustine Avenue, Grimsby.	2 TF	EDINBURGH AND DISTRICT R.S.	Edinburgh.
2 QI	HURST & LUCAS	Mayford Road, Balham, S.W.	2 TG	DR. T. F. WALL	Department of Applied Science, Sheffield University.
2 QJ	H. R. WALTON	70, Moorfield Road, Pendleton, Manchester.	2 TH		
2 QK	J. BEVER	85, Emm Lane, Bradford.	2 TI	H. BEVAN SWIFT, A.M.I.E.E.	49, Kingsmead Road, Tulse Hill, S.W.
2 QL	R. J. HIBBERD	Graywood School, Haslemere.	2 TJ	BURNDEPT, LTD.	St. George Street, Leeds.
2 QN	A. HOBDAY	Flint House, Northdown Road, Margate.	2 TL	E. V. R. MARTIN	128, Dairy House Road, Derby.
2 QO	P. PRITCHARD	Blenheim House, Broad Street, Hereford.	2 TM	L. H. MANSELL	Woodfield, Madersfield, Malverna
2 QP	L. C. GRANT	3, Langhorn Street, Newcastle. Wembley.	2 TN	C. E. STUART	Lynlon Lodge, Polesworth Tamworth.
2 QQ	BURNDEPT, LTD.	Handsworth, Birmingham.	2 TO	F. T. G. TOWNSEND	
2 QR	F. W. G. JOWERY	Ravenswood, 339, Brixton Road, S.W.9.	2 TP	C. W. ANDREWS	26, Melody Road, Wandsworth, S.W.
2 QS	S. WARD		2 TQ	T. C. MACNAMARA	31, Rollscourt Avenue, Herne Hill.
2 QT	C. C. BARNETT	Lower Farm, Nether Compton, Sherborne, Dorset.	2 TR	F. O. SPARROW	8, North Drive, Swinton, Manchester.
2 QU	HURST & LUCAS	Lansdown Road, Blackheath.	2 TT	P. HAMILTON, JUNR.	The Villa, Glenfield, Paisley.
2 QV	ALTRINCHAM WIRELESS SOCIETY	Plane Tree Road, Hale, Cheshire	2 TV	E. W. WOOD	79, Colwyn Road, Northampton.
2 QZ	B. H. COLQUHOUN	3, Eastbrook Road, Blackheath.	2 TW	A. R. C. JOHNSTON	Twvford Avenue, Baling, W.
					2 TX	S. SCOTT	Field Villa, Norton, Malton.
					2 TY	E. JONES	Newholme, Hempsshaw Lane, Olferton, Nr. Stockport.
					2 TZ		
2 RB	H. B. GRYLLS	Trenay Fawton, Carew Road, Eastbourne.	2 UA	S. P. B. BARNES	38, Avenue Road, Highgate, N.6
2 RD	G. W. FAIRALL	27, Newbridge Street, Wolverhampton.	2 UC	E. J. WINSTONE	West Kensington.
2 RG	E. W. SCAMELL	Birmingham.	2 UD	E. W. SMITH	77, Grove Lane, Camberwell.
2 RH	H. A. POUND	101, High Street, Broadstairs.	2 UF	H. BAILEY	51, Manchester Road, Denton, Manchester.
2 RJ	MAJOR F. S. MORGAN	East Farleigh, Kent.	2 UG	W. HUMPHREYS BURTON	103, Portland Road, Nottingham.
2 RK	A. E. BLACKHALL	7, Maple Road, Surbiton.	2 UI	A. R. OGSTON	41, Broomfield Avenue, Palmer's Green.
2 RM	D. CROSS	3, Norman Road, Heaton Moor, near Stockport.	2 UJ	L. R. ROWLANDS	Mona, 25, Cholmeley Park, Highgate, N.6.
2 RN	D. W. RICHARDS	"Mamety House," Bontnewydd Tce., Trelewis, Glam.	2 UK	COLERIDGE DAY CONTINUATION SCHOOL	King's Norton, Birmingham.
2 RP	F. W. EMERSON	178, Heaton Moor Road, Heaton Moor, near Stockport.	2 UM	H. LLOYD (B.Eng.)	3, Ventnor Place, Sharrow, Sheffield.
2 RQ	E. C. N. STRONG	119, Church Lane, Handsworth Wood, Birmingham.	2 UN	Y.M.C.A. (Boys' Dept.)	Cardiff.
2 RR	W. V. WADDOP	56, Wellington Road, Handsworth Wood, Birmingham.	2 UP	DEPT. OF PHYSICS	Armstrong College, University of Durham, Newcastle-on-Tyne.
2 RS	T. HESKETH	42, Castle Hill Avenue, Folkestone.	2 UQ	H. F. ABELL SANDERSON	23, Palace Road, Llandaff.
2 RT					2 US	WIRELESS SOCIETY OF HIGHGATE	Highgate Literary and Scientific Institute, 11, South Grove, Highgate, N.6.
2 RU	N-EASTERN INSTRUMENT CO.	Low Fell, Gateshead. Rowlands Mill Co., Nr. Newcastle-on-Tyne.	2 UV	W. E. F. CORSHAM	104, Hartlesden Gardens, N.W.10
2 RV	A. L. RAWLINGS	162, Burnt Ash Hill, Lee, S.E.	2 UX	A. T. HEADLEY	255, Galton Road, Warley, Nr. Birmingham.
2 RW	T. BELSHAW & D. M. BURN	6, Manor Gardens, Merton Park.	2 UY	W. FENN	Holly Cottage, Polesworth, Tamworth.
2 RY	S. HANLEY	Forbury, Kintbury, Berks.	2 UZ	C. V. SLEAD	29, Spolebrook View, Chapel-town, Leeds.
2 RZ	MR. WOOD	50, Parker Road, Winton, Bournemouth.					
2 SA	SIR HANBURY BROWN	Crawley Down, Sussex.					
2 SB	JOHN MAYALL, A.I.M.E.E., M.Soc.C.E. (France)	Burfield, St. Paul's Road, Gloucester.					
2 SF	C. MIDWORTH	Sumia, Ridgeway Road, Osterley Park, Middlesex.					
2 SG	ARTHUR TAYLOR	146, King's Road, Cardiff.					
2 SH	F. L. HOGG	37, Bishop's Road, Highgate, N.6.					
2 SI	L. C. HOLTON	112, Conway Road, N.14.					

2 VC	A. S. GOSLING ..	63, North Road, West Bridgeford, Nottingham.	2 XR	J. F. HAINES ...	36, Zetland Street, Poplar, E. 14.
2 VD	CAPT. E. L. CROWE ...	Juniper Rough, Hardres, near Canterbury.	2 XU	A. H. A. KILBOURN ...	Bath Street, Abington.
2 VF	H. A. BLACKWELL ...	Whyte House, Bispham, near Blackpool.	2 XW	H. A. WOODYER ...	118, Buckingham Road, Heath Moor.
2 VH	S. E. PAYNE ...	11, St. Mark's Road, Bush Hill Park, Enfield.	2 XX	D. F. YOUNG ...	23, Holcombe Road, Ilford.
2 VI	MR. CURTIS ...	Lower Hall Lane, Walsall.	2 XZ	L. T. DIXON ...	4, Fevthorpe Street, Southfields, S.W. 18.
2 VJ	B. J. AXTEN ...	78, Ealing Road, Wembley.	<i>2 XZ 1030 Station Manchester</i>		
2 VK	BURNDEPT, LTD. ...	Blackheath.			
2 VL	MESSRS. MITCHELLS' EXPERIMENTAL STATION.	McDermott Road, S.E. 15.			
2 VM	J. LIPOWSKY ...	614, Old Ford Road, Bow, E. 3.			
2 VN	M. H. DRURY-LAVIN ...	Old House, Sonning, Berks.			
2 VO	A. C. HOLMES ...	Aire View, Cononely, Keighley, Yorks.			
2 VP	P. G. A. H. VOIGT ...	127, Honor Oak Park, S.E. 23.			
2 VQ	H. OLD ...	St. Jude's Avenue, Mapperley, Nottingham.			
2 VR	H. J. JACKSON ...	8th Walthamstow Troop Boy Scouts.	2 YA	R. A. MILES ...	4, Cambridge Green, New Eltham.
2 VS	L. E. OWEN ...	186, Beulah Hill, Norwood, S.E. 19.	2 YF	J. R. CLAY ...	Upper Longbottom, Luddenden Foot, S.O.
2 VT	W. K. HILL ...	Norwood.	2 YG	L. G. BOOMER ...	42nd Camberwell Troop Scouts, Park Lane, London, W.
2 VU	J. W. HOBLEY ...	Mill Road, Wellingborough.	2 YH	BURNDEPT, LTD. ...	40, Park Lane, London, W.
2 VV	INSTALLATIONS, LTD. ...	Southampton.	2 YI	W. J. HEWITT ...	83, Reddings Road, Moseley, Birmingham.
2 VW	E. H. ROBINSON ...	125c, Adelaide Road, N.W. 3.	2 YJ	WIRELESS EQUIPMENT, LTD.	90, Charing Cross Road, W.C. 2.
2 VX	H. H. THOMPSON; ...	44, Northumberland Road, Coventry.	2 YK	T. M. OVENDEN ...	12a, Elgin Court, Elgin Avenue, Hampstead.
2 VY	R. ELY ...	Highlands, Brighton Road, Sutton.	2 YL	W. H. ALLAN ...	8, Newington Causeway, London, S.E. 1.
2 WA	J. PIGOTT ...	Manor Farm, Wolvercote Oxford.	2 YM	R. W. PIPER ...	62, Chiltern View Road, Uxbridge.
2 WB	G. W. JONES... ..	33-34, Worcester Street, Wolverhampton.	2 YN	A. W. THOMPSON ...	32, St. Nicholas Street, Scarborough.
2 WD	C. W. CLARABUT ...	Beechcroft, Beverley Crescent, Bedford.	2 YQ	W. P. WILSON ...	Christ Church Vicarage, South Norwood.
2 WF	PROF. A. M. LOW ...	"The Yews," Woodstock Road, Bedford Place, W. 4.	2 YR	W. PIKE ...	Hounslow Wireless Society, Council House, Hounslow, London, S.E. 1.
2 WG	GAMBRELL BROS., LTD.	Merton Road, Southfields, S.W. 18.	2 YU	G. W. HAYLE AND R. LYLE	36, Dagnal Park, S. Norwood.
2 WI	C. J. MUNDAY ...	Tiverton, Devon.	2 YV	G. M. WHITEHOUSE ...	Allport House, Cannock.
2 WJ	R. L. ROYLE... ..	"Southwold," Alderman's Hill.	2 YW	J. H. F. TOWN ...	4, Eversley Mount, Halifax.
2 WK	G. R. LEWIS ...	10, Lansdowne Road, Palmers Green, N. 13.	2 YX	F. E. B. JONES ...	Hill Crest, Wyld Green, Birmingham.
2 WL	F. J. CRIPWELL ...	Lonkhill, Thorpe Tamworth.	2 YY	O. H. PATTERSON ...	26, Allerton Road, Stoke Newington.
2 WM	J. W. PALLETT ...	24, Glenfield Road, Leicester.	2 YZ	WESTERN ELECTRIC CO., LTD.	North Woolwich.
2 WN	A. H. WILSON ...	67, Broad Street, Hanley, Stoke-on-Trent.			
2 WO	J. H. BROWN ...	Redbrook, Baguley, Cheshire.	2 ZB	CLACTON ELECTRIC CO. ...	Clacton-on-Sea.
2 WP	WESTERN ELECTRIC CO. ...	Witton, Birmingham.	2 ZC	GENERAL RADIO CO. ...	Twyford Abbey Works, Acton Lane, Harlesden, N.W. 10.
2 WQ	C. H. GARDNER ...	Denmark Hill.	2 ZD	A. WOODCOCK ...	Montague Road, Handsworth, Birmingham.
2 WR	L. W. BURCHAM ...	Gouzeacourt, Chestnut Avenue, Oulton Broad.	2 ZG	W. J. BADMAN ...	9, Orchard Street, Weston-super-Mare.
2 WS	H. SQUELCH (JUNR.) ...	35, Crown Lane, Bromley.	2 ZH	B.T. H. CO. ...	Rugby.
2 WT	H. CHADWICK ...	9, Raimond Street, Bolton;	2 ZK	W. L. TURNER ...	Purley, Caldly, near Birkenhead.
2 WU	CAPT. C. H. BAILEY ...	Monkswood, Usk, Mon.	2 ZL	H. W. GEE ...	44, Gordon Street, Gainsborough, Lincs.
2 WX	G. GARDNER ...	Holborn, London.	2 ZM	T. H. ISTD ...	Terling, Witham, Essex.
2 WY	A. W. GAMAGE ...	32, Wilbury Road, Hove, Sussex.	2 ZO	L. H. SOWNDY ...	60, Bellevue Road, Ealing.
2 WZ	A. HARE-HOBSON ...		2 ZP	G. H. FORWOOD ...	West Chart, Limpsfield, Surrey.
			2 ZQ	H. NUNN ...	49, Leigh Road, Highbury.
			2 ZS	F. J. DINSDALE ...	14, Highfield View, Stonycroft, Liverpool.
			2 ZT	C. M. BENHAM ...	"Benhilton," New Malden.
			2 ZU	T. Heckles ...	30, Thackeray Street, Liverpool.
			2 ZV	F. T. SMITH ...	Rutlands, Felstead.
			2 ZY	B. B. C. ...	Manchester Station.
			2 ZZ	D. V. L. FELLOWS ...	Cumberland Avenue, Park Royal, N.W. 10.
2 XA	Rev. C. H. TOWNSON ...	Wilts. Farm School, Warminster	5 AA	"THE LEICESTER MERCURY"	Leicester.
2 XB	A. T. CROUCHER ...	35, Douglas Road, Highbury.	5 AC	W. G. KIMBER ...	39, Bargey Road, Catford.
2 XC	H. JOHNSON ...	Avondale, Chestnut Walk, Worcester.	5 AF	J. A. H. DEVEY ...	232, Great Bricklin Street, Wolverhampton.
2 XD	H. R. GLADWELL ...	London Road, Abridge, Essex.	5 AG	A. E. GREGORY ...	77, Khedive Road, E. 7.
2 XF	E. T. CHAPMAN ...	Abbotsford, Serpentine Road, Poole.	5 AI	A. H. SHEFFIELD ...	139, Wallwood Road, Leytonstone, E. 11.
2 XI	R. WAGNER ...	6, Maresfield Gardens, N.W. 3.			
2 XJ	SHEFFIELD DISTRICT WIRELESS SOCIETY.				
2 XK	SHEFFIELD DISTRICT WIRELESS SOCIETY.				
2 XL	CAPT. E. DAVIS ...	22, Lavender Hill, S.W. 11.			
2 XM	DOWNSIDE SCHOOL ...	Stratton-on-the-Foss, Bath;			
2 XN					
2 XP	J. F. PAYNE ...	22, Shakespeare Crescent, Manor Park, E.			

2000 → 200 m

5 AJ	W. C. BARRACLOUGH	61, Bridge Street, Manchester.	5 DA	G. GORE	24, Brucegate, Berwick.
5 AK	H. G. MANSSELL	Cleeve View, Harvington, near Rvesham.	5 DB	C. H. P. NUTTER	243a, Selhurst Road, S.E. 25.
5 AN	W. J. JOUGHIN	Edison Bell Works, Glengall Road, Peckham,	5 DC	W. T. AKED	"Kasani," Devonshire Road, St. Annes-on-Sea.
5 AO	H. H. ELSON	142, Birchfield Road, Birmingham.	5 DD	CAPT. M. H. BARNES	"Akabo," Ainsdale, Southport.
5 AQ	D. DOUET	10, Ronington Gardens, Putney, S.W. 15.	5 DG	C. H. STEPHENSON	Penn Manor, Wolverhampton.
5 AS	F. A. BOURNE	10, Linley Road, S. Tottenham.	5 DI	C. J. MATTHEWS	450, Cranbrook Road, Ilford.
5 AT	THE DUBILIER CONDENSER CO., LTD.	Shepherd's Bush, W. 12.	5 DM	A. N. S. LEG	Grove House, Albert Grove, Nottingham.
5 AU	THE DUBILIER CONDENSER CO., LTD.		5 DN	CAPT. L. A. K. HALCOMB	106, Millhouses Lane, Sheffield.
5 AV	R. W. HARVEY	25, Shakespeare Avenue, Portsmouth, Southampton.	5 DO	E. J. WATTS	6, Ashley Road, Salisbury.
5 AW	F. HOUGH (SOUTHPORT), LTD.	60, Sussex Road, Southport.	5 DP	F. L. STOLLERY, SEA SCOUTS H.Q.	"Fairmead," Vista Road, Clacton-on-Sea.
5 AY	T. F. CROWTHER	29, N. Drive, St. Annes-on-Sea.	5 DQ	C. H. STEPHENSON	Pen Manor, Wolverhampton.
5 AZ	F. CHARNLEY	43, Reads Avenue, Blackpool.	5 DS	ARTHUR W. FITHIAN	51, St. James Road, S.W. 17.
			5 DV	D. WHITTAKER	56, Park Road, St. Annes-on-Sea.
			5 DY	THE CHELMSFORD RADIO ENG. CO.	Rainsford End, Chelmsford, Essex.
5 BA	CHASE MOTORS, LTD.	Sandyford Square, Newcastle-on-Tyne.	5 FF	H. ANSON	13, Nottingham Place, Marylebone, London, W. 1.
5 BB	VICKERS, LTD.	Vickers House, Broadway, Westminster, S.W.	5 FH	L. H. LEE	155, Rosefield Road, Smethwick, Birmingham.
5 BC	SIR TREVOR DAWSON, BART.	Edgwarebury House, Elstree, Herts.	5 FI	H. D. WEBB	59, Bradford Street, Walsall.
5 BG	J. B. KAYE	Close Hill, Huddersfield.	5 FL	T. W. PEVENSEY	Lewisham, S.E.
5 BI	G. E. BEALE	Bournemouh.	5 FM	R. STONE, HON. SEC., CAMBERWELL AND DISTRICT WIRELESS CLUB.	3d, Bushey Hill Road, Camberwell.
5 BJ	AUTOVEYORS, LTD.	84, Victoria Street, Westminster, S.W. 1.	5 FR	J. L. JEFFREE, F.R.A.	
5 BK	W. G. H. BROWN	52, Winstonian Road, Cheltenham.	5 FS	W. A. ANDREWS	1, Balmoral Mansions, St. Andrews Park, Bristol.
5 BL	MR. VICK	Gresham Road, Hall Green, Birmingham.	5 FU	UNIVERSITY COLLEGE	Nottingham.
5 BM	J. T. QUICK	164, Portland Road, Edgbaston.	5 FW	S. I. HOLT	51, St. Albans Road, St. Annes-on-Sea.
5 BT	L. V. CLARK	4, Compton Crescent, Grove Park, W. 4.	5 FX	GENT & CO., LTD.	Faraday Works, Leicester.
5 BV	H. N. RYAN	88, Home Park Road, Wimbledon Park.	5 FZ	LINCOLN WIRELESS SOCIETY	Lincoln.
5 BW	A. DE VILLIERS	79, St. George's Road, S.E.			
5 CA	N. L. YATES-FISH	"Clevelands," 10, Mansfield Road, Reading.	5 GB	LEONARD HUMPHRIES & Co.	67, Geraint Street, Windsor Street, Liverpool.
5 CB	K. E. HARTRIDGE	14, Westbourne Crescent, W. 2.	5 GF	H. STOPHER	14, Johnson Terrace, Cricklewood, N.W. 12.
5 CC	BATH ELECTRO-PL. WORKS	Foxcombe Road, Bath.	5 GI	R. HORROCKS	65, Leander Road, Thornton Heath, Surrey.
5 CD	G. WARD BOOTH	Albany House, Clarkson Ave., Wesbook.	5 GJ	J. BEVIS	Radex Villa, Linford Estate, near Stanford-le-Hope, Essex.
5 CF	F. G. S. WISE	12, Crouch End Hill, Hornsey, N. 8.	5 GP	J. E. SIMPSON	"Baskerville," Epsom Road Guildford, Surrey.
5 CG	F. L. W. DEAN	54, Pill Street, Cogan, Glam.	5 GQ	F. W. NIGHTINGALE	Pitsford School, Northampton.
5 CJ	J. BALDERSTON	6, Clough Terrace, Barnoldswick, via Colne.	5 GX	P. D. TYERS	30, Mildred Avenue, Watford.
5 CK	L. H. PEARSON	Long Row, Nottingham.	5 GY	G. H. HORWOOD	Buckland, 557, Lordship Lane, S.E. 22.
5 CP	D. V. L. FELLOWS	20, North Common Road, Ealing.			
5 CS	G. R. GARRATT	35, Abbey Road, St. John's Wood, N.W. 8.	5 HC	JOHN ALEX BEVERIDGE	"Dunelm," 8, Cluny Drive, Edinburgh.
5 CU	J. A. WALSHAW	Garnet Villa, Otley.	5 HD	H. ST. JOHN WARD	Blenheim Chambers, 1, Crowtree Road, Sunderland.
5 CV	R. J. HARRISON	"Blacklands," Sidney Road, Walton-on-Thames.	5 HI	LAWRENCE W. BIRCH	30, Limesford Road, Waverley Park, S.E. 15.
5 CW	A. H. S. COLEBROOKE	Sharbourne Street, Birmingham.	5 HL	G. E. VOWLES	St. Leonards, Hooley Street, Sherwood, Nottingham.
5 CX	A. HIGSON	161, Cotton Tree Lane, Colne, Lincs.	5 HN	D. R. ETHELLS	"Kingsley," Oaken, near Wolverhampton.
5 CY	L. GORDAN	133, Old Street, Ashton-under-Lyme.	5 HP	CUNNINGHAM, LTD.	160-171, Edgware Road, W. 2.
			5 HQ	E. A. POLLARD	Spring Bank, Limefield, Blackburn.
			5 HW	NATIONAL PHYSICAL LABORATORY,	Teddington, Middlesex.
			5 HX	C. H. GARDNER	Brooklands Track and District. For Motor Cars. For address see 2 WQ.
			5 HY	B. HONRI	Cromwell Hall, E. Finchley, N. 2.

5 IC F. C. HARNEY Sunset Avenue, Woodford Green, Essex.
 5 ID P. D. COATES 55, Ennismore Street, Burnley.
 5 IF H. FEATHERSTONE, A.M.I.E.E. 3, Cumberland Gardens, Tunbridge Wells.
 5 IG J. E. SHELDRIK "The Brambles," Third Ave., Denville, Havant, Hants.
 5 IK B. L. STEPHENSON 12, Sheringham Road, Withington, Manchester.
 5 IO R. H. BROWN WIRELESS EQUIPMENT, LTD. 10, Coverdale Road, London, W. 12.
 5 IP ROBERT H. KNOX 25, Bridge Street, Berwick-on-Tweed.
 5 IS J. S. FOORD 43, Herne Hill, London.
 5 IT B.B.C. STATION Birmingham.
 5 IY J. WYNN The Knoll, Widney Manor, Solihull, Warwickshire.
 5 IZ W. G. SHERRATT 11, Bath Road, I.O.W.

5 JC IVOR MORRIS The Compton, Cemnaes Bay, Anglesey.
 5 JD F. BULMER 4, Carlton Terrace, Scarborough.
 5 JG R. F. LONGLEY Kilworth, 81, Langdale Road, Thornton Heath.
 5 JH E. C. WADDINGTON 171, Great Horton Road, Bradford.
 5 JJ L. D. GOLDIE-MORRISON Cults House, Cults, near Aberdeen.
 5 JK NORTH OF SCOTLAND WIRELESS CO. 13, Bridge Street, Aberdeen.
 5 JM W. WOODS 8, Brighton Street, Barrow-in-Furness.
 5 JN S. WILKINSON c/o Bew & Co., Burslem, Stoke-on-Trent.
 5 JR W. C. P. HEPWORTH Moorings, Dovercourt, Essex.
 5 JS PERCY R. SOLDEN 76, Albert Road, Alexandra Park, London, N. 22.
 5 JV CAPT. J. H. B. HAMPSON ... 477, Earham Rise, Norwich.
 5 JX M. G. SCROGGIE 37, Clung Gardens, Edinburgh.
 5 JZ H. J. CHENEY 263, Thimble Mill Lane, Nechells, Birmingham.

5 KA G. C. BEDDINGTON "Stagsden," West Cliff Road, Bournemouth.
 5 KF W. BIRD Llangrove, Hedgesford Road, Cannock, Staffs.
 5 KL GORDON M. WOOD "Dingle Cottage," Simmondsley, Glossop, near Manchester.
 5 KN E. J. EARNSHAW 95, Mayfield Road, Sandstead.
 5 KO F. W. HIGGS 45, Howard Road, Westbury Park, Bristol.
 5 KP ALEX T. WALLACE Brettenham, Hedge Lane, Palmers Green, N. 13.
 5 KW RENE HODGES Holly Mount, Westdale Lane, Mapperley, Nottingham.
 5 KX W. WARD Agent for 5 KW portable.
 5 KY E. E. G. ALLSOPP Ingle Nook, Wigginton Road, Tamworth.

5 LA L. H. SOUNDY 60, Bellevue Road, Ealing.
 5 LB H. C. FOSTER Hornby Castle, Lancaster.
 5 LF SECRETAN & MALLETT, LTD. 149, Lawther Parade, Barnes, S.W. 13.
 5 LG J. F. JOHNSTON 48, Borough Road, Altrincham, Cheshire.
 5 LJ E. JACKSON 37, Manley Road, Whalley Range, Manchester.
 5 LK RADIO ELECTRIC CO. Craig-y-don, Penn, Wolverhampton.
 5 LO J. W. CLOUGH 142, Revidge Road, Blackburn.
 5 LP J. H. A. WHITEHOUSE Brighton, Cheshire.

5 LV N. WILLSON "Clairmont," Tenbury Road, King's Heath, Birmingham.
 5 LZ A. G. S. QUINN 61, Carnarvon Road, Stratford, E. 15.

5 MA R. MUNDAY 17, Malden Road, New Malden, Surrey.
 5 MC W. WOODHAMS 24, Marlborough Place, Brighton.
 5 MD R. W. HARDISTZ 5, Ethelbert Road, Canterbury.
 5 ML O. R. HEALEY 11, Glebe Road, Wallasey, Cheshire.
 5 MO W. G. DIXON "Dipwood," Rowlands Gill, near Newcastle-on-Tyne.
 5 MP COLIN BAIN 51, Grainger Street, Newcastle-on-Tyne.
 5 MR N. P. STOATE 15, Winterstoke Gardens, Mill Hill, N.W. 7.
 5 MU C. W. TITHERINGTON Dorset Motor and Coach Works, Dorchester, Dorset.
 5 MY W. G. WYATT INGRAM ... 41, Lambert Road, Brixton Hill, London, S.W. 2.

5 ND J. H. TAYLOR Macaulay Street, Huddersfield.
 5 NF R. W. GALPIN Bank House, Herne Bay.
 5 NH A. C. HULME 39, Poplar Avenue, Edgbaston, Birmingham.
 5 NN J. H. D. RIDLEY Newcastle.
 5 NO B.B.C. STATION
 5 NP ERIC P. BURGESS 2, Queen's Road, Manningham, Bradford.
 5 NT C. H. FRISHARZ 23, Tennyson Street, Lincoln.
 5 NU H. L. THOMSON 100, Old Fallow Road, Cannock, Stafford.
 5 NW E. J. ALLEN 8, Westfield Place, Dundee.

5 OC COL. E. C. JENNINGS
 5 OD R. BATES "Holmside," St. Catherines, Lincoln.
 5 OL J. F. CULLEN 68, Queen's Drive, West Derby, Liverpool.
 5 OW H. GREEN Norman House, Swinton, Manchester.
 5 OY BELVEDERE AND DISTRICT RADIO SOCIETY, Hagis, Robin Road, Belvedere Kent.

5 PH C. F. METCALFE Flacten Works, Halifax.
 5 PS J. E. CATT "Melrose," Alexandra Road, Farnborough, Hants.
 5 PU T. ALLISON 33, Wilton Grove, Merton Park, S.W.
 5 PW F. H. DE VEULLE Meriden House, Trinity Road, Handsworth, Birmingham

5 QB A. G. BAINTON ... "The Hollies," Palace Road, S.W. 2.
 5 QD G. H. WRAY ... 19b, Church Gate, Loughborough, Leicestershire.
 5 QI D. G. BIRD ... 8, Osbourne Terrace, South Shields.
 5 QM V. R. MILLS ... 122, Hughendon Road, Hastings.
 5 QV F. L. STOLLERY ... "Fairmead," Vista Road, Clacton-on-Sea.
 5 QZ NEWPORT AND DISTRICT RADIO H.Q. (Memorial Institute), Queen's Hill, N.

5 UA A. BARBER ... 15, Hartington Terrace, Lidget Green, Bradford.
 5 UC J. GARDENER ... Lewis Road, Sutton, Surrey.
 5 UL L. COVERNEY ... 12, Wallwood Road, Leytonstone, E. 11.
 5 UM H. ALLCHIN ... 78, Chester Road, Forest Gate, E. 7.
 5 UO R. L. SIMMONDS ... 61, Brightfield Road, Lee, S.E. 12.
 5 US J. CROYSDALE ... 5, Elm Grove, Burley-in-Wharfedale, Leeds.
 5 UV L. A. JEFFREY ... 90, Harringay Road, Green Lanes, N. 15.
 5 UY D. B. FRY ... "The Laurels," Mayfield, Sussex.
 5 UZ H. STEPHENSON ... "The Bottoms," Gildersome, near Leeds.

SUR

5 RB A. R. V. GARNETT ... "Bonair," Southwell Park Road, Camberley.
 5 RC W. BRIERLEY ... 59, Gayner Park, Filton, Bristol.
 5 RF L. F. HUNTER ... 18, Tansfield Road, Sydenham, S.E. 26.
 5 RP H. I. HUGHES ... Hughes & Watts, Ltd., Woodchurch Road, Oxtou, Birkenhead.
 5 RQ G. W. TONKIN ... 164, Coldharbour Road, Westbury Park, Bristol.
 5 RZ A. G. WOOD ... 93, Upper Tulse Hill, S.W. 4.

5 VC J. GARDENER ... Lewis Road, Sutton, Surrey.
 5 VD P. J. WAKEFIELD ... 31, Station Road, Church End, Finchley, N. 3.
 5 VK B. CALDWELL ... "Coverswall," Lower Walton, near Warrington.
 5 VL R. W. LEADER ... 93, Pinner Road, Harrow.
 5 VP G. F. KITCHEN ... 10, Beech Road, Green Lanes, N. 15.
 5 VT G. C. WEBB ... 10, Osborne Road, Stroud Green, N. 4.
 5 VU S. W. BUTTERS ... 51, Clarendon Road, West Croydon.
 5 VW W. V. HARRINGTON ... 51, First Avenue, Hoe Street, Walthamstow.
 5 VX J. H. IVES ... 49, Acme Road, Watford, Herts.

5 SC B.B.C. ... Glasgow Station.
 5 SF J. K. WILKIE ... "Avondale," Knowsley Road, Cressington Park, Liverpool.
 5 SI C. L. NAYLOR ... 43, Hill Crescent, Longden Road, Shrewsbury.
 5 SL JOHN S. YEOMANS ... 11, Hill View Terrace, Chapel Alterton, Leeds.
 5 SP E. WARNER ... "Djlnot," Horeham Road, Sussex.
 5 SQ A. P. MACGRORY ... 16, Main Street, Campbeltown.
 5 ST R. R. MORRISON ... Spring Grove, Kilbarchan, Renfrewshire.
 5 SU CAPTAIN IAN FRASER ... St. John's Lodge, Inner Circle, Regent's Park, N.W. 1.
 5 SW C. BEDFORD ... Turton Hall, Gildersome, near Leeds.
 5 SZ J. W. RIDDIOUGH ... "Lawnside," Baildon, Yorks.

5 WA B.B.C. ... Cardiff Station.
 5 WD K. ULLYETT ... 25, Harrington Road, Leytonstone, E. 11.
 5 WM J. B. RENSHAW ... "Wireless House," Old Chapel Street, Blackburn.
 5 WR C. C. MORRIS ... Southernhay, Heron Hill, Belvedere, Kent.
 5 WZ E. W. HETICH ... 1, King Street, Jersey.

5 WN

5 TA V. I. N. WILLIAMS ... "Mersk," Lees Road, Bramhall, Cheshire.
 5 TF P. A. GOODING ... 16, Cambridge Road, Hammer-smith, W.
 5 TH S. H. SUTHERS ... Jilmore, Petersfield, Hants.
 5 TI J. BONNETT ... 159a, Turner's Hill, Cheshunt.
 5 TL E. D'ERESBY MOSS ... 4, St. George's Terrace, Regent's Park, N.W. 1.
 5 TO H. RAYNER ... 32, Grange Road, Cleckheaton.
 5 TR J. H. J. COOPER ... 8, Cowley Road, Ilford, Essex.
 5 TU J. LEITCH RODGER ... "Woodside," Western Terrace, Falmouth.
 5 TV W. H. LLOYD ... 27, Copthall Gardens, Twickenham.
 5 TW R. S. BAUGH ... "Longfield," Wake Green Road, Moseley, Birmingham.
 5 TX R. S. BAUGH ... Portable.
 5 TZ W. G. SKERRATT ... 11, Bath Road, Cowes, I.O.W.

5 XM F. EUSTANCE ... 92, Briardale Road, Moseley Hill, Liverpool.
 5 XS F. B. THOMAS ... 7, Mornington Villas, Wandstead, E. 11.
 5 XT PHILIP B. THOMPSON ... 1, Chase Side Place, Enfield.
 5 XU T. N. LORD ... 6, Trafalgar Terrace, W. Park Street, Dewsbury.
 5 XX H. G. STYLES (Correspondence).
 5 XZ A. F. C. BOYES ... 48, Lavender Gardens, London

5 YB G. THOMPSON ... East Rigton, East Keswick, near Leeds.
 5 YD E. BRIDGWATER ... Premier Picture House, Widnes.
 5 YI A. L. GOODLIFFE ... 17, Malvern Road, Nottingham.
 5 YM E. H. ROBINSON ... Langmead, Pirbright, Surrey.
 5 YQ J. GALLOCHER ... 4, Havelock Terrace, Paisley.

5 ZH	CROMWELL ENG. CO.	... 127, Fulham Road, S.W.	6 DC	G. YOUNG	... 37, Burnard Road, Mount Estate, Gorton, Manchester.
5 ZO	W. F. MILLS	... 17, Stoney Hey Road, New Brighton, Cheshire.	6 DJ	A. C. COPSEY	... 27, Sutherland Road, Tottenham, N.17.
5 ZR	F. AUSTEN	... 53, Church Street, St. Peter's Broadstairs.	6 DM	C. KNIGHT-COUTTS	... 16, Vine Street, Evesham.
5 ZT	E. S. T. EDWARDS	... 18, Ripon Street, Moss Side, Manchester.	6 DP	NORMAN CROWTHER	... 219, Roundhay Road, Leeds.
5 ZV	W. HERRING	... 221, Newark Road, Lincoln.	6 DU	E. J. NEWTON	... 1, Jerningham Road, New Cross, S.E.14.
5 ZX	T. L. RAWSON	... Maudsley House, Victoria Road, Thornton, Preston.	6 DW	DOUGLAS H. JOHNSON	... 131, Clapton Common, London.
5 ZY	L. Headlam	... Stakesby Road, Whitby, Yorkshire.	6 DZ	CAPT. L. A. K. HALCOMB	... South Leue, 106, Millhouses Lane, Sheffield.
6 AA	DURHAM AND NORTHUMBERLAND COLLIERS' FIRE AND RESCUE BRIGADE.	The Rescue Station, 854, Scotswood Road, Newcastle-on-Tyne.	6 FB	W. GROCCOTT	... Church Road, Oxley, Nr. Wolverhampton.
6 AB	DURHAM AND NORTHUMBERLAND COLLIERS' FIRE AND RESCUE BRIGADE. (Portable.)	The Rescue Station, 854, Scotswood Road, Newcastle-on-Tyne.	6 FH	G. W. LIVESLEY	... 3, Spring Bank, Market Drayton.
6 AF	ROBERT H. RICE	... 70, Seaside, Birmingham.	6 FJ	C. V. JARVIS	... 21, Baltic Road, Tonbridge.
6 AG	W. H. FORTINGTON	... 237, Dudley Road, Rotton Park, Birmingham.	6 FK	WORCESTER CADET SIG. CO.	... R.C. of Sigs., Junior Tech. Sch., Sansome Walk, Worcester.
6 AH	R. H. P. COLLINGS	... 4, Dean Place, Liskeard, Cornwall.	6 FL	E. R. KIRKBY	... 36, B.K. Rhodes, Halifax.
6 AJ	G. ENSOLL	... 25, Victoria Road, Dukinfield, Cheshire.	6 FQ	A. B. RICHARDSON	... 9, Quarry Road, Hastings.
6 AL	JAMES PARKER MORTER	... 49, Westov Hill Upper Norwood.	6 FV	W. H. TAYLOR (?)	... 37, Bridge Street, Warrington
6 AO	A. V. RUDDLESDEN	... 24, Wakefield Road, Dewsbury, Yorkshire.	6 GM	E. A. WILSON	... "Roxburgh," 42, Heber Road, N.W.2.
6 AP	J. A. HOBSON	... Hill Close, Berkswell, near Coventry.	6 GO	L. A. SAYCE	... 5, Toward Terrace, Sunderland.
6 AQ	A. H. BIRD	... 35, Bellwood Road, London, S.E. 15.	6 GT	G. TURTON	... 3, Lydford Road, Maida Hill, W.9.
6 AW	EDWARD JAMES JARVIS	... "Naseby Cottage," High Street, Waltham Cross.	6 GW	PERCY BRIAN	... 79, Lakey Lane, Hall Green, Birmingham.
6 BB	JOHN BOLT	... Crouchly, Lymm, Cheshire.	6 GY	T. McL. GALLOWAY	... Wyntersted, Dollar, N.B.
6 BC	W. DOUGLAS CLAGUE	... White House, High Heworth, Gateshead-on-Tyne.	6 GZ	R. C. NEALE	... Farnborough Road, Farnborough.
6 BJ	C. SOLOMON (Portable)	... 10, Cavendish Road, Brondesbury, N.W.6.	6 HD	NATIONAL WIRELESS AND ELECTRIC, LTD.	Church Road, Acton, W.3.
6 BD	ABERDEEN STATION, B.B.C.		6 HK	J. W. F. CARDELL	... Tretthessas, Newquay, Cornwall.
6 BM	B.B.C. STATION	... Bushy Road, Bournemouth.	6 HO	NATIONAL WIRELESS AND ELECTRIC CO., LTD.	Church Road, Acton, W.3.
6 BN	G. E. MINVALLA	... "Dorothy," 25, Weighton Road, Anerley, S.E.20.	6 HR	W. O. KEILLER	... 51, Highworth Road, New Southgate, N.11.
6 BQ	J. L. CANNON (Portable)	... 14, Woodcroft Avenue, Broomhill, Glasgow, W.	6 HS	H SAVILLE	... Delamere Works, Longford Road, Stratford, nr. Manchester.
6 BR	G. H. RAMSDEN	... Overdale, Ilkley.	6 HV	W. J. BUTLER	... 15, Algernon Road, Edgbaston Birmingham.
6 BT	C. A. JAMBLIN	... 82, York Road, Bury St. Edmunds.	6 HX	C. H. NOKES	... Misidia, High Street, Ripley, Surrey.
6 BV	V. F. M. OLIVER	... Whitmore Lodge, Sunnyhill, Berks.	6 HY	F. DYER	... 59, Antill Road, Tottenham, N.15.
6 BW	J. C. MASON	... 8, Westmorland Road, New Briton.			
6 CF	W. C. LINGARD	... Bridgeholme Green, Chapel-en-le-Frith, Derbyshire.			
6 CG	A. W. EAGLE	... 42, Park Lane, Tottenham, N.17			
6 CI	C. E. TILLEY	... 10, Guthlaxton Road, Leicester.			
6 CW	D. BURNE-JONES	... "Gwafor," Rustic Avenue, Streatham, S.W.16.			

6 IC ARNOLD JOWETT 310, Hopwood Lane Halifax.
 6 IG EDWARD BRADY 6, Coltsgate Hill, Ripon, Yorks.
 6 IL J. H. ROSCOE 183, Chester Street, Birkenhead.
 6 IM L. G. KAMM 88, Hornsey Lane, Highgate, N.
 6 IR G. HORNSBY 14, Baring Street, South Shields.
 6 IX W. G. FUDGER "Brora," Priviswood Road, Godalming.

6 OB F. W. WOODWARD 5, Portland Gardens, Harringay, N.4.
 6 ON W. H. FELTON 47, Sompting Road, Worthing Sussex.
 6 OX B. QUENTIN Lislet Lodge, St. Sampson Guernsey.
 6 OZ H. THOMPSON 1, Rye Street, C.-on-M., Manchester.

6 JB WIMBLEDON RADIO SOCIETY Red Cross Hall, 59, Church Road, Wimbledon.
 6 JS PERCY R. SOLDEN 76, Albert Road, Alexandra Park, N.22.
 6 JV CAPT. H. J. B. HAMPSON ... 477, Earlham Rise, Norwich.
 6 JX R. J. W. LANKESTER Wanderings Farm, Kingston Road, Kingston-on-Thames
 6 JZ VYVYAN A. G. BROWN Fawley Lodge, Coley Avenue, Reading.

6 PD A. J. DIXON White House, Hertford Road, Enfield Wash, Middlesex.
 6 PG C. H. TARGETT 21, High Street, Dartford, Kent
 6 PJ F. ISON 47, Oxford Road, Walthamstow E.17.
 6 PK UNIVERSAL RADIO CO ... 129, New Bridge Street, Newcastle-on-Tyne.
 6 PT LEONARD LOTT "Gants Muir," Berrow Road, Burham-on-Sea.

6 QC GRAMMAR SCHOOL Loughborough.
 6 QY J. ALAN GODFREY 160, Bethune Road, London, N.16.

6 KC RADIO SPECIALITY CO. ... 41, Limbrick, Blackburn.
 6 KK J. COOKSON 66, Albert Road, Blackpool.
 6 KU H. G. CLACY 114, Bradshaw Road, Watford, Herts.

6 RK R. GREGSON 3, Bank Road, Blackpool, Lancs.
 6 RO ARTHUR TAYLOR 146, King's Road, Cardiff.
 6 RY H. LESLIE BOWEN 13, Daniel Street, Bath.

6 LB L. J. FULLER Glenburn, Seagry Road, Wanstead, E.11.
 6 LJ S. K. LEWER London, N.W.
 6 LW R. C. DAVIES Sunny Side, 22, Grainger's Lane, Cradley Heath, Staffs.

6 SB R. HEATHER 102, Lyndhurst Road, Peckham, S.E.15.
 6 SK A. E. VOLLMER 57, Lyttelton Road, Leyton, E.10.
 6 SQ CHAS. ROGERS 3 Alders Avenue, Chinley.

6 TD K. L. PALMER Vyrnwy House, Llansaintffraid, Montgomeryshire.
 6 TN E. H. WRIGHT 13, Boices Street, Brighton.

6 MD R. J. BROWN "Greba," Gledhow Lane Roundhay, Leeds.
 6 MG B. W. D. LACEY 33, Woodbridge Road Moseley, Birmingham.
 6 MQ G. C. PATCHING 84, Allcroft Road, Kentish Town, N.W.5.
 6 MU EDGAR J. WHITE Lansdowne Villa, 83, Rochdale Road, Blackly, Manchester.

6 UC A. C. CHATWIN 162, Hagley Road, Edgbaston, Birmingham.

6 NF A. D. GAY 49, Thornlaw Road, W. Norwood, S.E.27.
 6 NG J. W. C. CROPPER 10, Manor Street, Hooley Hill nr. Manchester.
 6 NH J. W. DAVIES Doddington Caterham Valley, Surrey.
 6 NJ C. W. WATSON Butts Mills, Barnoldswick Yorks
 6 NL BRITISH RADIO MFG. CO. ... 9, South Castle Street, Liverpool.
 6 NP W. GILL 7, Church View, Heckmond-wike.
 6 NS J. FRATER Felling-on-Tyne

6 VL R. W. LEADER 93, Pinner Road, Harrow (P. rtable.)

6 ZY L. GORDON 133, Old Street, Ashton-under-Lyne.

2 ADF A. M. ROBINSON The Lychgate House, Coombe Road, Croydon.

(To be continued.)

SOME NOTES ON LOW-FREQUENCY AMPLIFICATION

By G. P. KENDALL, B.S., Staff Editor, "Modern Wireless."

It is often thought that L.F. amplification is fool-proof and needs no care or skill to give good results, but such is by no means the case, and attention paid to securing efficient operation is well repaid by improved quality of reproduction and increased volume of sound. The essentially practical notes contained in this article should prove most helpful to those who have hitherto used their L.F. valves somewhat blindly.

IT may, perhaps, be useful at the commencement of these notes to give a brief explanation of the true function of L.F. amplification, for it seems that this is not so widely understood as it should be. It must be realised that amplification after rectification has a strictly limited sphere of usefulness; it cannot be made to bring in signals previously inaudible, nor does it amplify efficiently those which are extremely weak in the detector circuit. It thus cannot compete with H.F. amplification for bringing in distant stations, and should be regarded as a convenient method of increasing to almost any desired extent the volume of a signal which is already audible. It can, therefore, be made to serve the useful purpose of making signals strong enough to operate a loud-speaker, and will do so without too much distortion if certain precautions are observed, and the most careful attention paid to efficiency in details. The notes which follow should indicate how such efficiency is to be attained; they are not intended to be regarded as an exhaustive exploration of the subject, but simply as brief pointers to indicate the particular details to which attention must be paid to obtain really good results from L.F. amplification.

Prevention of Distortion

Distortion, of course, is the bugbear of L.F. amplification, and great care is necessary to keep it within bounds. Note-frequency rectification is a common cause, therefore try to work your valves well up the straight part of their characteristic curves, applying negative potential (sometimes called "bias") to their grids if necessary. The best procedure is usually to apply a fairly high plate voltage and then carefully to adjust the grid potentials until the clearest speech and the purest musical tones are produced. Since the exact value of grid voltage required varies with different valves, different H.T. voltages, varying filament current, and so on, it is desirable to have some switching device for making the adjustment easily.

Perhaps the most usual source of distortion, however, is an inefficient type of intervalve transformer, which may bring in a host of troubles, such as hysteresis effects in a poor quality iron core, or note-frequency resonance in a badly designed winding. Even the best of transformers are liable to produce a certain amount of distortion, and it is usually worth while to experiment a little with fixed condensers across their primary windings and resistances of the order of 100,000 ohms across their secondaries: a considerable improvement can often be effected by adjustment of the capacities of these by-pass condensers and resistances.

Prevention of Howling

"Howling" in the case of the L.F. circuits is simply self-oscillation at note frequency, and it should be stopped rather by removing its causes than by employing such palliatives as the use of positive bias on the grids, earthing of the transformer cores, etc. The immediate cause of such oscillation is, of course, reaction between the plate circuit of one of the valves and the grid circuit of a preceding one, which should be avoided by attending to the following points when designing an amplifier. The intervalve transformers should be mounted as far apart as possible, with the planes of their windings at right angles if it can be managed. All wiring should be well spaced out, and where wires cross let them do so at right angles. Particular care should be taken to keep plate circuit wires well away from those of the grid circuits. I have found it beneficial, also, to twist together the pairs of wires which go to the transformer primaries, thus making them practically non-inductive. (This involves their being sleeved with Systoflex, of course.) If all these precautions have been taken, and howling still occurs when the valve filaments are at all bright, reverse the connections of the primary winding of one of the transformers. Such reversal is worth trying with each transformer, since if one can get the electromagnetic and

electrostatic couplings both acting in the same sense in all the transformers increased amplification is obtained.

Another cause of howling which is often difficult for the beginner to locate is an anode battery of high internal resistance. This trouble can usually be removed by shunting the H.T. battery with a condenser of $2 \mu\text{F}$.

Type of Valve to Use

The best results are generally given by valves designed to work with a fairly high plate voltage. A good hard R valve, with 80 to 120 volts on the plate, is very suitable for all normal purposes, although if the greatest possible volume of sound and freedom from distortion are desired it is worth while to use the special "power-amplifying" or "loud-speaking" valves. It will usually be found that valves which are good rectifiers are not satisfactory as L.F. amplifiers, although there are exceptions to this rule.

Transformers

As will have been gathered from preceding notes, the intervalve transformers are the most important components in the amplifier, everything depending upon the efficiency or otherwise of their design and manufacture. I would, therefore, advise the amateur who desires really good results not to make his own, but to buy transformers of reputable make which are guaranteed to have passed some specified test. In this way he will be able to feel sure of immunity from those annoying failures due to burning-out of windings or breakdown of insulation that so often result from the use of poor quality transformers, which, in my experience, are cheap to buy, but not to use.

Switching

Some system of switching for varying the

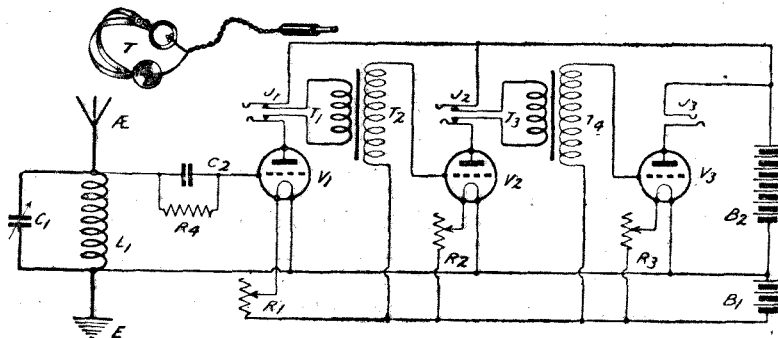

Fig. 2.—How jacks are wired up.

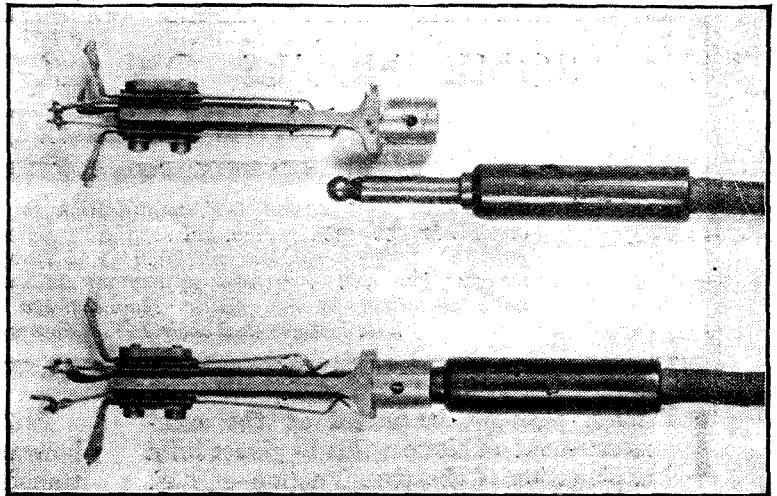

Fig. 1.—A simple type of plug and jack.

number of valves in use is extremely desirable, and is provided on every well-designed experimental set. It should be so designed as to permit the operator to bring in the L.F. valves one by one, or to cut them out altogether, so that he may adjust the strength of a given signal to give either a comfortable volume for head-phone reception, or sufficient power to work a loud-speaker. It also serves the useful purpose of enabling the user to judge whether each valve is doing its work properly, by noting whether each additional stage of amplification produces a proportionate increase of signal strength when it is brought into operation.

The switching system, however, must be properly designed or it will result in a mix-up of wires which is certain to produce howling. Probably the best solution of the problem from the point of view of efficiency is the use of the plug and jack system (Fig. 1), whose connections are as follows:—The telephones (or loud-speaker) are connected (either direct or through a transformer) to a plug, and in the plate circuit of the rectifying valve and each L.F. valve is connected a jack. The two outer springs of each jack are connected, one to the H.T. positive terminal, and one to the plate of the appropriate valve. The two inner springs are connected to the primary of the transformer which couples the given valve to the next one, thus arranging that when the plug is inserted in the jack the intervalve transformer is cut right out of circuit by the isolation of the two middle springs; "dead-end" effects are thus avoided (Fig. 2).

A further point deserving of mention in connection with the system of switching is the

FOR SECURING YOUR AERIALS

And a thousand purposes where great strength and strain is needed. **FLEXIBLE STEEL WIRE ROPE**. Aeroplane Cable made to Govt. specification to specified breaking strains. **PRICES BELOW COST**. Orders of 10/- and over carriage paid, otherwise, please add 1/- for postage.

No.	Dia.	Strain.	rooft.	No.	Dia.	Strain.	rooft.	No.	Dia.	Strain.	rooft.
0	1/16	5 cwt.	4/-	53	7/32	45 cwt.	12/-	7	11/32	100 cwt.	20/-
3	1/8	20 cwt.	8/-	5	1/4	70 cwt.	14/-	8	3/8	120 cwt.	21/-
51	5/32	25 cwt.	10/-	6	9/32	80 cwt.	15/-	9	13/32	140 cwt.	22/6

Strainers for use with above, right and left hand threads, 9d. each, or 8/6 per doz.
SMITH & ELLIS Ltd. (Dept. 85), 11, Little Britain, E.C.1. Tel. City 8924.

A HAPPY NEW YEAR TO EVERYBODY

ENSURE FREEDOM FROM WIRELESS TROUBLES BY DEALING WITH "RADIO STOCKS, LTD."

- Aluminium Vanes**, 5d. doz. **Aerial Pulleys**, 6d. **Anti-Capacity Handles**, 6d.
- Cats Whiskers**—Gold, 2d.; Silver, 1d.; Spearpoint, 1d. **Packet of 4**, 6d.
- Coils, Basket**, Set of 6, Duo wound, Waxless, 1/11; 4 1/2vt. **Batteries** (British), 5/9 doz.
- Coil Holders**, solid ebonite, 2-way, 4/-; 3 way, 5/-. **Sockets**, 7fd. each.
- Condenser and Grid-leaks**, 2.-. **Grid-leaks**, all megs., 1/- and 1/9.
- Condensers, Fixed**—To .001, 9d.; To .005, 1/-; To .01, 2/3; To .1, 3/-;
- Ditto., Variable**—ocr, 8/-; .0005, 6.-; .0003, 5/6; .0002, 4/6; .0001, 4/-.
- With aluminium end plates, .088 spacers.
- Condenser Dials**, o.180, 11d.; with knob, 1/4 and 1/9. **Bushes**—Top, 1f.; Bottom, 1d.
- Ditto End Plates**, 1/6 pair, drilled. Solid ebonite.
- Contact Studs**, 4d. doz. **Stops**, 2 a 1d. **Connecting Wire**, tinned copper, 3 yds. 2d.
- Crystals**. Every make stocked. **Zincite**, 9d.; **Bornite**, 6d.; **Talite**, 9d.; **Hertzite**, 9d.; **Galena**, Silicon, Carborundum, 3d.; **Copper Pyrites**, 6d.
- Gold Seal Elastic Mat** for fixing Crystals, 6d. box.
- Crystal Cups**, 4-screw, 1 1/2d. **Detector Glasses**, 4 1/2d. each. **Buzzers**, 2/6.
- Crystal Detectors**. Plain brass, 1/3; Nickel, 1/6; Dustproof, 1/6, 2/4; Plug-in Type, 3/6; Perikon, 2/3, 2/9 (with Zincite and Bornite).
- Crystal Detector Parts**, in envelope, 9/1, 1/3; Nickel, 1/-, 1/6.
- Earth Clips, adjustable**, 6d. **Ebonite**, 3/6 lb., any size. **Flt. Resist. C** at 7 1/2.
- Filament Resistances**, 1/6, 2/-, 3/-; porcelain base, 4/6.
- Foil**. Copper, 3d. foot. Tin, 4d. **Formers**, 12 by 2, 2d.; 12 by 4, 4d.; 12 by 5, 5d.
- Headphones**. Continental, 11/6 and adjustable 11/9, Brunet, 17/6, Pival, 1/6; British, Fellows, 18/6, T.M.C., 19/6, Brandes, 25/-.
- Insulated Hooks**, 1 1/2. **Tape**, 6d. roll. **Insulators**—Igg 1 1/2. Reef, 1d; Shell, 2d. **Frame Aerials**, detachable, in 24 x 6 x 6 case, 24 10 0.
- Jack and Plug**, 2/6 and 4/9. **Lightning Arresters**, 2/6 each. **Space Terminals**, 2 a 1d.
- Knobs**, finest, 4d. and 2d. **Lead-in Tubes**, 12 in., 11d.; 9 in., 10d.; 6 in., 9d.
- Screwed Rod**, 12 in. 2 B.A. 2 1/2d.; 4 B.A., 2 1/2d.
- Mica**, .002, 2d. sheet. **Nuts**, 2 B.A., 2 1/2d.; 4/5/6/8 B.A., 2d. doz.; O.B.A., 4d. doz.
- Scales**, Ivorine, o.180, 3d. **Set Name Tabs**, 6d. **Bell Wire**, 12 yds. 6d.
- Slider Rods**, 3 1/2. **Plunger**, 2d. **Best Ebonite**, 6d. **Wound Variocouplers**, 5/6.
- Spacers**, large, 2 1/2d. doz.; small, 1 1/2d. doz.
- Sleeving**, all colours, 3 yds., 11d. **Shellac**, 8d. bottle.
- Switches**, lacquered brass on ebonite, S.P.S.T., 1/-; S.P.D.T., 1/6; D.P.D.T., 2/-.
- Switch Arms**, 1st quality, 8d. **Screws**, all B.A.'s—To 1/2 in., 5d.; To 1 in., 9d. doz.
- Transformers, H.F. Plug**, 1, 250/600, 3/9; 2, 350/700, 4/-; 3, 500/900, 4/3; 4, 800/1,350, 5/6; 5, 1,600/3,200, 4/9; 6, 2,200/5,600, 5/-.
- Transformers**, approx. 5 to 1, L.F., 11/9 and 15/-; all guaranteed. "Powquip," 13/6; best nickel, 14/6. **Bobbins**, 1/6. **H.F. Formers**, 2/-.
- Terminals, W.O.**, 2d.; telephone, 1 1/2d.; pillar, 2d.; wood screw, 1 1/2d.
- Telephone Cords**, 10d. and 1/9; **Tablets** (Earth, Aerial, etc.), 1d. each. Flex (twin) 2d. yd.
- Variometers**, double wound, 2/11; Ebonite miniature, 3/9. **Formers**, 6d. pair. **Wound Coils**, 12 by 4, 2/5; 6 by 3, 1/8; 9 by 3, 2/3.
- Valve Holders**, finest ebonite, 1/3; moulded, 9d. (all with nut and washer).
- Valve Legs**, 10d. doz. **Valve Pins**, 9d. doz. **Voltmeters**, 5/6 and 8/6.
- Wander Plugs**, 3d. each. **Washers**, all B.A.'s, 1d. doz. **Wood's Metal**, 3d.

Largest Stocks in British Isles.

Impetative.—Kindly send ample postage; balance always refunded. SEND FOR FREE LIST. Trade supplied at separate trade counter.

RADIO STOCKS, Ltd.

Museum 4213. (Mail Order, "Radio House.")
 87/89, NEWMAN ST., OXFORD ST., LONDON, W.1.
 Between Oxford Circus and Tottenham Court Road,
 And at 44a, Cranbourn St., Leicester Square, W.C.2.

The 'Astra' VARIOMETER

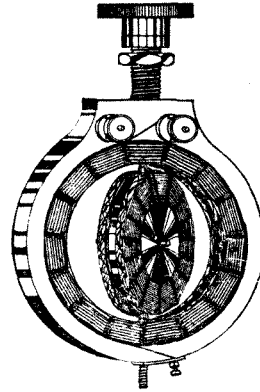

The Supersensitive Tuner

That all-important difference between moderate success and the crowning achievement of perfection in your tuning is definitely assured by use of the "ASTRA" Variometer, the supersensitive tuner.

Wound basket coils are employed, and the construction is such as enables it to be used with either crystal or valve sets. Supplied with one-hole fixing for panel, or can be mounted on horizontal base board. Range 0.600 metres on standard P.M.G. Aerial.

- Variometer complete - 12/6 post free.
- As Variocoupler - 14/6 "

The 'ASTRA' Valve Amplifier.

Amplification without Transformer!

A self-contained unit that takes the place of separate valve holder, grid leak, intervalve transformer, filament resistance, panel, terminals, etc., and literally adds a hundred miles or five volumes to your valve set without extra wiring, or enables you to add a loud speaker to your one-valve set.

Completely wired with valve holders, special resistance and a dual condenser; can be plugged into any valve holder either on the L.F. side (increasing volume five times) or on the H.F. side (greatly increasing range and clarity of set).

In polished Ebonite complete, 21/6, post free.

Other 'ASTRA' Components

include *Vernier Condensers, Wave Traps, Filstats, Permanent Crystal Detectors, and the famous 'ASTRA-PHONES'*, the self-contained headphones that actually embody their own crystal set in the earpiece of one phone and form a complete receiving station by merely attaching to earth and aerial.

Write for Full List—Now!

GEORGE MANUFACTURING CO.,

Wireless Specialists, Dept. 12,
 Nelson Chambers, 52, High Street, BIRMINGHAM.

ELECTRADIX RADIOMETERS.

- Wavemeters** from 100 to 10,000 metres. From £2 10 0. New Ex. W.D. Milliameters for Fine Tuning 17/6 to 35/-.
- Voltmeters**, Panel and Portable, 2 volts to 2,500 volts, 5/- to £5.
- Recorders**. Wireless Morse Inkers make long wave reception interesting. £6 10 0.
- Motor Alternators**. Wonderful £50 machines for £3. Ex Aircraft Potentiometers. Army 350 ohm 3/6. For details see "Wireless World" or our 3d. Catalogue.

We have many thousand pounds' worth of the pick of Government Wireless gear displayed at our London Showrooms at 9, Colonial Avenue, Minorities (near Aldgate Station).

LESLIE DIXON & CO. Ave. 4166.

A price reduction

JANUARY 1st.
1924

B.T.H.
R Type
RADIO VALVES

There is no better "general purpose" valve than the amber-tinted B.T.H. "R" type valve. It is unsurpassed for stability, freedom from distortion, and mechanical strength. At the new reduced price of 12/6, made possible by increased demand and consequent economies in manufacture, the B.T.H. "R" type valve undoubtedly represents the finest valve value in the world.

When next you buy "R" type valves, see that they are marked B.T.H. the sign and symbol of good reception.

Reduced Price **12/6** each.

The British Thomson-Houston
CO., LTD.
(WHOLESALE ONLY.)

Works: RUGBY, London Office: CROWN HOUSE, ALDWYCH.

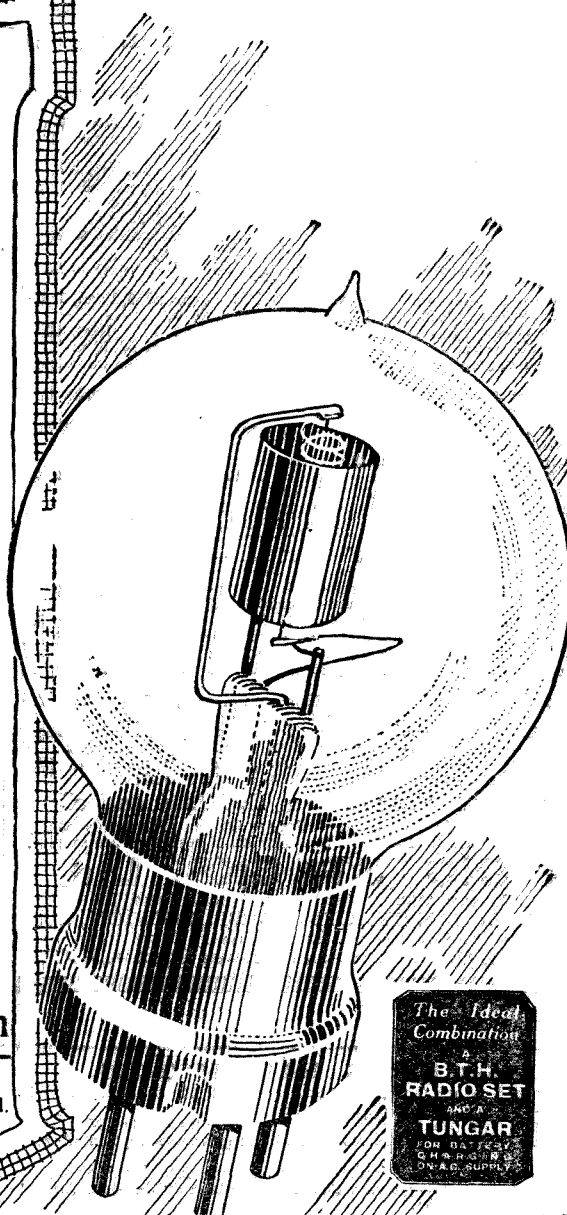

1922.



advisability of providing a switch to control the valve filaments, turning out those not in use. This switch should preferably be quite distinct from any switches or jacks whose function is to bring valves into circuit, in order that the operator may switch on the filament current of each additional valve before bringing it into circuit, readjusting the filament current of those already in use independently of the change. Such an arrangement is a great convenience when all the valves are run from the same accumulator, unless the latter is so large that switching on additional valves does not affect its voltage appreciably.

Power Amplification

When a very great volume of sound is required it is usual to employ what is known as a power amplifier, as to whose nature it would seem that there is some misapprehension on the part of many experimenters. It is simply an amplifier whose wiring is extremely carefully spaced out to prevent howling, and whose transformers are built to carry considerable currents without overheating and to withstand high voltages. The valves used are such as will handle larger energies than the ordinary receiving type can deal with, and a high plate voltage is applied to them. (The usual practice is to use 200-500 volts H.T.) Since power amplification is not within the reach of the average experimenter, it is not proposed to deal with it at length here. It may be added, however, that something resembling power amplification can be obtained by the use of really good hard receiving valves with a plate voltage of perhaps

150 volts, plenty of negative bias on their grids, and the best of intervalve transformers.

Resistance-capacity Intervalve Coupling

It is sometimes argued that resistance-capacity coupling should be used, in that it eliminates one of the chief causes of distortion, namely, the iron transformer core. It is very doubtful, however, whether this advantage is not outweighed by the introduction of distortion of another kind due to the rectification which is liable to occur to some extent in amplifiers of this type. Music and speech heard through such an amplifier certainly sound clearer and freer from "muffle," but it has a curiously thin, flat quality which is by no means satisfactory when heard from a loud-speaker.

If the reader desires to try for himself this system of intervalve coupling, he will find the following values give fairly good results in L.F. circuits :—

Anode resistances : 50,000 ohms.

Coupling condensers : .01 μ F.

Grid leaks : 1 megohm.

A final word of warning as to the number of valves to use for L.F. amplification : Remember that every additional "stage" of magnification increases the inevitable distortion, and any gain in loudness beyond a certain point is outweighed by the accompanying deterioration in quality. Strive always to obtain the greatest possible amplification from each valve, and limit the number of valves used. For all normal purposes *two* stages of L.F. amplification should suffice, three being necessary only when a very large volume is required.

□□□□□□□□□□□□□□□□□□□□□□□□
 □ **A HIGH-FREQUENCY** □
 □ **JACK.** □
 □□□□□□□□□□□□□□□□□□□□□□□□

Messrs. Elwell, Ltd., have sent for trial a mounted high-frequency jack unit, for cutting out stages of H.F. amplification at will. This is in the form of a box of moulded composition about 3 in. by 2 in. by 1 in., arranged to fasten on to panel or baseboard by two screws. It has three terminals for connection to anode of preceding valve, grid of following valve, and leak connection to L.T. ; and a jack fitting at one end.

A .0003 μ F fixed condenser and grid-leak of reliable make are incorporated.

On test the insulation was found excellent ; the components of the right value ; and the unit functioned correctly.

This jack should prove a great convenience for experimenters who use several H.F. stages.



The apparatus used for the transmission of opera from the "Old Vic." to the London Station.

SOME HINTS ON THE SELECTION AND DESIGN OF WIRELESS RECEIVING APPARATUS

By W. A. JACKSON.

THESE notes are written in the hope that they may be of some assistance to the would-be experimenter or beginner who contemplates constructing a suitable wireless receiving apparatus, or for the more experienced worker who wishes to discard his present, possibly crude or inefficient apparatus, in favour of a more ambitious installation, but who is unable to decide exactly on what lines to proceed.

A perusal of the articles and photographs in the various periodicals devoted to that most interesting hobby and branch of science now so familiarly and comprehensively defined by the term "wireless" cannot fail to quickly direct his mind to the very diversified practice which everywhere prevails in connection with the design and arrangements of wireless receiving apparatus, so that no wonder he hesitates before commencing work and makes enquiries from his more advanced radio friends.

The usual perplexing questions arise:—

"How many valves to use?"

"Whether to use high or low-frequency coupling?"

"Tuned anode, resistance capacity, plug-in or tapped transformer coupling?"

"Whether to mount the whole of the apparatus in one case or cabinet?" or—

"Whether to make several separate instruments or even component parts connected together on the bench?"

and so varied are the possibilities and so different the governing factors in each particular case that it is impossible to give a general answer equally applicable to everyone.

On the other hand, by ascertaining the nature of the experimental work proposed and the requirements of the completed set it is possible to systematically arrive at a working basis.

The ultimate size and cost of the completed installation is largely

dependent upon the wavelength, range and distance from which signals are required, and their strength.

Again, the question of compactness, portability, accessibility, and the possibility of expansion and alteration to the apparatus must be considered, whilst the embarrassing financial limit cannot be disregarded by many experimenters.

Far too many amateurs contemplating the construction of their first set ambitiously ask for a suitable diagram of a multivalve set, which they wish to be capable of receiving good signals (perhaps on a loud speaker) from all the usual high and low power stations, including amateurs, the B.B.C. Stations, and the like, on the whole range of wavelengths at present in use. However, as those who have attempted this are aware, such a course is full of obstacles and difficulties, and either the work is stopped before completion and remodelled on new lines, or else dissatisfaction reigns when it is used. This is particularly so if the whole of the apparatus has been mounted in one cabinet or case when any subsequent attempt to alter an inefficient portion of the circuit may be more trouble than to rebuild the whole set.

Unless a portable set is required there are few points in favour of making the whole apparatus into one instrument, whilst on the other hand, the unit system has many advantages.

Portability is not generally one of the requirements of an experimenter's set, for it is usually under test, alteration, or expansion. It is a different proposition when the professional wireless manufacturer turns out very elaborate instruments with the whole of the apparatus mounted in a nicely constructed box or cabinet with the adjustment controls neatly and symmetrically arranged on one panel, for it must be remembered that such tests are not made for the experimenter, or serious worker. They are intended to be used just

as they are, as finished instruments, not intended for alteration or extension without being dismantled and rebuilt.

The use of the unit system produces a very neat set always complete, but never completed, for an additional unit can be always added, or an unsatisfactory one altered, or replaced, without disturbing the others.

Another important point to be borne in mind is that although the science of wireless has advanced by leaps and bounds during the last few years, it is still in the comparative infancy of the experimental stage, and every week or so records some new development of a more efficient or more selective circuit. As there is no reason for supposing that such discoveries will not continue to be made for many more years before all the possibilities are found and the most satisfactory methods and apparatus devised, many of the present instruments may thus require continual alteration or replacement in order to keep pace with the developments of time, and here, again, the unit system is by far the simplest and easiest method of securing this elasticity.

Take, for example, the case of, say, a five-valve set employing two high-frequency, one detector, and two low-frequency valves, these might be concentrated into one large instrument or the following four separate units, each of which fulfils a distinct and different function, viz. :—

1. Tuner.
2. Two H.F. valves.
3. Detector.
4. Two L.F. valves.

In the event of a subsequent desire to employ a different circuit for, say, the high-frequency section, the alteration might cause a lot of inconvenience in the case of a large instrument which would have to be out of action for some time, whereas it would be a simple matter to temporarily remove the above No. 2 unit for alteration or

(Continued on page 279).

OTHER ETHER WAVES

By C. J. COZENS, M.C., B.Sc., Associate of University College, Southampton.

An article reviewing in a most interesting manner the range of known ether vibrations and their properties.

THE radio enthusiast is apt to lose sight of the fact that the ether waves which make possible the wonders of wireless do not constitute a unique natural phenomenon. As was pointed out by a writer in the first number of MODERN WIRELESS, the light and heat from the sun are also propagated through the intervening space by electromagnetic waves similar to wireless waves, but differing from them in wavelength. He suggests that the waves of light and heat are less wonderful to the human mind than electric waves, for the former are perceived by the senses and the

latter are not. That may be so, but there are other waves which do not directly affect the senses; X-rays, for example, must certainly

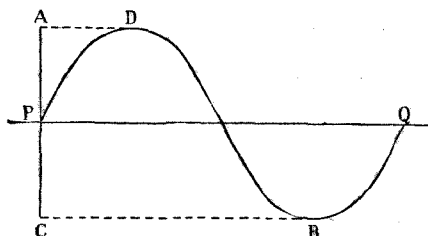

Fig. 1.—Diagram of a Wave.

“ELLA” BATTERY CHARGERS

They work from a Lampholder.

SAVE THEIR COST IN A FEW WEEKS.

Testimonial from a D.C. ELLA user.

Mr. A. P. Welch, 33, Eastwood Road, Goodmayes, Essex, writes:—
I believe I was one of your first customers for the “Ella” Battery Charger and as I have had the machine now for some time, and given it a thorough test, I should like you to know that it is satisfactory in every way, and is giving very good service . . . the machine is beautifully balanced. It has stood on the top of a bookcase on a rubber pad, not fastened down in any way, and it runs in this position quietly and without vibration, and may be left for long periods without attention. On several occasions I have left it running all the week-end while away from home. I can do this, because I am using it to charge three 250 ampere-hour House Lighting Cells, which are used for quite a number of purposes. A number of my friends have, on my recommendation, purchased a Converter and the opinion of them all agrees fully with my own.

“Wireless Weekly” says:—

“We are of the opinion after close examination of this sturdy little machine that at the reasonable price asked for it it represents good value and will prove a good investment to those who possess a valve set and have access to a D.C. supply.”

ELLA Wireless Volt Meters, portable and switchboard patterns for reading plate and battery volts on one scale.

Pocket type, £1. Switchboard type, £1 5s., post free.

All makes British Headphones. All patterns British Valves from Stock.

Trade also supplied.

LIONEL ROBINSON & CO., 36, Staple Inn, London, W.C.2. Phone: HOLBORN 6323

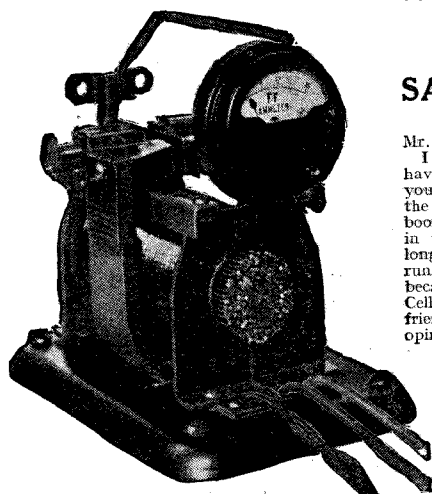

A.C. Model.

Output 5/10 amps. 9 volt. Complete with Pole Indicating Ammeter and all connecting leads and adapter. From stock, £6 6 0, f r frequencies 40 to 6), and voltages 100 to 220. Other frequencies and voltages, £1 extra and to special order.

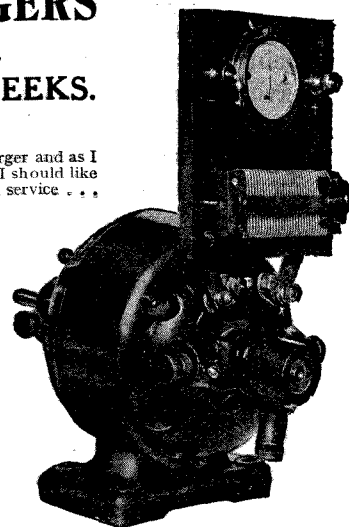

D.C. Model.

Output 5 amps. 9 volts. Machine only, £5 12 6 With Switchboard and Pole Indicating Ammeter and Regulating Resistance as illustrated, £6 15 0

ADVERTISEMENT RATES

“WIRELESS WEEKLY.”

ORDINARY POSITIONS.

13 insertions consecutive - £15 per page and pro rata.
6 " " - £15 plus 5% per page and pro rata.
1 to 5 " " - £15 plus 10% per page and pro rata.

NEXT MATTER (In columns only)

13 insertions consecutive - £20 per page and pro rata.
6 " " - £20 plus 5% per page and pro rata.
1 to 5 " " - £20 plus 10% per page and pro rata.

SCHEFF PUBLICITY ORGANISATION, LTD.

(Advertisement Managers, Wireless Weekly and Modern Wireless).

125, PALL MALL, LONDON, S.W.1.

Phone—Regent 2440 (2 lines).

be considered as wonderful as "wireless" waves, and it is only a matter of view-point as to which are the more useful to mankind. Wireless waves enable us to communicate with distant points not materially connected with ourselves, whilst by X-rays we are able to see through material substances.

All ether waves are fundamentally the same. They consist of vibrations in the ether, these vibrations being executed in a plane at right angles to the direction of propagation of the waves. The three characteristics of these waves are velocity of propagation, amplitude, and wavelength. The velocity is the same for all kinds of ether waves—namely, 300 million metres per second. Fig. 1 represents a wave which is travelling from left to right. The velocity with which the crest of a wave moves forward is the velocity of the wave. The height of the crest above the mean level is the amplitude. How does the amplitude affect the wave? It increases the intensity of the phenomenon, *e.g.*, other things being equal, light waves of greater amplitude give a sensation of stronger light to the eye, and electromagnetic waves of greater amplitude have a greater effect on the receiving instrument. For practical purposes, the most important characteristic of the wave is its length. The distance between one crest and the next is the wavelength. Ether waves, varying in length from 0.1 tenth-metres¹ (1 tenth-metre = 10^{-10} metre) to 20 or 30 kilometres are known and have been investigated.

The visible light from the sun does not consist of waves all of the same length; they range in length from about 4,000 tenth-metres to about 8,000 tenth-metres. Here different wavelengths give us the perception of colours, red light consisting of the longest waves, and violet of the shortest ones.

The waves given out by the sun bring us light as well as heat. The heat waves, usually known as the infra-red, are longer than any of the visible light waves. Infra-red waves from 7,600 tenth-metres up to about 600,000 tenth-metres (0.06 millimetres) have been discovered, and it is found that whereas the shortest heat waves have properties similar to those of visible light, the properties of the longest heat waves resemble those of wireless waves—a significant fact, as we shall see later.

¹ 10 tenth-metres = 1 micro-millimetre
 1,000 micro-millimetres = 1 micron
 1,000 microns = 1 millimetre
 1,000 millimetres = 1 metre

Thus 0.1 tenth-metres would be 1 hundred-thousand-millionth of a metre.

Still considering the waves from the sun, we find that the visible violet light waves are not the shortest. The shorter waves, called the ultra-violet, although not perceived by the eye, can be detected by their action on the silver salts of a photographic plate. For this reason they are, sometimes called "actinic" or "chemically active" waves. The longest ultra-violet waves closely resemble the visible violet light, but the shortest known ultra-violet waves have properties more closely related to those of X-rays. Here again is a significant fact.

At one part of the scale we have a range of waves of all lengths from 1,000 to 600,000 tenth-metres. Between these limits the properties of the waves have been definitely studied. Above and below these limits we have uninvestigated gaps.

The waves of greatest known wavelength are, of course, the "wireless" waves; the shortest known waves are the X-rays and the Gamma rays from radio active substances.

X-rays vary in wavelength from 1 tenth metre to 10 tenth-metres. They exhibit many of the same properties as light, *e.g.*, they affect a photographic plate; but the greatest difference is in their power of penetrating material bodies. The opacity of a substance to X-rays depends upon the nature of the substance; thus lead and mercury are very opaque to X-rays, cork and aluminium very transparent. Similarly bone is less transparent than flesh, and this fact has proved of great value in surgical science.

The Gamma rays (discovered in 1896, one year after the discovery of X-rays) are waves even shorter than X-rays. They are emitted by radioactive substances, such as uranium, during their transformation. These waves have lengths from 0.1 to 1.0 tenth-metre; and their properties differ very little from those of X-rays.

Thus, in order of increasing wavelength, we have Gamma rays, X-rays, ultra-violet (or chemical) waves, visible light (violet to red), infra-red (or heat) waves, and electromagnetic (wireless) waves.

Table 1 shows, in a general way, the complete range of wavelengths of ether waves. Owing to the enormous difference between the wavelengths of the waves at opposite ends of the range, it is impossible here to give this diagram to scale. The actual wave length of the various

(Continued on page 272.)

Approaching One Million & Half Satisfied
Customers Study Our Advertisements.

ELKAY WIRELESS CO.

BRITAIN'S LARGEST EXCLUSIVE WIRELESS STORES

QUALITY, QUANTITY AND
CONSISTENCY OUR MOTTO.

Pioneers of Cheap Prices.

SEE OUR SIX-WINDOW
DISPLAY OF BARGAINS.

You may require apparatus not detailed below. Be confident—we sell everything for wireless.
WRITE TO ELKAYS—WE STOCK IT.

ELKAY Lightweight Headphones, 4,000 ohms, all guaranteed per pair **12/9**
FELLOWS' New Lightweight 'Phones, 4,000 ohms, stamped B.B.C.... **18/6**
SUPER 'PHONES, Light, Easy Adjust- **13/9**
ment, 4,000 ohms, guaranteed ...
N & K (The genuine article), 4,000 **12/9**
ohms, all guaranteed ... Per pair
ALSO BROWNS, BRUNET, THOMSON-HOUSTON (French), ETC.

ALL MAKES OF VALVES IN STOCK
MARGONI R. EDISWAN, MULLARD and COSSOR (Red & Plain Top)
Dull Emitters, Ediswan & Marconi, 21/-
Special packing and post 1/- each extra. EACH,

State What Make of LOUD SPEAKER you Require.
EVERY TYPE IN STOCK.

DUTCH VALVES ... 6/11 & 7/11
L.F. TRANSFORMERS. Ratio 5 to 1. All guaranteed (postage 1/-) ... each 11/3
CRYSTAL DETECTORS ... 1/9, 1/3 & 10/3d.
CRYSTAL DETECTORS, enclosed in glass case 2/6, 2/3, 1/6
AERIAL WIRE, 7/22, guaranteed hard-drawn copper, 100 ft. (postage 1/-) ... 1/10 1/2
CONDENSER VANES, fixed or moving per doz. 3/3d.
REAL GOLD CAT'S WHISKERS ... each 2d.
REAL GOLD CAT'S WHISKERS per doz. 1/5
SILVER CAT'S WHISKERS ... each 1d.
SILVER CAT'S WHISKERS per doz. 7d.
CONDENSER SCALES, 0 to 180 ... each 3/3d.
BASKET COILS, set of 6, up to 3,000 metres 2/4
SLEEVING, 3 yds., assorted colours, for ... 11/3d.
NUTS, 2 B.A. ... per doz. 2/3d.
NUTS, 4, 5, 6, and 8 B.A. ... per doz. 2d.
WASHERS, 4 B.A. ... per doz. 1d.
WASHERS, 2 B.A. ... per doz. 1/3d.
CONTACT STUDS, with nuts and washers per doz. 4d.
TERMINALS, with nut and washers each 1d., 1 1/2d. & 2d.

IVORINE LABEL SET, 12 different titles the set 6 1/2d.
FILAMENT COMPLETE CIRCLE RESISTANCE SCALES, 0 to 300 ... each 6d.
BELL WIRE, Tinned Copper, 12 yds. ... 6d.
VALVE LEGS, nut and washer ... each 1d.
VALVE LEGS, nut and washer per doz. 10d.
VALVE PINS, nut and washer ... each 1d.
VALVE PINS, nut and washer per doz. 9d.
PLUNGER SPRINGS, complete ... each 1d.
SLIDER ROD, brass, 13 ins. long, 1/4 in. square, drilled ... each 3/3d.
SLIDER KNOB ... each 2d.
SWITCHES ON EBONITE, S.P.S.T. ... each 1/6
S.P.D.T., each 1/11; D.P.D.T. ... each 2/9
CONDENSER SPINDLES, all sizes in stock, from ... 1 1/2d.
SCREWED ROD, 2 B.A., 12 ins. long each 3d.
SCREWED ROD, 4 B.A., 12 ins. long each 2 1/2d.
RUBBER INSULATED LEADING-IN WIRE per yd. 1 1/2d.
VARIABLE GRID LEAK, Pencil type ... 1/11
INSULATORS, white reel, 2 in., each 1d.; per doz. 11d.
INSULATORS, white egg, each 2d.; per doz. 1/8

VARIABLE CONDENSERS of high quality. With aluminium top and bottom plates. Complete with knob and dial, guaranteed accurate:
Vernier ... 4/- .0005 ... 6/-
.0001 ... 4/- .00075 ... 7/-
.0002 ... 4/6 .001 ... 8/-
.0003 ... 5/6
SUPER-QUALITY 2-WAY COIL HOLDER ... 5/3
REAL EBONITE 3-WAY COIL HOLDER ... 7/9
O.B.A. NUTS ... per doz. 4d.
DETECTOR ARMS, Ball Joints, Ebonite Handle and Whisker Holder ... 3 1/2d.
WOOD SCREW TERMINALS ... each 1 1/2d.
SHELLAC ... per bot., 10 1/2d. & 6d.
AERIAL PULLEYS ... each 10 1/2d., 8 1/2d., 6d. & 4 1/2d.
TINFOIL ... large sheet 4d.
COPPER FOIL, 6 in. wide ... per ft. 6d.
GRID LEAKS, 2 1/2 and 2 meg. ... each 10 1/2d.
FLEX (Twin), various colours ... per yd. 2d.
CONNECTING WIRE, tinned copper, 20 gauge 3 yds. 2d.

OUR NEW BRANCH NOW OPEN 159, BISHOPSGATE, E.C.2. (12 DOORS FROM LIVERPOOL STREET STATION—ON SAME SIDE.)

EBONITE KNOBS, 2 B.A. ... each 2d. & 3d.
SPACING WASHERS, large ... per doz. 2 1/2d.
SPACING WASHERS, small ... per doz. 1 1/2d.
CRYSTAL CUPS, 2 screw ... each 1d.
CRYSTAL CUPS, 4 screw ... each 2d.
FIXED CONDENSERS, all capacities each 10 1/2d.
EBONITE, cut to any size by machinery while you wait ... per lb. 3/6
TELEPHONE TERMINALS, nuts and washers, each 1 1/2d.
W.O. TERMINALS, nuts and washers each 2d.
W.O. TERMINALS, nuts and washers per doz. 1/7
PANEL BUSHES, drilled ... each 1 1/2d.
PANEL BUSHES, drilled per doz. 1/3
TOP CONDENSER, bushes ... each 1d.
TOP CONDENSER, bushes per doz. 9d.
BOTTOM CONDENSER, bushes ... each 1d.
BOTTOM CONDENSER, bushes per doz. 7d.
SWITCH ARMS, 4 laminations, ebonite knob, complete with panel, bush, nuts, and spring washer 8 1/2d.
STOPS, with nuts ... per doz. 6d.
FILAMENT RESISTANCES, smooth action, marvellous value ... 1/9
With engraved dials ... 2/6

WOUND INDUCTION COILS (postage 9d.):
12 x 4 9 x 4 8 x 2 1/2 6 x 3 6 x 2
2/5 2/3 1/11 1/8 1/5
TAPPED INDUCTION COILS, 20 tappings wound to 1,600 metres ... each 2/6
VARIOMETERS (Tube type), complete with knob ... 3/11 & 2/11
DOUBLE 'PHONE CORDS, full length ... 11 1/2d.
HERTZITE, genuine, in box ... 8d.
TALITE, genuine, in box ... 8d.
PERMANITE, genuine, in box ... 8d.
ZINCITE, genuine, in box ... 8d.
BORNITE, genuine, in box ... 6d.
MIXED CRYSTALS (6 kinds) ... 9d.
CARBORUNDUM ... 5 1/2d.
ZINCITE and BORNITE, both in box 1/-
COIL PLUGS, real ebonite ... 1/3, 10 1/2d. & 9 1/2d.
EBONITE CONDENSER KNOB AND DIAL ... 1/6
FILAMENT RESISTANCE DIALS ... 8 1/2d.
H.F. PLUG TYPE TRANSFORMER:
1. 150 to 450 metres ... 3/9
2. 250 to 700 ... 4/-
3. 450 to 1200 ... 4/3
4. 900 to 2000 ... 4/6
5. 1600 to 3200 ... 4/9
6. 2200 to 5600 ... 5/-

ENAMEL WIRE in 1/4, 1/2 and 1 lb. reels:
22 24 26 28
per lb. 2/4 2/8 3/2 3/8
Note.—Bobbins 2d. each extra.
POTENTIOMETERS, guaranteed up to 500 ohms, superior make, compact size 7/3
CRYSTAL DETECTOR, glass enclosed, fitted on 4 x 2 ebonite panel with terminals for aerial, earth, and 'phones, already wired and beautifully finished ... 4/9
VALVE HOLDERS ... each 10 1/2d. & 1/3
BATTERIES, H.T., dry:
30 volts, including Wander Plugs ... 5/9
60 volts, including Wander Plugs ... 9/6
AMALGO PLASTIC METAL, for fixing crystals. No Wood's metal necessary ... 6d.
GOLD SEAL PLASTIC METAL, for fixing crystals ... 6d.
IVORINE NAME PLATES, all readings each 1d. per doz. 9d.
EARTH CLIPS, Copper, adjustable ... each 5 1/2d.
THE WONDERFUL TITANIC CRYSTAL SET, stamped B.B.C., including 1 pair of 4,000 ohms headphones, aerial wire, insulators, leading-in wire, lead-in tube, earth clip, etc. Maker's price 3 guineas. Our price 33/9

Please address Post Orders to: Please send ample postage.

MAIL ORDERS DESPATCHED
SAME DAY AS RECEIVED.
Goods sent to all parts of the
World.

"ELKAY" WIRELESS CO.

225 and 227 BISHOPSGATE, LONDON E.C.2.
OPEN SATURDAY ALL DAY, SUNDAYS 11—2.30. TRADE COUNTER NOW OPEN. Special Terms to Radio Clubs.
Telegrams: ELKAYWIRY AVE., LONDON. Telephones: CENTRAL 8544, RETAIL. BISHOPSGATE 2313, WHOLESALE.
REMEMBER—DON'T PAY MORE!

For alterations of prices see our
announcements in "Wireless Week-
ly," "Amateur Wireless" and
"Popular Wireless."

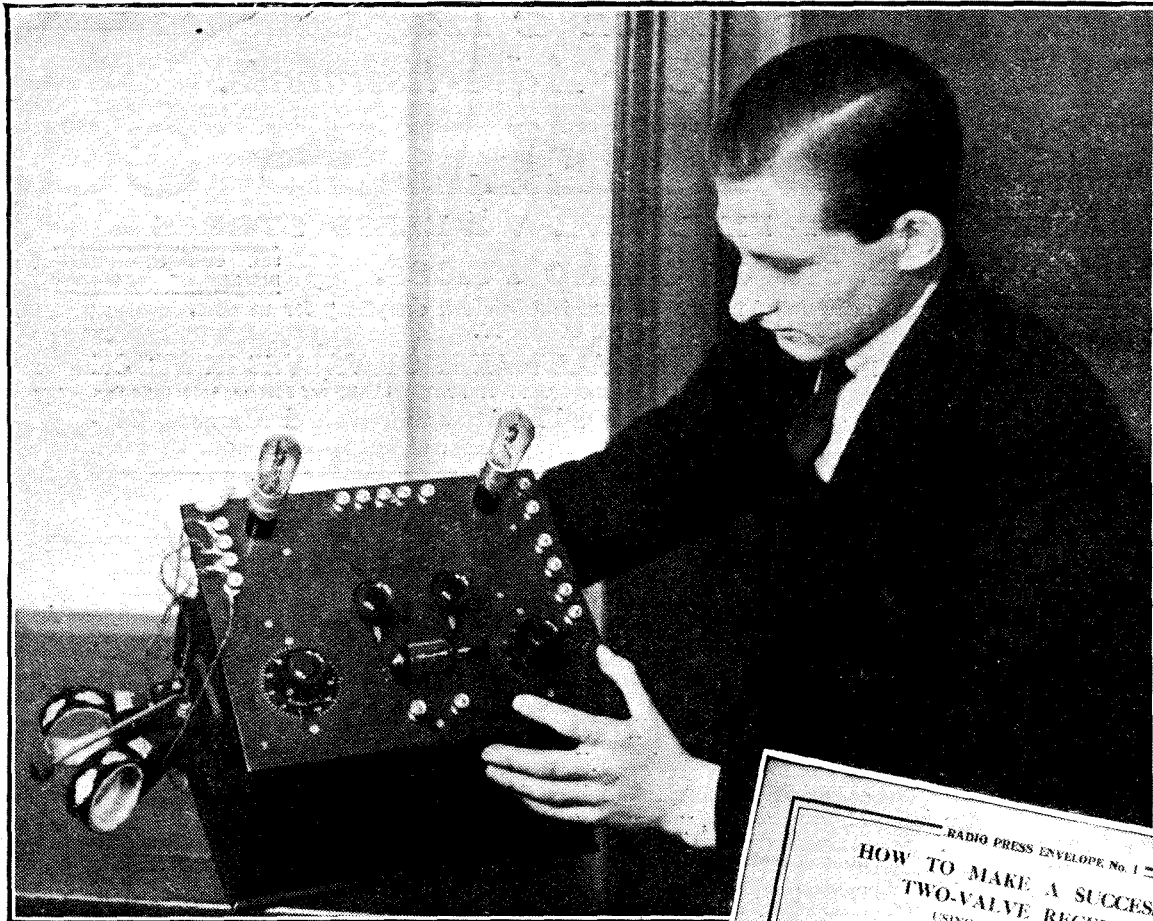

Full instructions for building this fine S.T. 100 Set:

THE tremendous success which followed the publication of constructional articles dealing with the S.T. 100 Circuit and the heavy demand from our readers for further articles on the same subject, has led us to place on the market an Envelope containing the fullest details about it.

This Envelope can be bought by anyone in full confidence that with the least amount of mechanical ability he can build a really first-class Receiver—similar in every respect to the one illustrated above.

But even more important, this Envelope contains working hints and instructions which will prove invaluable to anyone operating a Reflex Set for the first time.

We have aimed, in fact, to make the material contained in this Envelope as comprehensive as possible. Why not get one to-day and start building this most fascinating of Receiving Sets?

From all Booksellers

1/6

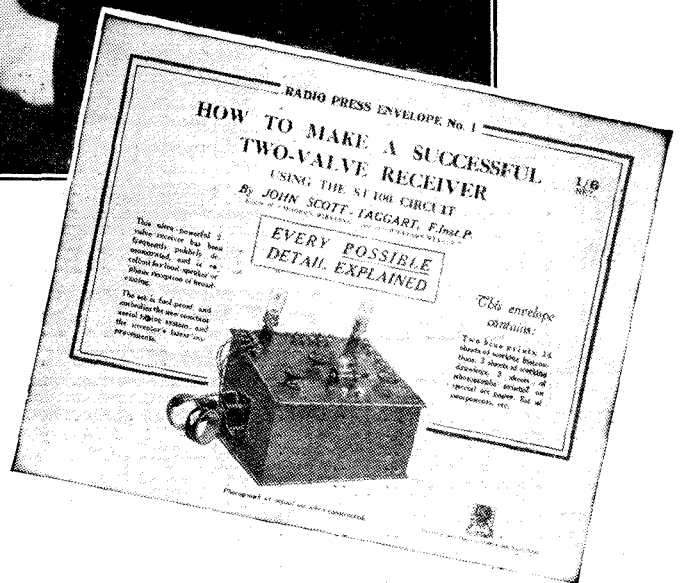

SIMPLEX RADIO CHARTS.

WE have just published a further series of envelopes, each of which contains a full size chart for building a Valve Receiver (see below) together with a booklet which explains exactly the components which are required for the construction of the Set.

- No. 1.—A Two-Valve Receiver 1/-
- No. 2.—A Three-Valve Receiver 1/-
- No. 3.—A Four-Valve Receiver 1/-

From all booksellers or direct (postage 2d. extra).

RADIO PRESS Ltd.—Devereux Court, STRAND, W.C. 2



A Valve Adapter Plug

From Messrs. Grafton Electric Co. comes also a valve adapter-plug to push in the valve-socket of sets which are already wired up, and carrying the valve itself in the regular type of socket on the upper surface; providing a tapping in the grid-circuit at which to introduce grid-bias from grid-cells or potentiometer, etc. This is in the form of a well-finished ebonite block, carrying the necessary plugs and valve-legs; and with a twin flex issuing from the side which completes the grid-circuit, across which the potentiometer, etc., is to be connected. On test, it adequately filled its purpose, and was convenient in use.

The fitting provides an extremely useful addition to an existing boxed up set, enabling stabilizing bias to be given to H.F. valves, or a negative bias to L.F. valves so as to reduce distortion in loud-speaking sets. There are also possibilities in the direction of adapting existing sets for dual-amplification by means of this fitting.

A Fixed Condenser-holder

A neat and useful little fitting is the small condenser-holder produced by the Grafton Electric Co., for use with their well-known clip-in type of fixed condenser. This is an ebonite strip carrying the necessary clips, in which the condenser is slipped (enabling it to be changed at a second's notice without disturbing any connection); and two small terminals.

On trial, the insulation was excellent; and the fitting held the condenser firmly, giving good silent contact, and easy replacement of the latter.

A Safety-Valve Holder

Messrs. Leigh Bros. have sent for inspection a form of valve-holder which is claimed to be "fool-proof," in that it is manifestly impossible to plug the valve in in such a position that the H.T. battery is connected, even momentarily, across the filament, with the all-too-familiar result. This is achieved by simply sinking the sockets well below the surface of the plug, so that unless the legs are presented in the right way round it is impossible to enter them far enough to make contact at all. It is also provided with screws instead of legs, and has a centre hole tapped No. 4 B.A. for fixing on the panel. This holder itself can be used as a drilling jig for drilling the panel. The unit is nicely finished, and at the moderate price at which it is offered should find wide application.

A Filament Resistance

Messrs. Marconi Scientific Instrument Company, Ltd., have submitted for test a filament resistance of an interesting type, by means of which extremely fine adjustment of filament temperature is possible. It is arranged for panel-mounting by means of three small screws; a brass template is provided for drilling the necessary holes in the panel. It occupies a space of about 2 in. square, and is 3½ in. long below the panel.

The resistance is wound as a close spiral on a rectangular block of insulating material which is pivoted at one side and pulled up by a small spring so as to make good contact between the wire and a copper spiral on the controlling

spindle. As this is turned, contact is established at any desired point in the length of the resistance-wire, giving a smooth and apparently certain action. The finish and workmanship are, as one would expect, of a high order; a clear and open white engraved scale giving a handsome finish.

On practical test, the resistance was found to be about 3½ ohms maximum, with a current corresponding to the demands of two ordinary R valves, the wire heated up considerably; and probably partly as the result of expansion by heat of the insulating former, there was exhibited a tendency for the pivots to seize so that irregular contact resulted. With the current for one valve-filament only, the wire remained cooler, and this effect was not noticeable; the adjustment was easy to make for a critical optimum and there were no noises due to irregular contact.

When tested, the insulation resistance was found to be very good. Substantial stops are provided, and there is a definite "off" position.

A Coil Holder

The Grafton Electric Co. have sent for examination and test a fixed coil-holder for mounting plug-in coils on base-boards and panel-fronts. This is neatly and substantially made; the insulation, on test, proved excellent; and the fitting was of standard size, giving good electrical connection. Small plated terminals are provided. A detachable plug is provided in case it is desired to reverse the coil in the holder.



USING A COMMON BATTERY WITH DULL EMITTERS

WITH dull emitters of the very low consumption type like the Ediswan A.R. 006, the Marconi Osram D.E. 3, and the B.T.-H., it is quite possible, if a set is used only for comparatively short periods on end, to work both filament and plate supply from the same battery. If this is done, it is desirable that cells of fairly large size should be used. Both the Ever-Ready Company and Messrs. Siemens make $4\frac{1}{2}$ -volt batteries which are

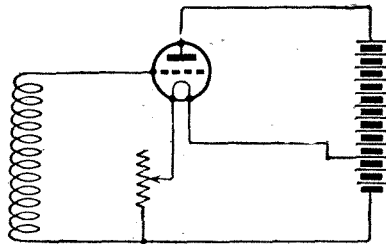

Fig. 1.—The circuit

very much bigger and heavier than the kind used for pocket flashlamp purposes. As the valves mentioned consume only 60 milliamperes in the filament circuit, these batteries are quite capable of standing up to the load put upon them if they are given plenty of time to recuperate.

The circuit which is shown in the diagram is perfectly straightforward: one simply fits the batteries with a clip connection provided with a plug and socket, and uses the last three of them for heating the filament. A simple and easily made clip connection is shown in Fig. 2. This consists of a short length of $\frac{1}{4}$ in. square brass

rod, in each end of which a hacksaw cut is made. 4 B.A. holes are drilled and tapped at right angles to the cuts, the screws inserted into them serving to clamp the clips tightly in position on the battery strips. Between the two tapped holes an $\frac{1}{8}$ in. plain hole is drilled which forms a socket for the Wander plugs.

The batteries should be used in rotation so that the load upon all is equalised and the longest possible

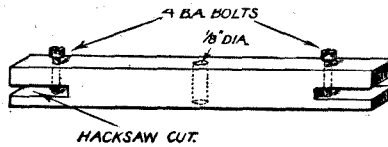

Fig. 2.—A clip connector.

time for recovering is given. One can easily do this by making a point of removing the three cells at the negative end after each reception and placing them at the positive end. This does not take a moment owing to the ease with which the clip connections can be unfastened and secured again, and if, say, a total of 54 volts is in use, it means that the batteries that have been employed to light the filament do not have the same load again for twelve days, even if the set is in daily use.

R. W. H.

CONTRIBUTIONS FOR THESE PAGES ARE INVITED AND WILL BE PAID FOR AT OUR STANDARD RATE.

CHEAP HOOKS FOR INDOOR AERIALS

CHEAP hooks for indoor aerials may be made by first procuring two or three feet of ebonite tube, having about $\frac{1}{4}$ in. bore. Cut this off in lengths of from 4 to 6 in. and plug each end with some deal dowel-rods of a corresponding diameter to the bore of the tubing. On one end is screwed a brass bracket, of the shape shown in the diagram, in which are two holes for the purpose of fixing to the wall with Rawl-plugs, and through a third hole a

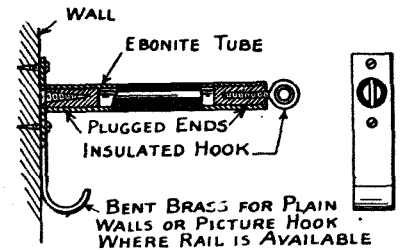

screw is passed from the back of the bracket into one of the plugged ends of the ebonite rod. The bent-over portion of the brass bracket acts as a picture hook. This is to be employed where picture rails are not available, but in the other case ordinary picture hooks may easily be adapted. The further end of the ebonite rod (which has been previously plugged) receives an insulated hook, as shown. This completes the making up, which is quite simple. The hooks are now secured to the wall in suitable positions, the aerial being passed round the room through the insulated hooks.

H. B.

EBONITE INSULATORS

THE ebonite insulators in Figs. 1 and 2 are for use on wooden panels, and may be recommended for their simple construction.

All that is necessary in the case of Fig. 1 is the cutting of ebonite tubing into lengths, just a shade less than the thickness of the board for which they are required. The terminals, etc., may then be

pulled up tightly on to the ebonite washers which are parted off from drilled ebonite rod, and placed on either side of the board.

In Fig. 2 the same method is employed as outlined above, except of course four holes are drilled for the valve legs in each ebonite washer, and four pieces of tubing cut off for each valve set.

E. L. B.

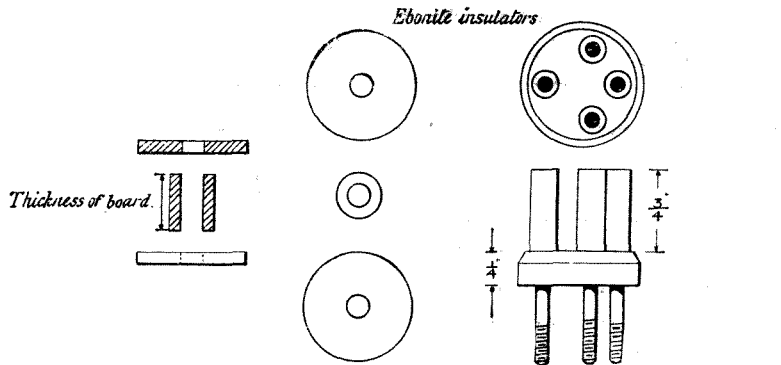
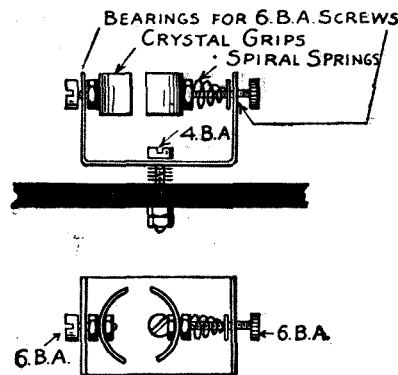

Fig. 1.—How to make ebonite insulator for panels.

A SIMPLE CRYSTAL HOLDER

A SIMPLE, effective and efficient crystal holder, having many advantages over the usual types, may easily



be made by the home constructor. The chief point in its favour is that any spot on the whole of the crystal may be found, as all the surface of the crystal is exposed

and may be turned completely round in any possible direction. The bracket is first made (as shown in diagram) from some strip brass, two holes being drilled to act as bearings, which should clear 6 B.A. screws, or smaller if desired. The crystal grips are made from some good springy brass, bent into a semi-circular shape, holes being drilled also to clear 6 B.A. One grip is fixed into the left-hand bore by means of a small 6 B.A. screw, washer, nut and lock nut, the nuts being so tightened as to allow the grip to turn round freely in its bearing. The other grip is fixed to the right-hand bearing in a similar manner, but a knurled head is desirable to the 6 B.A. screw. Between the grip of the bearing a spiral spring of fine steel is inserted. Now fix the bracket to the panel (as shown), by means of a 4 B.A. screw, a washer, spring washer and further washer on the upper side of the panel, and a nut

and lock nut on the under side of the panel. By pulling the knurled screw backwards, the crystal is inserted between two clips. The screw is then released and the screw grips the crystal, which may be now turned completely round on the two bearings, and may also be turned round in a different direction on the bearing of the bracket itself.

H. B.

CONSTRUCTING AIR SPACE VARIABLE CONDENSERS

AN air space variable condenser may be easily and cheaply constructed. That described in this article has the advantage of having a capacity indicator; i.e., a scale which indicates the width of the air space between the upper and lower plates, thereby enabling the experimenter to judge the relative capacity in operation.

First construct the lower plate

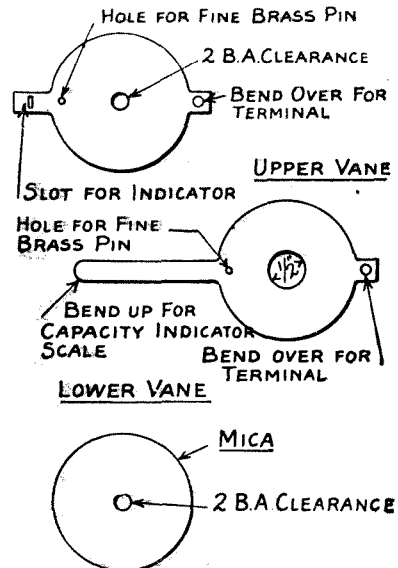

by procuring a circular piece of ebonite 3 in. in diameter, and drilling a hole through the centre to clear a 2 B.A. rod. Insert a length of such rod, about 3 in. long, and secure by means of lock nuts on the under and the upper sides. Next cut the lower vane from aluminium sheet. The long projecting portion acts as a capacity indicator, and the short projection, when bent over, as a connection for the terminal. Lay this plate exactly in position over the ebonite disc, bend the indi-

(Continued on page 280.)

(Continued from page 266).

kinds of radiation, however, may be seen from the following table :—

	Feet-metres.	Cms.
Gamma rays	0.1	0'000000001
X-rays	1.0	0'00000001
Shortest ultra-violet waves	600	0'000006
Shortest visible waves (violet), about	3,800	0'000038
Violet, about	4,000	0'000040
Blue... ..	4,500	0'000045
Green	5,200	0'000052
Yellow	5,700	0'000057
Red	6,500	0'000065
Longest visible waves (red)	7,500	0'000075
Longest waves in solar spectrum	53,000	0'00053
Shortest electric waves	40,000,000	0'4
Longest electric waves, more than	30,000 metres	3'0 x 10 ⁶

Table 2. Wavelengths of known ether vibrations.

It has been mentioned that the shortest actinic waves resemble X-rays and the longest heat waves resemble electromagnetic waves. It is a well-known fact, too, that red light affects a photographic plate less than any other kind of light, and red light is the light which differs most in wavelength from ultra-violet waves, which have the greatest effect on a sensitised plate. Does it not seem highly probable that we are discovering little by little a continuous range of ether waves, and that eventually we shall succeed in bridging the gaps and in understanding the gradual change in properties from the shortest radium rays to the longest wireless waves?

Gamma rays.	X-rays.	Undiscovered.	Ultra-violet.	Visible light.	Infra-red.	* Undiscovered.	Wireless waves.
-------------	---------	---------------	---------------	----------------	------------	-----------------	-----------------

Table 1. Showing wavelength relations.

* Since this article was written it has been reported that the "undiscovered" gap has been bridged by Dr. Nichols, of Cleveland, U.S.A.

REMEMBER!

The FEBRUARY NUMBER of
"MODERN WIRELESS"

will be a

Special BIRTHDAY Issue

containing many novel, interesting and instructive features.

ADVERTISERS send your order with copy for this remarkable issue not later than January 18.

SCHEFF PUBLICITY ORGANISATION, LTD.,
 125, Pall Mall, London, S.W.1.

Phone: REGENT 2440 (2 lines).

BRINGING HOME THE BROADCAST RECEIVER

Useful Advice to the Beginner

By E. L. R.

Do you feel puzzled about how to begin wireless reception? This article will give you confidence in buying and using your set.

IF the thoughts of hundreds of people variously engaged in doing the same thing any day—namely, wending their way from the wireless dealers with a parcel and a receipt to the nearest P.O., then purchasing a broadcasting licence, and so home—were analysed, the great majority would show very much the same semi-confused, mildly excited condition.

The small minority who have a definite knowledge of what is to be done, how to do it, and the opportunities to achieve their purpose, we are not concerned with; they require no assistance.

The remainder, from force of circumstances, must gain their knowledge as they go. These few lines are written in the hope that they may be of assistance in

minimising the labour and increasing the efficiency of the installation.

It's all very well to tell a man that a broadcast-set requires no technical knowledge to operate, all that is necessary is to connect it up to a "P.M.G." aerial, that is, an aerial containing 100 feet of "combined height and length"; another connection to earth; and all that remains is to operate the set.

Supposing he lives in the country, in a detached house with plenty of space around it, the matter is easy. But supposing he lives in a second-floor flat, the roof is three or more storeys off, and there is nothing at the back but a well to the courtyard and the thoroughfare at the front; the case looks hopeless.

Again, supposing he lives in the

"sub-bubs," and the maximum span to be got in the back garden or yard is 25 feet; how is he going to erect an efficient aerial?

We can tell him at once that no case is hopeless. Signals have been received in the workings of coal-mines. All these difficulties are to be surmounted by some means; but if they be as bad as those instanced, it is hoped that prior to visiting the dealer's to purchase the apparatus the new recruit will have consulted an experienced experimenter or other knowledgeable authority so that apparatus suitable to his special circumstances is obtained. Otherwise his parcel of standard gear is apt to be so much impedimenta, and the power of the set hopelessly inadequate to cope with the unfavourable conditions under which it is required to operate.

ECONOMIC ELECTRIC LTD.

Bevelled Dial and Knob, 3/- extra

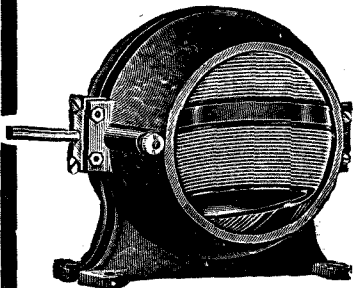

"One of the handsomest pieces of radio apparatus we have had the pleasure of handling, and which in actual operating efficiency in no way belies its appearance." — *Modern Wireless*, Dec., 1923.

"E.E.C." VARIOMETER.
Range 250-420 metres, with windings in parallel and 290-1250 metres with windings in series. Price 27/6.

BROADCASTING 13 miles distant audible 10 feet from a loud speaker using this variometer and a crystal detector only.

THE FAMOUS "FERROCLAD" L.F. TRANSFORMER.
(PATENTS PENDING.)

Unequaled appearance with remarkable amplifying properties. Constructed on a new principle, ensuring an absolute absence of distortion. Mounted in soft iron screening case, japanned dull black, with nickelled fittings. Price 20/-

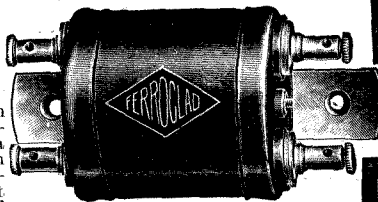

40-Page Radio Catalogue. Post Free, 4d.

Head Office: 10, FITZROY SQUARE, LONDON, W.1. Showrooms: 303, EUSTON RD., N.W.1. Branch and Works: TWICKENHAM.

Perfect Reproduction WITH THE NEW "Fuller" Tone Selector

After long months of patient research this marvellous tone control has been perfected, with the result that music can now be reproduced so faithfully as to be indistinguishable from the actual performance. The secret behind the success of this wonderful device is its ability to filter the sound, eliminating all those parasitic noises which result in the reproduction being harsh and distorted, allowing only the pure natural tones of the music to reach the Loud Speaker or Telephone. Another distinctive feature worthy of special mention is the 6-position switch enabling the quality of sound to be controlled to a degree hitherto impossible. It is supplied in a polished wood case with terminals marked "input" and "phones" and is for use with either low resistance Loud Speaker or Headphones.

Overall size 4 1/2 by 3 in. by 3 1/2 in. high. Code SELKE. Price £1 5s.

FULLER'S UNITED ELECTRIC WORKS, LTD.,
Woodland Works, Chadwell Heath, Essex.

Telephone: Ilford 1200 (6 lines).

Telegrams: "Fuller" Chadwell Heath.

We shall be pleased if you will come to our London Depot, 58, High St., W.C.2, and inspect our complete range of components, appealing particularly to experimenters. Anyway make certain of having our Catalogue No. 315 by sending a post card now.

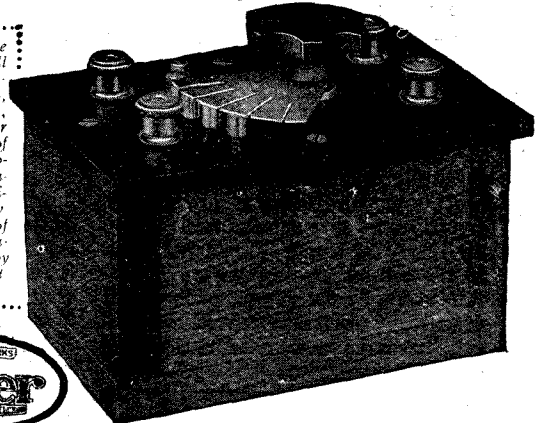

Broadly, then, we can formulate the rule "that adverse conditions result in loss of efficiency, which may be compensated by increase in power."

But we require some standards against which to compare individual circumstances, and for this purpose we can take it that the following constitute the chief requirements.

A single aerial should contain up to 100 feet of wire in all, measured from its free end along the horizontal length and vertical height of the down lead to where it is connected to the receiver.

The best all-round aerial of this type would be one erected in a clear, open space between two poles approximately 75 feet apart, and 35 feet high, giving an aerial of 70 feet horizontal span and a 30 feet down lead.

With this ideal arrangement as a guide we must reconcile it with our actual conditions.

If the length is beyond possibility it may be possible to increase the height, at all events at one end, possibly by a mast on the roof.

A careful study of aerials in and around London will exemplify the hundred-and-one dodges which have been resorted to in order to obtain the maximum possible under difficult conditions.

Some consist of pieces of packing case nailed upon clothes-line posts and chimney stacks to give a few more feet of height, others costly, some ingenious, and many of both sorts might be described as "Heath Robinsonian."

What a lot of disappointment there must be in many of those stations!

The owner has obviously done his best at great trouble, and yet omitted to carry the necessary precautions throughout.

One frequently sees the lead-in wire brought down from aloft by means of stays spacing it from the wall; many such aerials are insulated from the halyard by two or more insulators, yet the down-lead is simply carried on a piece of ebonite or a small insulator on the end of the stay.

Surely operation is affected on wet days, and after a few weeks' exposure to city smoke and grime, by the breaking down of the insulation at these points?

If a single aerial cannot be used so as to get tolerably near the standard, perhaps a double aerial will serve.

This is, of course, heavier than the single, with its duplication of insulation, spreaders and addi-

tional wire, so that the masts and running-gear must all be stouter and the expense increased accordingly.

The aerial wire itself should be properly insulated, that is, not allowed to touch any part of the running-gear, masts, buildings, trees, etc.

The insulators are made of non-conducting material such as glass, porcelain or ebonite, but unfortunately they lose their insulating properties when their surface is coated with a conducting medium such as moisture or soot, and it is to combat these contingencies that the insulators are made in peculiar shapes, and two or more used in series, thereby increasing the possible leakage path.

If feasible the aerial should point in the direction of the station from which the loudest signals are required, or which is most distant according to whether the aim is to get the loudest possible signals from the local broadcasting station or a distant one. The down-lead should be on the side nearest the station. Having considered all these factors and decided on the form and means to be employed, the aerial is erected.

All connections must be carefully made and the whole should be as secure as possible; besides the annoyance, the danger to life and limb consequent on a mishap to the aerial gear must be considered.

The next consideration is the installation of the "earth." The lead to this should be of insulated stranded cable.

Again a standard may be taken and used as a guide to the peculiar circumstances of any one case.

A good earth wire would be an insulated cable of about seven strands of 22-gauge wire run in porcelain cleats to a water tap or pipe about six or eight feet away from the set, the water-pipe running direct to the outdoor main. The connection to the tap or pipe would be made by a soldered joint.

To the uninitiated soldered joints are not as simple to make as it may sound, and to solder to a water system in this way a blow-lamp must be used; otherwise, owing to the thermostatic action of the water in the pipe, it cannot be heated sufficiently by the soldering iron to make the solder "take."

This is a little job that justifies calling in the local plumber, or a friend with the necessary gear; at most it will only cost a few shillings, and once made in a

workmanlike manner you can forget about it for ever. This is not true of the general alternative methods of obtaining an "earth."

An alternative is to bury a metal earth mat or plate in a damp hole in the garden. This may be surrounded by charcoal to guarantee the presence of moisture under all conditions. As a temporary measure the earth wire may be kept in close contact with the pipe or tap by means of a metal clip, somewhat similar to the clip used for attaching a bicycle pump to the frame.

In any case, the wire must be bared and it and the pipe made clean and bright by rubbing with emery cloth.

If it appears to some that the foregoing is somewhat laboured and pedantic, it is because so much depends upon an efficient aerial system; the "earth" is actually part of the aerial system. The best receiver made will not function on a dud aerial.

The electrical energy is originally so small, compared with other common applications of the force, that a leakage which would be of little account in lighting, or even telephonic circuits, is sufficient to cause complete loss in a wireless receiver.

This explains the reason why Jones, who is a thoughtful and painstaking amateur mechanic, gets better results under distinctly unfavourable conditions and with a less powerful set than Smith, who is best described as a "slapdash" mechanic, very possibly in spite of a good training. "Good enough," is Smith's motto. Jones demands the "best possible."

The erection of the aerial and installation of the earth will have taken considerably longer than may be supposed, and by this time the mild excitement sensed upon coming into possession of the "set" has increased to almost fever pitch; the moment arrives to "couple up" and "tune in."

According to the means and aspirations of the owner this will present a problem varying from the simple to the apparently difficult.

But if we first of all assume that it is a simple crystal set mainly intended for the reception of the local broadcasting station, the problem rapidly disappears.

The aerial and earth wires are connected to their respective terminals, also the telephones—which it is presumed have been supplied with the "set" and are of 4,000 ohms and upwards—these are

EVER-READY BRITISH MADE DRY BATTERIES & ACCUMULATORS

FOR EACH AND EVERY WIRELESS PURPOSE

INSIST ON
"EVER-READY"
WIRELESS
BATTERIES AND
OBTAIN SATISFAC-
TION AND 100 PER
CENT. EFFICIENCY

OVER 20 years' experience and research, the finest materials, expert supervision, and careful testing at all stages of manufacture are the reasons for the superiority of "Ever-Ready" Wireless Batteries.

The "Ever-Ready" series embrace all types of Batteries for every Wireless purpose.

Special types of large capacity Dry Batteries are provided for the filament heating of each of the newest types of low-temperature valves.

Write for particulars of these and the standard sizes and voltages of high-tension Battery units.



Service D.X. Department,
**The EVER-READY
Coy. (Great Britain) Ltd.**
Hercules Pl., Holloway,
LONDON, N.7.

Your Aerial!

TAKE a little trouble with your Aerial and you will be amply repaid by the vastly superior results you will get.

Besides, a poorly erected Aerial is often a menace—it might collapse and cause serious damage. Better put up a good one while you are on the job.

Get a copy of this Book and read how easily a good one may be erected.

**Radio Press, Ltd.,
Devereux Ct., Strand, W.C.2.**

From all
Booksellers
and News-
agents, or
1/1½ Post
Free.

Radio Press
Wireless
Library
No. 4.



How to erect your Wireless Aerial

By B. Mittell, A.M.I.E.E.

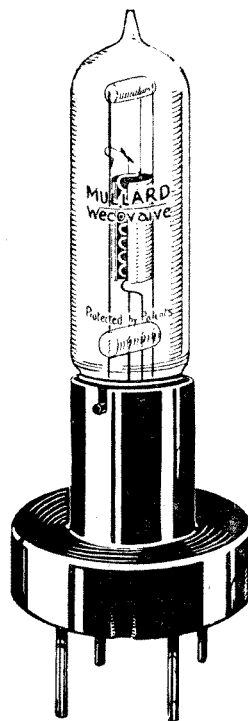

Mullard Wecovalves.

The Mullard Wecovalve, fitted with a standard 4-pin base, is the last word in Wireless Valves. It takes but a single dry cell to operate the filament, and a cell of normal size will last for months.

The cost of the valve is 30/- and its life is therefore of great importance compared with that of inexpensive dry cells.

In normal use, the Mullard Wecovalve filament will last for 4,000 hours, whilst mechanically it is unbreakable.

It is short and robust in construction and has in no way been attenuated in order to reduce current consumption.

The life of the valve is no longer than that of its filament.

*Turn these points over and then order
Mullard Wecovalves for your set.*

MULLARD

Advt. 1 The Mullard Radio Valve Co. Ltd., Balham, S.W.12
(E.P.S. 85)

now adjusted to the head of the operator.

Now for the "tuning-in."

The set will probably be provided with an inductance which is tuned by a sliding contact or by means of a series of tappings led out to studs over which a switch-arm is rotated, thereby varying the number of turns in the circuit; or it will be provided with a variable condenser; very possibly it will have both.

The crystal, in its cup, will be opposed by a thin spiral spring, known as the "cat's-whisker" straightened out at the end, or by another crystal.

The spring point or the movable crystal should be adjusted so as to be in light contact with the face of the fixed crystal.

The variable condenser is kept at zero, and careful listening should be exercised at each stud position of the switch-arm, or every few turns of the inductance covered by the sliding contact.

At each of these positions the condenser, if there is one, can be rotated slowly and haltingly through its range, returning to zero each time preparatory to the next change of contact or stud position.

Should the whole possible range be covered in this manner without result, a new contact on the crystal face should be tried and the operation repeated until signals are heard.

This is necessary because, unfortunately, crystals are not sensitive at all points, nor are they standard in performance and are easily rendered insensitive by the presence of dust, grease, etc., on the face or the point of the "cat's-whisker."

The operator should have paper and pencil handy, and whenever signals are heard should note down the following points, as they apply to the set being calibrated. Name of station, wave-length, tuner stud number, degrees on the condenser scale, remarks, and any other information required. By this means he will have the data at hand to facilitate tuning on future occasions.

It will be found that if the set is provided with more than one means of carrying out the tuning there will be several ratios of inductance and condenser values at which the same station may be heard. The best should be noted; generally, this will be the setting of maximum inductance value and

minimum condenser scale value.

Supposing it is a valve set which is to be calibrated; the same procedure holds good, but the actual connecting up is a little more involved.

The valves function because of the hot filament and the energised anode or plate, so that it is necessary to connect up those sources of energy in addition to the aerial, earth and telephones.

It is assumed that the low-tension accumulator and the high-tension dry battery were obtained with the set, or are otherwise suitable to the set, and that the accumulators are properly charged.

The appropriate terminals will usually be marked; + terminals on the set being connected to the + on the batteries, the same for the -. The wander-plug of the H.T. battery is usually the -. The connections having been made, the switch should be in the "off" position, or the wander-plug of the H.T. battery be disconnected, while the valve is fitted to its socket.

The filament resistance knob, which will normally be the "off" switch for the L.T. current, can be gradually rotated until the valve filament is white hot—not

THE CURTIS REFLEX

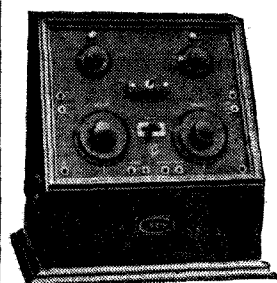

The Faultless Reproduction with the Curtis-Reflex is a REVELATION in Wireless Reception. It is as distinctive in appearance

as it is exclusive in operation. No terminals, enclosed valves.

Range All British Broadcasting Stations
Power. Equal to 4-valve Receiver, and will efficiently operate Loud Speaker at 40 miles or with any indoor aerial at 20 miles from station.

PRICE - - - £12 0 0
Royalties and Licence fee £2 2 6 extra.

CRYSTOR COWL INSULATORS



Guaranteed Maximum Efficiency.

Aerial Insulators 2/6 per pr.
Leads-in, 5/- each.

THE ONLY WAY.

THE RADIO-STRUCTA

Models of Essential Components

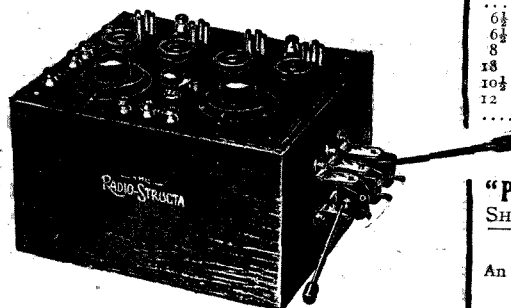

The Radio-Structa Hook-up shown in mahogany tray with removable bottom to facilitate connections. May be wired to any circuit in a few minutes.

PRICES.

THE RADIO-STRUCTA HOOK-UP.	
For 2 valves	- £4 0 0
" 3 "	- £6 2 6
" 4 "	- £8 0 0

3,000 SATISFIED USERS GUARANTEE

RADIONETTE

CRYSTAL RECEIVER	...	21/6
CRYSTAL and 1 VLF	...	70/-
CRYSTAL and 2 VLF	...	100/-

STOCKED by all reputable Dealers.

'PARAGON' Guaranteed Radio-Quality.

'The Best Made.' EBONITE PANELS.

STANDARD SIZES		Polished Mahogany Trays.
6 1/2 x 3 1/2 x 3/16	1/9 each	
6 1/2 x 3 1/2 x 1/4	2/3 "	5/-
8 x 6 x 3/16	2/6 "	5/-
18 x 6 x 1/4	3/3 "	8/6
10 1/2 x 8 1/2 x 1/4	5/6 "	10/6
12 10 x 1/4	7/-	

Other Sizes to Order.
Fine gran matt finish, ground edges. Each panel in sealed carton stamped.

"PARAGON RADIO-QUALITY EBONITE."
SHEETS, RODS, TUBES, MOULDINGS.

"PARAFLEX."
An Ebonite composition, high-resistance and indestructible.

INSULATING SLEEVING.
4d. per yard.

"PARALITE"
Valve Holders ... 1/- each.
Condenser Dials, 3 in. ... 1/9 "

Guaranteed free from surface leakage. Highly polished, does not dull from exposure.

CURTIS FILAMENT RHEOSTATS.
Guaranteed wound with Eureka Wire 1/6 each on Ebonite Former. 5 ohms.

THE SIMPLEX RADIO CHART.
reduces the wiring of the most complicated circuit to a mere mechanical operation. High frequency, tuned anode coupling with intervalve re-action for 2, 3 or 4 valves.

Price 1/- each.

Stocked by leading Wholesale Merchants, including Messrs. Brown Bros. Ltd., Great Eastern Street, E.C.2, and The Sun Electrical Company, 118, Charing Cross Road, W.C.2, Rose Bros. Electrical Co., Ltd., 25-27, Milton Street, E.C.2, and their respective branches.

PETER CURTIS, Ltd., 34, Whitfield St., London, W.1 Telephone: Museum 8489. (Off Tottenham Court Rd.)

"lit up" in the same sense as one considers an electric light lamp fully heated; some valves work better when only red or dull red.

The H.T. voltage most suited to the valve to be used should be previously ascertained and this value obtained by means of the wander-plug.

It will be noted that the legs of the valve, although in the same circle, are not evenly spaced, this should obviate plugging the valve legs into the wrong sockets. Should this be done by persuading the legs to go where they should not, and the H.T. current allowed to flow across the filament, it will be at the expense of a new valve; the valve filament will probably act as a fuse to the other parts of the set, but the loss of a valve, if it is a good one, is more than its monetary value, whereas, the "burn-out" is not even spectacular and offers no compensating excitement.

The filament being first heated proves that the valve is correctly inserted, and the H.T. current can be safely switched or plugged in.

The tuning operations are the same as for the crystal set, the calibration chart can helpfully contain an additional column to note the degree of heat of the valve filament for the best signal, this adjustment taking place when the other operations are completed.

Should the tuning be carried out by means of a variometer, the same rule holds good as for the tapping studs of a plain inductance coil; the variometer to be slowly and regularly moved through its range whilst listening for signals and operating the variable condenser.

In a multi-valve set reaction, capable of variation, may be employed. The best values of reaction for given settings of the tuner must be obtained by trial and noted, at least until operation of the set becomes easy.

With some sets calibration tables will be provided and these will considerably facilitate operation at first. In any case such a calibration table will serve as a guide and may be amended when the differences in values peculiar to the aerial system in use can be ascertained.

It must be remembered that all sets have their limitations, and unless the installation is carried out with thoroughness and due regard to the points raised, disappointment will ensue and the set be blamed for deficiencies it is not responsible for.

WHAT IS THE RANGE OF YOUR SET?

IN the comparatively limited wireless circles of pre-war days it was customary to assume that a given installation had, at night, approximately twice its daytime range, but it was known that freak results occurred sometimes, particularly round about dawn and dusk. The immense extension of wireless activity, which occurred during the war and after, has resulted in an accumulation of knowledge and experience which might be expected to bring the question of ranges down to something cut and dried, but actually and honestly we have to acknowledge now that the whole subject is governed by partially understood and entirely uncontrolled phenomena and that any statement of range must consist mainly of qualifications. There are wireless enthusiasts who claim so much for their sets that one is forcibly reminded of the proverbial big fish stories, and the Trade also is by no means blameless, for a glance through the advertisements will usually bring to light some such statement as the following:—

"The _____ two valve set receives all British Broadcasting Stations, The Hague, Paris, etc."

The experienced user will agree that this should read somewhat as follows:—

"The _____ two valve set will receive really satisfactorily under all conditions any British Broadcasting Station at a distance of about 25 miles provided an outside aerial is used, and there is no excessive local interference. Generally it can be relied upon to give good results at distances up to 100 miles or so. Occasionally really good results may be obtained from one or other of the more remote B.B.C. stations or from the low power French stations and still more occasionally from The Hague. It is possible even that American broadcasting may be heard, but this should not be counted on. In any case much depends upon atmospheric conditions and jamming, upon where you live, upon what sort of aerial and earth system you are using, upon your skill as an operator, upon your conscience *re* the use of reaction, and upon your individual opinion as to what constitutes good reception."

Range is, in fact, an extra-

ordinarily variable quantity, and although the stress of commercial competition will no doubt continue to bring forth unqualified and unreasonable claims there is an increasing tendency to look at the subject in the cold and truthful light of science, and to discredit extravagant statements of performance which can only do harm in the long run.

If any generalisation is permissible it is perhaps that, in these latitudes, daytime reception is more reliable than reception at night. When conditions are favourable, however, much greater ranges may be obtained after dark, but, on the other hand, atmospherics are, as a rule, more troublesome and marked fading effects may be experienced during twilight and at night. Given a means of eliminating (1) Atmospherics, (2) Fading and allied effects, and (3) Jamming, it should be possible to guarantee long-distance ranges wherever geographical conditions are known to be favourable, but these troubles are still practically beyond our control, and even the most expensive, elaborate and up-to-date commercial receiving stations are by no means immune in spite of precautions quite out of the question in the case of the private individual.

The use of a frame aerial is helpful for it has directional properties, and is somewhat less affected by atmospherics and jamming than is the open aerial, but it is only by increasing the relative value of signal strength that a real solution is to be found. This can be done by (1) increasing the power of the transmitting station, or, more effectively, by (2) reducing the distance between transmitter and receiver. Increase of power does not eliminate fading at long distances neither does it do away with night effect distortion and fuzziness, so that for good reliable reception, on B.B.C. wave length at any rate, it would seem that any but comparatively short ranges are outside the bounds of practical politics. From this point of view, if from no other, it must be deemed fortunate that in this country we have a growing network of main and relay stations which, in time, will bring practically every part of the British Isles within reliable distance of a broadcasting centre.

H. McC.

(Continued from page 237.)
 employed successfully for reception down to 600 metres, and I have myself used it with very fair results or broadcast purposes. The great thing is to get the anode voltage and value of the resistance exactly right. The value of the gridleak, too, is inclined to be critical on short waves.

Whichever form of high-frequency amplification it is desired to use,

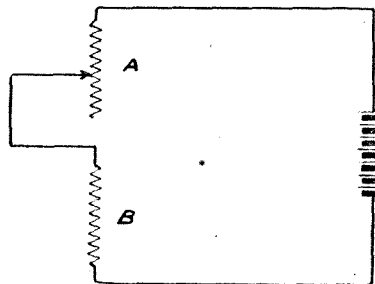

Fig. 12.—The principle of resistance coupling explained.

it must be remembered that success depends very largely upon the quality of the components and the way in which they are wired up. Those who intend to add one or more stages are strongly advised

to begin by making bench hook-ups and to get them working perfectly before they make any attempt to make up the set into cabinet form. If the circuit works perfectly on the bench and becomes unstable when placed in a cabinet, one may feel pretty sure that the fault is to be found either in the position of the inductances or transformers which is such as to allow interaction to take place, or in the wiring, which is probably not well enough arranged to reduce to a minimum the parasitic capacities whose effects may cause, as we have seen, a whole heap of troubles.

HOW TO MAKE YOUR OWN DETECTOR CRYSTALS

PERHAPS it has never occurred to the Amateur that he might make his own "Detector Crystals." If any boy takes the trouble to look

up "Galena" in an Encyclopædia he will find that "Galena" is Sulphide of Lead, and is composed of 86.6 per cent. of lead and 13.4 per cent. of sulphur. Therefore, proceed: Take a tin can of some sort and put in about 86 grams of lead and melt on the stove. When all melted, put in about 13 grams of sulphur and let the whole fuse together.

When the mass is cold, remove it from can and break off any unmelted lead, or portion not properly fused together. Break the rest into suitable sizes for mounting in the crystal cup of the detector, selecting the pieces which are found to have an even light-grey surface—usually on the edge where it has been broken—as the most sensitive.

Put a piece of the selected crystal in the detector cup and, using a fine copper wire as a "cat's-whisker," test it with the buzzer. If the piece selected be not sensitive, try another.

Editor's Note.—This little article, by a contributor, is published in the hope that it will stimulate experiments. We do not agree with our contributor's "theory," but the results probably justify the work.

Now on Sale.

A message to the man who has never built a Receiving Set.

FOR the man who has read Books and Articles on how to build Receiving Sets and who still feels that he does not possess the requisite amount of skill to build a really good one, we have a new idea.

We are shortly publishing a series of Portfolios, each one dealing with one Receiving Set in a very comprehensive manner. The Portfolio will contain a Booklet describing the Set, how it is made and operated and illustrated with actual photographs to show every stage of construction together with full size working drawings.

No effort has been spared to make these instructions clear and lucid and any man can commence building his Set with every confidence that he will achieve complete success.

Envelope No. 1.

Containing instruction Booklet, full-size working drawings, complete list of all components, etc., for building up a 2-Valve Reflex Receiver employing the well-known S.T. 100 Circuit. Designed by John Scott-Taggart, F.Inst.P.

2/6

Envelope No. 2.

Containing instruction Booklet full size working drawings, complete list of all components, for building up a family 4-Valve Receiver for use with headphones or loud-speaker and embodying a large number of entirely new features. Designed by Percy W. Harris (assistant editor *Modern Wireless*).

2/6

RADIO PRESS LTD.

Devereux Court - STRAND, W.C.2.

(Continued from page 264).

rebuilding, whilst units Nos. 1, 3 and 4 could be still employed unaltered in the meantime.

Similarly, the No. 3 detector unit could be replaced by a crystal in the event of a temporary accumulator failure, or a more selective tuner could replace unit No. 1.

Those of us who have to pay particular attention to the financial side of all these arrangements will derive particular benefit from the employment of this unit system, for if we are not in a position to immediately undertake the construction of an elaborate multi-valve set the work may be finished by instalments, *i.e.*, by units, and instead of having a partly finished five or six-valve set with all its complexities, we could have an efficient one-valve set completed with, say, a two-valve L.F. unit, in course of construction. In the meantime the set could be used as it stands—complete but not completed.

Another important point which is found in so many amateurs' apparatus is a multiplicity of switching arrangements for utilising different circuits or pieces of apparatus, and it does not appear to be generally recognised or

appreciated that this introduces a considerable source of inefficiency and loss of signal strength due to:

(a) Capacity effects from the switches, additional leads, and the manner in which different wires are brought into close proximity to each other.

(b) Increased resistance due to the switch contacts.

The experimenter's aim should be to reduce all switching arrangements to the very minimum necessary, always aiming firstly at efficiency, and secondly at convenience. An efficient two-valve set may give far better results than a three or four-valve set less carefully designed, and not only does every additional low-frequency valve increase the initial and running costs, but greater distortion and amplification of extraneous noises may result, and that "gramophone" sound be heard.

If the experimenter proposes departing from the more usually employed circuits or apparatus for any particular instrument, it is preferable and usually more convenient to conduct the initial experimental work with the apparatus unmounted and loosely coupled together on the work bench. This gives an opportunity of confirming the approximate

relative values of the component parts, and also it is frequently found that, say, a small blocking condenser inserted in a certain manner improves the effective operation of the circuit. Matters of this nature are more easily found before the apparatus is finally mounted and the connections soldered, and the different parts can then be easily disconnected and reconnected in any way as required.

However, even in temporary arrangements of this nature, particular care must be taken in making the connections, etc., for otherwise good circuits may be condemned as inefficient on account of some loose or badly made contact.

The practice sometimes employed of permanently utilising the whole apparatus in this loosely connected up and unmounted manner is not to be recommended, for, although it probably allows of greater facility in rearranging the circuits, the set has a very untidy appearance, connections are apt to become loose, wires entangled, and capacity effects introduced owing to the impossibility of keeping the leads sufficiently spaced.

I have frequently noticed that
(Continued on page 281).

WHOLESALE ONLY.

WIRELESS DEALERS. Our New 44-page Trade List of Radio parts now ready showing Trade and Retail prices. It is yours for the asking.

COMPLETE SETS, ACCESSORIES & COMPONENT PARTS

We were one of the very first Wholesale Factors of "Wireless," and our New Catalogue is the very latest thing in Wireless. Send Trade Card.

STAGGERING PRICES. HUGE STOCKS.
BUY FROM AN ESTABLISHED HOUSE.
IMPORTANT—Trade Only Supplied.

HOBDAY BROS., LTD., (Dept. B.), 21, 23, 25, & 27, EASTERN ST., LONDON E.C.2.

Phone:—CLERKENWELL 2300 (6 lines)

Some "Service" Offers.

HERE is a pleasant Centre—in which you can see all that is Good and New—get Special Bargains—Easy Payment Terms—Advice.

We specialise in LISSEN, IGRANIC, DUBILIER, POLAR, BURNEPT, G.E.C and other leading apparatus.

HERE ARE A FEW SPECIAL BARGAIN OFFERS from dozens of lines slightly soiled through Demonstration use:

Cosmos Crystal Cabinet, one pair of head phones and aerial equipment	£3 10 0
Tingley 2-Valve Panel	7 10 0
Fellows 2-Valve Cabinet, 1 Detector and 1 L.F. complete	5 0 0
F. Phones, adjustable	11 6
E. Phones, 4,000	10 0

Retailers should write for Wholesale List. **THE SERVICE COMPANY LIMITED.**

R.H. Wireless Dept., 292-3, High Holborn, London, W.C.1.

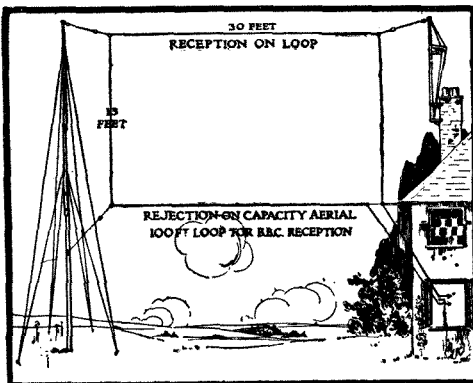

How to fix an efficient 100ft. Aerial in a 30ft. garden. 100ft. Aerial with Insulators, Slings, etc., 7/9
SIMPSON & BLYTHE, 8-9, Sherwood Street, Piccadilly, W.1. Phone—2650 Gerrard

'TURRET'

Columbian Pine Masts,
by Naval Experts.
REDUCED PRICES.

- 27 ft. Turret Two 37/6
- 28 ft. Turret Super 53/6
- 36 ft. in 3 sections 71/6
- 42 ft. Telescopic Top 79/6
- 56 ft. Telescopic Top, complete 86/4/9
- Turret Poles, 13 ft. 5/9
- 16 ft. 2 1/2 in. base 7/9
- 28 ft. with 2 pairs clamps 17/9
- 42 ft. with 4 pairs steel clamps 29/9

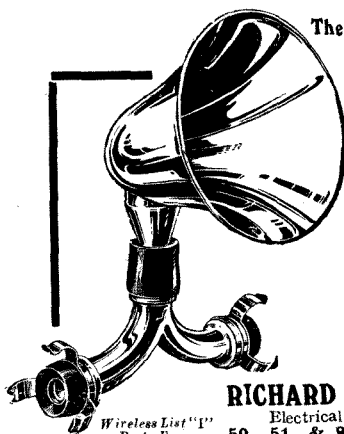

The "Gramaphix" Loud Speaker.

This is a most efficient device, to which the ordinary head-phones are clipped by a simple pressure on the spring clips. Mounted on the NEW IMPROVED RESONATOR, the voice is well and evenly distributed throughout the room, removing all necessity to "listen-in."

GRAMAPHIX, 10/6.
IMPROVED RESONATOR, 7/6.
Postage 9d. extra.

RICHARD MELHUISS LTD., Established 1828,
Electrical Engineers and Wireless Experts,
50, 51, & 84, Fetter Lane, LONDON, E.C.4

(Continued from page 271.)

cator upwards to an angle of 45°, bend the terminal tag downwards off the edge of the ebonite and secure with a terminal and finally fix with a fine brass pin in the position shown. Now place a spring of suitable tension over the 2 B.A. rod.

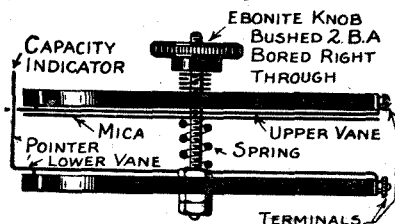

To construct the upper end, procure a similar piece of ebonite, 3 in. in diameter, and cut the vane from aluminium sheet, as shown. The ebonite and the vane are drilled in the centre to clear 2 B.A. and a brass bush may be inserted, if desired. Place the vane in position over the ebonite disc, bend the terminal tag upwards over the edge of the ebonite, and secure with a terminal. Finally fix by means of a small brass pin in the position shown, leaving the pointer which slips over the indicator in a horizontal position. Now procure a piece of mica 3 in. in diameter, and stick firmly to the aluminium plate by means of seccotine, or any

suitable substance. Place the top plate over the 2 B.A. rod, seeing that the slot in the pointer passes over the indicator at the same time. Now place over the 2 B.A. rod a washer, spring washer, a further washer, and a nut. Procure an ebonite knob, having a bush tapped 2 B.A. and from the other side of the knob drill a clearance hole right down to the tapping, to enable the knob to screw right down the 2 B.A. rod. To operate the condenser the vanes are brought together by screwing the knob downwards. By screwing the knob upwards, the vanes are forced apart by means of the spring between them. H. B.

BOOK REVIEWS

Interesting New Publications.

More Practical Valve Circuits. By JOHN SCOTT-TAGGART, F.Inst.P. (Radio Press, Ltd., 3s. 6d.)

A new book from the pen of the Editor of MODERN WIRELESS and of *Wireless Weekly* is always an event of great interest to novice and serious experimenter alike, and the volume under notice is no exception to the rule. On the contrary, it is likely to awaken widespread interest, since the author is probably best known as an originator of novel and valuable circuits, and his latest book contains all his more recent arrangements, and includes several new ones which have not previously been published.

The collection of circuits covers a very wide field, including so many of different types, from the simplest to the most complex, that every taste is catered for. A specially valuable section of the book is that which deals with dual amplification circuits, much useful practical information being given, and all the latest developments shown.

A particularly useful feature of the collection of circuits is the provision of full working values for each one, invaluable tables of plug-in coil data. Decidedly, no serious experimenter can afford to be without this book.

Home Built Wireless Components. (Radio Press, Ltd., 2s. 6d.)

To the real enthusiast one of

the greatest joys of wireless as a hobby lies in the ease with which one can make those little components and gadgets which give individuality and distinction to a home-made set. These pleasures are missed by the man whose receiver is assembled entirely from bought components, and it is certain that he misses more than the mere feeling of pride in a set which is *all* home-made; the possibilities of invention and progress in the design and construction of component parts are enormous.

The back numbers of MODERN WIRELESS and *Wireless Weekly* contain a vast quantity of information on the making of components of all sorts, and some of the best of it has been selected, re-edited, and arranged in this book in the form of practical designs with full instructions for the making of every imaginable component. A most valuable workshop encyclopædia.

Five Hundred Wireless Questions Answered. By E. REDPATH and G. P. KENDALL, B.Sc. (Radio Press, Ltd., 2s. 6d.)

Quite early in the career of every wireless enthusiast there is reached a stage at which he feels that he has a general understanding of his subject, but yet that there are hosts of things that he does not know, but which it is too great a labour to unearth from some advanced text-book.

This book seems admirably fitted to be his guide and helper at this period, and indeed all through his subsequent progress. It is most clearly arranged and indexed, so that the extraction of any desired piece of information is the work of a moment, and it provides a wealth of practical advice and assistance upon all the difficulties and problems which may arise during the use and construction of wireless apparatus or the study of wireless theory. A book which should prove invaluable to all who take even the slightest interest in wireless.

Twelve Tested Wireless Sets. By PERCY W. HARRIS. (Radio Press, Ltd., 2s. 6d.)

Of special interest to the home constructor of sets is this latest book from the pen of one of the most popular writers of constructional articles. The book contains a selection of the author's most successful sets, each one tested and subjected to vigorous practical trials, the fullest description being given of each one, and the practical details so fully and clearly explained that the veriest novice can make up the set without fear of failure.

WATCH FOR NEW
RADIO PRESS
BOOKS!

(Continued from page 279.)

whilst most experimenters at times make different arrangements in more or less the whole of their apparatus, yet their main experimental work is usually limited to one or two particular spheres, so that there is no necessity for keeping the whole of the apparatus in a temporary state.

For instance, there is no reason why an experimenter whose sole investigations are to be concerned with the selection or operation of H.F. valve circuits should not have a standard completed tuner, detector, and low-frequency unit. Similarly, one whose investigations are concerned with directional work, or the design of rejector circuits for the elimination of jamping and atmospherics, requires an adjustable tuner, but the detector and amplifiers can be standardised and completed.

Where portability is desired for demonstration purposes, or for picnicking, it is, of course, essential that the apparatus should be compact and light in weight, and the set should therefore be mounted in one case, if possible, or if too large it can be divided into one or two units according to the means of conveyance and the distance it is to be taken.

To prevent breakage of valve filaments by vibration and bumps, the valves should be removed from their sockets and transported in a specially constructed box, internally padded, so that they cannot jump about when being carried. The H.T. battery may be contained in the main instrument case, but the accumulators should not be so placed because of the possibility of spilling acid, which would quickly ruin the apparatus by attacking the metal work and destroying the insulation. On account of this, and also the great weight of accumulators, the recently introduced dull-emitter valves may be more conveniently used in spite of their expense in cases where portability is necessary, for the heavy accumulator may then be substituted by a dry battery.

However, for the general experimenter portability will not usually be one of the requirements, as a set of this description must naturally be compact and completely constructed, and many of the additional refinements which would have been insisted upon for an experimenter's outfit must be omitted in order to reduce the weight and size of the finished apparatus.

The method of tuning to be employed depends to a large extent

upon the wavelength range over which signals are required. If, for example, a short-wave broadcast set is required, working up to, say, 600-700 metres, the variometer will probably be the simplest and most efficient method of tuning, as no expensive variable condensers are required.

Cylindrical coils provided with tappings and variable condensers provide an easy way of quickly searching over a large band of wavelengths, and if provided with suitable dead-end switches they are quite efficient and easily constructed without the use of any special tools. The most laborious part of the task lies in the winding of the coils if they are of a large size, but this can be successfully accomplished if attempted in the right manner as elsewhere described.

However, above 5,000-10,000, metres cylindrical coils are rather clumsy, especially if a two-circuit coil is employed. If the higher wavelength range is required, suitable plug-in interchangeable coils (of which several good patterns are on the market) may be employed. They are compact and eliminate all dead-end effects, as a separate coil is used for each range.

These latter interchangeable coils may be employed for short and medium waves, too, and for most purposes they are preferable owing to their compactness and the entire absence of all dead-end effects. Further, they provide the beginner with a very convenient guide as to the approximate wavelength on which signals are being received, for each coil has a definite wavelength range which must include that of the transmitting station, and by observing the variable condenser setting the approximate wavelength may be estimated.

The tuning adjustments for any required station may similarly be found by reversing the procedure, *i.e.*, a coil, including the required wavelength, is selected and the condenser set approximately in its correct position by ascertaining whether the required wavelength is near the top or bottom of its range. The condenser may then be moved slowly first one side of this setting and then the other until the required signals are heard, after which the most critical position may be quickly found.

On the other hand, unless a wave metre is available or the station has been previously heard and the tuning adjustments noted for future reference, it is a somewhat lengthy process to tune in the signals on a large coil.

When it is desirable that all variable condensers should be omitted to reduce the expense, variometer tuning should be employed because of its advantages already referred to. The alternative method of using a slider on a coil instead of tappings is not desirable, for in addition to the question of bad contact at the bared portion, a particularly irritating noise, not heard with a crystal, may be obtained in the telephones when employing valves.

As to the method of H.F. coupling to be employed, this again depends to a large extent upon the wavelength range required. If for short waves or broadcast only, a tuned anode coil or transformer may be employed. If, however, the range is to be extensive, the transformer or anode coil must be tapped, tuned, or interchangeable.

Tapped transformers have the inefficient dead-end losses as with tuning coils.

For efficiency both the plug-in interchangeable transformers and anode coils are excellent, as dead-end losses are prevented, and efficiency over a short wave range may be obtained by each coil.

If it is desired to employ reaction coupled to the H.F. circuit to obtain the non-radiating circuit, the tuned anode method is very suitable as it offers an easy method of coupling. Either interchangeable tuning coils plugged into a two-coil holder or a tapped coil with the reaction coil sliding or revolving inside may be used, the tapped coil having slight dead-end inefficiency. In either case a small variable condenser is required for exact tuning.

Resistance capacity coupling is cheap and possesses the additional advantage of not requiring tuning, but it is of little use for amplification below 1,000 metres.

Tapped or interchangeable coils may therefore be used up to, say, 1,100 or 1,200 metres, above which resistance capacity coupling can be substituted.

Thus by setting out on the one hand the capabilities which we desire our completed installation to possess, such as wavelength and reception range, strength of signals, possibility of extension and alteration; and on the other hand, the limiting, or controlling features, such as expense, size and weight, and remembering efficiency, it is possible to obtain a most satisfactory type of apparatus for use under the conditions of each particular case.

(To be continued)

RESTORING LOST EMISSION

A Hint for Using Damaged Valves

ONE sometimes finds that valves with thoriated filaments show a falling off of emission after they have been in use for some time, or the drop may happen even though little work has been done if the filament is much overheated. This is caused by the fact that the layer of thoria on the surface of the tungsten is driven off. The valve therefore becomes temporarily a "bright emitter," and will not work with less than 4 or 5 volts unless some means can be found of bringing a further supply of thoria to the surface. This can be done, if one is careful, by "flashing the valve." Connect one of the filament prongs to the positive terminal of a high-tension battery giving about 50 volts. Attach a wire to the other, and with it just flick the negative terminal, making contact for the briefest possible instant. The valve should now be tried again to see whether an improvement has been made. If not, the process should be repeated until an increase is observed. There is, of course,

always the risk of burning out the valve by making a contact accidentally for a fraction of a second too long. However, as a valve whose emission has fallen off is not of very much use to anyone, we may regard this as a desperate case which justifies a desperate remedy.

Before you undertake flashing make quite sure that the emission has fallen off. I was using a D.E.V. the other day in whose plate circuit the milliammeter showed no readable current. Investigation, however, proved that the filament in this case was not at fault. The little metal caps of these valves are liable to become in time rather dull, as are the clips into which they fit. When this happens in the case of the plate con-

tacts the emission may fall off to almost nothing. This is actually what had occurred with the valve mentioned. A rub with a piece of fine emery cloth put matters right at once. Four-pin valves may suffer in the same way, and their prongs should be brightened every now and then, especially if they are left in the ordinary way for long periods without being removed from their sockets.

R. W. H.

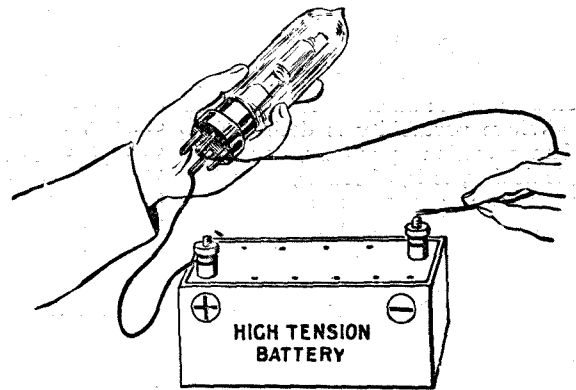

By Request!

POLAR

UNIVERSAL COIL HOLDER

Polar has once again in a practical way answered a universal demand by producing the "Universal Coil Holder." The call was for a coil holder which would enable experimenters to obtain wider limits of variation when coupling two circuits. See how the Polar Universal Coil Holder does this:—It consists of two parts. One is fixed and the other is displaceable either in the same plane, or at right angles to it, or COMPLETELY REVERSED. No other coil holder on the market offers these obvious advantages nor the Polar Guarantee of sound workmanship and satisfaction in every way. Purchase from your nearest "Polar Stockist" at these prices: Mounted 13/- For Panel Mounting 10/6.

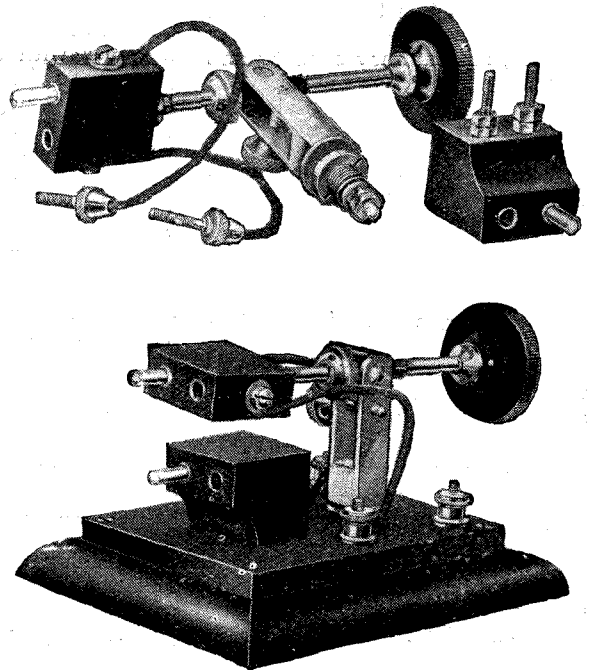

RADIO COMMUNICATION Co. Ltd.

34/35, Norfolk St., London, W.C.2.

Telephone:
Central 8, 85.

Telegrams:
"Radio-comco, Estrand, London."

PROVISIONALLY PROTECTED UNDER PATENTS
AND DESIGNS ACT.

AN IMPROVED AERIAL INSULATOR

WHEN one considers how little remains in modern multi-valve sets to remind us of the early days of wireless, it is hard to realise that aerial insulators have remained practically unchanged since the days of coherer and spark coil.

Reel, shell and egg insulators are all more or less efficient in dry weather, but may be troublesome in

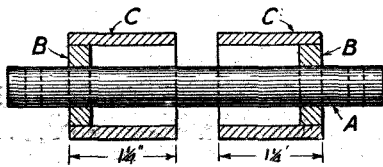

Fig. 1.—The complete insulator.

rain. In fact, with reels and eggs the surface leakage path is so short that the moisture deposited

during a heavy dew is quite sufficient to affect the high-frequency insulation resistance.

The essentials of a really good aerial insulator are: (1) A long surface leakage path; (2) that as much as possible of the surface shall be kept dry in all weathers; (3) that the insulator shall be fairly long in order to minimise capacity losses, and (4) mechanical strength.

An insulator fulfilling these conditions may be built up quite easily from ebonite rod, tube, and sheet. An examination of Fig. 1 will enable the general design to be understood. For the centre rod "A" a piece of round ebonite rod 1/4 in. long by 1/2 in. dia. is required. Two end pieces "B" are cut from 1/4-in. or 3/8-in. sheet ebonite. The outside covers "C" are each cut from 1-in. inside dia. ebonite tube. The covers and end pieces are drilled radially with 6 B.A. clearance holes, whilst the centre rod is drilled and tapped 6 B.A. A 3/16-in. hole is also drilled in each end of the centre rod.

The insulator may then be assembled and screwed up tight.

The surface leakage path of this type of insulator is approximately 7 1/2 in. in length as opposed to the

1 1/2 in. of a standard 2-in. reel, in addition to which about 3 in. of its surface is dry under all conditions.
R. A. F.

A CORRECTION

In the article by Mr. Percy W. Harris on the construction of a cabinet two-valve magnifier, which appeared in the December issue, reference was made to Elwell "S.M." plugs and jacks. These should be "S.F." jacks.

"RADIO VALVES AND HOW TO USE THEM"

It is to be regretted that an unfortunate delay has occurred in the production of "Radio Valves and How to Use Them," by John Scott-Taggart, F.Inst.P. This book will now be published on January 7.

Like an Expert at your elbow

the Bowyer Lowe Audibility Meter points out where your instrument fails, and enables you to test with precision its exact power.

Where previously you relied upon judgment, now you have clear dial readings telling you precisely your signal strength, and through that, just where losses take place in your instrument.

You may test tuning arrangements, detectors, transformers, valves, telephones, condensers and all the parts of your receiving set with this new Meter.

THE BOWYER LOWE

Audibility Meter

Price £2. Specially selected 4000 OHM Telephones 25/-

opens for you new interests, new possibilities. Write to-night for full particulars to "Tests Dept."

The BOWYER LOWE Co. LTD.,

Radio Works, Letchworth.

Wholesale Distributors—Scotland: Messrs. Robb Bros., Ltd., 69, West Nile Street, and North Street, Dundee. North of England: Messrs. Wadsworth Sellers and Co., Standard Buildings, Leeds. Midlands: Messrs. Robb Bros., Ltd., 9, Barnstone Road, Nottingham.



MODEL ENGINEER EXHIBITION. JAN. 4-11. STAND 28.

ROWLEY & LOUIS, 12, The Broadway, Muswell Hill, N10.

Telephone: Hornsey 668.

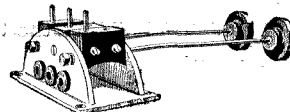

COIL HOLDERS

Aluminium and Ebonite. Anti-capacity handles. Highly finished and of excellent value.

3-way... 6/6. 2-way... 5/6

- Headphones:
 - Genuine Brunets, 4,000 ohms... 16/6
 - N. & K., best finish, very loud... 13/9
 - French D.L., 4,000 ohms... 11/6
- Aerial Wire, 7/22 copper, 100 ft. 2/2
- Lead-in Wire per yd. 2d. and 3d.
- Silk-covered J Twin Flex... per yd. 0/3
- Switch Arms, complete, best only 0/9
- Filament Resistances, best only 2/-
- Fixed Condensers... 1/-
- Best Condenser Leids... 1/3 and 2/-
- Basket Coils, 250-5,000 metres, set of 7 3/-
- Ebonite Valve Holders, best quality... 0/9
- Valve Sockets... per doz. 0/9
- Valve Pins... per doz. 0/6
- High class Guaranteed L.F. Transformer 9/6, 11/6, 15/-, 21/-
- H.F. Transformers, any wavelength... 3/6
- Crystal Detectors, in glass... 1/6
- Shaw's Genuine Hertzite, large 9d. and 1/6
- Herbo Cat's Whicker improves results on any crystal set... 0/6
- Phone Cords, best... per set 1/3
- Condenser Plates... per pair 13d.
- Contact Studs... per doz. 0/4
- Small Spacers... per doz. 23d.
- Large Spacers... per doz. 0/3
- Brass Bushes... each 13d.
- 2 and 4 B.A. Threaded Rod, per ft. 0/3
- Shell Insulators, large... each 0/6
- Shell Insulators, small... each 2d.

- Reel and Egg Insulators 2 for 13d.
- Insulated Hooks... each 13d.
- Spade Terminals, threaded, each 13d.
- Bushed Ebonite Knobs, best, each 0/3
- Lac-in Tubes, any length, per in. 0/1
- Best Ebonite, only in sheets, 1/8 in., 3/16 in., 1/4 in., per lb. 4/6
- Systoflex, best... per yd. 0/5
- Best quality Coil Holders, 2-way 5/6
- Best quality Coil Holders, 3-way 6/6
- Knife Switches for panel mounting 0/8
- Engraved Rheostat Dials each 3d. & 6d.
- Crystal Cups, with 4 screws, each 0/2
- C.A.V. Accumulator, 6 volt, 60 amp., in case with switch, fuses, etc... £1 19 0
- Special R type Dutch Valve, guaranteed best quality... 7/-
- Crystal Sets... 10/6
- Coil Plugs... each 9d.
- Variable Condensers... 0.0003, 0.0005 4/6

Instrument Wires.

No.	D.C.C.	per lb.	Enam. D.S.C.	per lb.	Enam. D.S.C.
18	2/6	3/9	2/3	3/9	2/3
20	2/6	3/9	2/3	3/9	2/3
22	2/6	3/11	2/6	3/11	2/6
24	3/4	4/6	2/6	4/6	2/6
26	4/-	6/6	3/4	6/6	3/4
28	4/6	8/-	3/4	8/-	3/4
30	5/4	8/-	3/9	8/-	3/9
32	7/2	8/6	3/11	8/6	3/11
34	8/-	9/10	4/4	9/10	4/4
36	8/6	11/6	4/8	11/6	4/8

All sizes in stock. rd. extra for reeling under 1 lb. All goods sent off same day as ordered.

ALL TYPES OF VALVES IN STOCK.

Enclose sufficient for postage, extra postage will be returned.

A NEW AID FOR THE HOME CONSTRUCTOR
 THE "RADIO PRESS" ENVELOPES

A SERIES of Radio Press publications of the greatest interest to the home constructor are the "Envelopes," regarding which detailed announcements appear elsewhere in this issue. They are intended to meet the pressing need for really full and complete constructional and operating details of a single receiving set. Most elaborate instructions and details are given, with full-size blue prints, numerous photographic reproductions showing views of the sets from various angles so that their construction is made perfectly clear, working diagrams, etc.

Further, the sets themselves have been designed to make the constructional work involved as easy and as simple as possible, yet the finished instruments are of good appearance and of the highest efficiency. The series is being prepared by the foremost constructional writers of the day, and every set is built to a well-tried design, the author himself having planned and constructed the instrument which is shown in the photograph contained in the Envelope.

The Envelopes now ready comprise one containing instructions for

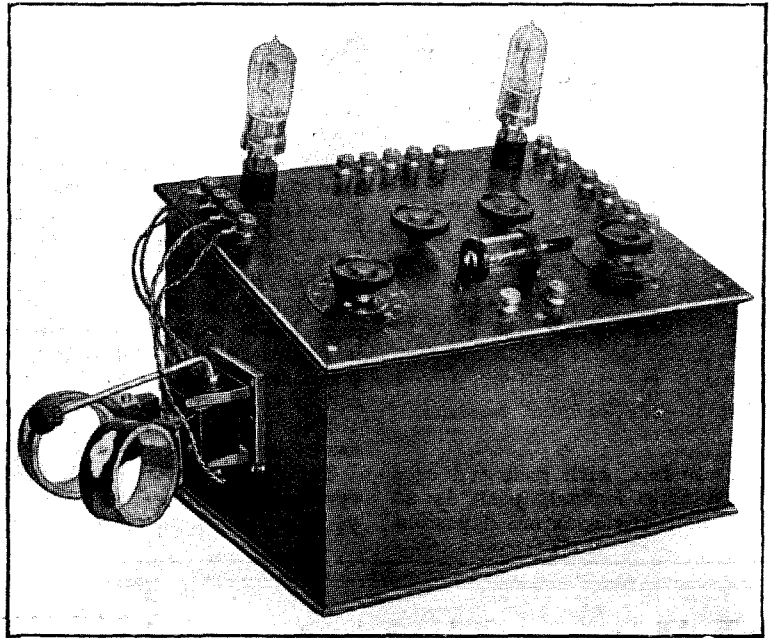

The compact ST 100 Receiver described in Radio Press Envelope No. 1.

building the ST 100 receiver in its latest improved form, by John Scott-Taggart, F.Inst.P. and another describing a four-valve set possessing switches to enable any

lesser number of valves to be used. The author of this second Envelope is Percy W. Harris, whose recent designs in this journal have proved so popular.

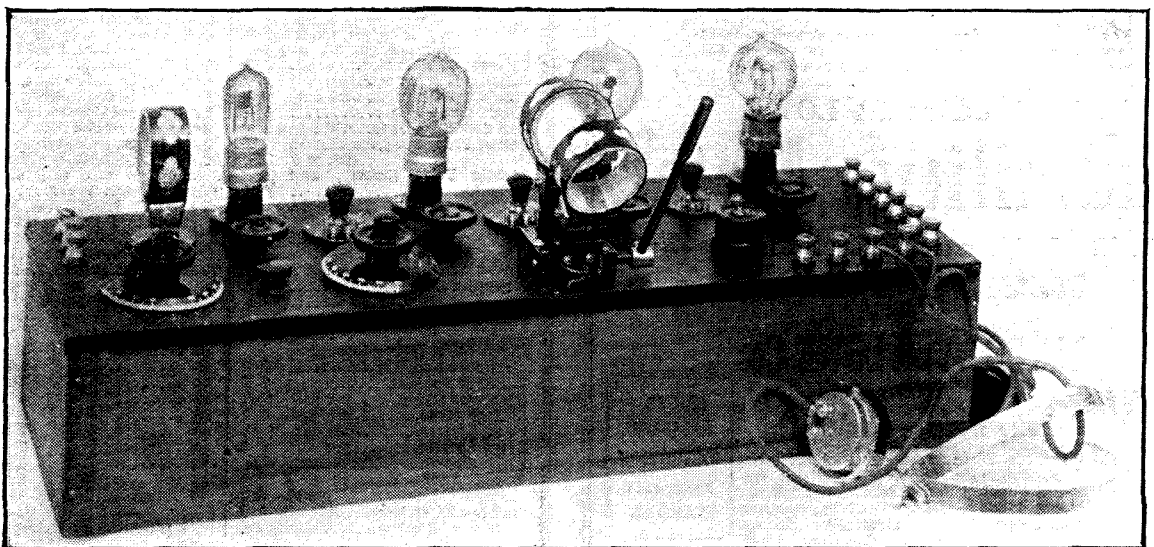

The four-valve "family" set described in No. 2 Envelope.

Demand FORMO Products

OBTAINABLE FROM ALL RELIABLE TRADERS.
THE FAMOUS FORMO TRANSFORMER IS THE MOST WIDELY USED.

It Sells by its Merit, and is unconditionally guaranteed as to performance and quality. Owing to stringent test, breakdown under all ordinary conditions is impossible. No other transformer can give such good results under all conditions.

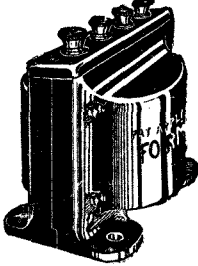

Supplied in the following windings:

- A.—Ratio 1—2
- B.— „ 1—3
- C.— „ 1—4
- D.— „ 1—5

D. is supplied as standard and we advise it for 1st stage and B. for 2nd stage.
One Price, 18/-

THE FORMO OPEN TYPE TRANSFORMER IS THE FINEST GENERAL PURPOSE INSTRUMENT OBTAINABLE AT 15/- BEWARE OF THE MANY IMITATIONS OFFERED. LOOK FOR THE NAME "FORMO."

A Sound Mechanical Job. Smooth and silent action. Machined from solid throughout. Price 2/6.

British-made Terminals, Screws, Nuts, etc., better than foreign, at Competitive Prices, made in our own works.

The FORMO COMPANY, (Arthur Preen & Co., Ltd.)
Offices and Works: 22, CRICKLEWOOD LANE, N.W.2.
Phone: Hamp. 1787.

THE FORMO PLUG-IN DETECTOR.

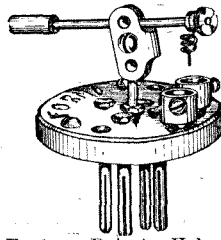

Replaces Detector Valve.
Price 4/-
Without legs, for panel mounting, 2/6

(Arthur Preen & Co., Ltd.)
Phone: Hamp. 1787.

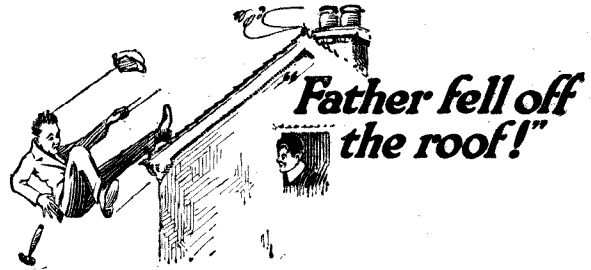

"Oh dear! But what was he doing on the roof? Fixing up an aerial! Well I'm dashed, he ought to have known better and bought a

CLIMAX MONOVALVE

No outside aerial. No earth. Portable as a gramophone. No installation cost: It gives loud and clear reception on local stations up to about 50 miles, while quite a pleasant volume can be obtained at distances of 100 miles and over.
The set on which "Popular Wireless" got all British stations at 3 miles from 2 LO.

Price of Climax Monovalve with Climax patented folding frame aerial £10
(if used with B.B.C. Licence—
Tax 11/- extra.)

Accessories required: Headphones, valve and batteries. Approximate cost £3
Any standard accessories can be used.
Write for full particulars: (Dept. MW)

CLIMAX PATENTS LTD.,
182, Church St., Kensington, London, W. 8
(Phone: Park 2023)

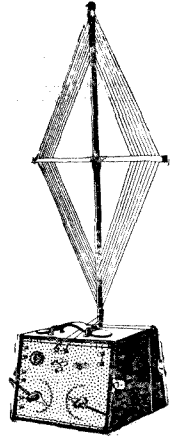

(E.P.S. 12)

The Mighty Atom CALIFORNIAN "RUZANE" CRYSTAL

Functions like a Valve.

THIS Wonderful Crystal is a mineral from the earth and is unmarred by any process. It is guaranteed equal to any on the market.

The envelope contains one piece of CRYSTAL and four Cat whiskers of 9 ct. gold, solid silver, copper alloy, and German alloy respectively. Experimenters can judge for themselves which is the best metal. Price 9d. complete. Postage 1½d. extra.

Agent:
BEDFERN'S, 91 & 93, Barker's Pool, Sheffield.

E. NALDER,
91, Tabernacle St., London, E.C.2.
Phone: Clerkenwell 7345.

TRADE INQUIRIES INVITED.



SCHEFF PUBLICITY ORGANISATION

125, PALL MALL, LONDON, S.W.1

are Advertisement Managers for

MODERN WIRELESS AND WIRELESS WEEKLY

Particulars on application of RATES for both publications.

Phone: Regent 2440 (Two Lines).

SERIES or PARALLEL or SERIES - PARALLEL in a moment with the DOMINOE CONNECTOR

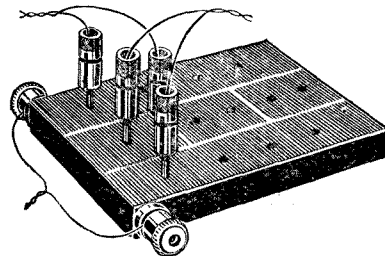

To connect up your extra pairs of telephones is always a matter of difficulty. The Dominoe Connector makes it a matter of SIMPLICITY and RAPIDITY. Connections include series, parallel, or series-parallel up to FOUR PAIRS of telephones.

3/6

for the dominoe
3d. each for KWIKPINS
Trade enquiries invited.

The Spring Contact ensures a firm grip of the KWIKPIN. Yet a change, say, from parallel into series is made in a moment. THE DOMINOE CONNECTOR will save time and trouble and is indispensable to the experimenter. Other applications—such as connecting up cells, condensers, inductances, etc.—in fact wherever the need of a clean, quick, and simple change of connection is present you should use the KWIKPINS AND THE DOMINOE CONNECTOR.

THE LOWNE ELECTRIC CLOCK & APPLIANCES CO., LTD.,

14, Carteret Street, London, S.W.1

Telephone: Victoria 9760.

Telegrams: "Lowne, Victoria, 9760."

JUST PUBLISHED

The Construction of Crystal Receivers

By Alan L. M. Douglas

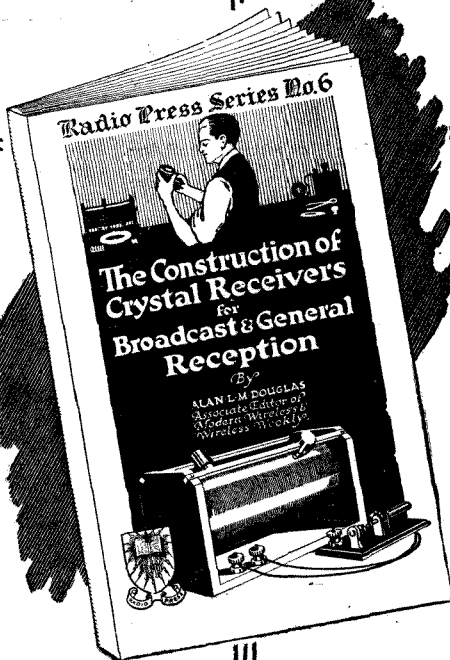

—and the Crystal Receiver still gives the purest speech

IN spite of the very marked advance in the design and construction of Valves, there is no shadow of a doubt that the Crystal still gives the purest speech.

Many remarkable long-distance reception tests have been recently carried out, and would show that the Crystal Receiver is far from being superseded.

Even if you already possess a Valve Receiver, it will be to your advantage to get this new Book and build one of the super-crystal Sets described in it. Besides enabling you to make interesting comparative tests, you will have a very useful receiver as a stand-by in case your Valve Set should fail you at a critical moment.

Published by
RADIO PRESS, LTD.,
Devereux Court,
STRAND, W.C.2.

1/6

Sold by all Booksellers and Newsagents, or 1/8 post free direct.

CONTENTS.

The Crystal Detector—its Development and Design.

Crystal Reception Circuits.

Inductances for Crystal Work. (Single layer solenoid, honeycomb, basket, slab, inductively coupled, etc.).

Condensers fixed and Variable. Full constructional details.

Telephone Headgear—including transformers and loud-speakers.

How to make a Crystal Receiver for British Broadcasting. (Wave-length range, 250-600 metres.)

How to make a long Range Receiver. (Wave-length, 300-3,000 metres.)

The "Mark III." Short-wave Government Tuner, and useful conversions and modifications.

Aerial and Earth Circuits—their faults and remedies.

Appendix containing instructions for making three extremely simple and practical sets.

Radio Press Series No. 6.

In replying to advertisers, use COUPON on last page

Junior Wireless

For Boys of all ages

Edited by Percy W. Harris

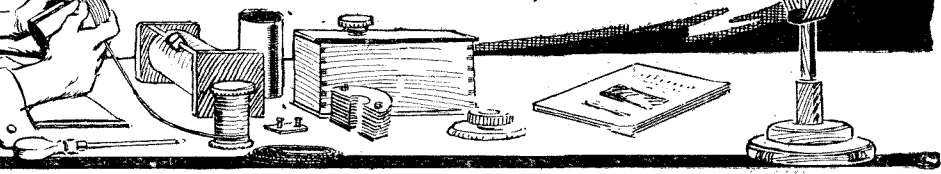

Vol. 1. No. 5.

JANUARY.

Published Monthly.

THE EDITOR'S CHAIR

A HAPPY New Year to all readers of JUNIOR WIRELESS! I suppose during the Christmas holidays more wireless sets will be made than ever before, not only by those who have not previously possessed a set, but also by the many readers who have one or more pieces of apparatus and are not satisfied with the results they obtain. In case you are one of those who are occupying their spare time in pulling existing apparatus to pieces with the object of building something new, let me offer you a few words of advice.

There are two ways of improving a set, one by increasing the volume of sound obtainable for it, the other by increasing the range over which it will receive. Many people have the impression that by adding another valve to their set they will increase the distance they can hear, but this is by no means always the case, for if the valve is used as a low-frequency magnifier, or "note magnifier" as it is sometimes called, the distance from which the set will receive will be practically the same. This is due to the fact that note-magnifiers will only increase the strength of signals you are already receiving in the instrument. A dozen note-magnifying valves will not make audible any speech or music which is not strong enough to pass the detector, whether it be crystal or valve.

In spite of the fact that note-

magnifying valves do not increase the range of a set, there are many advantages in adding them to your receiver. The first of course is that if you are using a large number of telephones which on your present set tend to make the signals weak, the addition of one valve as a magnifier will make them comfortably strong for any reasonable

your set. This will increase the range considerably, but the difficulties of so doing are considerable. Make a good study of the subject first and then start improvements. This will save you both time and money.

If you are a true wireless experimenter you will probably want to make different wireless sets from time to time. For example, by now you will have learned a great deal about note magnification, if you have used the two-valve note magnifier described in a recent JUNIOR WIRELESS. Perhaps you feel you would like to try your hand at the set described in this issue, using some of the parts from the note magnifier. If you do so, you will save a good deal of money, for the same terminal strips, filament resistance, fixed condenser, valve socket and one of the transformers will serve excellently.

Readers who live in the country and have valve sets should try a few experiments with long, low aerials—wires not more than five or six feet above the ground. Such aerials, if about ninety or one hundred feet long, often prove surprisingly efficient, besides saving the cost and trouble of high masts and chimney stack climbing. The earth wire can consist of a wire of equal length laid on the ground beneath the aerial, or can take the more usual form of a buried plate. Let me know the results.

THE EDITOR.

Contents.

	Page
Editor's Chair	61
The Simplest Way to Make a Crystal Set (Illustrated)	62
A Point in Aerial Efficiency	65
An Attache Case Wireless Set	66
By PERCY W. HARRIS. (Illustrated)	
Origin of the Catswhisker (Illustrated)	68
Testing with Telephones	69
By R. W. HALLOWS. (Illustrated)	
Some Interesting Catalogues	71
What a Boy of Fifteen Can Make (Illustrated).	72

number of pairs. If your signals are already quite strong, as will be the case with a good outdoor aerial up to six miles from a station, one or two note magnifiers will give ample strength to work a loud-speaker; up to ten miles one additional valve is generally sufficient for a small room.

Do not be in too much of a hurry to add a high-frequency valve to

THE SIMPLEST WAY TO MAKE A CRYSTAL SET

By G. P. KENDALL, B.Sc., Staff Editor.

Quite a novel way of making a crystal set is described in this article. The efficiency is very high and the cost low.

WHEN one comes to think of it, the parts which are really necessary in a crystal set are very few in number. The first essential thing is obviously a circuit between aerial and earth which can be tuned to any desired wave length, and there are many ways of providing such a circuit, the simplest from the constructional point of view being the use of a coil of fixed value and a variable condenser. Slider coils, variometers and tapped coils all have their advantages, but in each case a certain amount of constructional work is necessary, whereas if a variable condenser is used as the chief means of tuning all that needs to be done is to provide a socket into which a standard plug-in coil can be inserted.

Across the tuning coil must be connected the instruments for making the signals audible, and in the case of a crystal receiver all that is needed here is a pair of phones and the detector itself. The telephone condenser which is usually provided is by no means a necessity. It was originally used to act as a reservoir for the rectified pulses of current from the detector, but it seems that the average pair of phones with their leads must possess sufficient capacity of their own to serve the purpose, since I have never been able to discover any improvement in the reception of telephony on placing a condenser

across various makes of phones when used in crystal sets.

The actual necessities, then, are simply a variable condenser, a coil socket, a crystal detector, and various terminals. The photographs show the easiest way which I have yet found of combining these parts. No tools are needed beyond a drill, a screw-driver and a pair of pliers, and the whole job took me about twenty minutes.

The basis upon which to work is a variable condenser of 0.0003 or 0.0005 μ F (preferably the latter value) having square ebonite top and bottom plates of fair size. Such a condenser can be bought for about 6s. in the smaller size, and if its ebonite top plate is not large enough to carry the crystal detector it can be covered with a square piece of ebonite of the required size, a hole being drilled for the centre spindle. The condenser illustrated was obtained from Messrs. Scientific Appliances, and was already provided with two terminals. These became the aerial and earth terminals, two more being added (visible near the top in Fig. 1) to serve as telephone terminals.

A set of crystal detector parts was bought for 1s. 9d., and a piece of Hertzite. Those were mounted on the top plate of the condenser in the position shown in the photographs. The coil socket used was simply an ordinary coil plug of the flat-sided variety, costing

about 1s. 6d., and it was attached to the bottom ebonite plate of the condenser by means of a 3B.A. brass screw and nut. A hole was drilled through the centre of the

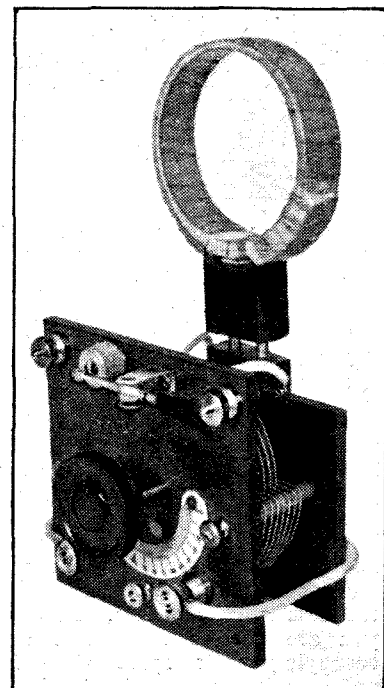

Fig. 1. The complete receiver with a coil in position.

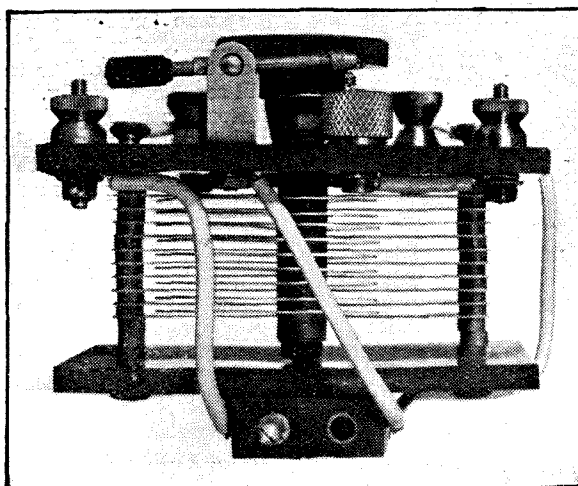
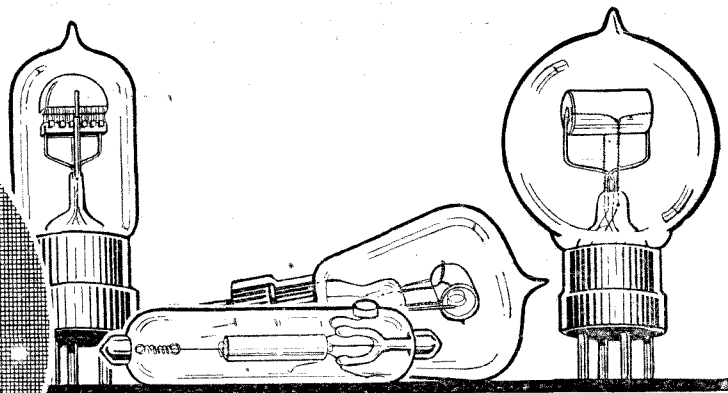
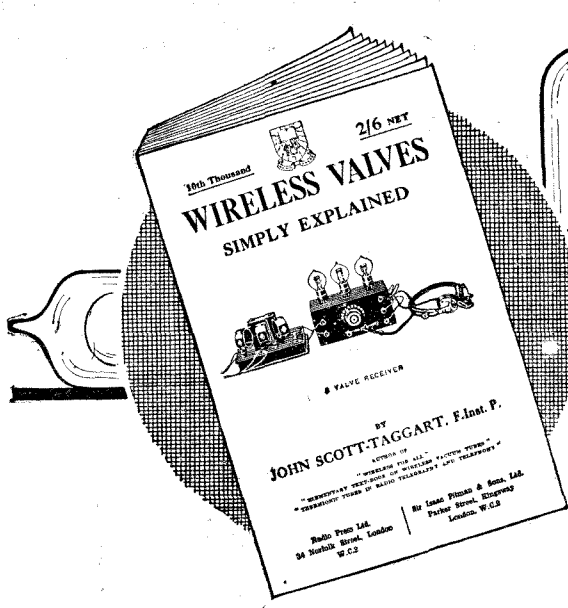

Fig. 2. A top view of the set.

coil plug and into the ebonite end plate, the screw being passed through this and the nut serving to clamp the parts firmly together.

The connections of this little set are so simple that it is unnecessary to make a diagram of them. They are as follows:—Connect the two screws of the coil socket one to the aerial terminal (the moving vanes of the condenser) and the other to the earth terminal (the fixed vanes). Take a wire from the aerial terminal to the crystal cup, and one from the catwhisker holder to one of the telephone terminals, connect the other telephone terminal to earth, and the set is finished.

The size of coil to use in the socket depends to a great extent upon the size of your aerial. However, for broadcast reception it will usually be necessary to use a 35 or 50 Igranic coil or a Burndept S₂ or S₃.



Valves

THE Valve is undoubtedly the most important part of any Receiver. If your Valve (or Valves) is not functioning correctly, you are not getting the best results from your Set.

Before you can hope to become a skilled driver and obtain the most pleasure from your car you must know how it works. So with Wireless. You cannot hope to get the greatest enjoyment from "listening-in" or experimenting until you have mastered the fundamental principles of Radio.

Dependent on this lies your ability to understand the theory of the Thermionic Valve. Know how it rectifies, how it oscillates, and how it amplifies, and your progress in obtaining further Radio knowledge will be rapid.

Wireless Valves Simply explained

By JOHN SCOTT-TAGGART, F.Inst.P.,

is the one Book on the Valve which will really teach you—commencing at the very beginning—everything you need know about the Valve. It has been recognised by all the experts as the standard popular-priced book on the subject.

Purely scientific explanations are omitted because the aim of the author has been to provide a book which, while being absolutely accurate, can be read and understood by novice and experimenter alike.

Get a copy to-day and begin to understand exactly what is happening while your Receiver is working.

Contents

- The Theory of the Thermionic Valve.
- The 3 Electrode Valve and its Applications.
- Cascade Valve Amplifiers.
- Principles of Reaction Amplification and Self-oscillation.
- Reaction Reception of Wireless Signals.
- Continuous Wave Receiving Circuits.
- Valve Transmitters.
- Wireless Telephone Transmitters Using Valves.
- Broadcast Receivers.

2/6

RADIO PRESS
Wireless Library,
No. 10.

From all Booksellers
or Newsagents,
or 2/8 post free.

Radio Press, Ltd.
PUBLISHERS OF AUTHORITATIVE WIRELESS LITERATURE
DEVEREUX COURT, STRAND, W.C.2.

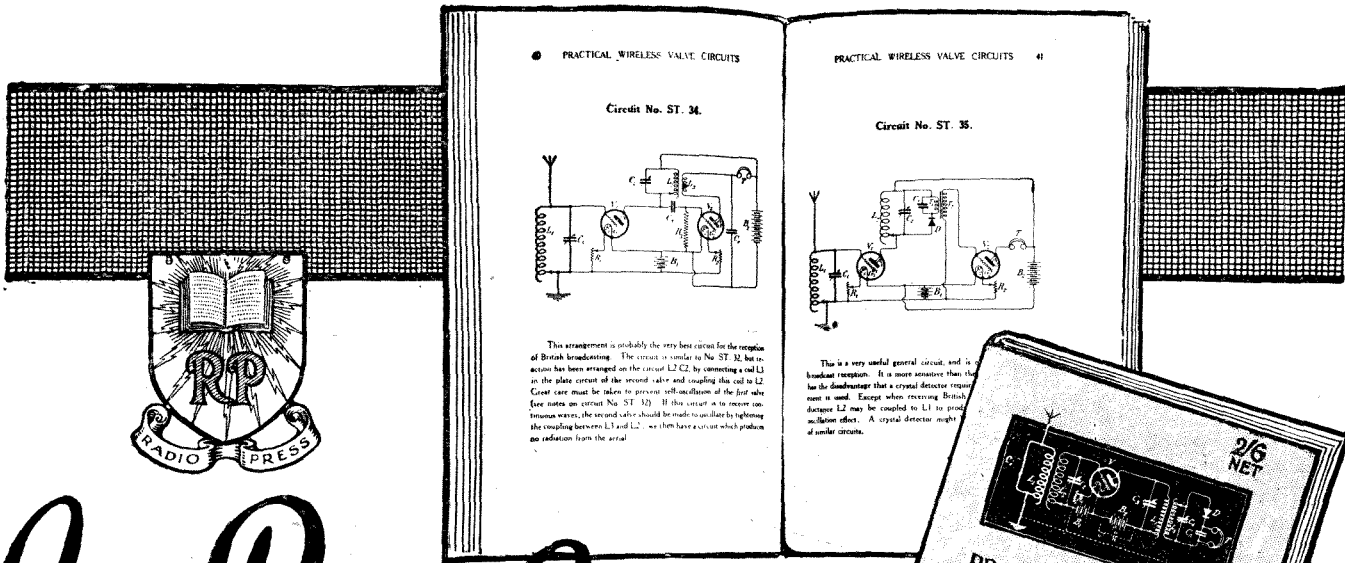

No Paper Circuits

Every one
the result of practical tests

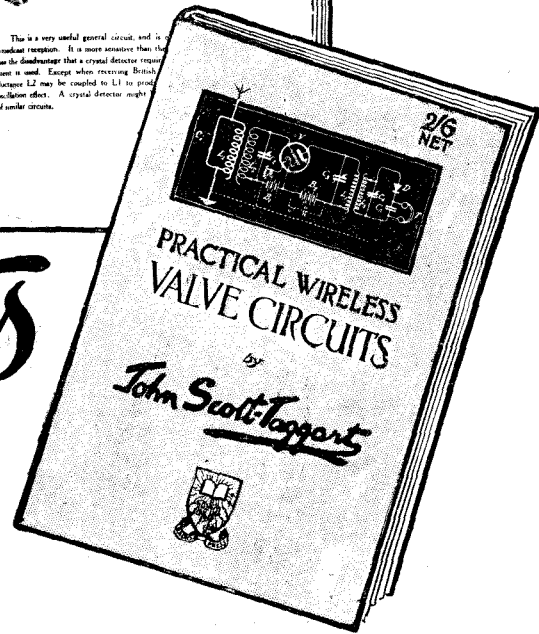

Circuits ST.1 TO ST.67

WHEN building your Set you will want to be confident that the circuit is the best possible. Many circuits often recommended are only "theoretical" circuits, and when the user comes up against the hard school of actual practice he is apt to get disappointing results.

If you get a Book like *Practical Wireless Valve Circuits*, you are guarded against this. Every circuit—and there are over 60 of them—has been actually tested under working conditions, and where necessary typical valves for fixed condensers and resistances are given.

Many circuits are quite new, and all are the result of many years' Radio research work by John Scott-Taggart, F.Inst.P. (Editor-in-chief of *Modern Wireless* and *Wireless Weekly*).

Buy a copy to-day—keep it for reference, you will find it a continual help.

RADIO PRESS, LTD.,
Devereux Court, Strand, W.C.2

Practical Wireless Valve Circuits

CONTENTS.

1. Crystal Detector Circuits.
2. Single-Valve Circuits.
3. Two-Valve Circuits.
4. Three-Valve Circuits.
5. Four-Valve Circuits.
6. Five-Valve Circuits.
7. Local Oscillators for Heterodyne Reception of C.W.
8. Valve Transmitter and Radiophone Circuits

2/6

From all Booksellers, or 2/8 post free from the Publishers.

A POINT IN AERIAL EFFICIENCY

AERIALS of the inverted L type are by far the most common nowadays; in fact, one probably sees two of them for one of any other kind. Their popularity is justified, for this aerial, if properly erected, is as efficient as can be desired, and its directional properties are so slight that it will receive almost equally well transmissions that come in from any quarter.

There is, however, one strong criticism that can be made upon the majority of amateur aerials of this type, and this concerns the point from which the down-leads are taken. Your own aerial may be without fault, but if you notice the hundreds that are visible as you enter London by train, tram, or bus, you will find that in an enormous number of instances the down-leads are attached to points from 3 ft. to 2 yds. or more from the ends of the wires.

If this is done the aerial is not really an inverted L at all. It is of the T type, and the arms of the T are of an equal length. Now each arm *plus* the lead-in has its own natural wave-length. Hence, in an aerial which resembles a lop-sided T, with one very long and one very short arm, there are two quite different fundamental wave-lengths. When the aerial is loaded by means of the tuning inductance and its condenser, each arm will be tuned. The receiving set is thus presented with a combination of two widely different wave-lengths, and anything like fine or accurate tuning is impossible. These points are of the greatest importance on the short waves now coming into use, and their effects are less noticeable upon the broadcasting wave-lengths.

In the ideal aerial the down-leads should come from the very ends of the suspended wires. This can be done if the wires themselves are used for the purpose. Each wire is taken through the hole of the insulator, then back on to itself, where it is "seized" or lashed with thin wire. The two loose ends are then twisted together and soldered, and a heavy lead-in is secured to the lowest point of the U so formed.

If sufficient aerial wire is not available to allow this to be done,

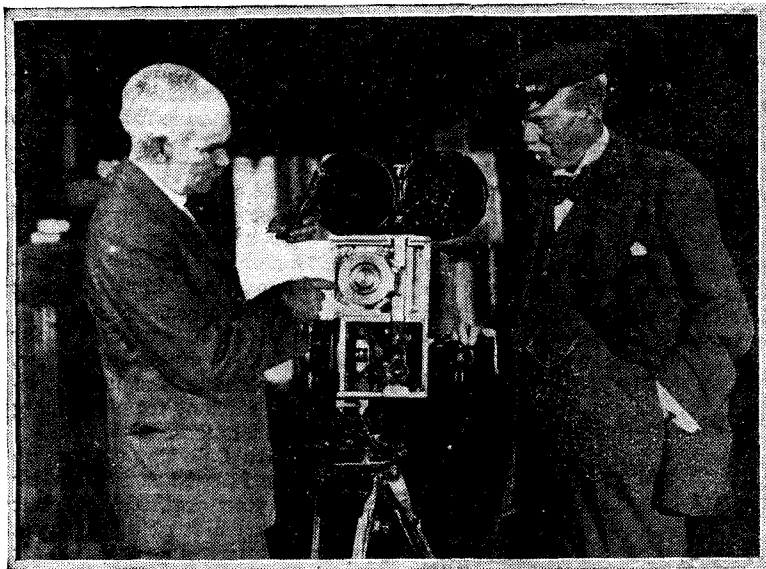

Two famous men. Dr. Lee de Forest explaining his "talking film" to Sir Thomas Lipton, of America Cup fame.

we can achieve our object in another way. Let us suppose that the wire is only long enough to allow a few inches of space at the lead-in end. We pass the wire through the hole in the insulator, and then splice a 3 in. length of $\frac{1}{4}$ in. brass rod to it by means of thin copper wire, the rod being fixed at right angles to the wire. The splice is made secure by running a little solder into it. The rod will now act as a stop, preventing the wire from running through the insulator, and the wire can be soldered to a heavy lead.

The second parallel suspended wire is treated in the same way, its end being soldered to the other end of the stout wire. The lead-in is then taken from the bottom of the loop formed.

If the aerial is of the T type it is most important that the arms should be of equal length. The mid-point of the wires should be found by careful measurement. The strands are then opened out for a few inches and those of the connecting loop are twisted into them and soldered. R. W. H.

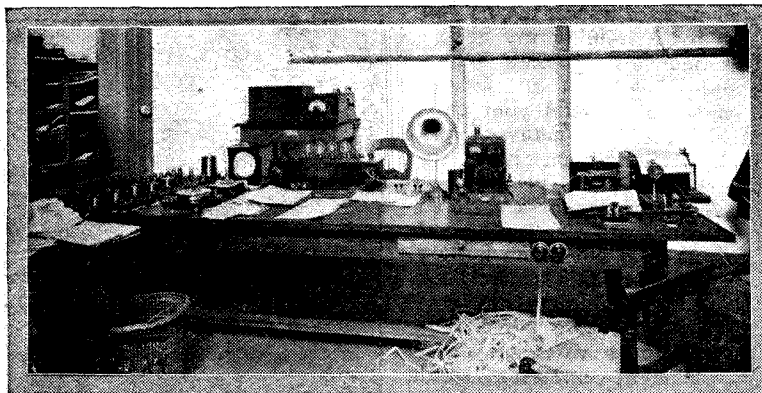

In a French receiving station. Note the increasing resemblance of the operating rooms of modern wireless stations to ordinary telegraph offices. (Observe the pile of perforated tape.)

AN ATTACHÉ CASE WIRELESS SET:

How to Use Your Existing Apparatus for Dual Amplification

By PERCY W. HARRIS.

LAST month I promised I would tell you how to make a portable set running off dry cells instead of accumulators, and using one of the new valves. There are several ways in which this can be done, and in thinking the matter over it occurred to me that perhaps you would like to use apparatus you already have, so that the number of things you will have to buy for this set will be

6. A .001 μ F fixed condenser.
7. Another variable condenser of any value from .0002 to .0025 μ F.
8. A cardboard tube about 3 inches in diameter.
9. A high-tension battery of about 40 to 50 volts.
10. One or two dry cells according to the kind of valve you will use.

If you have a variometer for aerial tuning so much the better, as this is perhaps the most convenient and efficient form of tuning in the circumstances.

This month I do not propose to give you the fullest instructions for making up your portable set, as it is just as well first of all to try a number of interesting experiments and, so to speak, "get the hang" of simple dual amplification. Let us consider for a few minutes what actually happens in dual amplification circuits.

Whatever kind of tuning apparatus is used, the object of it is to place our aerial in resonance or tune with the signals we want to receive. Across some part of the tuning apparatus (usually across the tuning coil, whether this be a fixed inductance or a variometer inductance) we connect a valve. The oscillations set up in this tuning inductance cause differences of pressure to occur across the ends of the inductance, and as to one end of the inductance we connect the grid of a valve, and to the

other end the filament, these differences of pressure will be communicated between the grid and filament of the valve. Those of you who have studied such books as "Wireless Valves Simply Explained" will know that the hot filament of a valve is, so to speak, spraying outwards a continuous discharge of electrons which pass across the intervening space to the metal cylinder we call the plate. This spray of electrons is really a flow of electricity, and in reaching the plate from the filament it passes through the space between the grid wires. Any differences of pressure which may be communicated to the grid wires from our tuning apparatus will diminish or increase this spray of electron. The electron spray, after passing across the space from the filament to the plate through the grid wires, passes back to the filament, through the circuit which is connected to the plate, forming an electric current. The fluctuations of current in this plate circuit are a faithful copy of the current flowing in our tuning coil, but they are of greater amplitude or strength. Our valve, therefore, acts as a perfect relay, taking our signal currents and magnifying them.

Let us first of all connect up our apparatus so that this little train of events can occur. We do this in the way shown in Fig. 1. The apparatus connected in this way is simply acting as a high-frequency

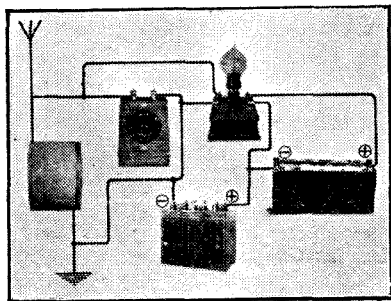

Fig. 1.—The first circuit.

reduced to a minimum. The simplest and most economical set to make is a one-valve dual amplification or reflex receiver. I know these words sound very formidable and may suggest to you that the design and working of such an instrument must call for a good deal of experience, but I can tell you right away that such is not the case. Even when built into a cabinet, a single valve dual amplification receiver is not a complicated piece of apparatus, as you will see by examining my article in this month's MODERN WIRELESS describing such a receiver. First of all look round your cupboard and see how many of the following articles you have on hand:—

1. A variometer, or a variable condenser with tuning coil (it does not much matter which as this is merely for aerial tuning).
2. A single valve panel containing a valve socket, a filament resistance and the necessary terminals.
3. A crystal detector.
4. An intervalve transformer.
5. A .0003 μ F fixed condenser.

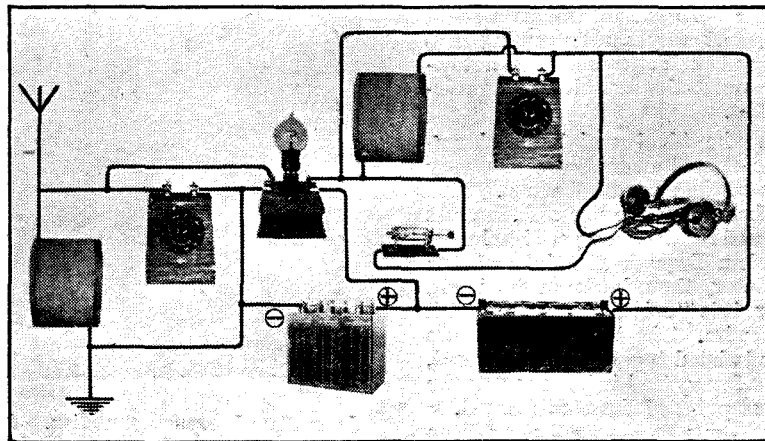

Fig. 2.—A simple valve-crystal receiver.

magnifier; the currents in the plate circuit are not of the kind which will affect the telephones, for no means of rectifying them has been incorporated, nor, for that matter, are telephones included. What must we do to make these currents audible to us? We can, if we like, introduce a grid condenser and leak, but there is another way, by means of a crystal. Let us put another tuned circuit in the plate circuit of our valve, as in Fig. 2. The pulsations of current in the plate circuit will now build up oscillations in this tuned circuit (it can consist of about 50 turns of wire on a 3-inch tube—No. 24 or 26 will do—across which is placed a variable condenser of any value from .0002 to .0005), and these fluctuations of current or oscillations will correspond exactly with those in our aerial-tuned circuit, only they will be much stronger

So far I have not mentioned any special valves, because any good valve will act in the way I have described, and if you have a bright emitter and accumulator handy you will very likely have tried the experiment with those. However, in our portable set we shall need to use a valve which will run from dry cells, and we have really a choice of three kinds; first of all, we have the older type of dull emitters, such as the D.E.R., A.R.D.E. and the Mullard low temperature valves. These take about .3 to .4 of an ampere at 2 volts and will thus need two dry cells and a filament resistance to run them. I do not, however, recommend you to use this kind of valve because the current taken is quite considerable; really a little too much for any dry cell except one which is very large and bulky and quite unsuitable for carrying in our portable set. The

more robust filament than the .06 ampere type and will stand knocking about far better. The price of these valves is £1 10s., and they are made to fit any ordinary socket, and can be operated with the ordinary filament resistances such as are fitted to your valve panel now.

You may think that having gone so far—*i.e.*, by magnifying the currents of the valve and then rectifying them in the crystal—we have got all the results we shall be likely to obtain without adding further valves. However, I want you now to carry out another experiment and you will see how we can use our valve twice over; first in the way already explained and tried, and secondly as a low-frequency magnifier. We can use a valve in a dual amplification circuit—that is to say, with amplification twice, first as high-frequency and second as low-frequency. Look at Fig. 3 and you will see that by making a very little alteration to your circuit the valve can be made to act the second time. Let us see what happens.

The crystal is connected to the plate of the valve and to one side of the tuned circuit in the plate, just as before; but instead of discharging the rectified currents through the telephones it passes them through the primary of the intervalve transformer, the secondary of which is connected to the lower side of the aerial tuning inductance and to the earth. Across this secondary is a fixed condenser of a value of .0003 μF , whilst across the primary is a fixed condenser of .001 μF . The telephones are now placed in series with the lead from the high-tension battery and may have a telephone condenser across them, but this is not always necessary. What happens now? The high-frequency currents are tuned as before, and instead of going straight to earth, as they did in the earlier circuit, they go through the .0003 μF condenser to earth. They cannot go through the secondary winding because this acts as a choke at high-frequencies. Thus, so far as high-frequency circuits are concerned, this condenser across the secondary acts as a short circuit to it. The rectified currents from the plate circuit pass into the primary of the intervalve transformer and the low-frequency differences of pressure are applied through the grid and filament. Whilst the high-frequency currents can go easily across this shunting condenser, the low-frequency currents cannot. The result is that not only do the

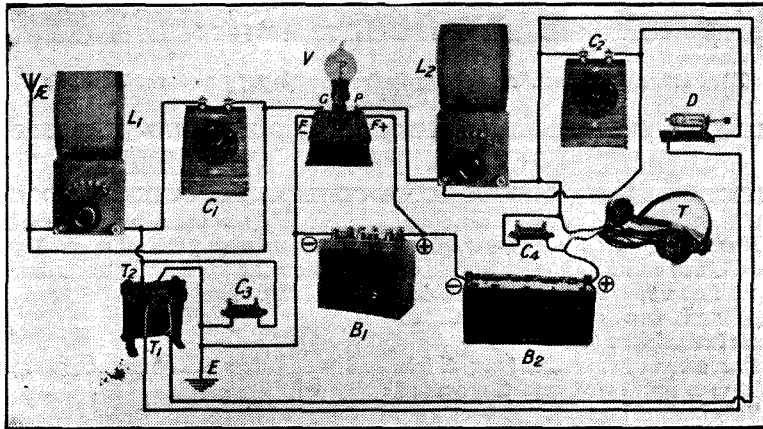

Fig. 3.—How the "dual" circuit grows out of Fig. 2.

because of the magnifying effect of the valve. Being high-frequency currents, they will not affect the telephones, so we must convert them into low-frequency pulsations, which we do by connecting a crystal detector in series with our telephones in the way shown. The crystal allows currents to pass one way only, and therefore turn the high-frequency currents into low-frequency pulsations, which, passing through the telephones, make themselves audible. On an ordinary aerial we shall get, of course, much better signals this way than if we were to use the crystal detector directly on to our tuning apparatus, for by the interposition of the valve we have been able to magnify the signals considerably and increase our range. In passing, I should mention that there is no great difficulty in making apparatus with one stage of high-frequency amplification. Two or more stages result in trouble,

second kind of valve we have is the type which includes the "Weco-valve," better known as the "Peanut," and the Cossor "Wuncell," just placed on the market. These take about half of the current of the old kind of dull emitters, and, what is more to the point, will work off *one* dry cell, which is a great convenience. The third kind of valve is the new type which burns with only .06 of an ampere; these are made by the Marconi Osram Valve Co., the Edison, Swan Electric Co., the British Thomson-Houston Co., and the Mullard Radio Valve Co. These use about a quarter of the current of the "Peanut" or Cossor "Wuncell," but they want a higher voltage to run them. Thus we must have three dry cells to operate them, whereas the "Peanut" and the "Wuncell" only need a single cell. For the present set I would recommend you to have either a "Peanut" or a "Wuncell," as these have a much

currents in the aerial become magnified by the valve, and rectified by the crystal, but they are passed back again and once more magnified, this time as low-frequency currents, making large fluctuation of currents in the plate circuit. The frequency of the magnified and rectified currents is such that they are able to pass through the telephones, and thus we hear in our telephone receivers the amplified speech or music we have been looking for. The degree of strength obtainable in this circuit is surprisingly high, as you will find when you try it, and within half a dozen miles of a broadcasting station is quite good enough to work a loud-speaker. When adjusting the circuit you will have to pay great attention to the crystal, for if this is not properly set you will neither hear good signals nor be able to prevent the set from oscillating and possibly interfering with your neighbours. When the crystal is properly set, however, you will not get any oscillation. I do not advise you to couple the two inductances together so as to obtain reaction; if you were to do so you would find the set would be very unstable, and I doubt whether you would get as good results as you would by using the apparatus as I have shown.

You will see that very little additional apparatus is needed to the ordinary boy who has a few parts of wireless apparatus in his cupboard, and I am sure many readers will be able to carry out all of the experiments without buying a single additional piece of apparatus. Next month I will show you how to place the apparatus in a small case, which will contain the high-tension battery, the dry cell, and all of the gadgets we have been playing with. Perhaps before next month's article appears you will have tried yourself to do this. If you do so, pay particular attention to the position of the two inductances (aerial inductance and the plate-circuit inductance). Be sure that these are at right-angles to one another and as widely separated as can be; also make the connection between the aerial tuning inductance (whether it be variometer or not) and the grid of your valve as short as possible. You will not need to have any grid leak or grid condenser in this set, so if your valve panel has a grid leak and condenser in it, it will be well to short-circuit them, or else take them right out and connect up the wires as shown.

BEFORE THE MICROPHONE

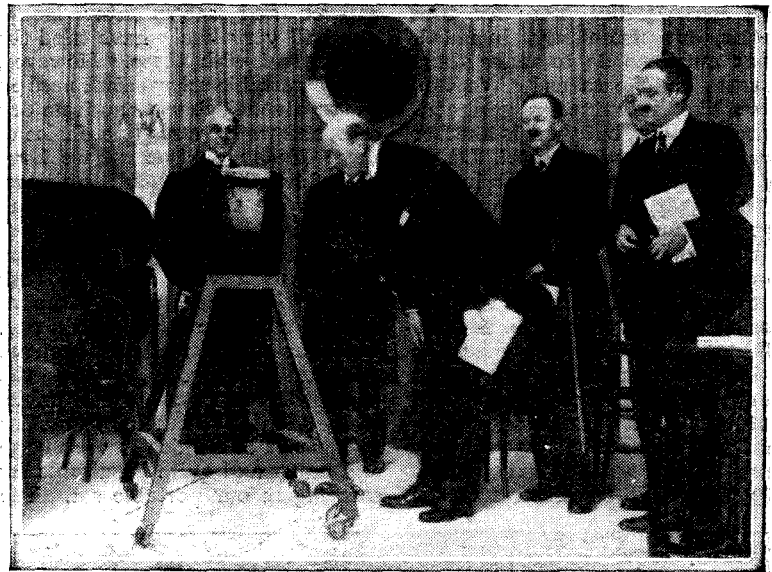

The Postmaster-General examining the broadcasting apparatus at the White City Exhibition.



ORIGIN OF THE CATWHISKER

To the Editor of JUNIOR WIRELESS.
 DEAR SIR,—The original contact for Galena consisted of a bunch of short fine wires soldered to a thick one, and two of them back to back looked like (1).

in which no resemblance can be traced to any part of a cat!
 Yours faithfully, A. HINDERLICH.



For convenience the long thick wire was spiralised, and the actual article looked like (2).
 By omitting a bunch of fine wires we get a plain helix like (3),

- (1) 
- (2) 
- (3) 

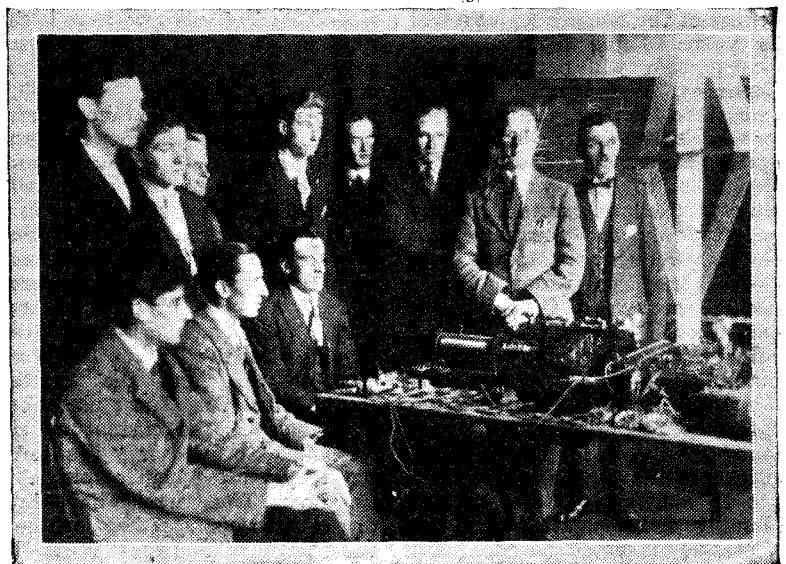

A flourishing Wireless Society. The Tottenham Wireless Society are adding to their members week by week. The picture shows some of the members with the Club's set.

TESTING
WITH
TELEPHONES

A useful fault-tracing article.

By

R. W. HALLOWS, M.A.

MANY people hanker after the possession of delicate and expensive measuring appliances to aid them in their search for the faults which must

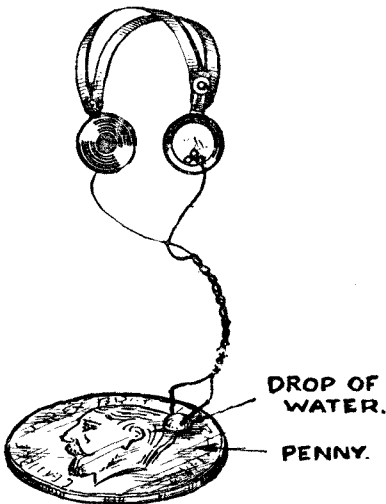
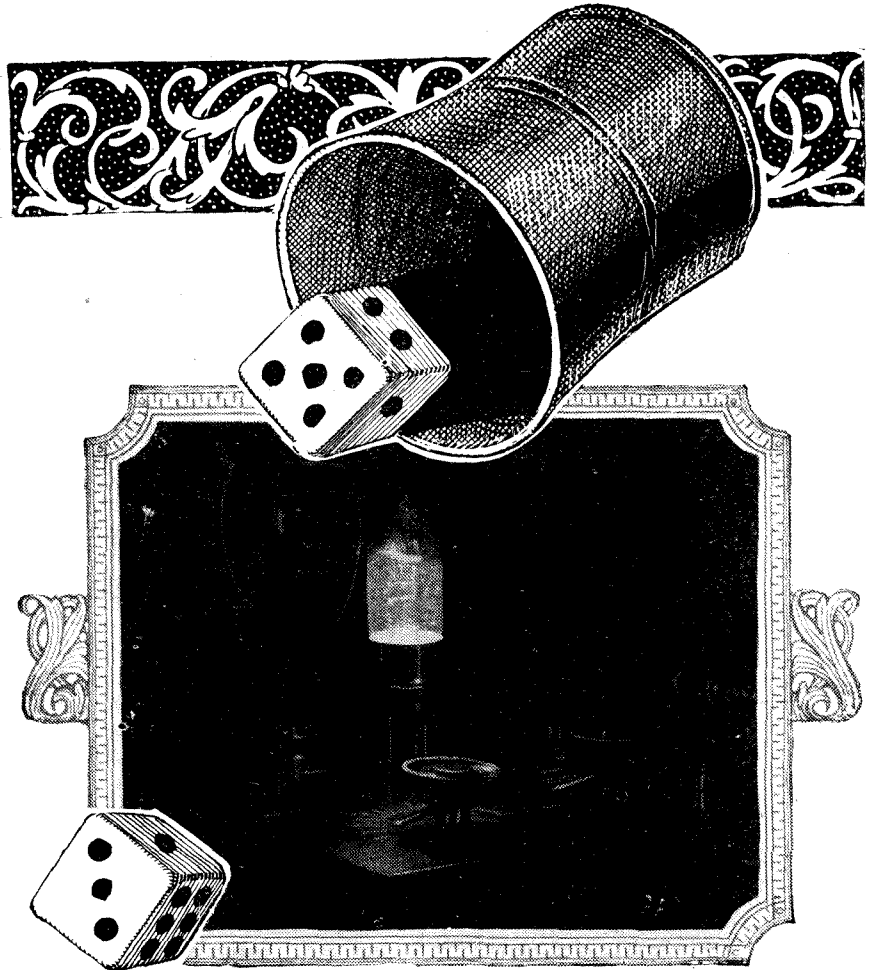

Fig. 1.—A test showing the extraordinary sensitiveness of a pair of telephones.

occur every now and then even in the best wireless set. Few perhaps realise that in the telephone receivers of their headset they have a piece of electrical mechanism which is a far more sensitive detector of the presence of electric currents than any but the most costly instruments such as the millivoltmeter and microammeter.

You can easily test for yourself the amazing way in which the receivers respond to minute impulses by making the very simple little experiment shown in Fig. 1. Place a drop of water upon the surface of a clean penny or two-shilling piece. Lay one of the phone leads in the drop and with the other rub the wet surface of the coin. You will hear a series of distinct scratching noises in the phones. If instead of rubbing the



Don't take
risks!



-insert

COSSOR
valves

Advertisement of COSSOR VALVE CO., LTD., Highbury Grove, N.5.

LONDON RADIO COLLEGE, LTD.

Stafford House,
82/83, HIGH STREET, BRENTFORD:

*Students trained for the
Marine Wireless Service
& Appointments obtained.*

Apply for full particulars Dept. M.

PLUGS and JACKS
Plug and Jack Complete
2/6 Post Free.



SCREWED JACK.



TWO-WAY PLUG.

A. ROBERTS & CO.,
42, Bedford Hill, Balham, S.W.12.

LOOK!

How attractive
these little
"ads." are on
the Pages of

JUNIOR WIRELESS

BOOK!

yours for the
February Special
Birthday Number.

**SCHEFF PUBLICITY
ORGANISATION, LTD.**

Advertisement Managers, *Wireless
Weekly and Modern Wireless,*

125, Pall Mall, London, S.W.1.

'Phone—Regent 2240 (2 lines).

coin you merely touch it with one of the leads a distinct click will occur whenever this lead makes contact with the wet metal. The current here is of the tiniest possible order, so tiny that it would be difficult to measure with even the most delicately made instrument. Yet even low resistance telephones will record its presence though the clicks and scratching noises are, of course, not so loud as they are with high resistance receivers. When you consider that even in the best telephones not more than one-thousandth part of whatever current is brought in by the leads does useful work you will realise what a wonderful feat this is. 99.9 per cent. of the energy which reaches the phones is wasted

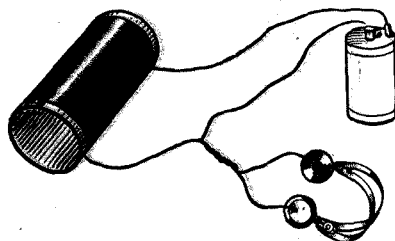

Fig. 3.—Testing continuity of windings.

chiefly in heating the windings of the magnets, but the remaining .1 per cent. is sufficient to operate them even from so feeble a source of energy as the cell formed by the wetted coin.

Having once realised that our telephones will respond to currents so minute as this we can see at once the very many ways in which they may be employed for testing purposes both with the set as a whole and with the small component parts which go to make it up. Suppose, for example you suspect one of your condensers of being leaky; here is a way to set about discovering whether it is really guilty or not. Connect the terminals of the condenser for a few seconds across a portion of the high tension battery. Then remove it, taking care not to short circuit it with the fingers or in any other way. Leave it on the bench for a quarter of an hour or so. Now put on the phones and touch the condenser's terminals with the leads (Fig. 2). If it is in good order there should be a loud click due to

the discharge of the stored-up current, but should the condenser be faulty no click will be heard for the current will have leaked away.

Inductances and transformers can be tested for continuity of windings

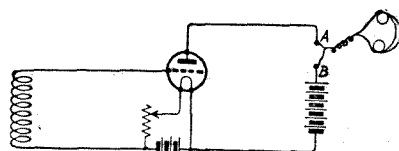

Fig. 6.—Testing the plate circuit.

very easily by the phones. Fig. 3 shows how it is done. Connect one end of the coil to either the positive or the negative terminal of a single dry cell or a pocket flash-lamp battery, joining the other end of the windings to one of the phone leads. Now touch the remaining battery terminal with the second telephone lead. If the windings are in order loud clicks will be heard at every touch. Should there be no clicks or should they occur intermittently then you may feel sure that something is amiss.

When you have wired up your panel you can test out your connections in the same way using the telephones and a small battery. This method is particularly useful in cases where a change-over switch arrangement has been provided, for it enables one to see at once whether the alternative paths for current are being properly controlled by the switch.

There is another most useful way in which the constructor may save himself a very great deal of trouble with the help of a pair of telephones. Much of the ebonite now sold at cheap prices has such poor insulating qualities that a set made

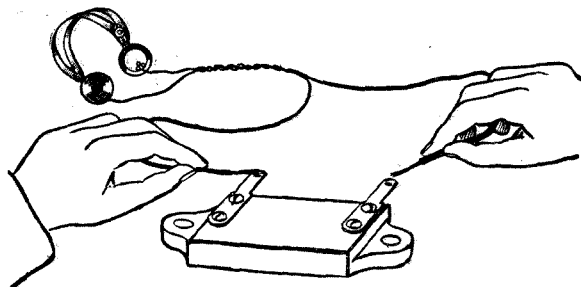

Fig. 2.—How to test a fixed condenser.

up with it will be most disappointing in its performances, if indeed it works at all. Before embarking on making up any piece of apparatus test it with the phones in this way. Drill two holes at opposite ends of the panel—they can be placed in a portion of the ebonite that will eventually be

trimmed off—and mount a terminal in each. Connect these two terminals to the high-tension battery, fastening one of the phone leads also to one of them. Put on the phones and with one hand touch the surface of the ebonite in various places with the unattached phone lead. Bad insulation will be shown up by the occurrence of clicks in the phones when the ebonite is touched in certain places. Sometimes the faultiness is due only to the highly polished skin of the ebonite and can be cured by removing all the polish with fine emery paper. But frequently the material itself is to blame, and if the test discloses that its insulating qualities are bad the panel should be returned to the vendor as useless for wireless purposes.

We now come to the ways in which the telephones may be used for finding faults in the set itself. We have already seen how they may be used for testing induct-

the trouble is likely to be found in either the grid circuit or the plate circuit of some particular valve. To test the grid circuit disconnect the lead running to the grid and insert the telephones into the circuit. With the filament switched on make and break the circuit by touching with one of the phone leads. If all is in order

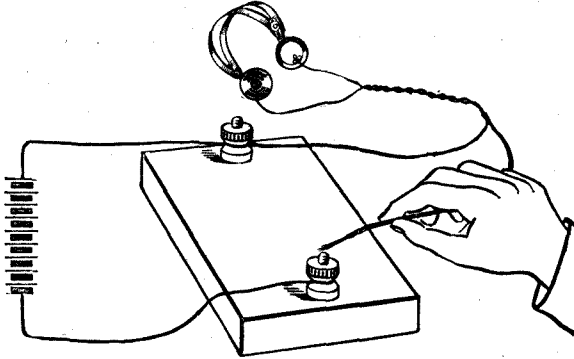

Fig. 4.—A test for ebonite insulation.

clicks will be heard owing to the passage of grid current. It may be necessary, by the way, to move the rheostat a little, for it might happen that you had struck the exact point at which the potential applied to the grid was just that required to stop the flow of grid current entirely at a given filament temperature. Should there be a condenser and a gridleak in the circuit the condenser should be bridged by the telephones as shown in Fig. 5.

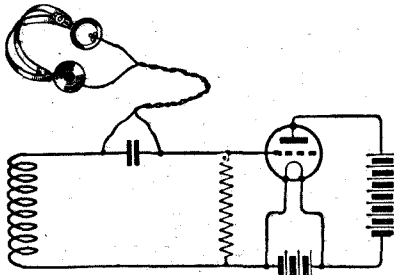

Fig. 5.—A grid circuit test.

The test for the plate circuit is very similar, the phones being placed in this circuit as shown at A, B in Fig. 6, and connection made and broken as before. There are very many other ways in which the responses of telephones to minute currents can be made use of by the owner of a wireless set, and these will suggest themselves. Practically every fault that can occur is due to either a broken circuit or a short circuit and the phones will enable you to discover either very quickly indeed.

R. W. H.

ances and condensers, and these are almost the only places in which a breakdown is likely to occur in the crystal set. With the valve set, however, there is a much wider field in which faults may develop. If the tests previously mentioned show anything wrong the cause of

Messrs. Woodhall Wireless Manufacturing Co. also send us a leaflet describing their condensers, fixed and variable, variometers, coil-holders, etc.

Messrs. Gamages, of Holborn, have issued an up-to-date catalogue describing their wireless apparatus. All types of loud-speakers, accumulators and components are listed.

From Messrs. Economic Electric Co. we have received a fully illustrated catalogue of apparatus. This includes a self-setting detector, and their "Xtraudion" valve. For this valve they claim a low current consumption, and the high amplification factor of 12.

Messrs. Burndept, Ltd., send us their latest catalogue for review. It is arranged into five sections:—

- (1) Broadcast receiving sets, including multi-valve sets in table form.
- (2) Standard Burndept receiving equipment, including many experimental sets.
- (3) Home constructional broadcast receiving sets.
- (4) Auxiliary apparatus, components and sundries. This contains a complete list of component parts and accessories.
- (5) Transmitting apparatus. This section is under re-arrangement, and is not yet complete.

Messrs. Fallons send us a leaflet of their condensers and variometers. The "Duanode," one of the listed condensers serves for controlling simultaneously two stages of high-frequency amplification as one.

Messrs. Harrold publish a leaflet describing their anti-capacity change-over switches. They can be used in all cases in which knife switches are used, and have the advantage, besides their very low-capacity, of taking up much less room on the panel than knife switches. The switches are very neat in appearance.

Messrs. Woodhall-Wireless Manufacturing Co., London, have issued a leaflet of condensers, variometers, resistances, and other components.

Mr. A. Hinderlich has recently issued a list of accessories, including crystals of all types, all kinds of wires, and other useful components including a combination crystal detector, called the "Tellite," which is claimed to be very sensitive and is stable when a sensitive spot is found.

Messrs. Clyde Electrical Co., of Glasgow, send us particulars with photographs of their new crystal set, the "Clydelco," which has several features claimed to be novel. It is tuned by means of a variometer and there are two detectors, either of which can be used.

Wooden boxes may also be constructed to fit any size of set, and the wiring may be altered with a minimum of trouble.

Messrs. Gent and Co. send a leaflet describing their "Tangent" low-frequency transformers. These are made in three different sizes.

SOME INTERESTING CATALOGUES.

From Messrs. Radio Communication Co., Ltd., we have received their book describing "Polar-Blok" system of elastic set construction. The different panels clip together on a metal framework (the metal is non-magnetic) which can be altered in size to any desired extent.

WHAT A BOY OF FIFTEEN CAN MAKE

THE accompanying photographs are kindly sent to us by Mr. E. K. Spiegelhalter, of Malton, Yorks. The apparatus shown was built without assistance and advice (other than that contained in No. 1 of MODERN WIRELESS) by his schoolboy son, aged 15½. The set is a dual-reaction receiver and gives remarkably good results from all the B.B.C. stations, both as regards strength and purity. The selectivity is also exceedingly good. We congratulate Mr. Spiegelhalter, jun., on his work, which should stimulate other boys to better efforts.

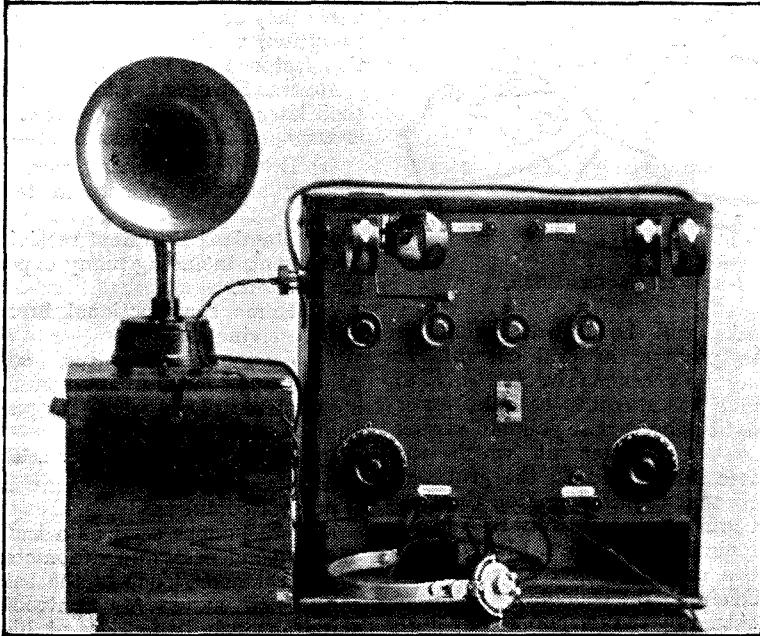

This dual-reactance set is the unaided work of a young wireless enthusiast of Malton, Yorks.

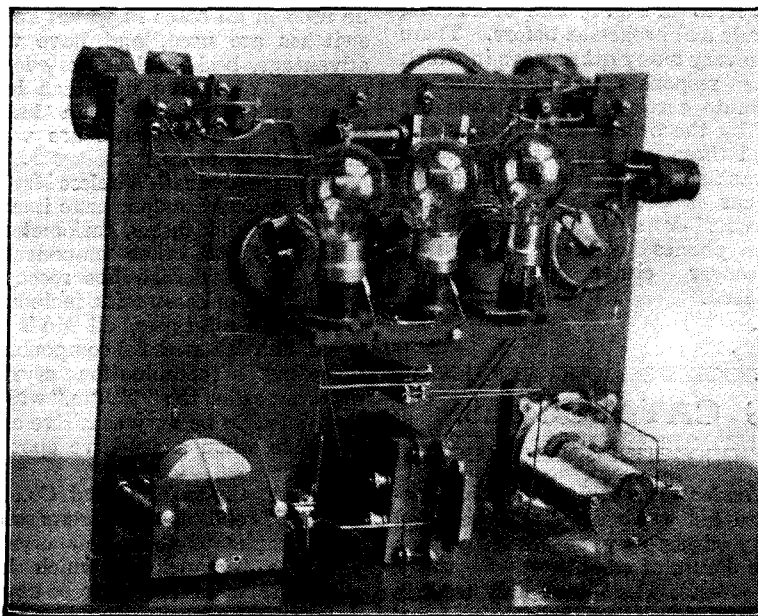

Note particularly the neat wiring and finish. The results are just as good as the workmanship.

AN INTERESTING STUNT

A TRICK that astonishes those who know little or nothing of wireless can be performed with any fairly powerful set. Disconnect the earth lead from its terminal and ask one of those present to hold it in his right hand. Signals will, of course, become very faint, if they do not altogether cease. Now get the person who is holding the wire to touch the earth terminal with a finger of his left hand. Signals come in with almost their original strength, having passed right through his body, or rather over its surface. Sometimes a chain of people holding hands can be made between the earth lead and its terminal.

SHOCKS

SOME people are vastly more susceptible to the effects of electricity than are others. The writer, for instance, can get quite a nasty shock from the output terminals of a three-valve set, though most people could place their fingers upon them with complete impunity. With direct currents it is largely a question of the thinness and the natural dampness of the skin. If the skin is thick and dry the resistance of the body may be as high as 35,000 ohms; if the opposite conditions are present it may average only 10,000 ohms in cold weather, and may fall as low as 200 when the atmosphere is hot and damp.

It has been calculated that a voltage drop of as little as three volts through the body with a current of 100 milliamperes may be sufficient to cause death. When murderers are electrocuted in the States the voltage used is 1,800, and the ammeter usually registers about 9 amperes. Yet it is quite possible to grasp in either hand electrodes with a potential difference of as much as 100,000 volts between them and to feel nothing at all!

If this voltage were *direct*, death would be instantaneous. But when it is alternating at very high frequency it produces no effects, for it passes over the skin and does not penetrate sufficiently deeply to cause paralysis of the nerve centres.

One of the most dangerous things that one can possibly do is to switch on or off the electric light whilst lying or standing in a hot bath.

R. W. H.

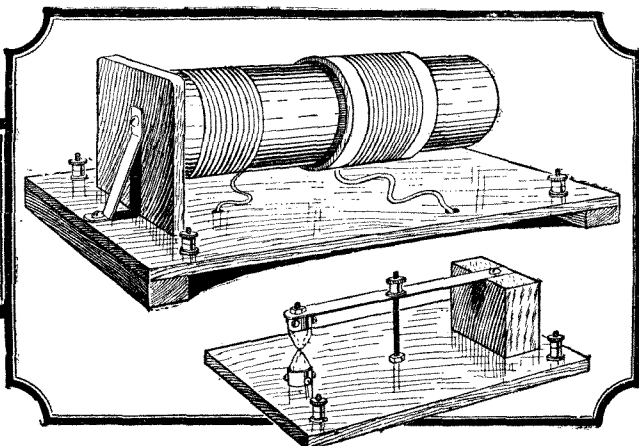

A Crystal Set is always useful—

No. 3
of the
RADIO PRESS
Series

WHEN your Accumulator runs down, or your Valve burns out, or your H.T. Battery suddenly develops noises—these are the occasions when you would give almost anything for some means of “carrying on.” Why not forestall these possibilities by making a Crystal Set now?

This new Book by John Scott-Taggart, Editor of “Wireless Weekly” describes three useful Sets which can be made by anyone without special skill in the use of tools. In fact, the simplest of them (illustrated above) can even be constructed of material you would find around the house.

All have been designed to give good results with a range of, say, 25 miles from your nearest Broadcasting Station.

Get a copy of this Book to-day—even if your present Set seems immune from breakdown, you will never regret the time spent on building a Crystal Receiver.

Contents

- Some General Principles.
- The Question of Licences.
- Parts of the Wireless Receiver.
- Crystal Detectors.
- Inductance Coils.
- The Construction of the Crystal Detector.
- Connecting up the Receiver.
- Operation of the Set.
- The Variable Inductances.
- The Telephone Condenser.
- Operation of the Circuit.
- Erecting your Aerial.
- Insulating your Aerial.
- General Dimensions of the Aerial.
- Constructional Details when using Masts.
- The Down-lead and Lead-in.
- Adjusting the Span of the Aerial.
- Twin-wire Aerials.
- The Earth Connection.
- The Aerial-earth Switch.
- Some remarks on Tuning.
- Receiving Paris Signals.

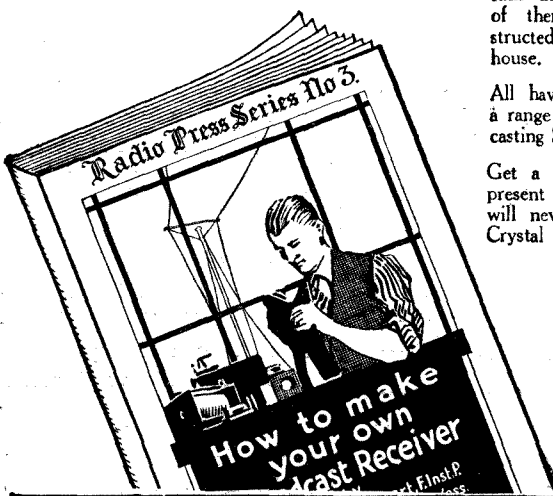

Radio Press, Ltd.
PUBLISHERS OF AUTHORITY WIRELESS LITERATURE
BEVEREUX COURT, STRAND, W.C.2.

From all Booksellers
and Newsagents, or
1/7½ post free direct

How to make your own Broadcast Receiver

By John Scott-Taggart, F.Inst.P.

1/6



No other Wireless Magazine Staff as *Wireless Weekly*

TO obtain the confidence of its readers, and to achieve complete success, a Wireless Magazine must be in the position to guarantee the accuracy and dependability of the information within its columns. *Wireless Weekly* is supervised by the finest staff of all-round Wireless technical experts in the country. Each department of *Wireless* is in the hands of a man who has had some considerable experience in dealing with it and who may be considered an expert in that particular phase of the Science. Such an organisation as this is of benefit to you in two ways. Firstly, because it is so complete in itself as to be independent, when necessary, of outside con-

tributors. Secondly, it is in a position to judge the value of contributions submitted for publication by outside research workers and technical men and able to criticise and correct faults which might otherwise have appeared in print unnoticed. You, as a keen wireless experimenter, want authoritative *Wireless* articles—thoroughly up to date and dependable. *Wireless Weekly* fulfils your requirements in a way no other Wireless Magazine ever has or can do. If you have not already become a regular reader, send a postcard at once for a free copy—you will be surprised that such a large and important Weekly Magazine can be produced for so little as sixpence

EDITORIAL STAFF,

Editor: JOHN SCOTT-TAGGART, F.Inst.P.
Assistant Editors: E. REDPATH AND PERCY W. HARRIS.
Staff Editors: E. H. CHAPMAN, M.A.; D.Sc.; A. D. COWPER, M.Sc.; G. P. KENDALL, B.Sc.; R. W. HALLOWS, M.A.; S. G. RATTEE, Scientific Adviser: Prof. G. W. O. HOWE, D.Sc., M.I.E.E.
Advisory Editors: Prof. R. WHID-DINGTON, M.A., D.Sc. Prof. C. L. FORTESCUE, M.A., M.I.E.E.

Wireless Weekly

Every Wednesday

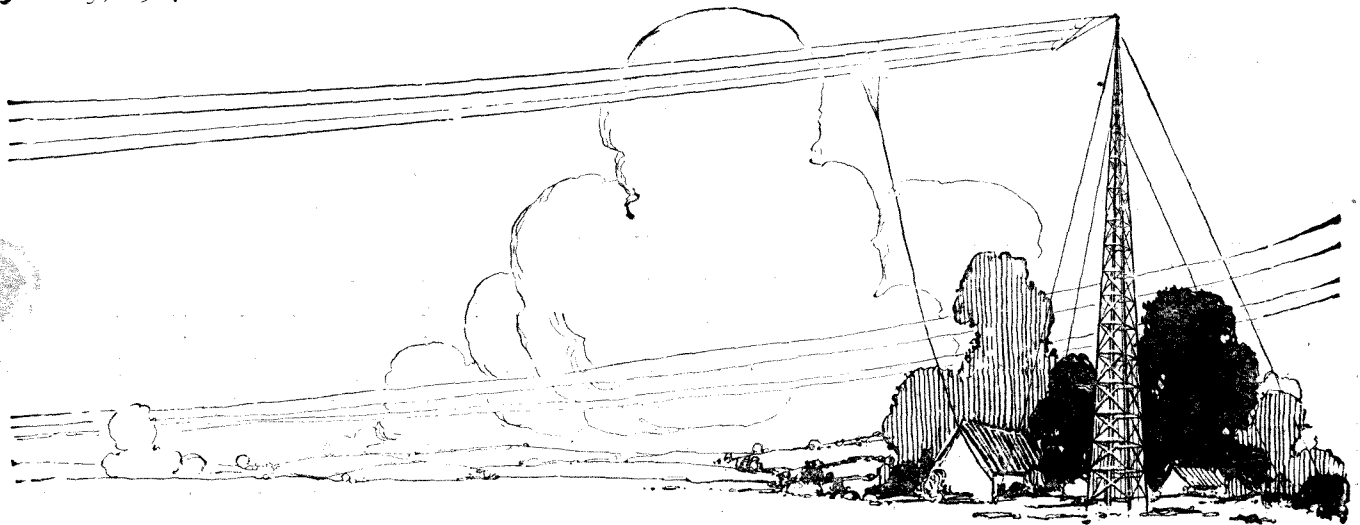

has such a complete Editorial
—read how you benefit.

Recent Constructional Articles.

Annual subscription (52 issues post free), 32/6. Subscribers are permitted the free and unrestricted use of our Information Dept. To others we are compelled to make a charge of 2/6 per question. Why not send your subscription along now and ensure your copy arriving punctually?

- A Simple Transmitting Set for Amateur Telephony.
- A 2-Valve Power Amplifier.
- A Super Heterodyne Receiver.
- A Pea-Nut Reinartz Receiver.
- A Regenerative Reflex Receiver.
- A Simple H.F. Amplifier for a Crystal Set.
- The Cowper Receiver (with two H.F. Valves).
- Wave Traps and Interference Eliminators
- An Attaché Case Armstrong Super.
- A 2-Valve Cabinet Receiver.
- Several Types of S.T. 100 Sets.
- And a large number of others.

Sold by all Newsagents and published by
RADIO PRESS, Ltd., Devereux Court,
Strand, W.C. 2.

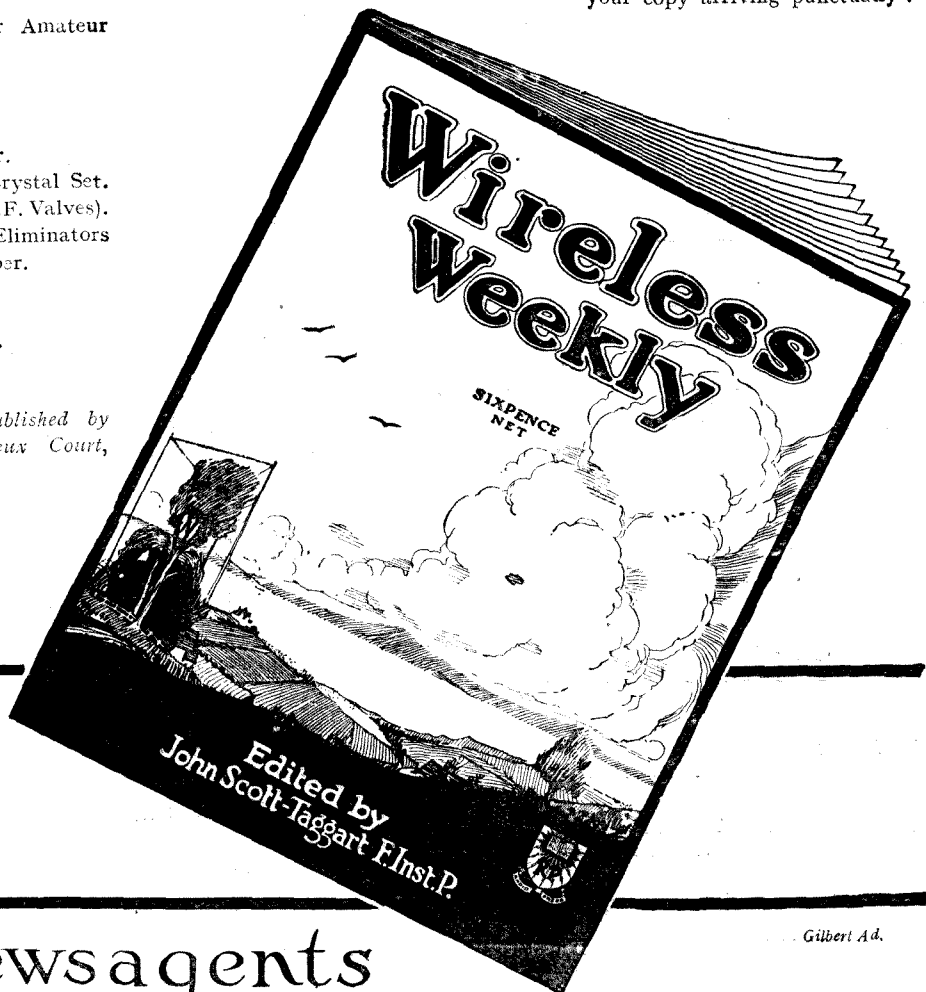

from all Newsagents

In replying to advertisers, use COUPON on last page

Gilbert Ad.

Index to Advertisers

	PAGE		PAGE		PAGE
Autoveyors Ltd.	xi	Formo Co.	XXX	Mullard Radio Valve Co. Ltd.	xxviii
Bowyer-Lowe Co.	283	Fuller's United Elec. Works, Ltd.	273	Nalder (E.) & Co.	xxx
British Battery Co., Ltd. (The)	vii	Gambrell Bros., Ltd.	v	New London Electron Works..	xi
British Thomson-Houston Co., Ltd.	xxv	General Electric Co., Ltd. (Facing matter)	i	Radio Instruments, Ltd.	Cover iv
Brown Bros.	vii	General Wireless Ltd.	xx	Radions Ltd.	vii
Burne-Jones, Ltd.	xx	George Mfg. Co.	xxiv	Radio Stocks, Ltd.	xxiv
Buss (T.O.)	xix	Hobday Bros.	279	Raymond (K.)	xviii
Chloride Elec. Storage Co.	ix	London Radio College Junior Wireless	70	Roberts (A.) & Co. Junior Wireless	70
Clarke (H.) & Co. (Manchester), Ltd.	xvi	Igranic Electric Co., Ltd.	iv & vi	Robinson, Lionel, & Co.	263
Climax Patents Ltd.	xxx	International Radio Mfns., Ltd.	xxiii	Rowley & Louis	283
Cossor Valve Co. Junior Wireless	69	Jackson Bros.	xxiii	Radio Communication Co., Ltd.	282
Curtis (Peter) Ltd.	276	Lowne Electric Co.	xxx	Service Co., Ltd.	279
Dixon (Leslie) & Co.	xxiv	McMichael (L.) Ltd.	v	Silvertown Co.	ii
Dubilier Condenser Co. (1921), Ltd. (Facing matter)	x	Melhuish, Richard, Ltd.	279	Simpson & Blythe	279
Economic Electric Ltd.	273	Metropolitan-Vickers Elec. Co., Ltd.	Cover ii	Smith & Ellis	xxiv
Edison Swan Electric Co., Ltd.	xiv			Thomson (J. E.) & Co.	xx
Elkay Wireless Co.	xxvi			Ward & Goldstone, Ltd.	xxii
Ever-Ready Co. (Gt. Brit.), Ltd.	xxviii			Western Electric Co., Ltd.	vi
Fellows Magneto Co., Ltd. (Facing matter)	xxii				

EDINBURGH.
Wm. Sinclair, 60-64, Thistle St., Edinburgh. All component parts in stock at lowest prices.

EDINBURGH.
Spensers (Scotland), Ltd., 119, George St., Edinburgh. Agents for Burndept, Ltd.

WIRELESS INVENTORS.
Advice Handbook on Patents and Trade Marks. Consultations free.—B.T. King, Regd. Patent Agent, 146a, Queen Victoria St., E.C.4. Phone: Central 682.36yrs.ref.s.

J. DYSON.
5 & 7, Godwin Street, Bradford. Complete Sets. All Accessories. Tele. 6037 & 6038. Telegrams: "Equipment."

A. Franks, Ltd., 95-97, Deansgate, 44, Market Street, 73, Oxford Street, 12, Victoria Street, Manchester, and 90, Bradshawgate, Bolton.

"EIFFEL TOWER" MASTS.
(Trade Mark) Reg. Des. 694837.
WILKINSON, Lonsdale Road, Write for Lists. Kilburn, N.W.6.

French Manufacturer headphones and loud speakers for wireless requires London representative having clients amongst wholesalers.—Falco, 7, Rue de Moscou, Paris 80.

"Eiffel Tower" Transformers.—L.F. 5 '1, wonderful value. 12/6, carr. paid. Each Transformer guaranteed perfect and tested.—Wilkinson Lonsdale Road, Queen's Pk, N.W.6. Est. 1900.

Accumulators.—We repair and recharge any make of cell. Trade or Private.—Wilkinson, Lonsdale Rd., Queen's Pk., N.W.6. Est. 1900. Makers of the "Eiffel Tower" Wireless Mast.

JUNIOR WIRELESS SECTION.
Are you interested in Wireless? Then why not make it your profession? Students trained for Marine Wireless Service and appointments obtained. Part of fees may be paid out of salary after appointment.—Apply, full particulars, London Radio College, Ltd., 82-83, High Street, Brentford.

CRYSTALS.—Genuine Russell & Shaw HERTZITE 1/-, ZINCITE, TELLURIUM 1/-, BORNITE, GALENA, SILICON 6d., G.E.O.'s "GEOBITE" 1/6. All post free. Trade supplied. All Wireless Accessories in stock. **V. ZEITLIN & SONS, 144, Theobald's Road, London. W.C. 1.**

COUPON

Questions and Answers

In future this coupon must be accompanied with
2s. 6d. P.O.

"MODERN WIRELESS" January, 1924.

USE THIS COUPON

in writing to advertisers in "Modern Wireless."

CUT HERE

In connection with your announcement in MODERN WIRELESS, please supply me with:

Enclosed please find remittance of.....
(Leave blank if not an order)

If an open envelope is used in applying for catalogues a half-penny stamp will cover postage.

Name.....

Address.....

Date.....

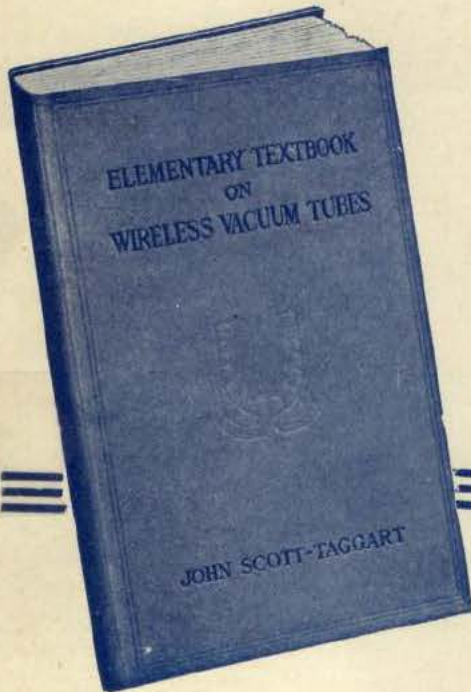

—a necessity for every Experimenter

Contents

1. Fleming Valves.
2. The 3-Electrode Vacuum Tube.
3. Cascade Vacuum Tube Amplifiers.
4. Regenerative Amplification and Self-oscillation.
5. Regenerative Reception of Signals.
6. C.W. Receiving Circuits.
7. Vacuum Tube Transmitters.
8. Radio-Telephony employing Vacuum Tubes.
9. Further Vacuum Tube Amplifications.

10/-

post free

THIS Book should be in the hand of every Experimenter who wants to obtain a thorough understanding of Wireless.

It is recognised as the only standard Text Book sold at a price within the reach of anyone. Beautifully bound in solid cloth and plentifully illustrated with circuit diagrams and charts, it is a vital necessity to the student, the research worker and the designer. If you are building a Set for pleasure or for profit, get a copy of this Book and understand the fundamental principles of Radio.

Obtainable from all Booksellers of direct from Publishers:—

RADIO PRESS, LTD.,
Devereux Court, Strand, W.C.2



Four-valve Set in Case with cover not interfering with valves or leads. Wave length range 300-4,000 metres. Price **£26**



The improved Anode Choke Coil. As recommended by "Modern Wireless." Price **10/-**.

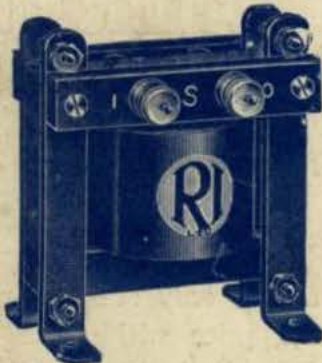

The famous R.I.L.F. Inter-valve Transformer. Price **25/-**.



Crystal Detector. Dust-proof Micrometer Adjustment. Permanent Stability. Price **8.6.**



A Mark That Counts

A little black and gold monogram, carrying with it a regular feast of good will and past acquaintances is our now famous mark.

It is a worker that has served us well, for it arouses a feeling of pleasure and satisfaction in the hearts of all radio experts. It is distinctive, which is all the stronger because of the distinction held by the firm whose work it represents.

TO YOU IT IS THE SIGN OF THE FIRM WHO HAVE

Built up the largest component business in the British Isles ;

Specialised on the manufacture of wireless sets and components only ;

Over a quarter of a century's radio experience ;

Set the standards recognised to-day by all the leading journals and institutions ;

Built the now famous R. I. TRANSFORMER.

We invite your inquiries and will forward our new 50-page catalogue post free on your suggestion.

RADIO INSTRUMENTS LTD.,

Managing Director: J. JOSEPH, M.I.E.E.

Chief Designer: W. A. APPLETON, M.B.E., M.I.R.E., late Admiralty Technical Research Officer.

Works, Offices and Showrooms:

12, HYDE STREET, NEW OXFORD STREET, W.C.1.

Telephone: Regent 6214-6215-6216.

Telegrams: "Instradio, London."

NORTHERN DEPOTS: 19, Hopwood Avenue, MANCHESTER and Trinity House, Commercial Street, LEEDS.