

Best of Maplin PROJECTS

XC06G

BOOK 5

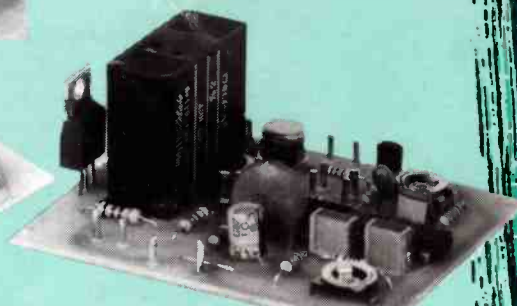
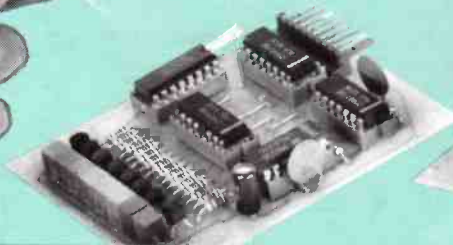
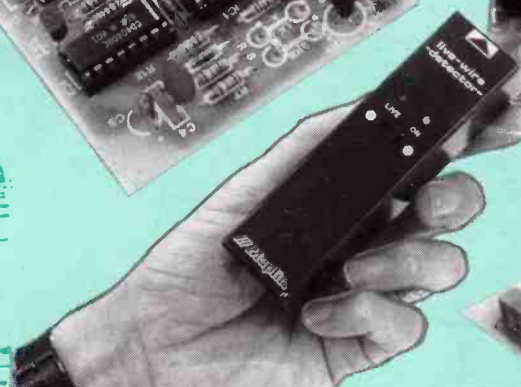
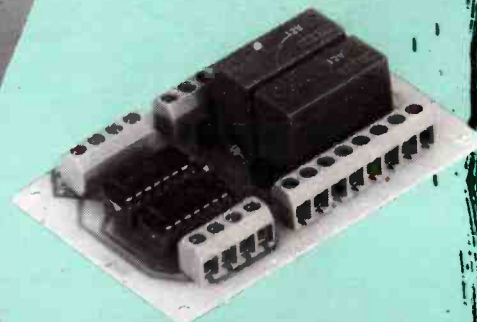
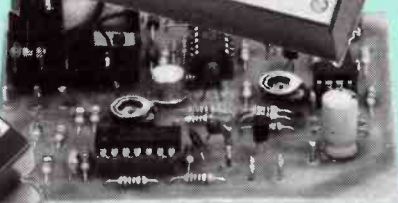
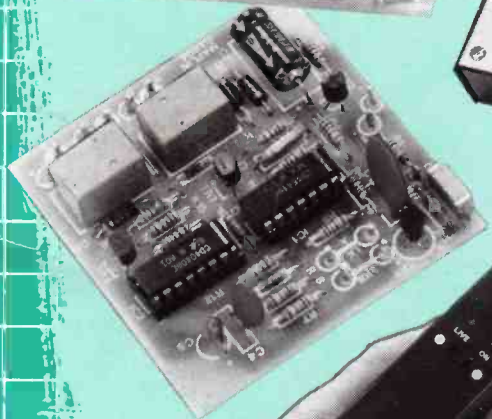
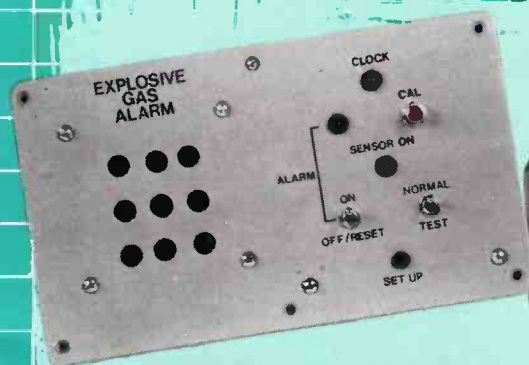

- ★ Programmable Timer
- ★ MOSFET Amp Bridging Module
- ★ Auto-Waa Effects Unit
- ★ TDA 7000 Radio Mk II
- ★ Watt Watcher
- ★ Xenon Flash Tube Driver
- ★ 12V Fluorescent Tube Driver
- ★ Mains Controller for Fluid Detector
- ★ PWM Motor Driver
- ★ Control-A-Train
- ★ Live Wire Detector
- ★ 8-Channel Fluid Detector
- ★ Low Power Radio Control System
- ★ Ultrasonic Car Alarm
- ★ Explosive Gas Alarm
- ★ Display Driver Module

CONTENTS

BEST OF MAPLIN PROJECTS BOOK SIX

EDITORIAL

Best of Maplin Projects Book Six, is a compilation of the most popular projects from 'Best of Maplin Projects Books One to Four', and *Electronics - The Maplin Magazine* Issue 27, all of which are now out of print. Other issues of 'Maplin Projects Books' will be replaced by 'Best of' projects books as they also go out of print. In addition, earlier 'Best of' projects books will be recompiled into newer versions to include the currently most popular projects. Back issues of *Electronics - The Maplin Magazine* are available until they, too, go out of print and will then be replaced by projects books. For kit prices, please consult the latest Maplin Catalogue and free price change leaflet, order as CA99H.



Editor Robert Ball. Compiled by Mike Holmes.
Contributing Authors Dave Goodman, Robert Penfold, Chris Barlow, Gavin Cheeseman, Nigel Jawcott, Robert Kirsch.
Technical Authors Robin Hall, Mike Holmes.
Technical Illustrators Paul Evans, Lesley Foster, Ross Nisbett, Nicola Hull.
Production Scheduler Steve Drake.
Print Co-ordinator John Craddock.
Publications Manager Roy Smith.
Development Manager Tony Bincknell.
Drawing Office Manager John Dudley.
Art Director Peter Blackmore.
Designer Jim Bowler.
Published by Maplin Electronics plc.
Mail Order P.O. Box 3, Rayleigh, Essex SS6 8LP.
Telephone Retail Sales: (0702) 554161.
Retail Enquiries: (0702) 552911.
Trade Sales: (0702) 554171.
Cashier: (0702) 552941.
General: (0702) 554155.
Shops: See below.
Fax: (0702) 553935. Telex: 995695.

Visit a Maplin Shop for Personal Service

You'll find Maplin Service in
Birmingham, Sutton New Road, Erdington
Brighton, 65 London Road
Bristol, 302 Gloucester Road, Horfield
Cardiff, 29-31 City Road
Chatham, 2 Luton Road
Coventry, 12 Bishop Street
Edinburgh, 126 Dairy Road
Glasgow, 264-266 Great Western Road
Leeds, Carpet World Building, 3 Regent Street
Leicester, Office World Building, Burton Street
London, 146-148 Burnt Oak Broadway, Edgware
107-113 Stanstead Road, Forest Hill
120-122 King Street, Hammersmith
Mord, 302-304 Green Lane
Manchester, 169 Cheetham Hill Road, Cheetham Hill
8 Oxford Road
Middlesbrough, Unit 1, The Forbes Building,
309-321 Linthorpe Road
Milton Keynes, Snowdon Drive, (next to Office World) Winter Hill
Newcastle-upon-Tyne, Unit 4 Allison Court, Gateshead
Northampton, 139 St James Road
Nottingham, 86-88 Lower Parliament Street
Portsmouth, 98-100 Kingston Road
Reading, 129-131 Oxford Road
Sheffield, 413 Langsett Road, Hillsborough
Slough, 216-218 Farming Road
Southampton, 46-48 Bevois Valley Road
Southend-on-Sea, 282-284 London Road, Westcliff-on-Sea
Stockport, 259-261 Wellington Road South

All our shops are open from 9.00am to 5.30pm Monday to Saturday (9.30am Friday). Shops that are open on Sundays are Brighton if local conditions permit. Edinburgh 10.00am to 4.30pm. Glasgow 9.00am to 5.30pm. Oxford Road and Cheetham Hill Manchester if local conditions permit. Newcastle 10.00am to 4.30pm. All shops are closed for Public Holidays. Shops do not close for lunch.

FOR MAIL-ORDER ENQUIRIES, PLEASE DO NOT CALL OUR SHOPS AS THEY WILL BE UNABLE TO HELP YOU. Send all mail to P.O. Box 3 Rayleigh Essex SS6 8LP.

PROJECTS

2 PROGRAMMABLE TIMER

Provides a means of pre-setting the duration for which a burglar alarm will sound when triggered.

Original Issue 5.

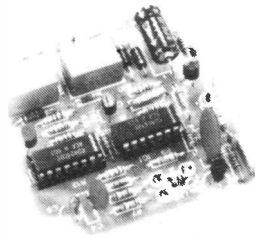

4 MOSFET AMPLIFIER BRIDGING MODULE

Converts two 150W MOSFET power amplifier modules into a 400W bridged amplifier.

Original Issue 6.

7 AUTO-WAA EFFECTS UNIT

Waa-waa for electric guitar using signal strength for depth control.

Original Issue 10.



11 TDA 7000 RADIO MK II

Improved version of the popular FM radio project with case and aerial.

Original Issue 27.

19 WATT WATCHER

A novel project which will tell if you are over driving your speaker system.

Original Issue 27.

22 12V FLUORESCENT TUBE DRIVER

To operate 8in. '12V' fluorescent tubes for cars, boats and caravans, etc.

Original Issue 10.

24 XENON FLASH TUBE DRIVER

Xenon flash tube module for strobing and other uses.

Original Issue 11.

27 8-CHANNEL FLUID DETECTOR

Display water levels in one or more containers or use to operate electric valves, pumps, etc.

Original Issue 10.

30 FLUID DETECTOR MAINS CONTROLLER

An adaptor enabling the fluid detector to control mains powered devices.

Original Issue 13.

32 PWM MOTOR DRIVER MODULE

A variable speed PWM model motor controller.

Original Issue 12.

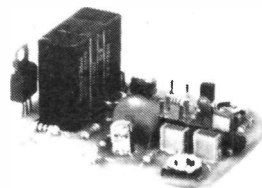

35 LOW POWER RADIO CONTROL SYSTEM

Transmitter and receiver for radio controlled models.

Original Issue 13.

41 CONTROL-A-TRAIN

Pulse width modulated output model train controller.

Original Issue 14.



46 LIVE WIRE DETECTOR

Locates concealed live mains cables.

Original Issue 14.

49 ULTRASONIC CAR ALARM

Monitors interior of vehicle with ultrasound to detect a break-in.

Original Issue 15.

53 EXPLOSIVE GAS ALARM

Detects the escape of most combustible gases.

Original Issue 13.

57 DISPLAY DRIVER MODULE

An easy way to build your own bargraph displays.

Original Issue 14.

Copyright. All material is subject to worldwide copyright protection, and reproduction or imitation in whole or part is expressly forbidden. All reasonable care is taken to ensure accuracy in preparation of this publication but Maplin Electronics plc cannot be held legally responsible for its contents. Where errors occur corrections will be published as soon as possible afterwards. Permission to reproduce printed circuit board layouts commercially or marketing of kits must be sought from the publisher.
©Copyright 1993 Maplin Electronics plc

EXTERNAL HORN PROGRAMMABLE TIMER

by Dave Goodman

- ★ Three timing settings from 2 minutes to 2½ hours
- ★ Switch over from sounder to flashing beacon when time is up
- ★ Directly replaces the previous external horn PCB
- ★ Two wire control with tampering detection

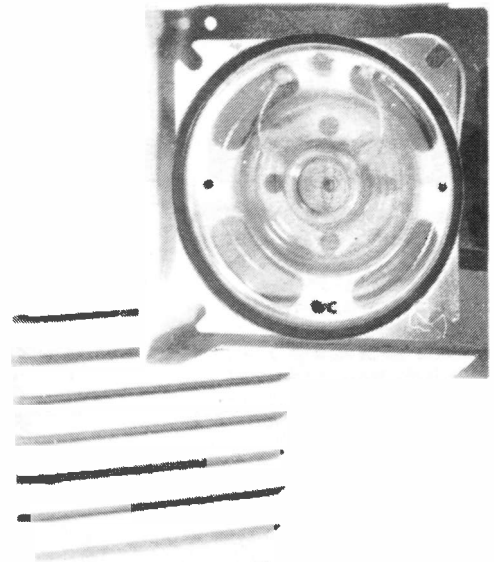

New recommendations concerning the use of burglar alarm sounders have recently been introduced, and apply only to sirens or bells fitted outside protected premises, not to those used internally, unless they are likely to be audible outside. The ruling comes under the noise pollution title, and requires that alarm sound indicators cease to function after a seventeen minute running period from switch-on. Presumably the alarm would, or should, have been raised within this time, and the appropriate authorities notified, making further ear-blasting and nerve-shattering decibels unnecessary. So that it is not forgotten that the alarm system has been activated a

flashing lamp or beacon can be switched on which will flash away until reset. Perhaps eye pollution will become a problem in the future!

Specification

A timer project has been designed for use with the Home Security System (see March issue) which will directly replace the previous External Horn PCB. Any type of siren, bell, or sounder requiring 12V at no more than 1A DC can be used, and in addition a lamp or beacon rated at 12V and less than 1A DC can be switched on after a preset time-out period has elapsed. One of three timing periods (see table 1) ranging from 2 minutes to 2½ hours can

be programmed by removing or adding two wire links as required.

A 12V battery supply is needed to power this system, and batteries, siren, and PCB will all fit into an external horn cabinet. Unfortunately, this PCB is larger than the previous one, and the mounting holes in the cabinet lid will not align with it, so a further two 6BA holes are required. The lamp may be fitted to the cabinet, or wherever it will be readily visible.

Circuit Description

R1 terminates a two wire loop connection from the mother board in the main alarm. Removal of R1 from the circuit, either by shorting or open

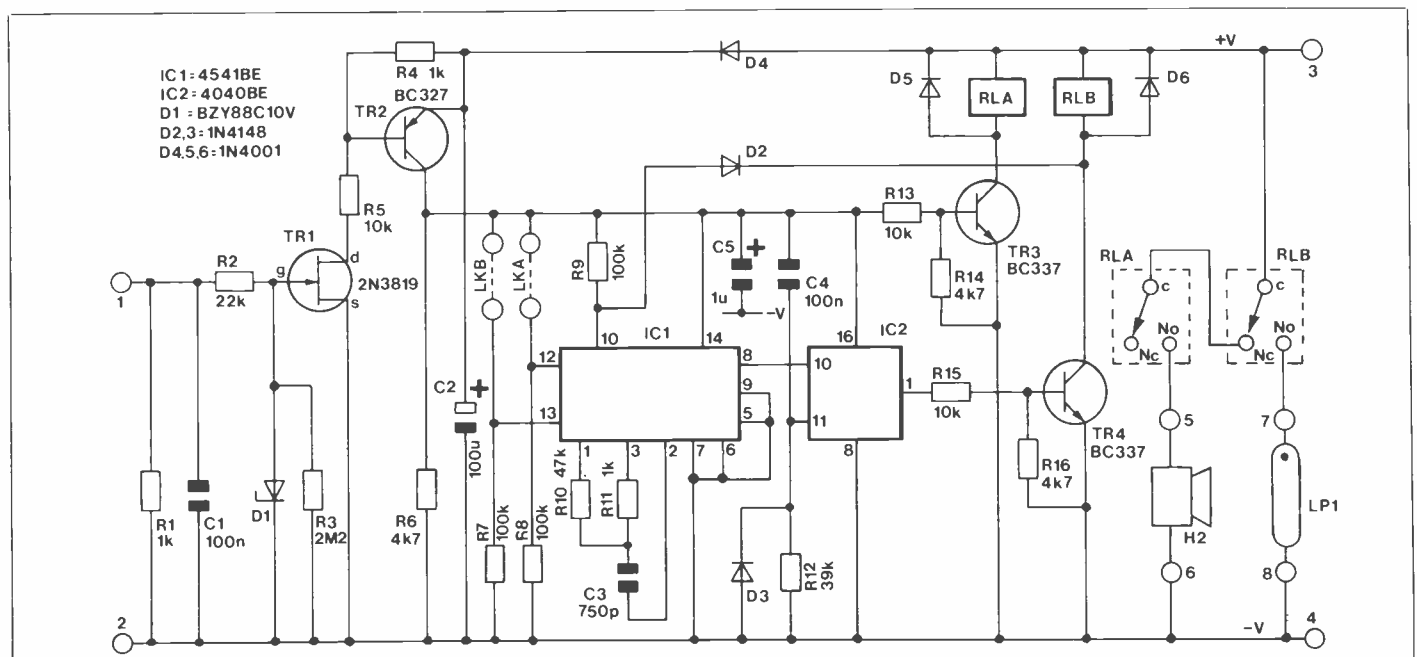

Figure 1. Circuit diagram.

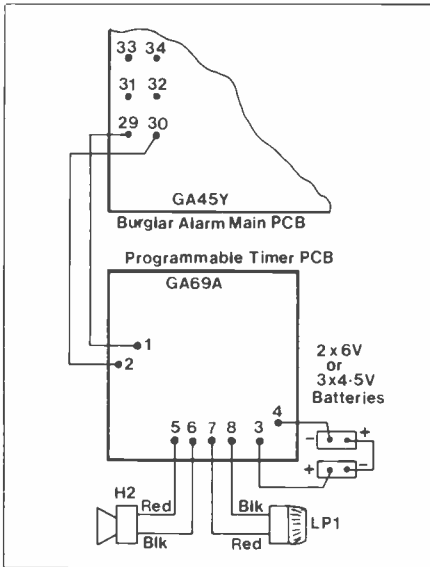

Figure 2. PCB layout and overlay.

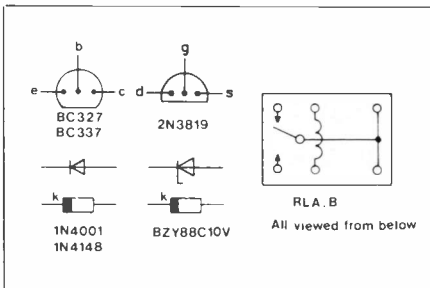
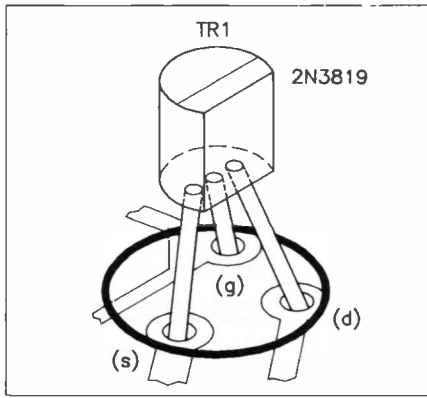
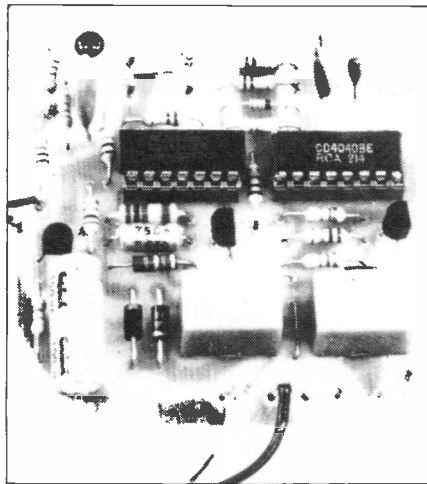

Figure 3. Wiring to main burglar alarm PCB.



Mounting TR1.

circuiting the loop, will trigger the main alarm. TR1 is an N-type J-FET device, and requires a negative potential between gate and source to prevent drain current flow. With Pin 1 or 2 disconnected, R3 holds TR1 gate to ground, allowing drain current to flow.

C1, R2 and D1 help prevent RF and voltage spikes, that may be introduced along the length of connecting cable used, false triggering the timer. Now, with TR1 conducting, the voltage drop across R4 and R5 is sufficient to allow TR2 to conduct, and connect the battery positive rail, via D4, to the supply rail. R13 monitors the positive supply rail, and TR3 immediately conducts, switching RLA, and allowing the siren connected between pins 5 and 6 to operate for a period of time (generated by IC1 and 2).

IC1 is a programmable timer, with an internal clock and four dividing stages. Clock frequency is set by R10, R11 and C3 to 16.5kHz, which is divided down by one of three stages set by links from the positive rail to pins 12 and 13 (Table 1). The Q output at pin 8 requires further dividing, and is applied to a 12 stage ripple counter, IC2. C4 and R12 apply a reset pulse to IC2, ensuring that all twelve dividing stages will function, and a positive-going output at pin 1 operates TR4 and relay RLB.

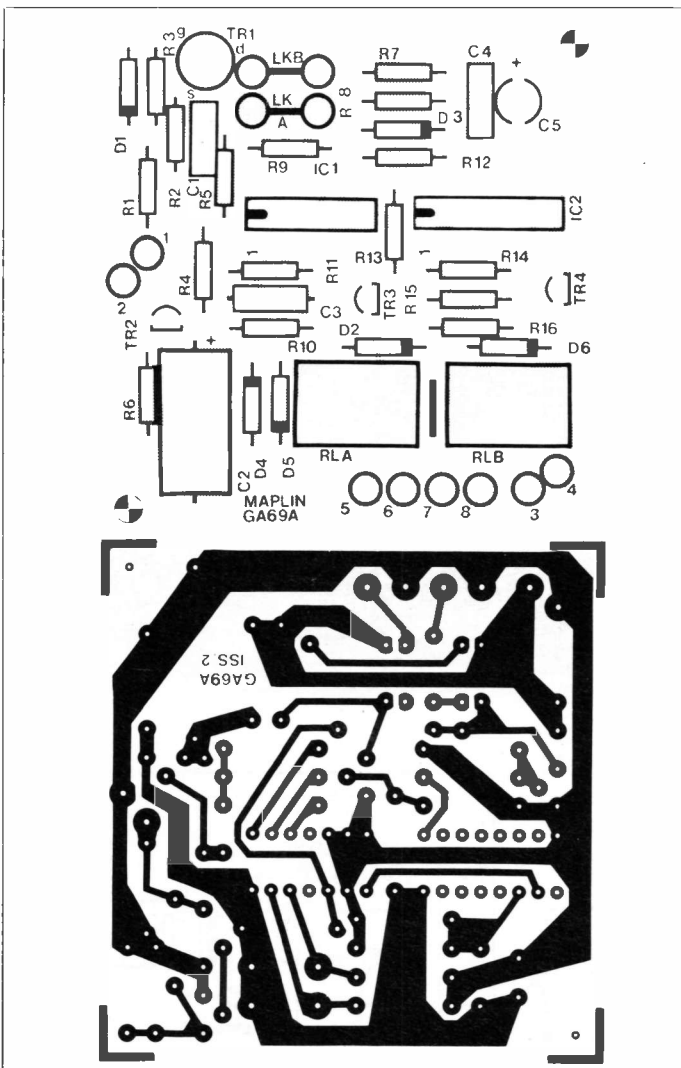

PROGRAMMABLE TIMER PARTS LIST

Resistors - all 0.6W 1% metal oxide unless specified			
R1,4,11	1k	3	(M1K)
R2	22k	1	(M22K)
R3	2M2	1	(M2M2)
R5,13,15	10k	3	(M10K)
R6,14,16	4k7	3	(M4K7)
R7,8,9	100k	3	(M100K)
R10	47k	1	(M47K)
R12	39k	1	(M39K)
Capacitors			
C1,4	100nF Disc Ceramic	2	(BX03D)
C2	100µF 25V axial electrolytic	1	(FB49D)
C3	750pF 1% polystyrene	1	(BX55K)
C5	1µF 35V Tantalum	1	(WW60Q)
Semiconductors			
D1	BZY88C10V	1	(QH14Q)
D2,3	1N4148	2	(QL80B)
D4,5,6	1N4001	3	(QL73Q)
TR1	2N3819	1	(QR36P)
TR2	BC327	1	(QB66W)
TR3,4	BC337	2	(QB68V)
IC1	4541BE	1	(QQ47B)
IC2	4040BE	1	(QQ27E)
Miscellaneous			
RLA,B	Ultra-min relay 12V SPDT	2	(YX94C)
	Programmable Timer PCB	1	(GA69A)
	Veropin 2141	1 Pkt	(FL21X)
	14-pin DIL skt	1	(BL18U)
	16-pin DIL skt	1	(BL19V)
	Construction Guide	1	(XH79L)
Optional			
LP1	12V Alarm Beacon	1	(YK39N)
*Printed below are the parts needed for the External Horn Case (if required)			
H2	Electronic siren	1	(XG14Q)
B1.2	6V lantern battery	2	
	Case	1	(XG07H)
	Grommet Small	1	(FW59P)
	No. 6 self-tapping screws x 1/2"	1 Pkt	(BF67X)
	Bolt 6BA x 1/2" (for PCB)	1 Pkt	(BF06G)
	Washer 6BA	1 Pkt	(BF22Y)
	Nut 6BA	1 Pkt	(BF18U)
	Spacer 6BA x 1/2"	1	(FW34M)
	Bolt 6BA x 1/4" (for Siren)	1 Pkt	(BF05F)
	Wire to suit		

A kit of parts is available for this project. It does not include the Beacon which must be ordered separately if required, nor does it include any of the parts shown as*

Order As LW98G (Programmable Timer Kit)

100W MOSFET Amp. Bridging Module

by Dave Goodman

The Maplin MOSFET power amplifier has proved an extremely popular project, and many requests have been received for increased power output levels. Power Bridging is an effective way of achieving this, but of course loudspeakers capable of handling high power levels cost more, and therefore protection from any possible damage becomes even more necessary. This system senses voltage offsets from the amplifier, and will switch the speaker out of circuit, as well as producing the inverted signals required for bridging two amplifiers together.

Power Bridging

Power bridging is a system where the output of two power amplifiers can be combined to provide a larger total output into a common speaker load (see figure 1).

If we assume that signal A is exactly 180 degrees out-of-phase with signal B, and that amplitude V of A and B is the same, then the combined signal amplitude across the speaker load in figure 1 will be 2V.

It is usual to express amplifier power ratings as RMS or peak output levels, and for the purposes of standardisation I will refer to RMS power (that being the most commonly used) throughout this article.

The expression used for calculating power into a given load is $W(Av) = \frac{(V_{RMS})^2}{R}$,

where W = RMS power and V = the RMS value of voltage measured across loud-speaker R.

Unfortunately the average power calculation does not consider true voltage and current RMS values, so calculations using this expression will be some 20% lower than the true RMS figures.

Now that we have an expression for power developed in a load for one amplifier, the two amplifiers shown in figure 1 will have the expression $W = \frac{(V_{RMS}(AMP1) - V_{RMS}(AMP2))^2}{R}$

because the load R is common to both amplifiers and W is the total power from both amplifiers.

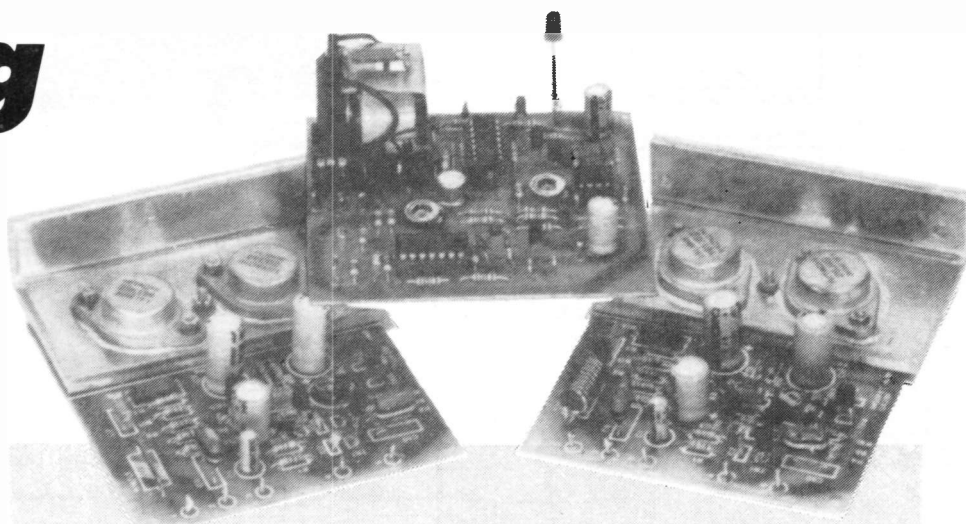

- * Increases power output to 400W
- * 'Anti Thump' delay at switch on
- * Loudspeaker protection
- * Short circuit and offset protection

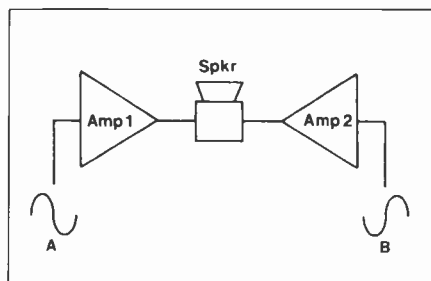
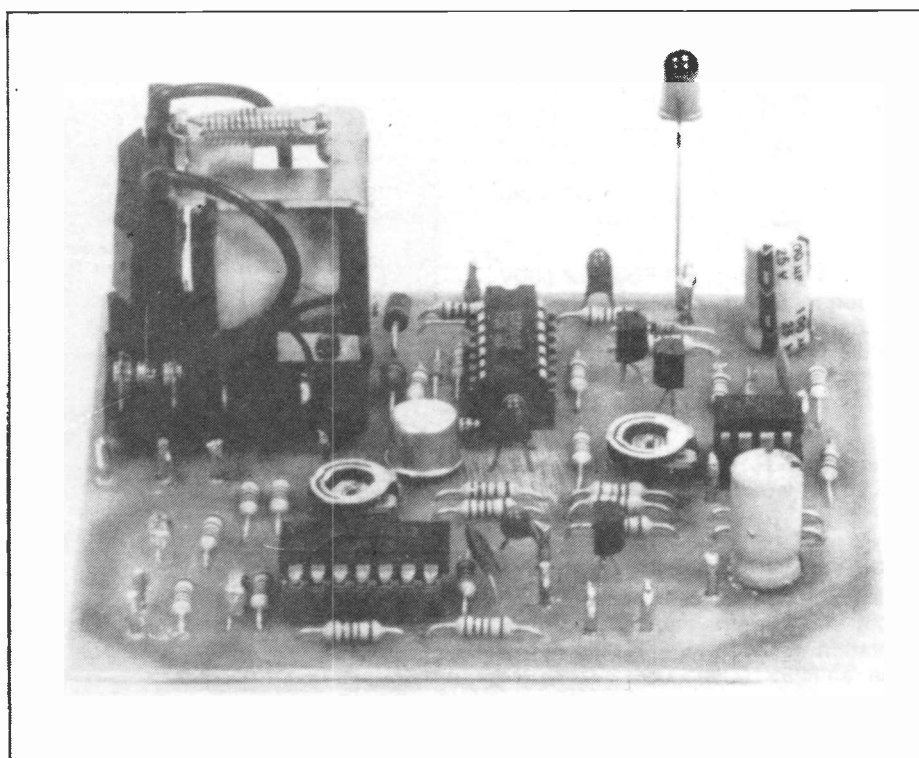

Figure 1. Two amplifiers in bridge.

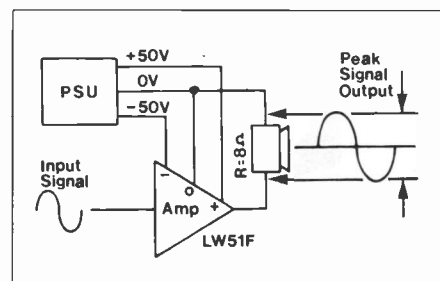

Figure 2. Typical connections to a single amplifier.

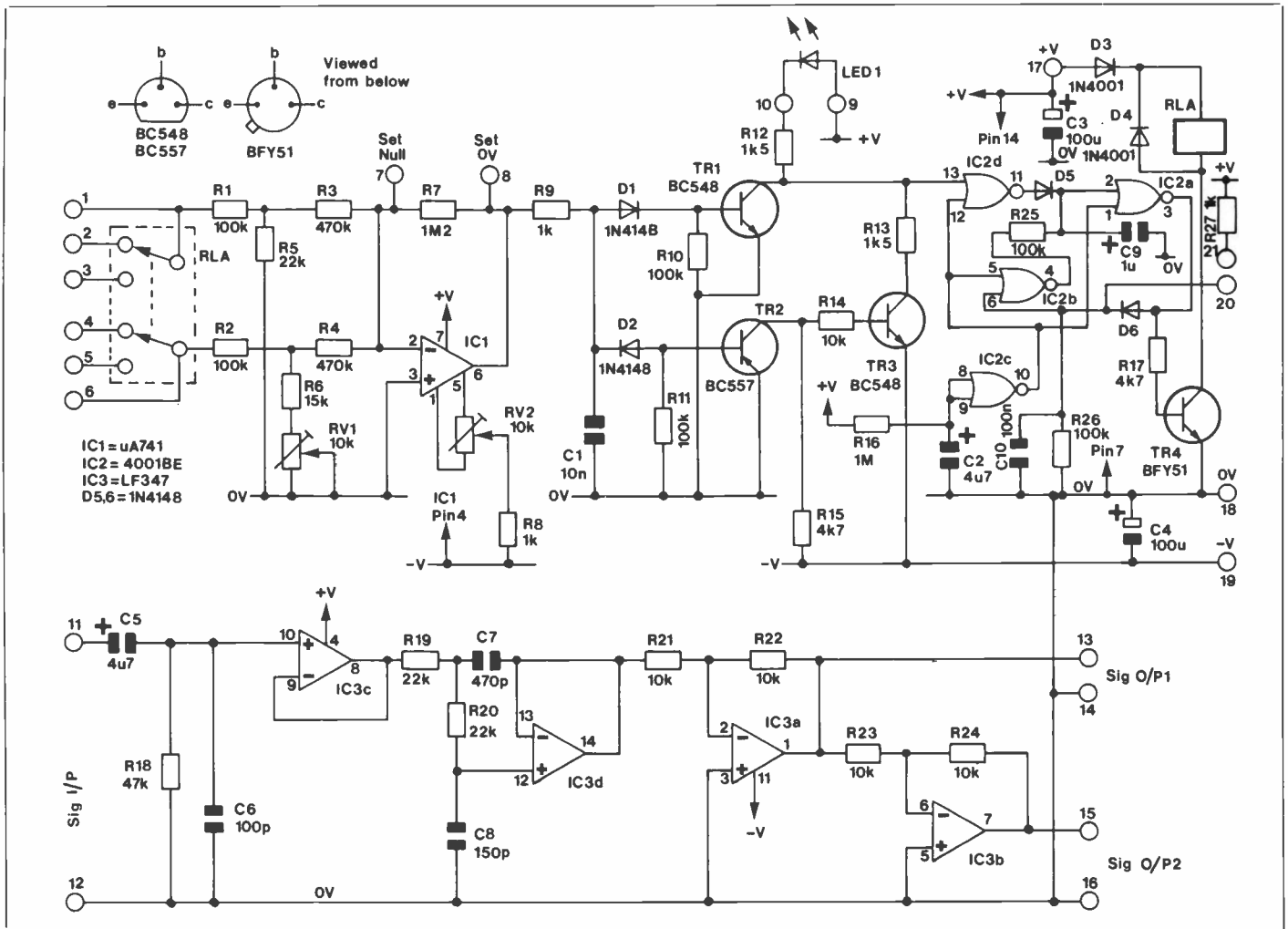

Figure 3. Circuit diagram.

To understand these formulae in real terms it is necessary to convert the peak voltage across the load into RMS volts which can be calculated from

$$V_{(RMS)} = \frac{V_{(PK)}}{2} \times 0.707$$

Given a power supply of +50V (or 100V DC) connected to a MOSFET power amplifier (LW51F) and an 8 ohm speaker as in figure 2, full drive at 1% distortion at 1kHz would develop 100V peak or $\frac{100}{2} \times 0.707 = 35.35V$ RMS

signal across R. Therefore the average RMS power would be $\frac{(35.35)^2}{2}$, or 156

Watts.

This magical figure works only in theory, and in fact losses due to heat, output stage inefficiency, and supply regulation would reduce this figure to a more realistic 100W RMS.

Connecting a second MOSFET amplifier as in figure 1, and referring to the expression $W = \frac{(V_{(AMP1)} + V_{(AMP2)})^2}{2}$

the RMS power output will be $W = \frac{(35.35 + 35.35)^2}{8} = 624$ Watts, or a realistic 400W.

All the above formulae show that bridging two amplifiers together doubles their combined power output, or quadruples a single amplifier output. Power supplies used for bridging must be capable of delivering 8 to 10 Amps at a well regulated 100 volts (+50V) if high

PARTS LIST FOR MOSFET BRIDGE

Resistors — All 0.4W 1% Metal Film unless specified

R1,2,10,11,25,26	100k	6 off	(M100K)
R3,4	470k	2 off	(M470K)
R5,19,20	22k	3 off	(M22K)
R6	15k		(M15K)
R7	1M2 (1/2W 5%)		(B1M2)
R8,9,27	1k	3 off	(M1K)
R12,13	1k5	2 off	(M1K5)
R14,21,22,23,24	10k	5 off	(M10K)
R15,17	4k7	2 off	(M4K7)
R16	1M		(M1M)
R18	47k		(M47K)
RV1,2	10k Hor sub-min preset	2 off	(WR58N)

Capacitors

C1	10nF disc ceramic		(BX00A)
C2,5	4u7F 16V Tantalum	2 off	(WW64U)
C3,4	100uF 25V PC electrolytic	2 off	(FF11M)
C6	100pF ceramic		(WX56L)
C7	470pF polystyrene		(BX32K)
C8	150pF polystyrene		(BX29G)
C9	1uF 35V tantalum		(WW60Q)
C10	100nF disc ceramic		(BX03D)

Semiconductors

D1,2,5,6	1N4148	4 off	(QL80B)
D3,4	1N4001	2 off	(QL73Q)
TR1,3	BC548	2 off	(QB73Q)
TR2	BC557		(QQ16S)
TR4	BFY51		(QF28F)
IC1	uA741		(QL22Y)
IC2	4001BE		(QX01B)
IC3	LF347		(WQ29G)

Miscellaneous

RLA	Power relay 12V		(FX48C)
LED1	Red LED		(WL27E)
	14-pin DIL sct	2 off	(BL18U)
	8-pin DIL sct		(BL17T)
	Printed Circuit Board		(GA17T)
	Veropin 2141	1 Pkt	(FL21X)

A complete set of parts is available for this project.
Order As LK03D.

power outputs are required, and this may make transformers difficult to find. Alternatively, two separate PSUs may be used, one for each amplifier, but they must track each other closely to avoid signal amplitude errors between amplifiers at full power outputs.

Also, the 0V connection from the power supply to the bridging module and MOSFET amplifiers should be made with heavy duty cable, and *not* thin wire! The latter can cause 0V setting problems. Try to choose cable with a current rating of 8 – 10A, it will also provide for minimum impedance earth returns.

Circuit Description

Both amplifier signal outputs are present on pins 1 and 6, which are mixed, then amplified by IC1. As both signals are out-of-phase with each other the expected output of IC1 will be close to 0V. If one signal input has a DC offset, or has no signal at all, the the output from IC1 will be presented to either TR1 or TR2. TR1 will only conduct to positive signals, and TR2 will only conduct to negative signals, with reference to 0V. TR3 inverts TR2 output, and, when conducting, pulls TR1 collector down from the positive supply rail to 0V, via potential divider R12 and R13.

IC2a switches to C/R timer C2/R16, and gives a three second turn-on delay, preventing IC2a, b, and d from changing state, and thus holding TR4 off. RLA will not operate during the timing period and a loudspeaker connected between pins 3 and 5 (RLA) will be out of circuit. When IC2c output finally goes high IC2b output will switch high and slowly charge C9. IC2a will switch high before C9 has fully charged, and D6 will conduct, causing IC2b output to change state to 0V and latch IC2a in a high state.

TR4 will now turn on and RLA will operate, presenting the loudspeaker to both amplifier outputs. If a fault condition turns on TR1 or TR3, IC2d output will switch high and D5 will conduct. IC2a output goes low and RLA will be released. IC2b then switches high, latching IC2a and holding TR4 off until reset by connecting pins 20 and 21 together. IC3c is a high impedance unity gain input buffer and IC3d is a low pass filter.

Our MOSFET amp has a large power bandwidth of some 70 to 100kHz or more, and for audio use it is not desirable to reproduce high power levels at these frequencies, so a low pass filter, IC3d has been added with a cut off frequency of 25kHz and a slope characteristic of 12dB per octave. This prevents h.f. signals from being amplified by reducing their level above the cut off point. IC3a is a unity gain buffer producing a signal output at pin 13 in phase with the pin 11 input signal, while IC3b inverts and produces a unity gain signal 180 degrees out-of-phase with the input, at pin 15. The two signal outputs are then connected to both MOSFET amp inputs (figure 5).

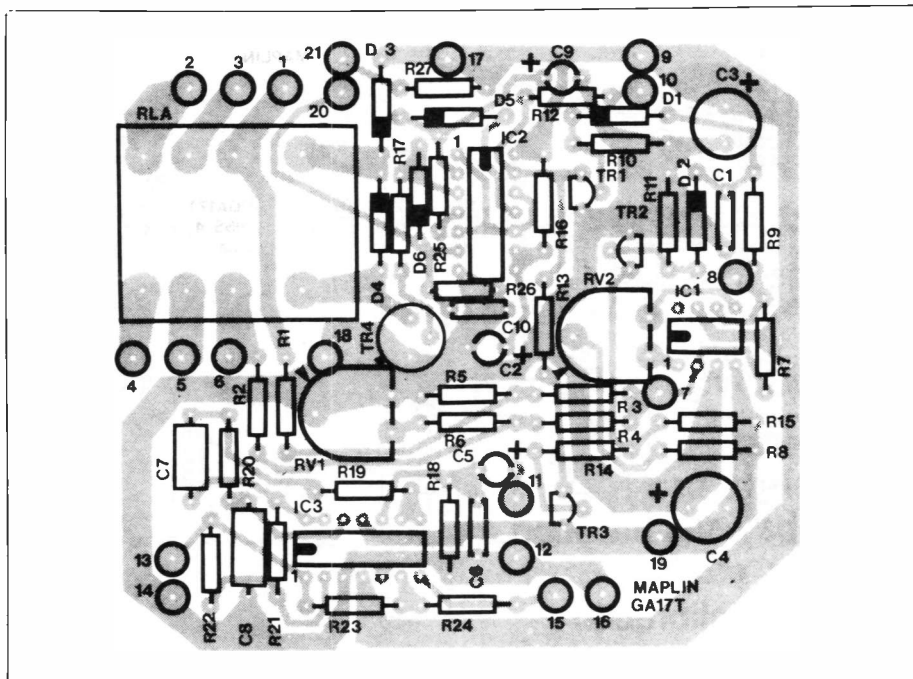

Figure 4. Legend

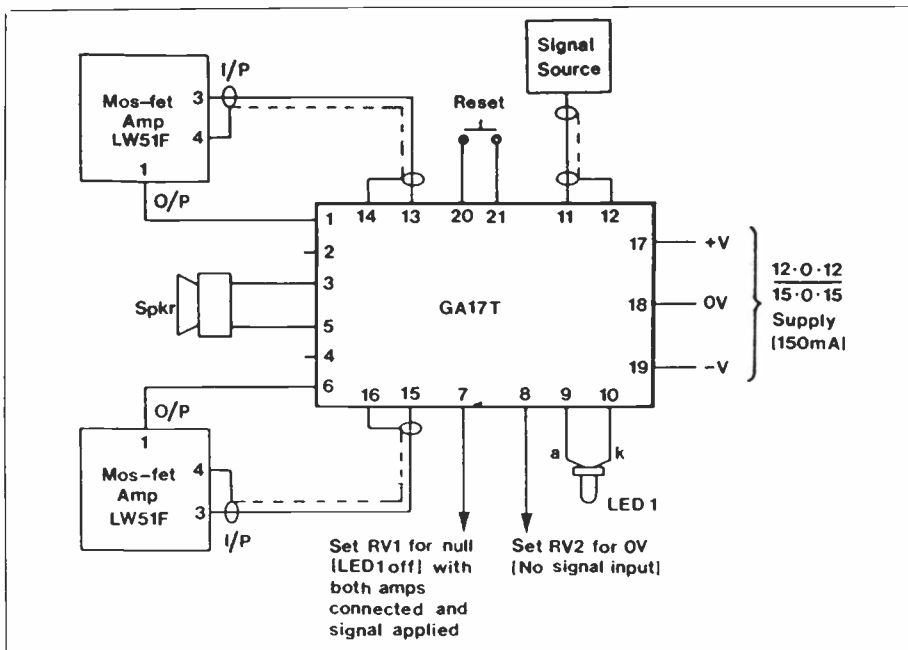

Figure 5. Connections for two amplifiers and bridge module.

Test and Use

Although ready built versions of this module are supplied tested and working, it may still be necessary to make slight re-adjustments for your particular system. Figure 5 shows wiring connections to and from the module; always use screened cable as shown for signal connections, and heavy gauge wire e.g. 5A mains, from the PSU.

Ensure both power amplifiers are working correctly before connecting this system!

When power is first applied, the relay will operate after a short delay period (approximately 3 seconds). Short circuit or open circuit signal lines or speaker wires will cause the relay to release, and LED 1 to come on. If a fault is suspected, then RV1 should be re-adjusted as follows:

1. Disconnect the speaker.
2. Apply a low frequency sine wave (e.g. 50Hz) to pins 11 and 12, at around 1V peak level (0dB r.m.s.).
3. Turn on power to module and amplifiers.
4. Place an oscilloscope or AC voltmeter between pin 8 and 0V.
5. Adjust RV1 for minimum clip reading.

The relay can be reset (operated) by temporarily connecting pins 20 and 21 together if required.

DC offset is controlled by RV2, which can be adjusted to force the DC output voltages of both amplifiers equal. The 0 volt setting can be in the range 0V to +20mV. If problems in setting 0 volts are encountered, R8 can be reduced in value, or replaced with a wire link.

AUTO~WAA

• EFFECTS UNIT •



There are several ways of producing the well-known and much used waa-waa effect, but in each case the basic effect is generated using some form of bandpass filter which is swept up and down over all or part of the audio band. This boosts a fairly narrow and continuously changing band of frequencies, and it is mainly the consequent variations in the relative strengths of harmonics in the processed signal that give the effect.

The difference between the various types of waa-waa effects units is the way in which the filter frequency is varied, and there are three main types. The most simple of these is where the filter is controlled manually using a foot-pedal. The other two types operate the filter automatically, one using an oscillator to sweep the filter in a cyclic manner, and the other using a sort of envelope generator to move the filter frequency in sympathy with the strength of the processed signal.

This auto-waa unit is of the third type, and this form of waa unit has the advantage of being very easy to use while giving an excellent range of effects. With this design it is possible to adjust the minimum filter frequency to practically any audio frequency, and a sweep depth control is also included. Another useful feature of the unit is a resonance control which enables the bandwidth of the filter to be adjusted. The filter is actually a 12dB per octave lowpass type, but positive feedback is used to give a peak in the response just above the cut-off frequency, and this type of filter probably gives the best waa effect. With the resonance control fully backed-off the filter operates as a straightforward 12dB per octave

by Robert Penfold

- ★
Automatic – no foot pedal needed
- ★
Very low power consumption
- ★
Wide range of musical effects

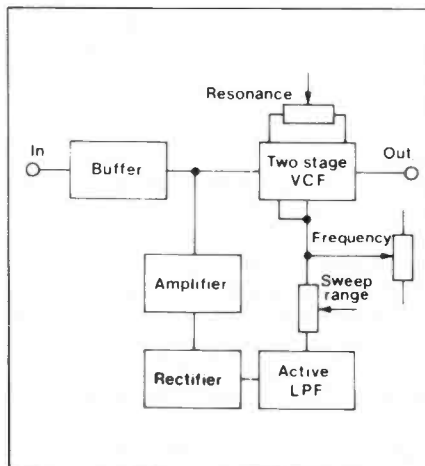

Figure 1. Block diagram.

lowpass type, and the unit then gives a more subtle but useful effect.

Block Diagram

The block diagram of Figure 1, helps to explain the general way in which the circuit functions.

A buffer stage at the input gives the circuit a reasonably high input impedance and provides a suitably low drive impedance for the subsequent stage. Some of the output from the buffer stage is fed through a two stage voltage controlled filter (VCF) and then to the output. The rest of the output from the buffer stage is fed to an amplifier, and the amplified signal is then rectified to produce a DC control voltage for the filter. The operating frequency of the filter is roughly proportional to the control voltage, and the DC output from the rectifier is roughly proportional to the amplitude of the input signal. As the amplitude of the input signal rises and falls the operating frequency of the filter is therefore moved up and down in the required manner. The sweep range control is included between the rectifier and the VCF, and the base frequency control is also in this part of the unit.

For this system to work properly it is essential for the control voltage to be an accurate reflection of the input level, and it must have fast attack and decay times so that it accurately tracks the input signal. On the other hand, the output from the rectifier must be well smoothed to prevent audio signals being fed to the control input of the filter and producing distortion products. In this design the use of a three stage active filter instead of a single smoothing capacitor gives fast attack and decay times with no significant break-through at audio frequencies.

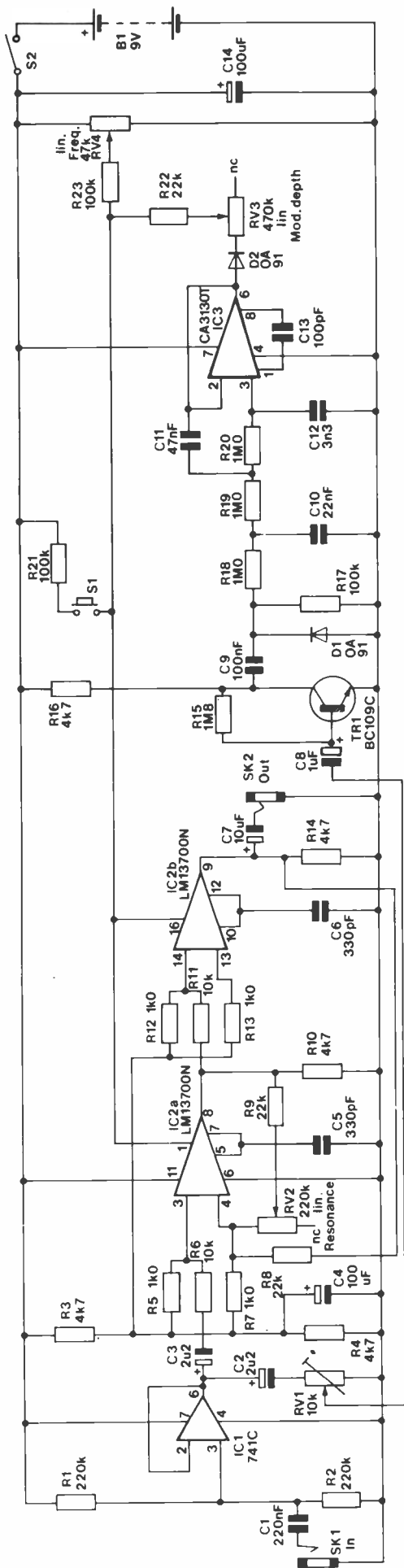

Figure 2. Circuit diagram.

The Circuit

The circuit is based on an LM13700N dual transconductance amplifier, as can be seen by referring to Figure 2.

IC1 is used as the buffer amplifier at the input of this unit, and this provides the circuit with an input impedance of over 100 kilohms. C3 couples some of IC1's output to the VCF which uses transconductance amplifiers and buffer amplifiers of the LM13700N, IC2.

With RV2 set at minimum resistance the circuit operates as a straightforward 12dB per octave lowpass filter with R8 and R9 setting the nominal voltage gain of the circuit at unity at pass frequencies. The frequency at which the roll-off commences is determined by the values of filter capacitors C5 and C6, and the gain of the amplifiers (which is in turn dependent on the bias current fed to pins 1 and 16). The cut-off frequency can therefore be varied by means of a control current, or a control voltage if a resistor is added in series with the control inputs so that the current flow is roughly proportional to the input voltage. The filter's cut-off frequency can be varied manually using RV4 which supplies a variable control voltage - R23 is the series resistor. The cut-off frequency can be set anywhere within the audio range. If S1 is closed, a strong bias current is fed to the filter regardless of the setting of RV4 so that the cut-off frequency is set above the upper limit of the audio band and the filtering is effectively removed. In practice S1 is a foot operated switch and it enables the waa effect to be easily switched in and out.

The filter is actually a state-variable type with bandpass filtering available at the output of IC2a, but this output is unused in this application. Instead, a form of bandpass filtering is obtained at the output of IC2b by adjusting RV2 for increased resistance so that the feedback over IC2a is decreased. This gives a boost in gain, but only over a narrow band of frequencies immediately below the cut-off frequency. This form of filtering gives the

required boost over a narrow band of frequencies, but it gives normal (unity) voltage gain at frequencies below this band. As a result of this there is no attenuation of the fundamental frequencies in the processed signal, and it is for this reason that this type of filtering gives what is generally accepted as a better waa effect than conventional bandpass filtering.

A certain amount of the output from IC1 is taken via preset attenuator RV1, and then amplified by TR1 which is used as a straightforward high gain common emitter amplifier. The amplified signal is rectified by D1 and then applied to the input of the active filter which is based on IC3. This is a conventional three stage circuit apart from the fact that R17 biases the input of the filter to earth and the filter only handles positive half cycles. A CA3130 is used in the IC3 position because this has a CMOS output stage which enables its output to go within a few millivolts of the negative supply rail. Most operational amplifiers, such as the standard 741C device, have a minimum output voltage of about 2 or 3 volts which is far too high to give acceptable results in this circuit. Another advantage of the CA3130 is that it has an extremely high input impedance, and due to the high value of filter resistors R18 to R20 this is essential. The filter resistors have been given such a high value in order to enable the low cut-off frequency of about 10 Hertz to be achieved using reasonably low filter capacitor values. This cut-off frequency gives more than adequate attack and decay times but ensures that there is no significant ripple on the DC output signal.

The output of IC3 is coupled to the control input of the VCF by way of D2, R22, and RV3. The latter acts as the modulation depth control. D2 is needed to prevent any interaction between the depth and frequency controls.

As the circuit has a current consumption of only about 4.5 milliamps a small (PP3 size) 9 volt battery can be used as the power source.

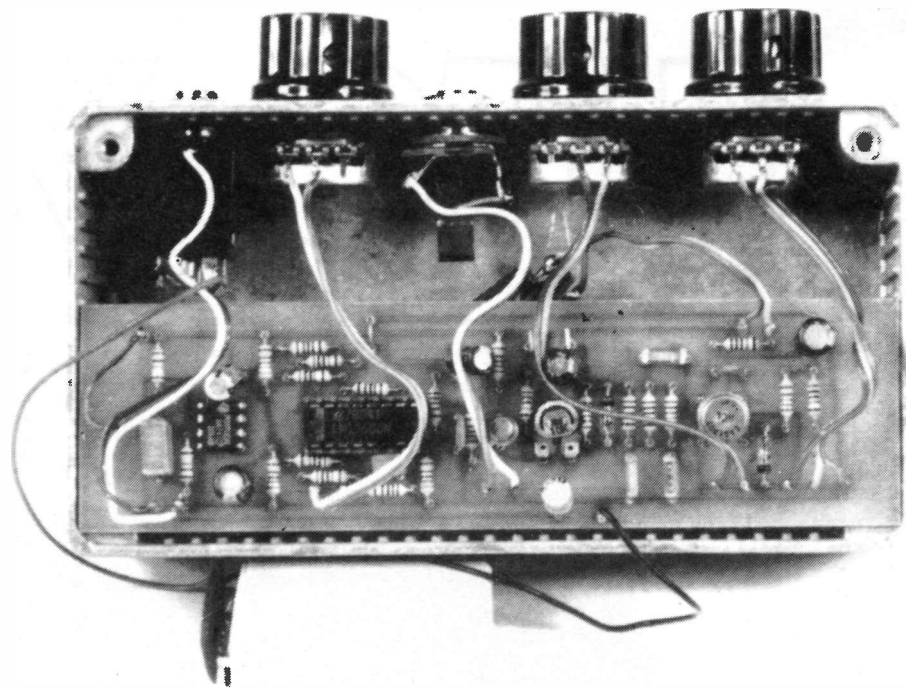

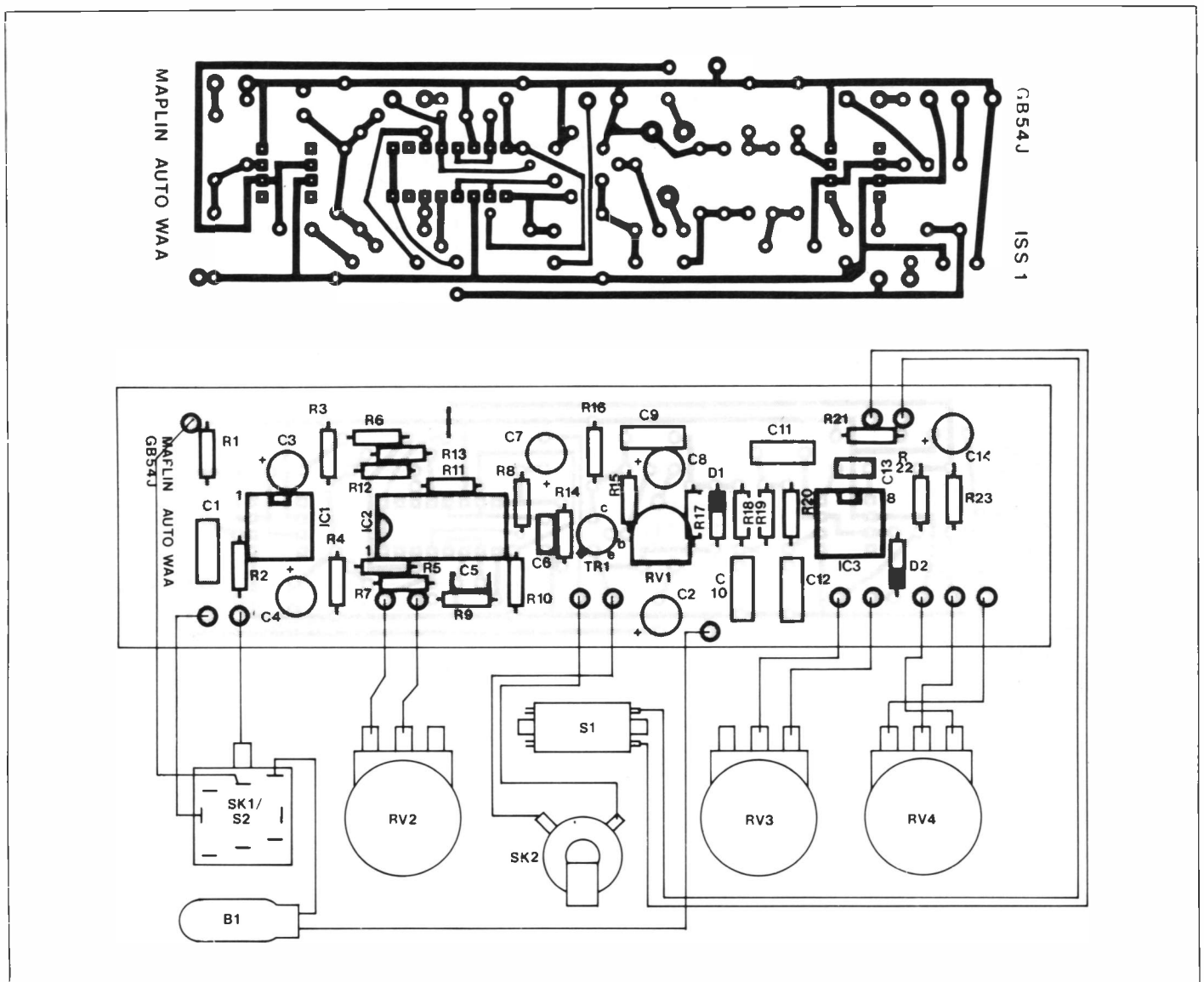

Figure 3. Legend, artwork and wiring diagram.

Construction

Full details of the printed circuit board are provided in Figure 3. The resistors, capacitors, and single link wire are soldered in place first, followed by the semiconductor devices. IC3 has a MOS input stage and should therefore be fitted in place of all, while taking the usual MOS handling precautions. D1 and D2 are germanium diodes which are more susceptible to damage by heat than silicon devices. Appropriate care not to overheat these components should be taken when they are being soldered to the board. It is helpful to fit Veropins at places where connections to off-board components will eventually be made.

For this type of project a very tough case is required, and one which screens the circuit from electrical noise is also an asset. A diecast aluminium box is ideal, and the printed circuit board has been designed to fit a 150 by 80 by 50mm case of this type. The two sockets and three potentiometers are mounted on the front panel (which is one of the 150 by 50mm sides of the case), and S1 is mounted centrally on the top panel. S2 is a pair of make contacts on SK1 and the unit is therefore automatically switched on and

off when a jack plug is plugged into and removed from SK1. An ordinary on/off switch could be used if preferred, but it would be difficult to accommodate this on the rather crowded front panel, and the suggested method is probably the most practical solution. Incidentally, this method of on/off switching is often used for musical effects units.

Next the hard-wiring is added, as shown in the wiring diagram of Figure 3. This is all quite straightforward and should not give any problems. Finally, the printed circuit board is fitted into the set of guide rails nearest the rear of the unit with the component side facing forwards. There is plenty of space for the battery to the rear of SK1, and a piece of foam material can be used to keep the battery in place.

Adjustment

The only preset control is RV1 which must be adjusted to suit the input signal level. If it is set too far in a clockwise direction the filter frequency will tend to go to its highest level even when the input signal has fallen well below its peak level. If it is set too far in the opposite direction the filter frequency will be virtually static at the level set using RV4. A suitable

setting for RV1 is found by empirical means, and is any setting that produces a good waa effect with the filter frequency sweeping up and down in sympathy with volume of the processed signal. The unit can handle a low level signal from (say) a low output guitar pick-up, or a high level signal from a high output pick-up, keyboard instrument, or any similar signal source. However a very low level signal, such as the output from a microphone, would require a certain amount of preamplification.

Results are likely to be best with RV2 well backed off, RV4 set for a base frequency around the middle of the audio band, and RV3 set for a medium to high modulation depth. However, a little experimentation will soon show what settings give the best effects. Setting RV4 for a low base frequency could result in fundamental frequencies in the processed signal being substantially boosted as the filter sweeps through them, and with a high level input overloading with attendant distortion could result. There is also a danger of overloading the equipment fed from the output of the unit, and the best effect tends to be obtained with the filter sweeping over medium and high frequencies anyway.

AUTO-WAA PARTS LIST

RESISTORS: All 0.6W 1% Metal Film (Unless stated)

R1,2	220k	2	(M220K)
R3,4,10,14,16	4k7	5	(M4K7)
R5,7,12,13	1k	4	(M1K)
R6,11	10k	2	(M10K)
R8,9,22	22k	3	(M22K)
R15	1M8	1	(M1M8)
R17,21,23	100k	3	(M100K)
R18,19,20	1M	3	(M1M)
RV1	Hor Encl Preset 10k	1	(UH03D)
RV2	Pot Lin 220k	1	(FW06G)
RV3	Pot Lin 470k	1	(FW07H)
RV4	Pot Lin 47k	1	(FW04E)

CAPACITORS

C1	Poly Layer 0.22	1	(WW45Y)
C2,3	PC Elect 2.2 μ F 100V	2	(FF02C)
C4,14	PC Elect 100 μ F 10V	2	(FF10L)
C5,6	Ceramic 330	2	(WX62S)
C7	PC Elect 10 μ F 50V	1	(FF04E)
C8	PC Elect 1 μ F 100V	1	(FF01B)
C9	Poly Layer 0.1	1	(WW41U)
C10	Poly Layer 0.022	1	(WW33L)
C11	Poly Layer 0.047	1	(WW37S)
C12	Poly Layer 0.0033	1	(WW25C)
C13	Ceramic 100	1	(WX56L)

SEMICONDUCTORS

D1,2	OA91	2	(QH72P)
------	------	---	---------

TR1	BC109C	1	(QB33L)
IC1	μ A741C 8-pin DIL	1	(QL22Y)
IC2	LM13700N	1	(YH64U)
IC3	CA3130E	1	(QH28F)

MISCELLANEOUS

SK1	DPDT Jack Socket	1	(BW80B)
SK2	Jack Skt Open	1	(HF91Y)
S1	Press Toe SPDT	1	(FH92A)
	Auto-Waa PCB	1	(GB54J)
	DIL Socket 8-pin	2	(BL17T)
	DIL Socket 16-pin	1	(BL19V)
	Knob K7B	3	(YX02C)
	7/0.2 Wire 10M Blk	1 Pkt	(BL00A)
	PP3 Clip	1	(HF28F)
	Pin 2145	1 Pkt	(FL24B)
	Constructors' Guide	1	(XH79L)
	Auto Waa Ins	1	(XK67X)

OPTIONAL

	Nicad PP3	1	(HW31J)
	Box DCM5005	1	(LH73Q)
	Feet Cab	1 Pkt	(FW19V)
	Bolt 4BA 1/4in.	1 Pkt	(BF02C)
	Nut 4BA	1 Pkt	(BF17T)

A complete kit of parts for this project, excluding optional items, is available:

Order As LK36P (Auto-Waa Kit)

TDA 7000

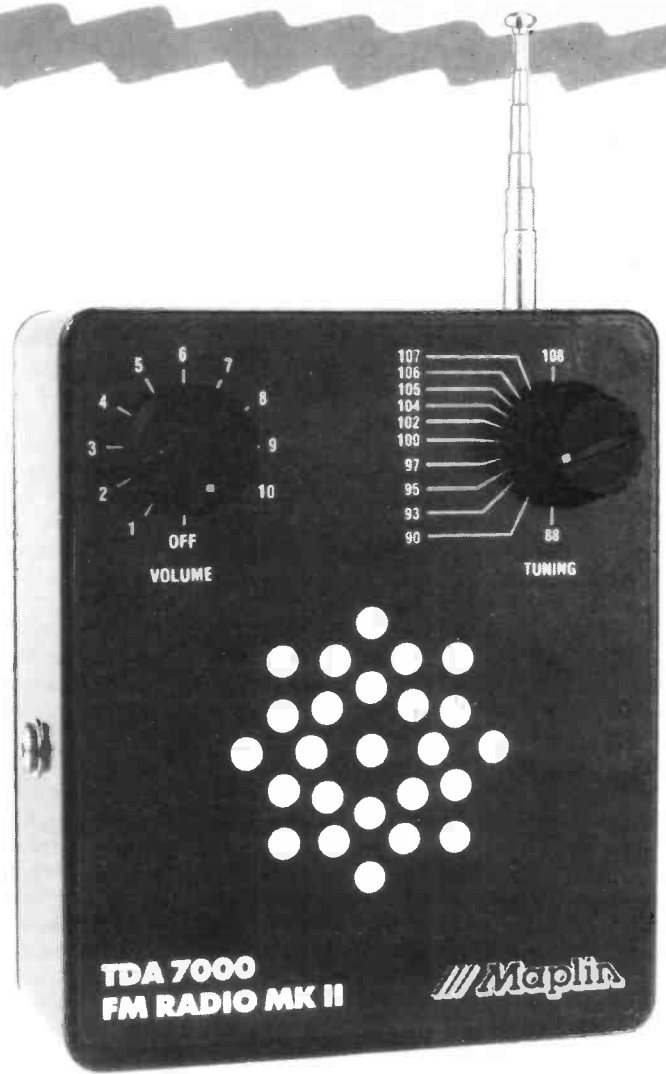

FM RADIO MK II

by Chris Barlow

- ★ *No alignment equipment needed*
- ★ *Easy to build*
- ★ *Ready wound RF coils*
- ★ *On-board power amplifier*
- ★ *Headphone/earpiece jack socket*

Specifications of Prototype

Radio integrated circuit	: TDA7000
Audio integrated circuit	: TBA820M
Operating voltage	: 4V to 8V
Supply current at 6V	: minimum volume 13mA
	: maximum volume 80mA
Power output 8Ω speaker	: 250mW RMS
Frequency coverage	: 88 to 108MHz
Aerial	: 6 section telescopic

Introduction

This project is an improved version of the radio originally presented in Electronics number 9 (now available as a Projects Book, see inside back cover). Conventional Band II VHF superheterodyne radios use a large number of tuned circuits as these are needed for filtering in the RF, mixer, oscillator, IF, and detector stages. Ceramic filters have become very popular in recent years, but these can only replace one or two IF transformers, and only marginally ease problems with alignment of the finished receiver. The TDA7000 is an imaginative integrated circuit which employs novel

techniques that enable a good quality FM broadcast receiver to have just two tuned circuits. The reason for this device being developed is that it offers radio manufacturers the advantages of reduced costs, both in terms of components and the setting up time for the finished receiver. For the home constructor it similarly gives the advantages of low cost and ease of alignment. In fact the finished receiver only needs to have the core of one coil and a trimmer capacitor adjusted to give the correct frequency coverage. A TDA7000 FM radio is actually no more difficult to align than a simple ZN414 based AM radio!

Low IF

Strictly speaking the basic system used in the TDA7000 is not a new one, and is essentially the same as that used in the so called 'pulse counting' FM tuner designs that were popular amongst home constructors around twenty years ago (the original designs used valves!). The block diagram of Figure 1 shows the way in which these operate. The RF, mixer, and oscillator stages are fairly conventional, but usually quite simple with just a broadband (preset tuning) filter ahead of the mixer, but a more complex arrangement could be used if preferred. It is at the IF and demodulator stages where the real departures from a conventional superhet arrangement occur. The IF amplifiers are virtually ordinary high gain audio amplifiers, but filter capacitors are used to roll-off the response above about 200kHz and the coupling capacitors only need to be effective at frequencies above the audio range. This gives an IF centred at around 100kHz or so, and no tuned circuits to provide IF filtering are required. The low IF enables simple C-R filtering to give adequate results, and there is no lack of performance in this respect. A pulse counting circuit plus an RF filter provides the demodulation, and the pulse counter is merely a diode-pump frequency-to-voltage converter. Other

types of circuit such as a phase locked loop or even just a monostable multivibrator can be used here to convert the frequency variations into the corresponding audio signal. While this system has obvious attractions, it is not without its drawbacks as well. The main one is the lack of any image rejection, due to the very low IF and the spacing of only a few tens of Kilohertz between these where the station is received, but is very severely distorted. As Band II FM broadcast stations tend to be well spread out this is unlikely to give problems with co-channel interference, but does make tuning the set a little awkward.

The TDA7000

Although pulse counting tuners were originally conceived as simple alternatives to conventional circuits, it would not be accurate to think of the TDA7000 as providing an inferior alternative to a conventional design. It uses a highly refined version of the pulse counting type of circuit, and in some respects it is

superior to more conventional designs. Figure 2 shows the arrangement used in this device, plus basic details of the discrete components required. The standard TDA7000 has an 18-pin DIL plastic package, but there is also a miniature 16-pin version, the TDA7000T. The input tuned circuit is formed by La, Ce, and Cf. Internal resistors of the TDA7000 heavily damp this filter so that it has a very wide bandwidth and no RF tuning is needed. La can in fact be a zig-zag of printed circuit track, but in the design featured here it is a small moulded coil with a ferrite core. The aerial, which is a simple wire or telescopic type, is coupled to the input tuned circuit by way of a capacitive tapping. A voltage controlled oscillator feeds the other input of the mixer stage. This VCO is a straightforward L-C type which achieves voltage control using a couple of variable capacitance diodes. There are three IF filter stages, and the first of these uses a second-order low pass Sallen-Key circuit, which is the type of filter used in scratch filters and similar applications. Cq and Cr are the filter capacitors, but the filter resistors and other components are part of the TDA7000. The second filter is a simple bandpass type, and again, the only discrete components are two capacitors. The final filter stage is a straightforward passive first-order lowpass type which uses discrete capacitor Cg. The reason for using discrete rather than on-chip filter capacitors is simply that it is difficult and expensive to include even low value capacitors in an integrated circuit. The -60dB bandwidth of the filters is approximately 500kHz, which is perfectly adequate for an FM broadcast receiver.

After filtering the signal is amplified and limited in the usual way, and demodulated by a quadrature detector. Unlike a standard 10.7MHz quadrature detector, no tuned circuit is required, just

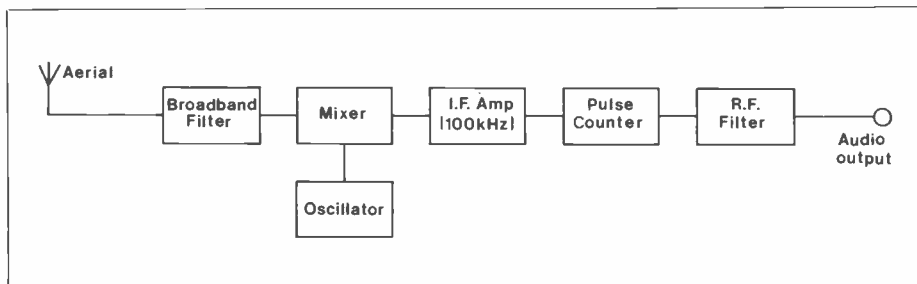

Figure 1. Block Diagram

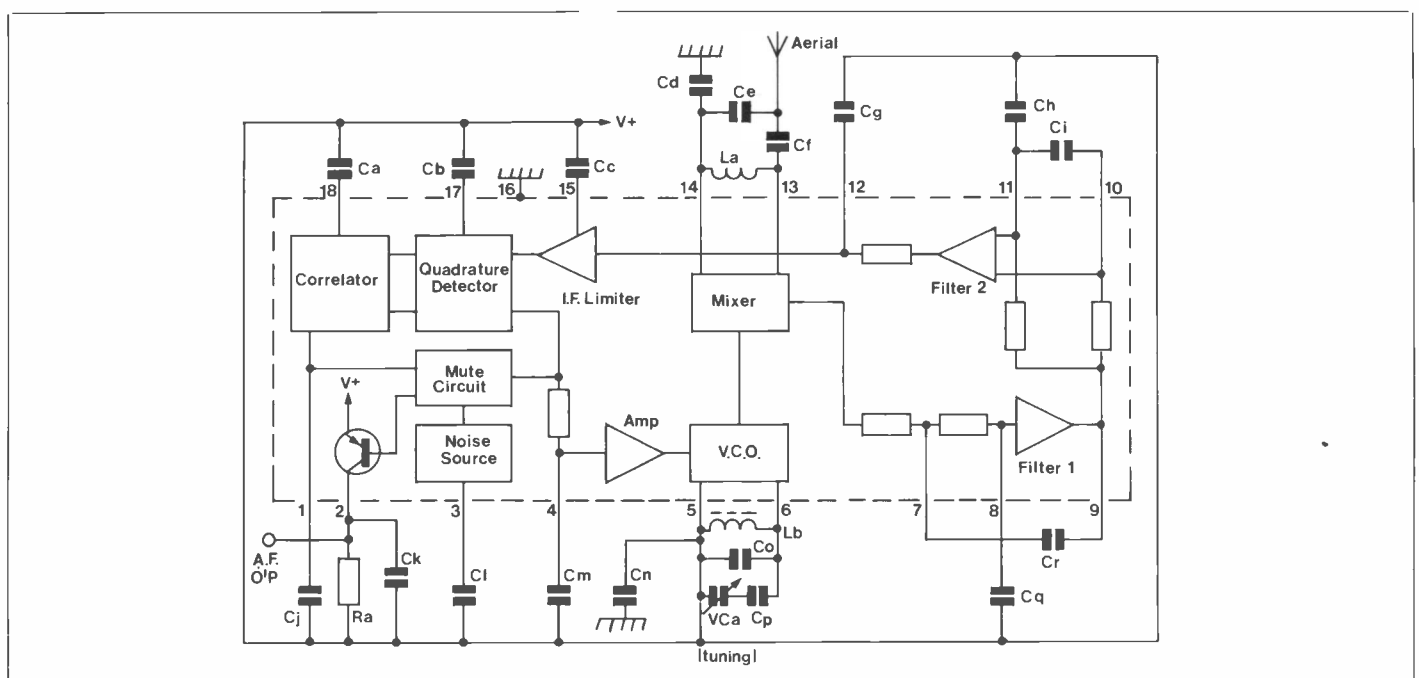
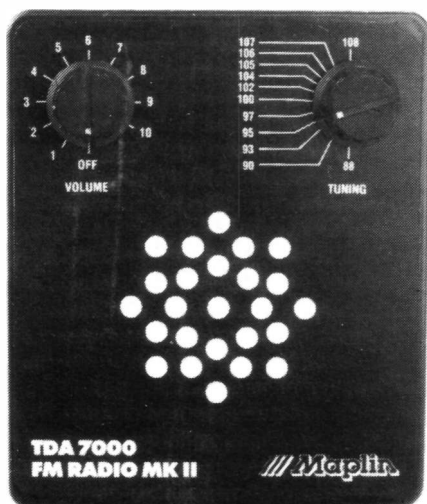

Figure 2. Connection Diagram for TDA7000

one phase shift capacitor (Cb). The intermediate frequency can be set at any reasonable figure by using the appropriate filter capacitor values, but a frequency of 70kHz would normally be used. Such a low IF eliminates any problems with the image signal of one channel interfering with reception of a transmission on the next channel. With the set tuned to one channel the image response falls roughly half-way between this channel and the next. The problem of using such a low IF is that it would result in severe distortion with signals having something approaching the full plus and minus 75kHz deviation. This problem is overcome by amplifying the audio output signal and feeding it to the VCO. This gives a form of negative feedback with the VCO following the input signal up and down in frequency. The deviation of the VCO is not quite equal to that of the input signal so that there is some variation in the frequency of the IF signal, but this is only about plus and minus 15kHz. The typical total harmonic distortion on the audio output is 2.3% at maximum deviation, which is satisfactory for portable radios and similar applications. A useful 'by-product' of the feedback to the VCO is that it gives a sort of automatic frequency control. Apart from counteracting any tuning drift, this effectively gives slow-motion tuning once the receiver has locked onto a transmission, and makes the set easy to tune even if only a small tuning knob is used.

Correlator

The correlator and mute circuits of the TDA7000 are used to suppress the image response as well as giving a conventional 'squelch' action. The correlator operates by delaying the IF signal by an amount equal to the duration of one IF half cycle. This signal is then inverted and compared with the unprocessed IF signal. If the tuning is correct, the two signals will be virtually identical and will have a high degree of correlation. However, if the tuning is not very accurate the IF signal will be



View of front panel.

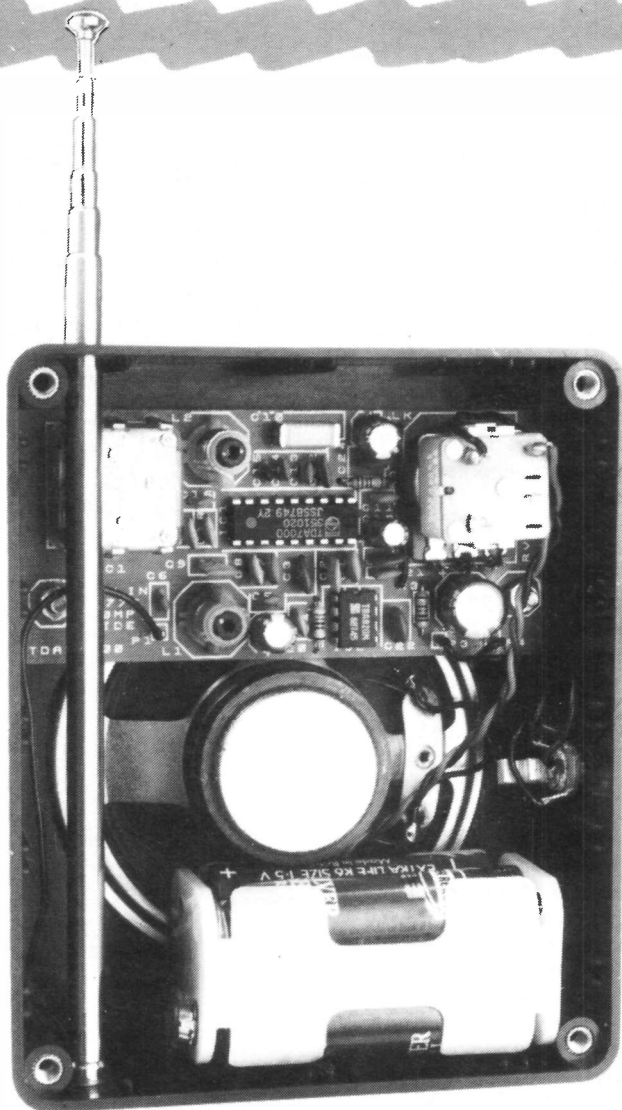

Inside the box.

displaced from its normal 70kHz figure, and the delaying circuit will not give a one half cycle delay. This introduces a phase difference and poor correlation, with the mute circuit switching off the audio in consequence. If the IF signal is noise, or largely consists of noise, this also gives very little correlation between the two signals and mutes the audio output. An interesting effect of this system of muting is that it eliminates the side responses that are normally found on FM radios. These are caused by the signal being 'slope' detected by the skirt responses of the IF filtering, and they can make accurate tuning a little difficult. Many FM radios have a tuning indicator to assist proper tuning. The TDA7000 muting system eliminates the side responses, and together with the frequency locking tuning system makes tuning very easy indeed. A detuning indicator can be driven from pin 1 of the TDA7000, but in practice it would be pointless to do so.

On its own the correlator does not eliminate the image response, but it does so in conjunction with the feedback to the VCO which was described above (the frequency locked loop or FLL as the IC manufacturer terms it). This locking system only operates with the set tuned to the main response, and not when it is tuned to the image, due to the inversion of the signal that occurs. If we take a simple mathematical example to demonstrate this point, let us suppose that the receiver is

tuned to a transmission which deviates between 100 and 101MHz, and that the oscillator is at 99MHz. This gives an IF range of 1 to 2MHz (100-99MHz and 101-99MHz). Of course, these figures have been chosen for their mathematical simplicity, and are not meant to be practical examples. As the IF signal moves up and down in frequency the audio output voltage also rises and falls, feeding a control voltage to the oscillator that shifts its frequency in the same direction as the input signal. The image response would occur with the oscillator at 102MHz, giving an IF range of 2 to 1MHz (102-100MHz and 102-101MHz). This frequency inversion of the IF signal appears as a phase inversion of the audio output signal. Where the oscillator frequency was previously taken higher and lower in sympathy with the received signal to effectively reduce the level of deviation, when tuned to the image response it is moved in the opposite direction so that the deviation is effectively increased. For example, with the input signal at 100MHz the IF signal is at 2MHz, giving the maximum audio output voltage. This sends the oscillator higher in frequency, giving an even greater IF signal frequency, greater audio voltage, and positive rather than negative feedback. When tuned to the image the IF signal does repeatedly pass through the acceptable IF range, but the value of Cj is chosen to give the muting circuit a slow response time so that it

ignores these transients, and the image is suppressed. Ra is the load resistor for the audio output stage, and Ck is the de-emphasis capacitor. A slightly bizarre feature of the TDA7000 is a noise generator which gives a quiet noise signal at the audio output when the main audio signal is muted! This is included because it is otherwise very easy to tune over a station without realising it is there. The null in the noise signal as the set is tuned through a station helps to avoid this. However, if desired the noise can be eliminated by omitting C1.

The Circuit

Figure 3 shows the circuit of a practical radio built around the TDA7000, and the circuitry associated with IC1 exactly follows the arrangement shown in Figure 2 and discussed earlier.

An audio output stage using a TBA820M (IC2) is included because of its low quiescent current, good ripple rejection and low crossover distortion. The signal from the TDA7000 (IC1) is fed via C19 to the top end of the volume control RV1. The wiper of RV1 is connected to the signal input pin of IC2, with R2 and C20 setting the gain of the amplifier. RV1 has an integral switch, S1 which is used to turn the DC power on and off to the circuit. C21 is connected to pin 1 for high frequency compensation and the zobel network R3 and C22 on pin 5 is connected to the negative rail. Pin 5 has a DC potential so a blocking capacitor C23 is used to feed the output of IC2 to a loudspeaker having an impedance in the range of 8 to 80 ohms. An output power of about 300 milliwatts RMS into an 8 ohm loudspeaker is available, and this is adequate for a portable radio. The output stage will also drive any magnetic type of earphone or headphones.

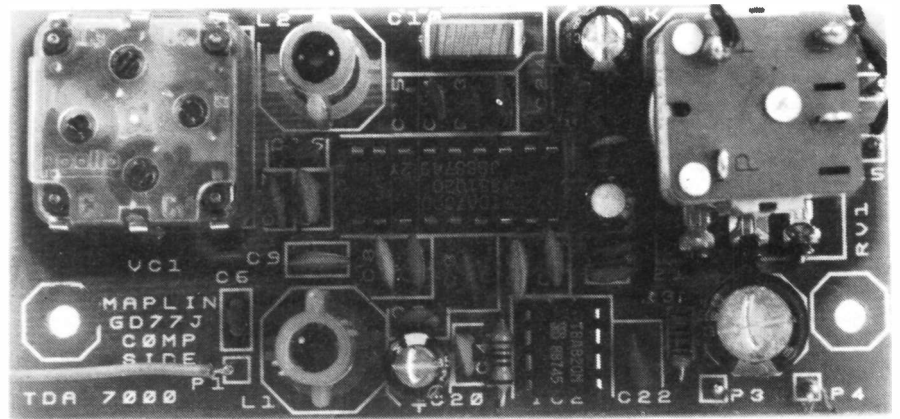

Top of PCB.

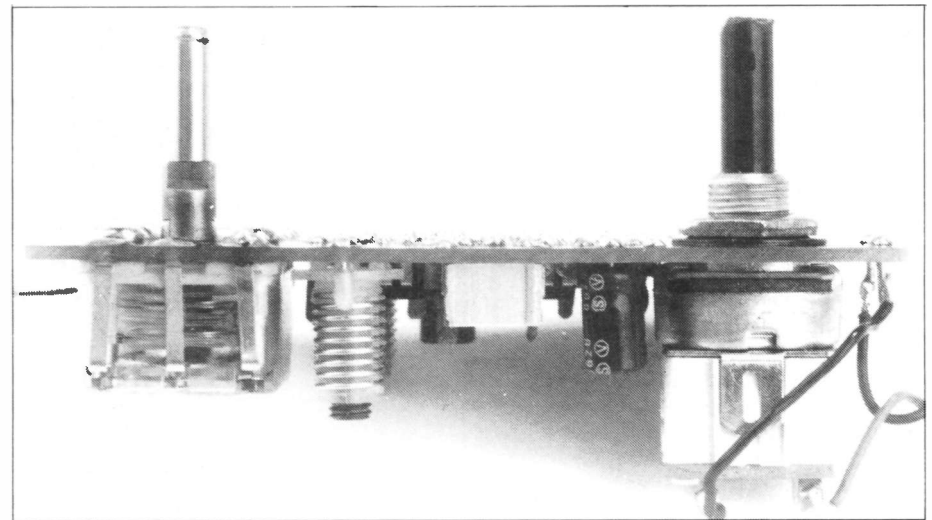

Side view of PCB.

PCB Assembly

A suitable printed circuit layout for the radio appears in Figure 4. The TDA7000 is not one of the many radio IC's that tend to be unstable at every opportunity, and the low IF eliminates problems with harmonics of the clipped IF

signal being picked up at the input of the circuit. However, with frequencies in the region of 100MHz involved it is not advisable to use a different layout unless you are familiar with radio projects and know exactly what you are doing. The

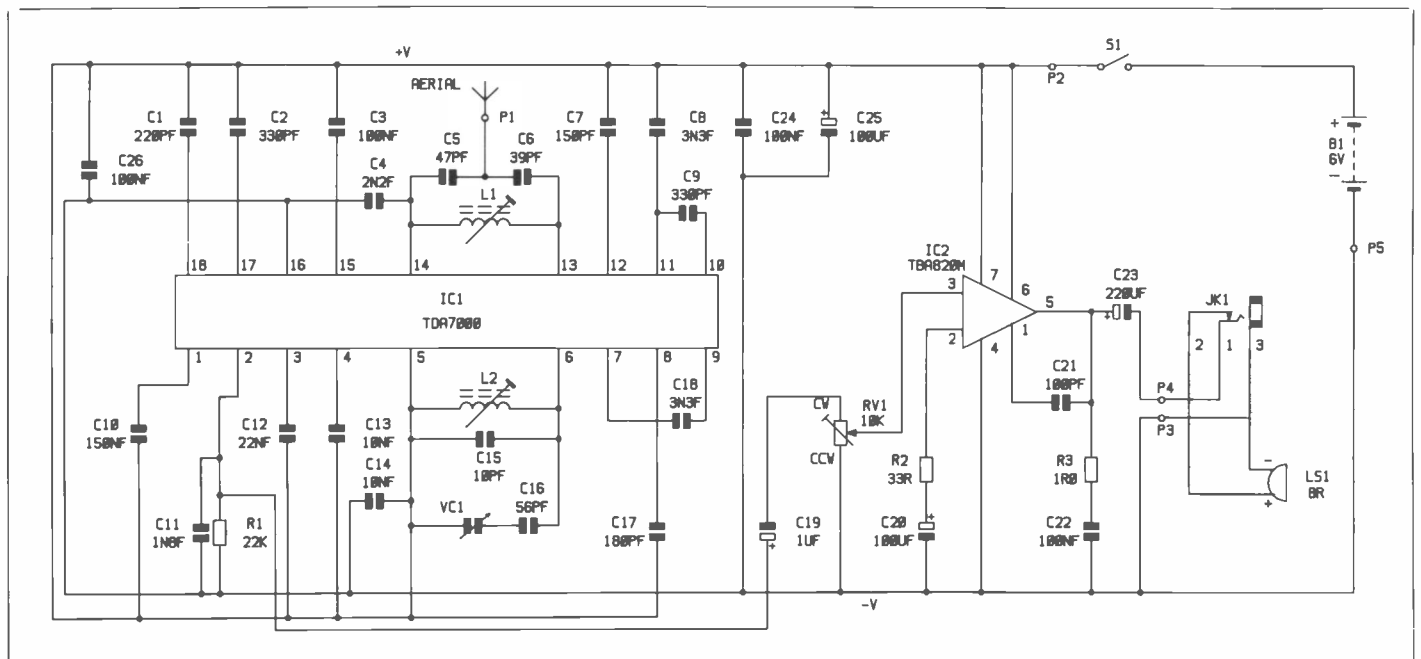

Figure 3. Circuit

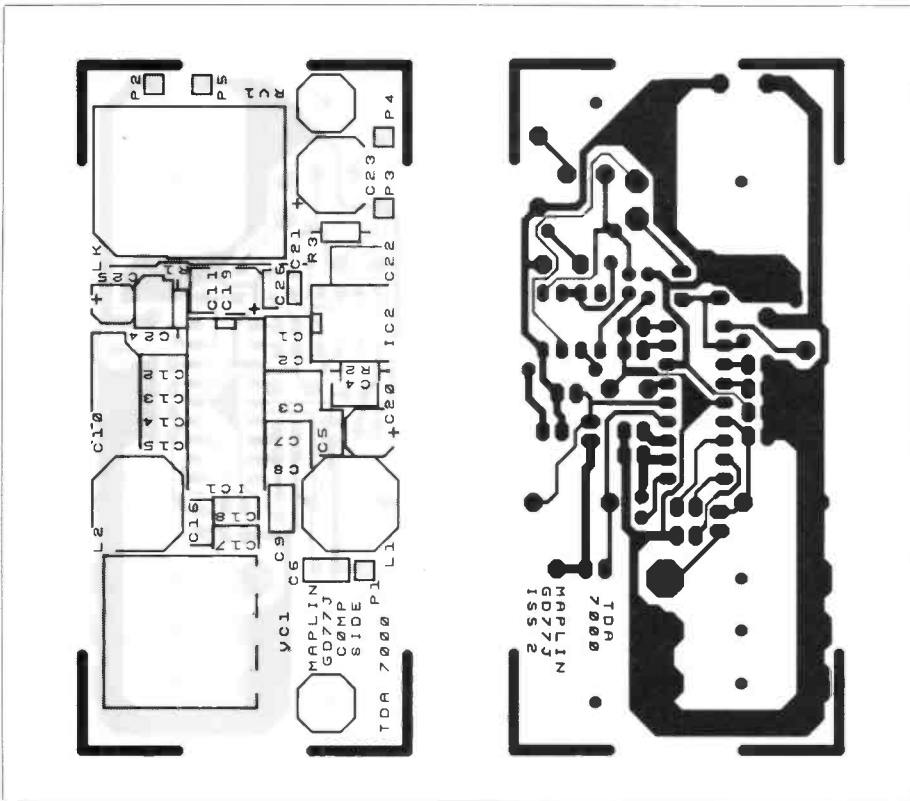

Figure 4. Track and Layout of the PCB

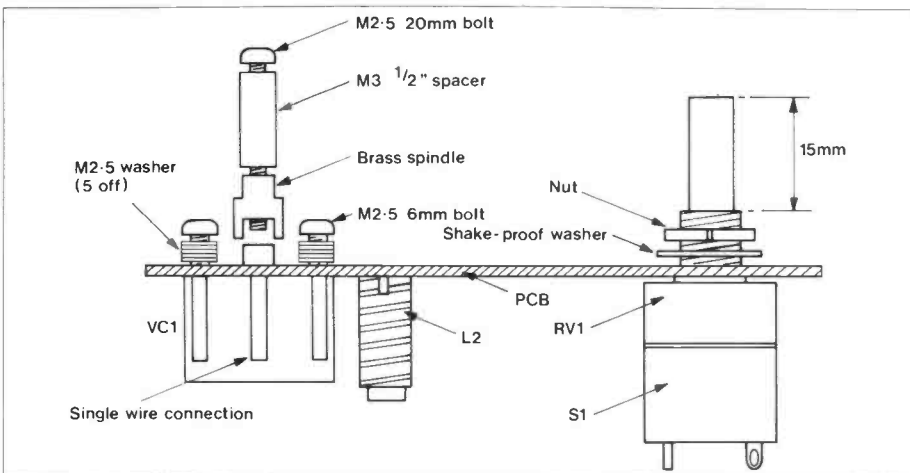
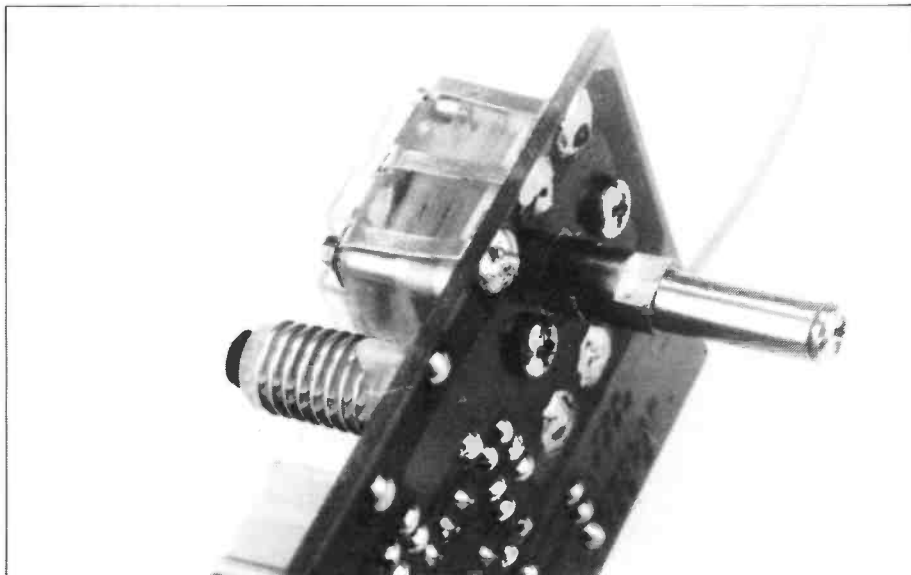

Figure 5. Spindle Preparation



Making the spindle longer.

PCB supplied in the Maplin kit is a single-sided, fibre glass type, chosen for maximum reliability and stability. However, removal of a misplaced component is quite difficult, so please double-check each component type, value and its polarity where appropriate, before soldering! The PCB has a printed legend to assist you in correctly positioning each component.

The sequence in which the components are fitted is not critical. However, the following instructions will be of use in making these tasks as straightforward as possible. It is usually easier to start with the smaller components. Begin with the pins at positions P1 to P5, then fit three more pins at RV1. Next, install the resistors, then the ceramic, polyester and electrolytic capacitors. The polarity for the electrolytic capacitors is shown by a plus sign (+) matching that on the PCB legend. However, on some capacitors the polarity is designated by a negative symbol (-) in which case the lead nearest this symbol goes away from the positive sign on the legend. **IMPORTANT!!** do not forget to fit the wire link (LK) on the PCB. Using a short length of insulated hook-up wire, connect one end at the hole near R3 and the other to the hole near C25, see Figure 4. Next, install the two IC's ensuring that you fit the appropriate IC in each position, matching the notch with the block on the legend. When fitting the two RF coils ensure that the correct colour coil is positioned as follows, red at L1 and white at L2. Also make certain that the two long plastic tags are facing each other.

Before mounting RV1, bend the three pot contacts back by 90°, so they lay flat on the pins as the pot is inserted. Secure RV1 by using the nut and shake-proof washer supplied with the pot, see Figure 5.

Finally cut the plastic spindle of RV1 to a length of 15mm.

Next install the tuning capacitor VC1, ensuring that the centre single wire connection is as shown in Figure 5. The capacitor is secured using two M2.5 by 6mm long bolts and its spindle is then constructed in the following manner. The short brass spindle with the two flat surfaces is supplied with the capacitor. However, this spindle must be extended by using an M3 half inch spacer, secured by an M2.5 20mm long bolt. **IMPORTANT!!** as the bolt is fully tightened, to prevent damage occurring to the tuning vanes inside the capacitor, the brass spindle must be held using a pair of long nose pliers.

This completes the assembly of the PCB and you should check your work very carefully making sure that all the solder joints are sound. It is also very important that the track side of the circuit board does not have any trimmed component leads standing proud by more than 4mm. Further information on soldering and assembly techniques can be found in the Constructors Guide included in the Maplin kit.

Wiring

If you purchase a complete kit from Maplin it should contain a length of hook-up wire. Carefully follow the wiring shown in Figure 6. The power on/off switch S1 is connected to P2 using a 50mm length of wire. Next cut the wires on the battery clip to 110mm and connect the red to S1, black to P5. **DO NOT** fit the clip onto the battery until it is called for during the testing stage.

Prepare a 100mm length of wire. Connect one end to the aerial input pin P1 and attach an M3 solder tag to the free end. This tag will be bolted to the base of telescopic aerial in the final assembly stage.

Finally, using four 65mm lengths of wire, connect the headphone socket JK1 to P3 and P4 and to the two terminals on the loudspeaker. When handling the speaker, be careful not to damage the paper cone, or the terminals on the back. This completes the wiring of the PCB assembly. Now check your work very carefully making sure that all the wires and solder joints are sound.

Testing and Adjustment

All the tests can be made with an electronic digital, or analogue moving coil, multimeter. The following test results were obtained from the prototype using a digital multimeter and a 6V battery pack as the power supply. Before commencing the tests, set the rotary controls as follows, **VOLUME OFF, TUNING 88MHz** (fully-anticlockwise). Next set the two RF coils and the trimmer capacitor as shown in Figure 7. The ferrite cores in the coils are very brittle, you must use the hexagon trimming tool supplied otherwise damage may occur. A miniature flat blade screwdriver, or preset type trimming tool can be used when adjusting the trimmer capacitor C1. The aerial input coil L1 forms part of a very wide bandwidth tuned circuit. This results in a flat tuning peak in the sensitivity of the receiver, which should occur when the core is flush with the top of L1. The setting of the oscillator coil L2 is more precise and its final position may vary from that shown in Figure 7. This also applies to the oscillator trimmer capacitor C1, however the positions shown in Figure 7 should provide a good starting point. Make a temporary aerial out of a piece of wire about 0.5 to 1 metre long and connect one end to the M3 solder tag.

The first test is to ensure that there are no short circuits before you connect the battery. Set your multimeter to read OHMS on its resistance range and connect the probes to the terminals on the battery clip. Turn on the power and with the probes either way round a reading greater than 60Ω should be obtained. Remove the probes and fasten the negative terminal of the clip to the battery box.

Next monitor the supply current, set your meter to read DC mA and place it in the positive line of the battery box. With the volume set to minimum, a current

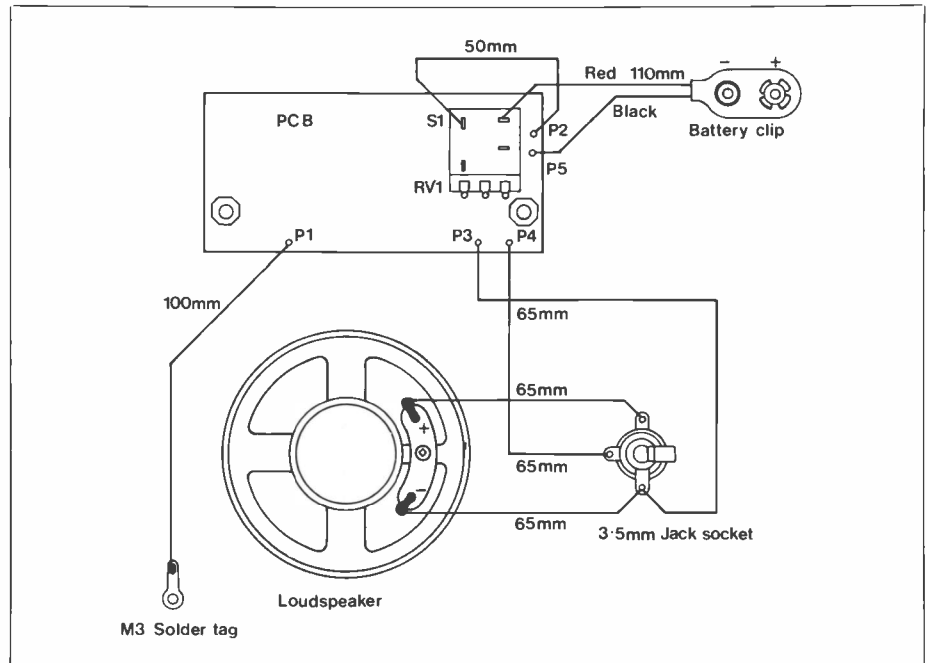

Figure 6. Wiring

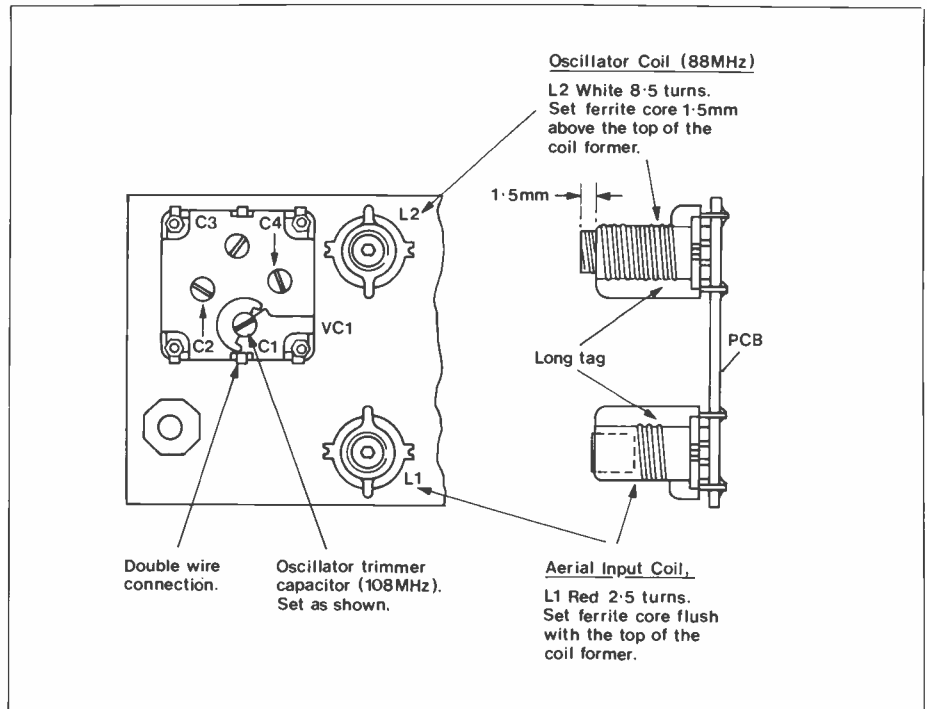

Figure 7. Receiver Adjustment

reading of approximately 13mA should be seen. As the volume control is advanced to its maximum setting, with no radio station tuned in, this reading will increase to approximately 26mA and a hissing sound should be heard. If a signal is received this reading can go as high as 80mA on sound peaks. However, when a headphone, or an earpiece is plugged into JK1 this reading will be significantly reduced. Remove your meter and fasten the clip to the battery box. Finally, check the tuning range, making any necessary adjustments to the oscillator coil L2 and the trimmer capacitor C1. You should set the low, 88MHz end of the band using L2 and C1 when adjusting the upper 108MHz limit. This completes the testing and alignment of the TDA7000 fm radio.

Box Drilling

The box that the unit is designed to fit is the black plastic MB3. Carefully follow the drilling instructions in Figure 8. The self-adhesive trim can be used as a guide for checking the positioning of the holes in the front of the box. However, **DO NOT** stick the trim down until the final assembly stage is completed. Having completed the drilling, at the same time clearing away any plastic swarf, clean the box using a dry cloth.

Final Assembly

Using a good quality impact adhesive, secure the loudspeaker to the inside of the box, but be careful not to get any glue on the paper cone of the speaker. Next mount

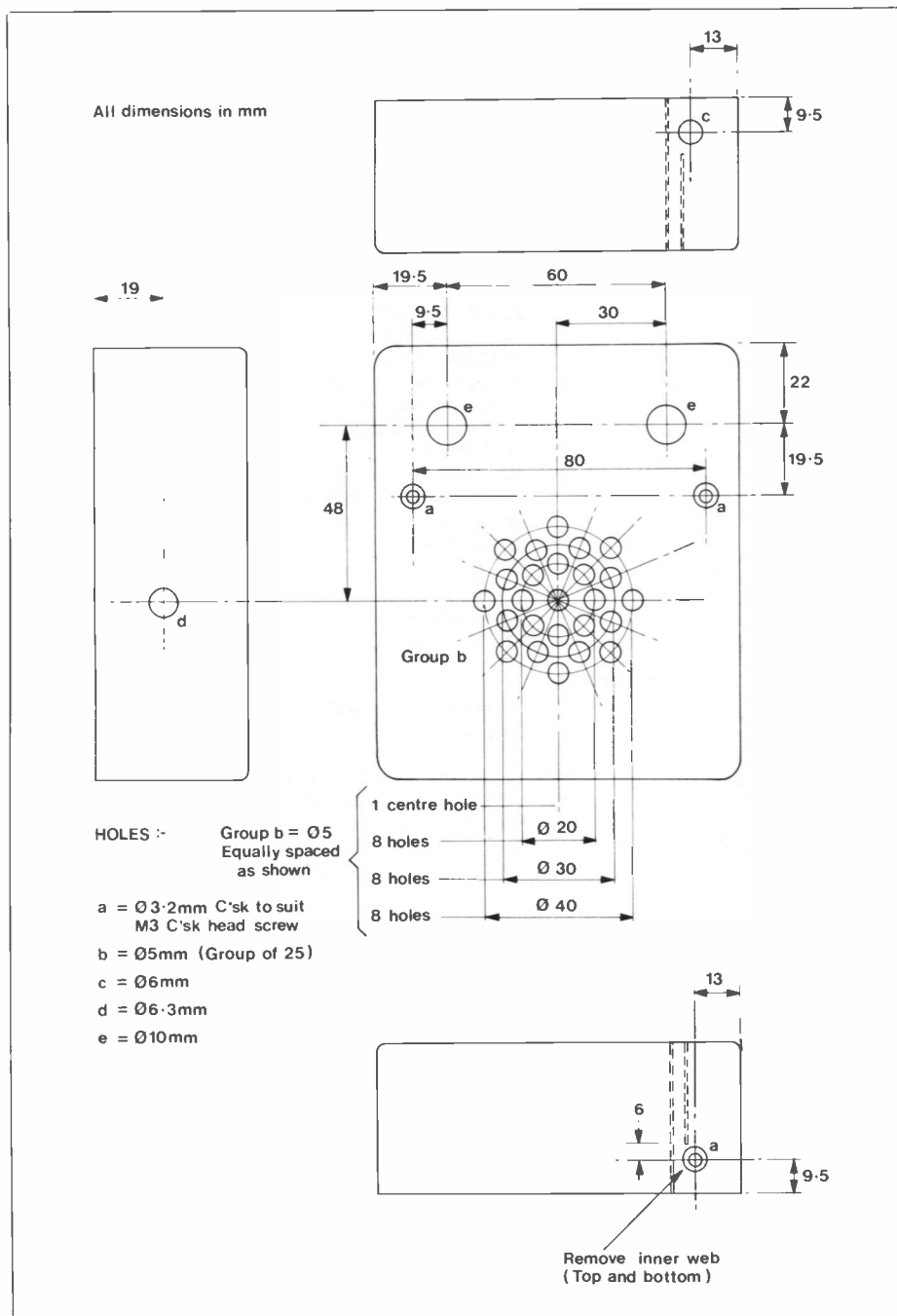

Figure 8. Box Drilling

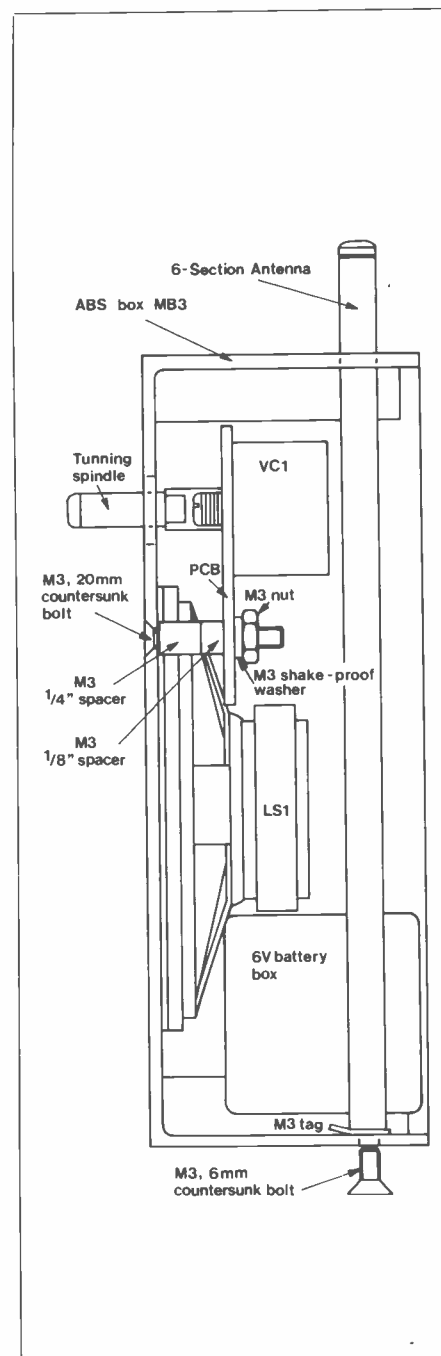
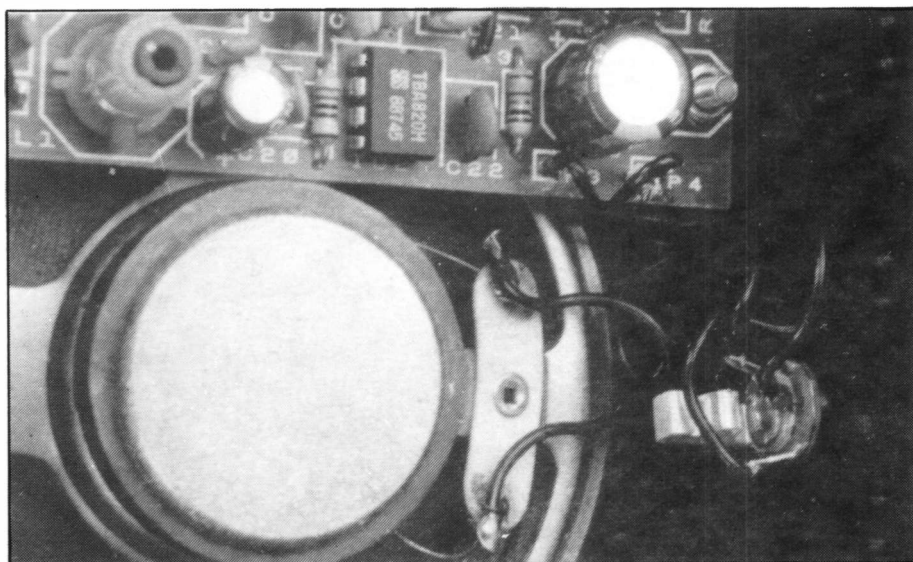

Figure 9. Final Assembly

the PCB assembly using the M3 hardware as shown in Figure 9. The 3.5mm headphone socket is then secured in the side of the box using the nut and washer provided. When fixing the telescopic aerial ensure that the M3 solder tag is tightly clamped under its base. Remove the protective backing from the trim and carefully position and firmly push it down using a dry, clean cloth until it is securely in place. Next fit the knobs so that their pointers are at the fully-anticlockwise position. Check that they travel smoothly round to the fully-clockwise position, without scraping on the front panel trim. Fit the power supply clip onto the 6V battery box and position it as shown in Figure 9. Before fitting the lid of the box, a small piece of foam rubber can be sandwiched between the battery and the inside of the lid. This will prevent the battery box from moving around inside the finished unit.



View of headphone socket.

TDA7000 FM RADIO MKII PARTS LIST

RESISTORS: All 0.6W 1% Metal Film

R1	22k	1	(M22K)
R2	33R	1	(M33R)
R3	1R	1	(M1R)
RV1/S1	10k Pot Log	1	(FW63T)

CAPACITORS

C1	220pF Ceramic	1	(WX60Q)
C2,9	330pF Ceramic	2	(WX62S)
C3,22,24,26	100nF Minidisc	4	(YR75S)
C4	2n2F Ceramic	1	(WX72P)
C5	47pF Ceramic	1	(WX52G)
C6	39pF Ceramic	1	(WX51F)
C7	150pF Ceramic	1	(WX58N)
C8,18	3n3F Ceramic	2	(WX74R)
C10	150nF Polylayer	1	(WW43W)
C11	1n8F Ceramic	1	(WX71N)
C12	22nF Ceramic	1	(WX78K)
C13,14	10nF Ceramic	2	(WX77J)
C15	10pF Ceramic	1	(WX44X)
C16	56pF Ceramic	1	(WX83H)
C17	180pF Ceramic	1	(WX59P)
C19	1μF 100V PC Electrolytic	1	(FF01B)
C20,25	100μF 10V PC Electrolytic	2	(FF10L)
C21	100pF Ceramic	1	(WX56L)
C23	220μF 16V PC Electrolytic	1	(FF13P)
VC1	AM/FM Min Tuner Cap	1	(FT79L)

SEMICONDUCTORS

IC1	TDA7000	1	(YH87U)
IC2	TBA820M	1	(W063T)

MISCELLANEOUS

L1	RF Coil 0.066μH	1	(UF63T)
L2	RF Coil 0.450μH	1	(UF69A)
LS1	8Ω L/S Lo-Z 768	1	(YW53H)
	PC Board	1	(GD77J)
	Control Knob K14B	2	(FK39N)
	Veropins 2145	1 Pkt	(FL24B)
	Aerial 6-section	1	(RK49D)
	Box MB3	1	(LH22Y)
	Front Panel	1	(JG28F)
	Wire 7/0.2	1 Pkt	(BL00A)
	Battery Holder 6V	1	(HF29G)
	Battery clip (PP3) Type	1	(HF28F)
	RF Coil Trim Tool	1	(UF70M)
JK1	3.5mm Chassis Socket	1	(HF82D)
	M2.5 x 6mm Isobolt	1 Pkt	(BF54J)
	M2.5 x 20mm Isobolt	1 Pkt	(JD15R)
	M2.5 Isowasher	1 Pkt	(BF63T)
	M3 x 6mm C/sk. Hd. bolt	1 Pkt	(BF36P)
	M3 x 20mm C/sk. Hd. bolt	1 Pkt	(JC71N)
	M3 Isotag	1 Pkt	(LR64U)
	M3 Isoshake	1 Pkt	(BF44X)
	M3 Nut	1 Pkt	(JD61R)
	M3 1/8" Spacer	1 Pkt	(FG32K)
	M3 1/4" Spacer	1 Pkt	(FG33L)
	M3 1/2" Spacer	1 Pkt	(FG34M)

OPTIONAL

Battery R6S Silver Seal	4	(FK59P)
Mag Earpiece 3.5mm	1	(LB24B)

A complete kit of all parts, excluding Optional items, is available:

Order As LM55K (TDA7000 FM Radio MKII Kit)

The following items are also available separately:

TDA7000 MkII PCB **Order As GD77J**

TDA7000 MkII Front Panel **Order As JG28F**

by Gavin Cheeseman

When running a speaker system it is useful to have an idea of the approximate level of power being used. In particular it is important that the loud speaker manufacturer's specification is not exceeded as this could result in severe damage to the speaker. The Watt Watcher is a simple circuit that may be fitted into a speaker cabinet to provide an indication of the relative power level and uses three LED's: a green LED lights when the power is at a relatively low level indicating that the system is running; a second (orange) LED indicates an intermediate level of power and a third (red) indicates an overload condition. The level at which the orange and red LED's (LD2 and LD3) light is set by fitting resistors of selected value, depending on the required power range. The Watt Watcher derives its power from the speaker line and hence requires no external power supply.

Circuit Description

With reference to the circuit diagram of Figure 1 it may be seen that the Watt Watcher effectively consists of three similar transistor switches. Each switch is biased to switch on LEDs LD1 to LD3 at different input voltages and these correspond to different power levels

depending on speaker impedance. The power, which is taken from the speaker terminals, is rectified and smoothed by two separate networks: R1, D1 and C1 provide a relatively smooth DC voltage for the supply rail, while R2, D2 and C2 provide a less smooth DC voltage for the transistor bias resistors to allow for fast changes in audio power level. Bias resistors R3, R4 and R5 determine the voltage at which the transistor will switch on and light the LED; TR1 is biased to switch on at the lowest voltage and TR3 at the highest. Zener diodes ZD1 to ZD3, serve to limit the brightness of the LEDs at higher voltage levels. Diodes D3 and D4 increase the voltage threshold at which LD2 and LD3 light, as orange and red LEDs have a lower voltage threshold than the green type. The current through the LEDs is limited to a few mA by R6, R10 and R14.

PCB Assembly

Insert and solder the components onto the PCB referring to the legend shown in Figure 2, starting with the resistors. R9 and R13 should be selected, depending on the speaker impedance and the power with which the Watt Watcher is to be used (refer to Table 1). The levels of power

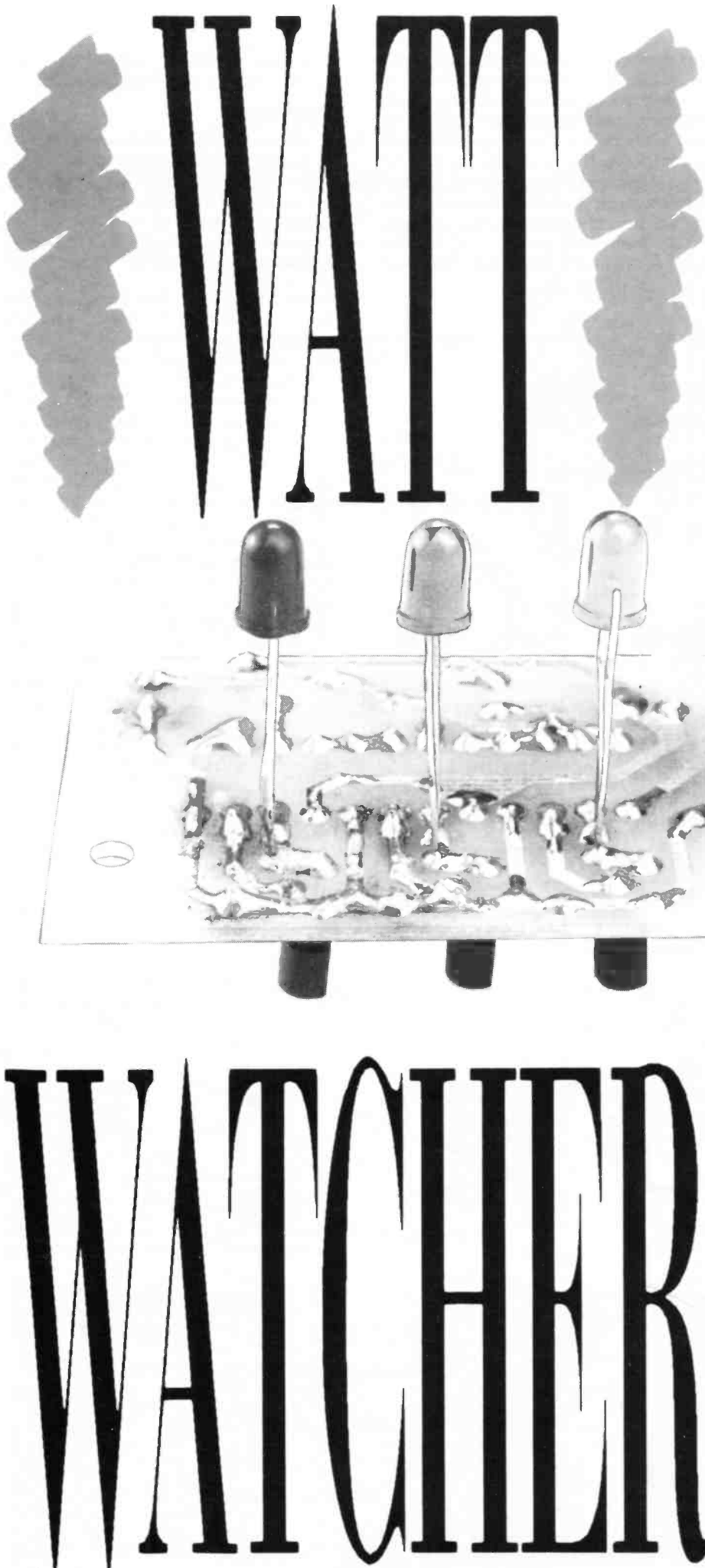

shown (RMS) refer to the approximate power at which LD3 will light. Capacitors C1 and C2 are fitted observing the correct polarity; the negative lead is indicated by a negative sign (-) on the side of the capacitor which goes away from the hole marked positive (+) on the PCB legend. Diodes D1 to D4 are then inserted with the correct polarity (the cathode is marked by a band at one end of the diode). Transistors TR1 to TR3 are positioned so

that their cases correspond exactly with the outline on the PCB legend. LEDs LD1 to LD3 are then installed on the track side of the board (see Figure 3). The length of the LED leads may be cut to suit individual needs, depending where the unit is to be fitted; it is important that they are inserted with the correct polarity (the short lead on the flat side of the LED is the cathode). Finally insert PCB pins P1 and P2. For more detailed information on construction

techniques please refer to the Constructor's Guide included in the kit.

Testing

Before testing the unit make sure that all components are soldered and that there are no dry joints or solder short circuits. If a multimeter is available the DC resistance between P1 and P2 can be measured; this should read several thousands of ohms. Connect P1 and P2 to

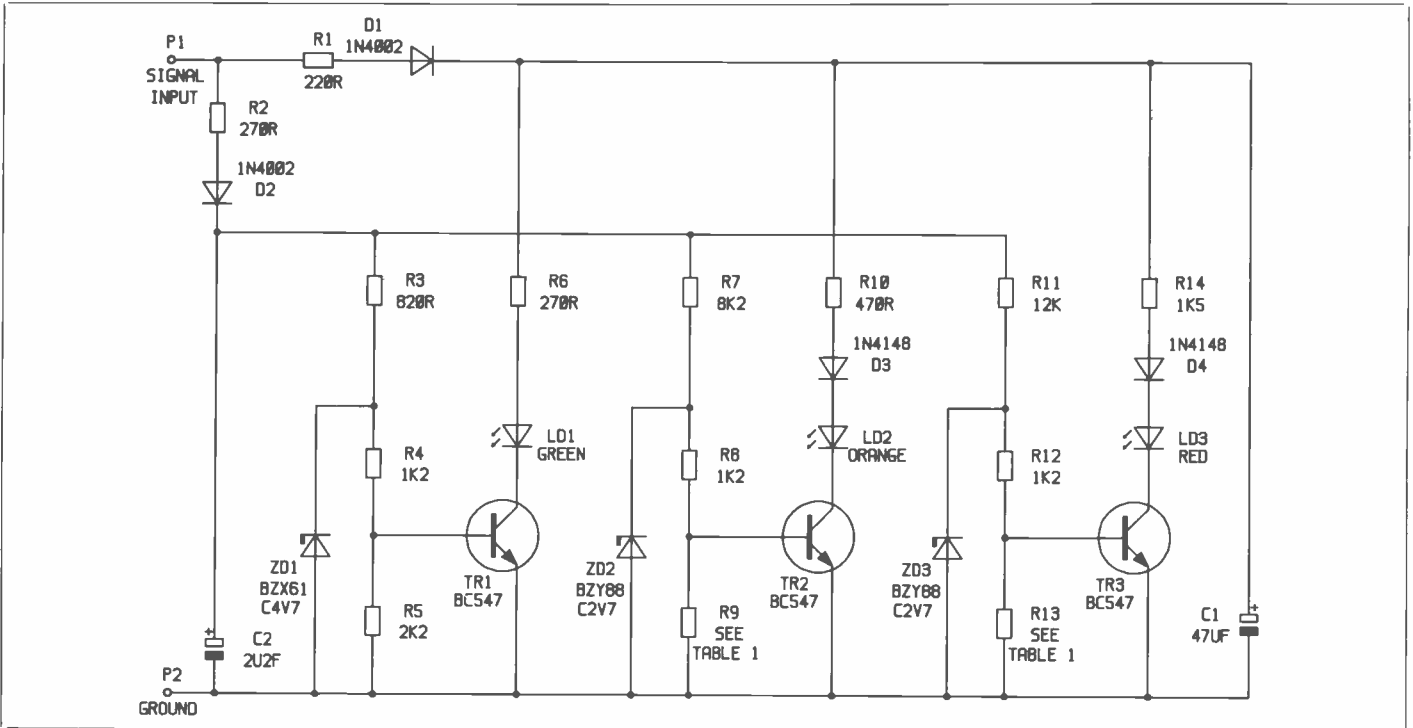

Figure 1. Circuit Diagram.

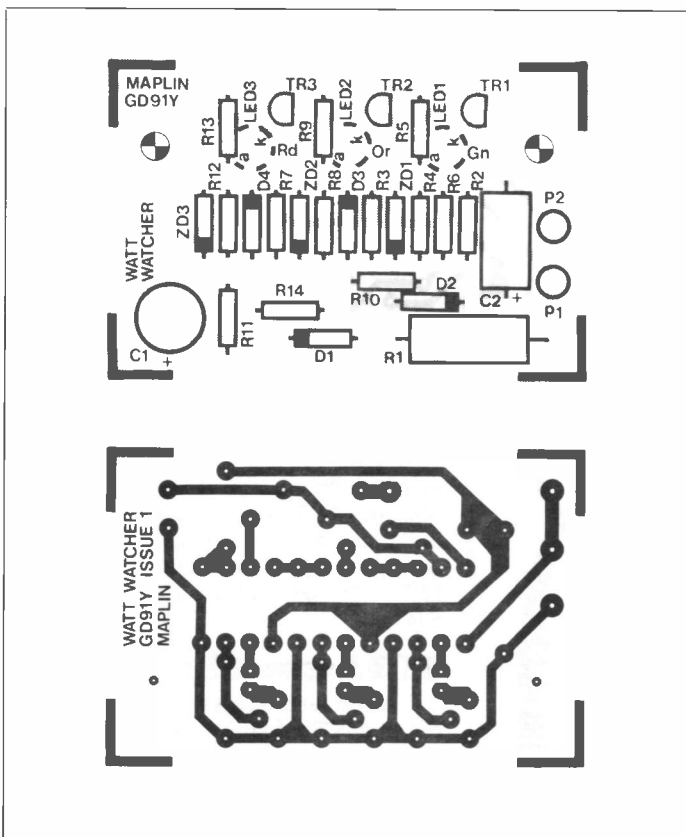

Figure 2. PCB Track and Overlay.

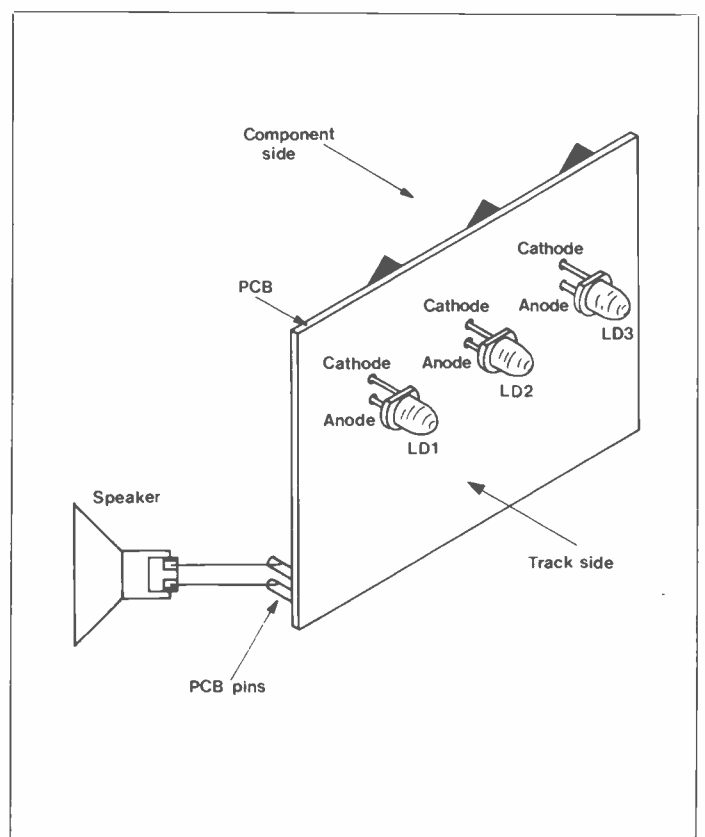

Figure 3. Mounting the LEDs.

the speaker terminals using insulated wire. Switch on and slowly increase the volume. The green LED LD1 should start to light at around 3 to 5 watts depending on speaker impedance. As the volume is increased LD2 should start to light indicating an intermediate level of power. The red LED LD3 should only light when the power level chosen from Table 1 is reached; this is intended to indicate an overload condition and under normal operating conditions should not light (other than perhaps an occasional flicker). An overload condition is indicated when LD3 is lit for the majority of the time. Table 2 shows the approximate input voltage levels at which LD2 and LD3 light for each power range. If all is well the Watt Watcher may be installed into the speaker cabinet or alternatively can be housed in a separate box. It should be noted that the Watt Watcher should not be used with systems running at power levels above the chosen range or with speaker impedances other than those specified as severe damage could result.

POWER		Resistor Value	
		8R Speaker	4R Speaker
25 Watts	R9	1k5	2k2
	R13	1k0	1k5
50 Watts	R9	1k0	1k5
	R13	820R	1k0
100 Watts	R9	820R	1k0
	R13	680R	820R

Table 1. Resistor values for various power levels and speaker impedances.

POWER RANGE (RMS)		Input Voltage (RMS)	
		8R Speaker	4R Speaker
25 Watts	LD2	9V	7V
	LD3	14V	10V
50 Watts	LD2	14V	9V
	LD3	20V	14V
100 Watts	LD2	18V	14V
	LD3	28V	20V

Table 2. Approximate input voltage levels required for LD2 and LD3 to light. Values shown for input frequency - 1kHz (sinewave).

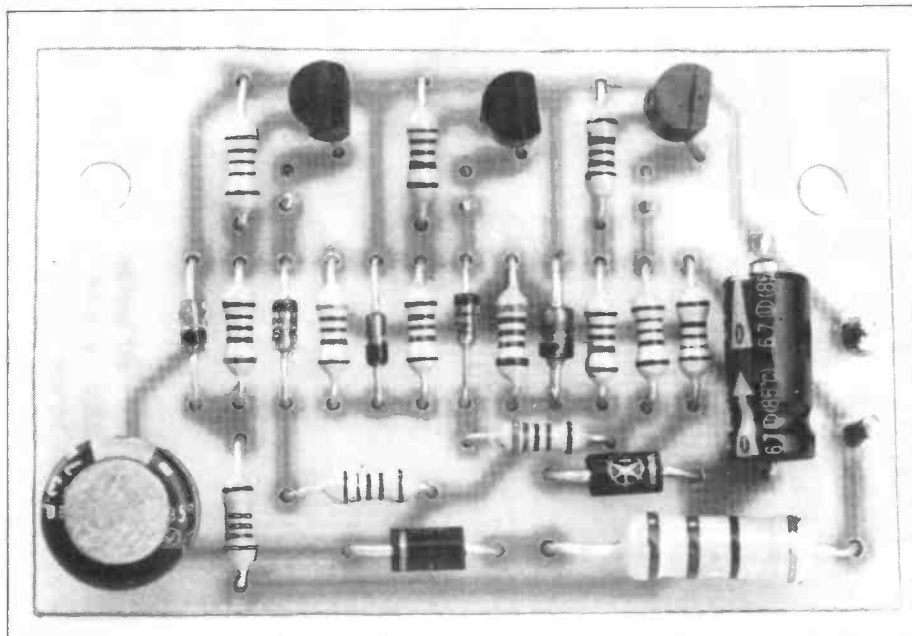

Component side of pcb.

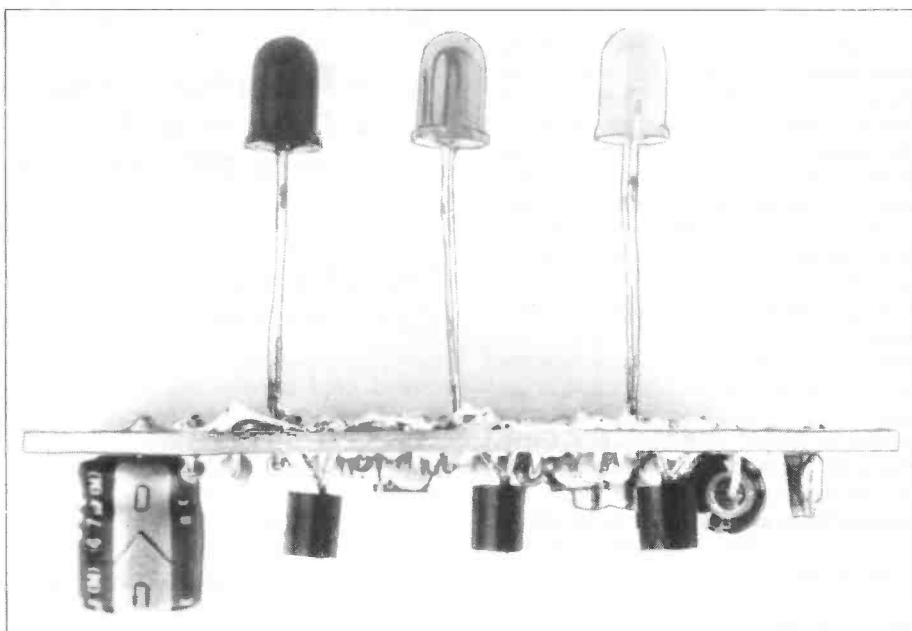

Side view of pcb.

WATT WATCHER PARTS LIST

RESISTORS: All 0.6W 1% Metal Film (unless specified)

R1	220Ω 1 Watt Carbon Film	1	(C220R)
R2,6	270Ω	2	(M270R)
R3	820Ω	1	(M820R)
R4,8,12	1k2	3	(M1K2)
R5	2k2	1	(M2K2)
R7	8k2	1	(M8K2)
R9,13	See Miscellaneous and Table 1		
R10	470Ω	1	(M470R)
R11	12k	1	(M12K)
R14	1k5	1	(M1K5)

CAPACITORS

C1	47μF 63V P.C. Electrolytic	1	(FF09K)
C2	2μ2F 100V Axial Electrolytic	1	(FB15R)

SEMICONDUCTORS

D1,2	1N4002	2	(QL74R)
D3,4	1N4148	2	(QL80B)
ZD1	BZX61C4V7	1	(QF45Y)
ZD2,3	BZY88C2V7	2	(QH00A)

LD1	LED Green	1	(WL28F)
LD2	LED Orange	1	(WL29G)
LD3	LED Red	1	(WL27E)
TR1,2,3	BCS47	3	(OO14Q)

MISCELLANEOUS

Constructor's Guide	1	(XH79L)
P.C. Board	1	(GD91Y)
Pin 2141	1 Pkt	(FL21X)

Select R9 and R13 from the following:

680Ω	1	(M680R)
820Ω	1	(M820R)
1k	1	(M1K)
1k5	1	(M1K5)
2k2	1	(M2K2)

A complete kit of parts is available:
Order As LM57M (Watt Watcher Kit)
 The following item in the above kit is also available:
Watt Watcher PCB Order As GD91Y

8 Watt 12 Volts Fluorescent Tube Driver

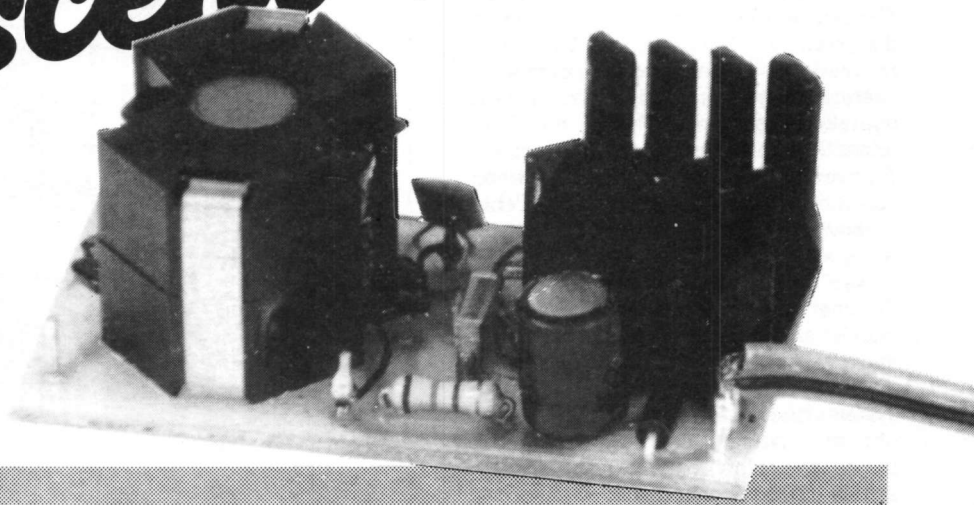

By Dave Goodman

Fluorescent lights have many advantages over incandescent lamps when used out of doors especially when limited power resources are available. Heat output is very low, reducing the risk of fire especially in tents and an average family car battery could supply sufficient power for up to 15 hours continuous use. Light output radiates from the length of the tube, not from one focused point making diffusers and reflectors unnecessary, and being much kinder on the eyes. Unfortunately there is one problem with fluorescent tubes: high voltages are required to 'strike' and run them, so a method of driving many hundreds of volts from a 12 volt source must be employed. Our fluorescent tube driver meets the requirements and provides a system at much lower cost than commercially available units.

Circuit Description

When power is applied, TR1 is turned on hard via R1 and L2. L1 is energised and passes a high current which induces a pulse in L2 and turns TR1 off for the duration of the pulse. No current flows through L1 at this time and L2 offers a low impedance path from R1 to TR1 base thus turning it on again. Due to this alternating field a large voltage is developed across L1 - around 100 volts - and step-up winding L3 generates several hundred volts, enough to strike the fluorescent tube. The load now remains constant across L3 and the oscillation frequency is maintained by time constant R1 and C2.

Under normal load running conditions a 50kHz square wave at 250 volts should be present across pins 5 and 6. In case of reversed battery connections, D1 prevents damage to both TR1 and battery from occurring, and it will not pass current under these conditions. C1 decouples the supply rails and prevents RF transmission from long battery-lead cables (see circuit diagram, Figure 1).

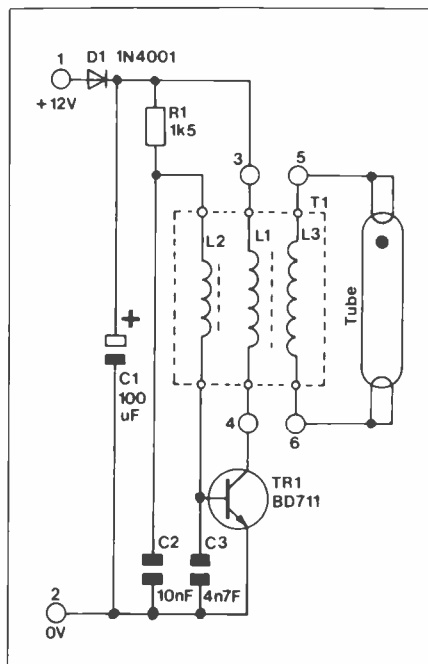

Figure 1. Circuit diagram

- ★ Ideal for Camping, Caravans and Boats
- ★ Runs from 12V Battery Supply
- ★ High Efficiency Light Output

Transformer Construction

Three separate windings are required, see Figure 2, these being:

Secondary L3: 200 turns of 34swg (0.3mm) E/C wire

Secondary L2: 15 turns of 34swg (0.3mm) E/C wire

Primary L1: 30 turns of 24swg (0.6mm) E/C wire

Wind L3 first on the bobbin (Figure 2a) by tinning the E/C wire and soldering it to

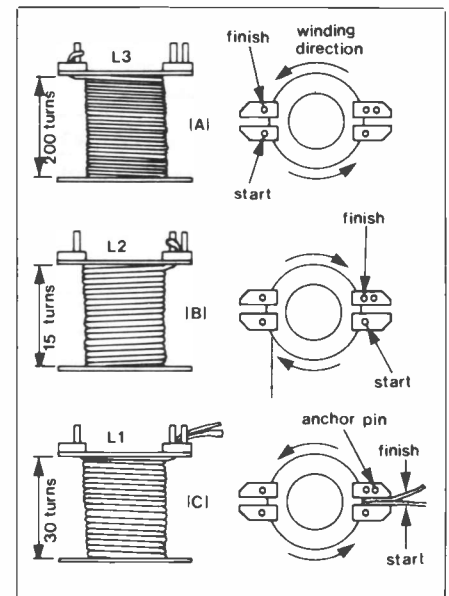

Figure 2. Construction of T1

the L3 start terminal. Wrap each turn close to the previous one and build up in layers. Approximately 30 to 32 turns can be made across the former, so six layers should be built up as neatly as possible. Terminate L3 at the finish terminal and insulate the windings with a single layer of PVC insulating tape wrapped tightly around the coil. Next wind L2 (Figure 2b) starting and terminating on the opposite two bobbin pins (3rd one not used). Again, spread all 15 turns tightly across the previous coil L3 - eight turns across and 7 turns back. Finally, wind L1 straight on top of L2 (Figure 2c). Wind two layers, 15 across and 15 back again leaving two inches of spare wire at each end. Wrap three turns

of PVC tape tightly around L1 to prevent it from unwinding and drop into one section of T1. Fit the remaining section over the bobbin and secure both halves with metal clips clamped over each end. Before fitting onto the PCB make sure the windings of L2 and L3 have been soldered correctly to their bobbin pins and remove any excess solder which may prevent insertion into the board.

PCB Construction

Refer to the parts list and Figure 3. Mount the capacitors C2,3 and resistor R1. Insert diode D1 correctly to the legend on the PCB to ensure correct polarity. Next insert Veropins 1 to 6. Position the vaned heatsink and mount TR1 (Figure 4) making sure that the leads of TR1 go through the board and tighten the nut and bolt. Insert C1, which is polarised, and finally fit T1. L1 is soldered to pins 3 and 4 and the two wire ends should be scraped to remove the enamel before tinning. Solder components and cut off all excess leads.

Using the Module

Connect an ammeter in series with pin number 1 and +12 volt supply; supply common or -ve goes to pin 2. Set the ammeter scale to allow a reading of 1 amp or more and apply power. A high pitch whistling may be heard, with a current reading of 0.4 to 0.5A. If the reading is 1A or more, switch off and reverse L1 connections to pins 3 and 4 and check again. Remove power and connect an 8W 12 inch fluorescent tube

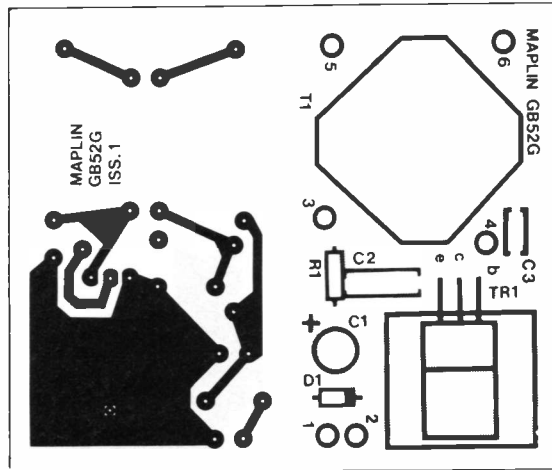

Figure 3. PCB legend

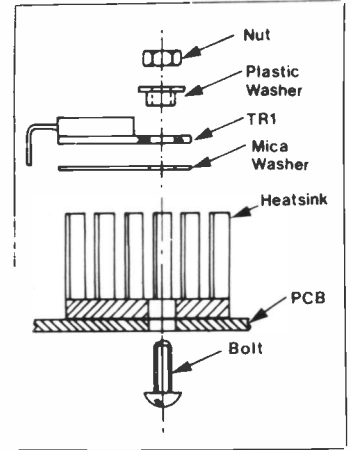

Figure 4. Mounting the transformer and heatsink

across pins 5 and 6. The tube will probably have two starter terminals at each end (four altogether). Join each pair together before connection to the pcb. Keep all connections short and insulate bare terminals to prevent the risk of shock. Remember high voltages are present here and could be dangerous, even with limited current availability!

Apply power again and the tube should glow dimly, then after a second or two light up completely. Check current reading is approximately 0.5A. No whistling should be audible and the tube should not flicker, but if this is not so, try reversing L1 connections to pins 3 and 4 or reverse tube connections to pins 5 and 6.

The inverter can drive two tubes in

series (not parallel), at slightly reduced light output levels and the supply current will rise by 100mA or so when doing this. Resistor R1 can be increased up to 2k to reduce light output (and supply current) or taken down to 470Ω for increased light output, with supply current up to 1A. With the specified value for R1, tube life expectancy should be high and the prototype has been running for a great many hours without problem.

For housing the tube, clear plastic piping as used on water tank overflows etc. can be utilised and fitted to a small plastic box containing the inverter. The module could then be potted for safety and a cork fitted into the open end of the pipe.

FLUORESCENT TUBE DRIVER PARTS LIST

RESISTORS: 0.6W 1% Metal Film

R1 1k5 1 (M1K5)

CAPACITORS

C1 PC Elect 100μF 25V 1 (FF11M)

C2 Poly Layer 0.01 1 (WW29G)

C3 Ceramic 4700 1 (WX76H)

SEMICONDUCTORS

D1 1N4001 1 (QL73Q)

TR1 BD711 1 (WH15R)

MISCELLANEOUS

L1 30 Turns 24 swg E.C.W.

L2 15 Turns 34 swg E.C.W.

L3	200 Turns 34 swg E.C.W.	1	(HX09K)
T1	Type 3 Core	1	(HX10L)
	Type 3 Bobbin	1	(HX11M)
	Type 3 Clips	2	(WR23A)
	Kit (P) Plas	1	(FL58N)
	Vaned Htsnk Plas Pwr	1	(FL24B)
	Pin 2145	1 Pkt	(GB52G)
	Tube Driver PCB	1	(BF06G)
	Bolt 6BA 1/2in.	1 Pkt	(BF18U)
	Nut 6BA	1 Pkt	(BL28F)
	EC Wire 0.56mm 24 swg	1 Rl	(BL42V)
	EC Wire 0.236mm 34swg	1 Rl	(LQ11M)
	12V Tube	1	(XH79L)
	Constructors' Guide	1	(XK66W)
	Fluor Tube Driver Ins	1	

A complete kit of all parts for this project is available:
Order As LK35Q (Fluor Tube Drvr Kit)

Xenon Tube Driver

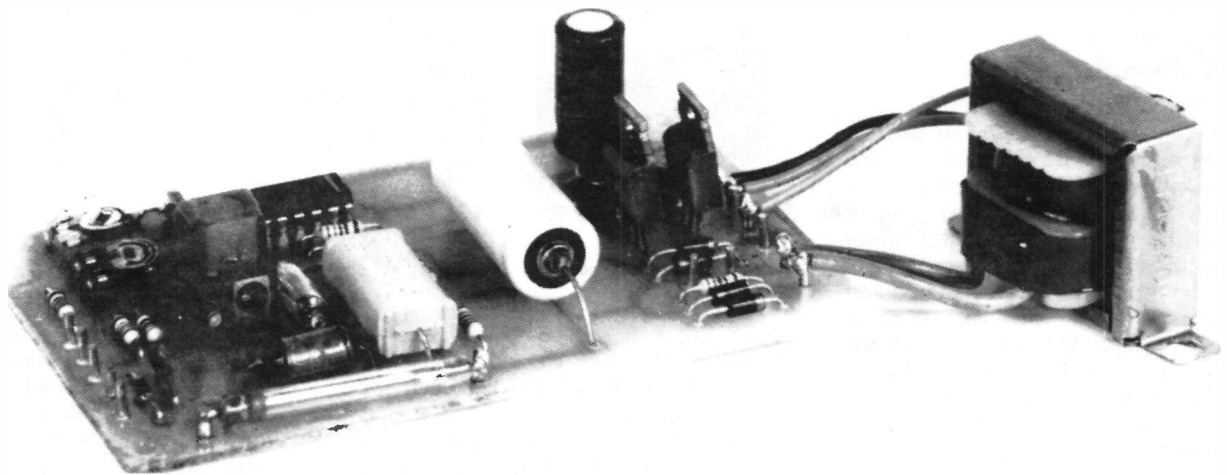

★ **Driver Module for Xenon Tube**
 ★ **Complete with Trigger Transformer**

★ **External Triggering or**
 ★ **Internal Strobe Oscillator**

by Dave Goodman

Introduction

The Xenon Tube, along with the Trigger Transformer required to operate it, are regular subjects of enquiry by many of our readers, therefore to put the books straight, a tube driver module with external triggering and 'on board' strobe oscillator is offered. The module can be used for photography, roadside hazard indication, navigation, distress beacons or perhaps underwater communications, and is ideal for further experimentation Xenon tubes are glass envelopes filled

with a gas which emits blue/white high intensity light when energised. A high voltage potential of 210 to 400V must be applied across both anodes, A1 and A2, (see Figure 4g) which will allow the gas to 'strike' when a 3 to 5kV pulse is applied to the trigger electrode strip, located along one side of the tube. To generate the EHT triggering voltage, a pulse transformer is used which is similar in action to the well known car ignition coil (see Figure 4f), stepping up the primary (B,C) voltage to the required secondary (B,A) voltage.

Circuit Description

To generate the xenon strike voltage a simple inverter system is employed. Each half of transformer T1 secondary is connected to a power transistor (TR3 and TR4) and the common centre tap is connected to +V supply. By alternately switching each transistor on and off, one half of T1 is grounded at a time, and maximum current flows through each winding in turn. By inductive effect a 50V peak pulse develops between TR3 and TR4 collectors (across T1 secondary)

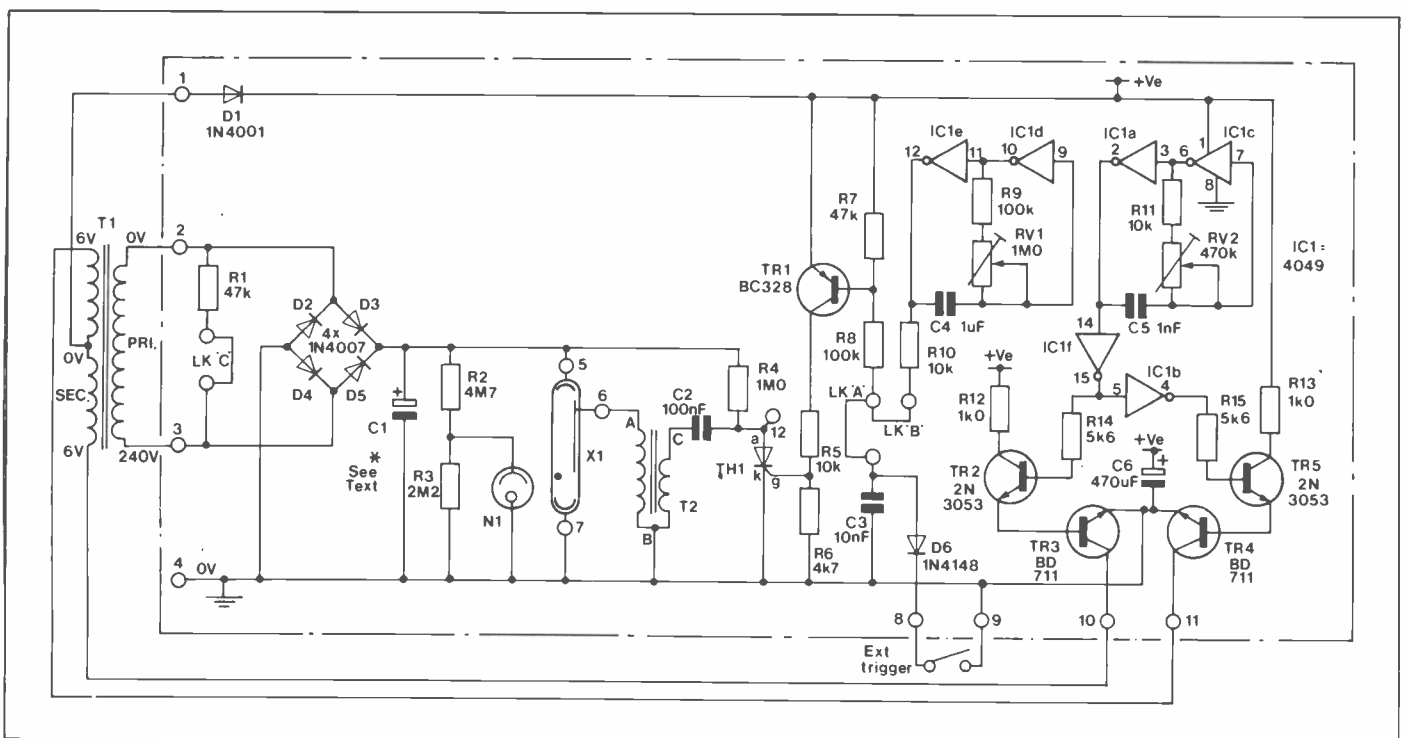
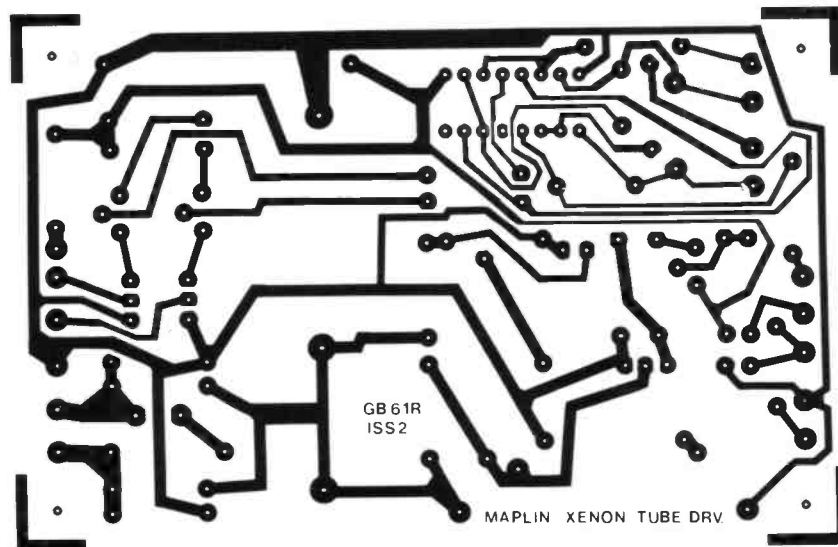
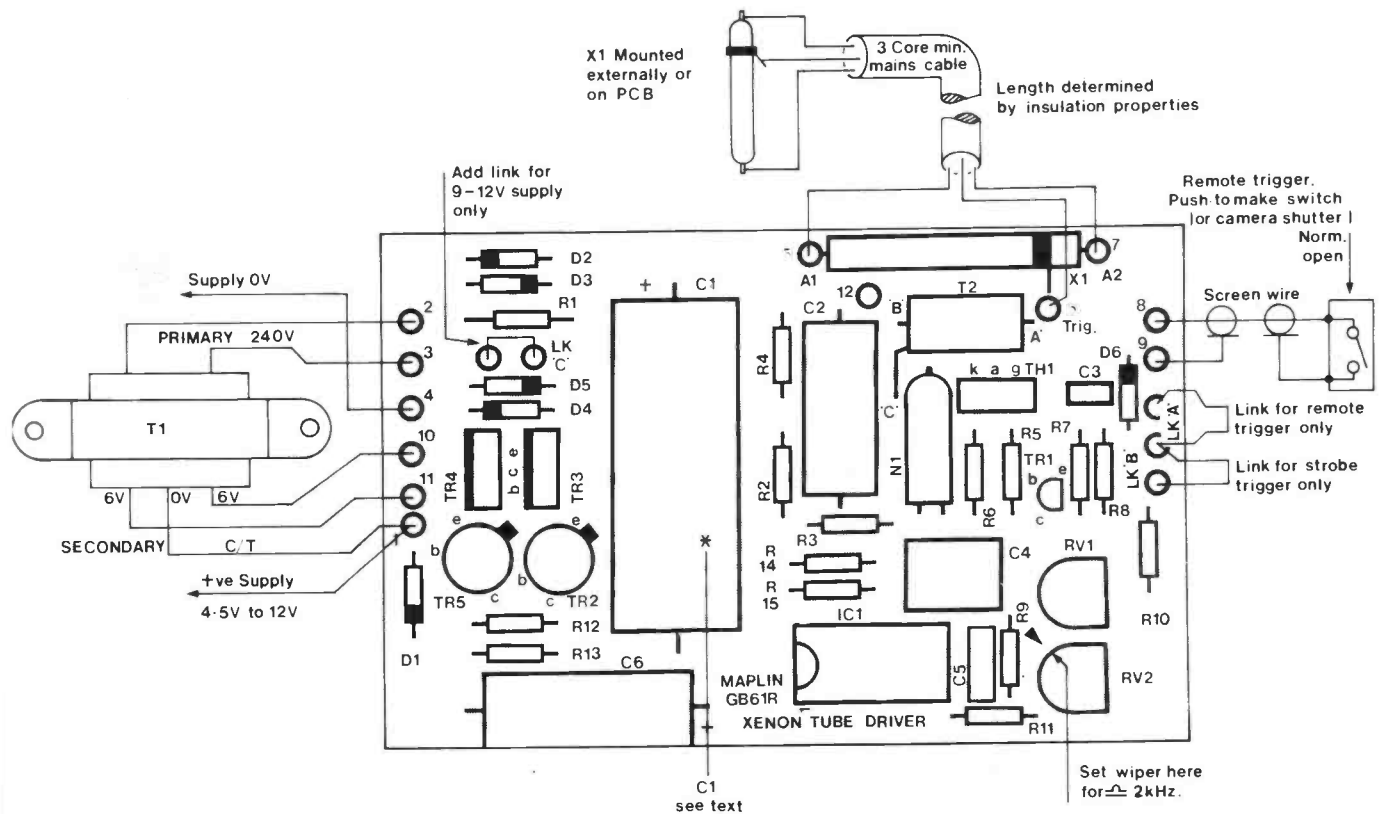

Figure 1. Circuit Diagram



Figures 2 and 3. PCB Track Legend and Wiring Diagram

which is stepped up by the primary winding approximately 20 times to produce a 1kV peak signal at pins 2 and 3. T1 is in fact a normal 240 to 12V mains transformer connected the reverse way round; instead of applying 240VAC for stepping down to 12VAC, we apply 12VAC and step it up to 240VAC, or in this case 1kVAC.

The alternating signal for switching TR3 and TR4 comes from a CMOS inverter/oscillator IC1a,c and f. IC1c has a variable resistance RV2, and R11 connected across it, which maintain the input voltage level close to the output level on pin 6. If IC1a output, pin 2, is assumed to

be low (0V) capacitor C5 will start to charge via RV2 and IC1c pin 7 input will be momentarily pulled low. By inverter action IC1c pin 6 will go high (+V) maintaining IC1a pin 2 in the low state. As C5 charges, the voltage across it increases until a point is reached when IC1c input pin 7 is potentially high enough to flip the output pin 6 low, IC1a pin 2 will then change state from low to high. At this stage the voltage across C5 is reversed and a discharge path via RV2 and R11 gradually drops the potential at IC1c input until the switching level is reached and the oscillation cycle repeats. RV2 determines both charge and dis-

charge times which can be varied from 25 μ s to 650 μ s, or between frequencies of 40kHz and 1.5kHz.

IC1f buffers the oscillator and drives the emitter follower driver transistor TR2. With output high, TR3 is turned on, IC1b goes low and TR4 is turned off. When IC1f output goes low TR3 is turned off, IC1b output switches high and TR4 turns on. C6 decouples the +VE rail and D1 helps prevent component damage in the case of supply reversals.

Once oscillation is established, D2 to D5 form a full wave bridge rectifier for charging C1. This capacitor must be of a high voltage rating, in this case 450V

working, and to keep the voltage within limits, R1 can be connected across T1 primary by inserting link 'C' if necessary (see Testing).

Neon lamp N1 indicates when the C1 charge voltage is high enough to strike the xenon tube, but as neons normally conduct at around 90V, a high impedance potential divider (R2, R3) is required to set this threshold. Resistor R4 charges a high voltage capacitor, C2 via the pulse transformer primary winding (T2, c and b). By discharging C4 to ground a fast rise-time spike of several hundred volts is generated in the primary of T2 which is stepped up to some 5kV in the secondary winding thus triggering the tube. C1 discharges a high current pulse through the tube to ground and is then re-charged by the inverter.

Connecting link 'A' allows an external make switch to momentarily connect D6 to ground, TR1 base potential is lowered via R7 and R8, TR1 conducts so that a positive gating voltage appears at R5, R6. Thyristor TH1, which can be viewed as a switched diode, conducts and C2 is discharged to ground from the anode to the cathode. Immediately after discharging, C2 re-charges via R4 so that the anode voltage rises positively, under this condition TH1 would remain in a permanently conducting state, even without further control gate signals! This is obviously not what is required and somehow the thyristor must be reset to a non-conducting high impedance state. Fortunately the effect of expanding T2 primary, by discharging C2 through it, results in the coil contracting back again, thus producing a high, negative voltage, spike in the reverse direction. This is applied via C2 to TH1 - making the anode more negative than its cathode. The conducting state is thus prevented by reverse biasing the anode/cathode junction and TH1 resets to the high impedance state, under gate control.

A second CMOS oscillator runs at a lower frequency than the inverter clock and with link 'B' inserted can be used to strobe the xenon tube from approximately 0.5Hz to 6Hz. If required links A and B can both be fitted for repeat and manual triggering.

Construction

Refer to the parts list and begin by bending the resistor leads for fitting into the PCB. Do the same with diodes D1 to D6 referring to Figure 4a for orientation. Mount both presets (RV1 and RV2), IC1, TR1 and C1 to C5. Figure 4c, d and e shows lead connections for TR2 and 5, TR3 and 4, also TH1 which must be fitted correctly to the legend. Next fit pulse transformer T2 with the primary lead C exiting on the left towards C2. Now fit vero-pins P1 to P11 from the track side of the PCB and push home with a soldering iron. All components may now be soldered and excess wire ends cut off. Clean the tracks with solvent and a brush, then inspect for solder splashes, dry joints, short circuits etc. Neon N1 can be fitted either way round, but X1 must be

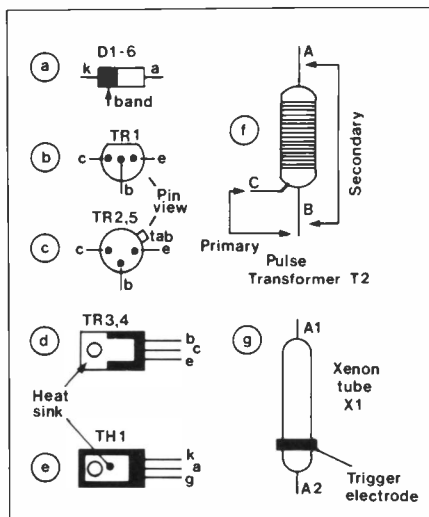

Figure 4. Component Reference

fitted with the double wire end to the right of the board. For test purposes carefully solder the anodes A1 and A2 to pins 5 and 7 respectively, and the trigger electrode directly to the component side of the PCB (Figure 3). Mount the min. mains transformer T1 with the primary (thick wires) to pins 2 and 3 and the secondary (three thin wires) to pins 10 and 11. The centre tap (middle wire) connects to pin 1 (+V). Finally re-check the construction and when completely satisfied, proceed with testing.

Testing

Connect a suitable power supply of from 4.5V to 12V with +V to pin 1 and 0V (-V) to pin 4. Adjust RV1 wiper to about half-travel and RV2 wiper to the arrow on the legend. Turn on the power whereupon a slight buzzing sound should be heard, after a few seconds the neon should start to glow. Now take a length of insulated wire, connect one end to 0V and momentarily touch the other end onto pin 12. The xenon tube should flash and a loud crack may be heard as the air around the tube expands; N1 will go out. If using a 9 to 12V power supply connect link 'C' to prevent excess charge across C1 and connect link 'A'. Re-apply power, wait for the neon to glow, then touch pins 8 and 9 together, once again the tube will

flash. Switch off the power, discharge the system by grounding pin 12, remove link 'A' and connect link 'B'. Re-apply power, the tube should flash at approximately 1 second intervals. Adjusting RV1 will vary the flash rate slightly, but not a lot. Switch off the power, discharge pin 12 to ground and remove the +V PSU lead, leave T1 centre tap in place. Now connect an ammeter between the +V supply lead and pin 1 on the PCB, set the range to 0.5 or 1A and switch on. The final current reading will be dependent on the supply voltage, on average it should be around 80mA for a 6 volt supply. Slowly adjust RV2 clockwise or anti-clockwise until the lowest reading is found, link 'B' may have to be removed before doing this check. If a frequency counter or 'scope is available, monitor the inverter clock on IC1 pin 15, it should be close to 2kHz at minimum current setting. Also an oscilloscope connected across C1 with a 10M ohm probe should read below 450V DC with a 12V supply and link 'C' inserted. Note that link 'C' will not be necessary when using a power supply of 4.5 to 9 volts.

Strobe Rate Adjustment

Capacitor C1 is supplied as 47μF but may be reduced in value providing its working voltage is kept at 450V or more. Because the inverter source is high impedance, the charge rate for C1 is slower for larger capacitance values and faster for smaller values. The final value chosen will depend upon the use to which the module is to be put. Thus faster strobe oscillator times will require C1 being lower in value, say 10μF or less, to increase the oscillator frequency still further, C5 can be reduced in value.

One major effect of reducing C1 in value is a reduction in discharge current through the tube, hence a reduction in light output, so this must be borne in mind when selecting C1. If it is required to use the 47μF value for C1, but light intensity needs to be variable, link 'C' can be inserted and the value of R1 decreased to suit.

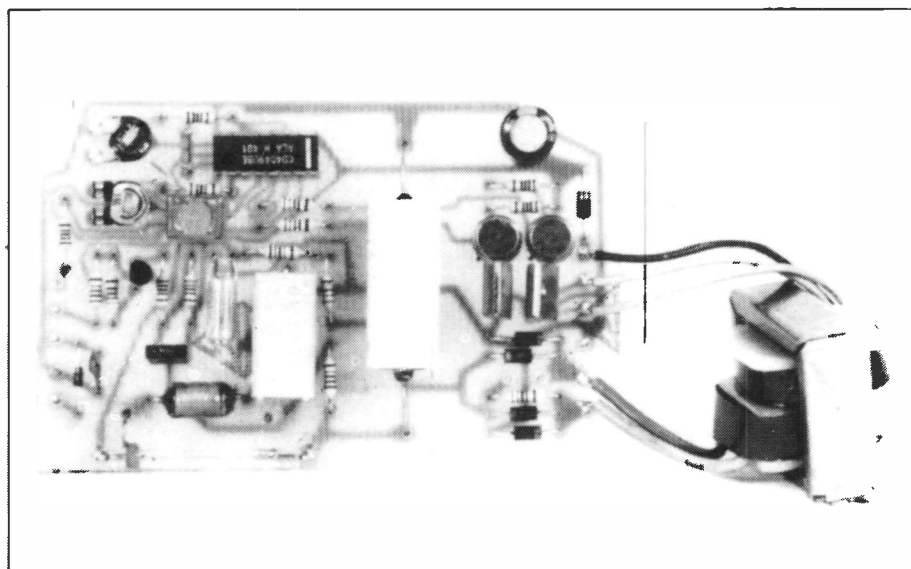

EIGHT-CHANNEL FLUID DETECTOR

by Nigel Fawcett Introduction

This project, as the title suggests, is a variation of the very popular fluid detector circuit, only here it has been taken a stage further, and has thereby increased the range of applications for such a device. The project came about as the result of building a darkroom and workshop into a garage which required a sink with hot and cold running water. Getting the water in was no problem, but getting it out again was a different matter. The garage was considerably lower than the house, and did not have immediate access to any main drainage point.

The only solution was to pump the water back up to house level, and thereby into the normal domestic waste system. The waste from the garage sink emptied into an expansion tank of the kind used in central heating systems, and was pumped out again with a self-priming pump purloined from a redundant washing machine. It was here that the need for a fluid detector lay. A means of determining the presence of water was required to switch on the pump. However, it was foreseen that a greater inflow of water than the pump could reasonably handle might occur. To overcome this problem, eight separate channels were incorporated to detect the increasing level of water in the tank, and so indicate the effectiveness of the pump.

Circuit Description

At the heart of the circuit (see Figure 1) is the LM1830 fluid detector chip IC2. This is the type of IC commonly found in drinks vending machines, washing machines, and a whole host of other domestic and industrial appliances. It is a well designed IC which includes an A.C. current to the probes to alleviate the problem of plating. The output is also pulsed, and can be used to drive a speaker or LED directly, but in this instance an 'on' or an 'off' condition was required to interface with the CMOS digital part of the design. This is achieved by the reservoir capacitor C4, which smooths the oscillator output, and the pull-up resistor R2.

The IC detects the presence of water by comparing the resistance across the probes with an internal resistor. One probe is connected to ground, whilst the other is connected to pin 10 of the IC. In this particular design, eight independent probes are connected to the single 8-channel analogue multiplexer/demultiplexer IC1. Each of the channels is scanned approximately once a second, and during the scan time IC2 checks for the presence of water (conductive fluid). If water is detected then the output of IC2 goes high and is written into the latch corresponding to the input channel of the 8-bit addressable latch IC3.

Both IC1 and IC3 have a three bit address bus to select the desired

- ★ **8 LED's Indicate Fluid Level or Monitor up to 8 Separate Levels**
- ★ **Based on LM1830 IC - Simplified Construction**

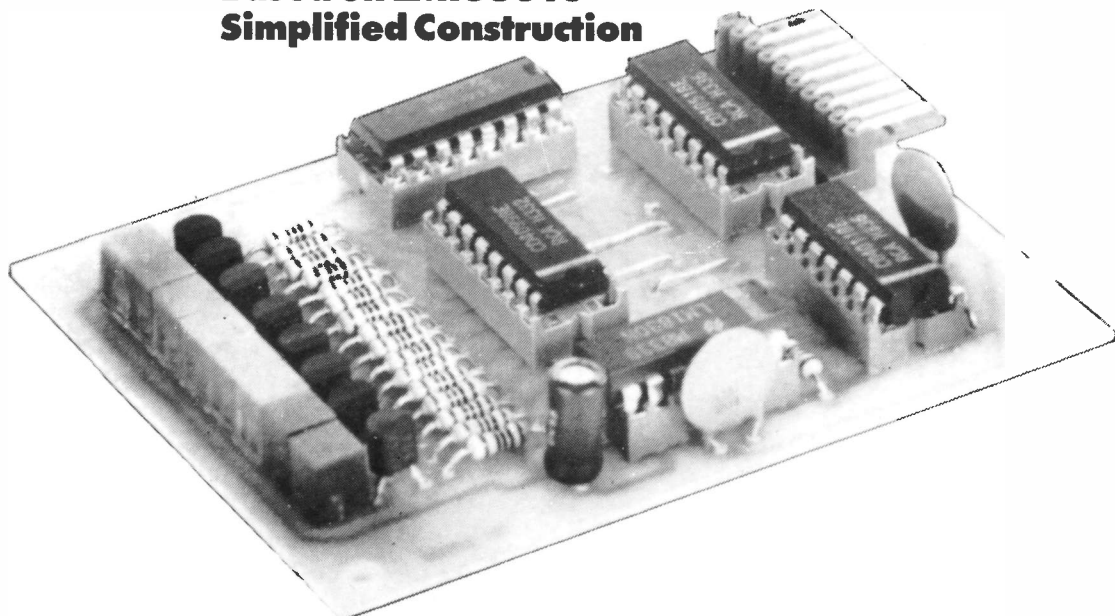

channel, and the addressing for the chips is provided by half of the dual decade counter IC5. The clock for the counter is formed from two of the dual input NAND gates of IC4, R1 and C1. The other two gates of IC4 and the other counter of IC5 are used to produce a short pulse during each scan cycle, to ensure that data is only written into the output latches when IC2 has had time to sense the fluid and settle down. The outputs from the latch are then used to drive the eight LED's and their associated circuitry. In the application described in the introduction, the LED's for channels 1-6 were green and channels 7 and 8 were red. This provided visual stimulation when things were getting dodgy. In practice the colours chosen will depend on the application (see applications). It should be noted here that a remote lead was taken from channel one output to a separate board which was used to switch the pump on or off.

Construction Details

All the components are fitted on the printed circuit board (see Figure 2). Start by inserting, and soldering, the wire links and resistors, proceed with the IC sockets, capacitors, PL1, the transistors and LED's, and finally insert the integrated circuits into their respective sockets. Normal MOS handling precautions should be observed with the CMOS integrated circuits, with care to ensure correct orientation. PL1 is a ten pin connector, but only nine pins are required, and in fact there are only nine holes in the PCB, so pin one must be removed from the plug before it can be mounted on the board. This is easily achieved with a small pair of radio pliers.

A twelve volt power supply is required and, although no construction details are described here, a suitable

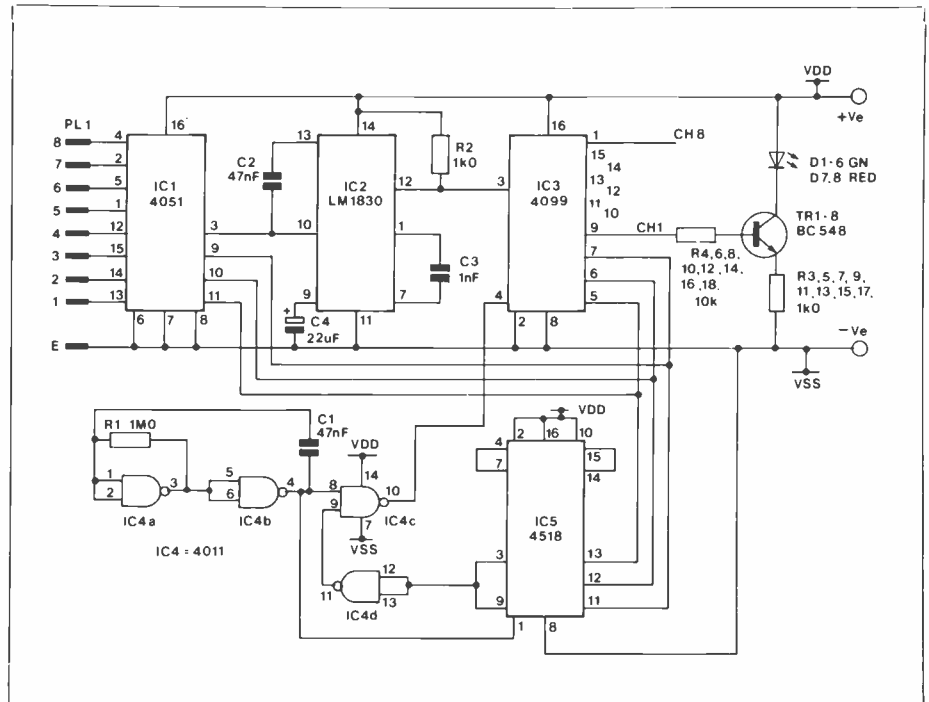

Figure 1. Circuit diagram

circuit can be found in the semiconductors section of the Maplin catalogue under regulators. As far as the construction of a probe is concerned, it would be beyond the realms of practicability to attempt the description of a suitable design, since it depends entirely on the application. The receptacle containing the fluid may be small or large, shallow or deep. There may be one individual container or up to eight separate ones. There may not even be a container at all (see applications). In many applications however, a simple narrow piece of copper strip Veroboard can be employed, using the strips horizontally, choosing appropriate strips for the particular levels, and connecting the ground terminal to the bottom strip.

Applications

Up to this point, most of the references to utilising this project have revolved around using all eight channels to monitor the fluid 'level' in a container. In the previous paragraph it was suggested that the various channels could in fact be used quite independently or in groups of any number. To explain this further, consider the following three applications for which the circuit has already been gainfully employed. Case one is for use in a car and is really rather a novel idea. The purpose here is to use the project to give a continuous visual indication of the amount of water in the windscreen washer bottle. When used in this way, the red LED's should be

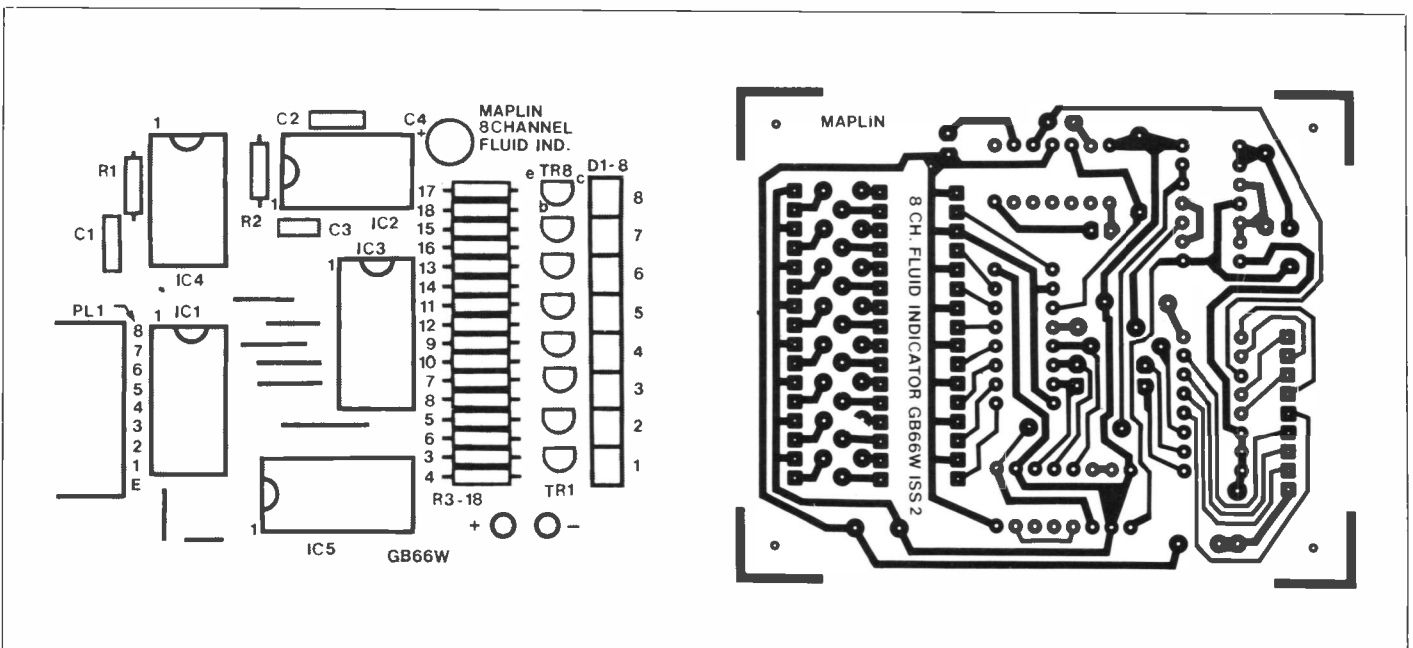
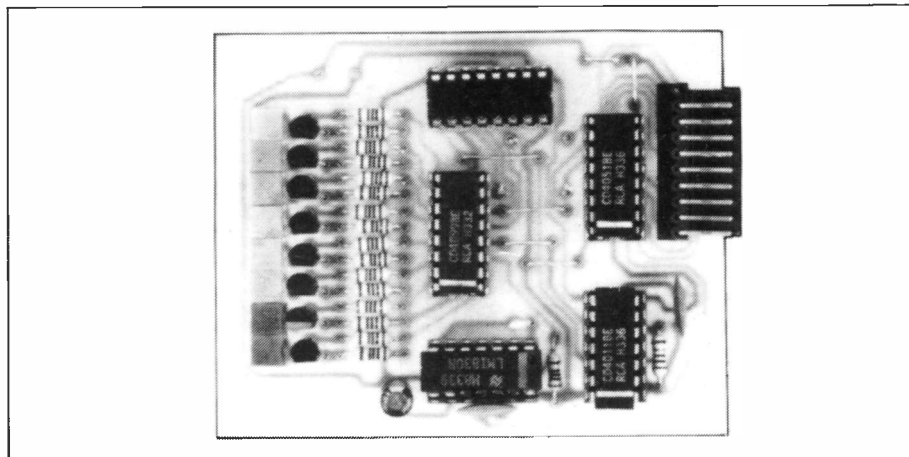

Figure 2. PCB track and layout

inserted in the positions for channels one and two, as a warning condition is now required when the water content is getting low. If you are using the idea in an estate car or any other car with a rear window washing facility then use two probes; channels 1-4 for one bottle and channels 5-8 for the other, and this time insert one red LED in channel one and the other in channel five. The strip of Veroboard was found to be ideal in this application.

Case two was for an installation which had a number of large tanks. These gradually drained over a period of time but when they got down to a predetermined level they were to be refilled by opening an electronically controlled valve. Here two channels were used for each tank, one channel opening the valve when fluid dropped below the minimum level, and the other closing the valve when the tank was full. Four tanks were able to be controlled by the one board.

Case three was for use in a nurseryman's greenhouses. The grower in question used mist sprayers in his



houses which gave the plants a good spraying whenever the water had evaporated from the surface of the probes, which were placed at regular intervals between the plants. The mist was turned off again when enough water had fallen to bridge the gap on the probe and therefore detect the presence of water again. As he grew a large number of different plants at different tempera-

tures and humidity, he was able to use each channel separately to give individual monitoring and control for all the environments he required.

There are obviously a great many more ways in which this circuit could be used, and these suggestions are only here to demonstrate the wide range of uses in which this project may be put to work.

8 CHANNEL FLUID DETECTOR PARTS LIST

RESISTORS: All 0.6W 1% Metal Film

R1	1M	1	(M1M)
R2,3,5,7,9,11,13,15,17	1k	9	(M1K)
R4,6,8,10,12,14,16,18	10k	8	(M10K)

CAPACITORS

C1,2	Minidisc 0.047µF 16V	2	(YR74R)
C3	Ceramic 1000	1	(WX68Y)
C4	PC Elect 22µF 25V	1	(FF06G)
D1-6	Shape LED R1 Green	6	(YY46A)
D7,8	Shape LED R1 Red	2	(YY45Y)
TR1-8	BC547	8	(QQ14Q)

IC1	4051BE	1	(QW34M)
IC2	LM1830	1	(YY99H)
IC3	4099BE	1	(QW57M)
IC4	4011BE	1	(QX05F)
IC5	4518BE	1	(QX32K)

SEMICONDUCTORS

PL1	RA Lch PCB P1 10W	1	(RK68Y)
	DIL Socket 14-pin	2	(BL18U)
	DIL Socket 16-pin	3	(BL19V)
	8 Ch Fluid Dctr PCB	1	(CB66W)
	TC Wire 0.9mm 20swg	1 Rl	(BL13P)
	Constructors' Guide	1	(XH79L)
	8ch Fluid Detector Ins	1	(XK71N)

A complete kit of all parts is available for this project:
Order As LK48C (8 Ch Fluid Dctr Kit)

Continued from page 26

XENON TUBE DRIVER PARTS LIST

RESISTORS: All 0.6W 1% Metal Film Unless Specified

R2	4M7	1	(M4M7)
R3	2M2	1	(M2M2)
R4	1M	1	(M1M)
R5,10,11	10k	3	(M10K)
R6	4k7	1	(M4K7)
R1,7	47k	2	(M47K)
R8,9	100k	2	(M100K)
R12,13	1k	2	(M1K)
R14,15	5k6	2	(M5K6)
RV1	Hor Encl Preset 1M	1	(UH09K)
RV2	Hor Encl Preset 470k	1	(UH08J)

CAPACITORS

C1	Axial 47µF 450V	1	(FB43W)
C2	IS Cap 0.1µF	1	(FF56L)
C3	Disc 0.01µF 50V	1	(BX00A)
C4	Poly Layer 1	1	(WW53H)
C5	Poly Layer 0.001	1	(WW22Y)
C6	Axial 470µF 16V	1	(FB72P)

SEMICONDUCTORS

D1	1N4001	1	(QL73Q)
D2-5	1N4007	4	(QL79L)
D6	1N4148	1	(QL80B)
TP,1	BC328	1	(QB67X)
TR2,5	2N3053	2	(QR23A)
TR3,4	BD711	2	(WH15R)
TH1	C106D	1	(QH30H)
IC1	4049UBE	1	(QX21X)

MISCELLANEOUS

T1	Sub-Min Tr 6V	1	(WB00A)
T2	4kV Trigger Transfmr	1	(YQ63T)
N1	Wire Neon	1	(RX70M)
X1	Xnn Tube High Energy	1	(YQ62S)
	Pin 2141	1 Pkt	(FL21X)
	Xenon Tube Dr PCB	1	(GB61R)
	DIL Socket 16-pin	1	(BL19V)
	Constructors' Guide	1	(XH79L)

A complete kit of parts is available for this project:
Order As LK46A (Xenon Tube Driver Kit)

MAINS CONTROLLER FOR 8-CHANNEL FLUID DETECTOR

by Nigel Fawcett

To follow the previous 8-channel fluid detector project here is some more detailed information on how to use the digital outputs to control mains devices. The first, and simplest form, is to replace any of the LED's with the coil of a relay. This is achieved by removing the 1k load resistor (R3, 5, 7, 9, 11, 13, 15, 17 depending on which channel is being used), and replacing it with a 100 ohm resistor. The LED is also removed and this is replaced by the coil of the relay. The relay should have a coil resistance of approximately 300 ohms, and a nominal voltage of 12V DC. The modified output stage is shown in Figure 1.

If a channel is used to switch the mains and the LED is also required then the circuit shown in Figure 1 is needed in addition to the output stage on the Fluid Detector PCB. A flying lead from the IC side of the 10k resistor (IC3 and R4, 6, 10, 12, 14, 16, 18, depending on which channel is being used) must be taken to a separate board with the relay drive circuit on it. Refer to Figure 2. This modification satisfies the requirements of the nurseryman and his greenhouse mist sprayers, as described in the previous article.

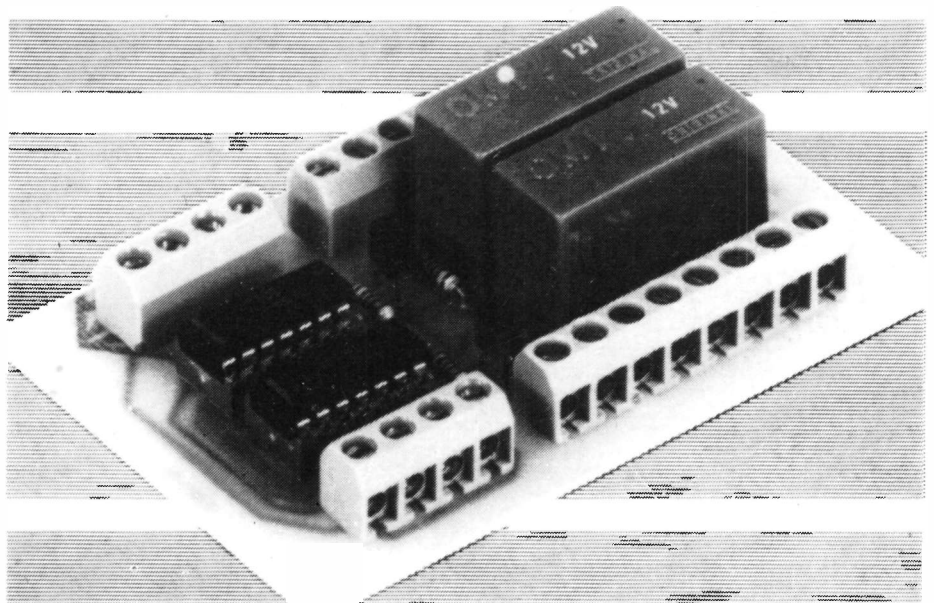

The second and more complicated control circuit is used, for example, where a tank is gradually filling up with water, which must be pumped out to prevent the tank from overflowing. In addition, the water flowing into the tank can be turned off by mains controlled valves. It is decided that the pump should

not start emptying the tank until it is half full, but should continue to pump out the contents until the tank is empty. If the inflow of liquid exceeds the outflow and the tank becomes full, then the inlet valves must be closed and remain closed until the tank is half empty. The requirements for the pump and the inlet valves

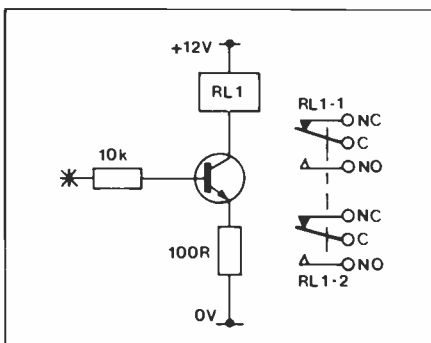

Figure 1. Relay driver

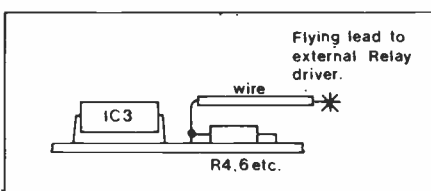

Figure 2.

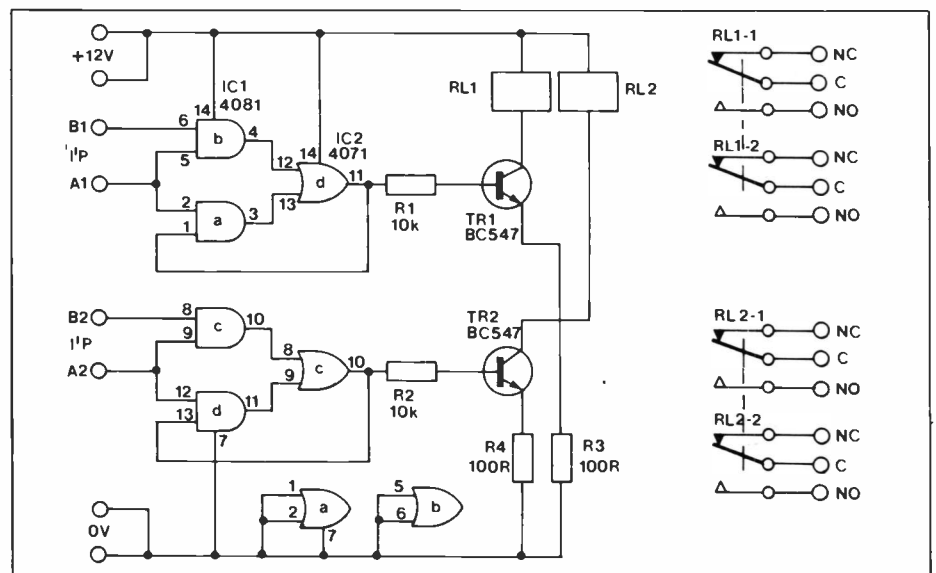

Figure 3. Circuit diagram

are actually the same, so two identical circuits are required. The logic for the circuit shown in Figure 3 is that the relay should be energised when two separate inputs are both 'high' and remain energised until both return to the 'low' state. In point of fact, only the 'A' input need go 'low' to release the relay, but the application hardware ensures that the 'B' input must already be logic 'low' before the 'A' input also becomes 'low'.

This second modification is the one that was used for the darkroom/workshop described previously, Figure 5 demonstrates this application in use.

Circuit Description

The circuit consists of two identical circuits, each of which comprise two AND gates, one OR gate, a relay driver and a relay. The 'A' input is used as the control input and is connected to both of the AND gates. The 'B' input is connected to one of the AND gates, and the outputs from the AND gates are in turn connected to the inputs of the OR gate. The output from the OR gate is used to control the relay, but is also fed back to the input of the other AND gate. When 'A' and 'B' are both low then the inputs to the OR gate are also low, holding the output low as well. When the 'A' input is taken high nothing changes, but when the 'B' input is also taken high the output from that AND gate goes high and in turn the OR gate output goes high, this switches the relay driver, but as the output is also fed back to the second AND gate, the output from the OR gate is latched high even when the 'B' input returns to the low state. The OR gate output will only return low when 'A' is also returned to the low state. In this way 'A' and 'B' can represent different fluid levels as output by the fluid detector board.

Construction

All components are fitted on the printed circuit board (see Figure 4). Start by inserting, and soldering the resistors, proceed with the IC sockets and PC terminals, followed by the transistors and the relays. Finally insert the IC's into their sockets. The 12V power supply is taken from the 8-channel fluid detector. Provision has been made on the PC terminals for the relays, for connecting earth wires, one of these should be taken to the earth point on the power supply.

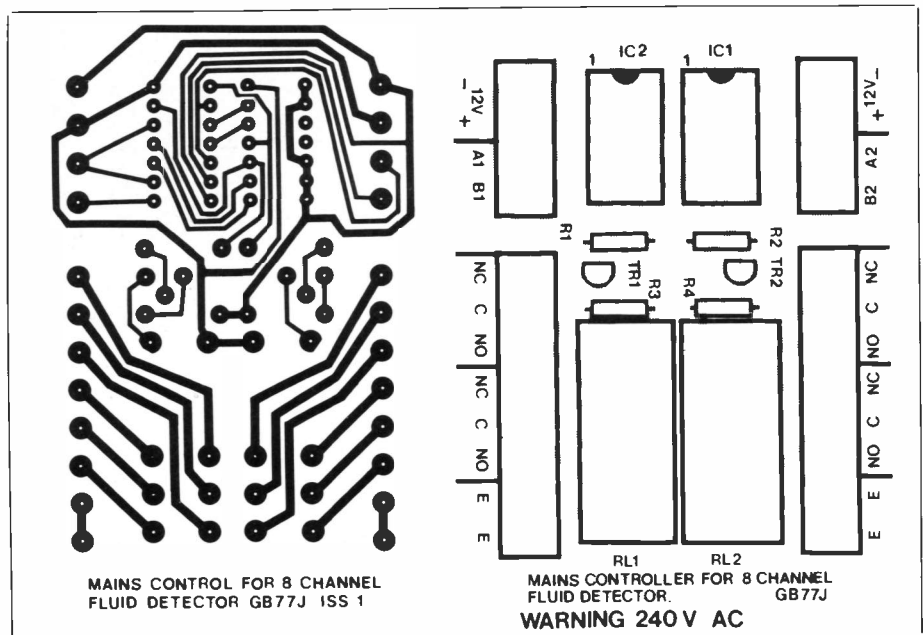

Figure 4. PCB track layout and overlay

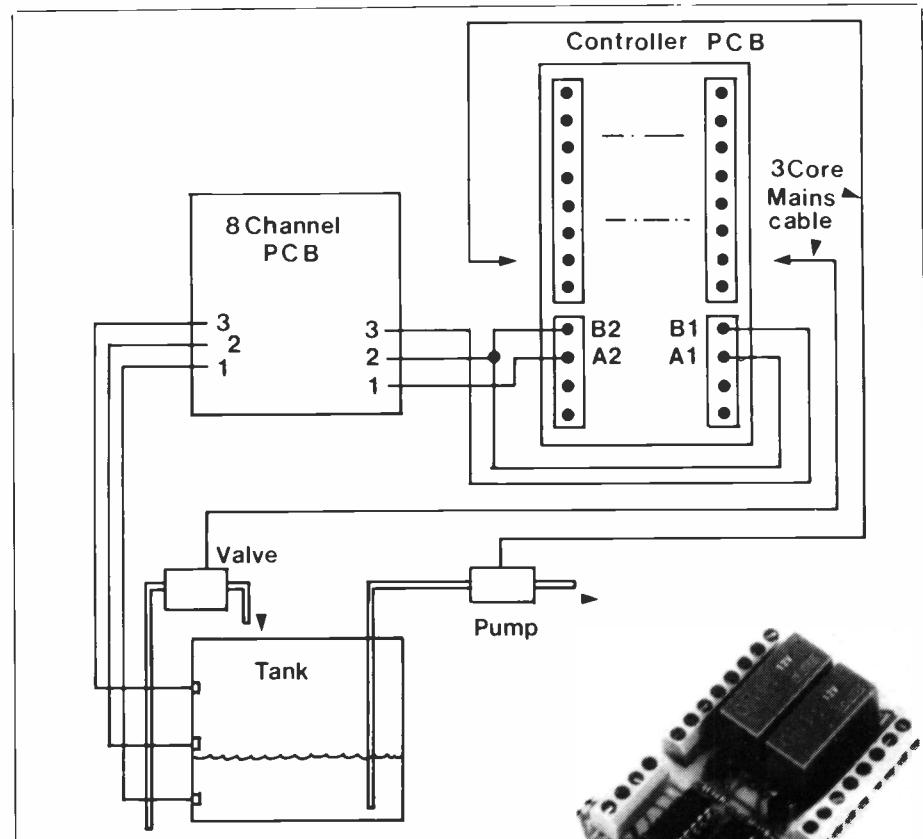
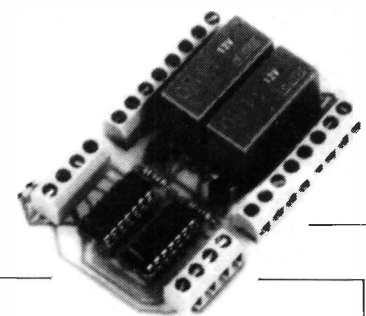

Figure 5. Applications schematic



MAINS CONTROLLER PARTS LIST

RESISTORS: All 0.6W 1% Metal Film

R1,2	10k	2	(M10K)
R3,4	100Ω	2	(M100R)

SEMICONDUCTORS

TR1,2	BC547	2	(QQ14Q)
IC1	4081BE	1	(QW48C)
IC2	4071BE	1	(QW43W)

MISCELLANEOUS

RL1,2	5A Mains Relay	2	(YX98G)
	Mains Cntrlr PCB	1	(GB77J)
	4-way PC Terminal	2	(RK73Q)

8-way PC Terminal	2	(RK38R)
DIL Socket 14-pin	2	(BL18U)
Constructors' Guide	1	(XH79L)
8ch Mains Controller Ins	1	(XK72P)

A complete kit of all parts is available for this project:
Order As LK59P (Mains Controller Kit)

The Printed Circuit Board is also available separately:
Mains Cntrlr PCB Order As GB77J

PWM MOTOR DRIVE MODULE

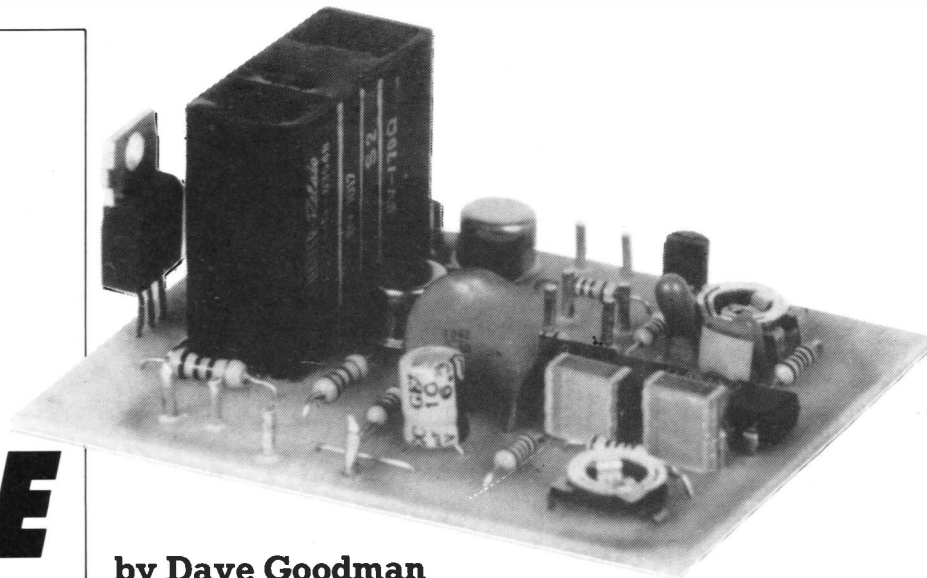

by Dave Goodman

- ★ **6 to 12V forward and reverse model motor driver**
- ★ **Proportional control offers smooth transition from off to full speed**
- ★ **Ideal for model boats, cars and robotics.**

This model speed controller will drive low voltage electric motors from a suitably encoded pulse width modulated signal. Both 6V and 12V systems are catered for by the output drive circuitry which will handle motor stall currents up to 5 amps, while the front end decoding section connects separately to a low voltage 4.8 to 6V supply obtainable from radio control Rx battery packs for instance. Although primarily intended for Radio Control model use, the project also finds application in Robotics projects where computer control of movement and direction is required.

Proportional Control

Unlike servos, the speed controller does not require positional feedback information. Essentially all that is required to start and stop an electric motor is to apply then disconnect power via a switch, and toggling the switch will alternately increase then decrease the speed at which the motor is running. If the switch could be held closed for a set time period and then held open for the same time, so that its 'mark' (closed) to 'space' (open) ratio becomes even, then the motor would be expected to run at approximately half power allowing for the overrun and starting losses.

Lengthening the switch make time and reducing the switch break time repeatedly will therefore mean that power is applied for longer periods and the motor will increase its speed accordingly. Conversely, reducing the switch make time and lengthening the break time will slow the motor. This principle is applied in PWM systems as shown in Figure 7.

The repetition rate, or switch on and switch off cycle, is standardised at 20ms and each complete cycle is called a Frame. The reciprocal value from this ($1 \div 0.02$) produces the Frame Rate and is 50 frames per second. During each 20ms

frame cycle the positive going pulse can be increased from a minimum width of 0.2/0.5ms, up to a maximum width of 2.0/2.5ms, the latter corresponding to maximum speed and the former to minimum. Obviously, manually operating a switch in the motor supply line at 50 times a second is slightly impractical and use of electronic switching ICs becomes desirable.

Circuit Description

In Figure 1, IC1 is a linear pulse width amplifier and expands the incoming signal at pin 14 into a pulse train whose mark/space ratio can be varied between zero (0V) and one (+V). Present RV2 and C4 set the internal monostable timing period and input pulses less than or greater than this period determine motor speed. Because both forward and reverse drive are necessary, a 'no drive' or zero position is required and RV2 can be adjusted to determine this. RV1 sets the 'dead band' area, or the relationship between motor speed and control 'stick' movement. Along with the pulse expansion component, C3, this preset can be adjusted for maximum speed and zero positions. IC1 pin 4 output determines motor direction and has a high (+V) output in one direction and a low (0V) output in the other.

One of two links A or B are inserted for operating RLA via TR1, TR2 and IC2b or IC2c, and are fitted according to the required direction of rotation of the motor armature. Pins 5 and 9 are NANDed by IC2a and produce a positive pulse train which switches TR3, TR4 and TR5. Either pin 5 or pin 9 is active, but not both together, and each signal is complementary to the other depending on forward or reverse direction signals. TR5 must be capable of switching high currents to the motor and R10 will supply drive signals to external NPN transistors if larger current handling becomes necessary (pin 10). Pin 4 output is either high or low with a selected direction and could be buffered for reversing-lights on a model car for example. Both relay contacts reverse connections to the motor when operated by RLA from IC1 pin 4, so that the same drive signal at TR5

is either high or low with a selected direction and could be buffered for reversing-lights on a model car for example. Both relay contacts reverse connections to the motor when operated by RLA from IC1 pin 4, so that the same drive signal at TR5

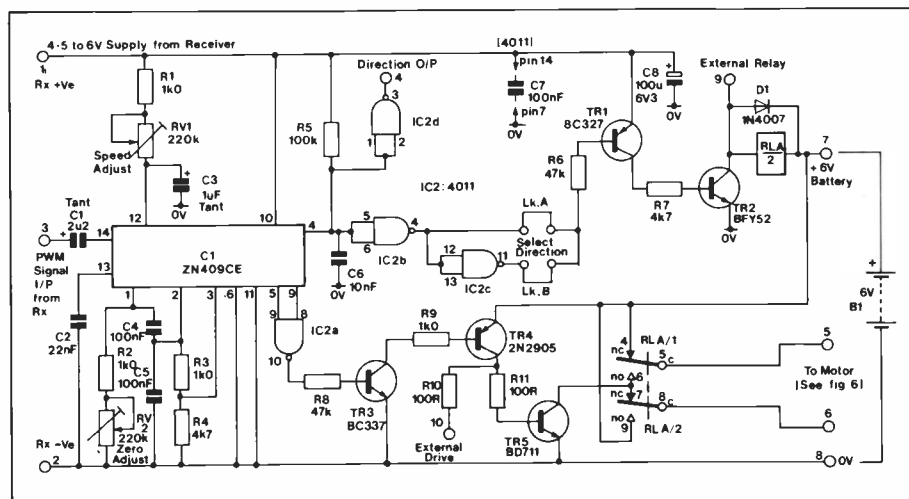

Figure 1. Circuit Diagram

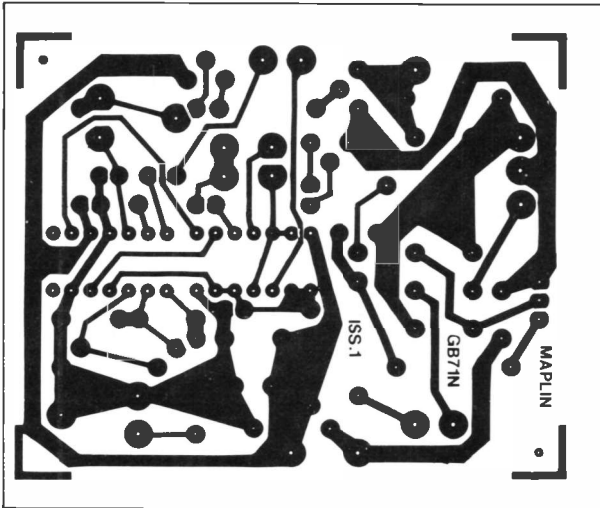

Figure 2. Artwork.

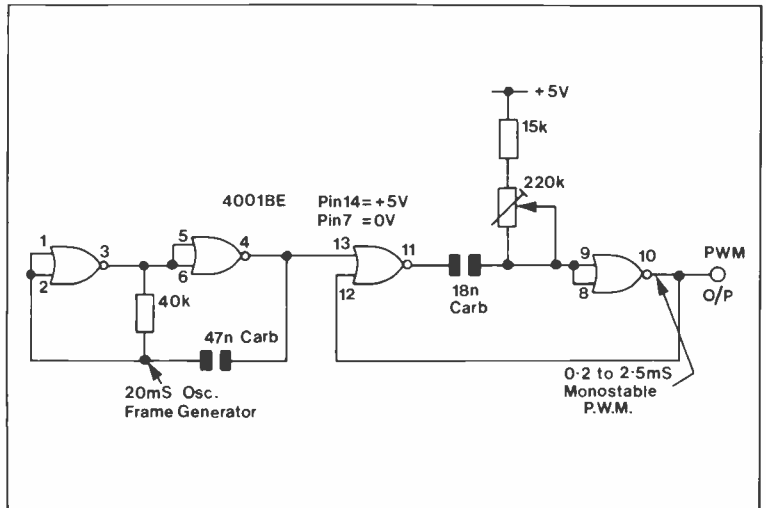

Figure 3. Test Circuit.

collector is available for both forward and reverse modes. Output pin 9 may be connected to an externally mounted relay if larger current switching is required.

Construction

Two links are initially required to be inserted directly into the PCB and are best formed from 24swg tinned copper wire. Excess lengths removed from resistor leads could be utilised for this. Next fit R1 to R9 and standard resistors R10 and R11 followed by D1, which must be correctly aligned as per the PCB legend. It may be convenient at this stage to solder these components and cut off excess leads, thus avoiding the inevitable jungle that would otherwise result.

Fit the fourteen pins from the track side and push the heads down to the respective pads with a soldering iron apply solder. Fit both presets RV1, RV2 and IC1, IC2. Be sure to fit ICs correctly by aligning the end notch with the legend otherwise they will be damaged in use and are not easy to remove after soldering! Fit all capacitors and note that C1 and C3 are polarised and must be fitted correctly with the +V markings in line. Polycarbonate capacitors C4 and C5 can either have their terminals broken quite easily, so exercise care when fitting both to the PCB. Again, solder all components in place, remove surplus wires and fit RLA, which can only be inserted in one position.

The parts list offers both 6V and 12V versions for the relay and is a matter of choice to suit individual requirements, but note that only the 6V version is supplied in the kit. Next, mount the five transistors. TR5 is positioned with its mounting bracket facing outwards, away from the PCB and the plastic body facing inward towards RLA. Later on, it may be necessary to heatsink TR5, so ensure reasonable length leads between the PCB and bottom of TR5. This will allow it to be manoeuvred over the edge of the PCB for easier mounting.

Finally, solder all remaining components, clean the track surface with solvent, to remove flux and solder splashes, and inspect the work. When satisfied that all is correct, proceed with testing the module. It is worth pointing

out that many problems develop from incorrect component recognition, poor soldering and messy track surfaces. Always carefully inspect and re-check parts for mistakes before applying power and this will ensure that any problems can be rectified before damage occurs.

Testing

Initial checks concern voltage and current measurements, and a multimeter is the minimum item of test equipment that should be available. Refer to Figure 4 connections diagram. Connect a 5V supply with -V to Pin 2 on the PCB, and +V to the + lead of a multimeter. Set the meter to measure DC current (100mA), connect its negative lead to Pin 1, and turn on the power. Set RV1 wiper to approx. 7 o'clock and RV2 wiper at approx. 11 o'clock as depicted by the arrows in Figure 4. A current reading of 5 to 6mA should be seen on the meter.

Remove power and meter, reconnect the supply +V to Pin 1 on the PCB and connect the meter with +V lead to Pin 1 and -V lead to Pin 7. Re-apply power and check the meter for a zero reading. Temporarily connect Link A and listen for a click in the relay. The meter should read approx. 10mA when using the 12V relay, or 55 to 60mA when using the 6V relay. Remove Link A. The meter should drop to zero and the relay should click as it releases. These checks should give an indication that the module is basically functioning, providing the above figures correspond to within a few percent.

With the absence of a suitable +V pulse PWM system, such as a radio control Tx and Rx, a simple CMOS test circuit is shown in Figure 3. This too requires a 5V supply and serves as a 20ms frame generator and variable monostable. Please note that the Figure 3

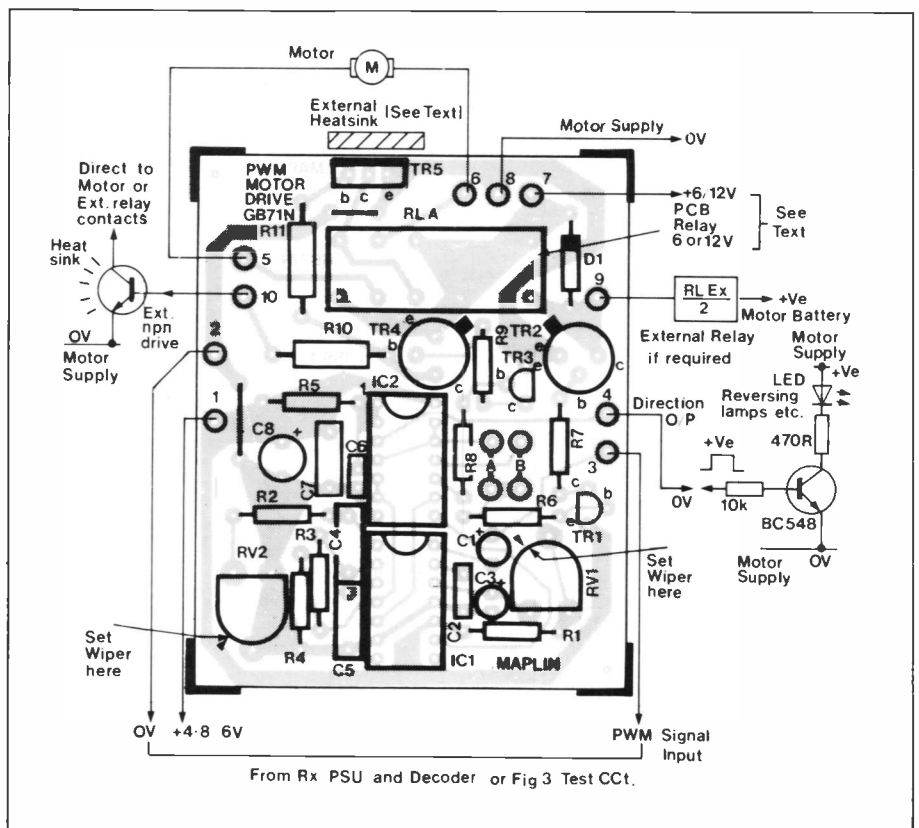

Figure 4. PCB Wiring and Legend.

circuit is not a project or kit and exists solely as a guide to assist with testing the module. Whatever system is used, connect the PWM O/P to Pin 3 on the module, and ensure a signal return path exists along Pin 2 (0V) connection. Figure 8 can be used for reference. Fit Link B only onto the module and apply both low and high power supplies as shown.

It is certainly not advisable to take the motor supply +V from module input or receiver supplies, as large current surges will affect both, causing glitching at least, or battery failure at worst. In use, low power Ni-Cds (4.8 to 6V) are perfectly adequate for the input supply, but larger battery packs (if used) will need to be either high power Ni-Cds or Lead Acid/Cadmium varieties for driving the motor. Remember to choose the motor supply voltage to suit both relay and motor ratings (6 to 12V). Do not connect the motor just yet, but switch on all supplies. Adjust either the appropriate transmitter stick, or preset (in the case of Figure 3) from centre zero, which should correspond to an approximate 1.5ms frame pulse down to 0.5ms, whereupon the relay should operate with a clock. Reverse stick or preset back through zero in the opposite direction, and the relay will release. When using Link A instead of Link B the relay will normally be in the operated state at first, and release during the test; this being the opposite condition. So Link A holds the relay operated for release mode and Link B holds the relay released for operate mode. In either case, connect a voltmeter adjusted to read 10 to 20V between 0V and PCB pin 4. The reading should be normal at 0V and +5V when moving the stick (pot!).

Connect a motor to PCB pins 5 and 6 and again with all supplies connected ensure full forward, zero and full reverse conditions can be established by varying the control stick or pot. It may be found necessary to readjust RV1 and RV2 on the module to ensure these conditions are met with a wide zero or motor off position, therefore trial and error settings will indicate optimum performance for your particular system.

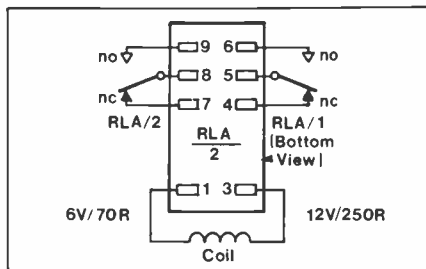

Figure 5. Relay Pinouts.

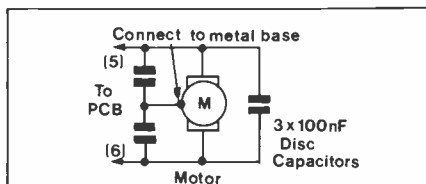

Figure 6. Motor Suppression.

Motors

Owing to the wide variety of motors and applications that could be used, it would be best to examine the limitations of the module rather than discuss individual requirements. For instance, Bullet type motors used with large model aircraft can draw 30 Amps or more and relays, drive transistors and PCB tracks must be capable of handling this for long periods. On the module, RLA can comfortably switch 5 Amps although TR5 will dissipate large amounts of power, especially under low speed or stall conditions, so without extra relays and drive transistors fitted, smaller motors of 1 to 2 Amps only should be used. As explained previously, Pin 10 can supply a further three of four NPN power transistors, and Pin 9 a second relay, should it be required to drive larger motors. Simply connect the transistor's emitter to Pin 8,

base to Pin 10, and collector to collector of TR5: in other words in parallel with TR5. Figure 6 offers a simple suppression circuit which should prove adequate for most motors without adversely affecting performance too much. Excessive capacitive loading will affect the pulse waveform at low speeds, so bear this in mind when using suppression.

Heatsinks

TR5 may tend to run hot under heavy load conditions and heatsinking will have to be used to prevent damage or loss of power. Any method used will depend entirely on the space available, and the weight allowance within the model. Model boats generally have plenty of space and buoyancy, and a large heatsink may add ballast for stability. One eighth and half scale cars often have a metal chassis and this could be utilised for heatsinking, but plastic kits may melt around TR5 or its heatsink, so allow plenty of airflow to keep temperatures down.

In conclusion, always keep batteries for the motor drive supply and logic drive separate; only use low power 1 to 2 Amp motors unless adding further power transistors; ensure adequate heatsinking and ensure all supplies are switched off after use.

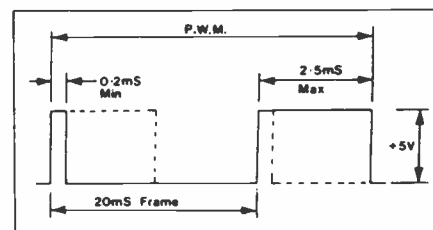

Figure 7. Control Waveform.

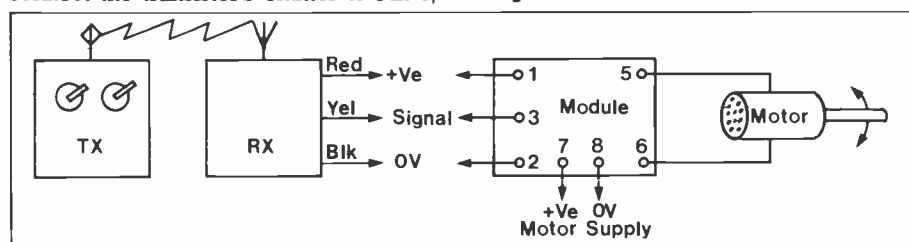

Figure 8. Block Diagram.

PWM MOTORS DRIVE PARTS LIST

RESISTORS: All 0.6W 1% Metal Film (Unless specified)

R1-3,9	1k	4	(M1K)
R4,7	4k7	2	(M4K7)
R5	100k	1	(M100K)
R6,8	47k	2	(M47K)
R10,11	100Ω	2	(M100R)
RV1,2	220k Hor Encl Preset	2	(UH07H)

CAPACITORS

C1	2n2F 35V Tantalum	1	(WW62S)
C2	22nF Ceramic	1	(WX78K)
C3	1nF 35V Tantalum	1	(WW60Q)
C4,5	100nF Poly Layer	2	(WW41U)
C6	10nF Ceramic	1	(WX77J)
C7	100nF 50V Disc	1	(BX03D)
C8	100μF 10V Minelect	1	(RK50E)

SEMICONDUCTORS

D1	1N4007	1	(QL79L)
TR1	BC327	1	(QB66W)
TR2	BFY52	1	(QF29G)
TR3	BC337	1	(QB68Y)

TR4	2N2905	1	(QR17T)
TR5	BD711	1	(WH15R)
IC1	ZN419/409CE	1	(YH92A)
IC2	4011BE	1	(QX05F)

MISCELLANEOUS

RLA	Min 6V 6A Relay	1	(FJ42V)
	PCB	1	(GB71N)
	Pin 2141	1 Pkt	(FL21X)
	Instruction Leaflet		(XK76H)
	Constructors' Guide	1	(XH79L)

OPTIONAL

Ca,b,c	100nF Disc	3	(BX03D)
	Min DPDT 6A 12V Relay	1	(FJ43W)

The Maplin 'Get-You-Working' Service is available for this project, see Constructors' Guide or current Maplin Catalogue for details.

The above items (excluding Optional) are available as a kit.

Order As LK54J (PWM Motor Drive Kit).

The following item is also available separately. PWM Motor Drive PCB, Order As GB71N.

LOW POWER RADIO CONTROL SYSTEM

- ★ **27MHz Operation For Ground-Based Model Control**
- ★ **Two Positive Pulse PWM Channels**
- ★ **Two Digital On/Off Channels**

Since 1981 and the legalising of Citizens Band Radio on 27MHz, the licensing requirement for model radio control is no longer operative. However, certain conditions apply to both users of this band, and for RC modellers this means that signal transmissions must be within the frequency range 26.96MHz to 27.28MHz at a maximum mean power of 1.5W. Higher frequencies on this band are used for CB transmissions. The 35MHz band (35.005 to 35.205) is also available for radio control, but for use with model aircraft only – not ground-based models, and the 458MHz band would be complex for constructors to set up and align. Therefore a 27MHz system is used with limited power output and receiver sensitivity to avoid interference both to and from other users on the band.

Transmitter

The simple transmitter design of Figure 1, centres on IC1 which basically consists of three sections namely: frame and pulse timing; logic encoding and modulation; RF and output stage. Although capable of six channel operation the design utilises two channels (1 and 2) for pulse width modulation (PWM) and four channels for encoded digital

by Dave Goodman



(on/off) information. A train of six pulses (Figure 3) is generated every 20ms (50Hz) from the frame timer, C5 and R4 and 4.6V reference supply at IC1 pin 4. C5 is allowed to alternately charge and discharge by an internal comparator switch to generate the 20ms frame which starts the pulse timer C6 and R1 at IC1 pin 8.

The internal encoder provides six discharge paths for C6 at IC1 pins 18, 17, 16, 1, 2, and 3 – R2 providing a fixed time constant for channels 3 to 6 (pins 1 and 16 to 18) and RV1 and RV2 variable time constant for channels 3 to 6 (pins 1 and 16 to 18) and VR1 and VR2 variable time constants for channels 1 and 2. The serial pulse output from the encoder appears at pin 12 where C8 modulation filter capacitor is added to improve the transmitted carrier bandwidth. This is desirable where adjacent carrier channels are 10 to 15kHz apart instead of the more usual 50kHz separation. From IC1 pin 13, an internal emitter follower buffers the pin 12 modulation signal and supplies the collector of an internal NPN transistor at pin 11. IC1 pin 10 is the base connection for this transistor and drive current is supplied by R5. X1 is a third overtone crystal connected between base pin 10 and tuned circuit C10, C11, and L1 primary.

Aerials

When calculating wavelength for 27MHz, the optimum aerial length is approximately 17ft. – hardly practical for a hand-held portable transmitter! Aerials of half, quarter, or sixteenth wavelength are far more practical, these being some 8½ft., 4ft., and 2ft. in length, but do not radiate as efficiently. A dipole system could be used, where a telescopic aerial is connected to L2 and an equal length of wire connected to 0V is left to hang towards ground. The aerial's capacitance would change as the wire is moved and transmissions become irregular so either centre or base loading of the aerial becomes desirable. Centre loading requires a telescopic aerial to be centrally cut and a coil inserted between both halves, whereas base loading, although not as efficient, does allow the impedance of the load at the feed point of the RF output stage to be adjusted, thus improving signal strength. With the output stage components as Figure 1, distances of 50 to 100 yards are possible depending upon terrain or surroundings.

Construction

Refer to the overlay and Figure 6. Pin 6 on the overlay is not used, as L2 fits over this position. Identify and insert resistors R1 to R5. Next insert capacitors C1 to C11. C1 is polarised and its + lead must align with the legend. C10 and C11 are a little large and will require being offset slightly to facilitate fitting. Ensure these components are pushed down as close as possible to the PCB. Solder all leads and cut off excess wire ends. Insert the crystal holder and IC1. Pin 1 is immediately below the circular indentation close to one corner of the package. Insert Veropins 1 to 5 and 7 to 9 and solder these and all remaining components.

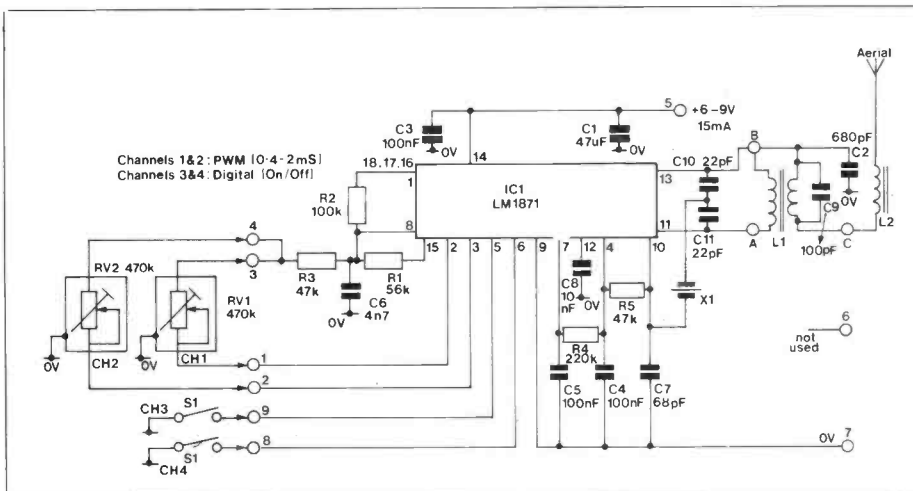

Figure 1. 27MHz Transmitter circuit diagram

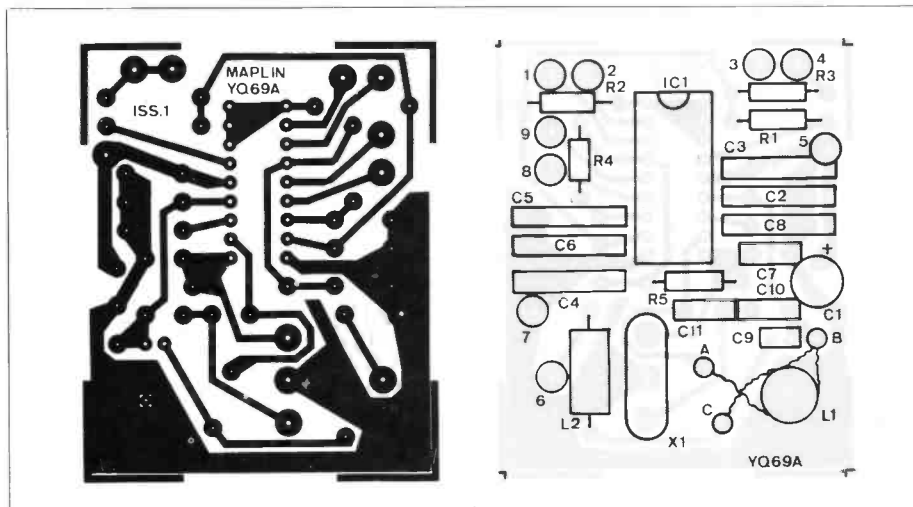

Figure 2. Track layout and overlay of Transmitter PCB

When the modulation output is high (+3.8V) at pin 13, the collector pin 11 and tuned circuit are pulled up into the active range of the internal transistor. RF feedback is via the crystal and pin 10, causing the tuned circuit to resonate at the desired frequency. Because third overtone crystals are used in this application a tuned collector load must be used to guarantee operation at the correct frequency. Tuning L1 by moving its dust core in and out of the former has very little effect on oscillator frequency, but does vary the angle of conduction and hence oscillator efficiency and harmonic suppression.

C3 and L1 secondary are also tuned to 27MHz and dust core adjustment determines coupling between both coils. For precise PWM detection it is necessary to produce a high on/off ratio when modulating the carrier. When modulation from pin 13 is low, crystal X1 continues to oscillate for some 500µs due to the high Q characteristics of the circuit. This 'ringing-on' would reduce the carrier modulation depth and C7 damps the crystal during this time; short carrier off times also help overcome this problem, but require X1 to be isolated from the aerial circuit, hence the split tuning capacitors C10 and C11. L2 further low-pass filters the transmitted carrier, thus reducing upper harmonic content and doubles as a base loading coil for the aerial.

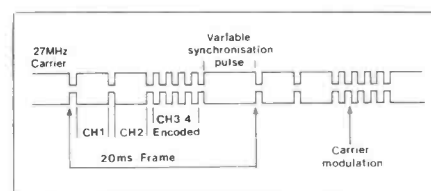
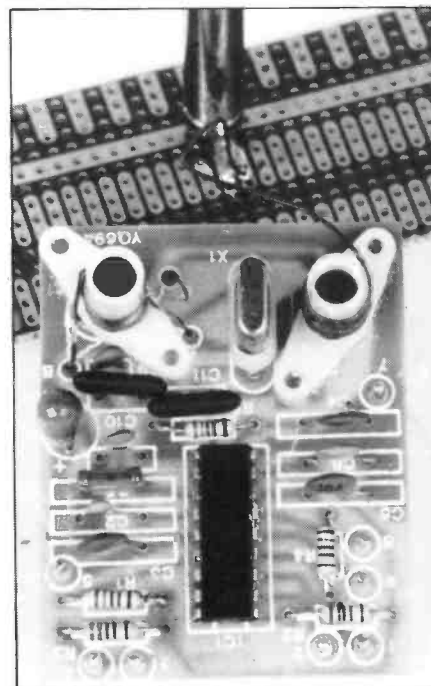

Figure 3. Transmitter envelope

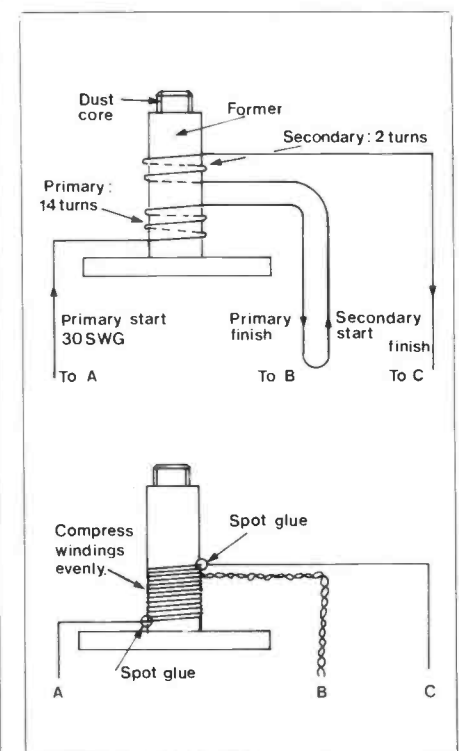

Figure 4. Winding details for coil L1



Good, accurate soldering is required if problems are to be avoided and cleaning the back face with thinners will help when inspecting the work.

Coil Winding (L1)

Both L1 and L2 have to be wound by hand. Although this may appear a daunting task, it is really not that difficult. For L1 you will need 1 metre (3ft.) of 30swg enamelled copper wire, a 7mm former and dust core and a tube of fast drying glue such as cyanoacrylate. Before construction examine Figure 4 to familiarise yourself with the turns requirements.

Primary winding A is begun at the base and fourteen complete turns wound up the tube. It does not matter which direction is chosen to wind the coil as long as both primary and secondary turns are in the same direction. It may be helpful to use the former's base mounting holes as wire anchor points when starting and finishing the coil as this will prevent the wire from unwinding until firmly glued. Once you have wound the primary coil, compress the windings together as shown and take up any slack by pulling the loose ends tight.

Apply a small amount of glue to the beginning and end of the coil and leave to harden. The finish wire from L1 primary is also the start for L1 secondary and allowance must be made for connecting it to point B on the PCB by looping the wire out a few inches. Continue winding up the tube in the same direction as before for two complete turns. There should now be two single wire ends (A & C) and a double wire (B) extending from the coil. Again, apply spots of glue to both start and end windings of L1 secondary and leave to harden.

Coil Winding (L2)

For L2 you will need 1 metre (3ft.) of 24swg enamelled copper wire and a 7mm former with dust core. Winding procedure is similar to L1 except that a single coil of 12 turns is wound up the tube starting 2mm from the base as shown in Figure 5. Because this wire is thicker, it will be necessary to remove any kinks by gently stretching the length before winding, else the coil will be difficult to compress neatly. The 2mm gap is not critical and the coil could be wound centrally along the tube if desired. A small allowance should be made though for tuning purposes. Glue the start and end windings as before and leave to harden.

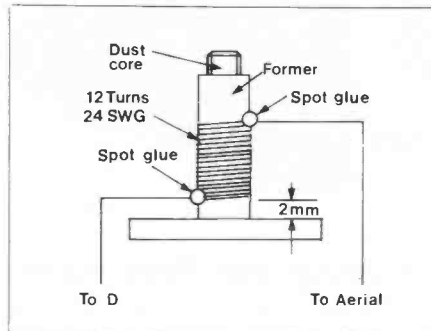

Figure 5. Winding details for coil L2

Mounting L1 & L2

Space is rather limited on the PCB, therefore both coils are mounted diagonally inwards from the right-hand corners as shown in Figure 6. Apply glue to each former base and stick the assembly in position. When mounting L1, be careful not to cover holes A and C and for L2 keep hole D clear. Leave both to harden before inserting the dust cores in case excess glue jams the threads. Insert a wire nearest to the base of L2 into hole D, then scrape off the enamel coating and tin with a soldering iron before soldering to the pad. On L1, insert the centre double wire into hole B, the primary start wire nearest the former base into hole A and the secondary finish, or topmost wire, into hole C. Each wire length from coil to terminating point should be kept short

and direct otherwise tuning may be affected. When soldering these connections, heat the wire close to its pad and apply solder. The enamel will melt allowing contact with the copper to be made, then solder in place. Finally remove excess wire ends and fit crystal X1.

Choice of Crystal

Table 1 lists six available channel frequencies. These crystals come as Tx/Rx (Transmit/Receive) pairs and the frequency is stamped on the body of each one. Choose the channel to be used and insert a crystal marked with the higher frequency into the socket on the transmitter PCB. The lower frequency fits into the receiver which is explained later.

Channel	Transmit frequency	Receive frequency	Code
Brown	26.995MHz	26.540MHz	HX30H
Red	27.045MHz	26.590MHz	HX31J
Orange	27.095MHz	26.640MHz	HX32K
Yellow	27.145MHz	26.690MHz	HX33L
Green	27.195MHz	26.740MHz	HX34M
Blue	27.245MHz	26.790MHz	HX35Q

455kHz IF and 50kHz channel spacing.

Table 1. Radio control matched crystal pairs.

Notes on Assembly

A close inspection of all components, assemblies and solder joints is worthwhile before applying power to the project. Ensure all components are fitted as closely to the PCB as possible and all leads are correctly soldered. Check for short circuits across the tracks and clean off any flux that may have accumulated. Many projects fail due to poor assembly detail and bad soldering, so be fastidious at this stage if problems are to be avoided!

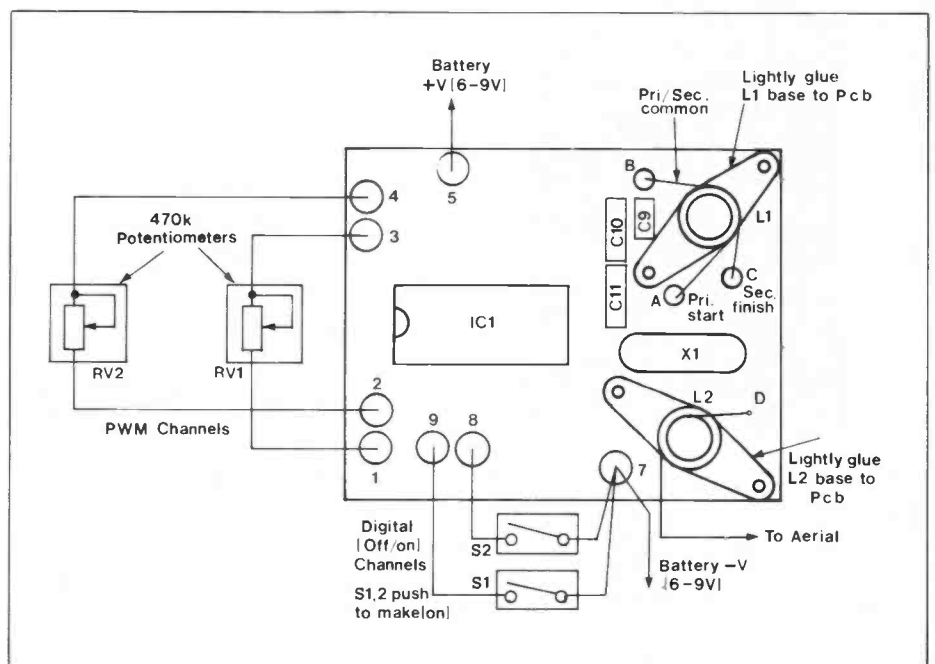

Figure 6. Wiring to Transmitter PCB

Wavemeter

Unfortunately, accurate adjustment of simple transmitters such as this does require test equipment other than a multimeter. A dedicated wavemeter, or grid dip meter that can be used as a wavemeter, is required for peaking L1 and L2. These items can be costly if not readily available so a simple circuit is given in Figure 7. If intending to build this circuit, it should be pointed out that no PCB is available and construction is a matter of choice. Figure 7B shows the prototype layout which was built on 0.1in. matrix Verostrip board. All components should be kept in close proximity with each other and the aerial soldered upright at its base. The coil is close wound on a 7mm former using 24swg enamelled wire (similar to L2, but without a dust core fitted). Make a small loop on top of the 18swg aerial wire and solder its base to the junction of L1, C1 and the diode. The circuit resonates at 27MHz and the meter indicates when a signal is being transmitted, but is not calibrated for field strength, and can only be used as a guide to maximum efficiency.

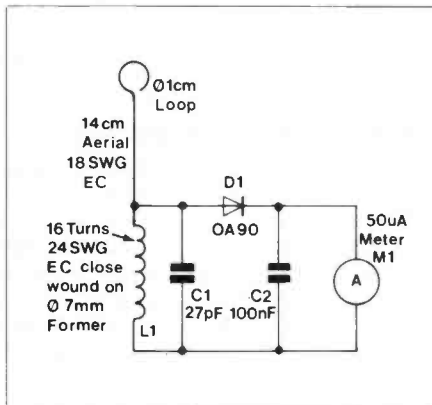

Figure 7A. Circuit diagram of a simple Wavemeter

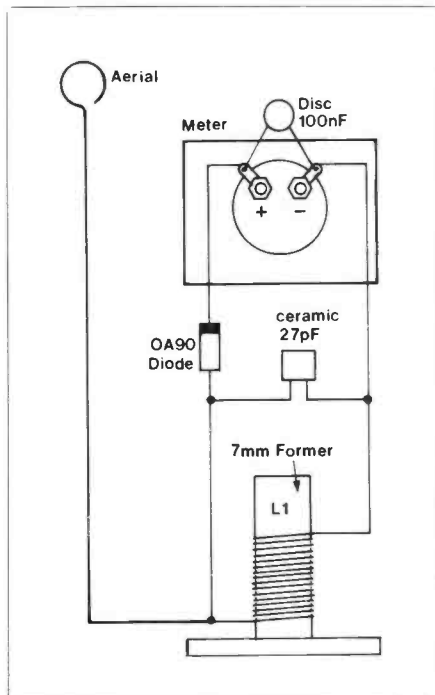
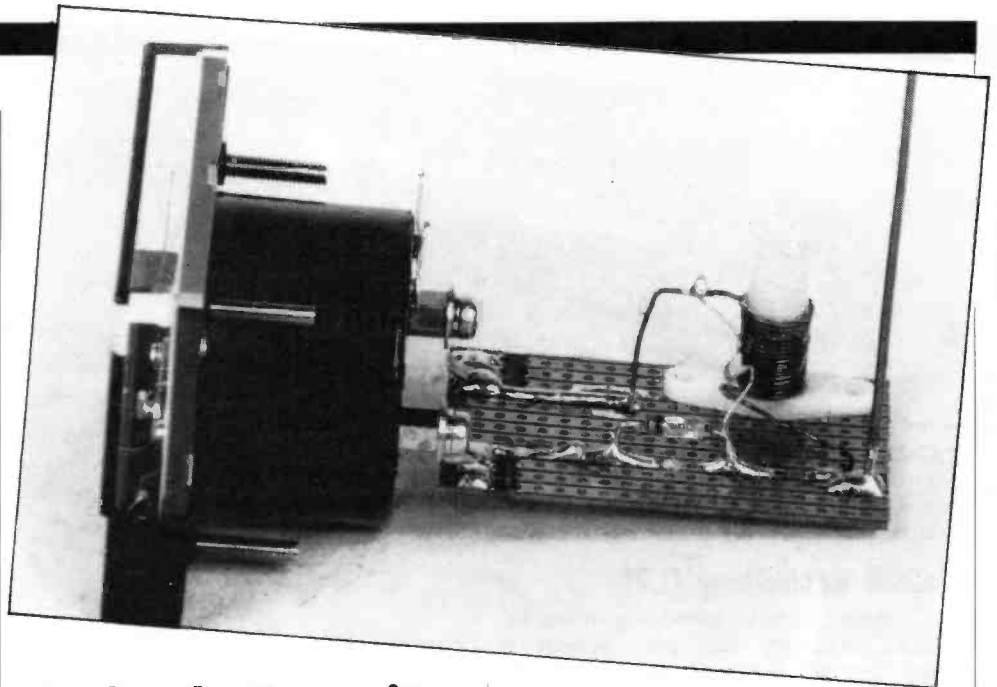

Figure 7B. Wiring diagram of simple Wavemeter



Testing the Transmitter

Connect RV1 between pins 1 and 3, and RV2 between pins 2 and 4 on the transmitter PCB (Figure 6). Connect the pot wiper to one of the resistance ends as shown in each case so that when turned its value is varied from 0Ω to $470k\Omega$. S1 and S2, if used, are wired between 0V (pin 7) and pin 8 or 9 as shown. These switches should be push-to-make and either latching or momentary action to suit requirements. Table 2 gives the result of S1/2 operation and approximate values for RV1/2. Current consumption of the transmitter is 10-15mA at 9V so a PP3 could be used for short periods. For preference use 6 AA size ni-cads (see Parts List) and a PP3 clip.

Connect the battery negative (black lead) to pin 7 and a multimeter between battery positive (red lead) and pin 5. The remaining wire end from coil L2 should be cut off allowing three inches extending from the coil. Place the pick-up from a wavemeter close to L2 or twist two turns of L2 round the aerial wire if using the Figure 7 circuit. Apply power and monitor the current on the multimeter set

to read milliamps. Screw down the dust core of L1 in a clockwise direction and check the wavemeter reading which should gradually increase to a maximum field strength and minimum current which will be around 13mA. The Figure 7 meter should read close to half scale (10-30). Screw L2 core clockwise down into the former and the wavemeter reading should gradually increase then decrease. Finally readjust both L1 and L2 for maximum field strength and minimum current readings. As a guide, the prototype unit peaked at 12.98mA with 9V supply and a reading of 35 on the Figure 7 wavemeter. These figures will of course vary between different transmitters, but give an idea of what to expect.

If the current reading does not change when tuning and the wavemeter gives no indication, recheck RV1 and RV2 connections again as modulation stops if these connections are missing. No constant RF carrier is developed; it is only there when modulation is present. Check that crystal X1 is fitted correctly into its socket and L1 has been wired up correctly to the appropriate terminals. No

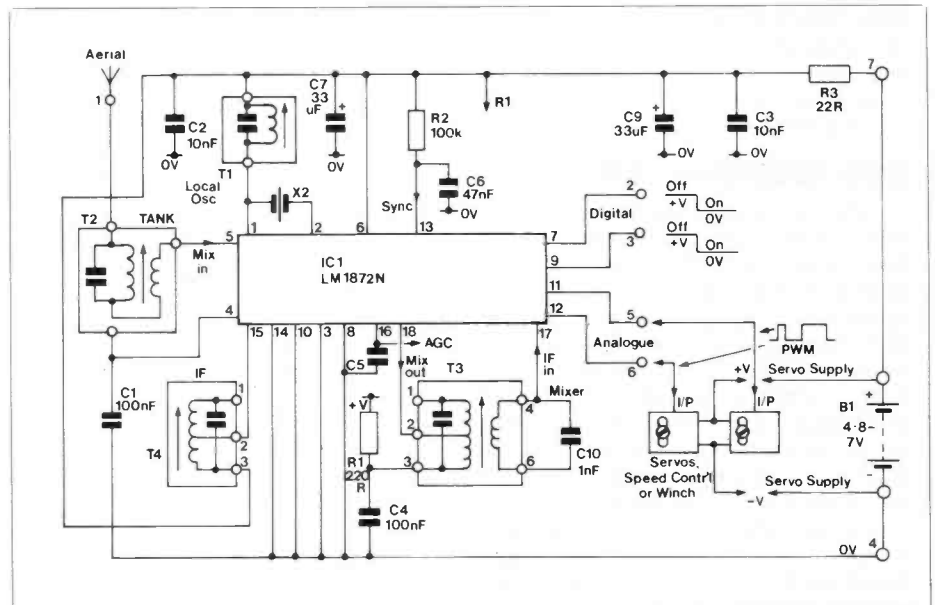

Figure 8. 27MHz Receiver circuit diagram

current or excessively high current readings could indicate anything from flat batteries to faulty meter leads or more serious PCB faults and further assistance must be sought. For constructors with oscilloscopes, connect a high impedance probe – preferably below 10pF capacitance to the aerial wire from L2 or wind a few turns of insulated wire around L2 connecting one end to 0V and the other to the probe. A waveform similar to Figure 3 (without the 1ms channel 3 and 4 pulses) should be displayed. If the scope bandwidth is low then you will only see the modulation present from IC1 pin 13.

Receiver

Figure 8, the circuit diagram, shows the receiver and external connections. Transmitted 27MHz signals are picked up by the aerial and coupled to the mixer via tank coil T2. This coil effectively keeps strong out-of-band signals like TV and FM broadcasts from cross-modulating with the required signal. A local oscillator consisting of T1 and X2 connects via IC1 pins 1 and 2 to the internal mixer section where the local oscillator and aerial signals are mixed at T3 primary (pin 18). The stepped down signal appears on IC1 pin 17 which is the intermediate frequency (IF) input. IF tuning is performed by T4. In the case of using 'blue band' crystals for example, the transmitter frequency will be 27.245MHz and the receiver local oscillator will run at 26.790MHz. When these two signals are present at the mixer, a difference signal is produced, in this case 27.245 – 26.790MHz = 455kHz. This is true for all crystal pairs which is why matching is important. The 455kHz signal or IF (since it is intermediate between the input RF frequency and the desired audio frequency) is recognised by a tuned bandpass filter T4, which only responds to frequencies in the range 455kHz ±3.2kHz (3dB). Sum and difference signals above 460kHz and below 450kHz are not amplified and become ineffective. This is basically how superheterodyne receivers, of which this is an example, function.

Pulsing the transmitted carrier on and off at set intervals will result in the IF producing a DC pulse related to this carrier modulation from an internal-detector within IC1. The detected signal is compared with an internal voltage reference so that whenever the peak IF exceeds 25mV, a comparator resets the internal digital envelope circuitry. This threshold level can vary according to the distance between the transmitter and receiver, which can result in high IF signal levels being developed. To minimise this, automatic gain control (AGC) is used to regulate the peak carrier level to 100mV by comparing it with an internal 100mV reference. An error signal is then produced which determines the gain of the IF amplifier at C5 pin 16. Digital outputs pins 2, 3, 5 and 6 are decoded and generated within IC1. Both pin 2 (channel 3) and pin 3 (channel 4) are normally high

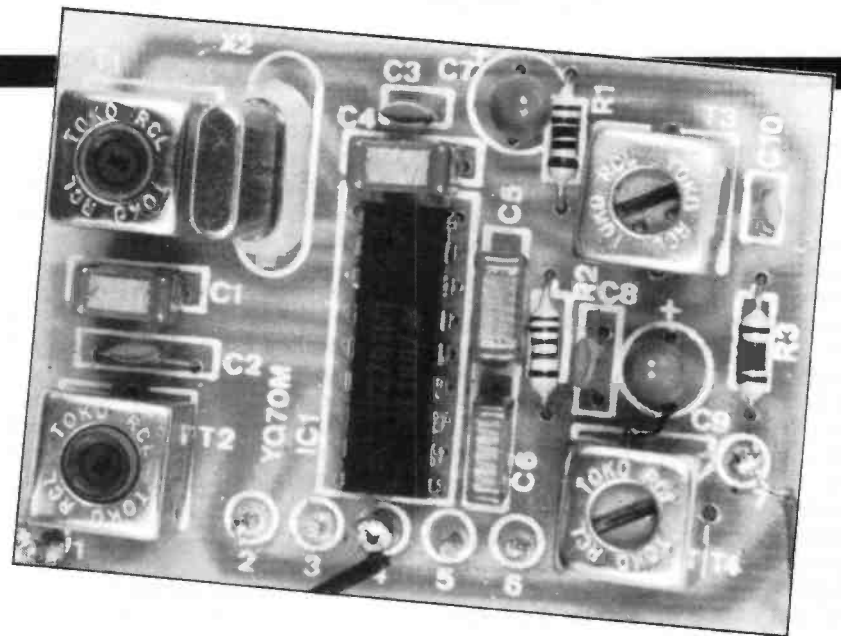

or positive and active low, so that a negative pulse is produced whenever S1 or S2 are operated at the transmitter end. See Table 2. Pin 5 (channel 1), controlled by RV1 (pins 1 and 3) on the transmitter, develops a positive pulse output, whose width is 0.3ms to 2.0ms, every 20ms. Similarly, pin 6 (channel 2) is controlled by RV2 (pins 2 and 4) with the same duration positive pulse variation. Both channels are independent of one another

and do not affect operation of channels 3 and 4 (see Table 3).

Construction

Identify and fit the three resistors R1 to R3. Insert IC1 and solder all leads onto their pads. Cut off excess wires and fit C2, 3, 8 and 10 followed by the remaining capacitors. C7 and 9 are both polarised and their positive leads must align with the PCB legend. Fit crystal socket for X2 and Veropins 1 to 7. Again solder all components and remove excess wire ends. Correctly identify T1 to T4. Identification codes appearing in the Parts List are printed on the side of the metal cans. These components can only be fitted one way round, but some may have extra wide screen terminals connected to the metal can. If so it will be necessary to trim a small amount from the width with a pair of cutters. Carefully solder the 20 coil terminals and 8 screen terminals onto the PCB. As mentioned in the transmitter construction, clean and inspect the back face of the PCB carefully before proceeding.

Transmit	Receive
RV1 or RV2 resistance	Pin 5 or 6 pulse width
0Ω	0.3ms
50kΩ	0.5ms
200kΩ	1.0ms
330kΩ	1.5ms
480kΩ	2.0ms
S1 open	Pin 2 high (+V)
S1 closed	Pin 2 low (0V)
S2 open	Pin 3 high (+V)
S2 closed	Pin 3 low (0V)

Frame rate = 20ms
Repetition frequency = 50Hz

Table 2. Transmit-to-receive characteristics

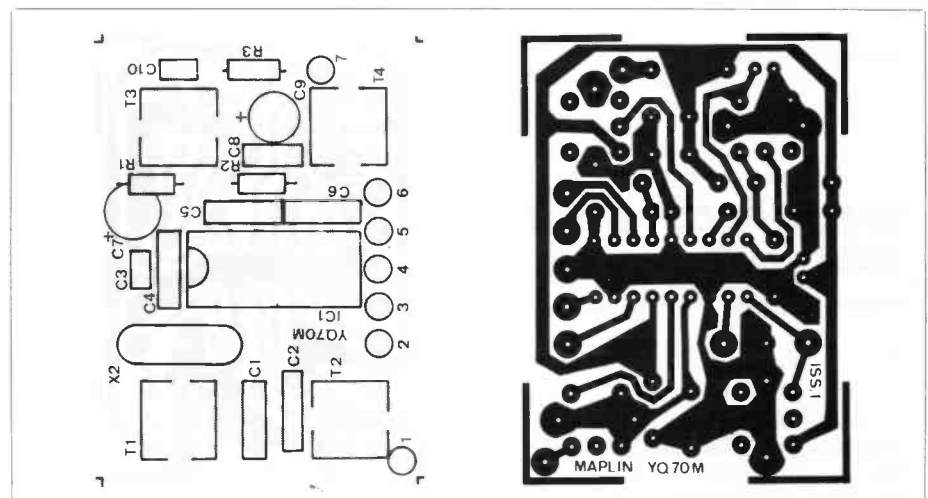

Figure 9. Track layout and overlay of Receiver PCB

Transmitter	Receiver	Description	Uses
RV1 – Pins 1 and 3	Pin 5	Channel 1 PWM O/P	Drives servo's, speed controllers and yacht winches.
RV2 – Pins 2 and 4	Pin 6	Channel 2 PWM O/P	
S1 – Pin 9 and 0V	Pin 2	Channel 3 Digital O/P	Active low operation, TTL compatible. Drives loads above 22kΩ.
S2 – Pin 8 and 0V	Pin 3	Channel 4 Digital O/P	

Table 3. Pin connections and channel functions

Testing the Whole System

It is likely that you will wish to use the transmitter as a hand-held device and operate a model of some kind. Therefore a suitable case is required in which to mount the transmitter PCB, batteries, pot's and switches. Although it is a matter of taste, it is suggested that a small plastic box be used, large enough to accommodate the hardware and small enough to hold comfortably. A static system could best employ a metal box for better ground plane effect and hence possible increased range, especially with a larger transmitting aerial (see Aerials section). Whatever system is employed, re-tuning of L1 and L2 will have to be done after boxing up as tuning will be altered according to the proximity of additional components and your hand. Repeat the transmitter setting up procedure as before for optimum results. Leave the transmitter operating at a level of three to four feet above ground. Hold the working receiver with aerial attached and battery

pack in one hand and move away from the transmitter. The earpiece buzz will most certainly stop after a while. Go back to the last working position and adjust T2 for maximum volume. Adjust T1 if necessary and continue moving away from the transmitter. Now T3 and T4 can be peaked for maximum. You will find that as the distance is increased, tuning becomes sharper and slug variations become smaller. In this way the optimum can be found for both transmitter and receiver.

Using the System

PWM output signals from either pins 5 or 6 (Rx PCB) will operate our servo and speed control projects for model boat and car applications. Because of the low power output from the transmitter, it is definitely not recommended that free-flying models be used as two or three pounds of balsa wood and aluminium hurtling out of the sky can be extremely dangerous! It is possible though for this

project to be used with robotics models, with a microcomputer replacing S1, S2, RV1 and RV2 via a digital or D to A interface.

Testing the Receiver

Insert the lower frequency crystal, from the selected pair, into the holder. Connect the PP3 clip with positive (red) to pin 7 and negative (black) to pin 4. Solder an M3 tag onto pin 1 and bolt a telescopic aerial to the lug with a 12mm M3 bolt. Aerials of 1 to 2 feet in length should be satisfactory for short distance use. 20swg wire could be used, but a telescopic aerial is easier to manage. With the recommended trimming tool, turn T1 and T2 tuning slugs until they are level with the can top plate. Screw T1 clockwise into the former for 2 full turns and T2 for 3 full turns. Carefully turn T3 slug anticlockwise as far as it will go, and then turn it clockwise - down into the former - for 1¼ turns. Do the same to T4. These settings are approximate to begin with and readjustment will be necessary

27MHz TRANSMITTER PARTS LIST

RESISTORS: All 0-6W 1% Metal Film

R1	56k	1	(M56K)
R2	100k	1	(M100K)
R3,5	47k	2	(M47K)
R4	220k	1	(M220K)

CAPACITORS

C1	Tant 47µF 16V	1	(WW76H)
C2	Ceramic 680pF	1	(WX66W)
C3,4,5	Minidisc 0.1µF 16V	3	(YR75S)
C6	Ceramic 4700pF	1	(WX76H)
C7	Ceramic 68pF	1	(WX54J)
C8	Poly Layer 10nF	1	(WW29C)
C9	Ceramic 100pF	1	(WX56L)
C10,11	Mica 22pF	2	(WX05F)

SEMICONDUCTORS

IC1	LM1871	1	(YY71N)
-----	--------	---	---------

MISCELLANEOUS

Former 351	2	(LB17T)
Dust Core Type 6	2	(LB42V)
PCB	1	(YQ69A)

Crystal Socket 25µ	1	(HX60Q)
EC Wire 0-315mm 30swg	1 Reel	(BL40T)
EC Wire 0-56mm 24swg	1 Reel	(BL28F)
Pin 2141	1 Pkt	(FL21X)
Instruction Leaflet	1	(XK09K)
Constructors' Guide	1	(XH79L)

OPTIONAL

X1	MCR Crystal (see Table 1)	1	(HX30H-HX35Q)
	Aerial 8-section	1	(RK48C)
	Aerial 6-section	1	(RK49D)
	PP3 Clip	1	(HF28F)
	Battery Holder 9V	1	(HQ01B)
	Battery AA Ni-Cad	6	(YG00A)
	Trimming Tool TT5	1	(BR50E)
RV1,2	Pot Lin 470k	2	(FW07H)
S1,2	Push Switch	2	(FH59P)

The above items (excluding Optional) are available as a kit.

Order As LK55K (27MHz Transmitter Kit)

The following item (which is included in the kit) is also available separately.

LM1871 Xmitter PCB Order As YQ69A

27MHz RECEIVER KIT PARTS LIST

RESISTORS: All 0-6W 1% Metal Film

R1	220Ω	1	(M220R)
R2	100k	1	(M100K)
R3	22Ω	1	(M22R)

CAPACITORS

C1,4,5	Poly Layer 100nF	3	(WW41U)
C2,3,8	Monores Cap 10nF	3	(RA44X)
C6	Poly Layer 47nF	1	(WW37S)
C7,9	Tant 33µF 10V	2	(WW74R)
C10	Ceramic 1000pF	1	(WX68Y)

SEMICONDUCTORS

IC1	LM1872	1	(YY72P)
-----	--------	---	---------

MISCELLANEOUS

T1,2	Toko CSK3464	2	(YG31J)
T3	Toko YRCS12374	1	(YG30H)
T4	Toko YMCS17104	1	(YG32K)

PCB	1	(YQ70M)
Crystal Socket 25µ	1	(HX60Q)
Pin 2141	1 Pkt	(FL21X)
Instruction Leaflet	1	(XK09K)
Constructors' Guide	1	(XH79L)

OPTIONAL

X2	MCR Crystal (see table 1)	1	(HX30H-HX35Q)
	Aerial 8-section	1	(RK48C)
	Aerial 6-section	1	(RK49D)
	PP3 Clip	1	(HF28F)
	Battery Holder 6V	1	(HF29G)
	Battery AA Ni-Cad	4	(YG00A)
	Trimming Tool TT5	1	(BR50E)
	Crystal Earpiece	1	(LB25C)

The above items (excluding Optional) are available as a kit.

Order As LK56L (27MHz Receiver Kit)

The following item (which is included in the kit) is also available separately.

LM1872 Receiver PCB Order As YQ70M

Control-a-Train

- ★ Pulse Width Modulated For Excellent Low Speed Performance
- ★ Inertia Control of Momentum and Braking
- ★ Box or Panel Mounted
- ★ Easy To Build
- ★ Low Cost

by Robert Penfold



We make no apologies for using three of Mr. W. Sherman's superb photographs of steam engines with his kind permission in this article about model trains, but we're all steam train nuts here at Maplin and we just loved the pictures!

Things have moved on from the days when model train controllers were little more than a rectifier and a high power potentiometer (called a 'rheostat'), and using modern electronic devices it is possible to produce a simple controller that has quite advanced facilities. This design is based on just two operational amplifiers but it has a pulsed output for good starting and low speed performance, plus simulated inertia, momentum and braking. It also has output current limiting which protects the circuit when the inevitable overloads and short circuits occur. The unit is designed to operate from the 15 volt AC output from a train transformer or the 15 volt AC auxiliary output of a train controller but it could easily be built as a self contained unit having a built-in mains transformer if preferred. It should also run properly if powered from the 12 volt DC output of a train transformer or controller.

Pulsed Control

Obtaining good results from a model train controller is more difficult than it might at first appear. Simply varying the voltage fed to the motor by means of a voltage regulator type circuit or a series rheostat might seem to offer excellent performance but in practice, the characteristics of the electric motor leads to problems. Starting tends to lack realism as a fairly high voltage is needed by the motor before it will start to operate but once it does start to run, only a relatively low voltage is needed in order to move the train slowly. As a result the train suddenly jumps to a high speed instead of having slow and realistic acceleration.

Another problem is that of poor low speed performance. This tends to be worse in the rheostat type of controller where the output impedance of the controller is inevitably quite high at low and medium speeds due to the high series resistance of the rheostat. This results in the output voltage actually decreasing slightly if the train comes to an incline and the current consumption rises as the motor is loaded more heavily. This prevents the motor from obtaining the increased power that it requires for stable running. If the train goes down an incline, the opposite occurs with the motor requiring less power, drawing less current but receiving increased voltage and a power level that is little changed. The practical result of this is a tendency for the train to run fast down the slightest of gradients and to stall when climbing a gradient.

A constant voltage type controller uses a voltage stabiliser circuit to eliminate these unwanted output voltage variations. This does not totally eliminate the problem though since the power level received by the motor still does not vary in a way that exactly matches its requirements. One way around the problem is to use an over-compensated voltage stabiliser, which is the method of

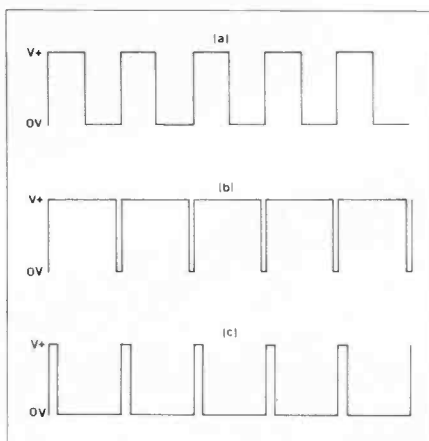
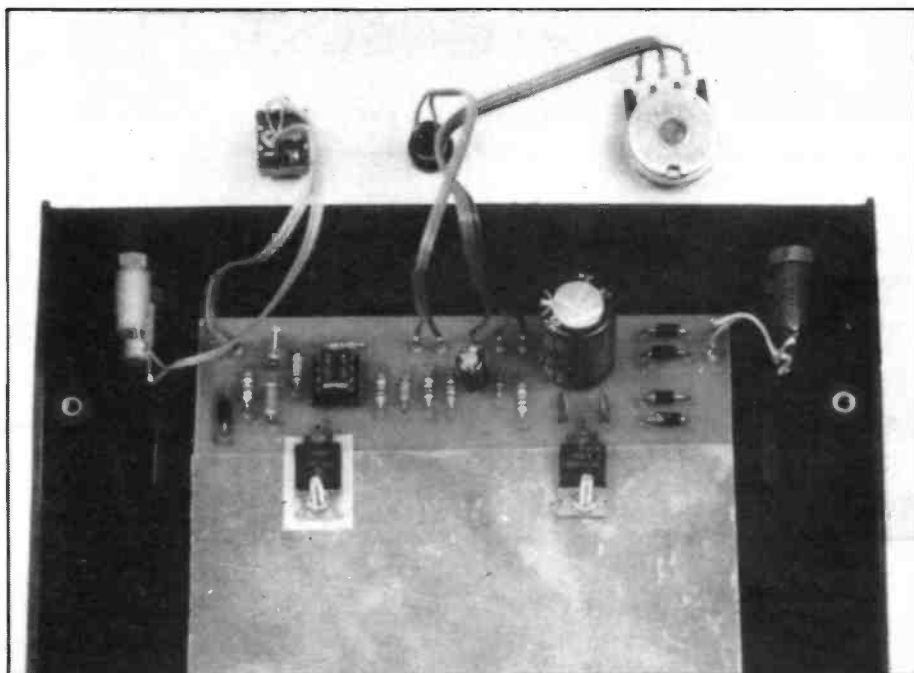

Figure 1. Output Waveforms; (a) Half, (b) Max & (c) Min Power Output speed stabilisation used in applications such as cassette recorders. What is probably a more simple and practical solution for the present application and the one which is used here, is a method of pulse control.

The idea of a pulsed output controller is to provide a series of output pulses that drive the motor at full power. The average output voltage (and thus the speed of the train) is varied by altering the mark-space ratio of the output signal. Figure 1 helps to explain the way in which this system operates.

This diagram shows typical output waveforms at various output powers. In figure 1 (a), the waveform is a square-wave having a 1 to 1 mark-space ratio. The average output voltage is therefore equal to half $V+$ and this gives half maximum output power. In figure 1 (b), the mark-space ratio of the signal is very high and the output is at $V+$ for the vast majority of the time. This gives an output power which is virtually equal to that obtained if the output was at $V+$ continuously. There is obviously a small power loss due to the brief periods when the output goes low but these are too short to give a significant power loss in practice and can be ignored. Finally, in figure 1 (c), the output consists of very brief pulses and most of the time the output is at zero volts. This gives a very low average output potential and would in fact fail to turn-over the motor at all.

Although small DC electric motors are not designed to operate from a pulsing supply, they will do so perfectly well provided the output frequency is not very low or very high. A frequency of a few hundred Hertz is satisfactory. In a train controller application, excellent results are obtained as the brief but powerful pulses nudge the train into movement and overcome the starting problem and the tendency to stall at slow speeds.

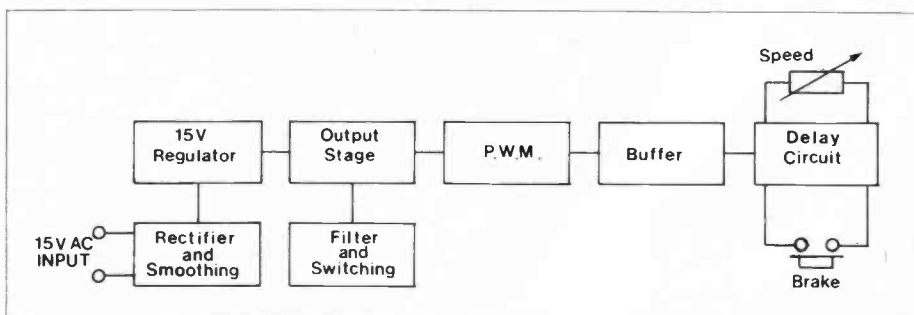

Figure 2. Block Diagram

Operating Principle

The block diagram for the controller appears in figure 2. The 15 volt AC input is rectified and then smoothed. A 15 volt regulator circuit is used to give a reasonably well smoothed and stabilised supply for the main circuit, although such a well smoothed and regulated supply voltage is by no means essential. The main reason for including the regulator is that it incorporates current limiting which protects the unit as a whole in the event of a short circuit or other overload on the output.

A pulse width modulator circuit is at the heart of the unit and this is an oscillator which has the mark-space ratio of its output signal controlled by an input voltage. Within the operating limits of the control voltage, the higher the control voltage, the higher the mark-space ratio of the output signal. A buffer stage at the output of the pulse width modulator enables the fairly high currents required by the motor to be comfortably accommodated. The speed of the train can be controlled by varying the input voltage to the pulse width modulator.

For straightforward speed control, a potentiometer to provide the control voltage is all that is required. In order to give simulated inertia and momentum a delay circuit must be added. This should give a fairly long attack time so that the acceleration of the train is restricted to a realistic level. With the power removed, a real train will coast for a considerable distance and an even longer decay time is required. However, the simulated braking is provided by a push button switch that can greatly reduce the normal decay time of the delay circuit.

Although the output signal is a pulsed signal there is little problem with radio frequency interference being generated due to the low voltages and low fundamental frequency of the output signal. A simple filter is included at the output to attenuate the weak high frequency harmonics that are generated and the direction control (a switch that controls the polarity of the output signal) is also included.

Circuit Operation

For a unit of this type, very few components are required as reference to the circuit diagram of Figure 3 will reveal. In this circuit, IC2b is used as virtually an ordinary operational amplifier relaxation oscillator. The motor will require a fairly high current of typically about 500 milliamps and Darlington power transistor TR1 is used as an emitter follower buffer stage to enable suitably high output currents to be supplied. D6 and C6 are suppression components and S1 is the direction control.

The basic action of this type of oscillator is for C5 to charge to a little over half the supply voltage via R7 and so on, with a squarewave being generated

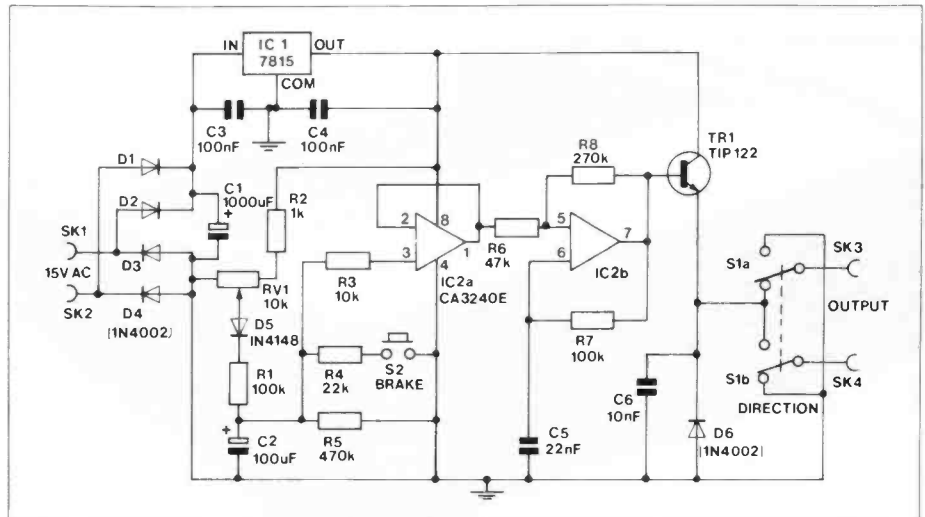
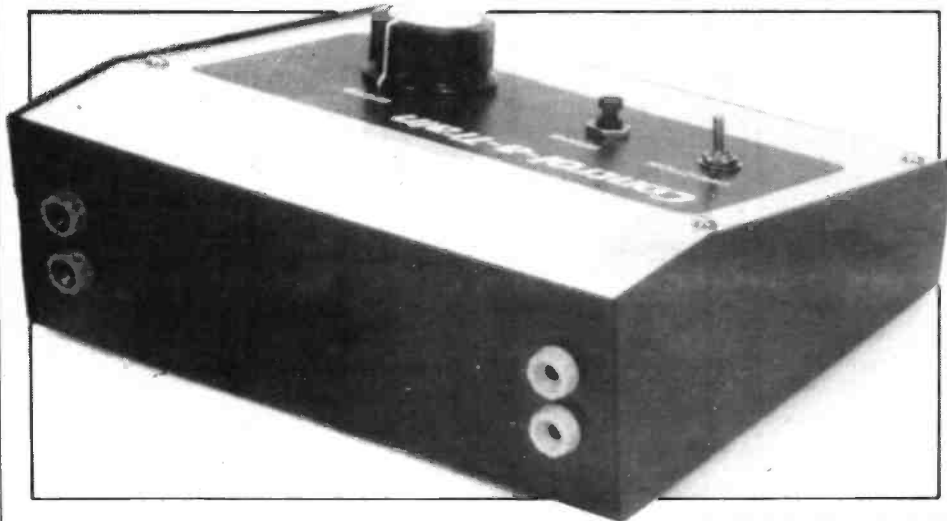

Figure 3. Circuit Diagram

at the output of the operational amplifier. This assumes that the input bias voltage to R6 is half the supply voltage but in this case, the bias can be varied and variations in this potential have the effect of altering the output waveform. In fact the effect on the waveform is to give an average output voltage that is roughly equal to the bias voltage. Thus the speed of the train can be controlled simply by controlling the bias voltage to the oscillator and the required pulsed output is obtained.

IC2a is used as a buffer in the bias voltage circuit and RV1 is the speed control. D5, R1 and C2 are a timing circuit which limit the acceleration of the train, giving the simple simulated inertia effect. When RV1 is backed-off, the only significant discharge path for C2 is through R5 and the train only reduces speed very gradually, giving the simulated momentum. Closing S2 shunts R4 across R5, giving a much faster reduction in speed and S2 therefore gives the simulated braking action. The specified





values will give excellent results but by altering the values of R1, R4 and R5, the inertia, momentum and braking characteristics can be tailored to suit individual requirements.

As explained previously, power is obtained from a 15 volt AC output of a train transformer or controller and this output should be rated at about 1.4 amps or more. The rectifier is a bridge type (D1 to D4) and C1 is the smoothing capacitor. The supply stabilisation is provided by the monolithic voltage regulator IC1 and this enables output currents of up to 1 amp to be provided. This is adequate for any of the popular small model railway gauges but owners of large gauge layouts should note that it might not be adequate for their purposes.

Construction

Start by making up the printed circuit board. Figure 4 and Figure 5 gives full details of both the printed circuit board and the hard-wiring. IC2 is a MOS input device and it would be prudent to observe the basic anti-static handling precautions when dealing with this component. Leave it in its protective packaging until the unit is otherwise complete and it is time for it to be connected into circuit. The device should then be fitted in a holder and handled as little as possible. Fit Veropins at the point where connections to the controls and sockets will be made and take care to fit the electrolytic capacitors and semi-conductors the right way around.

TR1 and IC1 are both mounted horizontally on the board and a piece of (approximately) 18 s.w.g aluminium is sandwiched between these components and the board. This aluminium fin should have dimensions of about 112 by 85 millimetres and it acts as a heatsink for TR1 and IC1. As TR1 operates in a switching mode, it actually dissipates only a modest amount of power but IC1 does have to dissipate several watts when the train is run at speed and without adequate heatsinking, it could be damaged. The printed circuit board can be used as a sort of template when marking the positions of the mounting holes in the heatsink. Position the piece of aluminium so that the metal undersides of TR1 and IC1 are fully in contact with it but the aluminium fin should not overlap the board so far as to risk it short circuiting to the leadout wires of either device.

IC1's heatsink-tab connects internally to its common terminal and thus to the negative supply rail of the controller. The heatsink-tab of TR1 connects internally to its collector terminal and therefore to the +15 volt line. In order to prevent a short circuit on the 15 volt stabilised supply, one or both devices must be insulated from the heatsink using a standard plastic TO-66 insulating kit. Probably the best solution is to insulate only TR1, leaving the heatsink at the negative supply potential. The insulating

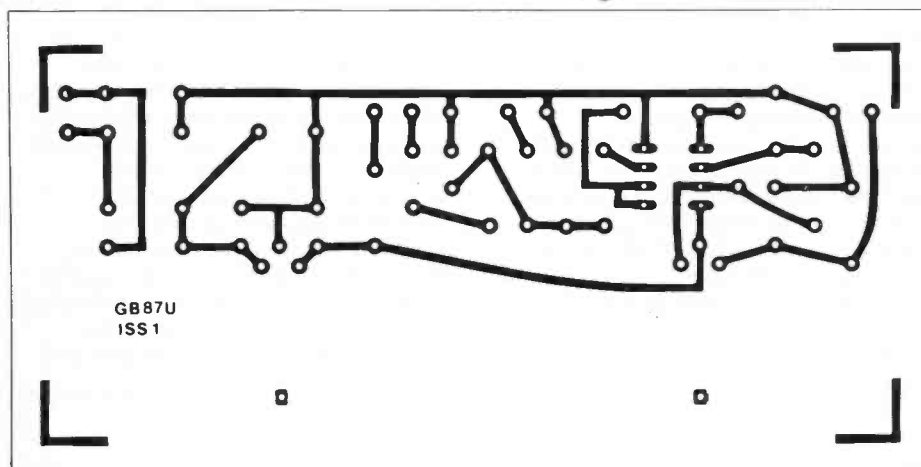

Figure 4. PCB Artwork

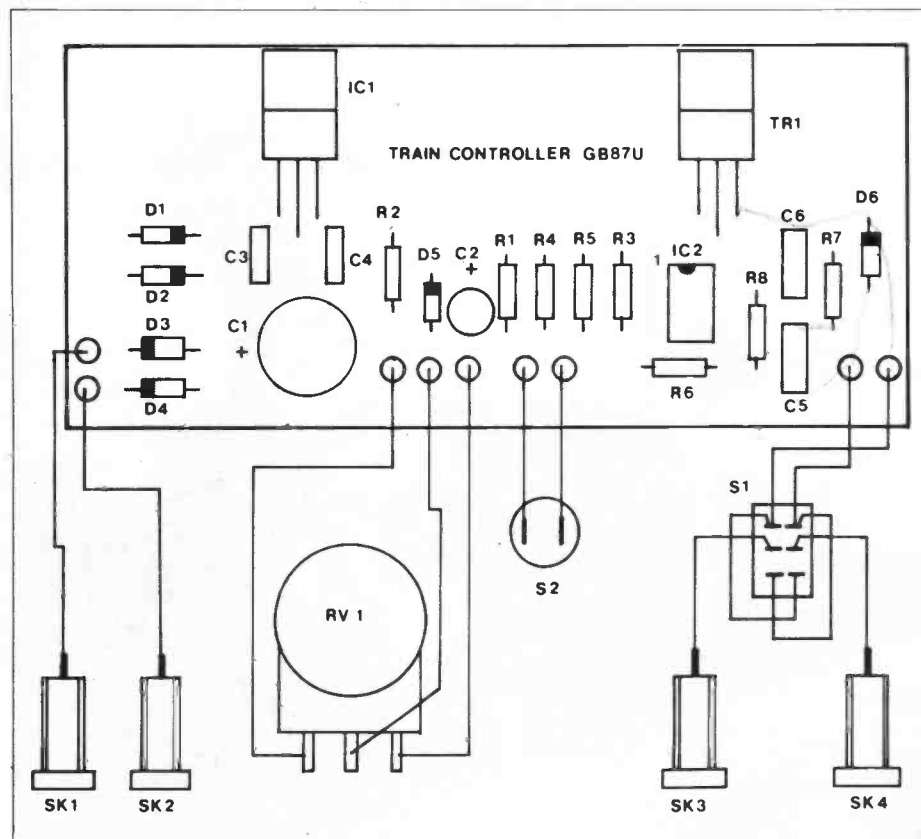

Figure 5. PCB Wiring and Legend

washer fits between TR1 and the heatsink with the plastic bush fitted on top of TR1 and into its mounting hole. In other words, the washer must insulate TR1 from the heatsink and the bush must insulate TR1 from the mounting bolt.

The board is secured to the base panel of the case by means of the mounting bolts for TR1 and IC1, which should be 1 inch long 6BA types. Also, 1/4 inch spacers are included on the mounting bolts between the base panel and the printed circuit board. The assembly is mounted with the board well to the rear of the case leaving sufficient room for the heatsink in the front part of the case. Once the board and heatsink have been mounted in the case, use a continuity tester to check that the insulating kit on TR1 is effective.

It is obviously not essential to use the sloping front case specified in the Parts List but this is the ideal type of case for a train controller and the suggested type is about the optimum size. The three controls are mounted on the front panel. SK1 and SK2 are mounted at one end of the rear panel while SK3 and SK4 are fitted at the opposite end of this panel. (See Figure 5.) To complete the unit the point to point style wiring is then added using ordinary multi-strand connecting wire.

If the controller is to be constructed as a mains powered unit with a built-in mains transformer, a substantially larger case will be required. The mains transformer should have a rating of 15 volts at 1.4 amps or more and the Maplin TR34V HP type (Order Code WB22Y) would be suitable. The 15 volt tapping of one secondary winding would feed the controller circuit while the other winding could be used to provide a 15 volt AC auxiliary output. An important point that must be emphasised here is that the



normal safety precautions for mains powered equipment must not be ignored. The case should be a type having a screw fitting lid so that easy access to dangerous mains wiring is not possible. Also, the negative supply rail of the unit plus any exposed metalwork such as fixing screws should be earthed to the mains earth lead.

Using the Controller

SK1 and SK2 connect to the 15 volt output of the train controller. SK3 and SK4 connect to the power rail. Make quite sure that you do not accidentally reverse these two sets of connections as this would almost certainly damage some of

the components. When set for minimum power, there is actually a low output power to the train and a slight hum might be produced from the motor. The train should not move though and should be well below the start-up threshold power level.

Excellent starting and low speed performance should be achieved but only if the track is kept clean so that the engine is always in good electrical contact with the track. Controllers of this type can be a little difficult to master if you have previously only used a simple type but so would driving a real train and the higher level of skill required is the whole point of inertia type controllers.

CONTROL-A-TRAIN PARTS LIST

RESISTORS: All 0.6W 1% Metal Film (Unless Specified)

R1,7	100k	2	(M100K)
R2	1k	1	(M1K)
R3	10k	1	(M10K)
R4	22k	1	(M22K)
R5	470k	1	(M470K)
R6	47k	1	(M47K)
R8	270k	1	(M270K)
RV1	Pot Lin 10k	1	(FW02C)

CAPACITORS

C1	PC Elect 1000µF 35V	1	(FF18U)
C2	PC Elect 100µF 25V	1	(FF11M)
C3,4	Minidisc 100nF 16V	2	(YR75S)
C5	Poly Layer 22nF	1	(WW33L)
C6	Poly Layer 10nF	1	(WW29G)

SEMICONDUCTORS

D1-4,6	1N4002	5	(QL74R)
D5	1N4148	1	(QL80B)
TR1	TIP122	1	(WQ73Q)
IC1	µA7815	1	(QL33L)
IC2	CA3240E	1	(WQ21X)

MISCELLANEOUS

SK1,2	4mm Socket Red	2	(HF73Q)
SK3,4	4mm Socket Blue	2	(HF70M)

S1	Sub-Min Toggle E	1	(FH04E)
S2	Push Switch	1	(FH59P)
	PCB	1	(GB87U)
	DIL Socket 8-pin	1	(BL17T)
	Kit (P) Plas	1	(WR23A)
	Pin 2145	9 Pins	(FL24B)
	Knob K7B	1	(YX02C)
	Bolt 6BA 1in.	2 Bolts	(BF07H)
	6BA Spacer 1/4in.	2 Spacers	(FW34M)
	Nut 6BA	2 Nuts	(BF18U)
	Ribbon Cable 10-way	1m	(XR06G)
	Front Panel	1	(FT40T)
	Heatsink	1	(FT53H)
	Instruction Leaflet	1	(XT50E)
	Constructors' Guide	1	(XH79L)

OPTIONAL

	ABS Console M6006	1	(LH66W)
	4mm Plug Red	2	(HF86W)
	4mm Plug Blue	2	(HF63T)

The above items (excluding Optional) are available as a kit.

Order As LK64U (Control-A-Train Kit)

The following items (which are included in the kit) are also available separately.

Control-A-Train Front Panel Order As FT40T
Control-A-Train PCB Order As GB87U
Control-A-Train Heatsink Order As FT53H

LIVE WIRE DETECTOR



by Dave Goodman

The Maplin Live-Wire Detector is a fascinating and novel device which will detect the presence of mains electricity whether there's a current flowing or not. It's better than neon screwdrivers or multimeters because you do not have to make contact with the wire – it signals the presence of mains up to two inches (5cm) away and better than metal detectors, because it only indicates if the wire is live; also it's considerably cheaper.

A Most Useful Instrument

It's the sort of device every household should own and anyone can use it because you don't have to actually touch dangerous points with any part of the Live-Wire Detector. Even if the wires are not connected to anything at one end, Live-Wire will tell you if they're live. You could use it to find buried wires in dry plaster or plastic conduit or under floor or ceiling boards, though keep in mind that its sensitivity is only about two inches, so don't put a four inch nail where there was a negative reading! However, if you get a positive reading of a wire in a wall and there's nothing else electrical on

that wall, then you can hammer the nail home with confidence anywhere else. The message then is: beware of negative readings.

Other uses of Live-Wire include detecting breaks in cables or appliance leads. If you have a suspect mains lead, plug it into the mains; run Live-Wire along the cable and at the point where the live wire is broken, Live-Wire will cease to sound and flash. If a fuse blows, Live Wire will indicate mains present up to all

the fuses and mains present on the wires leaving every fuse except the dead one. If you're wallpapering and need to remove a switch plate, first check that you get a positive reading with the mains on, then switch off or remove the fuse from the circuit you think is the right one. With Live-Wire in the same position as before, it will no longer sound if you've found the right circuit. There are probably hundreds of other uses and one or two we've thought of include detecting ringing on telephone lines, detecting the EHT in TV sets (though Live-Wire will probably need to be desensitised).

Live-Wire will also detect static electricity but in this case, it must be moved into or through the static field and only while it is moving will the instrument sound.

Circuit Description

An AC electro-magnetic field is detected at IC1 pin 1. The 4069 inverter is connected in a linear by placing a feed-

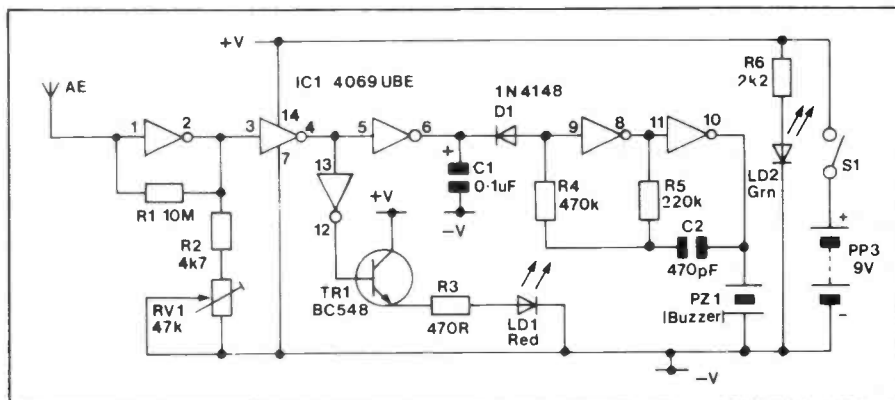

Figure 1. Circuit diagram of the Live-Wire Detector.



Inside view of the Live-Wire Detector prior to fitting the back panel.

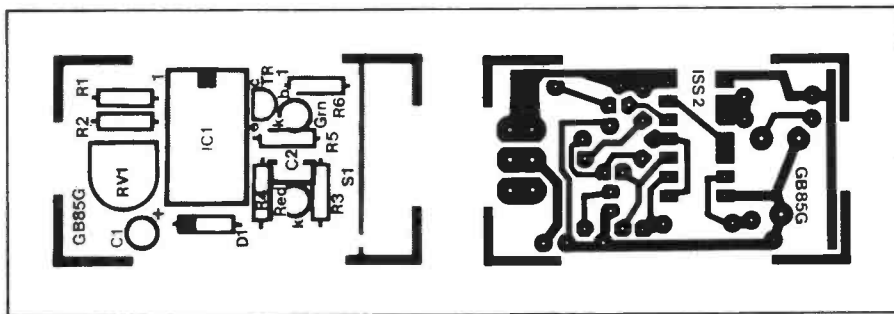

Figure 2. PCB legend and track.

back resistor between pins 1 and 2. The value chosen for R1 keeps the characteristics high CMOS input impedance so that changes in the surrounding electro-magnetic field produce a minute voltage change on the aerial track which are massively amplified in this stage.

RV1 sets the point at which the output from IC1 pin 4 will trigger the next two stages. This is necessary since the quiescent voltage at pin 2 will be different from one chip to another. Being a digital chip, this usually makes no difference but in linear mode, it is significant and RV1 has to be present to ensure that every Live-Wire can meet the specification. RV1, therefore, is adjusted to keep pin 4 high when not triggered.

Turning S1 on, lights LED2 which indicates that the circuit is active. If no electro-magnetic field is detected, then pin 4 will be high and the rest of the circuit is inactive. When an electro-magnetic field is detected, pin 4 goes low and pin 12 then goes high causing the emitter-follower TR1 to conduct, operating LED1.

At the same time, IC1 pin 6 goes high. D1 will now be reverse-biased which removes the continuous low 'hold-off' condition from pin 9 and allows the oscillator to run. The oscillator comprises the final stages of the 4069 and resistors R4, R5 and C2. The approximate frequency is 3.5kHz. The output of the oscillator drives the high impedance piezo-ceramic buzzer directly.

The circuit runs from a 9V PP3 battery. The current drain is approximately 10mA when the circuit is switched on and 17mA when it is detecting electricity.

An AC electro-magnetic field is one which is collapsing and re-establishing itself in phase with the frequency in the wire, e.g. for UK mains, it is 50Hz. This has the effect of turning D1 on and off, which stops and starts the oscillator, giving a characteristic buzzing sound. If the circuit was moved in a static electro-magnetic field, it will produce a pure high frequency tone.

As the circuit moves into a field, LED1 may operate before the buzzer starts to sound. It will gradually increase in brightness and during this time, at some point, the buzzer will sound before or just as the LED reaches full brightness.

Construction

With reference to Figure 2 and the Parts List, fit the components, with the exception of the slide switch, as follows: start by fitting each of the resistors into the positions shown. Next, insert the diode in position D1 ensuring that the device is correctly orientated. It is important that each of these components

lies flat to the PCB as shown in the photographs.

Fit the two capacitors in their respective positions, noting that C2 is a polarised device which needs to be installed the correct way round. Carefully solder all these components in place and clip off the excess lead ends. Now insert IC1 and TR1 (so that their orientation matches up with that shown in the corresponding board legends), and fit preset RV1 in the position indicated. Carefully solder all the leads of these three components and cut off the excess leads of the lead-lengths.

The red LED (LD1) is inserted into the position marked on the pcb as 'Red' in Figure 2. Likewise, the green LED (LD2) is placed in the 'Grn' position. Correct positioning of these items is also critical, and the cathode (marked as 'k' in Figure 2) is the shorter lead of the LED. Adjust the two LEDs until the base of each coloured package is 6mm above the top surface of the board. Holding the LEDs absolutely vertical in that position, solder the four leads and clip off the excess lead-lengths.

Cut the two wires from the battery connector (black = -Ve; red = +Ve) so that they are 50mm (2in.) long, tin them, and referring to Figure 3, insert each in the appropriate hole and solder in place. Cut the wires from the buzzer so that about 25mm (1in.) of each remains, tin them, insert in the two remaining holes on the PCB and solder them in position. Note that buzzer polarity is uncritical. With a small screwdriver or trim tool, adjust RV1 until its wiper points to C1 as arrow in Figure 2, and finally check that all components have been inserted and soldered correctly.

Final Assembly and Testing

Referring to Figure 4, place the switch in the box so that its lever protrudes through the rectangular cut-out in the case. Ensuring that the two LEDs protrude through the appropriate round holes, insert the M2 bolts through the two holes on either side of the switch cut-out, pass them through the mounting holes of the switch and terminate with M2 nuts. When the bolts have been sufficiently tightened, position the PCB on the switch

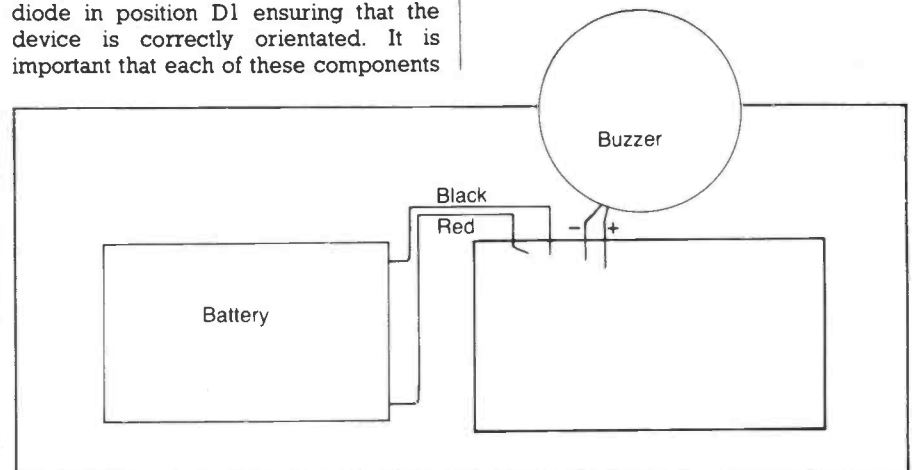

Figure 3. Live-Wire Detector wiring diagram.

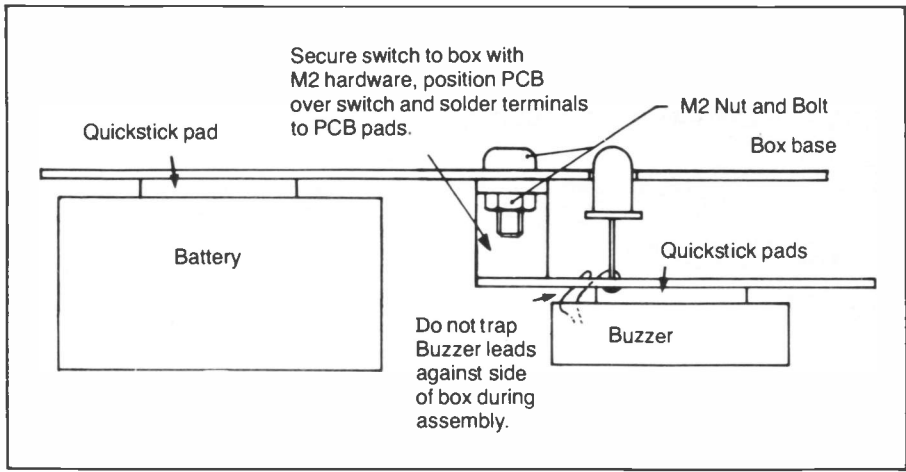

Figure 4. Overall assembly of the Live-Wire Detector.

terminals exposed within the case and solder in place. It must be checked that the board is mounted flush against the switch prior to soldering, otherwise undue strain could be placed on the PCB tracks. Please bear in mind that the switch effectively holds the PCB in place. Now solder the switch terminals to the PCB.

Stick the buzzer centrally onto the soldered side of the PCB using a quickstick adhesive pad, as shown in Figure 5, so that the mounting ears of the buzzer point to the corners of the PCB and the buzzer lead-out wires are nearest the edge of the board. Ensure that the adhesive pad is fixed to the base of the buzzer, and not the top (which has a large central hole on it, from which the sound is emitted). Please note that the diameter of the buzzer may vary slightly. If it is found that it is too large to fit into the box, carefully remove some of the plastic casing of the buzzer with a sharp knife.

Install a new PP3 battery, preferably of the alkaline type, ensuring that it is fitted to the battery clip the right way round, even a momentary incorrect connection could cause damage. Depending on the position of the on/off switch the Live-Wire Detector may already be switched on, indicated by the green LED

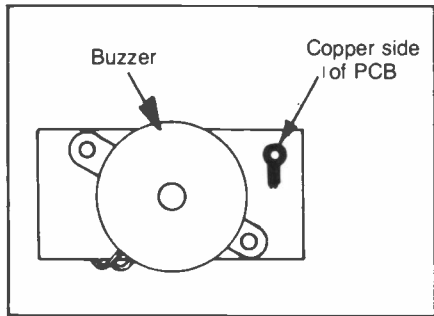

Figure 5. Buzzer mounting.

glowing, if this is the case, switch the unit off.

Plug an appliance into a mains socket and switch it on. Bring the assembly up to the cable, holding the battery end of the box. Switch the Live-Wire Detector on. The green LED should light and stay on. As you approach the appliance's cable, the red LED should light and the buzzer should sound.

RV1 must now be adjusted so that the unit starts to operate about 2 inches (5cm) from the cable. To increase the sensitivity, turn RV1 clockwise; vice versa to decrease the sensitivity. Do not try to make the unit too sensitive or you will find that it is occasionally triggered by your body, or for no apparent reason.

When RV1 is correctly adjusted, fix the battery into the box using the other sticky-pad, see Figure 4. Finally, screw the box lid on using the four screws provided.

Uses

This unit is extremely useful around the home, and because the user does not have to make actual contact with any part of a live circuit, it is perfectly safe to use. Even if the wires are not connected to anything at one end (i.e. no current is flowing), Live-Wire will reveal if they are live. Some of the many uses that we have identified include the following:

Finding wires concealed by plaster, plastic conduit, floor boards or ceiling panels. However, please bear in mind that the sensitivity of the unit is only about two inches, so do not hammer a four inch nail into a wall where there was a negative reading! However, if you get a positive reading and there is nothing else electrical on that wall, then you can confidently fix the nail anywhere else. Generally, negative readings should be treated with caution.

The detection of breaks in cables or appliance leads. If a mains lead is suspect, it is plugged into the mains and Live-Wire is run along its length. At the point where the live wire is broken, Live Wire will cease to sound and flash.

If a particular mains circuit needs to be isolated, for example, when a switch plate needs to be removed (e.g. for wallpapering a wall), first check that you get a positive reading with the Live-Wire Detector when the mains is switched on, then remove the lighting fuse and use Live-Wire Detector, in the same position, to verify that the correct fuse has been removed.

Detecting ringing on telephone lines.

Detecting the presence of EHT within a TV set (in this case, Live-Wire will probably need to be desensitised).

Live-Wire will also detect static electricity, but only when it is being moved into, or through, the static field.

LIVE-WIRE DETECTOR PARTS LIST

RESISTORS: All 0.6W 1% Metal Film (Unless Specified)

R1	Econ Res 10M	1	(B10M)
R2	4k7	1	(M4K7)
R3	470Ω	1	(M470R)
R4	470k	1	(M470K)
R5	220k	1	(M220K)
R6	2k2	1	(M2K2)
RV1	Hor Encl Preset 47k	1	(UH05F)

CAPACITORS

C1	Tant 100nF 35V	1	(WW54J)
C2	Ceramic 470pF	1	(WX64U)

SEMICONDUCTORS

TR1	BC548	1	(QB73Q)
D1	1N4148	1	(QL80B)
IC1	4069UBE	1	(QX25C)
LD1	Mini LED Red	1	(WL32K)
LD2	Mini LED Green	1	(WL33L)

MISCELLANEOUS

S1	Sub-Min Slide	1	(FH35Q)
	PP3 Clip	1	(HF28F)
	Min Piezo Sounder	1	(FM59P)
	Poziscrew M2 6mm	1 Pkt	(BF41U)
	Steel Nut M2	1 Pkt	(JD63T)
	Live Wire Det Case	1	(FT39N)
	Quickstick Pad	1 Strip	(HB22Y)
	PCB	1	(GB85G)
	Instruction Leaflet	1	(XK07H)
	Constructors' Guide	1	(XH79L)

OPTIONAL

B1	Battery PP3	1	(FK62S)
----	-------------	---	---------

The above items (excluding Optional) are available as a kit.

Order As LK63T (Live Wire Detector Kit)

Although a few years ago a couple of concealed switches provided a good and in most cases, adequate means of defeating car thieves, these days something a little more sophisticated is really required. One reason for this is that car thieves are generally familiar with simple forms of alarms, immobilisers, etc, and means of overcoming them. Perhaps of more relevance, it is common for quite expensive items to be left in cars, either in the form of loose items in the back of the car or as car accessories such as radios, cassette players, compact disc players, and the like. Many car alarms are of little or no use against someone who breaks or forces open a window and removes items from inside the car.

This burglar alarm design is basically the same as the ultrasonic movement detector type that is often used to protect homes and other buildings. By detecting movement inside the car, it renders the method of entry irrelevant, and even

someone reaching in through a window left slightly open should trigger the alarm.

The circuit incorporates an Exit Delay Timer which prevents the unit from being activated until several seconds after it has been switched on, giving the user an opportunity to leave the car without triggering the alarm. This is an important feature as it enables the on/off switch to be positioned inside the car, rather than having to rely on a concealed switch somewhere on the outside of the car. A short duration Entry Delay is also included so that the user can enter the car and deactivate the alarm before it sounds. However, for obvious reasons, this delay needs to be kept as short as possible and the on/off switch should obviously be concealed somewhere inside the car where it cannot easily be found.

by Robert Penfold

Once activated the alarm operates the car horn, and to make it more obvious that this is not merely some sort of electrical fault say, but genuinely an alarm, the horn is pulsed on and off at approximately 1Hz, creating an 'urgent' sound. Of course, some other alarm generator could be used if preferred.

To avoid unnecessary annoyance to others and to prevent excessive drain on the car's battery, the alarm is automatically switched off after about 2½ minutes (provided the unit is not still being triggered).

System of Operation

Alarms of this type rely on the well-known Doppler Shift effect. It is this effect which, for example, causes the pitch of a car engine to sound higher when approaching than it does when it has passed by and is moving away. In this case, an ultrasonic transmitter is used to generate high frequency sound waves that are inaudible to humans. A receiver circuit is used to detect the ultrasonic

ULTRASONIC CAR ALARM



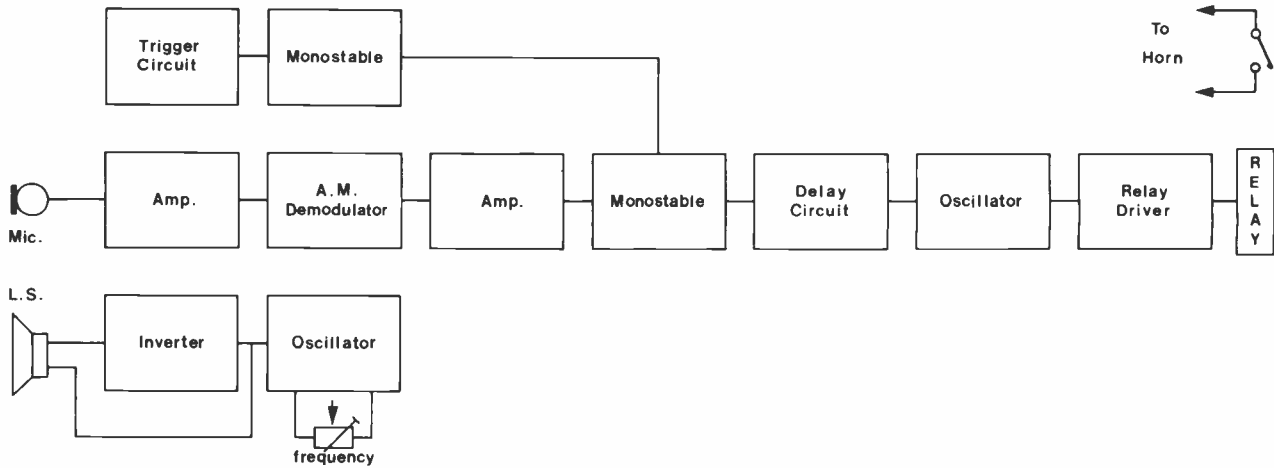

Figure 1. Block Diagram

sound waves, which will either be picked up direct from the transmitter, or via reflections from stationary objects. In either case, the received signals will all be the same as the transmitted frequency.

The same thing is not true if the sound waves are received by way of a moving object. If the object is moving away from the transmitting and receiving transducers, the Doppler Shift effect produces a downwards shift in frequency. If the object is moving towards the transducers, there is an upwards shift in frequency. It is by detecting this change in frequency that the alarm detects movement and is activated. In fact, it is not by directly detecting this shift in frequency that the unit functions but instead, it is a matter of detecting the interaction between the shifted and unshifted frequencies. This is a much easier and more reliable method.

The received signal is presented to what is really just an ordinary AM (amplitude modulation) detector of the type used in medium and long wave radios. The shifted and unshifted signals then produce a low frequency beat note which is equal to the difference in the two frequencies. For instance, if the unshifted signal is at 40kHz and the shifted signal is at 40.1kHz, the beat note will be 0.1kHz or 100Hz. This is the same effect that generates a tone when an AM radio is tuned to two stations that are on virtually the same frequency. In practice the beat note from an ultrasonic detector is normally between a few Hertz and around two hundred Hertz, depending on the speed and direction of the detected object. As a beat note is only generated when a shifted frequency is present, this signal can be amplified and used to activate the alarm.

Block Diagram

Figure 1 shows a block diagram of the car alarm. The transmitter is by far the simpler of the two sections, being little more than a 40kHz oscillator feeding into an ultrasonic transducer. A frequency of 40kHz is used only because the efficiency of both the receiving and

transmitting transducers peaks at around this frequency. In practice, the output frequency is trimmed to the one which gives optimum results. The output of the oscillator also feeds an inverter, such that the transducer is push-pull driven from the two antiphase (inverted and non-inverted) signals, receiving a high peak-to-peak drive voltage as a result.

The output from the receiving transducer is at a fairly low level, and is comparable to the output from an ordinary microphone. An amplifier is

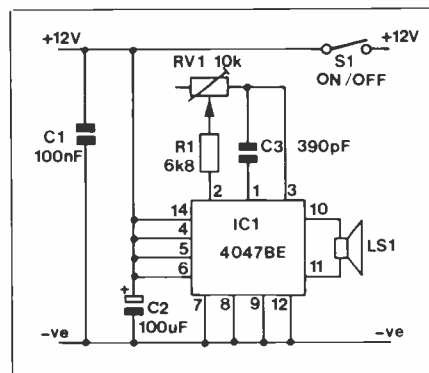

Figure 2. Ultrasonic Transmitter Circuit Diagram

therefore used to boost the signal to a usable level prior to demodulation. The demodulated signal is then used to trigger a Monostable Timer, but only if the amplifier supplies a suitably strong 'change' in output signal level. This first timer is controlled by a second Monostable Timer, which provides for the Exit Delay time period. This second timer is triggered at 'power-up' or switch-on, providing an output pulse of 10 to 12 seconds in length, which holds the first timer in an inactive state for the duration of this output pulse, during which time the ultrasonic receiver is allowed to settle down. Thereafter the circuit functions normally.

The main timer circuit controls a gated oscillator which is switched on when the unit is activated. A simple delay circuit between the monostable and the oscillator provides the Entry Delay. The oscillator operates the horn via a relay and relay driver circuit.

Circuit Operation

The transmitter and receiver circuit diagrams are shown separately in Figures 2 and 3 respectively.

Taking the transmitter first, this is based on a CMOS 4047BE monostable/astable device, which is obviously connected in the free running astable mode in this application. This device (when used in this mode) actually consists of an oscillator driving a divide by two flip/flop which has Q and \bar{Q} outputs. It is from these complementary outputs that the transmitting transducer is driven. Although this arrangement is somewhat more complex than the one outlined in Figure 1, it is essentially the same. RV1 is adjusted to set the optimum output frequency.

The receiving transducer connects direct to the input of a high gain common emitter amplifier based on TR1. Both the transducers are piezo-electric types and have an extremely high impedance. Consequently, no DC blocking capacitor is needed at the input of the receiver. TR1 provides a voltage gain of only about 40dB, which is substantially less than is normally utilized in an alarm of this type.

However, it must be borne in mind that in this case, the unit is to be used in the small confines of a car and a sensitive circuit with a large area of coverage is unnecessary. In fact it would probably be undesirable as it could easily lead to problems with spurious triggering of the unit.

D1 and D2 are a conventional diode demodulator circuit which feed the RF filter formed by R4 and C5. C5 has a larger value than normal for an AM demodulator, but this is due to the lower than usual carrier frequency and modulation frequency range.

TR2 is a transistor switch, which is 'normally off' due to R6 acting as a base leakage resistor tying the base connection to 0V. TR2 is forced into conduction momentarily by any abrupt change in the voltage charge across C5, which is communicated to TR2 via C6. TR2 provides the trigger signal for the horn timer IC2. This monostable is a 555 type but it is actually based on the CMOS

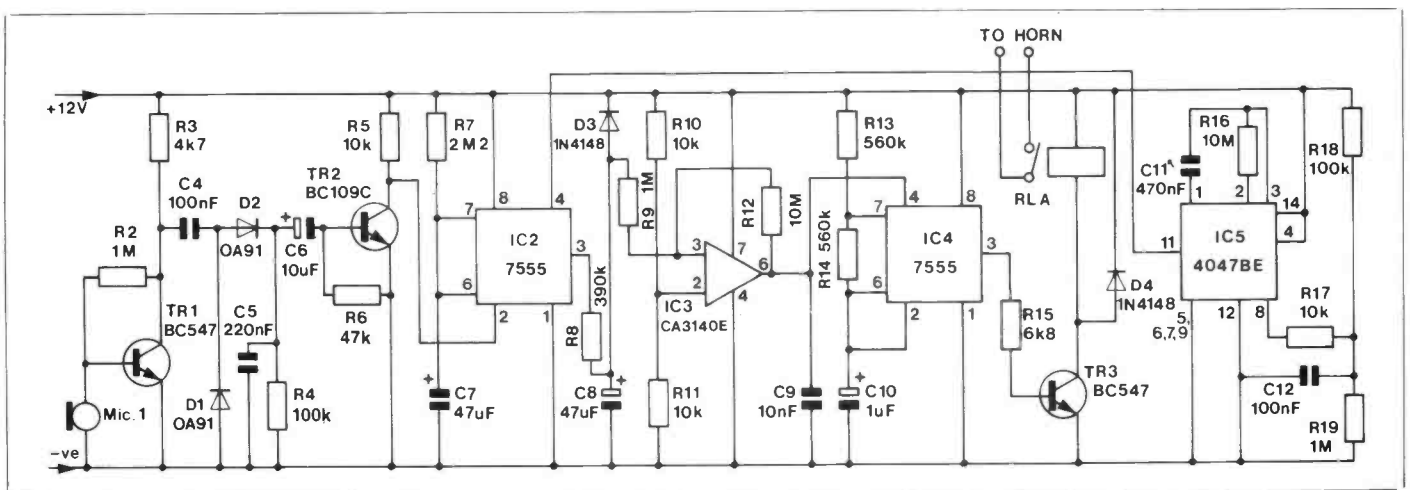

Figure 3. Receiver and Alarm Circuit Diagram

(ICM7555) version of the popular 555 timer. The 7555 has the advantage of a higher maximum operating voltage.

IC5 is a 4047BE CMOS device connected as a positive edge triggered (non-retriggerable) monostable, and it provides the Exit Delay time period. R17, 18 and 19 and C12 produce a trigger pulse at switch-on, whilst timing components C11 and R16 set the output pulse time at about 11.6 seconds. The Q output at pin 11 goes low for this period, and it inhibits IC2 by controlling the reset input.

R7 and C7 are the timing components for IC2, and it is these that control the length of time that the alarm will sound. C7 must be a low leakage electrolytic or tantalum bead type capacitor if the timing cycle is to be

terminated properly. In theory the output pulse duration of IC2 is about 2 minutes but in practice, it is likely to be somewhat longer at around 2½ minutes.

Once triggered, IC2 Q output pin 3 goes high, and activates the Schmitt Trigger circuit built around operational amplifier IC3. However, R8 and C8 form a simple C - R timing circuit that gives a delay of about 18 seconds before the trigger threshold is reached, and these provide the entry delay. D3 ensures that C8 largely discharges when the unit is switched off so that the entry delay circuit is almost immediately ready to function again if necessary.

IC4 is a 7555 used as an astable oscillator, which operates the horn via RLA. The reset input of IC4 is normally

taken low by the output of IC3, and the oscillator is disabled, but when the output of the schmitt trigger circuit goes high, the oscillator functions normally. The relay is activated during the period when the output of IC4 goes high and the switching transistor TR3 is turned on. The output waveform of IC3 is not a square-wave with a 1 to 1 mark-space ratio, as the 'on' time of the horn is double the 'off' time. This is perfectly satisfactory for the present application though.

Construction

The Car Alarm printed circuit board layout is illustrated in Figure 4 and there are several points which should be noted. Firstly, IC1 and IC5 are CMOS devices and IC3 has a PMOS input stage. The standard antistatic handling pre-

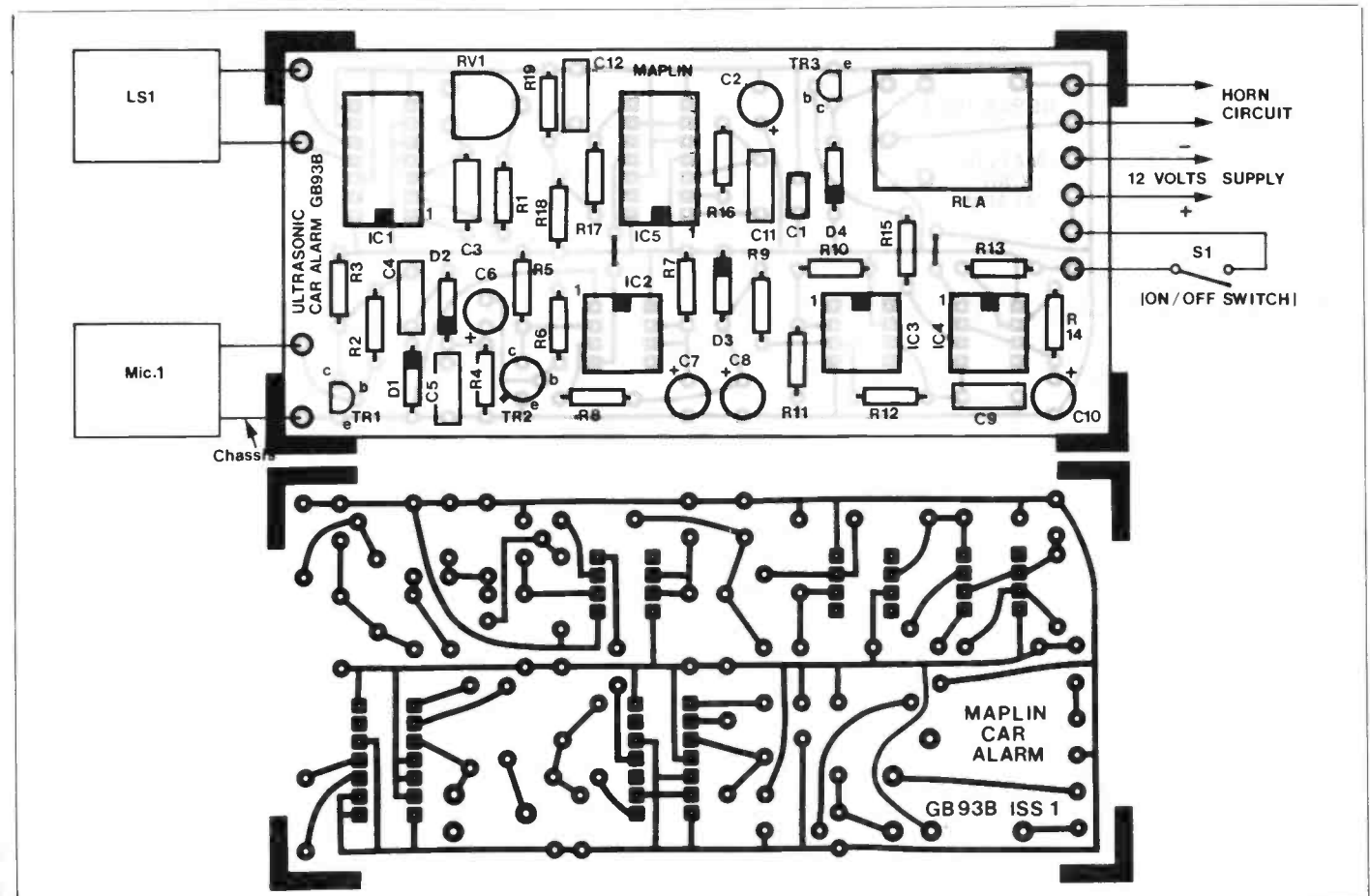

Figure 4. PCB Artwork and Legend

cautions, therefore, need to be taken when dealing with these three components. They should then be handled as little as possible and should be left in their antistatic packaging until they are ready to be pressed into their respective IC sockets, but not until these have been soldered to the PCB and the rest of the unit is, in other respects, finished. Note that although IC2 and IC4 are both CMOS devices, they have built-in protection circuitry that render any special handling precautions unnecessary. They are not amongst the cheapest of integrated circuits though, and it is advisable to fit them in IC sockets or holders anyway.

Diodes D1 and D2 are germanium types and these are more vulnerable to damage by heat than silicon types. It is not essential to use a heatshunt on each leadout wire while it is soldered in place, but the soldering iron should not be applied to each joint for any longer than is absolutely necessary.

The usual procedure might be to insert and solder all the IC sockets first, then all resistors, using the PCB legend and with reference to Figure 4. When mounting the capacitors be sure to insert the electrolytic types C2, C6, C8 and C10 the correct way round. These have their negative electrodes marked by a dark band and/or a - sign. The tantalum bead capacitor C7 has the positive electrode marked with a + sign.

Now fit the transistors TR1 - 3, and diodes D1 - 4, making absolutely sure that they are inserted the correct way round, with reference to the legend and Figure 4. The diodes will have their cathodes marked with a dark or coloured band, identify these and align them with the bars on the legend.

The unit can use any relay which has a 12 volt coil with a resistance of about 200 ohms or more and at least one set of make contacts of adequate rating, although it is advisable to use the type specified as the printed circuit board has been designed to accept it and it can be

plugged into the board and soldered in place just like the other components. Alternative types would almost certainly have a different base configuration and would not fit the board properly if at all without some adaptation. It would therefore be necessary to either make a suitably modified board or to hard-wire the relay to the board and then mount it somehow, either on or off-board.

Veropins are fitted to the board at the points where connections to off-board components will be made. The two transducers can be mounted on the board if desired but it is advisable to fit veropins and then solder them to these, either vertically or horizontally, using a generous amount of solder. The piezo transducer pairs supplied by Maplin are not identical transmitting and receiving devices. That which is marked 'T40-16' is LS1, and that marked 'R40-16' is Mic1. LS1 can be connected either way round, but Mic1 should have the terminal which is electrically connected to its body connected to the earth (0V) rail.

Mechanical construction and installation in the vehicle must be varied to suit the prevailing circumstances. Positioning of the unit in the car is not too critical due to the small volume to be monitored, but it should be placed somewhere that has the two transducers facing outwards into the interior of the car, and not straight under a seat or something of this nature. With any alarm of this type, it is usual to disguise it to some extent so that its presence is not obvious to potential intruders. The on/off switch should be well hidden and a keyswitch could be used. However, the wiring to the switch is likely to be vulnerable and a policy of making the switch and wiring difficult to find in a short space of time is probably the better way of doing things. The take-off points for the supply to the unit should be chosen so that power is not disconnected when the ignition is switched off. For the ultimate in security, the alarm could be powered from its own supply

and the reasonably low current consumption of the circuit makes the use of (say) ten AA Ni-Cad batteries as the power source, a practical proposition. The relay contacts would normally be arranged so as to supply power to the horn when they close. Again, for the ultimate in security, the unit would operate its own alarm generator circuit and there have been plenty of designs for these published in the past. Although the circuit is a negative earth type, there should in fact be no difficulty in using the unit with a positive earth vehicle (the vast majority of cars have a negative earth).

RV1 must be given a suitable setting before the unit will function properly but this can be done fairly easily without resort to specialised test equipment. However, a digital frequency meter could be used to determine the operating frequency of LS1, by connecting the DFM input to either electrode of LS1. It may still be difficult to determine the exact mid-band operating range for the piezo transmitter, which can be anywhere from 35 to 45kHz. However, strong second order harmonics would be generated if the transducer were being forced to operate outside of its normal bandwidth, which should be picked up by a reasonably sensitive DFM. Therefore RV1 would be set to a position to obtain a two figure reading in kHz. A reading of 70kHz or higher is the result of harmonics, and it should be possible to find the transducer's operating range, the limits of which are marked by a tendency of the DFM to 'jump' from 35 - 45kHz to 70 - 90kHz or higher. Alternatively, the car alarm can be temporarily connected to a 12V supply, and set up with a sheet of smooth card or similar hard surface approximately 48 inches directly in front of the piezo transducers. A multimeter set to say 5V DC can be connected across C5 and 0V. When the unit is switched on the meter should register an output from D2. Then all that is required is to adjust RV1 for the highest reading.

ULTRASONIC CAR ALARM KIT PARTS LIST

RESISTORS: All 0.6W 1% Metal Film (Unless Specified)

R1,15	6k8	2	(M6K8)
R2,9,19	1M	3	(M1M)
R3	4k7	1	(M4K7)
R4,18	100k	2	(M100K)
R5,10,11,17	10k	4	(M10K)
R6	47k	1	(M47K)
R7	2M2	1	(M2M2)
R8	390k	1	(M390K)
R12,16	10M	2	(M10M)
R13,14	560k	2	(M560K)
RV1	Hor Encl Preset 10k	1	(UH03D)

CAPACITORS

C1	Minidisc 100nF 16V	1	(YR75S)
C2	PC Elect 100µF 25V	1	(FF11M)
C3	1% Polysty 590	1	(BX52G)
C4,12	Poly Layer 100nF	2	(WW41U)
C5	Poly Layer 220nF	1	Kit Only
C6	PC Elect 10µF 50V	1	(FF04E)
C7	Tant 47µF 16V	1	(WW76H)
C8	PC Elect 47µF 25V	1	(FF08J)
C9	Poly Layer 10nF	1	(WW29G)
C10	PC Elect 1µF 100V	1	(FF01B)
C11	Poly Layer 470nF	1	(WW49D)

SEMICONDUCTORS

IC1,5	4047BE	2	(QX20W)
IC2,4	TLC555CP	2	(RA76H)
IC3	CA3140E	1	(QH29G)
TR1,3	BC547	2	(QQ14Q)
TR2	BC109C	1	(QB33L)
D1,2	OA91Y	2	(QH72P)
D3,4	1N4148	2	(QL80B)

MISCELLANEOUS

S1	SPST Ultra Min Tgggle	1	(FH97F)
RLA	10A Mains Relay	1	(YX97F)
Mic1/LS1	Ultrasonic Transducers	1 Pr	(HY12N)
	PCB	1	(GB93B)
	DIL Socket 8-pin	3	(BL17T)
	DIL Socket 14-pin	2	(BL18U)
	Pin 2145	10 Pins	(FL24B)
	Instruction Leaflet	1	(XK00A)
	Constructors' Guide	1	(XH79L)

The above items (excluding Optional) are available as a kit.

Order As LK75S (U/Sonic Car Alarm Kit)

The following item (which is included in the kit) is also available separately.

U/Sonic Car Alarm PCB Order As GB93B

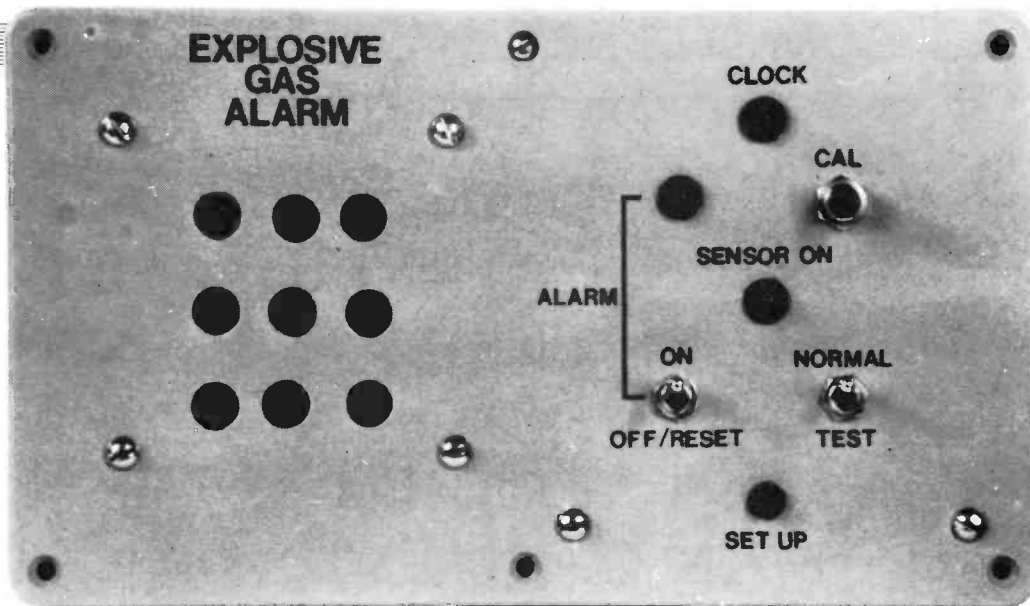

- ★ Operates from 12V battery ★ Very low average current consumption
- ★ Detects all common explosive or inflammable gases ★ Loud strident alarm

Dangerous gas leaks, particularly in confined spaces, causing explosions and fires, are becoming a more common occurrence, usually damaging property and often maiming or even killing people. The Maplin gas detector has been designed to prevent the build-up of these gases by sounding a loud alarm before sufficient gas has leaked to cause a damaging explosion. The sensor used consists of two separate units, the sensor itself and a reference compensator. Both elements are connected in series and used to form two legs of a Wheatstone bridge. The two elements have similar resistance under normal conditions and vary equally with changes of ambient temperature, maintaining the bridge in balance. The presence of an inflammable gas causes the sensor element to increase in temperature, due to the oxidization of the gas on the surface of its platinum heating element. This increase in temperature causes an increase in resistance of the element and thus the bridge becomes unbalanced, the detection of which causes the alarm to sound.

The fairly high current (about 400mA) required by the sensors and their associated circuitry make it undesirable to have the sensors permanently energised, particularly when installed in a boat or caravan where the power is supplied from a 12V battery. This problem is overcome by testing for gas once every 5 or 6 minutes and latching the alarm on when gas is detected. This test period is adequate because in most cases the build up of gas, due to a leak, is fairly slow and the alarm should operate well before a dangerous level is reached.

The system will detect all common explosive or inflammable gases such as Butane, Propane, Methane, Town Gas, Natural Gas, and Petrol Vapour. The sensors are enclosed in double wire mesh housings to prevent any chance of the sensor itself igniting any gases encountered.

by Robert Kirsch

EXPLOSIVE GAS ALARM

How It Works

The Wheatstone bridge, previously mentioned, consists of R2, R4, RV1, and the two sensing elements. The balancing of the bridge is performed by adjusting RV1. The CAL switch (S1) is used to unbalance the bridge by a small amount, simulating the presence of a small amount of gas, this being used in setting up the alarm for maximum sensitivity. The state of the bridge is monitored by the dual op-amp, IC1a and IC1b, whose output is used to turn on TR3 under alarm conditions. IC4 forms a dual oscillator to produce the warbling alarm tone, and its output is fed to TR4 which drives the Piezo tweeter which provides the audio output. The alarm, when activated, latches on and sounds continuously until reset by the action of S3, which also disconnects the speaker for testing purposes. Latching is performed by connecting the positive voltage fed from the collector of TR3 (under alarm conditions) back to the inverting input of IC1a via D3, D4 and R5.

The sequence timing of the alarm is carried out by IC3, which is a 14 stage ripple counter with built in oscillator. The frequency of the oscillator is determined by R17, C3 and C4 running at about 1 cycle every 4 seconds. The various outputs from IC3 are used to control the switching regulator TR1 and to enable the monitor circuit via IC2, R13 and D5. The sensors require at least 20 seconds to settle down after power is applied before a test can be made and for this reason the sensors are powered for about 80 seconds per test cycle, but the alarm is only enabled for the last 40 seconds of this period. The time between tests can be altered by selecting various straps but under normal conditions the shortest period is recommended. (Link A to B). The sensors require a stable supply independent of variations of the incoming supply voltage, this is achieved by the 5V regulator (REG1) which provides the

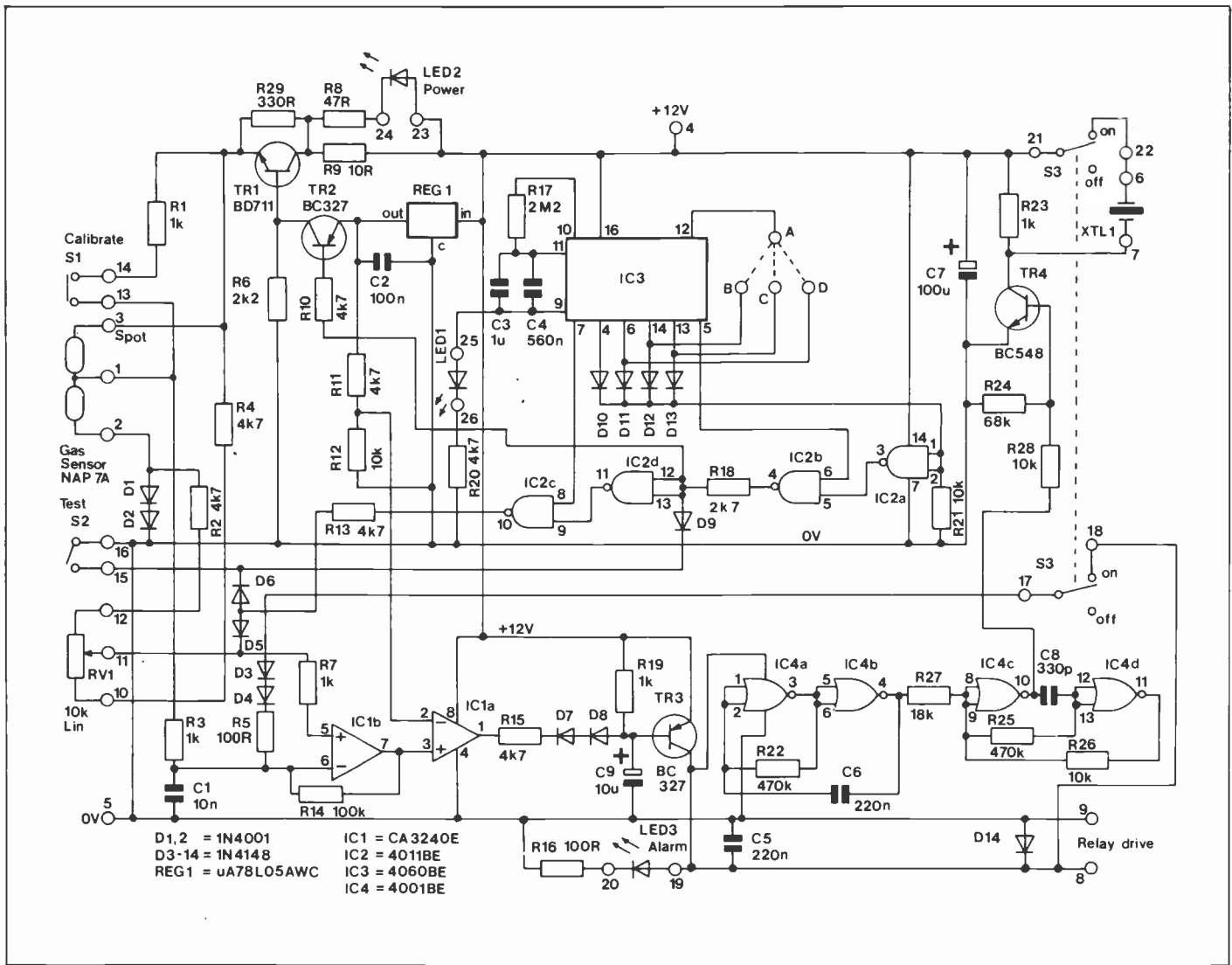

Figure 1. Circuit diagram of Gas Alarm

base current for the power switching transistor (TR1) via TR2, which forms part of the control circuit, fed from IC3.

The TEST switch (S2) overrides the timer connecting power to the sensors and also enabling the alarm circuit. LED2 lights whenever current is drawn by the sensors and will be on continuously when S2 is in the TEST position. Note that when the alarm is working, LED2 will only be on for the 80 seconds of the test period during each test cycle. LED3 gives an indication of an alarm even when the ALARM CANCEL switch (S3) is operated and is used for setting up purposes. LED 1 flashes at clock rate and is an indication that the timer is running.

Construction

Construct the circuit board referring to the Parts List and component overlay on the board. Ensure the correct polarity of all diodes, transistors, integrated circuits and electrolytic capacitors. The sensors should be mounted carefully on their board, avoiding excessive heat and making sure that the one marked with the spot is in the correct position. The required amount of cable should be connected to the sensor board at this stage but not terminated on the main board before testing.

Setting Up and Testing

Connect the 10 ohm test resistor provided with the kit in place of the sensors (between pins 2 and 3). Switch S3 to ALARM OFF and S2 to TEST. Connect 12-24V to the unit and observe LED1; this should flash regularly at about once

every 4 seconds. Connect a multimeter; set to a range that reads up to 10V, between -V battery supply (pin 5) and pin 3 (also connected to one end of test resistor). A reading of between 4.1 and 4.6 volts should be obtained at this point. Transfer the meter to pin 2; a reading of 1.4 to 1.8 volts should be measured.

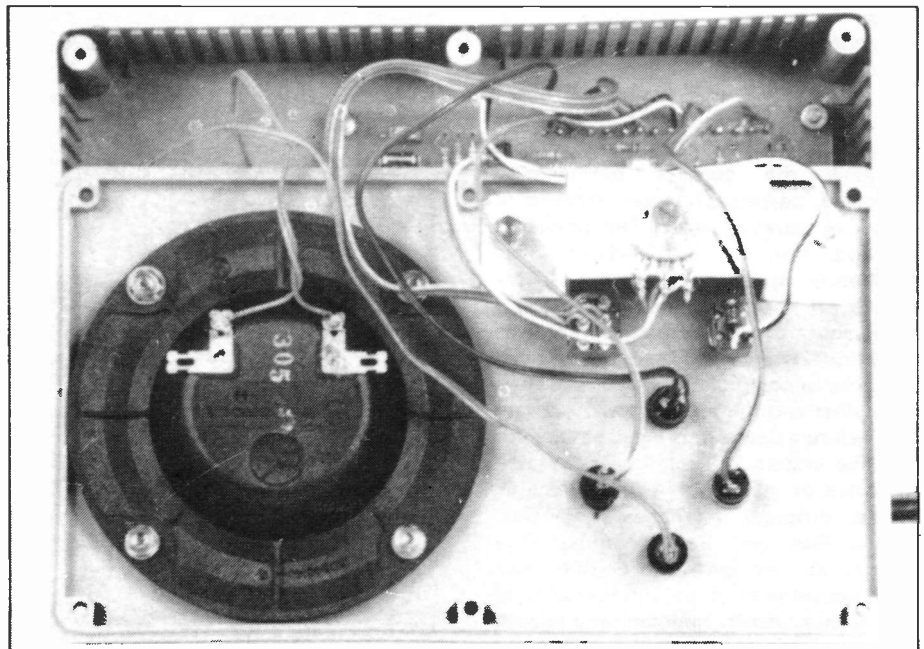

NOTE, if these readings are not correct DO NOT connect the sensors. WARNING, the test resistor will become HOT during this test.

When the above conditions are correct, disconnect the supply and remove the test resistor. Connect the sensor cable ensuring correct location of wires. Re-apply power and check that LED2 (Green) is on. When current is first applied to the sensors, a slight smell of burning may be noticed; this is quite normal. Turn RV1 fully clockwise; in this position LED3 (Red) should be out. Wait 20 seconds then rotate RV1 slowly anti-clockwise until LED3 is just on. Very carefully rotate RV1 clockwise again until the LED is just extinguished but can be made to light by pressing the CAL button. This process must be done with extreme care if maximum sensitivity is to be obtained.

Disconnect the power for about 1 minute. When the power is re-applied, the ALARM LED should light immediately but go out after a maximum of 30 seconds. If the LED remains on after this period, slightly re-adjust RV1 anti-clockwise but make sure the above test conditions are met. Check that the alarm sounds when the ALARM LED is alight and S3 is normal. The unit is now ready for use, but a further test may be carried out under actual working conditions. Place the

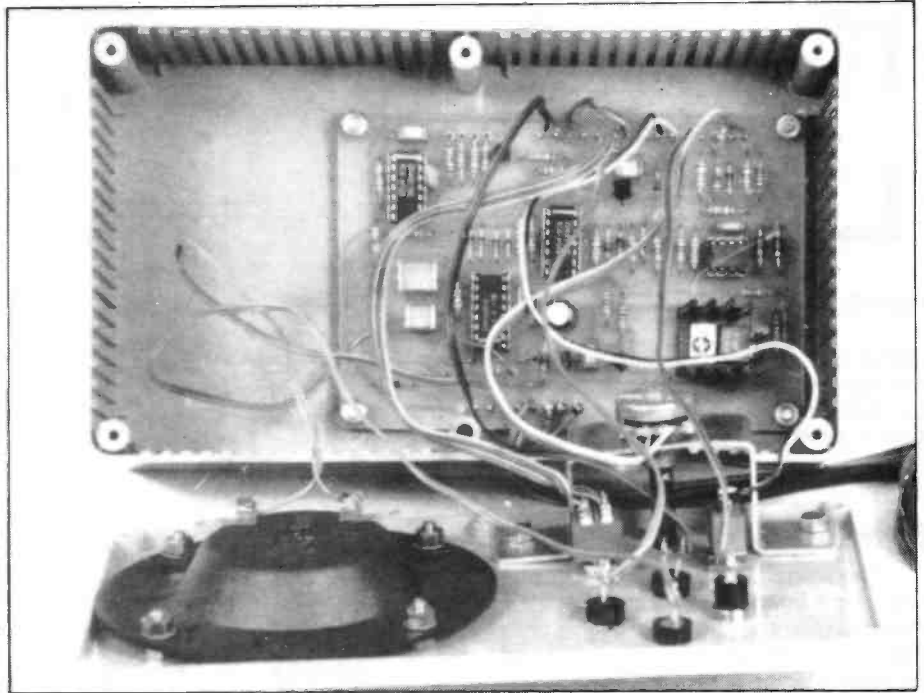

sensor board in a container of about 5 litres capacity (e.g. a large ice-cream container) and arrange a loose fitting card lid to cover it. Fill a small container of about 65cc (e.g. a small aerosol lid) capacity with butane from an ordinary

gas cigarette lighter and cover with card or a sheet of paper. With the alarm set, carefully slide the lid from the small container and pour the gas (Butane is heavier than air) into the large container; then cover this container. The alarm

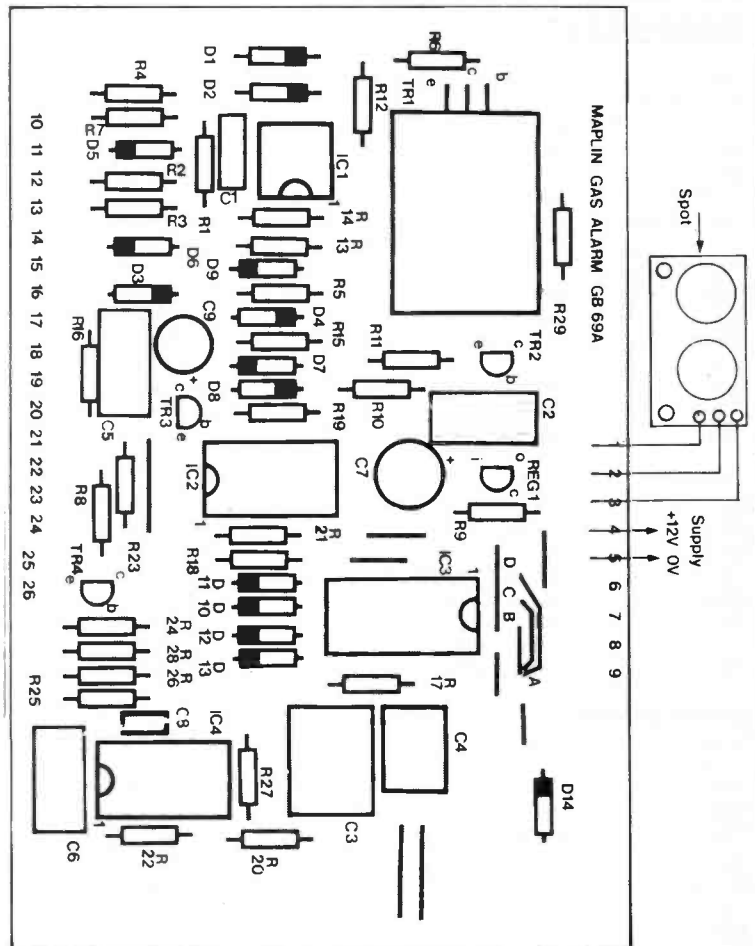
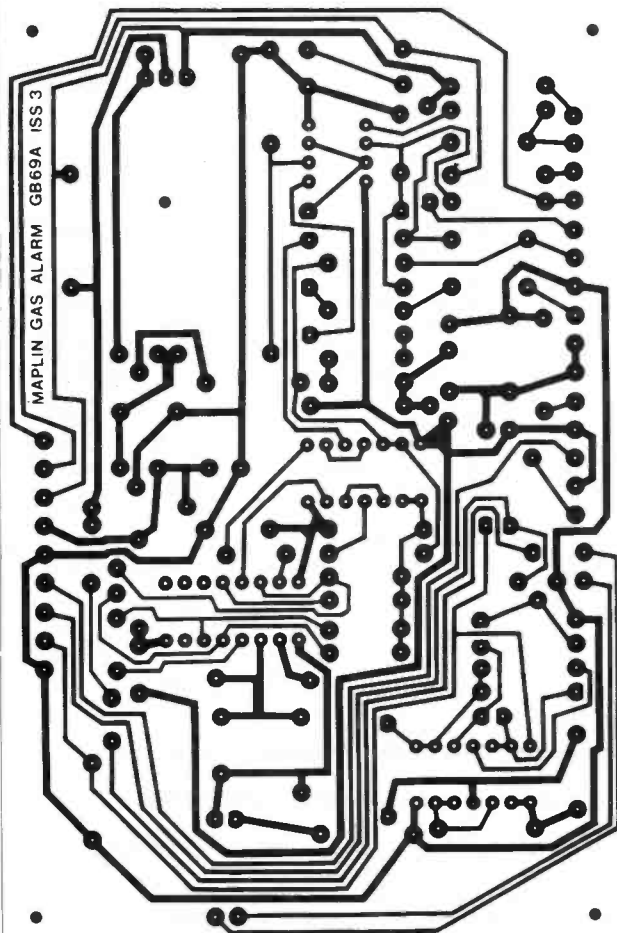

Figure 2. Track layout of main PCB

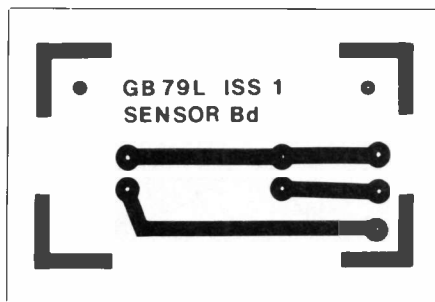

Figure 3. Gas Sensor PCB

should sound within a maximum of 6 minutes and remain latched until reset by S3. **WARNING**, do not carry out this test near a naked flame, near incandescent material or when smoking!

Installing the Alarm

The sensor board may be located up to 5 metres from the main alarm unit. Most common explosive gasses are heavier than air and therefore the sensors should be located at the lowest point where gas will collect. A free flow of air must be provided around the sensors and they must be kept free from contamination by oil or water. This alarm system is primarily designed for use in boats where power is supplied from a battery,

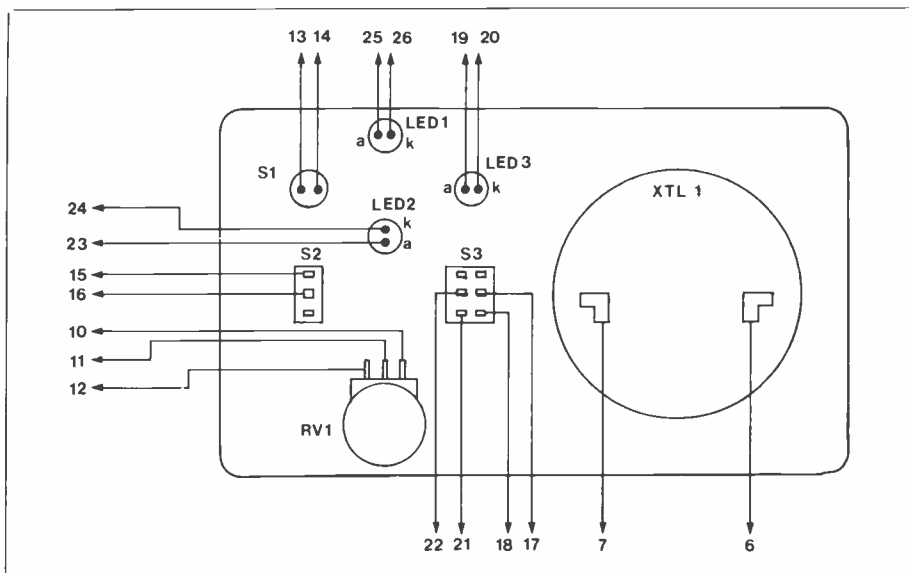
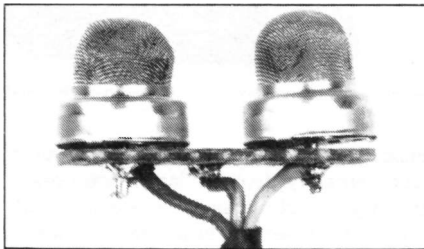

Figure 5. Wiring diagram



but it could also be used in the home when fed from a suitable mains power supply (requiring about 800mA at 12 volts). Finally, when gas is encountered, remember to ventilate the area well and beware of any form of ignition from naked flames, cigarettes, hot surfaces, sparks from electrical switching or other causes.

EXPLOSIVE GAS ALARM PARTS LIST

RESISTORS: All 0.6W 1% Metal Film (Unless Specified)

R1,3,7,19,23	1k	5	(M1K)
R2,4,10,11,13,15,20	4k7	7	(M4K7)
R6	2k2	1	(M2K2)
R8	47Ω	1	(M47R)
R9,RT	10Ω	2	(M10R)
R12,21,26,28	10k	4	(M10K)
R14	100k	1	(M100K)
R5,R16	100Ω	2	(M100R)
R17	2M2	1	(M2M2)
R18	2k7	1	(M2K7)
R22,25	470k	2	(M470K)
R24	68k	1	(M68K)
R27	18k	1	(M18K)
R29	330Ω	1	(M330R)
RV1	Pot Lin 10k	1	(FW02C)

CAPACITORS

C1	Poly Layer 10nF	1	(WW29G)
C2	Poly Layer 100nF	1	(WW41U)
C3	Poly Layer 1μF	1	(WW53H)
C4	Poly Layer 560nF	1	(WW50E)
C5,6	Poly Layer 220nF	2	(WW45Y)
C7	PC Elect 100μF 25V	1	(FF11M)
C8	Ceramic 330pF	1	(WX62S)
C9	PC Elect 10μF 100V	1	(FF05F)

SEMICONDUCTORS

D1,2	1N4001	2	(QL73Q)
D3-14	1N4148	12	(QL80B)
TR1	BD711	1	(WH15R)
TR2,3	BC327	2	(QB66W)
TR4	BC548	1	(QB73Q)
REG1	μA78L05AWC	1	(QL26D)
IC1	CA3240E	1	(WQ21X)
IC2	4011BE	1	(QX05F)
IC3	4060BE	1	(QW40T)
IC4	4001BE	1	(QX01B)

MISCELLANEOUS

LED1	LED Yellow	1	(WL30H)
LED2	LED Green	1	(WL28F)
LED3	LED Red	1	(WL27E)
	LED Clip 5mm	3	(YY40T)
S1	Push Switch	1	(FH59P)
S2	Sub-Min Toggle A	1	(FH00A)
S3	Sub-Min Toggle E	1	(FH04E)
	Gas Detector Sensor	1	(FM87U)
	Gas Detector PCB	1	(GB69A)
	Gas Alarm Sensor PCB	1	(GB79L)
	Pin 2145	29 Pins	(FL24B)
	Vaned Heatsink Plas Pwr	1	(FL58N)
	DIL Socket 8-pin	1	(BL17T)
	DIL Socket 14-pin	2	(BL18U)
	DIL Socket 16-pin	1	(BL19V)
XTL1	Direct Radiant Piezo	1	(WE54J)
	7/0.2 Wire 10m Blk	2m	(BL00A)
	Bolt 6BA 1/2in.	1 Bolt	(BF06C)
	Nut 6BA	1 Nut	(BF18U)
	Instruction Leaflet	1	(XT47B)
	Constructors' Guide	1	(XH79L)

OPTIONAL

Case	1	(LH62S)
Knob K7B	1	(YX02C)
Fittings	As Req.	

The above items (excluding Optional) are available as a kit.

Order As LK60Q (Explosive Gas Alarm Kit)

The following items (which are included in the kit) are also available separately.

Gas Detector PCB Order As GB69A
Gas Alarm Sensor PCB Order As GB79L
Gas Detector Sensor Order As FM87U

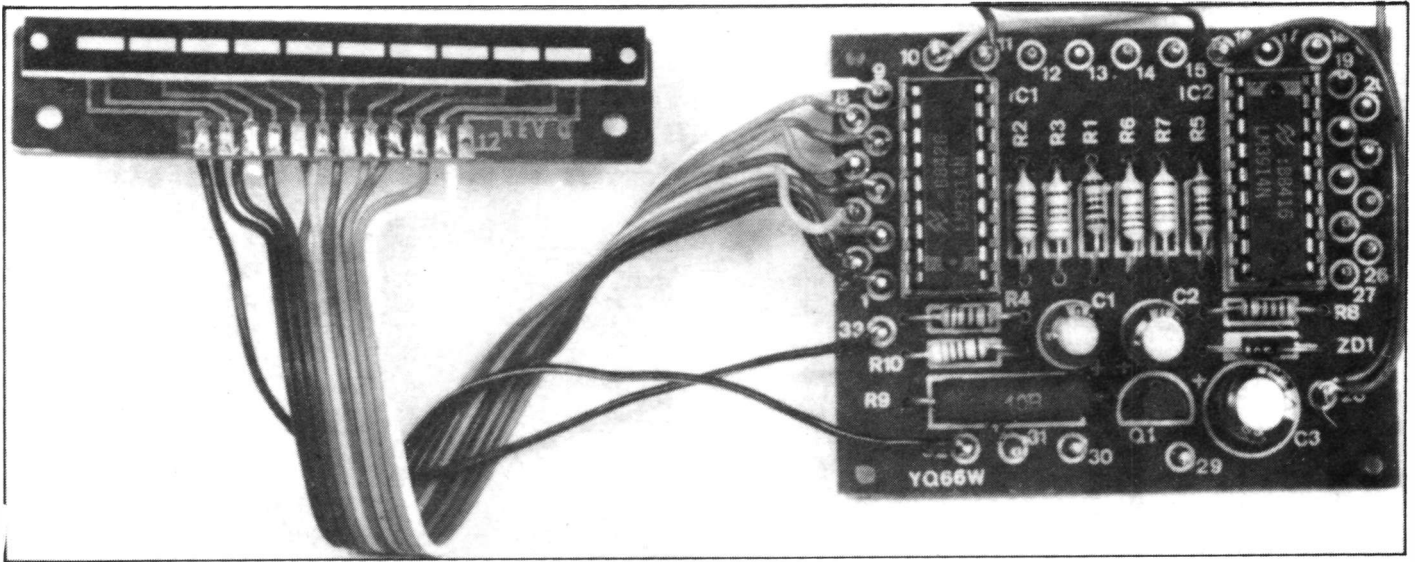

DISPLAY DRIVER MODULE

by Dave Goodman

- ★ Many Types of Display can be Driven
- ★ Choice of Driver Chips
- ★ Flashing Option
- ★ Easy to Build

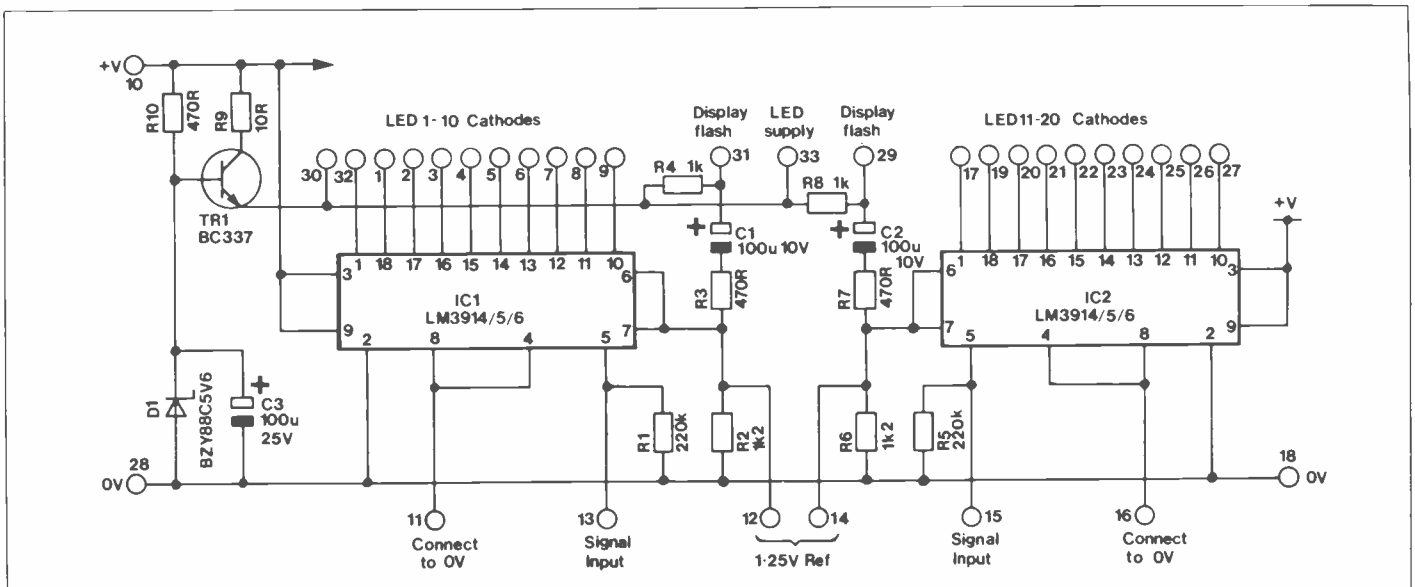

Figure 1. Circuit diagram

Many projects built by the Home Constructor require a LED display to give an indication or show a response to a set of circumstances. This article will describe a module which will drive up to 20 LED's and also show how to make those LED's flash on and off. Many different types of LED display can be used with this module and in addition to this, different driver chips can be used to give varying displays.

A dual display driver PCB for the LM3914-16 range of display driver IC's can be used for single DOT or sequential BAR mode control of the 20 LED's. Display brightness is adjustable and FLASH can be determined from any desired LED position. Three types of IC are available from MAPLIN's range which have identical operating characteristics but offer different response of input voltage to display output. Figure 5 is a graphic representation which shows the response curves of these IC's in BAR mode. Each of the LED's (1 to 10) are sequentially operated in turn as the input DC voltage is increased from approximately 50mV to 1.3V, and for the LM3914 a linear scale can be observed. For a logarithmic scale, the LM3915 is chosen, which increments each LED in 3dB steps and the LM3916 is suitable for VU displays.

Circuit Operation

IC1 (2) requires very little external components as all LED controlling elements are internal to the IC (see figure 7). Ten comparator output stages control each LED via an internal resistor ladder network, referenced to a 1.25V constant voltage source, and an increasing signal voltage applied to the high impedance voltage follower, switches each comparator in turn. Figure 1 shows the 5V regulator: R10, D1 and TR1, which feeds each anode of LED's 1 to 20. Either single LED's or common anode 10 LED displays can be used here, and R2 determines LED current or brightness. Reducing the value of R2 increases LED current (and vice-versa) and with the recommended value of 1k2, approximately 10mA flows through each LED. PCB pins 4 and 8

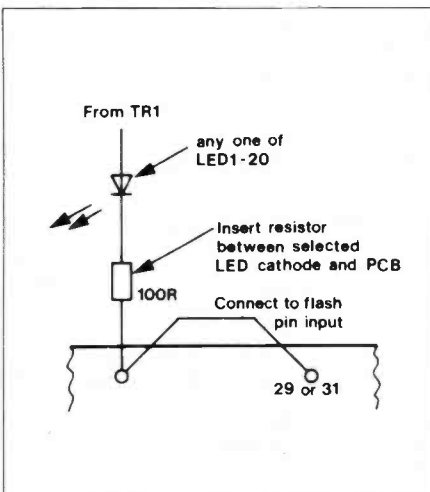

Figure 4. Connection for flashing mode

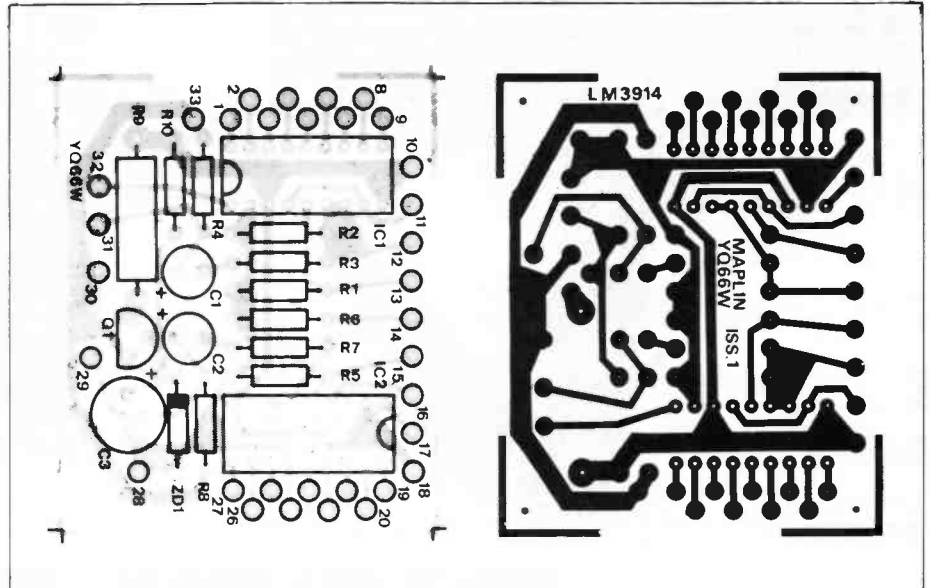

Figure 2. PCB track layout and overlay

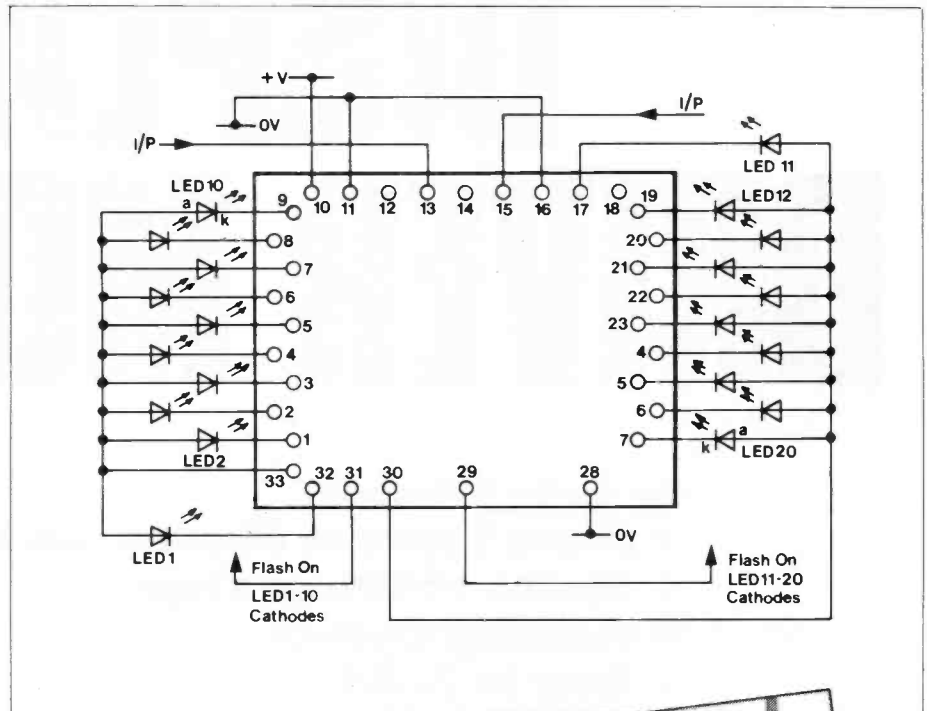
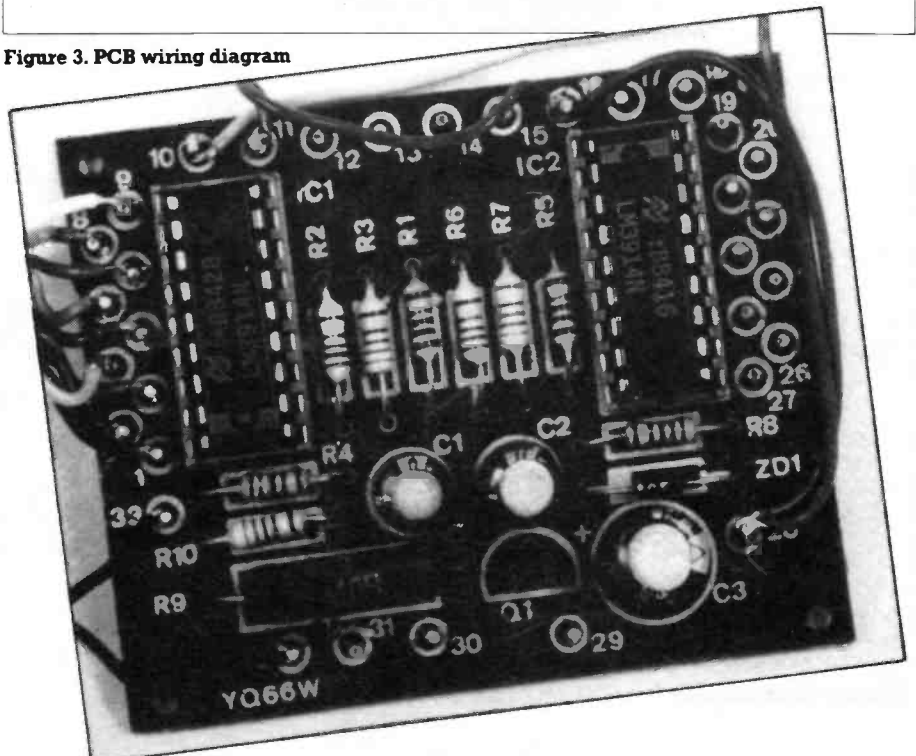

Figure 3. PCB wiring diagram



should be connected to 0V, although these inputs could be referenced positively above ground, thus changing the point with which input signals start to switch the LED's. LED 1 output will normally be active with input signals $\approx +0.1V$ when pin 11 is at 0V. Connecting pin 11 via a resistor to 0V raises the comparator threshold so that a higher input voltage will be required to drive the display. Figure 8 shows the appropriate connections to those pins and Table 1 indicates resistance values and the approximate minimum input voltage required to operate the first LED of the display.

Flashing

Flash input pin 31 (29) can be connected to any one (only) of LED's 1 to 10 (11 to 20) as shown in Figure 4. It is important to connect a 100 Ω resistor in series with the chosen LED otherwise insufficient discharge current for C1 (C2) is developed. For example, connecting LED 10 via a 100 Ω resistor to pin 9 on the PCB and connecting pin 9 to pin 31 flash input, will cause all ten LED's to flash twice a second and could signify display over voltage in a voltmeter project.

PCB Connections

Figure 3 shows external connections to the module. A power supply of 5 to 15V is required with 150mA current handling capability. Pins 1 to 9 and 33 are LED cathode connections to IC1 and pin 30 is the common anode +5V supply. Pin 31 is the flash input and can be wired to any one of the 10 pins previously mentioned. Pins 18 and 28 are common 0V connections and pin 10, the 5 to 15V supply. Pin 12 has a 1.25V reference output voltage available, pin 13 is the signal input terminal and pin 11 should be connected either directly to 0V or via a resistor (see Figure 8). Corresponding pins associated with IC2 perform the same functions as their counterparts on IC1 and operation of both sections is identical.

LED Displays

Figure 9 shows five of the most useful displays available from MAPLIN's Catalogue, along with terminal notations. The Parts List has stock codes of these components if required. These displays are suitable for use as voltmeter indicators, alarm flashers, sensor indicators, amplifier power level meters, graphic equaliser response, VU meters and the module could be used to replace panel meters in these applications.

Operation

So far, all input specifications refer to positive DC signals and not to AC signals. Sinewaves can be fed directly to the signal input for display, but problems may arise when calculating average or peak levels, or the amount of dampening required to ensure a readable display.

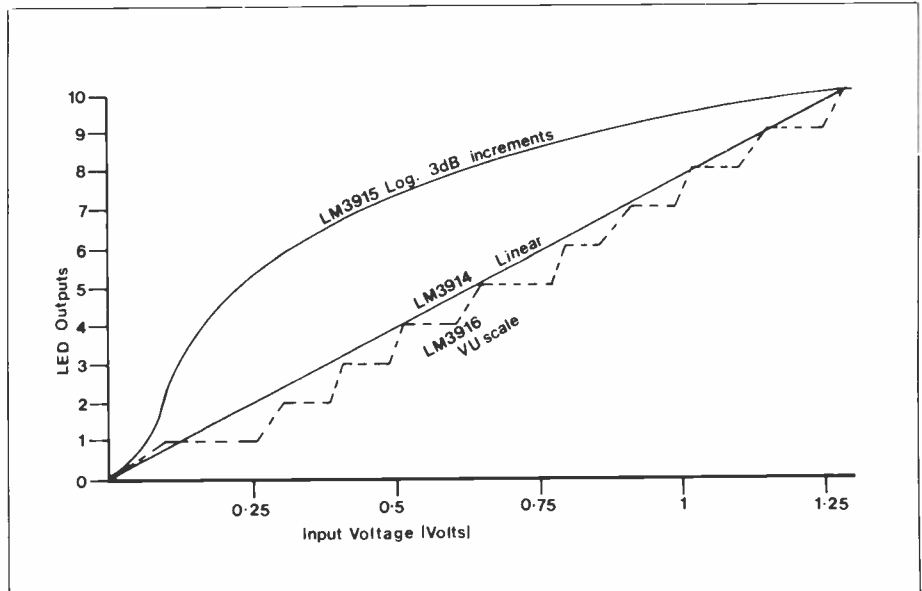

Figure 5. IC response curves

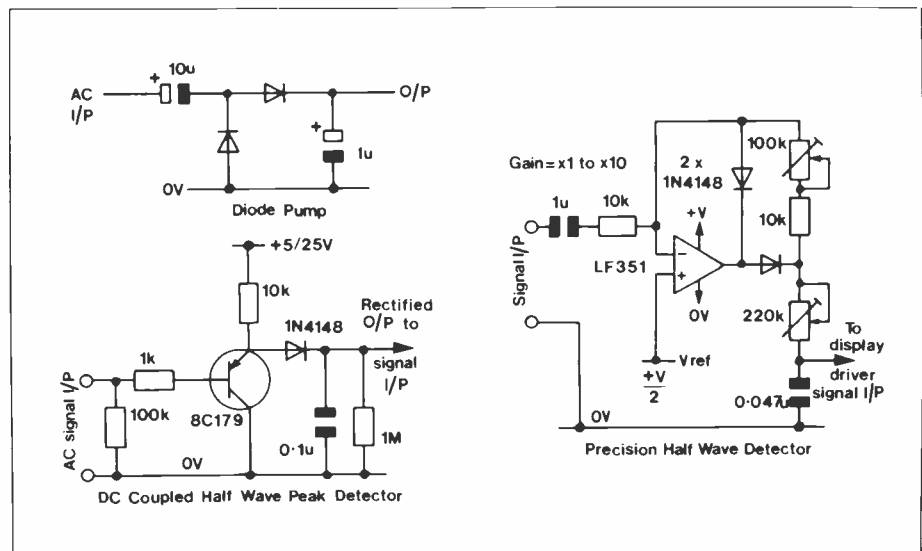

Figure 6. Input AC detector circuits

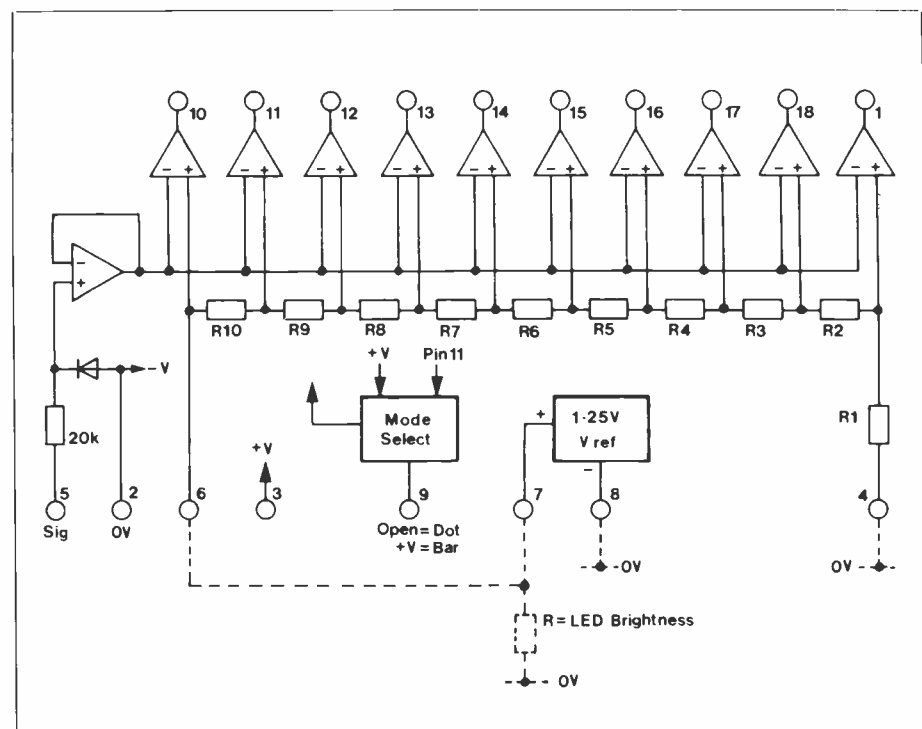
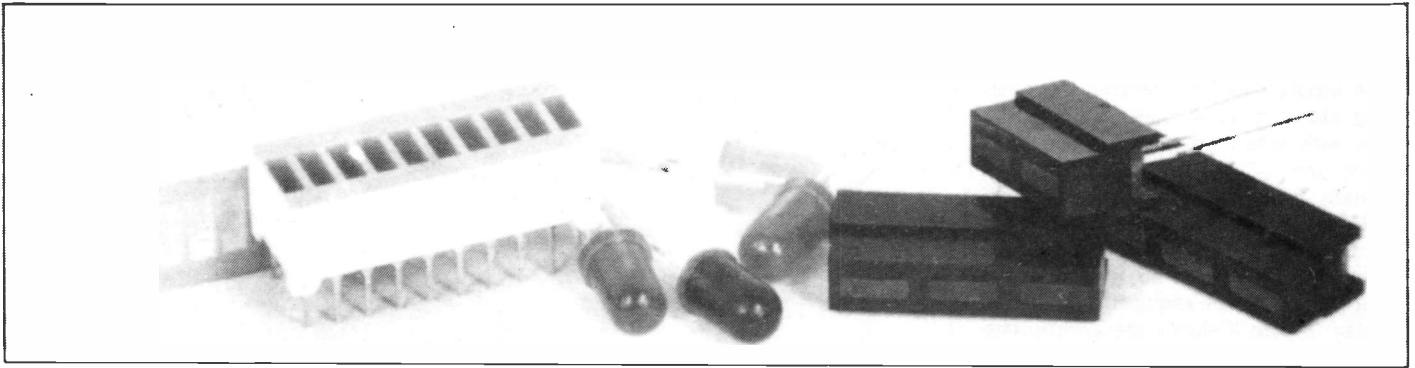

Figure 7. Internal circuit of LM3914/5/6



Some example circuits are given in Figure 6 which convert AC signals to DC voltages suitable for driving the module. The diode pump is the simplest to use, although its input impedance is low, and diode forward voltage drop must be considered. A capacitor at the output damps the display for a slow response reading and values are chosen accordingly.

Absolute maximum input signal voltages should be kept below 35V peak and wiring from LED's to module must be as short as possible to avoid HF noise radiation causing interference in audio equipment. DOT or single LED mode is simply produced by not inserting pin 9 on IC1 (2) into the PCB and is left floating.

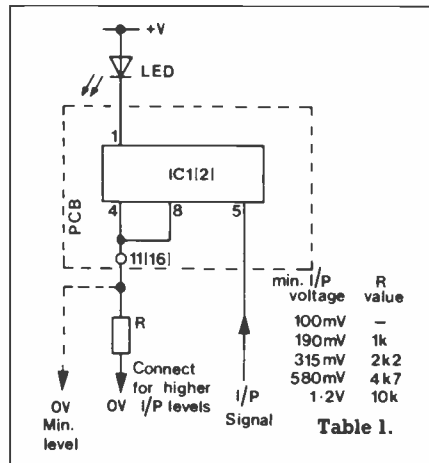

Figure 8. Input level reference

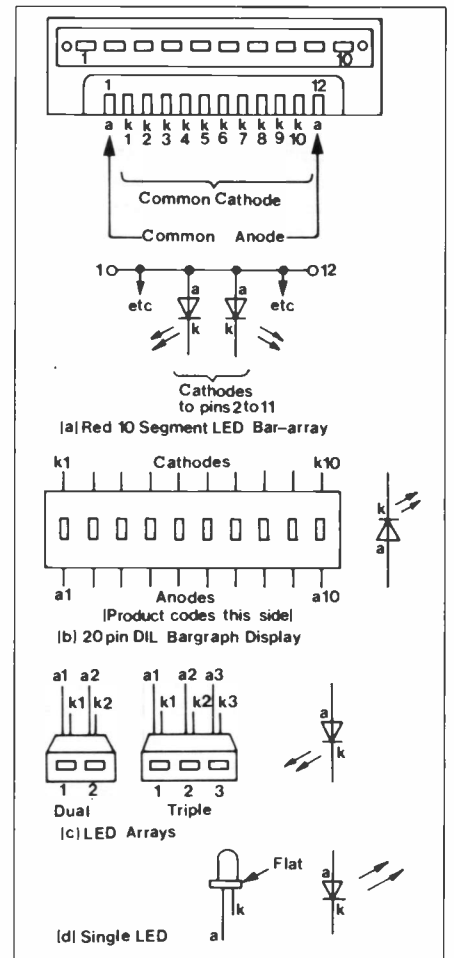
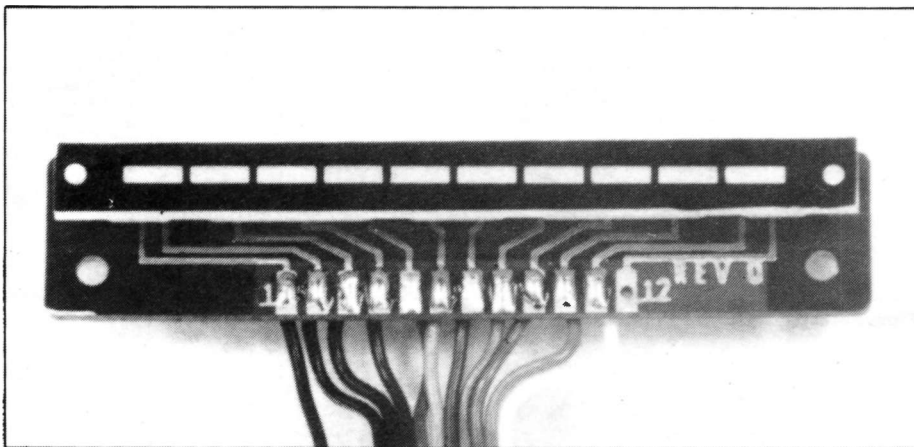

Figure 9. Pin connections of various displays

BARGRAPH DISPLAY DRIVER PARTS LIST

RESISTORS: All 0.6W 1% Metal Film (Unless Specified)

R1,5	220k	2	(M220K)
R2,6	1k2	2	(M1K2)
R3,7,10	470Ω	3	(M470R)
R4,8	1k	2	(M1K)
R9	10Ω 3W Wirewound	1	(W10R)

CAPACITORS

C1,2	PC Elect 100μF 10V	2	(FF10L)
C3	PC Elect 100μF 25V	1	(FF11M)

SEMICONDUCTORS

ZD1	BZY88C5V6/X55C5V6	1	(QH08J)
TR1	BC337	1	(QB68Y)
IC1,2	LM3914 or LM3915 or LM3916	2	(WQ41U)* (YY96E)* (YY97F)*

* Select device as appropriate, see text.

MISCELLANEOUS

PCB	1	(YQ66W)
Pin 2145	1 Pkt	(FL24B)
Instruction Leaflet	1	(XT48C)
Constructors' Guide	1	(XH79L)

OPTIONAL - Choose as required:

Red 10-Seg Bargraph	As Req.	(YH76H)
Red Bargraph Display	As Req.	(BY65V)
Green Bargraph Display	As Req.	(YG33L)
Dual LED Array Red	As Req.	(YH77J)
Tri LED Array Red	As Req.	(YH78K)
Dual LED Array Green	As Req.	(YH79L)
Tri LED Array Green	As Req.	(YH80B)
Dual LED Array Yellow	As Req.	(YH81C)
Tri LED Array Yellow	As Req.	(YH82D)
LED Red	As Req.	(WL27E)
LED Green	As Req.	(WL28F)
LED Orange	As Req.	(WL29G)
LED Yellow	As Req.	(WL30H)

Because of the many different applications possible for this project, none of the above parts are available as a kit. Select and make up a list to order the parts required.

/// Maplin /// Maplin

/// Maplin /// Maplin

