

# ELECTRONICS



<http://www.maplin.co.uk>

DECEMBER 1999 NO. 144 £2.65



## Solar Power

A bright future for  
Photo Voltaics

A brief history  
of number  
systems

## Inventions News

Using Bucky Tubes in  
field emission displays

## Technology Watch

What's new at the  
Hi-fi show

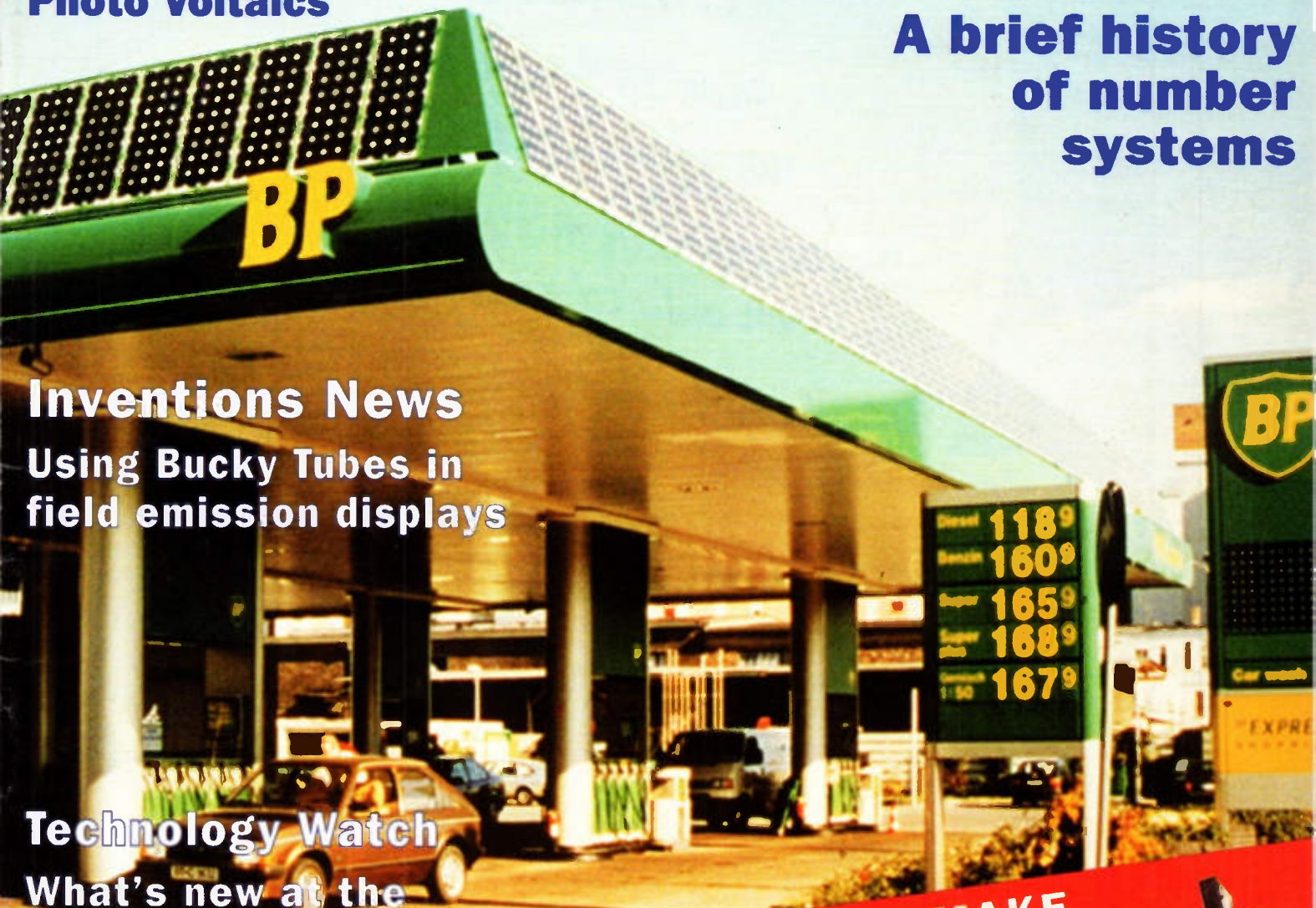

**PROJECTS FOR YOU TO MAKE**

- 10 Year Temperature Data Logger
- Guitar Effects Unit
- Easy Digital Recorder
- Mains Detector



**MAPLIN**  
ELECTRONICS

Britain's most widely circulated magazine for electronics!

By subscribing to  
*Electronics and Beyond*  
ye shall

Receive your first 2 issues free\*  
\* on a 12 month subscription

Save 10% on the  
normal cover price

Participate in monthly offers  
open only to subscribers!

Call the Subscription Hotline  
now on  
01702 554000



The Maplin Magazine



# THE MAPLIN MAGAZINE ELECTRONICS

December 1999

## and Beyond

Vol. 19 No. 144

### Projects

- 7** **Inventions News**  
Paul Freeman-Sear reports on some of the interesting developments from the Isle of Man.
- 16** **Single-Chip Sound Recorder**  
Dr. Pei An describes a simple, low-cost solid state sound recorder.
- 22** **Ten Year Temperature Logger with only Seven Components**  
Dr. Richard Whitaker describes a low power temperature logger design that could have many interesting applications.
- 45** **Guitar Amplifier With Effects**  
In part 2, Gavin Cheeseman gets down to construction.
- 68** **Mains Detector**  
John Mosely constructs this handy little kit from Velleman.

### Features

- 8** **A Brief History of Number Systems**  
Douglas Clarkson believes it has taken quite some time to credit ancient cultures with sophisticated numeric skills, here he discusses the proof.
- 14** **SET - The Secure Payments Protocol**  
With widespread concerns over Internet security, how are the financial associations addressing the problem of credit card usage? Michelle Grieg investigates.
- 18** **Solar Cells, The Present and The Future**  
Mark Hammonds of BP Solarex looks at how we are harnessing the sun's rays to produce electricity.
- 28** **Astrobiology**  
In part 2 - A Brief History Of Life - David Clark looks at some of the alternative theories about how and where life started in the universe.

- 32** **Edison 3 Reviewed**  
Gavin Cheesman samples a new piece of software from DesignSoft - and we are giving away a copy free!
- 41** **Car Audio Capers**  
Looking for better sound on the move? In part 2, Martin Pipe looks at the modification of existing equipment for external audio inputs and outputs.
- 53** **Easy Web Page Creation**  
In part 5 Mike Holmes expands on things to do with pictures - backgrounds, image maps and special fonts.
- 58** **Code Making & Code Breaking**  
In this last part, Mike Bedford takes a look at some of the sophisticated ciphers which are in use today, such as in the banking industry and corporations worldwide, and which will pave the way to the widespread adoption of e-commerce.
- 62** **The MPEG Standards**  
In the second part, Reg Miles looks at the latest MPEG standards - MPEG-4, MPEG-7 and the new MHEG standard.
- 71** **Uri Geller Extended Reality**  
Uri investigates our Seventh Sense.

### Regulars

- 2** News Report
- 33** @ Internet
- 50** Technology Watch
- 57** What's On & Diary Dates
- 67** Comment
- 70** Software Hints & Tips
- 72** In The Pipeline
- IBC** Subscribers' Offers



Cover pictures: ©Copyright 1999 Maplin Electronics PLC. All rights reserved. Main cover picture courtesy NASA STSCI.

Copyright 1999 Maplin Electronics PLC.

Copyright: All material is subject to worldwide copyright protection, and reproduction or imitation in whole or part is expressly forbidden. Permission to reproduce printed circuit board layouts commercially or marketing of kits must be sought from the publisher.

Advertisements: Whilst every reasonable precaution is undertaken to protect the interests of readers by ensuring, as far as possible, that advertisements appearing in the current issue of Electronics and Beyond are bona fide, the publisher and staff of the magazine cannot give any undertakings in respect of statements or claims made by advertisers, whether on printed page or on loose insert. Readers who have reasonable grounds to believe that they have been misled are advised to contact their local Trading Standards Office.

Editorial: The views of individual contributors/authors are not necessarily those of either the publisher or the editor. Where errors occur corrections will be published as soon as possible afterwards.

Publisher's Statement: Maplin Electronics PLC., take all reasonable care to prevent injury, loss or damage of any kind being caused by any matter published in Electronics and Beyond. Save in so far as prohibited by English law, liability of every kind including negligence is disclaimed as regards any person in respect thereof.

#### Editorial

**Editor** Paul Freeman-Sear BSc (Hons)  
**Technical Author** John Mosely  
**Editorial Assistant** Lynda Hardy  
**News Editor** Stephen Waddington BEng (Hons)  
**Technical Illustration** Set Square Designs

#### Production

**Design Layout Artists** Tracy Swann, Jason Hyatt  
**Published by** Maplin Electronics plc.,  
P.O. Box 777, Rayleigh, Essex, SS6 8LU.  
Tel: (01702) 554155.  
Fax: (01702) 554001.

#### Lithographic Reproduction by

**Planographic Studios,**  
18 Sirdar Road, Brook Road Ind. Estate,  
Rayleigh, Essex SS6 7UY.  
**Printed by** St Ives (Gillingham) Ltd.,  
Grant Close, Gillingham, Kent, ME8 0QB.

#### Management

**Manager**  
Paul Freeman-Sear BSc (Hons)  
**Marketing Services Manager**  
Steve Drake

#### Subscriptions

Maureen Harvey  
Tel: (01702) 554155 Ext. 311.

#### Advertising and Circulation

**Maplin Electronics plc.,**  
P.O. Box 777, Rayleigh, Essex,  
SS6 8LU. Tel: (01702) 554155.  
Fax: (01702) 554001.

#### UK Newstrade Distribution

Maplin Electronics PLC.

#### Export Distribution

**Comag Magazine Marketing**  
Tavistock Road, West Drayton,  
Middx, UB7 7QE



18



8

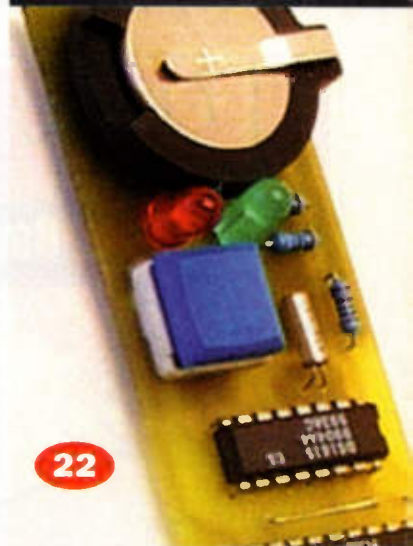

22



62

# ELECTRONICS

and Beyond

We have been particularly interested in environmentally friendly articles, and have included such articles over the past couple of years. This month we include an interesting article from Mark Hammonds of BP Solarex, which looks at the present and future development of solar panels. BP is currently in a programme of providing solar power to 200 of its petrol stations worldwide, including the U.K. Such stations will normally, during the day, produce more power than the station requires, so the excess will be exported back to the national grid.

Richard Whitaker describes the design and construction of a portable and miniature 10 year temperature logger that uses just seven components, which he primarily constructed to monitor his greenhouse temperature. But such a project has enormous possibilities, and next month we will include many suggestions, that can lead to the construction of several units.

Michelle Grieg continues her look at Internet security and the wide spread concerns over money transactions over the Web, and in particular, how the financial associations are addressing the problem of credit card usage? Michelle discusses one possibility, SET - the secure payments protocol.

The magazine cover features the title 'ELECTRONICS and Beyond' at the top. Below the title, it says 'Official Maple.co.uk' and 'DECEMBER 1999 No. 144 £2.95'. The main headline is 'Solar Power A bright future for Photo Voltaics'. Other headlines include 'A brief history of number systems', 'Inventions News Using Bucky Tubes in field emission displays', and 'Technology Watch What's now at the Hi-Fi Show'. At the bottom, there is a section titled 'PROJECTS FOR YOU TO MAKE' with sub-headings: '10 Year Temperature Data Logger', 'Culinar Effects Unit', 'Early Digital Recorder', and 'Metal Detector'. The cover image shows a BP petrol station at night with solar panels on the roof. At the bottom, it says 'Britain's most widely circulated magazine for electronics!'.

Britain's Best Magazine for the Electronics Enthusiast

# NEWS

## REPORT

### French Lab Makes Smallest Transistor In The World



Scientists at the French Atomic Energy Agency (CEA) in Grenoble have achieved a world first in electronics miniaturisation by developing the smallest transistor in the world, measuring just 20 nanometres, or 20-millionths of a millimetre, nine times smaller than the previously smallest transistors on the market. This new chip signals the approach of powerful products in the future. The size of these new micro transistors means that the equivalent of every book in the National Library of France can be stored on just one chip, according to researchers at CEA's micro-electronics department.

Apart from increasing storage capacity, miniaturisation of components also makes integrated circuits work faster. A transistor of 20 nanometres can make a microprocessor that works 40 times as fast as those on the market today.

These new benefits will make it possible in the future to integrate all the features of a PC into a mobile phone or to develop digital cameras capable of storing hundreds of photos and transmitting them cordlessly over thousands of kilometres.

According to micro-electronics experts it may be 15 years until these 20 nanometre transistors can be integrated into products to be used by industry but certain advantages might be realised sooner.

### Home of the Future by Philips Electronics

The home of the future is closer than you think. A new exhibition by Philips Electronics, called 'La Casa Prossima Futura: The Home of the Near Future', at Saks Fifth Avenue in New York City, features a series of home environment vignettes with over 50 futuristic electronic objects and concepts, like the Work Office shown here.



For further details, check: <[www.philips.com](http://www.philips.com)>. Contact: Philips, Tel: (0181) 689 2166.

## Handspring Introduces Expandable Handhelds

In bid to transform ordinary organisers into customisable handheld computers, the original team behind the 3Com Palm Pilot has launched a company called Handspring and introduced the Visor, the first product in a new family of expandable handheld computers.

Visor is claimed to be the first pocket-sized computing product that people can easily customise using an innovative Handspring technology called the Springboard expansion slot.

With the Springboard slot, people can simply plug in Springboard expansion modules that will range from MP3 audio players and digital cameras to pagers and wireless modems for Internet access.

The Visor family also introduces breakthrough pricing for the handheld market, with models starting around £100. Visor will be available in a variety of colours and can be ordered from the Handspring Web site.

For further details, check: [www.handspring.com](http://www.handspring.com).

Contact: Handspring, Tel: +1 650 230 5000.

BUSINESS WIRE Commercial Photo

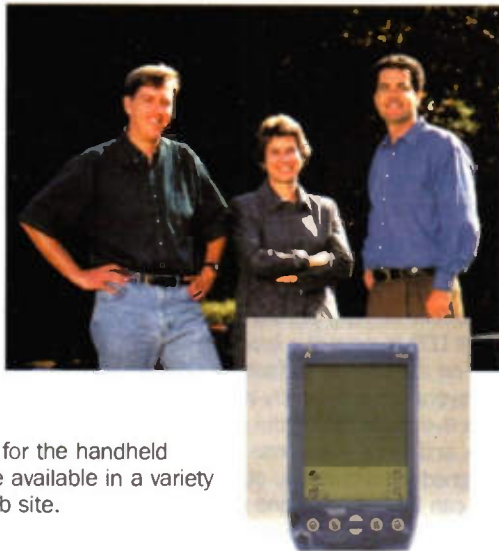

## Heavyweight Team Invests £1 Million To Bring Digital Loudspeaker To Market

1... Limited, the Cambridge company developing the world's first truly digital loudspeaker system, has secured over £1 million in funding from a group of heavyweight private investors which include Alan Wheatley, former senior partner of Price Waterhouse, London, and Barrie Morgans, ex IBM UK Managing Director.

The new investment values Cambridge-based 1... Limited at £6 million after the injection of the new money. 1... Limited will use the new money to accelerate the pace of the development of its digital loudspeaker to pre-production prototype, which it is planning to show early next year.

1... Limited will generate revenue through licensing and technology transfer. The company expects that serious manufacturers of loudspeakers and hi-fi systems will be using its unique and completely

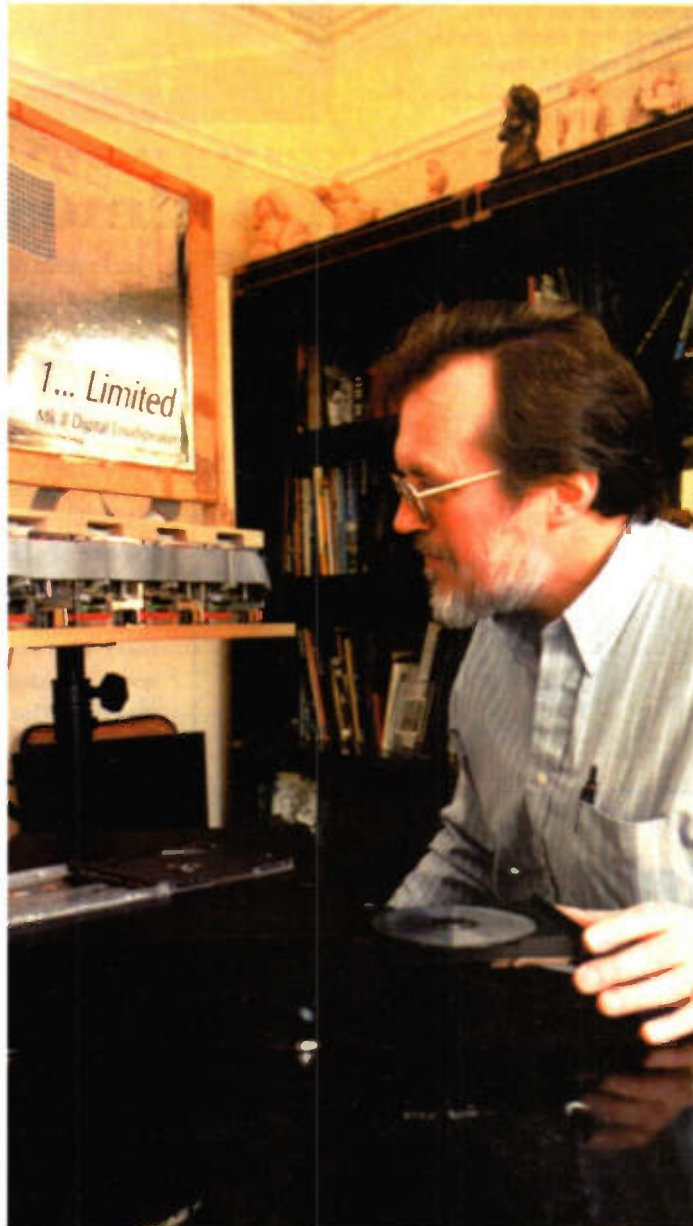

digital system of sound reproduction within five years, and will announce its first licensees by the end of the year.

For further details, check: [www.uno.to](http://www.uno.to).

Contact: 1... Limited, Tel: (01223) 422290.

## Tiny Scraps Free PC Deal

Computer manufacturer Tiny has scrapped its 'free' PC and Internet access bundle weeks after it was launched. The company blamed lack of consumer interest as the reason for scrapping the deal. Industry pundits meanwhile claim that the truth lies closer to the fact that customers refused to fall for a gimmicky underpowered, monitorless PC with virtually no software.

For further details, check: [www.tinyonline.net](http://www.tinyonline.net).

Contact: Tiny, Tel: (08701) 620620.

## NaturallySpeaking Allows Users to Take Control

The top-selling PC application for converting natural speech to text will be made even more accurate with the release of Dragon NaturallySpeaking Version 4.

The new version adds speech commands for the Internet, and includes several industry-leading enhancements, such as a dramatically increased active vocabulary size and significantly reduced training time.

Version 4 of NaturallySpeaking is due out in October and will be available in three options depending on functionality: Essential priced at £30; Standard priced at £50; and Preferred priced at £130.

For further details, check: [www.naturallyspeaking.com](http://www.naturallyspeaking.com).

Contact: Dragon Systems, Tel: (01628) 894150.

## Splash Out on a CD-Romp with Charlie

A dash of water can give a whole new dimension to your garden and with an increasing number of people seeking the beauty and serenity of their own pond, the booming UK aquatics industry is conservatively estimated to be worth £750 million a year.

Now, with the help of water garden superstar Charlie Dimmock, leading software publisher Europress has linked this huge business potential to the prolific world of home computing with a new CD-ROM.

Following on from Europress' successful Alan Titchmarsh Garden Designer program, the PC CD-ROM, priced £19.99, includes footage of Charlie introducing the many different styles of 'eau-zone' that users can create in their own gardens.

For further details, check: [www.europress.co.uk](http://www.europress.co.uk).

Contact: Europress, Tel: (01625) 855000.

## Force of Gravity is the Same for Atoms and Baseballs

Stanford physicists have put a modern twist on Galileo's classic 16th century experiment of dropping objects from the Leaning Tower of Pisa.

Instead of dropping balls of wood and iron to prove that gravity acts equally on objects made of different materials, as Galileo did, the Stanford researchers directly compared the force of gravity acting on individual atoms to the force it exerts on an object like a baseball that contains billions of atoms. Their conclusion is that the force of gravity is virtually identical at the atomic and the everyday, macroscopic levels.

To make this comparison, the researchers used a new technique, called atom interferometry, to make the most precise measurement ever made of the acceleration of gravity on individual atoms. They estimate that their measurement is accurate to three parts per billion.

By directly comparing this result with a measurement of the acceleration of gravity made with a state-of-the-art gravimeter, they were able to show that the gravitational force acting on atoms, which are subject to the laws of quantum mechanics, is the same as that acting on familiar objects governed by the classical laws of physics with an uncertainty of only seven parts per billion.

Although the finding does not come as a big surprise to scientists, it differs significantly from results of a series of experiments conducted by scientists at the University of Missouri-Columbia and elsewhere who attempted to measure the force of gravity acting on subatomic particles called neutrons.

Using a technique called neutron interferometry, they found a difference of a few percent between the gravitational force acting on neutrons and that acting on larger objects.

For further details, check:

<[www.stanford.edu](http://www.stanford.edu)>.  
Contact: Stanford University, Tel: +1 650 723 2300.

## Playstation Falls to £50 as Mark Two is Unveiled

Responding to the launch of Sega's Dreamcast, Sony has unveiled its next generation computer entertainment system to be called PlayStation2 but it won't be in the shops for at least six months. Supporting both the audio CD and DVD-Video formats, PlayStation2 is set to be launched in March 2000 and will offer consumers a wide range of music and video entertainment options.

Meanwhile Sony has slashed the price of its PlayStation to such an extent that some high street shops are selling the games machine for as low as £50.

For further details, check:

<[www.sony.co.uk](http://www.sony.co.uk)>.  
Contact: Sony, Tel: (0990) 111999.

## Stage Wimbledon at Home with Laser Tennis

Tennis can be a tough sport. Well, Tiger Electronics is going to put the fun back into tennis for all you armchair tennis players. Believe it or not, tennis and toy fans can now play table tennis without a ball and it's got all the speed and excitement of real tennis.

Tiger Electronics has launched a Laser Tennis table tennis game that actually uses a super bright LED to project a ball of light on the playing surface.

Players use a specially-made reflective racket to hit the ball back and forth. The game is designed for one or two players and can be played in one or three set matches against the computer or an opponent. There are four levels of play where the speed of the ball increases at each level.

For further details, check:

<[www.tigertoys.com](http://www.tigertoys.com)>.  
Contact: Tiger Electronics, Tel: +1 650 230 5000.



## Fuji Camera is Almost Analogue



The Fujifilm MX-1700 ZOOM features an improved, high-resolution 1.5-million pixel CCD with red, green and blue colour filters along with a newly crafted all-glass, miniature aspherical zoom lens. The results of these new features are near analogue image quality and superb colour reproduction, both hallmarks of Fujifilm digital cameras.

Fujifilm's newest megapixel model is roughly the size of a deck of playing cards, easily fitting in shirt pockets or pocket books. It records high-resolution images at 1280 x 1024, or at 640 x 480 resolutions, and the 3x aspherical zoom lens delivers 35mm equivalent of 35-114mm coverage. The MX-1700 will sell for about £400.

For further details, check: <[www.fujifilm.co.uk](http://www.fujifilm.co.uk)>.  
Contact: Fujifilm, Tel: (0171) 586 5900.

## Level One Communications Unveils Internet Exchange Architecture

Level One Communications, a subsidiary of Intel has unveiled a family of silicon components based on the new Intel Internet Exchange (IX) Architecture. The IX Architecture is a new approach to designing networking and telecommunications equipment based on reprogrammable silicon and open interfaces.

Manufacturers of networking and communications equipment can use components from the IX Architecture-based product portfolio for designing new, more intelligent network systems.

Level One's IXP1200 is a highly integrated network processor that includes a powerful StrongARM processor core along with six programmable RISC micro engines. Each IXP1200 can switch 2.5 million packets per second, and a scalable design allows multiple IXP1200 processors to be linked together to deliver terabit-class performance.

For further details, check: <[www.intel.com](http://www.intel.com)>.

Contact: Intel, Tel: (01793) 403000.

## Kensington Introduces MouseWorks and TurboBall

Kensington Technology Group has introduced MouseWorks mouse and TurboBall trackball, both for PCs and USB Macs. Kensington developed these specially-shaped symmetrical input devices to help keep users' hands and wrists in a

more neutral position, helping to reduce the risk of injury.

Powerful software gives the user maximum control to program four buttons and streamline repetitive tasks. Click once to open, to cut and paste, or to close - users can set the

choices for each button according to their preference.

For further details, check: [www.kensington.com](http://www.kensington.com), and Kensington Technology, Tel: (01296) 397 444.

## Eskape Labs' MyTV Supports PAL and SECAM

Eskape Labs, a Silicon Valley start-up dedicated to the development of USB and FireWire display appliances, has said that its MyTV USB TV tuner for the Macintosh will support PAL and SECAM video formats.

MyTV is the only TV tuner solution for the PC and iMac, that enables consumers to turn their computers into virtual television replacements.

The first product of its kind, MyTV will be available in Europe in October 1999 for a MSSP of approximately £100.

For further details, check: [www.eskape.com](http://www.eskape.com).

Contact: Eskape Labs, Tel: + 1 408 232 0123.

## NEC Develops Personal Robot

NEC has developed a prototype mobile personal robot designed to be a partner for people in their homes with its ability to recognize people, understand voice commands and talk with users.

The R100, as the robot is code-named, provides a much more natural, buttonless interface for people to a variety of electronic appliances while supporting communication between people, and is seen by NEC as the future of computing in the home.

The prototype robot has two cameras for eyes that provide a stream of visual data, analysed in real-time, enabling it to recognise people and avoid bumping into objects such as furniture. Its 'ears' consist of three microphones from which the robot can detect voices and understand orders given to it from a select vocabulary.

Movement is based on mechatronics specially developed for the robot, and consists of a simplified control structure based on four motors for locomotion. With Internet communications capability incorporated into the unit, the R100 enables users to send video e-mail messages by just talking naturally to the robot, as well as a whole range of other functions.

With these technical abilities, the R100 can recognise people approaching it and talk to them, while it will respond if called, turning its head and body to face the direction the voice came from. Just by talking to the robot, a range of commands can be given to it to operate appliances such as air-conditioners, televisions, and lighting.

The same features can also be used to send messages to other people, either by leaving a message with the robot for it to playback on a television for the intended person, or via the Internet as video e-mail.

For further details, check: [www.nec.co.uk](http://www.nec.co.uk).

Contact: NEC, Tel: (0181) 993 8111.

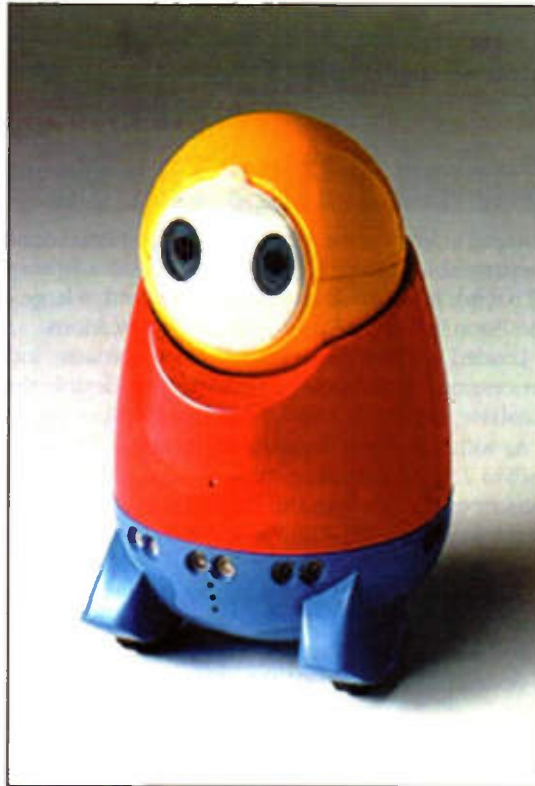

## Zoom Adds USB to V.90 Range

Zoom Telephonics, has begun shipping USB versions of its 56K V.90 external modem. The Zoom/FaxModem 56K USB is available in models for both Windows and Macintosh iMAC and Power Mac computers with a USB port and has an estimated retail price of £69.99.

Use of the USB port allows simplified installation and faster performance. The modem plugs quickly into a computer's external USB jack, whilst configuration is both automatic and reliable, without the potential conflicts of an RS-232 serial port or an internal modem.

For further details, check:

[www.zoom.com](http://www.zoom.com).

Contact: Zoom, Tel: (0870) 7600060.

## Sony Extends Mobile PC Line

Sony has expanded its family of VAIO computers with the introduction of three all-in-one F300 Series notebooks.

Designed as the ideal mobile solution for small to mid-sized businesses, education and SOHO markets, all three notebook models - the PCG-F360, PCG-F350, PCG-F340 - integrate such features as the inclusion of Microsoft Word 97 and Works Suite.

Sony multimedia software including digital video and photo editing capabilities for organising, managing and creating virtual photo albums and creating Web designs, presentations and video email all within a portable PC.

For further details, check:

[www.sony.co.uk](http://www.sony.co.uk).

Contact: Sony, Tel: (0990) 111999.

## Diamond and ESS to Jointly Deliver Advanced PC Audio

Diamond Multimedia Systems and ESS Technology are set to offer next-generation PC audio solutions, featuring sound innovations based on the ESS chip platform.

Diamond's next generation audio accelerators are expected to deliver the latest advancements in 3D sound technology for PC users who enjoy playing the hottest new 3D games and experiencing digital audio entertainment.

For further detail, check:

[www.diamondmm.com](http://www.diamondmm.com).

Contact: Diamond Multimedia, Tel: (01189) 444444.

## InetSupport Manager 5.0 Announced

NetSupport has announced NetSupport Manager version 5.0, PC remote control with several new integrated features including Voice over IP (VoIP), remote PC inventory, and support for Windows 2000.

NetSupport Manager allows administrators, help desk representatives, tech support, and telecommuters to remotely control a PC or group of PCs, thereby enabling real-time visual instruction, file retrieval, or remote operation and management.

The new PC Interrogation feature, which allows the control PC to perform a quick hardware and software inventory of the remote PC, is an especially useful tool in the help desk and tech-support markets.

For further details, check: <[www.netsupport.com](http://www.netsupport.com)>.

Contact: Netsupport, Tel: +1 602 350 9600.

## All for One According to Audio Chip Market Report

Forward Concepts, best known for its leadership in market research related to digital signal processing (DSP), observes that there is a clear convergence of personal computer, computer and professional audio markets that has significant effect on the semiconductor industry.

Historically, these were three separate and distinct markets. Chip companies targeting the PC space were not usually found in the consumer space and visa versa. The needs for the professional audio market were so different from either that there were separate organisations within the semiconductor manufacturers - each trying to address the specific needs of their market segment.

Today, there is a clear convergence of these three markets and the technologies that address them. With new audio product offerings like MP3, AAC, DVD Audio, Super Audio CD, and Dolby AC-3, chip houses are touting professional quality audio for home and PC sockets.

To gauge the extent of this convergence, Forward Concepts researched the market and has published 'The Convergence of Audio: A Chip Market Analysis.' The report covers audio data converters, stereo codecs and specialty audio chips as well as programmable DSPs for audio.

For further details, check: <[www.forwardconcepts.com](http://www.forwardconcepts.com)>.

Contact: Forward Concepts, Tel: +1 480 968 3759.

## Sega Dreamcast Games Platform Breaks Records

Sega's new 128-bit, Internet-ready Sega Dreamcast videogame console has started to fly off the shelves of US retail outlets following its launch at the beginning of September despite software bugs.

Sega sold a total of 372,000 Sega Dreamcast systems in just four days, easily surpassing the previous industry record holder, Nintendo 64, which took six days to hit 350,000 when it launched in 1996.

The new Sega platform is expected to hit the UK in time for Christmas and features an advanced 128-bit architecture that is designed to evolve and grow with advances in technology and the changing needs of the consumer market.

The Sega Dreamcast is built atop a 200MHz Hitachi SH-4 CPU and the NEC PowerVR 2DC 3D graphics chip, the most powerful 3D technology ever developed for a console system. The Hitachi SH-4 gives the Sega Dreamcast 15 times the power of a Sony PlayStation, 10 times the power of a Nintendo 64 and four times the graphics processing power of the fastest Pentium II processor.

For further details, check: <[www.sega.com](http://www.sega.com)>.  
Contact: Sega, Tel: (0181) 995 3399.



## Series 7 Flies The Psion Colours

Encased in leather, the sub-notebook sized Psion Series 7 is lightweight, offers a full day's use from its rechargeable battery (2-3 times more than a laptop computer) and delivers the best specifications all round: it has a full touch-type keyboard, a large memory, boasts the fastest processor of any of the Psion family and improved communications.

Loaded with the latest built-in Psion software, including full Internet connectivity, email, word-processing, spreadsheet, a powerful and flexible time manager and comprehensive contacts database, the Psion Series 7 has the core functionality of the award-winning Series 5mx.

As with the Series 5mx, the Psion Series 7 benefits from comprehensive PC-connectivity using PsiWin 2.3 and a docking cable as supplied. This offers email and agenda synchronisation and integrates PC files with the Psion Series 7 and allows the Psion Series 7 to be used as an extension of their desktop PC. The Psion Series 7 is compatible with all leading brands of software, including Lotus and Microsoft.

The Psion Series 7 will begin shipping in volume at the end of September. The suggested retail price is £700.

For further details, check: <[www.psi on.com](http://www.psi on.com)>.

Contact: Psion, Tel: (01235) 831010.

## Technophobes to Lose 'L' Plates

Global Communications Group, has launched the Global Computer Starter Kit, a combination CD-ROM and workbook package that will prepare company employees and private individuals for the European Computer Driving Licence (ECDL), the new Europe-wide qualification which will enable people to demonstrate their competence in computer skills.

Contact: Global Communications Group,  
Tel: (01483) 456 000.

## Dan Adds Colours to Home PCs

Dan Technology is the latest manufacturer to revamp its range of PCs to add a more colourful approach.

The new Dan Xplora Plus and Home Plus ranges sport the company's new Studio midi tower case, which is available in a choice of three cool, translucent colours: Aubergine, Aquamarine and Grenadine.

The Studio midi towers offer a total of six drive bays - one 3.5in. and two 5.25in. front loading, and three 3.5in. internal - so they offer plenty of room for expansion as well as stunning good looks.

For further details, check: <[www.dan.co.uk](http://www.dan.co.uk)>.  
Contact: Dan, Tel: (0181) 830 1100.



## World Beating Wonder Transformer

A revolutionary new wonder transformer the size of a strip of chewing gum which can outperform the best in the world in terms of size to power ratio is to be launched in the UK.

So advanced is the material used that it creates three times more power while being half the size of its closest rival used by NASA in the United States.



### Comparison of Performance for Piezo Power Supply

Parameter	American High Voltage	Eurospark* (available)	Eurospark* (new)
Dimensions (mm)	5 x 65 x 65	10 x 65 x 35 **	10 x 65 x 35 **
Input Voltage	3.3 - 6	3.3-27 (AC220,50Hz)	3.3-26 (AC220,50Hz)
Voltage Output, max	7500V	20,000V	20,000V
Current Output	1.3mA DC	1 - 10mA	1 - 15mA
Power Output, max	10W	20W	30W
Efficiency	74%	85%	90%

\* At the moment the piezo power supply is manufactured in Moscow

\*\* The thickness of 5mm can be easily achieved (5 x 65 x 35) by using conventional technology of sealing of high voltage piezo elements under high pressure (which is currently not used to make the price lower).

Researched in Russia and developed by Isle L.V Ignition Limited in the Isle of Man, the piezoceramic transformer which incorporates nano technology is likely to transform its sector of the electrical components market.

The secret of the new transformer lies in the way nano technology has been introduced into the piezoceramic material and used to generate high voltage and high frequency signals. Effectively this has created a new material 10 times more effective than that found in other piezotransformers. The transformer is smaller, lighter and more cost effective because the manufacturing process itself is simpler than for a conventional transformer.

The output has half the ripple compared to the US rival and the energy losses are halved when compared to other piezoceramic transformers.

The breakthrough in the size to performance ratio means it will have significant impact on a variety of markets. These would be in the plasma screen and display market such as giant televisions through to videos and computers. They would have a use in medical and scientific instruments, strip lights, starter motors, Xenon discharge lamps and oscilloscopes.

Once in full production, the cost of the

# INVENTIONS NEWS

new transformers is likely to be competitive with those currently available.

The Isle L.V Ignition range of technologies is currently being evaluated by some of the UK's largest companies, although there is no intention at this stage to grant exclusive licences.

Licence applications are available from Isle L.V Ignition, a subsidiary of CFB of Castletown, Isle of Man.

## Bucky Tubes Line Up

A technological breakthrough has been achieved. This has been the dream of electronic engineers world wide to bring "Bucky Tubes" into line and spacing them

out for the first time. The technology offers major savings for manufacturers of televisions, computers and mobile phones.

This pioneering development will have major implications for Thin Film Technology as it provides a missing piece to the jigsaw in the hunt for a major leap forward in the area of thin film cold cathodes. These require 50% less voltage than other cold cathodes available and are up to several thousand times higher in emission site density.

The Bucky Tube huster technology will be seen as a major boon by manufacturers of a range of electronic equipment using flat panel alphanumeric displays or backlighting.

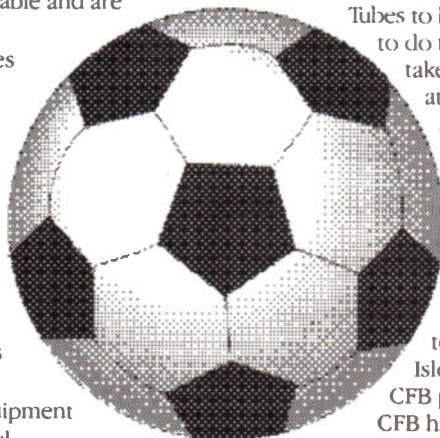

**The third allotrope of Carbon has a structure like that of the pattern on a soccer ball**

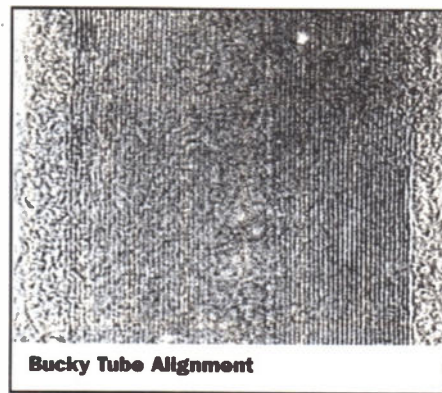

**Bucky Tube Alignment**

The new display would provide:

- Higher Brilliance High efficiency
- Evenly illuminated display
- Wide viewing angle
- Large operating temperature range
- Major cost savings

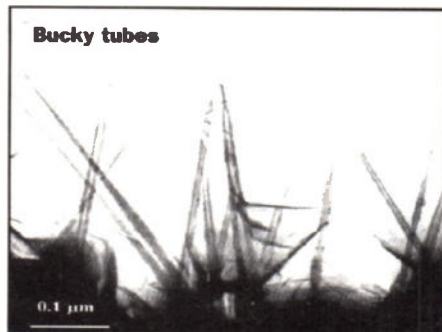

**Bucky tubes**

Ever since the discovery of the Buckminster Fullerene or Bucky-ball a collection of carbon atoms in the shape of a football, scientists have thought about stretching these into tube like structures as they could have significant potential use for electronic displays.

It was believed that they could be a replacement for silicon microtips, currently used in flat screen technology. However these are very expensive when used in large screens.

Researchers had been looking at carbon but no one had been able to produce a high enough quality. What was required was to get those Bucky Tubes lined up and spaced out to emit electrons.

Based on Russian research and developed by Islebright Limited in the Isle of Man, a revolutionary method of getting Bucky Tubes to line up has been achieved. In order to do this, the company has successfully taken graphite and added one single atomic layer of diamond to the top surface.

A unique method for the synthesis of graphite material with a predefined structure and composition is involved using vacuum deposition techniques.

Licence applications for the technology are available from Islebright Limited, a subsidiary of CFB plc of Castletown, Isle of Man.

CFB has been successful in acquiring the rights to the technology - along with

those for a number of other revolutionary Russian technologies, transferring them to the West.

# A Brief History of NUMBERED SYSTEMS

*Douglas Clarkson believes it has taken quite some time to credit ancient cultures with sophisticated numeric skills, here he discusses the proof.*

**M**ore and more of our technical landscape mirrors the embrace of a digital culture, reflecting the increasing use of numbers to store and convey knowledge and information. This also seems to be stirring an increase in the science of numbers, especially where in systems these appear to have elusive or curious properties.

## Early Beginnings

From whatever period of recorded history a basis of numeric representation of that era can be identified. We in the West are familiar with Babylonian, Ancient Egyptian, Greek and Roman number systems though somewhat less familiar with the cultures of South America and even less familiar generally with Chinese/Japanese systems. The records of many cultures, however, have vanished without trace. The culture that built the ancient megaliths of Britain - Stonehenge, Avebury and Callanish have left only the stones themselves as witness of their numeracy.

From the widespread use of counting in units of ten and the similarity in structures used in Indo-European languages, it is conjectured that the basic Indo-European mother tongue had the same method of counting.

Counting can also be undertaken in pairs of two as in one, two, two one, two two, two two one, two two two etc. This can usually be used for numbers up to ten. Some cultures in South America have used 4-12 to feature in counting systems while the Aztecs used a 5-20 count. These systems are indicated in Table 1. There is a trace of 20 count in some languages of Western Europe such as English, French and Danish.

Value	Representation 4/12 count	Representation 5/20 count
1	1	1
2	2	2
3	3	3
4	4	4
5	4 + 1	5
6	4 + 2	5 + 1
7	4 + 3	5 + 2
8	4 x 2	5 + 3
9	4 x 2 + 1	5 + 4
10	4 x 2 + 2	10
11	4 x 2 + 3	10 + 1
12	12	10 + 2
13	12 + 1	10 + 3
14	12 + 2	10 + 4

**Table 1: Representation of 4/12 count and 5/20 count**

Since many cultures have disappeared without trace, the greater part of the historical development of number systems and number understanding has been lost. Often the key to appreciating the number systems of ancient cultures has been through the discovery and decipherment of a single artefact - such as the Rhind papyrus of Ancient Egypt.

## The Numbers of Babylon

Some of the oldest records of numbers are in the first half of the third millennium BC among the Sumerians whose culture was supplanted by the Babylonians. From this

**Figure 1a: Examples of representation of Babylonian numbers as used in Plimpton 322 tablet: Symbols are used to establish digit values between 1 and 59.**

**Figure 1b: Representation of numbers in Babylonian cuneiform script using dialect of Plimpton 322 tablet - 52:14:41:09 = 11,284,869; 03:27:31:55 = 747,115; 49:06:00:30 = 10,805,630**

culture, around the time of Hammurabi in 1750 BC, surviving records provide an insight into numeric skill and competencies.

The method of writing numbers in this period is described as cuneiform (Latin cuneus - wedge) and utilises the base number 60. What looks like an exclamation mark represents 1 and a sharp left arrow 10. Some examples of numbers are indicated in Figure 1a. The significant feature of this number system was the use of place notation. We very much take notation for granted in our Arabic number system. Figure 1b gives examples of this use of place notation. In some records, there is some ambiguity as to whether such numbers record integers or fractions as recorded in the Plimpton tablet 322 and which subsequently will be described in some considerable detail.

## Babylonian Multiplication and Division

In Babylonian mathematics, multiplication was undertaken by means of the expression:-

$$ab = ((a + b)^2 - a^2 - b^2) / 2$$

Thus as an example  $35 \times 22$  is given by :-  $(57 \times 57 - 35 \times 35 - 22 \times 22) / 2 = 770$

One clay tablet found at Senkerah on the Euphrates in 1854 is thought to date from 2000 BC and held details of squares of numbers up to 59 and cubes of numbers up to 32.

The Babylonians undertook long division of integers by recognising that  $7/5$  could be expressed as the product of 7 times  $(1/5)$ . The Babylonians established tables of reciprocals as indicated in Table 2.

Denominator	Base 60 fraction component		
	1/60	1/3600	1/216000
2	30	0	0
3	20	0	0
4	15	0	0
5	12	0	0
6	10	0	0
8	7	30	0
9	6	40	0
10	6	0	0
12	5	0	0
15	4	0	0
16	3	45	0
18	3	20	0
20	3	0	0

**Table 2: Representation of reciprocals which have terminating base 60 fractions.**

Thus the fraction 1/12 can be expressed as 5/60 in base 60 representation. As with multiplication and division in decimal, an indication needs to be maintained of place significance of columns being manipulated. Numbers such as 7,9,11,13,14,17,19 etc. do not produce terminating base fractions but would be written as approximations. By comparison with denominators between 2 and 20, there are only seven terminating base ten fractions.

## Babylonian Square Roots

There is clear evidence that the Babylonians had a method of calculating square roots. This prompts a puzzle as to whether this method represented a trial and error approach that was found to work or reflects a deeper insight into number theory.

In an example, we start with an integer A and with N the largest integer such that its square is less than A. In the example of A=7, we can select N=2. A sequence of integers s(j) of increasing value is determined where

$$s(j) = 2 N s(j-1) + (A-N^2) s(j-2)$$

In this example this becomes

$$s(j) = 4 s(j-1) + 3 s(j-2)$$

Where s(0) is set to 0 and s(1) to 1, the sequence becomes

0,1,4,19,88,409,8827,41008 etc.

The actual expression giving the approximation of the square root is:-

$$\text{sqrt}(A) = N + (A-N^2)(s(j)/s(j+1))$$

where j has a value which gives a reasonable approximation to the square root value.

Table 3 indicates the results obtained in determining the square root of 7.

Derived expression	
r	r <sup>2</sup>
2 + 3 (1/4)	7.5625
2 + 3(4/19)	6.9252
2 + 3(19/88)	7.0104....
2 + 3(88/409)	6.99854...
2 + 3(409/1900)	7.000201..
2 + 3(1900/8827)	6.9999719..

**Table 3: Results of solution of derivation of Babylonian square roots for value 7.**

Jumping ahead many centuries, Archimedes (287-212 BC) is reported to have stated that the square root of 3 is given by the relationship:-

$$(265/153) < \text{sqrt}(3) < (1351/780)$$

This is from use of the ratio terms (896/2448) and (18272/49920) in the expansion of terms in the series. Thus either Aristotle had used the Babylonian square root generator system or had invented a comparable system. Leastways it gives the students of the history of mathematics something to debate - especially if you are a Greek mathematician seeking to

demean the achievements of the Babylonians.

Various of the Babylonian tablets read like school geometry books. One tablet number 7289 in the Yale Babylonian collection demonstrates a value of sqrt(2) as 1 24' 51" 10" which is accurate to 6 parts in 10<sup>7</sup>. It comes complete with diagram. The short QuickBasic programme EXAMPLE1 indicates the nature of the terms developed in the process of square root calculation for values of N less than 34.

```

10 REM Babylonian square roots (N<34)
15 DIM s(20) AS DOUBLE
20 PRINT "input value of number for square root:A"
30 INPUT a: IF a = 0 THEN STOP
40 PRINT "input value of N ( N*N<A)"
50 INPUT N
55 IF N * N > a THEN GOTO 20
60 s(0) = 0: s(1) = 1
70 FOR jj = 2 TO 8
80 s(jj) = 2 * N * s(jj - 1) + (a - N * N) * s(jj - 2)
90 NEXT jj
100 PRINT " s(jj) s(jj+1) r r*r"
110 FOR jj = 1 TO 7
115 r# = N + (a - N * N) * (s(jj) / s(jj + 1))
120 PRINT USING "#####"; s(jj); s(jj + 1);
130 PRINT USING "####.#####"; r#;
140 PRINT USING "####.#####"; r# * r#
150 NEXT jj
160 PRINT : PRINT
170 GOTO 20

```

In line 115, r# signifies double precision real number representation.

## Plimpton 322

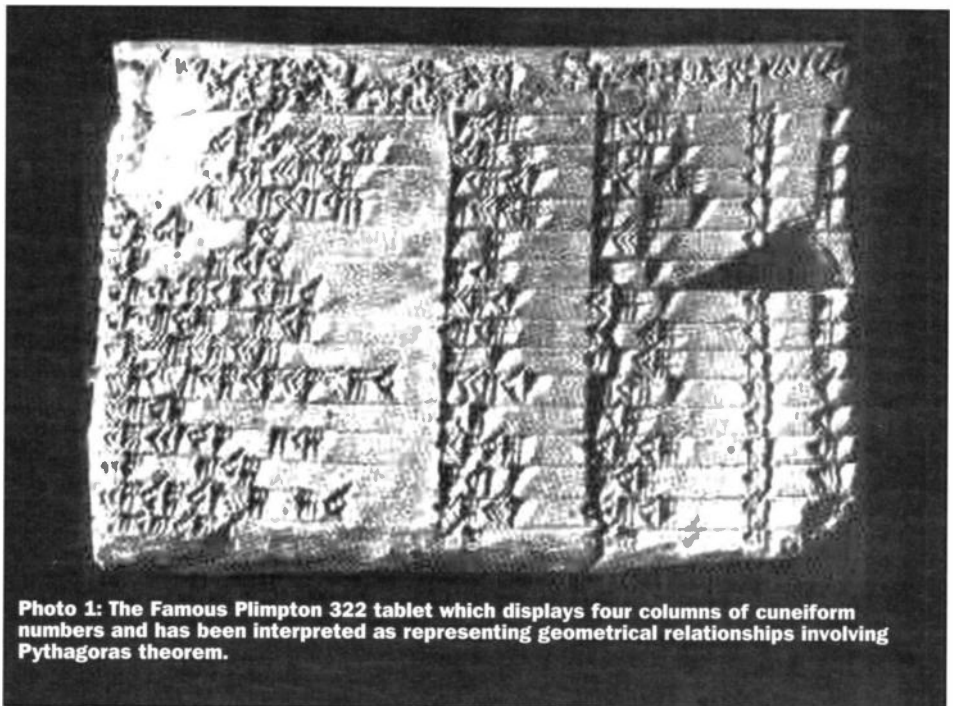

**Photo 1: The Famous Plimpton 322 tablet which displays four columns of cuneiform numbers and has been interpreted as representing geometrical relationships involving Pythagoras theorem.**

All students of the history of mathematics are familiar with Plimpton 322. This is a clay tablet in the G. A. Plimpton Collection at Columbia University and is shown in Photo 1. Estimates of its age range between 1900 BC to 1600 BC - so that it could be nearly 4000 years old. It was initially thought to record commercial transactions before O. Neugebauer interpreted the numeric content in an altogether different way.

With a small element of understanding of elementary geometry and arithmetic it is entirely possible to grasp the mathematical

structure of the table which is now widely accepted - although this is still a topic of some debate. The table with corrected numerical interpretation is indicated in table 4 in the base 60 notation and consists of fifteen lines of four columns of numbers. Numbering the columns from left to right, column 1 is more likely to represent a fraction, while columns 2, 3 and 4 integers. This set of values contains four corrections which are widely agreed and terms are indicated with \* in Table 4. Column four is acting just like an index of the lines of the tablet.

Column 1	Column 2	Column 3	Column 4
1:59:00:15	1:59	2:49	1
1:56:56:58:14:50:06:15	56:07	1:20:25*	2
1:55:07:41:15:33:45	1:16:41	1:50:49	3
1:53:10:29:32:52:16	3:31:49	5:09:01	4
1:48:54:01:40	1:05	1:37	5
1:47:06:41:40	5:19	8:01	6
1:43:11:56:28:26:40	38:11	59:01	7
1:41:33:45:14:03:45	13:19	20:49	8
1:38:33:36:36	8:01*	12:49	9
1:35:10:02:28:27:24:26	1:22:41	2:16:01	10
1:33:45	45	1:15	11
1:29:21:54:02:15	27:59	48:49	12
1:27:00:03:45	2:41*	4:49	13
1:25:48:51:35:06:40	29:31	53:49	14
1:23:13:46:40	56	1:46*	15

**Table 4: Base 60 notation values of corrected Plimpton 322 tablet. The 1: of the first column is added to all term as indicated.**

The Babylonians are thought to have been aware of the 'rule of the right angle triangle' as indicated in Figure 2. This is where for integer values of p and q, the sides of a right angle triangle are given by 2pq, p<sup>2</sup>-q<sup>2</sup> and p<sup>2</sup>+q<sup>2</sup> and relate to sides b, a and c. This would be the basis of what was later to become known as Pythagoras Theorem. The values in the second and third columns can be interpreted as p<sup>2</sup>-q<sup>2</sup> and p<sup>2</sup>+q<sup>2</sup> for relevant values of p and q. This holds except for line 11. So far so good. What about the first column?

**Figure 2: The Rule of the Right Angle Triangle as known to the Babylonians.**

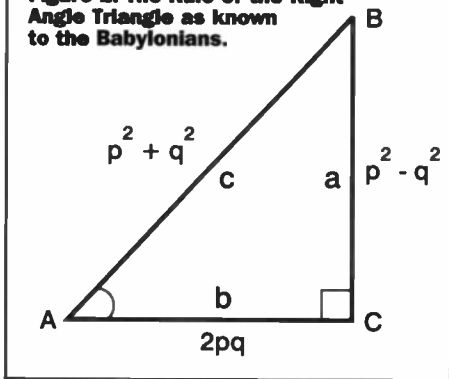

This corresponds to the ratio  $(c/b)^2$  if we use the number in column one as a fraction and add value one as indicated in the table. The ratio  $(c/b)$  corresponds to the trigonometric function of secant or  $(1/\cos)$  of the angle at vertex A on the triangle with reference to Figure 2. The table would appear to be that of the square of secants for angles between 45 and 30 degrees. The steps in angles are provided by the set of triangles for which the 'rule of the right angle triangle' holds. There is a missing line in this sequence between lines 11 and 12. It can never be proved, however, that this was the intended use of the table.

The values of angles and of term  $(c/b)^2$  are often reported in books, papers and on the Internet. It is obvious, however, that care is not being taken in ensuring sufficient resolution in undertaking the calculations to interpret the table.

The real surprise of the Plimpton 322 tablet is that the values of the fraction in column one are expressed as fully resolved to exact base sixty fractions. There is no point in calculating the value of a given fraction to see if it equals the value derived from the computer from calculating the value  $(c/b)^2$ . The 4000 year old fraction is exactly correct on paper - since the values are base 60 terminating fractions. What we do see, however, for six lines in the table is that double precision arithmetic, at 15 digits numeric resolution, demonstrates a finite difference between the value of the fraction and the calculated value  $(c/b)^2$ . This is, however, a limitation of the numeric representation of our modern digital computers and not of Babylonian mathematics. For line three we see, for example, that the Babylonians were able to express the ratio  $(343768681/182250000)$  as an exact series of base sixty fractions.

(p,q)	Difference $p^2 - q^2$	Sum $p^2 + q^2$	Index
12,5	119	169	1
64,27	3367	4825	2
75,32	4601	6649	3
125,54	12709	18541	4
9,4	65	97	5
20,9	319	481	6
54,25	2291	3541	7
32,15	799	1249	8
25,12	481	769	9
81,40	4961	8161	10
*,*	45	75	11
48,25	1679	2929	12
15,8	161	289	13
50,27	1771	3229	14
9,5	56	106	15

**Table 5: Integer values of sum and difference for Plimpton 322 for specific values of p and q.**

If we consider this issue further, we see that the denominator of the expression  $(c/b)^2$  has a value which is written as  $4p^2q^2$  can be expressed as a sequence of base sixty terminating fractions. Thus for index line seven, for example, the denominator can be expressed as  $2x2x3x3x3x2x3x3x2x5x5x5$ . The Babylonians apparently did not like irrational numbers.

For entry seven for example, a calculated value of the term  $(c/b)^2$  is exactly equal to the corresponding base 60 fraction. If we change a least significant digit in the fractional expression (i.e. 01:43:11:56:28:26:41) then the value of the difference is expressed as  $2.2 \times 10^{-16}$ . If we used single precision real numbers we would not be able to show the real accuracy of the Babylonian fractional values. Your typical pocket calculator would be of limited value.

The short programme EXAMPLE2, written in QuickBASIC, indicates how inputs of values in column 3 (sum) and column 2 (difference) yields parameters of the triangle and a value of  $(c/b)^2$  expressed in base sixty notation.

```

10 REM Babylonian Fractions EXAMPLE2
20 REM look at tablet Plimpton 322
30 PRINT "Input SUM of squares term (0 exits)"
40 INPUT sum: IF sum = 0 THEN STOP
50 PRINT "Input DIFFERENCE of squares term"
60 INPUT dif: IF dif > sum THEN GOTO 30
70 p# = ((sum + dif) / 2) ^ .5
80 q# = ((sum - dif) / 2) ^ .5
90 PRINT "p = "; p#
100 PRINT "q = "; q#
110 PRINT ""
120 a# = p# * p# - q# * q#
130 PRINT "a = "; a#
140 b# = 2 * p# * q#
150 PRINT "b(2pq) = "; b#
160 c# = p# * p# + q# * q#
170 PRINT "c = "; c#
180 x# = (c# * c#) / (b# * b#)
190 PRINT "(c/b)^2 = ";
200 PRINT USING "#.#####"; x#
210 a = ATN(a# / b#)
220 PRINT "angle A = ", a * 57.2958
230 PRINT "base 60 fraction:"
240 num# = sum * sum
250 den# = b# * b#
260 cyc = 10
270 FOR jj = 1 TO cyc
280 dig(jj) = INT(num# / den#)
290 PRINT dig(jj);
300 PRINT " ";
310 num# = num# - den# * dig(jj)
320 num# = num# * 60
330 NEXT jj
340 PRINT : PRINT
350 GOTO 20
    
```

The discovery of the tablet indicates how a single artefact can drastically revise the appreciation of the mathematical skills of ancient cultures.

### Numeric Scale and Precision

When it comes to scale and precision of numbers, we are basically determining a numeric representation with calculators or computers.

Base 60 Notation	Fraction	Value	
0:1	(1/60)	1.66666666666667	E-2
0:0:1	(1/60 <sup>2</sup> )	2.77777777777778	E-4
0:0:0:1	(1/60 <sup>3</sup> )	4.62962962962963	E-6
0:0:0:0:1	(1/60 <sup>4</sup> )	7.716049382716049	E-8
0:0:0:0:0:1	(1/60 <sup>5</sup> )	1.286008230452675	E-9
0:0:0:0:0:0:1	(1/60 <sup>6</sup> )	2.143347050754458	E-11
0:0:0:0:0:0:0:1	(1/60 <sup>7</sup> )	3.572245084590763	E-13
0:0:0:0:0:0:0:0:1	(1/60 <sup>8</sup> )	5.953741807651272	E-15
0:0:0:0:0:0:0:0:0:1	(1/60 <sup>9</sup> )	9.922903012752122	E-17

**Table 6: Value of base 60 fractions expressed in decimal format to double precision - 15 digits.**

The two aspects involved are digit precision and range of exponent. The range of exponent is not really the issue rather it is the precision of digits in which decimal numbers are expressed. Single precision calculations (typically 7 digit decimal resolution) are seen as especially weak when set against the demonstrated Babylonian resolution of  $(1/60^7)$  used in the Plimpton 322 tablet and where Babylonians fractions are more typically expressed as exact derivations due to the greater number of factors of base 60.

Great care is therefore required in trying to analyse 'old base 60' numbers since the assumptions of unlimited accuracy in base 10 arithmetic algorithms in digital computers do not always hold. It is a little disconcerting that the ancient Babylonians could write down fractional values of numbers with a precision that many of our modern calculating devices cannot match. Is this progress or were the Babylonians just fussy about numbers?

One thing to be careful of in computer calculations, when using standard real number representation (short) the significance is represented to only about 7 digits though numbers can be expressed with 15 digits of resolution.

### Egyptian Representations

The earliest Egyptian process of writing numerals used essentially repetition of symbols for one, ten, hundred, thousand, ten thousand, hundred thousand and million in a hieroglyphic system. The representation of such numbers is indicated in Figure 3. The hieroglyphs were written from right to left, and in this way it didn't matter which way the symbols were written, there was no place significance as used today in Arabic numbers or in the Sumerian/Babylonian system. There must have been a temptation, however, to write a single character for 1000 as an approximation rather than write a true value of 999 which would have required 27 characters.

In time this system of repetition of basic units of numbers developed to one of encipherment - the process of assignment of an individual symbol to a more complex number. Such hieratic forms were developed for numbers up to 1000.

The Rhind papyrus was purchased by the Scottish Egyptologist A. Henry Rhind in Luxor in 1858 and is shown in Photo 2. The papyrus is about 6m long and 30cm wide and is thought to be written by the scribe Ahmes as a copy of a document some 2000 years older. The papyrus itself is something like a 'how to' guide to basic arithmetic.

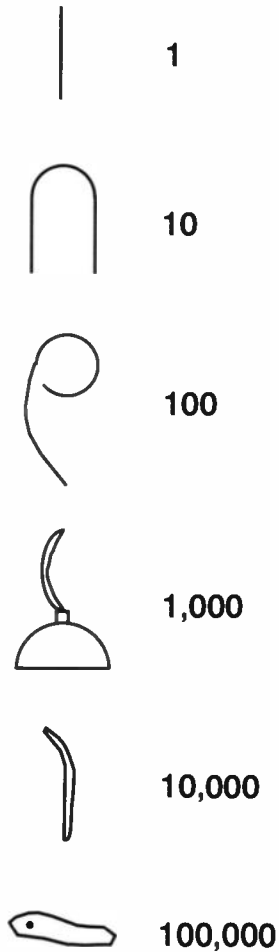

**Figure 3: Representation of Egyptian Numeric notation (hieroglyphics)**

Another famous papyrus, the Moscow papyrus is shown in Photo 3. Taking a stroll down history, it is instructive to see how the Ancient Egyptians would multiply 43 and 67.

The series of terms would be written of equivalent value:-

1	67	*
2	134	*
4	268	
8	536	*
16	1072	
32	2144	*
= 2881		

where the indicated terms (1, 2, 8 and 32) which add up to 43 are totalled. This looks very much binary arithmetic - multiplication by two. Its equivalent in binary representation is moving a binary number one place to the left. This concept was extended to dividing numbers - say 67 by 8.

A column of values would be written to represent:-

/8	1	*
/4	2	*
/2	4	
1	8	
2	16	
4	32	
8	64	*

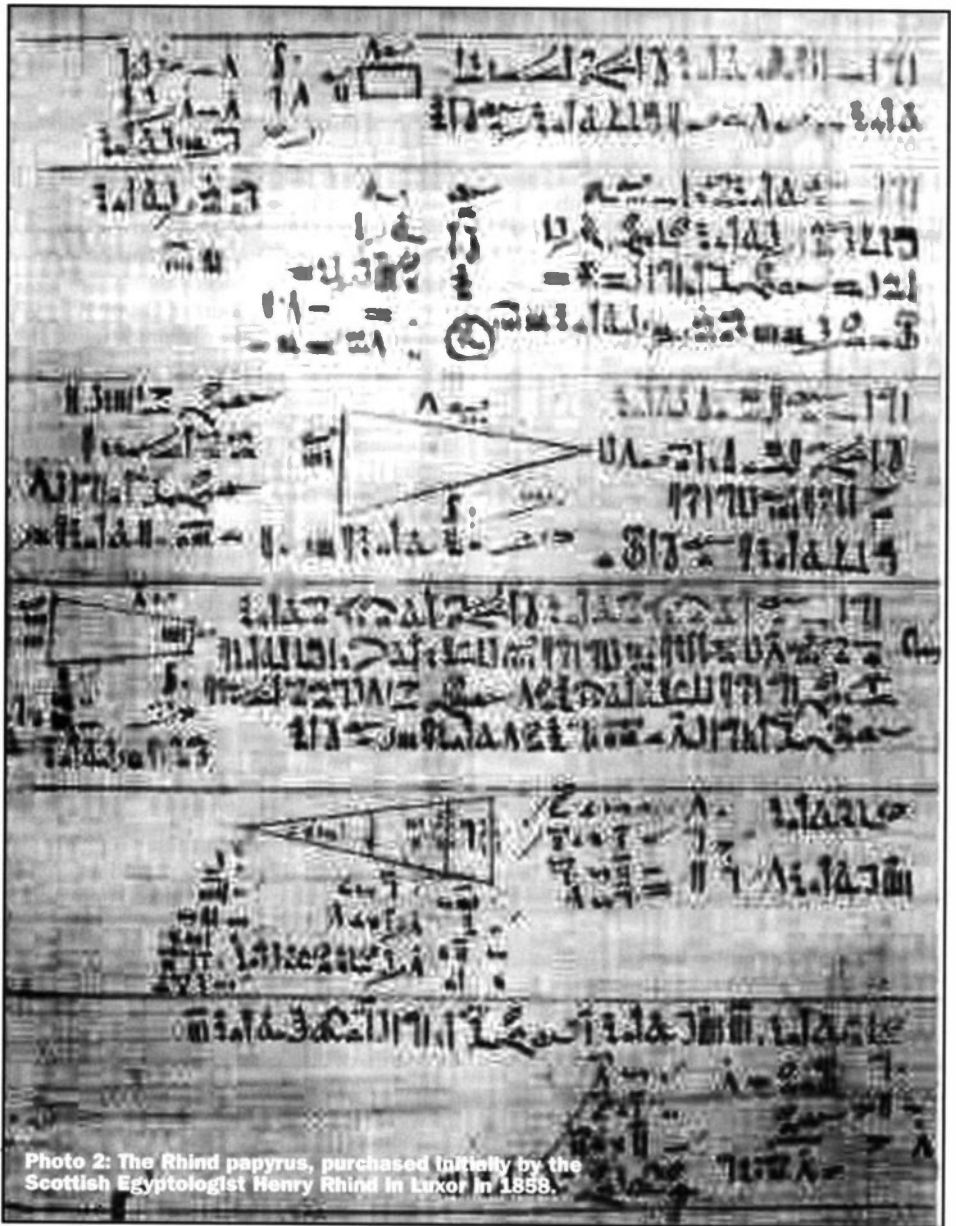

**Photo 2: The Rhind papyrus, purchased initially by the Scottish Egyptologist Henry Rhind in Luxor in 1858.**

where /8 represents the fraction 1/8.

The numerator value of 67 is given by adding 64, 2 and 1 in the right column which is equivalent to  $8 + 1/4 + 1/8$ .

If we want to divide 171 by 12, this method provides a solution but indicates a problem:-

/8		
/4	3	*
/2	6	
1	12	
2	24	*
4	48	*
8	96	*

By luck the division yields a value  $14 + 1/4$ . If the number had been 174 we would have to have added additional fraction values that would reduce to unit values as indicated:-

/12	1	*
/6	2	*
/4	3	*
/2	6	
1	12	
2	24	*
4	48	*
8	96	*



**Photo 3: The Moscow papyrus.**

This gives a value of  $14 + 1/4 + 1/6 + 1/12$ .

Using these basic techniques the Ancient Egyptians could correctly calculate expressions as complex as:-

$$\frac{2}{3} * (16 + \frac{1}{56} + \frac{1}{679} + \frac{1}{776}) * (1 + \frac{1}{2} + \frac{1}{7})$$

### Egyptian Fractions

The concept of division provides a good introduction to the world of Egyptian Fractions. We are perhaps familiar with the expression :-

$1/R = 1/R1 + 1/R2$   
as describing Resistors R1 and R2 in parallel.

The Egyptians would express a given fraction as the sum of a series of unique fractions with unit numerator. Thus the fraction  $2/7$  would be written as  $1/4 + 1/28$ . As a niche in the study of ancient number systems, there are groups who still study the significance of the use of Egyptian fractions in solving problems in modern number theory.

## Ancient Greece and Rome

The Ancient Greek system essentially used 27 characters to describe numbers up to 9999. The initial sequence of characters, based on the 24 letters of the Greek alphabet with some exotic additions described 1,2,...,9, 10, 20, ...,90, 100, 200 to 900. The comma was used to indicate a character describing 1000, 2000 etc. A dot could be used to indicate a scale factor of 10,000. This method of recording data was, however, of not much use in undertaking serious arithmetic.

The Greeks, however, tended to focus more on abstract mathematical thought than the very practical arithmetic of the Egyptians. The greater part, however, of Western mathematics has grown out of the legacy of mathematics left to use by the Greeks.

The Roman system had been derived from the Etruscans, with letters I, V, X, L, C, D and M representing 1, 5, 10, 50, 100, 500, 1000. Symbols had also been used to describe 5000, 10000, 50000 and 100000. The significance of such a system is that it was probably used as a means of recording numbers rather than undertaking the calculations. Most of the hard mental effort of calculating was probably done using counting boards where counters would signify numeric values.

## Hindu Arabic Numerals

The most significant development, in number representation, was that of Hindu-Arabic numerals.

The core language of Sanskrit in use around 2500 BC had incorporated within it a basic decimal system with terms for numbers 1 to 9, 10, 100 and higher powers of ten. By about the 3rd century BC the set of Brahmi numerals as indicated in table 7 were in common usage.

UNITS	1	2	3	4	5	6	7	8	9
TENS	10	20	30	40	50	60	70	80	90
HUNDREDS	100	2x100	3x100	4x100	5x100	6x100	7x100	8x100	9x100
THOUSAND	1000	2x1000...							

Table 7: Description of the Brahmi number system in use around 300 BC.

Numeric representation here used a 'composite' approach. Individual digits were defined and in addition individual symbols for the sequence 10, 20, 30, ..., 90. For counting above 100, two symbols, one for 100 and one for 1000 were introduced and used with place significance so that in this approach a number could be written (2) x (1000) + (30) + 6 for 2036 where if no term for hundreds was included a zero is

implied. Thus numbers up to 9999 could be represented from a selection of only 20 different symbols. This system further developed and around 570 AD the 'Arabic' system of numbers was in use within India.

The migration of this system out of India probably took place around 662 AD and with it first being assimilated by the Arabs who had no number system of their own. It is known that in 773 AD an Indian brought some writings in Astronomy by Brahmagupta to the Court of Caliph Al-Mansur in Baghdad. After having studied this work it was Al-Khwarizmi the mathematician who first described the use of the Hindu system, and subsequently Europeans began to access this information through Latin translations. The oldest mathematical European manuscript is the Codex Vigilanus from about 976 AD which contains the digits 1 through 9 but no zero.

Spain with its Moorish occupation at this period, was an interface between cultures which allowed the passage of the Hindu system into Western culture. The most important books in Latin describing the Arabic-Hindu system appeared in the 12th century.

We take our number system very much for granted with its implicit use of place notation. It was a very difficult leap to take in those times and in fact there are many indications that there was a period when Roman and Arabic were all mixed up within the representation of a single number.

The close trading links between the states of Italy and the Arabs around this period was a further factor which increased the acceptance of the Arabic number system. Leonardo of Pisa (also known as Finonacci) around 1200 AD was to study the Arabic system extensively and conclude that it was a superior system. It took some 500 years, however, from the first awareness of the system within Europe to its firm acceptance. The rest, as it were, is history.

## Mayan Numbers

The Mayan culture, unlike that of the Greek, Egyptian and Babylonian cultures was a living culture when it was first encountered by the Conquistadors around 1524 AD. The toppling of its power structure and wholesale and deliberate destruction of its culture caused a great deal of value to be lost. Also, while archaeological efforts have been primarily directed towards Indo-European cultures, serious study of Mayan culture and its system of counting and mathematics is fairly recent.

The number system of the Mayas was essentially vigesimal - to base twenty. Figure 4 depicts the basic representation of numbers between 0 and 19. This was achieved by using only three symbols - for zero, one (a dot) and five (a horizontal bar). Numbers were typically written vertically and with place notation. Zero was specifically designated with a unique symbol. Two separate 'type' of numbers,

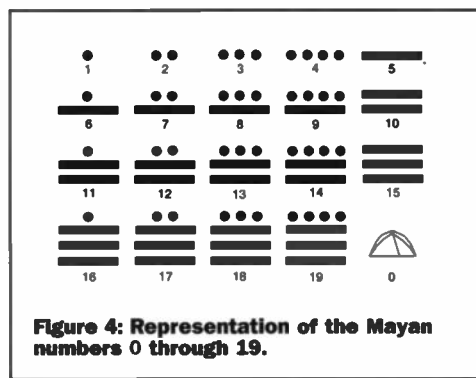

Figure 4: Representation of the Mayan numbers 0 through 19.

however, can be identified - the mathematical count and the calendric or 'long count' as indicated in Table 8.

Digit Position	Mathematical Count	Calendric Count
2	20 (20)	20 (20)
3	400 (20x20)	360 (18x20)
4	8000 (20x20x20)	7200 (18x20x20)
5	160,000 (20x20x20x20)	144,000 (18x20x20x20)

Table 8: Place significance values of Mayan count systems

We can represent numbers the decimal numbers 64404, 146849 and 122074 in the Mayan mathematical count representation as indicated in Figure 5.

The Mayan system of numbers provided a convenient means for recording numbers for everyday practical reckoning. Adding numbers was especially simple and straightforward. A series of glyphs were also associated with the numbers 0 to 19.

The most important use of such numbers systems, in particular the 'long count' system was in calendrical/astronomical observations. As studies of archaeological records progress, deeper insight is being provided into the processes of such astronomical observations. Observation of the planet Venus was of particular importance, and exploits of war and sacrifice were apparently linked to Venus's path in the sky. Such observations identified a Venus/Earth cycle of 584 days and with a longer cycle of 2922 days involving the position of the earth, Venus and the stars.

It has been suggested that the Mayan 'long count' 360,7200,14400,2880000 etc. could be related to the Platonic Year, the period of 25920 years for a complete precession of the equinoxes. Some researchers are trying to link 'important numbers' of the Maya culture, Ancient Egypt and Babylon to indicate a shared or common basis for systems of numeric representation.

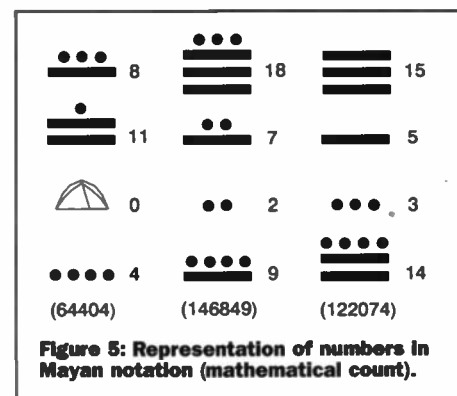

Figure 5: Representation of numbers in Mayan notation (mathematical count).

	UNITS	TENS	100's	1000's
1		—		—
2		==		==
3		===		===
4		====		====
5		=====		=====
6	—	—	—	—
7	—	—	—	—
8	—	—	—	—
9	—	—	—	—

Figure 6: System of Chinese reckoning blocks.

### Chinese Number Systems

There is generally less information available on Chinese number systems. The basic division of knowledge is between the reckoning devices such as count boards and the written text of numeric representation. It is likely that these two activities were kept relatively separate between the marketplace and the intellectual/literate class of China and this division is also characteristic of many parallel cultures. One approach used in counting was to use so called reckoning blocks, as indicated in Figure 6, where these can be considered numeric tokens used to represent numbers. The Chinese numerical notation was derived from these reckoning blocks but did not facilitate calculation. Its role would have been possibly comparable with Roman letters used to record an arithmetic result. The basic arithmetic system was based on factors of ten. In China the modern abacus was developed from about 900 AD. In the orient, the modern abacus is still used to great effect in undertaking highly complex calculations.

Proficiency tests in Japan during the 1960's, for example, required the adding of ten sets of 15 numbers, each up to 10 digits long, in 10 minutes. In the use of the abacus, properties of numbers such as symmetry and complimentary values are

harnessed to speed up number processing. This aspect, however, is almost completely lacking when we use computers and calculators to do the reckoning.

### The Role of the Abacus in Counting Systems

It is possible to distinguish two main divisions of number use and development. One level related to commercial, market place transactions while the other related to more abstract mathematical thought and astronomical reckoning. We are familiar with the abacus as beads on columns, but counting by means of counters such as pebbles can be traced to the very dawn of history. The word abacus in fact is derived from 'abax' meaning flat surface. Even the word calculate is derived from the Latin 'calculus' meaning pebble.

Pythagoras is credited with introducing the abacus into Greece which led to its subsequent uptake throughout the Roman empire. But it is not readily appreciated just how strong an influence the abacus/counting board would have on western culture. A typical Roman counting board is indicated in Figure 7 and displays the number 2862.

Counters cast between M and C (1000 and 100) would imply a value 500 and with 50

and 5 being also implied in mid lines. Numbers to be added would be represented side-by-side and the counters amalgamated from the units upwards. There were rules for subtracting multiplying and dividing. When a value was determined, it was recorded as the number of counters on the lines of the counting board. The real arithmetic was not done by manipulating

the written number.

Western Europe used this same method of counting board arithmetic widely until the 16th century though it was the French Revolution that would ultimately rule it out of favour. The term Chancellor of the Exchequer relates to the use of a large calculating table - the exchequer - which probably went out of use around 1783. The counters used to signify value in such a system were known as jettons. It is only relatively recently, therefore, that 'counting house' methods have been replaced by book work using Arabic numerals.

### Summary

It has taken quite some time to credit ancient cultures with sophisticated numeric skills. The example referenced in the Plimpton 322 tablet, when interpreted with double precision arithmetic shows that the Babylonians could compute with this accuracy or better around 4000 years ago. It is likely, however, that just as the last 150 years has witnessed a development in understanding such systems of records, even more rapid progress can be made using modern computers to decipher such records with caution and an ample measure of respect.

There is great curiosity, however, in revisiting ancient concepts of numbers since mathematics is itself a form of universal language which can pass from one culture to another. So in our highly numerate age, it is surely useful to obtain a sense of perspective in the way in which we use numbers now and how also previous cultures used them. This could even add a level of interest in acquiring numeracy skills.

### Further Reading

- The Book of Numbers. John H. Conway and Richard K. Guy, Springer - Verlag, 1996.
- The History of the Abacus, J.M. Pullan, Hutchinson & Co., 1968.
- Advanced Abacus: Japanese Theory and Practice, Takashi Kojima, Tut Books, 1980.

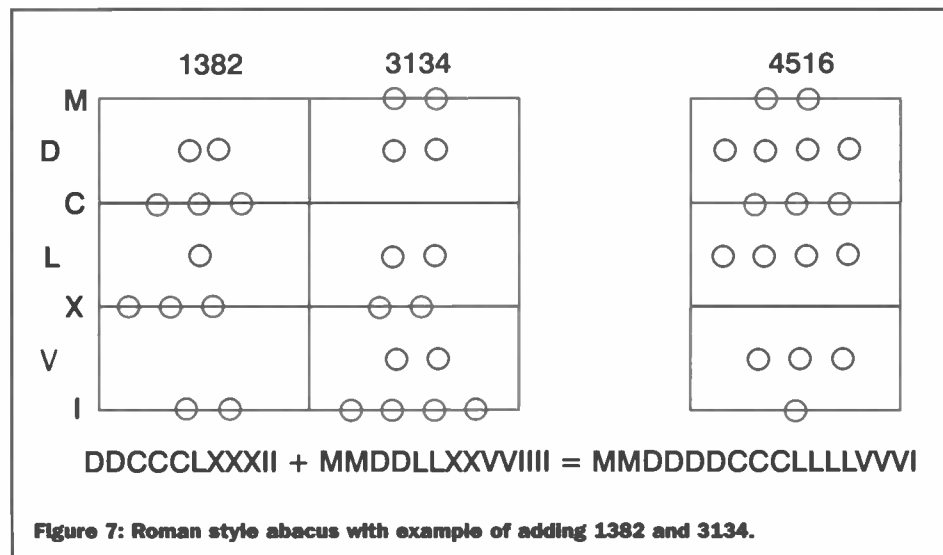

Figure 7: Roman style abacus with example of adding 1382 and 3134.

# Computer FRAUD

PART 2

**With widespread concerns over Internet security, how are the financial associations addressing the problem of credit card usage?**

**Michelle Grieg investigates**

**W**orldwide trade and access to the Internet has grown at an average 30% to 40% during the past ten years. A global standard for secure payments has become vital, and SET, a secure electronic transactions protocol must evolve, improve and become operational to meet this challenge.

e-commerce in industry currently accounts for US\$30 billion of business, with predictions for 2001 ranging between US\$100 to US\$600 billion. Visa International has predicted its share of consumer commerce on the Internet will grow at a rate of approximately 67% over the next five years and expects the share of virtual payment card usage to pass 'real' existing volumes in a matter of years.



SET, seeks to reinforce trust in global payments through the creation of an authentication process between and for the customer, merchant and bank. SET will therefore secure the banks' place in the virtual world as part of the payments chain. To understand SET, it is crucial to understand what may underpin the new order in the imminent revolution of payment relationships.

In its current form, SET is a PC keyboard-based payments protocol for electronic commerce used to secure credit transactions. The protocol was developed for magnetic stripe card usage over the Internet by MasterCard and Visa in conjunction with industry organisations including GTE, IBM,

Microsoft, Netscape and Terisa.

SET seeks to make the system secure through the use of digital certificates and



signatures. These digital certificates validate the identities of both the cardholders and merchants participating in transactions via the web, combined with the encryption of individual card numbers.

Amex and JCB joined Visa and MasterCard in December 1997 to form SETCo. to promote the use of SET. Visa used its first branded digital certificate over the Internet in the first quarter of 1997 using IBM software, and VeriSign certification.

SET transactions are treated as if the card holder is physically present. The SET protocol uses a longer encryption key for data than most software and issues customers with digital certificates. This is a fraud deterrent as a potential fraudster must know the user's credit card number and associated digital certificate to complete the SET transaction. SSL is an alternative standard using encryption and firewalls, but one which cannot identify users as it does not use digital certification. SSL is treated as a cardholder not present transaction.

## **Not Without Problems!**

Since its inception, SET has been beset with problems. Many CSPs (common service provider) see SET as a dying

standard or one that will have to change radically in the future, and that SET is only around due to the huge financial backing of the associations.

These charges are rebuffed by those in favour of or with a vested interest in SET, who claim SET is commonly misunderstood. Steve Hertz, SVP of Consumer Electronic Commerce at Visa International claims, "There is a probability that 99% of the time when we get a negative comment coming back it is due to people not getting the facts right."

Alan Clark, executive for Internet payments at IBM, points out that now the protocol has evolved it has become more flexible to implement. He argues it is the inherent flexibility of SET that has allowed it to silence most of the earlier criticism. He offered the analogy, "IBM's first implementation was to the letter of the protocol to validate SET itself." This rigid conformity to the letter of the protocol has since relaxed as time has redefined necessity, "When you move into a new neighbourhood, and you are not sure what to expect, you put ten locks on the door. Now, as you become more comfortable and familiar, you may only have two locks on the door."

A recent industry survey found the SET protocol has limited support among service providers, with products based on the SET specification criticised as

being excruciatingly slow with little, if any, client support.

Strategic analyst Datamonitor has published research showing merchants found SET to be too complex and expensive. The transaction process requires many players to sign off and verify, thus causing delays.

Recent research findings by the Gartner Group rebuff this claim. The study methods deployed volume modelling over time, comparing SSL and SET in

three different environments whilst seeking to normalise conditions of testing without making allowance for variable modem speeds, differing efficiency of individual PCs or network problems. The report concluded that SET, in isolation from influencing variables, outperforms SSL in multiple transactions, a result backed by IBM's trial evidence.

Alan Clark claimed retailers' hesitant attitude toward SET is due to naive ignorance or to basic cost issues, claiming in the long run, the cost of automation is higher than the real costs of running SET.







## Too Complicated?

SET is currently in trial stage across most of the globe. Europay International receives a new request to register for SET every ten days, and is poised to roll-out in Germany and Eastern Europe. China has also voiced support for the protocol. However, SET is perceived to be endlessly bogged down in trials. Steve Hertz concedes trials are an inevitable part of the process: "An institution doing a large roll-out needs to be sure that the product is interoperable before distribution. But in Japan several months ago, 150,000 CDs equipped with SET wallets were distributed to customers. Those figures are more than a roll-out."

SET is the only current effort at a global international standard that offers any degree of interoperability. However, some software companies have claimed SET is a complicated specification to develop, and concern from vendors over interoperability fears has led SETCo to launch month-long festivals for software vendors and merchants several times a year. It is widely predicted that e-commerce will prompt the first major application of smart cards in the US. But the card's crucial role may be more for authentication purposes than as a payment tool.



SET 1.0 already supports smart cards due to a facility in the software which provides an extension. This extension is utilised in the convergence of e-Com and C-SET. It was also used when Certicom, GlobeSet, MasterCard International, Mellon Bank, SETCo, Schlumberger, the US Treasury Financial Management Service and the Bureau of Engraving and Printing completed their first smart card SET trial on the Internet in July 1998, at the E-GOV conference in Washington DC.

SET version 2.0 is currently in development and will be trialed later this year. The new version will be more closely defined for smart cards, but will still be PC based. SET is primarily a PC application, which begs the question as

technology develops, will SET be rendered obsolete?

Rather than being stagnant, SET is likely to develop and integrate with set-top boxes and GSM phones. Alan Clark claims it to be an evolutionary process, a view backed by Hertz, "ET is transport neutral, so it can be put anywhere which has the capability and capacity for the software. In this sense SET is portable, not PC based." At the time of writing, no set top box vendor has formally adopted SET, but, as Hertz claims: "It is just a matter of time."

## Cryptography and Digital Signatures

In cyberspace we are all anonymous, so even with SET to authenticate Internet transactions, it is still necessary to prove we are who we claim to be. For electronic commerce to achieve its full potential, it must adhere to the same levels of privacy, integrity and trust that traditional business practices enjoy. The digital certificate is the obvious immediate solution operating as a virtual corporate identification badge.

To work, digital payments must incorporate:

- Privacy.
- Authentication.
- Integrity. (Once a transaction is signed it must be protected against tampering and forgery.)
- Nonrepudiation. After a transaction has been made, it cannot be revoked. Neither party involved in the transaction can deny their role in the exchange.
- Support of the legal system. A digital signature on a document must carry the same weight in a court of law as a written signature.

## How a Digital Signature Works

A digital signature is a kind of electronic stamp that can be appended to virtually any form of electronic transaction, fitted with its own tamper resistant seal using cryptography. It typically holds information such as name, address, a validity period, a unique serial number and identifying information about the Certification Authority (CA). Digital signatures can also be used to ensure the integrity of an electronic transaction. A digital certificate is issued in conjunction with a particular pair of encryption keys. The private key is used to create a digital signature, a unique coding of the message, that can only be decoded using the corresponding public key. If the message is altered after it has been signed, the recipient will know.

## Digital Certificates

Digital Certificates tell us the identity of the sender of the information. Before the exchange of data, each user will wish to

authenticate the identity of the other party. Consumers need to know what and with whom they are dealing.

To create a digital certificate, the CA creates a hash of the holder's identifying information and the public key, encrypts the hash and appends it to the identifying information. If the identifying information or public key contained in the digital certificate is changed in any way, the certificate will fail validation.

To check the validity of a digital certificate, the recipient recalculates the certificate hash using the same hashing algorithm on the certificate holder's identifying information and public key as it was received. The original certificate hash is decrypted using the CA's public key. If the recalculated certificate hash is the same as that of the decrypted certificate, the certificate is valid. The CA keeps its private key secret, and its digital certificate provides a reliable means of authenticity.

The Certification Authority issuance of certificates means validation of vendor, supplier and customer. When the procedure is adhered to properly and by all involved, it is difficult for the hacker to invade the system.

## Cryptography

Cryptography uses a mathematical function, an algorithm: to encrypt and decipher messages. For example, a simple algorithm may replace each character of text by skipping three letters, therefore A becomes E, B becomes F, and so on.

There are two types of encryption algorithms:

- Symmetric - Using the same key for encryption and decryption.
- Asymmetric - (public key) requires the use of two related keys, one for encryption, and one for decryption.

In a public key encryption, information encrypted can only be decrypted with its corresponding private key. These are intended for personal use and need to be securely stored on a computer or a hardware token, such as a smart card.

Public Keys can be shared either by making them available on an Internet server or by sending them to partners during the transaction.

Public Key Infrastructure (PKI) is used to protect the privacy of the transaction. By receiving an order, the merchant can give the consumer a copy of their key to decrypt the information, and, as long as the merchant keeps his key private and secure, the message will be secure.



# Single-Chip SOUND RECORDER

*Dr. Pei An describes a simple, low-cost solid state sound recorder.*

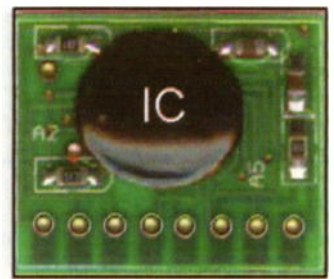

Pin 8 7 6 5 4 3 2 1  
Connector

Figure 1. PT8820 20sec sound recording module showing pin numbers.

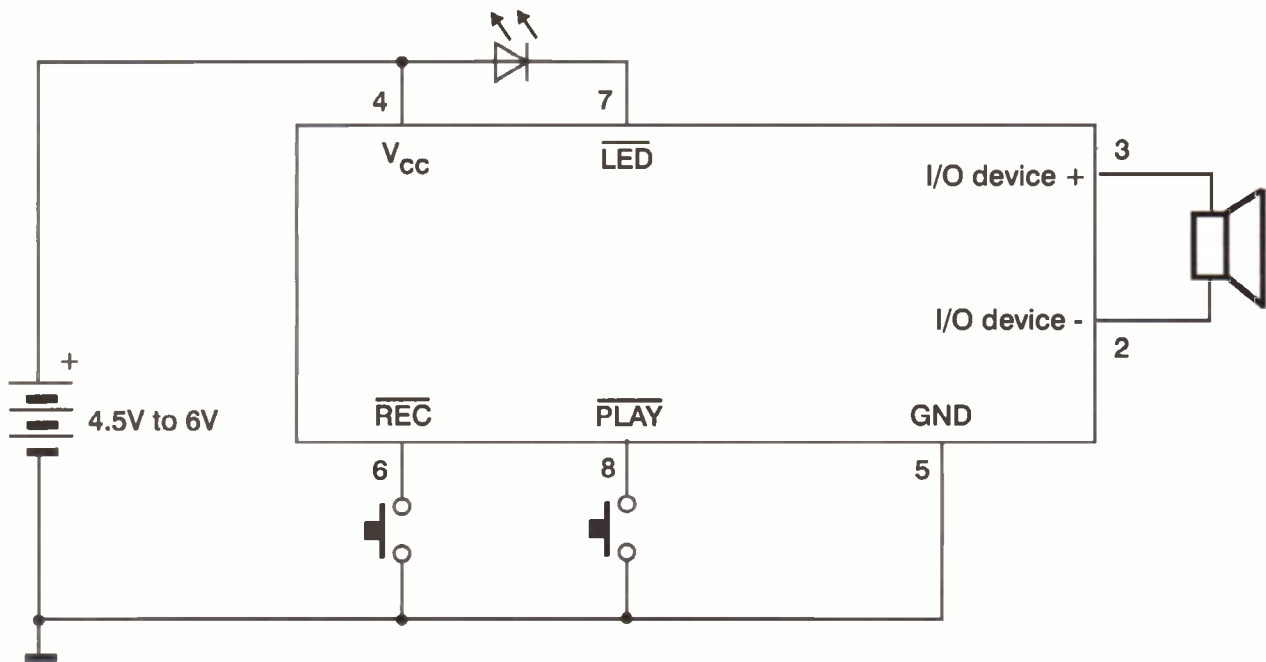

Figure 2. Typical connections for PT8820. Speaker is 8Ω.

**P**T-8820 is a 20 seconds solid state sound record/replay IC, but unlike other digital sound record/replay devices that involve an A/D converter, D/A converter and digital data memories, this device uses an analogue flash memory technique to record sound. Additionally, the sound is retained after the power supply is removed, and recording cycles are in excess of 100,000 times and data retention is 100 years!

It is so simple to build a complete sound recording and replaying system. It requires two switches (one for recording and one for replay), one LED to indicate the state of recording and one speaker (8Ω). The speaker produces sound as well as acts as a microphone during sound recording.

The PT-8820 module measures just 20 x 18 x 2 mm, and requires a power supply rated at 4.5V to 6.0V DC. In record and replay modes, current consumption is typically 25mA, but in idle mode this figure drops to a very small 1μA.

## PT-8820 Module

The PT-8820 module is shown in Figure 1. The module uses a PT-8820 IC and a number of surface mount devices. There are eight pins on the module. Pin pitch is 0.1in. The following is a list of what each pin does.

### Pins Functions

1	Audio line in
2	Speaker (Negative)
3	Speaker (Positive)
4	VCC (4.5 to 6V DC)
5	Ground
6	Recording (low active)
7	Recording LED (Low to indicate)
8	Replay (low active)

A typical connection for the module is shown in Figure 2, consisting of an LED, two push-to-make switches, one speaker (8-16Ω) and a battery pack (4.5-6V)

Pressing REC button continuously

causes the module to record sound. Users can record speech via the speaker. While recording is in progress, the LED illuminates. Recording is terminated either by releasing the REC switch or if the recording time exceeds 20 seconds.

Pressing the PLAY button once (press PLAY switch and then release it) causes the module to replay the recorded sound. The sound will be replayed from the beginning to the end. To stop it playing, Toggle the PLAY switch again. If the PLAY button is pressed continuously, the sound will be replayed again and again.

RMS value of the injected signal should be adjusted in order to get the best result. When the module is neither in recording mode nor in the replay mode, it is in the idle mode (battery saving mode). In this mode it only consumes 1μA current.

To obtain the best recordings, a microphone can be used. Such a circuit is shown in Figure 3. Alternatively, audio signals can be directly injected into the

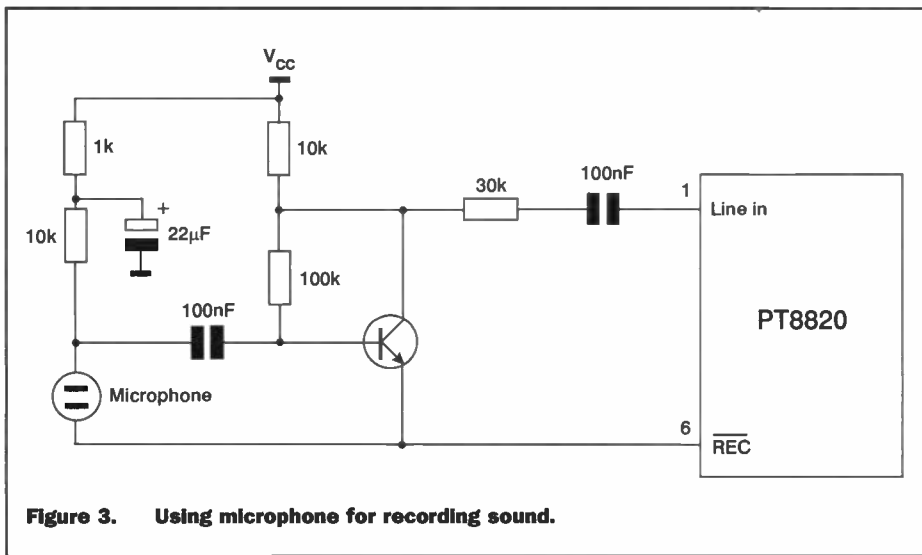

Figure 3. Using microphone for recording sound.

module through Pin 1 (see Figure 4). The RMS value of the injected signal should be adjusted in order to get the best results.

### Application Ideas

The basic circuit of a simple 20 second message recorder and player is shown in Figure 2. Holding the REC button will record sound. Toggling the PLAY button will replay sound.

The circuit can also be used as a doorbell. Unlike the conventional doorbells that only give a sound of chime or play a piece of music, this doorbell plays a speech you recorded.

It can be used as an audio reminder. A particular application is that it reminds you of a number of things to do before you leave your house. In this case a magnetic reed switch as used in home security systems is used to replace the push-to-make button.

PLAY input is active low. Instead of using a switch, it can be connected to a digital output

from a computer or from a digital circuit.

Another application is a remotely controlled audio warning system. A suitable message can be replayed under the control of a remote controller.

### Inside the PT-8820 IC

The internal block diagram of the IC is given in Figure 5. During recording, Pin 7 becomes low, which illuminates the LED. If a speaker is used to record sound, the signal generated by the speaker is feed into the IC via the bi-directional I/O control for sound recording. Recording starts when Pin 6 is pulled low. Recording is terminated either after 20 seconds of recording or after that Pin 6 becomes logic high. Replay starts when Pin 8 is pulled low. The bi-directional I/O control is in speaker mode. During re-play, sound replays from the start of the sound record.

### Technical Support

The single-chip sound recorder IC is available from the author at a price of £8.50 including postage and packing. Please direct any enquiries to Dr. Pei An, 11 Sandpiper drive, Stockport, Manchester SK3 8UL, Tel/Fax/Answer: 44-(0)161-477-9583. E-mail: pan@intec-group.co.uk

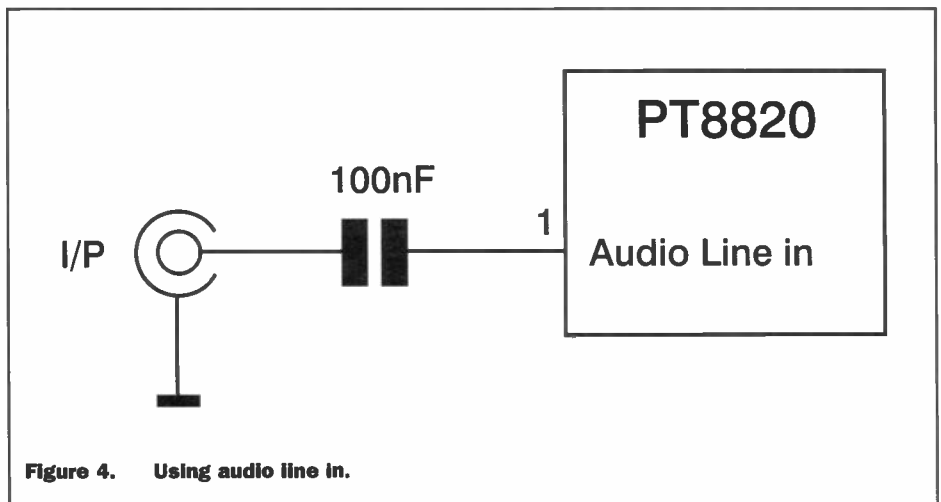

Figure 4. Using audio line in.

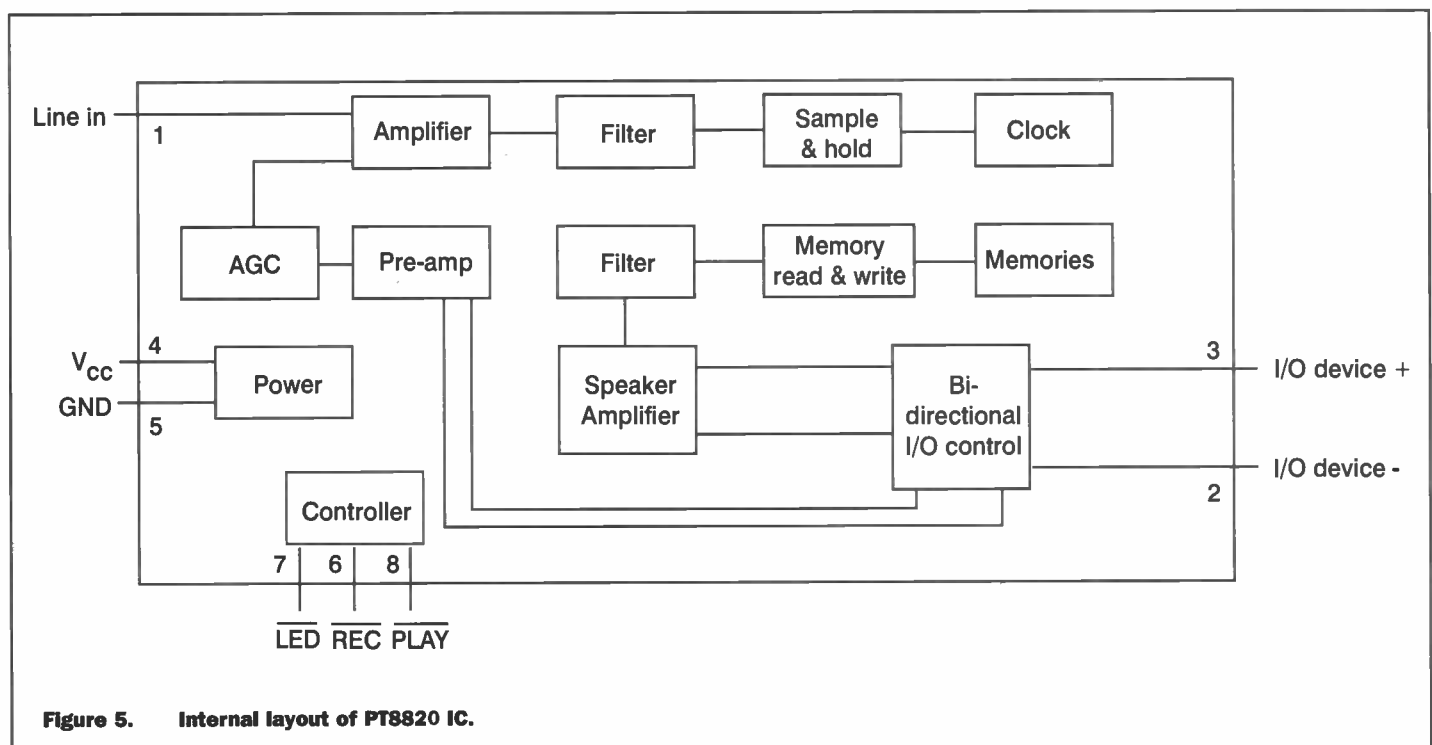
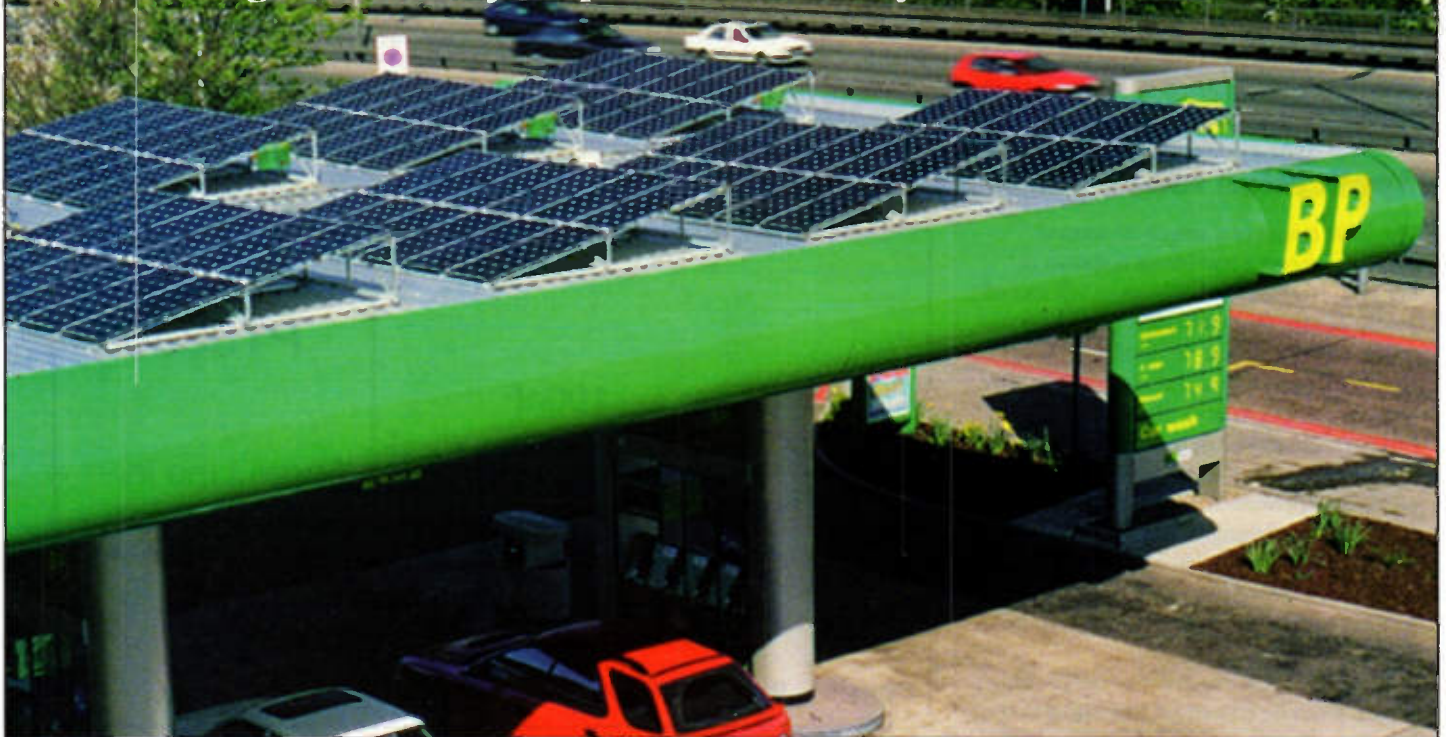

Figure 5. Internal layout of PT8820 IC.

# Solar Cells, THE PRESENT AND THE FUTURE

*Mark Hammonds of BP Solarex looks at how we are harnessing the sun's rays to produce electricity.*



**A**s we know the sun is responsible for most of the earth's energy in one way or another. Plant photosynthesis provides the basis of our fossil fuels such as coal and oil. At the same time heat from the sun is again indirectly responsible for other common forms of renewable energy such as wind and wave power. Solar power, in its accepted working definition, is the supply of energy directly from the sun. It is made up of two very distinct technologies, solar thermal and solar electricity. The first is based on the principal of using the sun's direct heat energy, and is most commonly used for supplying hot water for houses and swimming pools. It is solar electricity with which this article concerns itself. This is a technology where the light from the sun is converted directly into electricity - the process known as photovoltaics.

## The Past and Present

Despite its rise to prominence in the 1970s and 1980s, this industry can trace its origins back 150 years. The actual photovoltaic effect was first noted over 150 years ago by Professor Becquerel. He observed a light dependent voltage between two electrodes immersed in an electrolyte.

Albert Einstein united these threads with his theory of the photoelectric effect in 1905 which proposed the existence of the light photon (for which he received the Nobel Prize). Further practical application of this work had to wait until the acceleration of the space programme during the late 1950s. From there the industry has grown in leaps and bounds.

During the mid to late seventies, major improvements in material processing techniques resulted in cheaper, more efficient solar cells. This coupled with improvements i.e. reductions in power consumption in telecommunication devices, provided the necessary spur for the adoption of solar as a viable energy source for terrestrial applications. This time also witnessed a dramatic rise in conventional fossil fuel prices and the realisation that one day they would be exhausted. This gave a fresh impetus to the research and technology being undertaken in this area.

As further improvements in cell processing continued throughout the late 1970s and early 1980s, resultant cost reductions have made solar power an economic proposition for an increasing range of applications.

At the moment solar is not commercially

viable on an economic stand alone basis for either peak or base load electrical generation. The best technology produces electricity at something like double the cost of conventional sources for peak demand.

Technology is advancing and with appropriate public support and investment it is believed that solar will be competitive in supplying peak electricity demand within the next ten years.

## How Does It Work

At its simplest, the solar cell works like a diode. Silicon is intensely refined to remove all the unwanted impurities. Silicon has been the material so far by choice since it has low electrical conductivity because virtually all the electrons are immobilised in bonds. By adding a known amount of an impurity like boron, part of the silicon becomes what is known as p-type. The conductivity increases as boron introduces charge carriers which are positive. These are not electrons but gaps or 'holes' where electrons are expected to be in the bonds of the crystallographic structure. A layer of phosphorus doped silicon is added to the cell. This is known as n type silicon meaning

the main charge carriers are negative electrons as in most metals.

The interface between the two surfaces is known as the p-n junction and is the key part of the solar cell. The charge carriers at the interface between the regions combine cancelling each other out. However, the charged dopant atoms cannot move as they are locked within the crystallographic barrier.

Light is made up of very small amounts of energy called photons. When a light photon is absorbed by a solar cell it passes its energy to an electron in one of the bonds. The electron is released from the bond in the structure and becomes a charge carrier free to contribute to electrical conduction.

Where that electron was now becomes a 'hole' which is effectively positively charged and can also contribute towards electrical conduction.

The cell is designed so that most of the photons generate carriers (pairs of electrons and holes) in the junction. Due to their closeness the electrons move away from the boron into the junction and towards the surface, while holes move away from the surface towards the bottom. When the solar cell is connected in a circuit, with a grid on the front of the conductive metal and the back, there is a flow of electric current (effectively electrons travel from the front of the cell to the back where they recombine with holes).

The early work by Becquerel used Selenium, and it wasn't until 1954 that the present dominance of silicon began as the major raw material for solar systems. Silicon (in its many forms) is the second most abundant element on earth, its most well known manifestation is sand. Availability combined with high light to electricity energy conversions made it the predominant industry raw material. Future work on reducing the price of solar energy concentrates on this area of solar cells, these being the most expensive component of a solar system. This holds the secret of increased energy conversion efficiency of sunlight into electricity and at the same time improving manufacturing costs.

To withstand the harsh environmental conditions that they operate under, the cells are laminated between a layer of special high transmission glass and weatherproof plastic, commonly Tedlar polyester Tedlar ('Tedlar' is a Dupont trade mark). Silicon cells have an inherent voltage of about 0.6V DC open circuit. On their own, this is too low to power most items, consequently, they tend to be electrically joined in series to give higher workable voltages. They are also very fragile, so the cells are sandwiched between special high transmission toughened glass on the front, and an impervious tedlar/polyester/tedlar using Ethylene vinyl acetate as the bonding material in a lamination process. Consumers consequently buy the products as complete solar modules rather than individual solar cells. These tend to be packaged as 32-36 cells into a solar module typically up to 1.2m x 0.6 which can give nominally 12V DC and 75W under industry standard test conditions. These test conditions are 1000W/m<sup>2</sup> insolation (light), temperature 25°C and air mass 1.5 (latter derates for the effect of light passing through the atmosphere).

To get the most from the panels they

should face the equator which for U.K. readers is south. There is some reduction in output when orientated from south but this only becomes significant after about 60°. If left fixed, the panels should be fixed at about 55-70° from horizontal if maximising output in winter and 20-40° if maximising in summer or for most output over the year. Maximising in winter is obviously important if the same electrical load is required every day.

Before continuing it is worth mentioning the material gallium arsenide. This currently offers the highest efficiency of all current cells. However, due to its high price its use has been restricted to satellite applications. The key material used by the photovoltaic industry today as it has been for the last twenty years is crystalline silicon solar cells. The starting material is the lower specification silicon produced by the semiconductor silicon industry. The silicon industry is a volume dominated industry and it is only now that the volume is justifying manufacturers such as Kawasaki in Japan to look at setting up a solar grade silicon wafering plant.

There are three current ways of utilising this technology, monocrystalline, cast multi-crystalline silicon or ribbon multi-crystalline silicon. The first two are sliced into wafers of about 125mm square and 350µm thickness. This material has enabled relatively high stable conversion efficiencies typically 13-15% compared to other semiconductor materials. Monocrystalline is typically 1% more efficient on a like for like area than multicrystalline. The reason for different manufacturers going different routes has been dictated by the supply cost situation. Source material for monocrystalline silicon has traditionally been available in higher volume from the semiconductor industry. Multi or polycrystalline has had less wider uses in the semiconductor industry and consequentially been produced in lower volume.

Work continues to go into this technology and it is estimated that there are still major volume cost reductions to be had here. Studies such as the MUSIC FM project under the EC Apas program have shown it is possible to reduce by classic economies of scale (i.e. higher purchasing power, more efficient automation etc.) costs to 1 ECU per Watt peak i.e. over 80% less than current costs, that is about 70p per Watt peak.

Silicon cells are made as thin as practicable for cost reasons, yet are still between 200 and 350µm thick. Considerable research goes into the saws used in cutting the silicon into cells, due to the high cutting losses. The thinner the saw, the less the losses and therefore the cheaper the cell.

Later there will be a brief summary of new materials being evolved for this industry. The crystalline silicon industry continues to evolve. Two such examples of how BP Solarex is extending this technology is the use of laser grooved buried grid (LBGD)

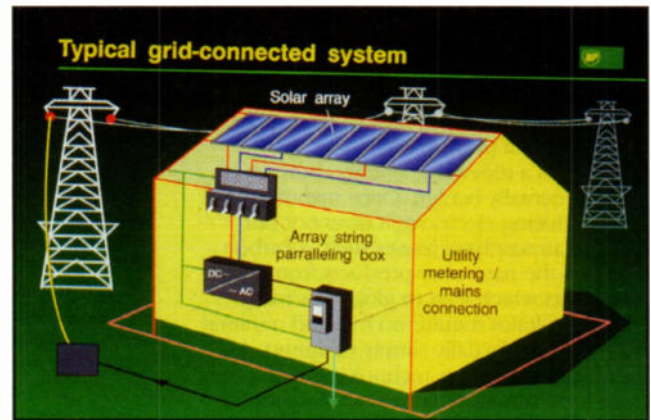
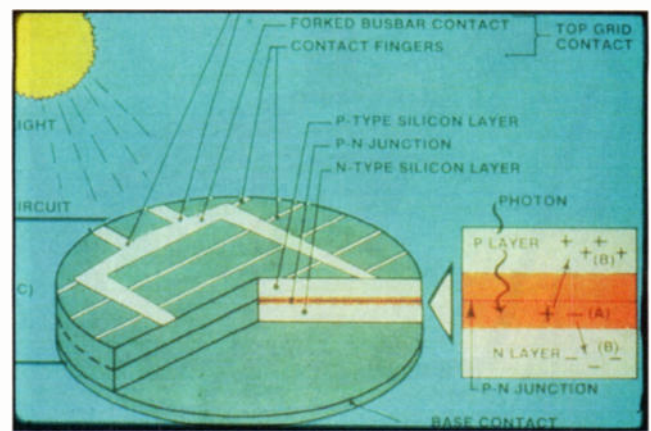

cells and concentrator systems.

The first process, pioneered by Professor Martin Green at the University of New South Wales, uses a laser buried grid process (LBGD) instead of a screen print to form the front contacts which collect the electricity. In a conventional cell, electricity grid lines of silver based alloy are screen printed on the front of the solar cell as the front 'collector' of electricity. This has the disadvantage of as well as collecting the electricity it also shades part of the cell from photons of light energy.

Using a laser, these grid lines are grooved in the top of the silicon cell and the collecting grid buried in the surface. This reduces cell shading and makes it possible to make greater collection enabling efficiency of 16-18% to be obtained. It has the additional effect of generating greater levels of power in regions with poor light levels such as Europe. Whilst very seasonal, a report from the Energy Technology Support Unit on behalf of the Department of Industry confirmed photovoltaics had the potential to provide up to 2/3 of the U.K. annual electrical requirements.

Those who remember the James Bond film Man with the Golden Gun will recognise the next big potential technology opportunity for solar. Here using mirrors, light is concentrated on specially modified cells with additional heatsink protection. This offers the potential to get more output from the same area. The negative aspects of this application is that there is a greater heat generated which conversely reduces output. Again starting with high efficiency processes, such as the laser buried grid design, and careful attention to heat dissipation, this concentration technology can actually be utilised as a practical saleable product. This will have a key role to play in utility line extension projects in the tropics where there is good direct light. On a large scale this technology offers cost and land utilisation benefits.

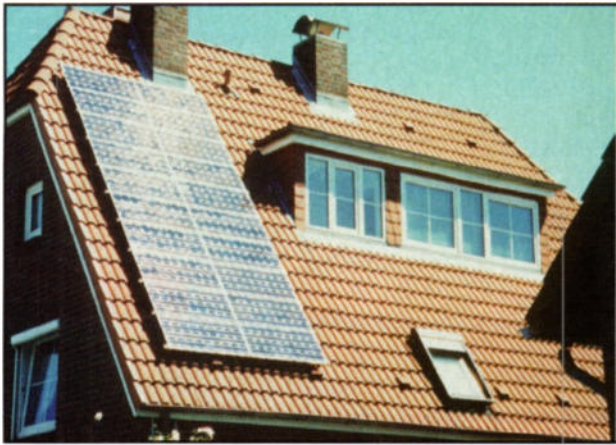

## The Benefits

Enough of the present. Where is this technology going and how is it getting there? To understand this it is best to remember the benefits of photovoltaics.

Firstly, as a renewable energy source it is environmentally benign. Once manufactured and producing electricity, it does not put into the atmosphere gasses such as carbon dioxide - the natural by-products from fossil fuel plants which lead to global warming.

Photovoltaics require no fuel and minimal maintenance (usually simply cleaning). As such a big use of this technology to date has been locations such as marine navigational aids, telecommunications repeater sites on mountains, where it is very expensive and difficult to bring in fuel for alternative power supplies.

Solar produces no noise when operating, and providing it has access to light, will generate electricity. This enables it to be by far the most appropriate renewable technology to be used in the urban area.

## Markets

To understand the technology and where it is going it is necessary to understand the markets.

The present PV market is characterised by a fairly high and stable increase of over 15% per year. As at today, the annual solar module production is estimated to be about 110 - 130MW - still only very small in comparison to conventional power station output but growing fast. But, whilst costs have fallen seven fold since 1981 it remains an expensive technology.

So how can the market be broken up and where is the growth coming from? There are several ways to look at market segments for solar, but one of the more common ones is the five key areas:

- telecommunications
- rural infrastructure
- consumer
- grid connect
- specialist segments such as navigational aids, cathodic protection (a process whereby passing a small amount of electricity down a pipe significantly inhibits the process of corrosion)

Not only are all markets growing but there is increasing growth in the segment known as grid connect. Here solar acts as a complement to the standard grid and solar is utilised in central power station markets, or on individual/company buildings to supplement power to the grid. The key drivers for this at present are the reducing

costs of large scale solar developments, but above all the key environmental benefits of using a renewable energy which does not add to the greenhouse gas problem or create pollutants. There are large government programs in place in many countries to stimulate the take up of solar. Of note are Japan, the U.S.A., Germany, Japan, and Switzerland. Markets are very diverse - we at BP Solarex have supplied some 180 countries from Iceland to Namibia. President Clinton alone in 1997 announced a program to

produce one million solar roofs for the U.S.A. To increase the take-up of photovoltaics, and allow mass manufacturing and a virtuous cycle of falling costs, some governments provide grants to reduce the cost of solar system to the end user and so increase take-up. Green parties are increasingly being voted into national and local governments across Europe reflecting increased concern over environmental matters.

One such recent example is where BP Amoco announced that around 200 of its service stations world-wide are to incorporate solar power - the largest single project of its kind ever undertaken.

Solar electricity will help meet the power needs of all new service stations to be built in the UK, Australia, Germany, Austria, Switzerland, the Netherlands, Japan, Portugal and Spain. Solar installations will also be incorporated into prototype sites in France and the US as part of an extended pilot programme.

The first phase of the two-year programme will see up to 400 solar panels installed on each canopy at some 200 service stations across eleven countries in a \$50 million, 3.5MW project, saving around 3,500 tonnes of CO<sub>2</sub> emissions every year.

The level of power generated will vary from site to site. But at each, the solar panels on the canopy above the pumps will generate more clean energy than is consumed by the site's lighting needs, and the power requirements of the pumps below. The installations, which will be connected to the local electricity networks, will allow any excess electricity to be exported during the day and the shortfall imported at night.

The announcement follows a successful pilot programme at 19 sites in Europe, Australia, Malaysia and the US.

## Effect on the Solar Industry

So what affect is this growth in the grid connect market having on the solar industry. Firstly companies are adapting to a different market. There is now a need to consider reduced installation costs and architectural choice in solar module design.

Companies are reacting to this by producing modules without the aluminium mounting traditional frames, so called 'laminates,' so they can be clipped into the roof. Modules of up to 2m square are also being produced as mechanical lifting gear is available to fit buildings, and this reduces installation time rather than the traditional design requirement of being able to hand carry to remote locations. The solar module

effectively becomes treated in the same way as glazing. They can form part of the roof in a framework which at first glance seems very similar to that used on greenhouses. It can be designed as complete glass 'curtain walling' for the sides of buildings. Such products would not be practical for some of the parts of Africa

Another unusual development is the demand for coloured cell modules by architects who want choice of colour (solar modules are typically blue or black attracting the highest number of light photons). By reflecting more light to provide different colours such as magenta/gold, electricity output is reduced, however this gives architects a wider portfolio of products to choose from.

## The Future

The holy grail of the solar industry is lower cost and a higher efficiency product to compete even further with conventional power sources. Market growth is important as it leads to increasing economies of scale. To get a 'step' change in cost, however, needs above all technological development.

Traditionally the market has been dominated by the use of silicon as the base semi-conductor - 80% crystalline silicon 20% amorphous. As the silicon used in solar cells makes up the bulk of the cost, it is an alternative to this that research is focused. As an indirect semiconductor, silicon has the disadvantage of absorbing parts of the solar spectrum rather weakly. As all the wavelengths of the solar spectrum are potential sources of photon energy, it is usually preferential to maximise as much as possible what can be obtained from all wavelengths. This, however, is mainly characterised by the semiconductor used. Therefore the absorbing layer of the cell must be fairly thick (>200µm) which leads to a large consumption of expensive high purity silicon material. It also depends furthermore on the processing of silicon wafers which complicates and therefore adds to the costs of module production.

Alternative solar cell materials and cell designs have been under development for a number of years in many laboratories. These are now beginning to be commercialised in volume.

## Thin Film Solar Cells

These new processes are collectively known as thin film technologies. Here the solar material is deposited thinly on a large substrate like glass or stainless steel. Using a laser, or alternative method, the same device can be made into a correct voltage/current module meaning that the production step from cell to module is greatly reduced. With silicon, as mentioned earlier, it is a question of fabricating individual solar cells then electrically interconnecting them together, and finally packaging them in a weatherproof design. Thin films offer much less steps, so these technologies offer the potential for mass manufacturing automation techniques. There are currently three main and three minor contenders.

## Amorphous Silicon Cells

Amorphous silicon has been the only thin film process to date in mass production. It has had traditionally limited applications in



consumer devices principally due to its inherent degradation problems known as the Staebler Wronski effect, after the two scientists who discovered the phenomenon, and low efficiency inherent in this material. To overcome this problem, some manufacturers are launching tandem or even triple junction amorphous silicon cells. Here extra layers are added to the process to capture light at different bandgaps, this increases overall efficiency at the expense of increased cost.

## Cadmium Telluride

One prime contender for leading thin film technology is cadmium telluride. Here cadmium telluride and cadmium sulphide are used to produce a low cost thin film without the inherent stability problems of amorphous silicon. This material is just entering volume manufacturing.

## Copper Indium Diselenide (Copper Indium Gallium Diselenide)

This is currently the furthest away of the three main thin film technologies (cadmium telluride and amorphous being the other two) from commercialisation, nevertheless there has been considerable laboratory work on this method, and at least one company has announced plans to commercialise this technology.

## Crystalline Silicon Thin Film

Here to extend the benefits of silicon, but also achieve the same benefits of lower material utilisation, silicon is deposited on ceramics or another low cost substrate. One US company is working on this and another commercial venture is underway in Australia.



## Organic Cells

This is the most intriguing of the thin films. It is commonly called, the Graetzel cell after the Swiss professor who invented the technology. It uses the same principles as photosynthesis. There is an organic dye film which is located on a titanium dioxide conductor in liquid electrolyte. Although only recently worked on in the laboratory, the watch manufacturer Swatch are already working with an Australian company to commercialise this technology.

## Conclusion

Photovoltaics continues to mirror all the classic signs of a start up industry. Markets are expanding. New applications are leading to new innovations and new products. In Asia where camels and donkeys have been used to carry the product to site, the technologies are rapidly being commercialised. With the issues of climate change and environment increasingly at the forefront of the political agenda, the prospects for this technology are immense.

## References:

### *Photovoltaic cells - An overview:*

W. Wittling, R.P. Mertens, W.C. Sinke, H.W. Schock (Eurosun 1996)

### *Factors which maximise the kWh/kWp performance of PV installations in northern Europe:*

N.B. Mason, T.M. Bruton and K.C. Heasman (German PV symposium 1997)

### *Thin films, past present, future -*

Ken Zweibel (National Renewable Energy Laboratory 1995)

### *The development of coloured silicon solar cells for architectural applications:*

N.B. Mason, T.M. Bruton, K.C. Heasman, R. Russel and R.D.W.Scott (Eurosun 1996)

### *The achievement of 20% efficiency in a CZ silicon solar cell under concentration:*

T.M. Bruton, K.C. Heasman, J.P. Nagle R. Russel (13th EC photovoltaic Solar Energy Conference 1994).

### *Multi-megawatt upscaling of silicon and thin film solar cell and module manufacturing or "music fm" (Apasren act 94 0008):*

T M Bruton, J M Woodcock, K Roy, B Garrard, J Alonso, J Nijs, A Rauber A Vallera, H Schade, E Alsema, R Hill, B Dimmler

### *Photovoltaics - Paving the way for the technology of tomorrow:*

ENDS Report 270

### *Overview of Energy RD&D options for a sustainable future:*

European Commission JOU2-CT 93-0280

### *21AD Architectural Design for the 21st Century:*

Roaf S. Oxford, Brookes University 1996

### *Introduction To PV:*

Simon Roberts

## Can Solar Cells Ever Recapture the Energy Invested in their Manufacture?

Richard Corkish of the Photovoltaics Special Research Centre at University of New South Wales, Australia says of this: The answer to the title question, which crops up with regularity is a resounding, yes. His conclusion is based on various studies.

In 1989 a study was carried out of the energy costs for photovoltaic power stations (including grid connection) of monocrystalline silicon (such as are made by BP Solar in Australia), polycrystalline silicon (such as are made by Solarex in Australia) and amorphous silicon solar cells. They considered the three cell types under (a) actual 1989 German manufacturing conditions using manufacturer's reported energy consumption and (b) projected 1994 conditions. For the 1994 cases they assumed that cell efficiencies, production volumes, the size of photovoltaic installations and production capacity all increased and that production technology slightly improved.

For monocrystalline silicon cells based on the 1989 situation it was estimated that an input of 20.5MWh of conventional energy was required to produce each peak kilowatt (kWp) of photovoltaic power station capacity, leading to a payback period of approximately 86 months. Under the 1994 conditions the embodied energy was found to be reduced to 12.2MWh/kWp and the payback period to approximately 51 months.

With polycrystalline technology the production energy was 20.0MWh/kWp and the payback period was 84 months in 1989. For the 1994 case, in addition to the changes mentioned above, the cell thickness was assumed to be reduced from 0.45 mm to 0.2 mm and the embodied energy and payback time reduced to 9.0MWh/kWp and 38 months. For amorphous modules, figures of 13.3MWh/kWp and 56 months were predicted to be able to be reduced to 7.5MWh/kWp and 31 months.

A more recent (1992) study used data from commercial production lines for polycrystalline silicon and amorphous silicon cells. The polycrystalline cell factory they considered used silicon waste from the electronics industry as its material source and there is no obvious methodology for the estimation of its energy content - What is the energy content of material which would otherwise be wasted? Calculations resulted in payback times for 12% efficient polycrystalline modules to be in the range of 1.6 to 2.7 years, depending on the choice of European location in which they were used.

The corresponding payback times for 6% efficient amorphous modules was estimated to be 0.9 to 1.6 years.

The above summary shows that energy payback times for modules incorporating thick silicon cells are, at worst, of the order of six to seven years and possibly less than three years. Since warranty periods of 20 years are routinely offered on such modules it is clear that the embodied energy should be easily recovered.

However, it should be noted that the above payback periods assume that the modules are always operated at their maximum power points and no photovoltaic power is wasted or dumped, as would sometimes occur in many stand-alone systems, such as those using battery storage. Grid-connected systems do not incur such losses.

Finally, for Si and CDTe thin film modules used in a grid-connected module, the payback time is below two years, and with further developments should fall to below one year in the near future.

# PROJECT

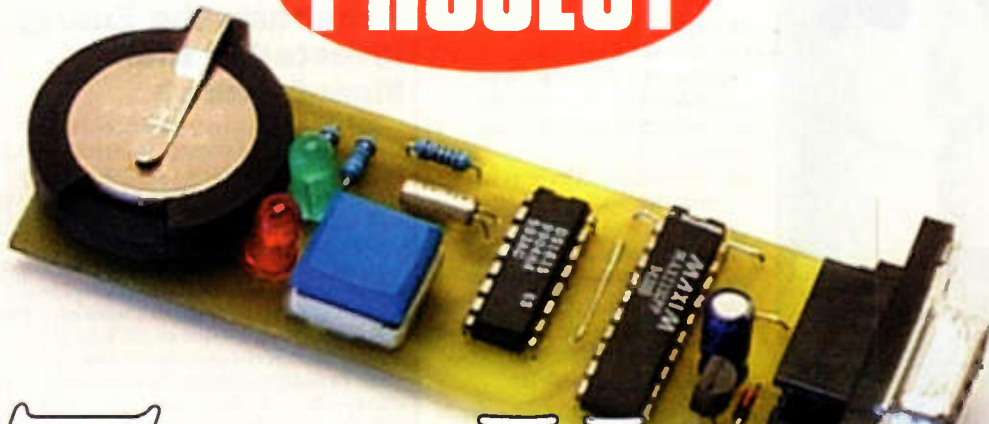

## Ten Year

# TEMPERATURE LOGGER

*Dr. Richard Whitaker describes a low power temperature logger design and the software.*

**W**hen I first saw the adverts for the DS1615 chip from Dallas, I was intrigued by the way it could capture temperatures and store them away, and all in one chip. The really amazing thing is that you only need seven components to make a working system.

### What's the Temperature in the Greenhouse?

I have always wanted to know how the temperature in my greenhouse varied during the day and on into the night. A max/min thermometer gives some idea of the extremes but can be fooled by the sun shining directly on the bulb or sensor, giving a false maximum temperature. A data logger giving a graph of temperature would tell the real story and this is the chip to make that possible.

Designs have to start somewhere so the first thing was to get the datasheet, which fortunately was found on the [www.dallas.com](http://www.dallas.com) Web Site. Providing data for new devices on the web is a great way to let people get started. Unfortunately the datasheet is only the start of the detective process which allows you to use

a programmable chip such as this. I wish data sheets had simple but real examples of how to use the device. I bet many clever chips aren't used because there are no good examples of how to use them.

The circuit is easily built on a piece of Veroboard, though a PCB gives a smaller size and it better controls the noise sources which can disturb the stability of the clock. I also wired up the switch and the red and green LEDs though these are not essential to run the device.

### The Circuit

The circuit in Figure 1 is made up of the DS1615 logger chip and a MAX232 RS232 interface. The MAX232 doesn't need any capacitors to generate the  $\pm 10V$  for the transmitted data. It would be cheaper to use a MAX232, but it would need four capacitors, which increases the component count.

The 5V supply for the circuit is collected from the RS232 interface. From the program, the DTR line is set high, which gives about +8V to +12V on pin 4 of the connector. The series diode D1 protects against having -12V on the pin, which is its low state. Finally the low drop out 5V regulator U2

provides power to the 5V side of the DS1615 and the MAX232. These together require about 2.7mA as measured in my circuit. Most RS232 sources will provide a short circuit limited current of 10 to 20mA, so we are well within range of the power which can be taken from the RS232 connection.

When the logger is disconnected from the PC and its RS232 interface, the DS1615 runs on the 3V lithium battery. Current consumption depends on how often the temperature is read, but calculations suggest that the lithium battery, type CR2032, will last for about 10 years at all sample rates. This doesn't take into account using current for the LEDs. I first used ordinary LEDs since they were to hand, but they are not bright at such low currents. It would be better to use special low current LEDs, which have a maximum current of 7mA. The current through the LEDs is given by the equation:

$$I_{LED} = (V_{BAT} - V_{LED}) / R1 \\ \text{which is } (3 - 1.4) / 1000 \\ = 1.6 \text{mA}$$

A low current saves battery power. For a brighter LED decrease the value of R1 to say 100 $\Omega$  for a current of about 16mA.

The switch SW1 and R3 are used to start a logging mission. The switch is debounced in the chip by needing to be held closed for at least half a second.

Neither the LEDs nor the switch is needed to run the circuit. All control can be done through the serial interface, though for testing it is good to see the lights flash.

The crystal is a 32KHz watch crystal. I used one from an old watch and also tried another from Maplin Electronics. Both seemed to work OK, but for accurate time keeping you should look at the Dallas data sheet for the best crystals to use.

There are other pins on U3, which can be used if the chip is directly connected to a microprocessor. Allowing pin 15, COMSEL, to go high selects the serial ASCII pins 13 and 14 instead of the microcomputer clocked serial interface. The serial ASCII is set to run at 9600 baud with 8 data bits. There is no choice of baud rate.

Pin 7, INT, can be enabled to generate a signal when the measured temperature exceeds the alarm values set in the chip. It can be used to generate an interrupt to a connected microprocessor. In this design I do not use it, at least not at the moment.

Be careful soldering the components. The crystal is sensitive to heat, so solder it quickly to prevent it getting too hot. The rest should be straightforward. Lithium cells are capable of sourcing high currents, which can be a hazard, so take great care not to short out the battery connections. The cell also has a potentially long life of 10 years. Any grease and moisture from handling the cell can add to the discharge rate and run it down before its time, so try not to bridge the positive and negative contacts with your fingers.

That's about all for the hardware of the logger, but it is no use without some software to set registers and read back data, so lets move on to making it active.

### The Detective Work

My first thought was that if all was working I could press the button and at least one of the LEDs would flash.

It was not so easy. When this did not work I looked around thinking about what may not be right. Was I providing power? The chip has two power



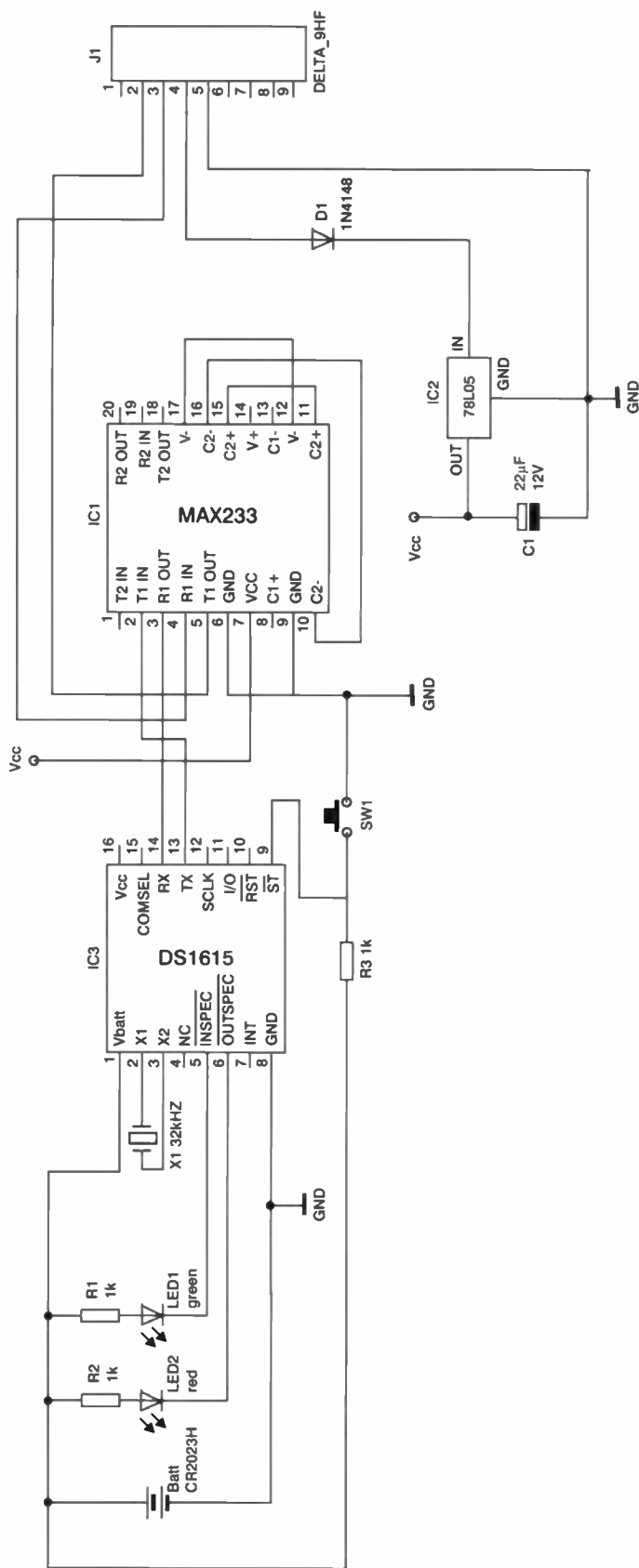

**Figure 1 - Circuit diagram**

supplies. One is the battery, which runs the circuit when it is recording data away from the PC, and the second is the 5V used to run the RS232 data link. The datasheet is a bit hazy on the battery voltage. I wasn't using a lithium battery for these tests. My experiments were with three rechargeable nickel

cadmium cells giving about 3.6V, and the 5V came from a stabilised power supply. What if I joined both power supplies together? Again it did not work. How about sending a command through the RS232 link to flash the LEDs? Still no success. After checking all the wiring and trying it all again I began to wonder if the chips I

had were faulty! In doubt blame the manufacturer. But I went back to the Web site and found an application note had appeared. There was more information about the battery and the 5V supply. For the RS232 interface to become active the 5V had to be applied to one pin and the battery had

to be no more than 90% of the 5V. In addition the battery voltage must be at least 2.7V.

Armed with this new detail I used a 3V lithium cell for the battery, and a 5V stabilised supply for the V<sub>CC</sub> pin. The LEDs still wouldn't flash, so I had to think again. I guessed that the crystal could be a problem, because I'd used one salvaged from an old watch which no longer had a working display. The datasheet says you should use a crystal designed for a 6pF load capacitance. I had no idea what my crystal needed. Again the datasheet says the crystal pins should have a 'guard ring' to prevent interference to the oscillator! My Veroboard didn't have any 'guard rings'; another source of doubt. I tried to use my oscilloscope to detect the oscillation, but it looked as though there was no sign of life. Perhaps with the whole circuit using so little power, by probing I was damping the circuit to the extent that it stopped. Another inconclusive test! I later found that you can probe pin 3 of the crystal circuit and see it oscillating, if it is turned on.

## Attacking the Serial Interface

It was back to the datasheet, and a fresh look at the RS232 commands that can read the data in the chip. Could I get it going and perhaps read some of the status bits? I am always nervous of commands, which consist of more than one byte. There are problems, of 'which bit is which'? Is D0 the least significant bit or the most significant bit? What are d0 to d7, a0 to a5, and a8 to a15? The more bytes the more chance of an error in understanding. Lets press on, though, the chip is split into 32byte blocks of memory called pages, so it should be possible to read page 0, without knowing the order of the bits. I use Power Basic, an MSDOS based Basic programming language, much like QBasic, running within Windows 95, to send the commands and read back the reply. MSDOS is still the easiest way to read and write to the serial port. The Dallas data sheet says that the bytes of a command must not be separated by more than 10-bit times, otherwise the system ignores everything. It seems that provided the bytes are sent in the same print statement, this is not a problem.

The following is an excerpt of code, which I would have liked to see in the data sheet:

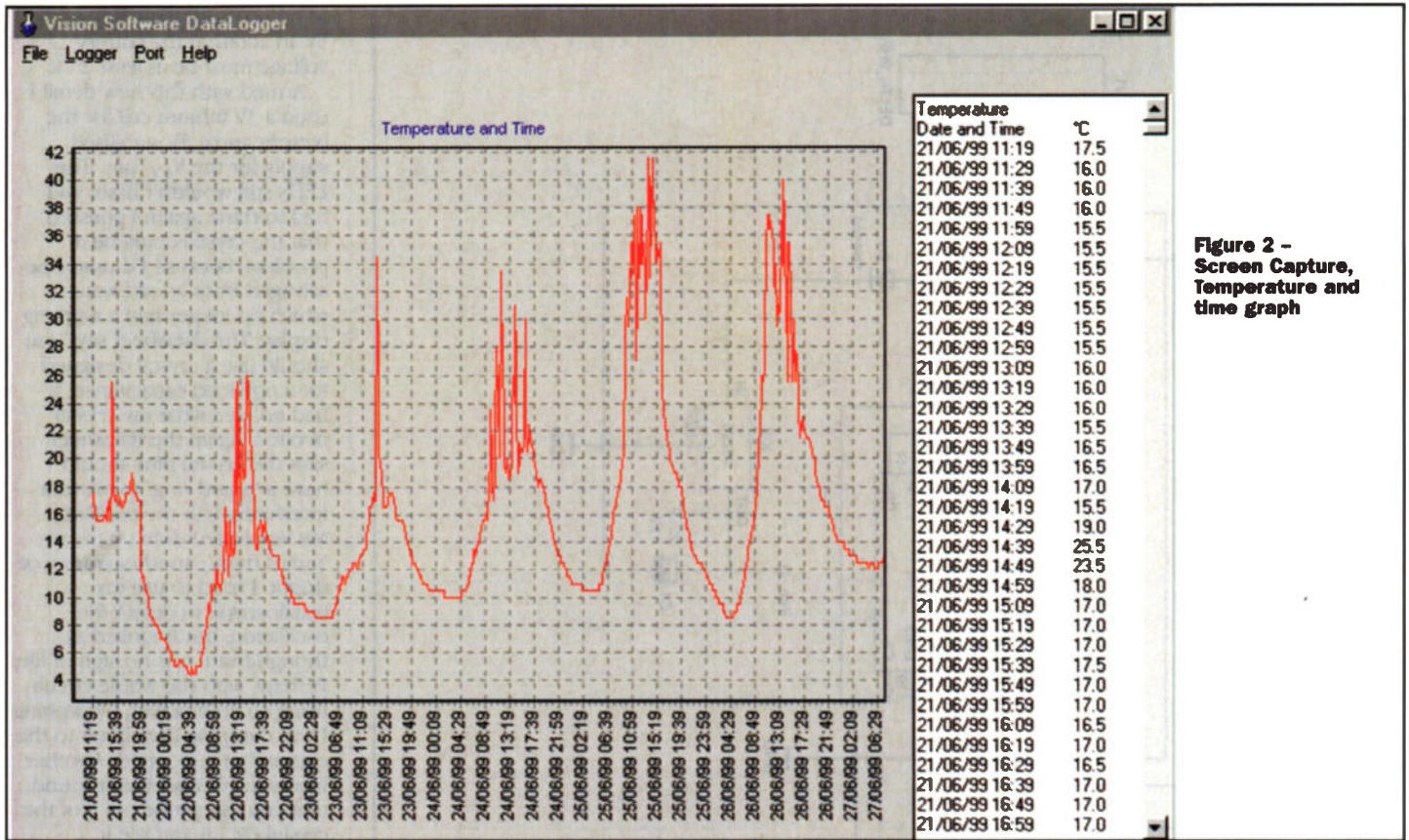

Figure 2 - Screen Capture, Temperature and time graph

The following is an excerpt of code, which I would have liked to see in the data sheet:

```

1 Open "COM2:9600,N,8,1,CS0,DS0,CD0,ME,FE" as 1 'the RS232 works at 9600 baud
2 delay 0.5 'allow -5V to settle
3 print #1,chr$(&H33);chr$(&H00);chr$(&H00); 'read data page 0
4 aa$=input$(32,#1) 'get 32 reply bytes
5 for i=1 to 32
6 print asc(mid$(aa$,i,1)) 'print the bytes 1 by 1
7 next i
8 ba$=input$(2,#1) 'read CRC which is 2 bytes

```

- Line 1 opens the serial port Com2 at 9600 baud and ignores all pins except 2 and 3, Receive and Transmit data.
- Line 2 is a delay of at least 0.5 seconds to allow the -5V to settle
- Line 3 prints the three-byte command to Com2 and onto the DS1615.
- Line 4 waits for 32 bytes to be read back.
- Lines 5 to 7 print the values on the screen.
- Line 8 reads the two byte Cyclic Redundancy Check that can be used to make sure the data was correctly received.

It worked! At last I could see the chip was alive. Prospecting through the data sheet reveals that the oscillator does not start if the EOSC bit is set to 1, which is the default value. Or at least that is true when the battery is the power source. When the 5V VCC is applied, the EOSC bit is ignored and the oscillator runs

anyway. I guess the default being that the oscillator is off, is so that when you deliver a 1 it but with almost no current drain. There are also a number of other bits to set up before the circuit is ready to start logging, though. This is the sequence to use:

1. Set the CLR bit to 1 to enable a Clear Memory
2. Set SE to 1 if you want to use the press button to start logging, or set SE to 0 if you want to use a program command to start logging
3. Send the Clear Memory Command
4. Send a Sample Rate command to set the number of minutes between samples and to start logging if a program set start is set up.

The code below resets the chip, then sets the temperature samples to one minute intervals, and waits for you to press the switch.

```

1 print #1,chr$(&H22);chr$(&H0E);chr$(&H50); 'clr=1 se=1
2 print #1,chr$(&HA5); 'Clear Memory - command
3 delay 0.5 'time for the memory to clear
4 print #1,chr$(&H22);chr$(&H0D);chr$(&H01); 'interval 1 minute

```

With the press button enabled, temperature logging does not start until the button is pressed and held for at least half a second. If you have the LEDs in the circuit, one or both will flash four times to confirm the start.

The built in real time clock will need programming to make best use of the collected data. I used the date and time in the PC to program the logger chip. When running on the battery, the clock acts like a watch keeping good time, with very little current drain. A battery such as the CR2032 should run the chip for about 10 years, if you don't use the LEDs!

## Displaying the Data - A Better Program

Having worked out how to program the chip I could now collect temperature data.

The temperature is measured in 0.5°C steps from -40°C to 85°C. Any temperatures, which have not been set in the logger memory show up as number zero, which decodes as a temperature of -40°C.

You can set the interval between temperature readings in one minute steps, up to 255 minutes. At one minute the 2048 samples gives recording just over 34 hours. At 255 minutes the total time is just over 362 days, but samples are some 4 1/4 hours apart. So there are quite a range of times that can be used before the 2048 bytes of memory are filled. If the memory overflows you can set the chip to record the last 2048 readings or freeze the first measurements. The histogram still gives the range of readings, when more than 2048 samples are taken.

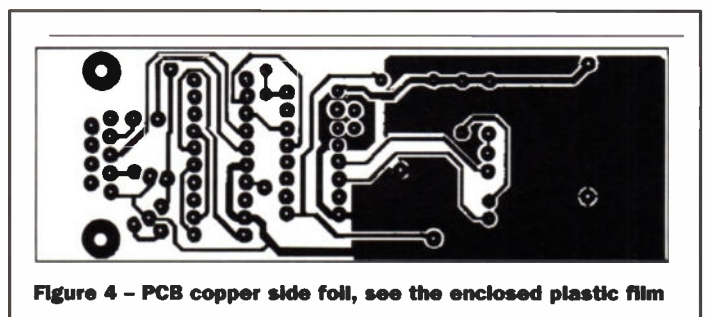

Figure 4 - PCB copper side foil, see the enclosed plastic film

## The Test Program

Here is a short program, which I set up to test the serial interface and read back some fairly raw data.

```
open "COM2:9600,N,8,1,CS0,DS0,CD0,ME,FE" as 1
10
cls
print
print "Commands"
print ""
print " q - Specification Test command - if recording data the LEDs will flash"
print " a - Read Page - zero, parameters, 32 bytes returned"
print " v - read all DS1615 data into the file data.txt"
print " z - Read Temperature - command, use 'a' to see the result"
print " c - Clear Memory and set the reading interval to 1 minute"
print " e - end"
do
loop until len(a$)>0
if len(a$)>0 then
if a$="e" then
print "Finished"
stop
elseif a$="q" then
' send the Specification Test command - if recording data the LEDs
will flash
print "Specification Test"
print #1,chr$(&H44);
elseif a$="a" then
cls
' Read Page - zero, parameters, 32 bytes returned
print #1,chr$(&H33);chr$(0);chr$(0);
aa$=input$(34,#1)
print "- page 0 -"
print "day ";hex$(asc(mid$(aa$,4,1))); " time
";hex$(asc(mid$(aa$,3,1)));
print " : ";right$("0"+hex$(asc(mid$(aa$,2,1))),2);
print " : ";right$("0"+hex$(asc(mid$(aa$,1,1))),2)
for i=1 to 32 step 2
if i=17 then print 0.5*(asc(mid$(aa$,i+1,1)))-40
print hex$(i-1),bin$(asc(mid$(aa$,i,1))),bin$(asc(mid$(aa$,i+1,1)))
next i
do
loop until instat
elseif a$="v" then
cls
open "data.txt" for output as #2
l=1
print #1,chr$(&H33);chr$(&H00);chr$(&H00); 'base data 0
aa$=input$(32,#1)
for i=1 to 32
print #2,asc(mid$(aa$,i,1))
next i
ba$=input$(2,#1) 'crc
rpint l
l=l+1
print #1,chr$(&H33);chr$(&H00);chr$(&H20); 'base data 1
aa$=input$(32,#1)
for i=1 to 32
print #2,asc(mid$(aa$,i,1))
next i
ba$=input$(2,#1) 'crc
print l
l=l+1
print #1,chr$(&H33);chr$(&H02);chr$(&H18); 'serial number
aa$=input$(8,#1)
for i=1 to 8
print #2,asc(mid$(aa$,i,1))
next i
ba$=input$(2,#1) 'crc
print l
l=l+1

for k=&H220 to &H27F step 32
hi%=k
shift right hi%,8
low%=k and &HFF
```

```
print #1,chr$(&H33);chr$(hi%);chr$(low%); 'alarms
aa$=input$(32,#1)
for i=1 to 32
print #2,asc(mid$(aa$,i,1))
next i
ba$=input$(2,#1) 'crc
print l
l=l+1
next k

for k=&H800 to &H87F step 32
hi%=k
shift right hi%,8
low%=k and &HFF
print #1,chr$(&H33);chr$(hi%);chr$(low%); 'histogram
aa$=input$(32,#1)
for i=1 to 32
print #2,asc(mid$(aa$,i,1))
next i
ba$=input$(2,#1) 'crc
print l
l=l+1
next k

for k=&H1000 to &H17FF step 32
hi%=k
shift right hi%,8
low%=k and &HFF
print #1,chr$(&H33);chr$(hi%);chr$(low%); 'temperature
aa$=input$(32,#1)
for i=1 to 32
print #2,asc(mid$(aa$,i,1))
next i
ba$=input$(2,#1) 'crc
print l
l=l+1
next k

close #2

print #1,chr$(&H33);chr$(&H10);chr$(&H20);
aa$=input$(32,#1)
delay .1
ba$=input$(2,#1) 'crc
print #1,chr$(&H33);chr$(&H10);chr$(&H20);
ba$=input$(32,#1)

laa$=aa$+ba$
for i=1 to 64 step 4
print hex$(i-1), 0.5*(asc(mid$(aa$,i,1)))-40,
print 0.5*(asc(mid$(aa$,i+1,1)))-40,0.5*(asc(mid$(aa$,i+2,1)))-40,
print 0.5*(asc(mid$(aa$,i+3,1)))-40
' print hex$(i-
1),bin$(asc(mid$(aa$,i,1))),bin$(asc(mid$(aa$,i+1,1)));
' print bin$(asc(mid$(aa$,i+2,1))),bin$(asc(mid$(aa$,i+3,1)))
next i
elseif a$="z" then
' Read Temperature - command
print #1,chr$(&H55);
elseif a$="x" then
' Write Byte - to address
address%=&H0E
idata%=&H10
print #1,chr$(&H22);chr$(address%);chr$(idata%);
elseif a$="c" then
print "interval 1 minute"
print #1,chr$(&H22);chr$(&H0E);chr$(&H50); ' clr=1 se=1
print #1,chr$(&HA5); ' Clear Memory -
command
delay 0.5
print #1,chr$(&H22);chr$(&H0D);chr$(&H01); ' interval 1 minute
else
print #1,a$;
end ifa$=inkey$
end if
goto 10

It works quite well but it is not very friendly to use. I wanted
something better.
```

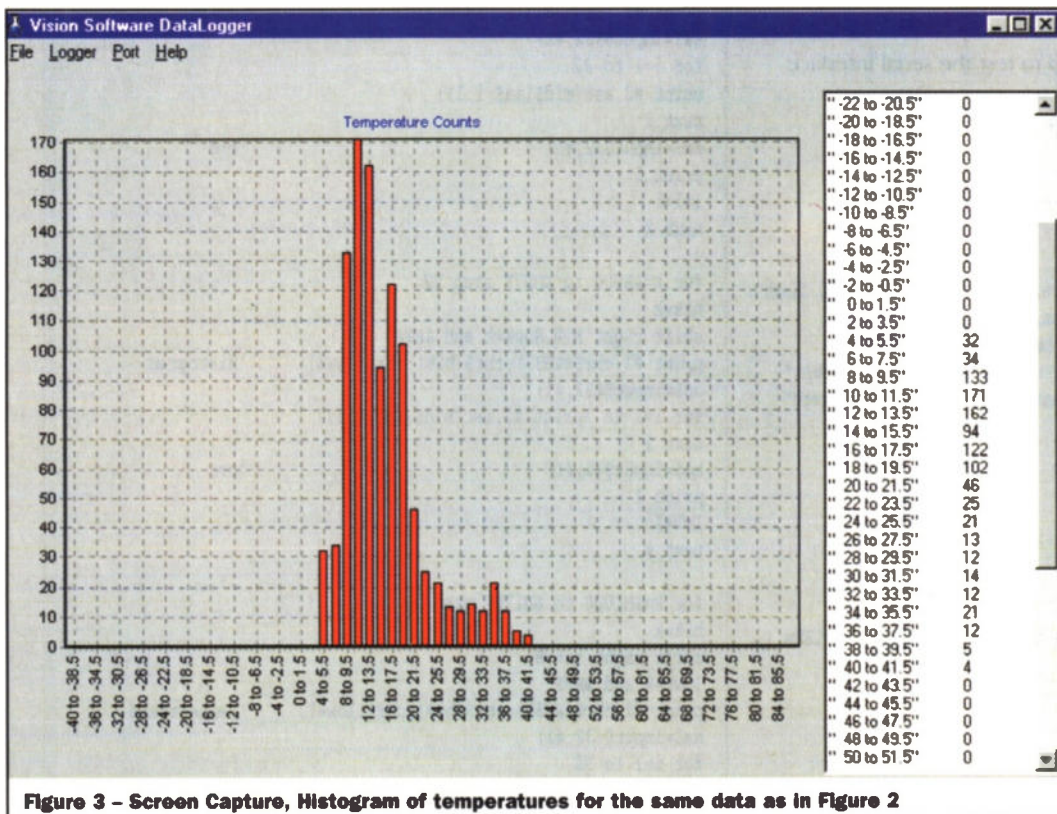

Figure 3 - Screen Capture, Histogram of temperatures for the same data as in Figure 2

To begin with I wrote the data to a file and used a spreadsheet to draw a graph. This worked well but took quite a time to work through. In the end I made a Windows program written in Delphi to control the logger and to draw graphs of the results. Delphi has a clever graph plotter, which draws the data quickly, allowing you to examine the detail through panning, and zooming. With the new program I could also extract extra information that the chip collects. In particular the histogram, which shows the count of the temperatures in two degree regions, is read and displayed. The chip also logs high and low alarm temperatures, which the new program can set and display. A couple of screens are presented here to show the output.

## Results

Now I could go back to the reason for building the circuit.

The screen shot in Figure 2 shows the temperature variation through six days in my greenhouse. There is a clear pattern of temperature rising during the day and falling in the night. Some of the other peaks correspond with the sun shining directly onto the DS1615 chip. It can raise the temperature well above the average. A maximum thermometer would only show the peak without showing the average. The logger gives much more useful information than a simple thermometer.

Zooming into the data displayed in the graph can be done by drawing a rectangle with the mouse from the top left corner to the lower right whilst holding the left mouse button down. You can also pan the graph by pressing the right mouse button and holding it whilst moving left, right, up, or down. The graph data follows

as the mouse moves. To reset the zoom, draw a rectangle with the left mouse button but start at the lower right and end at the upper left. If you zoom in enough you will see the 0.5°C steps in the readings. The time scale on the bottom of the graph will also show individual sample times.

The table on the right of the screen shows the measured data values, so you can look at the detail as numbers. You can mark the data in the table and copy it to a spreadsheet for special processing if you wish.

The DS1615 also collects counts of temperature readings in 2° intervals. These can be plotted as a histogram as shown in Figure 3. It shows which temperatures are most often recorded. Clearly the higher temperatures around +0°C only happen infrequently with most of the readings around 10 to 12°C, but with quite a few around 17°C.

Now I need a second logger to compare the inside and outside temperatures!

At last I have a way to log the temperature in my greenhouse. Perhaps I'll have a go at using the alarm output to turn on a heater in the cold of winter.

The program code can be downloaded as a file from the Vision Software site at [www.visionsoftware.freemove.co.uk](http://www.visionsoftware.freemove.co.uk). Both the PowerBasic and Delphi executable files are available.

## Points of Contact

1. References: DS1615 datasheet, Dallas Semiconductor, [www.dallas.com](http://www.dallas.com)
2. Application Note 116, Dallas Semiconductor

Thanks to Dallas Semiconductor and Silver Birch Marketing Ltd. for the samples.

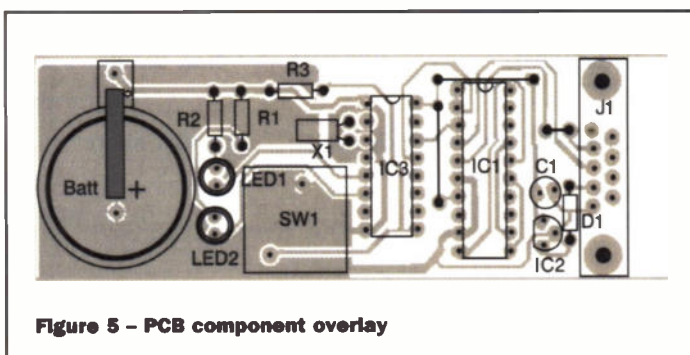

Figure 5 - PCB component overlay

## PROJECT PARTS LIST

### 10 YEAR TEMPERATURE LOGGER

**RESISTORS ALL 0.6W 1% METAL FILM UNLESS SPECIFIED**  
R1, 2, 3 1k

#### CAPACITORS

C1 22µF/12V electrolytic

#### SEMICONDUCTORS

D1 1N4148  
LED1 LED Low Current Green  
LED2 LED Low Current Red  
IC1 MAX233  
IC2 78L05  
IC3 D1615

#### MISCELLANEOUS

X1 32kHz watch crystal  
SW1 push to make  
J1 9pin D socket  
Batt CR2032 lithium battery



# Whats in store AT ABERDEEN



*Another Maplin store opens in Aberdeen.  
Information supplied by Debbie Hare, Store Manager.*

As now seems usual with a typical Maplin store opening, the queues were there waiting to see and buy the bargains on offer. Uri Geller also opened this store and performed his usual feat of spoon bending and radio aerial bending to the delight of the crowds. There was a variety of opening offers including the popular Xerox Work Centre 450 at £179-99. This was a particular bargain because it gave the customers a saving of £120. Needless to say, these items were extremely popular and they were all sold within days. The new store in Aberdeen has been a huge success in the first opening months. This is probably because there is nothing else like it in Aberdeen.

It takes all types to visit a Maplin store but an Elvis impersonator came into the store and bought an old fashioned style microphone and sang a few lines of an Elvis song before purchasing said item. Store manager Debbie Hare doesn't expect all her customers to perform a cabaret act before buying store items but it does make life more interesting!

Many customers are applying for the Maplin Freedom Card. This offers a quick and efficient method of paying for goods on account in store.

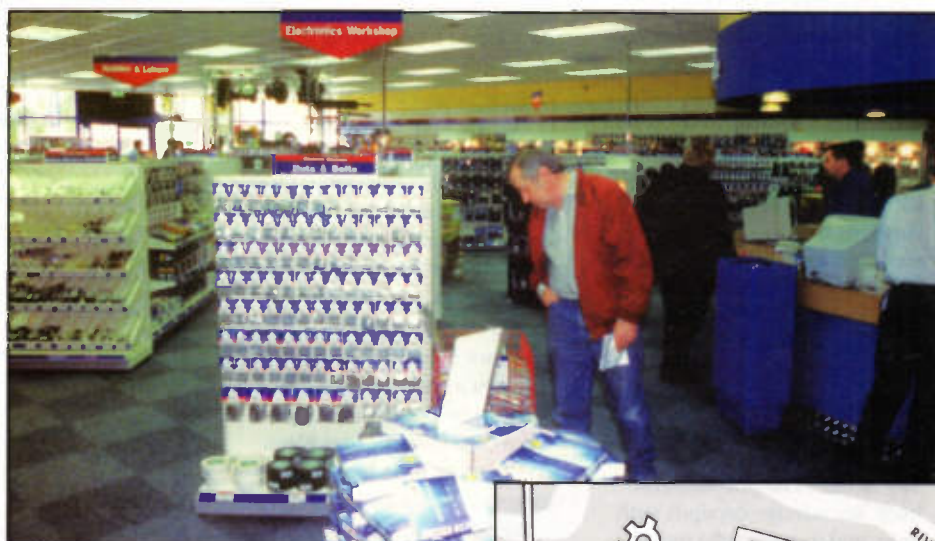

The Aberdeen store is 3500sq feet and holds a vast range of the Maplin products typically featured in the Maplin catalogue. As with all the other 52 stores, the new catalogue is available to pick up and buy.

If you are in the area, why not pop in and see what Maplin has to offer. The store can be found at: Unit 4, Haudagain Retail Park, Great Northern Road, Woodside, Aberdeen AB24 2BQ Tel: 01224 789567



# ASTROBIOLOGY

PART 2

*A Brief History of Life. In part 2 - David Clark looks at some of the alternative theories about how and where life started in the universe.*

## Historical Perspectives

Historically there have been several differing views on the origin of life, some of which seem ludicrous given the knowledge we have now. In a few hundred years will the knowledge available then make today's accepted views seem similarly naive?

## Divine Intervention

Theories about the creation of life have probably existed since the time when human beings developed thought, consciousness and an ability to discuss ideas. Common themes exist throughout all these theories though, and can be divided into categories. One, of course, is that the whole universe and everything in it were created by one god, a view espoused by today's relatively modern religions. Other religions revere more than one god, although one god is usually considered responsible for the creation and destiny of the universe. Earlier beliefs include ideas that have life emerging from under the earth, or that the Earth itself emerged from an oceanic world that existed before the Earth was created. Another theme is that of the 'cosmic egg', where the world breaks out from the shell, and yet another says that the world is the offspring of a primordial 'Earth mother' and 'sky father'. Like the universe itself, knowledge expands with time, and as more and more scientific knowledge has been gathered over the ages, less and less credence is placed in these theological and philosophical ideas, and yet throughout the world, a majority of people profess to believe in one God or another, including many eminent scientists. Science doesn't have the answer to everything!

## Early Modern Science

The sixteenth and seventeenth centuries were perhaps the time when the paths of science and religion began to divide. Mediaeval philosophers saw no problem with trying to understand the natural world; ultimately it was all still part of God's universe. However, once the suggestion was made that perhaps the Earth wasn't the centre of everything, the gloves were off. These times saw a rapid increase in the study and questioning of the natural world. William Harvey in the early 1600's was the first to show that living things could be studied experimentally but many scientists still believed the theory of spontaneous generation, or abiogenesis, which said that living things developed from non-living matter, for example maggots developed from rotting meat. Even after it was shown that complex organisms couldn't occur this way it was still believed that micro-organisms did until Louis Pasteur disproved this in the nineteenth century. Even Charles Darwin, the father of modern theories of evolution, not much more than a century ago was reluctant to publicise his theories as not only was he likely to be condemned by fellow scientists but his ideas could at the time have been judged to be legally blasphemous.

So despite all the evidence it isn't until comparatively recently that it became generally accepted that life evolved at all, let alone might have begun on another planet. However, there have been notable instances of far-sighted individuals, although unfortunately their unconventional wisdom became the cause of their downfall.

## Early Dissenters

In 1633, at the age of 69, Galileo Galilei was put on trial for teaching that the Earth went around the Sun. Because he recanted his beliefs leniency was shown and he merely suffered house arrest for the rest of his life. Perhaps he was a lot wiser than many of his fellow believers for on February the 17th, 1600, an Italian philosopher, astronomer, mathematician and former priest was gagged, bound to a stake and burned alive. A victim of Pope Clement VIII and the Venetian Inquisition, Giordano Bruno had believed and dared to say that the Earth circled the Sun and that the universe might be infinite and contain countless solar systems like that of the Sun, implying there might be life on these. The more fortunate Galileo was finally officially absolved of heresy in 1992. Which ridiculed beliefs of today might be conventional wisdom after the next four hundred years?

## Modern Alternatives

One alternative theory for the beginning of life is that it did not begin on the surface of the planet at all but beneath the surface. Evidence for this possibility is the existence of organisms deep underground in caves where there is no light at all, and perhaps even more incredible the existence of organisms living around the 'black smokers' on the deep sea beds, where volcanic material is being ejected through the Earth's crust. There is an abundance of minerals around these and a source of energy, namely heat, that has nothing to do with sunlight. Interestingly these organisms, as do some others in sulphur rich environments, use the sulphur atom in their metabolism where 'normal' organisms use oxygen.

## Molecular Self-Assembly

Another theory suggests that as conditions were so different to those of today, life may have originated from molecular 'self-assembly'. This is based on the discovery that under certain conditions of temperature and pressure, complex organic molecules form from simpler ones by the action of straight molecules physically linking with others. It does this by interlocking, like the links of a chain, rather than by chemically reacting with each other.

Figure 1 - Atoms

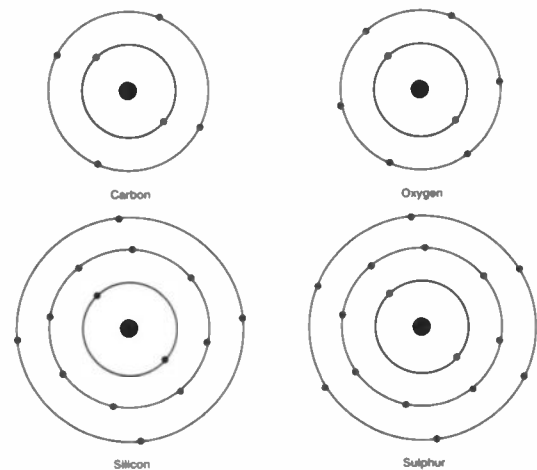

Atoms are composed of a positively charged nucleus (consisting of protons and neutrons) surrounded by negatively charged electrons in 'shells'. The inner electron shells are stable and shield the outer electrons from the nucleus, so that the outer electrons are free to interact with the electrons of other atoms. It is primarily the number of outer electrons present that determines how an element reacts and which compounds it will form, and so silicon is found to react similarly to carbon, and sulphur to oxygen.

Could life somewhere in the universe be made of silicon and sulphur instead of carbon and oxygen?

**Figure 2 - Cometary orbit**

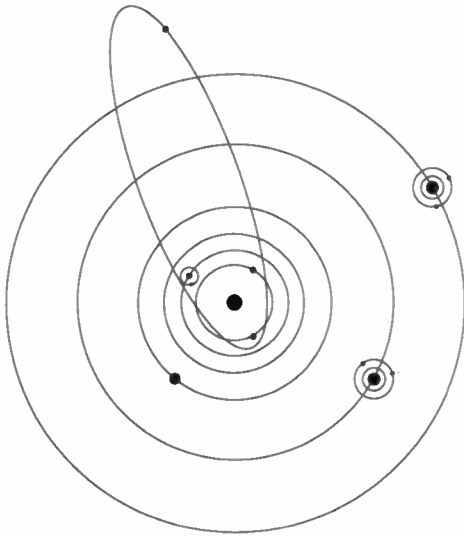

The path of many comets crosses the paths of planets. Could organic material or even primitive micro-organisms have been transferred from planet-to-planet by collisions?

## Life, Not As We Know It

Life on Earth is based on carbon and water. At the temperatures found on Earth the chemical bonds between carbon, hydrogen, oxygen and nitrogen are the most stable and hence most common, and the elements themselves are among the most common. At lower and higher temperatures other bonds become more stable, for example silicon bonds and silicon oxygen bonds, and there are other compounds that are

liquid at lower temperatures. Typical examples are ammonia and hydrogen cyanide; these also are composed of hydrogen, nitrogen and carbon. There are organisms on Earth that use sulphur instead of oxygen, and in fact at cellular level oxygen is poisonous, needing specialist structures within the cell to use it; this is probably a consequence of the first organisms evolving in an environment where there was little oxygen significant amounts of oxygen in the atmosphere only came about when plants started to convert

**Figure 3 - The Structure Of A Comet.**

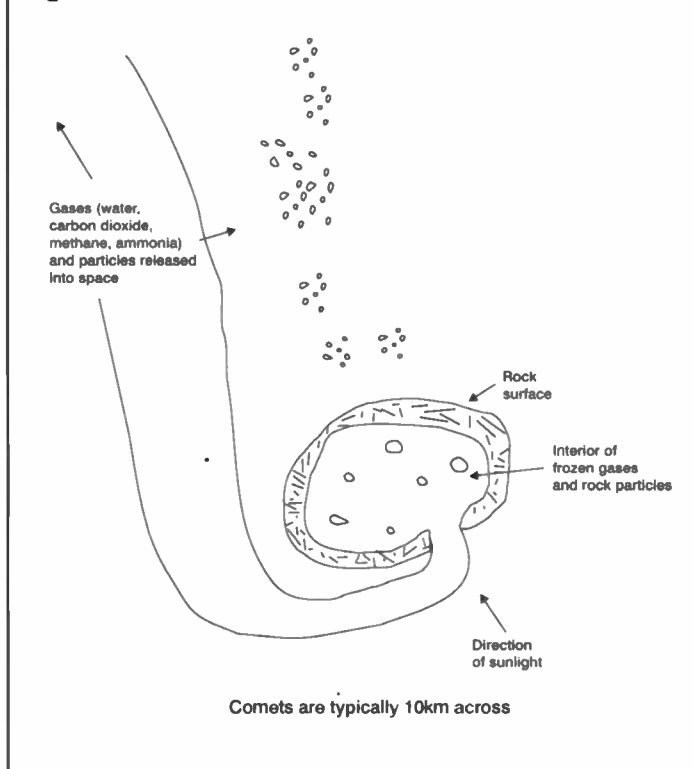

carbon dioxide to oxygen via photosynthesis. Could life based on these other compounds exist somewhere, and would it be recognisable as life to us since we have no experience of such life?

## Life Began On Mars

Mars is historically a very popular location for extra-terrestrial life, both scientifically and in fiction (probably as a consequence of Giovanni Schiaparelli's discovery of the 'canals' of Mars), and in fact is currently thought to be one of the most likely candidates for the discovery of present or past life, though probably not in the form of small green-coloured beings! At the time the claim was that the 'canals' on Mars were evidence of the work of extra-terrestrial life; the fact that they weren't canals at all wasn't proved conclusively until 1969 with the Mariner spacecraft missions, nearly a century after the first suggestion.

## Life From Other Planets

Also in the late nineteenth century the theory that life began somewhere in outer space and moved from planet to planet via radiation pressure became popular among some scientists. This theory is remarkably close to one of the currently favoured 'alternatives'. The original idea was that life came into existence at the same time as the planets (exactly how was not specified!) and 'drifted' through space, from planet to planet. Currently credible is the theory that life or pre-life (pre-biotic) compounds could have evolved elsewhere and been carried through space not by radiation pressure but in comets, asteroids or meteors.

## The Evidence

Going further and further back in time, less and less complex organisms are encountered until the point is reached where all life began, a single step from a non-living collection of chemicals to a living entity capable of maintaining its structure, interacting with its environment and replicating itself. At this point the environment would have been a liquid one, and the existence of water on a planet is one of the main criteria for the search for life there. Many things need to happen to reach even this

stage however and the beginning of life can really be considered to go back to the point when stars, planets and galaxies began to form as the universe expanded and cooled, for it is this point when the pre-conditions for the many possibilities of life-forms began. Every element, every atom of every molecule throughout the universe exists as the consequence of the creation and destruction of stars, but these materials aren't confined to the surfaces of planets, and the same ones aren't found everywhere in the same proportions. These proportions, or relative abundance's, provide good clues as to what came from where, and when.

## The Planets

The relative concentrations of the elements making up each planet depends on the differing 'local' conditions present when the planet formed. The relative abundance of all elements throughout the universe is known, a sort of 'universal' relative abundance, and each planet's 'local' relative abundance can be found. This might be quite similar to that of other planets, or it might be greatly different. Our own solar system shows great differences between the make-up of the planets and their moons; it surely cannot be impossible that this pattern is repeated along with many other variations throughout the many systems in the galaxies of the universe. The giant planets (Jupiter, Saturn, Uranus and Neptune) have compositions closer to that of the universe in general than do the inner Earth-like planets. Because they are larger and colder, these 'gas' planets have held onto their atmospheres of mainly hydrogen and helium, and also methane, ammonia and water.

The fact that they were cold enough for some of the gases to freeze is the factor that makes the giants become, and stay, giants. The smaller hotter planets Mercury and Venus however probably lost their lighter gases at an early stage through a combination of high temperature and lack of high enough gravity, although Venus has a dense atmosphere of carbon dioxide. Earth retained its atmosphere, but the subsequent development of life meant that the early composition was converted to the current abundance of

Figure 4 • Figure 4. Ecology.

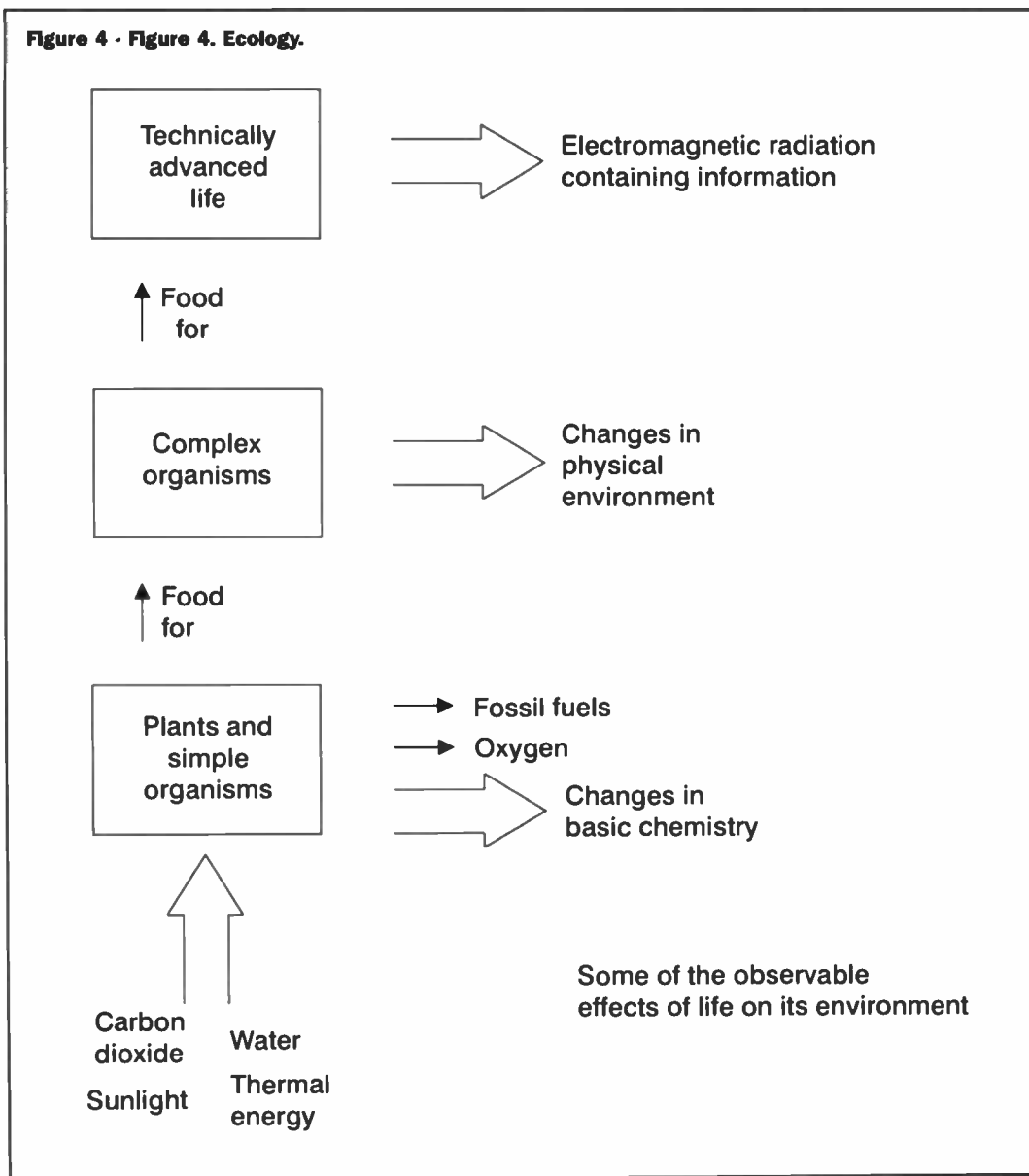

## Asteroids, Comets and Meteors

Asteroids, comets and meteors are all believed to originate in the asteroid belt, between Mars and Jupiter, and are pieces of material 'left-over' from when the planets formed. As such they haven't suffered the changes that usually occur to material on the planets, for example physical processes such as weathering and volcanic activity. Comet interiors are primarily water (80%) and some people believe that the continuous bombardment of Earth by small comets was sufficient for this to have provided the Earth's water. Comets are equally important as a possible source of pre-biotic chemicals, as they contain many carbon, hydrogen, nitrogen and sulphur compounds like the frozen gases carbon monoxide (CO) and carbon dioxide (CO<sub>2</sub>), methane (CH<sub>4</sub>), ammonia (NH<sub>3</sub>), and carbon disulphide (CS<sub>2</sub>). They also hold small pre-biotic chemicals such as hydrogen cyanide (HCN), methyl cyanide (CH<sub>3</sub>CN), and formaldehyde (HCHO), as well as larger molecules such as amino acids, purines and pyrimidines, chemicals found in all Earth life.

The larger molecules have been found in the meteorites known as carbonaceous chondrites that have been collected on Earth. The material composing a comet, ice and rock particles surrounded by a rocky shell, is slowly shed through the action of the Sun's heat or more dramatically through collisions as it orbits the solar system. The comets orbit the Sun like the planets, but the path is elliptical and can range from nearer to the Sun than the Earth, to around one third of the distance to the nearest star (Alpha Centauri, 4.3 light years away). The gases dissipate into space, but the particles remain in the same orbit as the parent comet, and these paths cross the paths of the planets, including the Earth, causing meteor showers. These can be seen dramatically at night as shooting stars, but in fact these collisions occur continually, adding around 400 tons of material to the Earth, including these pre-biotic molecules, every day. The comets have orbit periods that range from that of Halley's Comet's at 76 years to those of several millions of years - did one of

oxygen. Mars appears to have had an atmosphere and then lost most of it some considerable time later, but perhaps not before the time necessary for life to come into existence (life had developed on the Earth within the geologically short timescale of about one billion years after Earth formation). Could life have existed on Mars and then been extinguished when the atmosphere became insufficient to support it?

The relative abundance's of the elements composing the molecules of life on Earth, mainly hydrogen, carbon, nitrogen and oxygen, lie between the universal composition and the local Earth composition, fitting in with the theory that life evolved in a hydrogen-rich atmosphere and then evolved and oxidised the hydrogen, carbon, methane and ammonia to water, carbon dioxide and nitrogen, and once this stage was reached conditions were no longer

suitable for the development of other life-forms, and the line of evolution leading to the present day was in place.

Any system of planets orbiting a star must have the same pattern, planets near the sun being small and hot, those further away being large and cold. Part of the work of astrobiology is to find a range of conditions which will support an environment where life can exist, then see if newly discovered solar systems hold planets within that range, giving a good starting point on which to base the search for life.

### Planet Satellites

The satellites, or moons, of the planets were either formed at the same time as their parent planet, perhaps by catastrophic collisions which split the larger planet, or were independent bodies that were captured by larger ones. (Some are believed to be the result of the breaking

up and then the reformation of a planet-sized body). This explains how one planet can be surrounded by moons with greatly different characteristics. The size and hence gravity reflects the capability of a planet to capture another body and so as might be expected the larger planets have more satellites than the smaller ones.

Additionally, if the planet was hot at the time of satellite formation or capture then the satellites reflect a similar pattern to the planets around the sun in that the nearer ones tend to be rocky whereas the outer ones tend to be mainly frozen water and gases. The simple rules that guide the formation of planets, moons and solar systems must surely mean there are many similar systems in the universe with the range of conditions and materials necessary for life to come into existence.



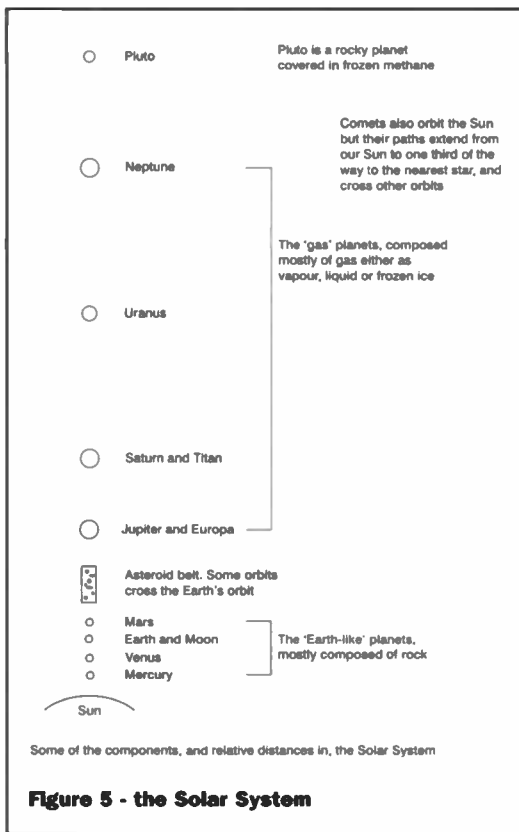

**Figure 5 - the Solar System**

these passes bring the material that gave the 'kick start' to the evolution of life? Materials from Mars, the Moon and Venus have been found in meteorites that have hit the Earth; they must have picked up that material on another collision. Could others have come from somewhere else in the solar system or beyond, transporting materials from another planet which was already carrying life or on its way to developing it?

These then are some of the basic facts largely accepted by current thinking. But as our knowledge of our own Earth and the life on it has increased, the number of possible alternatives has become larger, increasing the probability of the existence of life somewhere else. Our current knowledge of Earth micro-organisms shows that some bacteria can survive radiation, vacuum and extremes of temperature, which raises another incredible possibility.

## Extreme Life Forms On Earth

The number and variety of species of plants and animals, birds and insects, bacteria and fungus on Earth is spectacular, each with its own special adaptations to its own environment. Nevertheless the great majority survive only within a relatively narrow range of conditions, particularly with respect to temperature and moisture. More and more

salt solutions, and in the dark, cold and high pressure at the bottom of deep sea trenches. Additionally it is recognised that some of the extreme environments on Earth are similar to the environments of some of the planets and moons of the solar system. Parts of Antarctica are very dry (and cold!) and similar to the surface of Mars. Also in Antarctica, a large lake is known to exist beneath four kilometres of ice (Lake Vostock); the same type of lake is believed to exist beneath the icy surface of Jupiter's moon Europa. The organisms present in the Antarctic lake have been isolated from the rest of the planet for millions of years, pursuing their own independent evolution. What similarities might these two places exhibit? Could it have been guessed that bacteria accidentally introduced into a camera sent to the moon with the Surveyor 3 probe and retrieved by the Apollo 12 astronauts would come back to life on Earth in a petri dish, as if nothing had happened to them in three years of exposure to the moon's cold, vacuum and radiation?

This then raises the further dramatic possibility that not only could life exist in the more extreme conditions of another planet, but also that the life that evolved on Earth could have begun its existence on another planet and was transported to

Earth via meteorite hits. Could our most ancient predecessors have been carried from planet to planet by rocky spacecraft? These alternative theories are controversial - what evidence would be needed to prove them? How would that evidence be found? Scientists are discovering that the best way to find what to look for in space is to examine the Earth first.

## Environment

Once life has started and gained a foothold, then its immediate environment begins to be affected. Local chemicals are absorbed or converted and waste products are introduced. The population grows and must either move to find new sources of nutrient or adapt to the changed environment. For different species to survive together resources must be shared. If this is done successfully an increasing number of individuals and types form an ecosystem. The chemical nature of the environment is altered. Samples of the environment need to be analysed to find out how it is changing, and why.

## Biospheres, Nutrient Cycles and Activity

Collections of ecosystems themselves interact, and form a biosphere, the layer of a planet that contains life. As life evolves this grows from perhaps initially the surface of the oceans, and then eventually covers land masses too, and eventually stretches from the bottom of the deepest ocean into the atmosphere. Areas of land and sea can change colour on the short timescale of the yearly seasons, or over longer periods with the development and interaction of different species. Images of the surface over periods of time are needed to see this.

## Food Webs, Pyramids and Energy Flow

Energy from the sun, and heat from deep sea thermal vents, is used by countless simple organisms to convert simple chemicals such as carbon dioxide and water to more complex organic chemicals. These organisms become food for a smaller number of more complex organisms that can't

produce the basic materials themselves, and these in turn become food for a yet smaller number of even more complex creatures, and so on. This is a food chain composed of numbers that decrease as they increase in complexity, a pyramid structure. There is interaction between the food chains; a food web develops, and material and energy interconvert. Temperatures of large regions of a planet can change. Infrared imaging is a good way of showing regions of differing temperature.

## Populations, Co-operation and Intelligent Activity

Collections of individuals of a species form a population, and co-operate to make the most of their environment. Where capable, species physically alter their environment; buildings are made, towns and cities develop; roads and motorways grow. Large areas consist of angular shapes, and at night lights that can't occur by chance dot the planet surface. Close-up or ultra-high resolution images are needed to see these from space.

## The Final Stage? - Technological Sophistication

Information needs to be exchanged to run these systems effectively. Eventually communication needs to be made across time and distance; letters aren't fast enough; telephone wires can't be made long enough, or reach enough people easily enough; radio communication is needed. Electromagnetic radiation spills into space, and can easily be detected with suitable electronic equipment.

## Signs Of Life

Any living activity then, no matter how primitive, leaves its own signature, which we can observe if the appropriate scientific technique is used. To find life elsewhere we need to look for these signatures and make deductions from the results of those searches. In the concluding part of this series I'll be looking at what might be found, where it might be found, and at the science and technology of the equipment being used to find it.

# Edison 3 REVIEWED

Gavin Cheeseman samples a new piece of software from DesignSoft

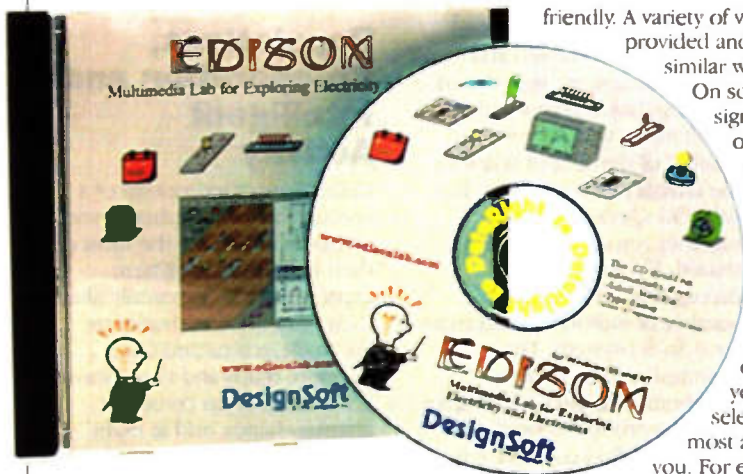

For anyone starting out in electronics, learning even the most basic principles can be a long and arduous task. Text book explanations are all very well but applying the theory to a practical situation is often a major hurdle. Those inexperienced in circuit construction may spend hours building a circuit only to find that it does not work when switched on. Even a small error can stop a project from working correctly and for the inexperienced fault finding is often near impossible. Even worse, errors can be quite expensive in terms of damaged components, and if your first circuit fails miserably you may well be put off electronics for life. There is also the point that hobbyists starting out in electronics often may not have access to equipment such as signal generators, oscilloscopes or variable power supplies.

Wouldn't it be nice if you could learn how to correctly wire up and fault find circuits in a safe environment where errors could be quickly identified and rectified without all the expense. You may be surprised to learn there is a piece of software that can help considerably.

Edison 3 is an interactive software package aimed at anyone learning fundamental electrical principles. The program, which that runs under Windows, provides basic tuition and allows experimentation within the safe virtual environment of your PC. The easy to use package allows users to attain an understanding of circuit operation and test equipment in a on screen environment before going to the expense of purchasing the real thing.

The software creates a 3D representation of a circuit board onto which components can be picked and placed. Most common component categories are catered for. Examples are resistors, capacitors, operational amplifiers and logic gates. The components may be selected and placed onto the virtual board where the required interconnections can be added. The whole process is simple to grasp and very user

friendly. A variety of virtual test equipment is provided and may be selected in a similar way to the components.

On screen power supplies, signal generators, oscilloscopes and voltmeters for use with the virtual circuit are all available at the touch of a button. The test equipment settings can be adjusted to enable various characteristics of the circuit to be displayed or alternatively you can let the software select what it considers the most appropriate setting for you. For example, the signal generator allows adjustment of the frequency, phase and amplitude.

The on screen oscilloscope display can be set for continuous or single shot operation. The latter is useful for displaying transient waveforms such as those produced by charging a capacitor through a resistor. The result is captured and by right clicking on the oscilloscope screen a larger scale graph may be displayed showing the timing in more detail. The software will even display some of the more complex parameters such as phase difference. Changes in signal amplitude as a result of the frequency response of RC circuits are also easy to demonstrate. For more accurate measurement of the virtual circuit, the oscilloscope has an on screen cursor that can be positioned at different points on the displayed waveform. Time and instantaneous amplitude values are shown numerically on the oscilloscope screen.

In addition to displaying the circuit as a 3D representation, the corresponding circuit diagram is also shown. This is generated automatically when the components are placed and connected. Component values may be entered by clicking on the relevant

component and typing in the required details. Once entered, the values may be changed at any time. This can be useful as you can design a basic circuit configuration and play about with the values on screen. The software will then carry out simulated measurements displaying responses and voltages. Although the software does not offer all the features of some more expensive circuit analysers, it is an ideal way for beginners to get to grips with rudimentary electronic principles and provides an aesthetically pleasing environment to work in. More experienced users may also find some of the simulation features useful.

The results are displayed in a number of ways. For example, the charging curve of a capacitor may be displayed as a mathematical function or in the form of a graph. But the fun doesn't stop there. In some cases an audio visual display is provided so that in addition to seeing what is happening with voltage and current in the circuit, you can also see lamps illuminating, hear the output from virtual loudspeakers and so on. Lamps even explode when over-voltaged and are accompanied by the sound of breaking glass! You can also repair the lamp as easily as you have destroyed it and such features are particularly useful when learning basic fault finding techniques.

A number of pre-designed problem sets are provided. Some of these present a faulty circuit and the student is asked to define which of the circuit elements is likely to be faulty. Other problems define working circuits and ask the student to calculate specific values for components or other parameters such as voltage and current.

There are also a variety of experiment sets. These are predefined circuit configurations that provide a graphic illustration of the operation of a circuit. The student can adjust component values or other circuit parameters and observe the results on screen. Prompts are given to explain what is happening on the screen and to show the user how to carry out the experiment.

A comprehensive demo is provided and is a quick way to familiarise yourself with some of the main features of the software. In addition there are step-by-step instructions on the disk but users who are familiar with the Windows operating environment should have little trouble with finding their way around the program.

All in all the software is very impressive and provides a good companion to traditional electronics text books. It is fine reading about the theory but with this program you can actually try circuits out for yourself and see the effects of different configurations without ever having to even look at a soldering iron. If you are starting out in electronics then this software package may be just what you need.

Edison 3 is available from **Maplin Electronics**, order code **VT55K**, price **£79.99** including VAT.

## WIN A COPY OF EDISON 3 FROM DESIGNSOFT

Fill in the coupon and return to the Editor, and the first name out of the hat will receive a copy. Entries to be returned by 10th December 1999.

Name \_\_\_\_\_  
Address \_\_\_\_\_  
Town \_\_\_\_\_ Post Code \_\_\_\_\_

All employees of Maplin Electronics are excluded from entering, multiple entries will be disqualified. You may photocopy this coupon. Send your entries to: The Editor, Electronics & Beyond, PO Box 777, Rayleigh, Essex, SS6 8LU.

## Freenetname

There are dozens if not hundreds of free Internet service providers - they seem to pop up day-by-day with a relentless regularity. Most of these offer me-too free Internet access (well, free as far as the service itself is concerned - phone charges, on the other hand, are another business) after all, but few of them have a good gimmick that makes people actually want to use the service they offer. Yes, some do give some small level of free phone calling access (say at night, or over the weekend) to grab customers, but we're a long way off yet having totally free Internet access.

Freenetname is a new service that tries a different tack to get customers. As well as offering Internet access for free, it allows registered users to have a free domain name. With an individual domain name you can have a Website with a pretty individual URL - something like <http://www.crazy-for-you.co.uk>, and a resultant email address [the-boss@crazy-for-you.co.uk](mailto:the-boss@crazy-for-you.co.uk) that's pretty individual too. Usually to get a domain name, Internet users have to pay a yearly sum to register and maintain it, and the registration procedure is often enough to put people off. However, Freenetname takes care of all the registration process for you, giving you your very own domain name and maintaining the Web space for that domain's Website - quite literally, for free.

Try it yourself, and grab a domain name that suits before someone else does, at <http://www.freenetname.co.uk>.

## GoClick

Mac users who need to generate HTML documents have many tools at their hands as around two-thirds of all Web pages on the Internet are produced using Macs, after all. But probably none so clever or so cool as GoClick - a Chooser extension that makes the Mac think it's printing to a conventional printer, when in fact it's generating HTML commands. All you need to do to use it once installed is to choose it in the Chooser (as a Mac user selects any printer to print to), then print. It's as simple as that. It doesn't matter what application you're running - be it Microsoft Word or any other word processor, Microsoft Excel or any other spreadsheet, any drawing package you care to use, or anything else - as long as it's got a Print command then GoClick will work. It's effectively a system-wide method of generating HTML code.

In the subsequent printing process GoClick saves your document as an HTML version, and saves any associated graphic images in a folder alongside the HTML document - it's just that GoClick prints to a disk file, not to a real printer, that's all. Where it can, GoClick converts text to the closest HTML text style it can, maintaining the appearance between your original document

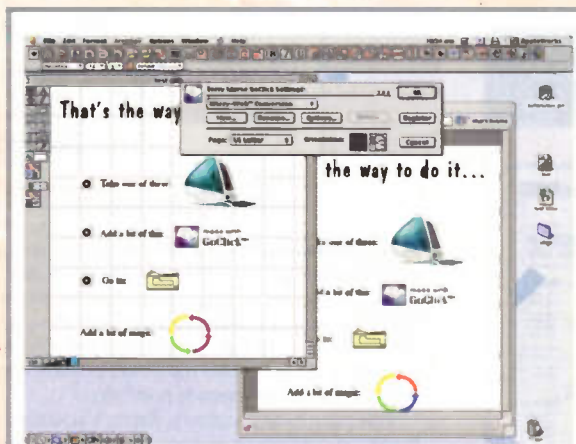

Creating a Web page from AppleWorks (left window), using GoClick (settings dialog box in centre), to a Web browser page (on the right, in the background)

and the outputted HTML document. If GoClick can't match text to an HTML style it converts the original text to an image, which it then places on the outputted HTML page. If you're a Mac user and this technique sounds familiar to you, it's probably because GoClick's sister utility Myrmidon, operates in a similar way. GoClick is merely better in its capabilities - being able to output HTML documents according to the latest HTML version 4.0 standard, with cascading style sheets and the means of handling overlapping objects, various text alignments and much more.

Get details of GoClick, and download a trial or full version from <http://www.terrymorse.com>. GoClick costs \$159 and discounts are available if you're an education user or if you're upgrading from Myrmidon 2.1.

## A More Secure Army

On 28 June this year, an Internet intruder hacked into the main Website of the US Army, maliciously modifying the Army's home page contents and also gaining access to an internal Army network, where he removed and modified computer files to prevent detection. Naturally, this wasn't considered the best of taste by the Army and, following an intense investigation by US Army CID investigators, the FBI arrested the culprit and his trial is awaited. This was no casual entrance to the Army Website neither - the 19 year old arrested is a Green Bay, Wisconsin US man, who has been identified as a co-founder of a hacker organisation calling itself Global Hell.

Simply because of what they are i.e. high profile and visible Websites, Government networks pose an obvious invitation to hackers. The US Department of Defense is now laying down the groundwork for more secure Internet sites that will prevent unauthorised access to information. The Website in question: <http://www.army.mil> was using Windows NT at the time, which is notorious for security loopholes and hacker incidents, but since the intrusion has moved to a new platform and software - Apple Macintosh personal computers complete with Mac OS software, running WebSTAR Web server software.

The decision to move to Apple Macintosh computers was based on the World Wide Web Consortium's (W3C) report on findings in a survey looking at the security issues of the various computer operating systems and Web server software packages that are available. According to the Consortium's published reports on its findings, the Apple Macintosh platform is inherently more secure than any other platform because it doesn't have a command shell, and because it doesn't allow remote logins. The report also says that the Consortium has found no specific security problems at all in either WebSTAR software or the server computer. Indeed, the W3C actually specifies that "The safest Web site is a bare-bones Macintosh running a bare-bones Web server."

The whole story of the US Army's change to Apple Macintosh servers is at: <http://www.dtic.mil/armylink/news/Sep1999/a19990901hacker.html>. Other US federal main Websites are also moving from PCs running Windows NT to Macs running MacOS, including the US State Department's main Website, the US Peace Corps, the National Institutes of Health, the NASA Ames Research Center, and the Los Alamos National Laboratory in New Mexico.

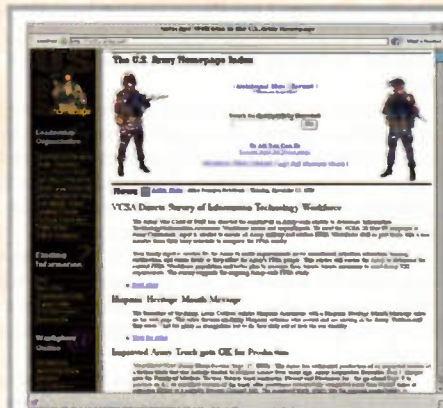

The US Army - now safe from hacks, with new Macs

## SETI@Home Searches for Intelligent Life in the Universe

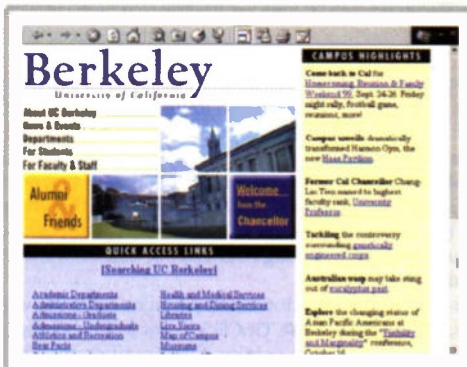

The popularity of the University of California's SETI@home screen-saver - software that allows anyone with a desktop computer to aid in the search for intelligent life in space - has literally skyrocketed in the three months since its release, with the number of participants worldwide now topping a million.

While no signs of alien life have yet been found, the SETI or Search for Extraterrestrial Intelligence craze has infected offices and classrooms in some 223 countries since the screen saver was made available in May by a team of scientists at the University of California, Berkeley.

Companies large and small, elementary and high schools, government agencies and universities have formed groups to compete to see whose computers can analyse the most chunks of data. The analysis is handled automatically by the screen saver program and the results sent back to Berkeley, while participants view the progress on their computer screen.

This success, Berkley researchers claim, proves the value of distributed computing, and has encouraged him to look around for other projects that could benefit from this technique. Distributed computing is a way of splitting large computations among many small computers.

On Windows and Macintosh machines, the computer program which can be downloaded from [www.berkeley.edu](http://www.berkeley.edu) acts like a screen saver, kicking in when the computer is idle and crunching data collected from a radio telescope in Puerto Rico, the 1,000ft diameter dish at Arecibo.

Statistics show that of the million people who have signed up with SETI@home and downloaded the software to let them analyse radio data from space, about 600,000 have completed at least one unit of data analysis, and some 370,000 are steady contributors.

The huge amount of computing power this puts in the hands of the authors of SETI@home is allowing them to tackle even more difficult and time-consuming analyses of the radio data from space. The backlog of data from the Arecibo telescope is rapidly disappearing, and Anderson and his team are currently updating the software to reanalyse data in search of more complex signals.

## Patent for E-mail Filtering and Forwarding Technology

USA.NET at [www.usa.net](http://www.usa.net), the world's largest e-mail outsourcer, has received a patent for its technology that enables e-mail filtering and forwarding, an integral component of USA.NET's e-mail engine architecture. Issued by the U.S. Patent and Trademark office, the patent (number 5,937,161) can be viewed at [www.uspto.gov](http://www.uspto.gov).

USA.NET also announced the availability of a new white paper on managed messaging, which takes a look at USA.NET's patented e-mail engine architecture.



## BT Boost for Cambridge



Cambridge's position as arguably the premier high technology city of Europe. Leading technology players in the city, including members of the Cambridge Network and the University, are to be given the opportunity of connecting to BT's world-leading ultra-high speed IP testbed.

This trial network, exploiting terabit routing technology, will help to define the next generation of Internet and multimedia services. Currently, the network links Cambridge and London with BT's advanced communications and technology centre, Adastral Park, at Martlesham Heath, near Ipswich. BT plans to extend the network to Paris, Frankfurt and other major European cities.

The Cambridge organisations will be offered the opportunity to develop and experiment with the innovative high-speed data applications which will shape the Internet of tomorrow.

BT at [www.bt.com](http://www.bt.com) also announced that exchanges serving the majority of Cambridge homes and businesses would have early upgrades for the latest broadband access services. These will turn an ordinary telephone line into a high speed digital connection capable of carrying information at between 10 and 40 times the speed of a conventional modem.

The company will be ready to accept wholesale orders from Internet and other service providers by the end of 1999 so that they can start offering combined retail packages of content and connection to their own customers.

## Egg Taps Excite as its First Portal Partner

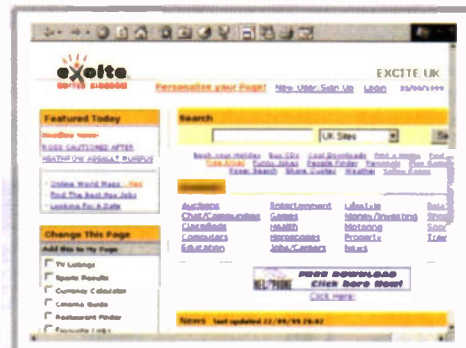

Excite at [www.excite.co.uk](http://www.excite.co.uk) has signed a deal worth in excess of £1 million with Egg, the UK's first Internet bank. The deal will give Excite users easy access to Egg's new Internet credit card to be launched later this year, and other Egg services designed to bring the benefits of e-commerce to the customer. It will also ensure that Excite is Egg's partner of choice when the Internet bank introduces new products and services to its existing portfolio.

This partnership extends Excite's position as one of the UK's leading e-commerce venues. Visitors to Excite UK will be able to apply for an Egg credit card, a loan or even a mortgage, quickly and easily, 24 hours a day, seven days a week. In addition, visitors to Excite's 'Money & Investing' channel will be able to learn how to save money on their taxes, get the latest tips on pensions, use the currency converter or get share quotes online.

## E-mail Outer Space

If you want to make contact with outerspace, bentspace.com could be the Web site for you. It only takes Bentspace.com users a few minutes to send a message that, travelling at the speed of light, will take 5 hours to reach the planet Pluto and 30,000 years to reach the centre of our Milky Way galaxy. Would-be cosmic communicators can visit the Bentspace.com Web site at <[www.bentspace.com](http://www.bentspace.com)> enter their message of up to 1,000 words and, for a credit card charge of approximately £6.50, send it out into the cosmos.

The sender will receive a confirmation from Bentspace.com computers that the communicate has been sent, as well as a customised certificate suitable for framing. Bentspace.com does not censor messages, nor is it responsible for any replies that come back

from the cosmos. If you are dubious about life beyond Earth or extra terrestrial activity you could be in a minority.

Since launching the service at the beginning of September, bentspace.com claims to have been deluged with requests over its Web site from people wanting to make contact with outer space. Only in the US? Not at all - requests hail from China, Hong Kong and the UK. Now where did we put that old radio transmitter?



## Free ISP - Worth Its Waitrose In Gold

Waitrose is hitting the headlines as an intrapreneurial force and major e-commerce player as it announces the launch of a free Internet Service Provider (ISP) product which marks a radical departure from the recent mould of ISP packages.

Waitrose.com, a free ISP, comes with a 24 hours a day, 7 days a week technical support help line which is totally free of charge to customers.

Uniquely for a service of this kind, Waitrose will be not be making a profit from telephone call charges, which generate a huge amount of income for other ISPs. Instead, all Internet revenue from phone calls made by visitors to the site will be donated to four charities, divided according to customer choice.

A free CD Rom containing installation and Internet software which is available to Waitrose customers in all branches can also be obtained by post through ringing freephone 0800 072 7666 (£1.50 postage and packing). Existing Internet users can download the software through <[www.waitrose.com](http://www.waitrose.com)>.

Waitrose.com is one of the few ISPs to offer users an e-mail bureau. This provides unlimited e-mail addresses accessible anywhere in the world and, for those with existing e-mail addresses, notifies friends and family of all new addresses at no charge. It is also the first to offer a quality broadsheet format, in keeping with the Waitrose/John Lewis customer profile, which the company believes is pivotal to the total success of the product.

The technical service is being provided by Internet Technology Group (ITG) who last year were voted best Internet service provider on the planet, recognising their considerable skill and competence in this area.

The move is not expected to be emulated by other ISP companies. Their share of income from telephone charges represents a vast percentage of their profit, and it is highly unlikely that shareholders would forego these huge sums for long! Waitrose, on the other hand, is part of the John Lewis Partnership which is owned by its employees and is not controlled by outside shareholders. The company will look to generate revenue principally from the sale of merchandise - even advertising will be kept to a minimum.

Customers of waitrose.com will be able to log on for the cost of a local call, accessing the most up to date and comprehensive food and wine associated information on the Web, as well having access to financial news, weather information and travel updates. Waitrose.com is specifically aimed at the upper end of the market. Reflecting the profiles and lifestyles of John Lewis and Waitrose customers, the site's content and style are broadsheet as opposed to tabloid, with news information, for example, being sourced from the Guardian.

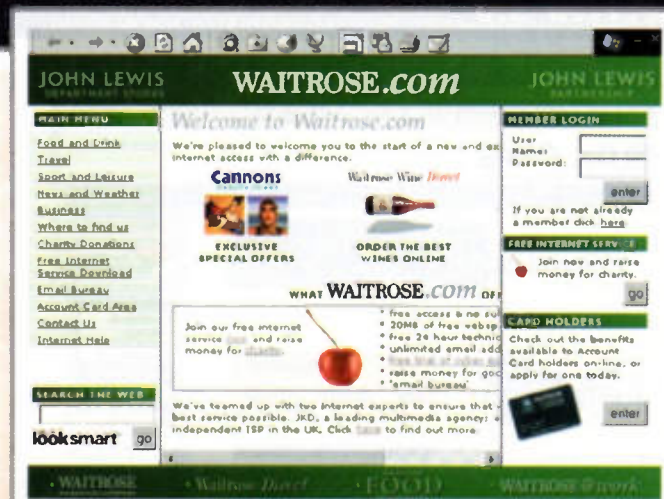

## UK MPs Still Not Ready for Online Democracy

Over 400 elected officials in 14 countries visited the IBM Institute for Electronic Government's 'Virtual Ballot Box' to participate in a Survey of Digital Democracy in Europe but many UK MP's stayed 'off-line'.

A large majority (74%) of Europe's 'e-politicians', who participated in the IBM Institute for Electronic Government (IEG) online survey about digital democracy, believe that information technology has the capacity to enhance democracy, and 50% would support the introduction of online voting alongside traditional methods.

This is one of the findings from the Institute's report The Virtual Ballot Box: A Survey of Digital Democracy in Europe, launched in the UK at the beginning of September at <[www.ieg.ibm.com](http://www.ieg.ibm.com)>.

In the UK, some 180 MPs - those who register an e-mail address on the UK government Web site <[www.parliament.uk](http://www.parliament.uk)> - were invited to participate.



## Now Web Surfers Can Join Raging Internet Debates

Now for the first time, Web surfers can find and join raging debates or dialogue taking place on the Internet. Third Voice developers of the free service that allows people to shape the Web by posting notes on any Web page, today released Third Voice Beta 3.0 with new features for the Microsoft Internet Explorer browser. Third Voice now includes a recommendation list of the most compelling notes on the top 50 Web sites where people instantly can find stimulating and entertaining discussions. Additionally, Third Voice introduced on-demand viewing to give users more control over the browsing experience.

Initially, Beta 3.0 for Inter Explorer will include a list of the most intriguing, thought provoking discussions from the top 50 Web

sites to help people link directly to raging debates online. Third Voice will expand the feature by continuing to add new Web sites to its current list of 50. Additionally, on a daily basis, Third Voice's editorial team will identify new, compelling discussions, and provide direct links from the Third Voice client.

Beta 3.0 gives people more control over the Web browsing experience through on-demand viewing, which allows people to turn on or turn off the Third Voice markers through a simple click. Third Voice will automatically load notes onto the page only when a person selects to click on the note toolbar icon to view the notes. Internet users with Microsoft

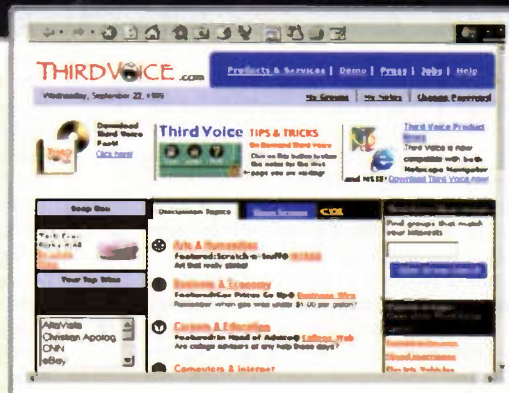

Internet Explorer 4.0 and 5.0 can download Beta 3.0 for IE for free from the Third Voice's Web site at <[www.thirdvoice.com](http://www.thirdvoice.com)>.

## Dr. DWG Announces Release of Dr. DWG NetView 3.0



Dr. DWG at <[www.drdwg.com](http://www.drdwg.com)> announces the release of Dr. DWG NetView 3.0, the upgraded Version of the Dr. DWG NetView 2.0. NetView is an Internet Browser Plug-in CAD Viewer and works on both Netscape and Internet Explorer.

The new version can View, Redline and Print AutoCAD files and 40 additional file formats including dwf, gif, tiff and jpeg. Dr. DWG NetView 3.0 has a significantly improved user interface compared to the previous version.

## Stars Come Out for Online Movie Alliance

BlackStar at <[www.blackstar.co.uk](http://www.blackstar.co.uk)>, Europe's leading online video and DVD retailer has announced a customer fulfillment alliance with BigStar Entertainment the company behind <[www.bigstar.com](http://www.bigstar.com)>, the US's leading online movie superstore.

Under the terms of the agreement, BigStar will use

BlackStar to complete orders for its customers based outside the US who require PAL format videos and DVDs. Likewise, BlackStar will refer its North American customers who require goods in the NTSC format to BigStar. Income on referred sales will be shared between the two companies.



## UUNET Boosts Regional E-conomy

UUNET at <[www.uk.uu.net](http://www.uk.uu.net)> has announced a multi-million pound investment programme to expand its UK regional network of fast, highly resilient gateways for better business access to the Internet.

Another eight of the UK's largest conurbations outside of London will benefit from the investment which is part of the £1.6 million a day expenditure by UUNET on new Internet infrastructure for business worldwide.

These eight new high bandwidth Points of Presence (PoPs), which go live over the next six months and allow more data to be transferred, will extend the world's most widely deployed and most rigorously engineered network backbone to a wider spectrum of metropolitan areas in Scotland,

Northern England, the East Midlands and the West Country.

The opening of these new PoPs and the continuing enhancement of existing UK infrastructure also paves the way for future upgrades of capacity ahead of customer demand. In July 1999, UUNET announced plans to implement MPLS or Multi-Protocol Label Switching technology between major European cities by September 1999. This technology will allow increases in bandwidth and capacity to 16 times above current levels.

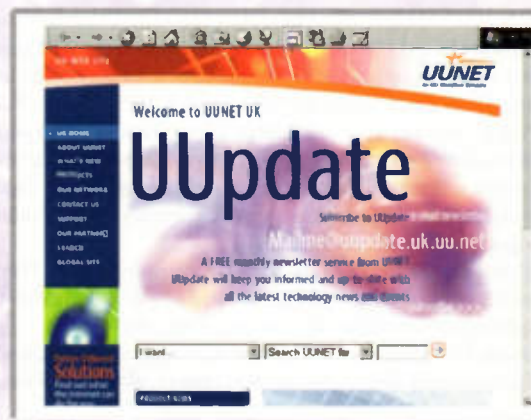

## IBM Digital Wallet Speeds Checkout for Online Shoppers

IBM at <www.ibm.com> has announced the availability of a new, standards-based version of its Consumer Wallet software that enables Web shoppers to make on-line purchases faster and with greater ease.

The IBM Consumer Wallet allows Web shoppers to enter their credit card information once and store it securely in an icon - or 'wallet' - for all future shopping. With the 'one-click' purchasing feature, digital wallets eliminate the need for repeated entering of such information, decreasing the likelihood of abandoned shopping carts by frustrated shoppers.

A report from Jupiter Communications on digital wallets found that 27% of online buyers abandon orders before check-out due to the hassle of filling out forms, thus decreasing the

number of completed transactions at merchant sites.

Available in time for the holiday shopping season, the IBM Consumer Wallet is available to consumers from financial institutions. MasterCard International is collaborating with IBM to distribute the new version of the Consumer Wallet by offering it through a special program to its member banks.

The IBM Consumer Wallet Version 2.1 is based on universal standards for data collection. It uses Electronic Commerce Markup Language (ECML), universal standards for merchant field data collection that were announced in June

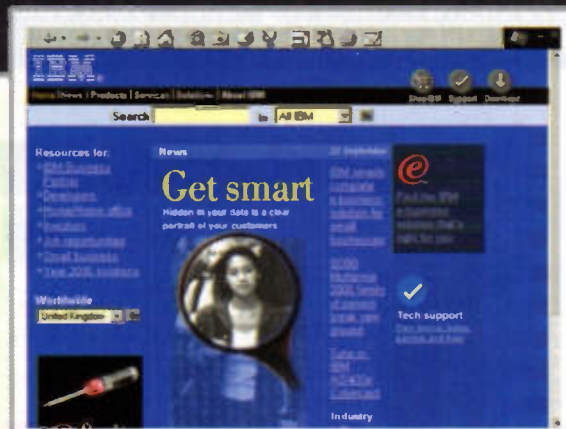

by e-commerce leaders America Online, American Express, Compaq, CyberCash, IBM, MasterCard, Microsoft, SETCo, Sun Microsystems, Transactor Networks, Trintech, and Visa.

## AOL UK First to Launch Kids Only Accounts



AOL UK at <www.aol.co.uk> is the first ISP in the UK to give kids their own customised surfing environment with the launch of KIDS ONLY accounts on AOL.

Called KIDS ONLY, the accounts are set up via AOL UK's Parental Controls and offer a fun, educational and safe online experience for kids aged 2 to 12 years. AOL is still the only ISP to offer fully integrated parental controls without the need to download special software.

Whilst not a replacement for parental supervision, AOL UK believes the KIDS ONLY accounts give parents, teachers and guardians even greater peace of mind when allowing children access to Internet and online services.

Kids signing on to AOL UK under a KIDS ONLY account are greeted by the customised KIDS ONLY Welcome Page. Here, kids can check their e-mail or search the Web via Kids' AOL Netfind. AOL's dedicated kid-friendly search engine that delivers pre-screened sites from the Internet.

## Yahoo! UK & Ireland Joins Forces with NatWest



Yahoo! has announced a relationship between Yahoo! UK & Ireland at <www.yahoo.co.uk> and the NatWest that will bring NatWest account information directly to the desktops of Yahoo! Finance at <finance.yahoo.co.uk> and My Yahoo! <my.yahoo.co.uk> users in the UK.

Yahoo! users will have the ability to check e-mail and stock quotes, read news from the UK and around the world, use the UK's favourite Web guide, and stay up to date on their NatWest account balances and transactions - all from one secure, convenient location.

This service will give registered Yahoo! users the ability to easily and securely view their NatWest current checking and savings account balances, as well as transaction history, each time they go to Yahoo! Finance or My Yahoo!. This service is expected to be available during Yahoo!'s fourth quarter.

## Listen.com and Liquid Audio Make Liquid Tracks Easier to Find

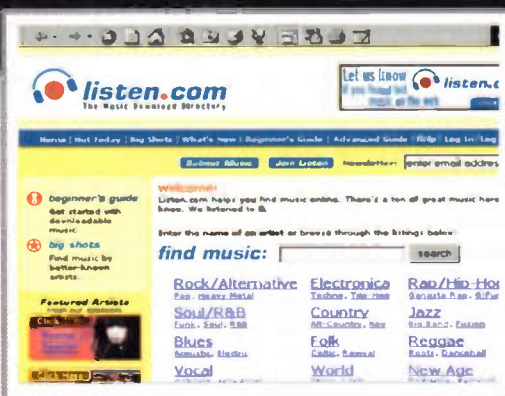

Listen.com at <www.listen.com> and Liquid Audio at <www.liquidaudio.com> are set to make it easier to find downloadable music in Liquid Audio on the Web. Listen.com is the Internet's comprehensive directory of downloadable music, and Liquid Audio is a leading provider of software and services for the digital delivery of music over the Internet.

A deal between the two companies will

pave the way to creating a system to facilitate the rapid review of and linking to Liquid Audio's catalogue of more than 25,000 secure downloadable Liquid Tracks by Listen.com's editors.

Currently, Listen.com's growing directory has approximately tens of thousands of artists and 75,000 tracks in nearly 600 musical genres. Listen.com links to all formats of downloadable music.

## Essential Surfing Gear Introduces Free Web Organiser



Essential Surfing Gear has introduced a free, context-driven Web organiser called esgear, that makes it easier, faster and more convenient for people to surf the Internet.

With one-click access, esgear automatically brings relevant actions, topics and sites of interest directly to users. Gear applications, organised in activity-based suites, are designed to assist people using the Web for research, shopping, community activities and entertainment.

While surfing the Internet, users' personal selections of gear applications act as private Web assistants and continuous search engines. Gear applications self activate, based on information in context, and alert users to related sources, services and conversations.

esgear, a recent CNET pick-of-the-week, is available free of charge at the Essential Surfing Gear Web site <[www.esgear.com](http://www.esgear.com)> as well as at all partner Web sites.

## AOL Introduces Instant Messenger 2.0



AOL at <[www.aol.co.uk](http://www.aol.co.uk)> has announced the availability of the latest version of the AOL Instant Messenger service, version 2.0. The AOL Instant Messenger service is an Internet version of AOL's popular Buddy List service, which lets millions of home and business Internet users know when their friends come online and allows them to send and respond to private, personalised electronic text messages instantly.

AOL pioneered and popularised the development and integration of its real-time communications technology into AOL's software for accessing the AOL subscription service in 1989. In 1996, AOL launched the Buddy List feature, a collection of messaging related features including a member-created community of friends, family, and colleagues, which fundamentally changed communications on the Internet.

## Intelligent To Do List

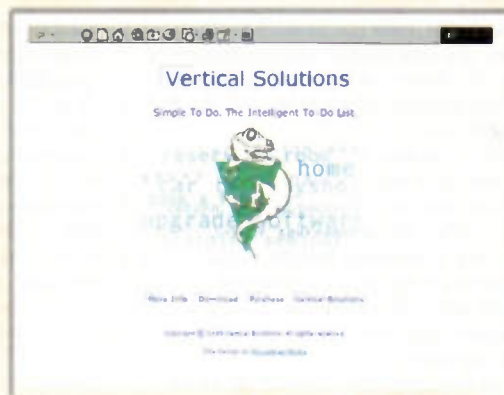

Vertical Solutions at <[www.verticalsolutions.com](http://www.verticalsolutions.com)> has created and released Simple To Do - The Intelligent To Do List which has the ability to help users choose what to work on next.

The new Macintosh software has the features expected in a list manager - it's hierarchical so users can create sub-items, prioritise, sort and mark items as done. Users can also create, display and work on multiple lists.

There are also unexpected features that Vertical Solutions says make Simple To Do both intelligent and easy to use, including the ability to ask Simple To Do's artificial intelligence what to work on next.

## ELSA Makes Internet Three-Dimensional

ELSA engineers have succeeded in visualising three dimensional Web content in a way which results in true spatial perception. For the first time, ELSA's i3Di software allows the technical community to experience the global Internet in an additional dimension and at consumer prices.

The advanced technology of the ELSA 3D REVELATOR glasses, which have already been acclaimed by the gaming community, provide the viewer with an image that appears to be truly three-dimensional.

ELSA at <[www.elsa.com](http://www.elsa.com)> is a leading provider of Internet access and computer graphics solutions for the PC. Its product range includes modems, ISDN adapters, videoconferencing systems, ISDN routers, cable modems, graphics boards and monitors.

## Power Line Transmission is Dead

United Utilities has abandoned its trials of Power Line Telecommunication, or 'PLT'. In an announcement to the London Stock Exchange at the beginning of September, the company said that it was set to close the NorWeb Digital Power Line joint venture with Nortel Networks.

The intention of the trials was to bring high-speed Internet access to homes by transmitting data along mains electricity cables.

The RSGB at <[www.rsgb.org.uk](http://www.rsgb.org.uk)> has been involved in discussions with the Radiocommunications Agency on this subject for three years and worked closely with other users of the HF spectrum, including the Ministry of Defence, Home Office, BBC World Service, GCHQ and the Civil Aviation Authority, in order to counter the 'data-over-power-lines' plans. The RSGB claims that the introduction of PLT would effectively wipe out large portions of the HF spectrum.

The RSGB's EMC Committee had demonstrated in a simulation that HF transmissions along mains cable could be heard at great distances and would raise the noise floor sufficiently to make reception of weak signals below 30MHz virtually impossible.

The reason given by United Utilities for dropping the project was that the projected volumes and profitability of the scheme was insufficient to justify the investment required. However, it seems likely that the robust lobbying by the RSGB and other groups was also a factor taken into account.



## Service Companies Get Bigger Bang from Net



If e-business is hot, for service sector growth companies, it's positively sizzling. Fast growing service companies are expecting to achieve more than twice the sales impact from the Internet as their product sector counterparts in 1999.

These are highlights from the latest PricewaterhouseCoopers Trendsetter Barometer survey, released earlier this month at [www.barometersurveys.com](http://www.barometersurveys.com).

According to their CEOs, a phenomenal 64% of the fastest growing companies are already involved in e-business. This group expects that 17.1% of their total revenues will be attributable directly and indirectly to the Internet in 1999.

## Daily Mail Acquires 50% Stake in Zoom



The Daily Mail has acquired a 50% stake in Zoom.co.uk at [www.zoom.co.uk](http://www.zoom.co.uk), the e-commerce and free Internet service provider, for a stake of £15 million, comprising £5 million in cash on completion and £10 million payable over the next five years. Zoom becomes a 50/50 joint venture between the two companies as a result of the transaction.

Zoom will benefit from the reach of both partners in the venture as both have agreed to use their existing businesses to promote the emerging Internet access provider. Zoom was set up to attract both existing and new users of the Internet through its unrivalled line-up of shopping, entertainment and communication as well as its online loyalty scheme (Zoom Points) and online credit account for customers (Zoom Account).

Zoom already draws on a powerful network for distribution of its disks and promotion of its brand - over 2,100 outlets and a database of 5.3 million storecard holders from Arcadia Group. This will now be strengthened by the addition of ANI's newspapers and magazines, which can bring Zoom to the attention of a combined weekly readership of over 9 million.

## Worldwide Internet Use To Reach 130 Million

Global Internet use will grow by 35.2 million people this year, to 130.6 million, according to a report from eMarketer at [www.emarketer.com](http://www.emarketer.com).

By 2003, Internet users will reach 350 million, a 267% increase from the end of 1998. The report, which incorporates data from hundreds of different sources, also found that worldwide electronic commerce revenues will increase from \$60 billion in 1999 to \$700 billion by 2003, while the US will earn a majority share of every e-commerce dollar.

Germany collects the second-highest level of worldwide e-commerce revenues, with \$600 million in 1998 and \$2.64 billion predicted for 1999, while the UK follows, with \$2.2 billion in 1999, up from \$900 million in 1998.

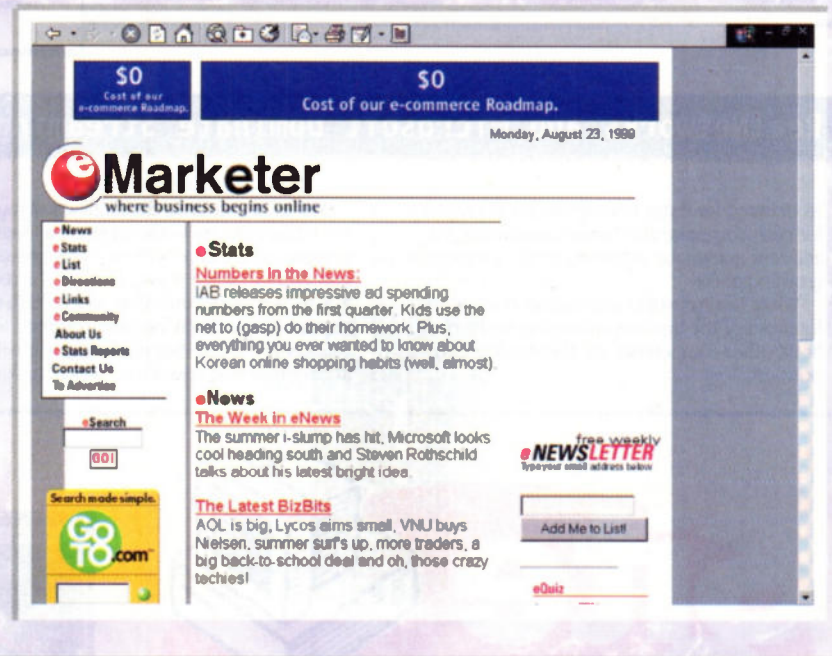

## iWare Personalises Desktop and Internet Experience

iWare, a new company pioneering desktop software, has launched a new application to simplify and personalise the computing experience. iWare enables both new and experienced Web users to tailor their use of desktop applications and the Internet, onto one simple taskbar.

Through intuitive features, iWare simplifies the Internet experience by making it easier to navigate, organise and stay informed right on the computer desktop.

iWare provides five primary functions: iStart, iSearch, iShop, iChoose, and customisable 'TouchTiles' all encompassed onto one simple task-bar or iBar located at the bottom of the user's screen. The application is free and downloadable at [www.iwareinc.com](http://www.iwareinc.com).

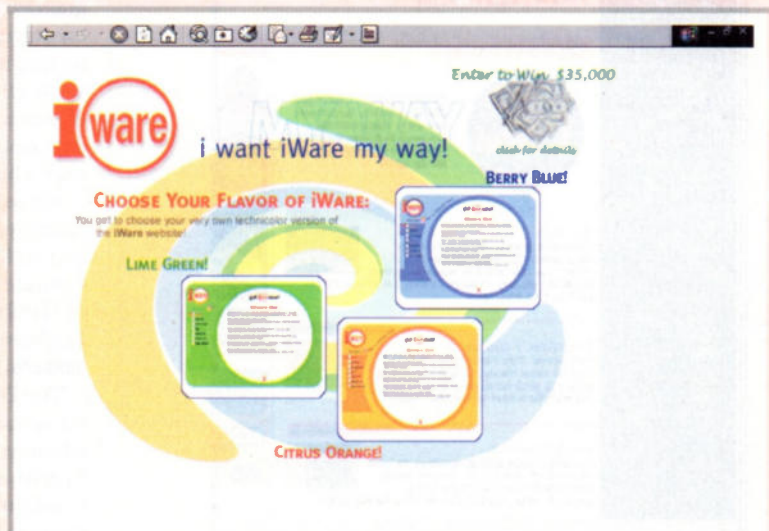

## Lycos Launches Personal Auctions

Lycos, the fastest growing Internet portal and the world's largest online community, has launched an auction service that brings buyers and sellers together in several new and unique ways.

Designed to serve users across the Lycos Network, the new auctions sites, Lycos Auctions at <auctions.lycos.com> and Tripod Auctions at <auctions.tripod.com>, will host individual sellers as well as retailers of all sizes.

Both buyers and sellers can link to these sites easily, giving them the option to promote their merchandise and watch for bargains from personal start pages, individual home pages and even virtual store fronts.

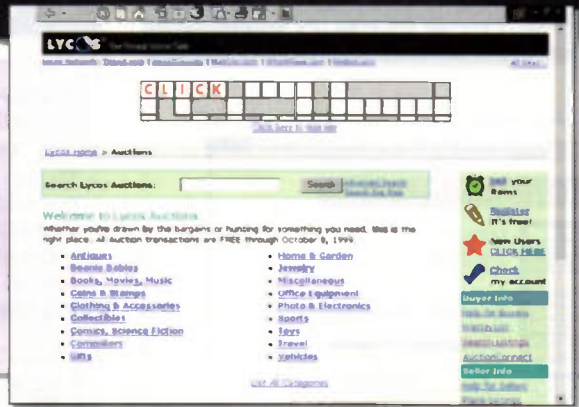

## RealNetworks and Microsoft Dominate Streaming Media

As demand for faster Internet access is supplied for both corporate and home-based users, the adjacent market for streaming media promises to grow in parallel.

While RealNetworks and Microsoft are at the forefront of the Internet streaming media rush hour, other competitors are also moving into position.

Not to be outdone, the Hollywood music recording industry is also pushing its way in, by insisting on a secure MP3-type compression standard for digital music. Despite the recent frenzy over broadband Web access, high-speed access will eventually become common for most users, and the Internet marketing war will shift from compelling speed to compelling content.

An overview of competitors' strategies is the focus of IP Video and Streaming Media - Servers and Services Market Overview and Forecast 1999 - 2001, a new report by MRG at <www.mrg.net>.

Many companies profiled in this report have placed streaming media in their core strategies, hoping to leverage their unique hardware and software strengths.

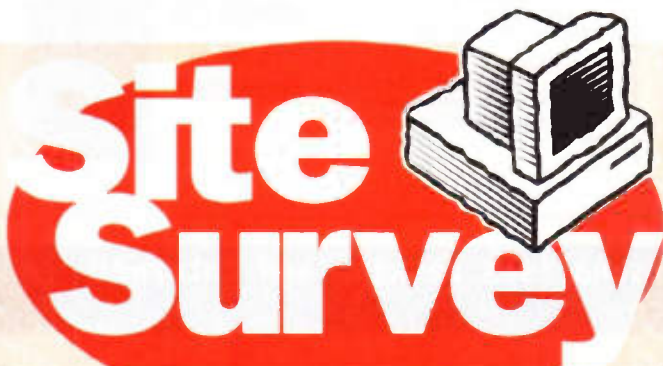

### The months destinations

While we're sure it is in the best possible taste, it's an oddball of a service that FinalThoughts undertakes (pun intended). People using the service, at: <http://www.FinalThoughts.com/> can leave email messages that are intended for distribution in the

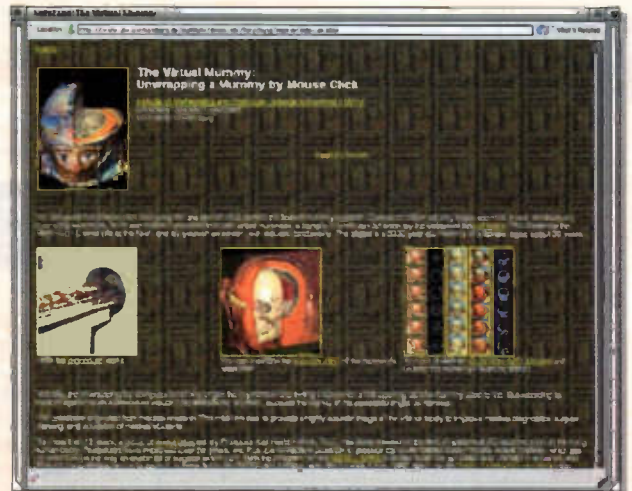

event of a user's death. The person also designates a 'guardian angel'. If (perhaps that should be when) the person dies, the guardian angel contacts the FinalThoughts service to unlock the messages, whereupon they are emailed to the intended recipients. Tacky in principal at least, but arguably sound business sense (the phrase it's an ill wind that does nobody any good comes to mind) FinalThoughts has plans to enhance the service with options of video and audio emails, as well as broadcasting a user's funeral over the Internet. Hmm.

We've looked at this Website before, but it's been enhanced recently so is worth another look, and it's a fascinating historical and archaeological surf. The Virtual Mummy site, created by the Institute of Mathematics and Computer Science in the University of Hamburg, has the ability to allow you to look inside an Egyptian mummy. Take an internal tour, at: <http://www.uke.uni-hamburg.de/institute/imdm/idv/forschung/mumie/index.en.html>

The Discovery Channel television channel has a site dedicated for school use, at: <http://school.discovery.com/schoolhome.html>, where you'll find a wide array of teaching tools and information. Everything from complete lesson plans, to keeping up-to-date on woolly mammoth excavations in Siberia is available. It's a useful Website for teachers.

# Car Audio

# CAPERS

PART 2



**Looking for better sound on the move? In part 2, Martin Pipe looks at the modification of existing equipment for external audio inputs and outputs.**

## You can CD point, can't you?

Last month, we looked at two car-audio related subjects. The first was how to install replacement speakers, while the second focused on 'pre-equalising' recordings that are tailored to the car's acoustics. Unfortunately, pre-equalisation isn't much help if you frequently listen to 'live' radio. The only solution here is to install a graphic equaliser, and adjust the tonal balance for best results. Unfortunately, very few car stereos give you the opportunity to break the internal link between tone controls and power amplifiers. Only high-end models have a line output, which can be used to drive graphic equalisers and external amplifiers of better quality (Maplin sells both varieties - check out the 'in-car entertainment' section of the catalogue). Fine, if you were planning to upgrade your stereo equipment to a better-specified unit. Unfortunately, aftermarket equipment tends to have a 'standard' DIN-E fitting. Many vehicles, notably modern cars (take the newer Forcls, for example) tend to deviate from this standard and go their own way, making the installation of

replacement units awkward - to say the least.

Another limitation of many car stereo 'head units' is that they don't make provision for an auxiliary input - such as a CD or Minidisc player. These digital sources sound somewhat better than cassette, with no wow and flutter, hiss or missing treble due to head azimuth alignment problems. Modern personal players don't jump or skip, thanks to the inclusion of 'anti-shock' buffer memory, and are hence well-suited to in-car use. If you're lucky, then your equipment will have a front panel-mounted 3.5mm stereo jack marked 'aux'. Sharp head units were among the first to include one of these, and these days even some of the cheap Far Eastern equipment has the facility. Some of the more expensive head units do, in fact, have a CD input, but it's intended only to be partnered with a CD changer from the same manufacturer. And guess what - there's no standard for the connection of such devices. The vast majority of these CD input features go further than simple audio connections. They also allow the CD player to be controlled from the head unit's front panel - a multi-way cable links the microcontrollers of both devices.

Because the switching and device control is so integrated, there's no easy way to 'force' the auxiliary input on, even if you could find out which pins on the 'CD' connector carried the audio signals. If you could obtain the circuit diagram of the unit, you may be able to find the switching chip. If you're lucky, it may be a discrete 4053-type analogue multiplexer so you may be able to switch the external input on by forcing the relevant switching input to ground or +12V via a toggle switch. Ah, if things were that simple! In my experience - particularly with modern units - the switching forms part of a microbus-controlled 'jungle' chip that also carries out other analogue functions. Note that circuit diagrams can usually be obtained from the manufacturer. Another good source for circuit diagrams - particularly if you're on a tighter budget - may be your local library. Some of the larger branches - notably Chelmsford in Essex - hold a good stock of manuals, and will obtain one for you if they don't have a copy. If you're not within convenient travelling distance of the library in question, your local one should be able to obtain it via 'interloan' for a small fee. Note, however, that service manuals from car manufacturers are very difficult to obtain. Fortunately, the equipment they build into their vehicles is usually bought in from other companies. As an example, Ford specified Philips gear for many years.

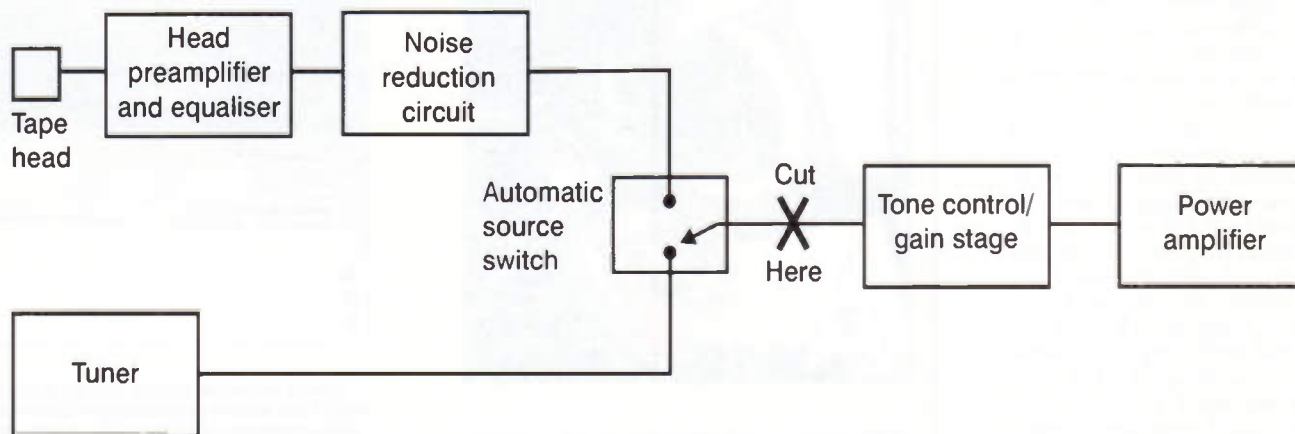

Figure 1. Block diagram of typical car radio/cassette player

## Modifying a Radio/Cassette Head Unit

A sizeable proportion of the existing base of cassette/radio head units can be modified for greater flexibility. If the link (refer to Figure 1) between the automatic source selector - which selects the tape deck when the cassette is inserted, otherwise defaulting to radio reception - and tone controls is broken, and brought out to an external 'breakout box', then a lot of options are available to you. First of all, a graphic equaliser could be inserted into the loop. Secondly, the output could be used to feed external equipment, such as high-power amps, line-level electronic crossovers and graphic equalisers. Finally, the output from a CD player or other line-level devices could be introduced here. Although you can buy 'cassette adaptors' that allow signals from external audio equipment to be fed into your head unit, the sound quality is lacking compared to a direct connection. These cassette adaptors were, by the way, discussed in detail last month.

Line level? I have modified a couple of cassette radios in this way, and have discovered in both cases with an oscilloscope that the signal level at the tone control input is - fortunately - roughly line level (in other words, about 0.7Vrms). For the purposes of this article, we'll refer to one of these units - a Kenwood KRC5570 - throughout this article. Basically, the signal from the cassette head is boosted by a pre-amp, and then fed into a noise reduction circuit (where fitted). At this point, it's line level. The output from the tuner is at a similar level. The automatic source selector is thus switching between line-level signals. The automatic source selector's output is fed to the active tone control circuit - which usually also provides a bit of voltage gain. The tone control's output then goes, via potential dividers - the volume and balance controls - to the power amp ICs. It's impossible to generalise, and it's conceivable that your equipment may deviate. For example, the output from the source selector may be at a higher or lower level, the relevant amounts of gain being added further up the chain.

In these cases, you would need to make provisions - all external connections would need to be line-level for compatibility reasons. If the signal level at the point between the automatic source selector and tone controls is fairly low, then your CD input would need to be attenuated by means of a potential divider. If you wanted to drive line-level amplifiers, things get a little tricky. You would need to boost the signal - we would recommend a dual op-amp for this job. A TL072 dual opamp is fine for this kind of job, and will run off quite happily off the 12V DC likely to be in abundance inside your car stereo. If you want to

# STEP-BY-STEP SPEAKER

STEP 1.

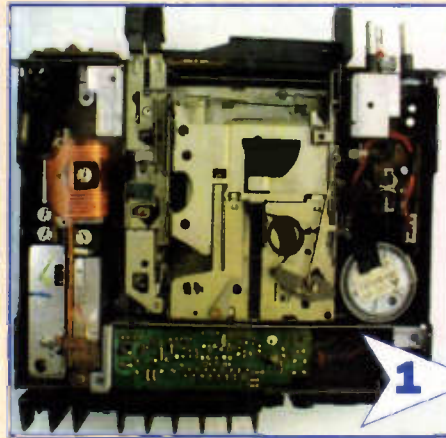

Here, the Kenwood's cassette mechanism has been unscrewed and unplugged for service. You also get access to the main circuit board. In some head units, the audio insertion point (the point between the automatic source selector and the tone controls) may be located somewhere on the main board.

STEP 2.

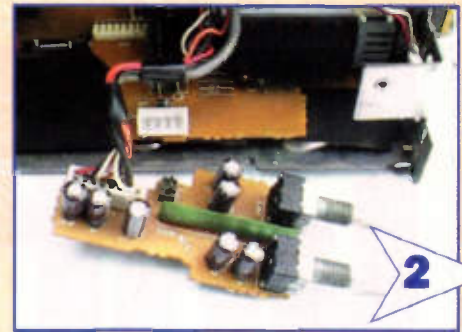

The Kenwood KRC5570 cassette radio's tone control board, with audio in/out cable attached. Note the use of heat-shrink sleeving, and that the cable screen is connected to a convenient ground point. At the other end of the cable is a DPDT switch, which selects either the Kenwood's cassette/radio source or, via a pair of phono sockets, an external input. Fortunately, the break point was at line audio level - otherwise attenuators and/or gain stages would be required, depending on whether you require input or output. These are covered in the text.

STEP 8.



On the prototype, the in-line DIN socket that contains the audio signals has to be passed through the rear of the mounting cage. The breakout box, the cable of which terminates

STEP 9.



The modified Kenwood head in use - here, a Diamond Rio is our audio source. Until somebody comes up with an in-car MP3 player, this is the next best thing!

STEP 7.



On the prototype, the in-line DIN socket that contains the audio signals has to be passed through the rear of the mounting cage. The breakout box, the cable of which terminates

STEP 6.

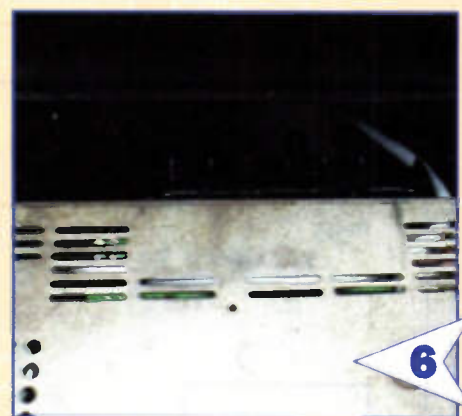

Inserting the modified Kenwood head unit into its mounting frame. If your head unit is a removable design, you'll have to take similar precautions. Most modern units, however, are fixed into the car - as an anti-theft measure, a security code has to be entered if the unit is removed from the vehicle (this design is a complete joke, seeing that code reprogrammers are advertised openly in the trade press).

# REPLACEMENT

## STEP 3.

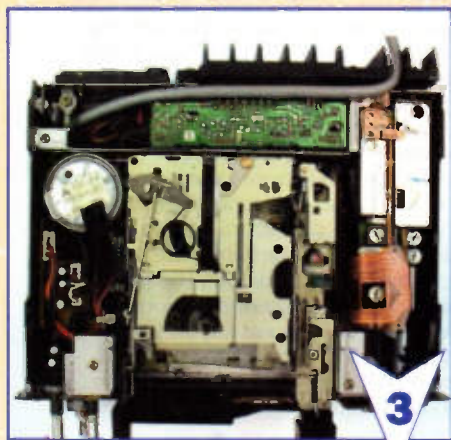

The Kenwood head unit, with tone control refitted and cable conveniently routed to the unit's rear.

## STEP 4.



Rear view of the modified Kenwood head unit. The unusual cable exit point on the back of the device is deliberate - this unit is 'removable'. This is one of the reasons for specifying the in-line DIN connections that can be seen to the left of the picture.

## STEP 5.

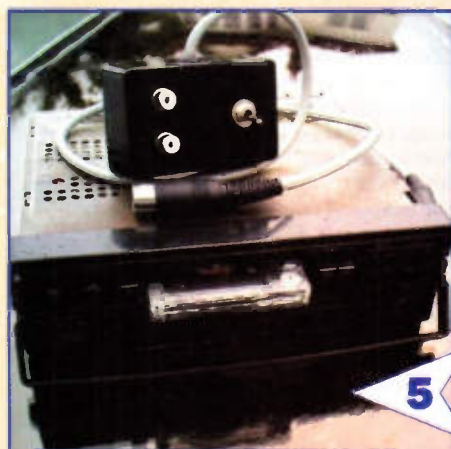

The modified Kenwood KRC-5570 head unit, prior to installing it in the car.

**Figure 2** Circuit diagram of single-rail audio amplifier based around TL072 op-amp. It may be needed to boost signals.

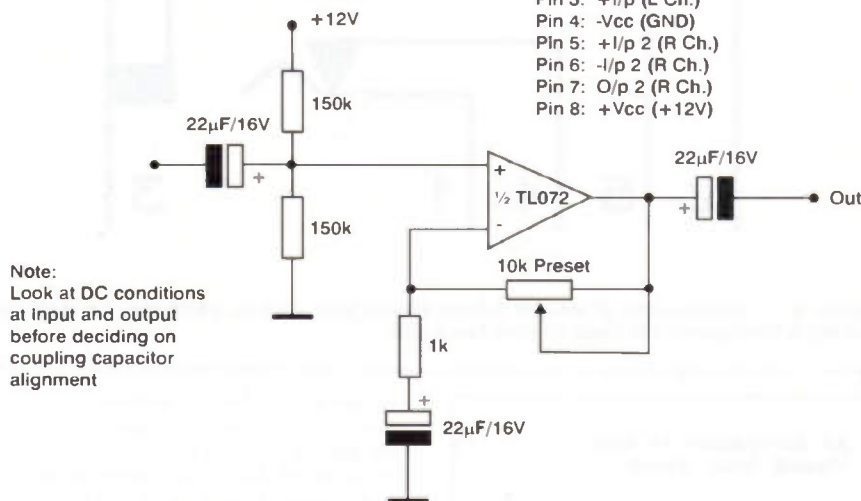

Note:  
Look at DC conditions at input and output before deciding on coupling capacitor alignment

accurately match signal levels. I would specify presets as the op-amp gain-setting resistors. Note that you will need to bias the inputs at half-supply potential - op-amps were designed to operate on split-rail supplies - and couple the inputs and outputs via capacitors. Some vendors sell op-amps that are happy working on single supply rails, but the TL072 sounds good - one respected UK hi-fi manufacturer even used the device in a phono preamp! A suitable circuit is given in Figure 2.

### Coupling Capacitors

Capacitor coupling may well be essential anyway, because there may be DC offsets at the audio switcher/tone control 'break' point of your particular car stereo. Remember this if you're using electrolytic capacitors to couple your inputs and outputs - orientation is important, and the negative side of the capacitor should be connected to the side of lower potential. A side-benefit of this approach is that the op-amps buffer the output of the source switcher, preventing loading (and possible volume reduction, as far as the head unit's own amplification is concerned). That said, most external amps have a high input impedance, and won't introduce any noticeable loading effects - I certainly haven't had any problems with my modified Kenwood unit, which didn't require any extra gain or attenuation stages. This is perhaps as well, if you're unfortunate enough to discover that the signal level at the point between the source selector and tone controls of your head unit is higher than line level. In this case, you will need additional gain to boost the line-level input from your CD player, and potential dividers to reduce the signal to a level compatible with external amplifiers.

I was very fortunate with the Kenwood, because its internal circuitry was laid out in a logical manner. I've seen similarly-designed head units from other manufacturers. Here, the (rotary) tone controls are built onto a separate PCB, with obvious screened leads for the input. The Kenwood tone control's DC supply and equalised output were interconnected by unscreened wires - presumably the active circuitry (a thick-film

module) on the tone control boosted the level to such a point where interference was unlikely to be a problem. Modification was thus straightforward, which is perhaps just as well because I didn't have the service manual to hand! After investigating the signals with a scope, the tracks were cut on the PCB, and wires soldered to the relevant points (solder on the component 'lands' where possible, since these are mechanically sound). You'll need four wires - input left/right, and output left/right. I used Maplin's XR23A four-core individually-screened cable for neatness and practicality - I wouldn't recommend the cheaper 'overall screened' variety, which may result in crosstalk problems.

### Modern Head Units

With more modern head units, things may be rather more different. Some are based around logic-controlled tone/volume controls, which are built into multi-function ICs governed directly by the microcontroller. With these, a service manual is essential if you want to find out whether the addition of inputs and outputs is a practical possibility - i.e., there's a suitable point in the audio path that can be broken. If there is, and you have to build additional circuitry into the unit, you have to ensure that there is sufficient room inside the unit. Note that most head units are somewhat densely packed with components. An alternative is to build the circuitry into the same external casing that contains the source switching and audio input/output connectors. Although XR23A is fine for the audio signals, we would recommend an additional heavy-duty wire to carry power to the op-amps. You could, I suppose, carry power via one of the audio wires - coupling capacitors at either end of the wire would block the DC from the audio signals. Whichever route you take, I would recommend inserting a low-value resistor or fuse at the head unit end - either would offer some kind of protection if the DC was to be accidentally grounded. Remember that we're dealing with a car electrical system here. Lead-acid car batteries are capable of delivering hundreds of amps - enough to start a fire in the event of a short

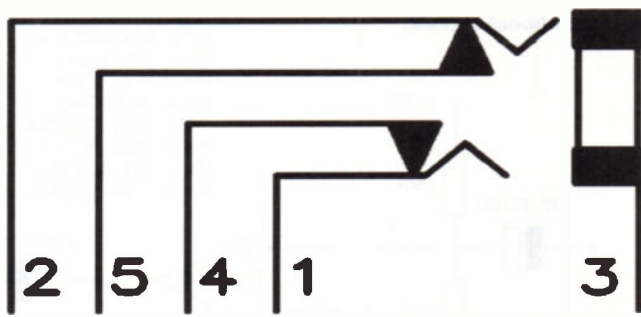

**Figure 3** Architecture of JM20W 3.5mm stereo jack socket, which may be ideal for adding a front-panel CD input to your head unit.

All dimensions in mm  
Viewed from above

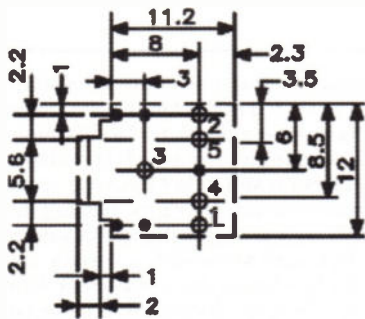

5 x Holes  $\varnothing$ 1.3

**Figure 4** Dimensions of JM20W 3.5mm stereo jack socket

that allowed either the internal cassette/radio (from the automatic source selector) or external input to be experienced. As can be seen from the photographs, I used standard phono sockets for the external input. I originally considered fitting a line input socket, but there was insufficient space for even a 3.5mm socket.

You might be more fortunate with your unit's front panel design, although it has to be said that drilling front-panel holes may spoil its appearance! In any case, you might want to restore your equipment to its original condition, or add other features (such as the line output). If you only need an external input and are prepared to make holes in the front panel, choose a 3.5mm socket with in-built switch (such as Maplin's JM20W, shown in Figures 3 and 4). That way, there's no need to bother with manually switching the source. When no plug is inserted, the 'common' output pins (1 and

## Is It Worth It?

OK, so it could be a lot of hassle - as you can see from block diagram Figure 5. You should only consider these modifications if your equipment is of a sufficiently high standard to make the effort worthwhile, or - thanks to the whims of the car's interior designer - there's no other option (such as replacement) available to you. If you take the time, the results are well worth it. I can now enjoy music from a variety of sources, and with far better sound quality than was possible from the old 'cassette adaptor'. I have successfully partnered the modified Kenwood with a notebook computer running Winamp (perfect for long journeys!), a Diamond Rio MP3 player, a Sony Minidisc Walkman and a Philips personal CD player. A subsequent modification was to break the 4-pin cable,

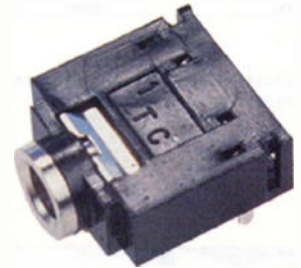

**This 3.5mm stereo jack socket (Maplin order code JM20W) has switching contacts, and is thus a good choice for simple auxiliary input modifications. Similar switching arrangements can be found in some cassette/radio head units with front-panel line-level inputs.**

and wire up DIN connectors to each end. A 5-pin DIN plug was soldered to the breakout box end, while the head unit end of the cable was fitted with matching in-line socket into the cable.

For times when an external source isn't needed, the breakout box is replaced by a 'blanking plug' that restores original operation - in other words, the head unit's source output is fed directly to its tone control input. If you want to be more adventurous, you could consider automatic signal switching. With a logic probe or 'scope, hunt around on your personal CD player (or whatever) for a logic signal that goes high or low when a disc is playing. This could then be used to switch in the audio signal at the appropriate time with a relay or analogue multiplexer. A suitable control signal should be found near the CD player's microcontroller. We would recommend buffering the logic output with a buffer, or a pair of hex inverters (e.g. two of the gates of a 4069) wired in series. The switching circuitry could be built into a breakout box. Another possibility is a carphone mute - some cellular hands-free kits have a suitable logic output that goes 'high' during the course of a call. This output, which is intended for modern car audio equipment could, in our modification, switch transistors that ground the audio signals.

In the final article next month, we'll look at the installation of head units - plus anything else we haven't yet covered.

## Watch It!

Maplin Electronics and the author accept no responsibility for your equipment, should you damage it whilst attempting modifications. So be careful!

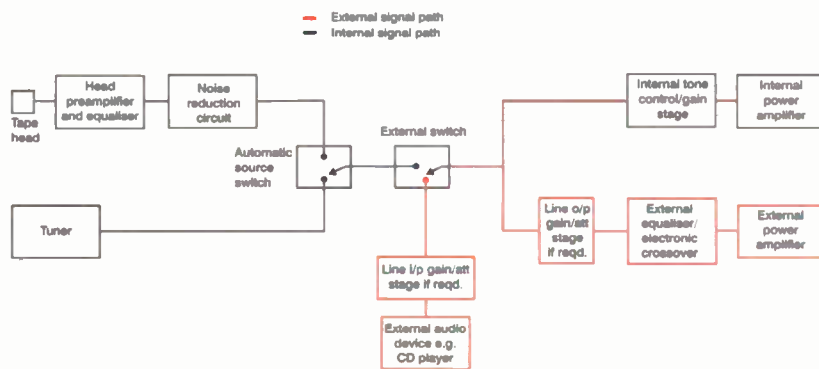

**Figure 5** Block diagram of complete system

circuit - and should be treated with the utmost respect.

A metre or so of the four-core audio cable was brought out from the Kenwood unit to a 'breakout box' via a hole drilled in the rear panel. The positioning of the cable was particularly important, since the Kenwood can - like many high-performance units of its vintage - be 'detached' from its mounting frame to avoid theft. If you have a similar unit, you have to be very careful when deciding where to drill the cable hole, otherwise it may foul the rear of the frame - and the connectors not mate properly! Note that the Kenwood unit was only modified for line input - it already has a line output, courtesy of a trailing DIN socket. The breakout box was fitted with a DPDT switch

2) will make contact with the normally-closed (4 and 5) contacts. When the plug is inserted, the normally-closed contacts will be isolated, the jack plug making contact with pins 1 and 2 instead. Pin 3, meanwhile, should be connected to ground. Some head units with a front-mounted line input work along exactly the same lines. There are a couple of points you should be aware of, though. Firstly, JM20W is a PCB-mounted socket, and you must find some way of holding it in place - epoxy resin, perhaps (but make sure that none gets into the socket itself)? Secondly, there must be sufficient room inside the head unit to accommodate any active circuitry that may be required.

# PROJECT

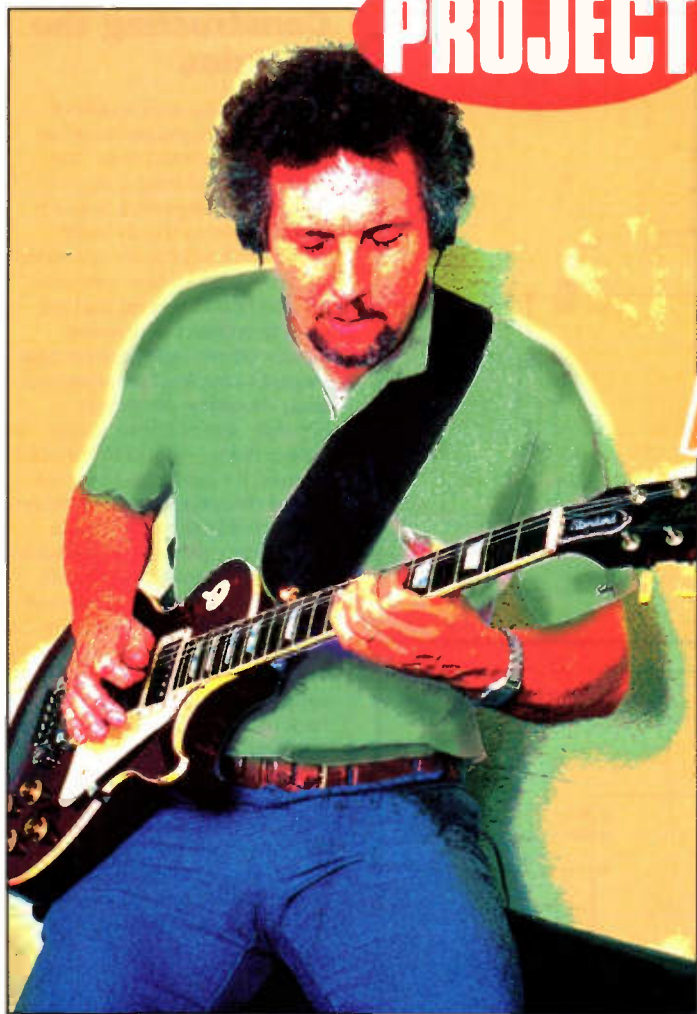

described last month, this type of effect is produced by clipping the signal. Signals are coupled to the input of the amplifier via C2. The maximum gain of the stage is set by the values of R3 and R4, however, when the output signal (IC1 pin 6) swings high or low enough for any of the diodes (D1 -

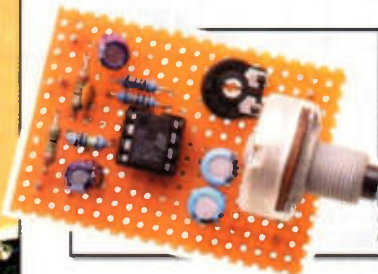

D4) to conduct, further signal swings in that direction are severely limited. The overall effect is to produce a clipped waveform rich in harmonics. The type of clipping produced by the circuit is determined by the diode configuration and this is controlled by switch S1. When S1 is closed only D1 and D2 are effectively in circuit (D3 and D4 are bypassed). This results in a waveform that is clipped symmetrically (at approximately the same point on each half cycle). With S1 set to the open position the effect is slightly different. In this mode the onset of clipping occurs at different

levels on the positive and negative parts of the cycle. The effect is a modified harmonic response and a different (perhaps less harsh) sound. Capacitor C5 limits the high frequency response of the circuit and C6 couples the output signal to terminal P5.

## Wah Wah Effect

The Wah Wah effect can be configured for either automatic or manual operation. Figure 3 shows the circuit. The stage comprising IC1, with R1, R2 and C2 providing a half supply reference for other relevant parts of the circuit. Supply decoupling is important in this circuit and is provided by C1, C3, C4, C7 and C8. The heart of the circuit is IC4, the popular LM13700 transconductance op-amp configured as a voltage controlled filter. Input signals are applied to terminal P3 and the output is available at P7. The centre frequency of the filter is determined by a positive voltage applied to P6 (this must not exceed the positive supply voltage). A variable voltage (for example, from a potentiometer) may be connected to P6 to allow the centre frequency to be manually swept. This creates the well known Wah Wah effect.

The filter may also be swept automatically. Op-amp IC2 and associated components form a simple low frequency oscillator. The switching threshold of the oscillator and ultimately the output amplitude is determined by VR1 and R5 and the oscillator frequency is set by R6, VR2 and C5. The output of the oscillator is buffered by IC3 and made available on terminal P5. The filter may be automatically swept by connecting the output at P5 directly to P6. This results in a variety of Wah Wah type effects depending on the settings of VR1 and VR2.

# Guitar Amplifier WITH EFFECTS

PART 2

*In part 2, Gavin Cheeseman gets down to construction*

## Introduction

This month we look at building a home guitar practice amplifier with integral Fuzz and Wah Wah effects.

## Input Stage

The circuit diagram of the input stage is shown in Figure 1. Based around a single operational amplifier, this circuit acts as a buffer providing a high impedance at the input to interface to a guitar transducer and a low output impedance suitable for driving effects circuits etc. The stage can also provide a level of gain when required, controlled by variable resistor VR1. Resistors R1 and R2 provide a half supply reference level for

the non-inverting input of the op-amp via R3 which is the main factor that determines the input impedance. The gain of the stage at audio frequencies is set by resistors R4, R5 and VR1. Capacitor C4 provides a low frequency roll off and C5 reduces gain at high frequencies. Supply decoupling is provided by C3 and C6. The output of IC1 is coupled to Output Level Control VR2 via C7. The output is made available on terminal P5.

## Fuzz Effect

The Fuzz Effect circuit is shown in Figure 2. In common with the input stage this section also uses a single op-amp but this time the inverting configuration is used. As

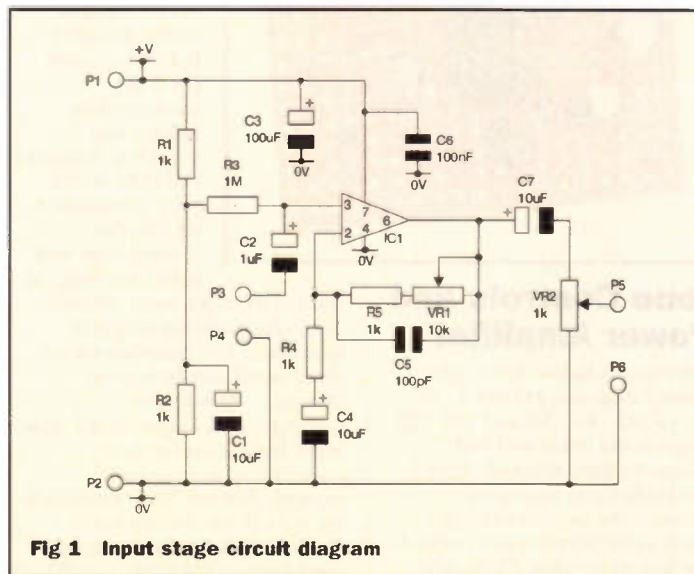

Fig 1 Input stage circuit diagram

## Constructing the Modules

All four circuits are capable of exhibiting gain and are therefore prone to unwanted noise and earth loop problems if an unsuitable component layout is used. Problems mainly occur where earth returns are connected incorrectly and where excessive lengths of unscreened lead are used to connect to sensitive inputs. Where signal connections exceed a couple of cm screened leads should be employed. Separate sets of power supply connections (+V and 0V) should be used for inputs and outputs and all 0V connections should be connected back to one single point (star earth). High frequency decoupling capacitors (100nF) should be connected as close to the relevant active components as possible. This helps to reduce any high frequency noise on the supply rails which can be coupled back to the circuit input.

Where possible, it is recommended that DIL sockets are used for the ICs, so as to avoid damage during soldering. Of course this does not apply to the power amplifier IC (tone control/power amplifier circuit IC4) as this does not use a DIL pinout. Furthermore, this device can operate at a relatively high temperature when fully driven and normally requires heatsinking. These points must be borne in mind when the deciding on the physical orientation of the IC, and most importantly, there must be adequate air flow around the device. As a precautionary measure, the IC case should not be allowed to come into direct contact with the circuit board and cable insulation should be kept clear, although when correctly heatsinked the temperature should remain within acceptable levels.

It is normal to mount the device in the upright position perpendicular to the PCB. If you are using matrix board, it may be necessary to slightly rearrange the lead positioning to correspond with the holes in the circuit board; however, the leads must not be allowed to short together as this could be disastrous. Remember to allow enough room for the heatsink. Power supply leads, both on and off board, should be suitable for the current drain of the amplifier IC (see power supply considerations).

Similar considerations apply resistors R10 and R12 of the power amplifier circuit. These normally run cold except under certain fault conditions but it is sensible to mount the two resistors such that the component bodies are raised slightly above the PCB.

Variable resistors can be mounted on or off board. Wiring the controls off board

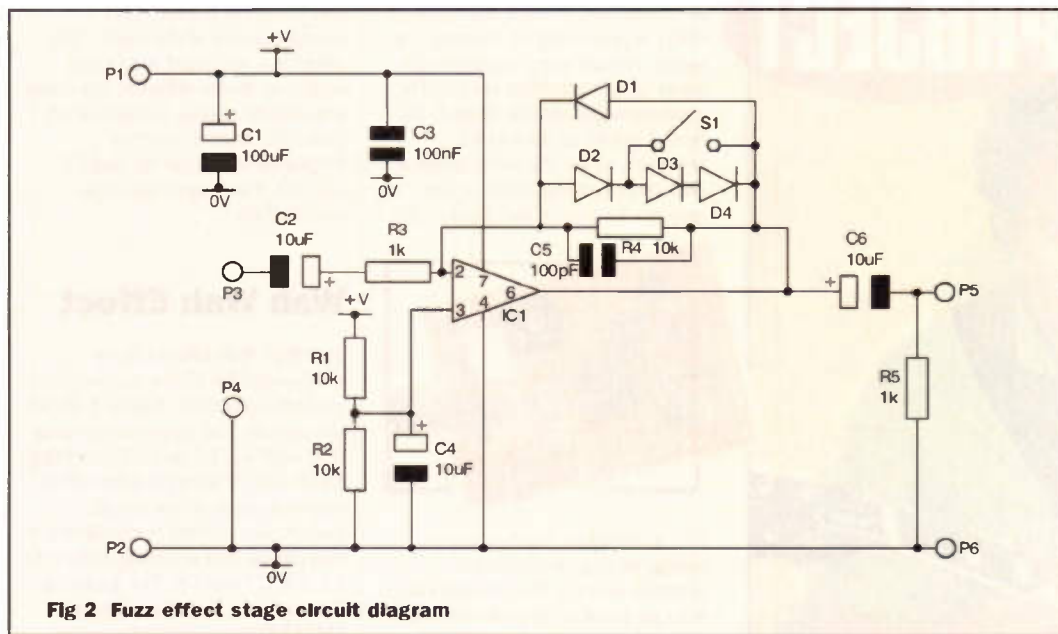

Fig 2 Fuzz effect stage circuit diagram

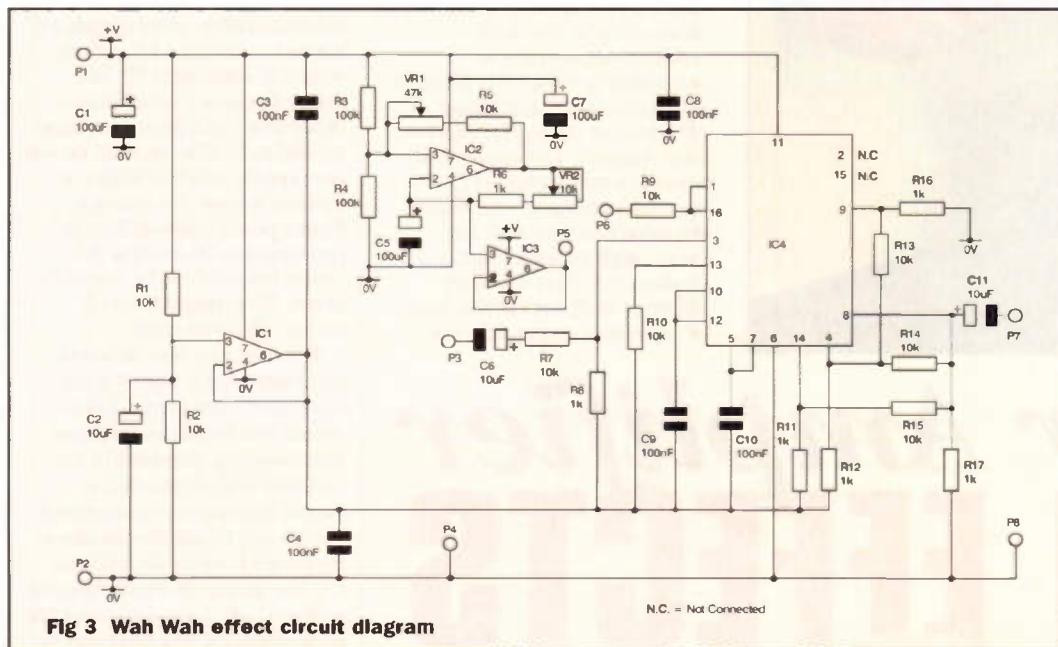
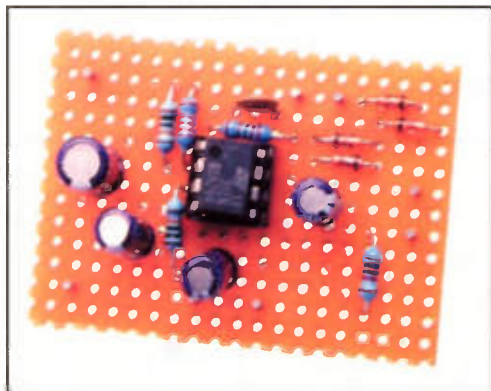

Fig 3 Wah Wah effect circuit diagram



VR1 set the input level. The output of the tone control stage is available at P5 and is coupled to one input of power amplifier IC1 via capacitor C5. IC1 is configured to provide two individual channels. The input on IC1 pin 1 is connected via the tone control stage and would normally be

used as the main input channel. The corresponding output is available at P10. Alternatively an input signal may be applied directly to P6 with the corresponding output on P9. This input has no level or tone controls and is an entirely separate channel. For convenience we will call this the auxiliary channel. Either output may be used to drive a suitable 4 or 8Ω

loudspeaker connected between the relevant output terminal and 0V. The power handling capability of the loudspeaker should be suitable for output level. Capacitors C13 and C16 are included to reduce the gain of the amplifier at high frequencies and values are typically in the order of a few pF. The actual value chosen depends on the required response. In practice these components can usually be omitted but may be required if instability or high frequency pick-up is a problem.

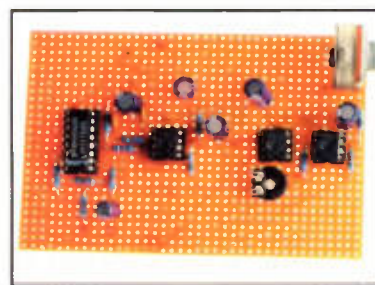

## Tone Controls and Power Amplifier

Referring to Figure 4, the tone control stage comprises C1 - C3, C7, C8, R2 - R4, VR2 and VR3. VR2 controls the treble and VR3 affects the bass although there is inevitably some interaction between the two controls. The input to the tone control circuit is applied on terminal P3. R1 and



Tone control stage.

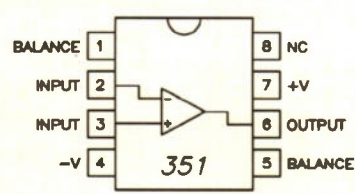
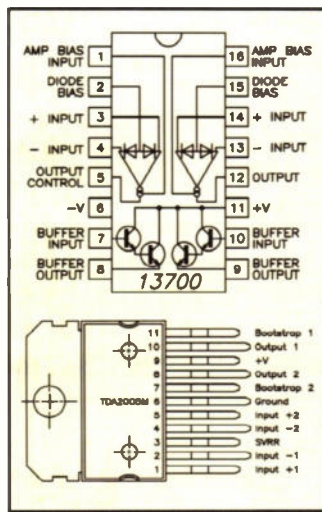
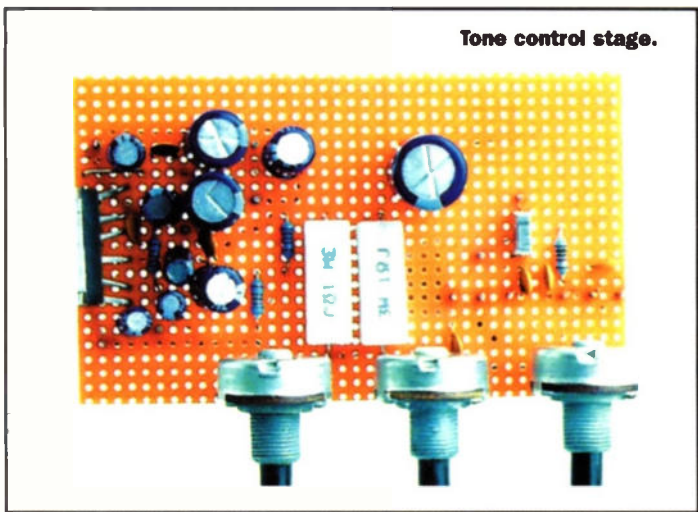

Fig 5 IC pinouts

## Testing the Amplifier

Before applying power check for all short circuits. For simplicity, we will assume that the connection configuration shown in Figure 6 is used and that the mode selection switch is set such that all four modules are connected in series and active.

The power supply terminal connections for each of the four modules are the same. The fused +12V connection is made to terminal P1 and 0V is connected to P2. A multimeter set to read current (amps) may be connected in series with the positive power supply rail so as to monitor the current consumption. It is sensible to set all variable resistor level controls to the minimum position to start with. This particularly applies to VR1 on the tone control/power amp module.

In order to test the unit a signal source is required. Initially, this may take the form of a signal generator or a guitar with a suitable pickup. An oscilloscope is also useful if available but is by no means essential.

Apply power to the guitar amplifier. With no input signal present, the current consumption should not exceed 200mA total. If a higher current drain is measured, this suggests there is a problem. In this case, switch off immediately and re-check all connections. Typical causes are incorrect connections, short circuits or instability. To provide additional protection when power is applied to the circuit for the

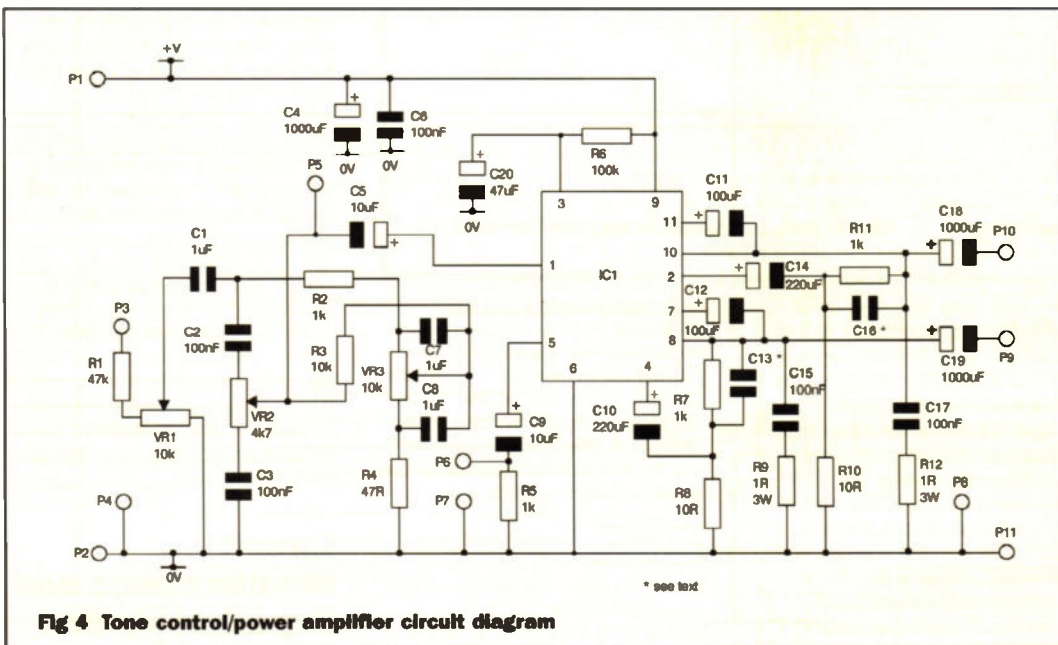

Fig 4 Tone control/power amplifier circuit diagram

may make panel mounting easier but can result in instability or noise pickup if lead lengths are excessive.

The pinout information for the main semiconductors used is shown in Figure 5.

## Connections

There are various ways to connect the modules. A suitable configuration using all four circuits is shown in Figure 6. The arrangement shown allows different effects to be switched in and out. Terminal designations for each circuit are shown in Figure 7 - Figure 10 for reference. Connections between the modules should be kept very short as far as possible. Of course, there is no reason why all four modules cannot be built as a single unit offering the advantage of minimising off board connections.

## Power Supply Considerations

All circuits are designed to operate from a 12V DC power supply. The power supply must

be capable of delivering enough current for the power amplifier stage. The actual current consumption depends on the loudspeaker impedance, how hard the amplifier is being driven and how many channels are in use. When driving a 4Ω loudspeaker from one channel a 1A power supply is adequate. If both amplifier channels are in use a higher current supply may be required.

**For safety reasons, it is essential that the power supply is suitably fused so as to minimise any damage should a short circuit occur.** A degree of protection is provided by the power amplifier IC itself, but this only applies to specific fault conditions such as output short circuit or thermal overload. Sometimes the power supply used may not be capable of delivering enough current to blow the fuse. If this is the case, check that the

necessary short circuit protection is provided within the power supply itself. Of course, it goes without saying that the 12V power supply output must be fully isolated from the mains supply. Never attempt to use a power supply that does not provide the appropriate protection.

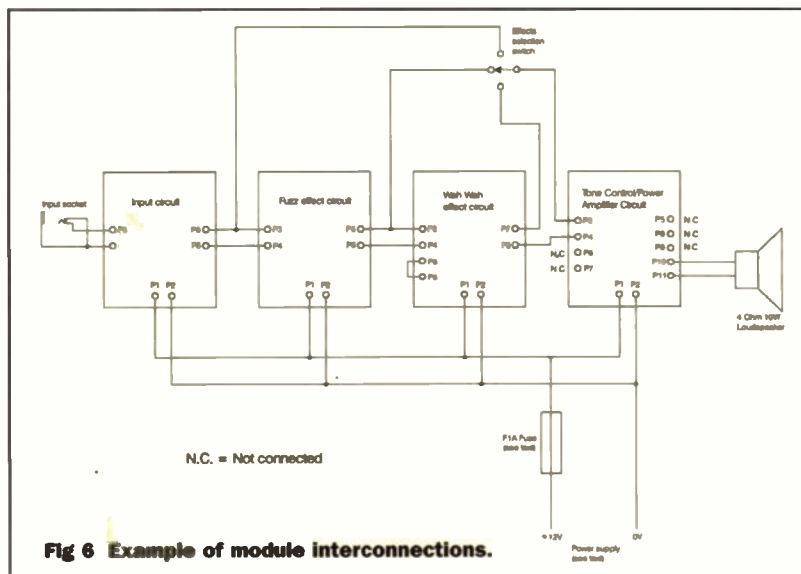
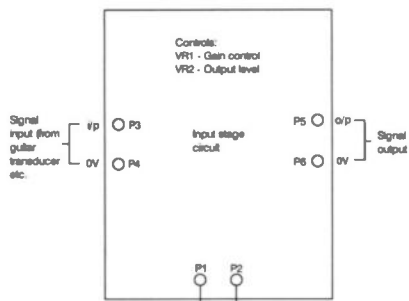
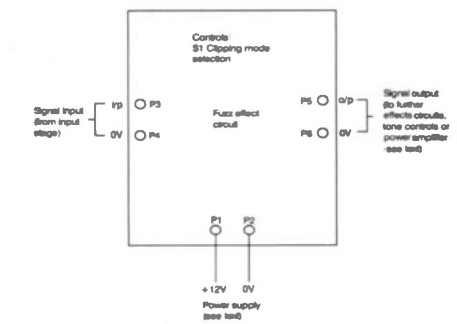

Fig 6 Example of module interconnections.



**Fig 7 Input circuit terminal connections**



**Fig 8 Fuzz effect circuit terminal connections**

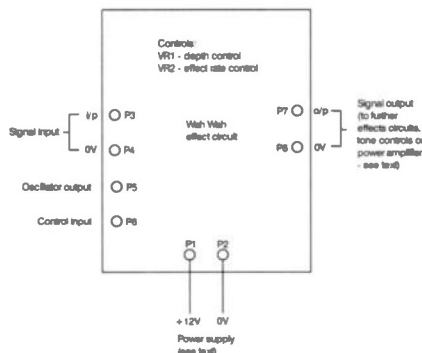

**Fig 9 Wah Wah circuit terminal connections**

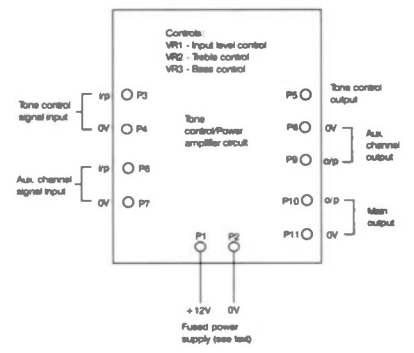

**Fig 10 Tone control/power amplifier terminal connections**

first time, you may wish to connect a lower rated fuse in series with the positive supply rail (e.g. F200mA). This fuse should be replaced with the standard rating, once it is determined that the current drain is within the correct limits.

Assuming that everything appears to be correct, slowly increase the setting of level control VR1 on the tone control/power amp module. With no signal applied, this should result in very little increase in supply current. It should be possible to hear noise from the loudspeaker as the volume is increased. Set tone controls VR2 and VR3 on the same module to centre position. Adjusting these controls will normally result in a variation in the output noise level. If available an oscilloscope may be connected to the power amplifier output terminals to check that no unwanted high frequency oscillation is present. Reduce the setting of VR1 such that the wiper is set to approximately central position.

Apply a suitable signal source between P3(i/p) and P4(0V) of the input module. Set VR2 on the input module to approximately half way position. If you are using a signal generator, the amplitude should be set to the lowest level to start with. Slowly increase the input signal level. An oscilloscope may be used to check that an output is present at input module terminal P5. An output should also be audible from the loudspeaker.

Adjusting input module gain control VR1 or level control VR2 should affect the level at the final output. If you have an oscilloscope, connect this to the output of the Fuzz effect stage

(P5) and note the effect of adjusting the input level. At low levels the signal should remain relatively undistorted but as the level is increased, distortion (clipping) should be introduced. The onset of distortion should be audible at the output but if the Wah Wah effect is in line this will be less noticeable due to the filtering effect of this stage. With S1 closed, clipping should be fundamentally symmetrical. Opening the switch contacts should result in a greater signal amplitude and loss of symmetry.

When the Wah Wah effect is switched in and configured to operate in automatic mode the swept filter effect is clearly audible at the amplifier output. Check that adjusting Wah Wah module controls VR1 and VR2 results in a variation to the depth and rate of the effect.

Once everything appears to be working correctly connect a guitar if you have not done so already and carry out any final checks to ensure that all sections of the guitar amplifier are operating.

## Housing

The sound of the amplifier is, to a large degree, as much dependant on the acoustic characteristics of the loudspeaker housing as it is on the electronics. Loudspeaker cabinet design is a complex subject but in general terms you cannot expect the same performance from a small box of random dimensions as you will achieve using a purpose designed cabinet. Although the tonal requirements for guitar amplifiers are probably somewhat different to those of hi-fi speakers, a little time planning

and experimenting can pay dividends in terms of achieving the sound you want. For those interested, a number of books are available covering speaker cabinet design (see Books Section of the current Maplin Catalogue). It is not by any means essential for the guitar amplifier to form part of the loudspeaker cabinet. The amplifier can be mounted in a separate case with an output socket to allow connection of an external loudspeaker. For example, although perhaps not ideal, a hi-fi speaker could be used, as long as it has a suitable impedance and power rating.

## Using the Guitar Amplifier

The modules described provide a low cost method of producing an amplifier for use with a range of guitars. The system is well suited to use with add on guitar transducers such as stock code BM97F. These provide a simple method of driving an amplifier from an acoustic guitar and are ideal for beginners. However, one characteristic of some types of transducer is that they are quite prone to acoustic feedback. When switching off the amplifier it is always a good idea to reduce the output volume control, so that next time you switch the unit on you are not deafened by a sudden blast of noise and howl round.

Although the design does not generally provide the same level of performance as can be expected from a commercial amp and effects pedals, a useful range of effects can be produced. By varying the settings of the Fuzz and Wah Wah circuits a number of interesting sounds can be created.

## Input Level

Because each of the modules is active and exhibits gain it will usually be necessary to adjust the level controls when switching from one effect to another. Always check that anything you intend to connect to the amplifier is fully compatible. The input stage is designed for relatively small signals in the order of a few mV and high level signals (e.g. line level) should not be used as these will result in overload. Also the input of the amplifier should not be connected to devices with a DC offset as this may overvoltage or reverse polarise the input coupling capacitor.

Gain Setting Depending on the signal input level driving the guitar amplifier, it may be necessary to adjust the gain of some of the stages. Level controls have been included to allow the gain to be reduced where the signal level is too high but if the input signal is insufficient to drive the Fuzz effect stage fully it may be necessary to increase the gain. Probably the easiest way to achieve this is to increase the value of R4 in the Fuzz effect circuit. It is recommended that the value does not exceed 100k.

The input level to the tone control stage can be increased by reducing in value or linking out R1 in the tone control/power amp circuit. The power amplifier will then be driven harder resulting in increased volume.

## Circuit Modifications and Experimentation

As mentioned earlier, the circuits described in this article are designed with experimentation in mind and the component values and circuit configurations are intended to provide a starting point. The circuits are functional but are not necessarily fully optimised. More experienced constructors may wish to make modifications to improve or change the operation of the circuit. Also it is possible to connect the circuits in a different order or leave a module out if not needed. For example you may not require the Wah Wah stage. This is not a problem as long as input and output levels for each stage are correctly set up. This is partially determined by the output level produced by the guitar pickup.

Some readers may be interested in adding further effects circuits to the existing configuration. For example a compressor/limiter could be connected between the input stage the Fuzz effect stage to provide a relatively constant input level. A simple experimental circuit is shown in Figure 11 as an example.

The variable resistors specified in the parts lists are a mixture of

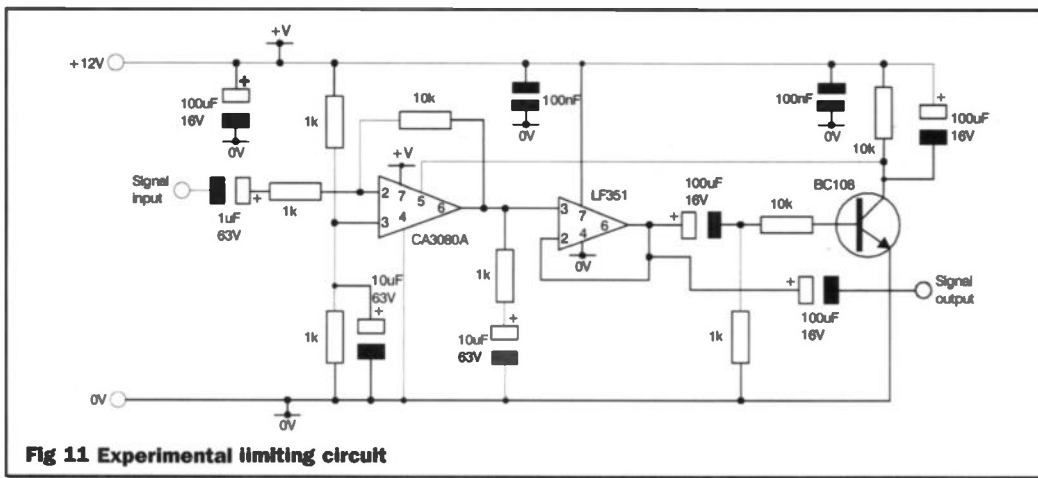

**Fig 11 Experimental limiting circuit**

voltage, which should not be allowed exceed the positive supply voltage (+12V) may be derived from a potentiometer. When set up correctly this allows a conventional foot pedal (with an internal potentiometer) to be used to control the effect. A switch may be used to select between automatic and manual settings (see Figure 12).

Other possible modifications include changing the response of the tone controls and modifying the frequency range of the wah wah circuit sweep oscillator. The latter may be achieved by changing the value of C5 in the Wah Wah circuit.

preset and panel mounting types depending on function. For example, the input stage gain control (input circuit VR1) is specified as a preset variable resistor. This is because regular adjustment will not normally be necessary once the most appropriate gain is set. Conversely input circuit level control (VR2) has been specified as a panel mounting device as adjustment of this control will probably be more frequent (to change the input level to the following Fuzz effect stage). As long as lead lengths are kept short there is no reason why panel mounting potentiometers cannot be used in place of the preset types to allow easy access.

Alternatively you may wish to minimise the number of panel mounted controls by replacing some of these with preset types. Suitable holes may be drilled in the guitar amplifier housing to allow access where necessary. Ultimately the choice is entirely down to the constructor.

### Controlling the Wah Wah Circuit Manually

If required, the Wah Wah circuit may be operated manually by disconnecting P5 from P6 in the Wah Wah effect module and applying a variable control voltage to P6. The control

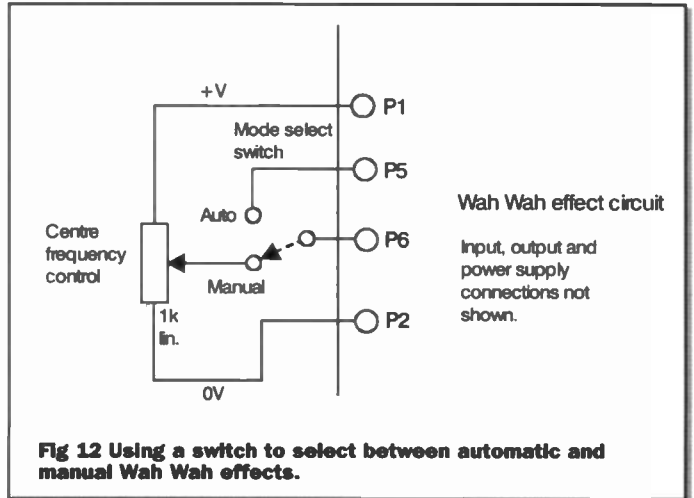

**Fig 12 Using a switch to select between automatic and manual Wah Wah effects.**

## PROJECT PARTS LIST

### INPUT STAGE

#### RESISTORS

R1, 2, 4, 5	1k Min Res	4	M1K
R3	1M Min Res	1	M1M
VR1	Hor Encl Preset 10k	1	UH03D
VR2	Pot Lin 1k	1	FW00A

#### CAPACITORS

C1, 4, 7	Gen Elect 10µF 63V	3	AT77J
C2	Gen Elect 1µF 63V	1	AT74R
C3	Gen Elect 100µF 16V	2	AT40T
C5	Ceramic 100pF	1	WX56L
C6	Minidisc 0.1µF 16V	1	YR75S

#### SEMICONDUCTORS

IC1	LF351N	1	WQ30H
-----	--------	---	-------

#### MISCELLANEOUS

P1-6	Pin 2145	6 pins	FL24B
	DIL Socket 8-Pin	1	BL17T

### FUZZ EFFECT

#### RESISTORS

R1, 2, 4	10k Min Res	2	M10K
R3, 5	1k Min Res	1	M1K

#### CAPACITORS

C1	Gen Elect 100µF 16V	2	AT40T
C2, 4, 6	Gen Elect 10µF 63V	3	AT77J
C3	Minidisc 0.1µF 16V	1	YR75S
C5	Ceramic 100pF	1	WX56L

#### SEMICONDUCTORS

IC1	LF351N	1	WQ30H
D1-4	1N4148	4	QL80B

#### MISCELLANEOUS

P1-6	Pin 2145	6 pins	FL24B
	DIL Socket 8-Pin	1	BL17T

### WAH WAH EFFECT

#### RESISTORS

R1, 2, 5, 7, 9, 10, 13-15	10k Min Res	9	M10K
R3, 4,	100k Min Res	2	M100K

R6, 8, 11, 12, 16, 17	1k Min Res	6	M1K
VR1	Hor Encl Preset 47k	1	UH05F
VR2	Pot Lin 10k	1	FW02C

#### CAPACITORS

C1, 5, 7	Gen Elect 100µF 16V	2	AT40T
C2, 6, 11	Gen Elect 10µF 63V	3	AT77J
C3, 4, 8	Minidisc 0.1µF 16V	3	YR75S
C9, 10	Poly Layer 0.1µF	2	WW41U

#### SEMICONDUCTORS

IC1-3	LF351N	3	WQ30H
IC4	LM13700N	1	YH64U

#### MISCELLANEOUS

P1-6	Pin 2145	8 pins	FL24B
	DIL Socket 8-Pin	3	BL17T
	DIL Socket 16-Pin	1	BL19V

### TONE CONTROL/POWER AMPLIFIER MODULE

#### RESISTORS

R1	47k Min Res	1	M47K
R2, 5, 7, 11	1k Min Res	4	M1K
R3	10k Min Res	1	M10K
R4	47R Min Res	1	M47R
R6	100k Min Res	1	M100K
R8, 10	10R Min Res	2	M10R
R9, 12	1R 3W W/W	2	W1R
VR1	Pot Log 10k	1	FW22Y
VR2	Pot Lin 4k7	1	FW01B
VR3	Pot Lin 10k	1	FW02C

#### CAPACITORS

C1, 7, 8	Poly Layer 1µF	3	WW53H
C2, 3, 15, 17	Poly Layer 0.1µF	2	WW41U
C4, 18, 19	Gen Elect 1000µF 16V	3	AT44X
C5, 9	Gen Elect 10µF 63V	2	AT77J
C6	Minidisc 0.1µF 16V	1	YR75S
C10, 14	Gen Elect 220µF 16V	2	AT41U
C11, 12	Gen Elect 100µF 16V	2	AT40T
C13, 16	See Text		
C20	Gen Elect 47µF 16V	1	AT39N

#### SEMICONDUCTORS

IC1	TDA2005M	1	YY70M
-----	----------	---	-------

#### MISCELLANEOUS

P1-11	Pin 2145	11 pins	FL24B
-------	----------	---------	-------

# TECHNOLOGY WATCH



with Martin Pipe

This year's Hi-Fi Show took place at Novotel London West in Hammersmith. The set-up was similar to that of Bristol Sound and Vision, which we visited in a previous Technology Watch. Exhibitors occupied a few of the main halls, but most of the action took place in the individual hotel rooms. These aren't the best for demonstrations, but it's better than nothing. Adrian, a hi-fi enthusiast and the photographer responsible for some of the pictures you see here, remarked on the venue's similarity to Heathrow Airport! In the six months that have elapsed between the two shows, there have been more developments in the battle between DVD Audio and SACD - CD's possible replacement(s). In the blue Sony corner, one could experience the sweet sonics from Sony's first commercial SACD players. Unfortunately, I couldn't personally because the because the demo room was locked at the time I visited. Even the Sony guy couldn't get in... In the red corner DVD-Audio was demonstrated by Pioneer and Technics. As with the Sony, the players looked like commercial products, rather than prototypes. Sound quality was - in both cases - excellent, and if my past experience is anything to go by, the competing SACD technology will offer broadly similar sonic benefits.

Although SACD has the benefit of backwards-compatibility with CD, the software will be more expensive to produce since all discs are dual-layered. One of the layers contains the Red Book-compatible (CD-standard) 16-bit 44.1kHz-sampled audio. The other layer, which has a much higher capacity of 4.7Gb, contains the high-resolution digital audio that can only be read by a SACD player. DVD Audio discs, which are not backwards-compatible with ordinary CD players, don't have to be multi-layered. The DVD specification does allow for dual layers, and indeed recording on both sides of the disc, if extra recording times are envisaged. Chances are that most

commercial releases will be of the single-sided, single-layered variety - these are being produced en masse by pressing plants worldwide for the increasing-popular DVD Video movies. Indeed, the ballooning popularity of DVD Video could mean that we'll eventually see affordable DVD Video Audio 'combi' players. This alone could seal the fate of SACD - nobody wants more than one standard. After all, look at what happened to Betamax in the video war, and - more recently - DCC in the home digital audio recording stakes.

CD is, however, not dead - far from it! A number of hi-fi manufacturers demonstrated high-end players, or launched new models at the show. Linn showed its CD-12 player, which it clearly sees as the CD equivalent of its legendary LP-12 turntable. Danish manufacturer Densen launched its £1000 'Beat' B-400 player, which it claims is the result of three years research and development. The B-400's transport, which is custom-made for Densen by Sony, is unusual in that it features glass - rather than plastic - optics in the laser assembly. According to the company, this aspect of the player's design has numerous benefits - including a reduction in the number of tracking errors (and thus less sound-degrading error correction), better resistance to ambient temperature and a longer life. Most players, conversely, employ standard mechanisms from component manufacturers. It's strange to imagine that a £2000 CD player could have the same mechanics as a £200 midi system! One reference DVD player has, at its heart, the

same DVD-ROM drive you might pay £70 for as an upgrade for your PC.

The Beat B-400 is, like many high-end players, compatible with the relatively-uncommon HDCD discs. HDCD (High Definition Compatible Digital - don't you just love all these acronyms) first made an appearance back in 1995. It offers the potential for the equivalent of 20-bit encoding, plus sampling rates that are noticeably higher than CD's 44.1kHz. HDCDs can be read by standard CD players, the extra information being inserted, apparently, into the last bits of the regular CD data packets. This extra information can only be decoded by a HDCD player. In these machines, a custom DSP chip takes this information - together with the existing 16-bit PCM data - and combines them to regenerate the original high-resolution signal, which is fed to the digital-to-analogue converter. Many HDCD-compatible players, including the B-400, employ the 28-pin DIL PMD100 HDCD decoder/digital filter chip from Pacific Microsonics - the American company that developed the system. Pacific Microsonics also sell HDCD encoders, but they're not cheap at around \$20,000 each. Many industry pundits see HDCD as a half-way house between CD and new formats like DVD Audio. Chances are that it will largely disappear once we have a winner in the Super CD format wars. That said, HDCD does have advantages in that standard CD pressing plants and media can be used.

Another HDCD-compatible player that employs the PMD100 chip is Arcam's £800 Alpha 9, which is widely recognised as one of the best in its class. Also present on the Arcam stand was the company's range of amplifiers, and the famous Alpha DAB tuner. At the Bristol show, Arcam proudly unveiled DAVE - 'Digital Audio/Video Entertainment' - a £900 analogue/digital surround-sound upgrade for its popular Alpha 10 integrated amplifier. This could, indeed, be witnessed at the 1999 Hi-Fi Show



Sony's SCD-1 - the world's first commercial SACD player



Linn's superb Dolby Digital home cinema system. Everything you need - minus DVD player and TV/monitor - for around £15,000!

too. A new £600 upgrade for the Alpha 10 could also be seen. MARC (Multi Area Remote Control) is a multi-room system that, in addition to the main listening 'zone', allows control of four additional zones and remote control of seven sources. Arcam also launched a new 'SE' version of the Alpha 7 CD player. Moving more upmarket, Chord arranged a very impressive demo around its ultra-fidelity DAC (DSC1500E, £4835), pre-amp (CPA3200E, £3785) and amplification (two SPM5800s, at £15000 each).

The speakers partnered with this esoterica were the columnar Bishops from Wilson Benesch, which sell for £20,000 a pair. In other words a hi-fi system that approaches the price of a house - and that's before you add the cost of the CD transport, equipment stands and cabling! It's just as well that the sound was so good - the light jazz we heard was breathtakingly realistic, and exceptionally well-controlled.

As one can expect, the Chord gear is built to military specifications - it's also rather heavy, much use being made of milled and die-cast aluminium components. The massive build quality also helps to damp out unwanted vibrations. Elsewhere in this article, you'll find a picture of the DSC1500E with its cover removed. Look at the quality of the electronic components, connections and PCBs, and you'll see why this sort of gear doesn't come cheap. The DSC1500E incorporates 24-bit 96kHz technology, and can be upgraded for SACD-compatibility with an optional module. It's compatible with HDCDs, courtesy of the same PMD100 decoder chip that's fitted to other upmarket DACs and audiophile CD players. The complement of inputs and outputs are impressive. In terms of inputs, you get one SP/DIF BNC, two TOSlink optical, plus two balanced AES XLRs and a AT&T optical input. There are gold-plated balanced (XLR) and single-ended (phono) audio outputs. Chord has also included digital outputs, presumably for loopthrough or yet more DACs if you're feeling particularly rich...

What else? In our review of the Bristol show, we reported on the return of Nakamichi to these shores. At the 1999 Hi-Fi show, its UK distributor - BBG - showed working models of its expensive Soundspace 'lifestyle' hi-fi systems, although some products were still in mock-up form. The most interesting of these was a concept MP3 player. Unfortunately, we weren't allowed to

take any photos. MP3, all the rage on the Internet, was otherwise conspicuous by its absence. Well, this is a hi-fi show! Just about every hi-fi mag in existence has reported that the 'near-CD' quality is not all it's cracked up to be. This is true enough, but it depends on the level of compression, and - just as importantly - the MP3 codec and source hardware/software used in the file's creation. Not only that, but most of these 'experts' have based their opinions by hooking up a MP3 player (like a Diamond Rio) to the line input of their expensive hi-fi systems. Using a PC to play the music would be somewhat fairer. If they were to take the SP/DIF digital audio output from a suitably-equipped PC soundcard and feed that to an external DAC, they might be pleasantly surprised. A 128kbps MP3 stream is not quite as good as a recent audiophile MD deck equipped with one of the latest ATRAC incarnations - but it comes very close.

Other companies very much into the 'lifestyle' concept are Kenwood, Sony, Denon and Technics - all of which had stands at the Novotel. Many of these lifestyle systems include built-in Dolby Pro-Logic - and, in some cases, Dolby Digital - surround decoders. Those to gain most from the increasing popularity of home cinema are, of course, the speaker manufacturers. There were many of these at the show, many of whom were demonstrating their wares with large-screen TVs and Dolby Digital/DVD sources. Acoustic Energy, which has added some new models to its well-received Aegis

range, unveiled a new subwoofer, centre speaker and subwoofer. Moving more upmarket, GT Audio demonstrated a range of visually-stunning horn speakers from the German company Avantgarde Acoustics. These speakers, which employ a much-refined version of the technology employed by the first gramophones, are capable of impressive speed and dynamics. To reproduce the lower octaves, though, you need a subwoofer. At the show, GT unveiled just the product - the Avantgarde SUB225CTRL Pro, which will go down to 20Hz. Also in the GT room was valve amplification from British manufacturer Tron, and the French Platine Verdier turntable from Laboratoire JC Verdier. This revered turntable, which was originally introduced some 20 years ago, has a massive platter coupled to the motor via a tiny belt. One can only imagine how long it takes to run up to speed! Other stands also showed high-end turntables, and various stalls were selling vinyl accessories and audiophile pressings.

Valve amplification was also well represented throughout the show. One of the most eagerly-anticipated demonstrations was that of the Quad II-forty - the 1999 Hi-Fi Show marked this product's first public appearance. The II-forty monobloc, which is scheduled for full production next spring, is an updated version of the legendary Quad II that enjoyed considerable popularity during the 1950s and 1960s. Although the basic circuit topology of the new model is basically the same, output power has been increased from 12 watts to 40 - hence the name. As with the original model, PCBs have been eschewed in favour of 'hard wiring'. The power amp was accompanied by a new control unit - the Q24 - that looks very similar to its predecessor of yesteryear. Unlike the original, though, the Q24 doesn't have a phono preamp - this is only available as an option. Quad wasn't in a position to give prices at the time of writing. Valve circuits are popular with DIY constructors - many of whom feature amongst the 'Electronics' readership - and it was good to see PM Components with its range of Golden Dragon valves. The PM Components stand also featured the chassis of a Marshall guitar amp so that the visitor could see, in the company's words, 'just how rugged and reliable tubes are in conditions of extreme use'.



Imagine one of these monster horn speakers - an Avantgarde Trio - in your living room!



British-made Cematic amps, plus a pair of American Big End subs and a Big End active filter unit. Just the thing for dance music - bass, and lots of it...



Inside the Chord DSC1500E, a DAC that sells for nearly £5000! Note the military-grade construction.



The Platine Verdier audiophile turntable, with SME tonearm. Note the massive platter, and the tiny belt that couples it to the drive motor.



A selection of the DAB hi-fi tuners currently available. Going clockwise from top left, we have models from Technics, Cymbol, TAG McLaren and Arcam. The concept 'two-button' DAB tuner developed by the BBC is on top. Photo courtesy of Adrian Caspersz.



Here's the CA30 from Cura Loudspeakers. The finish of this one-off sample reflects the country of manufacturer. Perhaps Geri Halliwell might consider a pair... Photo courtesy of Adrian Caspersz.

DAB was on demonstration, courtesy of the BBC and commercial competitor Digital One. BBC Radios 1 to 5 are currently simulcasting on DAB, while Digital One is currently in the test transmission stage. Digital One's multiplex - which will include the established Classic FM, Virgin Radio and Talk Radio service amongst its number - is scheduled to start by the end of the year. New Digital One stations will include Teen Chart (a style/music/lifestyle station), Classic Rock, Rolling News and Sport. Planned stations include dance music, culture (plays, books and comedy) and AOR-type music. The BBC will, in time, introduce new services including sports/news services to complement Radio 5, plus live coverage of Parliament. Next year, local services will also begin broadcasting via DAB. It's not known whether we'll begin to see subscription-only services, and neither the BBC nor Digital One could confirm whether they had plans to broadcast audio services via the Sky Digital satellite platform. Seeing that the installed Sky Digital base passed the million mark some time ago, and that current domestic DAB receivers sell for £500 or more, this might not be a bad idea. Expensive home receivers from Tag

McLaren, Technics and Arcam were on display in the BBC/Digital One room, as was the much-pictured 'concept' tuner developed by the BBC.

There was, sadly, no sign of the PC-based Radioscape receiver featured in an earlier Technology Watch, although the BBC and Digital One representatives were both aware of the development. DAB is primarily being sold as a car medium - although the potential for 'better-than-FM' sound quality obviously appeals to the audiophile. To this end, head units from Kenwood, Sony and Grundig amongst others were on show. It represented the only car audio at the show - if you want to see (and hear) more of this type of gear at a public exhibition, you had better wait until next year's 'Live' show at Earls Court! None of the broadcasters' representatives could, sadly, confirm whether Optimod-type audio compression would be applied to DAB services or not. Chances are that it might, seeing that not all car radios are equipped with the 'dynamic range restriction' button. Radio 1 may be subjected to the dreaded Optimod - as is currently the FM service - although there would be a real furore if Radio 3 got the same treatment. Exactly why there's a need for compression on Radio 1 is beyond my understanding, seeing that the pop

music is pretty compressed anyway. Why not just apply it to the DJ mikes? One can perhaps smell the vested interests of the music industry, who - understandably enough - want to discourage home taping off the radio in favour of CD purchases! But then again, many people are prepared to put up with mediocre sound. One doesn't suppose that many of them came to the Hi-Fi Show 1999, though.

The Hi-Fi Show 2000 will be held at the Novotel, London West, on 21st-24th September 2000. Enquiries: (0208) 774 0847

Software - it's your shout?

Have you - at any time - bought, or downloaded, a piece of software that failed to live up to expectations? Was it difficult to use, unstable, incompatible with your data or just poorly programmed? I would be very interested to hear from you by e-mail - regardless of your platform (Mac/Windows/DOS/Unix or whatever). Please try to avoid Bill-bashing for the sake of it, though! Your information will be used in the preparation of a future article - please state whether you wish to remain anonymous.

Martin Pipe welcomes comments and ideas. E-mail him as: [whatnet@cix.compulink.co.uk](mailto:whatnet@cix.compulink.co.uk) Or look out for him online! His ICQ ID is: 15482544

# MAPLIN Gift Token

MAPLIN GIFT TOKENS MAKE THE PERFECT GIFT!

Tokens are available from all Maplin Stores in denominations of £5.

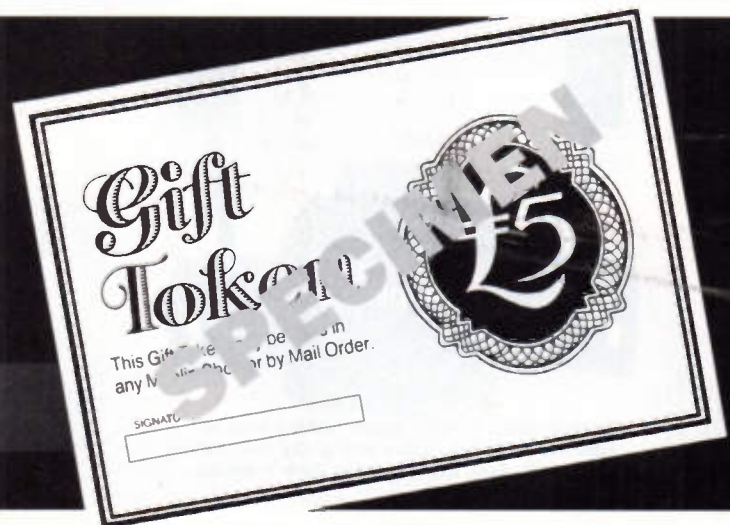

# Easy Web Page CREATION

PART 5

In part 5, Mike Holmes investigates Enhanced Layout Design including Tables and Frames

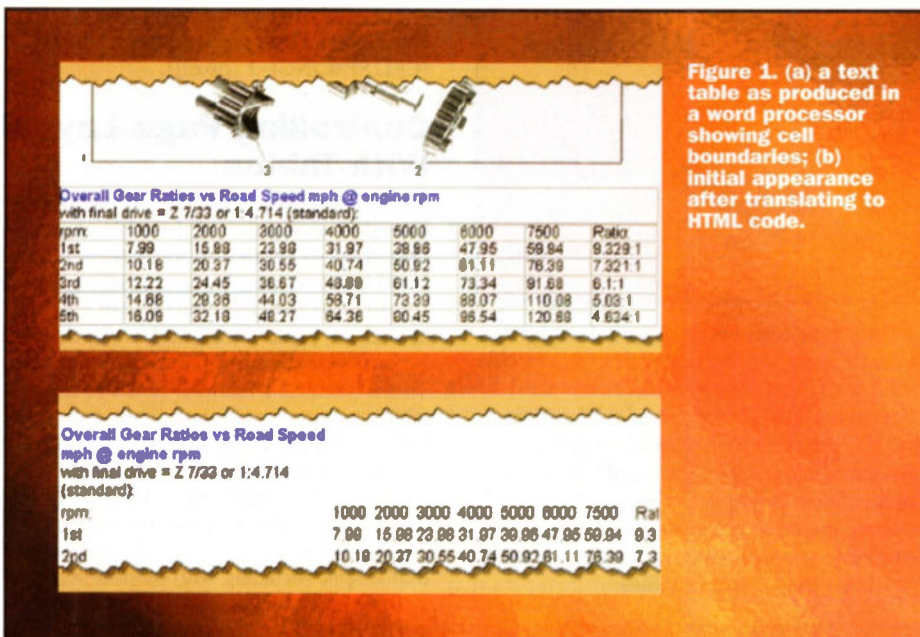

You may have found out already (by experimentation) that the popular Web browsers do not recognise the 'tab' key character in text - or if at all, it is interpreted as a space. This makes it difficult to display simple tables that may be made in this way, such as can most readily be done by most text editors.

To force the browser to display text with tabs, you could enclose the tabulated text in a `<PRE> ... </PRE>` (preformatted) element. This has two main snags though; preformatted text is displayed in the browser's default fixed width font, which may not be what you wanted, in addition to which you have no control over the actual tab positions.

## The Table Element

In HTML, proper tables can only be made with the `<TABLE>` element. Figure 1a shows an example of the nearest equivalent process in a word processor; to be more exact, one that can create tables as specific, separate 'objects', not merely conventional paragraphs containing tabulated text. (In this figure, the editor indicates the boundaries of 'cells' with dotted lines; obviously these are not printed, only the contents.)

Such a table comprises rows and columns of 'cells', where each cell can function almost like a miniature complete page, having its own tab ruler, margins, etc.

While the editor has its own controls for formatting its tables, to reproduce the equivalent for a Web page requires HTML code to be hand written:

```
<DIV ALIGN="CENTER">
<TABLE WIDTH="100%"> <!-- start table -->
<TR> <!-- start row 1 -->
<TD CLASS="f2fs11"><B><FONT
COLOR="#0000FF">Overall Gear Ratios vs Road
Speed mph @ engine rpm</FONT></B><FONT
CLASS="f2fs11"><BR>
with final drive = 2.7/33 or 1:4.714
(standard):</FONT></TD>
</TR> <!-- end row 1 -->
...
etc.
...
</TABLE> <!-- end table -->
</DIV>
```

The relevant parts are: DIV - (division) an all purpose container for separating the document into discrete divisions (not essential).

TABLE - the main HTML table 'wrapper'. In this case it is given the WIDTH attribute of "100%", which ensures that the table is

the full width of the page (or of the parent container), which is what is required in this case.

TR - (table row) a horizontal row, containing: TD - (table data-cell) cells that contain the actual 'blurb'.

CLASS - as an aside, and in this instance, an advanced attribute specifying the name of a text formatting definition contained in a `<STYLE>` element within the `<HEAD>` element. More conventionally you would use `<FONT>` in each and every cell.

The direct result of translating the table of Figure 1a into HTML is shown in Figure 1b - but now there is a problem. In the original, a single cell contains the first two lines and is the complete width of the table, while all following cells are nine across (nine columns).

## Controlling Table Layout

In the absence of more specific information, in Figure 2b the browser has interpreted that this first cell should be the same width as all the others and therefore should fit into column 1, which of course it doesn't, so it is 'scrunched up' to the left and the remaining cells are seriously uneven.

We need to tell the browser that this cell should be nine columns wide to fit it to the full width and appear as the word processor example:

```
<TR><TD COLSPAN="9" CLASS="f2fs11"><B><FONT
COLOR="#0000FF">Overall Gear Ratios etc...
```

The corrected result is that of Figure 2a. While this is fine for all practical purposes, there is something else about it that raises a couple of problems. The first is that the coding required to reproduce the second to seventh rows is verbose in the extreme - for example, row two looks like:

```
<TR><TD CLASS="f2fs11">rpm:</TD><TD
CLASS="f2fs11">1000</TD><TD
CLASS="f2fs11">2000</TD><TD
CLASS="f2fs11">3000</TD><TD
CLASS="f2fs11">4000</TD><TD
CLASS="f2fs11">5000</TD><TD
CLASS="f2fs11">6000</TD><TD
CLASS="f2fs11">7500</TD><TD
CLASS="f2fs11">Ratio:</TD></TR>
```

There are six rows like this, and not only is it a lot of typing, there are many duplications - unavoidable since each cell must have its own text formatting code - with the result that the final HTML document's file size is, to be honest, unnecessarily large. As was mentioned before about pictures, it is also helpful to prevent overly large Web pages if possible.

The most obvious thing to do is reduce the number of duplications. Leaving row 2 alone for the moment (the reason will become clear shortly), it can be seen in Figure 2b that even the word processor's version of the table may be simplified by reducing the number of cells for 'rows' 3 through 7.

The contents of cells in the same column can be combined to form a list of items enclosed in a single cell representing that column, as Figure 2b. This can be directly translating to the HTML method, as follows:

## Adding Colours

Returning to our current example, as an alternative to BORDER, the background colours of cells can be used to define parts of the table:

```
<TABLE WIDTH="100%" CELLSPACING="1" CELLSPACING="3">
and:
<TD BGCOLOR="#FFDCDC" CLASS="f2fs11">
with:
<TD BGCOLOR="#FFDCDC" CLASS="f2fs11">
```

If produces the final overall effect for this page as shown in Figure 4 (and which is why the cells of row 2, which form column sub-headings, were not also combined into those below). In addition, because most cells now have background colours, a small margin is added around the text contents, otherwise it would look a bit odd (CELLPADDING=3 [pixels]), and just for extra effect a tiny gap between cells (CELLSPACING=1 [pixel]).

## Controlling Page Layout With Tables

Curious as it may seem, the most obviously intended application of the table element as described so far, that is, for making tables, is not the commonest by current HTML authors.

The most frequent use of TABLE is, actually, to place things, with a fair degree of accuracy, on different parts of a Web page. This is because a browser tends to display page contents sequentially from top to bottom. Suppose you wanted two paragraphs displayed side-by-side in two separate columns, you couldn't do it, because by default one must be below the other.

Take a look at Figure 5a. This is a page that is split vertically, with definite left and right halves. This is very common for index or 'home' pages, especially commercial Web sites. As here, the left column is confined to listing hyperlink jumps to other pages or domains, while the larger remainder is the actual content of this page.

Furthermore, the difference is emphasised by the image that is used to 'tile' or fill the background of the browser window as specified by the BODY

Overall Gear Ratios vs Road Speed mph @ engine rpm  
with final drive = Z 7/33 or 1.4714 (standard)

rpm:	1000	2000	3000	4000	5000	6000	7500	Ratio:
1st	7.99	15.98	23.98	31.97	39.96	47.95	59.94	9.329:1
2nd	10.18	20.37	30.55	40.74	50.92	61.11	76.39	7.321:1
3rd	12.22	24.45	36.67	48.89	61.12	73.34	91.68	6.1:1
4th	14.68	29.36	44.03	58.71	73.39	88.07	110.08	5.03:1
5th	18.09	32.18	48.27	64.36	80.45	96.54	120.68	4.634:1

Figure 2. (a) as Figure 1b but with column spanning corrected; (b) illustration of reducing the number of cells results in (c), a more compact HTML table.

Overall Gear Ratios vs Road Speed mph @ engine rpm  
with final drive = Z 7/33 or 1.4714 (standard)

rpm:	1000	2000	3000	4000	5000	6000	7500	Ratio:
1st	7.99	15.98	23.98	31.97	39.96	47.95	59.94	9.329:1
2nd	10.18	20.37	30.55	40.74	50.92	61.11	76.39	7.321:1
3rd	12.22	24.45	36.67	48.89	61.12	73.34	91.68	6.1:1
4th	14.68	29.36	44.03	58.71	73.39	88.07	110.08	5.03:1
5th	18.09	32.18	48.27	64.36	80.45	96.54	120.68	4.634:1

Overall Gear Ratios vs Road Speed mph @ engine rpm  
with final drive = Z 7/33 or 1.4714 (standard)

rpm:	1000	2000	3000	4000	5000	6000	7500	Ratio:
1st	7.99	15.98	23.98	31.97	39.96	47.95	59.94	9.329:1
2nd	10.18	20.37	30.55	40.74	50.92	61.11	76.39	7.321:1
3rd	12.22	24.45	36.67	48.89	61.12	73.34	91.68	6.1:1
4th	14.68	29.36	44.03	58.71	73.39	88.07	110.08	5.03:1
5th	18.09	32.18	48.27	64.36	80.45	96.54	120.68	4.634:1

```
<!-- start row -->
<TR><TD CLASS="f2fs11">1st<BR>
2nd<BR>
3rd<BR>
4th<BR>
5th</TD>
<!-- column 2 -->
<TD CLASS="f2fs11">7.99<BR>
10.18<BR>
12.22<BR>
14.68<BR>
16.09</TD>
...
etc.
...
<!-- column 9 -->
<TD CLASS="f2fs11">9.329:1<BR>
7.321:1<BR>
6.1:1<BR>
5.03:1<BR>
4.634:1</TD></TR>
<-- end row -->
```

The result is shown in Figure 3, and it can be seen straight away how gathering specific parts of the text into single cells has also determined the placement of the borders, and if done properly the effect is quite pleasant. Larger values for BORDER produce thicker lines. By explicitly setting BORDER to zero, the table regains space originally reserved for borders between cells, allowing for particularly compact tables.

Overall Gear Ratios vs Road Speed mph @ engine rpm  
with final drive = Z 7/33 or 1.4714 (standard)

rpm:	1000	2000	3000	4000	5000	6000	7500
1st	7.99	15.98	23.98	31.97	39.96	47.95	59.94
2nd	10.18	20.37	30.55	40.74	50.92	61.11	76.39
3rd	12.22	24.45	36.67	48.89	61.12	73.34	91.68
4th	14.68	29.36	44.03	58.71	73.39	88.07	110.08
5th	18.09	32.18	48.27	64.36	80.45	96.54	120.68

Figure 3. Using the BORDER attribute.

This is considerably simpler than the previous method, coupled with a proportional difference in file size. In addition alterations to the text format for each column is easier. The direct result displayed by the browser is shown in Figure 2c. Note also that the affected 'rows' now appear closed up, as there was invariably some extra space introduced between cell boundaries in the previous version.

## Modifying A Table's Appearance

Several attributes can be added to table or cell elements to affect the appearance of a table. The simplest one is this:

```
<TABLE BORDER="1" WIDTH="100%">
```

## Tables Within Tables

It should be mentioned at this point that the <TD> element can contain almost anything that you could also put in a <P> or <DIV> element, including pictures, and, usefully, another complete table, as a sub-table.

In such a case BORDER provides the ability to emphasise some tables with respect to others; a table with a border of 4 containing a sub-table with a border of 1 looks much nicer than if they both share the same default border width.

The commonest reason for wanting to place a table in the cell of another is because the layout of the sub-table is too complex to be easily incorporated in the coding of the 'parent' table.

Overall Gear Ratios vs Road Speed mph @ engine rpm  
with final drive = Z 7/33 or 1.4714 (standard)

rpm:	1000	2000	3000	4000	5000	6000	7500	Ratio:
1st	7.99	15.98	23.98	31.97	39.96	47.95	59.94	9.329:1
2nd	10.18	20.37	30.55	40.74	50.92	61.11	76.39	7.321:1
3rd	12.22	24.45	36.67	48.89	61.12	73.34	91.68	6.1:1
4th	14.68	29.36	44.03	58.71	73.39	88.07	110.08	5.03:1
5th	18.09	32.18	48.27	64.36	80.45	96.54	120.68	4.634:1

Figure 4. The final HTML table with coloured cells.





'page', as below (and because the BODY is missing, no part of this root page is actually visible on screen). Framesets may be nested:

```
<HTML>
<HEAD>
<TITLE>HTML Reference Library</TITLE>
</HEAD>
<FRAMESET ROWS="85,*,65">
<FRAME SCROLLING="no" NAME="title" NORESIZE
SRC="title.htm">
<FRAMESET COLS="40%,60%">
<FRAME SCROLLING="yes" NAME="toc"
SRC="toc.htm">
<FRAME SCROLLING="yes" NAME="main_page"
SRC="main.htm">
</FRAMESET>
<FRAME SCROLLING="no" NAME="HLP_buttons"
NORESIZE SRC="buttons.htm">
</NOFRAMES>
</NOFRAMES>
</FRAMESET>
```

## Frame Syntax

The result of this is shown in Figure 6, displaying four actual HTML documents. The syntax is similar in scope and complexity to that used for tables, and was designed to be quickly processed by Internet client layout engines.

<FRAMESET> is the main container for a FRAME. It can define either ROWS or COLS, followed by a comma delimited list of values. These can be in absolute pixels, percentages between 1% and 100%, or relative scaling (+ or - a value).

The number of rows/cols is implicit in the number of elements in the list. Since the total height/width of all the values must equal the height/width of the window, actual sizes might be normalised to achieve this. To inform the browser that a row or column is required at this point, but without sizing data, an asterisk '\*' is used. The browser makes this region fill the remaining space. You cannot mix ROWS and COLS in the same frameset, hence in the example a second frameset inside the first defines the two columns.

<FRAME> defines a single frame in a frameset. There are six possible attributes: SRC, NAME, MARGINWIDTH, MARGINHEIGHT, SCROLLING, and NORESIZE. The SRC attribute is set to the URL of the document to be displayed in this particular frame. Frames without a SRC are displayed as a blank, flat grey panel sized as the frame would have been. Note that once created, the frame takes on all the aspects of a separate window, in the context of HTML coding (and especially scripts).

NAME gives the frame a name so that it can be targeted by anchors in other documents, commonly those in other frames in the same browser window, as in: <A HREF="toc.htm" TARGET="toc"> (see above).

By default all frame windows are unnamed. There are four reserved names which can be referred to in anchor TARGETs, but which you must not redefine as new frame names:

- \_Blank Always load this link into a new, unnamed main browser window (does not

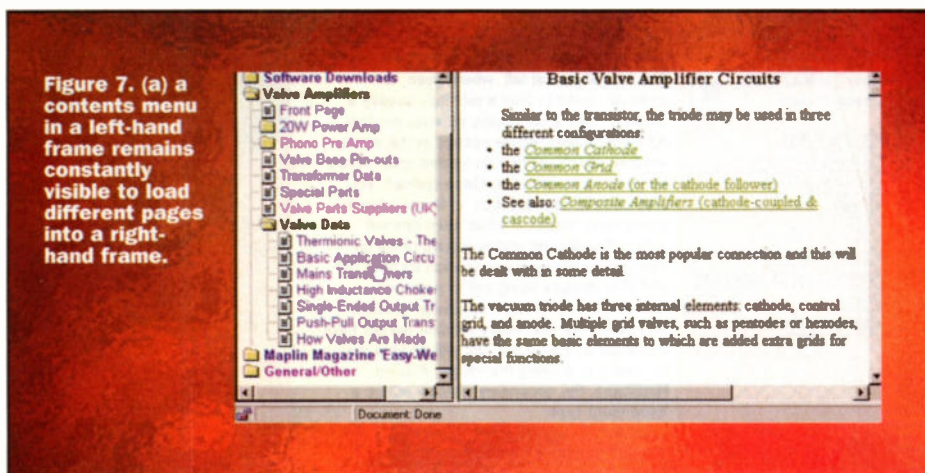

Figure 7. (a) a contents menu in a left-hand frame remains constantly visible to load different pages into a right-hand frame.

- \_Self Always load this link over myself.
- \_Parent Always load this link over the parent, meaning the main browser window (becomes self if there is no parent).
- \_Top Always load this link at the top level (becomes self if already at the top).

Formerly, only Netscape Navigator supported the use of '\_blank' to mean open a document in a fresh browser window, but this is being incorporated in recent browsers. Similarly, opening a hyperlink whose TARGET specifies a name you made up but which doesn't exist creates a new browser level window.

MARGINWIDTH and MARGINHEIGHT controls page margins in this frame, values in pixels.

SCROLLING="yes|no|auto": describes if the frame should have a scrollbar or not. Auto instructs the browser to decide whether scrollbars are needed, and place them where necessary. If unspecified, the default is auto.

NORESIZE is a flag indicating that the frame cannot be resized by the user. Otherwise, the frame is resizable by dragging its edge to a new position with the mouse.

FRAMEBORDER="yes|no": Formerly Internet Explorer™ specific, controls the frame border display (normally three-dimensional raised bars). If "no", the borders for the specific frame are not drawn (and if used in Navigator™ 4.x, cannot be resized). Setting this flag causes all borders in the set to disappear, and the result can look very much like a single page divided up as per the table method - except that each division of this 'page' is independently scrollable!

FRAMESPACING="value": also Internet Explorer™ specific, allows the setting of extra space around frames, to give the appearance of 'floating' frames (or thick borders).

## If The Browser Cannot Handle Frames

<NOFRAMES> provides alternative content that is viewable by non-frame-capable browsers. (A frame-capable browser ignores everything between this and </NOFRAMES>). The content should be a BODY element, as this will be the next intelligible thing a non-frame-capable browser reads after <HEAD>, so that in effect the result reads like a normal page.

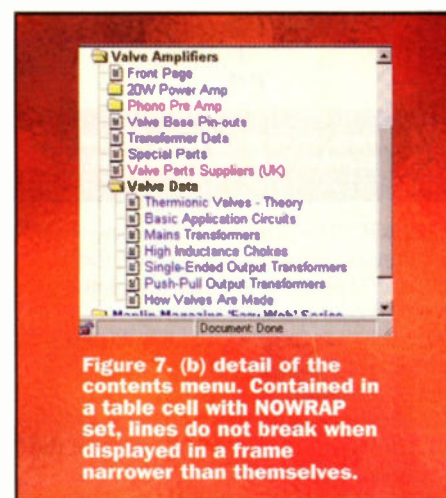

Figure 7. (b) detail of the contents menu. Contained in a table cell with NOWRAP set, lines do not break when displayed in a frame narrower than themselves.

The BODY could contain a copy of one of the framed pages - which is inefficient and difficult to maintain - or better still, something like:

```
<P>If your browser is unable to display frames click <A HREF="alternative.htm">here</A>.</P>
```

## Contents Menu Example

Using all these elements, an alternative to the table method illustrated in Figure 5a may be made with two frames as in Figure 7a. Here a left-hand frame contains a page menu 'tree', which remains visible at all times. Clicking on links in this menu bring up the required page in the right-hand frame.

Notice also how the lines of the menu items do not break - as this would interfere with the design of the tree - but disappear under the scrollbar and actually the page needs to be scrolled sideways to see the righthand ends. On its own the page looks like Figure 7b, but this does not give a clue as to what is going on.

In fact the whole menu is contained in a single table cell, and the cell is given the NOWRAP attribute, thus preserving the intended layout of the tree.

## For Next Time

You may have seen Windows-like objects embedded in pages - text input fields, selection lists, buttons - these are all sub-elements of a FORM, usually used by the client to return typed data back to the 'webmaster'. Next month we shall find out how they are made, and what sorts of things they can be used for.

## Diary Dates

Every possible effort has been made to ensure that information presented here is correct prior to publication. To avoid disappointment due to late changes or amendments, please contact event organisations to confirm details.

### November 1999

- 2 to 4 Nov.** e-business expo 2, Olympia, London. Tel: (0181) 910 7910.
- 2 to 3 Nov.** Sound Broadcasting Equipment Show, NEC Birmingham. Tel: (01398) 323 700.
- 3 to 5 Nov.** Voice Europe - Computer Telephony & Call Centres, Olympia, London. Tel: (01244) 378 888.
- 5 to 7 Nov.** PC@HOME - Small Office & Home User Computing Show, G-MEX Centre, Manchester. Tel: (01895) 630 288.
- 10 to 11 Nov.** Data Warehousing, Olympia, London. Tel: (0181) 879 3366.
- 12 to 14 Nov.** The Home PC Show, Telford International Centre. Tel: (01895) 676 224.
- 16 to 18 Nov.** Digital Media World, Wembley Exhibition Centre, London. Tel: (01244) 378888.
- 16 to 18 Nov.** Engineering & Production Technology, The Kings Hall, Belfast. Tel: +353 1490 0600.
- 16 to 18 Nov.** Electronic Information Display, Sandown Exhibition Centre, Sandown. Tel: (01822) 614 671.
- 17 to 18 Nov.** JAVA - Computer Software Trade Exhibition & Conference, Olympia, London. Tel: (01256) 384 000.
- 17 to 18 Nov.** Softworld in Sales & Marketing, National Exhibition Centre, Birmingham. Tel: (0181) 541 5040.
- 26 to 28 Nov.** Switched On - Internet Users Expo, Olympia, London. Tel: (0207) 323 4492 Fax 0207 323 4039.

### December 1999

- 29 Nov to 1 Dec 99.** TMA32 - Telecommunications Managers Assoc Exhibition, Brighton Centre, Brighton. Tel: (01372) 361000.
- 7 to 8 Dec.** Digital Signal Processing & Data Acquisition, Sandown Exhibition Centre Esher. Tel: (0208) 547 3947.
- 7 to 9 Dec.** Online Information, Olympia, London. Tel: (01865) 388 000.
- 19 Dec.** Scottish Computer Fair, SECC Glasgow. Tel: (01706) 299 902.

### January 2000

- 26 to 27 Jan.** Computer Trade Show, NEC, Birmingham. Tel: (0208) 541 5040.

### February 2000

- 2 to 3 Feb.** Legal IT 2000, Business Design Centre, London. Tel: (0207) 221 1155.
- 8 to 9 Feb.** Accounting IT, G-MEX Centre, Birmingham. Tel: (0171) 221 1155.
- 9 to 10 Feb.** Communications for Business, Barbican Centre, London. Tel: (01923) 676 867.
- 9 to 10 Feb.** Softworld in Human Resources & Payroll, Wembley Exhibition Centre, London. Tel: (0181) 541 5040.
- 10 Feb.** Video Forum - Video Equipment Trade Show, Wembley Exhibition Centre, London. Tel: (01273) 836 800.

Please send details of events for inclusion in 'Diary Dates' to: News Editor, *Electronics and Beyond*, P.O. Box 777, Rayleigh, Essex SS6 8LU or e-mail to swaddlington@cix.compulink.co.uk.

# What's On?

## Jobs Keynotes at Apple Expo Paris



Apple opened the sixteenth annual Apple Expo '99 conference in Paris on September 15 featuring a keynote address by Steve Jobs, Apple's interim CEO. During the keynote, Apple presented recently announced

products to customers for the first time in Europe, including: the Power Mac G4, its next generation desktop computer designed for professional and customers; the Apple Cinema Display, a spectacular 22in. LCD flat panel that is the largest LCD display ever brought to market; and Book, Apple's consumer and education portable computer.

The Expo featured over 230 exhibitors showing a wide range of solutions and services for the Macintosh platform. Specifically, the Showcase Village includes the latest Mac developer solutions for digital video production, Web publishing, education and business productivity, while the Music Village showcases applications and techniques that have made the Mac the platform of choice for musicians. A special area is also dedicated to the rapidly expanding number of games for the Mac.

For further details, check: [www.apple.com/uk](http://www.apple.com/uk). Contact: Apple, Tel: (0870) 600 6010.

## Lord Sainsbury Urges Science Communicators to Understand Public

It is not enough for scientists to just explain their science to people, Science Minister Lord Sainsbury said at the Science Communicators Forum at the British Association Science Festival in Sheffield at the beginning of September.

"The real challenge for scientists lies in engaging with the public in an open debate about new technologies and convincing them that the benefits outweigh the risks and that the risks are properly controlled by the regulatory system," said Lord Sainsbury.

"Scientists often talk about risk as if it were simply a question of teaching people about probabilities. This is very naive because what we are concerned about is how people react to risk. How they react to risk is very much affected in my experience by three things: whether they see benefits that outweigh the risks; whether they believe that government and industry can do anything to control or prevent the risks; and whether they feel they have a choice about whether they take the risks or not. As we introduce new technologies we need to take account of issues such as these. Lord Sainsbury drew attention to the Biosciences project, which gave an insight into the sort of information people want and how it can be provided. He also cited a recent public opinion survey that convincingly demonstrated that people are far more likely to approve of scientific advances if

they are linked to real benefits. Lord Sainsbury said, "What these studies show is that people's attitudes to new technologies is very much influenced by their view of the balance of the risks and rewards involved."

If we ignore this kind of evidence we have only ourselves to blame if we fail to communicate effectively with the public. Continuing, Lord Sainsbury emphasised the need to ensure that guidelines on scientific advice devised by the Chief Scientific Officer, Sir Robert May, are consistently adhered to across government. He also highlighted the crucial role played by the regulatory system. Lord Sainsbury said, "Particularly after the BSE crisis, people are no longer prepared to accept the view of scientific advice as 'speaking truth to power.' While most surveys show that scientists as a broad category are generally trusted, people are not prepared any longer to accept uncritically the views of experts. And that is why we need to make certain that the work of Advisory Committees is transparent to the public. These and other challenges will be considered in a review of science communication being undertaken by the Office of Science and Technology, which will report to Lord Sainsbury before next year's National Science Week."

For further details, check: [www.dti.org.uk](http://www.dti.org.uk). Contact: Department Trade & Industry Tel: (0171) 215 5000.

## Internet Access Company Sounds Warning to Small Businesses

Britain's small businesses could be compromising their commercial security by allowing their email to be stored on inadequately protected systems, a UK Internet access company has warned. Equinet believes small firms should stop relying on free e-mail services and switch to secure company e-mail systems, which are now priced realistically.

Many small firms could be at risk from their use of direct Access from their PCs to free e-mail services such as Microsoft's Hotmail, which was breached by computer activists.

Companies need to ensure that they avoid the damage that could be done to them by hackers infiltrating such services, Equinet says.

"E-mail is a fantastic tool for small firms and they have come to rely on it. But they should be using their own secure e-mail systems rather than public ones, allowing them to form a barrier between the Internet and their desktop e-mail," said Bob Jones, chairman of Equinet.

The key technology here is the firewall, a piece of software that provides a barrier based on the company's own policies. Without this, you're effectively closing the front door at night but forgetting to lock it.

Firewalls are widely deployed by large corporates as a measure for preventing unauthorised access to computers networks from both inside and outside of the organisation. They have traditionally carried relatively high price tags and have been perceived as too complex and expensive for smaller companies.

For further details, check: [www.equinet.com](http://www.equinet.com). Contact: Equinet, Tel: (01793) 603700.

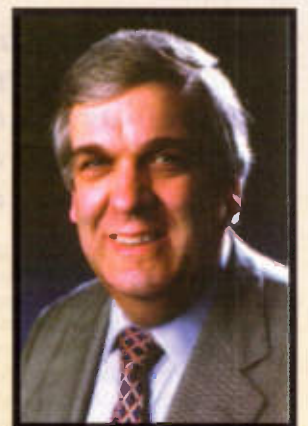

ELECTRONICS



# Code Making & CODE BREAKING

PART 3

*In this last part, Mike Bedford takes a look at some of the sophisticated ciphers which are in use today, such as the banks and corporations world-wide, and which will pave the way to the widespread adoption of e-commerce.*

So far in our investigation of code making - or cryptography to use the proper terminology - we've seen a progression from ciphers which can be used by hand to those which required machines to automate the encryption and decryption processes. We've also seen a trend towards automation in code breaking or cryptanalysis. Specifically, we saw how the first ever electronic computers were designed for the sole purpose of cracking German wartime ciphers - and these two trends continue hand-in-hand. As improving technology permits ever more sophisticated ciphers to be used, so the code breakers also turn to increasingly advanced technology. As cryptanalysis goes hi tech, then so the code making has to become cleverer still. But, whereas 50 years ago the hardware used for cryptography was rare, expensive, and protected by the Official Secrets Act, today it is commonplace. Any PC can be used to emulate the wartime cipher machines like Enigma or perform cryptanalysis in just the same way as the Bombe electro-mechanical or the Colossus electronic computers. And so there's been another trend in the world of cryptography. Since the tools of the trade are now easy to get hold of, ciphers are no longer the sole domain of spies and the military. Encryption is now an important commercial tool, especially as the potentially insecure Internet is being used to transmit sensitive information such as credit card details. This month, to bring our investigation of cryptography to a close, we'll take a look at

some of the sophisticated ciphers which are in use today. These are the ciphers which are used by banks and corporations world-wide and which will pave the way to the widespread adoption of e-commerce.

## Data Encryption Standard - DES

The Data Encryption Standard, or DES, was developed during the 70s in response to a US government initiative for the provision of a cheap, secure encryption technology for use in the protection of non-classified information, which would be available to all and appropriate for use in a wide variety of applications.

DES is described as a secret key, block product cipher. We've already come across the term 'product cipher' - one which uses a combination of substitution and transposition - but, if your knowledge of ciphers is limited to what you've read in the first two articles in this series, the other terms will be new to you. All the ciphers we've seen so far are stream ciphers, that is ciphers which operate on a single letter at a time. In a block cipher, the algorithm operates on a block of data at a time and in DES that block is 64 bits or eight ASCII characters long. The final term, secret key, is an intriguing one. It means exactly what it sounds like - that the sender and the receiver use a key which is kept secret from all other parties in order to maintain secure communication. Surprisingly, though, there

are other types of cipher where the key is not kept secret but we'll have to leave an explanation of this until later in the article.

The DES algorithm isn't especially difficult to understand - it can readily be implemented in hardware, and a high level language program runs only to around 300 lines - but it is a rather long and protracted process. In our description of DES, therefore, I shall rely heavily on flow diagrams. I suggest that you refer to the diagrams as you work your way through the textual description. Figure 13 is the overall flow diagram of the DES encryption process and Figure 14 is a more detailed view of what happens in each of the boxes in Figure 13 which are labelled 'Iteration 1' to 'Iteration 16.' Note that in each of these diagrams, blue boxes represent the data as it progresses through the process, changing from plain text to cipher text en route, yellow boxes represent keys, and green boxes represent operations. To give an example from Figure 13, the operation labelled 'Iteration 1' takes data L<sub>0</sub>, R<sub>0</sub> and key K<sub>1</sub> as its inputs and generates data L<sub>1</sub> and R<sub>1</sub> as its outputs. You'll notice that the flow diagrams show 16 keys labelled K<sub>1</sub> to K<sub>16</sub>, each of which is used in one of the iterations. In fact, DES requires just the one 56-bit key but this is used to generate the sixteen 48-bit keys used in each of the iterations. We'll take a look at how these sixteen keys are generated once we've worked through the main encryption process.

## Initial Permutation

As we've already seen, DES works on blocks of 64-bits. The first stage in the encryption process is a transposition - this is designated by the box labelled 'Initial Permutation'. This involves jumbling up the 64 bits according to a fixed transposition table. The 64-bit result is then divided into 32-bit left and right parts, L<sub>0</sub> and R<sub>0</sub> which are processed in the first iteration to give another pair of 32-bit parts, L<sub>1</sub> and R<sub>1</sub>. This continues until, after the 16th iteration is

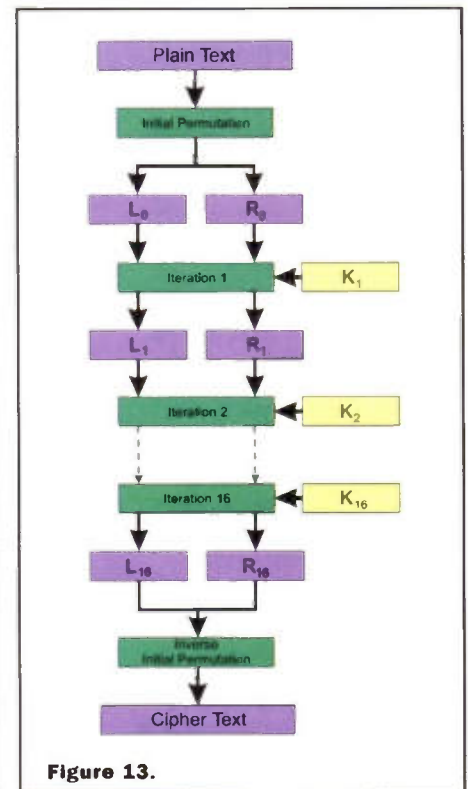

Figure 13.

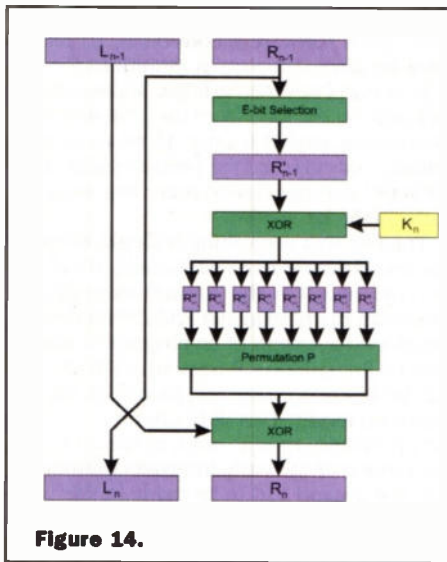

Figure 14.

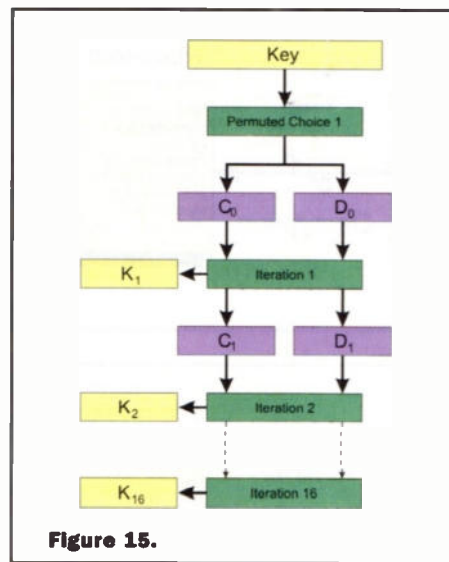

Figure 15.

complete, L16 and R16 are re-combined and finally subjected to the Inverse Initial Permutation - another transposition, in fact the reverse of the first transposition - to give the final cipher text.

So, now let's take a look at what goes on in each of those 16 iterations. The right-hand part of the input data to iteration n, R<sub>n-1</sub>, is transposed using another fixed table call the E-bit selection table. In fact, 16 of the bits are also duplicated as part of this process, thereby increasing the length to 48 bits. The result is now XORed with the 48-bit key for this particular iteration, K<sub>n</sub>. The 48-bit result is now split into eight groups of six bits each. The box labelled Permutation P is, in fact, a fixed substitution so each of these 6-bit values is substituted for a different value, each now 4-bits in length. The eight 4-bit values are now re-combined to give a 32-bit result, and this is now XORed with the left hand part of the input data to iteration n, L<sub>n-1</sub>, to give the right hand part of the output data from the iteration, R<sub>n</sub>. The left-hand part of the output data from iteration n, L<sub>n</sub>, is simply the right hand part of the input data, R<sub>n-1</sub>. Turning now to the generation of the Keys for each iteration, K1 to K16, we'll refer to Figures 15 and 16. As before, the first figure is an overall flow diagram and the second shows the detail of what goes on in each iteration. I won't go through these in detail - I'll just point out that the boxes labelled 'Permuted Choice 1' and 'Permuted Choice 2' involve a transposition of bits and that the second of these also discards some of the bits to produce K<sub>n</sub>, the 48-bit key for iteration n.

We haven't presented all this because we expect that many of you will feel inclined to write your own DES software - and you'd need the details of each of the transposition and substitution tables if you were to try. The reason for showing you the flow diagrams is to illustrate that, despite being somewhat convoluted, the process is really just a block-oriented extension of techniques we've already see. This contrasts with the RSA cipher which we'll look at next. But at this stage it's appropriate to address the question of whether this is a monoalphabetic or a polyalphabetic cipher. After all, we saw in the first part of this series that any monoalphabetic cipher - one which always causes a particular plain text letter to become the same cipher text letter

- is not very secure. Specifically, it can be cracked by measuring the frequency of occurrence of cipher text letters, letter pairs and triplets and comparing them to the frequency of occurrence in the English language. At first sight, DES does appear to be monoalphabetic - with the same key, one block of input data will always produce the same block of output data. However, the phrase monoalphabetic doesn't apply since the algorithm operates on blocks of 64-bits or eight characters at a time rather than on a single letter. Whereas a block will always encode the same way, if that block was composed of eight letter as, for example, those eight letters wouldn't all end up represented by the same eight bits in the final cipher text. Any attempt to crack a code by looking at the frequency of occurrence of blocks of eight characters - the equivalent of the method we used to crack monoalphabetic ciphers - just isn't an option.

## Public Key Ciphers

DES is described as a private key cipher as, for that matter, are all the ciphers we've seen so far. And in a private key cipher, only those parties authorised to encrypt or decrypt messages should have knowledge of that key. This seems so obvious and so much a part of all we've seen so far that it will probably come as a surprise to learn that there is a different class of cipher called the public key cipher. But before we look at this in more detail, let's give some thought to the problems with private key ciphers. Let's assume that I want to communicate with you over a communication channel which I know isn't secure. We've never communicated before so we'll need to agree on some method of encryption. OK, perhaps I take the initiative here so I decide on the DES encryption standard and I pick a key. But now, of course, there's a problem. How do I let you know the key I've picked - certainly I can't transmit it

to you over that insecure communication channel. In practice, the only really secure method would be for me to hand the key to you in person. But for someone who needs to communicate with a number of parties world-wide, communicating the keys would be a lengthy and expensive process. This problem of key distribution is the one which public key encryption is designed to overcome.

Another name for a private key cipher is a symmetrical key cipher. What this means is that the same key is used for encryption and decryption as shown in Figure 17. A public key cipher, on the other hand, is asymmetrical in that one key is used for encryption and a different key is used for decryption. This scheme is illustrated in Figure 18. The two keys are, obviously, related, but the cipher is designed such that someone can't work out the one key from the other. Strictly speaking, of course, it is possible to determine one key from the other but it would take a phenomenal amount of computing time. When I talk of something being impossible, therefore, what I really mean is that it's computationally impractical. So let's now look at how this helps overcome the problem of key distribution. All parties intending to communicate using public key encryption generate a pair of keys. Note that, although it's not possible to work out one key from the other, it is, of course, possible to generate a pair of keys with this strange relationship. One of the keys is kept secret which is called the private key and is never divulged to anyone else, and the other key is published. It would be possible, for example, for people to publish their public key in a directory of e-mail addresses. Now, if I want to send a message to you, I encrypt it using your public key. Only you will now be able to decrypt that message since the decryption process requires your private key. Similarly, to reply, you would encrypt the message using my public key and I would decrypt it using my private key. Only the public keys have to be distributed and there's no need to keep these secret, so the problem of key distribution has been solved.

## RSA Public Key Cipher

The most common public key cipher is called RSA in recognition of its three developers, Rivest, Shamir and Adleman. I'm not going to describe the inner workings of the RSA cipher at all. Unlike DES, which is

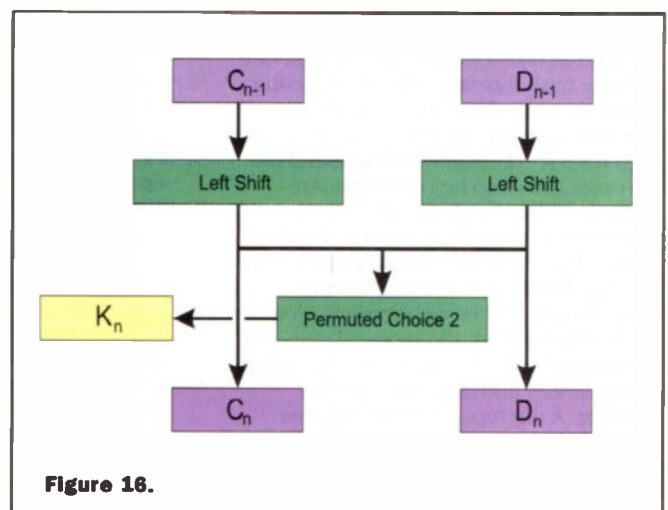

Figure 16.

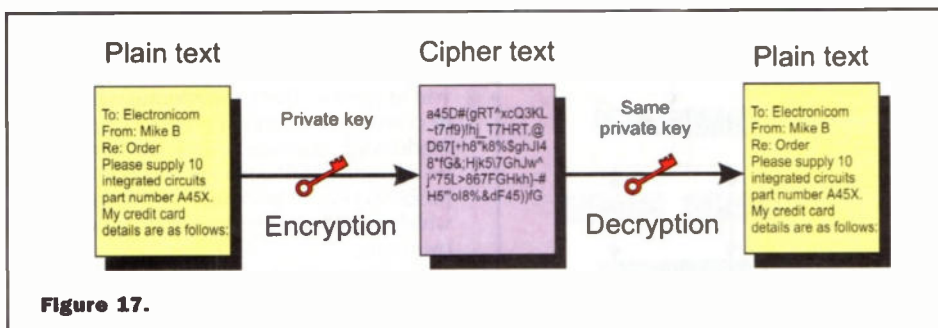

Figure 17.

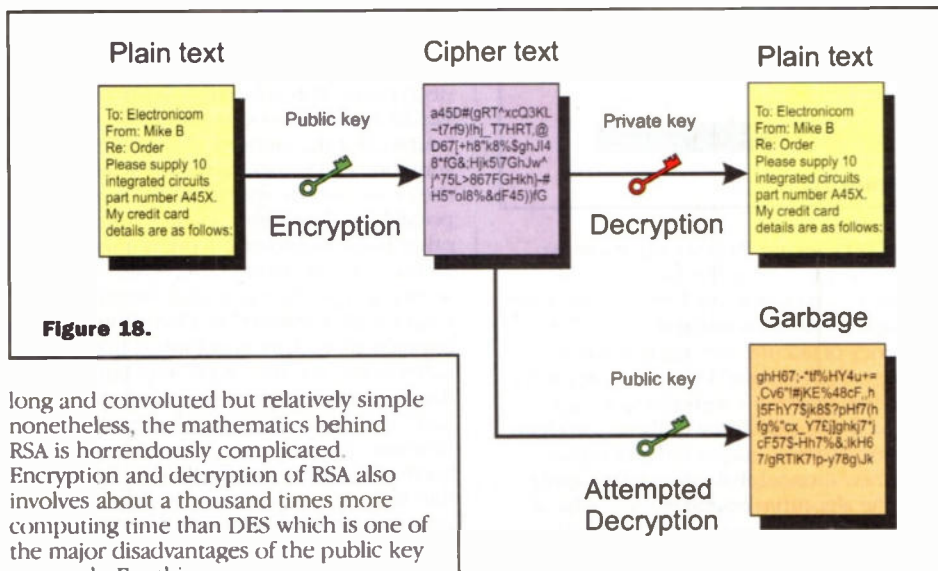

Figure 18.

long and convoluted but relatively simple nonetheless, the mathematics behind RSA is horrendously complicated. Encryption and decryption of RSA also involves about a thousand times more computing time than DES which is one of the major disadvantages of the public key approach. For this reason, a common technique is to use a public key scheme for the distribution of a key which is then used with a separate private key cipher. The private key would be used for just the one message and then discarded. Figure 19 shows this hybrid method in use.

At first sight, it would seem that another disadvantage of a public key cipher is that it doesn't allow authentication of the sender. With a private key cipher, if you receive a message, purportedly from a known party, the fact that you're able to decode it using a key known only to you and that party would indicate that it had indeed been sent by that party. As it stands, of course, no such authentication is provided by a public key cipher. Anyone could encode a message to you using your public key and you'd have no way of telling whether the message actually came from whom it claims to have been sent by. However, a well designed public key cipher, such as RSA, does allow a sender to electronically 'sign' a message in a unique way. Let's see how this works by referring to Figure 20. First of all, though, we need to take a look at the concept of a one-way hash function. This is a function which operates on a block of data to generate a unique value but for which there is no reverse function which would allow the original data to be recovered. An example is the checksum which is appended to the end of a block of data to allow the receiver to verify whether or not the data had been corrupted during transmission. The receiving party calculates the checksum from the received data and compares it with the checksum calculated by the sender and appended to the message. A discrepancy indicated data corruption. So, to return to the digital signature, the sending party encrypts the message using the intended recipient's public key using the method we've already

seen. The sender also performs a one-way hash function on the unencrypted text and encrypts the result of the hash function using his own private key. Now, RSA allows messages either to be encrypted using the public key and decrypted using the private key or vice versa. Encrypting using the private key is not normally very useful since anyone could then decrypt that message using the public key but it is useful in this instance. The recipient decrypts the message using his own private key and then performs the one-way hash function on the decrypted message. The recipient now decrypts the hash function result sent by the other party using that party's public key. If the result is the same as the locally-generated hash function result, this proves that the message had been sent by the party whose public key had been used to decrypt the hash function result. The sender is, therefore, authenticated.

## Political Wranglings

In the section on DES, we spoke about a key length of 56 bits. In fact, there has been quite some controversy over the years about the key length of this and other encryption algorithms. The standard which formed the basis of DES, IBM's Lucifer, had a 128-bit key. Before authorising it for public release, though, the National Security Agency – the USA's equivalent of MI5 – insisted on a reduction to 56 bits. As you could well imagine, this made the cipher substantially less secure, in fact, a brute force attack would manage to crack the 56-bit DES a few trillion times quicker than the full 128-bit variant. However, as you'll know if you've followed the political to-and-fros reported in the computer magazines, the US government imposed even more stringent

limitations on what could be exported. Encryption software is considered to fall into the same category as munitions for export purposes. Accordingly, such software can only be shipped from the USA with an appropriate export license. Licenses were, initially, only granted for products with a 40-bit keys - another 64,000 times less secure than the 56-bit version.

The fact that something is illegal, doesn't always prevent it from happening, though, as is evidenced by the Zimmermann saga. American mathematician Phil Zimmermann, developed a system of cryptography called PGP or Pretty Good Privacy which had a 128-bit key and could not, therefore, be exported legally. This didn't deter Zimmermann, though, and, in common with much of the early Internet community, felt that a stand had to be made in the interests of free speech. That stand involved making the source code of PGP freely available over the Internet and it came very close to gaining Zimmermann a four year spell in a Federal Penitentiary. Another line of attack against apparently unjust export restrictions was totally legal. Academics and hackers everywhere started a consorted attack on 40-bit versions of DES and similar ciphers. Some of the cryptanalysts were flying the 'free speech' flag by showing how insecure a 40-bit key was, for others the motivation was the pure technical challenge of cracking a cipher, but it's also significant that for many others the motivation was financial – cash prizes were on offer. And who was putting up this money? Well, if I tell you that the export restrictions were causing American software houses to loose out to foreign competition, you'll probably guess the answer – these companies had a vested interest in proving to the NSA that a 40-bit cipher is virtually useless. So how did these amateur cryptanalysts fare? In 1995, French student Damien Doligez cracked a 40-bit cipher in eight days using a combination of 120 workstations and a few supercomputers. The next year, a group of cryptographers estimated that a 40-bit key could be cracked in 12 minutes and a 56-bit key in 18 months using a \$10,000 machine consisting of 25 FPGAs. For \$10 million, a machine with 25,000 FPGA chips could crack a 56-bit DES key in 13 hours; one with 250,000 ASICs could do it in 6 minutes. In 1997, following RSA Data Security's announcement of cash prizes for the first person breaking each cipher of varying key lengths, Ian Goldberg, a student at Berkeley, walked away with a \$1,000 prize of cracking the 40-bit RC5 cipher in three and a half hours using a network of 250 computers that tested 100 billion keys per hour. A few weeks later, Germano Caronni of the Swiss Federal Institute of Technology won the \$5,000 48-bit prize. Caronni used more than 3,500 computers networked over the Internet to search 1.5 trillion keys per hour. The key was found after 13 days.

Well, to cut a long story short, the US government eventually relented about a year ago and encryption systems with key lengths up to 56-bits can now be exported. However, it's questionable how much more secure 56-bit key is today than a 40-bit key was when DES was first introduced. More recently, a team assembled by the Electronic Frontier Foundation cracked the 56-bit DES in less than 23 hours. In fact, a bill which will abandon all export controls on encryption products is in the process of

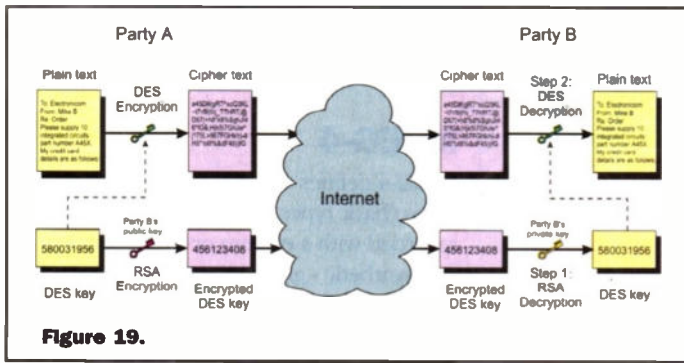

Figure 19.

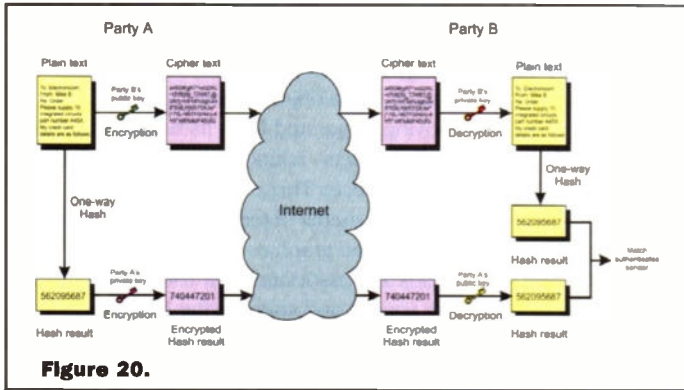

Figure 20.

being introduced. Until recently, though, it looked as if this bill only stood a chance of being approved if it required suppliers of products to build in a key recovery mechanism. Also referred to as 'the back door', this is a method, in theory known only to the supplier and to certain government departments including law enforcement agencies, which would permit a message to be decrypted without use of the key. Needless to say, civil liberty groups voiced opposition to this, as did other parties concerned that the back door could well jeopardise security. So, if you're concerned about civil liberties you'll be dismayed to hear, no doubt, that the British government, in its proposed forthcoming legislation, looks set to require something similar. But instead of a back door, the proposed solution is to use the services of a so-called Trusted Third Party. Users of encryption products would be required to lodge their key with this trusted third party. In the event of an investigation relating to criminal or terrorist activity, the police and other government departments would be able to apply to obtain the key from the trusted third party.

## Hands-on Encryption

To conclude our investigation of the world of cryptography, I thought it would be appropriate to give pointers on where you can get hold of cryptographic software. I'm not talking here of software which could be described as a curiosity -

software to illustrate the use of the various historical ciphers we looked at earlier in this series - I'm talking about software which can be used for real world applications. However, if you do want to play around with some of the historical ciphers, search engines will list a wealth of information. Bear in mind, though, that if you just look for words such as cipher, encryption, cryptography and the like you'll get just too many references and most of them will be to current day cryptography. So try looking for information on specific historical ciphers such as Playfair or Enigma.

But to return to my main emphasis, practical cryptographic software will, almost certainly, be based on the ciphers described in this article, that is DES or RSA. And commercial products are available from companies like Sophos ([www.sophos.com](http://www.sophos.com)) who specialise in computer security. In addition to encryption for the purpose of secure electronic transmission of data, packages which will encrypt data as it's

written to your hard disk and decrypt it as it's read back are also available. This, of course, provides protection from unauthorised access to your PC and secures your data in the event of the PC being stolen. However, there is also plenty of public domain software and shareware available for downloading from the Web. If you look around I'm sure you'll find plenty but here are a couple of examples of free software which you may like to take a look at. Do bear in mind, though, that you should properly virus-check any software you download from the Web before you use it. Scramdisk, available from <http://www.scramdisk.clara.net>, encrypts the data on your hard disk to protect it from prying eyes. The software decrypts data on the fly but only to a user who can enter the appropriate password (i.e. key). And a number of packages for file encryption and secure e-mailing can be downloaded from <http://abi.hypermart.net>.

Finally, as a parting shot, I thought you might also be interested in taking a look at <http://web.mit.edu/network/pgp.html> which is the Web site from which PGP - the software which got Phil Zimmermann into so much trouble - can be downloaded. However, you won't actually be able to obtain the software from that site, not unless you make some false declarations, that is, since it is still governed by US export restrictions. Specifically, in order to be provided with complete details of how to download the software, you have to electronically sign a declaration stating either that you're a US citizen living in the USA or that you're a Canadian citizen living in Canada. Personally, I wouldn't risk incurring the wrath of the CIA by making a false declaration.

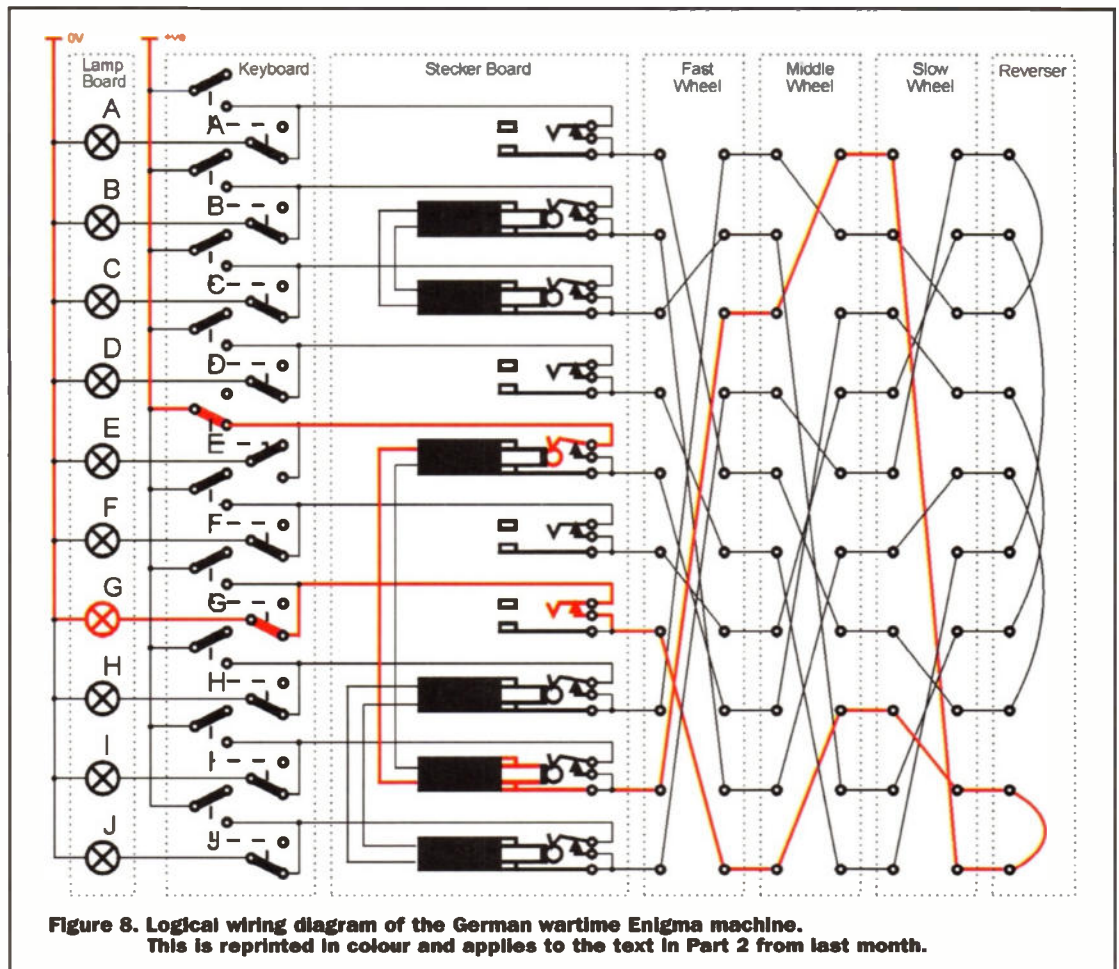

Figure 8. Logical wiring diagram of the German wartime Enigma machine. This is reprinted in colour and applies to the text in Part 2 from last month.

# The MPEG STANDARDS

PART 2

*In this second part, Reg Miles looks at the latest MPEG standards - MPEG-4, MPEG-7 and the new MHEG standard*



Sony Digital Mavica. Digital Movie Camera

In the first part I described the work of the Motion Picture Experts Group in developing the MPEG-1 standard and the broader and more versatile, but directly descended, MPEG-2. In this part, I chart the movement of MPEG into new areas, with MPEG-4 and MPEG-7, and also introduce the Multimedia and Hypermedia Experts Group and their MHEG standard.

MPEG-3 was absorbed into an expanded MPEG-2, thus leaving MPEG-4 as the next standard. This has the potential for very high compression ratios - up to 1000:1 in extreme cases, using object-based coding to represent audiovisual objects, and the relationship of those to other objects in a scene, as well as taking into account how a user can interact with those objects. In addition to broadcasting applications, MPEG-4 uses cover internet multimedia, interactive video games, multimedia mailing, optical discs, videoconferencing, and videophones... In fact, just about everything you can think of. And the first product has already been launched - the Sharp Internet ViewCam. This can store up to one hour of video on a 32MB SmartMedia card; which

can then transferred to a computer for sending as an e-mail attachment or to be posted on a web page. MPEG-4 became a

standard this year; and an MPEG-4 Version 2 with backwards compatible extensions is under development.

## MPEG-4

MPEG-4 defines the coded representations of two basic types of media objects: natural - recorded with a camera or a microphone, and synthetic - graphics, text, synthesised speech and sounds. These are arranged in heirarchical fashion. At the basic level are so-called primitive media objects: static objects - anything that is not moving, whether it be an object in the scene or a background, or any part of a still digital image; video objects - anything that is moving, separated from its background; and audio objects - sounds associated with the video objects. Those are the natural, primitive media objects. The synthetic ones are text and graphics; talking synthetic heads and associated text used to synthesise the speech and animate the head; and synthetic sound. Both the natural and synthetic objects can be 2-D or 3-D, plus both natural and synthetic objects can be combined.

Natural video objects are identified by algorithms that hold the parameters to describe them in terms of their shape (rectangular or arbitrary - the latter being first determined by blocks of pixels, and then the 'boundary blocks' receiving special treatment, giving a pixel-based shape), plus colour, texture, etc., and their motion. It takes a lot of processing but, once done, very little information is actually needed to describe those aspects from frame to frame (Figure 10). However, coding is similar to that used for MPEG-1/2, with motion prediction and compensation, followed by DCT-based texture coding (using either 8 x 8 DCT or shape adaptive DCT). In addition to block-based motion prediction and

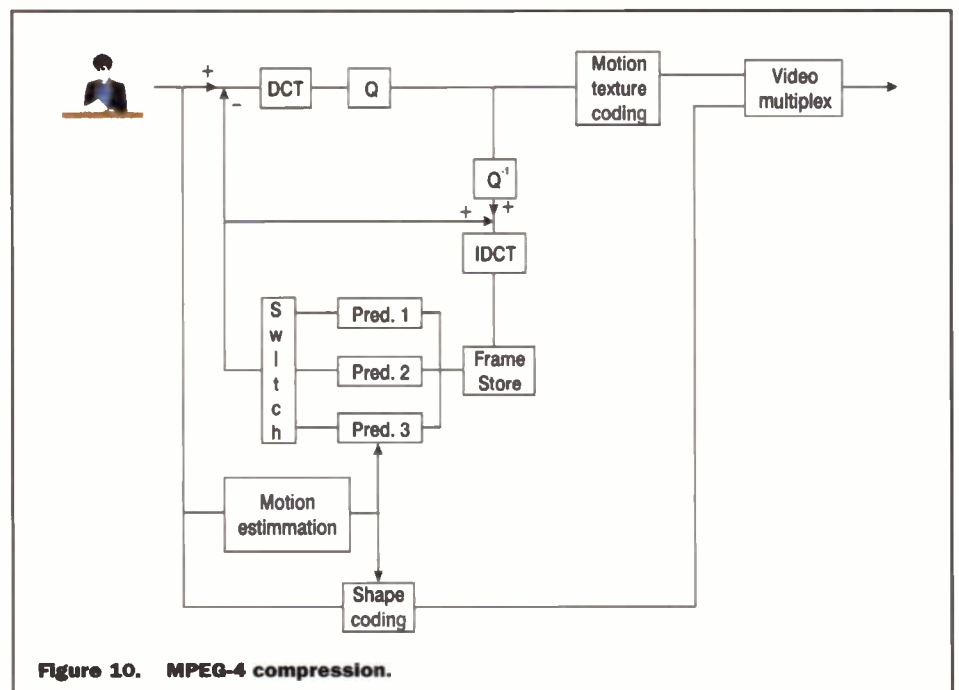

Figure 10. MPEG-4 compression.



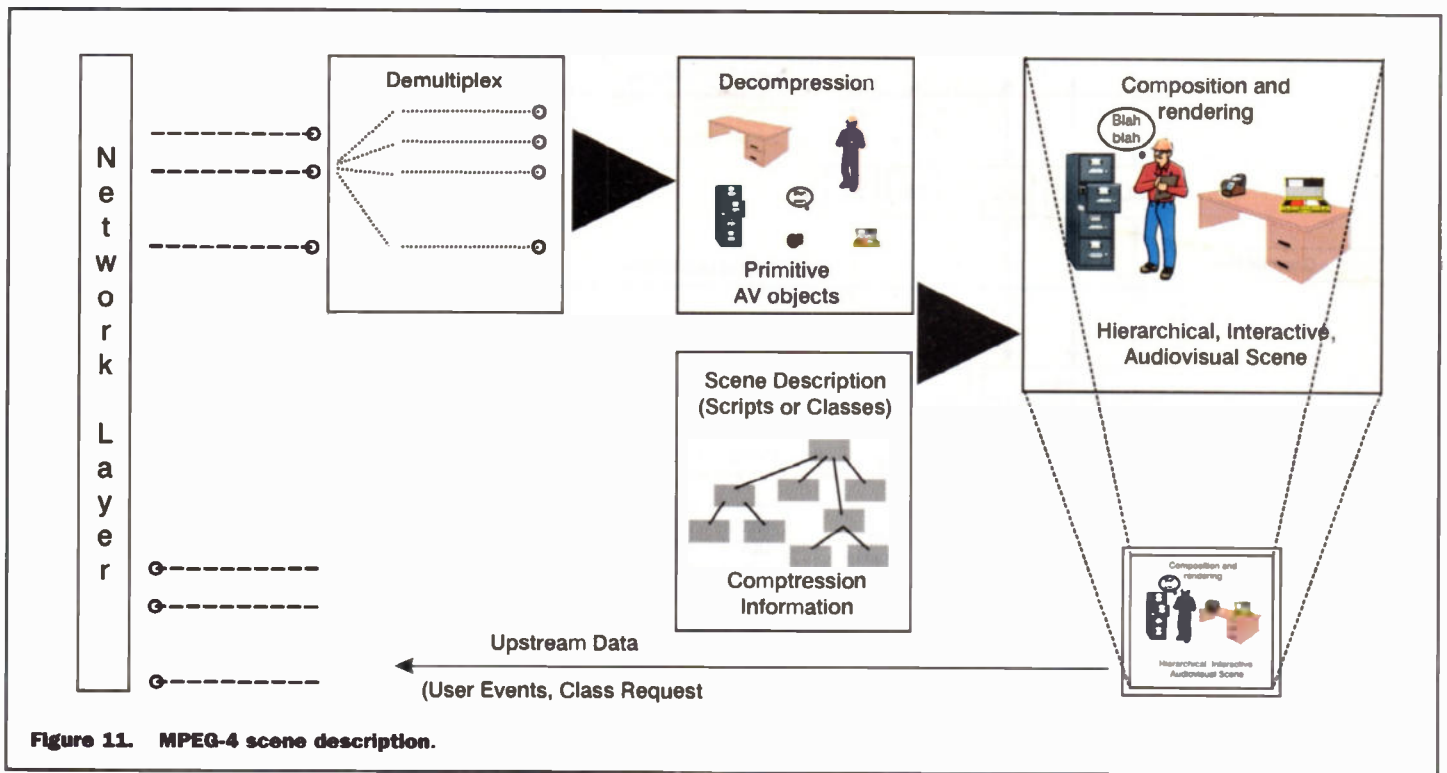

Figure 11. MPEG-4 scene description.

compensation, further compression can be achieved by using global motion compensation. This involves transmitting a static 'sprite' - a still image describing a panoramic background - to the receiver. This is then held in a sprite buffer, and only the camera motion relative to the background need be transmitted. Any moving foreground images will be coded as rectangular or arbitrary video objects and sent separately. The decoder then

reconstructs the image from the sprite, the camera motions and the video object(s).

For resolution up to MPEG-1 level, combined with frame rates of up to 15Hz, very low bitrate video (VLBV) can be used - a range of about 5-64kb/s. But MPEG-4 can also be used at up to 10 Mb/s; enabling uses such as multimedia and interactive TV, with quality equal to digital TV. MPEG-4 supports both progressive and interlaced scanning, up to CCIR 601, with sampling structures of

4:2:0 and 4:2:2 - and B&W, with pixel depths of up to 8-bits per component. And constant or variable bitrates.

## HVXC

The coding of natural audio objects is done by a variety of means, at bitrates ranging over 2-64kb/s - or less than 2kb/s when variable bitrate is used. Speech coding is handled by Harmonic Vector eXcitation Coding (HVXC) at 2-4kb/s; and by Code Excited Linear Predictive (CELP) for 4-24kb/s. HVXC can operate down to 1.2kb/s when using variable bitrate. CELP has two operating modes, for narrowband and wideband speech: the former operates up to 12kb/s, sampling at 8kHz; the latter up to 24kb/s at 16kHz. While the MPEG-2 AAC standard caters for general audio at 6-64kb/s; or TwinVQ can be used (Transform-domain Weighted Interleave Vector Quantisation), which is said to be technically superior to MP3.

Synthetic visual objects are built up using the latest techniques. A face, for example, can be constructed using shape and textures controlled by Facial Definition Parameters (FDP); and then animated by the Facial Animation Parameters (FAP) to create expressions and give the lip movements accompanying speech. And only the parameters need be transmitted. The same applies to synthesised bodies; only here it is BDP and BAP. Other objects are created by similar static and dynamic mesh coding and texture mapping.

Synthesised sounds are handled by different means depending on their type. Speech is generated from text input by a text-to-speech (TTS) coder, at bitrates from 200b/s to 1.2kb/s. Together with the means of synchronising it to facial animation, if that



Sharp Internet MPEG-4 Camera.

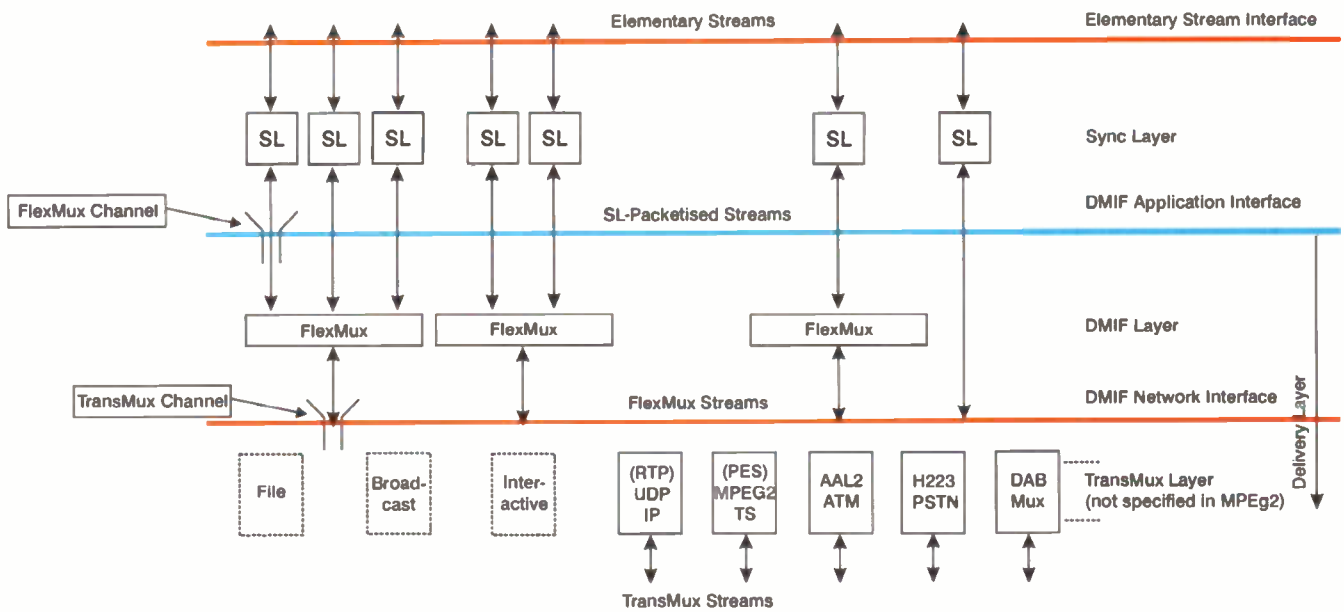

Figure 12. MPEG-4 data streams.

is required. Also, the particular language and dialect can be signalled in the bitstream. General sounds and music are produced in a synthesis language called Structured Audio Orchestra Language (SAOL - pronounced 'sail'). This defines an 'orchestra' of 'instruments' that produce the desired sounds under the control of downloaded scores in the bitstream, using the Structured Audio Score Language (SASL). It is also possible to use the MIDI protocol when such fine control is unnecessary. Or a wavetable bank format, in which sound samples are downloaded for wavetable synthesis, together with filters, reverbs, etc, for further processing.

Once coded each primitive media object is an individual entity, and can be worked on separately. These primitive media objects are then collected together to form compound media objects - a dog visually barking and the sound of the barks, for example. These groupings are then used to reconstruct the scenes. MPEG-4 provides a standardised way of describing such scenes: where everything goes and what those things relate to; whether they have some interactive quality; the required changes necessary if a scene is to be navigated through; and the starting and stopping of video and/or audio streams (Figure 11). The scene description information is coded and transmitted separately from the media objects (enabling easy changes to the composition), using a programming language called Binary Format for Scenes (BIFS). This was developed from the Virtual Reality Modelling Language (VRML) increasingly used to create virtual reality environments.

Of course, there could be more than one scene description: for example, a viewer could choose between presenters or news readers speaking different languages, rather than just a different soundtrack or subtitles.

Streamed data is carried in one or more elementary streams; with an object descriptor (OD) to identify all the streams that are associated with one object (Figure 12). Each stream also has its own descriptors for configuration information, such as determining decoder resources and timing. A synchronisation layer identifies the different parts of elementary streams (video or audio frames, etc) which will have been time stamped, and synchronises all the various elements. There is also a delivery layer, which contains two multiplexed layers - FlexMux and TransMux. The Flexible (content) Multiplex can carry groups of interleaved elementary streams; while the Transport Multiplex models transport protocols to enable MPEG-4 to be used in a

wide range of applications. The underlying TransMux layer can be used without FlexMux, if it provides all the necessary functions - but the sync layer must accompany it.

MPEG-4 has built on the MPEG-2 Digital Storage Media - Command and Control (DSM-CC), used to provide open application protocols to enable a variety of disparate services to be received by the user. This more advanced version has been renamed DSM-CC Multimedia Integration Framework (DMIF). As with MPEG-2 there are different Profiles to suit different applications.

The visual profiles are: Simple Visual Profile - error resilient coding of rectangular objects, for mobile networks; Simple Scalable Visual Profile - adding coding for temporal and spatial scalable objects, for

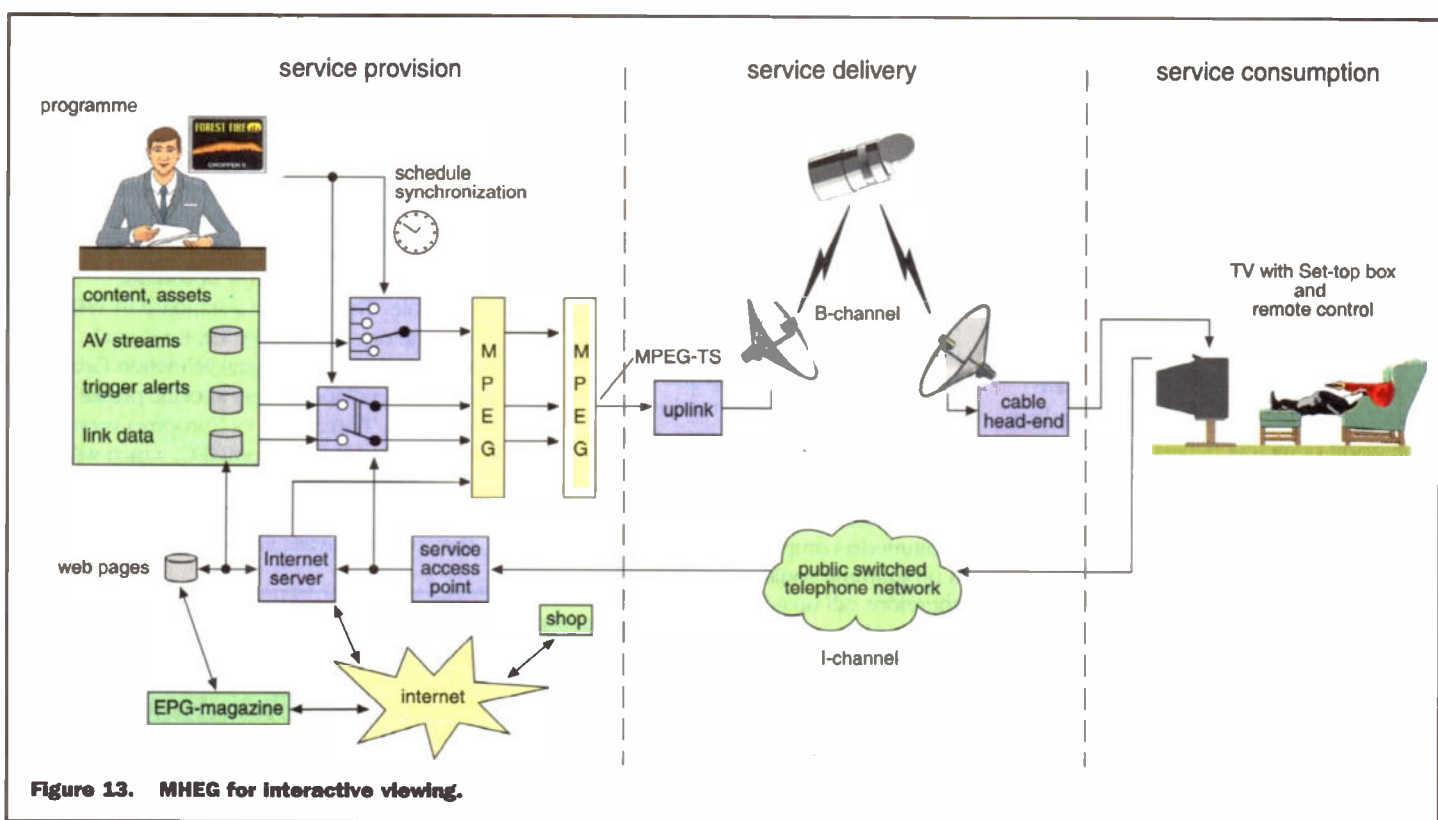

**Figure 13. MHEG for interactive viewing.**

Internet use - used by the Sharp camera; Core Visual Profile - adding further coding for arbitrary-shaped objects, for interactive multimedia Internet use; Main Visual Profile - adding coding for interlaced, semi-transparent, and sprite objects, for interactive and entertainment broadcast uses plus DVD; and N-Bit Visual Profile - adding coding for video objects with 4-12-bit depths, for surveillance.

The synthetic profiles are: Simple Facial Animation Visual Profile - which does as the name implies, and is suitable for such applications as AV presentations for the hearing impaired; Scalable Texture Visual Profile: - giving spatial scalability of still images, which can be used for games and digital still cameras; Basic Animated 2-D Texture Visual Profile - gives spatial scalability, SNR scalability, mesh-based animation for still images, and simple face animation; and Hybrid Visual Profile - combines natural video objects with synthetic and/or combined synthetic and natural objects (hybrids), ideal for multimedia.

There are also four audio profiles: Speech Profile - providing HVXC, CELP and TTS; Synthesis Profile - using SAOL, wavetables and TTS for very low bitrate applications; Scalable Profile - a superset of the Speech Profile, suitable for Internet and Narrowband Audio Digital Broadcasting (NADIB) with bitrates of 6-24 kb/s and bandwidths of 3.5-9 kHz; and Main Profile - a combination of the other three.

Then three graphics profiles: Simple 2-D Graphics, Complete 2-D Graphics, and Complete Graphics; and four scene description profiles: audio (for radio, etc), Simple 2-D, Complete 2-D, and Complete - for dynamic virtual 3-D.

Version 2 of MPEG-4 will add new profiles to the list, and is completely backwards compatible with Version 1. It will also add multi-user interactions; Advanced Audio BIFS for more natural sounds, particularly in relationship to the visual environment; improved natural video, including studio quality and stereoscopic images; improved 3-D models; and improved face and body animation.

### Apple's QuickTime Version

There will also be an MP4 file format for convenient handling of MPEG-4 information, based on Apple's QuickTime. It is a

streamable format, which supports streaming without actually being streamed itself. Metadata, known as 'hint tracks', will tell the server how to deliver the media over a particular TransMux. Another addition is MPEG-J, an Application programming Interface that combines MPEG-4 media with Java code. With the Java application delivered by a separate elementary stream. Work is also progressing to allow MPEG-4 programme elements to be added to MPEG-2 transport streams, and for complete MPEG-4 programmes to be carried in MPEG-2 broadcast multiplexes.

As with an increasing number of things these days, the hardware can be upgraded as needed. In this case the decoder can be

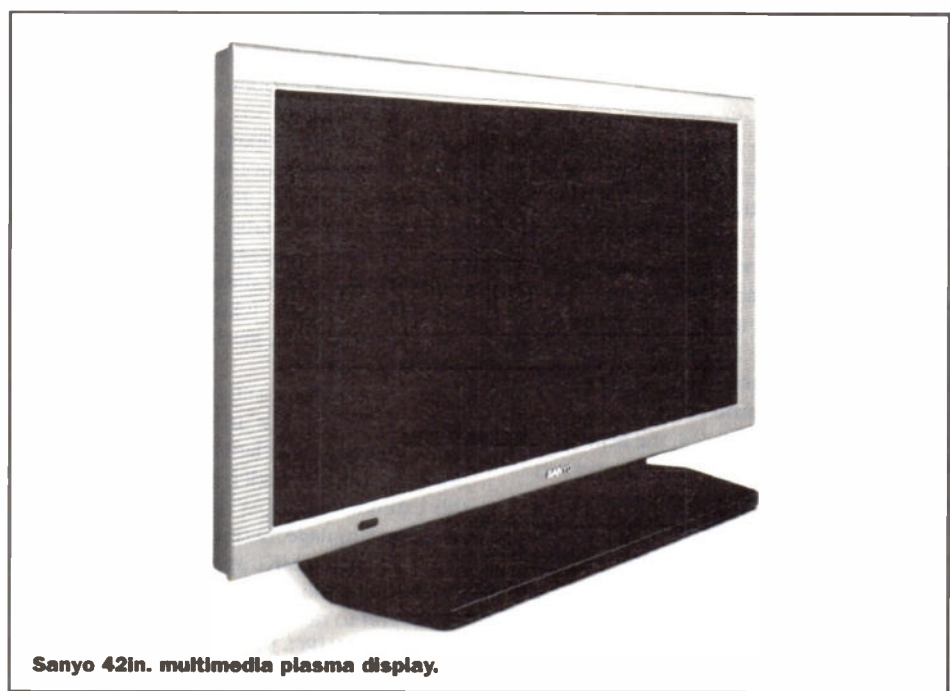

**Sanyo 42in. multimedia plasma display.**

programmed to one of three levels using the MPEG-4 Syntactic Description Language (MSDL). In Level 0 the decoder has only standardised algorithms; in Level 1 it also has standardised tools which can be configured into an algorithm by the encoder; while in Level 2 the decoder can download new tools and algorithms from the encoder.

Having got all this audio/visual/graphics stuff for computers (MPEG-4PC), TVs, whatever, it needs something else to be able to find what you want. Which is where MPEG-7 comes in (the break in the numbers is the result of Members deciding that the new project was such a break with what had gone before that 'lucky 7' was appropriate).

## MPEG-7

MPEG-7 (or Multimedia Content Description Interface) was inaugurated in 1996 to facilitate searching for audio, visual and graphics material. Whether that is for the day to day running of an archive, research, directory services, or TV viewers wanting to find programmes to suit their moods and preferences. The MPEG-7 committee will do this by specifying standard descriptions for all the different types of multimedia information and those will be used to label the contents. It is not the means of searching, but a guide for programs that will be doing the searching.

These descriptors can be held with the associated material, or called up by links from remote locations. MPEG-7 will also standardise Description Schemes (DS) for the descriptors and their relationships; and a Description Definition Language (DDL) to specify the DS. The descriptors do not rely on how the programme material is coded; they will work with both digital and analogue material, and can even be applied to printed images - it is 'What', not 'How'. And, by using MPEG-4 encoding, it will be possible to associate the descriptors with objects within scenes - natural and synthetic, vision and sound.

Different levels of discrimination will also be allowed, enabling searches to be made by people with different intentions. At one level it could be abstract: shape, colour, size, movement, etc; at another level it could be a description of the scene: girl in red coat crossing road. The same would apply for audio: key, tempo, location, etc; and at another level: a brass band playing in a park. While the same street scene could be searched for in terms of architecture, shops, the types of vehicles, the fashions worn by the pedestrians, etc. The abstract descriptions obviously lend themselves to automatic searching, whereas specifics would require a lot of intervention on the part of an operator.

Descriptions of the data itself may also be necessary, to determine whether it can be made use of. How it is coded, and how

large it is; whether it is copyright material, and, if so, what the conditions are for its use, and the price to be paid; and such like. It is anticipated that MPEG-7 will become an international standard in 2001.

## MHEG

In the meantime, MHEG is continuing to be developed. This stands for Multimedia and Hypermedia information coding Experts Group. As the name implies, this combines multimedia with hypermedia and the use of links to call up and navigate through additional information, as is done on the Web. But, in this case, with the emphasis on AV rather than text, thus suiting it to television (the MHEG group was formed in 1989 before the advent of multimedia computers). A viewer watching a programme could therefore call up additional information on something that aroused their curiosity or interest - such as background information on a film star or the local availability of an advertised car.

The group set to work under the title of MHEG-1 to produce a coding system that would represent multimedia/hypermedia interactive applications - what they are, what they do, and what can be done to them - within the structure of an interactive programme, complete with menus, buttons, etc. (similar to the Hyper-Text Markup Language - HTML - used for Web-based material). The applications are held by the programme provider and are downloaded to the user when required; an MHEG interpreter at the user end interprets the various parts of the application, displays the results, and responds to any interactions (Figure 13).

MHEG can encompass different video and audio formats, not just those developed by MPEG, and will group them into a single presentation with everything synchronised and operating as one. It is also intended that it should remain independent of any delivery or file interchange system, just so long as that is MHEG-compliant.

MHEG-1 became a standard in 1995. An MHEG-2 variant on it, using different encoding, was cancelled before it was finished. In 1991 work began on MHEG-3: this extended MHEG-1 by the use of a scripting language, Script Interchange Representation (SIR), and it became a standard in 1996. While, in 1993, MHEG-4 was begun to define procedures for registering MHEG-1 format identifiers - and it became a standard in 1995.

## MHEG-5

The year before that work began on MHEG-5. This is a cut-down version of MHEG-1, intended to be used where memory and processing power are limited such as in integrated digital TVs and set-top boxes, and for specific applications such as digital teletext and the various interactive possibilities that are now becoming available. This became a standard in 1996. It is the one used in the UK for digital terrestrial TV - the Digital Television Group having developed a very specific profile for use here. There is also a European version being developed, EuroMHEG, which will have a more advanced specification to take advantages of new or upgraded services as they become available.



Philips 32in. MHEG-5 Compatible integrated digital TV.

## MHEG-6

MHEG-6 (begun in 1995, became a standard in 1997) is a further development of MHEG-5, adding the capability for data processing and enabling it to communicate with external devices using Java code. 1997 was also the year that MHEG-7 was announced, but this is merely to specify the tests to ensure that an MHEG-5 interpreter conforms to the requirements necessary for any particular application. Incidentally, an MHEG-5 Maintenance Task Force was created in 1998 to sort out problems in the standard that have become apparent now that it is being put to use. Finally, this year has seen the creation of MHEG-8, to specify an Extensible Markup Language (XML) notation for MHEG-5.

It's just a pity that none of these technical developments will actually make the programmes themselves any better to watch.

# COMMENT



by Keith Brindley

It's bad enough that you just get comfortable in the armchair, glass of ale in one hand and a packet of crisps in the other (nobody's ever accused me of not being a couch potato!), ready to watch your favourite programme on the box, when the telephone rings and someone who you've never heard of tries to sell you something that you've never wanted, and won't get the heck off the telephone line so you can enjoy your evening.

I really don't want a new kitchen, or uPVC double-glazing. I resent the fact that they'd even call my year-old kitchen old, and what's the point of replacing my existing double-glazing with new double-glazing. The double-glazing I've got has a twenty year guarantee. And even if I was going to buy what the telemarketeer is trying to sell me, I certainly wouldn't buy it over an unsolicited phone call.

Yes, it's bad enough when that happens, but it's even worse when the telephone ringing is an incoming fax call. And it's even worse than this when the fax machine at the other end of the line is calling you in the early hours of the morning. Worse still when you don't even have a fax machine yourself!

This has happened to me recently on a number of occasions. I've never had a fax machine, and even if I had I'd have dumped it years ago in favour of email - a much more modern communications means. But still the faxes keep rolling in - and those at three in the morning from the States are particularly annoying. For a start - where have these people got my telephone number from, and why do they think it's a fax number anyway? Why don't they realise that the sending of faxes to the UK should be done during UK daylight hours?

At last, however, I have the technology to help stop all this invasion of personal privacy, and I'm going to spill the beans to any reader who wants to put a stop to irritating telemarketing tactics to help keep their own privacy uninvaded. It's a sort of modern-day Battle of Britain, and these new services are really just like a Spitfire, diving and swooping and blasting away at the unwanted (thus, by definition - junk) phone and fax calls that we're being forced to endure.

The Telephone Preference Service (TPS, and the Fax Preference Service (FPS), both allow any telephone user to register for free. You do this simply by telephoning the service numbers (the Telephone Preference Service registration number is 0845 070 0707, while the Fax Preference Service number is 0845 070 0702), and giving them your details. You have to register for the two services separately. A few weeks later (up to 28 days) your registered telephone number comes on line. You also receive written confirmation of your registration. From then on it is unlawful under recent regulations for anyone to make a direct marketing call to you, unless you have previously told them that you have no objection.

The two new services are similar to the Mailing Preference Service which has been in operation since 1983. This allows people to register that they do not wish to receive direct mail through the post. An email Preference Service is also being set up. The Direct Marketing Association's Website, at: <<http://www.dma.org.uk>>, gives details of all services.

Once registered, if a company you have not given permission to does contact you by either telephone, Fax, mail or email, you can make a complaint to the respective service, noting the company name together with the date and time of the call, or (if it's a fax) a copy of it. The latter may be a problem if, like me, you have no fax machine, and I'm not sure how you'd get around that other than phoning 1471 to at

least get the telephone number of the machine that is trying to send you the fax, I suppose. Thereafter, if the marketing company is found to be in breach of the act, it can be fined by the Data Protection Registrar.

Naturally, and as you might expect, a small number of direct marketing organisations are none too pleased. There is obviously some extra work involved in checking that a telephone number is or is not registered prior to calling it, and some unscrupulous organisations see infringing other people's privacy as a necessary part of their sales work. However, most direct marketing organisations agree totally with what the services are doing, and support them all fully. It is, after all, a small price to pay to make

sure that the person contacted does not class the call, fax, mail or email as an invasion of privacy as obviously no sale will result if the recipient does not want the invasion. Effectively, the schemes will get rid of the cowboys, swiftly and easily.

Unfortunately, the schemes do not operate outside of British jurisdiction. My occasional overnight incoming faxes from the US therefore will continue to wake me up. So, maybe it's time worldwide agreements were reached between direct marketers, similar to the new UK one.



The Direct Marketing Association's Website.

The two preference services have been set up to make sure that direct marketing organisations can follow the Telecommunications (Data Protection and Privacy) (Direct Marketing) Regulations act of 1998 properly. According to the act, which came into force on 1 May 1999, any direct marketing organisation must now consult the register of telephone numbers, and if a telephone number is listed they must not contact that number. These are statutory-backed schemes, and as such any direct marketing organisation are obliged to abide. Under the act, OFTEL (the Office of Telecommunications) has appointed the Direct Marketing Association (DMA) with the task of running the preferences

The opinions expressed by the author are not necessarily those of the publisher or the editor.

# PROJECT

**PROJECT RATING** **2**

- | FEATURES                               |
|--|
| LED indicator                          |
| Adjustable detection range (10cm max.) |
| 9V DC supply                           |
| Dimensions- 56 x 64mm                  |

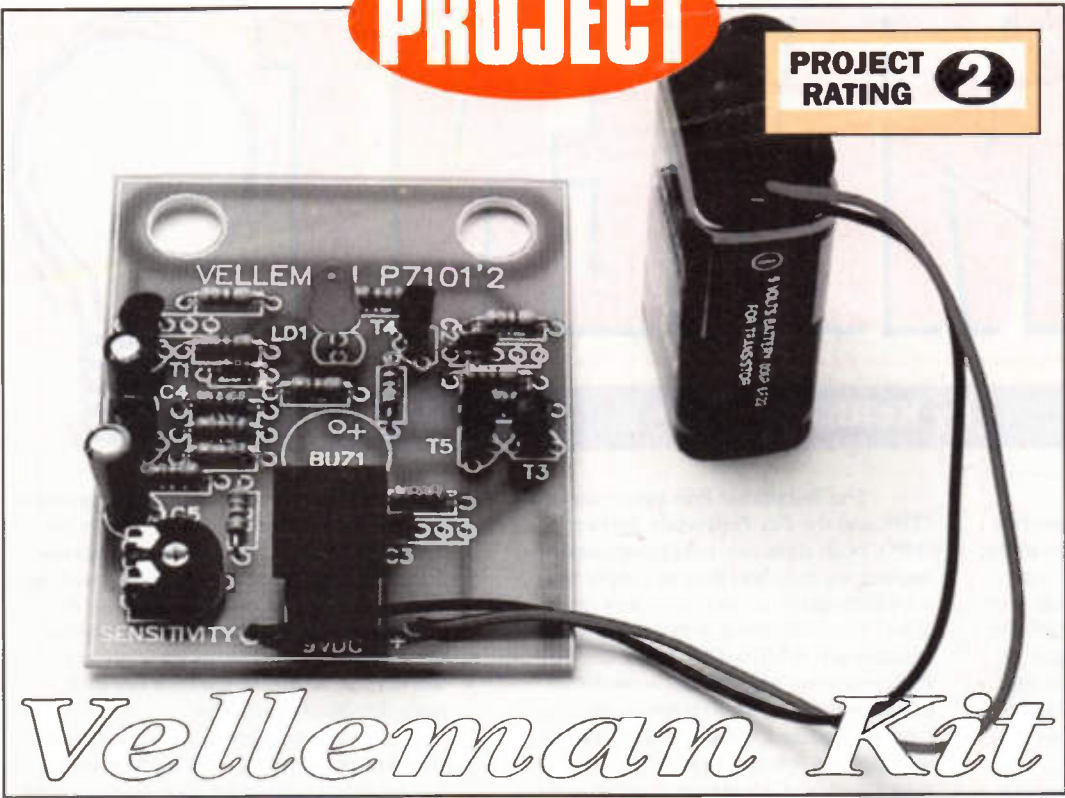

## Velleman Kit

# MAINS DETECTOR

*John Mosely constructs this handy little kit from Velleman.*

Often the hobbyist has a need to check whether a mains cable is live or not. This simple kit allows you to do just that plus it will allow you to detect wiring within walls or breaks within cables. A flashing LED shows whether a current flow has

been detected, while the speed at which the LED flashes indicates how close the detector is to the wiring. If you require an audible warning of the presence of mains, space is provided on the PCB to add a suitable buzzer. A 9V DC supply is required - a PP3 battery (not supplied) being the

ideal choice, and should last for a very long time. The whole project can easily be incorporated in a small plastic box.

### Construction

I have mentioned in these pages before about the quality of the Velleman PCBs, and their

kits in general. If you follow the instructions, and your soldering is OK, then it is difficult not to end up with a kit that works! Instructions are graphical where appropriate, and more-often-than-not even include a resistor colour code chart. Resistors, diodes and wire links are provided on a bandoleer - the order of the components on the bandoleer corresponding to the order of construction. Components are always of the highest quality, and to-date I have not had one 'faulty' kit, or one with missing components. Quality control at Velleman is first rate.

As usual construction starts with effectively the smaller components and works up in size. The circuit diagram is shown in Figure 1. Note that the detector loop is in fact a loop of copper track on the board. Again, take care to get the electrolytics, diodes etc. in the correct way round.

The height of the LED above the board is approximately 15mm. This is important for mounting in a suitable plastic box. Two will need to be drilled

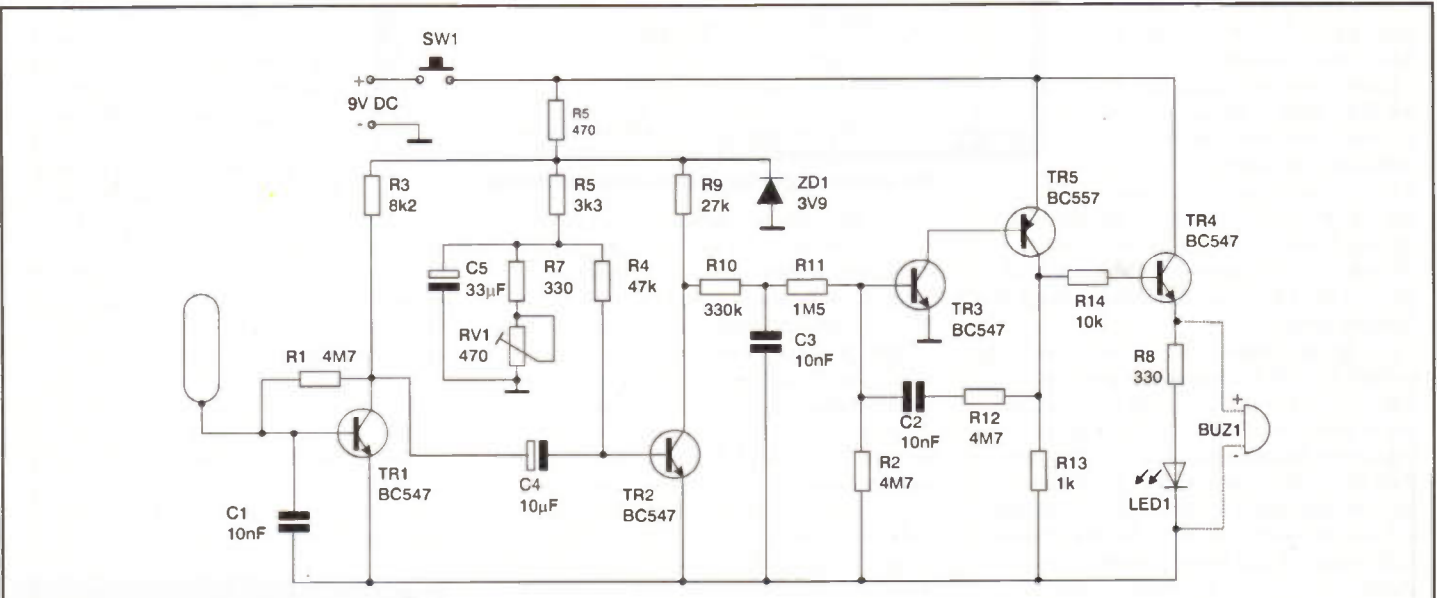

Figure 1. The circuit diagram.

in the box - one for the LED and one for the push switch. Figure 2 shows the hole dimensions for the push switch and the LED with respect to each other. You may want to provide extra holes for securing a piezo sounder if you opt to install one. If you want a sounder then JH24B or KU57M may be suitable candidates.

Finally, check the board for poor joints and shorted tracks. A few minutes spent checking can prevent a lot of problems later! Mount the board and battery in the box prior to testing.

## Testing

Select an area where there are no mains cables, and turn RV1 fully anticlockwise. Push the switch and the LED should briefly light up. Now adjust RV1 so that the LED is just extinguished. This is the most sensitive setting, and to decrease the sensitivity turn RV1 anticlockwise. The unit is now ready for use.

## Conclusion

The kit works very well, and for £9.99 is a useful piece of test gear that will be a handy addition to any toolbox. Order Code VF63T, £9.99 including VAT.

ELECTRONICS

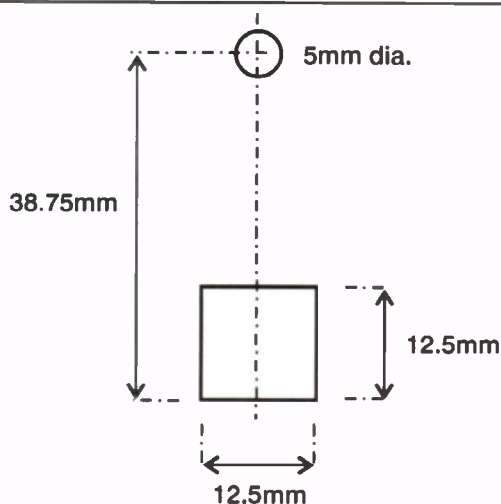

Figure 2. Hole drilling dimensions.

## PROJECTS PART LIST

### RESISTORS

R1, 2, 12	4.7M
R3	8.2k
R4	47k
R5	470
R6	3k3
R7, 8	330
R9	27k
R10	330k
R11	1.5M
R13	1k
R14	10k

### CAPACITORS

C1, 2, 3	10nF
C4	10µF
C5	33µF

### SEMICONDUCTORS

TR1, 2, 3, 4	BC547
TR5	BC557
LED1	5mm Red
ZD1	3.9V Zener

### MISCELLANEOUS

SW1	1-pole Push Switch Plastic Box
-----	-----------------------------------

### OPTIONAL

Buzzer

**OUR  
LATEST  
IRONS  
WILL SAVE  
YOU SOME  
BRASS**

Our quality range of thermally balanced irons is now even better than ever. Easier to handle, cooler to use, each iron is manufactured in the UK and meets CE conformity. There's an 'In Handle' adjustable temperature model and burn proof lead option and a wide selection of soldering bits.

That's the good news. The even better news is that all our irons are still very competitively priced.

Tel: 01822 613565 Fax: 01822 617598

[www.antex.co.uk](http://www.antex.co.uk)

**ANTEX**  
NOT JUST ANY OLD IRON

**H**ave you noticed how some people end up re-formatting their hard disk and re-installing Windows almost every other week? In most cases, it isn't really necessary (certainly I've never had to do this), it just seems that some people really love to tinker with their PC. If you come into this category, the utilities we're going to look at this month probably won't be new to you. If, on the other hand, you tend to stay well clear of this sort of thing, this column will be quite an eye-opener. I wouldn't want to suggest that you should use all of these utilities on a regular basis, but knowing about them may just help you to get the best out of your system.

## Delete Those Files

The first topic we're going to look at is disk defragmentation. However, if half your disk is full of files which could be deleted then it would be a waste of time to defragment it. If you do so and then delete those files, your disk will immediately be heavily defragmented again. So first of all, free up as much space as you can. This was a subject we looked at a few months ago – look back to that column for some suggestions. One useful facility we didn't look at on that occasion, was the Disk Cleanup utility. Since this is a system utility, it's appropriate to mention it now. You'll find it at Start > Programs > Accessories > System Tools > Disk Cleanup and the method of use is pretty much self-explanatory.

## Defragmentation

First a bit of background. With a new or newly formatted hard disk, files are written to the disk as you might expect – that is, starting at the lowest address and working upward. However, as the system is used and as files get deleted, the disk ends up with unused space interspersed between files. Eventually, especially as the disk starts to get full, all the spare space could be smallish gaps between files. This doesn't mean that large files can't be written but it does mean that they have to be written in an inefficient way. Rather than using an area of contiguous disk space, the file has to be written as a sequence of linked segments. A disk on which most of the files are like this is described as fragmented and the access time suffers. The first utility we're going to look at, is called the disk

# Software HINTS & TIPS

by Mike Bedford

*In this month's column we shed some light on lesser-known utilities such as the disk defragmenter and the maintenance wizard.*

defragmenter. It's job is to rearrange the data on the disk such that as many files as possible use contiguous blocks of disk space. To start up the disk defragmenter, select Start > Programs > Accessories > System Tools > Disk Defragmenter. If you want to watch the process then press the Show Details button and you'll be shown a dynamic status map of the disk. Beware, though, watching this is like watching paint dry – it will take at least a couple of hours. I would suggest using this facility perhaps a couple of times per year.

can occur, for example, if your PC crashes or is turned off while the disk is being written to. Errors of the second type are due either to manufacturing faults or to general wear and tear. The first type of check takes just a few minutes and is, in fact, carried out automatically whenever you start Windows having previously switched of the PC without exiting from Windows. The second test involves writing to and reading back from every location on the disk and is a very long winded process.

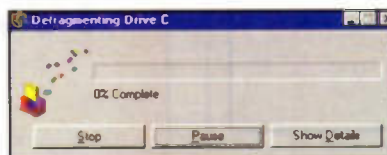

## ScanDisk

As part of the operation of the Disk Defragmenter, some diagnosis and correction of disk errors will occur. However, if you look at Start > Programs > Accessories > System Tools > ScanDisk you'll find a utility which is dedicated to this task. ScanDisk allows you to choose between two types of check, firstly that the file structure is correct and secondly that the surface of the hard disk has no errors. Errors of the first type

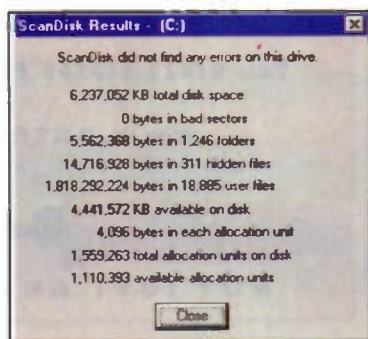

## Maintenance

The Maintenance Wizard is a utility which will perform optimisation on your PC on a regular basis without your intervention. You specify the frequency at which you want it to optimise your PC and you tell it what time of the day or night to do it (so long as your PC is switched on, of course) and after that it's all automatic. With the express setting, you can choose to perform any or all of the following as part of the maintenance schedule: speed up your most frequently used programs, check the hard disk for errors, delete unnecessary files from the hard disk. Exactly how it does this isn't clear until you decide to use the custom setting. Now you can control more exactly what happens and you'll find that the Maintenance

Wizard makes use of the three system utilities we've already seen, namely Disk Cleanup, ScanDisk, and Disk Defragmenter. This utility is at Start > Programs > Accessories > System Tools > Maintenance Wizard.

## Monitoring

The other class of system tool we're going to look at allows you to monitor key figures about your system during normal operation. The easiest way to see what these do is to try them out so let's start off by taking a look at the Resource Meter. By now I'm sure you'll know where to find it. The opening screen warns you that the Resource Meter itself actually uses processing power and may, therefore, slow down your system and when you press the OK button on this screen, the meter appears in the tool bar in the bottom right hand corner of the screen. At any time you can double click on the icon to open the Resource Meter. You'll find that it provides you with the current percentage of system resources, user resources and GDI resources which is free.

The other utility for monitoring the operation of your system is the System Monitor. You can choose to view an instantaneous figure, the current percentage use as a dynamic bar chart, or you can display a historical chart which shows how system resources have varied over time. There are lots of options to play around with here. For example, you can also choose exactly what's monitored – in addition to the default processor usage there are dozens of variables you can pick. You can also select the update frequency of the historical chart. The more frequent the update the more detail you'll see but the shorter the period of time over which the trend can be stored and displayed.

System Information is one other system utility you may like to take a look at but, unless you know exactly what you're doing, I'd advise against experimenting with the others, namely Drive Converter (FAT32), Compression Agent and Drive Space.

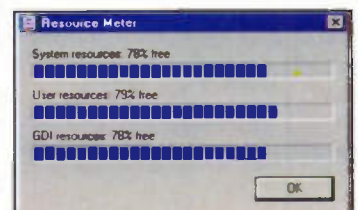



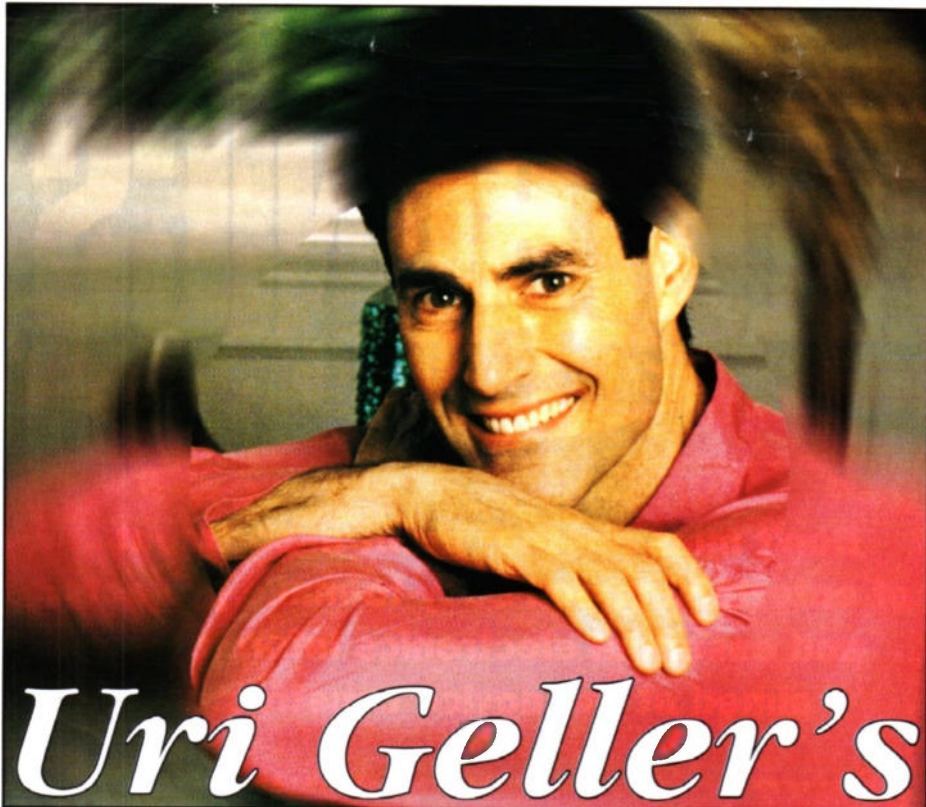

# Uri Geller's EXTENDED REALITY

## Our Seventh Sense?

About thirty years ago, a New York researcher named Cleve Backster caused quite a stir with his announcement that plants and shrimps could react to what he was doing in mysterious ways. If he advanced on a plant with the intention of cutting or burning it, it would show a reaction on his polygraph chart before he actually wounded it! When he dropped some live shrimps into boiling water, the plants seemed to go "ouch". The Backster Effect, as it came to be known, even operated over long distances.

Before long, everybody was talking to plants and playing Bach and Mozart to them, and the 'secret life of plants' soon became regarded as just another piece of New Age nuttiness. Then surprise! what do we find in one of the world's most prestigious scientific magazines (*Science*, 15 July 1983, page 277) but an article subtitled *Evidence for Communication Between Plants?* Yes, two researchers from Dartmouth College, New Hampshire, claimed to have recorded changes in the chemical activity of some tree seedlings after they had ripped off 7% of the leaves of another group of similar seedlings. This, they reckoned, was due to 'an airborne cue originating in damaged tissues which may stimulate biochemical changes in neighbouring plants'. No mention of Backster, of course, but it looked as if they had given his claims at least some support.

What kind of airborne cue could this be? The only one suggested so far is one of those chemical substances collectively known as pheromones, a word that comes

from the Greek 'to carry.' Pheromones actually transmit information. For instance, they tell animals and insects when there is a potential mate around in the case of some moths, up to two miles away. Ants and bees both send out a chemical alarm signal when their colony or hive is in danger. And how about humans?

This is still a controversial area, but it now seems very likely that we do respond to pheromoneborne information even if we are not sure exactly how. The most probable means is by way of a tiny structure in our noses called the vomeronasal organ (VNO), which processes incoming chemical signals quite independently of our old factory systems, which deal with smells. Pheromones are only received unconsciously, and have no 'smell' at all.

Some fairly strange experiments have been done to test human perception of pheromones. In one, some women were asked to look at a set of identical photos of a goodlooking man and choose the one they liked best. One of the prints had been sprayed with an odourless male secretion, and that was the one they all chose. Since pheromones are used in the animal kingdom most commonly for sexual purposes, it would not be surprising if we responded in the same way. Yet pheromones have other functions some of them rather sinister. Back in the eighties, BBC Radio 4 broadcast a talk in which it was suggested that they might be involved in instances of crowd behaviour, such as violence at football games or the 'mass hysteria' of the Nuremberg rallies. To avoid this, we should develop a 'peace gas' and spray it at people on their way in to any potential trouble

zone. As it happened, when the programme went out, the Centre of Football Research at the University of Leicester was working on ways to solve the serious problem of football hooliganism, the most tragic case of which took place at the Heysel stadium in Belgium.

My friend wrote to the Centre and suggested looking into the possibilities of some pheromonal crowd control. He received a reply part of which went as follows: "I hope you will forgive me for saying that I cannot take your idea seriously. Football violence is readily explainable in sociological and psychological terms, and there is no need to look for a biochemical component." So there.

Then, in 1990, another surprise! Researchers at the University of Warwick specifically mentioned football stadiums as one of the places where people might benefit from some chemical peacekeeping. Another was the London Underground, which in fact did launch a trial experiment on the East London line later that year. They were using ordinary perfume, not pheromones, and no mention was made of these either by them or the Warwick team.

This may be because it was already becoming evident that pheromones could be used for sinister purposes. In 1991, an enterprising fellow named David Craddock filed a patent application for a highly unusual method of getting people to pay overdue bills. As reported in the *New Scientist* (26th October), he sent out a number of debt repayment demands on ordinary paper, and an equal number on paper sprayed with androgenic steroids, which cause aggression or a feeling of threat. More of those who received the doped paper paid up than those who got ordinary paper, he said.

No harm in this, you might think. Yet this kind of thing could go too far. For example, suppose that lawyers started sending people letters that induced a feeling of panic or defeat? Suppose that some misfit with a degree in chemistry developed a kind of pheromonal hate-mail?

Enough of that for now. I think there should be far more research into pheromones, especially as you can now buy products that specifically claim that the pheromones they contain will improve your sex life. Some ingenious researchers at the University of Chicago have found that they can have a dramatic effect on menstrual cycles, so who knows what else they might affect? We have indeed discovered a seventh sense.

Uri Geller's new magazine *Beyond* is now on sale at £2.99. His latest book *MindMedicine* is published by Element Books at £20.00, and his novel *Dead Cold* is published by *Headline Feature* at £5.99.

Visit him at [www.uri-geller.com](http://www.uri-geller.com) and e-mail him at [urigeller@compuserve.com](mailto:urigeller@compuserve.com)

## Project Ratings

Projects presented in this issue are rated on a 1 to 5 for ease or difficulty of construction to help you decide whether it is within your construction capabilities before you undertake the project. The ratings are as follows:



**PROJECT RATING 1** Simple to build and understand and suitable for absolute beginners. Basic of tools required (e.g., soldering, side cutters, pliers, wire strippers, and screwdriver). Test gear not required and no setting-up needed.



**PROJECT RATING 2** Easy to build, but not suitable for absolute beginners. Some test gear (e.g. multimeter) may be required, and may also need setting-up or testing.



**PROJECT RATING 3** Average. Some skill in construction or more extensive setting-up required.



**PROJECT RATING 4** Advanced. Fairly high level of skill in construction, specialised test gear or setting-up may be required.



**PROJECT RATING 5** Complex. High level of skill in construction, specialised test gear may be required. Construction may involve complex wiring. Recommended for skilled constructors only.

## Ordering Information

Kits, components and products stocked at Maplin can be easily obtained in a number of ways:

1 Visit your local Maplin store, where you will find a wide range of electronic products. If you do not know where your nearest store is, telephone (01702) 554002. To avoid disappointment when intending to purchase products from a Maplin store, customers are advised to check availability before travelling any distance; 2 Write your order on the form printed in this issue and send it to Maplin Electronics PLC, PO. Box 777, Rayleigh, Essex, SS6 8LU. Payment can be made using Cheque, Postal Order, or Credit Card; 3 Telephone your order, call the Maplin Electronics Credit Card Hotline on (01702) 554002; 4 If you have a personal computer equipped with a MODEM, dial up Maplin's 24-hour on-line database and ordering service. CashTel. CashTel supports 300-, 1200- and 2400-baud MODEMs using CCITT tones. The format is 8 data bits, 1 stop bit, no parity, full duplex with Xon/Xoff handshaking. All existing customers with a Maplin customer number can access the system by simply dialling (01702) 552941. If you do not have a customer number, telephone (01702) 554002 and we will happily issue you with one. Payment can be made by credit card; 5 If you have a tone dial (DTMF) telephone or a pocket tone dialler, you can access our computer system and place your orders directly onto the Maplin computer 24 hours a day by simply dialling (01702) 556751. You will need a Maplin customer number and a personal identification number (PIN) to access the system; 6 Overseas customers can place orders through Maplin Export, PO. Box 777, Rayleigh, Essex SS6 8LU, England; telephone +44 1702 554000 Ext. 376, 327 or 351; Fax +44 1702 554001. Full details of all the methods of ordering from Maplin can be found in the current Maplin Catalogue.

## Internet

You can contact Maplin Electronics via e-mail at [crecipient@maplin.co.uk](mailto:crecipient@maplin.co.uk) or visit the Maplin web site at <http://www.maplin.co.uk>.

## Prices

Prices of products and services available from Maplin shown in this issue, include VAT at 17.5% (except items marked NV which are rated at 0%). Prices are valid until 3rd December 1999 (errors and omissions excluded). Prices shown do not include mail order postage and handling charges. Please add £2.95 to all UK orders under £30.00. Orders over £30.00 and MPS Account Holding customers are exempt from carriage charges.

## Technical Enquires

If you have a technical enquiry relating to Maplin projects, components and products featured in *Electronics and Beyond*, the Technical Service Dept. may be able to help. You can obtain help in several ways: 1 Over the phone, telephone 0897 501353 between 9.00am and 5.30pm Monday to Saturday, except public holidays (calls charged at £1/min BT rates); 2 By sending a facsimile, Fax (01702) 554001; 3 Or by writing to Technical Services, Maplin Electronics PLC., PO. Box 777, Rayleigh, Essex, SS6 8LU. Don't forget to include a stamped self-addressed envelope if you want a written reply! Technical Services are unable to answer enquires relating to third-party products or components which are not stocked by Maplin.

## Maplin 'Get You Working' Service

If you get completely stuck with your project and you are unable to get it working, take advantage of the Maplin 'Get You Working' Service. This service is available for all Maplin kits and projects with the exception of: 'Data Files'; projects not built on Maplin ready etched PCBs; projects built with the majority of components not supplied by Maplin; Circuit Maker ideas; Mini-Circuits or other similar 'building block' and 'application' circuits. To take advantage of the service return the complete kit to: Returns Department, Maplin Electronics PLC., PO. Box 777, Rayleigh, Essex, SS6 8LU. Enclose a cheque or Postal Order for the servicing cost (£24/hr min + parts) as indicated in the current Maplin Catalogue. If the fault is due to any error on our part, the project will be repaired free of charge. If the fault is due to any error on your part, you will be charged the standard servicing cost, plus parts. A kit building service is on offer for any of our kits. Please contact our customer service department for any pricing details.

# in the pipeline ELECTRONICS and Beyond

Don't miss another great assortment of entertaining and easy-to-make projects and essential electronics information aimed at the novice constructor.

Issue 145 will be on sale  
Friday 3rd December

## PROJECTS

413MHz Radio Microphone  
LED Lighting Effect for Christmas  
Velleman Metal Pipe Detector

## FEATURES

Astrobiology  
Valves in the 21st Century  
Applications for 10 Year  
Temperature Data Logger  
An Electrifying Century

# ELECTRONICS

and Beyond

**SUBSCRIBE TODAY AND QUALIFY FOR THESE AMAZING SAVINGS!**

**HURRY!** OFFERS OPEN FROM 1st NOVEMBER UNTIL 31st DECEMBER 1999

## Subscribers' Special Offers

### 100 X 50 ASTROSCOPE

Catalogue Price £49.99  
Subscribers' Price **£44.99**



### TOOLMATE<sup>1</sup>

Catalogue Price £28.60  
Subscribers' Price **£19.99**



### CLEAR SOUND 3000

Catalogue Price £64.99  
Subscribers' Price **£54.99**



### HIGH PRECISION DRILL KIT

Catalogue Price £64.99  
Subscribers' Price **£49.99**



### WIRELESS PIR LAMP

Catalogue Price £49.99  
Subscribers' Price **£44.99**



### HOT METAL GLUE GUN

Catalogue Price £20.99  
Subscribers' Price **£12.99**



When ordering any of these special offers which apply only for Subscribers and new Subscribers of Electronics and Beyond, please quote your Subscribers' Membership number (telephone Customer Services on 01702 554002 if not sure) and the special order code number. All items are subject to availability. Prices include VAT. Catalogue prices refer to the 1998 Maplin Electronics Catalogue. Overseas subscribers telephone +44 1702 554000 Ext. 326 for carriage charges. A £3.95 Carriage Charge will apply to all UK orders under £30.00 (Maplin Electronics Account Holding Customers exempt).

<http://www.maplin.co.uk>

## Interactive Internet Site - On Line Catalogue

Our new fully interactive on-line catalogue and ordering system improves accessibility of Maplin Electronics products to customers. This new service is a clever extension of paper-based and CD-ROM versions of the catalogue. Access to our full portfolio of over 30,000 products is quick, effective and user friendly



Elec/Comp  
Workshop

Computer  
Technology

Sound &  
Vision

Home &  
Office

Mod/Hob  
& Books

Comms

Q

Products



Ordering &  
Despatch



Stores



Technical  
Information



MAPLIN &  
Catalogue



17,000  
New Semis



[www.maplin.co.uk](http://www.maplin.co.uk)

Telephone Sales:

01702 554 000



- Fully interactive on line secure ordering
- Fully interactive on line catalogue
- Interactive product sourcing and ordering
- Check product availability
- Option to reserve products
- Ability to build up orders
- Order confirmation e-mail
- Order reference no.

This site will also have product promotions:

please be sure to visit regularly

you're just a click away