

ELECTROMUSIC • DISCO • INTERNET • HI-FI

No. 103

FULL  
SOR

Printed in the United Kingdom

# ELECTRONICS

*The Maplin Magazine*  
Britain's Best Selling Electronics Magazine

JULY 1996 • £2.25

**Dynamic Range Processor**  
**Better Sound Recording**

**Four Channel Running**  
**Light, Ideal for discos**

**Quality Laser Pointer Kit**

**Touch Dimmer Switch**

**Computing technology –**  
**The promise of much**  
**faster computers**



UEFA  
**EURO 96**  
*England*  
Competition  
inside

**FREE Book draw**  
Win the latest Sci-Fi book  
– The Diamond Age



# OUR LATEST IRONS WILL SAVE YOU SOME BRASS

Our quality range of thermally balanced irons is now even better than ever. Easier to handle, cooler to use, each iron is manufactured in the UK and meets **CE** conformity. There's an 'In Handle' adjustable temperature model and burn proof lead option and a wide selection of soldering bits. That's the good news. The even better news is that all our irons are still very competitively priced.



**A N T E X**

For further details, or a copy of our brochure,  
call or write to:

**ANTEX**  
(ELECTRONICS) LTD  
2 Westbridge Industrial Estate,  
Tavistock, Devon PL19 8DE

Telephone  
**01822 613565**  
or fax  
**01822 617598**



## PROJECTS FOR YOU TO BUILD!

### PATTRESS MOUNTING DIMMER SWITCH

9

A smart-looking touch dimmer wall switch, providing smooth up and down dimming and on/off switching of the lights from a single touch pad. Easy to build and fit, and with no moving parts to wear out, this project enables you to give a subtle yet effective modern touch to your living or working environment.

### LASER POINTER

24

Lend a high-tech impression to your presentations and lectures with this nifty hand-held laser pointer! The easy to construct and cost-effective kit contains a Class III laser, providing an intense red beam of adjustable focus, capable of effectively highlighting details from a long distance. What is more, batteries are included!

### DYNAMIC RANGE PROCESSOR

32

Use this versatile unit to improve the sound quality of your sound recordings and reproduction, by increasing or decreasing the dynamic range of the audio signal. The project achieves this by means of adjustable expansion or compression of the signal by up to a factor of three.

### NEWTON TONE CONTROL UNIT UPDATE

40

An improved version of the valve-based Newton Tone Control Module, featuring reduced distortion and a more linear response. Compatible with most solid-state amplifiers, and a perfect accompaniment to the acclaimed Newton stereo valve preamplifier, enabling creation of a terrific sounding valve Hi-Fi system.

### FOUR CHANNEL RUNNING LIGHT

56

Ideal for discos, parties or attention-grabbing applications, this unit drives four mains lamp outputs of up to 400W each via triacs, giving a cyclic sequence of changing lamp flashing patterns – left and right chasing effect, flip-flop action and all lamps flashing. The speed is adjustable, and a variety of clock arrangements can be selected.

## FEATURES ESSENTIAL READING!

### AEROGELS

4

This article by Douglas Clarkson investigates the development of an extraordinarily lightweight and efficient silicon-based thermal insulating material, having applications in optics and sound absorption technology.

### COMPUTING WITHOUT CLOCKS

16

Stephen Waddington's review of asynchronous microprocessors describes future computing technology that breaks free from the present restraints of clock speed limits in contemporary computers, delivering the promise of much faster and more flexible computers to come.

### EURO 96

22

Read all about the £10million technology that will support the EURO 96 football extravaganza in June – the largest sporting event ever held in the UK! The article by Alan Simpson describes the roles the big-name sponsors such as BT, Microsoft and Digital will play during the 16-nation programme. Plus – enter our hat-trick competition to win great EURO 96 prizes – see page 23!

### SOUND REINFORCEMENT SYSTEMS FOR GIGGING BANDS

37

The second part of Andy Rimell's article concerns the use of mixing desks and effects units, the building of loudspeaker and PA systems, practical advice on hiring equipment for gigs, and hints on preparation for hassle-free touring.

### DRIVING FOR CONTROL

50

The methods used to accurately govern the speed of the various types of motors available for particular applications such as drills, pumps and power-assisted servo systems are described in this article by Stephen Waddington.

### THE DIAMOND AGE FREE BOOK DRAW

63

Enter our free book draw for a chance to win *The Diamond Age* by Neal Stephenson. We have twenty copies to give-away to lucky readers!

### PRACTICAL GUIDE TO MODERN DIGITAL ICS

66

Ray Marston's final, eleventh instalment of this informative series describes ways of using special-purpose integrated circuits from the TTL and CMOS families, including bus transceivers, parity generators/checkers, priority encoders, analogue switches, rate multipliers and other relatively unfamiliar devices.

### VALUE ADDED INTERNET SERVICES

74

The third instalment of this series by Keith Brindley covers more crucial guidance on finding the best overall internet package that most suits your needs and budget.

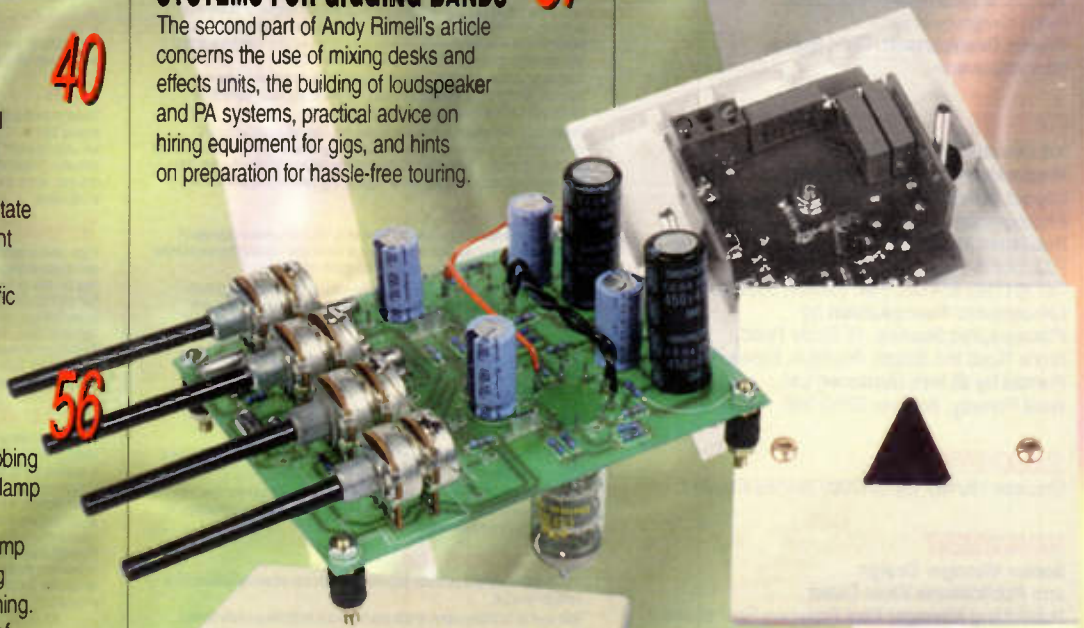

## REGULARS NOT TO BE MISSED!

FROM THE EDITOR...	2	CLASSIFIED ADVERTS	59	HOW TO SUBSCRIBE	62
TECHNOLOGY WATCH	3	NEXT ISSUE	60	NEWS REPORT	64
STRAY SIGNALS	15	WHAT'S ON DIARY DATES	60	@INTERNET	78
AIR YOUR VIEWS	59	ORDER COUPON	61	NEW BOOKS	80



# FROM THE EDITOR...

Hello and welcome to this month's issue of *Electronics*! As well as the usual fine collection of projects and features, we also have the continuing parts of our series'.

## Aerogels

Read Douglas Clarkson's article on the interesting properties of silicon aerogels. They have been used in space on the EUROpean RETrievable CARrier (as shown on the front cover) to absorb energy of fast moving space-dust particles. Potentially they offer a lot for the future.

## Competition Winners

We are pleased to announce the results of our Laurie Anderson competition and two free draws.

## Laurie Anderson

The lucky prize winners of the Laurie Anderson competition are: P. Morris of Croydon, Andy Worrall of Bristol, M. Hodgson of Whitehaven Cumbria, Darrell White of Skanklin IOW, and P. Kennett of Hailsham East Sussex.

## Hard Target

The *Electronics* 'Hard Target' free Book Draw winners are: D. Paton of Glenrothes, R. Ayers of Birmingham, B.R. Moss of Milton Keynes, G. Mundy of Haywards Heath, I. Watson of Bristol, P.R. Golledge of Somerset, P. Gwatkin of Doncaster, R. Gutteridge of Waterlooville, E. Wilson of Thornton Heath, R. Sproston of Merseyside, J.D. Hobson of Netherton Huddersfield, R. Meek of Cheltenham, T. Flett of Monifirth Angus, M.L. Peake Bilston of West Midlands, and N. Tree of Horfield Bristol.

## Science Museum

The winners of the Science Museum free Prize Draw are: D. Coulam of Horncastle Lincoln, P. Richards of New Romney Kent and Miriam Best of Macclesfield Cheshire.

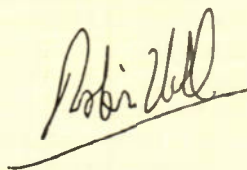

**ELECTRONICS**  
Britain's Best-selling Electronics Monthly Magazine  
GPS You'll be lost with out it!  
Digital Video  
CDJ2600 quality sounds  
Call for **NEW LOOK NEXT MONTH!**

## Next Issue

Keep an eye out next month for our new look magazine. Here is a taster of what to look for (above right). Great changes lie ahead.



Front Cover Picture: ©Copyright 1996 ESA/NASA  
EURO 96 logo: ©Copyright 1994 UEFA™  
All rights reserved.

## EDITORIAL

Editor Robin Hall FBIS, G4DVJ  
Technical Author Maurice Hunt BSc (Hons)  
News Editor Stephen Waddington BEng (Hons)  
Drawing Office Ross Nisbet  
Technical Illustrators Paul Evans,  
Kevin Kirwan Dip.Comp.  
Project Development Chris Barlow,  
Alan Williamson

## PRODUCTION

Art Director Peter Blackmore  
Production Controller Jason Hyatt  
Layout Artists David Holt, Daniel Drake  
Photography Co-ordinator Tracy Swann  
Published by Maplin Electronics plc.,  
P.O. Box 3, Rayleigh, Essex, SS6 8LR.  
Tel: (01702) 554155. Fax: (01702) 553935.  
Lithographic Reproduction by  
Planographic Studios, 18 Sirdar Road,  
Brook Road Ind. Estate, Rayleigh, Essex SS6 7UY.  
Printed by St Ives (Andover) Ltd.,  
West Portway, Andover SP10 3SF.

## SUBSCRIPTIONS

Maureen Harvey Tel: (01702) 554155 Ext. 311.

## MANAGEMENT

Senior Manager Design  
and Publications Steve Drake  
Publishing Manager Paul Freeman-Sear BSc (Hons)  
Product Manager Tony Bricknell

## ADVERTISING

Jackson-Rudd & Associates Ltd.,  
2 Luke Street, London, EC21 4NT.  
Tel: (0171) 613 0717. Fax: (0171) 613 1108.  
Advertisement Manager Eric Richardson.

## UK NEWSTRADE DISTRIBUTION

Seymour,  
Windsor House, 1270 London Road, Norbury,  
London SW16 4DH.  
Tel: +44 (0)181 679 1899. Fax: +44 (0)181 679 8907.

©Copyright 1996 Maplin Electronics plc.

Copyright: All material is subject to worldwide copyright protection, and reproduction or imitation in whole or part is expressly forbidden. Permission to reproduce printed circuit board layouts commercially or marketing of kits must be sought from the publisher.

Advertisements: Whilst every reasonable precaution is undertaken to protect the interests of readers by ensuring, as far as possible, that advertisements appearing in the current issue of *Electronics* are bona fide, the publisher and staff of the magazine cannot give any undertakings in respect of statements or claims made by advertisers, whether on printed page or on loose insert. Readers who have reasonable grounds to believe that they have been misled are advised to contact their local Trading Standards Office.

Editorial: The views of individual contributors/authors are not necessarily those of either the publisher or the editor. Where errors occur corrections will be published as soon as possible afterwards.

Publisher's Statement: Maplin Electronics plc., take all reasonable care to prevent injury, loss or damage of any kind being caused by any matter published in *Electronics*. Save insofar as prohibited by English law, liability of every kind including negligence is disclaimed as regards any person in respect thereof.

## Project Ratings

Projects presented in this issue are rated on a 1 to 5 for ease or difficulty of construction to help you decide whether it is within your construction capabilities before you undertake the project. The ratings are as follows:

- 1 Simple to build and understand and suitable for absolute beginners. Basic tools required (e.g., soldering iron, side cutters, pliers, wire strippers and screwdriver). Test gear not required and no setting-up needed.
- 2 Easy to build, but not suitable for absolute beginners. Some test gear (e.g., multimeter) may be required, and may also need setting-up or testing.
- 3 Average. Some skill in construction or more extensive setting-up required.
- 4 Advanced. Fairly high level of skill in construction, specialised test gear or setting-up may be required.
- 5 Complex. High level of skill in construction, specialised test gear may be required. Construction may involve complex wiring. Recommended for skilled constructors only.

## Ordering Information

Kits, components and products stocked by Maplin can be easily obtained in a number of ways:

Visit your local Maplin store, where you will find a wide range of electronic products.

If you do not know where your nearest store is, Tel: (01702) 552911. To avoid disappointment when intending to purchase products from a Maplin store, customers are advised to check availability before travelling any distance.

Write your order on the form printed in this issue and send it to Maplin Electronics, P.O. Box 3, Rayleigh, Essex, SS6 8LR. Payment can be made using Cheque, Postal Order, or Credit Card.

Telephone your order, call the Maplin Electronics Credit Card Hotline on (01702) 554161.

If you have a personal computer equipped with a MODEM, dial up Maplin's 24-hour on-line database and ordering service, CashTel. CashTel supports 300-, 1200- and 2400-baud MODEMs using CCITT tones. The format is 8 data bits, 1 stop bit, no parity, full duplex with Xon/Xoff handshaking. All existing customers with a Maplin customer number can access the system by simply dialling (01702) 552941. If you do not have a customer number Tel: (01702) 552911 and we will happily issue you with one. Payment can be made by credit card.

If you have a tone dial (DTMF) telephone or a pocket tone dialler, you can access our computer system and place orders directly onto the Maplin computer 24 hours a day by simply dialling (01702) 556751. You will need a

Maplin customer number and a personal identification number (PIN) to access the system. If you do not have a customer number or a PIN Tel: (01702) 552911 and we will happily issue you with one.

Overseas customers can place orders through Maplin Export, P.O. Box 3, Rayleigh, Essex, SS6 8LR, England; Tel: +44 1702 554000 Ext. 326, 327 or 351; Fax: +44 1702 553935.

Full details of all of the methods of ordering from Maplin can be found in the current Maplin Catalogue.

## Subscriptions

Full details of how to subscribe may be found on the Subscription Coupon in this issue. UK Subscription Rate: £23.78/12 months, £11.88/6 months.

## Prices

Prices of products and services available from Maplin, shown in this issue, include VAT at 17.5% (except items marked NV which are rated at 0%) and are valid between 10th May and 31st August 1996 errors and omissions excluded. Prices shown do not include mail order postage and handling charges, which are levied at the current rates indicated on the Order Coupon in this issue.

## Technical Enquiries

If you have a technical enquiry relating to Maplin projects, components and products featured in *Electronics*, the Technical Sales Department may be able to help. You can obtain help in several ways; over the phone, Tel: (01702) 556001 between 9.00am and 5.30pm Monday to Friday, except public holidays; by sending a facsimile, Fax: (01702) 553935; or by writing to: Technical Sales, Maplin Electronics plc., P.O. Box 3, Rayleigh, Essex, SS6 8LR. Don't forget to include a stamped self-addressed envelope if you want a written reply! Technical Sales are unable to answer enquiries relating to third-party products or components which are not stocked by Maplin.

## 'Get You Working' Service

If you get completely stuck with your project and you are unable to get it working, take advantage of the Maplin 'Get You Working' Service. This service is available for all Maplin kits and projects with the exception of: 'Data Files'; projects not built on Maplin ready etched PCBs; projects built with the majority of components not supplied by Maplin; Circuit Maker ideas; Mini Circuits or other similar 'building block' and 'application' circuits. To take advantage of the service, return the complete kit to: Returns Department, Maplin Electronics plc., P.O. Box 3, Rayleigh, Essex, SS6 8LR. Enclose a cheque or Postal Order based on the price of the kit as shown in the table below (minimum £17). If the fault is due to any error on our part, the project will be repaired free of charge. If the fault is due to any error on your part, you will be charged the standard servicing cost plus parts.

Kit Retail Price	Standard Servicing Cost
up to £24.99	£17.00
£25.00 to £39.99	£24.00
£40.00 to £59.99	£30.00
£60.00 to £79.99	£40.00
£80.00 to £99.99	£50.00
£100.00 to £149.99	£60.00
Over £150.00	£60.00 minimum

## Readers Letters

We very much regret that the editorial team are unable to answer technical queries of any kind, however, we are very pleased to receive your comments about *Electronics* and suggestions for projects, features, series, etc. Due to the sheer volume of letters received, we are unfortunately unable to reply to every letter, however, every letter is read – your time and opinion is greatly appreciated. Letters of particular interest and significance may be published at the Editors' discretion. Any correspondence not intended for publication must be clearly marked as such.

Write to: The Editor, *Electronics* – The Maplin Magazine, P.O. Box 3, Rayleigh, Essex, SS6 8LR, or send an e-mail to [AVY@maplin.demon.co.uk](mailto:AVY@maplin.demon.co.uk)

# TECHNOLOGY WATCH!

with Keith Brindley

I regard myself as being lucky, I joined the electronics world in my teens, when transistors were the norm and ICs were first appearing. I am not old enough to know my ECL83s from my 6X5GTs, so I am not that lucky. I was there when the 741 was the hottest thing since sliced bread. I remember the thrill of CMOS and the sheer luxury of the programmable microcontroller. Electronics in those days was a whirlwind of new ideas. Integrated circuits with new features and abilities appeared almost weekly, and as a result our abilities to create workable projects out of thin air quadrupled seemingly overnight.

I remember too, though, the dawn of the personal computer era. I had my hands on one of the very first Commodore Pet computers in the country, and had access to each new and varied personal computer as they appeared on the scene. I watched while the industry spawned and lost many great machines along with their equally great operating systems. A large number of electronics hobbyists made the move to personal computer ownership, and that put paid to the whizzy world of electronlcs. PCs changed the electronics world for hobbyist and engineers alike.

However, far from despising computers and the effect they were to have on electronics, most radio and electronics enthusiasts welcomed them with open arms. After all, a hobby is a hobby, so electronics magazines, like this one, are still there (albeit with fewer readers than in the good ol' days) and the projects are just as varied, although maybe biased a little towards use with personal computers.

But that is by the by. What happened with this proliferation of personal computers is that machines went in different directions. The IBM-compatible PC had Microsoft's DOS, and later Windows and OS/2. Apple (with its original Apple II, and later with its Macintosh MacOS) had its own proprietary operating systems. Acom had the BBC operating system and later its RiscOS.

Many other computers and operating systems existed, but these served merely to widen the divide between the main ones. Each operating system had its idiosyncrasies and meant that each group of users had its own range of application software. It did not matter a few years ago, for example, that many tens of word processor programs were available, some on one computer platform, some on another. Indeed, it did not matter that each computer platform had different applications at all.

Then application manufacturers began to produce their software for more than one platform. Microsoft's Word, for example, was produced in three versions; for DOS, for Windows and for MacOS. It became slowly apparent to software manufacturers (or at least to those that saw the writing on the walls and still survive) that multi-platform use is the way forward. Compatibility between platforms and a unified market is better than the segmented markets of incompatibility. In short, users of the main computer platforms are not going to give up their platforms without a fight, so instead of bringing the mountain to Mohammed.

So, after initially diverging, personal computers began to converge. Now there is about to be another step along this route with an ability to run not only the same applications on different personal computers, but also the power to run different operating systems. Think of it; a single computer that can run DOS, Windows, OS/2, Unix, MacOS, and even RiscOS. The best of all worlds in a single box!

The initiative is driven by the PowerPC Platform (PPCP), a computer architecture which has been developed by IBM in collaboration with Apple and Motorola. Two of the biggest names in computing and one of the biggest names in components. Of course, the largest-selling personal computer architecture in the world to date was developed by IBM, and it is the one which most people think of when they consider a personal computer – the PC, using

Intel-manufactured integrated circuits, together with DOS, Windows or OS/2 operating systems.

By the end of the year, there will be personal computers available (I can vouch that the prototypes are already up and running) which conform to the new PowerPC Platform architecture. Swapping between operating systems will almost be as easy as we swap between applications today. Initially these are likely to be quite expensive machines but, as do all things in electronics and computing, prices will rapidly fall.

Some manufacturers have been working towards this outcome for a while now. Mac users (after all, Apple is a member of the PowerPC Platform's consortium) have long been able to run Windows on their computers if desired, with a third-party product called SoftWindows, which emulates Microsoft's operating system. The latest version of this, hot off the CD-ROM press, is SoftWindows 95, which as you should gather from its name even lets you run all the latest Windows 95-ready software which is becoming available, on a Mac – now. While it is just an emulation, it does run reasonably fast, and does give Mac users' access to Windows-only programs which have not yet made the jump to cross-platform operability.

As good as SoftWindows 95 is, it is merely the start. The advantage gained by Intel and Microsoft, simply because IBM's first personal computer architecture was designed around Intel integrated circuits, is due to be challenged. Over the last ten years or so the term IBM-compatible has meant that Intel chips, together with a Microsoft operating system (DOS or Windows) was the norm. You could say that this was an unfair advantage enjoyed by Intel and Microsoft, if not a duopoly. The PowerPC Platform, finally, provides a level playing field on which the term IBM-compatible means something else – chips made by anyone, together with an operating system of the user's choice.

*The opinions expressed by the author are not necessarily those of the publisher or the editor.*

## LIFE WITH MICRO CHIP...



# AEROGELS

by Douglas Clarkson

In an age where silicon is used as the principal fabrication medium of semiconductors and the element likely to produce in the future, significant amounts of energy through photovoltaics, there is one other silicon technology likely to have an impact on society – that of silicon aerogels. Such aerogels can have a density of as low as 0.05g/cc – approximately four times that of air and 0.5% that of water. Such material can be formed into diverse shapes and forms.

**T**HE appearance of aerogel is such that it does not easily fit into standard descriptions of solid material. Being extremely light, it can also be formed into a great variety of shapes. Silica aerogels collapse upon contact with water and are non-combustible. The structure of aerogels consists of a mesh of pores which can vary in size from around 3nm to greater than 300nm.

In respect of applications, aerogels provide excellent insulation characteristics. Specific applications include, for example, highly insulating windows, solar thermal collector design and the design of general domestic and industrial installations and equipment. A one inch slab of silica aerogel provides the same insulation as 30 panes of glass. Thus, even relatively thin sections can provide high levels of insulation. The utilisation of aerogels is, however, in its infancy. Other possible applications could include battery electrodes and ultra filters for gases. One specialist use is to encapsulate pellets of 'fuel' for laser fusion experiments.

## History of Aerogels

The significant early work in aerogels was undertaken by Steven Kistler in what is now the University of the Pacific in Stockton, California. In studying gels and their formation and structure, Kistler speculated that such structures consisted of particles of solid linked by appropriate bonding and with the gaps between the solid structures occupied by the liquid of the gel. When a typical gel such as gelatin is allowed to dry out, surface tension effects of compartments of water tend to pull in the solid structure so that the volume of the gel reduces to a significantly smaller volume.

In investigating the properties of such gels, Kistler tried to remove the bound fluid of the gel without causing the gel to collapse. This

was achieved by heating the gel to a temperature and pressure above its so-called critical point so that in the case of an alcohol-based gel, the vapour outside the gel is in equilibrium with liquid inside the gel, while gradually reducing the pressure. This process of so-called supercritical drying allows the alcohol molecules inside the gel to be removed without the collapse of the solid structures. Kistler's original work was undertaken at pressures in excess of 80 atmospheres and around 240°C.

While the process of developing materials with ultra-low densities had been demon-

strated, the process for conditioning gels prior to supercritical drying was time consuming and not without a certain element of danger. The development of gels incorporating metal oxides in alcohol subsequently provided a relatively pure chemical mix from which the alcohol could be removed by supercritical drying. These so-called 'sol-gels' are now being developed for a wide range of possible applications.

While aerogels had been known for some time as a scientific curiosity, their utilisation received a major boost when 1,700 litres of

Photo 1. Lightweight SEAgel, an aerogel made from agarose, a product derived from kelp shown floating on soap bubbles. (Courtesy Lawrence Livermore National Laboratory).



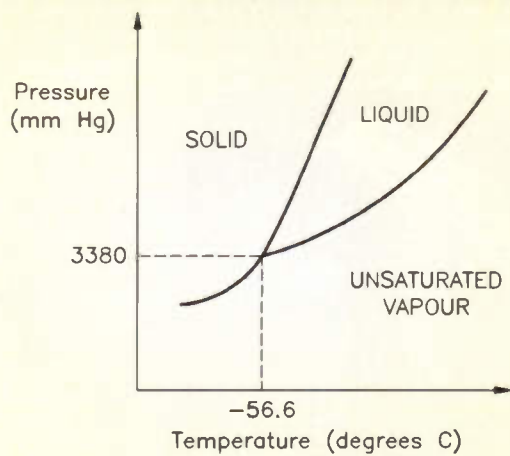

Figure 1. Supercritical point of Carbon Dioxide.

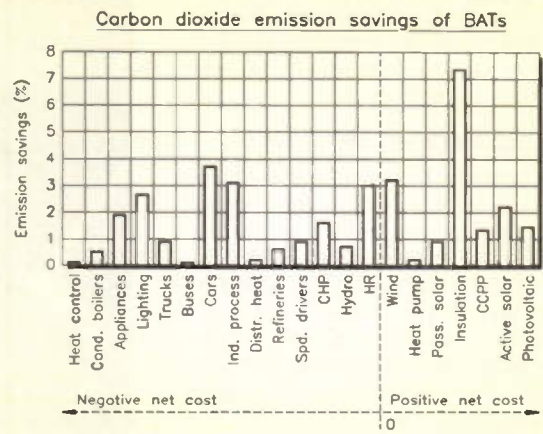

Figure 2. Carbon dioxide emission savings as estimated by use of Best Available Technology Options. (Courtesy THERMIE).

silica aerogel were utilised in the construction of a Cherenkov counter at the DESY particle accelerator in Hamburg during the 1970s. In this type of counter, gamma rays release part of their energy in the form of photons of light. The aerogel would interact with the incident radiation and being almost transparent, capture of the emitted photons could readily be undertaken. Up until the 1980s, aerogels were cloudy rather than translucent and the process of manufacture somewhat risky to say the least.

## Developments at Lawrence Berkeley Laboratory

In terms of the ease and safety of manufacture, the initial high temperature process had serious drawbacks. Researchers, however, at Berkeley in Lawrence Berkeley Laboratory, California, developed an improved process which initially under pressure replaced the alcohol in the gel by liquid carbon dioxide and then supercritically dried the aerogel. This process could be successfully undertaken under safer operating conditions of 33°C and 70 atmospheres pressure.

Initially, the process of aerogel production utilised toxic chemicals. Tetramethylorthosilicate (TMOS) had been introduced as a means of reducing the preparation time for aerogels from weeks to a few hours. In the search for a safer alternative, Dr. Arlon Hunt and his colleagues investigated tetraethylorthosilicate (TEOS). Aerogels produced by this method, however, tended to be more cloudy. More satisfactory results were eventually obtained by use of ammonium fluoride as an acid catalyst. There remained, however, the problem of processes involving alcohols under conditions of high temperature and pressure. These problems were graphically demonstrated when a manufacturing facility in Sweden exploded in 1984.

This led Dr. Hunt and his colleagues to develop a safer and also more economical process for the supercritical evaporation of the gels. The solution eventually developed was to replace the alcohol with carbon dioxide for the process of supercritical evaporation.

## Aerogel Production

The process of aerogel fabrication begins with mixing TEOS with water and using alcohol to promote mixing of the two primary fluids. The water in turn breaks up the TEOS –

creating an ester from which precipitates out particles of pure silica.

Using the catalytic action of ammonium fluoride and ammonium hydroxide to control the pH of the solution, the silica particles stabilise further by forming linkages throughout the liquid's structure. The quality of the resultant aerogel is critically dependent upon control of the growth stage of the silica linkages. The most transparent aerogels are formed with small pore sizes.

At this stage, the gel is transferred to the pressure vessel, where liquid carbon dioxide flushes out and replaces the alcohol trapped within the pores of the gel. The pressure is increased to beyond the supercritical point and the carbon dioxide slowly vented – leaving the aerogel behind.

Figure 1 shows the triple point of carbon dioxide. The transition in this system is across the liquid/unsaturated vapour line.

This principle of supercritical drying has been successfully used to produce aerogels from organic polymers to produce carbon aerogels. In this process, the hydrogen and oxygen atoms are driven out of the cross-linked organic polymer during the supercritical 'drying process'. Usually, the

aerogel is produced by being heated to high temperatures in an inert gas environment such as argon or nitrogen, or under vacuum conditions.

Work has also been undertaken at Lawrence Livermore National Laboratory in the development of aerogels. Photo 1 shows SEAgel, an aerogel made from agarose, a product derived from kelp. Yes, the SEAgel, some 10% lighter than silica aerogel, is floating on soap bubbles.

## Complex Aerogels

Whole new families of aerogel compounds have been developed through fabrication of so-called multi-component aerogels. This involves the production of a 'core' aerogel and the subsequent exposure of the gel to chemical vapour infiltration, which causes modification of the material of the aerogel at a very fine scale. Composites added in this way include those of pure carbon, metallic iron, iron oxides and elemental silicon. This method allows deposition of nanometre-sized deposits of particles. This optimises available surface area for chemical reactions involving catalytic processes. This process of 'complex

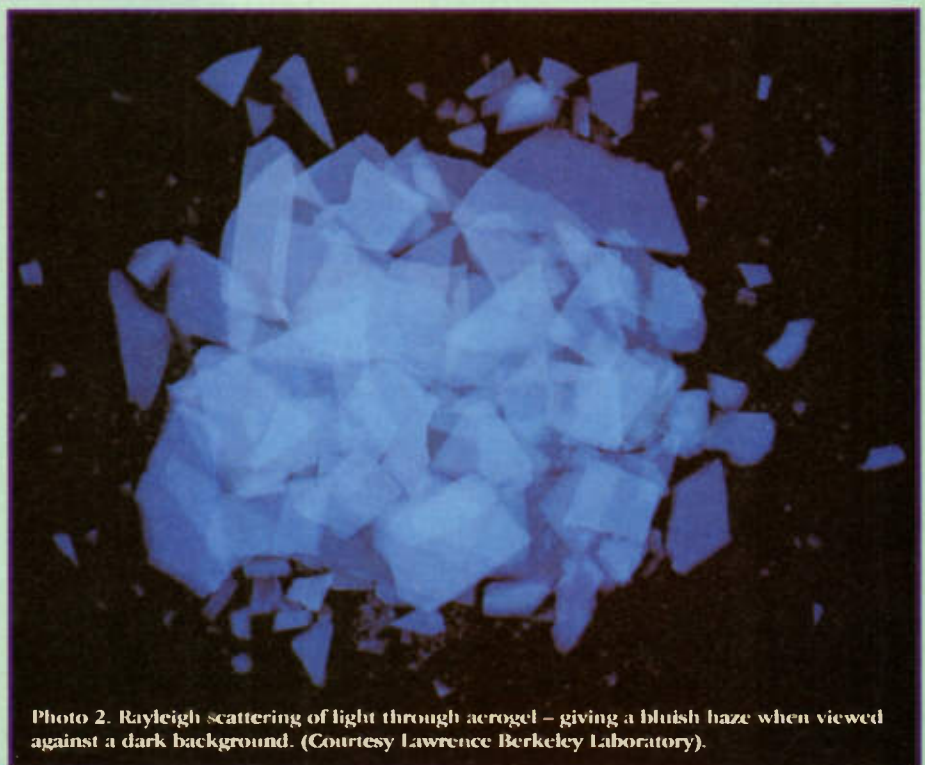

Photo 2. Rayleigh scattering of light through aerogel – giving a bluish haze when viewed against a dark background. (Courtesy Lawrence Berkeley Laboratory).

aerogels' provides wide scope for the development of materials of differing composition and physical and chemical properties. Current aerogel materials, however, cannot be used for processes involving liquids.

## Optical Properties

Aerogels, however, tend to scatter light transmitted through them. This gives the typical aerogel a somewhat 'milky' appearance, which may render them unsuitable for glazing insulation. Research using Transmission Electron Microscopes has indicated that a reduction in 'milky' appearance of the aerogel can be achieved by reducing both the relative number and the size of the larger pores within the aerogel.

Photo 2 shows the typical appearance of light scattering by an aerogel. The bluish appearance against a dark background is caused by Rayleigh scattering – where light of shorter wavelength is preferentially scattered. Such scattering is caused by light encountering structures of a size comparable to the wavelength of the incident light.

Detailed investigations of the structure of aerogels determined that typical particles of silica were extremely small – around 3 to 4nm in diameter and too small to contribute towards scattering. While pore sizes were typically around 20nm in diameter, TEOS aerogels did contain some pores as large as 300nm.

Photo 3 shows Dr. Arlon Hunt working with a light scattering measuring device – a nephelometer – to determine the optical quality of an aerogel under test.

By controlling the purity of reagent chemicals and processing systems, it has been possible to prevent the formation of pores of greater than 50nm in size. Good progress is being made, therefore, in developing a clear aerogel for use as a sandwich in double glazing applications.

## Optimising Insulation Properties

The superb insulation properties of silicon aerogels are indicated in Photo 4, where the heat from the gas flame is not transmitted to the finger on the other side of the section of aerogel. The properties of the aerogel can be improved even further by the removal of the air from the aerogel – improving performance by between a factor of two and three.

With the reduction in the number of air molecules in the aerogel, molecules become more likely to collide with the solid internal structure than with other gas molecules. Vibrations within the solid lattice are less likely to transmit energy than other free molecules. Significantly, lower values of thermal conductivity can be achieved under conditions of 10% pressure of atmospheric inside the volume occupied by the aerogel. Also, the performance of such an insulation system can cope with some degree of loss of vacuum, while other insulation systems using conventional high vacuum are dependent on the maintenance of a total vacuum.

In the drive to develop cheaper and more effective insulating aerogels, the key to improving performance is the reduction of transmission of infrared radiation from the 'hot' side to the 'cool' side. It has been identified that the addition of carbon to the aerogel effectively blocks this component of energy transmission – resulting in improved thermal insulation performance. The addition

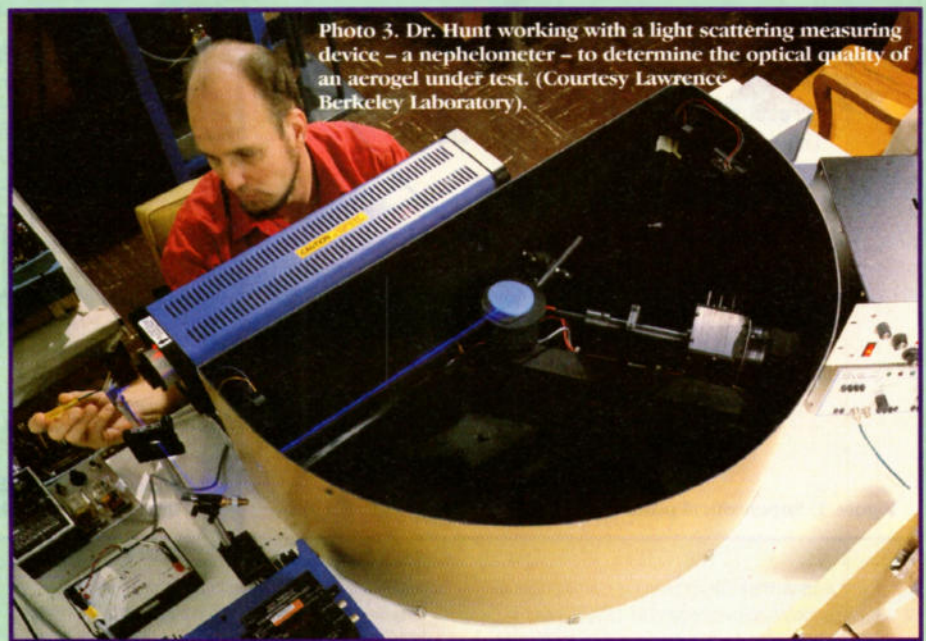

Photo 3. Dr. Hunt working with a light scattering measuring device – a nephelometer – to determine the optical quality of an aerogel under test. (Courtesy Lawrence Berkeley Laboratory).

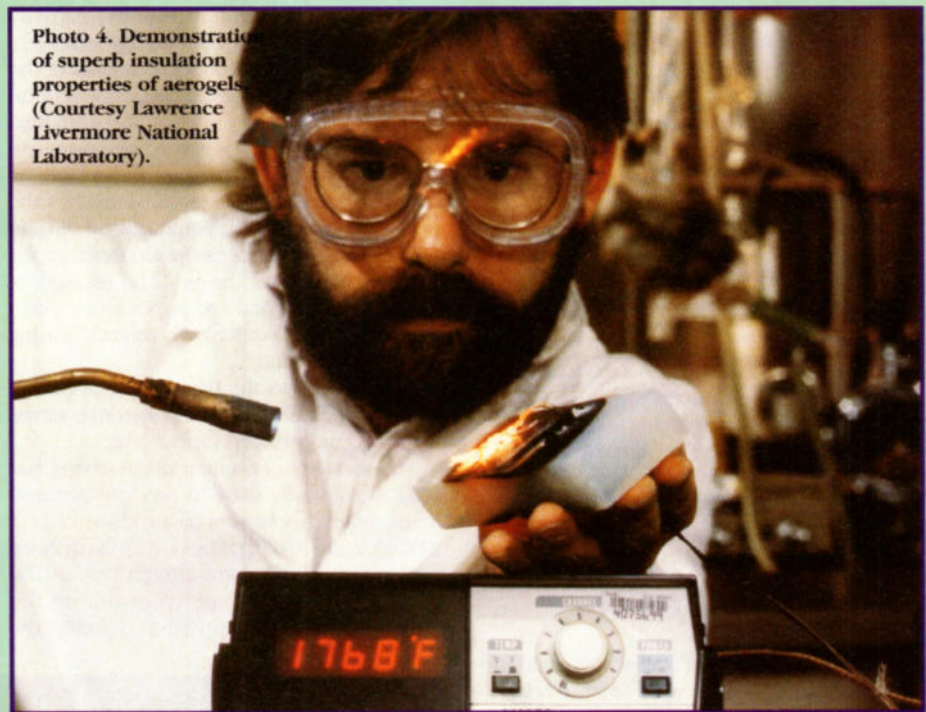

Photo 4. Demonstration of superb insulation properties of aerogels. (Courtesy Lawrence Livermore National Laboratory).

of carbon, however, makes the aerogel opaque or semi-opaque – rendering the material unsuitable for insulation where transparency is a requirement. At the same time, however, there are many applications where transparency is not required, e.g., in insulation of refrigerators.

The addition of carbon, moreover, improves the thermal stability of aerogels at elevated temperatures. Studies show that aerogels have significant potential to function at temperatures of around 500°C. This would open up significant new applications – to either reduce the size of existing thicknesses of insulation material or to improve the degree of insulation able to be provided.

Researchers have produced aerogels using solvents other than alcohol, with a density as low as 0.001g/cc. Such aerogels, however, generally have a weak structure.

In respect of relative insulation of aerogels, Table 1 indicates typical values of thermal conductivity for a range of materials.

Table 1. Relative values of thermal conductivity for a range of materials, including various types of aerogels.

Material	Thermal Conductivity (W/m <sup>2</sup> K)
Copper	380
Silica (fused)	1.4
Glass	1.10
Cork	0.42
Wood	0.21
Asbestos	0.13
Perlite	0.055
Mineral wool	0.039
Air (@ 0°C)	0.024
Polyurethane + CFC	0.021
Silica aerogel (air)	0.018
Silica aerogel (vacuum)	0.008
Carbon aerogel	0.0045

## Energy Conservation

It is, however, the superb insulation properties of aerogels which is, at present, their most important property being investigated. This is coupled to current concerns regarding the Greenhouse Effect. At a time when interest is



increasing in energy conservation, substances like aerogels could play a role in reducing carbon dioxide emissions based on more efficient use of energy derived from fossil fuels.

It is a sobering thought that every 1kWh of saving of electrical power produced by burning of fossil fuels can save up to 1kg of carbon dioxide from being released into the atmosphere. Recent cold weather during January 1996 in the UK drew an astonishing 48GW from the National Grid. If some 80% of this was from fossil fuels, then this corresponds to around a release rate of 10 tonnes per second of carbon dioxide.

## The European Dimension: THERMIE

On a Europe-wide scale, 3,042 million tonnes of carbon dioxide is produced each year, based on 1990 figures. This in turn amounts to only some 15% of total world emissions.

In the complex assessment of how Europe can reduce its greenhouse gas emissions, a study was undertaken as part of the THERMIE initiative. A range of so-called Best Available Technologies was identified which if developed, would reduce emissions. With each development is associated a cost of implementing such as system. It is apparently cheaper to make existing systems pollute less than develop new technology to produce 'green' power. The details of this summary picture are indicated in Figure 2. BATs of positive cost, however, generally have the advantage of zero greenhouse gas emission rather than a reduction from a specific level. The contribution played by insulation, however, is highly significant and could reduce Europe's energy consumption by over 7% if standards were suitably improved.

Often, however, in the definition of the standards of energy efficiency for appliances such as refrigerators, the standards reflect the availability and price of materials. If improved materials such as aerogels are available at suitable cost/performance, then this will in turn, jolt on the increased energy efficiency of major groups of equipment.

Already in the USA, the Appliance Efficiency Standards Act of 1987 requires significantly improved insulation performance for appliances such as refrigerators, deep freezers and water heaters. Also, polyurethane foam – the mainstay of conventional insulation – initially retains chlorofluorocarbons (CFCs) within its structure, but these subsequently leak into the atmosphere. Such CFCs are being phased out, since they have been shown to destroy ozone in the Earth's high atmosphere. These new standards require essentially a doubling of insulation standards and a ban in use of CFC-containing compounds.

In the search for the material to succeed CFC-expanded polyurethane foam – primarily in refrigeration insulation – there are primarily three main contenders. These include aerogels, silica powder and glass powder sealed inside steel sheets and with a partial vacuum established to enhance the insulating effect. When aerogels are evacuated to 10% of atmospheric, its insulating properties are increased by a factor of around three. If this level of insulation was being matched by silica powder, then a vacuum of a few parts in a thousand would be required. For glass beads, even higher degrees of vacuum would be required. The 10% level of vacuum, does not, however, present a problem for aerogel structures.



Photo 5. RIKVA satellite in earth orbit. (Courtesy ESA/NASA)

## Acoustical Properties

Aerogels can be produced with widely differing acoustic properties. Some types can demonstrate a sound absorbing property which could be utilised in both glazing technology and formal insulation technology. In the latter used to wrap round engines motors, the aerogel would keep in the heat and keep in the noise.

Many applications in acoustics relate to generation of sound and the detection of sound. Often, there is a problem of impedance matching between 'stiff' solid structures and 'compliant' media, such as air. The use of an aerogel with an intermediate degree of stiffness can help improve effectiveness of transmission of sound. Likewise, in sound detection, the aerogel can be used to increase sensitivity to incoming signals. Aerogels typically have low densities. Silica aerogels typically have velocities around 30m/s.

The mechanical impedance of a material that transmits longitudinal vibrations such as sound determines key properties such as reflection from interfaces and transmission through interfaces. The value of impedance of material is given by the product of its sound velocity and density.

Figure 3 shows vibrations passing from medium #1, through #2 and into #3. For maximum transmission, the matching layer,  $Z_2$ , must be an odd integral number of quarter wavelength thick and must have a characteristic impedance equal to the geometric mean of the other two, i.e.: where  $Z_1$ , etc., is

the impedance of the respective material.

This condition is only really met at the frequencies where the matching layer is an odd integral number of quarter wavelengths. Table 2 indicates how impedances are derived, based on values of density and velocity for air and silicon aerogel.

Material	Velocity m/s	Density kg/m <sup>3</sup>	Impedance
Silica aerogel	30	5	150
Air	300	1.2	360

Table 2. Mechanical impedance details of silica aerogel and air.

The use of aerogel could, therefore, provide for some interesting applications in acoustics. As a sound absorbing structure, aerogel could act to preferentially absorb frequencies of sound – like an acoustic sponge. There even exists the possibility of conditioning aerogel by voltage signals to dynamically adjust the impedance of the material to absorb selected sound frequencies.

Conversely, aerogel can act to facilitate the broadcast of sound from a solid vibrating source and provides additional scope for loudspeaker design. It could be possible, for example, to coat piezo-electric surfaces with aerogel, to produce large area sound generation systems.

One of the problems so far encountered, however, is the difficulty of maintaining uniformity of properties between production batches of aerogel.

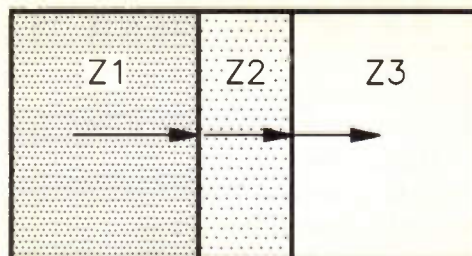

→ = Direction of sound

Figure 3. Principle of acoustic impedance matching.

## Electrical Properties

When electronic pulses are propagated along wires or across semiconductor material, then the speed at which pulses are transmitted is influenced by the dielectric constant of the material. In the case of the wire, the speed of propagation is inversely proportional to the dielectric constant of the insulating material.

Thus, the closer the dielectric constant is to unity, the faster the pulse will be transmitted. Silica aerogels typically have dielectric constants close to unity. It would be a considerable challenge, however, to fabricate semiconductor circuits in such a way that they could be masked with aerogel compounds to insulate conducting elements.

## Operation STARDUST

While of considerable scientific interest, sampling of interstellar dust is exceptionally difficult to achieve, due to problems of reducing the speed of such particles and isolating such material. Aerogels offer an excellent means of capturing such samples for scientific investigation.

Extensive research into the use of aerogels for the sampling of dust particles in space is being undertaken by various teams around the world, including Dr. Donald Brownlee at the Department of Astronomy, University of Washington in Seattle. Aerogel material is able to absorb the energy of fast-moving particles of space dust, so that their energy is dissipated in a controlled way without vaporising the incident particles. Such dust particles may be incident with a velocity of 6km/sec – with even higher velocities being encountered in Earth's orbit. Such aerogel dust sampling systems were flown aboard the European Space Agency EURECA mission – EUROpean RETrievable CARrier, as shown in Photo 5. This mission was initially launched by the shuttle Atlantis in 1992, and retrieved by the shuttle Endeavour in 1993.

The extensive experience obtained with aerogels on EURECA is being used in the planning of NASA's STARDUST mission, which is scheduled to intercept the p/Wild2 comet during 2003 with return of craft to Earth orbit in 2006. Sheets of highly pure silicon aerogel will be employed, with a density of 0.02g/cc.

One collector, of area 1,225cm<sup>2</sup>, will sample interstellar dust and a unit of similar collection area will be exposed during the comet flyby to sample comet dust material. Thicknesses of aerogel material used will be between 1 and 2cm. In an age where there is increasing interest in the nature and composition of dust and comet debris in space, aerogels are playing a key role in the capture and sampling of such material.

## Aerogel: Where Now?

The commercialisation of aerogels, however, is an uphill struggle. Dr. Hunt has been responsible for setting up a commercial company, Thermalux LP at Richmond, California, to develop processes for manufacture of aerogels.

BASF, the large German chemical and plastics manufacturer, has developed an aerogel product, BASOGEL, primarily for domestic and industrial insulation applications. Work on this product, however, is on hold, since it is considered that the market for the efficient insulation is not sufficiently developed. BASOGEL is apparently more dense than standard silica aerogels – presumably to give the material more strength and durability. At atmospheric pressure, it has a thermal conductivity of around 0.018W/m<sup>2</sup>K and a density of around 0.13g/cm<sup>3</sup>. The more dense BASOGEL does not improve as significantly as less dense aerogels with the application of conditions of higher vacuum. Table 3 indicates the improvement in insulation properties of BASOGEL with increasing conditions of vacuum.

Pressure (mbar)	Thermal Conductivity W/m <sup>2</sup> K
1,000	0.018
100	0.012
10	0.007
1	0.005
0.1	0.004

Table 3. Properties of BASOGEL under ranges of pressure for temperature of 50°C and density of 0.12g/cm<sup>3</sup>.

Aspen Systems of Marlborough in the USA have developed an innovative flexible insulation aerogel product termed 'Super-Insulation', which is being evaluated for potential use in the cryogenics and refrigeration industries.

While the potential benefits of aerogel are considerable, there appears to be no USA or European initiative to boost aerogel research to a level that would significantly speed up their commercialisation. As, however, new products and processes emerge in the next millennium, it could well be that aerogels will establish themselves in products yet to be set down on the drawing board.

## Further Information

Innovative Insulator, LBL Research Review, Volume 16, number 2, Summer 1991, pages 2-9.

Aerogels, The Lightest Solids, Dr. Arlon Hunt, pages 146-159, Science and the Future Year Book, 1996, Encyclopedia Britannica.

## Points of Contact

Public Information,  
Building 65B,  
Lawrence Berkeley National Laboratory,  
Berkeley,  
California, 94720, USA.  
Aspen Systems Inc.,  
184 Cedar Hill Street,  
Marlborough, MA 01752.  
Tel: 001 508 481 5058.  
Fax: 001 508 480 0328.

Dr. Eden,  
Colour Research Laboratory,  
BASF,  
PO. Box D-67056,  
Ludwigshafen,  
Germany.

THERMIE:-  
Commission of the European Communities,  
Directorate-General for Energy (DG XVII)  
THERMIE,  
Rue de la Loi 200,  
B - 1049, Brussels.

**AT LAST! NOW YOU CAN SEE THE COMPLETE MAPLIN RANGE OF GOODS ALL UNDER ONE ROOF AT**

**MONDO**  
MAPLIN

# THE MAPLIN SUPERSTORE

Virtually every catalogue item on display  
Hi-Fi separates from Pioneer and Teac  
Music/Disco Studio  
Audio Listening Bays  
Internet Demonstration Area  
In-store Cable-making Service  
Television/Satellite TV equipment  
In-store Demonstration Areas  
Equipment Hire and much, much more

**COME AND SEE WHAT WE'VE GOT IN-STORE FOR YOU AT MAPLIN'S BIGGEST, BRIGHTEST, BEST-EVER STORE!**

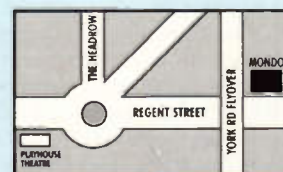

**MONDO Maplin, 3 Regent Street, Leeds. Tel: (0113) 244 9200**

**THE WORLD OF ELECTRONICS AND BEYOND**

# PATTRESS MOUNTING DIMMER SWITCH

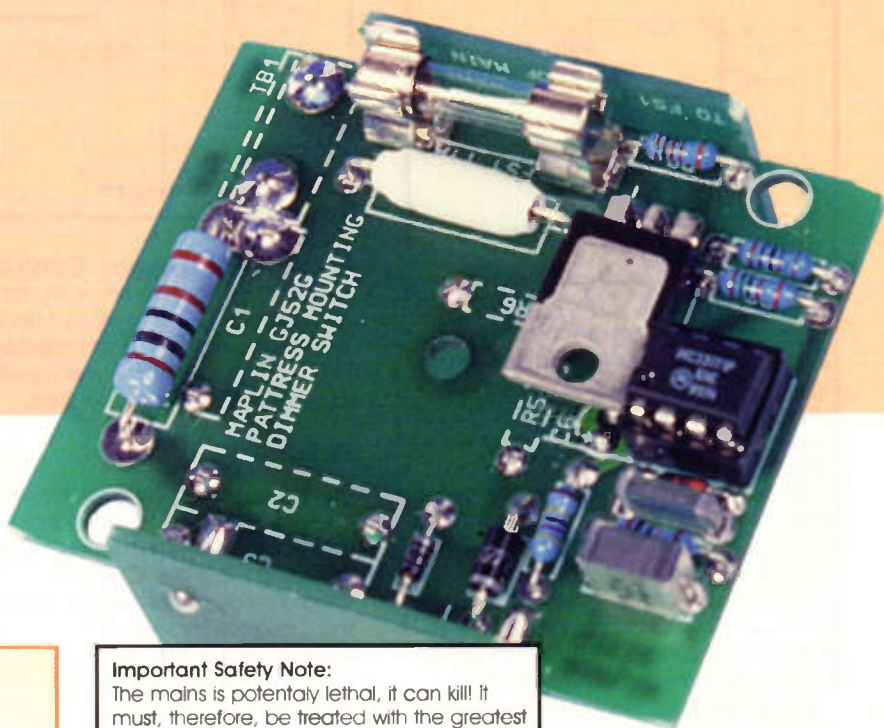
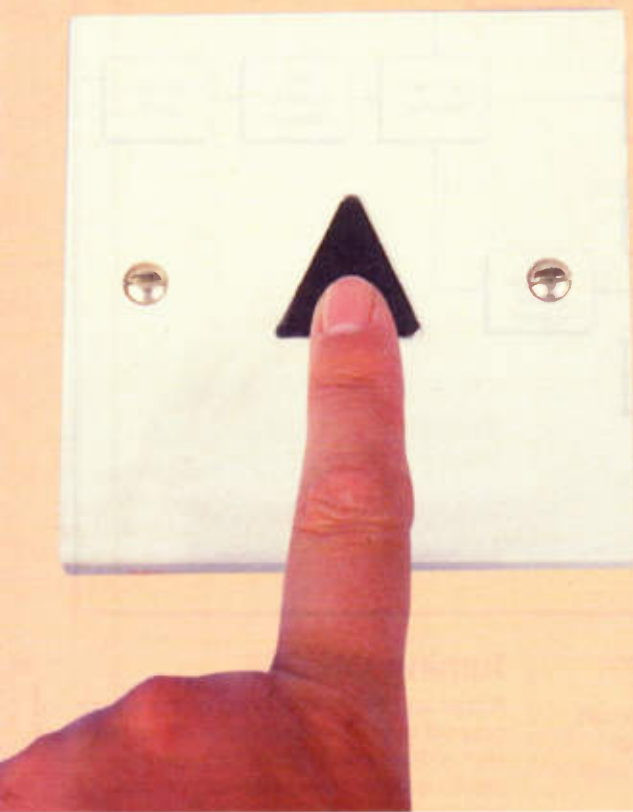

**4**  
PROJECT  
RATING

Design by Alan  
Williamson

Text by Alan Williamson  
and Maurice Hunt

## APPLICATIONS

- ★ Homes
- ★ Studios
- ★ Halls
- ★ Stage lighting
- ★ Offices
- ★ Shops

### Important Safety Note:

The mains is potentially lethal, it can kill! It must, therefore, be treated with the greatest respect at all times; for your safety, never test or operate the unit with exposed mains.

## FEATURES

- ★ Single touch pad control
- ★ Three-way functioning
- ★ Quiet operation

## Specification

Operating voltage:	240V AC mains
Maximum power rating:	240W
Housing:	Standard single wall pattress
Minimum pattress depth:	20mm from plaster surface
PCB dimensions:	93 x 57.5mm (prior to separation of insulating sections)
Overcurrent protection:	T1A 20mm Time-lag Glass Fuse

KIT  
AVAILABLE  
(95102)  
**PRICE**  
**£19.99**

**T**HE Patress Mounting Dimmer Switch, as its name suggests, fits into a standard wall patress fitting, more commonly occupied by a conventional rocker type light switch. However, this electronic version features single touch-pad control of the lights to switch them on and off, in addition to dimming the lamps up and down, with built-in memory retention of the previously set light level. The unit is also quiet in operation, when compared to certain types of conventional dimmer switches, which buzz loudly when the lights are dimmed. The kit comes complete with the touch pad and patress blanking plate, including mounting screws, to create an attractive touch dimmer switch that is an easily fitted replacement for the original wall switch.

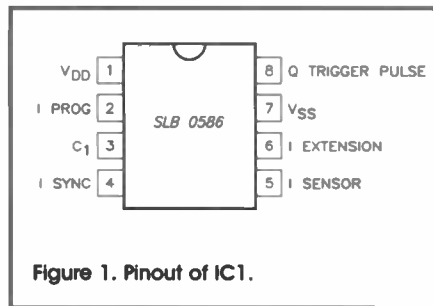

Figure 1. Pinout of IC1.

The circuit is based around IC1, a SLB0586, the pinout of which is given in Figure 1. This IC permits the design of fully electronic dimmers for resistive load incandescent light bulbs, operated by a single sensor. The lamp brightness is set by phase control. The digital electronics within the IC are synchronised with the line (mains) frequency. The circuit can replace conventional (2 wire) SPST light switches because the conduction angle is limited to a maximum of 152° of the half wave, leaving a minimum of 28° of the half cycle to power the circuit.

A digitally determined period of approximately 50ms ensures a high degree of immunity from interference from electrical variations on the control inputs, and allows an almost

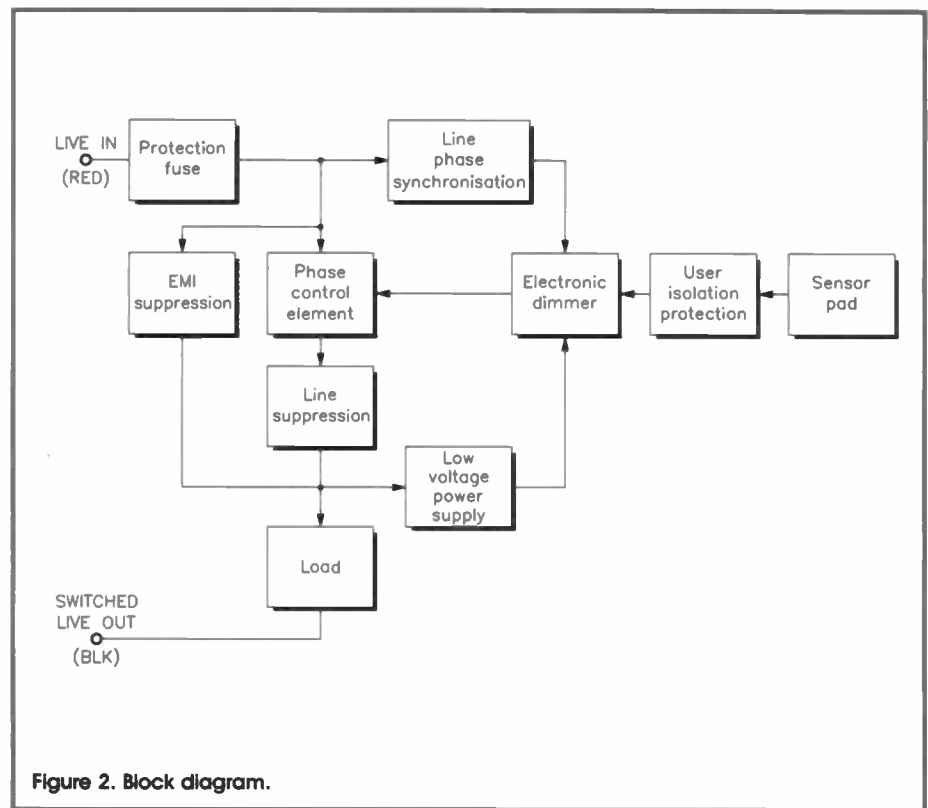

Figure 2. Block diagram.

instantaneous operation. During short line interruptions ('brown outs'), the dimmer cycle setting will remain stored when used with the recommended circuit. Longer line interruptions will reset the circuit to the OFF condition.

### Use

The device can distinguish between 'turning ON/OFF' and 'dimming' by the duration of the 'Control input' operation period. Pin 2 of the IC is the 'Programming input', which determines the 'Control Behaviour A, B or C' (set by a solder bridge link on the PCB). Note that Type B is the default setting, which requires no solder bridge link.

- Type A = Solder Bridge A
- Type B = OPEN (no Bridge)
- Type C = Solder Bridge C

### Turning ON/OFF

A brief touch (50 to 400ms) of the sensor pad will switch the light on or off, at the end of the period depending on its previous state. As can be seen in the timing sequence, types A & C have a 'soft' switch on to full brightness, achieved within 380ms; not only is it kinder to your eyes, but to the light bulb itself, by minimising thermal shock, the major cause of bulb failure. Type B switches on at its last pre-set brightness.

### Dimming

Touching the sensor pad for a longer period (50 to 400ms). Types A & C always start from minimum brightness, Type B will switch on at the last pre-set brightness. On successive dimming operations, type A will dim in the same direction until the minimum or maximum

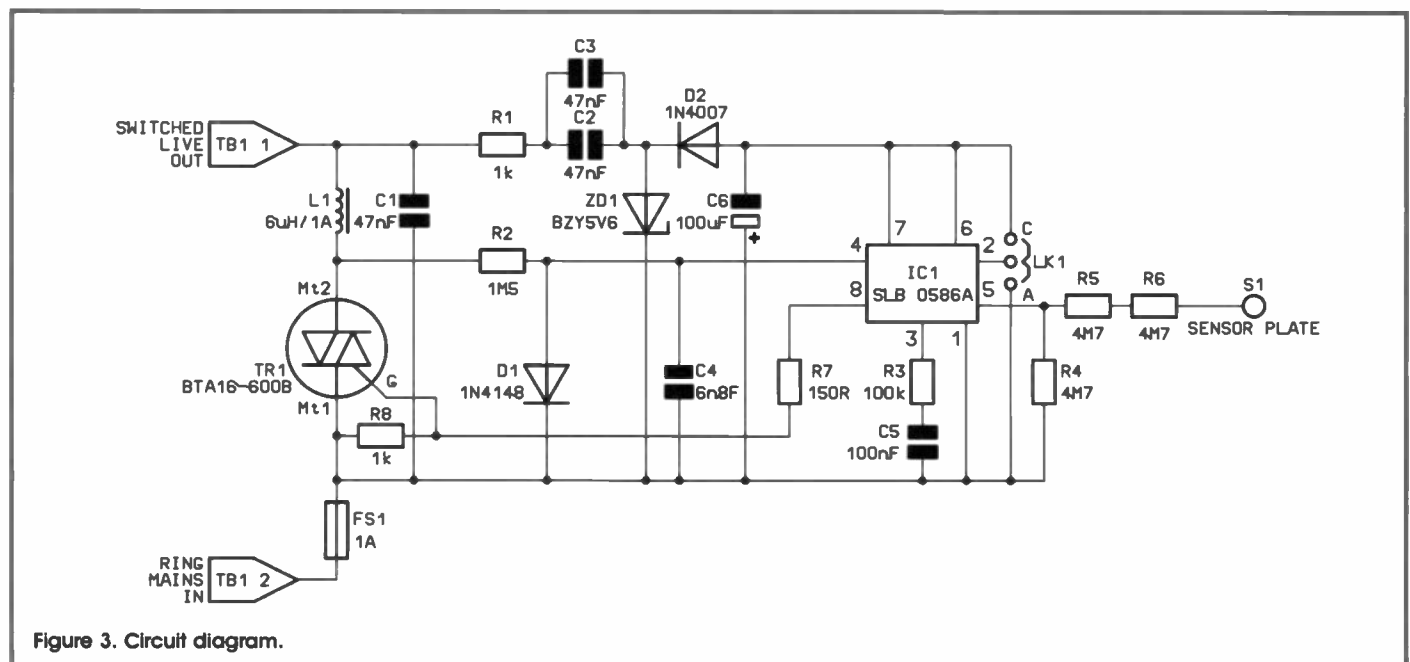

Figure 3. Circuit diagram.

is reached; while types B & C will alternate dimming direction.

During dimming, the conduction angle is continuously varied; executing a control loop in 7.6s (i.e., light-dark-light) and will continue the sequence until your finger is removed from the sensor pad. Note, when minimum brightness is reached, the IC will pause for a short period before increasing the brightness.

The phase control conduction angle is varied during the control loop sequence in a manner to simulate a perceived linear increase or decrease in brightness over the operating time.

## Circuit Description

Refer to the block and circuit diagrams shown in Figures 2 and 3. IC1 requires a low voltage supply, and the components responsible for current limiting are R1, C2 & C3, D2 is the half-wave rectifier, capacitor C6 provides the main reservoir decoupling and ZD1 is for supply voltage regulation.

R2 & C4 provide a filtered signal for synchronising the ICs internal Phase Locked Loop (PLL) timebase oscillator with the (mains) line frequency; the components also determine the conduction angle of the half wave phase. R3 and C5 are the integration unit for the PPL. Resistors R5 & R6 serve to

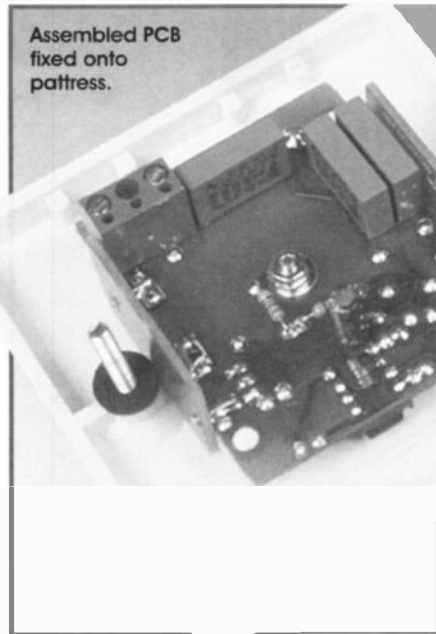

protect the user in fault conditions. NEVER replace R5 & R6 with a single resistor – should one resistor become short circuit (highly unlikely as more often than not, resistors become open circuit), protection is assured by the second resistor. Resistor R4 when combined with R5 & R6 will set the sensitivity of the sensor. L1 & C1 are used for EMI (Electro Magnetic Interference) suppression.

## Construction

Refer to the PCB legend and track, shown in Figure 4. Construction is fairly straightforward; most components are fitted to the usual legend side of the PCB, except the terminal block, R5, R6, C1-3 and C6, which are fitted to the track side.

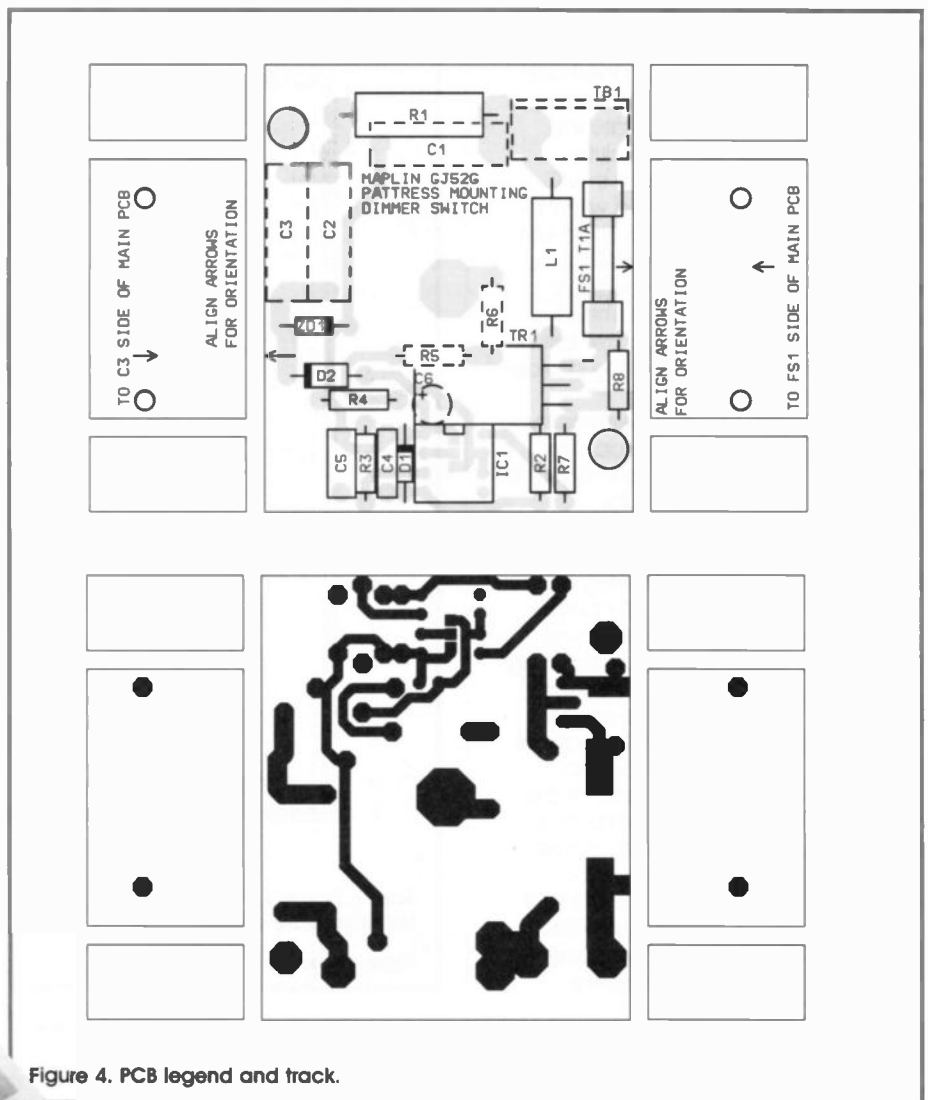

Figure 4. PCB legend and track.

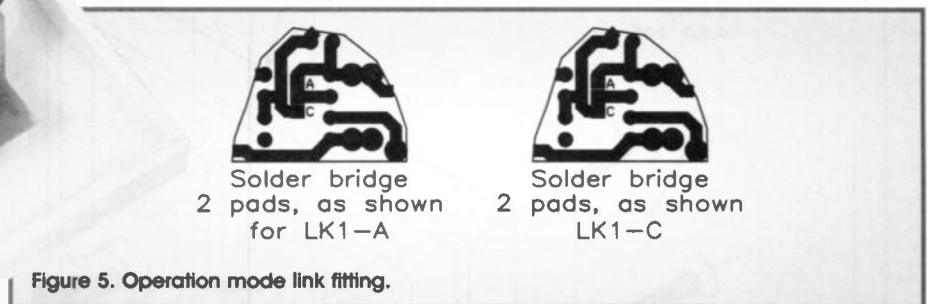

Figure 5. Operation mode link fitting.

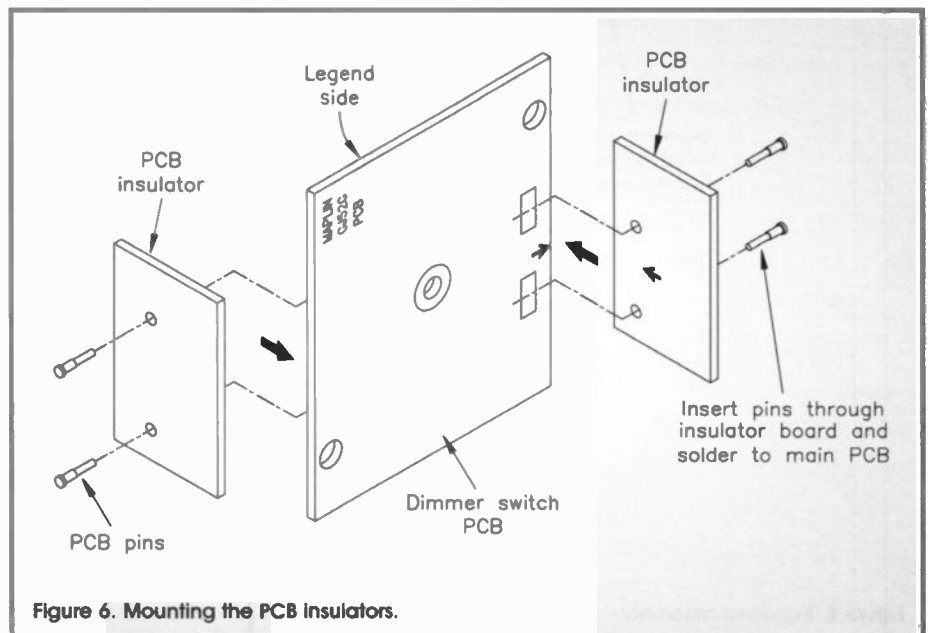
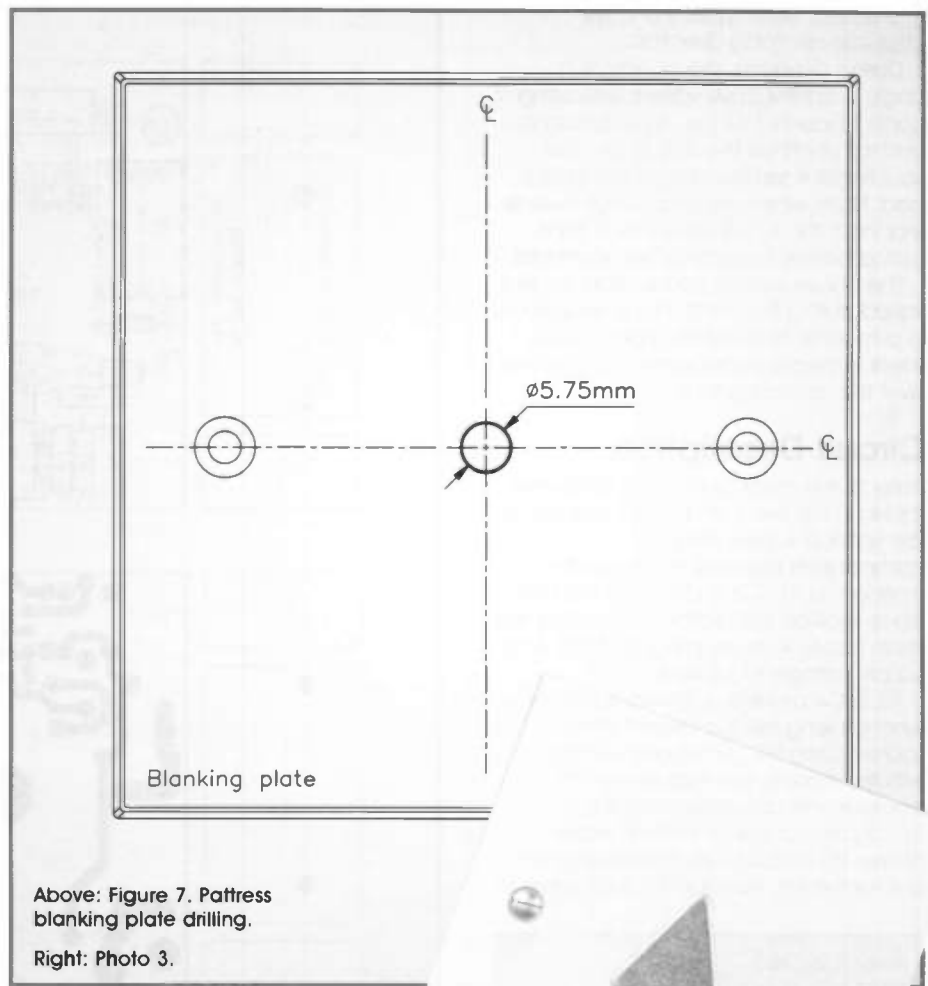

Figure 6. Mounting the PCB insulators.

Begin with the smallest components first, including the four PCB pins on the snap-off sections (fitted from the track slide), working up in size to the largest; be careful to correctly orientate the polarised devices, i.e., electrolytic capacitors and diodes. Install the IC socket with the notch aligned with the legend. Note that the triac is fitted with its metal tab side facing UPWARDS; its legs should be pre-bent through 90° prior to fitting it to the board. The IC should be inserted into its socket last of all, pre-forming the leads of the device beforehand.

To select type 'A' or 'C' operation (type 'B' is default), make the appropriate solder bridge on the PCB – see Figure 5. Thoroughly check your work for misplaced components, solder whiskers, bridges and dry joints. Finally, clean all the flux residue off the PCB using a suitable solvent; then double-check EVERYTHING! Fit the PCB insulators as indicated in Figure 6, carefully trimming the snapping points to remove sharp edges and give a tidy appearance.

Mark and drill the hole in the pattress blanking plate in accordance with Figure 7, then fit the touch pad; fit the module onto the blanking plate and secure in place with an M3 shakeproof washer and nut – see Figure 8, the exploded assembly diagram. DO NOT overtighten the nut. Before finally fitting the dimmer module to the wall pattress, double-check EVERYTHING again!



Above: Figure 7. Pattress blanking plate drilling.

Right: Photo 3.

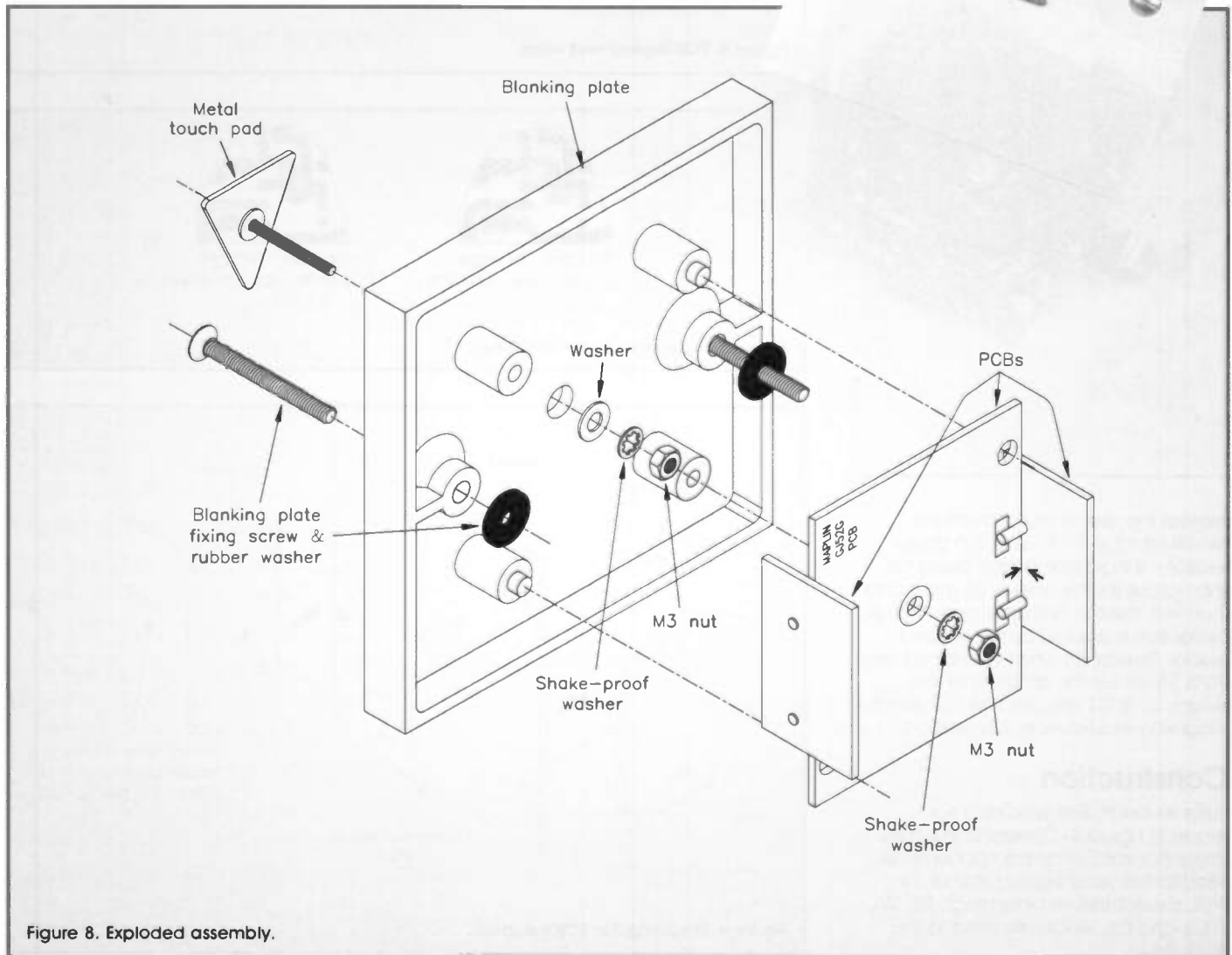

Figure 8. Exploded assembly.

This project is for INTERNAL use only; DO NOT install outdoors or in damp locations such as bathrooms, and do not expose to condensation. Full details of mains wiring connections are shown in this article. Every possible precaution must be taken to avoid the risk of electric shock during maintenance and use of the final unit. Safe construction of the unit is entirely dependent on the skill of the constructor – adhere to the instructions given in this article. If you are in any doubt as to the correct way to proceed, consult a suitably qualified engineer.

Note. This project is not suitable for use with fluorescent or halogen lighting.

## Testing and Installation

Refer to Figure 9, the wiring diagram. SWITCH OFF the power or lighting circuit at the FUSE BOX before proceeding any further. Unscrew the light switch mounting screws and note the wiring; one wire should be RED (LIVE IN) and the other wire BLACK, possibly fitted with a red band (SWITCHED LIVE OUT). If both wires are RED, make safe then switch the power back ON; with the switch OFF, find the LIVE IN using an electrical testing (neon) screwdriver, then switch OFF the power again; mark the LIVE IN wire. Replace the switch with the electronic dimmer (note the legend for the terminals).

If the pattress is a metal flush-fitting type, make sure it is earthed. Screw the dimmer onto the pattress; turn the power ON. Whilst touching the neon screwdriver cap, briefly touch the sensor pad with the screwdriver tip, the light should turn ON, a second brief touch will turn the light OFF. A long touch will dim the light up and down cyclically.

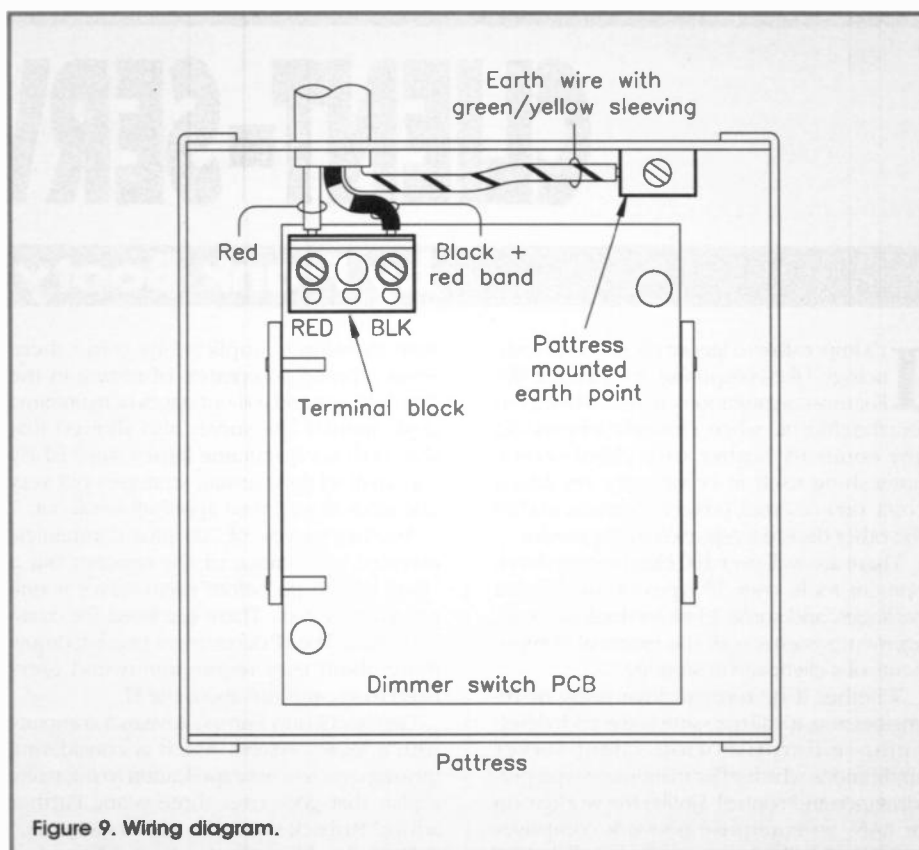

Figure 9. Wiring diagram.

## Further Testing

Set a multimeter to read minimum AC current (usually 2mA); connect one terminal of the meter to earth (if the pattress is an earthed metal type, the face plate fixing screws would be a convenient earth point). Connect the other meter lead to the touch pad, whereupon the light will begin to dim up and down and a current reading of <math>< 20\mu\text{A}</math> AC should be observed. If the

reading is significantly higher than this, switch off the power and inspect your assembly work for mistakes. Testing is now complete, and the dimmer switch is ready for use.

## IMPORTANT

In the event of the fuse requiring replacement, only fit a new one of the same (quality) type as the specified fuse.

## PATRESS MOUNTING DIMMER SWITCH PARTS LIST

RESISTORS: All 0.6W 1% Metal Film (Unless Specified)

R1	1k 2W	1	(D1K)
R2	1M5	1	(M1M5)
R3	100k	1	(M100K)
R4,5,6	4M7	3	(M4M7)
R7	1k	1	(M1K)
R8	150Ω	1	(M150R)

CAPACITORS

C1,2,3	47nF Metallised Film	3	(JR33L)
C4	6n8F Polyester Layer	1	(WW27E)
C5	100nF Polyester Layer	1	(WW41U)
C6	100μF 10V Radial Electrolytic	1	(AT30H)

WOUND COMPONENTS

L1	1A RF Suppressor Choke	1	(HW04E)
----	------------------------	---	---------

SEMICONDUCTORS

D1	1N4148	1	(QL80B)
D2	1N4007	1	(QL79L)
ZD1	BZY88C 5V6 Zener	1	(QH08J)
TR1	BTA16-600B	1	(UK55K)
IC1	SLB0586A	1	(UL43W)

MISCELLANEOUS

FS1	T1A 20mm Time-lag Glass Fuse	1	(CZ96E)
-----	------------------------------	---	---------

S1	Triangular Touch Pads	1	(HY01B)
	Fuseholder Clips	2	(KU27E)
	Blanking Plate	1	(HL86T)
	1mm Single-ended PCB Pins	1 Pkt	(FL24B)
	M3 Nut	1 Pkt	(JD61R)
	M3 Shakeproof Washer	1 Pkt	(BF44X)
	PCB	1	(GJ52G)
	Instruction Leaflet	1	(XV99H)
	Constructors' Guide	1	(XH79L)

The Maplin 'Get-You-Working' Service is available for this project, see Constructors' Guide or current Maplin Catalogue for details.

**The above items are available as a kit, which offers a saving over buying the parts separately. Order As 95102 (Pattress Dimmer Switch) Price £19.99**

Please Note: Where 'package' quantities are stated in the Parts List (e.g., packet, strip, reel, etc.), the exact quantity required to build the project will be supplied in the kit.

The following new item (which is included in the kit) is also available separately, but is not shown in the 1996 Maplin Catalogue

Pattress Mounting Dimmer Switch PCB  
**Order As 95103 Price £5.99**

# CLIENT-SERVER

by Frank Booty

It's impossible to ignore client-server technology. Like computing, it's a fact of life. For most organisations, it's not whether to join the club, but when. However, why should any company bother with client-server, enmeshing itself in complexity, retraining costs, people costs, project overruns, and all the other disasters reported in the media?

There are well over 100 client-server development tools, over 15 types of middleware packages, and some 13 or so database management systems – all the essential components of a client-server strategy.

Whether it be termed downsizing or re-engineering, it's all the same in the end: developing enterprise-wide client-server applications which offer mainframe-type performance and control. Unlike the workgroup or LAN, an enterprise network comprises incompatible databases running on all sorts of processors, from PCs and Unix workstations to mainframes. It is difficult enough to create client-server applications which can extract data from these scattered repositories. Now add in that the key task is to monitor these applications (and compound it by doing it without a central point of control, as with a host or database server). Welcome to hell.

Client-server is intended to provide companies with the ability to integrate their computer systems across multifarious platforms and move closer to the goal of enterprise-wide systems and universal data access.

A survey of 200 large UK organisations revealed a confidence gap between the use of mainframes and client-server platforms in the deployment of large-scale mission-critical applications. Key conclusion? Organisations are putting applications into production too soon and untested.

Users have a much lower level of confidence in their ability to roll out client-server

than mainframe applications (note there exists a broad acceptance of testing in the development and roll-out stages of mainframe applications). The survey also showed that sites with no mainframe legacy were falsely confident in their testing strategies but very unconfident with their application roll out.

Another survey, of 700 plus companies, revealed acceptance of the concept but a 'long way to go before client-server is universally adopted'. There is a need for cross-education. The IT department needs to know more about user requirements and users need to know more about the IT.

Gartner Group Europe advises a company with a legacy system which is considering moving over to a new application to not make a plan that goes over three years. Further advice? Payback should be within five years.

Users should construct an overall IT strategy for the enterprise; create a common integration framework for all implementations and get in touch with end users – they know what they need to accomplish, but they are ignorant about how a distributed IT system works.

As regards cost components, hardware is some 10%, as is the software licence. Two thirds of the overall bill is labour, which covers implementation, consultancy and training. Consultancy costs are usually five times the cost of the software licence. Internal efforts like sending people out for training – when they're not productive – or installing infrastructure help desks, are often as much as the cost of outside help.

Changing working practices among staff to take advantage of technology is as important as implementing the technology itself. Most emerging technologies, such as mobile computing, data warehousing, groupware and workflow, rely on graphical user interfaces (GUIs) and client-server architecture.

Many companies are not yet operating true client-server systems. There is no doubt that the market is moving towards client-server, but companies do have to be certain of their objectives. Anyone considering an implementation has to be aware of the products in the market, the cost, and begin the change only when there is a (perceived) business need.

## Armageddon

Could software in the shape of distributed transaction processing monitors be the answer to the anguish caused by client-server? According to US reports, yes. These monitors, which have been around for some time, allow multiple processes to participate in the same transaction even when it's spread over multiple databases. The software also promises to make client-server applications interoperable, manageable and scalable, i.e., to supply the underlying infrastructure for distributed computing.

Interoperability – the monitors are database independent; Manageability – encompasses management and security, including graphical interface, centralised monitoring, dynamic reconfiguration, client-server authentication and data encryption; Scalability – the ability to support large numbers of simultaneous users across geographically dispersed networks (there's no reliance on SQL statements and stored procedures for accessing relational databases).

So who makes them? Companies like AT&T with Top End, Digital with ACMSxp, IBM with CICS/6000, and Novell with Tuxedo. Drawbacks? No-one seems to know which standards are important to these products, particularly as they don't come under any one body's bailiwick – rather, it's several. Anyone contemplating this route must check a vendor's commitment to object-oriented programming (or grapple with questionable/proprietary tools).

# MAPLIN

## IMPORTANT NEWS FOR OVERSEAS READERS

Obtaining components and kits for the projects featured in **Electronics** is now easier than ever in the following countries and regions:

**Channel Islands**  
C.I. Components Ltd.,  
Crossways Centre,  
Broy Road,  
Vale, Guernsey.  
Tel: 01481 44177  
Fax: 01481 42291

**Middle Eastern Region**  
**Saudi Arabia**  
(Alkhobar Region)  
Fadan Establishment,  
P.O. Box 848  
Alkhobar 31952  
Kingdom of Saudi Arabia  
Tel: 3 898 2737  
Fax: 3 898 2737

**United Arab Emirates (U.A.E.), Bahrain, Kuwait, Oman, Qatar**  
Maplin Middle East Company,  
P.O. Box 47019,  
Hamdan Street,  
Abu Dhabi, U.A.E.  
Tel: (971) 02 760332  
Fax: (971) 02 760317

**Lebanon**  
N and Y Controls,  
P.O. Box 175414,  
Beirut, Lebanon.  
Tel: (01) 443091/397467  
UK Office:  
Tel: (44) 1702 347614  
Fax: (44) 1702 77161

**African Continent**  
**South Africa, Namibia, Botswana, Lesotho, Swaziland, Mozambique, Angola, Zimbabwe**  
Maplin South Africa (Pty) Ltd.,  
P.O. Box 1846,  
Somerset West, 7129  
Republic of South Africa.  
Tel: (024) 51 51 24  
Fax: (024) 51 51 27

**Mediterranean**  
**Malta**  
Cam Services, Cam Centre,  
Off Canon Road, Qormi,  
QRM 09, Malta.  
Tel: 484650  
Fax: 447174

**Gibraltar**  
Mail Order International,  
c/o Medsun,  
P.O. Box 225,  
93-99 Irish Town,  
Gibraltar.  
Tel: 79797  
Fax: 74664

**Far Eastern Region**  
**Pakistan**  
Link Pakistan, Suite Number 2,  
2nd Floor,  
I-R Plaza, Markaz F-10,  
Islamabad, Pakistan.  
Tel: 51 291406  
Fax: 51 282319

**Countries and Regions Not Listed**  
Export Department,  
Maplin Electronics plc.,  
P.O. Box 3, Rayleigh,  
Essex, SS6 8LR, England.  
Tel: +44 1702 554155  
xtn 326, 327 or 351  
Fax: +44 1702 553935

Export catalogue and pricing details are available from the listed distributors.

**MAPLIN**  
ELECTRONICS AND BEYOND



# Stray Signals

by Point Contact

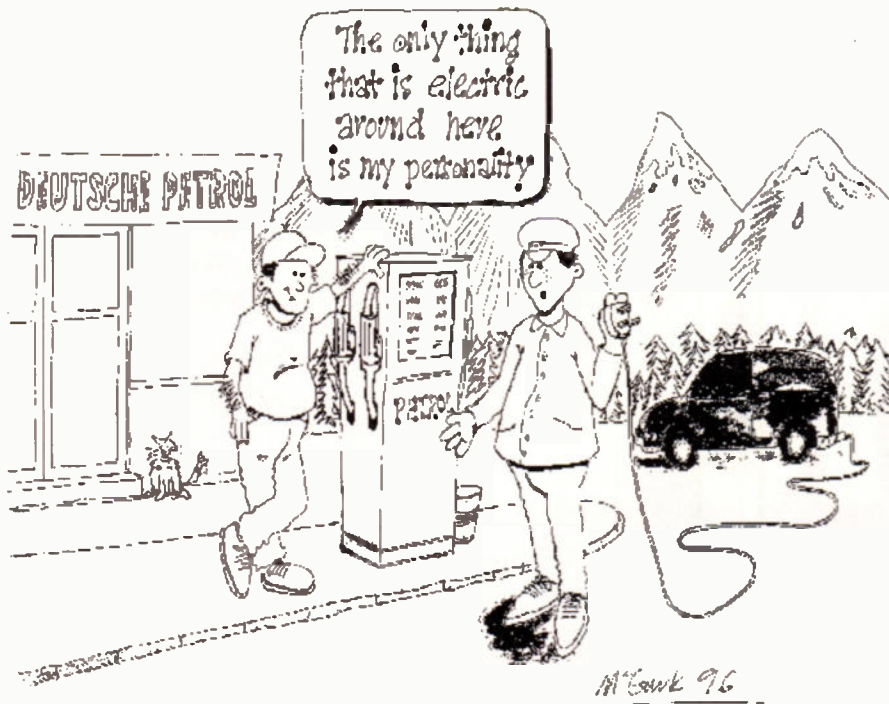

## The EVs are coming

Slowly but surely, Electric Vehicles are starting to gain acceptance, but I don't mean the humble milk float so common in the UK. EVs using zinc-air batteries are being tested by the Deutsche Bundespost Postdienst (German Postal Service). With initially three Corsa vans and three Mercedes-Benz MB410E heavy vans, the test plans are ultimately to involve 64 EVs. The 150kWh batteries in the heavy vans weigh only 20% of the gross vehicle weight, giving over 325km intercity driving with a full 1700kg load. If successful, half the fleet of 25,000 vehicles would be converted to EVs.

In the USA, BART (San Francisco's Bay Area Rapid Transit system) has begun testing small two-passenger EVs. Many commuters drive (in their petrol driven cars) all the way to their place of work because it is up to 10km from the nearest BART terminal. The EVs are meant to persuade them to leave their cars at home, or at least only drive to their local BART station, thus reducing pollution. The first cars in the test are not suitable for use on the freeways, but others with the necessary extra power will follow soon.

And in France, PSA Peugeot Citroen sold 900 of its model 106 Electric in the first three weeks. It expects to make 6,000 of them this year. The Ni-CD batteries are leased to customers, thus freeing them from the fear of an expensive eventual replacement.

## No such thing as

A free lunch, no; but many semiconductor companies are willing to supply not only free data books, but also free samples of their ICs, realising that this helps them with design-ins. Texas Instruments, Maxim and many others are happy to supply data books to design engineers working in companies both large and small, whereas some other semiconductor manufacturers, by contrast, expect customers to pay for their data books. The message seems to be getting through, though, and such scrooges are becoming rarer.

PC recently sent off for data on a new microwave transistor, an ultra low noise Pseudomorphic Hetero-Junction FET, to go in his file on Solutions in Search of a Problem. The data sheet duly arrived, giving the performance of the device at 12GHz (Vds 2V, Id 10mA) as: Noise Figure: 0.45dB; Gain: 12.5dB. Wow! But clipped to the data sheet for the NE32584C was a compliments slip, and clipped to the compliments slip was a short length of carrier-tape containing three samples of the device. Now what can I design that uses one (or more) of these?

## Readers' Feedback

Concerning my comments last time about a thermopile HT 'battery', E.G.W.M. of Glasgow wrote in to say he recalls them being advertised for sale in the late '30s, by Milner Ltd. He recalls that they were heated by gas, but has no further details,

as he never actually managed to get his hands on one.

A reader from Purley wrote in with a tale of woe concerning intellectual property rights. Apparently he produced some natty software, which admittedly needed some further work. A visit to a software house produced a lot of encouragement – they even provided some nice software development tools, and told him to come back in a couple of months with the code all neatly polished up. What he didn't realise was that in the meantime, they had registered the copyright, so at the end of the day he stood to get nothing for all his effort. So he turned to hardware design, only to find the same problem again. He asks if perhaps the Editor could find someone to write an article for *Electronics* on how to protect your brainchild with copyright, patent or whatever. One way is to publish it: make it clear that you are only selling the First British Rights, and subsequently the copyright reverts to you. Once published, no-one can subsequently patent it, so you can exploit your invention free of that fear at least. [I believe that the Patents Office is about to go onto Internet – Ed.]

## Tailpiece

It is said that if you visit all the countries of the EU in turn, taking with you £100 and changing it into local currency in each, on arriving back home and changing it back into Sterling, you will have – not very much: it has nearly all gone into the moneychangers pockets. So what a very good idea a common currency sounds; firms can quote firm delivery prices, NET, FOB or whatever, without having to worry about what is going to happen to the exchange rate in the meantime.

Well, the common currency may be some way off, but at least we have agreed on a name: it is to be called the EURO. Pronounced, naturally enough, EURO, what could be more straightforward? Well, the Brits and the Irish and a few others may say it more or less like that, though the French will manage to endow it with a Gallic accent. But in German, it will be pronounced "OY-ROE", whilst to the Greeks it will be "EV-ROE"! Is nothing simple? No, nothing (rien, nichts or what-have-you).

Yours sincerely,

*Point Contact*

*The opinions expressed by the author are not necessarily those of the publisher or the editor.*

# Computing without clocks

If you have recently bought a PC, the chances are that the clock speed of the processor was a key influencing factor. However, in the future, this may not necessarily be the case. Here, Fred Entwistle talks to Professor Steve Furber of the University of Manchester about clockless computing.

**S**YNCHRONOUS logic (in which a master clock beats the time for every logic gate and register in a system) has served computer designers well in the past. However, in recent years, its limitations have begun to stretch designers' ingenuity to the limits.

Power dissipation and clock skew problems have increased with rising clock speeds, and denser circuits. Today, modern high-performance microprocessors like Digital's Alpha or Texas Instrument's Viking SPARC can dissipate between 20 and 30W. Following current trends, future generations of microprocessors will dissipate several hundred watts.

As clock speeds get faster, clock skew becomes an increasingly important problem. Delays in the clock timing signal (skew) as it propagates across the chip can cause the more remote parts of the system to get out of step. Considerable engineering (and chip) resources are now being devoted to overcoming this problem. For example, Digital resorted to massive transistor clock drivers and hefty clock lines in its Alpha processor.

## Asynchronous Solution

Asynchronous logic promises a solution to both clock skew and power dissipation problems. The reason: in a conventional synchronous logic system, all parts of the system burn power with every clock tick, whether or not they are doing useful work. Pure asynchronous logic circuits, on the other hand, are event driven. They remain quiescent, consuming little or no power, until a logic event or sequence of events ripples through the logic network.

Clock skew is avoided, since asynchronous logic circuits are self-timing. The logic blocks are free-running and only need to

synchronize when they exchange data. There are potential speed benefits too. For example, the clock speed of a synchronous logic system is set by the speed of its slowest element. Much on-chip silicon may be devoted to optimizing this section. In an asynchronous design, the system speed is set by the most frequent operations, so there is a greater engineering return in optimizing these.

## International Research Effort

The potential benefits of asynchronous logic in power sensitive applications (such as mobile computing and telecommunications) and in other very large scale integrated (VLSI) systems, has inspired a resurgence of interest in the design methodology.

There are many major research teams around the world working in the field, including Professor Steve Furber's group in the Department of Computer Science at the University of Manchester. In the USA at Caltech, Alain Martin has led research into

asynchronous design for many years, developing the first asynchronous microprocessor in the late 1980s, whilst at Sun, Ivan Sutherland leads a group working on an asynchronous implementation of the well-known SPARC processor.

In Holland, researchers at Philips Research Laboratories under Kees van Berkel are working on asynchronous consumer electronics designs, and in Japan, a team at the Tokyo Institute of Technology under Professor Takashi Nanya are working on an asynchronous processor.

## The Amulet Project

The AMULET project got under way at the University of Manchester in late 1990. Its aim was to investigate the potential power savings of asynchronous logic design by re-engineering a commercially available microprocessor using an asynchronous design approach. This would allow a direct comparison to be drawn between the two design methodologies.

The target processor was the ARM RISC microprocessor. Developed by Acorn Computers ten years ago, it was the first single-chip microprocessor to incorporate the pioneering RISC ideas being developed at Berkeley and Stanford Universities.

According to Professor Steve Furber, "The ARM6 presented a particularly tough challenge, as it is the market leader in low-power, high-performance microprocessor applications. Besides testing the physics, we wanted to demonstrate the feasibility of applying asynchronous design techniques on a commercially interesting scale."

## Principles of Operation

Asynchronous logic design has a long history extending back to early days of computing. The ORDVAC, built by the University of Illinois, and the IAS built by John von Neumann's group at the Institute for Advanced Study at Princeton University, both used asynchronous logic. More recently, the MU5, built at Manchester University between 1969 and 1974, employed asynchronous control.

However, despite these early systems, the greater design simplicity that is possible with synchronous logic quickly won the day. Now, the development of more powerful computer-aided design tools has made it practical to look again at asynchronous logic.

When devising an asynchronous logic system, there are some fundamental design choices. One of the first is between level-sensitive or transition signalling. Level-sensitive signalling represents a logic-1 by a high voltage and a logic-0 by a low voltage. This has the attraction that the logic processing elements are familiar.

In transition signalling, the signal levels are of no significance. Only the transition (whether rising or falling) is significant. In this set-up, separate wires are used to signal the logical-1 or 0 states. A transition on one wire indicates a logic-0 while a transition on the other indicates a logic-1.

## Micropipelines

In his landmark Turing Award lecture given in 1988, Ivan Sutherland presented a fully worked-out asynchronous logic scheme, complete with a cell library. In Sutherland's architecture, processing elements are

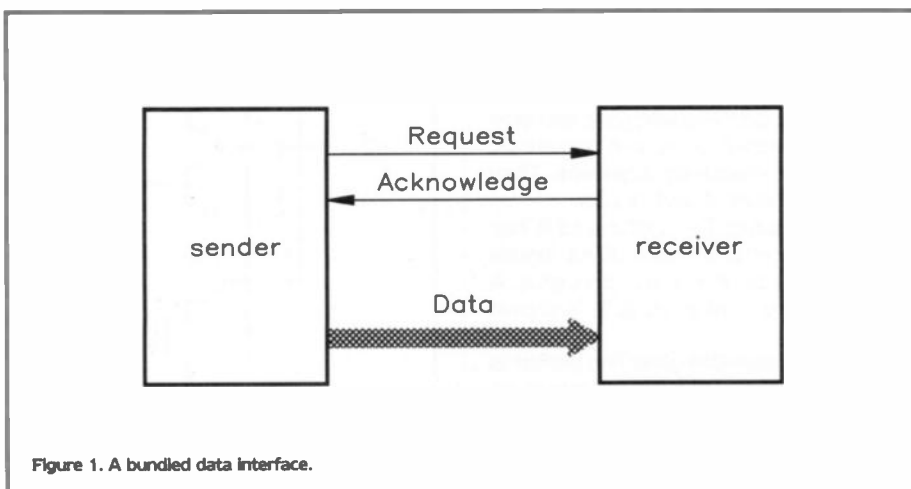

Figure 1. A bundled data interface.

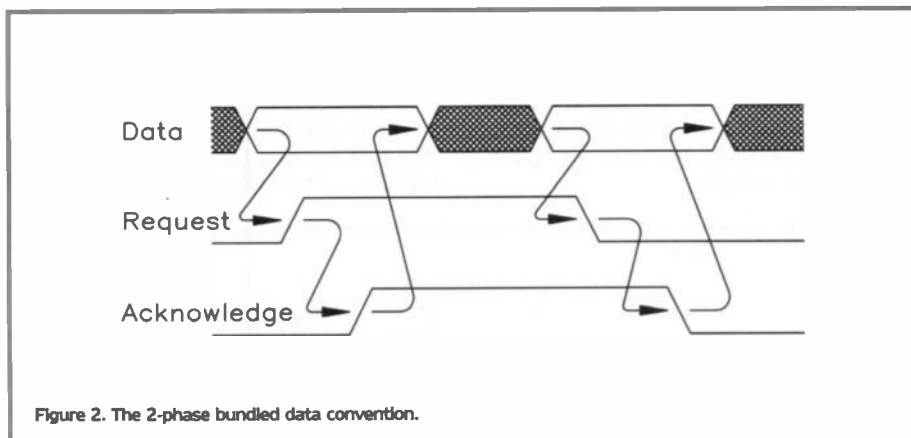

Figure 2. The 2-phase bundled data convention.

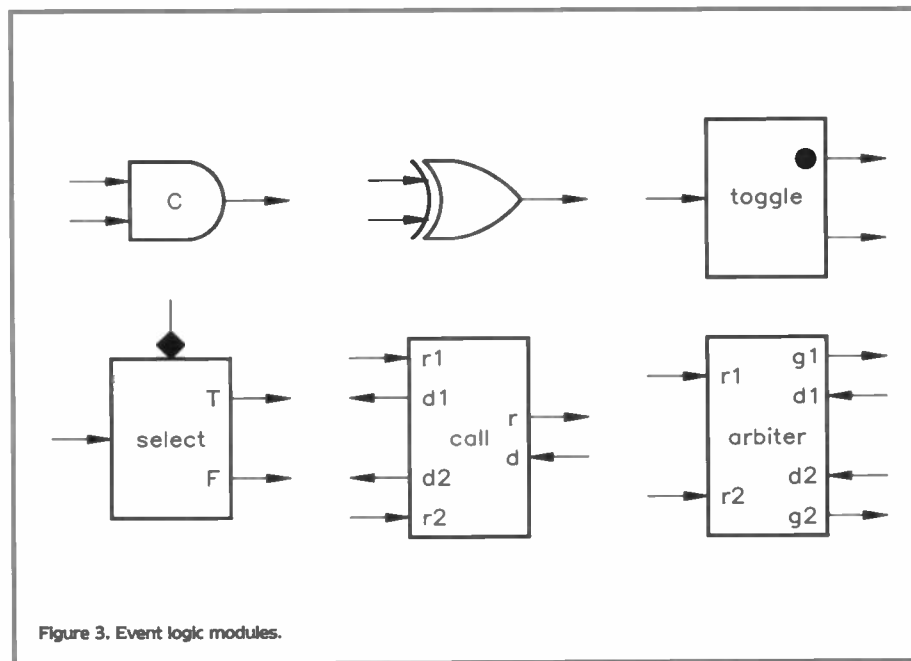

Figure 3. Event logic modules.

arranged in a 'micropipeline'. Each runs independently of its neighbours and only synchronizes with them to transfer data. A two-phase bundled data interface is used for this purpose, as shown in Figure 1.

Data is represented in a conventional level-sensitive form. The transfer from one block to another is controlled by means of separate Request and Acknowledge handshaking wires, which use transition signalling. A logical transition (whether a rising or falling edge) on either wire indicates an event.

The sequence of events is illustrated in Figure 2. First, a new data value arrives at a function unit in normal binary encoding on

a bus. Its presence is signalled to the receiver by a transition on the Request wire. This causes the receiver to accept the data. It signals its acceptance by initiating a transition on the Acknowledge wire. The sender data can then change to a new value. Events must occur in this strict sequence for the transfer to be valid.

The length of the delays between events does not matter. Since the micropipeline control logic is insensitive to delays, gate layout can be compiled automatically. This makes design a relatively straightforward matter. The only uniquely asynchronous problems are caused by potential deadlocks when processing elements compete for the same resource.

## Asynchronous Logic Building Blocks

From this description of the micropipeline, some of the transition-signalling logic elements needed to implement an asynchronous logic system are immediately apparent. They are shown in Figure 3, and include:

**The Muller C-gate:** This waits until it has received an event on both of its inputs before issuing an event on its output. A CMOS circuit for a Muller C-gate is shown in Figure 4.

**The XOR (exclusive-OR) gate:** This performs the merge function for events: a transition on either input results in a transition on its output. The toggle cell transfers an event from its input to its two outputs alternately. Other logic elements outlined by Sutherland include select, call and arbiter blocks as well as event-controlled latches that hold the data stable.

The arbiter unit is required where independent logic units can both access a common resource such as a memory. Its role is to enforce mutually exclusive access to the resource.

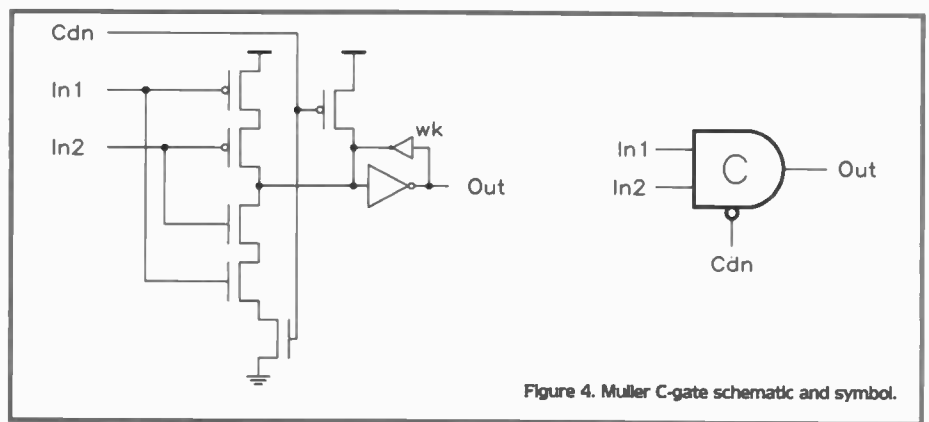

Figure 4. Muller C-gate schematic and symbol.

The event-controlled latch plays a critical role in building an asynchronous processing pipeline. Its function is to hold the data stable. Several of these registers can be chained together to form a first-in first-out buffer (FIFO).

Since it is not tied to clock cycle, the FIFO can pass data from input to output with a speed limited only by the gate switching speed. The micropipeline FIFO is fine as

a buffer, but performs no logical processing on the data that flows through it. By interspersing logic between the event registers in a FIFO, a micropipeline with processing functions can be built.

"We have modified Sutherland's scheme to fit our needs, but a full description of the logic building blocks in our design library is beyond the scope of this article", said Furber.

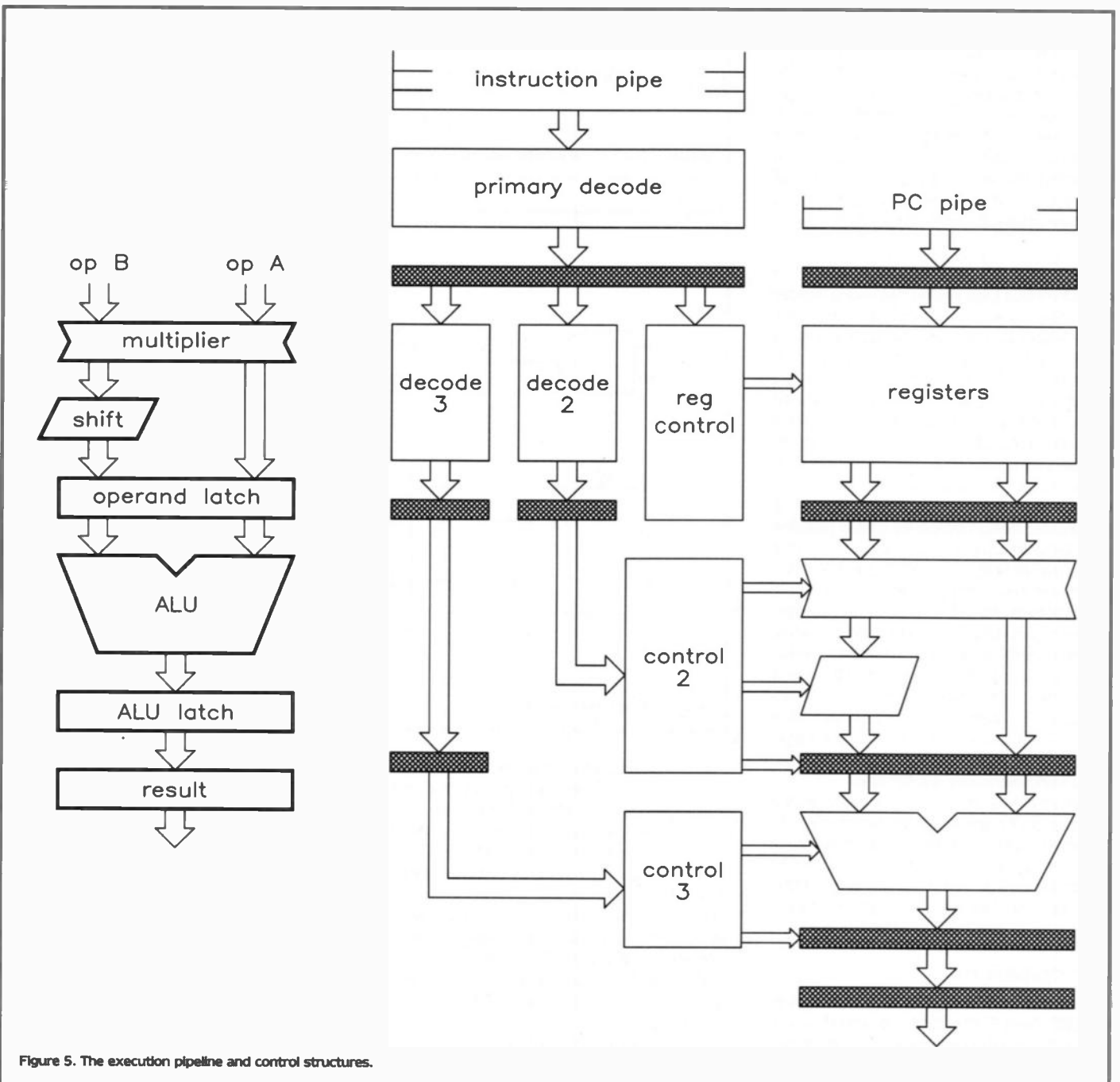

Figure 5. The execution pipeline and control structures.

## AMULET's Architecture

Sutherland's ideas on micropipelines fit nicely with a RISC processing architecture, as most RISC processors use pipelines to gain performance. In a RISC processor, processing elements are organised in a pipeline, each working concurrently on different data elements.

The ARM processor, for example, incorporates a three-stage pipeline. It is a register-based RISC processor, in which data processing operations require one or two operands to be read from the register bank and a single result is returned from the Arithmetic Logic Unit (ALU). The ALU is also used to perform other operations in the processor, such as branch and address calculations. The architecture requires a barrel shifter on one of the ALU input buses. The fetch, decode and execute stages form a three-stage pipeline.

In the asynchronous implementation, called AMULET1, instruction execution is further decomposed into a number of pipeline stages, as shown in Figure 5: the ALU forms one of these stages, as does the register bank and the barrel shifter. These functional units operate concurrently and synchronize with each other only to exchange data.

The organisation of AMULET1 is shown in Figure 6, and the overall pipeline structure of the processor is shown in Figure 7. The shaded boxes are the pipeline registers in the main decode and execute paths, and indicate the depth of pipelining employed in the design.

Several pipeline FIFO structures are employed as elastic buffer memories to queue data waiting for execution. A major difference between the asynchronous and synchronous versions is that in the synchronous versions instructions are executed one at a time; the fetch-decode-execute pipeline allows only one instruction at a time in the execute phase. In the asynchronous version, several instructions may each occupy a different pipeline stage in the execution unit.

## Layout and Fabrication

AMULET1 was developed as a full custom design using Compass Design Automation tools, and a PLA generator supplied by Advanced RISC Machines. It was fabricated on two CMOS processes: a 1µm process at ES2 and a 0.7µm process at GEC Plessey Semiconductors. The design resource required to complete the design was comparable with the clocked part. The design flow is shown in Figure 8.

The asynchronous ARM design was submitted for fabrication in February 1993. Both prototypes were immediately functional and executed programs produced by standard ARM development tools, such as the assembler and C compiler.

There were some minor design flaws, which relate mainly to the operation of interrupts and can be avoided by software and hardware patches.

## Comparison with the ARM6

When the two versions of the AMULET1 were benchmarked, they achieved an impressive performance but could not match the synchronous version. This is to be expected. The ARM6 as shown in Photo 1 is a highly optimized processor now into its

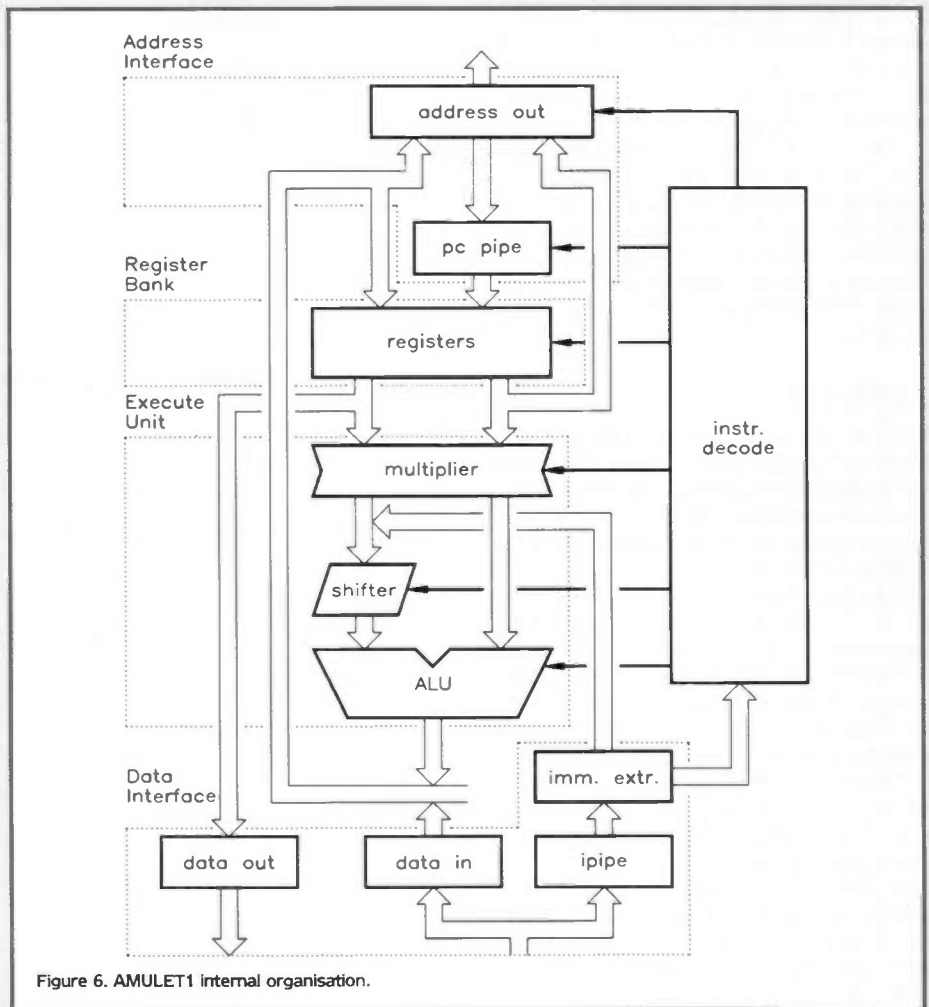

Figure 6. AMULET1 internal organisation.

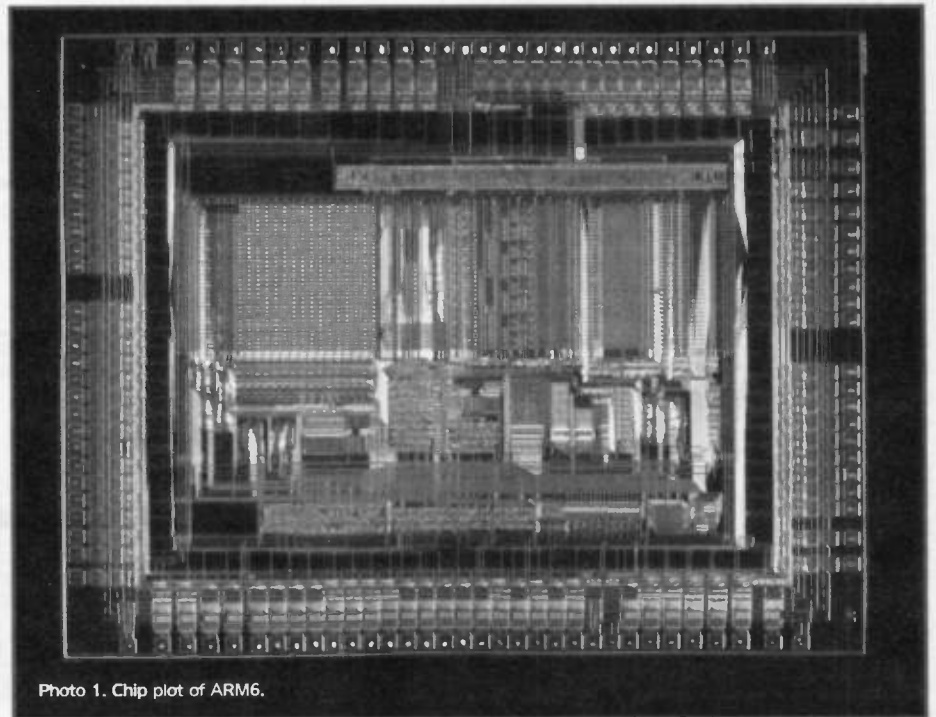

Photo 1. Chip plot of ARM6.

	AMULET1/ES2	AMULET1/GPS	ARM6
Process	1µm	0.7µm	1µm
Area (mm <sup>2</sup> )	55 x 4.1	3.9 x 2.9	4.1 x 2.7
Transistor count	58,374	58,374	33,494
Performance	20.5k-Dhry	40k-Dhry	31k-Dhry
Multipiler	5.3ns/bit	3ns/bit	25ns/bit
Conditions	5V, 20°C	5V, 20°C	5V, 20MHz
Power	152mW	N/A	148mW
MIPS/W	77	N/A	120

Table 1. Characteristics of AMULET1 and ARM6.

fourth generation, whereas AMULET1, shown in Photo 2, is the first of its line and uses very conservative design margins. A comparison of AMULET1 and ARM6 is shown in Table 1.

The macrocell size is 5.5 x 4.5mm on a 1µm CMOS process, which is about twice the area of the synchronous part. Some of this extra area is the result of the deeper pipeline and additional specialised circuitry to increase the multiplication speed. The overhead of the asynchronous control is closer to 20%.

## AMULET2

Work is now under way on AMULET2, an optimized design which should show real advantages over synchronous technologies. This new processor will integrate the CPU with a simple Memory Management Unit (MMU) and a cache memory. AMULET2 should give more MIPS/W than a contemporary synchronous ARM on the same geometry - a very difficult target.

This chip will operate asynchronously for all internal logic operations, but will interface to a standard external memory system through a conventional interface.

Other planned enhancements include faster instruction decode logic - a bottleneck in the current design. Also, a shorter pipeline will cut power consumption and chip area. The combination will form the basis of a deeply embedded (DE) macrocell that can be combined with other application-specific logic functions on the same chip.

AMULET2 forms part of the ESPRIT OMI/DE (Deeply Embedded project), while AMULET1 was funded through the ESPRIT OMI-MAP (Open Microprocessor systems Initiative - Microprocessor Architecture Project), and is one component of a broad look at power dissipation issues at the gate, chip and board level.

## A Clockless Future?

A major objection to asynchronous design has been the feasibility of developing asynchronous designs at levels of complexity which are comparable with commercial circuits. The AMULET1 work demonstrates that such circuits are feasible and points the way to the commercial exploitation of asynchronous circuits.

Significantly, Advanced RISC Machines Limited (ARM) has recently acquired rights to some of our work on asynchronous logic. Its ARM810 processor has already benefited from some of the ideas explored in AMULET. The next stage will be to investigate the use of complete functional blocks, like our high-speed multiplier, in future ARM designs.

In the future, asynchronous logic could find niche roles in otherwise synchronous designs. It is particularly attractive in power-sensitive applications with highly variable workloads, characteristics which are typical of many portable embedded systems.

A variable workload makes the most of the power saving potential of asynchronous logic. A synchronous approach is handicapped because the system clock must be set to match the peak load. Power management techniques (that power down idle logic circuits) are a poor substitute.

In summary, asynchronous logic should become established as a viable alternative

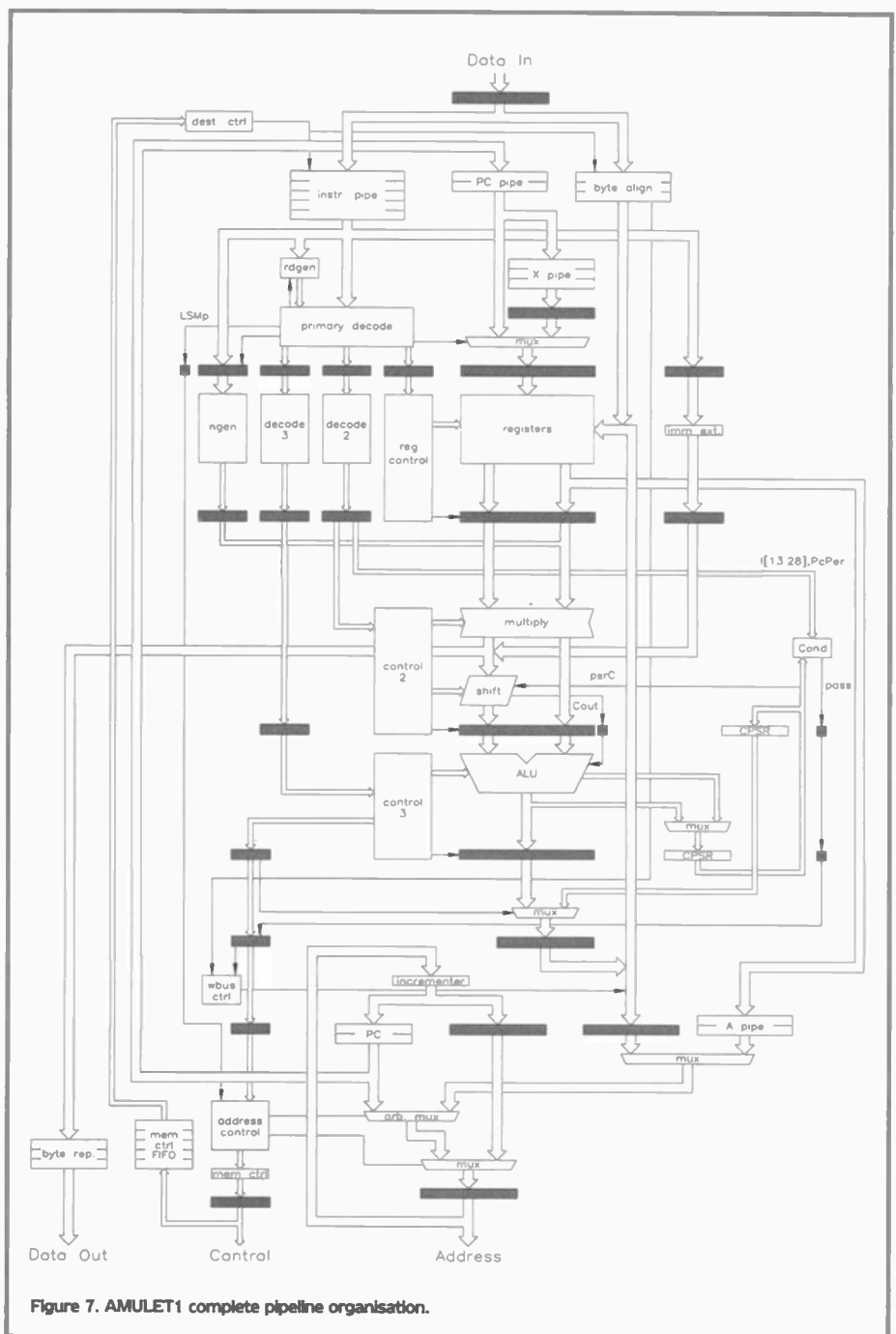

Figure 7. AMULET1 complete pipeline organisation.

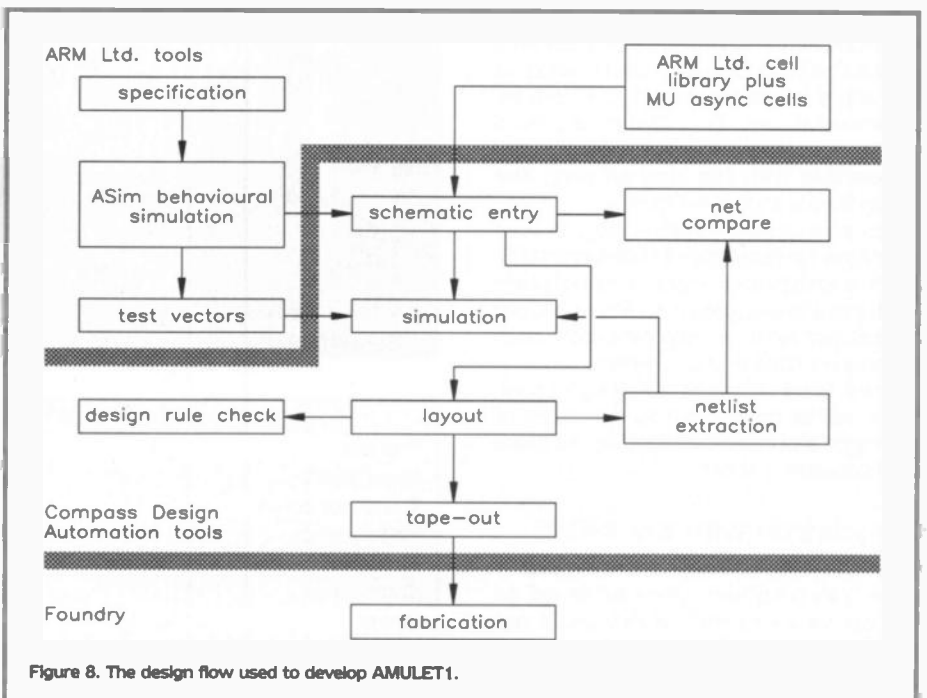

Figure 8. The design flow used to develop AMULET1.

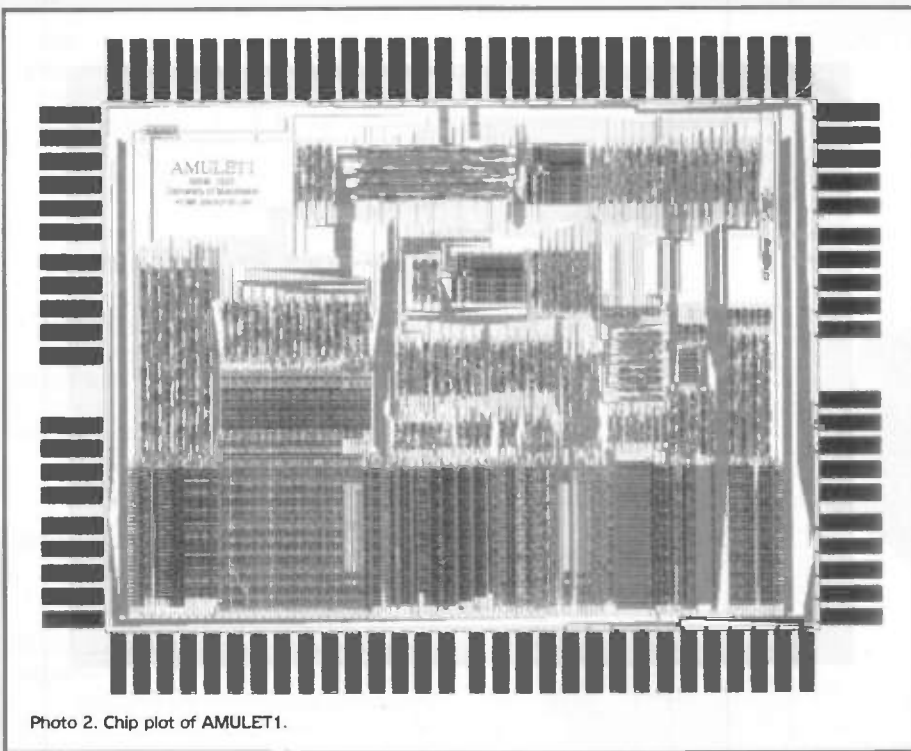

Photo 2. Chip plot of AMULET1.

technology in many application areas, and the technology of choice for some of these areas, over the next few years.

### Professor Steve Furber

Steve Furber is the ICL Professor of Computer Engineering in the Department of Computer Science at Manchester University. Prior to this appointment, he was in charge of the hardware development group within the R&D department at Acorn Computers, and was a principal designer of the BBC Microcomputer and the ARM microprocessor, both of which earned Acorn Computers a Queen's Award for Technology. He also led the team which developed the hardware architecture and VLSI components for the Acorn Archimedes. Since moving to the University of Manchester in 1990, he has established a research group with interests in asynchronous logic design.

### Further Information

For further information on the AMULET project, AMULET2, and asynchronous logic, contact the University of Manchester WWW site at: <http://www.cs.man.ac.uk/amulet>.

# MAPLIN NATIONWIDE STORES

Telephone  
01702 552911  
for details  
of your  
nearest  
store.

For personal service, visit our stores at:

**Belfast** 357-359 Lisburn Road.  
**Birmingham** Sutton New Road, Erdington.  
**Bradford** 28 Valley Road, Ham Strasse.  
**Brighton** 65 London Road.  
**Bristol** 302 Gloucester Road, Horfield.  
**Cardiff** 29-31 City Road, Roath.  
**Chatham** 2 Luton Road.  
**Cheetham Hill** 169 Cheetham Hill Road, Cheetham Hill.  
**Coventry** 12 Bishop Street.  
**Dudley** Unit 7, Sterling Park, Pedmore Road, Brierley Hill.  
**Edgware** 146-148 Burnt Oak, Broadway.  
**Edinburgh** 126 Dalry Road, Dalry.  
**Forest Hill** 107-113 Stanstead Road.

**Glasgow** 264-266 Great Western Road.  
**Hammersmith** 120-122 King Street.  
**Ilford** 302-304 Green Lane.  
**Leeds** Carpet World Building, 3 Regent Street.  
**Leicester** Office World Building, Burton Street.  
**Liverpool** Edge Lane, Fairfield.  
**Manchester** 8 Oxford Road.  
**Middlesbrough** Unit 1, The Forbes Building, 309-321 Linthorpe Road.  
**Milton Keynes** Unit 2, Office World Building, Snowdon Drive, Winterhill.  
**Newcastle-upon-Tyne** Unit 4, Allison Court, (The Metro Centre) Gateshead.  
**Northampton** 139 St. James Road.  
**Nottingham** 86-88 Lower Parliament Street.  
**Portsmouth** 98-100 Kingston Road.  
**Preston** Unit 1, Corporation Street.  
**Reading** 129-131 Oxford Road.  
**Sheffield** 413 Langsett Road, Hillsborough.  
**Slough** 216-218 Farnham Road.  
**Southampton** 46-48 Bevois Valley Road.  
**Southend-on-Sea** 282-284 London Road.  
**Stockport** 259-261 Wellington Road South.  
**Stoke-on-Trent** 39-45 London Road.





# Hi-Tech Kicks Off EURO 96

by Alan Simpson

By now, even the most dedicated electronics enthusiast must be aware that this is the year of football. Yes. EURO 96 kicks off in June and yes England as hosts are actually playing on the championship fields. Billed as the largest sporting event ever held in the UK, and the third largest in the world after the World Cup and Olympics, the 16 competing countries are expected to generate viewing figures in excess of 7 billion. Football will in effect be returning to its birthplace rules having been established by the Football Association (FA) back in 1863.

**A**T an early stage the FA (who host the tournament under the authority of UEFA, the European governing body of the sport) decided to work with a full-scale project team to provide all the necessary hardware, software, communications and systems integration and expertise. Project managing the chosen technology team of BT, Microsoft and Digital, is the SEMA Group. For the record, the technology being used for the development is based on client/server architecture with Digital PC's and servers, and Microsoft Windows NT and SQL server. The application code has been written in Microsoft Visual Basic 4.

The European Football Championship was the brainchild of Frenchman Henri Delaunay with the first tournament taking place in 1958. France incidentally got to the final but were

beaten by The Soviet Union. More for the record. England have entered eight of the nine European Championship tournaments and have qualified for the final stages five times but have never emerged the overall winner. This year, England who are one of the favourites to take the trophy play in the opening match against Switzerland at Wembley on 8 June.

## Venues & Teams

It obviously required the assistance of a high-powered computer to formulate the 16 nation programme. England and Scotland by the way are listed in the same group with the fourth contestant being Holland. If all goes well, England or Scotland (or both) could be competing in the final at Wembley

on 30 June. But they have to play and beat on the way, Bulgaria, Croatia, Czech Republic, Denmark, France, Germany, Italy, Netherlands, Portugal, Republic of Ireland, Romania, Russia, Spain and Turkey at UK venues covering Birmingham, Leeds, Liverpool, Manchester, Newcastle, Nottingham and Sheffield.

## Sponsors To The Fore

Seldom can such an illustrious group of teams have gathered on and off the field. Players apart, a host of household name companies are lining-up to offer their goods, services and not inconsiderable funds to further the football cause. Climbing aboard are such international names as Canon, Carlsberg, Coca-Cola (the red – not the blue one), Fujifilm, JVC, McDonald's, Opel and Philips. A one minute commercial has also been made which somehow manages to cram all the official sponsors into the one advertisement.

The technology team behind the EURO 96 football championships are no less impressive. The companies involved are effectively lending the tournament around £10m of kit in return for media exposure and rights to use the logo. The games will generate huge logistical challenges – from the accreditation of the 5,000 international media personnel expected to attend, to the co-ordination of the schedules of the 1,000 volunteers who will help the tournament in roles from VIP driver to stadium doorman to interpreter.

The information challenges are similarly considerable. The media need accurate, in-depth statistics from 31 matches in eight cities in real time. Broadcasters need accurate and instant information displayed on-screen in an imaginative and clear format. Overall, the Technology team will be expected to serve the EURO 96 organisation which is so large that it could be termed a 'virtual company', ranking among the top half of Europe's largest corporations. The company will be based at some 50 locations in 13 cities have 10,000 staff and a cumulative 'customer base' of 6.9 billion. IT will have a crucial role to play in the smooth running of EURO 96 and will effect virtually every aspect of the event.

## IT Blows The Whistle

According to Glen Kirton, EURO 96 Tournament Director, the technology team has been created from four major companies, each a leader in its own field. The system uses over 500 Digital PCs, LANs and powerful 64-bit AlphaServers, seamlessly using both Intel and Alpha architectures. The computers are running Microsoft Windows 95 and the Microsoft Office 95 on the desktops and the Microsoft Backoffice family, including Windows NT and SQL Server database, on the servers. All the sites are connected using BT's advance level communications capabilities.

At the hub of the affair is the leading information systems company the Sema Group which is project managing four key areas:

- Accreditation and media ticketing. Access to the secure areas at EURO 96 (media centres, the dressing rooms, the pitch, etc.) will only be available to suitable accredited people such as journalists, officials or the players themselves. In total, between 9,000 and 13,000 people are expected



to work within the controlled zones, each will be given a colour-coded pass, carrying their photograph, name, identity number and venue and data information.

- **VIP management.** There will be 200 VIPs from royalty to UEFA officials expected to be in attendance at the Championships at any one time, with more than 400 VIPs attending the championship at some point.
- **Volunteer management.** There will be over 1,000 volunteers working at the tournaments, including VIP drivers, doormen, ticket clerks, interpreters and accreditation centre operators.
- **Materials management.** A vast number of items will need to be registered and their use monitored throughout the event. For instance 140 cars, 500 mobile phones, 500 walkie-talkies, 500 pagers and hundreds of uniforms will have to be registered and tracked. In total the system will manage over 5,000 items, tracking the qualifying tournament schedule; fair play assessments.

Meanwhile, the Results System will provide clear graphical representation of match and tournament information for broadcasters to use on-screen. The statistics and facts generated can be mixed with the details held in the Information System, providing clear on-depth information to enhance the enjoyment and understanding of the cumulative audience watching the television footage.

For Tony Howard who heads the 24-strong SEMA Group team, the project has been ongoing for a year. "As the project management team for the Barcelona Olympic Games and for delivering the signalling and toll systems of the Channel Tunnel, we are well versed in proving State of the Art solutions against impossible time-scales. Regardless of how many problems we have, we know the kick-off will take place – the time-scale is immovable."

## Time To Call The Shots

Life has been equally hectic for BT's Simon Gordon who is masterminding the communications role at EURO 96. "One of our first actions was to ensure that all stadiums were equipped with BT ISDN2 service lines. A Central Control Room has been specially built at the BT Tower for the Championships, acting as the point of interface between Broadcast Services and the joint BBC/ITV sport broadcasters. From there, signals will be passed via permanent fibre links to broadcasters' London studios. By installing the CCR at the BT Tower, Broadcast Services can offer a high level of monitoring and control over signal distribution. The team will provide six video and audio circuits and a Transportable Earth Station truck at every match venue. From the truck, pictures will be beamed from the football ground via satellite to the BT Tower giving a back-up transmission path."

## Surfing The Action On The Internet

No, this does not relate to the number of goals being put into the net but to the Fans' Forum Web Site which aims to keep supporters of every country entertained, informed – and talking to each other. It can be accessed on: <http://www.euro96.com>.

The site has been developed by ISL worldwide, on behalf of the 11 official sponsors, says managing director Stephen Dixon "to create fun and involvement for the supporters – wherever they are. The world wide web is a fast-growing medium for communication and information so we have created a facility called web-chat to allow fans from around the world to talk to each other about EURO 96."

Apart from news on the sponsors, the site also features event information and a range of competitions, including a Trivia Quiz page which the supporters can create themselves, a Dream League and a Spot-the-Ball Competition. And more importantly perhaps, they can exchange news and views and information. Additionally a collection of approved EURO 96 merchandise will be available for sale via the site. The Fans' Forum site will sit alongside the Football Association's own web site <http://www.euro.org>, which is designed to provide detailed match information, news, player profiles and up-to-date match results. The web site has been developed to cater for users with simple, mainly text-based browsers and those with more sophisticated high-speed Net access. Microsoft was chosen by SEMA to provide the software for the FA Internet facility which is powered by Microsoft Windows NT Server and Microsoft Gibraltar WWW Server. The HTML application has been enhanced for Microsoft's Internet Explorer 2.0 browser.

## All Roads Lead To Euro 96

Media coverage apart, it will be hard to avoid EURO 96. Eye-catching colourful information signs bearing the tournament logo and the name of the relevant host city are being erected throughout the venue cities. The information signs are being placed on key traffic routes into the cities to ensure optimum viewing by the public and will remain in their prominent positions until the end of the games. The idea, says Tournament Director Glen Kirton is to provide a real sense of occasion in each of the host cities. As we said, 'there will be no getting away from EURO 96'.

# THE FOOTBALL CRAZY, FOOTBALL MAD COMPETITION

Have we got news for you. Thanks to *Electronics – The Maplin Magazine*, you can watch, listen or even eat to the sounds of EURO 96.

Due to the limited time scale, our first prize of two complimentary tickets for the Croatia v. Denmark match at Hillsborough on the 16th June 1996 is restricted to magazine subscribers only. We also have a runners-up prize (available to all readers) to win a lunch or dinner (plus a bottle of house wine) at London's latest theme restaurant 'FOOTBALL.FOOTBALL' in The Haymarket, possibly even watching on a giant screen a live EURO 96 match while you eat. If you don't score with the ticket or meal, then we have 6 albums of the EURO 96 theme song "We're In This Together" which is featured on the latest SIMPLY RED chart-hitting album.

### How to enter

All you have to do to enter, is complete the coupon (right), correctly answering the four questions, or send your answers on a postcard or back of a sealed-down envelope. Entries to be received by 31st June 1996. Subscriber's entries to qualify for first prize must be received by 7th June 1996.

Send your entry to:

**EURO 96 Competition, The Editor,  
Electronics – The Maplin Magazine,  
P.O. Box 3, Rayleigh, Essex SS6 8LR.**

Good Luck!

**Note that employees of Maplin Electronics, associated companies and family members are not eligible to enter. In addition, multiple entries will be disqualified. The prizes will be awarded to the first all-correct entries drawn. The Editor's decision will be final. Prizes are not exchangeable for cash. Any related travel costs will not be met by the publication.**

## EURO 96 Competition

Answer all the questions below, ticking one box for each question:

### 1. Who is the English Football Team Manager?

- Agassi.  
 Bill Wyman.  
 Terry Venables.

### 2. How many players will line up for each side?

12.  
 11.  
 15.

### 3. Which team beat Germany in the 1992 EURO final?

- Denmark.  
 Alaska.  
 Guyana.

### 4. What is match controller called?

- Referee.  
 Judge.  
 Umpire.



Name \_\_\_\_\_ Daytime Tel. \_\_\_\_\_

Address \_\_\_\_\_

Postcode \_\_\_\_\_ Subscriber's Number \_\_\_\_\_



# LASER POINTER

Text by Maurice Hunt



**KIT  
AVAILABLE  
(95120)  
PRICE  
£34.99**

## FEATURES

- ★ Adjustable lens focus
- ★ Lightweight
- ★ Compact

## APPLICATIONS

- ★ Lectures
- ★ Demonstration of laser properties
- ★ Presentations

## Specification

Power supply:	2 × 1.5V AAA batteries (supplied in kit)
Operating current:	50mA
Laser diode type:	Class IIIA
Wavelength:	660-680nm
Maximum output power:	< 3mW
Case dimensions (LWH):	116 × 25 × 15mm

**CAUTION:** Do not stare directly or indirectly into the laser output aperture, from which laser radiation is emitted, or retinal damage may occur.

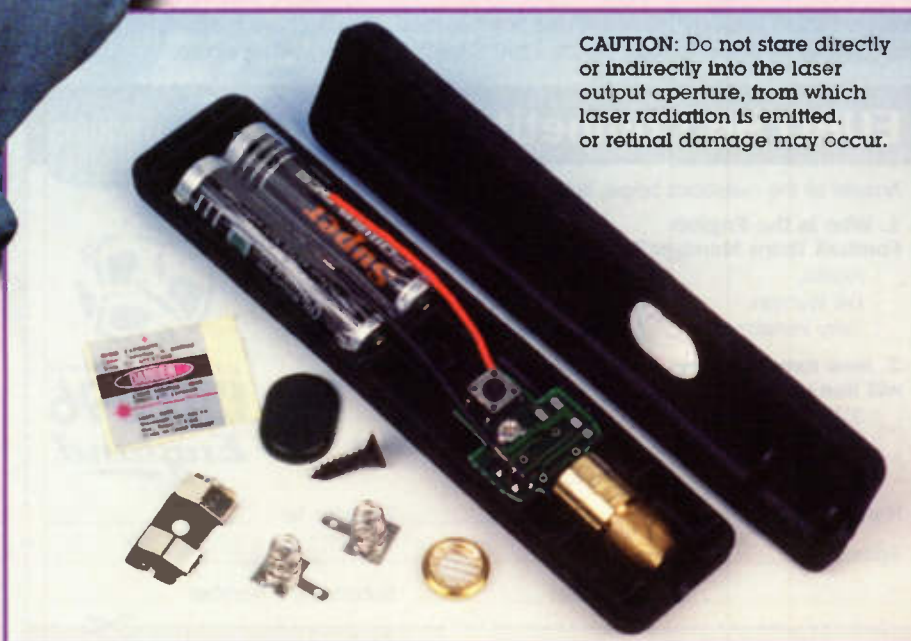

The Laser Pointer project presented in this article is ideally suited to teachers, lecturers and those involved in performing presentations, where a detail on an overhead projection, blackboard or similar needs to be pointed out to the audience, without obstructing the remainder of the material being shown. The laser pointer is also useful for the safe, low power demonstration of laser properties and laws of reflection (see Figure 1), for example, in school/college physics classes.

**T**HE Laser Pointer project is a simple to construct and cost-effective kit, which comes complete with a high quality moulded plastic box, push button, laser diode, battery connections and two AAA batteries, plus a safety warning label and full operating instructions. An optional line generating lens (Order Code 95121) is available, which can be easily fitted into the housing to enable the laser to produce a line beam output instead of a circular beam – this could be used for highlighting lines of text, for instance.

## Construction

The laser pointer project is very simple to build. Refer to the exploded assembly diagram, shown in Figure 2, for clarification of the various component placements. First, the battery connector terminals are fitted into their respective slots in the base of the box – one double-width connector at the end, and two single-width connectors, with solder tags facing upwards, fitted midway along the base. Next, the two leads from the laser diode PCB are soldered to the battery terminal solder tags – red lead to the '+' terminal, black to the '-' one.

The laser diode/PCB assembly is pressed into position in the base, held in by its snug fit against the mouldings. The two AAA batteries supplied in the kit are fitted into their compartment, observing polarity. The push button is located into its receptacle in the box lid, and the lid is fitted onto the base and secured with the single cross-head screw in the centre. Finally, the safety warning label is applied to the lid, adjacent to the laser aperture.

If the optional line generating lens (95121) is required, it is fitted into the casing, between the end of the laser diode and the case aperture. Note that the laser diode lens is adjustable by screwing the metal lens holder in or out as required. Figure 3 shows the exploded assembly of the lens assembly, which can be dismantled if required. The lens will have to be screwed in to allow sufficient space for the line generating lens to be fitted. Note that the lens can be orientated to produce a line of any desired angle in relation to the transverse axis of the pointer.

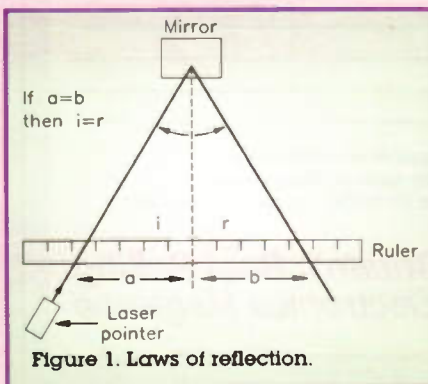
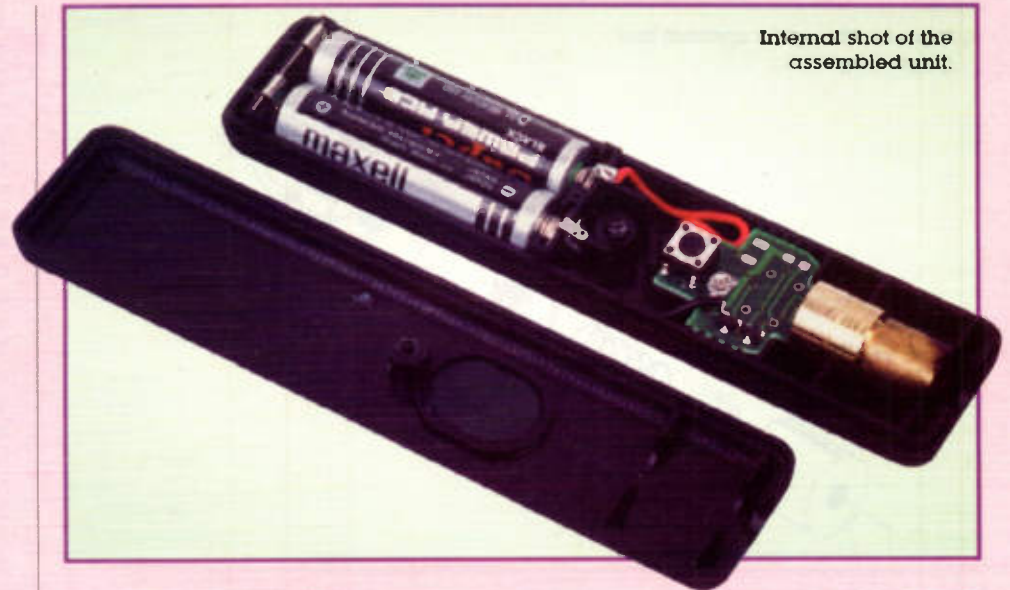

Figure 1. Laws of reflection.



Internal shot of the assembled unit.

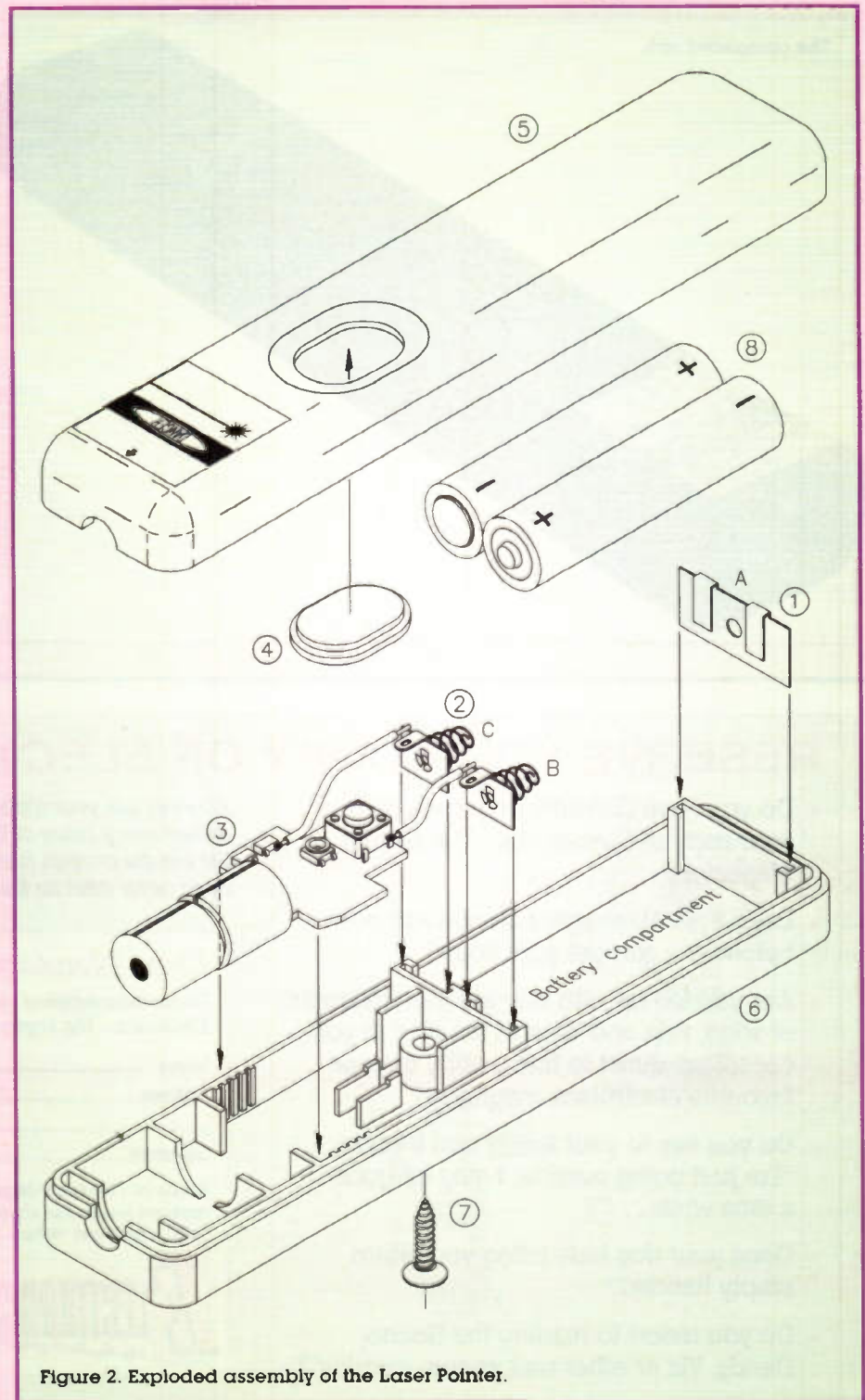
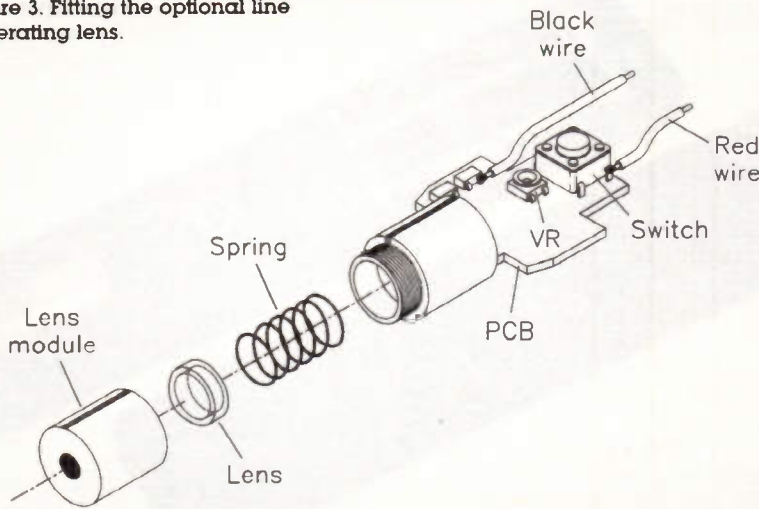

Figure 2. Exploded assembly of the Laser Pointer.

Figure 3. Fitting the optional line generating lens.



The completed unit.



## Using the Laser Pointer

The Laser Pointer is simplicity itself to use, just press the button and point the aperture of the unit at the item you wish to shine the laser beam at. Full operating instructions are provided in the kit if you are in any doubt. However, NEVER allow the unit to be aimed at the eyes of people or animals, as retinal damage may result. Also beware of laser reflections from mirrors, polished surfaces, etc. Keep the unit out of the reach of children, and only allow them to use the unit under supervision. The batteries should be replaced when the intensity of the laser beam diminishes beyond a useful level. It is recommended that alkaline types (e.g. Stock Code JY50E) should be used for longer life and leak resistance. 

## LASER POINTER PARTS LIST

Laser Pointer Kit 1 (95120)

### OPTIONAL

Line Generating Lens 1 (95121)

The Maplin 'Get-You-Working' Service is available for this project, see Constructor's Guide or current Maplin Catalogue for details.

**The above items (excluding Optional) are available in kit form only.**  
**Order As 95120**  
**(Laser Pointer Kit) Price £34.99**  
**Order As 95121**  
**(Line Generating Lens) Price £1.49**

Note: Some parts, which are specific to this project (e.g., PCB), are not available separately.

## RESERVE YOUR COPY OF ELECTRONICS TODAY!

- ★ Do you have difficulty in getting hold of your copy of *Electronics – The Maplin Magazine*?
- ★ Does your Newsagent always sell out before you can get your copy?
- ★ Are you fed up with braving the onslaught of wind, rain and keep fit fanatics in your ceaseless quest to find a copy of your favourite electronics magazine?
- ★ Do you say to your family and friends, "I'm just going outside, I may be gone a little while . . . "?
- ★ Does your dog hide when you return empty handed?
- ★ Do you resort to reading the Beano, Dandy, Viz or other well known 'comics'?

Why not ask your friendly local Newsagent to reserve or deliver every issue of *Electronics – The Maplin Magazine*? Fill out the coupon (below), hand it to your Newsagent and you need never miss an issue of *Electronics – The Maplin Magazine*.

### Dear Newsagent

Please reserve/deliver (delete as applicable) each issue of *Electronics – The Maplin Magazine*.

Name \_\_\_\_\_

Address \_\_\_\_\_

Signature \_\_\_\_\_

*Electronics – The Maplin Magazine* is published monthly and is distributed through your wholesaler by: Seymour, Windsor House, 1270 London Road, Norbury, London SW16 4DH. Tel: +44 (0)181 679 1899.



**Britain's Best Selling Electronics Magazine**

# SOUND REINFORCEMENT SYSTEMS

The aim of this two-part article is not so much a comprehensive discussion of sound reinforcement systems but more a practical guide to setting up a sound system for your band, to enable you to get out gigging.

## for Gigging Bands

### Part 2

by Andrew Rimell MSc BEng AMIEE

#### Mixing Desks

Mixing desks are the key to a well-balanced sound, and good mixing can make the difference between an average band and a great band: it doesn't matter how good the musicians are, if the relative levels are wrong, the sound will not be its best. A mixing desk basically consists of two sections, the input section and the output section.

#### Input Section

The input section consists of a number of identical channels and for each channel, it is possible to adjust a number of parameters:

- **Input gain:** It is possible to set the desk up so that all of the inputs have the same volume level when the fader sliders are in line.
- **Mic/Line switch:** The input can either be a balanced line XLR or an unbalanced jack; the switch selects the appropriate input.
- **Equalisation:** The tonal content of the signal on each channel may be individually changed with the equalisation (EQ) control. The amount of bass, mid and treble can be varied, and on some equipment, it is possible to vary the centre

frequency of the mid control (this is known as parametric EQ).

- **Effects send:** Most mixing desks have at least two effects (FX) channels, whereby it is possible to add an effect (e.g. reverb) to any of the input channels. On some desks, it is possible to select between pre-fade send and post-fade send. With pre-fade send, the amount of signal going into the FX unit is constant, regardless of the position of the channel slider. With post-fade send, the amount of signal going to the FX unit is dependent upon the position of the channel slider. For nearly all FX applications, post-fade sends are used.
- **Foldback:** Some desks have an individual foldback level control on each channel, which controls the amount of signal for that channel which is going to the foldback mix. The desk may have two foldback channels or it may have none; if it has none, the pre-fade FX send channels may be used.
- **PFL:** The pre-fade-listen (PFL) button allows you to listen to any channel (one or more) on your headphones, without affecting the main output.

- **Pan:** This control selects to which channel the signal will go (left, right, or a combination of left and right). For stereo inputs (e.g. keyboards, tape, CD), use two input channels and pan one to the left and the other to the right. The section on mixing will give advice on use of the stereo pan control.
- **Channel fader:** This fader controls the amount of a particular signal in the main mix. Once the desk has been set up for a particular concert, then the fader will be the main control that you use. Unlike all of the other controls for each individual channel (which use rotary controls), the channel fader is a linear sliding control, which gives you more control when moving a number of them at the same time.  
To the beginner, a mixing desk may look intimidating, but remember that it only consists of many identical channels and that each channel only really consists of a few controls.

#### Output Section

The output section will contain the main volume sliders (sometimes, one main slider controls both the left and right outputs and

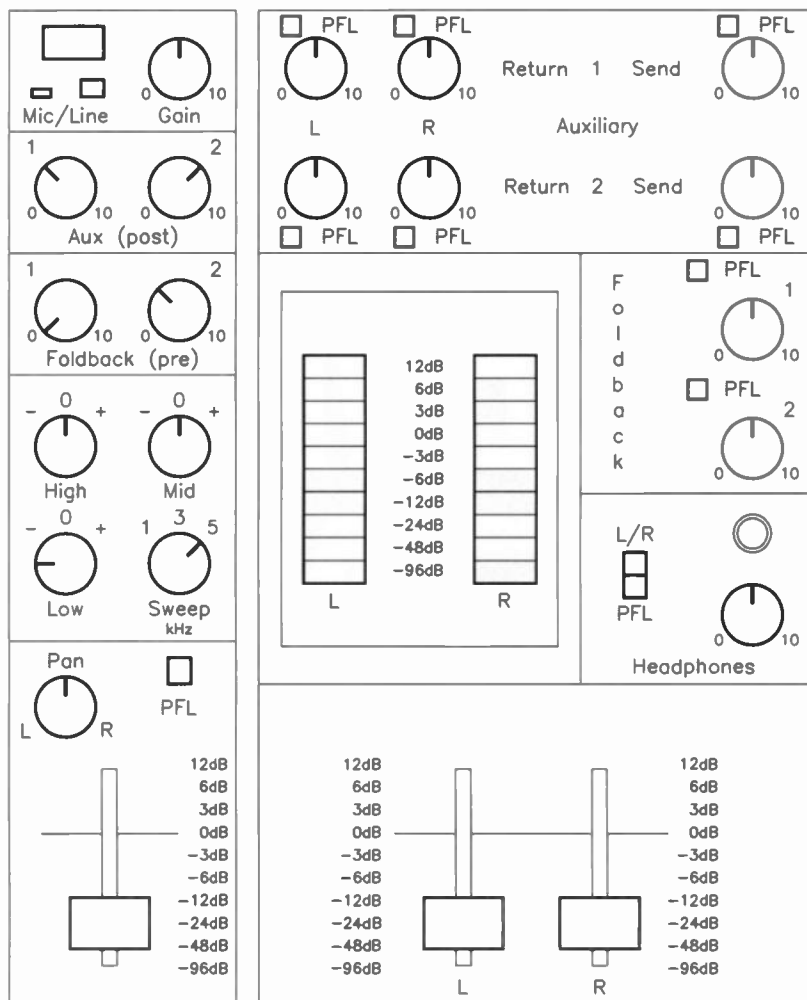

Figure 4. Typical input and output sections of a mixing desk.

sometimes there is a slider for each). Also in this section, are the FX send and return. There is a master FX level control, and this is to prevent you from overloading the input to your FX unit. There is also an FX return control (usually stereo), which allows you to control how prominent the reverb is in the final stereo mix. Desks with a foldback level control on each channel will also have a master foldback control, which will either be a slider or rotary control.

## Other Features

More advanced desks have sub-groups. The input channel, rather than going to the left or right, may go to one of, say four, stereo sub-groups and then these sub-groups feed the main left and right outputs. It is a good idea to feed all the vocals to one group, the guitars to another group, then it is possible to change the overall level of one of the sub-groups (say, vocals), but keep the relative levels of the different components (singers) just by moving a pair of sliders.

Figure 4 shows typical input and output sections of a mixing desk, while Figure 5 depicts the connection of effects processors a pair of sliders.

Some desks have 'insert points' on each channel, which enable you to 'insert' an effects processor in one particular channel between the main input gain control and the rest of that channel's controls. You may, for example, want to use a noise gate to clean up the sound on a noisy guitar channel.

Remember that during a concert, you will be mixing at the back of the hall and it will probably be dark, so always have a desk lamp available to light up the mixing desk. A normal 60W bulb is too bright and in a small hall, the light overspill will be distracting for the audience; I use a red 15W 'pygmy' bulb, which provides enough light to see the mixing desk but is not distracting to the audience.

## Selection

When selecting a mixing desk, it is important to buy one with enough channels; remember that stereo inputs (keyboards, etc.) require two input channels (although some desks have special stereo channels). It is recommended that you get a desk with 1.5 times the current number of inputs that you require, as it is surprising how often you need "just one more channel".

## Speakers

### Full Range

There are two main paths that may be taken with speaker systems. The first and simplest (and thus, cheapest) is the full range system, which uses full range speaker cabinets, that is, cabinets which house two or more drivers and a passive crossover. With these systems, only one amplifier channel is required for each output channel (i.e., one for

left and one for right). The speaker cabinets and crossovers shown in the Maplin catalogue are ideal for this purpose.

## Multway

The other possibility is to employ a multway system with an active crossover (the crossover is placed before the power amp), where two power amplifier channels are now required for each output channel. This is considerably more expensive than a full range system, as it is necessary to have more power amplifiers and speaker cabinets, however, this is by far the best system for high power systems (greater than 1kW).

A popular choice is to have subwoofers which operate up to about 200Hz and main speakers which cover the remainder of the audio spectrum; such systems are readily available from manufacturers such as Celestion, EV, Bose and JBL. Figure 6 shows the layout of passive and active speaker systems.

## Foldback Wedges

The foldback speakers are used to enable the performers to hear each other during the performance. The speakers are wedge-shaped, with the driver pointing up at an angle, and are usually positioned at the front of the stage on the floor, facing the performers. The mix through these speakers is very different to that going through the 'front of house', and generally consists of vocals and just enough instruments to enable the band to keep in time with each other.

## Home Made

Rather than buy the speakers, many people choose to build their own, and an excellent book of plans is High Power Loudspeaker Enclosure Design And Construction, published by the loudspeaker driver manufacturer Eminence and available from Maplin, Stock Code (WM82D). This book clearly describes how to build your own speaker cabinets for any application, from full range units to separate enclosures to foldback wedges. If you are prepared to spend some time building your own, then you can save a lot of money.

## Flight Cases

As has been said many times in this article, equipment is expensive and therefore, it really is worth looking after it, so that it will give you years of trouble-free use. The most common type of damage is that which takes place during transportation. All equipment should be put in strong storage boxes and not thrown around any more than is necessary. The ideal container is the aluminium flight case (preferably on wheels), however, these are expensive and can cost as much as the equipment they are protecting. One solution is to keep equipment in the original cardboard box and to strengthen the box by wrapping Gaffer tape around it. Another solution is to make your own storage boxes out of wood (remember to make them small enough to get through doors, up stairs, etc.). As flight cases/storage boxes can become very heavy when loaded, it is a good idea to ensure that there are good strong wheels and carrying handles fitted.

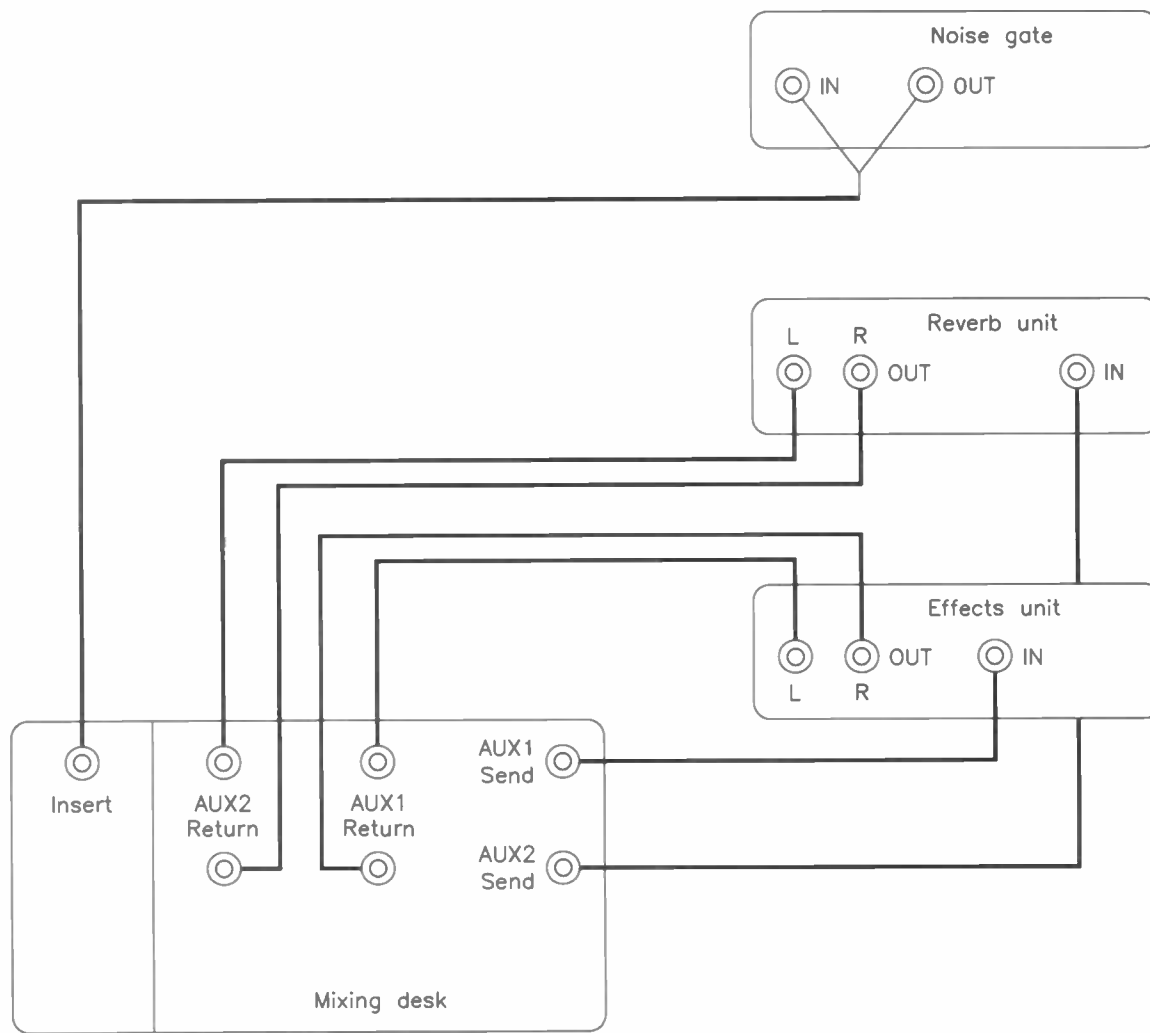

Figure 5. Connection of effects processors.

## Touring

When going on any type of tour, it is important to carry any spares and tools that you might need with you. On my tours of Eastern Europe, I had to carry a large spares kit, as it would have been impossible to get what I needed out there. The following items will help to make any problems on a tour that bit less painful:

- **Tool kit:** This should contain a selection of screw drivers, soldering iron, insulation tape, test meters, etc.
- **Fuses:** Have spare fuses for all of your equipment, not only the mains 13A type but also the ones that are contained in the back panels of amplifiers, etc. Make sure that you have the correct type of fuse for the equipment (time delay, quick blow, etc).
- **Cable and Connectors:** You may need to make a special converter lead or one of your connectors might get broken.
- **Tape:** Make sure that you have enough Gaffer tape to last the tour, also carry some electrical insulation tape with you for those emergency repairs.
- **Adaptors:** These include things like jack-phono connectors and also if you are going abroad, then don't forget a supply of heavy duty socket adaptors. Note that in most of Continental Europe, the mains sockets are rated at 10A, not 13A as in the UK.
- **Lamp:** You will need a table lamp, with a suitable low power bulb, to see the mixing desk and effects units at the back of a dark hall.

- **Headphones:** Headphones are essential in mixing because you can use them to listen to just one input channel on the mixing desk using the PFL button. Get some good headphones, don't use the Walkman type as their frequency response is limited.
- **Address list:** Take a list of suppliers, hirers and other useful lists of addresses with you.
- **Torch:** Just in case the power goes down, a torch may help you find a plug that has accidentally been pulled out by someone tripping over the mains lead.

## Hiring

Equipment is expensive, and it is very unlikely that anyone starting out will be able to buy all of the equipment they need at once. The best solution to this problem is to hire the equipment you don't have. You may have a simple system and are about to do a special gig or tour, then hire the extra bits and pieces you need just for that event.

There are many advantages of hiring over buying. You can try out different pieces of equipment to find out what you like and then buy the one you liked best. You can hire a special type of equipment that you would never be able to afford to buy (such as a set of radio microphones).

However, there comes a time for any band when you are hiring so often that you would be better off buying the equipment (possibly second-hand).

## Effects Units

Effects units are devices which modify the audio sound in some way. They fall into several categories: equalizers (EQs), which alter the tonal balance; dynamic controllers, which change volume levels; and special effects, which is a broad category covering any other device that changes the sound.

There are times when effects are indispensable, and others when sound modification takes away more than it adds. Here are some guidelines to help determine when to apply effects. Figure 5 shows how effects units are connected into a mixing desk.

Some effects units are somewhat specialised and may not get used very often. It is quite easy to operate without compressors, limiters, expanders and gates. The mixing desk usually contains enough EQ processing, and so if you were to have only one effects unit, it should be a general-purpose digital reverb/delay/effects unit.

With effects units, remember that just the right amount of effect can make a song sound great, but too much can really destroy the sound, so don't overdo it.

## Equalisers

The two main type of EQs that you are likely to meet are those found built into a mixing desk, and the free-standing multi-band graphic EQs. The mixing desk EQs have already been discussed, so we shall first look at a multiband graphic EQ and then look at some applications.

Graphic EQs are very popular because they are easy to understand. They are usually single or dual channel units, with anything from five to sixty-two fixed frequency bands, the most common ones having 10, 15, 27 and 32 bands. Generally, they use a series of linear sliders (one for each frequency band) to adjust the sound. The sliders are arranged with the lowest frequencies on the left and the highest on the right. When adjusted, the various physical settings of these sliders provide a rough representation of which frequencies the EQ is changing. In other words, they allow you to change signals in a visually predictive way.

One main application of an equaliser is to change the tone of a signal, and this can be done to correct for a non-perfect loud-speaker frequency response or to correct for a poor room frequency response. An EQ can also be used to reduce noise, a bass drum being a good example. In a bass drum, there may be some energy in the area around 3kHz that gives the drum some definition and crispness, but above that frequency, there is little or nothing to be heard. By rolling off the frequency response above 4kHz, hiss may be eliminated, as well as leakage from the cymbals. In a similar manner, low frequency signals can be reduced on mixer channels containing a hi-hat.

## Compressors and Limiters

Compressors and limiters reduce the overall dynamic range of the signal, by making the loud passages quieter, that is, they compress. Compressors can be used to make the volume of a dynamically uneven signal more consistent (such as that from a vocalist who may have trouble singing at a constant level). A compressor allows you to have 'automated' gain adjustments, since it can respond to and compress signals much more quickly than a person can. A compressor allows you to set a threshold level. Signals below this threshold pass through unaffected, and signals above the threshold are processed by the device.

A limiter is a special type of compressor with a specialised function: it can set a maximum level for a signal. With a limiter, once a signal has reached a pre-set limiting threshold, the signal is limited, and the output of the device stays the same. As with compressors, signals below the threshold level are unaffected. Limiters are useful in situations where there would be severe problems if a signal exceeds a maximum level, and are often used to prevent signals from overloading an amplifier (thus stopping the amplifier and speakers distorting, which could destroy the speakers).

## Expanders and Gates

Expanders function with the same type of controls as those found on compressors, but now the threshold control works in an opposite manner to compressors. Musically, expanders have a more specialised role than compressors, and they can be used to restore or enhance an instrument's dynamic range. In some settings, it can create a more 'alive' sound, although quiet passages can often be made too quiet and get lost in noise.

Gates are a special type of expander, and they are more commonly used. Gates, also

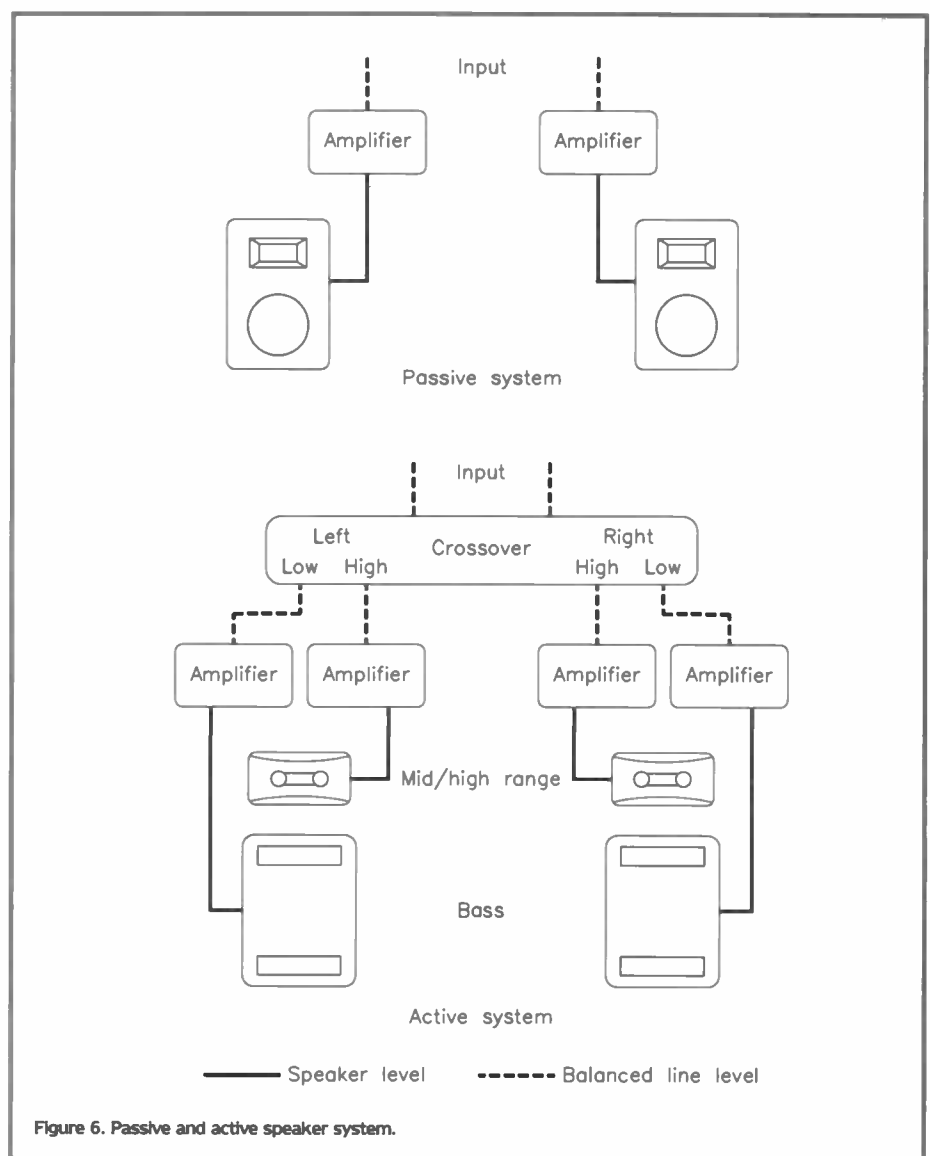

Figure 6. Passive and active speaker system.

known as noise gates, have a simple task: they are either 'open' or 'shut', depending on the signal's input level. When the input signal level exceeds the gate's threshold, the gate opens and the signal passes straight through. When the input signal level is below the gate's threshold, the gate closes and the signal does not pass through. Gates can be very useful for removing noise on a channel. In addition to singing, a microphone can pick up all sorts of unwanted sounds, such as lip smackings, breath noises, etc. With a gate, the threshold control can be set so that any singing passes through without being 'gated', and so any low level noises are removed. If the controls are properly set, the result is a nice clean vocal track with singing during the vocal sections and silence during the pauses.

## Reverb and Delays

In large concert halls, the sound bounces around many times before reaching your ears, while in a smaller venue, the sound may not bounce around as much, if at all. In order to create the feeling of being in a 'live' venue, it is sometimes necessary to artificially create the effect of sound bouncing around and being delayed.

A reverb unit repeats the sound many times, but each time the volume is decreased until finally, the sound fades away. When used well, the effect creates a feeling of being in a good quality concert hall,

but when overdone, the effect reduces the clarity and makes the mix muddy. Reverb often sounds best when used on simple sound sources, such as a solo instrument. Many venues that you encounter will have plenty of natural reverb (in fact, some will have too much) and additional reverb will not be required.

Reverb units are either analogue or digital. Analogue units usually consist of a set of springs which introduce delays into the signal. Digital units are usually rack-mounted boxes and provide much more control of the time delays. A digital unit will typically contain a number of both reverb and delay effects. Analogue spring type reverb units are often found in mixer amplifiers, and other low budget equipment. The digital units are not considerably more expensive than the analogue ones, and every setup should have at least one such unit.

Similar to a reverb unit is a delay unit. This generates one copy of the input and delays it by a preset time. Delay can be used to create some exciting effects, such as a guitarist playing with a delayed version of himself. In fact, the band may have songs which require specific types of delay at specific times in the song. Delays can also be used for time-aligning loudspeakers, so that the sound from different loudspeakers arrives at the audience at the same time (although this is only usually done in very large venues).

The best way to learn about reverb and



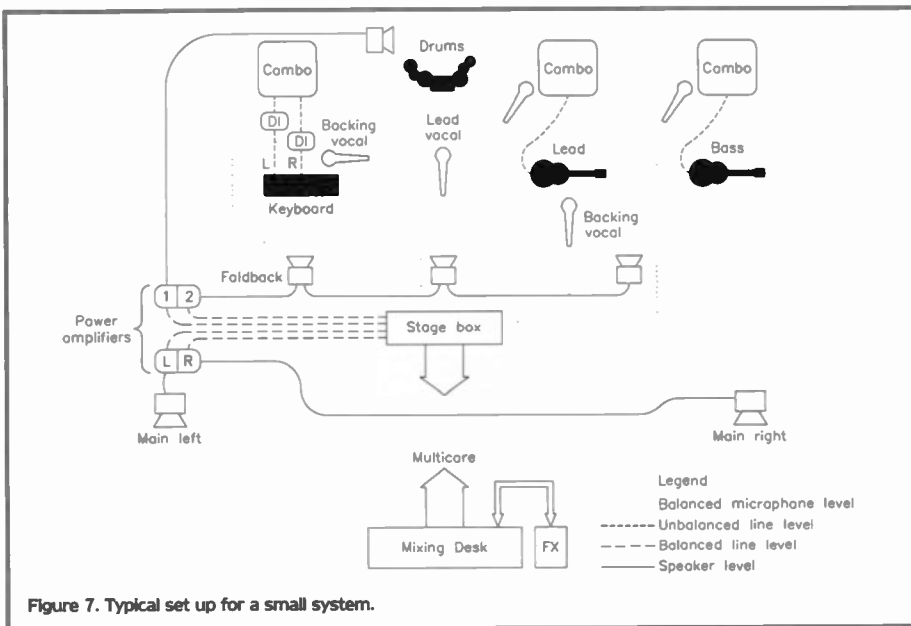

Figure 7. Typical set up for a small system.

delay units is to use them, try different delay times and get a feel for how they sound. A delay of 20ms is equivalent to moving 6.6m away from the sound source.

## Chorus

The chorus effect is useful for thickening a guitar or keyboard sound. The main principle behind the effect is the delay of sound. The sound is delayed by small amounts, creating the impression of many sound sources all working together (but a few milliseconds out of time, as in real life). Many guitarists have their own effects foot pedals, and if they do, they will certainly have a chorus pedal.

## Mixing

Mixing is the process where the individual channels are combined and become a unified whole. The mixing of a live band is a creative process, and because of this, there is no one right way of achieving a good mix. Some bands will be very precise about the way they want to be mixed, and others will give you more artistic freedom. In this section, we give you some tips on how to get the best from your mix.

## Stereo Placement

Part of the mixing decision process is what kind of stereo image to create. You need to decide where along the panorama from left speaker to right speaker you wish each instrument to be placed. This is an area where your creativity can take over, but it is possible to cause the listener discomfort when things are too unbalanced.

There are a couple of instruments in particular that can upset the balance of a mix: the bass drum and bass guitar. It is standard practice to place these sounds in the centre, i.e., with the 'pan' control straight up, in the middle of its travel. There can be exceptions to this rule, but you will find it uncomfortable to listen for a long time when one sonic element is too far to one side or the other. This doesn't mean that both the bass drum and bass guitar need to be dead centre, but it's good to keep them within 10° of the middle with only a slight spread. Any other 'heavy' tracks should also be reasonably central, such as synthesizer bass, unless

you are deliberately trying to create an effect.

Another disconcerting situation may result from 'hard panning', that is, placing a track all the way to the left or right. As with too many off-centre heavy elements, having a track only on one side can be tiring to listen to. It is natural to want to create as wide a spatial sense as possible, but it should be done with care. One way to open the spatial feeling of a mix is to add stereo depth, using a digital delay, chorus, flanging or reverb. Also, most drum machines, keyboards and MIDI modules can generate some superb stereo sounds.

## Balance

The goal in mixing the levels of the different channels is not to blend everything to the point of boredom, but rather, to work out how to highlight certain parts of the performance at different places. At the chorus, for example, it might work best for the vocals to be prominent, while the bridge might sound great with the sax part prominent. So, balance means that the channels that should be in front are clearly audible, but the background channels should be strong enough to provide a solid foundation for the mix to build on.

One common problem is pushing the lead channels so far to the front that they lose the support of the other channels. Even the most searing guitar solo will better captivate the listener when presented against a clearly audible backdrop of additional supporting and driving sounds. Similarly, there may be temptation to present each supporting channel as fully as possible. However, if each channel is pushed to the limit, nothing will have a chance to stand out.

## Two Typical Set-ups

To end this article, we show two typical set-ups. The example shown in Figure 7 is for a small setup, consisting of a mixer amp and vocal microphones. The instruments are amplified through their own backline combo-amplifiers. This style of setup is suitable for small venues.

The main disadvantage with the system shown in Figure 7 is that the relative levels of the instruments will be fixed, and it is difficult to obtain a well-balanced mix. The setup shown in Figure 8 is a typical arrangement where a mixing desk is used. The mixing desk is at the back of the hall, and the amplifiers are situated at the side of the stage. The sound engineer now has full control over the level of all the instruments, and the backline combo-amplifiers are only there so that the band can hear themselves. The foldback is used to let the band hear each other, so that they can keep in time, etc. In Figure 8, the drum microphones are not shown – this is done to keep the diagram clear. In practice, there would be a group of microphones covering the drums and these would be connected to the desk in the same way as the other microphones.

It should be remembered that there is no one correct way of setting up a sound reinforcement system, however, if you follow the guidelines given in this article, you should remove many of the problems commonly encountered.

## Acknowledgements

I would like to thank Martin Reed for his helpful comments and suggestions. I would also like to thank Lifeline and Cutting Edge for giving me the opportunity to gain live sound experience. **E**

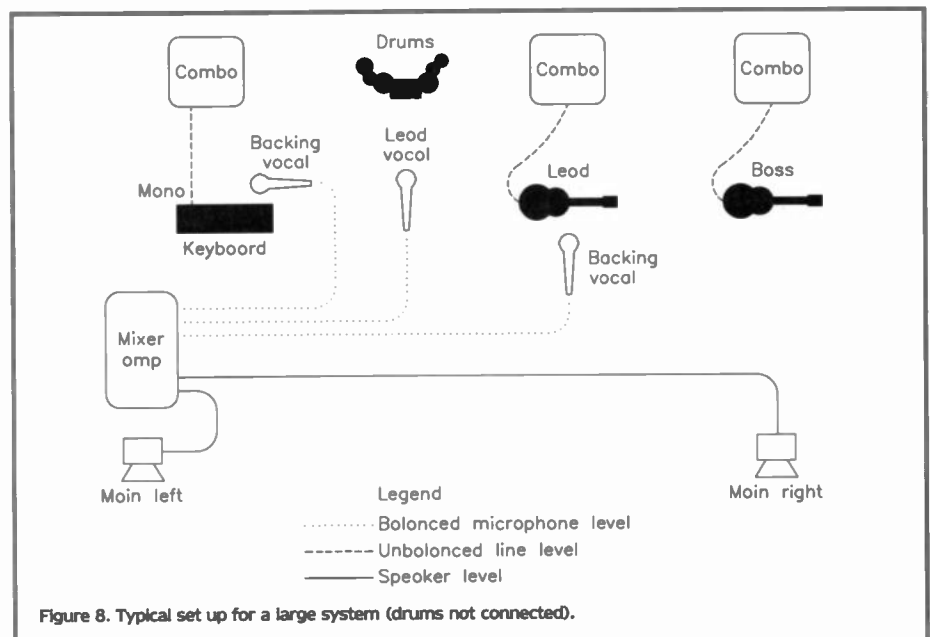

Figure 8. Typical set up for a large system (drums not connected).

## Specification

Operating voltage:	±15V DC dual-rail supply derived from 230V 6VA transformer
Input level:	0.5 to 1V rms (typical)
Output level:	±12V peak (maximum)
Bandwidth:	40Hz to 20kHz
Distortion (at 1:1):	0.1% Maximum (above 100Hz)
Control range:	3:1 expansion to 1:3 compression (typical, maximum)
Dynamic range:	90dB (typical)
PCB dimensions:	141 × 52mm

# Dynamic Range Processor

**Design by Paul Stenning**  
**Text by Paul Stenning**  
**and Maurice Hunt**

## Dynamic Range

The dynamic range of an audio signal is the difference between the quietest discernible part of the signal and the loudest undistorted part of the signal. It is normally expressed in decibels (dB).

With Compact Disc (CD), the possible dynamic range is often quoted at around 110dB. In practice, this sort of range is rarely used on commercial recordings, but the recording medium no longer imposes a restriction to the usable range.

The dynamic range available with cassette recording depends on the quality of the tape and the equipment. The limit is usually imposed by tape hiss at the lower end and saturation at the higher end. Noise reduction systems such as those designed and licensed by Dolby™ offer a useful increase in the dynamic range achievable, often at the expense of some higher frequency signals at lower levels.

With a cheap ferric cassette and no noise reduction system, the dynamic range can be



The assembled unit.

120dB or possibly even lower. At the other end of the scale, a high quality metal tape in a Hi-Fi cassette deck with Dolby S noise reduction can achieve 70dB. A typical domestic system with Dolby B will give a dynamic range of perhaps 50dB.

The range available with vinyl records depends primarily on the spacing between the grooves. With wider spacing, it is possible to achieve a higher recording level because the groove width itself can be greater. The lower limit is dictated by surface noise, which is dependent on the quality of the vinyl and pressing equipment used.

This explains the popularity of 12 in. singles in night-clubs – the wide groove spacing allows a higher recording level to be achieved and hence an increased dynamic range, up to about 60dB. The sound quality obtained from such records on a good quality playing system is often not far removed from that on CD.

On the other hand, albums where the record company have attempted to cram as much music as possible onto each side have a very limited dynamic range, sometimes as low as 10dB. This is sometimes referred to as 'groove jamming' and was common on the compilation albums issued by companies like K-Tel and Ronco in the seventies and early eighties.

## Dynamic Range Processor

The Dynamic Range Processor presented here allows the dynamic range of a signal to be increased (expansion) or decreased (compression) by a variable amount up to 3:1. The unit was developed for use when recording music from various sources.

For example, when recording CDs onto cassette for use in a car, it is helpful to use some compression so that the quieter sections are not drowned out by the engine noise. Also, it is useful to employ some expansion when recording tracks from poor quality records or pre-recorded cassettes. Suggestions for using this unit and processing music from various sources are given later.

Obviously, a system such as this could never be truthfully described as Hi-Fi, since any form of audio effect unit, by definition, 'distorts' the original signal. However, the unit has been subjected to extended listening tests and the design has optimised to produce the best possible results on a wide range of music.

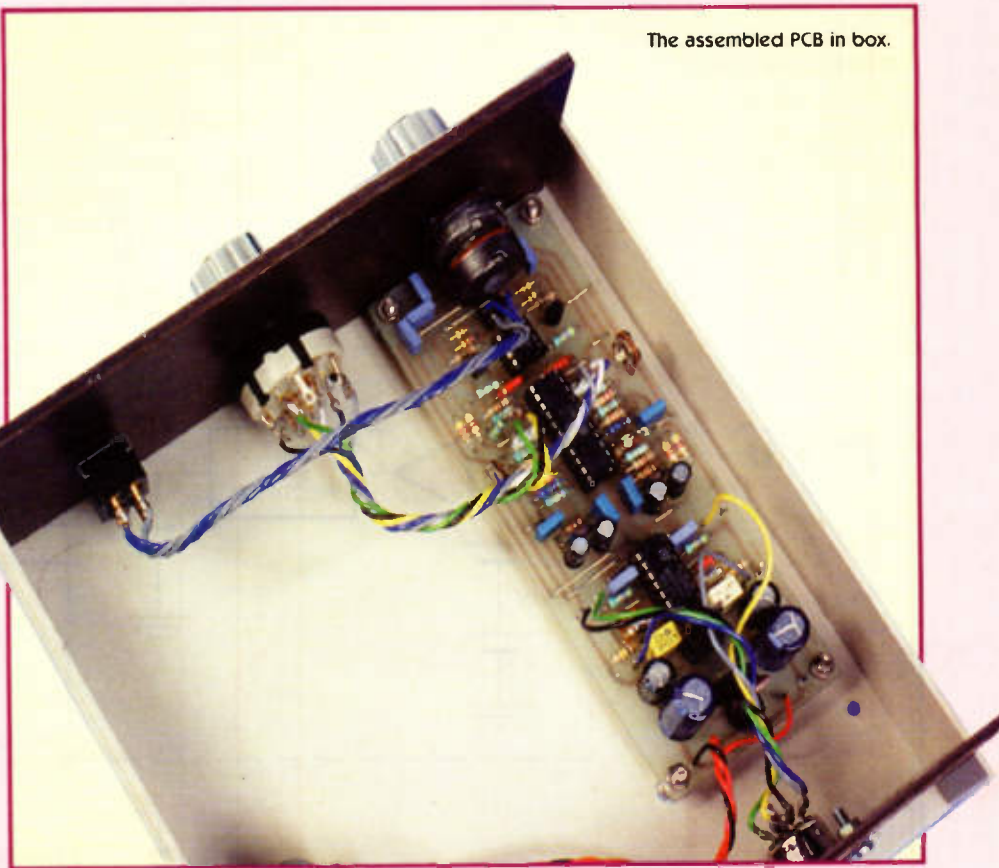

The assembled PCB in box.

## Circuit Description

Refer to Figure 1, showing the block diagram of the Dynamic Range Processor. The circuit is based on the SSM2120 dynamic range processor IC. This is available from various suppliers including Maplin, and costs about £10. The IC, the block diagram of which is shown in Figure 2, contains two level detectors and two voltage-controlled amplifiers, making it ideal for processing stereo signals. The circuit diagram for the two channels is virtually identical, so this discussion will concentrate on the left channel, illustrated in Figure 3 (the circuit diagram for the right channel is given in Figure 4).

## Level Detector

The level detection circuits contain a wide dynamic full-wave rectifier, logging circuit and a unipolar drive amplifier. These circuits will accurately detect the input signal level over a

100dB range, from 30nA to 3mA peak-to-peak.

Referring to the block diagram of the level detector shown in Figure 2, the REC-IN input is an AC virtual ground. When applying signals, a DC blocking capacitor (C-IN) is used, since REC-IN has a DC potential of about 2.1V above ground. The value of the input resistor is set to give a  $\pm 1.5$ mA peak signal. For  $\pm 15$ V operation, this corresponds to 10k $\Omega$ .

The full-wave rectifier is followed by a logging diode whose pair transistor has a fixed collector current set by R-REF. For 15V operation, R-REF is 1M5 $\Omega$ . The signal on the LOG-AV output is the log of the average of the absolute value of the input current. The value of C-AV affects the attack and decay times of the circuit.

The LOG-AV signal is buffered by a unipolar amplifier stage. RL provides an emitter load for the output transistor, while the 39/1k $\Omega$  feedback resistors give a gain of 40.

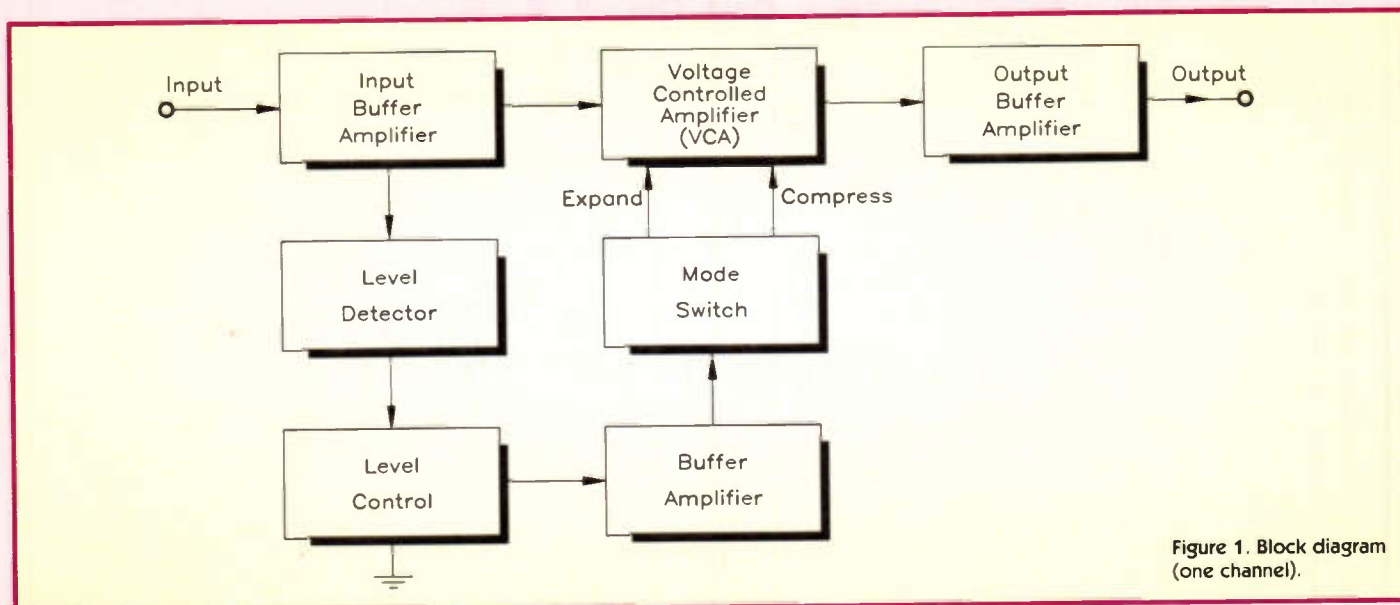

Figure 1. Block diagram (one channel).

Figure 2. Block diagram of the SSM2120 level detector.

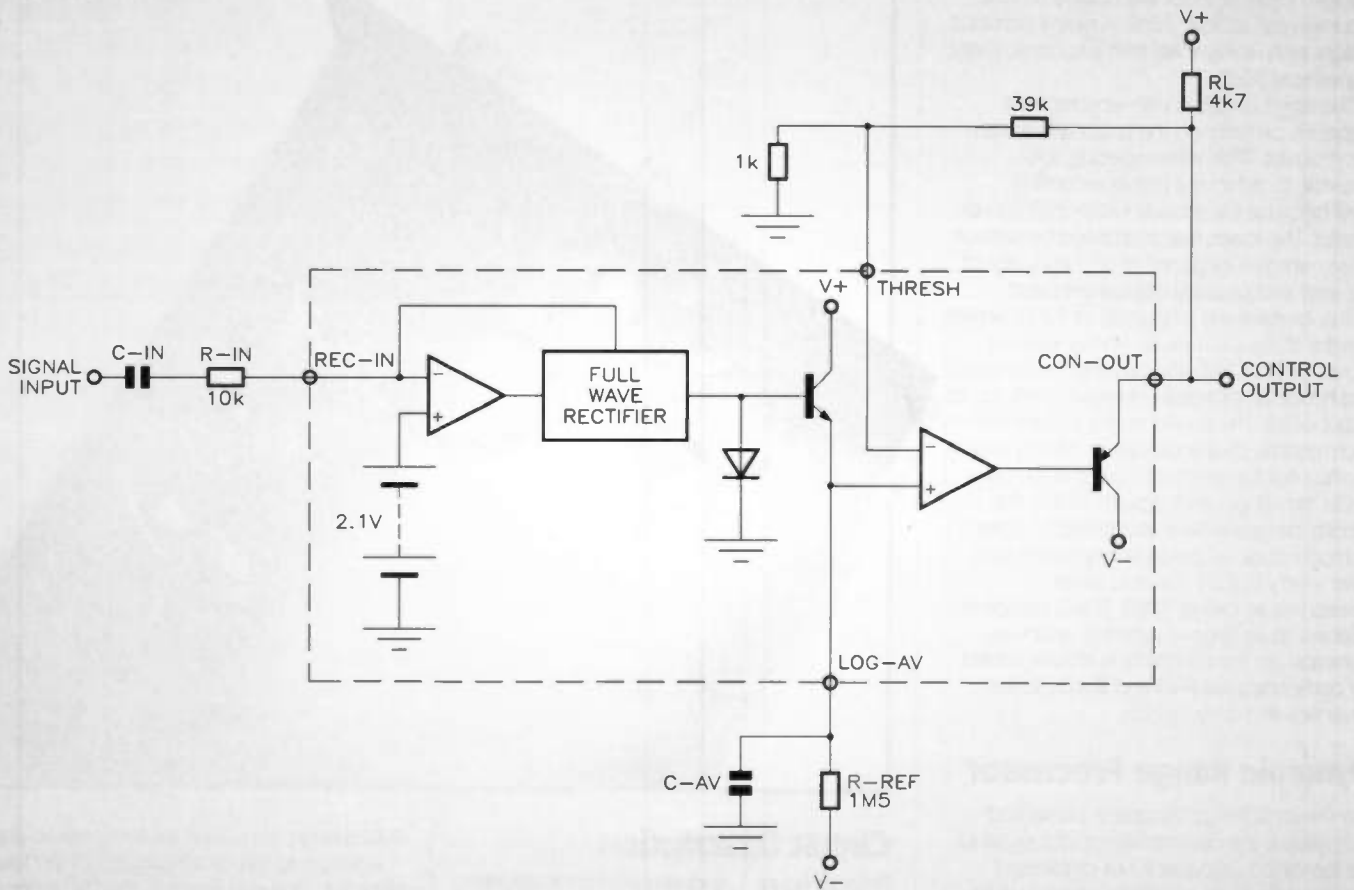

Figure 3. Left channel circuit diagram.

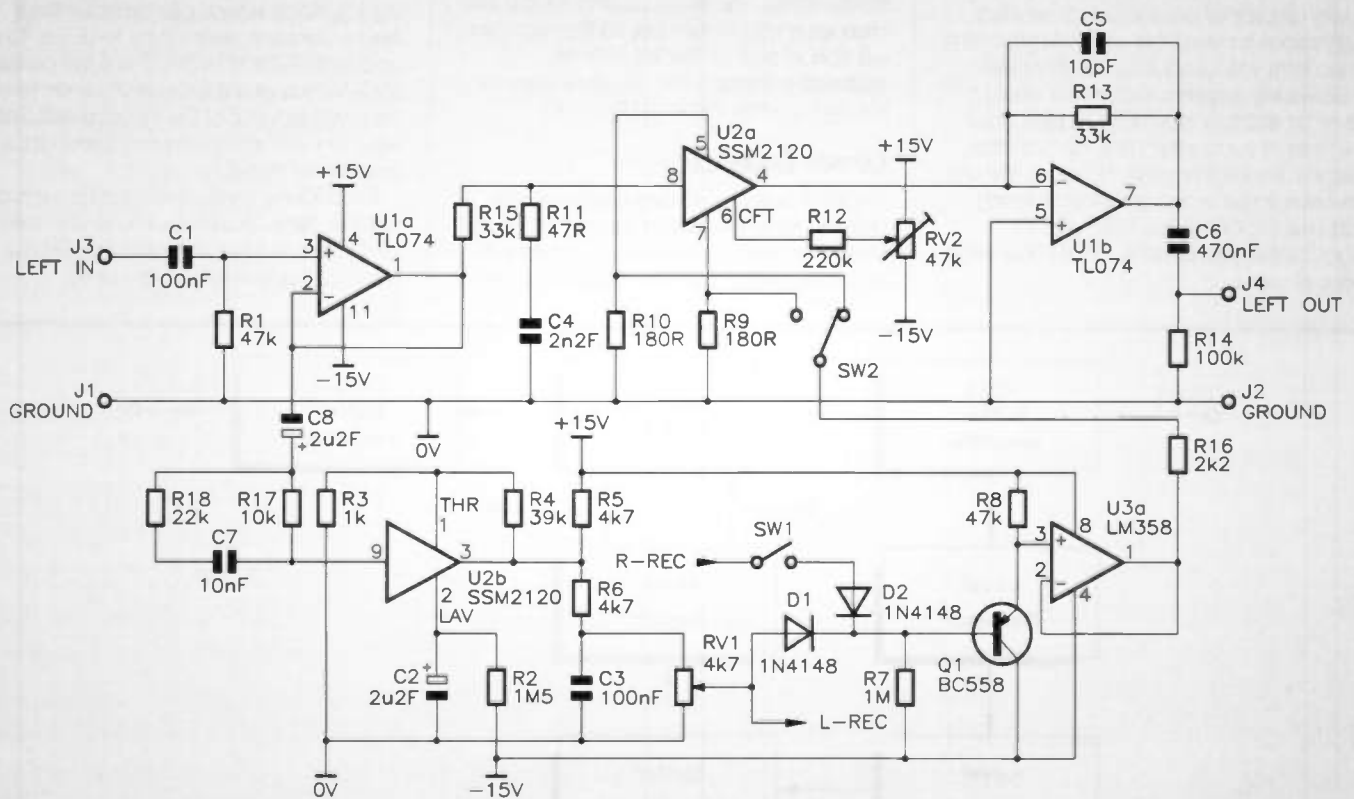
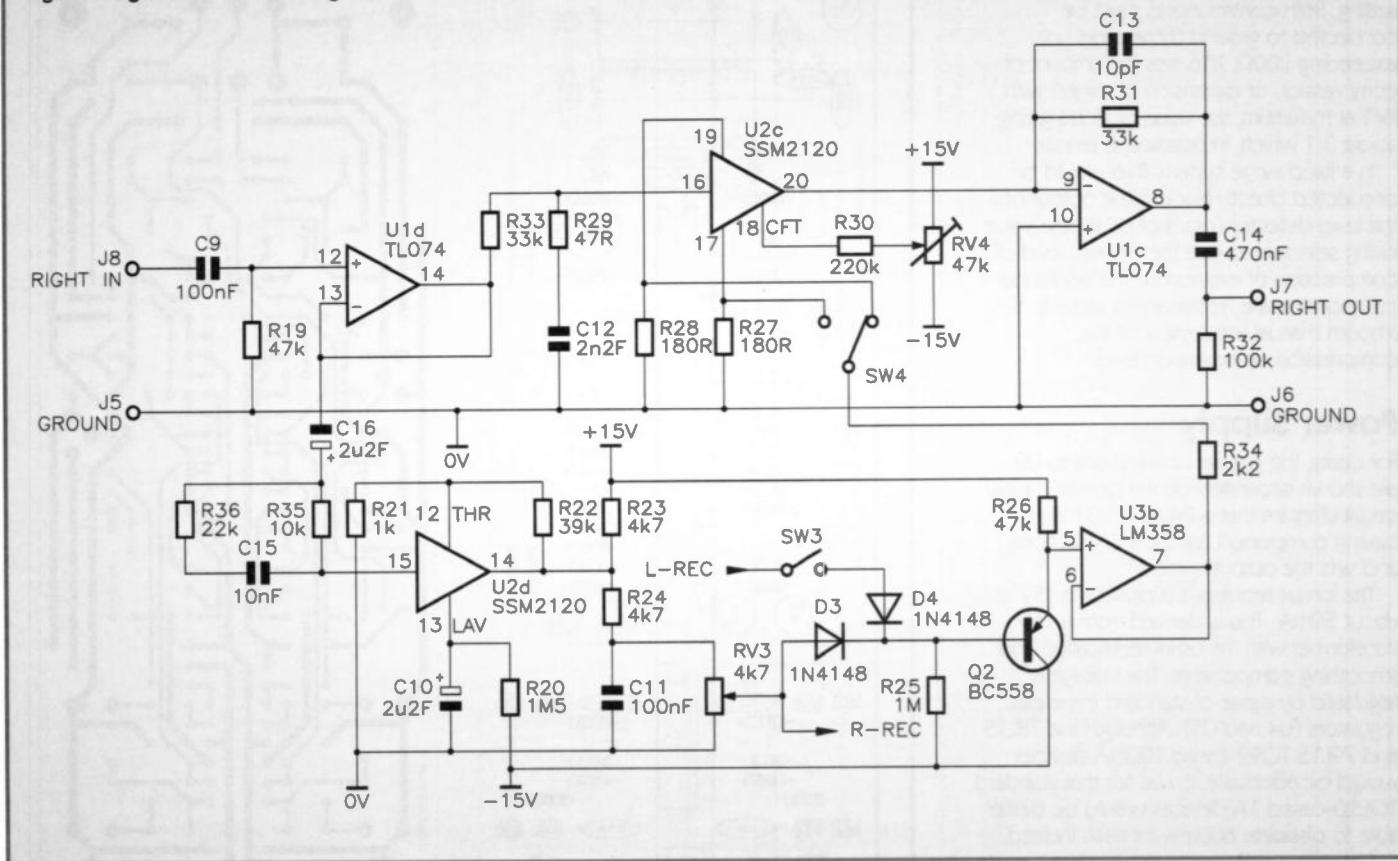

Figure 4. Right channel circuit diagram.



Referring back to the main circuit diagram (Figure 3), the relation to the components shown on the block diagram can be clearly seen. U2:B is the level detector section of the SSM2120. The value selected for C-AV (C2) is  $2\mu\text{F}$ , which was found by experimentation to give the best overall performance on a wide range of music. The level detector was found to respond to lower frequencies rather more than higher frequencies, so the input resistor (R17) was shunted by a high-pass filter (C7 & R18), which begins to take effect above about 1.5kHz. The values of these components were also established by experimentation and listening tests.

The level detector output passes to the dynamic range control (RV1) via a filter circuit (R6 and C3). This filter smoothens the sharp attack edges of the signal to reduce the audible effects when a high level of expansion is used.

SW1, and SW3 on the right channel, are contained in one double-pole component.

When the switch is open, each channel operates independently, and when it is closed, the two channels are controlled together. D1 and D2 ensure that the higher level detector output at that instant reaches the base of Q1. The transistor is configured as an emitter follower, and its base-emitter voltage drop compensates for the voltage drop in the diodes (to within 100mV). The final control signal is buffered by U3:A.

### Audio Signal Path

The audio signal into the unit is buffered by U1:A. This is preceded by a DC blocking capacitor (C1) to remove any DC offset on the input. The value of C1 together with R1 is set to give a low frequency roll-off, with a -3dB point at about 30Hz. Allowing lower frequency signals through at a high level can cause an unpleasant pumping effect on signals with a high bass content.

The input to the voltage controlled amplifier (VCA) section of the SSM2120 (U2:A) is a virtual earth. The audio voltage signal is converted to a current by R15, while R11 and C4 ensure stability. The current output from U2:A is converted back to a voltage signal by U1:B. C5 ensures stability, while C6 is a DC blocking component.

The current into the CFT input of U2:B is adjusted by RV2 for minimum distortion. This operates by trimming out internal voltage offsets, and the setting method is described later.

The VCA has two control inputs. Increasing the voltage on the '+' control input causes an increase in gain, while increasing the voltage on the '-' control input decreases the gain. SW2 (ganged with SW4 on right channel) selects the appropriate input depending upon whether expansion or compression is required. On the prototype, a three-position rotary switch

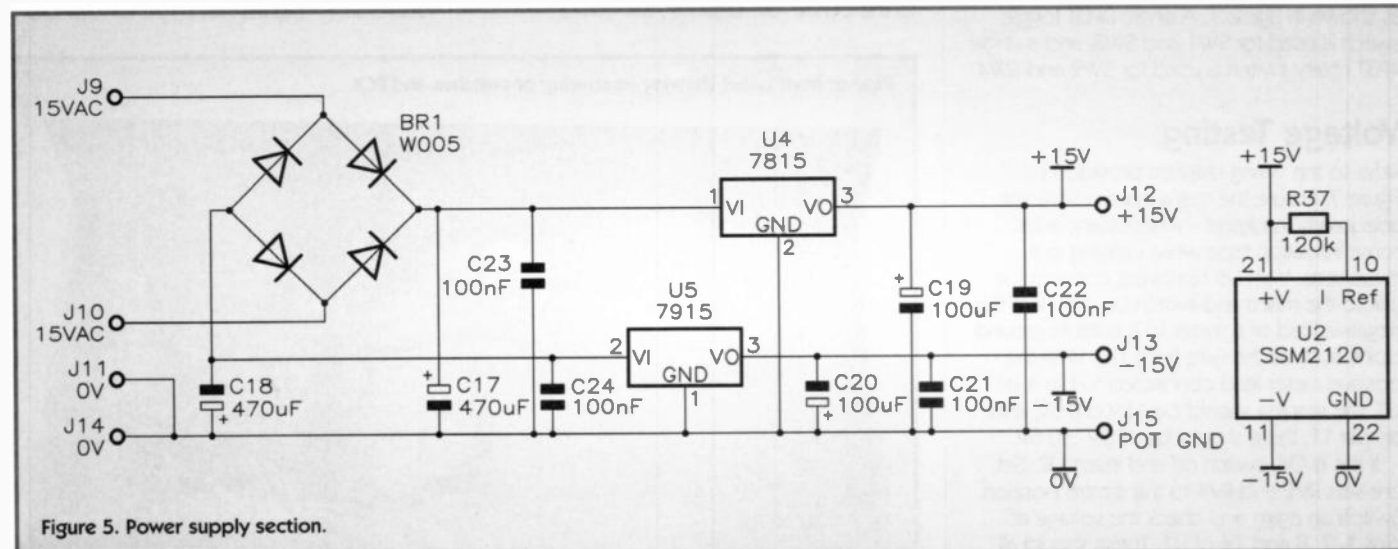

Figure 5. Power supply section.

was used with the centre position connected to neither input to give a 'flat' setting. Both control inputs must be connected to ground by resistors not exceeding 200Ω. R16 sets the amount of compression or expansion obtained with RV1 at maximum, the value of 2kΩ giving about 3:1 which, in practice, is ample.

In a fixed range system, R16 would be connected directly back to the output of the level detector (pin 3 of U2:B), the value being selected to give the desired level of compression or expansion. The additional components are necessary to allow a smooth manual adjustment of the compression or expansion level.

## Power Supply

For clarity, the power connections to U2 are shown separately on the power supply circuit diagram that is Figure 5. R37 is a biasing component for the VCA sections, and sets the output current.

The circuit requires a supply of ±15V at about 50mA. This is derived from a 15V transformer with the usual rectification and smoothing components. The voltage is regulated by a pair of standard three-pin regulators (U4 and U5). Although the 78L15 and 79L15 TO92-cased 100mA devices would be adequate, it was felt that standard TO920-cased 1A devices would be better able to dissipate 600mW of heat. Indeed, the power supply could power two circuits if separate compression and expansion arrangements were required for a record/playback system. No heatsinking is required.

## Construction

The whole circuit, with the exception of the transformer and switches, is constructed on a single-sided PCB – refer to Figure 6, showing the PCB legend and track. The dual track pot (RV1/RV3) should have PCB mounting pins, otherwise it will need to be mounted with short pieces of stiff wire. Build up the board in order of ascending component size, taking care to orientate the polarised components correctly.

It is advisable to use DIL IC holders to house ICs U1-3. If you do not have a 22-pin holder for U2, use a 14-pin and an 8-pin holder next to each other. Clean excess flux off the board using a suitable solvent. Do not fit U2 into the socket until the power supply has been checked. The completed PCB is then fitted into a suitable case and wired up as shown in Figure 7. A single DPDT toggle switch is used for SW1 and SW3, and a single 4P3T rotary switch is used for SW2 and SW4.

## Voltage Testing

Refer to the wiring diagram provided in Figure 7. Ensure the mains connections are adequately insulated – if necessary, add some insulation tape while carrying out these tests. With U2 removed, connect the unit to the mains and switch on. Connect the negative lead of a meter to a suitable ground point, such as the wire from J15. With the positive meter lead connected to pin 4 of U1, the reading should be 15V ±0.5V, and on pin 11, there should be -15V ±0.5V.

If this is OK, switch off and insert U2. Set pre-sets RV2 and RV4 to the centre position. Switch on again and check the voltage at pins 1, 7, 8 and 14 of U1. These should all

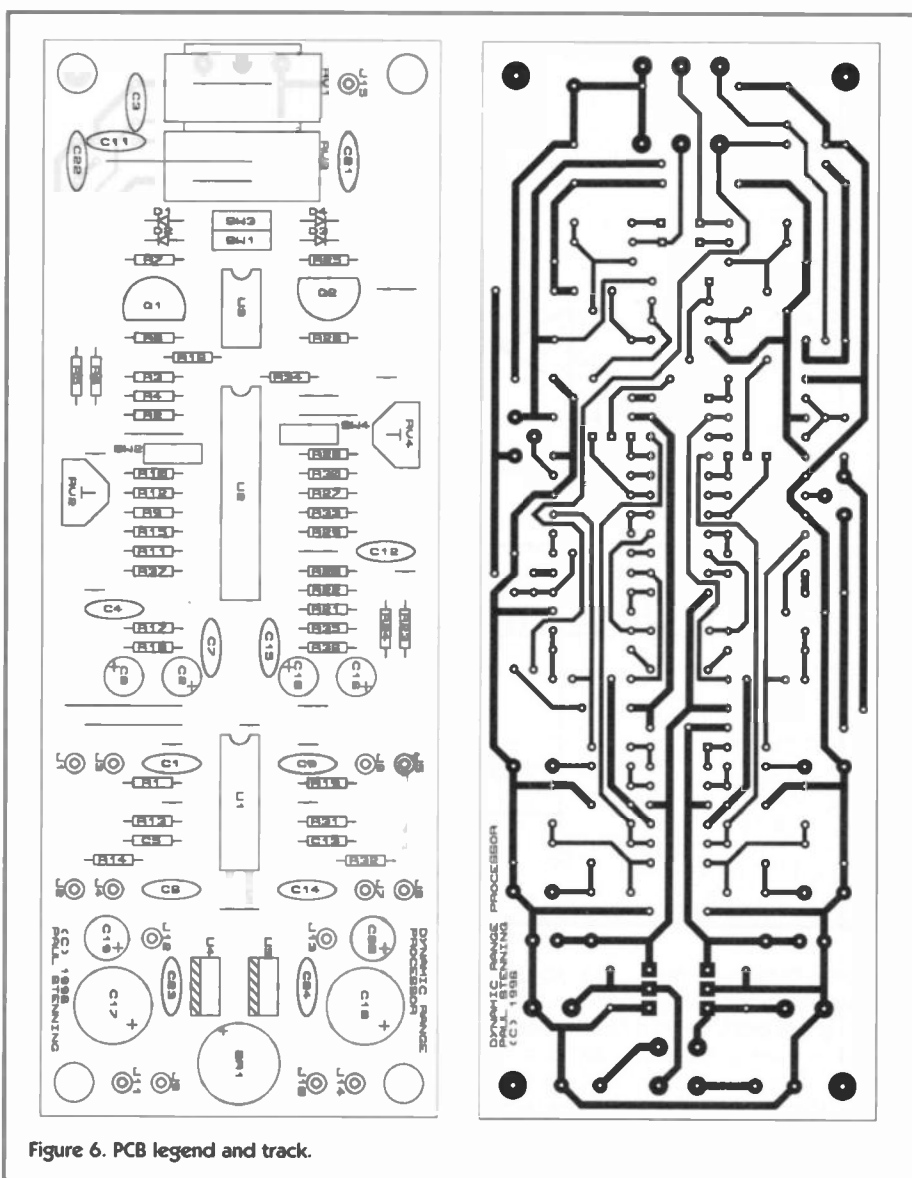

Figure 6. PCB legend and track.

be between +0.5 and -0.5V. With RV1/RV3 set fully anticlockwise, the voltages on pins 1 and 7 of U3 should be within the same range. If these voltage checks are OK, the unit can be tested with an audio signal.

## Audio Testing

Connect the inputs of the unit to a suitable audio source such as a cassette deck, and connect the outputs to an amplifier and speakers.

Set SW2/SW4 (compression/expansion) to the centre 'off' position, SW1/SW3

(combined/separate) to the open (separate) position and RV1/RV3 (range control) to minimum.

With the unit switched on, you should be able to play the tape through the amplifier as usual, with no degradation in audio quality. If you have a high quality system, you may notice a slight reduction in the bass response due to the input filter.

Now switch the unit to compression (SW2/SW4 anticlockwise) and gradually turn the range control clockwise. The first thing you will probably notice is an apparent decrease in volume, but if you turn up the

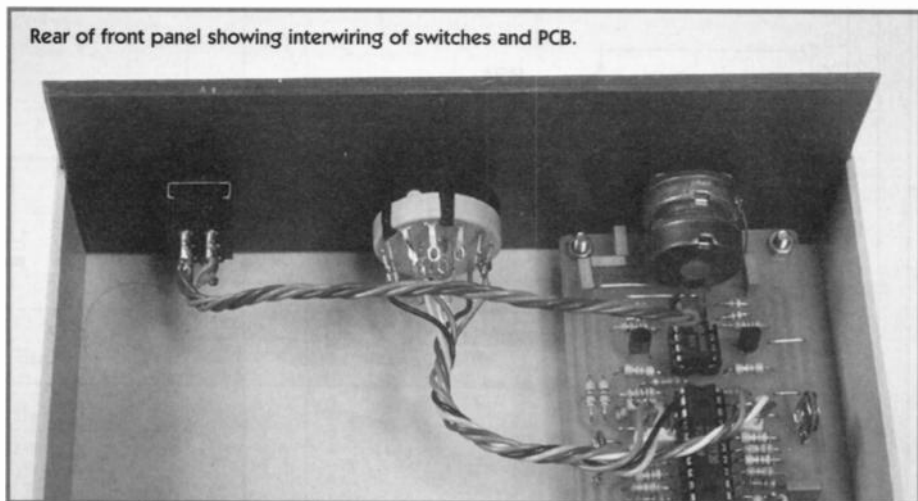

volume control on the amplifier, it will not sound quite the same. It should sound thinner, probably with a reduction in the bass. Vocals will be less pronounced and will tend to merge into the music. Any tape noise or record surface will be more noticeable, particularly between tracks. The higher the range control is set, the more pronounced these effects will be. The centre off position of SW2/SW4 allows a quick comparison.

Set the range control back to minimum and select expansion. Increasing the range control should now have roughly the opposite effect to that described above. Any bass beat will be noticeably more pronounced, and a pumping effect may be noticeable if the control is set above about half way. Vocals should be more pronounced and noise between tracks should be reduced.

The effect of the separate/combined switch (SW1/SW3) is less apparent. For testing, it is best to choose a track which has a pronounced difference between the left and right tracks. An early stereo Beatles recording is ideal, since the music is on one channel and the vocals are on the other. Select compression and turn the range up to about half way. Now set the amplifier balance control towards the channel that has the music. With SW1/SW3 set to 'separate' the music level should be reasonably consistent, and with the switch set to 'combined' the music level should reduce noticeably whenever vocals are present.

Sounds are very difficult to describe adequately in words, but the above descriptions should be clear enough for you to establish if your unit is working correctly.

## Distortion Trimming

If you have access to an audio signal generator and an oscilloscope, the VCAs can be trimmed for minimum distortion. Connect the signal generator to both inputs and the oscilloscope to one output. Set the signal generator to give a 10Hz sine wave (or the lowest frequency available if it does not go this low) with an amplitude of about 3V peak-to-peak (1V rms). Set the unit to expansion mode and adjust the range control to about midway.

There will probably be some noticeable distortion on the waveform displayed on the 'scope, at the zero crossing points. Adjust the relevant preset to minimise this distortion. This will occur when the zero-crossing distortion is equal on the rising and falling slopes of the waveform. Repeat this for the other channel. The unit will not normally be operating at such a low frequency, so the problem will not be significant in practice, even though it may look quite bad on the 'scope.

If you do not have access to suitable test equipment, the presets should be left in the centre positions.

## In Use

Use of this unit obviously depends on the original source material and what you are trying to achieve. I will give a few examples here.

My main use for the unit has been to attempt to improve poor quality recordings of music. Obviously, there are limits to what can be achieved – to quote an old cliché, "you can't make a silk purse out of a

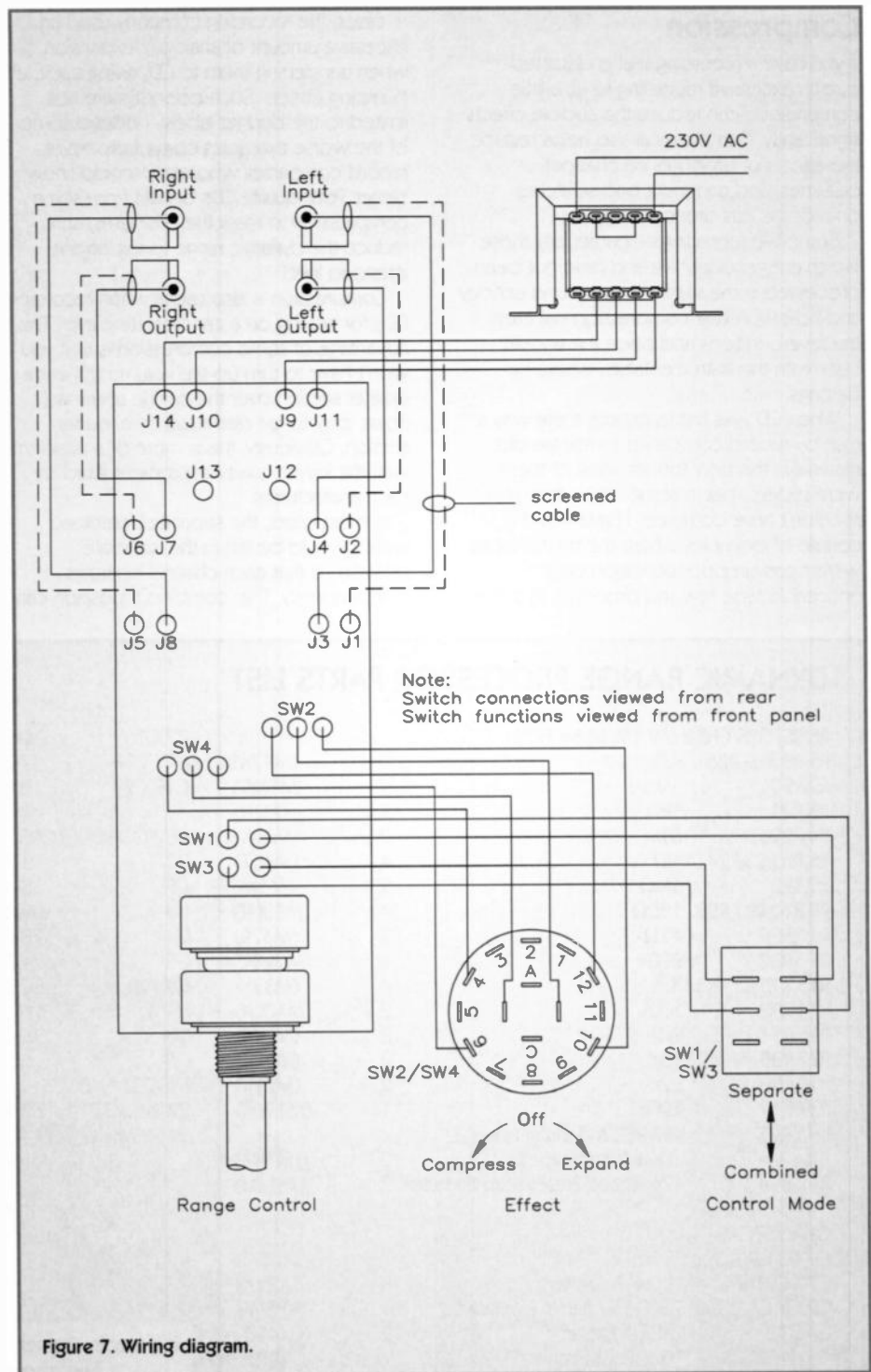

Figure 7. Wiring diagram.

sow's ear". If you use the range control in moderation, you should be able to achieve useful improvements without adding too many undesirable effects.

## Expansion

Compilation albums suffering from groove jamming, and lower quality pre-recorded cassettes can benefit from some expansion. This will tend to bring out the bass and vocals, and reduce the effects of noise. Normally, turning the control up to about one third is sufficient, you are only trying to compensate for the compression that was used when the record or cassette was recorded.

Setting the expansion too high tends to cause a couple of noticeable effects. The most apparent will be a pumping sound on the bass – difficult to describe, but easy to hear. A more subtle effect will be a fluttering variation in level, similar to that obtained from

a poor quality tape suffering from dropouts. If either of these effects are audible, the dynamic range should be turned down so that they are not objectionable.

Expansion can also improve the sound from tapes recorded on systems with automatic level controls, although sometimes, these level controls are so drastic that little can be done to eliminate their effects.

It is also worth trying some expansion on MW and LW radio stations, providing you have good reception without too much interference and noise. A vast amount of compression is used on AM broadcasting to ensure there is sufficient signal to mask the background noise. Most independent local radio stations broadcasting on FM also use compression in varying degrees, as well as limiting to cope with presenters who are not too proficient with the level controls. This explains why the BBC national stations often sound so much better on decent equipment.

## Compression

If you have a recording that is distorted due to excessive recording level, a little compression can reduce the audible effects significantly. Compression also helps reduce the effects of dropouts on cheaper cassettes, and can make bad scratches on records less pronounced.

Some live recordings – particularly those which are genuinely live and have not been processed in the studio – can sound echoey and hollow. A little compression will calm the reverberations and place the vocalist back with the instrumentalists, where he belongs.

When CD was first launched, there was a rush by record companies to release old material in this new format. Most of these were superb, but in some cases, they really shouldn't have bothered. I have heard a couple of examples where the master tapes were clearly in poor condition with noticeable tape hiss and dropouts. In some

cases, the recording company used an excessive amount of analogue expansion when transferring them to CD, giving audible pumping effects. Such poor CDs are not limited to the budget labels – indeed some of the worse examples come from major record companies who really should know better. Poor quality CDs benefit from some compression to mask the problems, and reduce the dynamic range to the original intended level.

Compression is also useful when recording CDs for playing on a car cassette player. The advantage of some compression is that you won't have to turn up the volume to hear a quieter section over the engine and road noise, only to be deafened by a louder section. Obviously, this is more of a problem with the lower quality equipment fitted by car manufacturers.

In most cases, the separate/combined switch would be left in the 'separate' position so that each channel operates independently. The 'combined' position can

be used when processing mono recordings or recordings where there is very little difference between the two channels. The 'combined' setting is also useful when dealing with tape problems such as dropouts and distortion which often affect one channel more than the other.

As I stated previously, compression and expansion should be used in moderation. Turning the control up too high will often cause unwanted effects to occur, which may be worse than the problem you are trying to reduce! The centre 'off' position on the compression/expansion switch is useful for quick comparisons – you will often find that the unit is having more effect than you thought when you were twiddling with the control.

## Acknowledgement

The word 'Dolby' and the various Dolby products named in this article are trademarks of Dolby Laboratories Licensing Corporation. 

## DYNAMIC RANGE PROCESSOR PARTS LIST

### RESISTORS (All 0.6W 1% Metal Film)

R1,R8,R19,R26	47k	4	(M47K)
R2,R20	1M5	2	(M1M5)
R3,R21	1k $\Omega$	2	(M1K)
R4,R22	39k	2	(M39K)
R5,R6,R23,R24	4k7	4	(M4K7)
R7,R25	1M $\Omega$	2	(M1M)
R9,R10,R27,R28	180 $\Omega$	4	(M180R)
R11,R29	47 $\Omega$	2	(M47R)
R12,R30	220k	2	(M220K)
R13,R15,R31,R33	33k	4	(M33K)
R14,R32	100k	2	(M100K)
R16,R34	2k2	2	(M2K2)
R17,R35	10k	2	(M10K)
R18,R36	22k	2	(M22K)
R37	120k	1	(M120K)
RV1,RV3	4k7 PCB Mounting Linear Dual Potentiometer	2	(FW84F)
RV2,RV4	47k Vertical Preset Potentiometer	2	(UH18U)

### CAPACITORS

C1,C3,C9,			
C11,C21-24	100nF Polyester	8	(CX21X)
C2,C8,C10,C16	2 $\mu$ 2F 63V Radial Electrolytic	4	(YY32K)
C4,C12	2n2F Polyester	2	(CX49D)
C5,C13	10pF Polystyrene	2	
C6,C14	470nF Polyester	2	(CX23A)

C7,C15	10nF Polyester	2	(CX18U)
C17,C18	470 $\mu$ F 35V Radial Electrolytic	2	(FF16S)
C19,C20	100 $\mu$ F 25V Radial Electrolytic	2	(FF11M)

### SEMICONDUCTORS

U1	TL074	1	(RA69A)
U2	SSM2120	1	(UL78K)
U3	LM358	1	(UJ34M)
U4	7815	1	(AV18U)
U5	7915	1	(AV21X)
Q1,Q2	BC558	2	(QQ17T)
D1-4	1N4148	4	(QL80B)
BR1	W005 Bridge Rectifier	1	(QL37S)

### MISCELLANEOUS

SW1/SW3	DPDT Toggle Switch	2	(FH04E)
SW2/SW4	4-Pole 3-Way Rotary Switch	2	(FF76H)
	Phono Sockets		
	Suggested Transformer 15-0-15V 6VA	1	(WB15R)
	Knobs		
	Case		
	PCB		
	22 Pin 0.3 in. Width IC Socket		

The Maplin 'Get-You-Working' Service is not available for this project.  
**The above items are not available as a kit.**

# Next month in ELECTRONICS

*The Maplin Magazine*

# MULTI-STROBE INTERFACE

The third part of the sophisticated Multi-Strobe project, the versatile interface unit allows the Maplin Sequencer (featured in *Electronics* Issue 100) to be used in conjunction with practically any make or model of strobe light that incorporates a remote trigger input. The interface features RS-232 I/O interconnections with the Sequencer, a strobe pulse output, 8-channel selector switch, and is mains-powered, with an additional mains output for supplying your strobe.

**DON'T MISS IT!  
NEXT MONTH!**



# SANYO

## TRC570 TWIN SPEED MICRO CASSETTE NOTETAKER



Attractive and easy to use pocket notetaker with one touch operation and twin speed to double recording time. It features voice activation which responds to the sound of your voice for convenient hands-free recording and cue/review with pause for effective editing. It is perfect for dictating letters and taking notes anywhere, anytime.

**Only £34.99** <sup>[A1]</sup>

Plus UK carriage £1.60

Also available from all Maplin and Maplin Mondo Stores

For more information call

**01702 554161**

Order Code 51293

## TALKING BUSINESS COMPLETE DICTATION SYSTEMS

# ELECTRONICS

*The Maplin Magazine*

## INDEX



A comprehensive index to *Electronics - The Maplin Magazine* is now available from Maplin. The index covers every issue from December 1981 to October 1995. Included are details of every article, series and project published during that period. Conveniently arranged, sectionally and alphabetically, it'll take minutes instead of hours to find the exact issue number and page you need. You'll be able to rediscover a wealth of information you never knew you had! A list of all the *Corrigenda* published is also included, so you will be able to find details of changes or amendments. You'll find the index an invaluable addition to the issues of *Electronics* that you have. If your collection is incomplete, many issues are still available as back issues. The Magazine index costs just 80p NV and can be obtained (subject to availability) from Maplin Stores countrywide; by Mail Order, using the Order Coupon in this issue, or by calling the Credit Card Hotline, Tel: (01702) 554161, Order As XU87U. You'll wonder how you ever managed without it!

### DID YOU MISS US ?

If you've ever wanted to lay your hands on an elusive issue of *Electronics - The Maplin Magazine*, then we can help! Many editions are still available, as back issues. Where issues are out of print, details of projects that are still current can be found in Maplin Projects Books and Best of Maplin Projects Books. Copies of back issues (subject to availability) can be obtained from Maplin Stores countrywide; by Mail Order, using the Order Coupon in this issue, or by calling the Credit Card Hotline, Tel: (01702) 554161. If you are not sure which issue or Projects Book you require, refer to the Magazine Index (XU87U) or call Customer Services, Tel: (01702) 552911. Photocopies of out of print feature articles are available; a charge will be made, dependent on the length of the article to be copied - call Customer Services for details.

### NO HANDLING CHARGES!

If you are *only* ordering a copy of *Electronics - The Maplin Magazine* Index or back issues of the magazine, the normal £1.55 Mail Order handling charge does not apply!



# NEWTON STEREO VALVE PREAMPLIFIER

## UPDATE

## Tone Control Unit

**KIT AVAILABLE  
(95131)  
Price £39.99 B1**

**Design by Mike Holmes  
and John Mosely  
Text by Mike Holmes**

**T**HERE is currently some heated debate among Hi-Fi fanatics as to whether tone controls *per se* should exist at all. Ideally, what should happen is that the recording (be it record, CD or tape) is accepted as the final version of the mixing and engineering process, since after all, this is how the producer and artists want their finished product to sound like. However, what if the listener has different ideas?

Speaking for myself, I am something of a 'knob twiddler' (if you'll excuse the expression!), because often my moods change and the way in which I perceive sound can also change almost from day to day. Consequently, I might feel on one occasion there is not enough bass, on another not enough treble, or too much. Then there is the compensation which may be necessary to overcome acoustic deficiencies in the domestic environment – it is one thing to listen to the recording in the studio with all the latest gear, but your own speakers or your room rarely measure up to this level of perfection.

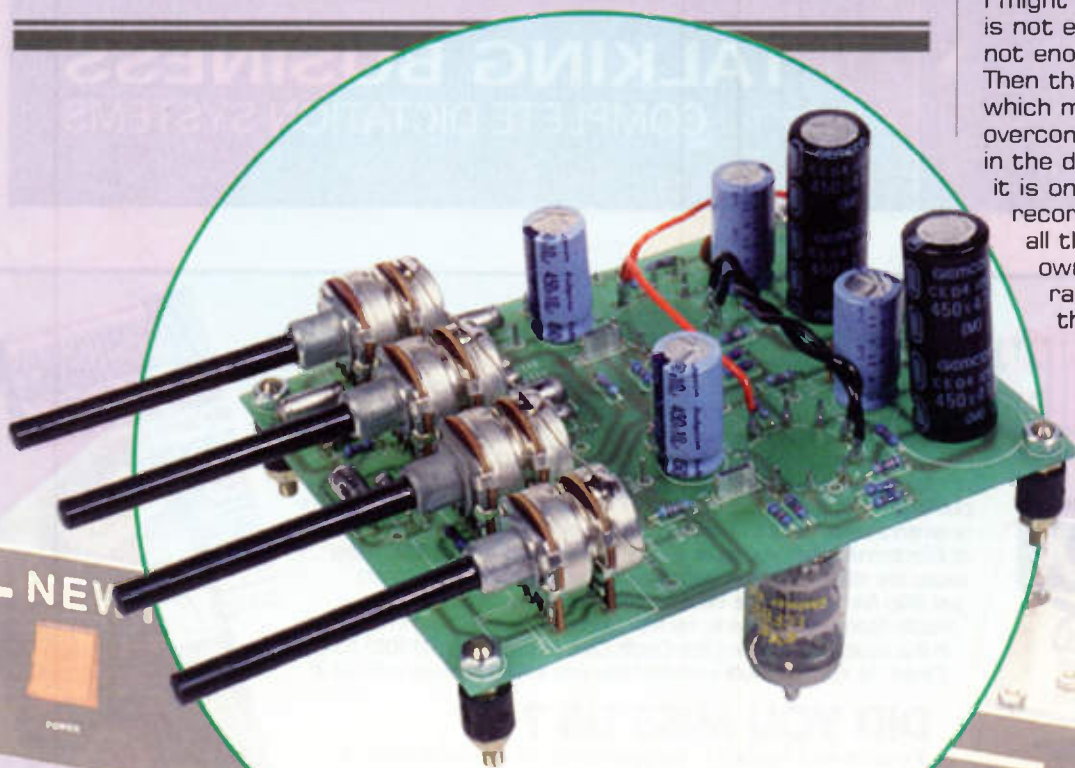

Assembled Tone Control PCB.

This updated version of the Newton Tone Control Unit, previously featured in Issue 86 of *Electronics*, incorporates alterations to the pentode stage to make it operate over a more linear working range of grid bias versus anode current, and to equalise the valve screen grid voltage with the anode voltage.

**4**  
PROJECT  
RATING

## FEATURES

- \* Simple PCB construction
- \* Compact stereo module
- \* Versatile connection options
- \* Passive tone control network
- \* Wide dynamic range
- \* Onboard low-impedance O/P buffer

## Specification of the complete system

### Phono stage

Input impedance:	51k $\Omega$ + 330pF*
Line output impedance:	1k $\Omega$
Overall gain, phono to line:	48dB @ 1kHz
Line output level:	1 to 2V peak (2.5mV @ 1kHz for 5cm/s)
Signal to noise ratio:	40 to 60dB (depending on cartridge)
RIAA equalisation network type:	Passive optimised

\* Select values to match the requirements of the cartridge used.

### Tone control stage

Line input impedance:	1M $\Omega$
Main output (to power amp) impedance:	< 10k $\Omega$
Overall gain:	6dB flat
Frequency response:	20Hz to 20kHz $\pm$ 0.5dB, -2dB @ 100kHz
Output noise:	< 200 $\mu$ V peak max.
Signal to noise ratio:	60dB for 100mV input level
Line input signal level:	0dB typical
Max. permissible input level before onset of clipping:	4V Pk-to-Pk
Bass boost and cut:	+16dB and -12dB @ 20Hz max.
Treble boost and cut:	+18dB and -19dB @ 20kHz max.
Balance offset boost:	+3dB max.
Tone control network type:	Passive Baxandall
Power supply:	230 @ 50Hz or 110 to 120V @ 60Hz
Power consumption:	30W approx.

I am, for instance, an advocate of the graphic equaliser (shock, horror, gasp), if only because it allows cassette recordings to be tailored, for listening in the car or from the personal stereo. Also I have come across recordings where the engineer's idea of what the tonal response should be is very strange - I'm sure there must have been something wrong with his hearing! (Could do with a trip to the doctor for a little de-waxing, perhaps.) While we are on the subject, what about listeners with hearing difficulties?

Enough of this. Suffice to say that tone controls have their uses, although they must be used intelligently, ideally set flat, but providing the option to 'tweak' the sound slightly if required. The Newton Tone Control Module not only meets this requirement, but also provides you with another capable line driver to feed the power amplifier(s), freeing the Phono Module's line driver for dedicated 'line out' functions.

A block diagram of the tone module is shown in Figure 1. Detailed specifications are listed in Table 1. It comprises a balanced 'Baxandall' style control network which is passive (i.e., not incorporated into the feedback loop of an amplifier), and driven by a first amplifying stage which adds the necessary gain to provide the bass and treble boost ratio. Rather than take the output directly from the network (as is the case with Mullard's 'two-valve' preamplifier), it is buffered by the line driver, which also allows a balance control to be included.

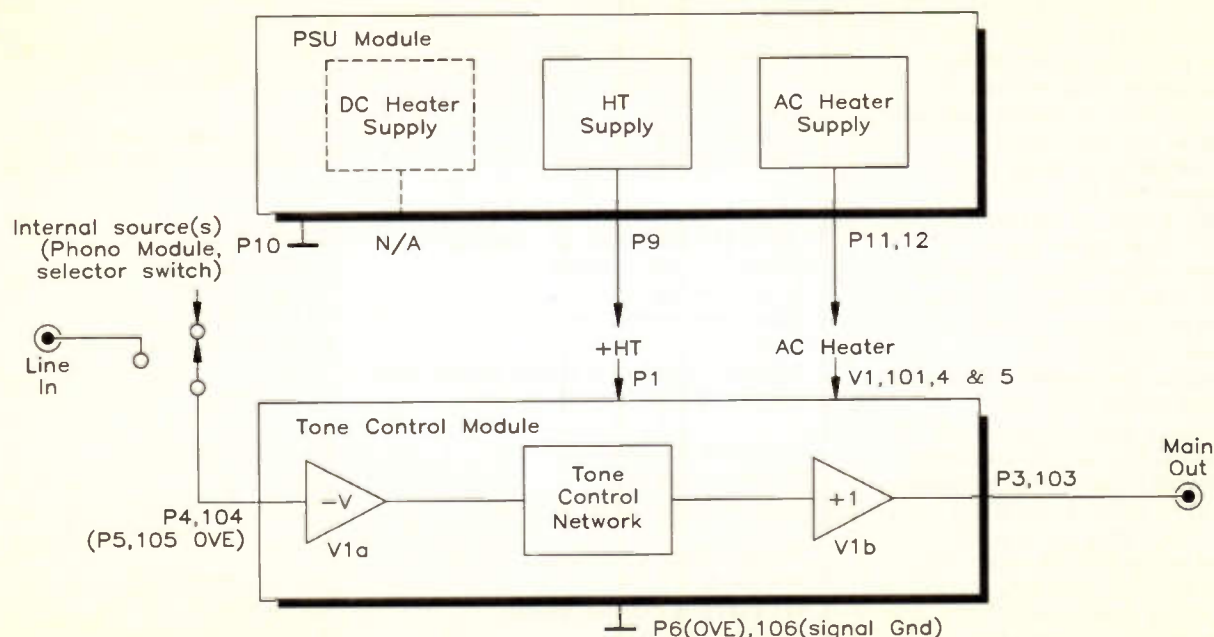

Figure 1. Block diagram of Tone Control Module.

## Circuit Description

The complete circuit diagram of the module is shown in Figure 2. Note that only one channel of a stereo pair is illustrated, although these share common supply components (R1, R2, C1, C2, C3 & C4). The tone control network is recognisable by the familiar Baxandall pattern (C11 to 15, R12 to 15, and RV1 & RV2), and is borrowed more or less complete and unchanged from Mullard's 'two-valve' circuit. However, I have been asked more than once why the potentiometers are logarithmic, and why the components on either side differ in value by a factor of 10:1.

The simple reason is because the network is passive, not 'active'. In the 'active' version, the 'high side' of the network forms a feedback chain for an amplifier, the 'output' (from the potentiometer 'wipers') being returned to the non-inverting input. The 'lower side' of the network then feeds the amplifier, operating in 'virtual earth' input mode. (The amplifier is typically an op amp, although before this a single inverting transistor stage was common.) The effect of this was that, while all scales in the network were linear (linear potentiometers, etc.), when the position of a control was mechanically changed by a linear degree, the actual gain of the amplifier was altered twofold, either up or down. This twofold, or doubling or halving, effect gives rise to the equivalent logarithmic increase or decrease of signal gain that is necessary to match the logarithmic response of the human ear to 'loudness'.

Consequently, if the active component (the amplifier) is removed, this does not happen. Hence it is necessary for the network itself to provide the logarithmic ratios of change. RV1 & RV2 are logarithmic so that while each is in a mechanically central position, the portion of track on the anticlockwise side of the wiper is one quarter (approximately) the value of the remainder of the track on the other side. Used to tap a proportion of a signal applied across the whole track, rotating the wiper fully clockwise will result in a fourfold increase (12dB) of signal level. Rotating it anticlockwise decreases the signal with similar behaviour. The reactances of the capacitors C11 & C12 and C13 set the maximum and minimum limits for the treble section, R13 & R14 the bass section. Note that C11 & 12 combined equal 820pF, one tenth the value of C13, similarly R13 & 14 are of the same ratio.

The one disadvantage of using logarithmic pots is that the accuracies of their track

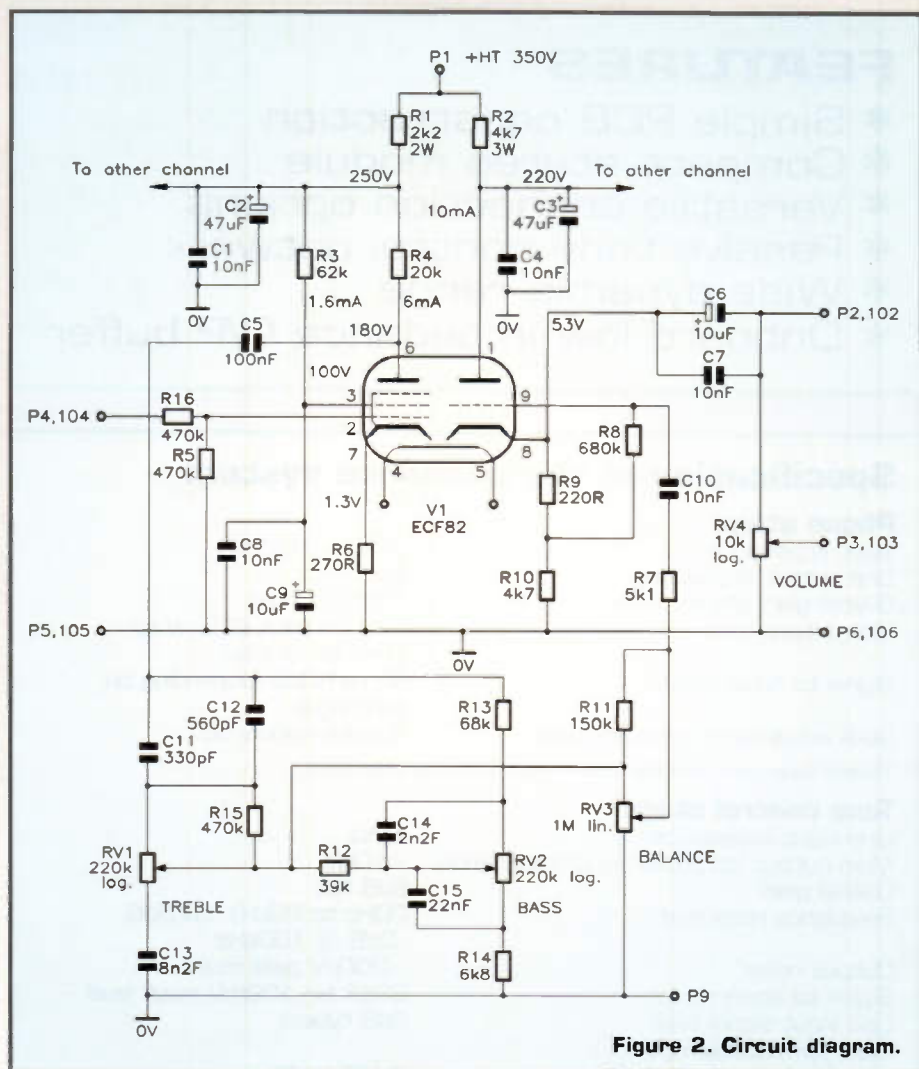

Figure 2. Circuit diagram.

### Specification

Volume setting:	Maximum
Bass setting:	Flat
Treble setting:	Flat
Balance setting:	Centre
Input signal level:	0dB
Input source impedance:	600Ω via 1.5m screened lead
HT supply:	320V + 100mV ripple @ 100Hz
Input impedance:	1MΩ
Output impedance:	< 10kΩ
Overall gain:	6dB
Frequency response:	20Hz to 20kHz ±0.5dB, 2dB @ 100kHz
Output noise:	< 200µV peak maximum
Signal to noise ratio:	60dB for 100mV input level
Maximum permissible input level before onset of clipping:	6V Pk-to-Pk
Maximum bass boost:	+16dB @ 20Hz
Maximum bass cut:	12dB @ 20Hz
Maximum treble boost:	+18dB @ 20kHz
Maximum treble cut:	19dB @ 20kHz
Maximum balance offset extra gain:	+3dB
Minimum balance offset gain:	Zero output
Pentode stage gain:	29dB, constant
Triode stage gain:	0dB
Tone control network type:	Passive Baxandall
Power requirements:	
HT supply:	300 to 350V DC
HT current consumption:	30 to 40mA
Heater supply:	6.3V AC @ 900mA

Table 1. Tone Control Module specification.

resistances are less precise than that for linear pots, giving rise to offsets, relative to the mechanical position, and possible mismatching between ganged tracks. Generally, the differences are small and can be ignored, however, some comments from 'reviewers' of the prototype suggested that the treble could do with improvement, that is, the control has to be increased slightly from the centre position to make the response truly 'flat'. This is all very subjective and at the mercy of the vagaries of track matching, however, a little treble boost (to recover losses due to the reactive input impedance of the network) is not out of place. R15 provides this by bridging the top half of RV1, shifting the centre point slightly in the opposite direction. If you find that in practice this is not necessary, then it can be removed. (In the Mullard 'two-valve' circuit, the network has a 47kΩ resistor on the other side, presumably to cut the treble.)

The reactive input impedance of the network can be a bit of a problem for the driving valve, becoming a considerable load at high frequencies, where the impedances of all the capacitors are at their lowest. The Mullard circuit employed an EF86 to drive its network, but it was not found ideal, as this valve typically has a high output impedance, and is not well matched to the task. Gain such as can be provided by a pentode is required, however, since to achieve the necessary boost levels for both treble and bass, a high signal level has to be put into the network in the first place, if only to ensure unity gain throughput in the 'flat' position.

The device that was finally chosen, and which I have had experience with in the past, is the ECF82 triode pentode. The pentode section is employed to drive the network, while the triode section forms the output buffer.

The ECF82 neatly combines a high current, wide band pentode with an even higher current triode in one B9A envelope. These are basically video valves, and the ECF82 was once commonly used in vision amplifiers and other forms of video processing in television broadcast applications. It has even been employed as the front-end for AM receivers, using the pentode as the mixer and the triode as the local oscillator. It is a very capable device in the AF range

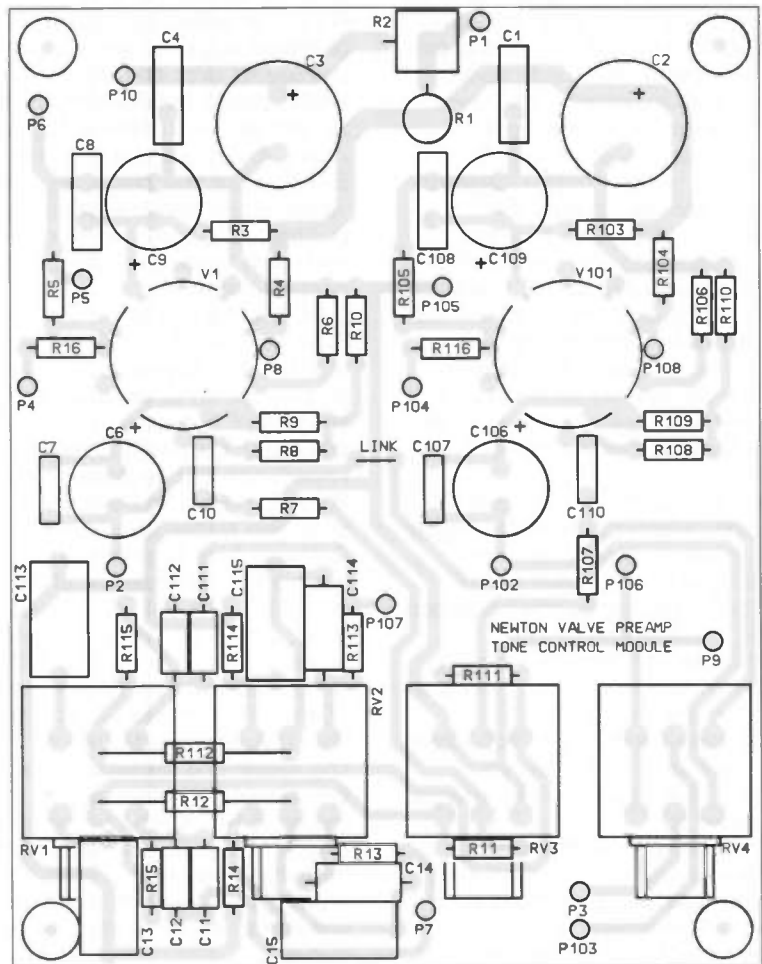

Figure 3. PCB legend.

Pin No.	Function	Channel
P1	+HT supply	Common
P2	Buffered output direct	Left
P3	Volume control output	Left
P4	Tone control main input	Left
P5	Input screen OV	Left
P6	Supply OVE from earth bus (PSU)	Common
P102	Buffered output direct	Right
P103	Volume control output	Right
P104	Tone control main input	Right
P105	Input screen OV	Right
P106	Signal OV for outputs and buffer	Common
P7	C5 to tone control network	Left
P8	V1 pin 6 to C5	Left
P107	C105 to tone control network	Right
P108	V101 pin 6 to C105	Right
P9	OVE for potentiometer screening	Common
P10	Buffer HT supply to valve holders	Common
V1 pins 4,5:	6.3V AC heater	Left
V101 pins 4,5:	6.3V AC heater	Right

Table 2. Tone Control PCB pin designations.

and is still used in at least one design of a modern Hi-Fi valve power amplifier:

In the Tone Control Module, the pentode, V1a, provides 29dB of flat gain from the line level signal at pin P4, raising it to an amplitude sufficient for the tone controls to work with. An anode load resistor of 15kΩ (R4) maintains a current of 6mA, while the screen grid current is slightly starved, producing a screen grid voltage of 100V DC compared with the anode's 175V DC. This has the effect of boosting the gain of the valve. Some local negative feedback is provided by cathode resistor R6 not being decoupled to signal ground. The gain of this stage limits line input level at around 3V peak; overload distortion becomes apparent at approximately 4V peak.

Some HF roll-off is apparent at the anode, which can be graphically shown by an oscilloscope while monitoring a squarewave at this point. This is caused by the combined reactive impedances of the capacitors in the network loading the valve in the HF range. However, the 'scope will also show the squarewave shape being recovered at the output of the network, which has absorbed the HF energy, not wasted it.

Both left and right channel pentode stages are supplied with HT via R1 and decoupled by C1 and C2, C1 removing any high-frequency components on the supply line, but each screen grid is decoupled separately by C8 & 9, and C108 & 109.

The common output of the tone control network goes to the dual ganged balance control, RV3, which has reverse connected tracks to achieve the left/right channel boost/cut action. R11 (and R111) is added to limit the degree of signal boost when one side is increased over the other, which might cause overloading problems for amplifiers further along the chain. It also recovers some of the 6dB loss of the balance control when in the 'centre' position. RV3 is 1MΩ, providing absolute minimum loading of the tone control network.

At the output of RV3, overall 'flat' gain is 6dB, all due to the gain of V1a. The high output impedance, at this point, is unsuitable for long lengths of screened lead and whatever may be the input impedance of the power amplifier, so a common cathode, non-inverting buffer is added, V1b. Cathode bias is properly derived from a series resistor chain, R9 and R10. The bulk of the voltage drop, which allows a sizeable signal voltage swing, is across R10 and is derived from an anode current of 10mA. This leaves R9 to develop the actual cathode bias of 2V, with the lower end communicated to the signal grid via the grid leak resistor R8. Both the pentode and triode of the ECF82 should have fairly high anode currents to ensure that each is maintained in the linear region of its operating curve.

As with the Phono Module's line driver, the input impedance of the stage is not determined by the

value of R8 alone. The action of the cathode following the signal grid results in an impedance multiplying effect for R8, so that instead of being 680kΩ the actual input impedance is nearer to 10MΩ. The small value of the polycarbonate capacitor, C10, which AC couples the input, is more than ample for this.

AC coupling at the output is via C6, a high voltage electrolytic. Generally electrolytics of this type are not a good choice for an audio signal path, but a high value is necessary to ensure good bass response into a (comparatively) low impedance load. HF performance is assured, however, by C7.

Alternatively, you might replace these with an equivalent value made up from audio grade polypropylene types, but these are very large and will have to be connected off the board with the space to accommodate them.

R7, in series with C10 and the signal grid, is a 'grid-stopper' (to use the vernacular), and serves to limit the bandwidth of the buffer stage. It should not be omitted, else the triode will go into common grid mode whenever the balance control is reduced to minimum, connecting the input directly to 0V. Where's the harm in that, you may ask? None, except that in this condition, the triode suddenly becomes a very capable RF noise generator whose output range extends into the UHF. While this may be very useful in different circumstances, it is not desirable here! This is a form of instability, prevented by R7.

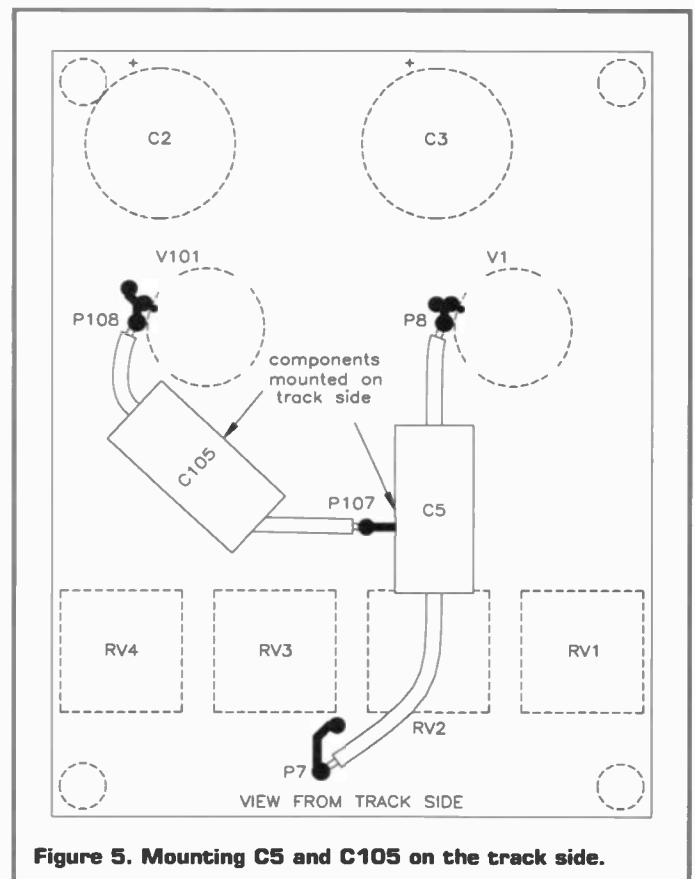
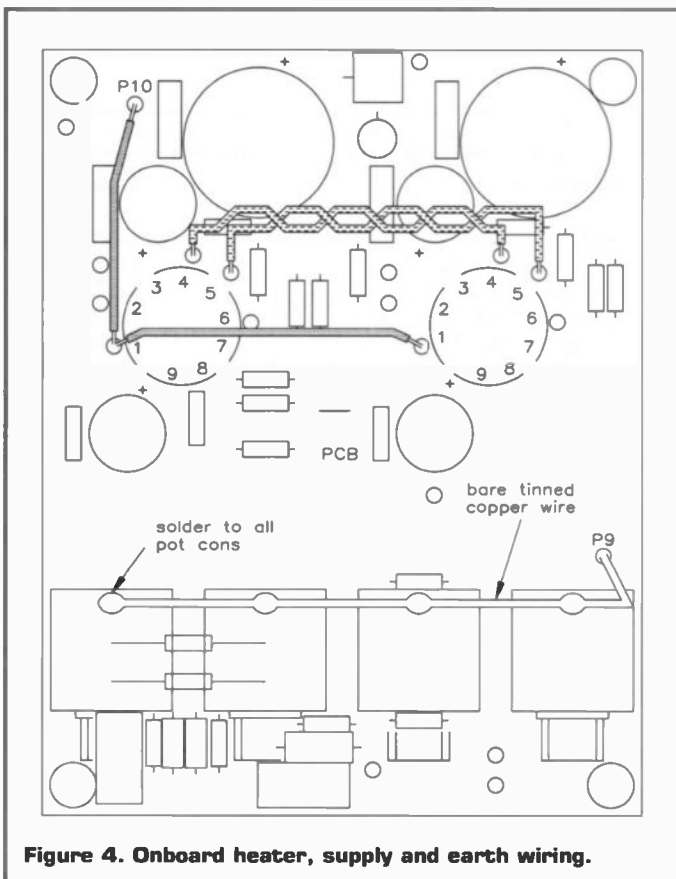

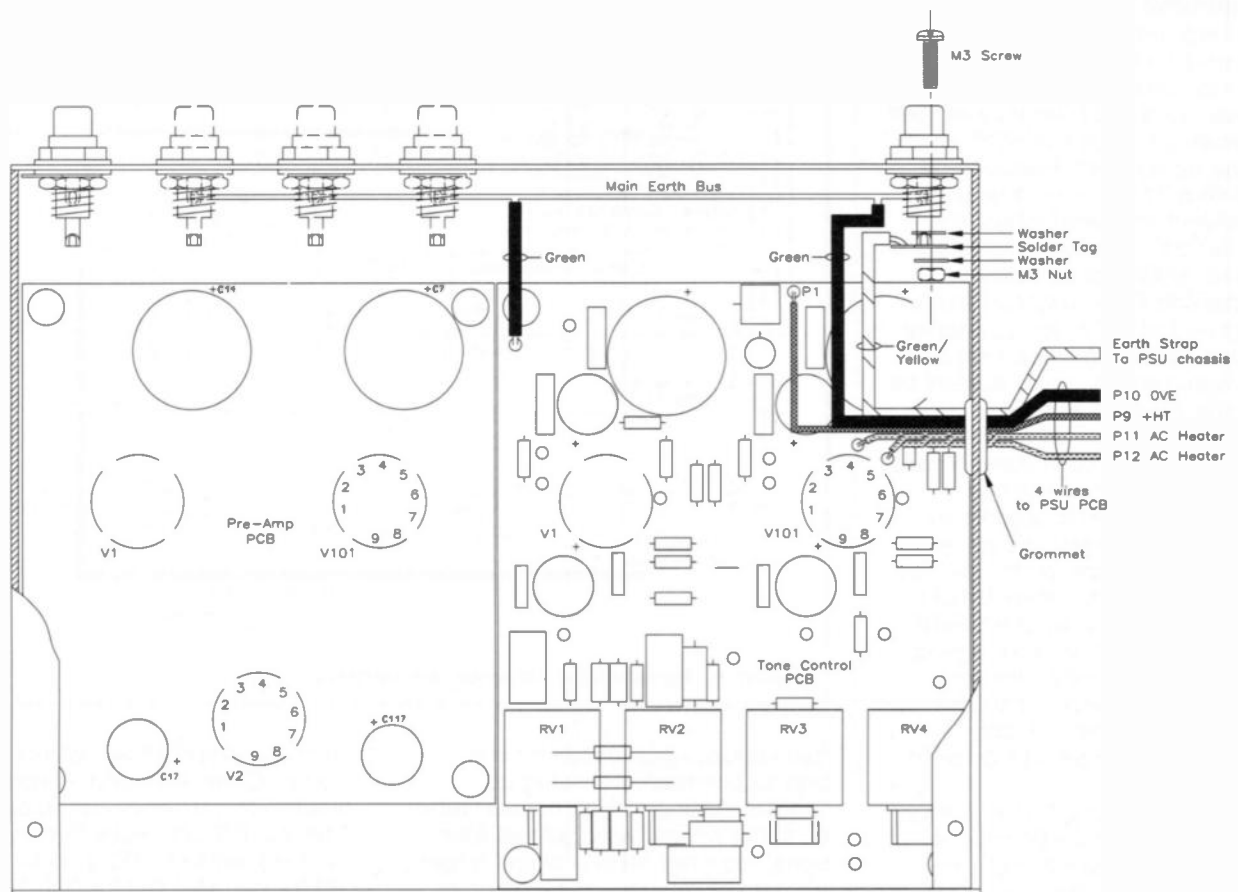

Figure 6. Basic supply and earth wiring of installed PCB.

Finally, a stereo ganged logarithmic volume control, RV4, connects across the output. The 10kΩ track is usually of low enough impedance to drive most types of screened lead with no discernible loss in HF performance. Alternatively, the buffer output is directly available at P2 (P102). You may use this if the power amplifier has its own volume control, or if you want to mount the preamplifier's volume control somewhere else on the front panel and fitted with a large knob, as some people prefer. In this case, RV4, normally mounted on the PCB, is located somewhere else and hard wired to P2, P102 and P106 (the common signal ground). Due to the low impedances here, screened lead is not necessary.

If no volume control at all is used (RV4 omitted), you MUST substitute the RV4 positions on the PCB with 10kΩ resistors, to ensure that the output side of C6 is referenced to OV DC at all times. This is so that the buffer does not deliver a hefty pulse down the line to the rest of the system as C12 charges up! One concern here was the danger of inflicting any solid-state circuits that are connected to the output of the buffer to high-voltage pulses on switching on or off. In practice though, the transition is very slow, both at warm-up and switch off, and peak deviations are rarely more than 2 or 3V. PROVIDED RV4 or equivalent resistors are fitted.

## Tone Control Module Construction

Refer to Figure 3 for the PCB legend. The PCB is a simple single-sided glass fibre type, and is strong enough to carry all the components including the valves in their holders. Note that it includes a solder resist layer on the track side, which will also help to minimise current 'creepage' across the surface between points of high potential difference when in use. Once the PCB has been assembled and tested, and is known to operate correctly and be ready for use, you are advised to apply conformal coating to the finished solder joints to augment this protection.

Begin construction by inserting and soldering the 30 PCB pins at P1 to P6, P10, P102 to P106, and also at the two valve holder positions. In each case, insert and solder nine pins from the track side into the outer of the two concentric rings of holes for each valve holder; that with the smaller holes. Next, carefully insert the B9A valve holder into the board from the track side, into the inner ring until it is fully seated flat on the PCB. Each pin of the valve holder is then bound to its corresponding PCB pin with a turn of bared bell wire and soldered to it (don't be sparing with the solder). If the wire insists on slipping off the valve holder pin then bend the

pin inward to form a hook. The wire loop must be soldered to both pins. A wire-wrapping pen may be useful here if you are in the habit of using one. Attach and solder a pair of opposing pins first and double-check that the valve holder remains true before continuing.

Some 'spare' holes will be left over; P7 to P9, and P107 & P108. These do not have PCB pins. (Table 2 lists the functions of the various pins and links.)

Next begin installing components by fitting the smallest first, working up to the largest. With the aid of the parts list and circuit diagram of Figure 2, identify, fit and solder all the small resistors. An ohmmeter will aid identification of values if you are unsure of the colour codes. Using an offset of resistor lead, insert and solder the short wire link at the position on the PCB marked 'LINK'. Then fit and solder all the small polycarbonate capacitors C7, C10, C107, C110. Fit and solder the polystyrene capacitors C11 to C15, and C111 to C115. CAUTION: these components can be damaged by overheating.

Install the ceramic disc capacitors C1, C4, C8 and C108. Fit the 2W metal film resistor R1. Note that this stands on end to conserve space on the PCB and to aid cooling in use. Bend one lead to lay flat against the body of the resistor, and insert the component vertically, orienting it to the PCB legend. Similarly, mount R2, the

white ceramic encapsulated 3W wirewound resistor according to the legend. In this case, include the ferrite bead, by sliding it over the lower wire that will be inserted completely through the PCB, so that the component is raised off the surface of the board by the thickness of the bead when in place. R2 can get quite hot and the bead, acting as a spacer, protects the PCB. The lead from the top end of R2 may need to be extended by adding tinned copper wire (twist together and solder) to reach the other PCB hole.

Install all the four smaller radial electrolytic capacitors, taking care to orientate them correctly according to the PCB legend. In each case, the negative lead is identified by a stripe and '-' symbol on the body. Insert the indicated wire lead into the hole OPPOSITE that marked as '+' on the legend. Next, insert and solder the two 47 F 450V capacitors into the PCB. Make sure that all the electrolytics are seated fully onto the PCB.

At this stage, check the quality of the work before installing the potentiometers, which make it difficult to access smaller components nearby, due to their size. Look for bad solder joints, solder bridges and misplaced components and rectify where necessary. It is still possible to double-check resistor values, as there are hardly any leakage paths to upset ohmmeter readings.

If you know the exact final length required for each potentiometer control spindle, you can cut them back with a junior hacksaw (while gripping the spindle, NOT the potentiometer body, in a vice). Otherwise, you can leave this operation until the PCB is installed in the chassis, as it is not difficult. The nuts and lockwashers are not necessary and can be discarded. Identify one of the 220k logarithmic potentiometers and install it the RV1 position, and then the other 220k potentiometer in the RV2 position. Note that these physically hide some small components nearby, especially R12 & R112, although there is plenty of space underneath the pots. DO ensure that the pots are seated fully on the board or the shafts will be off-centre and not line up.

Similarly, fit the 1M $\Omega$  linear potentiometer at RV3, and the 10k $\Omega$  logarithmic potentiometer at RV4. Next, it is necessary to connect the metal bodies of all four potentiometers to 0V. This is to provide screening of the internal tracks and wipers, which normally occurs if the pots are mounted in earthed metalwork. However, because in this case they are not physically attached to any metalwork, unwanted noise pickup

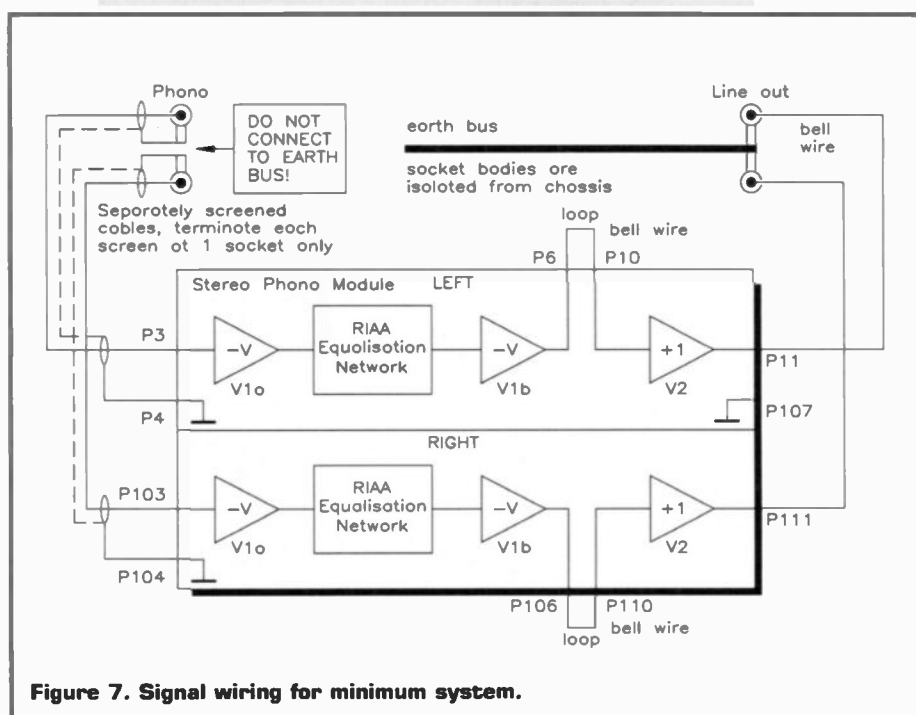

Figure 7. Signal wiring for minimum system.

can result, aggravated by the bodies themselves acting as 'aerials'. Using tinned copper wire or stripped bell wire, join all four cans together with a single length, with a solder joint at top rear of each can, with one end terminated at P9 on the PCB (0V), see Figure 4. This could be awkward to do unless you have a powerful soldering iron (25W minimum), but the screens are normally plated steel and take solder readily.

With two lengths of black bell wire tightly twisted together, join V1 pin 4 to V101 pin 4, and V1 pin 5 to V101 pin 5, wrapping them around the PCB pins – see Figure 5. Pin numbering for all the valves is clockwise as viewed from the component side of the board, and always with pin 9 at the bottom. The rings of PCB pins make all valve connections accessible. Using orange bell wire, join together V1 pin 1 to V101 pin 1, allowing some slack to avoid the other valve holder PCB pins. Also connect V1 pin 1 to P10 near C4. This provides HT for the output buffers, see Table 2.

Due to their physical size, it is more convenient, if a little unconventional, for the large yellow polypropylene capacitors C5 and C105 to be mounted on the track side, as illustrated in Figure 5. The way in which the PCB is mounted

in the chassis allows plenty of room. Cover exposed lengths of lead with the sleeving supplied in the kit. C5 connects between P7 and P8, while C105 is between P107 and P108, ON THE TRACK SIDE. The leads are pushed through the holes, bent over and cropped as usual, but soldered on the track side where they enter each hole. PCB and hole designations are listed in Table 2.

Finally, fit the four rubber couplings. These will be used as mounting pillars for the PCB. Remove the spring washers from each, replace the nuts and tighten carefully, to avoid splitting the rubber. The final distance will be approximately 17mm. Using the extra M4 nuts provided in the kit, attach each coupling to the PCB mounting holes on the track side. In use the PCB hangs upside down in the chassis, while the two valves will protrude through holes in the chassis top panel. Temporarily set aside the assembled PCB while you prepare the chassis, if you have not already done so.

## Preparing the Amplifier Chassis

An 8 x 6 x 2 1/2 in. chassis is supplied with the Phono Module Kit (LT76H), and instructions for

HT+ = 320V; junction of R1, C2, R3 & R4 = 250V

V1a Pin No.	Volts	V1b Pin No.	Volts	
7	1.5	8	55	cathode
2	0	9	53	signal grid
3	100	-	-	screen grid
6	175	1	225	anode

Table 3. Voltage test points.



preparing it for both Phono and Tone Control PCBs are included in leaflet XV11M.

## Combining the Chassis

When the PSU and amplifier chassis are joined end to end, the complete assembly becomes 16in. wide which is a typical width for most stereo items. The rear join should be made with a rectangle of aluminium plate 2½in high × 1in. wide with a hole at each corner for fixing using M4 hardware or pop rivets. Ideally, the front should have a covering front panel cut from 16swg aluminium sheet. All frontal holes will be duplicated in this panel. It can be any height you like (the prototype is 4in. high to fill a gap between two shelves). The separate front panel is rigidly attached to both chassis by M3 hardware in each corner of the front panels of both chassis. The panel can be painted, and the countersunk screws allow a stick on design to be attached, completely hiding the fixings.

## Installing the Tone Control PCB

The four flexible rubber couplings that are used as mounting pillars for the PCB, should, as already described, be fitted onto the PCB first. Experience has indicated that it is much easier to insert the threaded ends of the pillars through the chassis when the PCB is fitted, rather than the PCB over the pillars. This is especially true of the Tone Control PCB, which is larger than the Phono PCB and a little awkward to install due to the protruding spindles. The Tone Control module has to be inserted at an angle to push the control spindles through the front panel and at the same time, clear the flange at the end of the chassis. Once clear of the flange, it can be pushed down and straightened up, and the four mounting studs pushed through the top panel. Because of this, it is impossible to install or remove the Tone Control Module while the Phono Module is in place, as it is in the way. Since the mountings are flexible, it is a simple matter to 'hook' the studs through the chassis panel with a thin-bladed screwdriver if they do not go first time. Secure all four studs with the four M4 nuts and DO NOT over-tighten, or there is a risk of damage to the rubber. Rotary switches are fitted only after the Phono Module is installed.

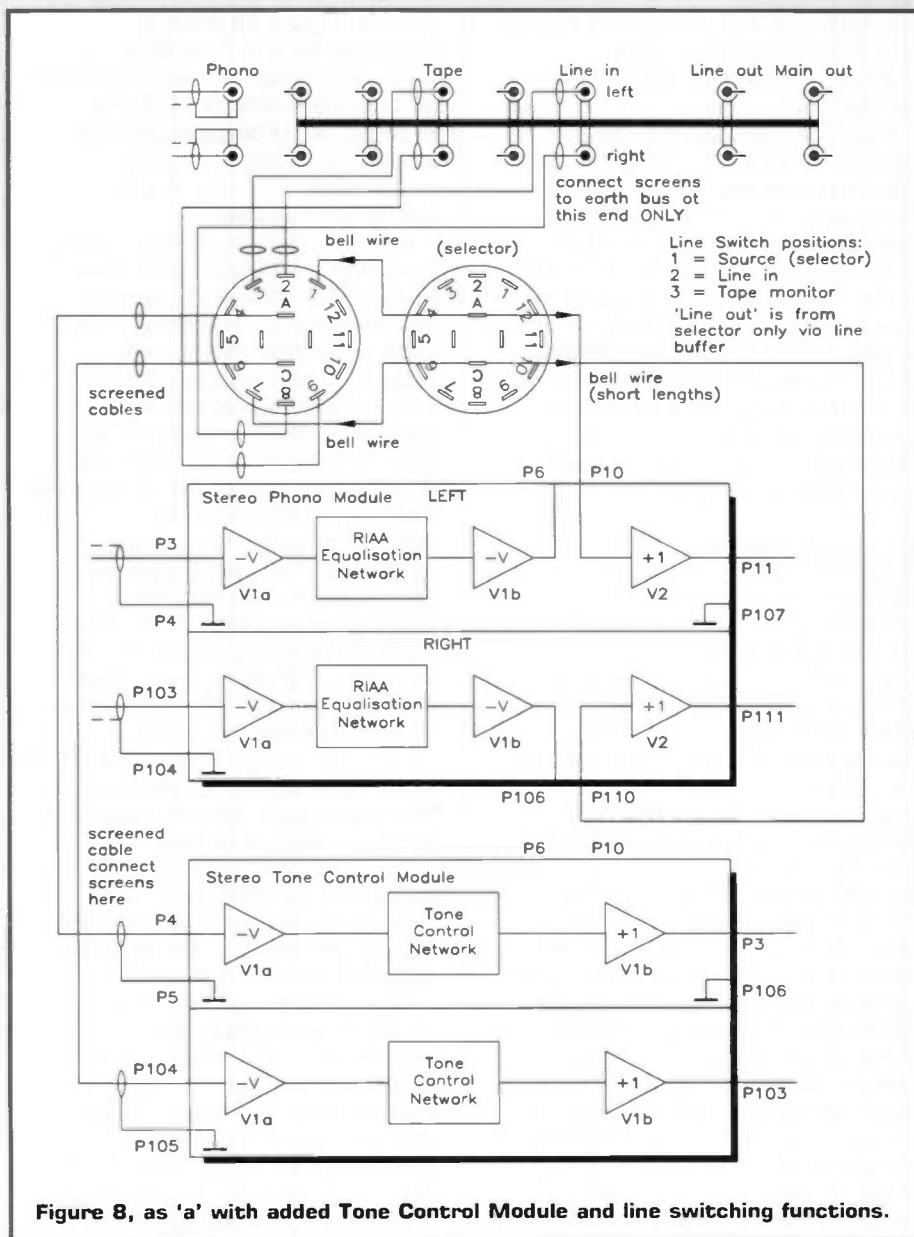

## Power Supply Wiring

Figure 6 shows the power supply, earth and heater wiring. As described in Part 1 (Issue 73 of *Electronics*), the screen tags of all input and output sockets (EXCEPT 'Phono!') are linked together by a length of tinned copper wire, connected at one end to P10 (0VE) on the PCB using green 6A power connection wire. This is the common 'earth bus', a reference point for most signal earth returns. P6 on the Tone Control PCB must be linked to the earth bus with green 6A wire. The heavy gauge of the wire ensures minimal resistance to ground for best performance of the system. HT is connected from P9 on the PSU PCB to P1 on the Tone Control PCB using orange bell wire. The AC heater supply is connected from P11 & P12 on the PSU PCB, directly to V101 pins 4 & 5, using a tightly twisted pair of black bell wires (see also Table 2). All these connections are via the grommet in the PSU chassis. These are the essential basic

connections to the Tone Control Module which must be carried out as described, with no deviations.

## Testing the Tone Control Module

As this point the module can be fired up and initially tested for correct operation. Plug in the two ECF82 valves and turn the chassis upside down and support it to keep the valves clear of the work surface. Reconnect the euro mains lead and switch on. In a short time, you should be able to establish that the heaters are glowing. If not, perform the complete SIDE procedure and examine the heater supply wiring for errors. WARNING: Never heat valve holder pins with a soldering iron while a valve is still plugged in; remove it first (heating a valve pin too quickly risks cracking the glass envelope).

If all valves are glowing, then the basic DC voltages around the circuit can be checked with reference to Table 3 (Test points). Due to the vagaries of the HT supply, these levels are

approximate, but measured values should not deviate greatly, a drastic difference will show an obvious fault.

If the DC tests are good you may go on to AC testing if you have the necessary equipment, such as an AF signal generator and oscilloscope. This will show whether the two identical circuits perform the same, if not, one of them has a fault. If a fault is found, carry out the complete SIDE procedure before rectifying it. At this stage, the PCB may be more easily disconnected and removed, AFTER the valves have been unplugged!

## Signal Wiring

Various configurations are possible, from the simplest to the more sophisticated. Figures 7 and 8 illustrate two configurations for a finished preamplifier system in wiring diagram form, using the versatile 'Newton' modules. Although the diagrams are self explanatory, clarification of some finer points may be in order.

Good quality screened cable, such as the 'single mic cable' (see Parts List) is recommended for all left and right channel signal input sockets. It may be possible to employ multi-core screened cable, sharing a common outer screen, to make life simpler where many inputs to a selector switch arrangement are desired. However, use this ONLY IF it is known that there is not likely to be two or more signals coming in simultaneously, or crosstalk between the conductors may result. This is because of the high input impedance of both the line drivers (Phono Module) and the Tone Control module.

For each left and right channel 'phono' input, the body of the socket connects to the equivalent input 0V pin on the Phono PCB ONLY via the cable screen. The cable becomes merely an extension of the record player's twin signal leads; the socket bodies must not be connected to the earth bus, or linked together. A 'hum-loop' will most definitely be the result in either case.

Where extra line level inputs are desired (Figure 8), the cable screens are connected to the earth bus ONLY. At the other ends, cut back the screen braid and wrap with insulation tape, so that only the centre conductors are free to connect to the relevant pins on the selector switch. Signal ground for each PCB is already referenced to the earth bus, so connecting these screens to 0V at both ends only causes hum-loops. Similarly, the screened leads linking the selector for line

switch, Figure 8) moving contacts to the Tone Control input have their screens earthed at the Tone Control PCB only. In practice, this makes wiring in the switching area very much easier, as only signal paths are involved.

In the drawings, 6-way rotary ('wave-change' type) switches are shown. Although you can use alternative switches, this type is, on the whole, very reliable, and probably second only to good quality wafer switches. This switch (FF74R) has 12 fixed contact pins and 2 moving contact pins, organised into 2 x 6-way, with an adjustable stop from 2-way to 6-way. The fixed contacts are numbered on the back, anticlockwise from '1' to '12', while the moving contacts are 'A' and 'C' ('B' and 'D' not used).

'A' connects to '1' to '6', while 'C' simultaneously connects to '7' to '12', hence if 'A' is set to '2' then 'C' is set to '8', and so on. For wiring up a stereo switching arrangement, it is simple to remember that this layout ensures that each pair of fixed contacts for left and right inputs are exactly diametrically opposite one another.

When the switch is fitted, it might be a good idea to introduce a very short squirt of WD40 through one of the four holes in the front of the plastic switch body (after removing the nut and washer). This ensures smooth operation and will keep oxides at bay for a reasonable time.

Line input impedance is about 1M $\Omega$  if the Tone Control Module is included, even when it shares the selector with the line driver input (Figure 8). This is because the line driver has a much higher impedance. In Figure 8, selector input impedance will rise to nearly 10M $\Omega$  where the 'Line' switch is set to a different function, removing the Tone Control impedance from the selector line. In this example, 'Line out' will always be the signal currently selected from one of the programme inputs (Phono, CD, Tuner, etc.), buffered with an output impedance of 1k $\Omega$ . 'Line out' and 'Line in' allow a 3-head tape recorder with monitoring facility, or a graphic equaliser, to be linked into the system. Tape monitoring to the line function switch is shown taken from the 'Tape' input sockets via screened lead, but in practice, it is easier to link across to the relevant pins on the nearby selector switch with bell wire. In fact, all connections between both switches and the Phono and line

driver PCB can be made with plain bell wire, even though the line impedance can be high, as the connections are very short.

The long-wire connections between the line driver outputs, Tone Control outputs and the output sockets are again bell wire, as the output impedances are low.

## Conclusion

Figures 7 and 8 illustrate how the 'Newton' modules can be configured in different ways to create a customised preamplifier. My own version (the prototype in the photos) follows the pattern of Figure 8, but having tape input and monitoring for two recorders, and two unswitched and four switched Euro mains outlets for six other components of the stereo system. If you play CDs more often than records, you might consider adding a miniature toggle switch to the rear panel of the PSU chassis, to turn off the phono preamp DC heater and preserve the life of the valves while they are not being used.

I think we all agree that the valve technology resurrection has coincided nicely with the increased availability of compact discs and players, and valves generally make the most of them. They are in their element, as it were, given the CD's high output and wide dynamics. This is very interesting, because it just goes to show how much the early valve equipment was compromised not only by some inferior electrical components (by modern standards), but also by the quality of the transducers of the time, all contributing to even less perfect recordings to be replayed. CDs are an improvement out of all proportion and don't seem to faze the modern valve amplifiers at all, in fact, they have given them a new lease of life. An interesting demonstration CD is available from Maplin (AY00A), which includes test tones, an organ recital, a drum solo and various far-out sound effects, including a jet fighter flypast!

What advantages are offered by the passive RIAA equalisation is still a moot point, though I will admit to hearing at least one extra instrument in a record I played recently. The record is over ten years old, but I've never noticed this detail before! Generally, records play really well and it's nice to have an output level on a par with other sources, such as CD.

## NEWTON TONE CONTROL UNIT PARTS LIST

RESISTORS: All 0.6W 1% Metal Film (Unless specified)

R1	2k2 2W 1% Metal Film	1	(D2K2)
R2	4k7 3W Wirewound	1	(W4K7)
R3,103	62k	2	(M62K)
R4,104	20k	2	(M20K)
R5,15,16,			
105,115,116	470k	6	(M470K)
R6,106	270Ω	2	(M270R)
R7,107	5k1	2	(M5K1)
R8,108	680k	2	(M680K)
R9,109	220Ω	2	(M220R)
R10,110	4k7	2	(M4K7)
R11,111	150k	2	(M150K)
R12,112	39k	2	(M39K)
R13,113	68k	2	(M68K)
R14,114	6k8	2	(M6K8)
RV1,2	220k Dual Logarithmic Potentiometer	2	(FX13P)
RV3	1MΩ Dual Linear Potentiometer	1	(FW91Y)
RV4	10k Dual Logarithmic Potentiometer	1	(FX09K)

CAPACITORS

C1,4,8,108	10nF HV Ceramic Disc	4	(BX15R)
C2,3	47μF 450V Radial Electrolytic	2	(JL18U)
C5,105	100nF HV Ceramic Disc	2	(FA21X)
C6,9,106,109	10μF 450V Radial Electrolytic	4	(JL11M)
C7,10,107,110	10nF Poly Layer	4	(WW29G)
C11,111	330pF 1% Polystyrene	2	(BX51F)
C12,112	560pF 1% Polystyrene	2	(BX54J)
C13,113	8n2F 1% Polystyrene	2	(BX85G)
C14,114	2n2F 1% Polystyrene	2	(BX60Q)
C15,115	22nF 1% Polystyrene	2	(BX87U)

VALVES

V1,101	ECF82 HF Triode Pentode	2	(ST30H)
--------	-------------------------	---	---------

MISCELLANEOUS

1mm PCB Pins	1 Pkt	(FL24B)
B9A Valve Base	2	(CR32K)
Rubber Coupling	4	(FB98G)
Anti-parasitic Beads	1 Pkt	(LB62S)
M4 Steel Nut	1 Pkt	(JD60Q)
Single Mic Cable	1m	(XR16S)
0.71mm 22swg Linned Copper Wire	1 Lenth	(BL14Q)
Bell Wire Black	1 Lenth	(BL85G)
Bell Wire Orange	1 Lenth	(BL90X)
Systoflex 2mm Black	1 Lenth	(BH06G)
Instruction Leaflet	1 Lenth	(XV12N)
PCB	1	(9513Z)
Constructor's Guide	1	(XH79D)

OPTIONAL

Knob K8A	4	(YR64U)
----------	---	---------

The Maplin 'Get-You-Working' Service is available for this project, see Constructors' Guide or current Maplin Catalogue for details.

**The above items (excluding Optional) are available as a kit which offers a saving over buying the parts separately.**

**Order As 95131 (Newton Tone Control Module)  
Price £39.99<sup>A1</sup>**

Please Note: Where 'package' quantities are stated in the Parts List (e.g., packet, strip, reel, etc.), the exact quantity required to build the project will be supplied in the kit.

The following new item (which is included in the kit) is also available separately, but is not shown in the 1996 Maplin Catalogue

Tone Control Module PCB **Order As 95132 Price £4.99**

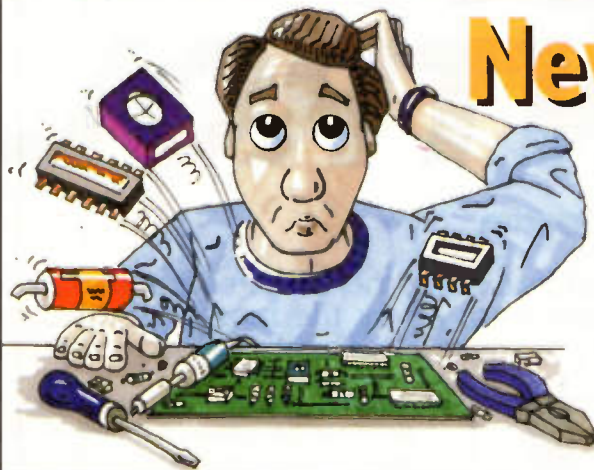

## New To Electronics? or just need a refresher!

**Cerco now offer you an electronics training course in one complete package!**

- A step by step guide takes you through the basics, instrumentation, soldering skills, simple, intermediate and complex logic circuitry, power supplies and simple fault finding.
- A video gives visual support in the important areas.
- A work book takes you through over 20 experiments, all of which can be conducted on our stand alone experimenter board (supplied as part of the Module)
- The experimenter board can be used beyond the end of the course for the development of your own or magazine circuits.

Send just £1.99 for an informative video

**"Learning More with Cerco"**

Telephone our Credit Card Hotline on 01270 626300 or send details to the address below.

Name \_\_\_\_\_

Address \_\_\_\_\_  
\_\_\_\_\_

Post Code \_\_\_\_\_

Send just £1.99 to cover handling, postage and packing. Please enclose your cheque / postal order for £1.99 made payable to CERCO TRAINING LTD.  
Ref: ECP1



Send coupon to:  
Cerco Training Ltd.,  
Alvaston Business Park,  
Middlewich Road,  
Nantwich, Cheshire,  
CW5 6PF.  
Tel: 01270 626300



Ref: ECP1



# DRIVING FOR CONTROL

by Stephen Waddington

If the government intends to foster greater competition among the water companies, as it announced earlier this year, by empowering consumers to select the most cost-effective company, regardless of location, then it will be necessary to create a 'national grid' of water pipes.

**T**HIS proposition is flawed. Its main fault is that water has a very low unit cost, while the cost of pumping it round the country would be prohibitively expensive. A national grid of water pipes would require a huge investment in motor driven pumps. This implies not only a massive initial investment cost, but also a large ongoing running cost. If the government is to follow this strategy, it must seek to adopt a different 'national grid' model to that of the electricity industry.

## Driving Demand

The water industry is already underpinned by a massive number of pumps. Pumping stations, reservoirs, sewage plants, sludge treatment and filtering stations are all reliant on motor driven pumps. Elsewhere, you cannot escape from electrical motors: water pumps. Applications are diverse, including: central heating control, as shown in Photo 1; electrical fridges; cooling fans; and air conditioning systems. In fact, it is estimated that electrical

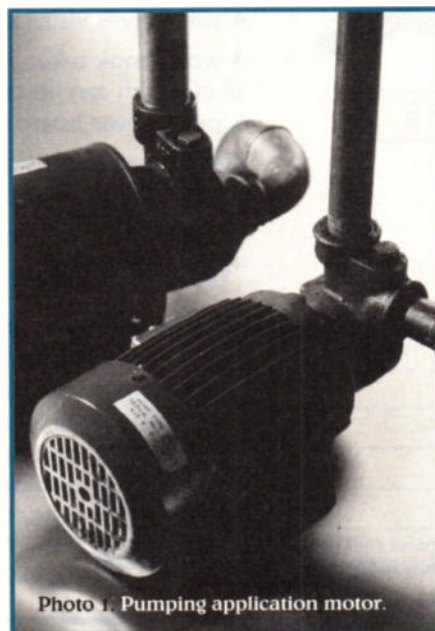

Photo 1. Pumping application motor.

motors account for more than 20% of electricity consumption in the UK. This figure could be significantly reduced by the increased use of variable-speed drives, and the application of control systems.

Variable-speed control is a method of accurately matching the speed of a motor to an application. Consider an example from the water industry. Flow control, which has traditionally been achieved by throttling or damping the fluid output by vanes or valves, is a prime target for variable-speed drives. Driving a pump at full speed, with its output modified by the use of some form of mechanical obstruction is not efficient.

Motors in the water industry are typically large, in the order of hundreds of kilowatts, so energy savings through the use of variable-speed drives can be large. However, let's consider an example where variable-speed control reduces wear, and enables a task to be performed with greater efficiency. It is only in the last ten years that domestic electric drills have been fitted with speed control.

Submersible Pumps	Submersible pumps are commonly used for waste water handling. The pump and the motor form a complete unit which is submerged in the water. Variable-speed control of such pumps makes it easy to provide a steady flow to biological sewage treatment plants, and allows smaller pump stations to high volumes of water. Frequency control is the most feasible method of speed control for submersible pumps.
Pump Stations	Large numbers of pumps are used in industry, power production and urban installations. These pumps handle clean or sewage water, pulp mixed with water, and chemicals. In some processes, several pumps may be connected in series or in parallel and are usually controlled by some form of automatic device or computer system. The regulation of such systems is enhanced by the application of speed control.
Forced Draft Fans	Combustion in modern power station boilers is assisted by forced draft fans to improve the capacity and efficiency of the boilers. Variations in heat demand and atmospheric pressure require that it be possible to control the draft. The best way to control forced draft is to apply speed control, providing better boiler control, less wear, less noise and subsequent energy reduction.
Sawmill	A sawmill line is a typical example of a process comprising several machines in the form of a production line. There are debarking drums, reducers, band saws and trimmers. In between these, conveyor belts are used to move timber around the mill. Using speed control, the production speed can be regulated and matched to the diameter and hardness of the logs.
Pulp Grinders	Pulp grinders convert logs to pulp. They are driven by large synchronous or induction motors. The feeder uses relatively small motors, and must be controlled to avoid overloads on the main driver motor as well as for good efficiency. The chain feed with a variable-speed drive can be controlled easily and reliably by measuring the load of the main drive motor and keeping it at a rated level.
Screw Conveyor	Screw conveyors are commonly used for moving chips, bark, cement and flour. They are also used in dosers. Speed control here gives better accuracy and causes less wear in mechanical parts.
Grinders	Rotary grinders are commonly used to grind metal products. The grinding stone diameter decreases over time due to wear. Speed control ensures that the perimeter speed can be kept constant.

**Table 1. Examples of variable-speed drive applications.**

Before then, a single-speed drill had to be used to drill in mortar, metal or wood. This fairly trivial example illustrates the essence of variable-speed control. Mortar should be drilled at a low speed, around 700 to 900rpm, while wood should be drilled at speeds around 2,500rpm. Metal, meanwhile, falls between the two. Using a single-speed drill for all three materials is inefficient, and causes undue wear on the drill bit, and this is a domestic situation. Imagine this example applied to an industrial pillar drill with typically ten times the power.

## Cost Saving and Reduced Maintenance

Engineers and indeed, accountants, are realising that the energy savings possible with variable-speed equipment are large, and that the outlay to purchase additional control equipment can be retrieved within a relatively short period of time. Energy savings, ease of control and lower maintenance are all benefits of controlling motors with a frequency converter. As a result, variable-speed drives are being used across a variety of industries and applications. Table 1 outlines a series of examples.

A variable-speed drive, usually shortened to drive, is a term used to describe a system

comprising an electric motor (either AC or DC) and a control circuit, called a converter. The converter allows a standard motor to be driven at various speeds other than its rated frequency. There are numerous types of different converter. Almost all rely on some form of electronic switching to control the output signal, and thus, speed of the motor.

## AC Drive Concept

A complete drive system is shown in Figure 1. In the context of this article, we will consider only DC systems, since these are used in the majority of industrial applications. AC drives, however, are making significant inroads into many industrial applications, favoured for their superior response and lower maintenance. These will form the subject of a subsequent article.

The role of the converter is to draw electrical energy from the mains at constant voltage and frequency, and supply energy to the motor in whatever form is required to deliver the desired mechanical output. As Figure 1 indicates, a converter typically consists of two elements, namely, a control section, and a power stage.

The control section takes external control signals from a computer or digital control system and feeds back signals from some form of rotational measurement device fixed on the shaft of the motor, as shown in Photo 2. The difference between these two signals is determined by the control circuitry, which feeds an appropriate input to the power circuit. The power circuit produces an output in proportion to the requested signal, in an attempt to match the rotational speed of the motor with the target output speed. Figure 1 indicates the presence of a single input representing the desired speed, and a single feedback loop indicating the actual speed. In reality, most drives will have several additional feedback mechanisms, such as torque and temperature.

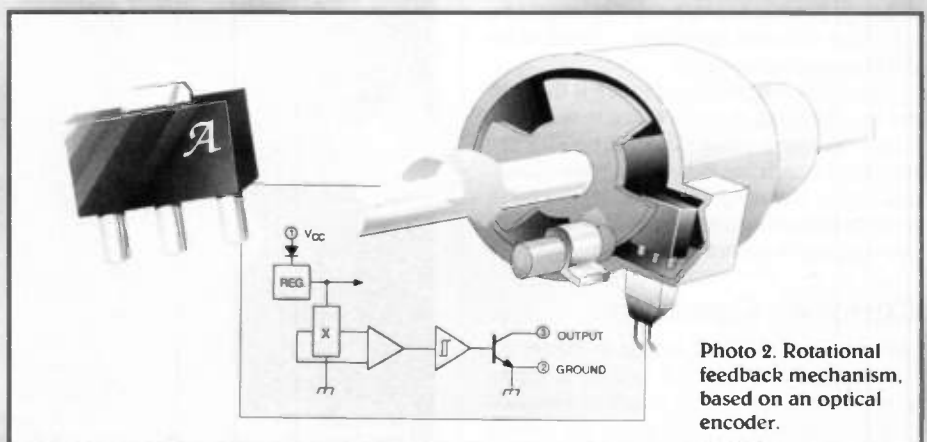
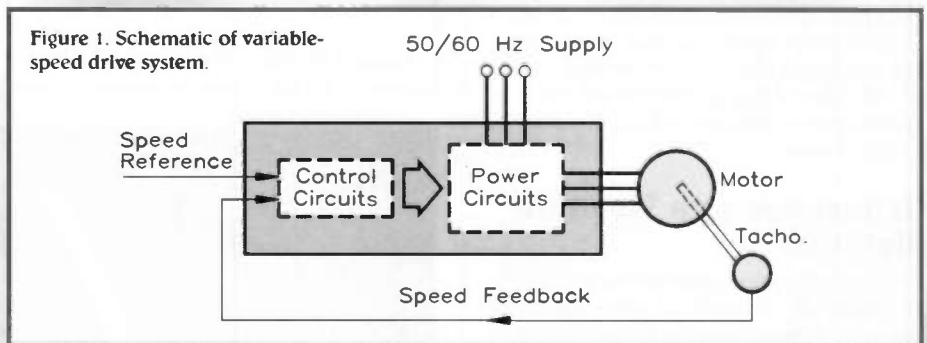

## Variable Resistance

Let's examine more closely how the voltage across the motor is generated and controlled. Initially, we will consider the motor purely as a resistive load of  $4\Omega$ . We will examine inductive properties shortly. Three different methods of controlling the voltage across the motor from a  $20V$  DC source are shown in Figure 2.

The first method, shown in Figure 2a, uses a variable resistor in a potential divider arrangement to absorb whatever fraction of the battery voltage is not required by the load. It provides smooth control, but power is wasted in the control resistor. For example, if the output speed of the motor is inversely proportional to the input voltage, then to reduce the motor to half speed, the load voltage will have to be halved to  $10V$ . To achieve this, the resistor  $R$  must be set to  $4\Omega$ , so that it absorbs half the supply voltage.

From Ohm's Law, we can calculate the current flowing through the circuit:

$$\text{Voltage}(V) = \text{Current}(I) \times \text{Resistance}(R)$$

$$I = \frac{V}{R} = \frac{(4+4)}{10} = 0.8A$$

The circuit load will be:

$$\text{Power}(P) = \text{Voltage}(V) \times \text{Current}(I) \\ = 0.8 \times 20 = 16W$$

The load power will be:

$$\text{Power}(P) = \text{Current}(I) \times \text{Voltage}(V) \\ = 0.8 \times 10 = 8W$$

This means that the overall efficiency of the circuit will be 50%, calculated thus:

$$\text{Efficiency} = \frac{\text{Output}}{\text{Input}} \times 100 = \frac{8}{16} \times 100 = 50\%$$

If  $R$  is increased further in order to obtain lower speed, the efficiency of the circuit will fall dramatically to zero. This assumes, of course, that both the resistor and the motor load exhibit ideal resistor characteristics, and that the input voltage versus output speed behaviour remains linear. In practice, neither of these factors remain true. As a consequence, this method of control is not suitable, except in the case of low power circuits such as model cars, windscreen wipers, fan heaters or hair dryers.

## Transistor as a Variable Resistor

The second method of motor control, shown in Figure 2b, is much the same the initial example. Here, a transistor takes the place of the manually operated variable resistor. The collector-emitter of a transistor operates like a resistor, with the resistance controlled by the base-emitter current.

The drawback of this approach is that like the first method, the efficiency is very low. Here, the spare power is absorbed by the transistor, which has to be large, well cooled, and hence, is usually expensive. It is for these reasons that transistors are rarely operated in this manner in power electronics.

## Chopper Circuit

Let's consider the final option in Figure 2c. Here, a mechanical switch is used to represent the concept of a chopper, or switched power regulator. By operating the switch repetitively, and varying the ratio of the 'off'

Figure 2. Methods of varying voltage to motor and hence speed, from a DC voltage source.

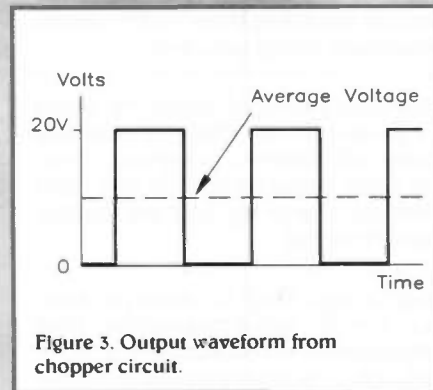
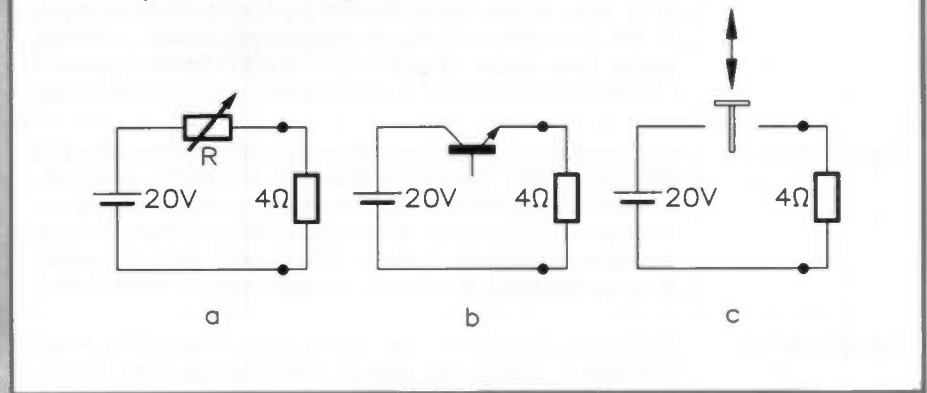

Figure 3. Output waveform from chopper circuit.

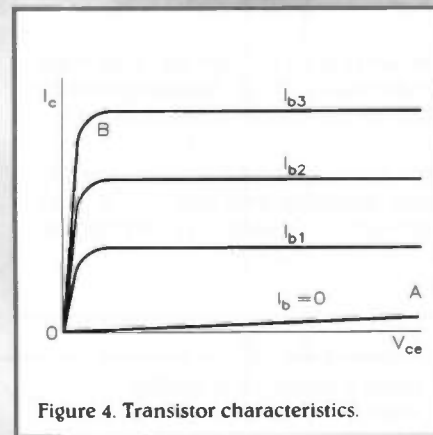

Figure 4. Transistor characteristics.

and 'on' time as shown in Figure 3, the average load can be varied between  $0V$  (switch constantly 'off') and the full supply voltage of  $20V$  (switch constantly 'on'). To achieve half speed for example, the ratio of 'off' cycles to 'on' cycles would be equal. The mean voltage supplied to load is shown as a dashed-line in Figure 3.

This approach is known as pulse width modulation (PWM). Its main advantage is that the switch does not absorb any power, and thus, the efficiency of the converter is 100%. In reality, the switching is performed electronically using a transistor arrangement. While this does have a power overhead, its effect is negligible when compared with the power required by the motor.

The main disadvantage with the PWM approach is that the voltage waveform supplied to the motor is an oscillating DC voltage. In order to maintain a smooth rotational output, the waveform delivered to the motor should be smooth. To achieve this, a high switching frequency is used. This is typically of the order of  $40kHz$ . At this frequency, variations in the DC component of the load voltage effectively become smooth.

## Transistor Switching

A switching frequency of  $40kHz$  is easily achieved using transistor technology. The collector-emitter of a transistor is driven as a

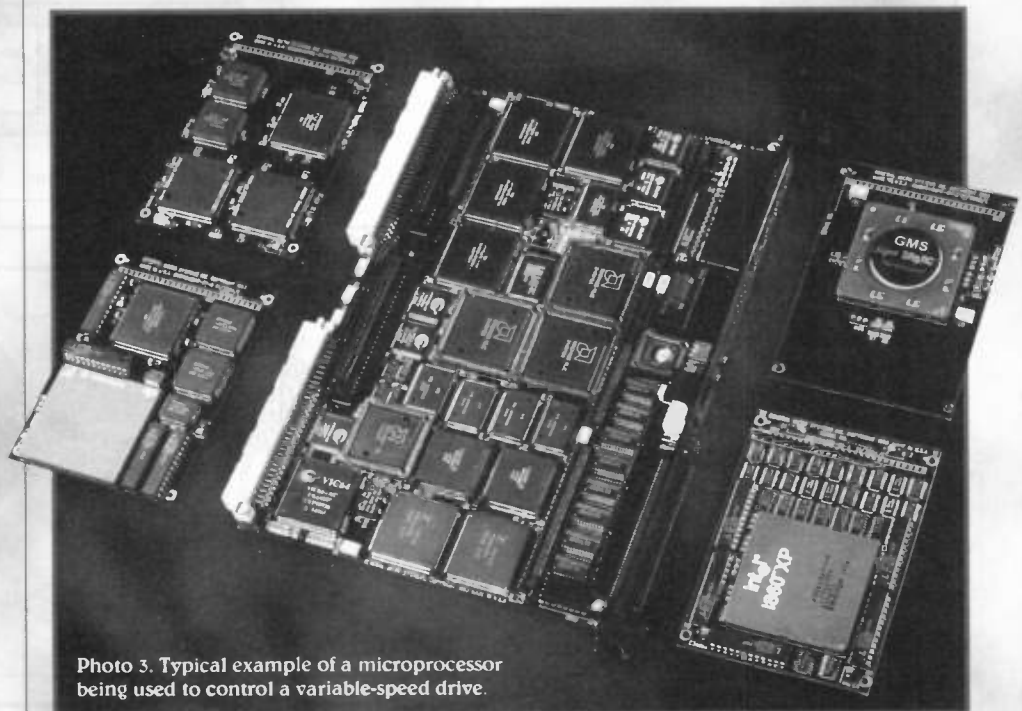

Photo 3. Typical example of a microprocessor being used to control a variable-speed drive.

fast switch in the area of its characteristic shown in Figure 4. The transistor is 'off' when the base-emitter current is zero. Viewed from the main collector-emitter circuit, its resistance will be very high as shown by curve OA. To turn the transistor fully 'on', a base emitter current is required. The base current required will depend on the size of the collector-emitter, or load current required. The aim here is to keep the transistor saturated so that it has a very low collector-emitter resistance, corresponding to curve OB in the graph. By keeping the transistor 'on' in its saturation region, its effective resistance remains low for high collector-emitter currents.

Having configured a transistor to act like a mechanical switch, an oscillator is required to switch the collector-emitter circuit. It is ultimately this driving mechanism which will control the motor rotation. The base drive is usually undertaken by a low powered oscillator, microcontroller, as shown in Photo 3, or microprocessor. Depending on the power requirement of the driving transistor, and the output drive capability of the oscillator, microcontroller or microprocessor, some intermediate amplification may be required.

## Inductive Loading

So far, we have considered PWM only in terms of a resistive load. However, in the case of a motor winding, the load will invariably have some form of inductive component. PWM control of inductive loads, is much the same as that for resistive loads, except protective elements must be added to the drive circuitry to prevent rogue voltages being fed back across the drive transistor. When an inductor is switched 'off', it generates an electrical voltage in a dynamo-type effect as its magnetic field collapses.

A diode, as shown in Figure 5 and Photo 4, is usually used to avoid damage to the transistor. The diode offers minimal resistance to current flowing from anode to cathode, but blocks and absorbs current flowing from cathode to anode. Hence, in the circuit shown in Figure 5a, when the transistor is 'on', current flows through the load, but not through the diode. When the transistor is turned 'off', as shown in Figure 5b, the current through it, and the supply drops almost instantly to zero, but the stored energy in the inductor means that the current does not fall to zero. Since there is no longer a current path through the transistor, the current diverts upwards through the low resistance path offered by the diode. Current stored in the inductor is dissipated by the diode as heat.

The load current waveform for a PWM drive motor considering both inductance and resistance is shown in Figure 6, against the load current waveform for a purely resistive load. Note that where both resistance and inductance are considered, the current rises and falls exponentially, resulting in a continuous waveform. This is because consideration of the motor inductance results in the current being much smoother than with a purely resistive load.

As we have seen, PWM is a highly effective method for controlling the speed of a motor. The electronic switches necessary to connect and disconnect the motor from the supply can be produced at low cost. Let's move on now, and examine the power circuitry necessary to drive commercial DC variable-speed drives.

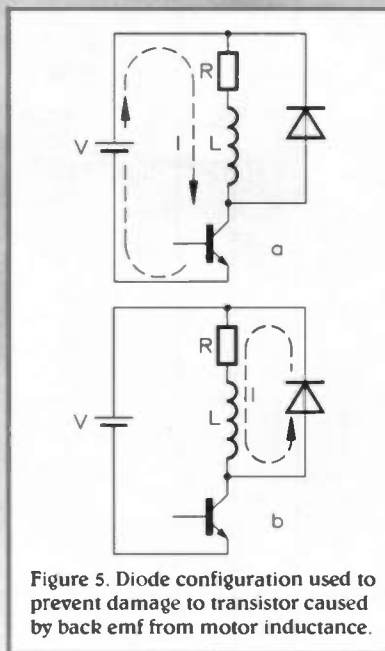

Figure 5. Diode configuration used to prevent damage to transistor caused by back emf from motor inductance.

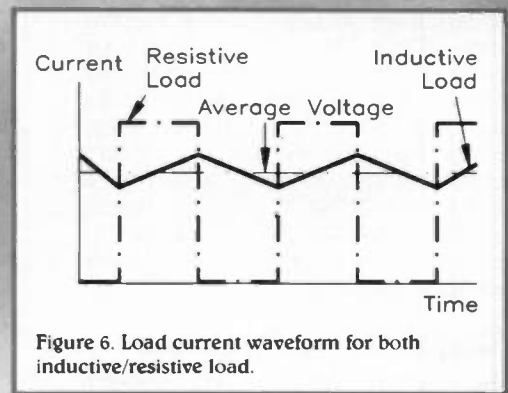

Figure 6. Load current waveform for both inductive/resistive load.

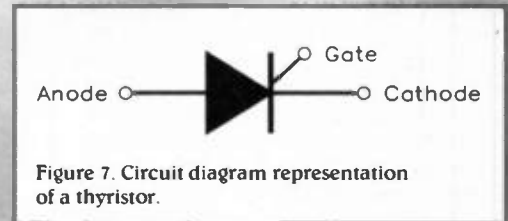

Figure 7. Circuit diagram representation of a thyristor.

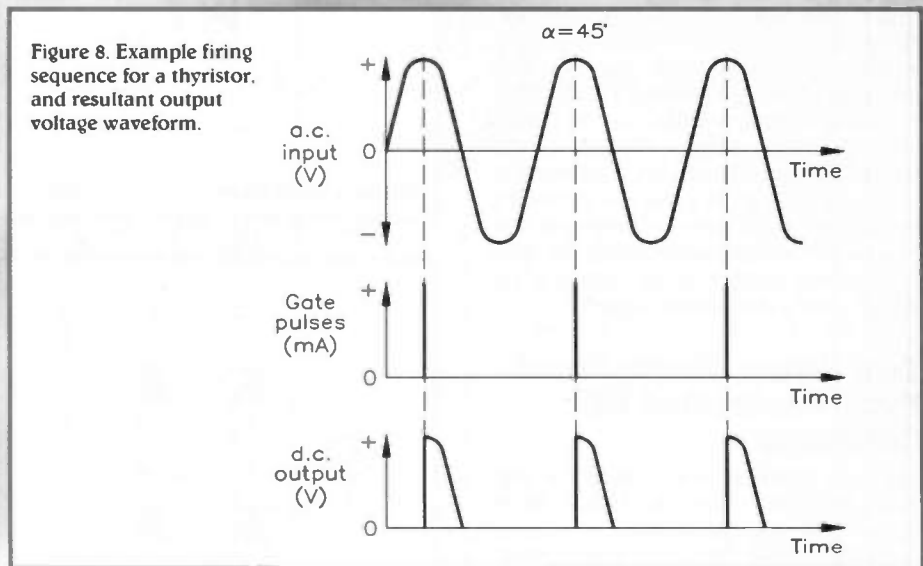

Figure 8. Example firing sequence for a thyristor, and resultant output voltage waveform.



Photo 4. A diode arrangement is used to prevent damage to drive transistors when the motor core is switched off.

## DC Drives

The majority of drives draw their power from the mains at 50Hz and use a rectifier to convert this AC supply into a DC voltage. Where a constant voltage output is required, a conventional diode rectifier is sufficient. However, where the mean DC output voltage must be controlled, a more complex controlled rectifier is used. A variety of conversion mechanisms are possible, based on a combination of power components, including diodes, transistors and thyristors, as shown in Photo 5. However, in modern DC drives, all the rectifying components are thyristors.

## Thyristors

A thyristor is a four-layer, three-terminal semiconductor device, as shown in Figure 7. When forward biased, a thyristor does not conduct until a positive voltage is applied to the gate. Conduction continues when the gate voltage is removed, and only stops when the supply voltage is switched 'off' or reversed.

The control of AC power is achieved by allowing current to be supplied to the load during only part of each cycle. A gate pulse is applied automatically at a certain stage during each positive half-cycle or input. This allows the thyristor to conduct and the load to receive power. An example is shown in

Figure 8. Here, the pulse occurs at the peak of the AC input, or  $\alpha = 45^\circ$  - this is known as the delay, or firing angle. During negative half cycles, the thyristor is non-conducting and it does not conduct again until halfway through the next positive half cycle. Current, therefore, flows only for a quarter of a cycle, but by changing the timing of the gate pulses, this can be increased or decreased. The power is thus varied from zero to that due to half-wave rectified DC.

## Single Pulse Rectifier

The simplest phase-controlled rectifier is shown in Figure 9. When the supply current is positive, the thyristor blocks forward current until the gate pulse arrives. Up to this point, the voltage across the resistive load is zero. As soon as the device turns 'on', the voltage across it falls to near zero, and the load voltage becomes equal to the supply voltage. When the supply voltage reaches zero, the thyristor regains its blocking capability, and no current flows during the negative half cycle.

The resultant load voltage consists of the positive half cycles of the AC supply voltage. This is not DC by any means, but it is positive in terms of its mean value. By controlling the firing angle by switching the thyristor, the mean output voltage can be tightly controlled. The output voltage should approximate to DC, but in fact, is very coarse, consisting of a single pulse per cycle. For this reason, this circuit is never used in drives. Instead, DC variable-speed drives use four thyristors for a single phase supply, or six thyristors for a three phase supply.

## Two Pulse: Single Phase Fully Controlled DC Converter

The main elements of a single phase fully controlled DC converter circuit are shown in Figure 10. Here, four thyristors are connected in a bridge format. The output voltage waveform is dependent on the firing angle for each of the thyristors. An added complication is that the output waveform is entirely different for resistive and resistive/inductive load. We will consider only the latter example here, for the case of a motor.

Thyristors T1 and T4 are fired together when terminal A of the supply is positive, while on the other half cycle, when B is positive, thyristors T2 and T3 are fired simultaneously. The output waveforms for firing angles of  $15^\circ$  and  $60^\circ$  are shown by the heavy lines in Figures 11a and 11b, respectively. There are two pulses per mains cycle, hence the description two-pulse or full-wave.

The dashed-lines in Figures 11a and 11b show the mean DC output. The diagrams illustrate that the larger the decay angle, the lower the mean DC output voltage. Were we to consider purely a resistive load, the voltage output would never drop below zero. This situation arises here because of the voltage generated by the inductance of the motor when the supply voltage falls to zero.

## Six Pulse: Three Phase Fully Controlled Converter

A three phase device is shown in Figure 12. While only two additional thyristors are used over the single phase bridge, the output voltage



Photo 5. Diodes, transistors and thyristors available in modern power electronics.

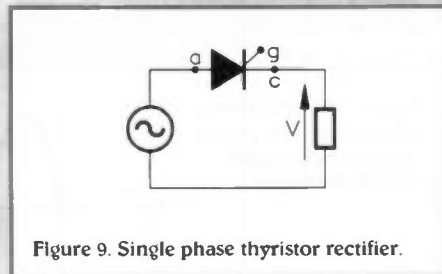

Figure 9. Single phase thyristor rectifier.

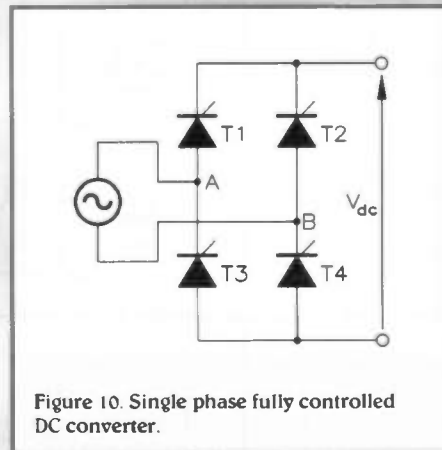

Figure 10. Single phase fully controlled DC converter.

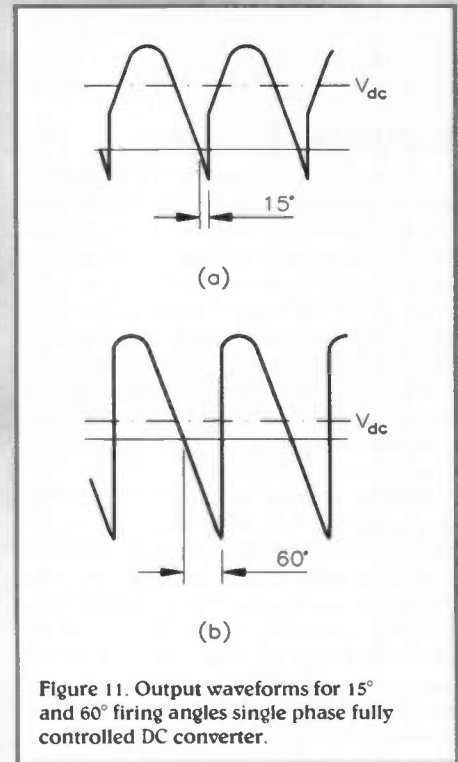

Figure 11. Output waveforms for  $15^\circ$  and  $60^\circ$  firing angles single phase fully controlled DC converter.

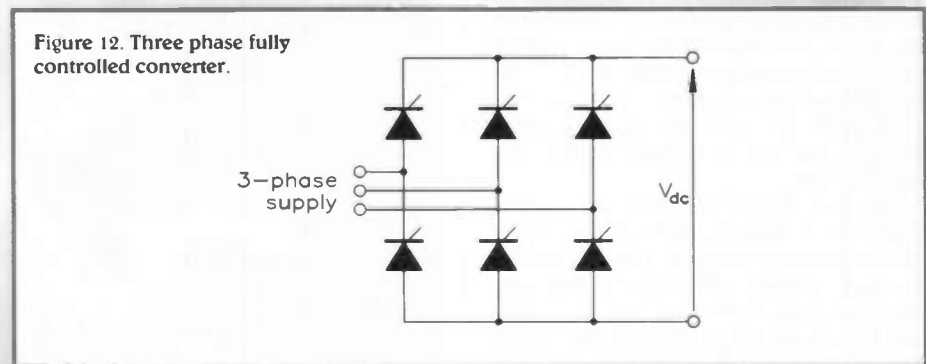

Figure 12. Three phase fully controlled converter.

is much smoother. This is because there are now six current pulses per mains cycle. The thyristors are again fired in pairs, with each thyristor carrying the output current for a third of the time. As in the single phase converter, the delay angle controls the output voltage, with  $\alpha = 0^\circ$ , corresponding to the point at which all phase voltages are equal, and thus, the output voltage maximum.

The improvement in the resolution of the output voltage compared with the previous

examples is obvious from Figure 13, which shows a variety of firing angles. The mean DC voltage is shown by the horizontal dashed-line. Occasionally, even a six pulse waveform is not sufficiently smooth for large motors. Here, two six-pulse converters are used with their outputs in series. A phase-shifting transformer is used to insert a  $30^\circ$  shift between the AC supplies to the two 3-phase bridges. The resultant ripple voltage consists of 12-pulses per mains cycle.



Figure 13. Output waveforms for a variety of firing angles for three phase fully controlled converter.

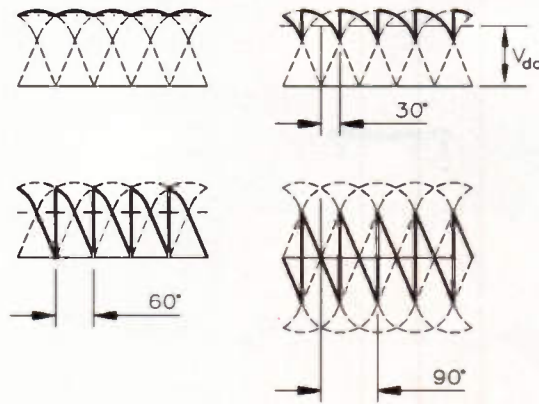

## Firing Circuits

The pulses that control the switching of the thyristors are low voltage and low power. These are usually generated by an Application Specific Integrated Circuit (ASIC). ASICs provide a neat method of synchronising the gate pulses with the appropriate delay angle, and locking the pulse train to the mains signal. An integrated circuit approach also simplifies external control, since the firing arrangement, and hence, the output voltage to the motor can be proportionally related to the input control voltage. This typically varies in the range 0 to 10V. To avoid direct connection between the low voltages in the thyristor firing

circuits and the main power circuit, the gate pulses are usually coupled to the thyristor by some means of opto-isolation or pulse transformer.

## Perfect Harmony

In common with most textbooks, the waveforms shown within the context of this article are what would be seen under ideal conditions. In reality, this is never the case. We have not considered the effects of mains harmonics. Harmonics are distortions of the mains supply, occurring at multiples of the supply frequency. They are caused by loads that do not draw a continuous current. Any equipment which uses electronic

devices to change one voltage and frequency to another will generate harmonic current. These include personal computer power supplies, frequency converters, some type of fluorescent lighting and many other items of domestic equipment.

Harmonic currents reveal themselves as multiples of the fundamental power supply frequency, superimposed on the fundamental. The multiple-frequency component of the harmonic voltage can have a damaging effect on equipment that uses the periodic nature of the mains for timing applications, such as electrical clocks and domestic television receivers. Equally, equipment incorporating electromagnets may also fail as spurious voltages cause magnetic fields to break down.

There are no internationally agreed standards, at present, for the level of harmonic distortion which AC devices must not exceed. However, all of the electricity authorities in the UK specify the maximum level and spectrum of harmonic currents at various levels in the power system. If a proposed installation exceeds these limits, appropriate filter circuits must be connected in parallel with the system. These can be costly, as their design is complex, since a variety of characteristics of the electricity supply need to be considered.

## Further Reading

*Electric Motors & Drives*, Austin Hughes.  
*Electric Motors*, Jim Cook.

## CORRIGENDA

### ISSUE 99 MARCH 1996

A Practical Guide to Modern Digital ICs, page 46 and 47. Please note that the lower junction between R3 47k and RV1 22k in Figure 18 should be connected. The same applies to the lower junction between R6 47k and RV2 22k in Figure 20, as shown in the revised drawings.

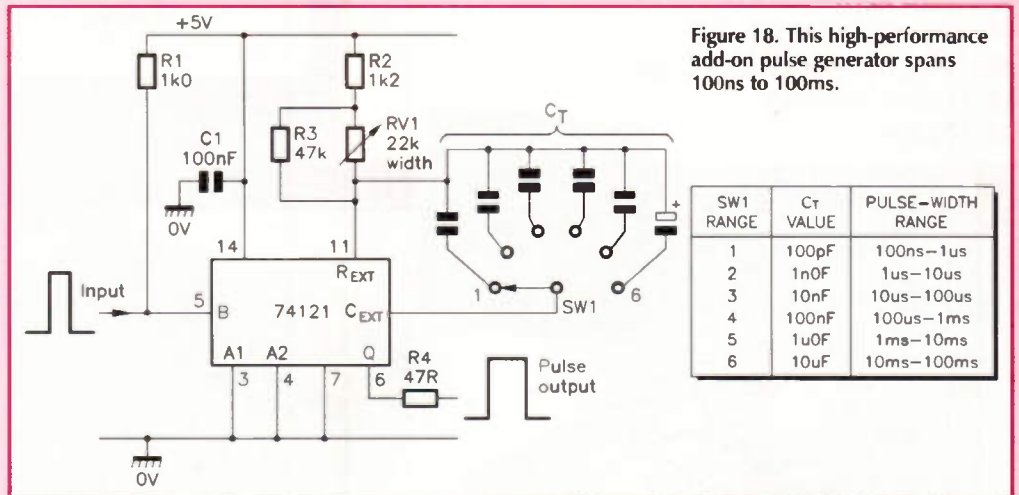

Figure 18. This high-performance add-on pulse generator spans 100ns to 100ms.

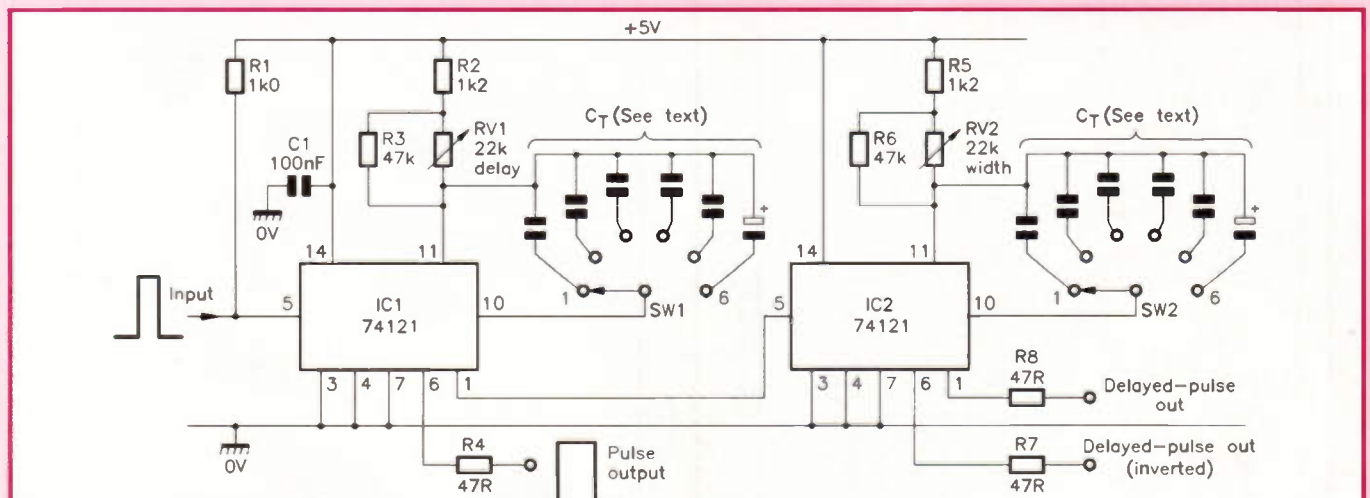

Figure 20. High-performance add-on delayed-pulse generator spans 100ns to 100ms.

# FOUR CHANNEL RUNNING LIGHT

## FEATURES

- ★ Automatic multiple pattern sequence
- ★ Variable speed rate
- ★ Synchronous or asynchronous operation
- ★ Zero-crossing switching

## APPLICATIONS

- ★ Promotional events
- ★ Shop window displays
- ★ Disco lighting
- ★ Parties

## Specification

Operating voltage: 230V AC mains  
 Output power: 400W maximum per channel  
 Switching modes: Synchronous, constant speed, with zero-crossing switching of the triacs  
 Asynchronous with adjustable clock speed  
 PCB dimensions: 110 x 85mm

## Important Safety Note:

It is important to note that mains voltage is potentially lethal. Full details of mains wiring connections are shown in this article, and every possible precaution must be taken to avoid the risk of electric shock during maintenance and use of the final unit, which should never be operated with the box lid removed. Safe construction of the unit is entirely dependent on the skill of the constructor, and adherence to the instructions given in this article. If you are in any doubt as to the correct way to proceed, consult a suitably qualified engineer.

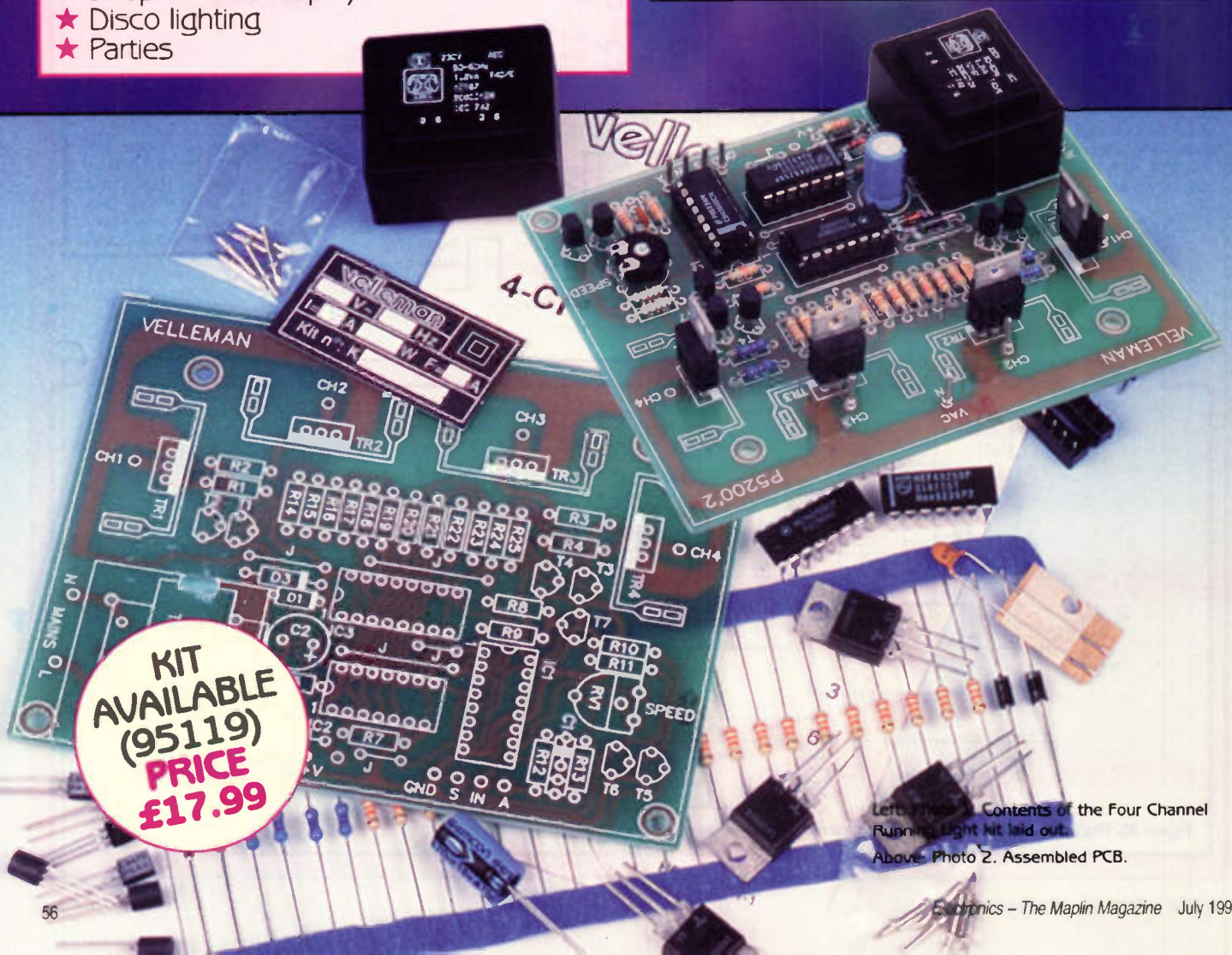

Left Photo 1. Contents of the Four Channel Running Light kit laid out.

Above: Photo 2. Assembled PCB.

**T**HE Four Channel Running Light project presented in this article is designed to drive up to four mains powered lamps rated at up to 400W each, by means of triac devices, for use in discos, parties or applications demanding some sure-fire attention grabbing! The project flashes the lights in a sequence of changing patterns – either running to the right, running to the left, flip-flop flashing of the two pairs of lamps, or all lamps flashing simultaneously. The four light effects follow each other automatically. In addition, the speed of the sequence is variable. The unit can be configured to provide zero-crossing switching of the triacs, thus minimising the possibility of interference with other electronic equipment being operated nearby.

The Four Channel Running Light kit comes complete with assembly instructions to construct the PCB assembly, which has an onboard mains transformer. However, to create a working system, it will be necessary to house the PCB in a suitable plastic box, and to connect a mains lead, together with a fuseholder containing an appropriately rated fuse.

## Circuit Description

Refer to the block and circuit diagrams shown in Figures 1 and 2, respectively. The power supply for the circuit is obtained by reduction and full-wave rectification of the AC mains by means of the transformer and diodes D3 and D4, while C2 smoothens out any excess ripple of the DC output. A synchronous clock, equal to twice the mains frequency, appears at the collector of transistor T6, which switches in anti-phase to T5, which is in turn switched by the positive-going supply voltages passing through D1 and D2, thus forming a zero-crossing detector. If the synchronous clock

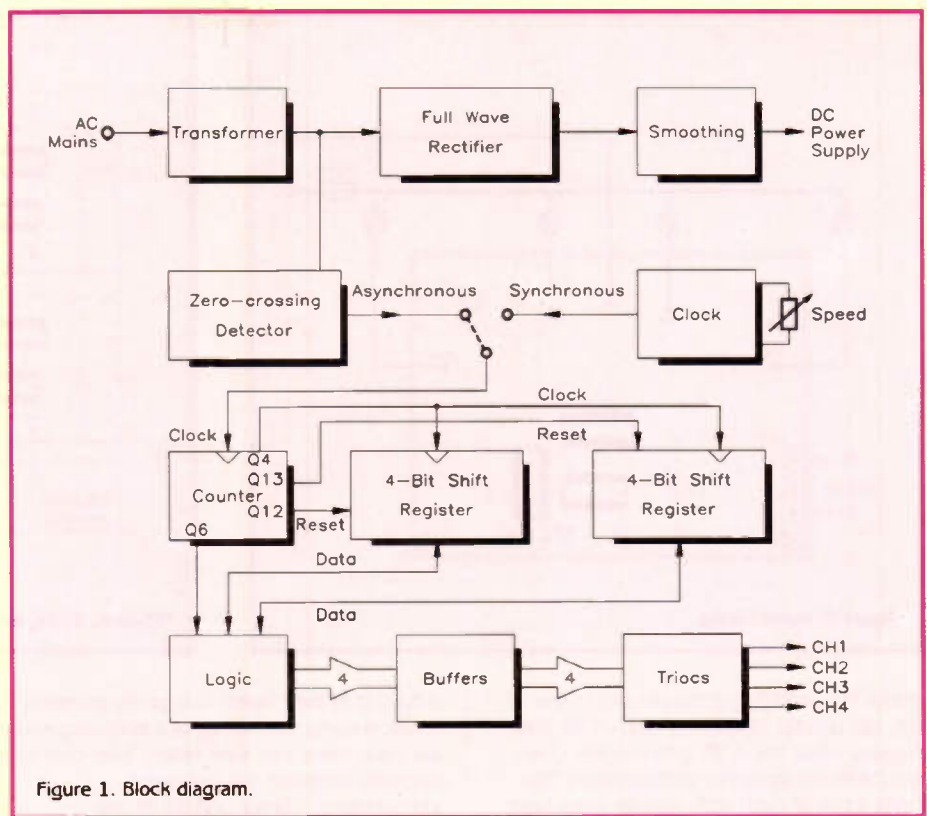

Figure 1. Block diagram.

is selected, the triacs will be switched on the zero-crossing part of the mains AC cycle, which avoids electrical interference being generated.

IC1 is a 4060BE 14-stage ripple counter, which is clocked either asynchronously via its on-chip oscillator, the speed of which is set by C1, R13 & RV1, or synchronously, with constant speed, via the T6 output. (A link between 'IN' and 'A' or 'S' sets the required clock type.) The Q4 and Q12 counter outputs are fed into the CLOCK and

RESET inputs, respectively, of one half of IC3, a twin 4-bit shift register. The Q4 and Q13 counter outputs are fed into the CLOCK and RESET inputs, respectively, of the other half of IC3. All four counter outputs are also applied to the logic network formed from NOR gate N2 (IC2) and the 2-input NOR gate formed from transistor T7 and R7-R9. The output of N2 goes high only if the counter output Q6 is low AND either or both Q12 and Q13 outputs are high.

The inputs of the other two IC2 NOR

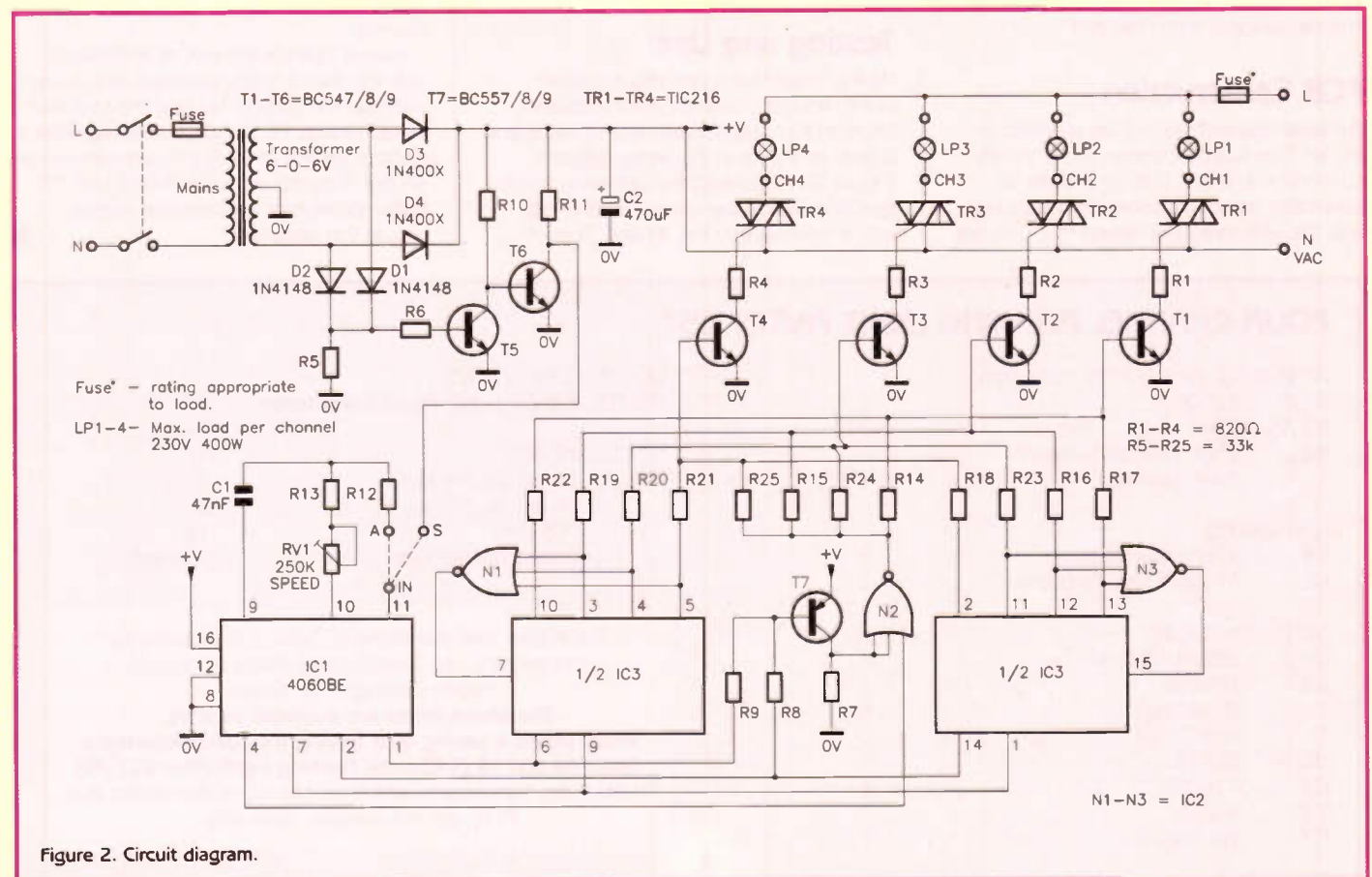

Figure 2. Circuit diagram.

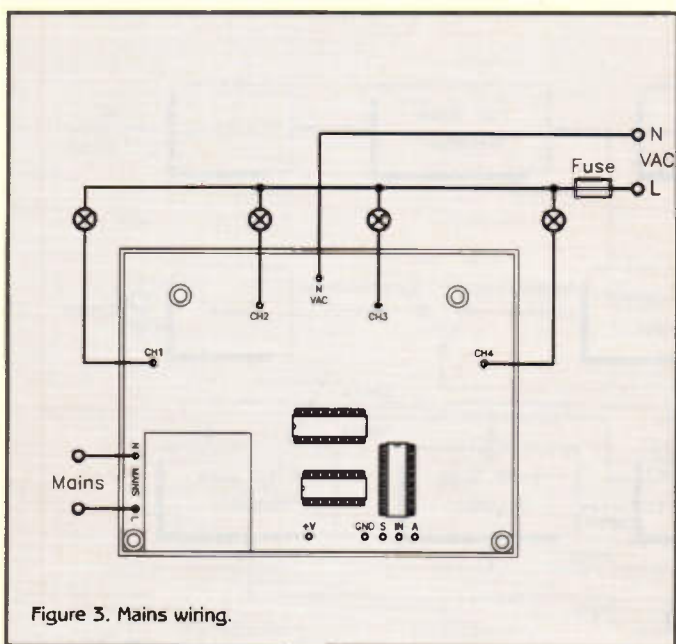

Figure 3. Mains wiring.

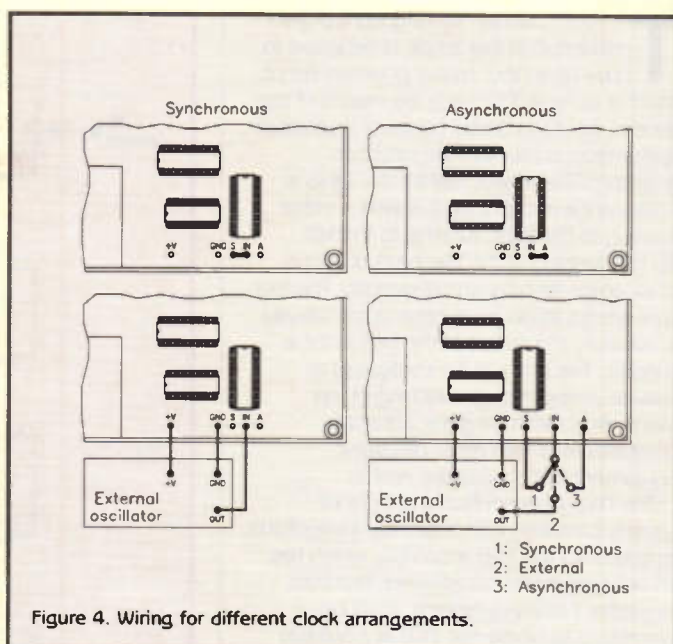

Figure 4. Wiring for different clock arrangements.

gates, M1 and M3, are connected to the Q3, Q2 and Q1 outputs of each 4-bit shift register, while the NOR gate outputs drive the DATA inputs of the shift registers. The DATA Input of each shift register goes high only when the shift register outputs Q<sub>1</sub>-Q<sub>3</sub> are all low.

The overall effect of this logic is to create a changing output sequence to drive the inputs of the triacs TR1-4 via transistors T1-4. There are four sequences, which follow on from one another after an allotted number of clock pulses from either the asynchronous or synchronous clocks. The sequences consist of the four outputs being triggered consecutively ('running') to the right, then to the left, then the two groups of two outputs being triggered alternately ('flip-flopping'), then all outputs simultaneously being triggered on and off. The sequence is then repeated.

## PCB Construction

Full assembly instructions are provided in the kit. The board's construction is mostly conventional, and is built up in order of ascending component size, commencing with the wire links. The eleven PCB pins are

a tight fit in their holes, but gently pressing them in using the hot tip of a soldering iron will ease them into their holes. Take care to correctly orientate the polarised components – semiconductors and electrolytic capacitor – and install the DIL holders in accordance with the PCB legend. The triacs are normally left free-standing, however, suitable heatsinks may be fitted if required. The copper trace that connects the four triacs to each other is not protected by solder resist, since a length of wire with a cross-sectional area of at least 1.5mm<sup>2</sup> should be soldered along the length of the track, to give increased current handling ability. Finally, check your work carefully for mistakes, solder whiskers, bridges and dry joints, then remove excess flux off the board using a suitable solvent.

## Testing and Use

Having installed the unit into a suitable plastic housing, connect the completed board to four output loads and to the mains supply as shown in the wiring diagram (Figure 3). Also select the operating mode – synchronous or asynchronous clocking, with a link between the 'IN' and 'S' or 'A'

PCB pins, respectively. Alternatively, an external clock and selector switch can be connected, as shown in Figure 4. Keep wiring as short as possible, and insulate the mains wiring connections. Ensure that a fuse of a rating appropriate to the load is connected in series with the live mains connection, and that strain-relief type grommets are used where cables pass through holes in the casing.

Switch on the power, whereupon the output loads should be switched in the four sequences, each sequence following on from the last after a period dependent on the clock speed. Note that the clock speed is only adjustable on the asynchronous setting. Only adjust the speed with the power SWITCHED OFF, by means of the onboard preset potentiometer, RV1 (unless an external oscillator is being used, of course).

Always operate the unit in accordance with the mains safety warnings, and never overload the outputs beyond the specified power ratings. Fit the triacs with heatsinks if loads in excess of 2A (up to a maximum of 4A per channel) are to be driven. Use M3 bolts, shakeproof washers and nuts to secure the heatsinks.

## FOUR CHANNEL RUNNING LIGHT PARTS LIST

RESISTORS: All 0.5W 5% Metal Film

R1-4	820Ω	4
R5-25	33k	21
RV1	250k Horizontal Preset Potentiometer	1

CAPACITORS

C1	47nF Ceramic Disc	1
C2	470μF Radial Electrolytic	1

SEMICONDUCTORS

D1,2	1N914/1N4148	2
D3,4	1N400X	2
T1-6	BC547/8/9	6
T7	BC557/8/9	1
TR1-4	TIC216	4
IC1	4060BE	1
IC2	4025BE	1
IC3	4015BE	1

WOUND COMPONENTS

TRANSFO	6-0-6V 1.2VA Mains Transformer	1
---------	--------------------------------	---

MISCELLANEOUS

	14-pin DIL Socket	1
	16-pin DIL Socket	2
	PCB Pins	11
	Tinned Copper Wire	1 length

The Maplin 'Get-You-Working' Service is available for this project, see Constructors' Guide or current Maplin Catalogue for details.

The above items are available as a kit, which offers a saving over buying the parts separately. Order As 95119 (4-Channel Running Light) Price £17.99 (Please Note: Some parts, which are specific to this project (e.g., PCB), are not available separately.

A readers' forum for your views and comments.  
If you would like to contribute, please  
address your replies to:

The Editor, Electronics – The Maplin Magazine  
P.O. Box 3, Rayleigh, Essex SS6 8LR, or send  
an e-mail to: AYV@maplin.demon.co.uk

### Radar Scanning

Dear Sir,  
I feel that Point Contact has omitted the most important of the titles used by the government radar establishment over the last half century. During the war, it was known by the title TRE and occupied the Malvern College. I started there in 1943 at a salary of £250 per year. This note is written from the local college, where I am on an Internet course. I look forward to receiving your Internet disc with free time on an Internet Provider, because I have not yet decided who to sign up with.  
**John Birchenough, Chichester, W. Sussex.**

We hope that you found the free AOL Internet cover disc provided with the May issue (No. 101) of Electronics to have been of value in helping you to find your perfect provider.

### Visit the Bookworm's Homepage

How about visiting the homepage of the largest UK electronics publisher, Butterworth-Heinemann? We are on <http://www.heinemann.co.uk/>.  
**Duncan Enright, Newnes Publisher.**

## STAR LETTER

In this issue, H. P. Brannen, of Newcastle-upon-Tyne, wins the Star Letter Award of a Maplin £5 Gift Token for being a bright spark.

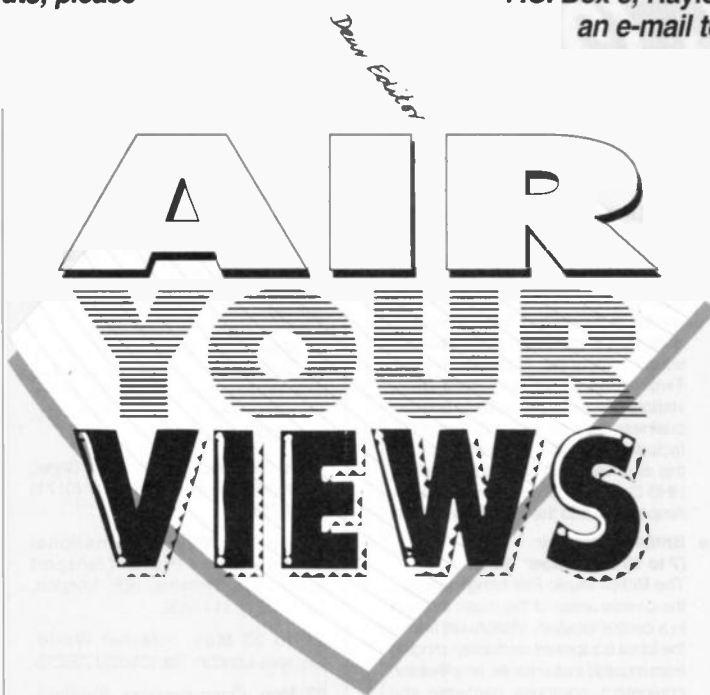

Dear Editor,  
With regards the Over-Rev Indicator project in the June issue (No. 102) of Electronics, I am writing to pass on a bit of information that may be useful to constructors of this project. An ignition system not mentioned but that is fitted to some of the more modern petrol engined vehicles, is DUAL SPARK or TWIN SPARK ignition. This simply means that each spark plug fires twice

per cycle instead of the more normal once per cycle. As a result, anyone building this project and calibrating it as described, then fitting it to a vehicle with such an ignition system will get an indicator that operates at half the desired engine speed (rpm). Therefore, constructors for whom this information applies should either recalculate the calibration frequency, or simply fit link LK1 in the 2-stroke position. Perhaps a simpler method of calibration, or for anyone who does not have a signal generator, would be to fit the unit to the vehicle, rev the engine to the desired speed, and turn RV1 until the indicator operates.

Thank you for passing on this information. The alternative type of 'twin spark' ignition system, used by a handful of manufacturers of performance cars such as Alfa Romeo, uses two spark plugs per cylinder. However, with this type of ignition, the setting-up of the Over-Rev Indicator would be as for a conventional engine, since only one spark plug lead would be used to activate the pickup sensor. As you suggest, it may be easier to calibrate the project by revving the vehicle's engine to the desired speed having installed the unit, but not every vehicle is equipped with a rev counter (tachometer), and even when one is fitted, it may not necessarily be accurate. Also, trying to alter the potentiometer whilst simultaneously keeping an eye on the rev counter and a foot on the throttle pedal could be tricky, unless one had assistance! Calibration using a signal generator is the preferred method, since it will be easier to set an accurate engine speed trip point.



### COMPUTERS

**ATARI 130XE COMPUTER** with a 'happy' and 'U.S. doubler' enhanced 1080 disk drive. Accessories and a large selection of software included. £88. Intel 486SX-2 50MHz CPU, £25. Tel: (01502) 568026.

### VARIOUS

**ELECTROSONIC AUDIO/VISUAL PRESENTATION UNIT ES3801**, by Edril Audio Visual Ltd. Offers to Peter, Tel: (01582) 620678.  
**HELP!** Anyone who has resolved the component problems of DOG2 circuit, please contact Alfred on (01977) 706713.  
**MARCONI VALVE VOLTMETER TF428B/1** NoA035, four ranges 1-5/3/18/180V, handbook, good condition, £10. Step-down transformer, 240/250 to 110 & 15V, H130mm W150mm D130mm, approx. 500VA, vgc, £12. Tel: Brighton (01273) 307995.

### WANTED

**CIRCUIT DIAGRAMS, SERVICE MANUALS, ETC.** For Philips 'Laservision' models VLP 600/700 series. Or write/telephone with advice. Brian Dickson, 54 Meadows Avenue, Larkhall ML9 2JG. Tel: (01698) 882598.  
**MOTHERBOARD MANUAL FOR PENTIUM III MAINBOARD** or a photocopy, willing to pay. Tel: (01782) 816504.  
**CIRCUITS AND INFORMATION** relating to the Siemens 0-01-25MHz test set, comprising: Frequency Generator G2021, Level Receiver D2021, Level Generator W2021. Mr M. Perry, 216 Maripool Lane, Kidderminster DY11 8DL.  
**MARCONI 405-LINE SYNC PULSE GENERATOR** (£500 offered), also image Orthon camera. Andrew Emmerson, Tel: (01604) 844130.

### BBS CORNER

**APPLE CRACKERS.** FirstClass Client BBS, mainly for AppleMac and PC users. Baud rate 2-4K-bit/s to 28-8K-bit/s, 8 data bits, no parity, 1 stop bit. Tel: (01288) 781318/780724.  
**MACTEL METRO/ICONEK.** FirstClass Client BBS, AppleMac and PC users. E-mail address on Internet for registered users. Baud rate 2-4K-bit/s to 28-8K-bit/s, 8 data bits, no parity, 1 stop bit. Tel: (0181) 543 8017 (Metro) or (0115) 9485417 (Iconex).  
**SPIDER! AMIGA BBS.** The lighter alternative. Mainly Amiga and some PC files. Fidonet, MercuryNet and Mufonet. Online games. Speeds up to 19200. Tel: (01868) 613820.

# CLASSIFIED

Placing an advertisement in this section of Electronics is your chance to tell the readers of Britain's Best Selling Electronics Magazine what you want to buy or sell, or tell them about your club's activities - Absolutely Free of Charge! We will publish as many advertisements as we have space for. We will print the first 30 words free, but thereafter the charge is 10p per word for each added advert per reader. Placing an advertisement is easy! Simply write your advertisement clearly in capital letters, on a postcard or sealed-

down envelope. Then send it, with any necessary payment, to: Classifieds Electronics - The Maplin Magazine, P.O. Box 3, Rayleigh, Essex SS6 8LR. Advertisements will be published as soon as possible, space allowing. No responsibility is accepted for delayed publication or non-inclusion of advertisements.

Readers who have reasonable grounds to believe they have been misled as to the nature of an advertisement are advised to contact the Publisher and their local Trading Standards Office.

### CLUB CORNER

**AARS (Aberdeen Amateur Radio Society)** meets on Friday evenings in the RC Hall, 70 Cairngorm Crescent, Kincorth. For details contact: Martin, (CM0JCN), Tel: (01569) 731177.  
**AMIGA-USER GROUP.** For free Welcome Pack, please send your name and address (no SAE required) to: Total Amiga User-Group, 80 Eatcourt Street, Newbridge Road, Hull HU9 2RR.  
**THE BRITISH AMATEUR ELECTRONICS CLUB** (founded in 1986), for all interested in electronics. Four newsletters a year, help for members and more! UK subscription £8 a year (Junior members £4, overseas members £13.50). For further details send S.A.E. to: The Secretary, Mr. J. F. Davies, 20 Ash Road, Cuddington, Northwich, Cheshire CW8 2PB.  
**BURY ST. EDMUNDS AMATEUR RADIO SOCIETY.** Meetings held at Culford School, 7.30pm for 8.00pm on the third Tuesday of each month, unless otherwise stated. Further details from Kevin Waterson, (G1GVD), 20 Cadogan Road, Bury St. Edmunds, Suffolk IP33 3QJ. Tel: (01284) 784804.  
**CRYSTAL PALACE & DISTRICT RADIO CLUB.** Meets on the third Saturday of each month at All Saints Church Parish Rooms, Beulah Hill, London SE19. Details from Wilf Taylor, (G3DSC), Tel: (0181) 699 5732.  
**DERBY AND DISTRICT AMATEUR RADIO SOCIETY** meets every Wednesday at 7.30pm, at 119 Green Lane, Derby. Further details from: Richard Buckley, (G3VGV), 20 Eden Bank, Ambergate DE56 2GG. Tel: (01773) 882478.

**ELECTRONIC ORGAN CONSTRUCTORS SOCIETY.** For details of meetings, Tel: (0181) 902 3390 or write to 87 Oakington Manor Drive, Wembley, Middlesex HA9 6LX. E.U.G. User group for all 8-bit Acorn Micros, since 1991. Still going strong. Programming, news, information, sales. Contact: E.U.G., 25 Bertie Road, Southsea, Hants. PO4 6PX. Tel: (01705) 781168.

**THE LINCOLN SHORT WAVE CLUB** meets every Wednesday night at the City Engineers' Club, Waterside South, Lincoln at 8pm. All welcome. For further details contact Pam, (G4STO) (Secretary), Tel: (01427) 788366.  
**MODEL RAILWAY ENTHUSIAST?** How about joining 'MERG', the Model Electronic Railway Group. For more details contact: Paul King (Honorary Secretary), 25 Fir Tree Way, Hassocks, West Sussex BN6 8BU.  
**PRESTON AMATEUR RADIO SOCIETY** meets every Thursday evening at The Lonsdale Sports and Social Club, Fulwood Hall Lane, Fulwood, (off Watling Street Road), Preston, Lancashire PR2 4DC. Tel: (01772) 794465.  
**Secretary:** Mr Eric Eastwood, (G1WCO), 56 The Mede, Freckleton PR4 1JB, Tel: (01772) 686708.

**SEEMUG (South East Essex Mac User Group)**, meet in Southend, every second Monday of each month. For details Tel: Michael Foy (01702) 468062, or e-mail to [mac@milesfoy.demon.co.uk](mailto:mac@milesfoy.demon.co.uk).  
**SOUTHEND & DISTRICT RADIO SOCIETY** meets at the Druid Venture Scout Centre, Southend, Essex every Thursday at 8pm. For further details, contact: P.O. Box 88, Rayleigh, Essex SS6 8NZ.

**SCIENCE AT YOUR FINGERTIPS**, for 'hands-on' science experiences and experiments, *Science at Your Fingertips Science Review*, Membership £2.50. For further details, please contact Daniel and Caroline Gee, The S.A.Y.F., 37 South Road, Watchet, Somerset TA23 0HG.  
**SUDBURY AND DISTRICT RADIO AMATEURS (SandRA)** meet in St. Cornard, Sudbury, Suffolk at 8.00pm. Visitors and new members are very welcome. Refreshments are available. For details please contact Tony, (G8LTY), Tel: (01787) 313212 before 10.00pm.  
**TESUG (The European Satellite User Group)** for all satellite TV enthusiasts! Totally independent. TESUG provides the most up-to-date news available (through its monthly 'Footprint' newsletter, and a teletext service on the pan-European 'Super Channel'). It also provides a wide variety of help and information. Contact: Eric N. Wiltsher, TESUG, P.O. Box 578 Orpington, Kent BR6 9WY.  
**THANET ELECTRONICS CLUB.** For school age Ham Radio and Electronics enthusiasts, enters its 16th Year. Meetings held every Monday evening from 7.30pm at The Quarterdeck, Zion Place, Margate, Kent. For further details contact: Dr. Ken L. Smith, (G3JDX), Tel: (01304) 812723.  
**WAKEFIELD AND DISTRICT RADIO SOCIETY** meet at 8.00pm on Tuesdays at the Community Centre, Prospect Road, Osselt, West Yorkshire. Contact Bob Firth, (G3WVF), (G7HR), Tel: (0113) 282 5519.  
**THE (WIGAN) DOUGLAS VALLEY AMATEUR RADIO SOCIETY** meets on the first and third Thursdays of the month from 8.00pm at the Wigan Sea Cadet HQ, Training Ship Sceptre, Brookhouse Terrace, off Warrington Lane, Wigan. Contact: D. Snape, (G4GWG), Tel: (01942) 211397 (Wigan).  
**WINCHESTER AMATEUR RADIO CLUB** meets on the third Friday of each month. For full programme contact: GAAXO, Tel: (01962) 860807.  
**WIRRAL AMATEUR RADIO SOCIETY** meets at the Ivy Farm, Arrowe Park Road, Birkenhead every Tuesday evening, and formally on the 1st and 3rd Wednesday of every month. Details: A. Seed, (G3FOO), 31 Withers Avenue, Bebington, Wirral L63 5NE.  
**WIRRAL AND DISTRICT AMATEUR RADIO SOCIETY** meets at the Irby Cricket Club, Irby, Wirral. Organises visits, DF hunts, demonstrations and junk sales. For further details, please contact: Paul Robinson, (G0JZP) on (0151) 648 8882.

# What's On?

## Carrera Drop-in Technology Sessions

Carrera Technology is running a series of free drop-in workshops designed to allow PC users to learn more about computer technology, and how it can aid areas of business and education.

Sessions will be held at Carrera's Central London Showroom in Tottenham Court Road, London, and will run from 5pm to 8pm. Topics areas to be covered over the next couple of months include:

Education	30 May
Legal and accountancy	13 June
Home working	27 June
Telecommunications	11 July
Internet	25 July

"It's not just enough for PC vendors to sell ever more boxes - customers are more sophisticated these days, and need suppliers to have demonstrated knowledge", said Colin Collier, managing director of Carrera. The evening will be held throughout the summer on an ongoing basis. Contact Carrera for further details of subject areas.

Contact: Carrera, Tel: (0171) 830 0486.

## New Look PLASA '96

In September 1996, London is set to become the international centre for the entertainment technology industry. In response to increasing demand for shows with broader scope, PLASA will be uniting with two key exhibitions to provide visitors with all the latest products.

This year's event is bringing together PLASA, Presentation Technology and the British Music Fair under one roof at Earl's Court, London. Space for the show is already sold out.

### ● PLASA '96 (8 to 11 September 1996)

The PLASA show, this year located for the first time in Earls Court One, will be showing state-of-the-art lighting and sound equipment. New to the exhibition will be a 'Specialist Sound Sector', dedicated to pro-audio and installation sound companies. Running on Level Two of the show, this area gives visitors an ideal opportunity to conduct business in an exclusive environment. Included amongst the exhibitors for this area will be Outboard Electronics, HNB Communications, Sound Design, Ampetronic and the TOA Corporation.

### ● British Music Fair (7 to 10 September 1996)

The British Music Fair brings together the diverse areas of the music industry in a central location. Visitors will find all the latest equipment on display, ranging from musical instruments, amplification equipment, computer hardware and software, to Karaoke, printed music and books.

### ● Presentation Technology (8 to 11 September 1996)

The Presentation Technology show caters for the expanding area of business-to-business presentations and professional AV. The show is designed to meet the needs of the professional hardware and software buyer, and is the only show in the UK targeted specifically at high powered display solutions. Presentation Technology gives visitors the chance to make comparisons between the full range of products available, from portable projection equipment to complete boardroom AV installations and large scale presentations.

Contact: P&O Events, Tel: (0171) 370 8229.

## DIARY DATES

Every possible effort has been made to ensure that the information presented here is correct prior to publication. To avoid disappointment due to late changes or amendments, please contact event organisations to confirm details.

**4 May.** RSGB Open Day, Potters Bar. Tel: (01707) 659015.

**13 May.** Astronomy, Stratford-upon-Avon and District Radio Society, Stratford-upon-Avon. Tel: (01789) 295257.

**16 May.** World Class Manufacturing for SMEs - Some of the Issues, IEE, The Dudley Centre for Competitive Manufacturing, West Midlands. Tel: (0171) 344 5446.

**17 to 19 May.** Mac Shopper Show, Wembley Centre, London. Tel: (0171) 831 9252.

**21 to 22 May.** International Conference on Public Transport Electronics Systems, IEE, London, Tel: (0171) 344 8432.

**21 to 23 May.** Internet World, Olympia, London. Tel: (01865) 730275.

**27 May.** Open Evening, Stratford-upon-Avon and District Radio Society, Stratford-upon-Avon. Tel: (01789) 295257.

**30 May.** Home PC Show, Earls Court, London. Tel: (0181) 849 6200.

**30 May.** Education Technology Seminar, Carrera Showroom, Tottenham Court Road, London. Tel: (0171) 830 0486.

**2 June.** Waters and Stanton Open Day, Hockley, Essex. As well as having a great day out, why not meet the *Electronics* editorial team. Free refreshments available. Tel: (01702) 206835.

**10 June.** 2m Direction Finding Contest, Stratford-upon-Avon and District Radio Society, Stratford-upon-Avon. Tel: (01789) 295257.

**13 June.** Legal and Accountancy Technology Seminar, Carrera Showroom, Tottenham Court Road, London. Tel: (0171) 830 0486.

**14 June.** Mid Sussex Amateur Radio Society Packet evening, Burgess Hill. Tel: (01444) 241 407.

**15 June.** RNARS, HMS Collingwood, Hants. Tel: (01707) 659015.

**18 to 20 June.** Multimedia, Business Design Centre, London. Tel: (0171) 359 3535.

**21 June.** Mid Sussex Amateur Radio Society Bar-B-Q evening, Tel: (01444) 241 407.

**24 June.** Repeater Management Group Chairman, Geof Dover G4AFJ, Stratford-upon-Avon and District Radio Society, Stratford-upon-Avon. Tel: (01789) 295257.

**26 to 27 June.** Electrical Engineering Exhibition, Airport Skean Dhu, Aberdeen. Tel: (01732) 359990.

**27 June.** Home Working Technology Seminar, Carrera Showroom, Tottenham Court Road, London. Tel: (0171) 830 0486.

**30 June.** Radio Rally, Longleat, Wiltshire. Tel: (01707) 659015.

**6 July.** Summer Social Event, Stratford-upon-Avon and District Radio Society, Stratford-upon-Avon. Tel: (01789) 295257.

**8 July.** 160m. Direction Finding Contest, Stratford-upon-Avon and District Radio Society, Stratford-upon-Avon. Tel: (01789) 295257.

**8 July to 30 September.** Science Museum Superhighway UK Tour, Exploris, Northern Ireland. Tel: (0171) 938 8192.

**11 July.** Telecommunications Technology Seminar, Carrera Showroom, Tottenham Court Road, London. Tel: (0171) 830 0486.

**22 July.** Construction Competition, Stratford-upon-Avon and District Radio Society, Stratford-upon-Avon. Tel: (01789) 295257.

**25 July.** Internet Technology Seminar, Carrera Showroom, Tottenham Court Road, London. Tel: (0171) 830 0486.

**4 August.** RSGB National Mobile Rally, Woburn, Beds. Tel: (01707) 659015.

**18 August.** Radio Rally, Manchester. Tel: (01707) 659015.

**18 August.** Radio Rally, Great Eastern, Kings Lynn. Tel: (01707) 659015.

**1 September.** Radio Rally, Telford, Shropshire. Tel: (01707) 659015.

**4 to 5 September.** Internet, Wembley Centre, London. Tel: (01923) 261663.

**7 to 10 September.** British Music Fair 1996, Earls Court, London. Tel: (0171) 370 8229.

**8 to 11 September.** PLASA '96, Earls Court, London. Tel: (0171) 370 8229.

**8 to 11 September.** Presentation Technology, Earls Court, London. Tel: (0171) 370 8229.

**18 to 19 September.** EMC UK, Olympia, London. Tel: (01981) 590481.

**21 September.** Radio Rally, Scottish Convention, Glasgow. Tel: (01707) 659015.

**24 to 29 September.** Live, Earls Court, London. Tel: (0181) 742 2828.

**25 to 26 September.** Digital Signal Processing, Sheraton Skyline Hotel, London. Tel: (0181) 614 8042.

**4 to 6 October.** RSGB International HF Convention, Windsor. Tel: (01707) 659015.

**7 October to 16 December.** Science Museum Superhighway UK Tour, Kelvingrove Museum, Glasgow. Tel: (0171) 938 8192.

**8 to 10 October.** Voice Europe, Olympia, London. Tel: (01244) 378888.

**18 to 19 October.** Leicester Amateur Radio Show, Leicester. Tel: (01707) 659015.

**28 to 30 October.** International Conference on Sizewell B - The First Cycle, IEE, London. Tel: (0171) 344 8432.

**29 to 31 October.** Electronics Commerce, Barbican Exhibition Centre, London. Tel: (0181) 332 0044.

**1 to 3 November.** Acorn World, Olympia, London. Tel: (01295) 788386.

**9 to 10 November.** Radio Rally, Llandudno, North Wales. Tel: (01707) 659015.

**7 December.** RSGB Annual Meeting, London. Tel: (01707) 659015.

Please send details of events for inclusion in 'Diary Dates' to: News Editor, *Electronics - The Maplin Magazine*, P.O. Box 3, Rayleigh, Essex SS6 8LR or e-mail to [swaddington@cix.compulink.co.uk](mailto:swaddington@cix.compulink.co.uk)



In the August 1996 issue (No. 104) of *Electronics - The Maplin Magazine*, there is another varied assortment of purposeful projects to build and informative features to read, including:

### PROJECTS

#### MULTI-STROBE INTERFACE

This project enables the sophisticated Multi-strobe Sequencer to be capable of driving any make or model of strobe lamp that is equipped with a remote trigger input. Features RS-232 data cabling interconnection for straight-forward, convenient construction of a mind-blowing strobe system!

#### SIREN KIT

A compact, inexpensive and easy to build siren module, producing a varying pitch hee-haw sound,

reminiscent of modern police sirens. Ideal for use in toys and models, or as the basis/extension of an alarm system.

#### GUITAR PHANTOM PSU

This mains-powered project acts as a battery eliminator for use with guitars having active pick-ups, avoiding the risk of the battery running flat mid-session, and acts as an enhancer for guitars fitted with passive pick-ups. The project supplies the required DC power via the conventional guitar lead, and contains a buffer amplifier to improve the drive signal from passive pick-ups.

#### DRILL SPEED CONTROLLER

A versatile mains-powered project designed to control the speed of electric drills or any other AC motors (which may be driven by a source other than the mains supply) having conventional carbon brushes. The circuit operates using the phase cutting principle, allowing accurate speed control without loss of torque at low speeds.

All this, plus all your favourite regulars as well!



BRITAIN'S BEST SELLING ELECTRONICS MAGAZINE

# ORDER COUPON

In any correspondence please quote your customer number. *Date* .....



P.O. Box 3, Rayleigh, Essex SS6 8LR.  
Telephone, Credit Card Sales (01702) 554161; Enquiries (01702) 552911.  
Overseas Customers, Telephone +44 1702 554000 Ext. 326, 327 or 351.

A different postal code is correctly shown on the reply paid envelopes.

**Please make cheques payable to 'Maplin Electronics plc'.**

On occasion Maplin Electronics may permit other reputable companies to make offers of products or services which we believe will be of interest to our customers. If you do not wish to receive this information please write no in the box.

Customer No. ....

Name .....

Address .....

Postcode ..... Phone No .....

**IT IS MOST IMPORTANT THAT YOU INCLUDE YOUR POSTCODE**

**Block capital letters please. Keep a copy of your order.**

\*Please enter catalogue page no. where item appears. If not in catalogue, write Mag for Magazine or SO for Special Offers etc. If not using 1996 catalogue, enter date of catalogue here: 19.....

Description (for your information only)	Page*	Order Code	Quantity	Price Each	£ Total	p	£ Carriage Charge	p
Price Change Leaflet (Please write 1 in quantity, if required)		C A 9 9 H		FREE	0	00	0	00
1996 Maplin Catalogue		C A 1 3 P		£3.45 NV			0	00
Electronics - The Maplin Magazine Subscription (UK 6 Issues)		X A 0 0 A		£11.88 NV			0	00
Electronics - The Maplin Magazine Subscription (UK 12 Issues)		X A 0 0 A		£23.76 NV			0	00
Electronics - The Maplin Magazine Index	467	X U 8 7 U		80p NV			0	00
Electronics - The Maplin Magazine Binder	467	X H 9 9 H		£6.99			0	00

Form ME94 Issue 1



Overseas Customers including Channel Isles and Eire, please deduct VAT where applicable and tick box.

Export Order

### Office Use Only

DOR  CQ  CA  PO

CNC  Total

CNM



PHONE BEFORE 5pm FOR SAME DAY DESPATCH

I authorise you to debit my credit card account for the cost of goods despatched.

Credit Card Number

Access/American Express/Visa ..... Delete as required.

Note: Goods will be despatched only if the address above is the cardholder's address. If ordering by credit card please sign:

Expiry date of Credit Card .....

Total this sheet	£						
Total other sheet(s)	£						
<b>Total for goods</b>	<b>£</b>						
Carriage charges for large, fragile, or heavy items as shown in catalogue. If total in this box exceeds £6.00 you need only pay £6.00 (Max. Carr. Charge per order £6.00).							
Deduct value of Credit Note No. Enclose the numbered Credit Note with this order.							
Deduct value of Gift Token No. (Enclose Gift Token with order.)							
Please add £1.55 Handling Charge. This amount must be added to each order placed.*		1		55			
*Except if only ordering a Catalogue or Magazine Subscription	<b>Total</b>	<b>£</b>					
						<b>Carriage Charges</b>	
						<b>A</b>	£1.60
						<b>B</b>	£2.30
						<b>C</b>	£2.90
						<b>D</b>	£3.40
						<b>E</b>	£4.00
						<b>F</b>	£4.70
						<b>G</b>	£5.50
						<b>H</b>	£6.00

# SUBSCRIBE TO

**\* BRITAIN'S BEST SELLING \*  
ELECTRONICS MAGAZINE!**



- \* **2 FREE ISSUES** if you agree to subscribe by Direct Debit or Continuous Credit Card, saving you £6.12!
- \* **FREE DELIVERY TO YOUR DOOR**, and there are no additional carriage charges.

- \* **YES, SAVE MONEY** by taking a subscription, it's cheaper than buying each individual copy.
- \* **REGULAR SUBSCRIBERS' SPECIAL OFFERS**  
Super savings on selected products!

\* **PLUS** – News, reviews, readers letters, competitions and lots, lots more besides!

To subscribe just send a cheque/postal order for £11.88 made payable to Maplin Electronics, P.O. Box 3, Rayleigh, Essex SS6 8LR. **OR** you can take advantage of our offer of two free issues by completing the coupon below and agreeing to pay by Credit Card or Direct Debit. The two free issues offer only applies if you use one of these two methods of payment. Simply fill in the 'Payment by Credit' or 'Payment by Direct Debiting Mandate' and return it to Maplin. Every time, about 1 month before your subscription is due, we will send you a letter giving details of the subscription rate and telling you the date on which we will charge your Credit Card or debit your bank account. If you do not wish to continue your subscription, you have until that date to let us know, and we will then cancel your authority to bill your Credit Card or cancel your mandate. Otherwise, if you do nothing, your subscription will continue. The authority or mandate you give us does not allow us to charge anything other than the Maplin Magazine subscription. The benefit to you is that you no longer need to remember to renew your subscription or send off any more cheques or postal orders. Payment is made automatically.

**OVERSEAS READERS – SUBSCRIBE NOW!** – Phone Maplin Export: +44 1702 554155 Ext. 326, 327 or 351. Full details on request.  
 Subscription rates for 6 issues are: £16.20 (or 40 IRCs) in Eire, Europe and surface mail outside Europe; £24.24 (or 60 IRCs) Air Mail outside Europe.  
 Subscription rates for 12 issues are: £32.40 (or 80 IRCs) in Eire, Europe and surface mail outside Europe; £48.48 (or 119 IRCs) Air Mail outside Europe.  
**AFRICAN READERS – SUBSCRIBE NOW!** – Phone Maplin South Africa: +27 24 51 5124.  
 Subscription rate for 6 issues is: R114,00; Subscription rate for 12 issues is: R215,00.

## TAKE THE NEXT 2 ISSUES OF THIS MAGAZINE FREE!!

Because we're so certain that now you've seen the Maplin Magazine you'll want to receive it regularly, we're offering to send you the next two issues free of charge with absolutely no obligation to continue. Just fill in the details below and if after receiving two issues you do not wish to continue, just let us know at least one month before the next issue is due and we will cancel your subscription. The two free issues will be yours to keep whatever you decide. If you already have a subscription, fill in the details below and we'll add two issues free of charge to your current subscription. **SEND NO MONEY NOW.** About 2 weeks before the third issue is due, we will charge you £11.88 for the next six issues, unless you have cancelled. This offer is not available to those already paying by Direct Debit or Continuous Credit Card or those who have stopped payment by either method within the last year. **THIS OFFER IS OPEN TO RESIDENTS WITH U.K. ADDRESSES ONLY.**

**PLEASE START MY SUBSCRIPTION WITH ISSUE**  (If left blank subscription will start from next issue.)

EITHER

### ★ PLEASE ADD YOUR ADDRESS, SEE BOTTOM RIGHT ★

**PAYMENT BY CREDIT CARD.** Please charge my Credit Card Account

I authorise you until further notice in writing to debit my CREDIT CARD account by £11.88 and in future, with any amounts which, after notification, MAPLIN ELECTRONICS plc may debit thereto in respect of my subscription to the Maplin Magazine.  
 Overseas subscribers see above.

Customer Number (if known) .....

Access  Visa  American Express  Expiry Date of Card  /

Account No.

Signature  Date

OR

**PAYMENT BY DIRECT DEBITING MANDATE** in favour of Maplin Electronics plc, P.O. Box 3, Rayleigh, Essex SS6 8LR.  
 Direct Debit payment option is only open to customers with bank accounts in the U.K. including Channel Isles, Isle of Man and N. Ireland.  
 Please note: Instructions cannot be accepted to charge Direct Debits to a Deposit or Savings Account.



Bank Sort Code

Bank Account Number

Name of account to be debited

Bank Address

I authorise you until further notice in writing to charge my account, with you, any amounts which MAPLIN ELECTRONICS plc may debit thereto by Direct Debit in respect of my subscription to the Maplin Magazine.

I will inform the bank in writing if I wish to cancel this instruction.

I understand that if any direct debit is paid which breaks the terms of this instruction, the bank will make a refund.

Signature  Date

Enter your address and Maplin customer number, if known.

Postcode

Put this form in an envelope and address it to: Maplin Electronics, Freepost, P.O. Box 3, Rayleigh, Essex, SS6 2BR.



Enter  
our free  
book draw!

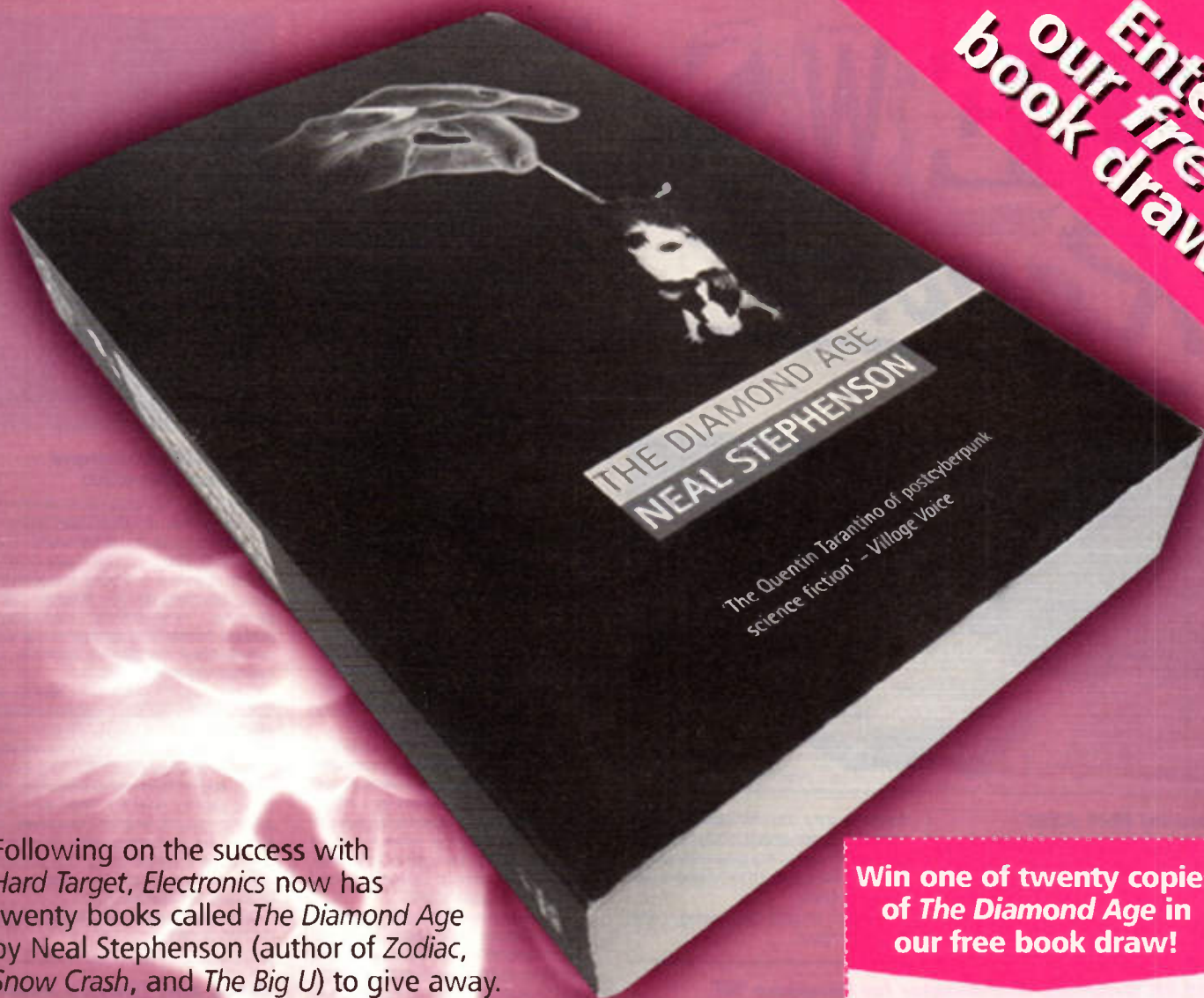

Following on the success with *Hard Target*, *Electronics* now has twenty books called *The Diamond Age* by Neal Stephenson (author of *Zodiac*, *Snow Crash*, and *The Big U*) to give away.

Far above the diamondoid bedrock of New Chusan, a powerful class of neo-Victorians is ruling 21st century Atlantis/Shanghai. John Percival Hackworth, a brilliant nanotechnologist, has created an illicit, magical book for the education of a young lady: an interactive device crammed with folklore, science and the martial arts that teaches young women how to think for themselves. What will happen to society if it should fall into the hands of someone like little Nell, a poor orphan girl with so much to learn?

# THE DIAMOND AGE

## NEAL STEPHENSON

Neal Stephenson grew up surrounded by hard scientists in a one-industry town in Seattle centred on a technical university. Programming computers from the age of fourteen, he became fluent in eight different computer languages. This background has given him the insight to write about highly credible futuristic technical detail in his novels. In 1995 Neal Stephenson joined Arthur C. Clarke and Alexander Solzhenitsyn in being the only writers to be commissioned to write fiction for *Time* magazine.

The *Diamond Age* is published on 6 June, priced £5.99.

Shortlisted for the 1996 Arthur C. Clarke Award.

**"A brilliant, tricky, twenty-first century version of Pygmalion"**

*Guardian*

**"A rattling good yarn ... its social and scientific extrapolations from our own world are all too believable"**

*New Scientist*

**"A comucopia of characters, a wealth of hip, social and technological riffs, stories-within-stories and not a few good jokes. Invest"**

*Time Out*

**"One of the best and most significant works of science fiction so far this decade. Outstanding"**

*Focus*

Win one of twenty copies of *The Diamond Age* in our free book draw!

Twenty lucky *Electronics* readers need not pay a penny for a copy of *The Diamond Age*. The first twenty readers whose names are drawn from the Editor's hat(!) on 24th June, will have a copy delivered to their home.

Fill in the coupon and send it to:  
'The Diamond Age Free Book Draw',  
P.O. Box 3 Rayleigh Essex SS6 8LR.

Name

Address

Post Code

Telephone No.

**ELECTRONICS**  
*The Maplin Magazine*

No purchase necessary. Entries on a postcard, back of a sealed-down envelope or photocopies will be accepted. Multiple entries will be disqualified.

# NEWS

## Report



### Parallel Port ASIC

Shuttle has introduced the EPAT Plus Parallel to ISA and floppy interface ASIC. The EPAT Plus is a 100-pin QFP port that enables peripheral devices such as tape, disk or CD-ROM to be interfaced to a standard parallel port.

Enabling data transfer rates of up to 1.5M-byte/s, the device is fully Windows compatible and is supplied with device drivers for Windows, DOS, Windows '95, OS/2 and UNIX.

Contact: Shuttle Technology, Tel: (01734) 770441.

### 128-bit Graphics Accelerator for Windows '95

UK company, VideoLogic, has launched a low cost PC 128-bit graphics and movie accelerator – the GrafixStar 600. Based on the 128-bit ET6000 graphics controller from Tseng labs, the GrafixStar 600 will give Windows users and games enthusiasts the graphics performance of current VRAM products, but at an estimated street price of under £150. The card will be available in May.

The GrafixStar 600 comes with 2.25M-byte MDRAM (multibank DRAM) on the board, and is upgradable

to 4.25M-byte. The use of MDRAM enables the GrafixStar 600 to achieve higher data throughput than both VRAM and WRAM alternatives – pushing 1G-bps at peak and 600M-bps sustained. By comparison, VRAM achieves only 400M-bps. However, the integration of MDRAM on the GrafixStar 600 creates a significant cost saving for the user of over \$40 in comparison with VRAM-based solutions. For further details, check: <http://www.videologic.co.uk>.

Contact: VideoLogic, Tel: (01923) 260511.

### Inter/Sharp Partnership Cuts Size of Flash

Sharp and Intel Corporation have succeeded in the development of a production technology for flash memory chips at the 0.4µm level, the first time this has been achieved in the world. As a result, both Sharp and Intel will soon begin production of flash memory chips based on the technology.

Until now, the most advanced flash memory has been produced using techniques that are capable of working down to the 0.6µm level. The new process allows mass production of chips 50% smaller than is currently possible and thus allows developers to cram more memory onto a standard size chip.

In practice, the new 8M-bit chip is actually half the size of the current 0.6µm version, and will soon be produced under the 28F008SC part number by Intel and the LH28F008SC part number by Sharp. The companies are also planning to produce 16M-bit versions using the new technology. For further details, check: <http://www.intel.com> or <http://www.sharpmeg.com>.

Contact: Intel, Tel: (01793) 403000; Sharp, Tel: (0161) 205 2644.

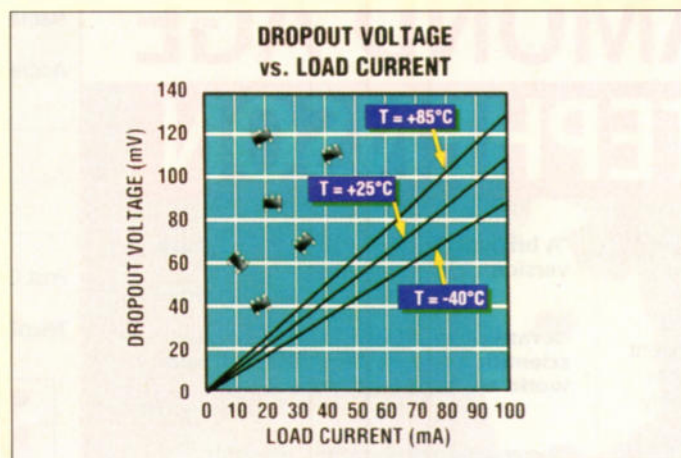

### Low Power Voltage Regulator

Maxim has announced a linear power regulator for mobile applications such as mobile phones, PDAs and modems, called the MAX8863T/S. The device features dual mode operation: it supplies either an adjustable 1.25V to 5V output, or a preselected output for a load of 100mA.

### BT Introduces Multimedia Kiosk

BT is planning to bring interactive multimedia information kiosks to London this summer. The kiosks, called Touchpoint, will be targeted at both tourists and locals alike, and will be located in travel terminals, shopping locations and leisure and tourist centres.

Content held on Touchpoint will range from what's on guides to suggestions of places to go and visit. News, sport, local news, horoscopes, as well as street and shopping guides will also be available. By simply touching the screen, customers will be able to access any area they choose, to see and hear the content in a mixture of text, picture and video formats.

Each kiosk will comprise a colour touch screen and a printer from where maps, vouchers and coupons can be printed. For further details, check: <http://www.bt.co.uk>. Contact: BT, Tel: (0171) 356 5369.

### Monitor Vendors Back New User Awareness Campaign

The failure by users to make a considered choice of monitor is once again the subject of a campaign by members of the Computing Suppliers Federation. Eight companies have joined together for a second 'Monitors Matter' programme, to increase user understanding of what constitutes a good monitor.

According to Federation General Manager, Roger Crumpton, "Users tend to focus on processor performance and other issues when selecting a PC or workstation. Scant attention is given to the monitor, which is often the most costly element in the system. The result can be years of poor productivity and unnecessary user fatigue".

Campaign members have produced a free 32-page user selection guide, which explains the complex technology in modern displays and helps them know what to look for when comparing one monitor with another. It also unravels the bewildering array of safety and ergonomic certifications that apply to monitors, so that users know what they are buying and what approvals have been obtained for that product. Sponsors include Aydin Controls, Hewlett Packard, Hitachi, Iiyama, Imago, Micro, Mitsubishi and Sony. Copies of the booklet can be obtained from the CSF. For further details, check: <http://www.csf.org.uk>.

Contact: CFG, Tel: (01905) 613236.

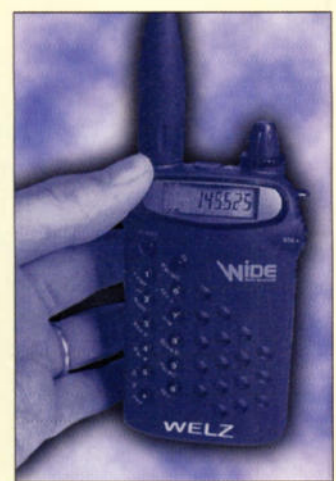

### WS1000E Wideband Monitor Receiver

The WELZ WS1000E it is claimed, is one of the smallest and lightest monitoring receivers in the world. The WS1000E ultra-compact in size is only 97mm x 58mm x 24mm and weighs 200g including the two batteries and antenna. Miniaturising technology enables this portable receiver to use two conventional AA alkaline batteries to operate for long periods.

Continuous coverage from 500KHz to 1299.999MHz. Three reception modes available, A3E(AM), F3E(NFM and WFM). These modes are automatically selected depending on the frequency used. 400 main memory channels, 10 band search memory channels and 80 skip search memory channels. It has twelve frequency steps plus one automatic. It utilises one of the highest scan and search speeds, twenty five channels per second.

Contact: Waters and Stanton, Tel: (01702) 206835.

### Cisco and Thames Share Joint Interests

In the month that Cisco acquired ATM switching specialist StrataCom, Thames Water Utilities purchased £3million worth of StrataCom's internetworking switches to integrate voice and data services across its 5,500 user enterprise network.

Analysts claim that Cisco acquired StrataCom in order to stay ahead in the corporate internetworking marketing. According to one Dataquest source, "Cisco has finally realised that routers cannot hack it as a high bandwidth WAN backbone technology".

The demand for reliable high bandwidth capability was one of the key reasons why Thames opted for StrataCom. "All of our operations, including water distribution and customer service, depend on communications", said Tony King, telecommunications manager for Thames Water Utilities.

"Our network is the lifeline between our job management, maintenance and customer information systems – activities that directly affect the performance of our company. If the network is not available, our staff can't make fundamental decisions on water-related services", added King.

The Thames Water internetwork carries a variety of applications, including SCADA (Supervisory Control and Data Access), involving telemetry applications responsible for reading water information on a per site basis. The network supports approximately 10,000 telephone connections, 5,500 data connections, 1,300 mobile telephones, 2,000 pagers, 1,250 mobile radios, over 3,000 leased lines and 150 environmental agency and river telemetry sites. For further details, check: <http://www.strata.com> or <http://www.cisco.com>.

Contact: StrataCom, Tel: (01252) 815554.

## Data Warehousing Earns Big Payback

IDC reports that companies that have invested in data warehousing, a technique which pulls data from various large databases into smaller ones to analyse trends and possible business opportunities, have realised a 400% return on their investments over three years. The study was based on 62 organisations that spent an average of \$2.2 million each on their data warehouse operations. For further details, check: <http://www.idcresearch.com>.

Contact: IDC, Tel: (+1) 508 872 8200.

## Intel Plans New Penang Plant

During the opening ceremony of Intel's seventh semiconductor plant in Penang, Malaysia, company general manager of components manufacturing, Michael Splinter, announced an eighth plant was on the cards. He said Intel would invest \$500million over the next four years to set up the factory, starting in June.

Splinter said it should be operational within a year. It is thought it will be on a site close to the new unit, PG7. The factory was originally an assembly and test plant, but it now makes microprocessors and other components. For further details, check: <http://www.intel.com>.

Contact: Intel, Tel: (01793) 403000.

## More Microsoft Viruses

First, there was the Word virus – now there's a Word Prank Macro Virus, located in a document on ActiveVRLM, Microsoft's software tool for developing three dimensional WWW sites. What's worse, is that Microsoft had to inform the programmers who attended its Professional Developers Conference last month that one of the CD-ROMs it distributed was infected. For further details, and information on how to remove the virus, check: <http://www.microsoft.com>.

Contact: Microsoft, Tel: (01734) 710021.

## Optimum Windows Operation

RAMGATE, a new piece from POW! Distribution, claims to improve Windows performance, and prevent Protection Faults (GPFs) and Unrecoverable Application Errors (UAEs), by ensuring that memory and resources are used effectively.

"Rather than jumping all over the place, RAMGATE ensures that when an application makes a request for resources, it is given a block immediately next to the previously allocated block. This provides a more efficient operation of Windows", said Bruce Parker, managing director and chief developer of RAMGATE.

For further details, check: <http://www.pow-dist.co.uk>.

Contact: POW!, Tel: (01202) 716726.

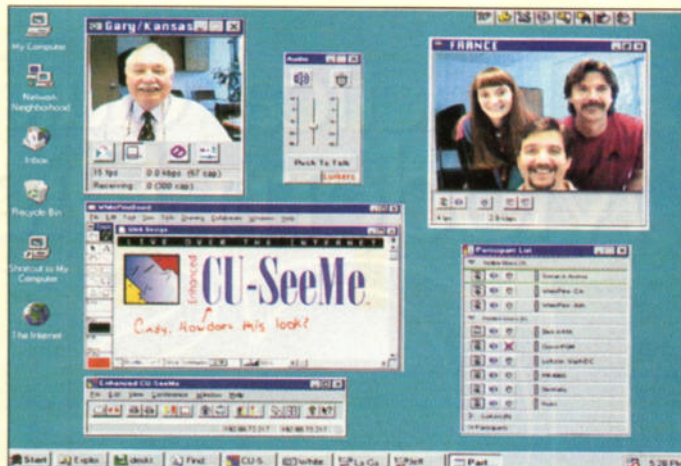

## Desktop Internet Videoconferencing

White Pine Software has released the commercial version of its desktop videoconferencing software, Enhanced CU-SeeMe for Windows. The software is used for person-to-person conferencing, group conferencing and live broadcasting over the Internet or any other TCP/IP network.

The software runs directly over the Internet or any TCP/IP network. This allows users to communicate globally without the need for expensive hardware. Real-time video and audio conferencing

can be achieved with as little bandwidth as a 28.8k-bps modem, and it works effectively over a 14.4k-bps modem for audio-only usage.

The software comes complete with the WhitePineBoard, which enables remote users to share documents and graphics, sketch ideas and mark up an electronic whiteboard. For further details, including purchasing information, check: <http://www.cu-seeme.com>.

Contact: White Pine Software, Tel: (+1) 603 886 0903.



## Single Chip Telephone

Philips has previewed its latest ASIC – a complete telephone on a chip. The TEA1069N includes on-chip speech handling, dialler and ringer circuits, music-on-hold, last number re-dial, repertory number dial, hands-free

controls and selectable ringing tones. Scanning logic for the telephone's keypad and all the memory required for last-number redial and repertory dialling are also included on-chip.

Contact: Philips Semiconductors, Tel: (+31) 40 272 20 91.

## Young Radio Amateur of the Year

The hunt is on for the Young Radio Amateur of the Year for 1996. The ward was initiated by the RSGB in 1988, and once again, is being supported by the Radio Communications Agency.

Nominees should be under the age of 18 and have an interest in amateur radio, although it is not necessary for them to hold a licence. The winner will be the applicant showing the most outstanding achievements in any of the following areas: amateur radio equipment construction, radio operating, community service, encouraging others, or school projects.

Between them, the 1996 Young Amateur of the Year and runner-up will receive prizes including a cheque for £300 from the Radio Authority, radio equipment from the RSGB, Icom and Siskin Electronics, and a residential course from the Mobile Radio Users Association.

The closing date for nominations is 31 July. For further details, contact Marcia Brimston at the RGSB.

Contact: RSGB, Tel: (01707) 659015.

## Memory Technology Breakthrough

A new type of memory, called Fusion Memory from IDT, is claimed to provide equal performance at one-third the die size and one-third the active power of traditional memory. Adding Fusion Memory cache to a system typically boosts performance by up to 20%.

Fusion Memory is already being used to replace traditional synchronous pipelined-burst cache SRAM solutions in Pentium processor systems at up to 166MHz. The IDT71F432 32k x 32 synchronous pipelined-burst cache memory device is the first product to use IDT's new Fusion Memory Technology.

The new memory technology combines the high performance of SRAM with the low manufacturing costs of DRAM. Traditional SRAMs use a 4- or 6-transistor cell architecture. Fusion Memory devices are built with a single transistor memory cell, giving a 70% reduction in die size, and offering significantly higher levels of integration and lower cost. For further details, check: <http://www.idt.com>.

Contact: IDT, Tel: (01732) 363734.

## Microsoft Pitches New PC Concept

In an attempt to counter Oracle's promotion of a new \$500 Internet device, Microsoft has plans to develop a Simply Interactive PC (SIPC), designed to move from the home office to the living room. This enables functions such as controlling the stereo, video disk player and household security system to be performed, while enabling family members to surf the WWW or play interactive games.

Gates kicked off the effort to make SIPC the official entertainment, Internet access, and communications device of choice at last month's Microsoft Windows Hardware Engineering Conference in San Jose, California. Gates introduced the SIPC concept during his keynote address, titled 'Making the PC an Appliance'.

The key features of SIPC seem to be high-quality sound and video, easy connectivity with other devices and low cost. Today's demonstration showed off the audio and video quality of the proposed system with demonstrations of enhanced audio, processed and driven from the PC through a consumer stereo system.

Don't look for a Microsoft-branded device to put on the shelf of your home entertainment system or your office. The software company is still a software company. What Microsoft is offering is an open standard that already has the endorsement of industry leaders like Toshiba, Compaq, Phoenix Technologies, Hewlett-Packard, and Intel.

The SIPC standard is scheduled for release in the second half of 1996. The heart of the system is the Win32 Driver Model, which provides a common driver architecture for the Windows '95 and Windows NT operating systems. Using the model, a single device driver can be written for both operating systems. That will make it faster and easier to develop higher-quality device drivers and innovative hardware.

Microsoft claims to have been working on the SIPC idea since last summer, and specifications include a proposed standard cable connection that could send data among the various components at speeds 30 times faster than today's typical PC connections, and a boot-up sequence that would take only three to five seconds. For further details, check: <http://www.microsoft.com>.

Contact: Microsoft, Tel: (01344) 710021.

## Billion Dollar Fabrication Plant

NEC Corporation has announced plans to spend 200 billion yen (\$1.87 billion) over the next ten years, to build a new production, research, and development centre based in Tokyo that will work towards building supercomputers the size of today's PCs and personal computers the size of today's wrist watches.

Currently, development work around the world has produced semiconductors built at 0.15µm resolution, although most chips are currently made with processes that provide a maximum resolution of 0.35µm or 0.25µm. NEC's new centre will work towards building chips at the 0.07µm level. For further details, check: <http://www.nec.com>.

Contact: NEC, Tel: (0171) 353 4383.



## Faxes for Kids Scheme

Organisations throughout the UK are being encouraged to donate their redundant fax machines to schools. Promoted by IT-supplier Gestetner, the 'Faxes for Kids' Scheme will be providing much-needed faxed machines free of charge to schools, donated by businesses replacing their own machines.

A similar scheme in 1995 succeeded in providing free laser printers to over 1,500 schools, thanks to donations from a wide range of companies throughout the country.

Contact: Gestetner, Tel: (0990) 143157.

# A Practical Guide to Modern Digital ICs

by Ray Marston

Part 11



So far, this series has dealt with purely run-of-the-mill digital ICs, such as logic gates, flip-flops, counters, latches, and other devices of the type that most digital circuit designers are likely to use on a regular basis. However, there are other useful types of digital IC that most engineers need to use only very rarely, and amongst them are Multiplexers, Decoders and Demultiplexers, Addressable Latches, Full-adders, and Bus Transceivers. The final part explains how to use these types of special-purpose ICs, and gives functional descriptions of a few other unusual and rarely used digital ICs.

of course, that it enables a whole stack of parallel data to be transmitted (in serial form) via a single data link, such as an electric or fibre-optic cable or a wireless carrier wave, etc.

Figure 2 shows, in greatly simplified form, an electronic version of the above circuit. Here, at the transmitter end of the system, SW1 is replaced by a 4-input multiplexer, the action of which is such that any of the four data input lines can be coupled to the OUT line by applying a suitable 2-bit binary address code (00, 01, 10, or 11). These codes are generated sequentially by the divide-by-4 counter (consisting of two cascaded divide-by-2 flip-flops), which is driven by a clock-pulse generator that produces narrow trigger pulses. The outputs of the multiplexer and the clock-pulse generator are mixed together in the 2-input AND gate and transmitted down the single data link; at the receiver end of the system, the clock pulses are extracted from the data link and used to drive another divide-by-4 counter that generates address codes for the 1-line to 4-line demultiplexer, which reconstructs the original input data and puts it out on four separate lines.

The above circuit is, of course, greatly simplified and, in practice, would need the addition of a pulse synchronization system and a few other refinements to make it work properly, but it does serve to illustrate the basic multiplexing principle. Note in particular, that multiplexers and demultiplexers are really meant to form individual elements in a highly specialised type of system but, that in practice, a multiplexer actually functions as an addressable data selector (like SW1 in Figure 1). A demultiplexer functions as an addressable data distributor (like SW2 in Figure 1) or as a

## Multiplexing Basics

A multiplexer is a device that enables two or more signals to be selected and combined into a single output that can subsequently be demultiplexed in a way that enables the original signals to be retrieved. Figure 1 illustrates the basic principle of a multiplexing system. Imagine here that the two switches are motor driven and continuously rotate, and are somehow remotely ganged so that SW2 is in position '1' when SW1 is in position '1', and so on; consequently, the 4-bit data from the four input lines is repeatedly sequentially inspected via SW1 and converted into serial form (multiplexed), and then shoved down the data link to SW2, where it is demultiplexed and reappears in its original 4-bit form on four separate output lines. The big feature of this system is,

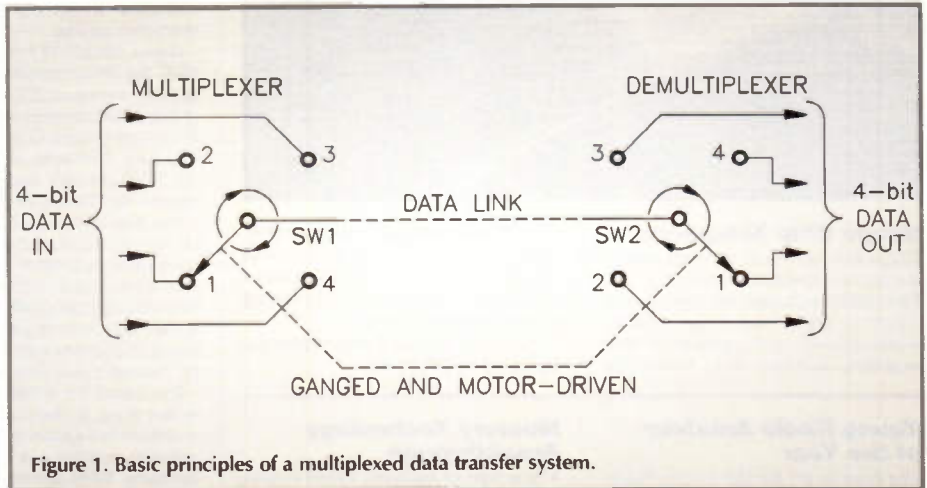

Figure 1. Basic principles of a multiplexed data transfer system.

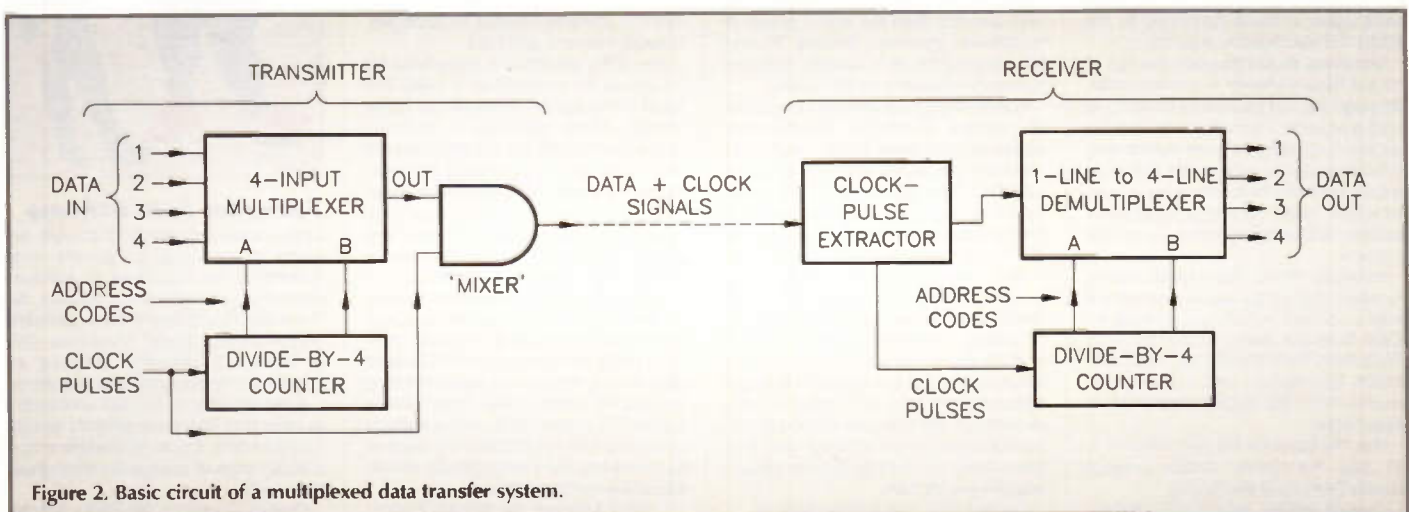

Figure 2. Basic circuit of a multiplexed data transfer system.

binary-code 'decoder', and in these modes, both types of device are so useful that they are usually described as 'multiplexer/data-selector' and 'demultiplexer/decoder' ICs.

Note in Figure 1 that SW1 and SW2 can both pass signals in either direction, and can thus be used as either multiplexers or demultiplexers by simply placing them in the appropriate part of the system. TTL ICs, however, can only pass signals in one direction, and make such poor imitations of electromechanical switches that they have to be produced in both 'multiplexer' and 'demultiplexer' versions. CMOS ICs, on the other hand, can be made to act as near-perfect bidirectional switches that can handle both digital and analogue signals; CMOS 'analogue switches' can thus be used as both multiplexers and demultiplexers, but for many years, were too slow for use in most TTL-type applications. Then, in the mid-1980s, the 74HC-series of fast CMOS was introduced, and its superb range of 'analogue switch' ICs quickly made many of the existing TTL multiplexer and demultiplexer ICs obsolescent, the upshot being that relatively few of these devices are now available in TTL form. The next two sections of this article describe some of the TTL types that remain, and the third section describes some of the CMOS 'analogue switch' ICs that are available.

### '74-series' Multiplexer ICs

The three best-known types of current-production TTL multiplexer IC are the 74LS157 Quad 2-input IC, the 74LS153 Dual 4-input IC, and the 74LS151 8-input IC, which are also available in fast CMOS form as the 74HC157, 74HC153, and 74HC151. The

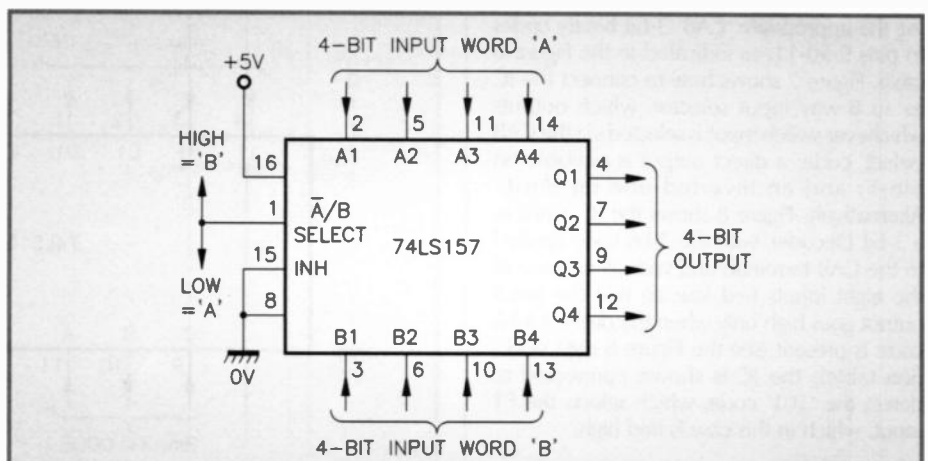

Figure 3. Normal connections for using the 74LS157 (or 74HC157) as a 4-bit data-word selector.

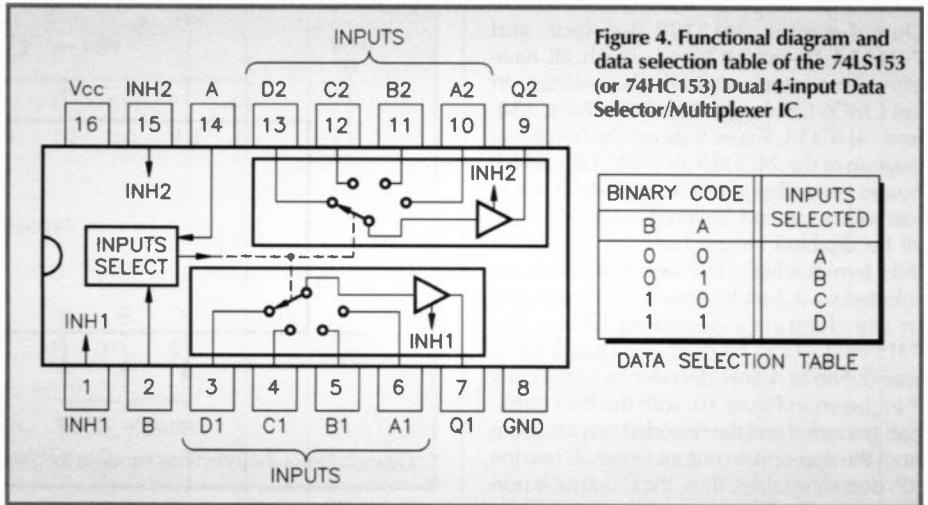

Figure 4. Functional diagram and data selection table of the 74LS153 (or 74HC153) Dual 4-input Data Selector/Multiplexer IC.

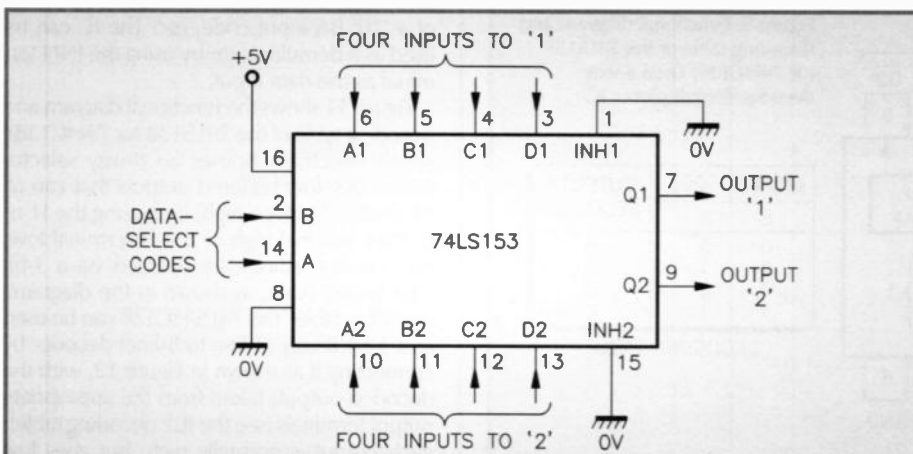

Figure 5. Normal connections for using the 74LS153 (or 74HC153) as a Dual 4-way input selector.

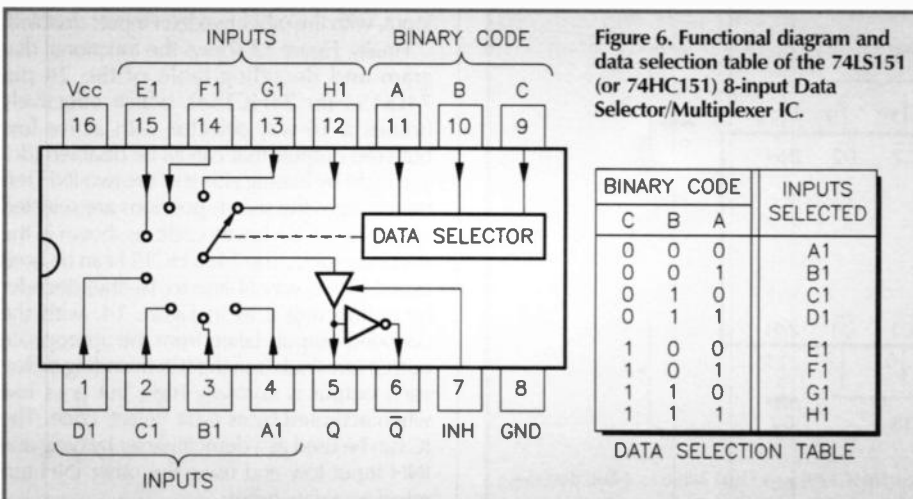

Figure 6. Functional diagram and data selection table of the 74LS151 (or 74HC151) 8-input Data Selector/Multiplexer IC.

74LS157 (and 74HC157) effectively houses four ganged 2-way ('A' or 'B') switches with buffered outputs that can be disabled (driven low) by biasing INH pin-15 high; the switch positions can be selected via pin-1, which selects position 'A' when biased low or 'B' when biased high. The 74LS/HC157 is very easy to use, and Figure 3 shows how to connect it as a data-selector that can select either of two 4-bit input words via pin-1. This circuit is useful in applications where, for example, either of two 4-bit codes need to be sent to the PRESET terminal of a counter/divider IC, etc.

Figure 4 shows the functional diagram of the 74LS153 (or 74HC153), which effectively houses two ganged 4-way ('A' to 'D') switches with buffered outputs that can be disabled (driven low) by biasing the appropriate INH terminal (pins 1 or 15) high; the switch positions can be selected by applying the appropriate 'BA' binary codes to pins 2 and 14, as indicated in the Figure 4 table. Figure 5 shows how to connect the IC as a Dual 4-way input selector, in which each 'switch' outputs the input data that is selected via the BA 'select' code. Note that the IC can be used as a Dual 2-bit Decoder by applying the 2-bit code to the BA terminals and tying all but one of each switch's four inputs low, so that the switch's output goes high only when the desired 2-bit code is present, as indicated in the IC's data selection table; thus, the '10' BA code can be detected by tying only the 'C' input high, etc.

Figure 6 shows the functional diagram of the 74LS151 (or 74HC151), which effectively houses a single 8-way ('A1' to 'H1') switch with a buffered output that can be disabled (driven low) by biasing the INH terminal high; the switch positions can be selected by apply-

ing the appropriate 'CAB' 3-bit binary codes to pins 9-10-11, as indicated in the Figure 6 table. Figure 7 shows how to connect the IC as an 8-way input selector, which outputs whichever switch input is selected via the CAB 'select' code; a direct output is available on pin-5, and an inverted one on pin-6. Alternatively, Figure 8 shows the IC wired as a 3-bit Decoder, with the 3-bit code applied to the CAB terminals and with all but one of the eight inputs tied low, so that the pin-5 output goes high only when the desired 3-bit code is present (see the Figure 6 data selection table); the IC is shown connected to detect the '101' code, which selects the F1 input, which in this case is tied high.

### '74-series' Demultiplexer ICs

The three best-known current-production TTL decoder/demultiplexer ICs are the 74LS139 Dual 4-output, 74LS138 8-output, and 74LS154 16-output types, which all have active-low outputs and are also available in fast CMOS form as the 74HC139, 74HC138, and 74HC154. Figure 9 shows the functional diagram of the 74LS139 (or 74HC139), which houses two independent 4-way (A to D) selectors with active-low buffered outputs that can all be disabled (driven high) by biasing the INH terminal high; the switch positions are selected via a 2-bit BA binary code, as shown in the diagram's decoding table. The 74LS/HC139 can be used as a Dual 2-bit 4-way (2-line to 4-line) decoder by connecting it as shown in Figure 10, with the INH terminals grounded and the decoded outputs taken from the appropriate output terminals (see the IC's decoding table); thus, the  $\bar{C}$  output is nor-

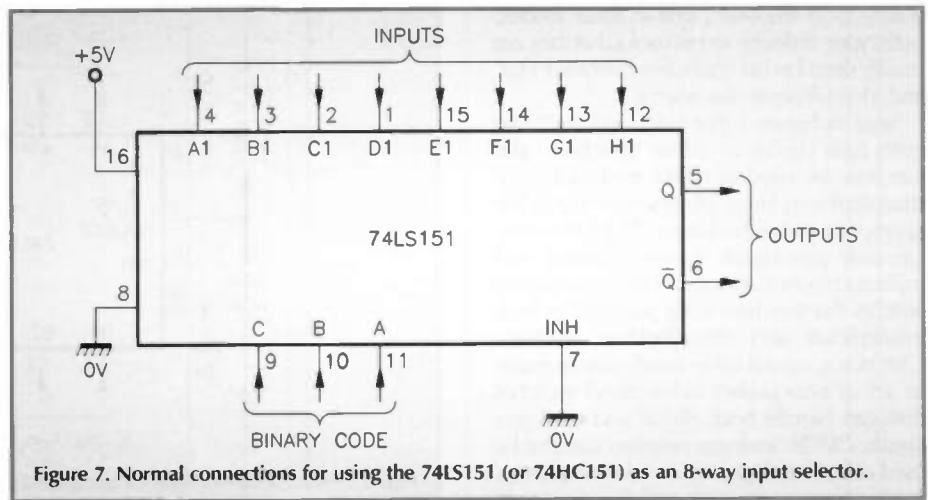

Figure 7. Normal connections for using the 74LS151 (or 74HC151) as an 8-way input selector.

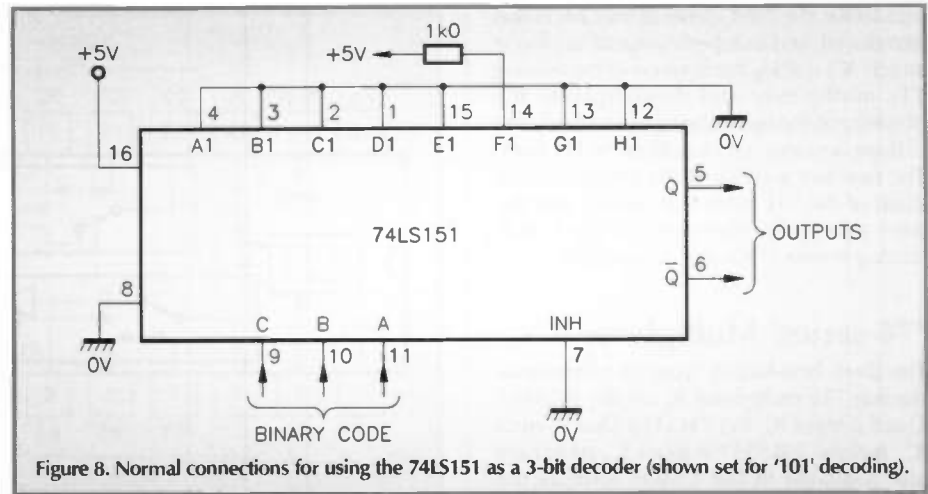

Figure 8. Normal connections for using the 74LS151 as a 3-bit decoder (shown set for '101' decoding).

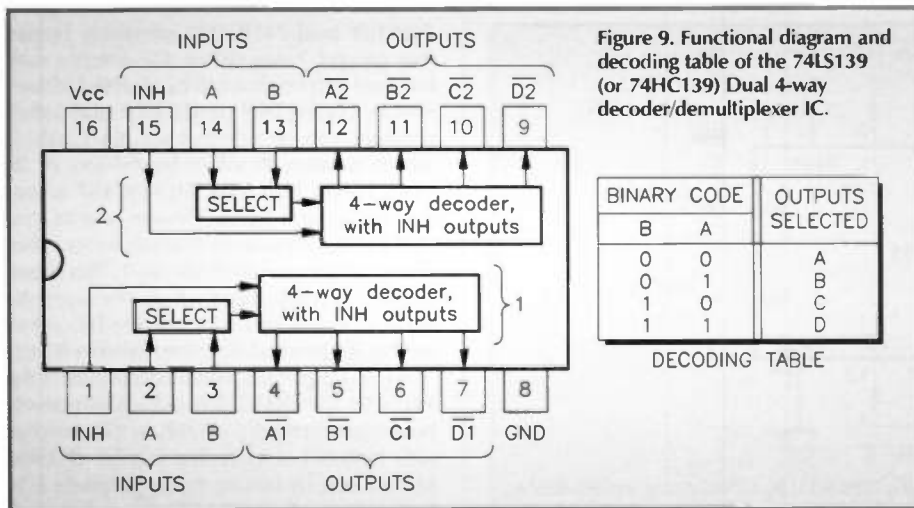

Figure 9. Functional diagram and decoding table of the 74LS139 (or 74HC139) Dual 4-way decoder/demultiplexer IC.

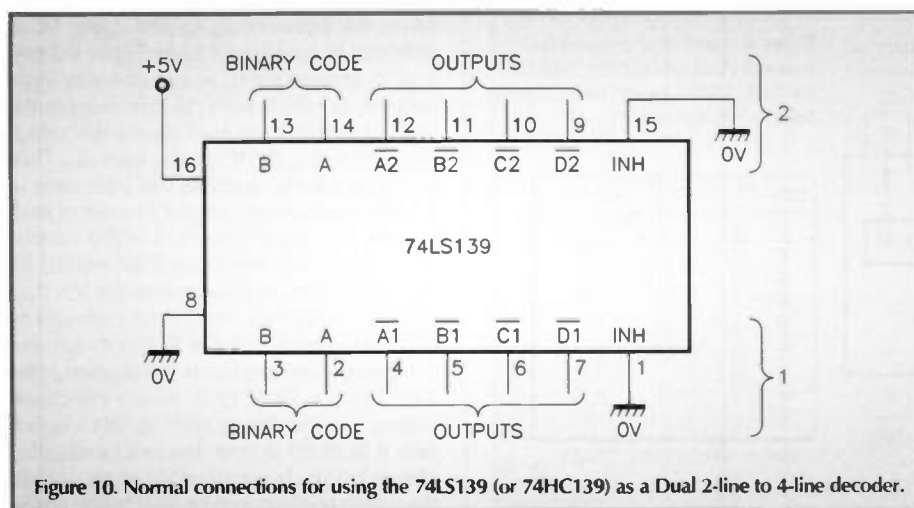

Figure 10. Normal connections for using the 74LS139 (or 74HC139) as a Dual 2-line to 4-line decoder.

mally high, and goes low only in the presence of a '10' BA input code, etc. The IC can be used as a demultiplexer by using the INH terminal as the data input.

Figure 11 shows the functional diagram and decoding table of the 74LS138 (or 74HC138), which effectively houses an 8-way selector with active-low buffered outputs that can all be disabled (driven high) by biasing the I1 or I2 INH terminal high or the  $\bar{I}3$  terminal low; the switch positions are selected via a 3-bit CBA binary code, as shown in the diagram's decoding table. The 74LS/HC138 can be used as a 3-bit 8-way (3-line to 8-line) decoder by connecting it as shown in Figure 12, with the decoded outputs taken from the appropriate output terminals (see the IC's decoding table); each output is normally high, but goes low when activated by its 3-bit 'select' code. This IC can be used as a demultiplexer by using one of the active-low INH terminals as the data input, with the other two INH inputs disabled.

Finally, Figure 13 shows the functional diagram and decoding table of the 24-pin 74LS154 (or 74HC154), which effectively houses a 16-way selector with active-low buffered outputs that can all be disabled (driven high) by biasing either of the two INH terminals high; the switch positions are selected via a 4-bit DCBA binary code, as shown in the decoding table. The 74LS/HC154 can be used as a 4-bit 16-way (4-line to 16-line) decoder by connecting it as in Figure 14, with the decoded outputs taken from the appropriate output terminals (see the IC's decoding table); each output is normally high, but goes low when activated by its 4-bit 'select' code. The IC can be used as a demultiplexer by tying one INH input low and using the other INH terminal as a data input.

## CMOS 'Analogue Switch' ICs

TTL elements can pass signal currents efficiently in only one direction and thus make rather poor imitations of electromechanical switches, which are inherently bidirectional devices. Some CMOS elements, on the other hand, can be made to act as near-perfect bidirectional switches, and for many years, a range of excellent '4000-series' CMOS 'analogue switch' ICs have been available. Many of these ICs have also been produced in fast 74HC-series versions since the mid-1980s, and can easily be used to replace existing TTL multiplexer and demultiplexer ICs in many applications.

The simplest of these 'analogue switch' ICs is the 4066B, which is also available in a 'fast' version as the 74HC4066, and acts like four independent bidirectional ON/OFF switches, each of which has a near-infinite OFF resistance and has a typical ON resistance of about 50Ω; the 74HC4066 switches can comfortably pass currents of up to 20mA when the IC is operated from a 5V supply.

The most widely used 'multi-way' variants of the '4000-series' range of CMOS analogue switch ICs are the 4051B, 4052B, 4053B, and 4067B, which are also available in fast '74HC-series' variants as the 74HC4051, 74HC4052, 74HC4053, and 74HC4067, in which form, they are described in manufacturers' data sheets as 'multiplexer/demultiplexer ICs'. Of these ICs, the 4051B and 74HC4051 are 8-channel (i.e. 8-way) ICs, the 4052B and 74HC4052 are Dual 4-channel ICs, the 4053B and 74HC4053 are Triple 2-channel ICs, and the 4067B and 74HC4067 are 16-channel ICs.

## Addressable Latches

Earlier parts of this series gave reasonably full descriptions of conventional data latch ICs, in which groups of latch elements are ganged together and activated by a single clock signal. An 'addressable latch' IC, on the other hand, is a special unit in which a single clock signal and data input, etc., can be 'addressed' (applied) to individual latch elements amongst a group, one at a time; the 'address' takes the form of a binary code (2-bits for four latches, 3-bits for eight latches). The best known TTL IC of this type is the 74LS259 8-bit addressable latch, which is also available in a fast CMOS version as the 74HC259; Figure 15

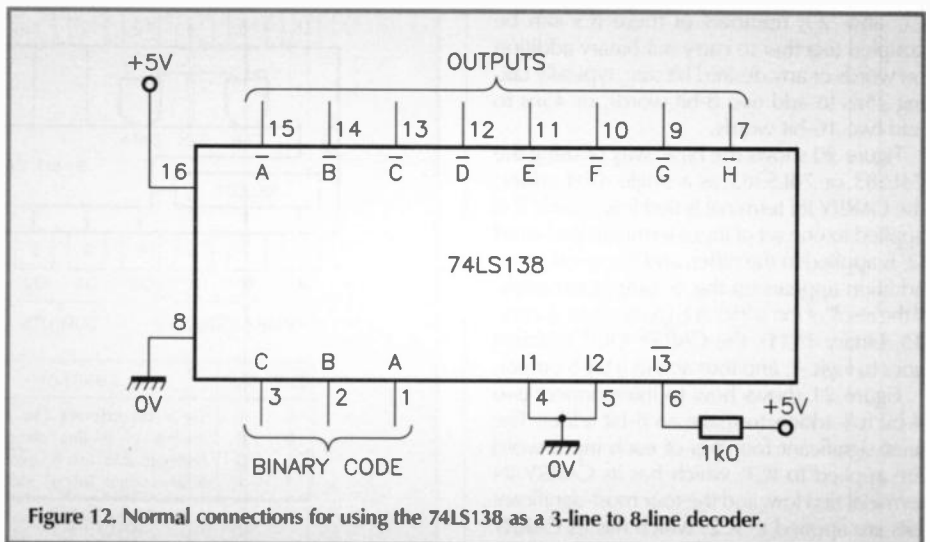
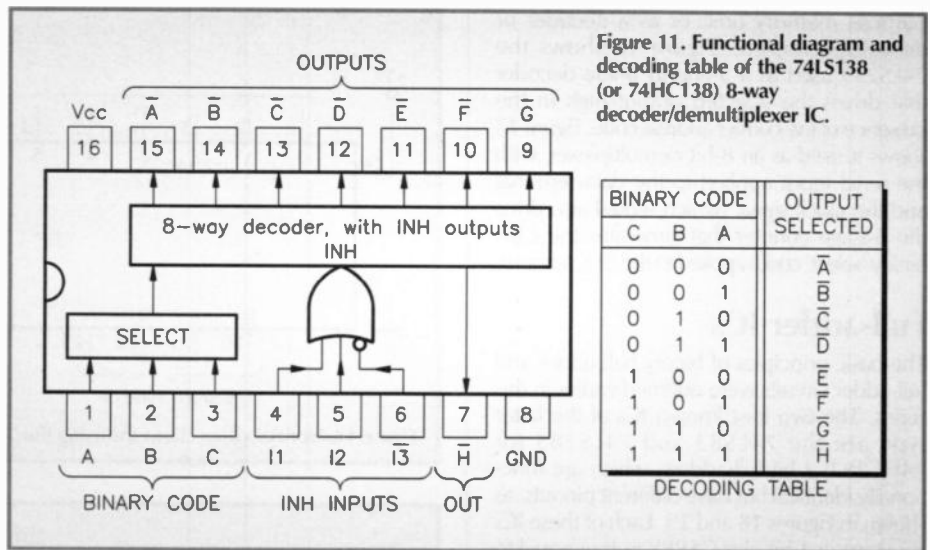

shows the functional diagram, address table, and function table of the IC, which has four basic operating modes (see the function table), as follows:

1.  $\bar{CLR}$  is low and CLK is high, all latches are cleared and the Q0 to Q7 outputs go low.
2. When  $\bar{CLR}$  and CLK are low, the IC acts as a 3-line to 8-line decoder (or demultiplexer) in which the selected output is active-high and all other outputs are low.

3. When  $\bar{CLR}$  is high and CLK is low, the IC acts as an addressable transparent latch, in which the Q-output of the selected latch follows the data input, and all other latches remain in their previous states.

4. When  $\bar{CLR}$  and CLK are high, the current data is latched into the selected latch.

The 74LS/HC259 is thus a reasonably versatile unit that can be used as an 8-bit serial-in to parallel-out converter, as a general-

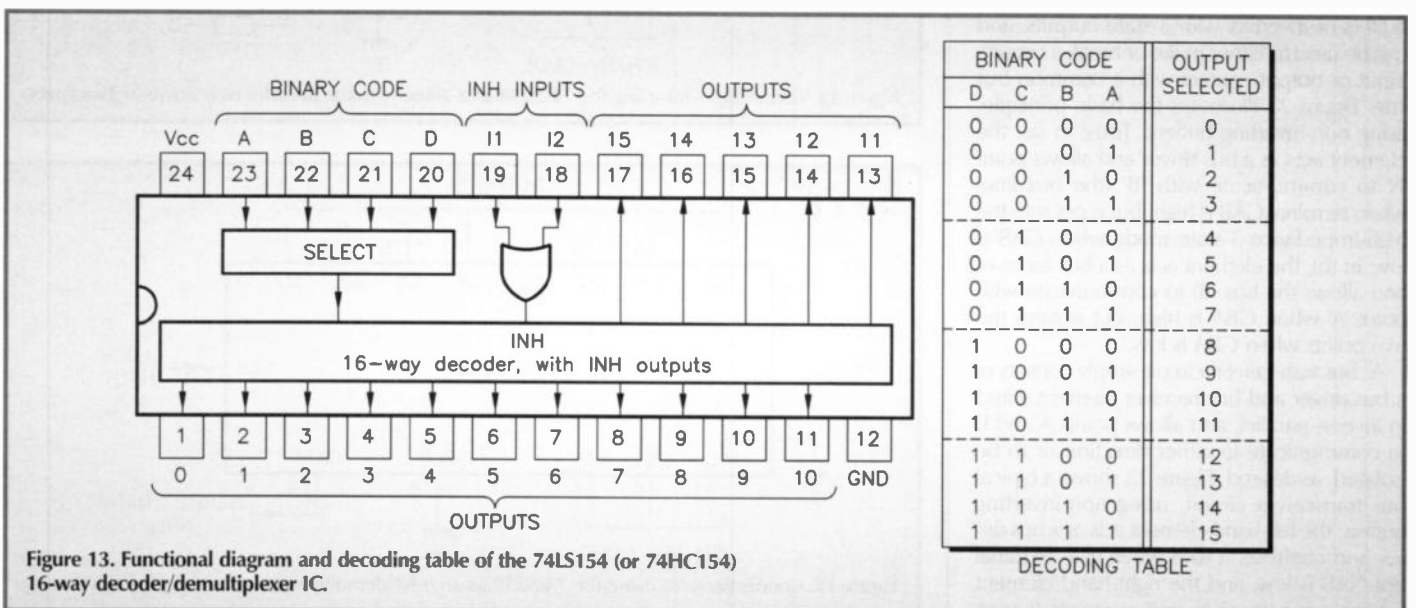

purpose memory unit, or as a decoder or demultiplexer, etc. Figure 16 shows the 74LS259 used as a 3-line to 8-line decoder that drives the selected output high in the presence of the correct address code. Figure 17 shows it used as an 8-bit demultiplexer, with the serial input applied to the data terminal and the clock signal (which would also drive the 3-stage counter that generates the CBA binary 'select' code) applied to the CLK terminal.

## Full-adder ICs

The basic principles of binary half-adder and full-adder circuits were outlined earlier in this series. The two best known ICs of the latter type are the 74LS83 and 74LS283 (or 74HC283) 4-bit full-adders, which are functionally identical but have different pinouts, as shown in Figures 18 and 19. Each of these ICs generates a 4-bit plus CARRY output equal to the sum ('S') of two 4-bit (DCBA) input words ('1' and '2'); numbers of these ICs can be coupled together to carry out binary addition on words of any desired bit size, typically taking 25ns to add two 8-bit words, or 45ns to add two 16-bit words.

Figure 20 shows the basic way of using the 74LS83 or 74LS383 as a single 4-bit adder; the CARRY IN terminal is tied low, word '1' is applied to one set of input terminals and word '2' is applied to the other, and the result of the addition appears on the 'S' output terminals. If the result of the addition is greater than decimal 15 (binary 1111), the CARRY OUT terminal goes to logic-1, and thus acts as a bit-5 output.

Figure 21 shows how to interconnect two 4-bit full-adders to make an 8-bit adder. The least-significant four bits of each input word are applied to IC1, which has its CARRY IN terminal tied low, and the four most-significant bits are applied to IC2, which has its CARRY IN terminal tied to the CARRY OUT of IC1. IC1 provides the four least-significant bits of the resulting sum, and IC2 provides the four most-significant bits plus a CARRY OUT, which acts as bit-9. This basic circuit can be expanded upwards to accept input words of any desired bit size, by taking the CARRY OUT of each successive lower-order stage to the CARRY IN terminal of the next higher-order stage in the chain.

## Bus Transceiver ICs

In digital electronics, 'bus driver' and 'bus receiver' elements are simply high fan-out buffers or inverters with 3-state outputs, and can be used to either make or break a circuit's input or output contact with a common bus line. Figure 22 illustrates the basic principle, using non-inverting buffers. Thus, in (a), the element acts as a bus driver and allows point 'A' to communicate with 'B' (the bus line) when terminal GAB is high, but is put into the high-impedance 3-state mode when GAB is low. In (b), the element acts as a bus receiver and allows the bus (B) to communicate with point 'A' when GBA is high, but isolates the two points when GBA is low.

A 'bus transceiver' circuit simply consists of a bus driver and bus receiver element wired in inverse parallel, and allows points A and B to communicate in either direction or to be isolated, as desired. Figure 23 shows a typical bus transceiver circuit, using non-inverting buffers; the left-hand element acts as a bus driver and connects A to B when gate terminal not-GAB is low, and the right-hand element acts as a bus receiver and connects B to A

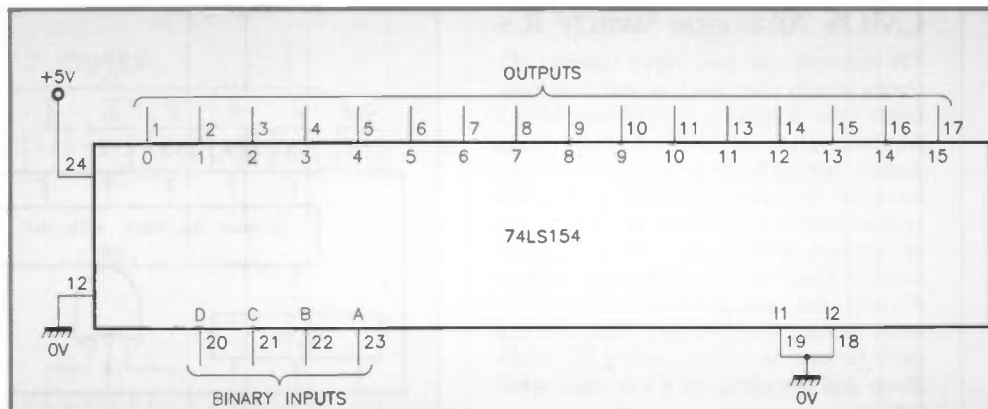

Figure 14. Normal connections for using the 74LS154 (or 74HC154) as a 4-line to 16-line decoder.

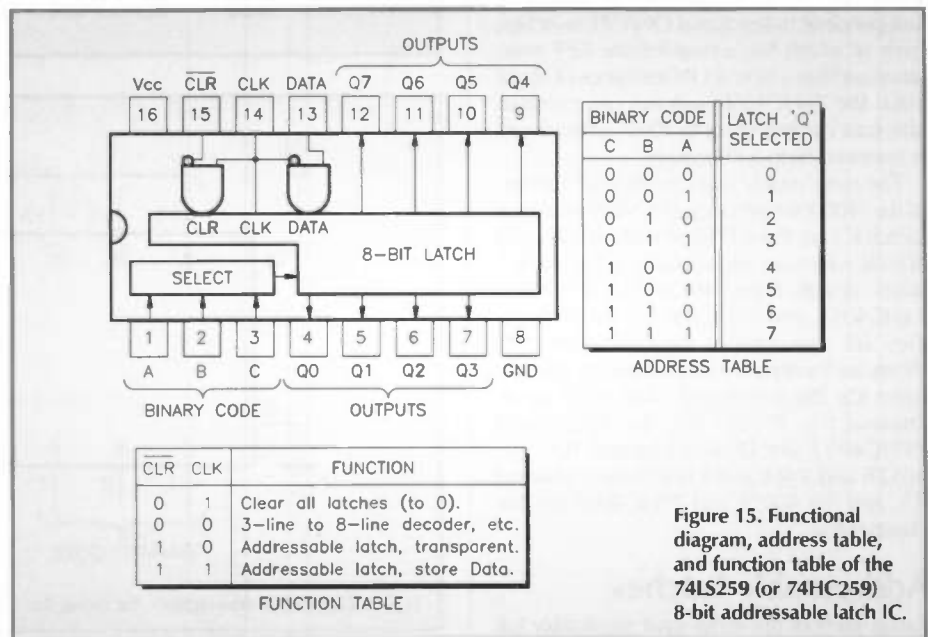

Figure 15. Functional diagram, address table, and function table of the 74LS259 (or 74HC259) 8-bit addressable latch IC.

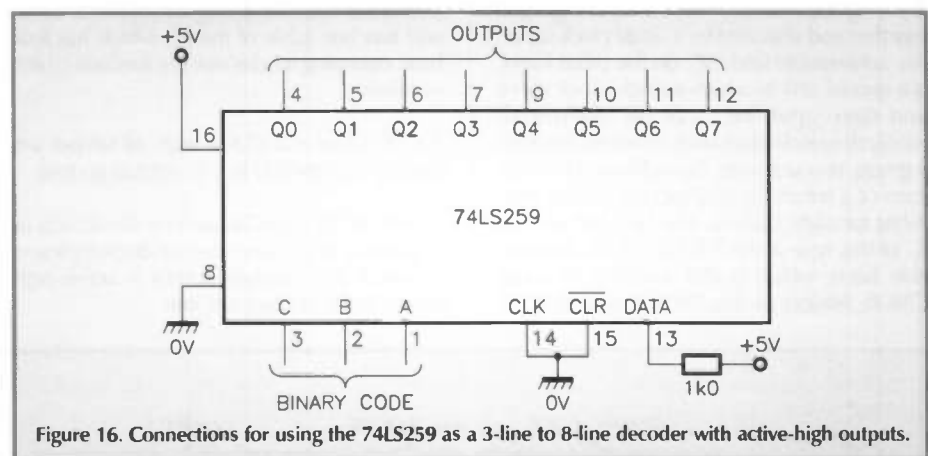

Figure 16. Connections for using the 74LS259 as a 3-line to 8-line decoder with active-high outputs.

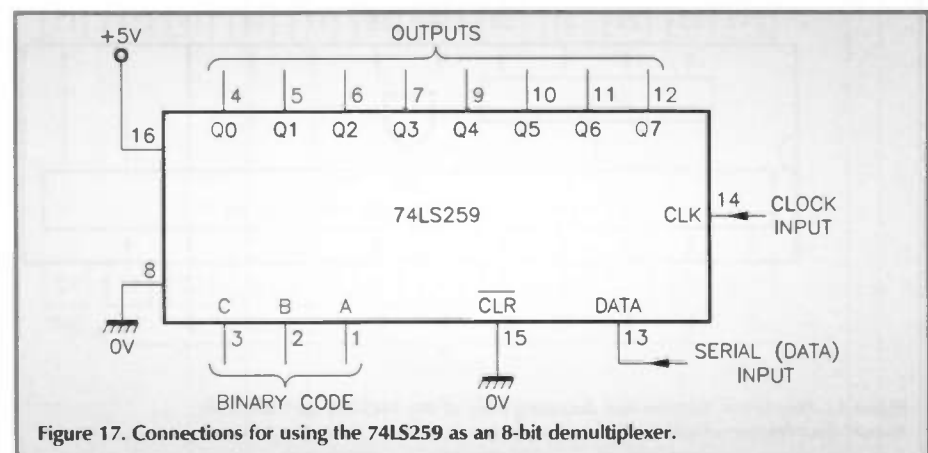
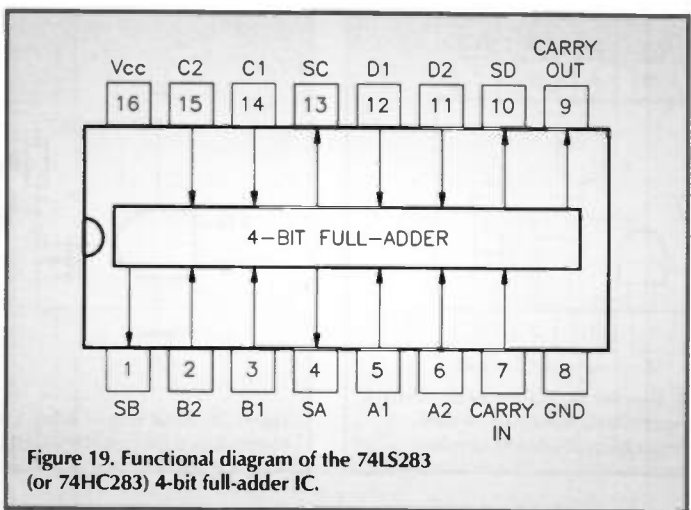
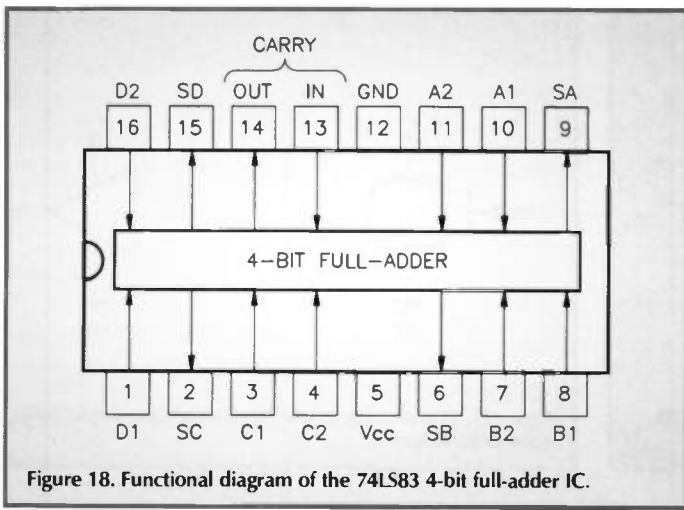

Figure 17. Connections for using the 74LS259 as an 8-bit demultiplexer.





when gate terminal GBA is high. The diagram also shows the circuit's function table; thus, the transceiver connects B to A when both gates are high, and connects A to B when both gates are low, and isolates both points when GAB is high and GBA is low. Note that the GBA-high/GAB-low condition is an illegal one; it turns both elements on, effectively shorting their outputs and inputs together, and possibly causing latch-up or wild oscillations.

The three best-known TTL bus transceiver ICs are the 74LS242, 74LS243, and 74LS245, which are also available in '74HC' form. The 74LS/HC242 (inverting) and 74LS/HC243 (non-inverting) ICs are 4-line transceivers with identical outlines and pin notations; Figure 24 shows the functional diagram of the 74LS/HC243, which has a function table identical to that shown in Figure 23. The 74LS/HC245 is an 8-line non-inverting transceiver which incorporates logic circuitry that makes it impossible for an 'illegal' input gating state to occur; this IC is housed in a 20-pin DIL package.

### Using Open-drain Outputs

A small proportion of digital ICs have open-drain (o.d.) or open-collector (o.c.) outputs. The cheapest IC of this type is the CMOS 40107B Dual 2-input NAND buffer/driver, which (in its popular 8-pin version) has the functional diagram shown in Figure 25, and is a useful device for demonstrating 'open-drain' basics. Note that each of this IC's two basic 'elements' effectively consist of a 2-input AND gate with its output connected to the gate of an n-channel MOSFET, which has its drain connected directly to the OUT terminal. This element can be made to function as a 2-input

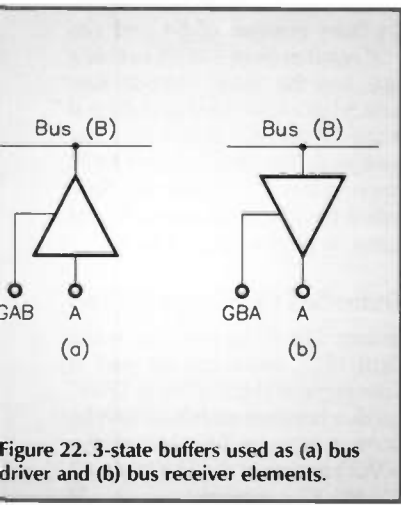
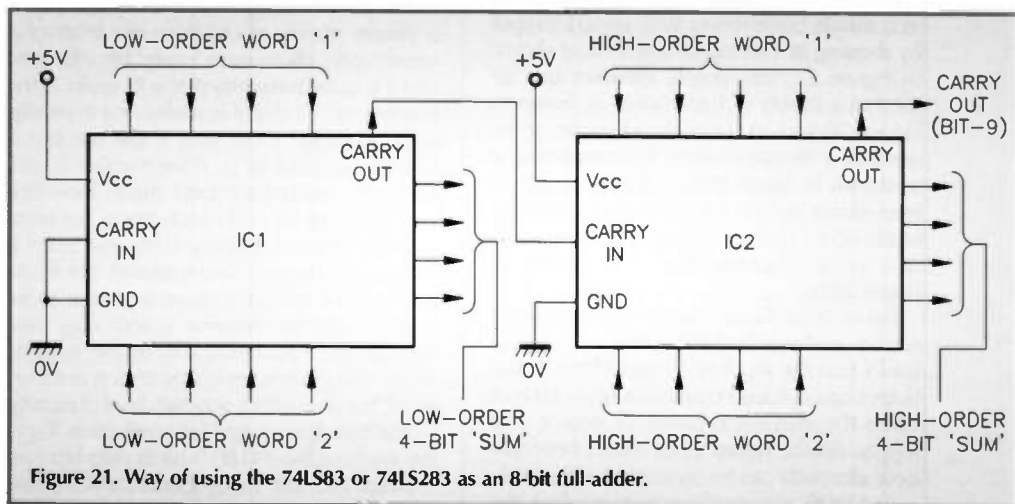
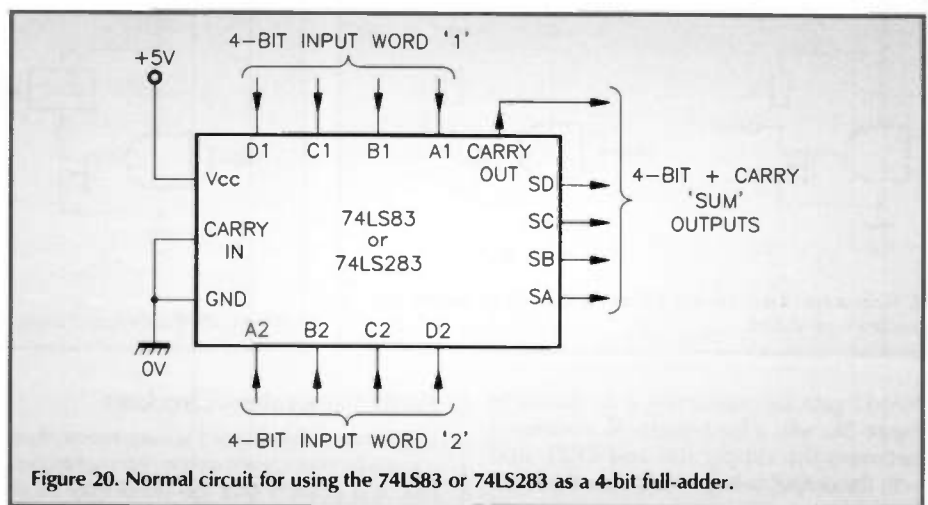

Figure 22. 3-state buffers used as (a) bus driver and (b) bus receiver elements.

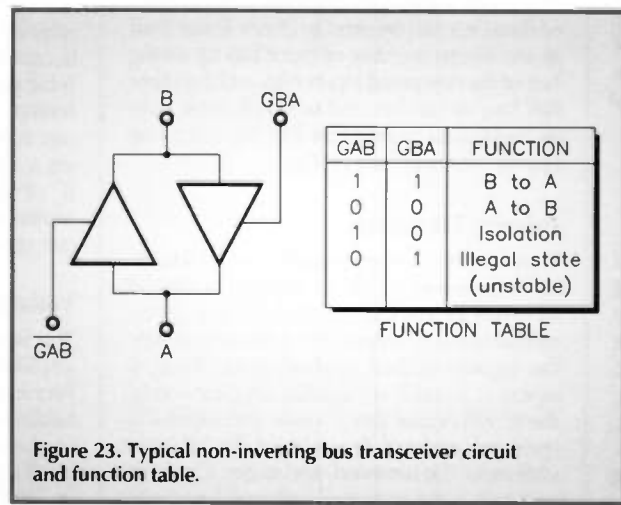

Figure 23. Typical non-inverting bus transceiver circuit and function table.

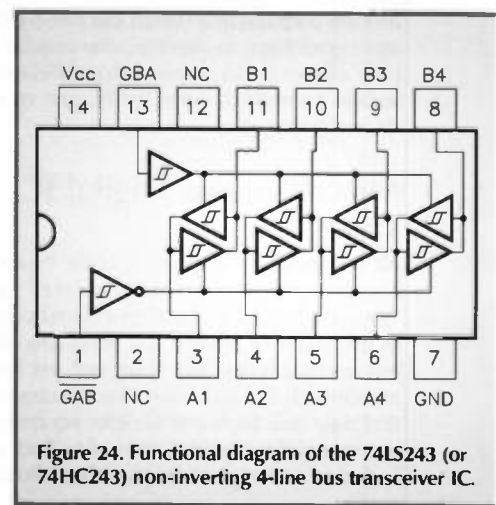

Figure 24. Functional diagram of the 74LS243 (or 74HC243) non-inverting 4-line bus transceiver IC.

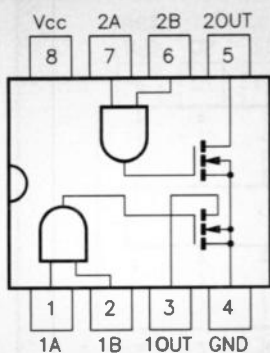

Figure 25. Functional diagram of the 40107B Dual 2-input NAND buffer/driver with open-drain outputs (8-pin DIL version).

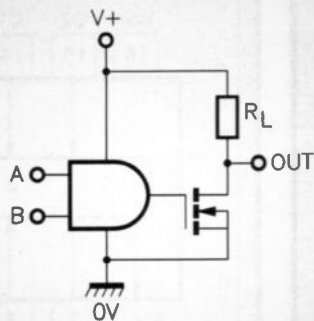

Figure 26. Basic way of using a 40107B element as a 2-input NAND gate.

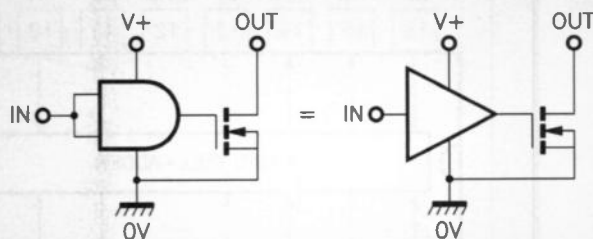

Figure 27. Way of using a 40107B element as a simple buffer with open-drain output.

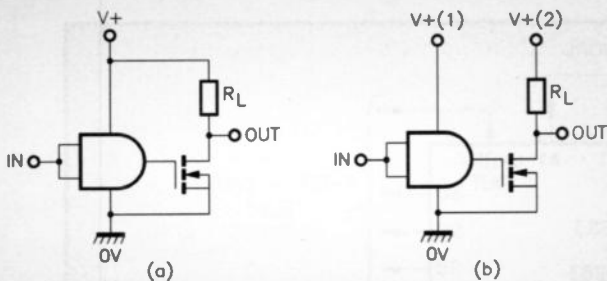

Figure 28. Basic ways of using a 40107B element as (a) an inverter or (b) an inverting level shifter.

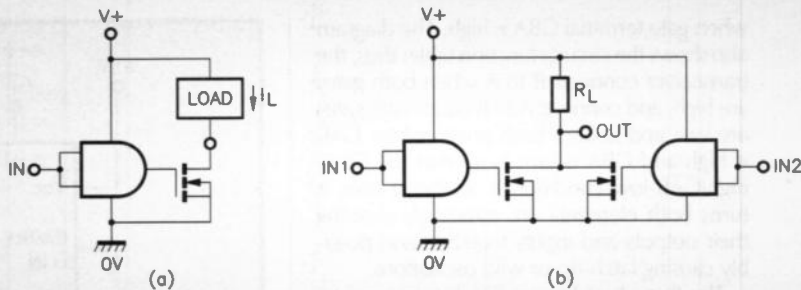

Figure 29. Basic ways of using 40107B elements as (a) load drivers or (b) 'wired NOR' gates.

NAND gate by connecting it as shown in Figure 26, with a load resistor  $R_L$  connected between the supply rail and OUT, and with the output voltage taken from the OUT terminal.

Each 40107B element can be made to act as a simple buffer/driver with an o.d. output by shorting its two inputs together, as shown in Figure 27; this simple element can be used in a variety of basic ways, as shown in Figures 28 and 29. Thus, the element can be used as a simple inverter by connecting it as shown in Figure 28(a), or as an inverting level shifter (which converts input switching levels of  $V+(1)$  into output switching levels of  $V+(2)$ ) by connecting it as shown in Figure 28(b).

Figure 29(a) shows how a 40107B element can be used as a load driver that activates the load when the input is driven to logic-1; the output can sink load currents of up to 100mA when the element is powered from a 15V supply. Finally, Figure 29(b) shows how two basic elements can be connected in the basic 'wired NOR' gate configuration, in which the two IGFET outputs share a common load ( $R_L$ ) and the output is thus driven low when either input goes high; in practice, any number of basic elements can be wired in parallel in this fashion to make a wired NOR gate of any desired 'input' size.

## Miscellaneous Digital IC Types

All of the most important basic types of current-production '4000-series' and '74-series' digital ICs have now been covered in this series of articles, but there are still a few special types that have not yet been mentioned, because they are obsolescent, and may only be found in older equipment, or are unduly expensive or hard to find, etc. Included amongst these are the following devices:

## Parity Generators/Checkers

Whenever a digital word is transmitted along a severely interference-prone communication link, it is possible that the word may be so degraded that its code is changed from that transmitted. Parity generator/checker ICs offer a simple means of checking the truth of a word's code, via an extra 'parity' bit; when the word is to be transmitted, the IC looks at the number of '1's that it contains and (typically) adds an extra '1' bit to it if the number is even, or an extra '0' bit if the number is odd. When the word is received, the IC looks at it and its parity bit and checks them for compatibility (parity); if parity exists, the word is assumed to be pure, and is passed, but if parity does not exist, the word is proven to be corrupt, and the receiver system may then request the retransmission of the original word. The parity-checking system is not fool-proof, but does offer a very high level of security.

The best-known current-production ICs of this type are the 74180 9-bit (8 data bits plus 1 parity bit) TTL Parity Generator/Checker, and the 40101B and 74HC280 9-bit and 4531B 13-bit CMOS Parity Generator/Checkers. Each of these ICs can be used to check fewer than its maximum number of input bits by wiring half of the unwanted inputs high and the other half low, or can be used to check more than its maximum number of bits by cascading appropriate numbers of ICs.

## Priority Encoders

These are multi-input (usually 8 or 10 line) 3-bit encoders in which the inputs are ranked in order of priority so that (at any given moment) the IC outputs the 3-bit code of only the highest ranked applied input. Thus, if inputs 1, 5 and 7 are applied simultaneously, the IC will output the '7' code until input-7 is removed, and will then output the '5' code until input-5 is removed, and so on. ICs of this type help a system to deal with problems/tasks

in a sensible order of importance. The best-known current production TTL ICs of this type are the 74LS147 decimal-to-BCD and 74LS148 Binary 8-line to 3-line Priority Encoders.

## Rate Multipliers

These are a special type of programmable divider, in which the divide-by value equals  $B/X$ , where X is a settable limited-range whole-number value and B is a fixed base number (either 10, 16 or 64); thus, if  $B = 10$  and X is set at 7, the IC will output seven pulses for every ten that are applied at the input and have a divide-by value of 1.4286. If X is stepped through numbers 1 to 9, the IC output will provide 1 to 9 pulses for every 10 input pulses, and have divide-by values that step through the values 10, 5, 3.333, 2.5, 2, 1.667, 1.4286, 1.25, and 1.111. ICs of this type are (or used to be) useful in performing arithmetic operations such as multiplication and division, and in A-to-D and D-to-A conversion, etc., but have now been generally superseded by more sophisticated types of LSI device. The best-known TTL Rate Multiplier ICs are the 7497 6-bit Binary Rate Multiplier, which has a base number of 64 and can accept any 'X' number from 1 to 63 (set via a 6-bit address), and the 74167 Decade Rate Multiplier, which has a base number of 10 and can accept any 'X' number from 1 to 9 (set via a 4-bit address). The best-known CMOS IC of the type is the 4527B Decade Rate Multiplier, which has a base number of 10 and can accept any 'X' number from 1 to 9.

## Voltage Controlled Oscillators (VCOs)

The best-known TTL IC of this type is the 74LS629 Dual VCO, which can be used at frequencies ranging from 1Hz to 20MHz. This IC is rather expensive, however, and should only be used as a last resort, when no cheaper alternative (such as the VCO section of the CMOS 4046B or 74HC4046 PLL IC) is available. E

The MICRO MODULE  
A NEW LOW COST controller  
that gives you customisation  
for as little as **£95** one off  
+ VAT

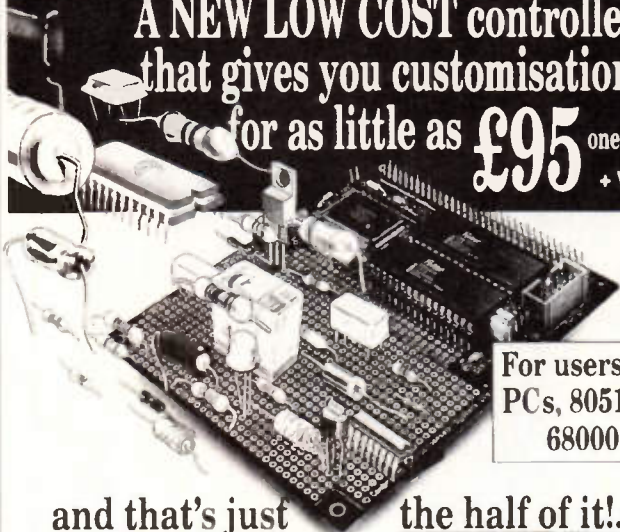

For users of  
PCs, 8051 &  
68000

and that's just the half of it!..

**FEATURES**

- 16/32 bit 68307 CPU for fast operation
- Up to 1 Mbyte of EPROM space onboard
- Up to 512Kbyte SRAM space onboard
- 32 Kbyte SRAM fitted as standard
- RS232 serial with RS485 option
- MODBUS & other protocols supported
- Up to 22 digital I/O channels
- 2 timer/counter/match registers
- I<sup>2</sup>C port or Mbus & Watch dog facilities
- Large Proto-typing area for user circuits
- Up to 5 chip selects available
- Program in C, C++, Modula-2 & Assembler
- Real Time multitasking Operating System
- OS9 or MINOS with free run time license option
- Manufacturing available even in low volumes
- A full range of other Controllers available

**P.C. 'C' STARTER PACK AT ONLY £295 + VAT**  
The Micro Module will reduce development time for quick turnaround products/projects and with the P.C. 'C' Starter pack allow you to start coding your application immediately, all drivers and libraries are supplied as standard along with MINOS the real time operating system all ready to run from power on.  
The 'C' Starter pack includes: A Micro Module with 128 Kbyte SRAM, PSU, Cables, Manuals, C compiler, Debug monitor ROM, Terminal program, Downloader, a single copy of MINOS, extensive example software, and free unlimited technical support all for £295.



Cambridge Microprocessor  
Systems Limited

Unit 17-18 Zone 'D', Chelmsford Rd, Ind. Est.,  
Great Dunmow, Essex, U.K. CM6 1XG  
Phone 01371 875644 Fax 01371 876077

# TECHNICAL INFORMATION SERVICES

76 Church Street, Larkhall, Lanarks, ML9 1HE  
Tel: (01698) 883334 Fax: (01698) 884825  
Technical Help Line (01698) 884585

We have the World's Largest  
Selection of:

## SERVICE MANUALS CIRCUIT DIAGRAMS

We also have 100s of Titles on TVs, VCRs,  
Satellites, Midi Systems, Computers, Test  
Equipment, etc...

Please Phone or Send an SAE for FREE  
QUOTE & CATALOGUE of Publications

Attention all our Southern African readers!

Subscribe  
now to  
Southern Africa's  
best selling  
Electronics  
Magazine

from

**MAPLIN**

**SOUTH AFRICA**

Maplin South Africa (Pty) Ltd.  
P.O. Box 1846, Somerset West, 7129, RSA  
Telephone: (024) 515124 Fax: (024) 515127  
e-mail maplin@aztec.co.za



**R114,00** for 6 issues  
and **R215,00** for 12 issues  
(All inclusive of VAT and P&P)

**L**AST month, I introduced a brand new Internet service from British Telecom. Called BT Internet, it is a dial-up style Internet service with a cleverly designed front-end. Intended for the mass-market it is available already in PC software, and will be available shortly for the Mac. The front-end is called, naturally enough, the Launcher, is similar in general function to other front-end services such as Pipex Dial.

On the other hand, it is different in that it is friendlier than most other front-ends. British Telecom's intention is obviously to take the technical strain out of surfing. The in-built World Wide Web browser is an enhanced version of Mosaic which, while not up to the standards of the latest version of Netscape's Navigator, say, is a decent enough browser after all.

What is different too, is the use of a Lo-call number from wherever you access the network, which guarantees you connect at the fastest possible rate and lowest call charges. The Lo-call number is in-built to the Launcher, and you select the one you want depending on whether you are calling from inside or outside of London. For laptop users on the move, for example, this feature alone will save much time locating a local number to access the Internet.

Price of the service is a \$15 a month (including VAT), although you can pay a single advance subscription of \$150 for a year (the equivalent of 12 months' use for 10 months' charge). So, while not the cheapest service around by a considerable amount (see UK Online's charges, last month), many potential users may well feel that the advantage of having British Telecom's name behind it is worth the difference in cost.

## On-line

That is enough about Internet service provision for the time being. Internet service provision is, after all, as we saw in the first part of this series in the May issue (issue number 101), basically just a socket in the Internet into which we can insert the plug of our computer.

The software we run on our computer to access the various parts of the Internet with such a service is very much a side issue. Many Internet service providers, ostensibly as part of the service (although customers are usually charged) are given the software as an integral part of the setup arrangement. Sometimes, all the customer gets is a set of instructions to plug the computer into the Internet service provider's socket – the customer has to locate any software required. Sometimes, like BT Internet and Pipex Dial, the software is provided as an integral front-end. Sometimes, the software is merely a collection of disparate parts.

Generally though, but not always, cost is the important differentiator between having an integrated front-end (usually more expensive) or a basic collection of programs (usually cheaper).

But there is another way to access the Internet, other than a plug-and-socket arrangement in which you need interfacing software. I am talking about the services known loosely as on-line services. There are several of these around, and they have been in existence for a while too; the most famous being CompuServe, AOL, and most recently the Microsoft Network.

In the past, on-line services traditionally restricted themselves to providing a sort of

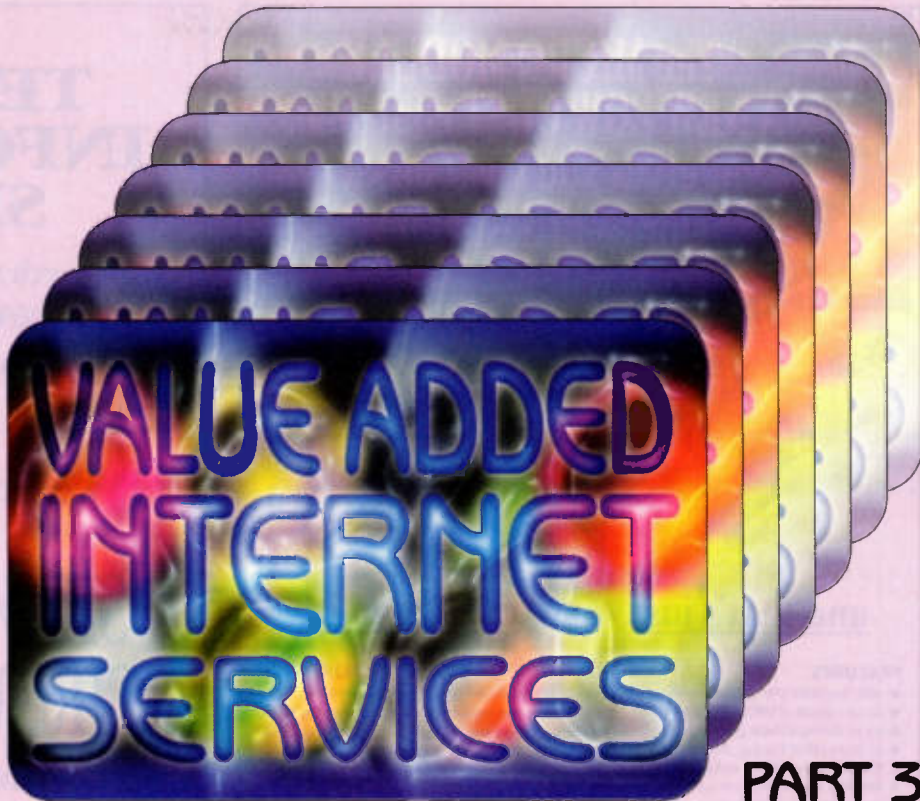

## PART 3

This month, delving deeper into the mire of Internet services, Keith Brindley surfaces with some winners.

bulletin board system. Customers could logon to the service, access information and files, transfer email to other users of the service and to Internet users or users of other on-line services, much like we've seen the Internet can be used for in the last couple of parts of this series. However, the big advantage of an on-line service is that all these facilities are available from an integrated graphical user interface. Moreover, the on-line services (well, the three big ones listed in the last paragraph, at least) have seen the explosion in popularity

of the Internet and the potential it holds, so have re-positioned themselves as front-end graphical user interfaces to the whole Internet – not just to the bulletin board style they evolved from.

This speaks volumes, of course. While the basic Internet service providers are re-positioning themselves and evolving into Internet services with value-added user-friendly extras, the on-line services are heading in the other direction; adding value-added Internet-based extras to their already user-friendly interface.

BT Internet browser.

The middle ground between Internet services and on-line services represents the future for all of them.

## CompuServe

The first on-line service we are going to look at is CompuServe. One of the oldest of the on-line services, CompuServe boasts over 4.5 million users worldwide. As an on-line service it is very much a worldwide network, and you can access it directly in full graphical mode in most parts of the world. In the UK, CompuServe is available with a local call to nearly everyone. However, it does have a few restrictions, in terms of speed of connection. Only access points in the major cities allow full 28.8K-bit/s access. At most other access points CompuServe makes use of the Mercury 5000 data network, which only allows connection at 9.6K-bit/s.

While this might not seem much of a problem, you have to remember that CompuServe is an on-line service and hence is graphical. As a result, several graphical images are downloaded to your computer during a typical on-line session, and these

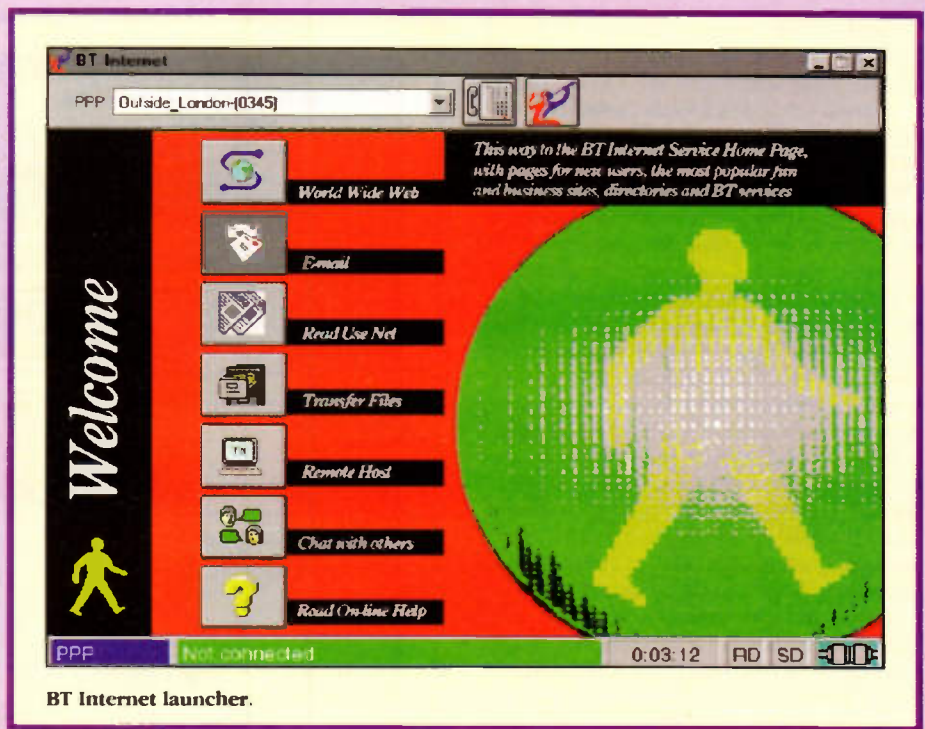

BT Internet launcher.

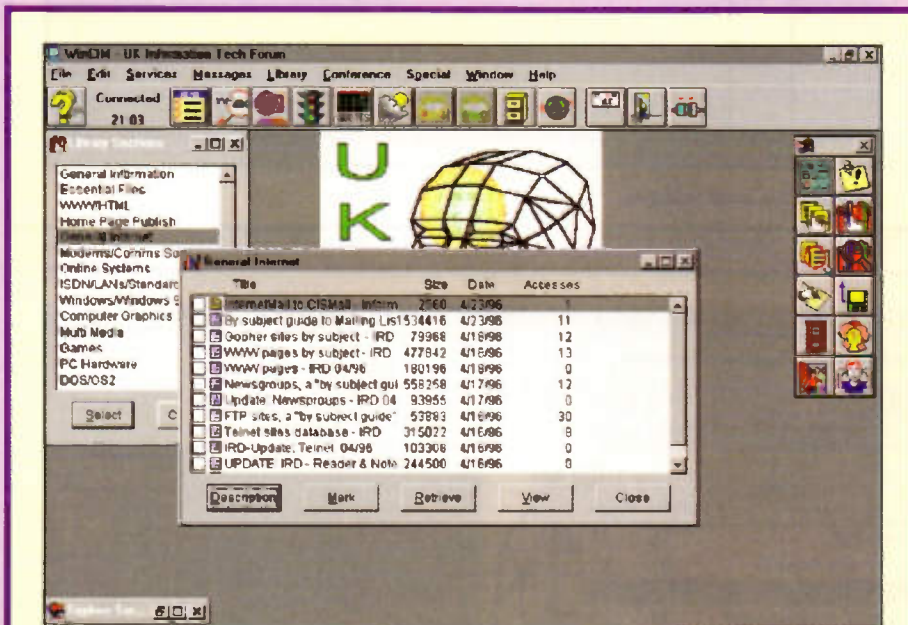

A forum library.

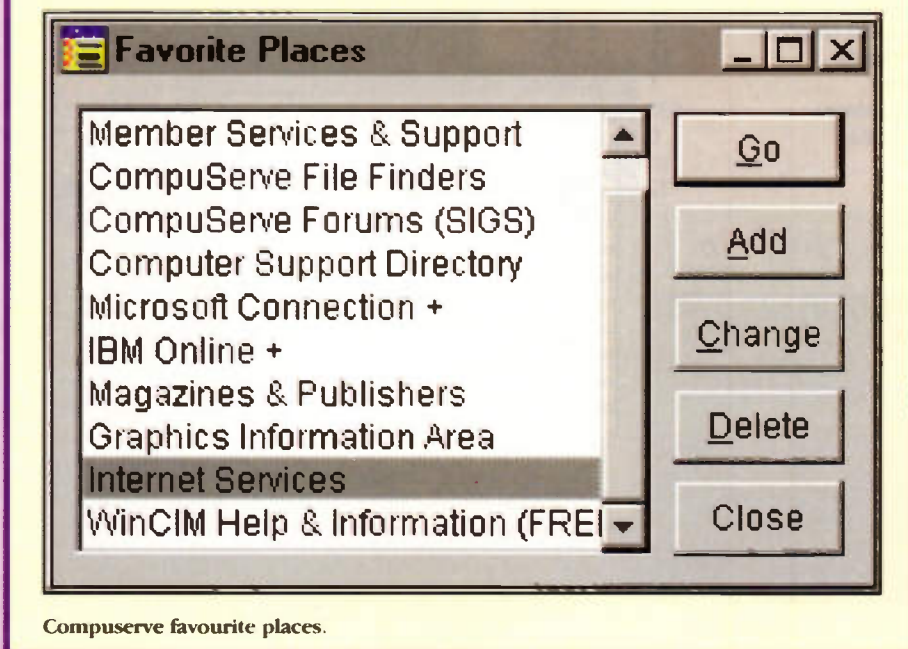

CompuServe favourite places.

naturally take time. At 28.8K-bit/s they might whizz down the telephone line, but at 9.6K-bit/s they take somewhat longer. Mind you, this is a problem with other on-line services too, and AOL is really the only one with adequate UK coverage with high-speed access points. Nevertheless CompuServe is a tried-and-tested, reliable on-line service which no potential Internet user can afford to ignore. We will look at AOL another time.

CompuServe's on-line service is accessed with the CompuServe Information Manager (CIM). As this is available in Windows and Mac flavours it is more usually known by its WinCIM or MacCIM titles, merely to differentiate. In fact, the interface is similar on either operating system. On launching, you get a Toolbar, with several buttons for commonly accessed services such as in and out baskets for mail, address book, favourite places and so on. The Services window gives other buttons for other common areas within the network.

Services and areas on CompuServe are arranged vaguely hierarchically, and you can usually step through the hierarchies pretty easily and logically, but there are far easier methods of locating an area you want or use regularly.

First, all services on CompuServe are allocated a quick-reference word, like UKWEATHER. Clicking the traffic light button on the Toolbar calls up the Go dialog box, where you can enter the quick-reference word. The command to access any particular service is usually written as GO COMMAND. When you enter the quick-reference word and click the Go button you are taken to the area whose quick-reference word you typed in – in this case the area where weather reports for the UK are located. If you know an area's GO word it's often the quickest way to access it. This is a wonderful feature which basic Internet service providers can't even begin to match, and it's a direct result of being an on-line service.

Second, you can list them in the Favourite Places menu, a kind of bookmarks list or hotlist. This is the place to store any areas or forums you use often, and provides fastest access of all once you've added the service to your list.

One of the greatest features about CompuServe is its use of forums. These are on-line areas about specific topics. Users worldwide can access a forum, read and post messages, and locate information and resources related to the forum's basic focus. There are nearly 1,000 forums on CompuServe, so chances are there's something of interest to most users, regardless of background and wishes. If you use CompuServe for any time at all, there is a good chance you will find at least a handful of forums which you regularly access. With so many available, it's not always easy to see what's accessible, but you can find forums by clicking the Find button and typing your topic of interest in the Find dialog box.

Forums have three main parts. First, messages are posted and read in message sections. Second, libraries are used to store software and related files. Third, and potentially most interesting, are conferences. In a conference, forum members can chat informally, often in real-time, and tune-in to on-going seminars and meetings. As you'll appreciate, forums are a powerful facility, which any CompuServe user is wise to exploit fully.

If CompuServe in its on-line mode is all you need from a service, then you may never want to go elsewhere. It provides a good bulletin board style interface, which is very user-friendly and quite nice to use. But, in keeping with the recent moves of most on-line services, CompuServe does let you have Internet access too. Several of the usual Internet services (file transfers, newsgroup access, and Internet email) are accessed directly from the CompuServe Information

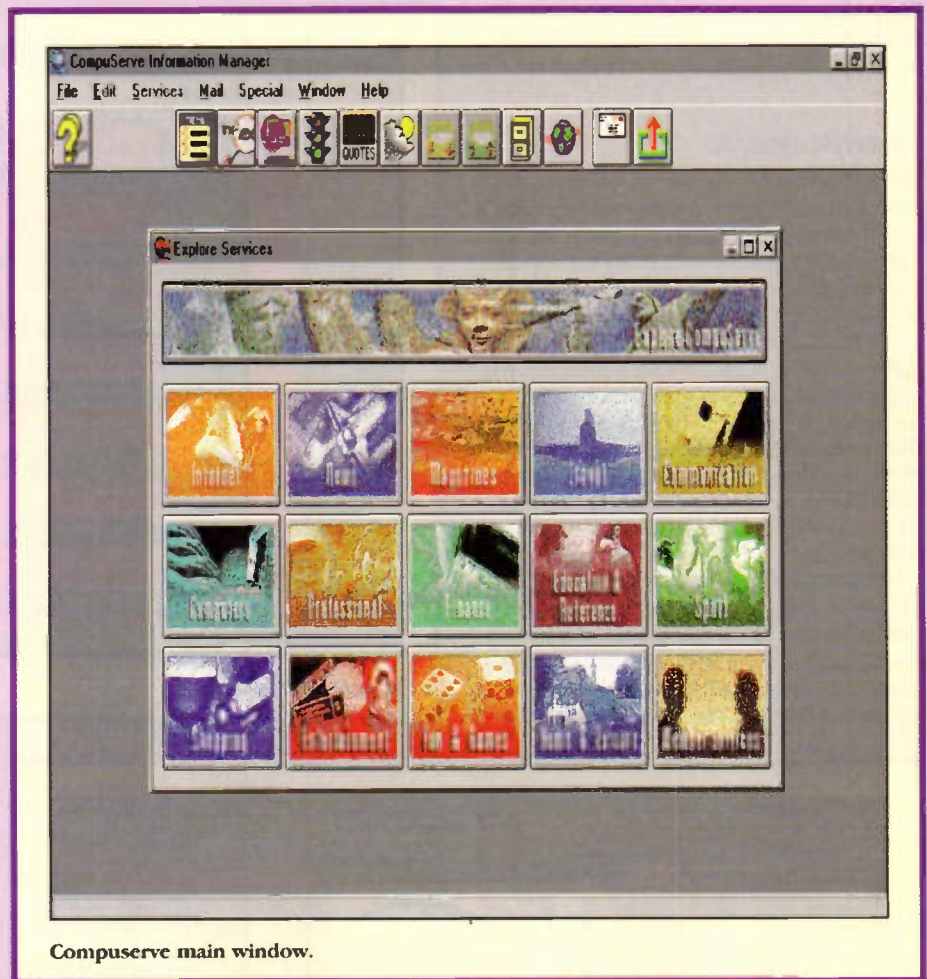

CompuServe main window.

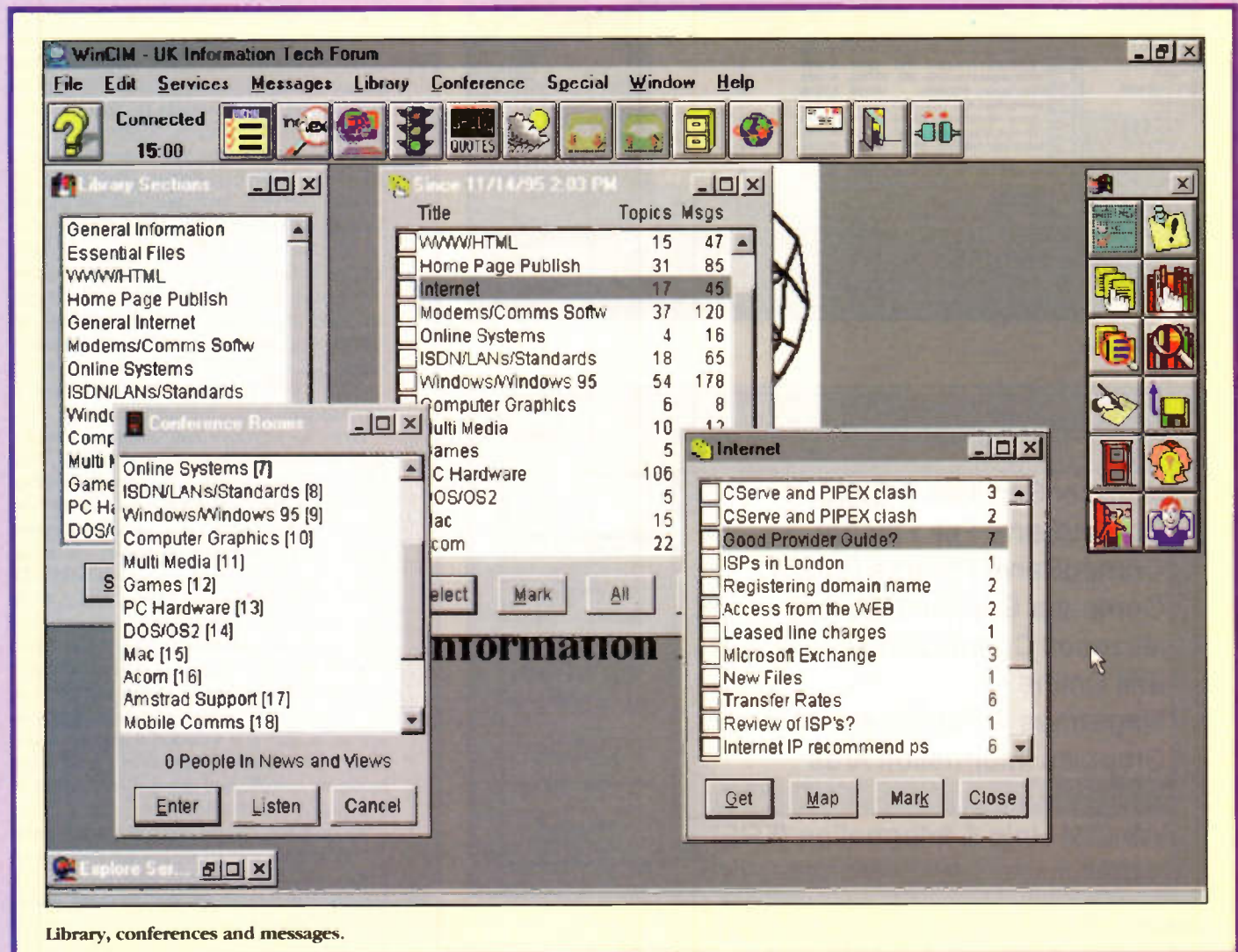

Library, conferences and messages.

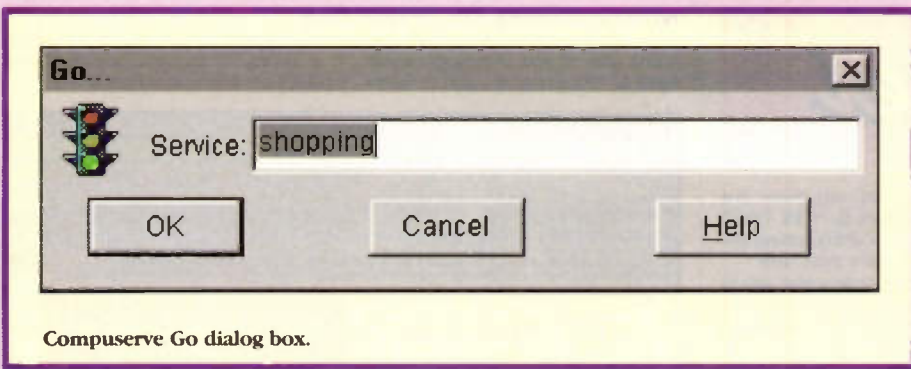

CompuServe Go dialog box.

Manager, and to most purposes you don't even realise you're doing something other than using the on-line service in standard mode. Getting to the Internet for these services is as simple as GO INTERNET, whereupon the available services are listed.

Accessing the World Wide Web, on the other hand, with a Web browser, is not quite as easy. As the greatest usage of the Internet (after e-mail services) is access of the World Wide Web, this is pretty important to most users. Access is made through the CompuServe network's ability to be controlled by point-to-point protocol (PPP), i.e. not in the normal on-line mode. Once connected with PPP you use a Web browser (you can download one from CompuServe on-line prior to this) in the standard way to get around the World Wide Web.

However, problems do arise. First, PPP access is via the CompuServe network. It is not directly available through the Mercury

5000 data network link-up arrangement. Users who live outside the CompuServe network's local call range therefore face larger phone bills than they would otherwise. Second, not all CompuServe network access points yet allow 28.8K-bit/s data rates – another cause for phone bill concern.

So, all in all, CompuServe is currently great if you want to use it as an on-line service, and OK as an Internet service provider, but a little limited if you live outside the local call range of its high-speed access points. Things will change over time, as more and more access points are upgraded to full 28.8K-bit/s data rates.

What is changing, is the CompuServe's subscription cost. With many, many Internet service providers jostling for users, the market is quite competitive and charges are quite low when you consider that you get unlimited usage once you've paid your subscription. CompuServe, historically charges by the hour for access. (Actually, in the UK, there's a flat

fee of £6.50 a month, which gives you upto 5 hours' usage. After that you pay £1.95 an hour.) So if you surf the Web for hours on end, an on-line service might not be the best option for you. However, CompuServe also offer a higher flat rate fee (£17.95), which covers up to 20 hours' usage, then £1.50 for each additional hour.

## The Upshot

While standard Internet service providers can upgrade the basic Internet connection, to give a collection of services similar to the front-end of an on-line service such as CompuServe, it's not as easy to build and maintain as they might like users to think. On the other hand, things are afoot in the Internet services world, and many Internet service providers are beginning to get their acts together.

So, at the moment, a decent on-line service seems to represent the peak of usability. It can be fully graphical, easy-to-use, and full of features which users can get to grips with. It's arguably the cheapest way to use Internet services, as long as you do so for only a limited time each month. Unfortunately, on the other hand, if you use the service a great deal it may be quite expensive. Once again, though, things are changing.

Next month we will look at another Internet service which is setting new standards in the usability stakes, and also look at the Microsoft Network and AOL on-line services which, like CompuServe, are facing up to the Internet service challenge head-on.

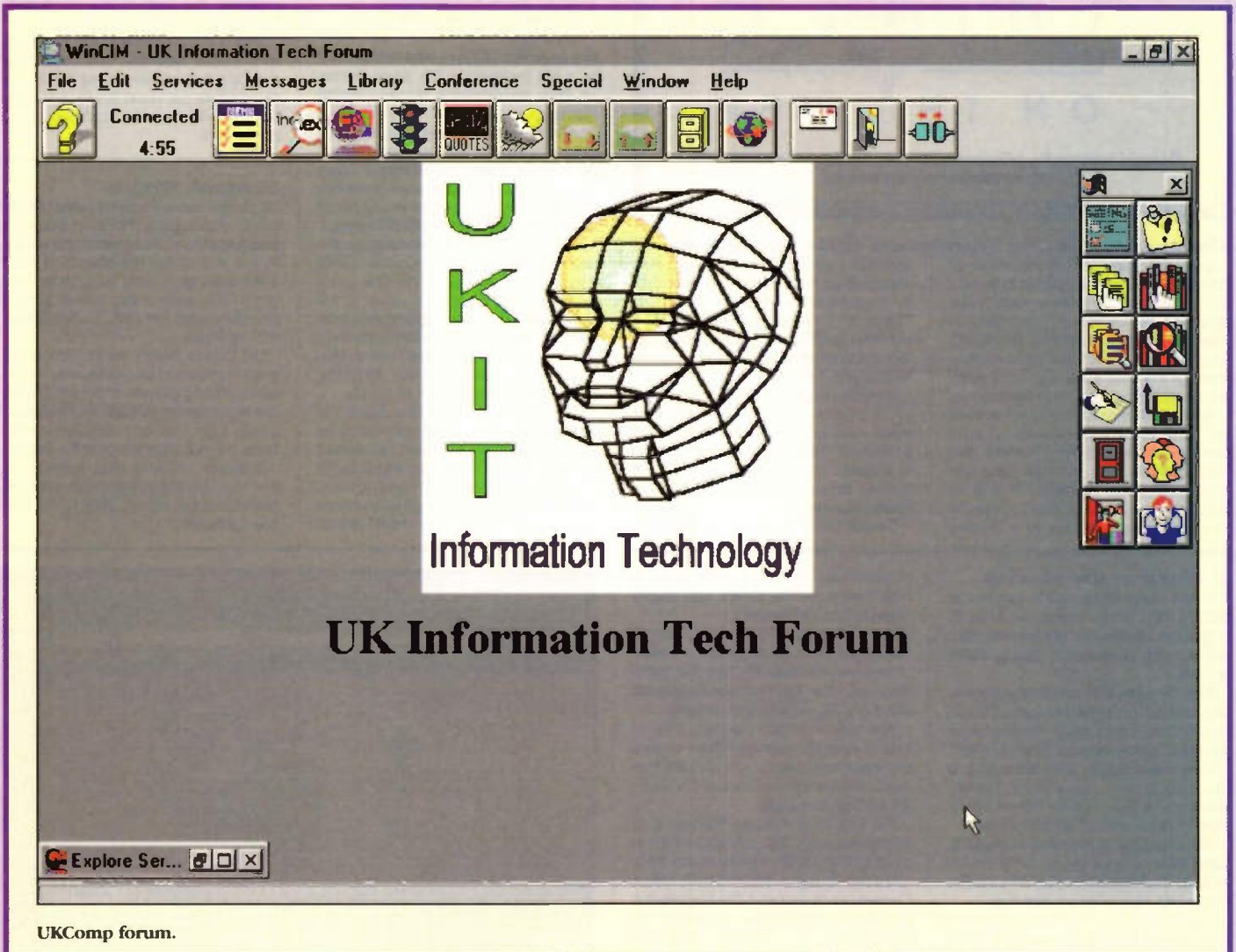

UKComp forum.

# @Internet

## HTML Transit

If you are thinking of producing your own hypertext markup language (HTML) documents ready for uploading to a World Wide Web server, quite a nice way to do it is with HTML Transit from InfoAccess. Unlike many products, which act merely as a smart filter from standard applications such as word processors and desktop publishing packages, HTML Transit is a stand-alone application. It works by you importing a document created in one of several common word processed formats, then converting them into HTML form, in a translation process. As part of the translation, styles you've set within the word processed documents are converted by HTML Transit to proper HTML styles.

Common import document formats include Word, WordPerfect, WordPro (and AmiPro), FrameMaker and Interleaf. Most graphics file formats

can be imported too, and these are converted automatically by HTML Transit to the requisite GIF or JPEG formats the output HTML document must have.

This is, inherently, quite a nice way to do the job. Effectively, any existing word processed document can be translated to HTML format, as well as any new ones you specifically create for the purpose. As a result, your whole archive of documents could be translated. While this is probably not the sort of thing anyone would need for World Wide Web publication, there is an increasing need for companies to publish standard company documents on an internal network for employees to access electronically (the so-called intranet) with a standard browser in a standard HTML way. Doing a whole archive of documents in bulk with HTML Transit could be an important time-saver in such a situation.

## Novell Unveils UK WWW Site

Novell UK has opened its own dedicated WWW site, at <http://www.uk.novell.com/uk>. The site is intended to be the

easiest and fastest way to get hold of a variety of product, customer and corporate information from Novell.

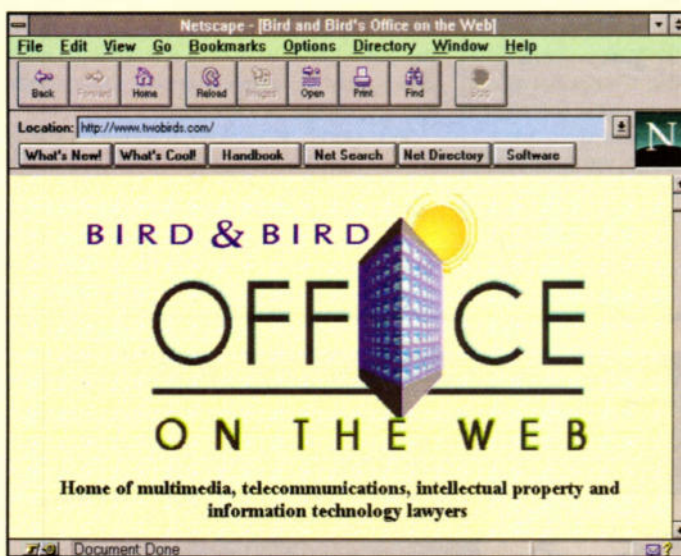

## Companies Leaving Themselves Open on the Internet

Over the last year, the number of companies using the Internet to market and sell their products has risen dramatically. However, according to Hilary Pearson of law firm Bird&Bird, very few companies have taken steps to manage the risks which can arise when an employee has access to the Internet.

"Many businesses have formal policies on how their employees should communicate with third parties, but these policies have not kept pace with the times", says Pearson. "It is quite possible for an unauthorised employee to commit his company to a binding

contract over the internet, or to give negligent advice or to infringe copyright by downloading unlicensed software. These and other activities present potential liabilities for the employer, yet few companies have policies in place to deal with this".

Bird&Bird has been advising a number of businesses on how to manage these risks and has now developed a proforma 'Internet Access Policy' to address the key areas of risk. For further details, check: <http://www.twobirds.com>.

Contact: Bird&Bird, Tel: (0171) 415 6000.

## A Night at the Movies

For film buffs, there are a number of WWW sites worth looking at. Most of major film distributors are represented, with a variety of alternative sites available as well.

First off is the UIP site at <http://www.ulp.com> with an interactive type approach to the films. There are a range of films covered, which include *Strange Days*, *Twelve Monkeys*, *Get Shorty* and *Sudden Death*. Apparently *Twelve Monkeys*, a Terry Gilliam Film of Monty Python fame, should not be missed.

The MGM site at <http://www.mgmua.com> covers a range of films which include *Moll Flanders*, *King Pin*, *Larger Than Life*, *House Arrest* and *fled*.

Then there is the Disney site at <http://www.disney.com> featuring the popular film *Toy Story*. There are a couple

of dedicated *Toy Story* sites to visit, <http://www.toystory.com> and <http://www.bvi.co.uk/toystory>.

The Columbia site at <http://www.columbiatristar.co.uk> covers a variety of films which include *The Net*, *The Swan Princess*, *The Indian in the Cupboard*, *Devil in a Blue Dress* and *Jumanji*.

The site for 20th Century Fox at <http://www.fox.com/film/html> covers the films *Broken Arrow*, *The Great White Hope*, *Independence Day* and *The Truth about Cats and Dogs*.

The Universal Pictures Website is at <http://mca.com>, the area to look for is UNIVERSAL V/IP. Forthcoming films covered *Dragon Heart* (with Sean Connery as Draco) and *The Frighteners*. Be warned that at least Netscape 1.1 must be used with a suitable plug-in for audio-visual.

## Virtual Porthole

Net surfers can now track sharks and other Florida sea life through the eyes of a robotic vehicle located on the ocean floor off the Florida Keys. The site at <http://www.aquarius.eds.com> was live from April 15 to 24. During this period, visitors were able to watch the underwater world using video-streaming technology to receive video images. The site now contains banks of video-clips recorded during the live event.

## Netscape Improves Performance with Borland

Netscape has tied up a deal with Borland in a bid to improve the performance of Java applications running inside Netscape Navigator, by including Borland's AppAccelerator 'just-in-time' dynamic compiler for Java applications. As a result, Netscape Navigator users will enjoy an enhanced Internet experience with faster execution of the thousands of Java applications available on WWW pages.

Currently, Netscape Navigator is the only Internet client software commercially available that supports the Java programming language. Java is the popular new programming language from Sun Microsystems for building platform independent distributed computing applications over networks, including the WWW, using Internet protocols.

Borland's AppAccelerator reads the intermediate byte code produced by Java development tools and translates it on-the-fly into machine-executable instructions on the local client system. Initially, AppAccelerator will be available for Windows '95 and Windows NT clients.

## Nifty Netscape

While most users of Netscape Navigator will already know about Navigator's smart ability to work out automatically what sort of file transfer protocol you want, even without the definitive prefix (<http://>, <ftp://>, <gopher://> and so on), not many users will know about the neat trick in the latest version, Navigator 2. If the World Wide Web site you want to go to has a full URL address of, say <http://www.companyname.com>, all you need to enter in the URL dialog box is *companyname*. Navigator puts together the rest of the necessary information from this.

This can be useful if you are trying to find out whether any particular company has a Web site, as most large companies (at least those based in the US) will have an address in the above form.

## Scottish Online

UK Online has launched a further fifteen points of presence (PoPs) in Scotland, enabling 85% of the country's population to get online for the cost of a local telephone call. This is far broader than any of the other major online service providers such as CIX, CompuServe, AOL or Pipex.

UK Online claims its service is the most economical on-line service for the family. Family membership costs £14.99 per month, which includes four individual e-mail addresses and unlimited access to the Internet and the UK Online service.

Scottish readers who wish to try out the UK Online service and get online can call (0645) 000011 for their free software.





### AOL Integrates Navigator

AOL has been quick to make the Netscape Navigator browser available through its online service after the two companies announced a partnership last month. AOL users can download the Netscape browser and a special WINSOCK.DLL file from the AOL Internet menu. Existing Netscape browser users can use Navigator under AOL, simply by switching WINSOCK.DLL files.

Navigator runs outside the AOL online service. Users must sign on to AOL and start Netscape Navigator from Program Manager. WWW access via AOL is currently very fast, but watch out as membership begins to pick up. The computing press in the US slammed AOL last year for its stodgy transmission speeds.

For further details, check: <http://www.uk.aol.com>.



### Financial Times Develops WWW Site

The FT has revamped its WWW site at <http://www.ft.com>, to include a daily intake of articles from the FT, with material specially prepared by a team of dedicated journalists throughout the day. Users can browse the site through the main headlines – or via structured content areas, such as Technology, White Collar Industries, World Focus, the top Lex stories of the past few days, arts and leisure.

Clearer page format, improved navigation, hyper-links and a new search facility give users a wide choice of routes through the hundreds of articles available daily. Reader interactivity is encouraged through e-mail and bulletin boards. The previously available share price and managed funds services have been redeveloped and expanded. FT.com now includes all the reference price services from UK and International editions of the newspaper in a searchable format.



### Netscape Unveils Netscape Destinations

Netscape Communications Corporation has unveiled Netscape Destinations at <http://www.netscape.com/escapes/index.html>, a new information site which is part of the Netscape WWW site and features some of the leading general, business and financial news and services on the WWW.

Netscape Destinations allows visitors to find a cross-section of useful information and services quickly and easily through a central source. The new site is aimed in particular, at business users who want and appreciate quick and easy access to late-breaking news, business and financial

information and related services.

Visitors to Netscape Destinations have access to information sources grouped under eight categories: general news, finance, technology news, hardware & software, sports, travel, entertainment and marketplace. To help Internet surfers locate useful information, Netscape Destinations also links to Netscape's Net Search page, Netscape's 'What's New' and 'What's Cool' pages and Netscape's People page, which displays a variety of White and Yellow Pages services to help users locate people and organisations on the Internet.



# Site Survey

## The month's destinations

All sites this month are for the more discerning computer and Internet user. By this, we mean the user who wants to get the best computer, run the best programs on this best computer, and know what the best thing for this best computer is. Oh, alright then, the sites are for anybody who uses a computer on the Internet!

Located in the Ames Laboratory of the Iowa State University in the US is a neat site which lets prospective computer buyers see how the computer they fancy lines up with the best of the rest (or lets you see how slow your current computer is,

compared with the best of the new ones just out). While only mainstream (and powerful to boot) computers are listed at the moment, it is worth a look at <http://www.scl.ameslab.gov/cgi-bin/hint.pl>.

Anyone who has surfed the World Wide Web will know the usefulness of a good search engine, but knowing which engine to use for a particular search type is not always obvious.

Check out <http://www.interlog.com:80/~esteele/newbie3.html> for a listing of all available search engines, together with brief descriptions plus hot links.

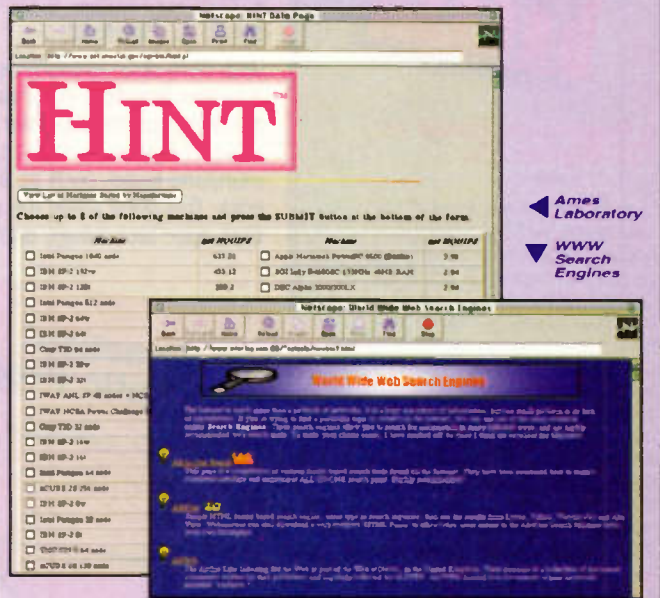

Ames Laboratory  
WWW Search Engines

If you are a computer user you will know what freeware and shareware is. If you are a computer nut like wot we is, you will have every freeware and shareware utility and program already loaded. Well, you might think you do – but not quite! Jumbo is a wonderful Web site for those of who want to be waylaid by the intricacies of irrelevancy. You can download

nearly 50,000 programs (maybe well over 50,000 by the time you read this) so go get, at <http://www.jumbo.com>.

Finally, carrying on with the un-stopping trend of publishing on-line, the US computer magazine Byte can be found at <http://www.byte.com>. It is the definitive magazine read by serious computer users.

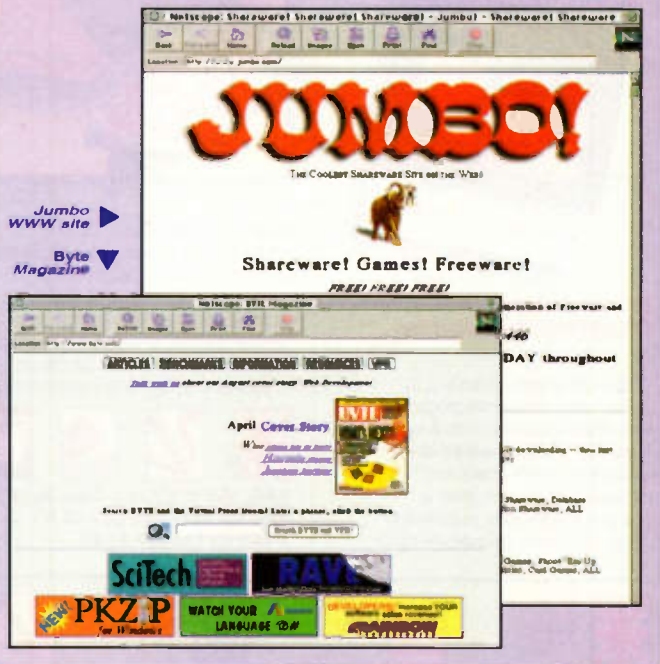

Jumbo site  
Byte Magazine

All of the books featured on this page are available from Maplin Regional Stores and by Maplin Mail Order. To find your nearest Maplin Regional Store Tel: (01702) 552911 or to order call the Credit Card Hotline on Tel: (01702) 554161

# NEW BOOKS



## A Beginners Guide to TTL Digital ICs

by R. A. Penfold

Logic circuits are now a part of everyday life, with practically every household equipped with numerous gadgets that contain TTL Digital ICs. Getting to grips with logic circuits can be difficult though, as many of the fundamental concepts can seem rather abstract. This book takes the beginner through the basic concepts of logic circuits and explains the functions, characteristics and uses of TTL Digital ICs. The emphasis is on the practical treatment of the subject, and all of the circuits are based on real-world TTL ICs and have been chosen to demonstrate their use in practical applications.



1993. 178 x 110mm. Order As 95146 (Beg Guide to TTL ICs) £4.95 NV

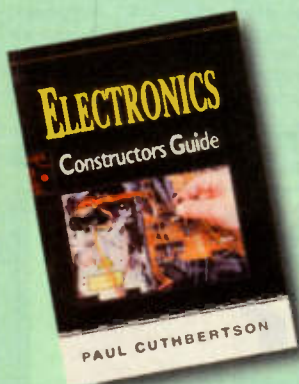

## Electronics Constructors Guide

by Paul Cuthbertson

Written for anyone intending to convert their ideas into products or their electronics skills into a profitable business, this book will be of interest to students, enthusiasts and professionals alike. It gives a practical introduction to common design problems, provides hints on

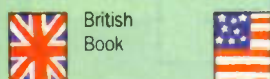

## PRACTICAL FIBRE-OPTIC PROJECTS

by R. A. Penfold

With fibre-optic networks springing up all over the country, it seems that fibre-optic cables are about to revolutionise our lives, but despite their high tech image and all the talk of super-highways, fibre-optic cables can be used for more mundane tasks, such as simple audio and computer data links. This book takes the reader through the basics of fibre-optic technology, and presents a series of practical



circuits for fibre-optic audio links, data links and a few other gadgets, such as an optically triggered alarm and an optical R.P.M. sensor.

1995. 178 x 110mm. Illustrated. Order As 95147 (Pract Fibre Opt Proj) £4.95 NV



design, presents classic circuit examples and explains how decisions are made, put into practice and checked out. Examples of good practice are given throughout, to provide the reader with a feel for the methods and ideas that contribute to excellent design and construction.



1995. 198 x 130mm. Order As 95148 (Elec Const Guide) £25.00 NV Add UK Carriage £1.60



## Electronic Engineer's Reference Book

5th Edition Edited by F. F. Mazda

Compiled from contributions from experts working in the world's leading electronics companies and academic institutions, this is the reference book that every electronic engineer should have close to hand. It gives expert coverage of all aspects of electronics, and is split into five main parts, covering techniques, physical phenomena, materials and components, electronic design and applications.



1989. 200 x 255mm. Order As 95145 (Elect Eng Ref Book) £40.00 NV Add UK Carriage £2.30

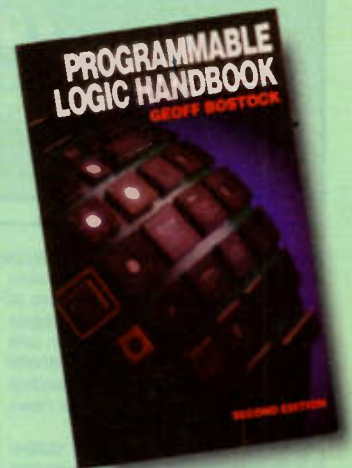

## Programmable Logic Handbook

2nd Edition by Geoff Bostok

This book has been written to provide electronic design engineers, technicians and students with a thorough grounding in programmable logic. Contents include an introduction to logic devices, logic structures, techniques, combinational & sequential PLDs, LSI & FPGAs, design support and programmable logic applications.



1993. 234 x 156mm. Order As 95144 (Prog Logic Handbook) £25.00 NV



# BIG SAVINGS for SUBSCRIBERS!

That's right, if you subscribe to *Electronics-The Maplin Magazine*, or take out a subscription NOW, you will qualify for these amazing savings!

Hurry! Offers end 30th June '96

## Continuity Tester Screwdriver

Tests fuses, wiring, lamps, etc. Complete with batteries

Catalogue Price £6.99

**SUBSCRIBERS' PRICE £4.99**



## 130mm Snipe Nose Pliers

Catalogue Price £4.29

**SUBSCRIBERS' PRICE £2.99**



**NEW!**

AS ADVERTISED IN NATIONAL PRESS  
**COMPARE OUR PRICE!**

## Magic Bond Epoxy Putty

Fast, easy and permanent repairs and patches for metal, wood, fibre-glass, etc. Even works underwater!

**SUBSCRIBERS' PRICE £3.79**

Code 51299



**STOP PRESS**

**UP TO 30% SAVINGS**

**Subscribe NOW!**  
see page 62 for details

## 6-piece Screwdriver Set

Catalogue Price £6.49

**SUBSCRIBERS' PRICE £4.49**



## Rechargeable Vacuum Cleaner

Catalogue Price £19.99

**SUBSCRIBERS' PRICE £14.99**



## Gas Torch Kit

Catalogue Price £26.99

**SUBSCRIBERS' PRICE £19.99**



When ordering, please quote your Subscribers' Membership number ('phone Enquiries on 01702 552911 if not sure) and the special order code number. All items are subject to availability. Prices include VAT. Catalogue prices refer to the 1996 Retail Catalogue as updated by the March price list, or the March 1996 MPS Catalogue. Overseas subscribers telephone +44 1702 554155 Ext. 326 for carriage charges. Normal UK mail order carriage charges apply. E&OE.

As a fully paid-up subscriber you can use the special Subscriber-only order codes and save up to **30%**

# SILICON EVOLUTION Crystal Clear

## Digital Potentiometers from Dallas Semiconductors

- ◆ Fit electronic volume controls to your own circuits
  - ◆ No moving parts to wear or become noisy
  - ◆ Simple push-button or pulse control
  - ◆ Zero crossing for silent 'wiper' operation
  - ◆ Low power consumption at 3V or 5V supply
- ◆ DS1802- Stereo log 10k pot, with mute/balance
- ◆ DS1666- Log 50k pot with 128 resistance steps
- ◆ DS1869- Lin 10k and 50k pots with position memory
  - ◆ Full data book available

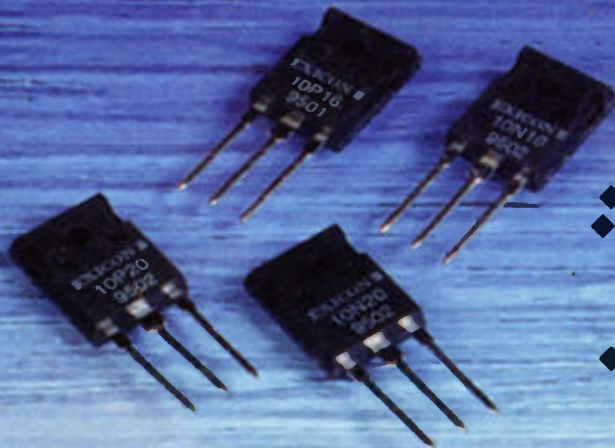
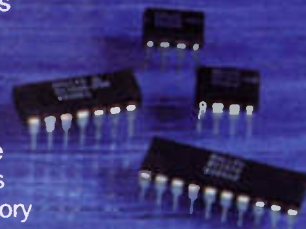

## Plastic Power MOSFETS from Exicon

- ◆ Full data sheets available at 90p per copy
- ◆ Simple one-hole fixing saves on time and mounting hardware
- ◆ Stable thermal characteristics help prevent overload damage
- ◆ Lower cost than metal version with the same 125W specification
- ◆ 8 Amp maximum current at up to 200V – ideal for power amplifiers

## Z80180 Microprocessor from Zilog

- ◆ Development system available, including full data and assembler
  - ◆ Z80 software compatible with 10MHz operation speed
  - ◆ Offers two built in UARTs for serial communications
  - ◆ Includes two 16-Bit timers for precise event control
  - ◆ Built in DMA controller for 1MByte address capability
  - ◆ Provides 8-Bit refresh addressing for system DRAM
  - ◆ On-chip clock generator and extended instruction set



The products featured here are just a small selection from the new ranges of semiconductors now available from Maplin Electronics. If you are interested in these devices, or would like a list of new semiconductors introduced to the Maplin range since publication of our September catalogue, please send a stamped, self-addressed envelope to the mail order address below. Please mark your envelope 'New Semiconductors'. We will send you an information pack containing shortform data for selected new products and a complete list of all the new semis.

Dual Digital Log. Pot., Order Code LE19V, £4.79  
 Digital Log. Pot., Order Code LE20W, £2.99  
 Digital Lin. Pot. 10k, Order Code LE21X, £3.69  
 Digital Lin. Pot. 50k, Order Code LE22Y, £3.69  
 Dallas Data Book, Order Code LE88V, £5.49

MOSFET N-Type 160V 125W, Order Code AX79L, £4.69  
 MOSFET P-Type 160V 125W, Order Code AX80B, £4.79  
 MOSFET N-Type 200V 125W, Order Code AX81C, £5.29  
 MOSFET P-Type 200V 125W, Order Code AX82D, £5.49  
 Zilog Extended Z80, Order Code LE36P, £11.99

Telephone 01702 552911 for details of your nearest Maplin or Mondo store, or write to Maplin Electronics, P.O. Box 3, Rayleigh, Essex SS6 8LR.

All prices include VAT. All items subject to availability. Handling charge £1.55 per mail order. E&OE.

**MAPLIN**  
ELECTRONICS AND BEYOND

ORDER NOW ON  
**0800 136156**

