

COMPUTERS • AUDIO • RADIO • AUTOMOTIVE

No. 65

# EA ELECTRONICS

*The Maplin Magazine*

Britain's Best Selling Electronics Magazine

MAY 1993 • £1.75



**Discover the  
Secrets of  
Electronics  
Assembly**

**How to Use  
Pro-Audio  
Equipment**

**Build a PC Relay Card and  
Personal Stereo Amplifier**



**Short Wave  
Broadcasting to  
- Speaking to  
the World!**



**6 PROJECTS**

# SERIOUS SOUND SERIOUS SAVING

## HIGH QUALITY PROFESSIONAL 100W POWER AMPLIFIER KIT – **SAVE £30**

★ Ideal for Instrument Amplification ★ Stage Foldback ★ Small Venue P.A. ★ Studio Monitor Amplifier



**T**his superb amplifier kit brings together five of the best and most popular 'Audio Building Blocks', to produce an amplifier of unrivalled sound quality at the price. The Power Output Stage is an excellent 150W MOSFET design which is currently Maplin's Best Selling Audio Kit. It is complemented by the excellent performance of the SSM2016 Differential Preamp which has also featured in Maplin's 'Top 20' kits. The superb audio stages are supported by a High Quality Power Supply Unit, sophisticated Monitoring Circuitry and a Thermal Protection System. Housed in a rugged 19in. rack mounting case, this outstanding amplifier is designed for longevity, purity of sound reproduction and ease of integration with other professional equipment. The kit contains everything you need to build this superb amplifier and is supplied complete with comprehensive constructional information.

### Features:

- ★ Standard 19in. 2U Rack Mounting Case
- ★ 100W RMS Power Output
- ★ Balanced Line Input
- ★ Loudspeaker Protection
- ★ Switch-on Mute
- ★ Thermal Protection

### Typical Specification:

Rated Load Impedance: 4 to 8Ω

Maximum Power Output:

4Ω 105W RMS

8Ω 90W RMS

THD @ 75W (1kHz): 0.02%

Frequency Response: 10Hz to 40kHz, -1dB

For a friendly welcome and the best of service, visit your local Maplin store: **BIRMINGHAM**; Sutton New Road, Erdington. **BRIGHTON**; 65 London Road. **BRISTOL**; 302 Gloucester Road. **CARDIFF**; 29-31 City Road. **CHATHAM**; 2 Luton Road. **COVENTRY**; 12 Bishop Street. **EDINBURGH**; 126 Dalry Road. **GLASGOW**; 264-266 Great Western Road. **ILFORD**; 302-304 Green Lane. **LEEDS**; Carpet World Building, 3 Regent Street. **LEICESTER**; Office World Building, Burton Street. **LONDON**; 146-148 Burnt Oak Broadway, Edgware. 107-113 Stanstead Road, Forest Hill. 120-122 King Street, Hammersmith. **MANCHESTER**; 8 Oxford Road. **NEWCASTLE-UPON-TYNE**; Unit 4, Allison Court, The Metro Centre, Gateshead. **NOTTINGHAM**; 86-88 Lower Parliament Street. **PORTSMOUTH**; 98-100 Kingston Road. **READING**; 129-131 Oxford Road. **SHEFFIELD**; 413 Langsett Road, Hillsborough. **SOUTHAMPTON**; 46-48 Bevois Valley Road. **SOUTHEND-ON-SEA**; 282-284 London Road, Westcliff. Plus a NEW STORE opening soon in **MIDDLESBROUGH**. Phone 0702 552911 for further details. Subject to availability. Price subject to change. Price inclusive of VAT. H indicates a carriage charge of £5.50.

**Maplin**  
ELECTRONICS

**CREDIT CARD HOTLINE**  
**0702 554161**

Mail Order to: P.O. Box 3, Rayleigh, Essex SS6 8LR

## EDITORIAL

■ Hello and welcome to this issue of 'Electronics'! I usually take this opportunity to highlight various projects and features in the current issue, but this month I am not going to do so. Instead I am going to mention an important aspect of electrical and electronic work – SAFETY. When dealing with mains electricity, some enthusiasts just don't bother to think before they act. The result is often a very nasty electric shock – which could all too easily be fatal. Related to 240V AC mains, here are a few figures for you: The current necessary to light a 60W lamp is sufficient to electrocute five people simultaneously. A shock of 100mA is likely to cause ventricular fibrillation and is usually fatal. A shock of 50mA can affect respiration and may cause death by suffocation. A shock of 2mA will cause involuntary muscle movement – possibly causing further injury. In the workplace, live working is only permitted when it is absolutely necessary to have the circuit live and only then if adequate safety precautions are taken – isolation transformer, insulated tools, earth leakage circuit breaker, etc. Work must also be carried out by competent persons, or under their supervision. It makes a lot of sense to observe the same precautions when building and testing electronic projects at home; it's better to be safe than sorry! Until next month, I hope that you enjoy reading this issue as much as the 'team' and I have enjoyed putting it together for you!

*R. Ball*

**ABC**  
ALPHABETICALLY OF CIRCULATIONS  
CONSUMER PRESS

- Editor Robert Ball AMPRE
- Project Development Tony Bricknell, Alan Williamson, Dennis Bulcher, Nigel Skeels
- Technical Authors Martin Pipe BSc Hons., Mike Holmes
- News Compilation Stephen Waddington, Alan Simpson
- Technical Illustrators Paul Evans, Lesley Foster, Ross Nisbet, Nicola Hull
- Production Co-ordinator Alan Wraight
- Print Co-ordinator John Craddock
- Advertisement Manager James Slater
- Advertising Jackson-Rudd & Associates Ltd., 2 Luke St., London EC2A 4NT. Tel: (071) 613 0717. Fax: (071) 613 1108
- Art Director Peter Blackmore
- Layout Artist Cindy Brown
- Published by Maplin Electronics Plc.
- Colour Separations Stirling Graphics Ltd., 16/22 West Street, Southend, Essex SS2 6HJ
- Printed by Severn Valley Press, ST. IVES PLC.
- Distributed by United Magazine Distribution Ltd., 1-11 Bennell Rd, London N7 7AX
- Mail Order P.O. Box 3, Rayleigh, Essex SS6 8LR
- Retail Sales: (0702) 554161, Retail Enquiries: (0702) 552911, General: (0702) 554155
- Cashier: (MODEM) (0702) 552941
- Fax: (0702) 553935, Telex: 995695

Cover Pictures: © Copyright 1993 (main and inset right) Radio Nederland Wereldomroep and (inset left) Murata.

© Copyright 1993 Maplin Electronics plc.

Copyright. All material is subject to worldwide copyright protection, and reproduction or imitation in whole or part is expressly forbidden.

The Publishers, Maplin Electronics Plc, take all reasonable care to prevent injury, loss or damage of any kind being caused by any matter published in 'Electronics'. Save insofar as prohibited by English law, liability of every kind including negligence is disclaimed as regards any person in respect thereof. Where errors occur corrections will be published as soon as possible afterwards. Permission to reproduce printed circuit board layouts commercially or marketing of kits must be sought from the publisher.

Advertisements. Whilst every reasonable precaution is undertaken to protect the interests of readers by ensuring, as far as possible, that advertisements appearing in the current issue of 'Electronics' – The Maplin Magazine 'are bona fide, the publishers and the staff of the magazine cannot give any undertakings in respect of statements or claims made by advertisers, whether on printed page or insert. Editorial. The views of individual contributors/authors are not necessarily those of either the publisher or the editor.

## PROJECTS

### 8 IBM PC RELAY CARD

■ This extremely versatile plug-in relay card provides eight sets of changeover contacts, and is easily controlled from BASIC.

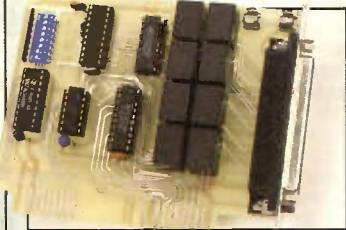

### 24 PERSONAL STEREO AMPLIFIER

■ This simple battery powered project allows a personal stereo to be used for general listening.



### 36 CAR HEADLIGHT REMINDER

■ Avoid getting a flat battery with this simple device.

### 40 8-CHANNEL MULTIPLEXER

■ Part of the Intelligent Motherboard Project – allows up to eight separate analogue inputs to be routed, under software control, to an A-to-D card.

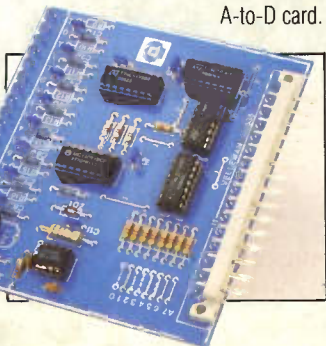

### 53 MIXER POWER SUPPLY

■ Describes construction of a suitable power supply for the Modular Mixer Project.



### 57 LED MOVING MESSAGE DISPLAY

■ In the final part of this superb project, the necessary control software is discussed.

## FEATURES

### 4 HOW TO DESIGN YOUR OWN MAINS TRANSFORMERS

■ The practical aspects of designing and making mains transformers.

### 16 INDUSTRIAL ELECTRONICS ASSEMBLY

■ How electronic products are manufactured using modern manufacturing techniques.

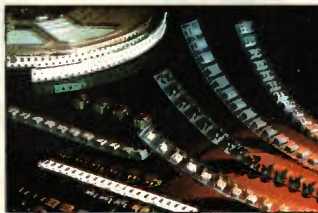

### 28 UNDERSTANDING FRAME RELAY NETWORKS

■ Frank Booty explains what Frame Relay is, and how it can be used to carry computer data efficiently.

### 32 SHORT WAVE BROADCASTING

■ Ian Poole explains why broadcasters think short wave broadcasting is so important.



### 38 THE PROPAGATION OF RADIO WAVES

■ How radio waves can travel long distances.

### 47 THE HISTORY OF COMPUTERS

■ Continuing this light-hearted series.

### 48 PROFESSIONAL AUDIO EQUIPMENT

■ Deals with choosing and using microphones.

## CORRIGENDA

■ April 1993 Vol. 12 No. 64 Professional Audio Part 1 Page 37, left column. The second equation down should read:

$$N_{dB} = 10 \log_{10} \frac{P_1}{P_2}$$

Page 37, middle column. 1. The third equation down should read:

$$\frac{1V}{0.775V} = 1.29$$

2. The antilog is *not* the 'inverse of the common logarithm', as is stated in the bottom quarter of the column. It is the *inverse operation*, known itself as the antilog, and can be deduced from a scientific calculator or mathematical tables.

## REGULARS

- |                      |                        |
|----------------------|------------------------|
| 2 NEWS REPORT        | 45 AIR YOUR VIEWS      |
| 7 CLASSIFIED         | 46 STRAY SIGNALS       |
| 15 TECHNOLOGY WATCH  | 52 COMPETITION WINNERS |
| 21 SUBSCRIPTIONS     | 55 TOP 20 KITS         |
| 22 ORDER COUPON      | 56 NEW BOOKS           |
| 31 NEXT ISSUE        | 64 TOP 20 BOOKS        |
| 44 NEWSAGENTS COUPON |                        |

Prices of products available from Maplin, shown in this issue, include VAT at 17.5% (except items marked *AV* which are rated at 0%) and are valid between 2nd April 1993 and 31st August 1993. Prices shown do not include mail order postage and handling charges, which are levied at the current rates indicated on the Order Coupon in this issue.

# NEWS

## Report

### The Flight of Information

At a cost of £2m, Ferranti International have supplied a management information system for Manchester Airport's new terminal 2. The system, which runs on two IBM RS6000 series 530H computers, provides the focal point for the distribution of data around the entire building. As well as driving the public information services, the system also supports a range of airport operational functions.



### Statistics, Damn Statistics and Wishful Thinking

No shortage of facts and figures this month! Electronics, including electrical engineering says the CBI, is now Britain's second largest manufacturing industry. Apparently, the UK is fourth in the world league behind the US, Germany and Japan.

According to Romtec Research, the direct share of the UK PC market will level off this year, following the boom in sales direct from manufacturers to end users over the past two years. At the same time, Romtec are forecasting that sales figures of 486 PCs are set to overtake those of 386-based machines by next year, breaking the dominant share of 386sx PCs. Intel has reinforced this view, by cutting the price of the 486sx to compete with the vendors of 386 clone chips.

Confirming the move towards Windows as a PC user environment, Romtec report that Windows applications overtook sales of DOS applications last year for the first time. Over the next five years, the research company expects the market share of DOS-based applications to decline to a single figure.

### Optical Health Cards

An optical card system, developed and manufactured by Canon, is being used in a pilot project for storing patients' personal medical records, for the Grampian region of the Health Systems Division of the NHS in Scotland, as well as in similar medical projects in Spain and Amsterdam.

In Scotland, the £750,000 contract to EDS-Scicon provides a pilot scheme, through which around 8000 Canon optical cards will be issued to half the patients registered with the Inverurie

### 'Electronics' Winners Vote Their Prize a Hit

A visit to the Hit Factory was the prize in the 'Out and About' feature on this famous recording studio. Fortunate winner Paul Debenham and his friend Andy White, both students, were given a conducted tour as well as a

presentation set of goodies. This included the latest Sade CD, and a Hit Factory T-shirt. According to Paul, a regular reader of 'Electronics', it was a highly stimulating visit: "Sound recording is far, far more complex than I had ever imagined. Our thanks to all involved at the magazine for making it all possible."



Health Centre, with the other half acting as a control group.

The optical cards, which can store up to four megabytes of data – including photographs, X-rays, images and fingerprints – will be held by the patient, who will give it to their hospital or GP when it is required. The pilot scheme will run until 1996 and, if successful, could become the basis of an all-Scotland system.

In the Spanish project at Cataluna, medical and dosimetric data, about people exposed to ionising radiation, is stored on personal Canon optical cards. This ensures quick and continuous availability of the information, which is necessary because of the mobility of people between different medical centres.

At the Academic Medical Centre of Amsterdam – one of the largest hospitals in Europe – a project using optical cards provides kidney patients with their own medical records. This enables them to travel more freely, even when waiting for a transplant, as the necessary medical information is directly available to any hospital with a suitable optical card reader.

### P45s for Meter Readers?

Spain is one of the first countries to introduce a system for reading water meters over the telephone. A Unix-based system automatically makes a call to a meter, and reads the information stored there. Any variations in data since the last call was made are checked before being entered into a database.

### Are There Stars in Your Eyes?

There is still time to enter the Maplin/PMI 'Carry On Karaoke' contest. You have until the end of April to rush out and buy the Pro-Sound stereo karaoke unit at just £49.95. The winner will have a free recording session (worth many thousands of pounds) at one of the world's most famous recording studios, Abbey Road – where the Beatles made their recordings. There are also numerous special runner-up prizes. Details from your local Maplin shop or from Alan Simpson (Tel: (081) 360 1729).

### Watch Out! Watch Out! There's a Camera About!

Philips Communications has won an order worth almost £3 million, to provide 156 new cameras for the M25 motorway. As one of the world's busiest roads, the new system will enable the police to monitor – by means of CCTV surveillance – accidents, congestion and roadworks.

When complete, the system will extend CCTV coverage to the trunk-road network of north-east London, and to upgrade the existing system in the south and west.

Philips are also assisting surveillance in the South Atlantic. The company has designed and installed a complete system which meets the British Antarctic Survey's requirements, not least of which was the need for the equipment to operate at temperatures as low as -40°C.

Meanwhile, Compaq Computer has IBM in its sights. The company is planning to increase its worldwide market for PCs to rival that of IBM. At the same time, new lower-cost products will be regularly introduced.

### Pen-Based Computing from Toshiba

Toshiba has signalled its entry into pen-based computing with the announcement of the T100X – a 3lb. hand-held computer aimed at an important new and growing market.

Operated by a cordless stylus pen, the T100X has a 9.5-in. transreflective, backlit screen providing a clear and bright image in most working conditions. Based around a low-voltage 25MHz 386SX processor, the new personal computer is capable of up to three hours use on one charge.

A maximum of 20MB memory is supported, with 4MB supplied as standard. Hard disk storage is via a 1.8-in. 40MB drive. Additional interfaces include two PCMCIA 2.0 slots, serial and parallel ports, connections for external keyboard and floppy disk drive.

The T100X is expected to have a retail price of around £2,500.



## Projecting a Computer Image

Elaborate software packages have, over recent years added a stylistic edge to the computer-literate speaker or lecturer. Presentation foils, prepared on programs such as Harvard Graphics, DrawPerfect, Autocad or Freelance, continue to hold the edge over hand drafted-alternatives. Coupled with slide show and animation packages, it is now possible for the PC-equipped speaker to produce a totally automated demonstration; pity, though, that such techniques are always restricted by the size of display monitor.

Fear not though, for Sharp have applied a system long since used for television projection to computing standards, enabling the output from a computer, VCR, laser disc player or video camera to be displayed on a large screen. Ideal for effective business, training or even academic presentations, the XV-710P, a portable LCD video projector, can display images of up to 2.5m across.

Incorporating a single 9cm active

LCD matrix panel with 100,386 pixels for each of the primary colours, the XV-710P guarantees consistently crisp, clear images – with 320 and 350 horizontal lines of resolution in PAL/SECAM and NTSC modes respectively. Not quite up to Super VGA (or even VGA) standards yet, though!

The XV-710P's newly developed metal halide lamp and micro-lens technology delivers a consistent level of illumination across the entire picture and, by projecting onto a specially developed polarized screen, allows high-contrast images to be viewed even in brightly-lit locations.

Designed for true portability and convenient set-up, the XV-710P weighs only 4.3kg, and is a fraction of the size of conventional video projectors. It even has a built-in amplifier and speaker, removing the need for separate audio equipment. Other features include a 'mirror image' button for rear projection applications, a tasteful blue 'mute screen' function, and four selectable memories, allowing various sources to be accommodated instantly without the need for readjustment.



## Good News for London

Potential radio broadcasters are hoping to be granted operating licences for the Greater London area by the Radio Authority (RA); who are currently inviting licence applications for new transmission frequencies. Applicants have to demonstrate that they are capable of funding and operating a radio station, as well as showing that there is a potential audience for their station. One hopeful applicant is London Christian Radio (LCR), a station set up to broadcast the Christian message across the air-waves. The station, if successful in its application, would broadcast to a potential 9.71 million adults in London and the home counties. LCR, supported by well-known personalities such as Kriss Akabusi, Roy Castle, Cliff Richard and David Suchet, are asking for pledges of support to demonstrate to the RA that there is an audience that wants Christian broadcasting. Applications have to be with the RA by June and the successful stations will be announced in September. Anyone interested in further details should contact London Christian Radio, Tel: 071-582-0408 or write to 186 Kennington Park Road, London, SE11 4BT.

## DTI Promotes Neural Computing Technology

Some six thousand British firms could benefit from the commercial exploitation of neural computing technology – the complex computers which are modelled on the brain – says the DTI. The government has set up a £5.75m neural computing awareness cam-

paign to encourage the transfer of technology. For further details, telephone (0782) 583322.

At the same time, the Patent Office has established an initiative to help British industry overcome its image as a producer of inventions that other countries exploit. Details of the initiative, which involves the Patent Office, Licensing Executive's Society, Cranfield School of Management, 3M and a national clearing bank, can be obtained by calling (0633) 813535.

## Approval Awarded to PA Alarm Systems

We reported some months ago how Spector/Luminex have designed the Public Address and Voice Alarm (PAVA) systems for both the new Chevron Alpha oil platform, and the Sizewell 'B' nuclear generation Plant. It is good news, therefore, to hear that the company's designs have recently been accepted by both the DTI, and certifying authority Lloyds.

Particularly impressive is the Self-Diagnostic Management System, included in the PAVA scheme to control inputs to the system. It also monitors the system's audio power amplifiers and loudspeaker distribution networks, generating alarm tones when appropriate – this ensures that operators are given an early warning of system deterioration.

During a catastrophic system failure, the Self-Diagnostic Management system can be configured to ensure that alarms and emergency instruction broadcasts are maintained. Fully distributed systems can also be configured, such that each outstation can operate independently during a major cable failure.

## Get the Clock Ticking

Decoding a serial data stream to extract the clock pulses, and subsequently decode data, is an ongoing problem for computer engineers. New ideas are continually being assessed and industry standards, such as Manchester encoding and modified frequency modulation (MFM) have arisen, to enable the vital clock signal to be re-established at the opposite end of a transmission line.

Always keen to offer solutions to fundamental problems, the Microelectronics Division at AT&T have designed the TRU050, a Clock Recovery and Data Re-timing Module. Housed in

a single 16-pin DIL package, the crystal-referenced PLL device is able to extract the clock signal from a data stream, and regenerate coded data. Input data should be of a nonreturn-to-zero (NRZ) format, at either TTL or CMOS logic levels.

The TRU050 contains a phase detector, op amp, voltage-controlled crystal oscillator and divider chain, and a quartz resonator. The oscillator frequency and division factor are factory-set to customer specification. Other chores for the compact device include frequency translation and clock smoothing.

## The Telephone Now on Platform 2...

Incredible as it may seem, BT has only just woken up to the potential of providing telephones in London Underground stations – although whether the limited number of telephones per station (600 payphones spread over 248 stations) will be able to cope with demand when trouble strikes is debatable.

BT are also making it less boring for you to while away the time while in your local post office queue. Up to 1,100 BT payphones are being installed in post offices nationwide under a new multi-million pound contract. And that is not all – BT payphones will also be installed in most of Marks & Spencer's 290 UK stores.



## Events Listings

**Now Open:** 'Flight' Aeronautics Gallery, and 'The Secret Life of the Fax Machine'. Science Museum, London. Tel: (071) 938 8000.

**5 to 7 April.** Cable and Satellite 1993, London. Tel: (021) 705 6707.

**20 to 23 April.** Which Computer Show, NEC Birmingham. Tel: (081) 948 9837.

**23 to 25 April.** 4th MIDI and Electronic Music Show, Wembley. Tel: (081) 547 1183.

**24 April.** Marconi Birthday Exhibition, Wireless Museum, Puckpool

Park, Seaview, I-o-W. Tel: (0983) 567665.

**24 April.** All-Format Computer Fair, Novotel, London. Tel: (0608) 662212.

**15 to 16 May.** Model Exhibition and Display, Sandown Park, Warwickshire. Tel: (0608) 662212.

**22 May.** All-Format Computer Fair, Sandown Park, Warwickshire. Tel: (0608) 662212.

Please send details of events for inclusion in 'Diary Dates' to: The Editor, 'Electronics – The Maplin Magazine', P.O. Box 3, Rayleigh, Essex SS6 8LR.

## PICTURE CAPTION CHALLENGE



This month, we mix latex, politics and computer hardware. But what is the reason for this unlikely combination? As usual, though, no prizes for the closest guess.

- ★ The Treasury announce that the recent solid-state replacement for the Chancellor of the Exchequer is already proving to be considerably more popular than Norman Lamont!
- ★ Thanks to privatisation, the BBC can no longer afford human interviewers for 'On the Record', since the

directors have preferred instead to award themselves huge pay rises!

- ★ In a heart-warming party political broadcast, John Major announces his new Information Technology initiative.
- ★ Spitting Image move into electronics, to keep them busy between television series. Almost, but not quite. Major John, courtesy of that rubbery Sunday-evening satire show, is seen here promoting the new improved Spider-Bridge R285 network bridge.

# MAINS TRANSFORMERS



**J. M. Woodgate**  
**B.Sc.(Eng.), C.Eng., M.I.E.E.,**  
**M.A.E.S., F.Inst.S.C.E.**

## Part Two— Pulling It All Together

**A**t the end of Part 1 we left our design, for a 20VA transformer to convert 24V AC to 10V AC, at the point where we had calculated the wire size and number of turns for the primary winding. It is worthwhile calculating the resistance of the primary winding at this stage, not least because it allows us to check that the previous calculations are not wildly out. You could find the resistance of 18.4m of 0.56mm diameter copper wire from wire tables, which is easy and boring, but with two pieces of data you can calculate the resistance of *any* size of wire at *any* temperature. The temperature matters – the winding heats up in use, and we can assume that it is going to get as hot as BS415 allows, which is 85K rise above an ambient temperature (which we will assume is 25°C), for the type of enamel used on Maplin magnet wires. The two pieces of data we need are the resistivity of copper,  $\rho = 15.5n\Omega m$  at 0°C, and its temperature coefficient of resistance,  $\alpha = 0.0036K^{-1}$  between 0 and 100°C. The resistivity refers to a 1m length of the BIG wire we met in Part 1, which has a cross-sectional area of 1m<sup>2</sup>. The resistance,  $R$ , of a length,  $l$ , of wire whose cross-sectional area is  $a$ , is given by  $R = \rho l/a$  at 0°C, remembering not to mix up metres and millimetres! In our case, this gives:

$$R = \frac{15.5 \times 10^{-9} \times 18.4}{\pi \times 0.56 \times 0.56 \times 10^{-6}} = 0.29\Omega$$

### Turning the Heat On

To find out what happens when the winding is at temperature  $\theta$ , we use the formula:

$$R_{\theta} = R_0 (1 + \alpha\theta)$$

and at  $\theta = 110^{\circ}C$ , we get  $R_{110} = 0.29 \times (1 + 0.0036 \times 110) = 0.40\Omega$ .

### Secondary Winding

We can use quite a lot of the information, that we obtained in designing the primary winding, in the design of the secondary winding. We found that we needed 6.54 turns per volt, so the first stab at the secondary winding gives 65.4 turns (66 in practice). However, we have to increase the number of turns to allow for the voltage drops in the winding resistances. We do this by going back to the equivalent circuit, which we saw early in Part 1. If the secondary winding fills the same winding area as the primary winding, the secondary winding resistance looks, from the primary side of the transformer, like another resistance *equal* to that of the primary resistance. This, as we have seen, is 0.40Ω, giving 0.8Ω in total. The current through this is composed of the useful current which supplies power to the secondary winding, the magnetizing current and the current that supplies the iron-loss power. From Part 1, the iron-loss power is 4.2W/kg<sup>-1</sup>, and the

core mass is 0.45kg, so, since the primary voltage is 24V, the current is  $4.2 \times 0.45 / 24 = 8mA$ . The load current at 20VA is  $20 / 24 = 833mA$ , and these currents add in-phase to give a total of 841mA.

### Magnetizing Current

We get the magnetizing current from the data we used to plot the curves in Figure 4 of Part 1. To generalize these data, we convert the current into magnetic field strength by the formula  $H = nl / m$  (where  $m$  is the magnetic path length;  $m = 6T$  for scrapless laminations). The peak value of magnetic induction (flux density) is derived from the voltage using the formula  $B_{max} = V / 4.44fna$ , which were explained in Part 1. This process gives the *magnetizing curves* shown in Figure 6, and these are usually published by the manufacturers of the laminations. I found that the data in Figure 6 did not agree with the curves in my 'black book', because developments in heat treatment of the iron have led to big improvements over the years. I am therefore grateful to Linton and Hirst Ltd., and Electrical Steel Products Ltd., for providing me with up-to-date curves to compare with my measured values. From Figure 6, we see that at 1.5T, we need about 450Am<sup>-1</sup> of magnetic field strength, and by rearranging the formula for  $H$  above, we get:

$$\hat{i} = \hat{H}m/n = \frac{450 \times 6 \times 22 \times 10^{-3}}{157} = 378mA$$

But this is the *peak* value, corresponding to  $B_{max}$ , so the RMS value is  $378 \times 0.71 = 267mA$ . (Actually, the magnetizing current waveform is not sinusoidal, so the ratio of RMS to peak might not be  $1/\sqrt{2}$ . However, I measured the RMS and peak currents for the Maplin 20VA primary winding, and their ratio *happened* to be very close to 0.71 at  $\bar{B} = 1.5T$ . At higher inductions, the waveform becomes very peaky, and at 1.78T, the ratio is 0.56, so using 0.71 gives an *overestimate* of the RMS current, which is an error on the safe side). This current lags the load current by 90°, so the total current is:

$$I_p = \sqrt{(841^2 + 267^2)} = 882mA$$

This current flows through the effective 0.8Ω resistance, giving a voltage drop of 0.71V out of the 24V available, equating to a loss of 2.9%. We therefore increase the number of secondary turns by 2.9% to compensate. Strictly speaking, the 0.53V is not exactly in-phase with the 24V, but it is only 18° ( $\arctan 267 / 841$ ) out, and to allow for this would be a 'small correction to a small correction', and not worth bothering with. This brings the number of secondary turns up to  $(66 \times 1.029) = 68$  turns.

We can now find the largest wire size for which 68 turns will not overflow the winding area, in the same way as we did for the primary winding in Part 1. The winding area is calculated from the measured winding width and depth that the bobbin allows, and is 121mm<sup>2</sup>. Because we are winding round wire into a rectangular area, and we cannot eliminate all the gaps between the wires, we have to allow a *geometrical factor* of  $\pi / 4$ , and a *space factor* of 0.7, leading to a real available area of 66.5mm<sup>2</sup>. Dividing by the number of turns gives the area of wire as  $66.5 / 68 = 0.98mm^2$ , and the diameter thus 1.12mm. This is close to 20 SWG (Standard

Wire Gauge, not to be confused with AWG, American Wire Gauge), which is Maplin BL26D or YN82D, and has a bare-wire diameter of 0.9 mm, or 0.96mm including the enamel, according to BS EN60182-2. We find how much we need by multiplying the mean turn length (see Part 1) by the number of turns, which gives 8m, so one 50g reel, or one fifth of a 250g reel, is required. We should check that this wire will carry the full-load secondary current, which is the VA rating divided by the secondary voltage, and is thus 2A. At  $4\text{Amm}^{-2}$ , 0.9mm diameter wire will carry 2.5A, so there is no problem. But this calculation would have shown up any error we might have made, so it is a useful check. Finally, the resistance of 8m of 0.9mm wire at  $110^\circ\text{C}$  is  $0.068\Omega$ , and this should be nearly equal to the primary resistance divided by the turns ratio squared, i.e.  $0.4 / (2.4^2) = 0.069\Omega$ , which is encouraging!

## Winding the Secondary

This you will have to do, whether you use the Maplin primary winding or a special one of your own devising. It is far from easy to do this winding by hand. The bobbin is difficult to hold, and if you are using wire thicker than about 0.5mm you will find it difficult and/or painful to wind tightly. If you are going to do any serious transformer winding, therefore, I strongly advise making a hand coil winder. Do not under any circumstances try to use power tools for coil winding – even thin wire is quite capable of cutting your fingers off!

To make a coil winder, you need a strong wood base (coated chipboard or block-board), and strong vertical side pieces, through which you pass both a plain metal rod or tube to carry the reel of wire, and another rod with a crank handle at one end, which will carry the bobbin. This rod can conveniently be a piece of 10mm studding,

obtainable from DIY stores. You will also need several nuts and washers. The bobbin is carried on a hardwood mandrel, carefully cut to be a tight fit inside the square bore of the bobbin, with a central hole through which the studding passes. The mandrel is clamped to the studding, so as to turn with it, by nuts and washers. To wind the bobbin, bring the wire from the reel onto the bobbin from underneath, so that you can turn the handle with one hand while putting tension on the wire with the other. For thick wires, a very great deal of tension is required to get a tight winding, and if the mandrel is not a good, tight fit, the bobbin may be crushed. The more carefully you wind, the more wire you can get onto the bobbin, and the less noise the transformer will make in operation. Some form of automatic turns counter is practically essential, Maplin stock a low-cost LCD counter module (FS13P), which, with a microswitch operated by a cam on the studding and a 1.5V AA cell to power the module, is about the simplest arrangement possible.

## Weather

If your transformer is going to be used anywhere other than in a permanently warm and dry living room, it is essential to prevent moisture getting into the windings. This is particularly important for something like a battery charger, which would be used in an unheated garage or even outdoors. It is possible to obtain proper transformer varnish in small quantities, but beware of polyurethane varnish, which may damage the enamel on the wire and cause short-circuits, and varnishes made for printed-circuit boards, which may contain enough solvent to damage the bobbin material. It is best to immerse the completed bobbin (with the outer box, which is a vital safety component!) in the varnish for at least an hour, and to swab off the surplus from

inside the bore before it dries, otherwise core assembly will be difficult. A second, brushed-on, varnish treatment, of the completed transformer, is best for charger transformers and the like, and for any application where acoustic noise from the transformer would be annoying. The solvents used in these varnishes are rather nasty, so observance of the instructions for use is important.

## Assembling the Core

Commercially-made transformers use various different ways of stacking the laminations, such as 'interleaved in three blocks' or 'interleaved in blocks of three', to speed assembly. The laminations may not even be interleaved, but clamped up and MIG- or laser-welded at the butting face. However, for our purposes, *full-interleaving* is the correct method. To do this, 'E' laminations are inserted alternately from each side of the bobbin. It is necessary to make sure, especially when the last few are going in, that they do lie directly on top of each other. For example, you should take care to ensure that the central tongue of each 'E' lamination lies on top of the next one (from the other side as interleaving is used) together with its side members – it can be all-too easy to accidentally force it beneath the next one. The bobbin must be filled tightly, and the last lamination may need tapping gently into position. It is important to keep it absolutely 'square' – otherwise it may cut through the bobbin moulding. The kits do contain a few spares, so don't expect to use all of them! The 'I' laminations are then put in, and the core is ready for 'banging up', which is nothing to do with a dry cell (groan! – Ed.), but a lot to do with heat and noise! Stand the transformer, with the axis of the bobbin vertical, on a firm wooden surface, and give the top surface of the core several careful blows with a soft-faced hammer, so as to drive the laminations together and eliminate the air-gap between the individual 'E' and 'I' laminations. If you cared to measure the magnetizing current before and after this operation, you would see a considerable decrease, indicating a worthwhile improvement in the magnetic properties of the core assembly. After this treatment, assemble the side-plates to the core and clamp up with the bolts provided.

## Eddy Currents

You may wonder why the bolts are provided with fibre washers. It is *not* to ensure that you can't do the nut up without the bolt going round! The idea is that the stray field of the transformer produces a voltage between one side-plate and the other, and if these are short-circuited, eddy currents flow. Now, if this occurs, it should show up as an increase in the no-load current of the transformer. I have to say that, when I tried it, the no-load current without the washers was no different to that with the washers. This was true even for the 100VA kit, but I have no doubt that with larger transformers the effect does occur.

The situation with *toroidal* transformers is quite different. If you have (as is usually the case) a central bolt, with a clamping disc, to fix the transformer to the base of a metal case, and the inside of the lid of the case touches the end of the fixing bolt (see Figure 7), the bolt and the case form a short-circuit

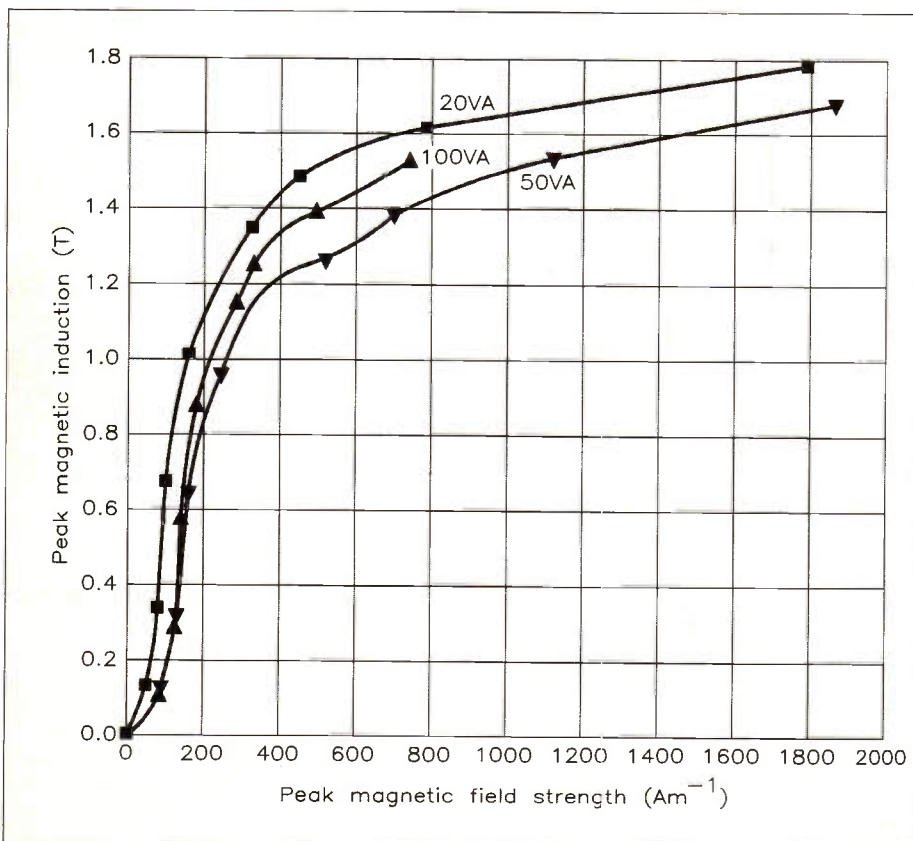
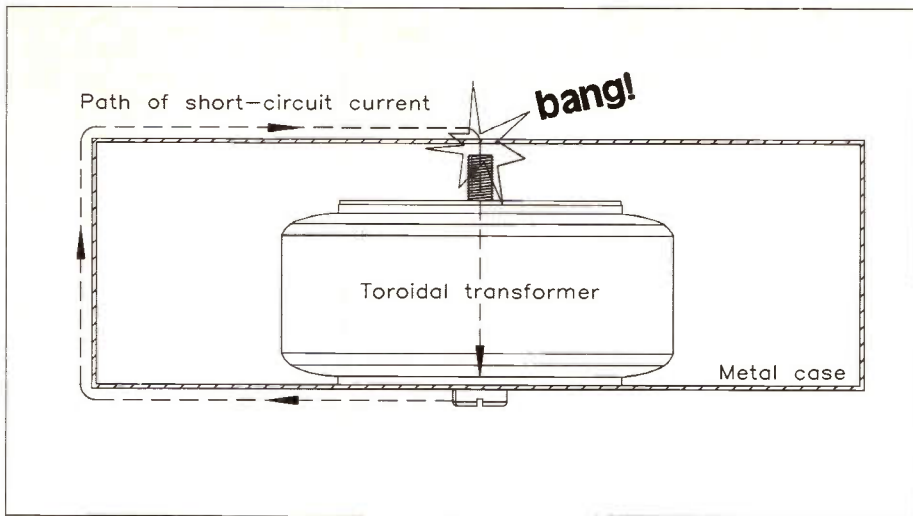

Figure 6. Magnetizing curves for the three lamination sizes.



**Figure 7. A nasty surprise caused by mounting a toroidal transformer without insulating the mounting bolt from a metal case.**

turn on the transformer! It is therefore necessary either to insulate the bolt head from the case, or to protect the end of the bolt so that the case cannot touch it, even if someone stands something very heavy on it.

## Lamination Patterns

It is alleged that laminations with holes in the corners are not as good as those without, because the area of iron is reduced, and magnetic saturation occurs round the holes. This would lead to an increase in magnetizing current. I tried to demonstrate this, with some laminations of the same size as those in the 20VA kit but with no holes. There was no real difference, but the grade of iron used, or the way in which they had been heat-treated, may not have been the same for both sorts of lamination. At very high inductions (say 1.8T), the effect *must* occur.

## Reducing the External Magnetic Field

Magnetic field escapes from the core all round, but especially along the axis of the bobbin. It is possible to reduce this field which may, for example, induce hum into a tape recorder head, or a guitar pick-up, in three ways:

(i) design the transformer to have a lower value of peak induction, such as 1.2T or even 1.0T. You can't easily do this with a kit transformer because you need a different primary winding, with more turns. Oscilloscope mains transformers are usually designed in this way.

(ii) wrap a sheet of high-permeability magnetic alloy round the complete transformer.

(iii) wrap a sheet of copper around the complete transformer.

Figure 8(a) shows that the copper sheet goes round parallel to the windings, while the magnetic sheet of Figure 8(b) goes round at right-angles to the winding direction. The magnetic sheet traps the magnetic flux issuing along the bobbin axis and returns it to the other end of the bobbin, thus preventing it spreading away from the transformer. The copper sheet, which must be quite thick and have a good, low-resistance soldered joint, acts as a low resistance path for eddy currents, which effectively force the net induction through the single turn to be nearly zero (eddy current  $\times$  nearly zero resistance = nearly zero

volts, and we saw in Part 1 (Equation 1) that  $B$  is proportional to  $V$ . This means that the flux issuing from the bobbin axis is forced to equal the sum of the fluxes in the side-limbs of the core, so there is none left over to spread away from the transformer.

Both of these methods are used in practice, but one often works better than the other; a theoretical reason can always be found, but it is not easy to predict which method will be best. There may also be a cost difference. I have also used a variant of the copper sheet method, in which copper sheet was substituted by a slice of thick-walled aluminium tube (scaffold tube!), with good effect.

## Electrostatic Screening

The mains supply contains a good deal of electrical noise at radio frequencies, and this is easily transferred across the capacitance between the transformer windings, where it may upset sensitive circuits, such as, for obvious reasons, AM receivers. This can be pre-

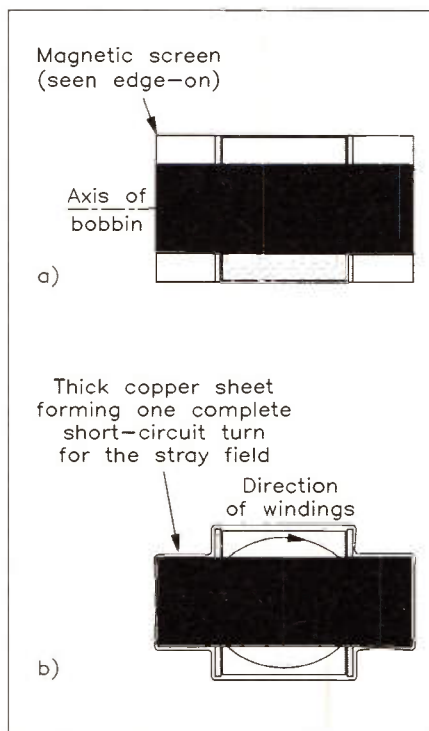

**Figure 8. a) Copper screen applied to a transformer. b) Magnetic screen applied to a transformer.**

vented by electrostatic screening between the windings, the screen being 'earthed', not necessarily to real earth, but to the 'zero-potential' point, of the sensitive circuits. It is often necessary to connect the core to the same point. The side-by-side winding plan of the Maplin transformers is a mixed blessing in this context, because while it reduces the capacitance between the windings (compared with the secondary being on top of the primary) it makes the insertion of an electrostatic screen more difficult. A screen can be made by sticking copper foil to the face of the centre web of the bobbin. This must not, clearly, form a short-circuited turn, so the ends must be overlapped and insulated from each other. A wire is soldered to the foil for earthing. The face of the foil is covered by a piece of stiff plastic sheet for insulation, and the secondary winding can then be added.

The barrier formed by a truly earthed electrostatic screen is a recognized way of complying with safety requirements. However, when properly wound, assembled and varnished, Maplin kit transformers should be able to pass the more severe test required for 'Class 2' ('double-insulated'  $\square$ ) equipment, so a screen is not necessary for safety reasons.

## Maximum Efficiency

If we put on a few turns on the primary winding, we would get a high induction, and thus high iron-loss and magnetizing current. However, the copper loss would be low. Conversely, if we put on many turns, the iron loss would be low and the copper loss high. What is the optimum? Well, this is a particular case of a very general rule about the efficiency of any sort of 'system' (in the sense of that word as used in thermodynamics), and it is not too difficult to prove that the efficiency is a maximum when the fixed (iron) and variable (copper) losses are equal.

We can prove this by considering the input and output powers of the transformer when supplying a resistive load. The ratio of these powers is the efficiency,  $\eta$ :

$$\eta = \frac{I_s V_s}{I_s V_s + I_s^2 R_{es} + P_i} = \frac{V_s}{V_s + I_s R_{es} + \frac{P_i}{I_s}} \dots (2)$$

where  $R_{es}$  is the total winding resistance referred to the secondary winding:

$$R_{es} = R_s + R_p \left(\frac{N_s}{N_p}\right)^2$$

and  $P_i$  is the iron loss power. The efficiency is a maximum when the denominator of Equation (2) is a minimum, and the denominator is a function of  $I_s$  as the independent variable. So a gentle application of differential calculus gives:

$$\frac{d(V_s + I_s R_{es} + \frac{P_i}{I_s})}{dI_s} = 0$$

and this is true when:

$$R_{es} = \frac{P_i}{I_s^2}$$

or

$$I_s^2 R_{es} = P_i$$

i.e. the copper loss is equal to the iron loss.

The iron loss is regarded as fixed because it depends on the input voltage, which is normally fixed, while the copper loss depends on the load current and can be regarded as variable. It is possible to take them the other way







# PC Relay Card for the IBM PC and Compatibles

Design by Tony Bricknell  
Text by Tony Bricknell and Robert Ball AMIPRE



## FEATURES

- ★ For use with IBM PC, PC-XT, PC-AT and Compatible Clones
- ★ Eight relay changeover contacts
- ★ Switches up to 24V DC/50V AC @ 2A resistive/1A inductive
- ★ Fused 5V output to power external circuits
- ★ Base address selectable
- ★ Multiple cards can be used
- ★ Fully programmable from BASIC

## APPLICATIONS

- ★ Robotics    ★ Process control
- ★ Time control    ★ Home automation
- ★ Controlling lamps, motors, solenoids

This project is a versatile relay card for use with the IBM PC, PC-XT, PC-AT and compatible clones. Each relay, of which there are eight on the card, has one set of change-over contacts. The relay contacts are able to switch 'moderate' loads, such as low voltage lamps, motors and solenoids.

The card slots into any one of the vacant expansion slots provided on the host computer. Power, control, address and data signals are obtained from the computer's expansion bus. The relays' contacts are brought out, together with a fuse-protected +5V supply, on a 37-way female D-type connector. The D-type connector protrudes through the expansion card slot allowing easy connection with the outside world.

The card is based around discrete logic, as opposed to a fully programmable input/output IC, this has the advantage that the card does not need to be configured or initialised before use. Data can simply be written to the appropriate address to set or

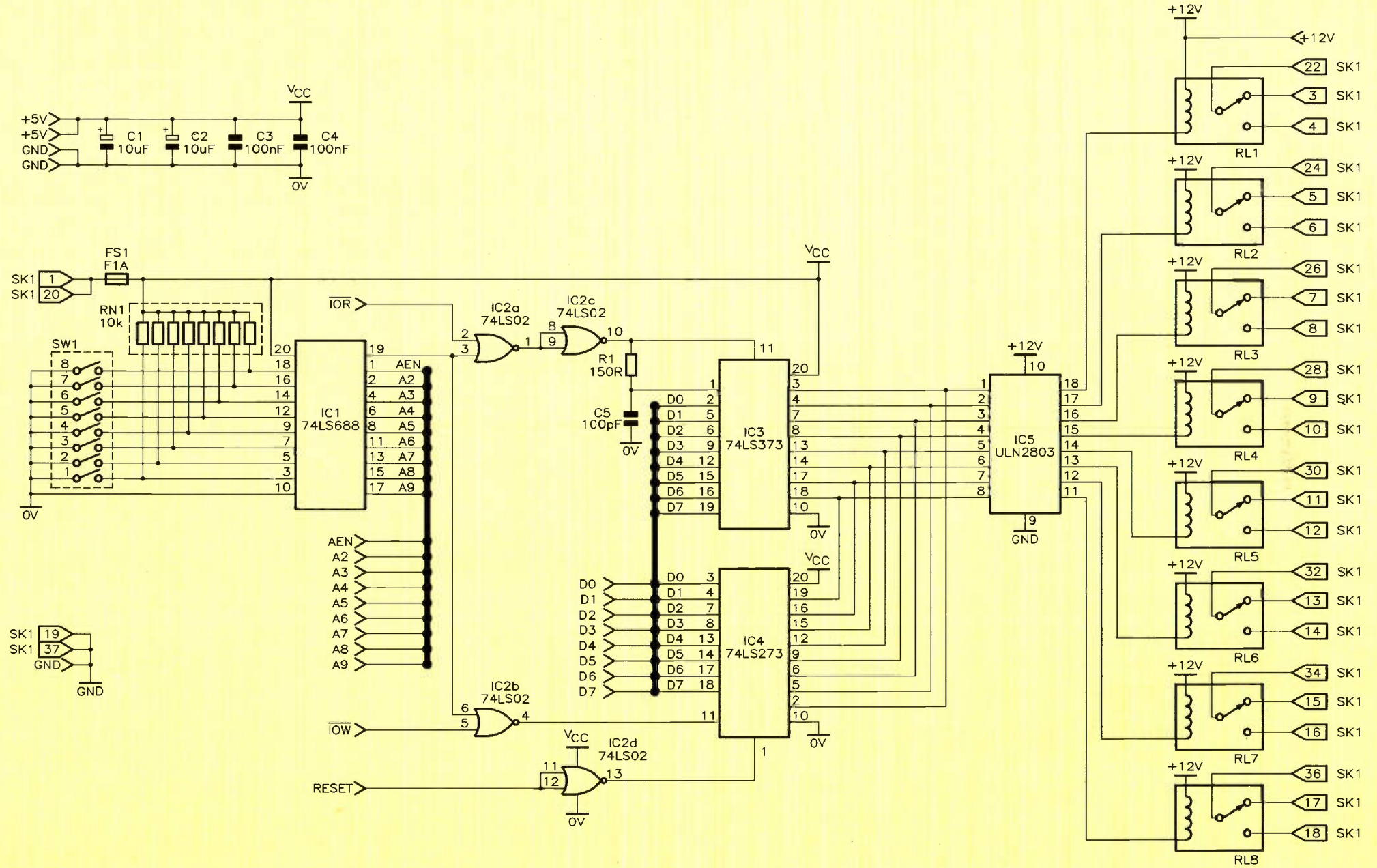

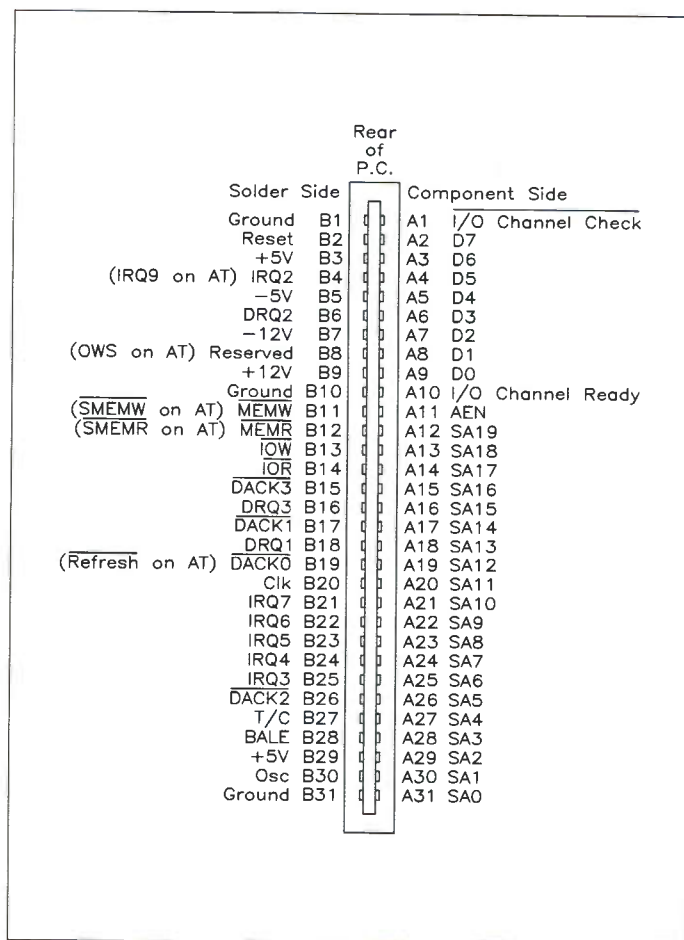

Figure 2. IBM PC expansion connector pin-out.

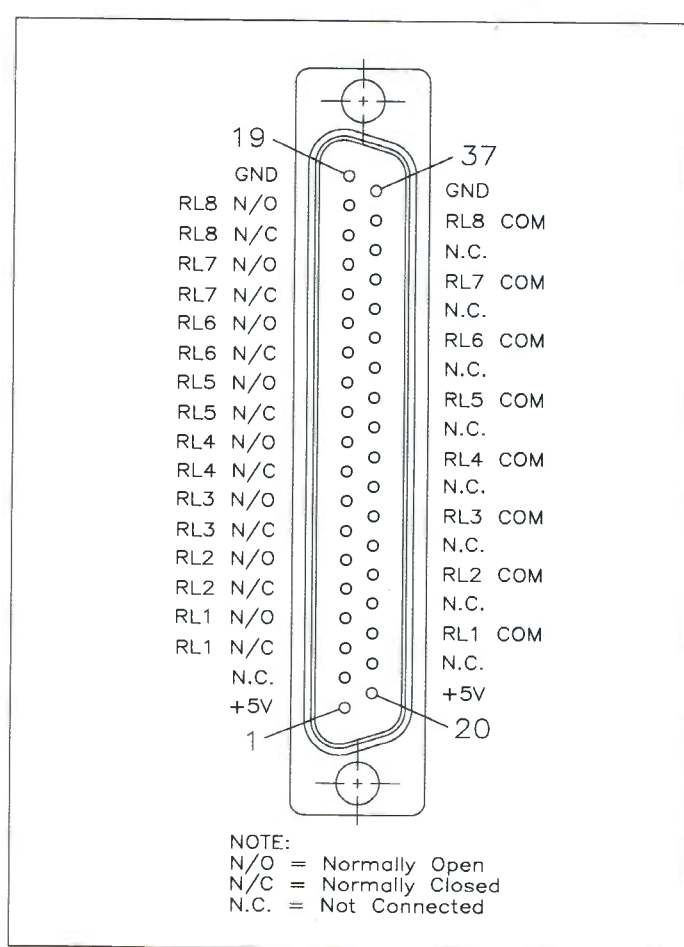

Figure 3. 37-way D-type connector pin-out.

reset the relevant relays. To simplify programming, it is possible to 'read back' from the card which relay outputs are set or reset, this avoids having to set or reset software flags to keep track of the current relay states. A further advantage is that a self-diagnostic routine could be written into the software to check the presence of the card at the correct input/output map location and whether the card is functioning correctly.

### Circuit Description

Figure 1 shows the circuit diagram of the PC Relay Card, and the following circuit description should help the constructor understand operation of the unit and assist fault-finding, should this become necessary. For clarity the pin-out of the computers expansion port connector and the card's 37-way D-type connector are shown separately in Figures 2 and 3 respectively.

When the computer is first powered up, a RESET pulse is placed on the bus. This is inverted by IC2d and fed to IC4 (an octal D-type flip-flop), resetting its outputs Q0 to Q7, ensuring that the Darlington buffer IC5 keeps all relays turned off during boot-up.

RN1 'pulls up' to logic 1 any address select switch lines that are not set at logic 0. IC1 is an eight-bit comparator and, when the address set up on the address bus matches that set by SW1, pin 19 goes low. This is accompanied by the computer requesting either a read or write from the card by pulling either IOR or IOW low, respectively.

If IOW is pulled low at the same time as the output of IC1 is valid (low), then a

write pulse is generated on pin 11 of IC4, by IC2b. This causes the information on the data bus to be written and latched into IC4, the latched data is output on Q0 to Q7 of the same device. This data is then buffered by IC5, an octal Darlington driver array, used to switch the relatively high currents required by the coils of RL1 to RL8. Note that IC5 features integral induced-emf clamp diodes, so that external diodes are not required to protect the IC from the voltage spikes produced when the relays de-energise.

On the other hand, if  $\overline{\text{IOR}}$  is pulled low at the same time as the output of IC1 is valid (low), then IC3, an octal D-type latch, is enabled by IC2a and c, transferring the data at Q0 to Q7 of IC4 to the computer's data bus. Resistor R1 and capacitor C5 ensure that IC3 is enabled before the chip is taken out of tri-state mode, alleviating any possible spurious data that might otherwise be written to the data bus.

### Construction

The PCB is a double-sided, plated-through hole type, with a gold-plated edge connector, chosen for maximum electrical reliability and mechanical stability. However, removal of a misplaced component is quite difficult with this type of board, so please double-check each component type, value and its polarity where appropriate, before soldering! The PCB has a printed legend to aid you in correctly positioning each item, see Figure 4.

The order in which the components are fitted is not critical, however, the following instructions will make the assembly task as straightforward as possible. For general

information on soldering and assembly techniques, please refer to the Constructors' Guide included with the Maplin kit.

During construction, be careful not to scratch the gold-plated edge connector or splash it with solder, as this is likely to affect operation of the card and computer.

Referring to the Parts List and PCB legend, insert the resistor network RN1, it is important that the pin 1 marker aligns with the dot on the PCB. Fit the dual-in-line switch SW1, ensuring that the 'on' side faces towards the edge of the PCB. Next, insert the IC sockets, ensuring that the notch on the IC sockets are aligned with the corresponding marks on the PCB legend. Insert and solder the two tantalum capacitors C1 and C2, taking care that the lead nearest to the + mark on the body is inserted into the hole adjacent to the + mark on the PCB. Insert the single resistor R1, the remaining capacitors C3 to C5, the fuse clip and fuse, and relays RL1 to RL8. Fit the 37-way D-type connector into the board and make sure that it is butted-up close to the PCB before soldering. Insert all the ICs, being careful to line up the pin 1 designator on each IC with the corresponding notch in the IC socket.

An end-plate is supplied in the kit, allowing the 37-way connector and PCB to be securely mounted to the back panel of your PC. This should be fitted as shown in Figure 5.

Clean up the board, by cutting off excess wires - no component lead should stand proud by more than 2mm. With a PCB cleaner and a stiff paint-brush, wash off any flux before inspecting the module. A close inspection of all tracks, joints and components is especially recommended on this board, before you insert the card into

your computer. Any mistakes, and your computer could make an unscheduled visit to the electronic graveyard in the sky – you have been warned!

## Installation

The installation of the PC Relay Card can be broken down into a number of steps.

1. Selecting an appropriate base address:

The I/O address area of an 8086/80286 machine is limited to 64k. The design of PCs reserves I/O addresses up to 00FF hex for use on the motherboard, and makes available I/O addresses 0100 to 03FF hex for use on expansion cards.

When selecting an I/O base address, it is important to avoid those already in use by existing cards. If you have two or more cards both addressed at, say 0300 hex, bus contention is likely to cause problems. For example, one card could pull the data lines high while another card is trying to hold them low, so that the data itself is undefined.

Addresses in use can be determined by consulting the installation instructions for the existing cards. In addition, Table 1 gives a list of designated I/O addresses. It is suggested that address 0300 hex is used, as this is designated for prototyping cards. However, as the PC Relay Card only occupies 4 bytes in the I/O memory map, up to seven cards can be installed in the address space between 0300 to 031F hex, giving a total of 56 relay outputs! However, it is unlikely that you will have sufficient vacant slots to cater for this many cards!

The base address of the PC Relay Card is set up as follows: The settings of SW1-1 to 8 can be determined by converting the required address into binary and taking the 8 most significant bits (A9 to A2) as the settings for the switches. SW1-1 corresponds to bit A2 and SW1-8 corresponds to bit A9, a logic 1 = switch 'off' and a logic 0 = switch 'on'. An example of how to determine the switch settings is shown in Table 2. Photo 1 shows the switch settings on the prototype corresponding to a base address of 0300 hex. Note that even though the card only uses one address (its base address), the last two bits A1 and A0 are not decoded, resulting in the card actually occupying four address locations. This is so that the card is given maximum versatility in the high-order bits, allowing the address

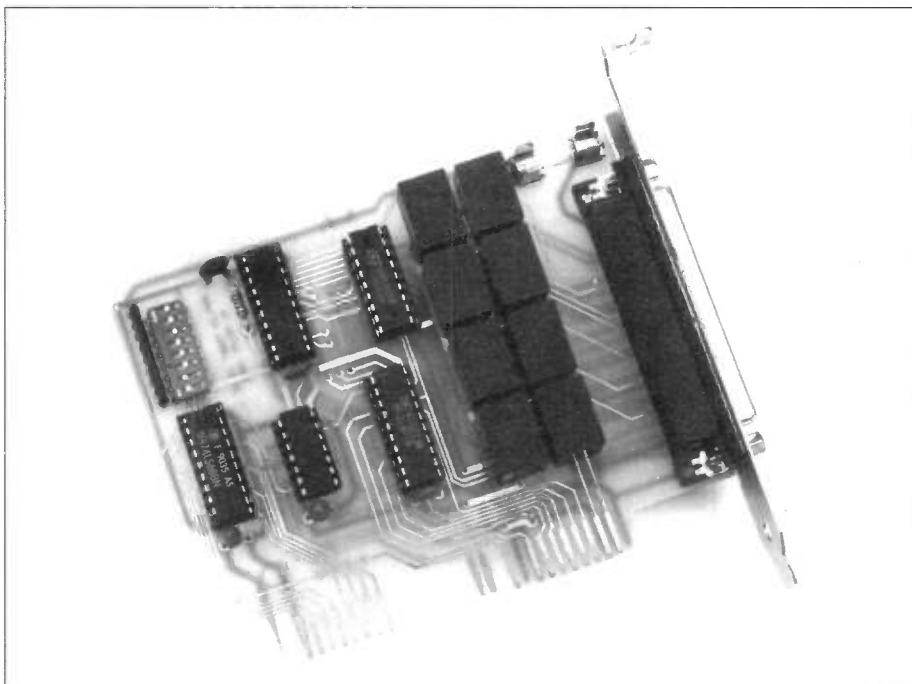

The assembled PC Relay Card.

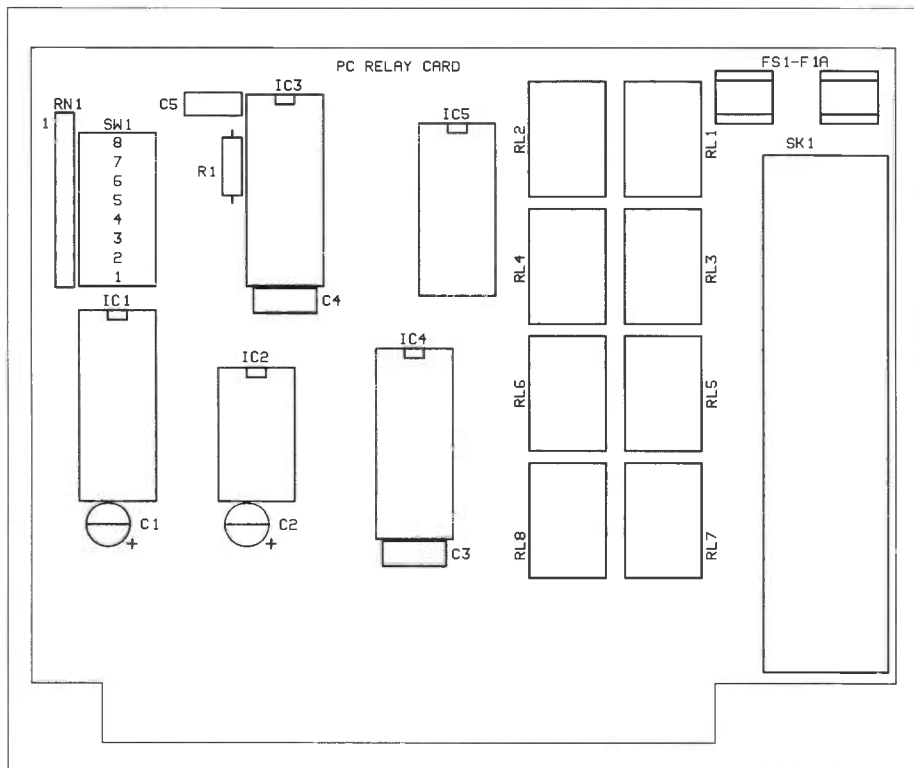
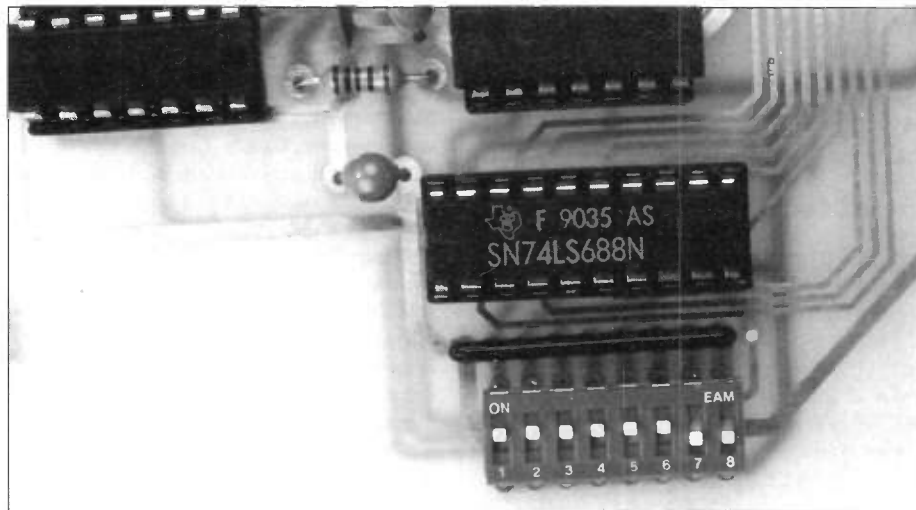

Figure 4. PCB legend.



Close-up of the address setting switches (0300 hex).

range of the card to be set from 0000 to 03FC hex. Now that is versatile!

2. Turn off the computer and disconnect the computer from the mains supply. Lethal voltages reside inside computers, and installation of the card with the computer switched on may result in permanent damage to you, your computer and/or the card.

3. Referring to the owner's manual, remove the cover from your computer to expose the expansion card area.

4. Locate a suitable empty expansion slot and remove the metal blanking plate cover screw and cover. Store the cover in a safe place for later replacement, should you wish to remove the PC Relay Card from your computer.

5. Carefully insert the card into the empty slot, pushing it fully home without

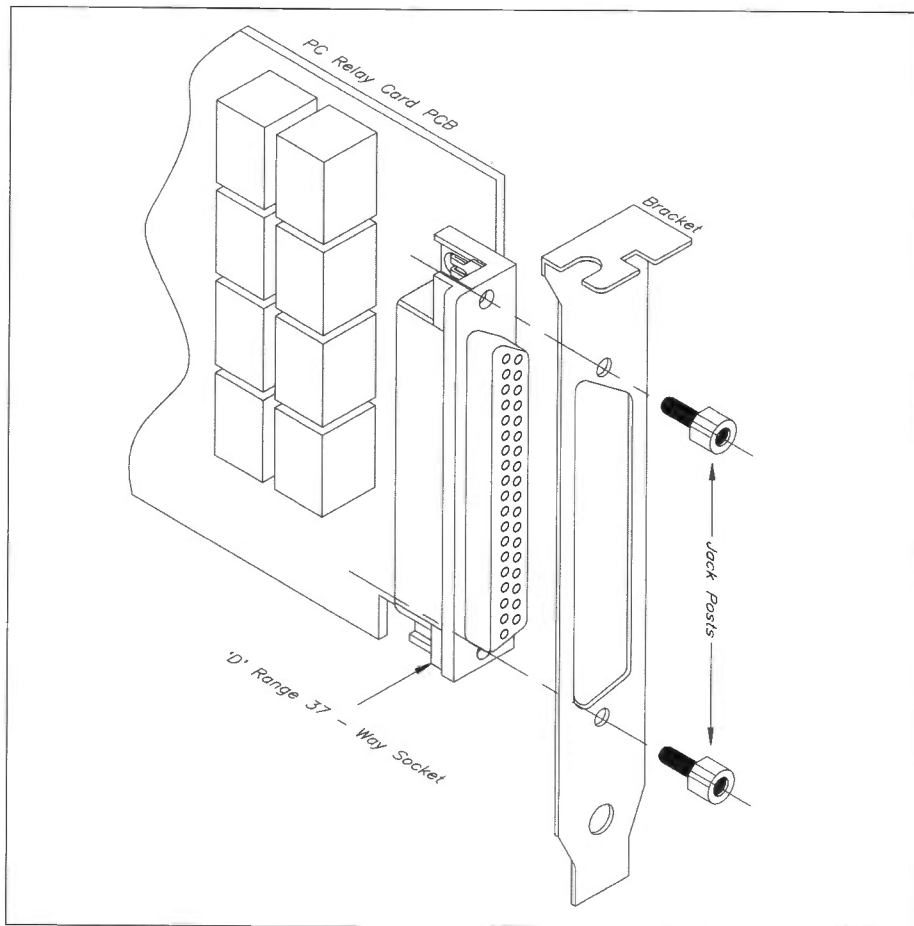

Figure 5. End-plate assembly.

```

100 BASEADD%=&H300           'Set up base address for card
110 OUT BASEADD%,&HFF        'Turn all relays on
120 PRINT "All relays on"
130 GOSUB 180                 'Call delay subroutine
140 OUT BASEADD%,0           'Turn all relays off
150 PRINT "All relays off"
160 GOSUB 180                 'Call delay subroutine
170 GOTO 110
180 FOR F=1 TO 5000           'Delay subroutine
190 NEXT F
200 RETURN

```

Listing 1. Simple program to test operation of PC Relay Card.

Description	Hex Address	
	PC/XT	PC/AT
Fixed disk	n/i	01F0-01F8
Games adaptor	0200-020	F0200-0207
Expansion unit	0210-0217	n/i
2nd Parallel printer port	n/i	0278-027F
Alternate EGA	02B0-02DF	02B0-02DF
GPIB (0)	02E1	02E1*
Data acquisition (0)	02E2-02E3	02E2-02E3*
Prototype card	0300-031F	0300-031F
Fixed disk	0320-032F	n/i
Network card	0360-036F	0360-036F
1st Parallel printer port	0378-037F	0378-037F
SDLC	0380-038F	0380-038F
2nd Bisynchronous	n/i	0380-038F
Cluster (0)	0390-0393	0390-0393*
1st Bisynchronous	n/i	03A0-03AF
Monochrome adaptor/printer	03B0-03BF	03B0-03BF
Enhanced graphics adaptor	03C0-03CF	03C0-03CF
Colour graphics adaptor	03D0-03DF	03D0-03DF
Floppy diskette controller	03F0-03F7	03F0-03F7

Note:  
 \* = these devices decode the full 16 address bits, allowing further devices to be located in the same category above 3FF, for example GPIB (1) = 22E1 etc.  
 n/i = not implemented

Table 1. Designation of input/output map addresses.

forcing it. Using the cover screw removed in (4) above, fix the end-plate to the back of your computer.

6. Double-check everything!
7. Replace the cover.

## Testing

Whilst crossing your fingers, eyes, toes and anything else you can think of, switch on the computer – it should boot in the normal way. If the computer behaves in an abnormal way, turn off the computer immediately and cry . . . no, remove the expansion card and check for a mistake you should have spotted earlier, solder whiskers shorting out adjacent tracks, etc.

A simple program written in GW BASIC can be used to test the card, see Listing 1. This program, when run, turns all relays on and then off again at short intervals. Each of the eight relays can be checked with a multimeter set to a low-ohms or continuity range, as shown in Figure 6. The delay may be adjusted to alter the switching speed of the relays; this is achieved by altering the number in line 180, presently set at 5,000. A lower number will decrease the switching interval, a higher number will have the opposite effect.

## Accessing the PC Relay Card from GW BASIC

### Defining the Base Address

The easiest way to define the base address for use in a BASIC program is to set an integer variable (% suffix) to the base address of the card. Then whenever the card needs to be accessed using the OUT or INP instructions the variable can be used instead of the actual address. This technique is good programming practice as the base address can be changed by modifying just one line of the program instead of tediously having to change every usage of the address. An example of this is shown in Listing 2.

```

10 BASEADD%=&H0300

```

Listing 2. Example line of BASIC to define base address.

### Controlling Relays

Switching any one, or any combination of relays, on or off is simply a matter of setting or resetting the eight binary weighted bits associated with the relays. Switching on a relay requires that its corresponding bit is set, conversely switching off a relay requires that its bit is reset. Since all eight bits are accessible in one byte of data, all of the relays can be controlled simultaneously. To set and reset the data bits, the PC Relay Card must be written to, using the OUT instruction. Calculation of the data value is easily achieved using a number line and adding the values where a Logic 1 (bit set) is required, see Table 3. This method is similar to that used to calculate the address switch settings earlier. Listing 3 shows an example of how to output data from BASIC.

## Reading Relay Status

As previously mentioned, it is possible to 'read back' the status of the relays, the data value returned is binary weighted in exactly the same way as that used for setting and resetting the relays. On a correctly functioning card, the data value read from the card will exactly replicate the data value last written. Reading the data value is achieved using the INP instruction. Listing 4 shows an example of how to read data from the card in BASIC; the data value is returned in the integer variable DAT%.

## Advanced Techniques

It is often necessary to switch on or off a relay without disturbing the other relays. This can be easily achieved, regardless of the previous states of all of the relays, by reading the data value from the card and logically ORing or ANDing the data with the binary weighted value of the bit to be set or reset. For example:

If RL5 is to be switched on, the data from the card (i.e. current relay setting) should be ORed with the binary weighted value for RL5 (16 decimal, 10 hex), see Listing 5a.

If RL7 is to be switched off, the data from the card should be ANDed with the complement of the binary weighted value for RL7 (64 decimal, 40 hex), see Listing 5b.

## Extending Switching Capability

For safety and reliability, the maximum voltage that should be switched by the PC Relay Card is 24V DC or 50V AC. Similarly the maximum current that should be switched is 2A resistive or 1A inductive. Voltages/currents above these limits should

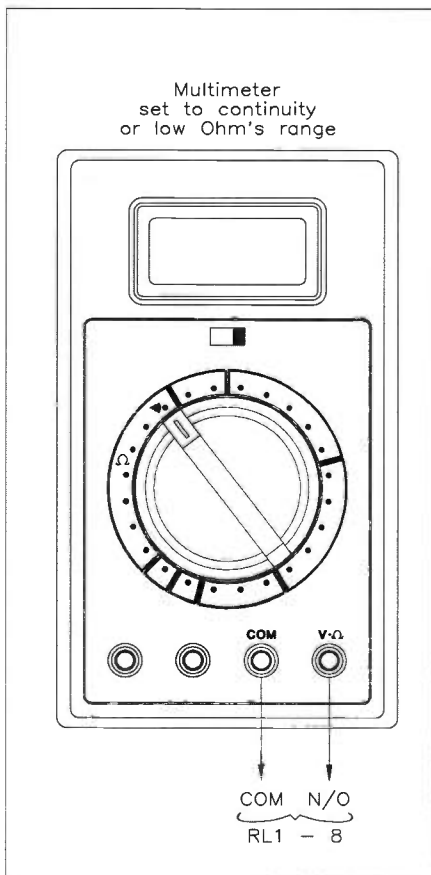

Figure 6. Method of testing relay contacts.

Required base address = 0300hex

0300hex = 11 0000 00xx

x = Don't care - as the PC Relay Card does not decode the last two bits A1 and A0, their setting is irrelevant.

Switch number =	SW1-8	SW1-7	SW1-6	SW1-5	SW1-4	SW1-3	SW1-2	SW1-1
Address line =	A9	A8	A7	A6	A5	A4	A3	A2
Binary value =	1	1	0	0	0	0	0	0
Switch setting =	OFF	OFF	ON	ON	ON	ON	ON	ON

Table 2. Calculating address switch settings.

Relay number =	RL8	RL7	RL6	RL5	RL4	RL3	RL2	RL1
Decimal value =	128	64	32	16	8	4	2	1

For example, to turn relays 3, 4 & 7 on, and relays 1, 2, 5, 6 & 8 off:

Relay number =	RL8	RL7	RL6	RL5	RL4	RL3	RL2	RL1
Decimal value =	128	64	32	16	8	4	2	1
Binary value =	0	1	0	0	1	1	0	0
	= 64+8+4							
	= 76 decimal							
	= 4C hex							

Table 3. Calculating bit values for setting and resetting relay outputs.

In hex:  
20 OUT BASEADD%,&H13 'Turn relays 1,2 & 8 on, 3 to 7 off

In decimal:  
20 OUT BASEADD%,19 'Turn relays 1,2 & 8 on, 3 to 7 off

Listing 3. Example line of BASIC to set/reset relay outputs.

30 DAT%=INP(BASEADD%) 'Read status of relays into DAT%

Listing 4. Example line of BASIC to read status of relay outputs.

not under any circumstances be connected to the PC Relay Card, however, additional switching circuits may be added to extend the switching capability.

## 240V AC Mains

Figure 7a shows how to switch 240V AC mains voltage, using a zero-crossing opto-

triac. The circuit, with suitable heatsinking, is suitable for switching up to 4A resistive. Ensure that the load is placed in the Live side of the circuit, however, extreme care should be exercised with respect to insulation and spacing as parts of this circuit are at full mains potential. This circuit uses the 5V output of the PC Relay Card to power the LED in the opto-triac.

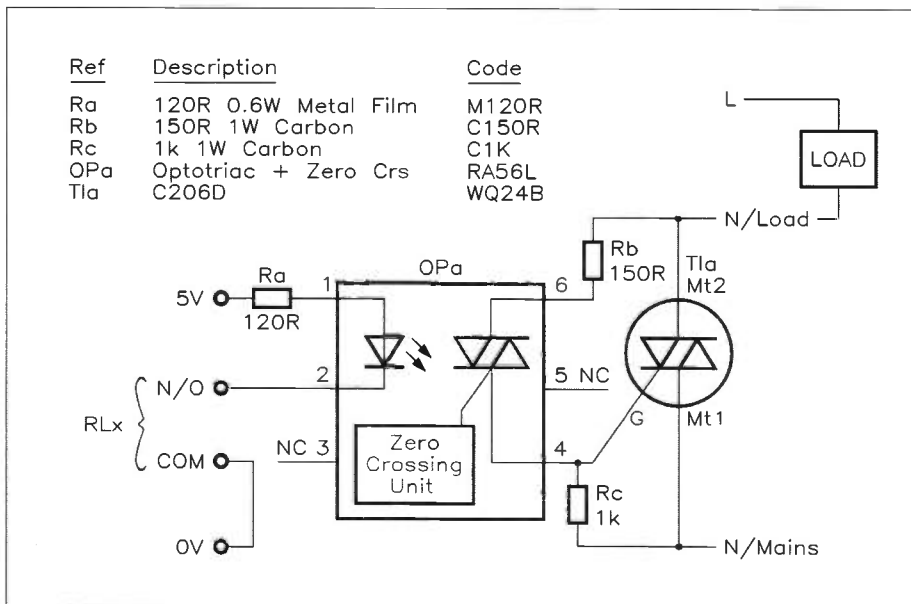
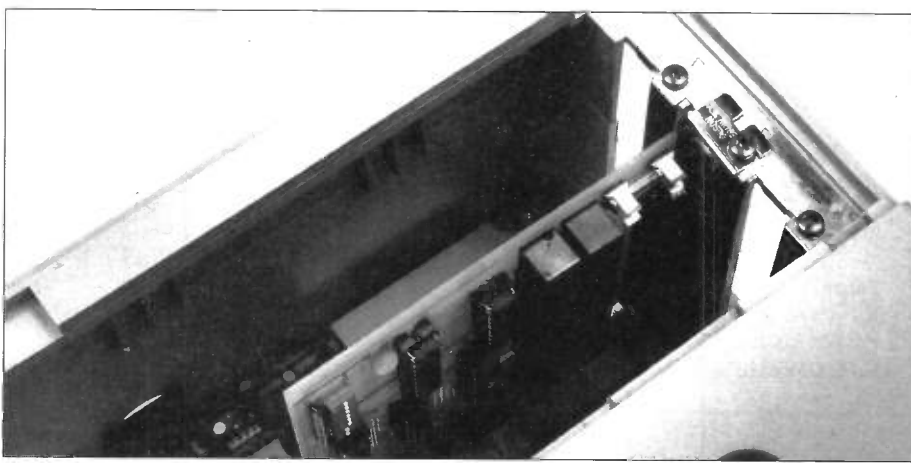

Figure 7a. Additional circuit for triac of switching a mains load.



The PC Relay Card installed in a computer.

In Hex:  
40 OUT BASEADD%, INP(BASEADD%) OR &H10

In Decimal:  
40 OUT BASEADD%, INP(BASEADD%) OR 16

Listing 5a. Example line of BASIC to bit mask and set a relay output.

In Hex:  
50 OUT BASEADD%, INP(BASEADD%) AND NOT &H40

In Decimal:  
50 OUT BASEADD%, INP(BASEADD%) AND NOT 64

Listing 5b. Example line of BASIC to bit mask and reset a relay output.

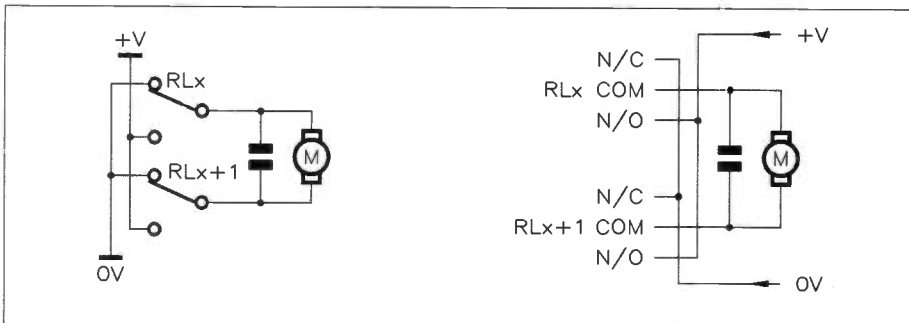

Figure 7c. Bidirectional motor control using the PC Relay Card.

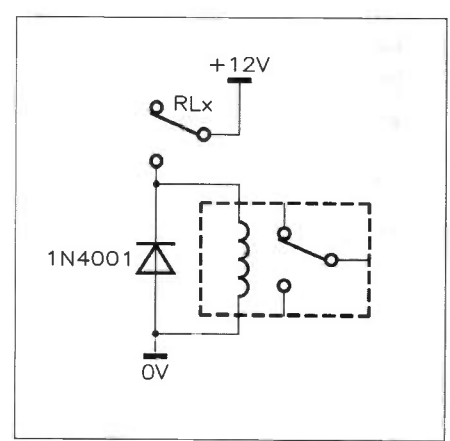

Figure 7b. Additional circuit for relay switching of a high power load.

### High Power Loads

Figure 7b shows how a high-power relay can be driven from the PC Relay Card to facilitate switching voltages and currents above the rated switching capability of the card. When switching inductive loads, to help reduce arcing and prevent welding of the contacts, place a suitably rated 100nF capacitor across the switching contacts of the relay.

### Bidirectional Motor Switching

Figure 7c shows how the PC Relay Card can be used to control a bidirectional motor. With both relays off (or on), both ends of the motor are held at 0V (or +V). By switching on one of the relays, the supply voltage is applied to the motor, allowing the motor to turn in one direction or the other (depending on which of the two relays have switched).

### Applications

The applications of the PC Relay Card are many and varied, limited only by the user's imagination (and budget): process control; robotics; time control; automation; controlling lamps, motors, solenoids, etc. Advanced applications include controlling electrical apparatus around the house to give the impression that the house is occupied.

## PC RELAY CARD PARTS LIST

RESISTORS: All 0.6W 1% Metal Film (Unless specified)

R1	150Ω	1	(M150R)
RN1	SIL Resistor 10k	1	(RA30H)

CAPACITORS

C1,2	10μF 16V Tantalum	2	(WW68Y)
C3,4	100nF 16V Minidisc	2	(YR75S)
C5	100pF Ceramic	1	(WX56L)

SEMICONDUCTORS

IC1	74LS688	1	(KP49D)
IC2	74LS02	1	(YF02C)
IC3	74LS373	1	(YH15R)
IC4	74LS273	1	(YH00A)
IC5	ULN2803A	1	(QY79L)

MISCELLANEOUS

	14-pin DIL Socket	1	(BL18U)
	18-pin DIL Socket	1	(HQ76H)
	20-pin DIL Socket	3	(HQ77J)
	Fuse Clip 20mm Type 1	2	(WH49D)

FS1	Fuse 20mm 1A	1	(WR03D)
SW1	Slimline 8-way DIL Switch	1	(QY70M)
RL1 to 8	Ultra-Miniature Relay 12V SPDT	8	(YX94C)
PL1	PCB 37-way D-type Socket	1	(JB38R)
	PC Bracket 37-way D-type	1	(CR45Y)
	PCB	1	(GH22Y)
	Instruction Leaflet	1	(XT88V)
	Constructors' Guide	1	(XH79L)

The Maplin 'Get-You-Working' Service is available for this project, see Constructors' Guide or current Maplin Catalogue for details.

*The above items are available as a kit, which offers a saving over buying the parts separately.*

**Order As LT16S (PC Relay Card Kit) Price £24.95.**

The following new items (which are included in the kit) are also available separately, but are not shown in the 1993 Maplin Catalogue.

PC Bracket 37-Way D-Type **Order As CR45Y Price £2.25.**

PC Relay Card PCB **Order As GH22Y Price £7.95.**



# TECHNOLOGY WATCH!

with Martin Pipe

No doubt you're wondering what has happened to your usual correspondent in these matters, namely Keith Brindley. Unfortunately, Keith has fallen ill, and so I am 'holding the fort' until next month, when Keith should return with renewed vigour. Anyway, let's press on with a look at the record industry. Taiwanese anti-piracy laws have, for some reason, been considered sufficiently lenient for many people to set up illegal CD and tape production plants there – in fact, most pirate CDs are produced in Far Eastern countries. The situation is not helped by the fact that a great deal of pirated products are now indistinguishable from the real thing; the methods used by the pirates have reached new standards of sophistication. Unfortunately for the pirates, things are now toughening up. Acting on evidence supplied by the International Federation of the Phonographic Industry (IFPI); UFO Records (a subsidiary of Warner Bros.), Polygram and officers from the Taiwanese Investigation Bureau (IB) raided two factories and one distributor – and over 15,000 pirate CDs were seized (most of them destined for the Hong Kong market).

Perhaps, however, if CDs were to be sold at a sensible price, the profit margins for pirates would be so low as to force them out of business. Remember that CDs are much cheaper to produce in large volumes than pre-recorded cassettes – and certainly vinyl LPs (at least now!). Thanks to volume production, the cost of producing a CD, since the system was first introduced, has plummeted – yet the average retail price has remained virtually static, or even increased slightly. And, as the Government is fond of telling us, inflation in the UK has generally been very low – and so CD prices should have, in fact, gone down somewhat.

Although most of us would agree that CD offers better sound quality than LP records, at least for those of us who can't afford £1,000 turntables, most of us would disagree with the amount of manipulation to which the record buyer is being subjected. Yes, against the wishes of a sizeable proportion of the public, LPs are being forcibly phased out – CD is the answer to the record industry's prayers (fewer rejects and customer returns), although better quality control and decent (i.e. non-recycled) vinyl would have supported the case for LPs. But tightening up on the quality would have upped the price per unit by a few tiny pence.

The term 'forcibly', incidentally, is used purposefully – have you seen the exorbitant prices being charged for the few new LPs still available? Some would say that this is due to the reduced demand for records – and it is; but it has been achieved by 'doctoring the market'; LP prices have been going up regardless to close the gap with the CD price, so that punters would

choose CD (well wouldn't you, for an extra £3 or so?). So what happens? Demand falls, the production cost per record goes up, and hence the retail price. It's a downward spiral from then on. Of course, there are sound commercial reasons for the large record shop chains to phase out, or stop selling records altogether, other than the bland 'we don't want to stock three formats' argument (well, you'll be stocking four when, and if, DCC and MD are established!). The reality is that they make more money through a CD sale, and it costs them money to deal with the comparatively high numbers of returned LPs – which are the primarily the fault of cost-cutting exercises at the pressing plant. Ironically, it is widely reported that WHSMITH have regretted their decision to stop selling LPs.

The scenario appears to be repeating itself for the 45rpm single – yes, that original icon of teenage culture; the price gap between these and CD singles is steadily closing. And, just as in the album case, it's not through lowering the price of its digital competitor. What must be taken into consideration is that album sales generally exceed single sales noticeably, at least over a considerable period of time. No great surprise, though, as sales of 30,000 units are enough to place a record in the Top 10 – compared with the healthy sales a few years back, this would indicate that UK listeners are turning to albums for their music. The high costs involved in producing a relatively small number of CD singles may force the record industry to remove any vinyl alternative – the present situation appears to be bearing this out.

Once vinyl records have been phased out altogether, two questions remain to be asked – what will happen to the disco and back-room DJ culture (the 'turntable arts' of beat-mixing and 'scratching') – and hospital/student radio stations, with their already hard-pressed funds?

Out of interest, a tape duplication company once said that, for 5p more a cassette, they could use superior chromium dioxide tape and use Dolby B HX-Pro – thus producing an excellent-sounding cassette. Yes, that's right – 5p on a pre-recorded tape that retails at £7 or more! But, as we all know, the record industry is renowned for its avariciousness. And, in any case, what grounds would there then be for selling DCCs?

## The Marcopolo Debate Continues . . .

Many thanks to all of the 'Electronics' readers who replied to last month's comments (refer to the News Report section) on the ex-BSB satellite saga. In particular, I would like to thank Reg Prior of Goodwick in Pembrokeshire, and L. R. Barber of Lossiemouth in Morayshire. Reg is dissatisfied with the technical quality of his terrestrial service – there is an obstructing hill between him and his

local repeater at Fishguard, and no alternative. Of course, such problems would never dog Marcopolo viewers – provided that they have an unobstructed view of the satellite. In particular, Reg is annoyed with the apathy that he has received in return for his licence fee. By the way, Reg, to receive World Service TV (WSTV), all you need is a D2MAC/Eurocrypt receiver, such as the Pace MRD920, a good 90cm dish/feed assembly and a low-noise LNB; all of these items are available in the UK. I see absolutely no reason why WSTV should refuse you a subscription, if they do, contact your local Trading Standards Office immediately. It is the BBC's duty, as the UK state broadcaster, to ensure that all UK residents have access to BBC programmes, assuming of course that they pay their licence dues! But you shouldn't have to go to such lengths – and, in any case, you wouldn't have access to ITV and Channel 4!

Mr. Barber, meanwhile, suggests a few other points in favour of using Marcopolo as a space-bound repeater of terrestrial TV programmes:

- (i) No more problems with transmitters going off-air due to power cuts (OK, there are brief eclipse periods every year, but on-satellite batteries overcome these).
- (ii) No more co-channel interference from Continental television stations – particularly annoying in the South-East, when high-pressure weather systems in Europe frequently cause tropospheric ducting.
- (iii) BBC national radio stations could be broadcast alongside the television channels. There are some areas that never get satisfactory radio reception, particularly the FM services.
- (iv) Using larger dishes, European hotels could pick up the signals – just what the travelling UK business fraternity and travellers need to keep them 'in touch' with what's going on back home. Since the receivers are individually addressable, the authorities can keep track of, and enforce, any subscription payments. As far as the BBC goes, though, there is a clear conflict of interests here with WSTV. You can't beat the complete service, though – as Dutch cable viewers will tell you!

No correspondence has yet been received from the ITC or, come to think of it, the BBC. If nothing is forthcoming from these organisations soon, I will be contacting them myself, on the behalf of 'Electronics' readers. If you have any comments to make, please contact me at the editorial address. Meanwhile, some food for thought. Astra dish owners will know that practically all of the German terrestrial services (RTL, ARD, etc.) are available on satellite, in PAL – and in the clear! Another DTH ('direct to home') satellite, Kopernikus (23.5°E), duplicates these and adds more. An example to us all!

## LIFE WITH MICRO CHIP...

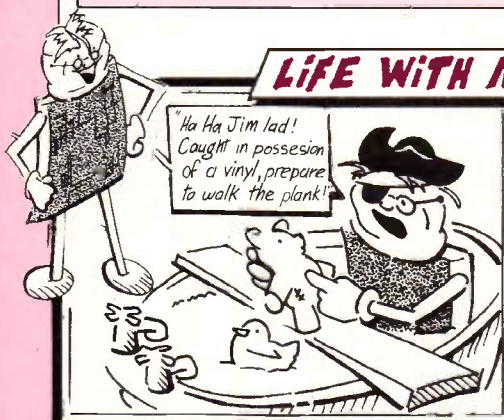

# Industrial Electronics Assembly-

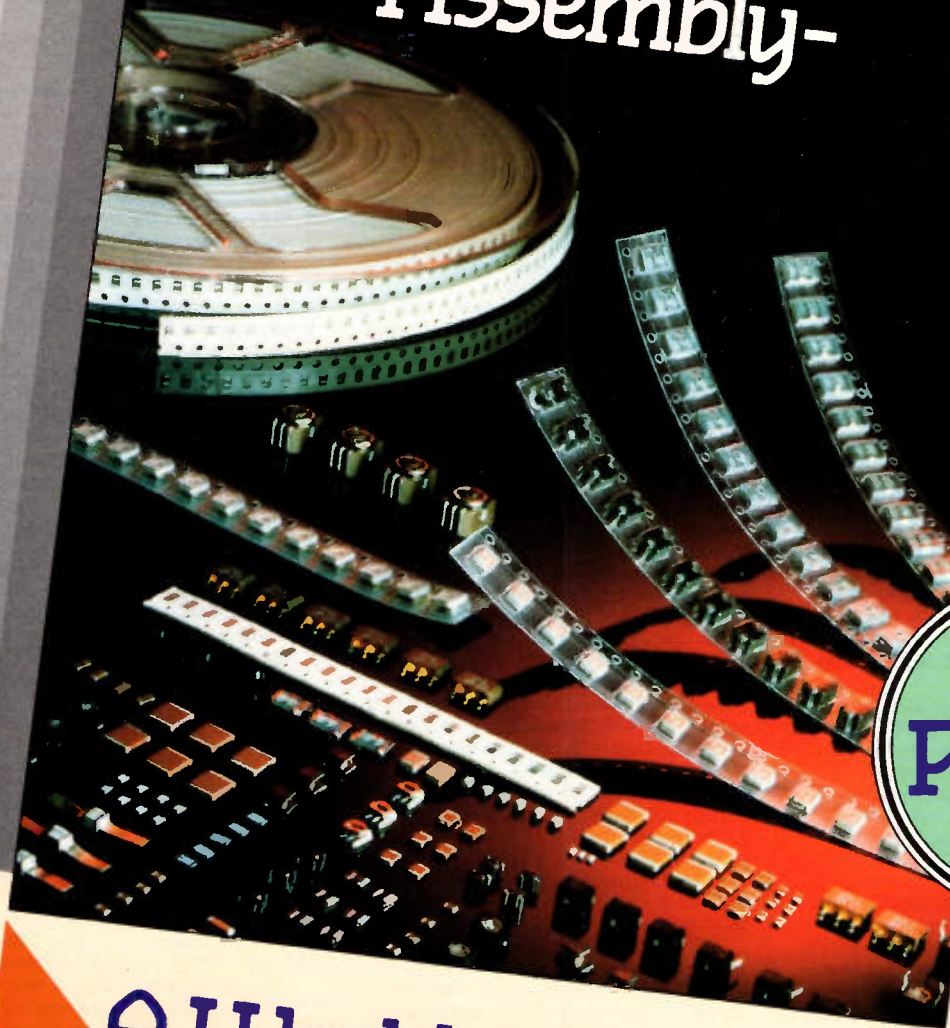

1  
PART

Selection of surface-mounted components, some loose, some taped, some reeled (Murata).

## A World Apart?

by Keith Brindley

For the hobbyist who builds projects from the pages of magazines such as 'Electronics', industrial methods of assembly must seem a very long way off. But, in fact, they're not too far removed from the standard hand techniques of inserting a component into a printed circuit board (PCB), and then soldering it. Indeed, a look at modern automated industrial practices can even teach the hobbyist a thing or two about the job in hand, as well as pointing the way to the future of project-building.

Methods used in industry, after all, only mirror processes undertaken by hand – perhaps a little faster, and possibly with a touch more accuracy – the end result, a working PCB assembly, is the desired aim of both the hobbyist and the industrial electronics engineer.

Not so very long ago, industrial manufacture of PCB assemblies was just a hand process anyway. Readers will probably have seen the BBC television series 'Making Out', in which teams of operators insert components into a PCB, and then solder them in. Generally, in such a

process each operator is responsible for soldering in a selection of components, and then the PCB is passed to the next operator, who inserts and solders a further selection of components. Such hand soldering processes (virtually identical to the hobbyist's methods) do still exist in industry but are, as they are labour-intensive, expensive. For this reason alone, such hand soldering is used only for small-volume quantities of PCB assemblies, where the expense of automating the process isn't justified.

Where large-batch, high-volume quantities of PCB assemblies are to be manufactured, on the other hand, hand assembly is unnecessarily expensive, so manufacturers look to full automation as the best method of manufacture. Here, components and bare PCBs are loaded in at one end of the production line – and fully assembled, soldered, cleaned and tested PCB assemblies roll off the other end. What happens between the two ends of the automated production line is what this article is about.

### PCBs

While components form the circuit, which any manufacturer aims to build, the heart of any modern electronic appliance is a PCB. The circuit itself is in the hands of the designer – it can be as simple as a basic transistor switch, or as complex as a microcomputer – but it remains *just* a handful of loose components until it has been connected together, with soldered joints, by a PCB.

A PCB relies on the principle that a layer of conductive material (*track*) is present on the surface of a thicker layer of insulating material (*base*). Component connecting terminations are soldered to the track at points (*lands or pads*), such that the track forms all necessary interconnections between components. Any reader of 'Electronics' knows this. Incidentally, the industrial manufacture of PCBs has already been discussed in a previous article entitled 'Across the Board', which was published in Issue No. 59 (November 1992).

If components used in a circuit are conventional resistors, capacitors, transistors and so on, the PCB is usually pretty basic, too. Components like these are commonly known as *through-hole components*, because their connections are formed by leads which go through holes in a PCB. For the same reason, such components are also commonly called *leaded components*, and PCBs that contain only these forms of component are often called *through-hole assemblies*.

In automated industrial electronics assembly processes (and even creeping into hand assembly processes), another type of component is becoming increasingly popular. This type of component has no leads to go through PCB holes. This is why they are commonly referred to as *leadless components*. Because they haven't got leads to go through PCB holes, they are simply mounted on the surface of a PCB, this giving rise to more exact terms; *surface-mounted components* or *surface-mounted devices* (SMCs or SMDs) and *surface-mounted assemblies* (SMAs). Surface-mounted components are much, much smaller than their leaded counterparts, simply because they have no leads acting as soldering terminations. Instead, the terminations of such components are formed by small metal areas that are soldered directly to the PCB pads. Both types of component are compared in Figure 1.

The mix of component types used within an electronics assembly generally defines the type of PCB used, and the particular manufacturing processes required. As a result, the designer of an electronic assembly now has to think of the final product in terms of the components used, PCBs and reliability, as much as the actual circuit itself.

There are several constructional variations possible with leaded and leadless components, shown in Figure 2. Those variations in which both component types are used are commonly called *mixed assemblies*. What percentages of either type of component are used, in an electronics assembly, varies from manufacturer to manufacturer, and from design to design. With time, however, more leadless



Assembly line, showing operators inserting leaded components into PCB assemblies (PAF).

components will become common. Eventually, in around ten years or so, it's likely that most manufacturers will use nothing but leadless components – mind you, they were saying that 10 years ago! This is an economic matter – leadless components are cheaper (they're easier to make and, being smaller, use less materials); and surface-mounted assemblies are cheaper to make (the manufacturing equipment, like the components, is simpler).

## PCB Classifications

There is a wide variety of PCB types for the designer to choose from; this is hardly surprising when you consider the large number of component types available – every time a different major form of component is developed, at least one new type of board usually has to accompany it. Consequently, the number of PCB types is regularly increasing; often, they overlap somewhat, and they are pretty arbitrary anyway.

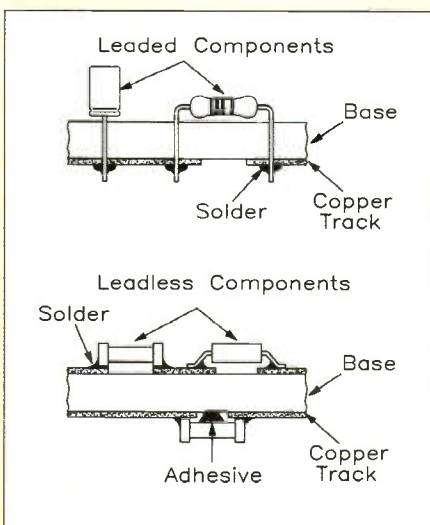

Figure 1. Leaded and leadless components compared. In fact, many leadless components have very short terminations which (it could be argued) are leads. But one fact still remains – these very short leads do not go through holes in the PCB!

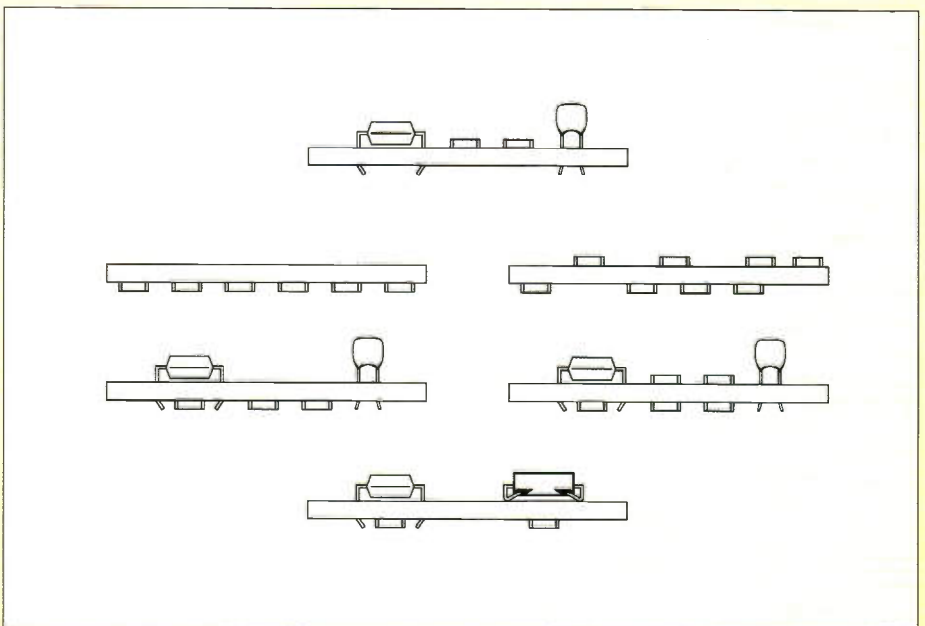

Figure 2. Variations in assemblies using leaded and leadless components.

However, by generalising, it's possible to appreciate that whatever the *type* of PCB, it falls into one of three main categories. Out of interest, the boards used in Maplin projects fall into the first two.

## Single-sided Boards

A single-sided PCB has conductive track on only one side of the base material. Usually, but not always, the components are mounted only on the other side. Typically, holes are drilled or punched through the board at lands, so that component leads can be positioned before soldering. Figure 3 shows a cross-sectional view of a single-sided PCB. Where surface-mounted components are exclusively used, of course, holes through the PCB are not required.

## Double-sided Boards

Double-sided PCBs have tracks on both sides of the base material. This simple fact allows the component density to increase greatly, without having to reduce track size. It is usually necessary to make electrical connections between the tracks on opposing sides, and the norm is to metallise the walls of holes through the board, using some plating process. Such *plated-through holes* (PTHs), which are for the specific purpose of track connection are known as vias. Note that the term 'plated-through hole' has no connection with the descriptive term 'through-hole, in reference to PCBs – the first refers to the fact that a hole through a board is metallised, the other refers to the fact that holes are used to mount components. Other methods are occasionally used to make connections between tracks, such as eyelets, wire, component leads, all of which require the two sides of the connection to be soldered. Figure 4 shows a cross-sectional view of a double-sided through-hole PCB. As a general rule-of-thumb, a double-sided through-hole PCB will feature leaded components on only one side. A double-sided, surface-mounted PCB, on the other hand, may have surface-mounted components on both sides.

## Multilayered Boards

Multilayered PCBs have several layers of tracks, two of which are on the outside surfaces of the board (as for double-sided boards). The remainder, however, are internal to the base material, being laminated together along with the insulating layers (which provide electrical insulation between the central layers). All layers are linked, in the relevant places, with plated-through hole vias giving the required electrical connections. Holes used purely for connection purposes are known as *through vias*, while vias which do not pass completely through the board are called *buried vias* or *blind vias*. Figure 5 shows a cross-sectional view of a multilayered PCB.

Once the loose components are gathered together with the bare PCB, it's time to assemble. Leaded component terminations are inserted through their respective holes, while leadless components are *inserted* on the surface (yes, I know there's no such word, really, but the slang

term 'insertion' has become so popular in the industry that we can't ignore it), of the PCB. A more correct term for positioning of surface-mounted components onto a PCB is *component placement*.

## Through-hole assembly

Leaded components, despite being much larger than leadless components, are more difficult to handle mechanically due to the fact that leads have to be bent correctly to allow them to fit into their PCB holes. This bending of leads is called *preforming* and a selection of common preform shapes is shown in Figure 6.

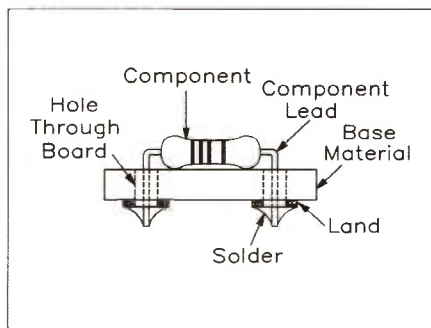

Figure 3. Cross-section of a single-sided, through-hole PCB with a leaded component.

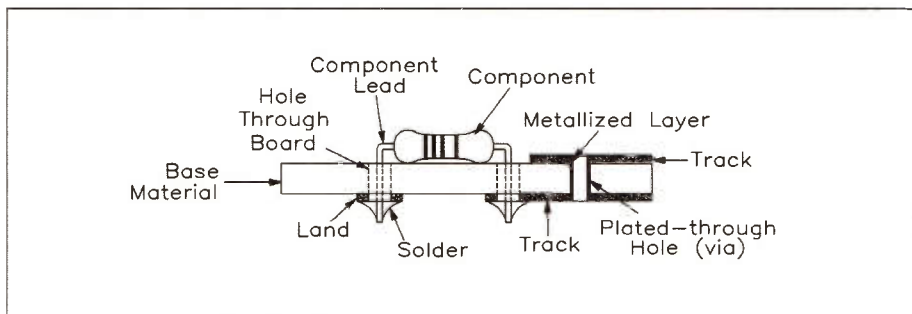

Figure 4. Cross-section of a double-sided, through-hole PCB, with a leaded component.

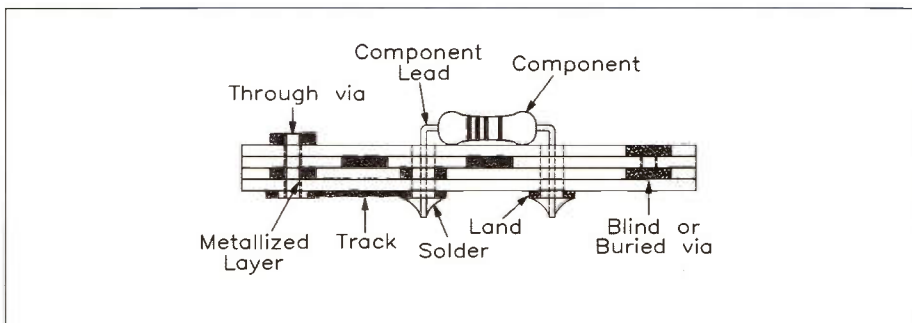

Figure 5. Cross-section of a multilayered PCB with leaded component.

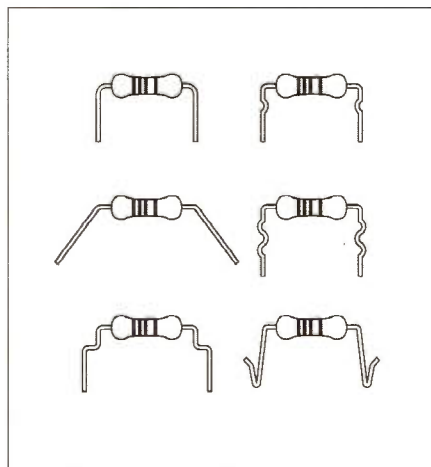

Figure 6. Common preform shapes for leaded component leads.

In an automatic assembly process, components have to be supplied to a mechanical insertion head. There are three main types of leaded component, of course – axial components, radial components and dual-in-line (DIL) components.

As a direct result, there are three types of insertion head. Manufacturers have to decide whether to have three insertion machines (or a single insertion machine with three rotating insertion heads), or to pass each PCB through a single machine three times (each time with a different bolt-on insertion head).

Components are supplied to whichever insertion head is used, in a process called *loading*. There are two variants here:

(i) Components are *sequenced* in the correct order of insertion, and fed directly to a stationary insertion head, which inserts each component into its correct position by moving the PCB underneath it

(ii) The insertion head moves to each component, *selecting* it before moving to the correct position above the stationary PCB.

Where axial components form the great majority, sequencing of components is simpler, but where large numbers of radial or dual-in-line components prevail, selection is best. Either way, the process is

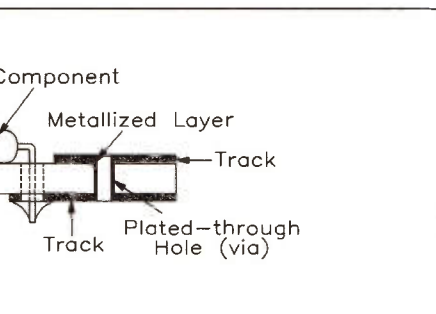

Figure 7. Taped and reeled axial leaded components.

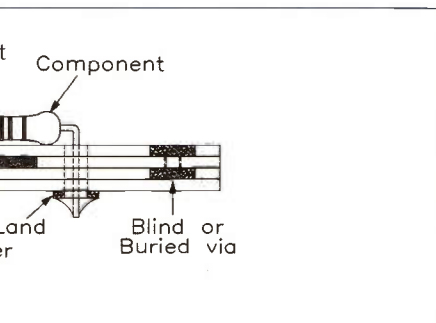
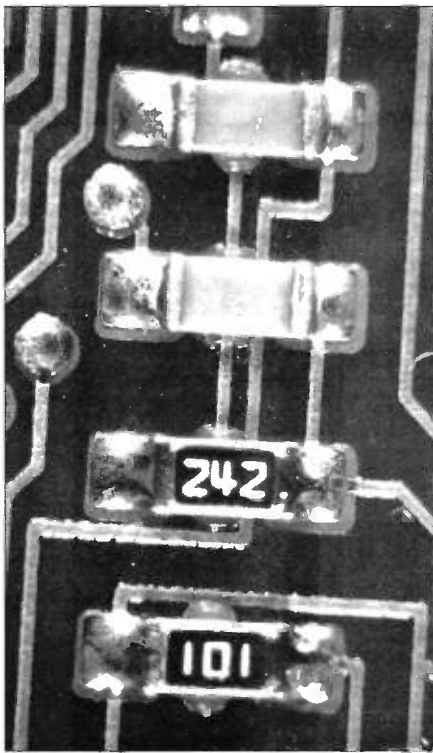

Figure 8. Pre-sequenced taped and reeled axial leaded components.



Two-terminal surface-mounted components, soldered to printed circuit board (Alpha Metals).

pretty complex, so insertion machines are typically computer-controlled.

For insertion heads using component selection, axial components are available in taped and reeled form, as shown in Figure 7. Dual-in-line components are typically supplied in magazine tubes, which usually slot directly into the insertion machine head.

Where insertion heads which insert sequenced components are used, it's common to supply the machines with pre-sequenced taped and reeled axial components, as shown in Figure 8.

Once a component is inserted it has to be maintained in place, so further bending of the leads is usual to clinch it in position. Clinching to an lead angle of around 45° is normal, followed or preceded by the trimming of the excess leads. Clinching and trimming can be carried out in a single machine as shown in Figure 9.

## Surface-Mounted Assembly

Although obvious and simple, it's worth reiterating the main difference between through-hole assemblies and surface-mounted assemblies – the leads of leaded

components go through holes in the PCB of through-hole assemblies, while the terminations of leadless components are soldered directly to the track of the PCB of surface-mounted assemblies. The main implication of this is equally simple, though by no means as obvious.

## A Sticky Problem

While leaded components are quite effectively held in place by the very fact that their leads go through holes in the PCB, surface-mounted components, on the other hand, are *not* effectively fixed in

place. Some other method of holding them temporarily – until the assembly is soldered – is necessary.

There are two main methods and they're – within reason – equally good:

(i) **adhesive** (pretty obvious, huh?) – where the adhesive used must set before the following application of molten solder.

(ii) **solder paste** – a glutinous mixture of solder and flux particles, sufficiently tacky to hold the components in place, before heating to melt the solder.

In general, pure adhesive is typically used where components are to be

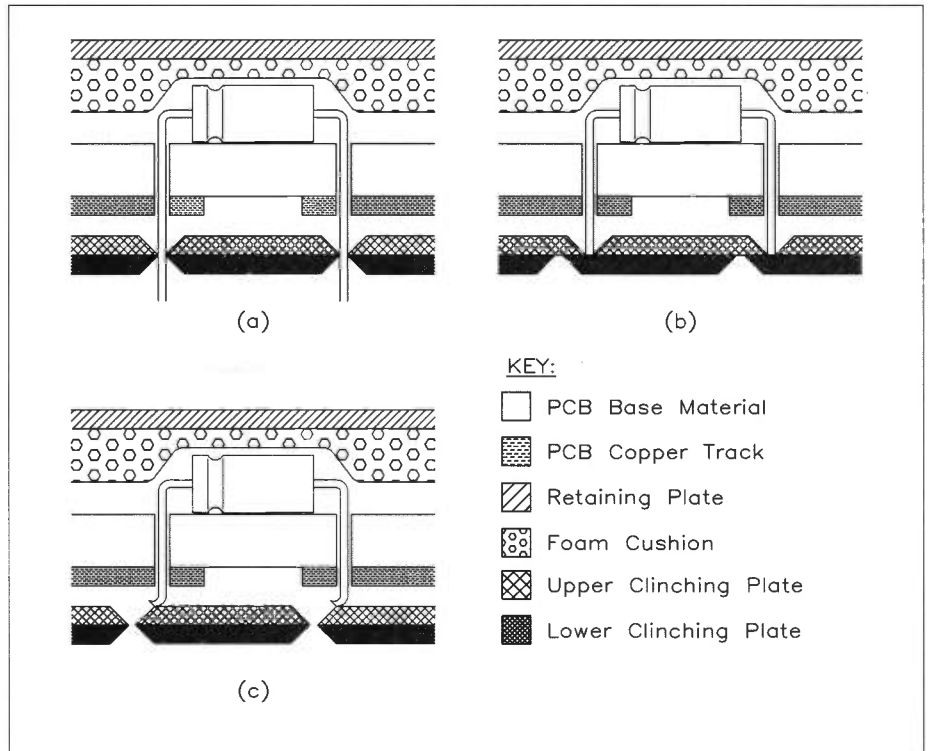

Figure 9. Mechanical clinching and cropping of component leads: (a) component is inserted; (b) lower clinching plate cuts off excess leads; (c) lower clinching plate clinches leads.

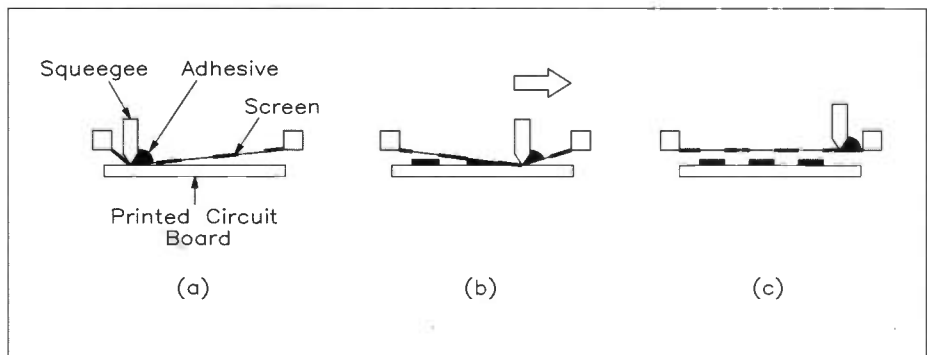
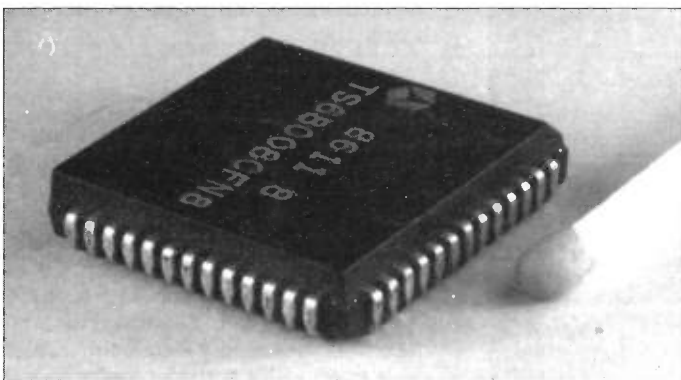
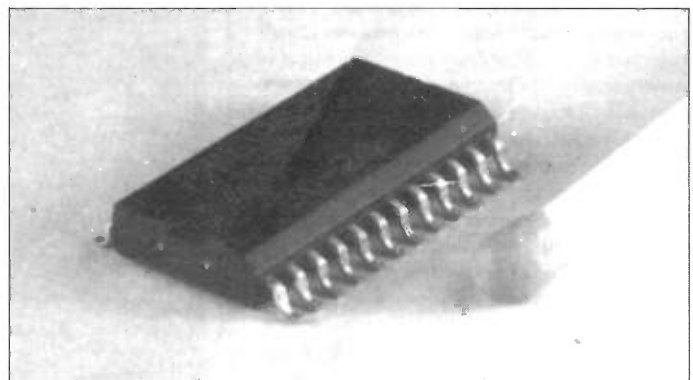

Figure 10. Screen-printing adhesive or solder paste onto the surface of a PCB.



Typical multiterminal surface-mounted integrated circuit component – a plastic leaded chip carrier (PLCC) (RJ).



A 24-pin surface-mounted small outline integrated circuit (SOIC) component (RJ).

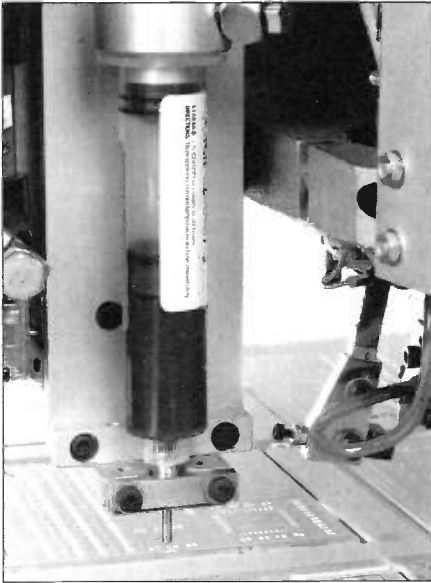
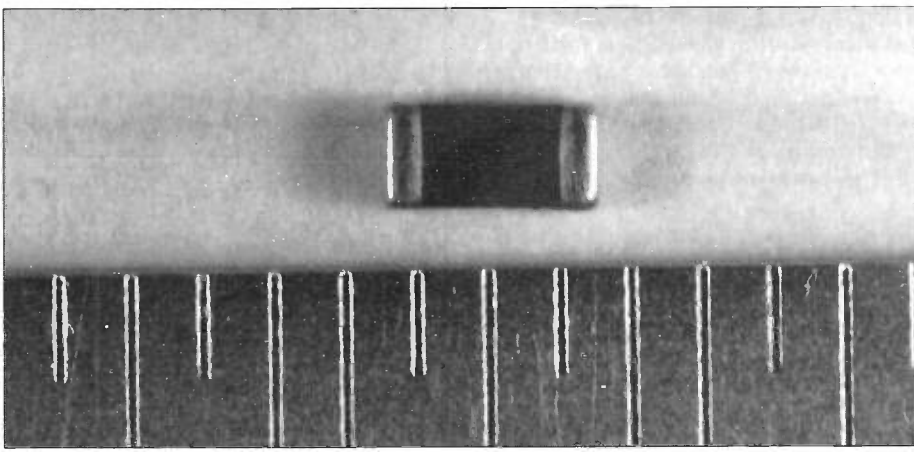

Above: Typical two-terminal surface-mounted component—scale in millimetres (RJ).  
Left: Adhesive syringe, applying adhesive to bare PCB, prior to component insertion (Dynapert).  
Below: Application of adhesive using syringe (Camelot).

(Figure 10b), forcing the adhesive or solder paste through the screen onto the board. After the squeegee is lifted (Figure 10c), only those areas of screen which are unfilled pass the adhesive or solder paste.

Definition of the printed image depends on the screen's hole size, which is referred to by the mesh size i.e. the number of openings per linear measure. Accuracy is limited, though surprisingly good.

(ii) **pin transfer** (Figure 11) – where a number of pins are first dipped in a reservoir of adhesive or solder paste (Figure 11a), before being lowered onto the board surface (Figure 11b). This process is suitable for use with adhesives of low to medium viscosity.

(iii) **dispensing from nozzles** (Figure 12) – syringe-type nozzles (Figure 12a) are connected with tubing to a pump, which forces adhesive or solder paste out from a reservoir, and onto the board (Figure 12b).

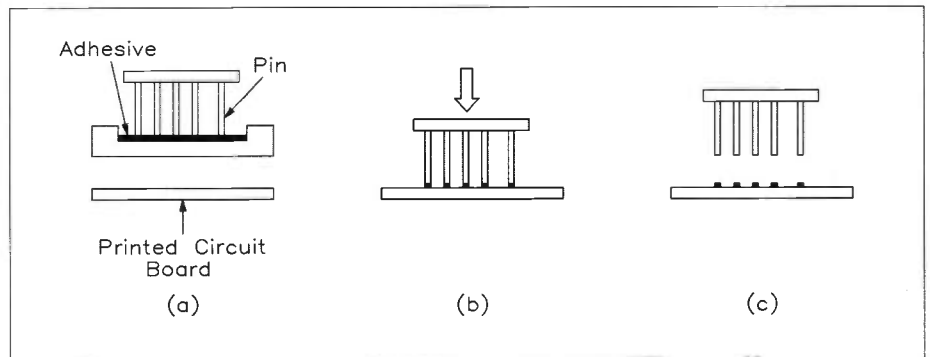

Figure 11. Pin transfer of adhesive or solder paste onto the surface of a PCB.

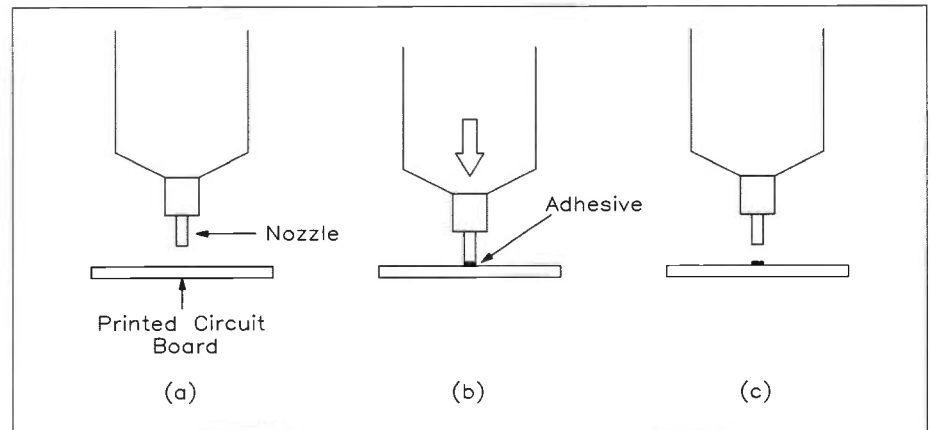

Figure 12. Nozzle dispensing of adhesive or solder paste onto the surface of a PCB.

mounted on the bottom of a board, or where the board is to be turned upside down in any subsequent operation (as solder paste will not necessarily prevent components falling off by gravity!).

Solder paste, on the other hand, is typically used where components are only mounted on the top of a board and where the soldering process does not require the board to be inverted. Solder paste comprises solder alloy in powdered form, together with flux and a solvent.

Whatever the method, adhesive or paste must be applied to the board before the component. A number of ways to do this are used, including:

(i) **screen-printing** – this simple and fairly cheap process is shown in Figure 10. It is an adaptation of the standard screen-printing process, used to print panels, clothes and the like. A wood or metal frame supports a stretched mesh of material – before the advent of man-made fibres, this would be silk (often the process is still referred to as silk-screen printing), but it is now usually nylon or a similar material – a small distance above the board to be printed. Adhesive or solder paste is applied to the top of the screen, while a 'squeegee' is used to push the screen down (Figure 10a). Holes between the fibres of the screen must be selectively filled with lacquer or similar substance prior to printing with a negative image of the image required on the board: that is, areas which are required to be clear of adhesive or solder paste have a corresponding area on the screen which is filled with lacquer. The squeegee is pushed along the screen

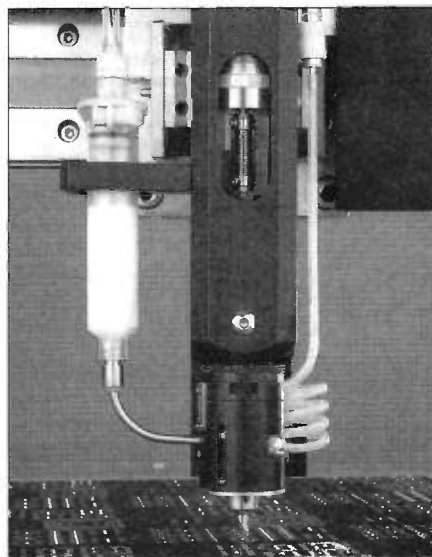

Suitable for adhesives of high viscosity.

Alternatively, adhesive may be applied individually to the bottom of each component, by nozzle dispensing or pin transfer methods, before placement onto the board.

## Next Month

We will look at component placement, mass soldering techniques and the implications of surface-mount technology for the electronics hobbyist.

Keith Brindley is a freelance writer and publisher who has written several electronics and computing books – many of them available from Maplin. His book 'Electronics Assembly Handbook', which deals specifically with the topics in this article, is available from Maplin – Order Code WT15R. Price £40.00 NV.

# SUBSCRIBE TO

\* **SPECIAL 5% DISCOUNT** \*  
\* **OFF MAPLIN PURCHASES** \*

# ELECTRONICS

The Maplin Magazine



\* **2 FREE ISSUES** if you agree to subscribe by Direct Debit or Continuous Credit Card.

\* **FREE DELIVERY TO YOUR DOOR**, and there are no additional carriage charges.

\* **PLUS**— News, reviews, readers letters, competitions and lots, lots more besides!

\* **SAVE OVER £1!** Yes, save money by taking a subscription, it's cheaper than buying each individual copy.

\* **5% SUBSCRIBERS' DISCOUNT CLUB CARD** saves you money on further purchases!

To subscribe just send a cheque/postal order for £9.48 made payable to Maplin Electronics, P.O. Box 3, Rayleigh, Essex SS6 8LR. OR you can take advantage of our offer of two free issues by completing the coupon below and agreeing to pay by Credit Card or Direct Debit. The two free issues offer only applies if you use one of these two methods of payment. Simply fill in the 'Payment by Credit Card' or 'Payment by Direct Debiting Mandate' and return it to Maplin. Every time, about 1 month before your subscription is due, we will send you a letter giving details of the subscription rate and telling you the date on which we will charge your Credit Card or debit your bank account. If you do not wish to continue your subscription, you have until that date to let us know, and we will then cancel your authority to bill your Credit Card or cancel your mandate. Otherwise, if you do nothing, your subscription will continue. The authority or mandate you give us does not allow us to charge anything other than the Maplin Magazine subscription. The benefit to you is that you no longer need to remember to re-new your subscription or send off any more cheques or postal orders. Payment is made automatically.

#### OVERSEAS SUBSCRIBERS

Subscription rates for 6 issues are: £11.70 (or 30 IRC's) in Eire, Europe and surface mail outside Europe: £18.00 (or 46 IRC's) Air Mail outside Europe.

## TAKE THE NEXT 2 ISSUES OF THIS MAGAZINE FREE!!

Because we're so certain that now you've seen the Maplin Magazine you'll want to receive it regularly, we're offering to send you the next two issues free of charge with absolutely no obligation to continue. Just fill in the details below and if after receiving two issues you do not wish to continue, just let us know at least one month before the next issue is due and we will cancel your subscription. The two free issues will be yours to keep whatever you decide. If you already have a subscription, fill in the details below and we'll add two issues free of charge to your current subscription. SEND NO MONEY NOW. About 2 weeks before the third issue is due, we will charge you £9.48 for the next six issues, unless you have cancelled. This offer is not available to those already paying by Direct Debit or Continuous Credit Card or those who have stopped payment by either method within the last year. THIS OFFER IS OPEN TO RESIDENTS WITH U.K. ADDRESSES ONLY. PLEASE START MY SUBSCRIPTION WITH ISSUE 66.

EITHER

### ★ PLEASE ADD YOUR ADDRESS, SEE BOTTOM RIGHT ★

**PAYMENT BY CREDIT CARD.** Please charge my Credit Card Account

Customer Number (if known) .....

Access  Visa  American Express

I authorise you until further notice in writing to debit my CREDIT CARD account by £9.48 and in future, with any amounts which, after notification, MAPLIN ELECTRONICS PLC may debit thereto in respect of my subscription to the Maplin Magazine.

Account No.									
Signature								Date	

OR

**PAYMENT BY DIRECT DEBITING MANDATE** in favour of Maplin Electronics plc, P.O. Box 3, Rayleigh, Essex SS6 8LR. Direct Debit payment option is only open to customers with bank accounts in the U.K. including Channel Isles, Isle of Man and N. Ireland. Please note: Instructions cannot be accepted to charge Direct Debits to a Deposit or Savings Account.



Bank Sort Code  _ _ _ _ _ _ _	Bank Account Number  _ _ _ _ _ _ _ _ _ _ _ _ _ _ _ _ _
----------------------------------	---

Name of Account to be debited

The Manager

---



---



---



---



---

I authorise you until further notice in writing to charge my account, with you, any amounts which MAPLIN ELECTRONICS PLC may debit thereto by Direct Debit in respect of my subscription to the Maplin Magazine.

I will inform the bank in writing if I wish to cancel this instruction.

I understand that if any direct debit is paid which breaks the terms of this instruction, the bank will make a refund.

Signature	Date
-----------	------

Enter your address and Maplin customer number, if known.

Post Code	

If you wish, you can put this form in an envelope and address it to: Maplin Electronics, Freepost, P.O. Box 3, Rayleigh, Essex SS6 2BR.  
May 1993 Maplin Magazine

# ORDER COUPON

In any correspondence please quote your customer number. Date .....



P.O. Box 3, Rayleigh, Essex SS6 8LR.  
Telephone, Credit Card Sales (0702) 554161; Enquiries (0702) 552911.  
*A different postal code is correctly shown on the reply paid envelopes*

Customer No. ....  
Name .....  
Address .....  
.....  
Post Code ..... Phone No. ....  
**IT IS MOST IMPORTANT THAT YOU INCLUDE YOUR POSTCODE**

On occasion Maplin Electronics may permit other reputable companies to make offers of products or services which we believe will be of interest to our customers. If you do not wish to receive this information please write no in the box.

**Block capital letters please. Keep a copy of your order.**

\*Please enter catalogue page no. where item appears.      If not in catalogue, write Mag for Magazine or SO for Special Offers etc.      If not using 1993 catalogue, enter date of catalogue here: 19.....

Description (for your information only)	Page*	Order Code					Quantity	Price Each	£ Total	p	Carriage Charge	
		C	A	9	9	H					£	p
Price Change Leaflet (Please write 1 in quantity, if required)		C	A	9	9	H		FREE	0	00	0	00

Form ME58 Issue 3



**Office Use Only**

Overseas customers including Channel Isles and Eire, please deduct VAT where applicable and tick this box.

Export Order

DOR  CQ  CA  PO

CNC  Total

CNM

I authorise you to debit my credit card account for the cost of goods despatched.

Credit Card Number

Access American Express/Visa/..... Delete as required.  
**Note. Goods will be despatched only if the address above is the cardholder's address.**  
**If ordering by credit card please sign:**  
.....

Expiry date of Credit Card.....

Total this sheet	£		
Total other sheet(s)	£		
<b>Total for goods</b>	<b>£</b>		
Carriage charges for large, fragile, or heavy items as shown in catalogue. If total in this box exceeds £5.50 you need only pay £5.50 (Max. Carr. Charge per order £5.50).			
Deduct value of Credit Note No ..... Enclose the numbered Credit Note with this order.			
Deduct value of Gift Token No ..... (Enclose Gift Token with order.)			
Please add £1.20 Handling Charge. This amount must be added to each order placed.	1	20	
<b>Total</b>	<b>£</b>		

**Carriage Charges**

A	£1.40
B	£2.00
C	£2.55
D	£3.05
E	£3.60
F	£4.10
G	£4.95
H	£5.50



# FOR BARGAINS AND MORE, VISIT YOUR LOCAL STORE

For personal service, visit our shops at:

**Birmingham** Sutton New Road, Erdington.

**Brighton** 65 London Road.

**Bristol** 302 Gloucester Road.

**Cardiff** 29-31 City Road.

**Chatham** 2 Luton Road.

**Coventry** 12 Bishop Street.

**Edinburgh** 126 Dalry Road.

**Glasgow** 264-266 Great Western Road.

**Ilford** 302-304 Green Lane.

**Leeds** Carpet World Building, 3 Regent Street.

**Leicester** Office World Building, Burton Street.

**London** 146-148 Burnt Oak Broadway, Edgware.

107-113 Stanstead Road, Forest Hill.

120-122 King Street, Hammersmith.

**Manchester** 8 Oxford Road.

**Middlesbrough** Unit 1, The Forbes Building, Linthorpe

**Newcastle-upon-Tyne** Unit 4, Allison Court,

The Metro Centre, Gateshead.

**Nottingham** 86-88 Lower Parliament Street.

**Portsmouth** 98-100 Kingston Road.

**Reading** 129-131 Oxford Road.

**Sheffield** 413 Langsett Road, Hillsborough.

**Southampton** 46-48 Bevois Valley Road.

**Southend-on-Sea** 282-284 London Road, Westcliff.

Plus a NEW store opening soon in MILTON KEYNES.

Ring 0702 552911 for further details.



## FEATURES

- ★ Rugged construction
- ★ Portability
- ★ 1-2W output power

## APPLICATIONS

- ★ Personal stereo amplifier
- ★ General purpose/test amp
- ★ 'Active' speaker

by Alan H. Bradley

The Walkamp is an add-on amplified-loudspeaker for use with a Personal Stereo, and has been designed primarily for portability and ruggedness, but has a reasonable output power and quality of reproduction. It is a mono unit which combines the left and right stereo signals, and therefore does not require two speakers that need yards of interconnecting cables, to get tangled and trip over. The unit is housed in a compact plastic box and is powered by four alkaline AA cells.

### Circuit Description

The circuit diagram of the Walkamp is shown in Figure 1. The heart of the unit is a TDA7052 bridge amplifier IC which, with a 6V supply, can deliver 1-2W rms into an 8Ω load. The IC has built-in short-circuit protection, but does not have thermal shutdown protection and therefore should not be used with loads of less than 8Ω impedance.

Resistors R3 and R4 form a non-inverting adder, producing a combined left and right signal for the TDA7052 input. C1 and C2 are DC blocking capacitors. RV1 provides variable attenuation of the input signal so that the amplifier can be set up to prevent distortion, even if the per-

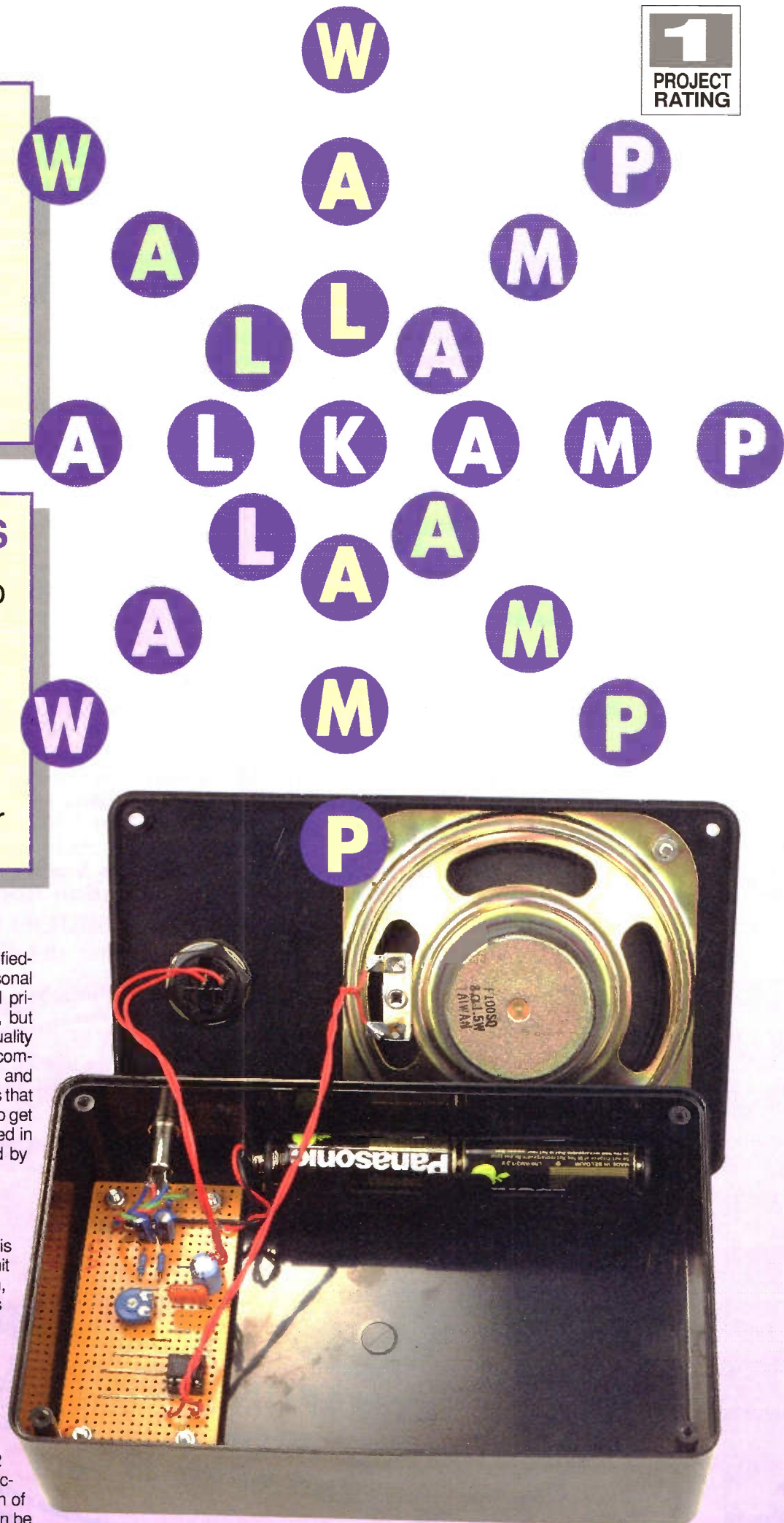

Internal view of the Walkamp prior to final assembly.

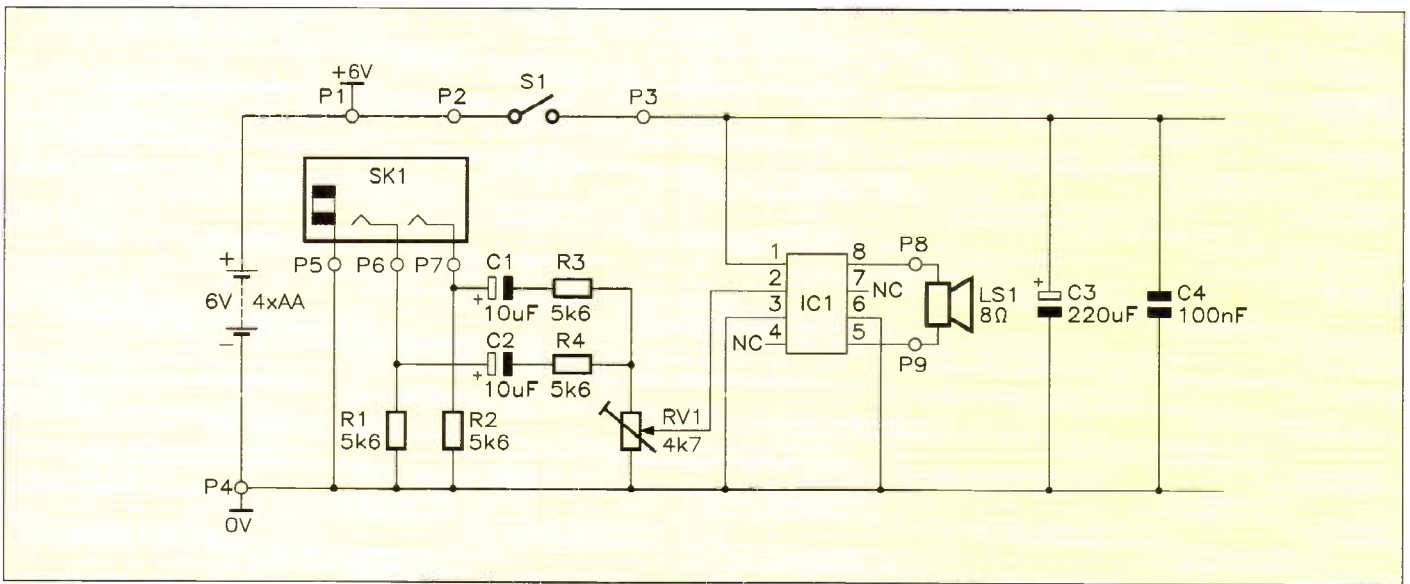
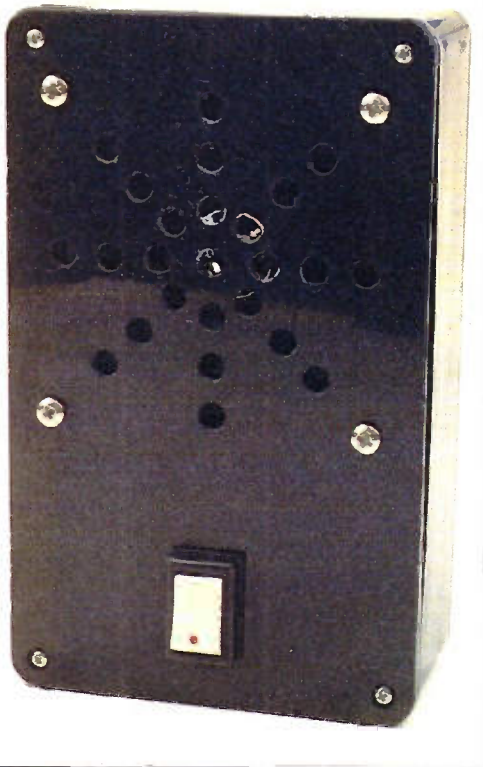

Figure 1. Walkamp circuit diagram.



Finished Walkamp.

sonal stereo volume control is set to maximum. Some Personal Stereo output stages require a DC path to ground and these are catered for by resistors R1 and R2. C3 and C4 are decoupling capacitors for the power supply. LS1 is a 4in., 8Ω, 1.5W speaker.

## Construction

### Stripboard Assembly

The circuit is built on a piece of stripboard, 34 holes by 16 strips, the layout of which is shown in Figure 2. Cut the tracks and drill the mounting holes as shown and then carefully fit all the components except the TDA7052. PCB pins are used for connecting the 'flying leads' and an IC socket is used for the TDA7052, allowing it to be fitted last, avoiding possible damage from overheating during soldering. Inspect the stripboard for poor joints, bridged tracks, etc.

### Drilling the Box

Box drilling details for the mounting holes and speaker grille are shown in Figure 3. Take great care when marking out the box as the appearance of the finished product will be spoiled by inaccurately placed holes or nasty scratches. Completely cover the front of the box with masking tape to prevent scratching, and also provide a convenient surface on which to mark the drilling details. To mark the speaker grille holes, it may be easier to use the speaker as a template to mark the four mounting holes, draw two diagonal lines between the hole centres to find the centre of the speaker. Use a pair of compasses, on the centre mark, to mark the three circles. Halve the length of each side and join opposite marks. You should now have a cross marking the centre of each hole, including the centre one. Use a sharp point, such as a compass point, to make

small indentations at each hole position as a location for the drill. Use a 1mm drill bit to produce an accurate pilot hole in each position, then open up each hole to its proper size. If you don't have an 18mm drill for the rocker switch hole, drill a hole, and then enlarge it with a sharp knife (be very careful!) or round file, or, using a pair of compasses, draw an 18mm circle and drill several small holes *inside* it which can then be joined by cutting with a knife or needle file, to remove the unwanted material. Tidy up the hole, using a round file.

### Final Assembly and Wiring

Fasten the speaker to the lid with four M4 x 10mm bolts, shakeproof washers and nuts. Fasten the stripboard into the box using four M3 x 16mm bolts, 1/4in. spacers, shakeproof washers and nuts. Mount the input socket and the on/off rocker switch. Referring to

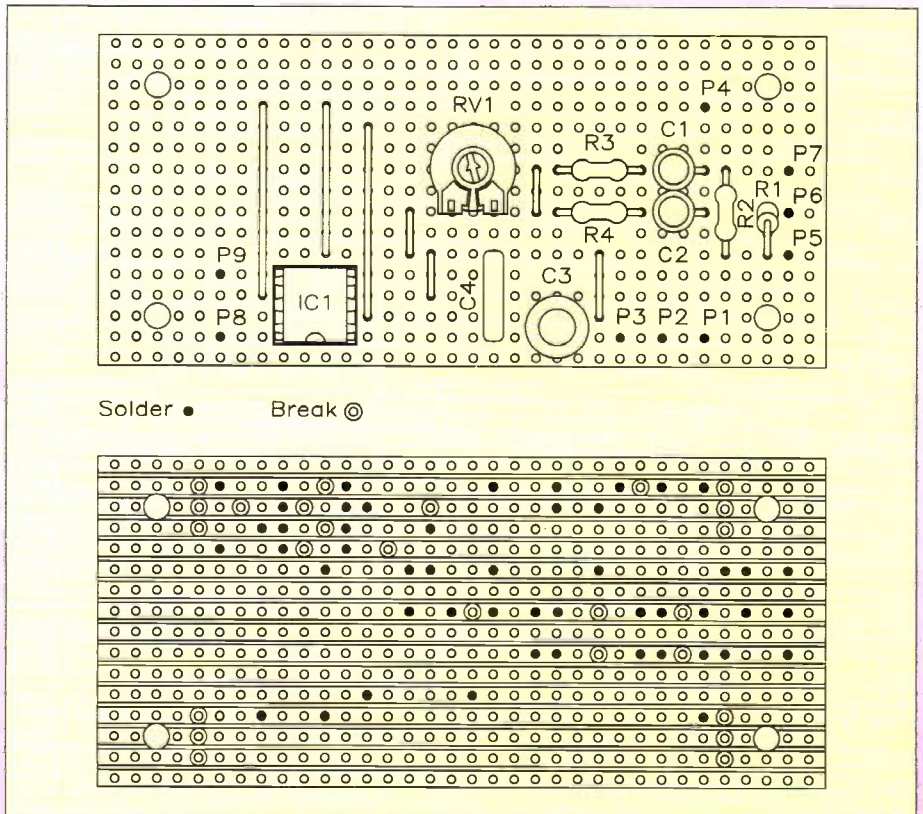

Figure 2. Stripboard layout.

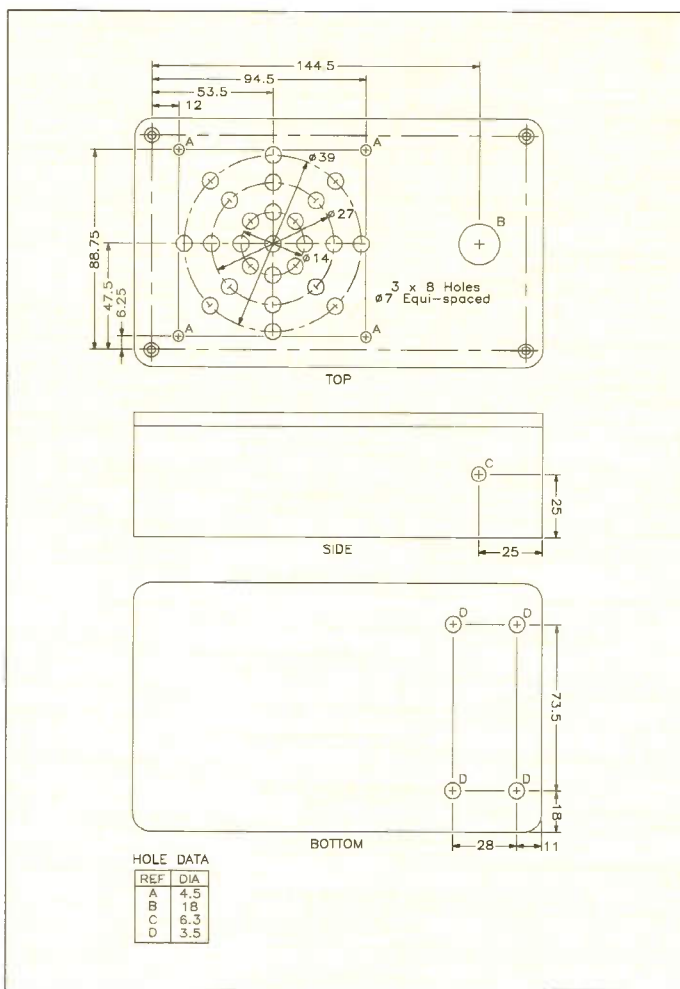

Figure 3. Box Drilling Detail.

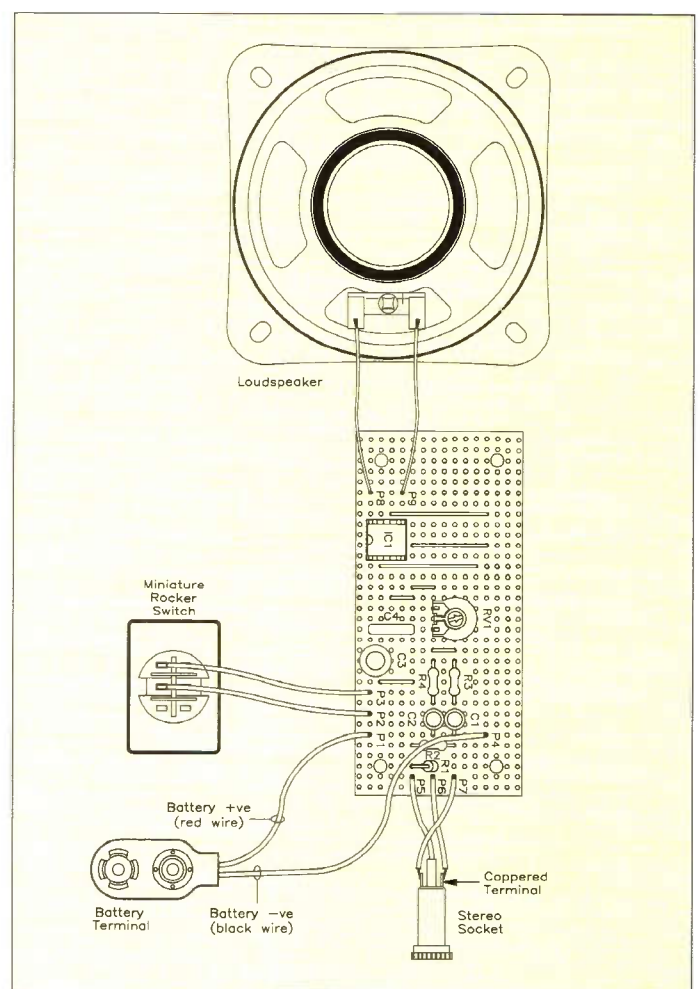
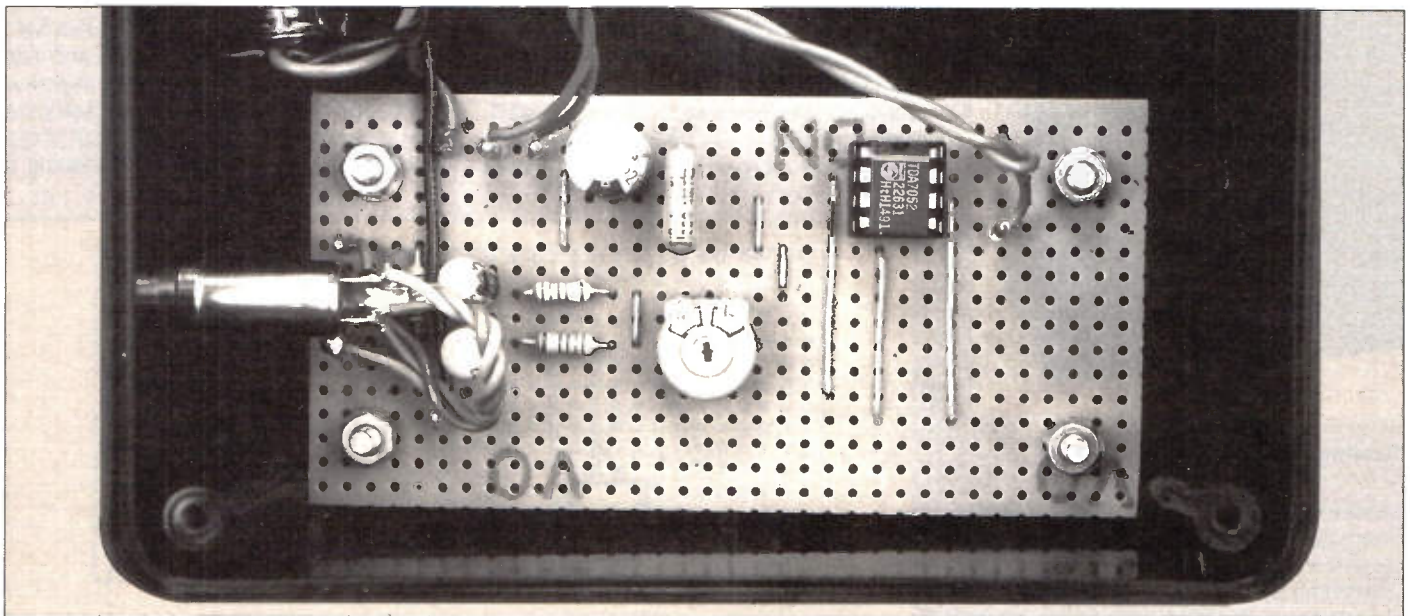

Figure 4. Wiring Diagram.



Assembled stripboard circuit.

Figure 4 wire up the stripboard, input socket, loudspeaker, switch and battery box; trimming the wires to the required length. The battery holder is fixed inside the box by means of self-adhesive backed velcro tabs enabling the battery holder to be completely removed for ease of battery replacement. Do not insert the AA cells at this stage.

Assemble the interconnecting cable, taking care not to bridge the terminals of the plug. The cable screen should connect the jack plug sleeve of both plugs and the two cores should connect the jack plug ring and tip of both plugs.

## Testing

If you have a multimeter, set the on/off switch to on and check for an open circuit between the battery connector terminals. Set the on/off switch to off, insert the batteries into the battery box and connect the battery connector. Fit the TDA7052 taking care to get it round the right way. Set RV1 to mid-travel. Connect a Personal Stereo with its volume set to minimum, via the interconnecting cable to the Walkamp. If you have a multimeter, connect it in series with the battery (set to a current range) to monitor the quiescent current. (After the initial surge caused

by the capacitors charging, the current should be in the region of 10mA.) Switch the Walkamp on and slowly increase the Personal Stereo volume, sound should be heard from the speaker. Check that RV1 controls the speaker volume. Set RV1 to minimum and turn the personal stereo volume control to maximum, then adjust RV1 for maximum undistorted output. If the Walkamp does not function as expected, switch off immediately and check all connections. Check that a defective personal stereo is not the problem. Finally secure the lid with the four screws supplied with the box.

## WALKAMP PARTS LIST

RESISTORS: All 1% 0.6W Metal Film (Unless Specified)

R1 to 4	5k6	4	(M5K6)
RV1	4k7 Horizontal S-min Preset	1	(UH02C)

### CAPACITORS

C1, 2	10µF 50V PC Elect	2	(FF04E)
C3	220µF 16V PC Elect	1	(FF13P)
C4	100nF Polyester	1	(BX76H)

### SEMICONDUCTORS

IC1	TDA7052	1	(UK79L)
-----	---------	---	---------

### MISCELLANEOUS

S1	Miniature Rocker Switch	1	(YX64U)
LS1	1.5W Loudspeaker	1	(YT25C)
SK1	Stereo 3.5mm Socket	1	(FK03D)
	Stereo 3.5mm Plug	2	(HF98G)
	Stripboard 29 x 39	1	(JP47B)
	PCB Pin 2145	1 Pkt	(FL24B)
	8-pin DIL IC Socket	1	(BL17T)

Verobox 305	1	(LH51F)
Alkaline AA Cell	4	(FK64U)
4AA Battery Box	1	(HF94C)
PP3 Clip	1	(HF28F)
Twin Screened Cable	1m	(XS23A)
Wire 7/0.2 x 10m Red	1 Pk	(BL07H)
Wire 7/0.2 x 10m Black	1 Pk	(BL00A)
Spacer M3 x 1/4 in.	1 Pkt	(FG33L)
Countersunk Bolt M3 x 16mm	1 Pkt	(JC70M)
Shakeproof Washer M3	1 Pkt	(BF44X)
Nut M3	1 Pkt	(JD61R)
Countersunk Bolt M4 x 10mm	1 Pkt	(JC73Q)
Shakeproof Washer M4	1 Pkt	(BF43W)
Nut M4	1 Pkt	(JD60Q)
Velcromounts	1 Pkt	(FE45Y)

The Maplin 'Get-You-Working' Services is not available for this project.  
The above items are not available as a kit.

# SAVE £££'s ON KITS AND COMPONENTS

If you would like to **SAVE £££'s** whenever you purchase kits, components or other goods from Maplin, then follow our 'as easy as ABC' guide to saving money!

**A**sk yourself – "Since I buy 'Electronics' regularly, why don't I take out a subscription? – it'll save me up to **£4.52\*** and I'll have each issue delivered to my door **Free of Charge** before it's available in the shops!"

**B**enefit – "I'll also *benefit* from having a **Subscriber's Exclusive 5% Discount Club Card** that I can use, with a few exceptions\*\*, on purchases of over £20 from Maplin."

**C**omplete – "All I have to do is *complete* the subscription form on page 21 of this issue, *what could be easier!*"

**SAVE £££'s ON KITS  
and COMPONENTS –  
IT'S AS EASY AS ABC!**

\* A saving of £4.52 is based on a Direct Debit or Continuous Credit Card Subscription that includes two free issues worth £3.50 and a subscription saving of £1.02.

\*\*Full details on how to make the most of the discount card are supplied with the card. Full terms and conditions are available on request.

## Don't Miss Next Month's Money Saving Special Offer! – Exclusive to Subscriber's Club Members!

### PCB / Schematic CAD - From £98

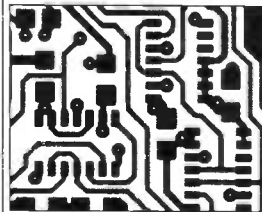

**EASY-PC** - For single sided and multilayer boards to 17"x17". Phenomenally fast and easy to use. Over 14,000 copies sold.

**EASY-PC Professional** for boards up to 32" x 32" at .001" resolution, 16 layers. Schematic capture and netlist extraction - integrates seamlessly with PULSAR and ANALYSER III. **Not Copy Protected.**

### Logic Simulation - from £98

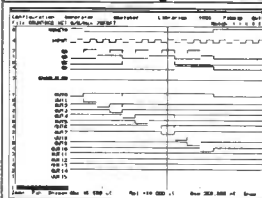

**PULSAR and PULSAR Professional** - Full featured digital logic simulators.

Allow you to test your designs quickly and inexpensively without the need for sophisticated test equipment.

**PULSAR** can detect the equivalent of a picosecond glitch occurring once a week! **Not Copy Protected.**

### Analogue Simulation - from £98

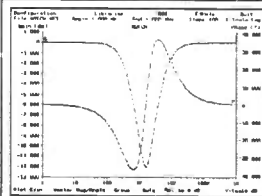

**ANALYSER III and ANALYSER III Pro.**

Powerful linear circuit simulators have full graphical output, handle R's, L's, C's, Bipolar Transistors, FET's, Op-Amp's, Tapped Transformers and Transmission Lines etc. Plots Input and Output Impedances, Gain, Phase and Group Delay. Covers 0.001 Hz to >10GHz **Not Copy Protected.**

For full info, phone, fax or use enquiry card

BRITISH  
DESIGN  
AWARD  
1989

**Number One Systems Ltd.**  
REF: MAP, HARDING WAY, SOMERSHAM ROAD,  
ST. IVES, HUNTINGDON, CAMBS, England, PE17 4WR  
Telephone: 0480 461778 (7 lines) Fax: 0480 494042  
International: +44 480 461778 Credit Cards Welcome

# FRAME RELAY PUT PLAINLY

by Frank Booty

**E**very now and again a topic becomes so important that some clarification is needed. Frame Relay has reached this point. Over the past few months Frame Relay technology has received unprecedented attention in the communications industry. Hardly a week goes by without some major new development, and, as most people know, whenever there is this much progress in such a short time, confusion abounds!

There have been tremendous advances in the knowledge base in general concerning Frame Relay. But while lots of users have a good understanding of what Frame Relay does, there is still a widespread misunderstanding of what Frame Relay does not do. One good way to tackle this situation is to play a game of '20 questions'.

1. In 25 words or less, what is Frame Relay? Frame Relay is a 'standard interface specification' optimised for transporting 'protocol oriented traffic'. Here 'standard' refers to the fact that the specifications have either already been approved, or are in the final steps of approval by all of the major standards bodies, including ANSI and CCITT. 'Interface' refers to the specification's applicable capability at the interface between a device (DTE) that supplies Frame Relay compatible frames, and a network designed to transport these frames. With functions equivalent to X.25 in this respect, the specification refers to the interface only – not to the transport within the network (see question 2). 'Protocol oriented traffic' indicates that the specifications for Frame Relay do not include retransmission of data to guarantee delivery. Because the vast majority of network traffic today – including X.25, TCP/IP and SNA – already performs this function, it is redundant to have both the network and the end devices guarantee delivery.

2. If the specifications are only for an interface, do I have interoperability? Yes. The intended functions for Frame Relay are to allow any DTE, such as a bridge or router, to pass Frame Relay traffic to any network, whether public or private. This removes the extremely complex task of trying to match a router with a specific network service or E1 multiplexer. (E1 = a transmission rate of 2,048 megabits per second.) Simultaneously, the interoperability does not extend to the network switches themselves. Each switch vendor

will optimise the transport to provide what it believes to be the best blend of price and performance. This will also provide the competitive 'fuel' to support advances in the technology. The interoperability provided by Frame Relay does not in itself allow a mix and match of equipment from various bridge/router manufacturers. Although there is significant work under way to provide this type of function, and a lot of the work is closely related to Frame Relay, this is not a specific function of Frame Relay.

3. This interoperability sounds good, but are there any other advantages? There are actually three major advantages to using Frame Relay technology. First, data within the network is statistically multiplexed. Because data is only submitted to the network when there is real data – not just idle 'sync fills' – to send, network efficiency is high. For private networks, this means a greater utilisation of network bandwidth. For public networks, it still means a better utilisation of facilities, and thus lower prices.

Secondly, a single physical interface may serve multiple logical connections. One connection to the network may have literally hundreds of terminations, thus reducing the number of interfaces needed on both the DTE and network switches. This boils down to reduced hardware costs.

Lastly, because these multiple locations can be served by a single interface, local access costs are reduced. Statistical mul-

tiplexing to the local service allows the connection to each destination to run at maximum speed when needed.

4. Aren't these the same arguments we were hearing 10 years ago, for statistical multiplexers and for X.25 based packet switching for asynchronous traffic? To tell the truth, yes. In fact, most of the arguments for statistical multiplexing and packet switching for low speed asynchronous traffic are also applicable for high-speed traffic.

5. So why are we only, just now, getting around to Frame Relay? Many people would like to have had statistical multiplexing at E1 speeds 10 years ago. The problem was that it just wasn't practical. Statistical multiplexing takes processor power. Statistical multiplexers only became economically feasible 10 years ago because of the availability of inexpensive (albeit low power by current standards) microprocessors. There is now enough processor power available at reasonable prices to do statistical multiplexing at higher speeds.

6. So how do I know whether Frame Relay will help in my network? Frame Relays real applicability will evolve. The statistical multiplexing here, is orders of magnitude faster than is needed for asynchronous ASCII traffic. The critical factors are the 'burstiness' (the frequency of the data bursts) of the traffic and the size and speed of the bursts. Statistical multiplexing worked because not everyone typed at once. The gaps between characters were

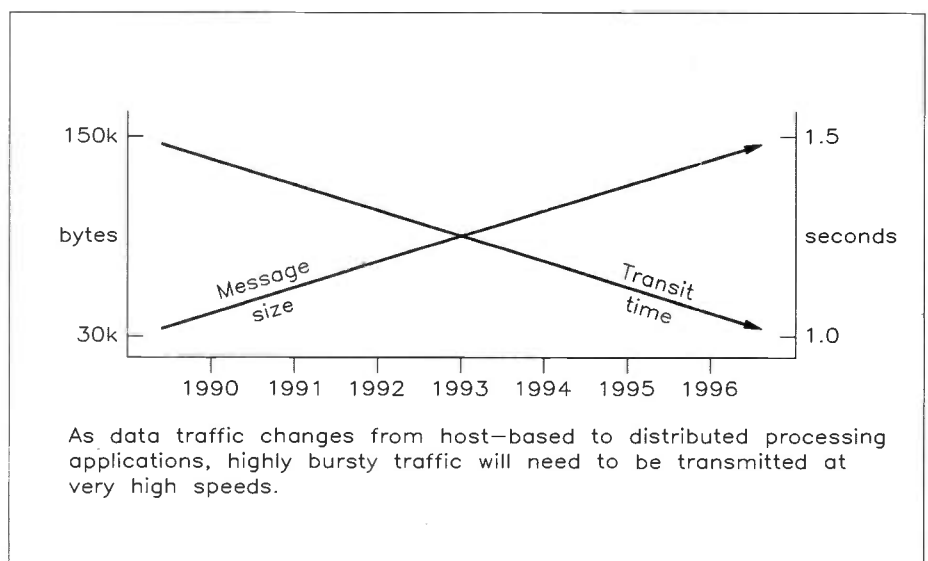

Figure 1. Projected data traffic growth by 1995.

filled in with characters from other sessions. In traditional host based processing, using terminal type interactions, the largest typical burst of data was 1920 characters (24 lines of 80 characters, or an 80-column screen full). Then the recipient would mentally 'process' the information for a period of time. Thus, with only a few users at relatively slow speeds, the traffic approximated a constant flow of data. Once the data flow is about constant, the advantages of statistical multiplexing essentially disappear.

Distributed processing, particularly with LAN-to-LAN interconnections, will change the basic data flow. Now, rather than transmit a screen at a time, we want to transmit a file at a time. With the information transfers averaging at least one megabyte, our 'new' computing models will generate highly 'bursty' traffic (please excuse the phraseology, but this expression describes a high frequency of data bursts) at very high speeds (see Figure 1). So, Frame Relay will give you the greatest advantages for high-speed, protocol oriented, 'bursty' traffic. Simply agreeing that the traffic is LAN-to-LAN is over-simplifying the problem. If the inter-LAN traffic is terminal oriented, Frame Relay doesn't provide great advantages, because the traffic for several terminals will approximate a steady flow. The real advantage comes in transferring large bursts of information at high speeds.

7. So what about voice and video? What's the Frame Relay story here? Frame Relay excels as a transport technology for 'bursty' data. In most applications today, voice and video tend to be what we usually refer to as 'constant bit rate' applications. This means they are not 'bursty'. Frame Relay is not inherently bad for these applications, and there is tremendous potential for voice and video services via Frame Relay. Voice capabilities have already been demonstrated using packetised voice - after all, the innate, half-duplex nature of voice makes it an excellent candidate for statistical multiplexing. A matter of personal preference also creeps into the equation here. If you want to continue putting voice on the private network, Frame Relay voice is a viable option. However, if you prefer to use a public service for voice, the ability to put voice on the Frame Relay network becomes a meaningless option.

8. It has been said that Frame Relay is just for private networks while SMDS and other technologies are for public networks. Is this true? Absolutely not! There are actually two types of Frame Relay networks - private and public. Private Frame Relay networks are certainly a viable option. In this implementation, the Frame Relay network is a technology complement/replacement for private E1 and private X.25 networks (see questions 13 and 15). But that is only half the story.

There have been calls for carriers to offer Frame Relay as a service. Traditional X.25 packet switching carriers such as BT, CompuServe and Sprint were among the first to offer such services. Inter-exchange carriers such as MCI, Sprint and AT&T are also offering these services. This drastically expands the options for using Frame Relay by opening the door for hybrid pub-

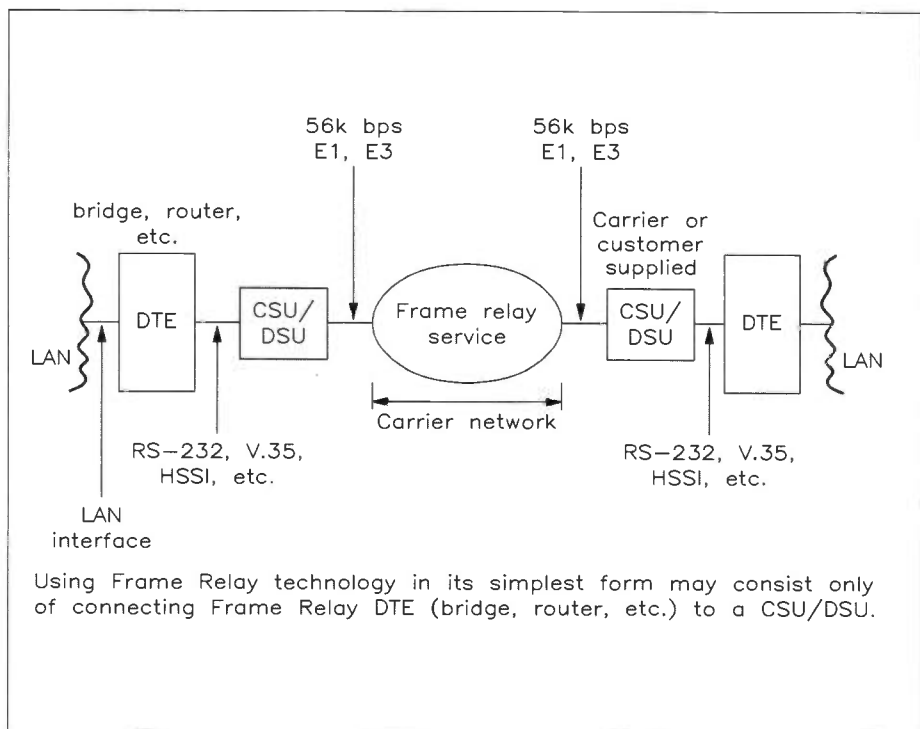

Figure 2. Equipment needed for Frame Relay.

lic/private networks. Moreover, work is also already in progress for network-to-network interfaces - the equivalent of X.75 - so the future for Frame Relay services looks increasingly bright.

9. But isn't Frame Relay limited to E1 speeds while SMDS is faster? No. Last year people didn't talk much about Frame Relay being faster than E1, so there was a common belief that this was a technological limit. In reality, there isn't a theoretical limit to the technology. You can send Frame Relay information as fast as you can process it with a reasonable amount of technology. Already there are HDLC framer chips available with speeds up to 50M-bit/s (bits-per-second), so there is confidence that Frame Relay is a reasonable technology up to at least E3 speeds. (E3 = a transmission rate of 34 megabits per second.) As there are few processors available today that can keep an E3 line full of statistically multiplexed data at these speeds, it's a reasonably safe bet that Frame Relay will be fast enough for most users for a long time.

10. Fine, so what type of equipment do I need to be able to use Frame Relay? In its simplest form, you may already have the equipment you need for Frame Relay. Many bridges and routers can be upgraded at little or no extra cost to be Frame Relay compatible. These devices can then use a public service. All you need is the bridge/router, a CSU/DSU, and a line to the service. As an option, some of the carriers even offer to supply the local access line and the CSU/DSU (see Figure 2).

11. Should I always use Frame Relay to connect bridges and routers? Not necessarily. If the bridge/routers are running point-to-point over dedicated facilities to connect only two points, Frame Relay may not really offer any strong advantages. The advantages of using Frame Relay become evident when connectivity is needed among several points. Then you start exploiting the shared physical interface. Point-to-point Frame Relay may be

economically advantageous. Comparing prices between dedicated facilities and Frame Relay services will determine this. Preliminary pricing information indicates that Frame Relay services will be quite cost-effective, but this must be determined by each network manager on a case by case basis.

12. What happens as my network grows? Frame Relay has a particular strength here that is seldom discussed. Using traditional networking methods, adding a new site to the network involves adding extra equipment at the connecting sites to support the new application. This could include extra line cards, multiplexer ports, etc., at several, most or even all of the connecting nodes. Frame Relay network services require that a physical change be made only at the new site to add it to the network. This site may then be connected to the rest of the network by making logical (software) definition modifications in the network and the existing nodes.

13. Does Frame Relay replace my TDM-based E1 network? Probably, eventually. It all depends on how your E1 network is used. The statistical multiplexing that is inherent in Frame Relay provides excellent bandwidth utilisation for 'bursty' traffic. However, once the traffic is coming from many different sources such that the 'bursty' nature disappears, due to the peaks from one session filling in the gaps of another, then there is no further bandwidth efficiency to be gained. At some point in the network, whether in the private network or in the carrier network, we'll still be providing time division multiplexing. Another key question here, though, is what the most cost-effective carrier services will be. Almost all current E1 multiplexer technology is based on managing dedicated bandwidth facilities. Some pricing exercises so far indicate that Frame Relay services may actually be less expensive than dedicated services, even if they are used all of the time. If this turns out to be the case, the future of the private

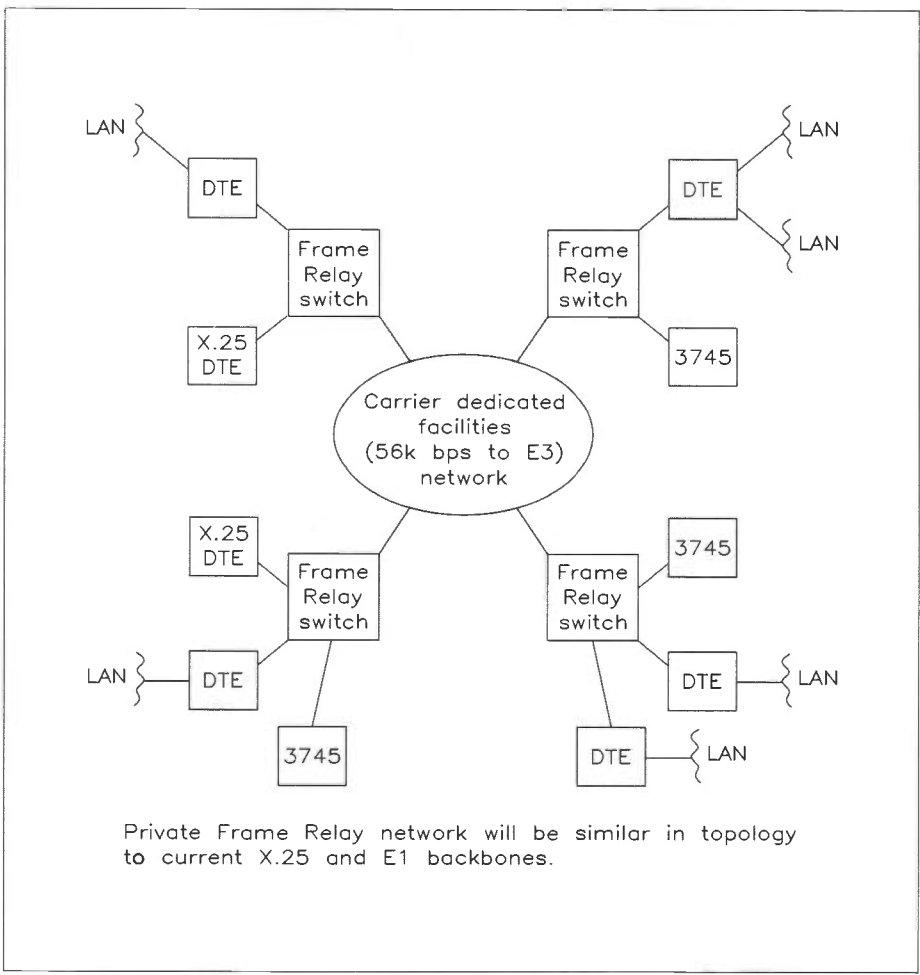

Figure 3. Upgrading to private Frame Relay.

network could be drastically altered. It may, in fact, turn out that the private network uses packet switched, rather than dedicated bandwidth, for the backbone transport.

For today though, do not delay buying a new anchor for your boat just because you may eventually have some spare multiplexers. Remember that this is an evolution, not a revolution – and, for some applications, E1 multiplexers will still be around for a long time to come.

14. So do I upgrade my current E1 backbone networking equipment, to support Frame Relay, or do I install a new network? Once again, this will be a network by network decision. A good first step may be to add some Frame Relay capabilities to the current network. Most of the E1 vendors are offering this option and, to a certain extent, it makes sense. The fundamental architecture of an E1 multiplexer, though, is based on time division multiplexing and circuit switching. High power Frame Relay applications will take on a packet switching architecture. Although upgrading the current level of equipment is not a bad starting strategy, at some point a new architecture will be needed. It's basically a question of when you will need enough power in the packet-based network to justify a new system. Of course, there's always the possibility of running a separate Frame Relay system over your existing E1 multiplexers. The E1 multiplexers would then provide the time division multiplexing, and Frame Relay would simply be another application running on this network. This approach may provide an excellent transition path for the evol-

ving network, with the Frame Relay network slowly growing while the TDM network gradually shrinks.

Another advantage to following this path is vendor independence. Although your current E1 multiplexer vendor may also provide the best Frame Relay solution, the move to Frame Relay should be viewed as a major network move. The fact that the vendor supplies an existing TDM based E1 network is not a sufficient reason to exclude all others from consideration.

15. Speaking of evolving networks, does Frame Relay replace a private X.25 network? Most of the preceding comments about E1 networks apply here as well. Although X.25 packet networks provide excellent functions now, Frame Relay is still a slightly different animal. These X.25 based networks already have basic packet switching functions but, depending on the architecture, these functions may have to be revised significantly to provide the throughput and speeds expected from a frame transporting network (see Figure 3). Once again, the move to a Frame Relay network is a major step, so it is worthy of consideration on its own. Upgrading the current network should be considered as a viable option, but this option will not always be appropriate. Remember, though, that while Frame Relay provides a quite significant subset of the functions of X.25, it is not a replacement per se. If you need all of the capabilities of X.25, especially guaranteed delivery of data, you still need X.25.

16. Where can I buy Frame Relay equipment? Anywhere. There are many equipment and service providers for

Frame Relay related equipment. As far as the devices to supply frames to a network, the major bridge/router vendors now support Frame Relay. Several companies also supply Frame Relay 'framers' to convert non-frame relay traffic into a Frame Relay format. For private Frame Relay network equipment, most of the traditional E1 multiplexer vendors and X.25 packet switching vendors are now supplying capabilities for Frame Relay networks. Also, some start-up companies are building networking equipment explicitly for the Frame Relay market.

17. Does Frame Relay offer a transition path to B-ISDN (ATM)? Isn't it 'narrowband ISDN' compatible rather than broadband compatible? The claims that Frame Relay is narrowband-ISDN compatible while SMDS (Switched Multi-megabit Data Service) is broadband ISDN compatible represent a fair amount of marketing hype. Although it is true that Frame Relay was first defined as part of ISDN prior to the inception of B-ISDN, this point is relatively meaningless. The really important question is whether there will be a smooth transition path from Frame Relay to B-ISDN, if and when B-ISDN becomes a reality.

In which case the answer is "yes". The only major difference between Frame Relay and connection oriented B-ISDN ATM (the form of B-ISDN that is currently under rapid development) is that Frame Relay uses variable rather than fixed length frames. Going from one to the other simply requires converting the addresses and segmenting the frame into a number of cells. With such a simple conversion, there is no reason to worry about compatibility between the two technologies.

18. Speaking of B-ISDN, what exactly is the difference between Frame Relay and cell relay? The difference is simple. Frames are variable-length units of data. If all of the units of data within a particular network – a known 'universe' – are of the same length, they are called cells. While this is the difference in a nutshell, the implications of it could fill several volumes with still no firm conclusions reached. Data transfers are a natural fit for frames, because data naturally occurs in frame sized chunks. However, there are numerous arguments, with varying degrees of validity, that cell based transport may eventually prove to be 'better'. At this point, most of the arguments for and against each technology are based on popular belief rather than fact. Both technologies will work, but, although the performance and price of a network will be influenced by these factors, beware of making any quick judgments that one is inherently better than the other without understanding all of the implications!

19. Frame Relay is said to be an 'interim' technology. Is this true? Yes, but all technologies are 'interim' technologies. The important questions for users to ask are, how long the interval for the technology is, and whether the technology will work well for this time. Frame Relay comes out very well in this respect. Its life cycle as the highest speed, highest performance technology may be in the range of four to eight years, which is not bad for a technology these days. After all, how many people who put in E1 multiplexers eight



years ago, and saw the technology pay for itself in the first six months, are now crying into their beer about having chosen an 'interim' technology? Frame Relay should provide statistical multiplexing for data streams up to at least 50M-bit/s. That much capacity will serve a lot of users for a very, very long time.

20. This seems 'too good to be true', leading to suspicion. What are the hidden risks? There are indeed a few hidden risks, but no more so than with any other technology; and the reduction of these risks is coming along nicely. One of the risks is the price/performance of current generation switches. With processor technology advancing so rapidly, at what point do you make a decision to buy? Although this is a valid concern, you should remember that all of those 'obsolete', slow microprocessors performed their jobs well. Sooner or later, it will be time to jump in and make a commitment, and from 1992 onwards, there's going to be a lot of products available at reasonable prices.

Even so, users will still be faced with a most confusing lack of consistency in performance measurement, so it will continue to be quite difficult to make 'apples-to-apples' comparisons. Measurements, such as 'frames per second' and 'megabits per second', are meaningless out of context. How big are the frames? Does the frame length affect this measurement? If so, how? What is the anticipated distribution of frame lengths in your network? This set of detailed questions just scratches the surface of the sort of concerns users should have when comparing performance.

Congestion control is another concern, but this a problem with LAN internetworking regardless of the transport technology. Control of most asynchronous ASCII devices with X.25 networks and statistical multiplexers was simple. When the network was overloaded, it sent a "receiver not ready" message, then the PAD sent an 'X-off' to the attached devices, and the data was temporarily halted.

Frame Relay provides sophisticated

notification to attached devices that congestion is occurring. In fact the congestion control in Frame Relay is probably the most robust of any of the fast-packet protocols! Nevertheless some of the devices, whose traffic the network is carrying, may still follow the LAN based assumption of essentially infinite, free bandwidth. Thus, they may or may not respond to this notification. Although this problem is being actively addressed, you need to be aware of it. Of course, nowhere are the 'seven Ps of perfection' more germane than in network congestion management: prior proper planning precludes pitifully poor performance.

## Summary

In the final analysis, the benefits of implementing Frame Relay far outweigh the risks. So long as you take care to follow a prudent evaluation and procurement cycle, it's time to start implementing Frame Relay technology.



Next month's superb issue of 'Electronics - The Maplin Magazine' will have all your favourite regulars plus more terrific projects and features to while away a pleasant summer evening! The June issue is on sale on the 7th of May and available from all Maplin's regional stores, and newsagents countrywide, and of course by subscription (see page 21 for details). Here's just a sample of the good things to look forward to:

### COMPUTER VIRUSES

A detailed look into the fascinating world of computer viruses, tackling such questions as who created the first computer virus and why, how they are spread around and how they behave, and how destructive they are. Virus effects can range from no visible damage to complete and obvious data destruction, or the more insidious randomly selected destruction. Today's sophisticated viruses camouflage themselves so well, that often, there are no indications of their presence. However, anti-viral software is

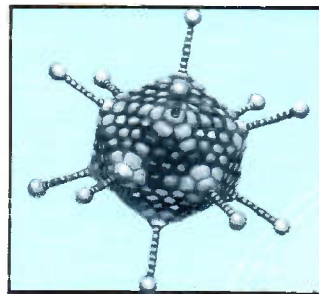

available, and the techniques used here are also described.

### TORCH FINDER

Be prepared for a sudden mains power cut! No more fumbling about looking for torches or candles. This wall mounted, mains powered project lights up, guiding you to the small clip-on torch it carries. An internal rechargeable battery is kept 'topped up' when the mains supply is on, and a rechargeable torch can be used if preferred. The circuit is powered by an inexpensive mains adaptor. A green LED indicates that the mains supply is connected, and operation of the torch bulbs during a power cut is fully automatic.



### TROUBLESHOOTING DIGITAL CIRCUITS

A great deal of digital troubleshooting can be carried out using just two relatively inexpensive and easy to use test instruments. These are the Logic Pulser, and the Logic Probe. These also have the merits of being small and compact, and requiring no power supply requirements of their own since the small amount of power that they need is drawn from the circuit under test. This article provides an in-depth description of how to go about fault-finding digital circuits.



### PC OPTO-ISOLATOR CARD

A versatile interface card for use with the IBM PC, PC-XT, PC-AT and compatible clones, featuring electrical isolation of both inputs and outputs using the optocoupling technique. It has separate, 8-bit parallel input and output connections, with an additional strobe input for the 8-bit parallel input. The card is especially useful where electrical isolation is required between the computer and the other circuit, and applications include isolated data links, switching, pulse detectors, robotics, timed control, home automation and many other uses.

### AUDIBLE TTL LOGIC PROBE

Whereas conventional logic testers use an LED to indicate high or low TTL voltage levels, and they also often have the useful facility of detecting very short pulses, sometimes they can be awkward to use. It can be tricky to keep a probe steady on a pin while looking at an LED, and there is a risk of the probes slipping and shorting adjacent pins, or shorting to a nearby component lead. With this audible logic tester changes of tone between high and low TTL levels are easily detectable while your eyes are otherwise engaged.

*Plus of course there's all the usual features for you to enjoy!*  
**'ELECTRONICS - THE MAPLIN MAGAZINE'**  
 BRITAIN'S BEST SELLING ELECTRONICS MAGAZINE

# SHORT WAVE BROADCASTING TODAY



Radio Netherlands  
Flevo transmitter site  
on the Flevo polder,  
east of Amsterdam.

Ian Poole G3YWX

Short Wave Broadcasting is more important than ever before. Despite all the developments in satellite technology, and the improvements in domestic broadcasting services around the world, the level of short wave broadcasting is still increasing. Broadcasters are actively trying to increase the number of bands they are allowed to use.

In the UK, most people listen to the domestic broadcasting services on VHF FM as well as the long and medium wave bands. In fact, with the introduction of all the BBC and Independent Local radio stations, the amount of time spent listening has increased. However, the success of the domestic broadcasting services in the UK hides all the activity which can be heard on the short wave bands. For anyone with a receiver which covers the short wave bands, the large number of stations broadcasting all over the world is immediately obvious.

For international broadcasting, the short wave bands are still the only viable way of reaching listeners all around the globe. Large numbers of people possess radios which can receive the short wave bands, so audiences can be very large.

## Beginnings

The need for international broadcasting has long been recognised. Since the very earliest days of broadcasting, people have sought to transmit overseas. In the UK, this need arose from the desire to be able to broadcast to every part of the British Empire at least once a day. As a result, the BBC Empire service was inaugurated in 1932 with transmissions from Daventry. However, an experimental service had been in operation since 1928.

During the Second World War, the importance of international broadcasting was realised and used to great effect. The infamous Lord Haw Haw regularly broadcast propaganda from Germany to demoralise the British people. However, the Germans were not the only ones using these techniques, the allies were also using similar tactics.

After the war, communism dominated Eastern Europe, and the West saw broadcasting as a very effective way of reaching people behind the Iron Curtain. In fact, in 1953 high power transmitters were installed in Berlin and around the Mediterranean, for

the purpose of transmitting western propaganda. Sometimes, these transmitters used exactly the same frequency as Radio Moscow – but more powerful.

Whilst many of these propaganda broadcasts were transmitted on the medium and long wave bands, there was plenty of activity on the short wave bands, as they were far more suited to international broadcasting because of ionospheric propagation, which enables the signals to travel much further.

Because broadcasting on the short wave bands could reach many people internationally, these services were seen as part of a country's foreign policy. Governments often set up the stations and spent huge amounts of money installing large and powerful transmitters.

During the Cold War years, this was particularly obvious. Radio Moscow and the Voice of America vied with each other to reach audiences in the other's country. In the UK, Radio Moscow ensured the communist view was heard by broadcasting, simultaneously, on many frequencies. However, these two powerful stations were by no means the



**Top left: Radio Netherlands studio centre.  
Top right: Studio mixing table, Radio Netherlands.  
Bottom left: Newsroom Radio Netherlands.**

**Bottom right: Radio Netherlands' Bonaire relay station Netherlands Antilles.**

only stations which were easily heard, Radio Tirana, broadcasting from Albania, was another powerful station.

In addition, there were many other stations which could be heard on the air waves. Some were less well known and many used far less powerful transmitters, but all sought to reach audiences outside their own countries.

## Today

Today short wave broadcasting is as important as ever. Despite the relaxation of the cold war, countries still feel the need to express their foreign policies over the air. Often, when a government wants to make a statement concerned with international affairs, it will use its short wave transmissions for this purpose. These transmissions are usually monitored by other countries, and makes an ideal medium, especially when other diplomatic means are not open.

Short wave broadcasting was recently used to great effect during the Gulf War. Prior to the start of hostilities, Iraq had built several large transmitters, some of which were capable of producing over a Megawatt. Using these transmitters, they were able to convey their message to large parts of the Arab world. The coalition forces were fully aware of the power of this type of propaganda and also used this medium to great advantage. In addition, they also set up a number of stations to broadcast to their own troops.

However, not all stations are used solely for propaganda. Some stations have sought to report the news and current affairs as accurately as possible. Of all the short wave broadcasting stations, the BBC World Service has gained a worldwide reputation for the quality of its programmes, and its impartial news service. In many countries, people tune to the BBC World Service to hear what is going on in their own country rather than

listening to broadcasts from their own radio stations.

Apart from the national stations which exist around the world, a number of stations have been set up for religious purposes. For example, the Vatican has its own station. Other religious stations include HCJB, which broadcasts from the Columbian Andes, and FEBA Radio, from the Seychelles.

Sometimes the short waves are used to carry domestic broadcasts. In very large countries, such as Russia and China, long and medium wave transmissions cannot cover the country without an extensive network of transmitters, so the short wave bands are used.

Another use of these bands for domestic broadcasting occurs in tropical areas of the world, where static levels can be very high, making the long and medium wave bands unsuitable. Special bands at the lower end of the short wave spectrum have been allocated specifically for this purpose.

## Transmitting Stations

Setting up and running a short wave broadcasting station is very costly. For instance, the BBC has a number of sites around the UK. Each site has several transmitters, or 'senders' as they are called, as well as a number of aerials. The senders are generally very powerful. 100kW is considered to be quite modest by today's standards and some senders are capable of producing half a megawatt.

In addition to the basic sites, many stations will have a number of relay stations around the world. By using these relays, it is possible to achieve much better coverage, especially when the broadcasts are intended to reach places that are far away from the country of origin. The BBC has a number of relay stations – Ascension Island, Hong Kong, and Masirah Island in the Gulf to mention just a few.

Relay stations usually receive their programme material via satellite links. However, in the days before satellites, short wave links had to be used, and this meant that the sound quality of a broadcast from relays was markedly poorer than that of a main station. Today there is virtually no difference, but satellite links do cause one interesting problem. The time delay caused by the signal having to travel to the satellite and back means that any time signals will be inaccurate. To overcome this problem, time signals are generated locally at the relay station.

Apart from the basic equipment, a large amount of planning is needed to ensure the station operates efficiently. Transmissions have to be aimed at a particular target area, and this may mean the transmission has to be in a particular language.

To ensure that the transmission reaches its desired area, stations will have a department devoted to calculating the optimum frequencies. These calculations are not at all easy, since the signal propagation will depend upon the state of the ionosphere – trying to predict this is a little like weather forecasting. Nevertheless, the degree of success is remarkably good.

## Bands

In view of the fact that many other services use the short waves apart from broadcasters, different frequency bands are allocated to different users. In this way listeners know where to look and interference between the different services is minimised.

There are a total of thirteen bands allocated for broadcasting which are spread over the short wave spectrum. By using different bands, broadcasters are able to use the propagation characteristics to target their transmissions to a particular area.

The bands are shown in Table 1. Of these the 120, 90 and 60m bands are for tropical broadcasting and are not generally available. They are used for comparatively local transmissions and not international use, the stations on them tend to operate on low power levels.

The 75m band is the lowest frequency band for general use. It is not one of the most popular bands because it is fairly small, and its propagation characteristics mean that signals do not carry particularly far. However, a number of larger stations can be heard, including the BBC.

The 49 and 41m bands are probably the most popular bands and as such they are very crowded. During the day they give coverage up to about 3000km. At night this range can be extended, although the stronger

120 Metres	2.300	–	2.498
90 Metres	3.200	–	3.400
75 Metres	3.950	–	4.000
60 Metres	4.750	–	5.060
49 Metres	5.950	–	6.200
41 Metres	7.100	–	7.300
31 Metres	9.500	–	9.900
25 Metres	11.650	–	12.050
22 Metres	13.600	–	13.800
19 Metres	15.100	–	15.600
16 Metres	17.550	–	17.900
13 Metres	21.450	–	21.850
11 Metres	25.670	–	26.100

All frequencies are in MHz

**Table 1. Short Wave Broadcast Allocations**

local stations often tend to mask out the more distant ones. The 31m band exhibits similar characteristics and is also quite popular.

The 25 and 22m bands give extended coverage, particularly at dawn and dusk. However, the 19 and 16m bands offer good long distance propagation, broadcasters use them quite heavily for daytime broadcasts to other continents.

Finally, there is the 11m band, which is not widely used because it is unreliable. When conditions are poor, it is likely that no signals will be audible.

## Modes

Currently AM is used for all short wave broadcasting on the long, medium and short wave bands. However, it has long been known that AM is not a very efficient form of transmission. Only a fraction of the power, which is broadcast, actually carries sound information, as

shown in Figure 1a. In addition, it uses a lot of the spectrum. Its main advantage is that it is easy to demodulate in the receiver, and this reduces the cost of radios.

Now that technology is advancing, the additional cost of a more sophisticated demodulator is comparatively low. This allows the possibility of other forms of transmission to be considered. It is planned to convert short wave broadcasting to single sideband (SSB) in the future. This form of transmission is a derivative of AM, but one sideband is removed and the carrier is reduced in level, as shown in Figure 1b. Some carrier is retained so that the receiver can lock onto it, to regenerate the audio correctly.

For communications purposes, such as ship to shore, aircraft and radio amateurs, another variant of SSB is used. It is basically the same as the version used for broadcasting but differs in that all the carrier is removed. This can be done because the effects caused by the removal of the carrier can be tolerated by these users.

By using SSB the power consumption is drastically reduced. This is of paramount importance when it is considered that a single sender may use a few hundred kilowatts, and there could be several senders on one site. The other advantage of SSB is that it uses less spectrum. Using SSB will result in less congestion on the airwaves.

To help introduce SSB broadcasting in the near future, the World Administrative Radio Conference, held at Torremolinos in February 1992, agreed to allocate a number of new broadcast bands. These bands are shown in Table 2 and they are to be used specifically for SSB broadcasting. Access will be given to broadcasters from the year 2007. However, it is also planned that all short wave broadcasting will use SSB by the year 2015.

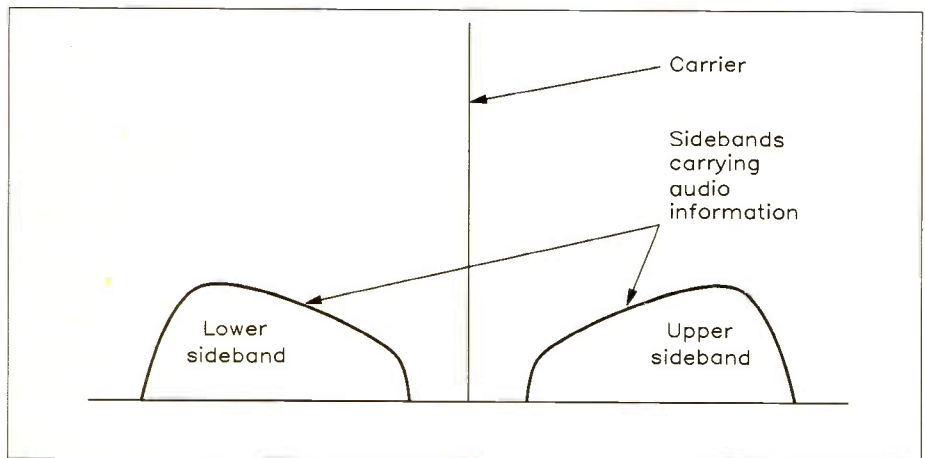

**Figure 1a. The Spectrum of AM Signals.**

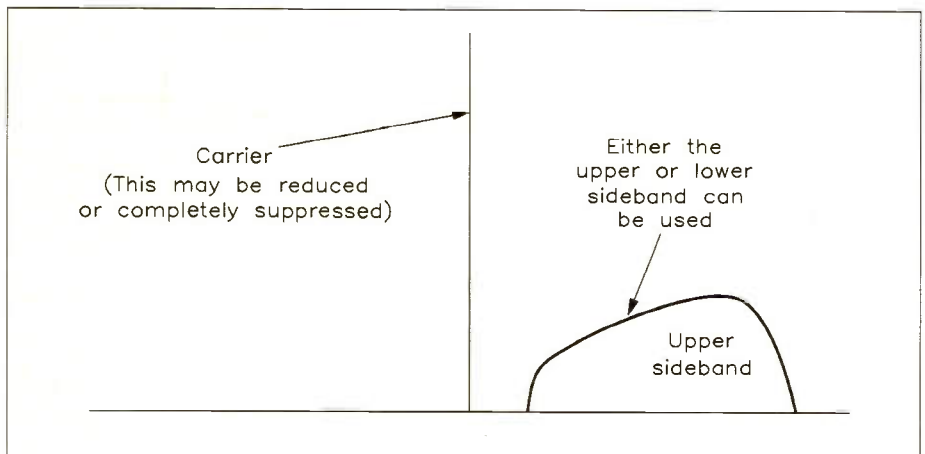

**Figure 1b. The Spectrum of SSB Signals.**

5.900	-	5.950
7.300	-	7.350
9.400	-	9.500
1.600	-	11.650
2.050	-	12.100
3.570	-	13.600
3.800	-	13.870
5.600	-	15.800
7.480	-	17.550
8.900	-	19.020

Frequencies in MHz

**Table 2. SSB Broadcasting Bands Available After 2007**

## Listening to Short Waves

Listening to short wave broadcasts can be very entertaining. There are a vast number of stations transmitting their programmes into the ether, which means that the choice of stations is very varied. However, they transmit to areas all over the world and a large number of languages are used. Fortunately English is widely used, so there is still a selection of programmes which can be understood by the British listener.

Most ordinary portable sets with short wave bands are not ideal, because it is not possible to set the dial exactly. World Band Radios overcome this problem by being digitally controlled. A keypad is used, as well as the usual tuning knob, to set the correct frequency which is viewed on a LCD display.

One example of this type of radio is the Multiband Stereo Receiver with Frequency

Synthesizer Tuning (stock number GK85G). This covers 150 to 29999kHz for AM/SSB/CW and 87.5 to 108MHz for FM stereo. With this coverage, it encompasses the long, medium and short wave bands, as well as the VHF FM band and costs £109.95 [H].

Another receiver of interest is the Sony ICF-SW 7600 (stock number XP52G), in the lower frequency ranges it covers 150kHz to 30MHz with AM/SSB/CW. Then in the VHF portion of the spectrum it covers 76 to 108MHz FM stereo, all of this for a cost of £159.00 [H]. A more sophisticated receiver is also stocked, the Sony ICF 2001D (stock number XP50E) has tuning steps down to 100Hz and 32 memories enabling a wide variety of stations to have their frequencies preset into the set. Not surprisingly this set with its additional features and better performance is a little more expensive but at £299.95 [H] it is still a good buy.

For those intending to take listening to the short waves more seriously, a full communi-

cations receiver is necessary. There is a wide variety on the market, but one which has earned itself a very good reputation is the Lowe HF150 (stock number CM23A) costing £359.00 [H].

## The Future

Activity on the short wave broadcast bands is increasing every year, and they are likely to remain in use for broadcasting for many years to come. With advances in technology, many improvements are taking place, the change to SSB has already been mentioned. Transmitters and aerials are continually being updated, being more powerful and versatile, the transmitters can re-tune to different frequencies very quickly.

Other new improvements are also taking place to enable listeners to pick up particular stations more easily. One new system being developed at the moment, actually updates a memory in the receiver with the latest frequency information from off air transmissions. With this information the receiver can select the best frequency for a particular station.

In addition to continuing the development of transmissions on the short waves, broadcasters are looking to satellite technology. A number of stations have put their programmes onto DBS satellites. Whilst comparatively few people listen to them directly at the moment, they are relayed onto cable systems where they can be rebroadcast by local stations.

## Acknowledgement

The author and publisher would like to thank Jonathon Marks, Head of English World Service, Radio Nederland Wereldomroep, for supplying photographs of the station's transmitters and other facilities.



**Radio Netherlands' Training Centre.**



**Sony ICF-SW7600 Pocket Size Receiver.**



**Sony ICF-2001D Portable.**



**LOWE HF-150 Communications Receiver.**



**Multiband Stereo Radio with Frequency Synthesis Tuning.**



# CAR HEADLIGHT ALARM



## Circuit Description

The circuit for the car headlight alarm is very simple (see Figure 1), and basically consists of one monostable timer (identified as N1 in Figure 1), two astable oscillators (N4 and N5) and two inverters (N2 and N3). The circuit takes all the power it needs from either the 'L' or the 'C' connection, or both, depending on whichever is at supply potential, and so draws no current when the vehicle is not in use. The circuit operates in the following manner.

## Version A – Warning to Turn Lights On and Off

If no link is fitted (dotted line in Figure 1, also shown as position 'J2' in Figure 2), then the unit is configured to sound a warning to turn the lights both on or off when the ignition is switched on or off.

To use the equivalent logic levels: if L = 1 (+V) and C = 0 (0V), or in other words if the ignition connection ('C') is off (at 0V) and the lights (connection 'L') are on (at +V), then a logic 0 is fed to pin 8 of N7 (the exclusive OR gate) via inverter N3, while a logic 1 is fed to pin 9 of N7 via the inverter N2. The output of N7 will then be at logic 1, which reverse biases D4 and D5, allowing the very low frequency oscillator N4 to run. The output of N1 is at logic 1, reverse biasing D2 because C2 is discharged. To summarise, D2, D3 and D6 are all reversed biased, therefore the buzzer will sound, albeit in pulses due to the oscillators sinking the current from R9 via D6 and D7. Inverter N2 also charges C2 via R10, and after a few seconds C2 will become charged and the output of N1 will change state, sinking the current from R9 via D2 and the output from the buzzer will cease.

On the other hand the situation where L = 0 (0V) and C = 1 (+V) results in the following. N3 output is at logic 1, therefore N7 output is at logic 1 also and reverse biases D4 and D5, allowing the N4 oscillator to run. The output of N2 is at logic 0, preventing C2 from charging, stopping the timer (N1) from 'timing out'. D2 will be reversed biased. The net result is that the buzzer will sound without timing out.

In short then, for the configuration of version A, if the ignition is turned off

Text by  
Mike Holmes

**This clever module will be invaluable to car owners whose vehicle's lighting switch allows the headlights to remain 'burning' even if the ignition switch is off! This will result in the battery being reduced to a discharged state, so that it will be unable to re-start the car, in a short space of time. The module is designed to give a repeated audible alarm tone to remind you that the main lights are on when the ignition is switched off, so preventing a flat battery. It can also be configured to give a continuous alarm tone to remind you to switch your lights on (this is a requirement in certain countries outside of the UK).**

Output ▾   Input ▶	Ignition 'C'ontact	'L'ights
<b>No Link Fitted:</b>		
No output	0V	0V
Timed bleep output	0V	+V
Continuous bleep output	+V	0V
No output	+V	+V
<b>Link Fitted:</b>		
No output	0V	0V
Timed bleep output	0V	+V
No output	+V	0V
No output	+V	+V

Table 1. 'Truth table' of circuit operation, with and without link J2.

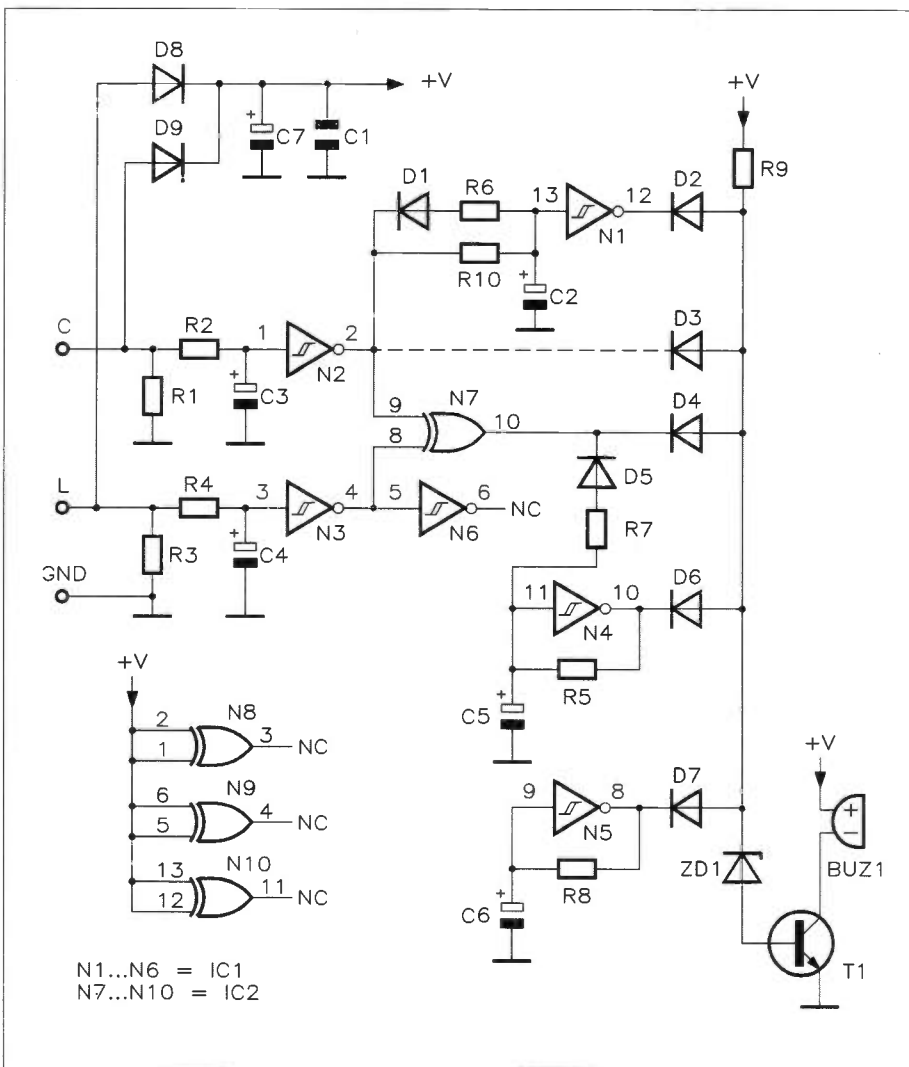

Figure 1. Circuit diagram.

and the lights are on then the alarm will sound for a short period. If the ignition is switched on (and the car started) but the lights are not also switched on, the alarm will sound continuously. (In some other countries dipped headlights are required at all times during driving, but is not applicable in the UK.)

### Version B – Warning to Turn Lights Off Only

Where  $L = 1 (+V)$  and  $C = 0 (0V)$  the operation of the circuit is the same as version A without the link, and provides a short warning that the lights are still on when the ignition is turned off, as described above.

Where  $L = 0$  and  $C = 1$  the fitted link has the effect of forward biasing D3 (because the output of N2 is at logic 0) and sinking the current from R9, therefore preventing the buzzer from sounding for normal daylight driving without lights. Table 1 sums up the various modes of operation and the effect of link J2.

### Construction

Construction is quite straightforward. Begin by fitting the diodes, ensuring that they are correctly installed before soldering as they are polarised devices. The Zener diode has a different coloured body from the signal diodes, this will

help you to identify it. Use the lead off-cuts for the wire links between the ICs.

Install the resistors, followed by the IC sockets, aligning the notch on the sockets with the notch on the legend. The capacitors are fitted next. Fit the electrolytic capacitors, with the minus symbol (-) on the body facing away from the plus symbol (+) on the PCB legend. Install the transistor, followed by the piezo buzzer. Align the plus symbol (+) on the buzzer with the plus symbol (+) on the PCB legend, and remove the protective sticker from the buzzer if fitted. Lock the 2-way and 3-way PCB screw terminal connectors together (they slide together), then install as a complete component onto the PCB. Finally insert the ICs into their sockets, making sure to align the notch on the IC with the notch on the socket.

The PCB is now complete, and it only remains to clean off the flux residue using a suitable solvent and check for solder whiskers, bridges and dry joints.

### Testing and Installation

A DC power source is required, and a 9V PP3 battery would suffice. Use Table 1 to check the operation of the circuit, with the necessary inputs to 'L' and 'C' being emulated with test leads or lengths of wire.

Once the circuit is found to operate correctly it can then be installed into the proposed vehicle, and wired up as shown in Figure 2.

Continued on page 44.

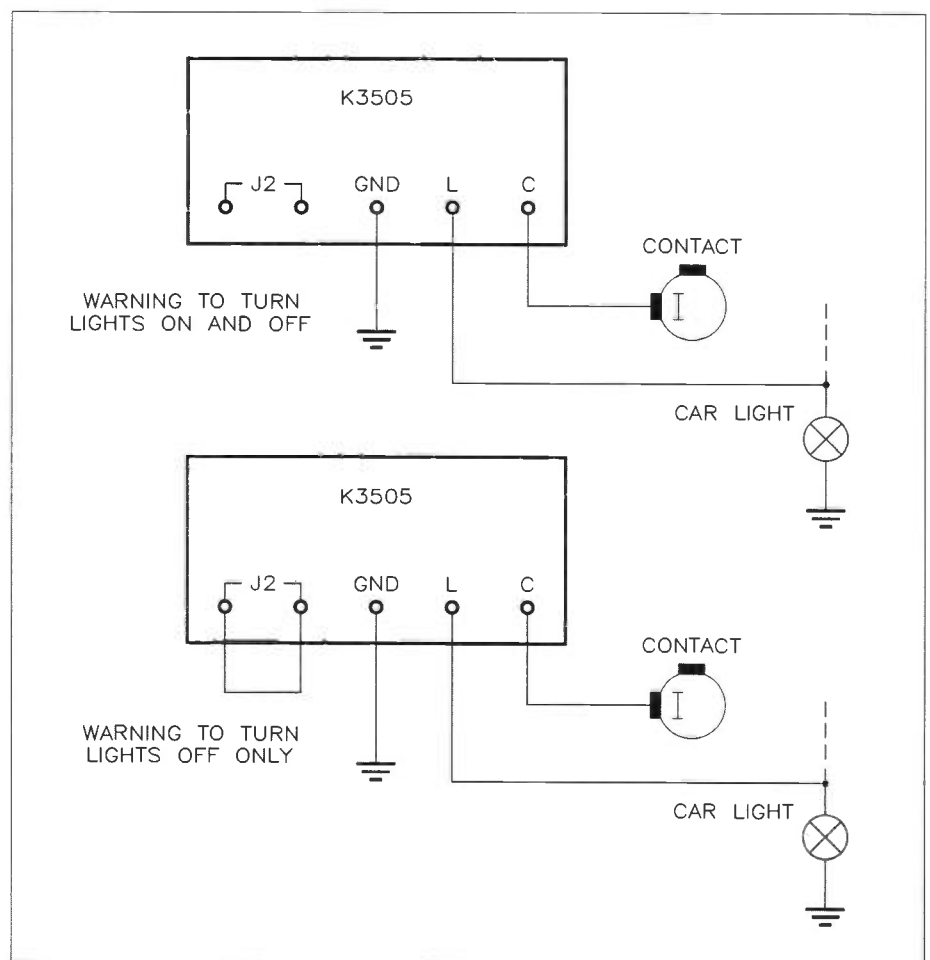



Figure 2. Alternative methods of connecting the Headlamp Alarm.

# A Listener's Guide to RADIO PROPAGATION



It is common knowledge that the density of the air decreases with altitude. This has an effect on the refractive index of the air – the more dense the air the higher its refractive index. As a result, the refractive index is higher nearer the ground. As light and radio waves bend towards the areas of higher refractive index, the radio signals will curve around the earth's surface and travel over much greater distances.

## Tropospheric Ducting

Sometimes, warnings are broadcast on television to say that there is the possibility of atmospheric interference. This is an indication that the distances which the signals are travelling has dramatically increased. The conditions which give rise to this can happen in a number of ways, all of which are connected with the weather, and by watching the weather forecast, it is often possible to predict when it will happen.

Like the way in which signals travel further than the line of sight, tropospheric ducting or 'tropo' is dependent upon a change in refractive index of the air. However, the conditions which cause it give a much greater change

## PART TWO – THE STORY ABOVE 30MHz

by Ian Poole G3YWX

The way in which radio signals above 30MHz travel, or propagate, is every bit as interesting as radio signals below 30MHz. Even though the distances which can be covered are not as great as they are on the HF bands, it is very surprising just how far signals do travel when the conditions are right. Although these distances cannot be reached all the time, it is not difficult to recognise the telltale signs which can indicate when to listen.

### Normal Conditions

When there are no abnormal conditions present, that can result in propagation over longer distances, signals will generally travel about 50km or possibly even as far as a 100km. This is very dependent upon the equipment being used at either end, the aeri-als and the power of the transmitters, and also the lie of the land between the two stations. If the transmitting and receiving stations are high up on hills, and can virtually see one another, then signals will be very good. However, if there are hills in the way, or the stations are not very high, then maintaining contact can be difficult.

Whilst signals at these higher frequencies might be expected to travel over a line of sight path, the distances which have already been mentioned are considerably in excess of this. The reason for this increase in coverage can be explained quite easily. It is caused by the fact that radio waves can be refracted or made to bend in the same way as light.

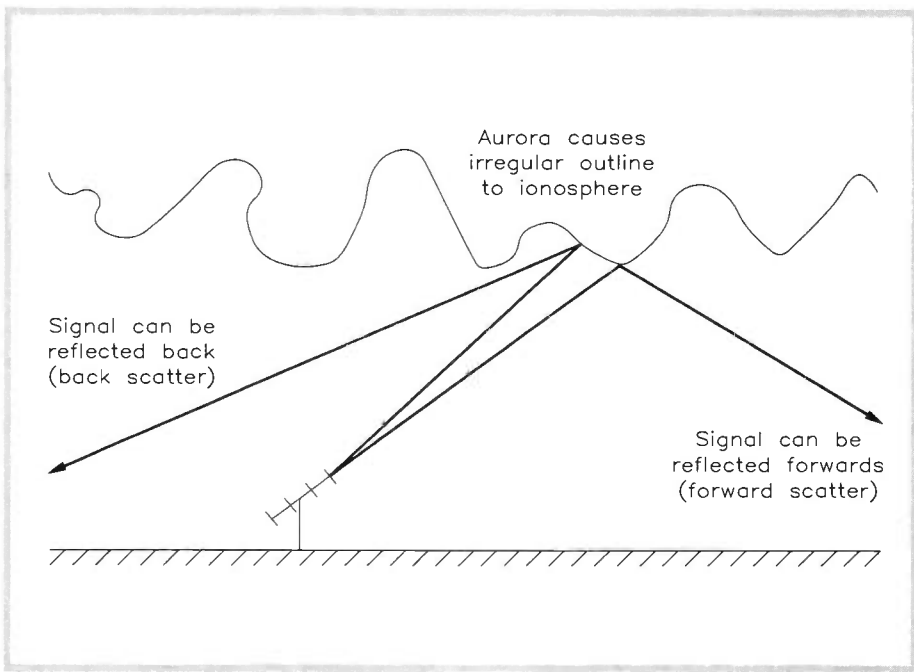

Figure 2. Propagation via Aurora.

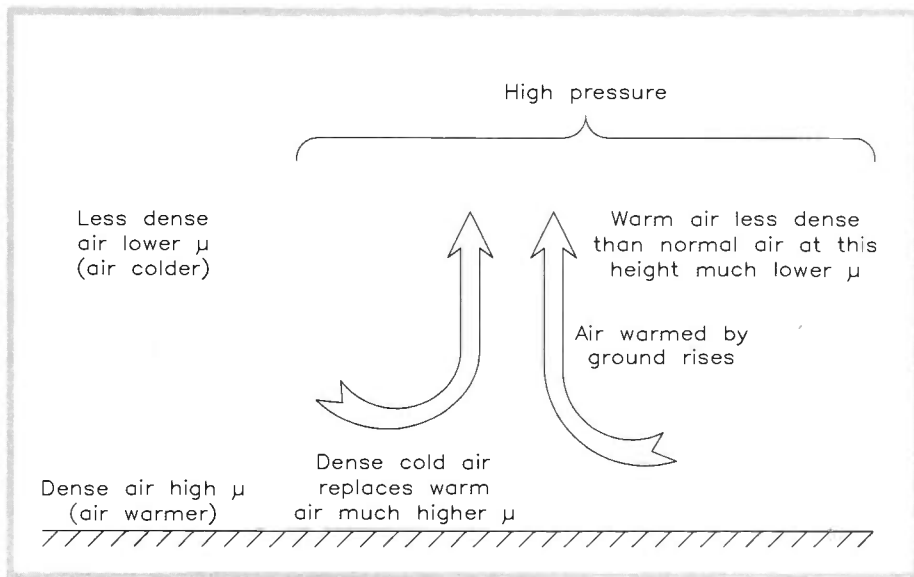

Figure 1. Conditions for Tropospheric Ducting.

than normally occurs, and it is possible for stations to be heard over much greater distances.

There are a number of different weather conditions which give rise to 'tropo'. The one that gives the best improvements in conditions occurs when an area of high pressure produces a spell of hot weather in the summer. The air which is warmed by the earth rises bringing colder air in beneath it, to give what is called a temperature inversion. As the warm air is less dense than the cold air, this accentuates the normal density gradient, and makes the normal change in refractive index much greater, see Figure 1. This allows for much greater refraction of the radio signals so that they can be heard over much greater distances.

Similar conditions are produced by a cold front. In this case a mass of warm air meets a mass of cold air. As the warm air is less dense than the cold it will tend to rise up over it, creating a temperature inversion with a sharp



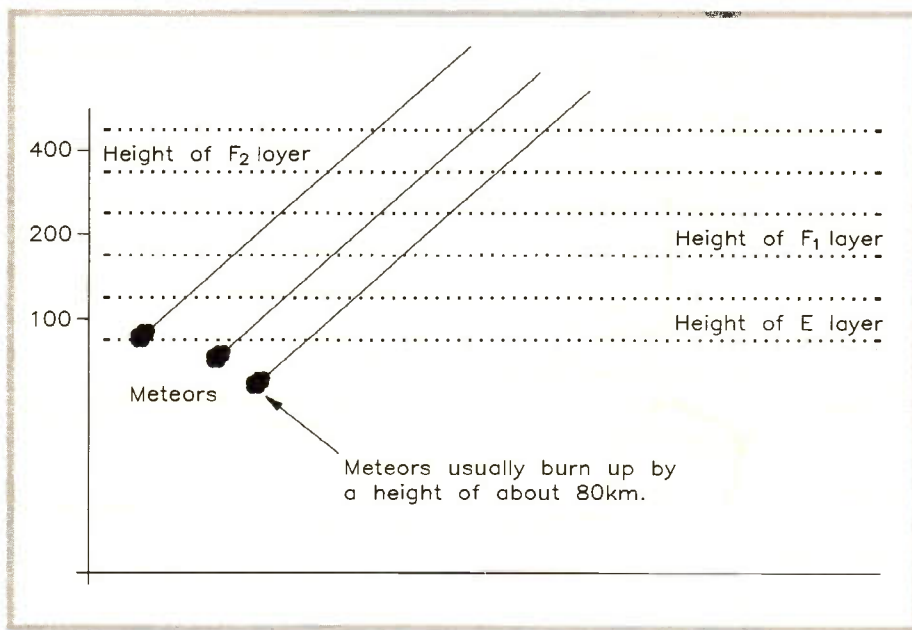

Figure 3. Meteors and the Atmosphere.

boundary. Although a front can produce some good conditions, they do not usually last as long as those produced by a high pressure area.

When there is a lift in conditions caused by 'tropo', distances of 200 or 300km can be reached quite easily. Distances of 500 or even a 1,000km are not uncommon. With this sort of increase in distance, it is easy to see why television signals have interference on them caused by stations which are normally far enough away not to cause any problems.

## Sporadic E

Back in the days of the old 405-line television, signals would regularly be disrupted in the summer months because of a mysterious phenomenon called 'sporadic E'.

'Sporadic E' occurs when clouds of highly ionised particles form in the 'E-layer'. These clouds are comparatively small in size measuring less than 100km across and usually only several tens of metres thick. The ionisation builds up steadily and first, signals in the lower part of the spectrum are affected. In fact the 27MHz CB band will often be affected. Its effect is most noticeable during periods of a sunspot minimum, when no long distance signals would normally be audible.

As the ionisation of the cloud increases the frequencies which can be reflected also increase. Often the 50MHz amateur band will be affected, as well as the VHF FM broadcast band. When this happens, broadcast stations from most of Europe can be heard quite strongly. The 2m amateur band is also influenced occasionally. However, this is about the maximum frequency which is affected by 'sporadic E', and as such it does not occur as often at these frequencies, and even then only for short periods of time.

As the name suggests, 'sporadic E' is not easy to predict. It occurs within the summer months reaching a peak in June and July. Even when it does occur, the effect is always changing, because the clouds are blown about in the air currents in the upper atmosphere. As a result, the area from which stations can be heard changes, and people who have directional aerials, or beams, have to constantly change the heading.

## Aurora

Although 'tropo' and 'sporadic E' are probably the best known forms of long distance propagation on these frequencies, they are by no means the only ones. There are a number of occurrences which enable signals to be heard over much greater distances than normal. One is associated with the Northern Lights, or Aurora Borealis, which are a magnificent sight. They can be seen in Britain on occasions, but they are visible more often in Scotland and the more northern latitudes. Unfortunately, they are only rarely seen in the south of England.

Both the visible lights and the effect on radio propagation is caused by the sun emitting large streams of charged particles. When the particles reach the earth they start to enter the earth's atmosphere but because of the magnetic field around the earth they are drawn towards the poles. The particles can disrupt the earth's field quite considerably, even making magnetic compasses change their direction. For radio propagation normal HF communications can be totally disrupted, but for the VHF enthusiast it can bring in long distance communications. The reason for this is that around the poles the level of ionisation increases dramatically, enabling signals with frequencies up to 150MHz, or so, to be reflected.

The ionisation, which occurs during an auroral 'event', is very uneven and constantly moving. This results in two effects. The first is that a signal being reflected by this ionisation can take a number of different paths, and this results in multipath distortion. The second is that the signal has small amounts of doppler shift on it from the changing state of the ionosphere. The combination of these two effects means that signals have a very rough but distinctive sound.

The distances which can be achieved using an aurora, can vary quite considerably. Sometimes a signal may be reflected almost back the way it came, whilst at other times it may be reflected much further away, see Figure 2. Even so, the furthest distances achieved using auroral reflections are about 2,000km. For those with beam aerials, it is also worth noting, that as the ionisation is centred around the poles, signals will come from this direction.

## Meteor Scatter

This form of propagation is unlikely to be used by scanner enthusiasts very often, but nevertheless, it is worth mentioning because it is used in many commercial systems, and by radio amateurs.

Date of Maximum	Name of Shower
3 to 4th January	Quadrantids
22nd April	April Lyrids
5th May	Eta Aquarids
7th May	Piscids
12th May	Nu Piscids
8th June	Arietids
26th June	June Perseids
12th July	Nu Geminids
12th August	Perseids
1st November	Taurids
13 to 14th December	Geminids
22nd December	Ursids

TABLE 1 Major Meteor Showers.

This form of communication relies upon the fact that the earth's atmosphere is constantly being bombarded by small meteors. Whilst this bombardment is going on virtually all the time, there are times when the earth passes through clouds of debris around the sun and these give rise to meteor showers at different times during the year. The time of each shower can be predicted quite accurately, because it is at a fixed point in the earth's orbit around the sun. See Table 1.

Many of the meteors are very small, but even so, as they enter the atmosphere they burn up and leave a trail of intense ionisation behind them, see Figure 3. This occurs at altitudes of around 100km. Although the area of ionisation is very small, it is still able to reflect radio waves at frequencies up to 150MHz or so.

To make use of this ionisation, very high powered transmitters and directional aerials are needed, otherwise, the amounts of power reflected by the small trails are too small to detect.

Some radio amateurs regularly use this form of communication especially during the meteor showers. However, communication is not easy because of the random nature of the ionisation trails, and often many attempts are needed. Even so, a number of commercial organisations use it for data communications transmitted to remote stations.

A high power transmitter directed towards the remote station uses the random meteor trails to establish contact. For most of the time there is no communication. However, when a meteor trail appears and contact is established, very high speed data is transmitted until the trail disappears. Whilst this form of communication may appear to be a little hit and miss, it is very useful when there is no other method, and time is not important. Surprisingly, it is more reliable than HF communication, and it is for this reason that it is used.

## Conclusion

Whilst at first sight propagation on the VHF and UHF bands may not seem to be as interesting as that on the HF bands, nothing could be further from the truth, as there is much variety and interest for the radio enthusiast.

If you have been using the A-to-D Converter Card, featured as part of this system in Issue 61, you may have found that there is a limitation in having only one input. This implies that if more inputs are desired, then extra A-to-D cards would be needed, and obviously this would work out to be quite expensive. To get around this problem, several inputs can be multiplexed, that is, the one A-to-D card is 'shared' amongst several peripheral devices. The 8 to 1 Channel Analogue Multiplexer does just this. There are eight inputs, each of which can be individually attenuated, and the output can be amplified by a factor of x 5, maximum.

## Circuit Description

As with any of the other plug-in cards for use with the extension system, a connection is made between the Multiplexer Card and the computer via the Intelligent Motherboard and Extension Card, which buffers the data signals, generates the necessary auxiliary signals and provides the power supply for the interface plug-in cards.

The circuit of the card is shown in Figure 1 and also includes the addressing circuitry that is common to all plug-in cards for this system. Since several of these cards can be installed in the Motherboard Extension Card at the same time, each is required to be uniquely addressed to prevent addressing contention between the cards. This is achieved through the fitting of links at the positions 'A0' to 'A7' on the PCB. IC4 and IC5 between them provide eight 2-input, exclusive-OR gates, which together form an 8-bit logic comparator. An 8-bit address bus from the motherboard is presented to A0 to A7 in Figure 1, while wire links may or may not be fitted between R20 to R27 and ground at positions 'A0' to 'A7'.

Each gate has an open-collector non-inverting output, and in each case, the exclusive-OR action requires that the two inputs must be at different logic levels to achieve an active high (output off) at the output. If both inputs are at the same level, either '0' or '1', the output is always '0' (output low, or on). Wherever a wire link is fitted at 'A0' to 'A7', there MUST be a logic '1' bit from the address bus corresponding to the same position, A0 to A7; similarly, where a link is omitted, the corresponding address bit must be '0'. Such a condition allows all the gates to release the common output line pulled up by R33, whereupon this card is properly selected.

IC6 provides two inverters which also have open-collector outputs. Once the eight exclusive-OR gates, properly addressed, are all off, it only remains for the I/O request control line GENIOREQ and the write enable line WR to both go low, to completely release the common output line, producing a positive going pulse at IC2 pin 9.

IC2 is a quad, D-type, positive-edge-triggered flip-flop, meaning that on each occurrence of the clock pulse input, pin 9, going high, the lower three data bits on D0 to D2 are transferred to the outputs and latched by the flip-flops. (Only three bits are needed to cover the range 0 to 7 in binary.)

# RS232 SERIAL PORT EXPANSION SYSTEM PART SEVEN 8 to 1 Channel Analogue Multiplexer Card

Text by Nigel Skeels  
and Mike Holmes

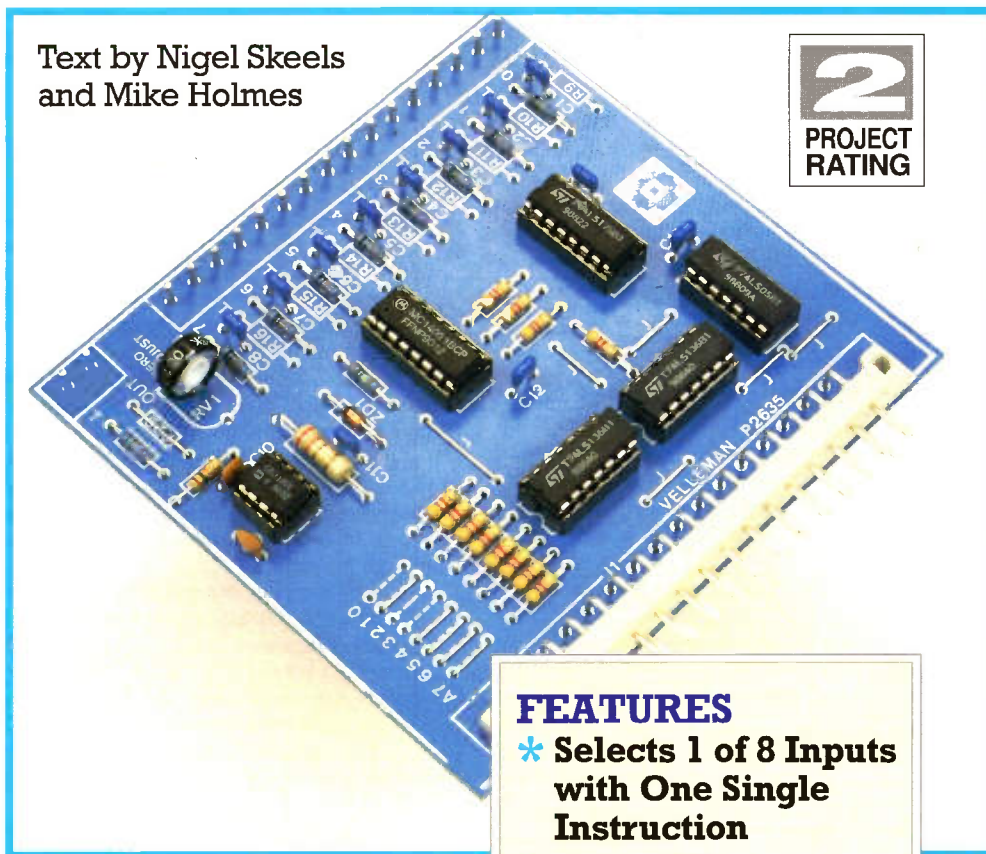

## FEATURES

- \* Selects 1 of 8 Inputs with One Single Instruction
- \* Attenuation of each Separate Input if Required
- \* Amplification of each Input
- \* On-board 8-Bit Address Decoding

## APPLICATIONS

- \* Instrumentation
- \* Automated Signal Switching

These then appear on the select control inputs of the multiplexer, IC1, at pins 11, 10 and 9. IC1 is a 1-pole, 8-way bidirectional analogue switch array, where the 3-bit control will then select one of the 8 analogue inputs and connect it through to the output, pin 3, which is then buffered and amplified by IC3.

## Construction

Construction is dealt with in greater detail in the booklet supplied with the kit, but the following notes are also helpful.

As a recommended sequence of events, firstly mount the wire links between the PCB holes marked 'j'. After fitting these the card's address must be chosen. There are two special addresses

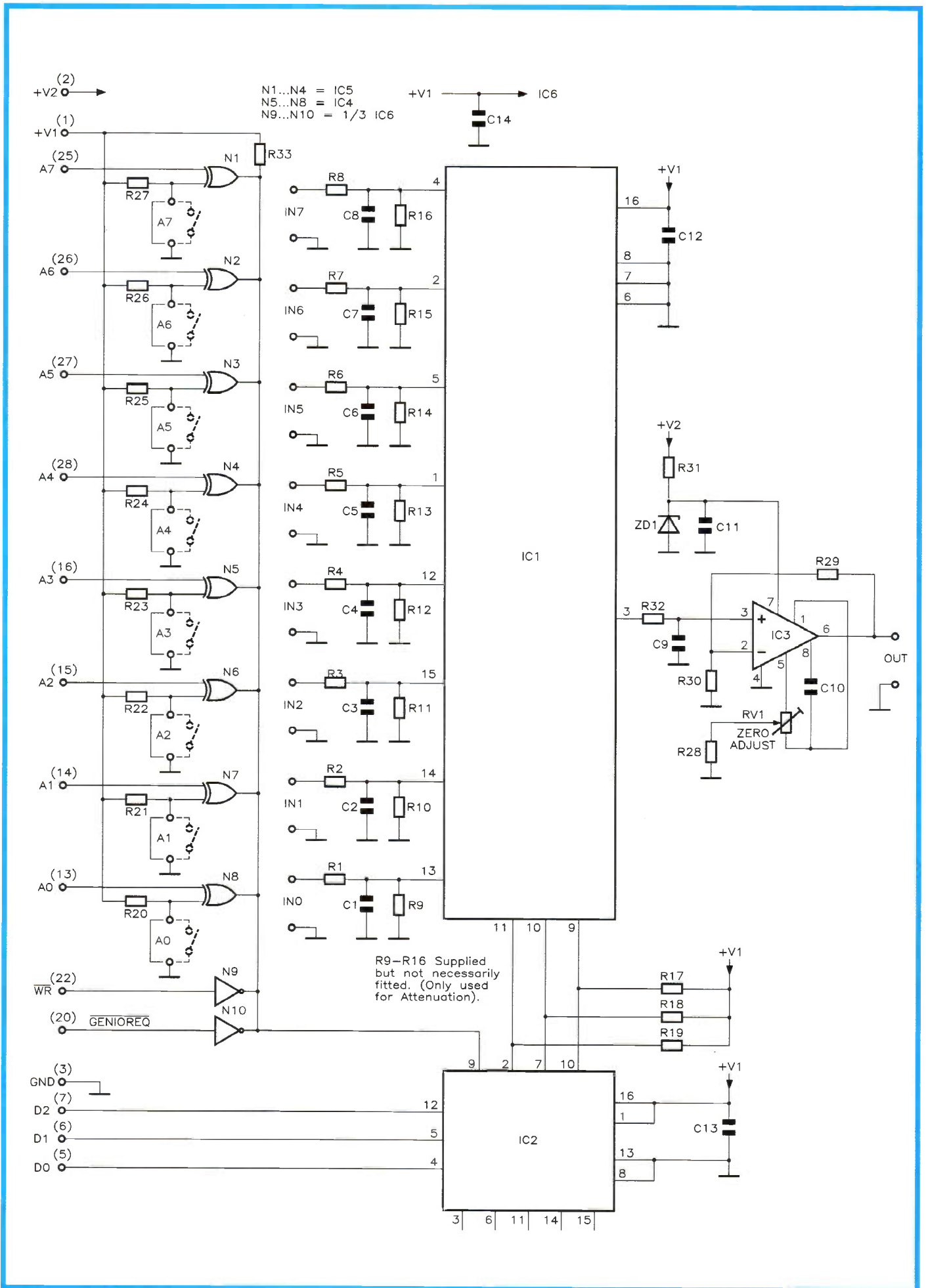

Figure 1. Circuit diagram of the Multiplexer Card.

for these cards, the second address is for a second Multiplexer Card if required. These addresses **MUST NOT** be used for other modules while using the Multiplexer Card(s)! The address for Multiplexer Card N\$1 with an A-to-D Converter Card is 1111 0010, and 1111 0011 for Multiplexer Card N\$2 with an A-to-D Converter. Fit the wire links in the appropriate positions of 'A0' to 'A7' to set the address. Note that the A-to-D Card must be set to the same address as the multiplexer.

However, be warned that once the addressing links are fitted, the pattern may not be easily modified without risk of damage to the PCB. One recommendation therefore is that, if you want the facility of being able to alter the address settings at any time for greater flexibility and to better mix different plug-in cards, to be inserted at any position in the Extension Card, then you could use an octal SPST DIL switch (XX27E) at positions 'A0' to 'A7'. The hole spacing in this area is deliberately compatible with the standard DIL layout for this purpose. This will allow you to quickly and easily alter the card's address at any time.

Next fit the resistors, including RV1. Decide upon the gain required for IC3 (the input voltage multiplied by the gain must not exceed 5V), which is determined by R29. This can be either 30k for  $\times 5$ , 15k for  $\times 3$ , 7k5 for  $\times 2$  or a wire link for unity gain. Fit the appropriate resistor or wire link.

Install the Zener diode, aligning the band on the Zener with the band on the legend. Fit the IC sockets, taking care to align the notch to the legend. Although not all the ICs are CMOS types, do not insert them into their sockets yet until all other work has been completed. Install the capacitors. Insert the 18 PCB pins from the component side of the PCB.

Fit the right-angled male PCB connector to the card by bolting in place using the hardware supplied **BEFORE** soldering, as shown in Figure 2. Similarly fit the female connector to the motherboard, and solder. Then attach the upright PCB edge guides to the motherboard with the self-tapping screws as shown in Figure 3.

Insert the ICs into the appropriate sockets, aligning the notch of each of the ICs with the notch on its socket.

Clean the PCB using a suitable solvent and check for misplaced components, solder whiskers, bridges and dry joints. Finally, recheck that the address has been correctly set!

## Testing and Setting Up

Before checking the output of the Multiplexer Card, remove all other cards fitted to the Expansion Card.

Connect the 'IN0' input to 0V, and connect a 1V DC source to input 'IN7', which can be obtained from a potential divider, shown as 'attenuator No. 1' in Figure 4.

Plug the Multiplexer Card into the Expansion Card and connect the System

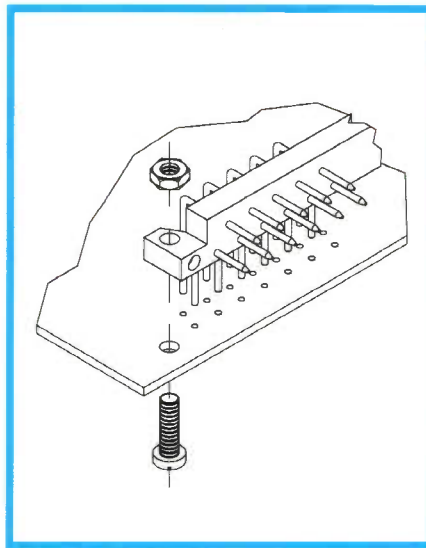

**Figure 2. Mounting the card edge connector.**

Module to the host computer and power up. Check the voltage on input 'IN7', which should be between 0.5 and 1.5V (Zener diodes are not particularly accurate voltage references).

Run the following program and monitor the output voltage (on the pin marked 'OUT') which every 5 seconds should toggle between 0V and the input voltage at 'IN7' multiplied by the set gain of buffer stage IC3 (as previously determined by R29; if a gain of 5 is chosen, then 5V should be output).

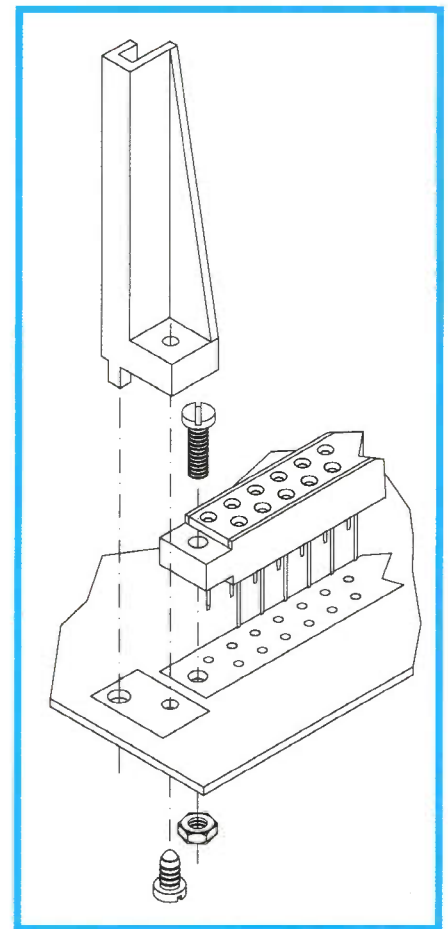

**Figure 3. Mounting the motherboard PCB socket and card PCB guides.**

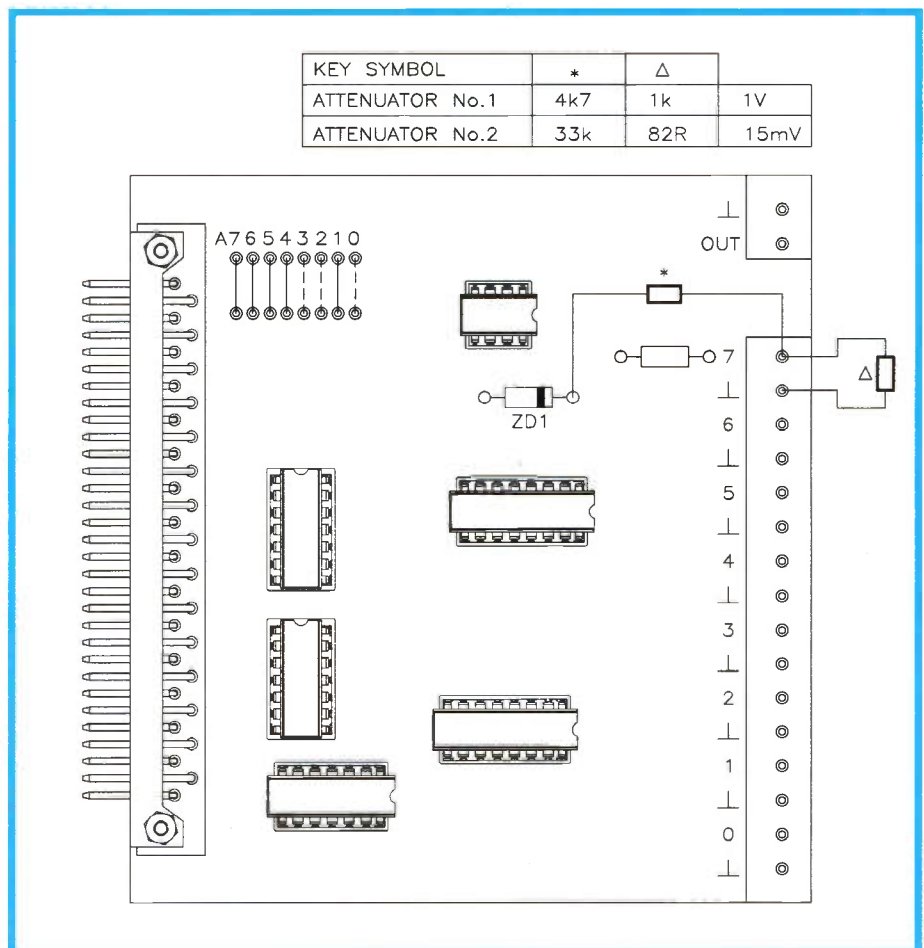

**Figure 4. Temporary attenuators for input testing.**

## Test Program

```
001 EPEX XX XX XX
002 EPTX XX XX XX
003 RDAN 0 XX XX X0
004 RDAN 7 XX XX X4
```

## Calibration

Halt the program and turn off the host computer. Remove the potential divider and replace it with a new potential divider 'attenuator No. 2', also shown in Figure 4.

Power up the host computer again and measure the input voltage using an accurate multimeter with a high input impedance. A reading of approximately 15mV (0.015V) should be expected. Adjust RV1 until a reading equal to the input voltage multiplied by the gain of IC3 is obtained. The Multiplexer Card is now ready for use.

## The Multiplexer Card in Use

The card is plugged into the Expansion Card motherboard using the supplied connecting sockets. As mentioned earlier its address should be shared with an A-to-D Converter Card. The output 'OUT' of the Multiplexer can then be wired directly to the 'AN. IN' pin of the Converter Card, as illustrated in Figure 5. Now, when the interface system controller writes to this address, it presents three bits of data to the

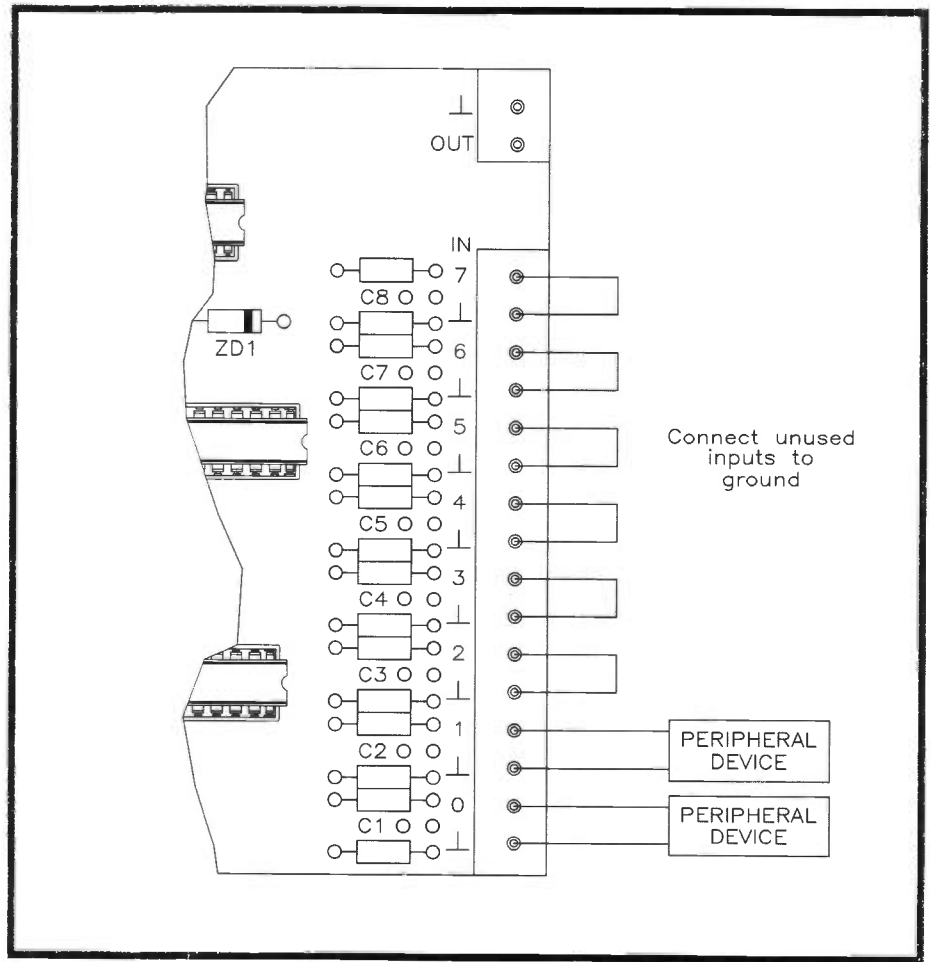

Figure 6. How the inputs should be connected.

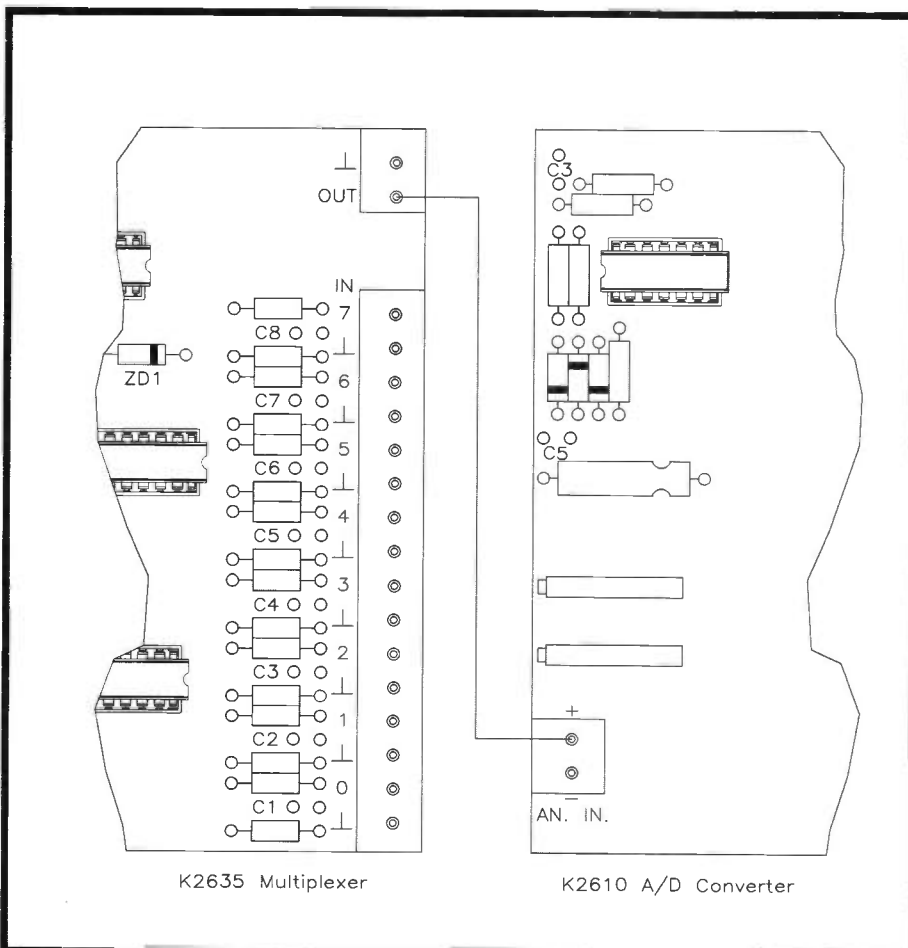

Figure 5. Connecting the output of the Multiplexer Card to the input of the A-to-D Converter Card.

multiplexer, selecting an analogue channel. But on reading this address, the 8-bit data brought back is from the A-to-D Converter Card, which was described in Issue 61. Moreover, this data will originate from a conversion performed on the analogue level found at the specifically chosen multiplexed input.

The main command for using the multiplexer with an A-to-D converter in this way is the special 'read analogue input' instruction 'RDAN'. This is followed by a parameter specifying which input you wish to read, i.e. 0 to 7, or, if two Multiplexer Cards are to be used, then this will increase to include 8 to 15 (16 possible channels).

After the host computer and system controller has selected the desired input to the Multiplexer Card, you should allow at least 1.5ms for the circuit to stabilise.

Figure 6 shows how any inputs not being used should be connected to ground, as this will inhibit false readings caused by stray pickup. The maximum input voltage to the Multiplexer Card is +5.1V, all input voltages must be positive, otherwise permanent damage to IC1 will occur. In this case IC3 should be configured for unity gain for this maximum input. If the possibility of spikes greater than +5V could occur, it is advised that a 5.1V Zener diode is fitted in the positions R9 to R16.

The resistor positions R9 to R16 are normally left open-circuit, unless an input voltage greater than +5V is to be monitored; in which case attenuation of the input would then be required.

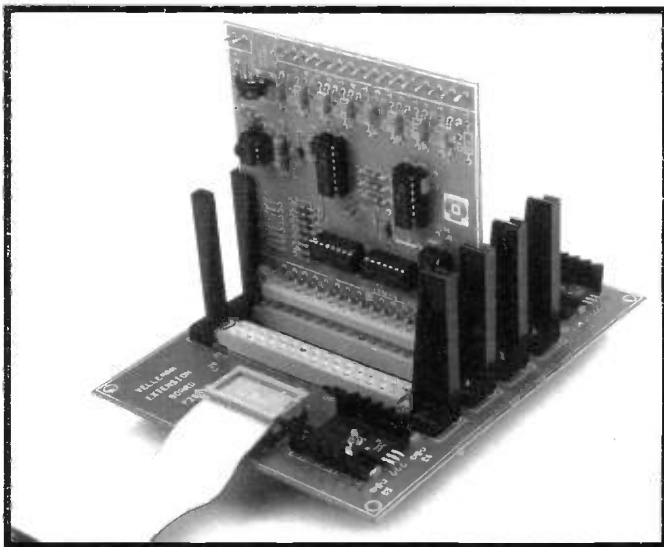

The Opto-Coupler Input Card installed in the expansion unit.

<b>CAPACITORS</b>		
C1-8,11-14	100nF	12
C9	100pF Ceramic	1
C10	56pF Ceramic	1

<b>SEMICONDUCTORS</b>		
IC1	4051	1
IC2	74LS175	1
IC3	CA3130	1
IC4,5	74LS136	2
IC6	74LS05	1
ZD1	6V2 Zener Diode	1

<b>MISCELLANEOUS</b>		
	8-Pin IC Socket	1
	14-Pin IC Socket	3
	16-Pin IC socket	2
	PCB Pins	18
	31-Way PCB Plug	1
	31-Way PCB Socket	1
	PCB Guides	2
	Screw M3 x 10mm	4
	Nut M3	4
	Self-Tapping Screw	2
	PCB	1
	Instruction Booklet	1

### 8-CHANNEL MULTIPLEXER CARD PARTS LIST

RESISTORS: All 5% 0.6W Metal Film (Unless specified)

R1-8	100k 1% Metal Film	8
R17-27,33	4k7	12
R28	10k	1
R29	30k	1
	or 15k	1
	or 7k5 (see text)	1
R30	7k5 1% Metal Film	1
R31	220Ω	1
R32	1M	1
RV1	22k Preset	1

OPTIONAL (Not in Kit)

	SPST Octal DIL Switch	1	(XX27E)
--	-----------------------	---	---------

The Maplin 'Get-You-Working' Service is available for this project, see Constructors' Guide or current Maplin Catalogue for details.

**The above items (excluding Optional) are available in kit form only.**

**Order As VE98G (8-Bit MUX Card Kit) Price £26.95.**

Please Note: Some parts, which are specific to this project (e.g., PCB), are not available separately.

Car Headlight Alarm continued from page 37.

### CAR HEADLIGHT ALARM PARTS LIST

RESISTORS: All 5% Metal Film

R1-4	47k	4
R5	220k	1
R6,7	470Ω	2
R8,9	10k	2
R10	1M	1

CAPACITORS

C1	100nF Ceramic	1
C2-6	22μF Electrolytic	5
C7	470μF Electrolytic	1

SEMICONDUCTORS

IC1	40106	1
IC2	4070	1
TR1	BC547B	1
D1-7	1N4148	7

D8,9	1N4000	2
ZD1	2V4	1

MISCELLANEOUS

BZ1	Piezo Buzzer	1
J1	3-Way Terminal Block	1
J2	2-Way Terminal Block	1
	14-Pin DIL Socket	2
	Instruction Booklet	1

The Maplin 'Get-You-Working' Service is available for this project, see Constructors' Guide or current Maplin Catalogue for details.

**The above items are available in kit form only.**

**Order As VF24B (Headlight Alarm Kit) Price £10.95**

Please Note: Some parts, which are specific to this project (e.g., PCB), are not available separately.



- ★ Do you have difficulty in getting hold of your copy of 'Electronics - The Maplin Magazine'?
- ★ Does your Newsagent always sell out before you can get your copy?
- ★ Are you fed up with braving the onslaught of wind, rain and keep fit fanatics in your ceaseless quest to find a copy of your favourite electronics magazine?
- ★ Do you say to your family and friends, "I'm just going outside, I may be gone a little while...?"
- ★ Does your dog hide when you return empty handed?
- ★ Do you resort to reading the Beano, Dandy, Viz or other well known 'comics'?

Then why not ask your friendly local Newsagent to reserve or deliver every issue of 'Electronics - The Maplin Magazine'?

Fill out the coupon (below), hand it to your Newsagent and you need never miss an issue of 'Electronics - The Maplin Magazine'.

Dear Newsagent

Please reserve/deliver (delete as applicable) each issue of 'Electronics - The Maplin Magazine' for me.

Name \_\_\_\_\_

Address \_\_\_\_\_

Signature \_\_\_\_\_

'Electronics - The Maplin Magazine' is published monthly and is distributed through your wholesaler by: United Magazine Distribution Ltd., 1 Benwell Road, London N7 7AX. Telephone: 071-700-4600.

**A readers forum for your views and comments.  
If you want to contribute, write to:**

**The Editor, 'Electronics – The Maplin Magazine'  
P.O. Box 3, Rayleigh, Essex, SS6 8LR.**

### **The Debate Continues (Heatedly)**

Dear Editor,  
While reading 'Air Your Views' in Issue 64 (April) I was a little concerned to see the argument developing about using the PC as a viable project base. Judging by the replies to both Mr. Smith and Mr. Hall, it would seem that it is your project designers and staff writers who are out of step with what the customer wants. What your project designers seem to forget is that we, the customers, are not 'professionals', and so shouldn't have the 'industry standard' PC forced on us. Your reader market is amateur by definition, so will most likely own 'home computers', not office PCs. The situation is like that of a few years ago when the BBC micro was pushed as the 'home micro 8-bit standard', despite the fact that most of us couldn't afford one. Similarly we can't now afford to spend another £1,000 or whatever on a PC. Also your comment that the PC must be popular because you sell lots of P/I/O cards must be flawed, because there is no other similar card for any other machine sold by Maplin to compare this with. The statistical significance of a sample of one is suspect. Why are there no other 16-bit cards, and why are all the 8-bit projects Maplin used to stock now discontinued? Forget about the industry and its standards, get back into the real world of the amateur again. Sorry to have gone on, but it needed to be said.  
**Barry Heath, Nottingham.**

*(Letter shortened)*  
*Crikey, have we stirred up a hornet's nest or what. Okay, let's try to clarify our point a bit better, if as briefly as possible, because of the industry's choice the world is now so populated with PCs that:* 1. *Very many of them are used in homes;* 2. *Due to be phased out (but still powerful) models can be bought for £250 – £550 new;* 3. *Some second-hand ones can be got for less than £100;* 4. *The software availability base is truly huge, thus encouraging domestic usage;* 5. *Our P/I/O card sells unusually well for such a specialised application. Other 16-bit machines don't seem to be quite as well catered for as the PC in a general sense. As for the 8-bits, the only reason we don't still sell the old cards is that people stopped buying them years ago. Why stock projects that no-one buys? Cold, heartless business logic dictates that it is not economically viable for Maplin to continue supporting them. Sorry! It's a tough life, as the saying goes. But we don't stop selling things that still sell. However, this shouldn't prevent us publishing a reader's 8-bit ideas, if relevant to a project, as a 'Circuit Maker'.*  
*As regards sales comparison, we know how many 8-bit cards we sold, and the P/I/O card has already outsold them several times over.*

### **Blinking, Bleeping Nuisance**

Dear Sir,  
It is not uncommon, when travelling on the road, to see vehicles indicating an imminent change of direction, which in fact the driver has no intention of carrying out. This is often due to poor positioning or illumination of the dashboard warning light, combined with a failure of the self-cancelling feature of the indicator stalk to switch off. In some cars the driver may be able to hear the clicking noise from the flasher unit itself, but a person with some degree of hearing difficulty may not. My hearing is not as good as it could be, and for that reason I have given thought to some form of amplified sound warning device to alert me to

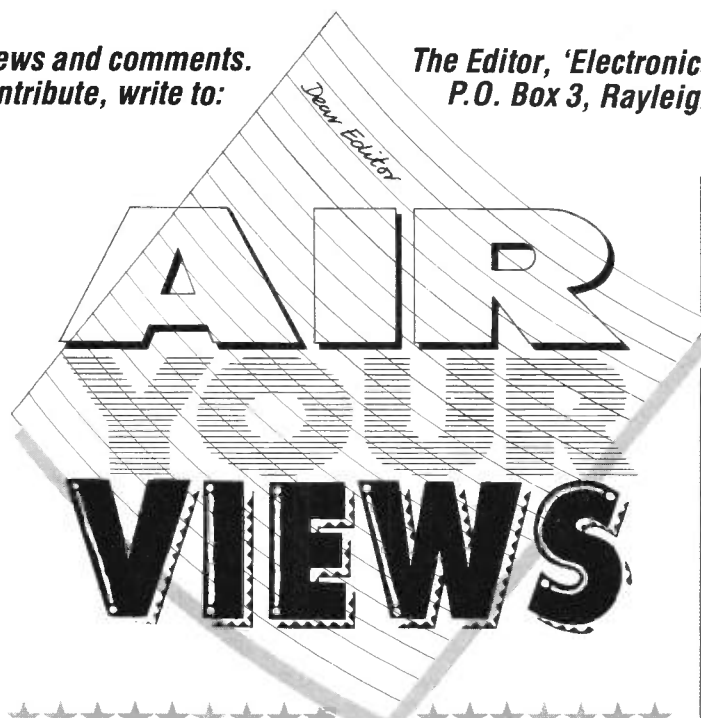

**STAR LETTER**

*This month's Star Letter Award winner of a £5 Maplin Gift Token is Mr. M. H. Dempsey, Epsom, Surrey, about the design of the NICAM Tuner Kit.*

### **An Ugly Duckling?**

Dear Sir,  
Some thoughts for your perusal! Why don't you put the NICAM decoder in a prettier box and give it an internal power supply? I can't believe that many people want a thing that looks like a piece of laboratory test gear perched on top of the TV set, or yet more spaghetti hanging out of the back! After all, most home entertainment equipment these days comes in a slate-grey box with discrete legends, not huge white buttons and massive lettering. You could say, "Well, make your own", but this is one area where it is very difficult to obtain a professional finish. And yes, I did read the article in the Maplin Magazine! Doesn't anyone make a box that does not look like it is home-made? What I would like to see is a range that looks like the 19in. rack mounting units, but without the handles and fixing wings, i.e. something in a nice charcoal-grey paint finish, like you get with Hi-Fi units. The plastic boxes you do at the moment are the prettiest, but are not very strong and cannot be screened/earthed. The metal boxes tend to have shiny aluminium fronts and tacky vinyl tops. I am a bit puzzled by the 2-way data switch box on pages 178/9 of the current catalogue. Why are all the D connectors female? If it is intended as a "T" switch for two computer printers, then the one on the flying lead needs to be male to match the parallel port on the computer! P.S. Can't you add the cost of your catalogue to the magazine subscription? My local branch of WHSMITH shut some time back, and my copy is usually six months out of date by the time I get around to ordering the new one!

*The Maplin NICAM decoder project ended up in its original case because that was the only practical option. A pretty case and injection-moulded front panel could have been made available, but the cost would not have been justified – owing to the low numbers of units involved, chances are that the price of these two items would have been that of the rest of the components put together! Mass-market items are*

*different though, and this explains why the ready-built Pro-Sound unit (GL43W) ended up in pukka packaging. We do sympathise with you – after all, many hobbyists end up building certain pieces of equipment simply because it is not commercially available – or is sold at a grossly-inflated price. The NICAM project was one of the first, if not the first, stand-alone decoder of its type – at the time, no 'mass-market' existed! An external PSU, by the way, was used for safety reasons. Plastic boxes do not, it is true, offer much screening potential, but they can be coated internally with electrically-conductive paint. We cannot do much about the strength, although most offer internal bracing for added rigidity. Next we move onto computers, and more specifically the 2-way data switch box. The 'printer' port connector on the back of your PC (indeed, most computers with a parallel port) is, as you say, a female 25-way 'D'-type. The convention is that ALL games and parallel ports are FEMALE, and ALL serial ports are MALE. Using a male-to-male 'D'-type lead, you can connect the computer's parallel (printer) port to the switch box. Then another 'D'-type male to Centronics male (adaptor) lead can thus be connected between the switch box outlet and the printer. If another computer user wishes to share the printer with you, then another male-to-male 'D'-type lead will be required – if you are fortunate enough to have a second printer at your disposal, you will need another 'D' type male-to-Centronics male lead. To be consistent with the convention, all the connectors on the computers AND the switch box are FEMALE, whereas all the connectors on the leads are MALE. Since there will always be subscribers who already have catalogues, or do not want catalogues, a great deal of additional paperwork would dog a 'catalogue with subscription' scheme. However, the catalogue can be obtained through our Mail Order service (contact (0702) 554161 for details) if you do not have a Maplin shop or WHSMITH outlet locally.*

this situation. A small speaker to give a short duration bleep, the level of which to be adjustable. I have in mind a simple, inexpensive unit with a sensing device to pick up a signal from the flasher system. Perhaps this could be achieved with an optocoupler of some sort. If the idea is developed by one of your boffins it would make quite a useful and interesting project, for a published design and kit of parts. What do you think?

**N. Jerram, Crowthorne, Berkshire.**

*Actually this can be done very easily. All you need is a bridge rectifier block such as QL10L, and a buzzer FL40T. Both of these can be easily screwed to a convenient panel or board to fix under the dash. Connect the AC leads of the rectifier between the two left and right indicator lamp circuits. Wire the buzzer to the (+) and (-) outputs of the rectifier. In action, when the indicators of one side are switched on by the flasher, the other side remains at 0V via the lamp filaments (because they're not on). The buzzer beeps in time with the flasher. If a hazard flasher is used it won't, because both sides will be at the same potential all the time. Word of warning, though – before motorcycles had self-cancelling indicators (now done with a timer), the bleeper idea was tried, and it drove everybody bonkers! 'Treatment' with wire cutters soon became very popular!*

### **Built-In Security – The Fax**

Dear Sir,  
I am writing regarding an article which appeared in News Report Issue 62 (February). The article entitled "Fax with Integrated Encryption" caught my eye, as I am a Fax Service Engineer, and I like to keep abreast with the latest technology. The article describes a plug-in unit which allows fax transmission and reception between similarly coded units only, thus eliminating the problem of a sensitive document being intercepted or sent to the wrong destination. A similar system of encoding has been present on nearly all the range of Canon fax machines for approximately five years, and is called 'Closed Network ID'. An ID code (8-bit binary) is set into the machine by a key operator or engineer and then the mode of operation is set. You can have the machine completely isolated from transmission or reception with other machines without the same code, or you can set it to have restricted transmission and unrestricted reception, or vice versa. But the best part is that it is a standard feature, so you don't have to pay extra money to get confidentiality. On a different note, I have noticed in the semiconductors section of the electronics bible that certain items have data sheets available. Do you have data sheets for all ICs? Could you possibly print a brief list of available data sheets? Finally, with reference to Mr. Moulton's suggestion about 'Maplin Electronics' labels for kits. Why not sell the labels separately in strips, so those of us who are proud to have the Maplin name on our projects can order as many labels as we want!  
**R. E. Gosling, Stoke-on-Trent.**

*Data sheets are available for all ICs currently sold by Maplin. To obtain a data sheet, order as DS00A and write, in the description box of the Order Coupon, "FOR IC No.", followed by the part number of the device (e.g., 741, 6502, MAX232, etc.), and its order code (do not put the latter anywhere on the coupon where it could be confused with an order for that device – unless you do want it, of course!). The cost is 80p per data sheet.*

# Stray Signals

by Point Contact

When PC was a lad, his Dad used to buy him a weekly comic. Or rather two, but since paper was still scarce just after the Second World War, the 'Dandy' and the 'Beano' used to appear on alternate weeks. They continued coming long after PC had really grown out of them, so when Pa asked if I wouldn't like something else instead, I said "Yes, 'Camm's Comic' please". If this name means nothing to you, you are clearly not one of our older readers. The said popular wireless magazine, colloquially if irreverently so known, had been edited by someone known as FJC since long before the war, and he continued up to at least 1958, to my knowledge. I recently met an interesting senior citizen who had worked for FJC before the war. She said that she thought he was probably, first and foremost, a journalist: certainly he would take a book home one evening and then dictate an article about it the following morning, whilst pacing up and down the office. Maybe, like so many in the world of wireless in those days, he had started out as a mechanical engineer; certainly PC can remember a cycle shop, in Acton High Street, which sold wireless components until long after the war. Anyway, FJC certainly caused me some trouble.

After I had graduated from 2V battery valves and components, all connected up with scruffy bits of double cotton covered wire and terminals, to mains

valves and soldered joints, my usual method of making a joint was to solder the wire to the tag as simply and quickly as possible, in my hurry to get the whatever-it-was working. Then I read a comment by FJC, that every joint should be a sound mechanical joint before ever it was an electrical one. Impressed by the idea, in my next effort each carefully scraped wire was passed up through the turret tag, or through the hole in a tag on a tagstrip, and neatly wound round for a couple of turns before being soldered. The result was fine, if no more reliable than before, at least up until two weeks later. By that time, I had decided to build a something-else, which due to absence of cash for more components, meant dismantling the whatever-it-was. After that, I returned to lay-on joints for good. Then, in the late 1960s, flatpack devices appeared and these were secured by reflow soldering – using the electrical joints also as mechanical ones. FJC must have turned in his grave. Now that we have full surface-mount construction he must be turning at about 3,000rpm!

Any thinking person must be concerned about the environment and what the activities of man are doing to it. So it's comforting to know that under the Montreal Protocol, the use of CFCs (chloro-fluoro-carbons, used in quantity in electronics production for cleaning flux residues off of printed circuit boards, amongst many other uses) must be

phased out by the year 1997. Let's hope that all the signatories to the convention keep their word, so that CFCs will no longer be produced. However, it is a sobering thought that there are, even now, an estimated three million tons of used CFC compounds in the various countries of the world. But a team in Japan have developed a process which electrically decomposes CFCs at high temperature – around 10,000°C - with the aid of water and caustic soda, reducing them to harmless salt and fluorites. The process is apparently almost 100% effective, in disposing of the CFC, so let's hope it is widely adopted, assuming that is that the International Community can decide whose job it is to pay for the work. As a first stab, why not make it the responsibility of the chemical companies which produced the CFCs in the first place? Meanwhile, another invention, this time British, is already being exploited. With eggs and chicken being such popular items in the family diet, due to their high nutritional value and low-cost, we have around one and a half million tons of chicken droppings to dispose of annually. Whilst some can be used as a natural fertiliser, it usually tends to pile up faster than it can be used. However, an inventive farmer in East Anglia has a fully operational power generating plant fired exclusively by the stuff, producing over 12MW of electricity. This only amounts to a tiny fraction of 1% of the country's electricity needs, but it is a start, and of course the fuel is a renewable resource.

Yours sincerely,

*Point Contact*





### 3. The Third Attempt: The Pascaline - Mechanisation Arrives

by Gregory M. R. Grant

The computer business divides neatly into two – analogue and digital. Both words describe methods of estimating phenomena and the difference lies in measuring as opposed to counting.

In part two we looked at the slide-rule – a device that measured. Now we take a look at the earliest device used to count – the mechanical calculator. This owed its creation to yet another thankless task, that of tax-collecting.

Blaise Pascal was the gifted, mathematically-minded son of the tax commissioner for Upper Normandy. Young Pascal, a crippled hunch-back, in agony from a nervous illness, had some startling mathematical achievements behind him, when as a teenager in 1642, he turned his attention to solving his father's problem.

Over the next couple of years, he toiled away at finding a solution to his father's problem of endless counting and lengthy adding calculations. He looked at a whole variety of ideas, designs, materials and components, until he came up with the arrangement shown in Figure 1.

What he did was number the teeth around the circumference of a gear-wheel, which gave him a mechanical system similar to the beads of an abacus. He then made the tooth at the top the significant one by placing a viewing window there. Very clever, so far.

Now all he had to do was create a gear ratio that related to the substance or material he intended to measure – in this case a national currency. He had to

# The History of Computers

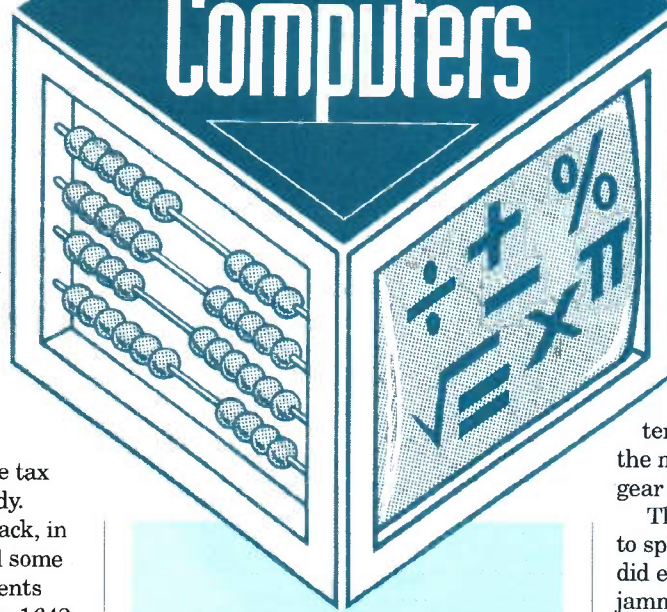

devise some way of linking this gearing arrangement so that it would perform 'carry' functions. Let's now look at what he came up with. The windows on gear-wheels C and A in Figure 1 read 21. Since gear-wheels A and B are joined on a common shaft, B rotates along with A. This means that every time A completes one revolution, the pair of teeth on B move C further along by two teeth or – since it has 20 teeth in all – one 'tooth' of a revolution.

Pascal termed one wheel the 'setting' wheel and the other the 'result' wheel. In fact, he had created what is now known as a two-register calculator, with the gears representing the quantities.

Although it could perform the four

major mathematical functions, the neatly-boxed little Pascaline, which on paper seemed very promising, in practise did not perform very well at all.

To begin with it contained from five to eight axles, each of which carried three gears with another perpendicular gear linking the axles to the indicating dials at the front. The numbered drums were also located on the axles. So, as a ten was 'carried' the ratchet between the main gears pushed the next highest gear forward and so on, down the line.

The ratchets of course were intended to speed the 'carrying' operation, but did exactly the opposite, for they usually jammed! This was hardly surprising, given the axle loading. No matter, the inventor pushed his creation, as vigorously as his health would allow, and a wide variety of people trooped through the family living room for a free demonstration. Whilst they were all impressed, not to say astonished by this elegantly-boxed piece of technology, the Pascaline was not a commercial success. There were three main reasons for this.

For starters its price – about £100 – was more than enough to keep a modest 17th century French family for the best part of a year. Secondly, there was an early indication of Luddism among clerks and accountants, and those that later became professional administrators. They deeply distrusted this mysterious enclosure with its spinning dials and muted internal clanking.

Finally, and perhaps less obviously, there was a new factor to consider – the technology of it all.

To manufacture such a device required considerable skill, and since the Pascaline was among the very first of its kind, practically none was available. Not only that, skilled craftsmen were expensive and the work involved was very time-consuming, which further increased costs.

If the Pascaline's manufacture was at the forefront of the technology of the time, its maintenance was even more so. Suitable 'service engineers' that were available, were few and far between, concentrating in the largest cities. They were also a deeply conservative crew, for example, not understanding why the odd bit of dirt in a gear could contribute to its inefficiency. After all, the gears of a corn mill were more or less permanently dirty and yet the mill still ground corn! Admittedly, perhaps more slowly over a

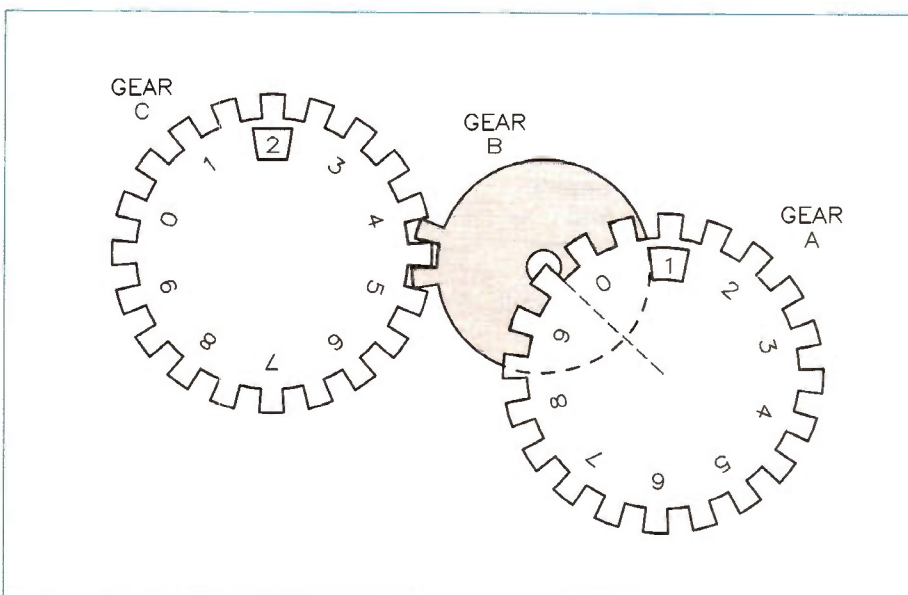
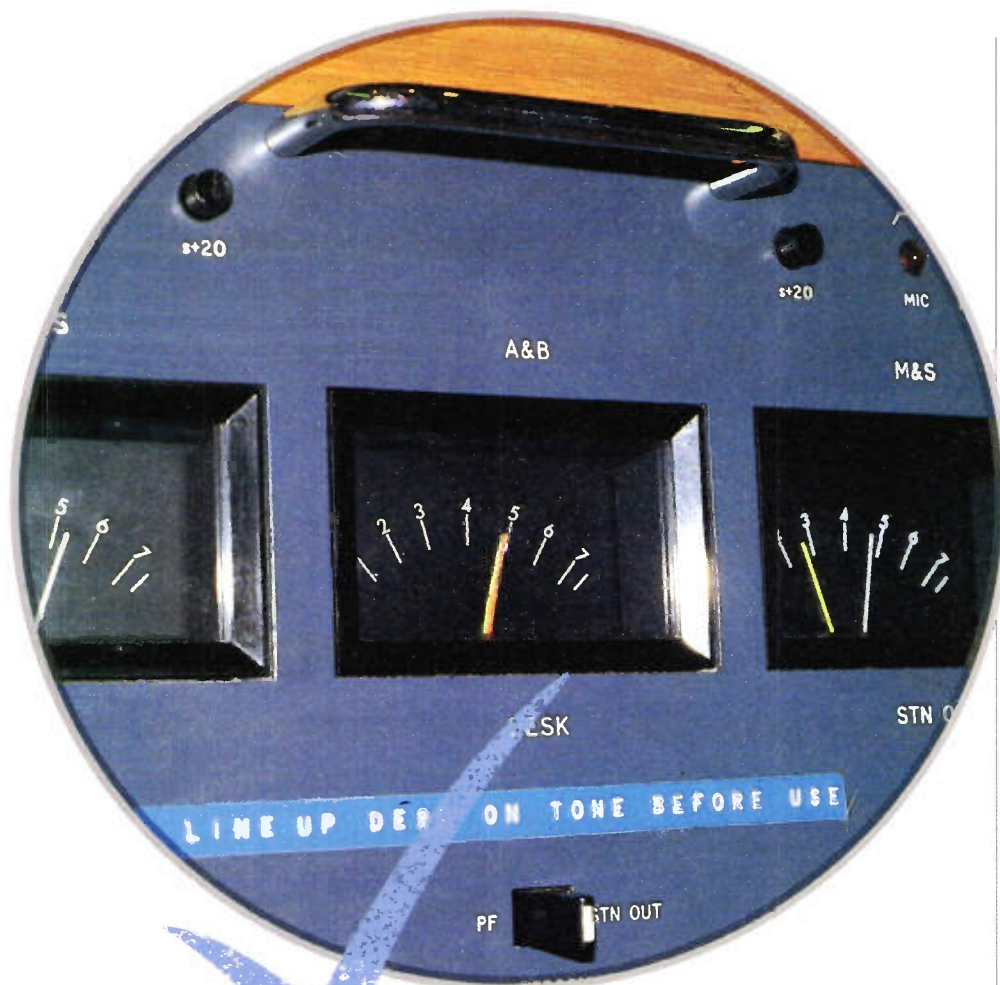

Figure 1. The 'Pascaline's' gear arrangement.

Continued on page 52.



# A GUIDE TO PROFESSIONAL AUDIO PART TWO

by T. A. Wilkinson

## Understanding Microphone Specifications

In the next three parts of this series, we take a look at what is perhaps the most commonly found and humble source of audio signals – the microphone. I shall introduce the various types and their polar patterns, and examine the techniques of using microphones and methods of amplifying low-level microphone signals.

Regular readers (aren't they all?), will recall an excellent feature on the theory of microphones by J. M. Woodgate in Issue 46 of 'Electronics' (October 1991). This article covered a lot of ground, and as it is not my intention to repeat what has gone before, I have tried to make this article complementary to Mr. Woodgate's, and as such will be mostly looking at the practical aspects and applications rather than the theoretical aspects. Anyone wishing to re-cap on the theory would benefit from looking back at this article.

Within the professional industry, there are literally hundreds of different microphones to choose from, with prices ranging from tens of pounds to thousands of pounds. Whilst the old saying 'rubbish in, rubbish out' may apply to a certain extent, 'most expensive' does not necessarily mean 'best'. It really is down to how the unit is used. To illustrate this point, I was once privileged to be a witness at a 'blind' listening session of various types of microphones. These were all used under the same conditions, with the same musical instrument being played by the same musician, and recorded using the same accompanying mixing and recording equipment. Prices of units under test ranged from around £30 to around £200. The test was quite simple – the instrument was played and recorded onto one track of a multitrack tape recorder. The microphone was then replaced with a different unit (taking care to reset the relative recording levels!), and recorded onto a different track of the tape. This was repeated for each microphone and the resulting recordings were assessed by switching between tape tracks whilst replaying the tape. The overall most liked sound (said to be the 'most natural') came from a low-cost unit that retailed for around £50. The expert judges were quite stunned...!

Microphones, like loudspeakers, are really quite subjective, and what one person may find quite 'pleasant', another will find objectionable, and most people who use them frequently will have a favourite range of 'stock' units which they will use for particular applications.

## Connectors and Impedance

The connectors most commonly used with microphones are the 3-pin XLR types, as described in Part 1. The microphone body itself will normally have a 3-pin male XLR built into it; possible exceptions to this are stereo units and the like, which may have special multipin connectors.

Microphone impedance falls neatly into two categories, High Impedance (Hi-Z) and Low Impedance (Lo-Z). Hi-Z microphones produce greater output levels than Lo-Z types, but are more prone to hum and buzz problems, and without careful matching to input stages can suffer severe loss of high frequency information. Furthermore, Hi-Z units are limited to only a few metres of cable run.

In order to overcome these problems, and to allow very long interconnecting cables to be used, most professional microphones will be of the low impedance variety – typically 200 to 600Ω – and their output will be balanced. This impedance may not necessarily be simply the impedance of the transducer, but an artificial figure created by the use of a transformer, or perhaps a pre-amp built into the body.

What is of crucial importance is the load impedance into which the microphone will operate. Manufacturers should

give details of minimum load impedance and impedance of the microphone itself, although the former, rather than the latter, is arguably more useful.

Commonly encountered impedances of most microphone input stages will be around the 1kΩ figure, and many manufacturers indicate this to be an optimum operating value. As a rule-of-thumb, microphone amplifier input impedances should typically be around 5 to 10 times that of the actual output impedance of the microphone.

## Sensitivity

The sensitivity of a microphone, often called the 'free field sensitivity', is a measure of the quantity of output voltage that can be expected for a given amount of sound pressure acting on the transducer. Free field sensitivity is determined by measurements conducted in a free sound field with the microphone in 'open circuit voltage' (unloaded) state.

Because the quoted sensitivity of a microphone must relate units of pressure to voltage units, sensitivities are often quoted in rather strange and unfamiliar units of measurement. To further complicate matters, not all manufacturers and suppliers use the same method of expressing microphone sensitivity.

The most often encountered units of sensitivity are listed below.

**(i) dB relative to 1V/dyne/cm<sup>2</sup>.**

Old Centimetre, Gram, Second system still quoted because of its operational usefulness.

**(ii) dB relative to 1V/newton/m<sup>2</sup>.**

Metre, Kilogram, Second units. To convert to 1V/dyne/cm<sup>2</sup>, subtract 20dB.

**(iii) dB relative to 1V per pascal.**

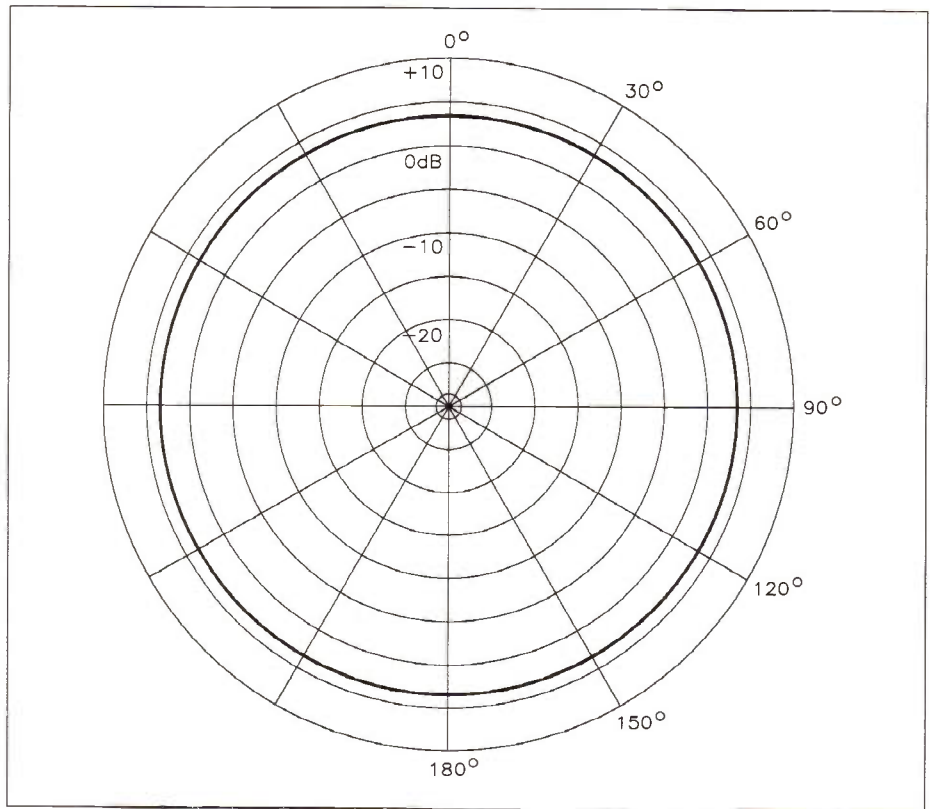

Figure 2. Horizontal directional response of a typical omnidirectional microphone.

The pascal (Pa) is the SI unit of pressure. 1Pa = 1N m<sup>-2</sup>. Thus -45dB relative to 1V N<sup>-1</sup> m<sup>-2</sup> = -45dB relative to 1V Pa<sup>-1</sup>

**(iv) Millivolts per 10μbar or millivolts per μbar.** 1 pascal = 10μbar. The bar is a non-SI unit of pressure.

The relationship between the voltage/pressure units given above is:

$$\begin{aligned} 1\text{V}/10\text{ dynes/cm}^2 &= 1\text{V N}^{-1}\text{m}^{-2} \\ &= 1\text{V Pa}^{-1} \\ &= 100\text{mV}/10\mu\text{bar} \end{aligned}$$

Perhaps the most useful unit of measurement is (i), as this can be very approximately directly related the common zero level (0dBu) convention used within the industry. Therefore a microphone with a quoted sensitivity of -65dB relative to 1V/dyne/cm<sup>2</sup> will require amplification of roughly 65dB to bring it up to zero level, and so interface with the rest of the audio chain.

If all of this sounds confusing, then that's because it is! In order to simplify things a little, some suppliers quote microphone sensitivities as a simple dB or voltage figure. For example, microphone YJ75S is said to have a sensitivity of '-76.5dB' (109μV). Without further information, though, this figure is useful but limited as we have no Sound Pressure Level (SPL), and thus no yardstick to relate this to.

In actual fact it is likely (but by no means certain), that this figure of -76.5dB is a measure of the open-circuit output voltage relative to the commonly encountered 1V/dyne/cm<sup>2</sup> unit. Furthermore, as 109μV does not convert directly to -76.5dB, but equates to -79.25dB, the dB term used here is probably either dBm or dBu; converting 109μV to dBu works out much closer at -77dBu.

## Polar Patterns

There are really only two types of microphone, directional and non-directional, regardless of transducer type. Whatever the directional characteristic of a microphone may be, it will be said to possess a particular 'polar response pattern'.

Polar patterns are usually broken down into the three common families - 'omnidirectional', 'cardioid', and 'figure of eight', although there may be less common derivatives within the basic groups such as 'supercardioid', which is a descendant of the cardioid family.

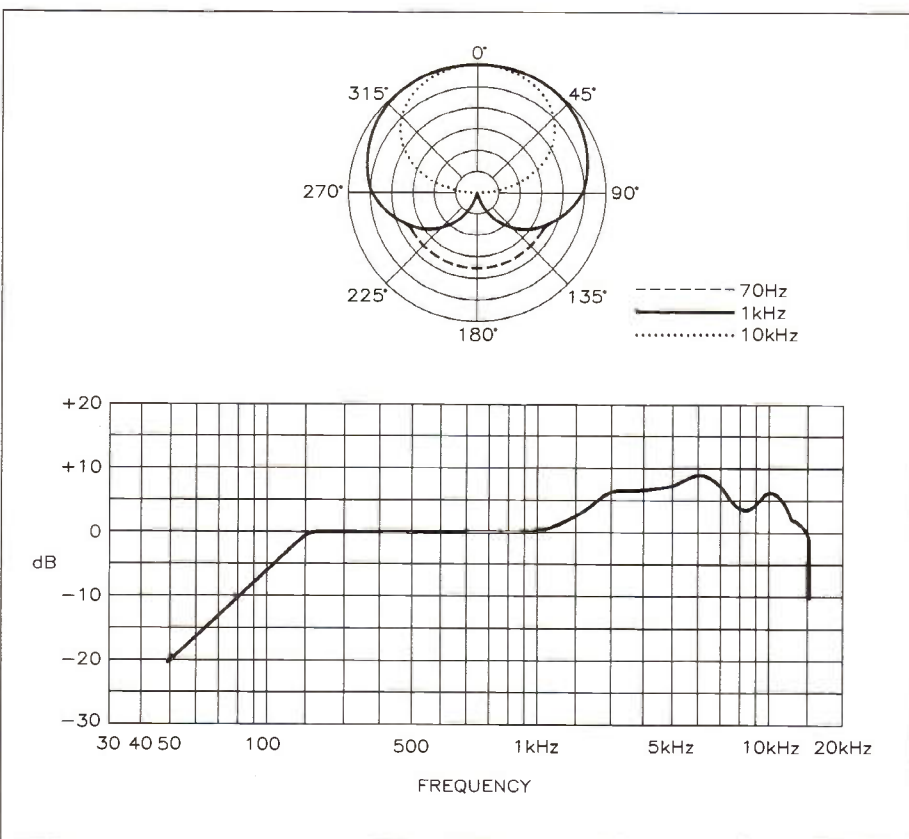
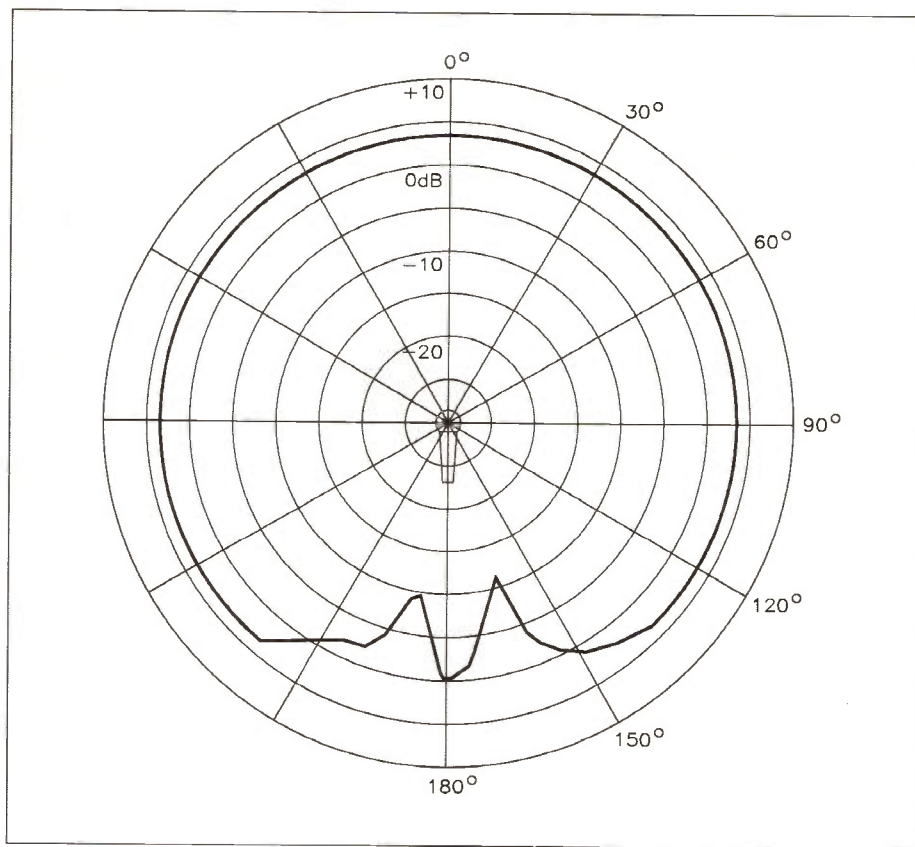

Figure 1. Frequency response graph of the Shure SM-58 dynamic cardioid microphone (BBC Microphone Data Book).



**Figure 3. Vertical directional response of a typical omnidirectional microphone.**

Polar patterns may perhaps be more accurately described as 'sound field capture patterns', and are usually presented in illustrations as two-dimensional diagrams. This is unfortunate because microphones are three dimensional devices, and so a little imagination is called for when examining these diagrams. It is important to realise the axis of the diagrams (horizontal or vertical), and the relative orientation of the transducer within the diagrams.

It is worth noting that, depending on manufacturer, diagrams are scaled using either voltage or dB units as a way of illustrating the microphone's sensitivity. With certain types of microphone, the voltage and dB scale will present quite different polar patterns when comparisons are made between the two.

The frequency at which a microphone's directional response is plotted is quite important – it is of limited value to produce a polar diagram plotted at a single frequency of, say, 1kHz; after all, the material that we are likely to feed into the microphone will comprise not one, but a mixture of many frequencies.

Fortunately, many manufacturers realise this and provide as many as six spot frequencies on the same diagram. Quite right too – after all they are trying to sell us a product, and if they do not reveal all then perhaps they have something to hide!

Manufacturers also produce frequency response curve graphs for their microphones. These give frequency response information across the usual audio spectrum of 20Hz to 20kHz and, where applicable, show the effects of using the microphone's 'bass cut' switches.

A typical example of such a graph, based on a cardioid unit, is shown in

Figure 1. This represents the microphone output voltage on a dB scale at various frequencies – note the gentle roll-off below 100Hz, and the slight 'peakiness' at mid-range and treble frequencies between 1 and 12kHz.

## Omnidirectional

By the very description of the word itself, 'omnidirectional' microphones provide (nominally) the same amount of signal output from sound sources in all directions. In addition, 'off-axis' frequency variation (subjectively manifesting itself as 'colouration') is less than with certain other types of microphone, such as cardioid. Certainly from the front and sides this would be the case; however, from the rear of the unit this would not be absolutely true, and a slight reduction of sensitivity, together with an uneven frequency response, would occur.

Figure 2 shows the horizontal axis response of a typical omnidirectional microphone. As can be seen, the microphone response in this plane is basically a circle with equal sensitivity in all directions. Figure 3 shows the vertical axis response, which is almost circular but has frequency response colouration at the bottom, attributable to the microphone body itself. This colouration is most prominent and severe at high frequencies.

Omnidirectional microphones have many uses, and are particularly suitable for ENG (Electronic News Gathering) applications, such as radio and TV journalism, and for use in general conference situations. In ENG applications, the omni mic can be positioned between the interviewer and the interviewee, and should capture an equal amount of sound from both parties without the need to point the mic directly at either. A possible added bonus is the fact that the mic will also capture a certain amount of ambient background noise.

Of course, this is only a bonus if you actually want background noise, and in some cases this may be particularly undesirable, but a radio journalist conducting an interview in a street market, for example, would want to capture the colourful, noisy, ambient surroundings. Should our jolly journalist wish to exclude the ambient noise, a microphone with a 'tighter' (i.e. less widespread) polar response would need to be pressed into service, but this also means pointing the microphone in the right direction!

Classical and orchestral music were, and still are to some extent, prime candidates for using good quality, well-positioned omnidirectional microphones. Many producers of this type of music like the natural sound that omnis are capable of producing, with their very even frequency response and sensitivity. The frequency response of an omni can, in this situation, out-perform even the most expensive of cardioid types, particularly where low frequencies are concerned.

As you may have gathered, omnidirectional microphones suffer from one possible drawback. Their inherent



**A range of professional microphones – from left to right; Coles Lip Ribbon, AKG D202, Shure SM58, Beyér M201, AKG C451, AKG C414.**

ability to pick up sound from a wide-spread area means that if used without due thought, they can produce quite unacceptable results.

If, for example, an omni was used to make a recording in a room with 'lively' acoustics, such as a sports hall (lots of reflected sound/reverberation), the mic would, wanted sound apart, also pick up much of the sound which has been reflected off the large flat wall and floor surfaces. The result would be a very muddled-sounding 'echoey' recording.

On the other hand, the same omni used in a room with a moderately well-damped acoustic (typical lounge or bedroom), would produce a very different recording without sounding as though it had been processed by an echo unit. These two situations are probably the extremes of the spectrum, and in most situations omni produce very acceptable results.

## Cardioid

The cardioid microphone has an inverted 'heart-shaped' response pattern, as shown in Figure 4. As can be seen, this has a more directional response than the omni, with maximum sensitivity being achieved from directly in front of the transducer, slightly less from the sides (about half) and almost no response from the rear. The 'nil' pick-up area at the rear is sometimes referred to as the 'point of maximum rejection' or 'null point', and in a cardioid this will always be at 180° to the area of maximum sensitivity.

In a basic cardioid, the directional response is achieved by using clever mechanics. Both sides of the transducer will, to some degree, be exposed to the sound source. One side (usually the front) of the transducer will be fully exposed, whilst the other side is exposed to the sound source via a mechanical

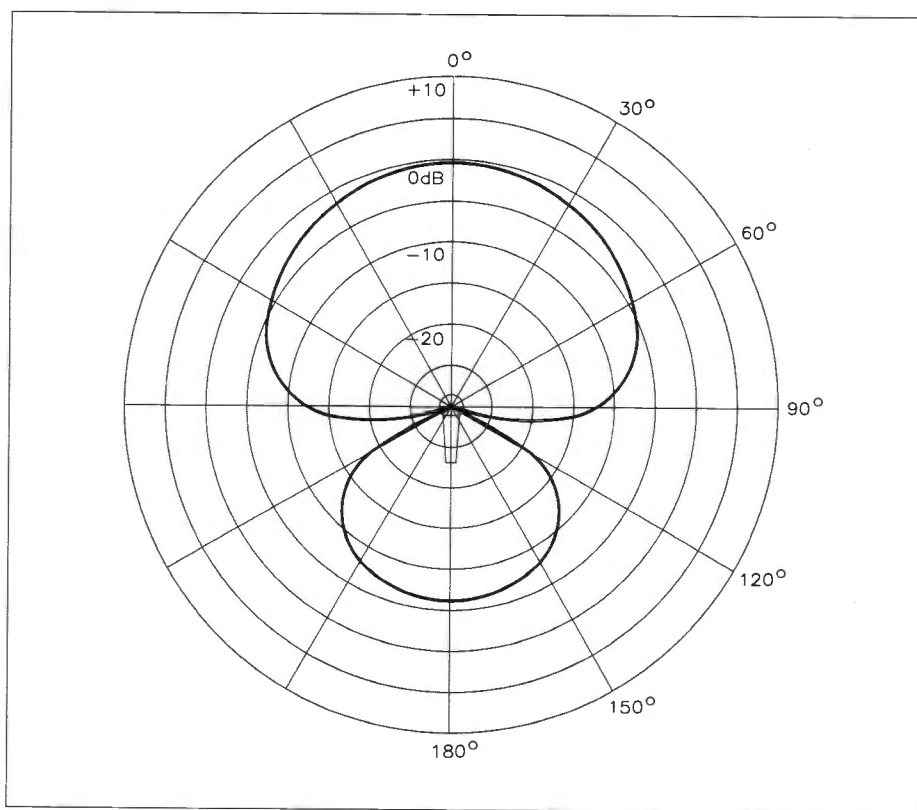

Figure 5. Directional response of a hypercardioid microphone.

system of deliberate phase error. By using the direct sound and the phase-shifted sound, phase cancellation can be employed to create the cardioid response.

In the more expensive condenser-type cardioid, the cardioid response may be just one of several response patterns available. The various responses may be achieved by electronically mixing together (adding or subtracting) the outputs of two or more transducers.

A typical characteristic of cardioid microphones is that of greatly extended low-frequency response when used very close to the sound source; this is known

as the 'proximity effect'. When the unit is placed further away, the low-frequency response progressively becomes more diminished. This is particularly apparent when one of these microphones is used by a vocalist – a 'close-miked' singer would seem to have a richer, more 'powerful' voice than a singer with the mic placed some distance away. In fact, at distances of a metre or greater, the sound may be quite thin and lacking in LF.

The proximity effect may, however, be undesirable in certain close-miked situations, and so many manufacturers provide a switchable LF filter system, which is either built into the microphone body itself or available on a remote control unit. The filter system will normally offer either (a) variable attenuation with a fixed frequency point e.g., 0, 7 or 12dB at 50Hz, or (b) fixed attenuation with variable frequency e.g., 12dB/octave at 75 or 150Hz.

Cardioid microphones are, in one guise or another, probably the most popular of modern microphones, and are to be found in every professional audio set-up in the world. Their popularity is almost certainly due to the flexibility of their directional characteristic, and in multi-mic situations cardioid units are essential if maximum separation of instruments (i.e. avoidance of 'over-spill' between instruments in close proximity) is to be achieved.

Cardioid microphones have two derivatives – hypercardioid and supercardioid. These two resemble the basic cardioid pattern, but offer a narrower field of capture and increased sensitivity from the rear of the unit.

Hypercardioid polar patterns appear as a mixture of cardioid and figure of eight (see Figure 5), with a usual amount of pick up from the front (although less wide than a normal cardioid), and a significant amount of pick up from the rear of the unit. The

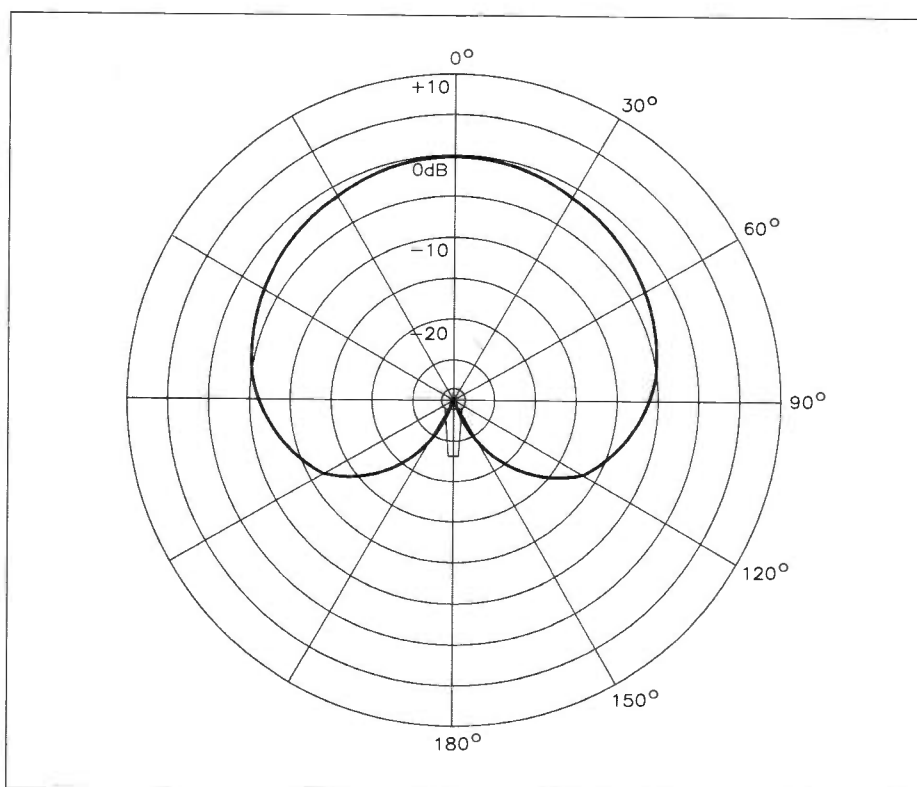

Figure 4. Directional response of a cardioid microphone.

supercardioid pattern, also known as 'cottage loaf', exhibits similar traits to the hypercardioid types but has a smaller (in some cases, very small) amount of sensitivity from the rear of the unit.

A range of cardioid microphones with even greater directional abilities exist. These have the 'ability' to 'focus' on a more distant sound source. These, referred to as 'gun mics', are used where it is not possible to get close to the object such as in TV news film work for example, or at a football match to get some 'on field' sound effects.

## Figure of Eight

Figure of eight is the least common of the three polar responses. A typical polar diagram is shown in Figure 6. Both sides of the transducer are exposed directly to the sound source, and an equal amount of maximum sensitivity is obtainable from the 0° and 180° areas but these are opposite in phase. There are two null points at 90° and 270° which exhibit minimum sensitivity, and in fact a very high level of rejection is possible at the two null points.

The applications of figure of eight microphones are sometimes a bit specialised, and include particular areas of vocal and stereo work, and also 'head to head' discussion/interview situations where both parties are sited opposite and facing each other. In this situation the 90° and 270° rejection areas to the sides can prove to be a particularly valuable asset for the purpose of reducing unwanted pick up to a minimum.

## Next Month

In the next part, we will look at the types of transducer (microphone 'inserts') that are at the heart of every microphone. We will also find out about cables and accessories.

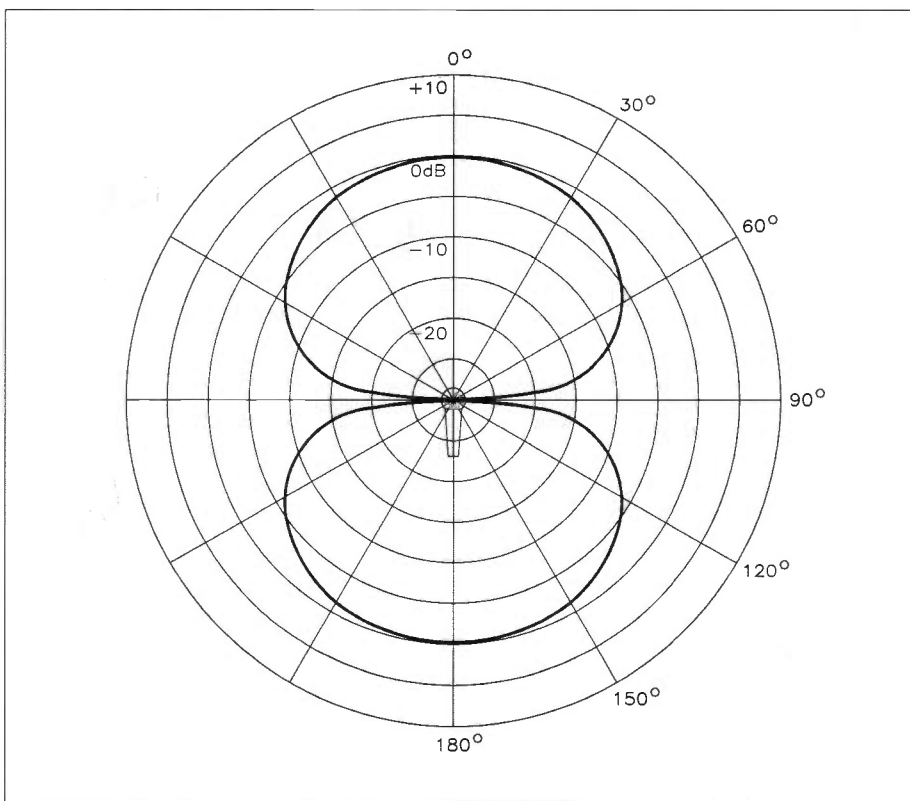

Figure 6. Directional response of a 'figure of eight' microphone.



A selection of Maplin's extensive range of microphones.

## Acknowledgments

Details on units of microphone sensitivity and frequency response graph courtesy of the BBC Microphone Data Book. Further details about the data book, and its availability, can be obtained Audio Operations, BBC Wood Norton, Evesham, Worcestershire WR11 4TF.

## References

1. Microphones, by John Woodgate; 'Electronics' Issue 46 (October 1991) pp.37 to 39, 67 to 70.
2. BBC Microphone Data Book.

Computer History continued from page 47.

period of time, but corn was still ground and flour produced.

However, the Pascaline suffered far greater disruption to its operation from dirt in its poor-tolerance gearing than any corn mill ever did. This led to slippage and therefore inaccuracy – and unhappy owners. Naturally disappointed, the Pascaline's inventor turned his powerful mind to other matters.

Among these were the mathematics of probability, the physics of fluids, and above all, the technicalities of the vacuum.

His work on the Pascaline had given him a taste for invention, and he later

developed his own version of the barometer, as well as a syringe and hydraulic press. Also, just before his death, he wrote a mathematical paper on the area of a cycloid, which pointed the way to Differential Calculus.

Of course, the Pascaline had one big flaw – its technique for multiplying and dividing. This laborious method caught the eye of one of the greatest all-round geniuses of the last three hundred years. He decided that this was just the sort of problem he could sort out. We shall discover the outcome in the next part.

To be continued...



# UNREGULATED PSU MODULE



## FEATURES

- \* Will work with both 6 and 12-Channel Mixing Systems
- \* Dual Power Supply Rails (+V, 0V, -V) for Op-Amp Circuits
- \* Fuse-Protected Outputs
- \* Versatile – up to 2A per Rail
- \* Transformers Available

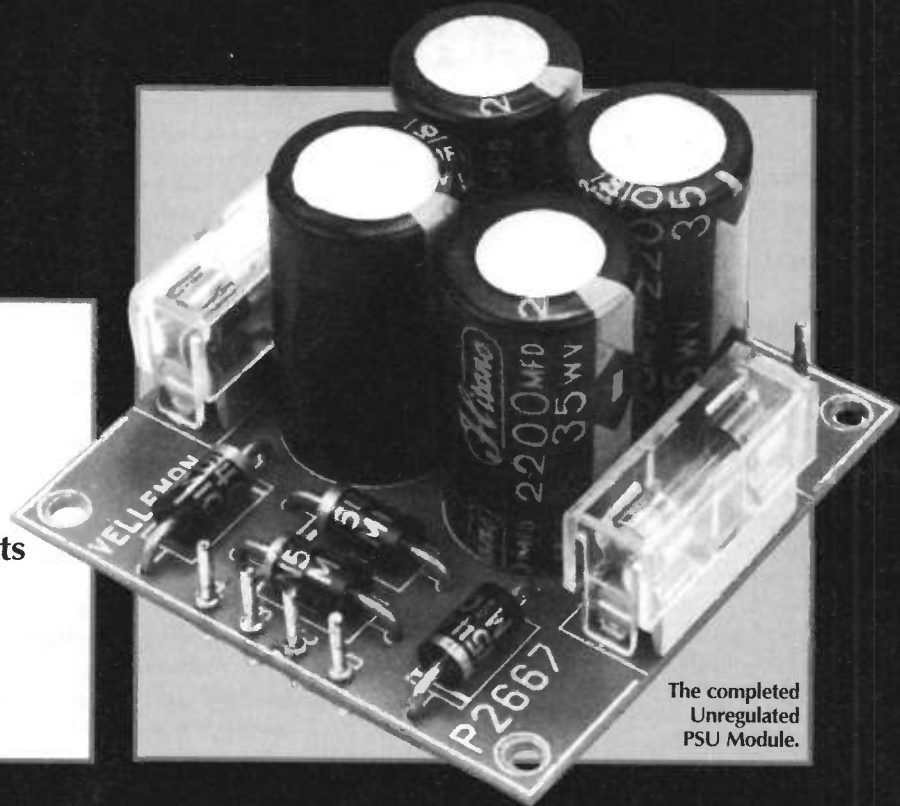

The completed Unregulated PSU Module.

This unregulated split-rail PSU module is intended for use with the Modular Mixing System, and when used with a suitable transformer (not supplied) will provide sufficient power for the various modules within the 6 or 12-channel mixers. There is nothing to stop you from using this module in the power supply circuits of other projects – the transformer requirements may vary, though. Some constraints are imposed – each secondary winding of the chosen transformer should not produce an AC voltage of greater than 18V; in addition, the current drawn from the module should under no circumstances exceed 2A.

Because the Unregulated PSU Module is a 'general purpose' circuit, a transformer is not supplied in the kit. If you are building one of the Modular Mixers, note that two suitable transformers of differing ratings are

available. If you intend to use this PSU with a 6-channel mixer, a 30VA 2 x 18V (YK12N) transformer should be used; if you are building the 12-channel version, the more powerful 80VA 2 x 18V (YK17T) transformer should be used to power the additional circuitry.

## Circuit Description

The Unregulated PSU Module is a symmetrical (+V, 0, -V) type supply, the circuit of which is shown in Figure 1. Four 1N5404-type diodes (D1 to D4) form a bridge rectifier, the two outputs (+, -) of which are 'smoothed' by four 2200µF reservoir capacitors (C1 and C2 for the positive rail; C3 and C4 for the negative rail). Interestingly, two 2200µF capacitors are used instead of one 4700µF capacitor, for each rail, to reduce the total height of

the PCB. In addition, the two smaller capacitors together have a lower overall equivalent series resistance (ESR) – this helps to reduce the noise present on the supply rails. There are also two PCB-mounted fuseholders in series with the output rails, after the capacitors. Four fuses (two 1A, two 1.5A) are supplied in the kit. The value of the fuses used depends upon the mixer used – 1A for the 6-channel mixer, and 1.5A for the 12-channel system.

Connections to and from the PCB are made via PCB pins.

## Construction

Begin by fitting the diodes, followed by the fuseholders. Next, insert the PCB pins from the component side of the PCB; use a hot soldering iron to press these in if a 'tight fit' is encountered. The final components to be

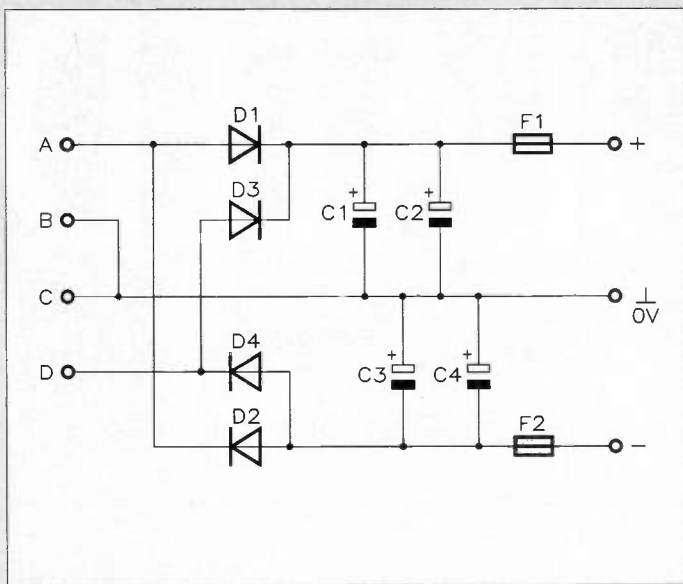

Figure 1. Unregulated PSU Module circuit diagram.

soldered to the PCB are the four electrolytic capacitors; please ensure that these components are correctly orientated as they are polarised. The PCB should now be thoroughly cleaned with a suitable solvent and checked for misplaced components, solder whiskers/bridges and dry joints. Finally, install the appropriate fuses into the fuseholders and replace the insulating covers.

The PCB is now complete, and is ready for installation.

## Transformer Secondary Wiring

Install the Unregulated PSU module, along with a suitable transformer, into its intended housing. On no account must the unit be powered from the mains until properly housed. If the transformer is a toroidal type (such as YK12N/YK17T), its securing bolt must never touch both the bottom and top halves of a metal case. If this precaution is not observed, another 'secondary' winding (short circuit), formed by the bolt and case, could result, as shown in Figure 2; this may cause severe problems and is potentially hazardous, as the transformer will be totally short-circuited! In such situations, the bolt should be trimmed to a suitable length, and a sheet of insulating material (e.g., perspex, PVC, hardboard etc.) should be glued to the area of the case just above the transformer.

If you are using the YK12N or YK17T transformers, the secondary windings should be wired to the PCB as follows: red to 'A', yellow to 'B', blue to 'C' and grey to 'D' – refer to Figure 3. If you intend to use your own transformer, then the colour coding specific to it should be followed. If your transformer has a centre tap instead of two secondary windings, connect the centre tap to pin 'B' or 'C', and the outer winding connections to pins 'A' and 'D' respectively – refer to Figure 4.

## Mains Wiring

Follow the mains wiring of Figure 3 very carefully – all exposed mains wiring must be insulated; use a insulation boot for the

fuseholder, and insulate the mains switch terminals with heat-shrink sleeving. Use a strain-relief grommet to secure the mains lead where it leaves the enclosure.

## Testing

Before testing, recheck all connections – particularly those to the secondary of the transformer, and the mains wiring. It is imperative that the latter is well-insulated, and that no possible short circuits can occur; in addition, check that the mains lead is secure.

*Remember – mains electricity can kill!*

Connect a mains plug, fitted with a 2A fuse, to the mains lead; testing can now begin. Set your multimeter range switch to 50V (or higher) and connect its negative lead to 0V (the centre output pin), and the positive lead to '+'. Connect the mains plug to a 13A outlet, and turn the mains switch on. An off-load reading of approximately 29.5V should be obtained for a YK12N transformer, and approximately 28V for a YK17T transformer. After disconnecting it from the module, refit the meter's positive lead to the 0V terminal on the board, and its negative lead to '-'. Similar results should

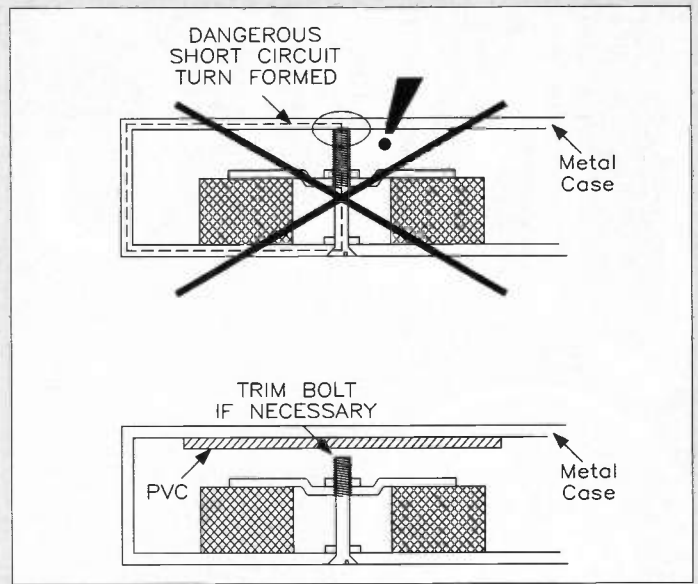
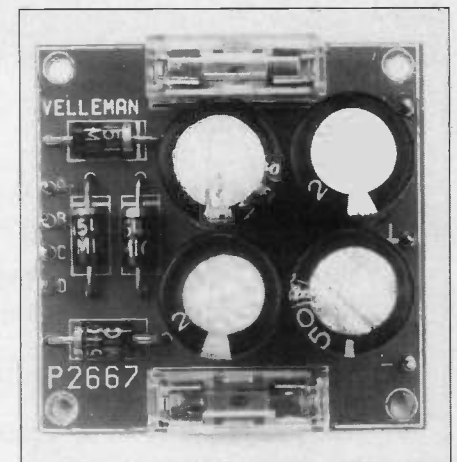

Figure 2. Fitting the toroidal transformer.

be achieved. Switch off the unit and disconnect from the mains supply. Allow the PSU to discharge and connect the output(s) of the PSU to the proposed load. Re-connect the mains lead to the supply and switch on; recheck the supply voltages as described earlier, readings of approximately  $\pm 24V$  should now be obtained.

The Unregulated PSU Module is now ready for use!



The fully assembled PCB.

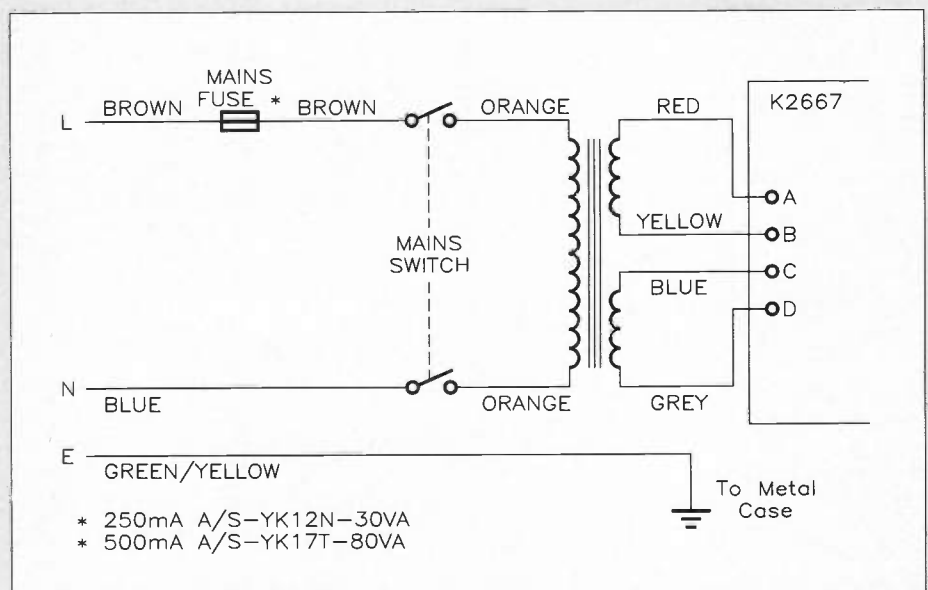

Figure 3. YK12N(30VA)/YK17T(80VA) transformer wiring.



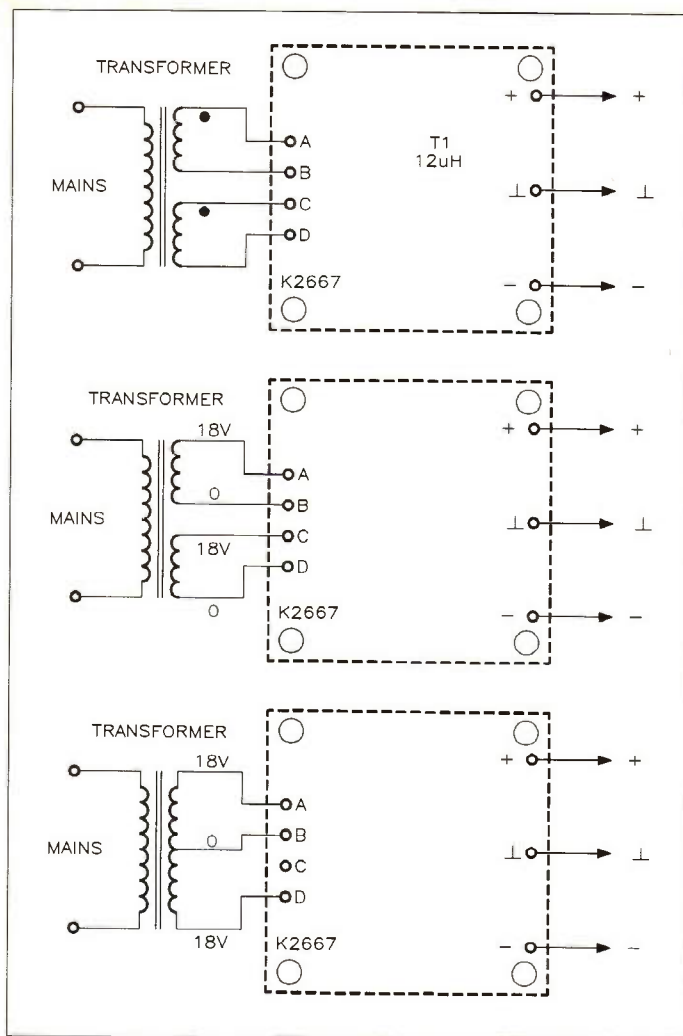

Figure 4. Transformer secondary connections.

## UNREGULATED PSU MODULE PARTS LIST

### CAPACITORS

C1-4 2200µF 35V Electrolytic 4

### SEMICONDUCTORS

D1-4 1N5404 or equivalent 4

### MISCELLANEOUS

PCB 1  
 PCB Pins 1 Pkt  
 PCB Mounting Fuseholder 20mm 2  
 Fuseholder Covers 20mm 2  
 Fuse 20mm 1A A/S 2  
 Fuse 20mm 1.5A A/S 2

### OPTIONAL (Not in Kit)

Toroidal Transformer 30VA 18V 1 (YK12N)  
 or  
 Toroidal Transformer 80VA 18V 1 (YK17T)  
 Fuse 20mm 2A A/S 2 (WR20W)  
 Heat-shrink Tubing As req.  
 Mains Cable As req.  
 Double-Pole Mains Switch 1  
 Mains Fuseholder 1  
 Mains Fuse 1  
 Fuseholder Insulating Boot 1  
 Strain-Relief Cable Grommet 1

The Maplin 'Get-You-Working' Service is available for this project, see Constructors' Guide or current Maplin Catalogue for details.

*The above items (excluding Optional) are available in kit form only.*

**Order As VE36P (Unregulated PSU Module) Price £12.45.**

Please Note: Some parts, which are specific to this project (e.g., PCB) are not available separately.

Combine business with pleasure –  
**TURN YOUR HOBBY INTO A WORTHWHILE CAREER WITH A FUTURE**



If you are an electronics enthusiast and are looking for an interesting career, with one of the UK's leading electronics suppliers, then look no further than Maplin.

Due to our Expansion Plan, we will have vacancies for

## Branch Managers Assistant Managers and Counter Staff

for our new stores opening throughout the UK.

Retail experience would be a great asset, and to become part of the team, you will need to be self-motivated and have a cheerful, outgoing personality.

Applicants must be of smart appearance, and have a good working knowledge of electronic components.

In return we offer excellent working conditions, a first-class basic salary plus commission, pension scheme, generous staff discounts, and real prospects for a secure and exciting career.

If you are seeking a fulfilling career in a High Tech Environment, then write to us **NOW!**

Send full career details/CV and an indication of the area that you would prefer to:

**The Personnel Manager,  
 Maplin Electronics plc,  
 Valley Road, Wombwell,  
 Barnsley, S73 0BS.**

**Maplin**  
 ELECTRONICS

# MAPLIN'S TOP TWENTY KITS

POSITION	DESCRIPTION OF KIT	ORDER AS	PRICE	DETAILS IN
1. (2)	◆ Live Wire Detector	LK63T	£ 4.75	Magazine 48 (XA48C)
2. (1)	◆ L200 Data File	LP69A	£ 4.75	Magazine 46 (XA46A)
3. (4)	◆ MOSFET Amplifier	LP56L	£20.95	Magazine 41 (XA41U)
4. (7)	◆ TDA7052 1W Amplifier	LP16S	£ 4.95	Magazine 37 (XA37S)
5. (10)	◆ Courtesy Light Extender	LP66W	£ 2.95	Magazine 44 (XA44X)
6. (5)	◆ Car Battery Monitor	LK42V	£ 9.25	Magazine 37 (XA37S)
7. (6)	◆ Lights On Reminder	LP77J	£ 4.75	Magazine 50 (XA50E)
8. (8)	◆ 1/300 Timer	LP30H	£ 4.95	Magazine 38 (XA38R)
9. (11)	◆ IBM Expansion System	LP12N	£21.95	Magazine 43 (XA43W)
10. (13)	◆ Mini Metal Detector	LM35Q	£ 7.25	Magazine 48 (XA48C)
11. (14)	◆ UA3730 Code Lock	LP92A	£11.45	Magazine 56 (XA56L)
12. (12)	◆ Partylite	LW93B	£12.45	Catalogue '93 (CA10L)
13. (3)	◆ LED Xmas Tree	LP83E	£ 9.95	Magazine 48 (XA48C)
14. (9)	◆ LED Xmas Star	LP54J	£ 7.75	Magazine 41 (XA41U)
15. (15)	◆ I/R Proximity Detector	LT00A	£10.95	Magazine 54 (XA54J)
16. (17)	◆ Music Maker	LT09K	£ 3.95	Magazine 57 (XA57M)
17. (20)	◆ TDA2822 Stereo Amplifier	LP03D	£ 7.95	Magazine 34 (XA34M)
18. (18)	◆ MSM6322 Data File	LP58N	£12.95	Magazine 44 (XA44X)
19. (16)	◆ RS232 TTL Converter	LM75S	£10.75	Magazine 31 (XA31J)
20. (-)	◆ Stereo Pre-Amp	LM68Y	£ 4.95	Magazine 33 (XA33L)

Over 150 other kits also available. All kits supplied with instructions.

The descriptions are necessarily short. Please ensure you know exactly what the kit is and what it comprises before ordering, by checking the appropriate project book, magazine or catalogue mentioned in the list above.

# NEW BOOKS

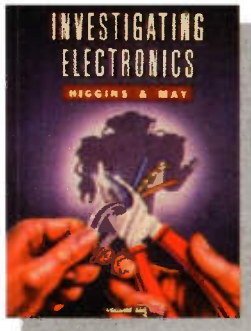

## Investigating Electronics

Volume 1

by R. Higgins and A. J. C. May

This book is intended for readers wishing to be introduced to practical electronics. Little or no previous electrical or electronic knowledge is assumed and it provides a basis on which the reader can build up a knowledge of electronics slowly and steadily from first principles. To help achieve this goal, text has been kept at a minimum while exercises and diagrams have been used extensively.

The book is divided into four sections: basic circuits and components including resistors, capacitors, diodes, transistors etc.; power supplies including transformers, rectifiers etc.; analogue electronics and power electronics. All circuit diagrams have been built and tested, so that the book may be used as a practical training programme. A list of components needed to carry out the practical exercises is also included.

This book along with volume two, 'Electronics and Investigating Digital Electronics', give an adequate cover of the EITB TR21 basic training requirement in electronics. Other groups who may find the books useful include those studying 'Design and Technology' in schools and students taking BTEC Engineering courses having a practical electronics content designed to meet the 'common skills' element of their course.

The layout of this book, and its contents, make it an invaluable source of reference to students of all ages embarking on electronic study. 1991. 130 pages. 245 x 189mm, illustrated.

**Order As WZ82D**  
**(Investigat Elec Vol1) £6.99 NV**

## Practical Electronic Design Data

by Owen Bishop

A handy comprehensive reference manual for electronics enthusiasts of all levels, be they hobbyists, students or engineers. The first chapter covers units, definitions and basic formulae. The following five chapters cover components, analogue, digital and radio circuits and power supplies.

The chapter on components includes surface-mounted devices and for each sort it lists the most useful and readily available types, complete with comprehensive details. A special feature



of this chapter is the easily followed charts and tables which advise the reader on how to select the best type of component for any particular purpose.

Over 150 practical circuit diagrams cover a broad range of functions, with an explanation of how to adapt these designs to a variety of applications. Many of the circuit descriptions include step-by-step instructions for using most of the standard types of integrated circuit such as operational amplifiers, comparators, filters, voltage converters, switch-mode power supply devices, as well as the principle logic circuits. 1992. 330 pages. 179 x 111mm, illustrated.

**Order As WZ70M**  
**(Prct Electr Design) £4.95 NV**

## Windows 3.1 - The Visual Learning Guide

by David C. Gardner and Grace Joely Beatty

This book is designed for the busy users who are either new to Windows or upgrading to the latest version.

The book will teach you to understand, customise and get the maximum benefit from working in the Windows

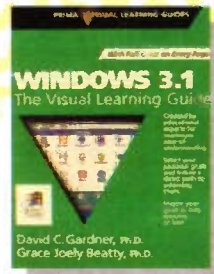

environment. Hundreds of full-colour graphics combined with an innovative 'point-and-click' layout make it virtually impossible for the reader to get lost or confused as progress is made through the book. The reader can either work through the book from the beginning to the end or skip around to master the skills that are required.

The book is divided into six parts; moving around Windows, customising Windows, printing, managing your files, using Windows programs and appendixes. Appendix A covers topics such as installation and disks and files back-up, installing a printer and DOS applications, while appendix B shows the reader how to boot up the mouse tutorial.

This easy-to-read and use book is an ideal companion for all Windows 3.1 users thanks to the attractive full colour, easy-to-read graphic screens that are used on every page. This book makes a perfect addition to the Window user's bookshelf.

1992. 286 pages. 233 x 186mm, illustrated. American book.

**Order As WZ77J**  
**(Windows 3.1 Visual) £18.45 NV**

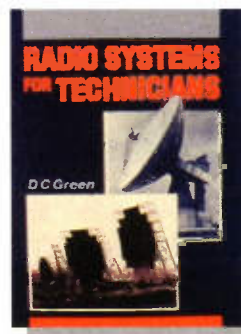

## Radio Systems for Technicians

by D. C. Green

This book provides a comprehensive coverage of the circuits and techniques used in modern radio communication systems and equipments. The BTEC scheme for the education of telecommunication technicians introduces the basic principles of radio systems in a unit intended for inclusion in certificate/diploma courses. This book has been written to provide a complete coverage of this unit.

The scope of the book is such that it covers all important aspects of radio engineering: from amplitude and frequency modulation, r.f. transmission lines, aerials and radio wave propagation, to the circuits and techniques used in modern radio receivers and transmitters and communication systems.

Many worked examples are provided in the text to illustrate the principles that have been discussed. At the end of the book a number of true/false, multiple choice and short exercises will be found, together with their answers. The questions have been divided into two groups those suitable for level II and those for level III students.

The book provides a comprehensive text on radio communication systems that should be eminently suitable for all non-advanced students of radio engineering.

1985. 288 pages. 246 x 190mm, illustrated.

**Order As WZ84F**  
**(Radio Syst For Techs) £14.99 NV**

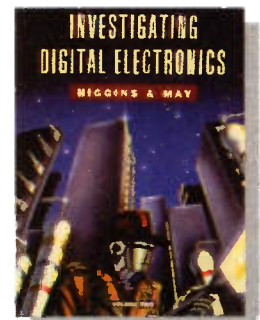

## Investigating Digital Electronics

Volume 2

by R. Higgins and A. J. C. May

This book is intended for readers who have completed volume one 'Investigating Electronics' or those who have some basic electronic knowledge. The book is written in the same style with text kept to a minimum and extensive use made of diagrams to explain important concepts. Practical exercises and self-assessment questions are provided to build confidence as the reader progresses through the chapters.

Divided into three sections, part one discusses the construction of logic gates, while part two follows with a detailed explanation of multivibrators, including bistables and flip-flop circuits. Part three investigates digital micro-electronics, integrated circuit logic gates, integrated circuit multivibrators, shift registers, adder circuits and counters.

A straightforward and informative text that will be welcomed by students of ETIB and BTEC courses containing a practical electronics content, and students of 'Design and Technology' who have a basic understanding of components and circuitry. 1991. 131 pages. 245 x 189mm, illustrated.

**Order As WZ83E**  
**(Invest Dig Elec Vol2) £7.50 NV**

# DISPLAY SYSTEM



## PART FOUR

### Software Development

Text by John Koushappas  
and Mike Holmes

Design by John Koushappas

Development by  
Tony Bricknell

In Parts 1 to 3 of the Moving Message Display project we looked at the design and construction of a high specification, expandable, moving message display system. Test and demonstration programs, shown in Parts 2 and 3, have illustrated the use of the display system at various stages of completion, for both single and multi-character displays. This, the final part, covers the full software development for all levels of the system. The programs have been written to run under GW-BASIC on a PC or compatible computer having hard and/or floppy disk drive(s), and with the Maplin PIO card (Order Codes: kit, LP12N; ready-built, AM11M) installed in an available extension slot.

This software was originally developed on a Computers Lynx 128K, which was a Z80

based home computer, circa 1983, but more recently re-designed to take advantage of the increased facilities that a PC or compatible machine and GW-BASIC provide. (NOTE: GW-BASIC has been given away free with MS-DOS 4, and now an introductory variation of Quick-Basic comes with MS-DOS 5.)

The software development consists of a suite of Basic programs which allow text input, bit pattern generation, file handling, run-time parameters, and the displaying of messages within an effective MMD environment. This includes 'auto-booting' MS-DOS batch files (operating at DOS level), which pass control to either the main MMD management menu or to the display program. The basic 'flow diagram' of how this works is shown in Figure 1 (further explanation follows later).

Through data generation and file handling, this suite of programs will allow any number of messages, each of which can be any size up to 1,000 characters, to be made and sequentially output to the display in any selected display mode. A hard disk is particularly useful, because not only can you easily boot the PC's operating system from it, but you can also use its high speed access to provide almost continuous message data flow, in other words transition from one stored message to the next would appear to be transparent to the viewer.

The programming has, as much as possible, been done in a top down fashion, thus there are several discrete modules all of which are 'interlinked' via a main menu program.

The programs presented here are still only the minimum 'bare bones'; there are no fancy windows to look into and very few frills. It is entirely up to you whether you want to add pretty 'front-ends' of your own, but

### FEATURES

- ★ Designed for use with any computer equipped with three 8-bit I/O ports – e.g., an IBM PC or compatible equipped with the Maplin 24-line PI/O card
- ★ Easily programmable from BASIC
- ★ Expandable to 32 boards by 'daisy-chaining' modules together
- ★ Large viewing area makes display highly readable in all lighting conditions
- ★ Programmable scrolling in all directions
- ★ Facilities for fade up/down
- ★ Programmable 'fizzle' effects
- ★ Direct pixel addressing for Speed (Animations, etc.)
- ★ Easy to Build

### APPLICATIONS

- ★ Shop Displays
- ★ Announcements in Public Areas
- ★ Attention Grabbing!
- ★ Special Effects

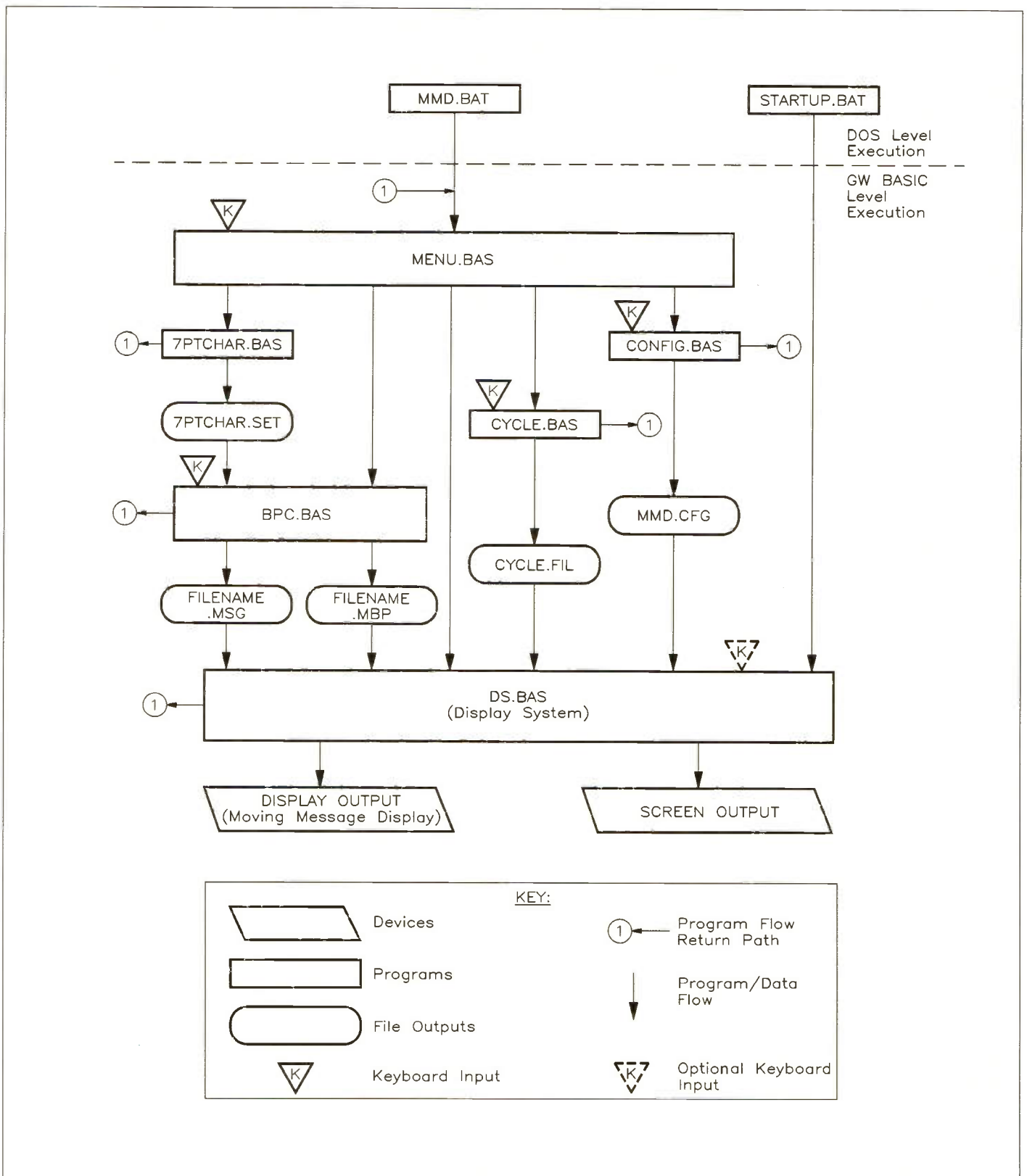

Figure 1. Flow chart of program execution of the system as a whole, showing the sequence of the individual programs and their data files.

you should not alter the core of each program if it can be avoided, as this is likely to introduce errors!

I must stress at this point that professional programming is all about writing programs that are idiot-proof. Unfortunately, I am not a professional programmer and these programs are not necessarily idiot-proof. If the conditions for correct input are not adhered to, these programs may stop with error messages. You will then have to restart the program you are in with a RUN statement (or, if an '.EXE' file, reload and rerun it at the DOS prompt by retyping its name -

more about these '.EXE' versions later) and try to identify the cause of the problem that occurred or avoid entering the bad data.

### Moving Message Types - An Attribute Classification

Before the actual programs are discussed in any detail, I will describe the three message types, as I have classified them, which are available in the Moving Message Display System. The three message types are: Type 1 = static, Type 2 = dynamic, and Type 3 = attribute functions. Type 2 is also subdivided

into two further parts: horizontal or truly dynamic, and vertically recalculated.

### Static Message Classification (Type 1)

This class of message is one which does not move across the board. In this case each column has its own memory which is the 74LS373 octal data latch (ICs 4 to 11 in Figure 5, Part 1, 'Electronics' Issue 62), and thus this is the standard mode of operation for this system. It provides the unique feature that you can load the screen up with a message, and then leave it there while you

do something else with the computer. The octal latches, acting as static memory, do not need to be refreshed or scanned and so will display the output indefinitely. Once the message is in the display memory, you are then free with your processor time to execute other functions. These include fade up, fade down and flash. These functions are carried out with the use of the display output enable hardware line.

## Dynamic Message Classification (Type 2)

### Horizontally, or Truly Dynamic

A horizontally scrolling message works by pointing, with an address pointer, to the start address of the memory containing the message. You then display the next 8 columns, followed by those for each of the remaining number of modules, on the screen. Because this does not involve any calculation, merely the incrementing of the message address pointer, and because the length of the message is independent of the length of the display, this type of scrolling is truly dynamic. By the same token, scrolling from left to right, i.e. backwards, is also truly dynamic. Another point to note is that, in the execution of the scroll, the actual message is not manipulated or interfered with in any way.

### Vertically, Recalculated

Messages which scroll in the Y-direction, i.e. up and down, are not truly dynamic scrolls. This is because the original data in the vertical scroll position is continuously read, and then a calculation is carried out for each

vertical scroll increment. This means the original data is no longer being displayed, but rather a remaining part of it is. This can be a little risky if not programmed accurately. It also takes up a fair amount of execution time.

## Attribute Functions (Type 3)

Attribute functions are not display scrolling routines, rather they are support functions for the correct logical operation of the display system. A complete summary of the message types and attribute classification is shown in Table 1 below.

## The Programs

There are six major programs which make up the latest Moving Message Display System software suite (this group does not

include the test programs featured in Parts 2 and 3). In addition to these there are two accompanying batch files, which allow immediate launch from power-up or from the DOS prompt.

We have made all the programs, including the test programs of Parts 2 and 3, available on a 360K 5 $\frac{1}{4}$ in. floppy disk, rather than you being faced with the (extremely) tedious task of copy-typing all the listings! In addition it has given us the opportunity to provide '.EXE' compiled versions of the main system suite which can be invoked like transient DOS commands, for those of you without a BASIC interpreter. Of the '.BAS' listings, the original GW-BASIC listings are provided, plus slightly varied versions which run in DOS 5's QBASIC environment. There is also an additional batch file provided at the root directory of the master disk which will 'install' the system for you, i.e. transfer the disk's

Program Name	File Name	Function
1. Installation	INSTALL.BAT	Make working copies on destination.
2. Configuration	CONFIG.EXE	Hardware configuration declarations.
3. Character Set	7PTCHRGN.EXE	7-point character set generator.
4. Cycle and Sequence	CYCLE.EXE	Orders display of messages.
5. Bit Pattern Compiler	BPC.EXE	Text input / generate bit pattern.
6. Display System	DSS/E.EXE	Displays the messages (2 versions).
7. Menu	MENU.EXE	Main menu program.
8. Display Auto-Start	STARTUP.BAT	Loads and runs DSS/E.EXE.
9. MMD	MMD.BAT	Loads and runs MENU.EXE.

Type	Attribute Number	Function
<b>Static</b>	3	Clear Screen Display - output message of blank.
	4	Output a Static Message the length of the display - loads the octal data latches which make up the screen memory.
	6	Slow Flash 10 Times - relies on 4 - toggling OE line slowly.
	7	Basic Fade Up - relies on 4 - toggling OE line quickly.
	8	Basic Fade Down - relies on 4 - toggling OE line quickly.
	9	Basic Fade Up, Delay, then Fade Down - relies on 4.
	16	Clear Screen Line by Line - relies on 4 - clearing of each latch by a full load, followed by emptying of the latch.
<b>Dynamic Horizontal True</b>	10	Scroll Message Left - pointer to start of message. Increment pointer.
	11	Scroll Message Right - pointer to end of message. Decrement pointer.
<b>Vertical Recalculated</b>	12	Scroll Static Message Up 1 - MODulus 256.
	13	Scroll Static Message Up 2 - Remainder of integer division.
	14	Scroll Static Message Down 1 - MODulus 256.
	15	Scroll Static Message Down 2 - Remainder of integer division.
<b>Attribute Functions</b>	1	Turn off Screen Display - OE line = 0.
	2	Turn on Screen Display - OE line = 1.
	5	One Second Delay - Delay loop.

Table 1. Message types / attribute classification.

contents to whichever other disk or drive you want the working version to run on. (The system cannot be run on the master itself.)

The names, functions and Input/Output of all these are as described below. The MMD programs should all be saved under a sub-directory called 'MMD', whether stored on a hard disk or floppy disk (this is automatically taken care of by the installation batch file).

## Program Names and Specifications

In the table above, the programs are referred to as '.EXE' versions for convenience, as these can be run immediately from the DOS environment. The equivalent source listings of these are found under the directories 'QB-PROGS' of the installed system, while the GW-BASIC listings are under the 'GW-PROGS' subdirectories. As space here is limited, the following is taken from the more comprehensive instructions supplied on the master disk.

## Program Inputs and Outputs

Look again at Figure 1 to see how the individual programs work together to produce a complete operational system of control. Notice that programs further 'down stream' need data, stored in files, that has been generated by programs 'up stream'. Such a module, for example 'DS', will be

entirely unable to run properly without these data files present and accessible. Example files are available from the master floppy disk by way of illustration of what these data files should be like.

**1. INSTALL.BAT** Input: user's choice of destination drive for working version, and MMD system level.

**Action:** transfer complete directory structure as working version to destination drive, generates 'MMD.BAT' and 'STARTUP.BAT', optionally re-configures 'AUTOEXEC.BAT' if present to run 'DSS/E' immediately on power-up.

**2. CONFIG.EXE** Input: user input hardware configuration type, number of modules in system, I/O ports' base address (PIO card).

**Output:** file MMD.CFG

### 3/1. 7PTCHRGN.BAS ONLY:

Input: user modifies program for first ASCII character number, last ASCII character number, number of bytes per character, add to 7 point character set data if expanded character set required.

**3/2. 7PTCHRGN.EXE** No inputs possible. Only outputs character patterns for ASCII values 32 to 90, or ' ' (space) to 'Z' inclusive.

**Output:** file 7PTCHAR.SET

**4. CYCLE.EXE** Input: user input file names, order of files to cycle through, cycle mode, editing/re-editing facility.

**Output:** file CYCLE.FIL

**5. BPC.EXE** Input: read file 7PTCHAR.SET; user input filename to save under, message text, message editor, message attributes script.

**Outputs:** files filename.MSG, filename.MBP

**6/1. DSE.EXE** Input: read files MMD.CFG, Message Cycle Filename (usually 'CYCLE.FIL'), and, as listed in the Message Cycle File (usually 'CYCLE.FIL'), both 'filename.MSG' and 'filename.MBP'; optional user input, name of alternative Message Cycle File.

**Output:** Moving Message Display on an expanded system of multiple modules with controller only.

**6/2. DSS.EXE** Alternative to above, required to output display to a single module without a controller.

**7. MENU.EXE** Input: Menu choice of program to execute.

**Action:** executes the selected program. Note that all selected programs will reload and rerun (or attempt to) the menu when they terminate.

## Programming Details

For the following, the GW-BASIC listings are referenced. The Q-BASIC versions are virtually identical, having only minor modifications, necessary for the somewhat different Quick Basic environment. Compiled .EXE versions are indicated between brackets.

### MENU.BAS (MENU.EXE)

This is a simple menu program which allows selection of all the programs in the software development to be accessed quickly and easily. All the programs accessible from the menu options return to this menu upon completion, thus making the system cyclic. (The compiled .EXE versions look to see whether MENU.EXE exists in the current directory before attempting to boot it.)

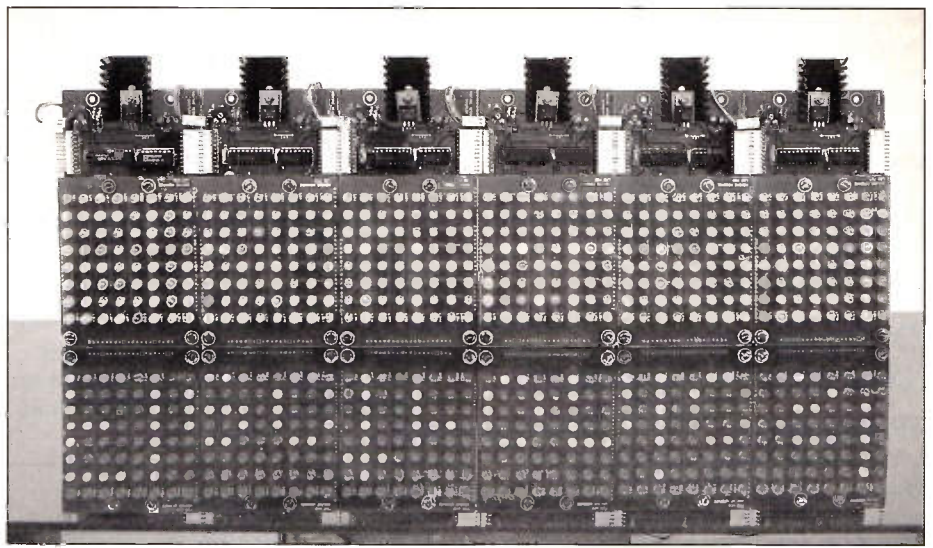

A bank of display modules.

### CONFIG.BAS (CONFIG.EXE)

This is a simple program which asks for your hardware details. It asks for your display's type (single module or expanded), and the level of construction in terms of the number of display modules you have if expanded, and for the 8255 PIO card's I/O port base address. This address is determined by which expansion slot the Maplin PIO card is plugged into. The program saves these parameters in a small file called 'MMD.CFG'. You only have to declare these parameters once, and if you change your hardware specification, you only need rerun this program and enter the new parameters once more. So long as 'MMD.CFG' exists and is accessible, 'DS' will be able to extract these details.

### 7PTCHRGN.BAS (7PTCHRGN.EXE)

In Part 1 of this project, a brief description was given of how the patterns for moving messages are made. The messages are made up from sets of bit patterns, each of which corresponds to a letter or alphanumeric (or graphic) character. The bit patterns for all the characters are held in a look-up table which is accessed by the Bit Pattern Compiler (BPC), which uses the table to generate the bit pattern for each character in the message text. (When created, the message text is merely typed at the keyboard as ordinary words.) Part 1 also stated that this look-up table could be embedded in the computer program itself (meaning the Bit Pattern Compiler), or it may be loaded by the (Bit Pattern Compiler) program as a data file.

Our system here uses the latter method, in the interests of flexibility. '7PTCHRGN' is the generator program that makes a 7-point character set, and saves it as a data file for use later by the Bit Pattern Compiler (BPC). The program need only be run once, and it generates a file called '7PTCHAR.SET'. The main reason for having a program generate the look-up table this way is that, eventually, it will allow for different character sets to be designed, selected, and expanded.

The program also saves three important parameters in the first three entries of the file which are the first ASCII character in the set, the last ASCII character, and the number of bytes per character. These parameters are needed by the Bit Pattern Compiler in order to derive the look-up table formula required for this character set.

One last point about the character set. You will notice that I have only included the characters up to ASCII value 90 (character capital 'Z'). If you want to include the rest of the set (e.g., 91 to 126), just continue the data statements in the same style as shown in the listing and save the program. NOTE: you can only edit either of the BASIC listings, you cannot alter '7PTCHRGN.EXE'.

### CYCLE.BAS - Cycle and Sequence (CYCLE.EXE)

This is where things start to get complicated. This program allows you to enter the names of the files containing the messages into a list, and arranged in the order that they will be displayed.

Firstly, you enter the number of names. Then you select whether you want the messages to cycle once or continuously. This is the cycle mode. Cycling once will mean that when the messages in the script generated by this program have been cycled through once by the display program, the display program will return to the main menu. If you select continuous cycle, the display program will run through the script of messages continuously until the program is escaped from or the computer is switched off. You then have the option of retrieving the existing 'CYCLE.FIL' file with the 'CYCLE' program, and adding to it or editing it. To create a new 'CYCLE.FIL', select 'N' for new.

Creating a new 'CYCLE.FIL' is easy. You type in the name of the file which will contain a message. Always use the extension '.MSG' for cycle file names. The next input is for the order number. The order number need not be the order in which you entered the message or the message file name. The order number tells the display program in which sequence to run through the script of messages. When all the file names have been input, a list showing what will be saved is displayed and a question asks for either 'E' for edit or 'S' for save. 'S' saves the data in 'CYCLE.FIL'.

Selecting 'E' for editing allows you to edit the message sequence you have just entered. If you no longer want the message to be displayed, you can enter a zero (0) for the order number, which will cause that message file name to be deleted from the messages script when the edited file is saved back to disk.

To edit the existing 'CYCLE.FIL' file, you

must first enter the number of file names, as before. This limits the number of names that will be read in from the original 'CYCLE.FIL', so you need to know how many names are already in there if you want to keep them. Entering a number greater than this implies you want to add entries to the existing 'CYCLE.FIL' list, and the program will create the extra entry spaces when you enter the editing screen. You will see these entries as blanks when you now enter edit mode. You must choose these edit line numbers, enter file names and order numbers. Upon completion the program returns control back to the main menu.

### BPC.BAS – The Bit Pattern Compiler (BPC.EXE)

The Bit Pattern Compiler takes as a file input the 7-point character set, '7PTCHAR.SET', which is the look-up table, and the message(s) input by the user. The user must also input a script or list of 'attributes', which control the format of output from the display program. The program has limited line editing facilities for the message input. You can enter a message of up to 1,000 characters, but no more than 100 characters per edit line number. The program automatically inserts a single space between the end of the last word on one line and the first word on the next line. This allows messages to be butted together continuously.

After loading up the 7-point character set, a screen summary of instructions is displayed. First you must enter the file name to save the message under. You must NOT include an extension, because the program automatically adds '.MSG' to the message file name, and '.MBP' to the file which will contain the message's compiled bit pattern. You are then presented with the message input line editor.

Your message is typed in as required. As you type in each line, <RETURN> terminates the line. To terminate message input, you must key <RETURN> at the beginning of a new blank line. Your message is then displayed back to you with edit line numbers. If you want to re-edit a line or lines, you can do so now, by re-typing the line(s) in question. Clearing a line in the message can be done by choosing to edit that line and keying <RETURN> on a blank entry. This will not terminate the rest of the message following it. It and other blank lines in the message will be skipped at compilation time. An "end of input / edit session" message acknowledges completion of your message.

You are then taken to the 'Attributes Script Mode' for the message. You must enter a series of numbers which will define how the message you have just entered will be displayed on the Moving Message Display system. The script allows for 16 entries, which should be more than enough for most messages. Each attribute number is a declaration to the display program to run a specific subroutine which performs the action, and it is important to choose the correct sequence of subroutines in order to obtain the desired effects. Examples are shown in Table 2. If you use less than the full 16 attributes, you must terminate the attribute sequence with a zero (0) to end. (Keying a carriage return on a blank entry is incorrect, and will actually cause the program to leave a file open.)

Function	Attribute Sequence	Comments
Static Message Fade Up	1,3,4,7,0	Must clear screen of old message first. Must load screen with message before fade up. 0 to finish attribute input early.
Static Message Fade Up, Hold, Flash, and Fade Down	1,3,4,7,5,5,6,8,0	Switch off, clear screen, load screen memory, fade up, hold 1 second, hold 1 second, flash 10 times, fade down, end.
Scroll Long Message Left	1,3,2,10,0	Switch off screen, clear screen memory switch on screen, scroll left, end.
Scroll Message Right	1,3,2,11,0	Best for short messages or effects.
Scroll Static Message Up from bottom to top of screen, Flash, then Fade Down	1,3,2,12,6,8,0	There are many possible variations.
Scroll Static Message Down from top to bottom of screen, 5 second hold, then line Clear Screen	1,3,2,14,5,5,5,5,16,0	Five 5's because attribute 5 is a one second delay.
Fade Up Message and leave it there	1,3,4,7,0	Until next message in messages script.

Table 2. Display sequences using attributes.

### The Order of Attributes

In order to get a sensible display output, the attributes you enter for your message must be entered in a logical order. If you imagine your moving message display screen as a window as shown in Figure 2, you will realize how messages must enter and leave the screen when scrolling. Providing you can make your attributes follow these conditions you should get good results. Table 2 shows a list of attribute sequences to perform various overall functions.

Upon completion of the input of your attribute sequence or script, you can sit back and watch the compiler do its work. A "Compilation completed successfully" message will indicate the bit pattern has been compiled correctly, and the bit pattern will be stored in the 'filename.MBP' file. The screen will clear and the message itself along with the attributes script and some run time parameters will be saved into the 'filename.MSG' file.

The program then terminates and returns control back to the main menu (or, more accurately, reloads and runs it from start). To enter the next message, just select the Bit Pattern Compiler program from the menu again.

### DS.BAS – The Display System Program (DSS.EXE, DSE.EXE)

The Display System Program is the main one in the suite of programs for the Moving Message Display system. It is also the most complex. It takes, as file inputs, configuration parameters from 'MMD.CFG', the file name and order script from 'CYCLE.FIL', and the messages files 'filename.MSG' and

'filename.MBP', with the display attributes, and their bit patterns generated by the Bit Pattern Compiler. The outputs are shown as text on the screen, and on the Moving Message Display system.

The program has two entry methods. It can either be invoked via the main menu, or by the batch file 'STARTUP.BAT', to which control can be passed from the PCs 'AUTOEXEC.BAT', so that the Moving Message Display is activated with the relevant input immediately upon power-up of the computer system. (This latter method is only applicable if 'INSTALL' found a copy of 'AUTOEXEC.BAT' at the root of the destination disk, and you answered 'yes' to the query 'modify AUTOEXEC.BAT? (y/n)' at installation time.)

The program opens by announcing itself, then loading the configuration parameters from 'MMD.CFG', then the I/O ports are initialised. There is then a conditional load of the script of file names, and their display order, from 'CYCLE.FIL'. This provides you the option of specifying an alternative file name if desired. A countdown to zero is displayed, allowing you to intercept the loading of the default 'CYCLE.FIL' within this time, and enter an alternative file name.

The alternative file can be another previously created with PBC as 'CYCLE.FIL', but subsequently renamed. If you do not intercept the countdown, 'CYCLE.FIL' is loaded and the file names are stored in one array, while their display order is stored in another array.

DSS.EXE and DSE.EXE are different in that the default file name needs to be

provided as a 'DOS command line parameter' before it can be used; if not provided, the program MUST stop and ask for a file name, whether intercepted or not. This means that any file other than 'CYCLE.FIL' can be specified for reading, and the Display System program will take this and start up the Moving Message Display without any human intervention. For example, at the DOS prompt: DSE CYCLE.FIL (default), DSE OTHER.FIL, DSS MESSAGE.DOC, etc. ('STARTUP.BAT' passes 'CYCLE.FIL' as the default.)

The program then enters its main loop. This sets up the conditions to cycle through the script of messages in the order determined by their order numbers. The message order is sorted on the message order number array to find each message file name order. That message is then loaded and displayed on the screen. Also included are parameters which indicate the size of the file, and the number of bytes per character, and the script of display attributes.

The message's bit pattern file is then loaded into a dynamic array. This is preceded with the loading of leading blanks, to the length of the display, followed by the loading of trailing blanks to the length of the display. These blanks are dynamically re-scaled whenever you change your hardware (in terms of the number of modules in your system), so that you do not have to retype all of your messages. The purpose of the leading and trailing blanks is to make sure that the screen is clear when a scroll left or scroll right operation is performed. You cannot rightly scroll left from an instantly displayed message, because you'll probably miss seeing the first few letters. The screen must be clear when a new message enters the display from the left or the right.

Having completed all the data file loads, the program now runs through the execution of the attributes script. Reading the attributes script numbers one by one, various subroutines are called as described on the menu screen for the attributes input of the Bit Pattern Compiler. Upon completion of the attributes script, the next message is loaded

and displayed as above. Upon completion of the displaying of all the messages in the messages script, a test is made to see if the cycle mode was for cycle once, or continuous cycle mode. If continuous cycle mode was selected, the main loop is continuously executed. If the mode was for one cycle, the program terminates and returns control back to the main menu.

The shift left routine is virtually the same as the 'MAPLIN2.BAS' demo of Part 3. The shift right routine is the same as the shift left routine, except that the pointer to the bit pattern points to the end of the message (hence the need for the trailing blanks mentioned earlier), and counts backwards. The fade up and down routines work by changing the on to off time of the display by toggling bit 0 of port C, which is the display output enable line, at a high speed. This is called varying the mark to space ratio. The slow flash is a derivative of the fading routines, slowed down to provide perfect visible flashing (unlike commercial ones which occasionally cut and blink half way along the display).

The scroll up and scroll down routines are each divided into two parts. The first part moves a message from below the bottom of the display upwards onto the display. The message must stop so that it can be read, else there would be little point in having a scroll up routine. The second part scrolls the message upwards off the top of the display, until the screen is clear. The two scroll down routines are exactly the reverse of the scroll up routines.

## The MMD Software Master Disk

There is a tutorial provided with the program suite when the system has been installed from the master disk, called 'MMDHELP.DOC'. The MMD software is installed by running 'INSTALL' on the master disk, giving it parameters specifying the destination drive where the system will be put, and whether the display driver to be used is for a single module or a base or

expanded system. This installation is unavoidable since, to make them all fit onto one 360K floppy disk, the files have been subjected to a storage compression technique, and have to be 'unpacked'.

## Batch Files

STARTUP.BAT is used to load up and run DSS.EXE or DSE.EXE (depending on how it's been configured at installation time), the Display program, immediately from power-up, provided that the host PCs AUTOEXEC.BAT has also been altered to pass control to STARTUP.BAT. You need not touch anything. Because DSS/E will automatically load CYCLE.FIL, it will also load and display a complete pre-set series of messages, indefinitely, if continuous cycle is selected. This batch file is thus useful for unattended (e.g., timer started) 'boot-ups' of the display.

MMD.BAT is another simple batch file, providing a fast and easy method of getting to the Moving Message Display environment and running MENU.EXE at DOS level. Both these batch files also append the MMD directory path to the PCs existing DOS environment path declaration variable (first time only).

## Differences Between DS.BAS required for a Minimum System and a Base/Expandable System

DS.BAS is designed for a Base System and above (if you intend to use it). Because of the slightly different way that a Minimum System clocks in its data (because the WR bar line is not implemented on the single module, and because you latch data by sending a logic low to the current latch control port), some lines need to be typed over DS.BAS. These lines are provided in TYPEOVER.BAS.

## Possible Enhancements

There are many, many effects that could be programmed and added into this software. A walk past some commercial moving message displays should generate some new ideas. I have seen effects such as stretching, random fizzle (easy in BASIC), character flash, and of course, a digital clock. Message clearing effects include a hungry pacman, a car, and a rotating wheel. With regard to keyboard entry of the message, it may be advantageous to design import facilities from an ASCII editor into the bit pattern compiler. This would allow re-editing of a message and subsequent re-compilation of that message.

## Acknowledgment

Thanks are due to Mr. Jason Morgan for highlighting fundamental programming concepts which would otherwise have not allowed these programs to be completed.

## Software on Disk

A 5 $\frac{1}{4}$ in. disk with the MMD Software is available from Maplin - Order as Moving Message Display Software Disk (XL57M) £9.95.

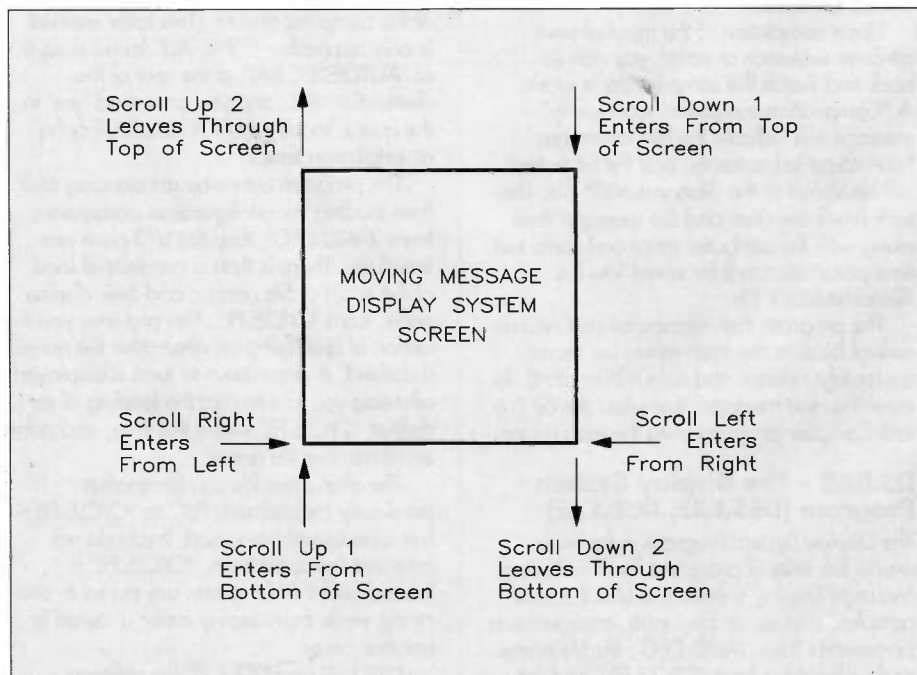

Figure 2. Representation of a single MMD display module as a window.



# TRAC PAL and D/D2MAC Conversion for

**Ferguson  
BSB Rx**



### Features

■ 60 Fully programmable channels with Remote Control ■ On Screen Graphics with Live Programme Information ■ Pre set for most popular PAL, D2MAC and DMAC Transmissions ■ Selectable LNB Type ■ External 12 volt switch facility

### D2MAC

■ Superb digital quality sound ■ Preferred Language facility ■ Covers all D2 and DMAC Audio channels ■ Background / Foreground sound mix facility ■ Switchable 16:9 with optional panning ■ Outputs in RGB, Video, Audio, UHF.

### PAL

■ Fully Tunable Audio per channel ■ Videocrypt (Sky) decoder interface ■ 14 / 18 Volt LNB switching ■ Outputs in Video, Audio, and UHF

### On Screen Menus

A total of 15 different on screen menus make programming exceptionally easy.

### Prices

CONVERSION KIT...Comprises a fully assembled and tested PAL/MAC sub assembly PCB, plug in software upgrade, assembly instructions and new user manual. **£49.00**

EXCHANGE CIRCUIT BOARD...Ferguson SRB1 circuit board complete with PAL, D2MAC and DMAC modules fitted. **£69.00**

COMPLETE RECEIVER WITH DBS ANTENNA... Fully modified, Brand New Ferguson SRB1 Receiver with new Matsushita squarial. **£149.00**

Post and Packing..Kit (Parcel Post) £3.50  
Exchange PCB..(Carrier next day) £6.90  
Receiver / Squarial.. (Carrier next day) £8.50

## D/D2MAC Conversion

For Ferguson, Decca, and Tatung BSB Receivers

- 35 Fully programmable channels
- On Screen Graphics
- 16:9 Format with Panning
- Live programme Information
- All audio channels accessible
- Digital quality stereo sound

The new software is supplied on a plug in sub panel with two additional IC's, full instructions, and user manual. Ideal for reception from TDF1 and TVSAT using your existing BSB squarial / compact dish or other clear D/D2MAC transmissions with the appropriate antenna.

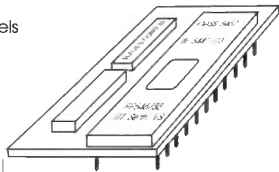

**£39.00**

## Satellite System Components

Over 500 different items in stock

Feed Horns, Polarisors, Polarotors, OMT's, Transitions  
Accessories, Amps, Splitters, Cable, Connectors, Fasteners,  
Antennas : Offset up to 1.00Mtr. Prime Focus up to 2.00 Mtr.  
LNB's : Dual, Triple, FSS, DBS, Telecom, Voltage switching, Twin.  
Large and small Polar heads, Ground and wall mounts  
Linear Actuators (Jacks), H to H mounts, Positioners  
Receivers, Decoders

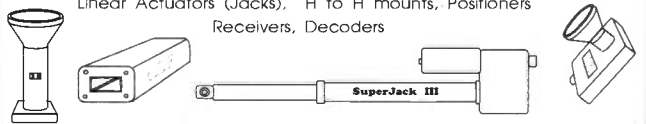

## FREE With every order over £40

Quote "MAPLIN" When you place your order and we will include absolutely free, a Ferguson BSB chassis, less MAC chip set, but with hundreds of other useful state of the art components.

### Philips D2MAC Conversion

We are currently developing a D2MAC Conversion for the Philips BSB Receiver. This will be to the same high standard as the Ferguson and Tatung £39.00 Conversion, and should be ready mid-May. Please call for further details.

**All prices include VAT.**



Please note...Technical queries and advice by phone only.

**REMEMBER :** We stock all major brands of satellite equipment, and try wherever possible not to be undersold. So before you buy, give us a ring and see if we can match your best quote.

## TRAC SATELLITE SYSTEMS

Commerce way Skippers Lane  
Middlesbrough Cleveland TS6-6UR

0642 468145 / 452555 FAX 440927



# ADVERTISE IN 'ELECTRONICS' AND REACH A WHOLE NEW POTENTIAL MARKET OF CUSTOMERS! BOOK YOUR SPACE NOW! TEL: James Slater (071) 613 0717



**DATING**  
ELECTRONICS LIMITED

Clayton Wood Close  
West Park  
Leeds LS16 6QE  
Tel: 0532 744822  
Fax: 0532 742872

**For products you can rely upon to give amazing results**

For information on **Active Antennas, RF Amplifiers, Converters, Audio Filters, the Morse Tutor and Speech Processors** send or telephone for a free catalogue and selective data sheets as required.

All our products are designed and made in Britain.

Orders can be despatched within 48 hours subject to availability.



— VISA AND ACCESS WELCOME —



These are our top twenty best selling books based on mail order and shop sales during January '93. Our own magazines and publications are not included in the chart below.

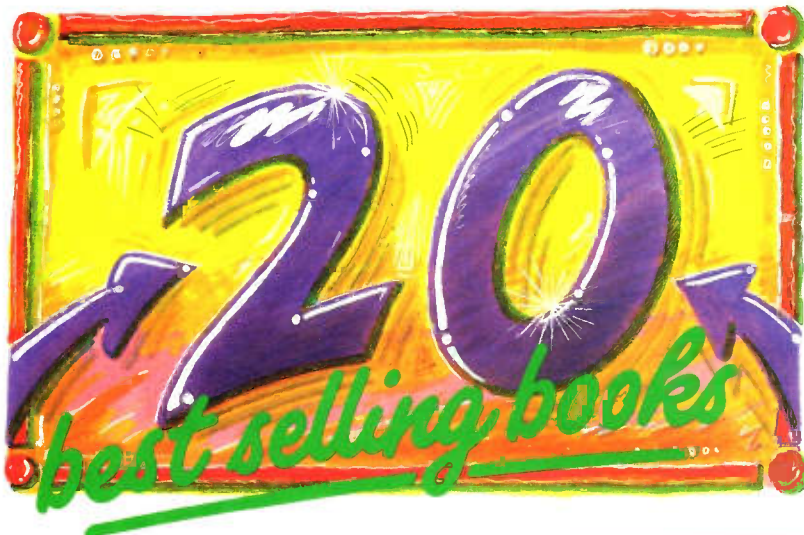

**2**

**NO CHANGE**

Home VCR Repair Illustrated, by Richard Wilkins & Cheryl Hubbard. (WZ32K) Cat. P89. Previous Position: 2. Price £13.95.

**3**

**NO CHANGE**

IC555 Projects, by E.A. Parr (LY04E) Cat. P76. Previous Position: 3. Price £2.95.

**4**

**NO CHANGE**

Loudspeaker Enclosure Design and Construction, (WM82D) Cat. P79. Previous Position: 4. Price £9.95.

**5**

▲▲▲

An Introduction to Loudspeakers and Enclosure Design, by V. Capel. (WS31I) Cat. P79. Previous Position: 6. Price £2.95.

**6**

▼▼▼

Power Supply Projects, by R.A. Penfold. (XW52G) Cat. P73. Previous Position: 5. Price £2.50.

**Number ONE**

**Getting The Most From Your Multimeter**  
by R.A. Penfold

A unique, and very useful book, showing you how to best use your multimeter. (WP94C) Cat. P70. Previous Position: 1. Price £2.95.

**7**

▲▲▲

The Washing Machine Manual, by Graham Dixon. (WS98G) Cat. P89. Previous Position: 8. Price £11.95.

**8**

▲▲▲

International Transistor Equivalents Guide, by Adrian Michaels. (WG30H) Cat. P66. Previous Position: 10. Price £3.95.

**9**

▲▲▲

How to Expand, Modify and Repair PCs and Compatibles, by R.A. Penfold. (WS95D) Cat. P102. Previous Position: 12. Price £4.95.

**10**

▼▼▼

The Complete VHF/UHF Frequency Guide, by B. Laver. (WT70M) Cat. P86. Previous Position: 9. Price £9.95.

**11**

▼▼▼

A Concise Introduction to MS-DOS, by N. Kantaris. (WS94C) Cat. P98. Previous Position: 7. Price £2.95.

**12**

▼▼▼

How to Use Oscilloscopes and Other Test Equipment, by R.A. Penfold. (WS65V) Cat. P70. Previous Position: 11. Price £3.50.

**13**

▲▲▲

Scanners, by Peter Rouse. (WP47B) Cat. P85. Previous Position: 15. Price £8.95.

**14**

NEW ENTRY

50 Simple LED Circuits Book 2, by R.N. Soar. (WG43W) Cat. P77. Previous Position: New Entry. Price £1.95.

**15**

▲▲▲

The Robot Builder's Bonanza, by G. McComb. (WT71J) Cat. P103. Previous Position: 19. Price £14.95.

**16**

▲▲▲

Towers' International Transistor Selector by T.D. Towers. (RR39N) Cat. P66. Previous Position: 20. Price £19.95.

**17**

▼▼▼

How to Use Op Amps, by E.A. Parr. (WA29G) Cat. P69. Previous Position: 16. Price £2.95.

**18**

▼▼▼

Servicing TV and Video Equipment, by Eugene Trundle. (WS76H) Cat. P89. Previous Position: 13. Price £25.00.

**19**

▼▼▼

Electronic Security Devices, by R.A. Penfold. (RL43W) Cat. P75. Previous Position: 17. Price £2.95.

**20**

RE-ENTRY

Radio Amateurs Examination Manual, by G.L. Benbow. (WP87U) Cat. P83. Previous Position: Re-Entry. Price £6.75.

## HOBBYIST STARTER TOOL KIT

Selected to suit the typical needs of the new electronics hobbyist, it is presented in a cloth tool roll and contains the following: Soldering kit with soldering iron, iron stand and a pack of solder, desoldering tool, side cutters, long nosed pliers, flat blade screwdriver and a crosspoint screwdriver.

Order Code SK01B **£24.95**



## STUDENTS TOOL KIT

A 15-piece set, selected for electronics courses at schools and colleges or the electronics hobbyist. It includes a 25W soldering iron with two interchangeable bits, iron stand, desoldering tool, a supply of solder and a pot of flux, wire wrap tool, two crosspoint and two flat blade screwdrivers, wire cutters, pliers, and for delicate or PCB work, a 'Helping Hands' and a pair of tweezers. The kit is housed in a sturdy plastic case with a carry handle and two catches, the individual tools are held in compartments which prevent them from moving during transit.

Order Code BZ60Q **£19.95**



Excellent value tool kits designed with the electronics hobbyist in mind, but also suitable for a wide range of general purpose uses.

# WHEN A JOBS WORTH DOING...

## ADVANCED TOOL KIT

Housed in a large, robust, plastic box with a removable tray, the Advanced Tool Kit, comprises side cutters, long nosed pliers, 100mm long flat blade light duty screwdriver, 75mm long chrome-vanadium 5mm flat blade screwdriver, size 0, 1 and 2 crosspoint drivers, easy-to-use combined wire cutter and stripper, Soldering kit with soldering iron, iron stand and a 5m pack of solder.

Order Code SK02C **£29.95**

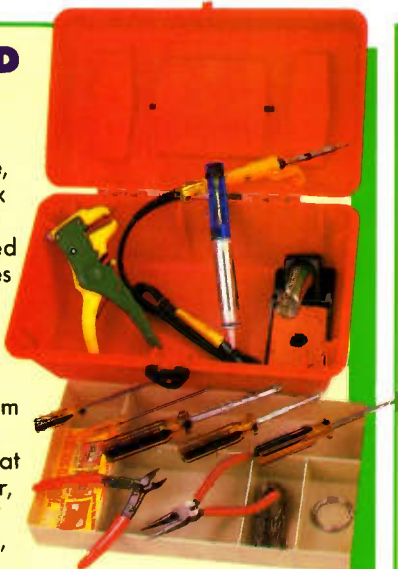

## ENGINEER'S TOOL KIT

A very comprehensive selection, housed in a large plastic box with a removable tray, and comprises: side cutters, long-nosed pliers, heavy-duty electricians pliers, 75mm long chrome vanadium 5mm wide flat blade screwdriver, a set of long shaft screwdrivers (two flat blade and one crosspoint), light duty 100mm long flat blade screwdriver, 75mm long size 1 crosspoint driver, 100mm long size 2 crosspoint driver, a cased 11-piece precision screwdriver set, a preset trimmer tool, a retractable blade knife, combined wire stripper and cutter tool, junior hacksaw, needle file set, 6 in. stainless steel rule, desoldering tool, Soldering kit with soldering iron, iron stand and 5m pack of solder.

Order Code SK03D **£46.95**



# ...IT'S WORTH DOING WELL!

All items are subject to availability. All prices include VAT. Handling Charge £1.20. [B] indicates carriage charge of £2. [D] indicates carriage charge of £3.05. Prices subject to change. Overseas orders please phone 0702 552911 in first instance. Visit your local Maplin store in: **BIRMINGHAM**; Sutton New Road, Erdington. **BRIGHTON**; 65 London Road. **BRISTOL**; 302 Gloucester Road. **CARDIFF**; 29-31 City Road. **CHATHAM**; 2 Luton Road. **COVENTRY**; 12 Bishop Street. **EDINBURGH**; 126 Dalry Road. **GLASGOW**; 264-266 Great Western Road. **ILFORD**; 302-304 Green Lane. **LEEDS**; Carpet World Building, 3 Regent Street. **LEICESTER**; Office World Building, Burton Street. **LONDON**; 146-148 Burnt Oak Broadway, Edgware. 107-113 Stanstead Road, Forest Hill. 120-122 King Street, Hammersmith. **MANCHESTER**; 8 Oxford Road. **NEWCASTLE-UPON-TYNE**; Unit 4, Allison Court, The Metro Centre, Gateshead. **NOTTINGHAM**; 86-88 Lower Parliament Street. **PORTSMOUTH**; 98-100 Kingston Road. **READING**; 129-131 Oxford Road. **SHEFFIELD**; 413 Langsett Road, Hillsborough. **SOUTHAMPTON**; 46-48 Bevois Valley Road. **SOUTHEND-ON-SEA**; 282-284 London Road, Westcliff. Plus a NEW STORE opening soon in **MIDDLESBROUGH** Phone 0702 552911 for further details.

**Maplin**  
ELECTRONICS

**CREDIT CARD HOTLINE**  
**0702 554161**

Mail Order to:  
P.O. Box 3, Rayleigh, Essex, SS6 8LR.

BUYER'S GUIDE TO ELECTRONIC COMPONENTS 1993

# Maplin



BS 5750  
Part 2 1987  
Level B:  
Quality Assurance  
RS12750



**Order your copy of the New MAPLIN Catalogue on sale NOW!**  
Pick up a copy from any branch of WHSMITH or from our chain of shops for just £2.95 or  
post this coupon now to receive your copy for just £3.45 inc. p&p. If you live outside the  
U.K. send £5.50 or 14 IRC's for Airmail in Europe/surface mail outside Europe,  
or £10.65 or 27 IRC's for Airmail outside Europe,  
I enclose £3.45/£5.50/£10.65 (delete as applicable).

Name.....  
Address.....  
Post Code.....  
Send to Maplin Electronics,  
P.O. Box 3, Royleigh,  
Essex, England,  
SS6 8LR,  
MM93

Over 700 product packed pages with  
hundreds of brand new products.  
On sale now, only £2.95

Available from all branches of WHSMITH and  
Maplin shops nationwide. Hundreds of new  
products at super low prices!

