

E

BRITAIN'S BEST SELLING ELECTRONICS MAGAZINE

No 43

ELECTRONICS

The Maplin Magazine

APR-MAY '91 • £1.45

DIGEST FREE inside!



Reviewed inside...



Watch as you build
beginners' kit



- **Win London Planetarium Tickets** • Data File: **SSM 2045**
- **Music Voicing IC** • How to build a **Temperature Controller**
- **IBM PIO Card** • Maplin 'Ranger' **AM/SSB/CW Receiver** • Read all about **HDTV** • **BASIC Programming** • **Robotics** • **Cochlear Implants** and **AFILS**



SPECIAL OFFERS! SPECIAL OFFERS! SPECIAL OFFERS! SPECIAL OFFERS!

Twelve great reasons to get Electronics under cover...



Available for the first time! The new Maplin magazine binder that holds twelve issues of Electronics, the Maplin magazine. If you have not got the world of Electronics covered, now's your chance! This great, quality binder comes in hard wearing, laminated art board, that not only looks good on your bookshelf or workshop desk, but is also a great way to build up an Electronics reference library of your own!

Now you can keep all of your copies of Electronics, the Maplin magazine, together and on hand for when you need that extra piece of information. To order your binder simply fill in the order form provided in this issue of Electronics. Only £5.25 (plus £1 handling charge). Order no: XH99H.

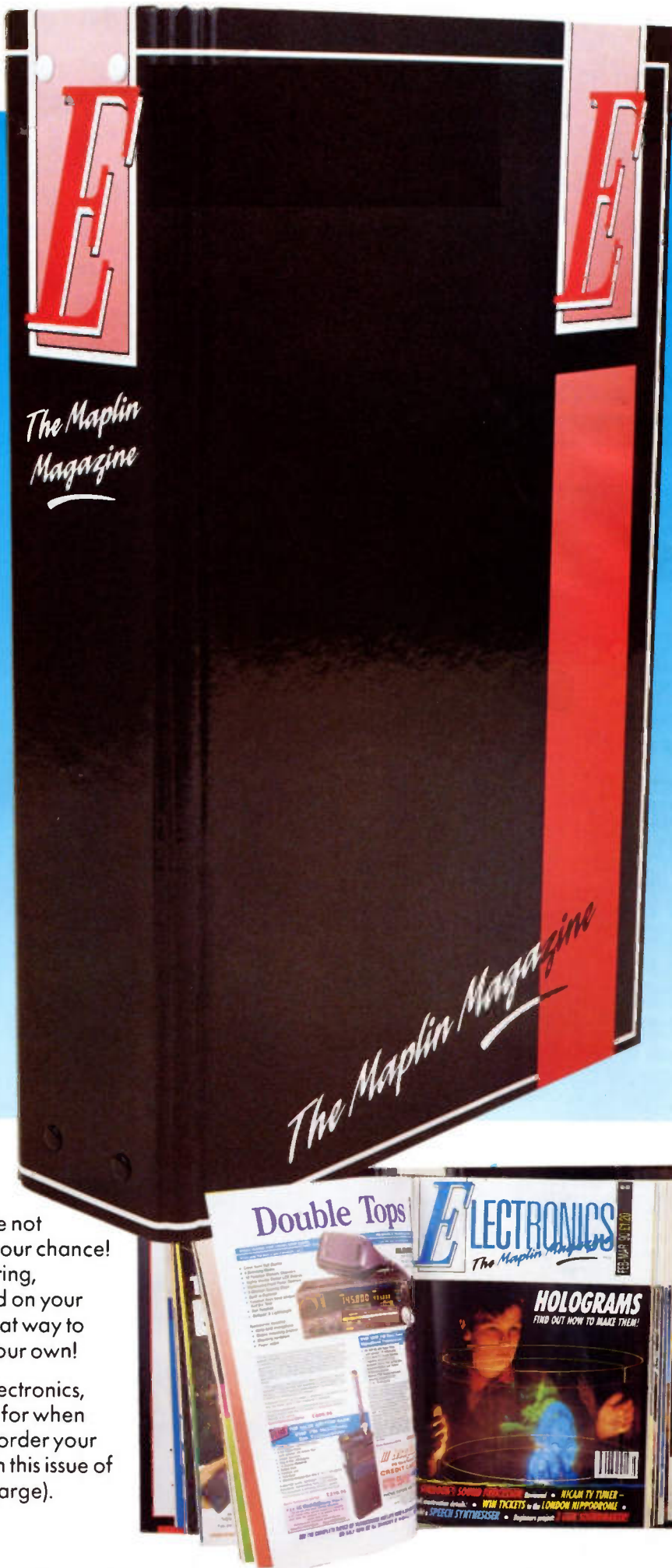

**THE NEW MAPLIN MAGAZINE BINDER...
A GREAT WAY TO GET THE WORLD OF ELECTRONICS COVERED!**

NEWS

Report

Instant 32-Bit Performance Enhancement

Cost-effective and easy to install, the FASTCache-SX plug-in accelerator card from MicroWay enhances 16-bit 286 IBM compatibles with 32-bit performance.

Based on a 16MHz 80386SX micro-processor, it maintains complete hardware and software compatibility with existing 16-bit systems and enables AT users to run 80386-based multi-tasking operating environments such as UNIX 386, DESQview 386 and Windows 3, as well as 32-bit protected mode code such as the MicroWay NDP-386 series of compilers.

In performance tests, using the Whetstone benchmark as a basis for comparison, the FASTCache-SX was shown to be ten times faster than a 6MHz IBM AT and 85% as fast as a 16MHz 80386 computer.

Designed to fit into a short or standard expansion slot in the I/O channel of the AT, the FASTCache-SX half length card includes 32K of high speed cache memory (expandable to 64K), which accelerates 16-bit and 32-bit applications such as Lotus 1-2-3, AutoCAD and MicroWay's NDP-386 compilers. A socket for an optional 80387SX floating point co-processor accelerates the speed of numerically intensive applications.

Several innovative features distinguish the FASTCache from other cached accelerator cards. System

performance, for example, is improved by up to 50% by placing data in the "write buffer" before passing it to system memory during write operations. Consequently, the processor can continue to execute code from the cache while the previous write to system memory is being completed.

A four-way set associative cache, more efficient than direct-mapped and two-way caches, enhances system speed by achieving hit rates in excess of 90%. Coherency between the cache and main memory contents is maintained utilising a "snoop bus", a connection to the I/O channel which monitors DMA accesses so that stale data is not left in the cache.

Both 16-bit 80286-based code and 32-bit 80386-based applications can be run on the FASTCache without modification. The 80386SX/80387SX processor pair used on the card is completely compatible with software written for real address mode, virtual-8086 mode, protected 80286 mode and protected 80386 mode.

MicroWay is currently offering a Window 3/FASTCache-SX bundle, which enables PC users to run Micro-soft's popular 80386-based multi-tasking operating system on their 80286 machines. Prices start at £360.00.

Further information can be obtained from Mr Yehia Oweiss, Technical Manager, MicroWay (Europe) Limited, 32 High Street, Kingston-upon-Thames, Surrey, KT1 1HL. Tel: 081-541 5466.

Very Trendy

Trend's Test and Analysis Division has signed a sole distribution deal for Tekelec's (Tekelec Inc. of Calabasas, California, U.S.A.) full range of data communications diagnostics test systems, in the U.K. and Eire.

Trend, already a leading player in the test and analysis market believe that the Tekelec partnership not only extends their already quality range, but gives them the opportunity to introduce new products to the market quickly. As confirmation, the agreement coincides with the launch of the new ChameLAN 100, a FDDI (Fibre Distributed Data Interface) network test system. The unit is the first truly portable LAN analyser for FDDI developers and users to be offered in the U.K. The ChameLAN 100 is also the first FDDI test system to ensure continuous network testing regardless of traffic loads or problems on the network, for the full 100Mbps bandwidth.

tional markets, including Europe and the Middle East. The portable Testman 705 can perform in both field service and development environments, combining a wide variety of protocol analysis, data line monitoring and testing capabilities together with ISDN protocol decodes and emulation. The Testman 705 range is fully upgradable, from the 705 Super to the top of the range 705 CEPTI. The Testman 705 supports not only ISDN but also a number of other protocols including X25, SNA, DDCMP and BERT/BLERT at speeds from 50bps to 2Mbps.

Completing the current Trend/Tekelec offering is the Message Generation Test System MGTS, a multiprotocol evaluation system for Signalling System Number 7 (SS7). This product prevents SS7 service disruption by testing worst case conditions before the network is installed, protecting the network with in-service surveillance and complete SS7 node simulation. The MGTS system also supports the



Trend's Test and Analysis Division are also able to offer the Chameleon 32 and Chameleon 20 in Tekelec's range of protocol analysers. Chameleon 32 has established itself as a leading product for supporting data communication protocol development for X25, ISDN, SNA, OSI, FTAM and X400 systems. The Chameleon 20 has been adopted by many PTT's worldwide for use in End Office Test Systems for maintenance of X25, X75 and ISDN networks, in particular DASS II and DPNSS for the U.K. ISDN market.

Already launched in the U.K. is the Trend Testman 705 field portable protocol analyser range for WAN and ISDN networks. Trend's agreement on the Testman 705 extends into interna-

GSM signalling system in use with cellular telephone networks.

Trend's Managing Director Arthur Fisher commenting on the partnership said "We are pleased to add Tekelec's systems to our product offering because they are already highly respected by the data communications community". The agreement provides Tekelec with a safe pair of hands for its products, Peter Vicars, Tekelec president and Chief Executive Officer agreed "Trend as a member of the Telemetrix plc Group has a winning mix of marketing and technical skills to match our distribution objectives."

For further information please contact Sharon Bernstein, Corporate Counsel Limited. Tel: 071-637 8575.

Too Little and Probably Too Late

BT's new Electronic Data Interchange service planned for later this year has been dubbed 'too little and too late'. According to Michael Naughton of Applied Network Research, the leading U.K. EDI authority, most major U.K. markets have already been sewn up by such suppliers as ISTEEL and INS. "There could however be some opportunities in Europe for a BT service. While the global reach of BT Tymnet value-added data networks is very impressive, the built-in PTT/Post Office culture of BT may impede its move into the highly commercial world of EDI".

Meanwhile, Michael Naughton sees EDI booming over the next four years with large users and vendors being encouraged to join the club by their customers. "What we are seeing is EDI moving from awareness to implementation. Increasingly companies are implementing EDI not just as a high tech tool, but as a practical and effective business solution".

'Cowabunga!'

Turtlemania has reached the computing world. Currently riding high on the top selling computer games software charts, those Teenage Mutant Ninja Turtles have emerged from the depths to challenge such delights as 'Space Invaders' and 'PACMAN'. Best sellers are the Spectrum, Amstrad, Commodore and Atari versions.

Cable Connections

With OFTEL putting increasing pressure on the cable television companies to get out and start digging, the Cable authority is claiming that in broadband cabled homes, the proportion of viewers watching cable and satellite programmes is nearly 50%. Not unexpectedly, the most popular channel is Sky Movies from British Sky Broadcasting. In fact, Sky Movies and Sky One have overtaken Channel 4 and BBC 2 in the ranking charts, for homes which can receive satellite broadcasts.

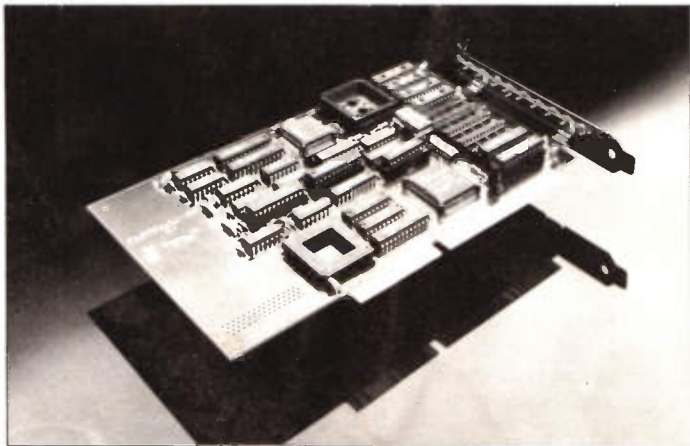

Getting the Picture

One range of products not affected by the Christmas economic shopping slow-down was that of Camcorders. Now Sony have introduced an 8mm video cassette recorder for camcorder users. The Sony EVS550 features Hi-Fi stereo recording and playback with a 60 channel NICAM tuner, plus a choice of terminals for easy connection to a stereo TV or Hi-Fi system. Various

playback modes can be selected in either direction by use of editor shuttle, which can also act as a recorder or player control for another compatible camcorder or video recorder. Supplied with the system is a remote commander with LCD panel. Up to six events one month in advance can automatically be set by remote control with a memory facility for four favourite settings. Price £549.99. Details: 0784 467371.

Testing the Spectrum

Closer to home, in Wiltshire to be precise, Raychem has installed a special facility to design and test equipment against the Electromagnetic Spectrum. The centre is equipped to evaluate the performance of products as regards both susceptibility to electromagnetic radiation and radiated emissions, and conducted susceptibility and conducted emissions. Extensive varieties of powerful pulse generators are available to simulate lightning and electro-magnetic pulse effects under EEC directives. Details: 0793 528171.



Backroom Boys in Top Gear

It's not often that the automobile industry gets much of a look-in in 'News Report', but this issue aims to change all that. Engineers at Ford's research and engineering centre at Dunton, Essex - down the road from the Maplin editorial offices, as it happens - are leading the development of a plastic engine which generates 30% less noise than an equivalent metal unit. The BRITE engine project, which saw the light of day back in 1987, has now culminated in road testing an engine which, apart from its combustion chambers, cylinder walls and moving mechanical parts, makes use of special fibre-reinforced plastic. So watch out for that specially modified Fiesta quietly purring around the highways and byways of Essex.

Chips with Everything

Those backroom boys at IBM obviously did not take much time off over the Christmas break. They have just announced that they have built transistors out of a promising computer chip material called 'silicon-on-insulator' that runs three times faster than comparable pure silicon transistors. The transistors are the Complementary Metal Oxide or CMOS type of electronic devices, a mainstay of computer chips that power laptop and personal computers. The development, says IBM, indicates the long range promise of silicon-on-insulator, a material that could someday speed operation and decrease errors in computer circuits. No mention as yet of IBM experimenting with the Ford developed plastic material.

Schools Out

A final note on education. 'Computergram' reveals that U.S. students now believe that it is more important to know how to use computers than to merely understand how they work. Apparently, for the third consecutive year, the number of degrees awarded in computers and information sciences was down. Experts blame the decline on a lost love affair with personal computers.

Wrong Number

What do you get if you ring a friend in Hong Kong? Answer: A Wong number. What do you get if you phone someone in London? A polite operator telling you to re-dial using the prefix 071 or 081. Now, just when we have got used to the new BT numbers, comes the news that BT is proposing yet further changes. Apparently BT is seeking to change to a ten digit numbering plan for its fixed network. This would involve the insertion of the extra digit '1' in each STD code after the '0'.

It now seems that pressure on the existing numbering capacity is mounting with the increasing demand for numbers for additional telephone lines and as a result of new services and facilities.

The proposed change, says BT, would enable a range of new numbers to become available through the use of additional digits other than '1'. Currently, the Office of Telecommunications (OFTEL) is examining the proposal. If approved, then this time perhaps OFTEL will pay some regard to the customer and help reimburse the costs of producing new stationery!

At least, such changes will not be necessary in China. According to the industry bible 'Computergram', with one telephone per 100 people in the People's Republic of China, the aim is to increase that number to three per 100 by the end of the century.

However, the 'extra number' news will not please at least one enterprising company, Datapoint, who are marketing a new computer-based telephone directory system. This allows users to automatically find telephone numbers through a computer terminal, PC and modem. The system allows anyone access to BT's Phone Base service. Designed for tele-marketing operations, the system has an access rate of five numbers per minute - less presumably if that extra digit is incorporated.

Intelligent Phone-Ins

Aimed at TV and radio phone-in shows and response lines, BT is introducing an Intelligent Network. Any sudden deluge of calls to a station results in engaged numbers and irritated callers. The new system, which involves GPT and Tandem Computers, makes use of a database clustered around the network's telephone switches, to anticipate heavy demand before it happens. Lets hope the system will be extended to certain box offices which handle top line rock events and West End musicals.

Getting the Picture, 2

A video telephone system which transmits video images over a standard telephone line has been developed by Imagebase Technology. The colour Photophone lets you use your telephone to communicate both voice and images, interactively. As a result, users can see and discuss the texture and colour of fabric at a supplier's centre, the colour coding on a circuit board, or any drawing where colour is critical to making a decision. One of the first users was Ford, who have installed the system in their design engineering plant. Details: 081991 1396.

Taking the concept one stage further, a development by leading French manufacturers including Thomson and Matra is a colour video telephone that transmits moving images alongside speech and data over telephone lines. But don't all rush at once. Currently available at about \$6,000, by 1995 the price is expected to have tumbled to just \$1,000.

Getting Your Cards

Having devoted much time, energy and money to saturating town and country with telephone boxes, BT and Mercury are now turning their attention to Phonecards. Apparently BT executives have their business cards printed on 10-unit Phonecards. At least the recipients will not instantly ditch their cards. Meanwhile, Mercury will be featuring team photographs of many of the top English teams on their telephone cards. To encourage collectors, Mercury are planning a further 4,000 card phones in the U.K. during the next six months.

Hole in the Wall

According to a recent report by the banking ombudsman, nearly 100 users of banking cash cards received a cash bonus in the past twelve months. The bad news is that the banks' automatic teller machines recognised the fault and debited the appropriate accounts with the amount paid out - not for the sum requested.

Even more strange, only five of the lucky users disputed the fact that they had received the extra cash.

Not before time perhaps, a leading bank has donated an operational automatic teller machine to the Science Museum. Although not quite in the historic class, at least the exhibit does work.

Top Quality

Top marks must go to British Telecom whose quality of service is now achieving record levels. In the past six months, more than 99% of the 80 million calls made every day get through at the first attempt. Also 96% of BT's 95,000 public payphones are in full working order at any one time. On average, the company adds, fault on a line will occur only once in every six years. Any adverse comments on these claims to BT, please, not to the Editor!

Moving with IBM

At the risk of this issue of 'News Report' turning into an IBM House Magazine, mention must be made of the news that IBM is setting up its Communications Systems Headquarters in London. The division develops the full range of IBM networking products and services around the world. The move has been welcomed by Peter Lilley, U.K. Trade and Industry Secretary, who lost little time in suggesting that it was the U.K.'s liberalised and deregulated environment which encouraged IBM to choose London. On their part, IBM suggest that the move has been triggered by the need to capitalise on expanding business opportunities in a unified Europe and around the world. (Job) details: 0532 1212.

Sky Wars

British Sky Broadcasting has put at ease those unfortunate purchasers of the rival BSB service. Not only does Sky intend to continue broadcasting the full 'BSkyB' service of five channels on the Marco-Polo satellite in an indefinite period, subject to the franchise being withdrawn by the IBA, but will replace the receiving equipment of everyone who has installed BSB with the Astra-based satellite TV equipment, with installation free of charge! Details: 071 782 3000.

Sound Sense

If you haven't yet invested in the Maplin NICAM digital stereo TV sound system, you had better look sharp. The IBA has now successfully completed the first phase of installations bringing NICAM to ITV and Channel 4 throughout the country. The target, to make NICAM available to 79% of viewers, and to every ITV region (except Channel), has been reached. This year will see the second phase of NICAM increasing coverage to over 90% of the population. Details: National Transcommunications, 0962 822582.



Picture Caption Challenge

Now, just what is BT up to?

Answers please on the back of a new five pound note to the editor:

- ★ BT cleans up its act after Mary Whitehouse watches a replay of a Crystal Palace football club match relayed by satellite.
- ★ BT sponsors a detergent commercial.
- ★ Having run out of payphones to clean, BT turns its attention to satellite dishes.

★ BT's Chairman trying to scrub the government's duopoly review out of his hair.

★ Those graffiti writers get everywhere!

Well, realising that the chances of you finding any clean five pound notes are remote, the editor will save you money and postage and reveal the true answer.

A BT rigger finalises the installation of a new satellite dish to provide speech and data communications facilities for a North Sea Oil platform.

**DATA
FILE**

SSM2045 MUSIC VOICING SYSTEM

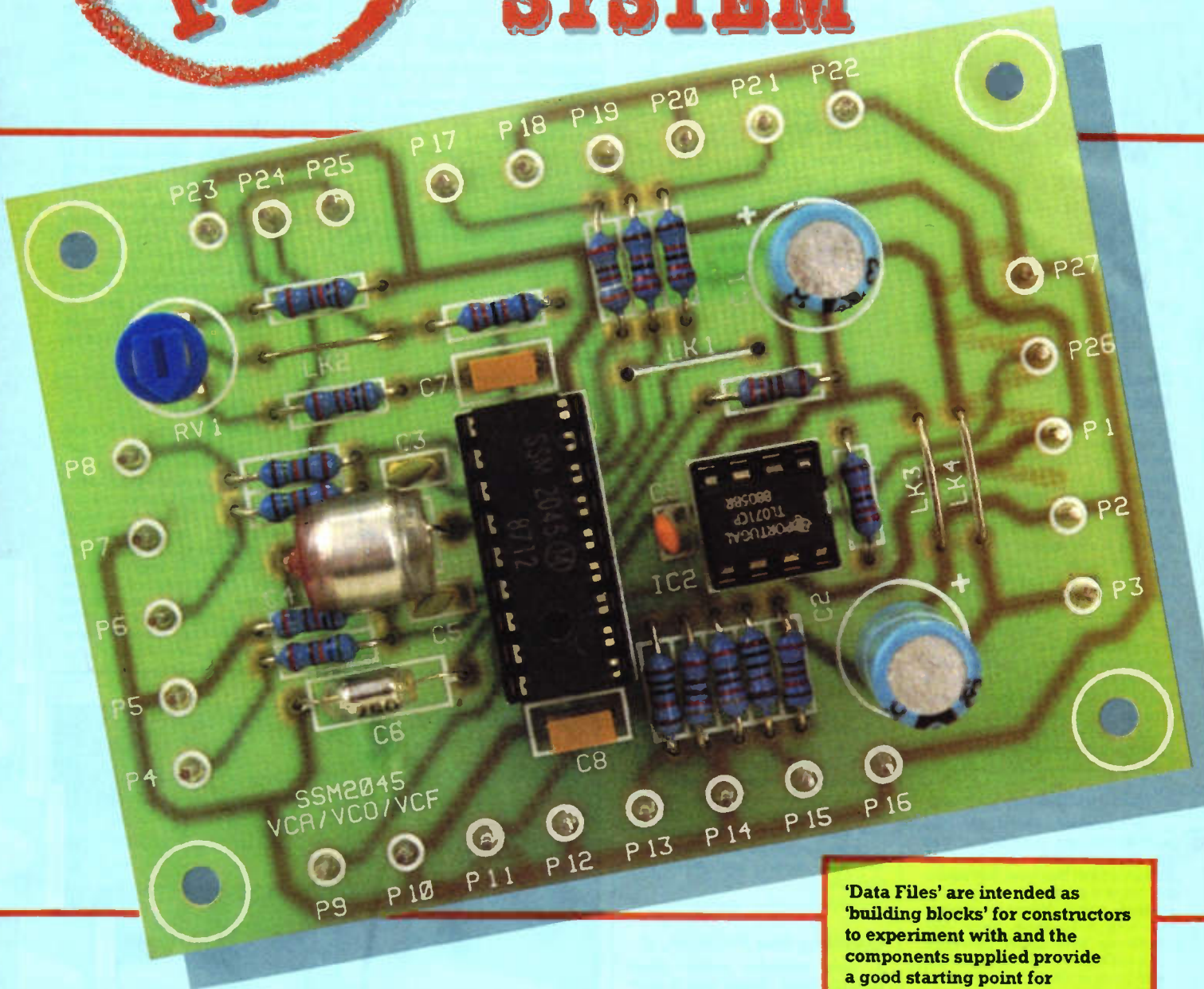

'Data Files' are intended as 'building blocks' for constructors to experiment with and the components supplied provide a good starting point for further development.

FEATURES

- ★ 2-POLE AND 4-POLE LOW PASS FILTER
- ★ ON-CHIP MIXER/VCA
- ★ LOW NOISE

APPLICATIONS ★ Electronic Music ★ Sweep Oscillators

Introduction

The SSM2045 is a general purpose IC offering a wide range of filter and mixer options. A Voltage controlled Low Pass Filter with both 2-pole and 4-pole outputs is provided on-chip, together with an uncommitted mixer/VCA combination. Figure 1 shows the IC pinout and Table 1 shows some typical electrical characteristics for the IC. Figure 2 shows the IC block diagram.

IC Description

The SSM2045 is effectively in 2 parts; the filter section, and the VCA.

Filter Section

The filter section provides both 2-pole and 4-pole low pass functions. Input levels up to a maximum of 150mV peak to peak may be used, and the signal input has an impedance of approximately 900Ω. Higher levels may be used within the specified maximum limits, but an increased level of distortion will be apparent – this may actually be desirable for some sounds – and input signals can be summed using a resistor network. The signal to noise ratio for the filter section is approximately 84dB for a signal of 150mV peak to peak at the input.

The 'Q control' input accepts a control current from a source which must be above approximately +0.6V. An internal 1.8kΩ resistor in series with the emitter of a grounded base PNP transistor provides short circuit protection. This current modulates a voltage controlled feedback amplifier which provides built-in electronic Q of the filter stages as a whole, with a minimum of in-band loss at the oscillation point. With a low Q the response of the filter block is nearly flat, whereas with a high Q the response can be sharpened up to the point of oscillation.

It is also possible to sweep the operating frequency of the filter over a range of 5000:1. However, the sweep is usually restricted to 1000:1 to remain practical and this corresponds to ±90mV range at the F_C input, pin 5, of the IC.

Mixer Section

The mixer/VCA section is entirely independent of the filter section allowing optimum flexibility. In addition to the mixer's control inputs ('Lin Mix 1'

Parameter	Conditions	Min	Typ	Max
Supply voltages:				
Positive		+5V	+15V	+18V
Negative	*see note below	-5V	-15V	-18V
Supply current:				
Positive		+3.7mA	+5.0mA	+7.0mA
Negative	pin 5 = 0V, current pin 15, 17 = 0mA	-5.8mA	-6.5mA	-7.1mA
Signal input level (pin 2)	peak to peak		150mV	300mV
Q current required at pin 17 for oscillation		120μA	150μA	185μA
Distortion (THD):				
Filter section in band	input = 150mV peak to peak		0.1%	
Filter section max.	input = 150mV peak to peak		1%	
Mixer/VCA section	input = 40mV peak to peak		0.3%	
Filter output level	peak to peak		1V	3V
Filter output source current		5mA	10mA	15mA
Filter output sink current		600μA	750μA	900μA
VCA gain	I pin 15 = I pin 16 = 500μA, V pin 14 = 0V	3842μs	4085μs	4330μs
VCA signal to noise ratio			82dB	
Frequency control range		1000:1	5000:1	

*A resistor is required in series with pin 10 of the IC for voltages more negative than -6.8V.

Table 1. Typical electrical characteristics.

and 'Lin Mix 2'), there is a third input provided called 'Expo Mix', which may be used to determine the *relative levels* of the input signals in the final mixed output.

Power Supply Requirements

The SSM2045 is optimised for use with a ±15V power supply. Positive supply voltages down to +5V can be used, but with a progressive degradation of performance; in particular the VCA offset and control feed-through are affected. However the negative supply rail can be any value greater than -5V without any significant variation in performance. A negative supply voltage greater than -6.8V is clamped by an internal zener diode, and so it is necessary to connect a current limiting series resistor between pin 10 of the IC and the negative supply rail if this is the case.

Kit Available

A kit of parts is available to build a basic application circuit using the SSM2045. The kit includes a high quality fibreglass PCB with a screen printed legend to aid construction. Figure 3 shows the circuit diagram and Figure 4 shows the PCB legend and track. Note that, because the module may be used in many different applications, some of the

component values supplied in the kit have been assigned an arbitrary value. For this reason minor modifications may be necessary to adapt the circuit to individual purposes.

The module requires a split rail power supply in the region ±10V to ±15V that is capable of delivering at least 50mA. It is important that the power supply is adequately smoothed and regulated to prevent any mains derived noise from entering the

system via either supply rail. Power supply connections are made to P1 (+V), P2 (0V), and P3 (-V). Figure 5 shows the wiring diagram.

Signals to the filter input are applied via P6 (input), P7 (0V) and P8 (input). Resistors R3 and R4 connect these to a common point at the IC and enable the initial summing of the two input signals, which are directly coupled and should be referenced to 0V (P7).

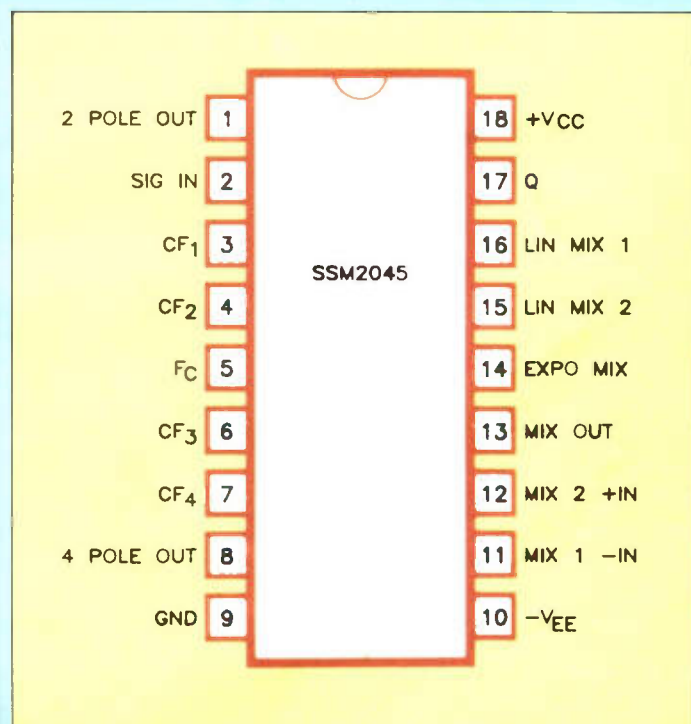

Figure 1. IC pinout.

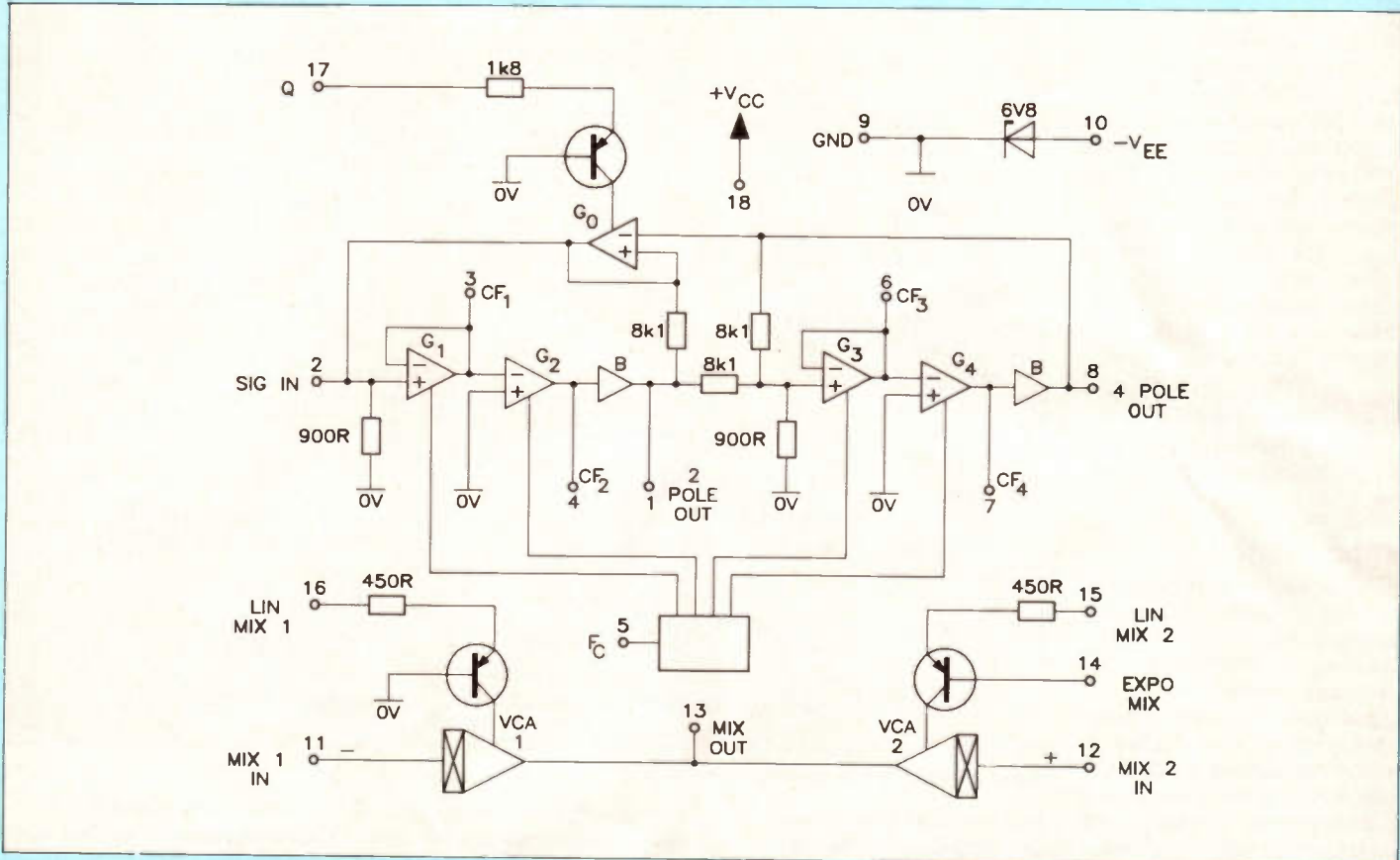

Figure 2. IC block diagram.

Q control adjustment is achieved by either using the on-board preset RV1, or an external potentiometer. Wire link LK2 selects which type of control is used. If LK2 is not fitted, then the module is configured to accept an external Q control potentiometer. A

suitable value is 22k and this is connected between P23 (+V), P24 (input) and P25 (negative end stop). If configured in this way then both R15 and RV1 are not required. If LK2 is fitted then the Q control is via the on-board preset (RV1) and it is not possible to use an external Q

control. A quality cermet preset is used to ensure long term reliability.

Frequency control is achieved by applying a voltage between P4 (Fc input) and P5 (0V). To prevent damage to the IC, input voltages at this pin should not be allowed to

exceed the supply voltage.

Two outputs are provided from the filter. A 2-pole output is available between P9 (o/p) and P10 (0V) and a 4-pole output between P11 (o/p) and P12 (0V).

The input to VCA 1 is between P13 ('-i/p) and P14 (0V), and the input to VCA 2 is

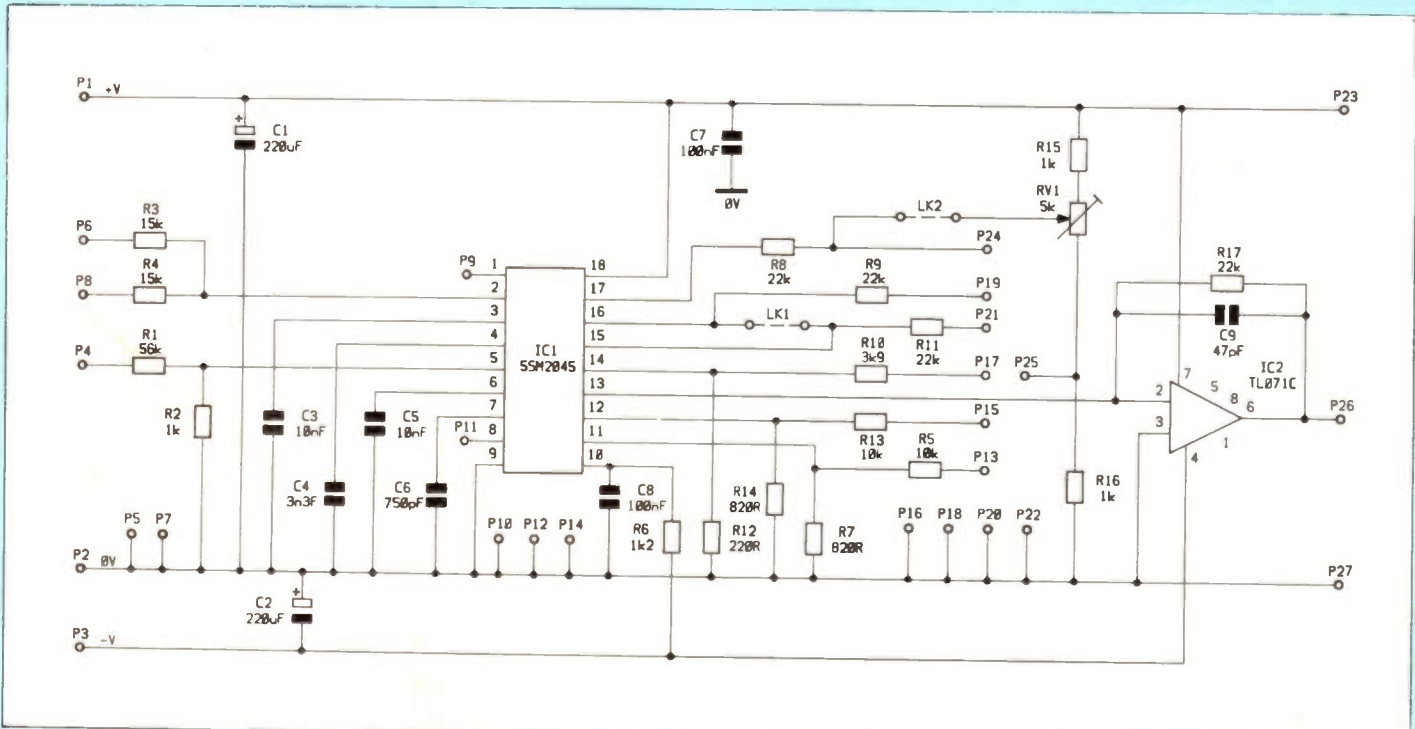

Figure 3. Module circuit diagram.

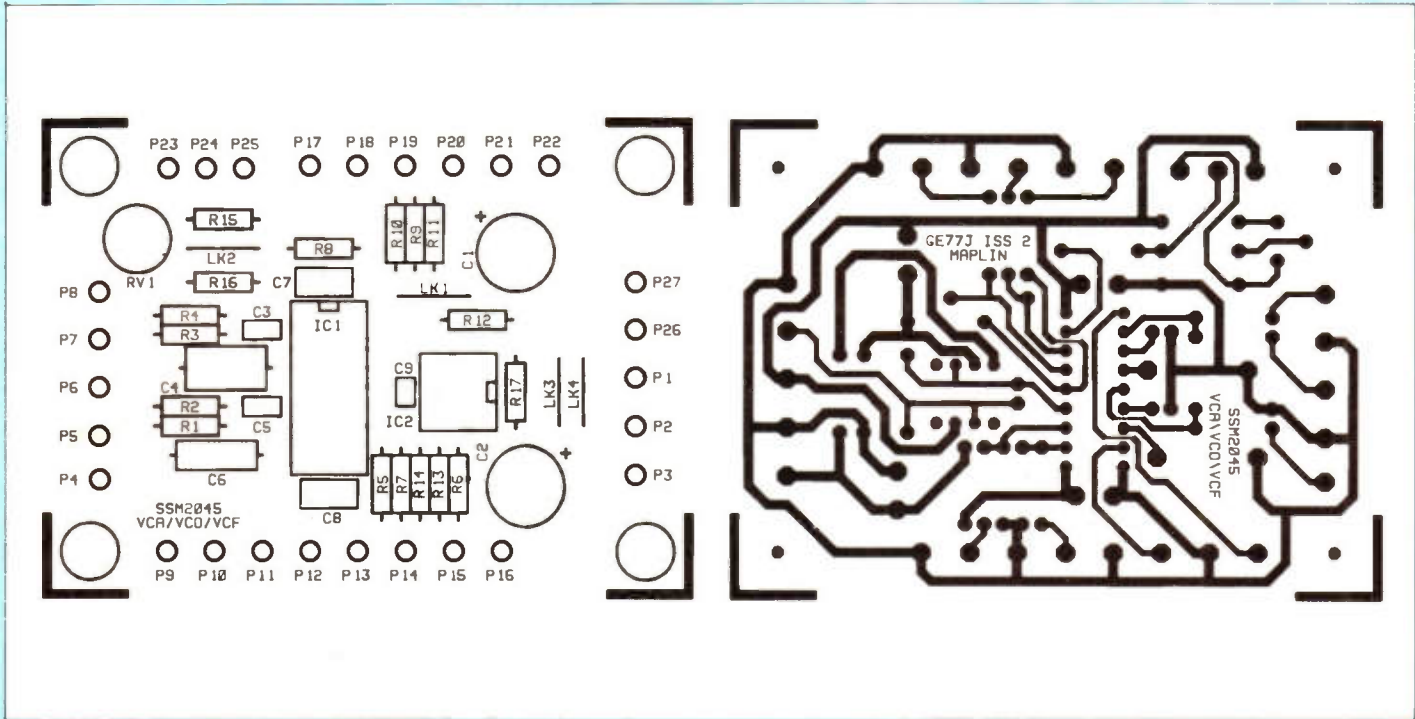

Figure 4. PCB legend and track.

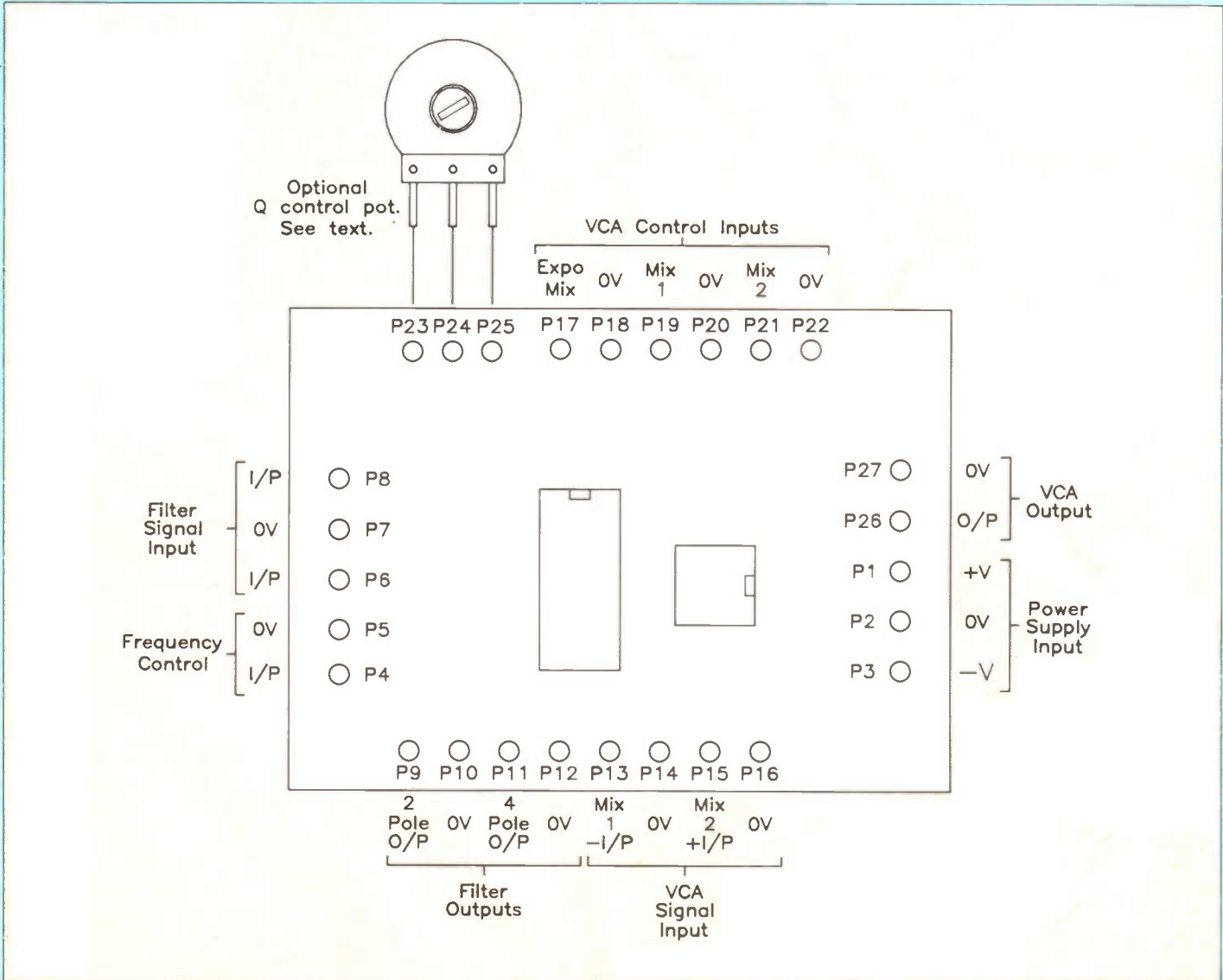

Figure 5. Wiring diagram.

Continued on page 70.

TEMPERATURE CONTROLLER

by Joe Fuller

Features:

- ★ Moisture Proof Enclosure
- ★ Optional Back-up Cell
- ★ Outputs for Heating and Cooling
- ★ Optically Isolated Zero Crossing Triac Mains Switching
- ★ Switches Resistive and Inductive Loads
- ★ 3m Long Temperature Probe
- ★ Clear 12.7mm Display
- ★ Temperature Displayed in Celsius or Fahrenheit
- ★ LED Power On and Output On Indicators
- ★ Optional Temperature Logging Output

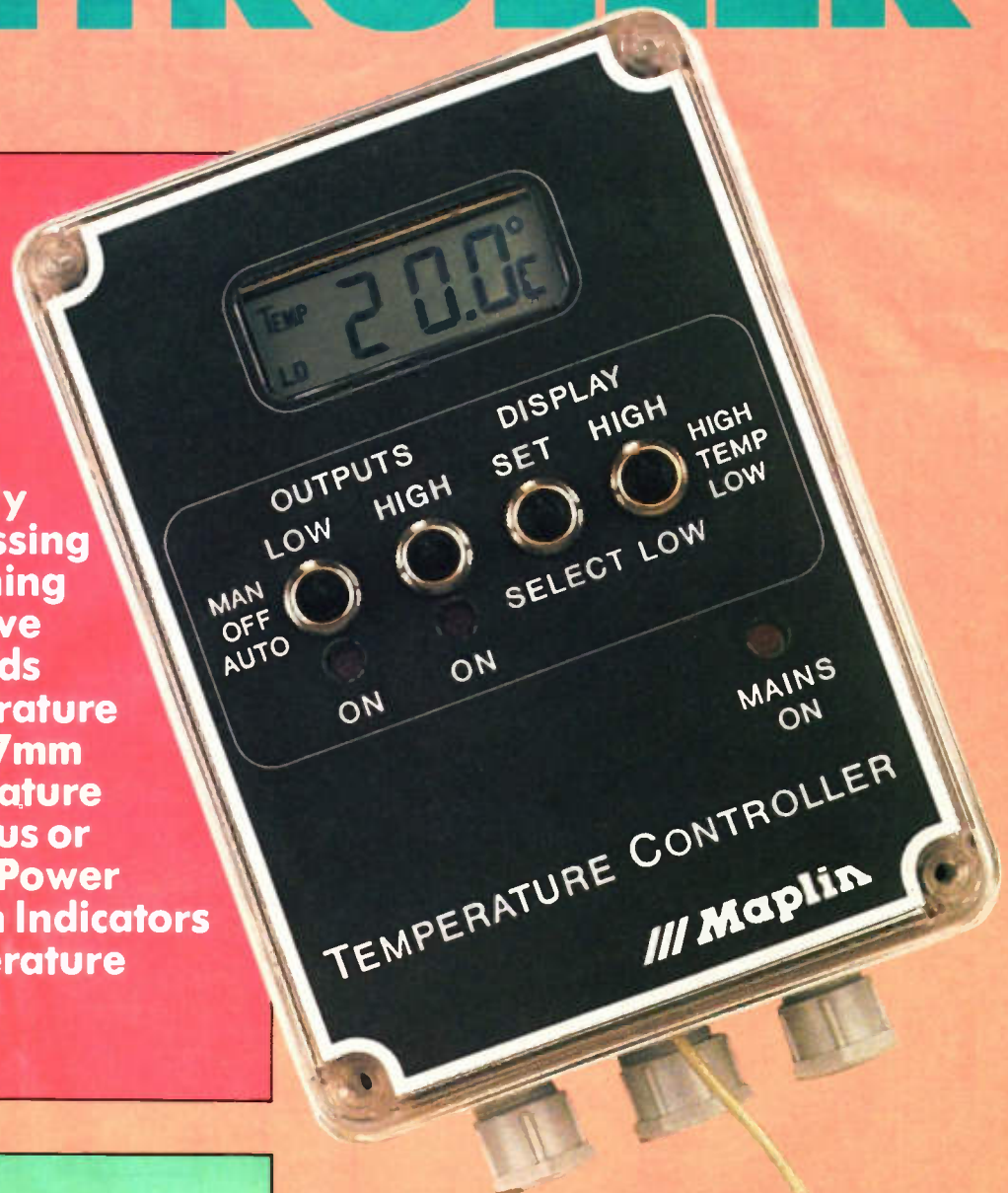

Important Note

WARNING: The 240V AC U.K. domestic mains supply is *dangerous* and potentially *lethal*.

All reasonable steps have been taken to ensure that this project complies with the relevant U.K. electrical safety regulations and that information presented here is accurate. However please use common sense when building, testing and using this unit. If you have *any doubts* as to your ability to construct this project, *do not* proceed and consult a qualified electronics engineer, or if you have *any doubt* as to how the mains wiring should be connected, *do not* proceed and consult a qualified electrician.

Specifications

General

Dimensions:	150 x 110 x 70mm (excluding controls and glands)
Supply Voltage:	240V AC Mains 50Hz
Back-up Supply:	1.5V AA Alkaline Cell
Display:	12.7mm high LCD
Temperature Sensor:	3m External probe
Output Modes	
Low-temperature:	Manual, Off, Automatic
High-temperature:	Manual, Off, Automatic
Display Mode:	High and Low Set-points and Temperature
Set-point Adjust:	Set and Select
Cable diameter:	5 to 8mm
Fixing:	4 x 1 inch nylon bolt

Mains Outputs

Number of Outputs:	2 (low and high temperature)
Switching Capacity	
Resistive:	240W
Inductive	240W

Switching Arrangement: Live Side Zero Crossing Triac, Optically Triggered

Temperature Logging

Data Format: 13-bit serial
Clock: Data limited

Temperature Module

Operating Temperature: -5°C to +50°C
Display Range
Celsius: -19.9° to 69.8°
Fahrenheit: 0° to 159.8°
Display Resolution: 0.1°
Basic Accuracy
-10°C to +40°C ±1°C @ 1.5V
-20°C to -10°C ±2°C @ 1.5V
+40°C to +70°C ±2°C @ 1.5V
Change in basic accuracy by probe length: ±0.83°C.m⁻¹
Temperature Set-Points: 1° steps
Supply Voltage: 1.25V to 1.65V (1.5V nominal)
Supply Current: 15µA approx.

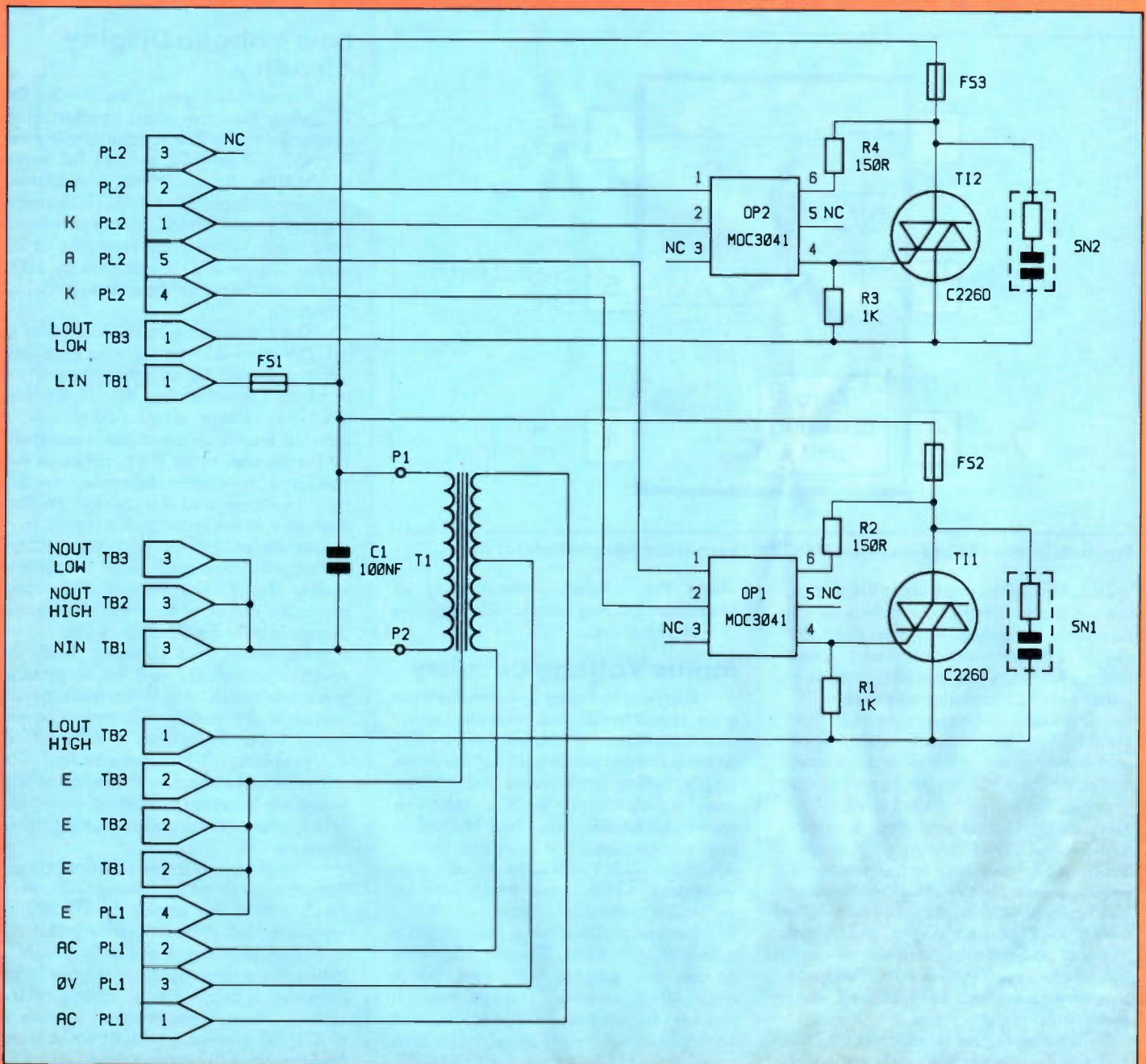

Figure 1. Circuit diagram of the mains voltage circuitry.

Introduction

The Temperature Controller project was originally designed for use in a greenhouse, and as such the whole unit is designed to be fully moisture proof. The unit is therefore ideal for use in other damp environments such as a shed, outbuilding or garage. The unit has numerous uses in other areas where a temperature controller is required.

The unit is based around a 'Maplin Precision Gold' Temperature Module type FE33L, which drastically simplifies the design. The temperature module provides a digital readout of temperature, in either fahrenheit or celsius, on an LCD display. Temperature sensing is by means of an external thermistor probe which is connected to the module in place of the original self contained thermistor.

The controller is housed in a water-proof box with a transparent lid, allowing the LCD display and LED indicators to be clearly seen whilst maintaining a sealed

is desirable to maintain the temperature set-points, which would otherwise be lost if the mains power supply failed. Obviously, during a mains power failure mains operated heating and cooling will fail to operate, but if a back-up supply is provided, normal operation will resume when the mains supply is restored.

Circuit Description

The circuitry for the temperature controller is split across two circuit boards, comprising the mains voltage circuitry on one and the low voltage display circuitry on the other. The mains voltage circuit diagram is shown in Figure 1 and the low voltage display circuit diagram is shown in Figure 3. It should be noted that circuitry is split in this way for safety reasons, and a secondary benefit is that the assembly and testing of the temperature controller is easier.

It is as well to understand the circuit operation as this will not only serve to

the devices used in the temperature controller. The isolated low voltage inputs to OP1 and OP2 are connected via PL2. Firing the triacs at the zero crossing point of the mains cycle is desirable as this virtually eliminates all switching noise which would otherwise occur. R2 and R4 limit the current flow through the triac halves of the optoisolators and therefore also limit the gate current through T11 and T12. R1 and R3 help to prevent false triggering of the triacs by mains borne noise or interference. Note that R1, R2, R3 and R4 are rated at 1W, this is not due to power dissipation requirements, but simply because 1W resistors have a higher voltage rating than the standard 0.6W Metal Film resistors which are used elsewhere in the unit. Snubber networks SN1 and SN2 help to protect the triacs from spikes produced by inductive loads. FS2 and FS3 serve to protect the triacs against overload. The mains outputs from the unit are taken via TB2 and TB3.

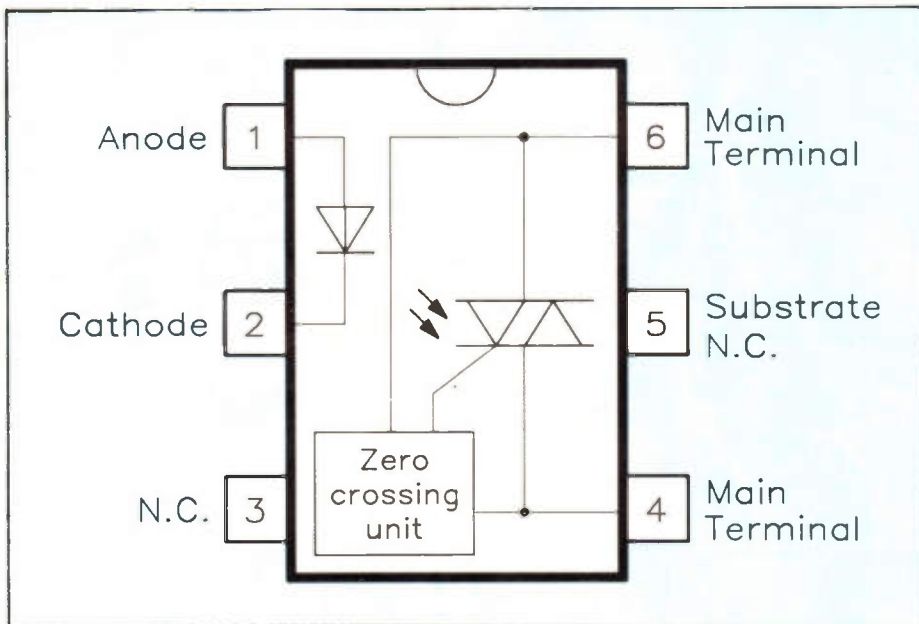

Figure 2. Internal diagram of the MOC3041 zero crossing optoisolator triac.

enclosure. Mains cables enter the enclosure via water-proof cable glands, which also serve to firmly anchor the cable. The toggle switches, which are used to select various functions, are sealed by means of water-proof polychloroprene covers.

The unit is designed to operate from the 240V AC U.K. domestic mains supply and provides two triac-switched outputs for controlling heating and cooling appliances. The two outputs are termed 'Low Temperature Output' and 'High Temperature Output'. Both outputs can be controlled either manually or automatically. When set to automatic, the low temperature output will switch on when the temperature falls below a pre-set level (i.e. to switch on heating). Conversely, the high temperature output will switch on when the temperature exceeds a pre-set level (i.e. to switch on cooling).

The temperature set-points are held in the temperature module's memory, which is volatile. For this reason a back-up supply

widen the reader's understanding of electronics, but also assist trouble-shooting should a fault occur.

Mains Voltage Circuitry

Referring to Figure 1, the mains input is connected to TB1, and protection of the temperature controller is afforded by FS1 which is fitted in the Live side of the mains supply. Supply borne noise and interference is attenuated by C1, which is connected between Live and Neutral. A low voltage supply is provided by T1, which develops 9-0-9V AC across its secondary, which is fed along with an earth wire to the display board via PL1.

Switching of the two mains outputs is achieved with triacs T11 and T12, these devices are isolated tab types, which means that insulation washers are not required between these devices and the heatsinks. The triacs are triggered by zero crossing optoisolator triacs OP1 and OP2, and Figure 2 shows the internal diagram of

Low Voltage Display Circuitry

Referring to Figure 3, the 9-0-9V AC supply from the mains transformer is connected to the low voltage circuitry via PL1. D1, D2 and C2 provide full wave rectification and smoothing. A regulated +5V supply is provided by RG1, decoupling capacitors C3 and C4 serve to remove noise and interference from the +5V supply. 'Power On' is indicated by LD1, and R5 sets the current flow through LD1 to 10mA.

The temperature module requires a +1.25V to +1.65V supply to operate, and this is provided by an elementary shunt regulator formed around R6, D3, D4 and D5. The voltage developed across a forward biased silicon diode is assumed, by convention, to be 0.6V, although this voltage is somewhat dependent on the type of diode and the current flowing through it. In this instance, the current flow is just under 1.5mA and the voltage developed across each diode is approximately 0.56V. The voltage developed across the output of the shunt regulator is approximately $3 \times 0.56V = 1.7V$.

D6 serves two purposes: firstly, in conjunction with D7 and B1, to provide automatic switch over to the back-up cell supply in the event of a mains power failure. Secondly to 'drop' a further 0.1V, thus providing a 1.6V supply for TM1. C5, a low leakage tantalum capacitor, serves to provide a degree of 'hold up' during the switch over process and prevents glitches reaching TM1.

Under normal mains-powered conditions, the anode of D6 is some 0.2V more positive than the anode of D7. D7 is reverse biased, whilst D6 is forward biased and thus provides the supply to TM1. When the mains supply is removed, the converse is true, with the anode of D7 some 1.5V more positive than the anode of D6. D6 is reverse biased, whilst D7 is forward biased, allowing B1 to maintain the supply to TM1.

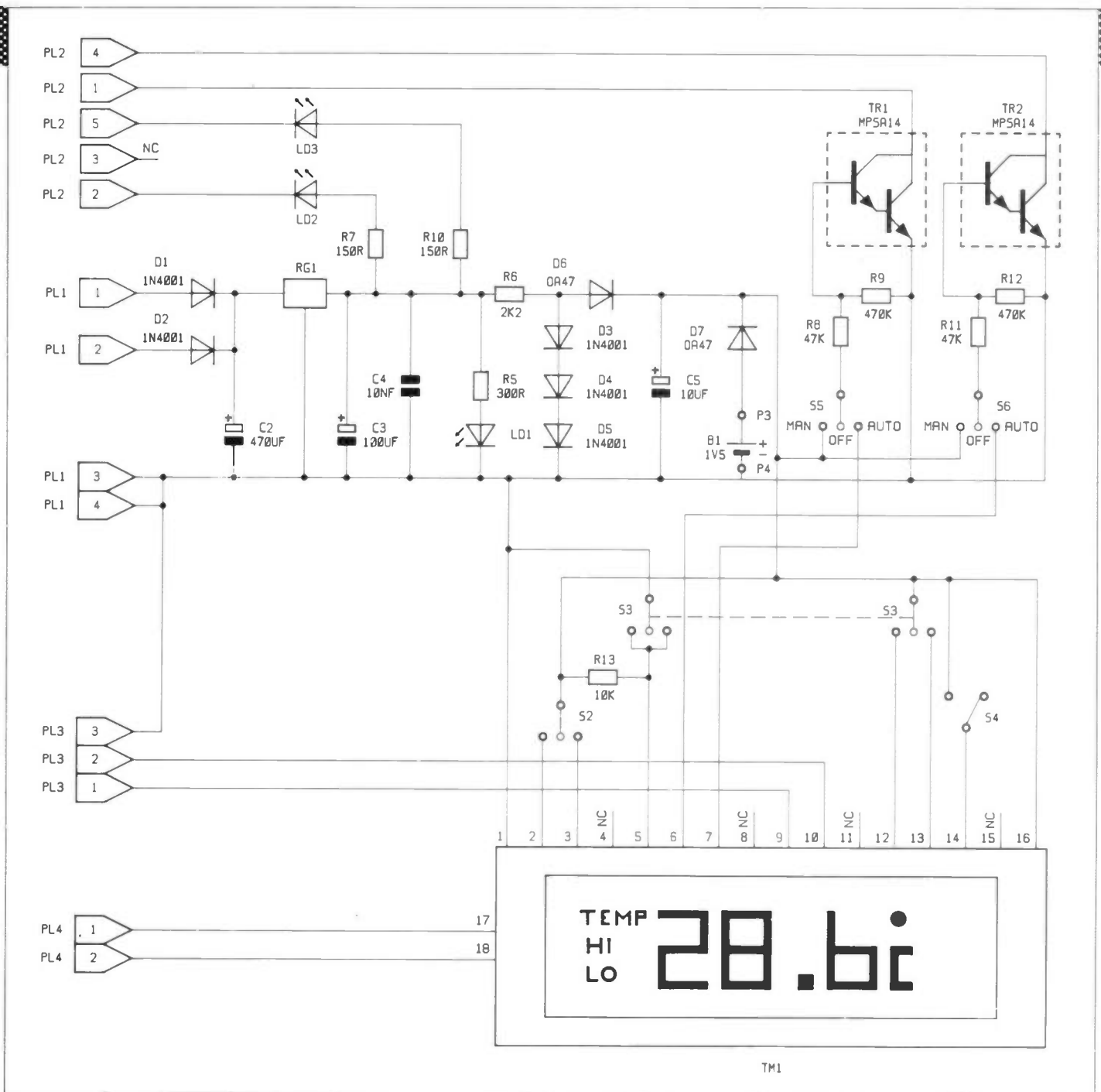

Figure 3. Circuit diagram of the low voltage display circuitry.

Connection to the external probe is by means of a 2-pole minicon connector PL4. The external probe is connected in place of the internal thermistor; pins 17 and 18 of TM1 are the pads on the temperature module where the thermistor was located prior to its removal.

The display switch, S3, is a centre-off double-pole change-over switch. In the centre position, the probe temperature is sampled at 1 second intervals and displayed. When S3 is in the up position, pin 12 of TM1 is pulled high and the HIGH temperature set-point is displayed. When S3 is in the down position, pin 13 of TM1 is pulled high and the LOW temperature set-point is displayed. A (peculiar) requirement of the temperature module is that the sample rate must be slowed to 10 second intervals to allow the set-points to be adjusted. This is facilitated by means of one half of S3 and a pull-up resistor R13. If required the sample rate can be permanently set to 10 second intervals by

omitting R13. When either set-point is displayed S2 may be used to adjust the temperature set-point.

The set and select switch, S2, is a centre-off single-pole change-over switch, biased both ways. When S2 is in the up (SET) position the selected temperature set-point will increment in 1° steps and when S2 is in the down (SELECT) position the selected temperature output can be enabled or disabled. LO and HI segments on the display indicate which outputs are enabled.

S4 selects either fahrenheit or celsius temperature scales, when S4 is off the display is in degrees celsius and when S4 is on the display is in degrees fahrenheit. If permanent selection of temperature mode is required, S4 can be omitted (celsius) or replaced by a link (fahrenheit).

The high and low set-point outputs from TM1, pins 6 and 7 respectively, are connected to S5 and S6. S5 and S6 select the operating modes for the two mains

switched outputs. Each switch may be in one-of-three positions; 'MAN', 'OFF' or 'AUTO'. In the MANUAL position the relevant output is switched on; in the OFF position the relevant output is switched off; and in the AUTOMATIC position the relevant output is under control of the temperature module TM1.

R8 provides base bias to TR1 when either S5 is set to MAN or S5 is set to AUTO and the high set-point output switches on. This causes TR1, which is a darlington transistor, to conduct and current will flow through R7, LD2, OP2 (mains voltage circuit, see Figure 1) and TR1 itself. Whilst TR1 is conducting LD2 will illuminate to indicate that the low-temperature output is on. R9 ensures that TR1 turns off when base bias is removed. The circuitry around TR2 operates in the same way as described above except its operation is relevant to the high-temperature output.

The fahrenheit/celsius temperature mode switch, S4, is mounted on the

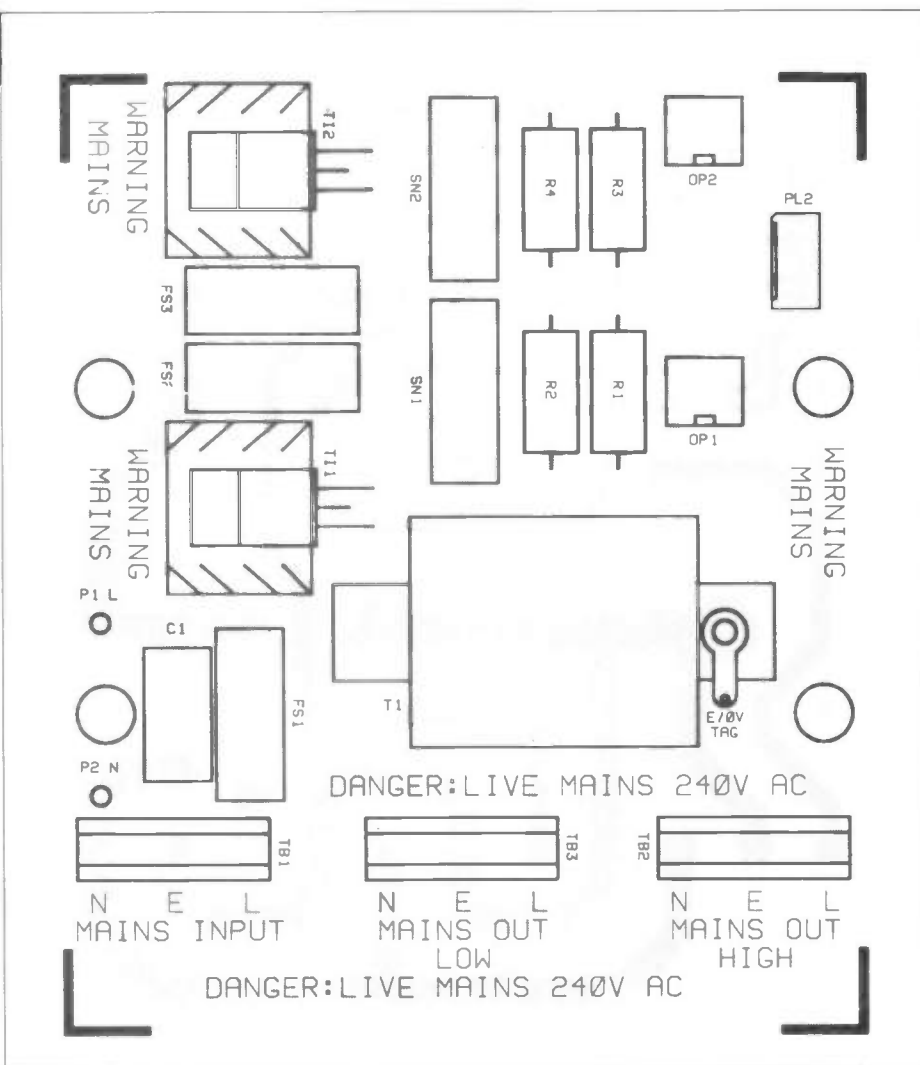

Figure 4. Mains PCB legend.

underside of the Display PCB and should be set before final assembly. Please note also that operation of S4 will clear the temperature set points from the temperature module's memory. *On no account should any attempt be made to operate S4 with the mains supply connected.*

Construction

Assembly of the two PCBs is relatively straightforward, however it is advised that the following guidelines are thoroughly read before construction is undertaken. The mains voltage PCB is a single sided glass fibre PCB and the low voltage display PCB is a double sided plated through hole glass fibre PCB. It is important to realise that the mains PCB carries 240V AC mains and it is therefore crucial that this PCB is correctly assembled. The low voltage display PCB houses a number of components on both sides of the PCB and it is important that the assembly order is followed carefully otherwise it will be found that it is difficult or even impossible to fit some components after others have been fitted. Numerous diagrams have been included to ensure that the assembly procedure can be easily followed without resorting to lengthy descriptions.

Mains Voltage PCB

It is recommended that construction of the mains voltage PCB be undertaken first. Referring to Figure 4 and the Parts List, assemble the PCB as follows:

Start by inserting the four resistors R1

to R4 ensuring that the correct value resistors are fitted in the appropriate positions. Carefully insert the optoisolators OP1 and OP2, ensuring that they are correctly orientated in relation to the pin 1 marker on the package and the PCB. Be careful not to overheat these devices when soldering as DIL sockets are not used. Insert the three terminal blocks TB1 to

TB3, ensuring that the cable entry side of each terminal block faces *towards* the edge of the PCB. Next insert the three fuse holders, do not at this stage fit the fuses. Insert PL2 ensuring that the orientation tab faces *away* from the edge of the PCB. Insert capacitor C1 and snubber networks SN1 and SN2. Next, using a pair of snipe-nose pliers and with reference to Figure 5, bend the leads of triacs T11 and T12 so that they will fit the PCB. Referring to Figure 6 fit the triacs and the heatsinks to the PCB with the M3 hardware.

The transformer assembly can be seen in Photo 1, this should assist in the next construction stage. Trim the blue and brown primary wires of transformer T1 so that they are 100mm long, then strip, twist and tin them. Cut two 90mm lengths of heat-resistant sleeving and carefully thread the primary wires through the sleeving. To prevent the sleeving from fraying, use four 10mm lengths of heat-shrink sleeving at each end of each of the heat-resistant sleeves. A further 10mm length should be placed about half-way along the sleeved primary wires to keep them neatly together. *Carefully* shrink the sleeving into place by using a hot-air gun or the heat from a soldering iron. Trim the three secondary wires so that they also are 100mm long. Strip, twist and tin the wires as for the primary. Prepare in the same way a 125mm length of the green 16/0.2 wire, attach the M3 solder tag to one end and cover the joint with heat-shrink sleeving. Cut two 90mm lengths of heat-resistant sleeving and thread the two (white) 9V AC wires down one sleeve and the 0V (black) and earth (green) wires down the other. Before fitting the minicon terminals to the wires, thread three 10mm lengths of heat-shrink sleeving over the sleeved secondary wires and shrink the sleeving in place as previously described. Referring to Figure 7, fit minicon terminals to each of the three secondary wires and

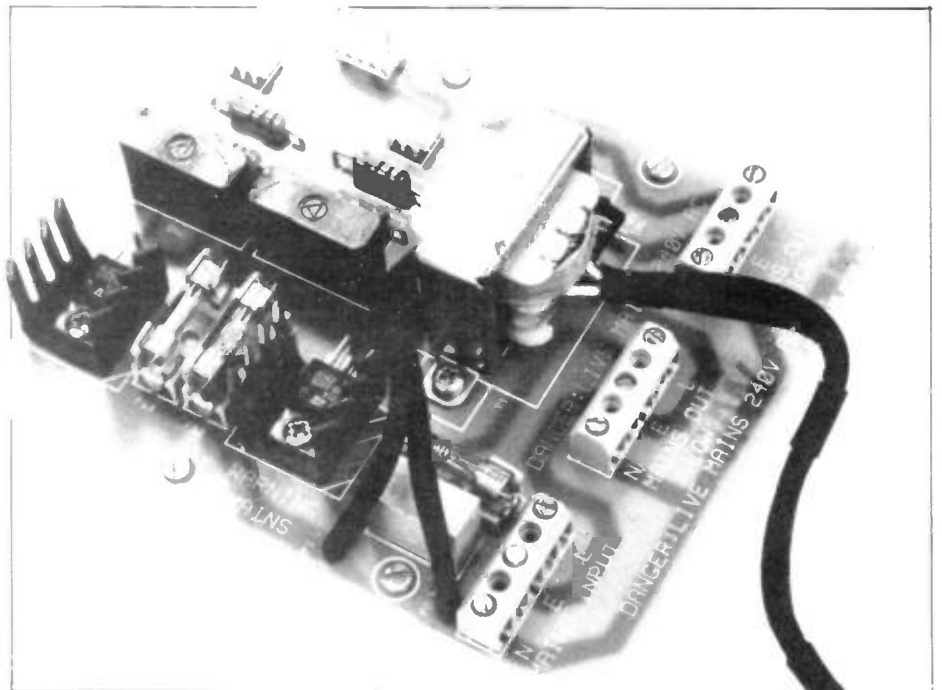

Photo 1. The assembled mains voltage PCB.

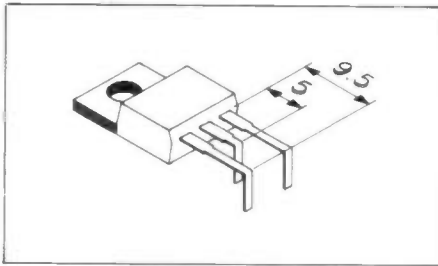

Figure 5. Bending triac leads.

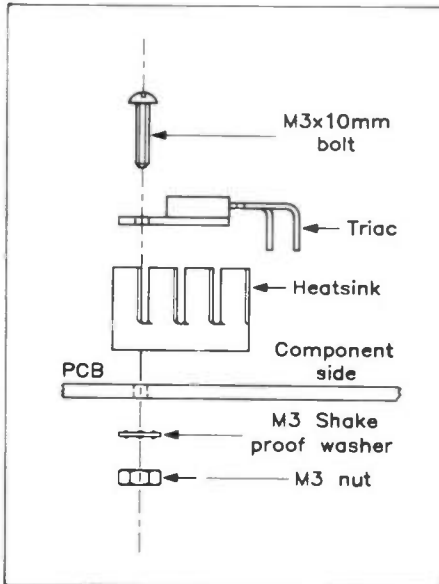

Figure 6. Mounting the heatsink and triac assembly.

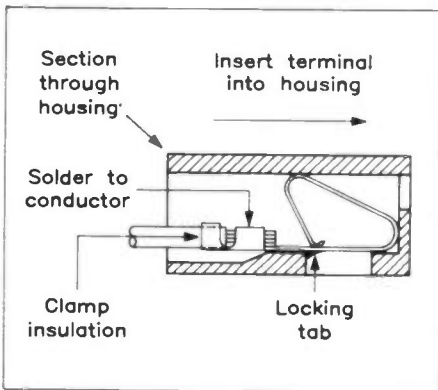

Figure 7. Assembly of 'minicon' connectors.

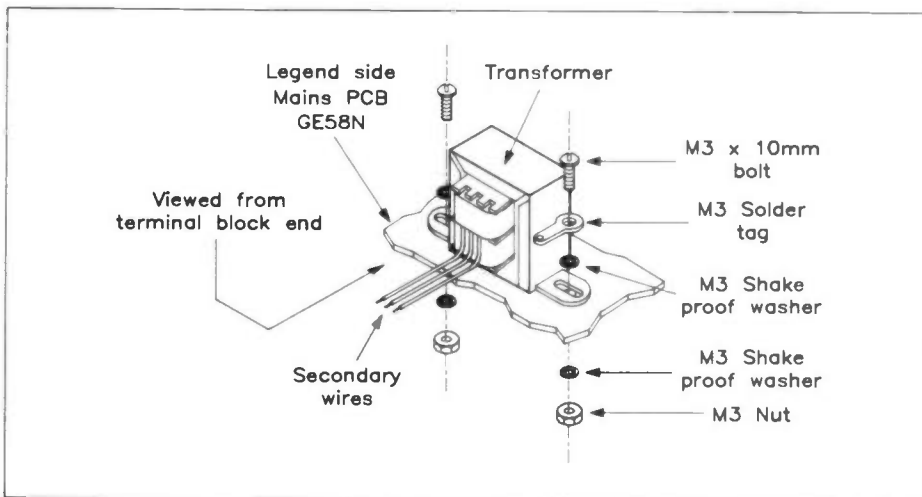

Figure 8. Mounting the transformer assembly.

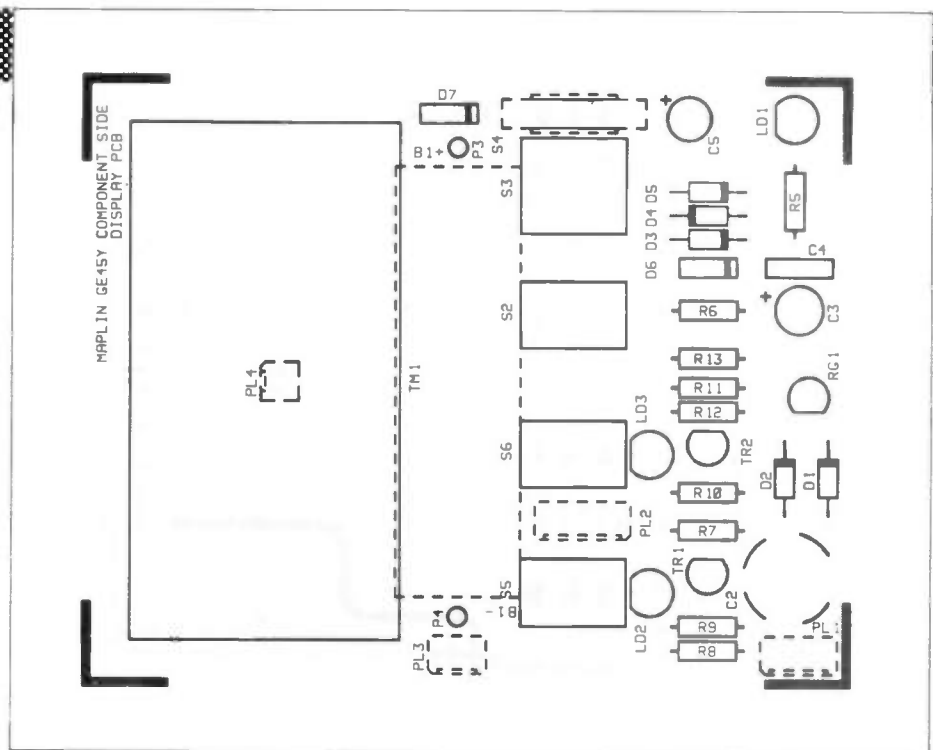

Figure 10. Low voltage PCB legend.

earth wire and fit the assembled terminals into the four-way housing as follows: 9V AC wires – positions 1 and 2, 0V wire – position 3, earth wire – position 4. Next fit the transformer assembly and the M3 tag to the PCB using the M3 hardware as shown in Figure 8, ensuring that the secondary wires are nearest to the terminal blocks. Solder the brown primary wire into the PCB at the position marked 'P1 L' and the blue primary wire into the PCB at the position marked 'P2 N'.

Next fit the PCB retaining screws and nylon captive retaining nuts. The nuts also act as spacers thus supporting the PCB at the correct height from the bottom of the box. Figure 9 shows how the nuts and screws are fitted to the PCB. If a 6BA box spanner is to hand it will be found that this will assist in the task of fitting the nuts, otherwise the nut may be held in place with a pair of pliers. With the nut held firmly drive the screw into the nut with a flat bladed screwdriver. The screw/nut assembly should not be over-tightened otherwise it will not be possible to screw the PCB into the box!

Finally, carefully examine the PCB,

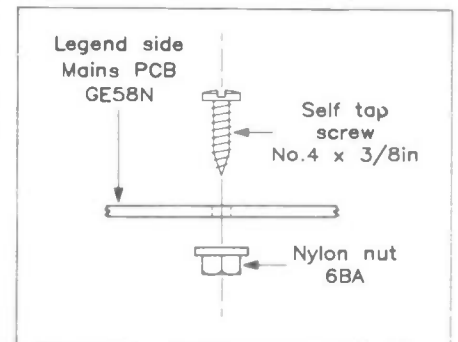

Figure 9. Fitting the mounting screws and captive nuts.

checking for misplaced components, solder splashes, untrimmed wires, etc. Photo 1 shows the assembled mains voltage PCB.

Low Voltage Display PCB

Please note that the components which are to be fitted to the underside of the PCB are indicated by the dotted portions of the legend. Referring to Figure 10 and the Parts List, assemble the low voltage display PCB as follows:

Start by fitting resistors R5 to R13, ensuring that the correct values are fitted in the appropriate positions. Next fit the silicon diodes D1 to D5, ensuring that the stripe on the body of each of the diodes tallies with the corresponding stripe on the legend. Carefully fit the germanium diode D7, ensuring correct orientation. The glass envelope of D7 is fragile and will break if excess force is used, and it is also important to avoid overheating this diode. *Do not insert D6 at this stage!* Next fit C5 to C7, C5 and C7 are both polarised types. C5 should be fitted as follows: the negative lead of C5 is indicated by a negative (-) stripe on the can, this lead should be placed in the hole in the PCB furthest away from the hole marked with a positive (+) symbol on the legend. The positive lead of C7 is indicated by a positive symbol on the

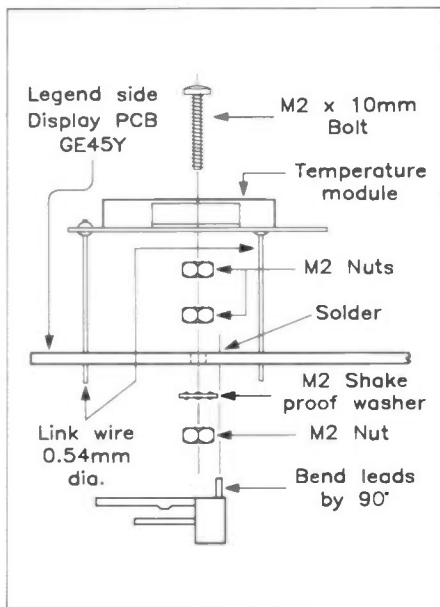

Figure 11. Assembly of PL4 and the temperature module.

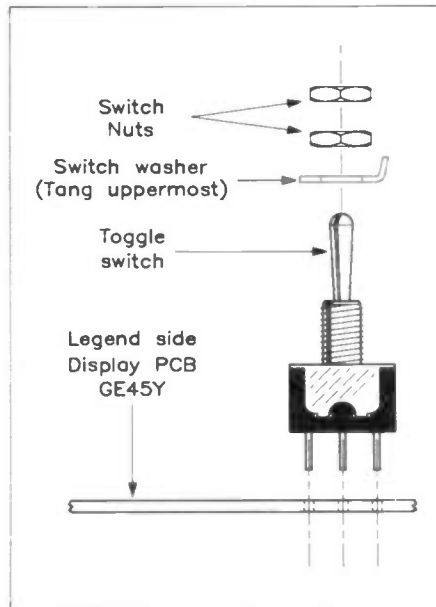

Figure 13. Fitting the toggle switches.

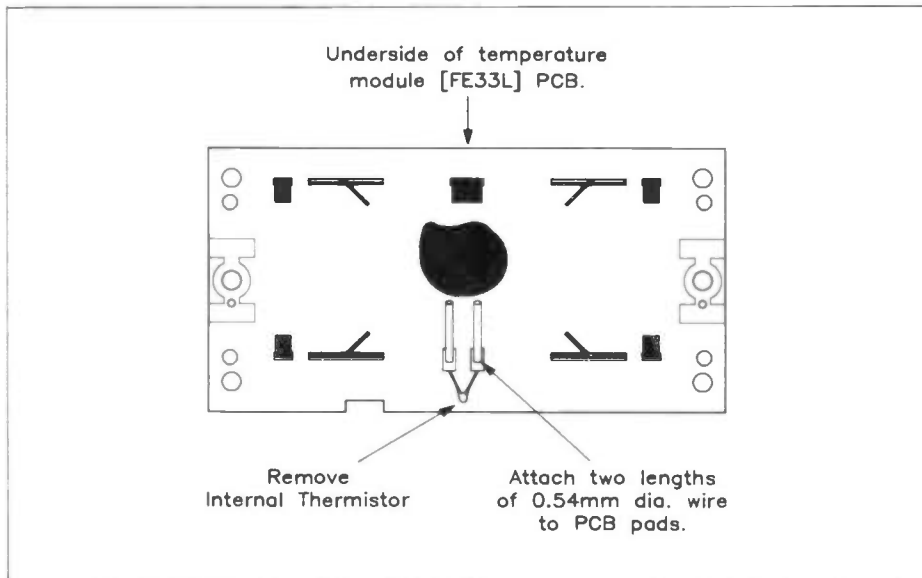

Figure 12. Removal of the internal thermistor from the temperature module.

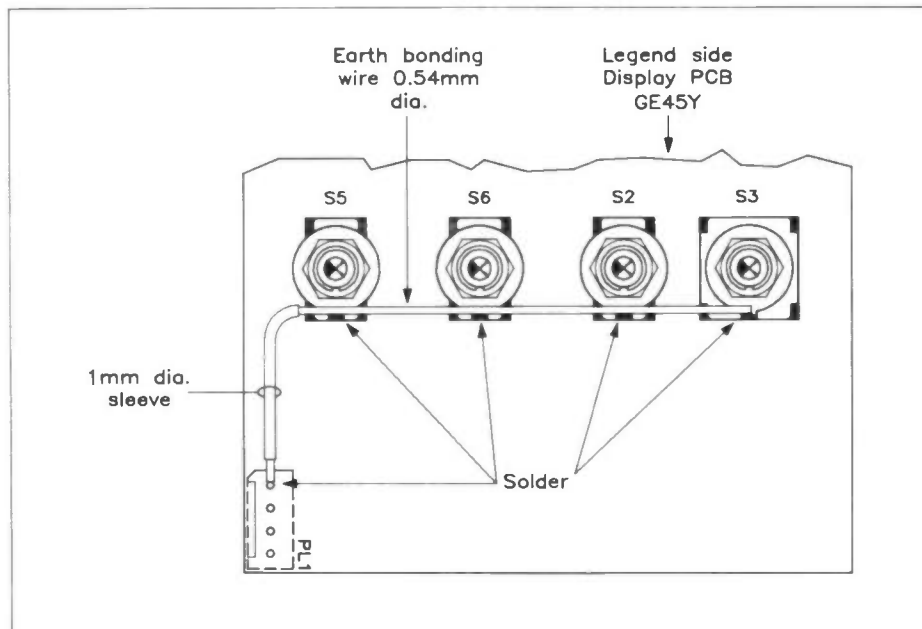

Figure 14. Attaching the earth bonding wire.

body, this lead should be placed in the hole nearest to the hole marked with a positive symbol on the legend. Fit regulator RG1 and transistors TR1 and TR2, ensuring that they each line up with the legend on the PCB; take care not to confuse the regulator and the transistors as they have the same case style.

Fit minicon plugs PL1 to PL2 (PL3 is optional), these are mounted on the underside of the PCB with the orientation tabs facing towards the edge of the PCB. Before PL4 is inserted its leads must be bent through 90° so that the connector lies flat against the PCB, this is illustrated in Figure 11.

It is necessary to modify the temperature module TM1 before it can be fitted. The plastic cell box must first be removed, this is achieved by carefully removing the securing screws. Next remove the internal thermistor, as indicated in Figure 12, and fit two 20mm lengths of 0.54mm diameter tinned copper wire in place of the thermistor. Take great care not to damage any of the surrounding tracks or components. Bend and thread the two wire lengths through the holes in the PCB adjacent to PL4, and secure the temperature module to the PCB with the M2 hardware as shown in Figure 11. Thread sixteen 20mm lengths of 0.54mm diameter tinned copper wire through the holes in the PCB and corresponding holes in the temperature module PCB, and solder and trim each wire (top and bottom) as you go. Take care to ensure that each wire passes through the correct hole as it is very difficult to correct any mistakes!

Referring to Figure 13, fit toggle switches S2, S3, S5 and S6. S2 is biased both ways, whilst S5 and S6 are unbiased. Before soldering the switches in place ensure that:

1. Each switch is fitted flat against the PCB;
2. The correct switch is located in the correct position, and that
3. The locating slot in the mounting shaft faces away from the temperature module.

Abrade the inside edge of the tang on each of the switch washers to facilitate soldering. Loosely fit the switch washer (tang uppermost) and the two nuts to the switch shafts. Referring to Figure 14, solder an 85mm length of 0.54mm diameter tinned copper wire to each of the tangs; this is to provide earth bonding to the exposed metalwork. Thread a 20mm length of 1mm systoflex sleeving (or insulation from 16/0.2 wire) over the bonding wire and solder the free end of the wire to the pin of PL1 nearest to R8. The nuts on the switch shafts may now be fully tightened.

Next fit LEDs LD1 to LD3, these devices should be fitted proud of the PCB by 5mm. The correct spacing may be achieved by using 5mm lengths of 1mm diameter systoflex sleeving (or the insulation from 16/0.2 wire) as shown in Figure 15. Ensure that the LEDs are correctly orientated, as indicated by the legend.

Referring to Figure 16 fit S4 to the

underside of the PCB. It may be necessary to *carefully* squeeze the case tags closer to the body of the switch with a pair of snipe-nose pliers to avoid the tags fouling PCB tracks.

Next fit C4 to the *underside* of the PCB ensuring that it is correctly orientated. The polarity of C4 is indicated in the same way as C5.

If cell back-up is required then secure the optional AA cell holder to the *underside* of the PCB with M2 hardware as shown in Figure 17; the coil spring end should be nearest the hole in the PCB marked 'P4/B1 -' on the legend. Using two short lengths of wire connect the tags on the cell holder to the holes in the PCB marked 'P3/B1 +' and 'P4/B1 -'.

Finally, carefully examine the PCB checking for misplaced components, solder splashes, untrimmed wires, etc.

Photos 2a and 2b show the assembled low voltage display PCB.

Case

The case has been specifically chosen to provide a moisture proof enclosure, therefore care must be exercised when drilling the box. Referring to Figure 18, drill the lower half of the box. However if only one output is required then drill only two out of the three holes for the cable glands (left-hand side = mains in, middle = mains output low (heater), right-hand side = mains output high (cooling)). Drill four holes

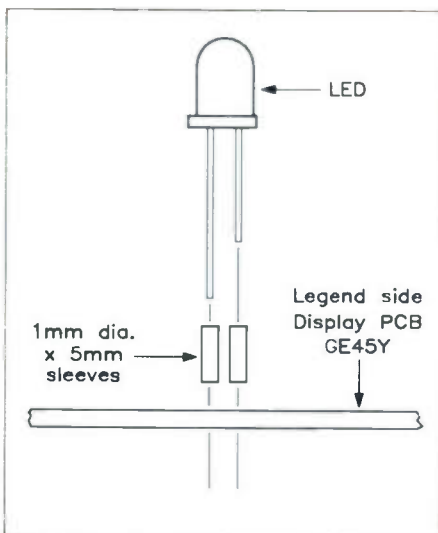

Figure 15. Mounting the LEDs.

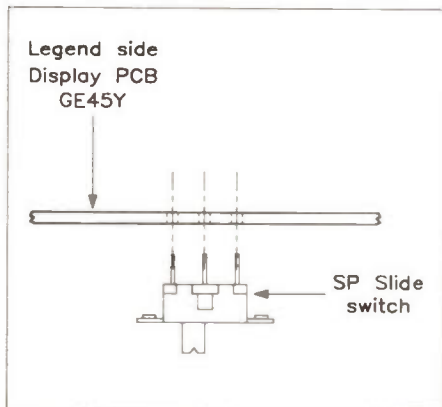

Figure 16. Fitting the slide switch.

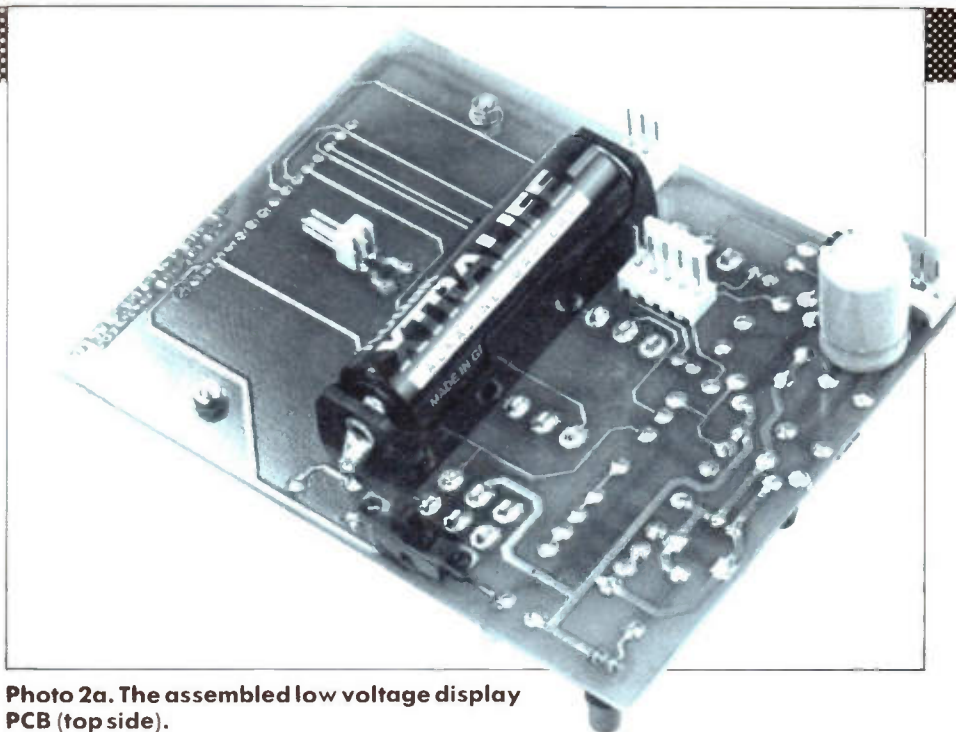

Photo 2a. The assembled low voltage display PCB (top side).

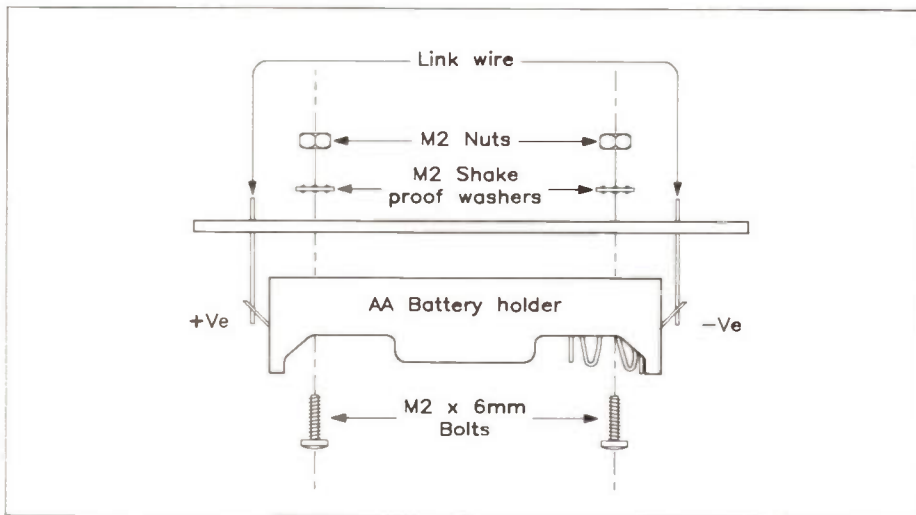

Figure 17. Fitting the AA cell box.

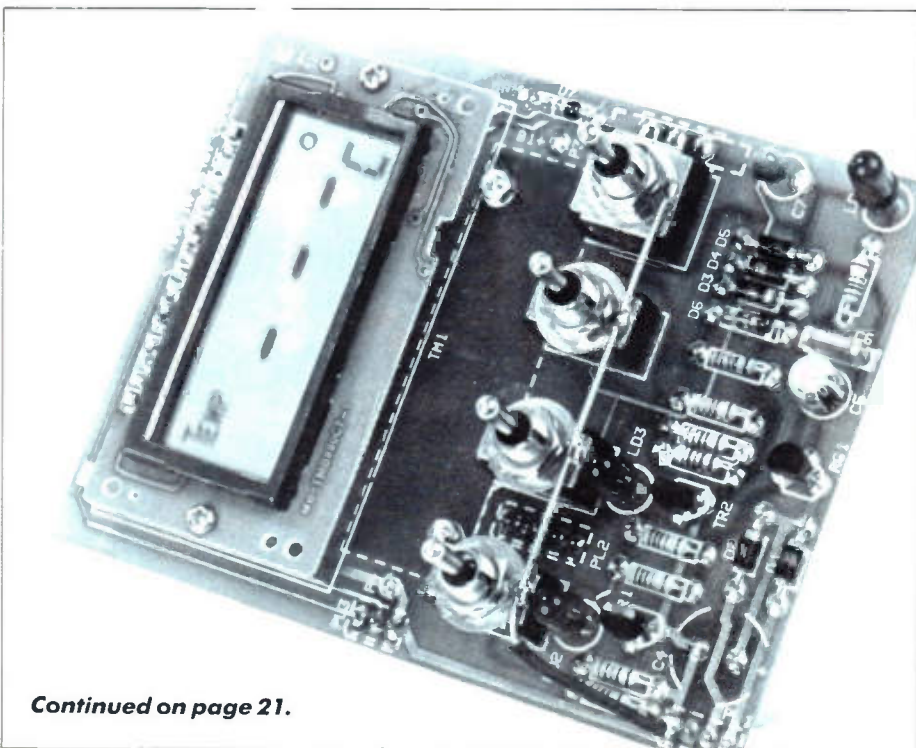
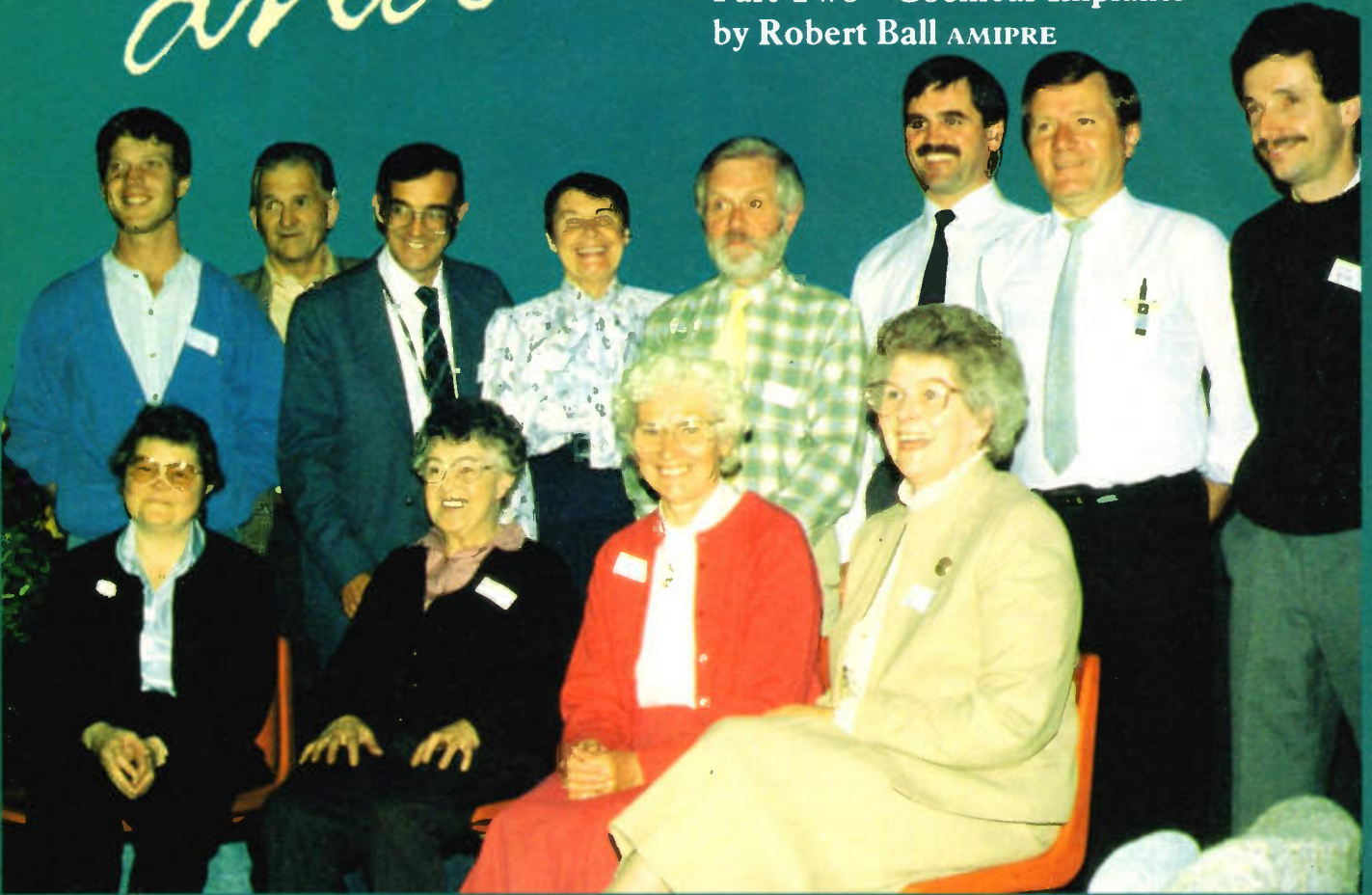

Photo 2b. The assembled low voltage display PCB (under side).

Continued on page 21.

HEARING, DEAFNESS *and*

Part Two – Cochlear Implants
by Robert Ball AMIPRE



Picture shows some of the many people who have received the UCH/RNID Cochlear Implant.

ELECTRONIC TECHNOLOGY

Foreword

The following article, which is the second in a series of articles on Deafness and Electronic Technology, has been written in association with the University College Hospital and the Royal National Institute for the Deaf. It explains a comparatively new technique of using implanted electronics. It is hoped that it will encourage both deaf and hearing people to accept deafness as part of life, and encourage positive thinking and action to help deaf people to integrate with society as a whole. Every person, whether deaf or hearing, has a vital role in today's world, each with their own, totally unique, contribution.

Introduction

Conventional hearing aids can be of enormous benefit to people with moderate or severe hearing losses whether of the conductive or sensory neural type. However, a small group of people have such a profound degree of sensory neural deafness that they hear little or nothing, even with the most powerful hearing aids.

A recent development, the cochlear implant, may be of help for such people, particularly where they were born hearing but have since become profoundly deaf. The cochlear implant is an electronic auditory prosthesis which bypasses the damaged cochlea (organ of hearing) and stimulates the auditory nerve (nerve of hearing) directly with an electrical signal. Unfortunately for people born deaf, unless they are implanted at an early age, the implant seems to be of little benefit because they haven't acquired a memory of sound. A memory of sound is necessary to make

sense of the electronic sounds heard through the implant.

Before examining the cochlear implant, it is necessary to understand the structure of the ear, how it functions and what can go wrong. If readers have joined the series at 'part two', it is worthwhile to order a copy of the last issue of 'Electronics - The Maplin Magazine' (XA42V), for a full explanation.

Cochlear Implants

Currently there is no cure for sensory neural deafness, however cochlear implants may help to restore some degree of hearing. Cochlear implants are not transplanted parts of the ear, but electronic devices which can be surgically implanted in the ear. The implant works by stimulating the auditory nerve with low-level electric currents. An implant will not restore normal hearing, but a wide range of different sounds can be heard and recognised. In most cases it does not allow speech to be understood without lip-reading, but the implant does make lip-reading much easier and helps to improve communication greatly. As people with implants can hear themselves, their own speech often improves. The sounds heard with an implant may also help to mask tinnitus (noises in the ears) so that it is no longer annoying and in some cases, it disappears completely.

The implant enables the person to hear environmental sounds, so that they know what is going on around them and 'feel part of the real world again'.

System Overview

The cochlear implant system consists of a microphone and a signal processing

unit, the output of which is linked to a number of implanted electrodes. The implant stimulates the auditory nerve by passing an alternating electric current between a pair, or pairs, of electrodes. These electrodes will be placed either inside or outside the cochlea (intra-cochlear or extra-cochlear respectively), depending on the system configuration used. The signal processing unit can be categorised into two distinct varieties, analogue or speech feature extraction, both of which will be explained further.

The Feature Extraction Processor

By using signal processing techniques, the speech waveform can be translated into electrical waveforms which represent pitch, timbre and amplitude. These signals are fed to a multiple electrode array implanted within the cochlea itself. A single-channel system, which provides pitch information alone has also been developed.

The Analogue Signal Processor

The analogue processor presents an analogue electrical signal, corresponding to the sound picked-up by the microphone, to the implanted electronics, which in turn provide electrical signals for the electrodes. The analogue processor can be either single-channel or multiple-channel; the multiple-channel types split the sound into a number of frequency bands and feed several pairs of electrodes, whilst the single-channel types feed the sound signal to a single pair of electrodes.

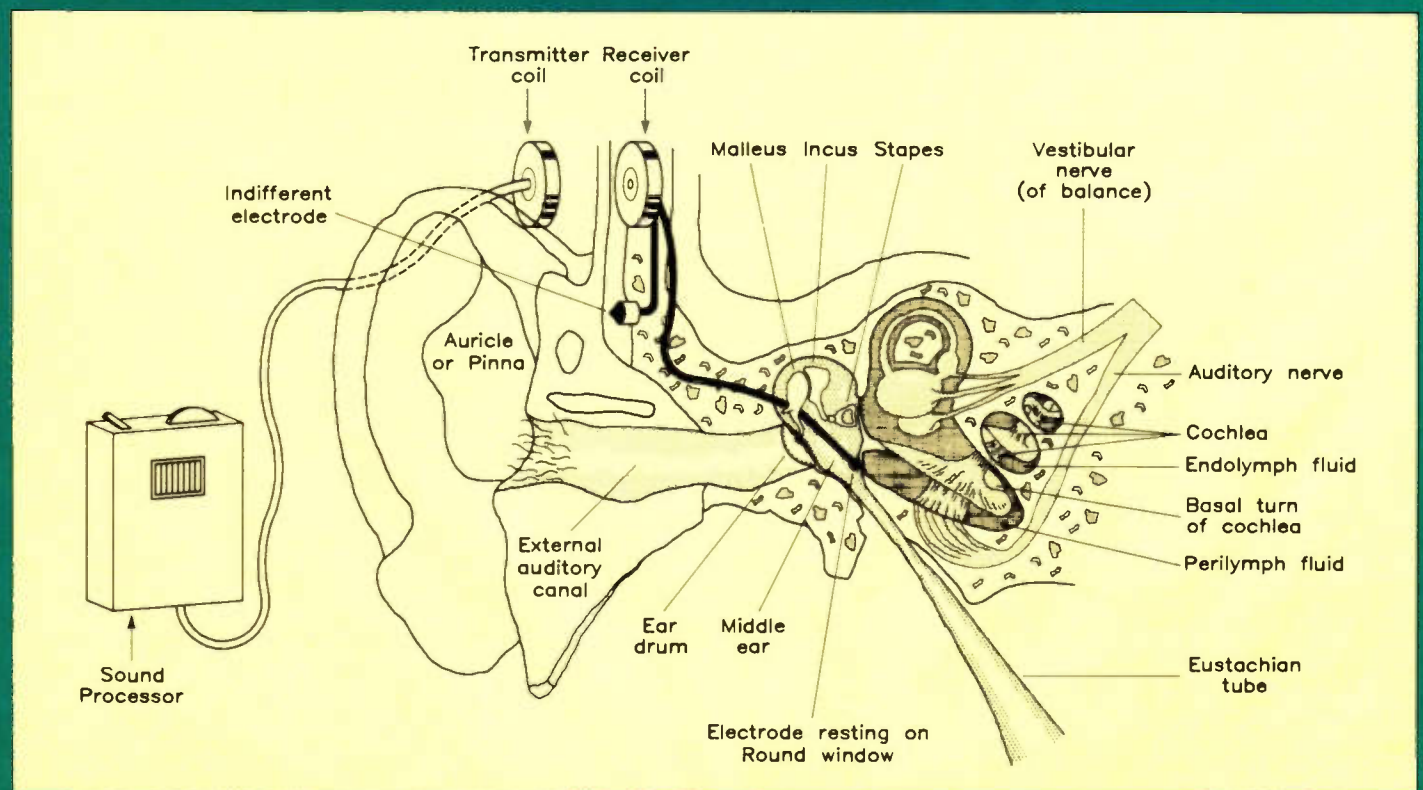

Figure 3. The human ear with the UCH/RNID cochlear implant fitted.

Signal Link

For signals to pass from the sound processor to the implanted electrodes, a form of signal link must be provided. The barrier to this is of course the skin. It is possible to use a percutaneous (through the skin) connector, which literally allows the processor to be plugged into the patient! It is however, more common for the link to be provided by using electromagnetic induction (or AM radio link) as this avoids the risk of infection and skin reaction. In such a system the signal from the processor drives a coil which is placed in close proximity to a second coil. The second coil is implanted under the skin behind the ear. By this means, the signal path is established without any breach of the skin or direct electrical connection. The disadvantage is that the electrical power required for an inductive transcutaneous link is substantially higher than for a direct percutaneous link. The increased power requirement results in the sound processor being physically larger than would otherwise be required, due to battery size.

The UCH/RNID Cochlear Implant Programme

The University College Hospital and the Royal National Institute for the Deaf have jointly developed a cochlear implant system. The system is of the single-channel analogue type with a body-worn sound processor and an implant shown in Photos 3 and 4 respectively. An electrode pair is placed against the round window and under the temporal muscle see Figure 3.

Patients do not have to pay for the UCH/RNID cochlear implant as the implant programme is funded by the Government and the operation is performed in an NHS (National Health Service) Hospital by NHS staff. However, the programme has only received Government funding since April 1990. Prior to this the implant programme was funded by the Sir Jules Thorn Trust. Without the trust's generosity the implant programme would not have got off the ground. Many other individuals and organisations have contributed time and finance to support the programme.

By maintaining a price tag for the prosthesis below £1,000, a figure which is significantly lower than for other commercially available systems, the programme is able to provide as many people as possible with cochlear implants. In a few cases, people will receive commercial systems.

The UCH is hoping to establish a children's implant programme, however the major obstacle is raising sufficient funds to start the programme.

How it Works

Figure 4 shows the overall block diagram of the UCH/RNID cochlear implant system. The following deals with each block individually.

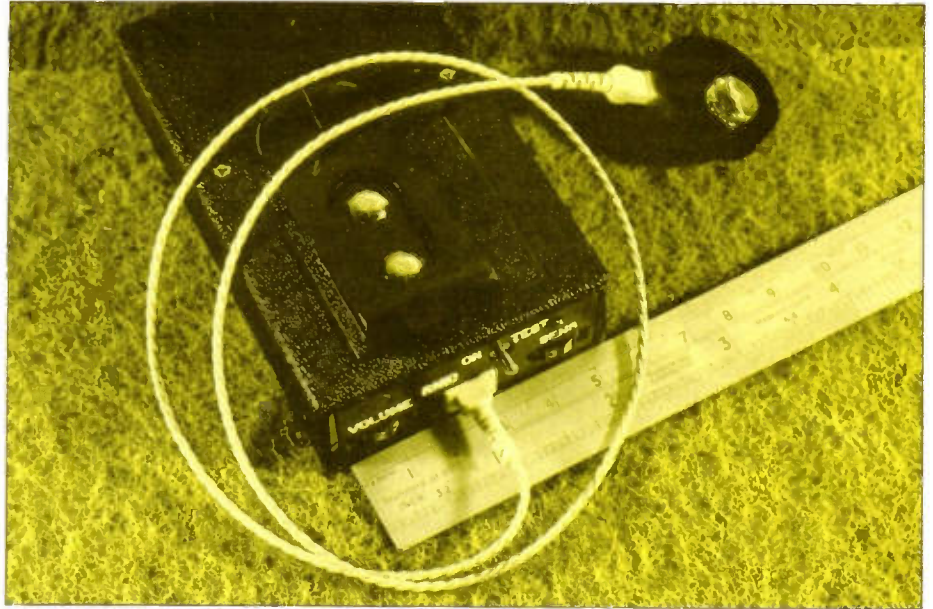

Photo 3. The UCH/RNID body-worn audio processor and transmitter coil.

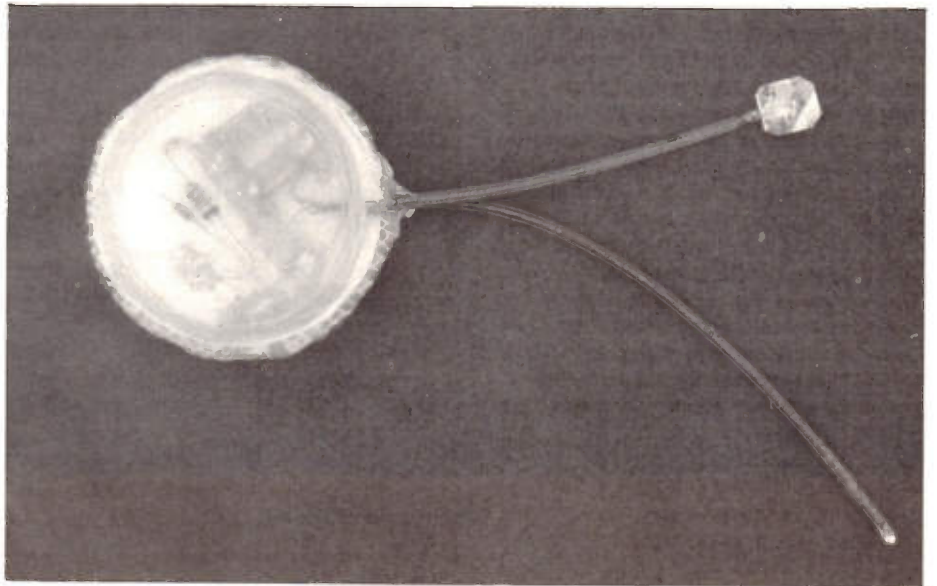

Photo 4. The UCH/RNID cochlear implant.

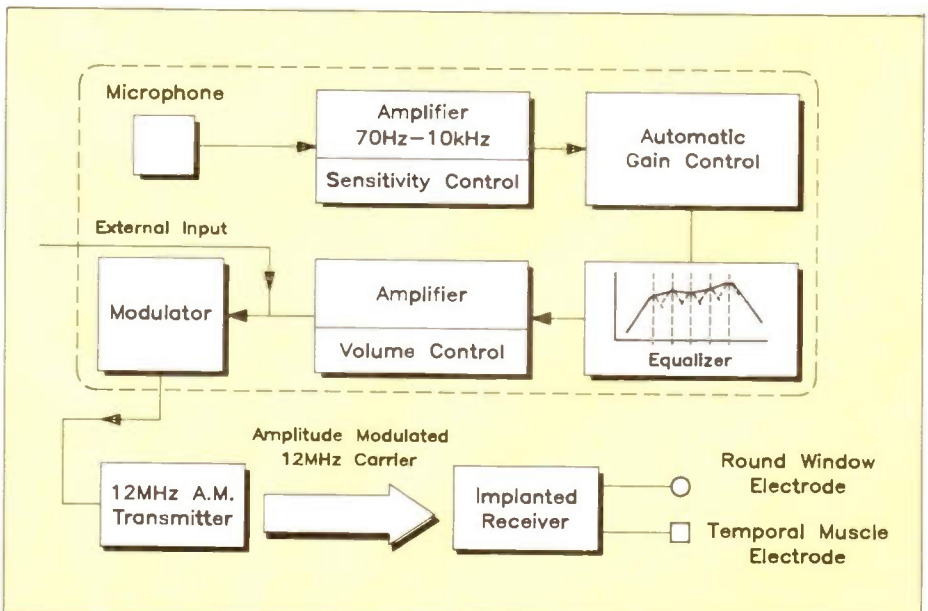

Figure 4. Block diagram of UCH/RNID cochlear implant system.

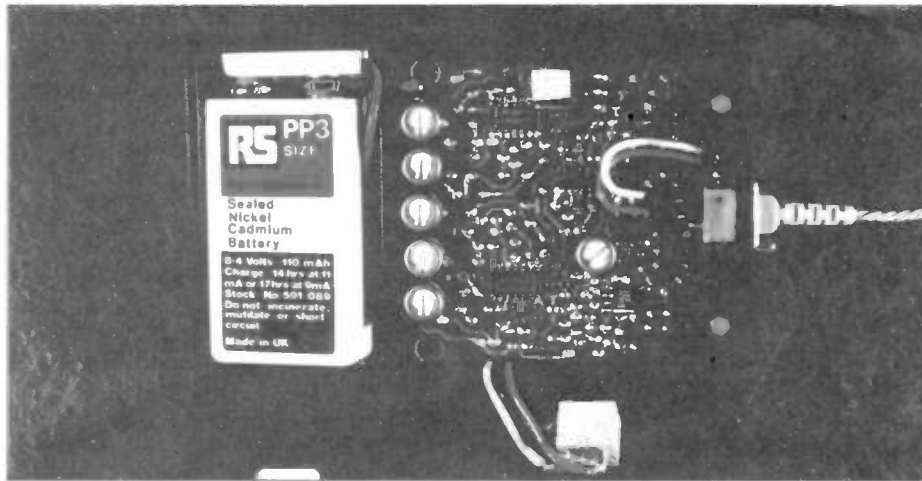

Photo 5. Inside the UCH/RNID audio processor.

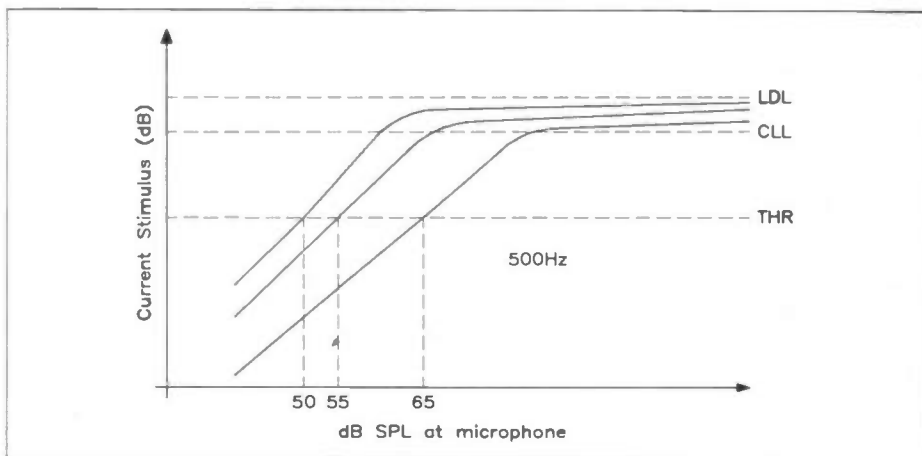

Figure 5. AGC characteristic with varying sensitivity control settings.

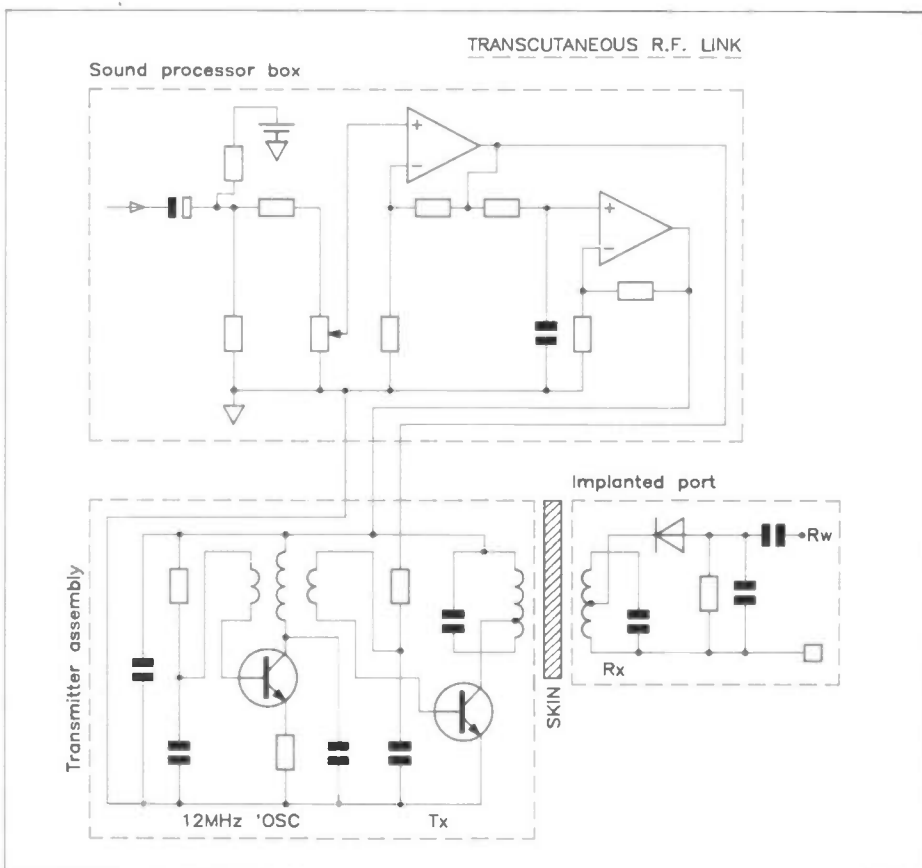

Figure 6. Circuit diagram of the transcutaneous link.

Microphone

Sound waves are picked up by the microphone and converted into an analogue electrical signal which represents the sound. This signal is fed into a pre-amplifier, which serves to increase the very low level signal produced by the microphone.

Preamplifier and Sensitivity Control

The gain of the preamplifier may be adjusted to suit the hearing threshold of the patient by means of a sensitivity control. This control is set so that the background noise level falls below the hearing threshold, whilst the wanted sound, usually speech, is above the hearing threshold. The sensitivity control is positioned conveniently on the top of the processor so that the control may be adjusted as required.

The frequency response of the system as a whole is band limited by the preamplifier to pass frequencies in the range 70Hz to 10kHz. The low end roll-off helps to reject low frequency noises such as traffic rumble. Frequencies above 10kHz contribute little to improving speech intelligibility and are therefore rejected as well.

AGC

Following the preamplifier is an AGC (automatic gain control) stage, the purpose of which is to protect the patient from loud sounds which might otherwise cause discomfort, whilst still allowing perception of different levels of loudness. When the AGC is operating at maximum compression, the dynamic range of the sound is reduced tenfold. The response time of the AGC side-chain is set to provide a fast attack time of 1ms and a much slower release time of 1s. The fast attack time allows quick response to sudden loud sounds, whilst the slow release time helps to prevent the system from 'pumping' or 'breathing'; which is a common problem often associated with AGC and compressor circuits. The AGC characteristic is shown in Figure 5; the curves labelled 8, 4 and 2 represent different settings of the sensitivity control and the dotted lines labelled THR, CLL and LDL represent threshold of perception, comfortable listening level and loudness discomfort level respectively.

Equalisation

The frequency response of the unit can be adjusted so that pure tones in the range 125Hz to 6kHz are perceived to be equally as loud. A five band graphic equaliser is utilised, the centre frequencies being 100Hz, 300Hz, 1kHz, 3kHz and 10kHz. Equalisation of each of the bands is set by means of a preset potentiometer and is not adjustable by the patient. The exact setting of each band is determined by a series of audiometric tests after the implant has been fitted. The five preset potentiometers may be seen in photo 5, which shows the inside of the audio processor, and they are located adjacent to the nickel-cadmium recharge-

able battery. The sixth potentiometer is used to adjust the RF (radio frequency) carrier level and so optimise the processor's power consumption, this will be dealt with later.

Amplifier and Volume Control

After the equalisation stage the signal passes through another amplifier. This serves to provide the required level of signal to the RF modulator, which forms part of the transcutaneous link. A volume control is provided, again it is conveniently located on top of the processor, so that the patient has overall control of the signal fed to the implant. It should be realised that the volume control and sensitivity control perform quite different functions.

Modulator

The circuit diagram of the RF modulator, transmitter and receiver is shown in Figure 6. The function of the modulator is to control the RF carrier level and provided amplitude modulation of the carrier. The level of RF carrier required will depend on the patient's sensitivity to electrical stimulation. A sensitive patient will require a low level of RF carrier for undistorted audio-frequency signal transmission, whilst with a patient insensitive to electrical stimulation the converse is true. Correspondingly, with a low carrier level, less power will be consumed by the transmitter than for a high carrier level, and therefore battery life will be extended.

The circuitry associated with the modulator is based around a quad Op-amp, however only two out of the four Op-amps are used in this part of the circuit.

Transcutaneous RF Link

The transmitter assembly is positioned so that it is in close proximity to the implanted receiver. The transmitter is based on a transformer coupled 12MHz oscillator and RF amplifier, the collector load of which is a parallel-resonant circuit comprising the transmitter coil itself and a capacitor. The choice of 12MHz for the carrier frequency was chosen to maintain compatibility with existing implant systems. The RF carrier level is controlled by varying the supply voltage to the link and amplitude modulation is effected by superimposing the audio signal onto the bias voltage for the transistor in the RF amplifier.

The implanted AM receiver contains a parallel resonant circuit L1, C1 which is tuned to the 12MHz transmitter frequency. This is followed by a diode detector and a DC-blocking capacitor C3. The output from the receiver is fed to two electrodes via wire leadouts, one of which is placed in contact with the round window, the other is inserted into the temporal muscle. The transcutaneous RF link has been designed to tolerate up to 16mm of misalignment, thus allowing some degree of movement of the transmitter assembly before the signal becomes severely attenuated.

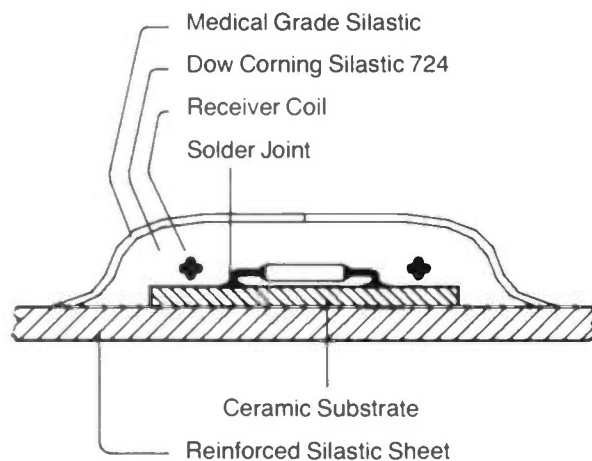

Figure 7. Cross section of the implanted receiver.

The Implant

Obviously the implanted AM receiver must not cause harm to the patient, and therefore must be systemically and biologically inert. The electronic components are assembled on a ceramic substrate and hermetically sealed, the implant is shown in Photo 4 and a cross-section of the assembly is shown in Figure 7. A silastic polymer 'outer skin' provides a barrier to physiological salts but allows water vapour to pass through, and the silicone rubber encapsulant provides good adhesion to glass and ceramic but is impervious to water vapour. Initial failures due to water vapour ingress of the implant have been solved, and reliability since has been found to be good. The implant is held in place by anchoring the reinforced silastic sheet to the mastoid bone.

Protruding from the assembly are two wires, at the ends of which there are the electrodes. The round window electrode consists of a 1mm diameter metal alloy sphere made from 80% platinum and 20% iridium and the temporal muscle electrode consists of a 5mm square foil of the same alloy.

Battery Life

The power to the audio processor is provided by an PP3 size 8.4V nickel-cadmium battery. Battery life varies from sixteen hours with sensitive patients to three hours with the least sensitive. Typically battery life is around eight hours, at which point the discharged battery can be replaced with a fully charged battery and the discharged battery placed on charge.

Conclusions

So far sixty patients have been implanted at UCH and the majority have found the implant to be of great use in their daily lives. The research team hope to develop a new sound processor incorporating many improved features. They also hope to develop a competitively priced multi-channel system, but this will of course depend on the project receiving adequate funds. Much has been achieved, but there is still much to be done to help profoundly deafened people.

Next Time

In part three of this series David Holroyd and Alan Simpson will take a look

at some of the modern devices currently available that can be used to help the deaf person in every day life.

References

- The Ear and How it Works; Royal National Institute for the Deaf.
- Cochlear Implants; The University College Hospital & Royal National Institute for the Deaf.
- Supplement 18, The Journal of Laryngology and Otology; M. J. Conway, P. Boyle, J. G. Fraser, H. R. Cooper, L. Carpenter, W. Aleksy, C. L. Booth, T. E. Read, J. M. Graham.

Acknowledgements

- Huw Cooper, Audiological Scientist, University College Hospital, London.
- Louisa Booth, Research Assistant, University College Hospital, London.
- Mike Conway, Hospital Physicist, University College Hospital, London.
- The University College Hospital, London.
- Royal National Institute for the Deaf, London.
- Sir Jules Thorn Trust.
- Royal National Throat, Nose and Ear Hospital.
- Addenbrooks Hospital, Cambridge.
- London School of Hygiene and Tropical Medicine.

Additional Information

Additional information may be obtained from the Royal Ear Hospital (UCH), the Royal National Institute for the Deaf or the National Association of Deafened People, whose addresses are given below:

Cochlear Implant Programme
The Royal Ear Hospital (UCH)
Huntley Street,
London. WC1E 6AU.

The Royal National Institute for the Deaf
105 Gower Street,
London. WC1E 6AH.

The National Association of Deafened People
c/o The Honourable Membership Secretary,
103 Heath Road,
Widnes,
Cheshire. WA8 7NU.

Temperature Controller Continued from page 15.

at the circular mounting points in the bottom of the box to accept the 2BA nylon bolts. Before fitting the cable glands, smear the mating surface of the box and flange of the cable glands with quick set epoxy resin to seal the box. Assembly of the cable glands is shown in Figure 19.

Place the self adhesive plastic panel onto a cutting board and carefully cut out the aperture through which the display is to be viewed with a sharp knife, a scalpel is ideal for this. Remove the backing sheet and position the panel on the front of the box. Carefully and accurately drill four small pilot holes for the switches, using the cross-hairs on the panel as a guide for the centres. Enlarge the holes with a larger drill and clean away any plastic swarf with a knife. If PCB switch-shafts will not fit through the holes, use a small round file to obtain a good fit.

Wiring

Cut a 100mm length of the ten-way ribbon cable and using a knife, carefully pare away a four-way section from the length. Strip, twist and tin both ends of the four wires and attach minicon terminals to each of the wires at *one end only*. Cut a 90mm length of heat-resistant sleeving and thread the 4-way ribbon cable through the sleeving. Cut two 10mm lengths of heat-shrink sleeving and place these over the ends of the heat-resistant sleeving to prevent the sleeving from fraying. Attach minicon terminals to the remaining end. Next the terminals should be inserted in the five-way housings as follows: P1 connected to P1, P2 connected to P2, P3 leave housing vacant at both ends, P4 connected to P4, P5 connected to P5. Double check that the cable has been wired 'straight' (P1 connected to P1) and not 'mirrored' (P1 connected to P5).

Thread the probe cable through the small hole in the box (above the centre cable gland), allowing 190mm for connection inside the box. Using a small amount of the quick set epoxy resin, seal the cable entry. After the resin has set, cut a 180mm length of heat-resistant sleeving and thread the cable through the sleeve. Place and shrink two 10mm lengths of heat-shrink sleeving over each end of the heat-resistant sleeve as previously described. Cut, strip and tin the cable ends and fit the minicon terminals and two-way housing.

Testing

Connect the temperature probe to the low voltage display PCB (PL4) and set all of the toggle switches to their centre positions. Set S4 to the degrees celsius position (°C indicated on the underside of the PCB). Do not plug in any other minicons at this stage.

If optional cell back-up is not required, skip this paragraph. Fit a 1.5V cell upon which the display should almost immediately

show the ambient temperature in degrees celsius. If the display does not appear or all the segments appear, remove the cell, wait five seconds and try again. Remove the 1.5V cell.

Connect a 9V to 12V DC power source (e.g. PP3 battery) to the low voltage display PCB, with positive to the cathode of D1 and negative to the earth bonding wire on the toggle switches. LD1 should illuminate. Using a multimeter, check that with respect to the earth bonding wire there is +5V on the output of RG1 (connects to positive lead of C5) and that there is approximately +1.7V on the anode of D3. Disconnect the power source and fit D6, observing the same precautions as for D7. Reconnect the power source and the display should appear almost immediately. If the display does not appear or all the segments appear, disconnect the power source, wait five seconds and try again. Operating S4 should switch between degrees celsius and degrees fahrenheit. Operating S3 should display the upper and lower temperature set

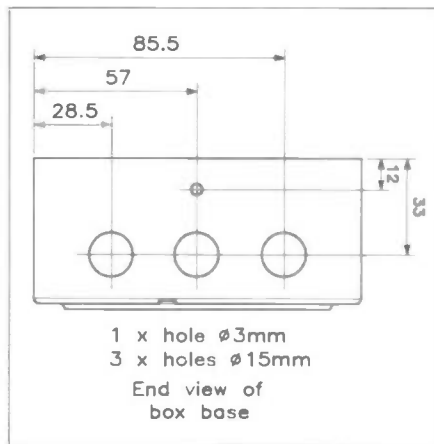

Figure 18. Box drilling details.

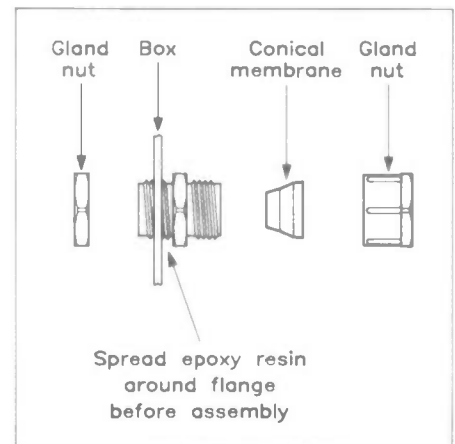

Figure 19. Cable gland assembly.

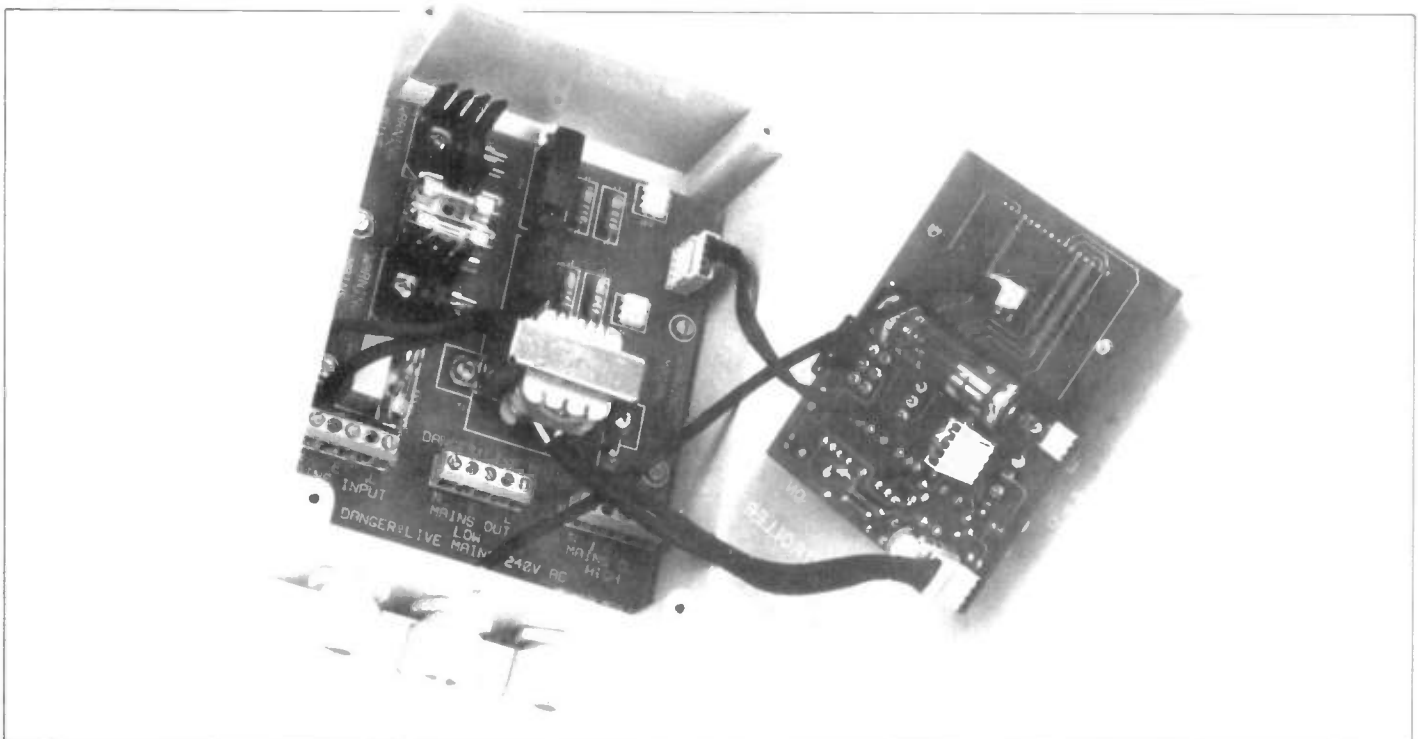

Photo 3. The complete unit prior final assembly.

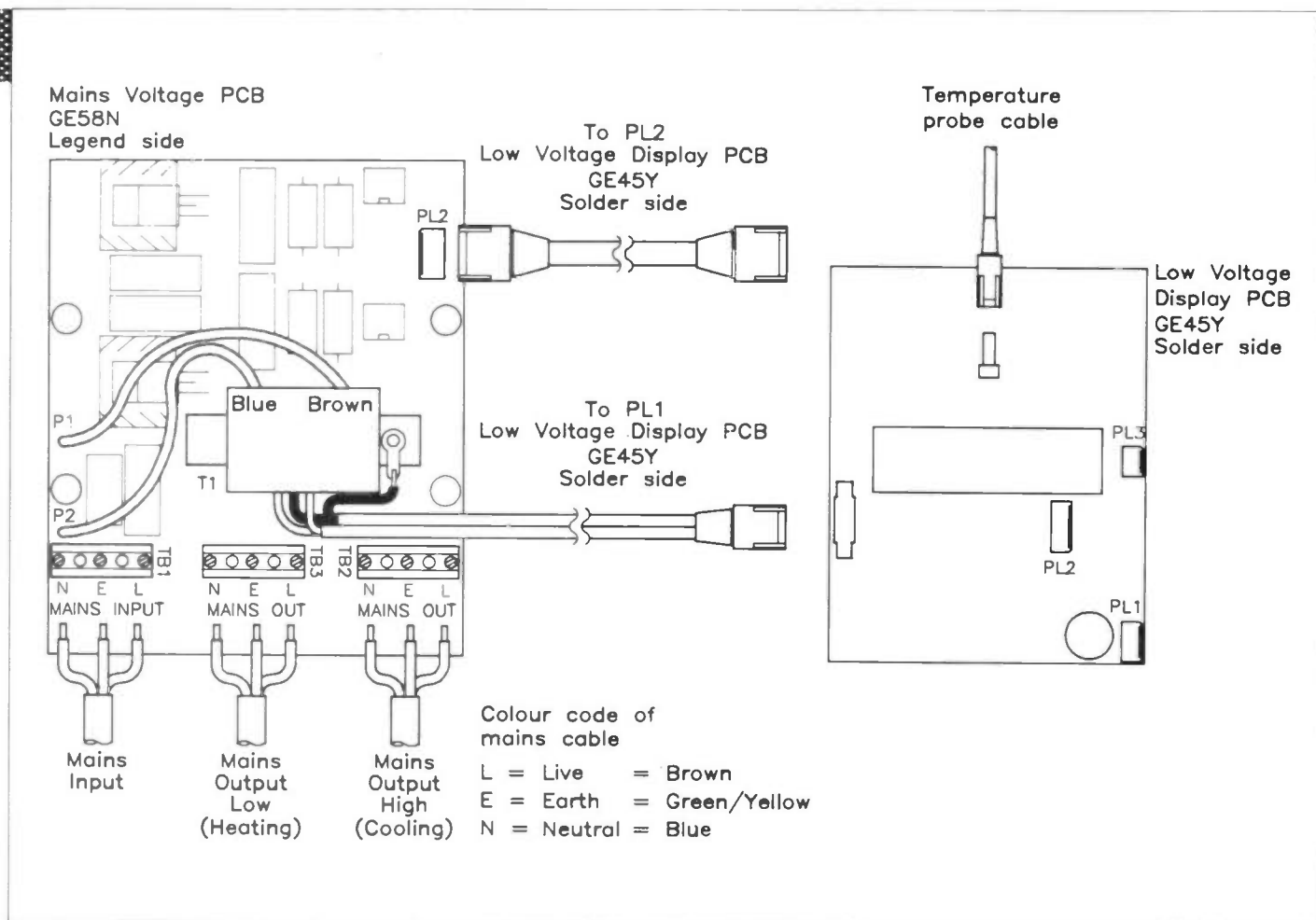

Figure 20. Wiring diagram.

points and S2 should allow the set points to be adjusted. Disconnect the power source. Disconnect the temperature probe.

Double check that the mains voltage PCB has been correctly assembled. Screw the mains voltage PCB into the lower half of the box and fit fuses FS1 (T3-15A), FS2 and FS3 (T1A). Refer to Figure 20. Using a length of 6A three-core mains cable, wire the mains cable to TB1. Connect the Live wire (coloured brown) to the terminal marked L, the Earth wire (coloured green and yellow) to the terminal marked E and the Neutral wire (coloured blue) to the terminal marked N. Wire a 240V, 40W to 100W light bulb to TB3 using a suitable lamp holder and cable (i.e. table lamp). Wire a 13A plug fitted with a 5A fuse to the mains input cable in accordance with the instructions supplied with the plug. Double check all the mains connections.

Connect the miniconnector on the secondary wires of T1 to PL1 on the low voltage display PCB. Connect both PL2s on the mains voltage and low voltage PCBs with the interconnecting cable. Reconnect the temperature probe. If the optional cell back-up is required, fit the 1.5V cell. The display should appear as before.

Fit the low voltage display PCB into the top half of the box and secure it by fitting the toggle switch covers. Take care not to stress the polychloroprene part of each of the covers, otherwise they may split. Check that all of the toggle switches are in their centre positions.

Secure the upper and lower halves of the box with the screws supplied. Plug the temperature controller into a 240V 13A AC socket and switch on. LD1 should

illuminate and the display should show the ambient temperature. Switch the LOW OUTPUT switch (S5) to MANUAL; the corresponding LED (LD2) and test lamp should illuminate. Set the LOW temperature set point to 30°C, switch the LOW OUTPUT switch to AUTOMATIC and the test lamp and LD2 should illuminate (providing ambient temperature is below 30°C!). Warm the temperature probe (warm hands should be sufficient), and when the display exceeds 30°C the test lamp and LD2 should extinguish. Allow the probe to cool, when the temperature falls to 30°C the test lamp and LD2 should illuminate again. Switch the LOW OUTPUT switch to OFF and both the test lamp and LD2 should remain off regardless of temperature. Disconnect the temperature controller from the mains supply and if cell back-up is being used, the display should remain. Remove the upper part of the box. Disconnect the test lamp from TB3 and re-connect the test lamp to TB2.

Replace the upper part of the box and reconnect the mains supply. Switch the HIGH OUTPUT switch (S6) to MANUAL, the corresponding LED (LD3) and the test lamp should illuminate. Set the HIGH temperature set point to 30°C, switch the HIGH OUTPUT switch to AUTOMATIC and the test lamp and LD2 should extinguish (providing the ambient temperature is below 30°C). Warm the temperature probe, and when the display reaches 30°C the test lamp and LD2 should illuminate. Allow the probe to cool, when the temperature falls below 30°C the test lamp and LD2 should extinguish. Switch the LOW OUTPUT switch to OFF and both the test lamp and

LD2 should remain off regardless of temperature. Disconnect the temperature controller from the mains supply, remove the upper part of the box and disconnect the test lamp from TB2. This concludes testing of the unit.

Installation, Use and Maintenance

The exact way in which the unit is installed will depend on the exact application. Figure 20 shows the basic way in which wiring is connected to the unit. It is important that the unit is installed, used and maintained in a safe manner. However please take note of the following points for your own and others' safety:

If the unit is to be used in a damp environment, shed, greenhouse, outbuilding, etc. then a Residual Current Circuit Breaker (RCCB) of the earth leakage type (ELCB) *must* be fitted to the mains supply feeding this unit. It is advised that installation of a permanently wired RCCB is undertaken by a qualified electrician only.

A double pole mains isolator switch or a suitable switched plug and socket *must* be provided *within* 2 metres of the unit as an ON/OFF switch has not been included on the unit. If the unit is to be used in a damp environment the mains isolator switch or plug and socket used *must* also be suitable for use in a damp environment. Suitable isolator switches, plugs and sockets for use indoors and in damp environments are available from electrical retailers and wholesalers.

If the unit is to be used in a damp environment it is advised that the PCBs are

coated with PCB lacquer, however take care to mask-off switches, connectors, etc, otherwise operation will be impaired.

All wiring and appliances connected to this unit *must* be connected in accordance with the relevant U.K. electrical safety regulations. If the unit is to be used in a damp environment wiring and appliances *must* also be suitable for use in a damp environment. Suitable cable, connectors and appliances for use in damp environments are available electrical retailers and wholesalers.

This unit, whilst designed to be used in damp environments, *should not* be exposed to rain, snow, spray from watering systems, etc.

If there is *any doubt* as to how the mains wiring should be connected, *do not* proceed and consult a qualified electrician.

Do not under any circumstances

undertake work on this unit, wiring or connected appliances with the mains supply connected.

When fixing the unit, nylon (or other non-conducting) fixing bolts *must* be used to avoid the possibility of a short circuit to the underside of the mains voltage PCB.

If the unit is required to switch loads in excess of 240W then it is suggested that the unit be used to control high power industrial relays, for example JG60Q and JG64U, which are capable of switching loads up to 10A at 240V AC (2.4kVA resistive). These relays would need to be mounted in a suitable enclosure. Full details of these relays may be found in the switches section of the current Maplin Catalogue.

Seals and gaskets on the unit and associated equipment *must* be checked regularly for any signs of deterioration or ingress of moisture; if there are *any signs of*

such, the mains supply must be *disconnected immediately* and the appropriate item replaced.

Since the back-up cell is only used in the event of a power failure, cell life should be in the same order as the battery's shelf life. It is advisable to check the condition of the cell both physically and electrically by periodically disconnecting the mains supply. When checking the physical condition of the cell there should be no signs of electrolyte leakage (often pre-empted by swelling of the case). The contrast of the display should not *drastically* reduce when operating from the back-up cell. If the cell shows any sign of deterioration then a new cell should be fitted, a good quality alkaline cell should be used, primarily because of good shelf life and immunity to electrolyte leakage. It would probably not go amiss to change the cell at least once a year.

TEMPERATURE CONTROLLER PARTS LIST

RESISTORS: All 0.6W 1% Metal Film (Unless Specified)

R1,3	1k 1W Carbon Film	2	(C1K)
R2,4	150Ω 1W Carbon Film	2	(C150R)
R5	300Ω	1	(M300R)
R6	2k2	1	(M2K2)
R7,10	150Ω	2	(M150R)
R8,11	47k	2	(M47K)
R9,12	470k	2	(M470K)
R13	10k	1	(M10K)

CAPACITORS

C1	100nF IS Cap	1	(JR34M)
C2	470μF 35V PC Elect	1	(FF16S)
C3	100μF 16V Minelect	1	(RA55K)
C4	10nF Polylayer	1	(WW29G)
C5	10μF 16V Tantalum	1	(WW68Y)

SEMICONDUCTORS

D1-5	1N4001	5	(QL73Q)
D6,7	OA47	2	(QH70M)
LD1-3	LED Red	3	(WL27E)
TR1,2	MPSA14	2	(QH60Q)
OP1,2	MOC3041	2	(RA56L)
TC1,2	BTA08-600B	2	(UK54J)
RG1	μA78L05AWC	1	(QL26D)

MISCELLANEOUS

TM1	Temperature Module	1	(FE33L)
SN1,2	R-C Network	2	(YR90X)
FS1	3-15A 20mm A/S Fuse	1	(RA11M)
FS2,3	1A 20mm A/S Fuse	2	(WR19V)
S1			<i>see text</i>
S2	Sub-Min Toggle D	1	(FH03D)
S3	Sub-Min Toggle F	1	(FH05F)
S4	SP Slide	1	(FF77J)
S5,6	Sub-Min Toggle B	2	(FH01B)
T1	Sub-Min Transformer 9V	1	(WB01B)
TB1,2,3	3Way HV PC Terminal	3	(JR80B)
PL1	Minicon Plug 4 Way	1	(YW11M)
PL2	Minicon Plug 5 Way	2	(FY93B)
PL4	Minicon Plug 2 Way	1	(RK65V)
	Minicon Hsng 4 Way	1	(HB58N)
	Minicon Hsng 5 Way	2	(BH66W)
	Minicon Hsng 2 Way	1	(HB59P)
	Minicon Terminals	2 Pkt	(YW25C)
	Toggle Switch Cover Small	4	(JR79L)
	20mm PCB Fuseholder	3	(RX49D)
	Temperature Module Probe	1	(FE34M)
	Cable Gland 5-8	2	(JR76H)
	Mea Waterproof Clear Box	1	(YM93B)

Isobolt M2 x 6mm	1 Pkt	(JD11M)
Isobolt M2 x 10mm	1 Pkt	(JD12N)
Isobolt M3 x 10mm	1 Pkt	(HY30H)
Isonut M2	1 Pkt	(LR59P)
Isonut M3	1 Pkt	(BF58N)
Isoshake M3	1 Pkt	(BF44X)
Isoshake M2	1 Pkt	(LR61R)
Iso Tag M3	1 Pkt	(LR64U)
Self Tap Screw No. 4 x 3/8in	1 Pkt	(BF65V)
Nylon Nut 6BA	1 Pkt	(BF80B)
Nylon Bolt 2BA x 1in	1 Pkt	(BF71N)
Nylon Nut 2BA	1 Pkt	(BF78K)
Nylon Washer 2BA	1 Pkt	(BF82D)
Vaned Heatsink	2	(FL58N)
16/0.2mm Wire Green	1 Pkt	(FA29G)
TC Wire 0.56mm 24swg	1 RI	(BL15R)
Ribbon Cable 10 Way	1m	(XR06G)
Heat Resistant Sleeve Black	1m	(BL66W)
Heat Shrink CP 64	1m	(BF90X)
Front Panel	1	(JX43W)
Display PCB	1	(GE45Y)
Mains PCB	1	(GE58N)
Double Bubble Sachet	1	(FL45Y)
Mains Warning Label	1	(WH48C)
Instruction Leaflet	1	(XK32K)
Constructors' Guide	1	(XH79L)

OPTIONAL (Not in Kit)

PL3	Minicon Plug 3 Way	1	(BX96E)
	Minicon Hsng 3 Way	1	(BX97F)
	Minicon Terminals	1 Pkt	(YW25C)
	C6A Mains Cable Orange	1m	(XR05F)
	PCB Lacquer	1	(YB75S)
	PCB Cleaner	1	(YJ45Y)
	Alkaline KAA Battery	1	(FK64U)
	AA Battery Box	1	(YR59P)
	Cable Gland 5-8	1	(JR76H)
	Waterproof Mains Connectors		<i>see text</i>
	Heater		<i>see text</i>
	Fan		<i>see text</i>

The above items, excluding Optional, are available as a kit:
Order As LP38R (Temp Controller Kit) Price £59.95

The following items are also available separately, but are not shown in our 1991 catalogue:

Front Panel **Order As JX43W Price £2.25**
Display PCB **Order As GE45Y Price £10.95**
Mains PCB **Order As GE58N Price £3.95**

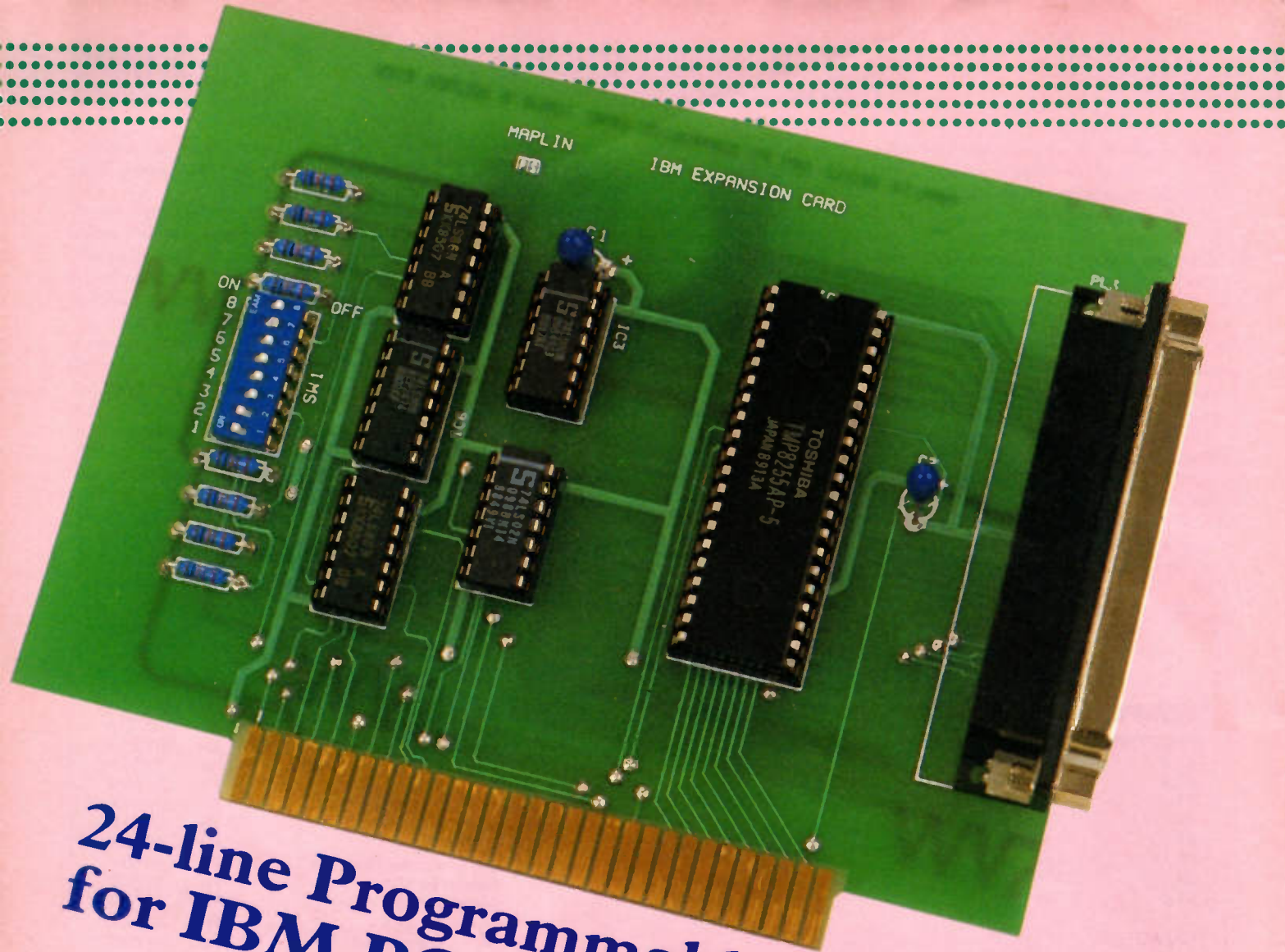

24-line Programmable I/O Card for IBM PC and Compatibles

Design by Peter Long
Text by Robert Ball AMIPRE

Features

- ★ For use with IBM PC, PC-XT, PC-AT and Compatible Clones
- ★ 24 Input/Output Lines
- ★ Fully Programmable from BASIC using INP and OUT
- ★ Base Address Selectable
- ★ Uses Industry Standard 8255 PPI IC

Applications

- ★ Data Logging
- ★ Robotics
- ★ Process Control
- ★ Interfacing to External Sensors
- ★ Controlling Lamps, Motors, Relays, Solenoids
- ★ Driving Non-Standard Peripherals

Introduction

This project is a 24-line digital I/O (Input/Output) card for use with the IBM PC, PC-XT, PC-AT and compatible clones. The card is based around the industry standard 8255 PPI (Programmable Peripheral Interface) IC, which provides 24 I/O lines under user control. The card slots into any one of the vacant expansion slots provided on the host computer. Power, control, address and data signals are obtained from the computer's expansion bus. The 24 I/O lines and +5V and 0V are connected to a 37-way male D-type connector fitted to the rear edge of the board. The D-type connector protrudes through the expansion card slot to facilitate connection with the outside world.

Circuit Description

Figure 1 shows the circuit diagram of the I/O card and the following circuit description should help the constructor understand operation of the unit and assist in fault finding should this become necessary.

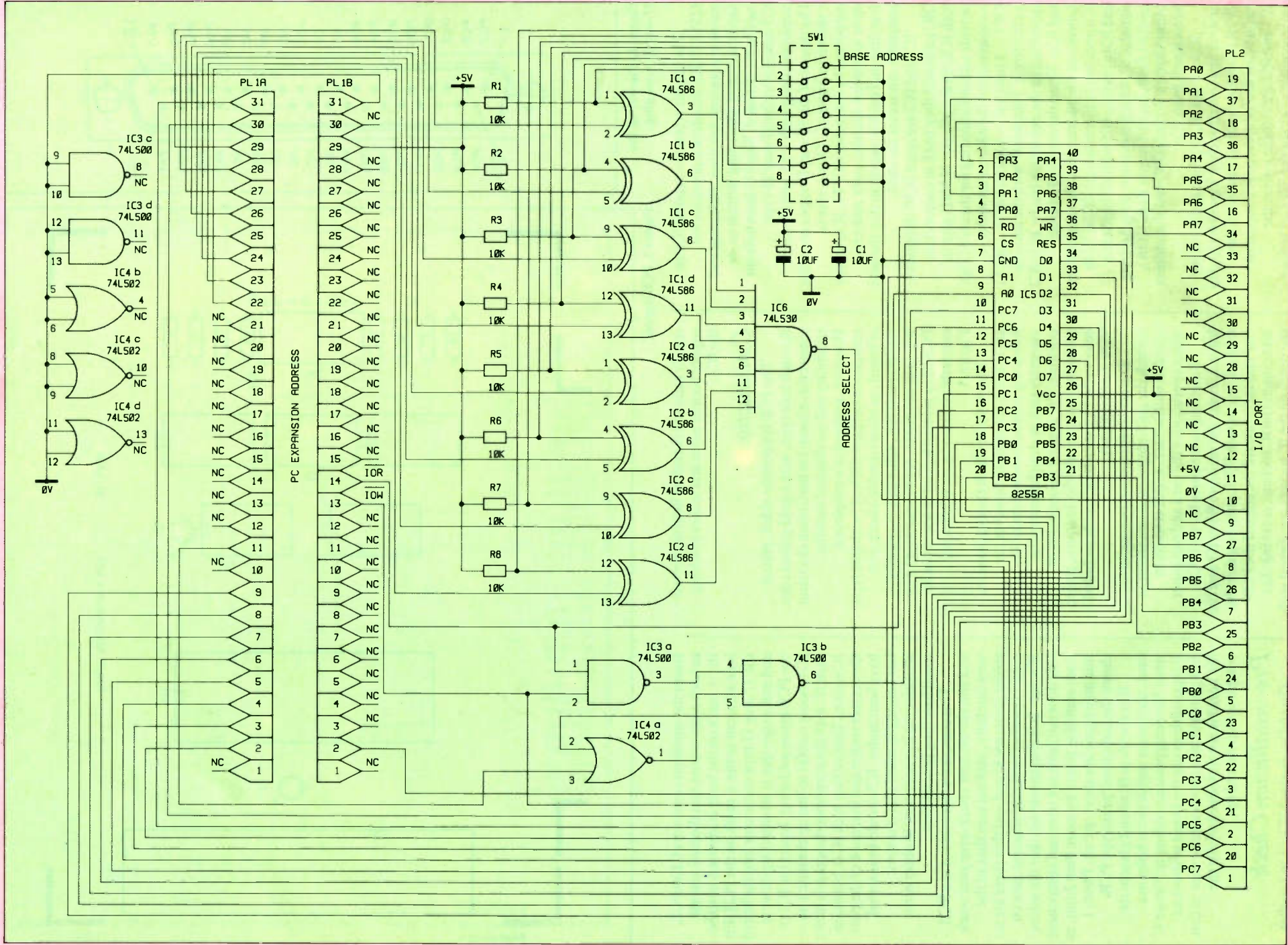

Figure 1. Circuit diagram of the PC I/O Card.

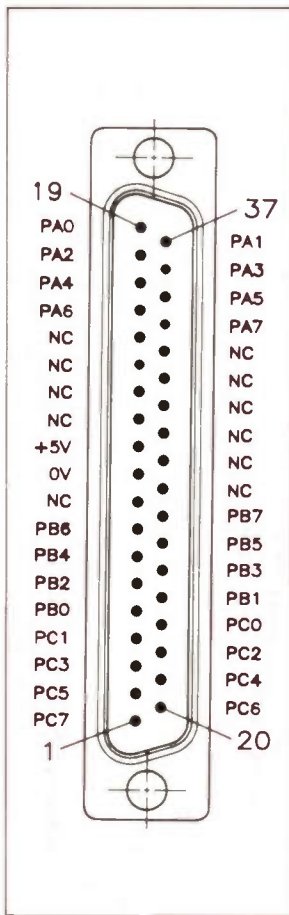

Figure 2. Pin-out of the 37-way D-type plug.

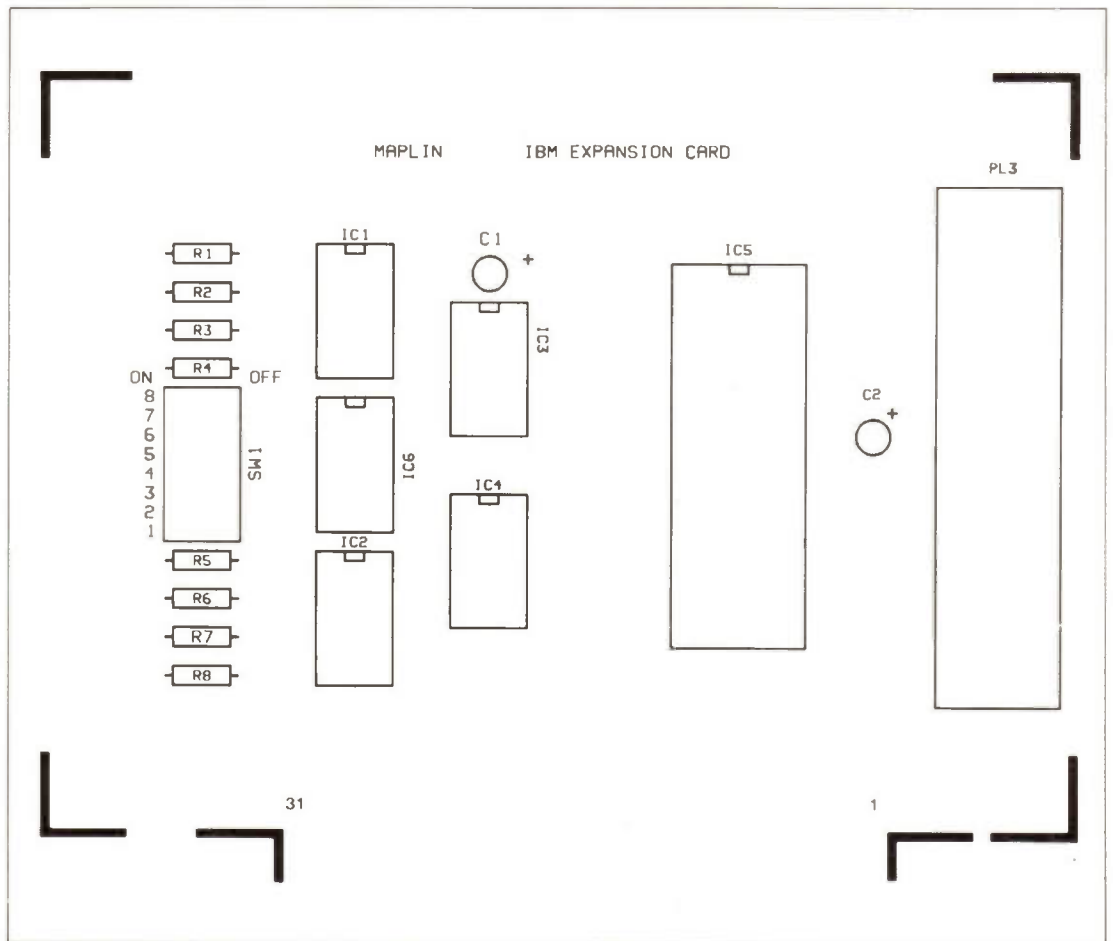

Figure 3. PCB legend.

The circuit is centred around IC5 an 8255 PPI IC, this device provides the necessary control, latching, buffering and handshaking of data being written to, or read from, the card. The I/O lines to/from IC5 connect to the 37-way D-type connector along with +5V and 0V lines. The pinout of the 37-way D-type connector is shown in Figure 2. This device is supported by a number of TTL ICs, which serve to provide the necessary address decoding and enable signals so that the host computer can access the card.

IC1 and IC2 are quad EOR (Exclusive OR) gates and they work in conjunction with IC6, an eight-input NAND gate to provide address decoding for the card. The complement of the address set up by SW1 - 1 to 8 ('on' = logic 0, 'off' = logic 1) is effectively 'compared' with the address appearing on the expansion bus by IC1, IC2 and IC6. When the required address appears on the address bus, the output from IC6 goes low (address select). IC3a, IC3b and IC4a provide IC5 with a Chip Select signal (\overline{CS}), which is derived from Address enable (Aen), Input/Output Read (\overline{IOR}), Input/Output Write (\overline{IOW}) and the address select signal from IC6.

IC3c, IC3d, IC4b, IC4c and IC4d are unused and therefore their inputs are tied to 0V. R1 to R8 are pull-up resistors, they ensure that the 'address select' inputs to IC1 and IC2 are at logic 1 when the corresponding switches of SW1 - 1 to 8 are open (off). C1 and C2 serve to decouple the

supply rails and therefore help to prevent supply borne noise and spikes reaching the ICs.

Construction

The PCB is a double-sided, plated-through hole type, with a gold-plated edge connector, chosen for maximum electrical reliability and mechanical stability. However, removal of a misplaced component is quite difficult with this type of board, so please double-check each component type, value and its polarity where appropriate, *before* soldering! The PCB has a printed legend to assist you in correctly positioning each item, see Figure 3.

The order in which the components are fitted is not critical, however the following instructions will make the assembly task as straightforward as possible. For general information on soldering and assembly techniques, please refer to the Constructors' Guide included with the Maplin kit.

During construction, be careful not to scratch the gold-plated edge connector or splash it with solder, as this is likely to affect operation of the card and computer.

Referring to the parts list and PCB legend, insert the resistors R1 to R8 and the dual-in-line switch SW1, ensuring that the 'on' end faces toward the edge of the PCB. Next insert the IC sockets, ensuring that the notch on the IC sockets are aligned with the corresponding marks on the legend.

Insert the tantalum capacitors C1 and C2, in both cases ensure that the lead nearest the + mark on the body is inserted into the hole adjacent to the + mark on the PCB. Fit the 37-way D-type connector into the board and make sure that it is butted-up close to the PCB *before* soldering. Insert the IC1 to IC4, being careful to line up the notch on each IC with the corresponding notch in the IC socket. Ensure that each IC is located in the correct socket and that none of the pins have bent under. IC5 should be inserted last bearing in mind that it is static sensitive; so it is necessary to observe the usual handling precautions.

This completes assembly of the PCB and you should now check-over your work very carefully, making sure that all the solder joints are sound and that there are no solder splashes bridging adjacent pins on ICs, etc. It is also important that the solder side does not have any trimmed component leads standing proud by more than 2mm, as this may result in a short circuit. Photo 1 shows the completed prototype PCB.

If you wish to fit an end plate to the card, the easiest way is to cut holes in a spare blanking plate according to Figure 4. It is possible to use the board without an end plate but you must exercise care so that the board is not dislodged whilst the computer is powered up.

Pre-installation Check

Carefully operate SW1 - 1 to 8 so that they are set to 'on' i.e. the actuators are

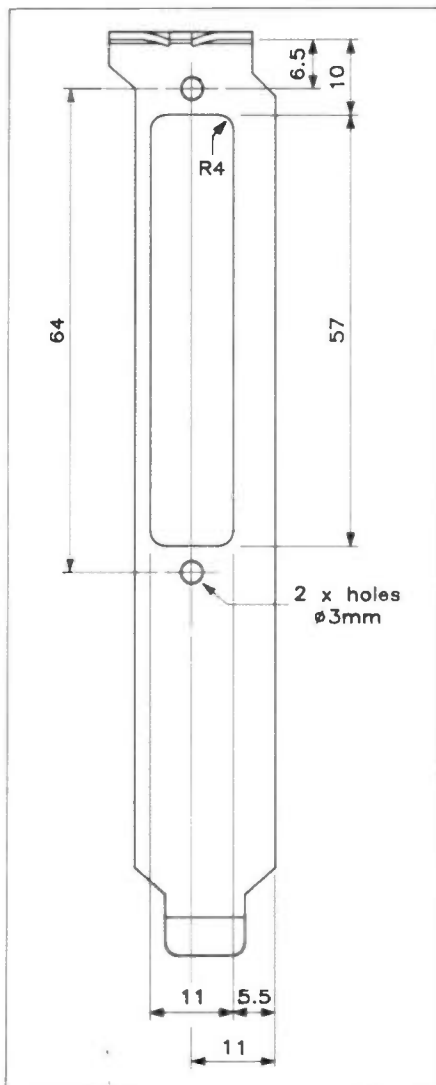

Figure 4. End plate cut-out.

facing toward the edge of the PCB. Turn the PCB over so that the solder side is uppermost and the gold-plated edge connector is facing towards you, Pin 1 of the edge connector is on the left and Pin 31 is on the right. Using a multimeter, measure the resistance between Pin 29 (+5V) and Pin 31 (0V), be careful not to scratch the contact surface with the test probes, a reading of approximately $1.2k\Omega$ should be obtained. A reading substantially higher than this indicates that SW1 is inserted incorrectly and a reading substantially lower than this indicates a short circuit.

Installation

The installation is broken down into a number of steps. These steps must be followed carefully to avoid problems.

1) Select an appropriate I/O base address, it is important to avoid those already used by existing cards otherwise a bus contention will occur and the computer will crash. Addresses already in use can be determined by consulting the installation instructions for the existing cards, alternatively the Table 1 gives the designated I/O addresses. It is suggested that address 0300 hex is used, unless of

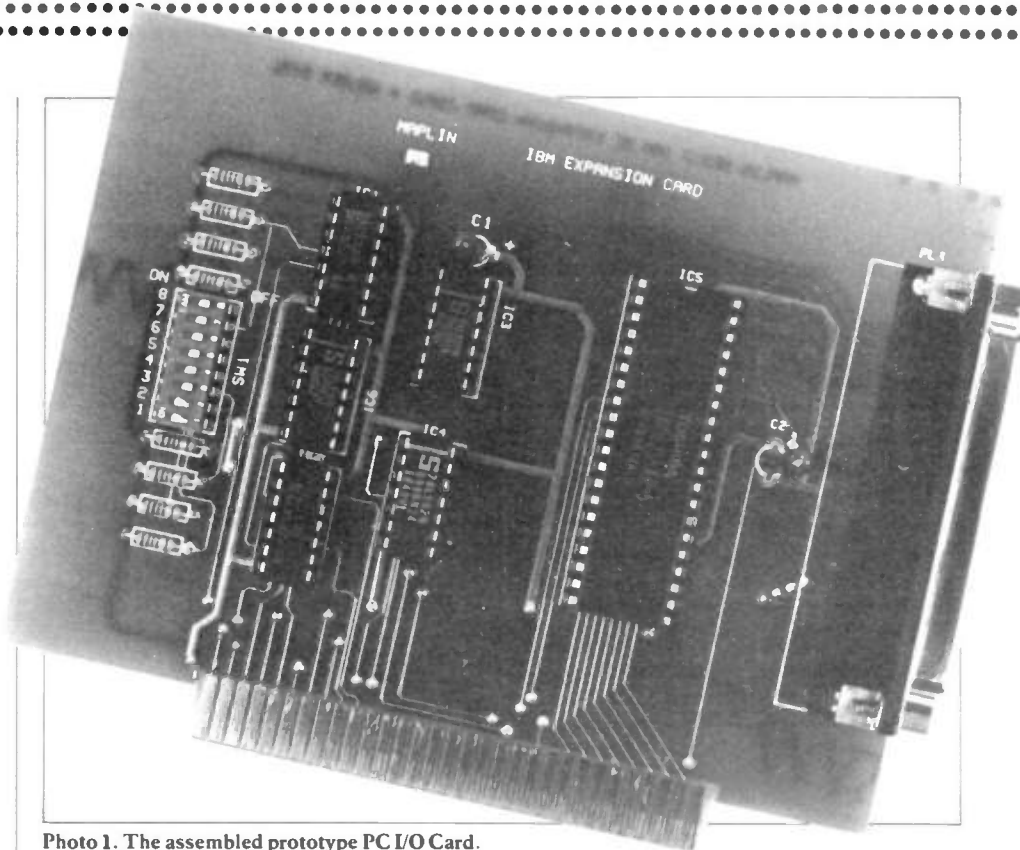

Photo 1. The assembled prototype PC I/O Card.

Description

Hex Address

Description	PC PC - XT	PC - AT
DMA controller	000 - 00F	000 - 01F
Interrupt controller	020 - 021	020 - 03F
Timer	040 - 043	040 - 05F
PPI	060 - 063	n/i
Keyboard	n/i	060 - 06F
DMA page register	080 - 083	080 - 09F
NMI mask register	0A	070 - 07F
Interrupt controller	n/i	0A0 - 0BF
Sound generator	n/i	n/i
DMA controller 2	n/i	0C0 - 0DF
Clear/reset math co-processor	n/i	0F0 - 0F1
Math co-processor	n/i	0F8 - 0FF
Joystick	200 - 20F	200 - 207
Expansion unit	210 - 217	n/i
Parallel printer	n/i	278 - 27F
Serial port	3F8 - 3FF	3F8 - 3FF
Serial port	2F8 - 2FF	2F8 - 2FF
Prototype card	300 - 31F	300 - 31F
Fixed disk	320 - 32F	1F0 - 1F8
Parallel printer	378 - 37F	378 - 37F
SDLC	380 - 38F	380 - 38F
Bi-synchronous communications	n/i	3A0 - 3AF
Monochrome adapter/printer	3B0 - 3BF	3B0 - 3BF
Colour/graphics adaptor	3D0 - 3DF	3D0 - 3DF
Diskette controller	3F0 - 3F7	3F0 - 3F7

Note:
n/i = not implemented

Table 1. Designated I/O Addresses.

course this address is already occupied! This address is designated for prototyping cards.

The address is set up as follows: A9 to A2 select the base address, A1 and A0 select the appropriate register within the 8255 (see later). The settings of SW1 - 1 to 8 can be determined by converting the required address into binary and taking the 8 most

significant bits (A9 to A2) as the settings for the switches. SW1 - 1 corresponds to bit A9 and SW1 - 8 corresponds to bit A2, a logic 1 = switch 'on' and a logic 0 = switch 'off'. An example of how to determine the switch settings is shown in Table 2. Photo 2 shows switch settings on the prototype corresponding to an I/O address of 0300 hex.

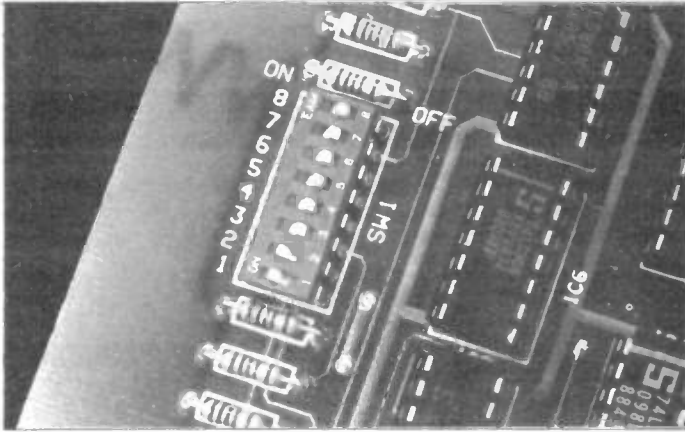

Photo 2. Close-up of the address selection switches (0300 hex).



Photo 3. PC I/O Card installed in a computer.

Base address = 0300 hex

0300 hex = 11000000nn

A9 to A2 = 11000000xx

A1 to A0 = xxxxxxxxnn

where:

x = Don't care

n = register selection bit

Switch number:	SW1 - 1	SW1 - 2	SW1 - 3	SW1 - 4	SW1 - 5	SW1 - 6	SW1 - 7	SW1 - 8
Address line:	A9	A8	A7	A6	A5	A4	A3	A2
Binary Value:	1	1	0	0	0	0	0	0
Switch setting:	ON	ON	OFF	OFF	OFF	OFF	OFF	OFF

Table 2. An example of how to determine switch settings.

```

10 BASEADD% = &H300
20 OUT BASEADD% + 3,128
30 OUT BASEADD%,&HFF
40 OUT BASEADD% + 1,&HFF
50 OUT BASEADD% + 2,&HFF
60 PRINT "LOGIC 1"
70 GOSUB 140
80 OUT BASEADD%,0
90 OUT BASEADD% + 1,0
100 OUT BASEADD% + 2,0
110 PRINT "LOGIC 0"
120 GOSUB 140
130 GOTO 30
140 FOR I = 1 TO 2000
150 NEXT I
160 RETURN
  
```

' Set up base address for I/O card
' Set 8255 to Mode 0 control word 0
' Set all pins to logic 1

' Call delay subroutine
' Set all pins to logic 0

' Call delay subroutine
' Repeat
' Delay Subroutine

Listing 1. A simple program to test the I/O card.

2) Turn off power and disconnect the computer from the mains supply. Failure to take these steps may expose potentially lethal mains voltage and installation of the card with the computer switched on may result in permanent damage to your computer and/or the card.

3) Remove the cover on the expansion card area of the computer or remove the computer case (dependent on model).

4) Locate an empty expansion slot and remove the metal cover plate fixing screw and cover.

5) Insert the card into the empty slot pushing it firmly home without forcing it.

Photo 3 shows the prototype card installed in the authors' computer.

6) Replace the cover/case.

Testing

Switch on the computer, it should boot up in the normal way. If you have a system without a hard disk drive, you will need to insert a 'System Disk'. If the computer behaves in an abnormal way, turn off the computer immediately and remove the expansion card.

A simple program written in GWBASIC can be used to test the board, see Listing 1. The program sets all three

ports to outputs and toggles them between logic 1 and logic 0 at short intervals, thus producing a square wave at each output pin. Each of the 24 output lines can be checked with a logic probe, oscilloscope, multimeter or the test circuit shown in Figure 5. Figure 6 shows a suggested strip board layout for the test circuit. Photo 4 shows the test circuit assembled on a piece of strip board.

The delay may be adjusted to alter the period of the square wave output; this is achieved by altering the number in line 140, presently set at 2000. A lower number will decrease the periodic time and hence increase the frequency of the square wave. A higher number will have the opposite effect. A logic probe will show alternately logic 1 and logic 0. Whilst a scope will show a square wave (suggest delay in line 140 of 5, sweep speed of 20ms, attenuator set to 0.2V/cm, input DC coupled and the probe set to 'x 10'). With an analogue multimeter (set to 10V DC range) the needle will read alternately $\geq 2.4V$ and 0V. With a digital multimeter (set to 10V DC range) the display will read alternately $\geq 2.4V$ and 0V. With the test circuit shown in Figure 5 connected to each port in turn (A, B and C) the LEDs will flash on and off together.

8255 Operating Modes

As previously stated, the card utilises an 8255 PPI IC, which is a general purpose I/O device. The 8255 has 24 I/O lines

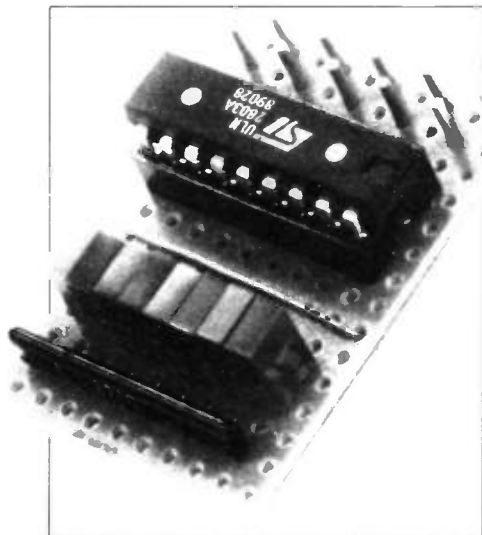

Photo 4. The suggested test circuit.

divided into three ports of 8-lines each; Port A, Port B and Port C. The three ports are configured in two groups of 12-lines, these are referred to as Group A and Group B. Group A comprises of all 8-lines of Port A (PA7-0) and the upper 4-lines of Port C (PC7-4). Group B comprises of all 8-lines of Port B (PB7-0) and the lower 4-lines of Port C (PC3-0). This is summarised in Table 3.

The way in which the function of each of the 24-lines is defined is determined by

Group A - Port A (PA7-0) and Port C (PC7-4)

Group B - Port B (PB7-0) and Port C (PC3-0)

Table 3. 8255 Grouping of Ports.

the Mode. There are three possible operating modes and these can be summarised as follows:

Mode 0; Each group of 12-lines can be configured, in a set of 8-lines and a set of 4-lines, to be either inputs or outputs.

Mode 1; Each group of 12-lines can be configured to have 8-lines of I/O. Three of the remaining lines in each group are used for handshaking and a further two lines are available for I/O.

Mode 2; Group A is configured to operate in a bi-directional bus mode using 8-lines from Group A for the bi-directional bus, and 4-lines from Group A and 1-line from Group B for handshaking. The remaining lines from Group B can be configured to operate in either Mode 0 or Mode 1.

The operating mode and definition of each port is defined by writing information to the Control Register located at three bytes above the (previously determined) base address in the I/O map. The control register can only be written to and not read from. Data may be written to and read from each of the three ports at the first three consecutive addresses starting from the base address. The arrangement of the 8255

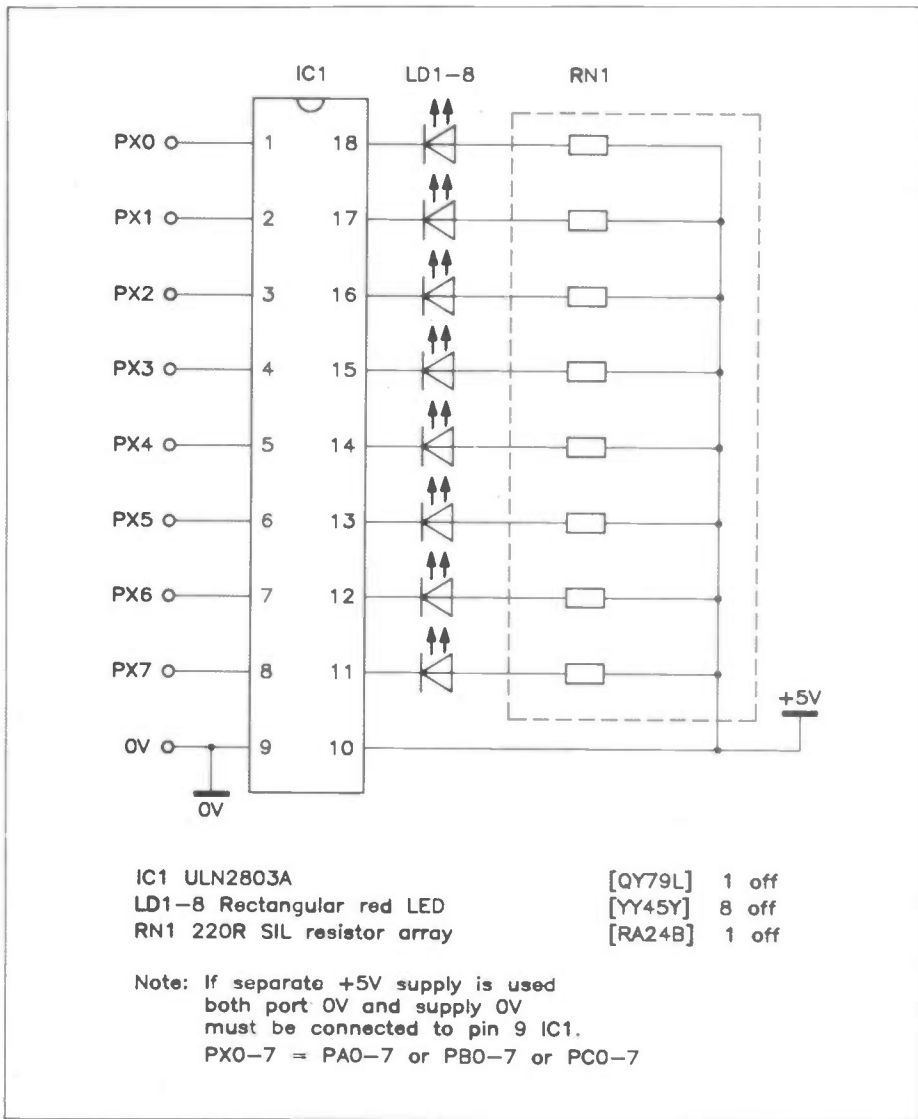

Figure 5. Circuit diagram of a suitable test circuit.

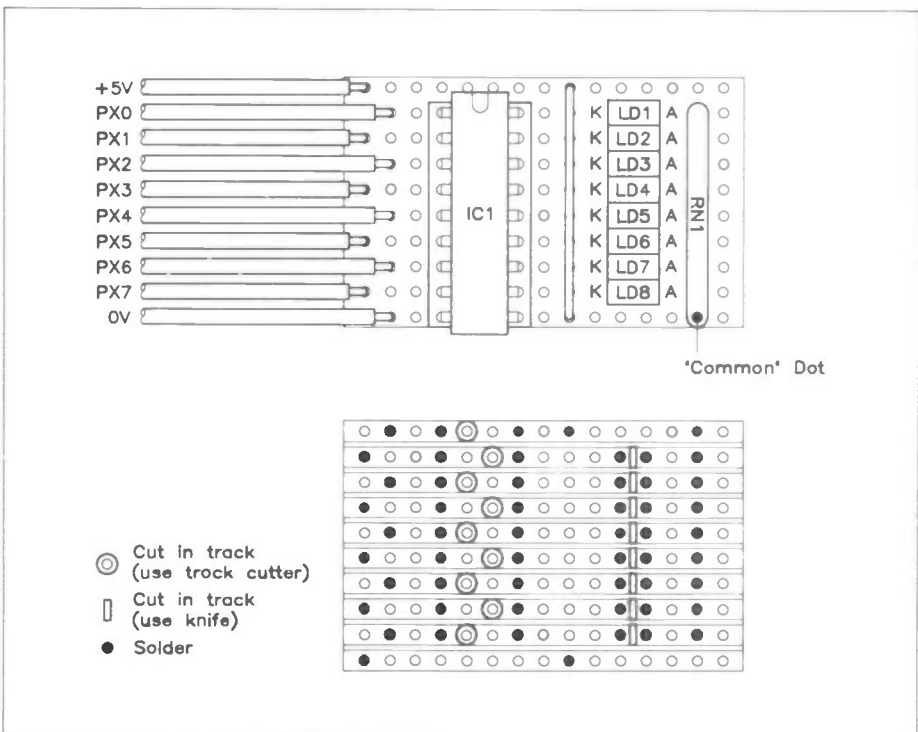

Figure 6. Suggested strip board layout for the test circuit.

Read Mode		
Offset from base address		Input operation
0		Port A → Data bus
1		Port B → Data bus
2		Port C → Data bus
Write Mode		
Offset from base address		Output Operation
0		Data Bus → Port A
1		Data Bus → Port B
2		Data Bus → Port C
3		Data Bus → Control Register

Table 4. Writing to and reading from the 8255 Registers.

D7		=	Mode/Bit Set/Reset Flag
1		=	Mode Set
0		=	Bit Set/Reset (see text)
Group A			
D6	D5		Mode selection
0	0	=	Mode 0
0	1	=	Mode 1
1	x	=	Mode 2
D4			Port A
1		=	Input
0		=	Output
D3			Port C (upper)
1		=	Input
0		=	Output
Group B			
D2			Mode selection
0		=	Mode 0
1		=	Mode 1
D1			Port B
1		=	Input
0		=	Output
D0			Port C (lower)
1		=	Input
0		=	Output

Table 5. The 8255 Control Register (Mode Selection).

Output line	=	Px7	Px6	Px5	Px4	Px3	Px2	Px1	Px0
Decimal value	=	128	64	32	16	8	4	2	1

Where: x = port A, B or C

Example:

Output line	=	PB7	PB6	PB6	PB6	PB2	PB1	PB0
Decimal value	=	128	64	32	16	8	4	2
Binary value	=	1	0	0	0	0	1	0
	=	128 + 4						
	=	84 hex						
	=	132 decimal						

Table 7. Setting and resetting output lines.

registers is shown in Table 4. Table 5 shows the function of the 8 data bits within the control register, D7 is used to select the Mode/Bit Set/Reset, in most cases D7 will be set to logic 1. An example of how the 8255 can be set up by writing to the control register is shown in Table 6.

Accessing the I/O Card from GWBASIC

Defining the Base Address

The easiest way to define the base address for use in a BASIC program is to set an integer variable (% suffix) to the base address value. Then whenever the card

Mode 0	
PA7 - PA0	IN
PC7 - PC4	OUT
PB7 - PB0	OUT
PC3 - PC0	IN
D7 = 1	Mode Set
D6 = 0 D5 = 0	Mode 0
D4 = 1	Input
D3 = 0	Output
D2 = 0	Mode 0
D1 = 0	Output
D0 = 1	Input
Control Byte =	10010001 binary
	= 91 hex
	= 145 decimal

Table 6. An example of setting 8255 Ports in Mode 0.

needs to be accessed using the OUT or INP instructions the variable (plus offset where necessary) can be used instead of the actual address. This technique is good programming practice as the base address can be changed by modifying just one line of the program instead of tediously having to change every usage of the address. An example of this is shown in Listing 2.

Setting the 8255 Operating Mode

The operating mode of the 8255 can be set by first determining the correct value of data that needs to be written to the 8255 control register (which was dealt with earlier), then writing the data using the OUT instruction. An example of this is shown in Listing 3.

Setting and Resetting Output Lines

To set and reset output lines, the appropriate port must be written to, using the OUT instruction, with data corresponding to the binary weighting of the output lines. Calculation of the data value can easily be achieved by using a number line and adding the values where a Logic 1 is required. Table 7 shows a binary weighted number line together with an example of how to calculate the data for setting Port B line PB7 and PB2 to logic 1 (the remaining lines will be set to logic 0).

Listing 4 shows an example of how to output the data to the Port B register.

Reading Data from Input Lines

Using the INP instruction, data from an input port can be read. The value of the data will be determined by the binary weighting of the logic levels on the input lines – the opposite process to calculating data to set and reset output lines. An example of how data can read from Port A is shown in Listing 5.

```
10 BASEADD% = &H0300
```

Listing 2. Example line of BASIC to set base address variable to 0300 hex.

```
In hex:
20 OUT BASEADD% + 3, &H91

In decimal:
20 OUT BASEADD% + 3, 145
```

Listing 3. Example line of BASIC to set 8255 to MODE 0 with Port A & Port C (lower) to input and Port B & Port C (upper) to output.

```
In hex:
30 OUT BASEADD% + 2, &H84

In decimal:
30 OUT BASEADD% + 2, 132
```

Listing 4. Example line of BASIC to set Port B lines PB7 and PB2 to Logic 1 and reset the other lines to Logic 0.

```
40 DAT% = INP(BASEADD%)
```

Listing 5. Example line of BASIC to read data from Port A.

Interfacing with the Outside World

The I/O lines on the 8255, when configured as outputs, are not capable of sourcing or sinking large amounts of current. Similarly the I/O lines, when configured as inputs, are not designed to accept voltages outside the range of the normal logic levels associated with 5V TTL and CMOS logic. It is necessary for outputs to be buffered according to the load that is to be driven and inputs be conditioned to conform to the correct logic levels. Flaunt these requirements at your (or rather the computer's and I/O card's) peril, you have been warned!

Figure 7 shows a number of output buffering circuits and Figure 8 shows a number of input conditioning circuits. These circuits must be considered as a basis for your own experimentation, no warranty is given for suitability in particular applications.

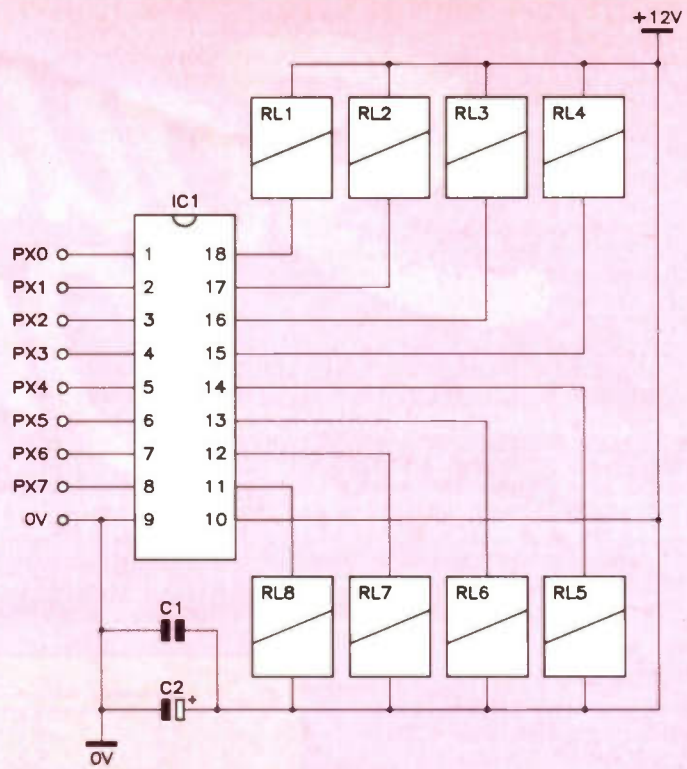

- IC1 ULN2803A QY79L
 - RL1-8 BX47B, YX94C, YX95D, YX96E, JM81U, JM67X, YX97F, YX98G, YX99H, FJ43W.
 - C1 0.1uF Minidisc YR75S
 - C2 100uF 25V PC Elect FF11M
- Note: A separate +12V supply must be used and both port 0V and supply 0V must be connected to pin 9 IC1.
C1 should be mounted as close to IC1 as possible.
Choose RL1-8 to suit load to be switched.

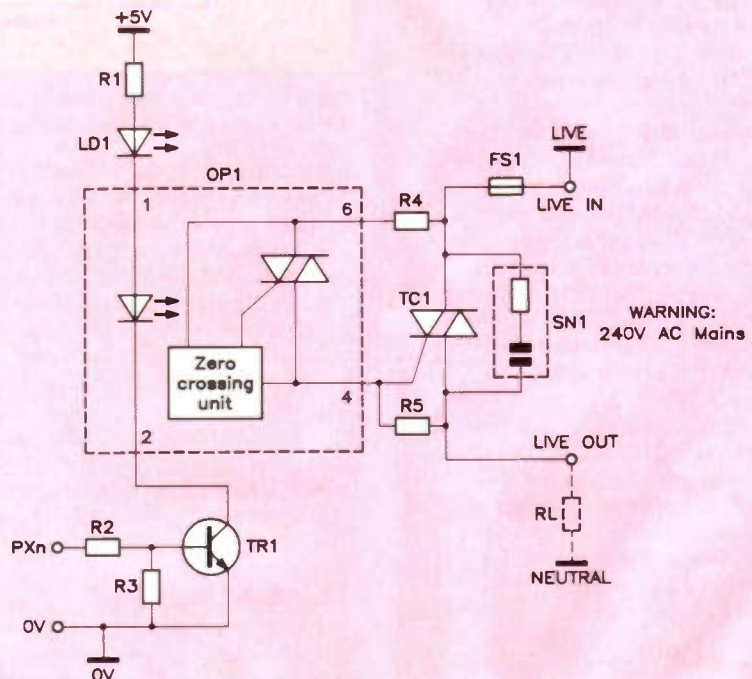

- R1 150R
- R2 8K2
- R3 M82K
- R4 150R 1W
- R5 1K 1W
- TR1 BC548
- OP1 MOC 3041
- TC1 BTA 08-600B
- SN1 R-C NETWORK
- LD1 RED LED
- FS1 1A
- M150R
- M8K2
- M82K
- C150R
- C1K
- QB73Q
- RA56L
- UK54J
- YR90X
- WL27E
- WRO3D

NOTE:
If separate +5V supply is used both port 0V and supply 0V must be connected to the emitter of TR1.
TC1 should be mounted on a heatsink.
All components to the right of and including OP1 are at mains potential.
PXn = Any Port Output.

Figure 7. Output buffer circuits.

Continued on page 39.

Square One

A First Course in the Theory and Practice of Electronics

Part 7 by Graham Dixey C.Eng., M.I.E.E.

Introduction

In the last issue we considered logic chips as systems or components of systems. This approach is justified because of the trend towards putting 'more and more into less and less'. Going back a couple of decades in time, a look inside most items of electronic equipment would reveal a vast array of discrete components with few, if any, integrated circuits. Today the reverse is the case. Many electronic boxes, when opened, reveal a neat array of 'chips' with only a few discrete components to support them. But not only have the discrete components given way to integrated circuits, but the latter have become more complex themselves. For example, we have already met a logic function known as 'exclusive OR (XOR)' which we were able to construct from four 2-input NAND gates – occupying all of the four gates available on a single 7400 TTL IC. However, apart from learning about the operation of such a circuit, when it comes to practical use, there is no need to make the function up in this way at all. The 7486 TTL chip has four such gates on board and, consequently, is known as a 'Quad Exclusive-OR Gate' package. Being a 14-pin IC, it occupies exactly the same volume as the 7400 chip and many others in the 74-series of TTL logic chips.

This is a relatively small step up in the integration process. Let us take a rather larger one and consider the microcomputer as a system. Figure 1 shows the simplest way of representing the essential parts of such a system. There are only four blocks, each playing its own particular role in the operation; connecting these four blocks together are three 'highways', known in computer parlance as 'buses'.

The Buses

Each bus is just a collection of parallel conductors which all have a common function. They are usually drawn as a broad highway rather than as a set of individual wires, largely because this simplifies the drawing (both from the

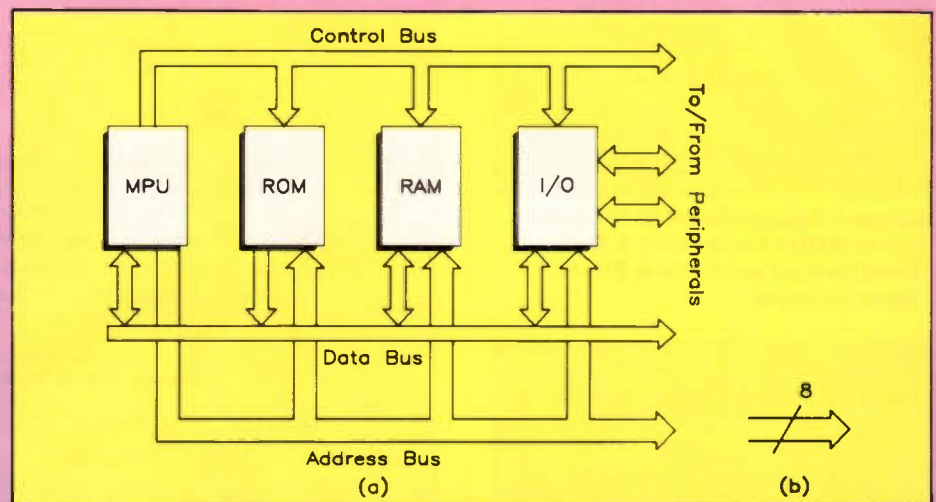

Figure 1. (a), block diagram of a microcomputer; (b), method of indicating number of wires in a bus, in this case eight.

viewpoints of the person drawing it and those viewing it later) and conveys just as much information anyway. To indicate the number of conductors forming the bus it is usual to put a slash through it and write the number of conductors alongside. This idea is shown in Figure 1(b) for an 8-bit bus, that is one comprising eight conductors each carrying a single binary digit (bit).

The buses just referred to can be thought of as being the means by which the different blocks of the computer communicate with each other. Specifically their roles are as follows:

The Address Bus

In a computer each byte of data is stored at a unique memory location. A byte here means an 8-bit word and the previous statement obviously assumes that data words are normally of 8-bit lengths. This is not, of course, true in all cases since many computers nowadays have 16-bit data words. In these cases the memory locations would have to be large enough to store 16-bit 'words' rather than 8-bit 'bytes'. But whatever the size of the data the same principles would apply; each would require one unique memory location in order to store it. 'Unique' means in this context nothing more than that each

location can be identified as a separate entity. It is rather like a block of flats, for example, where all flats are identical but each has its own 'flat number' – in other words its address, to complete the analogy.

It is the address bus that carries the information that, at any instant, identifies (that is 'addresses') any specific memory location. This operation always takes place either when the contents of the memory location are to be 'read' by the microprocessor unit (MPU), or when the latter is to 'write' new data into the memory location. To perform this addressing task, the MPU puts a binary pattern that corresponds to the required address onto the address bus. Special logic within the memory block, known as 'decoding' logic, and not shown in Figure 1, then looks at this binary pattern and allows the correct memory location to be accessed.

The number of individual addresses (and hence the number of possible memory locations) depends upon the number of conductors making up the address bus. For the case of a 16-bit address bus the lowest binary number is quite clearly 'sixteen zeros' and the maximum binary number is 'sixteen ones'. In between are all the possible combinations of zeros and ones. There is

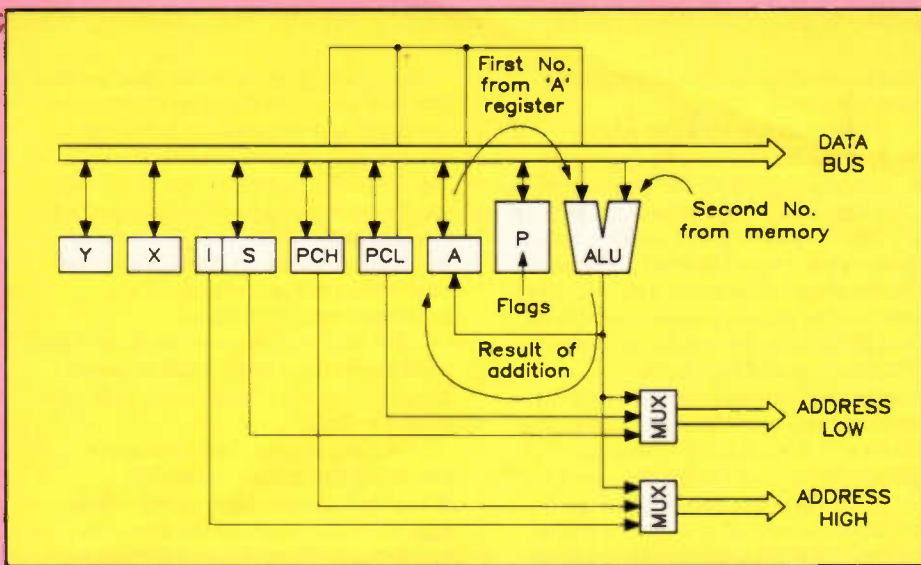

Figure 2. Adding two numbers in a microprocessor.

an easy way of determining how many locations can be addressed by a given size of address bus, by using the relation: number of addresses = 2^n , where 'n' is the number of address bus lines.

For a 16-bit address bus, there are $2^{16} = 65,536$ addresses. This gives a memory capacity of $65536/1024 = 65K$ -bytes. For a 24-bit address bus, there are $2^{24} = 16,777,216$ addresses. This gives a memory capacity of $16777216/1024 = 16384M$ -bytes.

It sometimes comes as a surprise to learn that the prefix 'kilo' means 1024 in a computing context, instead of the expected 1000 used to describe physical quantities in electronics. There is a reason for this, but which has more of an historical relevance and is, therefore, not of much importance at the moment, except to say that it is convenient to describe chunks of memory organised as 2^{10} , which is the nearest that binary notation can get to a round 1000. Suffice to say that, as far as binary is concerned, 1024 is a round number working to the base of 2 as is 8, 16, 32 etc. Note also that a capital 'K' is used in such a case to distinguish it from the normally used small 'k', which genuinely means 1000 - this is similar to other distinguishing computer conventions, for instance while 'disc' is a flat round object, 'disk' is a magnetic computer storage medium.

The individual lines of the address bus are identified by the letter 'A' followed by a numerical suffix. For a 16-bit address bus, the lines are numbered $A_0 - A_{15}$; the numbering always starting at 'zero' and not 'one' as might be expected. This numbering system uses the 'power of 2' for each column as the suffix.

The Data Bus

As the name implies, this is the highway for the transfer of data between the various blocks of the computer. It is the number of bits on this particular bus that is used to express whether a 'micro' is an '8-bitter' or a '16-bitter'. To quote examples from one maker alone, the Commodore C64 is an 8-bit machine, while the later Commodore Amiga is a 16-bit machine. This is because the MPU that each uses, a 6502 and a 68000 respectively, has in the first case an 8-bit

data bus and in the second case, a 16-bit data bus. Since the data bus can be used to transfer data in either direction between MPU and memory, it is said to be 'bidirectional'. The address bus, by comparison, is a 'unidirectional' bus since the MPU sends the addresses out to memory and not vice-versa.

The numbering of the data bus lines follows the same scheme as for the address bus. For an 8-bit bus, the lines are numbered $D_0 - D_7$.

The Control Bus

This bus is concerned with controlling and co-ordinating the operation of MPU and memory when running a program. To do this the MPU generates a number of signals that are carefully timed to perform specific actions. At the heart of this co-ordinated effort is the clock oscillator, usually part of the MPU itself, but with an external crystal to control its frequency. This generates a regular train of pulses at a frequency that is commonly in the range 1 - 16MHz. These might be thought of as the 'heart beat' of the computer - not too far out as an analogy since, if the pulses stop the computer will certainly be 'dead'! Events in the program, such as READs from memory and WRITEs to memory are

synchronised by the clock pulses. Other lines in the control bus will be used to determine whether the MPU is reading or writing data from/to memory. A line marked R/W is a control bus line that performs this function. The number of lines forming this bus vary according to the nature of the MPU.

Figure 1 shows four blocks joined by the buses just described. This is not intended to imply four chips, though that is a possibility in a very simple system. Taking each of these blocks in turn:

The MPU

This is the chip that does all the real work. The term MICRO Processor Unit (MPU) is derived from the earlier term CENTRAL Processor Unit (or CPU), the MICRO prefix merely indicating that the CPU of the original mainframe computer has been scaled down by the advances in micro-electronics to give us the version that has brought about the desktop computer revolution of the past decade or so. The term CPU is sometimes used interchangeably with MPU when discussing microcomputers where the context is understood.

The MPU contains a number of 'registers' which, for now, need only be thought of as devices for the temporary storage of data while it is being processed in some way. Figure 2 is used to introduce a physical picture of what happens inside the MPU when two numbers are added together. It is assumed that one of these numbers has previously been 'loaded' into the register marked A while the other has been 'fetched' from a memory location on the data bus.

The ALU

The arithmetic operation of addition is carried out in a unit within the MPU chip, known as the Arithmetic-Logic Unit (ALU). This unit has two 'input ports' and one 'output port', as also shown in Figure 2. It will be noticed that one of these ports is linked to the A register, while the other is linked to the data bus; these connections show how the data to be added enters the ALU. What happens after the addition has

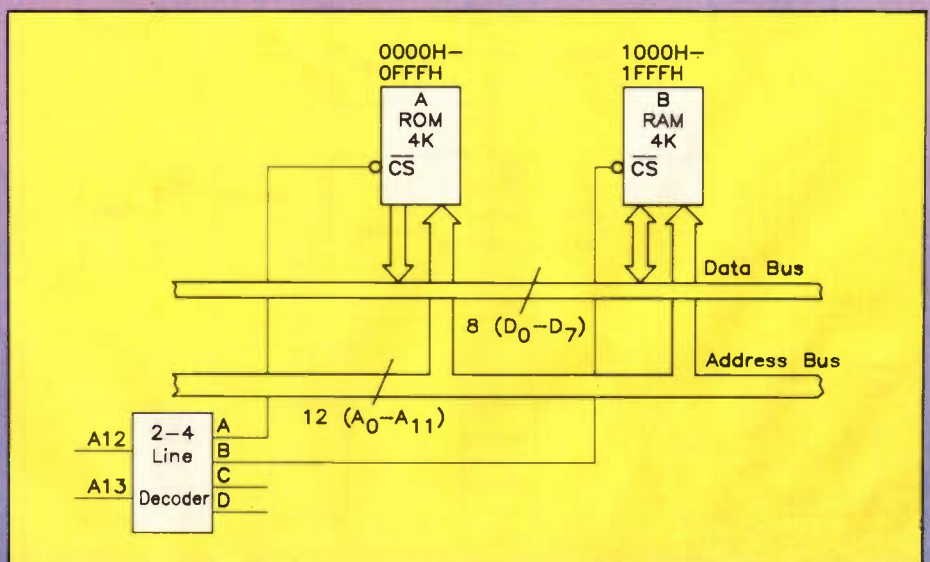

Figure 3. Decoding ROM and RAM chips in a computer.

been carried out is indicated by the connection from the output port of the ALU back to the A register. Thus, the following sequences of operations occurs when two numbers are added together:

- (i) The first number, in the A register, is placed in the ALU.
- (ii) The second number is fetched from the memory and also enters the ALU where it is added to the first number.
- (iii) The sum of the two numbers is formed and this is loaded into the A register, over-writing its original contents.

The Status Registers

There is also a connection to another register, known variously as the status or 'flags' register. While this plays no actual part in the addition operation, it records salient facts about the result, such as whether it has 'overflowed', i.e. is too large to be held in the A register. A more obvious use of the flags register occurs during a subtraction when it will indicate whether the result is positive, zero or minus. Such indications are of great value in helping the MPU in decision making.

Space obviously does not permit a discussion of the purpose of all MPU registers, but they serve here as a pointer to the complexity of this block.

The System Memory

Moving on to the next block we usually find two different sorts of 'memory', one type of memory is known as ROM, for 'Read Only Memory', to give it its full title. This form of memory holds a permanent store of data which cannot be changed at all during normal program execution, since its purpose is to control various aspects of computer operation. Without a ROM the computer would be unable to perform even the simplest of tasks. One of these would for example read the keyboard and give the appropriate responses. ROMs are also used to hold specialised applications

software, such as high level programs, assemblers, etc.

There are types of ROM whose contents can be changed by wiping out the current program and re-programming it. The Erasable Programmable ROM (EPROM) is an example. This has a quartz window on top through which the actual memory chip can be seen. If this window is exposed to intense ultra-violet light for about 20 minutes, the result is a blank EPROM which can then be re-programmed using a hardware/software device known as an EPROM programmer. This type of ROM is ideal where the updating of its contents is anticipated, or simply for a programmed ROM to be produced cheaply. The program that is resident in a ROM is often referred to as 'firmware', to make a fine distinction (sometimes ignored) between the 'software' held on disks, either floppy or hard.

Another form of memory, RAM or Random Access Memory, appears in the next block. Unlike ROM, this type of memory can be both read or written to; the data in it can be changed at will just by writing fresh data 'over' the old. This is where 'user programs' and data are stored. Programs, or data loaded from disk, or typed in via the keyboard are placed in the computer's RAM type of memory. Naturally, the larger the available RAM, then the more data or the larger the programs that can be stored there. As one who, at one time, only had a measly 20K or so of RAM available with which to type his masterpieces (!), the author now appreciates the 512 of RAM currently at his disposal. Even so, this is small compared with the Megabytes of RAM that some machines offer - and need!

Dynamic and Static RAM

There are two types of RAM. Taking the latter first, the bits held in static RAM are stored as the opposite states (logic 0 and logic 1) of a two-state device known as a 'bistable'. Storing a logic 0 involves

'flipping' the circuit into one state; causing it to 'flip' back into the other state means that it will now store a logic 1. For this reason, such devices are often termed 'flip-flops'. The simplest type of flip-flop can be made using just two transistors. If this is capable of storing a single bit of data, a quick bit of arithmetic shows just how many are needed to store any significant amount of data.

For example, to store one byte (8 bits) would need 8 flip flops, while to store a modest 1K-bytes of data needs $1024 \times 8 = 8,192$ flip-flops!

While it is possible to produce extremely tiny transistors within integrated circuits, each draws a finite amount of collector current when it is conducting (50 percent of the transistors will always be conducting). This makes this type of memory rather thirsty for power. On this score the other type of memory, the dynamic variety, wins hands down.

In dynamic memory, the logic level is stored as a charge on a minute capacitor, which is in fact the capacitance formed between the gate and source of an MOS transistor. No charge indicates a 'logic 0', and a charged capacitor signifies a 'logic 1'. The current drain and, hence, power consumption in this type of memory is negligible. This allows the production of economical, high capacity memory chips. However, because the stored charge is so tiny, it is rather 'vulnerable', and so it is common for dynamic RAM to be of the 'refresh' type, where all the data bits throughout the whole chip are sequentially rewritten with the same logic level - virtually reloaded with themselves, so to speak! This may be done by a dedicated part of the microprocessor for example between normal memory access operations.

Volatile and Non-Volatile

Memory can also be divided into a further two classes depending on whether the data is still held after the computer has been switched off. In this context, the terms volatile and non-volatile appear to be mere alternatives for describing RAM and ROM. This is essentially true since programs stored in RAM are lost once the power is disconnected, even momentarily, while data in ROM, of whatever type, is retained. However some computers have what is known as 'battery backed RAM'.

The RAM chips aren't actually any different from normal, it is just that there is a small rechargeable battery that receives a trickle charge during normal computer operation, and which continues to supply power to the RAM chips when the main power source is off. This makes it possible to type a program into RAM, switch the computer off and come back to it a week or more later. You can then carry on where you left off - provided someone else hasn't used the machine in the meantime and loaded their program over yours! Such RAM is normally of the static (flip-flop) type in MOS with a special low voltage, low power, memory retention 'sleep' mode.

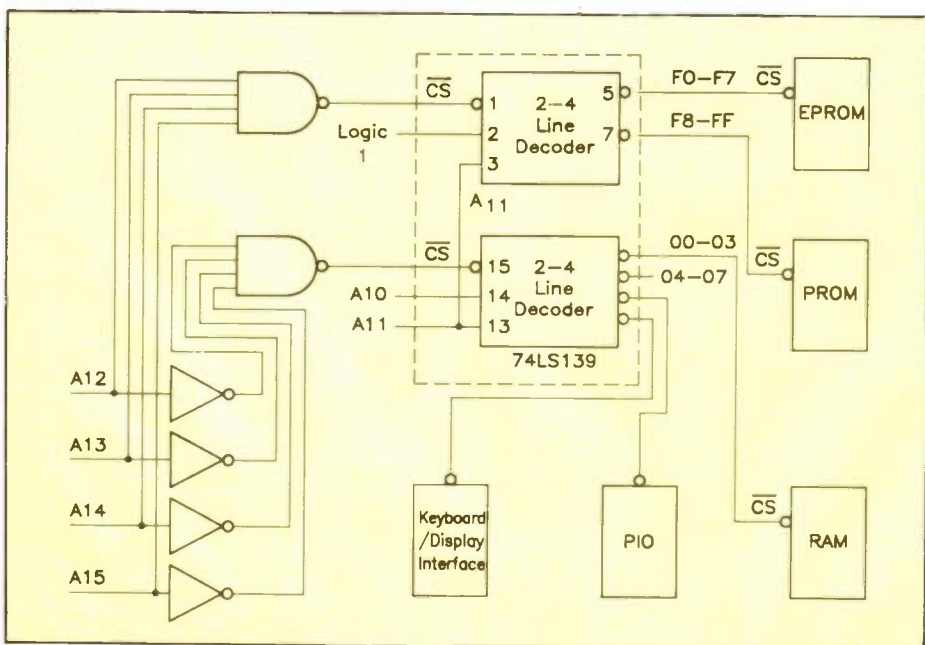

Figure 4. An exercise for the reader in decoding address ranges for several devices.

Decoding and Controlling Memory

If there are several memory chips in a system, it is necessary to be able to distinguish between them when it comes to accessing a specific memory location. Suppose, for simplicity, there are just two memory chips, as in Figure 3. One of these is the ROM chip, the other the RAM chip. Each chip will have its own set of addresses, among which will be the required location. How will the computer be able to access the data in the locations specified? It must be able to disregard one chip in favour of the one containing the specified address. It does this by the use of 'decoding' logic.

Decoding logic is nothing more than an arrangement of gates, whose inputs are connected to some of the address bus lines, so that a particular binary pattern on the address bus will produce an output that will cause the correct memory chip to respond. Figure 3 shows that each of the memory chips has a pin which is marked CS (CS-bar).

The bar (as well as the round 'bubble' at the terminal) indicates that if that pin is taken 'low', that is to logic 0, that memory chip will be selected. Chip inputs of this type are said to be 'negative acting' or 'active low' inputs; they are quite common in microprocessor systems. The 'bubble' implies that this input is internally inverted to a logic '1' before passing on to the chip's decoding logic which normally responds to a level '1'.

The same figure also shows that these CS pins are connected to two of the outputs of a block that is marked as a '2-4 line decoder'. It is so called because it has two inputs, giving the four binary combinations 00, 01, 10 and 11 (0-3), each of which will cause just one output to go low at any one time. For example, the input combination 00 will cause output A to go low, input combination 01 will cause output B to go low, and so on. The two inputs to the chip are the address lines A_{12} and A_{13} . Consider this last statement carefully.

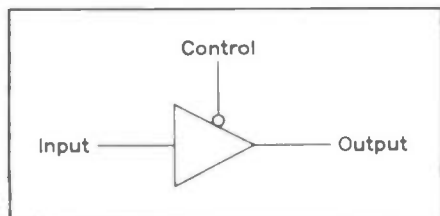

Figure 5. A tri-state buffer.

What it means is that the memory chip driven by output A will have to contain addresses in which address lines A_{12} and A_{13} are both 'zero', and the memory chip driven by output B will have to contain those addresses in which the address lines A_{13} and A_{12} are 'zero' and 'one' respectively. There is no need to consider the two other outputs in this case since there are just the two memory chips in our example.

This decoding merely selects one chip in preference to the other; it has not

For the ROM chip A:

Address lines:	A_{13}	A_{12}	A_{11}	A_{10}	A_9	A_8	A_7	A_6	A_5	A_4	A_3	A_2	A_1	A_0
Lowest binary pattern:	0	0	0	0	0	0	0	0	0	0	0	0	0	0
Highest binary pattern:	0	0	1	1	1	1	1	1	1	1	1	1	1	1

This corresponds to a hexadecimal range of 0000H - 0FFFH

For the RAM chip B:

Address lines:	A_{13}	A_{12}	A_{11}	A_{10}	A_9	A_8	A_7	A_6	A_5	A_4	A_3	A_2	A_1	A_0
Lowest binary pattern:	0	1	0	0	0	0	0	0	0	0	0	0	0	0
Highest binary pattern:	0	1	1	1	1	1	1	1	1	1	1	1	1	1

This corresponds to a hexadecimal range of 1000H - 1FFFH.

Table 1.

actually given us access to the individual memory locations within the selected chip. This is because the memory chip does its own decoding for the memory locations themselves; once the chip is selected in the manner just described, the chip then decodes the binary pattern on the other address lines, $A_0 - A_{11}$, to access any given location.

Both chips are shown connected to the address lines $A_0 - A_{11}$ and so each has the same number of locations, in other words the same 'capacity'. This is given by $2^{12} = 4096$ bytes or 4K-bytes.

The above information is sufficient to allow us to determine the actual range of addresses present in each chip. We merely write out the lowest and highest binary patterns that must be present on the address bus, for the case of each chip, as shown in Table 1.

Figure 4 shows the 74LS139 dual 2-4 line decoder chip being used to select between a number of devices, which include: EPROM, PROM (another type of

ROM known as Programmable ROM), the main user RAM, a device known as a PIO (explained later) and small area of RAM contained in the keyboard/display interface chip. The address ranges for each, in terms of the address lines $A_{10} - A_{15}$ only, are given, and it is left as an exercise to the reader, if he/she so desires, to work out how these addresses are obtained. All that is needed is an understanding of what has just been explained!

Note on Hexadecimal Numbers

The hexadecimal number systems uses the denary digits 0 - 9 and the alphabet letters A - F, to represent the values 0 - 15 inclusive. The latter values can, alternatively, be written as 4-bit binary groups so that, for example, at one end of the scale 0 is written as 0000 and F (15) is written as 1111. With this in mind, to write a long binary number in

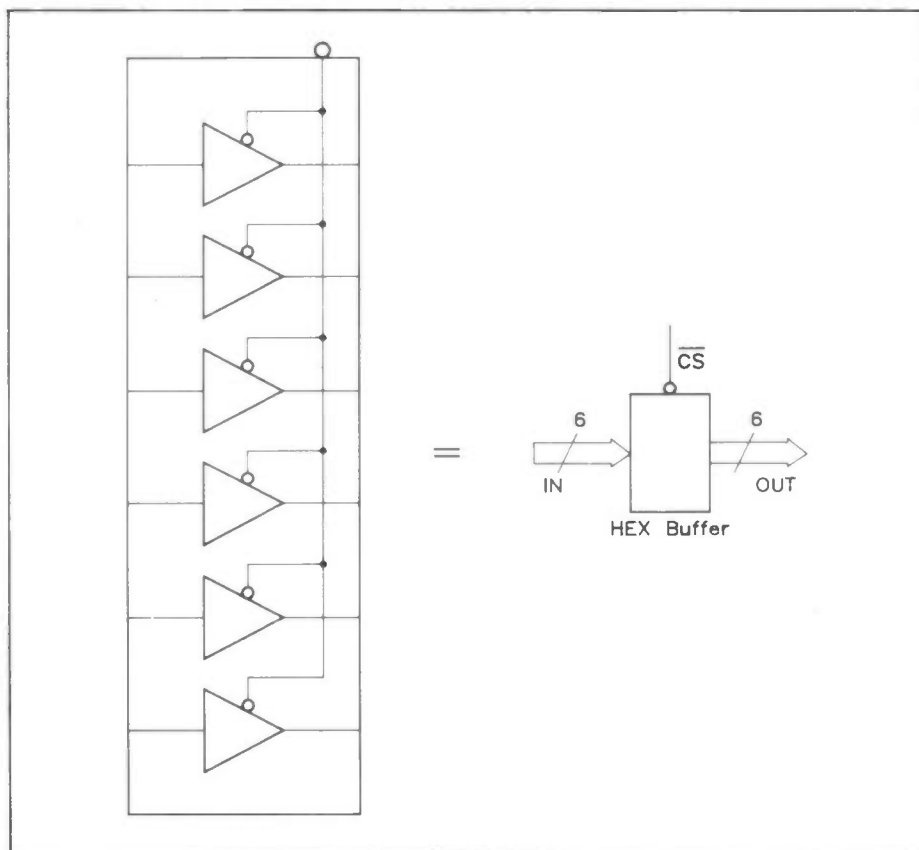

Figure 6. Six buffers on a single chip, enabled simultaneously.

hexadecimal, it is only necessary to divide it into 4-bit binary groups starting from the right, adding any zeros at the left to complete the highest group if it happens to have less than four bits (as in the above cases, where it only has two bits). Then each 4-bit groups is replaced by the equivalent hex. digit.

Thus, 011111111111 consists of groups 01 1111 1111 1111, which is then made up to 0001 1111 1111 1111 by adding two leading zeros to the highest group. This gives the hex. digits 1 F F F.

There is one point that may have been noticed about the bus arrangement of Figure 3. All address and data bus connections to each chip are the same. In fact, however many memory chips there are in the system, they will all appear in parallel on both buses. This means that, if the MPU is sending a byte of data along the data bus to a particular memory location, this data byte will appear on the data pins of all memory chips at the same time. Not only that but the address bus pattern will appear on the address pins of all chips. Yet we know that only the chip selected by the decoding is supposed to respond. How is this guaranteed?

Tri-State Logic

This method is common to all devices connected to microprocessor buses. The term 'tri-state' logic seems to defy the concept that only two logic levels exist in digital systems. The reader can be assured that this latter statement is still true. The so-called 'third state' is not a different level at all, but represents the case where the logic device is effectively disconnected from the bus. This is not done in a physical sense by unplugging the device or using mechanical switches, instead an internal switching action occurs upon a control signal being applied that effectively puts the bus connections of the device into a 'high impedance' state, just as if they had been disconnected.

Figure 5 shows a tri-state device, in this case a 'buffer', a device that has no effect on the logic input except to raise its power level in order to drive other devices connected to the bus. The triangular symbol represents the direction of signal flow with the input and output clearly identified. A third connection is for the control signal, and it should be noted that the 'bubble' indicates that it is active low. This may well spark a train of thought. However, before pursuing it further, consider the expanded diagram of Figure 6 in which there are now six such buffers within a single block; all are switched at the same time by a common control input. To its right is a single block symbol representing the same device in the form in which it might appear on a circuit diagram. And the control input has now been labelled, that's right, CS!

This should answer the original question as to how only one memory chip is able to respond to the data on its data pins. All of the others have been 'tri-stated' out of harms way by taking their CS pins high.

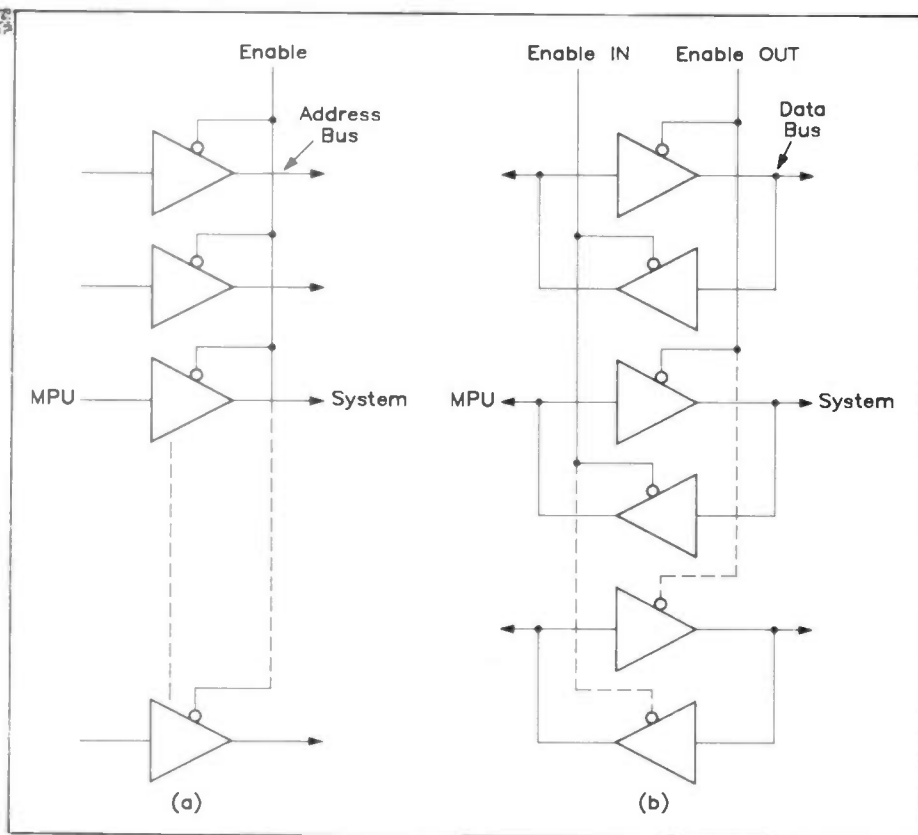

Figure 7. (a), unidirectional address bus buffer; (b), bidirectional data buffer.

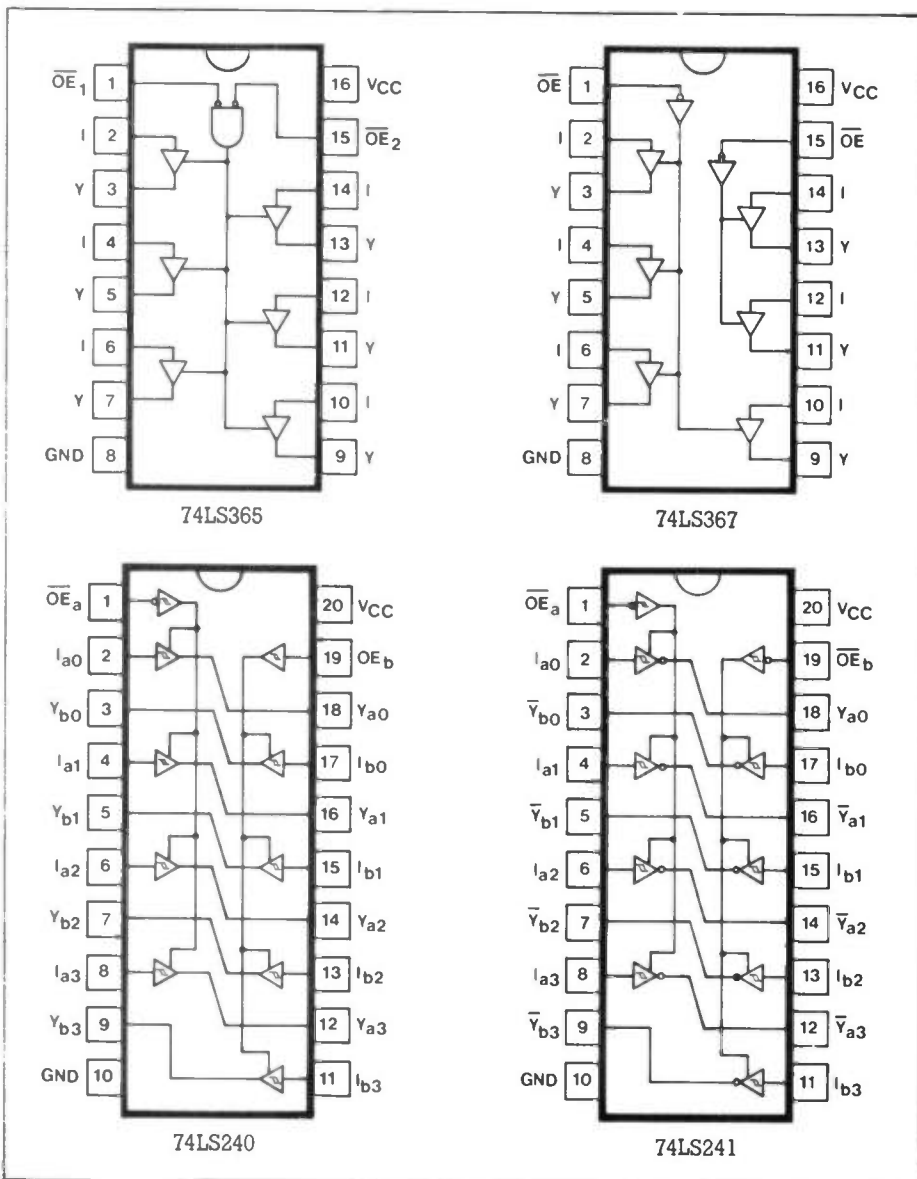

Figure 8. A selection of bus buffer pin-outs.

Buffers

It might be as well to explain why buffers are needed, apart from providing the tri-state action just described. Previous references to saving power consumption provide a clue, of course.

On the MPU chip the component packing density is extremely high, leading to the use of very small, low power output transistors to drive the buses. The current that such devices can handle is extremely limited. This is especially true where MOS transistors are concerned. However, in a very simple computer without much memory and where there is limited interaction with peripheral devices, this may not pose much of a problem. But in many cases, especially where MOS devices have to drive bipolar types, it becomes necessary to use buffers to increase the current handling capacity. Thus, as always, in a general sense a buffer is a device that is interposed between a source and a load in order to reduce the loading effect of the latter on the former.

On the address bus, a simple unidirectional (one way) buffer is all that is needed [Figure 7(a)], in the form illustrated in Figure 5. But on the data bus, a *bidirectional* arrangement must be used, as shown in Figure 7(b). Each line of the bus requires its own amplifier, or pair of amplifiers, and all amplifiers for a particular direction of data transfer must be enabled together. In the case of the bidirectional buffer only one direction is enabled at any one time.

There are many buffer 'packages' available in both TTL and CMOS. These are usually in the form of 'hex-buffers', which means that there are six buffers on a single chip. Figure 8 shows a few buffer pin-out diagrams. Buffers are available as either 'inverting' or 'non-inverting'. The former will turn all logic 0's into logic 1's, and vice versa; the latter type will leave the logic level unaltered. There are also some octal buffers available, which are useful for buffering 8-bit wide data lines.

The Input/Output Block

In order for the computer to communicate with or control any external device (known generally as a peripheral), it must have some form of input/output device. As the name implies it is where data is either INPUT to the computer or OUTPUT from it. It will also have its connections to the system buses, and in some systems it merely appears as addresses in memory, alternative to those in the internal computer memory. This type of input/output is referred to as 'memory mapped'.

There are a great many devices that can perform these input/output functions, some of which have been discussed in other series recently in this magazine. The intention here is merely to show how yet another example of a 'logic system' on a chip performs its own special role in the microcomputer.

A typical PIO or Parallel Input/Output chip will have two 8-bit ports which can be set up as either input or output ports under

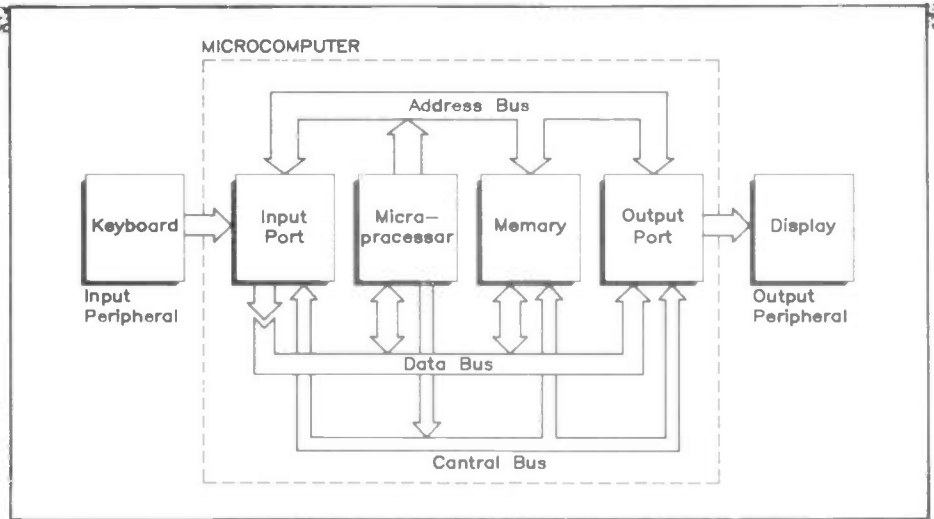

Figure 9. PIO communicating with both input and output devices.

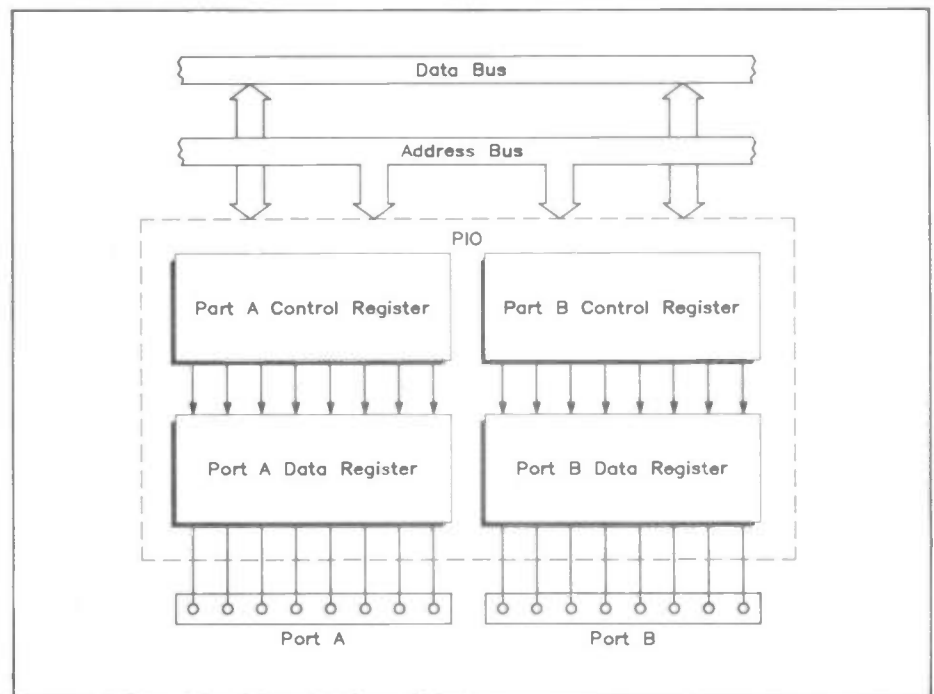

Figure 10. Layout of a 2-port PIO.

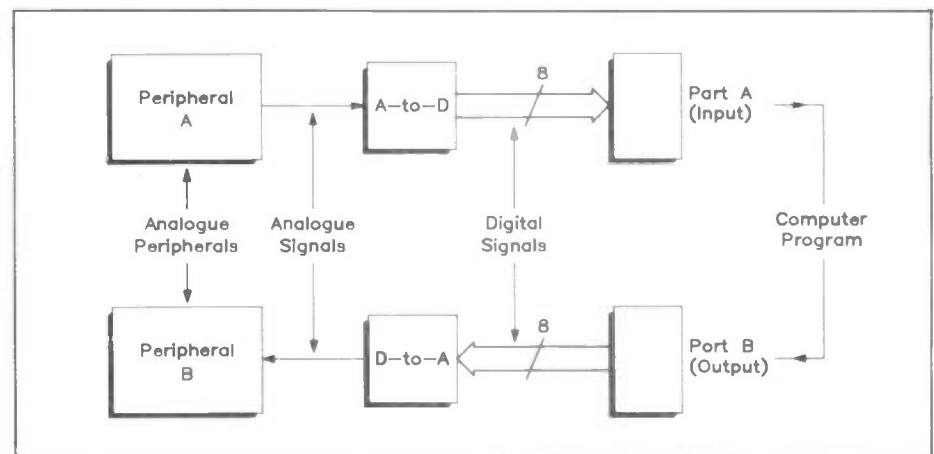

Figure 11. PIO connected to two analogue peripherals.

the control of the software. A port means an entry or exit point for data to/from the computer, and is physically some form of plug and socket arrangement, depending upon what is connected to it. A printer is an example of a device that will be connected to a port, but the keyboard and display unit (monitor) are other examples of 'peripheral devices' that need ports in order to communicate with the computer.

See Figure 9 which shows such an arrangement.

The PIO chip will usually contain, at the very least, a data register and a control register for each port. Figure 10 shows a PIO block with two ports and, hence, four registers all together. The function of the data registers is to act as temporary stores for the data entering or leaving the computer, while the control registers are

used by the programmer to establish whether a port is to be an input or an output port.

It is seen from the previous figure that the function of a port is just to transfer binary data between the computer and peripheral device, under the control of the program. With an 8-bit port, the data is transferred a complete byte at a time. This type of data transfer is known as 'parallel transfer'. Some types of peripheral cannot accept data in this form, but require the bits to be passed to them one at a time. An example of such a device is a MODEM which communicates with other computers over the telephone system. Bit by bit transfer is known as 'serial transfer'.

Another problem that arises when connecting a computer to certain types of peripheral is where the latter are analogue devices. These can neither provide nor accept binary data. Some conversion must, therefore, be made between the two forms. Figure 11 shows a

situation where both peripherals are analogue devices. Peripheral A provides the computer with an analogue signal, which is converted into digital form in an Analogue to Digital Converter (ADC). Peripheral B requires the computer to supply it with an analogue signal. The digital output from the computer must, therefore, be converted into this form by passing it through a Digital to Analogue Converter (DAC).

Summing Up

This article has discussed the basic ideas behind the main blocks of a digital computer. It has also given some insight into what such blocks contain. It is hoped that what has been presented is a picture of the computer as a 'system', comprising a large number of basic blocks. Consider any of the blocks and they will be found, in general, to be a number (sometimes a very large number indeed) of sub-

sections which differ from those of another type in only a very few ways. For example:

The register, which is a string of bistable devices, each able to store a single binary digit (bit) of data. Memory may be thought of merely as a vast replication of such registers, giving the capacity to store large amounts of data, expressed in kilobytes. The MPU itself and the input/output ports also contain registers, for holding and manipulating data.

Logic gates are building blocks that allow functions such as the decoding of memory to be carried out.

Tri-state buffers allow us to connect other devices to the system buses without loading the latter unduly with excessive current demands and with the bonus of protecting devices on the bus. In addition these buffers, being tri-state, effectively disconnect chips from the bus when they are not in use.

Stray Signals

by Point Contact

A notable feature of the electronics scene is the questionable standards of professional and commercial probity of individuals and of companies, both large and small. In the United States companies, mostly but not exclusively semiconductor manufacturers, are for ever suing and counter-suing each other for enormous sums, to the scarcely disguised glee and continuing profit of the legal profession. The campaign waged between Intel and AMD is only one of many, stretching back over the years. Skulduggery is rife, but then 'twas ever thus, as a shocked Point Contact discovered at a tender age.

P.C. used to haunt a local radio repair shop (no televisions in those days) on Saturday afternoons, where one or two like-minded persons also used to congregate thanks to the tolerance of the proprietor. We used to scrounge second-hand parts, such as a volume control where the mains switch section was duff but the potentiometer

OK, or vice versa, for wireless sets we were building from out-of-date pre-war battery set bits we were given by good folk who now had a "mains set". Fred, the proprietor, had a way with radio repairs, or indeed several - some more devious than others. When a valve needed replacing, he would often make out a "failed under guarantee" form regardless of the age of the valve. He would then wind this around the valve, wrapping it in corrugated cardboard and brown paper all nicely secured with string and duly addressed and stamped, before hitting it with a hammer and popping it in the post. Most valve manufacturers would usually accept that it was a genuine failure under guarantee - difficult to prove otherwise when the item returned was damaged in the post - provided one did not pull the trick too often, but Fred reckoned "Dear old Tungstam" were good for a free replacement every time. I wonder if you could get away with the same

trick nowadays with a dead transistor?

In the early days of the semiconductor revolution, transistors were always made of germanium. I even made a few for myself, after hours; not too difficult if you happened to work as a student apprentice in the solid state physics lab at Central Research Laboratories, with a vacuum system and furnace conveniently to hand. (Transistors were like gold-dust in those days, and I also made a number of convincing dummies which I left temptingly lying around, but that's another story.) For many years now, however, silicon has ruled the roost. But a long-standing interest on the part of research labs all over the world has been the development of semiconductor devices using GaAs - gallium arsenide. Due to the much higher mobility of carriers in this material, much faster devices can be made. Whilst GaAs discrete devices such as microwave GaAs FETs for frequencies beyond 10GHz have been available for some time, the development of LSI and even VLSI (very large scale integration) ICs has taken rather longer. However, I see that a consortium of Japanese companies, after devoting over 800 man-years and much cash, including some £70 million of government support, to the project, have developed a parallel processing engine capable of executing over 10GFlops. For those not up with the computerese jargon, that means ten thousand million floating point operations per second; more than P.C. (Point Contact that is, not Personal Computer) could manage in a month of Sundays with his pocket calculator. Or even with his trusty old slide-rule, long since pensioned off. Still, though the slide-rule may have been supplanted by the pocket calculator, the latter won't in its turn be displaced by a 10GFlop/s GaAs parallel processor just yet, since it needs a supply of liquid nitrogen to cool it to a temperature of 77K (-196°C).

Yours sincerely,

Point Contact

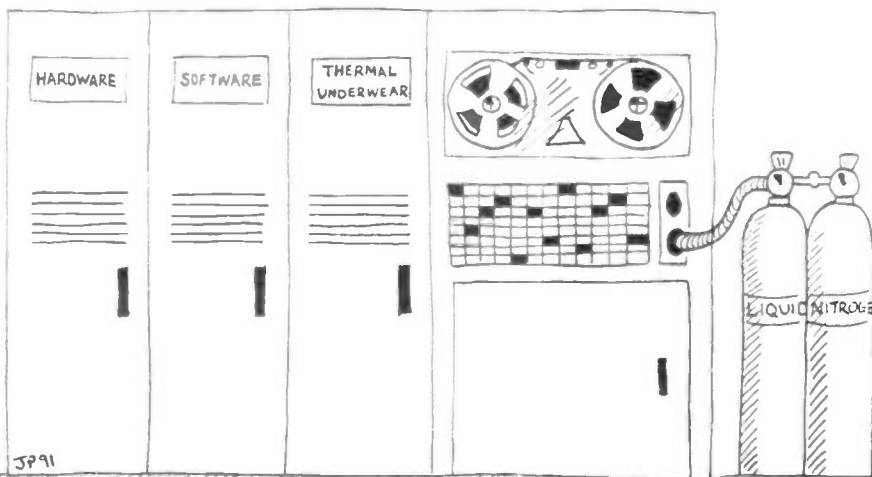

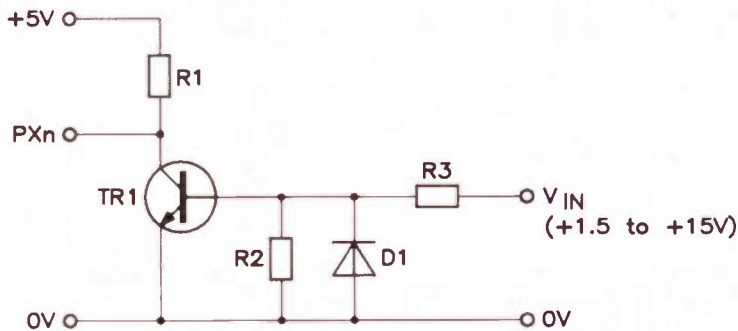

- R1 = 2K7 M2K7
- R2 = 220K M220K
- R3 = 22K M22K
- TR1 = BC548 QB73Q
- D1 = 1N4148 QL80B

Note:
 Input Voltage 0V must be connected to Port 0V.
 Input is protected against negative voltage.

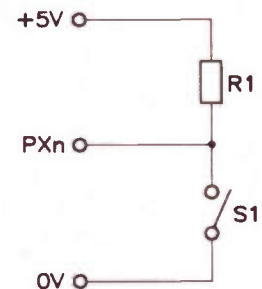

- R1 = 2K7 M2K7
- S1 = Switch

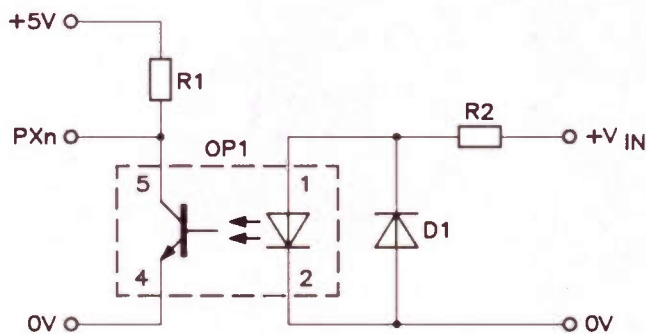

- R1 = 2K7 M2K7
- OP1 = Hi Sensitivity OPTO RA57M
- D1 = 1N4148 QL80B
- V_{IN} = +1.5V R2 = 18R M18R
- V_{IN} = +5V R2 = 360R M360R
- V_{IN} = +9V R2 = 750R M750R
- V_{IN} = +12V R2 = 1K M1K

Note:
 Input is isolated from output.
 Input is protected against negative voltage.

Further Information

As can be seen, the 8255 is an extremely flexible device, offering a wide range of operating configurations. For simplicity, only Mode 0 has been dealt with here, for readers wishing to utilise the other operating modes, a 24 page data book is available separately, order As (8255 Data Book) XK97F Price 75p. Numerous buffer ICs may be found in the semiconductor section of the current Maplin Buyers' Guide, data sheets for which may be obtained through the Maplin Mail Order Service, currently the price of data sheets is 40p (correct at time of going to press).

Figure 8. Input conditioning circuits.

IBM PC EXPANSION KIT PARTS LIST

RESISTORS: All 0.6W 1% Metal Film			DIL Socket 40-pin	1	(HQ38R)
R1-8	10k	8	PC Board	1	(GE31J)
			Constructors' Guide	1	(XH79L)
			IBM Exp. Leaflet	1	(XK29G)
CAPACITORS			OPTIONAL (Not in Kit)		
C1,2	10µF 16V Tantalum	2	D-Connector Jack Post	1 Pr	(FP31J)
			8255 Data Book	1	(XK97F)
SEMICONDUCTORS					
IC1,2	74LS86	2			
IC3	74LS00	1			
IC4	74LS02	1			
IC5	8255A	1			
IC6	74LS30	1			
MISCELLANEOUS					
S1	Slimline 8W DIL Switch	1 Pkt			
PL2	RA D-Range 37-Way Plug	1			
	DIL Socket 14-pin	5			

The above items, except Optional are available as a kit:
Order As LP12N (IBM PC Expansion Kit) Price £17.95
 The following items are also available separately:
IBM PC Expansion PCB Order As GE31J Price £11.95
8255 Data Book Order As XK97F Price 75p NV

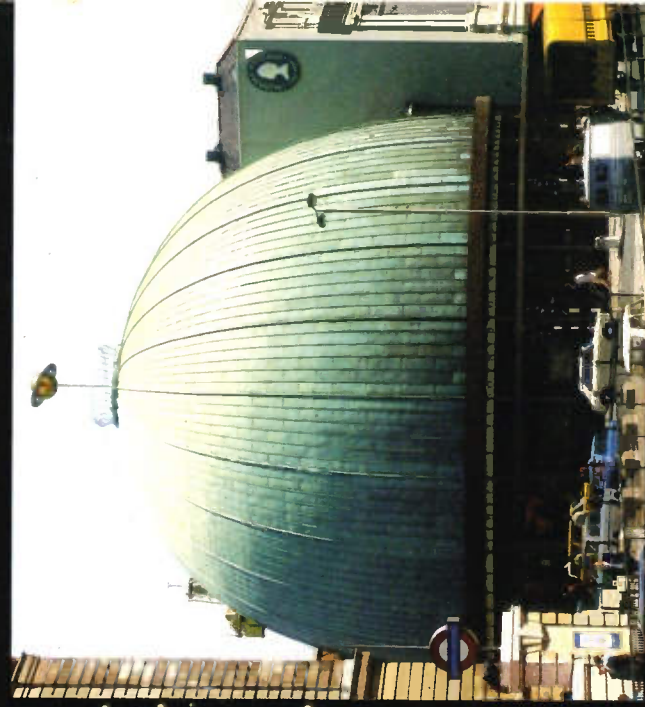

ASTRONOMERS' DELIGHT

by Alan Simpson



OUT AND ABOUT



One of the many sights of London town might be the constant and sizeable queue of visitors patiently waiting to get into Madame Tussauds and the associated London Planetarium. This is however not exactly surprising – where else in London can you have a guided tour of the world, the stars and indeed the universe all in the space – and space is, for once, the operative word – of a half hour or so.

There might be the all too typical April showers in London's Baker Street, but inside the Planetarium it is cloudless skies every day. Here getting a fix in space is comparatively easy as artificial skies, times and distances disappear. Even our own Earth almost disappears – it being just a dot in the vast perspective of space. Just to clear the air: Astronomy is the science or study of the stars. Astrology is fortune-telling.

A visit to the Planetarium may not exactly chart your future as seen in the stars, but it will without doubt make you starry-eyed. According to the brochure, no-one knows just how big the universe really is or even if it has any boundary at all. What is for sure is that it contains thousands of millions of galaxies like our own, and that each of these contains thousands of millions of stars. One of these stars in fact is our own sun. As to whether planet Earth, where hundreds of millions of years of evolution produced intelligent life, has a replica companion out there in space is still a matter for conjecture.

Heavenly Bodies

It was the very first 1000lb bomb of the blitz that destroyed the Madame Tussauds cinema, covering a site large enough for a major Planetarium. In fact that well-known outer copper dome is



Above: The Zeiss star projector.

Left: Under the Planetarium Dome (1985).

Inset: The Planetarium 'Dome' and Madame Tussauds viewed from Baker Street.

Below: Just part of the awe-inspiring display.

separated from an inner one by several others, two of concrete, others of fibreglass, bituminised felt, cork and other sound absorbing material. Even genuine alien space invaders would find it difficult to penetrate that robust level of construction.

The innermost dome is a giant projection screen, made up of panels of perforated aluminium, which serve for both acoustic insulation and ventilation. Any optical projection needs very clean air, and it is especially important in a planetarium to ensure that the 5000 beams of light passing at any one time from projector to the dome cannot be seen. In addition, silent filters behind the dome keep the artificial cosmos dust-free.

Unlike the associated Madame Tussauds Rock Circus exhibition, which features such heavenly bodies as Tina Turner, Diana Ross and Madonna, the Planetarium reveals a stunning array of comets, meteors,



asteroids, planets, moons, stars and galaxies. Satellites at the London Planetarium certainly fly higher and wider than our own British Sky Broadcasting channels.

The London Planetarium, which was formerly opened by The Duke of Edinburgh in 1958, is one of the largest planetariums in the world. Apart from special 'live' educational presentations for schools and various astronomy groups and clubs, regular 'star' shows are presented. Currently on show is the 'Solar Swoop' spectacular, which for the first time ever is using lasers to enhance the beauty of the night skies and to create two over-chatty eagles who decide to go on a trip of the universe.

Distance Matters

Their story swoops from the London skyline to the open skies of the country. On their way to the sun, the pair have many close encounters of the universe kind together with an 'Astro-fax', a computer screen which at regular points of the journey, relays basic astronomical data. We quickly learn that light travels at the speed of some 300,000 km per second, and that on this basis the oft used 'light year', implying the distance covered by light in one Earthly year, is something in the region of 94.6 billion kilometres (94,600,000,000 km). For the purpose of the show this distance is covered in one Earthly minute. While the organisers proclaim that the Planetarium is just one minute from Baker Street, distances in the show are measured in light years. In fact a day on Earth in the Planetarium can take no more than three minutes, while the passage of the sun and planets can be speeded up to make a year pass in just eleven seconds!

Above: Earth as seen from the moon.
Right: The Zeiss star projector
beneath the London Planetarium
Dome. Installed in 1958 when the
Planetarium opened, it still projects
the 'night skies' every day except
Christmas Day.

Projecting the Universe

Central to the visual effects is the Zeiss Star Projector, which looks and works nothing like any ordinary film projector. Each of the star globes contain 16 metal plates in which are punched holes of the correct size and in the correct positions for the stars. The light source inside each globe is a 1000-watt bulb. Almost 9000 stars are projected – all those which in theory can be seen by the naked eye. Each globe shows the stars of one hemisphere – that is, north or south.

As the stars dip towards the

horizon, mechanical blinkers or 'eyelids' swing over the corresponding projection lenses, producing the realistic effect of stars gradually dimming as they set. The 42 brightest stars each have their own separate projectors, often in characteristic colours. Within the lattice-work which joins the two star globes are projectors for the Sun, Moon and planets. Each has its own movement, so that at any given time they will appear in the right position relative to each other, and to the stars. The Moon's phases are also shown.

The projector is moved via a specially designed gear mechanism which can simulate the movement of the Earth, which causes the movement of the stars. In addition, by turning the projector on its east-west axis, the sky can be seen from any point on the Earth's surface, whether from the North Pole (where all the stars appear to circle overhead without rising or setting), or from the southern hemisphere, many of whose stars are unfamiliar to us in Britain.

Additional projectors can show

Continued on page 47



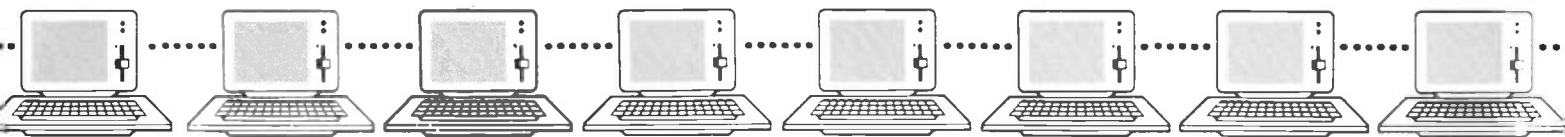

Subroutines

When one begins writing a program of even moderate complexity, it may quickly become apparent that a particular process needs to be carried out more than once during 'one pass' through the program. One method is simply to duplicate the process where its requirement occurs a second or third time. However, this is inefficient, time-consuming to do and 'debug', and is wasteful of memory. Furthermore, if the process needs modifications later, then all its duplicates will also need changing. It is all too long-winded and complicated. The second method is much better – create it just the once, and make it a 'subroutine'.

Subroutines can be regarded as small, 'stand-alone' mini-programs in their own right with their own identity. They are complete in themselves, each carrying out a specific task. The beauty of the principle is that the main program can call on any of these subroutines as many times as it likes, in any order, and subroutines can even call on other subroutines in the same way. A subroutine may be used hundreds of times in just one pass through the main program, but there is only one of it in existence.

There are several more good reasons for wanting to use subroutines. In a very large program there may be several small, clearly defined and identifiable tasks, and

in order to be able to write and, even more importantly, understand the program and what it's doing, these small itemised tasks are best written as subroutines with copious explanatory 'REM' statements describing what each one does. Also, in a large program having several subroutines, some of these may be called on to carry out a task very simply by 'IF / THEN' statements, whereas coding required to carry out the same task locally to the 'IF / THEN' statement itself would rapidly become horrendously complex and inflexible. It also makes 'vectoring' within the program much easier. Our old friend, the menu example we looked at last time, is actually all that there is of a main program. If a number choice correctly matches one of the options available within the allowed range, the statement 'ON OPT GOSUB' <line number> is executed. For example, choice '3' will cause a 'GOSUB' to line number '3000', as this is the third line number in a following list of available line numbers. Subroutines are known by their line numbers, and in this case execution begins with the selected subroutine on a 'second level'.

The menu could just as easily have used 'ON OPT GOTO', but this might not be such a good idea, because it means that every 'block' of BASIC code which carries out the required process has to 'GOTO'

back to the main section. This means you've got two 'GOTO's for any one block – one to jump to the block, and one at the end of the block to jump back to the main section. This increases any problems that the programmer might have in finding and keeping track of specific line numbers in the program twofold. Secondly, the program runs slower, because the interpreter must actually search for every line to 'GOTO' to. Actually this is also true of 'GOSUB', but the interpreter will only need do half as many line searches, because instead of 'GOTO' to get back to the main section, 'RETURN' is used instead, which is totally different.

GOSUB's, RETURN's and Levels

Using BASIC in 'real time' by getting the interpreter to respond to statements and print answers immediately has been called 'direct mode' or the command level. When, in response to the direct, 'real time' statement 'RUN', the interpreter begins executing statements in the form of a BASIC program in memory, it can then be said to be in 'program mode' or on a 'first level'.

When a 'first level' BASIC program calls a subroutine, with the statement 'GOSUB <line number>', something very important happens. The interpreter effec-

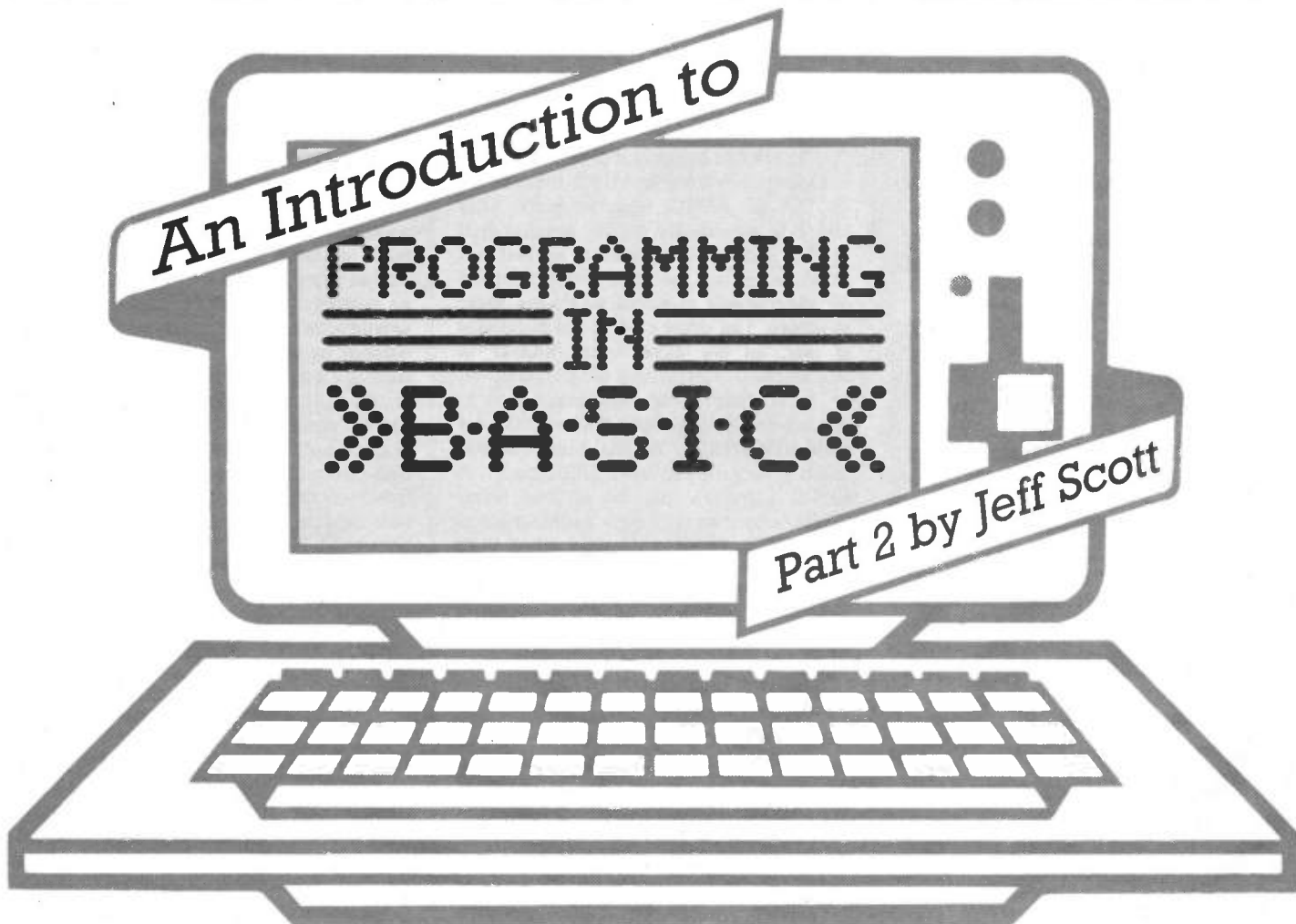



tively puts a 'book mark' in the place in the program where it got up to and then goes immediately to begin executing the indicated subroutine. The subroutine must exist or else the interpreter stops with 'undefined statement error', meaning it couldn't find the BASIC line specified.

The interpreter actually 'remembers' its position in the calling program (right down to the precise position in the BASIC line) by putting the address of this location on a 'stack', a 'last-in-first-out' data storage structure (and which is often the micro-processor's own stack). Execution of the subroutine continues until the interpreter reads the 'RETURN' statement.

A 'main' BASIC program should terminate with an 'END' statement, but every subroutine must finish with 'RETURN'. It literally means 'return to where you were before'. Until then the interpreter is on a 'second level', and if this subroutine calls yet another subroutine, putting another location address on the stack, execution goes onto a 'third level', and so on. It is not necessary to know in great detail how this stack is used, but while developing a BASIC program using subroutines it is important to have a concept of these 'levels' and to keep track of program execution from one level to another. Otherwise the chance will arise where a 'GOTO' will be made to the wrong level, or a 'RETURN' missed altogether. If you never use 'GOTO' to jump into or out of subroutines, then these problems are hardly likely to occur. Figure 1a shows in block form the sort of layout for a BASIC program which employs a number of subroutines. In BASIC the 'main' part of the program is usually first (at the beginning), a position where it can be started easily with just 'RUN'. The subroutines follow after, usually in the order in which they have been written, but can be called in any order. An 'END' statement must terminate the 'main' program or else execution will 'crash through' into the 1st subroutine.

Figure 1b tries to illustrate the concept of levels. Horizontal lines represent the execution of consecutive BASIC statements in progression from 'start' to 'end' until a 'GOSUB <line number>' is encountered. Then the current level of execution is interrupted and the subroutine is begun. A 'RETURN' will cause the interpreter to resume the previous level and *carry on where it left off*. This is much faster and more efficient than the 'GOTO' method. The following is an example of a subroutine. In BASIC, all variables are 'global', which means to say equally accessible by the whole program and its subroutines.

```
7000 REM *****
7010 REM SUBROUTINE TO CALCULATE VAT
7020 REM VAT% IS DEFINED AT START OF MAIN PROGRAM
7030 REM (CURRENTLY 15%)
```

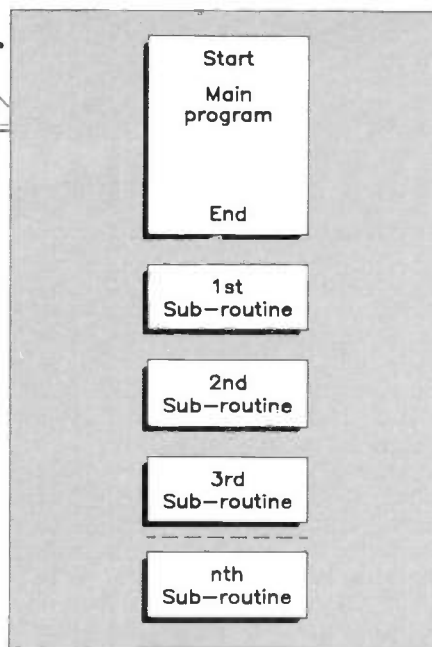

Figure 1a. Schematic illustration of how a typical BASIC listing of a program with subroutines would appear.

```
7040 REM INPUT IS EXCL.VAT: PRODUCT IS VAT.AMOUNT AND TOTAL
7050 REM *****
7060 LET ERROR% = 0
7070 IF EXCL.VAT = 0 THEN VAT.AMOUNT = 0 : TOTAL = 0 : RETURN
7080 IF EXCL.VAT < 0 THEN ERROR% = 1 : RETURN
7090 LET VAT.AMOUNT = (EXCL.VAT / 100) * VAT%
7100 LET TOTAL = EXCL.VAT + VAT.AMOUNT
7110 RETURN
```

Now Hear This

There has been, and probably still is, a raging controversy about the use of 'GOTO' in BASIC programming. One lobby is steadfastly of the opinion that 'GOTO' should not be used at all, and that all activities can be exclusively handled by subroutines in some workable logic structure. The other side of the argument is that, as we have seen, 'GOTO' is invaluable in simplifying the construction of local loops, for example, and in implementing constructs that we may not have, like 'WHILE / WEND'. The trouble is that it is very easy to write BASIC badly. A BASIC program can be written using 'GOTO's entirely with nary a subroutine in sight. If the program is very small then there is no advantage in having them, but it is quite a different story as its size increases. Suffice to say that even a moderately sized BASIC program is much more readable, logical, understandable and flexible to changes and updates if all its steps are broken-down into specific logical tasks, and a subroutine written to take care of each task. This is called 'structured' programming. A program which is held together entirely by 'GOTO's is so tangled and rigid that future changes, for improvements and the addition of further facilities, are *impossible* without re-writing the whole program. These



problems are difficult for the beginner to appreciate - until he/she comes across them at first hand!

What's more, getting used to this idea will be invaluable should you want to progress on to using any of the other high level languages at a later date. They also have 'subroutines', or something like them. In PASCAL they are called 'procedures'; in COBOL, 'paragraphs'; in C, 'functions'. With some of these languages you have no choice as to whether you want its subroutines or not; COBOL, like BASIC, is not too fussy, but on the other hand 'GOTO' is virtually illegal in C, although it is allowed for some very rare special cases - in other words, if you're really desperate. FORTH, a language with such a long history that it can practically be described as 'quaint', is even more odd, where a 'program' comprises a vocabulary of programmer defined action keywords, each of which does a specific thing or set of things through using more keywords. The concept of using subroutine like structures, then, is very much at the root of many computer languages, and should not be viewed as an exception or a luxury.

Information Storage - Sequential Files

Data can be held within a BASIC program by means of 'DATA' statements. It is however impractical to hold very large amounts of information in this way as it uses up memory space. It is especially awkward if the information is not of a static nature, in other words is not constant, but likely to be altered often. This will require that the program be changed (to change the data statements), which is very inefficient. It is much better to hold records for processing say telephone bills on a separate 'file' in magnetic storage, and have a program access these records as required to produce bills. Similarly, a wordprocessor will keep all its texts in storage as files. The commonest of such files are organised sequentially, in other words to access them the computer reads the file in storage from the beginning and goes on until it gets to the end. Even to find one particular place, such a file must be 'scanned' from start to finish. Any location of a random access file, however, can be accessed immediately because it comprises individual component parts which are 'mapped', hence 'random access'. But random access storage is a very complex subject, so for the time being we shall concentrate on the easier storage of sequential files.

BASIC makes certain assumptions about the storage medium, so that the interpreter knows exactly where programs are coming from or going to for 'LOAD' and 'SAVE'. Similarly 'LPRINT' causes a program listing to be printed on paper by the line printer instead of on screen, as the interpreter knows what this is too (but some machines don't recognise

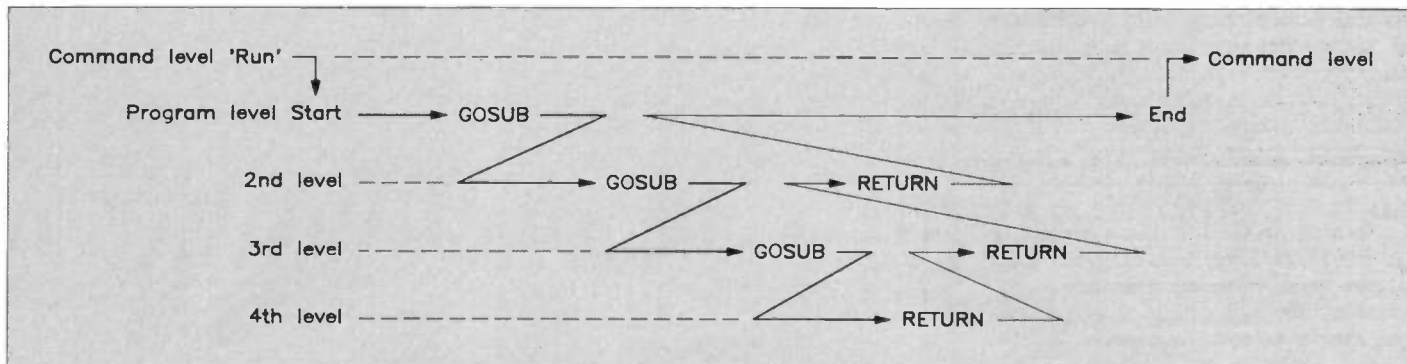
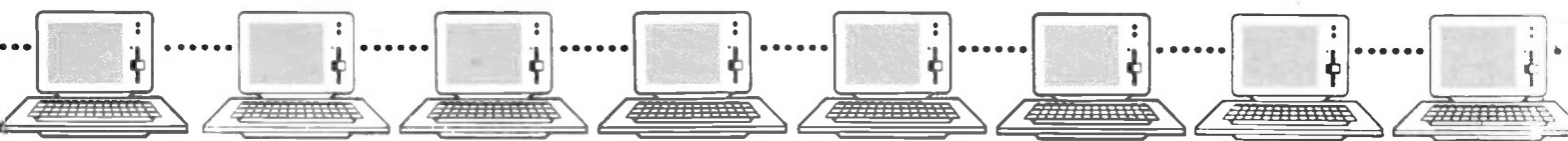

Figure 1b. An illustration of the concept of levels of program and subroutine execution. On return, execution resumes from the last position on the previous level.

'LPRINT'). 'INPUT' concerns taking data from the keyboard, and 'PRINT' is about displaying it on the VDU. But to use these with any other device calls for a BASIC standard modification to these statements, by adding a hash '#' to the end. 'INPUT#' and 'PRINT#' are not actually the same keywords as 'INPUT' and 'PRINT'; because of the extra hash character, they are often seen by the interpreter as quite different words.

OPEN and CLOSE

In order to be able to write or read information to or from storage which is *not* a program, but variable information used by a program, BASIC requires that we first 'open a communication channel'. The syntax for such instructions is as varied as the number of different makes of micro-computer that exist. Some require that the 'external device' (e.g. disk drive) is specified by an identification number. Others which, like PC's, use some kind of DOS (Disk Operating System), may already have a drive selected as the current device by the DOS. Whatever, BASIC needs a means for identifying the communication channel, and this is usually in the form of a 'logical file number'. Hence, before a BASIC program can 'communicate' with the device, the channel must be 'opened', and it must know the identity of the channel. Information usually has to be provided about the type of device and the direction of the data. As an example, a Commodore computer needs to send this information to its disk drive as part of the 'OPEN' statement:

```
OPEN <logical file number>, <device
number>, <secondary address>,
"<filename>, <mode>, <file type>"
```

The BASIC for the IBM PC and its 'clones' is slightly different.

```
OPEN "<mode>," # <logical file
number>,"<filename>."<extension>"
```

'<mode>' indicates whether the intention is to 'write' to disk via the opened channel or 'read' from it, and in the latter example, "O" for '<mode>' means 'Out' to write; "I" means 'In', to 'read'.

The reason why there is a logical file number, instead of just opening a communication channel to a disk, is that

we can have more than one communication channel open to the same device at the same time. This is why a numbering system is required to identify the different channels open to the same device, there being no other means of distinguishing them. The total number of logical files that can be open to one or more devices collectively is typically 10 or more with most BASIC's.

So in this way, a BASIC program can communicate between a number of devices at the same time, and also with two or more channels to the same device. In the case of the storage medium, a BASIC program could copy data from one file to another, or alternately read two opened files, or select or compute results taken from a 'read' file and create another file to 'write' to on the same disk. Or another disk. Or the printer.

The following program makes a list of bills which still have payments outstanding from a file of such recorded bills.

```
10 REM PRODUCE LIST OF OUTSTAND-
ING BILLS PROGRAM
20 REM CALLED "OUTSTGEN.BAS"
30 REM LOOKS FOR UNPAID BILLS
ACCORDING TO FLAG 'UNPAID'
40 :
50 OPEN "I", #1, "BILLS.DAT"
60 OPEN "O", #2, "OUTSTDNG.LST"
70 IF EOF(1) THEN 160
80 INPUT NUMBER% : PRINT NUMBER%
90 INPUT#1, NAME$ : PRINT NAME$
100 FOR N = 1 TO 3 : INPUT#1,
ADDRESS$(N) : PRINT ADDRESS$(N) :
NEXT N
105 INPUT#1, DATE$$ : PRINT DATE$$
110 INPUT#1, ITEM$ : INPUT#1,
AMOUNT : PRINT ITEM$;" £"; AMOUNT
120 INPUT#1, UNPAID%
130 IF UNPAID% THEN GOSUB 1000
140 PRINT : GOTO 70
150 :
160 CLOSE 1, 2
170 END
180 :
```

```
1000 REM SUBROUTINE TO ADD TO LIST
OF UNPAIDS
```

```
1010 :
```

```
1020 PRINT#2, NUMBER% : PRINT#2,
NAME$
```

```
1030 FOR N = 1 TO 3 : PRINT#2,
ADDRESS$(N) : NEXT N
```

```
1040 PRINT#2, "£"; AMOUNT;
"outstanding since "; DATE$
```

```
1050 RETURN
```

```
1060 :
```

The result is a sequential file which just contains the names, addresses and amounts of the bills as yet unpaid, and which can be read from disk and printed on paper by another program as it stands.

When writing is complete the file must be closed or else some data will be lost, especially if the device is a disk drive. Closing the file by a 'CLOSE <logical file number>' statement ensures that the disk file is saved properly, and preserves the integrity of the disk storage. It is also useful if there are more than the maximum allowable number of files that have to be accessed throughout the program, since the logical file number could then be assigned to another file. If several files are open at the same time, they may all be closed by a single 'CLOSE' statement alone without specifying any numbers, but this is dependent on the BASIC version used.

The above method described for creating a text file of a list is invaluable where several computers share one printer (admittedly more a problem in the office than the home!), otherwise the program could have generated the list on paper directly. This avoids one computer tying up the printer for unnecessarily long periods, preventing access by other machines. Using the method shown, the data is processed and the results written to disk. Only afterwards is the information in the results file retrieved and sent to the printer, which will take a comparatively shorter amount of time.

There is one disadvantage to adding data to or changing data in a sequential file, in that the whole file must be rewritten on the disk, not just a part of it. The following procedure must be adopted.

```

20 DIM X(10), Y(10), Z(10)
30 DATA 13, 12, 22, 1, 5, 10, 15, 19, 17, 18,
    20, 50, 45, 20, 3, 6, 7, 1, 9, 5
40 FOR I = 1 TO 10
50 READ X(I), Y(I)
60 Z(I) = X(I) + Y(I)
70 NEXT I
80 PRINT "CONTENTS OF ARRAY X";
90 FOR I = 1 TO 10
100 PRINT X(I);
110 NEXT I
120 PRINT
130 PRINT "CONTENTS OF ARRAY Y";
140 FOR I = 1 TO 10
150 PRINT Y(I);
160 NEXT I
170 PRINT
180 PRINT "CONTENTS OF ARRAY Z";
190 FOR I = 1 TO 10
200 PRINT Z(I);
210 NEXT I
220 END

RUN

CONTENTS OF ARRAY X 13 12 2 1 5 10 15 19 17 18
CONTENTS OF ARRAY Y 20 50 45 20 3 6 7 1 9 5
CONTENTS OF ARRAY Z 33 62 47 21 8 16 22 20 26 23

OK

```

Figure 2. Manipulating arrays.

The file must be opened for reading, and a second file opened for writing. The data from file 1 is read in and copied to file 2, and the changes or extra data inserted as and when their position is found. The first file is then deleted, and if necessary the second file renamed with the name of the first file in the interests of consistency. The best example of this is wordprocessor text files. To make even one small change to a text file (down to adding just one character), the whole file has to be loaded into the area of memory used by the wordprocessor for this purpose, the change made, and then the file re-saved back to storage, in such a way that it replaces its previous version.

Arrays

The use of the 'LET' and 'DATA' statements for variables and constants have been covered. But sometimes it is necessary to hold related pieces of information together and be able to select each bit equally and process it in the same way. This is true of lists, and especially lists which are 'cross referenced'.

For example, in a telephone bill calculation one could have the name of the registered owner, the last meter reading, the recent meter reading, charge for units used, the rental and total charge to be calculated for each customer.

The layout of the data for each customer might look like table below:

These quantities could be assigned to different variables and the bills handled separately, but this method is not flexible. If a statistical analysis of the types and quantities of instruments rented was required, or an idea of the calling rate for a

particular area was under study, then all of the details for each person would need to be read in over and over again.

Even in very large computer systems where hundreds or thousands of separate groups of information need to be processed, storage reading is unavoidable as it will not all fit into memory at once. However, for smaller quantities, access to each piece of data can be very rapid if the information is held in arrays.

It has been shown in Part 1 how data statements can be used to keep several items of information available to the program, be they numbers or words. But these are 'constants' - the only way to change them would necessitate altering the program. This is no good for continually changing data, or data the value of which is unknown beforehand to the program. It could be got from the program user through a series of interrogating 'INPUT' statements, or it could exist, albeit in a temporary form (until the next time it is updated), as a file in storage, and the above is an example of this. But also, while a list of constants can be stored within a program as 'DATA' items, a list of variables can be kept in an 'array'.

'Array' means literally an array of identical elements, which together can be treated as a whole as a 'list' or a 'table'. Each element is handled like an ordinary variable, except that it is indexed by a number representing its position in the table. Therefore 'A(7)' is the seventh element in an array declared as 'A' with so many elements. In BASIC these elemental variables of an array are called 'subscripts'.

Actually BASIC allows small arrays to

Name	Recent reading	Last reading	Charge for units	Rental £	Total charge £
Jones	600	500	5	13	18
Smith	800	400	20	18	38
and so on.					

be used without having to make any special preparations for them first. In the above example of a program for compiling a list of names and addresses from unpaid bills, a three line address is stored as 'ADDRESS\$(1)', 'ADDRESS\$(2)', and 'ADDRESS\$(3)', and are handled with 'FOR / NEXT' loops. The counter variable 'N' is used to index what has become a small array called 'ADDRESS\$(x)'. This is quite different from 'ADDRESS\$', which would be a quite separate independent string variable in its own right if it were used too, but which it isn't in this case. BASIC allows subscripted variables from 1 to up to 10 elements in total to be created and used indiscriminately - although in fact there is also a zero subscripted variable too, making eleven in all. Most of the time subscript 0 is hardly used though, and this entry in the list usually remains 'empty', to use the vernacular. It is however useful to remember it while test running a program which uses arrays. If you have decided that the smallest subscript is going to be '1', but a statement makes reference to subscript '0' then there is an error somewhere or an unassigned variable is being used as the index (value = 0). If element '0' is given some easily recognisable value it can be spotted in the course of diagnostic printouts during 'de-bugging'.

BASIC only allows up to eleven elements to an array initially because arrays can be quite large, and use up valuable memory space. If you are certain that you need a bigger array than that, it must be 'declared'. This is done with the 'DIM' (DIMension) statement, and it must be used before any other variables are assigned, at the start of the program, as it needs memory space allocated for it. Attempting to dimension an array *after* assigning variables causes a 're-dimensioned array' error.

```
DIM NAMES$(50)
```

creates a string array of 50 elements (actually 51 counting subscript '0'). This can be used to hold 1 to 50 strings which are names, in this example. This is a 'single dimension array', just one list of names.

Arrays can also be of several dimensions. For instance, in the list of telephone charges above, the readings columns could be combined into a two-dimensional array:

```
DIM UNITS%(50,2)
```

The complete list of 'phone charges can be accommodated in a number of arrays of different types of both single and multiple dimensions:

```
DIM NAMES$(50), UNITS%(50,2),
CHARGE(50,3)
```

```
RECENT = 1 : LAST = 2 : UNITS = 1 :
RENT = 2 : TOTAL = 3
```

Any single quantity in the whole table can be found by indexing the relevant column:

```
500 FOR X = 1 TO 50
```



```
510 IF CHARGE(X,TOTAL)< 30
THEN 530
520 PRINT NAMES$(X);
UNITS%(X,RECENT); UNITS%(X,LAST);
CHARGE(X,UNITS); CHARGE(X,RENT);
CHARGE(X,TOTAL)
530 NEXT X
```

This will cough up a complete display of only those entries where the total charge is £30 or more, ignoring the rest. The required elements of the various arrays are indexed by the counter variable, X.

Two more examples of what can be done with arrays are shown in Figures 2 and 3. Figure 2 shows how corresponding elements of two different arrays can be added together and the results placed in a third array. The program in Figure 3 shows how the elements within an array can be associated.

If there are several 'columns' to an array, then it has 'breadth' as well as 'length'. As we have seen, the 'cells' within an array, like boxes on a checker-board, can be described by means of horizontal and vertical co-ordinates. Normally, the computer 'looks' at the array row by row, and so this is usually how the array is filled with data. Figure 4 shows an array which is 6 elements wide and 4 elements deep, and each 'box' can be described by its

```
10 DIM X$(10)
20 DATA TALL, SHORT, FAT, THIN, OLD
30 DATA HANSEL, GRETEL, JACK, JILL, GEORGE
40 FOR I = 1 TO 10
50 READ X$(I)
60 NEXT I
70 FOR I = 1 TO 5
80 FOR J = 6 TO 10
90 PRINT X$(I); " "; X$(J); " ";
100 NEXT J
110 PRINT
120 NEXT I
130 END
```

RUN

```
TALL HANSEL TALL GRETEL TALL JACK TALL JILL TALL GEORGE
SHORT HANSEL SHORT GRETEL SHORT JACK SHORT JILL SHORT GEORGE
FAT HANSEL FAT GRETEL FAT JACK FAT JILL FAT GEORGE
THIN HANSEL THIN GRETEL THIN JACK THIN JILL THIN GEORGE
OLD HANSEL OLD GRETEL OLD JACK OLD JILL OLD GEORGE
```

OK

Figure 3. Manipulating data within an array.

co-ordinates. Such an array might be dimensioned as 'DIM A (4, 6)', where the length is defined first and then the number of columns, or the width. This array can be loaded from storage with two 'FOR / NEXT' loops:

```
100 FOR I = 1 TO 4
110 FOR J = 1 TO 6
120 INPUT#1, A(I,J)
130 NEXT J, I
```

where 'I' is the vertical co-ordinate, and 'J' the horizontal. This is a very small multi-dimensional array - in theory, there is no limit to the size of an array, except memory space. Arrays can take up large

	J					
	1	2	3	4	5	6
I						
1						
2					2,5	
3				3,4		
4						

Figure 4. Simple array 6 elements wide x 4 elements deep shown in box form.

amounts of memory, especially string arrays (each element can be up to 256 bytes long). Consequently arrays much larger than 100 or so elements are unusual.

The London Planetarium continued from page 42

the solar system including the Earth, as it would appear from somewhere far out in space, and the system has the remarkable ability to reveal in close-up the planets and their moons, moving spacecraft, exploding stars, and what black holes might look like.

High Tech Flies High

To create the high tech picture, the Planetarium makes use of a wide assortment of projectors and mixers. Within the 67ft dome, which has a seating capacity of 418, a series of ancillary projectors support the main Mk IV Universal Zeiss (current replacement value, over £2m), 16mm film with sound backed up by 4 Sony Hi-band Umatic video players, laser disk players and video mixers. On the sound side, two 4-channel Otari tape decks and TEAC mixer serve 8 Gauss stage speakers, 4 infra bass speakers; 4-channel H&H 500W; and FET 800 1/2 octave white equalisers. A 'star operator' controls the Zeiss while all other effects are handled by computer, with no other technicians involved.

Star Shows

The planning and production of a new show takes some 120 hours with the designers confined together with an Apple II computer to a dark room. Split second timing is the key to the

developers. The narration is recorded, precisely timed to coincide with the movement across the sky. The tape is edited, and musical extracts carefully chosen to create a mood, or to enhance the dramatic impact of a visual image. One track on the finished tape is used as an electronic 'clock' which automatically signals the various projectors to switch on or off.

At the close of the respective

shows, there is a definite reluctance to leave the comfort of the raked seating for the more down to earth world outside. But with the organisers speculating that if only 1% of all the stars in the universe has planets, and that only 1% of these had some kind of life, and that only 1% of these had intelligent life - that is already several thousand 'earths'. It is therefore possible that we will not be alone.

COMPETITION

We have secured not one but no less than six sets of family tickets (2 adults and 2 children, worth £8.40), plus a free guide book (worth £1.20) for The London Planetarium. All you have to do to win one of the six sets of tickets is to correctly answer the following questions. The first six all-correct answers pulled out of our editor's now somewhat battered hat will be able to soar into the universe - courtesy of Maplin 'Electronics'. But hurry, tickets are only available up to 31st May 1991.

Zap your answers on a post card to: 'The London Planetarium Contest', The Editor, Electronics - The Maplin Magazine, P.O. Box 3, Rayleigh, Essex, SS6 8LR. Don't delay, we are closing the contest 30th April. Employees of Maplin Electronics and family members of

same are not eligible to enter. Also please note that multiple entries originating from one and the same family group will be disqualified.

- Neil Armstrong and Buzz Aldrin were the first men to walk on the Moon. When?
 - 1969.
 - 1975.
 - 1950.
- Spot the odd one out.
 - Nikolaus Copernicus.
 - Galileo Galilei.
 - Halley's Comet.
- How many constellations are there in the Zodiac?
 - 52.
 - 12.
 - 365.
- Which of these planets is nearest to the Sun?
 - Earth.
 - Jupiter.
 - Pluto.

'MAPLIN RANGER' 160m RECEIVER

B Y G A V I N C H E E S E M A N

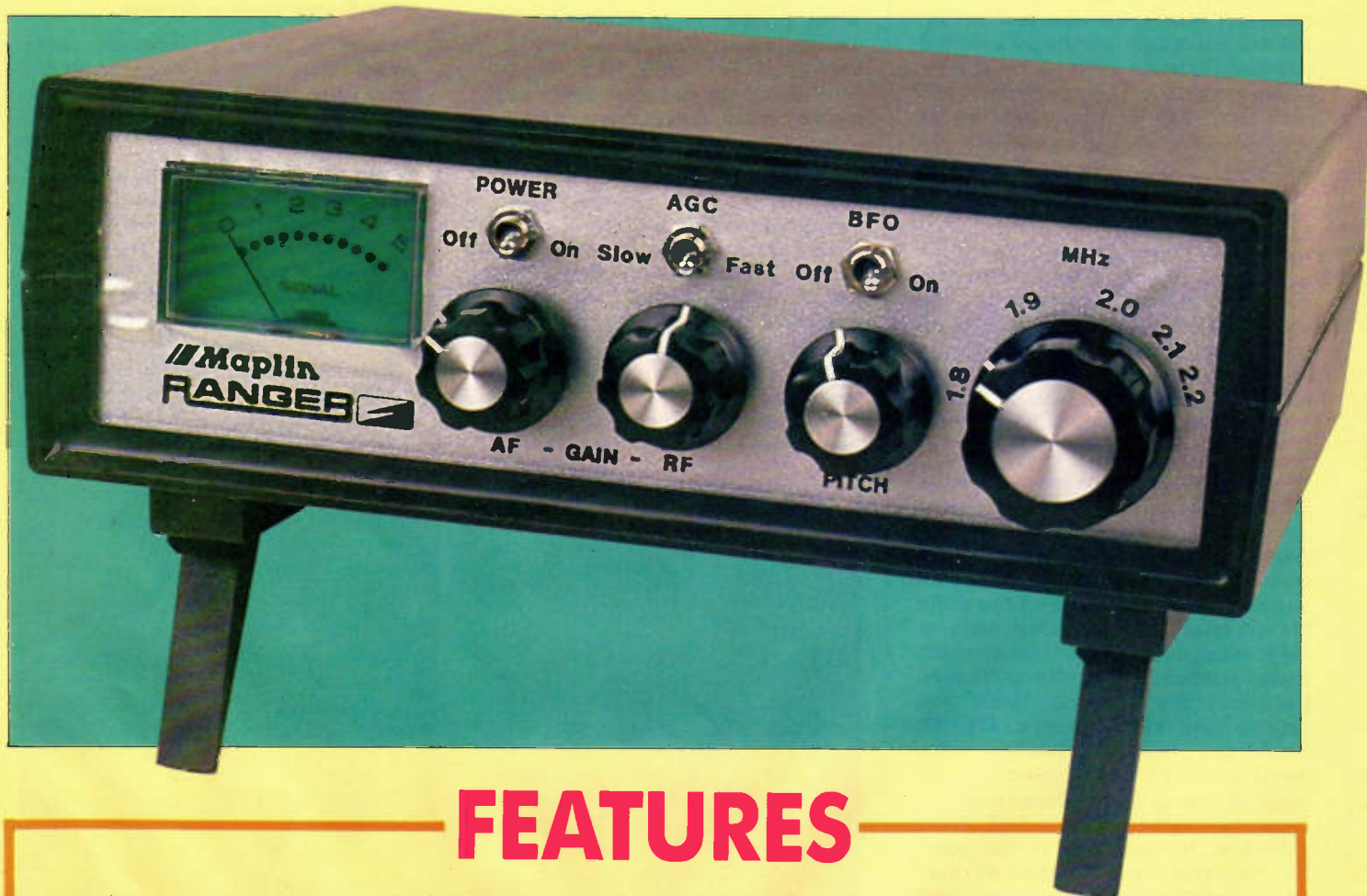

FEATURES

- ★ Receives AM/CW/SSB Transmissions
- ★ Superheterodyne Design
- ★ Variable Frequency BFO
- ★ Frequency Coverage: 1.8 – 2.2MHz
- ★ Switched AGC Time Constant
- ★ Moving Coil S-Meter

Introduction

The 160m receiver is designed to cover a frequency range between approximately 1.8MHz and 2.2MHz and is capable of receiving both AM and CW/SSB modes. Many different services share the band, using a host of different transmission modes. Probably one of the most interesting parts of the band (and that for which the receiver was primarily designed) is the portion between 1.8MHz and 2.0MHz which is allocated for use by amateur radio operators. Other users of the band include 'ship to shore', coast stations and marine navigational beacons.

The receiver uses the superheterodyne principle in which the incoming signal is mixed with an internal local oscillator to produce an output at a much lower intermediate frequency (IF). The IF output is then amplified, filtered and demodulated to produce the final audio frequency signal which after further filtering and amplification is used to drive a loudspeaker or headphones. Although this system seems complicated at first sight it does have several significant advantages. Since all signals are converted to one common intermediate frequency, it is possible to achieve relatively sharp bandpass filter characteristics using standard fixed frequency LC filter technology. Any additional beat frequency oscillators (BFO) may be injected at the IF and require no further adjustment as the received frequency is changed. In addition there are also disadvantages. During the mixing process, other unwanted frequencies are also produced in addition to the required IF and care must be taken to ensure that these do not interfere with the wanted signal. Due to the nature of the mixer, an

'image' frequency is also converted to the IF as well as the wanted frequency. The frequency of the unwanted image is the difference of the IF and the local oscillator frequency. To avoid interference from strong stations, operating at the image frequency it is important that adequate filtering is used in the RF input stages of the receiver. In general the advantages and versatility of the superheterodyne receiver, outweigh the disadvantages.

Circuit Description

In order to illustrate the operation of the receiver, a block diagram is given in Figure 1 showing the basic stages of the circuit. Referring to Figure 2, it may be seen that the receiver is based around the LM3820 AM radio sub-system IC (IC1). This IC forms the basis of an AM superheterodyne receiver, containing the mixer and most of the necessary RF and IF amplifiers. Signals coming in from the aerial are initially filtered by T1/C6 and amplified by TR1 which is a dual gate FET. The signal is applied to gate 1 of the transistor and gate 2 is used to control the gain of the stage via RF gain control RV1. The amplified output from TR1 is filtered by C4/T2 and fed to the RF amplifier input of IC1. After further RF amplification, the signal is fed to the internal mixer, where it is mixed with the local oscillator. Variable capacitor VC1, T7 and associated circuitry determine the operating frequency of the local oscillator. The output from the mixer contains a wide range of frequencies and it is necessary to separate signals of the required intermediate frequency (IF) from the unwanted signals which are present. IF transformers T3, T4 and T5 together with associated components perform the IF filtering and the filtered

signal is amplified by the internal IF amplifier of IC1. An internal AGC circuit maintains the final IF output at a set level. Capacitors C8 and C13 determine the AGC time constant and S2 allows either fast or slow AGC times to be selected.

The output from IF transformer T5 is demodulated by two different types of demodulator. Germanium diode D4 together with associated components is used to demodulate AM signals. This type of circuit is fine for standard double sideband AM stations but CW and single sideband suppressed carrier (SSB) signals need to be mixed with a local Beat Frequency Oscillator for correct demodulation. This process is carried out by IC4 which is configured as a product detector.

The BFO circuit is based around Field Effect Transistor TR2. IF oscillator coil T6 and associated components determine the frequency of oscillation. Frequency adjustment over a limited range is provided by applying the variable voltage produced by RV3 to a reverse biased diode (D3); this diode effectively acts as a varicap diode, changing the resonant frequency of the oscillator. Darlington transistor TR3 acts as a buffer, minimising the effect of components connected to the oscillator output.

Either the AM or SSB/CW mode may be selected using switch S3a. Switch S3b offsets the BFO frequency to avoid problems with oscillator breakthrough in the AM mode. The demodulated signal is fed to audio power amplifier IC3, via filtering components C26, C27 and R25. The input level to IC3 is controlled by volume control RV5. The output of the amplifier is fed to loudspeaker LS1 and via current limiting resistors R36 and R37 to headphone socket SK3. The switching is

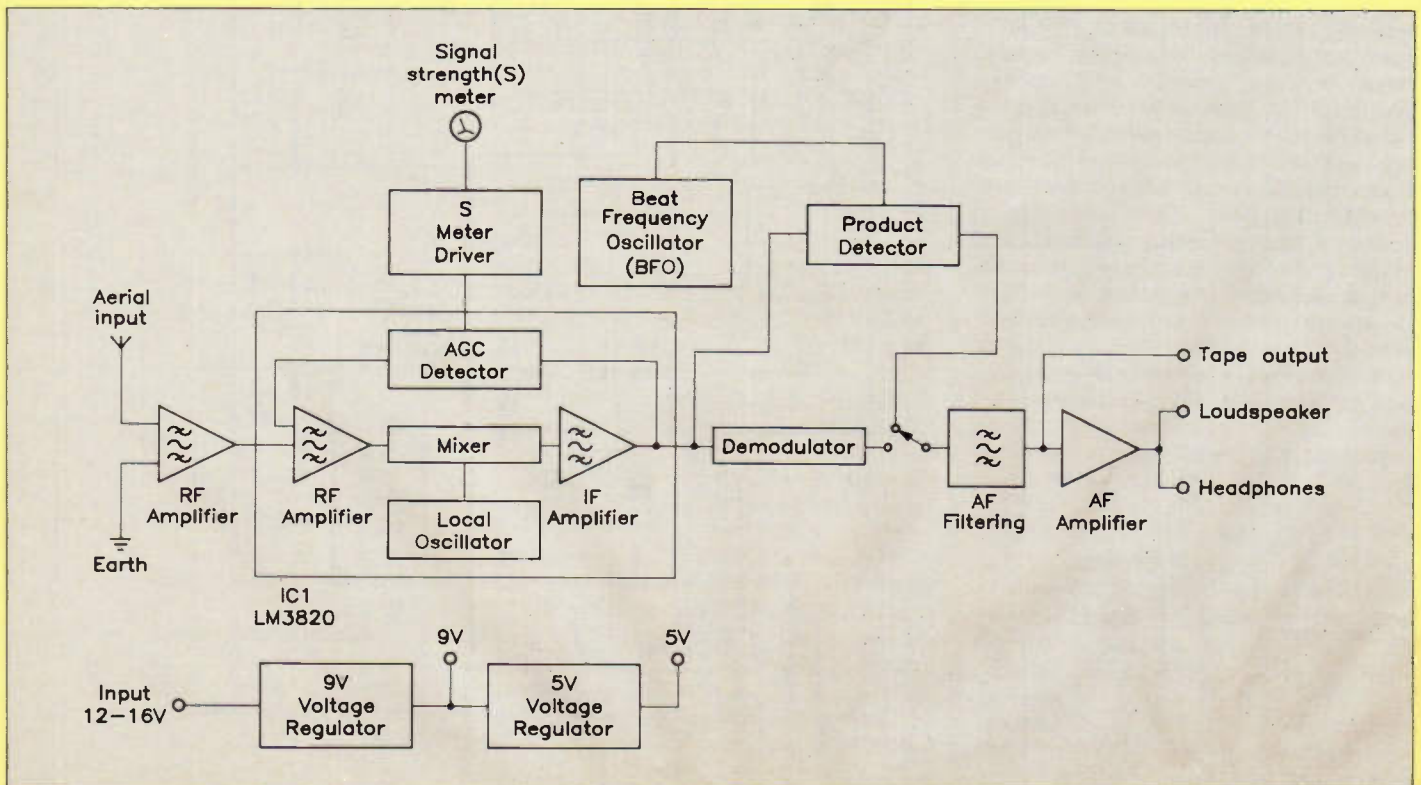

Figure 1. 160m receiver block diagram.

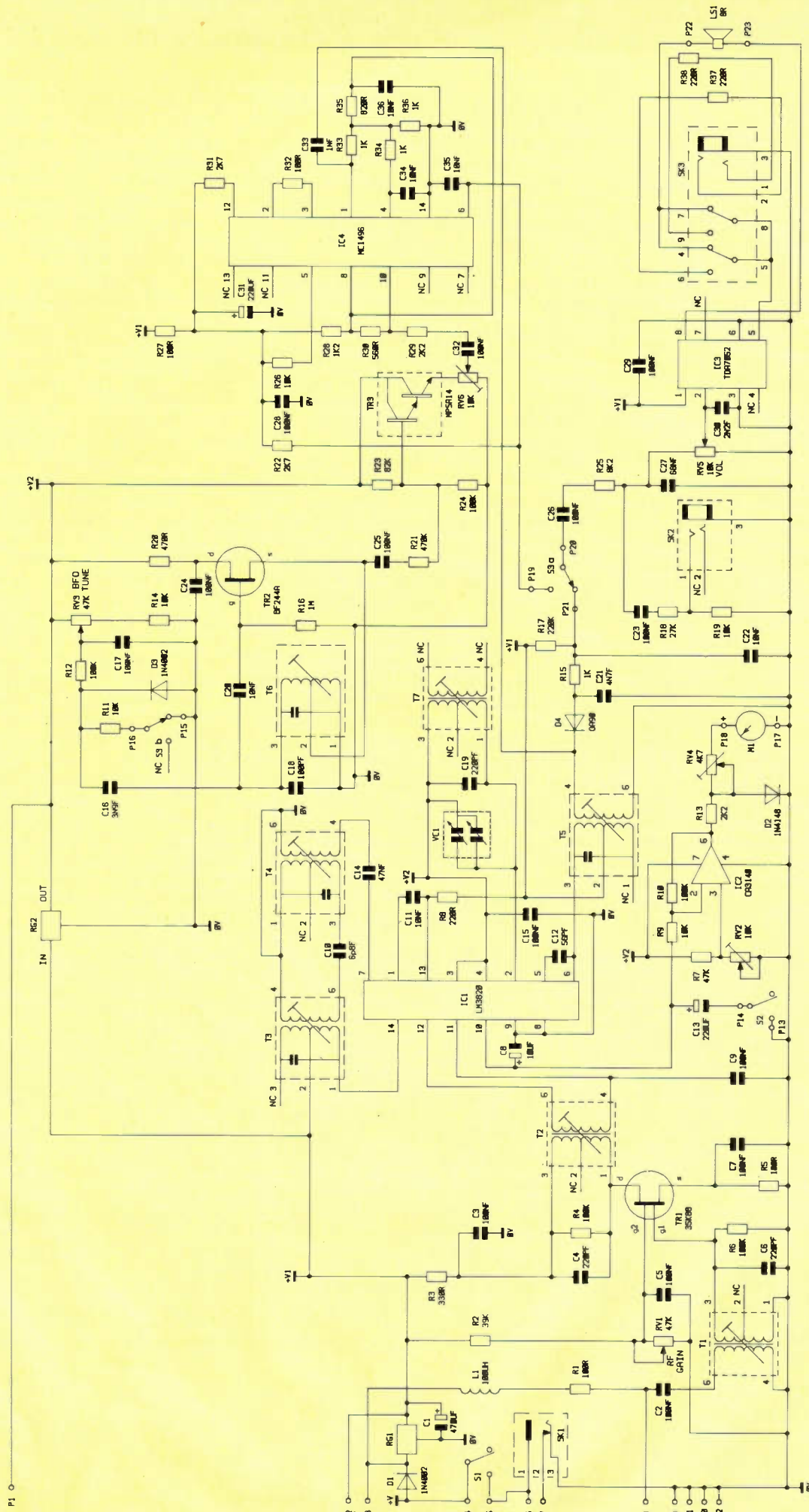

Figure 2. Circuit diagram.

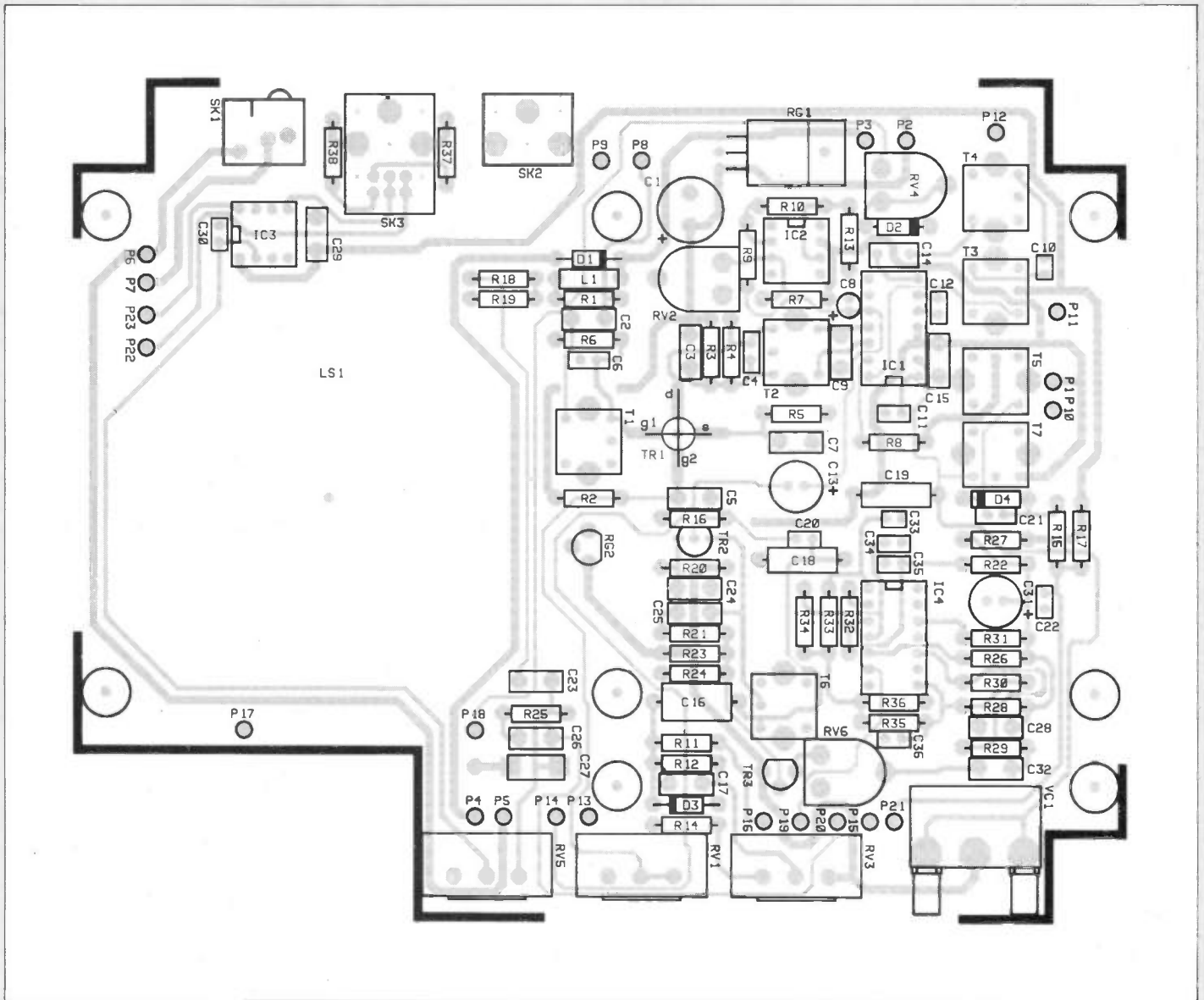

Figure 3. Legend.

arranged such that the loudspeaker is switched out of circuit when a jack plug is inserted into the socket. Mono jack socket SK2 provides a fixed amplitude low level audio output for cassette recorders etc.

The S meter circuit is based around CMOS Op-amp IC2 and is derived from the AGC voltage produced on pin 10 of IC1. Variable resistor RV2 zeros the meter and RV4 sets the meter sensitivity.

To allow the receiver to operate over a wide range of power supply voltages the circuit uses two separate regulators. RG1 is a 9V regulator and this provides the main regulated 9V supply for stable and reliable operation of the circuit. A second regulator (RG2) generates a 5V low current supply for the more critical oscillator circuitry and is also used as a reference for the S meter circuit. Although IC1 has facility for a zener stabilised supply, better stability is achieved using an IC regulator in this particular application. Diode D1 provides reverse polarity protection, preventing the power supply being connected with the wrong polarity. A low current unregulated supply is also fed to the aerial input via D1, R1 and choke L1; this is intended for operating low

current equipment connected to the aerial socket such as preamplifiers or active aerials.

Construction

The receiver uses a high quality, double sided PCB with plated through holes and a screen printed legend. Insert and solder the components onto the PCB referring to the PCB legend (Figure 3). Because of the difficulty involved in removing components from this type of PCB it is essential that all components are correctly fitted the first time round. Most of the construction is straightforward and probably requires no further explanation; there are however a few points that require special attention and these are detailed below.

Before commencing construction it is recommended that you check the components against the parts list to make sure that these are correct. Start by fitting the resistors and other small components. The IC sockets should be fitted before any high profile components as these must be kept flush with the PCB. Ensure that the end of the socket marked by a notch corresponds

with that shown on the PCB legend (do not fit the ICs at this stage). Install sockets SK1, SK2 and SK3 ensuring that the base of the socket is flush with the PCB. Insert and solder the PCB pins using a hot soldering iron. If the pins are heated to the correct temperature, only light pressure is required to press them into position. Once in place, the pins may then be soldered. When fitting the electrolytic capacitors it is essential that the correct polarity is observed. The negative lead of the capacitor, which is usually marked by a negative (-) symbol on the side of the case should be inserted away from the hole marked with a positive (+) symbol on the PCB legend.

Transistor TR1 is supplied in a 4 lead flat package and should be handled with care as it is a static sensitive device. The transistor is soldered onto the appropriate pads on the track side of the PCB as shown in Figure 4. As with all semiconductors, the transistor is easily damaged by heat and care should be exercised to make sure that the device is not overheated during soldering. TR2 and TR3 are inserted such that the transistor case corresponds with the outline on the legend.

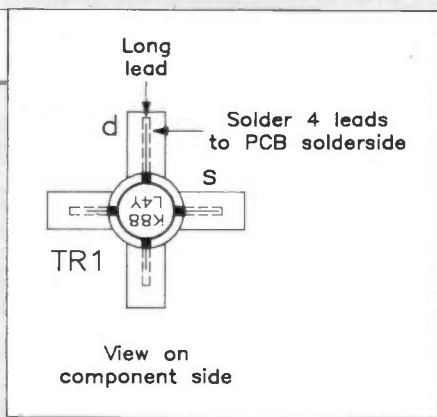

Figure 4. Mounting TR1.

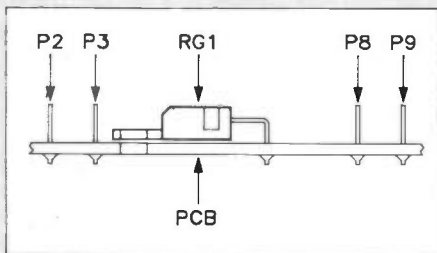

Figure 5. Mounting RG1.

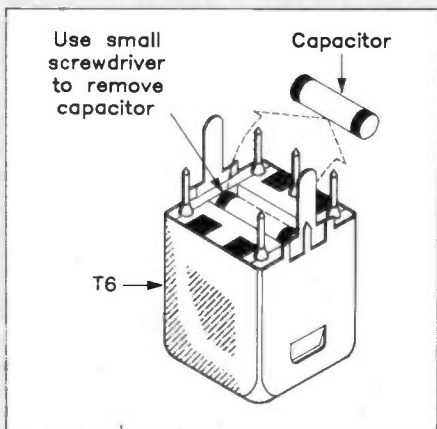

Figure 6. T6 internal capacitor removal.

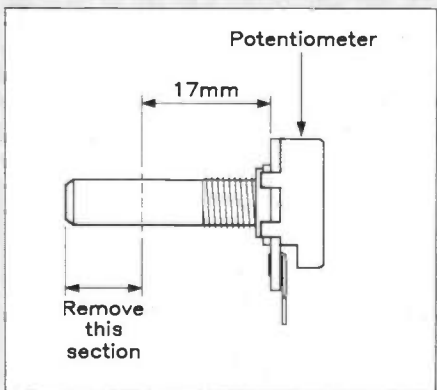

Figure 7. Cutting the potentiometer spindles.

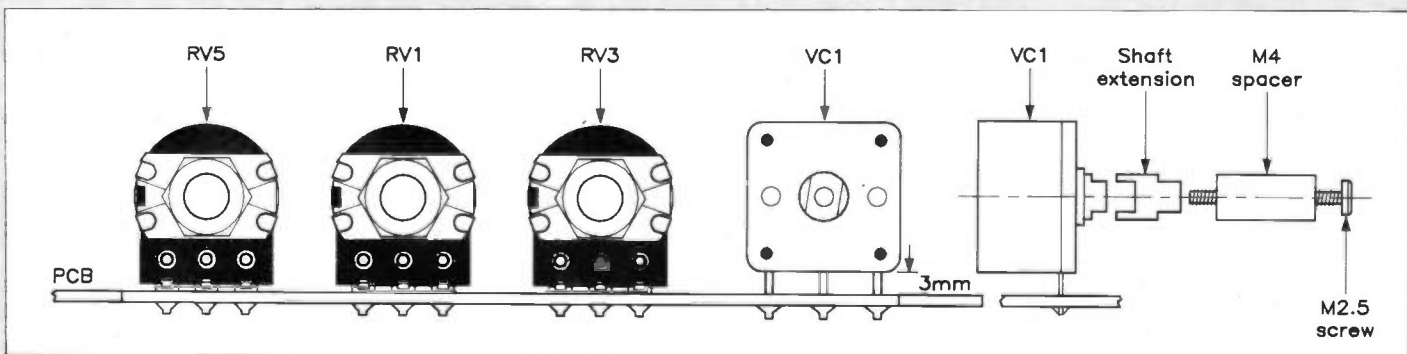

Figure 8. Fitting the PCB mounted front panel components.

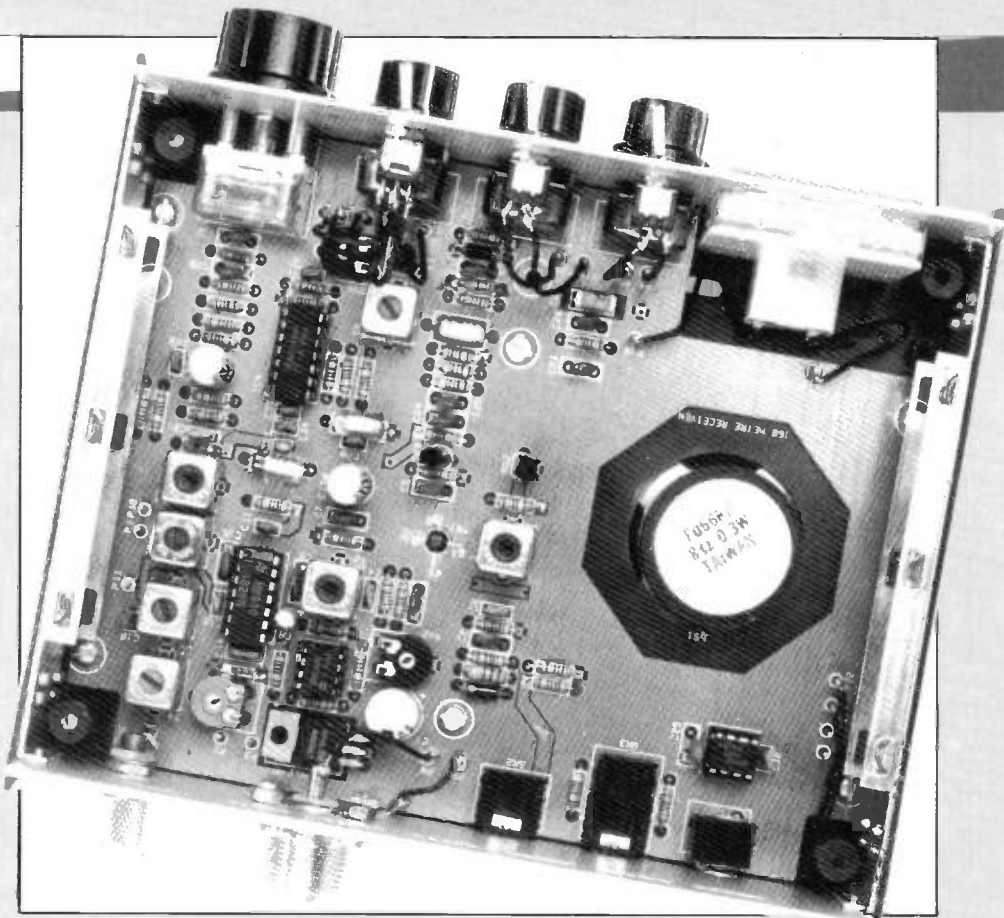

Photo 1. Inside view of the prototype unit showing the completed PCB fitted and wiring to switches, aerial and earth.

The diodes should be inserted such that the band at one end of the diode corresponds with the band on the PCB legend.

Regulator, RG1 is supplied in a 3 pin plastic package and is positioned as illustrated in Figure 5. The pins are bent, inserted into the PCB and soldered so that the regulator case lines up with the legend. It is not necessary to bolt the regulator to the PCB; however, a suitable hole is provided for those who wish to bolt the device down. RG2 is positioned such that the case corresponds with the appropriate outline on the legend.

Tuning cans T1 – T7 are fitted as indicated by the legend. T6 requires special attention as it is necessary to remove the internal capacitor from the base of the can before it is fitted onto the PCB. Figure 6 illustrates a suitable method of removing the capacitor using a small screw driver. Do not apply excessive force to the plastic base of the can as this is easily broken. Before fitting potentiometers RV1, RV3 and RV5 it is necessary to remove part of the spindle as shown in Figure 7 using a small hacksaw.

When installing the potentiometers, ensure that the potentiometer pins are inserted as far into the PCB holes as possible. Next, fit VC1 such that the case is positioned approximately 3mm above the component side of the PCB (see Figure 8); this height is based on housing the receiver in the suggested box and may vary if a different box is used.

Switches S1 – S3, signal strength meter M1 and loudspeaker LS1 are wired to the appropriate PCB pins using the hook-up wire provided in the kit. Figure 9 shows a wiring diagram. After all other components have been fitted the ICs should be inserted into the appropriate IC sockets on the PCB ensuring that the notch at one end of the IC corresponds with that on the socket.

For further information on soldering and constructional techniques refer to the constructors' guide included in the kit. Before applying power to the finished receiver PCB, it is recommended that you double check your work to make sure that there are no dry joints or solder short circuits.

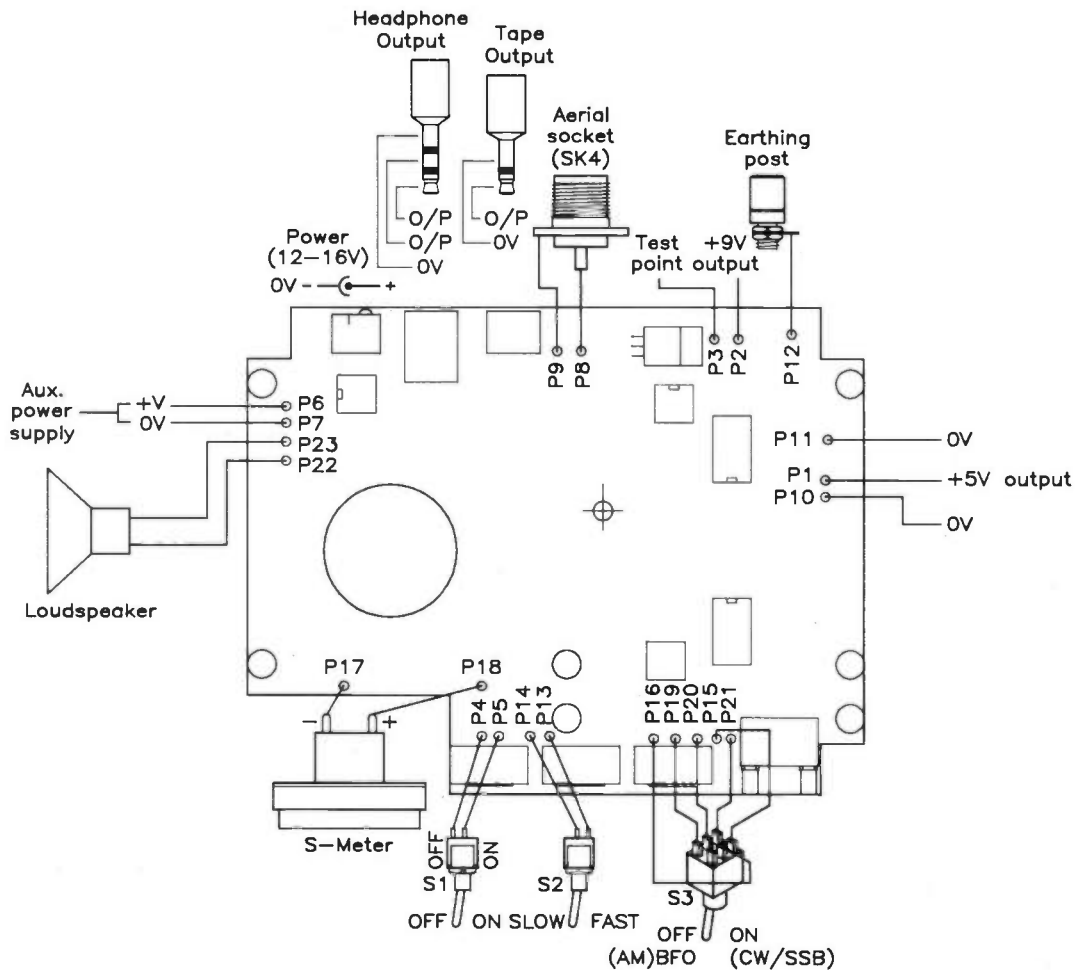

Figure 9. Wiring diagram.

Testing and Alignment

Using the superheterodyne principle, correct operation of the receiver is very much dependent on setting up the various tuned circuits correctly and on the use of the correct oscillator injection levels. These are best set up using the correct test equipment but this is not essential and the receiver can be set up by "ear".

The receiver will operate from a power supply of between 12V and 16V DC. Current consumption varies with volume, but a 300mA supply should be adequate. The power supply used for the prototype was Maplin stock code XX09K. The use of IC regulators in the design allows for relatively large fluctuations in power supply voltage without adverse results.

There are several different methods of alignment and to detail all of these would be outside the scope of this article. The two methods described below will probably be found the most useful for the home constructor:-

Alignment Using an Off Air Signal

This method entails the use of an off air signal of known frequency to align the receiver. To align the receiver using this method, a suitable aerial will be required. Initially, the IF may be approximately aligned using the internal background noise of the receiver. Apply power to the receiver and set S1 to the on position. S3 should be set to the AM position. Set preset resistor RV6 to the centre of its travel. Set volume

control RV5 to maximum and adjust T3, T4 and T5 until a peak in the noise level from the loudspeaker is obtained. The noise level is relatively low and this should be done in a quiet environment or alternatively, using headphones. Once a peak has been obtained, the BFO frequency may be aligned. For this set S3 to the CW/SSB position (BFO on), set RV3 to the centre of its travel and adjust the T6 for a peak in noise. Any necessary final adjustments can be made when the remaining sections of the circuit have been aligned.

Unless a signal of known frequency is available, precise alignment of the receiver is not possible; however, the circuit may be aligned approximately by turning the ferrite core of T7 anti-clockwise until it is level with the top of the can and then turning it clockwise 4 turns. This method of frequency alignment is far from accurate but it does allow the receiver to be set approxi-

mately in the correct band. Reduce the volume to a comfortable level and connect an aerial to P8 and a suitable earth to P9 if available. Adjust T1 and T2 to obtain a relatively flat noise level over the whole band.

Alignment Using a Signal Generator

This is much preferred to the above method as it uses a signal of known frequency. The IF and RF amplifier tuned circuits may still be adjusted as described above. To align the local oscillator circuit, apply a signal between P8 (i/p) and P9 (0V) at a frequency of 2MHz. The amplitude of the signal should be between 1mV and 50mV peak to peak. Set VC1 to the position shown in Figure 10 and set RV1 fully anticlockwise. Adjust T7 until a strong signal is obtained. A strong unmodulated signal

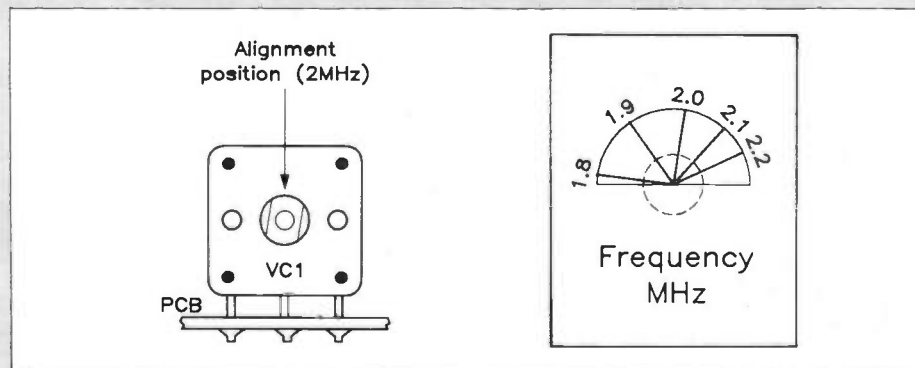

Figure 10. VC1 alignment position.

should be fully quieting in the AM mode and should produce a loud sinusoidal tone in the CW/SSB mode.

For those who wish to generate a 2MHz signal but do not possess a signal generator, Figure 11 shows the circuit diagram of a suitable low cost crystal calibrator using a 2MHz crystal. This circuit is relatively straightforward and provides a suitable reference signal with which to align the receiver.

To set up the S meter, remove any aerials/signal generator from the aerial input (P8) and set meter sensitivity preset RV3 to $\frac{3}{4}$ of its maximum travel. Adjust RV2 until the S meter indication is just fractionally above 0. When a signal is applied to the aerial input, the meter reading should then increase to indicate the relative strength of the signal. Further adjustment may be made as required.

Housing the Receiver

A suitable box in which to house the receiver is Maplin stock code YN33L. Pre-drilled front and back panels are available for the 160m receiver; these simply replace the un-drilled panels supplied with the box. The front and rear panel layouts are shown in Figure 12a and 12b respectively. For those of you who wish to drill the front panels for yourself, Figures 12c and 12d show drilling details for the front and rear panels. Loudspeaker LS1 is held in place by the PCB and the speaker magnet should protrude through the large hole provided. If required, the speaker may be glued in place using a general purpose adhesive. Figure 13 shows how to mount the front panel components. The S meter can be fixed to the front panel using glue or self adhesive pads. If adhesive is used care should be exercised to keep this away from the part of the meter that protrudes through the front panel. PCB mounting information is shown in Figure 14.

Using the Receiver

To achieve optimum performance from the 160m receiver, a reasonable aerial is a must. In general, in the 160m band, this entails the use of the longest piece of wire practically possible; this should be erected high and in the clear. Nevertheless the receiver will operate (less efficiently) with shorter aerials where space is limited. Another very important factor affecting quality of reception at this frequency is the aerial earth; this is almost as important as the aerial itself. If possible the receiver should be connected by a short length of thick cable to a suitable earthing point such as a length of copper pipe, driven into the ground. It is realised that in many situations the type of aerial installation described is just not practical but even so it is still possible to obtain reasonable performance from the receiver using much simpler installations. The design of aerials is a wide and complex subject, outside the scope of this article; however, a list of books containing useful information on radio and aerial systems is given at the end of the article.

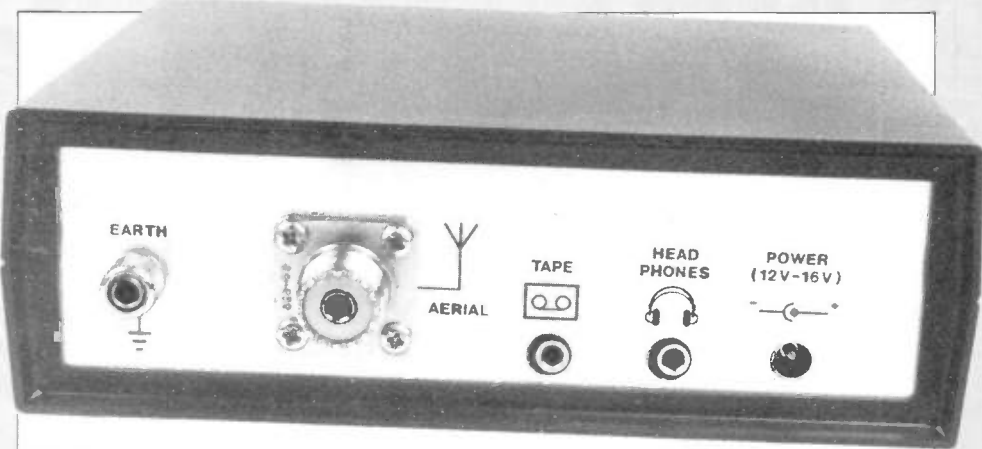

Photo 2. Rear view of the prototype unit.

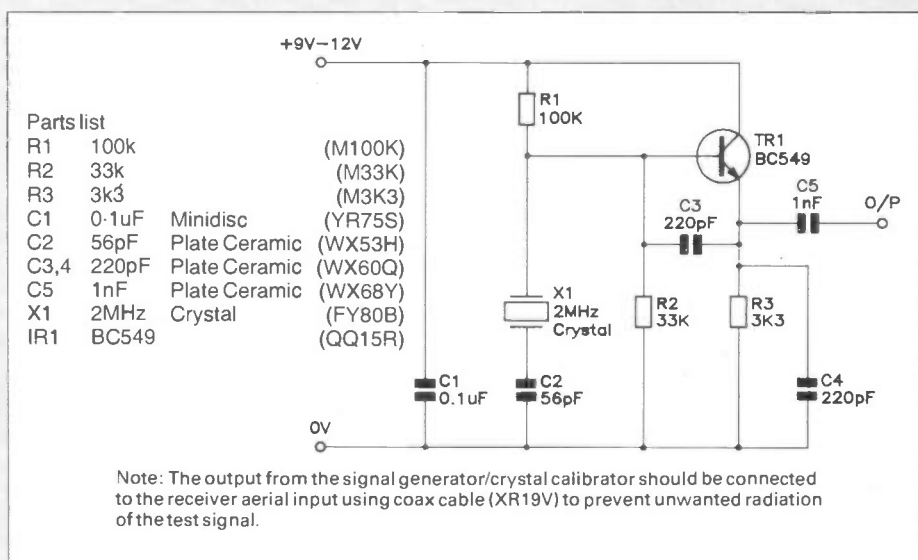

Figure 11. Low cost crystal controlled calibrator.

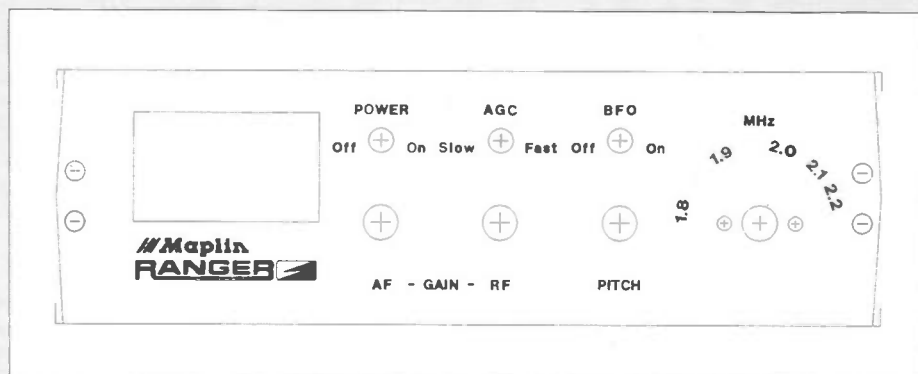

Figure 12a. Front panel layout.

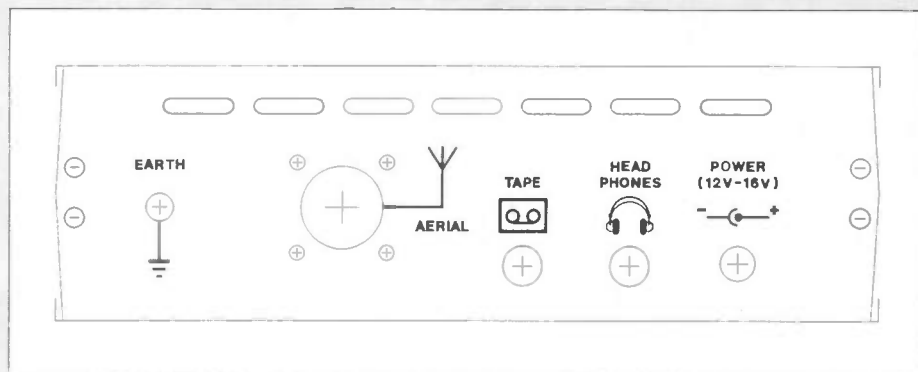

Figure 12b. Rear panel layout.

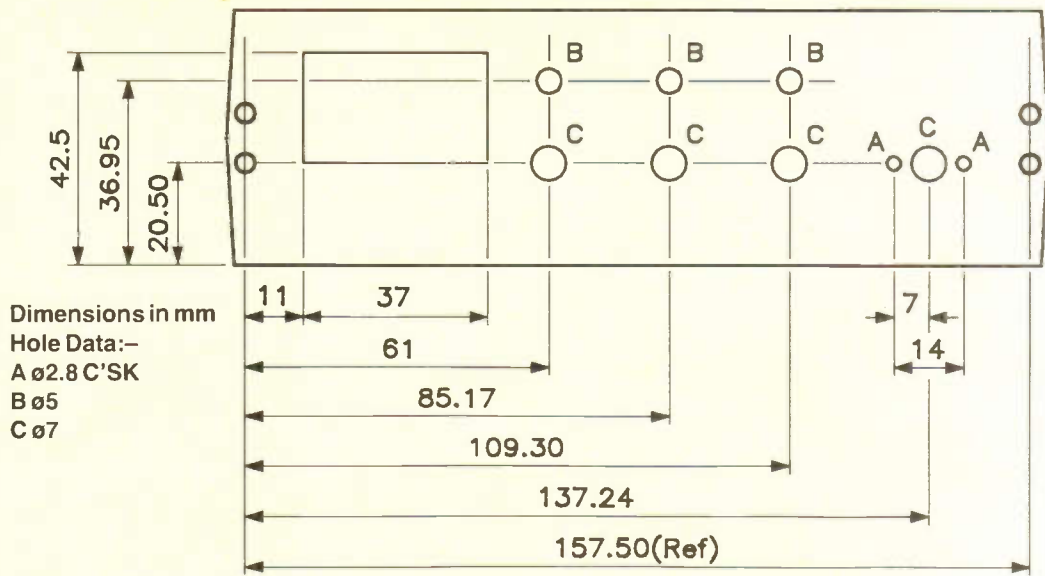

Figure 12c. Front panel drilling details.

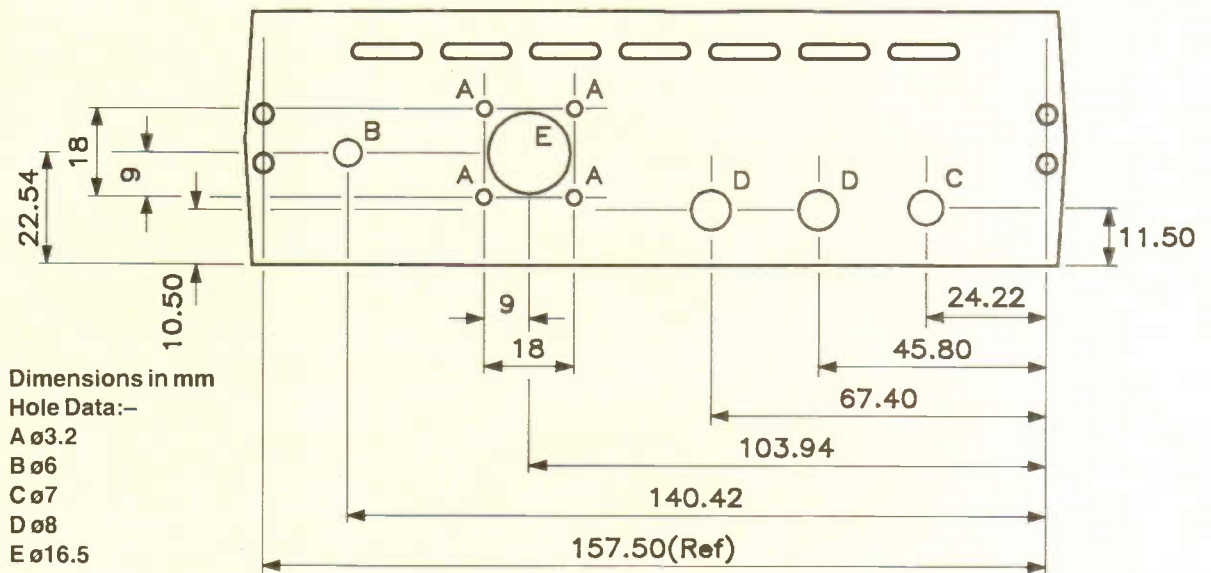
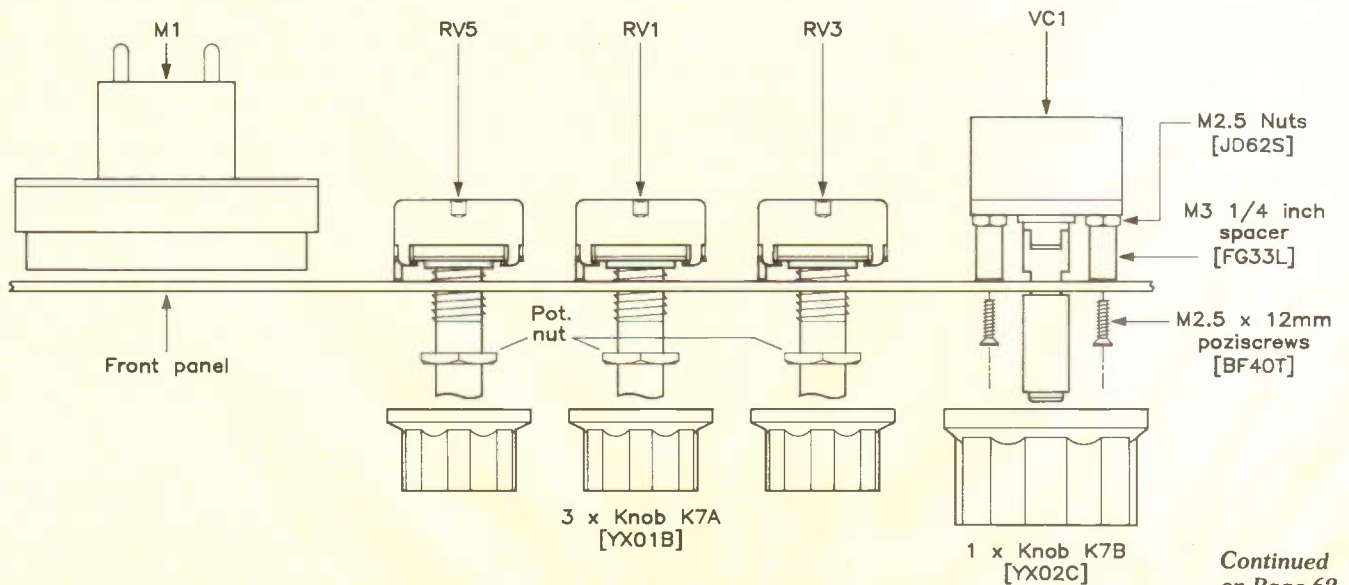

Figure 12d. Rear panel drilling details.



Continued
 on Page 62.

Figure 13. Mounting the front panel components.

PRACTICAL ROBOTICS TECHNIQUES

Part 2 – How to interface a robot vehicle to a microcomputer

by Alan Pickard

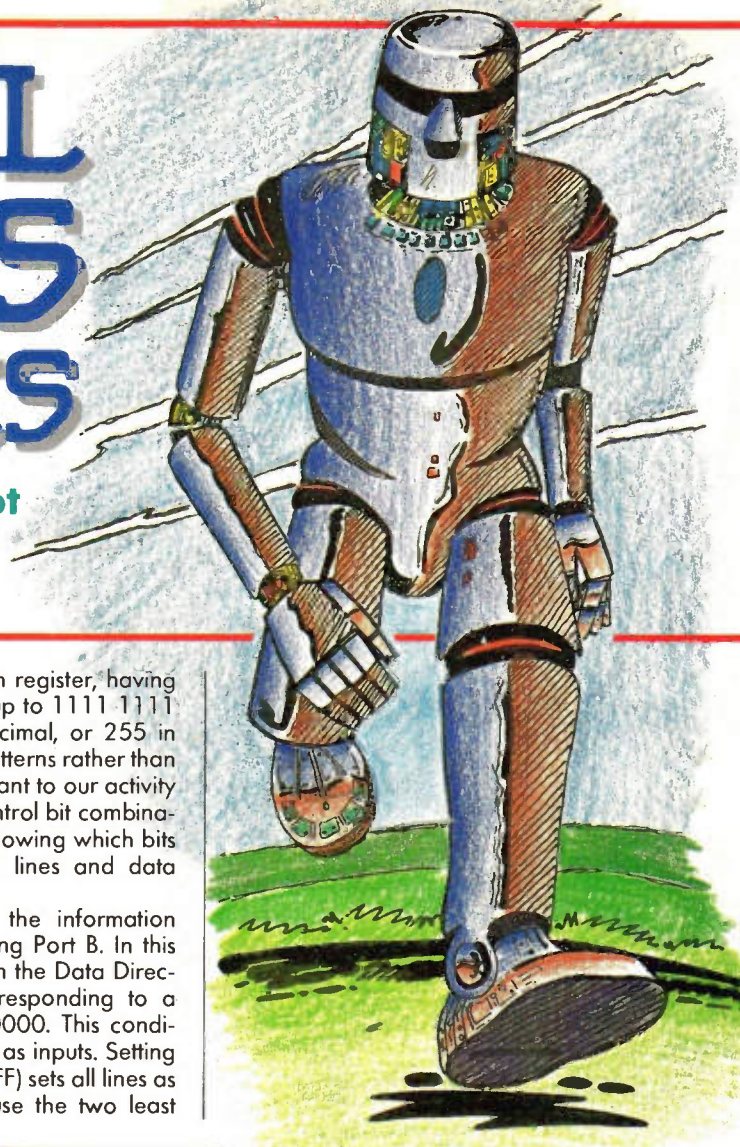

The material covered in Part 1 dealt with very basic control experiments but will be useful for reference when investigating the interfacing of a robot vehicle to a microcomputer user port. As before, the BBC Micro will be used as the control computer, but all hardware including the individual and composite circuits can easily be controlled by any micro with an 8-bit user port. This can be achieved via a high level language such as BASIC or a resident assembler (e.g. 6502), but a dedicated microcontroller could also be employed. Later in the series, one or two microcontroller examples will be included and it would be useful if we attempt to use a standard pin numbering system such that it is possible to test individual circuits on more than one control computer or even a complete robot system.

Figure 1 shows the basic requirements for a robot vehicle system under computer control. The user port is an integral part of the microcomputer and in the case of the BBC Micro is based on a 6522 VIA (Versatile Interface Adaptor) IC. Other machines which have different interface chips require the user to be familiar with them. The 6522 contains two 8-bit programmable ports but as one is designated for printer use (Port A) this leaves Port B for the user port.

Port B provides 8 separate input/output (I/O) lines which can be individually programmed to act as inputs or outputs. There are two registers in the chip associated with programming it. They are the Data Direction Register (DDR) which determines which lines are set as input and which are set as output. The actual data sent out of the port to an output device (e.g. motor) or received from an input device (e.g. switch) is placed in the Data Register (DR).

The 6502 is a memory mapped microprocessor device and is unable to distinguish the registers in the 6522 VIA from ordinary memory locations. They are in fact wired into the address decoding circuitry of the microcomputer and their unique addresses in hex are as follows:

Data Direction Register (Port B) is &FE62
Data Register (Port B) is &FE60

where the ampersand (&) denotes a

hexadecimal value. Each register, having 8 bits, can store values up to 1111 1111 in binary, FF in hexadecimal, or 255 in decimal. Individual bit patterns rather than numeric values are relevant to our activity so when deciding on control bit combinations we need a table showing which bits are set to provide I/O lines and data values.

Figure 2 indicates the information required for programming Port B. In this example the hex value in the Data Direction register is 00, corresponding to a binary value of 0000 0000. This condition sets all port lines up as inputs. Setting them all to 1 (hex value FF) sets all lines as outputs. If we wish to use the two least

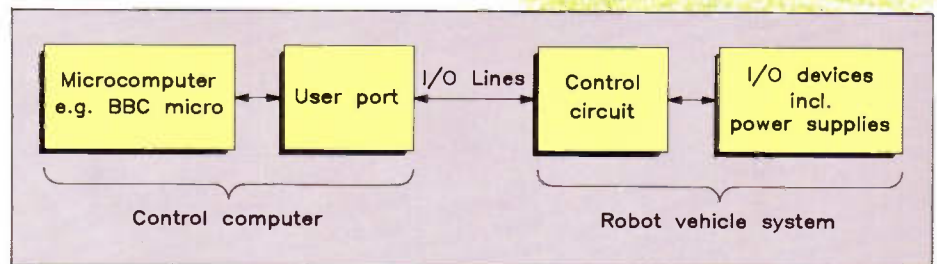

Figure 1. Block diagram of robot vehicle under computer control.

significant port lines as outputs to a motor circuit (2 lines being used to enable direction change) then the data Direction Register value would need to be 0000 0011 = 3 in hex.

To actually cause the switching on of a motor via a relay a data value must be placed on these two lines (PBO and PB1). This is achieved by placing a suitable code in the Data Register. For example, let us assume that PBO = logic 1 and PB1 = logic 1 for a motor circuit to cause forward motion. The hex value placed in &FE60 must be &03. This may be confus-

ing as both registers have similar addresses, similar names and now we have two identical contents! Perhaps this will be less confusing when we use more lines. The Data Direction Register must be kept separate in your mind from the Data Register, but they are obviously closely related.

Care must be taken not to input to a port line when it has been programmed as an output. Careless software programming may cause hardware damage!

Using the format of the table in Figure 2, in our example which will be used in

		PORT B BIT SETTINGS									
REGISTER	ADDRESS	7	6	5	4	3	2	1	0	HEX	ACTION
DDRB	&FE62	0	0	0	0	0	0	0	0	&00	ALL LINES AS INPUTS
DRB	&FE60	0	0	0	0	0	0	0	0	&00	NO DATA (ZEROS)

Figure 2. Table of register addresses and contents.

our first interface control circuit, &FE62 contains &03 and &FE60 contains &03. These values can be set by using the BBC BASIC version of POKE, i.e.

```
?&FE62 = &03
?&FE60 = &03
```

An Interface Control Circuit

Our first experiment involves switching on a motor which drives a single wheel in both a forward and reverse direction. The previous test vehicle or simulated control vehicle from Part 1 may be used. This experiment is the basis of driving and steering a robot vehicle. Two port lines are used and as will be seen later we want to control two wheels

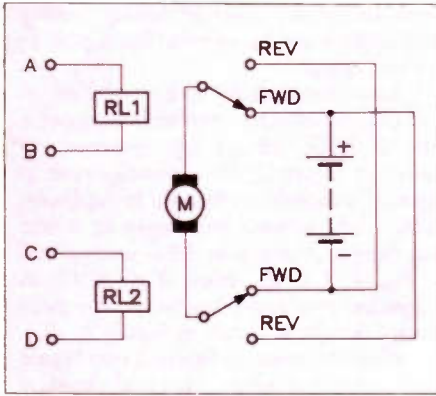

Figure 3. Interface control circuit for simple robot.

separately so a total of four output lines will be employed.

Switching off the motor is achieved via a changeover relay. Two relays enable the polarity of the motor supply to be reversed as shown in Figure 3.

It can be seen how relay operation affects the energising of the motor and also how polarity and therefore direction is changed. A simple logic truth table illustrates the operation of the circuit:

HEX	BINARY	ACTION
00	00	REVERSE
01	01	STOP
02	10	STOP
03	11	FORWARD

Figure 4. Truth table for single motor control.

Figure 4 shows a binary combination of 11, e.g. PBO and PB1 lines set to 1 and the corresponding hex value assumes PB2 - 7 inclusive are logic 0. Depending on how wires are connected to battery and motor, this combination should produce forward (clockwise) rotation of the motor.

This circuit is incomplete as it only shows the motor/relay contacts/battery connections, but it is important to understand exactly what you are doing, particularly if investigating errors. It is a good idea to get this section working separately before we look at how to connect up the user port. Relay operation can be tested

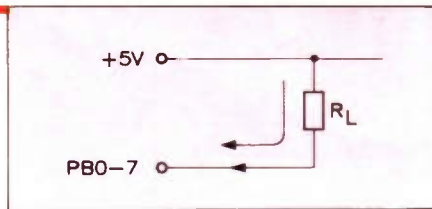

Figure 5a. Sinking current.

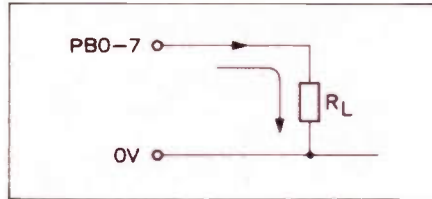

Figure 5b. Sourcing current.

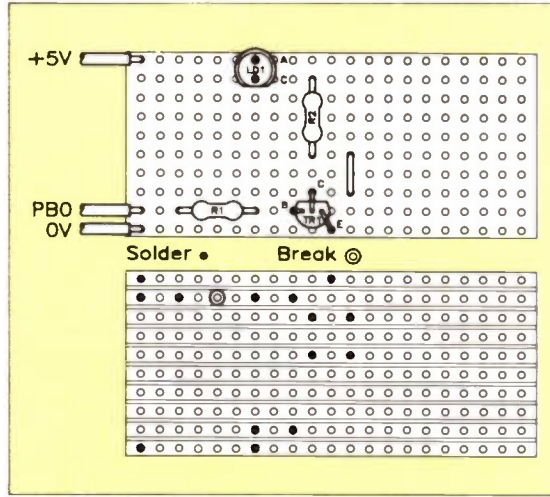

Figure 6b. Suggested stripboard layout (LED).

by simply connecting a supply directly across the coil from for example a PP3 battery. By referring to Figure 1 it will be seen that the control circuit which actually interfaces the motor switching section to the computer user port has yet to be provided.

Motors (and relays) cannot be connected directly to the user port lines PBO - 7, nor for that matter can LED's even with a series resistor. This is because although the I/O lines can cope with a certain amount of current it is best to keep this to an absolute minimum by buffering with a transistor stage.

When a load, e.g. a resistor, is connected to an I/O line on the 6522 it is said to sink or source current. This is demonstrated in Figures 5a and 5b.

In Figure 5a current flows from the TTL level +5V supply through RL and into a PB line. In this case the I/O line *sinks* the current (draws current from the supply).

In Figure 5b current flows *out of* a PB line to the 0V supply. In this case the I/O line *sources* the current (provides current for the load).

Both of these conditions cause current flow when the appropriate logic level is present on the I/O line, i.e. logic 0 in Figure 5a and logic 1 in Figure 5b.

Once this principle is understood, it can be applied to an output circuit using a transistor, as shown in Figure 6a.

This circuit is an extension of Figure 5b where a logic 1 at PBO provides sufficient bias voltage to forward bias the base-emitter junction of the transistor. This

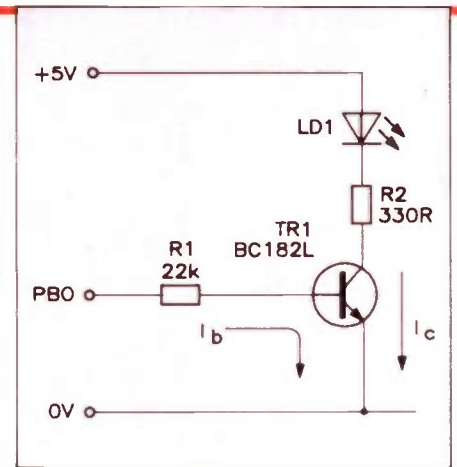

Figure 6a. Simple LED output circuit.

```
10 ?&FE62 = &01
20 :
30 ?&FE60 = &01
40 FOR T = 1 TO 2000
50 NEXT T
60 :
70 ?&FE60 = &00
80 FOR T = 1 TO 2000
90 NEXT T
100 :
110 GOTO 30
```

Figure 7. Simple test program for Fig. 6a circuit.

circuit is sourcing current through R1 and TR1 base-emitter with a larger current flowing through the load LED. Thus a current of less than ten times that required by the load is drawn from the user port line PBO, the transistor providing protection for the IC's I/O lines.

This is a useful test circuit enabling the user to use the computer to switch on LED1 by placing a logic 1 on PBO or off with a logic 0. This can be achieved from the keyboard or via a simple test program loop which utilises ?&FE60=&01 or ?&FE60 = &00.

A suitable test program not unlike the one used in Part 1 is shown in Figure 7.

Line 10 sets PBO I/O line to be an output and lines 30 & 60 put the ON and OFF data values respectively on to PBO. A suitable time delay can be achieved by experimenting with T values.

It may be worthwhile to take the trouble to build this simple circuit on stripboard simply for the experience of producing a control circuit, getting it to work and being able to operate it with software. A suggested stripboard layout is shown in Figure 6b.

Once tested, this circuit can be used to switch a relay (for motor operation) but needs some modification as shown in Figure 8.

As can be seen, a number of diodes are included for protection, due to the presence of a relay coil in the circuit. Diode D3 is described as a commutation diode whose function is to short-circuit the relay on switch off when back EMF is

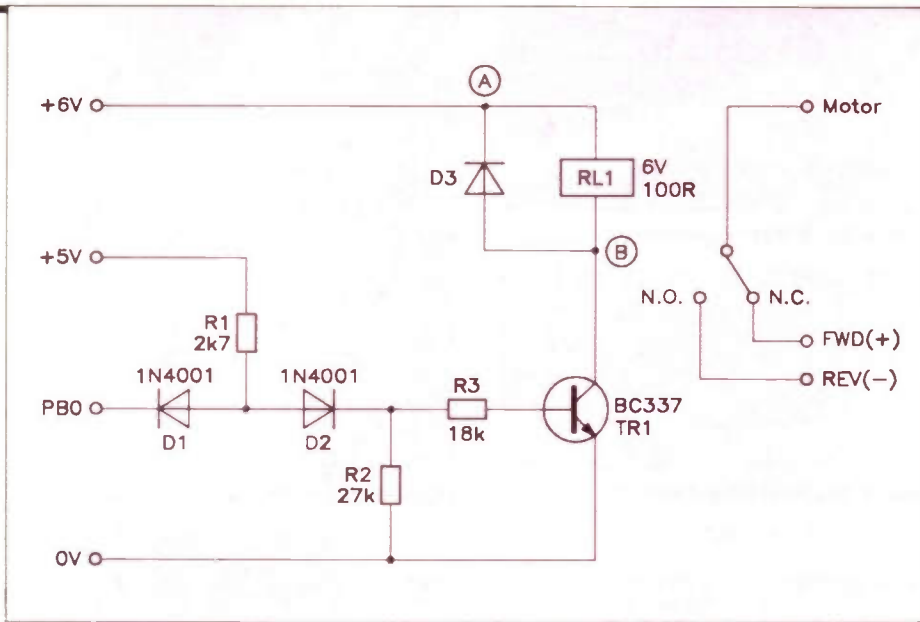

Figure 8. Extended circuit of Figure 6a.

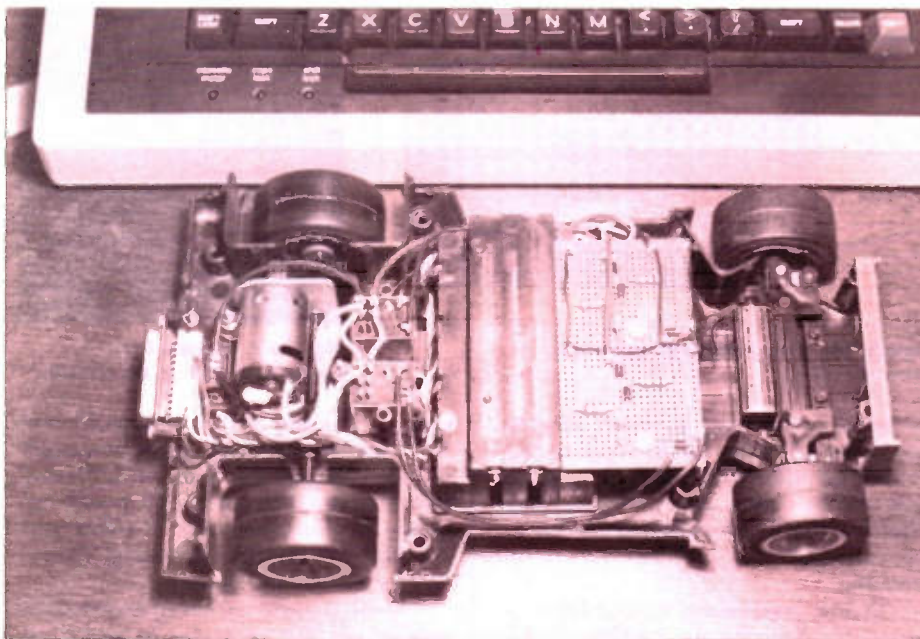

Photo 1. User port control of single motor vehicle.

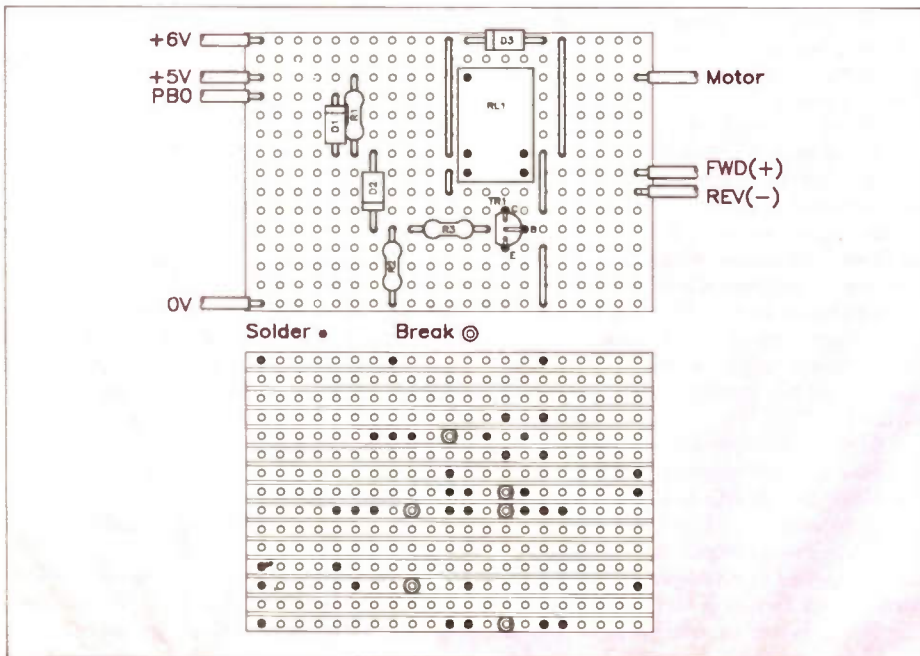

Figure 9. Suggested stripboard layout for single motor control (two of these required).

generated. In normal operation the diode presents a high resistance (reverse bias) path so current passes through the relay coil. Diode D2 requires forward biasing for current to pass through the base emitter circuit and its only effect on the circuit is to drop about 0.7 volt across it providing a suitable bias level for the transistor base-emitter. A logic level of 0 at PBO forward biases D1 and current will flow from +5V into PBO (sinking current). A logic 1 however will reverse bias D1 and then current will flow from +5V through D2 and thus the logic 1 will turn on the transistor. Thus the two diodes act as a switch depending on whether logic 0 or 1 is present.

A relay requires its own supply voltage and current source which cannot be provided by a user port device. For test purposes a PP3 battery can be used but a more substantial (rechargeable) battery combination will be needed for a pair or pairs of relays.

To enable a motor to be switched on and off and also to operate in reverse, a pair of SPCO relays are required, as shown in Figure 3. The control circuit in Figure 8 is therefore required in duplicate. Relay 1 connections are shown as A and B in Figures 3 and 8 and the second half of Figure 3 is for relay 2 (C & D). A suggested stripboard layout for the (two) control circuits is shown in Figure 9.

A combination of Figure 3 and Figure 8 will provide a motor drive and direction circuit for one motor, with two inputs PBO and PB1.

A truth table for this circuit function is shown in Figure 10.

This table should relate to the motor control circuit and depends on how the motors and battery polarities are connected. Trial and error is probably the best method of establishing this. Note that one of the relay switches needs to be 'open' to break the circuit and provide a stationary robot!

A complete circuit will be provided in Part 3 based on these experiments and will also include the next two circuit functions.

An Additional Output Device

To keep the robot simple but making use of all available I/O lines, a suitable and useful output device can be provided in the form of the LED used for testing earlier. In fact a pair of LED's can be used to demonstrate software control and even provide coded visual information, for example indicating motor direction or providing a test flash at the beginning or end of a process.

The practical circuit in Figure 11 is all that is required for one output line or port bit to turn on and off an LED. (See stripboard layout Figure 6b.)

With logic 0 at PB4 & 5 the transistor(s) is off and logic 1 provides the necessary bias to turn on TR1 which conducts causing current to flow through the LED. The binary codes for operating these two circuits separately are 00 (both off) 01 (LED1 ON, LED2 OFF), etc. Hex values are shown in the table in Figure 12.

Simple test programs in BASIC can be written to test this circuit, using a FOR . . . NEXT loop as in the earlier motor test programs.

To conclude this article, we will utilise the simplest input device, a switch. Although this aspect can be achieved with a simple toggle switch, a more immediate application in robotics is to use a momentary action or push-button switch such as the non-latching push-to-make type. The application of this is in collision detection, such that if it is strategically placed on a vehicle it can notify the microcomputer (control computer) that a collision has occurred and the vehicle can then be programmed to take appropriate action, for example by switching its motors to reverse. A pair of switches is especially useful for detecting a 'right' collision and a 'left' collision and then taking appropriate action, for example reversing and then turning to avoid a repeat, not to mention anticipated, collision. From this point on it is all down to programming.

Figure 13a shows a simple collision detect circuit. As before, two of these circuits are needed to provide a two-bit collision detection function.

No separate supplies are needed for the circuit(s) as the +5V and 0V are available at the user port. With the switch contacts open PB6 & 7 read logic 1 (from +5V), and when the switch is closed they read logic 0 (0V short circuit to input). A suggested stripboard layout is shown in Figure 13b.

Programming for the reading of the collision detect switch can be achieved in BASIC by using the logical operator AND. Taking PB7 on its own, bit 7 (MSB) has a value of 1000 0000 = &80, or in decimal 128. An IF . . . THEN instruction provides comparison between a fixed value and the actual value present on PB7 (the comparison is actually made with the whole of the user port byte, &FE60). A simple program is shown in Figure 14.

Running this program causes the robot vehicle to go forward until a collision occurs, when it reverses for a period and then repeats the process.

Line 10 places the binary value 0000 1111 into the data register for forward movement.

Line 20 tests bit 7 by ANDing the binary value 1000 0000 with whatever is in the Data Register. If bit 7 is at logic 0 then a collision has occurred. This is explained as follows:

```
&FE60 = 0000 0000
AND   = 1000 0000
-----
result = 0000 0000
```

This result (= &00) then causes the program to jump to line 40 and the reverse action occurs.

If the result is not zero then line 30 is effected and the ANDing process is carried out as follows:

```
&FE60 = 1000 0000
AND   = 1000 0000
-----
result = 1000 0000
```

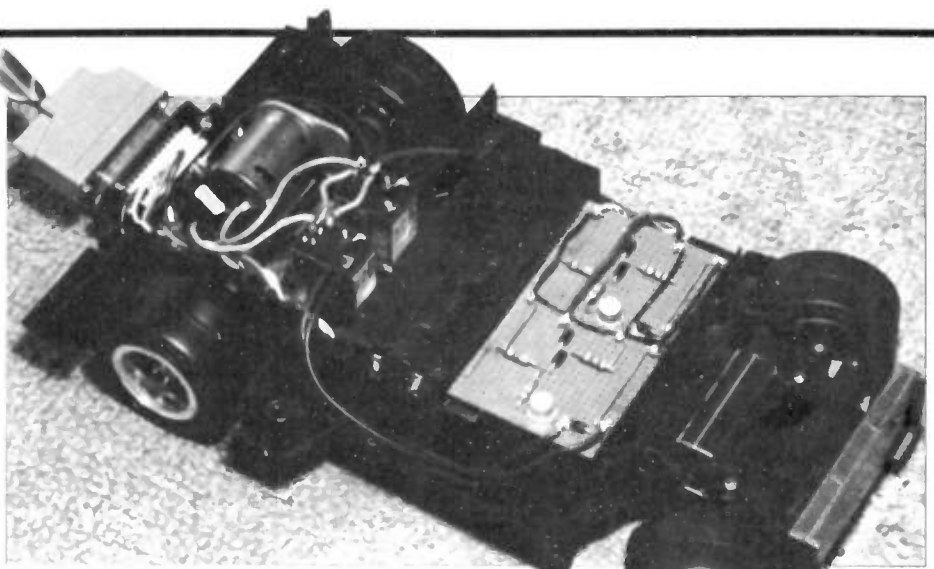

Photo 2. Vehicle under computer control.

PB1	PB0	RELAY 1	RELAY 2	ACTION
0	0	OFF	OFF	REVERSE
0	1	OFF	ON	STOP
1	0	ON	OFF	STOP
1	1	ON	ON	FORWARD

Figure 10. Truth table for control circuit (Figure 8).

PB5	PB4	LED2	LED1	HEX VALUE
0	0	OFF	OFF	&00
0	1	OFF	ON	&10
1	0	ON	OFF	&20
1	1	ON	ON	&30

Figure 12. Binary and hex codes for LED control.

This result (= &80) means that PB7 is at logic 1, representing no collision and the program loops back to begin testing again.

It should be realised that the state of bits PB0-PB6 are irrelevant to collision detection as the AND function is only dealing with bit 7 and the other bits are effectively masked out.

It should also be evident now that using the above program module enables a program to be written which will deal with either a left or right switch sense by reversing initially and then turning away from the collision site before moving off in a different direction.

Stepper Motors

Stepper motors, as their name suggests, differ from the ordinary D.C. motor in that, although they can provide continuous motion, they operate in discrete steps. That is to say, one complete revolution of a stepper motor always consists of a specific number of steps, unlike the D.C. motor where one revolution may be considered as a function of a time period.

A typical step angle is 7.5 degrees. This means that there are (360/7.5) degree steps in one revolution, i.e. 48 steps. Stepper motors are ideal where positional accuracy is required, for example in floppy disk drive mechanisms. For robotic applications the designer can choose either a D.C. motor ('analogue' or stepper motor ('digital'). For most purposes, a robot vehicle can be satisfactorily

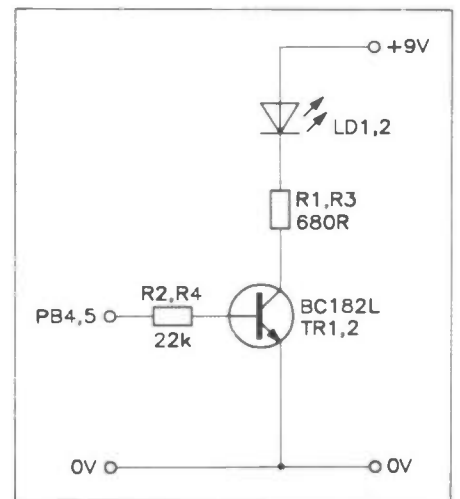

Figure 11. Turning on an LED.

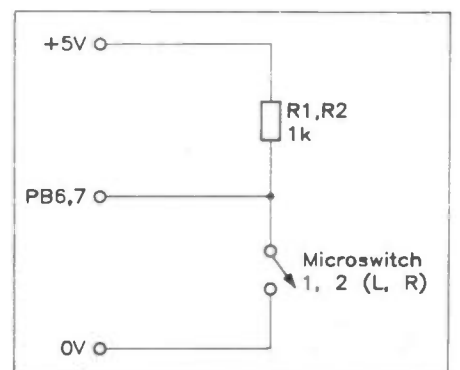

Figure 13a. Simple collision detection circuit.

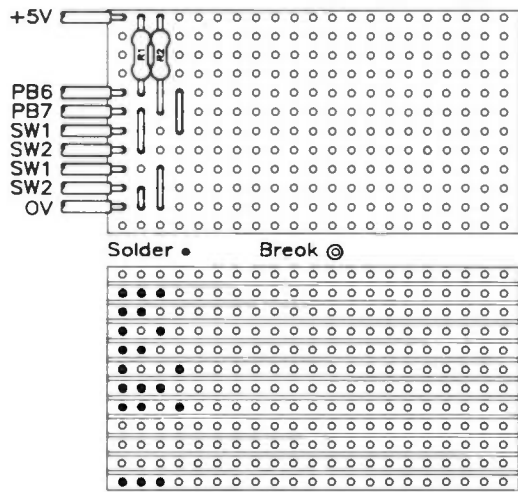

Figure 13b. Suggested stripboard layout (collision detection).

```

10 ?&FE60 = &OF
20 IF (?&FE60 AND &80)=&00THEN
  GOTO 40
30 IF (?&FE60 AND &80)=&80THEN
  GOTO 20
40 ?&FE60 = &00
50 FOR T = 1 TO 2000
60 NEXT T
70 GOTO 10
  
```

Figure 14. Collision detection test program.

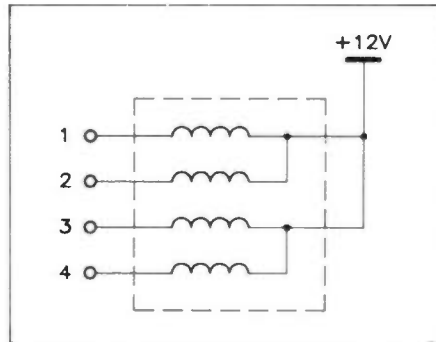

Figure 15. Stepper motor windings (4-phase unipolar).

driven by D.C. motors as positional accuracy is not essential, particularly if a feedback system is in operation, for example via collision detection switch sensors or sonar ranging equipment.

The final design in Part 3 uses D.C. motors as they are adequate for this vehicle. They are also cheaper and easier to control electronically. However, for completeness and to provide the designer with a choice, details of a stepper motor interface circuit are as follows:

A typical stepper motor is the 12V, 4-phase unipolar type as shown in Figure 15, available from Maplin (see components list). To produce rotation a stepper motor is stepped from one position to the next when pulsed. The pulsing provides the appropriate sequential combination of fields in the motor. A typical pulse sequence is shown in the table of Figure 16.

If the switching follows the sequence 1-2-3-4-1, etc., then a clockwise rotation

STEP	4	3	2	1	
1	0	0	1	1	CW ↑
2	1	0	0	1	
3	1	1	0	0	
4	0	1	1	0	
1	0	0	1	1	ACW ↓

Figure 16. Step sequence for 4-phase motor.

will result. 1-4-3-2-1, etc., will produce a counter-clockwise rotation. If all windings are de-energised, the motor will remain at its last position, held by the permanent magnet in the motor.

The drive sequence may be achieved by a ring counter circuit, based on a shift register, or four output port lines of a microcomputer user port may be used, driven by a suitable program.

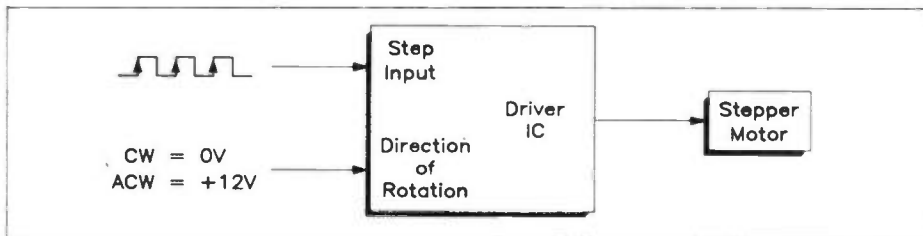

Figure 17. Simple block diagram of stepper motor drive circuit.

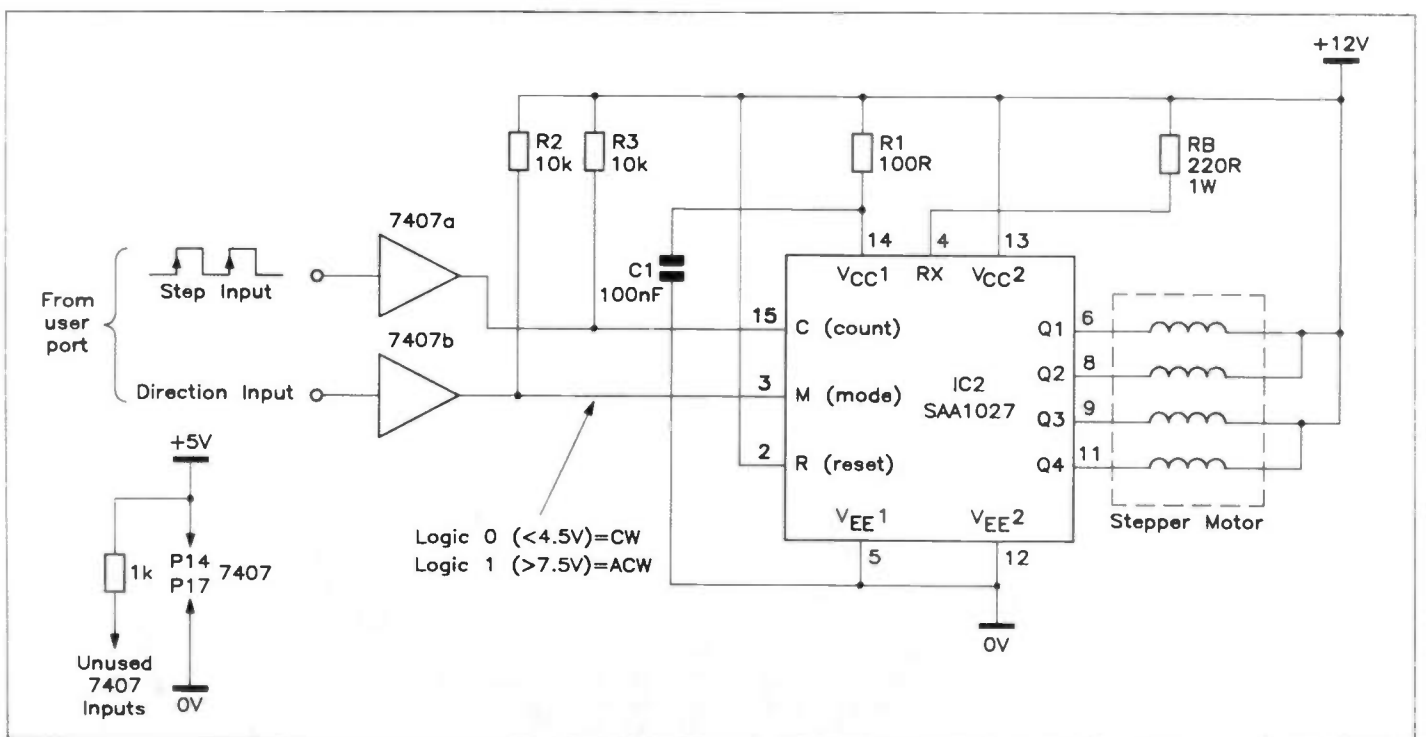

Figure 18. Stepper motor drive circuit using SAA 1027 and TTL input buffers.

An even easier method of stepper motor control is to use a stepper motor driver IC such as the SAA1027. This enables a stepper motor to be driven using only 2 output port lines: one for starting the rotation sequence by outputting a suitable pulse waveform, and one to select the direction of rotation by logic level. The principle of operation is shown in Figure 17.

Figure 18 shows a schematic circuit diagram of a stepper motor drive circuit using the SAA 1027 driver IC.

Pin 3 requires +12V for anti-clockwise operation or 0V for clockwise. The open collector inverters (7407) act as buffers and effectively convert a +5V logic

1 to the +12V required by the SAA1027. The use of two inverters restores the logic polarity. Pin 15 is the input for the pulses and a suitable pulse waveform is generated by software in accordance with the manufacturer's specification. This waveform is typically positive going with a pulse width of 20µsec. minimum and a minimum delay between pulses of 3msec. A reset pin is also provided to enable the resetting of the internal counter, but this is normally tied to +12V (inoperative).

A complete stepper motor, driver IC, PCB and passive components are available from Maplin (see components list). The kit includes full details of pin connections, voltage limits, etc.

The Next Stage

This article has covered enough ground to enable a constructor to put together a robot vehicle having 8 I/O lines, 4 of which are used to drive or 'steer' two motor/wheel units, 2 lines for LED's and the remaining 2 lines to detect collisions. By trying out these experimental circuits it is easy to see how a complete microcontrolled and therefore fully programmable vehicle can be constructed.

In Part 3 a complete circuit will be given for the robot developed in this article, including simple ideas for test programs and also some examples of 6502 machine code test programs.

Parts Lists

LED Circuit (Figure 6b)

RESISTORS: Carbon Film 1/2W

R1 330Ω 1 (E330R)
R2 5k6 1 (E5K6)

SEMICONDUCTORS

LD1 LED Red 1 (WL27E)
TR1 BC182L 1 (QB55K)

Relay Circuit (Figure 9)

RESISTORS: Carbon Film 1/2W

R1 2k7 2 (E2K7)
R2 47k 2 (E47K)
R3 10k 2 (E10K)

SEMICONDUCTORS

D1-D3 1N4001 6 (QL73Q)
TR1 BFX84 2 (QF23A)
Relay Ult-Mn 6V SPDT 2 (FM91Y)

Collision Detect Circuit (Figure 13b)

RESISTORS: Carbon Film 1/2W

R1,2 1k 2 (E1K)
Microswitches to suit

Stepper Motors (Figure 18 schematic)

Stepper Motor Size 1 1 (FT73Q)
Stepper Motor PCB 1 (GD14Q)
or:
Stepper Motor + Driver Kit* 1 (LK76H)

* includes all passive components except 7407
TTL open collector buffers

MISCELLANEOUS

Stripboard, rechargeable batteries and holders to suit;

1Ah Lead Acid Battery 6V (YJ66W)
Small Motor, 1.5V to 3V (YG12N)
Micro-Min Relay 6V (FM89W)

MUSICAL

MAPLIN touch-sensitive electronic piano. Complete and working in case with keyboard and Maplin 50W amp. Will split if required. Any offers? Please Tel: Truro (0872) 76186.

VARIOUS

COMPONENTS FOR SALE: resistors, capacitors, semiconductors, relays, hardware, power supplies, etc. New surplus stocks at low prices. Send SAE for list to M.A. Priestley, 32 Bankpark Grove, Tranent, East Lothian EH33 1AU.

SME3009 ALLOY HEADSHELL. Mint condition £5. Plus Scotch T tapes and other audio accessories. SAE for full list to Mr Nott, 47 Roseberry Crescent, Great Ayton, Middlesbrough, (0642) 723204.

TRIO COMMUNICATIONS RECEIVER R600. 0-30MHz. Excellent condition, cost £300 - unused £250 ono. 2 years old. Tel: Merseyside (051) 342 2804.

A WIDE RANGE OF COMPONENTS in big packs with resistors, capacitors, semiconductors, etc. Complete with touch switch circuit. Only £2 per pack. R.Narramore, 15 Cleeve Road, Gotheringham, Cheltenham, Glos GL52 4EW.

MINISONIC SYNTHESIZER PCBs 4 BOARDS 1 with spare 74ls £10. MC1595L IC £5. Circuit Sine/Sq/Tri generator working £15. Tel: Merseyside (051) 342 2804.

HALF PRICE MEMORIES (suit computer upgrades), fast logic, racks, disk drives and misc. Mostly new in original packing, due to impending move abroad. Tel: Basingstoke (0256) 475925/27054 anytime.

NAD 3130 stereo integrated amplifier. Nominal 30+ watts per channel. Hardly used, perfect condition in box, moving abroad, cost £169.95 - sell for £140 ono. Tel: Basingstoke (0256) 475925/27054 anytime.

ROCKER SWITCHES: SPST, SPDT 40p each. DPST, DPDT 50p each. Electrolytic capacitors: 22µF, 47µF, 10µF, 22µF, 47µF, 100µF 6p each. Postage 70p. Cheques/PO's to: R Davies, Maplin Mag., P.O. Box 3, (Ref: ZA), Rayleigh, Essex SS6 8LR.

MAGAZINES GALORE! 150 altogether. 47 x ETI 1978-81, 33 x Everyday Electronics 1976-79; others include Elektor, PW, REW, PE, Ham Radio. Take them off my hands. Offers to Chris Pollard on (0506) 411099.

FOR SALE. Sony CRF160 FM/AM 13 band receiver. Sanyo DCX 6000K stereo tuner amp. TEAC A107 cassette deck. £30 each, carriage extra. Seon Smyth (0436) 71181.

CLASSIFIED

If you would like to place an advertisement in this section, here's your chance to tell our 35,579 readers what you want to buy or sell, or tell them about your club's activities - absolutely free of charge. We will publish as many advertisements as we have space for. To give a fair share of the limited space, we will print 30 words free of charge. Thereafter the charge is 10p per word. Please note that only private individuals will be permitted to advertise. Commercial or trade advertising is

strictly prohibited in the Maplin Magazine.

Please print all advertisements in bold capital letters. Reference Boxes are available at £1.50 each. Please send replies to address below quoting Reference Box Letters. Please send your advertisement with any payment necessary to Classifieds, Maplin Mag., P.O. Box 3, Rayleigh, Essex SS6 8LR.

For the next issue your advertisement must be in our hands by 1st April 1991.

GIANT CLEAROUT! Lots of different components including IC's, capacitors, resistors, some in large quantities. Send SAE for list. M.J. Dean, Blenheim, Walton Lane, Bosham, Chichester, West Sussex PO18 8QF.

DIGITAL FREQUENCY COUNTER £37. Geiger Counter £33. Elektor Capacitance Meter £27. Eagle Stereo Graphic Equaliser £25. Eagle Ultrasonic Remote Switch £15. Computer compatible Cassette Recorder £15. Tel: (0502) 566026.

ETI SMART TALKER, built and working £25 ono. Organ component clearout, SAE for list please to: Fred Wright, 29 St Andrews, Houghton-Le-Spring, Tyne & Wear DH4 5NT. Tel: Durham (091) 385 4734.

GIANT CLEAROUT! Lots of different components, some in large quantities. Send SAE for list. Also devices for cars that tell you the distance you are from a wall when reversing. Send SAE for more information: M.J. Dean, Blenheim, Walton Lane, Bosham, Chichester, West Sussex PO18 8QF.

FOR SALE. Issues 1-12, 18-41 of 'Electronics - The Maplin Magazine'. £20 Inc P&P. Tel: (051) 677 3670.

LASER FOR SALE. 1.6mW, helium neon type. As good as new. £56. Tel: (0745) 560699 after 4.30pm.
MAPLIN NICAM television tuner with remote control. Brand new and fully operational. £159.00. No NICAM here till 1993 so check before you ring Peter on (0730) 68900 evenings.

LASER & CONTROLLER FOR SALE. Maplin laser and non-working controller: for £100 or offer. Mike Cox (0252) 316200.

UNFINISHED PROJECT. Mapsat Decoder/PSU board, Framstore, Input board, CPU board, Modulator PSU, High Resolution board, UHF 137 MHz pre-amp, 19" rack & backplane. All fully built to high standard, no time to finish, £70. Also Gould OS300 20 MHz dual trace scope with probes + soft case, PSU fault, hence £30.00. Tel: (08675) 4682.

COMPUTERS

6502 SYMBOLIC CROSS ASSEMBLER FOR IBM PC and clones. At last you can write 6502 assembly code on a PC! Software runs from floppy or hard disk. Source files can be written and edited using integral line editor or standard wordprocessor. Assembled files can be output as an ASCII listing, Hex dump or Intel format dump. Intel format dump can be uploaded directly into EPP1 EPROM Programmer. Supports 1500 lines of code and 300 labels, plus user definable macros. Demo disk available. Send SAE to Maplin Mag., P.O. Box 3, (Ref: ZB), Rayleigh, Essex SS6 8LR for details.

12" SAMSUNG amber monitor till/swivel 5 months old £50. Hercules mono printer card £12. Acoustic modem 300B £10. CC:MAIL Electronic mail software, best offer over £100. Mel Saunders, 7 Drumcliff Road, Thurnby Lodge, Leicester LE5 2LH. Tel: (0533) 419742.

ATARI ST/STE computers, public domain software only 99p per disk. Tel: (0634) 723659 (between 4 - 6pm) or write to ST P.D., 66 Abbey Road, Strood, Kent for more details and list.

PRINTER INTERFACE for Commodore 64/128; includes extended buffer, screen dumps, fonts, printing effects and other features. Has never been used. £30 ono. Tel: (091) 236 4470.

FOR SALE. Atari 2600 games machine with adaptor, joystick, aerial plug and ten games. Worth £150. Selling for £75 ono. Tel: (0823) 666291, (between 4 - 8pm).

HOUSTON INSTRUMENTS 'HIPAD' DIGITIZER. Complete with handbook! Little used, £150 ono. Telephone (0371) 856409 anytime.

IMAGE ARTIST CAD SYSTEM Including: Electronics unit, 20 MByte hard drive, 800 KByte floppy drive, Computer cards, Graphics cards, Power supplies housed in 19" 5U high rack, RGB monitor, Mono amber monitor, Digitising pad, pen, Keyboard, Wealth of software including Paint and 3D, Tektronix 4695 colour printer plus all manuals. £1,950 ono. Tel: Mold (0352) 740694.

WANTED

WANTED: The 3 following IC's in good working order. LM1894, TL094 and TDA3810. Must be fair prices including postage. Mr D. Macted, 22 Birch Gardens, Sandbach, Cheshire CW11 0HB.

WANTED: Schematics of Tanktek modules, pay £3.5 each; book 'Electronic Music Circuits' £20 if mint. Contact G. Calderini, via Vasco de Gama 72, 00042 Anzio, Rome, Italy.

WANTED: Olivetti ET221 Electronic Typewriter. Condition immaterial preferably working. Circuit diagram would be useful. Tel: (0268) 546211.

WANTED: Oscilloscope 20MHz dual trace, preferably Hameck R.C. oscillator, working and good condition. Avi (081) 204 2123 after 7pm.

WANTED: Sennheiser MKE 2-6 tie clip microphone. Giles Rowland (0923) 34303.
ALLOPHONES WANTED. A list of allophones for commonplace words, any target chip. Please phone (0483) 303568 or write to Stuart Conway, 7 Chevremont, Jenner Road, Guildford GU1 3QL.

WANTED: Circuit diagrams for FM transmitter 5 to 25 watt output, Radio Control For Beginners and How To Make Walke Talkies books. Write: Dada Wilson, 57 North Grove, Tottenham, London N15.

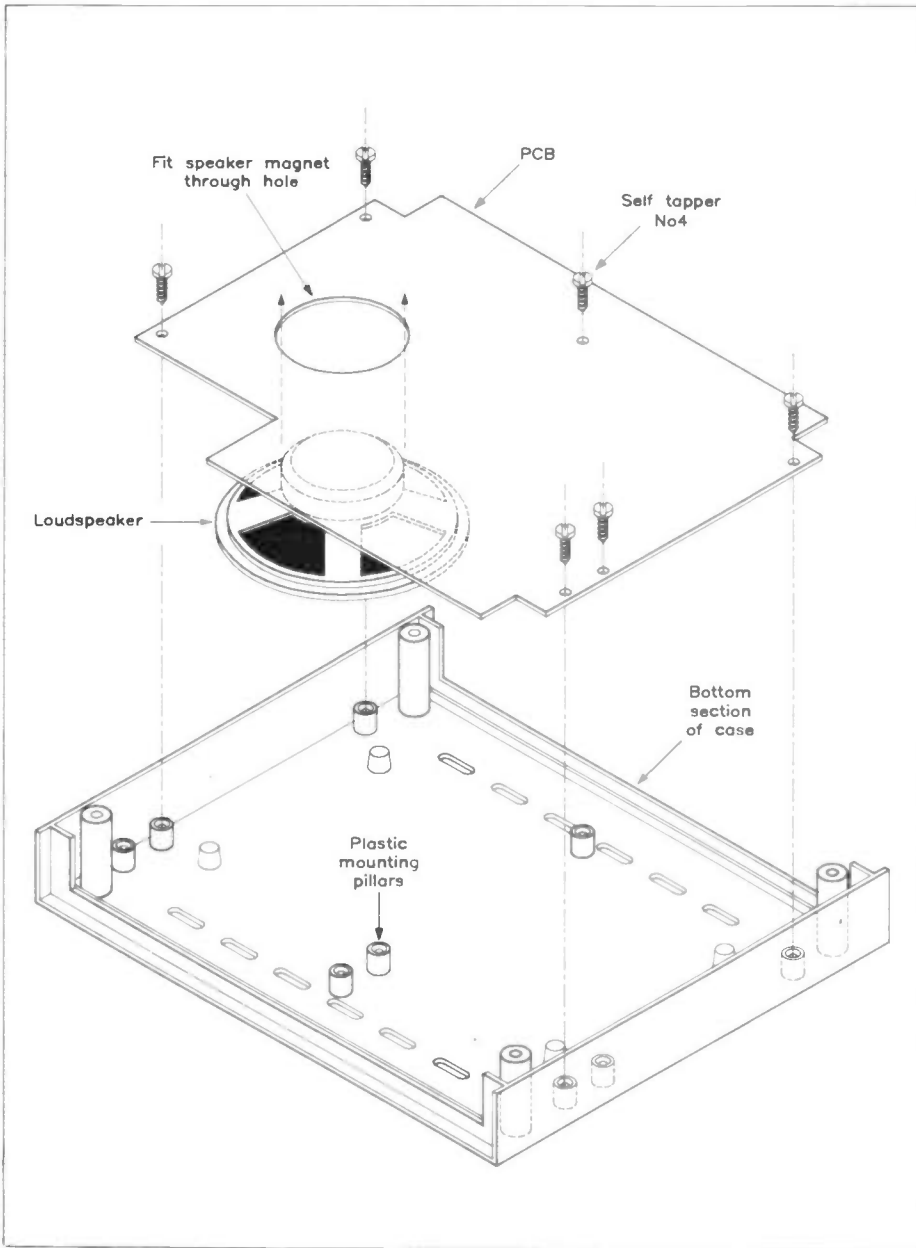

Figure 14. Mounting the PCB.



Photo 3. Front view of the prototype unit.

Because of the general propagation conditions at 160m, the band is usually most active during periods of darkness. During daylight hours, propagation limits effective communication range to a few tens of miles and for this reason, the number of stations to be heard in the day is that much lower than at night. During darkness hours however, ranges up to several thousand miles are often possible.

Although the majority of stations received will be using SSB, CW or data modes, AM is still very popular with amateur radio operators in some areas and it is for this reason that the AM mode is incorporated in the receiver design. Because of the type of design and the nature of the mode, the receiver is not as sensitive in the AM mode; nevertheless, reasonable performance should be obtained on the stronger signals.

Whether the AGC is set to fast or slow depends on the prevailing band conditions. There are no hard and fast rules regarding AGC settings and the choice of setting is really down to the user.

Finally Table 1 shows the specification of the prototype 160M receiver.

Power Supply	
Voltage	12V - 16V
Power Supply current (quiescent)	33mA
Frequency	
Range	1.795MHz - 2.24MHz
Sensitivity AM	less than 2.0µV
	CW SSB less than 0.5µV
Headphone Output	4Ω - 32Ω
Intermediate	
Frequency	455kHz nominal
Local Oscillator	
Frequency	1.34MHz - 1.785MHz

Table 1. Specification of prototype.

Bibliography

The following books from the Maplin catalogue provide a wealth of information on antennas and receiving techniques:

Introduction to Antenna Theory (WP78K). This book explains the basic theory behind antennas, enabling the experimenter to design antennas for a variety of applications.

HF Antennas for All Locations (WS16S). A book covering a wide range of antenna ideas suitable for use in the HF band.

Shortwave Listening Handbook (WS61R). This book covers both the theory and the more practical aspects of short wave reception as well as detailing various peripherals such as aerial tuners and noise limiters. The book also explains what can be heard at different frequencies and the different types of propagation.

Additional books covering radio and related subjects may be found in the books section of the Maplin catalogue.

160 METRE RECEIVER PARTS LIST

RESISTORS: All 0.6W 1% Metal Film (Unless specified)

R1 5.27.32	100R	4	(M100R)
R2	39k	1	(M39K)
R3	330R	1	(M330R)
R4.6.10.12.24	100k	5	(M100K)
R7	47k	1	(M47K)
R8.37.38	220R	3	(M220R)
R9.11.14.19.26	10k	5	(M10K)
R13.29	2k2	2	(M2K2)
R15.33.34.36	1k	4	(M1K)
R16	1M	1	(M1M)
R17	220k	1	(M220K)
R18	27k	1	(M27K)
R20	470R	1	(M470R)
R21	470k	1	(M470K)
R22.31	2k7	2	(M2K7)
R23	82k	1	(M82K)
R25	8k2	1	(M8K2)
R28	1k2	1	(M1K2)
R30	560R	1	(M560R)
R35	820R	1	(M820R)
RV1.3	47k Min Pot Lin	2	(JM73Q)
RV2.6	10k Hor Encl Preset	2	(UH03D)
RV4	4k7 Hor Encl Preset	1	(UH02C)
RV5	10k Min Pot Log	1	(JM77J)

CAPACITORS

C1	470µF 16V PC Elect	1	(FF15R)
C2.3.5.7.9.15.17.23.26.28.29.32	100nF Minidisc	14	(YR75S)
C4.6	220pF Ceramic	2	(WX60Q)
C8	10µF 16V Minelect	1	(YY34M)
C10	68pF Ceramic	1	(WX54J)
C11.20.22.34.36	10nF Ceramic	6	(WX77J)
C12	56pF Ceramic	1	(WX53H)
C13.31	220µF 16V PC Elect	2	(FF13P)
C14	47nF Monores	1	(RA47B)
C16	3n9F 1% Polystyrene	1	(BX63T)
C18	100pF 1% Polystyrene	1	(BX46A)
C19	220pF 1% Polystyrene	1	(BX49D)
C21	4n7F Ceramic	1	(WX76H)
C27	68nF Polylayer	1	(WW39N)
C30	2n2F Ceramic	1	(WX72P)
C33	1nF Ceramic	1	(WX68Y)
VC1	Min AM Tuner	1	(FT78K)

SEMICONDUCTORS

IC1	LM3820	1	(WQ37S)
IC2	CA3140	1	(QH29G)
IC3	TDA7052	1	(UK79L)
IC4	MC1496	1	(QH47B)
TR1	3SK88	1	(UH63T)
TR2	BF244A	1	(QF16S)
TR3	MPSA14	1	(QH60Q)

MISCELLANEOUS

RG1	µA78509UC	1	(UJ55K)
RG2	µA78L05AWC	1	(QL26D)
D1.3	1N4002	2	(QL74R)
D2	1N4148	1	(QL80B)
D4	OA90	1	(QH71N)
S1.2	SPST Ultra Min Toggle	2	(FH97F)
S3	DPDT Ultra Min Toggle	1	(FH99H)
SK1	DC Power Skt PCB 2.5mm	1	(FK06G)
SK2	PCB 3.5mm Sto Skt	1	(JM23A)
SK3	PCB 3.5mm Sto DPCO Skt	1	(JM21X)
T1.2.7	KANK3333R	3	(FD02C)
T3	YRCS11098	1	(HX42V)
T4	YRCS12374	1	(YG30H)
T5	YHCS11100	1	(HX43W)
T6	YMCS17104	1	(YG32K)
M1	Signal Strength Meter	1	(LB80B)
L1	Choke 100µH	1	(WH41U)
	8 Pin DIL Socket	2	(BL17T)
	14 Pin DIL Socket	2	(BL18U)
	Pins 2145	1Pkt	(FL24B)
	Loudspeaker Lo-Z668	1	(WB13P)
	Isobolt M2.5 20mm	1Pkt	(JD15R)
	M4 x 0.5in Spacer	1Pkt	(FG37S)
	Hook-Up Wire (7.0.2mm)	1Pkt	(BL00A)
	PC Board	1	(GE49D)
	Constructors' Guide	1	(XH79L)
	160m Receiver Leaflet	1	(XK28F)

OPTIONAL (not in kit)

SK4	SO239 Skt (Square)	1	(BW85G)
	Grounding Post with 4mm Skt	1	(JL99H)
	Isobolt M3 x 6mm	1Pkt	(BF51F)
	Steel Nut M3	1Pkt	(JD61R)
	Isoshake M3	1Pkt	(BF44X)
	Isotag M3	1Pkt	(LR64U)
	Case 3502	1	(YN33L)
	Poziscrew M2.5 12mm	1Pkt	(BF40T)
	M3 1/4in Spacer	1Pkt	(FG33L)
	M2.5 Nuts	1Pkt	(JD62S)
	Self Tapper No 4	1Pkt	(FE68Y)
	Front Panel	1	(JX41U)
	Back Panel	1	(JX42V)
	Knob K7A	3	(YX01B)
	Knob K7B	1	(YX02C)

The above items, excluding Optional, are available as a kit:
Order As LP31J (160m Receiver) Price £36.95

The following items are also available separately but are not shown in our 1991 catalogue:

160m Receiver PCB Order As GE49D Price £11.95

Front Panel Order As JX41U Price £3.25

Back Panel Order As JX42V Price £3.25



- ▶ Do you have difficulty in getting hold of your copy of 'Electronics - The Maplin Magazine'?
- ▶ Does your Newsagent always sell out before you can get your copy?
- ▶ Are you fed up with braving the onslaught of wind, rain and keep fit fanatics in your ceaseless quest to find a copy of your favourite electronics magazine?
- ▶ Do you say to your family and friends, "I'm just going outside, I may be gone a little while . . .?"
- ▶ Does your dog hide when you return empty handed?
- ▶ Do you resort to reading the Beano, Dandy, Viz or other well known 'comics'?

Then why not ask your friendly local Newsagent to reserve or deliver every issue of 'Electronics - The Maplin Magazine'?
Fill out the coupon (below), hand it to your Newsagent and you need never miss an issue of 'Electronics - The Maplin Magazine'.

Dear Newsagent

Please reserve/deliver (delete as applicable) each issue of 'Electronics - The Maplin Magazine' for me.

Name

Address

Signature

'Electronics - The Maplin Magazine' is published bi-monthly and is distributed through your wholesaler by: United Magazine Distribution Ltd., 1 Benwell Road, London N7 7AX. Telephone: 071-700 4600.

Audio-Frequency Induction Loop Systems

by J.M. Woodgate B.Sc.(Eng.), C.Eng., M.I.E.E., M.A.E.S., F.Inst.S.C.E.
Part 5 – On the Receiving End

New Readers Start Here

This series started in Issue 39 of 'Electronics', and you really need all of the Parts to understand this one, so why not order the back-issues now?

Briefly, an audio-frequency induction-loop system (AFILS) consists of a source of audio signals (microphone, tape or disc player etc.), an amplifier which drives current through a loop of wire surrounding the area to be covered, and some sort of receiver (not a radio receiver) which responds to the audio-frequency magnetic field produced by the current in the wire.

Applications

AFILS are widely used for communicating with people with hearing problems, in which case the 'receiver' is a hearing aid equipped with a 'telecoil', a coil wound on a rod of magnetic material which acts as an antenna for magnetic fields. AFILS are also used for communicating with staff, for relaying a commentary in such places as museums, and for an increasing range of other purposes. An AFILS can be much less expensive than a radio paging system, for example, if the area to be covered is not too large, and one communication channel (or a zoned system) is enough. For these latter purposes, it is often assumed that a sending-end bandwidth wider than the 5kHz bandwidth specified (BS6083-4) for hearing-aid systems is necessary. That this is unlikely to be true can be seen from the continuing use of AM radio, where the transmitted bandwidth is only 4.5kHz, and by the time the signal has negotiated the average 'trannie', 2.5kHz is nearer the mark. It is important not to provide more sending-end bandwidth than necessary, because it means a bigger amplifier, and also because the potential for interference (either with other nearby AFILS or with other systems) is increased. Furthermore, unlike the case of AM radio, it is perfectly feasible to provide frequency response correction at the receiving end to restore the overall system bandwidth, even to 20kHz, without significant loss of signal-to-noise ratio.

AFILS should be clearly distinguished from carrier induction loop systems (CILS), in which the audio frequency

signals are used to modulate a high-frequency carrier, which is then fed to the loop. Such systems do use a form of AM (or NBFM) radio receiver.

A Staff Communication or Commentary-System Receiver

NOTE: This device is not a hearing-aid and should not be used for that purpose.

In designing a receiver, the most critical component is the magnetic antenna coil, because the characteristics of this determines the amount of gain, and the frequency-response equalisation required. In Part 4, I suggested a type of coil which is suitable, but subsequent work has shown that the Maplin stock item 'Telephone pick-up coil' LB92A is very suitable for this application. Curiously, it does not appear in the 'Wound Components' section of the Catalogue, but under 'Microphones'. I can, however, confirm that neither of my samples is at all microphonic!

Input Stage/First Equaliser Design

Just in case the supply source changes, the coils that I have used are marked with a silhouette of a telephone and 'TP-11'. This coil has an inductance L of 164mH and a resistance R of 355 Ω . The simplest way to equalise a rising frequency response from an inductive source is to

feed it into a low resistance; this usually gives good noise performance and accurate equalisation. It is also easy to do: just connect the coil to the virtual earth presented by the inverting input of an op-amp with resistive feed-back (Figure 28). This works very well, down to the frequency where the resistance R of the coil begins not to be negligible in comparison with its inductive reactance. The response then falls off towards low frequencies, but this can easily be corrected by putting a capacitor of the right value C in series with the feed-back resistor. The calculations are not too difficult. Let L be the inductance and f be the frequency at which the resistance and inductive reactance are equal. Then:

$$R = 2 \times \pi \times f \times L$$

so that:

$$f = R \div (2 \times \pi \times L)$$

If we need a gain of A times from the input stage, the feed-back resistor value is $A \times R$, and the capacitor value is then:

$$C = 1 \div (2 \times \pi \times f \times A \times R)$$

or:

$$C = L \div (A \times R^2)$$

However, there is a slight snag. These values give a gain of A at frequency f , whereas we are likely to measure the output voltage of the coil produced by a known magnetic field strength at 1kHz, and choose A from this value (see later). Consequently, we have to change the feed-back resistor from $A \times R$ to $(1000 \times A \times R) \div f$, and change the capacitor value from $1 \div (2 \times \pi \times f \times A \times R)$ to $1 \div (2000 \times \pi \times A \times R)$.

Applying the measured values of R and L for LB92A and choosing $A = 31.62$ (30dB), we get 33k Ω for the feed-back resistor and $C = 18$ nF for the capacitor. The choice of 30dB is based on knowing the input sensitivity of the final amplifier, which we haven't come to yet. We have to put a high-value resistor across the feed-back network to provide DC feed-back for the op-amp, and a 1M Ω resistor causes the response to roll off below 25Hz, which is a good thing.

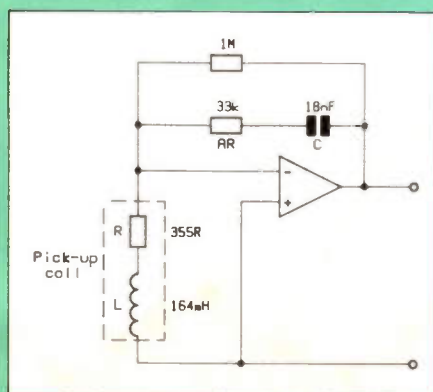

Figure 28. Basic input stage and first equaliser.

The overall response of this combination of coil and equaliser (measured with a current independent of frequency in the measuring coil described next) is flat within 1dB from 50kHz to 20kHz, and is 3dB down at 20Hz.

Measuring the Pick-Up Coil Output Voltage

The samples that I used gave an output voltage of 2.3mV at 1kHz for a magnetic field strength of 0.56Am⁻¹. For best accuracy, each coil should be measured. This can be done with a 1kHz (±1%) oscillator feeding an amplifier, which in turn feeds a square, single-turn coil 500 × 500mm through a 3.2Ω resistor (4.7Ω and 10Ω 1% in parallel). One volt output from the amplifier then gives the required magnetic field strength at the centre of the coil. *Don't forget* to keep the coil well away from anything metal, especially ferrous metal, and switch off all unnecessary equipment containing mains transformers and/or CRTs.

Gain Budget

To drive the headphone (or earphone or a small loudspeaker), the LM386 (UJ37S) is a good choice. This will produce 2.3V from a 8.4V rechargeable PP3 battery, and is used in the 26dB (× 20) gain mode, so it requires an input of 115mV. The first stage gives an output voltage of 2.3mV × 31.62 = 72.7mV. Allowing for the unit not being operated with the volume control at maximum, a gain of 9 (19dB) in the second stage is convenient, and will allow reception in areas where the magnetic field strength is reduced by distance or the effects of metal-work in the building.

Second-Stage EQ

All our previous sending-end designs have been based on the loop current being allowed to fall by 3dB at 5kHz. Without changing this specification, but by applying further equalisation in the receiver,

we can obtain an overall response flat to 20kHz. The penalty is a reduction in high-frequency signal-to-noise ratio, but for any likely application we can afford to lose some of that. What we do is to produce a 'step-network' frequency response, in much the same way as for the low-level equaliser for a voltage-drive amplifier described in Part 3 (see Figure 15, for example), except that here we want the step to run from 5kHz to 20kHz (see Figure 26 in Part 4). This is quite easy to do; we make a feed-back amplifier with a capacitor connected across part of the feed-back injection resistor (Figure 29). Using a 100kΩ feed-back resistor and a non-inverting configuration, the total injection resistance (Rf = Rf1 + Rf2) can be calculated:

$$(100 + Rf) \div Rf = 9$$

giving Rf = 10kΩ for a gain of 9 at 1kHz. At 20kHz, we need the gain to be 4 times higher, giving Rf1 = 2.7kΩ. However, the first stage response is a little down at 20kHz, so 2.2kΩ gives slightly more correction. The other feed-back resistor Rf2 is then 10 - 2.2 = 7.8kΩ, say 8.2kΩ. The capacitor Cf is in parallel with the 8.2kΩ resistor, and should have a reactance equal to 8.2kΩ at 5kHz, which gives a value of:

$$Cf = 1 \div (2 \times \pi \times 8200 \times 5 \times 10^3) = 3.9nF$$

Taking into account that we have provided a little more EQ than theoretically necessary by using 2.2kΩ instead of 2.7kΩ, we can expect to obtain a response up to 20kHz without problems.

Which Op-Amp?

Since the LM386 operates from a single 9V supply, and the Small Remote Control Box (LH90X), which holds one PP3 battery, would be convenient to use for the receiver case, a dual op-amp designed to operate from a single 9V

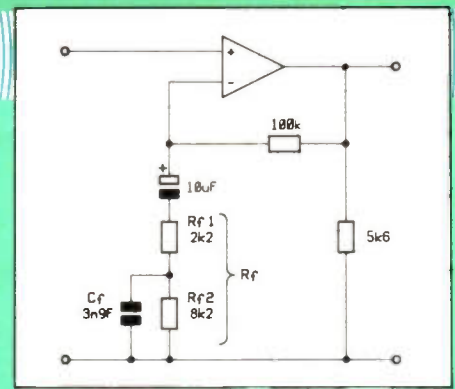

Figure 29. Basic second stage amplifier and second EQ for receiver.

supply is indicated. This is available as the LM358 (UJ34M), which also features low current drain and constant, low bias current. This device, and the quad LM324, have some features which are distinctly different from those of other op-amps, and can cause problems if you do not know about them. One of these features is the need to connect a 5.6kΩ (or 6.2kΩ) resistor directly from the output to 0V for AC coupled applications. (According to the data sheet, this is to set the output stage current; in fact the device tends to oscillate without the resistor.) Another is the need to have equal charge time-constants for the bias voltages on the inputs, otherwise there may be a long delay at switch-on before the device settles into the linear mode.

Final Amplifier

The second EQ stage is followed by a conventional volume control, which feeds the final amplifier LM386. This circuit is completely standard, except for the 56Ω resistor in series with the output. This is required if the receiver is used with headphones, to protect the user as far as possible from excessive sound pressure levels. If a 64Ω miniature loudspeaker (such as YT27E) is used, the resistor is not required. The complete circuit of the receiver is shown in Figure 30, and the overall response of a system (sending amplifier input to receiver output) is shown in Figure 31. Note that, though the loop current is -3 dB at 5kHz, the overall response is less than 3dB down at 20kHz.

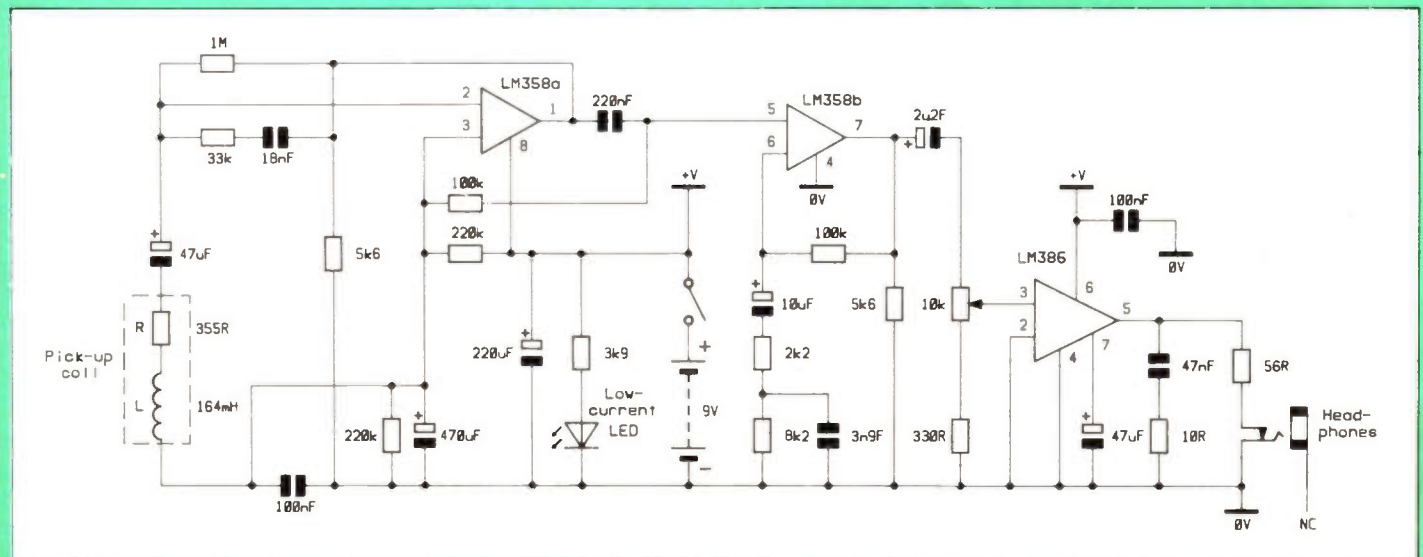

Figure 30. Circuit of the wide-band receiver.

A Monitor Receiver and Field Strength Meter with PPM Characteristics

There are a number of AFILS field strength meters available, with prices up to about £400. However, most of them have meters or displays with undefined or inappropriate dynamic characteristics. This is partly because the importance of these characteristics has not been recognised, and partly because BS6083-4 defines the field strength requirement in terms of the long-term average level of speech signals, without defining 'long-term'. Since nobody talks forever, the level for an infinite averaging time is clearly zero! What actually happens as the averaging time increases is that the level continues to fall, and there is no clear 'end-point' at which one can say 'this is the long-term level'. The BS also says that the average level over 0.125s is 12dB (4 times) higher than the long-term level, and this gives a clue to the derivation of these specifications, which is an American standard (ANSI 53.5:1969) for measurement of Articulation Index, not a list of juggernauts but a way of quantifying speech intelligibility.

The Peak Programme Meter (PPM)

This meter was developed by the broadcasters in order to control the peak levels of audio signals and so prevent overmodulation of the transmitters. We are also interested in controlling the peak levels, so as to prevent overloading of the sending-end amplifier. Furthermore, measuring the peak level of the signal gives a better idea of whether it is strong enough. The long-term field strength specification of 0.1Am^{-1} corresponds, as nearly as two independent tests can confirm, to a field strength of 0.56Am^{-1} (15dB higher) measured on a PPM.

Basically, the PPM consists of a full-wave rectifier with a defined, fast attack time and a defined, slow fall time. The output of this rectifier is fed to a logarithmic converter (to produce a linear scale in decibels) and then to a meter or LED or LCD display. The attack time-constant should be about 3ms and the discharge time-constant about 650ms. It is very convenient (and economical) to use an LM3915 (YY96E) as the logarithmic converter and display driver. This device drives ten LEDs in steps of 3dB, to give a total scale 'length' of 27dB (from 'LED No. 1 just on' to 'LED No. 10 just on'). In order to measure both signal levels and background magnetic noise levels, we need a total range of more than 40dB. There are two ways of doing this. One is to use two LM3915s, feeding one directly from the rectifier output and the other through a DC amplifier with 27dB gain, while the other way is to use one LM3915 and provide a range switch to insert a 27dB gain audio amplifier before the rectifier.

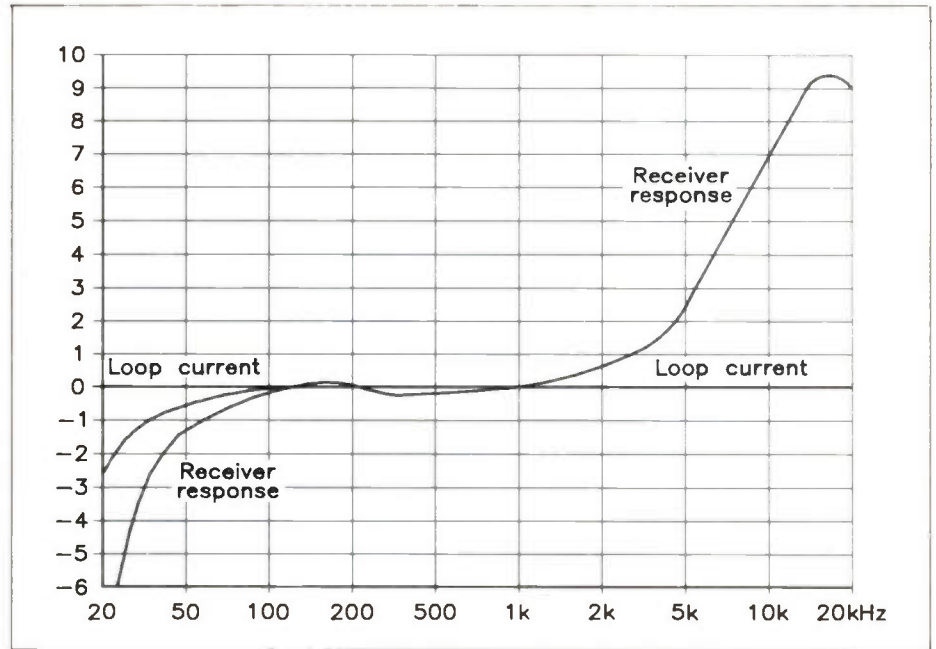

Figure 31a. Response to 'constant' loop current, showing 'second equaliser' characteristics.

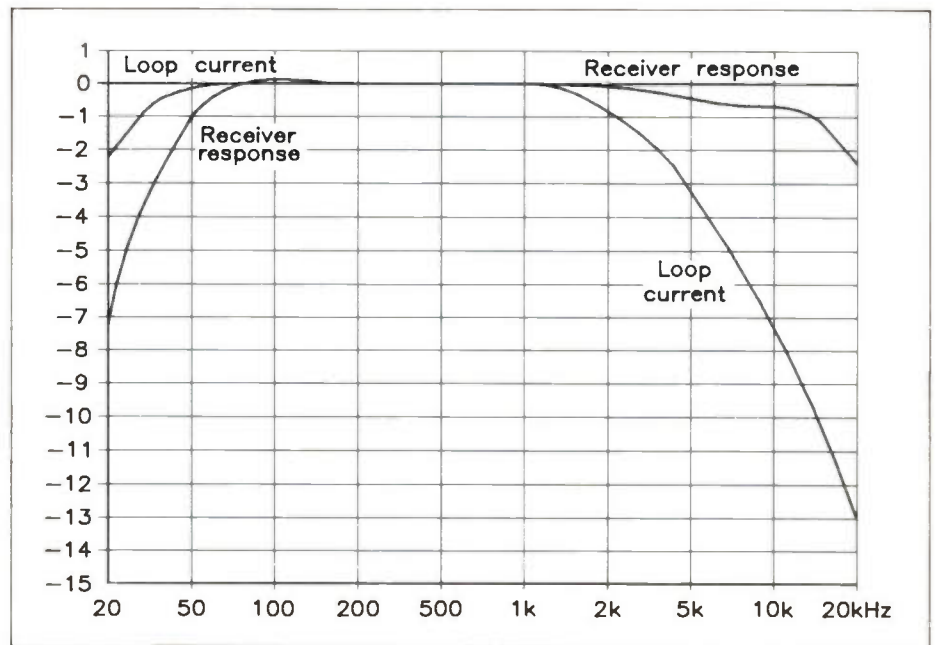

Figure 31b. Response to loop current falling at high frequencies -3dB at 5kHz (standard sending-end response).

Both systems work, but the simpler and slightly lower-cost second solution is described here. An extra gain of 27dB gives an effective 3dB overlap between the ranges, which is essential, otherwise field strengths in a range of just less than 3dB at the bottom of the top range would not cause any LED to light on either range.

Frequency Response

To use the meter for measuring the overall frequency response of a system, we need a flat response meter, with EQ to correct for the rising response of the magnetic antenna. For this, we can use the same circuitry as for the wide-band receiver, without the step-network in the second stage. We need, however, to control the frequency response more closely than for the receiver, so that

out-of-band signals do not cause inaccurate meter readings. We now have more parts to accommodate, including a string of LEDs for the PPM display. The 'Calc Box' (YK24B) is suitable for this job, and takes two rechargeable PP3 batteries. This is an advantage, because it is somewhat 'hairy' to design the rectifier around a single-rail device. With two batteries we can use dual-supply op-amps, and LF353 (WQ31J) or TL082 (RA71N) are suitable. It may be worth the extra few pence to use the lower-noise TL072 (RA68Y) for the first two stages. The board layout is easier if dual devices are used rather than one quad.

For assessing the sound quality of an assisted-hearing system (using the head-phone amplifier), and for measuring the noise level, we need a frequency response

which is close to that of a typical hearing aid, not forgetting that the aid does not (normally) compensate completely for the rising response of the magnetic antenna and that the earpiece also has a rising frequency response up to 3.5 to 5kHz (depending on the type of hearing loss for which the aid is prescribed) and a steep fall thereafter, whereas that of the monitoring headphones is likely to be much flatter. If we attempted to use a flat response for these purposes, the effects of mains-derived interference would be far too great, and the meter readings completely misleading. The required response has 12dB/octave slopes at both ends of the spectrum, and -3dB points at 630Hz and 5kHz (Figure 32). This is rather different from the specification in the draft BS Code of Practice for AFILS, but is very nearly the same below 5kHz as the 'H-weighting' curve used in Sweden, and the more rapid high-frequency fall-off is considered preferable, to help eliminate inaudible 'hash' coming from CRT displays. The BS specification may be brought into line before publication.

The Band-Pass Filter and Wide-Band Filter

The band-pass filter is the one described above, with -3dB points at 630Hz and 5kHz. With this ratio of corner frequencies, it is just possible to use one op-amp follower to work two Sallen and Key filters. There is some interaction between them, but a modest tweak gives a response very close indeed to the specification. This filter has about 4dB insertion loss (between 1kHz and 3.15kHz).

The wide-band filter is the one that just controls the band-ends of the 'flat response', which otherwise extends below 20Hz and above 20kHz. A passive band-pass filter is convenient here, particularly since we have to include 4dB insertion loss so that the calibration (at 1kHz) is the same when using either filter. To design this filter, we choose -3dB frequencies of 40Hz and 14kHz. Referring to Figure 33, an insertion loss of 4dB is an attenuation of 0.63:

$$R2 \div (R1 + R2) = 0.63$$

Now, I have a 'crib-sheet' that shows the best combination of preferred-value resistors for any attenuation (perhaps it could appear in the 'mag' sometime), and this gives $R1 = 3.3k\Omega$ and $R2 = 5.6k\Omega$.

For -3dB at 40Hz,

$$C1 = 1 \div (2 \times \pi \times 40 \times (3300 + 5600)) = 470nF,$$

and for -3dB at 14kHz

$$C2 = 1 \div (2 \times \pi \times 14000 \times 3300 \times 5600 \div (3300 + 5600)) = 5.6nF$$

The Rectifier and Display

The rectifier is a standard 'precision full-wave rectifier' as featured in many op-amp data sheets. The use of two

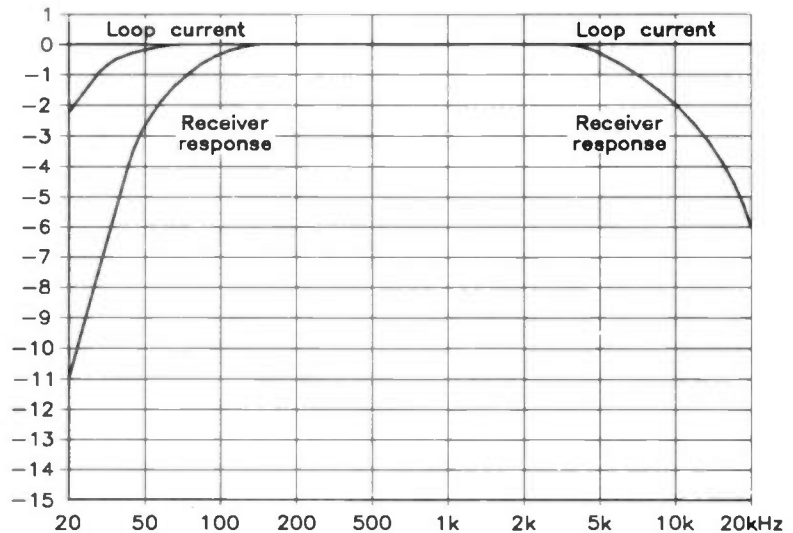

Figure 32a. 'Flat' response and loop current response. The 'flat' response is used only for measuring sending-end frequency response, and monitoring sound quality of wide-band systems.

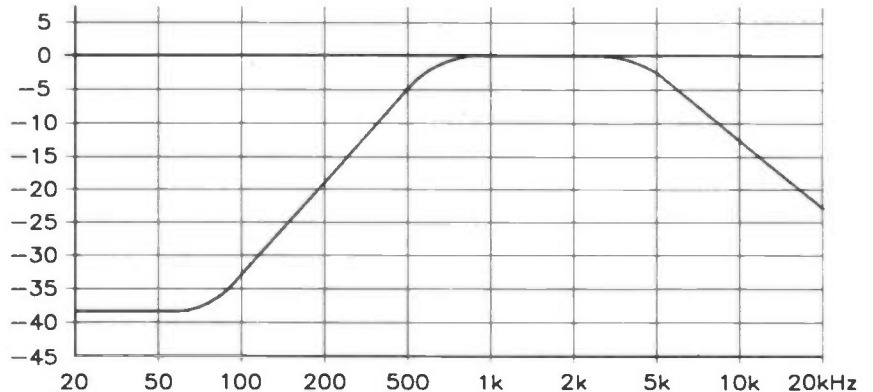

Figure 32b. 'Normal' response, simulating a hearing aid. The 'normal' response is used for measuring field strength of programme signals, noise levels, and monitoring sound quality of assisted hearing systems.

resistors in series in two places helps to ensure close matching, if they all come from the same batch. It would be very convenient to design this part of the circuit to have the standard PPM sensitivity at the rectifier input (LED 9 = PPM 6¼ = +9dBu: see Figure 35 for the meaning of '6¼'), so that it could be used as a 'building block' elsewhere. Fortunately, this is quite easy, and suits the LM3915 running from a 9V battery supply very well. In order to keep the current drain low, the LEDs are low-current types,

which need only 2mA or so for a bright display. The LM3915 will not, by itself, allow such a low current, so an emitter follower is added to supply the internal resistor network. This does put a small negative temperature coefficient on the chip reference voltage, but not enough to matter. The normal data-sheet design equations for the resistors around pins 7 and 8 also do not give quite the right answers under these circumstances, so a little tweaking is needed to give the values shown in Figure 34.

The Headphone Final Amplifier

Once again, we can use the same design as for the receiver, and to equalise the current drain on the batteries, we run the LM3915, which has to be DC coupled to the rectifier, from the 'top' battery and the LM386 from the other one. To get a reasonable volume control position, an attenuator is needed at the input, and this allows a simple step-network to be included, compensating for the 5kHz sending-end roll off, so that a signal to the correct specification sounds like a full-bandwidth signal and the listener does not need to keep in mind, when assessing

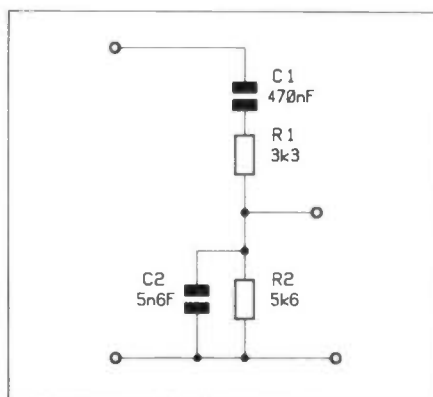

Figure 33. Basic circuit of the passive wide-band filter.

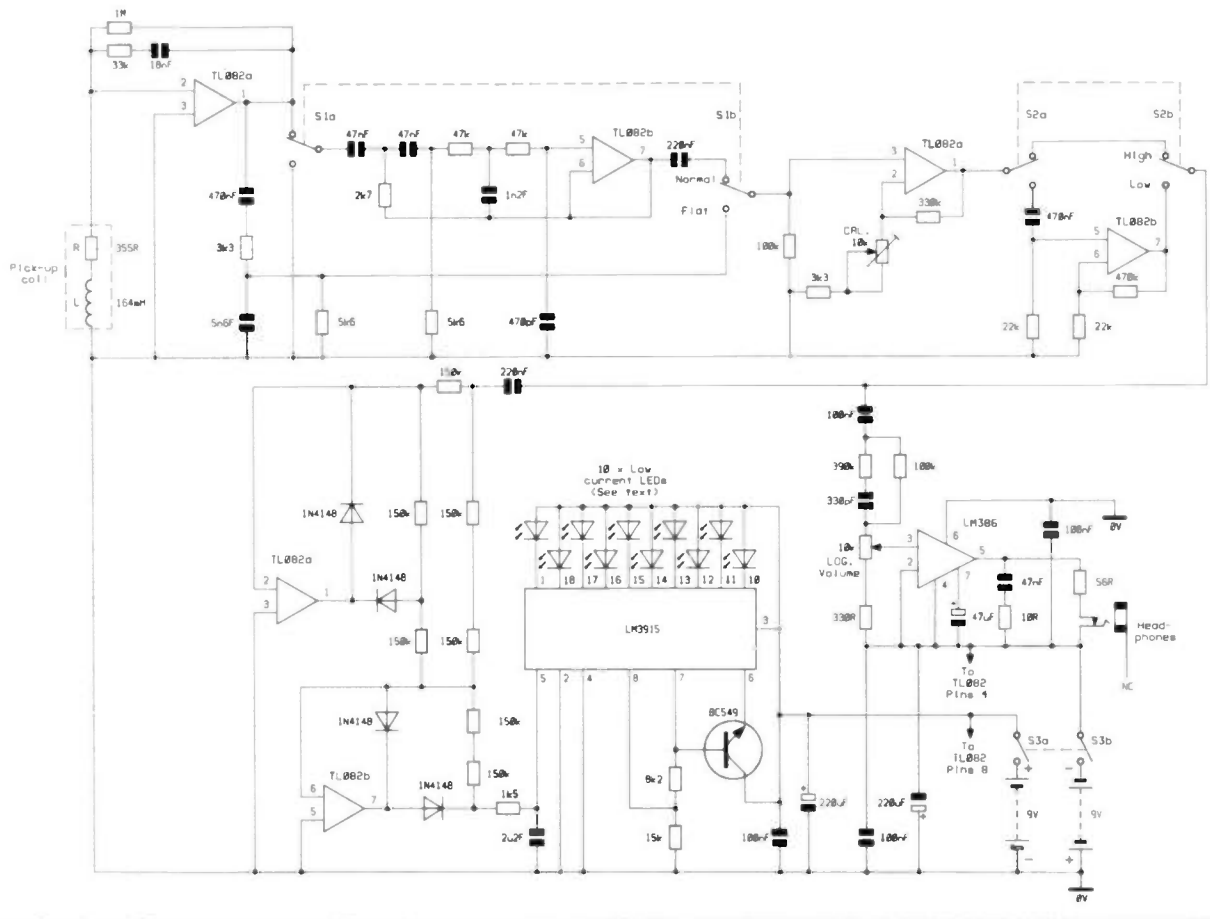

Figure 34. Circuit of the field strength meter/monitor receiver.

sound quality, that the system has only 5kHz bandwidth.

Scale of the Display

The LM3915 creates a scale with 3dB steps and a range of 27dB. There are three standard PPM scales, with ranges of 43dB, 28+dB and 48dB (IEC268-10 2nd Edition). The nearest to our case is that of 28+dB, which is the BBC/EBU PPM. This uses a pointer instrument display, graduated in 4dB steps, but the two versions have different scale markings. The relation between these scales and ours is shown in Figure 35. The sequence of LED colours, from LED 1 to LED 10 is red, yellow, yellow, yellow, yellow, yellow, green, green, green, red. LED 9 corresponds to 0dB = 0.56Am⁻¹, so LED 10 indicates too strong a field, which is inevitable close to the loop conductor, and any green LED indicates a field strength that may be acceptable if the background magnetic noise is low enough. LED 1 indicates, on the top range (+3 to -24dB), a noise level (in the absence of signal, of course) which is too high, and the same level is indicated by LED 10 on the low range (-24 to -52 dB). A green indication on the low range shows an acceptable signal-to-noise ratio. A yellow or red indication on the low range is suspect, because hardly any building with mains power gives such a low magnetic noise level. For AFILS for assisted hearing, all these measurements are made with the bandpass filter in circuit, the 'NORMAL' position. The 'FLAT' position is used ONLY for checking the frequency response of systems, with sine-wave signals fed to the sending amplifier. For wide-

band systems, the 'NORMAL' position gives a rather too-heavily weighted noise measurement, which is still useful if an earphone or small loudspeaker with restricted l.f. response is used. In any other case, the 'FLAT' position is used for sound quality assessment and gives an unweighted noise measurement. An external A-weighted r.m.s. or CCIR-weighted quasi-peak meter could be connected to an extra jack at the rectifier input, if required.

Calibrating the Meter

This is carried out using the 500mm square coil described before. All that is needed is to set the coil input voltage to 1V at 1kHz, and adjust the 'CAL.' preset so that LED 9 just lights. The other levels on both ranges can then be checked, bearing in mind that the meter will be measuring stray mains-derived fields as well as the coil field, and then the frequency responses in the two switch positions (see Figure 32). It is not normally necessary to

adjust the gain of the 27dB amplifier if 1% tolerance resistors are used.

Looping the Loop

This is the end of the regular series on AFILS, but there may well be more in future. I have not forgotten the current-drive amplifier with high-featured pre-amplifier, for example. I hope that you have found these articles as interesting to read as I have found them to research (since 1986!) and write.

When the BS Code of practice is published, there will naturally be much more information in it, although much of this concerns professional installation practice, operator training and system maintenance, all important subjects but not to be dwelt on at great length in an electronics magazine, perhaps. Don't forget that you will be able to borrow a copy of the Code through your Public Library service, when it is published. Perhaps you might even buy a copy...

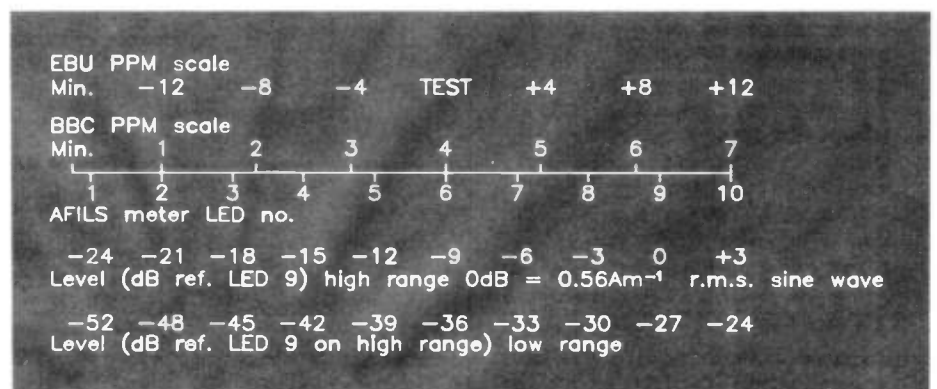

Figure 35. Relationship between 'our' PPM scales and the standard scales.

Watch as you build...

LOUDSPEAKER RADIO RECEIVER

Reviewed by David Holroyd

The Right Man for the Job

I was uncertain as to whether it was a compliment to my writing, or a recognition of my electronic illiteracy, that led the Editor to ask me to review the latest clever Maplin idea – a video cassette guided project, which has the self-explanatory title 'Watch as you build... Loudspeaker Radio Receiver'. The kit is supplied neatly packed into a standard video box and consists of a bag of components, a step by step VHS video cassette and an accompanying leaflet. As wizardry of this nature was new to me I also obtained a Maplin Starter Tool Kit.

Novices Start Here

The video kit is designed for those of us who can still recall school physics and our electronic interest but for various reasons have let it lapse. In other words novices or 'voltage virgins'! The objective is to follow the instructions on the video and be introduced to basic techniques such that at the end of the project a simple radio circuit has been constructed and is working – let me brag straight away, it worked, first time.

The kit is reasonably priced at £11.95 (correct at time of going to press) which is pretty good value for money. The instructions all start from the video. Just like the Blue Peter or cookery programmes the video instructor always makes a good joint, never drops a component or misplaces anything.

Step by Step

The instructions on the tape are clear, slowly but not patronisingly delivered, and relate perfectly to what is going on and what needs to be done on the board. The advice to watch the entire project through once is absolutely crucial. The various stages of the project do have a few false endings which you could miss if you jumped straight in.

The tape invites us to tackle the project stage by stage. The stages are well defined and there is a good description and picture of how the Board should look after each stage. The Board is, I am told, a relatively straightforward one and certainly none of the required tasks should defeat the average 'plug wiper and dipstick checker'.

That all seems honey and roses – so what about the draw backs? I would certainly have appreciated a few simple soldering exercises to begin with. The advice about how to solder is excellent but some means of practising this important



task would have been a useful confidence builder. I would certainly commend the video training technique of building in a 'PAUSE' screen. Had I not been using a remote controlled video cassette recorder I would have either burnt the carpet, the cat or the video recorder, maybe all three. The instructions run into each other and unless you are swift there is a lot of rewinding needed. A simple 'PAUSE' or 'HOLD' screen would give the builder time to stop the video, without having to rewind, once the particular task was finished.

At the end of the project the instructor offers some advice about what to do if you have not achieved sound from your board. His mention of testing with a multi-meter is I know, sound advice. Sadly he does not tell us what a multi-meter is, how to use one or how or where to beg, borrow or buy one.

Summary

All in all the 'Watch as you build... Loudspeaker Radio Kit' is fun. I found it more satisfying than Airfix kits and not as soul destroying as matchstick tower building. The instructions are clear even if a couple of reminders to only put components in a certain way do come a bit late.

What is vital is to ensure the user is properly equipped. I had a Maplin Starter Tool Kit. This was almost designed for the job and I dread to think what the result would have been had I scabbled around the tool shed and used ordinary domestic items – in other words forget about trying to use gardening secateurs, plumbers

solder and a blow-lamp – get the right tools for the job!

I was very proud of my achievement. I built the board in around three hours using the video and I would like to show it off to the neighbours, however all the video suggested was to mount it on a baffle board. An optional kit to mount the radio in a posh case would have made me very chuffed.

Upon reflection a very pleasant and satisfying way for a non-electronics person to spend a few hours. I think two or three sessions rather than my one long spell is to be recommended. But for the price of two theatre tickets or the first course at a modest restaurant I got a sense of creation and if I can ever master the carpentry a useful extra radio.

Perhaps the next kit should be a video recorder remote control unit – before the new breed of video taught, board builder addicts set the house on fire!

How to Get Yours

The kit itself and the tool kit mentioned are available from Maplin, either via their chain of retail stores or by mail order.

Watch as you build... Loudspeaker Radio Kit Order As SK00A Price £11.95. Starter Tool Kit Order As SK01B Price £19.95.

Editorial Note

It is planned to introduce other kits to the 'Watch as you build' range, watch this space for details.

Maplin

*Do you Enjoy your work?
Or would you prefer to
Work at what you enjoy?*

If you are an electronics enthusiast and looking for an interesting career with a future, Maplin has the answer.

We currently have vacancies for

TECHNICAL SALES STAFF

At **CARDIFF, GLASGOW
and SHEFFIELD**

These vacancies are being created as a result of the Maplin expansion programme and offer real prospects up to and including Branch Management.

A knowledge of sales, although an asset, is not essential. But, to become part of the team you do need to be self motivated and have a cheerful personality. Applicants should also be smart and have a knowledge of electronic components.

We offer excellent working conditions and job security, plus a good salary with commission and a realistic pension scheme.

Apply in writing enclosing CV to: David Snoad, P.O. Box 3, Rayleigh, Essex. Or for further information, ring 0702 554155.

If you are seeking an interesting career in a High Tech environment then contact us

NOW!

MAPLIN'S TOP TWENTY KITS

POSITION	DESCRIPTION OF KIT	ORDER AS	PRICE	DETAILS IN
1. (3)	◆ Digital Watch	FS18U	£ 1.98	Catalogue '91 (CA08J)
2. (2)	◆ Live Wire Detector	LK63T	£ 3.95	Projects 14 (XA14Q)
3. (18)	◆ 1 300 Timer	LP30H	£ 4.95	Magazine 38 (XA38R)
4. (1)	◆ MOSFET Amplifier	LW51F	£19.95	Magazine 41 (XA41U)
5. (4)	◆ Car Battery Monitor	LK42V	£ 8.95	Magazine 37 (XA37S)
6. (10)	◆ Partylite	LW93B	£ 9.95	Catalogue '91 (CA08J)
7. (5)	◆ PWM Motor Driver	LK54J	£ 9.95	Best of Book 3 (XC03D)
8. (14)	◆ TDA7052 Kit	LP16S	£ 3.95	Magazine 37 (XA37S)
9. (6)	◆ Mini Metal Detector	LM35Q	£ 5.25	Magazine 25 (XA25C)
10. (8)	◆ I R Prox. Detector	LM13P	£ 9.95	Projects 20 (XA20W)
11. (15)	◆ Watt Watcher	LM57M	£ 5.25	Magazine 27 (XA27E)
12. (16)	◆ 8W Amplifier	LW36P	£ 6.95	Catalogue '91 (CA08J)
13. (9)	◆ Car Burglar Alarm	LW78K	£ 9.95	Best of Book 2 (XC02C)
14. (13)	◆ Siren Sound Generator	LM42V	£ 4.25	Magazine 26 (XA26D)
15. (11)	◆ U Sonic Car Alarm	LK75S	£19.95	Projects 15 (XA15R)
16. (19)	◆ IR Remote Switch	LM69A	£18.95	Magazine 33 (XA33L)
17. (7)	◆ LM386 Amplifier	LM76H	£ 3.75	Magazine 29 (XA29G)
18. (-)	NEW ENTRY ◆ Control-a-Train	LK64U	£11.95	Projects 14 (XA14Q)
19. (12)	◆ TDA2822 Amplifier	LP03D	£ 6.95	Magazine 34 (XA34M)
20. (-)	RE ENTRY ◆ 15W Amplifier	YQ43W	£ 6.95	Catalogue '91 (CA08J)

Over 150 other kits also available. All kits supplied with instructions.

The descriptions are necessarily short. Please ensure you know exactly what the kit is and what it comprises before ordering, by checking the appropriate project book, magazine or catalogue mentioned in the list above.

DATA FILE DATA FILE DATA FILE DATA FILE DATA FILE DATA FILE DATA FILE DATA FILE

Continued from page 7.

between P15 ('+ i/p) and P16 (0V). The gain of each VCA is controlled via a separate control input. VCA 1 is controlled by applying a voltage between P19 (i/p) and P20 (0V), and VCA 2 by applying a voltage between P21 (i/p) and P22 (0V). Wire link LK1 is included to allow the two VCA control inputs to be strapped together with a minimum of modification; this allows control of both VCA's from a single voltage source.

The gain of VCA 2 can also be controlled by applying a voltage between the 'expo mix' input (P17) and 0V (P18). The voltage may be positive or negative, and should not be allowed to exceed the supply voltage. However note that a further two links, LK3 and LK4, are additional to the links

previously mentioned and must always be fitted regardless of which options are selected.

Applications

The SSM2045 module may be used in a host of different applications including electronic music circuits, sweep oscillators and mixers. Because of this versatility the inputs and outputs are directly (DC) coupled to provide optimum flexibility; however, it should be remembered that in some cases capacitive coupling will be necessary between this and other circuits whose inputs or outputs are not at earth (0V) potential, to prevent problems due to DC offsets. Table 2 below shows the specification of the prototype module.

Power supply voltage	± 10V - ± 15V
Power supply current (quiescent)	10mA at ± 15V
Total harmonic distortion (THD):	
Filter section (at 1kHz for 100mV RMS input)	Less than 0.9%
VCA section (at 1kHz for 100mV RMS input)	Less than 0.9%
Frequency range	10Hz - 25kHz
Frequency control input voltage (maximum)	± 14V

SSM2045 VOICING SYSTEM PARTS LIST

RESISTORS: All 0.6W 1% Metal Film (Unless stated).

R1	56k	1	(M56K)
R2,15,16	1k	3	(M1K)
R3,4	15k	2	(M15K)
R5,13,	10k	2	(M10K)
R6	1k2	1	(M1K2)
R7,14	820Ω	2	(M820R)
R8,9,11,17	22k	4	(M22K)
R10	3k9	1	(M3K9)
R12	220Ω	1	(M220R)
RV1	Cermet 5k	1	(WR41U)

CAPACITORS

C1,2	PC Elect 220μF 35V	2	(JL22Y)
C3,5	Ceramic 10000pF	2	(WX77J)
C4	1% Polystyrene 3300pF	1	(BX62S)
C6	1% Polystyrene 750pF	1	(BX55K)
C7,8	Monores Cap 0.1μF	2	(RA49D)
C9	Ceramic 47pF	1	(WX52G)

SEMICONDUCTORS

IC1	SSM2045	1	(UL20W)
IC2	TL071C	1	(RA67K)

MISCELLANEOUS

P1-27	Pin 2145	1 Pkt	(FL24B)
	DIL Socket 18-pin	1	(HQ76H)
	DIL Socket 8-pin	1	(BL17T)
	SSM2045 Voicing PCB	1	(GE77J)
	Constructors' Guide	1	(XH79L)
	SSM2045 Instructions	1	(XK30H)

The above items are available as a kit:
Order As LP46A (SSM2045 Voicing Kit) Price £9.95
The following item is also available separately,
but is not shown in our 1991 catalogue:
SSM2045 Voicing PCB Order as GE77J Price £2.45

SUBSCRIBE TO

ELECTRONICS

The Maplin Magazine

- * Save 90p! Yes, save money by subscribing for a year, it's cheaper than buying each individual copy.
- * FREE D-I-G-E-S-T Supplement! With every issue there is a mini Catalogue of products for you to collect.
- * FREE delivery to your door, there are no additional carriage charges.

- * It's bursting at the seams with projects and interesting features to read.
- * It's streets ahead of its rivals, with full colour pages and far less advertising space.
- * Plus – News, reviews, readers letters, competitions and lots, lots more besides!

To subscribe just send a cheque/postal order for £7.80 made payable to Maplin Electronics, P.O. Box 3, Rayleigh, Essex SS6 8LR. OR you can take advantage of our offer of two free issues by completing the coupon below and agreeing to pay by Credit Card or Direct Debit. The two free issues offer only applies if you use one of these two methods of payment. Simply fill in the 'Payment by Credit Card' or 'Payment by Direct Debiting Mandate' and return it to Maplin. Every time, about 1 month before your subscription is due, we will send you a letter giving details of the subscription rate for the next year and telling you the date on which we will charge your Credit Card or debit your bank account. If you do not wish to continue your subscription, you have until that date to let us know, and we will then cancel your authority to bill your Credit Card or cancel your mandate. Otherwise, if you do nothing, your subscription will continue. The authority or mandate you give us does not allow us to charge anything other than the Maplin Magazine subscription. The benefit to you is that you no longer need to remember to re-new your subscription or send off any more cheques or postal orders. Payment is made automatically.

OVERSEAS SUBSCRIBERS

Subscription rates for 6 issues are: £11.00 (or 46 IRC's) in Europe and surface mail outside Europe; £25.00 (or 104 IRC's) Air Mail outside Europe.

TAKE THE NEXT 2 ISSUES OF THIS MAGAZINE FREE!!

Because we're so certain that once you've seen the Maplin Magazine you'll want to continue to receive it, we're offering to send you the next two issues free of charge with absolutely no obligation to continue. Just fill in the details below and if after receiving two issues you do not wish to continue, just let us know at least one month before the next issue is due and we will cancel your subscription. The two free issues will be yours to keep whatever you decide. If you already have a subscription, fill in the details below and we'll add two issues free of charge to your current subscription. SEND NO MONEY NOW. About 2 weeks before the third issue is due, we will charge you £7.80 for the next six issues, unless you have cancelled. This offer is not available to those already paying by Direct Debit or Continuous Credit Card or those who have stopped payment by either method within the last two years. Please start my subscription with the next issue. THIS OFFER IS OPEN TO RESIDENTS WITH U.K. ADDRESSES ONLY.

EITHER

★ PLEASE ADD YOUR ADDRESS, SEE BOTTOM RIGHT ★

PAYMENT BY CREDIT CARD. Please charge my Credit Card Account

Customer Number (if known)

Access Visa American Express

I authorise you until further notice in writing to debit my CREDIT CARD account with £7.80 and in future, with any amounts which, after notification, MAPLIN ELECTRONICS PLC. may debit thereto in respect of my subscription to the Maplin Magazine.

Account No.											
Signature										Date	

OR

PAYMENT BY DIRECT DEBITING MANDATE in favour of Maplin Electronics plc, P.O. Box 3, Rayleigh, Essex SS6 8LR.

Direct Debit payment option is only open to customers with bank accounts in the U.K. including Channel Isles, Isle of Man and N. Ireland. Please note: Instructions cannot be accepted to charge Direct Debits to a Deposit or Savings Account.

Bank Sort Code

Bank Account Number

Name of Account to be debited

The Manager

I authorise you until further notice in writing to charge my account with you any amounts which MAPLIN ELECTRONICS PLC. may debit thereto by Direct Debit in respect of my subscription to the Maplin Magazine.

I will inform the bank in writing if I wish to cancel this instruction.

I understand that if any direct debit is paid which breaks the terms of this instruction, the bank will make a refund.

Signature										Date	
-----------	--	--	--	--	--	--	--	--	--	------	--

Enter your address and Maplin customer number, if known.

										Post Code	

If you wish you can fold this card, put it in an envelope and write on the envelope, Maplin Electronics, Freepost, P.O. Box 3, Rayleigh, Essex SS6 2BR.

HDTV

PICTURES STILL OUT OF FOCUS

by Alan Simpson



Philips HDTV set.



One Sunday evening in the year 2010, somewhere between Tokyo, Paris and New York, someone switches on his high definition television set. He decides to watch a film. The flat screen, larger than the one on his old receiver, produces pictures as pure as those he is accustomed to seeing in the cinema. The stereo sound quality reminds him of his old compact disc player. The film is broadcast in the original language, although three other languages are available, since the stereo television is equipped with eight sound tracks.

"The film is interrupted by a break for advertisements. Not in the least annoyed, our man simply instructs his television to turn itself into a computer and display the first draft of the text for a lecture he is to give in Hong Kong the following week.

"This is just one of the facilities which HDTV may be offering in a few years' time. Other features are already in operation or under study:

★ "Cinemas could receive HDTV film pictures and sound from another town via satellite;

★ "Thanks to the picture quality and



HDTV screen shot received at BBC TV Centre during the World Cup.

enhanced colour reproduction it offers, doctors specialising, say, in microsurgery will be able to use HDTV to teach their students;

- ★ "Art galleries will be revolutionised: comfortably installed in an armchair, visitors will be able to view paintings by Matisse or Picasso faithfully reproduced by HDTV cameras and stored in a video data bank;
- ★ "HDTV will be a boom to printing, publicity and other sectors".

High Definition – High Stakes

So runs a paper issued by the International Telecommunications Union, the worldwide authority and forum for communications.

Certainly these are exciting times for the TV industry – regulators, broadcasters, cable and satellite operators and not least, the consumer (whose role is to pay for the new technology). That HDTV has become the focus of world attention is hardly surprising given the industry estimate of a market-place worth up to \$100 billion.

Worldwide Battleground

Billed as the next generation TV system HDTV, when it finally does arrive, will turn out to be the next but one generation. HDTV is certainly coming. Everybody knows it is coming but no one it seems knows quite when. This in fact has been the story of HDTV ever since Japan first started working on the new technology back in 1974. Then it was known as Hi-Vision, a system which uses 1125 interlaced scanning lines (doubling the standard NTSC colour TV standards) and sixty fields per second.

The main drawback was that it was not compatible with existing TV systems, a factor clearly recognised by the world authority CCIR when they did not adopt the system as being the single international standard in 1984. A result which incidentally did not displease European and American industry developers. Two years later we saw the launch of The Eureka 95 programme, which aimed to develop a system which unlike, the Japanese project, would not oblige people to change their

TV sets. More than 20 companies including Philips, Thomson and Bosch produced an intermediate approach called MacPacket, which was demonstrated at Brighton during 1988. The prototype system uses 1250 lines/50Hz/2:1 for interleaved scanning.

During the initial phase of implementation, programmes will be broadcast using MacPacket transmissions (C-MAC, D-MAC and D2-MAC) via satellite. Subsequently, high definition Mac signals (MAC HD) will take over. MAC HD will be compatible with MacPacket, with the result that MacPacket receivers will still be able to receive high definition signals, although only with enhanced conventional quality. MAC HD receivers will be capable of receiving both types of signal.

As the ITU states, Europe has chosen an extended implementation schedule, passing through an intermediate solution pending the arrival of high definition. This path was also chosen by the United States who are adopting a stage-by-stage approach compatible with their current television environment. However the U.S. has set the acceptable bandwidth at just

6MHz. Compression techniques are having to be incorporated which will mitigate the loss in quality. In fact the solution could well be with the emerging ISDN (Integrated Services Digital Network) which is currently being standardised by the CCITT (International Telegraph and Telephone Consultative Committee).

In this respect the U.S. has lost little time. A fully digital system has already been demonstrated by the U.S. General Instruments Corporation which immediately encouraged such companies as Philips, Thomson and NBC to form yet a further consortium to introduce a completely digital HDTV system. It is now generally accepted that the proposed systems are moving from being essentially analogue-based to being part of entirely digital. Digital signals can also be transmitted over long distances by means of telecommunication digital transmission channels.

Essential HDTV

HDTV generally provides twice the definition of current TV systems in both the vertical and horizontal planes. The aim is to get a worldwide cinematographic film quality standard with compact disc sound. But the new system is considerably more sophisticated and complex, and therefore more costly than existing systems. Defining HDTV is not easy – it has in fact been a matter for discussion over many years. But basically the problems involve the dichotomy between 50 and 60Hz systems, image format, signal definition and of course the far from compatible NTSC colour TV standards (1050 lines/60Hz, the U.K. PAL and the French SECAM standards). Also having to be formatted are new methods of coding image and sound in order to achieve better quality within a higher compression of information in order to fit into the lower bandwidth requirements.

There is certainly no shortage of standards-making bodies involved in HDTV – almost as many as there are producers and developers. Their problem is not exactly helped by the advances taking place in technologies at a very fast pace, and by the National objectives of Europe, Japan and the U.S. authorities.

Recently the CCIR extended its study period of some six or seven rival systems until 1994. This is mainly in order to complete a full digital specification, but within that timescale period, standards can be ratified at any time.

Game Set and HDTV Match

Last year, the BBC set up HDTV demonstrations at The Ideal Home exhibition and Wimbledon. Two BTS HDTV cameras on Centre Court produced the pictures, coupled with HDTV graphics. Also for the first time, a quarter-picture inlay facility was being demonstrated which inserted a 625-line picture, from any one

of the 625-line cameras used in general Wimbledon coverage, to show for example play or interviews from other courts.

A specially designed fibre-optic distribution system fed the HDTV signals from the outside broadcast vehicle to the spectator viewing centre, where a 50-inch Philips projection system allowed visitors to see at first hand the quality of the HDTV picture and sound.

The high-definition pictures were produced using the standard proposed by the Eureka 95 HDTV project – set up to develop a method for transmitting HDTV to the home in a manner which is compatible with existing European DBS (Direct Broadcasting by Satellite) transmissions. As the BBC point out, because of the need for compatibility, the pictures produced in the HDTV studio must have a number of lines which bear a simple relationship to the 625 lines used in present day television. Therefore the studio standard has a total of 1250 lines; 1152 of these are occupied by the active picture and 98 by vertical blanking. The horizontal resolution is also increased in proportion, resulting in the luminance bandwidth being in the region of 25 to 30MHz. The picture aspect ratio (ratio of the width to the height) is 16:9, and the field reception rate is 50Hz. The Eureka proposals allow for both 2:1 interlaced and non-interlaced (progressively scanned) versions of the studio standard: the picture displayed at Wimbledon used the interlaced variant.

Prior to transmission, the HDTV studio signals must be bandwidth-reduced by a factor of 4 and encoded into a format which is compatible with the MAC family of standards, used for DBS transmissions within Europe.

The BBC are determined that when regular HDTV broadcasts begin in 'a few years' time', a new HDTV receiver will be required to view the pictures in all their high definition glory, but it will be possible to view the broadcasts in 625-line form on the standard MAC television sets now becoming available. However, it will also be possible to view the HDTV pictures in 625-line form on an ordinary 625-line television set, using an add-on MAC decoder. Reassuringly, the BBC state that, as in the case of the move from black and white to colour, viewers will not immediately need an expensive new HDTV set in order to continue to receive the programmes.

To meet this HDTV switch-on, the BBC is stockpiling a library of programmes which include the FA Cup Final, Wimbledon Tennis Finals, Covent Garden ballet, Promenade Concerts, Tina Turner, Musee D'Orsay and a number of studio programmes. But the BBC do make the point that equipping their studios with HDTV is going to be expensive. In fact the additional cost of equipping a large studio to operate at HDTV could be as much as £2M above the cost of a comparable 625 line installation at present. And with some 50 studios, 33 outside broadcast units, and 100 plus single camera units, not to

mention the additional operational costs involved in producing high detail programmes, the cost is enormous.

Paying the Costs

All authorities agree that HDTV is not a technology for screens less than 40 inches – currently only 5% of TV sets sold are bigger than 25 inches. And even the most optimistic forecasts, mainly from Japanese manufacturers, are that set prices will increase by some \$300 rather than the \$3000 often quoted for HDTV sets.

If the higher figure does prove to be the case, then initial sales of HDTV sets will be negligible.

Moreover the HDTV has not been helped by the demise of BSM satellite services, which made use of high definition D-MAC chips. Only one year ago Peter Bull, BSM's director of marketing, was forecasting that MAC was the route for the future. He also said that there was room in the U.K. for two completely separate satellite services, particularly if integrated TV sets became available. At the same time, David Chance of SKY was agreeing that both services will survive in the short term but that there would ultimately be one clear winner. We all now know just who that clear winner was, and how short 'short term' meant!

However, all is not lost. Operators of the low power Astra satellites, as used by SKY, are proposing a compromise which will allow contractors to choose their own standards, whether PAL, SECAM or MAC. Meanwhile, the HDTV 'global wars' continue with the contenders Japan and Europe, the key date is the 1992 Olympics where MAC D2 systems will be highly visible.

But what is certain is that the long term future of HDTV lies in the digital domain and in the early creation of the worldwide standards. Not only will these make for significant economies in terms of the scale of programme production and transmission, but lower receiver manufacturing costs. Also certain is the fact that HDTV will not be readily available in your local high street shops until 1995. But that is a date well worth waiting for.

Meanwhile, the development of HDTV will have a major impact on computer and chip producers. In fact Micheal Naughton of high technology consultancy Applied Network Research sees HDTV leading to a hybrid television set and personal computer. "Already computers have a higher image quality than TV sets. Bit mapping drives the computer produced image, while TV sets simply display an image. HDTV will impact on digital processing of real-time video, high performance displays, high density magnetic and optical data storage and high powered circuits. In fact, tomorrow's TV sets could more resemble a PC than a cinema screen". Though just who really needs a 40 inch word processing screen is not made clear.

NEW BOOKS



CMOS Pocket Guide

Volume 1: Standard 4000 series

Provides a comprehensive listing of all commonly used 4000 series CMOS logic ICs available from all the major manufacturers. The format and content make this guide easy to use; each page describes one device only and is divided into 8 sections. Data which applies to the CMOS series as a whole is not repeated for every component, but presented in an introductory section, saving space for other vital information. The first section shows the internal schematic diagram of the device, using a clear and simple logic diagram within the familiar package leadout icon identifying pin functions. This is followed by a brief description of the device with reference to its internal structure.

The next section provides details about operating the device, describing input signals or levels at particular pins. This indicates how the device is controlled and its resulting output signals. A fourth section lists major applications followed by a summary of essential data. Below this a table indicates from which manufacturers the device is available and finally, device description and the type number reference which can also be used to find a known device. The Pocket Guide extracts all the essential data from the manufacturers' own data books and presents it in a clear and concise format, and is invaluable as an aid to choosing a device or identifying an unfamiliar component. English translation of the German original. 1990. 185 x 105mm. 234 pages, illustrated.

Order As WT34M (CMOS Pocket Guide 1) Price £11.95 NV

An Introduction to Amateur Communications Satellites

by A. Pickard

Communications and broadcasting satellites are normally inaccessible to individuals unless they are actively involved in their technicalities by working for organisations such as BT, the various space agencies or military bodies. Even those who possess a satellite television receiver system do not participate in the technical aspects of these highly technological systems.

There are a large number of amateur communications satellites around the world, traversing the globe continuously and they can be tracked and their signals received with relatively inexpensive equipment. This equipment can be connected to a home computer such as the BBC micro or an IBM compatible PC for decoding the signal.

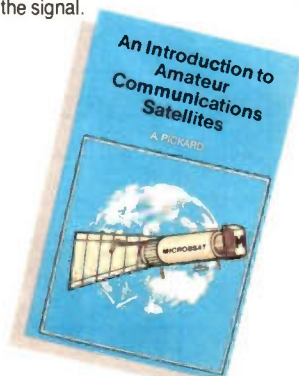

This book describes several currently available systems, their connection to an appropriate computer and how they can be operated with suitable software.

The results of decoding signals containing such information as telemetry data and weather pictures are demonstrated and will hopefully encourage the reader to become actively involved in pursuing this fascinating activity, which embraces many aspects of electronics, engineering and science as well as being an encapsulation of information technology.

1990. 178 x 110mm. 102 pages, illustrated.

Order As WT24B (Intro Amtr Comm Sat) Price £3.95 NV

IBM PC Assembly Language and Programming

by Peter Abel

The spread of microprocessors has also caused a renewed interest in assembly language, because a program written in assembly requires considerably less memory space and execution time. Secondly, a knowledge of assembly language and its resulting machine code provides an understanding of the machine's architecture that no high level language, even such as Pascal or C,



can possibly provide. Although most software writers develop new applications in a high level language, which is easier to write and maintain, a common practice is to recode 'bottleneck' routines in assembly. Programs such as terminate-and-stay-resident (TSRs) and interrupt service routines are almost always developed in assembly language.

High-level languages were designed to eliminate the technicalities of a particular computer. An assembly language however is designed for a specific computer or, more accurately, for a specific processor. Consequently, in order to be able to write in assembly for your PC, you have to be familiar with its architecture, and this book supplies all the basic material. Among the material and knowledge required for this topic are: access to an IBM PC (XT, AT, or PS/2) or compatible; a copy of the PC, DOS or MS DOS preferably a recent version, and familiarity with its use; an assembler program on diskette, preferably a recent version. You do not necessarily need prior knowledge of a programming language, although such knowledge will help you to grasp some programming concepts early, neither do you need prior knowledge of electronics or circuitry. The book provides the necessary information about PC architecture that you will require for assembly language programming your PC.

This second edition book can act as both a tutorial and a permanent reference, including DOS feature

through to version 4.01, information unique to the IBM PS/2 series, features of Borland's turbo assembler, features of Intel's 80386 and 80486 processors, the use of simplified segment (addressing) directives and later additional interrupts, memory management, program overlays and keyboard buffer details. American book. 1991. 234 x 176mm. 560 pages, illustrated.

Order As WT32K (IBM PC Assembly Lang) Price £19.95 NV

The Transputer Handbook

by Ian Graham and Tim King

The Transputer Handbook describes the software and hardware implementation of transputer parallel processing systems, bringing together information from a multitude of sources in a readily accessible form.

Intended to act as a guide to the capabilities of the transputer family and transputer based systems, the book will show the reader the process of how software and hardware solutions are found for particular problems. Not that the average Maplin customer is likely to possess one of these devices, nevertheless the book gives an insight into this latest development in computer hardware, which while being quickly pressed into service is still little known about on the amateur front. Examples of transputer processors mentioned include the T225, T400 and T800 series. An introduction to the OCCAM programming language developed alongside the transputer is introduced, but you will notice several examples alternatively written in 'C'.

Not only are example hardware connection circuits provided but also the common transputer assembly language instruction set. If you want to know how transputers work and what they do, you must read this book! 1990. 234 x 172mm. 210 pages, illustrated.

Order As WT27E (Transputer Handbook) Price £19.95 NV

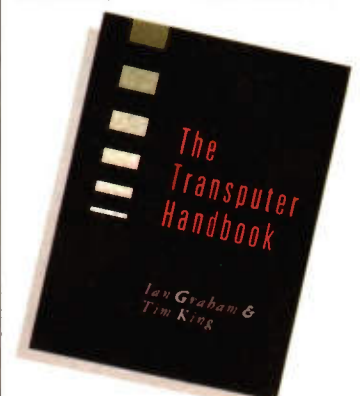

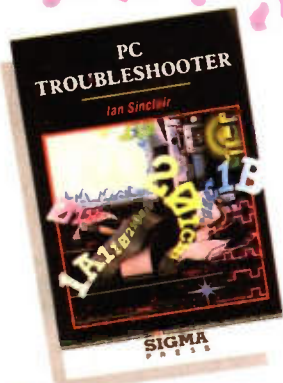

PC Troubleshooter

by Ian Sinclair

Many problems that computer owners and users encounter have remarkably simple solutions. Some arise simply from misunderstandings with manuals or because some manuals are inadequate. Others arise from software faults, and only a very few are traceable to faults that require a soldering iron to be applied to any part of the computer's circuitry.

This book is based on the amount of trouble-shooting that any PC owner/user can carry out short of soldering work. This means, in practice, about 90% of the faults that are mentioned in letters to magazines and to authors of books on computing. It is confined to the type of PC machine using 8088, 8086, 80286 or 80386 processors, and described as being IBM compatible, but excluding some of the most recent PS/2 models.

Topics covered include: video, disks and drives, keyboard and mouse, printers, serial ports, MS-DOS, programming, PC expansion and many other problems.

1990. 230 x 151mm. 194 pages, illustrated.

Order As WT30H (PC Troubleshooter) Price £12.95 NV

The PC Upgrader's Manual

How to Build and Extend Your System

by Gilbert Held

Although it may not be obvious, personal computers can provide you with a long and useful service. For the same reasons that most of us would not buy a new car every time there is a model change, so also most of us do not buy a new computer each time a new advance in microprocessor technology occurs. In recognition of this, this book focuses on how to prolong the useful life of the original IBM PC series and compatible computers with techniques to improve performance of members of the IBM PC series, and upgrades to the more recently introduced family of IBM PS/2 computers. So whether you purchased

the original PC, PS/2 or compatible or you acquired one of these at a later date, this book will assist you in maximising its potential.

The book is based on a series of PC seminars conducted in the U.S. and Europe over a number of years. Although these covered software, hardware and communications, the common concerns of the delegates included the differences among members of the IBM PC and PS/2 series, the techniques for upgrading these and information about the use of IBM compatibles. The book attempts to answer these questions and more. Because the utility of a PC is based to a great degree on the techniques used to maximise its performance,

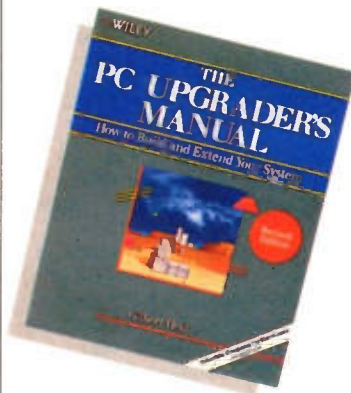

information to assist the reader isolate and resolve problems is also provided, should they occur.

American book. 1991. 234 x 190mm, illustrated.

Order As WT31J (PC Upgraders Manual) Price £23.95 NV

Understanding PC Specifications

by R.A. Pentfold

If you require a microcomputer for business applications or a high quality home computer, an IBM PC or compatible is often the obvious choice. They are competitively priced and are backed up by an enormous number of applications programs, hardware add-ons, etc. The main difficulty for the uninitiated is deciding on the specification that will best suit his or her needs. PCs range from simple systems of limited capabilities up to complex systems that can happily run applications that would have been considered beyond the abilities of a microcomputer not so long ago. It would be very easy to choose a PC system that is inadequate to run your particular applications efficiently, or one which goes beyond your needs and consequently represents poor value for money.

While explaining PC specifications in

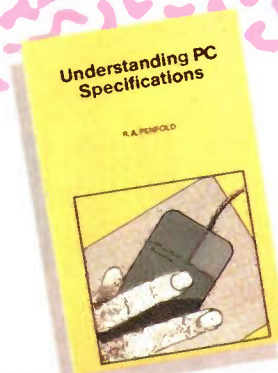

detail, subjects covered include: differences between types of PC (XT, AT, 80386 etc.); maths co-processors; input devices (keyboards, mice, and digitisers); memory, including both expanded (EMS) and extended RAM; RAM disks and disk drives caches; floppy disk drive formats and compatibility; hard disk drives (including interleave factors and access times); display adaptors, including all standard PC types (C.G.A., Hercules, Super V.G.A., etc.). Contains everything you need to know if you can't tell your E.M.S. from your E.G.A.!

1990. 198 x 128mm. 104 pages, illustrated.

Order As WT26D (Understanding PC Spc) Price £3.95 NV

Electronic Circuit Design

Art and Practice

by T.H. O'Dell

The theme of this textbook is the practical element of electronic design. There is more to circuit design than a good theoretical foundation augmented by a considerable amount of laboratory experience, as anyone who has tried to build a working example of a 'hypothetical' textbook circuit will know! There is in fact the question of design itself.

Where do new circuit ideas come from? This question is followed in the first chapter, and the discussion is maintained throughout the following eight chapters dealing with high and low frequency, small-signal amplifiers, optoelectronic circuits, digital circuits, oscillators, translinear circuits and power amplifiers. One or more experimental circuits are described in



each chapter in detail for the reader to build, a total of thirteen project exercises in all. The last chapter draws some conclusions about the fundamental problem or design in the light of the circuits that have been dealt with in the book. Can be used alongside a foundation text on the theoretical basis of electronic engineering.

Emphasis is placed on basic principles and the application of those principles in practical terms, linked to examples and test questions. If nothing else the book also provides a fascinating insight into logic and linear IC circuits, what Schottky TTL is, what ECL is, and the extraordinary ways in which transistors are combined in a manner not possible using discrete devices which are not all identical parts of one chip.

1988. 228 x 151mm. 182 pages, illustrated.

Order As WT29G (Electronic Cct Dsgn) Price £10.95 NV

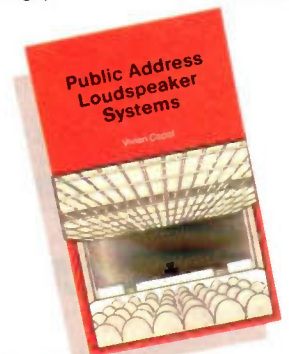

Public Address Loudspeaker Systems

by Vivian Capel

The loudspeaker system is a critical part of any public address installation. All too often, it is woefully inadequate, resulting in poor intelligibility and unnatural reproduction. This book examines the various systems and their drawbacks, describing LISCA, the Line Source Ceiling Array. This gives astonishing clarity, coverage and reduced feedback, natural source location and even a pseudo-stereo effect. It promises to be the ultimate system for small to medium sized halls. Full step-by-step constructional and installation details are given.

Also included: low impedance matching, 100V line systems, transmission lines, and how to design and install inductive hearing-aid loops. Few public address systems could not be improved from the information supplied in this book.

1990. 178 x 110mm. 114 pages, illustrated.

Order As WT25C (Public Address Spkr) Price £3.95 NV

Shakespeare?

Dear Sir,
To whinge or not to whinge... arguably some people seem to expect everything to be handed to them on a plate and this is perhaps emphasised in the amateur electronic field where in some cases technical expertise appears to stop at being able to unpack a Japanese 'black box' but having said this there are many more difficulties than of yesteryear. My interest started in radio around 55 years ago, with crystal set 2 volt valve receivers, TV receivers from surplus units, transmitters and probably peaked at assembling a UK101 computer kit but many advances today present difficulties. In the early days circuits were easy to follow, the valves glowed, each component had one or two in and out connections and it was easier to determine their functions and trace faults. You knew what a tuned circuit should do but how about describing even a simple phase-locked loop IC to today's newcomer. All they often see is a black blob or chip with lots of legs and no way of knowing if they are faulty (not Maplins of course) or have been damaged during construction or wrong connections made. They should expect to experiment a lot with the simpler projects, with ideas of their own and yes, buy or borrow books. It needs some effort but if they are really interested this should be enjoyable and in my case some solutions often came in the middle of the night. They do not deserve to be criticised as 'whingeing' for everyone has their limits – ever tried to find a fault in a computer without the expertise and test equipment. There is no end to knowledge as I find by reading the interesting articles by Graham Dixey etc. Some pet theories go by the board and I still learn a lot of fundamentals. I would not like to be accused of being patronizing but feel that too much adverse criticism from either camp does not help and it reduces the space for interesting technical topics.
Yours faithfully,

N. Smith, Staffs.

P.S. I have just put a properly DC rated Tantalum capacitor across the output of a switch mode PSU to try and reduce the hash – ever seen the purple smoke they give off when they explode?

Non-Working Kits

The letter in Feb/March Electronics from J. Clark prompted me to write. Electronics is a hobby that can only be learnt and enjoyed by the efforts of individuals. It cannot be learnt in a day. I have been interested for 40 years and still learning. I am sorry to say failure, while a disappointment, is an unavoidable part of the hobby

and a fact of life. It has been said before that far more is learnt from a non-working item than a first time success. If a 100% successful first time result from an electronic project is expected then instead a ready built item should have been purchased. When it comes down to it what has actually been achieved from building a kit that works perfectly first time? Practice in soldering, using a few tools – but apart from following the instructions and circuit, very little electronics. Most of my experience has been gained from failures, picking up scrap/non-working items from junk stalls and repairing equipment without any form of circuit or service data. And most important reading everything I could beg, borrow or afford to buy. A 50p/£1 scrap radio is not a waste of money when eventually thrown in the dustbin, it is well in excess of this value in experienced gained. It does not matter if a mistake is made that does irreparable damage to the junk stall radio and if it is made to work it can be experimented on to introduce faults and to see the effects for future reference. It is no good complaining about lack of experience or lack of helpful advice. All another person can do is offer advice. It is up to the individual to learn – experience has to start somewhere. The first time you use a soldering iron and you burn your finger, experience has been gained. It is an unfortunate fact of life there is no universal answer to a letter that says "I built your kit and it won't work, why?". There is the true story of a person that took a blown fuse back to the shop because "the shop must have sold him a faulty fuse as it blew when he put it in". I was asked why an amplifier that had just been built did not work. I had not seen it so started making suggestions as to likely causes. When I got to checking resistors for correct value, I was told I could not do so, as when they were soldered in all the paint and colours burnt off. These are just to indicate learning has to start somewhere. Failure to work must be accepted as a part of the hobby, I do not have success every time even now. Kits from well established suppliers are generally very reliable, such as Maplins who offer a repair service for their kits if the constructor is really stuck (do not expect them to be repaired though if all the paint has burnt off the resistors)! In my experience a first time non-starter has boiled down to my bad soldering, misreading a resistor colour code, or a silly mistake, and it is very hard to spot your own errors so ask a second person. If all else fails why not put an ad in the local paper and ask if there is a local enthusiast prepared to help, and joining a local radio club is a

mine of information and assistance. OK, so this is written with many years of experience but remember I had to start somewhere. I can confirm I progressed more from my own efforts than complaining about my lack of experience to firms. But I would not hesitate to complain loudly, if necessary, if sold faulty equipment. Finally before someone writes in and says electronics is a lot different now to when I started with valves, okay I agree, but the principle of self-learning and experience has not changed only the components with their different requirements.

M. Perry, Worcs.

Two letters offering great advice, what more can I say!

Second to None

Dear Sir,
I have used Maplin's for a number of years now. The very first time that I have needed to return an item was on 24th September 1990. It is a pleasure to be able to report to you that I have received a replacement which arrived F.O.C. at my address on 10th October 1990 followed by a letter from your Customers Services stating that I would receive a credit for the cost of mailing the damaged item back to you. It is more common for customers to complain when things do not go right than to praise when things go well. I would like to take this opportunity to redress the balance a little by offering my thanks to your employees for the courteous way that I have always been treated. You have an organisation which, in my opinion, is second to none in terms of the quality of your staff, ordering and delivery procedures. My opinion of your company has been further enhanced by the way with which my one and only complaint has been dealt. Even though I have not offered my thanks directly to you in the past, I have often sung your praise to friends and colleagues, some of whom have become your customers. I am sure that any sum of money that your company has lost in the short term due to the replacement of my defective car aerial will have been more than made up by the goodwill that you have thus generated. Be assured that I shall continue using Maplins with confidence.

J. Whittaker, Bucks.

It's good to know that we get things right even when things go wrong!

Uninterruptible Power

Dear Sir,
After reading A. Stiles letter in the last edition I would like to take the idea further and suggest that a project to build an on-line uninterruptible power supply (UPS) for small home computers be considered. It would ideally

have a capacity around 200 – 250VA, with a back-up of around 5 minutes, employing the use of your sealed lead acid batteries. This I am sure would appear to computer users with a hard disc, as the thought of the heads crashing and causing untold damage due to a sudden power loss does not do much for the nerves. One other feature would be the inclusion of a good mains filter to remove the ever increasing amount of mains borne rubbish. Now another suggestion, in your components lists you always show resistors as being your 0.6W 1% type however it is not always necessary to use this type of resistor. I am sure that like myself many constructors have stocks of 1/3W 5% and 0.4W 1% resistors of the type you supplied in the past, would it not be a good idea to mark the components list with an asterisk where a 0.6W 1% resistor is absolutely needed and then it could be assumed that any other resistors could be of either of the above types.

A. Challis, Cambs.

Your idea for a UPS is a good idea and has been passed on to the back room boys. On the subject of resistors, we specify 0.6W 1% resistors as standard because they are our standard low-cost range. The advantage of this range is that they offer excellent characteristics of high stability, good power dissipation low noise, low temperature coefficient, as well as close tolerance. In fact in some cases it is the characteristics other than close tolerance that are important. That said, in some, but not all, cases 0.4W 1% metal film and 'ordinary' 5% 1/3W carbon film resistors would do the job. As a guide, any project that requires a degree of precision, low noise, accuracy or safety should always be constructed with the specified resistors. For instance a reference voltage developed by a potential divider would probably require 1% resistors, whilst a series resistor for an LED may not, although in the case of the series resistor it might need to be 0.6W rating rather than 1/3W or 0.4W power rating. If substitutions are to be made, then the effect on the circuit must be checked; will the substituted component handle the voltage and current (hence power), will performance and accuracy be affected, will the circuit still work even. This can best be determined by a good working knowledge of electronics, circuit behaviour and practical experimentation. It must be remembered that we cannot guarantee performance of a project if components other than those specified are used. Incidentally we do sell 5% metal film resistors, but only in packs of 100.

These are our top twenty best selling books based on mail order and shop sales during December 90 and January 91. Our own magazines and publications are not included in the 'chart' below.



Number ONE

Getting The Most From Your Multimeter

by R.A. Penfold
A unique, and very useful book, showing you how to best use your multimeter.
(WP94C) Cat. P74.
Previous Position: 2
Price £2.95

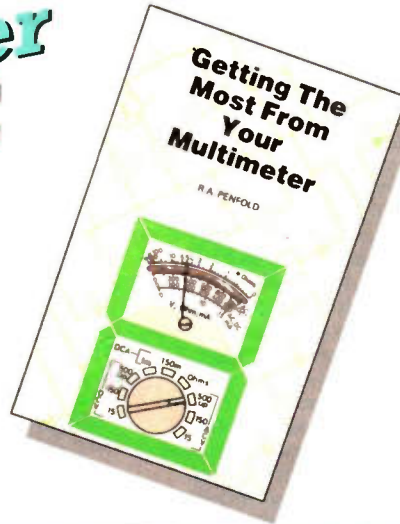

The Maplin order code of each book is shown together with page numbers for our 1991 catalogue. We stock over 250 different titles, covering a wide range of electronics and computing topics.

2



A Concise Introduction to MS-DOS, by N. Kantaris. (WS94C) Cat. P91. Previous Position: 6. Price £2.95.

3



A Concise Advanced User's Guide to MS-DOS, by N. Kantaris. (WS44X) Cat. P91. Previous Position: 3. Price £2.95.

NO CHANGE

4

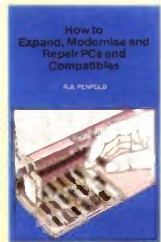

How to Expand, Modify and Repair PCs and Compatibles, by R.A. Penfold. (WS95D) Cat. P93. Previous Position: 9. Price £4.95.

5

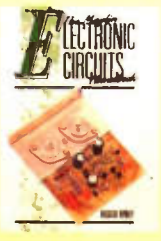

The Maplin Electronic Circuits Handbook, by Michael Tooley. (WT02C) Cat. P75. Previous Position: 1. Price £10.95.

6



IC555 Projects, by E.A. Parr (LY04E) Cat. P78. Previous Position 5. Price £2.95.

7



Power Supply Projects. By R.A. Penfold. (XWS2G) Cat. P77. Previous Position 8. Price £2.50.

8



International Transistor Equivalents Guide, by Adrian Michaels. (WG30H) Cat. P70. Previous Position: 10. Price £3.95.

9



How to Use Oscilloscopes and Other Test Equipment by R.A. Penfold. (WS65V) Cat. P74. Previous Position: 16. Price £3.50.

10

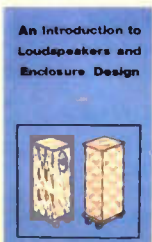

An Introduction to Loudspeakers and Enclosure Design by V. Capel. (WS31) Cat. P80. Previous Position: 13. Price £2.95.

11



Loudspeaker Enclosure Design and Construction. (WM82D) Cat. P80. Previous Position: 4. Price £9.95.

12



Scanners, by Peter Rouse. (WP47B) Cat. P85. Previous Position: Re-Entry. Price £7.95.

13



Remote Control Handbook, by Owen Bishop. (WS23A) Cat. P77. Previous Position: 11. Price £3.95.

14

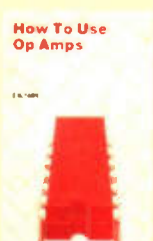

How to Use Op-Amps, by E.A. Parr. (WA29G) Cat. P73. Previous Position: Re-Entry. Price £2.95.

15



Washing Machine Manual by Graham Dixon. (WS98G) Cat. P87. Previous Position: 15. Price £11.95.

16



Practical MIDI Handbook, by R.A. Penfold. (WP96E) Cat. P82. Previous Position: Re-Entry. Price £5.95.

17

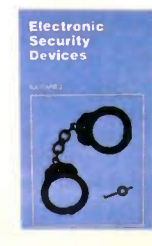

Electronic Security Devices, by R. Penfold. (RL43W) Cat. P77. Previous Position: Re-Entry. Price £2.50.

18

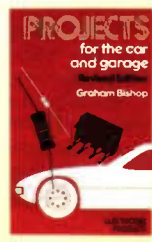

Projects for the Car and Garage, by Graham Bishop. (XW31J) Cat. P77. Previous Position: Re-Entry. Price £7.99.

19

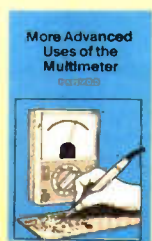

More Advanced Uses of the Multimeter, by R.A. Penfold. (WS63T) Cat. P74. Previous Position: New-Entry. Price £2.95.

20



Radio Amateurs Examination Manual, by G.L. Benbow. (WP87U) Cat. P83. Previous Position: 7. Price £6.45.



NICAM

...set your sights on a better sound!

Experience a new sensation. An experience that opens up a whole new spectrum of sound.

Put yourself on stage at the Albert Hall, surrounded by a great orchestra. Imagine the sound you will hear, every nuance, every note; or travel up the Nile with an intrepid explorer, a journey not only full of breathtaking beauty and colour, but rich in the sounds of another continent; or capture the hidden gasps of 100,000 hardened fans at Wembley for the F.A. Cup Final, when the ball skims the crossbar with the last kick of the match; follow with your ears as well as your eyes, dodging the bullets, as your favourite hero battles out of yet another tight corner, it's just like being in a cinema!

Nicam hi-fi stereo will turn your living-room into a living room of

sound! You don't settle for second best with television picture quality, why settle for second best in television sound quality? Nicam sound is the new high quality digital stereo sound system, pioneered by BBC, ITV and TV/video manufacturers. In fact so good is Nicam it is comparable to the superb sound reproduction of the compact disc, when played through your existing hi-fi arrangement. If your television hasn't got a built-in Nicam decoder, you will need the Maplin Nicam Tuner System. Ultimately almost all of your favourite programmes will be broadcast in superb hi-fi quality stereo-sound. Without a Maplin Nicam Tuner you won't be able to capture every sound to its full.

Nicam hi-fi stereo. Catch your breath, open your eyes, and pin back your ears! It's what your hi-fi system was made for... It's what your ears are made for!

DIGITAL STEREO TV SOUND FROM YOUR HI-FI

The complete kit contains all the components required to build the unit. However you will also need: a power supply, 12V at 600mA regulated e.g. YZ21X at £8.95; a co-ax Y adaptor e.g. FS23A at £1.20; a co-ax lead to connect to your TV or video, RW36P 2m long at £1.28, JW39N 5m long at £1.98, or JW40T 10m long at £2.95; a phono lead to connect to your hi-fi e.g. RW50E at 98p or a SCART/Peritel lead JW36P at £4.95. An Infra-red remote control kit is also available LP20W at £29.95.

Complete kit LP19V only £139.95 incl. VAT + £1 mail-order handling charge.

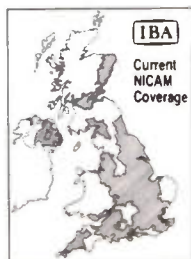

IBA
Current
NICAM
Coverage

Maplin ELECTRONICS

**CREDIT CARD HOTLINE
0702 554161**

For a friendly welcome and the very best of service why not visit our shops in Birmingham, Brighton, Bristol, Leeds, London (Edgware and Hammersmith), Manchester, Newcastle-upon-Tyne, Nottingham, Reading, Southampton and Southend-on-Sea.

Subject to availability. Prices subject to change.

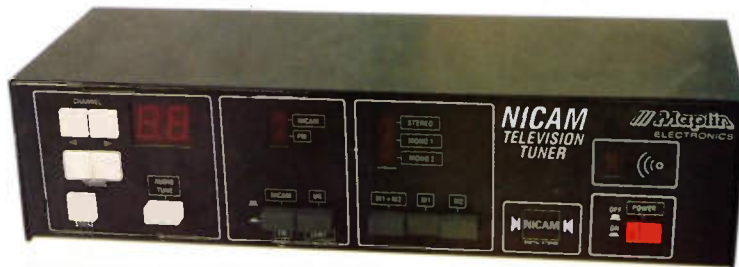

Digital stereo sound companion for your TV set.

1991 BUYER'S GUIDE TO ELECTRONIC COMPONENTS

Maplin

FEATURING:
**AN ELECTRONICS
CAST OF
THOUSANDS!**

**POWER-PACKED
WITH OVER
600 PAGES!!**

STARRING
**HUNDREDS OF
NEW PRODUCTS
AT SUPER
LOW PRICES!**

**SHOWING
NOW!**
at your local
WHSMITH

PERFORMANCES DAILY
At your local branch
of **WHSMITH**
ONLY £2.45

Order you copy of the New MAPLIN Catalogue on sale NOW
Pick up a copy from any WHSMITH for just £2.45 or post this coupon now to receive your
copy for just £2.45 + 50p p&p. If you live outside the U.K. send £4.95 or
20 International Reply Coupons. I enclose £2.95

Name
Address

Post Code
Send to Maplin Electronics,
P.O. Box 3, Rayleigh,
Essex S56 8LR.

MM91

KOD BROWN