

# Electronics

THE MAPLIN MAGAZINE

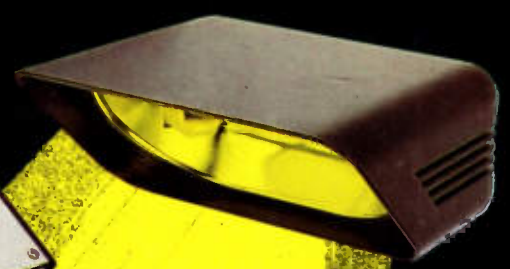

**INTRUDER ACTIVATED  
FLOODLIGHT CONTROLLER  
TURNS THE SPOTLIGHT ON  
ELEVEN NEW PROJECTS INCLUDING:**

**Computer Interface to transmit  
& receive data over the mains!**

**Oscilloscope Logic IC Interface  
displays current state of  
16 pins simultaneously**

**Golfball Printer for a price  
you won't believe!**

**Spectrum Parallel/  
Serial Port**

**And many more!**

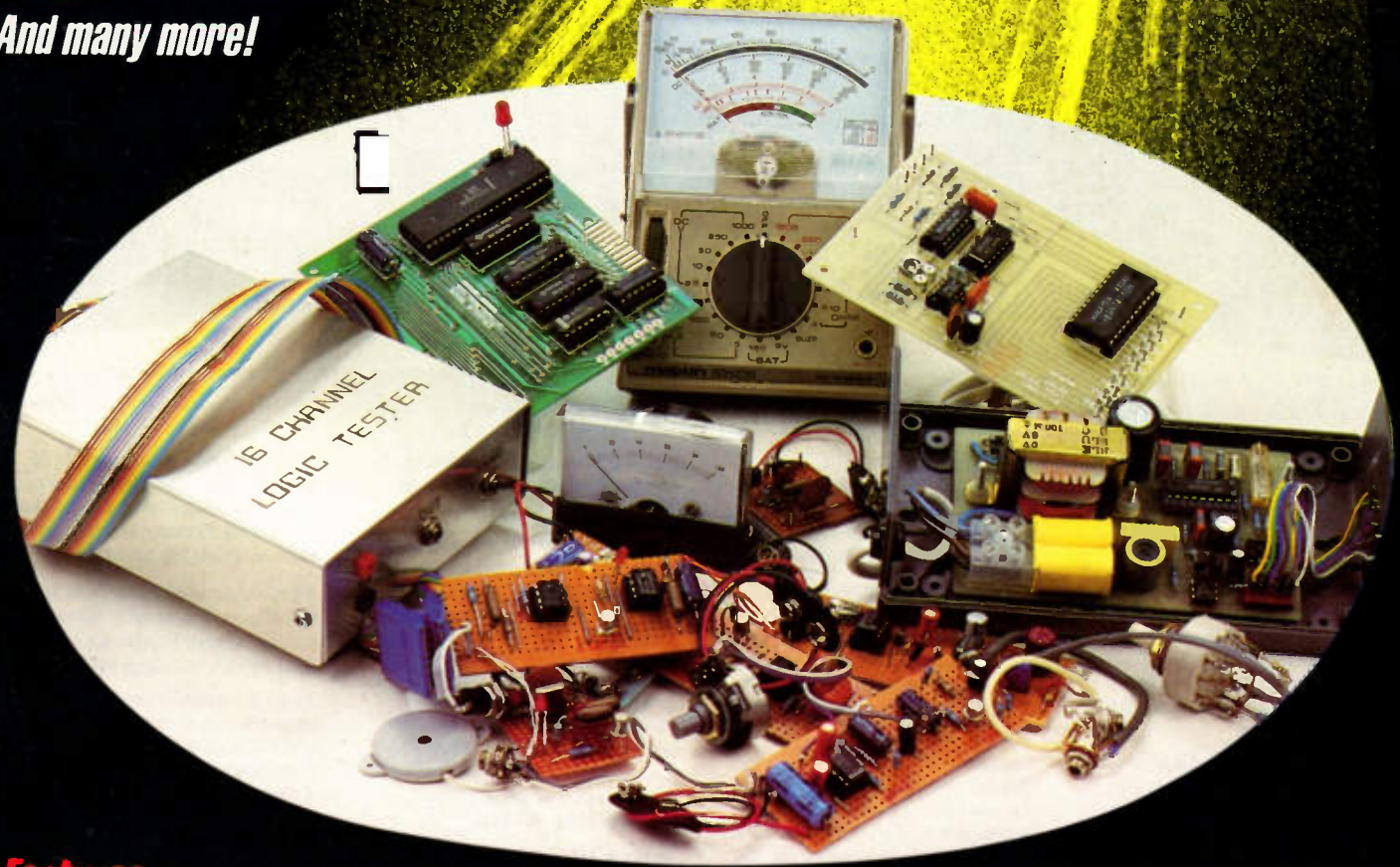

**Features:**  
**Beginners guide to Multimeters ★ Fault Finding on Digital Circuits ★ Many More**



# MAPLIN'S 5 REGIONAL SHOPS

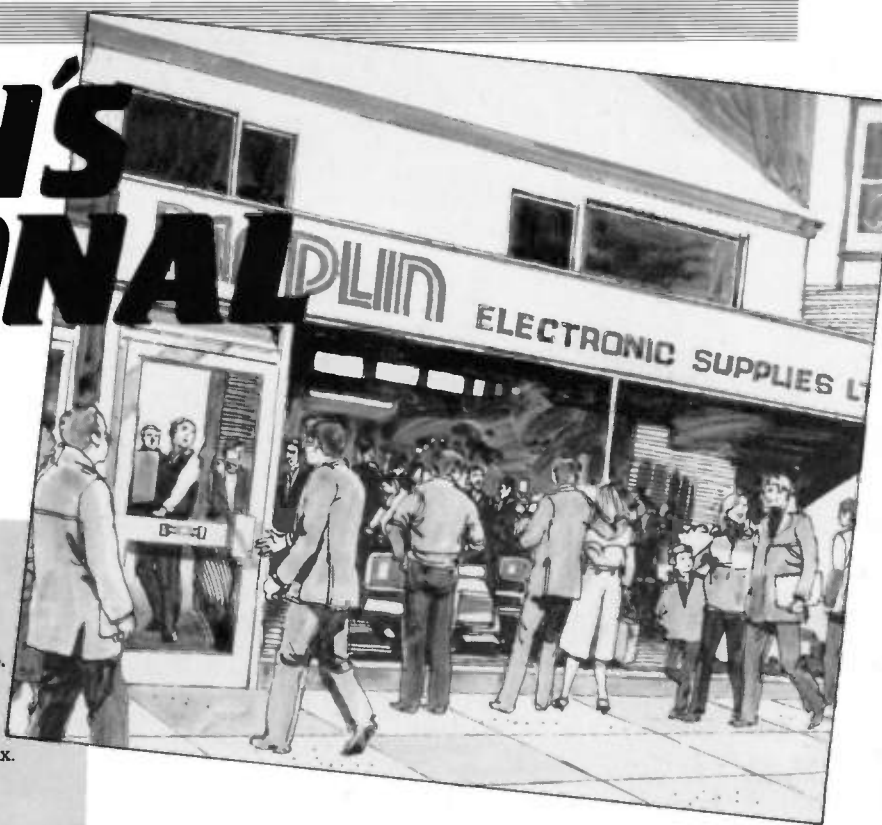

## HELP SERVE YOU BETTER!

**Birmingham:** Lynton Square, Perry Bar. Tel: 021 356 7292.

**London:** 159-161 King Street, Hammersmith W6. Tel: 01 748 0926.

**Manchester:** 8 Oxford Road. Tel: 061 236 0281.

**Southampton:** 46-48 Bevois Valley Road. Tel: 0703 225831.

**Southend-on-Sea:** 282-284 London Road, Westcliff-on-Sea, Essex.

Tel: Southend-on-Sea (0702) 554000.



Before you send your next order to us by post, take a look and see if there's a Maplin shop near you. In our shops you'll find that personal service that even the best mail-order operations cannot match. And you can look at the products before you buy. If you're coming for a particular item, a quick phone call will enable you to be certain the shop has everything you want in stock.

Our shops are pleased to accept Access, Barclaycard, American Express and Mapcard, and also cheques up to £50 with a cheque guarantee card. We'll even accept ordinary money as well!

All our shops are close to excellent parking facilities, meters in London and Manchester, and free elsewhere.

### The South

In the South our Southampton store is conveniently placed for easy access from all parts of Hampshire and surrounding counties and is just 15 minutes from Portsmouth (from the M27 junction 6, turn left onto the A335).

### London

Our London store situated just to the west of the pedestrian shopping centre in Hammersmith, is just 5 minutes from the end of the M4 and only a short walk from the

District, Piccadilly and Metropolitan lines' Hammersmith station.

### The Midlands

In the Midlands our Birmingham store is just 5 minutes from the M6 on the A34, and only a little farther from the M5 (junction 1) on the A4040.

### The North

Our self-service store in Manchester serves the North and is just off the Mancunian Way, opposite the BBC, about 5 minutes from the end of the M602 or junction 10 on the M63.

### South-East

Essex and Kent are served by our

Southend shop which is right on the A13, just 2 minutes before you reach the centre of Southend. And we're only 30 minutes from the M25 (junction 29) as well.

All our shops are open from 9 a.m. to 5.30 p.m. Tuesday to Saturday (closed all day Sunday and Monday) and do *not* close for lunch.

There's a friendly welcome in store for you at any Maplin shop. Our helpful staff may often be able to help with a technical problem or a constructional difficulty.

Call in at a Maplin store and get what you want today. We look forward to serving you.

**PROJECTS**

**Golfball Printer Part 1..... 2**

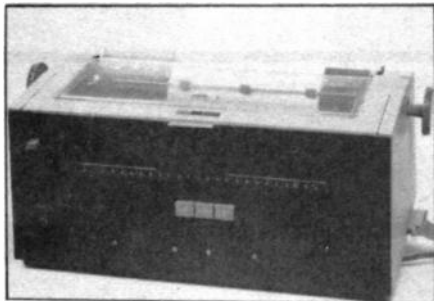

A correspondence quality printer, based on a surplus IBM golfball machine, interfaces to any home computer having ASCII Centronics facility. Secondhand golfball printers still have plenty of life left, and for a modest financial outlay and a little work you too can own one of these rather exclusive machines for use with your own computer system. Part 1 describes how to get the printer mechanism itself into tip-top working condition.

**Floodlight Controller..... 14**

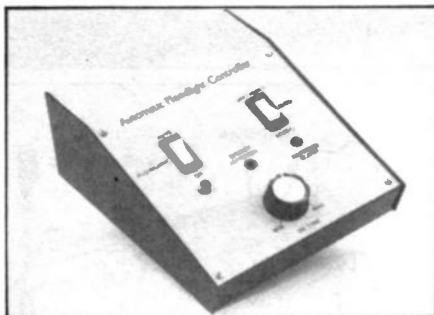

Used in conjunction with our Infra-red Intruder Detector Kit, this unit provides intruder activated mains power switching for powerful floodlamps, sirens etc.

**Seven Super Circuits ..... 23**

Seven more useful and easy to build projects comprising a Transistor Checker, SW Aerial Amplifier, a Telephone Indicator which shows whether someone has tried to contact you when you were out, a Microphone Preamplifier, a Speech Processor for communications and public address applications, Baby Alarm/Intercom Amplifier, and an Audio Millivoltmeter.

**Spectrum Parallel/Serial Interface ..... 37**

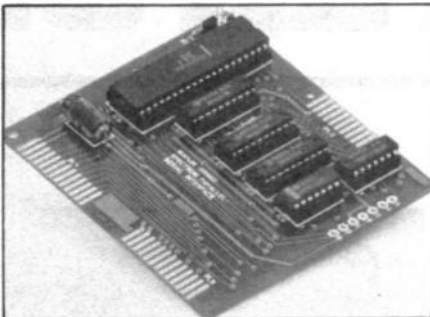

Continuing with our series of Spectrum add-ons, this useful project gives 8 bit I/P and O/P parallel transfer with a UART programmable for 5 to 8 bit serial transfer.

**Mains Tx/Rx Data Communications System.. 44**

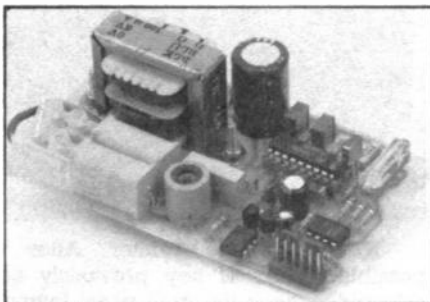

A mains powered data communications system which uses the mains wiring itself to transmit and receive information between units sharing the same building.

**16-Channel Logic IC Tester..... 54**

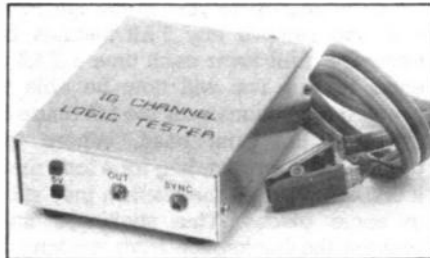

Simultaneously monitors all pin-outs of any DIL packaged logic IC having up to 16 pins whilst operating in-circuit, and generates a 16-channel display of all logic states on your oscilloscope screen.

**FEATURES**

**How to Use Multimeters ... 10**

The multimeter is probably the most often used instrument if anything needs to be measured - but it will be next to useless if used wrongly or if its readings are not properly understood.

**Electronic Chronicles..... 20**

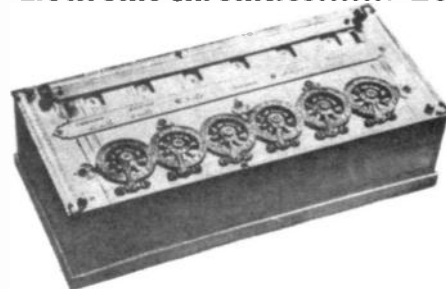

The final part of this historical account of electronics through the ages brings us, logically enough, to the advent of more and more complex calculating machines culminating in today's microcomputer technology.

**First Base ..... 42**

Part 9 continues with the principles of multiplexing, multiplexed memory devices and microprocessor busses and control.

**Project Fault Finding ..... 50**

Part 4 of this series deals with fault finding on digital circuits and includes details on how to use logic probes and pulsers.

**Make it with Maplin..... 58**

In Part 3 of this series we are taken on a tour of the Manchester and Southampton shops.

**NEWS**

Catalogue Amendments .....	63
Catalogue For 1986 .....	64
Classified Advertisements .....	64
Corrigenda .....	49
Project Servicing Rules .....	34
New Books .....	29
New Products .....	62
Order Form .....	35
Price Changes List .....	31
Price List of Items Since Catalogue .....	30
Subscriptions .....	36
Top 20 Books .....	19
Top 20 Kits .....	49

**Mail Order**

P.O. Box 3, Rayleigh, Essex SS6 8LR.  
Telephone: Retail Sales: (0702) 532911.  
Trade Sales: (0702) 532961. General: (0702) 554155.  
Computer Ordering: (0702) 552941.

Shops: See inside front cover.  
All shops closed Mondays.

**Editorial & Production**

**Editor** Roy Smith  
**Production Manager** Mike Holmes  
**Technical Editors** Robert Kirsch, Dave Goodman, Peter Blackmore  
**Art Director** John Dudley, Lesley Foster  
**Technical Artists** John Dudley, Lesley Foster  
**Secretary** Angela Harley

**Published by**  
**Typesetting by**

Maplin Electronic Supplies Ltd.  
Essex Process and Engraving Co.  
Graphic House, Stock Road,  
Southend-on-Sea, Essex.

**Printed by**

Greenaway Harrison Ltd.,  
535 Sutton Rd, Southend, Essex.  
**Distributed by** Spotlight Magazine Distribution Ltd., 1-11 Benwell Rd, London N7.

Copyright. All material is subject to world wide copyright protection, and reproduction or imitation in whole or part is expressly forbidden. All reasonable care is taken to ensure accuracy in preparation of the magazine, but Maplin Electronic Supplies Ltd. cannot be held legally responsible for its contents. Where errors occur corrections will be published as soon as possible afterwards. Permission to reproduce printed circuit board layouts commercially or marketing of kits must be sought from the publisher.

© Copyright 1985 Maplin Electronic Supplies Limited.

# IBM GOLFBALL PRINTER DRIVER

by Paul Reeve Part 1

**T**he high cost of a correspondence quality printer has made it feasible to convert a golfball printer to have a centronics type interface. The printer mechanism is driven by 17 solenoids which are sequenced by the on board processor, according to the ASCII codes received. The driver card and its program are an integral part of the completed project so none of the host computer's memory is required to run this printer.

The driver card and the special program will be explained in Part 2. First, however, you will need the IBM Golfball Printer Mechanism; available from P & R Computer Shop, Salcote Mill, Goldhanger Road, Heybridge, Malden, Essex, telephone (0621) 57440. At time of going to press this mechanism costs £45 in operational condition but may be likely to require a general overhaul, or £55 fully working, adjusted and serviced. This first part of the article will be concerned with checking out the printer mechanism.

## Printer Checkout

The printer has two cables, one is a mains lead, the other is the 'driver/feedback loom'. Connect the mains lead to a plug, note the colour code may be unfamiliar.

LIVE	Black
NEUTRAL	Black
EARTH	Green/Yellow

The live and neutral can be interchanged as they are only used to drive the printer motor and are therefore, isolated from the chassis. Make doubly sure that the earth is connected. Once, by physically checking that the wire is connected to the chassis and also by measuring the resistance between the plug earth pin and the printer case. Fuse the plug with a 3 Amp fuse.

**WARNING:** The printer mechanism, when switched on, has enough energy (thermal, mechanical and electrical) to cause serious injuries. I therefore recommend that you think carefully about what you are doing before putting your fingers inside! Switch off at the mains socket and pull out the plug before making any adjustments.

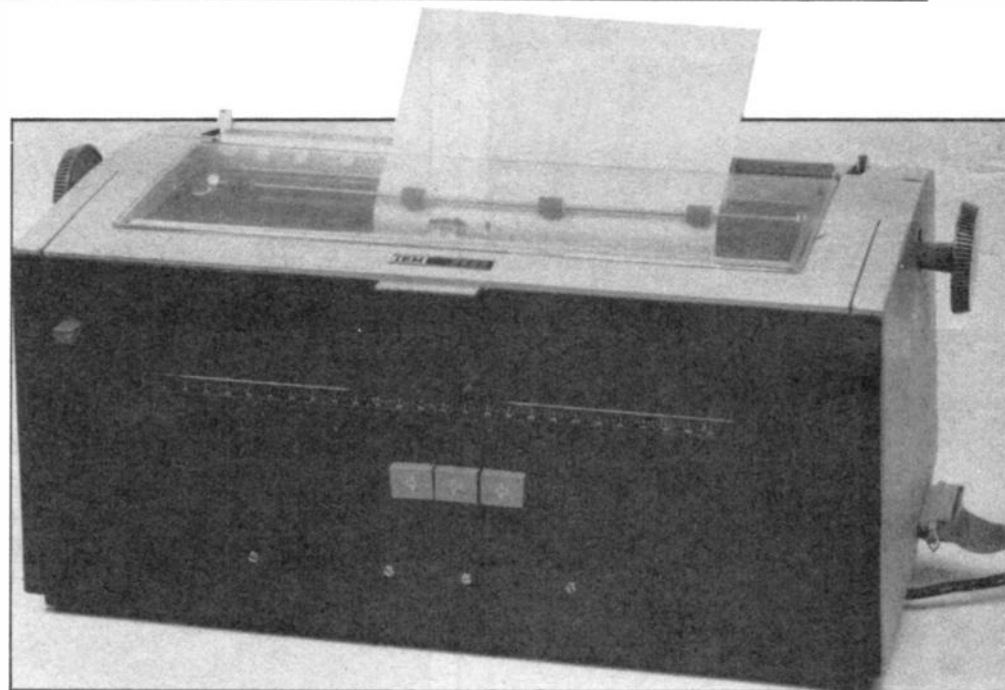

Switch on the printer. After a possible clatter of any previously set solenoids, check the front panel buttons (if nothing happened then check the mains switch under the printer is in the up position). From left to right, they perform TAB, BACKSPACE and CARRIAGE RETURN, verify that these work. Open the lid and move the left margin stop, which is on the flat bar which is nearest to you, to the left hand end and remove any TAB settings by lifting the TAB lever each time a TAB is encountered. You will now be able to check the functions over the full range of travel of the print head. Where the printer has been standing for a long time, it is likely that the mechanism may stick in some places. This stickiness may prevent the backspace from working at all. If you are getting these problems, you may be better to free the mechanism by printing a succession of 'CR's followed by

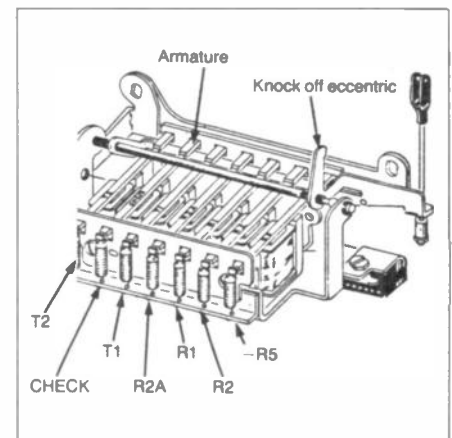

Figure 1. Print Solenoid Assembly

'TAB's once the interface has been built. If you cannot even hear a response when you push any of the buttons, turn off, open the lid and examine the mechanical linkages from behind the buttons. If the

SOLENOID	GOLFBALL FITTED		WIRE COLOUR		
	Normal	Bank	Lower	Upper	
T2	b	B	RV	⌘	Yellow
CHECK	-	-	TF	-	Yellow/Light Blue
T1	w	W	CR	+	Yellow/Black
R2A	q	Q	8	0	Yellow/Brown
R1	y	Y	7	1	Yellow/Red
R2	q	Q	8	0	Yellow/White
-R5	j	J	BC	&	Yellow/Orange

Table 1.



linkages appear to function but the buttons do not work, then the static checks to be performed later will check out the appropriate solenoids:

Load a sheet of paper into the printer and support it so that the underside is accessible before turning it on. Switch off and unplug the printer. If you can support the printer so that it is tipped backwards by approximately 45 degrees, you will see a row of seven solenoids in the bottom left corner. From left to right, these solenoids are T2, CHECK, T1, R2A, R1, R2 and -R5, label these before switching the printer on (see Figure 1). Manually pushing the tops of these solenoids will print characters which will depend upon the type of golfball fitted and whether upper or lower case is current. See Table 1 for expected results.

This manual check will probably already have been carried out by the supplier of the printer, as a confidence check that the print mechanism works. If all is OK so far, you have all the functions you require to build a functional printer; therefore, be sure to see these demonstrated or you may be buying a useless mechanism.

Unplug the printer and open the lid. Remove the roller by pushing the small lever at each end, note that the toothed wheel for the line feed drive is on the right. Remove the bright, metal, paper guide which has now been exposed, note the rear edge is curved to help with the loading of paper from the rear. The four pinch rollers can now be removed; note how they are installed and that the larger diameter pair go to the rear.

**WARNING:** You must assume that spares for this machine will be very difficult, perhaps impossible, to obtain, so treat everything very gently as you could jeopardise the whole project by breaking something.

Remove the white part of the cover by pulling the two latches under the bottom rear corners towards you (as shown in Photograph 1). This will enable you to lift the lid several inches before you have to undo the connector on the wires which are holding on to the lid. This wire goes to the paper out detector (Figure 2) which is not used in the interface because, when using single sheets of paper, it is inconvenient not to be able to print in the bottom three inches of the paper.

With the printer placed with the front panel down, strip the insulation from the large diameter cable up to a point approximately one inch from the metal 'P' clip. On the other side of this clip, you will see that the unused wires have been bound together with sticky tape, unwrap them and then slide these wires out one at a time. You may be tempted to use some type of solvent to clean the wires, avoid this for now unless you are certain that the solvent will not remove the coloured stripes from the remaining wires. Cut the remaining wires in the loom so that they are 24 inches long, measured from the P clip (this is not the final length but it does make them more manageable).

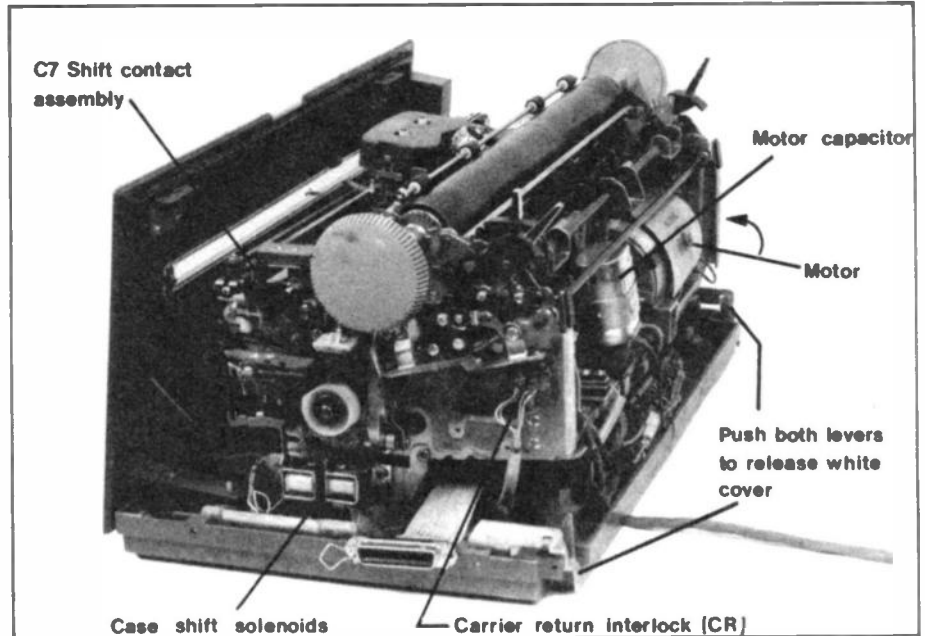

Photograph 1. The Printer with covers removed

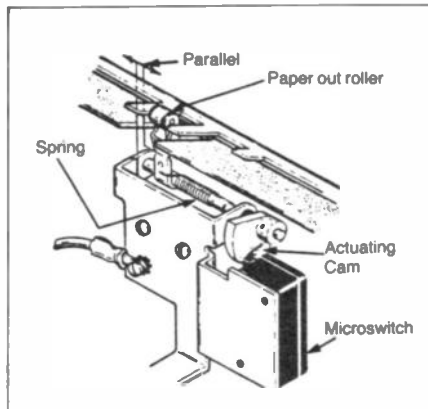

Figure 2. End of Paper Detector

As you can see from Figure 3, each of the solenoids has a reversed diode connected in parallel to clamp the voltage overshoot when the current is turned off. It is necessary to prove that these solenoids, diodes and wire colours are correct before risking the interface card, which could be damaged.

The colours given in Table 2 cannot be guaranteed, so be sure to confirm and label each wire as it is checked out.

Turn the printer onto its back face and locate the seven print solenoids. Directly above these you will see a row of terminals. Unscrew these two blocks.

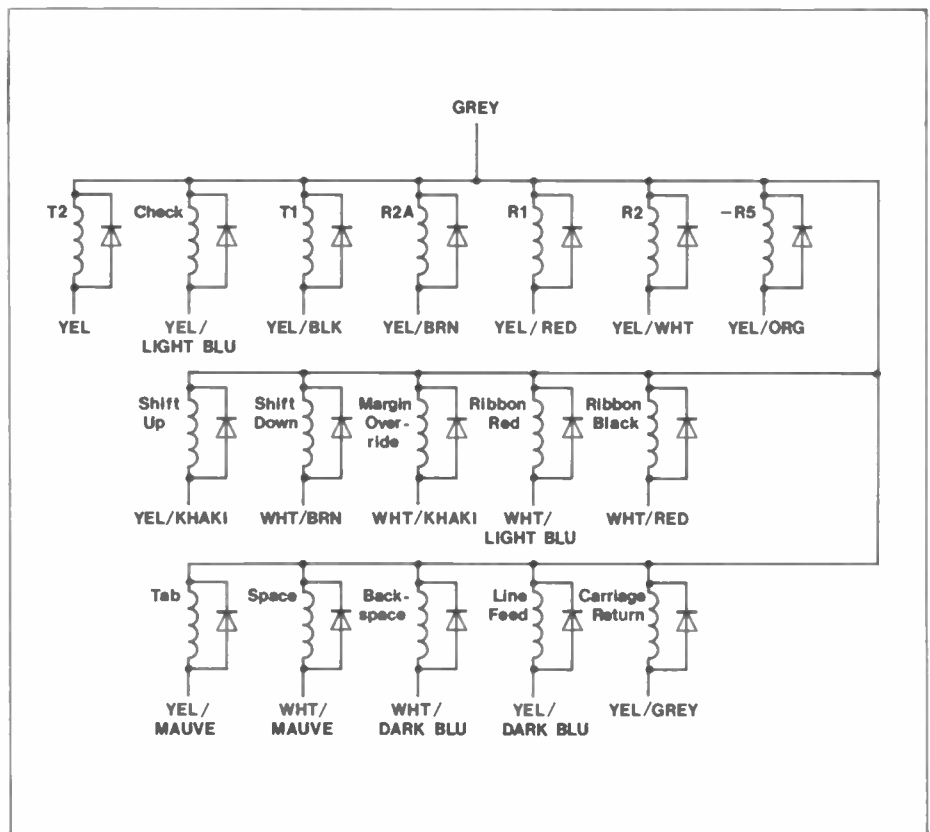

Figure 3. Solenoid Wire Colours

## Adjustments and Principle of Operation

**NOTE:** It may not be necessary to do all of the adjustments that will follow, but they have to be included because you are unlikely to be able to obtain any support or servicing except that supplied by yourself.

To explain the various functions of the printer, I will adopt the principle of working backwards from the required function. Hopefully this will be the most familiar place to start from. During this section, hand cycling will be mentioned many times. This involves turning the printer motor by hand which allows you to stop the cycle at any point to do adjustments. Try a sample hand cycle now by turning the motor shaft so that the top of the belt is moving into the printer; once any preset latches have cleared, the motor will be easy to turn. Push the carriage return button on the front panel, turn the motor and observe the slow carriage return. Needless to say it is not a good idea for the printer to remain plugged in at the mains socket whilst you are doing this!

With the print head at the left hand side of the carriage (if not check that the margin stop on the front rack is at the left hand end and recycle), remove the right hand half of the black plastic shield as shown in Photograph 2. Lift the front enough to unclip it gently, remove without damaging or straining anything. Hand cycle as many TABs as necessary to move the head to the right hand end and remove the left half of the plastic shield in the same manner. This will make the examination much easier.

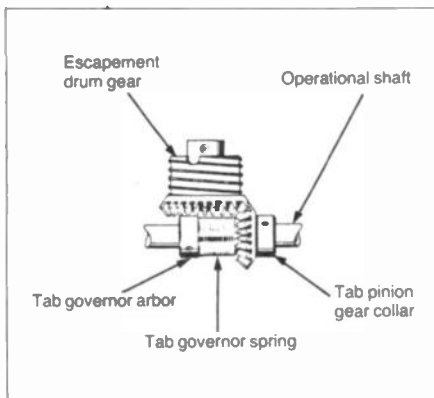
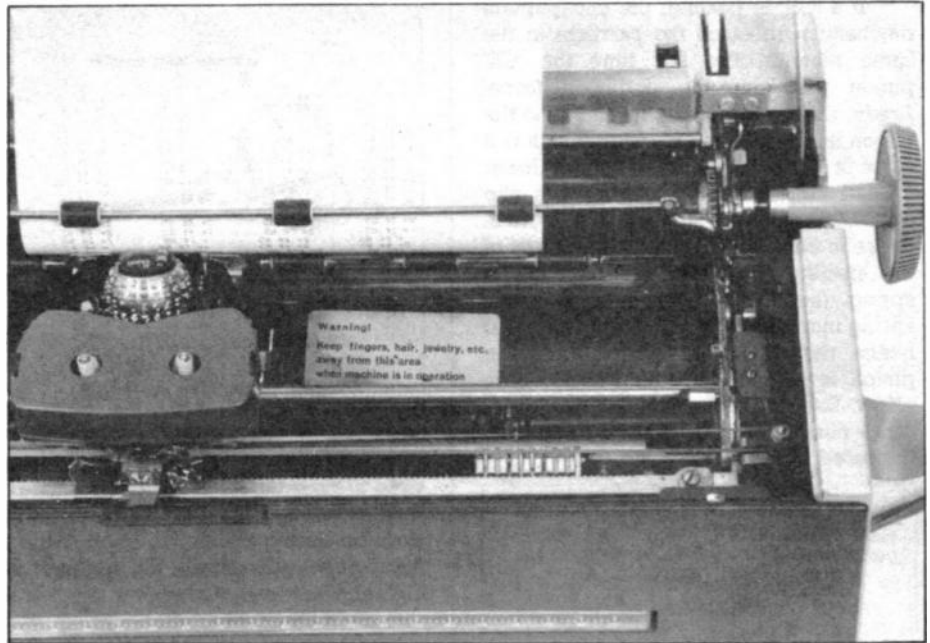

Figure 7. Tab Governor Pinion

If you now cycle a carriage return, you will see that the head is being driven by a steel wire which is unwinding from one reel, whilst the other end winds onto another, which is on the same drive shaft. Further out on the same shaft is the spring which has its tension increased during a carriage return. This provides the force to move the print head forward when printing single spaces or characters (see Figure 6). If you hand cycle a TAB, the head will be driven forward and the spring is unwound so the motor will be easier to turn. Repeat as many times as necessary. If the wire stretches, it has the slack taken up by the pulley at the right hand end, which is mounted on a



Photograph 2. The Warning Label is on the righthand Plastic Shield

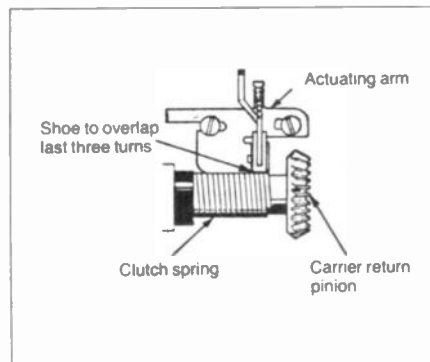

Figure 8. Carrier Return Clutch

spring tensioned slide. These two springs do not look strong enough for this wire but if you try to squeeze two turns together with your fingers, then I think you will be surprised at their strength.

Mainspring tension should be adjusted to give enough torque to move the print head, but not so high that a carriage return would stall the motor. Remove the motor capacitor clip (you may need to remove the capacitor first), which will expose the black mainspring cage. At the right hand end of its travel is the cage stop screw which has a rubber head; the tension can be set by removing this screw and measuring the pushing force on the print carriage as it passes the point where the screw had been. This should be  $\frac{1}{2}$  to  $\frac{3}{4}$  pounds of force. Adjustment is carried out by changing the number of turns on the mainspring, the spring is not as strong as it appears. To unlatch the cage, rotate it clockwise slightly and withdraw the unit towards you. Adjust the tension, replace the cage and re-measure the force. Should you not have the means to measure this force then there is no need to remove the cage stop screw. Position the carriage at the right hand end and then adjust the mainspring cage so that it has 5 turns on it. This is meant to be an approximate setting, but the prototype appeared to have about double this number, so the measuring

technique appears more satisfactory.

The other end of the shaft has the spool for one end of the wire, and also has crown type gears, (i.e. the cogs' driving faces are at 45 degrees) hence the cogs are at 90 degrees to one another. If you turn the motor without a 'CR' or 'TAB' then neither of the driving cogs produce any movement because the print carriage is being held in place by what the IBM book calls the Print Escapement Mechanism (see later). When the carriage is released, (by selecting a TAB) the driving cog nearest the right hand

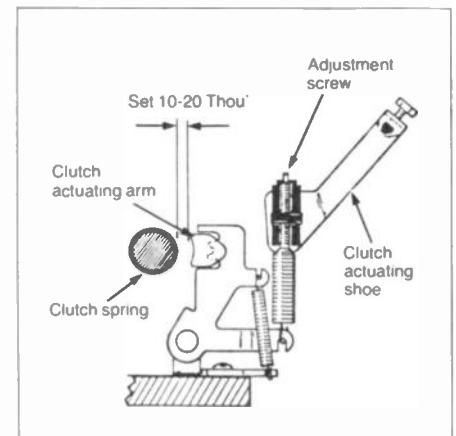

Figure 9. Brake adjustment

end is allowed to move the carriage. This cog is trying to drive all of the time by means of a slipping clutch; the clutch consists of a spring which is used as a crude regulator for the perpendicular force on the clutch. This spring has turns of rectangular cross section, and is rotated in such a way that, should the driven end attempt to stall, then the spring would try to unwind. This would effectively reduce the number of turns and hence if fully squashed, the spring is shorter. Initial setting of the spring is obtained by inserting a 0.005 inch feeler gauge between the TAB pinion gear and its collar and adjusting the TAB governor arbor for no play (see Figure 7).



If a 'CR' is pushed, the escapement mechanism releases the carriage in the same manner, but this time the 'CR' pinion will give the dominant force. Again, a spring is used, but this time the pinion has a tubular extension which is a close fit on the inside of the spring. Under normal conditions, the spring will slip over the pinion's extension but a small brake is applied to the last three turns of the spring which causes drag on the spring (see Figure 8). Dragging the spring increases the number of turns and hence the diameter reduces until the pinion is gripped by this strangulation effect. Should the force from the brake block need changing, adjust the screw as indicated in Figure 9.

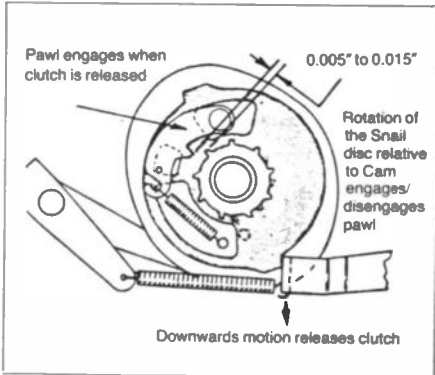

Figure 10. Snail Disc

On the shaft that is driven by these 'clutches' are two cams which are used as follows. The right hand cam is for 'CR', and is only activated for a 'CR' or a 'LF', (note a carriage return without a linefeed is not possible). Rotation of the cam is via a pawl which engages on the rotating ratchet wheel. This pawl is engaged/disengaged by the 'snail' disc in between the cam and the pawl (see Figure 10). I have called this a 'snail' disc because of the slot it has for lifting/lowering the pawl, normally the pawl is disengaged

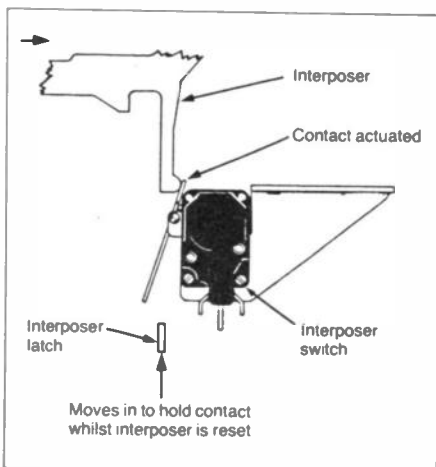

Figure 11. Return Interposer Switch

and the snail is prevented from rotating by a small barb on its edge. When a carriage return is requested, a latch is released which:-

1. Operates the Carrier return Interposer Switch (CIS).
2. Frees the snail which engages the ratchet pawl.

You will note that the 'CR' cam is really two cams, the light coloured cam is

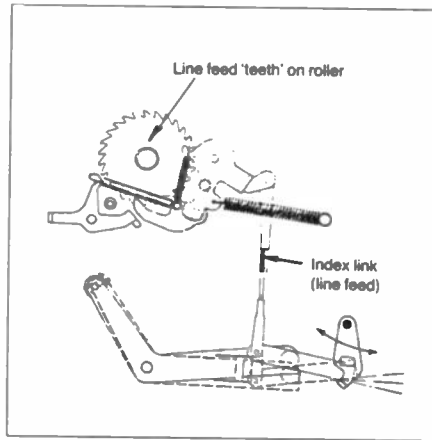

Figure 12. Linefeed Drive

used to reset the latch during the cycle as well as holding the CIS switch in the on position during the cycle. Hand cycle to familiarise yourself with the action of the CIS, and adjust the mounting bracket so that the CIS breaks when cycled. Also adjust the keeper to hold and release as it moves during the cycle. (See Figure 11). As the CIS is activated on 'CR' and 'LF' you must check that your adjustments work on both. This is not always possible as wear on the pivot of the microswitch will allow it to tilt before rotating in the required direction. If you are unable to adjust or repair this microswitch, so that it works on both, then adjust it for the linefeed to work correctly, as it is possible for the software to ignore this contact and operate in open loop mode.

The main cam drives the two rollers which, if you lift by hand, will operate the line feed mechanism. Be sure to note the adjustable linkage in case you need to adjust later. When viewed from behind, you will notice a stop which allows you to coarse set the 'LF' movement (see Figure 12). This should be in the correct position already. Whilst you lift the cam up and down, watch from behind the printer and push the 'CR' button. Note that the latch has allowed a barb to hook onto the 'LF' actuator which has increased the force required to lift the cam up and down. The extra function performed is to lift the brake into a position where it will engage the 'CR' pinion gear. An extension to the rod that operates this brake appears on the right hand end of the printer, where a

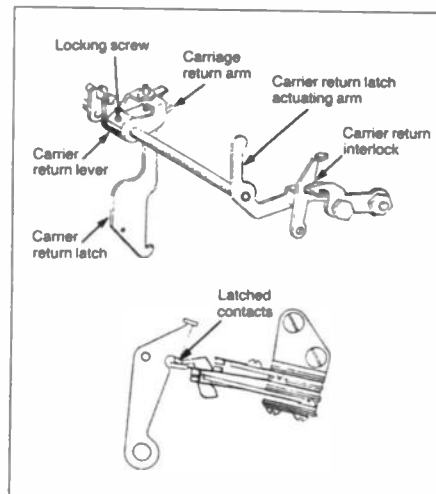

Figure 13. Carrier Return Interlock

latching mechanism holds the brake in an engaged position until the 'CR' is completed.

In Figure 13, you can see that the latch is also used to hold the Carrier Return Interlock switch in an activated position. I have noted that there are two types of contact on the printers I have seen, so yours may vary from the diagram. Only the normally open contacts are used, so adjust this gap to allow approximately 0.020 inches when open and then check electrically that the contacts switch at the correct time when hand cycled. Contact bounce may occur when the printer is running at full speed; this is caused by the moving contact transferring some of its momentum to the stationary contact which then starts to move in the same direction, hence the contacts momentarily open again. The

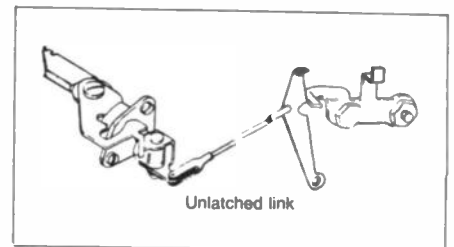

Figure 14. Carrier Return Clutch unlatching

time of this bounce is mainly dependent on the restoring force from the stationary contact, so some springs may cause long or multiple bounces. To avoid problems caused by this bounce, the output of the switch can be ignored for a longer time period, or if the switch is totally non-functional, the software can run in the open loop mode for a carriage return. The release mechanism for the latch can be traced by following the black rod towards the front of the printer (see Figure 14). This rod is pulled by the margin rack. Adjust the black actuating

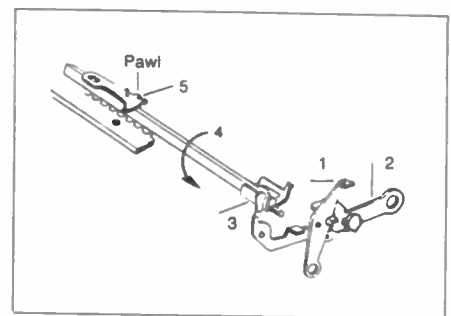

Figure 15. Pawl to Interlock Link

clip on the margin rack so as to be able to work the linkage even if the rack is tilted. The linkage on the end of the pull rod can now be adjusted to give approximately 0.040 inches of latching.

Also operated by this 'latch' is the device for disabling the print escapement pawl; this will be dealt with later (see Figure 15). Likewise, the 'TAB' cam also has a ratchet and pawl driven as before, plus an extra cam which is used solely to reset the latches during a cycle. This cam also controls the 'SPACE' and 'BACKSPACE' functions.

As with the 'CR' cam, a latch is released which allows it to start its cycle, Maplin Magazine September 1985

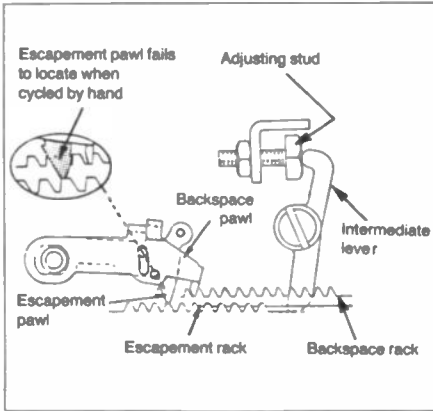

Figure 16. Backspace Rack

during which the latches are reset. This time all three functions cause a latch to hook a barb on to the lifting mechanism which is mainly obscured by the mainspring which was adjusted earlier.

The 'BACKSPACE' is an easy one to follow, so hand cycle a few times and note the two racks moving relative to each other. The starting point of this motion is determined by the adjustable nut just above the mainspring; note where this is for now, but do not adjust until the print escapement mechanism has been understood as the two are interrelated (Figure 16).

The 'SPACE' operates the rod which is also used to terminate the 'TAB' cycle, but this time it is only tilted momentarily before being released. Therefore, only one position is moved. A threaded stop determines the rest position of the linkage (Figure 17), whilst an adjustable pusher varies the limit of the travel. This 'SPACE' mechanism is also used every time a character is printed, to move the print head to the next position. This time, the motion is transferred via the linkage which passes between the two cams with its adjustable link in between the cams. Hand cycle one of the printing solenoids and note how the linkage is pulled by the small cam which is driven by cogs at the left hand end of the printer (Figure 18).

The 'TAB' actuates the black rod which disables the escapement pawl; this latches in position at its left hand end, until it is released by the lower black rod, which indicates that a TAB has been found, or it is the end of the line (Figure 19). During the latched time, the malselect microswitch is held in a closed position. If this does not function, then the printer could be used without tabs but if required, a long delay could be inserted in the software to allow for the slowest

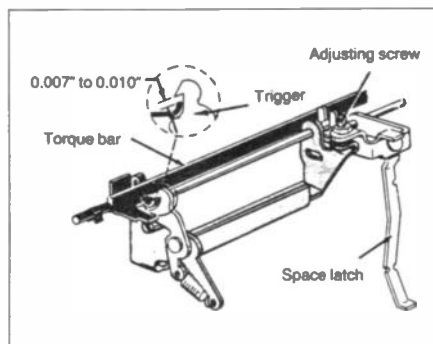

Figure 17. Space Mechanism  
September 1985 Maplin Magazine

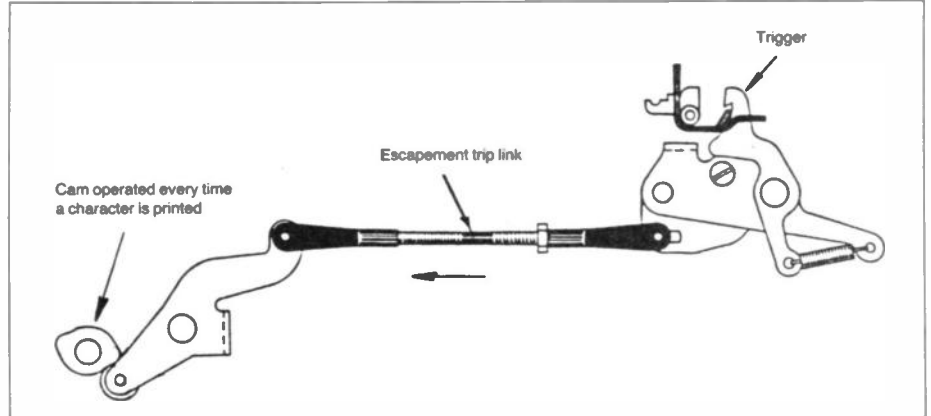

Figure 18. Escapement Cam and Trip Link

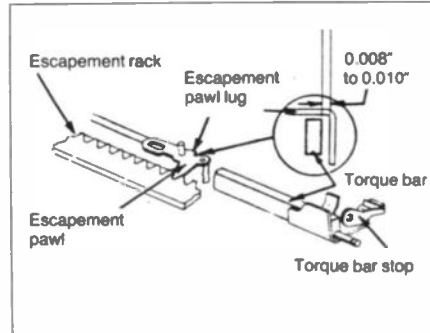

Figure 19. Escapement Pawl

'TAB' to happen.

Once the escapement pawl has been pulled out, it is latched in position as shown in Figure 20. When a 'TAB' or end of line is encountered, the tab pawl is pushed until it unlatches itself and the escapement pawl, allowing it to reengage with the escapement rack and release the malselect contact.

Lift the 'TAB' lever on the front panel to see the 'TAB's cylinder twist in a direction which will cause the appropriate 'TAB' to be disabled by the pusher, which is screwed on to the print carriage. Because of its shape, the tip must be aligned to push on the 'TAB' and its forward/backward position adjusted to set the off position of the 'TAB'; Figure 21 shows a cross sectional view of the pusher mechanism and the position of the pusher.

When the end of the rack is reached, the 'TAB' pawl is reset and the Last Character microswitch is activated, adjust the switch as required.

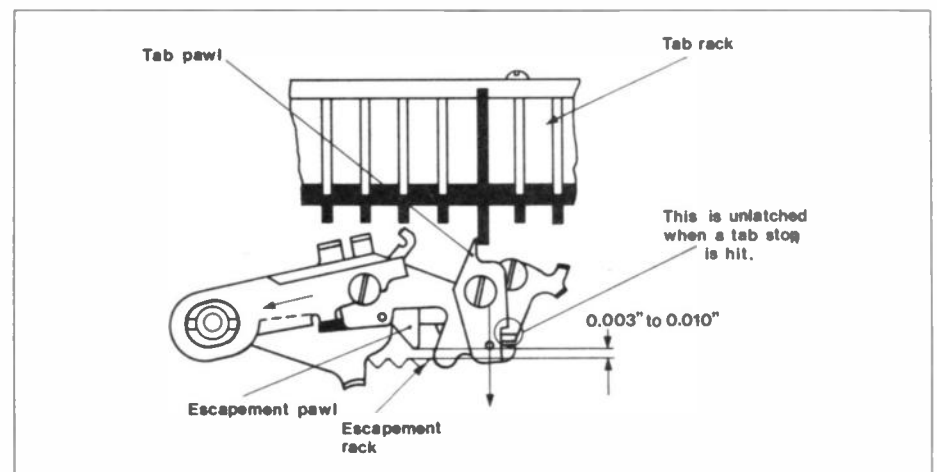

Figure 20. Tab unlatching

## Printer Head Operation

Remove the ribbon from the print carriage. This allows a better view of the moving parts. Trip one of the print solenoids and cycle a character by hand to see what happens. The head will tilt and rotate before lifting to strike the paper.

Tilt and Rotate are two different functions which are transmitted to the golfball by means of two tapes which are driven from the static part of the machine. Tilting motion is transferred by the tape which does a full loop in the horizontal plane, the end which goes to the right hand side of the print head is fixed via a screw which passes through the top of the carriage and through a hole in the tape termination. The other end enters by the left end of the carriage and is partially wrapped around a white nylon pulley before being terminated as the other end. The centre of the tape is guided round pulleys so it is free to travel and only a change in the length of the loop will affect the position of the white pulley. A very light pull on the tape will cause the head to tilt slightly; removing the head will expose the push rod used to convey the horizontal rotation of the pulley to the vertical rotation (tilt) of the golfball. Obviously, it is not very likely that the tape could give repeatable results as it will tend to demonstrate some elastic properties, so the golfball is locked in place when it has been placed near enough by the tapes. Examine the



left hand side of the tilt pivot for the golfball, the lower edge of the moving part has four slots in it which are used to lock the head (see Figure 22). Hand cycle any character and note how the linkage is driven by the cam through several levers to lock the tilt, whilst locked you will notice that the tension in the tape is much higher, as the pulley end is now effectively fixed.

How is the length of the tape changed? Figure 23 shows the left hand end of the tilt tape driver. All motion is transferred by T1 and T2 being pulled downwards or not, T1 is the one furthest away from the fulcrum. These two, with two possible states each, give four possible positions, as the fulcrum is not symmetrically placed between T1 and T2. To show the variation, assume the pulling is done through a distance of three units. If both T1 and T2 are selected, then neither will move and the net result is zero motion. If neither T1 or T2 is selected, then both will be pulled and the fulcrum will be pulled by three units. Should T1 only be selected, then only T2

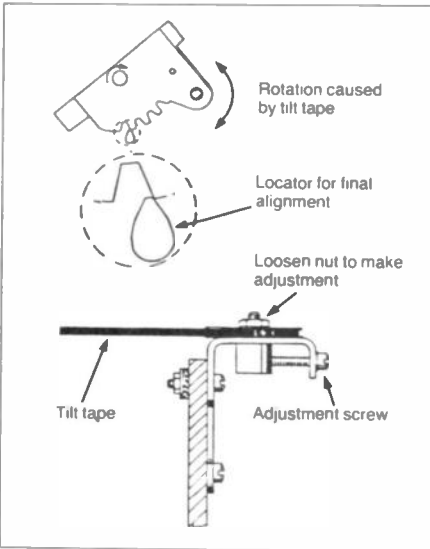

Figure 22. Tilt honing

is pulled and the fulcrum will be pulled by an amount which is between 3 and 0, but is nearer to the value of the T2, by choosing the fulcrum to be only one third of its length from the T2 end giving a net pull of two units. Likewise, if only T2 is selected, then only T1 pulls, giving a net one unit of pull. So all four combinations give a different result. If the top row of the golfball is row 0 then the tilt occurs as below:

T1	T2	Row
0	0	0
0	1	1
1	0	2
1	1	3

Selection of the T1 and T2 will be described later. Any offset can be adjusted by varying the length of the tape by adjustment in the position of the pulley at the right had end of the tilt tape (as in Figure 22). If the error needs adjusting due to the increments being the wrong size, then it is possible to alter this by moving the position of the tilt arm link (see Figure 23).

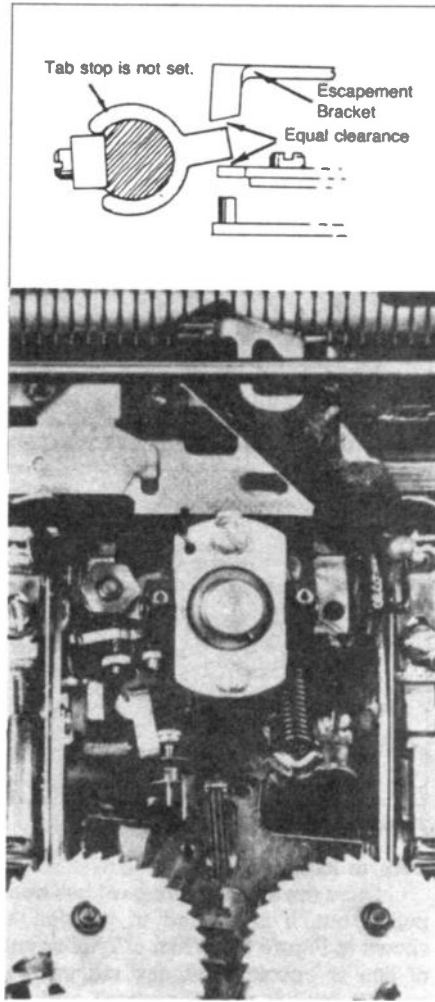

Figure 21. Tab Pusher adjustment

The rotation of the golfball is caused by another tape which has its end joined to a metal pulley on the print head which rotates when the length of the rotate cord is varied. As before, the length of the cord is not accurate enough to produce constant results, so the rotation is locked in place. Hand cycle a character to find out what is happening and note the way the rotation is locked in place; if you did not have the head in position, you will have missed the lock, as the ball itself has the teeth that the lock engages with (Figure 24).

**NOTE:** When the golfball is not installed correctly and the printer is running, there is a high chance that a tooth will be knocked off the golfball by this mechanism.

Selection of the tape length is similar to the tilt function but it has one extra

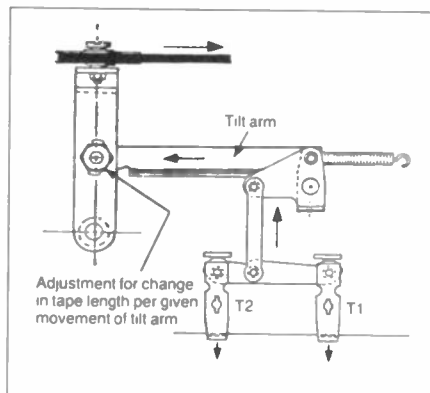

Figure 23. Tilt Arm motion

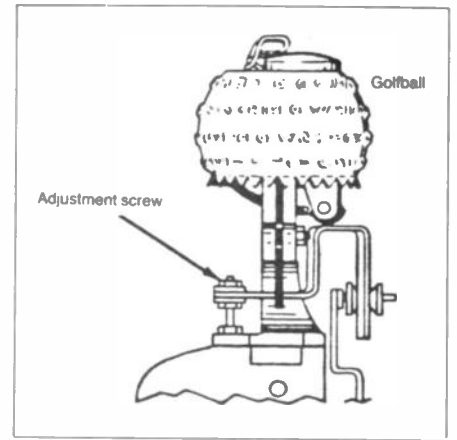

Figure 24. Detent Actuating Lever

stage (Figure 25). The top of R1 and R2 behave in the same manner as before and this is then combined with R2A as before, but this time the fulcrum is 0.6 of the total length away from R2A. The resultant of R1 and R2, with a full scale pull of one unit, will be either zero, one third, two thirds or one. When combined with R2A, which has a position of one or zero, the total resultant will be equal to the position of R2A plus 0.6 times the difference in position of the R2/R1 combination. See Table 3 for clarification.

R2A	R2	R1	
0	0	0	0 as nothing is pulled
0	0	1	$0 + \frac{1}{3} * 0.6 = 0.2$
0	1	0	$0 + \frac{2}{3} * 0.6 = 0.4$
0	1	1	$0 + 1 * 0.6 = 0.6$
1	0	0	$1 - 1 * 0.6 = 0.4$
1	0	1	$1 - \frac{2}{3} * 0.6 = 0.6$
1	1	0	$1 - \frac{1}{3} * 0.6 = 0.8$
1	1	1	$1 - 0 * 0.6 = 1.0$

Table 3.

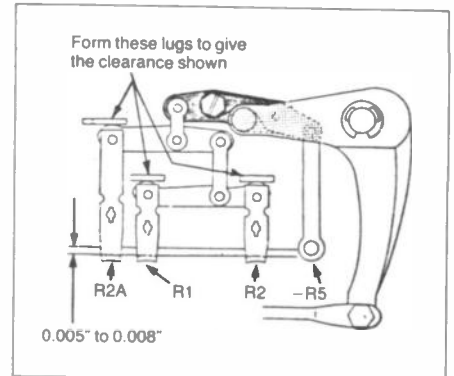

Figure 25. Rotate latches

In Table 3, a '1' refers to the item being pulled and as such is negative logic for solenoid selection. Six different positions are given here and all represent a positive rotation from 0 to +5.

On the lever which takes the resultant to the rotate tape is yet another arm to be summed into this movement. It is actuated indirectly by the print solenoid -R5, which adds in a negative rotation of five characters. This extends the range of rotates to eleven, i.e. from -5 to +5 (Figure 26).

Eleven characters account for one half of the golfball which generally is the upper or lower case of a normal type

golfball. To obtain the other half, the tape length is changed by the case shift mechanism. Examination of the pulley at the right hand end of the printer shows that the pulley used for the rotate has its position changed by the cam on which it sits. Hand cycle a case change and watch the pulley move in or out. Whilst at this part of the machine, adjust the shift contacts (if necessary) so that they are normally closed, but open during a shift. As before, the method of selection of the solenoids will be described later.

With the ribbon cartridge removed, the drive method can be seen if you hand cycle any character; the pulling action is introduced by the same cam that is used for lifting the print head. The ribbon direction can be changed manually by the levers or an auto reverse is used when no more ribbon is available. To remove the plate which holds the ribbon spools, undo the two screws which will then allow you to remove the plate. This is a very frustrating exercise which involves moving the golfball holder forward (by hand) whilst gently moving the ribbon carrier to the right to disengage it from the cam.

It is now possible to see how the ribbon is lifted, and the amount of lift. Two levers are visible on the back of the carriage, the right hand one is used to produce stencils, so pushing this towards the front of the printer lifts the ribbon to a height where the golfball strikes the paper underneath the ribbon. The left hand lever has several settings and is used to vary the amount of lift, by shifting a pivot point; fully back gives zero lift. Colour changing of the ribbon is obtained by changing the length of the tape which adjusts the stop that is connected to the left end. This causes two different stop heights, hence top or bottom of the ribbon is available. Adjustment is fairly critical, so trip the appropriate solenoid at the far left edge of the tape and adjust the position of the pulley at the right end of the tape.

The remaining cam is on the right side of the carriage and is used to fire the golfball at the roller. Although it is possible to do adjustments in this region, the distance of flight is adjustable by the small lever to the right of the golfball, so use this for any trimming you need to do. In addition to this, the roller is adjustable for the thickness of paper (or number of sheets) by the lever at the back left of the printer. This drives two small cams on either side of the machine, which normally work loose, so set to equal positions and tighten.

The tilt and rotate selections have had their magnitudes explained; now we will see how the selections are made. Lay the printer on its back edge and activate one of the solenoids. Immediately you will hear the clutch being unlatched via the black pull rod. You can reset the clutch by lifting the top end of the spring, which is directly above the pull rod. Check that every one of the solenoids is able to trip the clutch. When viewed from above, you can see that the outside of the clutch (just left of drive belt) rotates. This

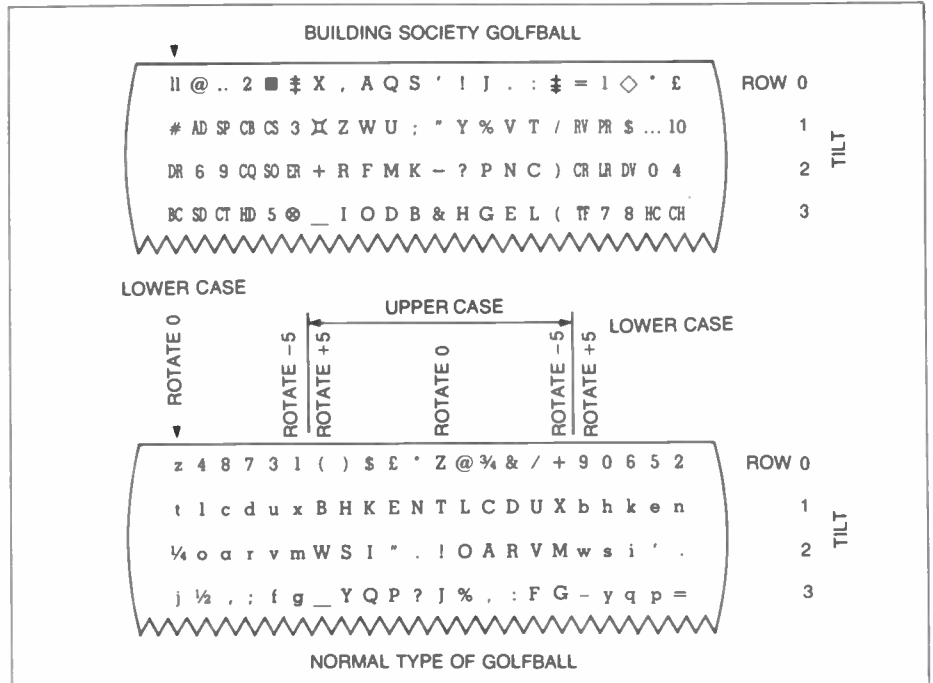

Figure 26. Golfball characters

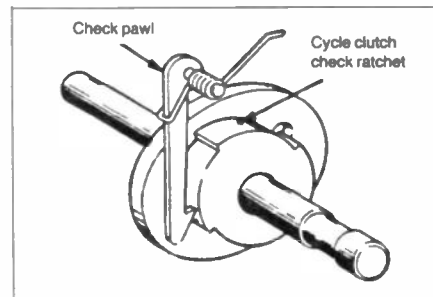

Figure 27. Cycle Clutch/Check Pawl

is similar to the clutch of the print functions. When the outside rotates relative to the inside, a spiral arrangement engages the clutch. During the rotation, the ratchet on the outside of the clutch moves until it gets caught after rotating 180 degrees which then disables the clutch, the trip mechanism having been reset by the cam, adjacent to the clutch, during the cycle. When the print shaft has finally come to rest, a pawl at the other end engages and prevents a reverse rotation, the forward movement being halted by the ratchet shape on the clutch, holding it from forward rotation (Figure 27).

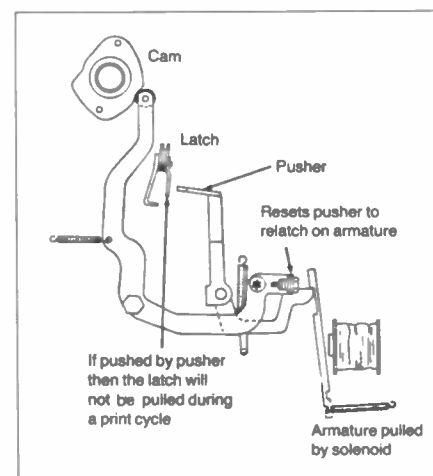

Figure 28. Latch Pusher Operation

On the shaft, in between the two ends are five cams arranged as two pairs and one single one. The inner pair are used to reset the activated solenoids during the print cycle. The description is rather difficult, so I suggest that you cycle a character and watch the very small movements associated with this reset. The outer pair are used to move the frame which pulls all of the positive rotate latches.

With the printer on its back, push the R2A solenoid, then cycle slowly noting the following. First, the reset bar moves away from the solenoids, allowing any tripped solenoids to release its pusher (repush R2A if it did not release). The pusher in turn pivots and lifts the

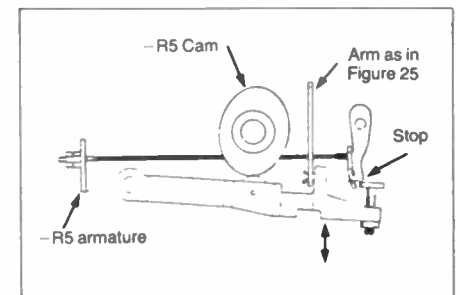

Figure 29. -R5 Actuating Mechanism

appropriate puller away from the pulling frame which will now start pulling, leaving the R2A behind. This method applies to all of the positive rotate and tilt latches (Figure 28).

The CHECK solenoid is used as a method of tripping the clutch without selecting any of the print solenoids. -R5 is tripped in the same manner as the positive rotate latches, only this time, a stop is removed by the pusher to allow the -R5 cam to be followed (Figure 29).

This completes the mechanical testing of the printer. In Part 2 we shall move on to the printer driver electronics and details of the necessary power supply and the special programs which will be resident in an EPROM device.





# MULTIMETERS

## AND THEIR USE FOR TESTING ELECTRICAL APPLIANCES

The Multimeter is so vital in servicing electrical appliances that without it, one would be working in the dark. It reveals the exact nature of the fault in the appliance or circuit, and provides information to enable you to discover the cause and provide a cure.

How well and how quickly you will be able to do this will depend on your electrical knowledge and experience. So to assist you to acquire this electrical knowledge, let me briefly explain the fundamental principles underlying the units of electricity, and their application to an electrical circuit. The strength of a steady direct current of electricity flowing in a closed circuit is directly proportional to the electromotive force, and inversely proportional to the resistance of the circuit where I equals the current expressed in units of amperes (A), E equals the electromotive force expressed in units of volts (V), and R equals the resistance expressed in units of ohms ( $\Omega$ ). The above is known as Ohms Law, and states that the electromotive force divided by the current is equal to the resistance of the circuit, and is shown in a formula as  $R = E \div I$ . The current flowing in the circuit is calculated by dividing the electromotive force in volts, by the resistance in ohms, which is shown in formula as  $I = E \div R$ , and lastly, the electromotive force is found by multiplying the current in amperes by the resistance in ohms, which is expressed in a formula as  $E = I \times R$ . A simple method of remembering this formula is by drawing a triangle as shown in Figure 1, and by placing a finger over the *wanted* quantity, the required formula will be left. For example, to find resistance, place a finger over R, leaving  $E \div I$ . To find the current, place the finger over I, which will leave  $E \div R$ , and to find the electromotive force, place the finger over E, leaving  $I \times R$ .

By R. Richards

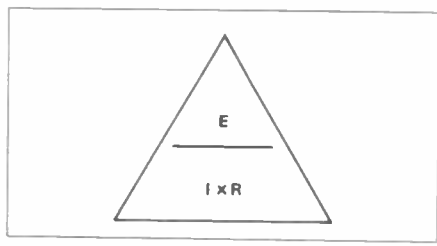

Figure 1. Ohms Law Triangle

the wanted quantity I, it would leave:-

$$\frac{E}{R} = \frac{240}{60} = 4 \text{ amperes.}$$

Likewise, by placing the finger over the wanted quantity R, the resistance would be:-

$$\frac{E}{I} = \frac{240}{4} = 60 \text{ ohms.}$$

And lastly, by placing the finger over E, it would leave:-

$$I \times R = 4 \times 60 = 240 \text{ volts.}$$

### Electric Power

The electrical unit of work performed in unit time is one joule per second, and is known as the watt, which is expressed in formula as P. The power

expended in watts is equal to volts multiplied by amperes. Therefore, the power is given in formula as  $P = E \times I$ . The power can also be expressed in formula as:-

$$P = I^2 \times R,$$

or

$$P = \frac{E^2}{R}$$

That is, the current squared multiplied by the resistance, or the EMF squared divided by the resistance.

### Example 2

If a 2 kilowatt electric fire is connected to a 250 volt supply, (a) what current will flow through the element? (b) what is the resistance of the element?

In the case of (a), the power in watts is given as  $P = E \times I$ , therefore the current will be:-

$$I = \frac{P}{E} = \frac{2000}{250} = 8 \text{ amperes}$$

For (b) the resistance of the element equals:-

$$R = \frac{E}{I} = \frac{250}{8} = 31.25 \Omega$$

To calculate the power dissipated in the element:-

$$P = E \times I = 250 \times 8 = 2000 \text{ watts,}$$

or

$$P = \frac{E^2}{R} = \frac{250^2}{31.25\Omega} = 2000 \text{ watts,}$$

or

$$P = I^2 \times R = 8 \times 8 \times 31.25 = 2000 \text{ watts.}$$

Or 2 kilowatts (kW). The foregoing information is a brief description of electrical units such as volts, amperes, ohms and watts, together with examples to show how they are applied to an electrical circuit, which will assist you in making logical deductions when testing electrical appliances or circuits. In this article we shall be using 'mundane' household appliances as examples, but the same principles apply to more sophisticated electronics circuits, where each individual stage in a complex system can be regarded as a circuit in its own right. Detailed trouble-shooting of electronic

### Example 1

If an electric kettle with a 60 ohm element was connected to a 240 volt supply, calculate the current flowing in the element. By placing the finger over

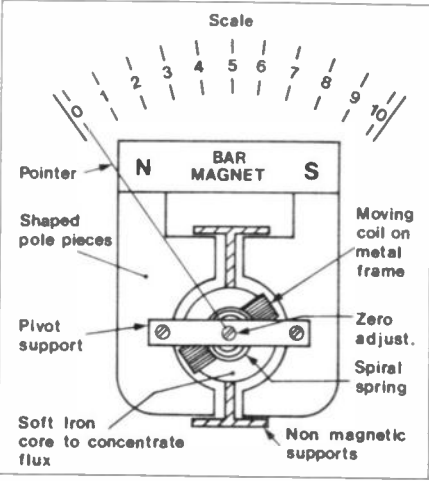

Figure 2. A meter movement

circuits of this type is a subject already covered by the series 'Project Fault Finding' as featured in this magazine.

## The Meter Movement

Let us now look at the working principles of a typical multimeter which is illustrated in Figures 2 and 3, which show a typical layout of the components. Figure 2 shows the moving coil pivoted between the shaped poles of a permanent magnet. Any current flowing through the coil will set up a magnetic field in opposition to the field of the permanent magnet which will deflect the pointer against the torque of the two spiral springs. These spiral springs also serve to restore the pointer to zero when the current ceases to flow. The instrument is designed so that the amount of current flowing through the coil deflects the pointer to a position on the scale proportional to the amount of current flowing through the coil.

## Ammeter

For example, if a moving coil was designed with a resistance of 108 ohms and a full scale deflection (FSD - needle at right-hand end of the scale) current chosen at one milliampere to flow through the coil, this would act as an ammeter with a range of 0 to 1 milliampere (1 mA - one one thousandth of one ampere). By shunting the moving coil with a 12 ohm resistor, 1 milliampere would flow through the coil, and 9 milliampere through the 12 ohm resistor, hence giving a full scale deflection for 10 milliampere (10 mA), thus increasing the range of the ammeter to 0 to 10 milliampere, as in Figure 4 (a). It is in this way that the instrument functions as an ammeter, and by shunting the coil with different resistors the instrument can be made to measure current over a number of different ranges.

## DC Voltmeter

When the instrument is used as a voltmeter, the switch is turned to the range of the voltage required. This operation connects resistance *in series* with the 108 ohm moving coil, as in Figure 4(b).

For example, if a resistor of 4,892 ohms was connected in series with the 108 ohm coil, giving a total resistance of 5,000 ohms, and a current flow of one milliampere in the coil, i.e. one thousandth of an ampere, then by Ohms Law  $E = I \times R$  we have  $0.001 (A) \times 5000 (\Omega) = 5$  volts for a full scale deflection, giving a range of 0 to 5 volts. Likewise, by connecting a resistance of 249,892 ohms in series with the 108 ohm coil, which gives a total of 250,000 ohms, and by using Ohms Law  $E = I \times R$  we have  $0.001 (A) \times 250,000 (\Omega) = 250$  volts, giving a range of 0 to 250 volts. This explains the principles involved in adopting the instrument as a voltmeter to measure DC voltage. If a variety of series resistances were made available by a selector switch then a number of different ranges are made available.

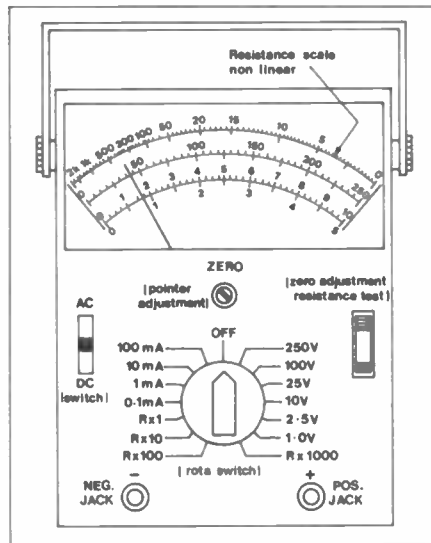

Figure 3. A typical multimeter

## AC Voltmeter

When the meter is switched to measure AC voltage, a rectifier is connected in series with the moving coil and its series resistance, thus converting the AC voltage to DC voltage. The meter is calibrated (series resistance chosen) so that the rectified DC voltage across the coil gives an equivalent reading to the actual AC voltage in the circuit, and it is in this way that the meter is converted to measure AC current and voltage. Because the voltage under test is alternating, the range of switchable series resistances are invariably somewhat lower in value to those used for DC, this is because the meter must measure the root mean squared (RMS) value of the AC waveform. It follows from this that as a result only sinusoidal waveforms can be accurately measured, and although a square or pulse waveform will operate the meter movement, the actual reading is usually quite meaningless!

## Voltmeter Impedance

It will have to be borne in mind of course that any additional resistance added in parallel to any part of an

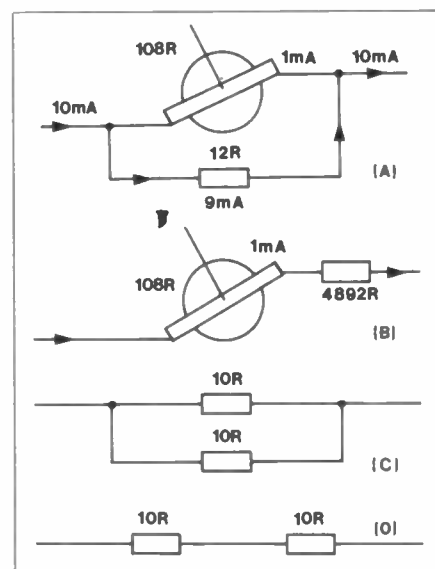

Figure 4. (a) 10mA ammeter with shunt resistor; (b) Series resistor to convert to 5 volts FSD; (c, d) Resistors in parallel and series

existing circuit will change the effective impedance of that part of the circuit. This is what can happen when connecting a voltmeter (DC or AC) into a circuit, in that the meter itself adds to the load. If the source impedance is high then the additional load of the voltmeter will cause the voltage across that part of the circuit it is attempting to measure to drop, creating an erroneous reading. In the case of our hypothetical voltmeter described above, because the full scale deflection sensitivity of the movement is 1mA, and subsequent series resistances are chosen accordingly for particular voltage ranges, the instrument can be said to have an impedance of 1 kilohm per volt ( $1k\Omega/V$ ), the actual total impedance depends of course on the actual series range resistance chosen. Therefore, the meter cannot be used for measuring voltages in a circuit where the current flow in the circuit is much less than 10mA without causing errors by upsetting the impedance of the circuit. Most general purpose multimeters use a standard of  $20k\Omega/V$ , which requires that the meter movement should have a full scale deflection sensitivity of 50 microampere ( $50\mu A$  - 50 millionths of one ampere), enabling voltage readings to be taken from high impedance circuits where the current flowing is not much less than  $500\mu A$ , without significant error. For measuring circuits of a higher impedance the true voltage can be calculated if the circuit and voltmeter impedances are known.

For consistency, where the AC voltmeter will have a rectifier in series with the meter movement for conversion to DC current, there is invariably a second rectifier shunting the movement in the reverse direction. This maintains the voltmeter circuit as a whole presented as a load to both positive and negative going cycles of the AC waveform. In order to indicate very low voltages (of a few hundred millivolts) with any reasonable accuracy, these rectifiers are generally germanium diodes which have a low forward voltage drop.

## Ohmmeter

To use the meter as an ohmmeter by switching to R x 1, a battery and variable resistance is connected in series with the moving coil. When the two ends of the test leads are put together causing a direct short, the current from the battery will flow through the moving coil, deflecting the pointer hard over to the right-hand side of the scale. The variable resistance is now adjusted to bring the pointer back to the zero position on the resistance scale. When the short circuit is removed from the ends of the test leads, the pointer will return to the left-hand side of the scale, and if any resistance is now placed between the ends of the test leads, the pointer will take up a position on the scale proportional to the resistance between the test leads. The above conditions are applicable with the switch turned to R x 1, and each division on the scale equals one ohm. When the switch is



turned to  $R \times 100$  each division is equal to 100 ohms. Likewise, when switched to  $R \times 1000$  each division will represent 1000 ohms. With reference to Figure 3, you will see that the scales for voltage and current divisions start at zero at the left-hand end, culminating in the full scale deflection value at the right-hand side. But the scale for resistance, numbers right to left. The reason for the latter is in accordance with Ohms Law, i.e. the smaller the current the greater the resistance and vice versa.

From a study of the multimeter shown in Figure 3, you will see that the centre switch can be turned to any scale for Current, Voltage or Resistance. The switch on the left selects the AC or DC mode of voltage measurement, and the control on the right operates the zero adjustment for the resistance scale. The small screw above the centre switch and on the meter movement itself adjusts the pointer to the zero marks on the voltage and current scales. When using a multimeter as a voltmeter it is important that you start with the meter switched to the highest range, and then switch down to the lower (more sensitive) ranges. This is done in order to avoid damage to the pointer by allowing heavy currents to flow through the coil, which will cause the pointer to bang hard against its end-stop. Such treatment should be avoided!

It is also important that before using the meter to measure resistance, the meter must be calibrated by shorting the ends of the test leads, and then adjusting the pointer to zero on the resistance scale, using the control for this adjustment provided on the right-hand side of the multimeter - *not* by means of the screw on the meter movement! If necessary *this* adjustment can be carried out before starting to use the multimeter, where for example the instrument has been moved and is now to be used whilst standing upright whereas before it was lying flat. Such a change in attitude can have the affect of unbalancing the needle causing it to drift off zero. The use of the multimeter is illustrated and described in Figures 5 to 9.

## Using the Multimeter

Let us use as an example the measurement of the AC mains voltage with a multimeter. Turn the centre switch of the meter to the 250 volt range, and the switch on the left-hand side of the meter to the AC position. First touch the insulated probe of the negative (black) test lead to the mains neutral (N) terminal, and then touch the insulated probe of the positive (red) test lead to the mains live (L) terminal. *Please* note that there is a high element of risk involved in such an operation, and the mains connections must be made available for the purpose in a responsible manner. Under *no* circumstances should for example, bare wire ends of a plug and cable be used, nor should you do it by jamming nails, etc. into a wall socket. A three way terminal block for the live, neutral and earth wires, properly attached to a cable, terminated with a

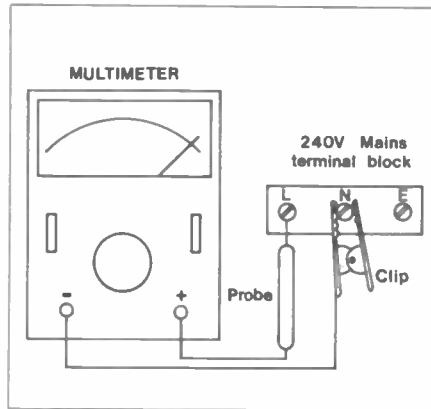

Figure 5. Measuring mains supply voltage

three pin plug is probably the quickest and most convenient method. Even so, the power should not remain on for longer than necessary, and the probes are only applied to the screw heads of the terminal block for only as much time as is required to take the reading. Immediately afterwards switch off and pull out the plug.

The multimeter will give a reading of between 230 and 250 volts, depending on

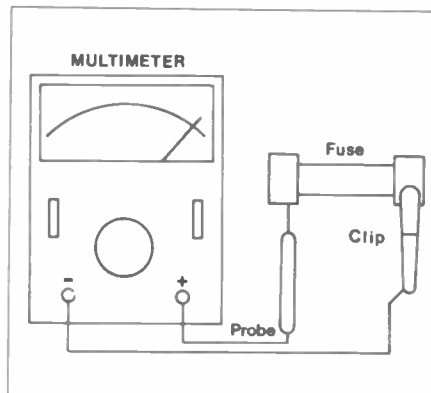

Figure 6. Testing a fuse

the mains voltage of your area. Such a measurement can be invaluable if, for example, you wish to accurately determine the secondary output voltage of a transformer otherwise unknown, in which case the mains terminals of the transformer itself can be used.

## Testing a Cartridge Fuse

Turn the centre switch to the resistance scale  $R \times 1$  and adjust the

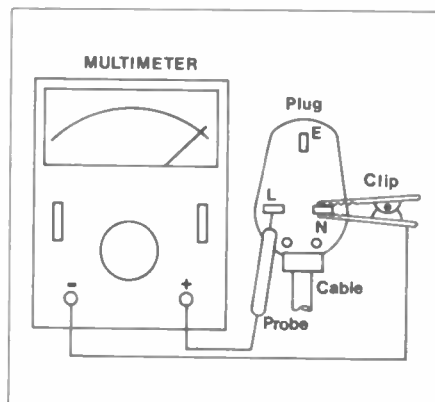

Figure 7. Testing for continuity from main plug to appliance

reading on the resistance scale to zero. Connect the positive lead to one end of the fuse and the negative lead to the other end, which will give a full scale deflection if the fuse is good. No deflection indicates a faulty fuse.

## Testing an Electrical Appliance

Before attempting to open the appliance, the following tests should be made from the three pins of the plug to ascertain the nature of the fault. First turn the centre switch to the resistance scale marked  $R \times 1$  and turn the switch on the left to the DC position. Secondly adjust the pointer to zero on the resistance scale. Connect the positive lead to pin L and the negative lead to pin N. The meter will now give a reading equivalent to the resistance of the appliance; any reading below 16 ohms should be suspected of short circuit providing the appliance is under 3000 watts, i.e. 3 kilowatts (3kW).

If no reading is obtained, check if the appliance has got an ON/OFF switch and that it is in the ON position. Still no reading would indicate an open circuit, which could be due to a blown fuse, loose connection in the plug, broken wire in the flex, faulty switch, or faulty element in the appliance.

The appliance must now be tested for leakage to earth. This is done by connecting the negative lead to pin E and by touching pins L and N with the insulated probe. Any reading on the meter would indicate an earth leakage fault.

It is important that the appliance must be proved clear of earth problems or short circuit faults before replacing the fuse and putting back into service.

## Testing a Refrigerator

Figure 8 illustrates the use of the Continuity Tester. The first test is to find the nature of the fault, and secondly to isolate the fault by systematic testing based on logical deductions.

The multimeter can be used as a continuity tester when it is switched to the resistance scale  $R \times 1$ .

**Test No. 1.** The nature of the fault can be found by testing for continuity from points 1 to 2, which will test continuity of all the components in the circuit and by testing for continuity from point 3 to points 1 and 2 will reveal any earth fault.

**Test No. 2.** Having decided the nature of the fault, test from points 1 to 8 which will eliminate half the circuit. If the fault is in section 1 to 8, make another test from points 1 to 5 and isolate the fault to a quarter section. It will be obvious that if the fault is in section 1 to 5 it is a blown fuse, loose connection on the plug or faulty cable. Should the fault be in section 5 to 8, then it will be a faulty thermostat because the cabinet light and door switch will be isolated when the fridge door is closed. If the fault is in the other half of the circuit, it should be treated in a similar manner by dividing into sections

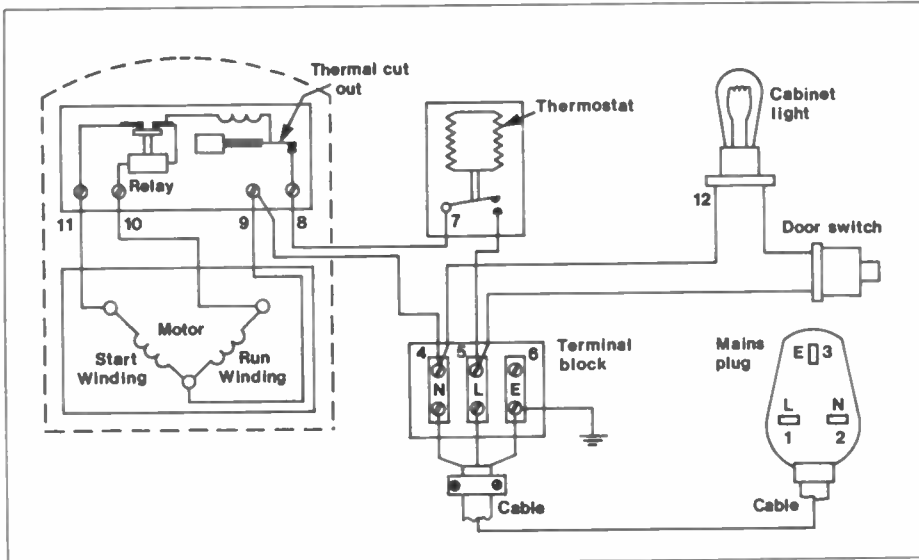

Figure 8. Test points in the electrical circuit of a refrigerator

until the faulty component is isolated.

If the total resistance of all the components are more than 100 ohms, the multimeter will have to be switched to the R x 10 scale, and switched back to the R x 1 scale when the faulty section has been isolated to less than 100 ohms.

## Testing a Double Element Electric Fire

The centre switch on the meter is turned to R x 1 on the resistance scale. The switch on the left is turned to the DC position, and the pointer adjusted to zero on the resistance scale. Connect the negative lead with the alligator clip to pin N and the positive probe to pin L of the plug. Everything being normal you would get a reading of 62.5 ohms with the switch in the OFF position, and 31.25 ohms with the switch in the ON position. The reason for the latter reading being that when the switch is in the ON position the resistance of the elements are connected in parallel, and as explained in Figure 4 (c), the method of calculation is:-

$$62.5 \times \frac{62.5}{62.5} + 62.5 = \frac{30906.25}{125}$$

which equals 31.25 ohms. Any full scale deflection or small reading at this stage would indicate that the appliance was short circuit.

To carry out a routine test on the appliance, leave the negative lead on pin N of the plug and move the positive probe to point 6 where a full scale deflection will be obtained proving continuity of the negative side of the circuit. No deflection would indicate a broken negative wire in the flex, or a loose connection in the plug or terminal block and a very small reading would indicate a high resistance joint between pin N and point 6.

Now move the alligator clip from pin N to pin L on the plug, and shift the positive probe to point L on the block terminal where a full scale deflection will be obtained proving continuity of the positive wire in the flex, the fuse and that there is no loose connection in the plug.

Move the positive probe to point 2, with the switch in the ON position which will give a full scale deflection. No reading at this point would indicate that the switch was faulty. A full scale deflection will also be obtained at points 3 and 4, and a reading of 62.25 ohms at points 5 and 6. No reading at these points would indicate an open circuit. Remove both elements and test them for continuity. This system of testing would indicate the position of any open or short circuit in the appliance.

To test the appliance for leakage to earth, you would need a 500 volt insulation tester, i.e. (a megger), but most earth

faults can be located with the multimeter by using the following method.

Turn the multimeter switch to R x 1000 and adjust the pointer to zero on the resistance scale in the normal manner. Put the alligator clip on pin E of the plug and touch pins L and N with the positive probe of the test lead; any reading on pins L or N would indicate a leakage to earth.

For example, if a reading is obtained on pin L, keep the positive probe on this pin to maintain a steady reading on the meter. The circuit can now be disconnected at points 1, 2, 3, 4, 5, 6 and 7 and note the meter reading at each point. If the reading goes off when disconnected the fault is clear to that point but if the reading is unaltered, the fault is between the last two test points. In this manner, the position of the earth fault is detected.

Before putting the appliance back into service, the earth system must be checked. This is done by connecting the negative lead to pin E on the plug and the positive probe applied to every exposed metal part of the appliance which should give a full scale deflection, proving continuity to earth and that the appliance is correctly earthed.

You will note that the current ranges on some meters may not be much more than a few amperes. Some appliances are highly rated, so to overcome this difficulty, the resistance and voltage is measured and the current calculated by Ohms Law, i.e.  $I = E/R$ .

Most tests are carried out with the multimeter switched to the R x 1 scale but there are appliances with resistance of over 100 ohms which will require the higher ranges to be used. For your guidance all appliances under 600 watts will have a resistance of over 100 ohms. For example - the resistance of a 25 watt soldering iron would be as follows:  $P = 25$  watts.  $E = 240$  volts. Therefore, the current would be:-

$$I = \frac{P}{E} = \frac{25}{240} = 0.104A$$

Therefore:-

$$R = \frac{E}{I} = \frac{240}{0.104} = 2307\Omega$$

With a little forethought, together with the given examples and tests, you should be able to apply these to the testing of any electrical appliance and be able to make logical deductions as to the nature and position of the fault.

When fitting or renewing mains leads, if in doubt, always use a size larger, never a size smaller. The sizes and ratings are as follows:-

Size (mm <sup>2</sup> )	Current Rating (Amps)	Power Rating (Watts)
0.5	3	720
0.75	6	1440
1.0	10	2400
1.25	13	3120
1.5	15	3600
2.5	20	4000
4.0	25	6000

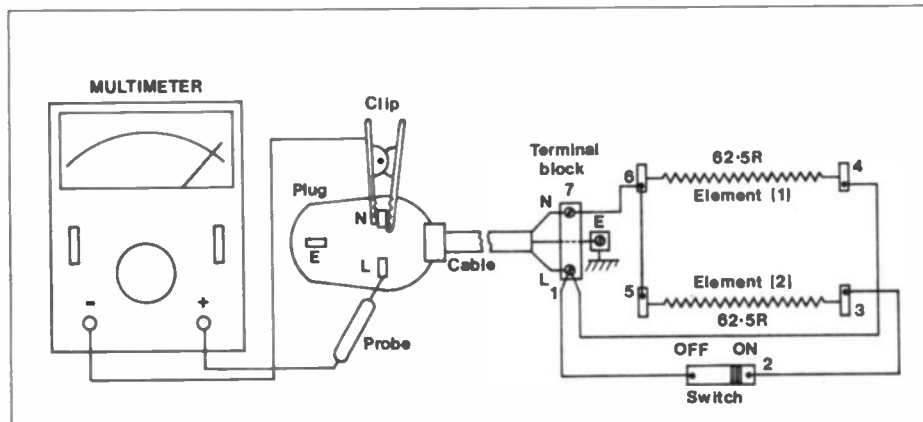

Figure 9. Testing a double element electric fire

- ★ Interfaces with other Security Systems
- ★ Adjustable Time Delay
- ★ Switches up to 1kW
- ★ Manual or Automatic Control
- ★ Local Alarm Indication
- ★ Recorded Alarm
- ★ Lamp Failure Indication



by Robert Kirsch

**T**he Floodlight Controller described here was primarily designed as a security device in its own right, although provision has been made for it to be linked into a larger security system. This controller also has other applications where it is required to switch on a mains-powered device for a preset period of time after which it will automatically switch off until re-triggered.

The controller was intended to be triggered by the Infra-red Movement Detector (kit LK33L – see 1985 catalogue page 219), described in the December 1983 to February 1984 edition of 'Electronics' Volume 3 Issue 9, although it could be operated from any make or break detection device. The Infra-red Movement Detector (LK33L) is intended for indoor use in its standard form and special precautions should be taken if it is to be used outside.

The detector should be protected from direct rain or sunlight by a suitable housing but do not cover the window of the unit as most materials will seriously reduce the sensitivity of the device.

After setting up and testing has been completed, the casing should be taken apart and then reassembled using liberal amounts of silicon grease on all the joints, not forgetting the LED hole and the cable entry through the ball joints. Care should be taken to prevent silicon grease coming into contact with the window material.

In the automatic mode, the controller will switch on the floodlight when the sensor is activated, and it will remain on for a preset period of time after the sensor releases. This time period may be adjusted by the 'DELAY' control, from 20 seconds to 4 minutes, using the timing capacitor (C3) supplied. A larger value capacitor may be used if longer delays are required.

During the floodlight ON time, the buzzer will sound and the neon indicator light. The 'RECORDED ALARM' LED will also light and remain on until the 'OFF/RESET' switch is operated, thus giving an indication that the system has

been tripped. The floodlight may be turned off at any time by using the 'RESET/ARMED' switch which also resets the timer. The floodlight may be turned on manually by using the 'AUTO/ON' switch. The neon also serves as a lamp failure indicator as it will remain permanently on if the lamp filament or connecting cable become open circuit.

### How it Works

The infra-red movement detector is connected to the controller via terminals A, B, G and H. Regulated +12 volts DC is delivered to the detector via terminals A and B. Terminals G and H are connected to the relay contacts in the detector which are made when no movement is detected. These contacts connect the +12 volts via R8 and R11 to the input of the Schmitt inverter, IC1b. In the event of

# Automatic Floodlight Controller



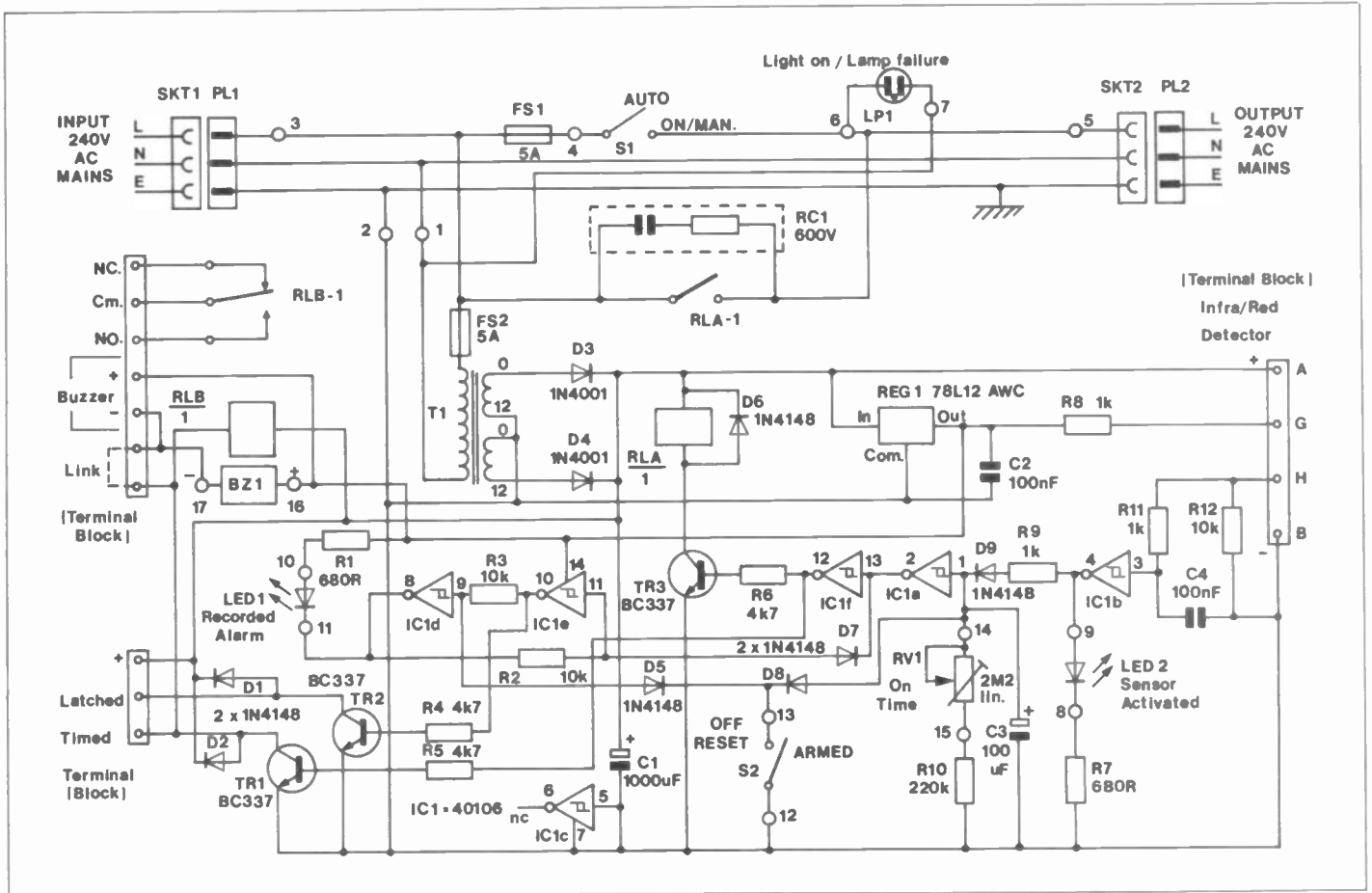
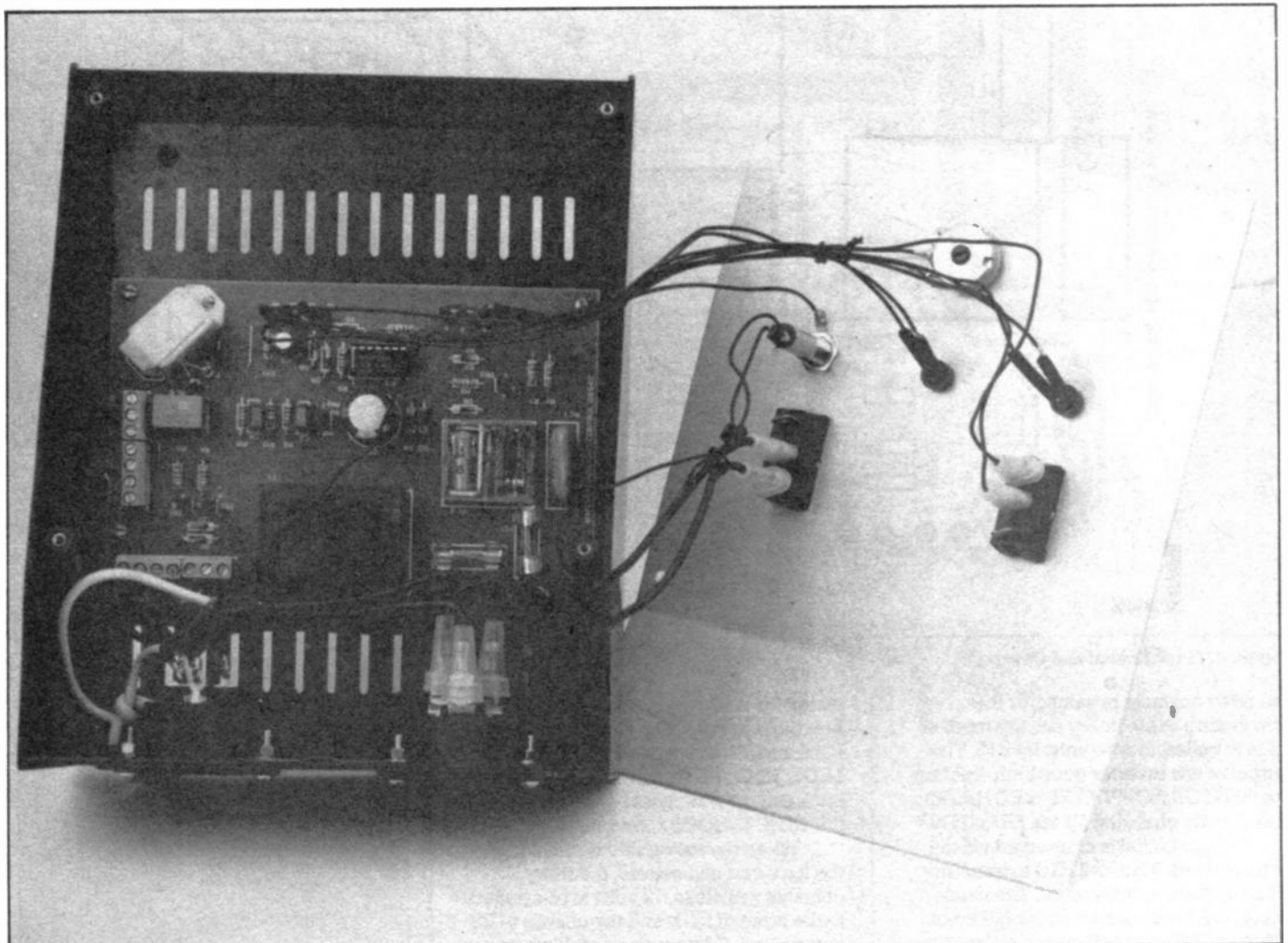
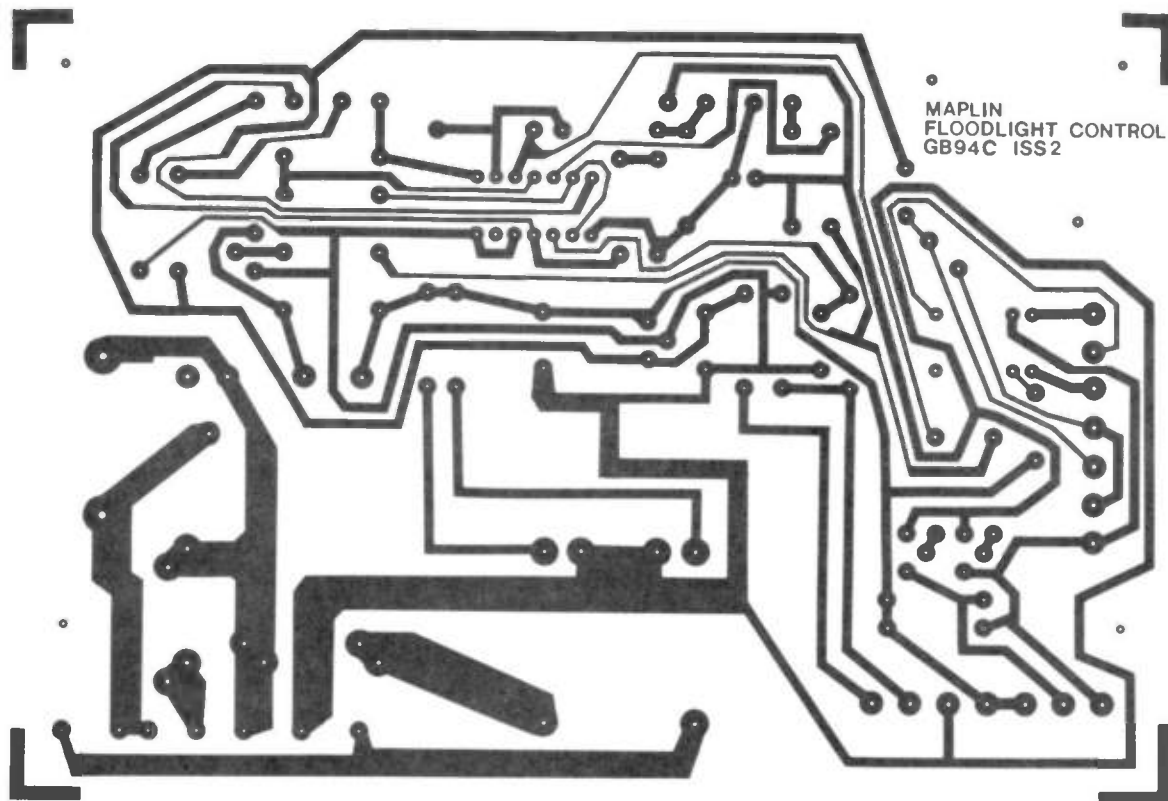

Figure 1. Circuit Diagram





MAPLIN  
FLOODLIGHT CONTROL  
GB94C ISS2

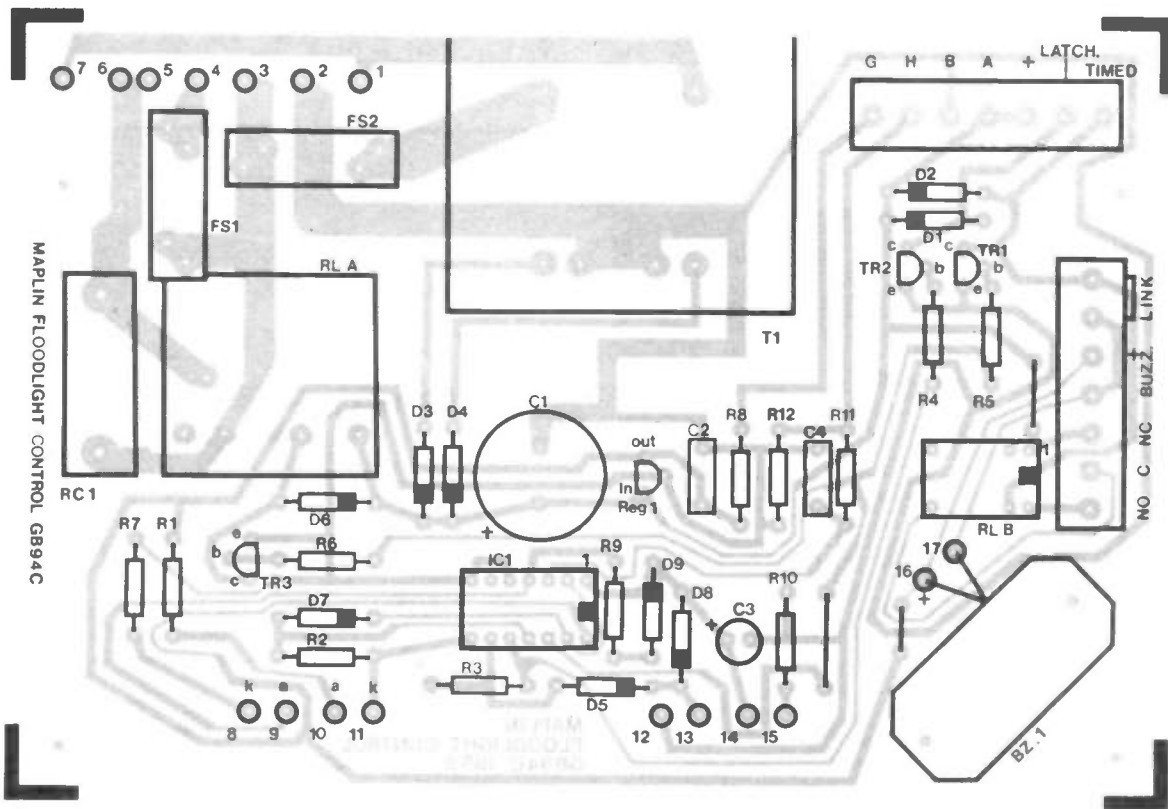

Figure 2. Track Layout and Overlay

the relay contacts breaking or the connecting cable being cut, the input of IC1a is pulled to zero volts by R12. The output of this inverter goes high, lighting the 'SENSOR ACTIVATED' LED (LED2) and rapidly charging C3 via R9 and D9.

This potential is connected via the two inverters IC1a and IC1f to transistor TR3 via its base resistor R6. The mains relay RLA is connected in the collector circuit of TR3 and will operate when the

transistor is biased on, thus causing the floodlight to light. The latch formed by IC1d and IC1e is tripped via D7 causing LED1, 'RECORDED ALARM' to light. This latch can only be reset by the action of the 'RESET/ARMED' switch.

When the movement detected by the infra-red unit ceases, the relay contacts will close, 12 volts is re-applied to the input of IC1b and the charge to C3 is removed. C3 now starts to discharge

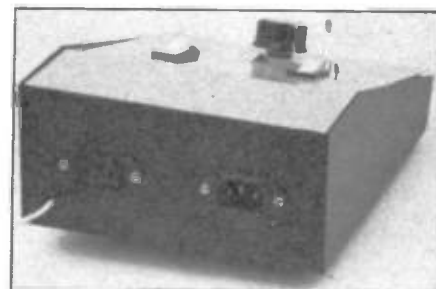

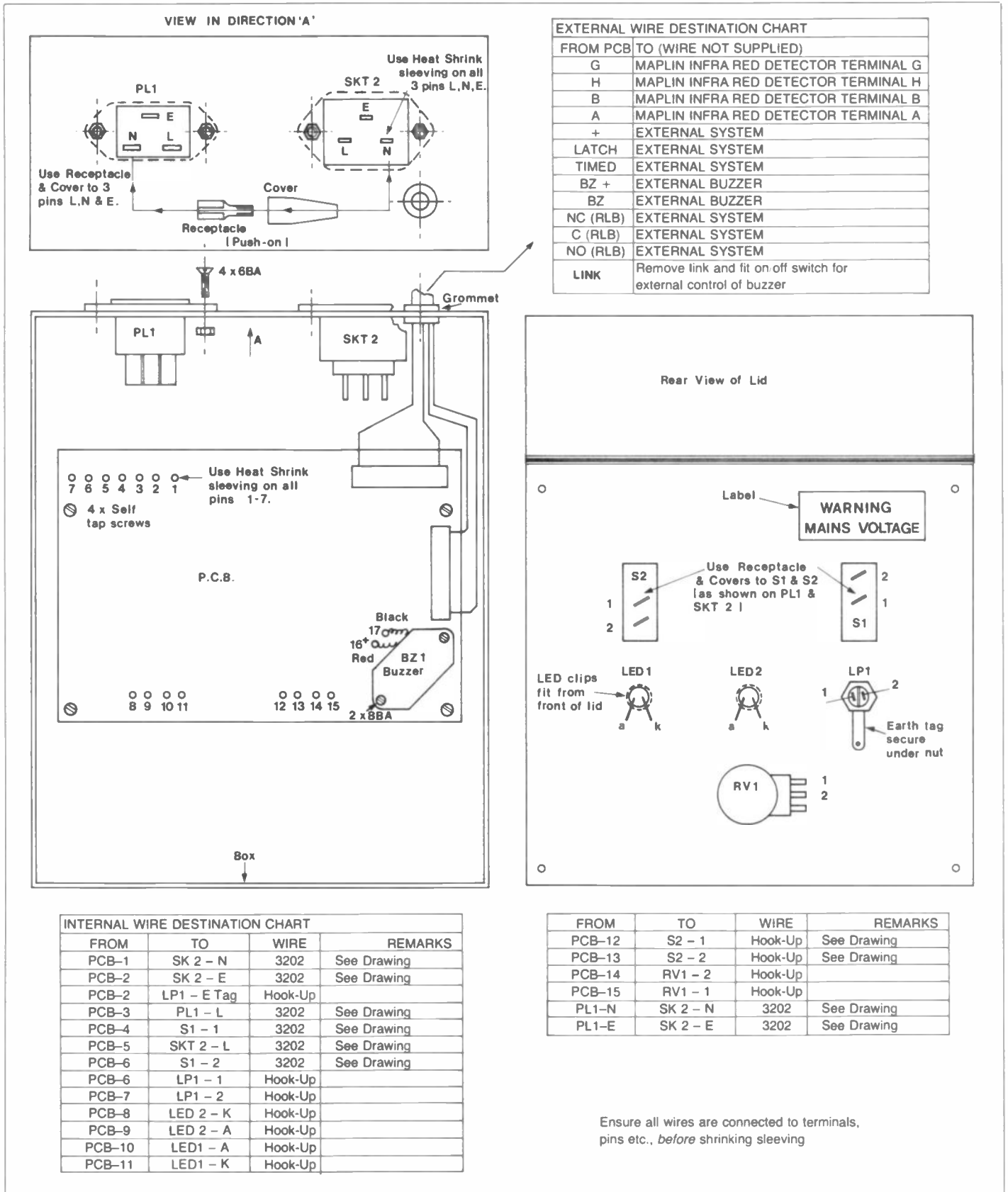

**Figure 3. Interwiring Diagram**

via R10 and the 'DELAY' variable resistor (RV1) until the voltage reaches the threshold voltage of IC1a's input, at which time the inverters will switch and the relay release, turning off the floodlight.

When the 'RESET/ARMED' switch is operated, any charge on C3 is discharged to ground and the latch is reset via diodes D8 and D5. This prevents the relay operating and extinguishes the

**'RECORDED ALARM' LED.**

The buzzer and relay RLB, controlled by TR1 will operate during the floodlight on period. Both of the relays make and break contacts are brought out for connection to an external security system. TR2 provides a latched output for direct connection to a low current alarm bell (e.g. YK85G) which will ring from the time that the detector is tripped until reset by the 'RESET/OFF' switch.

**Construction**

Insert and solder all the components on the printed circuit board referring to the legend on the board and the Parts List. Insert Veropins from the under side of board, through the holes marked with a white circle. Remember to observe polarity of electrolytic capacitors, diodes and transistors. Refer to Figure 3 for wiring information between PCB, con-



trols and sockets. Figure 4 shows drilling details for the recommended box.

## Testing

**WARNING:** 240 volts are present on the PCB when the controller is connected to the mains and therefore, DO NOT apply power to the controller whilst the box is open.

Connect a 240 volt test lamp to the floodlight plug and insert it into the appropriate socket on the rear of the unit. Connect a short length of twin flex to terminals G and H and feed through the rear of the box. Bare and temporarily twist the two wires together. Set 'AUTO/ON' switch to AUTO and 'RESET/ARMED' switch to RESET. Attach the front panel to the box with all four screws and connect the controller to a mains supply. At this stage, no indicators should be alight. Separate the two wires which were twisted together. The 'SENSOR ACTIVATED' and 'RECORDED ALARM' LEDs should now light, the buzzer sound and the test lamp come on. Rejoin the two wires and check that the 'SENSOR ACTIVATED' LED is extinguished and the buzzer stops but the 'RECORDED ALARM' LED remains on. The test lamp should remain on for a period of time between 20 seconds and 4 minutes, depending on the setting of the 'DELAY' control. Repeat the test with various settings of this control to ensure it is functioning correctly. Check that with the 'RESET/ARMED' switch set to RESET and the wires disconnected, the test lamp will not light, and that the 'RECORDED ALARM' goes out. Switch the 'AUTO/ON' switch to ON and check that the test lamp lights.

**REMEMBER,** in case of problems or before making any connections to the controller, ALWAYS disconnect it from the mains supply. This completes the testing of the controller and it is now ready for service.

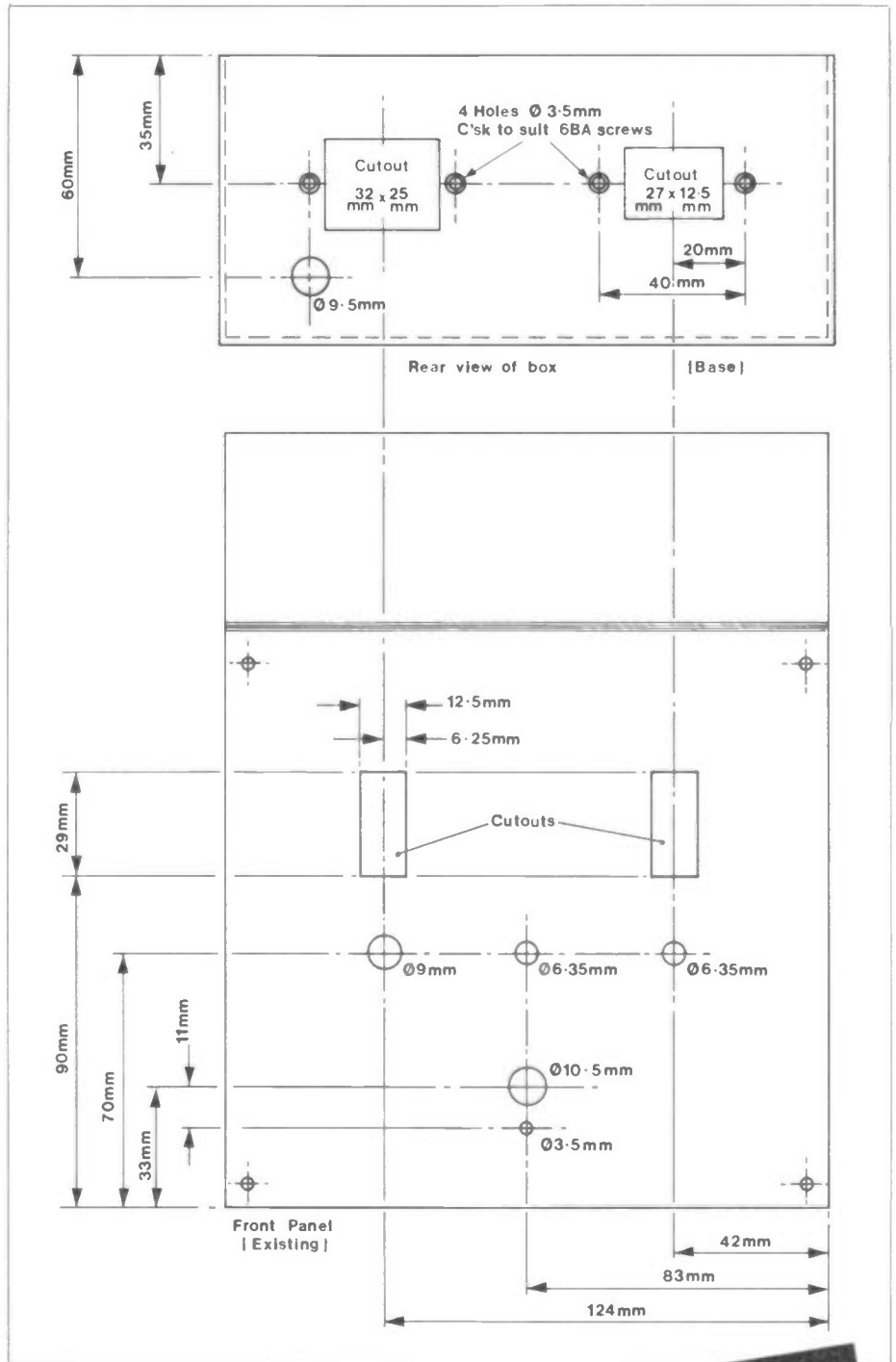
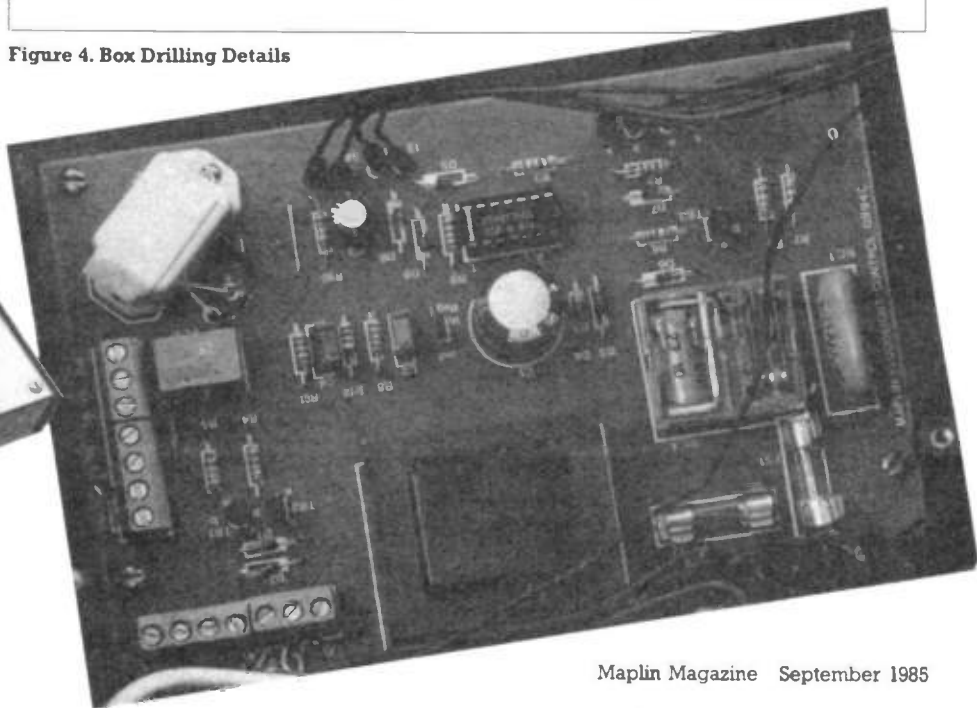
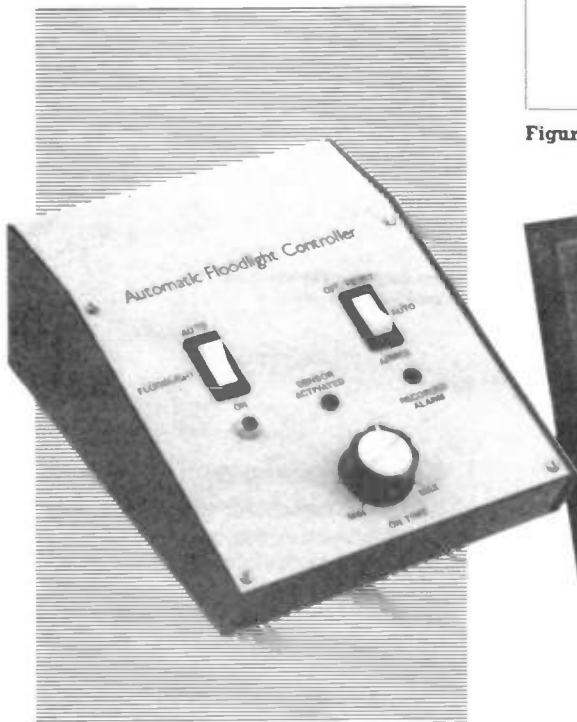

Figure 4. Box Drilling Details



## FLOODLIGHT CONTROLLER PARTS LIST

RESISTORS: All 0.4W 1% Metal Film

R1,7	680Ω	2	(M680R)
R2,3,12	10k	3	(M10K)
R4,5,6	4k7	3	(M4K7)
R8,9,11	1k	3	(M1K)
R10	220k	1	(M220K)
RV1	Pot Lin 2M2	1	(FW09K)

CAPACITORS

C1	1000μF 35V P.C. Electrolytic	1	(FF18U)
C2,4	100nF Carbonate	2	(WW41U)
C3	100μF 25V P.C. Electrolytic	1	(FF11M)

SEMICONDUCTORS

D1,2,5-9	1N4148	7	(QL80B)
D3,4	1N4001	2	(QL73Q)
TR1,2,3	BC337	3	(QB68Y)
IC1	40106BE	1	(QW64U)
REG 1	μA78L12AWC	1	(WQ77J)
LED 1,2	LED Red	2	(WL27E)

MISCELLANEOUS

RC1	Suppressor R-C Network	1	(YR90X)
T1	PCB Tr 0-12 x 2 @ 250mA	1	(YJ54J)
RLA	Relay Flat 12V	1	(HY20W)
RLB	Ultra-Min. Relay 12V SPDT	1	(YX94C)
S1,2	SPST Rocker	2	(FH30H)
BZ1	Buzzer 12V	1	(FL40T)
FS1,2	Fuse 20mm 5A	2	(WR07H)
LP1	Neon Chrome Red	1	(BK55K)
	Fuse Clips	4	(WH49D)

LED clips	2	(YY40T)
Floodlight Controller PCB	1	(GB94C)
Knob K7C	1	(YX03D)
ABS Console M6007	1	(LH87X)
14-pin DIL Socket	1	(BL18U)
Veropin 2145	1 Pkt	(FL24B)
Bolt 8BA x 1/4in.	1 Pkt	(BF08J)
Nut 8BA	1 Pkt	(BF19V)
C/S Screw 8BA x 1/4in.	1 Pkt	(BF12N)
Nut 8BA	1 Pkt	(BF18U)
BNC Earth Tag	1	(QY22Y)
Mains Warning Label	1	(WH48C)
Grommet Small	1	(FW59P)
Eurosocket	1	(HL16S)
Europlug	1	(HL15R)
Euro Outlet Slt P675	1	(FT63T)
Euro Outlet Plug P686	1	(FT64U)
3-Way P.C. Terminal Block	2	(RK72P)
4-Way P.C. Terminal Block	2	(RK73Q)
Heatshrink CP48	1 Mtr	(BF89W)
Heatshrink CP64	1 Mtr	(BF90X)
Wire 3202 Black	1 Mtr	(XR32K)
Hook-up Wire, Black	1 Pkt	(BL00A)
Self Tap Screws No. 4 x 3/16in.	1 Pkt	(BF65V)
Push-on Receptacle	1 Pkt	(HF10L)
Push-on Covers	1 Pkt	(HF12N)

A kit of parts for this project is available:  
**Order As LK73Q (Floodlight Cntrl Kit) Price £27.95**  
 The following items in the above kit are also available separately, but are not shown in the 1985 catalogue:  
**Floodlight Controller PCB Order As GB94C Price £4.95**  
**Euro Outlet Socket P675 Order As FT63T Price 65p**  
**Euro Outlet Plug P686 Order As FT64U Price £1.75**

# TOP TWENTY BOOKS

1. (1) Loudspeaker Enclosure Design and Construction. (WM82D) Cat. P47.
2. (4) Mastering Electronics, by John Watson. (WM60Q) Cat. P42.
3. (3) Remote Control Projects, by Owen Bishop. (XW39N) Cat. P44.
4. (9) How to Build Your Own Solid State Oscilloscope, by F.G.Rayer. (XW07H) Cat. P45.
5. (5) International Transistor Equivalents Guide, by Adrian Michaels. (WG30H) Cat. P38.
6. (8) How to Design and Make Your Own PCB's, by R.A. Penfold. (WK63T) Cat. P41.
7. (2) Power Supply Projects, by R.A. Penfold. (XW52G) Cat. P43.
8. (11) Radio Control for Beginners, by F.G. Rayer. (XW66W) Cat. P44.
9. (19) How to Use Op-amps, by E.A.Parr. (WA29G) Cat. P41.
10. (7) Electronic Synthesiser Projects, by M. K. Berry. (XW68Y) Cat. P48.
11. (6) IC555 Projects, by E.A. Parr. (LY04E) Cat. P46.
12. (13) Electronic Security Devices, by R.A. Penfold. (RL43W) Cat. P44.

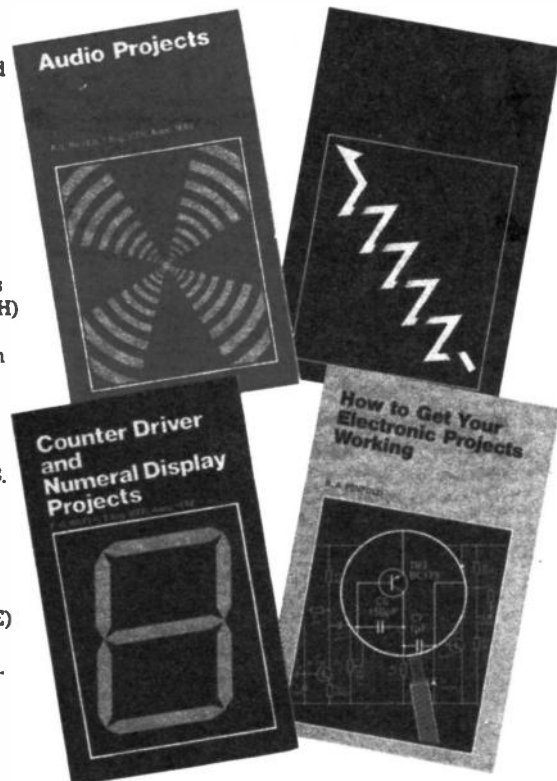

13. (10) A Z80 Workshop Manual, by E.A. Parr. (WA54J) Cat. P55.
14. (15) Audio Amplifier Construction, by R. A. Penfold. (WM31J) Cat. P47.
15. (18) How to Design Electronic Projects, by R. A. Penfold. (WM67X) Cat. P41.
16. (12) Electronic Music Projects, by R.A. Penfold. (XW40T) Cat. P48.
17. (-) Micro Interfacing Circuits Book 1, by R.A. Penfold. (WM79L) Cat. P53.
18. (-) Audio Projects, by F.G. Rayer. (WG46A) Cat. P47.
19. (-) Counter Driver & Numeral Display Projects, by F.G. Rayer. (XW34M) Cat. P47.
20. (-) How to Get Your Electronic Projects Working, by R.A. Penfold. (WA53H) Cat. P42.

These are our top twenty best selling books based on mail order and shop sales during April, May and June 1985. Our own magazines and publications are not included. The Maplin order code of each book is shown together with page numbers for our 1985 catalogue. We stock over 500 different titles, covering a wide range of electronics and computing topics.

# ELECTRONIC CHRONICLES

## A Brief History of Electronics

by Mike Wharton Part 6  
The History of the Digital Computer

Ever since man has had a need to count, he has devised a variety of aids in order to speed his calculations. One of the earliest such devices is the abacus, still used today as a form of mechanical calculator. Thus the modern computer could be thought of as a glorified type of abacus, but one which is infinitely more versatile in the way in which it is able to manipulate data.

Before the introduction of effective computing aids, the preparation of logarithm tables required the organisation of large teams of human computers. In 1874 the French government decided to have a new set of logarithm and trigonometric tables prepared. A team of six mathematicians were used to supervise the work of seven or eight 'calculators' who handed out work to around eighty 'computers'. Each calculation was double checked and it took 2 years to complete the work. The results were not printed, since this would have introduced too many errors.

### CHARLES BABBAGE

Most tables, even in the 19th century, contained many errors. For instance, the British Nautical Almanac, which had a high reputation, was still found to contain 58 mistakes in the 1818 edition. Charles Babbage and John Herschel were in Babbage's rooms at Cambridge checking some calculations which they suspected contained errors. "I wish to God these calculations had been executed by steam!" exclaimed Babbage. "It is quite possible," remarked Herschel. This set Babbage, now regarded as the founding father of computers, to thinking of the design for an automatic calculating machine.

The first adding machine had been made by Blaise Pascal in 1642, when he was just nineteen. 30 years later, Gottfried Leibnitz improved on the original idea and made a machine which could add, subtract, multiply and divide. The mechanism he designed was still in use in some of the mechanical calculators produced in this century.



Blaise Pascal

All of the work done by Pascal seems to have gone largely unheeded, for it was not until some years later that Babbage produced a working model of what he called his Difference Engine. Pascal had invented a mechanism consisting of a series of wheels with figures engraved on them and so interlocking that the operation could be carried out manually by turning the wheels one at a time, carry-overs being effected from one wheel to the next but it was a very cumbersome machine.

In Babbage's Difference Engine only integers, or whole numbers were considered, but negative numbers were

represented by their arithmetic complement as in today's computers. In 1822, he produced a working model of a simpler machine for which he received a Gold Medal from the Astronomical Society. This recognition of his work encouraged him to pursue his goal further and make a start on his scheme for a larger machine. For this, he was granted an award of £1,500 from the Treasury in order to finance the work, for he had managed to persuade some influential friends that his scheme was a viable proposition. Unfortunately, their enthusiasm was short-lived, for the machine could not be made to work properly and it was eventually shelved.

However, Babbage was undaunted by this early failure, having realised during the time spent on the original ideas that a far superior form of calculating machine could be built, using similar principles. It must say something of the character of the man that he was able to commence this second project without ever having really overcome the problems inherent in the first design. His conception was for a machine which he called his Analytical Engine. Here, it was intended that results generated in one part of the machine would be used as the inputs to other parts, or as Babbage described it, "to eat its own tail." Again,

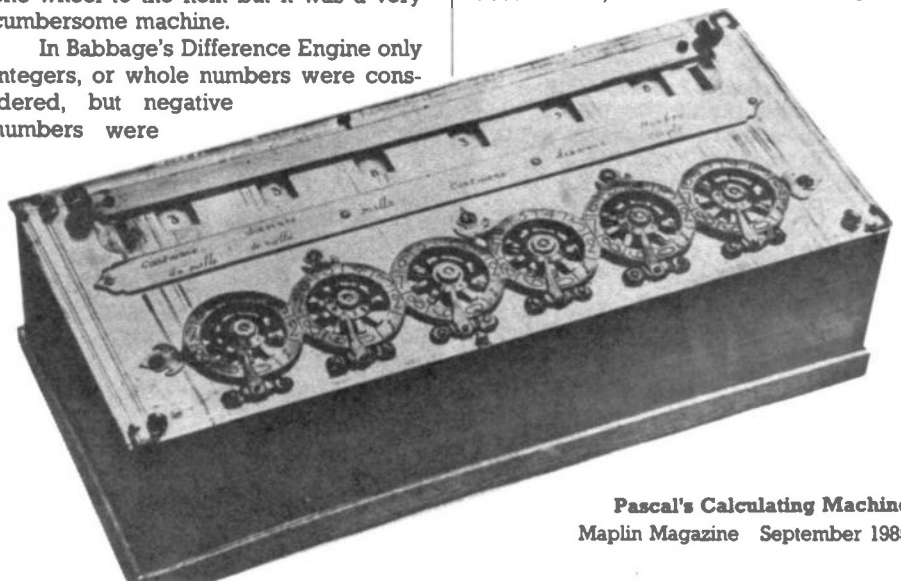

Pascal's Calculating Machine  
Maplin Magazine September 1985





**Gottfried Wilhelm Leibniz**

here is an idea which pre-empted the operation of the modern electronic computer.

The Analytical Engine was to consist of three main parts:-

1. The Store: where numbers were to be held for transferring to the Mill.
2. The Mill: where all the arithmetic operations would be carried out.
3. The Printing Mechanism: which would print out the results of the calculations.

Numbers were to be held in mechanical registers in the Mill. Upon activation, the processes of addition, subtraction, multiplication and division were carried out. The 'program', which had to control the sequence of operations, was stored on punched cards, an idea borrowed from the silk weaving loom invented by Jacquard earlier in the century. This is not a stored program in the modern sense, for the program was stored in a different form from the variables. However, it was possible for a jumping in the sequence of cards to be performed, like the branching of a modern program.

In 1842, the Government decided that they were no longer going to support his efforts, and the project was abandoned by them and left entirely to Babbage. This was brought about mainly as a result of arguments between him and the instrument makers employed to make the parts for the Engine; Babbage was continually improving and refining

his ideas which meant that new parts were ordered before the first ones had been finished or paid for by the Treasury.

At this point, a lady by the name of Ada Augusta, Countess of Lovelace appears on the scene. She was in fact the only daughter of the poet Byron and his wife Anabella and had made the acquaintance of Babbage as the result of attending one of his lectures in Edinburgh in 1834. Surprisingly, she was a lady of quite remarkable mathematical ability, at one time having been given tuition by a Professor de Morgan, whose name should be recognised by anyone who has ventured into the realms of electronic logic. She arranged a meeting with Babbage and persuaded him to continue his work, which would be financed by the money she intended to win by backing horses according to a scheme based on mathematical probability! Inevitably, the scheme failed and



**Charles Babbage**

Countess Lovelace twice had to pawn the family jewels to pay the bookmakers. After she died in 1852, Babbage continued with his quest which had long since become an obsession with him.

He was, unfortunately, way ahead of his time, for his ideas could not be put into practice in the mechanisms which could be built with the available technology. His original Difference Engine was destined to become a museum piece, but somewhat surprisingly a Swedish printer named Scheutz had made a simplified

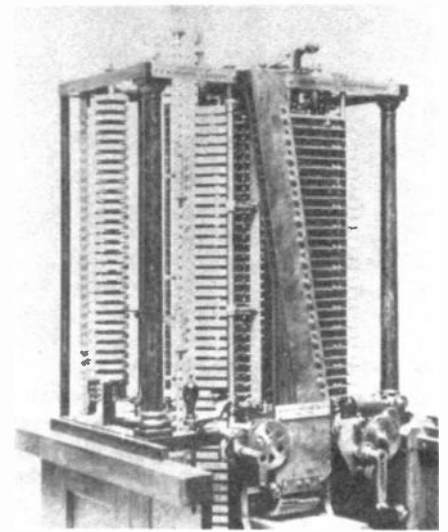

**Babbage's Difference Engine contained columns of cogged wheels**

version after reading an account in the Edinburgh Gazette of the same lecture that the Countess had attended. Another model was also made by Donkin in London which was actually used by the Registrar-General's Department for the computation of statistical tables.

Charles Babbage lived to a ripe old age, dying in 1871 at the age of 80. During the later years of his life, he still continued to tinker with computing machines but he must have felt very sad and disillusioned that his far-sighted vision had not been put into practice. Indeed, it was not until a hundred years later that his prophetic vision eventually came to fruition in the shape of the microprocessor.

## HERMAN HOLLERITH

For many years after the death of Babbage, little or no interest was to be shown in the idea of mechanical computation, until the advent of the electrical systems. The use of electricity as the 'driving force' allowed much greater versatility and removed the need for precision engineering which had always been the major obstacle facing Babbage. Some of the earliest schemes, in fact, took over some of the ideas which had been pioneered by him but using electro-mechanical devices rather than cogs and gears. One of the first of these machines which was eventually to lead to the conception of the modern computer was invented by an American named Herman Hollerith. He was given the task of collating all the statistical information gathered during the American census of 1890.

The method he used was based on the same idea Babbage had incorporated for storing his programs, that of the punched card. Hollerith devised a machine where metal pins arranged in a matrix could make contact with a pad if a hole had been punched in the appropriate position in the card. Each pin formed part of an electrical circuit, connected in turn to a simple counter. Operators placed the cards in the pin-presses, closed the lid and a counter automatically notched up one more piece

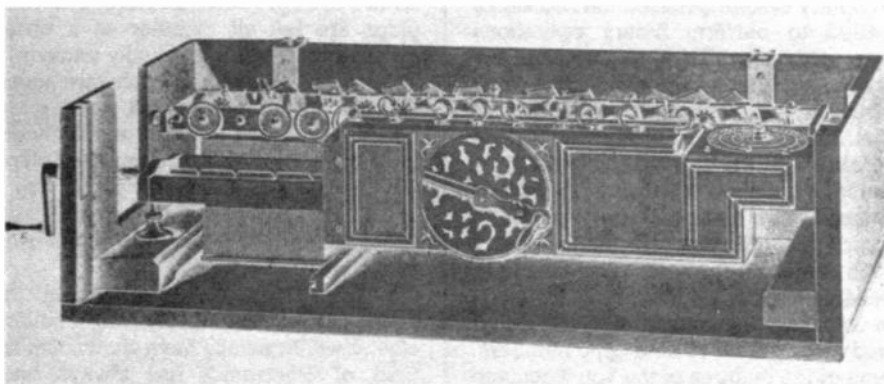

**Leibniz's Calculating Machine could multiply and divide**  
September 1985 Maplin Magazine

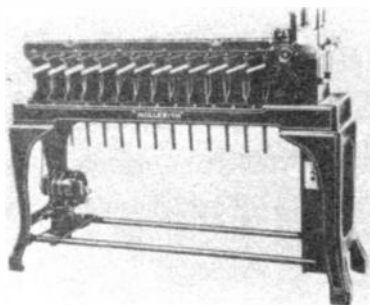

**Hollerith's Tabulating Machine**

of information. The machines were such a success that the results of the census were able to be published in 2½ years, whereas the previous one had taken seven. In 1896, Hollerith set up the Tabulating Machine Company to exploit the commercial aspects of his census machine and in 1911, a Hollerith machine was used for the British census. Eventually this company merged with others to become the International Business Machines (I.B.M) Corporation in 1924.

## Electro-Mechanical Computers

By 1937, interest in automatic computation, which had lain dormant since Babbage's death, began to revive. Alan Mathison Turing, a mathematician working in Britain, had published a paper which defined very precisely his concept of a 'universal computer'. He also put forward the idea of machines teaching themselves by a process of trial and error; another of his insights was not to prove so well informed, since he predicted that there could not be more than about half a dozen computers in the country because of the need for highly trained mathematicians to operate them.

In the same year, Howard Aiken of Harvard University used the principle of the punched card tabulator and similar components used in telephony to build an automatic computer of the type envisaged by Babbage. Aiken approached I.B.M for assistance, as the components he needed were already being used by them. Over the next seven years, he and a team of engineers built the Automatic Sequence Controlled Calculator which was presented to Harvard in 1944. This machine, also known as the Harvard Mk. I, was an enormous beast, 51 feet long, 8 feet high, weighing 5 tons and containing 500 miles of wire. It took around 1 second to perform an addition and 10 seconds for division. The life of these relay based machines was short, for by 1946, the first electronic machines had been built and demonstrated, working at a speed 1000 times faster than the best relay machine could achieve.

## Computers Using Valves

In a way, it is surprising that it took so long for the electronic computer to arrive. The triode valve had been

invented in 1906 by Lee de Forest, and in 1919 Eccles and Jordan had devised a circuit which allowed a pair of these valves to act as a bistable flip-flop. The first electronic, as opposed to electro-mechanical, computer was designed and built by John Mauchly and J. Presper Eckert of the Moore School of Electrical Engineering at the University of Pennsylvania, Eckert being particularly responsible for the design of a ring counter. It was actually made for the US Government, and was completed in 1946, only 2 years after Aiken's. This new computer of Mauchly and Eckert was called ENIAC, standing for Electronic Numeric Integrator and Calculator. It was also a vast machine, 100 feet long, consuming 100kW of power and containing 18,000 valves!



**John von Neumann**

## Data Handling and Storage

All of these machines held values in decimal form, but in 1946, John von Neumann swept up a number of thoughts that went right back to Leibnitz and brought into existence the modern concept of programming. Leibnitz had foretold of the advantages of using the binary scale and this had been taken up in the mid-nineteenth century by George Boole (who gave us Boolean algebra). Neumann recognised the advantages of the binary system because the two states needed to perform binary operations were easily provided in electronic terms by opening or closing a switch. Still more important was Neumann's recognition of what Babbage had called 'judgement' – the ability of the machine to modify its course of action according to results obtained. The Neumann concept of the stored program machine demanded a much larger storage capacity than was available on these automatic calculators. He estimated that such a machine would need a store able to hold 1000 numbers. Some of the features of the von Neumann concept had actually been anticipated by Alan Turing, and quite remarkably by

one Konrad Zuse. His work in war-time Germany had produced an electronic machine in 1941 but his achievements went unrecognised until 1947.

Over the subsequent years many forms of data storage were evaluated, including the magnetic drum, a cathode ray tube store and magnetic core stores. Most of these have been superseded by the semiconductor storage devices which have become so prominent in recent years. Perhaps public interest in computers first arose as a result of the correct prediction by a UNIVAC machine that General Eisenhower would win the 1952 US Presidential election. This also sparked off the discussion as to whether such machines could think. As it happens, Lady Lovelace had dealt with that question 110 years earlier, when she wrote "the Analytical Engine has no pretensions to originate anything; it can only do what we know how to order it to perform."

## The Microprocessor

The development of the digital computer over the last 30 years has really been synonymous with developments in semi-conductor technology. From the invention of the transistor at Bell Telephone Labs in 1947, the rate of progress has been ever quickening. In 1958, Jack Kilby, then working at Texas Instruments, produced the first 'integrated circuit', which contained just a couple of transistors on a chip about 1 centimetre square. A few years later, the first 'microprocessor' chip appeared. This came about as a result of some lateral thinking on the part of the team at Intel who were producing calculator chips. It was realised that it would make more sense to produce a single device which could be programmed to do different jobs, rather than a number of dedicated devices.

Since then, ever more powerful devices have been produced with associated improvements in all manner of silicon support devices, from ROM's to RAM's and everything in between! This pace of development seems to show no sign of halting and the next step will probably be towards silicon systems, with all the back up store contained in non-volatile RAM. One particular development in this direction is the wafer-scale integration which Sinclair are known to be working on. Here, individual chips are left all together as a wafer, rather than being individually packaged. The main problem is that software accessing of these devices will need to be adaptive in order to avoid any defective locations within the interconnected chips. By this means, it is anticipated that a silicon 'disk' of up to 3 megabytes could be produced but without any of the usual hardware.

This brings to a conclusion this series of Electronic Chronicles; if nothing else, it will hopefully have shown that the field of electronics has always been varied and exciting, and promises to be ever more so.

# Seven Super Circuits

by Robert Penfold

## Transistor Checker

Most transistor checkers rely on simple DC tests to indicate whether or not test devices are serviceable, or in some cases, to give measurements of their current gain. This is quite satisfactory in the majority of cases, but a satisfactory outcome from DC tests does not necessarily indicate that devices have good dynamic performance, especially at high frequencies. A comprehensive transistor analyser to measure such things as gain at a specific frequency, noise, and so on, is an extremely complex piece of test gear, and equipment of this type is often quite difficult to use. Something much more basic is acceptable for amateur users, where precise figures for gain and noise are not required and we simply wish to know whether or not test transistors function well at high frequencies.

There is more than one way of tackling the problem, but it really boils down to two basic approaches. Either the test device is connected in an amplifier which is fed with an RF signal and an RF strength meter is used to monitor the output level, or the test device is connected in an RF oscillator circuit and an indicator circuit is used to show whether or not any output signal is present. The first approach is more informative as it gives an indication of relative gain, but the second approach is

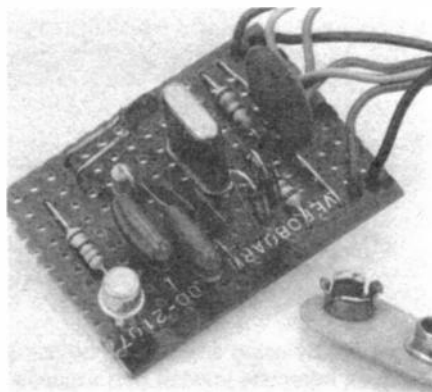

more simple and the straightforward 'go'/no-go' result is adequate for most purposes. The second approach is the one adopted in this tester.

If we first consider the circuit with an npn device connected to SK2, the device operates as a common emitter amplifier. R1 acts as the collector load resistor, while R3 provides base biasing. Crystal X1 acts as a sort of tuned circuit in conjunction with C1 and C2, with the two capacitors giving what is effectively an earthed tapping on the tuned circuit. This circuit acts as a form of single wound transformer and like an ordinary circuit of this type, the signal fed in at one end produces an out-of-phase signal at the other end. In this case, the circuit is connected between the collector and base of the test transistor and it provides

positive feedback at the operating frequency of the crystal. With a serviceable device connected, the circuit should therefore have sufficient gain and feedback to produce oscillation at about 4MHz. The precise crystal frequency is not important but a frequency of about 4MHz is reasonably demanding on the test transistor, although not excessively so.

With a pnp device connected to SK1 the circuit is much the same as before, but R2 is the collector load resistor. Depending on which type of transistor (nnp or pnp) is being tested, either R1 or R2 plays no active role in the circuit. However, the unnecessary resistor does not prevent the circuit from operating properly, and this arrangement avoids the need for npn/pnp switching.

The output of the oscillator is fed to a rectifier and smoothing circuit, which drives LED indicator D3 by way of switching transistor TR1. Provided the oscillator has a reasonably strong output (which any serviceable test device will provide), LED indicator D3 will switch on.

It is worthwhile mentioning that the unit is not only suitable for testing RF devices, and that high speed switching transistors can also be checked. In fact, most silicon transistors for audio use have FT's in the 100 to 300MHz region and can be given a dynamic check using this circuit.

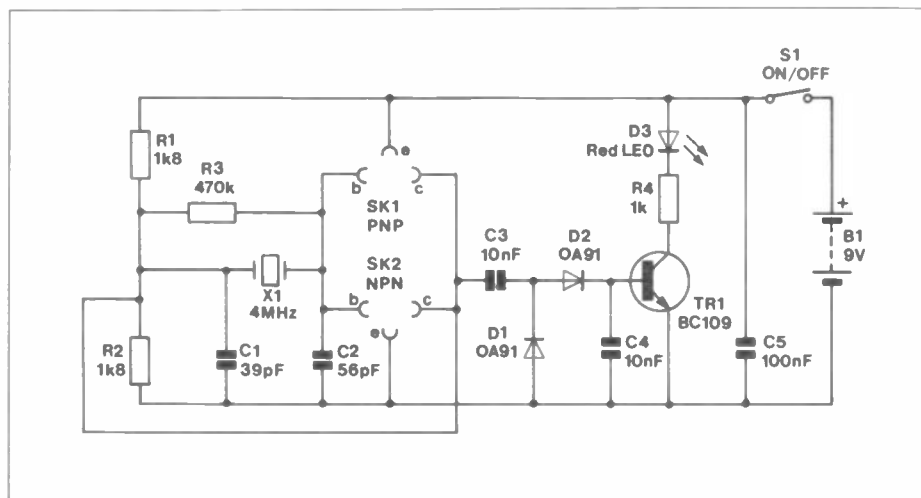

## Telephone Indicator

While a telephone answering machine represents the best solution to the problem of the inevitable telephone call during ones absence, unfortunately it remains a fairly costly solution. There is a simple and inexpensive alternative in the form of an indicator which shows whether or not there has been a call during one's absence. Although this does not give any idea of who was calling or their message, it can still be useful on occasions. For example, if you are expecting a call from someone but have to leave the house for a time, the indicator will show whether or not a call was received during your absence. If a

call was received, then the chances are obviously very much in favour of it being the awaited call and appropriate action can be taken. If no call was received, one's mind is put at rest as the awaited call has clearly not been missed.

This unit activates a flashing LED when a telephone call is received, and the unit is easy to install as it does not require any direct connection to the telephone. It operates by picking up the sound of the telephone bell (or whatever) using a microphone placed near the telephone. Due to the method of pick-up, the unit should, in fact, operate perfectly well as a doorbell monitor if desired.

Obviously, a very simple circuit can achieve the desired result, but things are not quite as easy as one might hope. The complication is that the unit will need to be left running for long periods of time in normal use and it must therefore have a quite low current consumption in both the stand-by and activated modes if it is to run economically from a 9 volt battery supply. The current consumption of this circuit is only about 100 microamps or so in the stand-by mode, rising to an average level that is still well under 1 milliamp when the unit is activated. This gives many hours of operation from even a small 9 volt battery.

The microphone is an inexpensive crystal microphone insert or a ceramic resonator (the latter seeming to give substantially better sensitivity). The output from the microphone, even when placed quite close to the telephone, is not very large and TR1 is used to amplify the microphone signal. TR1 operates in the common emitter mode, but with a low collector current of around 45 microamps. The necessarily low collector current gives a relatively low voltage

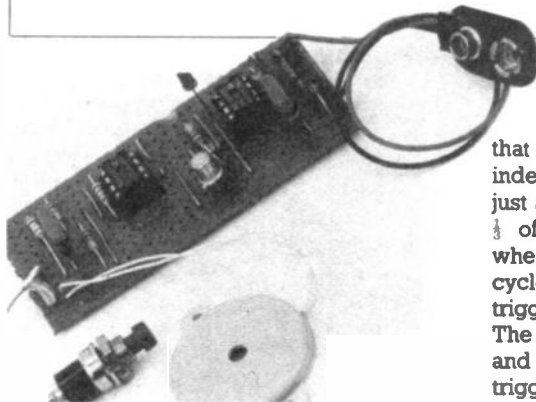
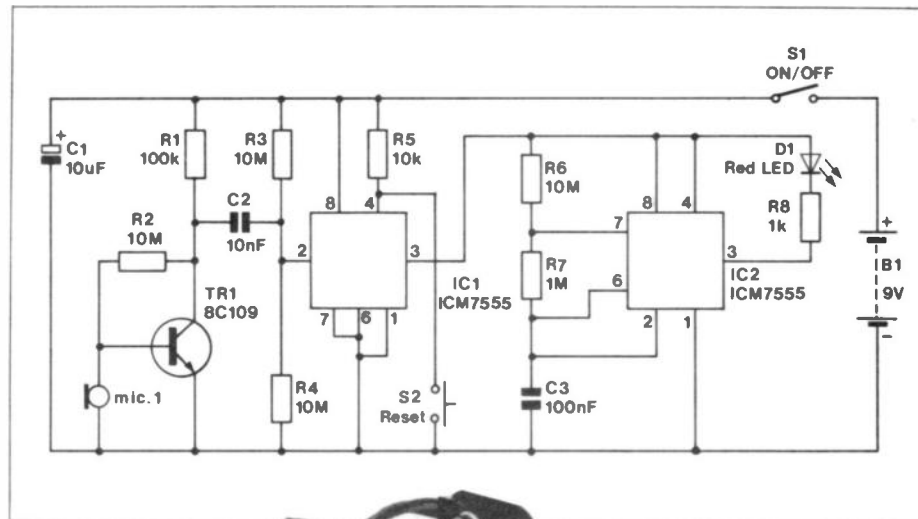

gain, but by using a high gain device for TR1, an adequate level of performance in this respect, is obtained. IC1 is a 7555, the low current CMOS version of the popular 555 timer device. IC1 does not actually operate as a timer in this circuit but acts as a sort of latch. It is effectively connected in the monostable mode, but with pins 6 and 7 connected to the negative supply rail, so

that once triggered the output goes high indefinitely. R3 and R4 hold pin 2 of IC1 just above the trigger threshold, which is  $\frac{1}{3}$  of the positive supply voltage, but when the unit is activated, negative half cycles from TR1 take pin 2 below the trigger threshold and pin 3 goes high. The circuit can be reset by activating S2, and this should be operated if the unit triggers at switch-on.

The output of IC1 drives IC2, which is another 7555. This one is connected in the astable mode and it flashes LED indicator D1 at a frequency of about 1Hz. The 'on' time of D1 is only one eleventh of the 'off' time, and although a LED current of a few milliamps is used, the average LED current is only about 500 microamps.

In use, the unit should function properly with the microphone placed anywhere close to the telephone.

## Baby Alarm/Intercom Amplifier

This circuit can be used as a baby alarm or with the addition of suitable switching it could operate as a simple intercom. It is really just a high gain audio preamplifier driving a small power amplifier. The input and output both connect to high impedance loudspeakers, with the one at the input operating as a sort of crude moving coil microphone. This does not give particularly good audio quality, especially in terms of the frequency response which tends to be rather limited at the high frequency end and to have quite strong resonances. However, the quality is adequate for use in a baby alarm and is just about passable for use in an intercom system where it is the standard arrangement. In order to use the unit as an intercom, switching must be included to permit the roles of the two loudspeakers to be swapped over to provide communication in either direction.

A small integrated circuit power amplifier is the obvious basis for a unit of

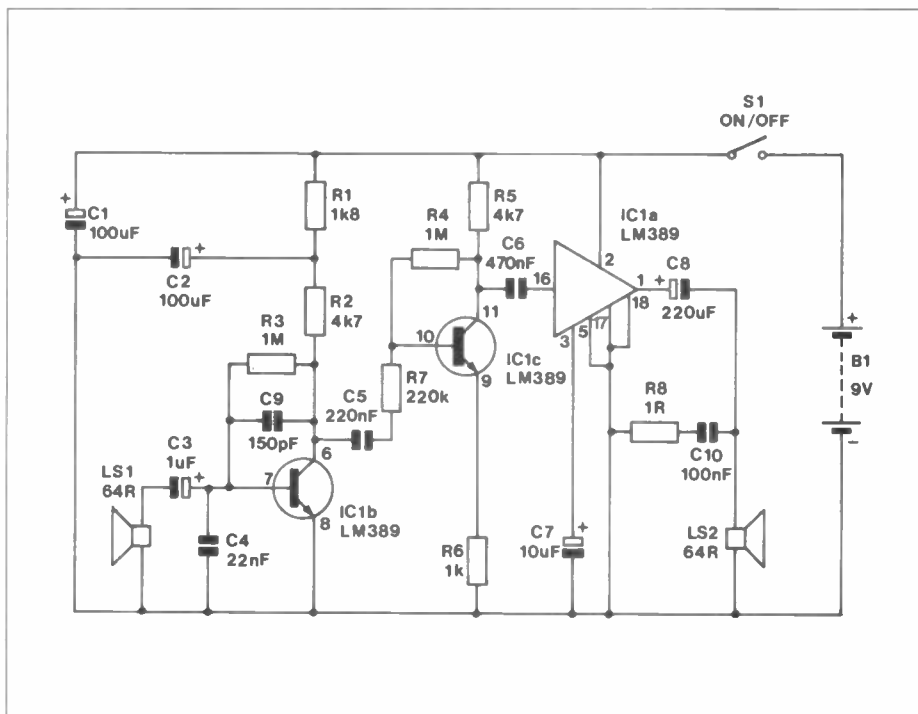



this type, but few devices can provide the high level of voltage gain required in this application. The output from a high impedance loudspeaker, when operated as a microphone, is typically well under a millivolt rms, and is comparable to a low impedance dynamic microphone. The audio power amplifier device used here is the very versatile LM389. This is basically just a standard small audio power amplifier which has inverting and non-inverting inputs that can be left floating or referenced to earth. What makes it so much more versatile than most other audio power amplifiers is the three uncommitted high gain npn transistors it contains. These all have their three terminals externally accessible and for all practical purposes they can be used just as if they were discrete components.

Only two of the transistors are utilized in this design, and the third is just ignored with no connections being made to its terminals. One transistor operates at the input as a high gain common emitter amplifier. C4 is an RF filter capacitor

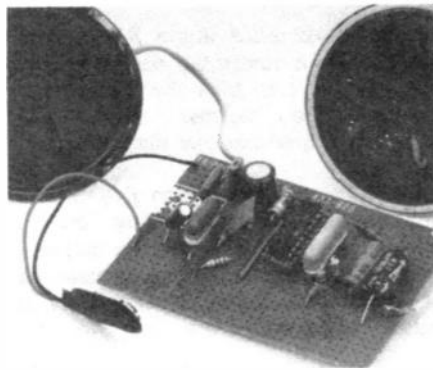

which removes any radio frequency signals that are picked up in the microphone cable and which could otherwise cause audio breakthrough at the output. It is not essential to use a screened cable at the input, but doing so ensures a low level of mains 'hum'. The second transistor is used in another common emitter amplifier but this stage has a much lower voltage gain due to the negative feedback provided by emitter resistor R6. If necessary, the gain of the circuit can be increased somewhat by

making R6 a little lower in value but do not use so much gain that the output stage becomes prone to overloading, as this results in a very poor quality output signal.

C6 couples the output of TR2 to the input of the power amplifier stage. The latter gives an output power of only about 140 milliwatts rms into a 64Ω load but this is adequate for the present applications. C7 is a decoupling capacitor for the supply to the preamplifier stage of IC1.

The quiescent current consumption of the circuit is about 8 milliamps but it rises substantially when the unit operates at maximum volume as IC1 has a class B output stage. An ordinary 9 volt battery is suitable as the power source if the unit is used as an intercom, but a mains power supply unit or rechargeable batteries would be more suitable if it is used as a baby alarm, since it would then be necessary to leave it running for long periods of time. Ordinary batteries would prove short-lived and an expensive power source in the medium and long term.

## Audio Millivoltmeter

Although one of the most useful pieces of test equipment, audio millivoltmeters do not seem to be one of the most popular items of equipment amongst home constructors. Some designs are admittedly quite complex and expensive, but even a very simple type such as the one described here can be invaluable when testing audio equipment. When used in conjunction with an audio signal generator, it is possible to measure such things as voltage gain, signal to noise ratio, input impedance, and frequency response. This circuit has three ranges with full scale values of 10 millivolts, 100 millivolts, and 1 volt rms. The response varies by less than a decibel from 20Hz to 20kHz, and the response is in fact, reasonably flat up to about 100kHz. The input impedance is high at approximately 1 Megohm.

On the face of it, a millivoltmeter need consist of nothing more than an audio amplifier driving a moving coil panel meter by way of a rectifier circuit. In practice, such an arrangement does not work well due to the non-linearity of the rectifier. In the case of a silicon diode, about 0.5 to 0.6 volts is required before it will start to conduct significantly and unless the signal was to be amplified to a very high voltage, this would result in severe non-linearity. Obviously, the meter could be recalibrated to take the non-linearity into account but this is not a very practical solution for a home constructor instrument.

A much better solution is to include the rectifier in the negative feedback loop of the amplifier, so that feedback compensates for the non-linearity of the diodes. This is precisely what is done here and the bridge rectifier formed by D1 to D4 is included in the negative

feedback loop of IC2. When the diodes are supplied with insufficient voltage to produce conduction, IC2 is effectively open loop and a minute input voltage is enough to produce a large output voltage. However, once the output voltage reaches the point at which the diodes come into conduction, a high level of feedback and low voltage gain results. The non-linearity of the feedback distorts the output signal from IC2 so that it counteracts the non-linearity of the diodes. The diodes are germanium types which have better linearity than silicon types and help to optimise results. S2 enables the meter to be connected

across the supply via series resistor R10. The meter then becomes a simple 0 to 10 volt DC type which monitors the battery voltage. The battery should be replaced when a reading of under 7.5 volts is obtained.

IC1 is an input stage which gives the circuit a high input impedance and also provides most of the circuit's voltage gain. IC1 is preceded by a three step attenuator which provides the unit with its three ranges. Although the attenuator is in a high impedance part of the circuit and is not frequency compensated, it does not produce any significant irregularities in the response over the

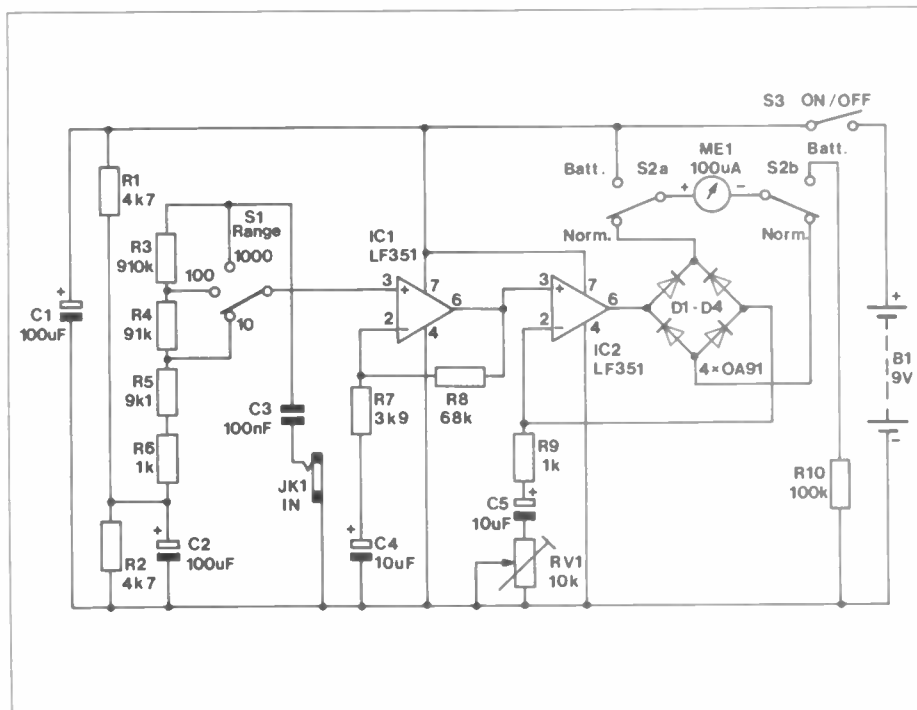

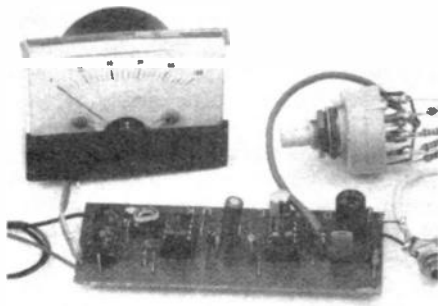

20Hz to 20kHz audio range. R1, R2, and C1 generate a centre tap on the supply which is used to bias the circuit and obviates the normal (operational amplifier) requirement of dual balanced supplies.

RV1 must be adjusted to give the unit the correct sensitivity. Any known voltage, within the range of the unit and at a suitable frequency, can be used as the calibration signal. It is merely a matter of setting the unit to the

appropriate range and adjusting RV1 for the correct reading. One way of tackling the problem is to use an audio generator set to a middle audio frequency of about 1kHz. Use a multimeter set to a low AC voltage range to measure the output of the generator and adjust the output level control for a reading of 1 volt rms. Then set S1 to the 1 volt range, connect the output of the generator to JK1, and adjust RV1 for precisely full scale deflection on ME1.

## Microphone Preamplifier

A perennial problem when using audio equipment is that of a component in the system which provides an inadequate output level to drive the input with which you would like to use it. One of the most common offenders is the humble microphone and all common types have an output level of a few millivolts rms or less. In fact, low impedance dynamic microphones, and some other types, have typical output levels of only a few hundred microvolts rms. Many amplifiers and other items of audio equipment only have high level inputs which require a few hundred millivolts rms, and (possibly) an RIAA equalised cartridge input which may have adequate sensitivity but is unusable anyway, due to the strong bass boost and treble cut of the equalisation.

The problem is easily overcome by using a suitable preamplifier to boost the signal to an adequate level to drive a high level input. This preamplifier circuit is designed for use with a low impedance (200Ω to 1k) dynamic microphone or a type which has similar characteristics (some electret types for instance). It provides a voltage gain of up to about 80dB (10,000 times) and with a maximum output level of over 2 volts rms from a low source impedance, it can provide sufficient output to drive any normal high level input. Although the unit is inexpensive to build, it achieves a fairly high standard of performance with a good signal to noise ratio of around 70dB under typical operating conditions.

A three stage circuit is used with TR1 and TR2 acting as a low noise input stage and voltage amplifier. These are connected in a well known direct coupled configuration, which has both devices in the common emitter mode. TR1 is operated at a low collector current of approximately 50 microamps in order to give a good signal to noise ratio. The noise level is not as low as can be obtained using one of the best audio operational amplifiers or preamplifier ICs, but the noise performance is superior to that obtained using inexpensive operational amplifiers. However, the cost is comparable to inexpensive operational amplifiers and is far less than that of special low noise integrated circuits. R5 introduces negative feedback which reduces the volt-

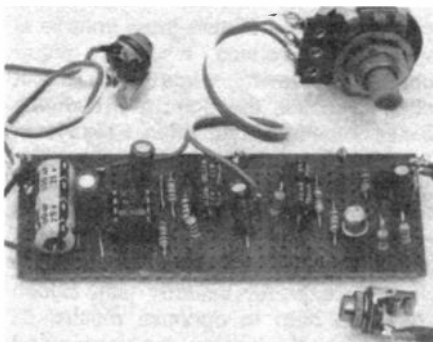
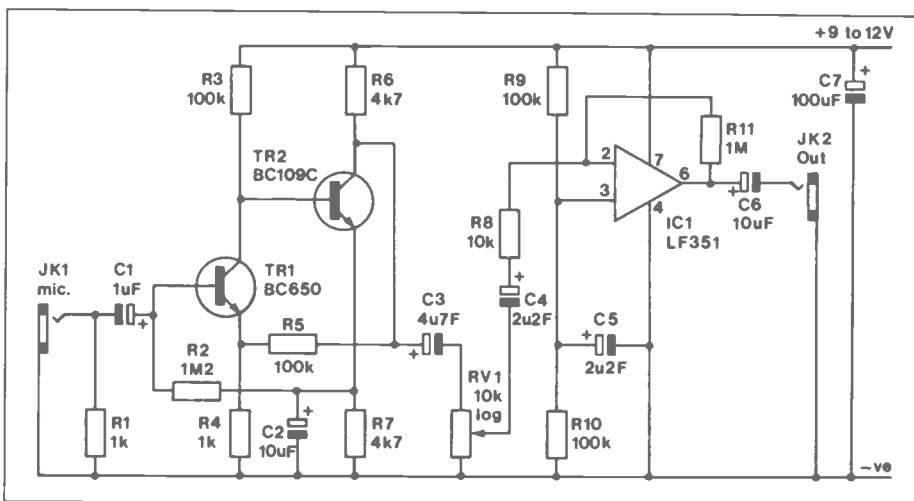

age gain of the amplifier to about 40dB (100 times) and gives improved distortion performance.

C3 couples the output from TR2 to gain control RV1, and from here the signal is coupled to the output amplifier. This is a straightforward inverting amplifier which, like the input stages, has a nominal voltage gain of 40dB. The biFET operational amplifier specified for IC1 gives good noise and distortion performance.

The circuit has a current consumption of about 3 to 4 milliamps, and a 9 volt battery is suitable as the power source. The input and output of the amplifier are out-of-phase, and problems with instability due to stray feedback are unlikely. It is still essential to keep all the wiring near the input of the unit as short as possible and to use a screened lead to connect JK1 to the circuit board. It is definitely advisable to house the unit in a case of all metal construction and earthed to the negative supply rail to provide overall screening against mains hum and other sources of electrical interference.

## SW Aerial Amplifier

Most short wave receivers intended for serious DX reception have an input stage that is designed to be fed from a longwire aerial, dipole, or some other fairly elaborate outdoor aerial. This leads to problems if such a receiver is used in conjunction with a very simple aerial, such as a short piece of wire or a telescopic aerial. Apart from the reduced level of signal pick-up in a shorter aerial, the output impedance of the signal voltage that is present can be quite high with the aerial at just a small fraction of a wavelength.

With most receivers, it is possible to obtain much better results with a short aerial by adding a preamplifier between the aerial and the receiver. Ideally this should be a tuned type but even a very simple and inexpensive broadband circuit, such as the one featured here, will normally give a substantial improvement in results. When used with a Trio QR666 receiver, the prototype boosted 80 metre amateur band signals that were otherwise barely perceptible, to the point where they were loud and clear, bringing the AGC circuit into action. Results on the 20 metre amateur band were similar. The unit should in fact work well over the entire 1.6 to 30MHz spectrum of the short wavebands. One point must be emphasized and that is the unsuitability of the unit for use with anything other than a short aerial of no more than around two metres or so in length. An aerial longer than this would almost certainly overload the amplifier for the majority of the time, giving poor results with an output signal

## TRANSISTOR CHECKER PARTS LIST

RESISTORS: All 0.4W 1% Metal Film

R1,2	1k8	2	(M1K8)
R3	470k	1	(M470K)
R4	1k	1	(M1K)

### CAPACITORS

C1	39pF Ceramic	1	(WX51F)
C2	86pF Ceramic	1	(WX53H)
C3,4	10nF Polyester	2	(BX70M)
C5	100nF Polyester	1	(BX76H)

### SEMICONDUCTORS

TR1	BC109C	1	(QB33L)
D1,2	OA91	2	(QH72P)
D3	LED Red	1	(WL27E)

### MISCELLANEOUS

SK1,2	T05 Socket	2	(WR31J)
S1	SPST Ultra Min Toggle	1	(FH97F)
X1	4MHz Crystal	1	(FY82D)

## TELEPHONE INDICATOR PARTS LIST

RESISTORS: All 0.4W 1% Metal Film

R1	100k	1	(M100K)
R2,3,4,6	10M	4	(M10M)
R5	10k	1	(M10K)
R7	1M	1	(M1M)
R8	1k	1	(M1K)

### CAPACITORS

C1	10µF 50V P.C. Electrolytic	1	(FF04E)
C2	10nF Polyester	1	(BX70M)
C3	100nF Polyester	1	(BX76H)

### SEMICONDUCTORS

IC1,2	ICM7555	2	(YH63T)
TR1	BC109C	1	(QB33L)
D1	LED Red	1	(WL27E)

### MISCELLANEOUS

S1	SPST Ultra-Min Toggle	1	(FH97F)
MIC1	Min. Piezo Sounder	1	(FMS9P)
	8-Pin DIL Socket	2	(BL17T)

## BABY ALARM/INTERCOM AMPLIFIER PARTS LIST

RESISTORS: All 0.4W 1% Metal Film

R1	1k8	1	(M1K8)
R2,5	4k7	2	(M4K7)
R3,4	1M	2	(M1M)
R6	1k	1	(M1K)
R7	220k	1	(M220K)
R8	1Ω	1	(M1R)

### CAPACITORS

C1,2	100µF 10V P.C. Electrolytic	2	(FF10L)
C3	1µF 100V P.C. Electrolytic	1	(FF01B)
C4	22nF Polyester	1	(BX72P)
C5	220nF Polyester	1	(BX78K)
C6	470nF Polyester	1	(BX80B)
C7	10µF 50V P.C. Electrolytic	1	(FF04E)
C8	220µF 16V P.C. Electrolytic	1	(FF13P)
C9	150pF Ceramic	1	(WX58N)
C10	100nF Ceramic Disc	1	(BK03D)

### SEMICONDUCTORS

IC1	LM389	1	(WQ36P)
-----	-------	---	---------

### MISCELLANEOUS

LS1,2	66mm Dia. 64Ω Speaker	2	(WF87M)
S1	SPST Ultra Min Toggle	1	(FH97F)
	18-Pin DIL Socket	1	(HQ76H)

## AUDIO MILLIVOLTMETER PARTS LIST

RESISTORS: All 0.4W 1% Metal Film

R1,2	4k7	2	(M4K7)
R3	910k	1	(M910K)
R4	91k	1	(M91K)
R5	9k1	1	(M9K1)
R6,9	1k	2	(M1K)
R7	3k9	1	(M3K9)
R8	68k	1	(M68K)
R10	100k	1	(M100K)
RV1	10k Hor Sub-min Preset	1	(WR58N)

### CAPACITORS

C1,2	100µF 10V Axial Electrolytic	2	(FB48C)
C3	100nF Polyester	1	(BX76H)
C4,5	10µF 25V Axial Electrolytic	2	(FB22Y)

### SEMICONDUCTORS

IC1,2	LF351	2	(WQ30H)
D1-4	OA91	4	(QH72P)

### MISCELLANEOUS

ME1	100µA 2in Panel Meter	1	(RW92A)
S1	3 Way 4 Pole Rotary	1	(FH45Y)
S2	DPDT Ultra-min Toggle	1	(FH99H)
S3	SPST Ultra-min Toggle	1	(FH97F)
B1	9 Volt PP3 Battery Clip	1	(FK88N)
	8-Pin DIL Socket	1	(BL17T)
JK1	Jack Socket	1	(HF82D)

## MICROPHONE PREAMPLIFIER PARTS LIST

RESISTORS: All 0.4W 1% Metal Film

R1,4	1k	2	(M1K)
R2	1M2	1	(M1M2)
R3,5,9,10	100k	4	(M100K)
R6,7	4k7	2	(M4K7)
R8	10k	1	(M10K)
R11	1M	1	(M1M)
RV1	10k Log. Pot	1	(FW22Y)

### CAPACITORS

C1	1µF 100V P.C. Electrolytic	1	(FF01B)
C2,6	10µF 50V P.C. Electrolytic	2	(FF04E)
C3	4µF 63V P.C. Electrolytic	1	(FF03D)
C4,5	2µF 100V P.C. Electrolytic	2	(FF02C)
C7	100µF 10V P.C. Electrolytic	1	(FF10L)

### SEMICONDUCTORS

IC1	LF351	1	(WQ30H)
TR1	BC680	1	(QB74R)
TR2	BC109C	1	(QB33L)

### MISCELLANEOUS

JK1,2	3.5mm Mono Jack	2	(HF82D)
-------	-----------------	---	---------

## SHORT WAVE AERIAL AMPLIFIER PARTS LIST

RESISTORS: All 0.4W 1% Metal Film

R1,2	100k	2	(M100K)
R3	1k	1	(M1K)
R4	560k	1	(M560K)
R5	1k5	1	(M1K5)
R6	47Ω	1	(M47R)

### CAPACITORS

C1	10nF Polyester	1	(BX70M)
C2	470pF Ceramic	1	(WX64U)
C3	100nF Ceramic Disc	1	(BK03D)

### SEMICONDUCTORS

TR1,2	BC847	2	(QQ14Q)
-------	-------	---	---------

### MISCELLANEOUS

S1	SPST Ultra Min. Toggle	1	(FH97F)
SK1	Coaxial Socket	1	(HH09K)

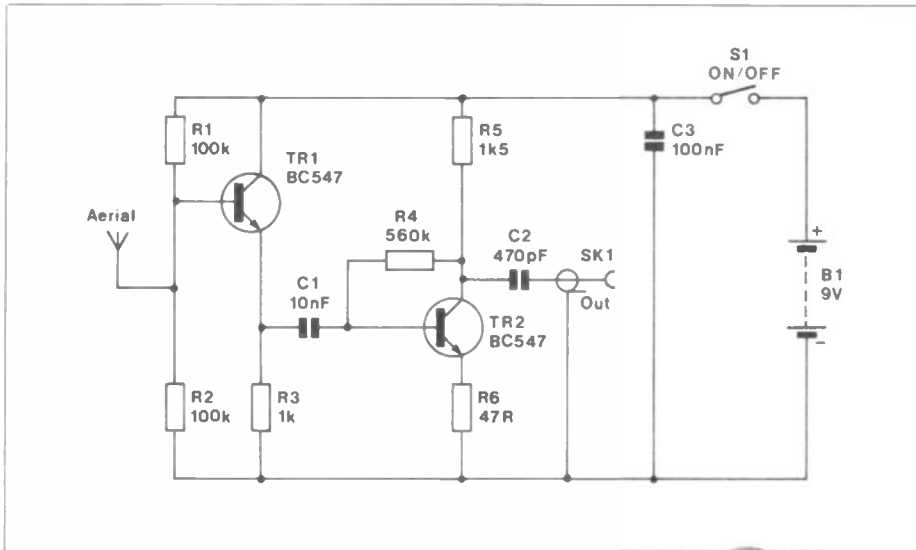

that would be little more than RF noise. Remember that the unit is a broadband circuit which is dealing with a vast number of signals over a broad frequency spectrum and some of these signals will inevitably be very strong.

The circuit is very simple and apart from the low value coupling capacitors, it looks very much like an ordinary audio amplifier. In fact, the two transistors utilized in the design are audio frequency types but they seem to work well in this application. In fact, trying more expensive radio frequency types in the circuit seemed to produce no improve-

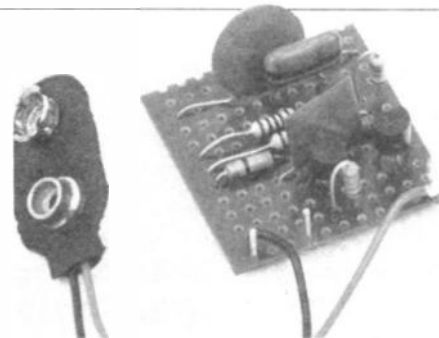

ment in any aspect of performance. There are two stages to the unit, an input buffer amplifier and a voltage amplifier. TR1 acts as the buffer amplifier and this

is a straightforward emitter follower buffer stage which provides a high input impedance and a low output impedance. This matches the high output impedance of the aerial to the fairly low input impedance of the voltage amplifier, thus ensuring good efficiency. The voltage amplifier is a simple common emitter amplifier operated at a moderately high collector current of about 3 to 4 milliamps in order to give good radio frequency performance. The full gain of this stage is not needed and if operated at maximum gain there would be a tendency for the circuit to become unstable and to overload too easily. R6 is therefore used to introduce some negative feedback which reduces the voltage gain. If desired, R6 can be made somewhat lower in value to give increased gain, or increased in value to give reduced gain and less risk of overloading. The ideal value depends on the aerial you use.

Power is obtained from a 9 volt battery, and the current consumption is about 8 milliamps. It is consequently advisable to power the unit from a fairly large 9 volt battery such as a PP9 or equivalent. A twin lead (which need not be a co-ax type but should be reasonably short) carries the two connections from SK1 to the aerial and earth sockets of the receiver. It is essential that the connection from the negative supply rail of the aerial amplifier to the earth terminal of the receiver is included if the amplifier is to function properly.

## Speech Processor

Speech processors of one form or another are used with many types of communications and public address equipment. The general idea is to process the speech signal in some way to make it stand out better from a noise background but without increasing the peak level of the signal. It is possible to do this due to the waveforms of normal voice signals. These tend to have a peak level that is quite high in comparison to the average signal level. As far as the listener is concerned, this gives a fairly low volume level compared with that which would be obtained from a signal, such as a sinewave, under identical operating conditions.

A compressor can be used to improve matters by ensuring that the signal is always at, or close to, the maximum permissible level, but this does not overcome the problem of the high peak to average signal level. This can only be combatted using a clipping circuit of some kind, to limit the signal peaks and modify the speech waveform. A simple clipping circuit will in fact do this, and effectively gives some conventional compression as well, but a side effect of distorting the wave shape in this way, is the strong distortion products (both harmonic and intermodulation) that are produced.

Some speech processors use quite complex means to overcome this

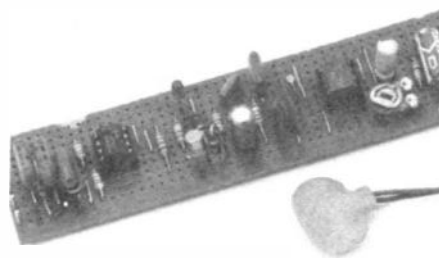

problem but good results can be obtained using a relatively simple circuit which consists of nothing more than two active filters and the clipping circuit. First the signal is processed by a highpass filter which has a cut off frequency at about 250Hz. Frequencies below 250Hz are not needed for intelligible speech and can usefully be removed as, when clipped, these signals would produce strong harmonics across the middle of the audio frequency range, giving what would subjectively be very obvious and objectionable distortion products. After this first stage of filtering the signal is clipped, and then it is subjected to lowpass filtering. The lowpass filter attenuates signals at frequencies of more than about 3kHz. Again, these are not needed for good intelligibility. The clipping generates strong distortion components at frequencies above 3kHz, and so the lowpass filtering substantially reduces the distortion on the output signal. Inevitably a significant amount of

distortion remains, but the increase in 'talk power' outweighs the disadvantage of this distortion.

The speech processor circuit shown here is intended for use with a high level input signal level of a few volts peak to peak. It must therefore be used in conjunction with a microphone preamplifier such as the one described elsewhere in this feature. A third order (18dB per octave) highpass filter having a cut off frequency of about 250Hz is used at the input of the circuit and IC1 acts as the buffer stage for this active filter. The clipping circuit uses R6, C5, D2, and the base-emitter junction of TR1 to clip the signal at about 1.2 volts peak to peak. When the signal is above the positive clipping threshold, TR1 is biased into conduction and LED indicator D1 lights up. The microphone gain control should be advanced just far enough to cause D1 to light fairly brightly when talking into the microphone. IC2 is used as the basis of the lowpass filter, and this is a fourth order (24dB per octave) type having a nominal 3kHz cut-off frequency.

The output from IC2 is about 1.2 volts peak to peak, which will seriously overload any normal microphone input. R11 and RV1 form a variable attenuator at the output of the circuit, and RV1 is adjusted to give an output level that is comparable to that of the microphone used with the unit.

*Continued on page 61.*



# New Books

## Easy Add-on Projects for Commodore 64, VIC-20, BBC Micro and Acorn Electron

by Owen Bishop

This book describes how to build a number of useful add-on electronic circuits which can be used with the Commodore 64, VIC-20, BBC Micro or the Acorn Electron - but if the reader is using the BBC Micro Model A then a user port upgrade and, for one of the projects, the analogue upgrade too will be required. All the projects are simple and easy to build, having a minimum component count and utilise inexpensive ICs. Once built the add-ons are easy to use, and sample programs are provided to help those less experienced at programming to get started, but the projects are not limited to this and the more experienced programmer can have a lot of fun writing elaborate programs which use any of the projects.

After an introductory section, each project is described in detail in following sections and include a picture digitiser, model controller, pulse detector, lamp flasher, light pen, photo-flash, rain detector, thermometer and many more. A special decoder circuit is described which is required to enable all the add-ons to be interfaced easily.

176 x 110mm, 194 pages, illustrated.

Order As WP29G (Easy Add-Ons BP134) Price £3.25

## The TTL Data Book, Volume 2

Texas Instruments  
The 1984 edition volume 2 is packed with the design data, internal circuit and pin-out diagrams, and dynamic parameters information for some 300 Advanced Low-Power Schottky (ALS) and Advanced Schottky (AS) logic ICs. Included in this volume is a functional index to all types of bipolar digital devices available or under development showing the available technologies for each type, TTL, Schottky, AS, ALS etc. There is also a short explanatory section on the new IEEE standard 91-1984 logic symbols for new circuit diagrams.

210 x 150mm, 815 pages, illustrated.

Order As WP31J (TTL Data Bk Vol 2) £10.95

## The Amstrad CPC-464 Advanced User Guide

by Mark Harrison

The book assumes that you have got your 464 running, and you have had some experience writing simple programs for the Amstrad. Even so, it begins with a description of how the 464 works and how it communicates with other external devices, together with a brief summary of BASIC. A comprehensive reference section is included offering explanation of any BASIC command or keyword.

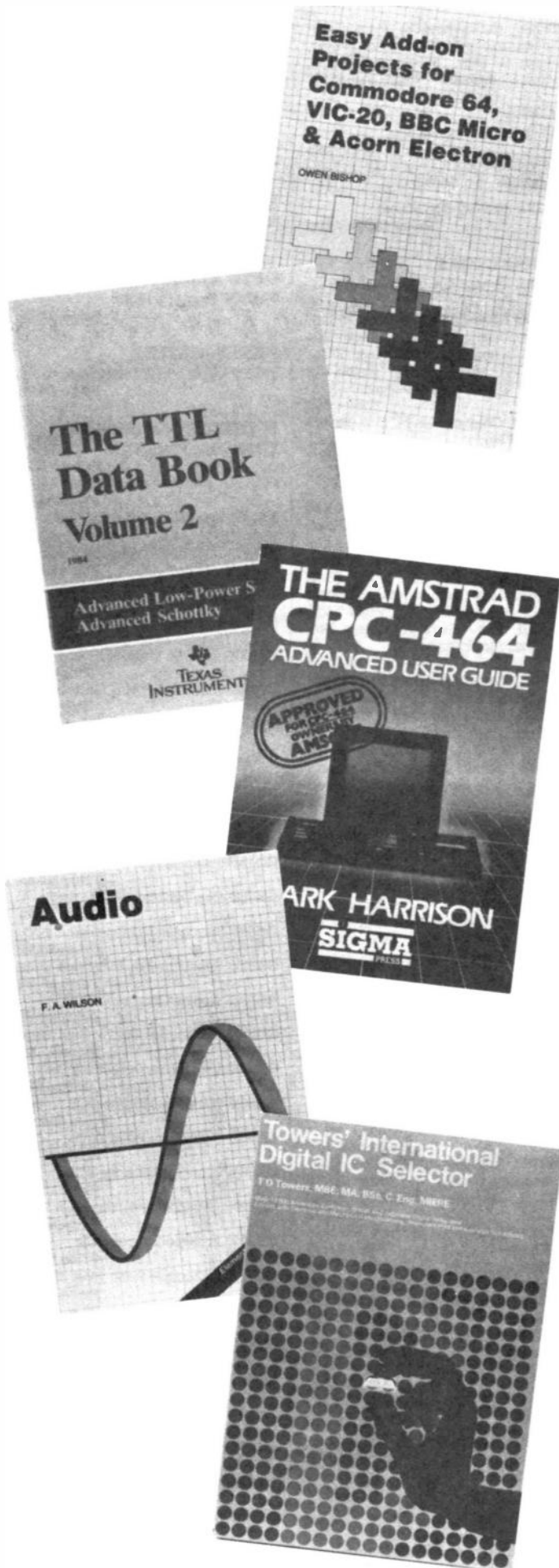

The book contains forty complete programs ready-to-run, ranging from the short demonstration type through to large, complex programs for code breaking, databases, sorting, and graphics. The book is divided into sections dealing with strings and characters, Input/Output, arithmetic operations, memory mapping, time, clocks and interrupts, data processing and structures, graphics and sound. 219 x 149mm, 140 pages, illustrated.

Order As WP32K (Amstrad Advc Usr Gde) £7.95

## Audio

by F.A. Wilson

A very educational and useful reference book for anyone wanting to know more about the behaviour of sound and AF electronics in order to further their understanding of audio amplifiers, loudspeaker systems, electronic music etc. The book begins with an analysis of the sound wave with an explanation of acoustical properties and what they mean, followed by a study of the mechanism of hearing and how we hear various sounds. This logically introduces musical instruments and how they work, the principle of stereophonic sound and the meaning of unwanted 'noise'. This takes the reader on to room acoustics and the essential design requirements of microphones and loudspeaker systems, followed by subsequent sections on amplifiers of various types, descriptions of 'gramophone' disk and magnetic tape recording, and electronic music synthesis. The book finishes with some useful data and formulae.

179 x 110mm, 308 pages, illustrated.

Order As WP30H (Audio BP111) Price £3.95

## Towers' International Digital IC Selector

by T.D. Towers, MBE, MA, BSc, C. Eng, MIERE

Contains over 13,000 American, European, British and Japanese digital ICs with electrical and mechanical specifications quoting manufacturers and available substitutes. The 'Digital IC Selector' is written in the same way as the 'International Transistor Selector' by the same author, and is designed to provide, in one handy reference volume, a comprehensive body of readily accessible, user-oriented information across the range of digital ICs. The tables are supported by separate appendices giving additional useful reference information on logic types and coding, package outlines and pin-out diagrams, and a glossary of abbreviations and terminology, etc.

248 x 175mm, 246 pages, illustrated.

Order As WP33L (Towers Dig IC Select) £11.45

# NEW ITEMS PRICE LIST

The following is a list of all items introduced since our 1985 catalogue, excluding new items in this issue.

## BOOKS

- WM94CA** An Introduction to Programming the Sinclair QL by R.A. & J.W. Penfold. Price £2.15NV  
**WM95D** Basic & Forth in Parallel by S.J. Wainwright. Price £2.15NV  
**WM97F** An Introduction to Programming the Amstrad CPC464 by R.A. & J.W. Penfold. Price £2.45NV  
**WM99H** The Complete Guide to Satellite TV by Martin Clifford. Price £13.45NV  
**WP00A** The Fibre Optics & Laser Handbook by Edward L. Safford. Price £15.45NV  
**WP01B** BBC Hardware Projects by Don Thomasson. Price £8.95NV  
**WP02C** Spectrum Micronet Book by Alan Giles. Price £6.30NV  
**WP05F** Practical Electronics by Barry Woollard. Price £8.10NV  
**WP06G** Assembly Language Programming on the Sinclair QL by Andrew Pennell. Price £7.95NV  
**WP07H** Essential Electronics by George Loveday. Price £8.15NV  
**WP08J** Electronic Fault Diagnosis by George Loveday. Price £6.05NV  
**WP09K** Electronic Systems and Technology by K. F. Ibrahim. Price £6.95NV  
**WP10L** Electrical and Electronic Applications by Noel Morris. Price £7.65NV  
**WP11M** An Introduction to Z80 Machine Code by R. A. & J. W. Penfold. Price £2.40NV  
**WP12N** Micro Interfacing Circuits Book 2 by R. A. Penfold. Price £2.40NV  
**WP13P** Easy Programming for the Atari Micros by Eric Deeson. Price £8.40NV  
**WP14Q** The Working Amstrad by D. Lawrence and S. Lane. Price £7.10NV  
**WP15R** Practical Programs for the Amstrad CPC464 by Owen & Audrey Bishop. Price £6.95NV  
**WP16S** Dynamic Games for the Amstrad by Clive Gifford. Price £7.40NV  
**WP17T** Adventure Games for the Amstrad CPC 464 by A.J. Bradbury. Price £8.95NV  
**WP18U** The BBC Micro Add-On Guide by A. & M. Scott & P. Gardner. Price £6.95NV  
**WP19V** Exploring Adventures on the Atari 48K by Peter Gerrard. Price £7.90NV  
**WP20W** How to Write Amstrad CPC464 Games Programs, by W. Simister. Price £2.85NV  
**WP21X** High Performance Loudspeakers, by Martin Colloms. Price £15.95NV  
**WP22Y** Filing Systems and Databases for the Amstrad CPC464, by A.P. Stephenson and D.J. Stephenson. Price £9.45NV  
**WP23A** The BBC Micro ROM Book, by Bruce Smith. Price £10.95NV  
**WP24B** Telecom Circuits Data Book. Price £13.75NV  
**WP25C** Ins and Outs of the Amstrad, by Don Thomasson. Price £7.95NV  
**WP26D** Get More from the Epson Printer by Susan Curran. Price £8.45NV  
**WP27E** BBC Micro Wargaming by Owen and Audrey Bishop. Price £9.95NV

**WP28F** Understanding Data Communications by George E. Friend, John L. Fike, H. Charles Baker, John C. Bellamy. Price £16.35NV

## BOXES

**FT31J** Small Narrow Box. Price 88p

## CABLE

**XR79L** 50-Way IDC Cable. Price (30cm) 80p

## CONNECTORS

- BK96E** 34-way IDC Socket & Cable. Price £3.85  
**FK01B** 2.5mm Mono PCB Mounting Jack Socket. Price 15p  
**FK16S** 2-way Screw Terminal Strip. Price 18p  
**FK17T** 4-way Screw Terminal Strip. Price 28p  
**FM12N** Gold-plated ¼ inch Stereo Jack Plug. Price £2.15  
**FT36P** Filtered Euro Chassis Mains Inlet. Price £7.95  
**FT37S** Fused Euro Chassis Mains Inlet. Price £1.20  
**FT38R** 2-Way PCB Mounting Terminal Block. Price 24p  
**FT45Y** 5 Metre Telephone Line Jack Extension Cord. Price £3.25  
**FT46A** Twin Flush Mounting Master Jack Unit 5/4A. Price £4.98  
**FT47B** Twin Flush Mounting Secondary Jack Unit 5/6A. Price £3.95  
**FT48C** Surface Mounting Master Jack Unit 2/4A. Price £3.98  
**FT49D** Small Surface Mounting Master Jack Unit 1/4A. Price £3.98  
**FT50E** Small Surface Mounting Secondary Jack Unit 1/6A. Price £2.98  
**FT51F** BT IPC Insertion Tool. Price 48p  
**FT52G** 6-Way IPC Plug 631/A. Price 88p  
**FT60Q** 2x25-Way IDC Edge Connector. Price £4.95  
**FT62S** Right Angle Euro Mains Inlet Line Socket. Price £1.95  
**FT63T** Mains Outlet Chassis Socket P675. Price 65p  
**FT64U** Mains Outlet Line Plug P686. Price £1.75  
**FT65V** Right Angle Euro Mains Outlet Plug P685. Price £1.95  
**FT66W** 2x25-Way Cable + IDC and Transition Header Connectors. Price £9.95  
**FT67X** Right Angle Polarised Locking Minicon Plug 17-Way. Price £1.10  
**FT70M** 2x25-Way IDC Edge Connector + Cable. Price £7.95  
**FT71N** 2x17-Way IDC Edge Connector + Cable. Price £5.95  
**FT72P** Right Angle 20-Way IDC PCB Header Plug. Price £1.75  
**FT86T** 2x8-Way IDC Edge Connector. Price £1.95  
**FT87U** 2x10-Way IDC Edge Connector. Price £2.45  
**FT88V** 2x13-Way IDC Edge Connector. Price £2.95  
**FT89W** 2x17-Way IDC Edge Connector. Price £3.45  
**FT90X** 2x20-Way IDC Edge Connector. Price £3.95  
**QY73Q** Polarising Key. Price 5p

## HEATHKIT

- HM05F** Analogue Circuit Design Course EE-1003. Price £89.95  
**HM15R** Computer Fundamentals Course EC-2001. Price £129.95  
**HM20W** Hero Jr. Programming Language RTC-1-10. Price £49.95

- HM21X** Hero Jr. Games, Musical Chairs, Acey-Ducey and Mind Reader RTC-1-11. Price £43.50  
**HM26D** Hero 1 BASIC ROM ET-18-9. Price £59.95  
**HM27E** Laser Technology Course EE-110. Price £139.95  
**HM32K** Laser Trainer ET-4200. Price £344.95

## MUSICAL AND EFFECTS

**XG68Y** 12 Volt Disco Deck P295. Price £42.95

## OPTO ELECTRICAL

**FM99H** Reader's Light. Price £4.25

## PANEL METERS

**FM98G** Hi-Z 50µA Meter. Price £6.98

## PROJECTS & MODULES

- FJ37S** Logic Probe Case. Price £1.48  
**FM49D** Musical Announcer Front Panel. Price £1.55  
**FT39N** Live-Wire Detector Case. Price £1.10  
**FT40T** Control-A-Train Front Panel. Price £1.75  
**FT41U** Trundle Motor Assembly. Price £3.99  
**FT42V** Trundle Wheel. Price £1.95  
**FT43W** Trundle Bracket. Price 35p  
**FT53H** Control-A-Train Heatsink. Price 38p  
**FT69A** Guitar Equaliser Front Panel. Price £1.75  
**GB69A** Gas Detector PCB. Price £2.45  
**GB75S** Musical Announcer PCB. Price £2.75  
**GB77J** Mains Controller PCB. Price £2.99  
**GB78K** Flash Meter PCB. Price £1.75  
**GB79L** Gas Sensor PCB. Price £1.15  
**GB80B** Spectrum I/O Controller PCB. Price £5.75  
**GB81C** Spectrum Pin Extension PCB. Price £1.85  
**GB82D** Active Crossover PCB. Price £4.75  
**GB83E** 4 Channel Servo Controller PCB. Price £7.95  
**GB85G** Live-Wire Detector PCB. Price 50p  
**GB86T** Z80 CPU Module PCB. Price £10.95  
**GB87U** Control-A-Train PCB. Price £1.99  
**GB88V** Trundle Memory PCB. Price £2.45  
**GB89W** Trundle Interface PCB. Price £4.25  
**GB90X** Trundle Sensor PCB. Price £2.45  
**GB91Y** 3 Channel Amp PCB. Price £4.95  
**GB92A** Guitar Equaliser PCB. Price £5.45  
**GB93B** Ultrasonic Car Alarm PCB. Price £4.95

- LK55K** 27MHz Tx Kit. Price £9.95  
**LK56L** 27MHz Rx Kit. Price £10.95  
**LK57M** Musical Announcer Kit. Price £13.50  
**LK58N** Flash Meter Kit. Price £13.95  
**LK59P** Mains Controller Kit. Price £8.95  
**LK60Q** Gas Alarm Kit. Price £23.95  
**LK61R** 4 Channel Servo Controller Kit. Price £21.95

- LK62S** Trundle Kit. Price £49.95  
**LK63T** Live-Wire Detector Kit. Price £2.95  
**LK64U** Control-A-Train Kit. Price £10.99  
**LK65V** Spectrum I/O Controller Kit. Price £17.95  
**LK66W** Zero 2 Robot Kit. Price £79.95  
**LK67X** Z80 CPU Module Kit. Price £29.95  
**LK69A** Active Crossover Kit. Price £16.95  
**LK70M** 3 Channel Amp Kit. Price £18.45  
**LK71N** Sharp Serial Interface Kit. Price £26.95  
**LK74R** Guitar Equaliser Kit. Price £26.95  
**LK75S** Ultrasonic Car Alarm Kit. Price £19.95  
**QY72P** Sharp Interface EPROM 2716/M9. Price £4.95  
**XG67X** Guitar Buddy Practice Amplifier. Price £20.75  
**YJ64U** Zero 2 Mains Adaptor. Price £7.95

## PROTECTION

- FM87U** Gas Detector Sensor. Price £6.99  
**FT35Q** Fuseholder Insulating Boot. Price 30p

## RESISTORS

**FT68Y** Miniature Slide Pot 20K LIN. Price £1.45

## SEMICONDUCTORS

- QY74R** 256K RAM 41256 150ns. Price £6.95  
**QY75S** 256K EPROM 27256. Price £14.95  
**QY76H** SAA1027. Price £3.75  
**QY77J** UCN5801A. Price £7.95  
**QY78K** ULN2801A. Price £1.72  
**QY79L** ULN2803A. Price £1.82

## SPEAKERS AND SOUNDERS

**FM59P** Mini Sounder. Price 78p

## SWITCHES AND RELAYS

- FT56L** Right Angle PCB Rotary Switch 1x12-Way. Price £2.95  
**FT57M** Right Angle PCB Rotary Switch 2x6-Way. Price £2.95  
**FT58N** Right Angle PCB Rotary Switch 3x4-Way. Price £2.95  
**FT59P** Right Angle PCB Rotary Switch 4x3-Way. Price £2.95  
**QY68Y** Sub-miniature PCB Hex Encoded Rotary Switch (On=0). Price £2.75  
**QY69A** Sub-miniature PCB Hex Encoded Rotary Switch (On=1). Price £2.75

## TEST GEAR

**FT44X** Wire Cutter/Stripper Tool. Price £4.95

## WOUND COMPONENTS

- FT32K** 50W Ferrite Transformer Kit. Price £4.75  
**FT33L** 100W Ferrite Transformer Kit. Price £5.75  
**FT73Q** Stepper Motor 12V 4-Phase Unipolar. Price £9.95  
**LK76H** Stepper Motor Driver Kit. Price £13.35  
**YJ61R** 20W Transformer Kit. Price £6.75  
**YJ62S** 50W Transformer Kit. Price £9.45  
**YJ63T** 100W Transformer Kit. Price £11.95









1986 Catalogue Page No.	VAT Inclusive Price	1985 Catalogue Page No.	VAT Inclusive Price	1986 Catalogue Page No.	VAT Inclusive Price	1985 Catalogue Page No.	VAT Inclusive Price	1986 Catalogue Page No.	VAT Inclusive Price
<b>Page 357</b>		<b>Page 372</b>		<b>Page 388</b>		<b>Page 403</b>		<b>Page 425</b>	
QMH6W NE 555	28p (F)	YH53B AM7910	£34.95 (A)	XQ74R Car PA 15W	£17.95 (A)	BK48C Ult-Mn Relay 6V DPDT	£1.75 (D)	FM97F HSS Drill Set	DIS (B)
QMH7X NE 566	85p (E)			WY13P Elliottical Spkr L7853	£7.95 (B)			YL20C MagniCamp	DIS (D)
YH83T ICM 555	£1.35 (D)	<b>Page 373</b>		WF11M Rd Speaker L7830	£3.95 (B)	<b>Page 404</b>		FJ44X Iron Type C	£7.75 (B)
UF32K ZN1034E	£2.30 (C)	QY43W XR2211CP	£7.95 (C)	WF53H 20W Squawker	£4.45 (C)	FX4W 40 Sub-Min Relay 12V	£3.95 (C)	FY82S Iron CS	£7.95 (B)
		UF44X ADC0820CCN	£17.95 (A)	FJ40T Speaker Clamp Kit	£2.25 (D)				
<b>Page 358</b>		<b>Page 375</b>		<b>Page 389</b>		<b>TEST GEAR</b>		<b>Page 426</b>	
QH69A NE 567	£1.98 (D)	UF43W ZN448E	£9.95 (B)	XG39N Speaker 5in 50W 8R	£18.95 (A)	<b>Page 407</b>		FY84Y CS Kit SK5	£10.95 (B)
WQ39N LM3909	£1.15 (E)	<b>Page 377</b>		XG40T Speaker 5in 50W 16R	£19.95 (A)	FK32K Solder Test Prods	48p (F)	FR12N Iron XS	£8.25 (B)
		WR32K IC Slt B-Lead	DIS (E)	XG44X Spkr 10in 50W TC 8R	£26.95 (A)			FR14Q Element X25	£3.95 (C)
<b>Page 359</b>				XG45Y Spkr 10in 50W TC 16R	£28.95 (A)	<b>Page 408</b>		FY85A NS Kit SK6	£11.45 (A)
WQ32K LM334	£1.85 (D)	<b>Page 378</b>				FY730 Logic Probe	£14.95 (A)	FR13P 12V Iron MLXS	£10.95 (B)
		XX140 Soldercons	£1.95 (E)	<b>Page 390</b>		YR95D Lo-Cost Scope Probe	£2.95 (C)	FR20W Stand ST4	£2.95 (C)
<b>Page 360</b>		BL17T DIL Socket 8-pin	5p (H)	XG46A Spkr 10in 100W GP 8R	£32.95 (A)				
YY75S ICL7880CPA	£2.95 (C)	BL18U DIL Socket 14-Pin	8p (G)	XG47B Spkr 12in 50W GP 8R	£28.95 (A)	<b>Page 411</b>			
		BL19V DIL Socket 16-pin	9p (G)	XG48C Spkr 12in 50W GP 16R	£28.95 (A)	FM58N Current Checker CCA	DIS (A)	<b>Page 427</b>	
<b>Page 364</b>		HQ79H DIL Socket 18-pin	10p (G)	XG49D Spkr 12in 100W GP 8R	£31.95 (A)			XG56K Sldr Stn TCSU1(CSTC)	£79.95 (A)
QD02C 8502	£7.95 (B)	HQ77J DIL Socket 20-pin	11p (G)	XG50E Spkr 12in 100W TC 8R	£34.95 (A)	<b>Page 414</b>		XG58L Sldr Stn TCSU1(XSTC)	£79.95 (A)
WQ43W MC8800P	£4.45 (B)	HQ78K DIL Socket 22-pin	14p (G)	XG51F Spkr 12in 100W TC16R	£34.95 (A)	LH80B Clamp Meter	£38.95 (A)	FT13P CSTC Iron For TCSU-1	£19.95 (A)
WQ44X MC8802P	£4.95 (B)	BL20W DIL Socket 24-pin	14p (G)	XG52G Spkr 15in 100W 8R	£39.95 (A)	YK38R Crotch 3132	£367.80 (A)	FT28D CSTC Element	£11.95 (D)
		BL21X DIL Socket 28-pin	15p (F)			YK39R Low-Cost Counter	£89.95 (A)	FT28F 40 Watt Iron XSTC	£18.95
<b>Page 365</b>		QK38R DIL Socket 40-pin	22p (F)	<b>Page 391</b>		XB83E		FT27E XSTC Element	£11.95 (D)
WQ46A MC6821P	£2.95 (C)			XG54J Spkr 16in 300W 8R	£84.95 (A)	YK38R		XG57M Sldr Stn TCSU-D(XSD)	£88.95 (A)
UF25C 8522 VIA	£3.95 (B)	<b>Page 381</b>		<b>Page 392</b>		YK39R		FT12N XSD Iron For TCSU-D	£18.95 (A)
WQ48C MC6850P	£2.45 (C)	WY08U Standard Fan	£13.95 (A)	XV75D 10W Shelf Spkrs	£21.95 (A)			FT29G XSD Element	£11.95
QW00A Z80-CPU	£3.25 (B)			XV76H Megaphone	DIS (A)	<b>Page 415</b>			
QW03D Z80-PID	£3.75 (B)				£74.95 (A)	YK79K Fluke 73 Multimeter	£84.95 (A)	<b>Page 428</b>	
		<b>SPEAKERS &amp; SOUNDERS</b>		<b>SWITCHES &amp; RELAYS</b>		YK81C Fluke Meter Hoister	£12.95 (A)	YK85A B50 Brit Flattened	£4.45 (C)
<b>Page 366</b>						YK91L Fluke Meter Case	£11.95 (B)	YK70M B50 Lamp	£8.25 (B)
QW01B Z80-CTC	£3.75 (C)	<b>Page 382</b>		<b>Page 393</b>				YK71N B50 Holder	95p (E)
YH40T 8080A	£4.45 (C)	FL38N Buzzer 6V	£1.25 (E)	FM99H DPDT Ultra Min Toggle	95p (E)	<b>Page 416</b>		FGB8J Soldering Aid Set	£2.95 (C)
YH41U 8085A	£4.95 (B)	FL40T Buzzer 12V	£1.25 (E)	FM00A Sub-Min Toggle A	95p (E)	LH85D DMM 100	£104.95 (A)	FR23A Solder Sucker	£2.95 (C)
YH46A 8224	£3.25 (C)	FK81C 6V Buzzer	£1.65	FM02A Sub-Min Toggle E	DIS (A)	YK01B RF Frequency Meter	£84.95 (A)	FR28D Desolder Tool	£3.95 (B)
YH50E 8255A	£4.15 (C)	FK83E PT Buzzer	£1.80 (D)	FF72P Sub-Min Toggle L	£2.45 (C)	YB04E Grid Dip Meter	£84.95 (A)	FY70M 1/2kg Reel Solder	£10.95 (A)
		FK84F HP Buzzer	£2.25 (D)	FH12N Std Toggle DPDT	99p (E)				
<b>Page 367</b>		<b>Page 383</b>		<b>Page 394</b>		<b>Page 417</b>		<b>Page 430</b>	
YH49D 8251	£3.95 (C)	FK80B Musical Buzzer LBM 7	£3.95 (D)	XV73D H/D Toggle Type 9	£3.95 (C)	FY07H Min Screwdriver Set	£1.10 (E)	YK81Y Esselte Spray 3	£4.45 (C)
YH44X 8212	£2.45 (D)	FL38R AC Bell	£2.80 (C)	XQ72P Megaphone	95p (E)			YK98G Date Buds Pk of 10	19p (C)
		YK58P Small Electric Siren	£3.45 (B)	<b>Page 395</b>		<b>Page 419</b>		<b>Page 431</b>	
<b>Page 368</b>		XG14Q Electronic Siren	£24.95 (A)	FX20W Duck Toggle Type 9	£3.95 (C)	LH75S Spiraldriver	.DIS (C)	YJ48C Gloves PGS050	45p (F)
YH89W MC1488N	75p (D)	YK61R Staccato Electric Sdr	£11.95 (B)	FX047B Round Rocker SPST	£1.15 (E)				
YH90X MC1489N	75p (D)			YK64U Min Rocker SPST	95p (E)	<b>Page 420</b>		<b>WOUND COMPONENTS</b>	
WQ18U AY-3-1015D	£4.75 (B)	<b>Page 384</b>		YK65V Min Rocker DPDT	£1.80 (D)	BR72P Side Cutters S55	£6.95 (C)	<b>Page 432</b>	
QD04E 6402	£3.45 (B)	WF54J Direct Radiant Piezo	£4.95 (C)			YW87X Tweezers	38p (F)	THX05F Small Pot Core	£1.76 (D)
QD03D MC6845	£10.95 (A)	WF09K Piezo Horn Flush	£3.95 (B)	<b>Page 396</b>				<b>Page 433</b>	
		WF55K Piezo Horn Recessed	£3.95 (B)	BK48D End Chucks	£1.45 (E)	<b>Page 421</b>		HX12N Large Pot Core	£1.45 (E)
<b>Page 369</b>		WF56L Wide Angle Piezo	£12.95 (A)	FX57M Rotary Mems	98p (E)	FY29G Low-Cost HD Pliers	.DIS (C)	HX54J GE Cool LS	.DIS (C)
QW11M 2102 450ns	£1.45 (C)	LB23A Mag Espiece 2.5mm	30p (G)	<b>Page 398</b>		XX11M Blade L4421	£8.45 (B)	HW27E Choke 10H	£2.39 (C)
WQ45Y MC5810AP 450ns	£2.95 (C)			FF91Y Click Cap Gray	DIS (G)			<b>Page 434</b>	
WQ12N 2114 450ns	£1.95 (D)	<b>Page 385</b>		FF93B Click Cap Red	DIS (G)	<b>Page 422</b>		WH47B Choke 1mH	75p (E)
UF33L 6116 (448) 150ns	£2.95 (B)	LH82D Boom Mic Headphone	£17.95 (A)	<b>Page 399</b>		FY26G Crescent Wrench 210	£5.95 (C)	<b>Page 435</b>	
UF34M (8264-150ns)	£7.95 (A)	WF13P Stereophone SH150	£7.95 (B)	1YJ36P Membrane Keyboard	£15.95 (A)	FY02C Utility Knife	£1.99 (D)	WB01B Sub-Min Tr 9V	£1.95 (D)
WQ42V MCM4027 250ns	£1.95 (C)			<b>Page 400</b>				YJ50E Min Tr 0-6 0-8 1A	£3.25 (C)
QW53B 4116 250ns	£1.45 (C)	<b>Page 386</b>		1FH70M Latchswitch 8-pole	£1.45 (D)	<b>Page 423</b>		YJ51F Min Tr 0-6 0-8 2A	£8.25 (B)
QD06G 4164 200ns	£4.45 (B)	YV54J 15W Cone Tweeter	£4.25 (C)	1FH71N Latchswitch 10-pole	£1.71 (D)	FG08K Hand Nibbler K-88	£11.95 (B)	WB10L Min Tr 12V	£4.45 (B)
		WF24B Multi-Cell Tweeter	£7.95 (B)			FG06G 7 pc Tap Set	DIS (D)		
<b>Page 370</b>		WF33L Free Stand Tweeter	£6.95 (B)	<b>Page 401</b>				<b>MISCELLANEOUS</b>	
QW13P 2708 450ns	£7.98 (B)	XG34M Bullet Tweeter	DIS (A)	FL32K Rd Latchbutton Green	DIS (G)	<b>Page 424</b>		<b>Page 439</b>	
QD07H (2716 350ns)	£3.95 (B)			BW13P Sm Latchbutton Black	18p (G)			XG61R Alcohol Tester	DIS (A)
QD08J (2732 350ns)	£4.45 (A)	<b>Page 387</b>		BW14D Sm Latchbutton Chrm	28p (F)	<b>Page 425</b>			
QD09K (2784 250ns)	£7.45 (A)	YJ01B Tweeter J40 8R	£17.95 (A)	BW17T Latchbush Drange	DIS (E)	FG06G Hand Nibbler K-88	£11.95 (B)	<b>Page 440</b>	
YH88V 27126		FG43W HPX4 Crossover	DIS (B)			FG06G 7 pc Tap Set	DIS (D)	BK68W UM1286 Modulator	£14.95 (A)
		WF46A Controlled Crossover	£13.45 (A)					HQ30H Wiper Control	£11.95 (B)
<b>Page 371</b>								YK85G Speed Sensor	£19.95 (A)
YJ84F Sofly 2 System	£24.25 (A)								
FJ58L Spare UV Bulb Epr Er	£14.95 (A)								
WQ58P RD-3-2513	£9.95 (B)								

# MAPLIN SERVICE

With most electronic projects, performance will depend on the conditions of use. Recommendations and suggestions made in the articles in this magazine are for guidance only, since conditions of use are beyond our control.

## Repairs and Get-You-Working Service

Our 'Get-You-Working Service' is available for any of the projects published in this magazine, provided they are constructed on our ready-etched printed circuit boards, and that they use a majority of components supplied by us. We regret we cannot extend this service to the 'interest' circuits, for which we do not provide ready-made boards, or supply as projects or kits; nor for projects or kits that have been customised or modified by the constructor.

We cannot enter into correspondence with regards to fault-finding, and recommend you return the unit to us for servicing if you are unable to rectify the fault yourself.



## Project Servicing

If the problem has been caused by a faulty component supplied by us, then there will be no charge for the work performed or the components used. If the fault has been caused by error(s) in construction, then there will be a charge for the work performed at a rate of £10 per hour, or part of an hour plus the cost of any damaged components which need to be replaced. If *no fault* is found on the unit, then there will still be a

charge of £10 per hour or part of an hour for the time involved in establishing this fact.

Projects returned for repair should be addressed to:-

**Service Department**  
Maplin Electronic Supplies Ltd  
P.O. Box 3  
Rayleigh  
Essex  
SS6 8LR



★ **ONLY £3** ★

**FOR A WHOLE YEAR'S SUBSCRIPTION TO 'ELECTRONICS - THE MAPLIN MAGAZINE'**

- ★ Every issue sent to you as soon as it's printed, post free.
- ★ Packed with interesting and novel projects that you can build with all components easily obtainable.
- ★ Many features on electronics subjects to keep you up-to-date with latest developments.
- ★ More pages to read than the monthly magazines.
- ★ And much, much cheaper too. Many of the monthlies are now £1 or more per issue!

**BUYING A SUBSCRIPTION IS THE BEST WAY TO BUY 'ELECTRONICS'**

'Electronics' is different from any other electronics magazine for two reasons:

1. It's quarterly, so it's hard to remember when a new issue is due out both for you and your newsagent.
2. We don't carry any advertising, which means that having lots of copies sitting on the newstands waiting for casual sales is of no advantage to us. The newsagent will normally have plenty in stock of those magazines which advertise because in almost all cases, he can return them if they are not sold - so he doesn't pay for them.

'Electronics' has no advertisers to pay for unsold copies, nor does it need to have an impressively large circulation, so the newsagent must buy all of his delivery of 'Electronics' and cannot return those he doesn't sell. Therefore, he may not want to take stock of too many. Before you know where you are, 'Electronics' has sold out!

That's why you'll need to place a firm order with your newsagent to be sure of obtaining each new issue. Better still, place the order directly with us by sending £3.00 now and we will send you every issue for a year, post free.

Despite having very few casual sales, 'Electronics' sells as many copies as the top selling monthly magazines. So we can justly claim if not quite the largest, definitely the largest committed readership in the U.K. of any electronics magazine.



Please send me the next ..... issues of 'Electronics - The Maplin Magazine' at 75p per copy (minimum £3)\*. Please start with issue number ..... Overseas surface mail add 24p per copy, air mail add 87p per copy. I enclose cheque/P.O. for £..... Customer No. (if known) .....

Name .....  
Address .....  
.....  
..... Post Code.....

\* Order as many copies as you wish, you will not be affected by future price increases until your subscription ends.



**C**ontinuing our series of add-ons for the Spectrum, presented here is a general purpose parallel/serial system for expanding the computer via our I/O controller module (Electronics issue 14). One 8-bit input port has an associated control line which can be used to hold presented data, and the other 8-bit output port has an extra latching 9th bit, for flag or strobe purposes.

The UART serial port transmits and receives data at TTL levels with 5 to 8 bit word formats, 1 to 2 stop bits and full parity control. Baud rates for both Tx and Rx are determined by external clock oscillators which have not been included on the module.

### Circuit Description

CS1 to 3 select lines are gated with the read and write control lines to determine data direction to each of the three I/O ports. IC1 is a read only 8-bit input port selected when CS1 and RD are both low. Data inputs D0 to D7 are connected to the common data bus PD0 to PD7 when pin 1 is low via IC5d. The LATCH pin can be taken low to hold input data in the latch, and should be taken high for new data input. IC2 is a 'D' type latch extending the common PD0 to PD7 bus out when CS1 and WR are low. The extra STB line is taken from a spare output from latch IC3. UART, IC4, is used to change parallel 8-bit data into its serial counterpart.

When CS2 and WR are low IC6b controls data transmission. Similarly, gate IC6a controls received data with CS2 and RD low. IC3 is a write only register used for setting up word protocol in the UART, CS3 and WR are both low for this. Finally, IC4 has an internal status register which is read with CS3 and RD low via IC6d. An LED connected across pins 1 and 2 will flash off and on when data is transmitted, and is off when the transmitter register is busy. External clock inputs are required on pins 3 and 4 and serial data I/O is available on pins 8 and 9. Both clock and serial signals are at TTL 0/5V levels only.

### Construction

Refer to the Parts List for component designations and values. Mount the 4k7 resistor at R1 and the 470Ω resistor at R2 on the pcb. Insert TR1 with the package aligned to the legend. Then insert C2, this tantalum has a '+' symbol next to one lead, which should be inserted into the hole on the board also marked with a '+' sign. In similar fashion, mount capacitor C1, but note the polarity is marked with a '-' sign. Do not insert this lead into the hole marked '+' on the board! Next insert two 14 pin IC sockets at IC5 and IC6, and three 20 pin IC sockets at IC1, 2, and 3. Insert the 40 pin IC socket and solder all legs on the opposite side of the pcb. As the board has plated through holes, double check everything before soldering, as components are very difficult to remove afterwards. When fitting LED 1, insert the cathode (flat on package or shortest lead) into pin 2 and the anode

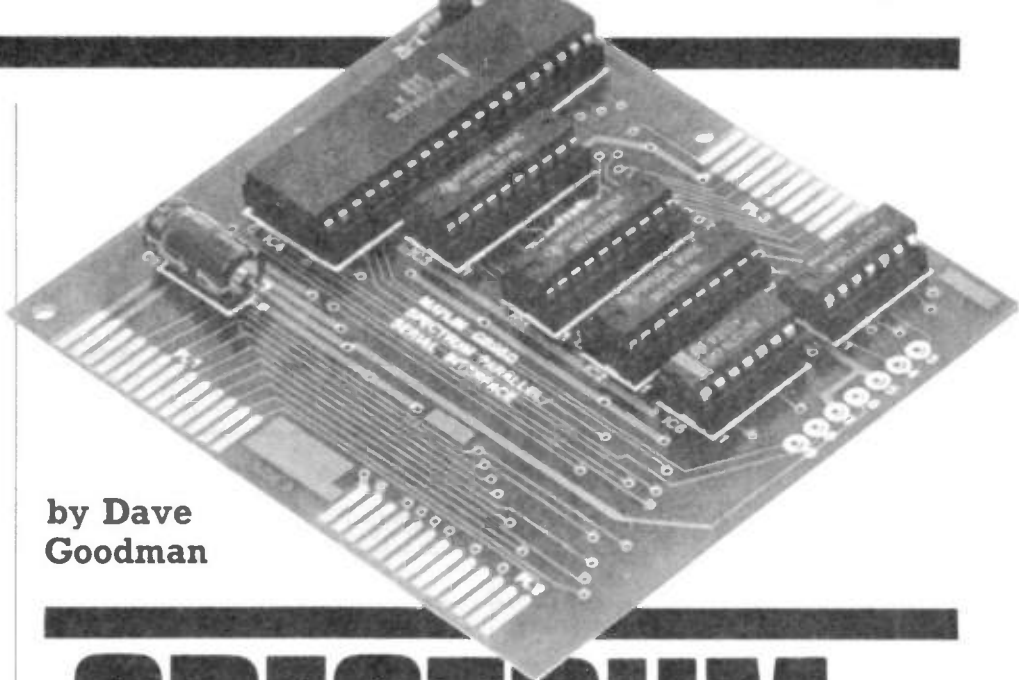

by Dave  
Goodman

# SPECTRUM PARALLEL / SERIAL PORT

- ★ 8-bit Input and Output Ports for Parallel Transfer
- ★ UART Programmable for 5 to 8-bit Word Serial Data Transfer
- ★ Connects Directly to the Maplin Spectrum Input/Output Controller Module

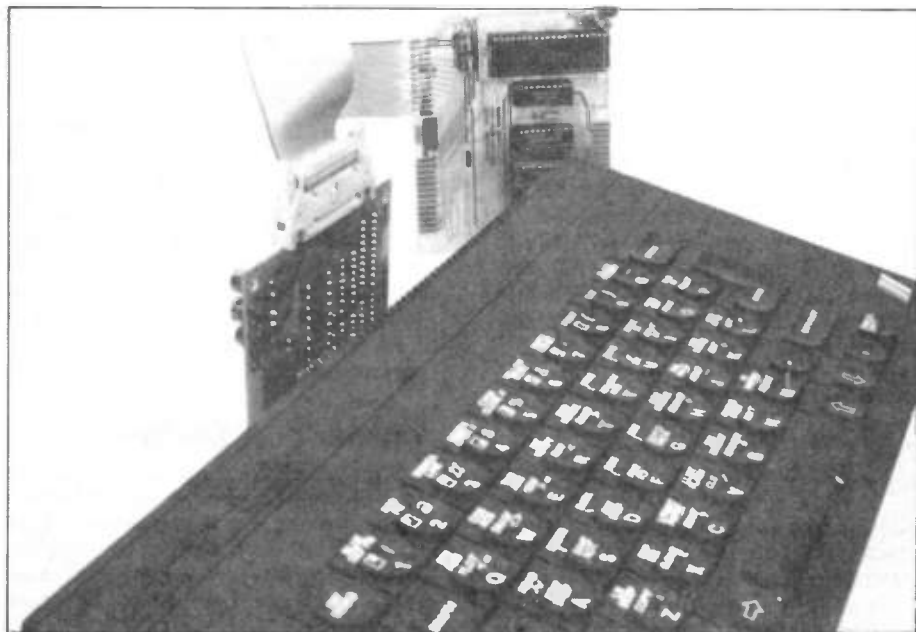

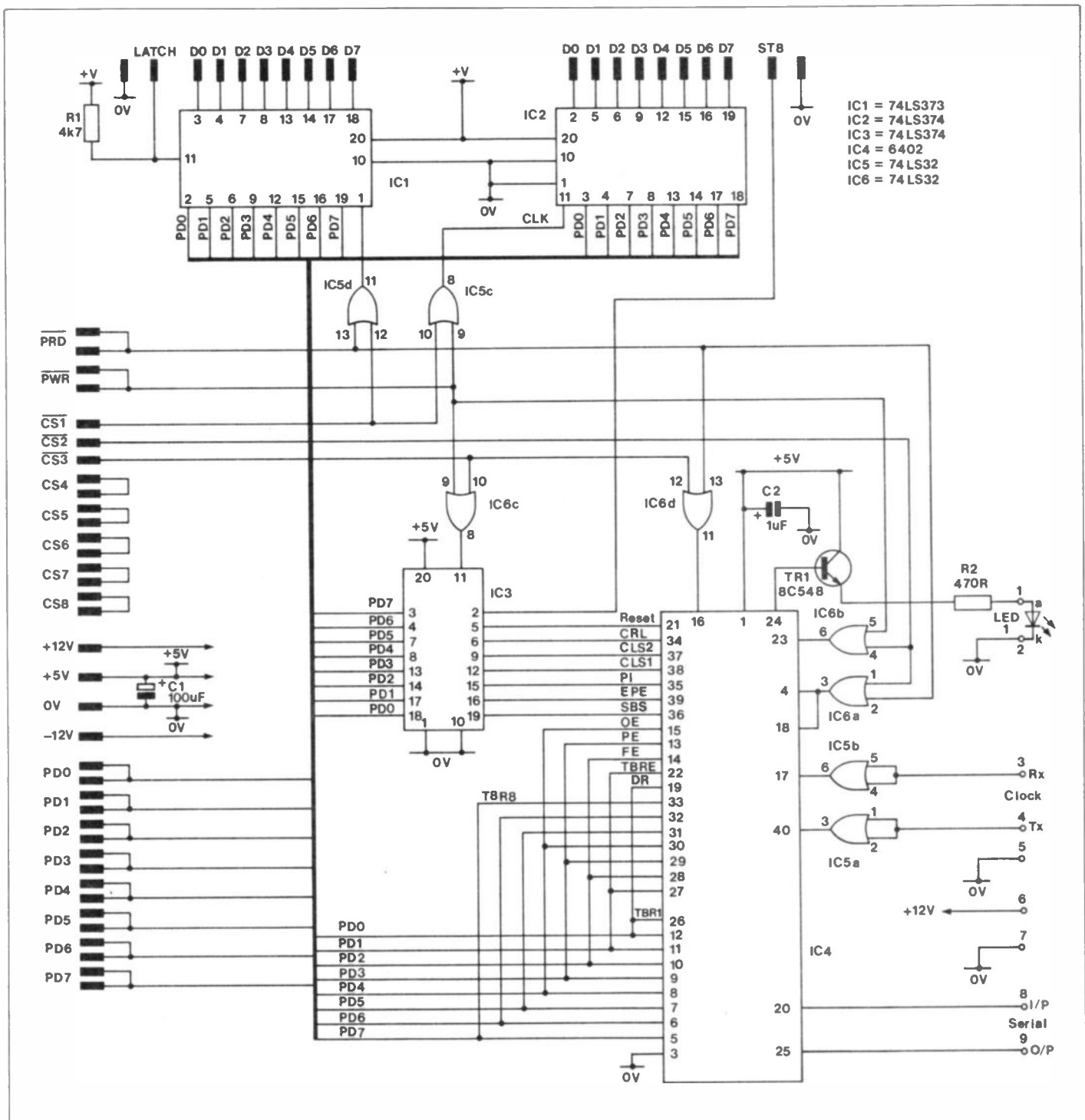

Figure 1. Circuit Diagram

(longest lead) into pin 1. Solder the LED in place and cut off all excess leads.

Fit the UART (IC4) into its socket with the D-shaped notch toward the top edge of the pcb. Fit the 74LS374 IC's at IC2 and IC3, then the 74LS373 at IC1. The last two 74LS32 IC's are fitted at IC5 and 6. These last five ICs should all have their D-shaped notch facing downwards.

## Connections to I/O Controller

Figure 4 details wiring arrangements to Maplin's Spectrum I/O Controller module. A 26-way plug and cable is used, which plugs into a header socket on the controller. To connect the unterminated cable end, separate each wire and strip ½in from each end. Tin each wire tip and

solder the first (red-striped) wire to -12V at PL1 which is on side 1 of the port module. Solder the second wire to +12V which is the first position of PL1 on side 2. The third wire then goes to +5V on side 1, the fourth wire to 0V on side 2 and so on. All odd numbered wires beginning at the red-striped end go to PL1 side 1 and all even numbered wires go to PL1 side 2 (component side).

## Expansion Output

Figure 3 shows all connections on the port module. PL2 is the expansion output from PL1, but the three select lines CS1 to 3, although used in the module, are not brought out. Further connections to the controller module can be made from this output position, PL2, if required.

## Parallel Ports

PL3 is the parallel input/output port. The ten terminals on side 2, which is the top or component side of the pcb, are the input port. The output port terminals are directly beneath on side 1. Pcb 'finger' terminals are used for PL1 to 3 to facilitate various socket arrangements, or for direct wiring. Standard 'D' series connectors can be fitted to these positions as can 0.1in. edge connectors or IDC header pcb plugs. (See Parts List options).

## RS232

If RS232 voltage levels are required for use on the serial port, then a level converter must be used. The UART is only capable of driving at TTL levels and

should not be connected to RS232 or very low impedance lines. A level converter is available and connections to this are shown in Figure 3.

## Using the Ports

Port address decoding is taken care of by the controller module and the select lines used are given in Table 1.

Address	CS	Direction	Port
31	CS1	RD	8-Bit I/P
31	CS1	WR	8-Bit O/P
63	CS2	RD	Serial I/P
63	CS2	WR	Serial O/P
95	CS3	RD	Status Reg.
95	CS3	WR	Cntrl Reg. and STB

Table 1. Address decoding

Test procedures for the Controller module are included in the kit so this will not be covered in depth here. To read parallel input, the command PRINT IN 31 should be used from BASIC on the Spectrum. For parallel output, use OUT 31,N where N is a data value from 0 to 255. The output port will latch any data sent to it, so if all eight outputs are connected to each corresponding input port pin and the commands OUT 31,N: PRINT IN 31 are entered, the selected value of N will be printed. To test the LATCH input control, output a suitable value for N, take the LATCH input to 0V and PRINT IN 31. With the LATCH input held low, output different values of N and PRINT IN 31 again. The original value should still be there, even though different data values have been sent.

The STB output line is a spare latching output from the CONTROL register, whose address is 95 (see Table 1). The command OUT 95,N is used for this register but remember that data bit D7 is the STB connection; the other 7 bits, D0 to D6, are used to preset the serial port as follows.

## Port 95 Status and Control

Combinations of bits D0 to D4 can be set to determine the number of bits per character (5 to 8), the number of stop bits (1 to 2) and either parity odd, parity even or no parity check. Bit D5 loads data from port 95 into the UART and bit D6 resets the UART (see Table 2).

D0	SBS	Stop Bit Select
D1	EPE	Even Parity Enable
D2	PI	Parity Inhibit
D3	CLS1	Char. Lgth Select 1
D4	CLS2	Char. Lgth Select 2
D5	CRL	Cntrl Reg. Load
D6	MR	Master Reset
D7		Latch output to STB pin

Table 2. Bit functions

Table 3 details various control codes for setting protocol of serial transmission. For example, code 29 will format the serial word to 8 bits, no parity check and 2 stop bits. This is the most common format for 300 baud modem use.

D6	D5	D4	D3	D2	D1	D0	DATA	CHR	PARITY	STOP
RESET	CRL	CLS2	CLS1	PI	EPE	SBS	CODE	BITS		BITS
0	0	1	1	1	x	1	29	8	DIS	2
		1	1	1	x	0	28	8	DIS	1
		1	1	0	1	1	27	8	EVEN	2
		1	1	0	1	0	26	8	EVEN	1
		1	1	0	0	1	25	8	ODD	2
		1	1	0	0	0	24	8	ODD	1
		1	0	1	x	1	21	7	DIS	2
		1	0	1	x	0	20	7	DIS	1
		1	0	0	1	1	19	7	EVEN	2
		1	0	0	1	0	18	7	EVEN	1
		1	0	0	0	1	17	7	ODD	2
		1	0	0	0	0	16	7	ODD	1
	0	1	1	x	1	1	13	6	DIS	2
	0	1	1	x	0	1	12	6	DIS	1
	0	1	0	1	1	1	11	6	EVEN	2
	0	1	0	1	0	1	10	6	EVEN	1
	0	1	0	0	1	1	9	6	ODD	2
	0	1	0	0	0	1	8	6	ODD	1
	0	0	1	x	1	1	5	5	DIS	1.5
	0	0	1	x	0	1	4	5	DIS	1
	0	0	0	1	1	1	3	5	EVEN	1.5
	0	0	0	1	0	1	2	5	EVEN	1
	0	0	0	0	1	1	1	5	ODD	1.5
	0	0	0	0	0	0	0	5	ODD	1

Table 3. Control register (OUT 95)

In Table 3, 'x' = Don't Care; 'PI' = High to inhibit (PE forced low); 'EPE' = High for even, low for odd parity; 'RESET' = High to reset UART, low to run (see Figure 5); 'CRL' = High to load code into UART (see Figure 5). To load data into the UART (CRL) add 32 to the data code given. To reset, any code with D6 set, i.e. decimal 64 to 255, can be used.

## Baud Rates

Serial data is transmitted or received by the UART which requires a clock oscillator to shift serial data to parallel and vice-versa. The frequency of transmission for serial data is its baud rate and several standards are used for communication purposes from 45.45 to 9600 baud or even up to around 32k Baud

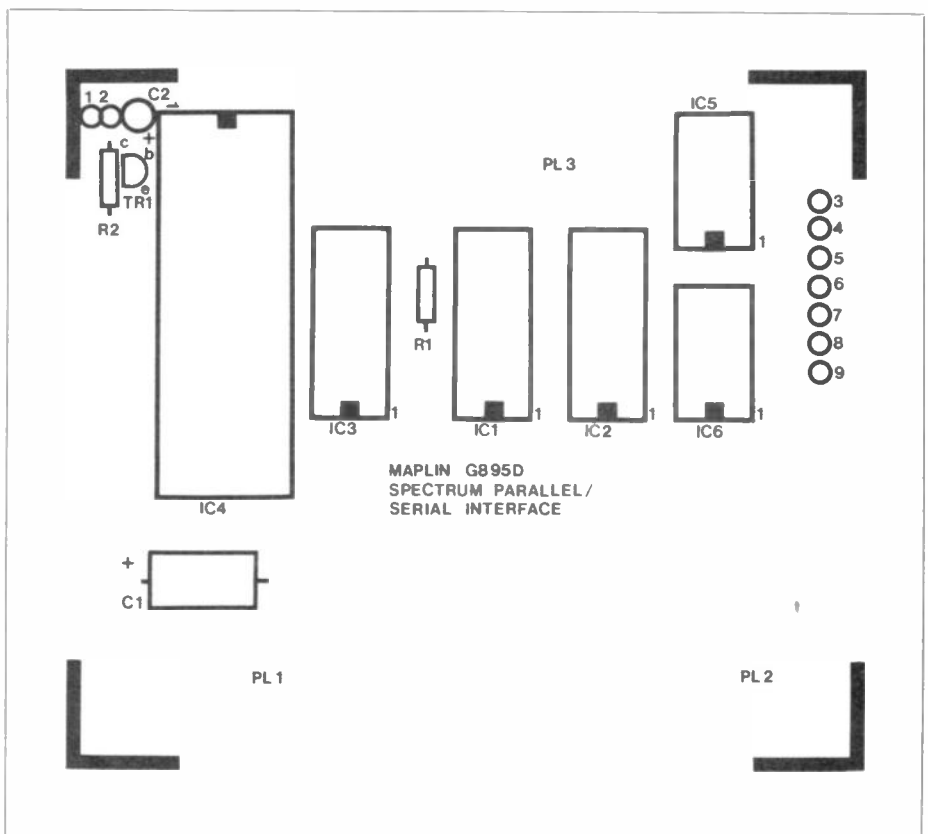

Figure 2. PCB overlay

FUNCTION	COLOUR
Tab	Yellow/Mauve
Backspace	White/Dark Blue
Carriage Return	Yellow/Grey
Space	White/Mauve
Ribbon Red	White/Light Blue
Ribbon Black	White/Red
Shift Down	White/Brown
Shift Up	Yellow/Khaki
Linefeed	Yellow/Dark Blue

Table 2.

Examination will show that the connector links in blocks of three going across, and that the common can be identified by the linking wires between blocks. The diodes which are moulded in the insulation can also be noted to go to these common blocks. Using Table 1 and 2 and Figure 3 as a guide, try to identify the colour wire for the solenoid you are checking, then with an ohmmeter, measure the resistance between the grey common wire and the wire from the table. A reading of approximately 400 ohms will be obtained for the coil/diode combination. Disconnect the common side of the solenoid from the block, a slight twist with a pair of long nose pliers should release the pin, the reading will now indicate the diode on its own and it should have a good forward to reverse characteristic.

If any of the diodes need replacing, then a 1N4148 is a suitable replacement for the damaged one. Peel back the insulation and scrape the old diode leads to aid tinning; solder the new diode to the legs of the old one. This must be a good joint because it relies on the diode protecting your interface card.

Carry out the same sequence of checks on the other print function solenoids which are positioned as shown in Figure 4. The case shift solenoids are on the right hand end of the printer with their connecting block directly underneath them as shown in Photograph 1. The remaining solenoids are the red/black shift ones which are in a similar position on the other end of the printer, but they are partially obscured by the case retaining latch.

All of the solenoids wires should now be labelled and checked to show that the coil and diode of each are intact. Also label the function solenoids as shown in Figure 4, this will be useful later during the adjustments and familiarisation section. You may have noticed that the margin override white/khaki has been ignored because this is a useless function for normal correspondence type printing. The wire can therefore be cut off by the P clip. Gather all of the solenoid wires together to form a small sub-loom and separate this from the remaining loom wires.

The remaining wires contain the sensing contacts which indicate the state of the printer. If you look at Figure 5, you will see the contacts drawn in their normal position. These contacts will be used to tell the driver card when the

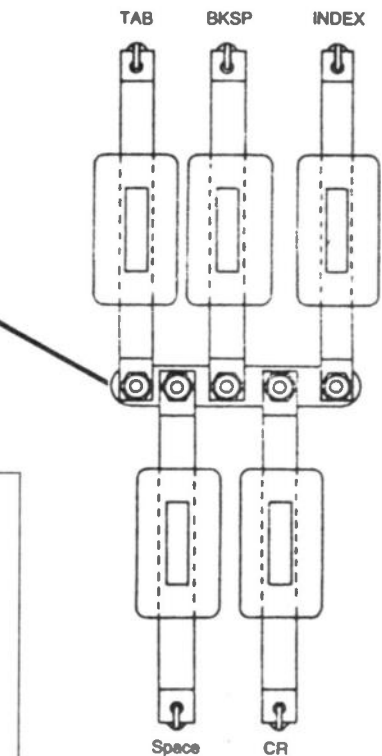
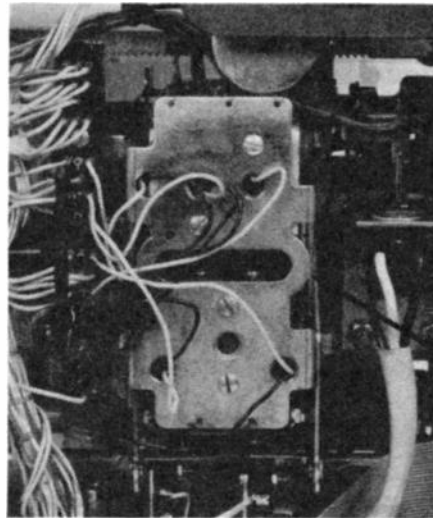

Figure 4. Position of Print Function Solenoids

printer can take the next character (closed loop mode) which is faster than waiting a fixed time before printing the next character (open loop mode). Ignore the roller present and paper out contacts, because the printer will normally be printing one sheet at a time and it would be necessary to jam the paper out contact to allow printing on the bottom 3 inches of paper. Cut off these surplus wires, the remaining contacts may require setting which will be covered in the adjustments section.

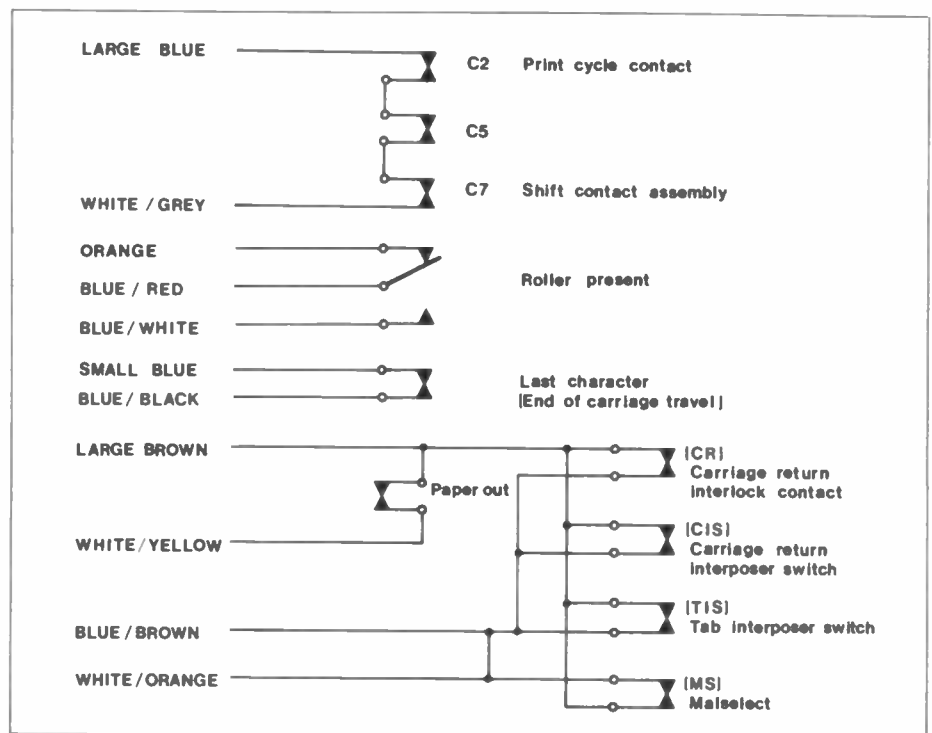

Figure 5. Feedback Contacts

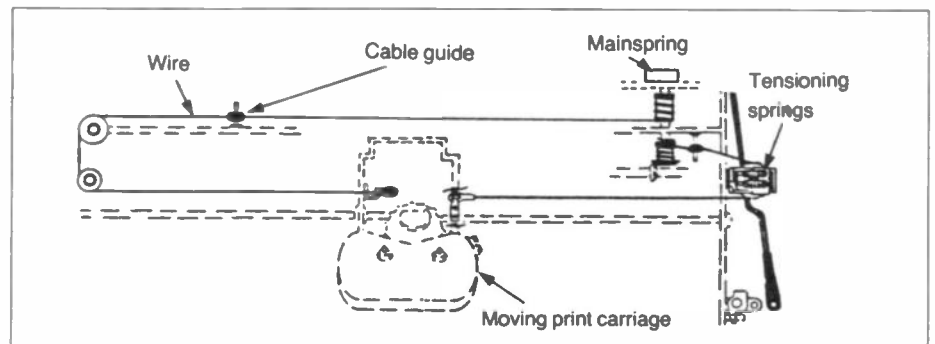

Figure 6. Path of Print Carriage driving wire



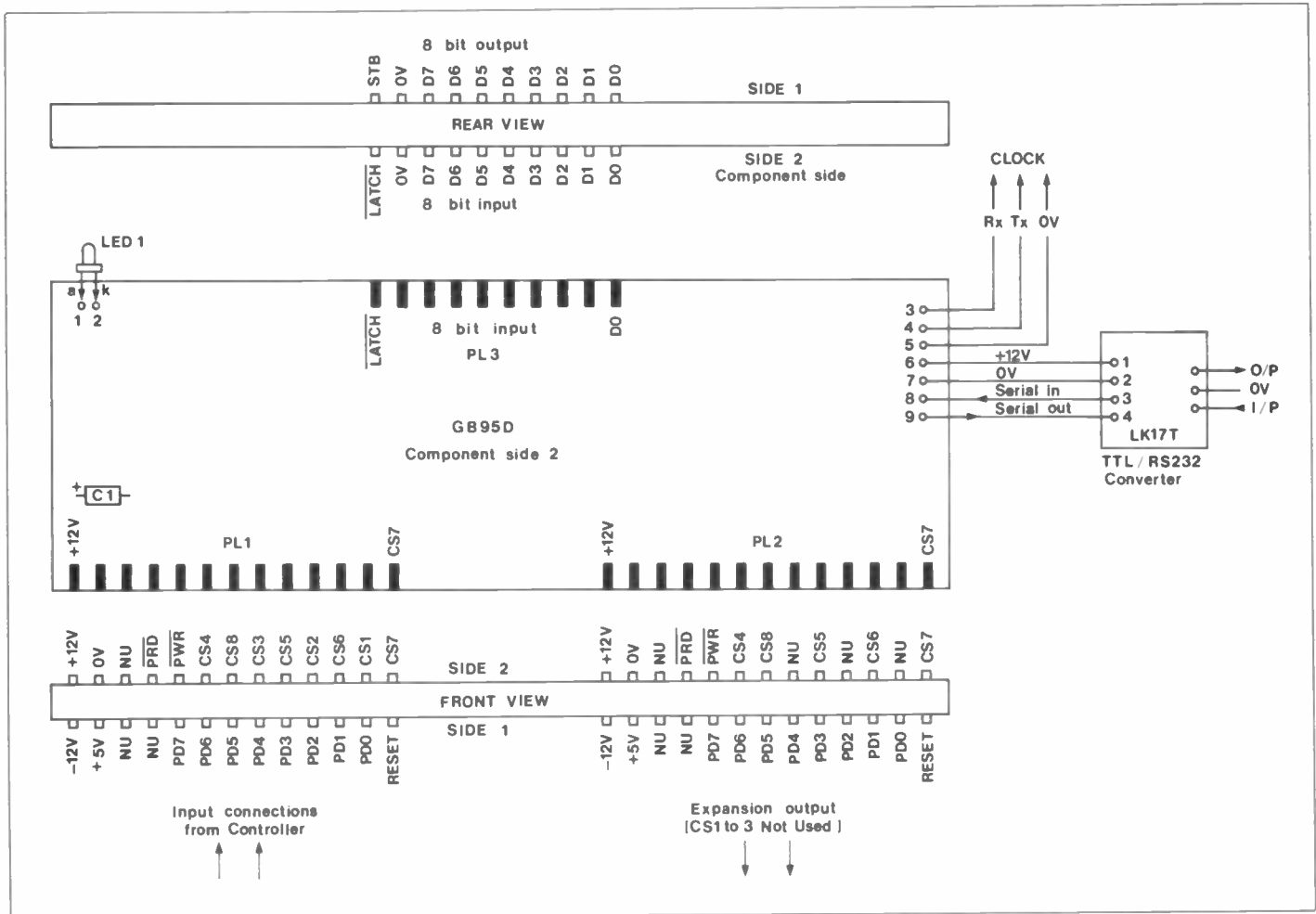

Figure 3. PCB edge connections

in the case of 'MIDI' systems. In any case, the clock frequency has to be 16 times the required baud rate. For example, for 300 baud, the clock is  $(300 \times 16)\text{Hz}$  or 4.8kHz, and for 9.6k Baud the clock is 153.6kHz. The UART is specified up to 40k bps (640kHz), although rather specialised programming techniques will be required to print information on the Spectrum at this speed. As both Tx and Rx clock inputs are available, split baud rates can be handled using two different clock oscillators. For example, 1200 baud for receive and 75 baud for transmit (19.2kHz and 1.2kHz) as used with PRESTEL and MICRONET. Because there is a wide variation in this area, the clock generating system is left to the constructor and not supplied with the project.

## UART Programming

Firstly determine the required baud rate and set the clock(s) frequency accordingly. Then reset the UART by setting port 95, D6 high, then low to run. Next determine the required word format and write it to port 95 with D5 set high. Now write the same format code with D5 set low to prevent accidental changes in this data. Table 4 shows the internal conditions available from the status register (Port 95 I/P). So to receive data, read the status register (IN 95) to see if the data received flag is set. If not, either repeat the read or go to transmit. When the data received flag (227) is set, then read the input register (IN 63) for rec-

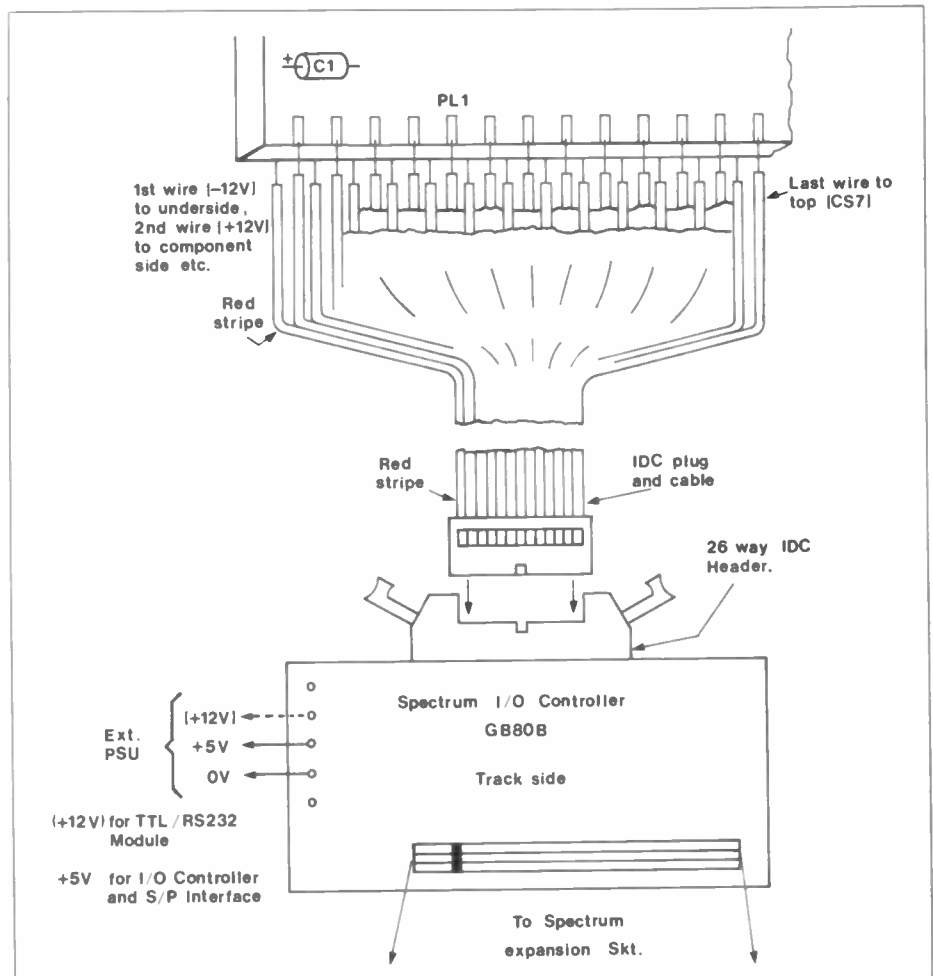

Figure 4. Connecting to the controller

eived characters. The data received flag will automatically reset during this read. To transmit data (OUT 63, N) note that the Tx buffer is loaded into the Tx register during a high to low transition on IC4 pin 23. The Tx register status can be read at any time.

This information serves only as a guide to programming and data sheets are available from Maplin for the 6402 UART. Finally, Program 1 can be typed in and run. Connect serial O/P pin 9 to serial I/P pin 8 and then the serial system will be checked, producing a message on the display. Line 60 can be changed to any required string. Remember also, that a suitable 5V PSU is required for both I/O controller and parallel/serial port modules and in addition, +12V is needed for the TTL to RS232 voltage converter.

```

10 LET port = 63 : LET status = 95
20 OUT status, 64 : PAUSE 10
30 OUT status, 29
40 OUT status, 61
50 OUT status, 29
55 REM ***** TEST DATA *****
60 LET a$ = "Serial Port Test"
65 REM **** TRANSMIT DATA ****
70 FOR i = 1 TO LEN a$
80 OUT port, CODE a$(i)
85 REM **** TEST DATA I/P ****
90 LET d = IN status
100 IF d>227 THEN LET sync = IN
    port : GOTO 80
110 IF d<227 THEN GOTO 90
115 REM ***** READ CHR$ *****
120 LET w = IN port
130 PRINT CHR$(w);
140 NEXT i
145 REM *** SCROLL & REPEAT ***
150 POKE 23692,255 : PRINT
160 GOTO 70
  
```

Program 1.

	D7	D6	D5	D4	D3	D2	D1	D0	Data Code
Normal Condition	1	1	1	OE	PE	FE	TBRE	DR	226
Tx Buffer Full	NU	NU	NU	0	0	0	0	0	224
Serial Data In	0	0	0	0	0	1	1	0	227
Invalid Stop Bits	0	0	0	1	1	0	0	0	230
Bits Mismatch	0	1	0	1	0	0	0	0	234
DR Flag not cleared	1	0	0	1	0	0	0	0	242

Table 4. Status register (IN 95)

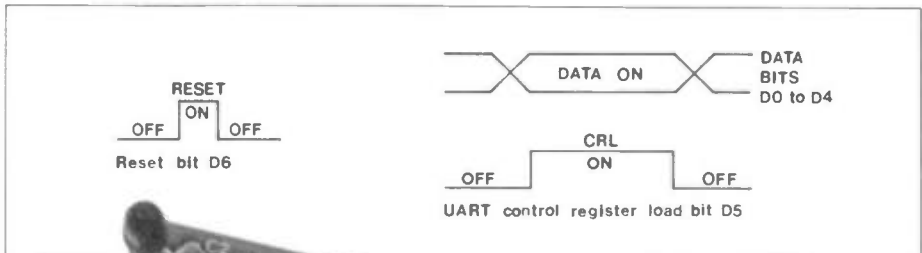
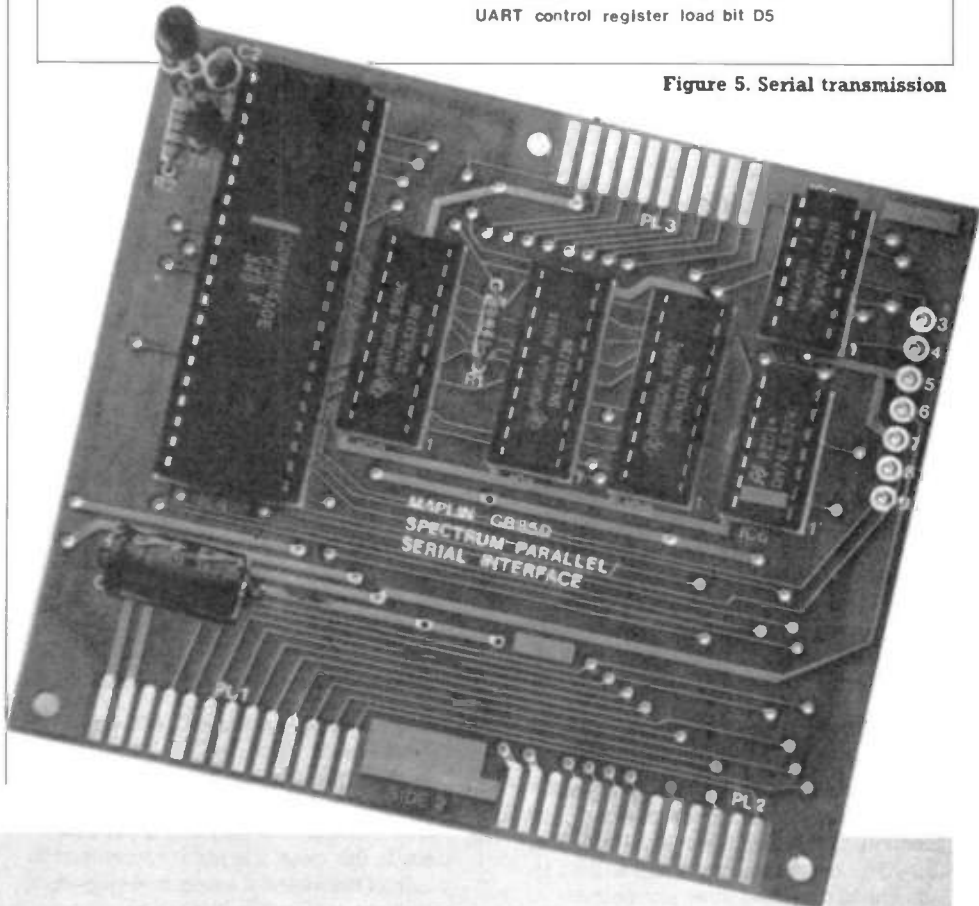

Figure 5. Serial transmission



## SPECTRUM INTERFACE PARTS LIST

RESISTORS: All 0.4W 1% Metal Film

R1	4k7	1	(M4K7)
R2	470Ω	1	(M470R)

CAPACITORS

C1	100μF 10V Axial Electrolytic	1	(FB48C)
C2	1μF 35V Tantalum	1	(WW60Q)

SEMICONDUCTORS

IC1	74LS373	1	(YH15R)
IC2,3	74LS374	2	(YH16S)
IC4	6402	1	(QQ04E)
IC5,6	74LS32	2	(YF21X)
TR1	BCS48	1	(QB73Q)
LED1	LED Red	1	(WL27E)

MISCELLANEOUS

	Spectrum Interface PCB	1	(GB95D)
	DIL Socket 40-Pin	1	(HQ38R)

DIL Socket 20-Pin	3	(HQ77T)
DIL Socket 14-Pin	2	(BL18U)
Veropin 2145	1 Pkt	(FL24B)

OPTIONAL

Spectrum I/O Controller Kit	(LK65V)
26-Way IDC Socket/Cable	(FJ03D)
RS232/TTL Converter Kit	(LK17T)
26-Way IDC Header	(FJ15R)
D-Range 25-Way Plug	(YQ48C)
D-Range 25-Way Socket	(YQ49D)
2 x 28-Way P.C. Edgeconnector	(FG23A)

A kit of the above parts, excluding the optional items, is available:  
**Order As LK72P (Spectrum Serial/Parallel I/F Kit) Price £16.95**  
 The following item in the above kit is also available separately, but is not shown in the 1985 catalogue:  
**Spectrum Serial/Parallel I/F PCB (GB95D) Price £7.45**

# FIRST BASE



by Mike Wharton

## A Beginner's Guide To Logic Design.

Part Nine

**F**irst it is perhaps necessary to explain the meaning of this term. In systems where data has to be sent from one device to another, it would appear to be convenient if each signal had its own line, and which only contained the same signal. This apparent convenience disappears where many signal lines are required, since the multiplicity of wires and separate connections would tend to overwhelm the rest of the circuitry. Moreover, there is another consideration where integrated circuits are involved, since the major portion of the cost of these is due to the cost of packaging. Thus, there is an economic incentive to reduce the pin count (i.e. the number of 'legs') on an IC to a minimum.

### Multiplexers

The idea of multiplexing is thus simply one of allowing different signals to share a common line or interconnection. Obviously, it would be meaningless if all possible signals had access to the line at the same time, and some arrangement for sharing has to be laid down. For digital signals this is usually done on a time basis, each signal having access for a fixed time in turn; this is known as time division multiplexing.

Let us now look at a simple example of what is involved in this idea. As before it is a circuit which may be made up on 'breadboard' and tested practically. Figure 1 shows the circuit diagram which contains both a multiplexer and a demultiplexer; the 74150 is the multiplexer and the 74154 the demultiplexer. A train of clock pulses forms the input data to the 74150 at channel 8 and leaves at channel 3 on the 74154. How are the channels selected? On the 74150 the 4-bit binary word 1000 is applied to the channel select pins, D C B A. On the 74154 the 4-bit word 0011 is applied to the output channel select pins. It is thus possible to select any one of 16 input channels and any one of 16 output

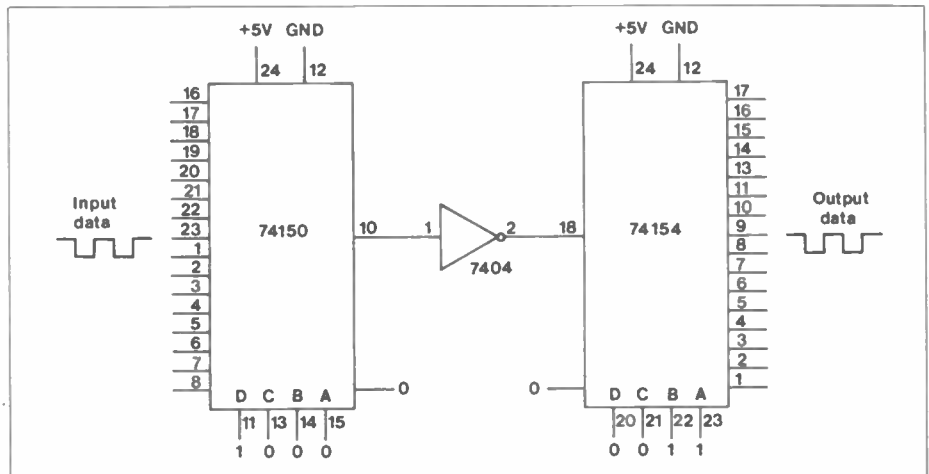

Figure 1. Circuit containing a multiplexer and a demultiplexer

channels using the two sets of 4-bit binary inputs.

One possible use of this type of combination is to minimise the number of wires needed over which to send TTL data. In this case, it is more convenient to connect the channel select lines together, as shown in Figure 2. Instead of a possible 16 lines, the data may be transmitted by just 6; 4 for the channel select, 1 for data and 1 for common return. The channel select lines would probably be connected to a 7490 or 7493

binary counter, and sequence through the channels 0 - 16. The only disadvantage is that the data on each channel is not transmitted simultaneously.

A second example of a slightly different nature is shown in Figure 3. This employs a 7442 bcd to decimal decoder as a 1-of-8 demultiplexer. Figure 4 shows the Truth Table of the 7442; notice that the output lines 8 and 9 are not used, for these cannot be selected with only a 3-bit binary word. Clearly, the 7442 may be

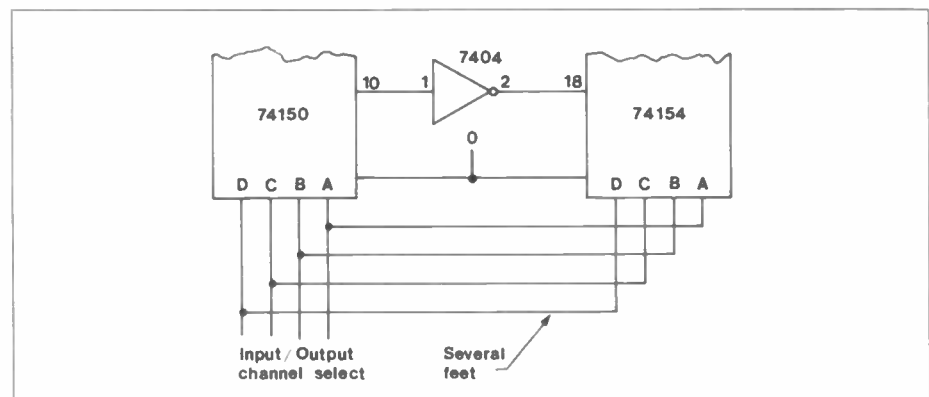

Figure 2. Channel Select lines connected

used to demultiplex input data to any one of eight different output lines; the data being transmitted without any inversion. Another way of showing this is given in Figure 5.

## Multiplexed Memory Devices

As mentioned previously, it is of major economic significance to reduce the pin count on an integrated circuit. With memory devices of ever growing capacity, this can present a problem. Take, for example, a 64k by 1-bit dynamic RAM. This size of memory could require 16 address lines, but the number is reduced by the use of multiplexing. Figure 6 shows a common arrangement used for a 16k RAM, which might ordinarily need 14 address lines, but in practice has only 7. The necessary 14 address lines from the host microprocessor are connected to the RAM via two quad 2-input multiplexers. By the use of only one more signal line, CAS/RAS (Column Address Strobe/Row Address Strobe), first the top 7 address lines are connected to the RAM, followed by the next 7 address lines. Internal decoding within the RAM device along with CAS/RAS enables the addressing of the 16k locations. Of course, this is very diagrammatic, since the refreshing of such a dynamic RAM and how such a strobe signal may be obtained has been completely ignored.

## Microprocessor Buses

This idea then leads us onto a similar area in which signals intended for different devices share a common route. It is usual in most microprocessor based equipment for it to communicate with more than one single device; for example, the information from several different memory devices. The signal path along which this information flows is called the Data Bus. In order to speed up the flow of data, and hence the speed of operation of the machine as a whole, the trend has been toward parallel buses and the 8-bit data bus is still the most common. The means whereby the microprocessor selects which device shall have access to the bus, either to accept or transmit data, makes use of the tri-state type of output, which we have encountered previously.

A typical microprocessor will have three parallel buses; one is the Data Bus, mentioned above, the second is the Address Bus and the third the Control Bus. These last two buses are used together to determine precisely which device is to be accessed by the microprocessor and whether data is to flow along the Data bus in one direction or the other.

Figure 7 shows a highly simplified block diagram of such a system in order to illustrate these points. This 'system' has a 4-bit address bus, a 4-bit data bus and a 1-bit control bus. Of course, this is much simpler than any 'real' system, but more of those in due course. With a 4-bit address bus only 16 memory locations

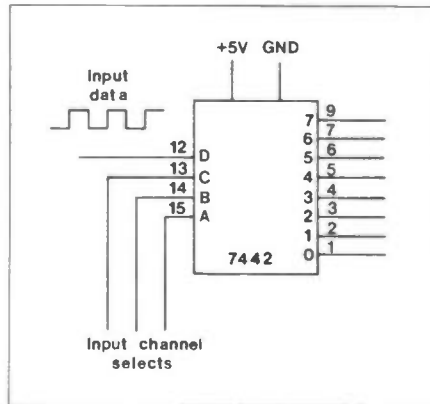

Figure 3. Using a 7442

could be addressed and to make our scheme even more artificial, these have been located in two separate devices. Also, with a 4-bit data bus, only 16 unique 'words' could be encoded which means our simple microprocessor would have a basic instruction set of 16 operations.

Truth table for 7442

INPUTS				OUTPUTS							
D	C	B	A	0	1	2	3	4	5	6	7
0	0	0	0	0	1	1	1	1	1	1	1
0	0	0	1	1	0	1	1	1	1	1	1
0	0	1	0	1	1	0	1	1	1	1	1
0	0	1	1	1	1	1	0	1	1	1	1
0	1	0	0	1	1	1	1	0	1	1	1
0	1	0	1	1	1	1	1	1	0	1	1
0	1	1	0	1	1	1	1	1	1	0	1
0	1	1	1	1	1	1	1	1	1	1	0
1	0	0	0	1	1	1	1	1	1	1	1
1	0	0	1	1	1	1	1	1	1	1	1
1	0	1	0	1	1	1	1	1	1	1	1
1	0	1	1	1	1	1	1	1	1	1	1
1	1	0	0	1	1	1	1	1	1	1	1
1	1	0	1	1	1	1	1	1	1	1	1
1	1	1	0	1	1	1	1	1	1	1	1
1	1	1	1	1	1	1	1	1	1	1	1

Figure 4. 7442 truth table

This is another reason why its tasks would be limited, although there are ways round the problem. Finally, the control bus has been restricted to a single Read/Write line, such that if this line is high, data is flowing into the processor and when low, out from it.

With such a simple system only a minimal amount of extra hardware is needed for address decoding. This performs the function of selecting the appropriate device by acting on the address presented on the address bus and producing a single signal which is connected to the Output Enable pin of the memory device which is used to enable its tri-state outputs. The Read/Write line of our simple control bus then sets the direction in which data is to flow.

The operation of such a system would be such that when the microprocessor wishes to read a data 'word' from memory, it sets the appropriate address on the address bus and the Read/Write line high. The data presented by the selected location would then flow along the data bus into the processor for

SELECT INPUTS			OUTPUT CHANNEL AT WHICH DATA APPEARS
C	B	A	NUMBER
0	0	0	0
0	0	1	1
0	1	0	2
0	1	1	3
1	0	0	4
1	0	1	5
1	1	0	6
1	1	1	7

Figure 5. Channel selection

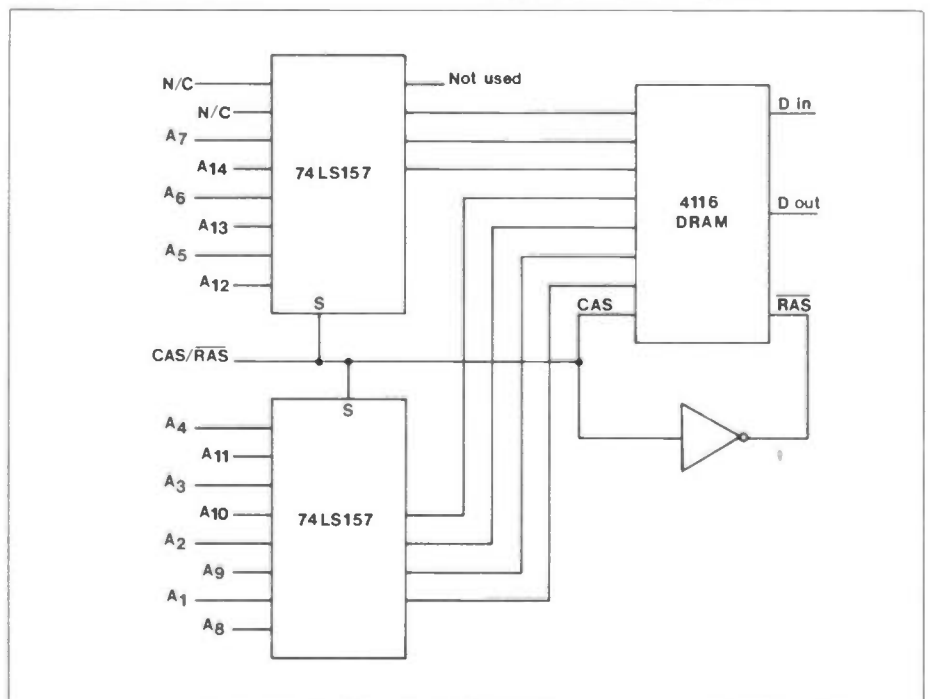

Figure 6. Common arrangement for 16K RAM

Continued on page 53.



# MAINS Tx/Rx DRIVER MODULE

- ★ Transmits or Receives Serial Data over 240V AC Mains Wiring
- ★ Transmission Rates up to 4.8k Baud
- ★ Suitable for Computer Data Links and Security Systems

by Dave Goodman

Mains wiring is a convenient medium for connecting intercommunications devices over short distances on the same phase. The mains voltage must be isolated from the driver electronics and a modulated carrier signal applied to both LIVE and NEUTRAL cables. In a domestic situation, several ring mains systems would be terminated at the consumer fuse panel and the carrier would be transmitted through to all socket outlets in the house. The maximum data frequency able to be carried on any ring main is determined by the impedance and noise of the line. For instance, triacs used for power and light control, transmit a high level of switching noise down the mains wiring, as do motors and pumps when first switched on. These factors are variable in every case and should be considered when determining data speed. Tests in a factory environment have produced good results over hundreds of feet with RS232 and TTL computer communications up to 4800 baud, although this cannot be guaranteed in every case!

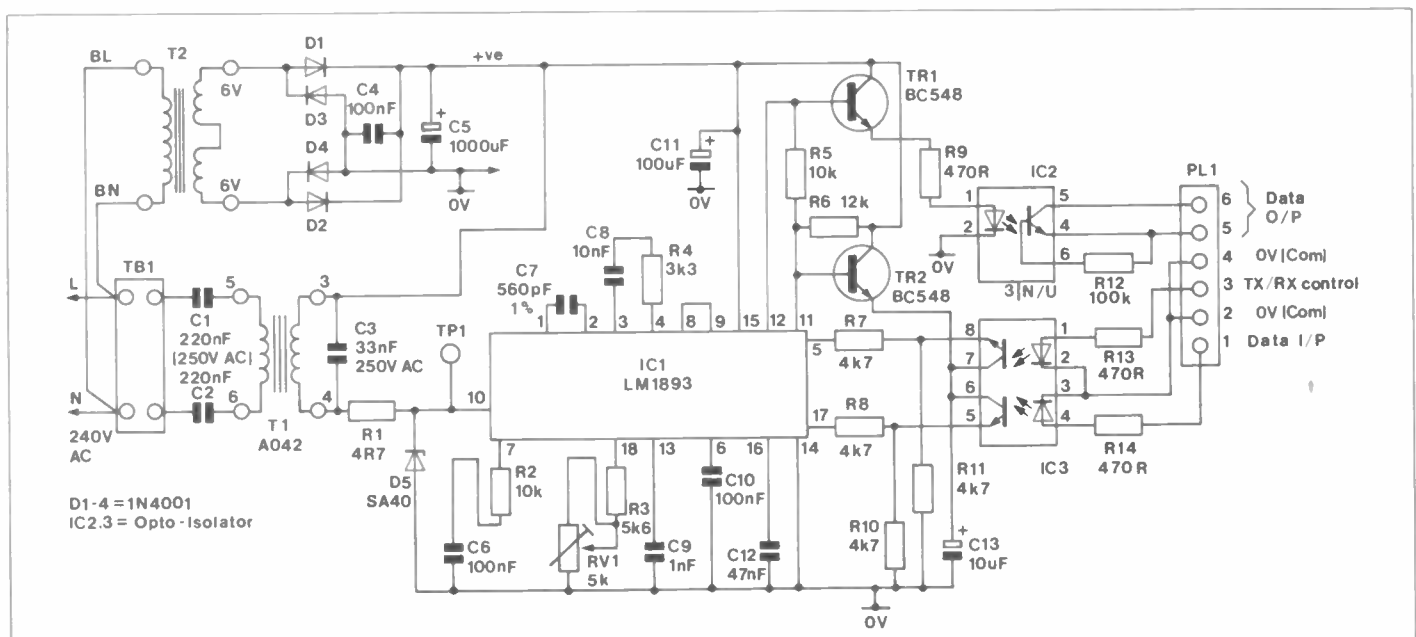
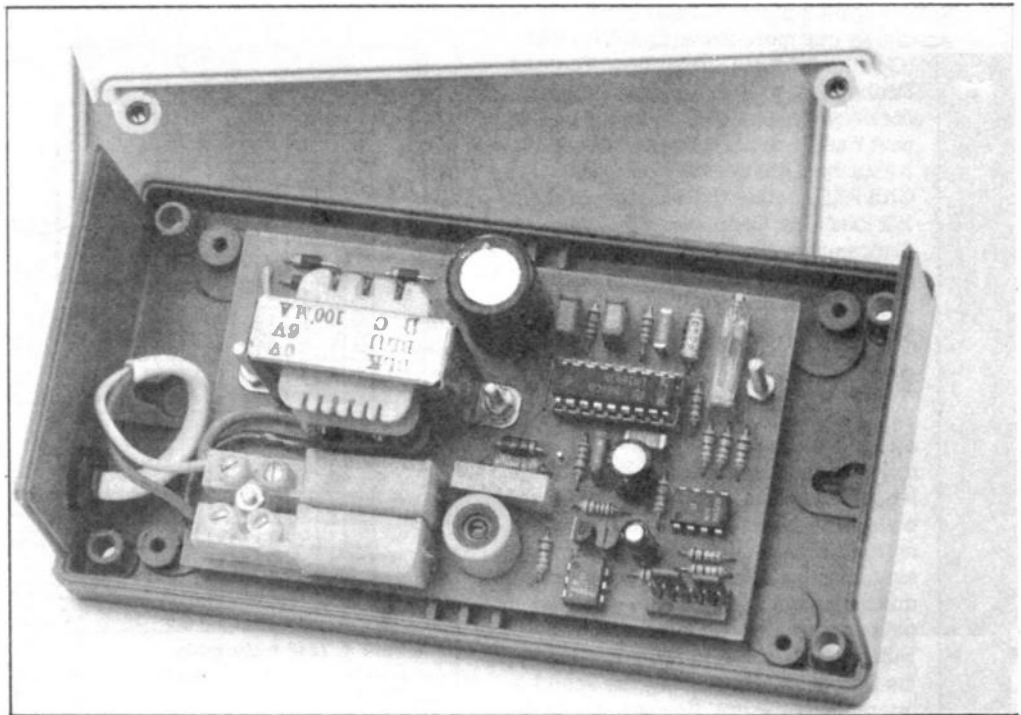

Figure 1. Circuit Diagram

## Caution

It must be pointed out that the Mains Driver Module, by nature, is connected directly to 240V AC and therefore an element of danger exists to the constructor. Physical contact with the mains can be lethal and every precaution MUST be taken to prevent this from happening, either by accident or from poor constructional ability.

## Circuit Description

IC1 is an LM1893 Bi-line Carrier Current Transceiver which performs half-duplex serial data transmission with the Tx/Rx control line high, or receives with the Tx/Rx control line low. Opto-couplers are incorporated to ensure the complete isolation of connecting devices from the mains system. Data input is via IC3, which switches an internally generated 5V from IC1 pin 11 via emitter follower TR2 to IC1 pin 17. This input is normally at 0V with data low at PL1 pin 1. The Tx/Rx control input at PL1 pin 3 should be low (0V or no connection) to receive data or taken high to transmit data, which restricts operation to half duplex or one way operation at anytime. IC1 pin 5 is the control input and is normally at 0V or in receive mode. Data output signals are available from IC1 pin 12 and are buffered by emitter follower TR1 to IC2. Both collector and emitter junctions are taken out to PL1 pins 6 and 5 so that either inverting or direct outputs (see Figure 7) can be made available. T2, D1 to D4 and C5 supply the power to IC1, which is approximately +14.8V DC off load. This IC requires a minimum of 14V DC for correct operation and associated components on IC1 have been optimised for this voltage. T1 is the interface between IC1 and the mains power line, connected via high voltage isolating capacitors C1 and C2. With C3 and R1, this tank circuit resonates at 125kHz which is the centre frequency of the FSK generator in IC1. Two frequencies are generated and they are 127.750kHz for data low which is  $1.022 \times 70$ , and 122.500kHz for data high. During data transmission, both frequencies are applied from IC1 power driver output pin 10 to the tank circuit. The signal amplitude at TP1 is approximately 20V peak and is coupled at a low impedance to the power line. RV1 allows a small amount of control of the PLL oscillator and is used during initial adjustment and C7 determines the oscillator centre frequency.

In the receive mode, C1 and C2 block the mains voltage but allow a small degree of HF carrier into the tank circuit. As the tank is tuneable, optimum band-pass characteristics can be set and most line noise rejected. D5 acts in parallel with an internal zener on IC1. This device is an extremely fast switch and grounds short period transient spikes that often appear on the mains. Without this protection, the input stages of IC1 would be easily damaged. An internal limiter/gain stage or ALC is effective during both Tx and Rx modes and the R2/C6

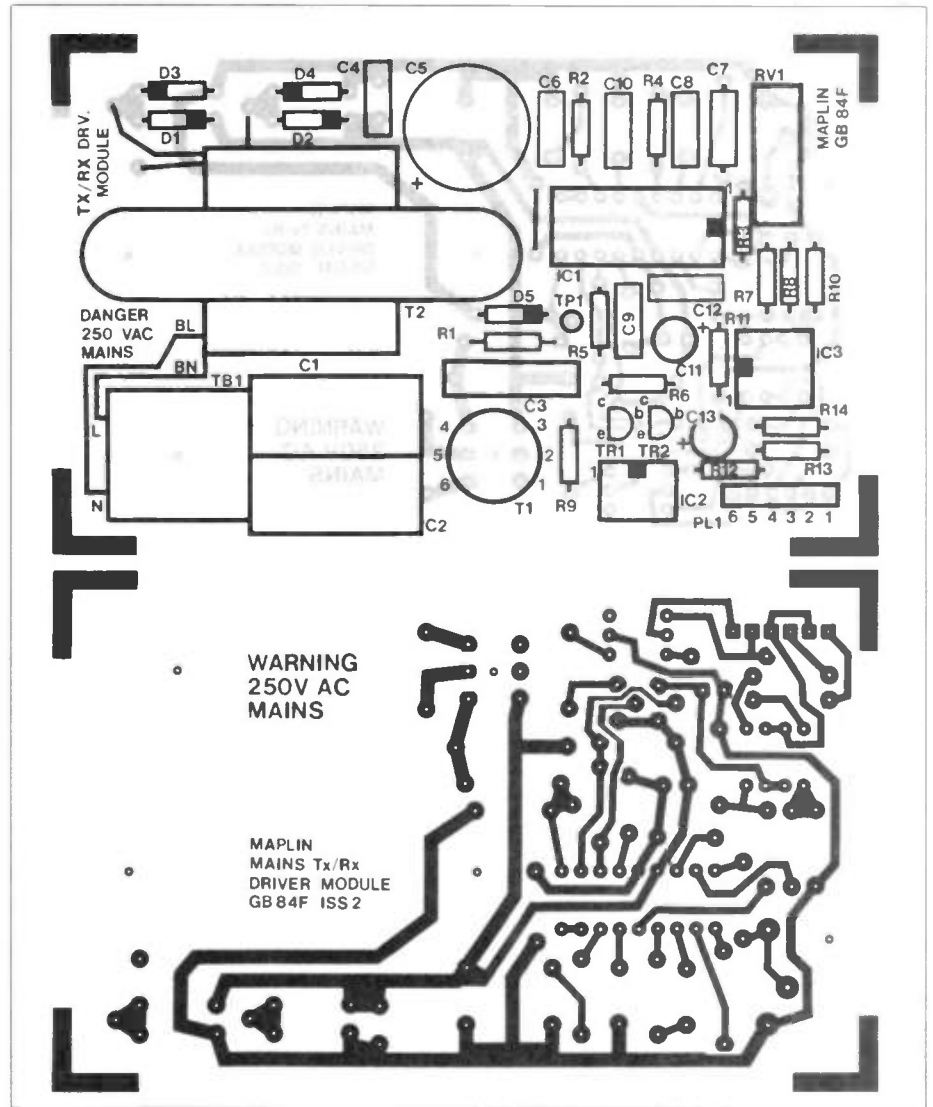

Figure 2. Artwork and Legend

time constant sets the ALC response time. One important feature of the output driver stage is its ability to balance carrier amplitude with line impedance. Very low impedance lines would otherwise severely load the tank circuit, thus damping it and increasing both supply current and out of band harmonics, neither of which are desirable! C9 (pin 13) rejects short, line impulse noise pulses. The capacitor determines the filter characteristic and thus the max-

imum usable data frequency. Noisy mains will require a higher capacitance, perhaps 47nF, with a reduced 'BAUD' rate at this pin 13.

## Construction

Great care must be exercised during soldering on this project to prevent connections being made between mains input stages and low voltage areas. There is one link required, to be fitted just below IC1 at the pin 9 and 10 end. Make

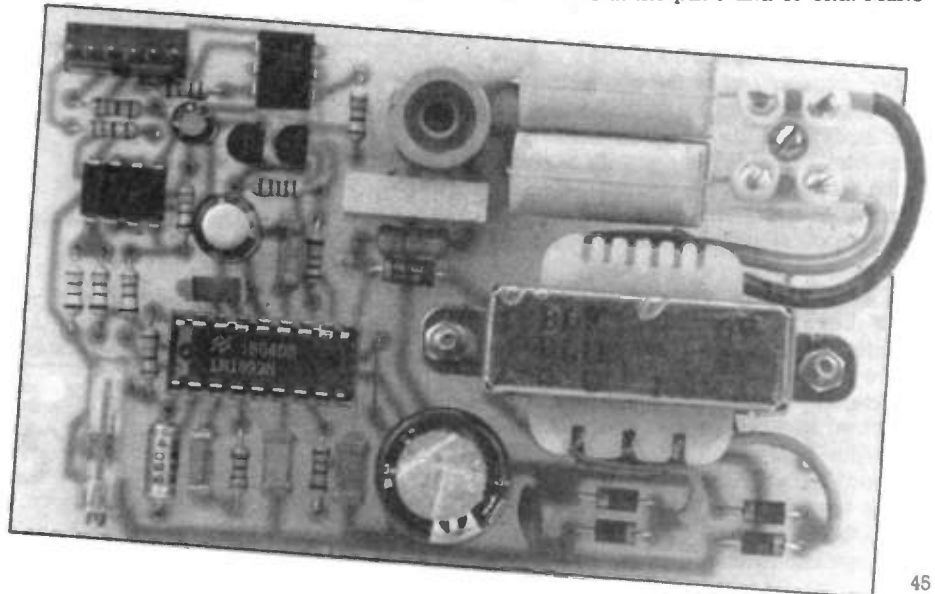

and insert the link and fit the larger standard resistor R1. Identify and insert the remaining resistors, R2 to R14 and carefully solder, then trim, these components. Ensure when fitting R12 that enough clearance is allowed for the 6 way housing to sit onto PL1 properly.

Next insert the five diodes. D5 may look similar to the 1N4001 rectifying diodes and the body markings should be carefully examined. Mount each of the diodes with the silver banded end in line with the white bar on the PCB legend; do not reverse them.

Fit the 18 pin IC socket and the polycarbonate capacitors C6, C8 to C10 and C12. Solder in and trim these components. Insert IC2 and IC3 directly into the PCB, IC2 is the 6 pin device. Fit TR1 and TR2 directly above IC2 with the body flat section aligned with the legend. The ICs may have either a notch cut in one end which should line up with the notch on the legend, or pin 1 may be marked with a circular indent on top of the package. Insert a polystyrene 560pF capacitor at C7 and a multi-turn cermet, RV1, with adjusting screw head facing the PCB edge. Mount C5, C11 and C13, with the longest lead to the +V sign on the board, the short lead should be

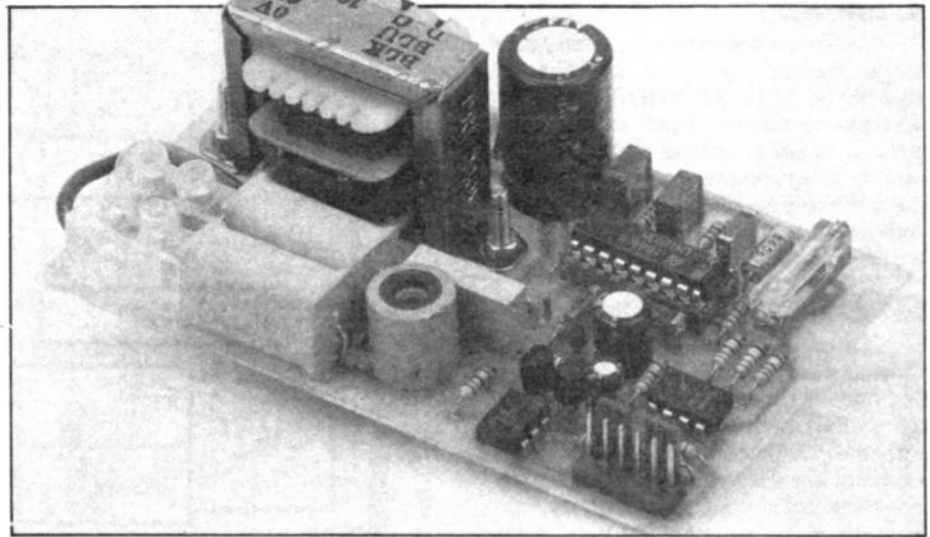

mounting lug between C5 and D5 but do not fit a bolt through the outside lug at this stage. Also, do not fit C1 and C2 or the 2-way terminal block on the PCB at this stage. Solder any remaining terminals to the board, trim and inspect all components and tracks. Clean the solder joints with a PCB solvent and brush, especially around the area of T1.

## Testing

Insert IC1 into its socket and fit T2 mains wires (thicker) into the 2-way terminal block TB1. Connect a length of two core mains wire into the terminal block and a suitable mains plug onto the other end, ready for plugging into the mains and switching on. Certain items of test equipment are necessary for accurate alignment of the unit. You will require a good voltmeter, a 9V battery, e.g. PP3, and some clip leads. An Oscilloscope or Frequency Counter is also required for setting the PLL oscillator and tuning T1.

Connect a voltmeter with negative lead to either D3 or D4 anode (opposite to band end), which is supply 0V. Switch on the mains power and measure +14.5 to +15V DC on IC1 pin 15. If this reading is not correct, then *switch off immediately* as there may be a fault. Check IC1 pin 11 for +5V to +5.5V DC and TP1 for approximately +14V DC. Do ensure that adequate insulation is

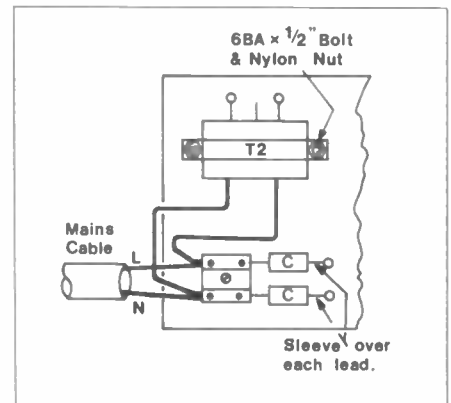

Figure 4. Connections to PCB

provided between the PCB and work top and keep your hands well clear of the terminal block. Switch off the mains supply and remove the mains lead from the 2-way terminal block.

Take HV mains capacitors C1 and C2, cut off two 10mm lengths of sleeving and slide over one lead of each capacitor (see Figure 4). Cut each remaining lead to 10mm long and insert each one into the terminal block so that the capacitor body fits up against the terminal block with no gaps. Tighten both terminal screws. Insert both sleeved ends into the PCB at C1 and C2 and place each capacitor firmly into the board with the terminal block mounting hole directly above a hole in the PCB.

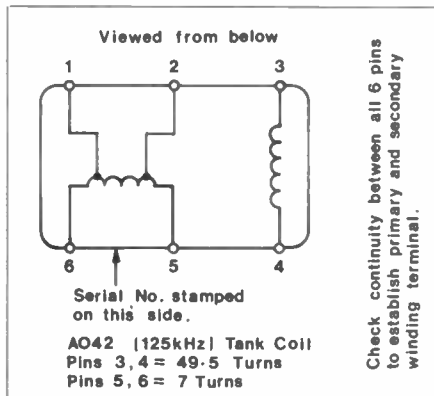

Figure 3. Tank Coil

marked with -V signs along the capacitor body. Insert the rectangular HV capacitor C3 and disc capacitor C4, veropin TP1 and PL1. Solder all components and remove excess lead ends. Ensure all components are pressed down onto the PCB and not 'floating in the air'. Refer to Figure 3 for details on tank coil T1. The former has six pins, arranged with three per side. Pins 5 and 6 are the 'LIVE' connections to the mains and are on the same side as the AO42 stamping on the body. If in doubt where these pins are, check for continuity with a resistance meter. Insert T1 into the PCB with pins 4, 5 and 6 closest to C1 and C2 position. This component MUST be fitted correctly.

Mount mains transformer T2. One side has two thick leads, for 240V connection, and the other side has the three thinner secondary wires. The centre, 0V, wire on the secondary is not required and can be cut off or soldered into the spare pad nearby (see PCB legend) while the remaining two thinner wires are fitted, any way around, at D1/3 and D2/4 (see Figure 4). Use a single 1/2in 6BA bolt and nylon nut through the inside

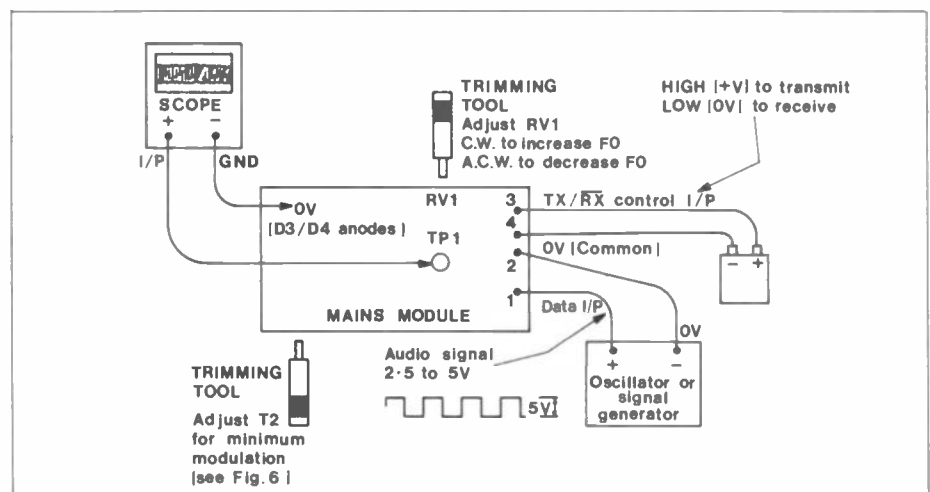

Figure 5. Test Set-up

## Final Assembly

Split the box into two sections and retain the lower grey half. Refer to Figure 9 and lay the PCB inside the box section approximately centrally. Mark all three 'A' holes through the PCB with a pencil. One next to RV1, one through T2 outside lug and one beneath the terminal block. Drill the holes using a 3mm drill bit and also a 12mm hole in one end panel, closest to T2 as shown. Countersink the three small holes from the outside and fit three countersunk 1in. 6BA bolts as Figure 10. On the inside, fit a shake washer and two 6BA nuts over each 1in. bolt and tighten up. Drop the PCB over the bolts and press down onto the lock nuts, then fit a 6BA nylon nut over each bolt. Ensure one mounting bolt inserts through the terminal block.

Fit the SR grommet three inches along from the unterminated end of the flat mains cable and insert the locking peg. Squeeze the peg into the grommet with pliers or in a vice and insert into the large hole previously drilled in the end panel. Terminate both mains cable and T2 secondary wires as shown.

## Final Testing

Connect a 9V battery with negative lead to pin 2 and positive lead to pin 3 on PL1. Note that the common 0V on this plug does not join to the power supply 0V (see Figure 5). Clip on a Frequency Counter or an Oscilloscope with earth to D3/D4 anode and TP1. Plug in the mains leads and switch on. With a trimming tool, adjust RV1 for a reading of  $127.750\text{kHz} \pm 100\text{Hz}$ . When this is done, also connect the battery positive lead to data I/P pin 1 on PL1. The frequency should drop to approximately  $122.5\text{kHz}$ . Remove the battery positive from data I/P pin 1 only but keep the connection to pin 3 (Tx/Rx) on PL1. If a low frequency signal generator is available, connect this between 0V pin 2 and data I/P pin 1. A signal amplitude of at least 2.5V peak is required at a frequency of 100Hz. Monitor the modulating waveform from TP1 on the Oscilloscope with reference to Figure 6. Turn the slug in T1 anti-clockwise until level with the can top, then screw down carefully with a trimming tool (plastic) for  $2\frac{1}{2}$  turns to begin with. The carrier oscillogram should increase in amplitude to around 20V peak and the modulation gradually disappear. Adjust for maximum amplitude with minimum modulation of the carrier. If a signal generator is not available, alternatively connect, then disconnect, battery positive to data I/P pin 1 by hand while following the previous instructions.

Aligning the tank circuit while connected directly to the mains will optimise the module for maximum efficiency with the wiring medium. If doubtful about doing this test while connected to the mains, simulate the wiring with a  $\frac{1}{2}$  Watt 3R3 resistor instead. Remove both C1 and C2 leads (power off, of course!) from each terminal block and solder the test resistor to C1 and C2

leads. Proceed with the alignment as before. This method of simulating the line does not fully optimise the tank circuit, but is recommended for those with a 'nervous disposition'!

## Using the Module

Figure 8 shows the general method of using the driver module. It must be remembered that this unit is only an interface between communicating equipment and the mains and is not a complete encoding/decoding system with protocol and handshake. Communicating devices can be of any form, e.g. alarm systems, RS232 keyboards or TTL outputs from microcomputers.

Both input and output connections are opto-isolated and require external

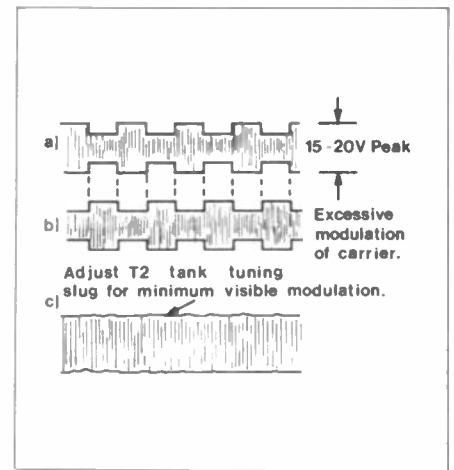

Figure 6. Tx Envelope

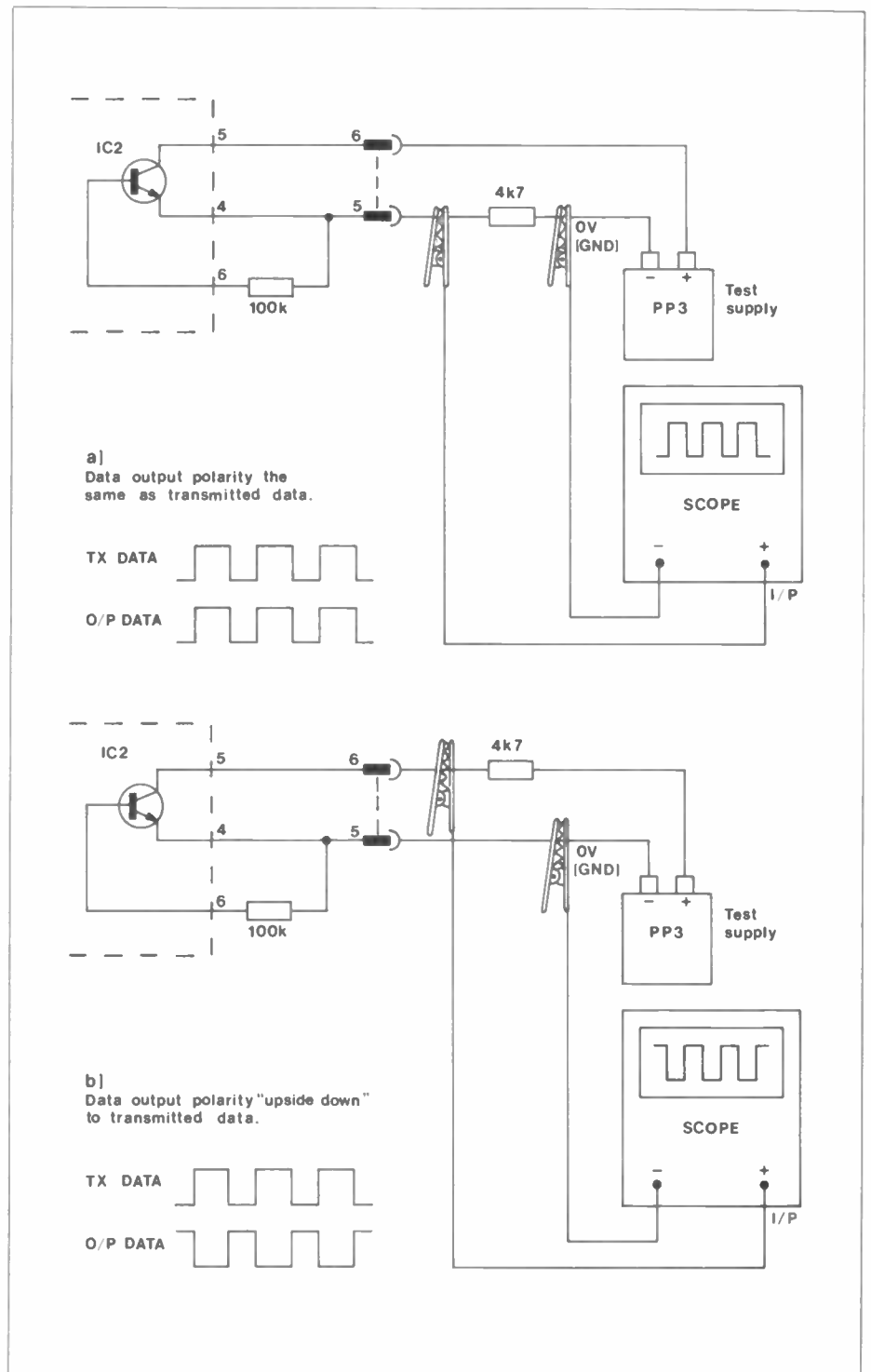

Figure 7. Data Output



sourcing to operate LEDs or collector/emitter junctions. Figure 7 shows both inverting or direct connections from the data output pins on PL1 but this can only be checked if at least two driver modules are 'on line', one transmitting and one receiving. One method of using these modules could involve connecting the Tx/Rx control line via a battery and 'Make' contact from a burglar alarm sensor. A second driver module could be connected to a burglar alarm placed anywhere without restrictions from contact wiring. When the sensor is activated, the carrier is transmitted and the receiver data O/P will go high (or low) to suit requirements. This is then used to trip the alarm unit. Any number of sensors or modules could be used, but independant channel recognition is not possible without tone or data encoding. If an intelligent computer communications

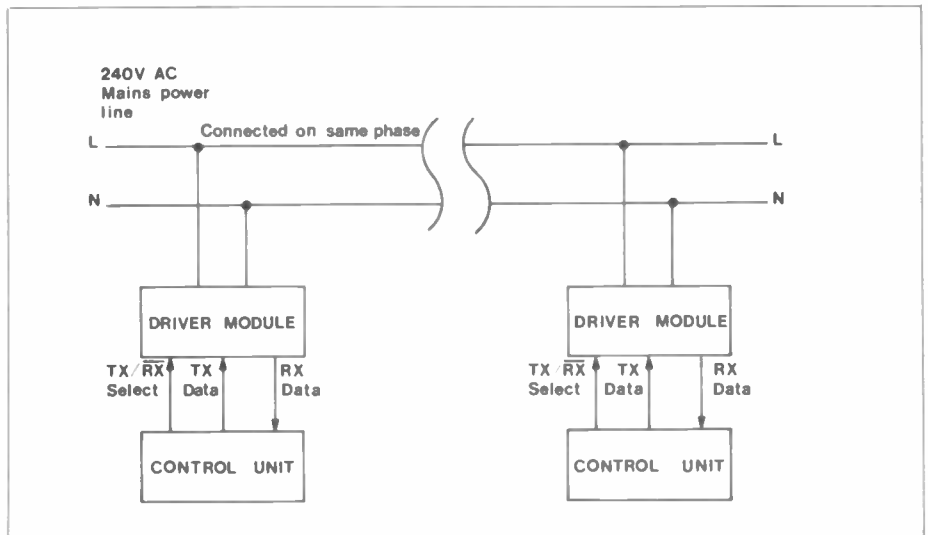

Figure 8. Connecting to Mains

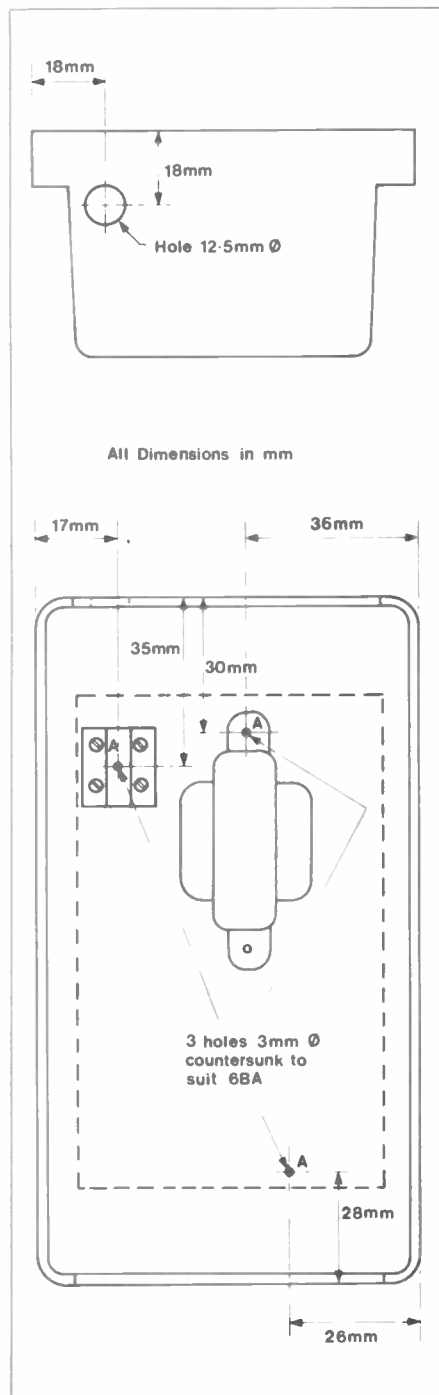

Figure 9. Box Details

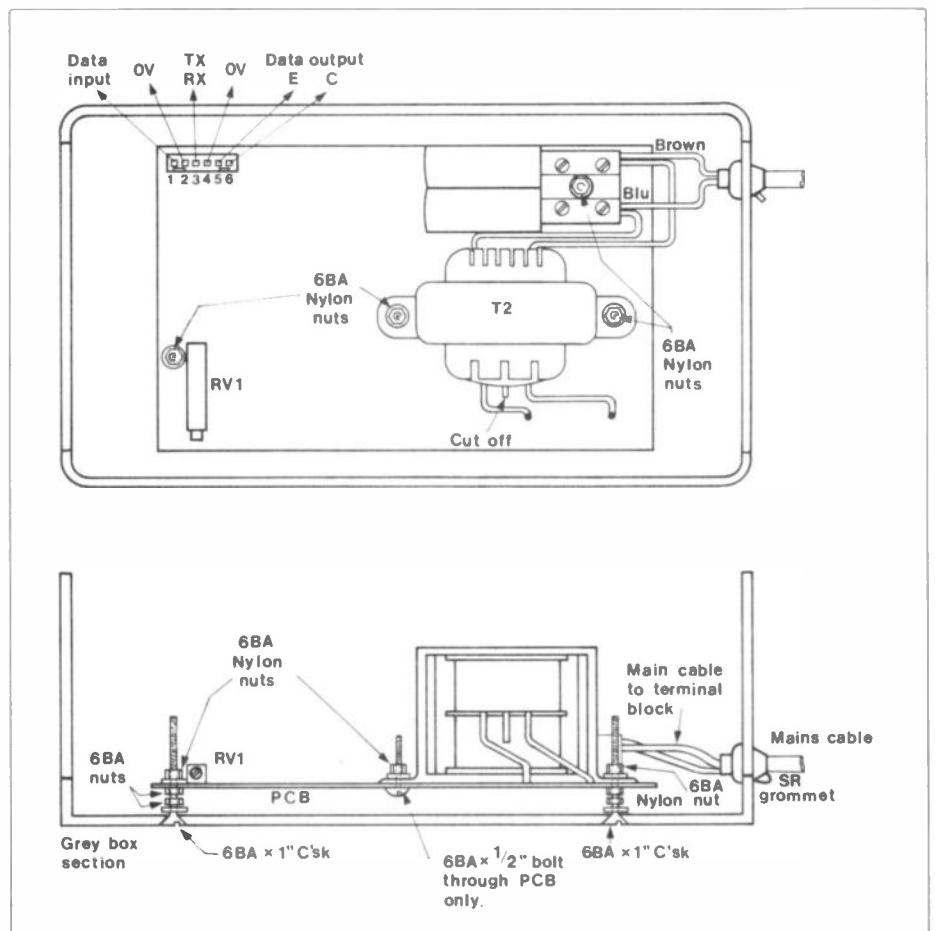
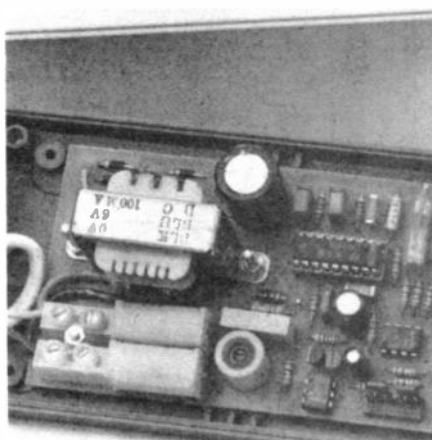

Figure 10. Assembly

link is to be used, then polling several terminal units could be implemented. A master unit transmits a recognition WORD and the appropriate receiver responds. The communications channel is then established between these two devices only until further control words are recognised.

This type of system has been successful on an experimental basis using RS232 links to the driver modules. Baud rates of up to 4.8kbps have been used, although standard 8-bit words at 300bps are less prone to noise and interference and better suited in this environment. As a general guide, limit the maximum data frequency to below 2.5kHz.

## MAINS Tx/Rx DRIVER MODULE PARTS LIST

RESISTORS: All 0.4W 1% Metal Film unless specified

R1	47Ω ½W Carbon Film 5%	1	(S4R7)
R2,5	10k	2	(M10K)
R3	5k6	1	(M5K6)
R4	3k3	1	(M3K3)
R6	12k	1	(M12K)
R12	100k	1	(M100K)
R7,8,10,11	4k7	4	(M4K7)
R9,13,14	470Ω	3	(M470R)
RV1	5k 15 Turn Cermet	1	(WR48C)

### CAPACITORS

C1,2	IS Cap 220nF	2	(FF57M)
C3	33nF 250V AC	1	(FT34M)
C4	100nF Minidisc	1	(YR75S)
C5	1000µF 35V P.C. Electrolytic	1	(FF18U)
C6,10	100nF Polycarbonate	2	(WW41U)
C7	560pF Polystyrene 1%	1	(BX54J)
C8	10nF Polycarbonate	1	(WW29G)
C9	1nF Polycarbonate	1	(WW22Y)
C12	47nF Polycarbonate	1	(WW37S)
C11	100µF 25V P.C. Electrolytic	1	(FF11M)
C13	10µF 50V P.C. Electrolytic	1	(FF04E)

### SEMICONDUCTORS

D1-4	1N4001	4	(QL73Q)
D5	Zener SA40A	1	(QY71N)
TR1,2	BC548	2	(QB73Q)
IC1	LM1893N	1	(UF50E)
IC2	Opto-Isolator	1	(WL35Q)
IC3	Dual Opto-Isolator	1	(YY62S)

### MISCELLANEOUS

T1	Tank Coil AO42	1	(FT58K)
T2	Sub-min. Tr 6V	1	(WB00A)
	Terminal Block 6A	1	(HF01B)
	Bolt 6BA x ½in.	1 Pkt	(BF06G)
	Nut 6BA	1 Pkt	(BF18U)
TP1	Veropin 2145	1 Pkt	(FL24B)
	Mains Tx/Rx PCB	1	(GB84F)
PL1	Minicon Latch Plug 6 Way	1	(YW12N)
	Heatshrink CP16	1 Mtr	(BF86T)
	Case Vero 102	1	(LH01B)
	DIL Socket 18-Pin	1	(HQ76H)
	Csk Bolt 6BA x 1"	1 Pkt	(BF13P)
	Nylon Nut 6BA	1 Pkt	(BF80B)
	Shake Washer 6BA	1 Pkt	(BF26D)
	SR Grommet 3P-4	1	(LR47B)

### OPTIONAL

	Twin Mains DS White	As req	(XR00A)
	Minicon Latch Housing 6 Way	1	(BH65V)
	Terminal Pins	6	(YW25C)
	Test Resistor 3Ω3	1	(S3R3)
	13A Plug	1	(RW67X)

A kit of parts is available (excluding Optional)  
Order As LK68Y (Mains Tx/Rx Drvr Kit) Price £29.95

The following items in the above kit  
are also available separately, but are not  
shown in the 1985 catalogue:

33nF 250V AC Capacitor Order As FT34M Price 24p  
Zener SA40A Order As QY71N Price £1.58  
Tank Coil AO42 Order As FT55K Price 99p  
Mains Tx/Rx Drvr PCB Order As GB84F £3.95

## CORRIGENDA

### Vol. 4 No. 13

**Flash Meter.** Please note that the infra red sensor (YY66W) is no longer obtainable. However, a substitute device is available, the TIL81 (QY82D) price £1.20. It fits directly into the PCB and the tab on the case designates the emitter.

**Low Power Radio Control System.** In Figure 8, the 27MHz Receiver Circuit, IC1 pin 15 is connected via T4 (pin 3) to the positive rail (IC1 pin 6).

### Vol. 4 No. 14

**Zero 2.** The Zero 2 'turtle' robot article was written by David Buckley, whose name unfortunately somehow went missing from the article. We hope Mr. Buckley will accept our sincere apologies.

### New Products, IPC Insertion Tool.

This IPC insertion tool has been described as being required to connect cables to the 4-way or 6-way IPC line plugs, this is incorrect. The tool is used for connecting wires to Master or Secondary Jack Units having a BT type number with the suffix /3A.

### Vol. 4 No. 15

**Sharp MZ-80K Serial Interface.** In Figure 2, WRB is the seventh 'finger' down from the top, RDB is the eighth, then there is a spare 'finger', then IORQB.

## MAPLIN'S TOP TWENTY KITS

THIS LAST MONTH	DESCRIPTION OF KIT	ORDER KIT CODE	KIT PRICE	DETAILS IN PROJECT BOOK
1. (1)	◆ Live Wire Detector	LK63T	£2.95	14 (XA14Q)
2. (2)	◆ 75W Mosfet Amplifier	LW51F	£15.95	Best of E&MM
3. (4)	◆ Car Burglar Alarm	LW78K	£7.49	4 (XA04E)
4. (12)	◆ Logic Probe	LK13P	£10.95	8 (XA08J)
<i>Case also available: FJ37S Price £1.48</i>				
5. (8)	◆ Ultrasonic Intruder Detector	LW83E	£10.95	4 (XA04E)
6. (3)	◆ Partylite	LW93B	£10.95	Best of E&MM
7. (11)	◆ 8W Amplifier	LW36P	£4.95	Catalogue
8. (20)	◆ Noise Gate	LK43W	£9.95	Best of E&MM
9. (6)	◆ Computadrum	LK52G	£9.95	12 (XA12N)
10. (-)	◆ DXers Audio Processor	LK05F	£9.85	7 (XA07H)
11. (5)	◆ Light Pen	LK51F	£10.95	12 (XA12N)
12. (-)	◆ Ultrasonic Car Alarm	LK75S	£19.95	15 (XA15R)
13. (13)	◆ Harmony Generator	LW91Y	£17.95	Best of E&MM
14. (9)	◆ Syntom Drum Synthesiser	LW86T	£12.95	Best of E&MM
15. (7)	◆ ZX81 I/O Port	LW76H	£10.49	4 (XA04E)
16. (15)	◆ Burglar Alarm	LW57M	£49.95	2 (XA02C)
17. (16)	◆ 15W Amplifier	YQ43W	£5.75	Catalogue
18. (17)	◆ PWM Motor Driver	LK54J	£9.50	12 (XA12N)
19. (-)	◆ Xenon Tube Driver	LK46A	£11.75	11 (XA11M)
20. (14)	◆ Spectrum Easyload	LK39N	£9.95	10 (XA10L)

Over 100 other kits also available. All kits supplied with instructions.

The descriptions above are necessarily short. Please ensure you know exactly what the kit is and what it comprises before ordering, by checking the appropriate Project Book mentioned in the list above - see inside back cover for details.

# PROJECT FAULT FINDING

by Robert Penfold Part 4

## USING LOGIC PROBES & PULSERS ON DIGITAL CIRCUITS

Until about 15 to 20 years ago a project fault finding series would only need to deal with analogue circuits since digital projects were, to say the least, very rare and home computer add-ons did not exist. Things are very different now and digital projects of one kind or another are probably in the majority. A glance down the Maplin top twenty projects list certainly shows about half the projects to be digital types, and several of the others contain at least some digital element.

Some fault finding techniques apply to both analogue and digital circuits and this is generally true of the simple methods outlined in Part 1 of this series. Problems with things such as accidental short circuits, wrongly orientated components and broken printed circuit tracks are just as likely to occur with digital circuits as they are with analogue types. In fact, the intricacy of the printed circuit boards for many digital circuits results in a far higher likelihood of simple mechanical faults being produced and a great deal of care needs to be exercised when building complex digital circuit boards. The techniques used for tracing this type of fault are much the same whether the circuit in question is an analogue type or a digital one.

The method of testing using voltage checks which was outlined in Part 2 of this series is not usually applicable to digital circuits. On the face of it, voltage tests should be ideal when checking digital circuits as there is little problem in determining what voltage should be present at each point in the circuit. There are only two voltage levels; logic 0 (low) or typically about 0.8 volts or less, and logic 1 (high) which is typically about 4 to 5 volts. The precise voltage range that is acceptable for each logic state varies slightly from one logic family to another and in the case of CMOS devices which can operate over a wide voltage range, the particular supply voltage in use must be taken into account.



In practice voltage tests are often of little value, although they can still be useful sometimes if you know how to interpret results properly. One obvious test to make and one which is clearly fully applicable to digital circuits, is to check that the power supply is present and to check that it is reaching each integrated circuit. Check the voltage at the pins of the integrated circuits themselves rather than at the soldered joints on the printed circuit board. Then any problems with 'dry' joints, buckled integrated circuit pins, or faulty IC holders will be brought to light. Measuring voltages direct at the pins of an integrated circuit can be a little awkward and care has to be taken to avoid accidentally short circuiting two pins together. An integrated circuit test clip can make this task very much easier when dealing with 14 and 16 pin DIL ICs (types for use with 0.6 inch spacing devices do not seem to be available).

The problem when making voltage tests other than simple supply checks is that many points in the circuit will not be at static levels, but will be pulsing. Where a pin of an integrated circuit should be at a static level, it might be worthwhile checking that it is at an acceptable voltage. In the case of CMOS circuits just what constitutes high and low logic levels depends on the particular supply voltage in use. As a general rule of thumb, a low logic level is one that is about 30% of the supply voltage or less, while a high logic

level is approximately 70% of the supply potential or more. A voltage level somewhere between these two levels would normally indicate a fault and probably a fault in the output that is providing the signal. It is not necessarily the case though, and a faulty input could excessively load an output and thus generate an invalid voltage level. Another point to watch is where a CMOS output is used to drive a load that requires what is in CMOS terms a fairly high output current. A LED indicator would be a typical example. In order to obtain a sufficiently high drive current, a high level of loading might be placed on the CMOS output, pulling it to an invalid potential. This is perfectly satisfactory and should not give any problems provided the output is only driving the LED or other load and is not also driving another CMOS input or inputs.

The only other logic family in common use these days is the TTL type, although this is really a number of closely related logic families with a number of variations on the basic 74 series of integrated circuits. The most popular TTL variation is the 74LS series which is used more frequently than even the standard TTL series. For most testing purposes it makes little difference which type is in use as they all have similar characteristics. A low logic level is about 0.8 volts or less, while a high logic level is around 2 volts or more. The table on page 301 of the current Maplin catalogue gives some useful information on the basic characteristics of a number of logic families.

Voltage checks on pulsing outputs can sometimes be helpful, except where very low frequencies are involved they are not conclusive. The voltage might be generated by a correct pulse signal or it might be a true DC level and indicative of a fault. Anyway, the general principle is to first get some idea of the mark-space ratio of the expected signal and to then calculate roughly the average voltage

level that this will produce. It is the average potential that an ordinary analogue multimeter will indicate (most digital instruments will fail to work at all with pulsing signals and are not usable for this type of testing).

If we take a simple example; if a flip/flop is operating as a divide by two circuit, its output signal will be a squarewave with an accurate one to one mark-space ratio. The average output voltage will therefore be half way between the static high and low logic levels. As shown in Figure 1, this does not necessarily mean that the voltage will be about half the supply voltage, since the low logic level is often virtually equal to the 0 volt rail, whereas the high logic level is often only around half the positive supply voltage. With CMOS circuits the output voltage would normally be very close to half the supply voltage but with TTL circuits, something in the region of 2 volts or a little less would be more likely.

If an output is high for the majority of the time and has only brief and relatively infrequent negative excursions, then the average voltage indicated by the multimeter should be close to the voltage one would get if the output was fixed at a high level. Similarly, if the output is low for the majority of the time and provides only relatively few and brief positive pulses, the average potential should be little more than the static logic 0 voltage for the particular type of integrated circuit concerned.

## Logic Probes

What are almost certainly the most useful pieces of inexpensive test equipment for checking digital circuits are logic testers and pulsers. Logic testers can in fact be quite complex, but in their most simple form, they consist of a small probe with a few LED indicators. Usually there are three LEDs which indicate the state of the point in the circuit which is being monitored. These correspond to 'high', 'low', and 'pulsing'. The precise way in which the state of the input signal is displayed does vary slightly from one unit to another though. In order to be of real use, it is essential that a clear indication of the input state, including a proper 'pulsing' indication, can be provided. The more complex types of tester are used in much the same way as a simple logic probe, but they provide additional facilities, such as the ability to monitor a number of points in the circuit simultaneously.

If we now take a simple example of how a logic probe can be used, consider the circuit of Figure 2. This is the 'Oric Talkback' unit from issue 9 of 'Electronics', incidentally. It serves our present requirements well as it has a number of features that are commonly found in computer add-ons and other digital circuits.

We will assume that the problem is a lack of output from the unit when it is fed with speech addresses. Like many digital circuits, this one is not entirely digital in nature, and there are some analogue

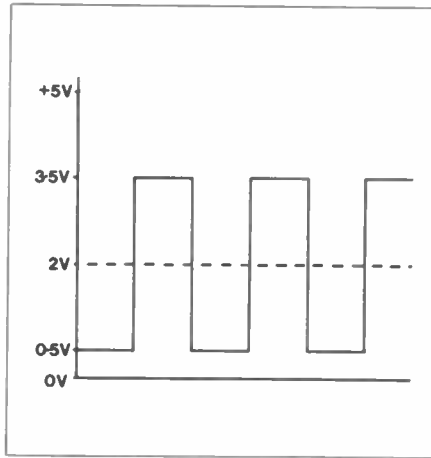

Figure 1. An Analogue Multimeter reads the average potential of a pulse signal.

circuits. These are the lowpass filter (R2/C3/R3/C4) and the output amplifier based on TR1. It would probably be best to check these circuits using a signal tracer to ensure that the problem is a lack of output from IC6, rather than a break somewhere in the audio signal

path. Here we will assume that these checks have been made and that no output is generated at pin 24 of IC6.

The first step is to ascertain that the signals from the computer are reaching the appropriate integrated circuits (IC1 to IC4). The data, address and read/write lines all contain a complex series of signals, but when taken singularly, they contain what is really just a series of random pulses. The logic tester could therefore be used to check the integrated circuit pins that connect to these lines, and it should indicate a continuous pulse stream in each case. Always check the signals direct at the pins of the integrated circuits, and not at the soldered joints on the underside of the board. The board connects to the computer via a ribbon cable, and a thorough check should, of course, be made to ensure that this is connected correctly.

IC1, IC2, and IC5 are used to decode some of the address lines to produce pulses that control IC3, IC4, and IC6. IC4 is a tri-state buffer and under stand-by

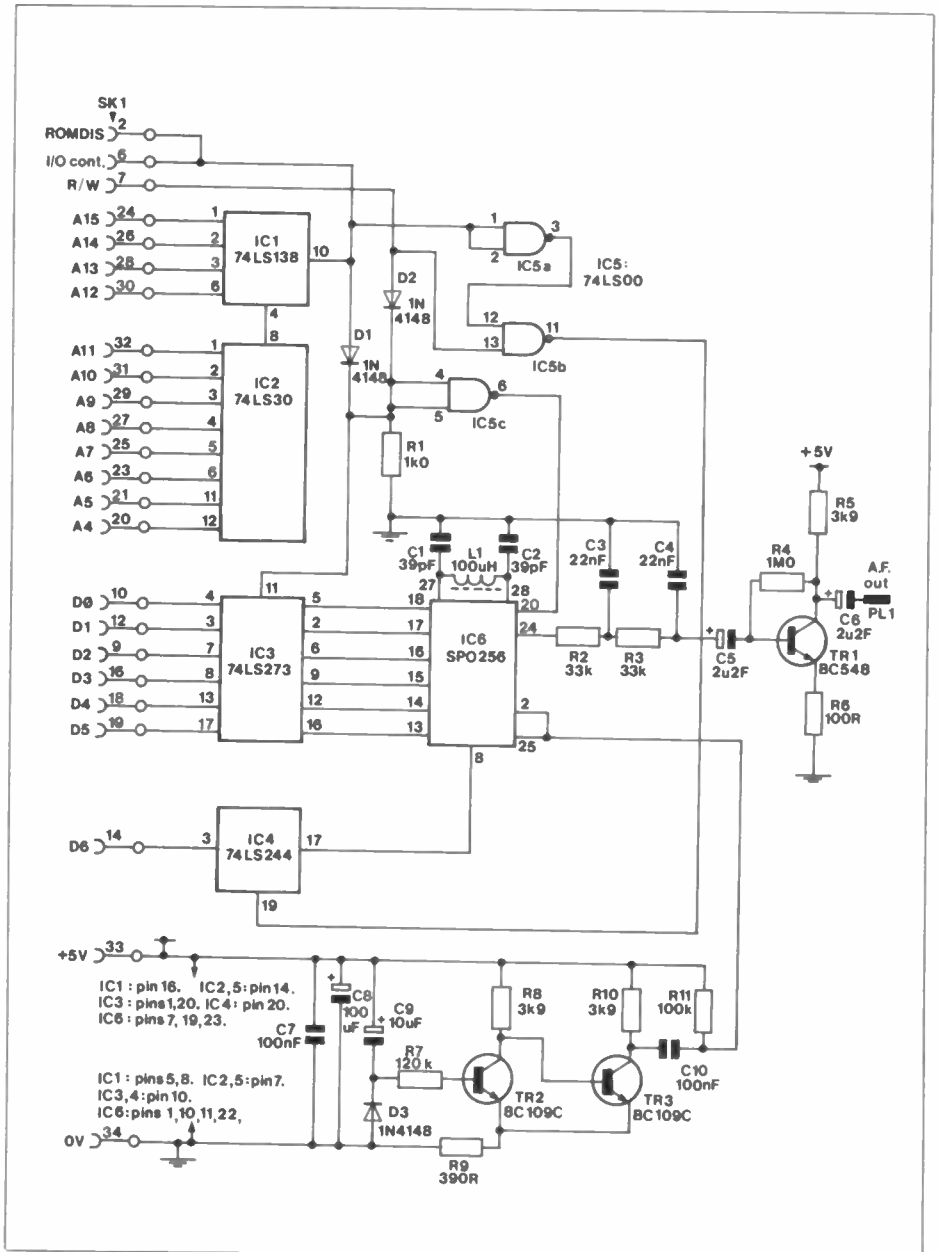

Figure 2. Oric 1 Talkback circuit.



conditions, its output at pin 3 is in the high impedance state. When the computer reads a suitable address, a negative output pulse is produced by IC5b, taking the output of IC4 to the active state. It then forces D6 of the computer's data bus to whatever state is present on the input which is controlled by pin 8 of IC6. The latter is normally low but it goes high while the unit is 'talking'.

This part of the circuit can initially be checked by testing the static levels. For instance, the input to pin 19 of IC4 should be high under stand-by conditions and there should be no pulses here if the address decoder circuit is operating correctly. The output at pin 8 of IC6 would be expected to be in the high state if the unit is not producing any output. If it should be in the low state, this would suggest that the chip is being triggered into action but is not progressing any further. This could indicate that the clock circuit (which has discrete components C1, C2 and L1) is not functioning properly, or perhaps the reset circuit is not functioning properly. R11 should take the reset inputs of IC6 (pins 2 and 25) high under stand-by conditions but a fault such as R11 going open circuit or an accidental short circuit somewhere could take the reset inputs permanently low. Checking the state of pins 2 and 25 of IC6 with a logic tester might not work as R11 has a fairly high value and loading by the logic tester could affect results. Using a multimeter would be better but unless this is a high input impedance type, it would still be necessary to take into account the loading of the multimeter which could result in a fairly low reading (about 2.5 volts with a 20k $\Omega$ /volt instrument set to the 5 volt range).

To check that the address decoder is presenting enable pulses to IC4 properly, it would be a matter of monitoring the signal at pin 19 of IC4, and then reading this input port by typing PRINT PEEK #BFFF into the computer. On hitting return the logic probe should indicate a pulse at pin 19 of IC4.

Although it might seem that the input port section of the unit could not be responsible for a lack of audio output from the unit, bear in mind that a software loop monitors this port and prevents any output to the speech chip until a suitable reading is returned. Thus a fault here could prevent the unit from functioning and it would result in the software hanging-up indefinitely. If the input port seems to be functioning properly or the software simply runs through the list of addresses very rapidly without any audio output being produced, this would suggest that the addresses (and) or trigger pulses are not reaching the speech chip.

IC3 operates as a six bit data latch and the latching pulse is provided at pin 11 by the address decoder. Under stand-by conditions, there should be a static high level at pin 11 of IC3 but there should be a brief negative pulse here when data is written to the speech unit. To test this part of the circuit, pin 11 of

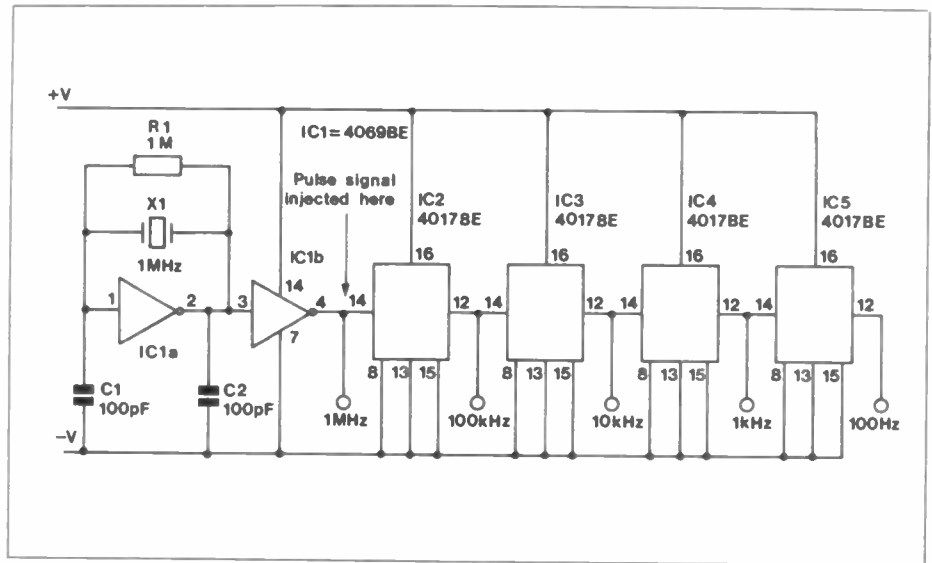

Figure 3. Testing a divider chain using a Logic Pulsar.

IC3 could be monitored using the logic probe and a value of 0 could be written to the speech synthesiser (i.e. POKE #BFFF,0). Hitting the return key should give a pulse indication from the logic probe and testing the logic levels on the outputs of IC3 should indicate that they are all low. Writing 63 to the speech unit (i.e. POKE #BFFF,63) should set the six outputs of IC3 high and again, a pulse should be obtained on pin 11 of IC3 as the return key is operated.

A more likely cause of the fault would be a lack of the trigger pulse to pin 20 of IC6. This is a positive pulse which loads the address on the six data inputs into the speech chip and triggers the device into operation. A low logic state should therefore be present at this point in the circuit under quiescent conditions and when any value is written to the speech chip, a brief positive pulse should be generated.

Having found a fault of some kind, say an absence of the trigger pulse to IC6, it is still necessary to track down the exact cause of the problem. This is really just a matter of testing at earlier points in the circuit in order to find a point where the expected signals are present. The fault then lies in the circuitry immediately after this point. This is much the same as testing an analogue circuit using a signal tracer as described in a previous article in this series. In fact, logic probes and pulsers are direct digital equivalents to signal tracers and injectors.

If we pursue this example where the trigger pulse to IC6 is absent, the next test would be at pins 4 and 5 of IC5c. The latter operates as an inverter and what we should find here is a normally high logic level with a brief negative pulse when data is written to the speech chip. This is in fact the signal that is used to drive the clock pulse input of IC3 and was checked earlier. The fault would therefore probably be in IC5c but there are other possibilities such as a short circuit on the output of IC5c or a fault on the trigger input of IC6. Some further investigation would be needed in order to track down the precise nature of the fault.

## IC Testing

When checking logic circuits, it often becomes necessary to test an integrated circuit in order to trace the precise nature of the fault. This can be achieved most easily using one of the special testers that are available. The basic way in which these operate is to connect the device being checked in a simple test circuit and to then check with LED indicators that the appropriate output signal or signals are being produced. The diversity of logic integrated circuits makes it necessary to have a different test set up for practically each type of logic IC that is tested.

If you do not have a logic IC tester, it is quite easy to improvise one from a solderless breadboard and a 5 volt logic supply. Take our earlier example where IC5c of the Oric Talkback was suspected of being faulty. The suspect device would be plugged into the breadboard and the 5 volt supply would be coupled to the appropriate pins of the device (+5V to pin 14 and 0V to pin 7). IC5c is a 2 input NAND gate, which has the truth table shown below:-

INPUT 1	INPUT 2	OUTPUT
LOW	LOW	HIGH
LOW	HIGH	HIGH
HIGH	LOW	HIGH
HIGH	HIGH	LOW

The device could be tested by first wiring the two inputs to the 0V supply rail and checking with a logic tester or multimeter that the output is high, then wiring input 2 to the +5V supply and again checking that the output is high and so on, until all four input combinations had been checked and proved (or not) to give the correct output state.

Obviously not all logic devices can be tested so easily but with most devices, it is possible to devise a simple test circuit that will show up any faults. It is more than a little useful to have some logic IC data books which give precise information on the function of complete families of logic devices.

## Pulsers

A pulser merely provides pulses that can be used to operate a logic circuit, normally at something well below the usual operating speed of the equipment. A good example of a circuit where a pulser could be used to good effect is in the clock oscillator and divider chain of Figure 3. This consists of a 1MHz crystal oscillator based on IC1 which feeds into a four stage divide-by-ten circuit, with the latter giving additional outputs at 100kHz, 10kHz, 1kHz and 100Hz.

One way of testing the circuit would be to check the output of each stage using a logic tester. However, the problem might not be a straightforward break in the signal path and it could be something such as one of the stages simply coupling the signal straight through without giving a divider action, missing pulses, an incorrect mark-space ratio, or something of this nature. A simple logic probe would then fail to give sufficient information to track down the faulty stage.

The ideal solution is to use an oscilloscope to check the output frequencies and waveforms but an oscilloscope is a relatively expensive item of test gear and one to which many electronics constructors do not have access. A pulser offers a slower and less convenient means of testing the divider chain but has the advantage of very low cost. The basic idea is to disconnect the crystal oscillator from the input of the divider chain and to then use the pulser as the signal source. Provided integrated circuit holders are used in the circuit, there should be no difficulty in disconnecting the output from the crystal oscillator and this involves nothing more complex than unplugging IC1. A pulser should never be connected to a logic output as this is unlikely to give proper operation and could easily damage the pulser or components in the test circuit.

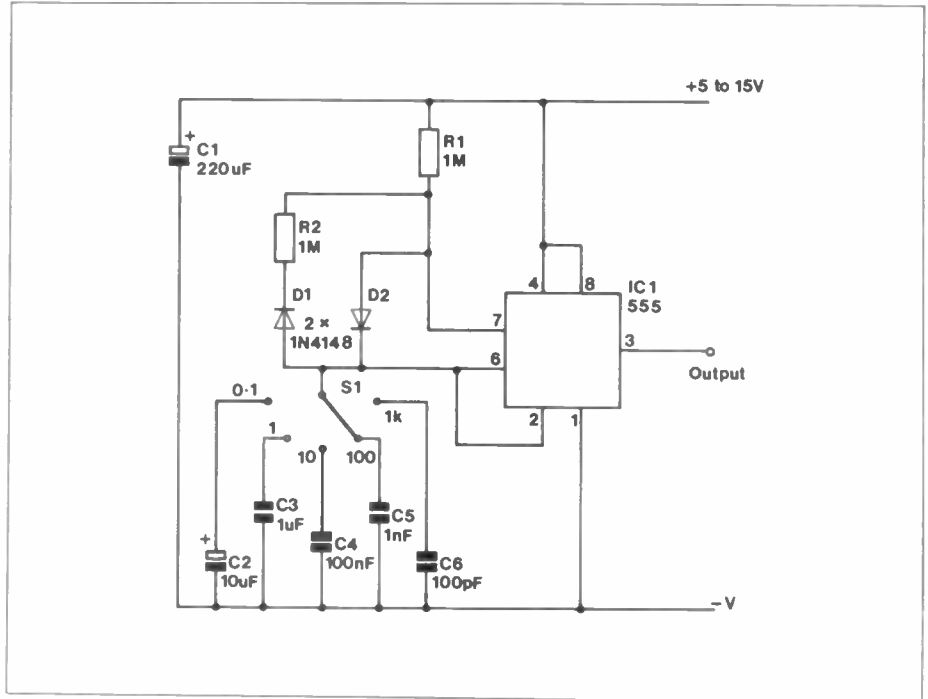

Figure 4. Circuit for a simple Pulser.

The pulser would initially be set for a fairly low operating frequency, say about 10Hz. This would give an output frequency of only about 1Hz from IC2 and a multimeter or logic probe could then be used to check the output signal. The output frequency from IC3 would be just 0.1Hz and again a multimeter or logic probe could be used to check that the waveform and frequency are roughly correct. At the output of IC4, the frequency would be down to a mere 0.01Hz or one cycle every 100 seconds. This is inconveniently slow and at the output of IC5, things are even worse with one cycle every 1000 seconds. When checking these, it would be better to use a higher output frequency from the pulser in order to permit the waveforms to be checked reasonably swiftly. If the pulser cannot provide a high enough

output frequency, an alternative would be to remove IC3 and to inject the output from the pulser into pin 14 of IC4. With a 10Hz pulser output, this would give frequencies of 1Hz and 0.1Hz from IC4 and IC5.

This method of slowing down a logic circuit to permit easy analysis of exactly what is happening can be applied to many logic circuits. It does not apply in every case though and it would not be applicable to most home computer additions, for instance.

A pulser is an easy piece of equipment to construct and Figure 4 gives the circuit of a simple pulser based on a 555 astable circuit. This has five switched output frequencies of 0.1Hz, 1Hz, 10Hz, 100Hz, and 10kHz, with a squarewave output signal. It is compatible with CMOS and TTL circuits.

## FIRST BASE *Continued from page 43.*

it to act upon. This process might be repeated, or for a write to memory, the address is again set, the Read/Write line goes low and data flows from the microprocessor to modify the contents of a memory location. With such a simple 'address decoder' as this (one inverter!), one memory device would be connected to the data bus at all times. However, since the purpose is to prevent more than one peripheral device having access to the bus at any one time, this would not be a problem.

Next time, we shall examine the action of more realistic microprocessor based systems. Readers who want to pursue this fascinating subject may wish to consider the Z-80 based CPU project published in the last issue of this magazine as a suitable basis for some practical experiments.

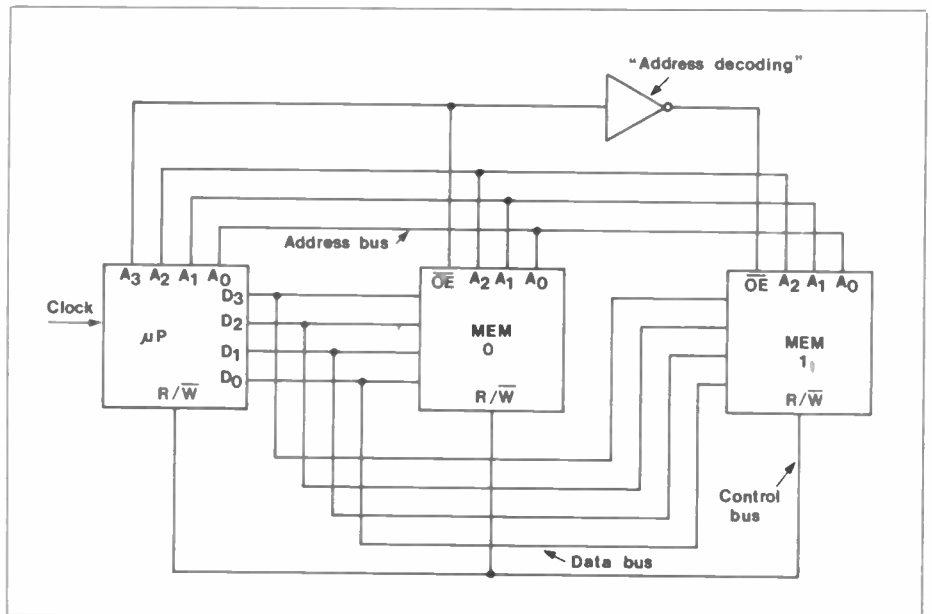

Figure 7. Simplified Microprocessor

# Sixteen Channel Logic Tester



by Robert Penfold

- ★ Simultaneous Testing of up to 16 IC Pin-Outs
- ★ All 16 Channels Displayed on Your Oscilloscope Screen
- ★ Easy to Construct

While logic circuits are in many ways very simple, having just two stable signal states, they can nevertheless be quite difficult to test. The point in the circuit where the fault lies may show clear signs of incorrect operation with perhaps, a static logic level where there should be a pulse stream or an indeterminate DC level, rather than a proper logic 0 or logic 1 potential. However, there are often a vast number of points in the circuit that must be checked one by one in order to trace the point where the fault exists.

This oscilloscope add-on was designed to speed up fault finding on digital equipment by enabling a number of points in the circuit (up to 16) to be monitored simultaneously. There is more than one way of doing this, and several approaches were tried. A self-contained tester with a couple of LED indicators to show the signal condition at each test point would be feasible, but a reasonably sophisticated logic probe type circuit would be needed for each pin in order to give really good results. This would result in a relatively high component count and cost. Another approach is to have a sort of sixteen channel trace splitter, although it would only need to deal with logic levels and a normal linear type of splitter would not be needed. This would be ideal in that it would display the waveform at each test point but in practice, it would require a fairly sophisticated circuit to work properly. Even then the height for each trace would be rather restricted and the overall display brightness would probably be rather low.

The basic idea adopted in the final circuit is to have an integrated circuit test clip which fits onto 14 and 16-pin DIL integrated circuits, and couples the signals on the pins through to the oscilloscope interface unit. The interface combines the signals so that they produce a simple histogram display on the screen of the oscilloscope, and the signal level for each pin can be seen at a glance. If a pin has a pulse signal and is not static, this shows up as an unstable area of display. The accompanying oscillographs show the types of display that are obtained. The unit provides market signals which ease the task of

relating each part of the display to its relevant integrated circuit pin. Again, these can be seen by referring to the oscillographs.

## System Operation

The unit is built around a 16-line to 1-line decoder, as can be seen from the block diagram of Figure 1. The decoder has 16 inputs and a single output with one of the input signals being coupled through to the output terminal. Just which of the inputs this is, depends on the four bit binary code fed to the control inputs of the device. In this case, these are fed from the four least significant bits of a 5-

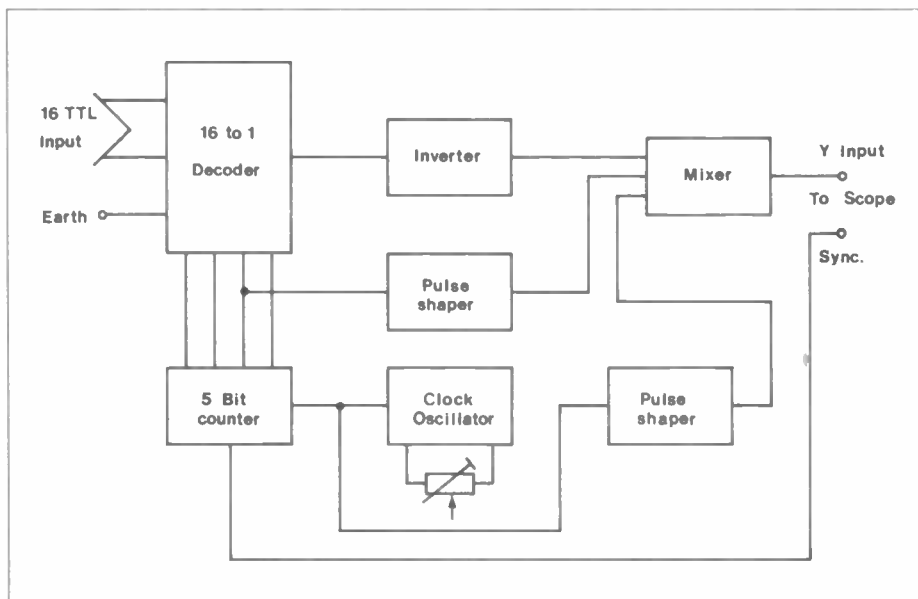

Figure 1. Block Schematic

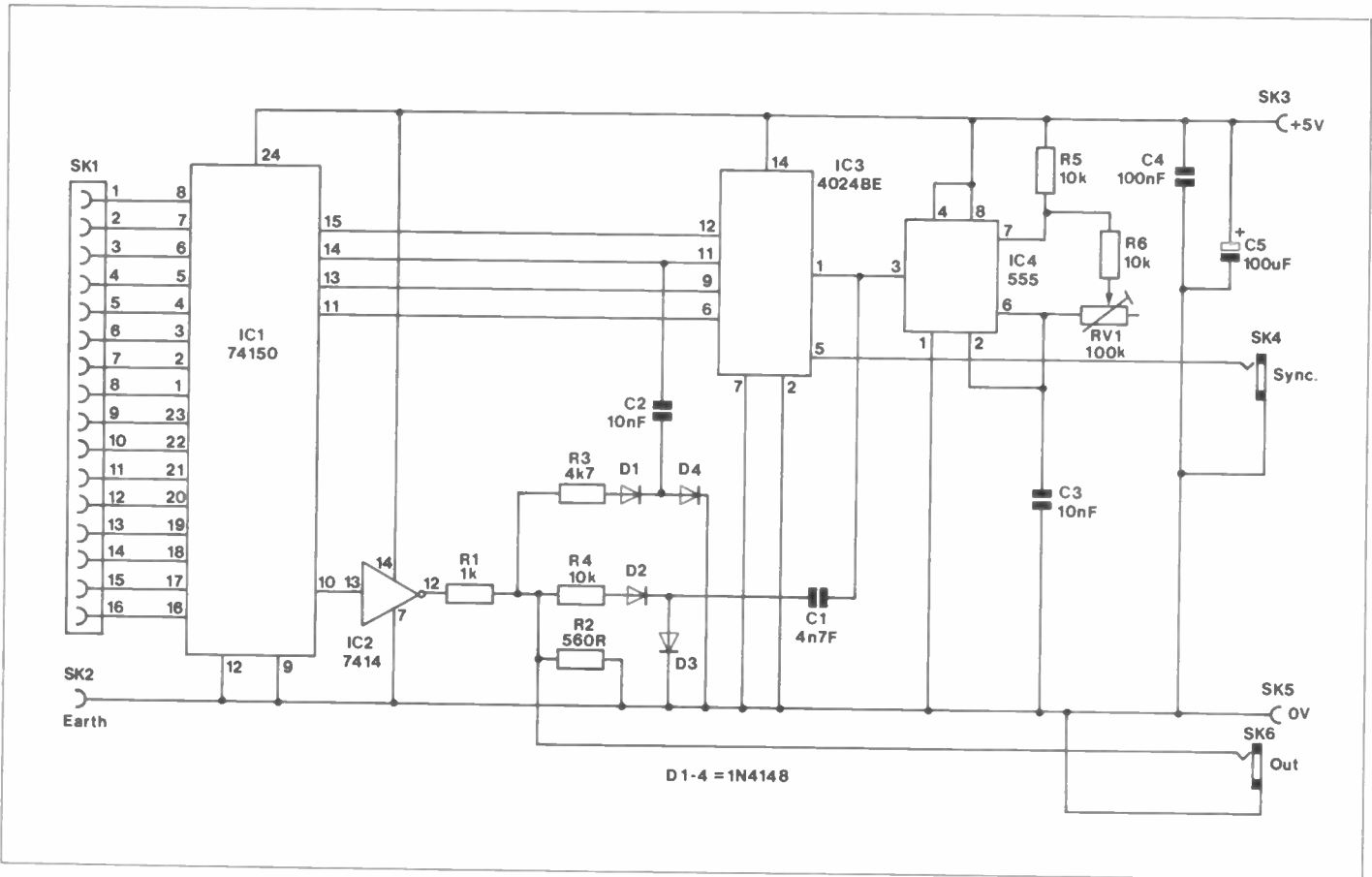

Figure 2. Circuit Diagram

bit binary counter and this circuit is in turn, driven from a clock oscillator. Initially, input 1 is coupled to the output but after one clock pulse, input 2 is coupled through to the output, then input 3 after a further clock pulse, and so on until input 16 is coupled through to the output. The circuit then cycles back to the original state with input 1 being fed through to the output, and it cycles indefinitely in this manner.

The 16 to 1 decoder inverts the signal and an inverter is therefore connected at the output of the decoder to re-invert the signal back to its original polarity. The output from the inverter is connected to the Y input of the oscilloscope via a simple passive mixer circuit. The waveform fed to the oscilloscope contains information that can be used to show the logic of each input but on its own, this is insufficient. The problem is simply that there is no way of telling which part of the display relates to a given pin of the test device.

To overcome this, the oscilloscope is set to the external synchronisation mode. The synchronisation signal is taken from the most significant bit of the binary counter. This ensures that a meaningful display is obtained, starting with pin 1 on the left and running through to pin 16 on the right. This assumes that the clock oscillator is adjusted to give, reasonably precisely, sixteen clock cycles per sweep of the screen. For this reason the clock frequency is made adjustable so that it can be trimmed to a suitable frequency. Most oscilloscopes have switchable positive and negative synchronisation modes but some instruments

only have one mode or the other. In this case, either mode will do since each full cycle of the 16 to 1 decoder corresponds to just one half cycle at the synchronisation output. Thus, triggering on the leading or falling edge of the signal gives the desired result. The display is less bright than for a free running sweep since, in

effect, only every other sweep is performed, but this does not dim the display to a significant degree.

A problem with this basic arrangement is that it can be difficult to rapidly relate each part of the display to its corresponding pin number as the graticule is unlikely to have a convenient

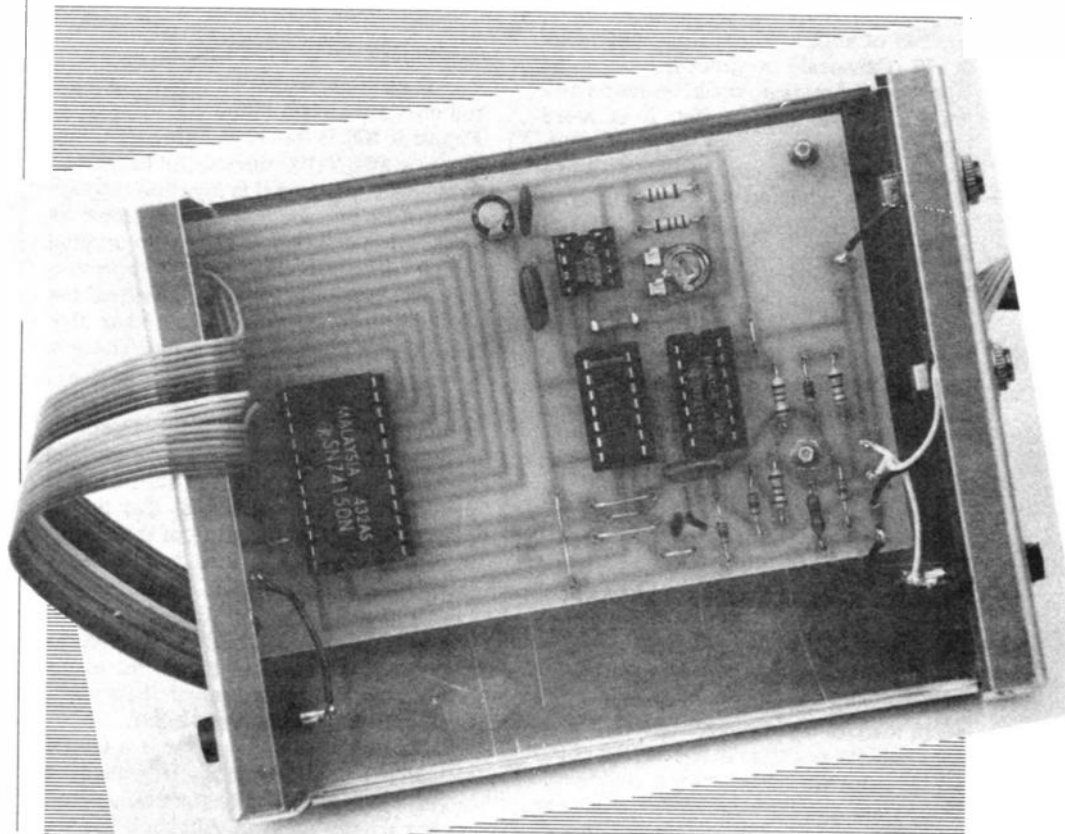



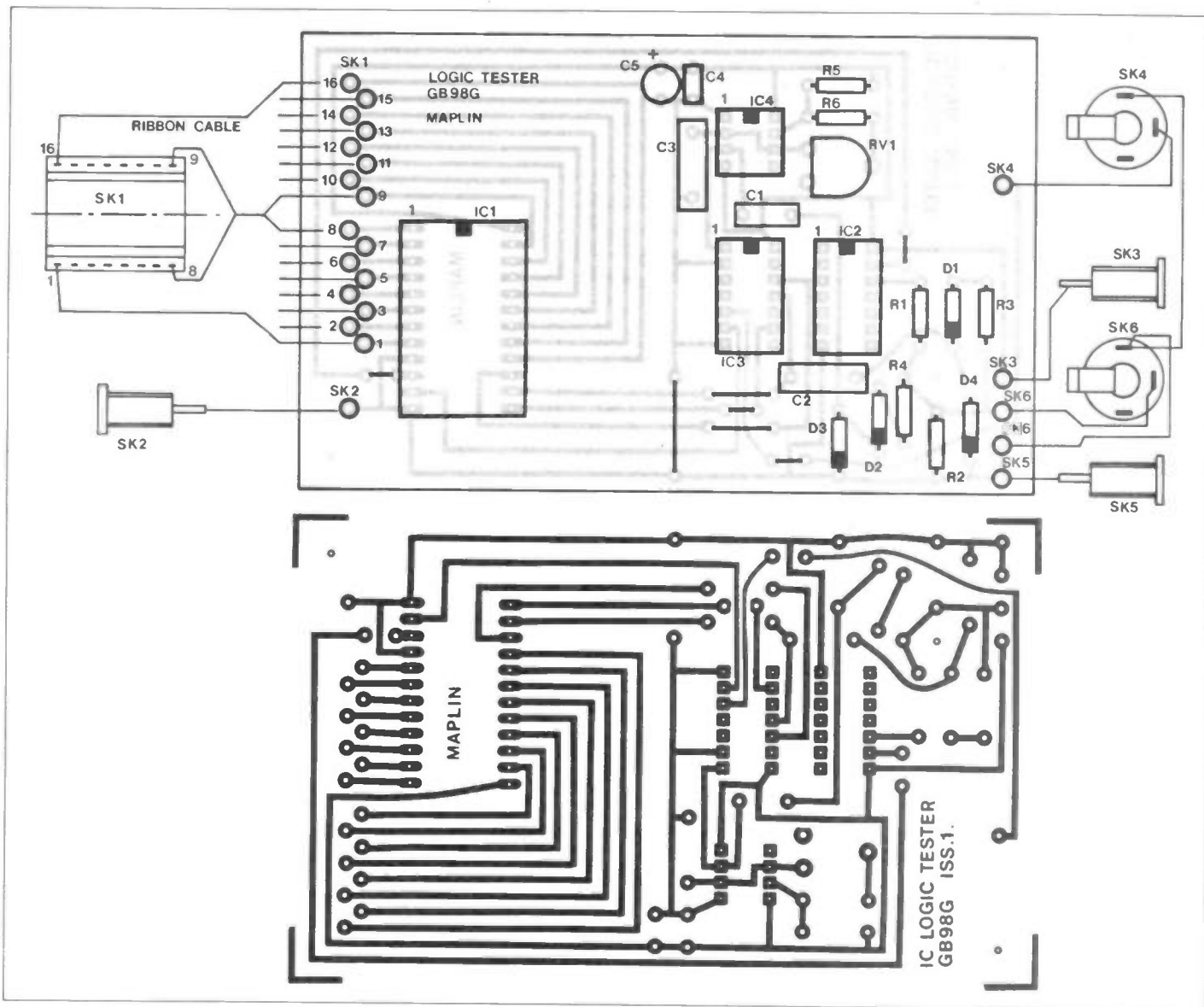

Figure 3. PCB layout and wiring

number of horizontal divisions, such as 8 or 16. Obviously a graticule or some other form of marker, could be made and fitted onto the screen, but it is more convenient to use some form of electronic marker. In this case, negative pulses are modulated onto the display to indicate the divisions between parts of the display. Apart from pulses to divide the display into its sixteen basic parts, there are stronger markers which divide the display into quarters. This enables the section of the display which relates to any given pin number to be rapidly and easily located, or working the other way, any given part of the display to be easily translated to the appropriate pin number of the device under test.

The sixteen marker signals are generated by feeding the clock signal to a pulse shaper circuit which converts the roughly squarewave signal into a train of negative pulses. These are then combined with the main output signal at the mixer stage. The four larger marker signals are produced in essentially the same manner but the signal for the pulse shaper is taken from the second bit of the binary counter. This gives a divide-by-four action and the required one marker pulse for every four clock pulses.

## Circuit Operation

A very simple circuit is used, and the full circuit diagram of the unit appears in Figure 2. IC1 is the 16 to 1 decoder, and this is a TTL 74150 device. As explained previously, the signal is inverted through this device and the output signal must be re-inverted in order to retain the original signal polarity. One of the inverting Schmitt Triggers of IC2 provides the necessary re-inversion. The other five inverters of IC2 are left unused. There is a negative enable input at pin 9 of IC1 and taking this high, holds the output terminal high. This function is not needed in this application and pin 9 is simply tied to the earth rail. Note that an earth input is included and it is essential that this is connected to the earth rail of the equipment under test to ensure that the input levels are referenced to the earth rail potential of the equipment under investigation. Without this connection, the two earth rails might not be at the same potential, and even if they were, problems with noise could occur.

The 5-bit binary counter is a CMOS 4024BE device, IC3. This is actually a seven stage type, but here the last two stages are just ignored. Although IC3 is a

CMOS device and IC1 is a TTL type, IC3 is able to drive the inputs of IC1 satisfactorily. The reset input of IC3 (pin 2) is not required here and is just connected to earth. The synchronisation signal is taken direct from the stage 5 output of IC3, and any oscilloscope which has an external synchronisation input should trigger reliably from a 5 volt logic signal.

The clock signal is generated by IC4 which is a 555 timer device connected in the standard astable configuration. RV1 is adjusted to give a suitable clock frequency. Spare inverters of IC2 could be used to generate the clock signal but in practice, it is better to use a 555 clock circuit as this gives much better stability and avoids the need for frequent retrimming of the clock frequency.

A passive mixer circuit is used at the output of the unit and this consists of just four resistors (R1 to R4). These have been given fairly low values so that, in conjunction with the input capacitance of the scope, they introduce little lowpass filtering and do not seriously degrade the bandwidth of the system. The values of R1, R3 and R4 set the relative strengths of the main signal, the four large marker signals and the sixteen marker signals respectively. Each pulse shaper merely

consists of two diodes and a capacitor which provide brief negative pulses. The value of the capacitors set the pulse widths and in order to make them stand out better, the four marker signals have roughly double the width of the sixteen markers. The width and amplitude of the marker signals has to be a compromise between clearly marking the borders and encroaching on the main part of the trace to such an extent that ambiguities are produced. The specified values give a good compromise but the values of R3, R4 C1 and C2 can be altered to suit individual preferences if desired.

The circuit requires a 5 volt supply and it has a current consumption of about 70 milliamps. No built-in power supply has been included as there should be no difficulty in finding a suitable external supply in most cases. The prototype is used in conjunction with a Crotech 3132 oscilloscope which conveniently provides a 5 volt supply output for use with add-on circuits. If your oscilloscope does not have a suitable supply output, the circuit under investigation may well be able to supply the modest current requirement of 70 milliamps, or a bench power supply set for an output of 5 volts can be used.

## Construction

The printed circuit track pattern and component layout are shown in Figure 3. Start by fitting the link wires, veropins, resistors, capacitors, and then fit the diodes and integrated circuits. IC3 is a CMOS device and it should consequently be fitted in a (14-pin DIL) integrated circuit holder. The other normal anti-static handling precautions should be taken, with IC3 being fitted in place only when all the other components have been added and all the wiring has been completed. Leave IC3 in the anti-static packaging until then and use a minimum of handling when plugging it into the holder. Although IC1 is not a MOS device, it is a fairly expensive type and a socket for this device should be considered essential.

The printed circuit board is connected to the integrated circuit test clip via a piece of 16-way ribbon cable, about half a metre or so long. As this cable is carrying high speed signals in parallel, it is advisable not to use a long cable. Although 16-way cable is not available, it is easily produced by tearing off 4 ways from a 20-way cable. The integrated circuit test clip is not polarised and it will fit onto test devices either way round. This could lead to confusing results in this application and it is advisable to put a mark on it next to pin 1 to reduce the risk of clipping it onto a test device with the wrong orientation. Of course, fitting it the wrong way round will not cause any damage but the various sections of the display will not correspond to the pins of the test device in the way you think they do, giving misleading results unless the mistake is spotted.

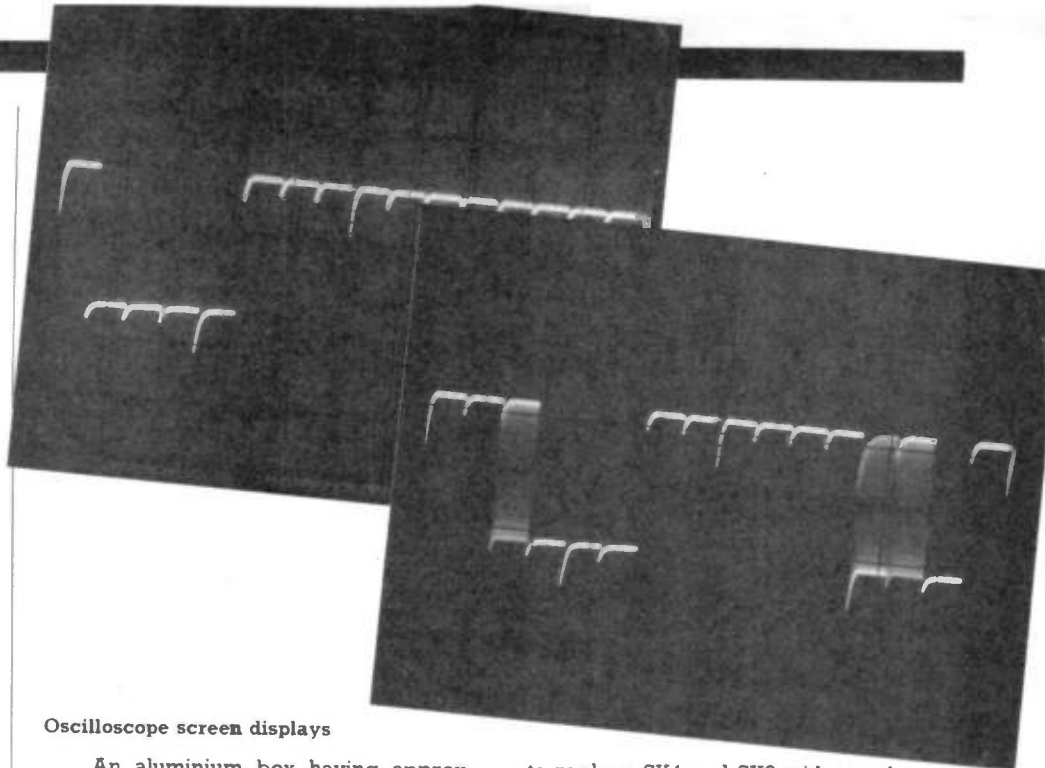

Oscilloscope screen displays

An aluminium box having approximate outside dimensions of 133 by 102 by 38 millimetres will accommodate all the components but this represents about the smallest size that will do so. The printed circuit board is mounted on the base panel of the case using M3 or 6BA fixings and as the case is a metal type, it is obviously essential to fit spacers to keep the connections on the underside of the board well clear of the case.

The ribbon cable can be taken out between the top and base sections of the case at one end of the unit, and SK2 is fitted at this end of the unit. The other four sockets are mounted at the opposite end of the case. SK2 to SK6 are then wired to the board using ordinary insulated multistrand hook-up wire, and this wiring is all included in Figure 3.

## In Use

Two test leads are required in order to connect the unit to the oscilloscope. Assuming the oscilloscope has BNC type connectors, both leads should consist of about half a metre of 50Ω (UR76 type) cable fitted with a BNC connector at the oscilloscope end, and a 3.5 millimetre jack plug at the tester end. These connect the output of the tester to the Y input of the oscilloscope, and the sync. output of the tester to the sync. input of the oscilloscope. An alternative and cheaper way of making the connections would be

to replace SK4 and SK6 with panel terminals that would enable the normal test leads of the oscilloscope to carry the two sets of interconnections.

With the test clip left unconnected, everything else connected up (including a suitable power source) and the oscilloscope set at a sweep rate of about 1ms per centimetre, a stable trace should be obtained, provided external synchronisation is selected and the sync. level control is adjusted to a suitable setting. A fairly low sensitivity of about 0.5 volts per centimetre should suffice. This level of sensitivity may actually appear to be rather on the high side for logic signals but bear in mind that there are losses through the mixer stage at the output of the unit, and the output is consequently not at normal logic levels. It is best to use DC coupling, if this option is available, as this enables static levels to be accurately measured, but AC coupling gives usable results.

RV1 is simply adjusted to give precisely sixteen sectors from one side of the screen to the other but make sure that the horizontal shift control is set properly before adjusting RV1. If the oscilloscope has a "fine" sweep speed control, it is quite acceptable to give RV1 a roughly mid-setting and then adjust the sweep speed to give the correct trace. Note that when the inputs are left floating, being TTL types they float to the high state.

The unit is then ready for use. With any piece of equipment of this general type, it is a good idea to try it out on some pieces of digital equipment that are functioning correctly to familiarise yourself with the types of display that should be obtained. An important point to keep in mind is that the unit has standard TTL inputs and it therefore increases the loading on the test points by one TTL load. This additional loading will be unimportant in most cases but it could produce problems when testing some types of logic circuit (particularly those which use old type CMOS devices).

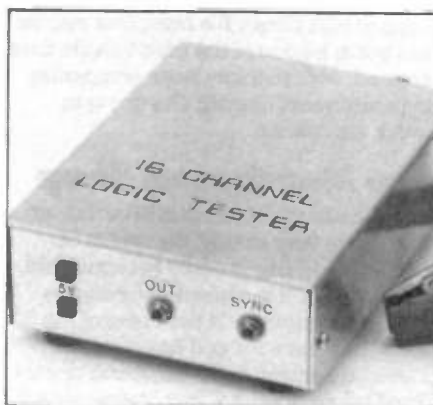



Manchester Shop Front

Southampton Shop Front

# MAKE IT WITH MAPLIN

by David Snoad Part Three

In this issue of Electronics, the Maplin article takes us from almost one end of the country to the other. We have already looked at the Westcliff, Hammer-smith and Birmingham shops, which leaves the Manchester and Southampton branches for us to visit. I shall not dwell for too long on any mail order memories this time, as it has been decided to extend the series to a fourth part. This will give me the opportunity in the next issue to give you an exclusive guided tour around the various departments contained within our Head Office/Warehouse and bring you right up to date with Maplin experiences.

## The Maplin Road Show

After the successful opening of the Birmingham shop in August 1982, it did not take long to decide that another branch, further north, should be equally successful. Manchester was chosen for several reasons, a not insignificant fact being that the Greater Manchester conurbation is second only in size to London. But one fact that has always remained in my mind is the wonderful reception which Maplin received at Manchester when we held the Maplin Mini Road Show back in September 1981. Some readers may remember this event; it was held shortly after the "Matinee" organ project had been completed and during a period when Maplin was recognised as one of the leading suppliers of Atari computer equipment in the UK. The show visited several cities including Edinburgh, Newcastle, Birmingham and Norwich; it was a

success at every venue, but I must confess it was an absolute treat to meet such an enormous amount of enthusiastic Maplin customers at Manchester. Many people travelled considerable distances to see professional organists put the "Matinee" through its paces and the Atari demonstrations were sophisticated even by today's standards.

## A Changing Industry

It is good that Maplin are flexible enough to keep in touch with the ever-changing face of the electronics industry and thus stay up to date with the latest products. But nevertheless, it is a shame to see projects such as the "Matinee" nearing the end of its life. Although Maplin enjoyed a respectable place in the home computer market during the early years, the decision to pull out about two years ago has not been regretted. We are pleased we had the foresight to recognise that the High Street Stores were starting a war which no-one could hope to win. Surely the computer market has got to be one of the most volatile ever created, with so many large companies in recent years coming and going in quick succession.

## The Manchester Shop

Choosing premises in Manchester was really very simply, the merits of Oxford Road being easily recognisable. To start with, it is conveniently accessible, being virtually in the centre of the motorway network and has plenty of metered parking in the adjoining streets. The Oxford Road Railway Station is only

100 yards away and bus stops for those travelling either north or south-bound are almost outside the shop. Oxford Road is on route for many of the city's buses. With the unmistakable advantage of the massive University and Polytechnic just down the road and the City Centre less than a mile away, you will understand why we believe this to be the best site we could have chosen to suit the majority of Manchester customers.

## Self Selection

Before we started the unenviable task of fitting out the new shop and pouring in almost 7,000 different stock lines, it was decided that maybe the time had come to break with tradition. Up until this time, Maplin had followed the usual pattern associated with electronic shops in this country, i.e. a counter service, a situation requiring a sales person to collect virtually all the customers order. The decision was taken to test customer response at Manchester and give this more modern approach to shopping a try. Self service has become a way of life in many stores these days with some companies going to the extreme of becoming so impersonal that the customer becomes just a number on a video screen. Maplin certainly did not want to lose touch with customers at Manchester; this was one of the reasons for the installation of a sort of 'cold meats counter' or rather, component counter as it is known. The component counter carries all the products which would be either difficult to merchandise or items which might require sales staff assist-



Manchester shop staff (left to right) Gavin, Tim and Bob

ance. This includes for example, semi-conductors, resistors, capacitors and wire. The advantages of self selection are prevalent in the areas where customer choice can be satisfied by making the wide variety of connectors, switches, etc., available for close inspection. If you have not visited this shop yet, then we would like to offer an open invitation to come and have a browse and meet the staff.

## Manchester Staff

The staff at the Manchester store are all young and very enthusiastic about this hi-tec business in which they are involved. Three out of four of the team joined the company together when the store first opened in August 1983.

The only member of the team who was a customer, rather than an employee when the shop first started, was Keith Watherson who came to Maplin about 15 months ago. Prior to joining Maplin, Keith spent 6 years in the army as a Telecommunications Technician, an experience which provided Keith with the opportunity to learn much about electronics and radio. During his time in the army, Keith visited many parts of the world, serving a short spell in the Falklands. He was sent there just after the action had finished and was present when Margaret Thatcher visited the

Island. Keith's interests include motor-cycling and computing, but not at the same time! He is an expert with the Atari and has helped to provide programs which assist him with one of his functions at the shop, which is looking after the stock control.

Tim Beswick is Assistant Manager at the Manchester branch, accepting this position after proving himself a worthy member of the team. His dedication could well come from the disciplines learnt in one of his hobbies which is Kung-Fu. He has achieved a brown belt in this martial art. This enthusiasm for fitness does not however stop there, because he runs 5 miles a day in addition to the mileage covered jetting about the shop. Tim previously worked in a large supermarket and found his other hobby, electronics, just the experience he needed when he saw the opportunity to join Maplin. After building several electronic projects, Tim has become particularly interested in digital electronics and like so many other people in the country, Tim has a ZX81 tucked away somewhere safe in a cupboard at home.

Another keen electronic hobbyist is Gavin Wright, who built several projects before joining Maplin; projects mainly associated with his interest in music but in particular, the guitar, for example, amplifiers and musical effects units.

Gavin says he is settling down nicely into his job with Maplin, which is his first after studying at Manchester Polytechnic. While at college, Gavin acquired several qualifications including the one which is necessary to get a radio licence. His call sign is G6WTF, although I do not think he has much time for radio with all his other interests. As well as playing squash, Gavin captains a local table tennis team. I'm told that Gavin's hobbies also include women and drinking real ale but even these take second place to his passion for motor car rallying. He says he is going to be a champion one day. We wish him luck.

It seems that real ale also appeals to Bob Raynor, another of the Manchester team, which is not too surprising as I expect he needs to quench his thirst after some of his rather energetic pastimes. Since I have known him, Bob has played Rugby Union and badminton; he has also been secretary of a local crown green bowling club but I believe this sport has now changed to ten pin bowling. He also enjoys wind surfing and hiking and occasionally relaxes with a game of chess. Before joining Maplin, Bob spent several years as an apprentice TV service engineer which has been invaluable experience when helping customers with any problems they may encounter with their electronic construction.

At present, the Manchester store does not have a permanent manager; we expect that an appointment will be made quite soon, but in the meantime, the shop is being looked after by one of Maplin's capable sales team.

## Shop Re-arrangement

Within the next few weeks, it is intended to re-organise parts of the Oxford Road shop. The proposals include moving the component counter to the first floor, changing the stock layout and certain improvements in decoration. It is hoped that these changes will make it easier for customers to browse and find what they want and help staff to give the best service possible. It is this personal service that Maplin have tried so hard to provide, which has helped build the favoured reputation of which Maplin staff can be proud. A service which is fast becoming appreciated by many of the electronic component consumers in the Manchester area. Customers at the shop appear to be more varied than other branches, but this would seem to be due to the many students who visit the shop regularly. Naturally, the Manchester store appeals to small and large companies alike, from service engineers to representatives of large companies such as G.E.C. and Ferranti. Two of the most interesting customers have been firstly, the BBC, sited just over the road, with some of their interesting applications for components in film sets and a small company in South Wales, who are building a remote control submarine for use in an attempt to salvage the Titanic.

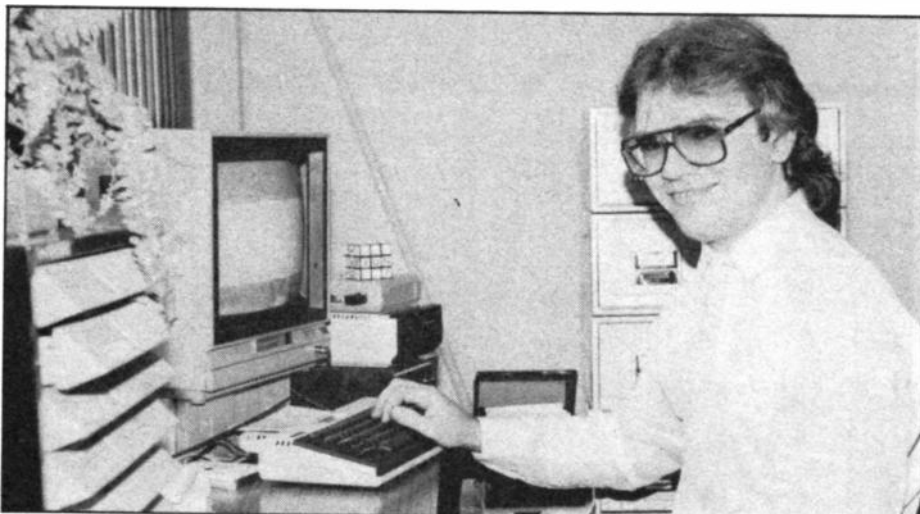

Keith is in charge of Stock Control  
September 1985 Maplin Magazine



## Places of Interest

As I said earlier, a welcome awaits you at the Manchester shop and as with our other branches, you can be guaranteed many interesting places to visit in the near vicinity, if a day trip needs to be justified. Places such as the recently opened Museum of Science and Industry, which I am reliably informed is worth a visit. For beer lovers, an authentic 14th Century Tudor Pub and Restaurant in Shambles Square, and for theatre goers, the recently re-opened Palace Theatre is only a couple of hundred yards away with plenty of cinemas a short walk down the road. For the ladies, a visit to Europe's largest undercover shopping centre, the Arndale, has got to be irresistible. If, after visiting the Manchester branch, you have any comments you would like to make on the subject of self selection against counter service, I would love to hear from you via P.O. Box 3, Rayleigh, Essex. The best letter may be published and will earn you a fiver.

## Moving South

Originally, it was intended to open the following shop to Manchester the next year, but the prevailing circumstances teased Maplin into acting rather faster than was first anticipated. As with any national company intending to expand into a new area, one of Maplin's first tasks, after deciding on a town or city, had to be a thorough survey of the district. Maplin have never believed that prime shopping centres or high streets are very suitable for our type of business. We understand that the needs of our customers often include the necessity to drive up, quickly get the required components and then leave without having a mile trek back to the car. Bearing this in mind, the ideal position appeared to be mid-way between the City Centre and University, a position which could easily be reached by out-of-town customers coming from the M26. After some research, we found that this ideal location was already occupied by another electronic component retailer with the name of Valley Radio. Situated in Bevois Valley Road, we soon discovered that this was a well established company with a history all of its own.

## Southampton Shop

Fortunately for Maplin, we were quickly able to establish through our enquiries that the proprietor of Valley Radio, Mr Ken Miles, was very keen on the idea of a change to the Maplin image. His shop, as can be seen from the early photograph, dates back to the period when one of the main services was re-charging accumulators at tuppence a time. Over the years, Ken has seen many changes to the family business, one of these being the move into a booming Hi-Fi market in the mid 1970's. Another change includes several modifications to the shop front, being due either to the blitz, vehicles driving into it or more recently of course, the Maplin look.



Mr. Ken Miles, Southampton shop manager

Valley Radio was first started by Ken's father in 1932, who started the business selling ex-government equipment including, later on, radios from submarines. He, in turn, learnt the trade from his father, who moved to Bevois Valley in Southampton at the turn of the century selling gramophones, phonographs and records.

It is really interesting listening to Ken reminisce, sharing his vivid memories of an industry which has changed out of all recognition since his youth. He remembers when, as a boy, he spent most of his time helping his father by topping up the many batteries with distilled water. He is also proud to tell people of Southampton's first radio licence which was issued to his father back in 1923 and it still hangs on the shop wall to this day.

Ken joined the family business after spending 12 years with 'Vickers Armstrong' working as an Aircraft Design Draftsman. He spent most of his time there assisting with the development of the acclaimed 'SPITFIRE'. Married, with a son, Ken has maintained a very active lifestyle. He enjoys a round of golf and has played table tennis in Southampton every season since the league was reformed in 1945.

When Valley Radio became Maplin in the Autumn of 1983, Ken Miles changed his role and became a Maplin Manager. He noticed that some of his established customers resented the change at first, thinking that they would lose the personal service to which they had become accustomed. They need not have worried; Maplin also believe in providing the best service possible.

In addition to Ken, the Southampton shop is staffed by two salesmen and Mrs Doris Stearn. Working as a part-time employee, Doris helps with stock control and other clerical duties. She has not encountered any problems adapting to the new Maplin systems, being a competent secretary who has worked for Ken for no less than 19 years.

The Assistant Manager at Southampton is Michael Hogg who started with Maplin at the Hammersmith branch, but who moved South to assist with setting up the latest shop. He joined the company after leaving college and looks forward to the day when he can manage his own branch. Recently married and buying his own home,



Valley Radio in the early days



Southampton shop staff (left to right) Bob and Michael

Michael spends a lot of his time on D.I.Y. but says he hates every minute of it; he says it is a necessity rather than a pleasure but does admit to enjoying the end result. Michael's wife, who is a nurse in the local hospital, participates with her husband on the computer but they admit it almost only gets used for games. Other interests which occupy Michael's time are table tennis and war games. He also appreciates the ease of getting into the country for a stroll after the confines of London.

The other table tennis playing member of staff at Southampton is Bob Goldsmith. He also plays for the local league; that's when he is not out fishing with his friends. Bob has almost completed a home study course on photography, a subject which is taking up more of his time these days. He also enjoys sport, plays five-a-side football and generally likes keeping fit. Before joining Maplin in October 1983, Bob worked for a year with another retail company prior to which he spent 2 years as a trainee technician with the R.A.F.

The staff at Southampton would like to meet you, whether hobbyist or trade. They suggest that they are now very easy to reach with the completion of the M27 and new sections of the M3 and as the Maplin catalogue indicates, many buses pass the door. I must confess that I find Southampton an enjoyable place to stay.

# CHOOSE A FREE GIFT



There are many interesting places to visit, to name a few, the Maritime Museum, the Mitchell Memorial Museum with many historic aircraft including a Spitfire, the Tudor House Museum which is in town; there is a Zoo and not many miles away is the New Forest with Beaulieu and Buckler's Hard.

## Free Offer

As with the last two issues of Electronics, we are extending a free offer

to customers visiting the shops mentioned in this article. Should you now be convinced that Southampton or Manchester are worth a visit, then bring this magazine with you, spend more than £25 and we will give you one of the items illustrated, absolutely free of charge (while stocks last). This offer is only open at Manchester and Southampton and is not available by mail-order or at any other shop.

In the next issue, I look forward to showing you around our Head Office/Warehouse.

## SEVEN SUPER CIRCUITS *Continued from page 28.*

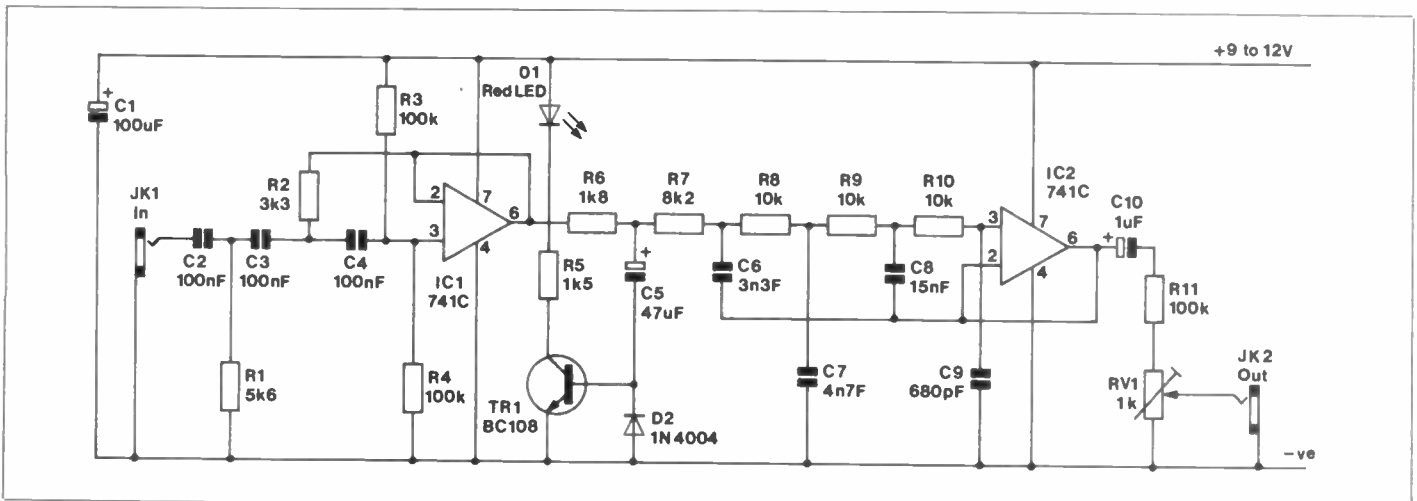

## SPEECH PROCESSOR PARTS LIST

RESISTORS: All 0.4W 1% Metal Film

R1	5k6	1	(M5K6)
R2	3k3	1	(M3K3)
R3,4,11	100k	3	(M100K)
R5	1k5	1	(M1K5)
R6	1k8	1	(M1K8)
R7	8k2	1	(M8K2)
R8,9,10	10k	3	(M10K)
RV1	1k Sub-Min. Preset	1	(WR55K)

### CAPACITORS

C1	100µF 25V P.C. Electrolytic	1	(FF11M)
C2,3,4	100nF Polyester	3	(BX76H)

C5	47µF 25V P.C. Electrolytic	1	(FF08J)
C6	3n3F Polycarbonate	1	(WW25C)
C7	4n7F Polycarbonate	1	(WW26D)
C8	15nF Polycarbonate	1	(WW31J)
C9	680pF Polystyrene	1	(BX34M)
C10	1µF 100V P.C. Electrolytic	1	(FF01B)

### SEMICONDUCTORS

IC1,2	µA741C	2	(QL22Y)
TR1	BC108C	1	(QB32K)
D1	LED Red	1	(WL27E)
D2	1N4004	1	(QL76H)

### MISCELLANEOUS

JK1,2	3.5mm Mono Jack Slt	2	(HF82D)
-------	---------------------	---	---------

**NEW IDC CABLE**  
Colour Coded

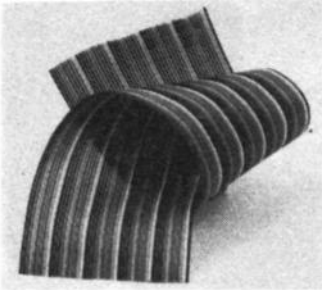

We can now supply a range of Flat IDC Cable, colour coded as our Ribbon Cable. Available in 16-way, 20-way, 26-way, 34-way, 40-way and 50-way. Each wire has a coloured sheath and is spaced on a 0.05 inch pitch. Stranded cores are 7 x 0.127mm. The cable is manufactured to UL2697. Priced per 30cm length.

- Order As**  
**XR80B (Clr Cd IDC Cable 16W)** Price 32p  
**XR81C (Clr Cd IDC Cable 20W)** Price 40p  
**XR82D (Clr Cd IDC Cable 26W)** Price 54p  
**XR83E (Clr Cd IDC Cable 34W)** Price 70p  
**XR84F (Clr Cd IDC Cable 40W)** Price 82p  
**XR85G (Clr Cd IDC Cable 50W)** Price 99p

**NEW STYLE BT LINE CORD**  
Flat 4-Way IPC Cable

Four way flat D section telephone line cord specifically designed for use with the latest style BT 4-way IPC (Insulation Piercing Connector) jack plugs. The stranded wires are 7 x 0.15mm, and colour coded Red, Blue, Green and White, and are sheathed overall in a light grey PVC sheath. To fit the cable to the IPC plug, simply

# NEW PRODUCTS

provide a clean cut across the end, and strip off 11 to 12mm of the outer sheath. Allow the four wires to separate from one another by approximately 1mm, then push and tease them gently into the plug, which has locating guides built in for each conductor. Once fully home (the coloured wires can be seen through the slot

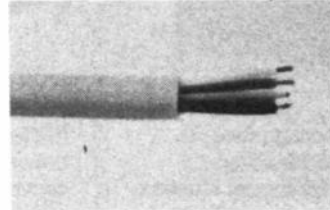

behind the contacts) use heavy duty pliers or a small vice to press the four gold coloured contacts flush with the plug body; push down the small strain relief members immediately behind the contacts, then force down the cable clamp at rear. Priced per metre.

**Order As XR86T (4-Way Flat BT Cable)** Price 18p

**G Clamp Set**



A three piece, diecast G clamp set comprising three different size clamps having maximum capacities of 20mm, 30mm and 40mm respectively. A nylon shoe on the end of the threaded screw protects the workpiece, the screw is operated by a knurled knob. A round, magnetic base is included, which incorporates a slot to accept any of the three clamp frames, such that two may be combined to form a small table edge vice, or to make the clamp free standing for holding small items. Ideal as a third hand for holding PCBs etc, holding together small objects being bonded until set, and many other uses.

**Order As FT76H (Mini G Clamp Set)** Price £4.95

**NEW TOOLS**



**0 Size Pozidriver**  
Size 0 Pozidrive screw driver with chunky handle and Chrome-vanadium steel blade for those

small, fiddly screws. Length of blade, 60mm, handle 77mm.  
**Order As FT54J (Size 0 Pozidriver)** Price 85p

**Stainless Steel Rule**

A 12 inch (300mm) stainless steel rule, having minimum imperial graduations of  $\frac{1}{16}$ ,  $\frac{1}{8}$  and  $\frac{1}{4}$  inches, or  $\frac{1}{20}$ ,  $\frac{1}{10}$  and  $\frac{1}{5}$  inches. Minimum metric graduations are 1.0 and 0.5 millimetres. The rule is approximately 1mm thick.

**Order As FT75S (12in Stainless Stl Rule)** Price £3.45



**Toolbox**

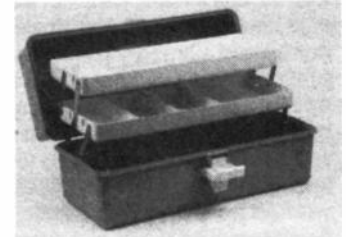

A tough, shatterproof blue plastic toolbox with hinged lid and recessed foldaway carrying handle and all plastic catch. The lid also withdraws two partitioned trays on opening, each tray is 297 x 110mm overall by 22mm deep. The lower tray has three compartments 110 x 60mm, and one 110 x 115mm. The upper tray has one of 110 x 43mm, two of 74 x 44mm, one of 160 x 74mm, and one 34 x 283mm long. When withdrawn the trays reveal the bottom compartment of the toolbox having a total area of 320 x 130mm, and a depth of 70mm. Overall dimensions: length 340mm, width 145mm, height 150mm.

**Order As XG69A (Plastic Toolbox)** Price £5.95

**16 CHANNEL LOGIC TESTER** Continued from page 57.

**16 CHANNEL IC LOGIC TESTER PARTS LIST**

RESISTORS: All 0.4W 1% Metal Film

R1	1k	1	(M1K)
R2	860Ω	1	(M860R)
R3	4k7	1	(M4K7)
R4,5,6	10k	3	(M10K)
RV1	100k Sub-Min. Hor. Preset	1	(WR61R)

CAPACITORS

C1	4n7F Polycarbonate	1	(WW26D)
C2,3	10nF Polyester	2	(BX70M)
C4	100nF Ceramic	1	(BX03D)
C5	100µF 10V P.C. Electrolytic	1	(FF10L)

SEMICONDUCTORS

IC1	74160	1	(QX89W)
IC2	7414	1	(QX46A)
IC3	4024BE	1	(QX13P)
IC4	NE885	1	(QH66W)
D1,2,3,4	1N4148	4	(QL80B)

MISCELLANEOUS

SK1	IC Test Clip	1	(FY74R)
SK2,5	Black 2mm Sockets	2	(HF44X)

SK3	2mm Socket Red	1	(HF47B)
SK4,8	3.8mm Mono Jack Case AB10	2	(HF82D)
	Printed Circuit Board	1	(LF11M)
	24-Pin DIL IC Socket	1	(CB98G)
	14-Pin DIL IC Socket	1	(BL20W)
	8-Pin DIL IC Socket	2	(BL18U)
	Ribbon Cable 20-Way	1	(BL17T)
	Hook-Up Wire	1 Mtr	(XR07H)
	Bolt 6BA x 1in.	1 Pkt	(BL00A)
	Nut 6BA	1 Pkt	(BF07H)
	Spacer 6BA x 1/2in.	1 Pkt	(BF18U)
		1 Pkt	(FW38Q)

OPTIONAL

PL2,5	BNC Plug	2	(HH17T)
PL4,6	2mm Plug Black	2	(HF38R)
PL3	Plug Plus 3.8mm	2	(HF80B)
	2mm Plug Red	1	(HF41U)
	Low C Cable	1 Mtr	(XR19V)

A kit of the above parts, excluding the optional items, is available:  
**Order As LK77J ("Scope Logic Tester Kit) Price £12.95**  
 The following item in the above kit is also available separately, but is not shown in the 1985 catalogue:  
**IC Logic Tester PCB GB98G Price £2.95**



# AMENDMENTS TO 1985 CATALOGUE

**5-BAY DIRECTOR AERIAL XQ38R** (Page 25). The front/back ratio quoted in the specification table is actually 17-27dB. The Acceptance angle is  $\pm 17-28^\circ$ .

**14-BAY DIRECTOR AERIAL XQ43-46** (Page 25). The group headings for the specification table have been erroneously shifted left one column.

**21-BAY DIRECTOR AERIAL XQ50E** (Page 25). Again the acceptance angle is  $\pm 10-24^\circ$ .

**FERRITE ROD AERIAL LB12N** (Page 29). The circuit details of a medium/long wave receiver supplied with this aerial is actually a very old design and recommends the use of germanium transistors for example. To use this circuit successfully a fair amount of modification and replacement of out of date components may be required.

**UNIVERSAL BATTERY CHARGER YK31J** (Page 34). This universal nickel cadmium battery charger has changed in style but is essentially the same as the style shown in the catalogue. The new type is not supplied with a carry case, nor does it have monitor meter. The charger will take up to four AA, C or D type cells including PP3, but not button cells. Size 210mm long x 104mm deep x 55mm high, colour black with transparent lid. Fitted with 1.6 metres of mains lead.

**E.H.T. WIRE XR22Y** (Page 79). The copper conductor actually comprises 16 strands 0.2mm dia. and not 7 strands of 0.25mm dia.

**LOW CAPACITANCE SCREENED CABLE UR76, XR19V** (Page 82). This coaxial cable now has the following specifications: - stranded core 7/0.32; dia. 5.0mm; 100pF/m; 50 $\Omega$  impedance; -4dB/m @ 100MHz; 2kV max.

**SINGLE-ENDED AND AXIAL ELECTROLYTICS** (Pages 93, 94). The column headings for the specification table at top right of page 93 is transposed with the column headings of the table at top left of page 94.

**1/4in MONO CHASSIS SOCKET CHROME BEZEL HF90X** (Page 117). This standard 1/4in moulded jack socket does NOT have gold plated contacts.

**UNIVERSAL PLUG HE38R** (Page 129). This adaptor lead may or may not include a 2-pin plug and mating 2-pin socket 200mm from the end of the lead, entirely depending on the supplier. To save any further confusion it can be said that the leads are not provided with said plugs/sockets, as this is the case with our current new stock.

**HI-FI DISTRIBUTION BOX WY16S** (Page 130). The four way Euroboard is fitted with 1 metre of 3-core mains cable, and not 2 1/2 metres as stated in the description in the catalogue.

**SECONDARY LINE JACK UNIT FG28F** (Page 132). This item has been described as a Secondary Line Jack (2/4A), whereas it should be (2/6A).

**BBC ANALOGUE PORT CABLE** (Page 134). This cable assembly has a 15-pin D range plug, and not 16-pin.

**ROOM THERMOSTAT YB20W** (Page 140). This item has been changed for a replacement type, but the photograph still shows the old type. The description is correct.

**HERO JUNIOR KIT KA00A** (Page 167). This kit version of Hero Jr now includes the RS232 interface RTA-1-3, and the cartridge adaptor RTA-1-5. The Hero Jr Kit has also been reduced in price to £549.95.

**BLACK ANODISED KNOBS, HB39N & HB40T** (Page 179). The photographs in the catalogue of these knobs have been incorrect for some time, but have managed to slip through the net yet again! The text is correct however.

**MICROPHONE INSERTS LB93B - QY62S** (Page 182). The input impedance of any amplifier with which these microphone inserts are to be used should be as follows: crystal inserts,  $\geq 1M\Omega$ ; dynamic inserts,  $\approx 50k\Omega$  to  $100k\Omega$ ; electret  $\approx 50k\Omega$ .

**MINIATURE TIE-CLIP MICROPHONE YW71N** (Page 185). This tie-clip microphone is not supplied with a battery as stated in the catalogue.

**GRAPHIC EQUALISERS AF60Q, AF27E & AF59P** (Page 189). The slider controls fitted to these do have a multi-position click effect, but not a specific centre clickstop action as stated in the descriptions in the catalogue.

**ACOUSTIC GUITAR TRANSDUCER YL08J** (Page 191). The 'Professional' transducer does not include a connecting lead with a mono jack plug attached as shown in the photograph.

**GUITAR STRINGS LB60Q** (page 191). The photograph shown should not include the packet of nylon strings, LB60Q is sold as a set of steel strings only.

**LOW-COST PHOTOTRANSISTOR YY66W** (Page 198). This device now has a TIL78 package and not TO106, and has only two leads for collector and emitter. The collector is denoted by a flat on the package and the shorter of the two leads. Electrical characteristics are Light Current at 940nm  $V_{ce} = 5V$ ,  $H = 20mW/cm^2$ , 7mA; Dark Current at  $V_{ce} = 30V$ ,  $< 0.1nA$ ; Peak Spectral Response, 940nm.

**RECTANGULAR METERS RW98G - RK53E** (Page 208). The photograph shown of a Rectangular Meter is incorrect. These meters actually look like the Large Meter on opposite page, with a black coloured bottom portion of the face.

**V-Q VEROBOARD HQ48C** (Page 210). This Veroboard has holes punched on a 0.1 x 0.1in. matrix but which are 1mm diameter, not 0.1in.

**ETCH RESIST PEN HK02C** (page 214). This pen has been changed for an improved, easier to use type. The text is correct but the photograph is of the old pen, which little resembles the new type.

**40W STEREO AMPLIFIER XH48C (MES33)** (Page 232). We regret that it has become necessary for us to discontinue kit XH48C. Some of the special parts are no longer available. Please check before commencing construction that all the parts you are going to need are available and order any that appear on page 232 of the 1985 catalogue at once, as all these items will be discontinued when all present stocks are exhausted (i.e. are currently 'while stocks last'). If you are now unable to complete this project as a result of our inability to supply all the parts, we will consider requests for re-funds, and you should write at once giving full details of your claim to:

The Sales Manager,  
Maplin Electronic Supplies Ltd,  
P.O. Box 3, Rayleigh, Essex  
SS6 8LR.

**ZX SPECTRUM KEYBOARD KIT LK29G** (Page 267). The ready-made keyboard includes the adaptor and case, the kit does not.

**PANIC HORN FK75S** (Page 275). Where the description states the requirement of one PP3 battery, this must be a high power alkaline type e.g. Gold Seal FK67X.

**ANTI-STATIC GUN LX04E** (Page 281). This has now been changed for the combined antistatic gun and record cleaner RC2000. The head of the cleaner has a pad of tiny conductive fibres and a brush for the surfaces of records.

**RESISTANCE WIRE BL64U** (Page 286). This constantan resistance wire is supplied as 1 oz reels, not 2 oz reels.

**2N3819 QR36P** (Page 297). This JUGFET device will henceforth be in a T092d case style, and not a T0106f package as before.

**HEX NON-INVERTING 3-STATE BUFFERS YH11M & UB78K** (Page 307). The captions for the internal circuit and pinout diagrams are transposed with the 7407 & 7417 devices which are actually the 14-pin package. The 74LS365 and 74HC365 devices are in the 16 pin package.

**UF04E** (Page 307). In the table of order codes UF04E has been described as 4049UBE, whereas it should be 74HC4049.

**OCTAL NON-INVERTING 3-STATE BUFFER QQ56L, UB65V, UB66W** (Page 308). In the case of the 74LS244, 74HC244 and 74HCT244 devices, the output enable control input pins 1G and 2G are both active low, i.e. both internal control buffers should have inverting input symbols (like 74LS240 inverter version etc), and not as shown.

**QUAD BUFFERS 3-STATE 74LS125 YF49D** (Page 308). The internal architecture and pin outs diagram is implied as belonging to the 74LS124; it should of course be the 74LS125.

**4512 CMOS 8-LINE TO 1-LINE MULTIPLEXER QW84F** (Page 319). This IC is incorrectly described in the specifications table as the 4521, also the pinouts diagram labelled 4521 does not apply. The device has propagation

delay characteristics for a low to high transition at 5V  $V_{DD}$  100ns, at 10V 50ns and at 15V 40ns; high to low at 5V 130ns, at 10V 65ns, and at 15V 50ns.

**1-POLE 8-WAY ANALOGUE SWITCHES QW34M, UF06G & UF14Q** (Page 319). The captions of the pin-out diagrams for these devices are transposed. The 74HC4351 is actually in the 18-pin package and the 40S1BE and 74HC4051 have the 16-pin package.

**DIGITAL SOUND EFFECTS GENERATOR PCB YQ42V** (Page 341). Full details of the various circuit applications of the Digital Sound Effects Generator are not supplied with the PCB.

**NE555 TIMER IC QH66W** (Page 356). May be supplied as a MC1455PI, this is correct. The MC1455 IC is a direct equivalent device and a pin for pin replacement for the NE555, having the same electrical characteristics.

**500mA/1A + V PSU** (Page 363). In the parts list for all voltages, C2 should be listed as Axial 4.7 $\mu$ F 63V (FB23A).

**1A & 12A POWER CONTROLLERS QY37S, QY38R** (Page 364). These power controllers should have the suffix R in the type number, i.e. PC1R, PC12R. The suffix letter A is incorrect.

**EPROMs 2716, 2732 & 2764 QQ07H, QQ08J, QQ09K** (Page 370). These EPROMs are quoted as having access times of 250ns, whereas in actual fact they have a minimum of 350ns. For most practical purposes they can be regarded as being 450ns and suitable for use with microprocessors having a 500ns clock period.

**AXIAL FAN WY08J** (Page 381). The supporting 'spider' will be composed of aluminium and not zinc alloy.

**STANDARD STEREO HEADPHONES WF13P** (Page 385). The photograph of these headphones is now out of date. They do not have a padded headband and the lead is straight not coiled.

**200W 15 INCH BIG CAT XG53H** (Page 391). The specifications table should read 200W continuous rms, and not 100W rms.

**DUAL-IN-LINE SWITCHES XX26D XX29G** (Page 394). The photographs showing these DIL switches, and the 8-way type in particular, are no longer current. The switches now come in a white encapsulation with the sliders numbered 1 to 8 in black; the sliders are correspondingly colour coded brown, red, orange, yellow, green, blue, violet, grey.

**KEYBOARD CASES YJ15R & YJ14Q** (Page 400). The case YJ15R is actually for the keyboard without numeric key-pad YJ12N, and case YJ14Q is to house the keyboard with numeric pad YJ13P. Prices are correct.

Continued on page 64.



# CLASSIFIED

## VARIOUS FOR SALE

**Maplin AM Tuner Module** and power supply transformer. Both less than a year old and barely used. Over £20 new, sell for £15 or near offer. Please contact Mr. A. Gonnet, Sun Cottage, Bellingdon, Chesham, Bucks HP5 2XW.

**Pocket Multimeter ETU-101** 1000 ohms/volt. Good condition, complete with battery, instructions and original container. £3.50.

Telephone Luton 575060.

**Maplin Modem for sale.** 300 Baud, RS232, assembled but never used. May need setting up with an oscilloscope. Complete with case £50 ono. Phone Martin on 021 453 4753 after 6pm.

**Solarscope Solartron type CD711S-2 CT414** dual beam, 64 valves (needs 3 more valves). Big and heavy. £40.

Contact J. Horton, 149 Mill Road, Deal, Kent, CT14 9BB.

**Radio Control Transmitter.** Built and working as issue 13 of Electronics. Pots and instructions included. Requires crystal. Worth £11. Offers phone Gravesend 62272, ask for Nicholas.

**Oscilloscope Telequipment D61** twin beam. Good condition, little used. 10x probe. £120 ono. Telephone Banbury (0295) 53475.

**Oscilloscope Maplin XB82D** (Crotech 3030) guaranteed perfect condition, used only once, plus BW05F probe BNC (set) and WG34M oscilloscope book, complete £199 o.n.o. Tel: (047 335) 8136, Woodbridge, nr. Ipswich.

**Maplin PWM Motor Driver Module,** kit LK54J. Needs attention, £6. Telephone (0272) 603110.

**Rechargeable Soldering Iron,** cost £36, will accept £15. High power rechargeable Headlamp with 6 volt, 8 amp, hour battery, incredible beam. Brand new, £30. Ring Worcs (0905) 840995.

**Disco outfit complete.** Twin BSR decks, quickstart switching, bomb-proof OMP110 amp. OMP '1000' professional mixer, monitor phones, mic, mic muting/override, aux/tape input. Built in 3 channel Sound-to-Light, ditto Chaser. Loads of home-made lights, cables, bits, etc. Plug in and go! £450 or might swap for Poly Synth. Telephone Richard on Dursley (0453) 3948.

## COMPUTERS

**Commodore printer plotter** and MPS 801, as new, offers, ring Keith on (0223) 247980.

**Revitalise your VIC-20** with a PROM/RAM expansion kit. Includes a board and instructions, just add a

If you would like to place an advertisement in this section, here's your chance to tell Maplin's 200,000 customers what you want to buy or sell, or tell them about your club's activities - absolutely free of charge. We will publish as many advertisements as we have space for. To give a fair share of the limited space, we will print 30 words free of charge. Thereafter the charge is 10p per word. Please note that only private individuals will be permitted to advertise. Commercial or trade advertising is

strictly prohibited in the Maplin Magazine. Please print all advertisements in bold capital letters. Box numbers are available at £1.50 each. Please send replies to Box Numbers to the address below. Please send your advertisement with any payment necessary to: Classifieds, Maplin Mag., P.O. Box 3, Rayleigh, Essex SS6 8LR.

For the next issue your advertisement must be in our hands by 1st October 1985.

2716/2732 PROM or a 6116 RAM. Send £4.25 to Seddon, 63 Portland Road, Birmingham.

**128K QL Computer** with software, blank cartridges, leads, and mags. Boxed and ready to post. Immaculate condition only £280 o.n.o. Telephone Paul at (0278) 684770.

**ZX Spectrum** latest software on tape to swap, send your list and ask for mine, some 400 items long. Also details of sound on TV, for 20p stamp from Hamid-Reza Tajadeh, 4th Floor No.11, Street No.3, Naarmack, Tehran 16479, Iran.

## CLUBS

**Issue 9 of Monitor magazine** is now available. It is full of excellent programs and tutorials for Atari computer owners. Have you got your copy? Send a cheque/P.O. for £1.30 (includes P & P) to the 'U.K. Atari Computer Owners Club', P.O. Box 3, Rayleigh, Essex.

## MUSICAL FOR SALE

**Leech 120 watt amp** with built in distortion, plus 4 x 12" cabinet. Excellent condition. Also Roland DR55 programmable Drum Machine, as new. £40. Phone 01 680 0236 after 6.30 pm.

**Maplin Matinee organ cabinet** and stool. Also 20 various Marble-effect Key Tabs. Offers, telephone (0952) 598472.

**Maplin Matinee organ.** Mint condition. Had little use. £295. Please ring 021 588 2682.

**MES 53 organ,** unfinished, many parts not even unwrapped. Contains power supply unit, keyboard, contacts, spring-line, etc. £45. Telephone John Wearne on 051 342 7805 evenings/weekends.

manual and batteries.

**SAFE BUDS YK98G** (Page 430). These cotton bud cleaning aids have been quoted in the catalogue as being available only as single items, whereas they are in fact sold in packs of ten for the same price.

**15W LINE TRANSFORMER YX66W** (Page 435). This item has been erroneously omitted from the catalogue, and is still available. Current price £3.95.

## WANTED

**Oscilloscope** in good working order. Prefer double beam. Anything considered under £50. Ring Keith on 0223 247980.

**Dual Trace Scope,** signal generator and power supply unit 0-30V @ 1.5A. Telephone Hawthorn (0225) 811086.

**Design and make service** for remote control circuits in robotised domestic furniture units. Write to F. McCauley A.R.I.B.A., 17 Cornwall Mansions, Cremorne Road, Chelsea, London, SW10 0PE.

**Circuit diagram or Handbook** for Sony Radio Receiver CRF220 (World Zone). Write to Mr. Ogilvie, 33 Cliff Gardens, Minster, Sheppey, Kent, ME12 3QY. Quote for original or photocopy.

**KEF B139 Bass speaker** or would consider a pair. Details to Mr. Jay on Norwich 720566, evenings only.

**Wanted, Maplin Auto-Organ** leaflet MES 56 etc, either sell or loan, reasonable price paid plus postage. Telephone (0621) 773304.

**Wanted, 32 Note Organ Pedalboard** with or without contacts. Please write J. Lane, 10 Ashley Road, Thames Ditton, Surrey, KT7 0NJ.

# LOOK OUT!

## Coming Soon

### The New 1986 Maplin Catalogue on sale 9th November

Pick up a copy from any branch of W.H. Smith or in one of our shops. The price is still just £1.45.

Alternatively, you can get a copy by post by sending £1.85 (including postage) to our Rayleigh address and quoting CA03D.

## Overseas Prices

Europe surface mail	£2.50
Europe air mail	£3.75
Outside Europe surface mail	£2.50
Outside Europe air mail	
(depending on distance	£4.25/£5.50/£6.25

For surface mail anywhere in the world you may send eleven International Reply Coupons.

# LOOK OUT!

## CATALOGUE AMENDMENTS

Continued from page 63.

### LOW COST FREQUENCY

**COUNTER YK38R** (Page 410). This portable, battery powered digital frequency meter has changed slightly. Specifications are: Input Impedance, 1M $\Omega$ /20pF; Bandwidth, 10Hz to 50MHz; Power Supply, 6 x AA batteries or V DC @ 100mA; Battery Low Indicator, flashing unit sign; Battery Life, 4 hours; Dimensions, 111 x 36 x 125mm; Weight, 500gms. Supplied with BNC terminated coaxial test lead, instruction

# DID YOU MISS THESE ISSUES?



**Project Book 1 Universal Timer.** Programmable mains controller. Combo-Amplifier. 120W MOSFET power amp. Temperature Gauge. 10°C - 100°C, LED readout. Pass The Bomb! Pass-The-Parcel with a difference. Six easy-to-build Projects on Vero-board. Car batt. monitor; Colour snap game; CMOS Logic Probe; Peak Level meter; Games timer; Multi-colour pendant. **Order As XA01B (Maplin Project Book No. 1) Price 70p NV.**

**Project Book 2 Digital Multi-Train Controller.** Controls up to 14 model trains. Home Security System. Six in-dependant channels. Digital MPG Meter. With large LED display, a must for more economical motoring. **Order As XA02C (Maplin Project Book No. 2) Price 70p NV.**

**Project Book 3 ZX81 Keyboard.** 43 keys, plugs directly into ZX81 with no soldering. Stereo 25W MOSFET Amp. 25W r.m.s per channel; Disc, Tape, Tuner & Aux. Radar Intruder detector. 20 metres range, may be used with our security system. Remote Control for Train Controller. Remote control by infra-red, radio or wire. **Order As XA03D (Maplin Project Book No. 3) Price 70p NV.**

**Project Book 4 Telephone Exchange.** Up to 32 extensions on 2-wire lines. Remote Control for Amplifier. Volume, balance and tone controlled via infra-red link. Frequency Counter. 8 digit DFM, 10Hz - 600MHz range. Ultrasonic Intruder Detector. Areas up to 400 square feet can be covered. **Order As XA04E (Maplin Project Book No. 4) Price 70p NV.**

**Project Book 5 Modem.** 300 baud transmission speed over normal telephone lines. Inverter. 240V AC 60W from 12V car battery. ZX81 Sound Generator. 3 tone generators fully controlled from BASIC. Central Heating Controller. Optimised performance with this advanced system. External Horn Timer. Exterior intruder alarm. Panic Button. Add on to our Home Security System. Model Train Projects. Add on to our Multi-Train Controller. Interfacing Micro processors. How to use parallel I/O ports, with circuits. **Order As XA05F (Maplin Project Book No. 5) Price 70p NV.**

**Project Book 6 VIC20 & ZX81 Talkbacks.** Speech synthesis projects. Scratch Filter. Tunable active circuit 'reclaims' scratched records. Bridging Module. Converts two 75W MOSFET amps to one 400W full bridge amplifier. Moisture Meter. Finds damp in walls and floors.

**ZX81 TV Sound and Normal/Inverse Video.** TV sound and inverse video direct. Four Simple Veroboard Projects. Portable Stereo Amp; Sine Generator; Headphone Enhancer and Stylus Organ. **Order As XA06G (Maplin Project Book No. 6) Price 70p NV.**

**Project Book 7 CMOS Crystal Calibrator.** For amateur radio receiver calibration. DX'er's Audio Processor. Improved sound from Communications Receivers. Enlarger Timer. An accurate timer for the darkroom. Sweep Oscillator. Displays AF frequency response on an oscilloscope screen. VIC20 and ZX81 Interfaces. RS232 compatible. **Order As XA07H (Maplin Project Book No. 7) Price 70p NV.**

**Project Book 8 Spectrum Modem/RS232 Interface.** 2400 baud self contained operating system. Synchime. Simulates bells, gongs and other chiming sounds. Dragon 32 RS232/Modem Interface. Plugs into ROM expansion port. CodeLock. Programmable electronic lock. CMOS Logic Probe. Digital display shows logic states. Minilab Power Supply. Versatile unit for the test bench. Dragon 32 I/O Ports. Two 8-bit ports. Doorbell for The Deaf. Flashing lamp attracts attention. **Order As XA08J (Maplin Project Book No. 8) Price 70p NV.**

**Electronics Issue 9 Spectrum Keyboard.** 47 full travel keys. VIC Extendi-board. Three expansion ports, one switchable. Oric Talkback. Speech synthesiser for the Oric 1. Infra-Red Movement Detector. 30 metres range outdoors. TDA7000 FM Radio. Complete FM receiver on a chip. ZX81 High Resolution Graphics. 256 x 192 fine pixel display. Ten Projects! Personal Stereo Dynamic Noise Limiter; Logic Pulser; ZX81 1K Extendi-RAM; TTL/RS232 Converter; Pseudo Stereo AM Radio; and more. **Order As XA09K (Maplin Magazine Volume 3 Issue 9) Price 70p NV.**

**Project Book 10 Spectrum Easyload.** Helps cassette loading with the Spectrum. 80m Receiver. Simple SSB direct conversion receiver. Fluorescent Tube Driver. 8W 12V for camping and caravanning. Auto-Waa. Automatic waa-waa effects unit. Digi-Tel Expansion. Expands Maplin Telephone Exchange to 32 extensions. Oric 1 Modem Interface. Adapts the Oric 1 to the Maplin Modem. Dragon 32 Extendiport. Makes the Dragon's cartridge socket more accessible. **Order As XA10L (Maplin Project Book No. 10) Price 70p NV.**

**Electronics Issue 11 Mapmix.** Six channel audio mixer. Xenon Tube Driver. Xenon flash tube module with strobe. Enlarger Exposure Meter. Simple inexpensive tool for the darkroom. 8 Channel Fluid Detector. Check/control fluid level in up to 8 containers. Servo & Driver Module. Servo mechanism with driver module kit. Mk II Noise Reduction Unit. Improves signal/noise ratio of tape recordings. Cautious Ni-Cad Charger. Controlled charging of ni-cad cells. Motherboard for The BBC Micro. Gives easy access to ports. **Order As XA11M (Maplin Magazine Volume 3 Issue 11) Price 70p NV.**

**Electronics Issue 12 RTTY Unit.** The TU1000 receives/transmits Radio Teletype; connects to computer via RS232. Computadrum. Use your computer as a drum synthesiser. Light Pen. Draw onto the TV screen or select menu options. PWM Motor Drive. Reversible model motor driver for 6V and 12V. **Order As XA12N (Maplin Magazine Volume 3 Issue 12) Price 70p NV.**

**Electronics Issue 13 Explosive Gas Alarm.** Flammable gas detector. Flash Meter. Get your exposure right when using your flash gun. Musical Announcer. A doorbell with a difference. Mains Controller. An add-on for the 8-Channel Fluid detector. **Order As XA13P (Maplin Magazine Volume 4 Issue 13) Price 75p NV.**

**Electronics Issue 14 Live Wire Detector.** Invaluable aid for the handyman. Trundle. The line follower robot as featured on Channel 4. Zero 2. High quality 'turtle' robot. 4-Channel PWM Controller. Digital control of motors and servos. Display Driver Module. How to use our LED bargraph display ICs. Control-A-Train. Full inertia control of model trains. **Order As XA14Q (Maplin Magazine Volume 4 Issue 14) Price 75p NV.**

**Electronics Issue 15 Z80 CPU Module.** Expandable CPU based controller. Zero 2 Ins & Outs. Connecting up to the Commodore 64, BBC-B and Spectrum. Sharp MZ-80K Serial Interface. Get into communications with this project. Ultrasonic Car Alarm. Stop car thieves. Active Crossover. Includes matched output power amplifiers. Guitar Equaliser. Specifically for six string electric guitars. Fabulous Five. A selection of interesting circuits. **Order As XA15R (Maplin Magazine Volume 4 Issue 15) Price 75p NV.**



# HOME STUDIO SELECTION

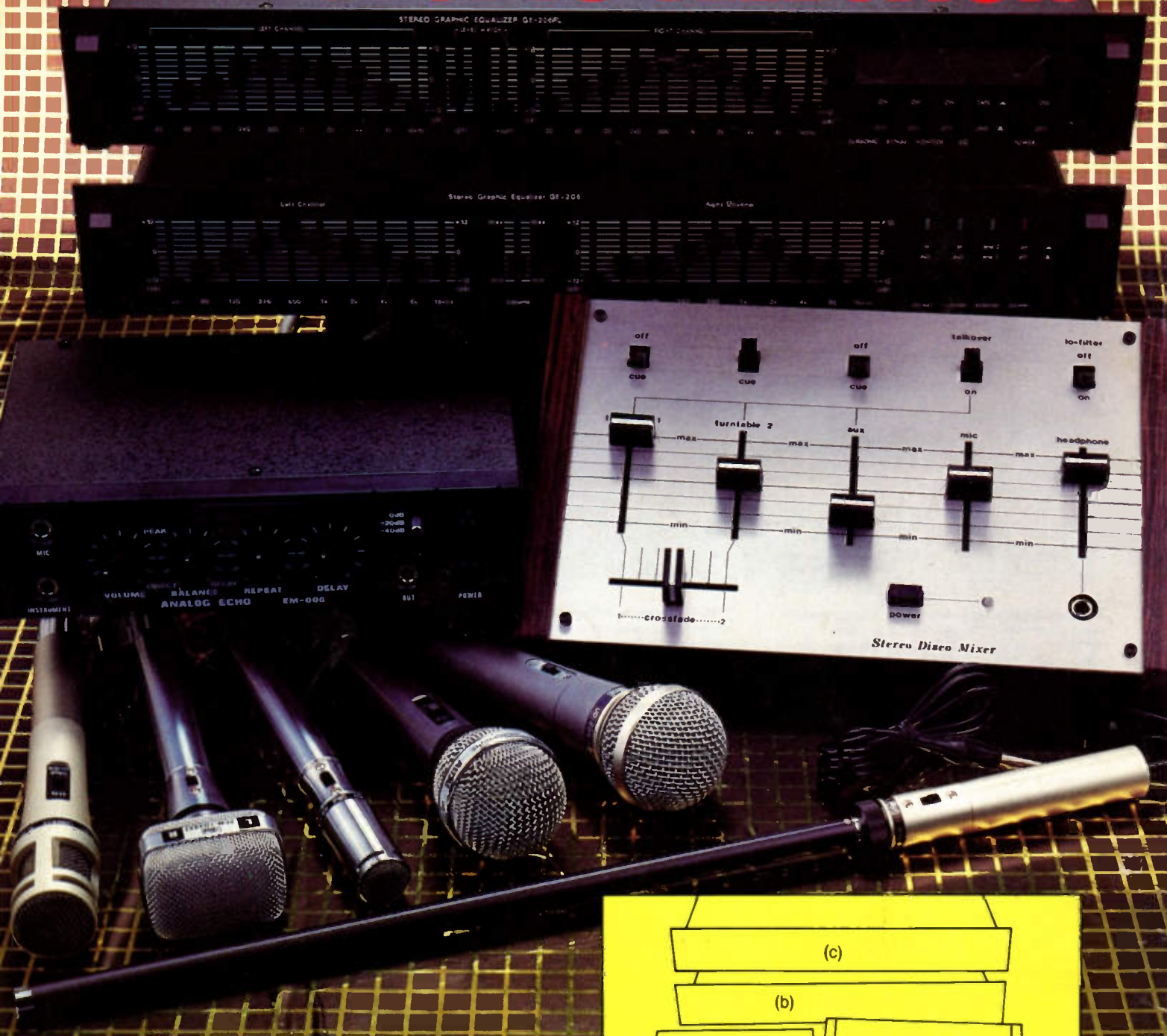

Now you can choose from our comprehensive range of audio products and accessories to equip your home studio, whether you are a musician, a recording enthusiast or a hi-fi addict. In addition to our popular effects machines, graphic equalisers and mixers we offer an extensive range of professional quality microphones to suit every application – and all at competitive prices!

All prices inclusive of VAT and postage and packing. Prices firm until 10th November 1985.

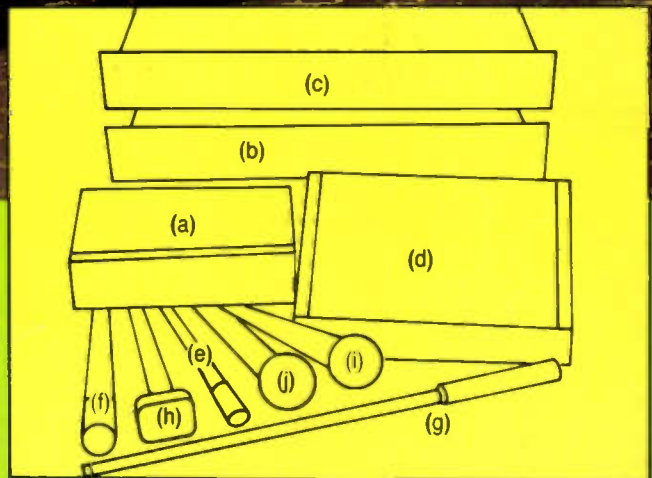

- (a) Echo Machine • (XG30H) • £78.00
- (b) 10 Channel Graphic Equaliser • (AF60Q) • £77.95
- (c) 10 Channel Equaliser with VU Meters • (AF27E) • £94.95
- (d) Stereo Disco Mixer • (AF99H) • £63.95
- (e) Omnidirectional Electret Microphone • (YK65V) • £21.95
- (f) Unidirectional Electret Microphone • (YK66W) • £29.95
- (g) Ultra Directional Electret Stick Microphone • (YK67X) • £28.95
- (h) Stereo Unidirectional Electret Microphone • (YK68Y) • £21.65
- (i) Dynamic Cardioid Microphone • (YK69A) • £35.95
- (j) Dynamic Unidirectional Ball Microphone • (WF35Q) • £12.45