

INDUSTRIAL ELECTRONICS

OCTOBER 1966

5s 0d

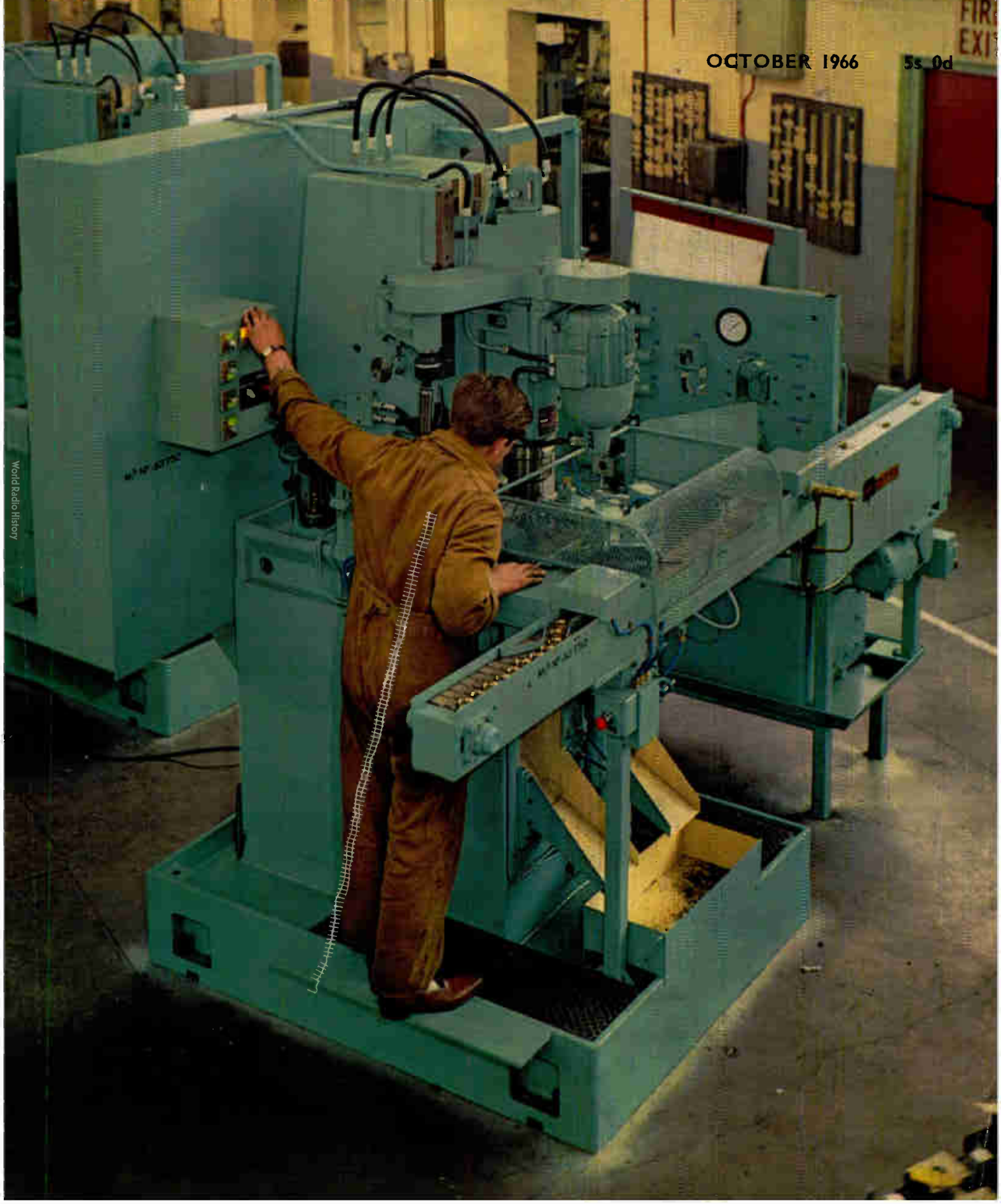

FIRE
EXIT

World Radio History

A large part of the **WORLD'S MOST ADVANCED INSTRUMENTATION** is available in the U.K. — from one source.



2

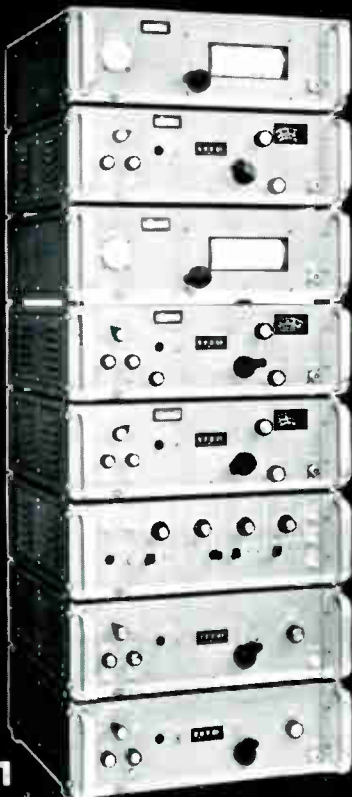

1

We are showing here a very small part of that large part!

If British electronic engineers are to keep pace with international competition, their most important need is for the type of equipment which is not only of the highest possible quality in design and construction, but also the most advanced of its kind for any given application.

The B & K Group, long aware of this fact, have specialized for many years now in seeking out such equipment in whatever part of the world it may be found, and making it available through one convenient source to British industry.

Hence today, a great many of the world's leading manufacturers of electronic apparatus are making use of this facility and we are showing here a small selection of typical types available.

1. Modular Microwave Signal Generating equipment from POLARAD, pioneers of microwave instrumentation and still world leaders.
2. BARNES IT-3 Infra-red Thermometer, measures the temperature of any object or part of it from a remote distance without contact.
3. ESTERLINE-ANGUS Speed-Servo Recorder, with 1/8th second response, adjustable zero and adjustable span.
4. THERMO-SYSTEMS 10/10A Constant Temperature Anemometer, now being used for flow measuring applications which were previously considered impossible.
5. DANA Digital Voltmeter Type 5600, the most sophisticated DV in the world!
6. TSI Digital High Frequency Counter-Timers, with fantastic stability and accuracy.
7. NUCLEAR-DATA ND-110, a versatile but low priced 128 channel Pulse Height Analyzer for routine radiation analysis.
8. MAGTROL Dynamometer, the most reliable and modern means of measuring speed-torque characteristics.



5

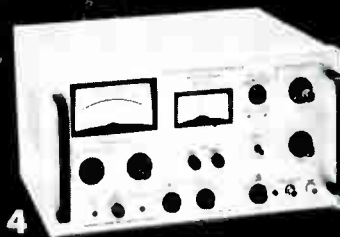

4



3

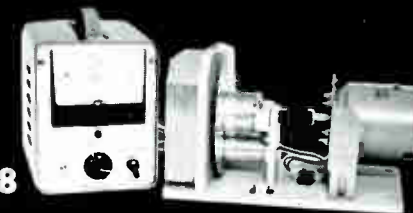

8



7

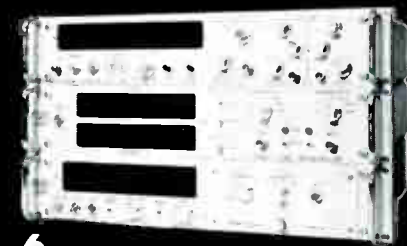

6

B & K INSTRUMENTS LTD

59 UNION STREET, LONDON, S.E.1 Telephone HOP 4567

INDUSTRIAL ELECTRONICS

Incorporating British Communications and Electronics

Communications Automation Instrumentation Control

Contents October 1966

Editor-in-Chief W. T. COCKING, M.I.E.E.
Editor T. J. BURTON
Editorial: K. G. HOLMES
T. A. KELLY
Production D. R. BRAY
Drawing Office H. J. COOKE
Advertisement Controller G. H. GALLOWAY
Advertisement Manager R. H. C. DOHERTY

453 **Comment**

454 **Machine-Tool Control by 'NOR' Switching**

by D. S. Nicholls

The 'NOR' switching element can be used for many control purposes. This article explains the application of these units for machine-tool control and outlines the manner in which a complete control circuit is built up.

458 **Computers in Industry: Back-up Control**

by J. A. Robinson, B.Sc. and N. L. Leece, B.Sc.

Last month, the ways in which direct digital control has been applied at I.C.I.'s Fleetwood chemical plant were described. In this article, some of the developments in back-up control techniques in the post-Fleetwood era are discussed.

462 **Why is Industry Shy of Automation?**

by Gerald Thomas

A certain amount of reluctance is being shown by industry in the adoption of automation techniques. This article discusses some of the reasons for this and outlines the type of cost saving that can be achieved by the use of automated plant.

466 **Fluid-Logic Control Devices**

by K. Foster, M.A., Ph.D. and G. A. Parker, B.Sc., Ph.D.

The article on fluid-logic systems which appeared in the December 1965 issue of *Industrial Electronics* discussed only the 'turbulence amplifier', a device already being manufactured in this country. The research and development into pure-fluid systems is not, however, restricted to this one device, and this article briefly describes other elements which are useful for many control applications.

VOLUME 4

NUMBER 10

continued overleaf

© Iliffe Electrical Publications Ltd., 1966

Permission in writing from the Editor must first be obtained before letterpress or illustrations are reproduced from this journal. Brief abstracts or comments are allowed provided acknowledgment to the journal is given.

Published on the last Thursday of the preceding month by

Iliffe Electrical Publications Ltd., Dorset House, Stamford Street, London, S.E.1

Managing Director: W. E. Miller, M.A., M.I.E.R.E.

Telephone: Waterlor 3333. *Telegrams/Telex:* Electronics Iliffepres 25137 London

ANNUAL SUBSCRIPTION, HOME £3 0s. 0d. OVERSEAS £3 10s. 0d.
CANADA and U.S.A. \$10.00.

INDUSTRIAL ELECTRONICS

Incorporating *British Communications and Electronics*

Communications Automation Instrumentation Control

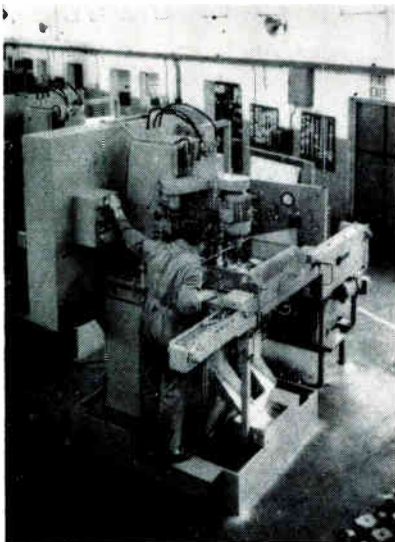

OUR COVER

The front-cover picture this month shows a machine manufactured by High Precision Equipment which is used to turn two faces on a gear-box component. This machine can be controlled by 'NOR' switching techniques and represents a typical application of these techniques. Elsewhere in this issue, an article outlines the basic principles of machine-tool control by 'NOR' switching and describes how a complete control system may be built up.

INDEX TO PRODUCTS

For the convenience of the reader who requires rapid access to information on specific products, an 'index to products' is provided on the same sheet as the reader enquiry cards.

Contents *continued*

473 **Transistorized Current Controller** *by N. H. Sabah, M.Sc.*
In this article a controller is described which is capable of maintaining constant to within 0.5% the discharge currents of 6- or 12-V batteries. Although the controller is primarily intended for battery discharge tests, it is possible to adapt the unit for other similar applications.

479 **Talkabout by Nexus**
This month, Nexus takes a look at the development of automatic aircraft-landing systems in the U.K., noting in particular the progress being made by Smiths Industries. The go-ahead, think-big attitudes that permeate much of the American electronics industry also come in for enthusiastic comment, and finally some of the activities of the Electrical Research Association are discussed.

493 **Farnborough Show 66**
Concurrent with this year's Farnborough Air Show was a static exhibition of aviation instruments and equipment. The electronic equipment on show included autopilot systems, navigational aids and other flight instrumentation as well as units with wider industrial applications. This report includes details of some of the equipment on display.

What's On and Where?

A regular feature which lists forthcoming events. Professional meetings, symposia, conferences and exhibitions are included. For easy reference this item is positioned facing the inside back cover.

Features

- | | | | |
|-----|---|-----|---|
| 457 | New Unit for Gear Checking | 478 | Manufacturers' Literature |
| 461 | Communication System for Motor Cars | 480 | Electro-Hydraulic Position Control |
| 465 | Communication by Tropospheric Scatter | 481 | New Apparatus |
| 469 | Applications and Techniques | 496 | Industrial News |
| 478 | Technical-Information Service for Electronic Engineers | 498 | New Books |
| | | 74 | <i>Classified Advertisements</i> |
| | | 81 | <i>Index to Advertisers</i> |

Next Month

An article on automatic vehicle location and identification appears next month, as does a progress report on ultrasonic cleaning. The final part in the series 'Computers in Industry' discusses the user response, and the issue will also include illustrated highlights of the Business Efficiency Exhibition.



Stoppage

Emergency Call! *New selective pocket paging plus two way speech....



Instruction



Action

Maintenance men with **SELECTIVE** two way radio weighing only 5½ ozs. can be found, be instructed and deal with emergencies—instantly.

Stoppage and emergencies mean time lost—output lost—money lost—lives risked.

Multitone systems save time . . .

Please write briefly describing your plant and number of maintenance staff for a specimen instant communication scheme.

*All radio UHF/VHF, two way speech, designed for inter-working with automatic alarms and the Sinus automatic industrial telephone range.

MULTITONE *instant communication*

Multitone Electric Company Limited
12-28 Underwood Street, London N.1.
Telephone: Clerkenwell 8022

For further information circle 203 on Service Card

CAPACITOR & RESISTOR

DECADE UNITS

These units are sturdy and inexpensive instruments suitable for both industrial and academic use. High grade industrial components are used throughout the construction and the cases are made up from standard components of the Lektrokit Chassis Construction System

£8-10-0

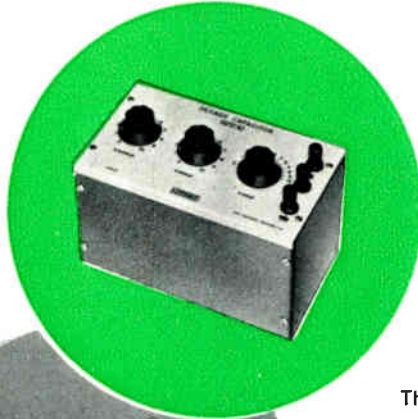

LKU-111 DECADE CAPACITOR

The Decade Capacitor covers the range 50 pF to 0.111 μ F with an accuracy of 5%. The unit consists of a variable air-spaced capacitor covering 50-1000 pF in parallel with two switched decades

£13-0-0

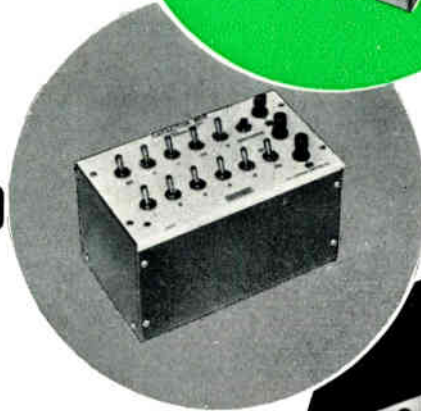

LKU-121 CAPACITOR BOX

This unit covers the range 0.05 to 28 μ F in steps of 0.05 μ F, each capacitor being separately switched. An additional switch is provided enabling the total capacitance of the box to be switched in or out of circuit in one operation

£13-0-0

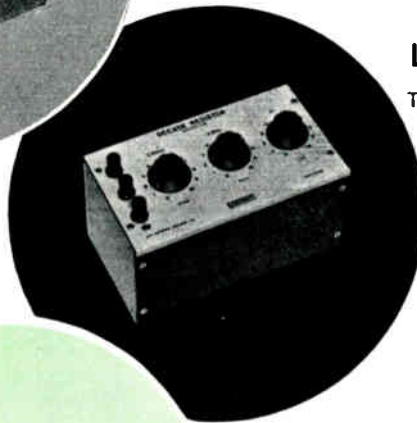

LKU-211 DECADE RESISTOR

This unit covers the range 0 to 1.11 k Ω in steps of 1 Ω with an accuracy of $\pm 2\%$, the resistance elements being heavy-duty wirewound resistors made from low temperature coefficient wire

£13-0-0



LKU-221 DECADE RESISTOR

This unit, which covers the range 0 to 1.11 M in steps of 1 k with an accuracy of 0.5% is very similar in construction to the LKU-211. The two units together form a convenient and inexpensive 6-decade resistor

ALL THESE UNITS ARE AVAILABLE FROM STOCK



**A.P.T.
ELECTRONIC
INDUSTRIES LTD.**

Chertsey Road, Byfleet, Surrey
Tel. Byfleet 41131/2/3/4 PABX
Grams. APTRAN, BYFLEET

Please send me your leaflet on:

- DECADE RESISTORS
 CAPACITOR BOXES

NAME

ADDRESS

For further information
circle 205 on Service Card

IDEALLY

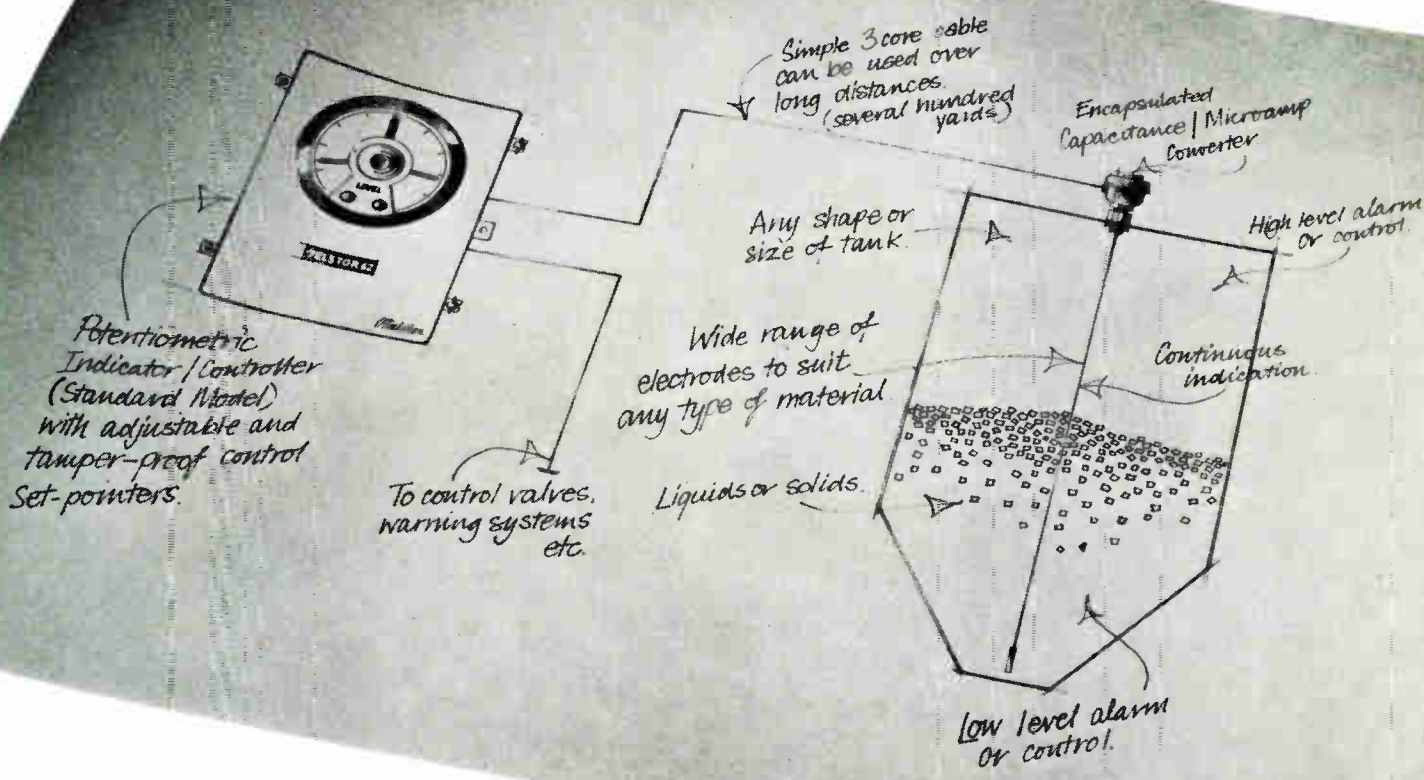

The new Fielden Potentiometric Indicator Controller has everything!

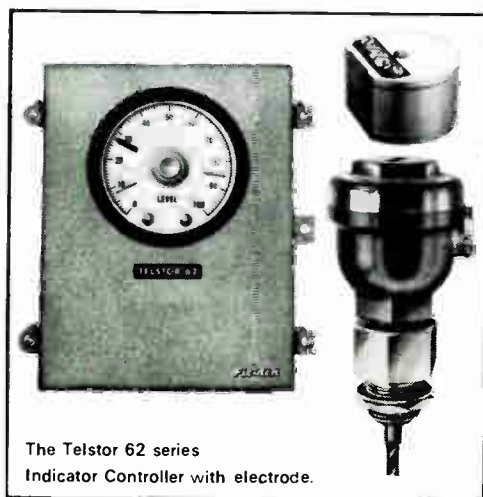

The Telstor 62 Series is a revolutionary simplification of equipment and application technique, offering continuous level measurement with single or dual control facilities plus all the advantages of potentiometric indication. High and low level control, or control within a predetermined band, plus continuous indication is achieved *using only one Electrode.*

The Electrode

The rugged, easy to install electrode is chosen from a vast standard range to suit the needs of the particular application and gives accurate measurement with any level differential from 12 inches up to 100 feet or more.

The simple inexpensive transmitting circuit mounted in the head of the electrode operates as a linear capacitance-to-microamp converter of high accuracy.

The Potentiometric Level Indicator/Controller

This is a fully transistorised wall mounted instrument providing robust electronic, servo-motor operation with potentiometric accuracy. It has an accurate 12½" easy-to-read scale and tamper-proof setting for control pointers. A wide range of control actions is available to meet the needs of any process. Please send for leaflet giving full details.

FIELDEN ELECTRONICS LIMITED

Wythenshawe, Manchester 22 Telephone: Wythenshawe 3251/8
Telegrams: Humidity Manchester. Telex: 66531

Offices: LONDON, WALSALL, HARROGATE and SCOTLAND Agents throughout the World

Manufacturers of 'Bikini' temperature instruments Temperature and pressure transmitters Three-term controllers and type 'A' Displays E/A Converters Temperature scanning, monitoring and controlling equipment

Fielden

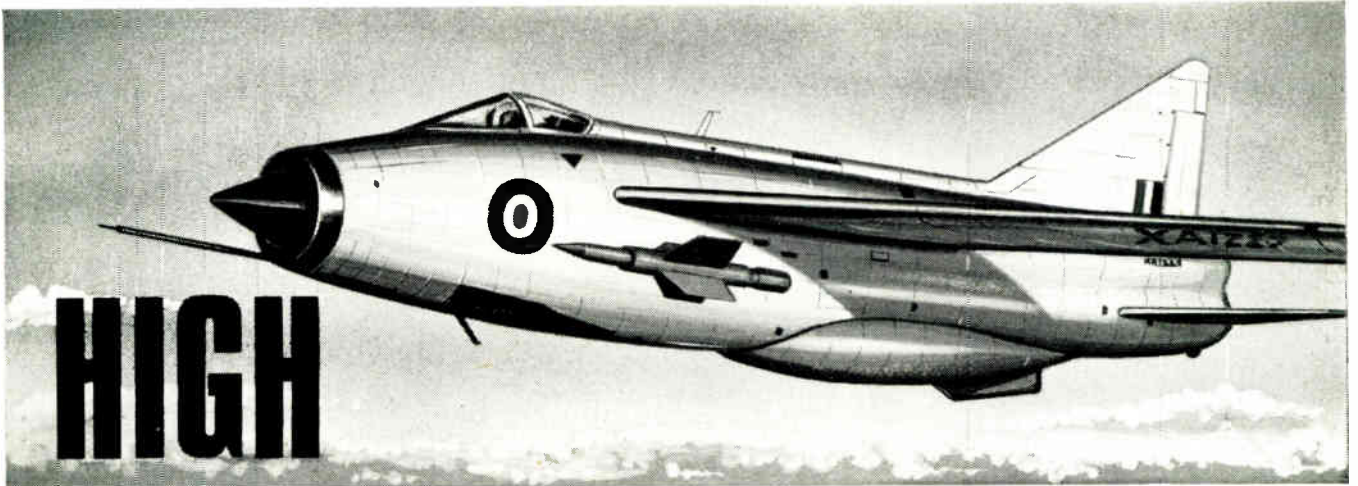

... getting
the measure
of it

Dawe manufacture a wide range of instruments which provide easily obtained, accurate and objective readings as a basis for scientific noise abatement. These range from a simple hand-held sound level meter to specialised equipment for testing vehicle and traffic noise, as well as a wide selection of audio frequency analysers, acoustic calibrators, etc.

Full details of how Dawe can help you solve today's noise problem are contained in a special summary leaflet. Ask for a copy today.

INDUSTRIAL division of **DAWE INSTRUMENTS LTD.**,

WESTERN AVE., LONDON, W3 Tel: AC0rn 6751 A member of the *Simms* group of companies

For further information circle 206 on Service Card

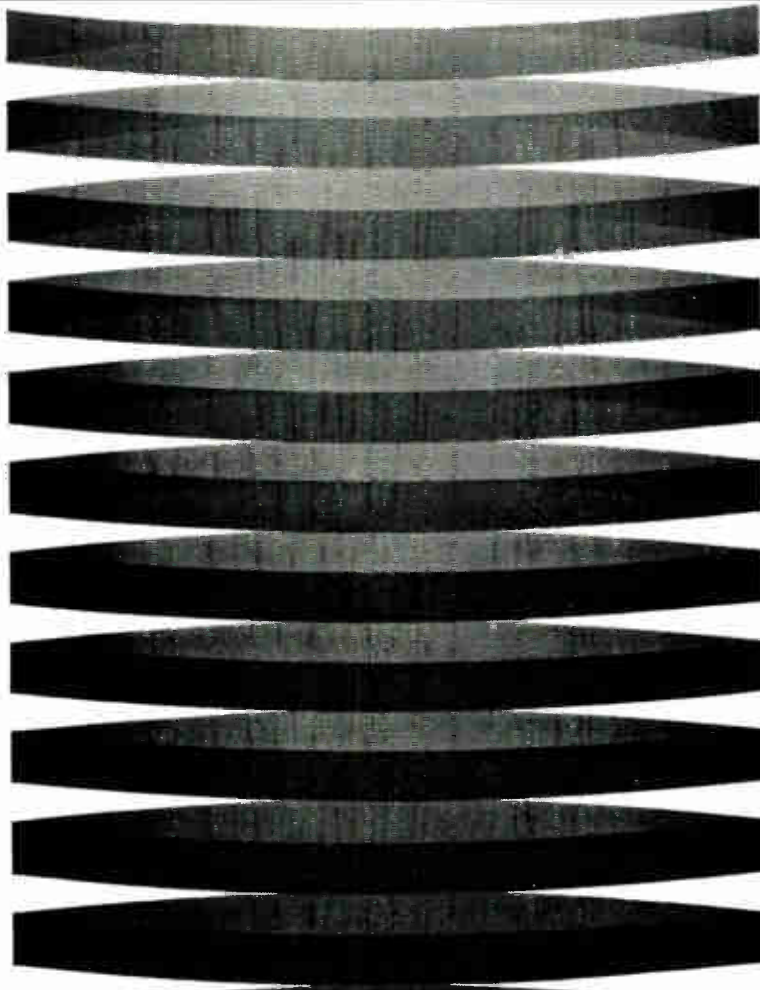

ETHER GENERATE POWER 

Switch-on with ETHER power supplies

Power supplies – an integral part of any electronic design – can be a headache. Consult Ether at the design stage of any project.

Specialist designs available in addition to a wide range of off-the-shelf equipment, all with power-in-reserve including:

High-stability units (single and multi-output) variable, plug-in and programmed equipment with wide choice of current and voltage ranges, a.c. voltage regulators, silicon or germanium units.

“ TALK POWER WITH ETHER ”

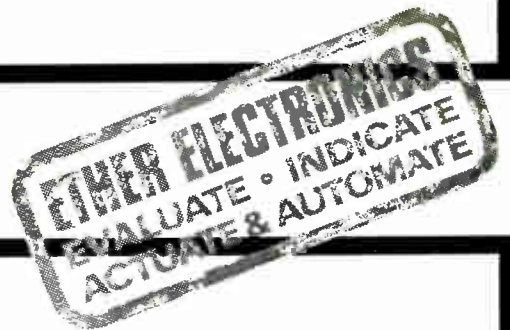

ETHER

ETHER LIMITED, General Products Division, Caxton Way, Stevenage, Herts. Telephone Stevenage 4422.

G.P.1

For further information circle 207 on Service Card

Mullard

integrated circuit programme— 5 further releases

Amplifiers for audio, operational and wideband applications now available

Five new integrated circuit linear amplifiers have now been released by Mullard. The new circuits comprise a comprehensive selection of amplifiers for audio, operational and wideband applications. Full details are given below under individual type references.

Items in this range are of monolithic semiconductor construction and are all in flat-pack encapsulations except for the low-level amplifier type TAA263 which has a 4-lead TO-18 metal envelope.

Amplifiers—type TAA263 and type 270TAA

These are general purpose low-level amplifiers recommended for telecommunication audio applications, recording systems and hearing aids.

Amplifier type TAA263 consists of a three-stage direct coupled circuit for use at frequencies from d.c. to approximately 600 kHz. It is encapsulated in a 4-lead TO-18 envelope.

The type 270TAA amplifier has a very low quiescent current drain and provides excellent performance in all high-gain low-current applications. Unique characteristics enable a minimum of 60dB gain to be obtained from one of these circuits operating at single-cell voltage (1.55V). Encapsulation is in $\frac{1}{4} \times \frac{1}{4}$ inch flat-pack.

Operational amplifiers—type 182TAA and type 192TAA

Designed specifically for analogue instrumentation and control systems, both of these amplifiers offer high input impedance, low drift and maximum reliability. Applications for these circuits will be found in transducer amplifiers, pre-amplifiers, voltage comparators, band-pass and buffer amplifiers. The main difference between the type 182TAA and type 192TAA amplifiers is that the former has provision for both single-ended and differentiated outputs. Encapsulation is in $\frac{1}{4} \times \frac{1}{4}$ inch flat-pack.

Wideband amplifier—type 231TAA

This item incorporates a direct coupled two-stage amplifier with integral negative feedback arrangements to ensure stable operation over the full specified temperature range. Applications for these devices will arise mainly in communication and radar systems in which they can be used with frequency selective elements to build up an i.f. amplifier with a.g.c. capabilities. In addition, an oscillator mixer stage can be formed by using an external crystal. A 'military' version of this circuit, type 232TAA, is also available with a T_{amb} range of -55 to $+125^{\circ}\text{C}$. Encapsulation is in $\frac{1}{4} \times \frac{1}{4}$ inch flat-pack.

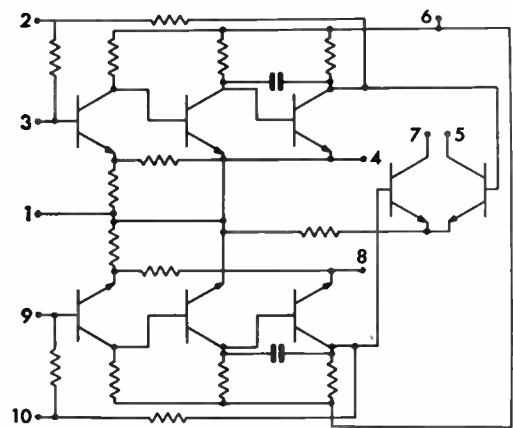

270TAA General purpose low-level amplifier

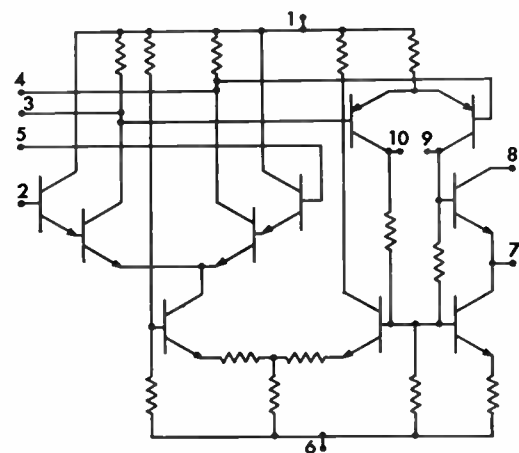

182TAA Operational amplifier for analogue and control applications

For further details of Mullard linear integrated circuits, please use the reply card of this journal (see reference opposite).

What's new from Mullard

A new television camera tube for monochrome and colour

High sensitivity, fast response independent of light level, and small size are features of Mullard's new television camera tube the "Plumbicon".

The Plumbicon provides better pictures with less technical complexity, particularly in colour cameras or in outdoor locations under poor lighting conditions. It is the latest development in the field of television pick-up tubes, possessing the best properties of both the vidicon and the image orthicon tubes.

Compared with the vidicon, the Plumbicon, although only slightly larger, has much higher sensitivity

and faster response. It combines the small size, simple construction and ease of operation of the vidicon with the further advantages of low dark current, high sensitivity, fast speed of response and resolution equal to or better than that of the image orthicon. The excellent signal-to-noise ratio of the vidicon has also been maintained.

For colour applications, the tubes are designated for the appropriate colour channel.

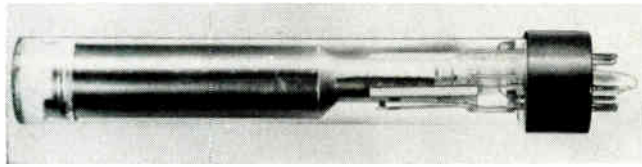

Silicon planar transistor range extended

Two new silicon planar epitaxial n-p-n transistors, types BFX43 and BFX44, have been recently added to the already wide range of Mullard devices of this type. In addition, a substantial number of JEDEC transistors in a similar category are available. In full production, the BFX43, BFX44 and JEDEC transistors are offered with immediate availability. All types are in TO-18 encapsulation with collector connected to the metal envelope.

Type BFX43

Transistor BFX43 is designed for high frequency amplifier applications, typical examples of which are found in the output stages of aerial amplifiers in bands I to III (up to 230MHz) and in exciter circuits for mobile transmitters operating in the V.H.F. band.

Type BFX44

Introduced as a low distortion common-base amplifier, the BFX44 provides linear performance from d.c. to 150MHz with an output voltage swing of at least 20V across a 400Ω load, characteristics ideal for amplifiers of the type used in the vertical amplifiers of wide-band oscilloscopes.

JEDEC selections

JEDEC devices in a similar category to the family group of the BFX43 and BFX44 are also available. All of these devices conform to the requirements of the JEDEC specification to which their type number refers:—

2N706	2N744	2N2369
2N706A	2N753	2N2369A
2N708	2N914	
2N743	2N2368	

Brief data:	BFX43	BFX44
V _{CBO}	30V	40V
V _{CEO}	15V	—
V _{CER}	—	23V
I _{CM}	250mA	250mA
P _{tot} (T _{amb} = 25°C)	360mW	360mW
f _T (I _c = 10mA, V _{CE} = 10V) min	500MHz	500MHz

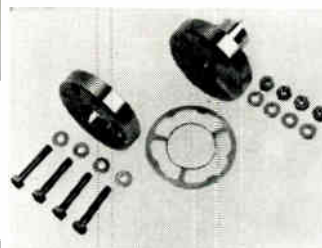

Ultra-high vacuum fittings

Comprehensive range of connectors, flanges and gold seals

Full details of all items in the comprehensive range of Mullard connectors, flanges and gold seals for 3/8 in. to 6 in. bore ultra-high vacuum systems have now been released. All items in this range are the products of an extensive design study and life test programme and will consequently provide guaranteed long-life with utmost reliability in any vacuum plumbing system. Each item may be purchased separately, a factor of considerable interest to users who prefer to prefabricate their own systems. All flanges and connectors in this range are made from the highest quality stainless steel (EN58B). The flanges, specially designed for use with gold wire seals of up to 1mm wire diameter, are flat-faced and consequently sexless.

The gold seals described are unique Mullard products patented on a world-wide basis. They are self-locating and thus easier to use than other types. The shim used to locate the seal also serves as a compression gauge, thus, when making a joint there is no need to carry out feeler-gauge or torque measurements to ensure a reliable ultra-high vacuum seal.

The standard of the ultra-high vacuum joint obtained with Mullard fittings is extremely good; the specification for the joint states that it will remain leak-tight at temperatures ranging from -196°C to +500°C and that leakage will be less than 10⁻¹⁰ torr l/s.

125V series of miniature capacitors

A 125V range has been recently added to the popular Mullard series of C295 miniature polystyrene capacitors. Capacitance coverage in the new range is from 1500pF to 0.082μF with a tolerance of ±1% and a long term stability better than 0.5%. The high stability of these capacitors makes them an ideal choice for professional standard tuned circuits and filters.

The full series of C295 capacitors is now:

Working voltage (d.c.)

C295AH	63V	3600pF to 0.16μF
C295AA	125V	1500pF to 0.082μF
C295AC	500V	680pF to 0.24μF

C295 capacitors are of extended foil construction with a polystyrene dielectric. This results in low self-inductance, low series

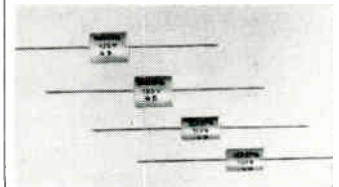

resistance and low h.f. losses; their tan δ is less than 2 x 10⁻⁴ at 1kc/s. Encapsulation is in yellow synthetic resin and meets the requirements of I.E.C. climatic group 40/70/21.

FURTHER DETAILS of the Mullard products described in this advertisement can be obtained from the address below or through the Reader Information Service of Industrial Electronics using the appropriate code number shown below.

Integrated circuit linear amplifiers	IE 334
"Plumbicon" camera tube	IE 335
BFX43, BFX44 silicon planar transistors	IE 336
Ultra-high vacuum fittings	IE 337
125V miniature capacitors	IE 338



Mullard Limited, Mullard House, Torrington Place, London, WC1. Telephone : LANgham 6633

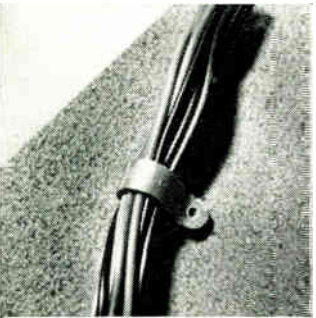
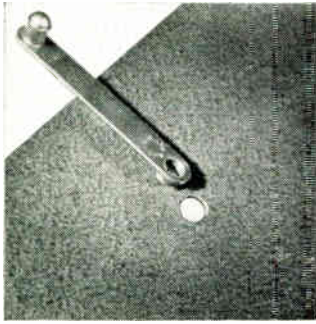

an intriguing new range of cable straps and grommets

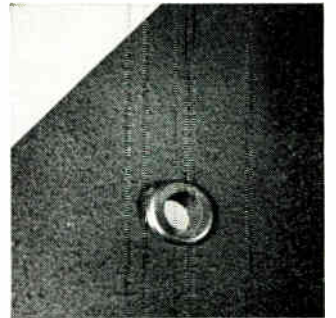
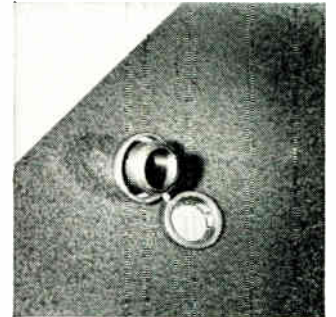
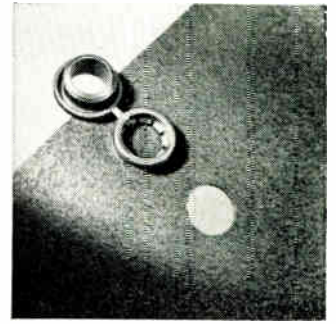

Imhofs have recently added to their list of products this simple but effective idea for securing cables to metal panels and insulating cables passing through metal panels. They are made from tough, flexible, polyethylene which is inert chemically, has excellent dielectric properties, an indefinite life and is good from -100° to $+205^{\circ}$ F. The grommets are made in eight sizes and the cable straps in four, all having an aluminium coloured finish.

There is available a trial kit which costs £1 (post and packing free) consisting of ten of each of the twelve items, together with instructions so that you can see for yourself how quick and easy they are to fix. *Send now for descriptive leaflet.*

easy to fix — won't pull out

handles and

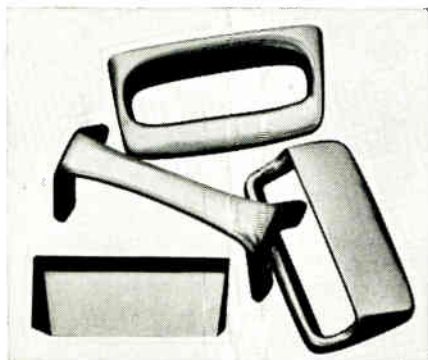

There is an Imhof handle to suit virtually any application—you can choose from a range of nearly ninety models, many of which are exclusive designs. They vary from distinctive die-cast types to simple bar-type handles, all worthy of fitting to the world's finest instruments. Send today for the "Handles and Accessories" catalogue which gives full details of the range together with a whole host of accessories, such as hinges, locks, castors, etc.

accessories

Alfred Imhof Limited
Dept IE/10 Ashley Works
Cowley Mill Road
Uxbridge Middlesex

Telephone: Uxbridge 37123 (in London dial UX3 7123)

Telegrams: Imcase-Uxbridge-Telex

Telex: 24177

Agents in

Algeria, Austria, Australia, Belgium, Brunei, Canada, Denmark, Finland, France, Germany, Holland, Iraq, Israel, Italy, Lebanon, Luxembourg, Morocco, New Zealand, Nicaragua, Norway, Portugal, Saudi Arabia, Singapore, South Africa, Sudan, Sweden, Switzerland, Syria, Thailand, Tunisia, USA, Zambia.

IMHOFS

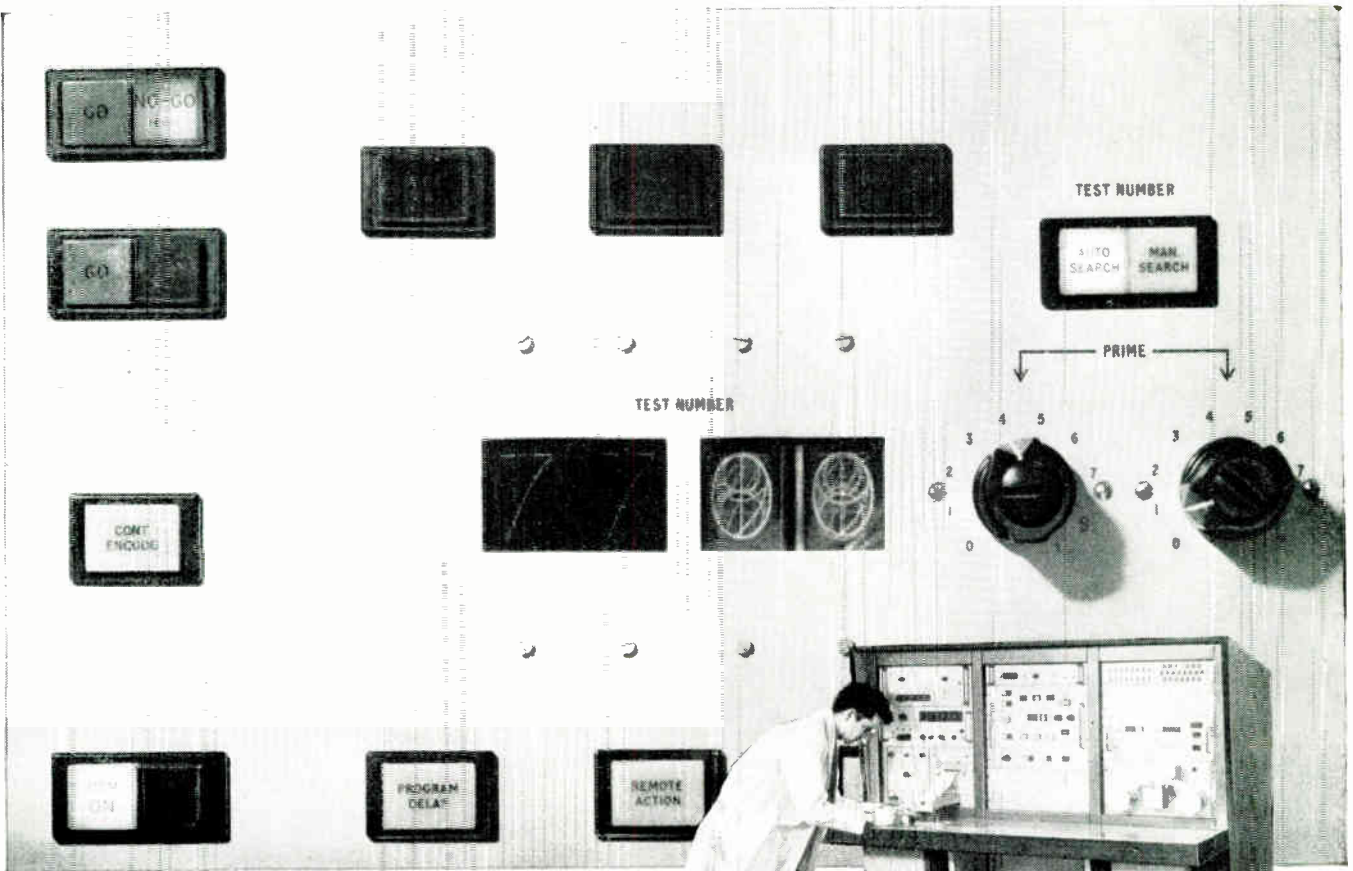

meet A.T.E. the chief inspector's right hand man

This *other* inspector is called A.T.E: Automatic Test Equipment. Its principal advantages can be summed up under six headings:

Flexibility A.T.E. is a flexible system capable of testing an extensive range of products. It is as efficient an inspector of a very small number of large complex products like a military aircraft, as it is of production line quantities of small electronic assemblies.

Reduced testing time A.T.E. cuts testing time and hits overall costs dramatically. In one application it reduced the manual test programme time from 576 to a mere 15 man hours. In a factory producing complicated electronic components, testing that once took half a day is now done by A.T.E. in 20 minutes. In most applications studied to date the use of A.T.E. has, on average, reduced testing time by a factor of 10.

Increased economic efficiency Saving time, of course, means added economy in several directions. A.T.E. does not demand any specialised knowledge of computers or

programming, nor any prolonged training. Highly skilled manpower may thus be released for other work. It does all the work itself, including the recording of results, making written reports by the operator unnecessary.

Self checking A.T.E. has a built-in, self-checking routine which ensures that its own system is working perfectly.

Tape controlled test routine A.T.E. is adaptable: the use of punched paper tape not only enables the test routine to be automatic but also permits a library of test routines to be prepared, stored and brought into use when required.

Printed and visual display A digital display gives the operator a point by point check of the test routine and a printed record of the test results is produced which can be kept to form a test record of each unit.

For a factory demonstration or information on what A.T.E. can do for your Inspection Department write to British Aircraft Corporation, Industrial Products Group, Stevenage, Herts or telephone Stevenage 2422.

INDUSTRIAL PRODUCTS GROUP

BRITISH AIRCRAFT CORPORATION

STEVENAGE HERTS

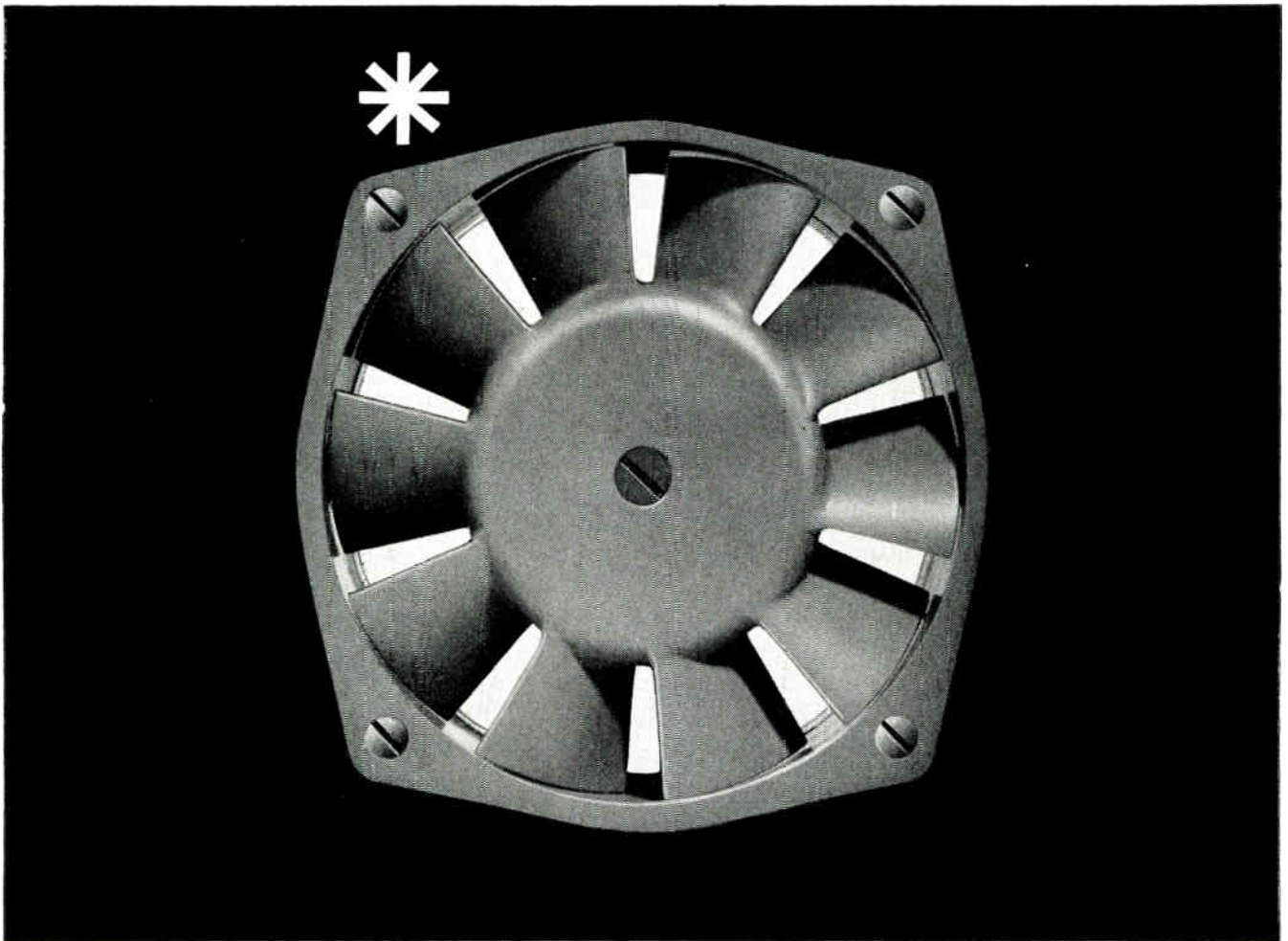

* actual size

New 3½" Plannette Blower

- * Blows 25 c.f.m. free air
- * Compact — only 1¼" deep
- * Fitted with precision ball-bearings
- * Plastic housing and impeller
- * No capacitor required

The new 3½" Plannette has been developed especially for designers and manufacturers of electronic and electrical equipment — from computers to control gear and general instrumentation, in fact anywhere that hot-spot headaches need relieving!

The 3½" Plannette is the latest addition to a range of blowers extending up to a 12" model (3" deep) blowing 1000 c.f.m. free air. Because Plannettes are slim-line, designers can slip them — late in the design stage — into confined spaces where they will cool quietly and efficiently.

With Plannettes or one of our other 1000 purpose-built blowers, we solve temperature control problems throughout industry. Send for details now.



Plannair Limited
 Kingston Road, Leatherhead, Surrey
 Telephone: Leatherhead 5341 (10 lines)

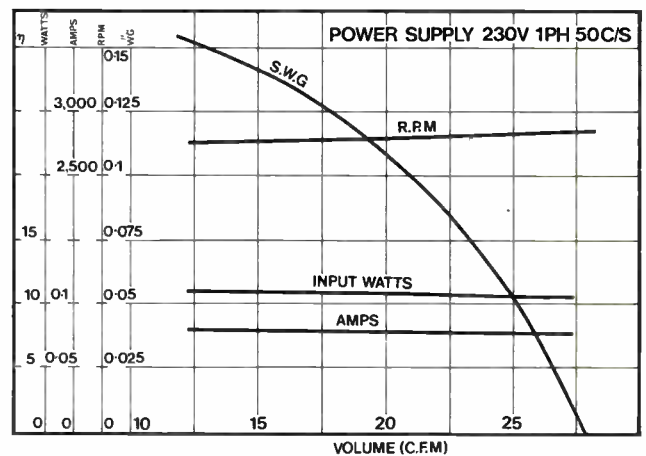

To: Plannair Limited

Please send me full details of the Plannette range of blowers

Please arrange for your representative to call (*tick as appropriate*)

Name _____

Position _____

Company _____

Address _____

For further information circle 212 on Service Card

T H E R M O F I T
 ▼▼▼
 HEAT-SHRINKABLE TUBING
 ▲▲▲

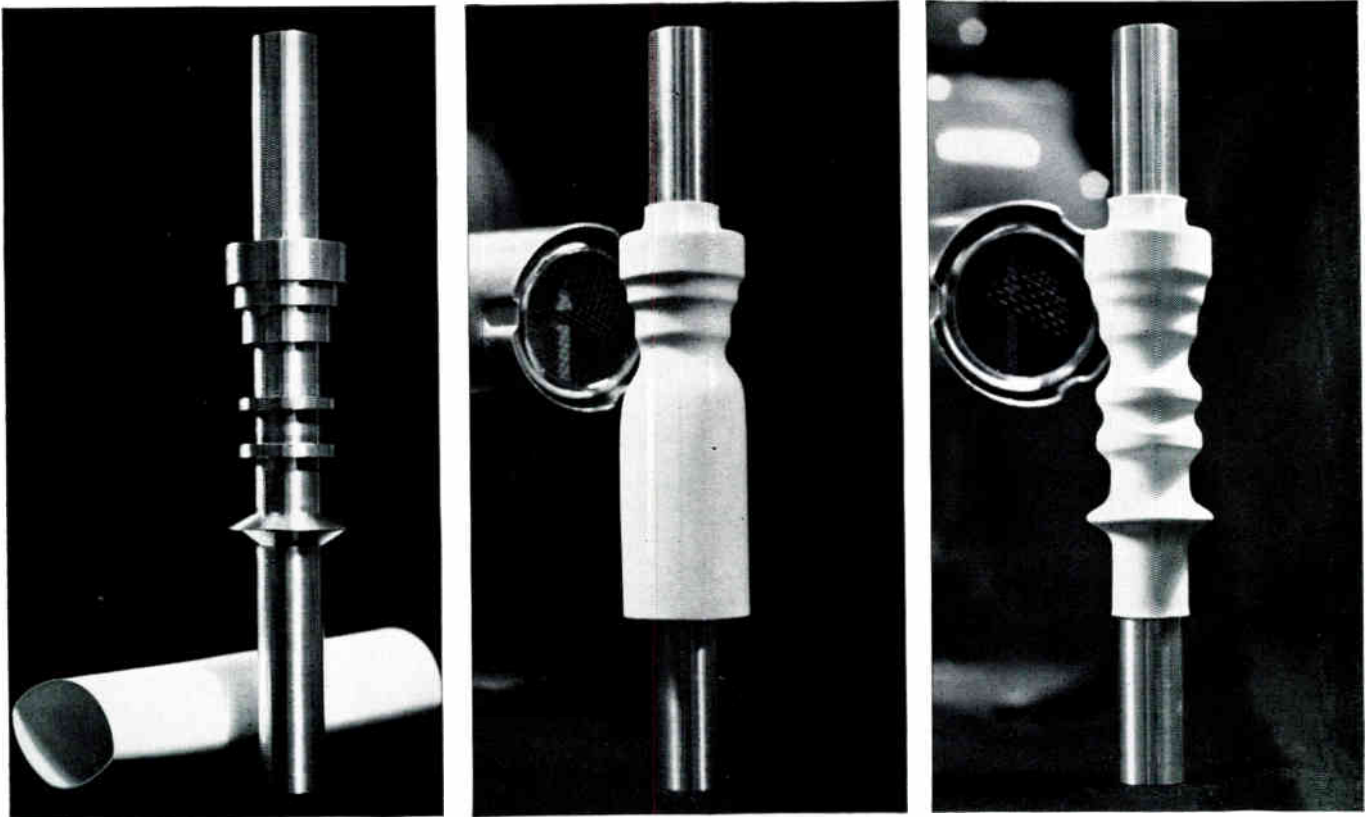

slip on...heat...it shrinks to fit

...giving immediate insulation and environmental protection

THERMOFIT heat-shrinkable tubings are among many innovations pioneered by Raychem in the field of radiation chemistry to meet the exacting demands of the aero-space industry. Today irradiated plastic tubings are widely used in an extensive range of electronic, electrical, and mechanical applications.

THERMOFIT heat-shrinkable tubing is available from stock in a wide range of materials including Polyolefin, PVC, Neoprene, PTFE, and Kynar in a variety of sizes, lengths and colours.

Write or phone for Raychem Bulletin RU-7000 — a comprehensive summary of types available and their uses.



RAYCHEM

RAYCHEM LIMITED • CHENEY MANOR • SWINDON • WILTSHIRE
 TELEPHONE SWINDON 27146 • TELEX 44732

IE/2/10/6

B*

For further information circle 213 on Service Card

THINK
SOLARTRON
FOR
DYNAMIC
ANALYSIS



MEN AND MACHINES

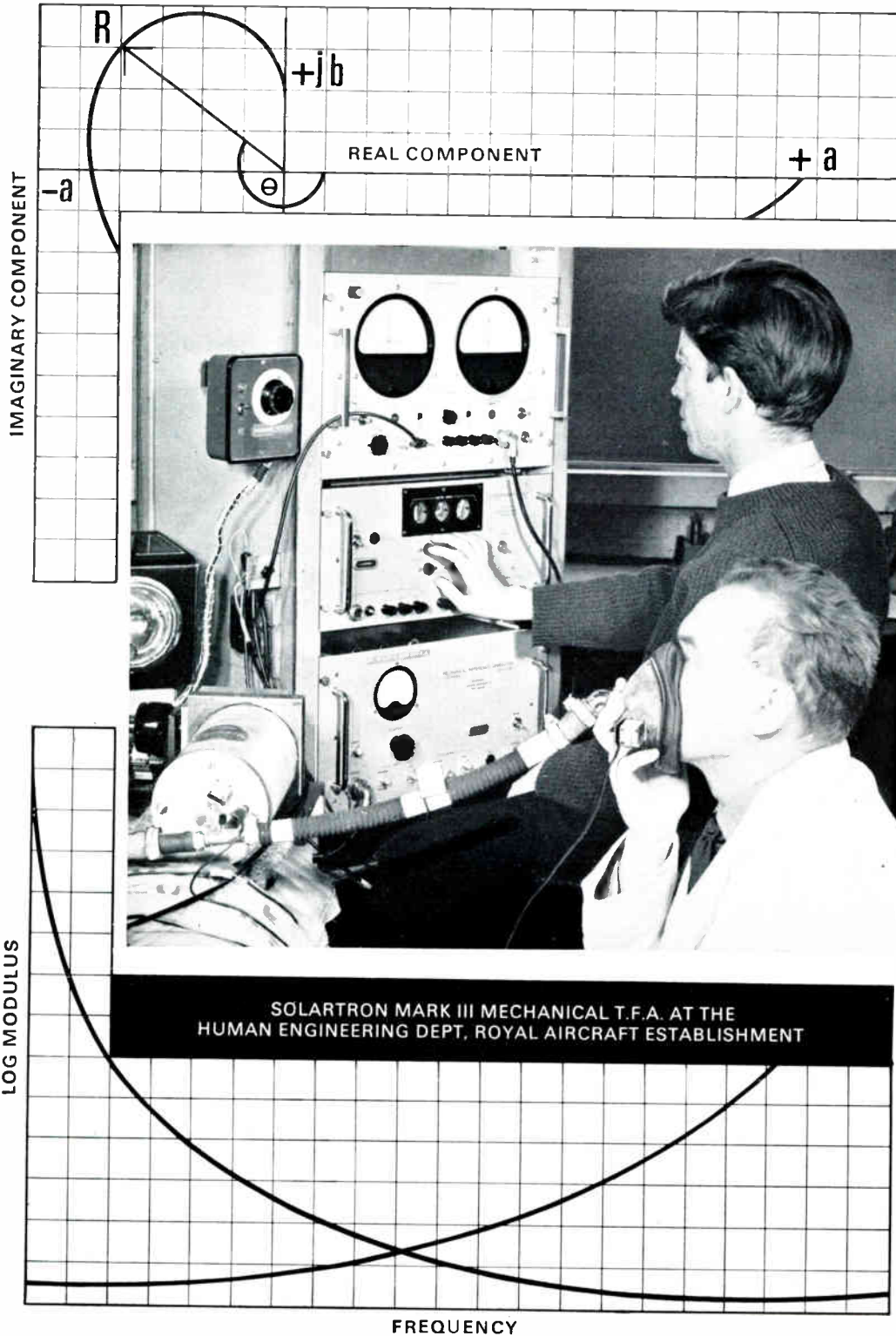

SOLARTRON MARK III MECHANICAL T.F.A. AT THE HUMAN ENGINEERING DEPT, ROYAL AIRCRAFT ESTABLISHMENT

MATERIALS

- Viscosity
- Elasticity
- Relaxation

COMPONENTS

- Power Factor
- Core Loss
- Filter and Network analysis

EDUCATION

- Stability Criteria
- Servo-mechanisms
- Computing
- Vector theory

ELECTRO-MEDICAL

- Stimuli for Psychology
- Neurology
- Physiology

CONTROL

- Vibration
- Bio-Engineering
- Electronics
- Research
- Civil Engineering

For further information circle 214 on Service Card

THINK
SOLARTRON
FOR
WORLD CLASS
PERFORMANCE



SOLARTRON- WORLD LEADERS IN DYNAMIC ANALYSIS

SIMULATED ENVIRONMENT

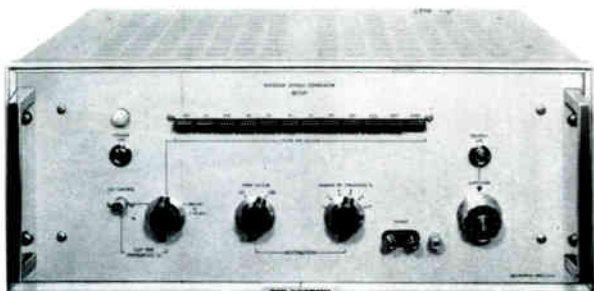
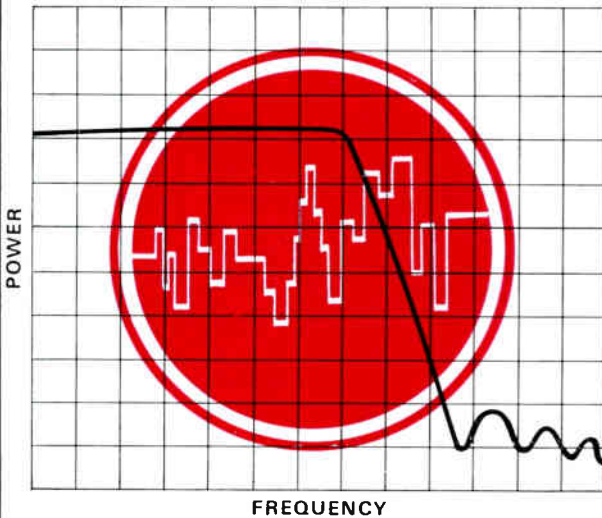

Random Signal Generator BO 1227

WHY DYNAMIC ANALYSIS?

The study and measurement of dynamic performance has been a SOLARTRON speciality for well over ten years.

Whether it is a servo-mechanism or a shock absorber, a vibrating structure or a vibrant body SOLARTRON can help you.

Electrical, mechanical, hydraulic or pneumatic—we can provide you with a quick and easy measurement of stability, gain, phase, open loop or closed loop response in Nyquist, Nichols or Bode—single ended or balanced, earthed or isolated.

No matter if your signals do have ten times more harmonics and noise than fundamental frequency, do not despair—this problem is also catered for.

Now for a test of your system under simulated actual environmental conditions, call for a SOLARTRON PRECISION RANDOM SIGNAL GENERATOR BO 1227. We guarantee the same certainty and precision of measurement as in Frequency Response Analysis, verifying design and optimising performance.



THE SOLARTRON ELECTRONIC GROUP LTD.

FARNBOROUGH, HANTS, ENGLAND
TEL: FARNBOROUGH (HANTS) 44433
TELEX: B5254 SOLARTRON FARNBOROUGH
CABLES: SOLARTRON, FARNBOROUGH

A MEMBER OF THE
SCHLUMBERGER GROUP

PAM S228

For further information circle 215 on Service Card

everything

you ever looked for in a top quality relay

+ 3

to make you satisfied only with TMC

+1

Fully bridged mounting frame eliminates base distortion—safeguards coil leads

+2

Swaged low reluctance core/yoke junction using circular core—improves magnetic circuit

+3

Three point cover location—makes removal really easy; replacement really secure

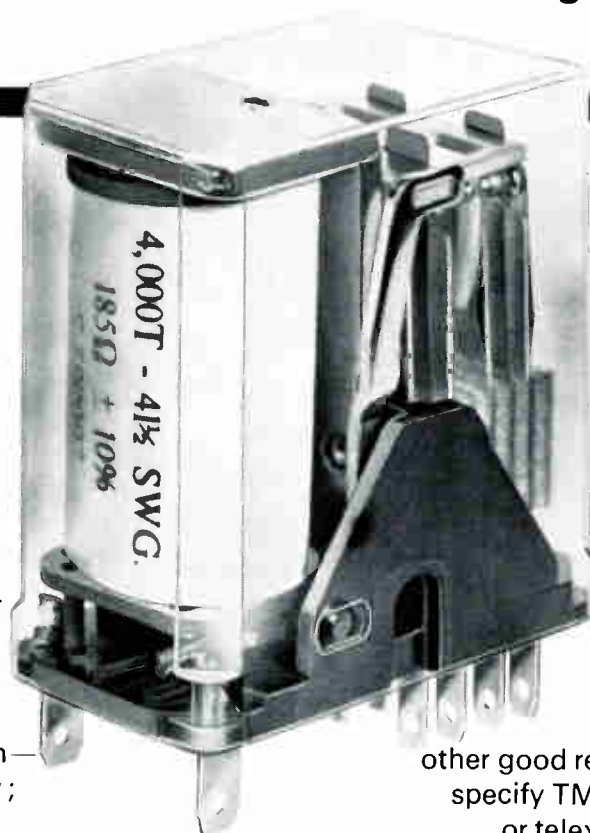

Fully interchangeable with all other British and Continental types

We can give you many other good reasons why you should specify TMC relays. Write, 'phone or telex for full details—today

GENERAL PURPOSE RELAYS

TELEPHONE MANUFACTURING COMPANY LIMITED

Components Division Roper Road Canterbury Kent Telephone: Canterbury 66577

A member of the  group of companies

Telex: 28115

For further information circle 216 on Service Card

WHAT'S THE WORLD'S FASTEST 1/2" CAPACITY N/C DRILL? -THE MIDDLESEX NC100

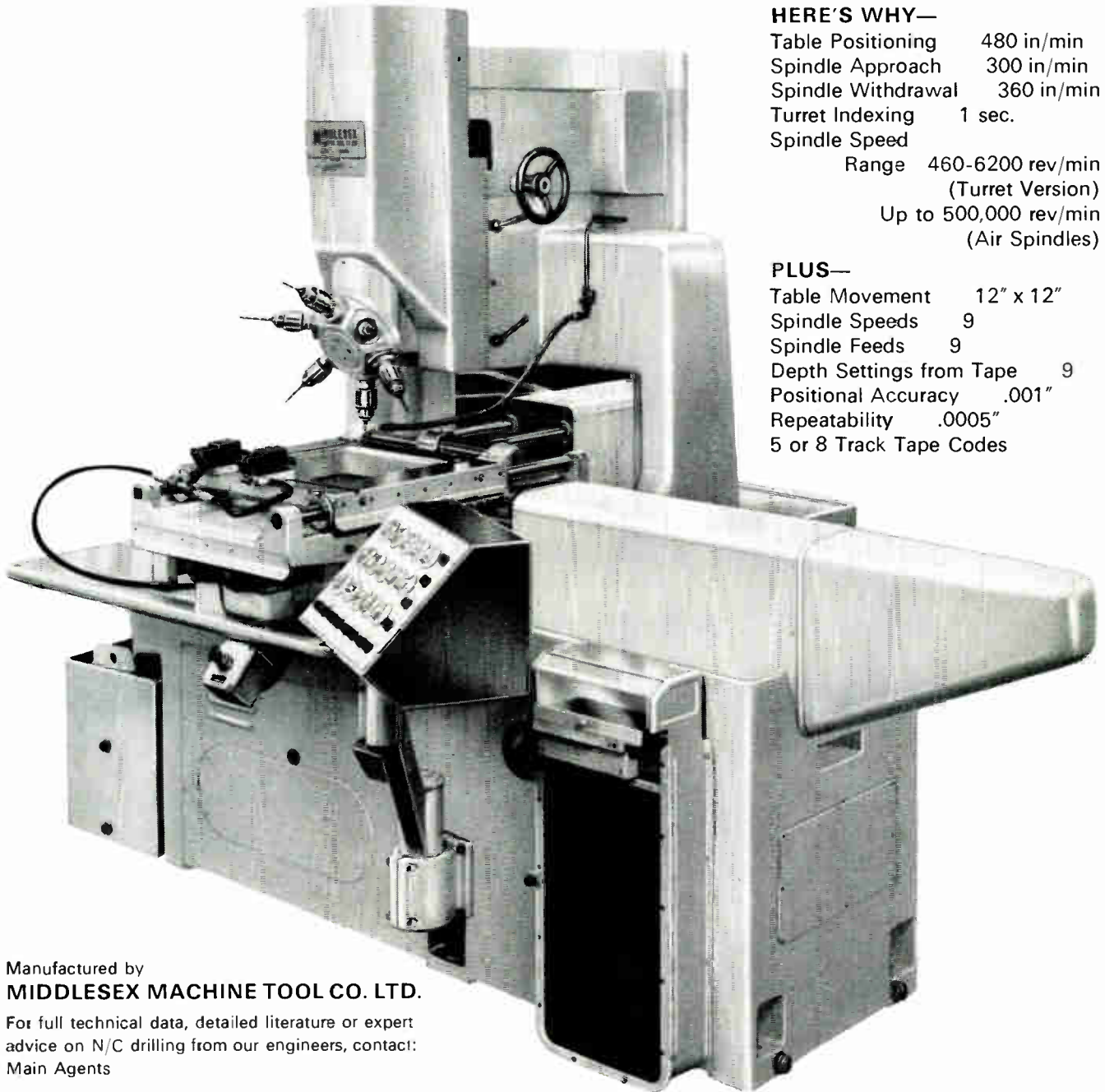

HERE'S WHY—

- Table Positioning 480 in/min
- Spindle Approach 300 in/min
- Spindle Withdrawal 360 in/min
- Turret Indexing 1 sec.
- Spindle Speed
 - Range 460-6200 rev/min (Turret Version)
 - Up to 500,000 rev/min (Air Spindles)

PLUS—

- Table Movement 12" x 12"
- Spindle Speeds 9
- Spindle Feeds 9
- Depth Settings from Tape 9
- Positional Accuracy .001"
- Repeatability .0005"
- 5 or 8 Track Tape Codes

Manufactured by
MIDDLESEX MACHINE TOOL CO. LTD.

For full technical data, detailed literature or expert advice on N/C drilling from our engineers, contact:
Main Agents

M.T.G. (SALES) LTD

Member of the Middlesex Group
PARK ROYAL ROAD, LONDON, N.W.10. TEL: ELGar 5361-5

For further information circle 217 on Service Card

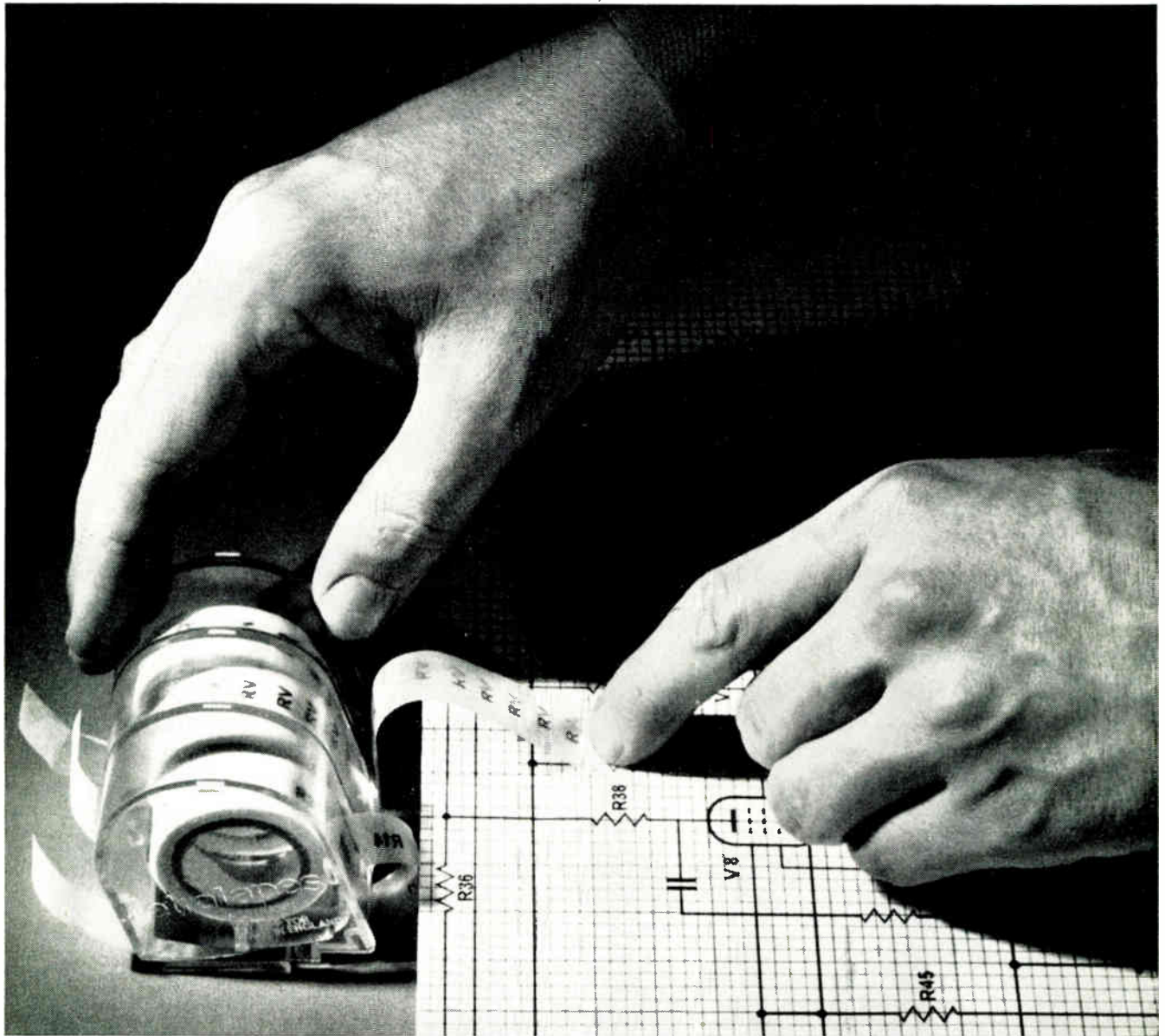

Letraset tapes the new repetitive marking technique

Instant Lettering is fast, but Letraset Tapes are faster. No rubbing down, simply pull from the special tape dispenser; the symbols are automatically "released" and only light finger-tip pressure is required to ensure complete adhesion to any surface.

Letratapes provide a new and convenient method of repetitive marking in the many stages of production of electronic equipment. Letratapes can be used on circuit drawings, printed circuits, chassis and panel markings, and for architectural and engineering drawings. The Letratape range of 120 tapes includes all commonly used component references for electronic codings, numerical sequences and frequently used set words.

Two letter sizes are available, $\frac{1}{8}$ " and $\frac{3}{16}$ ". Type face Grottesque 216, Black only. All characters are dyeline (diaz) heat resistant.

Think quality, think Letraset

A Letraset Product, produced & manufactured by Letraset Limited, St. George's House, 195-203 Waterloo Road, London, SE1, England.

Pull out

Press down

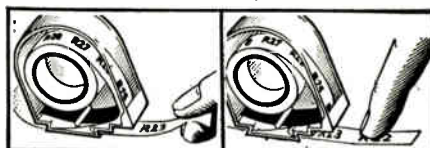

Please send me further information

name _____

address _____

company _____

L17



Letraset

For further information circle 218 on Service Card

33 ASR
Automatic Send Receive Page Printer



all
Teletype
equipment
now
from

DATA DYNAMICS

The complete range of Teletype page printers and other data processing equipment is now supplied by Data Dynamics Limited; this includes a **110 characters per second tape punch** using the Teletype head, which is available for early delivery.

The outstanding features of Teletype—the wide range, modular construction, adaptability and economy—are perhaps too well known to detail, but it is worth noting that Data Dynamics provide not only the full range of equipment but a comprehensive service covering applications and the adaptation of these equipments to individual customers' requirements.

DATA DYNAMICS LIMITED
Uxbridge Industrial Trading Estate · Arundel Road · Uxbridge
Middlesex · Telephone: UXBRIDGE 36267

 DD1

For further information circle 219 on Service Card

RCA 2N4068
(actual size)



NEW RCA NPN SILICON TRANSISTOR FOR CRITICAL INDUSTRIAL APPLICATIONS: Wide-band amplifiers—Distributed amplifiers—Video amplifiers in TV cameras, camera chains, monitors, oscilloscopes—Video marker generators—Relay drivers—NIXIE[®], neon-indicator and electro-luminescent-indicator driver circuits—Direct on-off control circuits... much more

—Registered Trade Mark: Burroughs Corporation

$BV_{CE0} = 150 \text{ V min.}$

$C_{cb} = 3.5 \text{ pF max.}$

$f_T = 50 \text{ Mc/s min.}$

PLUS

- Low Leakage Current— $I_{CBO} = 50 \text{ nA max at } V_{CB} = 120 \text{ V}$ • High Gain— $h_{FE} = 30 \text{ min at } I_C = 30 \text{ ma, } V_{CE} = 10 \text{ V}$ • Low Saturation Voltages— $V_{CE}(\text{sat}) = 1 \text{ V typ, } V_{BE}(\text{sat}) = 0.68 \text{ V typ, at } I_C = 30 \text{ mA, } I_B = 1 \text{ mA}$ • High Current Capability— 200 mA max. • High Power Dissipation— $0.5 \text{ watts free air at } 25^\circ \text{ C}_{TFA}$ • Wide Temperature Range—operates from -65° C to $+175^\circ \text{ C}$
- Hermetically Sealed Metal Case

RCA 2N4069 is the same as RCA 2N4068, except for an integral heat sink to provide twice the dissipation capability (1W).



As Wide-band amplifiers the 2N4068 and 2N4069 easily cover bandwidths to 4.5 Mc/s and higher; as general purpose amplifiers, they operate up to 100 Mc/s. The very high BV_{CE0} , the low collector-to-base feedback capacitance, the low leakage and saturation voltages give assurance of top performance in critical applications. The RCA 2N4068 and 2N4069 also feature exceptionally linear transfer characteristic and high-temperature capability compared with germanium and plastic-encapsulated silicon devices.



THE MOST TRUSTED NAME IN ELECTRONICS

RCA GREAT BRITAIN LIMITED Electronic Components and Devices Sales, Lincoln Way, Windmill Road, Sunbury-on-Thames.
Associate Company of Radio Corporation of America Telephone: Sunbury 5511

For further information circle 220 on Service Card

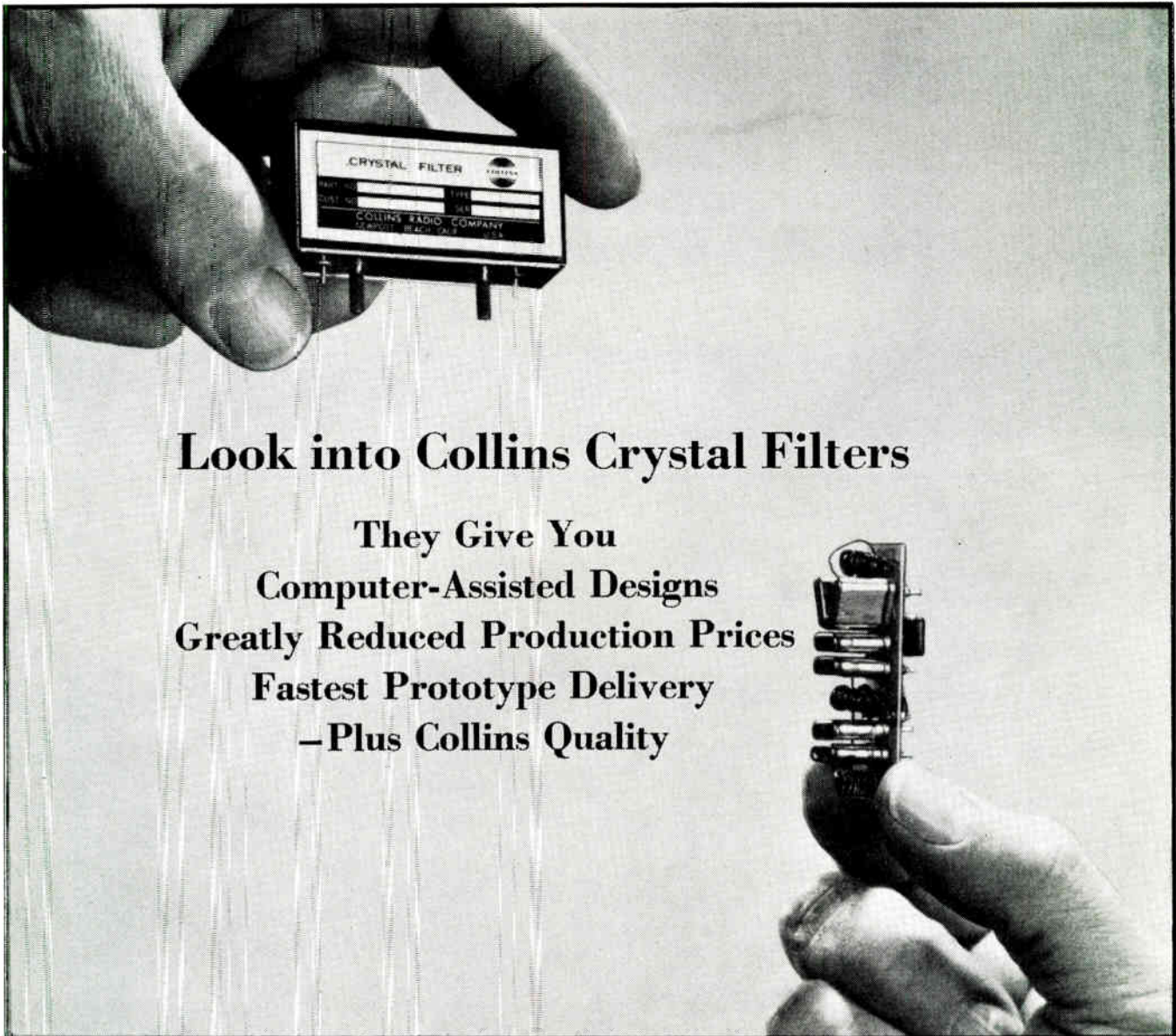

Look into Collins Crystal Filters

**They Give You
 Computer-Assisted Designs
 Greatly Reduced Production Prices
 Fastest Prototype Delivery
 — Plus Collins Quality**

Here's why:

Reason 1: Design and Manufacturing Techniques. Computer-assisted modern network theory methods allow us to design, build and deliver a custom filter for your requirement with short lead time. And you can be sure of the exactness of both the design and the completed filter. Complete vertical integration of all processes from crystal-slicing to packaging — and the elimination of hand labor wherever possible — assures you of uniformity and dramatically reduces costs.

Reason 2: Experience. The years of designing and manufacturing that have gone into building the most complete facility in the filter industry will result in the fastest, most effective answers to your requirements.

Whatever your filter requirements, contact Collins today.

COMMUNICATION/COMPUTATION/
 CONTROL



COLLINS RADIO COMPANY
 DALLAS, TEXAS · CEDAR RAPIDS, IOWA
 NEWPORT BEACH, CALIFORNIA
 TORONTO, ONTARIO

BANGKOK · BEIRUT · FRANKFURT · HONG KONG
 KUALA LUMPUR · LOS ANGELES · LONDON
 MELBOURNE · MEXICO CITY · NEW YORK · PARIS
 ROME · WASHINGTON · WELLINGTON

For further information circle 221 on Service Card

A truly automatic 500 MHz frequency converter

- Automatic frequency measurement to 500 MHz.**
- No tuning or interpolation.**
- Automatic level-setting.**
- Counter accuracy retained.**
- Sensitivity 100 mV.**
- No ambiguity.**

The Racal Auto Frequency Converter type SA.565 affords direct, automatic and continuous frequency measurement to 500 MHz from most 100 MHz counters. An entirely new design concept eliminates measurement ambiguities and offers many unique advantages to the research, development and production engineer.

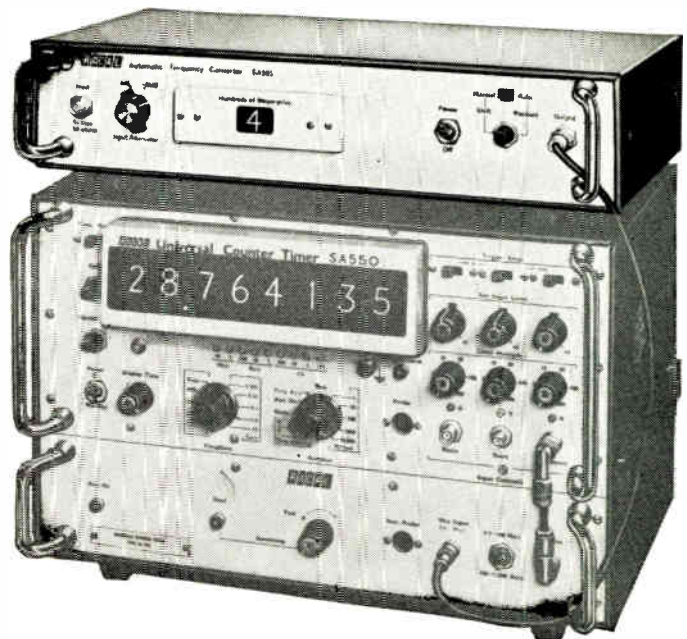

RJ/A105

Racal research and development maintains world leadership in Digital Measurement.

RACAL

Write for fuller details to:
Racal Instruments Limited
 Dukes Ride, Crowthorne, Berks.
 Tel: Crowthorne 227213 and 3763.
 Telex: 84166. Cables: Racal, Bracknell.

For further information circle 222 on Service Card

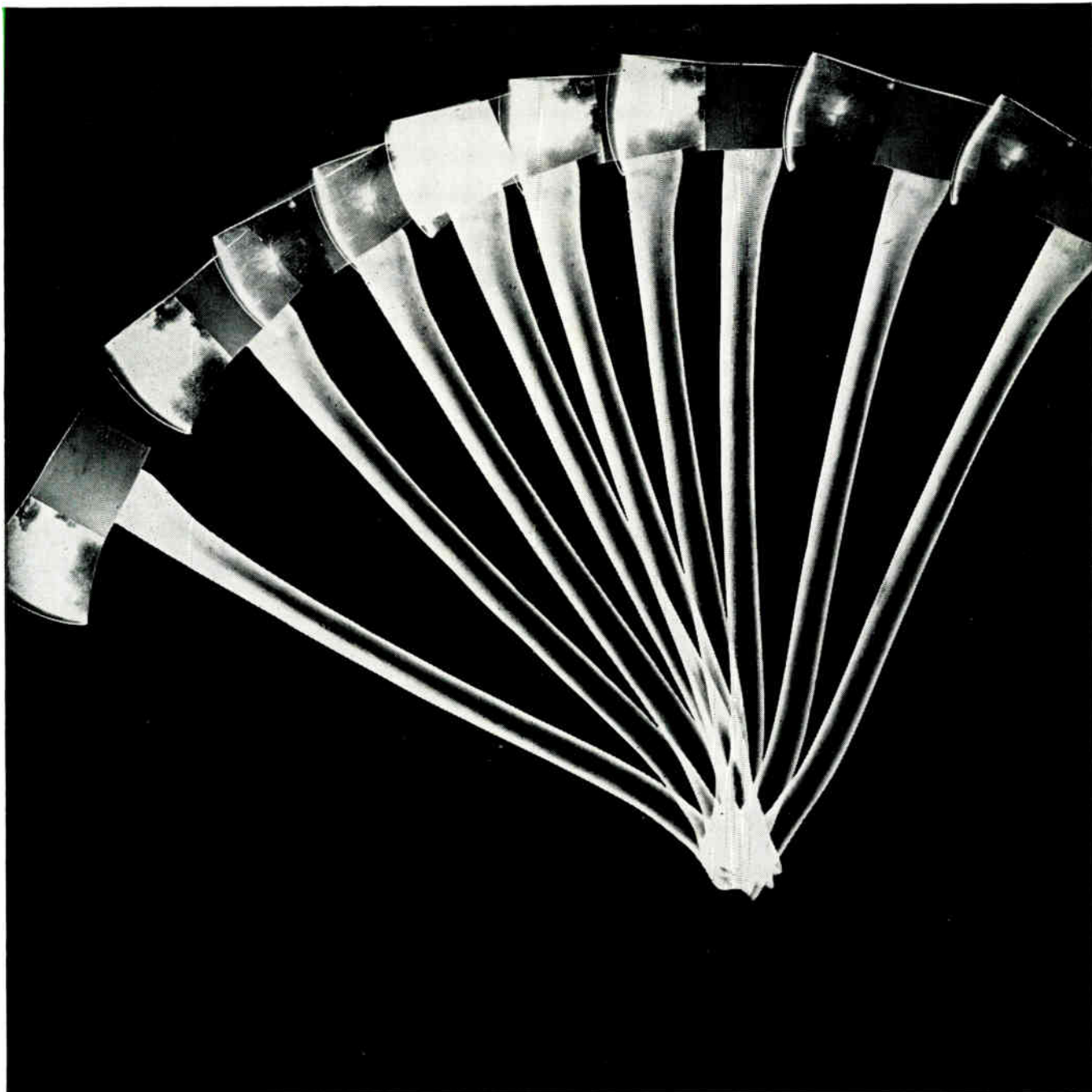

Cheapest way to chop

DC-to AC with an AEI Synchronous Chopper. It fits a standard B9A 9-pin thermionic valve holder, is suitable for feeding both high resistance and transformer-coupled low impedance circuits, its low noise level allows a 1 microvolt signal to be detected. Typical applications are: recording thermo-couple and ionisation chamber outputs; drift correction in analogue computer amplifiers; general instrumentation. Stability is high, operational life is long. Available in two models: CK3 for 50 c/s; CK4 for 100 c/s.

AEI
SWITCHGEAR

CK3 AND CK4 SYNCHRONOUS CHOPPER

Write to: Power Protection and Meter Department, AEI Switchgear Division, Trafford Park, Manchester 17, or your nearest AEI office.

ASSOCIATED ELECTRICAL INDUSTRIES LIMITED SWITCHGEAR DIVISION TRAFFORD PARK MANCHESTER 17

SM 302/1

For further information circle 223 on Service Card

miniature *or* **standard** . . .
 you'll find just the size you need in

SILVER STAR CAPACITORS

SMALLEST
C5E
 $.3 \times .3 \times .1$ in
 $7.6 \times 7.6 \times 2.5$ mm
 5 to 680 pF



LARGEST
A48E
 $2.0 \times .75 \times .75$ in
 $50 \times 19 \times 19$ mm
 120,000 to 250,000 pF

SYNTHETIC RESIN ENCAPSULATED

SMALLEST
C5F
 $.275 \times .275 \times .15$ in
 $7 \times 7 \times 3.81$ mm
 200 to 1000 pF

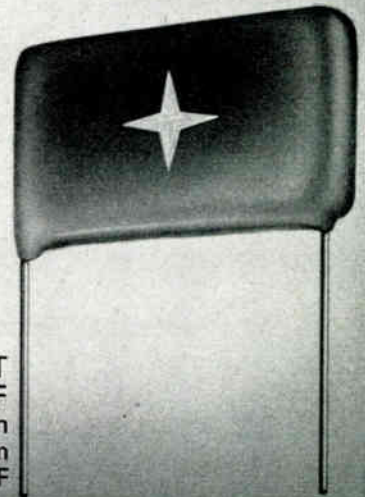

LARGEST
C77F
 $1.75 \times 1.18 \times .425$ in
 $44.5 \times 30 \times 10.8$ mm
 35,000 to 250,000 pF

SYNTHETIC RESIN DIPPED

—and you'll find a wide range of steps in size
 between the ones that are shown here

Our data sheets will tell you—just ask for them

Johnson 
Matthey

JOHNSON, MATTHEY & CO., LIMITED

73-83 HATTON GARDEN, LONDON, E.C.1 Tel. Holborn 6989 Telex: 21465
 Vittoria St., Birmingham, 1 Telephone: Central 8004 75-79 Eyre St., Sheffield, 1 Telephone: 29212

MT 20 First dust proof humidity-proof wire wound trimmer

at anything like this price

MT20 is a simple, proved, all-British design of TO5 transistor size, ideal for printed-circuit use, with single-turn top end adjustment, positive mechanical end stops, self-locking shaft.

Dust-proof, moisture-proof, shock-resistant and reliable over temperatures -20 to +125°C.

50 to 2K 16/6, 5K to 10K 17/6 for 500's. Smaller quantities a shilling or two more. Delivery 3/4 weeks. Many values ex-stock.

For full data write to Miniature Electronic Components Ltd
St. Johns Woking Surrey Woking 63621

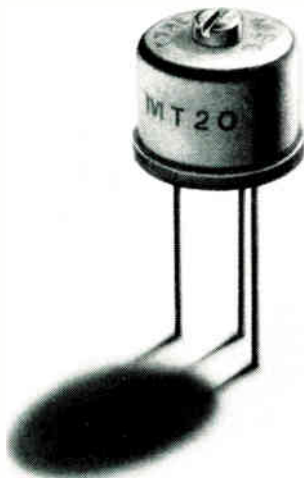

m-e-c

Trimmer Potentiometers
Wire-wound Resistors
Miniature Switches
Elapsed Time Meters

ME22

For further information circle 225 on Service Card



Approved

The Erie 1200-025 and 1215-000 Broadband R.F.1. Filters are now approved by the Ministry of Aviation for radio frequency interference suppression in military aircraft systems.

These are but two of Erie's 1200 Series Broadband R.F.1. Filters which consists of some two dozen styles, each with a specifically designed performance.

As the Erie 1200 Series are the smallest commercially available filters of their

type, they are used extensively in sophisticated systems such as space research, civil aviation, communications and data processing.

Erie's progressive programme of research and development has shown once again that they are capable of keeping abreast of the constant changes in technology.

Erie take a pride in Performance



Write for catalogue to:

ERIE RESISTOR LIMITED,

Gt. Yarmouth, Norfolk, England.

Telephone: Great Yarmouth 4911

Cables: Resistor Great Yarmouth Telex: 97421

Don't choose a temperature controller until you've seen the Sunvette range

62011

AEI, pursuing their policy of extending their range of solid state temperature controllers, has now entered the 'low cost' market with the 'Sunvette' range. Designed to replace industrial thermostats, Sunvette units provide precise control from -50°C to $+300^{\circ}\text{C}$ by means of thermistors.

There are three types:

- ON/OFF—the lowest cost of all.
- FULLY PROPORTIONAL—the most sophisticated of all.
- SIGNAL OUTPUT—for driving AEI thyristor power regulators—the most flexible of all.

'Sunvette' Type TH1

The ON/OFF Temperature Controller with a future.

- fully transistorized with self-contained 2kW power vacuum switch.
- mean differential less than 0.1°C .

'Sunvette' Type TH2

The FULLY PROPORTIONAL Temperature Controller for best performance.

- all solid state with built-in thyristors for 1kW loads.
- adjustable proportional band width down to 2%.

'Sunvette' Type TH3

The FULLY PROPORTIONAL Temperature Controller for power unlimited.

- the output signal drives any of the AEI thyristor power regulators—4, 6 and 10kW standard—or more if you want it.
- adjustable proportional band width down to 1%.
- adjustable rate of 'ramp up' too.

TEMPERATURE CONTROL

For further information please write to Associated Electrical Industries Ltd., Industrial Components Dept., P.O. Box 1, Harlow, Essex, Tel: Harlow 25781 (STD OBS 96); Telex B1291—ASSOCELECT HRLW; or your nearest AEI office.



AEI ELECTRONICS

WESTON—FOREMOST FOR MOVING COIL RELAYS

MODEL S 170
for control applications

The Model S 170, permanent magnet moving coil relay. Combines extreme sensitivity with high precision. It is eminently suitable for control applications when a relay operating within close tolerances is necessary. The minimum signal current is 5 mic A. d.c.; shunts and series resistors can be incorporated for currents and voltages up to 5 A and 250 V d.c.



MODELS S 124
a miniature alarm relay with "hold-on" contacts

The Model S 124 is of the permanent magnet moving coil type and can be supplied to operate on currents as low as 2 mic A. d.c. High contact pressure is ensured by magnetic attraction between the contacts; these will "hold-on" until reset manually or by remote electrical control. Front-of-panel and flush mounting relays are available.



MODEL S 115
a miniature switching relay

The Model S 115 functions as an "on-off" switching relay and is supplied for operating currents down to 50 mic A. d.c. Single and double coil windings are available. The relay can be mounted in any position and is magnetically self-shielding. The space occupied on the chassis is only 1½ in. x ¾ in.; weight, 1¼ oz.



For full details of the Weston range of relays, please write to:—

SANGAMO WESTON LIMITED • ENFIELD • MIDDLESEX
Telephone: Keats 1100. Grams: Sanwest, Enfield. Telex: 24724

For further information circle 228 on Service Card

This is the handy Elcometer thickness gauge



*Actual Size

It measures paint, electro-plating, enamel, glassfibre, plastic, rubber, bitumen and other non-magnetic materials on a ferro-magnetic base. Measuring range from 0.2 thou to 0.2" thick with 44 different scales calibrated in English and Metric. Three basic models have contacts adapted to a variety of surfaces including bar material of only ¼" diameter. Ferrite content in stainless steel can be measured between 4% and 29%. There are 78 scales with 3 model permutations.

A pointer locking device permits measurement in inaccessible places. Accuracy is guaranteed at ± 5% or 0.0001". *Overall size is 3½" x 2" x 1". Weight 6 oz.

Price 15 gns.

For details of this and our other measuring instruments contact:



ELCOMETER INSTRUMENTS LTD
FAIRFIELD RD
DROYLSDEN 11
MANCHESTER
Tel: DROylsden 2790

For further information circle 229 on Service Card

CGS

individually tested vitreous enamel wirewound **RESISTORS**

Proved reliability-qualification approval embraces RCSC types RWV4J-K & L, 1Ω to 100KΩ

CGS resistors offer you highest standard of quality and performance at extremely competitive prices, due to specialisation, an efficient production organisation and selective buying of raw materials. Up to 100 of any RCSC type resistors are available from stock. Leading manufacturers, GPO, Ministry of Aviation, Admiralty, and NATO are among the many users of CGS resistors. RCSC type approved to DEF 5111-1, manufactured under EID and ARB approved inspection conditions.

For price list, catalogue and stock list write or phone: **THE C.G.S. RESISTANCE CO. LTD.**

Marsh Lane, Gosport St., Lymington, Hants.

Tel.: Lymington 3282
Telex: 47691

For further information circle 230 on Service Card

Fast Recovery
Differential DC Amplifiers

Analogue/Digital Converters

Sample & Hold Amplifiers

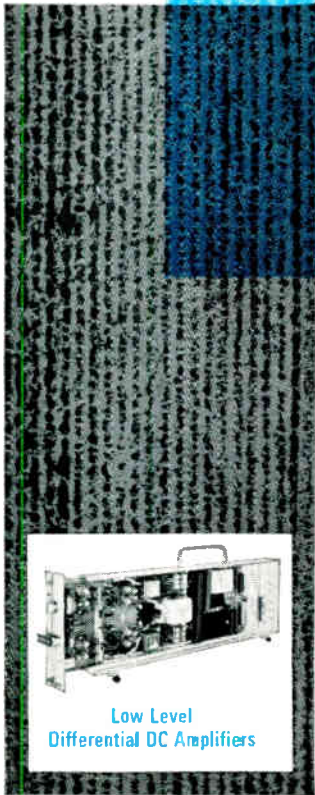

Low Level
Differential DC Amplifiers

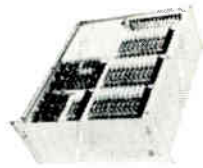

A/D Multiplexer
Combination Systems

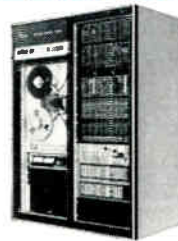

Digital System

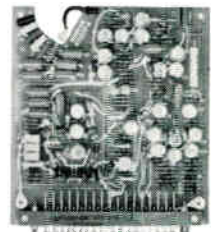

Plug-In Amplifiers

BUILDING BRICKS to a complete digital system

■ Benson-Lehner are now engineering and building complete digital systems for use in data acquisition and system control.
■ Their Redcor range of precision components provides accuracy and reliability through the

most sophisticated solid state circuitry on the market today.

■ All components are fully compatible with each other: buy the system, or buy the "bricks" and build your own system.

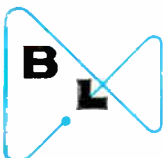

For full details of how BENSON-LEHNER, with the competence of a dedicated group of engineers, can help you in the data systems field, telephone SOUTHAMPTON 27831/2, or write to DIGITAL SYSTEMS DIVISION.

benson-lehner LTD / WEST QUAY ROAD / SOUTHAMPTON

For information on: DIGITAL SYSTEMS / PLOTTERS / FILM ANALYSERS / TRACE READERS / RECORD EDITORS

For further information circle 231 on Service Card

How Spaulding's big investment

making "problem parts" in lighter, cheaper, tougher Spaulding-engineered materials . . . this has always been the nature of Spaulding's service to industry. That service has been so widely accepted that, to handle the flow of new business, Spaulding have now moved to a new plant at Edenbridge with double the floor area, to accommodate considerably more production capacity. So Spaulding can increase their materials output and, through increased automation and more advanced research facilities, develop improved and even entirely new materials—they're better-than-ever equipped to solve your parts problem.

SPAULDING MATERIALS—AT WORK FOR ECONOMY



Spauldite

Spaulding Ltd., replaced a bronze pillow block set (above) with canvas base Spauldite laminated plastic at a saving to the customer of 20/- per set. Original cost of the bronze part was 34/6d. By using Spauldite canvas-phenolic laminate the price was reduced to 14/6d. while the function was maintained. The Spauldite was particularly well suited to this application because it requires no lubrication, does not seize or gall, and will not corrode. In addition, the Spauldite absorbs minute abrasive particles thus minimizing wear on the mating parts.



Spaulding Filawound

Excellent dielectric characteristics and high hoop strength of Filawound are demonstrated—and needed—in this high voltage fuse cut-out. The Filawound material is wound directly on a section of Vulcanized Fibre Tubing. This provides the necessary arc-quenching action.



Vulcanized Fibre

Arc-quenching properties, structural strength, good machinability, high dielectric strength. These make Vulcanized Fibre ideal for lightning arrestors. The fibre evolves a gas which instantly extinguishes an arc—and deionizes the air. Explosive forces generated in the explosion chamber are easily withstood by the fibre tube assembly.



Value Analysis - puts parts-efficiency into overdrive

Problem: A "V" ring is used to electrically insulate the commutator segments in an automotive starter motor. Because of the high pressure applied during assembly and a subsequent baking operation, it was felt that only an expensive molded mica ring could be used.

Solution: Using Spauldo, a 100% rag paper material which can be formed by punch press, Spaulding designed a ring which performed the function better.
Result: 60% cost reduction.

SPAULDING'S FABRICATION DIVISION

has industry's most complete facilities—accepts undivided responsibility from material manufacture to finished part. Spaulding fabrication service engineers, production specialists, skilled machinists have the technical experience that means better, more economical finished parts for you.



SPAULDING
economy through improvement

Station Road, Edenbridge, Kent.
Tel: Edenbridge (OSE 271) 3383, 3405
Telegrams: Vulcabilia Edenbridge
BRITISH VULCANIZED FIBRE LIMITED
Bridge Mills, Hadfield, via Hyde, Cheshire.
Telephone: Glossop 3184. Telegrams: Fibrine Hadfield

For further information circle 233 on Service Card



**Everything
you need for
precision
soldering
from
Enthoven**

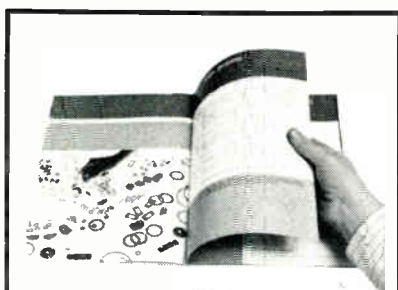
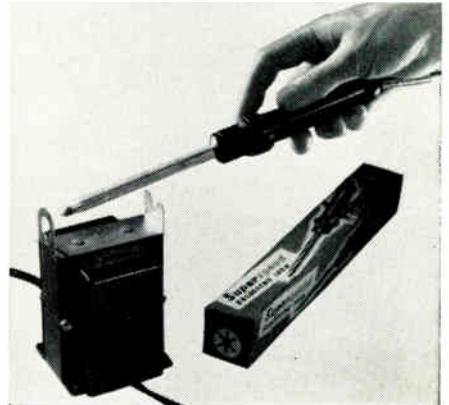
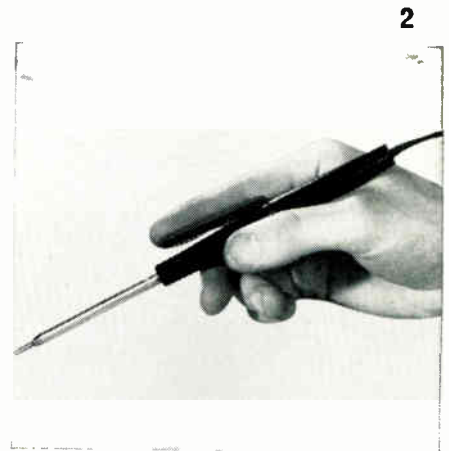

New free booklet describes the complete range of Enthoven Solder products. Ask now for your copy of 'Soldering with Enthoven'.

Tools, materials and knowledge. Two of the neatest irons ever made. The finest, most reliable materials—backed by over 150 years' experience of smelting and refining non-ferrous metals. And intimate knowledge of modern soldering techniques, the product of special experience built up over the years, confirmed when necessary in one of Europe's most advanced metallurgical laboratories. This is what Enthoven offer you. 1 Washers and preforms, cored and solid, standard and special. 2 Miniscope soldering iron for fine work. 3 Superspeed six-second heat soldering iron. 4 Preservative, metal, Tricene de-oxidant, lacquer, flux, and thinners for printed circuits. 5 Superspeed solder . . . stellate cored, wide range of alloys, gauges and packings.

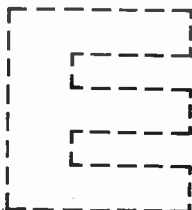

**ENTHOVEN
SOLDERS LIMITED**

Sales Office & Works · Upper Ordnance Wharf · Rotherhithe St. London SE16 · Bermondsey 2014 · Head Office · Dominion Buildings South Place · London EC2 · Monarch 0391

For further information circle 234 on Service Card

Switch over to Reliable Relays

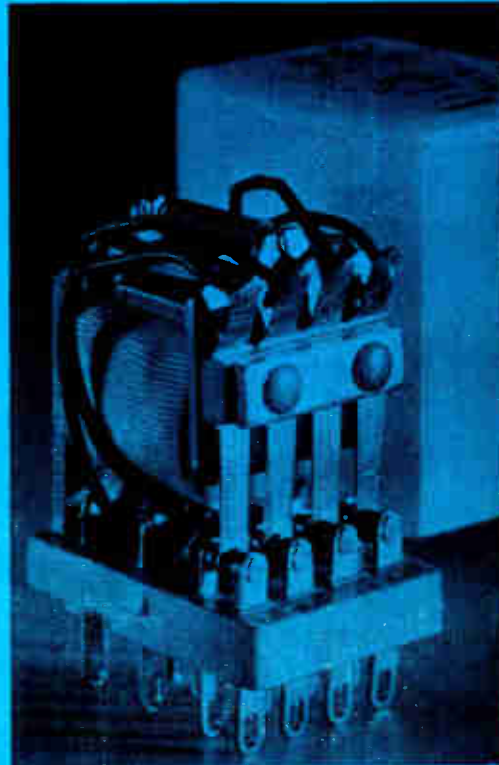
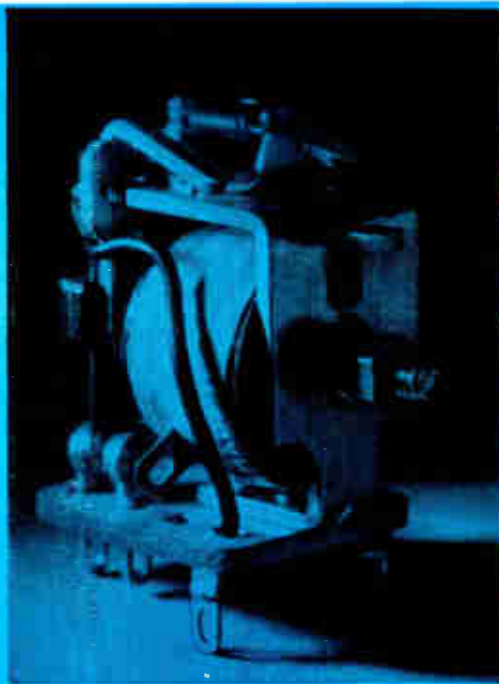
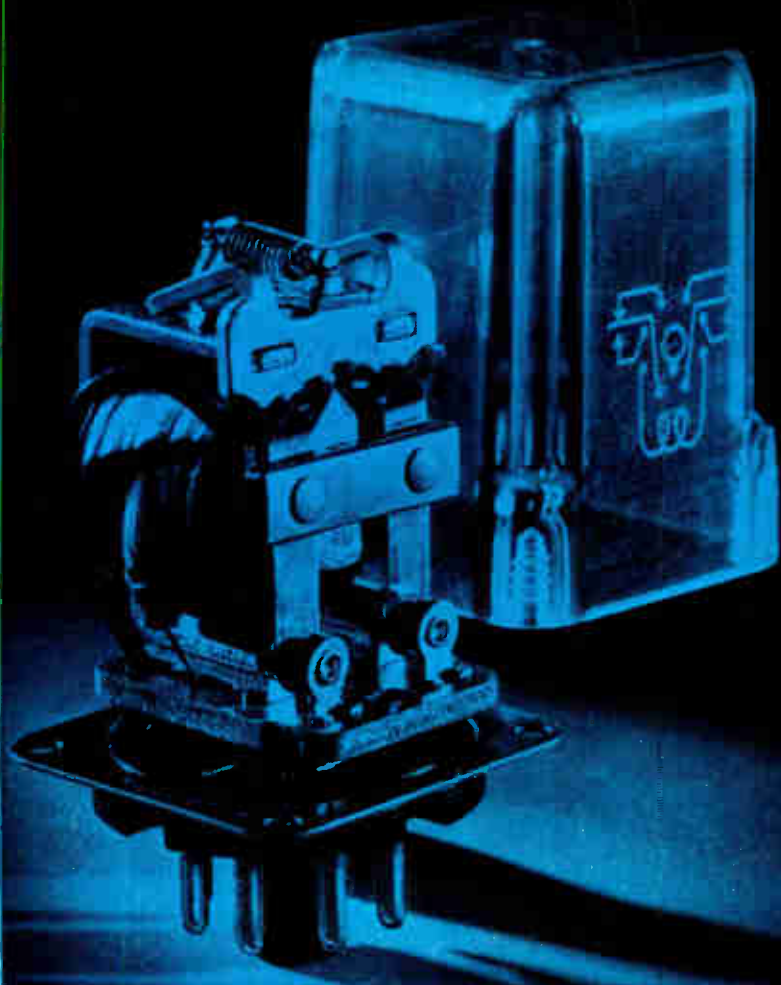

Radiospares for long-life relays! They're made to the highest standards of quality throughout and all types are available "by return of post".

Miniature plug-in relays—12V or 24V. D.C. coils, 115V. A.C. coils.
4 P.C.O. contacts rated 3A. A.C.
Open series—12V. D.C. or 230V. A.C. coils 2 P.C.O. contacts rated 250V. 5A. A.C. Also 6V. D.C. coils with 115V. 2A. A.C. contacts.
Plug-in relays—D.C. and A.C. coils with 2 or 3 P.C.O. contacts rated at 2A. or 5A. or 10A. 250V. A.C.



Radiospares Ltd.

4-8 MAPLE STREET · LONDON W.1 · ENGLAND · TELEPHONE: EUSTON 7232 (8 LINES)
TELEGRAMS and CABLES: RADOSPARES, LONDON W.1

For further information circle 235 on Service Card

ISOLA-
base-materials:
for printed circuits for all purposes.

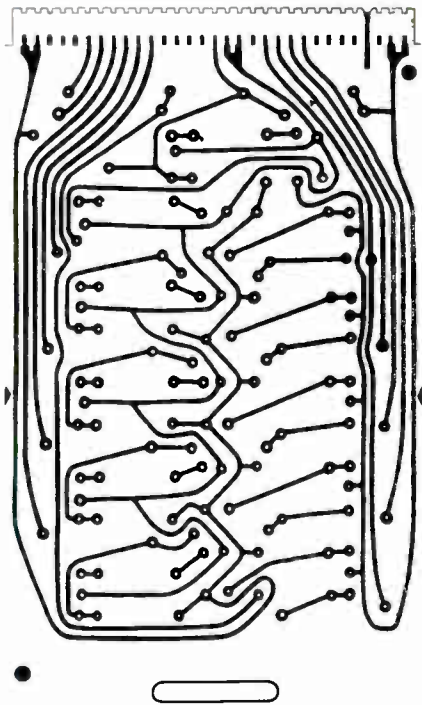

SUPRA-CARTA-Cu
quality 96

Supporting-material laminated paper on phenolic resin base, top quality for radio and television industries and for other commercial applications. Corrosion-proof, can burning according to ASTM C-835-56 T, cold-punchable.

SUPRA-CARTA-E-Cu

Supporting-material laminated paper on epoxy resin base, low dielectric-loss factor for all frequencies, high resistance values, track resistant, good mechanical strength.

VERRODUR-E-Cu

Supporting-material fibre glass laminate on epoxy resin base with highest electrical and mechanical characteristics in extreme climates, quality 100, corresponding to NEMA-Part 10, G 10 quality 110, corresponding to NEMA-Part 10, G 11. Ask for our technical information-bulletins and samples.



Isola Werke A. G.
5160 Düren
Federal Republic of Germany
U. K. agent: J. M. Harding Assoc. J. E. E.
12 Offington Gardens, Worthing, Sussex

For further information circle 236 on Service Card

EKCO H.V. SUPPLY UNITS

Proved by hundreds of thousands of hours reliable service in civil and military airborne radar installations.

Typical standard types:



Type M6052A (14kV)
M6053A (10kV) and **Type M6054A (3kV)**

General purpose, low impedance CRT supply.

Type M6051A
18kV high brightness,
high definition CRT
supply.



Type M6055A
5 to 10kV for direct
viewing storage tubes.



Type M6056A
30kV regulated
supply for projection
systems.

Designed to meet the stringent environmental conditions of airborne operation, these highly efficient encapsulated units provide voltage from 3kV to 30kV.



EKCO ELECTRONICS LIMITED
AVIATION DIVISION
SOUTHEND-ON-SEA · ESSEX

For further information circle 237 on Service Card

11 DIFFERENT TYPES



ARROW

**ROTARY
PACKET SWITCHES**

850 VARIATIONS

The Arrow range of Rotary Packet Switches is so wide, so varied, and so flexible that every possible need of circuit designers can be fully met, however exacting their requirements. The Arrow range of 850 standard variations meets most applications, but by using interchangeable components, literally thousands of different variations can be supplied, completely eliminating time and money-wasting demands for "specials".

Full details, dimensions etc. of the complete range of Rotary Packet Switches are contained in the Arrow Catalogue. Every circuit designer should have one. Write, or 'phone now for your copy.

ARROW ELECTRIC SWITCHES LTD.
BRENT ROAD · SOUTHALL · MIDDLESEX
Telephone: SOUTHALL 2442



AS1

For further information circle 238 on Service Card

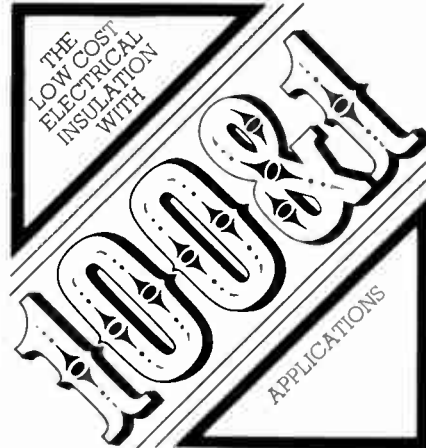
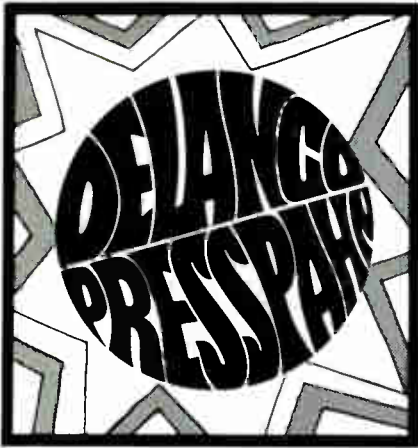

ROLL OR SHEET!

Immediately available in roll- or sheet form, and just a few days service for coils cut to any width up to 36".

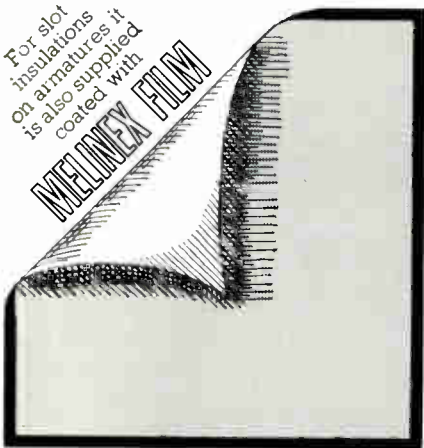

YOUR OWN STAMPED COMPONENTS

For users wishing to make their own stamped components, it can be supplied in strip, or continuous coil for roll fed operation. Or our own fully equipped works can supply the components machined to your drawings.

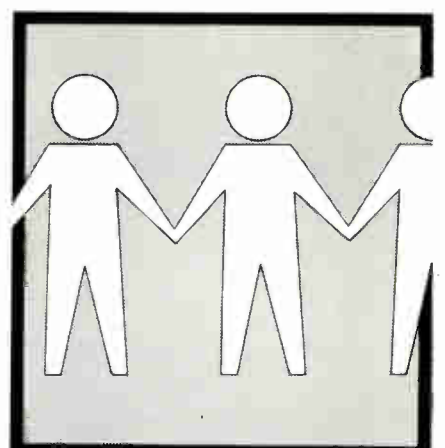

Thickness range from

.004"
to
3/64"

for coils, or up to 1" in sheet or strip.

SQUARE OR RECTANGULAR TUBE

For transformer bobbin formers in calendered or matt finish.

SAMPLE

A sample piece for testing, and price details will be sent to you upon application (see coupon below).

You can save time and money by using Delanco Presspahn send now for full information.

To: Anglo-American Vulcanized Fibre Co. Ltd.
Cayton Works, Bath Street,
London, E.C.1. CLE 8484.

Please send me a sample of Delanco Presspahn and price details

Name

Company

Position

Address



STC SEMICONDUCTOR REVIEW

OCTOBER, 1966



High power transistors

The STC range of silicon semiconductors covers frequencies up to at least 400MHz. They are suitable for medium and high power amplification of all types of signals including A.M. and S.S.B. C.W. Power outputs range from 1W to 50W; in the extreme, 20W output can be achieved typically at 400MHz with the 3TE440.

The range of devices includes JEDEC and Pro-Electron types and the standard range of "3TE" types. Encapsulations include TO-3, TO-39 and TO-5, strip-line and stud-mounted packages.

Strip-line packages are used on the higher frequency devices, providing greatest bandwidth, power gain and lower output. Most types have the emitter connected to the case thereby minimizing internal lead inductances to give very high power gain and maximum bandwidth, and to facilitate the mounting of the heat sink. Supply voltages of up to 40V can be used with many types; certain types have been designed to operate at 18V and below, e.g. 3TE350.

The highest power transistors within the range employ resistor stabilisation which results in increased output power, increased power gain, and lower intermodulation products in single side band operation. They can be biased in class AB without an external emitter resistor.

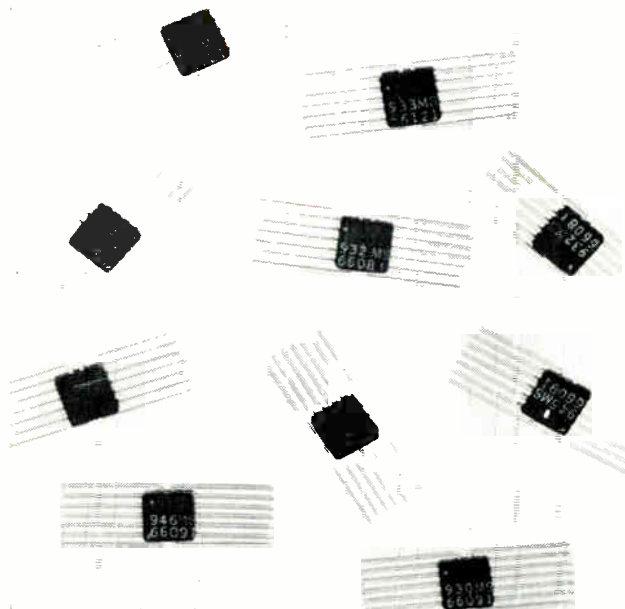

Integrated circuits

Integrated Circuits

STC announce availability of the following monolithic integrated circuits:—

MIC930	Dual 4-input expandable NAND GATE
MIC932	Dual 4-input expandable Buffer
MIC933	Dual 4-input fan-in expander
MIC945	J-K/R-S Flip-Flop
MIC946	Quad 2-input NAND gate

These units are direct pin-for-pin replacements for the Fairchild μ L930 series and are currently available in the $\frac{1}{4}$ " x $\frac{1}{4}$ " flat pack for operation over the temperature ranges 0-75°C and -55 to +125°C.

The MIC930 series features: Low power dissipation—typically 8mW/gate High noise immunity—typically 1V.
 Single power supply operation: +4.5 to +5.5V.
 Logical flexibility—wired "OR" capability, combined with expandable fan-in and a high fan-out.

For full details of all STC Semiconductor products write, phone or telex

S.T.C. Semiconductors Limited

Footscray, Sidcup, Kent.

Telephone: FOOTscray 3333. Telex: 21836.

STC
SEMICONDUCTORS

For further information circle 240 on Service Card

THE WORLD'S MOST
RELIABLE
CONTACT IS THE

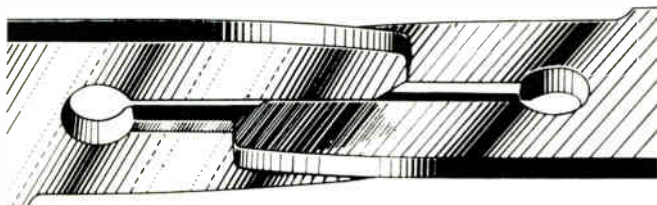

VARICON*
CONTACT

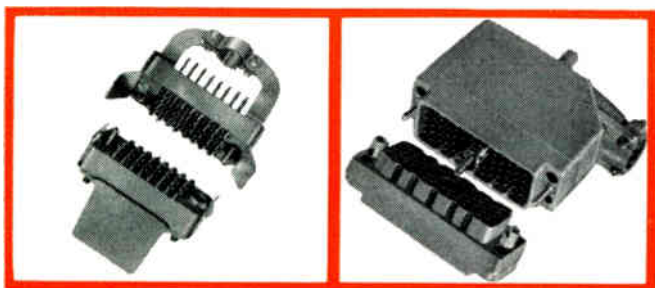

Series 8125
32 way Miniature Plug
and Socket.
Available with cover or bracket.

Series 8016
38/56 way Connector.
Available with side or
top entry.



Moulded Edge Connectors
5007—12, 16, 20 and 24 way
7002—21 and 25 way
7008—17, 23, 29, 35 and 41 way

Board to Board Connectors
Series 5201 at right angles
Series 5301 parallel
Series 5101 edge to edge

VARICON* Contacts solve most of the packaging and reliability problems met with in the most sophisticated projects. This versatile, low resistance fork shaped hermaphroditic contact with four mating areas is used in a range of MULTIWAY PLUGS AND SOCKETS, PRINTED CIRCUIT BOARD-TO-BOARD CONNECTORS AND MOULDED PRINTED CIRCUIT CONNECTORS. Specify THE VARICON* RANGE, proven to be the World's most reliable contact.

*TRADE MARK

M.O.A.—A.R.R.E.—A.R.B. Approved Inspection Can be supplied to meet P.O. Approval

MAGNETIC DEVICES LTD
Newmarket, Suffolk
Newmarket 3451 (10 lines) Telex 81245

VARELCO LIMITED
Newmarket, Suffolk
Newmarket 3451 (10 lines) Telex 81245

Under licence from the Elco Corporation, Willow Grove, Pennsylvania, U.S.A.

RS 101/H

For further information circle 241 on Service Card

WHITELEY

ELECTRICAL RADIO CO. LTD.

**ELECTRONIC
COMPONENTS
& EQUIPMENT**

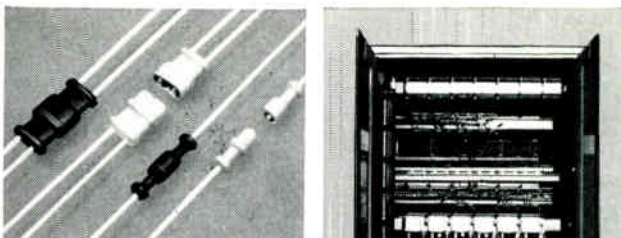
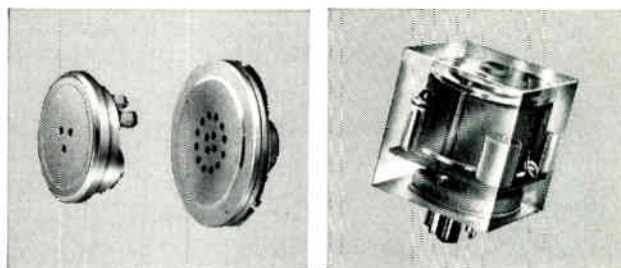
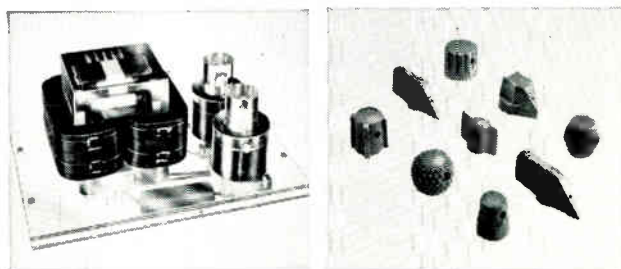

*
Whiteley Electronic Components are designed and precision-built in the Company's own factories. Every operation is strictly controlled, every part is vigorously inspected and tested. Nothing is left to chance—hence Whiteley's enviable reputation.

WHITELEY ELECTRICAL RADIO CO. LTD

MANSFIELD · NOTTS · ENGLAND Tel: Mansfield 1762/5
London Office: 109 KINGSWAY, W.C.2 Tel: HOLborn 3074

WB186

For further information circle 242 on Service Card

INTEGRATING, 180dB C.M.R., ALL-SILICON, MODULAR CONSTRUCTION



What else can we say about the new DM2006?

Just this; thoroughbred though it may be, this new Dynamco DVM throws no temperaments. Long term accuracy (0.01% f.s.d. $\pm 0.02\%$ reading) can be relied upon over a $+10^\circ$ to $+40^\circ\text{C}$ ambient temperature range, within $\pm 7\%$ power variations, for at least twelve months. The plug-in input modules now available give a choice of manual, remote or automatic ranging and these will be followed by modules giving greater sensitivity, a.c. measurement etc. Ask for full details of this high performance 4-decade integrating DVM, together with prices. Details of long-term leasing arrangements are also available on request.



DYNAMCO

Dynamco Instruments Limited *incorporating Digital Measurements*
Salisbury Grove · Mytchett · Camberley · Surrey · Telephone Farnborough 44422

For further information circle 243 on Service Card

New 7035A/AM High-Performance, Low-Price X-Y Recorder

Electrostatic paper hold down: either standard or undersized paper can be used, no noise or mechanical troubles.
Solid-state design: lighter weight, less power consumption and no fan!
Floating and guarded inputs: eliminate ground loops and simplify signal connection.
Common mode noise rejection: 30-110 dB depending on range.
Included in price: rack mounting brackets, tilt stand facility and electric pen lift.
Options: rear input terminals and retransmitting potentiometers for X and Y axis.

Available with choice of metric or inch scales. The 7035AM (metric) provides five calibrated ranges from $400 \mu\text{V}/\text{cm}$ to $4 \text{ V}/\text{cm}$. The 7035A (inch) provides ranges from $1 \text{ mV}/\text{inch}$ to $10 \text{ V}/\text{inch}$. Accuracy $\pm 0.2\%$, linearity $\pm 0.1\%$, resetability $\pm 0.1\%$.

Price: £337

Contact your hp sales office for full information on this or any other X-Y recorder in the wide Moseley range.

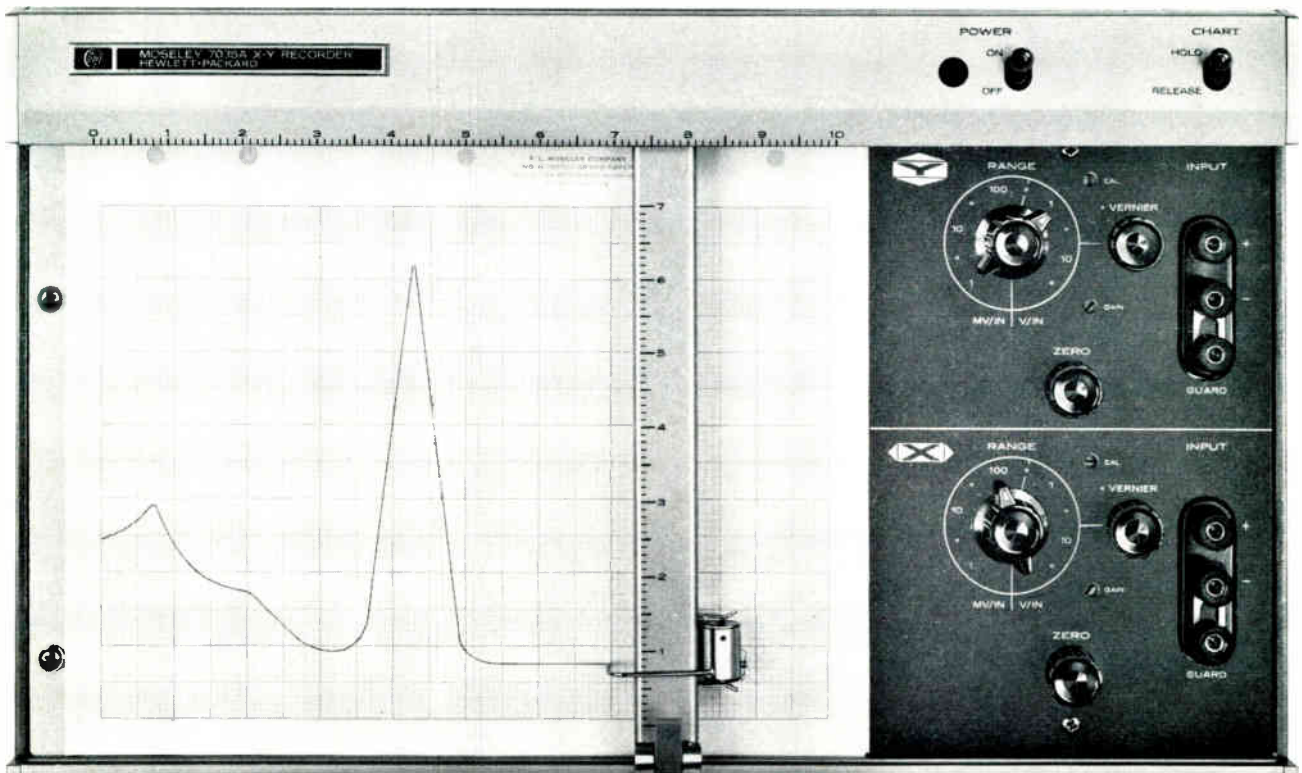

HEWLETT  PACKARD
LIMITED

Hewlett-Packard Limited
224 Bath Road, Slough, Bucks.
Tel.: Slough 28406 and 29486

Headquarters in USA: Palo Alto (Calif.)
European Headquarters: Geneva (Switzerland)
European Plants: South Queensferry (Scotland)
Böblingen (Germany)

705

INDUSTRIAL ELECTRONICS

Incorporating British Communications and Electronics

The Technical Information Explosion

Last year, it has been estimated, some sixty million pages of technical literature were published throughout the world, and statistics indicate a doubling of the annual output of technical documents every twenty years. What is not indicated, however, is how an engineer is expected to extract from this mass of technical information precisely what he wants when he needs it.

At present, if he has the time, he will probably glance through those publications that he knows to be relevant to his subject, and perhaps he will consult a few journals of abstracts. He might even peruse a guide to such journals, but guides to such guides exist, and no doubt guides to these guides will be necessary before long. In the face of this proliferation (and, no doubt, duplication) of technical references, the engineer who manages to keep in touch with all the progress in his particular field may, in so doing, be left with no time to practise his profession.

Wherein, therefore, lies a solution to his problem? Perhaps in the complete mechanization of information handling, utilizing the techniques of remote-access, high-speed, large-store computers.

An approach to this method has already been made by I.B.M. with their Current Information Selection system (see *Industrial Electronics*, Vol. 4, No. 6, page 269, June 1966), which is a 'normal-text' information-retrieval system that stores technical abstracts and references in code on magnetic tape and extracts these according to an engineer's 'profile'. But this service is not 'on-line' to the engineer, whose enquiries are answered only once a month.

A more advanced documentation system, now being evaluated at the Massachusetts Institute of Technology, involves the use of teleprinters connected to a computer. Users type instructions to the computer which specify their requirements (such as subject matter, authors, etc.), and receive an immediate reply in plain English. The problems here are to increase data-storage capacity and to perfect optical character recognition machines.

These two systems rely on digitally encoding information and then translating the stored text back into plain English. Storing information visually is already quite common, using microfilm techniques, but it is the indexing and extraction of the information that creates the difficulties. Perhaps one of the most interesting applications of a direct visual method is the 'Videofile' system developed by Ampex and currently being used by N.A.S.A. In this, documents are recorded on videotape and can be selected instantly either for display on a cathode-ray tube or for reproduction as hard copy.

Clearly, such a system has potential, but its cost at the moment (over \$1 million) will be prohibitive to all but the largest concerns. So what can be done for the individual to ensure that he is kept fully informed in his specialization?

A national technical-information centre could be set up (backed, perhaps by the Ministry of Technology). At least a start could then be made on establishing a comprehensive record of the world's technical literature, indexing and coding it so that a subscriber could extract it on demand. If such a service is not forthcoming, there is a danger that technical documentation will become so much paper and ink, with no one having the time to find out whether it is worth reading or not.

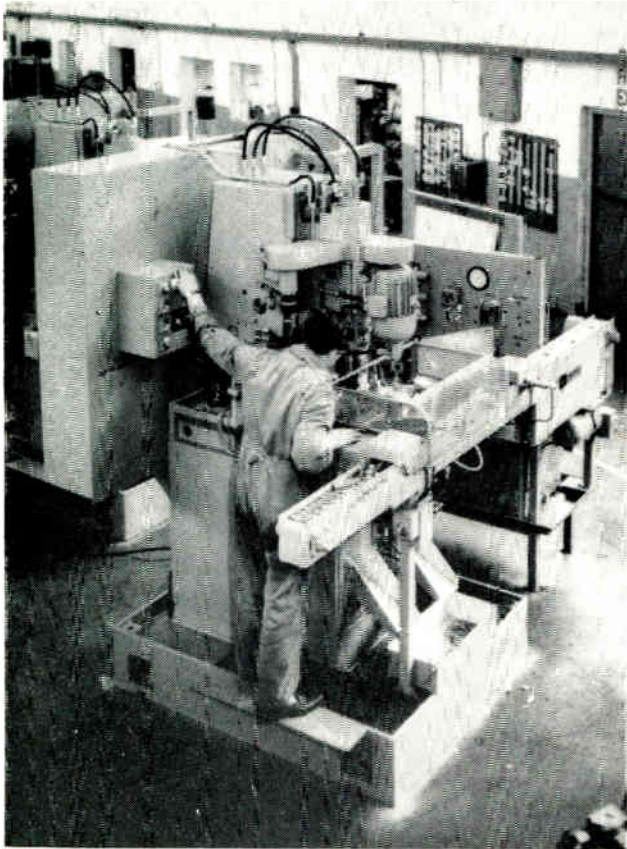

This machine is typical of the type that requires control not only of machining of the metal but also of the handling equipment used for automatic loading and unloading of the machine

The 'NOR' switching element can be used for many control purposes. This article explains the application of these units for machine-tool control and outlines the manner in which a complete control circuit is built up.

Machine Tool Control By NOR Switching

By D. S. NICHOLLS*

IN an earlier article¹ the working principles of the 'NOR' switching element were explained and the modular construction of these devices was described. These units perform a particular switching function which is essential in many electronic control systems. The field of machine-tool control in particular makes use of this function. For this application, signals generated by detectors located on the machine must be combined to switch logic gates on or off to enable a control system to regulate the machine automatically throughout its operating sequence. The NOR elements perform part of the switching function.

In practice, the machines will require control of ancillary handling equipment for automatic loading and unloading of the machine as well as control of the actual metal cutting or other machining function. The machine depicted above is typical of this type. Its function is to turn two faces on a gear-box component to a predetermined finishing limit of high accuracy at a fairly rapid operating-cycle.

The Automatic Operating Sequence

The operating sequence for this machine when under automatic control is as follows. With the machine correctly prepared by an operator and with the part to be machined correctly located at a pick-up point, mechanical grippers close around the part and lift it clear of the machine structure. A further set of grippers closes around the previously-machined workpiece and removes it from the machining position. While this component is being moved to an unloading position, the new component is transferred to the machining position. Suitable detectors sense the positions of these components and if these positions are proved to be correct, the grippers open and release the components. The new workpiece is accurately positioned and rigidly clamped while the previous workpiece is moved to the

correct position for the next stage of the complete manufacturing process.

The workpiece is rotated at high speed and the cutting tools are fed in. Two different rates of tool feed are used, a high initial speed followed by a low speed. Selection of the tool feed rate depends on the permissible speed of metal removal for each particular job. During the metal cutting, the grippers are returned to their original positions. When the cutting operation has been completed, and after detectors have produced an electrical signal to indicate or prove that this is so, the tools are retracted from the workpiece and the rotation is stopped. Further sensors provide a signal to signify that the rotation has stopped and the clamp is released from around the workpiece. Provided that a new workpiece is at the pick-up point and that the exit is clear for the finished workpiece to be unloaded, the machine will repeat the sequence continuously. Built-in facilities enable the machine to be controlled manually during individual steps as required.

As can be seen from the above sequence, before the machine moves from one stage to the next the control system must receive a signal from a detector to prove that the preceding stage has been satisfactorily completed. Various types of detectors are available and can take the form of hydraulically- or pneumatically-operated pressure switches, mechanical limit switches, electronic proximity switches or, for specific uses, manual switches. The electronic proximity switches, suitable for use in arduous conditions, mainly incorporate solid-state circuitry. No physical contact is required for operation; an output will be produced if an object comes within a certain critical distance from the sensing head. Having no moving parts, they readily lend themselves to use in static switching systems.

Although the above refers to the machine shown in the

*MTE Control Gear Ltd.

title picture. many other machines exhibit similar features and are suitable for the same sort of control.

The Use of the NOR Switches

Within the limits of an article of this type it is impractical to cover in great detail the complete design approach for a particular scheme, but the examples which follow indicate the principle employed.

It is usual to include in the system a number of safety checks and interlocks. Before the sequence can be set in motion by the operator, these checks and locks must signify that certain conditions have been met and that the system is ready for operation. For example, the checks and interlocks may be required to indicate that ;

the hydraulic pump is running AND the swarf-clearing conveyor is operating AND the load and unload conveyors are running AND a component is in the pick-up position AND the safety guard is closed.

The switches or detectors which indicate that the above conditions have been met must be combined in such a manner that the operation of the machine depends on each one being simultaneously correct when the starter button is pressed. This constitutes a basic AND logic situation. The contacts of ordinary switches could be connected together in series, as in Fig. 1, to perform this function. For various technical reasons, however, electronic proximity switches cannot be connected in series. The circuit of Fig. 1 must be replaced by a gating module which will form an electronic equivalent of the series circuit. An AND gate made up of NOR elements can be used and is connected to the switches and detectors as in Fig. 2.

It is unlikely that all the conditions will remain unchanged once the sequence has started. The 'component present' signal will alter when the component is removed from the pick-up point and transferred to the machining position and the starter button will probably be released. It is therefore necessary for the system to remember the initial conditions throughout the whole sequence. This memory function is performed by a simple memory circuit constructed of NOR elements and connected to the AND gate as in Fig. 3.

If a visual indication is required that the conditions for the start of the cycle have been established, an amplifier with a suitable lamp fitting can be connected to point Y as in Fig. 4.

Once initiated, a starting circuit of this type would maintain its output as long as the memory signal (at point R in Fig. 3) remains present. When other circumstances occur to remove this memory signal, the output will be terminated. This function could be performed by a further AND gate connected as in Fig. 5. The operation of this gate could depend on, say, a 'stop' signal and an 'end of cycle' signal.

The output signals are taken from points X or Y depending on whether a 1/0 or a 0/1 mode of operation is needed.

This circuit is, in fact, a short-term 'information store' (i.e., the necessary starting conditions are remembered until deliberately cancelled). Various other parts of a control system are required to perform this function and, as a result, this sort of circuit pattern appears frequently, in various combinations, in complete scheme diagrams.

The Control System

Any complex circuit can be broken down into a number of sub-sections such as that shown and these are then linked together in accordance with logic design demands. It is only necessary to define clearly the actual sub-section conditions and then literally to substitute

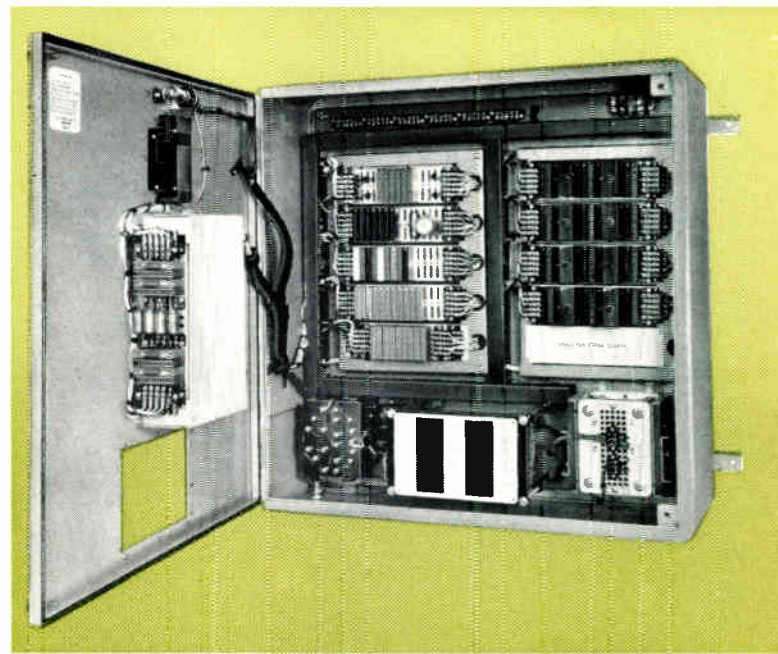

This shows a solid-state controller for use with a pneumatic conveying system

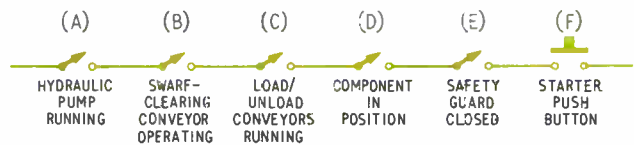

Fig. 1. This illustrates how ordinary on-off switches would be connected to signify to the control circuit that the required starting conditions have been met

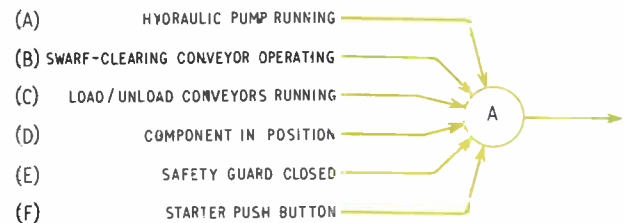
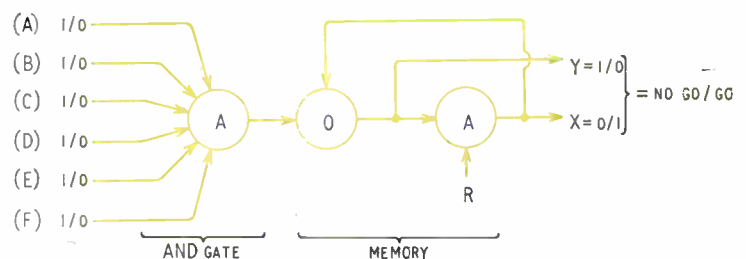

Fig. 2. The outputs of proximity switches would be connected to the AND gate as shown here

Fig. 3. In this schematic diagram a simple memory circuit can be seen connected to the AND gate of Fig. 2.



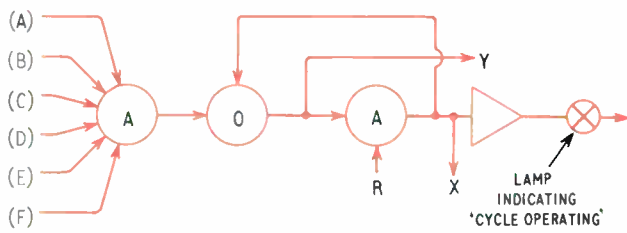

Fig. 4. This shows an indicating lamp connected to the output of Fig. 3

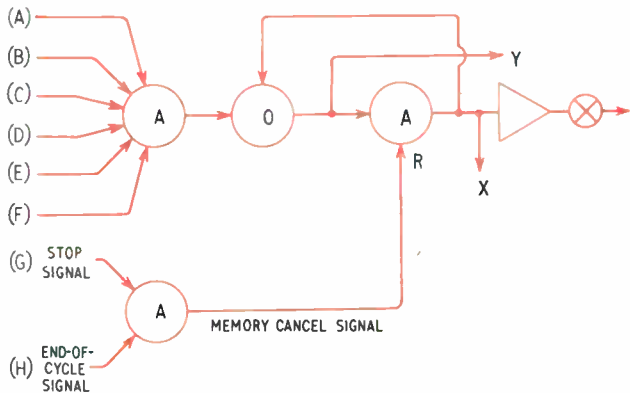

Fig. 5. The output from the additional AND gate to point R will terminate the output of the memory circuit

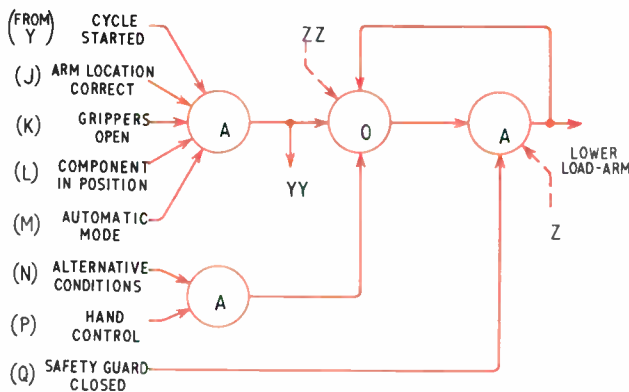

Fig. 6. This shows the circuitry required to produce a 'lower load-arm' signal

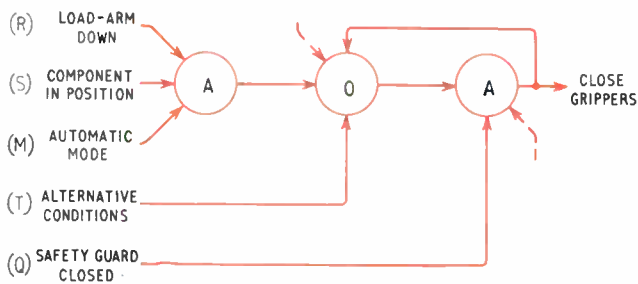

Fig. 7. The circuit shown here will provide an output to close the grippers

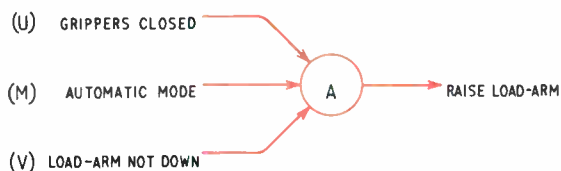

Fig. 8. The output from this circuit, which will cause the load-arm to be raised, would be fed to the memory circuit of Fig. 6 to cancel the 'lower load-arm' signal

logic module symbols to provide an equivalent interpretation.

Consideration of the requirements for part of a typical component-handling mechanism (in the machine referred to at the beginning of the article) will illustrate the procedure.

Let us assume that the specification for the system states that:

- (a) All mechanical operations require energization of a solenoid for action;
- (b) There is no intermediate condition permissible between two opposing actions (i.e., 'energize up' = 'not energize down');
- (c) No permanent information storage is necessary and an instantaneous change of mechanical direction is permissible.

The component-handling mechanism must be controlled to operate only if certain conditions have been established. If the required movement is the lowering of the load arm, this can only be accomplished if the complete machining cycle has started, if the arm is in the correct initial position, if the component is in the pick-up position and so on, or if certain alternative conditions have been met. The 'lower load-arm' signal can be said to be equivalent to the signals signifying that the required conditions have been met as the lowering of the arm is the next logical step after the establishment of these conditions. The sequence can be written in simple logical terms thus:

Lower load-arm =

$$\left\{ \begin{array}{l} \text{cycle started AND arm location} \\ \text{correct AND grippers open AND} \\ \text{component in pick-up position} \\ \text{AND automatic mode selected} \\ \text{OR} \\ \text{Required alternative conditions} \\ \text{met AND hand control} \\ \text{mode selected} \end{array} \right\} \text{AND safety guard closed}$$

The switching is performed by the circuit in Fig. 6. The memory loop (shown dotted) is required because the conditions will alter during the next operation. The original states must be remembered to ensure that the output of the circuit will remain as 'lower load-arm'. With reference to item (b) of the specification, if the output changes it becomes 'not lower load-arm' which is the same as 'raise load-arm'. The output can be cancelled as required by an input at the terminal marked 'Z' or at the terminal marked 'ZZ'.

The grippers are now required to close, the conditions for this being:

Close grippers =

$$\left\{ \begin{array}{l} \text{Load-arm down AND component} \\ \text{in pick-up position} \\ \text{AND automatic mode selected} \\ \text{OR} \\ \text{Alternative conditions met} \end{array} \right\} \text{AND safety guard closed}$$

The circuit of Fig. 7 produces the signal for this stage of the sequence.

The next operation, 'raise load-arm', can be considered as 'not lower load-arm' as stated before. Only those conditions which must apply need be taken into account. A practical sequence would be:

Load-arm up =

$$\text{Grippers closed AND automatic mode selected AND 'not load-arm down' signalled}$$

This stage of the operation, therefore, must cancel the 'lower load-arm' signal from the circuit in Fig. 6, the signal which performs this function being taken from the circuit of Fig. 8.

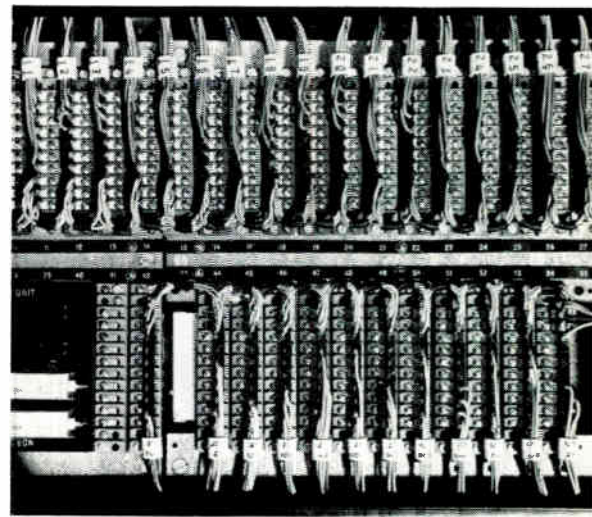
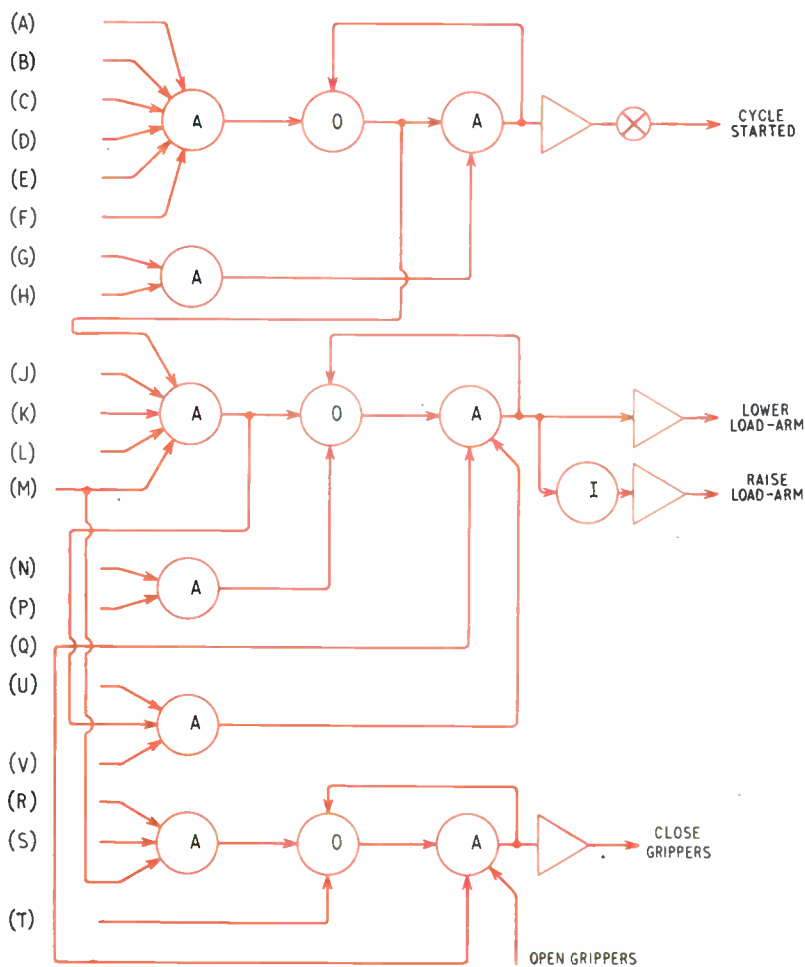

This panel, supplied to a manufacturer of diecasting machines, shows the form of construction used for a control system using NOR switching elements

Fig. 9. This composite circuit will control the machine through its sequence from the starting of the cycle to the point where the component is raised clear of the machinery prior to being placed in the machining position

Fig. 9 shows the circuit of Fig. 6 modified with the circuit of Fig. 8 and combined with the previously-described circuitry. This combined circuit will control the machine through the sequence up to the point where the load-arm lifts the component clear of the machinery prior to transferring it to the machining position.

The procedure outlined can be extended as necessary to fulfil the full specification requirements for every stage of operation. The total number of AND gates, OR gates, MEMORIES and INVERTORS depends on the overall system complexity. NOR units can be used for every one of these functions, thus demonstrating the flexibility of these modules and the ease with which they link together in a practical system.

One method of modular construction which has already been used in over two hundred working systems and exploits all the 'NOR' features is illustrated above. This shows a section of the interior of a panel supplied to a manufacturer of diecasting machines, and clearly indicates the physical form of construction used. Other control systems which have been built include a unit which is used for control of an automatic weighing system in the chemical industries, a grinding-machine controller, and many others in diverse sections of industry.

Conclusion

Reliability of a control system is of paramount importance. Although much has been said by many different authorities on the relative reliability of systems, it is worth

noting that the company with whom the writer is associated already has in excess of 50,000 of these modular NOR devices working under actual service conditions. In the 3½ years during which results have been recorded, there has been no known instance of a unit failing under normal usage.

Reference

¹ Nicholls, D. S., 'A Solid-State Switching Module', *Industrial Electronics*, Vol. 4, No. 8, September 1966.

New Unit for Gear Checking

A gear testing unit which indicates directly on a chart the variations in angular velocity of a pair of gears in mesh has been developed by the Ministry of Technology's National Engineering Laboratory. It is being manufactured by J. Goulder and Sons.

In operation a master gear of known accuracy is meshed with the gear under test. Radial optical gratings are mounted co-axially on the gear shafts and electrical signals are obtained from optical read-out heads as the gears are rotated. Any non-uniformity in the relative motion of the shafts, due to the tooth meshing errors, causes a phase difference in these signals. A phasemeter, which provides a voltage proportional to the phase difference, actuates a pen recorder. From this record the composite meshing errors in the gear pair are derived. The 'equivalent' cumulative pitch error and the tooth profile error of the test gear can be calculated from the chart.

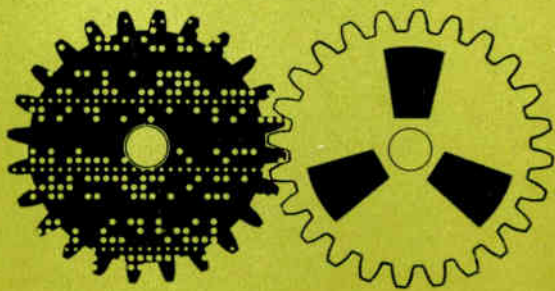

COMPUTERS IN INDUSTRY

Back-up Control

By J. A. ROBINSON*, B.Sc.,
and N. L. LEECE*, B.Sc.

Last month, the ways in which direct digital control has been applied at I.C.I.'s Fleetwood chemical plant were described. In this article, some of the developments in back-up control techniques in the post-Fleetwood era are discussed.

* Ferranti Ltd.

THE Fleetwood experiment showed that direct digital control was possible and that an acceptable reliability could be achieved. It did not, however, require any form of standby control, since the plant characteristic was such that the plant valves could be 'frozen' for several minutes while manual control was taken over by plant operators. This situation was unique in our experience, and almost every system experienced to date has required some form of back-up control in the event of failure of the main parts of the central computer control equipment.

There are many methods of providing standby control, ranging from the simple manual system to the provision of a separate controller per control loop. The decisions on the method to be employed depend upon the complexity of the plant, the costs involved and whether any of the process materials are dangerous. In practice, no more than 25% of loops will require full back-up control.

Analogue Back-Up Systems

The computer can operate in series through analogue controllers (in the so-called 'supervisory' mode) or in parallel with the controllers, which is in many ways more satisfactory. Figs 1 and 2 show typical series-type and parallel-type back-up systems.

For an analogue controller to take over with minimum disturbance, the computer must constantly up-date the desired value and the integral term to the same desired valve position as that required by the computer.

In the event of cessation of computer control, either due to a fault or to allow changes to be made to the program or data, the isolation system operates. This has two simultaneous effects: the 'raise' and 'lower' pilot valves are de-energized, thus cutting off air to the valve bonnet; and a changeover system of three solenoids operates, connecting the pneumatic controller to the air supply and to the valve bonnet. At the same time, the integral chamber (having been maintained at bonnet-operating pressure) is disconnected from the valve and, as a result, changeover takes place in a 'bumpless' manner.

Digital Back-Up Systems

In large installations, the additional cost may justify the provision of a simple proportional-only control system on all loops, rather than two to three-term control on only a few loops.

Fig. 3 shows a design for a time-shared digital controller for a 500-loop d.d.c. system. The heart of the arrangement is a core store which holds data (for each loop) consisting of set point, proportional constant and last-calculated demanded valve position. Data is transferred between computer and store by a fail-safe system, which prevents the passage of incorrect data on isolation.

Incremental Control Systems

The above methods of providing back-up analogue control rely on the provision of stand-by analogue controllers. At least one instrument manufacturer (George Kent Ltd.) has set out to design a new range of controllers which avoid duplication of equipment by the computer manufacturer. This is expected to result in a decrease in cost, which has been one of the factors inhibiting the growth of process control by computer.

The computer can still operate in a time-shared mode, as described earlier, producing 'raise' or 'lower' instructions; but whereas in the Fleetwood-type system it was necessary to read in valve positions 20 times per sec and to store on bistables the control bit-pairs for all valves, it is possible with the Kent interface system to dispense with measurement of valve (or regulator) position and to issue

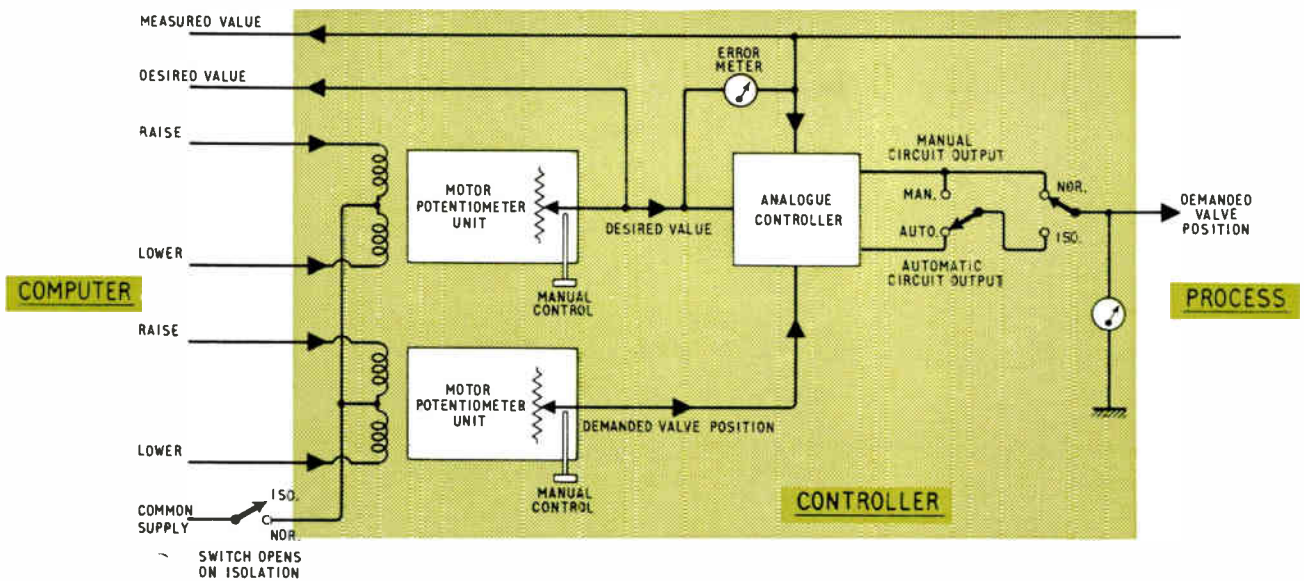

Fig. 1. This block diagram shows a typical series-type analogue back-up control system

instructions in the form of an incremental demand. The computer can generate either a constant-duration increment (or 'raise' or 'lower' demand) at regular intervals or, alternatively, one of variable duration at less-frequent intervals.

This philosophy, of course, requires the regulator to have a reasonably linear response to incremental demands of position. In one such case, an electro-pneumatic converter (actuated by a small two-phase electric motor) is used; the motor is driven by raise/lower pulses derived from timing equipment and has the merit of failing safe in the event of cessation of control pulses.

We have already seen that the frequency with which control instructions must be passed to a valve or regulator

depends upon the required resolution and the end-to-end travel time of the valve; thus if 1% resolution is required on a valve having a 10-sec travel time, new instructions must be issued at least 10 times per sec. The same effect is achieved in the Kent interface equipment with the use of a common time-shared digital-to-analogue converter and a simple electronic circuit per regulator as shown in Fig. 4.

The computer feeds a 5-bit incremental demand (allowing 0-32 demands) to the digital-to-analogue converter, which generates a corresponding voltage that is stored on a capacitor in the regulator. The sign of the charge on the capacitor determines whether a 'raise' or 'lower' relay is operated and its amplitude decides for how long the

Fig. 2. Another kind of back-up system, in which the analogue controller is in parallel with the computer, is this one currently in use at an I.C.I. experimental installation

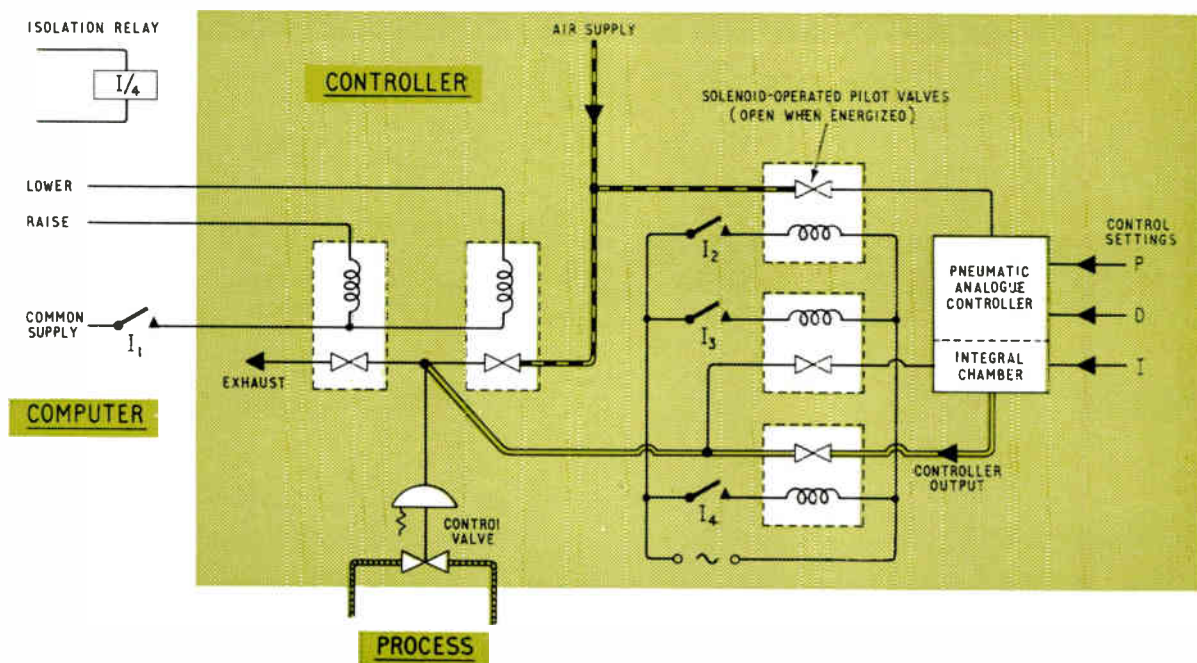

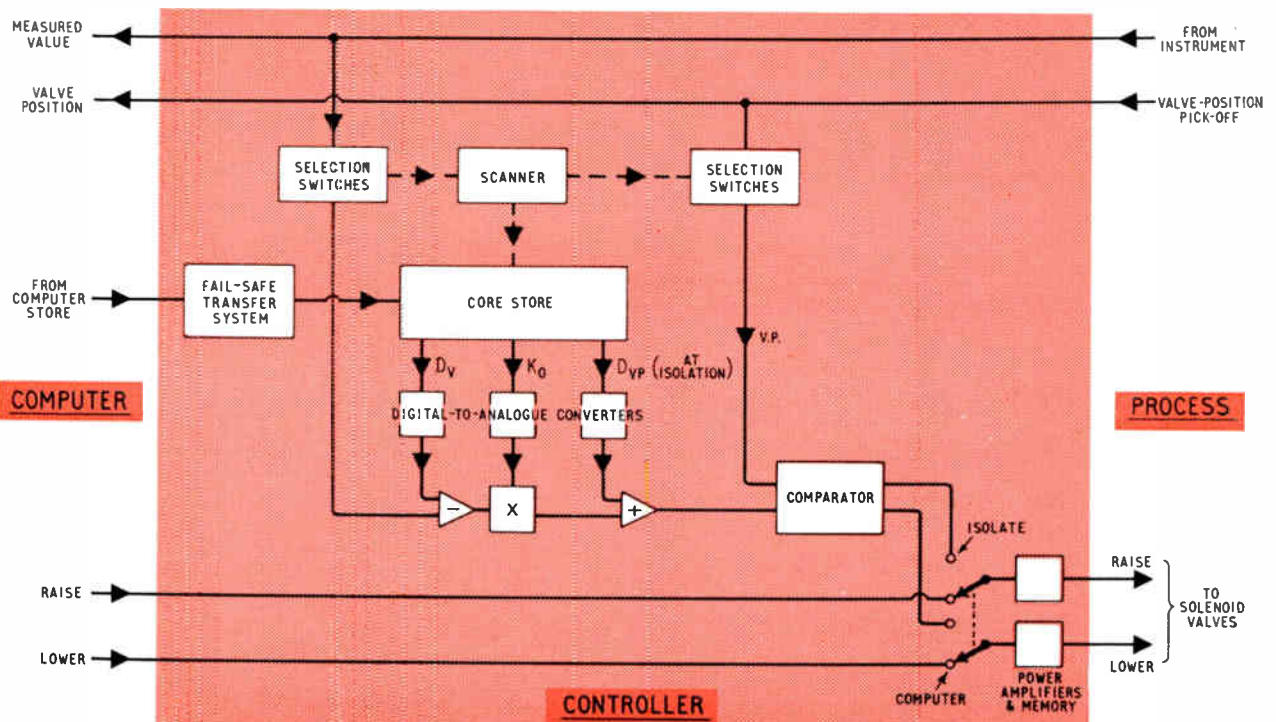

Fig. 3. For large installations, a digital back-up control system may be used instead of an analogue one. This diagram shows a back-up control design for a 500-loop d.d.c. system

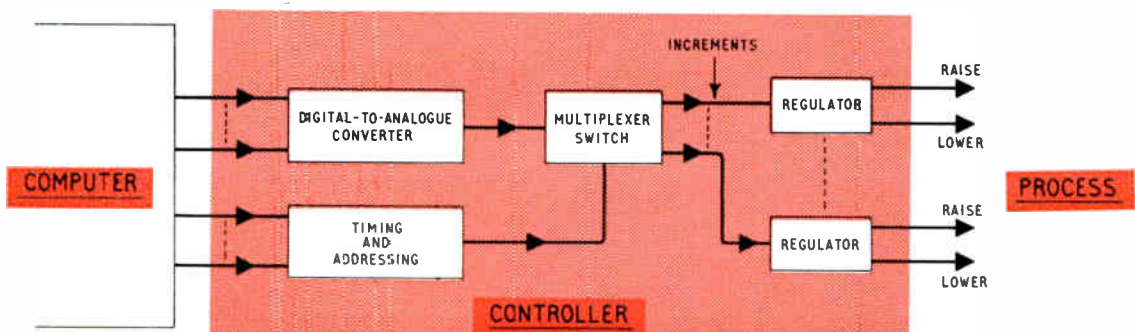
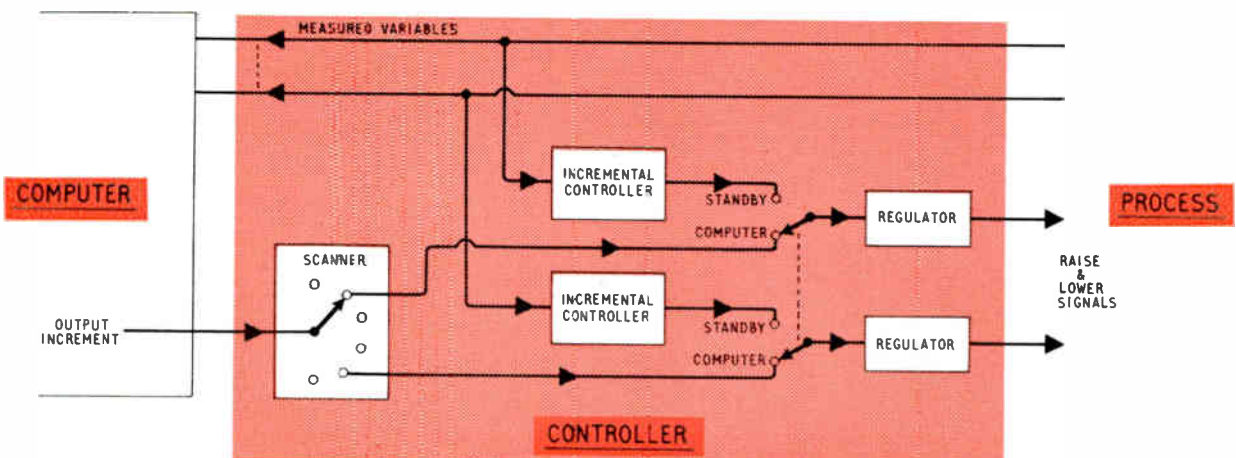

Fig. 4. This basic incremental control system employs a time-shared digital/analogue computer, with a simple electronic circuit per regulator

Fig. 5. A 'boundless' standby control system, which employs Transdata controllers and generates incremental outputs



relays are to be energized. A simplified block diagram of a standby system that generates incremental outputs is shown in Fig. 5.

Conclusion

In our three articles 'On-Line Control', 'D.D.C. in Action' and 'Back-Up Control', we have attempted to survey some of the techniques of d.d.c. and some of the attempts to solve the cost and reliability problems.

Considerable interest is now being shown (both in this country and in Europe) in future applications, and it has been heartening to note the change in attitude of British industry over the past two or three years, while at the same time wishing that interest were stronger. There remains much to be done by all concerned, and the attitudes of the Government and its agencies in offering encouragement and incentive to industry to use these modern techniques will be watched with great interest.

Communication System for Motor Cars

A system of communication for private motor cars and other motor vehicles has been developed in the U.S.A. by General Motors. As well as providing communication between the vehicle and a service station, the system gives advance warning of road signs and displays directions for a preselected route.

A modified transmitter-receiver working on the American Citizens Band of frequencies is used for the driver-to-service station link. Coded requests for road or travel information, police, an ambulance, fire engine, or breakdown vehicle are dialled by the motorist, using a telephone-type dial, and relayed to the base station by roadside repeaters. The messages are automatically recorded and the base-station operator acknowledges by normal speech communication. Normal two-way voice communication is also possible over the transmitter-receiver.

Information about road conditions, service facilities and other features of the road ahead is transmitted to the vehicle from low-power roadside transmitters. Magnets buried beneath the surface of the road actuate switches in the vehicle to switch on the receiver for reception of the tape-recorded messages. In addition emergency messages from a control centre may be relayed to the vehicles by these roadside units.

A visual display of road signs is also actuated by buried magnets. The display, fitted on to the dashboard, includes indications of speed limits, halt signs, give-way signs and other standard road signs. An audible note is emitted to alert the driver. This 'sign minder' is intended to supplement, not replace, existing traffic signs.

For the automatic display of route instructions a punched card is used. Using this system a driver can follow a route without the need to use a map. The punched instructions on the card correspond to the required route. When the punched card is inserted into the equipment, signals are produced which are compared with signals produced when the vehicle travels past further buried magnets. These magnets would be located at major cross roads. Panel lights indicate to the driver whether to turn right or left or to proceed straight through.

This is a significant advance in the facilities offered to the motorist. At a recent lecture given at the Royal Society of Arts on 'World Communication', Professor Colin Cherry suggested that bad driving and the anti-social behaviour of some drivers was due in part to a lack of any real means of communication which the driver could use. This General Motors scheme could play a large part in rectifying this problem.

This shows the equipment installed in a motor vehicle. The inset shows in greater detail the indicator panel which is fitted above the dashboard



A certain amount of reluctance is being shown by industry in the adoption of automation techniques. This article discusses some of the reasons for this and outlines the type of cost saving that can be achieved by the use of automated plant.

AN article by S. R. Jarvis¹ pointed out a number of ways in which industry is failing to take advantage of well-proven, economic and readily available electronic aids to automation. Mr. Jarvis does industry a service by giving voice to the thoughts of many of us engaged in providing it with aids to increased and improved production. Progress is indeed painfully slow, and as a target for criticism industry presents itself as a sitting duck . . . but . . .

In general, engineers are able to assess the benefits of automation where they ease production difficulties, improve quality or result in an increased output. Management—still a little awed by the proliferation of new equipments, each, of course, better than the last—are eager to introduce automation if only someone can demonstrate to them how it will affect their costs, their profits and their position in a competitive market—both short term and long term.

Management and Engineer—A Lack of Communication

However, each is slow to speak the other's language. Engineering vanity is not restricted to those engineers who make control equipment, and management often exercise remarkable restraint in continuing to employ those production, test and quality control engineers who place technical elegance on a pedestal and spurn the reality of the company balance sheet. One company in the writer's experience employing ten girls on a small production line developed a specialized and sophisticated machine capable of producing twice the number of items in the same time as the ten girls. The company was delighted. So delighted that some time elapsed—and the production team dispersed—before it was pointed out that the, predictable, maintenance and running costs of the new machine were equivalent to the cost of employing twenty-four girls; moreover the item being made was scheduled to be replaced by one the machine could not produce. As a direct result it became extremely difficult for the engineering department to get permission to obtain or develop other equipments which would have made a genuine contribution to company efficiency and productivity. Many firms are, justifiably, reluctant to wager a large part of their produc-

Flight Refuelling Ltd.

tion against the chance of a failure in a machine they do not understand and, sometimes, cannot repair. Management has the feeling that it no longer controls its own production. These feelings are not unreasonable, and it is up to the control and automation supplier to provide both equipments and reasons that dispel them. Most suppliers operate good after-sales services, will recommend suitable spares to be held by their customers, and in some cases are willing to train operators and maintenance staff so as to obtain optimum use of the equipments.

As has been pointed out, simple solutions to problems and a range of reliable flexible equipment are prime necessities—and here it is worth digressing slightly to emphasize that flexibility applies in two ways. Not only must the supplier of control equipment employ devices which can assume a number of different guises and can perform a number of differing tasks by simple combinations and permutations of well-proven units, but once installed the equipment must be capable, within reason, of adaptation to suit subsequent changes in production methods. Usually the two requirements are met at the same time but it is always worth questioning the prospective customer's staff so as to elicit possible ways in which future changes can affect the tasks performed by the control equipment.

However, all this is still not enough, and as a consequence of the type of experience described above, and of the lack of a common language in which engineers and management can speak, only those systems which immediately, obviously and clearly demonstrate their great technical value to everyone are installed.

Those equipments which make for less obvious savings or improvements, those which are less glamorous, and those which reduce costs by less direct means are regarded with considerable scepticism, or, most often, pronounced as being too expensive without an accurate assessment of their true worth.

A considerable proportion of the blame for this situation can be fairly laid at the door of the suppliers of control systems and equipments. A prospective customer is supplied with technical descriptions of equipments and an attractive dissertation on the types of problems solved by these equipments in a number of industries. Subsequently an applications engineer (or even a team of them) will be available and keen to discuss the particular features of the customer's problem and the exact manner of its solution. The first stage of the game is played by engineers . . . when they have finished management are allowed a turn, and it is in the second stage that the suppliers of control equipment most often fail . . . to strain the metaphors somewhat; the ball is passed to the accountant or the financial director in the most sloppy and unskilled way so that all he can do is kick for touch.

WHY IS INDUSTRY SHY OF AUTOMATION?

By GERALD THOMAS*

The Financial Aspect

How many application/sales engineers are competent to discuss the problem in terms of tax relief (just ask the nearest one to speak for three minutes on the significance of the latest Government proposals), of cost savings realizable upon the introduction of the new equipment, immediate and long term (not the fancied or the theoretical but the expected savings as shown by past examples), of the economic benefits and handicaps of the various side effects that invariably accompany the introduction of automatic equipment?

Its purchase *may* be justified by the reduction of the production scrap rate alone, or by the increase in sales due to better quality, or by the savings in direct labour, or by the ability to use cheaper bought-in materials, or to reach a previously unattainable market, or by any single one of a number of other factors; but it is much more likely that the economic justification will lie in some combination of factors. Not all these factors will be seen at once by either the prospective customer or the control engineer, and the exact contribution of each factor will in any case be hidden from the latter. However, it should be regarded as part of his task to lead his prospective customer into a consideration of the ways in which cost reduction or profit increase can take place—quoting examples from his experience where possible. Of course, these discussions must be undertaken with the same integrity which the control engineer habitually exercises in his technical role. It is only by respecting the fancied fears of a breach of commercial security that he can keep his respect in the eyes of his customer. The subject of trade secrets or commercial security and the ways in which it ties the hands of those who are its greatest proponents is too large to be discussed here—and wild horses will never drag from me the name of the industry wherein each member zealously guards the same number of identical 'trade secrets' from every other member. That commercial security is recognized and respected by reputable control engineers where there is a need for it, as well as where there is not, is established without question.

The supplier of automation and control equipment must learn to speak the language of management. As well as being an expert in his field of engineering he must also gain sufficient knowledge of the ways in which the installation of his equipment can alter the appearance of its purchaser's balance sheet, to be able to explain, suggest, and guide. Given these abilities together with a suitable range of equipments on which to draw, he can do much to bring an end to the failure of industry to grasp the advantages of automation, and avoid the admittedly catastrophic results of its mis-application.

Before considering an example, one important point needs

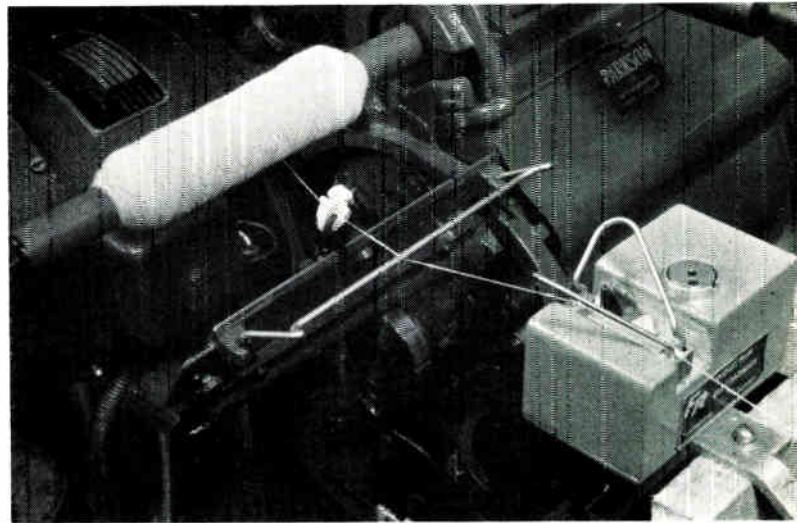

The slub detector shown here also utilizes reed switches

to be made. In attempting to demonstrate the financial abilities of his control equipment, the engineer begins to speak the language of the accountant; he is about to enter the field of capital budgeting. This field is now providing accountants with considerable interest, much new work, and a great deal of discussion and argument. It, therefore, ill behoves the engineer to rush in, using a particular set of rules by which he arrives at an answer for the rate of return on the capital invested, if, as is likely, his rules and assumptions are going to be called to question. All he can do, and all he should do, is (a) to provide a customer with the basic figures to which the discounting techniques employed by that customer can be applied, and (b) to quote examples of actual savings from his past experience.

An Example of Automation in Industry

Now let us consider an example—imaginary in detail but real enough in principle—that of a control system to be used to synchronize a number of drives in a carpet-making machine.

Technical Advantages

The technical advantages of the control system are as follows:

1. The introduction of the system enables one operator to control the whole of one process—one operator is released for other work.

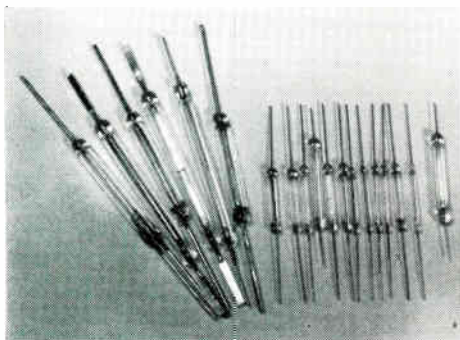

These reed switches can form the basis of many units in control systems

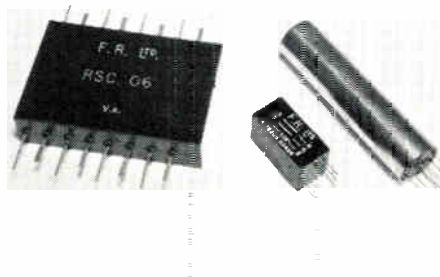

Here can be seen examples of relays which incorporate the reed switches

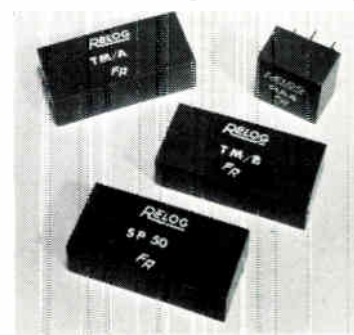

These logic elements incorporate the basic reed switch

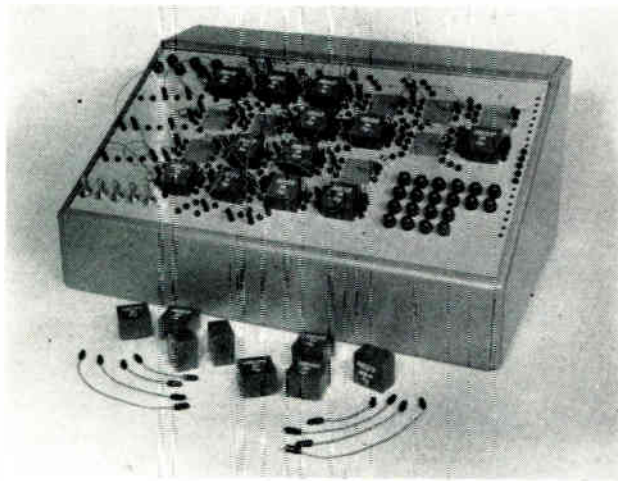

This teaching kit is constructed from a number of the standard logic modules

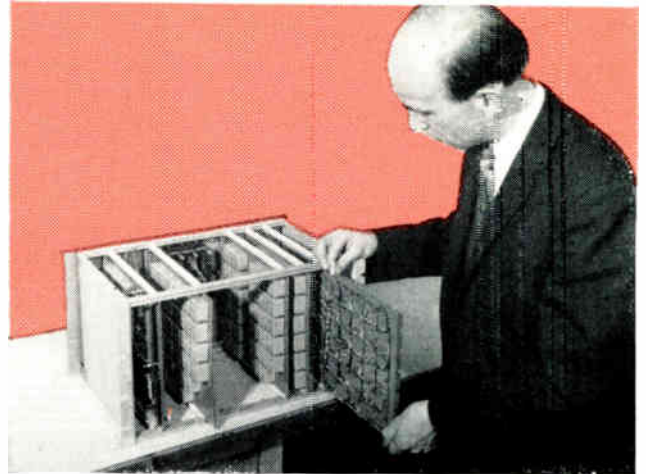

Shown here is part of a complete control system. Standard logic elements can be seen incorporated into the design

2. Throughput speed is instantly adjustable—previously adjustments took up to half an hour at least twice per day.
 3. Quality is maintained at a constant high level—carpet lengths are not spoiled.
 4. Faster rates of throughput become realizable.
- The cost of the installation is £3,000.

Financial Advantages

The factory is situated in a development area and 40% of equipment cost price can be reclaimed as a cash rebate (this is anticipating somewhat). The cost is then £1,800.

If this was invested at 10% for five years the principal would yield £1,100 approximately. Thus the 'actual' cost is £2,900. (Let us suppose that although this whole cost is written off in five years, no tax allowance for depreciation is included. This will make it harder to justify the expenditure, of course, but will also make our justification even more plain.)

One operator is released for other work . . . he is *not* dismissed but used to man another process at present working at half volume. The net saving is, however, of the order of 50% of his salary = $\frac{1}{2}$ of £1,000 per annum = £500 per annum. Over five years this is £2,500.



This programmed test rig is constructed of standard equipment such as the tachometer illustrated on the next page

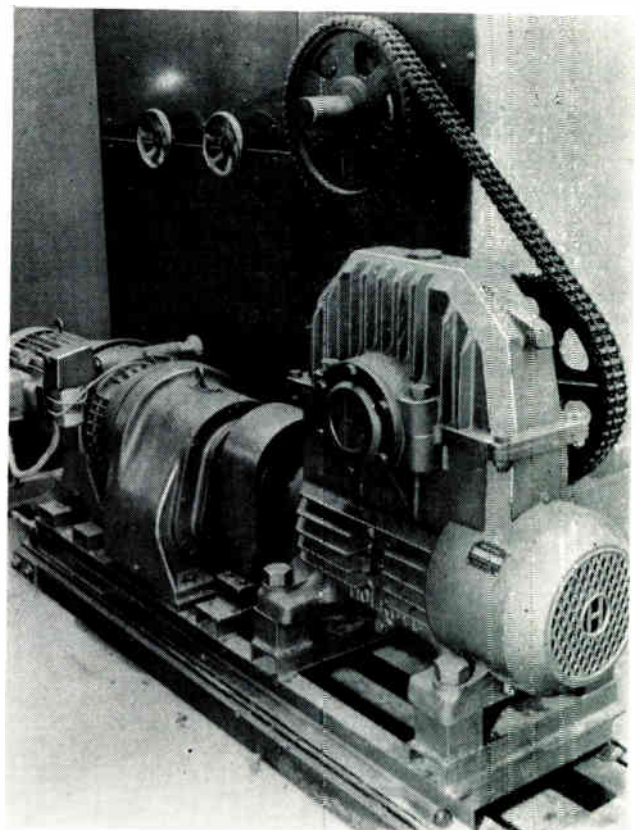

(Right) The speed and acceleration of this equipment are controlled by special equipment built from standard parts. Control installations such as this can pay for themselves in as short a time as six to 24 months

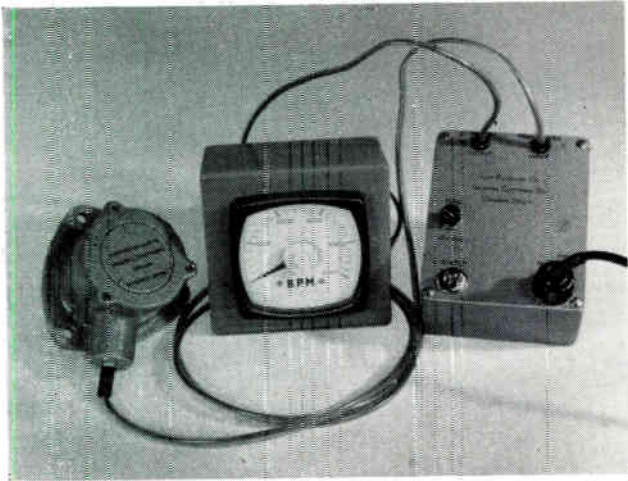

This shows a standard industrial tachometer which can be used in various types of units for specific applications



Here a standard tachometer can be seen installed on the left-hand side of this speed and acceleration control unit

Changes to the throughput rate formerly took the two operators about 8 hours per week; the machine usually worked some 48 hours per week. Thus there is a saving of 1/7 of production time. The corresponding financial saving is hidden from us; we could make some sort of guess but let us be content to allow the customer to arrive at his own figure.

Quality is maintained and lengths are not spoiled. Here we can make some more accurate assessment because the technical director has already told us that, in spite of every precaution, some inferior material has reached his customers, and, although this was a very small amount, he was prepared to allot £200 per annum to prevent any re-occurrence. In addition some £500 worth of material was scrapped each year. Here the saving is calculated, over five years, as only $£500 \times 5 = £2,500$ since the reduced cost of the inspection effort is not known.

Faster rates of throughput are now attainable. This manufacturer was failing to meet the demand for his product. The increase in production rate could be reflected immediately in a proportional increase in sales—and, therefore, profits. Past experience shows the usual increase in production to be between 5 and 10%.

Down Time and Maintenance

A failure in the control system would not result in a complete stoppage of the machine since manual control could be used, but this would be expensive. A rough analysis, using the known reliability figures for the control equipment, shows the direct costs over five years to be a maximum of £100.

A table can now be built up.

Costs		Savings	
Purchase	£2,900	Direct Salary	£2,500
Maintenance	£100	Reduced Scrap	£2,500
	<hr/>		<hr/>
	£3,000		£5,000
	<hr/>		<hr/>

This already shows a credit of £2,000 and neglects the financial advantages of increased sales, better quality, increased utilization of machines and tax allowances. Past experience has shown that, in fact, similar costs have been recovered in between six and 24 months. As has previously been stated, these figures provide the accountant with a task of his own and will be modified in one of a number

of ways. However, it is up to the control engineer to present them in the first place.

Acknowledgment

The author wishes to thank the management of Flight Refuelling Ltd. for permission to publish this article and for the use of photographs of equipment.

Reference

¹ Jarvis, S. R., 'Automation: A Rational Approach', *Industrial Electronics*, Vol. 4, No. 1, page 2, January 1966.

Communication by Tropospheric Scatter

The Marconi Co. is to supply the East African Posts and Telecommunications Administration with a new type of low-capacity radio-communication system that will provide six telephone or telegraph channels between Mwanza and Bukoba, which are some 112 miles apart.

The system, known as thin-line tropospheric scatter, can provide a limited number of circuits over distances up to 200 miles without the need for repeater stations. It operates free from the interference and distortion usually associated with h.f. radio circuits, and costs considerably less than the normal high-capacity tropospheric-scatter equipment.

The system transmits a narrow band (790 to 960 Mc/s) of low-power (7 to 10 W) radio energy almost parallel to the ground and in the required direction; a small part of this energy is scattered by discontinuities in the troposphere (the lower part of the atmosphere), and a proportion of this scattered energy is then picked up by sensitive, low-noise, solid-state receivers located well over the horizon from the transmitting station.

The frequency is crystal controlled, frequency diversity being used to provide additional reliability in the system without increasing the transmitter power, and 30-ft dish aerials are employed at both the transmitting and receiving stations.

FLUID-LOGIC CONTROL DEVICES

By K. FOSTER*, M.A., Ph.D., A.M.I.Mech.E.
and G. A. PARKER*, B.Sc., Ph.D.

The article on fluid-logic systems which appeared in the December 1965 issue of 'Industrial Electronics' discussed only the 'turbulence amplifier', a device already being manufactured in this country. The research and development into pure-fluid systems is not, however, restricted to this one device, and this article briefly describes other elements which are useful for many control applications.

DIAPHRAGM valves and spool valves have been used for many years to perform very simple logic operations, but they were not designed specifically for such tasks until the early 1950s. At that time, diaphragm units operating at low power levels, and specifically designed for logic operations, were reported from Germany and Russia, but little interest was shown in them and the devices were not apparently used on a large scale.

In about 1959, however, elements having no moving parts were reported from Russia and the U.S.A., and in the latter country interest in research and development grew quickly, probably because of the possibility of using the devices in space and military applications. Conferences held at the Harry Diamond Laboratories, Washington, in 1962, 1964 and 1965 have produced a vast amount of literature on various types of proportional amplifiers and switching elements. With the upsurge of interest, more effort was put into the development of ball and piston valves, ball valves being produced with 0.025-in. diameter balls operating in cylinders only 0.04-in. long.

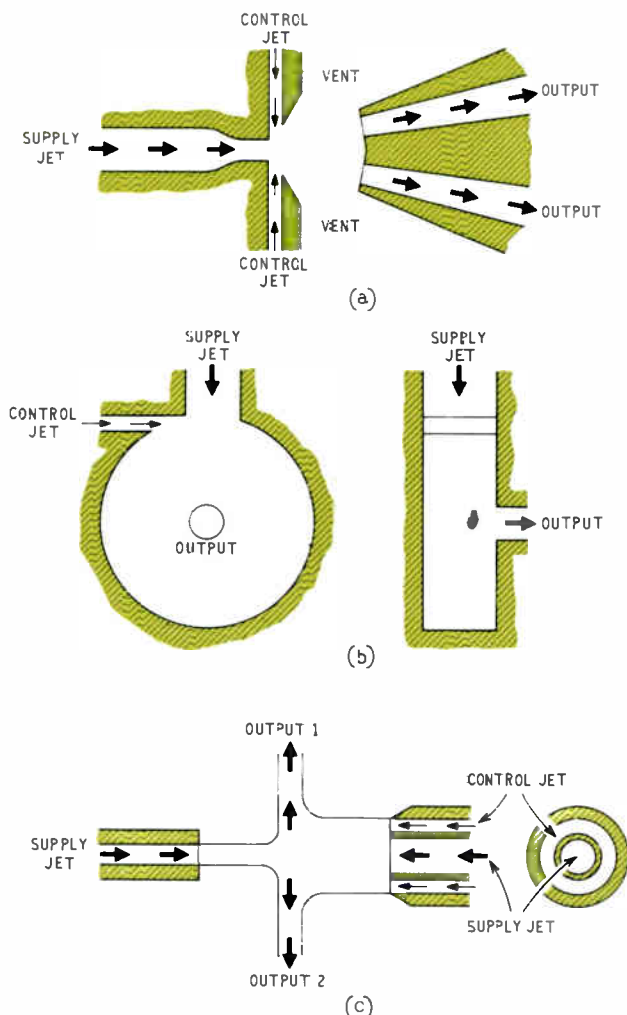

Proportional Amplifiers

Most interest, however, has been shown in the devices without moving parts, due to their higher operating speeds and the greater reliability which may be expected of them. The following discussion will be restricted to such devices.

Various types of proportional amplifiers are shown in Fig. 1. In the momentum-controlled amplifier, Fig. 1 (a), a main supply jet is diverted by the momentum of one of two control jets, and a variable-flow or pressure differential is created in the two output channels.

The vortex amplifier, Fig. 1 (b), has its main supply flow directed radially into a circular chamber, and it passes out at the centre. A tangential control flow causes a vortex to be set up in the chamber which results in an increase in pressure at the outside of the vortex with respect to the pressure at its centre. This pressure rise restricts the main flow, and the characteristics of this amplifier are rather similar to those of a triode valve, where pressure replaces voltage and flow replaces current.

Another device—the impact modulator, Fig. 1 (c)—is based on the effect of the direct impact of two parallel jets

* Department of Mechanical Engineering, University of Birmingham.

Fig. 1. Three types of fluid devices with no moving parts: (a) the momentum-controlled proportional amplifier; (b) the vortex proportional amplifier; and (c) the impact modulator

forming a flow perpendicular to the axis of the jets. The direction of the perpendicular flow is altered by only a small change in one of the main supply jets, which is effected in practice by a jet directed from a separate control nozzle surrounding one of the main supply jets. By putting a receiver in the line of the resulting flow, pressure or flow output changes may be observed.

Of the proportional devices, only the first (the momentum-controlled amplifier) is currently used in digital systems, usually as a passive two-input AND gate, shown in Fig. 2 (a). If signal A alone is present, or if signal B alone is present, then there is no flow in channel C. If signals A and B are present together, however, a signal appears at C.

The turbulence amplifier device shown in Fig. 2 (b) represents a multiple-input NOR gate, and was described in detail in the earlier article. (In commercial components there are usually four inputs).

The Turbulent-Reattachment Amplifier

Finally, the device which has received the greatest attention is the turbulent-reattachment amplifier, shown in Fig. 3 (a). The main jet of this device has sufficient velocity for it to become turbulent immediately upon leaving the nozzle. The turbulent jet draws air from the atmosphere into it via the vents, thus lowering the pressure on either side of it. Any slight disturbance to the jet causes it to move towards one of the two walls, the pressure on that side lowering still further so that the jet is drawn even more towards it.

Finally, an equilibrium position is reached where the jet forms the arc of a circle, the centripetal acceleration of fluid around the circle balancing the pressure difference across the jet. A small control flow is sufficient to detach the jet from one wall, and it quickly attaches itself to the opposite one. This amplifier may be used as the flip-flop (bistable) device shown in Fig. 3 (a), as a pulse amplifier, as an inverter (biased so as to become monostable) or as the two-input OR gate (again biased to be monostable) shown in Fig. 3 (b).

The amplifiers most used for logic applications have been the turbulence amplifier and the turbulent-reattachment amplifier (in one or other of its forms). A major difference between the two is that the turbulence amplifier, working under laminar-flow conditions, operates at a much lower supply pressure than the turbulent-reattachment device. This means that the air consumption of the former is much lower than that of the latter, which is an important consideration since both are continually consuming air, whether operative or not. (A typical power-consumption value for the T.A. is 0.1 W, compared with 3 W for the T.R.)

Against this, the switching speed of these types of fluid devices is a function of the transport time of a fluid particle through the element, and the T.R. gains by virtue of its smaller physical size and higher air velocity in the element. The switching time of a T.R. can be better than 1 msec, as opposed to the 2-msec 'off' and 5-msec 'on' switching times of a T.A.

Work at the department of mechanical engineering of the University of Birmingham, which has been going on for several years, has been concentrated mainly on the turbulent-reattachment device. A number of circuits have been constructed of flip-flop and NOR/OR elements using T.R.s, while momentum-exchange devices have been used as two-input AND functions. For example, circuits have been designed for a binary counter, a Gray-code to natural-binary converter, a ring counter, and various forms of digital comparators. One of these circuits will be briefly described, illustrating the application of fluid amplifiers to sequencing control.

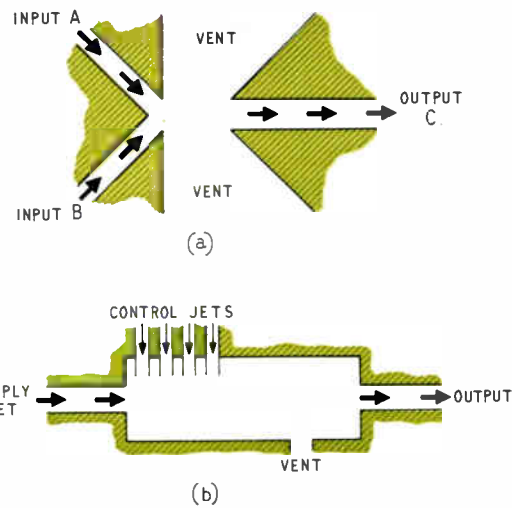

Fig. 2. (a) The momentum-controlled proportional amplifier as a passive two-input AND gate
(b) A turbulence amplifier device representing a four-input NOR gate

Sequential Control

The sequencing circuit shown schematically in Fig. 4 controls a drilling operation on 1-in. diameter steel parts. Each part is fed into position, drilled, and then ejected after the feed mechanism has withdrawn to be ready for the next part. The circuit consists of four T.R.s used as flip-flops, two passive AND elements, four 'flapper' valves (used as microswitches) and a resistance/capacitance delay.

The flip-flops are initially all in the position (0). When a part passes from the feed chute to the base plate, microswitch M_1 operates and sets flip-flops F_1 , F_2 and F_3 to their (1) positions. (F_2 and F_3 are set after a time lag caused by the resistance/capacitance delay, a monostable element being used before the capacitance in order to amplify the signal from the microswitch.) F_1 causes the cylinder C_1 to operate and eject any part on the drill stand. After F_3 has been set to position (1), a signal goes to F_1 so that it returns to position (0), thus retracting the ejector ram.

At the same time, the feed cylinder C_2 pushes the next workpiece into position. When the workpiece has been clamped by C_2 , microswitch M_2 operates and sends a signal to the AND gate A_1 , which is already receiving a signal from F_3 . A_1 therefore operates to set F_4 to its (1) position, thus allowing C_3 to move the drill to the workpiece. When the drill has travelled a predetermined distance, microswitch

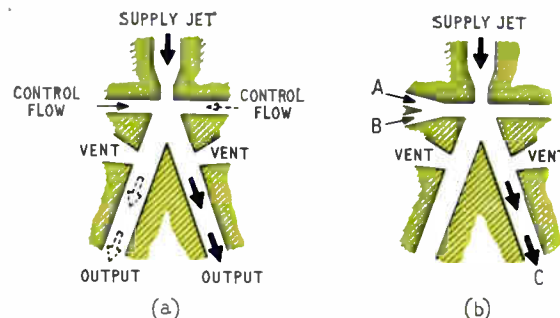

Fig. 3. Two forms of a turbulent-reattachment amplifier: (a) as a flip-flop (bistable) device; and (b) as a two-input OR gate (biased to be monostable)

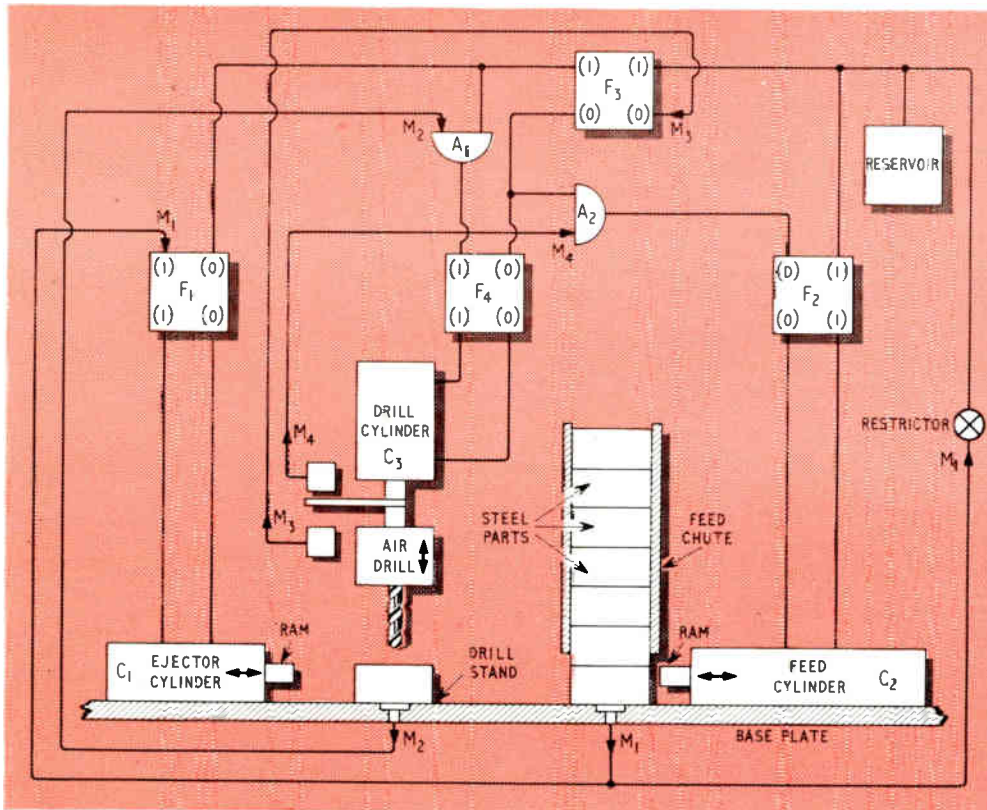

Fig. 4. A schematic diagram of a sequential-control circuit (incorporating turbulent-reattachment devices) for drilling operations

M_3 operates and resets F_3 to position (0). F_3 then sends a signal to the AND gate A_2 , at the same time resetting F_4 to return the drill. On completion of the drill retraction, microswitch M_4 is operated, thus opening gate A_2 and resetting F_2 to its (0) position. This operates cylinder C_2 ,

which returns to accept the next part from the feed chute. It will be noted that very few demands are placed on the switching speeds of the logic elements in the sequencing circuit described above, the main emphasis being placed on reliability, compactness and cheapness.

Digital-Feedback Control

In digital-feedback control circuits, however, the dynamic switching characteristics of the devices used are more important, and T.R. elements appear to be the most promising fluid devices for these applications. In many such systems, a digital-position feedback signal is generated by a shaft-encoder disc in natural binary-code form, and a pneumatic pure-fluid circuit has been constructed to provide an unambiguous natural-binary signal output from an encoder disc using the well-known 'V-scanning' technique. Fig. 5 is a photograph of one stage of the pure-fluid integrated circuit used to implement the logic, and it was manufactured by etching the channels in 'Dycril' plastic. It consists of one monostable T.R., a two-input OR/NOR gate, and two passive AND gates. The circuit has been operated at frequencies up to 300 c/s, although some difficulty has been experienced in synchronizing the output signals.

There are many control-system applications in which high-speed switching is not required, and it is in these areas that it is envisaged that pure-fluid circuits will be most widely used in the future. Their potential advantages of reliability in adverse environments, cheapness and fast response (compared with conventional electro-mechanical components) will tend to complement rather than compete with existing electronic technology.

Fig. 5. One stage of a pure-fluid integrated circuit, formed in plastic. Its actual size is $3\frac{1}{2}$ in. by $4\frac{3}{8}$ in.

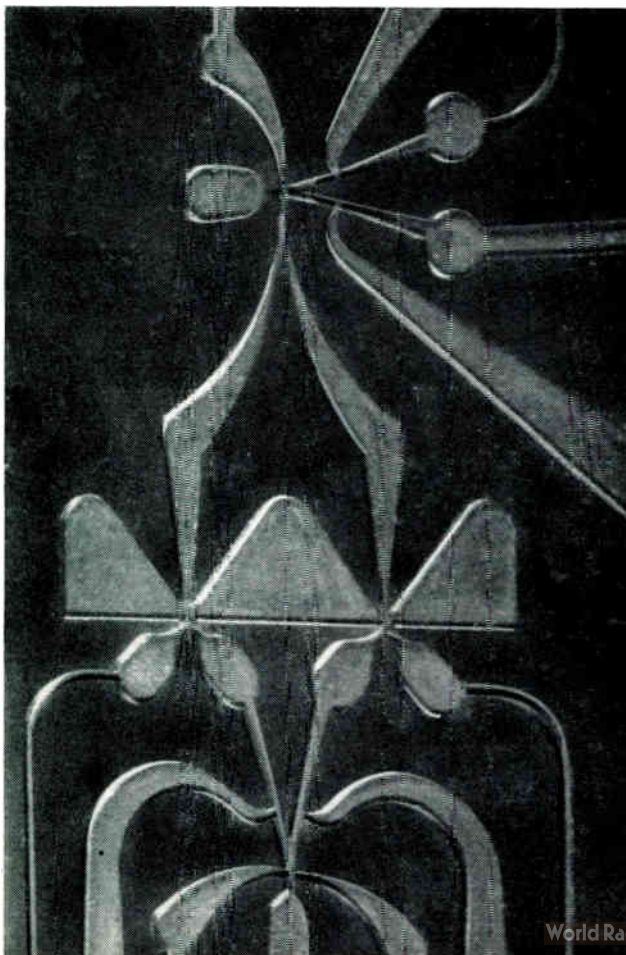

When it's a question of **SEMICONDUCTORS**

WESTINGHOUSE **IS THE POWER BEHIND THEM!**

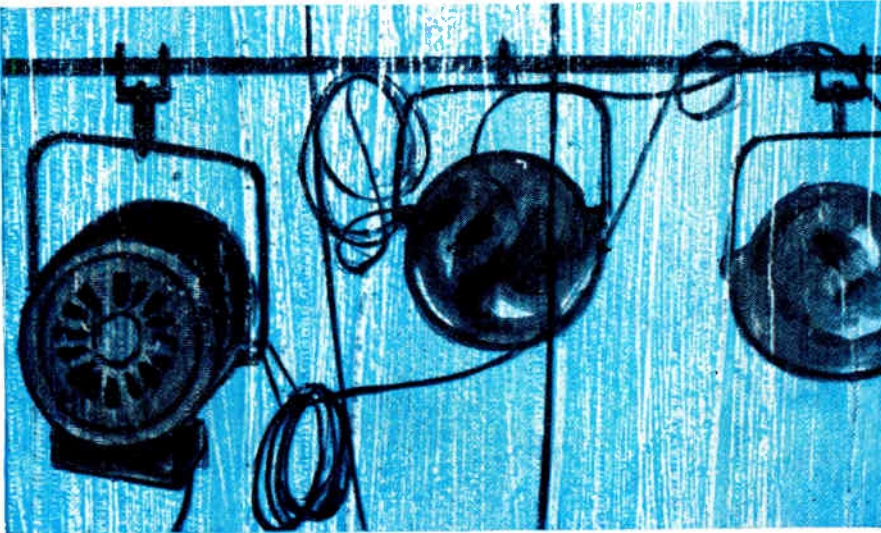
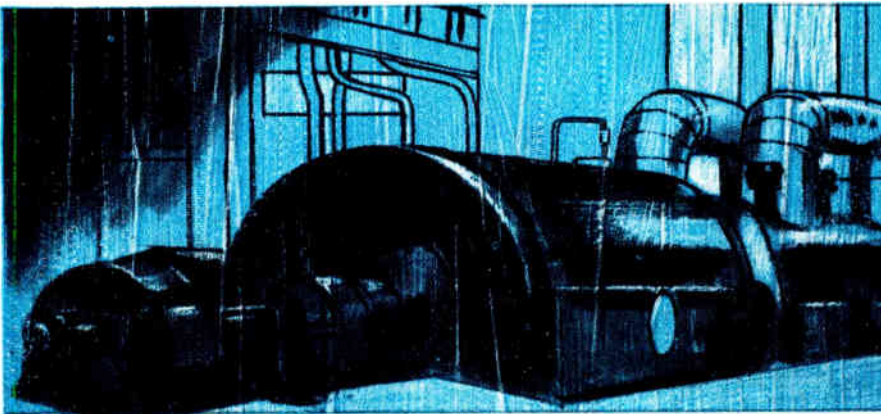

WESTINGHOUSE not only make very good semiconductors—they also make the widest range. That's why such a variety of industries use them. The Westinghouse range includes devices for the smallest electronic application to the largest industrial plant. A special compression bonding technique in manufacture eliminates thermal fatigue to give improved performance and greater reliability. Trouble-free, instant in action—that's Westinghouse Semi-

conductors. And they're backed by over 40 years experience in rectifier design and development. What more could you ask? Write for a copy of our abridged SEMICONDUCTOR brochure showing the Westinghouse range of Silicon Diodes, Thyristors and Rectifier Assemblies.

Dept. IE10/66 **WESTINGHOUSE BRAKE AND SIGNAL COMPANY LIMITED**
82 York Way, King's Cross, London N.1
Terminus 6432 Telex 2-3225

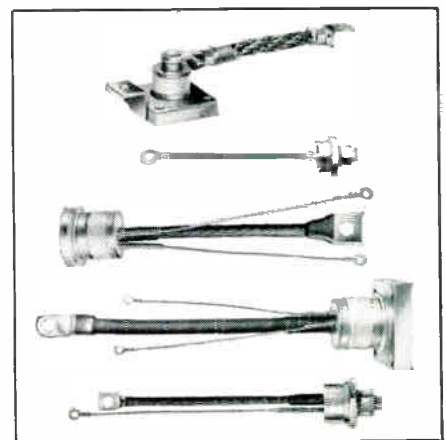

* **The Westinghouse brochure** gives abridged information about: Silicon Diodes ranging from 200mA to 300A at 100 to 1800V and Thyristors from 500mA to 250A, 25V to 1200V according to type.

***Fast switching
silicon planar diodes
BAY 38, BAY 39
plus 6 JEDEC types***

Now available for immediate delivery

Eight fast switching diodes, designed for use in computer logic circuits, are the latest additions to the Mullard range of silicon planar diodes. Their outstanding features are high conductance, fast recovery time and low leakage currents. Planar construction gives them the advantage of high reliability and tightly controlled characteristics.

The complete range is hermetically sealed in

DO-7 encapsulation.

Check your requirements against these brief specifications. For additional data and price and delivery information, just get in touch with your usual Mullard supplier or write direct to Mullard Limited, Industrial Markets Division, Mullard House, Torrington Place, London WC1. Tel : LANgham 6633. Telex : 22281

	P.I.V.	I_{FRM} max	t_{rr} max	I_{F-min} ($V_F = IV$)	C_d max	I_R max
BAY38	50V	225mA	4ns	50mA	2pF	50nA at 50V
BAY39	75V	750mA	160ns	500mA	7.5pF	100nA at 75V
1N914	75V	75mA	4ns	10mA	4pF	25nA at 20V
1N916	75V	75mA	4ns	10mA	2pF	25nA at 20V
1N3064	75V	225mA	4ns	10mA	2pF	100nA at 50V
1N3065	75V	225mA	2ns	20mA	1.5pF	100nA at 50V
1N3604	75V	150mA	2ns	50mA	2pF	50nA at 50V
1N4009	25V	75mA	2ns	30mA	4pF	100nA at 25V

Mullard **Si**
planar

Applications and Techniques

Multiplex Equipment for Apollo Project

Multiplex equipment provided by General Telephone & Electronics will be utilized aboard three tracking ships during the Apollo moon-shot project to convert voice, telemetry and data signals from the space vehicle into a form for transmission on conventional voice channels.

The ships can be deployed in any of the world's oceans to assure constant communications contact with the spacecraft, which is of particular importance when it is out of direct range with land-based stations.

Signals are received at different radio frequencies, and a Lenkurt multiplex set will convert the information for transmission to a communications satellite. The satellite will then relay the information to a ground station for final transmission to N.A.S.A.'s ground control site at Houston, Texas. The procedure is reversed for transmission from Houston to the space vehicle.

The various electronic and pneumatic controls for guiding and operating the contour-seaming unit can be seen mounted above the overlock machine, behind which is the control console

Automatic Contour-Seaming of Fabrics

The knitting division of English Sewing Ltd. have installed a specially-developed automatic contour-seaming unit in their Macclesfield factory. The machine can handle very large

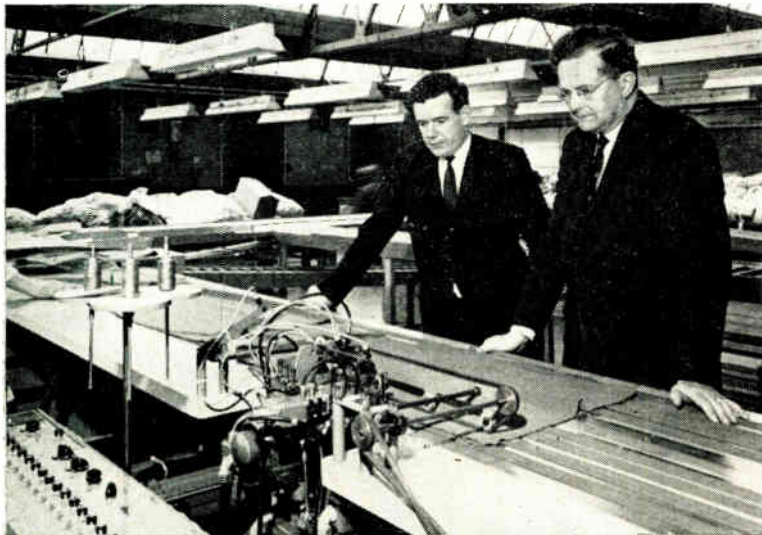

garments and follow their edges with complete accuracy, a pneumatic system holding the fabric flat as it passes through the machine and then removing and stacking the seamed parts at the end of the process. Photoelectric cells actuate such sequences as guiding the hydraulically-controlled overlock along the fabric edge, trimming the thread-ends and operating the lifting-arm at the correct time intervals, and the system can cope with all types of material except open-work lace fabric.

As the garment parts approach the overlock, a photoelectric cell scans the fabric edge and aligns the sewing needles; the machine is actuated by a second photoelectric cell as the fabric reaches the needles, and a third cell operates the tail-thread cut-off and stops the machine. Garment parts can be fed in any sequence, and the machine automatically follows the correct line, compensating for any variations and eliminating fabric wastage caused by wrong alignment. Different fabrics can be fed in any sequence also, the only limiting factor being the unsuitability of the same thread for varying fabrics.

Malt Blending Control

Whitbread & Co. Ltd. have introduced into their Chiswell Street (London) Brewery an automated system for controlling the types and quantities of malt to be blended for any required brew. The weighing and control equipment was provided by W. & T. Avery Ltd., in collaboration with engineers from Brookhirst Igranic & Whitbread.

The brewery uses twelve types of malt—nine grades of white malt and chocolate, brown and crystal-coloured malts—the blending system being directed from a central console containing a mimic diagram. Coloured lights indicate the operations as they occur, and permutations of blends can be controlled by punched cards, which also indicate to which of the twenty grist-feed hoppers the blend is to be delivered.

When a punched card is inserted in the card reader, the control equipment opens the appropriate slide gates to the white-malt lift and the storage hoppers, a 'route clear' signal being returned to the weighing-control console. The white malts are then drawn off and weighed as required, and three minutes later the coloured malts are fed in, thus ensuring that a proper blend is achieved. Each blend is fed via an elevator and screw conveyors to the grist-feed hoppers, after which the equipment is reset for the next batch.

Large-Screen Television Projection in Daylight

A further development by Peto Scott Ltd. of their 'Eidophor' television-projection system has made it possible for large-screen picture presentation to be achieved in full daylight (see picture).

The Eidophor is an electronic/optical instrument that can project black-and-white or colour

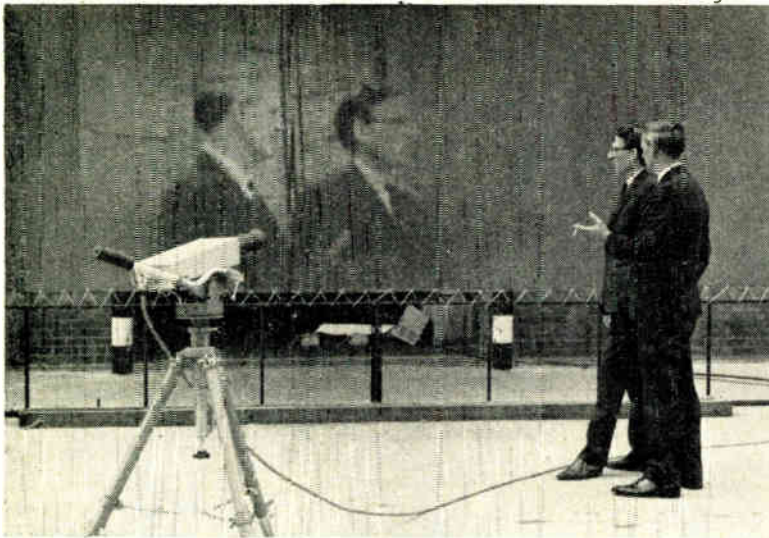

Here the daylight operation of an Eidophor, linked to a camera, is being demonstrated (using back projection) at Peto Scott's Croydon factory. The screen, whose surface is specially treated with vinyl plastic, was designed by Andrew Smith Harness Ltd.

television pictures on to large screens, either directly from a camera or from video tape. It uses an independent high-intensity Xenon-arc lamp to throw a powerful light beam on to a thin film of oil evenly spread over the surface of a concave mirror.

This thin control layer is scanned by a fine beam of electrons, focusing of which is controlled by video signals. The resulting electrostatic charge on the oil film alters the nature of its surface and, depending on the degree of concentration, the light is focused through a system of mirrors on to the screen.

Corrosion-Resistant Probe

A capacitance-type probe, which has overcome a corrosion problem associated with level measurement in the steel industry, has been developed by using an insulator made by Royal Worcester Industrial Ceramics Ltd.

The device is being used by the Guest Keen Iron and Steel Works, at Cardiff, for detecting the level of the highly-abrasive material in the hoppers of their iron-ore sinter plant. It consists basically of a brass or copper-foil strip, which acts as an electrode and is sandwiched between two insulators made of 'Regalox'—a hard high-density alumina ceramic having exceptional resistance to extremes of temperature and corrosion.

Measuring 4½ ft long by 9 in. wide, the probe is backed with a steel plate and attached to the interior wall of the hopper. As the material in the hopper rises and falls, it brings about a probe-capacitance change, which is fed into an amplifier for accurate level measurement.

Tape Recorders Aid Fish Detection

The use of echo-sounding equipment to detect shoals of fish is already an established practice throughout the world. The White Fish Authority's industrial development unit at Hull, however, has been experimenting with the use of tape recorders to build up a library of tapes

containing the echoes produced from a variety of species of fish.

High-frequency echo recordings have been made in a number of different conditions of weather, depths and fish distributions, and the data obtained has provided valuable information for designers of more advanced equipment. The 3M Co. Ltd. has supplied a specially robust three-channel recorder for this purpose, and it is being used in conjunction with three prototype narrow-beam echo sounders to record signals at a minimum frequency of 30 kc/s; unwanted noise at other frequencies is filtered out of the system.

Signals are transmitted vertically downwards from a fishing vessel to a depth of 300 fathoms, an area 60 ft along the sea bed and 8 ft above it being scanned, but the eventual aim is to develop a horizontal-signal system, which could locate fish up to one mile away in any direction.

Plastic-Fibre Light Guides

Plastic fibres that transmit light as easily as copper wires conduct electricity have been developed by the Du Pont Company. Called 'Crofon' light guides, they are claimed to be a considerable improvement on the glass-fibre types that have been used in the past. Applications of the light guides (which will not be available in Europe before 1967) include illuminating relatively inaccessible areas, lighting many locations from a single source, confining light to a small area, and conducting light to photo cells for various sensing and control systems.

In fibre optics, light travels in a zigzag motion along a transparent core by internal reflection from a surrounding medium of a lower refractive index; the fibres are made up into bundles, the number of strands in each bundle determining the amount of light that will be transmitted.

The 'Crofon' guides are extremely tough and

Each of these jacketed light guides is made up of 48 individual fibres. Other guides will be available having 16, 32 or 64 fibres

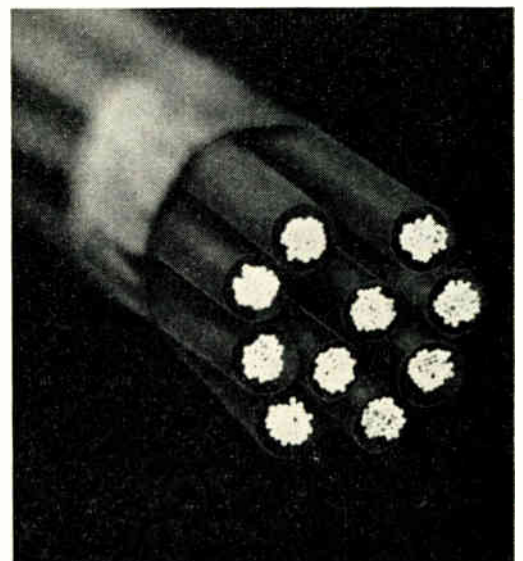

flexible (an individual 0.01-in. diameter fibre can be tied tightly in a knot without breaking) and have a maximum continuous-service temperature of about 80 °C.

Fluidic Control System for Pipelines

The fluidic systems division of Honeywell Inc. have developed a fluidic-control system for the start-up, operation and shutdown of natural-gas pipeline engines and compressors. It combines sensing, logic and display capabilities, and the first production model is expected to be installed in the U.S.A. this year, at a price comparable to pneumatic and electro-mechanical systems at present used by the pipeline industry.

Complete safety and high reliability of operation are claimed under hazardous and remote operating environments, and except for the displays indicating engine and compressor states, there are no moving parts to the system, which is powered by either compressed air or natural gas.

The equipment has been designed to initiate and verify pre-lubrication oil pumping, starter gas-valve operation, main-fuel gas-valve operation and ignition switching; to display and monitor engine and compressor states; to shut down the engine automatically should low oil pressure, excessive speed, high exhaust temperature or excessive vibration be detected; and to indicate what condition caused the shut-down.

For further information circle 51 on Service Card

Electroforming Nickel and Copper

The tool division of the London & Scandinavian Metallurgical Co. are now using electroforming solutions (similar to those used for manufacturing moulds for plastics) for the production of nickel and copper products. The applications for this type of work are particularly wide in the electronics and aeronautical fields, where the manufacture of small intricate components or instrument screens is very often more readily achieved by this process.

Although electroforming is often used to produce small component pieces, the size limitation is dependent more upon the type of product being manufactured, and it is quite possible to produce pieces weighing 500 lb in copper or 250 lb in nickel. Each specific product requires its own master, which is usually made of stainless steel, brass or plastic; in the case of stainless steel, it is usual to get many repeats from the same master without any undue change in surface finish.

For further information circle 52 on Service Card

Blast-Cleaning Electronic Parts

The time factor involved in de-flashing minute electronic components (such as plastic slip-ring and rotary-switch assemblies) has been reduced by Vacu-Blast Ltd. in association with i.d.m. Electronics Ltd.

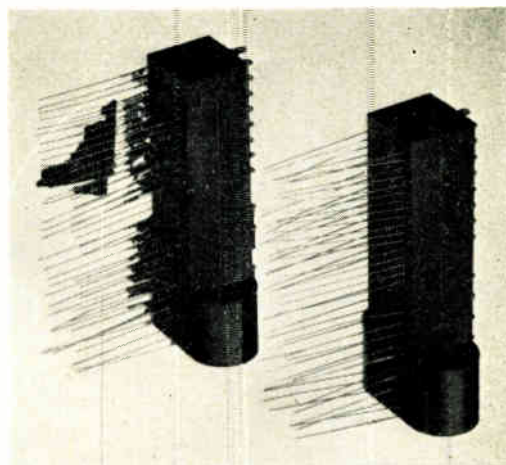

An i.d.m. Electronics brush unit before and after blast-cleaning

Hand de-flashing of, for example, the component illustrated took up to 14 min, but using Vacu-Blast's 24/24 Dry Honer unit it was de-flashed in under a minute. In addition to this time saving, the process detects component imperfections (such as porosity of the terminals, which may be plated with precious metals) and causes no damage to the terminals.

For further information circle 53 on Service Card

Colour-Picture Transmission

The *Liverpool Daily Post*, using equipment designed and manufactured by Muirhead and Co., recently printed a colour picture that was the first to have been transmitted directly from a colour original by any British newspaper.

The transmission machine contained a drum on to which a Polaroid colour print was placed; the machine then scanned the picture three times with colour filters for cyan, magenta and yellow, resulting in three separate negatives being transmitted to the receiving end for block making.

For further information circle 54 on Service Card

Proximity Detectors for Traffic-Light Control

An interesting traffic-light control system, using long-range proximity-detection equipment manufactured by G.E.C.'s rectifier and control engineering division, is now in operation at the Rowrah limestone quarry at the Workington Iron and Steel Co.

The problem at the quarry was to achieve the most efficient passage of three seven-ton dumper trucks through a 300-yd one-way tunnel leading from the quarry face to the crusher house, and in G.E.C.'s system encapsulated permanent magnets are suspended under the front axles of the trucks to actuate detector heads embedded in concrete near both entrances to the tunnel.

Each detector head comprises a saturable-iron inductor (potted in epoxy resin), which generates a signal when influenced by an external magnetic field. A magnet that approaches the head saturates the iron circuit and reduces its impedance, thus permitting a

50-c/s signal to increase in amplitude and actuate a thyristor; this closes a heavy-duty changeover relay which controls the operation of the traffic lights.

Timing relays allow an adequate period for a vehicle to pass through the tunnel before the lights change, and if the lights do not change when a vehicle passes over a detector head, the driver knows immediately that there is another vehicle in the tunnel and that it is not safe to enter.

For further information circle 55 on Service Card

Printed-Circuit Production

A process for manufacturing copper plated-through-hole printed-circuit boards without the use of dissimilar metals, and with virtually no restrictions on the dimensions of lines and spaces, has been introduced by Shipley Chemicals Ltd. With their C-t-H (copper-through-hole) process, a resolution capability can be provided which makes practical the design and manufacture of circuits with lines and spaces as small as 0.0001 in.

In processes which use dissimilar metals as the etch resist, the edges of the metal laminate are often excessively undercut during the etching cycle, thus causing the overhang to flake off and cause short-circuits. The new process eliminates pattern plating and considerably reduces undercutting by using a positive-working photo resist as the etchant; this controls undercutting and leaves practically no overhang on the profile of the printed-circuit line.

A further advantage is that by using the multiple-exposure capabilities of the resist, gold or rhodium finger contacts can be plated without hand masking or depth plating.

For further information circle 56 on Service Card

Temperature Control by Pressure Measurement

A technique for the control of cold-room temperatures by measuring the compressor-circuit pressure instead of using conventional temperature-sensing devices has been developed by Scientific Systems Ltd. It is being used with

their 'Transrice' supervisory control system by James Howden & Co., of Glasgow, on cold-room compressor plants.

A pressure transducer, connected to the refrigerator coils, transmits to the controller an electrical signal that is proportional to the pressure in the coils and thus to the prevailing temperature. The controller compares the value of this signal against a pre-set value and initiates the opening or closing of a compressor-capacity control valve to increase or decrease the refrigeration output, as required. The valve is powered by a Rotork electric actuator, which in turn feeds back a signal to the control unit, confirming the valve position.

The technique is claimed to have the advantages of fully-modulated control, overcoming problems of response inertia, reducing power consumption and thereby providing more efficient and economical operation.

For further information circle 57 on Service Card

Electronic-Fault Detection

A portable self-contained device for detecting latent defects in all types of electronic equipment has been introduced by Honeywell's aeronautical division. Known as the RF (radio frequency) probe, it is a broad-band tuned radio-frequency amplifier that detects and measures noise in the 20 to 30-Mc/s frequency range, and thus spots intermittent electronic faults that characteristically emit r.f. energy.

The 5-lb probe consists of a pick-up device, radio-frequency and audio amplifiers, earphones, rechargeable batteries and cabling, and its operation requires no special training. The system, subsystem or printed-circuit board is slowly scanned with the pick-up device, and the r.f. noise levels in the equipment can then be monitored directly through the earphones or transmitted to an oscilloscope or recording device. Once the noise levels have been studied, the faulty component can be located by reducing amplifier gain and varying the pick-up's position and orientation.

It has been found that it is generally necessary to stimulate the noise in a suspected device, and this can be done by tapping it with a non-metallic rod and comparing the noise level with that of other devices.

A schematic diagram showing the principle of refrigeration control by pressure measurement developed by Scientific Systems Ltd.

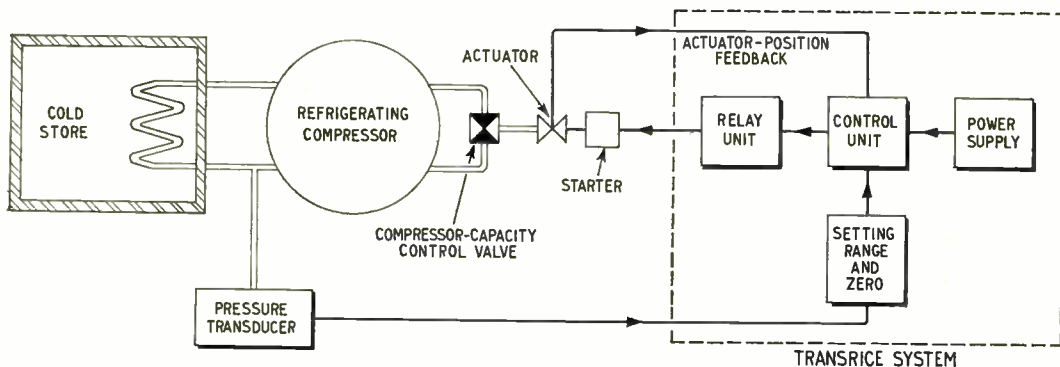

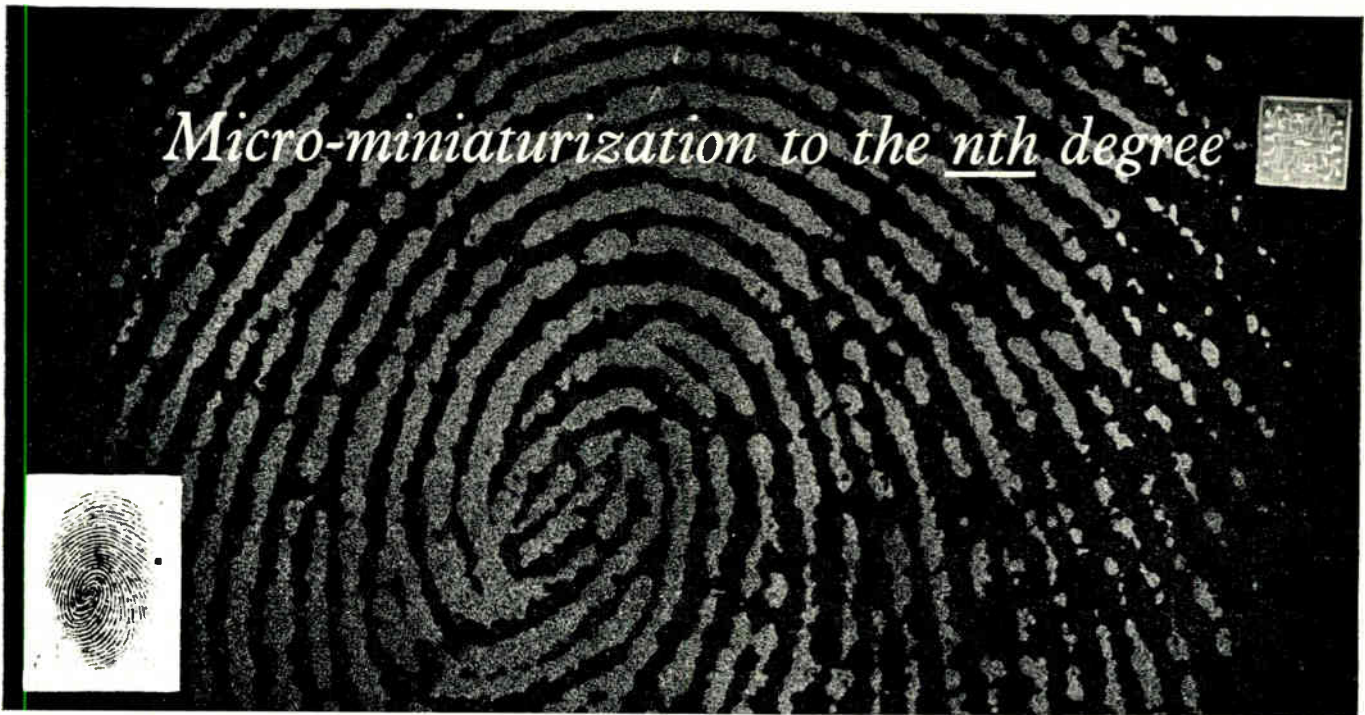

Micro-miniaturization to the nth degree

Meet Argus 400/500: the world's most advanced process control systems

Available here and now from Ferranti

Incredibly tiny silicon logic circuits (no bigger than this full stop.) make Ferranti Argus 400/500 the most advanced, most *reliable* process control systems in the world.

Wiring has been virtually abolished. Circuitry is the most sophisticated in existence. Volume has been reduced from twenty-four to a compact 0.7 cubic feet. Here at last are high speed performance and assured reliability in a system that makes low-cost automation a reality.

Argus 400/500 Systems are right for your process, your plant, your industry. They can be tailored to fit individual requirements precisely, whether you have one dozen or one thousand functions to control. Regulating the heating of steel ingots in soaking pits, for example. Controlling temperature and quantity variables in a chemical plant. Predicting and matching generating station output over half the UK. Providing real-time, on-line guidance of a radio telescope.

As you expand, so the System expands with you. Core storage can be doubled, trebled, quadrupled as and when you dictate.

Ferranti installed the world's first direct digital control system at the ICI Soda Ash Plant, Fleetwood. One in every three computer controlled systems installed or ordered in the UK is by Ferranti. Give them the opportunity to put this unique experience to work for you. Call in a Ferranti Sales Engineer and let him explain how Argus 400/500 can bring advanced automation at low cost to *your* industry. Write or telephone today.

Remember: Argus 400/500 — the most advanced process control systems in the world — are available here and now from Ferranti.

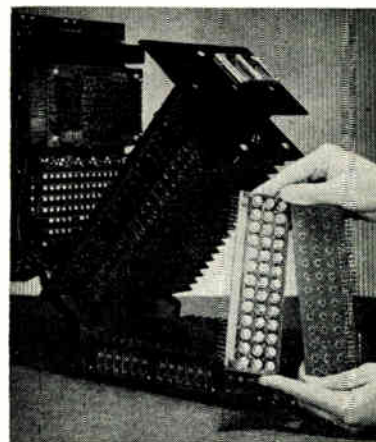

FERRANTI

ARGUS 400/500 SYSTEMS

The breakthrough in low-cost automation

Ferranti Ltd . Automation Systems Division . Simonsway . Wythenshawe . Manchester (061) MERcury 7291

FAS9

For further information circle 247 on Service Card

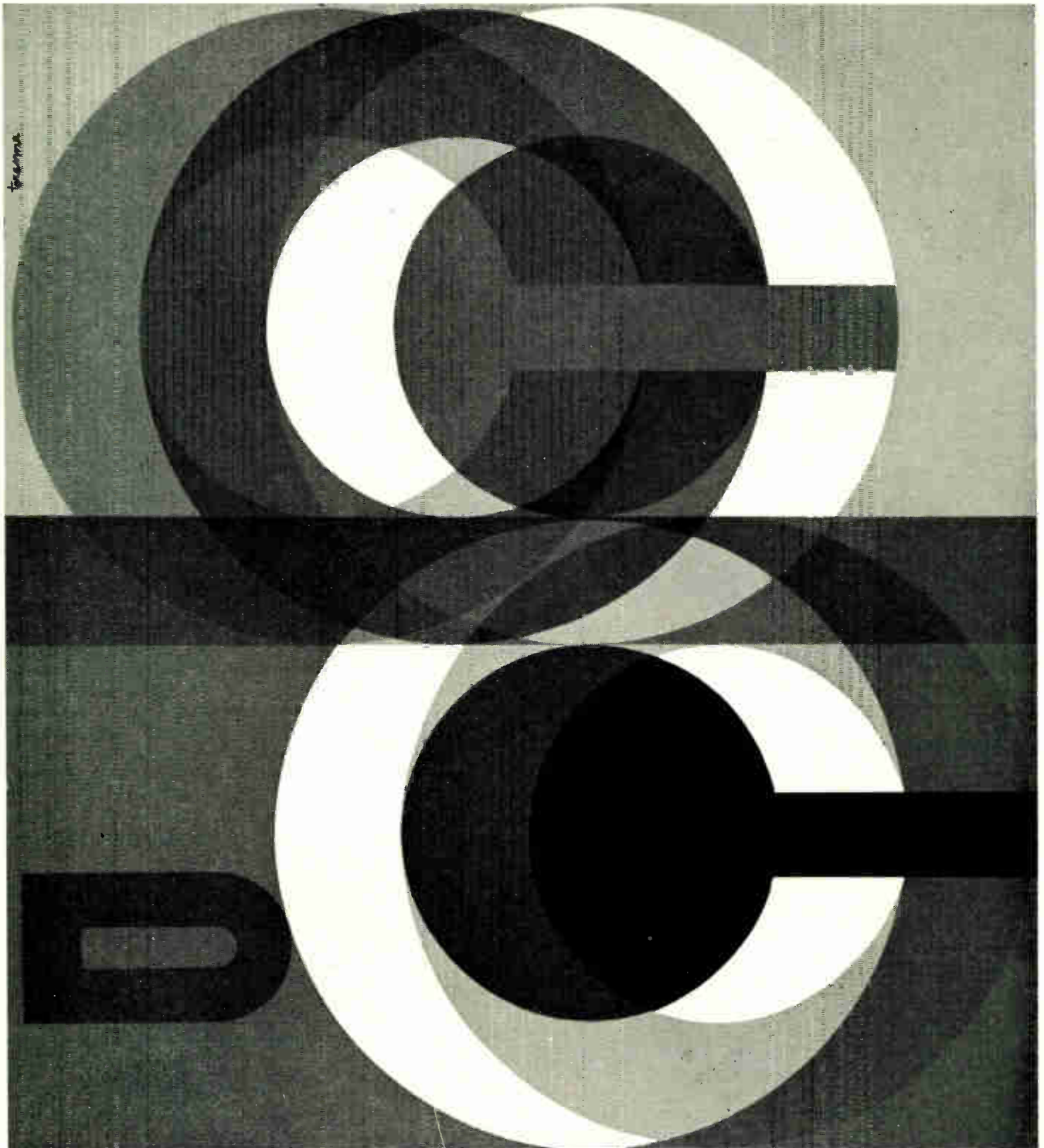

electronics

electronic measuring instruments ● te-
 lemetering equipments ● closed circuit
 television ● tape recording equipments ●
 data processing systems - *automatic*
data scanning, logging and comput-
ing ● magnetic and acoustic measur-
 ing equipments ● radio-navigation
 equipments ● tracking equipments ●
 civil and military applications.

11001398

COMPAGNIE DES COMPTEURS france

C.D.C. (GREAT BRITAIN) Limited
 Terminal House · Grosvenor Gardens · London S.W. 1
 Telephone · SLOane 8271 · Telex · 23372

For further information circle 248 on Service Card

TRANSISTORIZED CURRENT CONTROLLER

In this article a controller is described which is capable of maintaining constant to within 0.5% the discharge currents of 6- or 12-V batteries. Although the controller is primarily intended for battery discharge tests, it is possible to adapt the unit for other similar applications.

By N. H. SABAH*, M.Sc.

THE transistorized automatic current controller described in this article was developed at the Industry Institute in preparation for a testing programme on lead-acid starter batteries for the Lebanese Standards Institution. The recognized method^{1,2} of checking the rated ampere-hour capacity of such batteries is the slow discharge-rate capacity test, in which the battery is discharged continuously from its fully-charged state at a constant current equal in amperes to one-twentieth of the rated ampere-hour capacity of the battery. The actual ampere-hour capacity is then given by the product of this current and the time taken for the terminal voltage of the battery to drop to 5.25 V for a 6-V battery, or to 10.5 V for a 12-V battery, with a correction for temperature if the average of the initial and final temperatures of the electrolyte differs from 25 °C.

The specification for the current controller stipulated that the current should be kept constant to within 1% for a drop in battery terminal voltage from 7.5 to 5 V for a 6-V battery, and from 15 to 10 V for a 12-V battery, combined with a change in ambient temperature of 10 °C. The value of discharge current should be continuously adjustable between 1 and 7 A for a 6-V battery and between 0.5 and 4 A for a 12-V battery. The controller developed easily meets this specification and does not depend on the a.c. mains supply for its operation. It can be used for charging batteries at constant current, and the circuit described can be easily adapted for other applications in which a direct current is to be maintained constant to a high degree of accuracy, as in precision d.c. vernier potentiometer measurements.

The Basic Circuit

Basically, the battery under test is discharged through a transistor Tr_1 in series with a resistor R_s , Fig. 1 (a). A control circuit compares the voltage drop across R_s , due to the discharge current I_d , with a reference voltage. Any variation in the value of I_d gives rise to an 'error' feedback signal which is amplified by the control circuit and applied to Tr_1 so as to correct for the variation in I_d .

If the current drawn by the control circuit in Fig. 1 (a) is neglected, then it is clear that R_s can be drawn as a load-line on the output characteristics of Tr_1 , Fig. 1 (b). It follows from this figure that if I_{b1} is maintained constant, then for a

decrease in V_d of ΔV_d , I_d will decrease by $\frac{\Delta V_d}{R_{01} + R_s}$, where

R_{01} is the output resistance of Tr_1 for constant input current and is given by the slope of the output characteristic. In order to keep I_d constant as V_d decreases, I_{b1} should be increased.

It is advantageous to have R_{01} as high as possible, since for a given variation in V_d , and for a given value of R_s , the resulting variation in I_d decreases as R_{01} increases. For the same current gain in Tr_1 , this also entails a smaller correcting change in I_{b1} . Ordinarily, the common-base configuration

has the highest output resistance for a given transistor but is impracticable because it does not give any current amplification. With an ideal current source drive the output resistances of the common-emitter and common-collector configurations are equal; but as the resistance of the driving source decreases, the output resistance of the common-emitter configuration increases slightly while that of the common-collector configuration decreases appreciably. In practice, however, the output resistance is not a decisive factor in the choice of a configuration for Tr_1 , because, in the first place, the control circuit is current-operated so that the driving source resistance of Tr_1 is appreciable, and, in the second place, the effect of a low value of R_{01} can be offset quite easily by increasing the gain in the control circuit. As will become apparent later, the choice between the common-emitter and the common-collector configurations is governed by the practical consideration of avoiding additional bias supplies in the current amplifier, and by the need of having the correct sign of feedback in the circuit. On this basis, the common-collector configuration was chosen for Tr_1 , as is shown in Fig. 1 (a).

Control Circuit

Since it is generally simpler to obtain current rather than voltage amplification in transistor circuits, a two-stage current

Fig. 1. (a) The basic circuit of the current controller. (b) A load line superimposed on the output characteristics of the transistor

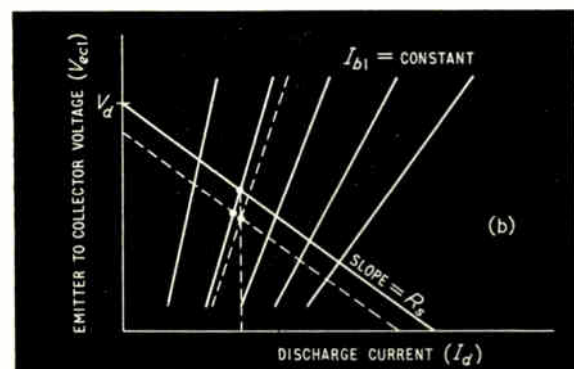
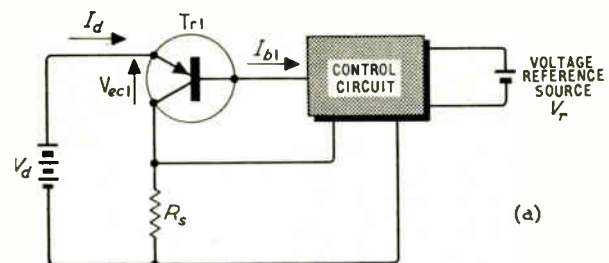

* Industry Institute, Lebanon.

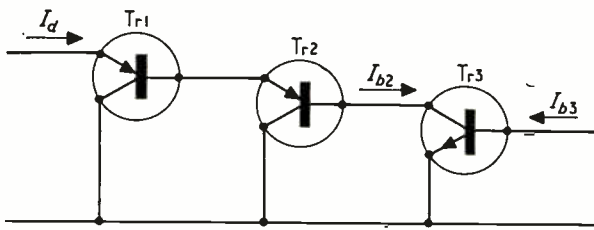

Fig. 2. The basic current amplifier circuit

amplifier is used to supply Tr_1 , Fig. 2. Tr_2 forms a Darlington pair with Tr_1 , whereas Tr_3 is an n-p-n transistor connected in the common-emitter configuration. The use of a complementary transistor not only makes it possible to change the configuration of the transistor, but, in addition, alters the direction of the input current and hence the sign of feedback in the circuit. As noted above, no additional bias supplies are required for the current amplifier if Tr_1 is connected in the common-collector configuration.

With the type of current amplifier shown in Fig. 2, leakage currents set the limit to the minimum controllable value of I_a . The major contribution to the leakage current in the output circuit of Tr_1 comes from the leakage current of Tr_3 , since this is amplified by both Tr_2 and Tr_1 . Even with a low-leakage transistor, such as the OC 140 used for Tr_3 , the leakage value of I_a was of the order of 1.5 A, with $V_d = 15$ V and the base of Tr_3 open-circuited. In order to reduce this leakage current, I_{b3} is made equal to the difference of two currents: a constant current, I_r , and a current, I_{c4} , proportional to the error signal (Fig. 3). By this means, I_{b3} can become negative, thus reducing the collector current of Tr_3 practically to zero³. The minimum controllable value of I_a is then determined by the leakage currents of Tr_2 and Tr_1 . For the transistors used, the leakage value of I_a is now reduced to less than 0.2 A which is well below the specified limit of 0.5 A. If it is desired to control I_a right down to zero, the constant current should be connected to the base of Tr_1 .

The control circuit is completed by connecting an n-p-n transistor, Tr_4 , as shown in Fig. 3, with the reference voltage source, V_r , in its base circuit. If I_a increases, the base-to-emitter voltage of Tr_4 increases, thus increasing I_{c4} . Since I_r is constant this decreases I_{b3} , and hence I_a .

The constant-current source, I_r , is used not only to reduce the leakage current of Tr_3 , but has two other important functions. If I_r was omitted, it would still be possible to have a control system by using a p-n-p transistor for Tr_4 , leaving V_r connected as it is in the base circuit. However, with large amplification, I_{b3} would be of the order of a few microamps, so that the p-n-p transistor would be operating with a collector current of this order of magnitude. Because of

Fig. 3. The basic control circuit

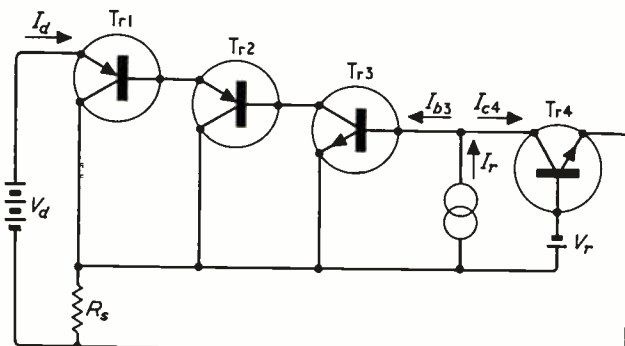

the shape of the input characteristic of the transistor, the sensitivity would be low at such small values of current, since a relatively large variation in the voltage drop across R_s would be required to produce a given change in the collector current of the transistor. The constant current, I_r , overcomes this disadvantage by biasing, in effect, the operating point of Tr_4 into a more sensitive region of its input characteristic. Furthermore, with the p-n-p transistor, if I_a is interrupted for any reason, so that the voltage drop across R_s disappears, the voltage reference source will discharge through R_s and the forward-biased emitter-to-base junction of the transistor, with consequent damage to itself and the transistor. This does not occur when a constant-current source is used with an n-p-n transistor, because the voltage-reference source then biases the emitter-to-base junction of the transistor in the reverse direction.

Practical Circuit

The actual circuit of the current controller is shown in Fig. 4. S_1 and S_3 are three-pole one-way switches, S_1 being an on-off switch and S_3 a 6-V or 12-V battery selector.

The 2N1147 transistor used for Tr_1 is rated at a maximum continuous dissipation of 87 W and a maximum collector current of 15 A. Since the battery is not to be discharged right down to zero voltage, it is advantageous to include a resistor R_1 in series with the collectors of Tr_1 and Tr_2 as, by reducing the emitter-to-collector voltage of Tr_1 , the power dissipated in Tr_1 and Tr_2 is thereby reduced. The resistor R_1 also limits the current through Tr_1 in case of maloperation and adds to the output resistance of this transistor. The value of R_1 is determined by considering the lowest limit of battery voltage (e.g., 10 V for a 12-V battery) and allowing a 1.5-V drop across R_s , at the maximum discharge current of 4 A, and another 1.5-V drop across Tr_1 in order to avoid the bottoming region of this transistor. The value of R_1

can then be made equal to $\frac{7}{4} = 1.75 \Omega$. It can be easily

shown that the maximum power dissipation in Tr_1 and Tr_2 occurs at maximum V_d and at that value of discharge current which makes the emitter-to-collector voltage of Tr_1 very nearly equal to the sum of the voltage drops across R_1 and R_s . For a 12-V battery, this value of I_a is approximately 3.5 A, so that the maximum power dissipation in Tr_1 is about 27 W. The resistor R_3 serves a similar purpose with respect to transistor Tr_3 . When discharging 6-V batteries the values of R_1 , R_3 and R_s are suitably altered by parallel switching.

For the constant-current source, an OC 75 transistor, Tr_5 , is used in the common-emitter configuration with a series emitter resistance of 1.2 k Ω . Two 1.5-V penlight-size dry cells are connected in series to provide the collector bias for Tr_5 . Two 1.35-V, Mallory-type RM-502R, mercury cells in parallel provide both the reference voltage in the base circuit of Tr_4 and the base voltage for Tr_5 . The value of I_r is approximately 1 mA and the output resistance of Tr_5 is of the order of 0.5 M Ω .

Theoretically, it is best to connect the base of Tr_4 directly to the negative terminal of V_r , without the potentiometer VR, since the resistance in series with the base of Tr_4 will then be very small giving maximum change in the collector current of Tr_4 for a given change in the voltage across R_s , and hence maximum sensitivity. In order to vary I_a , R_s should then be varied. Thus since the voltage across R_s remains practically constant, being the sum of V_r and the emitter-to-base voltage of Tr_4 , increasing R_s will automatically reduce I_a and vice versa. As it is not very convenient, however, to have R_s variable for the specified range of I_a , it was considered sufficiently accurate for this application to vary I_a by means

(Continued on page 475)

**Four new
high-performance p-n-p
silicon planar epitaxial transistors
BSY40 · BSY41 · BFX12 · BFX13**

Competitively priced, these four new p-n-p silicon planar epitaxial transistors from Mullard have been designed for use in complementary circuits with types like the BSY38, BSY39 and CV8615. The BSY40 and BSY41 have fast switching speeds (90ns max) which make them suitable for even the most stringent digital applications. Types BFX12 and BFX13 are general purpose small signal transistors but their better than normal switching speed (150ns max) enables them to be used in medium to high speed switching applications.

TO-18 encapsulation is used for all four transistors. They are in large quantity production and available for immediate delivery.

	BSY40	BSY41	BFX12	BFX13
V _{CE}	20	20V	15	15
h _{FE} (I _C =10mA, V _{CE} =.35V)			20-60	40-200
(I _C =10mA, V _{CE} =.5V)	20-60	40-120		
f _T min (I _C =10mA, V _{CE} =1.0V)			150	150
(I _C =10mA, V _{CE} =10V)	140	140Mc/s		
t _s max (I _C =10mA)	90	90ns	150	150
P _{tot} (T _{amb} =25°C)	300	300mW	300	300

Full technical data on these and other devices is available on request.
Mullard Limited, Industrial Markets Division,
Mullard House, Torrington Place, London WC1 LAngham 6633. Telex 22281

Mullard **Si** 
planar

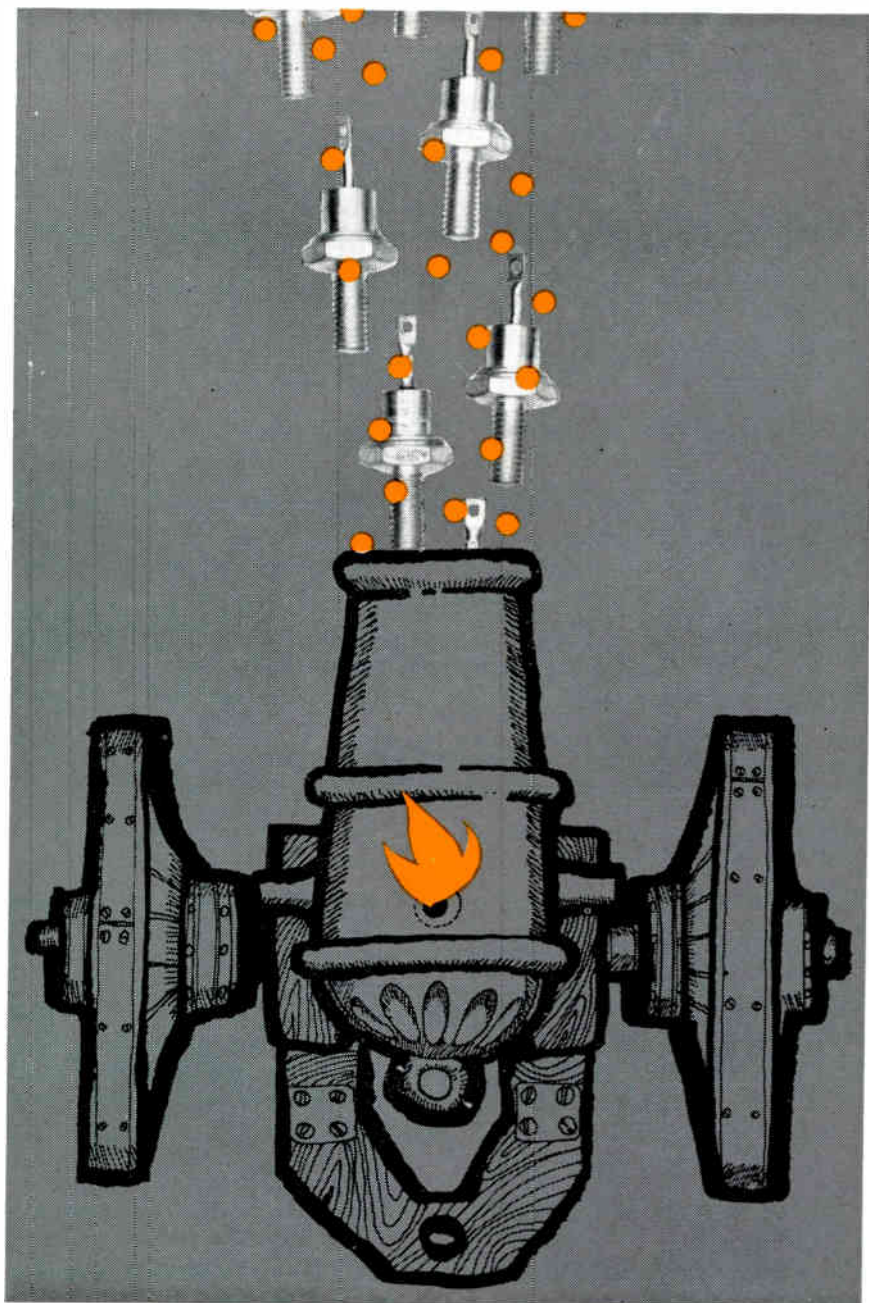

FIRE!

**—and they're
on their way**

immediate delivery of IR silicons

Need 6- or 12-amp diffused-junction silicon diodes in a hurry? International Rectifier has them, now, for immediate delivery. And we mean diodes, not promises: rugged, all-welded diodes that give you top quality rectification at junction temperatures from -40°C to $+140^{\circ}\text{C}$, with PRV's from 50V to 1kV. Exhibiting extremely low voltage drops (only 650mV at rated current) at frequencies up to 1kHz, silicon diodes are immediately available with a total of 28 different voltage-current ratings, including reverse-polarity types. Also, 10- and 16-amp thyristors are in stock now, ready to meet your requirements—fast. So contact International Rectifier today and we'll guarantee our deliveries will be on target.



INTERNATIONAL RECTIFIER · HURST GREEN · OXTED
SURREY · TELEPHONE OXTED 3215
TELEX RECTIFIER OXTED 95219



INTERNATIONAL RECTIFIER

For further information circle 250 on Service Card

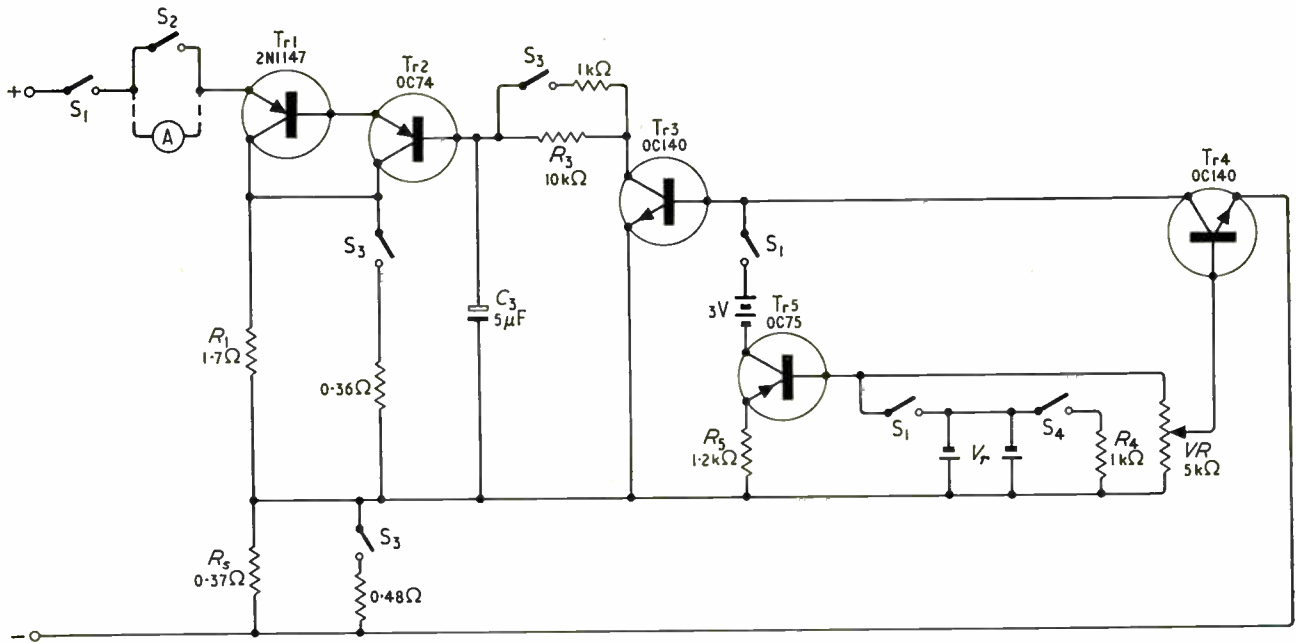

Fig. 4. The practical circuit of the current controller

of the potentiometer VR. The value of this potentiometer is then a compromise between excessive drain on the voltage reference source and reduction in sensitivity due to too high a resistance value in series with the base of Tr₄.

It is interesting to note that if VR was omitted altogether and if Tr₄ has a lower current gain than Tr₅, then since the collector currents of Tr₄ and Tr₅ are almost equal, the base current of Tr₄ will exceed that of Tr₅ and a charging current

will flow through the voltage reference source. By balancing this current by means of a suitable resistance connected across the reference source, it will then be possible to reduce the current drain on this source practically to zero. It is also worth noting that if I_r is varied, such as by making part of R_5 variable, then since I_{c4} will practically follow I_r , it is possible to obtain very fine variation in I_d .

Because of the high amplification and the inherent phase

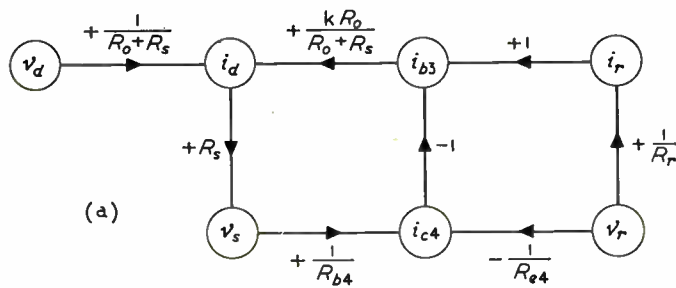
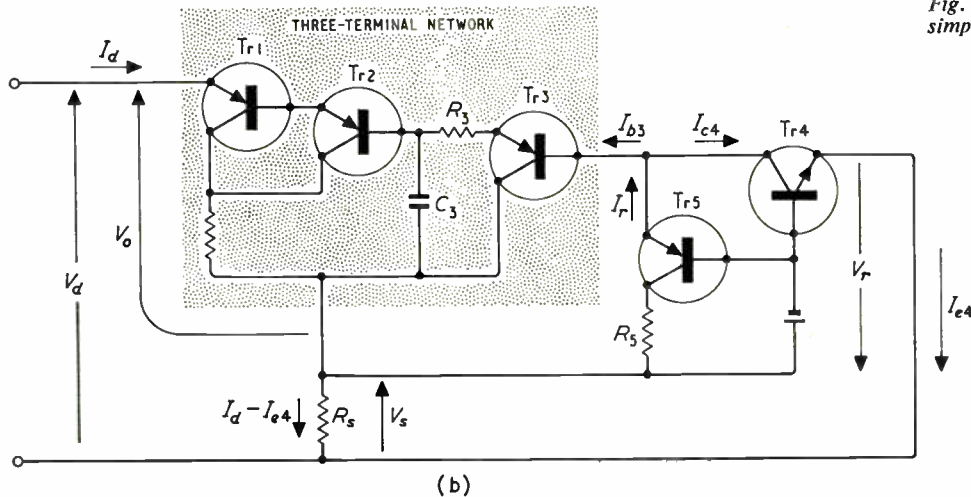

Fig. 5. (a) Signal flow diagram. (b) A simplified circuit of the controller



shifts, the circuit oscillates at about 80 kc/s if C_3 is omitted. By reducing the high-frequency gain in the system, C_3 stabilizes the system, but slows its response. For battery-discharge tests the speed of response is not important. More sophisticated means of stabilizing the circuit, with less reduction in speed of response than that caused by a single capacitor C_3 , can be resorted to, if necessary.

A high-stability resistor is used for R_5 , R_5 is wound with Nichrome wire, whereas ordinary copper-enamelled wire is used for R_1 .

Circuit Analysis

For a practical evaluation of circuit performance it is convenient to make an approximate analysis using a signal flow diagram, Fig. 5 (a), in conjunction with the simplified circuit of Fig. 5 (b). The lower-case letters in the signal flow diagram denote small changes in the d.c. quantities shown in Fig. 5 (b).

Starting with Tr_4 , changes in the collector current of this transistor can result from changes in V_s or V_r , the transistor being effectively in the common-base configuration for changes in V_s and in the common-emitter configuration for changes in V_r . In both cases the input resistance of Tr_3 (of the order of 1.5 k Ω) is small compared with the output resistance of Tr_4 , so that the output of this transistor may be considered short-circuited. If only V_s changes,

$$i_{c4} = \frac{v_s}{R_{b4}} \approx v_s \frac{\alpha_4}{R_{tb}}$$

where α_4 is the short-circuit current amplification factor of Tr_4 and R_{tb} its common-base input resistance, which is nearly equal to $r_e + r_b(1 - \alpha_4)$, so that R_{b4} is of the order of 20 Ω when there is no external resistance in the base circuit. If a 5-k Ω potentiometer is used in the base circuit, as shown in Fig. 4, and is set at 2.5 k Ω , this resistance is added to r_b so that R_{b4} becomes of the order of 50 Ω .

If only V_r changes,

$$i_{c4} = \frac{-v_r}{R_{e4}} \approx -v_r \times \frac{1}{R_{te}} \times \frac{\alpha_4}{1 - \alpha_4}$$

where R_{te} is the common-emitter input resistance, which is nearly equal to:

$$r_b + \frac{r_e}{1 - \alpha_4}$$

so that R_{e4} is practically equal to R_{b4} .

Considering Tr_5 , we similarly have:

$$i_r = \frac{v_r}{R_r} \approx v_r \times \frac{1}{R_{te}} \times \frac{\alpha_5}{1 - \alpha_5}$$

so that R_r is practically equal to R_5 .

To account for Tr_1 , Tr_2 , Tr_3 and their associated resistances, it is convenient to regard them as a three-terminal network with an input current I_{b3} , an output current I_a and an output voltage V_o , and consider the experimentally-determined output characteristic of this network with I_{b3} as parameter. Such a characteristic is shown in Fig. 6 for the 12-V case. If I_{b3} remains constant, then for a change i_a , corresponding to a shift from point B to point D (BD) in Fig. 6, the change in V_a corresponds to a shift from A to C (AC) in the figure, so that

$$i_a = v_a \frac{1}{R_0 + R_s}$$

where R_0 is the output resistance of the three-terminal network with constant input current and is given by the slope of the output characteristic at the operating point. If V_a remains constant, then for a change i_{b3} , the operating point moves along the load line and the change in I_a corresponds to a shift from A to E (AE). Had R_s been zero then the change in I_a would have corresponded to a shift from A to F (AF). Now

$$\frac{AF}{ib_3} = k$$

is the short-circuit current amplification of the three-terminal network, so that, for a change corresponding to AE,

$$i_a = i_{b3} \left[\frac{kR_0}{R_s + R_0} \right]$$

It will be noted from Fig. 6 that both R_0 and k decrease as I_a increases, and that for $I_{b3} = 3 \mu A$, $R_0 = 3.26 \Omega$ and k is of the order of 500,000 at very low frequencies. As the frequency increases, k decreases due to C_3 . For simplicity R_s is shown linear in Fig. 6; but when the temperature-compensating network of Fig. 7 is used, the operating point has to be determined with the aid of the characteristics of the diodes and the incremental resistances of the diodes used in evaluating R_s . Neglecting the current I_{e4} in R_s , $v_s \approx i_a R_s$.

With the signal flow diagram completed, it is now possible

Fig. 6. Experimentally-derived characteristics for the three-terminal network of Fig. 6 (b)

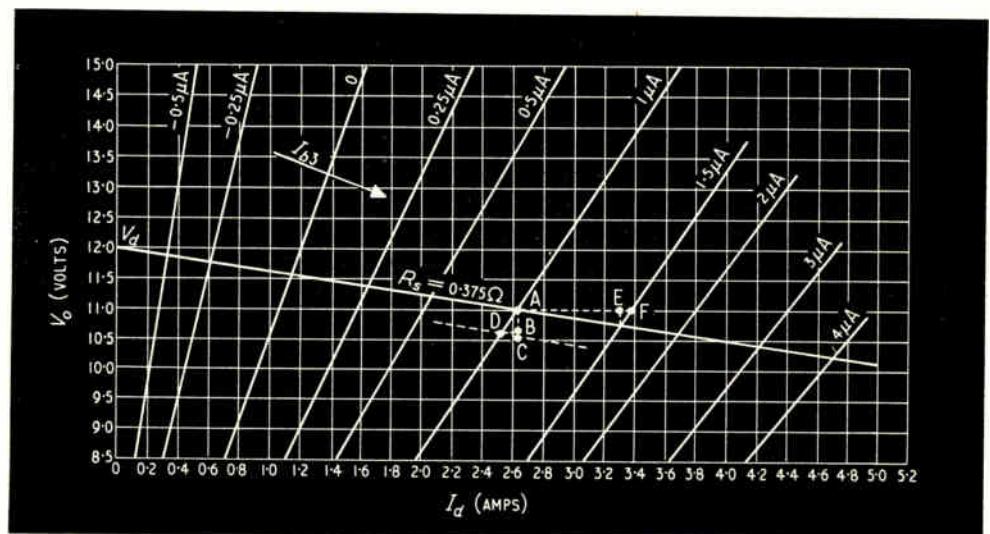

to derive the approximate relations between the various variables. Thus, with V_r constant:

$$\frac{i_d}{v_d} = \left[\frac{1}{R_0 + R_s} \right] \times \left[\frac{1}{1 + \frac{kR_0R_s}{R_{b4}(R_0 + R_s)}} \right] \approx \frac{R_{b4}}{kR_0R_s} \approx 3 \times 10^{-5} \text{ A/V} \dots (1)$$

For variations in V_r alone:

$$\frac{i_d}{v_r} = k \left[\frac{R_0}{R_0 + R_s} \right] \times \left[\frac{\frac{1}{R_r} + \frac{1}{R_{e4}}}{1 + \frac{kR_0R_s}{R_{b4}(R_0 + R_s)}} \right] \approx \frac{1}{R_s} \approx 2.7 \text{ A/V} \dots (2)$$

For variations in I_{c4} alone:

$$\frac{i_d}{i_{c4}} = -k \left[\frac{R_0}{R_0 + R_s} \right] \times \left[\frac{1}{1 + \frac{kR_0R_s}{R_{b4}(R_0 + R_s)}} \right] \approx -\frac{R_{b4}}{R_s} \approx -55 \dots (3)$$

and

$$\frac{i_d}{i_{b3}} = \frac{-i_d}{i_{c4}} \approx \frac{R_{b4}}{R_s} \approx 55 \dots (4)$$

Performance

From Equ. (1) above, it is clear that the sensitivity of the system is very high, so that if a 12-V battery is discharged from about 13.2 V to 10 V, the discharge current will not vary by more than a few tenths of a milliampere. This was confirmed by actual measurement. In practice, the accuracy of control is more likely to be determined by the stability and performance of the voltage reference source. The RM-502R has a voltage stability over a 24-hr period of approximately 2 mV at a current drain of 50 μ A, and 3 mV at a current drain of 100 μ A. The useful life of the cell at this value of current drain is about 18 months, and its internal resistance is less than 1 Ω . Resistor R_4 in Fig. 4 is switched in for a short period prior to discharging a battery, so as to stabilize the voltage of the mercury cells, and is then switched out at the commencement of the discharge.

The circuit is self-protecting with respect to failure of all the voltage supplies. Thus if the battery undergoing test is disconnected with S_1 on, Tr_4 is cut-off by the reverse bias of the reference voltage source. I_r , however, can still flow through the base-to-emitter junction of Tr_3 , which should consequently be capable of passing I_r through its base connection without damage. If the reference voltage source or the collector bias supply of Tr_5 fails, then I_r vanishes and the discharge current falls to a low value. Connecting a battery with the wrong polarity will not cause any damage.

Temperature Effects

As the ambient temperature increases, I_r tends to increase due to the fact that, at constant current, the emitter-to-base voltage of a germanium transistor, just like a germanium diode, decreases by about 2 mV/ $^{\circ}$ C^{3,4}. This increase in I_r is opposed by the increase in the collector saturation current, I_{c0} , of Tr_4 . As can be seen from Equ. (4), and since I_{b3} is of the order of a few microamps, even a 100% change in I_{b3} will cause a negligible change in I_d .

By far the most significant temperature effects are found in the emitter and base circuits of Tr_4 . Here, the voltage drop across R_s is opposed by the emitter-to-base voltage of Tr_4 plus that fraction of V_r tapped by the potentiometer.

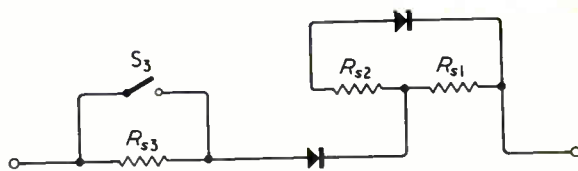

Fig. 7. A temperature-compensating network to replace R_s

The temperature coefficient of an RM-520R cell between 0 $^{\circ}$ C and 45 $^{\circ}$ C is approximately 0.20 mV/ $^{\circ}$ C at a current drain of 100 μ A, and since the two arms of VR will both vary proportionately, the effect of temperature on the reference voltage tapped at the base of Tr_4 is not very significant. The resulting effect on I_d is also opposed by the small increase in R_s with temperature, which for Nichrome wire is about 0.01% per $^{\circ}$ C. But the emitter-to-base voltage of Tr_4 , by decreasing 2 mV/ $^{\circ}$ C has a significant effect on I_d . Thus for a change in ambient temperature of 10 $^{\circ}$ C, this voltage decreases by 20 mV, so that the voltage drop across R_s will drop very nearly by this much. Across a resistance of 0.37 Ω , this represents a change of 0.05 A, which amounts to 1.25% at a discharge current of 4 A and to larger percentages at smaller values of discharge current.

The most satisfactory method of compensating this temperature effect is by including as part of R_s a germanium diode connected in the forward direction. Compared with a germanium diode, a silicon diode has a larger forward voltage drop for the same current, and a smaller temperature variation of 1.2 mV/ $^{\circ}$ C. It was found, however, that a single OA31 germanium diode has a temperature variation of 1.5 mV/ $^{\circ}$ C, and since two diodes in series overcompensated for temperature changes, the network of Fig. 7 was used. The net temperature variation is now

$$\left[1 + \frac{R_{s1}}{R_{s1} + R_{s2}} \right]$$

times that of a single diode, and by a suitable choice of values for R_{s1} and R_{s2} it is possible to obtain almost full temperature compensation as well as the correct voltage drop across the network for discharging 6-V batteries. For 12-V batteries an extra resistor R_{s3} is switched in.

Conclusion

Three current controllers of the type described in this article were built and used in the battery testing programme referred to in the introduction. They proved themselves to be very robust and reliable, gave a completely trouble-free service and a performance well within the specified limits.

The type of circuit described is inherently capable of even better performance than that of the controllers built and has several important features which makes it attractive for some specialized applications.

Acknowledgment

The writer is indebted to Dr. M. D. Attiyah, Director of the Industry Institute, for his permission to publish this article and to Mr. R. Nassar for his help throughout this work.

References

- ¹ 'Lead-acid starter batteries', publication 95-1 (1961) of the International Electrotechnical Commission.
- ² 'Battery Specifications', The Association of American Battery Manufacturers, Inc.
- ³ *Mullard Reference Manual of Transistor Circuits* (1961), pages 51 and 52.
- ⁴ Shea, R. F. (editor), *Transistor Circuit Engineering*, page 63, John Wiley and Sons (1957).

Technical-Information Service for Electronic Engineers

One of the problems in the electronics industry has always been the difficulty of obtaining details of available components and the names of the manufacturers supplying them. A firm's reference library is often unable to keep abreast of the rapid changes in product specifications (or is too unwieldy to use), and for some time there has been a need for a comprehensive national technical-information service.

A system using computer and microfilm techniques, and devised by Technical Evaluations Ltd. (a company formed 18 months ago), may go some way towards solving this problem. It is offering to provide electronic design engineers with essential technical information on any available component, and nearly two hundred different organizations are claimed to be using the service at the moment.

Information is supplied free to registered electronic-circuit engineers (or those directly involved in choosing and specifying 'bought out' components), for the component manufacturer pays for the service on a cost-per-enquiry basis. Many leading electronic-component manufacturers are said to be participating in the scheme, and even those who are not have their names mentioned as suppliers, with the difference that their technical specifications are not included.

Each registered engineer is supplied with a reference manual and a requisition card; when information on a specific product is required, the engineer consults one section of the manual and completes the requisition card simply by deleting numbers on it. If the product is known by name, a thesaurus gives a rapid guide to the appropriate page in the manual; but if no name is known, the engineer can follow a logical index (in terms of product performance) to find the correct page. This method of indexing ensures that the engineer is always made fully aware of all possible products that perform similar functions.

When the requisition card is returned to Technical Evaluations Ltd., the request is set up on an IBM 082 computer, which outputs master cards giving the code listings of all those components meeting the engineer's requirements. All component specifications are recorded on 3M microfilms, which are mounted in special tabulating cards that can be punched to correspond with the master reference cards and can, if desired, be sorted automatically. The information (complete with graphs and tables where appropriate) is then prepared for the engineer either by making a print of the microfilm or by copying it.

For further information circle 58 on Service Card

Manufacturers' Literature

Medium-Speed Data Links. A nine-page technical pamphlet is now obtainable from G.E.C. on their DT 1200 series of medium-speed data-transmission systems for use over telephone circuits. A general description of the series (including block diagrams) is followed by full technical details of the equipment and the additional facilities available.

G.E.C. Computers and Automation Ltd., East Lane, Wembley, Middlesex.

For further information circle 59 on Service Card

Digital Systems. An 18-page brochure (CT-180) on the numerical presentation of a series of analytical results from a rotational source is now available from Hilger & Watts. It describes (with photographs) the basic units employed, and discusses (with block diagrams) examples of a number of applications.

Hilger & Watts Ltd., 98 St. Pancras Way, London, N.W.1.

For further information circle 60 on Service Card

Extruded Aluminium Busbars. The advantages of aluminium over copper as an electrical conductor are discussed in an eight-page booklet (publication No. 71) from James Booth Aluminium Ltd. The design considerations and joint preparations necessary for busbar installations are described, and the booklet includes a series of tables comparing the electrical characteristics of copper and aluminium busbars.

James Booth Aluminium Ltd., Kitts Green, Birmingham 33

For further information circle 61 on Service Card

Media Conversion Systems. Two 20-page booklets on computer input-media conversion systems are now available from Ampex. Illustrated with photographs and diagrams, they describe the

company's punched-card to magnetic-tape converter (the C/T 1500), and their punched-paper-tape to magnetic-tape converter (the P/T 1000).

Ampex International, 72 Berkeley Avenue, Reading, Berks.

For further information circle 62 on Service Card

Zirconium and Hafnium. A 32-page illustrated booklet giving detailed engineering data on zirconium, zirconium alloys and hafnium has been published by Carborundum Metals Climax Inc. Information is included on machining, joining and fabricating the metals, and their applications in the nuclear and chemical-process industries are discussed.

Carborundum Metals Climax Inc., P.O. Box 32, Akron, New York 14001, U.S.A.

For further information circle 63 on Service Card

Power Supplies and A.C. Voltage Regulators. This 16-page catalogue lists the standard range of Ether's power supplies and a.c. voltage regulators for laboratory and industrial applications. It includes full specifications of the types available, and each unit is illustrated.

Ether Ltd., Caxton Way, Stevenage, Herts.

For further information circle 64 on Service Card

Ultrasonic De-burring. A six-page application report (No. 2) on ultrasonic de-burring has been published by Radyne Ltd. It compares conventional de-burring procedures with ultrasonic techniques, and describes the latter in detail. Also available is application note No. 1, on on-line ultrasonic cleaning of wire and strip metal.

Radyne Ltd., Wokingham, Berks.

For further information circle 65 on Service Card

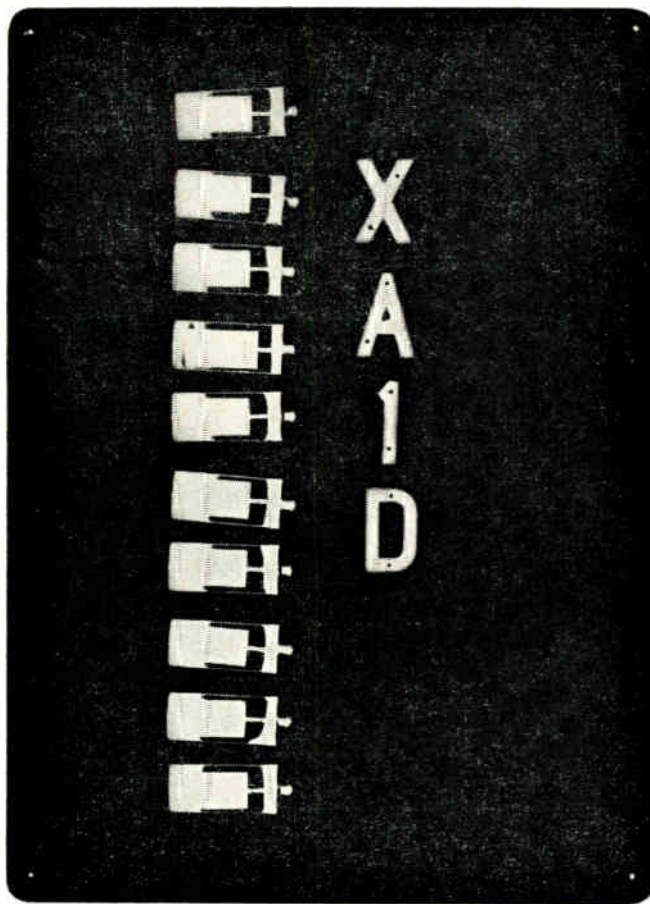

One of these Kemet Capacitors never left the factory



— which one and why not?

Most people would find it difficult to say. In fact, it was the fourth from the top. And the reason? A flaw so small that it took special X-ray equipment to detect it. Now such a flaw does not affect normal operational performance, and this particular capacitor would have proved perfectly satisfactory in a conventional circuit. But Union Carbide scrapped it without hesitation because all Kemet capacitors must meet the criteria laid down in Aerospace and

Defence specifications. How does Union Carbide impose this rule inflexibly, yet keep prices down? The answer is stringent quality control throughout the manufacturing process. By obtaining all raw materials from approved sources and by constant attention to detail throughout production, Union Carbide ensure that reliability is "built-in" not "tested-in". This means the scrap rate is negligible and prices remain among the most competitive on the market.

If you would like to know more about Kemet solid tantalum capacitors and the advanced manufacturing and test methods which ensure their operational reliability, contact Union Carbide now!

Kemet Capacitors
another practical product of



UNION CARBIDE LIMITED, -KEMET DEPT., ENGINEERING PRODUCTS DIVISION, P.O. BOX 2 LR, 8 GRAFTON ST., LONDON W.1 MAYFAIR 8100
Sales and Enquiries: Aycliffe Industrial Estate, Co. Durham. Aycliffe 2303/4.
UK Distributors for 'J' Series Capacitors: SASCO Gatwick Rd., Crawley, Sussex.

CHEMICALS • CRYOGENICS • DYNEL FIBRE • ELECTRIC WELDING • ELECTRONICS • FERRO-ALLOYS • FLAME PLATING • PRESTONE CAR POLISH • SILICONES • SUPERALLOYS • UCON LUBRICANTS
The terms Dynel, Prestone, Ucon and Union Carbide are registered trade marks of Union Carbide Corporation. EC90

For further information circle 251 on Service Card

A COMPLETE RANGE OF SE RECORDERS

- * DIRECT PRINT-OUT ON UV LIGHT — SENSITIVE PAPER.
- * SENSITIVITIES OF MINIATURE MIRROR GALVANOMETERS UP TO 0.8 μ A/CM.
- * NATURAL FREQUENCIES OF GALVANOMETERS UP TO 10 KC/S.
- * MULTICHANNEL RECORDING UP TO 50 CHANNELS.
- * TIMER AND GRID LINES RECORDED SIMULTANEOUSLY WITH TRACES.

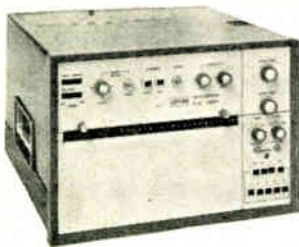

SE 3012

12, 25 or 50 channel bench or rack-mounting models. 12 inch paper width. Crystal-controlled timer. Timer lines at $\frac{1}{100}$, $\frac{1}{10}$, 1 and 10 second intervals. Every 10th line accentuated. Trace identifications and numbering. Event numbering. Master or slave timing, when using two or more recorders. Full remote control.

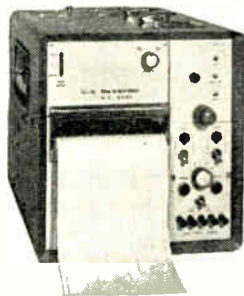

SE 2005

Low cost UV recorder. 6 or 12 channel bench-mounting model. 6 inch paper width. RC timer, independent of mains supply. Timer lines at of $\frac{1}{100}$, $\frac{1}{10}$ and 1 second intervals. Remote control of chart drive.

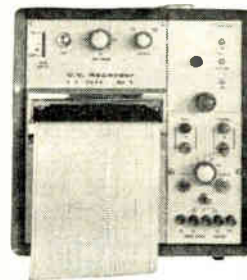

SE 2000

12 or 25 channel bench-mounting model 6 inch paper width. Crystal-controlled timer. Timer lines at of $\frac{1}{100}$, $\frac{1}{10}$, 1 and 10 second intervals. Every 10th line accentuated. Shot control. Trace interruption. Master or slave timing, when using two or more recorders. Full remote control.



SE 2800

12 or 25 channel bench or rack-mounting models. 8 inch paper width. Crystal-controlled timer. Timer lines at $\frac{1}{100}$, $\frac{1}{10}$, 1 and 10 second intervals. Every 10th line accentuated. External synchronism to paper speed. Preselection of recorded paper lengths. Trace identification and numbering. Master or slave timing, when using two or more recorders. Full remote control.

- * WRITING SPEEDS UP TO 60,000 INCHES PER SECOND.
- * 15 PAPER SPEEDS RANGING FROM 0.0625 TO 3000 MM/SEC.
- * EVENT MARKERS AND REFERENCE TRACES PROVIDED.
- * WIDE RANGE OF CHART PAPER WIDTHS.
- * TRACE AND EVENT NUMBERING.



SE LABORATORIES (ENGINEERING) LTD

a subsidiary of S.E. Laboratories (Holdings) Ltd.

North Feltham Trading Estate, Feltham, Middlesex, ENGLAND Telephone: Feltham 1166

Northern address

57 Mansfield Road, Nottingham Telephone: Nottingham 44620

For further information circle 252 on Service Card



TALK ABOUT

It was a dreary summer, not made any brighter by the economic crisis. It now looks like being a bleak winter but we can, at least, hope for a brighter spring next year.

But looking back through the summer months it was by no means all gloom. There were some happy social occasions graced by fair weather. The sun dutifully shone when the Duke of Beaufort, on behalf of Her Majesty, presented to Smiths Industries the Queen's Award to Industry.

As this award was for technical innovation in developing autoland equipment for aircraft it was fitting that Smiths' management asked that the award be made at the company's Cheltenham works where all autoland development and production is centred.

At a small exhibition staged in conjunction with the ceremony there were a few reminders that Smiths have been in aviation longer than most of us care to look back. Silk diaphragm airspeed indicators were shown dating back to 1914 including one for airships. The Smiths compass used by Alcock and Brown on their historic first-ever crossing of the Atlantic was there together with the first Smiths auto-pilot of 1931.

And it came as something of a shock to be reminded that automatic landing dates back to 1947 when the then Ministry of Supply (takes you back a bit!) formed the Blind Landing Experimental Unit. The first automatic landing took place in 1948. Over 15,000 landings have taken place since then, culminating in the historic flight number BE343 on June 10 last year when a B.E.A. Trident, non-piloted by Captain Eric Poole, made the world's first automatic touchdown with fare-paying passengers.

On June 7 this year test pilot Dennis Tayler of Shorts made the first ever hands-off landing of the 100-ton

R.A.F. Belfast transport. In fact autoland is becoming so common that from sheer economic necessity Smiths have had to discontinue the free issue of commemorative ties—at least to airline passengers.

The story of Smiths and autoland is not only one of technical competence. It is also a story of faith and considerable fortitude. It is now ten years since Mr. A. M. A. Majendie, a former Captain of the B.O.A.C. Comet fleet and now managing director of Smiths Aviation Division, prepared the operational requirement for the development of an autopilot capable of automatic landing to civil

By NEXUS

safety standards. This, he recalls, was an adventurous and exciting gamble with a stake of £1 million and the odds, at the time, anybody's guess. There was no customer, no knowledge of the types of aircraft which might be involved, and no certainty that the airlines would want it.

This illustrates the faith of Smiths in a ten-year private investment which, it was calculated, had a reasonable chance of commercial success in an environment of stability with consistency and continuity in Government aviation policy. The fortitude, of course, came from having to live not through stability but violent convulsions of policy through the years. That Smiths persevered through all the difficulties and came up smiling is to their eternal credit. And this credit is due no less to the 400 workers who watched and applauded the presentation ceremony than to the management on the platform who accepted the award on their behalf.

The sun also graced and brightened the day for the 1,000 guests at what is always a pleasurable occasion—the annual cricket match at Aldermaston when Mr. J. S. Clark's County XI play Sterling Cable C.C.

This was the 15th in a series which becomes more enjoyable every year. It is a social event on the grand scale with a fine garden party atmosphere accompanied by brighter cricket. The home team declared at 239 for 14 (on this occasion Sterling are permitted 16 batsmen) but were handsomely beaten by the visitors who included a strong contingent of County players as well as Leslie Crowther, better known on television than in cricket, but a useful performer with bat and ball.

Proceeds this year went to the Bert Lock Testimonial Fund and the Electrical Industries Benevolent Association.

Mr. J. S. Clark, whose interest in club cricket dates back to pre-1928, is chairman and managing director of Sterling Cables Ltd., and he was recently elected president of The Electric Cable Makers Confederation.

Under his guidance Sterling Cables has gone from strength to strength. They were the first in the U.K. to introduce the vertical extrusion continuous vulcanization process and have a fine reputation for producing 'specials'. Not least of the appreciative customers for this service are near-neighbours the A.W.R.E. who often need perhaps only a yard or so of very special cable for their closely guarded experiments. The Sterling technical expertise is exercised equally with the one-off 'special' as in the thousands of miles of more conventional cable which pours annually from the main plant.

A major factor in Sterling's success is a marked sense of participation in the team by all the employees. In any grading of 'happy families' the company would be high on the list. This spirit can be seen in the mass participation of the staff in giving up a weekend every year to man the bars, serve the food and do the hundred and one jobs necessary for the smooth running of an event which ranks high on the social calendar of the industry.

Since the products of Nexus Research Laboratory Inc. were reviewed in this journal (August issue, page 391) a number of readers have asked me to declare my interest. I hasten to disclaim any financial interest and I do so with a certain amount of sorrow. For here is a company which is doing very nicely.

I first came across Nexus not at Canton, Mass., where they were founded in 1962, but earlier this year at the Paris Components Show. They popped up again at the I.E.A. Exhibition at Olympia as one of the participants in the joint American exhibit. Their products are now being handled in the U.K. by Livingston Components Ltd. Nexus were the first company in the U.S.A. to crash the 20-dollar barrier for operational amplifiers. Cheapest in the range sells there for 19 dollars and if you must be cheese-paring you can get them for 10 dollars each provided you order in 10,000 lots.

Founders of the company are Roger R. Noble and Alan R. Pearlman, both of whom were senior engineers with G. A. Philbrick Researches Inc. They started in 1962 with four employees at a tough time when even the American Government was making cut-backs in electronic spending. Nevertheless, staff has now topped the 150 mark, the million dollar turnover target was hit squarely by 1964 and the three million (profitable) dollar bonanza was celebrated last year.

Roger Noble is an operational-amplifier enthusiast. He sees them being used not only in instrumentation and industry but in the car and even in domestic appliances in the home. He is on record as having forecast a unit price of three dollars by 1971.

You don't have to go to the U.S. to sense the enormous get-ahead urge that motivates every citizen and, presumably, puts the thrust into companies like Nexus or, on a larger scale, Ling-Temco-Vought, in electronics and aerospace, who have shot up the charts to 204th in the U.S. Top 500

companies since James Ling, still only 43, started in business in 1946 with £500 capital.

Thinking big, talking big and acting big all seem to pay off. It is only fifty years ago that the Massachusetts Institute of Technology loaded their entire staff and students into a barge at Boston and ferried across the Charles River to the present site at Cambridge. It is not recorded how big they were thinking at the time. I suspect there was a strong element of the old pioneering spirit but even the American aptitude for thinking big could not have conveyed any idea of the expansion to come. The latest addition is a £21 million complex of buildings on 29 acres, due for completion in 1971. This will be a research centre for N.A.S.A. and will include a microwave radiation laboratory and 700 graduates among the 2,000 employees. M.I.T. currently have 7,000 students and the Lincoln Laboratory, administered by the Government, has 600 graduate scientists.

The new N.A.S.A. complex will not, as may be supposed, work on the Apollo man-on-the-moon programme. That's small time stuff. The space planners have already laid down the electronic reliability for the new equipment to go into the longer missions to Mars and Venus when the mean time before failure (m.t.b.f.) must be measured in years. This is the sort of thing that will be investigated with a nice 'fall-out' for industry in technical know-how and money-making orders.

M.I.T. is not quite the soulless technological hell it sounds. Dr. Julius Stratton who has now retired from the presidency of M.I.T. to become chairman of the Ford Foundation said earlier this year at the graduation cere-

mony: "In my view the humanities have become central to our endeavours rather than peripheral". This still sounds to me a very technological way of putting it. But ex-students, however technical they may have become, were still human enough to give over half of the £14 million received by M.I.T. in gifts during the past year.

I commend the Electrical Research Association and Mr. L. Jervis, their ebullient press officer, for organizing a series of working lunches in London. This was a fashionable way of introducing the latest work of ERA to the technical press. Hospitality was first-class and discussion was to the point.

At the lunch I attended, Mr. E. E. Dweck, head of the E.R.A. Computer Group explained the work of the E.R.A. Integrated Computer which will emerge as a full hybrid machine when funds can be raised for the digital extension. If enthusiasm could spirit a digital computer from the air it would have landed on the table.

Unfortunately, enthusiasm was not enough on this occasion. The figure needed is £30,000, not much by today's standards, to extend the E.R.A. research on network analysis and related problems.

E.R.A. staff have had a big hand in developing and building the very large analogue computer now in use. They are now busy designing and installing the analogue/digital conversion equipment. The Ministry of Technology has been applied to for a grant.

There is now the long wait during which I hope the enthusiasm will not evaporate to a point where the E.R.A. scientists look longingly to the West and wonder whether to join their British compatriots at M.I.T.

Electro-Hydraulic Position Control

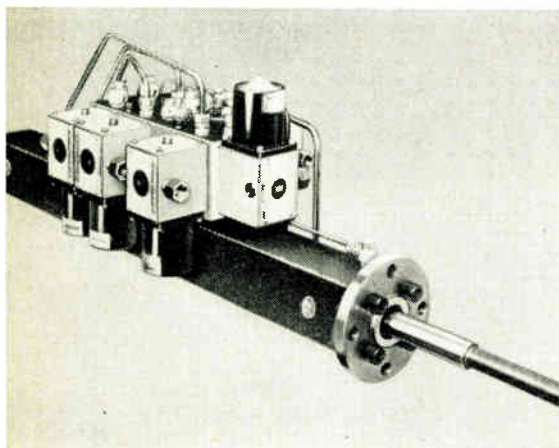

A NEW concept in control and positioning systems, introduced by the Sperry Gyroscope Co. Ltd., has been adopted by a Swedish saw-mill machinery manufacturer to move the saw head and drive to any one of 128 different working positions, in increments of $\frac{1}{16}$ in. Overall positioning accuracy is to within ± 0.005 in., with a repeatability of one of these positions to within ± 0.0002 in.

The system employs an electro-hydraulic linear digital actuator (see picture), designed to move a load to a preselected position in response to an electrical binary signal; in this application, a mass of up to 5 tons is

moved against a friction force of 1 ton to any position in less than 2.5 sec.

Basically, the actuator comprises a series of seven jacks, or pistons, arranged axially within a cylinder. Each jack represents a unit of the binary system, being either fully retracted or fully extended to correspond to binary command signals of '1' or '0'. The strokes of the various jacks are arranged in geometric progression ($\frac{1}{16}$ in., $\frac{1}{8}$ in., $\frac{1}{4}$ in. etc.), so that any extension from 0 to $7\frac{7}{8}$ in. may be achieved in increments of $\frac{1}{16}$ in., integral-flow control valves and hydraulic damping devices permitting smooth shock-free operation.

Planning your next move?

ASK ABOUT "SELLOTAPE" ELECTRICAL TAPES

because you'll find the solution to many problems in the manufacture of electrical components in the versatile "Sellotape" electrical range—a range tailor-made for a wide variety of taping jobs—insulating, securing, protecting, holding, identifying (by printed tape) and many others. Whether the job calls for an extra-thin insulating material or for an extra-tough tape for heavy duty work . . . whether a component has to withstand freezing conditions or operate at very high temperatures you can be sure that "Sellotape" have a tape for it.

1 "Sellotape" electrical tape is a neat, secure replacement for the usual metal lamination clamp on printed circuit components and in double-sided form it secures the component to the circuit board.

2 Electrical grade 1609 used as an insulating film and holding medium for the copper electrostatic screen in transformer windings.

3 "Sellotape" Polyester Thermosetting 1607 for security on stick-wound coils.

4 "Sellotape" electrical grade tape is an inexpensive, easy-to-apply insulating and protective medium for flexible printed wiring systems.

5 "Sellotape" electrical tape wound on a mandrel adhesive outermost makes inexpensive insulating formers.

There is a team of "Sellotape" specialists constantly at work in this field. The benefit of their experience and advice is always freely at your disposal.



1

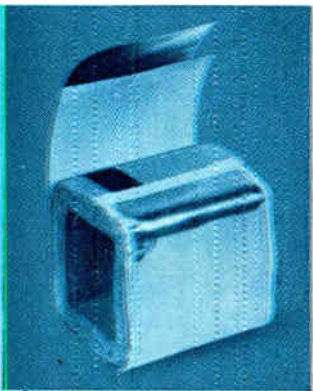

2



3

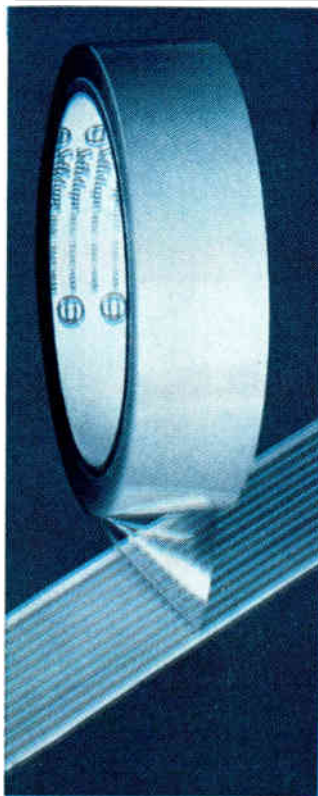

4

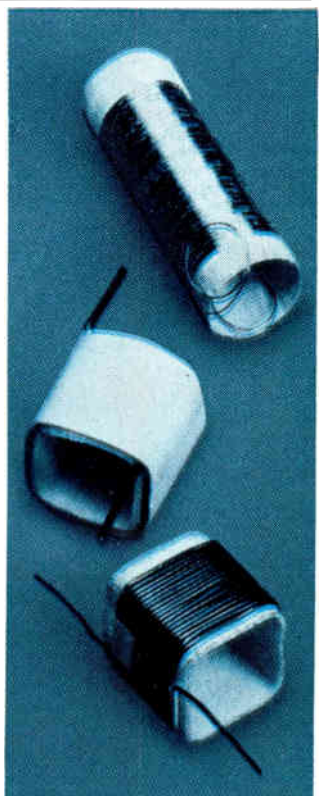

5



Sellotape products—a plus on every production line

SELLOTAPE PRODUCTS LIMITED, INDUSTRIAL DIVISION, SELLOTAPE HOUSE
54-58 HIGH STREET, EDGWARE, MIDDLESEX. Telephone: EDGware 2345. Telex: 262462
DUBLIN OFFICE: 1/2 LOWER MOUNT STREET, DUBLIN 2. Telephone: 61108/9
Associated Manufacturing Companies in Australia, Canada, Eire, New Zealand and South Africa

"SELLOTAPE" is the registered trade mark of Adhesive Tapes Limited

For further information circle 253 on Service Card



DIRECT NUMERICAL READ-OUT of STRAIN, LOAD, DISPLACEMENT, PRESSURE etc.

C71 TRANSDUCER METER

unique automatic carrier null-balance technique gives degree of accuracy and long-term stability unobtainable by other methods. **£850**

- ± 999 digits (with $\times 10$ multiplier)
- accuracy $\pm 0.1\% \pm 1$ digit
- sensitivity variable from $1.25 \mu\text{V}$ to 50 mV . (1 to 40,000 microstrain)
- continuously follows reading or captures + or - peaks.
- Binary coded decimal output.
- rack ($19" \times 10\frac{1}{2}"$) or bench versions.

COMPLETE DATA LOGGING SYSTEM AVAILABLE

Provides automatic scanning of multiple inputs with print-out facility.

SCANNER

10 inputs per unit. Zero control of each channel. Automatic or manual scanning.

SERIALIZER

Converts output to form suitable for printer-drive. (Add0-X printer supplied standard).



BOULTON PAUL AIRCRAFT LIMITED

WOLVERHAMPTON Tel. Fordhouses 3191 Telex: 338220

MEMBER OF THE DOWTY GROUP

For further information circle 254 on Service Card

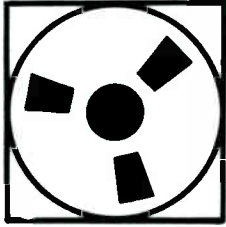

NEW APPARATUS

ELECTRONICS COMMUNICATIONS INSTRUMENTATION CONTROL

1. Punched-Paper Tape to Magnetic Tape Converter

An off-line system (the PTS-1000) that converts data from 5, 6, 7 or 8-level punched-paper tape to computer-compatible magnetic tape has been introduced by Ampex International. The equipment will thus perform the routine data conversion normally carried out by a computer (hence allowing more time to be used by the computer for more complex work) and will enable users to feed converted information into computers up to 120 times faster than hitherto. Any magnetic-tape code format may be set by programming edit instructions into the paper tape, and in a single conversion operation the system can handle up to 1,300 ft of 4½ mil (or 2,350 ft of 2½ mil) chaded or chadless, oiled or unoled paper tape.—*Ampex International, 72 Berkeley Avenue, Reading, Berks.*

For further information circle 1 on Service Card

2. Temperature Indicator

A. Levermore and Co. have announced the addition of six further heat increments to their line of

Markal Thermomelt surface-temperature indicators. Temperature ratings of 932 °F, 1,425 °F, 1,480 °F, 2,100 °F, 2,150 °F, and 2,200 °F have been added to bring the total number of ratings to 86, covering a range from 100 °F to 2,200 °F. Marks made with Thermomelt Indicators on a heated surface melt immediately when the specified temperature of each indicator is reached, giving the exact surface temperature of the object being heated. All indicators up to 600 °F are free of lead, zinc, cadmium, sulphur, chlorine, bromine, iodine and fluorine that might affect stainless steel, nickel and other alloys during heat treatment.—*A. Levermore & Co. Ltd., Broadway House, Broadway, London, S.W.19.*

For further information circle 2 on Service Card

3. Hotplate and Stirrer

A combined hotplate and magnetic stirrer has been introduced by Cenco Instrumenten. It has been designed for use under difficult laboratory conditions such as with irregularly-shaped vessels, in vacuum or under pressure. Fast and uniform heating

of the aluminium heating surface is provided by a 600-W heating element. Stepless temperature control is ensured by a thermostat, and separate controls for heat regulation and stirrer-speed regulation are located on the front panel. A beltless direct-drive motor propels the stirring mechanism and the stirring speed can be adjusted from mild agitation to vigorous churning.—*Cenco Instrumenten Mij., Konijnenberg, 40, Breda, The Netherlands.*

For further information circle 3 on Service Card

4. High-Pressure Nozzles

Danfoss have announced the type OD range of high-pressure atomizing nozzles for oil burners. The nozzles are available in two models, one with a solid spray pattern (model 'S') and the other with a hollow spray pattern (model 'H'). They are precision-made in brass, heat being rapidly conducted away and the nozzle temperature being maintained at a minimum. This ensures against any drop in capacity and any tendency to sooting and carbonization. The orifice nib and distributor are con-



structed of wear- and acid-resistant chrome-nickel steel. The nozzles are available with spray angles of 30°, 45°, 60°, and 80°.—*Danfoss (London) Ltd., 6 Wadsworth Road, Perivale, Greenford, Middlesex.*

For further information circle 4 on Service Card

5. Electrostatic Copier

A high-speed electrostatic copier which produces quarter-sized copies of originals is obtainable from Conroy Copying Consultants Ltd. Designed and manufactured by Copygraph Ltd., it is known as the Copygraph 313. The clear, readable copies are produced on 2½, 3 and 4-in. wide paper reels of length 250 yd. Solid black areas and half-tone illustrations can be reproduced as well as written, typed or printed texts. A three-position contrast control allows for adjustment to suit normal, faint or dark originals. Low-cost, operation is featured, the cost for one copy of an 8×10-in. original

being 0.72d.—*Conroy Copying Consultants Ltd., 33 New Cavendish Street, London, W.1.*

For further information circle 5 on Service Card

6. Fluidic Binary Counter

A monolithic four-bit fluidic binary counter constructed of four fluid-amplifier binary-counter stages has been announced by Electrosil. This device counts 16 discrete numbers, resetting to zero at the count of 15. A random set and reset facility is provided so that the user can set the unit to start counting on any number and to return to zero on any number. Any number sequence in the 16-digit framework can be accommodated. The unit obviates the need to mount and connect four separate counters for this function. This reduces response times as the length of connecting passages is reduced by 50%.—*Electrosil Ltd., Pallion, Sunderland, Co. Durham.*

For further information circle 6 on Service Card

ELECTRONICS

7. Turbo-Generator Excitation

A semiconductor rectifier unit producing an output of over 2 MW suitable for a static source of d.c. excitation for large turbo-generators has been developed by G.E.C. Using silicon diodes, it consists of six three-phase full-wave bridges. Each bridge, together with its associated control and protective equipment, is mounted in a separate compartment of a sheet-steel cubicle. The six bridge units are usually connected in parallel but each one can be isolated for servicing. The input to the unit is taken from a 100-c/s alternator direct-coupled to the rotor of the main generator. Fuses, fuse indicator lamps, surge-suppression equipment and interlocks on the cubicle doors and the isolator are

4



NEW

**ELECTRONICS
COMMUNICATIONS
INSTRUMENTATION
CONTROL**

5



6

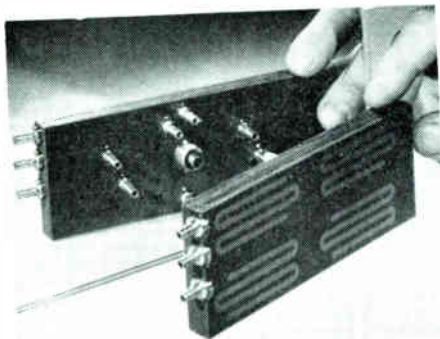

8

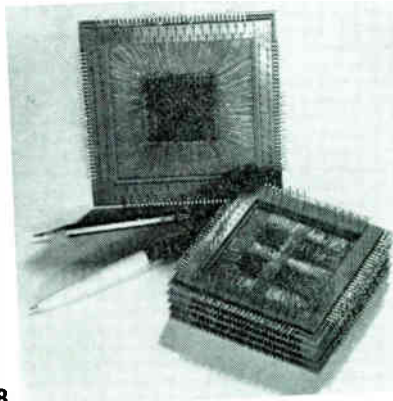

7

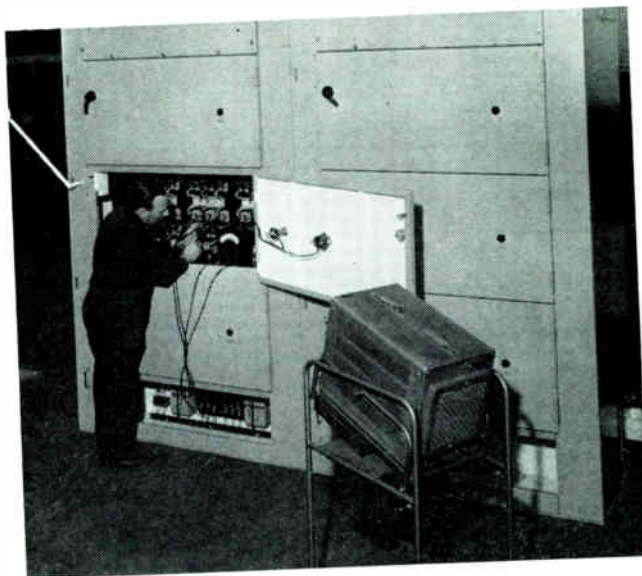

9

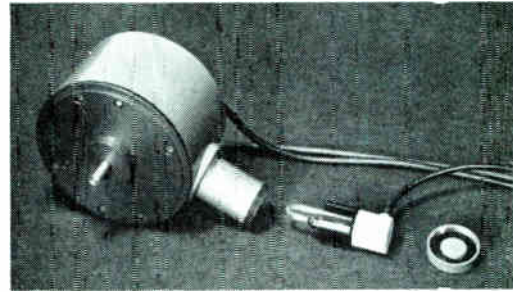

10

11



included.—*The General Electric Co. Ltd., Birmingham, 6.*

For further information circle 7 on Service Card

8. Core Matrices for Desk Calculators

A low-cost range of single-plane core matrices specially designed for small desk calculators has been announced by Mullard. These will retain stored data even after the calculator has been removed from its power supply. The lithium-nickel ferrite cores permit operation in a temperature range of 0–70 °C. Drive requirements are reduced by the use of two-turn X, Y and Z windings enabling relatively simple drive and selection circuits to be used. The matrices are ruggedly constructed and the connecting pins can be soldered directly on to a printed-circuit board.—*Mullard Ltd., Mullard House, Torrington Place, London, W.C.1.*

For further information circle 8 on Service Card

9. C.R.T. Display System

Ferranti have introduced a cathode-ray display system which can be driven from a digital computer output. It produces a tabular format of 8, 16, 32 or 64 lines of alphanumerical characters and symbols. The characters and symbols, displayed in two sizes, can be posi-

tioned singly or in groups anywhere on the display. Pictorial representations can be produced and graphs can be displayed. A keyboard and control panel enable an operator to modify or manually produce displays. Units with 14, 17 or 21-in. tubes are available.—*Ferranti Ltd., Automation Systems Division, Simonsway, Wythenshawe, Manchester, 2.*

For further information circle 9 on Service Card

10. Optical Shaft Encoder

The optical shaft encoder FD 98 is now available from Hilger & Watts for applications requiring a high resolution. The digitizer gives a combined single-turn and multi-turn output. Readout is effected by a xenon-flash tube having a flash duration of 50 μsec and a repetition rate of 25 flashes per second. Mounting arrangements conform to international synchro standards, and the overall dimensions of the encoder are 6 in. diameter, by 4½ in. deep. Resolution of the FD 98 is normally 8190 discrete steps in cyclic permuting binary (Gray) code, with 32 turns count; or 10,000 steps in reflected decimal code, with 50 turns count. Encoders giving a C.P.B. coded output have a reversing track to give an increasing count for either clockwise or anti-clockwise rotation.—*Hilger & Watts Ltd., 98 St. Pancras Way, London, N.W.1.*

For further information circle 10 on Service Card

11. Analogue-to-Digital Converter

A completely self-contained analogue-to-digital converter mounted on an integrated circuit card is now under production by Pastoriza Electronics Inc. Designated the model ADC 10_{IC}, it has a 10-V input range and produces a 10-bit parallel binary output. A version with a serial binary output is also available. A resolution of 10 mV is featured as well as a 10-μsec conversion time. A digital-to-analogue converter, model DAC 10_{IC}, is also available mounted on a similar 4½ × 2½ × ⅞-in. integrated circuit board.—*Pastoriza Electronics Inc., 385 Elliot Street, Newton Upper Falls, Massachusetts 02164, U.S.A.*

For further information circle 11 on Service Card

12. Pulse Generator

The Datapulse model 111 pulse generator, distributed in this country by Dynamco Instruments, features independently-variable rise and fall times of 2–500 nsec, single or double pulse outputs to ±5 V, and full baseline offset. The repetition rate is variable from 4 to 40 Mc/s and a simulated 50-Mc/s p.r.f. can be obtained with the use of the double-pulse mode. The pulse duration is from 5 nsec to 500 msec and a variable pulse delay is incorporated. Jitter is less than 0.01%.—*Dynamco*

12



13



14

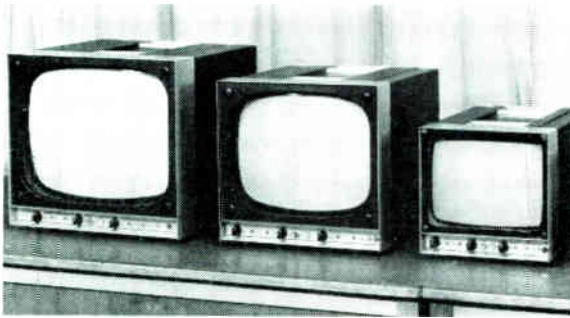
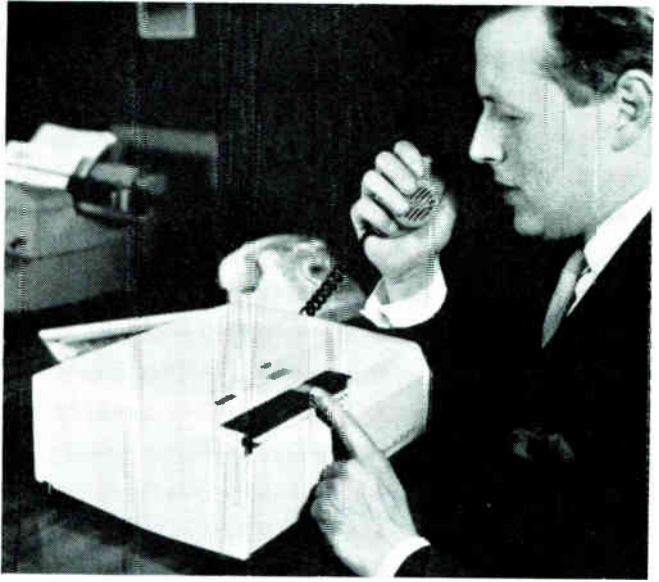

15

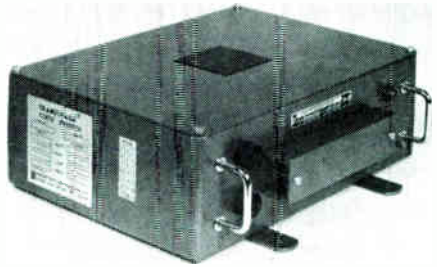

16

NEW

ELECTRONICS
COMMUNICATIONS
INSTRUMENTATION
CONTROL

17

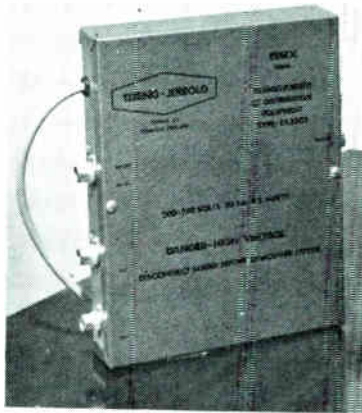

18



19

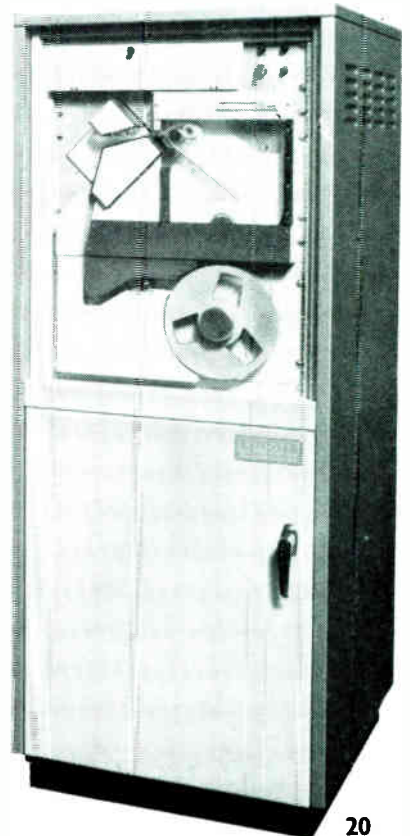

20

Instruments Ltd., Salisbury Grove, Mytchett, Camberley, Surrey.

For further information circle 12 on Service Card

13. High-Voltage Power Supplies

The latest additions to the BETA range of high-voltage stabilized power supplies produced by Brandenburg are the models 905 and 906. The output voltage of these units can be adjusted, by coarse and fine potentiometers, to any value between 6 and 60 kV and is monitored by a front panel meter. Provision for current metering is included on the rear panel. The model 905 has a positive polarity output while the model 906 has a negative output. Both are suitable for bench or rack mounting, measuring $7 \times 17 \times 19$ in.—*Brandenburg Ltd., 139 Sandstead Road, South Croydon, Surrey.*

For further information circle 13 on Service Card

COMMUNICATIONS

14. Phone-Answering Machine

Shipton Automation have brought out a Tel-Stor telephone answering and recording machine type CR which not only enables businessmen to record their own messages, but to build up a library of answer tapes to be used again whenever needed. The tapes are each encased in their own containers which can be slipped in and out of Tel-Stor CR in a matter of seconds. An added feature of the model is its automatic gain control device so that when it is being used to record telephone conversations, and one of the speakers comes over more faintly than the other, the volumes of the voices are balanced out on the recording.—*Shipton Automation (Sales) Ltd., 64 Kingsway, London, W.C.2.*

For further information circle 14 on Service Card

15. T.V. Picture Monitors

Pye T.V.T. have introduced a range of three solid-state television picture monitors. These are a 17-in. model, type 2845, a 14-in. model, type 2844, and the type 2843, an 11-in. version. These operate on 625, 525 or 405-line standards and multi-standard versions of each are available. With the multi-standard versions, line-standard selection is either local or remote. Brightness and contrast and the selection of one of two video

inputs can also be remotely controlled. All the circuit wiring is carried on printed-circuit panels, the two main panels being mounted on hinges for ease of access. Protection against overloads and voltage transients is included.—*Pye T.V.T. Ltd., Coldhams Lane, Cambridge.*

For further information circle 15 on Service Card

16. Inverters

A range of static inverters, the 'TRANSIPACK' series, has been designed by Industrial Instruments for use with teleprinters. Operating from a 24-V d.c. input, each unit in this range will supply power to operate a teleprinter used with mobile equipment or where no mains supply is available. The units produce outputs between 200 and 250 V a.c. at 50 c/s. Illustrated is the type 606/2L. Other types include a portable version and a unit operating from a 12-V d.c. input.—*Industrial Instruments Ltd., Stanley Road, Bromley, Kent.*

For further information circle 16 on Service Card

17. Telephone Repeaters

A range of Philips transistorized line equipment for normal and small-bore coaxial telephone cables is available from M.E.L. It is suitable for use with 4-, 6- and 12-Mc/s bandwidths. All the controls for this equipment are centred at the terminal stations so that the repeaters, employing minimum circuitry, are reliable enough to be buried. The main intermediate or terminal repeaters are rack-mounted in surface buildings. They include power supplies for the buried repeaters, adjustable equalization and automatic regulation of signal levels for compensation of line attenuation changes. Two buried types of repeater are used: regulated repeaters, controlled from the main repeaters, and non-regulated repeaters having fixed gain and equalization.—*The M.E.L. Equipment Co. Ltd., Manor Royal, Crawley, Sussex.*

For further information circle 17 on Service Card

18. Communal Aerial Amplifiers

Following an agreement with the Jerrold Corp. of America, Teleng Ltd. have introduced the Teleng-Jerrold Essex series of transistorized amplifiers for communal television aerial systems. Two amplifier stages are used, a wideband output stage, with a capacity for six

or seven channels, and a series of single-channel preamplifiers. Output levels of 100–200 mV are produced, making the equipment suitable for installations of up to 150 points, and gains of up to 60 dB are possible. A simplified unit employing a wideband amplifier only is also available having a gain of 24–29 dB and being suitable for smaller systems.—*Teleng Ltd., Church Road, Harold Wood, Romford, Essex.*

For further information circle 18 on Service Card

19. Video Tape

The 3M Co. have introduced the 'Scotch' type 399 video tape which has been developed specifically for 625-line operation. It is suitable for colour as well as monochrome recording. An improvement on earlier 'Scotch' tapes, the type 339 is claimed to have an extended life without introducing an increase in head wear. A video signal-to-noise ratio of 50 dB is exhibited. The 2-in. wide tape is supplied in lengths of 2,400–7,200 ft for running times of $\frac{1}{2}$ –1½ hr.—*The 3M Co. Ltd., 3M House, Wigmore Street, London, W.1.*

For further information circle 19 on Service Card

20. Data Transmission

A range of low-cost data-transmission equipment has been introduced by Elliott Brothers (London) Ltd. This transmits data over the public telephone network at a rate of 75 or 100 characters per sec. It accepts 5-, 6-, 7-, or 8-hole punched paper tape and transmits data in blocks of 15 characters. The receiver terminal checks each block and, if an error is detected, a signal is sent back to the transmitter for it to re-transmit the faulty block. Odd or even parity checks are included or can be omitted as required. The equipment has been designed for off-line operation but on-line operation to a computer is possible with the use of an appropriate interface.—*Elliott Brothers (London) Ltd., Elstree Way, Borehamwood, Hertfordshire.*

For further information circle 20 on Service Card

21. Loudspeaking Telephone

A transistorized loudspeaking direct-access telephone which can be operated from a PAX power supply has been developed by AEI Telecommunications. Intended for executive use, it allows an operator to call any one of 20 extensions with the use of push buttons. Engaged extensions are automati-

cally recalled and the operator can join existing conversations on any of the 20 extensions. A handset is provided which allows for private conversations, the loudspeaker being cut off when the handset is lifted. A dial is also provided for calling further extensions in the normal manner.—*Associated Electrical Industries Ltd., Telecommunications Division, Woolwich, London, S.E.18.*

For further information circle 21 on Service Card

INSTRUMENTATION

22. Intrinsically-Safe Ohmmeter

An ohmmeter designed for testing electrical resistance in explosive atmospheres has been introduced by John Davis and Son. The ohmmeter is classified intrinsically-safe for class 1, 2a, 2c, 2d and 2e gases. The meter is scaled from 0 to 3 k Ω and a slide switch enables a second range

from 0 to 30 k Ω to be selected. The instrument is contained within a bakelite moulding housed in a rugged brass case. Power to operate the meter is derived from a mercury cell which is designed for renewal every six months.—*John Davis and Son (Derby) Ltd., All Saints Works, Derby.*

For further information circle 22 on Service Card

23. Vibration Measurements

The dual-channel synchronous filter model 1034, manufactured in the U.S.A. by Ad Yu Electronics Inc. and available in the U.K. from Livingston Laboratories, is for use in the determination of the responses of test pieces on vibration tables. When used with a synchronous converter, the unit tunes to the frequency of the table drive. Signals from the components under test are fed to the model 1034, converted to a carrier frequency and passed to a narrow-bandwidth crystal filter for removal of noise and distortion. The amplitude of the filtered carrier,

which is indicated on separate front panel meters for each channel, gives a figure for the response of the component.—*Livingston Laboratories Ltd., Livingston House, Greycaines Road, North Watford, Herts.*

For further information circle 23 on Service Card

24. Milliohmmeter

The latest addition to the range of resistance test equipment from Keithley Instruments is the portable battery-operated milliohmmeter model 502A. This provides full-scale resistance ranges from 0.001 Ω to 1 k Ω , allowing values as low as 30 $\mu\Omega$ to be detected. A 'voltage limiting mode' restricts the voltage applied across a sample to 25 mV peak-to-peak, limiting the power dissipation. This makes the unit suitable for checking fuses, explosive devices and dry circuit contact resistances. An alternative measuring method is the 'normal mode' which reduces the maximum dissipated power in the sample to 2 μW thus permitting

21



22



NEW

ELECTRONICS
COMMUNICATIONS
INSTRUMENTATION
CONTROL

24

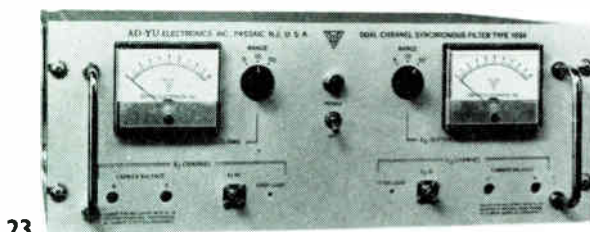

23

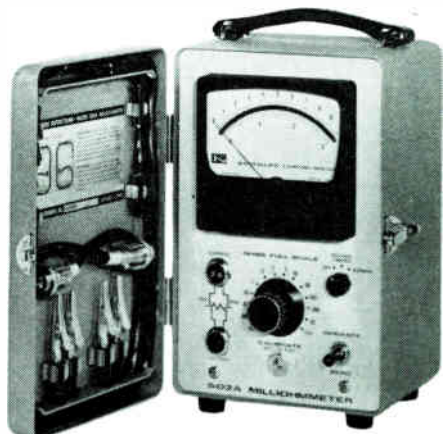

NOW ... LOW COST SPEED CONTROL SYSTEMS

for variable speed
drives to
.5% accuracy



FR Mk. III Control Unit

The FR 'Servotor' can be easily adapted to practically any type of variable speed drive—either new or retrospective fitting—to provide a self-compensating, no-hunt, servo-loop control system of proven reliability and low cost.

The system is simple to install, operate and maintain, fully accessible—ready to provide automatic control of any process function by transducer, with suitable electrical output. Notably successful uses include the control of nylon fibre plant, carpet and linoleum production, chemical processing machinery, wire drawing plant, compressor test rigs, etc.

The Industrial Electronics Division of Flight Refuelling welcomes all enquiries for the design of control systems to customers' specifications.

FR industrial electronics

FR Flight Refuelling Ltd., Wimborne, Dorset Tel: Wimborne 2121
Cables: Refuelling Wimborne Telex: 41168

TA3739

For further information circle 293 on Service Card

WHERE SECONDS COUNT

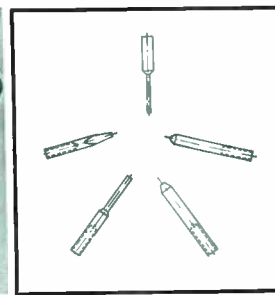
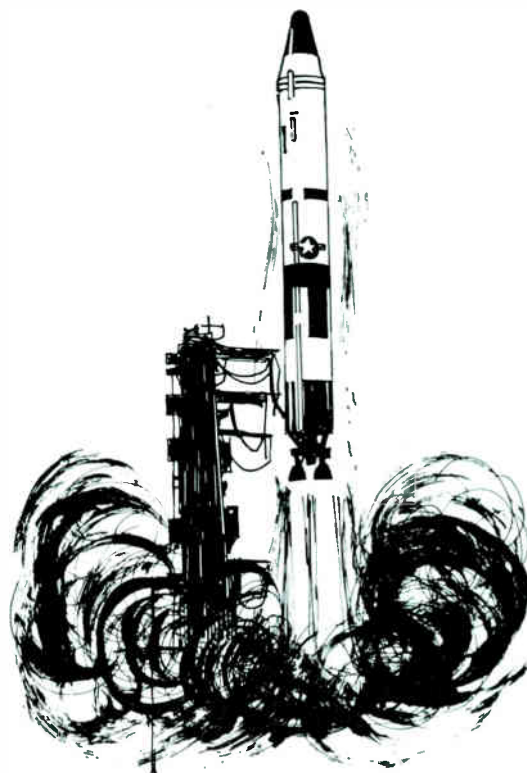

Safely use Elremco low voltage soldering irons and systems. High thermal efficiency, light weight—our type SMS weighs only 2 oz. Wide range of bits and elements give versatility and economy.



For further details.....

ELECTRICAL REMOTE CONTROL CO. LIMITED
P.O. BOX No. 10 BUSH FAIR · HARLOW · ESSEX
Tel.: Harlow 24285 Telex: 81284 Telegrams: ABAcontrol Harlow

For further information circle 255 on Service Card

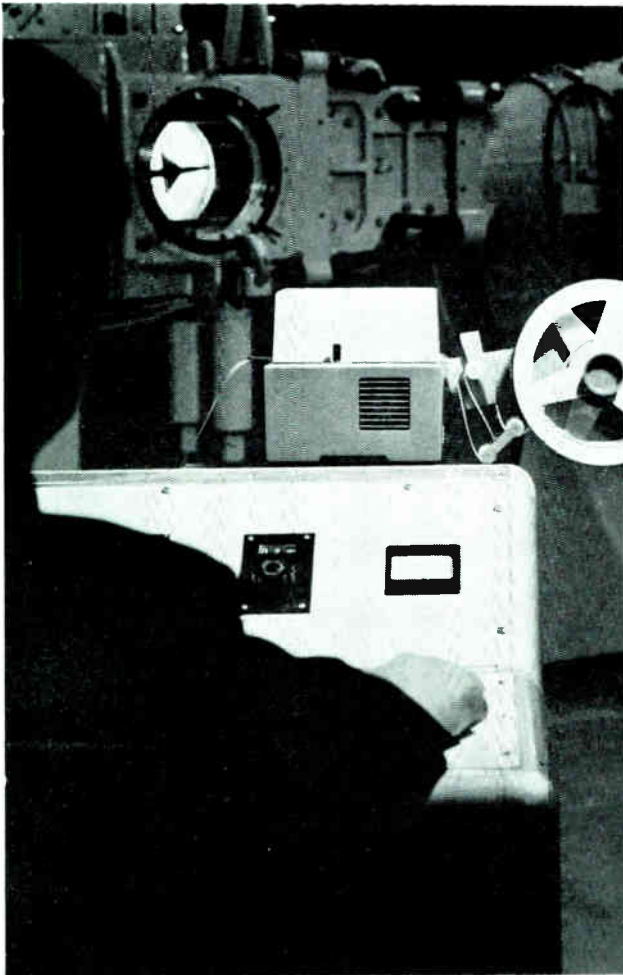

Facit PE 1500 Tape Punch

- 1
Computers
- 2
Data transmission
- 3
Data logging



punched
tape output
up to 150 characters per second
▶ including tapes for TTS

Facit-Odhner Electronics Ltd.
Eastgate Court
Rochester Kent
Telephone: Medway (OME 4) 43465 & 43487
Cable: Facitroc Rochester Kent

For further information circle 256 on Service Card



**SOLDERING
EQUIPMENT**

**SPECIALISING FOR THE
SOLDERING JOINTING INDUSTRY**

Illustrated

$\frac{3}{16}$ " BIT INSTRUMENT
(LIST 64)
IN
PROTECTIVE SHIELD
(LIST 700)

ALL VOLT RANGES
FROM
6/7 to 230/250V

BRITISH & FOREIGN PATS.
& REG. DESIGNS, ETC.

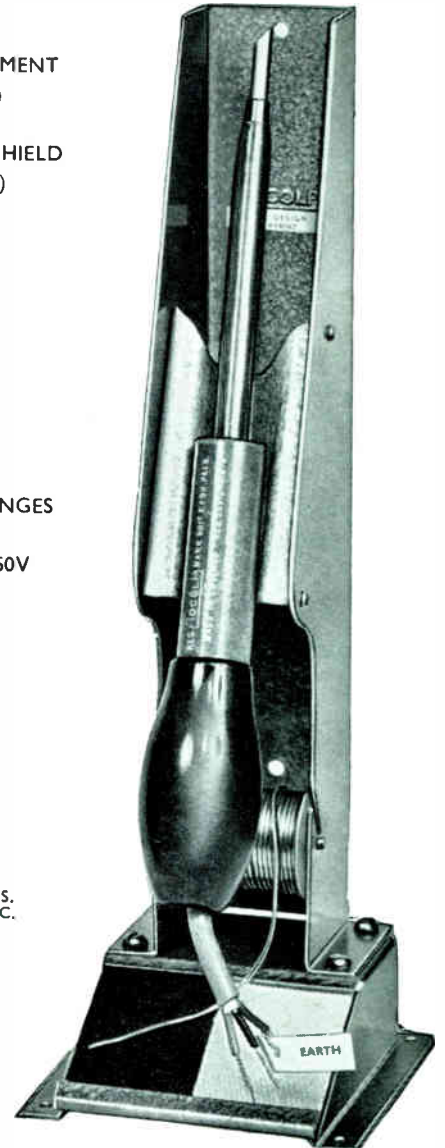

Apply Direct for Catalogues:

ADCOLA PRODUCTS LTD.
ADCOLA HOUSE
GAUDEN ROAD
LONDON, S.W.4

Telephones MACaulay 0291/3
Telegrams SOLJOINT LONDON S.W.4

For further information circle 257 on Service Card

25

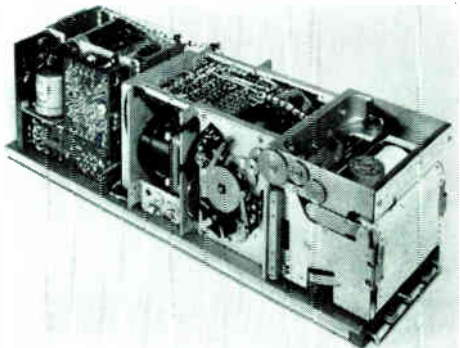
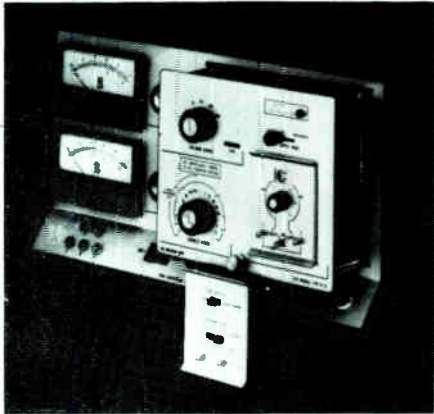

NEW

ELECTRONICS
COMMUNICATIONS
INSTRUMENTATION
CONTROL

27



28

accurate measurements to be made at $\pm 3\%$. Available in the U.K. from *Livingston Laboratories Ltd., Livingston House, Greycaine Road, North Watford, Herts.*

For further information circle 24 on Service Card

25. Semiconductor Tester

A plug-in module for the Birtcher model 70A semiconductor test set permits full-scale leakage measurements as low as 100 pA and breakdown measurements with full-scale currents as low as $1 \mu\text{A}$. Designated the Module 10-CD, it is available in the U.K. from Wessex Electronics. A regulated power source provides constant voltage or constant current output for the direct measurement of leakage and breakdown in transistors and diodes. Readings of leakage and breakdown up to 10 mA at up to 1 kV are provided.—*Wessex Electronics Ltd., Royal London Buildings, Baldwin Street, Bristol, 1.*

For further information circle 25 on Service Card

26. Synchro Transmitter-Receiver

Smiths Industries have added a servoed synchro transmitter-receiver to their range of test equipment

designed to check electro-mechanical servo systems and components. The twin pointers of the indicator dial are coupled to two synchros and driven by a motor tachogenerator. One of the synchros is a control transformer displaying input angles in conjunction with a servo-amplifier. The other synchro is a torque transmitter which will transmit any angle shown on the dial. A calibrated speed-control servo loop can be used on transmission to provide either a continuous rate of angular displacement or any fixed angle as required. The transmitter synchro position may also be controlled externally.—*Smiths Industries Ltd., Kelvin House, Wembley Park Drive, Wembley, Middlesex.*

For further information circle 26 on Service Card

27. Potentiometric Recorder

AEI Electronics have introduced an improved version, mark 4, of their 4-in. potentiometric chart recorder. This solid-state unit is available as a recorder producing a single continuous trace or as a multi-point recorder accepting signals from two, three or six channels and printing out in coloured dots. The instrument has

an accuracy within 0.5% and a resolution of 0.2%. The response speed is 1 sec and the standard multi-point printing speed is one point every 5 sec, although this can be reduced to 2 sec on request. External control of the chart speed is provided and the input unit allows a rapid change of range and function.—*Associated Electrical Industries Ltd., New Parks, Leicester.*

For further information circle 27 on Service Card

28. Frequency Monitors

A range of digital mains-frequency monitors (types 728-50, -60 and -400) for 50, 60 and 400-c/s mains supplies is now available from Dawe Instruments. The circuit utilizes a crystal oscillator to measure the monitored frequency over a single cycle of the input. Thus the measurement is made in 20 msec in the case of a 50-c/s supply, sampling occurring at intervals of $\frac{1}{2}$ sec. At the nominal frequency the displayed digits are accurate to $\pm 0.02\%$, but at frequencies other than the nominal an error appears. A correction curve is provided to compensate for this.—*Dawe Instruments Ltd., Western Avenue, Acton, London, W.3.*

For further information circle 28 on Service Card

29. Strain Transmitter

The model T-62A telemetry transmitter has been designed by the Industrial Electronics Corp. to operate with a strain gauge bridge to transmit strain from moving shafts, pistons, etc., without the use of slip rings or wires. The unit is completely encapsulated in tough epoxy resin to withstand extreme shock and acceleration. It will operate while immersed in lubricating oils and most common chemicals and within a temperature range of -40 to $+125^{\circ}\text{C}$. A built-in bridge balance adjustment and a radio-frequency tuning adjustment are included as well as provisions for change of sensitivity. Measuring $1\frac{3}{4}$ in. in diameter and $\frac{3}{4}$ in. long, the unit weighs 2.1 oz. —Industrial Electronics Corp., Melbourne, Florida 32902, U.S.A.

For further information circle 29 on Service Card

CONTROL

30. Limit-Switch

The 'EdyTECT' switch has been introduced by the Donovan Electrical Co. to act as an automated limit switch when buried in concrete, immersed in water, sunk into metal, and under many other arduous environments. A range of 14 detector heads is available for limit-switch, counter, liquid-level control and other applications. All heads are interchangeable and the temperature range is -15 to $+85^{\circ}\text{C}$. The switch is fully transistorized and is suitable for a supply of 110, 240 or 440 V single-phase a.c. at 50 c/s or any d.c. voltage down to 24 V.—The Donovan Electrical Co. Ltd., Northcote Road, Stetchford, Birmingham, 33.

For further information circle 30 on Service Card

31. Miniature Solenoid

The model 60 miniature d.c. solenoid recently introduced by Expert Industrial Controls is interchangeable with the Teen series Decco a.c. solenoids and is suitable for operating $\frac{1}{8}$ -in. hydraulic valves. The unit has a stroke of 4 mm and an operating force of 1 kg rising to about 4.5 kg when closed. It is available with coil voltages of 6–240 V. With the base measuring 1.875 in. square, the height of the unit is $2\frac{7}{16}$ in., the case diameter being $1\frac{1}{2}$ in.—Expert Industrial Controls Ltd., Lount Works, Ashby-de-la-Zouch, Leicestershire.

For further information circle 31 on Service Card

29

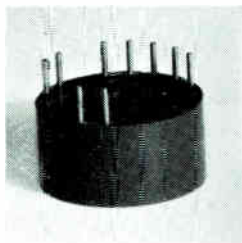

NEW

ELECTRONICS
COMMUNICATIONS
INSTRUMENTATION
CONTROL

31



30

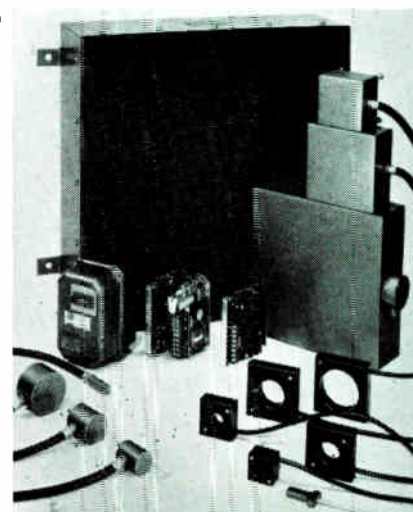

32

32. Tank Level Control

Water level in tanks can be indicated and/or controlled by means of either the Telstor 62 continuous level indicator/controller or the Tektor TT6 discrete level controller (illustrated), manufactured by Fielden Electronics. Indication can be adjacent to the tank or remote from it. Both systems operate on the capacitance principle. For continuous indication a level-sensing electrode extends to the tank bottom. For simple on/off control at one or two levels short stub electrodes are inserted into the tank. The output signals can be fed to a suitable control circuit.—Fielden Electronics Ltd., Wythenshawe, Manchester.

For further information circle 32 on Service Card

33. Gas Burner Control Unit

A recently-introduced unit known as the unitized gas burner control type GVK20 has been designed by Danfoss for use with gas-fired heating appliances. This unit will maintain a constant pressure for a gas supply to a main burner and will close down the main and pilot-flame supplies if the pressure falls below a predetermined limit. A thermo-electric pilot

safety device is fitted which causes an automatic shut-down of main and pilot supplies if the pilot is extinguished. A solenoid-actuated on/off valve for the main burner is also included.—Danfoss (London) Ltd., 6 Wadsworth Road, Perivale, Greenford, Middlesex.

For further information circle 33 on Service Card

34. Time Delay Relay

Solid State Controls are manufacturing a plug-in transistorized time-delay relay of high reliability and economic cost. Known as the TDR/407 it is robust, completely encapsulated, has no moving parts and is unaffected by vibration, shock and transient voltages. Available in three voltage ranges, 12–35, 35–70, 70–150 V, it will switch inductive or resistive loads of up to 1 A at 150 V and is capable of tolerating large in-rush currents normally associated with contactor or motor switching circuits. The adjustable time-delay periods are available in four ranges from 0.2 sec to 11 min. The timing accuracy when subject to extremes of ambient temperature and operating voltage is 5%, the repetitive accuracy being 1%.—Solid State

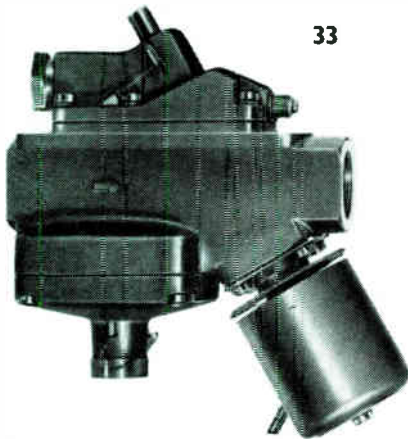

33



35

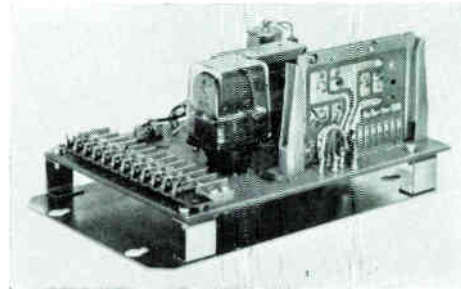

37

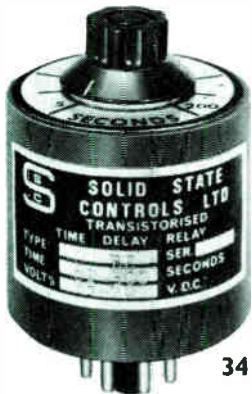

34



36

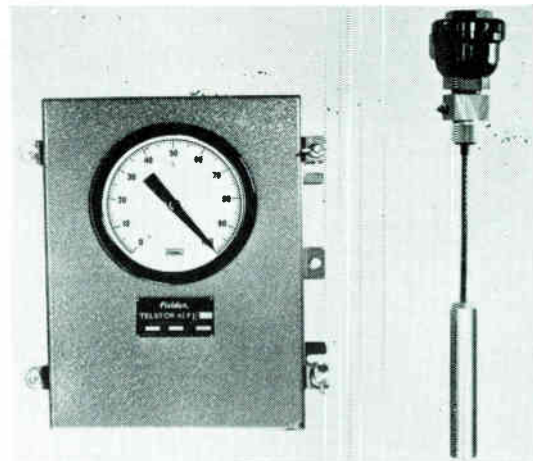

38

Controls Ltd., 30/40 Dalling Road, London, W.6.

For further information circle 34 on Service Card

35. Miniature Integrator

The 'Minigrator' type ZM/54 integrator, a miniature version of the range of precision d.c. counters manufactured by Fernsteuergerate, o.h.g., of West Berlin, is now available in the U.K. from Universal Control Equipment. Designed to integrate electrical values in instrumentation and process control, this unit has an accuracy of better than 0.2%. It is particularly suited to totalizing liquid and material flows. Input voltage and current ranges are from 0-0.3 V to 0-5 V and 0-5 mA to 0-1 A. Counting speeds between 10 and 100 digits per hr are standard.—*Universal Control Equipment Ltd., Frome Buildings, London Road, Stroud, Gloucestershire.*

For further information circle 35 on Service Card

36. Solid-State Power Unit

A solid-state equivalent of the variable transformer has been developed by Industrial Electronic Controls. A range of equipment known as the series 75 'Twinstat' has

been produced and the units in this range cover outputs of 20-300 A for mains voltages of 120, 240 and 440 V single-phase. Variation of the a.c. output is by use of a calibrated control which may be remotely wired. The circuitry provides a stepless variation of the output. Applications include control of heaters, motors, vibrators, power supplies and many other electrically-operated processes.—*Industrial Electronic Controls (Manchester) Ltd., Russell Street, Heywood, Lancs.*

For further information circle 36 on Service Card

37. Photoelectric Control Unit

The model FA15 transistor control unit has been developed by Kappa Electronics for use with photoelectric receivers. It can be supplied for use with the standard cadmium sulphide cell or with the fast-response silicon photo duo-diode. The conventional on/off output control contacts are provided which operate on the breaking and the re-establishment of a light beam. This switching action can be supplemented by input paralysis timing (i.e., delay of control action for a pre-set time) or by timed interval

functions where the output is maintained for a pre-set time. Various output devices such as solid-state switching are available in place of the standard relay. Fail-safe conditions can be obtained. A variable control enables adjustment of the switching point to meet ambient lighting conditions.—*Kappa Electronics Ltd., 159 Hammersmith Road, London, W.6.*

For further information circle 37 on Service Card

38. Level Indicator/Controller

Continuous level measurement, with or without single or dual-control facilities, can now be provided with full potentiometric indication by the Telstor 62FJ (3 step) level indicator/controller from Fielden Electronics. The equipment permits the measurement and control of almost any type of liquid, powder or granular solid in an industrial container, its single electrode being chosen from a large available range; accurate measurement is obtainable with any level differential from 12 in. up to 100 ft and above. On/off control at adjustable high and low levels, together with any combination of fail-safe high and fail-safe low features, are offered, being achieved by means of

centrally positioned knobs on the indicator and shown by pointers against the main scale.—*Fielden Electronics Ltd., Wythenshawe, Manchester.*

For further information circle 38 on Service Card

COMPONENTS

39. Cermet Potentiometers

Two cermet linear-motion trimming potentiometers for printed circuits are now included in the Morganite range. Known as types 80 and 88, the area of board space which they occupy is less than a quarter of a square inch. They are available in selected values between 10 Ω and 2 M Ω . Both types have terminal pins plated with noble metal and spaced for the standard 0.1-in. grid. The resistance track is unaffected by humidity and is resistant to chemicals.—*Morganite Resistors Ltd., Bede Trading Estate, Jarrow, County Durham.*

For further information circle 39 on Service Card

40. Printed-Circuit Wirewound Pots

Miniature single-turn wirewound potentiometers designed for direct

mounting on printed-circuit boards have been announced by W. Greenwood. They are rated at 1.5 W (at 50 °C) and are available in resistance ranges from 10 Ω to 50 k Ω ; they measure 12.7 \times 14.25 \times 10 mm. Environmentally they are designed to various U.S. Mil specifications.—*W. Greenwood (London) Ltd., 21 Germain St., Chesham, Bucks.*

For further information circle 40 on Service Card

41. 28-Day Programming Switch

A dual drum Actan Programming Switch, providing a long-term programming capability, is now available from Sealectro. This switch features a drive drum with rotational speeds from 5 r.p.m. to a revolution in 28 days. The secondary drum moves one step with each 360° rotation of the drive drum providing the extremely long term control function. The illustrated unit has 36 programme positions and 16 independent contact stations per drum. Other units are available with up to 120 programme positions and 57 independent contact stations per drum. This new programming switch may also be driven with a remotely-controlled solenoid actuator to provide stepping and counting functions. Sliding contact activators provide simple and fast field adjustment of programmes without the

need for special tools.—*Sealectro Ltd., Walton Road, Farlington, Portsmouth, Hants.*

For further information circle 41 on Service Card

42. Capacitors

'Superlytic' capacitors, recently introduced by the TCC division of the Plessey Components Group, are designed to have a service life of up to ten years. The operating temperature range is between -25 and +85 °C and the leakage current will not exceed 5 μ A or a value equal to 0.01 \times the capacitance \times the voltage applied, whichever is the greater. The capacitances available are 1-3,000 μ F with working voltages between 3 and 250 V d.c.—*The Plessey Components Group, Kembrey St., Swindon, Wilts.*

For further information circle 42 on Service Card

43. Subminiature Wirewound Pots

The TRIMPOT Division of Bourns Inc., U.S.A. have developed a range of worm-gear-actuated wirewound potentiometers measuring only $\frac{1}{4} \times \frac{1}{4} \times 0.17$ in. The model 3260 has only 14 parts. The unique design incorporates all electrically functional parts into one sub-assembly. The unit maintains its stability under rugged environments including 30 g

NEW

ELECTRONICS
COMMUNICATIONS
INSTRUMENTATION
CONTROL

39

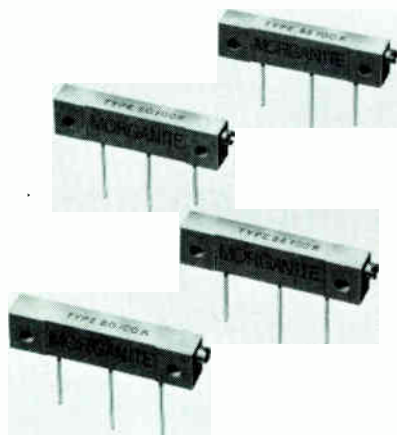

40

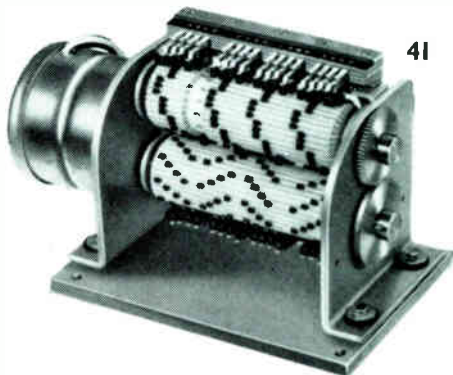
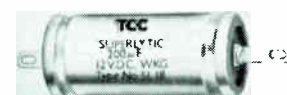

41



42

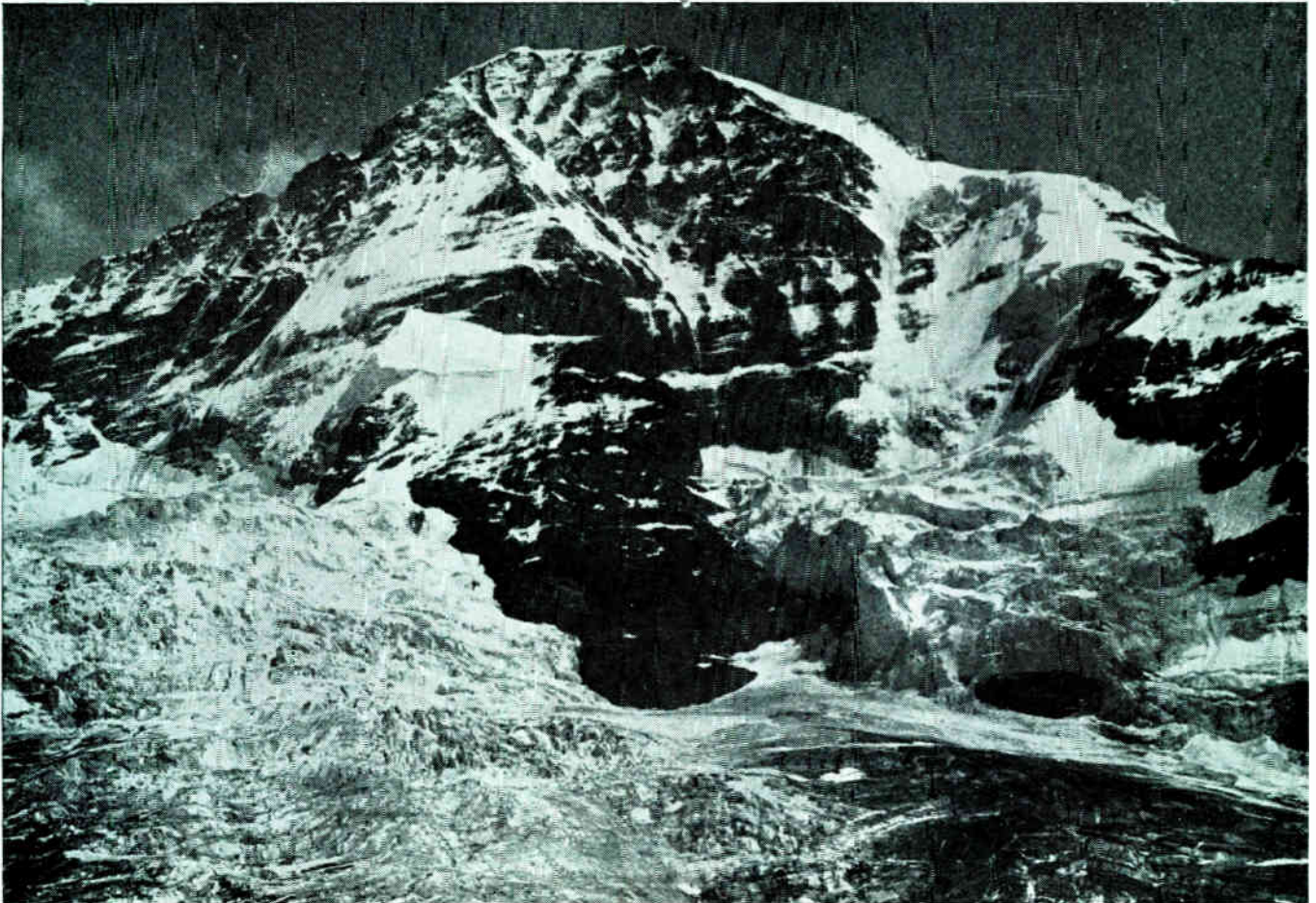

Have a good look at your Associated Aerials array before it's installed

(There's one up there, somewhere, but nobody's seen it for years.)

Associated Aerials make aerial arrays and associated equipment for every kind of transmission and situation from compact RT aerials (for taxis and fire-brigades, for instance) to huge broadcasting networks. Omnidirectional and directional aerials for remote territories; marine and ground-to-air; TV and communications; VHF, UHF.

Aerials that you can rely on.

Aerials for places that are so high, cold, wet or plain miserable that you don't want to see them again for a long, long time.

Get details about Associated Aerials — the most easily forgotten aerials in the world.

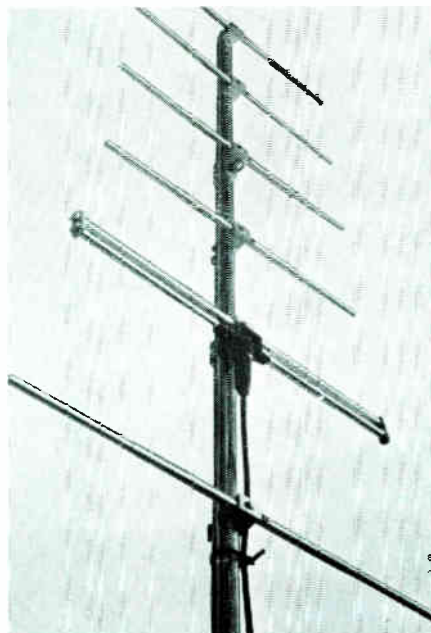

For example, this is what the aerial up there on the mountain looked like when it was put up in 1961. It is a yagi aerial cut to a frequency of 165 Mc/s with excellent electrical characteristics, rugged mechanical construction to stand up to high winds and heavy ice loading, internal heating so that even severe icing cannot affect its performance.

Today, it looks the same; it works the same; it's just colder.

ASSOCIATED AERIALS LTD

Knight Road, Strood, Kent, England.

Telephone: Medway 78255

Telex: 96146

A COUBRO & SCRUTTON COMPANY



For further information circle 260 on Service Card

Ampex instrumentation recorders come in all shapes and sizes

there's a great big field-recorder (FR-1800)
and a great little portable (FR-1300)

FR-1800

A great addition to a distinguished line of high performance recorders. It has 60% fewer parts than any transport with comparable performance. In tests, the FR-1800 has pulled over 50 million feet of tape (about 10,000 miles!) without failure or significant wear.

□ Fast response servo reduces time base error □ zero loop capstan reduces flutter □ transport provides seven-speed, bi-directional facilities □ electronics provide flexible and convenient operation □ high, medium or low bandwidths available, manually or electrically switchable □ pneumatically-cushioned chute guides improve tape guiding and virtually eliminate tape wear □ IRIG specifications ensure compatibility.

Key performance characteristics: Up to 1.5 MHz bandwidth □ time base error 1.5μ sec. at 120 ips □ dynamic skew 2μ sec. at 120 ips □ flutter .25% at 120 ips.

FR-1300

The smallest portable instrumentation recorder with full 14-track capability with 300 KC on Direct, and 20 KC on FM. It took three years to develop and test the FR-1300 and it represents a simplification of proven design techniques from Ampex's accumulated experience in the field of instrumentation recording. FR-1300 does more—costs less. □ Capstan servo drive for speed and accuracy

□ electrically switchable speed change □ full 14-track capability □ solid state electronics □ straight-line tape path for simplified threading □ tape lifters for increased head life □ controls interlocked to safeguard tape □ improved flutter □ available in rack-mounted version. IRIG specifications □ many "extra performance" options available.

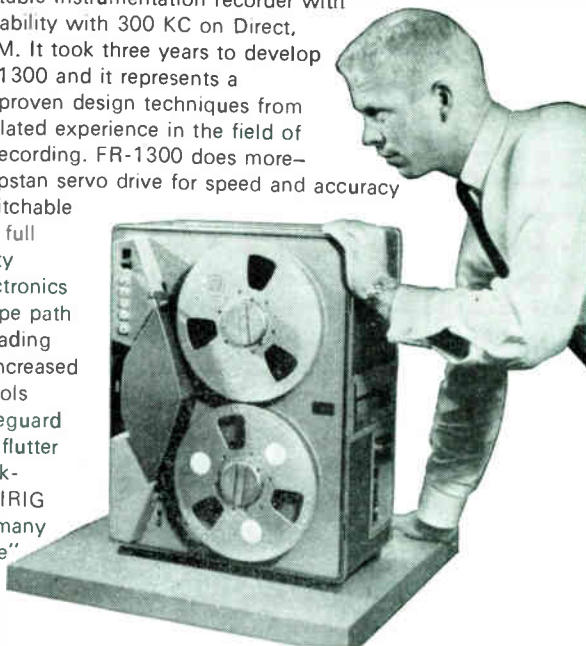

Ampex is the world's largest maker of magnetic tape recorders. Wherever there's a need for recording, one name stands supreme. Ampex. The name on the finest recording equipment.

AMPEX

Ampex sales and service facilities are conveniently located throughout Europe and the Middle East. For more information write to: Ampex Great Britain Ltd., Acre Road, Reading, Berkshire, England. Telephone: Reading 84411. Ampex S.A., Via Berna 2, Lugano, Switzerland. Telephone: 091/3.81.12. Ampex Europa G.m.b.H., 6 Frankfurt/Main, Düsseldorf Strasse 24, Germany. Telephone: 252001-5. Ampex, 41 Avenue Bosquet, Paris 7e, France. Telephone: 705.38.10.

For further information circle 261 on Service Card

NEW

ELECTRONICS
COMMUNICATIONS
INSTRUMENTATION
CONTROL

43

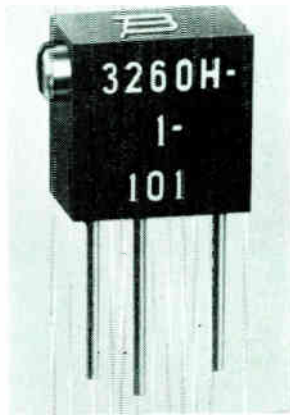

45

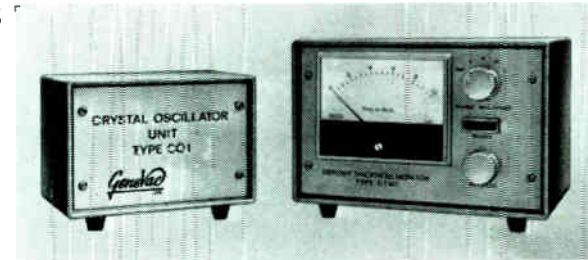

vibration and 100 g shock. The range covers resistance values from 10 Ω to 20 k Ω . The units meet all humidity requirements of MIL-R-27208A.—*Bourns (Trimpot) Ltd., Hodford House, 17/27 High Street, Hounslow, Middx.*

For further information circle 43 on Service Card

PRODUCTION AIDS

44. R.F. Shaping Press

A press for the moulding of shapes from laminated ply has been introduced by Electroheating (London) Ltd. This has a two-platen press which allows one side to be used for moulding while the other side is being loaded. A visual indication of the end of each heating cycle is provided. A changeover switch transfers the power to the freshly-loaded side and before the heating cycle can commence on this side a protective door must be moved

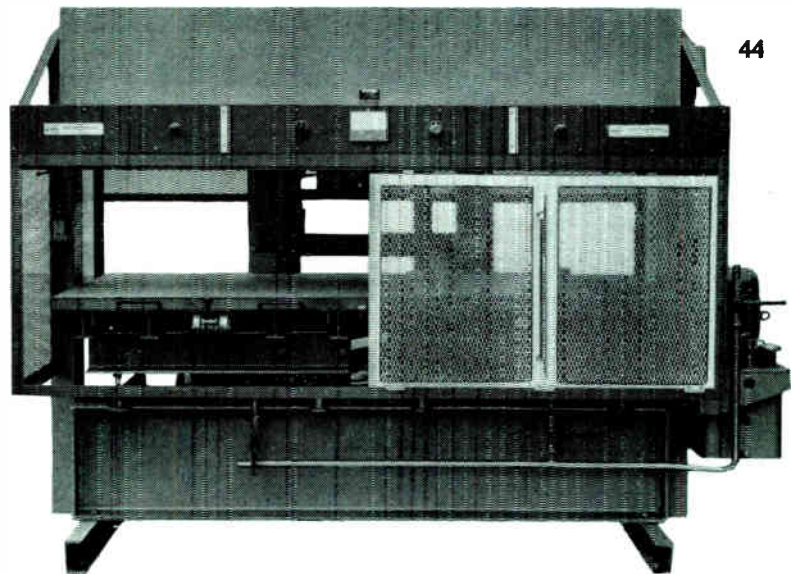

44

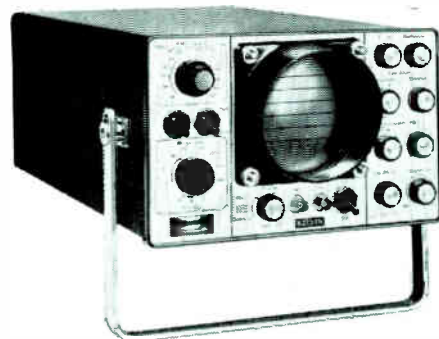

46

across.—*Electroheating (London) Ltd., Belmont Works, Station Road, Belmont, Surrey.*

For further information circle 44 on Service Card

45. Thin-Film Monitor

A quartz-crystal film-thickness monitor available from Genevac Ltd. has been designed to measure the total thickness and the rate of deposition of vacuum-deposited thin films. It operates by collecting a portion of the evaporant stream on a quartz crystal mounted in the evaporator. As the mass of the crystal increases, the resonance frequency changes. This change is indicated as a displayed d.c. voltage. Feedback can be taken from the instrument to control the rate of deposition. Also the end-point of the evaporation can be preset by using the instrument to operate an electro-mechanical shutter. The instrument can be used to control laboratory and production depositions.—*Genevac Ltd., Pioneer Mill, Radcliffe, Manchester.*

For further information circle 45 on Service Card

46. Flaw Detector

The Kelvin mark 8 ultrasonic flaw detector is a fully-transistorized portable unit. A high sensitivity and a good signal-to-noise ratio are claimed and the timebase ranges of the cathode-ray tube display are calibrated in centimetres. The operating frequencies are 0.5–10 Mc/s. The unit can be powered from internal batteries, mains supplies or an external 12-V supply. A removable battery-charger unit is supplied.—*Kelvin Electronics Co., Wembley Park Drive, Wembley, Middlesex.*

For further information circle 46 on Service Card

47. Bench-Welder Control Panel

A solid-state bench-welder control panel, type CR175, for precision a.c. resistance spot welding and other applications is now available from International General Electric Co. of New York Ltd. This uses thyristor control for the adjustment of the output current providing a smoother variation of heat than the use of taps on the weld transformer or a variable

NEW

ELECTRONICS COMMUNICATIONS INSTRUMENTATION CONTROL

impedance. The effective weld current is controlled by a variation of the instant at which the thyristors start to conduct on each positive half-cycle of the current fed to them. The duration of the weld current can also be controlled. The two available models provide maximum outputs of 55 and 270 A respectively.—*International General Electric Co. of New York Ltd., 296 High Holborn, W.C.1.*

For further information circle 47 on Service Card

48. Magnetic Wire Marker

Identification of bare or covered steel wires in the range 22–12 s.w.g. is facilitated by the Addison Electric magnetic wire marker. This places a magnetic code on the wire at intervals

of 8 ft. The code, which includes the name of the wire manufacturer and the date of manufacture, can be read with the use of a small pocket compass. The equipment, operating from normal mains supplies, operates at a maximum speed of 1,500 ft of wire per min.—*Addison Electric Co. Ltd., Beckenham, Kent.*

For further information circle 48 on Service Card

49. Clean Room

The Laminair flow clean room has been introduced by John Bass for precision assembly work in dust-free conditions. One wall of the room is made up of blower units which move the air in the room with uniform velocity along parallel flow lines. The filters in the blower units filter 99.98% of dust particles 0.4 micron in size and 100% of particles 2 micron in size. A panel showing temperatures, humidity and airflow is incorporated for control of these para-

eters.—*John Bass Ltd., Fleming Way, Manor Royal, Crawley, Sussex.*
For further information circle 49 on Service Card

50. Automatic Warehousing

The 'Fotoscan', a photoelectric package-scanning device produced by English Electric, has specific application in automatic warehousing systems. The packages are marked with black rectangles arranged in special patterns. As each package moves on a conveyor past a scanning head, two photoelectric cells produce outputs corresponding to the light reflected from the pattern on the package. These outputs are passed to a recognition system. This produces command pulses for control equipment for routing and other functions.—*The English Electric Co. Ltd., English Electric House, Strand, London, W.C.2.*

For further information circle 50 on Service Card

47

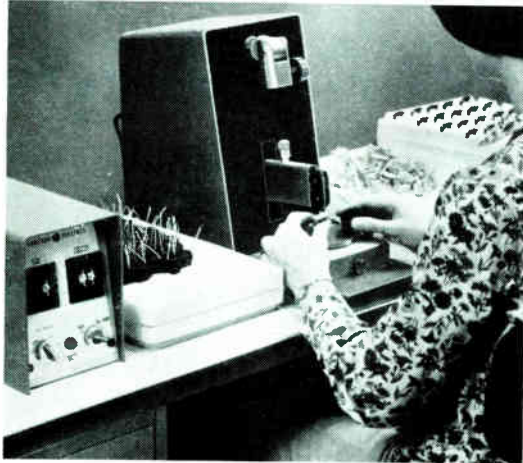

48



49

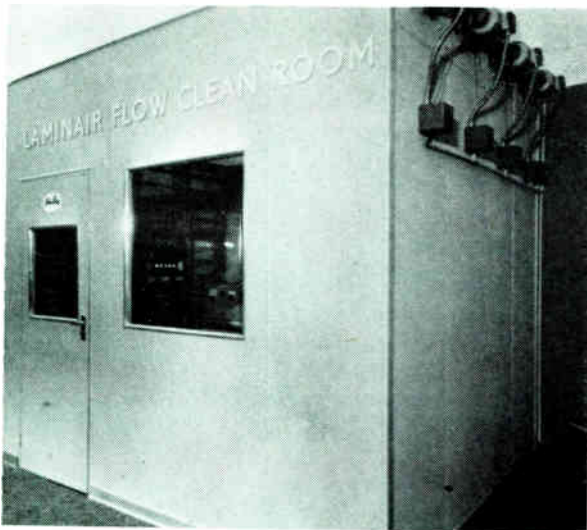

50

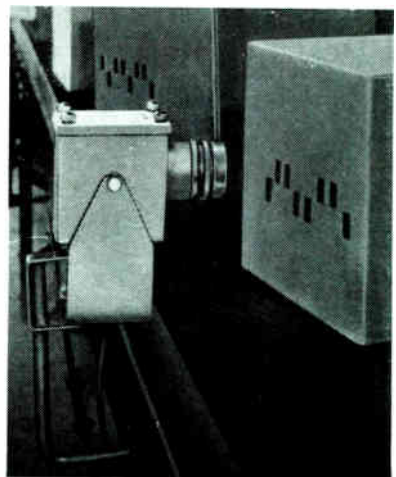

TYPICAL REVERSE IMPEDANCE UP TO

300,000,000,000Ω

FERRANTI

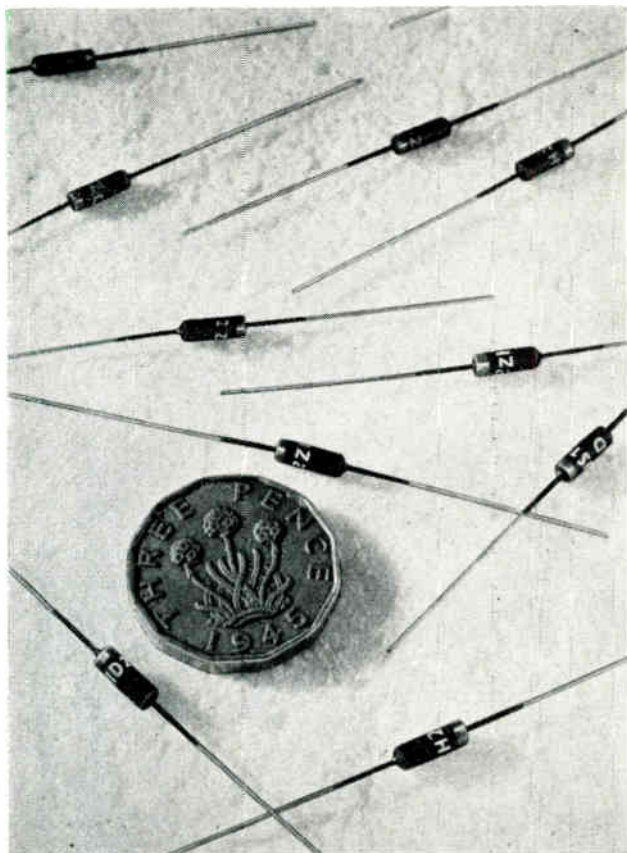

Sub-Miniature
Silicon
High Voltage
Rectifiers

RATINGS AND CHARACTERISTICS

	ZHS 101	ZHS 102	ZHS 103	ZHS 104	ZHS 105	ZHS 106	UNIT	CONDITIONS
Max. Peak Inverse Voltage	2000	2000	2000	3000	3000	3000	V	
Max. Mean Rectified Current	100	100	100	100	100	100	mA	up to 25°C
Max. Mean Rectified Current	40	40	40	40	40	40	mA	at 100°C
Max. Reverse Current at P.I.V.	0.03	1.0	0.1	0.05	1.0	0.1	μA	at 25°C
Max. Reverse Current at P.I.V.	5.0	20.0	10.0	5.0	20.0	10.0	μA	at 100°C
Max. Forward Voltage Drop	5.0	5.0	5.0	5.0	5.0	5.0	V	at I _F = 50mA
Operating and Storage Temperature Range	-55°C to + 150°C							
OUTLINE	VASCA SO-6 :: I.E.C. A1A :: JEDEC DO-7							

FERRANTI

First into the Future

Write now for details to:

FERRANTI LTD · GEM MILL · CHADDERTON · OLDHAM · LANCs

Telephone: (061) MAIn 6661

FE:270

For further information circle 262 on Service Card

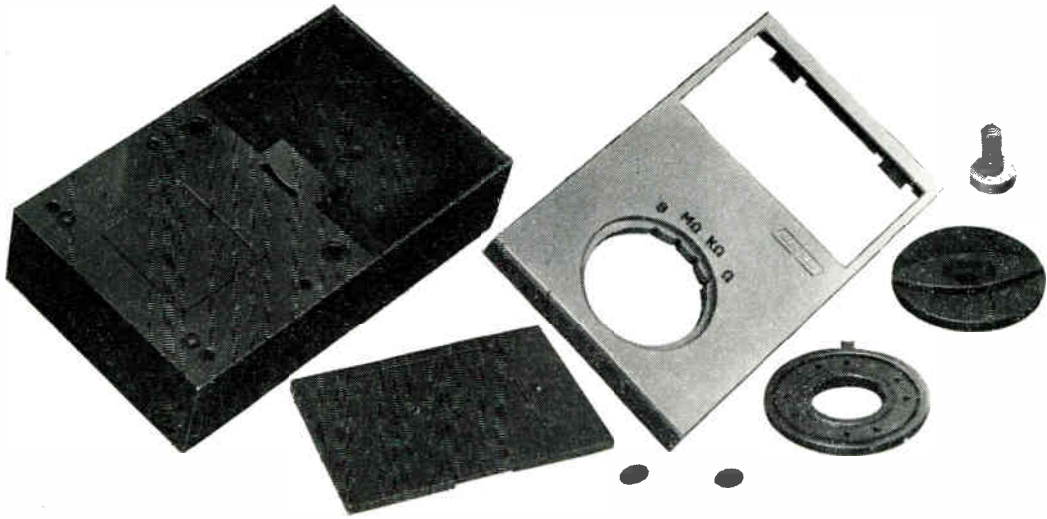

PUT THEM TOGETHER AND WHAT HAVE YOU GOT?

The latest Megger Tester *and* another Hellermann success story. Although success doesn't always come so easily—even at Hellermann. The Megger Tester caused a bit of head scratching in our toolmaking department but when you've got 37 qualified and experienced high precision toolmakers working there, problems don't stay problems for long. It's just one of many jobs, big and small, difficult and easy, undertaken by Hellermann every day. We provide a complete range of specialised services, which include: the initial design of your product, a development team, fully qualified chemists and laboratory staff and, of course, our completely self-contained toolmaking department. These services are complemented by experienced technicians who supervise production, modern plant, superior techniques, a large finishing department for final inspection and assembly plus, a nation-wide network of technical representatives.

You get the benefit of attention to detail as well as experience at Hellermann.

Maybe you don't need a Megger Tester but you could have a problem in plastics that we can solve. Contact any of our offices at the addresses below and let Hellermann do the worrying for you.



HELLERMANN PLASTICS LTD

Largest independent injection moulders and extruders of thermoplastics in the United Kingdom.

HEAD OFFICE: Gatwick Road · Crawley · Sussex · Tel: Crawley 28888
Telex 87163 (Prefix message HELPLAS)

MIDLAND AREA OFFICE: 380 Boldmere Road · Sutton Coldfield
Warwickshire · Tel: Erdington 6160

NORTHERN AREA OFFICE: Warsall Road · Sharston Trading Estate
Wythenshawe · Manchester 22 · Tel: Wythenshawe 4809

SCOTTISH AREA OFFICE: 32 Woodville Street · Glasgow, S.W.1.
Tel: Govan 3681

A member of the Bowthorpe Holdings Ltd. group of companies



FRED WICKENS, Toolroom Superintendent, discusses the new Evershed and Vignoles Megger Tester with his assistant, Alf Bridges.

For further information circle 263 on Service Card

Farnborough Show 66



THIS year the Society of British Aerospace Companies (S.B.A.C.) presented the 25th Farnborough Air Show. Held as usual at the Royal Aircraft Establishment by arrangement with the Ministry of Aviation, it included for the first time European aircraft, all those on display containing British equipment and being powered by British engines.

Accompanying the flying display was a static display of aircraft and aviation instruments and equipment. Many of the electronic exhibits in the static display were equipment specifically for aviation use but also included units having wider industrial applications.

Autopilots and Navigation Equipment

The aircraft in the static display included a Hawker Siddeley 748 airliner used by Smiths Industries for the development of their series 6 flight control system (67). This transistorized lightweight equipment is an improvement on earlier equipment designed for Category 1 operation (operation to a height of 200 ft with a visibility of $\frac{1}{2}$ mile) and is intended for use under conditions of poor visibility. A radio altimeter, accurate to 2 ft, automatic throttle control, an autopilot monitor and other additional equipment has been developed.

Sperry were also among the exhibitors of autopilots. Their SPL.45 system (68) is suitable for aircraft varying in size from light executive

aircraft to feeder liners. A modular construction enables the user to expand an installation for Category 2 (visibility 1,300 ft at a height of 100 ft) and Category 3 (reduced height and visibility on Category 2) operation. As well as five possible combinations of pitch-roll-yaw control, automatic altitude or airspeed control, heading lock to a compass system and radio coupling may be selected.

A system which can be linked to an autopilot is the 'Omnigraph' (69) exhibited by Decca. Based on a digital computer, this system plots on a chart the progress of a flight. It provides the pilot with a direct indication of position. Also the system can be used to set into the computer any point to

which autopilot controlled flight is required or where range and bearing information are needed.

Communications

Communications play an important role in aviation and several items of communication equipment were on display. Marconi were showing their AD470 communication system (70). Initially designed for use in the TSR2, it has now been modified to provide high-power long-range communication for a wide range of civil and military aircraft. Operating in the frequency band of 2-30 Mc/s, it offers both d.s.b. and s.s.b. operation. Selective calling is available, this facility obviating the need for a pilot

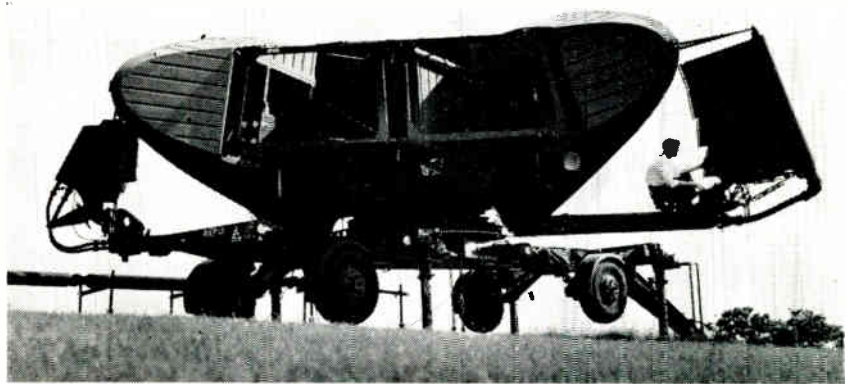

▲ The mobile radar depicted here was exhibited by The Marconi Co. It combines both surveillance and height-finding radar and is controlled from a central operations vehicle. Providing a high-performance system for ground-controlled interception, it can also be used for early warning or air-traffic control applications (71)

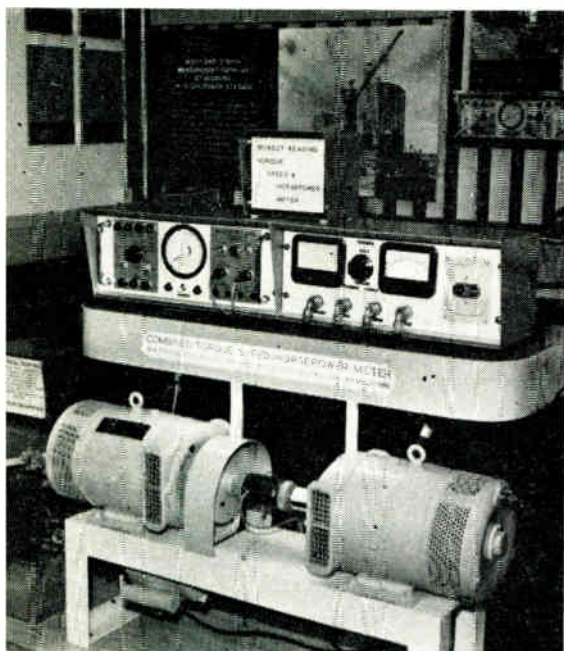

▲ *Cossor were exhibiting their digital information display system, DIDS/400. This can be linked to a computer to provide a display of information such as aircraft seating plans, passenger lists or any other required data. Clear characters and symbols are provided on the c.r.t. display and a keyboard facilitates the input or editing of data (79)*

▲ *This demonstration of the combined torque/speed/horsepower meter indicator, type TM 9-2, was exhibited by the Saunders-Roe division of Westland Aircraft Ltd. Direct indications of the three parameters are provided and the applications include the testing of electric motors, generators and similar equipment (80)*

to monitor continually the radio channels for reception of a call. A visible or audible warning indicates when communication is required.

G.E.C. were showing, for the first time, the 'Sky 505' aircraft transmitter (72) for use in light aircraft. Providing air-to-ground communication, it offers 380 frequencies between 117 and 135.95 Mc/s.

Ground-based transmitters and receivers were among the STC exhibits. Included in these were the DU.6-A (73), a general-purpose transmitter operating on three frequency bands between 100 and 156 Mc/s, and a single-frequency trans-

mitter, the DU.8-B (74). Two preset receivers, the RX.25-A and the RX.25-B (75), intended for use where high reliability with unattended operation are required, were also to be seen on this stand.

A control system for combined radio and intercommunication networks formed part of the Plessey display. Known as the 'Minicom' (76), it consists of transistorized control units each having a capability for five radio channels and 10 intercommunication channels. A complete system will provide overall control of h.f., v.h.f. and u.h.f. radio and duplex intercommunication. The number of

radio channels can be increased in increments of five to a maximum of 70, and an unlimited increase in multiples of 10 is possible with the intercommunication channels.

Aircraft communication often encounters the problem of high ambient noise levels especially on aircraft flight decks. Much headset and microphone design at present is consequently directed towards eliminating ambient noise not only in the aviation field but also in other environments. Amplivox were among the exhibitors of this type of equipment and included in the display a recently-developed throat microphone (77). It was shown in conjunction with an 'Ampliguard' ear-defender headset (78). The use of these two together will eliminate the effects of high noise levels.

▼ *This computer is one in the Hybrid Series 7 computers exhibited by Solartron. These analogue machines will function with digital computers to provide a system offering both digital and analogue techniques. Patchboard programming is featured and an error indication and fault-finding facility is included in this and other computers in the range (81)*



Data Recorders and Other Instrumentation

During the development and during the routine flying of aircraft it is necessary to measure and record various parameters. The recorded measurements assist in the design of the aircraft, indicate where maintenance is required during the routine operation of the aircraft and, if the recorder is housed in a suitable container, will assist in the location of faults which may have caused an aircraft to crash.

For this purpose various transducers are placed on the airframe and throughout the aircraft equipment. Examples of these transducers were displayed by Electro Mechanisms Ltd. and they included a wide range for the measurement of accele-

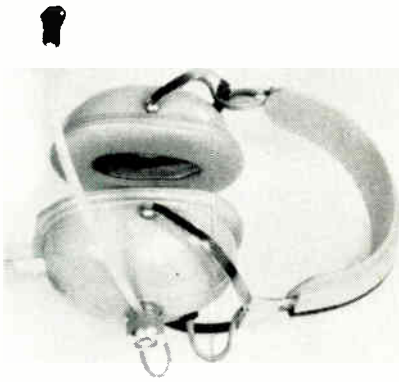

▲ S. G. Brown Ltd. were displaying this headset (code no. 4 B 100) designed especially for aircrew use (86)

Ekco were exhibiting weather-radar systems which can be seen here. The equipment on the right is a standard system for large aircraft offering alternative types of indicator, while the equipment on the left is a system of lower power for light aircraft (87)

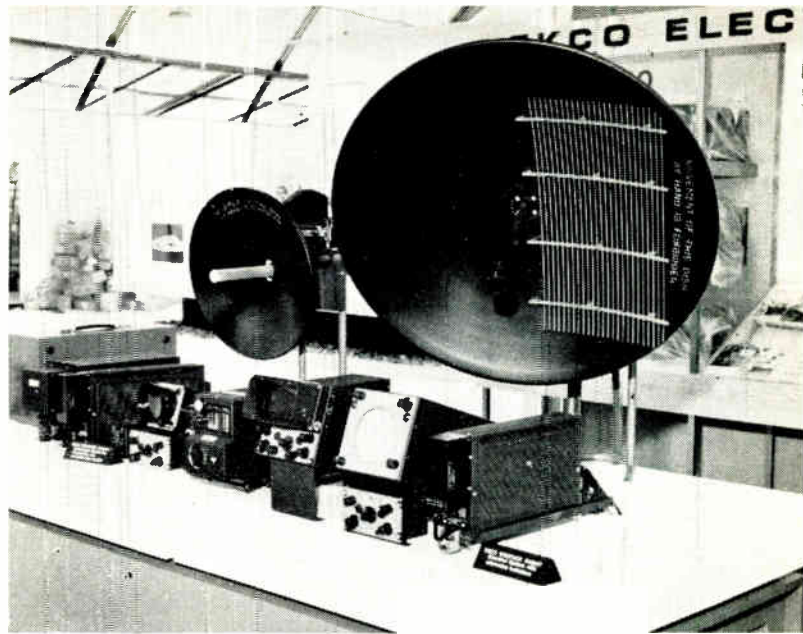

ration, displacement, force and load, pressure, strain, velocity and vibration (82). Among the new instruments on this stand were a range of displacement transducers. Operating from a d.c. supply, these produce an output which is proportional to the actuating movement.

Magnetic-tape recorders for flight-data recording were featured on the Royston Group's stand. The 'Midas' CMM/7T recording system (83) was included and versions of this are capable of continuously recording 1,305 individual parameters of data in analogue form plus 45 bits of information in digital form. Up to 60 hr recording time can be obtained. The transistorized equipment features plug-in sub-units to give the system flexibility with regard to signal bandwidths, tape speeds and power supplies. Signal-conditioning equip-

ment, which accepts the incoming signals and converts them into a form suitable for the recorder, was also displayed as well as crash-proof and fire-proof containers.

Other flight instrumentation on show included a contactless telemetry system (84) displayed by Ether Engineering. This has wide industrial applications and is used to transmit signals over short distances from strain gauges and other sensors. It can be used to measure parameters on moving parts of machinery or where connecting wires are impractical. The carrier signal of a transmitter is modulated by the signal produced by a sensor attached to the machinery being measured. A receiver demodulates the carrier and the receiver output can be displayed on a meter or fed to a suitable recorder.

Airborne computers are widely used

at present for real-time processing of data from measuring instruments such as those described above or from navigational instruments, radio data links, etc. A general-purpose computer suitable for such functions was to be seen on the Computing Devices of Canada stand. This, the miniature digital computer type AN-UYK-501 (85), made its first European appearance at the show. When linked to suitable equipment, it will produce outputs for guidance to autopilots, for symbolic displays of the 'head-up' type and for other forms of display for cock-pit or flight-deck use. On-line control of industrial plant, general data processing and other tasks are also within its capabilities.

For further information on the exhibits in this report circle the appropriate number (in brackets after each item) on the Service Card

This shows the display of Norden encoders exhibited on the Vactric Control Equipment stand. Various types of encoders and analogue-to-digital converters are available including both brush and magnetic types. Units for various binary codes can be obtained (88)



▶ The Ferranti F 1600 B computer was on display. This is a digital machine designed for real-time data processing. The modular construction enables it to cover a variety of configurations. A microminiature version, the FM 1600 B, is also available (89)

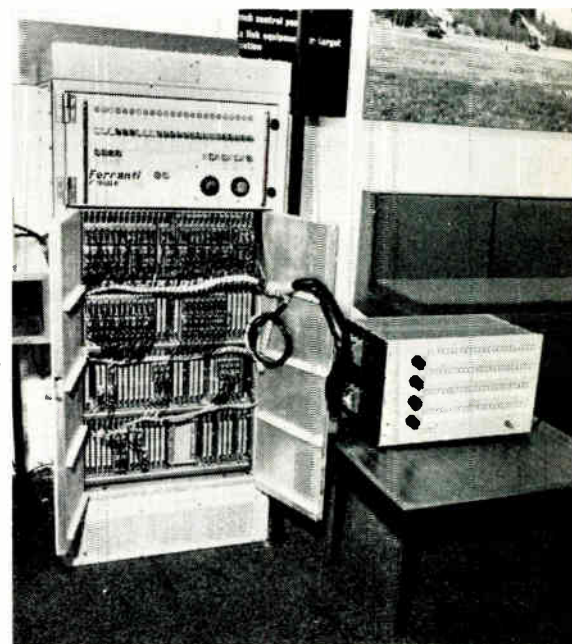



Personal News

R. J. Clayton has received the appointment of managing director of G.E.C. (Research) Ltd. **J. Bell**, formerly managing director of The M-O Valve Co., has joined the board of G.E.C. (Electronics), and **V. A. Cheeseman**, a director of The M-O Valve Co., has been appointed general manager.

EMI Electronics have announced two appointments in the commercial division. **Charles Dain** has assumed the post of technical manager and **Jack Sharpe** that of general manager (sales).

The Brush Electrical Engineering Co. Ltd. have announced that **W. S. Tunnicliffe** is now the manager of their research division. In this capacity he will have complete responsibility for research and development work on all new projects, particularly semiconductor equipment.

The former deputy managing director of A. C. Cossor Ltd., **J. M. C. Dukes**, has succeeded **R. C. Norwood** as managing director. Mr. Norwood is returning to the U.S.A. to take up an appointment with the parent organization, the Raytheon Co. He retains his seat on the board of Cossor.

Obituary

Basil E. Talbot, associate editor of our sister journal *Electrical & Electronic Trader*, died recently after a short illness. He had been first with the old *Trader* company, and later with Iliffe Electrical, all his working life, having started in 1927. Well known in the radio industry, 'Jim' Talbot will be sadly missed by all who knew him.

Keyswitch Relays Ltd. have announced the appointments of **Keith E. Harris, M.Inst.M.S.M.**, and **Desmond A. Malden, Grad.I.E.R.E.**, as main board directors. Mr. Harris, who joined Keyswitch in 1961, was appointed sales manager the following year. Mr. Malden joined Keyswitch as technical manager in 1960.

William B. Horner has joined Ultra Electronics as marketing manager. He was formerly a divisional manager of General Precision Systems.

Company News

The machine-tool, small tool and kindred interests of **The Birmingham Small Arms Co.**, formerly contained in the B.S.A. machine tools division, have been merged with the similar activities of **Alfred Herbert Ltd.** The B.S.A. machine-tool companies concerned will be grouped into a recently formed subsidiary of Alfred Herbert known as **Herbert-B.S.A. Ltd.**

Pye Printed Motors Ltd. have changed their name to **Printed Motors Ltd.** and have acquired premises at Upper Street, Fleet, Hampshire. This move brings the company's facilities together in one location whereas formerly they were divided between **Pye Ltd.** at Cambridge and **Technograph Printed Circuits Ltd.** at Fleet.

Multicore Solders Ltd. have recently completed extensions to their Hemel Hempstead factory. These extensions will provide a greater production capacity.

The **Royal Institution of Naval Architects** (whose membership totals 4,850) has been elected a constituent member of the Council of Engineering Institutions. Fourteen Institutions are now represented on the Council, which has a joint membership of some 135,000 corporate members.

Solartron are now to market in the U.K. magnetic data recording equipment manufactured by the associated French company **Tolana**. The maintenance and spares supply responsibilities for existing installations has been taken over from **Flexonics Ltd.**

Seventeenth N.R.D.C. Report

The recently-published 17th report* of the National Research Development Corporation covers the period 1st July 1965 to 31st March 1966. It predicts that, by early 1968, the Corporation will be committed up to the £25 million limit of its present borrowing powers, and that the growth of its business in backing inventions and new technology will probably require an application to Parliament for more money.

During the last nine months, the N.R.D.C. has supported 28 new pro-

THIS LASER-COLOUR SELECTOR, which operates at electronic speeds, is being used to determine which of several colours a multi-colour laser will generate and emit. Developed by I.B.M., the colour selector may lead to the development of computer memories in which a hundred million bits of information could be stored, in layers, on 1 sq. in. of photographic film. Here, a green light beam has been selected, and is shown travelling through the selector (centre) and prisms (lower centre) on to a screen (right centre). The prisms are not part of the selector, but serve in this multiple exposure to separate the dots on the screen, which represent the other colours that can be selected.

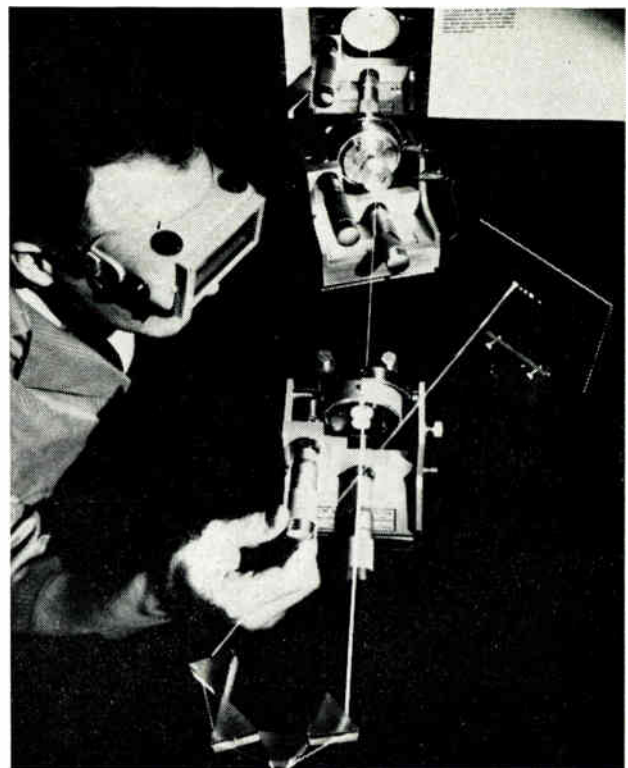

jects (covering a wide field that includes scientific equipment, electrical engineering, programmed learning, computers and automation) as well as continuing its backing for 93 others, initiated in previous years; over one-third of the total number of these development projects are joint ventures between the Corporation and Industry.

The Corporation's twice-yearly bulletin ('Inventions for Industry') is now available to industrial concerns and libraries, and can be obtained from the N.R.D.C., Kingsgate House, 66-74 Victoria Street, London, S.W.1. (Phone: Tate Gallery 3400). It contains details of the Corporation's aims and activities, and describes a number of recent inventions available under licence for industrial exploitation.

* H.M.S.O., London. Price 4s. 6d.

T.V. Colour Tube Company Formed

RCA and Radio Rentals Ltd., in a joint venture, have formed a company known as RCA Colour Tubes Ltd. This will manufacture colour television display tubes for the British and European markets.

The factory for the manufacture of these tubes is to be located at Skelmersdale, Lancashire, and is due for completion in mid-1967. Initially, the products will include 25-in. and 19-in. rectangular tubes similar to those at present manufactured in quantity by RCA in the U.S.A. The tubes will operate equally well on any of the proposed colour systems.

The company is two-thirds owned by RCA Great Britain Ltd., a wholly-owned subsidiary of RCA, the remaining third being owned by Radio Rentals.

Information Service on Electronic-Component Supplies

As a result of frequent requests for sources of supplies of new electronic components and sub-assemblies, a suitable service has been set up by the Engineering Capacity Exchange. It will draw on information registered with the Exchange's punched-card memory system, from which data can quickly be extracted.

Companies who find themselves with spare-production capacity for electronic components or sub-assemblies may, for a modest fee, register with the Exchange in London; similarly, companies wishing to locate new sources of supply can write to the Exchange with their requirements, whereupon a confidential and up-to-

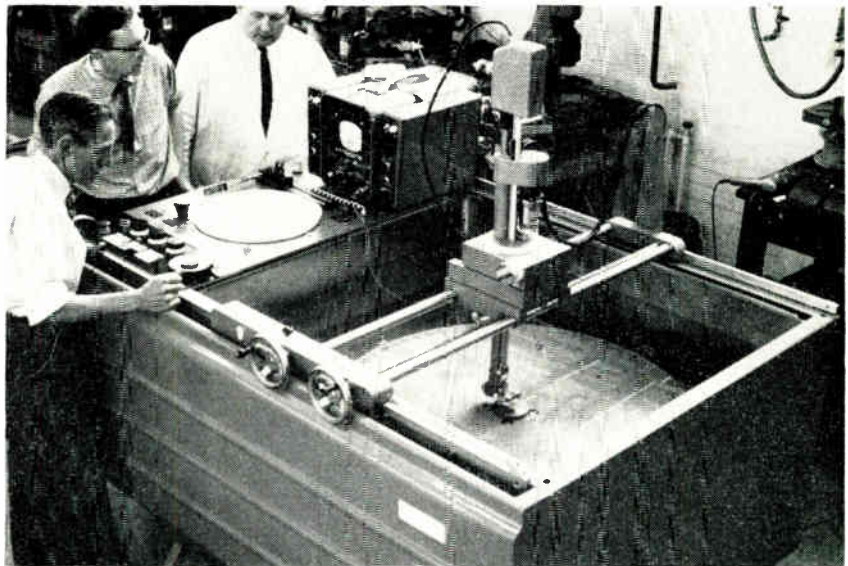

THIS AUTOMATIC 'ULTRASONOSCOPE' TESTING UNIT was recently installed by M. Falk and Co. at the Paris works of SNECMA (the French aircraft-engine manufacturers) to be used for testing the blanks for the Concorde airliner's Olympus engines. The equipment is required to record automatically the presence of a defect only 0.5 mm in diameter at a testing speed of 200 ft per min, and will do so in either a double-pen or high-speed single-channel spark recording mode. All movements of the machine are interlocked, being remotely operated from a control panel, and various constant linear or constant testing speeds are available

date report on current facilities will be provided free of charge and without any obligation.

For further information circle 66 on Service Card

British Marine Equipment Council

In order to increase Britain's share of the estimated £600 million annual international market in marine equipment, a British Marine Equipment Council has been formed.

The Council has already received a considerable amount of support from the Government and industry, and in the export field it will encourage practical co-operation among members in organizing overseas agencies and exhibitions, providing market reports and advisory services, and planning export missions.

The aims of the new Council are set out in a prospectus which is available from the B.M.E.C. at their temporary headquarters at 12 Devonshire Square, London, E.C.2. (Phone: Bishopsgate 0396).

Air-Traffic Control System for London

A computer-controlled flight-plan processing system has been ordered by the Ministry of Aviation for installation in 1969 at the London air-traffic control centre at West Drayton. It will be based on a triplicated Marconi Myriad computer system, which will

handle flight plans and control data for all aircraft under en-route air-traffic control in the southern half of the country.

The system will be capable of future extension to link up with similar control centres throughout the rest of the world (as they become operative), and plans have already been formulated by the International Civil Aviation organization for a fully-integrated world-wide air-traffic control system to meet the demands of the 'supersonic age'.

First Computer for National Computing Centre

The National Computing Centre, the formation of which was announced last December (see *Industrial Electronics* Vol. 4, No. 2, page 96, February 1966), has ordered its first computer; it is an English Electric-Leo-Marconi KDF9, worth approximately £400,000, and will be installed in April 1967 at the Centre's headquarters now being built in Manchester.

It is hoped to apply the machine to the task of establishing a comprehensive computer-program index (which would be the first in the world), in addition to furthering the Centre's other aims of organizing computer education, providing information and advisory services, standardizing software, and developing new computer techniques and uses.

NEW BOOKS

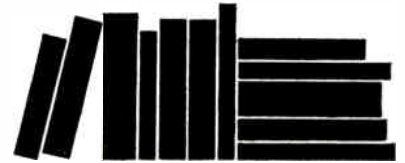

Introduction to Transistor Electronics

By R. I. WALKER. Pp. 341 + ix. Blackie and Son Ltd., 5 Fitzhardinge Street, Portman Square, London, W.1. Price 50s. (hard cover), 27s. 6d. (paperback).

This book provides a full and detailed explanation of transistor action and circuitry. It commences with a discussion on the physics and mathematics of semiconductor materials, on the doping of materials and in detail on the formation and action of junctions.

With the semiconductor theory firmly established, the text continues to explain the internal workings of diodes and transistors and includes a mathematical analysis of the junction transistor. Transistor parameters and equivalent circuits are then introduced and transistor characteristics and the use of transistors as amplifiers are also discussed. Various types of circuits, power amplifiers, video amplifiers, switching circuits, logic circuits and others, are explained in detail. A chapter on developments in semiconductor devices, including notes on field-effect transistors and tunnel diodes, is provided.

Applied Underwater Acoustics

By D. G. TUCKER, D.SC., and B. K. GAZEY, PH.D. Pp. 244 + xvi. Pergamon Press, Headington Hill Hall, Oxford. Price 27s. 6d.

The principles of acoustics as applied to underwater systems are outlined in this book. Following an introduction to the applications of underwater acoustics, such as sonar systems, marine seismology and underwater communication, the text deals with the general engineering problems of signal reception, detection and display as encountered in this field. It continues to discuss the fundamental principles of sound propagation.

The text then applies the fundamental principles to the special problems of acoustic propagation under the sea. It includes treatment of ray tracing, sound channels and shadow areas as well as the wave equations, acoustic impedance, reflection and refraction. The concluding passages describe underwater transducers and directional arrays.

Advanced Electric Circuits

By A. M. P. BROOKES, M.A., A.M.I.MECH.E. Pp. 186 + vi. Pergamon Press, Headington Hill Hall, Oxford. Price 17s. 6d.

Based on lectures given to undergraduates at Cambridge University, this book extends the range of an earlier book, *Basic Electric Circuits*, to include all the circuit analysis required for an Honours Degree in Electrical Engineering.

Commencing with a chapter on vectors and the j notation, the text continues to derive and explain the network theorems. These principles are then applied to d.c. and a.c. bridge circuits of several types and to tuned circuits and filters. Passages follow on polyphase circuits and on non-sinusoidal and transient excitation.

Active circuits form the subject matter for later chapters and valves and transistors as circuit elements are discussed. Valve and transistor characteristics are outlined and the use of these devices in amplifying and oscillatory circuits

is explained. The book is concluded with a chapter on elementary line transmission.

Typical examination questions, with answers, are included as well as some worked examples.

Introduction to Electronics for Students of Biology, Chemistry and Medicine

By VINCENT A. SUPRYNOWICZ. Pp. 324 + ix. Addison Wesley Publishing Co. Inc., 10-15 Chitty Street, London, W.1. Price 72s.

Electronics has been harnessed to perform many functions in the fields of biological, chemical and medical research. Electronic aids to the handicapped are now well known and the techniques of analysing substances by investigation of their electrical properties is well established. It is therefore useful, and in the future it will become essential, for workers in these fields to understand the principles behind the operation of the instruments and devices in use.

This book has been written specially with the chemical, biological and medical student in mind. It provides a thorough but uncomplicated survey of the electronic principles and circuitry involved and constant reference is made to instruments which use these principles and circuits. Such techniques as vector-electrocardiography, automatic titration, the use of telemetry for the measurement of various parameters in animals are among those discussed. An appendix provides a review of electrical fundamentals.

Electronic Designer's Handbook

By T. K. HEMINGWAY, B.SC. Pp. 296 + viii. Business Publications Ltd., Mercury House, 103-119 Waterloo Road, London, S.E.1. Price 63s.

This practical guide to transistor-circuit design has been prepared by the circuit consultant and chief of advanced circuit development of Marconi Instruments Ltd. Basic and special circuits are discussed, as well as useful techniques.

Peaceful Uses of Automation in Outer Space

The Proceedings of the First I.F.A.C. Symposium on Automatic Control in the Peaceful Uses of Space (held in Stavanger, Norway, June 1965).

Edited by J. A. ASELTINE. Pp. 577 + xxiii. Published by the Instrument Society of America, and distributed by Plenum Press, 227 West 17th Street, New York 10011, U.S.A. Price \$22.50.

Modulation, Resolution and Signal Processing in Radar, Sonar and Related Systems

By R. BENJAMIN. Pp. 184 + xii. Pergamon Press Ltd., 4 & 5 Fitzroy Square, London, W.1. Price 55s.

Basic Matrix Analysis and Synthesis

By G. ZELINGER, M.I.E.R.E., M.I.E.E.E. Pp. 228 + xv. Pergamon Press Ltd., 4 & 5 Fitzroy Square, London, W.1. Price 45s.



more than 500 switches

—this is the current NSF/CUTLER-HAMMER Catalogue

Includes all latest developments in this dependable range.

If the list you hold is dated earlier than November 1965 please write to us and we will send to you the up-to-date copy

"THE SWITCH PEOPLE"

NSF LIMITED

31-32 ALFRED PLACE, LONDON, W.C.1

Telephone: LAngham 9561 Telegrams: Enesef Telex London Telex: 21907

Head Office & Works: KEIGHLEY, YORKSHIRE

A MEMBER OF THE *Simms* GROUP OF COMPANIES

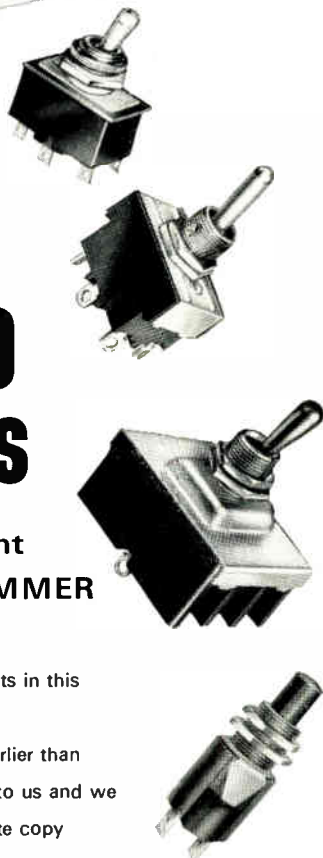

ELECTROLUBE* MEANS EXTRA RELIABILITY

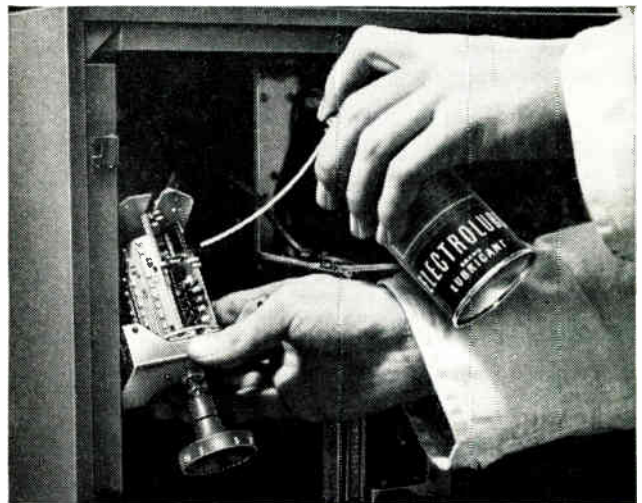

Electrolube 2A-X is the highly efficient and completely safe electrical and mechanical lubricant which improves contact performance and inhibits tarnish and sparking. Electrolube also improves the mechanical operation of plugs and sockets, rotary and sliding switches and all types of electro-mechanical device—giving an extra reliability factor to equipment and components wherever it is used.

ONLY ELECTROLUBE 2A-X

Available—through wholesalers and agents all over the world—in the economical aerosol pack—compatible with all plastics, rubbers and paints.

For full technical details write to:—

U.K. Enquiries: Electrolube Ltd., Oxford Ave., Slough, Bucks
Telephone: Slough 25574
Telex: Electrolube Chamcom Slough 84314

Overseas Enquiries: Electrolube Ltd., 16 Berkeley Street, London W.1
Telephone: MAYfair 7654



* Registered Trade Mark

For further information circle 264 on Service Card

For further information circle 265 on Service Card

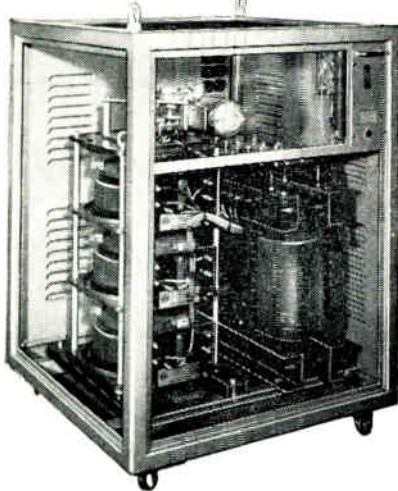

50B

THE STRAIGHT ANSWER TO VOLTAGE REDUCTIONS

and maintain production under load shedding conditions

BERCO CVS STABILISERS

guarantee full production and consistent quality of your finished products this coming winter by installing a BERCO CVS Voltage Stabiliser now. In many cases it can repay its initial cost in a few days. BERCO CVS Voltage Stabilisers reduce maintenance costs too. Delivery ex-stock for certain models. List 636/0S tells you all about them.



Specialists in Current and Voltage Control.

THE BRITISH ELECTRIC RESISTANCE CO., LTD.

Queensway Enfield Middx. Tel: Howard 2411 Grams: Vitrohm Enfield

For further information circle 266 on Service Card

Solenoids



by
Phil-Trol

The solenoids illustrated above are just two from our very large range. The small type 45 is suitable for $\frac{1}{8}$ " spacing, the larger (type 38) $1\frac{1}{8}$ " wide gives a pull of 40 oz. over $\frac{1}{4}$ " on AC, or 14 oz. over $\frac{1}{4}$ " on DC (25% duty cycle). A complete range of AC and DC solenoids is available including push and pull types, spring return, models fitted with changeover switches at the rear for intermittent duty performance on continuous duty applications, and DC fitted with fully damped silicon rectifier circuits for AC supplies.



for details of the complete range ask for leaflet 113E

PHILLIPS CONTROL (G.B.) LTD.

Dept. K7, Farnborough Rd., Farnborough, Hants.

Telephone: Farnborough 41129.

Grams & Cables: Philtrol, Farnborough, Hants.

For further information circle 267 on Service Card

LUSTRAPHONE EQUIPMENT

wherever better standards are required
for **SOUND COMMUNICATION**
MICROPHONES and all their accessories
"RADIOMIC" SYSTEMS
PORTABLE P/A SYSTEMS with or without
"Radiomic"
NOISE CANCELLING INTERCOM-SYSTEMS
AUDIO EQUIPMENT
ACCESSORIES—COMPONENTS—FITMENTS

LUSTRAPHONE

OUTSTANDING IN QUALITY AND PERFORMANCE
BRITISH IN DESIGN AND MATERIALS

LUSTRAPHONE

St. George's Works, Regent's Park Road, London, N.W.1

Telephone: PRIMrose 8844

For further information circle 268 on Service Card

Thorn sub-miniature lamps and lampholders

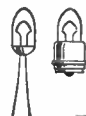

have the measure of today's panel and instrument lighting problems

The lamps have an operational life of 60,000 hours when operated at 5 volts, or 5,000 hours at 6 volts, with a light output of .35 lumens at .06 amps and .75 lumens at .07 amps respectively.

They have been vibration tested to BS.2G.100 grade B and meet the requirements of E.I.D. release and other similar specifications.

Two types are available: L.1122—a wire ended lamp with $\frac{1}{2}$ " leads, NATO Stock No: 6240-99-995-1189; and L.1123—capped version, NATO Stock No: 6240-99-995-1198.

Lampholders, as illustrated (left to right) 1

Sub-miniature Indicator Light type 0951.

Sub-miniature Indicator Light type 0978.

TA4522

Sub-miniature Light type 0976.

Midget Indicator Light type 0977—related in size but uses a 28 volt .04 ampere lamp with a light output of 3.75 lumens and an operational life of some 25,000 hours.

Sub-miniature Lampholder type 2348.

Sub-miniature Indicator Light type 1081.

Sealed Sub-miniature Lampholder type 0430.

Please write for full details to:



Thorn Special Products Ltd

Great Cambridge Road, Enfield, Middx. HOwARD 2477

A member of the Thorn Electrical Industries Ltd. group of companies

TSP14

For further information circle 269 on Service Card

ONLY TRYGON SHR SERIES POWER SUPPLIES give you all these features

- ★ All silicon—50°C operation
- ★ Constant voltage/constant current
- ★ .01% regulation; 0.5 mV ripple
- ★ Voltages 20, 40, 60 V fully variable
- ★ Remote sensing—remote programming
- ★ Automatic overvoltage protection option
- ★ Half Rack Size—Bench or rack mount
- ★ NOW BRITISH MADE

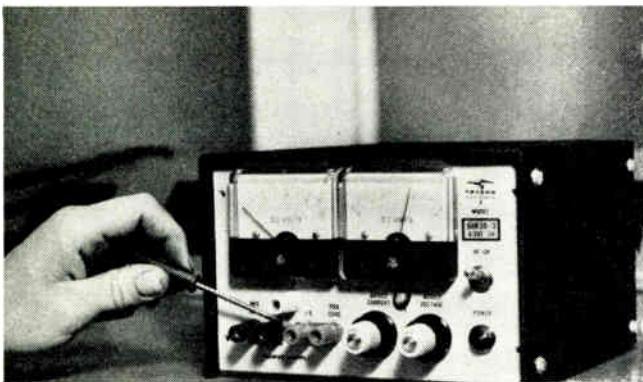

Current limiting with shorted output is just one of the many features of Trygon power supplies.

Please send me full information on the Trygon range of power supplies.

I would like to arrange a demonstration.

Name

Address

THE Livingston GROUP

LIVINGSTON ELECTRONICS LIMITED
LIVINGSTON HOUSE, GREYCAINES RD.
NORTH WATFORD, HERTS
Telephone: WATFORD 44344

For further information circle 270 on Service Card

EVERSHED SERVOMOTORS

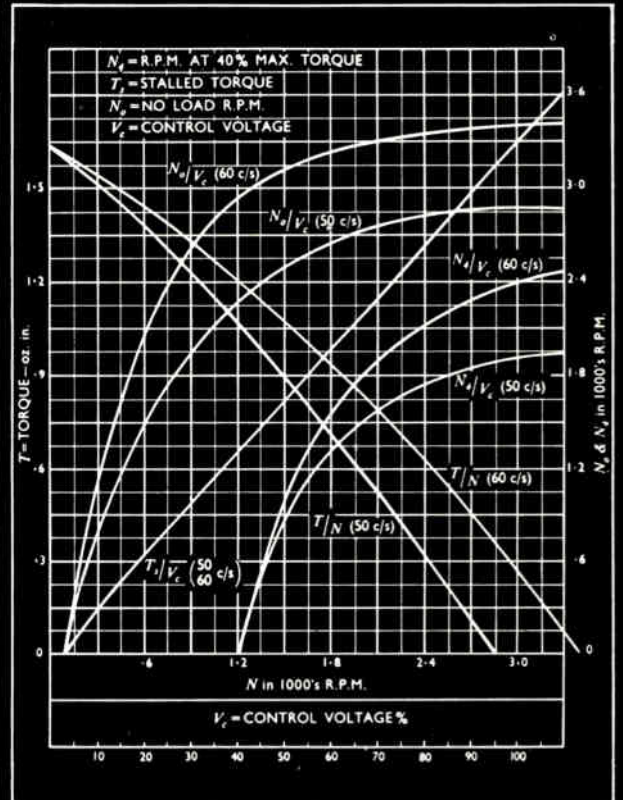

Whatever the problem or application engineers and designers can find the answer in the wide range of Evershed F.H.P. motors, tachogenerators, amplifiers, gearheads, magnetic clutches and brakes. A technical advisory service is available.

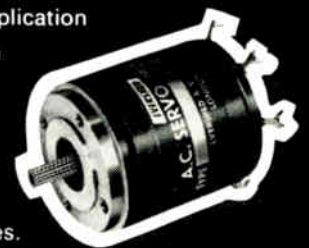

EVERSHED

Evershed Division of George Kent Ltd.

Evershed & Vignoles Ltd.
F.H.P. Motors Division
Devonshire Works, Dukes Ave.
Chiswick W4. Tel. Chiswick 7801



TW2112

For further information circle 271 on Service Card

ETHER LOW-COST RECORDERS

Xactline Transistorised Indicating Recorders

- Self-contained transistorised potentiometric indicating recorders; operating from thermo-couples or resistance bulbs to indicate and record temperature—or any variable which can be converted to a d.c. millivolt signal
- Up to six point operation
- Calibration accuracy: $\pm 1\%$ of span
- Sensitivity: $15\mu\text{V}$
- Wide temperature range: up to $1750\text{ }^\circ\text{C}$
- Minimum span 5.0mV (nocold junction compensation) 7.5mV (for thermo-couples) 10Ω ($25\text{ }^\circ\text{C}$ —resistance bulbs)

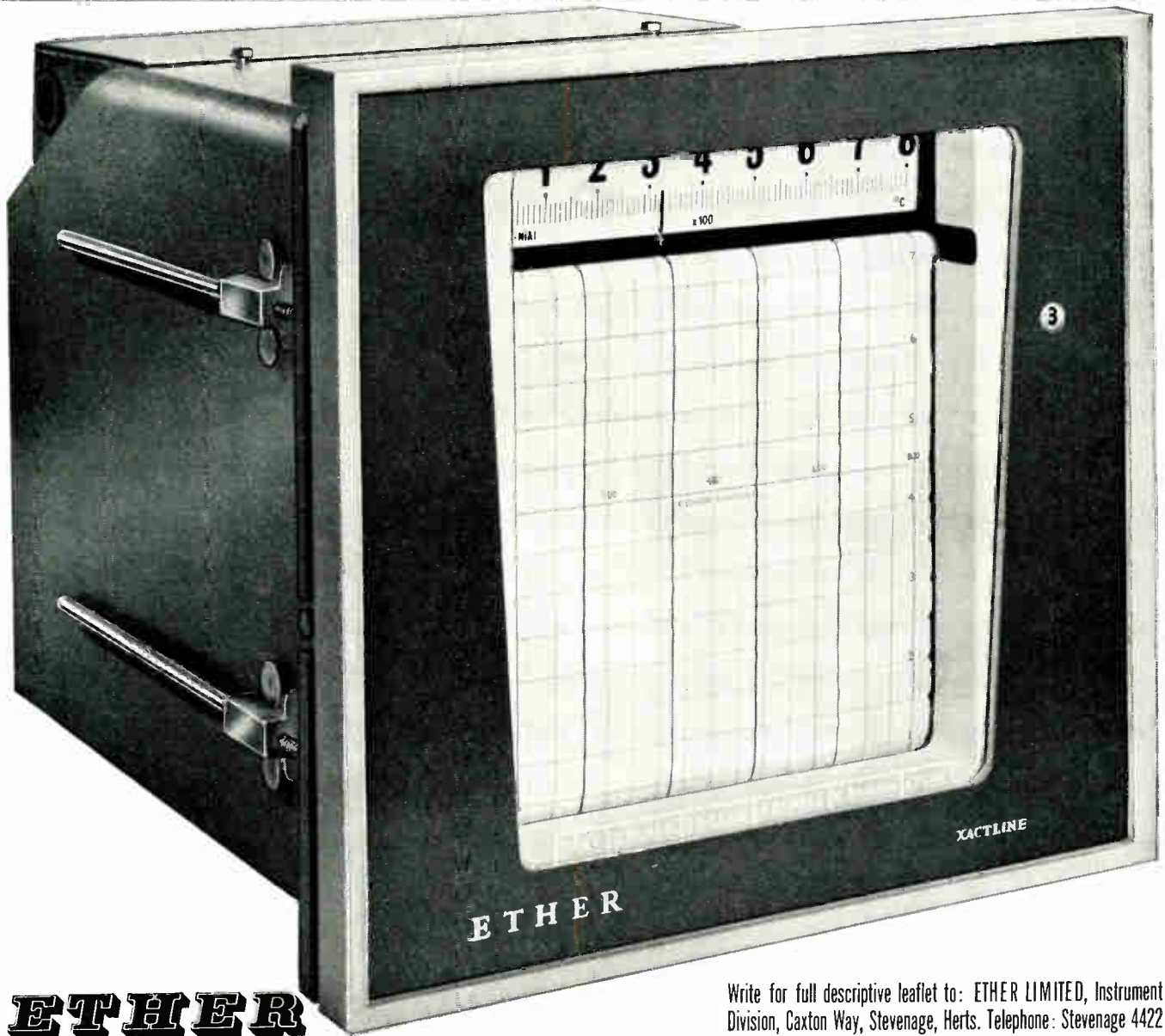

ETHER

Write for full descriptive leaflet to: ETHER LIMITED, Instrument Division, Caxton Way, Stevenage, Herts. Telephone: Stevenage 4422

For further information circle 272 on Service Card



Porcelain
Steatite

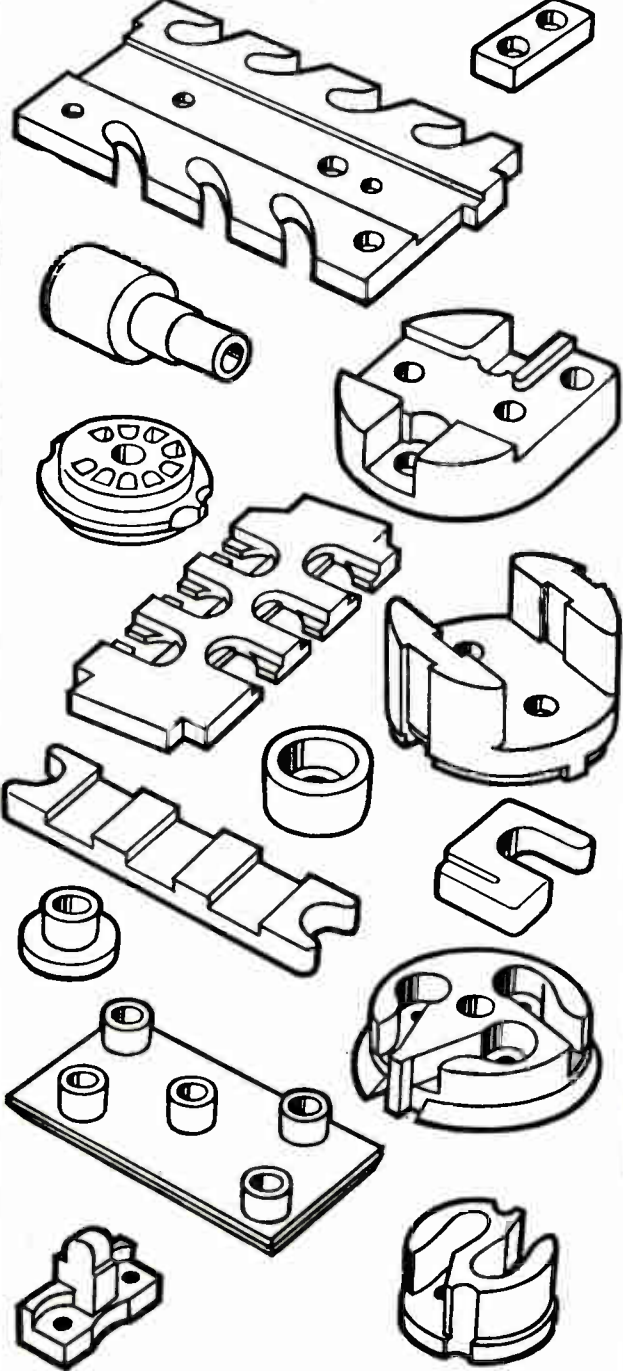

PARK ROYAL PORCELAIN CO LTD
INCORPORATING V.G. PORCELAIN CO LTD

GORST ROAD
 PARK ROYAL
 LONDON, N.W.10

Telephones:
 ELGAR 1411/7
 Telex:
 London 25589

For further information circle 273 on Service Card

PLASTIC
MOULDINGS
 THERMO-SETTING THERMO-PLASTIC



ACTUAL SIZE

FREDERICK W. EVANS LTD.
 Plastic Works, Long Acre, Birmingham 7.
 Telephone: STD. 021 EAST 3071 (4 Lines)

For further information circle 274 on Service Card

POLAR

STAND OFF
INSULATORS

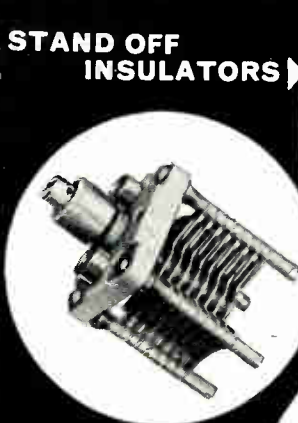

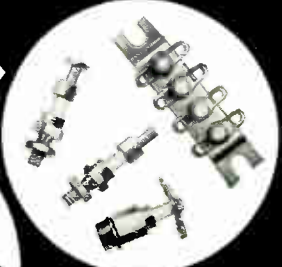

TRIMMERS

Photographs actual size

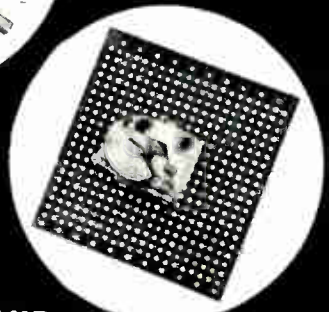
AND
P.T.F.E. LEADTHROUGHS



WINGROVE & ROGERS LTD

DOMVILLE ROAD · LIVERPOOL 13

Telephone: Stoneycroft 2265

LONDON OFFICE: 75 Uxbridge Road · Ealing W 5. Tel: EALing 7046/7

For further information circle 275 on Service Card

*so our
design engineers
went broody...*

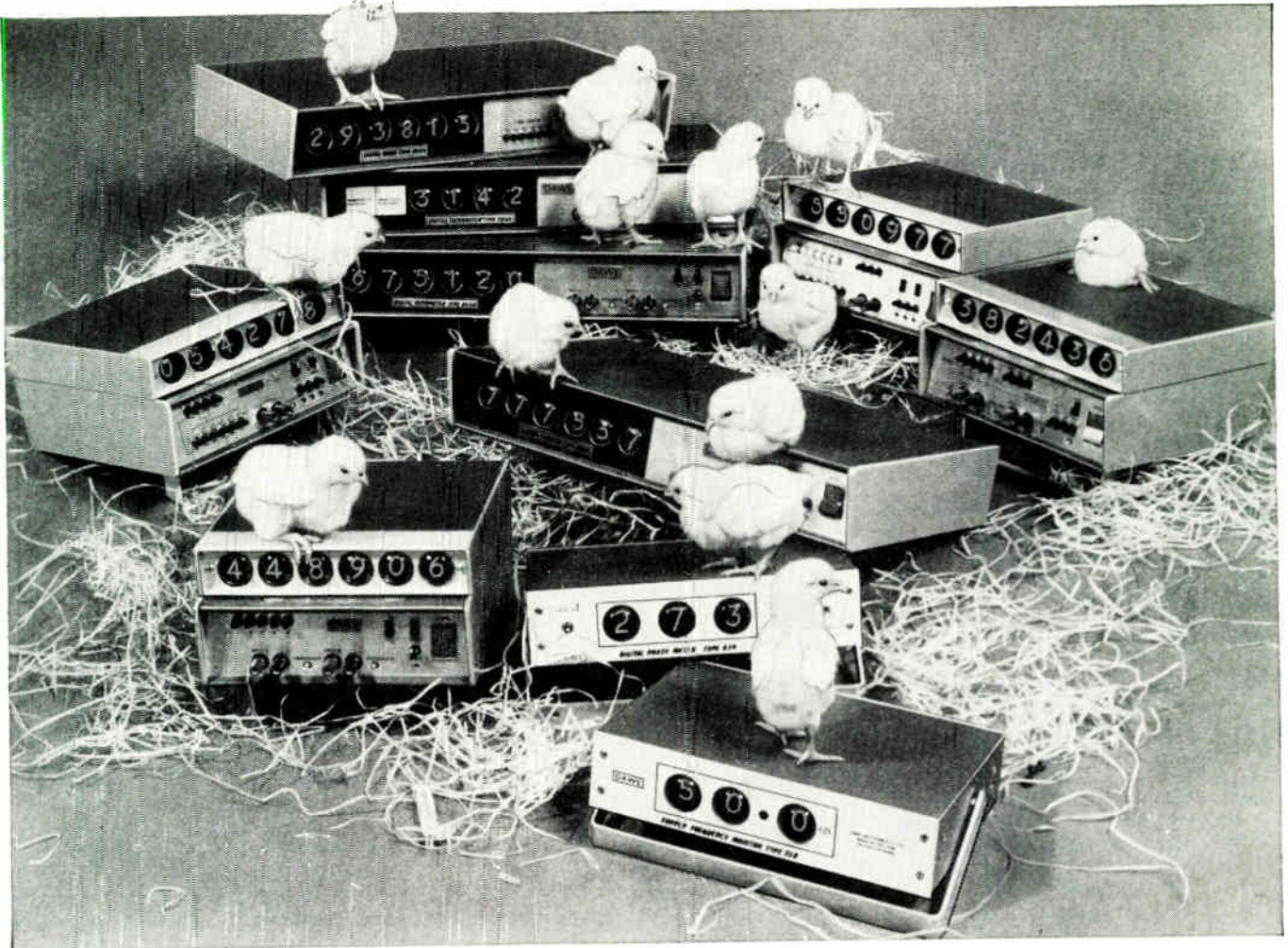

*and
hatched out
a whole new family
of DAWE
digital instruments!*

Tall ones, short ones, fat ones, slim ones—modular construction explains the family resemblance, those elegant good looks, those frank, open, easy to read faces. It also explains the remarkably low cost (for example, the Type 920A 4 digit, 1Mc/s, Frequency Meter and Counter, £113) and the ease with which modified versions can be made up to meet your individual requirements. For a start the range consists of seventeen of the little beauties—counters, timers, tachometers, ratio meters, frequency meters and multiple function units—but like all proud parents we hope to add to our family from time to time!

Full details available from:—

INSTRUMENT
and digital measurement

division of **DAWE** INSTRUMENTS LTD.,

WESTERN AVE., LONDON, W3 Tel: ACOrn 6751 A member of the *Simms* group of companies

For further information circle 276 on Service Card

Your questions answered

WEIGHT?

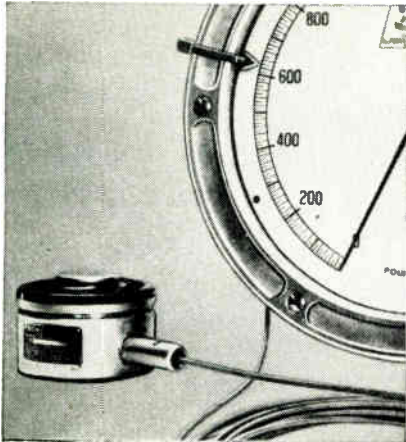

Hydrostatic Weighing Unit

This unit has been developed to cover a wide field of industrial weighing applications.

The basic unit consists of a completely sealed hydrostatic load cell connected to a Bourdon tube load indicating gauge by means of a flexible metallic capillary. Loads of 100 lbs. to 100 tons may be displayed on gauges ranging in size from 4" to 24" diameter. The gauge may be located up to a maximum distance of 200 ft. away from the load cell. Accuracy is better than 0.5% of scale capacity.

ANGLE?



Minitac Optical Shaft Encoder

The Minitac incremental encoder provides the means of determining precisely the angular position of a shaft, its angular velocity and acceleration.

The output from the encoder is sinusoidal corresponding to discrete angular increments of shaft position. Direction of rotation is also sensed enabling the encoder to be used in digital control systems. Various resolutions are available to suit specific applications.

TOTAL?

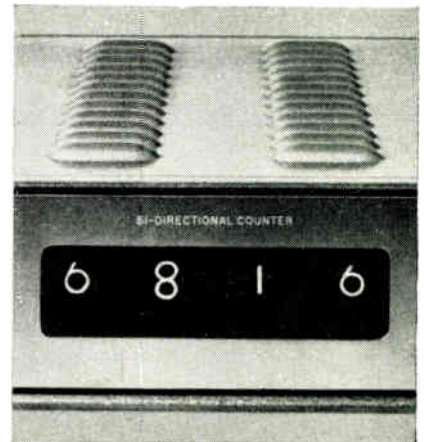

Bi-directional Electronic Counter

Designed principally for use with shaft encoders this counter is equally applicable to any linear device giving a serial output. A bank of numerical display tubes are arranged to provide any number of decades. The instrument counts up to any pre-arranged maximum after which the next positive pulse resets the display to zero. A similar sequence follows when negative pulses are applied. A zero setting button enables the counter to operate with the encoder in any selected position.

Any of these individual units may be incorporated in the users system or combined to form the basis of a digital control system in a wide field of applications.

Don't hesitate to send for the technical data sheets, or ask us about your particular needs—that's what we are here for.

Brown

S. G. Brown Limited Chiswick Division : Devonshire Works, Dukes Avenue, Chiswick, London, W.4. Tel: CHI 7494.



A HAWKER SIDDELEY COMPANY

For further information circle 277 on Service Card

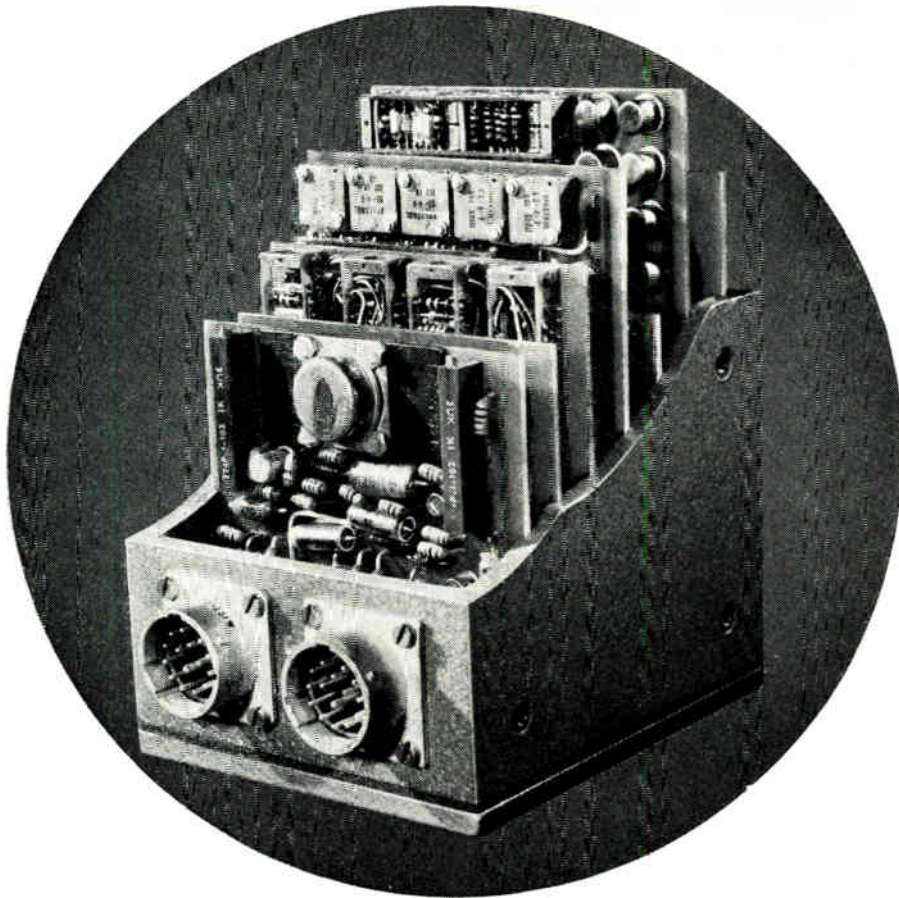

THE HEART OF A DATA HANDLING SYSTEM

The A/D Converter (type 1L 6170/2) has been proved under operating conditions—in aerospace applications—as severe as any it will be expected to meet in industry.

High performance and long-term reliability are therefore assured when it is used for less demanding applications such as data logging, computer and general scientific systems.

Fast conversion rates make the A/D Converter especially suitable for computer and high-speed data acquisition work; its sealed unit and rugged construction for industrial use e.g. in steelworks and process control.

- * fast conversion rate
- * rugged sealed unit
- * increased production costs of the past two years have been absorbed: price unchanged at £795 ex. works
- * excellent delivery time: small quantities off the shelf
- * demonstrations arranged in customer's works

Input	Analogue range 0 to -6v d.c. Impedance 10 k.ohms Read Pulse A pulse going from earth to a positive level, between 6v to 12v
Conversion	Minimum conversion time 200 micro-secs Maximum conversion rate 5000 words/sec Resolution 1 part in 1024 Accuracy $\pm 0.1\%$ full scale $\pm \frac{1}{2}$ least significant digit
Output	Pure binary 10 bit parallel words, stored until succeeding read command Digital representation '0' by 0 volts '1' by + 10 volts Impedance 5 k ohms for a logical '1' 1 k ohms for '0' Internal 66 Kc/s clock available for synchronising
Supplies	- 12 v \pm 0.25 v at 180 mA + 12 v \pm 0.25 v at 300 mA
Temperature range	-20°C to +55°C Full accuracy over range 0°C to 40°C
Size/weight	4 $\frac{1}{8}$ x 3 $\frac{1}{2}$ x 3 $\frac{3}{8}$ ins 2.6 lbs

BRITISH AIRCRAFT CORPORATION

GW DIVISION
BRISTOL WORKS FILTON BRISTOL
Telephone: 693831

IPC3

For further information circle 278 on Service Card

Mackie Static

A NEW
POWER
IN
INDUSTRY

Mackie, pioneers for more than 80 years in the manufacture of power conversion and generating equipment, now offer a range of transistorized Static Inverters giving outputs up to 500VA, at 50Hz, 400Hz, and 1,000Hz, square or sine wave. Compact and of robust construction Mackie Static Inverters have been designed as alternatives to the already well established Mackie low-voltage rotary converters.

Enquiries are welcomed for Research and Development projects on specific units to meet customers' requirements.

Mackie also design and produce 400Hz, and 1,000Hz, Alternator Sets and G.P.O. type Dynamotors for all industrial applications.

Below: Inverter producing 400 Hz. $\pm 1.5\%$, $< 2^\circ$ distortion, 140 W (-40° C to $+ 85^\circ$ C). Provision for phase-locked synchronizing take-over

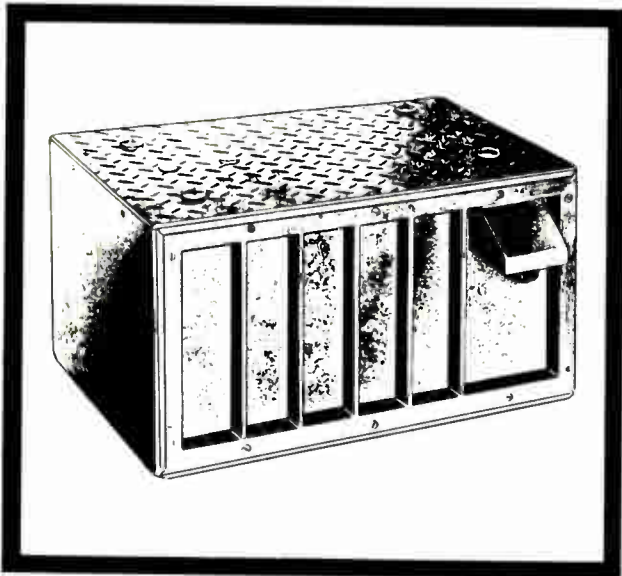

mackie

W. MACKIE & CO. LTD., WILLOW LANE, MITCHAM, SURREY
Telephone: Mitcham 0951-6 Telegrams: Mackie Croydon Surrey Telex: 264041

For further information circle 279 on Service Card

this is the draughtsman

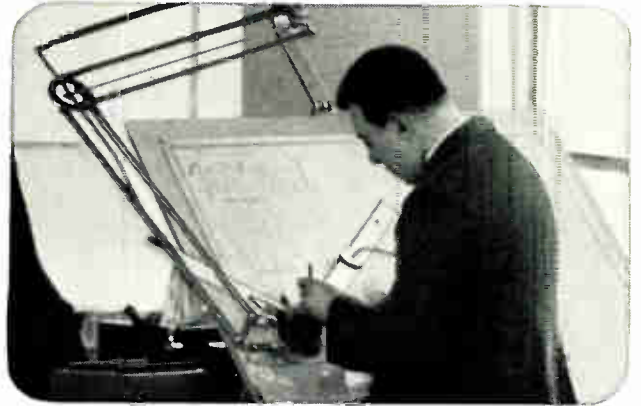

who insists on hydraulic-magnetic

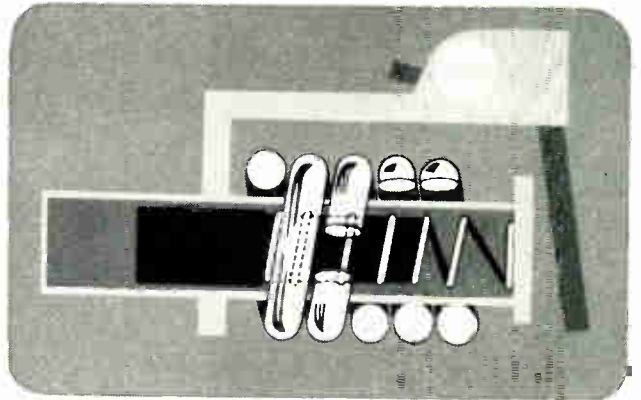

reliable engineering characteristics

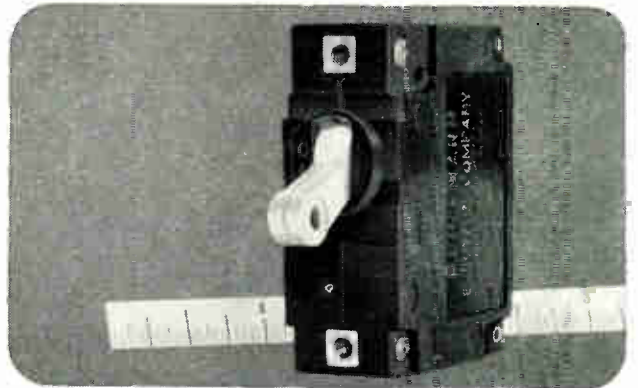

of Heinemann Circuit Breakers

Heinemann, the people who first originated the magnetic hydraulic Circuit Breaker, who developed the most advanced sub-miniature unit of its kind in the world, have now produced a NEW popular priced miniature Circuit Breaker. It is the JA. To be used up to 20 amps. above this you still need the AM12. Remember all Heinemann Circuit Breakers have hydraulic magnetic time relays to give reliable, repeatable overload protection without nuisance tripping. The Siloconetic time relays use the same principle. Send for literature.

FOR MINIATURE AND SUB-MINIATURE CIRCUIT BREAKERS,
ROTARY SWITCHES AND PRECISION RELAYS

SWITCH TO
Austinlite
LIMITED

Pickersleigh Rd
Malvern
Worcestershire
Malvern 61786
Telex: 33267

London Office:- Wingate House - 93-107 Shaftesbury Avenue - London W.1 - GERrard 1736 - Telex. 262242

For further information circle 280 on Service Card

Big performance - small package

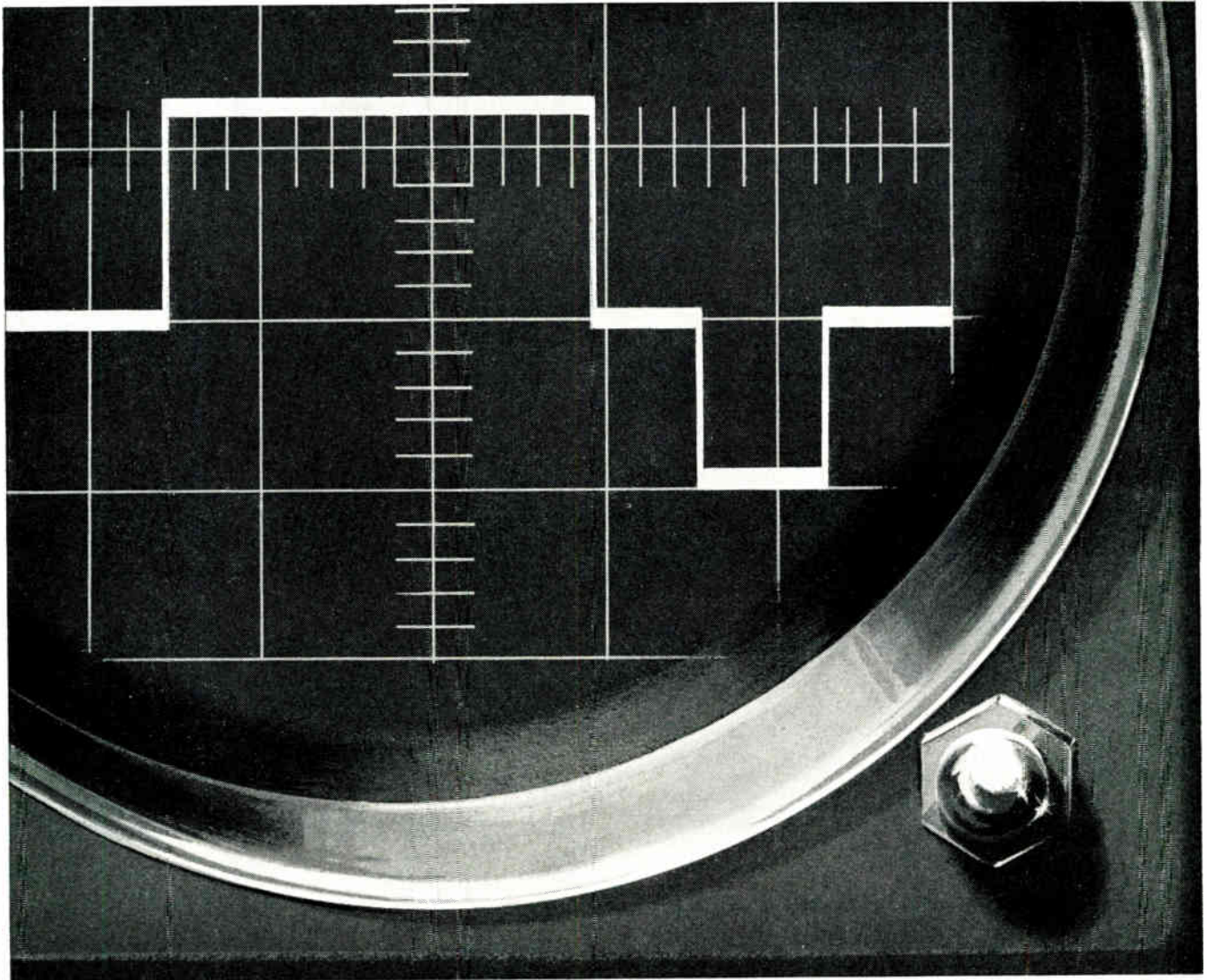

EMINSTRUMENTS OSCILLOSCOPE TYPE 101

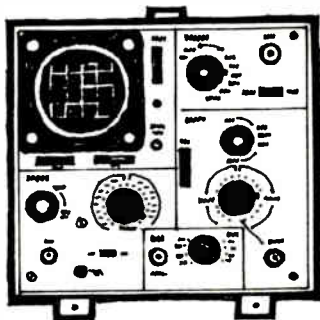

This new 3-inch general purpose solid state 'scope gives you 15 Mc/s bandwidth performance plus a combination of features that no other 'scope can offer at its price! How has it been done? By detailed research into user requirements, inspired solid-state design, and exclusive manufacturing techniques. Here are some of the features of the 101—the features you want in a general purpose 'scope. □ Light weight: only 17 lb. □ Compactness: 8.5 in. x 9 in. x 15 in. □ Low power consumption: only 20 W. □ 18 Calibrated sweep speeds □ Mains or battery operation □ Can be supplied with internal re-chargeable DEAC battery □ Wide bandwidth: d.c. to 15 Mc/s. □ Built-in voltage calibrator. Send for full details to:—



EMI ELECTRONICS LTD · INSTRUMENT DIVISION · HAYES · MIDDLESEX · TELEPHONE: HAYES 3888 · EXTENSION 2291

EE 3819

For further information circle 281 on Service Card

**WE ARE
LOOKING TO
THE FUTURE**

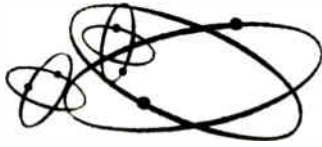

YOURS

OR TO BE MORE PRECISE, YOUR COMPANY'S AND WE HAVE FORSEEN AUTOMATION PROBLEMS ARISING IN THE GENERAL FIELD OF SEQUENTIAL CONTROL, DATA PROCESSING & LOGIC CIRCUITRY, WHICH WILL REQUIRE AN ECONOMICAL SOLUTION THAT'S WHERE WE COME IN!

Whatever the size of your company automation of your operations can take you straight into the 70's C. & N. and their electronics 'know-how' are already thrusting forward the production systems in other companies by a decade, bringing greater efficiency, reducing expensive labour costs and increasing production.

Why lag behind when automation can do the same for you C. & N. can provide economical answers to your particular problems. They can be analysed, converted into practical propositions, manufactured and installed as a complete system.

Our specialist team of engineers was formed to carry out such projects on behalf of the U.K. Atomic Energy Authority and we are now in a position to extend this expertise into industrial fields.

Why not make your problem our problem and see how quickly we can solve it.



**C. & N. (ELECTRICAL) LTD.,
THE GREEN, GDSPORT, HAMPSHIRE.
TEL: GOSPORT 82391/9 TELEX: 86121**



For further information circle 282 on Service Card

PCT MINIATURE PLUG-IN RELAYS

**NEW TWIN CONTACT
LIGHT DUTY TYPES**

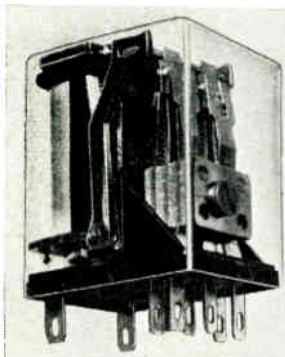

- New low cost manufacturing techniques
- Prices *only slightly* above single contact relays
- Coil not derated
- 2 Pole and 4 Pole

Write for further details



PERIVALE CONTROLS COMPANY LTD.
TELFORD WAY, LONDON, W.3 Tel.: SHEphers Bush 1015 (5 lines)
A MEMBER OF THE BENTIMA GROUP

For further information circle 283 on Service Card

N.C.BROWN LIMITED

INDUSTRIAL
SALES
DIVISION

pacesetters in storage equipment

DRAWER UNITS

Keep any kind of small item easily to hand and quickly found in stores.

There's a size and combination to suit your needs in our range — from a 2-drawer unit at only **£1.8.4.** to a 108-drawer cabinet costing **£36.15.0.**

All units are made from heavy gauge best quality steel, stoved enamelled dark green.

Illustrated: 'POPULAR' 54A
Overall size 42" high, 35" wide, 12" deep 54 drawers.
£18.0.0.

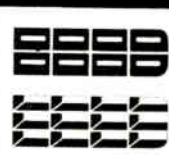
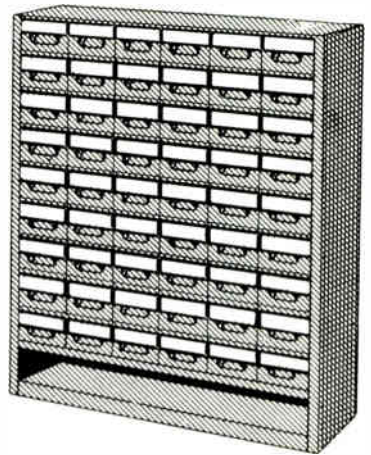

**TO: N. C. BROWN LTD. Dept. E.38
Heywood Lancs Tel. 69018 London: Dept. E.38
5 6 Staple Inn, W.C.1. Tel: HDLborn 5223**

Please send me a copy of your free illustrated catalogue

NAME _____

ADDRESS _____

For further information circle 284 on Service Card

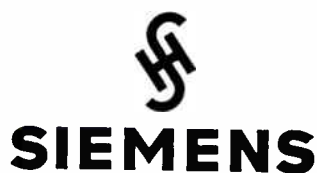

Versatile Moving iron MULTIZET®

ROBUST CONSTRUCTION

A.C. OR D.C. MEASUREMENT
WITHOUT RESETTING

1.5% ACCURACY IRRESPECTIVE
OF WAVE SHAPE

HIGH OVERLOAD CAPACITY

5 RANGES OF UP TO 600V
AND 30A

TAUT STRIP SUSPENSION



**IT ALL ADDS UP TO THE
FINEST VALUE IN AV METERS
AVAILABLE TODAY**

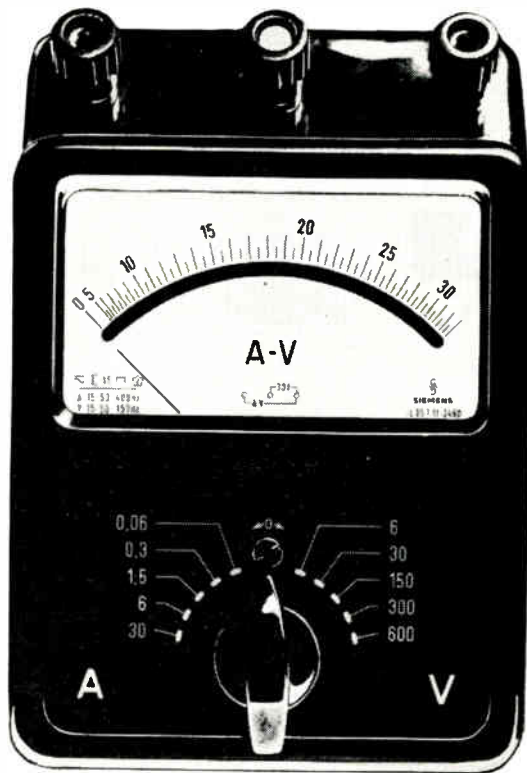

£19

It's hard to put a value to the extra quality of a Siemens instrument: superior accuracy, robust reliability—This is just one of a range of Multizets; handy, accurate meters. What does it offer? Well robust moving iron construction, yet true RMS reading and minimal consumption. We put a price to the Multizet—but at £19 it is certainly the finest value in AV meters available today.

A leather carrying case is available for a further £3.10.0.

RELIABLE INSTRUMENTS FOR MODERN ELECTRONICS

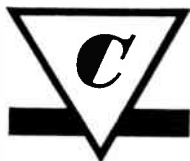

R.H. COLE ELECTRONICS LTD.

CROYDON SURREY MUNICIPAL 4411

For further information circle 285 on Service Card

WALMORE ELECTRONICS

ROUND BAR KNOBS

Walmore Electronics Limited 11/15 Betterton St., Drury Lane
London WC2 · Telephone: TEMple Bar 0201-5

Round Bar

Concentric Round/Round Bar

Round Bar Ring Skirted

Concentric Round Ring Skirt

Dial Skirted Bar

Concentric Round/Dial Skirt Bar

RAYTHEON

For further information circle 286 on Service Card

A new addition to the famous range of
PRECISION BUILT STAND MAGNIFIERS

sponsored by
ENBEECO



MAUTNER ILLUMINATING MAGNIFIER

Special features
include:

- High quality optical lens 5" diameter 10" focus, giving flat field, good magnification & stereoscopic vision.
- Illumination by five 6 volt 5 watt lamps ringed round the lens.
- Built-in transformer in the base of the stand with fuse and switch.
- Stand adjustments include upright column, 11" high with transverse sliding arm, 13½" long. Lens mounting adjustable for tilt.

Price

£24 - 15 - 0

Complete catalogues of
magnifiers, microscopes,
etc. sent on request.

PURSER'S LONDON (HOLBORN) LTD.

(Associated with Newbold & Bulford Ltd.)
12 FULWOOD PLACE · HIGH HOLBORN
LONDON, W.C.1 · Tel.: HOLborn 5268

For further information circle 287 on Service Card

BAUDAT

CABLE SHEARS
are operated
with one hand

Designed to cut Electric Cables
effortlessly in seconds

Model M. 1: Cuts Electric Cables up
to ¾" dia.

Power Ratio: 20:1 PRICE: £5.0.0

Model K. 11: Cuts Electric Cables up
to 1½" dia.

Power Ratio: 30:1 PRICE: £8.0.0



We maintain large stocks in
CUTTERS, PLIERS AND TWEEZERS
for the Instrument and Electronic Trades
Made by leading Continental manufacturers
Comprehensive range available

PLEASE ASK FOR COMPLETE PRICE LIST

ERIC H. BERNFELD LTD
282 Kingsland Rd., London E.8. Tel.: CLIssold 4837

For further information circle 288 on Service Card

Accuracy is vital in weighing machine control - just one reason why Avery specify Klaxon geared motors

Take for instance the Avery pre-packaging scale whose mechanism is shown below. This weighs the goods, computes the price and issues a printed ticket giving a description of the goods, price per pound, weight and price. It issues up to 22 tickets per minute and is often called upon to work at a rate of 10,000 per day.

KLAXON

Driving the printer is a Klaxon geared motor, chosen for its compact size and high standard of reliability. The motor in question (Klaxon Type EM5, permanent capacitor type, with WP51 worm reduction gearbox) suitable for mains voltage and frequency, developing 10 lb/in torque at 170 rev/min.

Klaxon can provide the right fractionals and geared units for your equipment, too.

For full details, contact: Klaxon Limited (Fractional H.P. Motors Division) Warwick Road, Tyseley, Birmingham. Tel: Acocks Green 1654-6

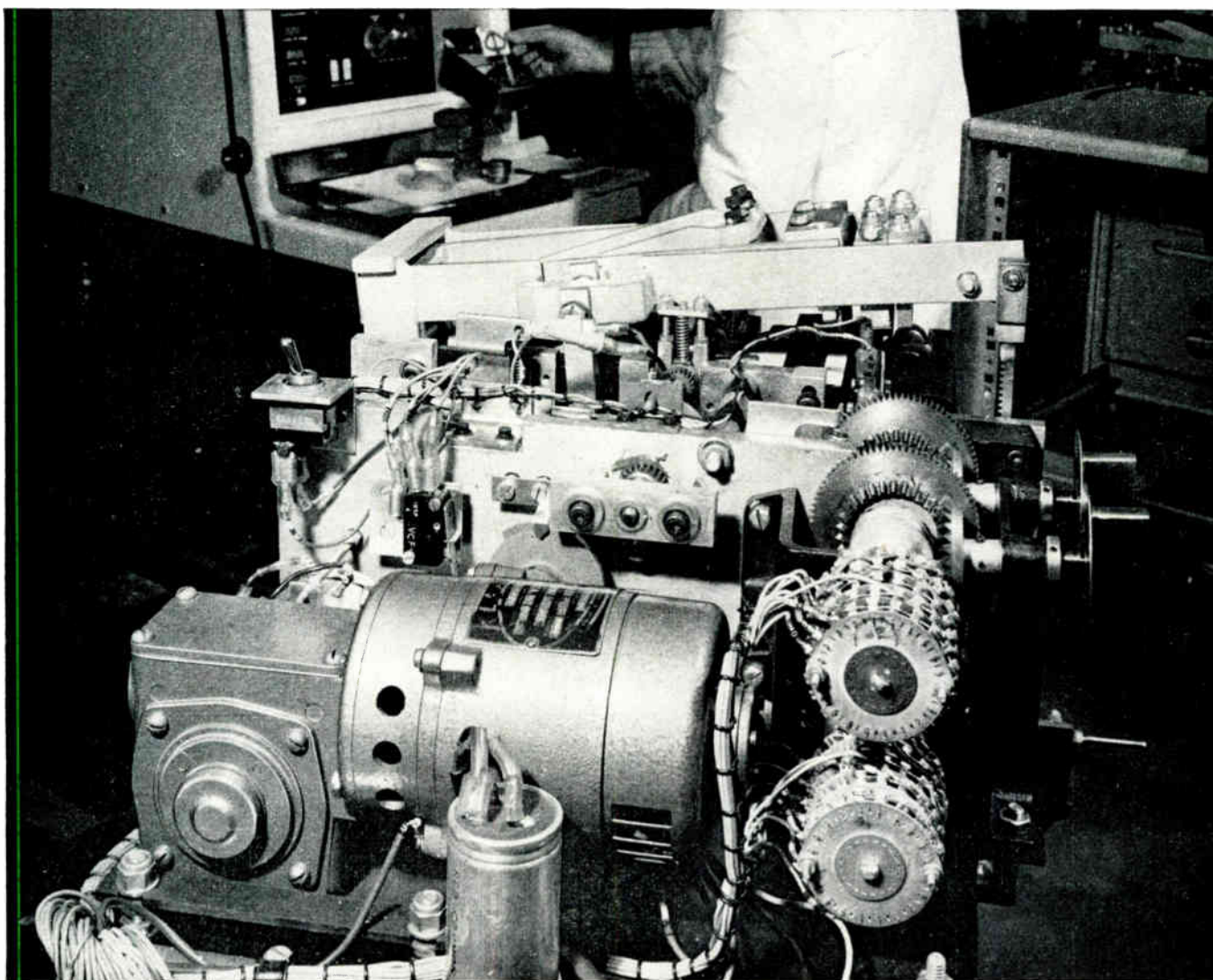

For further information circle 289 on Service Card

MUIRHEAD CUSTOM-BUILD

PRECISION RESISTANCE NETWORKS

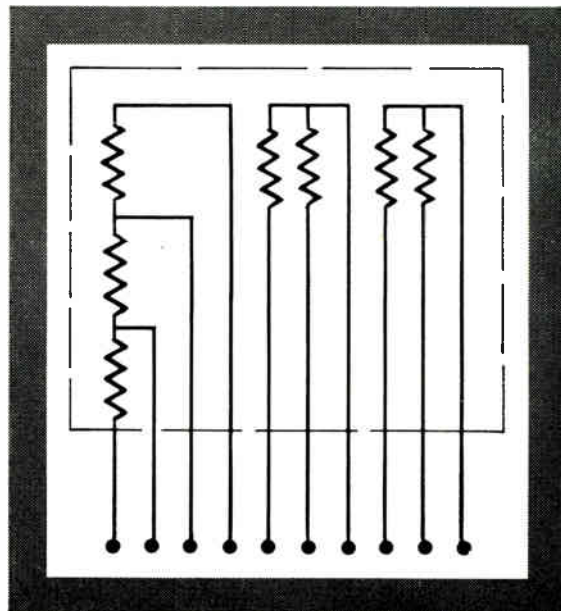
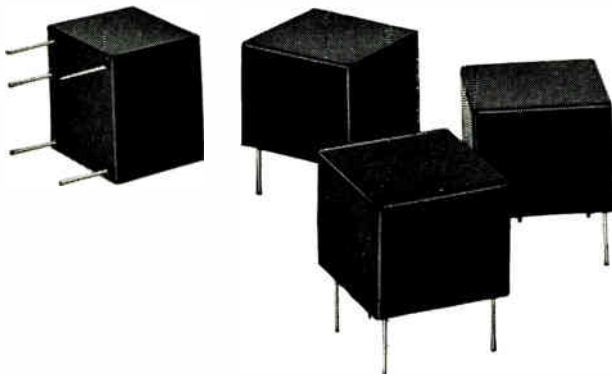
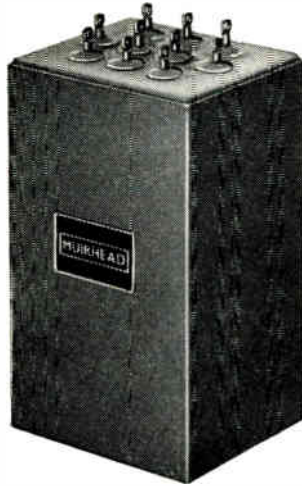

Digital Voltmeters—Computers—Precision Power Supplies—Comparison Bridges. In these and many other applications, modern technology demands performance to the limits of current engineering knowledge and skill. To meet the exacting requirements, Muirhead produce custom-built resistance networks, with precision resistors adjusted to an accuracy of 0.005% and matched to 20 parts in 1 million. Values from 500 ohm to 3 M ohm are produced using fully aged wire, with a temperature coefficient of 0.0005% per °C average between 20°C and 125°C. After winding the resistors are artificially aged for 3 weeks to ensure that the stability is better than 0.002% per year. Selected wire is used in the production of matched sets of Resistors for networks to maintain the resistance ratio to better than 0.0002% over a working temperature range of 0°C—45°C. Custom-built networks may be supplied as sets of matched resistors, or ready wired and sealed in nitrogen filled steel containers fitted with glass seal terminals. For switched networks, Muirhead offer a range of high quality stud switches having a high insulation resistance and extremely low contact resistance, suitable for manual or remote control.

MUIRHEAD TECHNIQUE

MUIRHEAD & CO. LIMITED

BECKENHAM · KENT · BECKENHAM 4888

Please send me full information on custom-built precision resistance networks.

Ask your engineer to call on me for consultation.

My Telephone No. is.....

NAME.....

POSITION.....

ADDRESS.....

SD/1254/749

For further information circle 290 on Service Card

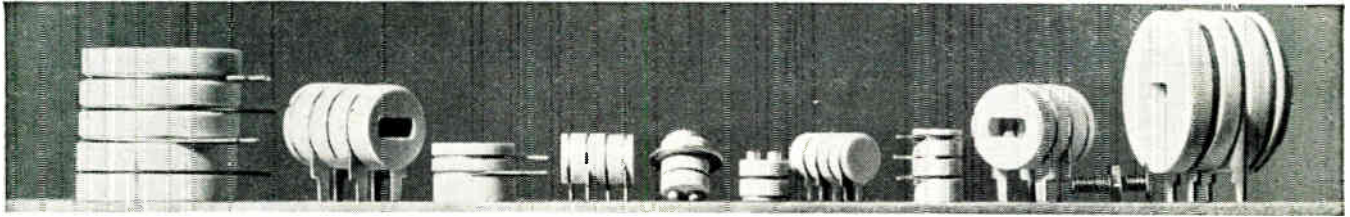

Do the tough jobs with

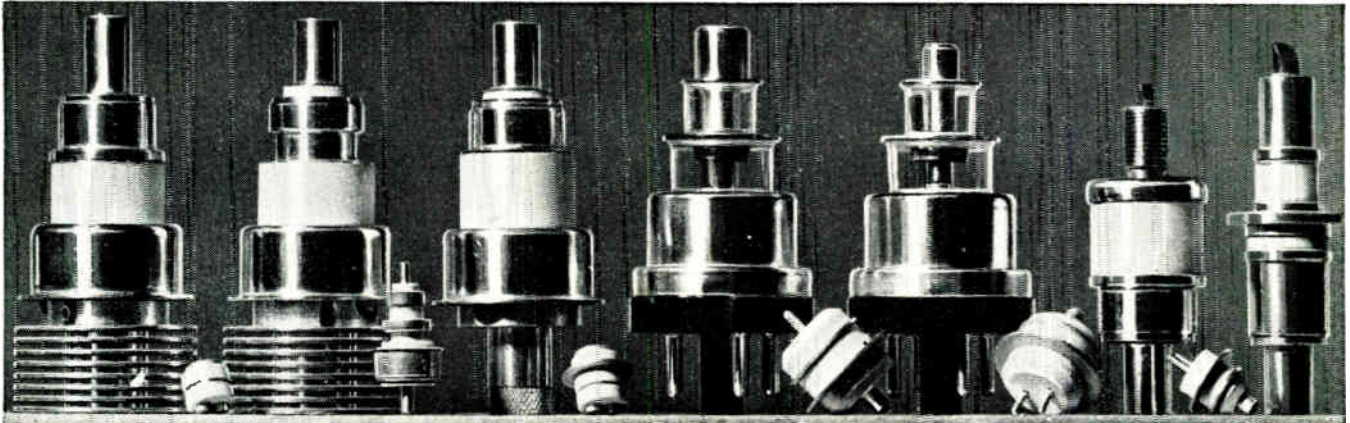

metal-ceramic planar tubes from

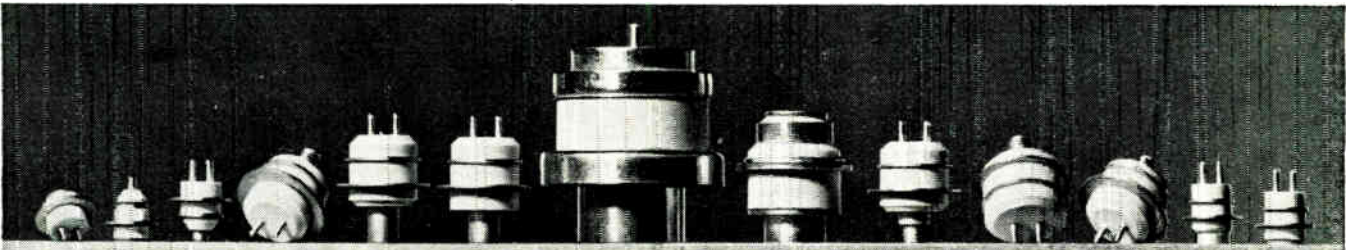

General Electric Company of U.S.A.

From DC to 10 gc, ceramic triodes are often the most practical way to achieve small size and weight . . . at low cost . . . without sacrificing performance. Sometimes they're the only way.

These tubes, from General Electric Company, U.S.A.*, are of planar construction; terminals are integral parts of the structure.

As a result, these tubes rate high in power output (milliwatts to 5 KW peak). Low in noise (fractions of a db at low frequency). High in gain and wide in band (gain-band width products up to 5000 mc).

And when it comes to performance under adverse conditions, ceramic tubes from General Electric, U.S.A., are unsurpassed.

They tolerate temperatures as low as -55°C or as high as 400°C. These tubes withstand impact shocks of up to 600 G's for 3-5 M.Sec., RMS vibration up to 48 G's (100-2000 cps, 3 min. each plane). And they've tolerated nuclear radiation of 10¹⁸ NVT total integrated dose.

For full information on the whole line—only a fifth of it is listed here—contact International General Electric Company of New York, Ltd., 296 High Holborn, London, W.C.1, or General Electric Company, Dept. EC-66-03, 159 Madison Ave., New York, N.Y. 10016, U.S.A.

*GENERAL ELECTRIC COMPANY, U.S.A., IS NOT CONNECTED WITH THE BRITISH COMPANY OF A SIMILAR NAME.

Classification	Type	Maximum Ratings		Typical Application	Useful Frequencies Extend to**
		Plate Dissipation (Watts)	Current (milliamperes)		
Triode (Class A Operation)	7077	1.0	Ik=10	Low-noise UHF Amp.	3000 mc
	7768	5.5	Ik=30	Low-noise VHF Amp.	3000 mc
	Y-1032	0.6	Ik=10	Low- μ , Low-plate-voltage Osc., Amp. or Mult.	3000 mc
Triode (Class B or C Operation)	6897	100.0*	Ik=125	UHF Power Amp. Osc. or Freq. Mult.	3000 mc
	7486	1.0	Ik=10	UH Power Amp. Osc. or Freq. Mult.	3000 mc
	7913	5.5	Ik=30	UHF Power Amp. Osc. or Freq. Mult.	3000 mc
Triode (Pulse Operation)	6442	7.5*	Ip=2500 Iq=1250	Pulsed Oscillator or Amp.	6000 mc
	7815	100.0*	Ip=3000 Iq=1500	Pulsed Oscillator or Amp.	3000 mc
	7910	1.5	Ip=600	Pulsed Oscillator	7500 mc
	7911	6.5	Ip=2500	Pulsed Oscillator or Amp.	6000 mc

*At this dissipation level, anode cooling is usually necessary to prevent exceeding maximum permissible seal temperature.

**The frequency listed is one at which significant application data are available or expected. It does not represent an absolute frequency limit.

GENERAL ELECTRIC COMPANY OF U.S.A.

For further information circle 291 on Service Card

CLASSIFIED ADVERTISEMENTS

FULLY DISPLAYED : £3 per single column inch.
RUN-ON : 5/6 per line of approximately 7 words.
 Where an advertisement includes a Box Number is extra.
SERIES DISCOUNTS : 12 insertions, 15%.
 Remittances payable to "Industrial Electronics".

Copy is required by 11th of the month for insertion in the following month's issue, by 6th of the month if proofs are required.

Address to:
 Classified Advertisement Dept.
 Industrial Electronics
 Dorset House, Stamford St., London, S.E.1.

SITUATIONS VACANT



THE RANK ORGANISATION

As a result of our continued development the following vacancy has arisen in our chemicals plant at Elstree, Herts. Here we manufacture the chemical products used in the Company's highly successful copying equipment.

senior quality engineer

FROM £1,500 P.A.

A Senior Quality Engineer is required to be responsible for the design of electro-mechanical test equipment. The successful applicant will be over 25 and possess H.N.C. in electrical engineering, probably with endorsements in applied thermo-dynamics or engineering physics.

Applications for the above position should be sent to:

Mr. R. Barnett, Personnel Officer
 Rank Xerox Ltd., Drayton Road, Borehamwood, Herts
 Tel.: ELStree 4551



RANK XEROX
 LIMITED

A DIVISION WITHIN THE RANK ORGANISATION
 JOINTLY OWNED WITH XEROX CORPORATION

[667

ELECTRONIC ENGINEERS

required to work on the considerable and varied problems associated with instrumentation, recording and data logging in connection with a fundamental study of flames using a 1,500 lb/h pilot scale rig. A degree or H.N.C. and some experience will lead to appointment at a salary in excess of £950 and could be appreciably higher, dependent on qualifications and experience. More junior applicants will be appointed at an appropriate salary level and will be granted facilities for further study.

Salaries reviewed annually within progressive grading scheme. Contributory Pension Fund. Five-day week.

Apply for application form to Assistant Secretary, Ref. 8, The British Coal Utilisation Research Association, Randalls Road, Leatherhead, Surrey.

ELECTRONIC ORGAN ENGINEERS

Engineers required for Testing and Fault-finding on Electronic Organs, in rapidly expanding Anglo-American Company.

Apply with full details to:

D. S. Howard, General Manager
 SELMER ELECTRONICS LTD.
 40 Theobalds Road
 London, W.C.1
 CHAncery 6141

[675



MECHANICAL ENGINEERS IN ELECTRONICS

Electronic devices and systems, no matter how brilliantly conceived, need for their development and utilisation sound mechanical design characteristics. At MULLARD RESEARCH LABORATORIES we recognise this and wish to recruit further PROFESSIONAL MECHANICAL ENGINEERS to assume responsibility for the mechanical design of complex electronic and electro-mechanical equipment, as well as original experimental apparatus.

Suitable candidates will preferably be qualified to Mechanical Engineering Degree level and/or be Corporate Members of the Institution of Mechanical Engineers, although those qualified by relevant practical experience will also be considered eligible. All applicants will be expected to possess wide mechanical engineering knowledge (experience in vacuum technology, microwave components, electron optics, integrated circuits or thin film technology, will be particularly relevant), together with the ability to develop new technologies and work in a research environment.

Support facilities available include Drawing Office and well-equipped modern Model Shops with much special equipment.

If you are interested in this activity, please write briefly, outlining your relevant qualifications and experience, and quoting reference No. 824, to: Dr. S. A. Ahern, Mullard Research Laboratories, Salfords, Nr. Redhill, Surrey.

[668

CHARING CROSS GROUP OF HOSPITALS

Fulham Hospital, St. Dunstons Road
 W.6

SENIOR TECHNICIAN

required for automated artificial kidney systems. Training given if necessary. Qualifications, City and Guilds Electrical Engineering or "A" level or National Certificate. Salary £1,000-£1,200 plus London Weighting.

Applications to Professor H. E. de Wardener or, for further information, telephone 748 2050.

[676

TECHNOCRATS

We have vacancies throughout the Electronics Industry for **QUALIFIED ENGINEERS** and **TECHNICIANS** of all grades. Our service is comprehensive, confidential and free to the applicant.

Write or telephone for an appointment, which can be outside working hours.

DESIGN & DEVELOPMENT	£1,200-£2,400
FIELD TRIALS, INSTALLATION TEST & SERVICE	£950-£1,400
DESIGN DRAUGHTSMEN	£1,300-£1,750
DRAUGHTSMEN TECHNICAL WRITERS	£1,000-£1,400
SENIOR INSPECTORS	£1,100-£1,400

TECHNOCRATS

52 Shaftesbury Avenue, London, W.1
GERrard 5316-7

(1 minute from Piccadilly Circus, opposite Globe Theatre)

Situations Vacant (continued)

SOVIET JOURNALS

Subscriptions for Soviet technical and scientific journals must be placed by November 20th to ensure receipt of the first issue in 1967.

SEND FOR 1967 CATALOGUE

- (a) All technical and scientific specialised journals and popular and literary magazines.
- (b) Journals of Abstracts and Engineering Digests.

Collet's

Denington Estate, Wellingborough
Northants.

1673

EDUCATIONAL

CRANFIELD

4th-16th December, 1966

Postgraduate Short Course

in

DIGITAL TECHNIQUES

A residential course of instruction in theoretical and practical digital techniques. The coverage of the course will be broad, including components and circuits, combinational and sequential switching theory and applications to digital computers and to industrial instrumentation and control systems. Lectures will be supported by experimental work in well-equipped laboratories and by demonstrations. Fees, including tuition and full board-residence £54.

Further details and forms of enrolment from:

The Registrar
The College of Aeronautics
Cranfield, Bedford

1671

LIVINGSTON NEEDS . . . CONTROL ENGINEERS

. . . preferably experienced in the field of industrial control panels. Applications are invited from qualified engineers capable of working on their own initiative. Ref. PU.1

SENIOR AND JUNIOR DRAUGHTSMEN

. . . able to layout to the customer's requirements, instrument panels of room height and up to 100 feet long to control industrial processes. Must be able to prepare working drawings and have had experience in one or more of the following fields: sheet metal fabrication, panel wiring or small bore tight fittings. Ref. HRF.1

These jobs offer excellent conditions, good salary and staff pension scheme. Write giving details of experience, or telephone:



The Personnel Officer
Livingston Group
Livingston House
Greycaine Road
N. Watford, Herts.
Tel. 44344

CAPACITY AVAILABLE

AIRTRONICS LTD.

for coil winding, assembly and wiring of electronic equipment, transistorised sub-units, sheet metal work. 3a, Walerand Road, London, S.E.13.

Telephone: LEE Green 1706.1650

CAPACITY AVAILABLE

Assembly and Wiring of Electronic, Electro/Mechanical equipment. Competent team with supervision and Inspection facilities available now to meet your immediate requirements.

PERSHORE MOULDINGS LTD.

Trading Estate, Pershore, Worcs. 1672

SITUATIONS VACANT

DETECTION SYSTEMS ● FLAW VISUALISATION ● TANKLESS INSPECTION

ON-LINE
COMPUTER
CONTROLLED
FLAW

GLASS DEVELOPMENTS LTD.

VACANCIES IN AN EXPANDING FIELD

Continued development has opened the way to completely automatic ultrasonic flaw detection systems. Progressive positions are available for men with qualifications and experience in

MECHANICAL DESIGN (for mechanical systems or light mechanisms and instruments)

DRAWING OFFICE WORK (with workshop training)

Write today to :—

140/180 Stewarts Road, London, S.W.8.

ULTRASONIC FLAW DETECTION

FULLY AUTOMATIC DIGITAL FLAW EVALUATION ● HIGH SPEED

BUSINESS OPPORTUNITIES

LOOKING FOR PROFITABLE NEW LINES?

OPPORTUNITIES — ONTARIO STYLE

Manufacturers from Ontario, Canada, wish to contact successful established sales organisation covering the U.K. Please send full particulars of your Company and product interest to:

Government of Ontario
Trade and Industry Branch
Ontario House, 13 Charles II Street
London, S.W.1 1670

CONSULTANTS

DETECTIVE BUREAU. Confidential investigations. B.B.I., 16 St. Andrews Road, London, N.9. How. 3543. 1674

BOOKS

"TELEVISION Receiving Equipment." By W. T. Cocking, M.I.E.E. The fourth edition of one of the most important British books on television deals in a comprehensive manner with television receiver equipment and gives many practical details and much design data. The circuits of a television receiver are split into a number of sections and a separate chapter is devoted to each. Other chapters deal with general principles, the signal, superheterodyne interference problems, special circuits, the aerial, the complete receiver, faults and servicing. 30s net from all booksellers. By post 32s 4d from Iliffe Books Ltd., Dorset House, Stamford Street, S.E.1.

CONTOUR FOLLOWING
●
INSPECTION

THE VARIAC* variable transformer is the most useful and versatile device ever developed for the control of a.c. voltage, or of current, power, heat, light, speed. It provides smooth continuous adjustment of output voltage from zero to line voltage and above, either hand-operated or motor-driven.

Only Variac has Duratrak*—a patented track surface giving longer life, increased overload and surge capacity and maximum economy in maintenance.

There are over 600 Variac models and assemblies to suit virtually every possible requirement, ranging from small units for laboratory or instrument use to large ganged assemblies for high power 3-phase operation. The range includes low-voltage, high-frequency, dual-output and narrow-range types, open, covered, portable, metalclad and oil-immersed constructions, plus many special models. This is the largest range of variable transformers available today.

The technical superiority and dependability of Variac are the result of over 30 years of development and refinement since the introduction of the first Variac models—the *original* variable transformers.

*Variac and Duratrak are registered trade marks

Variacs are made in England by The Zenith Electric Co. Ltd. London, and exclusively distributed in the U.K., Eire and British Colonies by Claude Lyons Ltd.

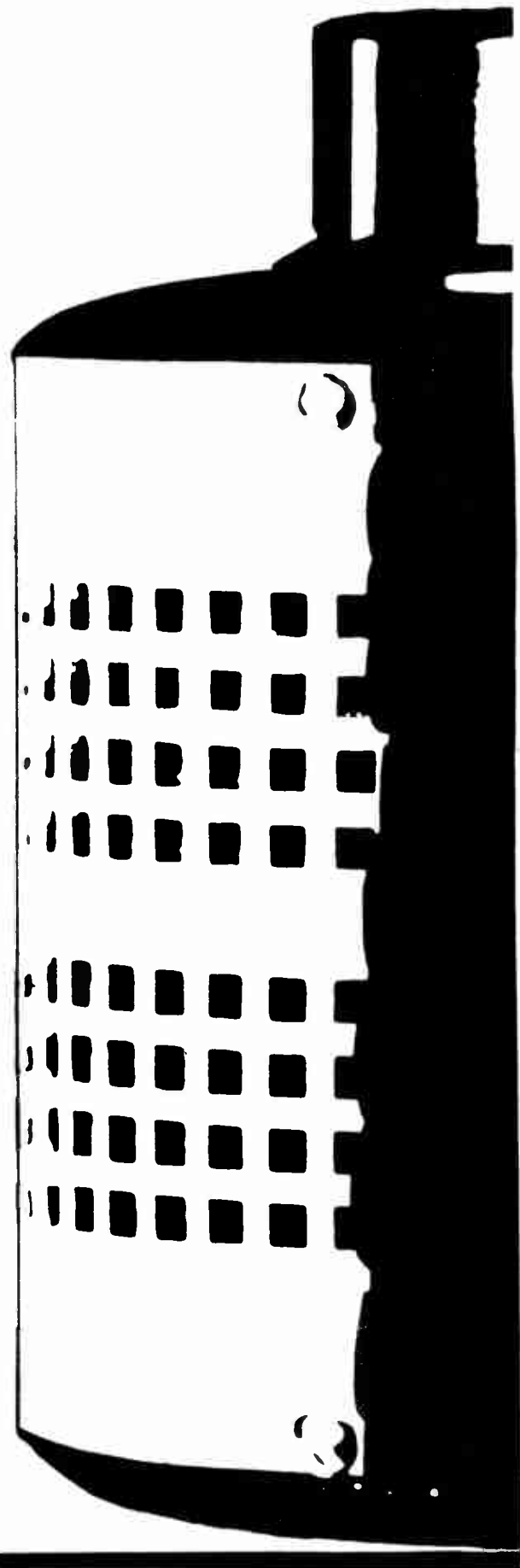

Variac

TEGO

variable transformers

—over 600 models
to suit every possible
requirement



Write for comprehensive catalogue to Publicity Department, Hoddesdon

CLAUDE LYONS LTD

Valley Works, Hoddesdon, Herts
76 Old Hall Street, Liverpool 3

Hoddesdon 67161
MARitime 1761

Telex 22724
Telex 62181

CL46

For further information circle 302 on Service Card

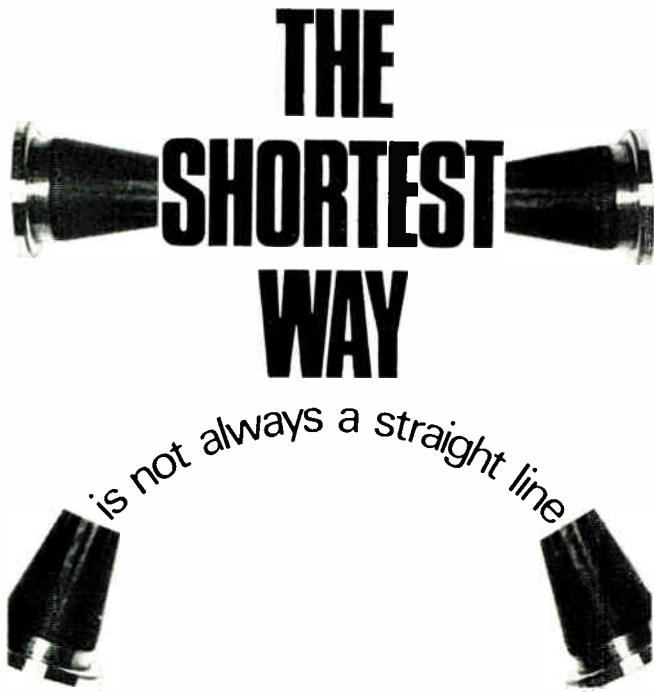

Take a radar or communication system, for example, with awkward design or dimensions. Or a system where part of it moves and the rest is stationary. Or when the housing dimensions vary.

In such cases, the shortest, quickest, least expensive way is the flexible way by—GABRIEL.

Gabriel guides come in two forms—twistable and non-twistable. Both types can be used in pressurized systems if necessary. Both provide exceptionally good VSWR and low attenuation characteristics.*

If you have a problem of getting microwave energy from here to there in your system, there's one shortest, quickest, cheapest way—contact our technical staff. The answers will be straight—but your waveguide will probably bend a little.

*Specifications for your requirements available on request.

GABRIEL

Gabriel Manufacturing Co. Ltd • Newton Road • Torquay • Devon
Telephone: Kingskerswell 3333 (2 lines)
A Member of the Tecalemit Group of Companies.

For further information circle 292 on Service Card

transistor bias tables

an invaluable book for the designer or builder of transmitter amplifiers

E. Wolfendale, B.Sc.(Eng.), M.I.E.E.

This collection of accurately computed tables has been compiled to assist anyone wishing to design or build a transistor amplifier. The tables can be used either directly, to provide the values of the three resistors required for the conventional bias circuit, or alternatively, as a starting point for more detailed bias circuit analysis. Optimum values are not given in the tables as these depend on a number of factors outside the control of the author, such as the tolerance of the resistors to be used, the range of the ambient temperature over which the amplifier is to operate and the likely variation in the supply voltage. Sufficient information is provided however to enable the designer to arrive rapidly at values near the optimum for the conditions for which he is designing. The author has been closely associated with research into and development of transistors for many years and he is a well known lecturer on transistors and their applications.

55 pp. illustrated 21s net 22s by post
available from leading booksellers

ILIFFE BOOKS LTD.

DORSET HOUSE, STAMFORD ST., LONDON, S.E.1

For further information circle 293 on Service Card

ELECTRONICS PRINTED CIRCUITS

An extremely comprehensive service is available to industry which is unique in its scope and unprecedented in its quality of workmanship and speed of service while at the same time giving that all important individual attention and very competitive price terms that every buyer seeks.

The service consists of inclusive facilities for the design, development, and large scale production of all types of electronic equipment, instruments, etc., together with all processes involved in the design, development and production of printed circuit boards.

The unique location of T.E.S. Ltd., allows this first class service, which is to be found nowhere else, to be brought to your doorstep by an almost daily transportation service to 100 miles all for the price of a telephone call. Shanklin 3096.

Special attention will be given to very welcomed enquiries from customers outside the U.K.

TRANSMETRIX ELECTRONIC SYSTEMS LTD.
Hyde Works, Shanklin, Isle of Wight, Hants

For further information circle 294 on Service Card

VITALITY



Miniature and Sub-Miniature
Indicator Bulbs in sizes from 4.5mm

Catalogue from

VITALITY BULBS LTD
MINIATURE LAMP SPECIALISTS

BEETON'S WAY, BURY ST. EDMUNDS, SUFFOLK. TEL: 2071 STD 0284/2071

For further information circle 295 on Service Card

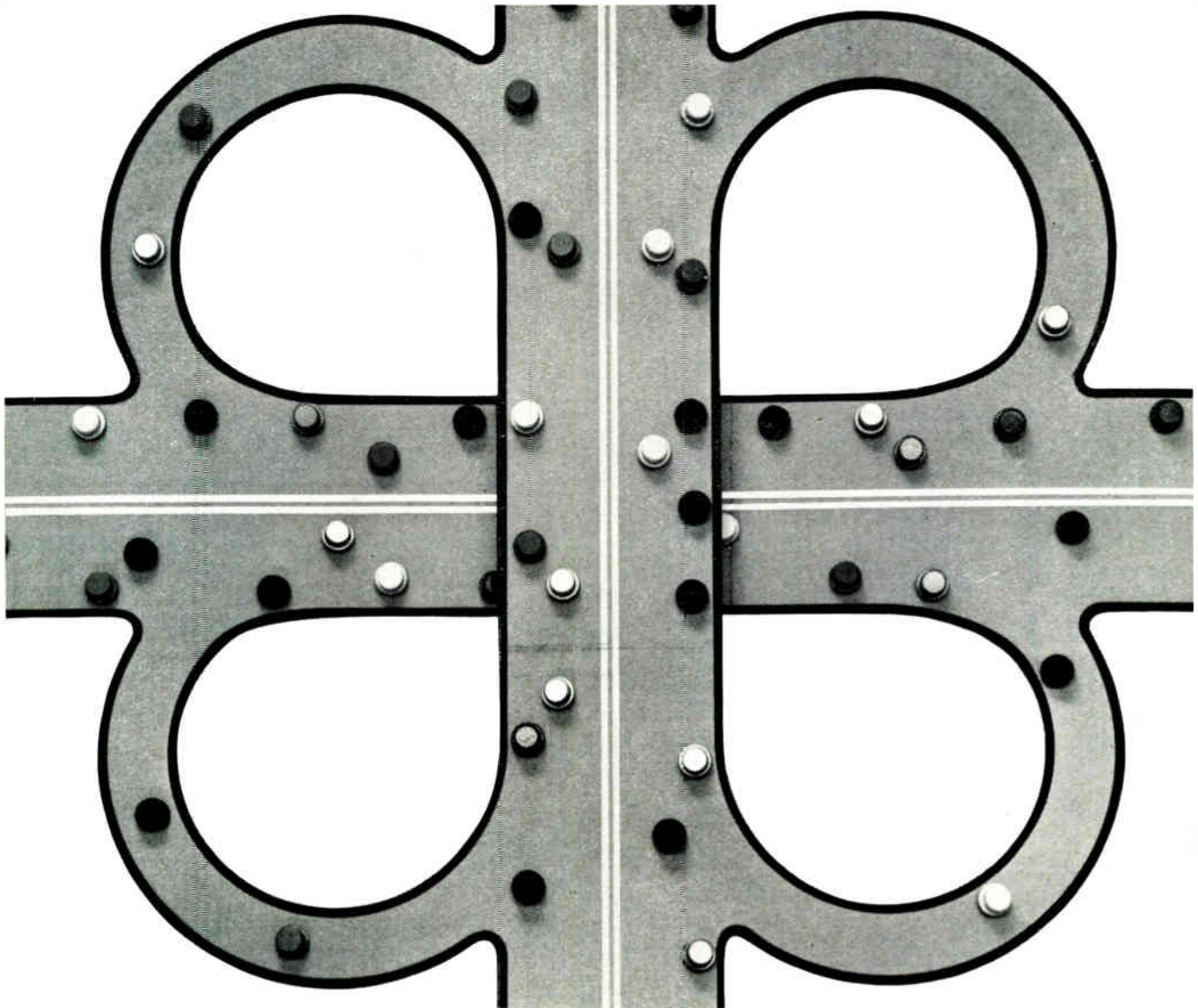

21,000,000 Car Owners Depend On Motorola Rectifiers

For a few pence* per amp, you can, too!

Every day since 1960, the Motorola-developed — and patented — pressfit rectifier has been highway-proven in more than 100 billion device-hours of rugged operation in automotive alternators.

Now, this 25-ampere device is available for your medium-current industrial applications *up to 1000 volts* at low prices we defy you to find equaled anywhere else!

Consider these pressfit design advantages:

- you can save up to 75% mounting time — quick, economic, single-part mounting enables effective, secure heatsinking in about a fourth of the time necessary with stud devices
- Motorola pressfits give you 300-ampere current surge protection — unsurpassed by any other device in the up-to-25-ampere area
- life testing of the basic pressfit rectifier cell represent-

*50-volt pressfit, large volume distributor quantities

ing over 1,400,000 device-hours at maximum ratings indicated a maximum expected failure rate as low as 0.005%/1000 hours

■ we test-sample and destroy nearly 1500 devices *each day* to ensure consistent rectifier quality and reliability

FIND OUT NOW . . .

How you can clip, clamp, saddle or “pressfit” these rectifiers into virtually *any* medium-current application *quickly* and *economically* — send for “Mounting Techniques for Pressfit Silicon Rectifiers” and a new “designers” data sheet . . . including “worst case” designs; see your Motorola distributor for evaluation units — do it today!

U.K. STOCKISTS:
CELDIS LTD.
 4 Trafford Road, Richfield Estate,
 Reading, Berks.
 tel: ORE-4-56256 telex: 84370



MOTOROLA

Semiconductor Products Inc.

YORK HOUSE • EMPIRE WAY • WEMBLEY • MIDDLESEX • DIL 0944

For further information circle 296 on Service Card



A.C. Power Supplies give you exactly what you need

		
KM2N Output Power 700 watts	PPA2.5 Output Power 2,500 watts	KRF Output Power 1,000 watts
Frequency Range 30 c/s - 5 Kc/s	Frequency Range 50 c/s - 10 Kc/s	Frequency Range 5 Kc/s - 100 Kc/s
Distortion 0.1%	Distortion 3%	Distortion 5%
Voltage Stability ± 0.03%	Regulation 1%	Output Voltage 25 - 100 Volts

Full specification and details of other types on request

Savage A.C. Power Supplies are available for :-

- **1, 2 or 3 PHASE**
OUTPUTS OF
- **35 VA - 35 KVA**
FREQUENCIES OF
- **6 c/s - 100 Kc/s**

For Industrial applications and processes;
Research; Testing and Calibration

Our Engineers will be pleased to advise on all specific problems

Now Manufactured & Marketed by:-

PYE T V T LIMITED

COLDHAMS LANE · CAMBRIDGE · P.O. BOX 41
Telephones Cambridge (Office and Works) 45115
Cables TeeVeeTee, Cambridge: Telex 81103

For further information circle 297 on Service Card



WATERTIGHT ELECTRICAL CONNECTORS

Heavy
duty
Multi
- pin
Mechan
- ically
operated
patterns



WILLIAM M^cGEOCH & CO. (BIRMINGHAM) LTD.
(Telex: 338346 M^cGEOCH Bham)
BORDESLEY, BIRMINGHAM 10

For further information circle 298 on Service Card

MEASURING METHODS AND DEVICES IN ELECTRONICS

A. C. J. Beerens

An English version of a highly successful book from Holland. It deals with the general measurements that are a daily necessity for the electronics technician and describes the measuring instruments in current use.

140 pages 150 illustrations (Philips Technical Library) 35s

SEMICONDUCTORS, Volume 1: Physics and Electronics

E. J. Cassagnol

Presents a complete physical study on diodes and transistors and also treats in detail the equivalent circuits for audio and radio frequencies, in particular those used in transistorized circuitry. There are exercises on all the main topics.

310 pages 241 illustrations (Philips Technical Library) 72s

ELECTRONICS THROUGH EXPERIMENTS, Volume 1: Components

E. T. Glas

An introduction to electronics in which the theory is clarified by elementary mathematical exercises as well as examples in the form of practical experiments. Deals with tubes, transistors, resistors, capacitors and inductances, their fundamental properties and the layout of simple circuits.

264 pages 230 illustrations (Philips Technical Library) 32s
Volume 2: Devices—to be published in December, 1966

MACMILLAN Little Essex Street, London, W.C.2

For further information circle 299 on Service Card

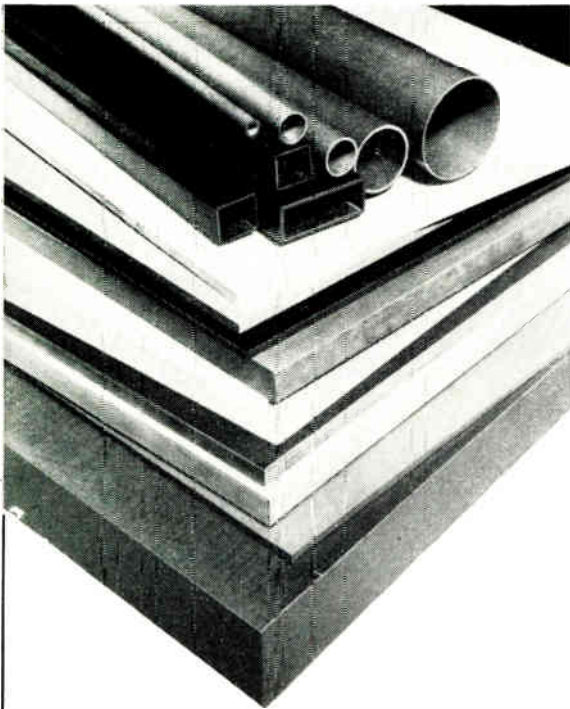

Electronic Engineering demands

ASHLAM INSULATION

Synthetic Resin Bonded

LAMINATES

*Paper, Fabric or Glass Fibre Base
with all Resin Systems*

Copper Clad Laminates and Films

**ALL LAMINATES CONFORM TO
RELEVANT B.S. AND SERVICE
SPECIFICATIONS**

Write for technical catalogue to **MICA & MICANITE SUPPLIES LTD.**

BARNSBURY SQUARE :: LONDON, N.1.

Telephone: NORth 3032 (P.B.X.)

Telegrams: MICASULIM, LONDON, N.1.

For further information circle 300 on Service Card

NOW!

a direct weekly contact with
all who work with computers



You can reach the people who matter in computers through **COMPUTER WEEKLY**. From the computer operator right up to the company director. If you have been advertising in National Daily or Sunday newspapers for computer staff, you have been forced to accept a staggering wastage of readership and money. With **COMPUTER WEEKLY** you can reach the people who programme, operate and service computers, and who make or influence the decision to purchase computers and ancillary equipment. And reach them *economically*. Costs per insertion are low. There'll be no wastage. **COMPUTER WEEKLY** has a controlled circulation of 10,000 in specific categories. Your advertising will achieve 100% penetration.

**First Issue
22 SEPT.**

COMPUTER WEEKLY

The newspaper for all who work with computers

Please ask for advertisement details from A. H. Vickers, Iliffe Electrical Publications Ltd., Dorset House, Stamford Street, London S.E.1
Waterloo 3333 (65 lines)

For further information circle 301 on Service Card



Meetings

The Institution of Electrical Engineers

Savoy Place, London, W.C.2. (Phone: Covent Garden 1871).

All meetings are held at Savoy Place and begin at 5.30 p.m. (tea at 5 p.m.) unless otherwise stated.

6th October. President's inaugural address on 'The Ionosphere and the Engineer'.

10th October, 2.30 p.m. Joint I.E.E./I.E.R.E. Computer Groups meeting on 'Micro-Programming and Fixed Stores'.

11th October. Lecture on 'Automation and Industry—the technical and economic approach to wider utilization'.

18th October. Discussion meeting on 'Transfer-Function-Measuring Instruments'.

24th October. Joint I.E.E./I.E.R.E. Television Groups lecture on 'A Slow-Motion Video Tape Recorder'.

27th October. Lecture on the 'Mechanisms of Microwave Generation in Gunn Oscillators and Avalanche Diodes'.

The Institution of Electronic and Radio Engineers

8-9 Bedford Square, London, W.C.1. (Phone: Museum 1901-3).

5th October, 7 p.m. Lecture on 'The Development of Satellite Communications', to be held at the Hornchurch College of Further Education.

5th and 6th October, 7 p.m. Lectures on 'Colour Television', to be held at Edinburgh University (5th) and the Institution of Engineers and Shipbuilders, Glasgow (6th).

12th October, 6 p.m. Lecture on 'The Communications Aspects of the Post Office Tower', to be held at the Institute of Mining and Mechanical Engineers, Newcastle-on-Tyne.

12th October, 7 p.m. Lecture on 'Commercial Personal Portable Communications Schemes', to be held at the Bristol Technical College.

12th October, 7.15 p.m. Lecture on 'The Principles of F.D.M., T.D.M. and P.C.M. as applied to Telephone Trans-

mission', to be held at the Wolverhampton College of Technology.

13th October, 7 p.m. Lecture on 'M.O.S. Transistors', to be held at the Farnborough Technical College.

13th October, 7 p.m. Lecture on 'Education and Training of Electronic Engineers', to be held at the Huddersfield Technical Teachers Training College.

19th October, 6.30 p.m. Lecture on 'Numerical Control of Machine Tools', to be held in the Walker Art Gallery, Liverpool.

19th October, 7 p.m. Lecture on 'Microelectronics', to be held at the A.E.I. Research Laboratories, Harlow.

26th October, 7.30 p.m. Joint I.E.R.E./British Productivity Council meeting on 'Reliability of Electronic Components and Microelectronic Circuits', to be held at the Reading College of Technology.

27th October, 7.15 p.m. Lecture on 'Radiophonic Effects in the B.B.C.', to be held at the University of Birmingham.

Society of Electronic and Radio Technicians

33 Bedford Street, London, W.C.2. (Phone: Covent Garden 1152).

5th October, 7.15 p.m. Lecture on 'Colour Television', to be held at the Charles Trevelyan College, Newcastle.

12th October, 7 p.m. Lecture on 'Hybrid Television Receivers', to be held at the Royal Society of Arts, London, W.C.2.

12th October, 7.30 p.m. Lecture on 'Colour Television', to be held at the College of Technology, Southampton.

26th October, 7.15 p.m. Lecture on 'Television Systems', to be held at the College of Technology, Swansea.

The Institution of Production Engineers

10 Chesterfield Street, London, W.1. (Phone: Grosvenor 5254/9).

7th October, 7 p.m. Lecture on 'Automation and Process Control', to be held at the Newport and Monmouthshire College of Technology.

16th November. Lecture (to be given in Bristol) on 'A Survey of Microelectronics, including Future Developments'.

The Society of Engineers

Abbey House, Victoria Street, London, S.W.1. (Phone: Abbey 7244).

3rd October, 5.30 p.m. Lecture entitled 'An Appraisal of the Use of Solar Energy', to be held in the apartments of the Geological Society, Burlington House, London, W.1.

Conferences, Symposia and Colloquia

5th October. One-day conference on trends in patient monitoring, to be held during the SIMA Medical Equipment Exhibition at The Hospital Centre, 24 Nutford Place, London, W.1. Details from the Scientific Instrument Manufacturers' Association, SIMA House, 20 Peel Street, London, W.8. (Phone: Park 2614).

WHAT'S ON AND WHERE

Continued

5th October. Symposium on 'The Applications of Electron Microscopy and Allied Techniques in Industry'. To be held at the Royal Aeronautical Society, London, and organized by the British Scientific Instrument Research Association, South Hill, Chislehurst, Kent. (Phone: Imperial 5555-9).

7th-12th October. 14th International Communications Congress, Genoa, Italy. Organized by The Secretariat, Istituto Internazionale delle Comunicazioni, Viale Brigate Partigiane 18, Genoa.

11th October, 2.30 p.m. Symposium on 'Relay Aspects of Educational Television'. To be held at the Institution of Electrical Engineers, London, and organized by the Society of Relay Engineers, Obelisk House, Finedon, Northants. Tickets will be required.

12th-13th October. International Design Congress—'Profit by Design'. To be held at the Royal Garden Hotel, Kensington, London. Organized by the Council of Industrial Design, The Design Centre, 28 Haymarket, London, S.W.1. (Phone: Trafalgar 8000).

12th-14th October. IMEKO Symposium on 'Microwave Measurement', to be held in Budapest. Organized by the Scientific Society for Measurement and Automation, P.O. Box 457, Budapest 5, Hungary.

12th-15th October. The 1966 Ultrasonics Symposium, to be held in Cleveland, Ohio. Sponsored by the sonics and ultrasonics group of the Institute of Electrical and Electronics Engineers, 345 East 47th Street, New York 10017.

13th-14th October. Fourth Canadian Symposium on Communications, to be held at the Queen Elizabeth Hotel, Montreal. Details from Prof. G. W. Farnel, McGill University, 805 Sherbrooke Street, W. Montreal, Canada.

18th-19th October. Symposium on 'Liquid Scintillation Counting'. To be held at the National Physical Laboratory, Teddington, Middlesex. Organized by The Institute of Physics and The Physical Society, 47 Belgravia Square, London, S.W.1. (Phone: Belgravia 6111).

24th-26th October. Second International Convention on 'Microelectronics', to be held in the Congress Hall of the Munich exhibition grounds during the Electronica 66 Exhibition. Organized by the International Electronics Association, Theresienhohe 15, 8 München 12, W. Germany.

9th-11th November. Conference on 'Automatic Operation and Control of Broadcasting Equipment'. To be held at and organized by The Institution of Electrical Engineers, Savoy Place, London, W.C.2. (Phone: Covent Garden 1871). Sponsored jointly by the I.E.E., I.E.R.E. and The Television Society.

11th-13th November. Technical Conference on 'Production and Inventory Control', to be held in the Grand Hotel, Brighton. Sponsored by the London Chapter of the American Production and Inventory Control Society and organized by Conference Services Ltd., 11 Whitehall Court, London, S.W.1. (Phone: Whitehall 8518).

Exhibitions

4th-9th October. Ljubljana

The Thirteenth International Exhibition of 'Modern Electronics', organized by the Yugoslav Committee for electronics, telecommunications, automation and nucleonics (ETAN). Details from Gospodarsko Razstavisce (Ljubljana Fair), Ljubljana, Titova 50, Yugoslavia.

4th-12th October. London

The 58th National Business Efficiency Exhibition. To be held at Olympia, London. Organized by the Business Equipment Trade Association, 109 Kingsway, London, W.C.2. (Phone: Holborn 6233).

10th-14th October. Amsterdam

Fairex '66, an exhibition of electronic components and testing equipment and professional electro-acoustic equipment. Further information from the Secretariat, Fairex Committee, Amsterdam, Minervalaan 82 hs.

10th-14th October. London

The Second Export Services Exhibition, to be held at Olympia and sponsored by the Institute of Export. Details from Scientific Public Relations Ltd., Clifford's Inn, London, E.C.4. (Phone: Chancery 8509).

11th-12th October. London

Exhibition and Conference on 'Ultrasonics for Industry', to be held at St. Ermin's Hotel, Caxton Street, London, S.W.1. Sponsored by the journal *Ultrasonics* and organized by Iliffe Exhibitions Ltd., Dorset House, Stamford Street, London, S.E.1. (Phone: Waterloo 3333).

17th-22nd October. Basel

Third International Exhibition and Congress of Laboratory, Measurement and Automation Techniques in Chemistry (ILMAC), to be held in the halls of the Swiss Industries Fair. Details from the Secretariat, Schweizer Mustermesse, 4000 Basel 21, Switzerland.

20th-26th October. Munich

Electronica 66, an international trade exhibition of electronic components and related measuring and production equipment. Details from Exhibition Consultants Ltd., 11 Manchester Square, London, W.1. (Phone: Hunter 1951).

24th-27th October. New York

Twenty-first Annual International I.S.A. Exhibition and Conference on Instrumentation, Systems and Automatic Control. To be held at the New York Coliseum, and organized by the Instrument Society of America, 500 William Penn Place, Pittsburg, Pennsylvania 15219, U.S.A.

24th-28th October. Antwerp

Exhibition and Congress on Instrumentation and Automation in the Paper, Rubber and Plastics Industries. Further information from P.R.P. Automation, Jan van Rijswijklaan 58, Antwerp, Belgium.

26th-29th October. London

International Radio Communications Exhibition, to be held in the Seymour Hall, London, W.1. and sponsored by the Radio Society of Great Britain. Details from Mr. Thorogood, Museum House, Museum Street, London, W.C.1. (Phone: Museum 2606/7).

16th-19th November. Nairobi, Kenya

Radio and Electronics Show, to be held in the City Hall, Nairobi. Organized by The East African Institute of Engineers, Electronics Group, P.O. Box 14285, Nairobi.



Ci-5000



Ci-150

HYBRID...

ANALOGUE...

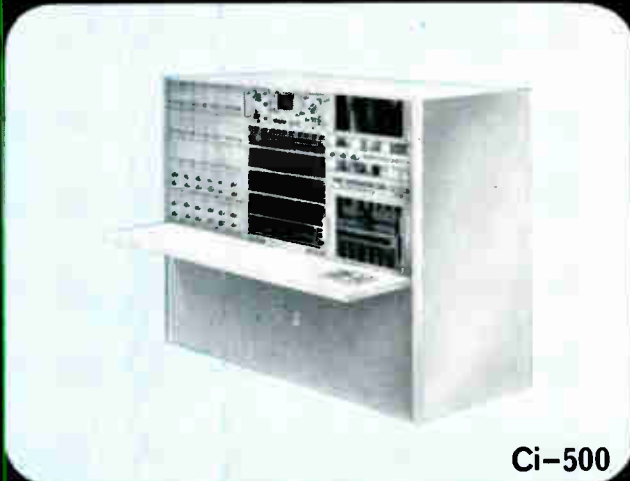

Ci-500



Ci-175

BY REDIFON-ASTRODATA LTD

100 VOLT...ALL-SOLID-STATE...FIELD PROVEN SCIENTIFIC COMPUTING SYSTEMS

Redifon-Astrodata Ltd. introduces new standards of speed, accuracy, and reliability with this highly sophisticated precision equipment—bringing Britain into the lead in the world computer market.

These RAL machines are specialised research tools designed to cover the complete spectrum of scientific applications. Each computer uses the same Ci-308 Operational Amplifier for outstanding performance—the 100-volt, all-silicon, chopper-stabilised, plug-in amplifier, utilising the latest FET techniques, that has been developed specifically for high-speed computation. All the RAL systems are pre-wired to accept these plug-in units without the need for additional wiring. Thus, the entire range has the maximum in flexibility and compatibility, and expansion of each computer is simple and economical.

Described below are the four illustrated examples of computers available from REDIFON-ASTRODATA:

The Ci-5000 Analogue/Hybrid computer is a fully-integrated hybrid

machine with high-speed digital logic address and control and built-in digital interface. The largest and most comprehensive system in RAL's range, it can handle a wide variety of scientific problems. For unusually large problems, two or more Ci-5000's can be slaved together. Already there are more Ci-5000 systems in operation than any other solid-state hybrid computer.

The Ci-500 Analogue/Hybrid computer is a large, general-purpose system which combines the hybrid capabilities of the Ci-5000 machine into an economical and versatile tool for less involved problems.

The Ci-175 Analogue/Hybrid computer is a medium-capacity, general-purpose machine with integral digital logic facilities incorporating separate analogue and logic patchboards. It has a capacity for 75 Ci-308 amplifiers and extensive non-linear facilities. All these features are housed in a compact, desk-style cabinet.

The Ci-150 Analogue computer is a medium-capacity, low-cost, easily-operated system in a small desk-style console. It holds up to 75 amplifiers and has full non-linear capability.

For technical details, write or call now to:



REDIFON-ASTRODATA LTD

Brookside Avenue Rustington Sussex Telephone Rustington 4166 Telex 87361

A Member Company of the REDIFFUSION Group

For further information circle 201 on Service Card



Your idea: use VOSPER ELECTRIC to carry out the systems control – Brilliant! – saving your time for yet more ideas – doubly brilliant!

The services of VOSPER ELECTRIC are being used, among others, by the Crown Agents, Vickers Ltd., W. H. Allen & Sons Ltd., and the Ford Motor Company Ltd.

VOSPER ELECTRIC offer a service of Design, Engineering and Manufacture of Electromechanical and Electronic equipment for industry covering the fields of process and supervising systems control. The VOSPER service is a complete service—providing experienced advice and undertaking the entire task of production and installation of the control system, using the finest components, chosen from world-wide sources, to achieve the maximum efficiency at the lowest cost.

If you have a control problem, off-load it now on to VOSPER ELECTRIC. Send us your enquiries or ask for one of our Engineers to call.

VOSPER ELECTRIC

INDUSTRIAL & MARINE CONTROLS DIVISION OF VOSPER LTD
 Castle Trading Estate, Portchester, Fareham, Hants.
 Telephone : Cosham 79481



A Member of the David Brown Group.

For further information circle 202 on Service Card