

11th OCTOBER 1961

VOL. 133

NUMBER 3435

THE ORIGINAL  
'DO-IT-YOURSELF'  
MAGAZINE

# HOBBIES *weekly*

FOR ALL  
HOME CRAFTSMEN

## Instructions for making . . .

Also in this issue:

USE FABRICS TO  
MAKE PICTURES

COLLECTORS' CLUB  
AND STAMP HINTS

BUILDING MODEL  
RAILWAY LAYOUTS

BALANCING THE  
CAMERA TONES

PROJECTS FOR  
VENEER WORK

FRETWORK PATTERNS

ETC. ETC.

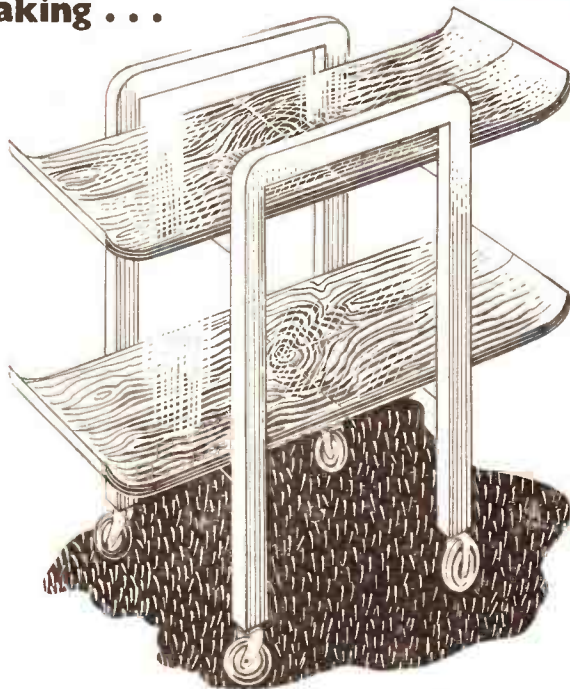

## TWO-TIER TROLLEY



Up-to-the-minute ideas

Practical designs

Pleasant and profitable things to make

5<sup>p</sup>



**G**UY CLAXTON of School House, King's School, Worcester, writes — 'Please do you think you could have an article in "Collectors Club" on beer mat collecting? I only started collecting beer mats last year, but I have 200 now. A boy in our house has 600, all different.'

## BEER MATS

Nearly all breweries issue beer mats for advertising purposes, and use at their inns and taverns. Pub landlords are the best people to approach for mats. I have never been refused yet. If you write to the breweries for mats, always enclose return postage — this is important.

Many beer mat designs are replicas of those found on beer labels. Among unusual designs we find portraits of Queen Elizabeth II, Sir Winston Churchill, and American Presidents on Australian mats. Also pictures of Sydney Harbour Bridge, various badges, and animals.

A set from New Zealand shows Mount Cook, Lakes Wakatipu and Taupo, and native art. The kiwi and other birds are also featured.

Czechoslovakian mats cover most subjects, including views, castles, hotels, crests, trinkets, uniforms, flowers, animals, etc.

Many breweries at home and overseas issued special mats to commemorate the Olympic Games of 1960.

In 1956 a Danish firm produced a set to mark the Jubilee Jamboree of the Boy Scouts Organization. Many other attractive mats have come from Denmark for commercial use, and for collectors. These mats are found everywhere in Denmark. But so many are produced that it would be difficult to keep trace of them all.

Some of the world's most beautiful beer mats come from Austria. Designs show seaside towns, ships, athletes, Coronation scenes, bridges, famous men, and women, etc.

Beer mats cover an enormous field. Often they are an accessory to stamp, and label collecting, enabling collectors to give additional interest to their chosen field by adding mats illustrating certain points not fully brought out by other issues.

If you collect beer mats, and need pen friends for exchange write to any of the following readers — George E. Hardy, Breakneck Hill Road, Framington, Mass. R.F.D.2, U.S.A. Alois Blahna, Ceska Kamenice 71, Czechoslovakia. J. Soeters, Graaf Florisstraat 1 GB. Rotterdam 3, Holland. Alfred Kronegger, Graz-Eggenberg, Bayernstrasse 12, Austria. Folkmann Eduard, Krenngasse 31, Graz, Austria. P. Bristol, 73 Wilton Street, Shankill Road, Belfast, N. Ireland.



*E. A. Amuah*

PETER TRIPP of 34 Northgate Way, Little London, Terrington St. Clement, King's Lynn, Norfolk, would like to exchange match labels with fellow readers throughout the world.

'My hobbies are collecting postcards, stamps, and labels', says E. A. AMUAH, of P.O. Box 199, Tarkwa, Ghana. 'I am 17 years of age, and would like pen friends.'

'I started collecting advertising pencils about a year ago, and today my collection amounts to 145', writes GERARD VINEY of 52 Coriolis Avenue, Rose Hill, Mauritius.

'Most of my pencils come from local firms. But I have a few from Australia and England. I have some nice souvenir pencils. My other hobbies are photography, fretwork, and postcards.' Gerard would like to hear from readers to exchange postcards against advertising pencils. He will also exchange colour slides of Mauritius against slides of any country.

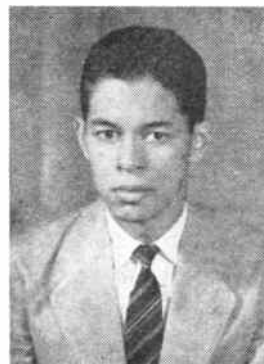

*G. Viney*

Illustrated on front

# TWO-TIER TEA TROLLEY

**T**HIS pleasing piece of furniture is easy to make if these instructions are carefully followed. It is a full size trolley with easy running wagon castors and trays with contemporary curved ends.

The trays can be fixed to the cross rails 3 or can be left free to be lifted off. If left free, four small blocks should be fixed, two at each end, to prevent the tray from sliding off the trolley. These small blocks will also act as feet.

sapele or walnut. These panels can be obtained direct from Hobbies Ltd, Dereham, Norfolk, price 27s. 6d. postage 3s., or from any Hobbies branch or stockist.

Commence by cutting the uprights 1, the top rails 2, and the cross rails 3, to size. The cross rails are mortised and tenoned into the uprights as seen in Fig. 2 and the top rails as in Fig. 3. These joints should be glued together and the excess glue wiped off before it has time to dry.

After fixing the top rails and allowing them to dry, the corners should be rounded off as indicated in the side view. The veneered panels are fixed as shown in Fig. 4, the screws being recessed by boring a  $\frac{3}{8}$  in. diameter hole. Take care to ensure that the holes are all drilled to exact depth so that the screws will not protrude through the panel.

Finish off by staining and filling the grain, sanding lightly before applying polish or varnish.

The 2 in. wagon castors are fixed after the finish has been applied. They can be obtained from Hobbies Ltd, by post 4s. per set of four, postage and packing 1s. 9d. (M.h.)

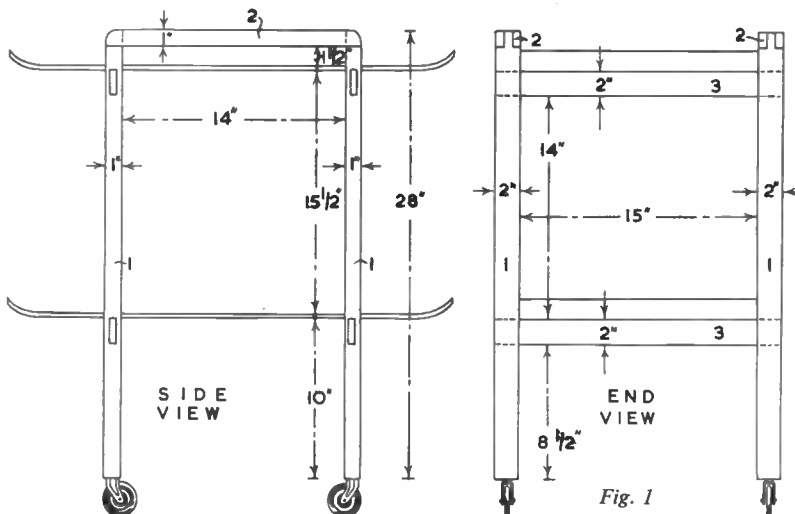

Fig. 1

Before cutting the timber, study the diagrams to get a clear idea of the work involved. Fig. 1 shows the side and end views, giving the main measurements. Notice that the trolley itself is made entirely from 2 in. by 1 in. material. Use oak for preference and stain to match. The trays are two of Hobbies veneered panels with curved ends and measure 28 in. by 15 in. They are available in oak,

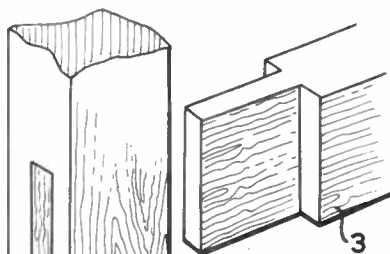

Fig. 2

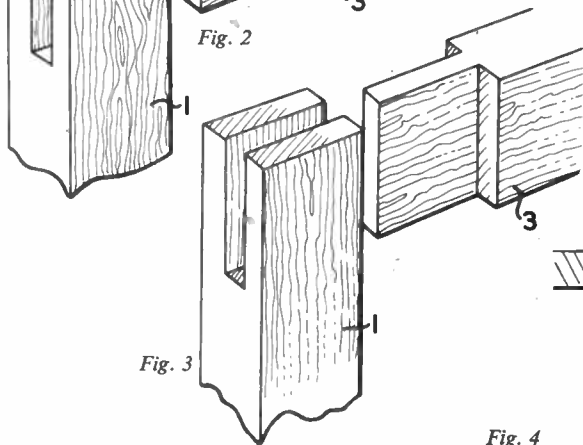

Fig. 3

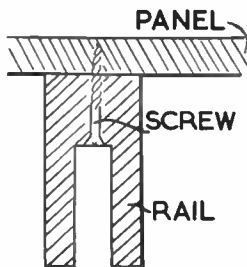

Fig. 4

## Marshall's Book of Railways

**I**N this book will be found a rich collection of hitherto unpublished photographs, many from overseas. The fascinating stories of inter-company rivalries, their struggles for railroad supremacy and many of their achievements are related by a distinguished list of contributors.

However wide your knowledge of railway history, it is safe to say you cannot fail to find further enrichment in the fresh information gathered together in this new presentation of aspects of the world's railways.

This beautifully produced book is excellent value for money and has real 'gift' appeal. Its general interest theme should make it a welcome addition to any bookshelf.

Published by Percival Marshall & Co. Ltd, 19-20 Noel Street, London, W.1. Price 12s. 6d.

Next week's free design will be for a handsome Extending Workbox on legs.  
**MAKE SURE OF YOUR COPY**



# USE FABRICS TO MAKE PICTURES

WHEN an assortment of differently coloured materials are cut out into a variety of shapes they can be combined by either making fabric pictures or designs. While these may ultimately be made into a picture for framing and hanging on a wall, they may also be arranged into a design, and the resulting panel utilized for decorating a useful article. For example, use them as panels in place of tapestries for fire screens, glass-topped tables, and all manner of things.

*By Anne Bradford*

We have two methods at our disposal, and each will be found useful according to the type of material being used. There is some relation in this work to the established form of appliqué or patchwork.

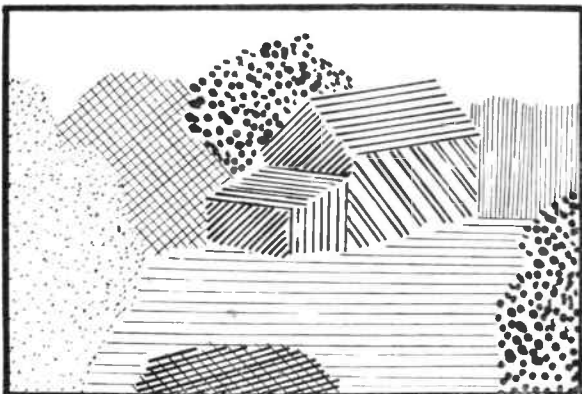

*A simple picture which is easy to make with a variety of fabrics*

First of all the material has to be selected for the ground, and this may be either a soft self-coloured flannel fabric or a strip of fine canvas interlining. When canvas is used — as in our example — it is almost like painting a picture, and work proceeds until all the base has been covered. A self-coloured material will, in some circumstances, supply part of the background, but much depends on the design. A picture or design is planned, pieces of other materials cut out to a desired shape, and sewn on to the base by blanket stitching all the way round.

It is mostly a matter of working backwards, and you will realize that the background must be the first to be attached, while details are the last, and the work progresses until the entire canvas is covered. For example, a country scene may be made by using a pale blue background, but we shall have to cover the foreground with pieces of green materials to represent grassland. Fields, buildings, and other features are then added in appropriate materials. On the other hand, a modernistic design may be in the nature of a patchwork, but here it is advisable to use a canvas base, and attach your coloured materials, which will necessarily overlap in places.

The alternative method avoids stitching. Pieces of fabric are attached to a stout paper backing by means of a rubber mountant, like Fabrex or Copydex, ultimately cutting out and sticking on to the basic fabric. Note that this method is suitable for fabrics which fray, and that it is best to apply the

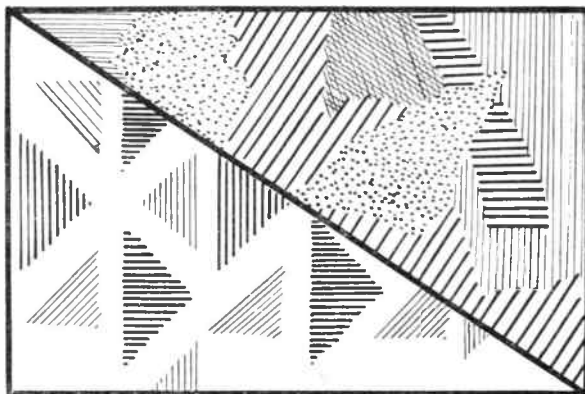

*How to make either a geometric design from one shape of different sizes or an all-over patchwork design*

adhesive to the paper, laying the fabric on top, and applying medium pressure. Excessive adhesive may penetrate and spoil the fabric, and this method is not always suitable for thin, silky materials. We should also mention that blanket stitching in itself is decorative.

When preparing a panel for a particular object, as with the waste paper bin, it is essential that the basic strip should fit, measurements being taken for the circumference and the depth. Templates are prepared for cutting out the shapes, and a variety of materials assembled. In this instance a leaf design



*Wastepaper bin covered with a fabric design. Note the braid at the top and bottom rims*

was used, so templates in a number of sizes were employed for preparing suitable shapes. In addition, printed fabrics, again depicting leaves, were also incorporated in the design.

The basic canvas is laid on the table, and the fabric cut-outs arranged in position. Some of them may overlap. They are pinned in position, and stitching should not be done until you are perfectly satisfied that the resulting combination is both pleasing and satisfactory.

As already stated, a blanket stitch may be used for sewing the pieces to the canvas background, but the extreme ends are left unfinished until it has been wrapped around the container. This can be done when the major portion of the

● **Continued on page 26**

# NEW Thoughts on

# RAILWAY MODELLING

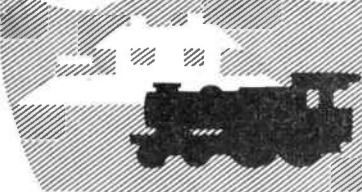

I SAID in my last article that I would be telling you how to build up a model railway layout, and that we would take it step by step. Firstly, let us consider the size of the layout we wish to adopt, and then make up our minds as to what form it is to take. Next we must decide what type of material we are going to use. One of the proprietary brands like Hornby Dublo, Trix, or, perhaps, Triang, or hand-built scale. We have next to make up our minds about the actual scale we are going to adopt — OO gauge, TT 3, or one of the larger scales. Another point for consideration is the type of construction. Shall it be a permanent layout

parts can be obtained as the work progresses. In order to cut down the cost as much as possible I shall be giving you ideas for building much of the layout from scratch, and from materials that are readily obtainable. In this way you will find it cheaper.

## BUILDING A LAYOUT—1

I am describing in this article a couple of plans for layouts which will fit into a comparatively small room. In both cases the layouts are only a nucleus of a finished model, and can be expanded at the will of the builder.

I have recently been able to test the Kitmaster Electric Motorised Bogie and the Box Van with motor complete, and I can report that they are superb in every way. I fitted the Motor Bogie into a Kitmaster Coach as per the instructions and this is quite easy to do. I like the way the motor bogie is mounted into the roof. It is quite heavy and so holds the track well, but a suggestion is to put some weight in the coach over the other bogie to keep it on the track. I found that this bogie seems to 'float around' a bit, especially overpointwork.

Two other recent models I have made in the Kitmaster range are of the Restaurant Car and the French Railway Coach. Both are excellent kits in every way. In the first named the seats are too small, so that scale figures cannot be used, but the detail of the tables and in the lavatories at each end is astounding. There are even taps on the sinks. The French car is the most detailed model yet. Not fitted with seats, I am sorry to say, but the detail in the sides and on the roof and the ends is really superb.

stations for passenger train working, and also a goods station, and a couple of sidings, and there is room for a small en-

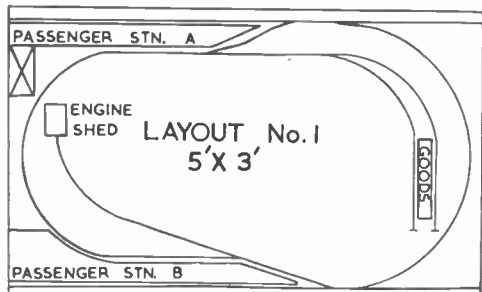

or sectioned for easy assembly and removal, like my Maryville, Fredricton, and Westbury Model Railway.

Naturally, the decision will be governed by the size of the room available, and also how much you are prepared to spend on the project. This last item is, naturally, of the utmost importance, but one should realize that it is not essential to purchase all the material at once. The

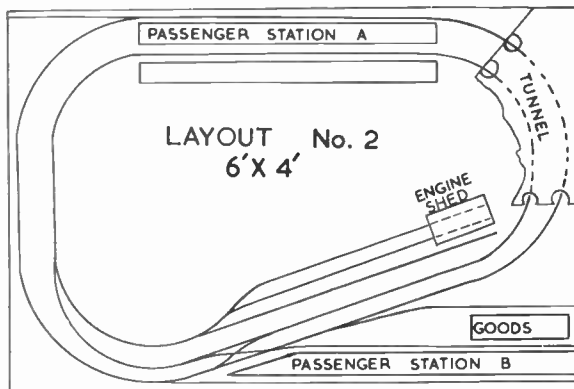

Layout No. 1 is 5 ft. by 3 ft. in size. Quite small, but you could have some interesting running with it. It houses two

engine shed. There is room on this layout for continuous running around the ends, and also you will see that by adding other boards the layout can be expanded as time, space, and money permit. Scenic work will be added later.

It should be pointed out that this layout is for single line working only, and is designed for OO scale, but it could be adapted quite simply for TT 3, when, of course, one would have a little more running than is possible with the larger scale. There is no complicated pointwork, but curves would have to be kept down to the minimum.

Layout No. 2 is much more ambitious. It is 1 ft. wider in each dimension,

### FOR YOUR LAYOUT

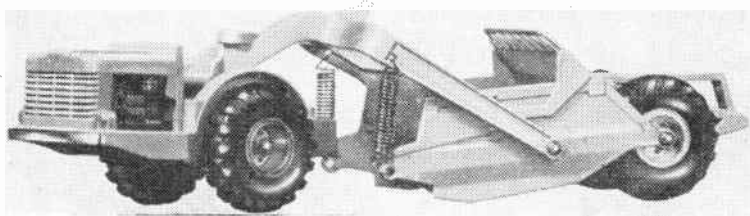

Allis-Chalmers earth scraper. '00' scale 15 cm. long. 'Matchbox' model, 4/11

# BALANCING THE TONES

**P**HOTOGRAPHY experts tell us to avoid the high sun, and the hours close to noon. A brilliant high sun floods a scene with overall brightness, giving few shadows, and they are short, hard, and contrasty. The print easily becomes a soot-and-whitewash effect of brilliant highlights and splashes of black shadow. Overall brightness, just as in the case of overall dullness, causes lack of visual interest in the print — we lose the interesting inter-play of light and shade through to deep shadow.

*By E. G. Gaze*

A high summer sun gives the most brilliant overall lighting. At other seasons the lighting is more mellow, and evening and morning sun does give longer, softer, and more luminous shadow play. But often on holiday or an outing, the most interesting places seem to be reached when the sun is high in the sky! In these latitudes it is never directly overhead, so there is always *some* shadow, even if short, and by choice of camera position much can be done to find shadows to break up otherwise over-brightly lit foregrounds.

With high sun position the high-lights will lose texture, especially if your exposure is adjusted to bring out detail in the shadows and, with any fairly high, bright sun position, it is generally useful to visualize a scene in terms of composition tonal values, choosing camera position relative to the sun to balance high-lights, deep shadows, and more luminous ones to avoid a 'bitty' effect.

In fact it is a very good policy, whatever the sun position, to move around the scene. Find a snapping position which breaks up large areas of foreground with as much shadow detail as possible, which concentrates the high-lights against the shadows in the main scene in a way which gives a 'smoothness' to the composition, and avoids 'bittiness'.

Photograph No. 1 was snapped with a high sun almost facing the camera. The result is an overall bright road foreground lacking in interest. There is a 'bittiness' about the splashes of highlight elsewhere. The shadows are short and hard and splashed around throughout the scene. A soot-and-whitewash, 'bitty' effect with no balance in composition and tonal values.

For No. 2 there was a high, strong sun, but camera position was chosen to make the most of the fairly short, deep shadows of trees to break up the brightly lit foreground. High-lights are quite large in area on the print, but are not 'bitty'. The lighter shadow areas are also massed in area.

The sun was not so high in the sky for No. 3, but was still strong. The



Fig. 1—Visually 'flat'—and bitty

shadows and high-lights form well defined areas, avoiding 'bittiness' and balancing with each other. Very often, too, in strong sun-light with a high sun, clouds are light and airy against the blue. Skies tend to print light, and a deep yellow or green filter will give tone, and make the most of light cloud forms.

Completely toneless, blank skies don't give a 'natural' look to the print, and a filter will give some tone even on a cloudless day, provided exposure is not over-much. On a brilliantly lit scene a small filter-exposure factor of  $1\frac{1}{2}$  or even 2 can be ignored. Tone will be obtained in the sky portion, and sufficient exposure given to the main scene. It is a matter for individual experience matched with your normal exposure and film development technique, but a little experimenting with filters on a bright scene will enable you to judge for yourself the effect you wish to get.

Another way to break up a clear blue, strongly lit sky is to chose a camera position which places a tree shape against the background sky. This is particularly effective in the leafless days, when branch patterns are delicate and attractive. Often a large tree in the middle foreground when in full leaf will itself be either too dark a shadow mass, or too



Fig. 2—Short deep shadows break up 'flat' foreground





Fig. 3—Shadowed foreground, remainder balanced to concentrate interest and avoid bitterness



Fig. 4—Spring sun, quite high but softer sky

onflicting an area of deep shadow and reflecting high-light leaves. It may then steal' eye interest from the main scene. But in spring, late autumn or winter, tree shapes are useful without necessarily being too prominent in the print. In No. 4 — the spring sun is soft. Shadows are softer and longer when used to break up the high-lighted road surface in the foreground. The sun position is still quite high, but high-light and shadow areas are massed in area, and not

'bitty'.

From these examples it can be seen that, even with a high or fairly high strong sun, the 'bittiness' of brilliant highlights and scattered shadows, even the lack of contrasting tonal values due to overall bright, even lighting, can usually be avoided by a little care in choosing the camera snapping position. Aim to balance tonal values in masses to concentrate visual interest in the print, and still obtain an effect of bright, high

sunlight. Morning or evening sun, throwing softer, longer shadows, avoiding harsh shadows, giving luminosity to the shadows, lends itself to pleasant tonal values. But even with a high, strong sun care in a camera position relative to the angle of lighting, and massing of the contrasting tones to avoid visual 'flatness' or 'bittiness', will give visually pleasing prints while retaining the effect of a bright, sunny time of day.

● Continued from page 21

## MODEL RAILWAY LAYOUTS

and it also houses two passenger stations, one of which has two platforms. There is a goods shed, a larger engine shed, two roads, and up in the far right-hand corner a tunnel which spans two tracks.

This layout is designed for two track working. It has continuous lines, and the curves are not so sharp in radius as Layout No. 1. This is quite a sound little layout, and will allow for quite a bit of scenic work, which will be described later.

I shall give you some more layouts in my next article, the aim being to give you the idea of how much can be put on a board of a given size. This ground work is most essential, it is not much use just making up your mind that you are going to build a layout of a certain size without first considering what you want to put on it. One has to cut one's cloth, as it were, according to the pattern, and the important decision to make is 'just what do I want?'

If you want to run long passenger trains, then you must have a larger layout. Nothing to my mind looks worse than long trains running on tight curves. One must consider the size of things. A large Pacific class engine measures about 11 in. long, and coaches are not far short of this measurement, so you can see a five-coach train with engine will measure over 4 ft. long, and on a layout of 5 ft. by 3 ft. it would be a case of the train chasing its own tail-light all the way. But on the same layout a small engine with, say, two or three small coaches, would look just right.

I will deal with two more layouts in my next article, and then we will get on to the method of building up the baseboard to take the railway.

# "THE QUARTET" TODDLERS



## TOOTH BRUSH TIDY



THE ONLY  
TOOLS  
NEEDED

THIS PROJECT  
WOULD MAKE  
AN IDEAL  
GIFT FOR  
ANY YOUNGSTER

HOBBIES JIGSAW  
PUZZLE PICTURE  
"THE QUARTET"

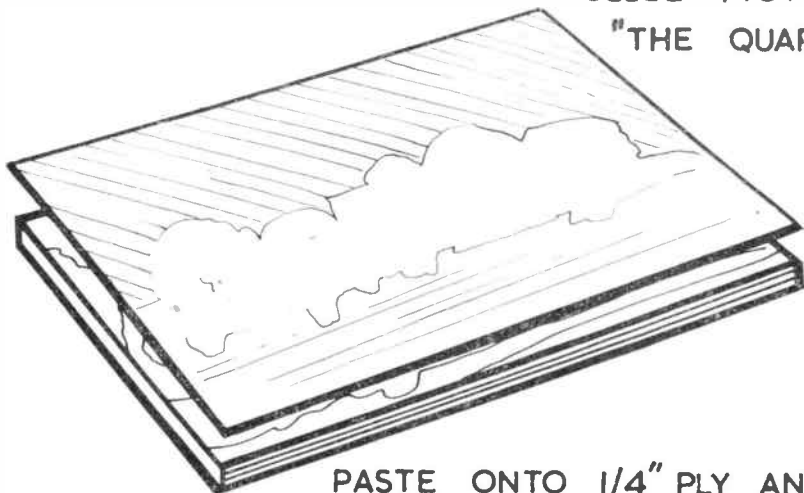

PASTE ONTO 1/4" PLY AND CUT  
OUT AS INDICATED

THIS  
WILL  
UPON  
OF TOG



AFTER PASTING PICTURE TO  
1/4" PLY CUT OUT AS BELOW

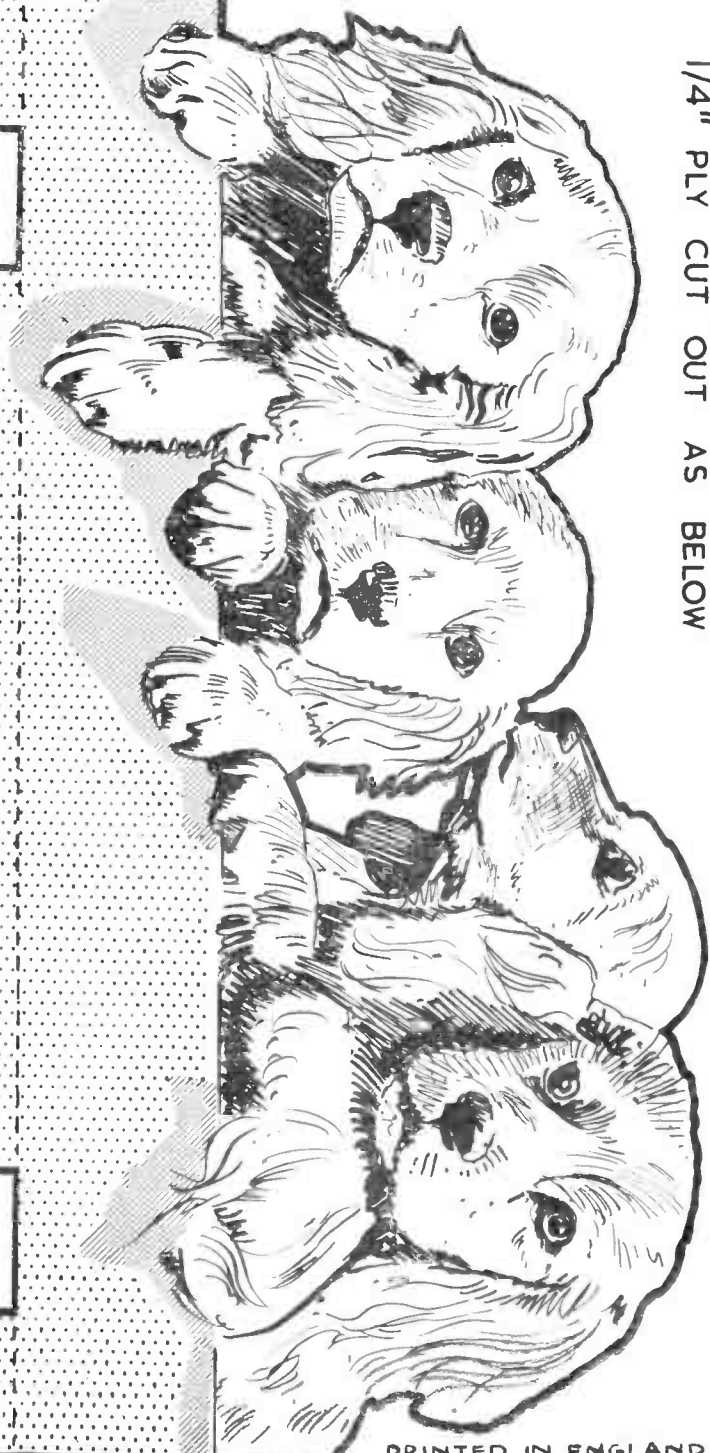

CUT ONE FROM 1/4 IN.



HOLE  
DEPEND  
THE SIZE  
WITH MUG

PRINTED IN ENGLAND

# PROJECTS FOR VENEER WORK

THOSE who are not temperamentally equipped to make marquetry pictures calling for time and patience will be interested in another use for veneers. The types of articles that can be made are shown in the photographs and the reader will undoubtedly think of many others which could provide a profitable and inexpensive pastime. The only materials required are a packet of veneers (or left-overs from making a marquetry picture), pieces of plywood, a tube of glue and panel pins.

The idea is simply to make the box or other object first with scrap pieces of plywood glued and panel pinned together as shown. Then cover it with different veneers until no trace of the original plywood can be seen. Joints are not necessary but it is important to cut the pieces accurately and to glasspaper thoroughly to provide a perfectly flat base on which to glue the veneers. Ensure that the panel pin heads do not protrude above the surface of the wood after glasspapering. Curved surfaces can also be veneered but it is advisable to begin with flat surfaces.

You can use a contact adhesive for gluing the veneers to save time in waiting for the glue to set, but remember that there will be no 'second chance' once the piece of veneer has been placed in position. Cut the veneer slightly larger than the surface to be covered (about  $\frac{1}{8}$  in.

By  
*J. H. Parry*

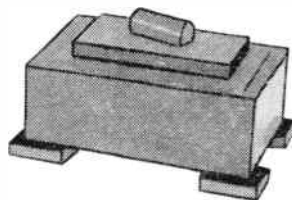
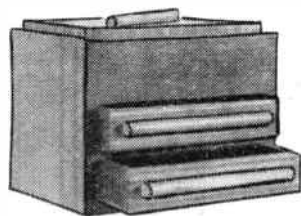
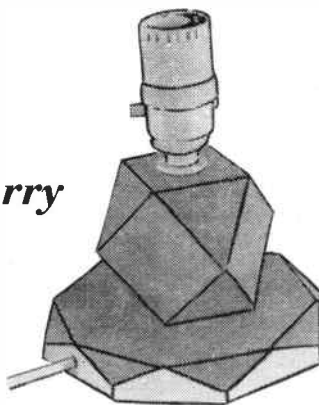

(Top Right) Small cabinet suitable for stationery  
(Bottom Right) Cigarette or Trinket Box  
(Left) Faceted table lamp veneered as described

all round) and place in position. After a few seconds the edges can be trimmed off with a sharp knife or a small Hobbies fretwork plane and finished off by glasspapering.

When all the veneering has been completed, smooth down well with glasspaper and round off all the sharp edges and corners. Polish with wax as used for marquetry or french polish. Wax polish should be well rubbed in and given an occasional rub down with fine glasspaper in between. French polish gives a better gloss and can be applied with a brush. This should also be glasspapered down

in between coats.

Finally, do not overlook the insides of boxes and small cabinets. These should be lined with suitable material. Self adhesive plastic covering is very useful and small pieces are often left over from other jobs. Glue pieces of felt under any objects that stand on polished tables to prevent them from scratching the surface.

● Continued from page 20

## FABRIC PICTURES

work has been completed. It is not advisable to have any overlap of the canvas at the joint. Trim the ends so that they touch, sew together, keeping the picture as taut as possible, then cover this joint with the addition of the few remaining fabric pieces.

You will notice that braid has been added to the top and bottom rims. While this is decorative, it also hides the raw edges of the canvas, and can be stuck into position by means of a light application of Fabrex.

Perhaps we should mention that a large toffee tin was obtained for this purpose. The grooved rim was levelled by filling with a plaster filler, and then painted. The inside and the bottom were also painted in a light pastel colour.

The term 'fabric pictures' should be construed in a wide sense, for while it is possible to make pictures in the ordinary manner, experiments can be made with modern fabric designs, using conventional geometric shapes in many colours, or by using odd shapes for novel effects as in the diagrams.

PIECE OF DOWEL  
SCREWED FROM INSIDE

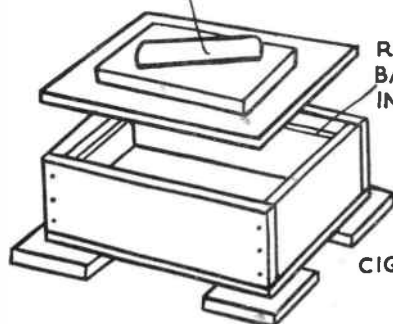

RIM OF 1/8" SQUARE  
BALSA WOOD GLUED  
INSIDE TO HOLD LID

MAKE UP OF  
CIGARETTE BOX

MAKE UP OF LAMP BODY

HOLE FOR  
FLEX

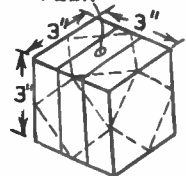

AND BASE

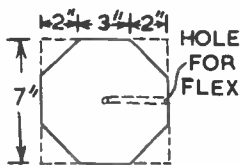

# NEW Angles

# on OLD favourites

## from these Books bulging with BRIGHT IDEAS

Any volume in this most interesting range of books, each dealing with a different aspect of gummed paper-craft, will show you a wealth of ideas, the way to carry them out, and give hours of intense enjoyment.

Each is the key to an economical hobby that is rich in variety, ranging from the making of a charming picture to framing it delightfully — from three dimensional models to wall decorations, from paper sculpture to charming flower studies.

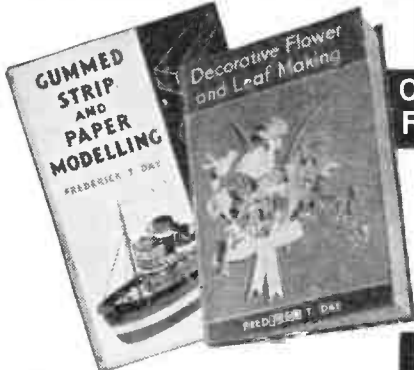

### Other books by FREDERICK T. DAY

- Coloured Paper Decoration .. .. 7/6
- Coloured Papercraft for Schools .. 7/6
- Coloured Papercraft for Infants' Schools.. 6/-
- Lampshade and Parchment Craft .. 8/6
- Decorative Flower and Leafmaking .. 8/6
- Gummed Strip and Paper Modelling .. 7/6
- Paper Sculpture for Schools .. .. 7/6



# 8/6

All books obtainable from:  
Newnes & Pearson Ltd.  
Tower House, Southampton St., Strand, W.C.1.  
Ask your stationer to show you the Butterfly range of  
handicraft materials.

## SAMUEL JONES & CO., LTD.

STATIONERY MILL, CAMBERWELL, LONDON, S.E.5. RODNEY: 5064



for holding  
**POWER**

# SECCOTINE

There's nothing like real SECCOTINE! For over sixty years Seccotine has been indispensable to every handyman. For sheer adhesive power buy Seccotine with the efficient new "pop-on" seal and open-nozzle tube ready for use.



STILL ONLY  
**1/3**  
PER TUBE

Sole Manufacturers — McCaw, STEVENSON & ORR LTD., BELFAST

## FOR A SENSE OF ACHIEVEMENT!



### JOHNSON DO-IT-YOURSELF OUTFIT

See your own work come to life with a Johnson Do-it-yourself Outfit! At last a range of easy-to-use photographic outfits for the keen photographer who wants to develop and print his own films. There are outfits for beginners and for the more advanced enthusiast. Each outfit has everything you need, including full, easy-to-follow instructions. Johnsons make a wide range of photographic equipment and chemicals, stocked by all photographic dealers. Prices from £1.17.6 to £5.12.6.



FOR CONFIDENCE IN PHOTOGRAPHY



...ab evenly on the paper th... to know if you ex... wish to make some pla... nter? (R.P. — Wolverhampton.)  
...ht and hang to dry under... to go over the wallpap... on the same... Channel 10 would

# Replies to Readers

...a... V. and 15V... more.)... is a brush point... fully, as... was made by fixing... board over a sto...

## Rust Preventer

**I** WISH to prevent rust on steel which is exposed to damp weather. Your advice would be appreciated. (C.M. — Bromley).

**H**ERE is a cheap simple treatment which you can make up yourself. It consists of four volumes of orthophosphoric acid and one volume of water. Orthophosphoric acid is a syrupy liquid which you can obtain from a dispensing chemist. Simply stir it with the water until an even solution is attained. Scratch brush the steel to remove any existing rust, and immerse in the mixture for a few hours. Lift and allow to dry without rinsing. The steel blackens, and may be improved by a light rubbing with thin oil.

## Re-gluing Joints

**I** HAVE some furniture which needs re-gluing owing to looseness of joints. Having stripped it down, I find an excessive amount of glue. Can you tell me an easy method of removing it? (J.W. — Manchester).

**I**F it is really necessary to remove the glue from the joints, the safest method is to soak the tenons in hot water, and

scrape the glue away. We think, considering the looseness of the joints, which points to bad workmanship, the best plan would be to remove part of the glue by careful chipping, and possibly filing, then to re-glue and clamp up. If you remove the whole of the glue you will have to use a thick mixture to fill up the joints again, which will take time to harden.

## Car Anti-freeze

**C**AN you please give me a recipe for an anti-freeze as used in cars? (W.S. — Aberdeen).

**A** SIMPLE anti-freeze can be made from one volume technical grade glycerine, and three volumes water, thoroughly mixed. It is used neat, will stand 22 degrees of frost, and is non-corrosive to metal. Also commonly used is a neat mixture of equal volumes of ethylene glycol and water. Provided you use technical grade glycerine, the first recipe will prove the cheaper. If you cannot obtain it from a local pharmacist or laboratory furnisher, you should contact a soapmaker, such as J. Crosfield Ltd, Warrington, Lancs., or Thom Ltd, Pendleton, Manchester.

## Painting a Boiler

**C**OULD you suggest a remedy for rust on a galvanized (electric) wash boiler? I have tried aluminium paint, but this keeps peeling off. (C.R. — Cookham).  
**T**HE important thing is first to remove the rust, using one of the preparations sold by ironmongers, as well as emery cloth. This should be followed immediately with a heat-resisting enamel.

## Colouring Water

**C**AN you advise me as to what chemicals to use in colouring water? I intend to fill jars and bottles with it, and place lights behind them. (S.J. — Derby).

**T**HE cheapest method is to use red, green, blue, and violet inks, or cake icing colours, suitably diluted with water. Chemicals will give a wider range if desired, and the following are very suitable for the purpose:

Cobalt chloride	red
Potassium dichromate	orange
Potassium chromate	yellow
Nickel sulphate	green
Copper sulphate	mid-blue and pale blue
Copper sulphate and clear ammonia	deep blue
Methyl violet	violet
Potassium permanganate	purple

Strength will have to be a matter of judgment, for effectiveness depends on the thickness of solution through which the light must pass. To make up the solutions, powder the chemicals and stir them into the water, a little at a time, until the required depth of shade is reached. In the case of copper sulphate and ammonia for deep blue, first dissolve the copper sulphate, and then add ammonia little by little until the solution deepens no more; this solution can then be diluted with more water if it appears too deep.

## Rust in Iron Tank

**T**HE inside of our galvanized cold water storage tank has rusted. Is there any way of removing this and preventing its recurrence? (W.H. — Portslade).

**Y**OU should empty the tank and dry. Remove rust with a vigorous rubbing with a wire brush, and dust out. Now apply two coats of lime white, prepared thus: slack quicklime with water to form a thick cream, add a little glue dissolved in hot water, and  $\frac{1}{2}$  pint linseed oil to each gallon of the wash. Thoroughly mix and rub well into cracks and crevices. When dry, apply a second coat, and let that dry, too, before filling the tank with water.

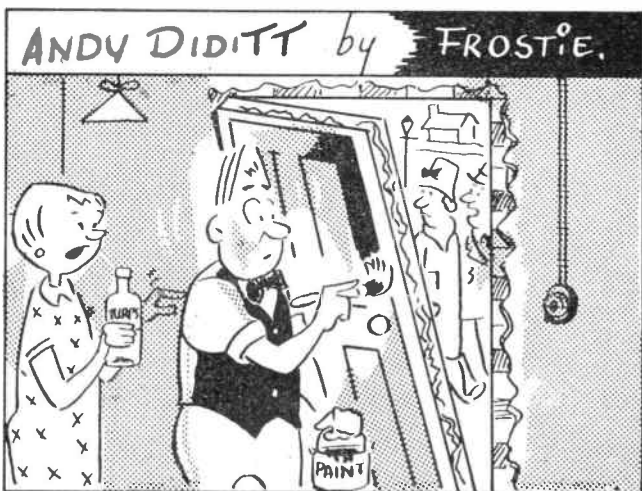

"WE'D BETTER THIN THAT PAINT DOWN A LITTLE MORE, ANDY."

54 page Edition  
**WHERE'S THAT CAR FROM?**

Price 1/- (Postage 4d.)

Entirely new! Brief Guide to  
**INN SIGNS**

Price 1/6 (Postage 4d.)

Of all Booksellers

or

**RALEIGH PRESS, Exmouth, Devon**

**HANDBOOKS** on Photography, Model Aircraft, Lampshade Making, Painting, Sketching, Conjuring, etc. 4/6 post free. Or send S.A.E. for lists. — John Reade, 11 St. Michael's Gardens, Shrewsbury.

**WILL PAY** worth while for one or more compass lens combination, sandwich type, stamped Made in England. New, used. — Alexei Zardzke, 340 Bowery, New York 12, New York, U.S.A.

**MUSCLES IN A MONTH!** Complete Body-Building Course, 10/6. Post Free. — Pioneer Publications (Dept. XI), 9 Courtland Terrace, Merthyr Tydfil, Glam.

**PAINTING** offers relaxation and profit. Even beginners can make art pay, painting their preferences. Endless demand. Exciting free brochures. Popular Art Services (HW), Clun, Shropshire.

**PERSONAL COLUMN LTD.** Falcon House, Burnley, Lancs. — Pen Friend — all hobbies. Correspondents in almost every Country All ages. S.A.E. for details.

A certain young fellow named Moore... tried dancing, but fell on the floor!

So—a man of resource—he took ESCORT'S quick Course

—And now he's got partners galore!

Can't afford private lessons? Learn ballroom dancing at home! Send for exciting booklet *Dance Escort* — FREE to readers of *Hobbies* — which explains the dynamic SURE STEP system. Send name and address to:  
**ESCORT DANCE INSTRUCTORS**  
Studio H.32 Harrogate  
(or Rock 'n' Roll Course — send 4/6 P.O.)  
OLD TIME Course 8/6 or CHA-CHA Course 5/6 or Escort Complete Ceili Course 6/6

**100 DIFFERENT** stamps free! Request 4d. upwards discount approvals. — Bush, 53 Newlyn Way, Parkstone, Dorset.

**ENJOY WRITING?** Then write for Profit. Send for 'Writers' Handbook' (free) detailing countless opportunities for beginner or experienced. — Writers' Ring (HW), 5 Edmund Street, Birmingham.

**EARN EXTRA MONEY** with your sewing machine by making cushion covers. Profitable and interesting. Regular work guaranteed. Apply Dept. 28, Arnold Company, 10 Shelley Road, Worthing, Sussex.

**LEARN**  
**RADIO & T/V SERVICING**  
**for your OWN BUSINESS/HOBBY**  
● by a new exciting no-maths system, using practical equipment recently introduced to this country  
FREE Brochure from:—  
**RADIOSTRUCTOR**  
DEPT. G81, READING, BERKS. 11/10/61

**HULL**  
**DO YOU KNOW?**

**HOBBIES LTD. have a branch at**

**42 SAVILE STREET**  
(Removed from Ferensway)

where the manager and staff are always willing to give you the benefit of their experience with any of your handicraft problems. Why not pay a visit?

**The New SLIM LEGS**

supplied with metal blocks

**PLAIN FERRULED BEECH**

No. 601 — Per set of 4  
6 in. 9/6 15 in. 12/6  
9 in. 10/6 18 in. 13/6  
12 in. 11/6 20 in. 14/6  
24 in. 16/6

Postage and packing 2/6 extra

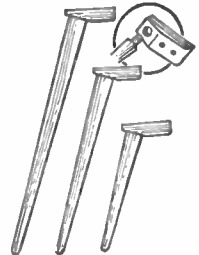

**PLAIN BEECH with wood blocks**

No. 580 9 in. 7/-  
No. 581 15 in. 9/-  
No. 582 20 in. 11/-  
No. 583 29 in. 22/6

per set of 4

Postage and packing 2/3 extra.

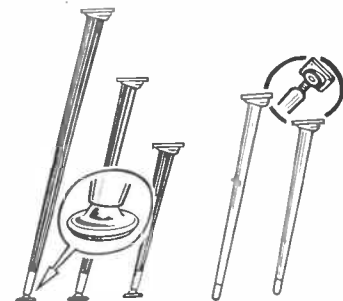

**EBONYISED with Ferrules & Glides**

No. 604 — Per set of 4  
6 in. 14/- 12 in. 16/- 18 in. 18/-  
9 in. 15/- 15 in. 17/- 20 in. 20/-  
24 in. 23/-

Postage and packing 2/6 extra

**HOBBIES LTD.**

(DEPT. 991)

**DEREHAM**

**NORFOLK**

You simply pour out these

**NOVELTIES**  
with NEW LIQUID PLASTIC

Here's the hobby to make your spare time pay dividends. You simply choose your mould and pour out beautiful castings. We supply everything, including instructions. Wonderful results achieved — wonderfully quickly! Start right away — no training needed. Send 6d. stamp for exciting book and market details. No obligation.

**QUALITY PLASTICS LTD.**

Dept H33, Feering Factory, Kelvedon, Essex



**THE 'MARVEL' BENCH MOTOR-DRIVEN SAW**

To meet modern needs. Just plug in and switch on from any house lighting point. For either A.C. or D.C. mains. With 230-250 volt motor, flex, switch, etc.

**£13 10 0**

(without motor  
**£5 10 0**)

Easy Payments Available

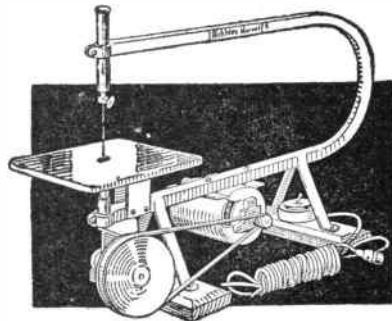

**HOBBIES LTD (Dept. 991), DEREHAM, NORFOLK**



# Stamp Collector's Corner

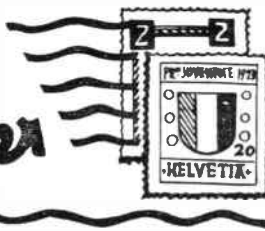

WE have already written about what to collect, now we come to the all-important question of what to do with what has been collected — that is, placing in the album.

There are three kinds of albums to consider. First we have the lowest priced type, each page of which is ruled in squares or rather oblongs. Into each of these you are supposed to place a stamp. We will assume that the stamps are ready for mounting — that is, they have had all the paper taken from the back either by placing them face upwards in a dish containing wet blotting paper or by treating with one of the patent solutions for removing paper. But remember, please, that stamps printed by the photogravure process, and that includes the present day issues of Great Britain, must not be placed in benzene, or the colour will be destroyed. Try putting a 2d. Queen Elizabeth stamp in benzene, and see what you get when it dries out.

Now one of these printed albums will have sufficient spaces for the stamps of a beginner, but if, for example, you have a relative abroad who sends you lots of stamps from one country, then you must be prepared to place a neat piece of paper in the album to help out the space for such a country. Suppose you consider the arrangement of the stamps of Great Britain, because you should have more of the issues of your own country than of any other. These must be arranged according to the reign in which they were issued. For instance, all the stamps during the reign of Queen Victoria must come first, then those of the reign of King Edward VII, followed by those bearing King George V's portrait. Then King Edward VIII, and so on.

What amount of space should be allowed for each reign? Well, if you are the possessor of a Stanley Gibbons catalogue — the simplified version is all that is necessary at this stage — you will see that they have listed eighty-four stamps as issued during the reign of Queen Victoria. Then they have eighteen for the reign of King Edward VII, forty-seven for King George V, four only for the very short reign of King Edward VIII, forty-two for George VI, and so far thirty-one for Queen Elizabeth. These figures do not include all the regional

stamps — Jersey, Guernsey, and Isle of Man (a 3d. stamp each), and Northern Ireland, Scotland, and Wales (3d., 6d., and 1s. 3d.). Also, there are the postage due stamps, and the official issues.

The stamps of each reign must be kept separate. Nothing looks worse than to see a page of stamps in which the portraits of the monarchs are all confusion.

---

## ARRANGING THE COLLECTION

By L. P. V. Veale

---

Now it is hardly likely that you will have all the stamps from Great Britain, nor is it likely that the stamps you have are in exactly the same proportions as those mentioned in the catalogue. You should have practically all the thirty-one stamps for the reign of Queen Elizabeth, and also a large part of the forty-two issued in King George VI's reign, but you will only have a few of the stamps of King Edward VII. The best thing to do is to count up the stamps of each reign that you have, and allow space according to that requirement, remembering the other figures, so that you will be able to estimate how many spaces you are likely to fill for each reign.

It is fortunate for us that all the stamps of any one set of Great Britain are the same size and shape. That is not exactly true, because the £1 of the Postal Union Congress issue of 1929 is very large, while the low values are the usual shape. But as the £1 stamp is costly, either used or unused, it is not likely that many beginners will be worried with that.

Before we go on to describe the way to arrange the stamps in a loose-leaf album we had better give a little advice on albums. Although you may be able to get a better and bigger album, consider if it is the best thing to do. Nothing is more disheartening than to have an album of large proportions but with only a very few stamps in it. It is much better to stick to your small album until you have more stamps than you can mount

in it. Then when you decide to get a larger album you will have plenty of stamps to go in. A new album also gives you the opportunity of arranging your stamps in a proper fashion, and to clean them up.

Of course, the loose-leaf album is the best for most purposes. If it is a normal size then you can always get some spare sheets as they are needed. You have the advantage of being able to house a large collection from one small part of the world as well as a general collection. But you have to take quite a lot of care in arranging your collection.

Suppose we examine a definite case — the last set issued for the Gold Coast before it became Ghana. There are ten stamps in the set up to the 2s. 0d. value. The stamps are oblong 3.4 by 2.5 cm. Seven values, the ½d., 1d., 1½d., 3d., 4d., 1s. 0d. and 2s. 0d. are horizontal, and the 2d., 2½d., and 6d. are vertical. To mount these directly in order of value, the ½d. first, and so on, would make a very poor show. You would have three horizontal and two vertical, then two horizontal, one vertical, and two more horizontal. If, however, you decide to mount them so that they look nice, you will have the first four horizontal stamps on one line, three more horizontal on the next, and then three vertical stamps at the bottom.

By being even more careful you can improve on this. Each value shows a medallion with the portrait of Her Majesty. In some the portrait faces to the right, and others to the left. Try to arrange the stamps so that the portraits face inwards. If you have not got all the stamps of the set at the time you want to mount, well mount those that you have got in the best possible manner. When you do get the rest, rearrange them all. After all it is only going to cost you a few stamp mounts.

The arrangement of the colonial stamps is fairly easy, because you know which monarch came after which, and that is your guide. But with the foreign stamps things are much more difficult, and you can hardly be expected to know where to put them unless you have a catalogue. This is not very expensive, and it is not by any means necessary to have a new one as soon as it comes out. In fact for most countries an out-of-date catalogue is quite sufficient, and can be picked up quite cheaply. Any stamp that you have which is not in the catalogue must have been issued after the catalogue was printed, so that gives you a guide to the date.

Now how about rearranging some of those pages in your album? Take one country at a time. Do not pull all the stamps out at once. Choose a fairly easy country first, and when you see the improvement, you will almost certainly want to get on with the others.



# Canadian Bracket

CUT one each of A and B from  $\frac{1}{4}$  in. wood using a fretsaw. Glue A into B, clean up and stain. Finish with clear varnish. Fix to wall by means of Rawlplug and screw. (M.p).

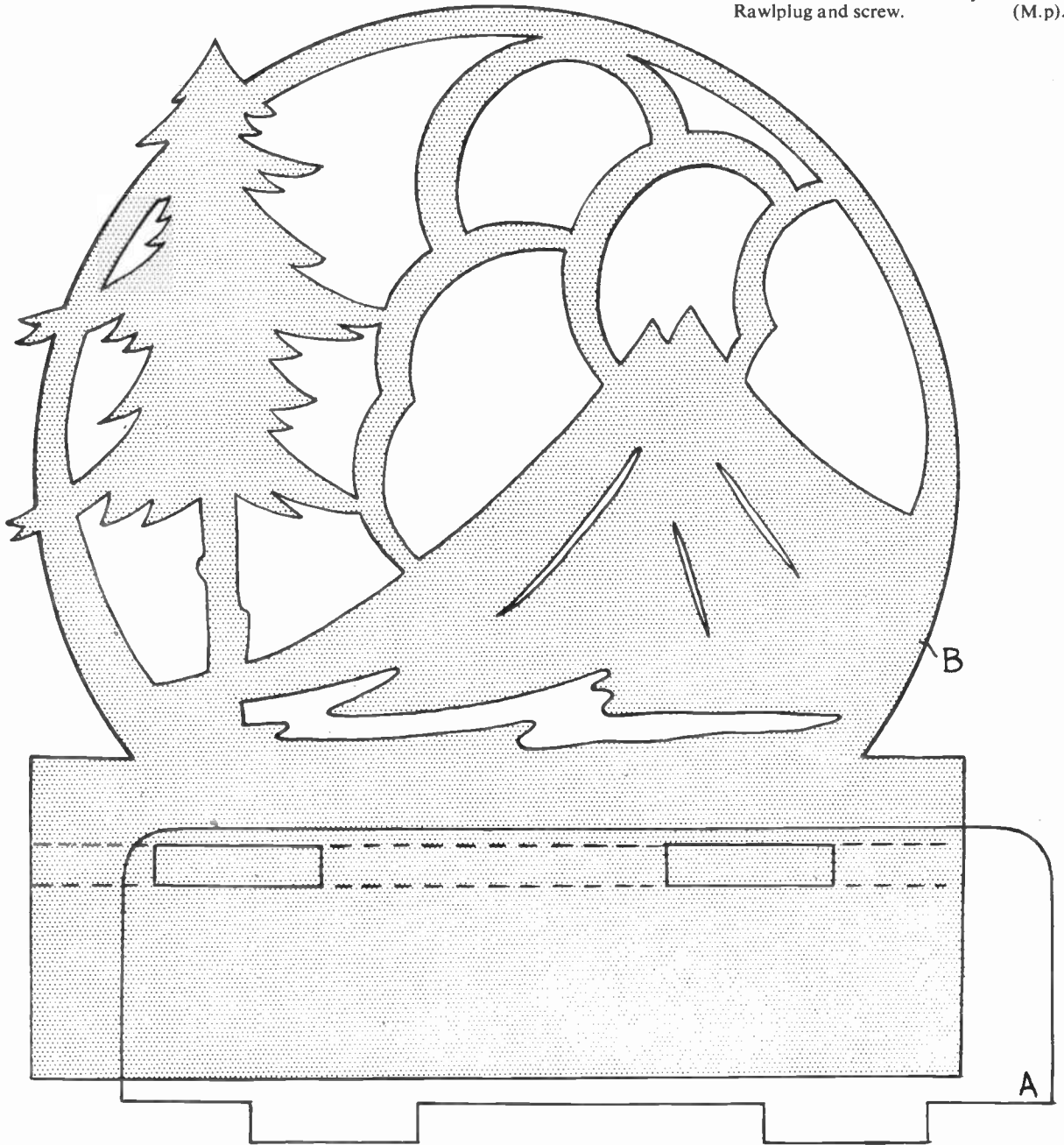

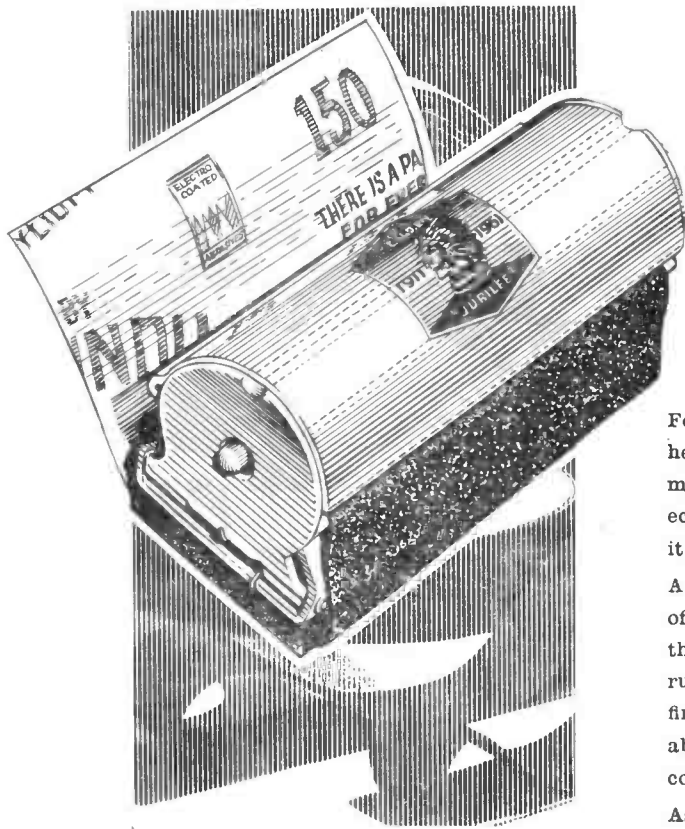

For the professional or amateur handyman here is a device that was really needed. It makes sand papering easier, quicker, more economical and gives a better result too – it uses all the abrasive paper uniformly.

A steel cylindrical container holds a roll of abrasive paper which is withdrawn through a slot and folds round the resilient rubber base where it is firmly held by fingers and thumb – the rubber base enables the abrasive to make a better all-over contact.

As each portion is used to the limit, the roll is pulled out just the width of the base again – no waste in time or material.

# the new **SLIK**

# sander

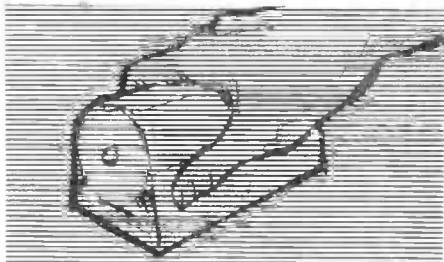

Refill rolls of Cabinet paper in fine, medium and coarse grades are available . . . .

From Ironmongers, Hardware and Do-it-Yourself Shops.

THE  
**CARBORUNDUM**  
COMPANY LTD  
TRAFFORD PARK  
MANCHESTER 17

