

6th JANUARY 1960

VOL. 129

NUMBER 3343

THE ORIGINAL
'DO-IT-YOURSELF'
MAGAZINE

HOBBIES *weekly*

FOR ALL
HOME CRAFTSMEN

FULL INSTRUCTIONS FOR MAKING

Also in this issue:

A HOME-MADE
PLATE CAMERA

MAKING A
BILLIARDS TABLE

COLLECTORS' CLUB

MIDGET BATTERY
2-VALVE SET

DOLL'S HOUSE
FURNITURE

USEFUL FORMULAS

ETC. ETC.

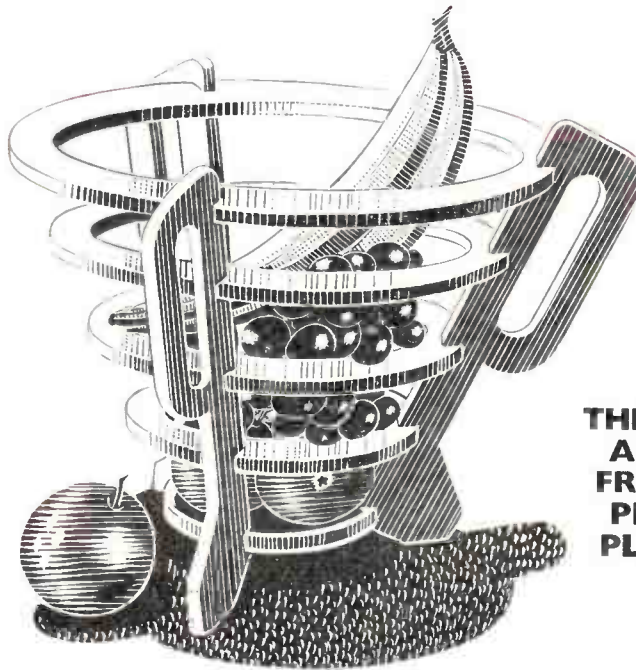

THE 'RINGS'
ARE CUT
FROM ONE
PIECE OF
PLYWOOD

A NOVEL FRUIT BOWL



Up-to-the-minute ideas

Practical designs

Pleasing and profitable things to make

World Radio History

5^D



WEATHER prophets say that a mild spring-like January, though good for cattle, is bad for the farmer. 'No man's cellar', says a Portuguese proverb, 'is filled by January's bloom.'

There are three days in the month on which the state of the weather should be carefully noted. On the 22nd, which is St. Vincent's Day, a bright sun encourages hope, for it is a sign of prosperous weather during the rest of the year. In wine countries the sap rises to the branches of the vine on that day, and is comforted by the sun. Should frost prevail, it will sink again to the roots. Therefore, a bright 22nd of January augurs plenty of wine and possibly a scarcity of water. On the 25th of January, which is both St. Paul's Day and Burns' birthday, sunshine indicates a good year. Other predictions are: snow or rain, a poor year; clouds or mist, bad for cattle; thunder, gales and general disaster; windy, war.

January anniversaries which may be

depicted in stamps:

1st, 1901, Commonwealth of Australia inaugurated. Australia 1951, 1s. 6d. brown — Federal Parliament House, Canberra — 1s. 6d. mint.

1st, 1947, Nationalization of coal industry. Hungary 1950, 8 filler grey — Miners — 1d. mint.

JANUARY

4th, 1948, Burma became independent republic. Burma 1946, 9 pies green — Burman and Map — 3d. mint.

6th, Feast of the Epiphany. Luxembourg 1955, 1 franc 20 cents green — Twelfth Night.

10th, 1840, Penny Postage introduced in England. Great Britain 1940, ½d. green — Queen Victoria and King George VI — 2d. mint.

10th, 1946, First General Assembly of the United Nations opened in London. United Nations 1951, 2 cent violet — U.N. Emblem — 3d. used.

15th, 1778, Capt. Cook discovered the Sandwich Islands. Cook Islands 1933-6, 1d. black and red — Capt. Cook — 3d. mint.

20th, 1265, First English Parliament met in London. Aden 1946, 1½ annas carmine — Houses of Parliament, London — 3d. mint.

20th, 1936, Death of King George V. Australia 1935, 2d. red — George V. on horseback — 2d. used.

22nd, 1901, Death of Queen Victoria. India 1892, 3 pies red — Queen Victoria — 1d. mint.

30th, 1649, King Charles I executed. Barbados 1939, ½d. green — Charles I — 1s. 6d. mint.

30th, 1948, Mahatma Gandhi assassinated. India 1948, 1½ anna brown — Gandhi — 4d. used.

31st, 1797, Franz Peter Schubert. Austrian composer, born. Austria 1922, 10 krona purple — Schubert — 10d. mint.

January is appropriately named after Janus, the two-faced god of the Romans — god of Beginnings and Ends. He is usually shown carrying a key in the left hand.

ROYAL BURGH

Archibald Smith, 27 Caponflat Crescent, Haddington, East Lothian, collects stamps, labels, and cards, depicting ships and craft.

Archie has good reason to be proud of Haddington, which lies on the Great North Road some 17 miles east of Edinburgh. It is an ancient Royal Burgh and the County Town of East Lothian. It is beautifully situated in the Tyne Valley in the centre of the richest farmlands of all Scotland.

Its greatest distinction is in its architecture, and it represents the height of the Scottish urban tradition. Here, comparatively unspoilt by later additions, lies a very complete example of a Georgian County Town which embodies all the graciousness of life at this period and the skill of the stonemason.



St. Mary's Church, Haddington

Illustrated on front page

MAKING THE FRUIT BOWL

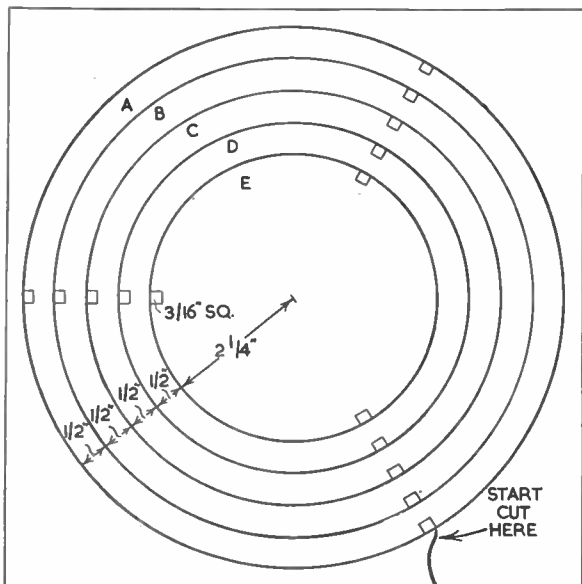

Fig. 1

THIS bowl may be cut entirely from plywood with a fretsaw, and when completed looks very attractive as shown by the illustration.

The main feature is the method of cutting the rings from one piece of wood as shown by the diagram in Fig. 1. Mark out on to a piece of plywood 9 in. by 9 in. by $\frac{3}{8}$ in. and cut round the outside. Cut out each ring in turn, drilling and starting at one of the $\frac{3}{8}$ in. square leg notches in each case. Make sure when cutting that the fretsaw is held perfectly upright.

Three sides (F) are required and these are shown full size in Fig. 2. Trace and transfer to $\frac{3}{8}$ in. wood by means of carbon paper. When all the pieces have been cut, clean up with glasspaper and glue together as indicated in Fig. 3. Note that the notches in the rings fit into the notches in the sides. Scrape away any excess glue. Lay it on one side for twenty-four hours before painting.

Fill the grain with woodfiller and give one undercoat. Rub down lightly with silicon carbide paper and give two top coats of high-gloss paint or enamel.

(M.h.)

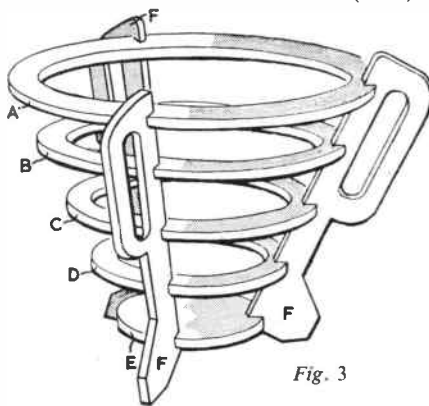

Fig. 3

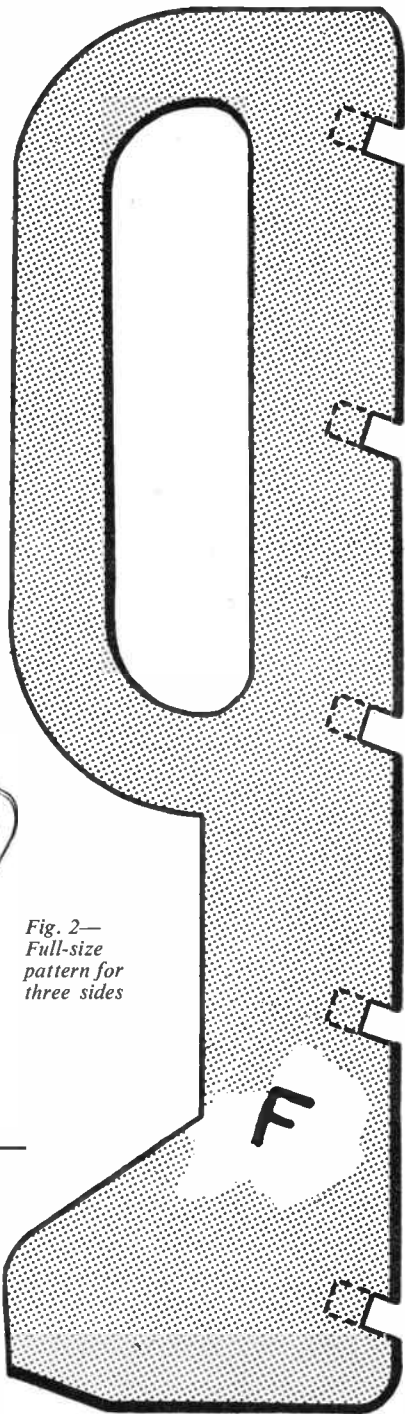

Fig. 2—
Full-size
pattern for
three sides

Next week's free design will be for a Piano Cigarette Box — just move a lever and a cigarette automatically appears.

MAKE SURE OF YOUR COPY.

A Bargain 'Buy'

TWENTY-TWO years ago Mr A. G. Breheny bought a Hobbies 'Gem' machine for £2 10s. Then he decided to go in for our 'Marvel' motor-driven fretmachine and sold the old 'Gem' — for £2. 10s. As Mr Breheny says in a letter 'If anyone ever got value for money, I certainly did when I bought your machine.'

A HOME-MADE PLATE CAMERA

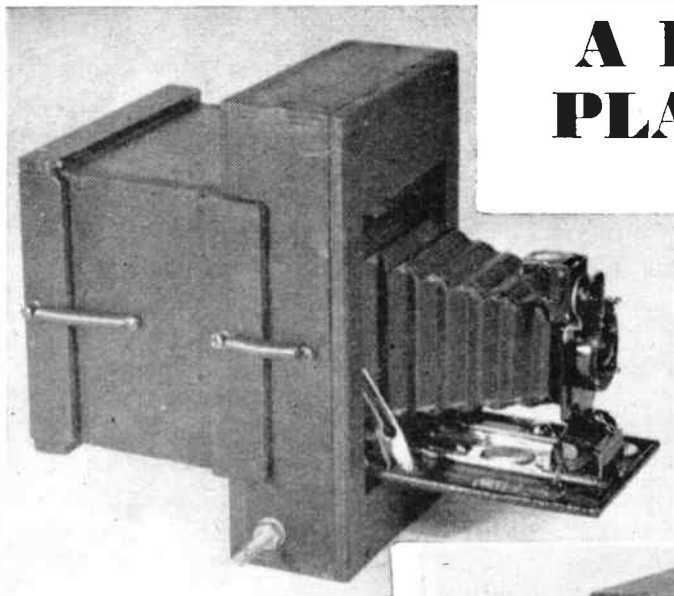

IN the field of table-top photography and also when photographing small objects or plants, it is often useful to be able to compose carefully on a ground-glass screen and to take just one shot so that it can be developed and inspected quickly. It is inconvenient and irritating to have to wait until the whole of a film has been used up, when it will often be too late to do a repeat. In any case, if a repeat is necessary, it is far better to do it when the idea and set-up used is fresh in the photographer's mind.

The amateur photographer will most probably be asked at some time to take a shot of a particular model or other object belonging to a friend, and he would be expected to be able to produce a result

wooden box (A) made to take the camera, which was secured by a plywood panel screwed to one side, and with an opening through which the bellows and folding front of the camera could protrude. The other side of the box A was partially closed, leaving an opening of about 4 in. square. A second box (B), open at back and front, was made to fit over the opening. The panel (C) with guides to carry the plate-holder, could either be attached directly to the camera back for normal photography; for example, landscape work or other long-distance shots, or to the box B, thus giving a wider separation between lens and plate for close-up work. By this means, a double or even a triple extension can be obtained (the latter by having a second, larger box B) giving a large image.

With double extension, the lens-plate distance can be increased to twice the focal length of the lens and will produce a full-sized image. This is a usual facility

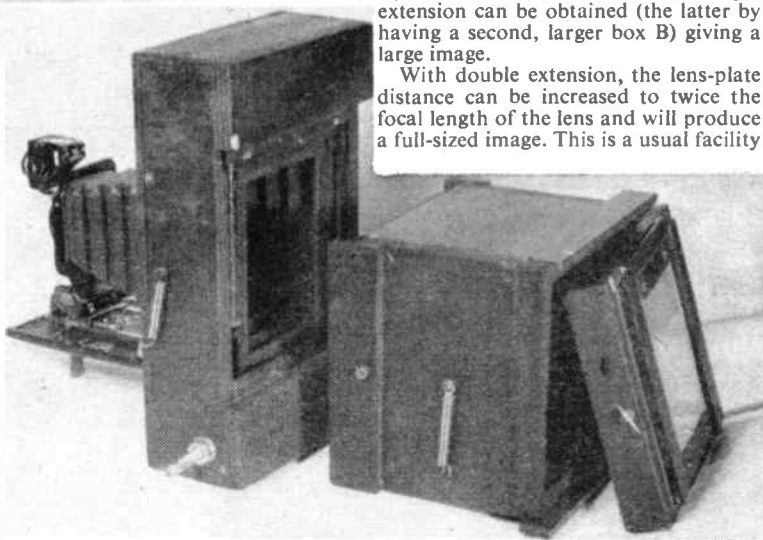

Another view of the various parts

quickly. The ideal instrument for this work is, of course, a plate camera with which individual photographs may be composed and taken. Although these may be obtained second-hand, an average cost would be around £10, the outlay on which would probably not be considered justified for occasional use.

The adapted plate camera illustrated was made from a Kodak Junior Autographic I camera of over thirty years of age. In common with many folding cameras of its time, this one had a sliding extension for focusing, which is almost an essential feature for the successful adaption to a plate camera.

The back of the camera, which was clipped on, was removed and a shallow

of a commercial plate camera. Larger extensions will produce a magnification of the object; this is useful for the photography of very small objects and avoids the use of a supplementary lens. The length of the box B will thus depend upon whether a double or triple extension is required and it should be arranged to separate the lens and plate holder by two or three times the normal lens to film distance.

The various pieces are held together by means of small springs slipped over screw heads, and light-tightness is ensured by sticking velvet ribbon (obtainable from drapers) on to the edges.

The guides on the panel C should be
Continued on page 250

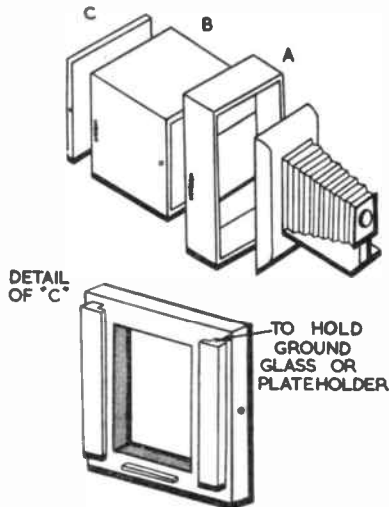

Have a shot at this . . .

MAKE A BILLIARDS TABLE

IT was generally assumed among my friends that a quiet game of billiards at home was out of the question, because the table would be as heavy and as awkward about the small house as a grand piano. To prove them wrong I built my own small table, a lightweight but fully serviceable affair, for about £5, and the constructional details may be of interest to others. It is made to a standard size, and is matched by $1\frac{1}{2}$ in. balls, and cues, which are the only completely 'bought out' items.

The base is the obvious starting point, and this is a piece of blockboard, 30 in. by 60 in. Laminated ply $\frac{1}{2}$ in. thick is better, but more expensive.

The first operations on the base are to cut the pocket gaps with a fretsaw, spokeshaving the edges clean. Then drill for the cushions to be added later. Fig. 1 shows the details and measurements. As



By William Alan

an insurance against the table twisting, and for support, make a framing from $1\frac{1}{2}$ in. by $1\frac{1}{2}$ in. wood, drilling $\frac{1}{8}$ in. holes

pad. Just under the head of each bolt, drill a small hole and drive through a pin to act as a tommy bar (Fig. 4).

The nut-holder is made from thin brass (24g); first the plate (Fig. 5), then the cage itself (Fig. 6). By bending at A, B, and C a closed box of four sides is formed, and bending at D and E gives flanges and a shade like Fig. 7. Place this nutholder on the baseplate, mark off the position of the holes in the flanges, and drill the base to suit. Note that a hole is also provided in the baseplate to take the bolt. Now rivet the two parts together and you will get a composite piece like Fig. 8.

Now slip the square nut into the cage and secure it by turning down the triangular fins (Fig. 9) and screw the full assembly into the $\frac{3}{4}$ in. hole in the runners (Fig. 10). These will give finger adjustments for levelling the table.

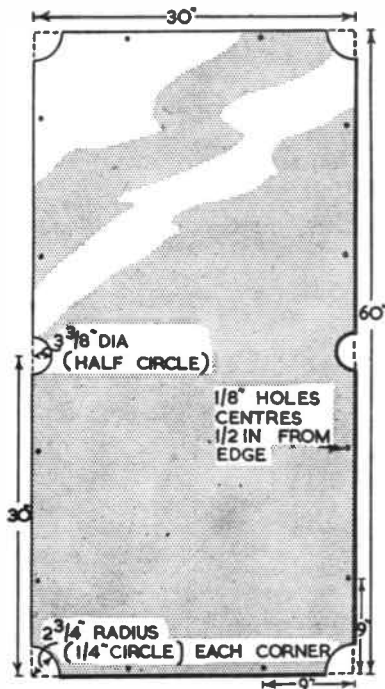

Fig. 1

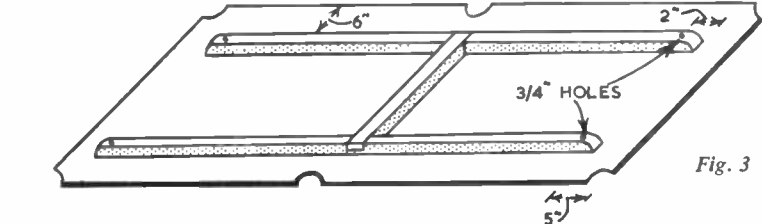

Fig. 3

through where shown and counter-sinking (Fig. 2). Now screw this framing underneath the table top, and drill $\frac{3}{4}$ in. holes 1 in. deep in the long runners of the framing (Fig. 3).

The adjustable feet come next. Take four round-headed 1 in. by $\frac{1}{8}$ in. bolts with square nuts and full threads. File the heads flat and glue to each a rubber

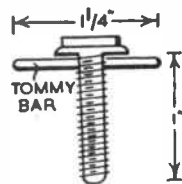

Fig. 4

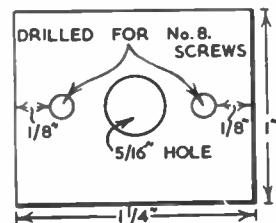

Fig. 5

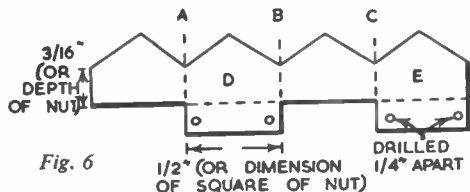

Fig. 6

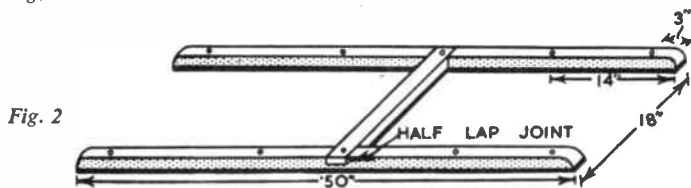

Fig. 2

Don't economise too much on the quality of cloth you use. A good smooth baize 72 in. wide costs 25s. a yard, and you need $1\frac{1}{2}$ yards of this. Cut a piece 63 in. by 32 in. and stretch it on the base fairly tightly. Some trial and error will be needed for this, to eliminate any suspicion of a wrinkle, and the ideal is to have an equal amount of tension in both length and width. Pin the baize to the base at the distances shown in Fig. 11.

This completed satisfactorily and securely, cut out the shapes of the pocket holes, allowing an inch of cloth for folding over. Before fastening these pocket allowances, by gluing and pinning, a number of V cuts must be taken out, as in Fig. 12. Having got this far, the baize is now properly in place, and you can pin the surplus under the edge of the straights. This ties it and gives extra security.

A black ball-point pen is a good instrument to use for drawing the baulk line, which is $13\frac{3}{8}$ ins. from one end. The semi-circle springs from this and is $4\frac{7}{8}$ ins. radius. The black spots are cut $\frac{1}{4}$ in. diameter from a very thin material and glued on. Fig. 13 gives all the dimensions for marking out.

We come now to the top frame and the cushions. My table used 5 yards of

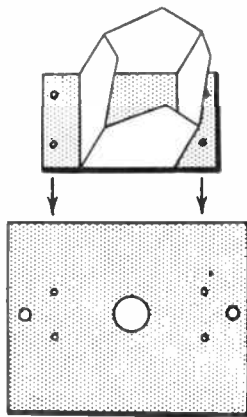

Fig. 7

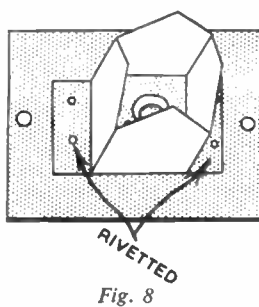

Fig. 8

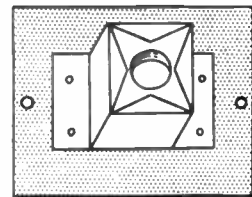

Fig. 9

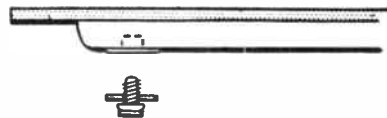

Fig. 10

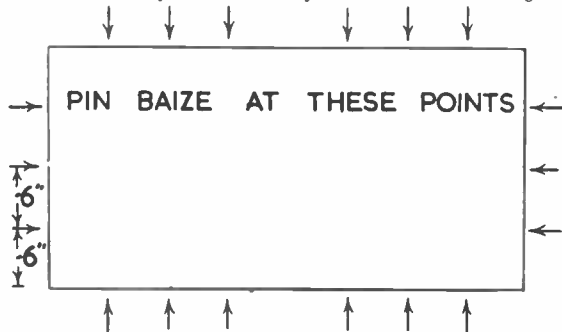

Fig. 11

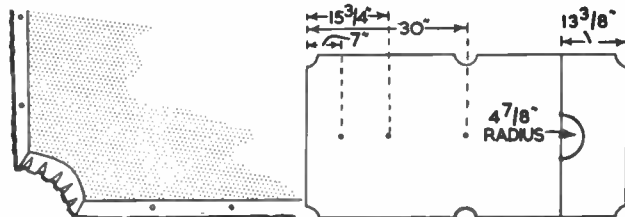

Fig. 12

Fig. 13

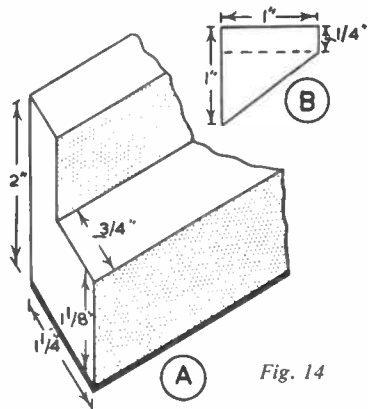

Fig. 14

catapult rubber, which is $\frac{1}{4}$ in. \times $\frac{1}{4}$ in. section. This is quite satisfactory, though $\frac{3}{8}$ in. \times $\frac{1}{4}$ in. might be better. But first for the timber backing. You need 13 ft. 6 in. of 2 in. \times $1\frac{1}{2}$ in., and the same length of 1 in. \times 1 in. These have to be worked to produce the profiles shown in Fig. 14.

If you are without the facilities for dealing with these jobs accurately in the lengths needed, you can build up the sections instead, as indicated by the dotted line. Either before or after forming the correct sections, depending upon what space you have for handling lengths, cut into the proper lengths, viz. four at $26\frac{7}{8}$ in. and two at 26 in. for the 2 in. by $1\frac{1}{2}$ in.; and four at $26\frac{7}{8}$ in.

and two at $25\frac{1}{2}$ in. for the 1 in. by 1 in.

The shorter pieces are for the ends; the others for the long sides between the pockets. The latter have to match up with the perimeter of the centre pockets, giving a slight overlap at the corner pockets when fitted. Figure 15 shows how they are fitted, and securely screwed to the base. The lengths profiled from 1 in. \times 1 in. have to be curved off at the ends, to a definite pattern, and this is very important because it will govern the ability to 'pot' properly.

If you rest each length in its proper position on the table and pencil an identification letter A, B, or C on it, according to the plan in Fig. 16, you can then add the pencilled figures x and y, as the sketch also shows.

Now to interpret these signs into action at the bench. Each 'x' represents a curve of $6\frac{3}{4}$ in. radius, and each 'y' a

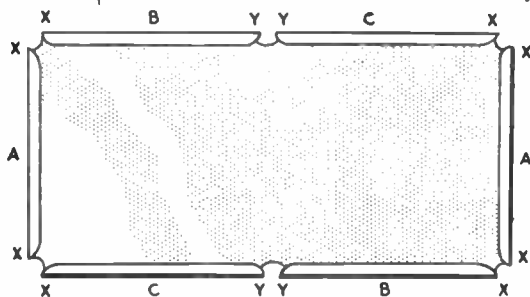

Fig. 16

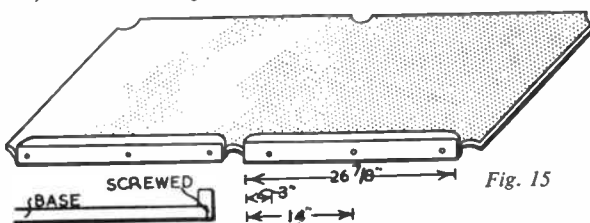

Fig. 15

curve of radius $2\frac{1}{2}$ in. The section Fig. 17 shows the circle centre and line of cut. Each curve so made must now be

undercut with a spokeshave to taper it away, as shown by dotted lines in Fig. 18.

Now we are ready to glue the rubber on to the $\frac{1}{4}$ in. flat face of each strip, and when this is completed and dry, cut pieces of the baize left over to cover each strip as in Fig. 19.

Three things to note: the curves must be worked in smoothly and without wrinkles; the length of baize must be joined along the back; and the 'free' section (A) must be neither baggy nor strained tight, but just pulled straight.

We are ready to fit the cushions to the

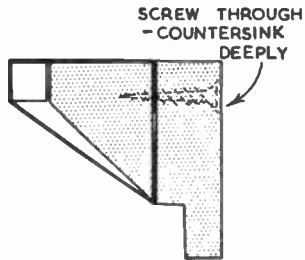

Fig. 20

table, following the A, B, C plan, in the manner shown in Fig. 20. If everything has gone together correctly each pocket aperture should be $1\frac{1}{2}$ ball diameters across; using $1\frac{1}{8}$ in. balls, within the limits $2\frac{3}{8}$ in. to $2\frac{1}{2}$ in. Purely for decorative effect, half-round beading may be run along the edges of the table to cover the screw holes.

Good pocket carriers can be made from $\frac{1}{4}$ in. diameter copper pipe shaped as in Fig. 21. The shaped ends are pressed or hammered flat and two holes drilled in each for screwing to the cushion.

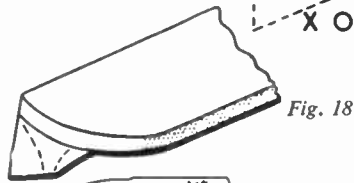

Fig. 18

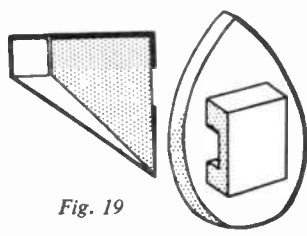

Fig. 19

Fig. 22

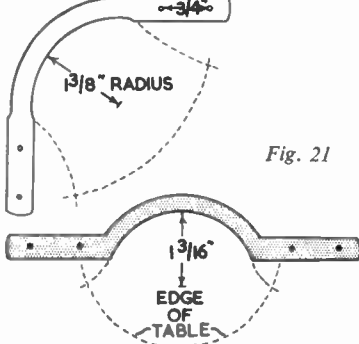

Fig. 21



Fig. 23

pelmet rail, each 2 ft. long, and drill each one at $\frac{1}{2}$ in., 16 in. and $23\frac{1}{2}$ in. from one end.

Now cut six pieces each $\frac{1}{2}$ in. long from the $\frac{1}{4}$ in. copper tube as used for the pocket supports. Next, in a short piece of 1 in. by $\frac{1}{2}$ in. timber, cut with a plough plane a groove $\frac{5}{16}$ in. wide by $\frac{1}{16}$ in. deep on the $1\frac{1}{2}$ in. face. Then cut off four $\frac{1}{2}$ in. lengths.

From three-ply cut four pear shapes, $1\frac{1}{2}$ in. long by $\frac{3}{4}$ in. wide and pin them to the channelled pieces. Fig. 22 shows the assembled tally, with the tunnel through which the brass rail passes. On the upper rail the pears point down, and on the lower rail, they point upwards.

Using 24 in. by 6 in. planking as a base, screw the rails to this, using the $\frac{1}{2}$ in. lengths of copper pipe to hold them clear of the board (Fig. 23). Finally, paint on the numbers 0-19 in the left-hand section, and 20-100 by twenties in the right. And don't forget to put a bold black spot on the two top markers.

Pockets can be made from two string shopping bags of good quality, double-knotted. It is easier to experiment than to describe how to fasten one edge of one of these bags to the support. Allow an adequate pocket to form, and close the bottom and sides by stapling the net to the table. Practise economical cutting, and two shopping bags will be found sufficient for the six pockets. It remains only to screw in the adjustable feet (Fig. 4) and your table is complete.

For a marker take two lengths of

PRESERVATION OF AMERICAN MOGUL LOCOMOTIVE

A FURTHER interesting American engine has been placed in permanent preservation in the Nevada State Museum at Carson City. This locomotive is a 2-6-0 Mogul type named 'Glenbrook', No. 1 of which was built early in 1875.

It is a wood burner with extended wagon-top boiler, and for almost all its working life it was employed in industrial service, principally in timber haulage on the steep grade between Spooner Summit and Glenbrook, Lake Tahoe, Nevada. The engine is a very excellent specimen of the early American 2-6-0 type, and as far as can be recorded is the only example of a Mogul engine in preservation in any country.

It is interesting to observe that the 2-6-0 engine first appeared in America in the 1850s, principally as a freight

type, but in later years it was used in semi-fast passenger and mixed traffic service, and many industrial concerns purchased this type of engine from the main line railroads for service in their

plants. From the early 1850s to about 1910, over 11,000 examples were built in America.

Our photograph shows a Mogul locomotive of the Baltimore & Ohio R.R., No. 2443, Class K.17, at Cincinnati, Ohio, in 1946. The engine is a coal burner for heavy duty switching (shunting) service. (A.J.R.)

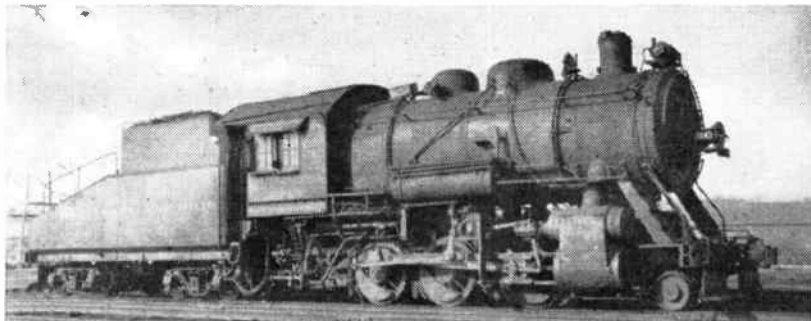

For speaker or headphones

MIDGET BATTERY 2-VALVER

THIS receiver, complete with batteries, is only 3½ in. high, 4½ in. wide, and 3 in. deep, and this very small size is achieved without any special components which might be difficult to obtain.

The circuit is shown in Fig. 1, and uses two 'all dry' valves which need a 1½V. filament supply, and 45V. or 67½V. H.T. supply. The 67½V. will be most satisfactory when working a loudspeaker, and a miniature speaker can be fitted by increasing the height of the panel to suit. With a 45V. supply, volume is ample for really loud headphone reception, or reasonable speaker reception from local stations. The set can also be connected to a full-sized speaker, if to hand.

Both medium waves and long waves are tuned, the latter being very useful in some parts of the country. Coil connections shown in the wiring plans are for the specified coil, but other coils can be used instead, provided they are wired to agree with the maker's instructions.

Panel and baseboard

The panel baseboard is of 3-ply, the valveholder tags projecting below, so that most wiring is underneath. The baseboard is 2½ in. by 4½ in., and the panel 3½ in. by 4½ in., the two being

A MEDIUM
AND LONG
WAVE SET

Designed
by
'Radio
Mech'

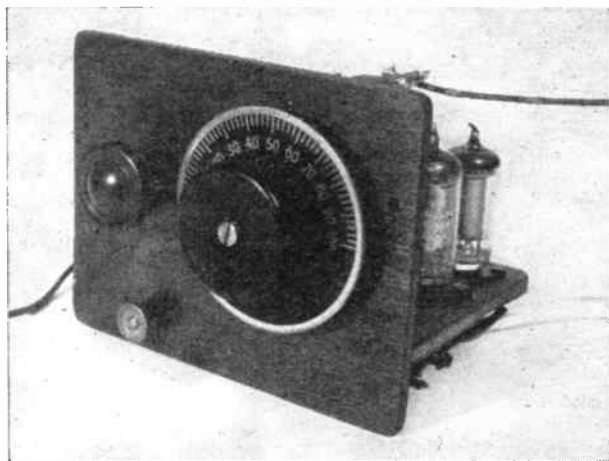

panel with the nuts provided, and the moving plates tags are joined, and a few inches of wire left to take to the earth line, this connection being marked E in Figs. 2 and 3. Lead G from the tuning condenser fixed plates tag also passes down through the baseboard, to the grid condenser and coil, this point being marked G in Fig. 3 also.

The specified coil has one tag fitted with a loop, for mounting and earth

wired as shown; that is, counting clockwise from the earth bolt E—1 to G, 2 to aerial, 3 to E, and 4 to wavechange switch contact.

The reaction winding has two tags at the top end of the coil. These are marked R in Fig. 2. One tag goes to the fixed plates of the reaction condenser. Lead P is attached to the other tag, this going to P in Fig. 3, which denotes detector plate or anode, which is also the high fre-

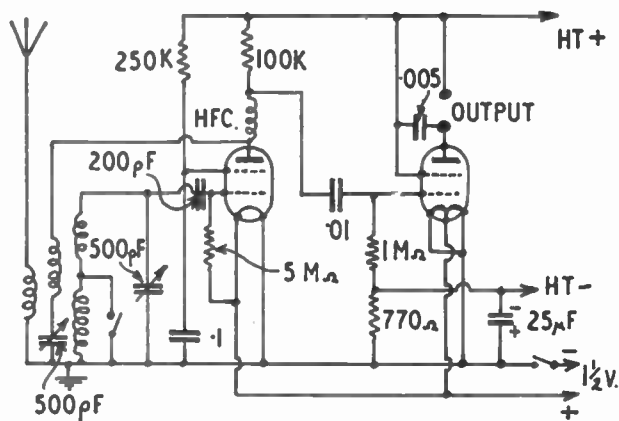

Fig. 1—Receiver circuit

quency choke connection. In a compact receiver of this kind there is little free space, and Fig. 3 should be followed carefully when wiring up. Leads must not touch each other at any point where they are not insulated. Nor must joints, etc., touch the unused tags on the valveholders.

Wiring up

The two condensers are fixed to the

connection. This loop is held by a 6 BA bolt, which forms point E in Fig. 3. Four holes are drilled so that leads can go to the four remaining tags this end of the coil, as shown in Fig. 3. Wiring up will be simplified if a few inches of wire are soldered to each tag, before mounting the coil, these leads being threaded down through the four holes when the coil is secured. It is necessary that the tags are

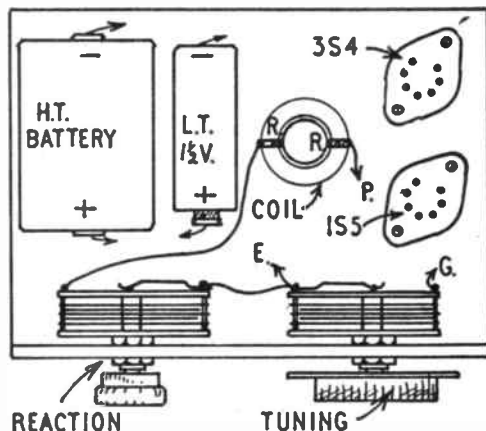

Fig. 2—Chassis layout

complete, and wiring can be checked in advance as follows:

1S5 holder. 1 and 3, earth. 4, 250K and $\cdot 1\mu\text{F}$. 5, H.F. choke and coil. 6, 200pF fixed condenser and 5 megohm. 7, L.T. positive.

batteries must only be used for L.T. if the cells are joined in parallel. Normally, the cells will be in series, giving 3V. or $4\frac{1}{2}\text{V}$., and they must not be used in this manner. With many 3V. batteries, the two cells can be removed easily. They

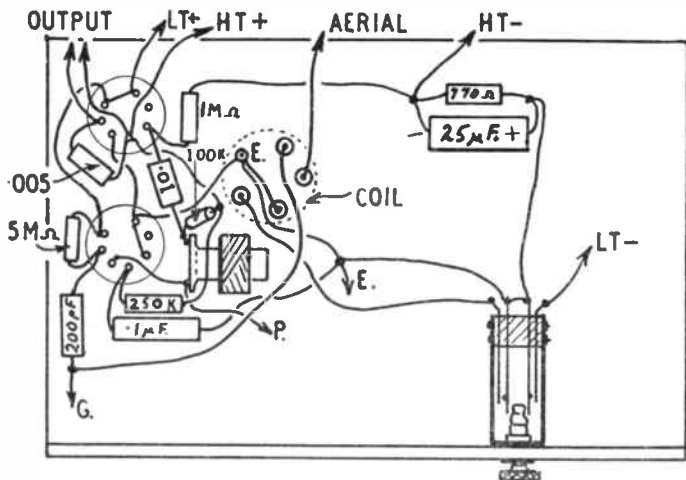

Fig. 3—Wiring and components underneath

3S4 holder. 1 and 7, L.T. positive. 3, $\cdot 01\mu\text{F}$ condenser and 1 megohm. 4, H.T. positive, output, $\cdot 005\mu\text{F}$ condenser, 100K resistor, and 250K resistor. 5, earth. 6, output and $\cdot 005\mu\text{F}$.

Pieces of thin flex are used for battery connections. If clip-in type batteries are to be used, these leads can be taken to suitable clips cut from thin metal and screwed or bolted to the baseboard. For other types of battery, small plugs will be needed. In no circumstance must more than $1\frac{1}{2}\text{V}$. ever be connected to the L.T. circuit.

The two output leads in Fig. 3 are taken to sockets on the back of the cabinet, for phones or speaker. The aerial lead is similarly taken to another socket, for aerial.

The switch

This is a surplus item with the plunger fixed so that it has three positions. In one position both contacts are opened, for "off". With the knob half pulled out, the contacts joined to E and L.T. negative close. This gives long wave reception. When the knob is fully out, the other contacts close also, switching the coil to medium waves.

Rotary switches for such purposes may be obtained, but will take up most space. Alternatively, two separate switches can be used, one for the L.T. circuit, and one for wavechanging.

Batteries

These have been mentioned, but it should be noted that torch or flashlamp

can then be held in a clip, both zinc cases together forming negative, and both end caps providing the positive terminal. A single cell will also provide $1\frac{1}{2}\text{V}$., but it is better to use at least two cells in parallel because this gives longer running without much fall in voltage.

For H.T., a miniature layer battery providing $67\frac{1}{2}\text{V}$. can be used, or two or more $22\frac{1}{2}\text{V}$. batteries can be wired in series. Two such batteries will provide 45V., while three will supply $67\frac{1}{2}\text{V}$. The batteries can be held by clips bolted to the wooden baseboard.

Peeps at Nature

THE 'UMBRELLA' PINE



COMPONENT LIST

Dual range coil with reaction. (4/9, Astral Radio, 82 Centurion Road, Brighton.)
 1S5 and 3S4. Two B7G holders.
 Two 500pF solid dielectric variable condensers.
 200pF, $\cdot 005\mu\text{F}$, $\cdot 01\mu\text{F}$, $\cdot 1\mu\text{F}$, and $25\mu\text{F}$ 12V. fixed condensers.
 770 ohm, 100K, 250K, 1 megohm, and 5 meg, ohm resistors.
 Small control knob. Large knob or dial.
 Small dual range H.F. choke.
 Separate switches or 3 position 2 pole switch.
 (Annakin, 25 Ashfield Place, Otley, Yorks.)

Using the set

If a speaker is to be operated, it must have the usual matching transformer, as it cannot work without this. The receiver output leads go to the transformer primary, and the secondary is wired to the speaker. If the transformer is already fixed to the metal frame of the speaker, the secondary connections will usually be already made.

If phones are used, these can best be of the usual medium or high impedance type. No transformer is needed for use with these.

Should an earth ever be available, it can be wired to L.T. negative. For the aerial, almost any indoor or outdoor wire will do. Foreign stations will, naturally, be received at better volume with an outdoor aerial, or good indoor aerial, especially during the hours of darkness. For phone listening, a few feet of wire will be sufficient.

The reaction control knob should be carefully turned clockwise, to build up volume. The best setting for any particular station can easily be found. Turning this knob too far will cause oscillation and poor reception. If reaction is unsatisfactory, reverse the leads going to tags R in Fig. 2.

THE Stone Pine, *Pinus pinea*, although mainly a native of Italy and Spain, where it occurs in the Mediterranean coastal regions, and often figures in landscape painting, thrives in Britain when in a suitable situation. Its somewhat unusual shape gives rise to the alternative name, Umbrella Pine. It appears to have been introduced into this country over 400 years ago and although it may reach up to 100 feet in height in its native habitat, here it seldom attains 50 feet.

The leaves are bright green and nearly six inches long. The cones take about three years to ripen, and the seeds are enclosed in a very hard shell, hence the name 'stone' pine. In Italy the seeds are eaten as a sweet. (P.R.C.)

PIECES 1. CUT THREE 1/2 IN.
GLUE TOGETHER

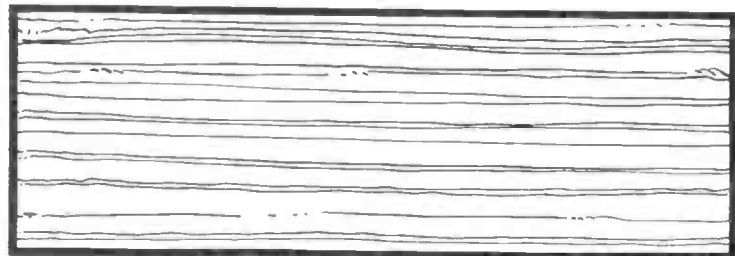

PIECES 2. CUT TWO 1/8 IN.

BIFURCATED
RIVET

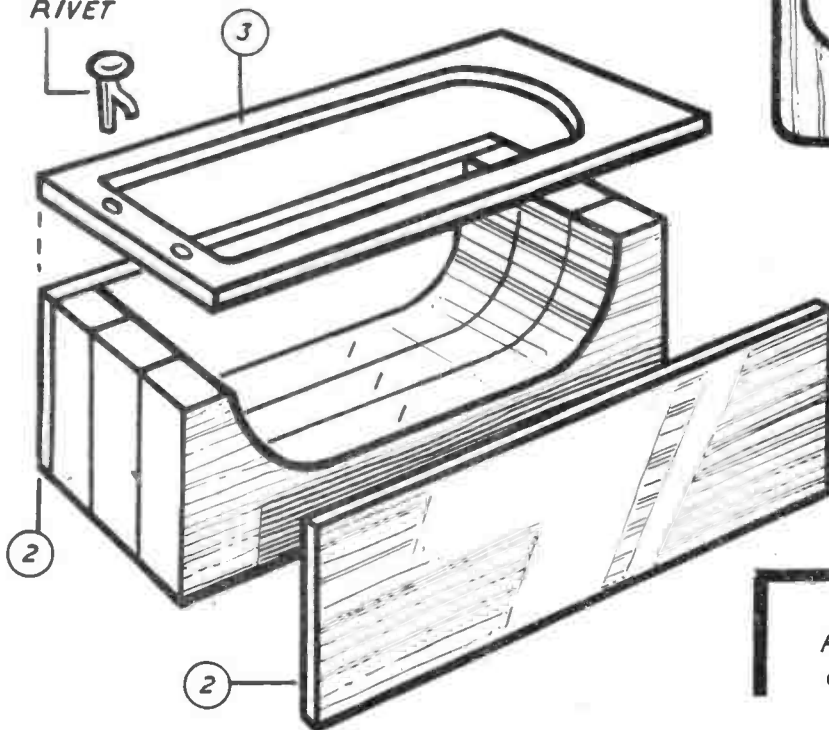

PIECE 3.
CUT ONE
1/8 IN.

BATH
•
WASH -
BASIN
•
TOILET
•

PIECE 5. CUT
ONE 1/2 IN.

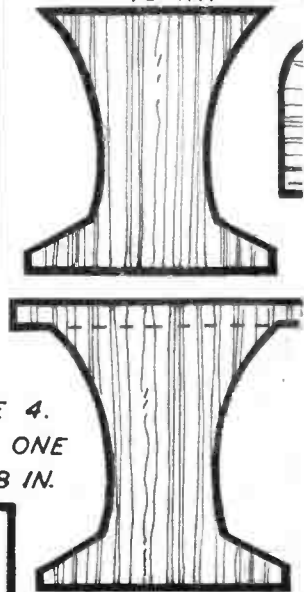

PIECE 4.
CUT ONE
1/8 IN.

PANELS OF WOOD REQUIRED
ONE ND 8. ONE G2.

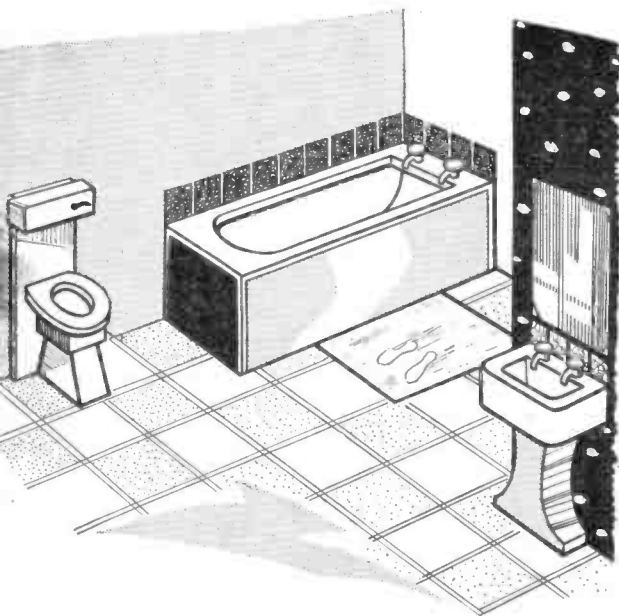

PIECE 8 CUT ONE
1/8 IN.

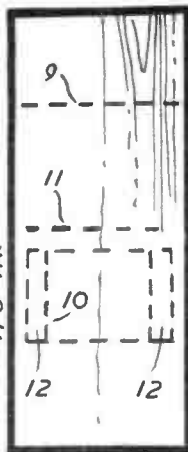

PIECES 12. CUT
TWO 1/8 IN.

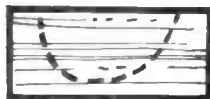

PIECE 11. CUT
ONE 1/8 IN.

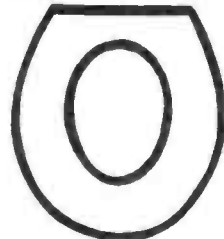

PIECE 9. CUT ONE 1/2

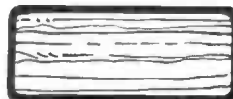

PIECE 13. CUT
ONE 1/2 IN.

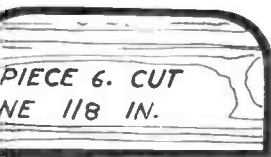

PIECE 6. CUT
ONE 1/8 IN.



DOLL'S HOUSE FURNITURE PATTERN



PIECE 7.
CUT ONE
1/2 IN.

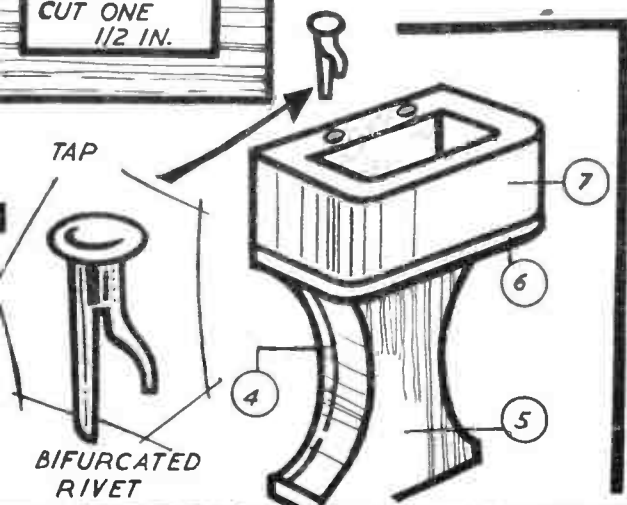

TAP

BIFURCATED
RIVET

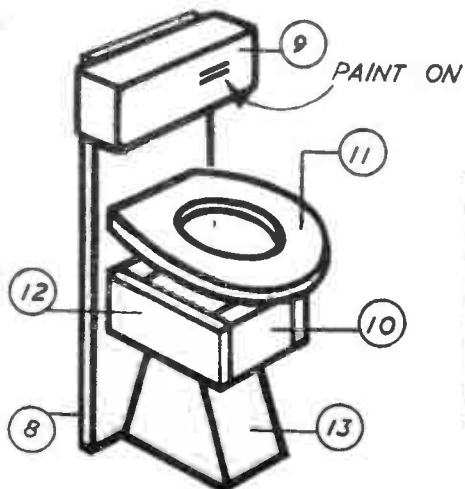

PAINT ON

PRINTED IN ENGLAND

FUSES, TRIPS AND CHARGING

FUSES are used to protect a circuit when an unusually high current arises. For example, if a train should short circuit the conductor rails a very heavy current would flow, and this could soon permanently damage a transformer, rectifier, or accumulator used to run the model.

By 'Modeller'

In other cases, such as accumulator charging, a large current may be caused by shorted leads, or joining up a battery in the wrong polarity. A fuse would also avoid damage in such circumstances.

Ready made cartridge fuses can be used, and clip into small holders, as shown in Fig. 31. These fuses are specially suitable for mains circuits (such as transformer primary), and can then fit in an insulated, totally enclosed holder. In the primary circuit of a transformer used to run a model the current flowing is quite small. A 1 amp fuse can thus be used. This gives more protection than the 13 amp or 15 amp fuses used for house power circuits.

Such fuses can also be used in low voltage circuits. However, a re-wirable fuse will be much cheaper here, because a small card of fuse wire will make scores of fuses. It is only necessary to fit two small terminals about 1 in. apart on a strip of insulated material, and fix a length of fuse wire between them, as shown in Fig. 31.

Fuses of 2 or 5 amp rating will do for

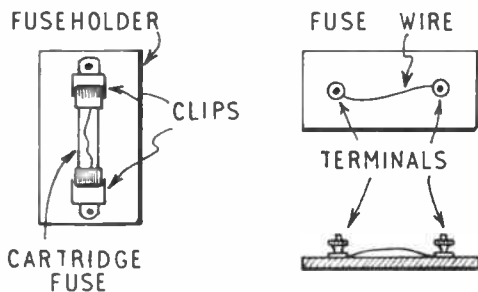

Fig. 31—Fuses for circuit protection

most models, the 2 amp rating often being sufficient. Thin tinned copper wire is suitable, 40 SWG being fitted for 2 amps, with 38 SWG for 3 amps, and 35 SWG for 5 amps. Or the thin fuse wire sold for re-wirable mains fuses can be used, and is equally satisfactory.

The fuse is wired in series with one

lead from the accumulator, transformer secondary, or rectifier. With dry batteries, a fuse need not be used, because a very large current cannot flow. But shorts should, of course, be avoided, or the battery will soon be discharged.

Overload trip

A type of 'mechanical fuse' is sometimes used with trains or other models where frequent replacement of a fuse may be troublesome. A unit of this kind is shown in Fig. 32.

Current to the model passes through the magnet windings, to a flat spring which bears on the pivoted strip. The armature keeps the trip set in the position shown, and with normal current flowing the trip remains in this position, because the magnet is not strong enough to move the armature. When a high current flows, due to a short circuit, the magnet attracts the armature, which

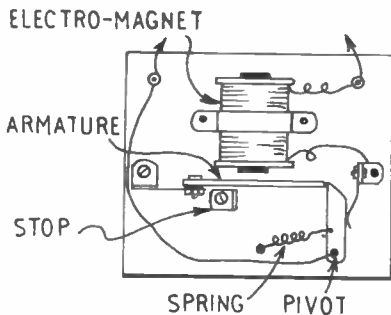

Fig. 32—Overload protector or trip

releases the pivoted catch. The circuit is then broken automatically, and remains interrupted until the catch is re-set by hand.

The magnet can be made up as described for a buzzer, except that it is wound with 14 SWG to 16 SWG wire. By adjusting the position of the magnet, the current at which the unit breaks the circuit can be modified. When a short

arises, the trip springs open as described. The fault should then be corrected. The trip is then re-set, this being the equivalent of replacing the blown fuse.

Accumulator charging

Accumulators are used for large models, and various other purposes, and can easily be charged at home from A.C. mains. A complete charging circuit is shown in Fig. 33.

The transformer is for 200/250 volt mains, and has a secondary voltage rather higher than the voltage of the largest accumulator to be charged. For 6 volt batteries, 10 volt to 12 volt will do, with up to 18 volt or 20 volt for 12 volt batteries. This extra voltage is necessary to compensate for the voltage drop in the rectifier and resistance, and because each 2 volt cell will rise to about 2.8 volts when fully charged.

The rectifier is a full-wave metal type, as described for use when running D.C. models from A.C. mains. A 2 amp 6 volt rectifier will permit 6 volt accumulators to be charged at up to 2 amps. For 12 volt batteries, a 12 volt rectifier would be used. The rectifier can also be used at lower currents and voltages, when required. For many small batteries, a charging rate of 1 amp will be sufficient. Larger batteries can also be charged at this rate, but will have to be left on charge longer than would be so if 2 amps were available.

The meter can read up to 1 amp or 2 amps, according to the maximum current which will be drawn. The resistance can be of 0 to 5 ohms, also 1 or 2 amp

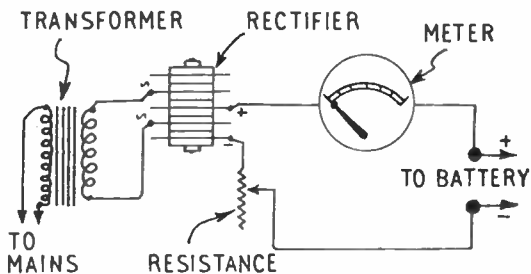

Fig. 33—Accumulator charging from A.C. mains

rating. Construction is exactly the same as with the transformer and rectifier units described in parts 6 and 7 of this series.

No current can flow until the battery is connected, and the correct polarity must be observed. Many accumulators have a suitable charging rate marked on them. For example, 25 hours at 1 amp.

It is then only necessary to set the resistance until the meter shows 1 amp, and leave the charger working for 25 hours.

If no charging rate is given, then the accumulator should be charged until the specific gravity, as shown by a hydrometer, ceases to rise. If necessary, a little distilled water should be added. As charging progresses, the meter reading will usually fall back a little. There is no need to charge the battery in one continuous period, if this is inconvenient for any reason. Nor is it necessary to wait until the accumulator is fully discharged, before charging it. It can therefore be kept in good condition always. Old, sulphated accumulators which have been allowed to stand in a discharged condition can be greatly improved by a long, slow charge. This can be about $\frac{1}{2}$ amp, for several days if necessary.

If the charger cannot supply the current indicated on the accumulator, this is not very important, because the battery can be left on longer. For example, 50 hours at $\frac{1}{2}$ amp would give a similar charge to 25 hours at 1 amp.

Electroplating

By means of electroplating a very thin layer of one metal is deposited upon a second metal, or upon a conductive coating, such as graphite. A harder, superior metal is usually deposited on an inferior metal.

Current for plating may be drawn from an accumulator, or from a circuit like that in Fig. 33. Or a half wave rectifier circuit and transformer, as shown in Fig. 34, can be used. Small experiments in plating can be done with dry batteries, though a mains or accumulator supply will be better.

The voltage applied to the plating vessel is quite low — say 1 volt to $1\frac{1}{2}$ volts, and this can be adjusted by means of the resistor. High voltages will result in a high plating current, which will give a crumbly deposit. As a guide, a current of 1 amp for each 5 sq. in. of the object to be plated will be sufficient.

If the object is to be plated all round, it can be suspended in the centre of the vessel, with an electrode each side. If it is to be plated only one side, however (as when doing a clock dial), then this side should face the electrode.

The object to be plated must be absolutely clean, or plating will be uneven. Boiling in caustic solution can be used to free the surface of all grease, the object then being placed in the tank at once, care being taken not to touch it by hand.

Wax casts in which a wire is embedded can be coated with graphite dust, taking care to see that the graphite is in good contact with the wire.

The best electrode is a solid plate or rod of the metal which is being deposited.

It forms the positive pole. The object itself is the negative pole, and is suspended on a wire.

Copper plating is simplest for initial work, as no dangerous chemicals are needed. The vessel is filled with a solution made up by adding 2 oz. concentrated sulphuric acid to $\frac{1}{2}$ gallon of water, a few ounces of copper sulphate then being dissolved in a little warm water, and added. A copper rod or strip is required for the electrode, and it will be helpful if the solution can be kept at about 70 to 75°F.

The object can be examined from time to time to see how plating is progressing. If thin places or holes are found in the plating, this shows that the object was not absolutely clean. A good coating of copper will stand moderate polishing, exactly as if the object were of solid

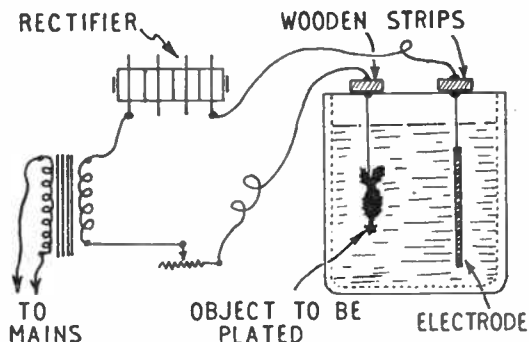

Fig. 34—Electroplating circuit

copper, but coarse abrasives should not be used.

If plating in other metals is required, the solution should contain metallic salts of the type required. Some processes are rather difficult. For example, if steel is to be chromium plated two processes are required, the first to deposit nickel, which provides a base for the chromium.

'Jack' for Removing Boots

WEARERS of rubber Wellingtons will appreciate a simple apparatus which can be used to remove dirty wet boots without soiling the hands. Such a gadget can easily be made from two pieces of wood, shaped and joined together as shown.

The main section is made from a piece of wood 16 in. long, 5 in. wide and 1 in. thick. Mark the shape on to the wood and cut out. To get the shape symmetrical it is best to mark the centre line down the wood and draw out one side. Trace this, then turn the tracing paper over and mark off the other side.

A second piece of wood 5 in. × 2 in. × 1 in. is now cut to shape as shown. Drill two holes to take $2\frac{1}{2}$ in. long screws and countersink on the bottom edge. Join to the main section with the screws in the position shown.

The rear edge of the main section and the bottom edge of the small piece are now chamfered off

so that the 'jack' stands firmly on the ground when in use.

The edges should be thoroughly glass-papered, especially the section into which the heel of the boot is placed, so that there is no risk of any splinter damaging the boot.

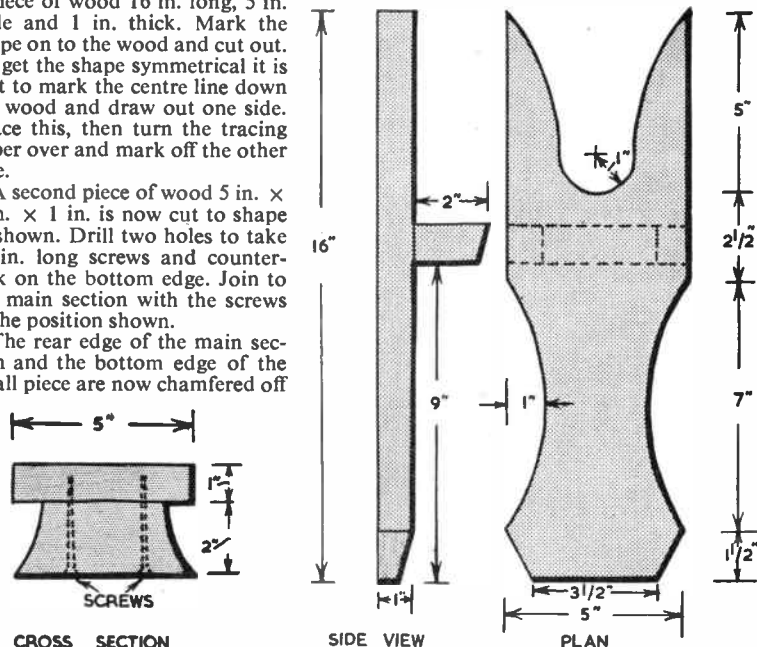



ORNITHOLOGY

ABOVE the windswept crag a lone eagle soared, surveying his kingdom with the mightiness of royalty.

Down in the valley a lazy stream meandered, nonchalantly, through the trees. Bird songs filled the air from dawn to dusk. Flitting from branch to branch in the cool, succulent shade afforded by such a green veranda was an excited blue-tit. Was he excited by the activities of the woodpecker tapping out his steady beat on a tree across the stream?

The ground was carpeted in a luscious green, flecked here and there with bluebells. . .

Such joys of nature can be yours if you are a naturalist, or simply one who loves nature, but add to this the thrill of taking part in scientific research and the satisfaction of satiating that insatiable thirst for knowledge that is in all of us. What can we do to lead such a life? We only have our spare time for such things. Right, then why not try bird-watching as a hobby? Don't like the name? Too corny? Then what about calling it ornithology, for that is indeed its true name?

Not just a fascinating hobby, it can be a serious study. There are gaps in our knowledge of bird behaviour too numerous and large to mention here. Some of the mysteries, once solved, can be of immense value to mankind. Mysteries of migration. How birds navigate their long journeys, etc. Questions like these have baffled man for centuries. They can only be answered by long, serious research.

All research of this nature is done by amateurs. Birdwatchers, ornithologists, call them what you will, are doing some marvellous work discovering facts that will become common knowledge to our children's children. Perhaps we are on the brink of some great discovery that may alter the whole future of mankind! This is the essence of research. This is the great drive behind the members of the British Trust for Ornithology.

Membership of this organization is open to anyone who shows an interest in this field, be he Sunday afternoon rambler or serious ornithologist.

The Trust's aim is ' . . . to promote research into the lives, habits and numbers of British birds.'

All work done by members, research

results, and all current activities, are published in *Bird Study*, the Trust's quarterly journal. This journal is sent free to all members and includes such titles as *The Origin of Winter Visitors to the British Isles*, *The Storm Petrel Colony on Roaninish*, as well as the results of research into the matings of various birds.

The Trust have permanent investigations into all aspects of bird life, the

HELP TO TRACK MIGRANT BIRDS

most famous of these being the bird-ringing scheme. Birds are trapped, quite painlessly, in various parts of the country. A numbered ring is fixed to the bird's leg and it is set free. Anyone finding these birds, either dead or otherwise, should send the ring to the British Museum of Natural History, London, giving details of location. In this way ornithologists can track a bird's movements.

The Trust also make grants to aid research. Other services members are entitled to are too numerous to name in their entirety. On becoming a member you may make use of the lending library, report bird behaviour to your regional representative, send dead birds to the Trust for post mortem. In fact your membership could help research no end, apart from the obvious pleasure you yourself get from it.

How, then, do you become a member of the Trust? It is not complicated, and if you are seriously considering it the

● Continued from page 240

A Home-made Plate Camera

arranged to allow a standard 2½ in. by 3½ in. plateholder to slide in. The top and bottom edges are light-trapped by sticking on a short piece of velvet ribbon.

For focusing, a piece of ground-glass is slipped into the guides. It may be necessary to pack the edges by sticking on gummed tape so that the ground side comes in exactly the same place as

address to write to is: The British Trust for Ornithology, 2 King Edward Street, Oxford.

I am sure you will find this a delightfully rewarding hobby, and an inexpensive one too! The only essential piece of equipment is keen observation.

If you are a beginner in the field of ornithology you will receive expert guidance from the B.T.O. On becoming a member your first step is to contact your regional representative and from him you will reap a harvest of information. He will put you in touch with other ornithologists in the district and introduce you to the local Natural History Society. You will be encouraged to take part in surveys and general enquiries and you may expect plenty of assistance.

The regional representatives have a pretty busy time of it. Apart from this service to beginners they arrange meetings, organize B.T.O. surveys, answer queries about the area for intending visitors and no end of smaller jobs. They also serve as an important link between the local Natural History Society and the B.T.O.

An interesting example of how bird-watchers help the B.T.O. appeared in *Bird Study*. It was an article on migration.

'One evening in November, 1954, there was a noticeable arrival of winter immigrants in Britain. These immigrants were mainly blackbirds and were believed to have come from southern Sweden and Denmark. Their path ploughed across Britain and some carried on to Ireland. Their route was plotted exactly by the B.T.O. from reports sent in by birdwatchers, many of whom were just on casual bird-spotting rambles and noticed the large number of birds moving across the sky. Of course, official bird observatories play a large part in these reports, but small-time ornithologists are just as invaluable.'

So, you see, you can be an important link in the vast chain of scientific research, another Peter Scott, or a James Fisher, and at the same time enjoy a most interesting hobby. (R.A.)

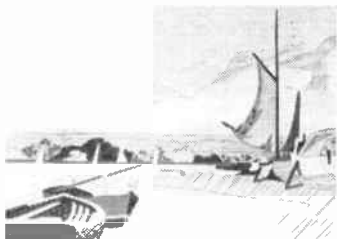

No. HH/4 Tidal Waters

From
Branches
or
Stockists
or direct
by post



9s. 6d
each
(post 1s. 6d.)

MARQUETRY SETS

Contain only the finest of veneers, cement, guide print, etc. Pictures 8½ in. × 6 in. on baseboard (not shown) 10 in. × 8 in.

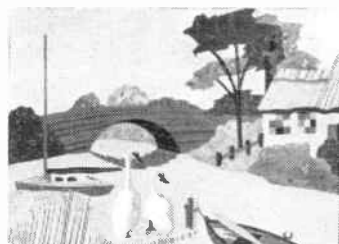

No. HH/3 A Quiet Mooring

Excellent results can be achieved by beginners in marquetry.
Any of these four pictures will give an air of distinction to the modern home.



No. HH/2 The Gateway



No. HH/1 Elm Hill, Norwich

To **HOBBIES LTD.**, Dept. 99, Dereham, Norfolk.

Please send me free copy of *Profitable Leisure*, showing other kits available, and

Marquetry Set No. price **9s. 6d.**
plus postage 1s. 6d.

Name

Address

P.O. or Cheque for enclosed.

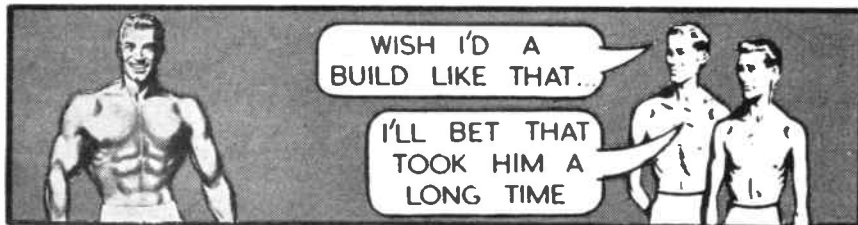

"Nonsense!"

Says
CHARLES ATLAS

"He built himself my way and I'll prove I can make you a HE-MAN, too, in only 7 days!"

Look at my photo. That build twice won me the title of "The World's Most Perfectly Developed Man". Yet as a youth I was a 7-stone insult to manhood. "Dynamic Tension"—*that's my secret!* I developed it to transform my body — and yours. No gadgets, no contraptions. You simply use the "sleeping" muscle-power in your own *vitality-starved* body. This easy, natural way takes only 15 minutes daily in your own room. Before you know it, you're a real man — full of energy, ambition — healthy and handsome!

ACCEPT MY TRIAL OFFER

If you don't see and feel a vital difference in your health and fast-growing muscles within one week, you won't owe me a penny. You can watch yourself develop in front of your mirror. See those shoulders swell, that chest fill out, the pulsating, red-blooded energy flooding through your entire system. Man — you'll feel it's good to be really A-L-I-V-E!



Send for my 32-page illustrated book **FREE**

It contains proof of what I have done for thousands of chaps of all ages. See how they looked — before and after. See what I can absolutely do for you. Rush

coupon in the post to:
CHARLES ATLAS (Dept. 102-A)
10 Chitty Street, London, W.1

251

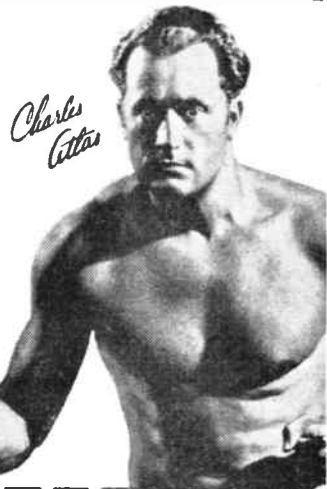

CHARLES ATLAS (Dept. 102-A)
10 Chitty Street, London, W.1

Send me your book "You, Too, Can Be A New Man" **FREE**, and details of your amazing 7-DAY TRIAL OFFER.

NAME **AGE**
(CAPITAL LETTERS PLEASE)

ADDRESS

FURTHER USEFUL FORMULAS

STUBBORN drawer runners are usually given the homely treatment of a rubbing with soap. A much cleaner treatment is to dust the runners with a mixture of equal weights of zinc stearate and talc. Unlike soap, this mixture contains no water, and hence cannot cause any local effect on the wood. It will not stain white fabrics, should it come in contact with them.

ACID-PROOF CEMENT

A cement for use on wood and metals, and which will resist the action of even hot nitric acid, may be made by mixing water glass 2 parts by weight, asbestos powder 1 part, and sand 1 part, working in enough warm water to make a thin paste. Spread evenly over the surface to be protected, and leave it until quite dry and hard. At least a week should be allowed before using the treated article.

WATERPROOF GLASS CEMENT

This cement depends upon the principle that a soluble dichromate renders glue insoluble in water after exposure to light. To make it, soak 1 gram of glue in 8 c.c. of water overnight, and then heat up to dissolve, using a water bath. Add a solution of 0.2 gram of potassium dichromate in 2 c.c. of warm water. Brush on to the broken glass surfaces and clamp them together. Put the article in a window or other well lit place for several days. The glue will then have become insoluble, and the clamps may be removed. The cheapness of this product does not warrant keeping any which is left over, but if this is desired for any reason, it should be kept out of contact with light. It gels on cooling, but may be reliquified for use by immersing its containing vessel in hot water.

COLOURING CEMENT RED

Where it is intended to lay a cement step or floor, and to stain with a red tile polish, it is useful to remember that the cement itself can be coloured, and thus be polished with the ordinary uncoloured polishes, which are easier to apply. Fifteen per cent by weight of ferric oxide is mixed with the dry cement, and this then used in the normal way. This proportion works out at the rate of 17 pounds of ferric oxide per hundred-weight of cement.

PASTE ADHESIVE

A cheap paste adhesive for paper may be made by dissolving 1 ounce of alum in 1 pint of boiling water. Stir into this 3 ounces of plain flour previously mixed to a thin paste with cold water. Continue stirring for a few minutes, and then mix in 5 drops of oil of cloves.

JEWELLER'S CEMENT

In a covered vessel melt together at as low a heat as possible 3 parts by weight of rubber and 1 part of sulphur. This is a smelly process, and is best carried out in the open air. Apply a little of the hot cement, press the articles together, and allow to grow quite cool.

FLOOR POLISH

A good polish for floors may be made by melting together in a double boiler

By L. A. Fantozzi

2 ounces of paraffin wax and $\frac{1}{2}$ ounce of beeswax. Turn out the flame and add $5\frac{1}{2}$ to 6 fluid ounces of oil of turpentine (not turpentine substitute). Stir well to incorporate, remove the inner vessel, and when the melted polish is cooler but not set, pour out into a tin.

BRONZE FINISHING

Where a matt brown finish is desired on bronze castings, this may be attained with the aid of a special preparation. Dissolve 4 grams of ammonium chloride (sal ammoniac) and 1 gram of potassium hydrogen oxalate (salt of sorrel) in 210 c.c. of vinegar. Potassium hydrogen oxalate, though not a scheduled poison, has, like many other chemicals, poisonous properties if swallowed, and hence is best kept out of reach of young children.

Use the solution in a warm room. Apply it to the bronze with a soft brush and work it about on the metal until it is dry. Repetition of the treatment should be carried out until the desired depth is reached. Finally rinse the metal in water.

PARISIAN BRONZE LACQUER

A fine lacquer for the protection of bronze against tarnish is made by putting 3 grams of shellac in a screw-cap bottle together with 24 c.c. of methylated spirit, closing the bottle and shaking occasionally until the shellac has dissolved. Grind 0.75 gram of camphor with a little oil of lavender, and add the shellac solution to this, mix well and pour back the now finished lacquer into the bottle. Since solvent evaporation may occur through the usual cardboard cap disc, an extra disc of sheet rubber should be inserted if the lacquer is to be kept.

WATERPROOFING BOOTS

Landworkers will welcome a simple preparation to make their leather footwear rain- and snow-proof. Melt together 1 ounce of beeswax and $\frac{1}{2}$ ounce of mutton fat, apply the proofer

liberally, and leave the footwear overnight. Then wipe off the surplus with a woollen cloth.

BLACKBOARD SURFACER

Young children like to play at school, and if dad makes the blackboard, there may be an outcry if the surface will not take chalk well. Fortunately, this is easily provided for. Dissolve 4 ounces of shellac in 1 quart of methylated spirit by putting both into a closed bottle, and shaking occasionally. Then add 6 drams of lamp black, 1 dram of ultramarine, 3 ounces of powdered pumice stone and 2 ounces of powdered rottenstone. Shake well to disperse, and keep the mixture stirred now and again during the brushing on the blackboard.

NAIL RETAINER

There are occasions when nails tend to work loose from woodwork — notably in boxes which come in for much rough usage. This can be obviated by dipping the nails in a special solution and allowing to dry before use. Nails which are already giving trouble may also be removed and treated in the same way, except where there is too much enlargement of the existing hole through friction. To make the solution, simply dissolve $\frac{1}{2}$ ounce of rosin in 4 fluid ounces of benzene (not benzine). Benzene is a coal tar product and chemically different from benzine, which is a petroleum distillate. Keep the solution in a well closed bottle. It is inflammable.

METAL PROTECTION

Steel and iron exposed to laboratory fumes soon become rusted unless enamelled. Where enamelling is inconvenient, such as in the case of nails and hooks, protection can be given by dipping in an easily prepared solution. Warm up 2 fluid ounces of solvent naphtha in a pan of hot water (no flame, for the naphtha is inflammable) and add 1 ounce of lanoline, stirring until dissolved. This product may also be used for general rust prevention in the home and workshop, though it should not be used where there is objection to the slightly greasy surface imparted to the treated object.

Can we help?

MR D. F. S. Price, of 8 Ingleby Crescent, Ermine Estate, Lincoln, has helped other readers in their search for old designs published by Hobbies Ltd. In turn, Mr Price would now like to make a model of the Taj Mahal and wonders if any reader can help with a copy. He would also like to make a model galleon approximately 36 in. long with a 9 in. beam.

Making toys, models and novelties is a paying pastime, and with a machine you can double your output right from the start. In fact you have a factory in the home.

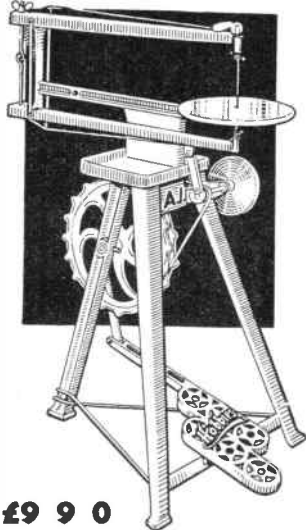

£9 9 0

'A.I.' TREADLE SAW

A sturdy machine with cast metal legs, metal table, wooden arms, special saw tension action, etc. Easy to treadle, smooth running and rigid. Provides a factory at home for the handyman — a machine for profit and pleasure.

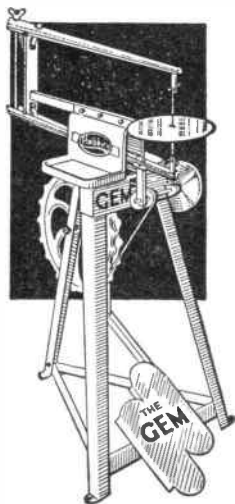

THE 'GEM'
£5 17 6

A lighter machine with pressed metal legs, but easy running and a reliable worker. Sound value and a machine for all kinds of work. Spare blades, instructions, and designs are included with each.

THE 'MARVEL' BENCH MOTOR-DRIVEN SAW

To meet modern needs. Just plug in and switch on from any house lighting point. For either A.C. or D.C. mains, with 230/250 volt motor, flex, switch, etc.

£12 5 0

Also Bench Machine without motor for 97/6

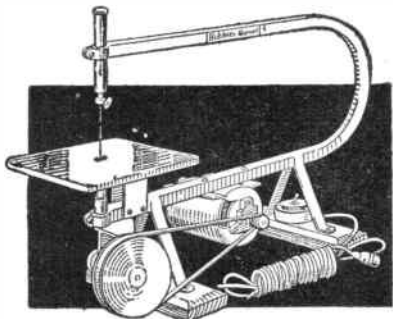

EASY PAYMENTS

A system is now in operation whereby a machine can be despatched carriage paid after the initial down payment, and subject to the completion of a simple form of Agreement. The slight additional cost over cash price is to cover extra clerical work, books, interest charges, etc. It is impossible for us to allow this system to apply in any part of Ireland, or anywhere outside Great Britain.

Agreement Forms are obtainable at any Hobbies Branch, where machines may be seen, and money paid each month. Or, you can do the business through Hobbies Head Office at Dereham, Norfolk, sending your instalments there.

GEM MACHINE

£1 5s. 0d. DOWN and 6 monthly payments of 16/11. (Cash Price £5 17s. 6d.)

A.I. MACHINE

£2 0s. 0d. DOWN and 8 monthly payments of £1 1s. 0d. (Cash Price £9 9s. 0d.)

MARVEL (without Motor)

£1 0s. 0d. DOWN and 6 monthly payments of 14/2. (Cash Price £4 17s. 6d.)

MARVEL (with Motor)

£2 10s. 0d. DOWN and 9 monthly payments of £1 4s. 9d. (Cash Price £12 5s. 0d.)

This model farm cost less than 2/6

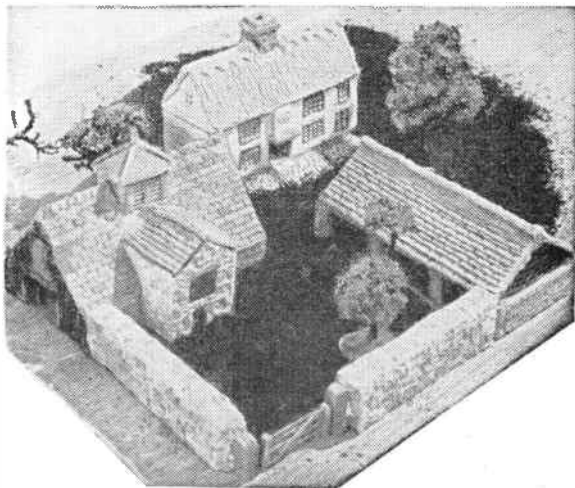

It was made from a half-crown tin of Sankey's PYRUMA — farmhouse, barn, implement shed, walls and gate — and there was still plenty of this grand modelling material left to build many more farm features, by simple methods described in the Instruction Book (see Coupon below).

PYRUMA, plastic and ready-for-use, becomes stone hard after drying or baking, and can be painted in natural colours. For permanent modelling —

MAKE IT AND BAKE IT IN



Obtainable from your local Ironmonger or Hardwareman and many Art Material dealers. Ideal for making —

Model Railway Buildings and Accessories, Harbours, Ship Models, Airport Buildings and Features, Houses, Bookends, Ashtrays, Animals and Figures, Plaques, etc.

Post this Coupon today for your Instruction Book

J.H. SANKEY & SON, L^{TD}

Established over a century
Dept. H, ILFORD, ESSEX

Please send ILLUSTRATED INSTRUCTION BOOK with full colour pages on Pyruma Modelling.

Enclosed Postal Order value 6d. (not stamps)

NAME (Block letters).....

ADDRESS.....

★ LEARN ★ RADIO & T/V SERVICING for your OWN BUSINESS/HOBBY

● by a new exciting no-maths. system, using practical equipment, recently introduced to this country.

FREE Brochure from :—

RADIOSTRUCTOR

DEPT. G81, 46, MARKET PLACE,
READING, BERKS. 6/1

125 DIFFERENT STAMPS free to applicants for 3d. upwards approvals. — Read, 19 Kelstern Close, Cinderhill, Nottingham.

BUILD your own Midget Transistor radio 28/6, with full instructions. Other kits from 8/6. Radio, Television books. S.A.E. details. — Hamilton Radio (H), 237 Sedlescombe Road North, Hastings.

FREE stamp album and 20 stamps. Request approvals, enclosing 6d. Additional gifts given. — Beeze, 8 Langland Villas, Mumbles, Swansea.

MAKE A MUSICAL BOX for as little as 19/9. New kits and tunes available. Movements 11/9. Please send 3d. stamp for free illustrated catalogue. Swisscross Ltd, Dept. B, 202 Tulse Hill, London, S.W.2.

Refund if not worth double!



TV TABLE &
EXTRA LARGE
RECORD CABINET

ONLY 59/6

Not only sand polished but also sprayed light or medium WAL-

NUT tone. NOTE — ROOMY BOOK CASES AT BOTH ENDS — one converts to Magazine Rack by insertion of sloping panel provided, as illustrated. Amazing offer — 59/6, carr. 6/6 or sent for £1. Balance 6 monthly payments 8/-, plus carr. A well-built contemporary piece of furniture to solve your record problem and also ideal as stand for TV, Radio or Record Player. 30" x 15" x 24" high. Modern sliding doors. Roomy interior, partitioned for classifications, holds up to 200 records (upright for perfect condition). Entirely of seasoned timber. Detachable legs. SEND quickly. LISTS, FURNITURE.

SEND FOR OUR FREE ILLUSTRATED CATALOGUE OF BINOCULARS, EVERY KNOWN MAGNIFICATION, WATCHES, RADIOS, FURNITURE, ETC. ALL AVAILABLE ON THE EASIEST OF TERMS.

HEADQUARTER & GENERAL SUPPLIES LTD.

(HOBW/96) 196-200 Coldharbour Lane,
Loughboro Junc., London, S.E.5. Open Sat.

BUILD YOUR OWN HI-FI at home! At last, for reasonable cost — the chance to make your own quality HI-FI audio equipment and to gain the knowledge to service and maintain it. FREE brochure from — Dept. HW20, Radiostructor, 46 Market Place, Reading, Berks.

Completely new 54 page Edition

WHERE'S THAT CAR FROM?

Price 1/- (Postage 4d.)

Of all Booksellers

or

RALEIGH PRESS, EXMOUTH, DEVON

100 DIFFERENT stamps free! Request 3d. upwards discount approvals. — Bush, 53 Newlyn Way, Parkstone, Dorset.

STAMPS FREE — Empire Packet including SPictorials and Victorians with approvals. — Robert J. Peck, 7A Kemp Road, Bournemouth.

LEARN RADIO and ELECTRONICS the LNEW practical way! Very latest system of experimenting with and building radio apparatus — 'as you learn'. FREE brochure from — Dept. HW10, Radiostructor, 46 Market Place, Reading, Berks.

FREE STAMPS—send 3d. stamp to—Satalight Stamps, 66 Caxton Street, Derby.

EXTRA CHEQUES from writing. Send for 'Ideas for Writers' (free). Scores of suggestions for beginners and others. Typewriter unnecessary. — Writers' Ring (H.W.), 5 Edmund Street, Birmingham 3.

BUYING OR SELLING ?

Classified advertisements on this page are accepted at a cost of 6d. per word prepaid. Use of a Box No. is 1/- extra. Send P.O. with advertisement to *Hobbies Weekly*, Advert. Dept., Dereham, Norfolk. Rates for display advertising on application.



BRANCHES: LONDON

78a New Oxford St., W.C.1
87 Old Broad Street, E.C.2
81 Streatham Hill, S.W.2
151 High St., Walthamstow, E.17

GLASGOW

326 Argyle Street

MANCHESTER

10 Piccadilly

Head Office & Factories—HOBBIES LTD, DEREHAM, NORFOLK

BIRMINGHAM

100a Dale End, Birmingham 4

SHEFFIELD

4 St. Paul's Parade

LEEDS

10 Queen Victoria Street

HULL

179 Ferensway

SOUTHAMPTON

134 High St. (Below Bar)

BRISTOL

65 Fairfax Street

NEWCASTLE

42 Dean Street

GRIMSBY

88 Victoria Street

ALL-STEEL CORNER CRAMP

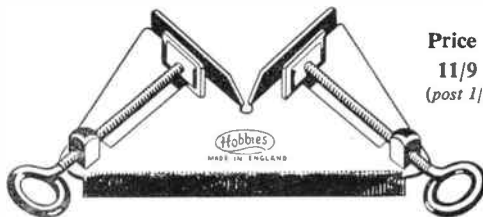

Price

11/9

(post 1/3)

A Picture Frame Cramp made from steel and practically unbreakable. It is well made and finished and will take work up to 2½ in. wide. For ordinary moulding it is a very serviceable article. From branches or—

HOBBIES LTD, DEREHAM, NORFOLK

STICK TO SECCOTINE

Regd.

it sticks everything



1/3
PER TUBE

Sole Manufacturers—

McCAW, STEVENSON & ORR LTD., BELFAST



The HALTRAC MIDGET HOIST

Weights 1 lb. Breaking strain 1,000 lbs.

PRICE 57/6

will pull or lift anything. Self-lubricating solid nylon pulleys — 72ft. nylon rope — rustless aluminium construction throughout. Standard equipment for the Motorist, Caravaner, Gardener, Workshop, etc. etc.

Available from all good Stores, Ironmongers, Halford Branches, Yacht Chandlers, etc., or from:

HALTRAC LTD. (Dept. HW.11)
BOURNE WORKS, WEIMAR STREET,
LONDON, S.W.15

Trade enquiries also invited

Make it for mother

A USEFUL STRING BOX

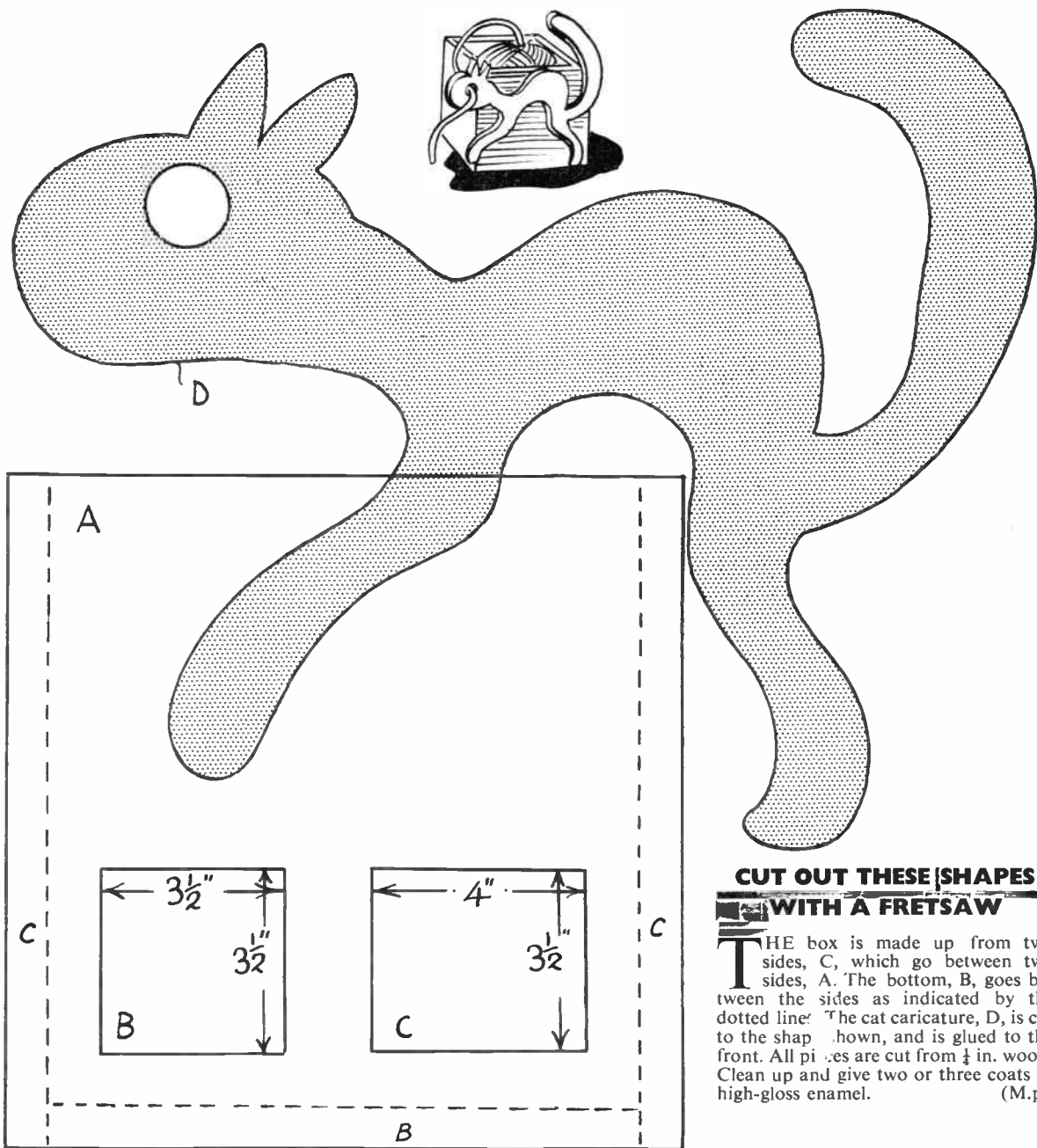

CUT OUT THESE SHAPES WITH A FRESAW

THE box is made up from two sides, C, which go between two sides, A. The bottom, B, goes between the sides as indicated by the dotted line. The cat caricature, D, is cut to the shape shown, and is glued to the front. All pieces are cut from $\frac{1}{4}$ in. wood. Clean up and give two or three coats of high-gloss enamel. (M.p.)

NEW Angles on OLD favourites

From these Books bulging with BRIGHT IDEAS

Any volume in this most interesting range of books, each dealing with a different aspect of gummed papercraft, will show you a wealth of ideas, the way to carry them out, and give hours of intense enjoyment.

Each is the key to an economical hobby that is rich in variety, ranging from the making of a charming picture to framing it delightfully — from three dimensional models to wall decorations, from paper sculpture to charming flower studies.



Other books by FREDERICK T. DAY

- Coloured Paper Decoration 7/6
- Coloured Papercraft for Schools .. 7/6
- Coloured Papercraft for Infants' Schools .. 6/-
- Lampshade and Parchment Craft .. 8/6
- Decorative Flower and Leafmaking .. 8/6
- Gummed Strip and Paper Modelling .. 7/6
- Paper Sculpture for Schools 7/6



8/6

All books obtainable from:
Newnes & Pearson Ltd.
 Tower House, Southampton St., Strand, W.C.1.
 Ask your stationer to show you the Butterfly range of handicraft materials.

SAMUEL JONES & CO., LTD.

STATIONERY MILL, CAMBERWELL, LONDON, S.E.5. RODNEY: 5064



NEW DO-IT-YOURSELF PRINTING OUTFIT

£1 · 17 · 6
 COMPLETE

Everything you need to print your own snaps. Combined safe light and exposing light. Three 1/2 plate dishes (orange, white and grey). Printing frame with masks. Two graduated measures. Two forceps. Thermometer with case. Con-Sol developer. Acid Fixing powder and full instructions.

JOHNSONS
 OF HENDON LTD

FOR CONFIDENCE
 IN PHOTOGRAPHY

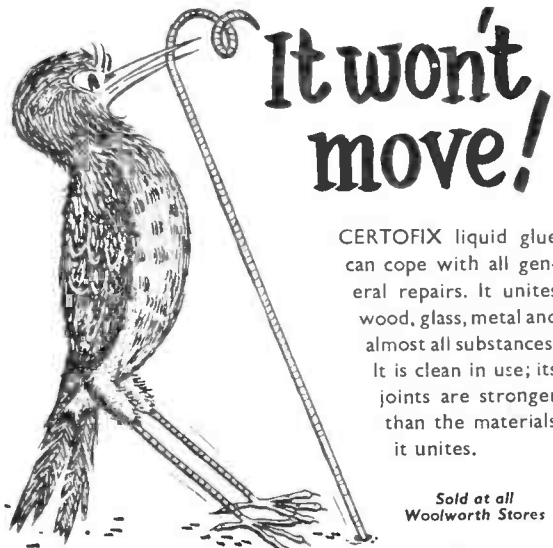

CERTOFIX liquid glue can cope with all general repairs. It unites wood, glass, metal and almost all substances. It is clean in use; its joints are stronger than the materials it unites.

Sold at all Woolworth Stores

CERTOFIX WILL Really FIX IT!