

# HOBBIES *weekly*

FOR ALL  
HOME CRAFTSMEN

## FULL INSTRUCTIONS FOR MAKING . . .

*Also in this issue:*

MODEL 'HANSOM  
CAB' PATTERNS

COLLECTORS' CLUB

MAKING A  
MULTIMETER

CHEMISTRY AND  
PHOTOGRAPHY

BUILDING THE  
'HOBBY SOARER'

PROJECTS FOR  
THE HOME

ETC. ETC.

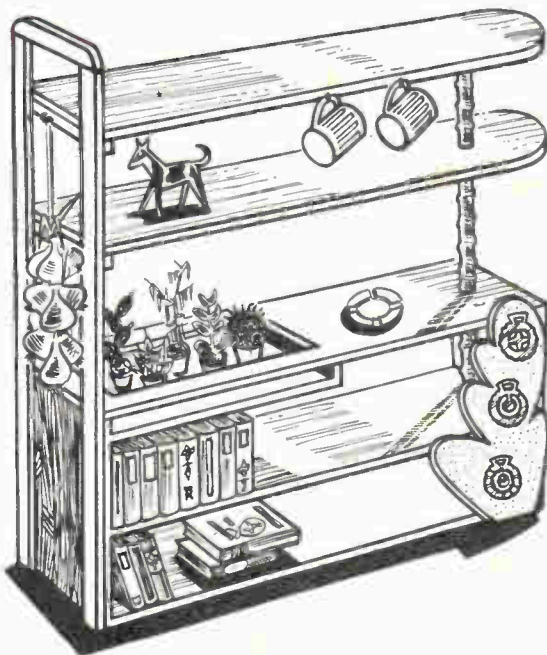

IN  
'RANCH  
HOUSE'  
STYLE

## A ROOM DIVIDER



*Up-to-the-minute ideas*

*Practical designs*

*Pleasing and profitable things to make*

WorldRadioHistory

**5<sup>D</sup>**



**R**EADERS with musical talent who wish to share interests with pen friends should write to Alan Whiting of 307 High Street, Sheerness, Kent.

Alan, aged 15, plays the trumpet. He belongs to a brass band and most of his spare time is spent in practice. He attends the Sittingbourne Grammar School. His main interest is chemistry. In a recent letter he said:

'I have no brothers or sisters, and,

although I have been quite happy up till now, I thought it would be a good idea to have a friend of similar age and interests, who could also teach me something of another country. I can speak a little French and recently visited France. Many of my friends are regular readers of *Hobbies Weekly*.'

When Alan wrote for an American pen friend he was introduced to P. H. Cummings, Grassy Lane Farm, California. Mr Cummings forwarded Alan's

letter to his 17 year old nephew who lives near Boston — a real friendship has resulted because Alan's new friend plays the piano, clarinet and saxophone.

Michael Staniford of 86 Colwall Road, Berrinsfield, Dorchester, Oxford, plays the piano, piano-accordion and violin. He is organist at local church services. Other hobbies include stamps, match labels, model aircraft and radio construction.

A. Millington, 'The Firs', Cross Houses, Salop, is a keen stamp and label collector with many duplicates for exchange.

Trevor Mann, 2 Lambs Plot, Chetnole, Sherborne, Dorset, wishes to trade stamps and match labels for English and foreign cigarette labels.

Anthony Graham Burfield, 45 King's Road, Tonbridge, Kent, has many hobbies. 'At the moment', he says, 'I am making a telephone system between my bedroom and the kitchen, incorporating two loudspeakers and microphones.



Barrie Hayes



Alan Whiting



A. G. Burfield

## 'The Death of Nelson'

**T**HIS song, once the great favourite of tenors, amateur and professional, was composed and sung by the famous singer, John Braham.

Braham, a Jew, was born in London. In early youth his condition was little better than that of a 'street arab'. But at thirteen years of age he was singing 'The Soldier Tired of War's Alarms' with great success at Covent Garden, and a bright future was prophesied for him.

When his voice broke he took to the piano, but soon reappeared at Bath as a singer. Braham then went to Italy to study music. Some months later he made his appearance before the public at Covent Garden, this time with tremendous and unequivocal success.

So complete was his triumph, that he was allowed by musicians and the public to compose the music of his own part, no matter in what opera he appeared.

It was during the period of his great popularity that he composed 'The

Death of Nelson', by which — apart from his reputation as a singer — he is chiefly held in remembrance.

This story may be added to your thematic album. Stamps depicting Nelson have been mentioned in previous articles, and, many more feature music, etc.



A. Millington

'My chief hobbies are chemistry and radio, both of which I follow in copies of *Hobbies Weekly*. I also collect stamps, match labels and books. My friends and I often visit Somerhill Park (Tonbridge) to photograph wild life.'

Barrie Hayes, 4 Fourth Avenue, Slade Park, Headington, Oxford, is fond of gardening, stamp and match label collecting and TV.

In 'ranch house' style

# IDEAL ROOM DIVIDER

IN the modern house, with its dual purpose rooms, the 'divider' is an essential part of the furniture. It serves as a screen and a useful fitment for books, ornaments and house plants. Our design gives a casual appearance with a distinct 'ranch house' effect. The horse brasses and cacti or house plants make an attractive contemporary layout.

No sizes are given in the illustrations because these will obviously depend upon individual requirements. It will however be an easy matter to decide upon the height, length and width. Use  $\frac{3}{4}$  in. thick wood where possible, with  $1\frac{1}{2}$  in. by  $\frac{3}{4}$  in. and 1 in. square stripwood for the ends. Plywood may be used for the shelves, since it is less likely to crack or warp.

The end and top shelves are made up as shown in Fig. 2. The end pieces are  $1\frac{1}{2}$  in. by  $\frac{3}{4}$  in. stripwood and the battens 1 in. square stripwood. Secure with countersunk screws and glue, wiping off excess glue before it dries. Draw out the shape shown in Fig. 3, and cut out from  $\frac{3}{4}$  in. plywood using a fretsaw. Fix it to the front as in the finished illustration.

The heavy cane may be purchased

from a hardware store or alternatively you can use an old curtain rod. The one shown in the illustration was secured when a new carpet was purchased. The carpet was wrapped round the pole, which of course was put on one side for future use.

Finish off by cleaning with glasspaper. Give one undercoat and two top coats of high gloss enamel. (M.h.)

SEE THE  
FINISHED  
PROJECT ON  
FRONT PAGE

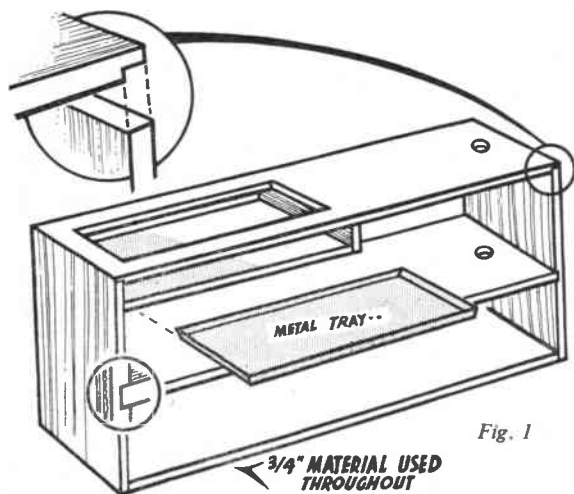

Fig. 1

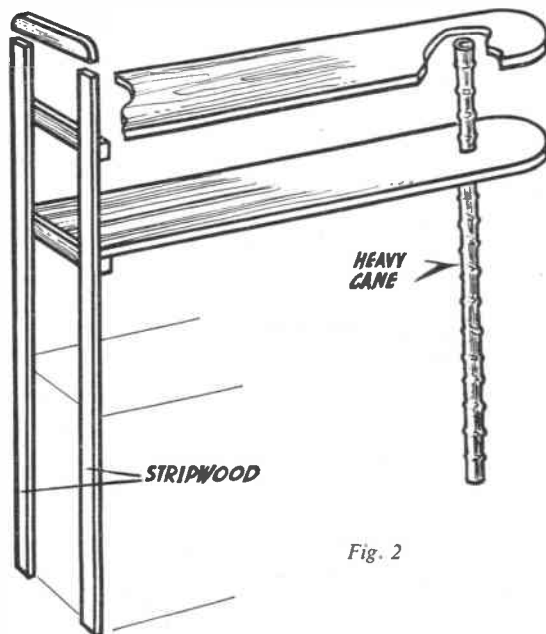
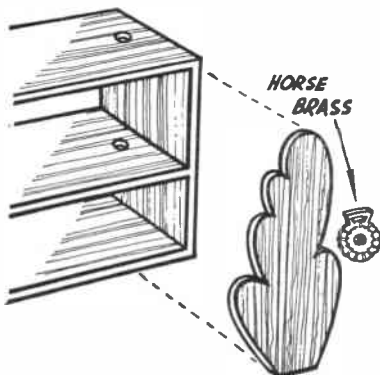

Fig. 2

Commence by making up the main carcass shown in Fig. 1. The pieces may be butted together and secured with glue and screws. Joints shown in the details are optional, but will definitely give a better appearance and stronger construction if you can tackle them.

The opening for the cacti tray is cut out with a fretsaw, or may be cut by boring and starting with a keyhole saw. A fretsaw, however, is quicker and neater and the piece of wood removed need not be wasted.

The tray is supported by two pieces of wood screwed in position as shown in Fig. 1 and should not be more than 2 in. or 3 in. deep. Metal trays can be purchased quite cheaply, and in some localities it may even be possible to have one made to size. Ready made plastic trays may also be used and there are plenty of these to choose from.



Workshop History

Next week's free design is for making a Tea Trolley suitable for when you have meals in the garden or for indoor use. It should prove a worthwhile project for the handyman.

MAKE SURE OF  
YOUR COPY

# HOW TO MAKE A MULTIMETER

By  
*A. Fraser*

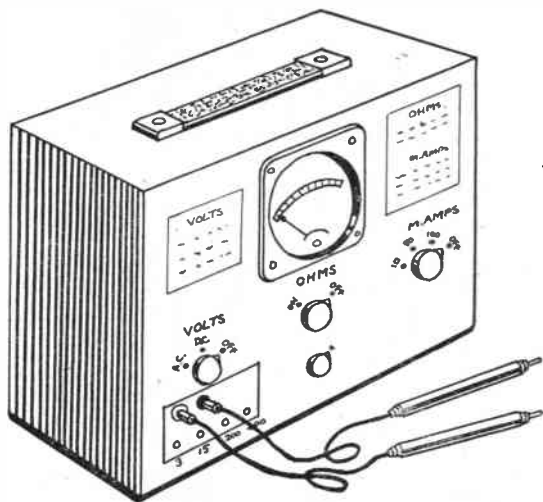

**A**NYONE who takes a real interest in radio as a hobby knows that instruments to measure voltage (voltmeter), current (milliammeter) and resistance (ohmmeter) are things that he should have. The multi-meter combines all three instruments in one. Measurements taken by such a meter on a working set can be very instructive to the learner, while on a faulty set, they can help to reveal the source of trouble.

The multi-meter described here can easily be built fairly cheaply. It has the advantage that each section can be built separately. Thus, one could build only the voltmeter section, and leave the milliammeter and ohmmeter to be constructed later, when convenient.

Incidentally, the voltmeter is an A.C./D.C. arrangement, so that both alternating current and direct current may be measured as is necessary. This is a great boon, as any radio hobbyist knows.

The basis of the multi-meter is a 1 milliammeter of the moving-coil type. These may be purchased at various places, and some addresses are given to help those readers who meet difficulty in procuring supplies of this kind in their area. Flush and projecting types are obtainable, but the flush is the better type because it allows the meter to be fixed in with its face level with the front of the case or cabinet — much neater in appearance.

The actual meter used by the writer was a 1 mA, moving coil type, flush mounting, and of internal resistance of 100 ohms. It was purchased from Henry's Radio. The dial is scaled from 0 up to 1 — a convenient arrangement for a multi-meter. It is well to ask the resistance value of the meter when buying, because this is important.

## The voltmeter

We will first deal with the voltmeter section, as this is the one most in de-

mand in radio work. In the front view of the multi-meter, in Fig. 1, it will be seen that this occupies the left-hand side.

The front panel should be cut out of plywood ( $\frac{1}{4}$  in. or  $\frac{5}{32}$  in. thick.) Paxolin would be ideal, but more ex-

## PARTS LIST

- Voltmeter.**  
1 mA moving coil meter (flush mounting) (a).  
4-pole 3-way switch.  
1 mA meter rectifier (b).  
**Milliammeter.**  
3-pole 4-way switch.  
Eureka wire (enamelled 28 gauge) (c).  
Paxolin tubing (c).
- Ohmmeter.**  
4 pole 2-way switch  
Potentiometer 1K.  
Resistor R5, 3-9K.  
4-5 volt battery.
- Milliammeter.**  
3-pole 4-way switch.  
Eureka wire (enamelled 28 gauge) (c).  
Paxolin tubing (c).

- (a) Henry's Radio, 5 Harrow Rd., London, W.2.  
(b) J. E. Annakin, 25 Ashfield Place, Otley, Yorks.  
(c) Post Radio Supplies, 33 Bourne Gardens, London, E.4.

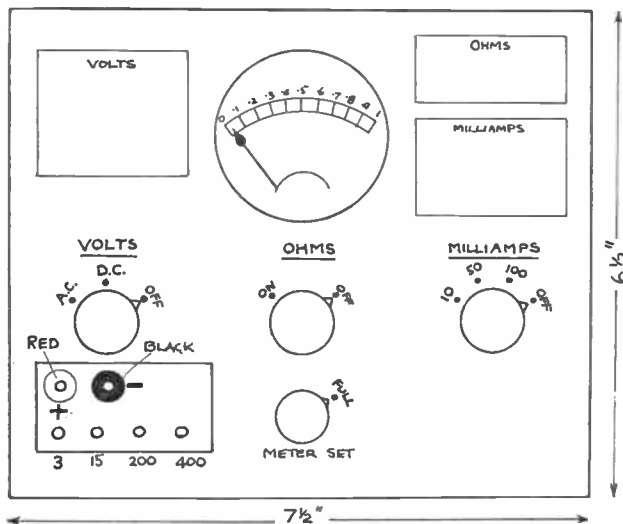

Fig. 1

pensive. The precise dimensions of the panel will depend on the size of the meter obtained, so the measurements given should be altered to suit the individual circumstances. The meter cut-out can be done with a fretsaw.

The holes for the switch shafts should be  $\frac{3}{8}$  in. diameter.

For the voltage selector panel, use a rectangle of Paxolin. The sockets are ordinary wandler plug sockets. The two

top sockets are red and black respectively. If you cannot get them ready coloured, then make coloured discs to fit around them. Or just paint broad rings around them. It is important to distinguish the two sockets in some such manner as suggested. One can also put in positive (+) and negative (-) signs, as an extra precaution.

Now fix in the voltmeter switch. This is a 4-pole 3-way switch and should be

positioned as shown in Fig. 2. (This is the panel seen from the back).

The meter rectifier must be a 1 milliamp type. (Obtainable from Annakin's for 5/-). Examine the tags and it will be seen that two have an S sign adjacent to them, while the other two are red and black respectively. To the S tags attach green leads. Join a red lead to the red tag and a black lead to the black tag. Make the leads about 4 in. long to start with — they can be cut shorter in due course.

Fix in the rectifier to the panel (a simple screw does this), and place it in the position shown in the diagram, Fig. 2.

Join one green lead from the rectifier to tag 12 on the switch. The other green lead goes to tag 3. Join the red lead from the rectifier to tag 9 on switch. The black lead goes to tag 6. Now join tag 2 to tag 5, and tag 8 to tag 11.

Join a red lead to centre tag C on the switch and take to the red (positive) terminal on the meter. (A solder tag is useful for this last connection). Join a black lead to centre tag B and take to the black (negative) terminal on the meter, using a solder tag again.

Join tag A to the negative socket on the voltage selector panel. Join tag D to the positive socket.

The voltage resistors are easily wired in by reference to the drawing. These

resistors should be 1% or 2% tolerance. 5% or 10% resistors will give correspondingly less accurate readings.

As this meter is 1 milli-amp, and therefore 1,000 ohms per volt must be used, then for measuring 3 volts, 3,000 ohms less 100 ohms (resistance of meter), that is 2,900 ohms resistor must be used. R1 therefore should be 2,900 ohms. If this cannot be obtained, then use two resistors in series which add up as near as possible to 2,900.

R2 can be 15K ohms, to measure 15 volts. R3 should be 200K ohms, to measure 200 volts. All these three resistors are joined to the positive plus socket. But resistor R4 is joined in series with R3. It is 200K (the same as R3), and in series with R3 will make 400K altogether, thus allowing readings up to 400 volts. Additional voltage ranges could be added, as there is room for further sockets.

This completes the voltmeter section. How it is used is described later.

*The next article will deal with the construction of the ohmmeter and milliammeter sections.*

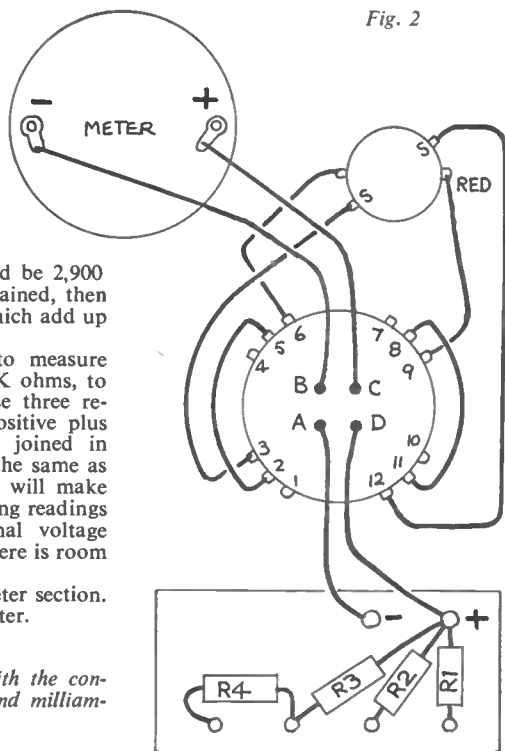
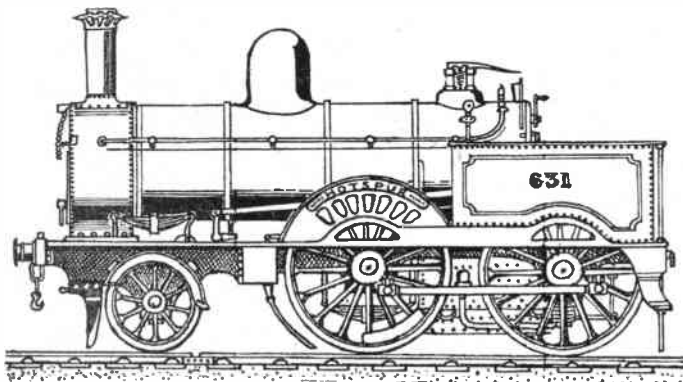

Fig. 2

## INTERESTING LOCOS—No. 20



THE first 2-4-0 tender locomotive of Mr. John Ramsbottom's design for the L. & N.W.R. was the 2-4-0 'Samson' class, the first engine, No. 633 'Samson', being built at Crewe in May 1863. This became the forerunner of a class of 90 similar engines for goods and passenger work, 50 being built by Mr. Ramsbottom between 1863-65, and 40

by Mr. Webb between 1873-79. The 'Samson' class were the first L. & N.W. engines to have the sandboxes fitted below the footplate and to be equipped with coiled springs under the trailing axle, and the Ramsbottom ornamental chimney fitted was the first on the L. & N.W.R. to widen out at the top. The tenders fitted to the first of the class

were Mr. Ramsbottom's type with wooden frames and weighing only 17½ tons in working order. Mr. Webb later replaced these tenders with his standard tender weighing 25 tons in working order and carrying 1,800 gals. water and 4 tons coal. Leading details of engine — Coupled Wheels diam. 6ft. 1½in., leading 3ft. 7½in. diam. cylinders 16in. by 20in. Working Pressure 120 lbs. sq. in. (later increased to 140 lbs.) Total heating surface 8,500 sq. ft. weight in working order on leading wheels 8 ton 8 cwt. on driving wheels 10 tons, on trailing coupled wheels 7 tons 14 cwt. Total = 26 tons 2 cwt. Length of engine and Webb tender over the buffers was 44ft. 10ins. The 'Samson' class was a true and typical Ramsbottom design and proved ably capable in operating the heavy goods and express duties of the line for many years.

### SOURCE OF DANGER

Electric power points fitted in low positions are a source of danger to mischievous children who are likely to push metal objects into the sockets. Always play safe and keep a 'dummy' plug.

# Continuing the 'Hobby Soarer'

**H**AVING completed the fuselage, including the wing-mount and tailplane platform, the next stage is the construction of the fin, tailplane and underfin. Begin with the tailplane.

Draw the shape of the tailplane ribs full-size on cartridge paper, using the squares on the drawing as a guide. Cut out the shapes, paste them temporarily to the  $\frac{1}{8}$  in. balsa and use them as patterns to cut out the ribs themselves.

In a similar way draw out full-size the shapes of the three pieces comprising each tailplane tip and cut them from  $\frac{1}{4}$  in. hard balsa. Cement them together to form the tip shapes.

Now cut the tailplane spar from hard balsa to the dimensions given on the drawing. Mark the positions of the rib slots and cut them  $\frac{1}{8}$  in. wide and exactly half the depth of the spar. Clip the spar on a flat board between two

rows of pins. The slots in the ribs interlock with the slots in the spar. When cementing the ribs in place (Fig. 2) ensure that they are at right angles to the spar, are parallel to each other, and are vertical in relation to the building board.

When they are thoroughly set cement the leading and trailing edges in place by cementing at the appropriate positions on the members and pinning them against the ribs with straight pins. Do not push the pins through the balsa but fix them against the edges. Both the leading and trailing edges can be bought pre-shaped or they can be cut to shape with a knife and glasspaper from  $\frac{1}{4}$  in. square strip and  $\frac{3}{8}$  in. by  $\frac{1}{8}$  in. strip respectively, after they have been cemented to the rib structure.

Before removing the structure from the board try the tips for fit and trim

where necessary. Cement them in place and when set, (Fig. 3) unpin the structure, and cut the surplus trailing and leading edges away. Shave the edges of the tips to a tapering shape, trim any rough edges and finish with fine glasspaper. Cover the centre three ribs with a strip of  $\frac{1}{2}$  in. sheet balsa using cement and glasspaper smooth.

The fin and underfin are both *flat* units made up, as indicated on the drawing, from sheet and strip (Fig. 1). Cut out the parts and cement them together directly over a full-size drawing of the components, using straight pins or slender panel pins to hold the individual items in position. Then remove them and round off the leading edge and tip of the fin with glasspaper and taper the trailing edge to a triangular section. Also radius the curved edge of the underfin.

Now start construction of the wing.

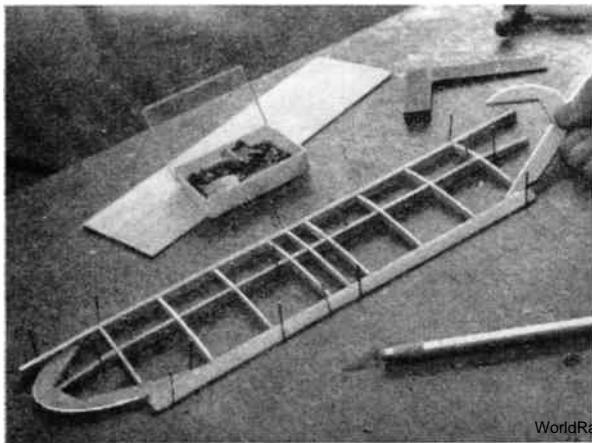
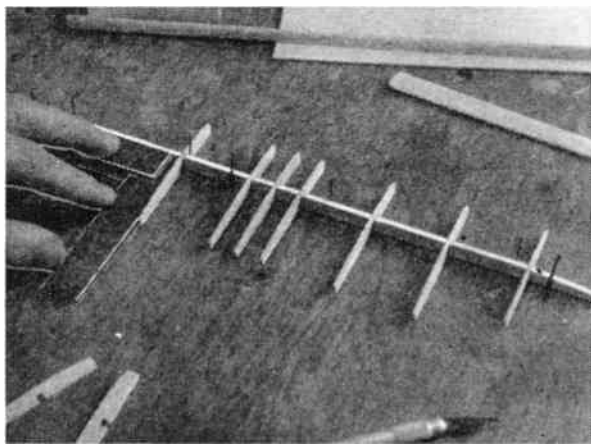
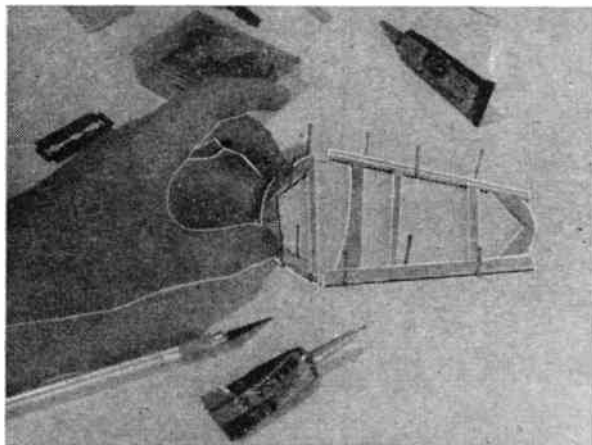

1. (top left)—Structure of fin and underfin complete and ready for trimming to final shape.

2. (top right)—Check each rib for 'trueness' as you cement it in place, using a set-square or engineer's square.

3. (bottom left)—Built-up tip is fitted to the almost completed structure of the tailplane. Leading and trailing edges are later trimmed.

First cut out all the wing ribs in a similar way to that used for the tailplane ribs. Use a thin plywood template if you prefer it for those ribs which are alike. Build the centre section of the wing first—that is, the portion of the wing minus the tips. Cut the spar, as before, fit the ribs (Fig. 5) and add the leading and trailing edges (Fig. 6). Make sure the ends of the spars are 'angled' to allow for the outer wing panel dihedral.

Remove the section, cut the wing tip pieces, and cement them together. Build up the wing tip panels in the usual way and cement them to the centre panel at the leading and trailing edges and the spar. The two wing ribs at these joint positions are not fitted at this stage. Support the outermost tips at their correct height above the horizontal (see front view) on books or blocks of wood.



While the tips are setting, mark out the shapes of the 'dihedral keepers' on to millimetre plywood. These 'keepers' are situated at the joints between the centre panel and the outer wing panels. They are approximately  $1\frac{1}{2}$  in. long and each 'keeper' is cranked in the middle to the dihedral angle of the outer wing panels. Mark them out in pairs; one pair the depth of the leading edge (i.e.  $\frac{3}{8}$  in.) and one pair the depth of the wing spar ( $\frac{5}{16}$  in.). Cut them out, cement them in position and hold them until they are set, using spring pegs. Then fit the two remaining wing ribs (Fig. 7) which will have to be trimmed at the front and at the

4.—Tailplane is covered on underside first. A second piece is applied to the upper surface working from one tip.

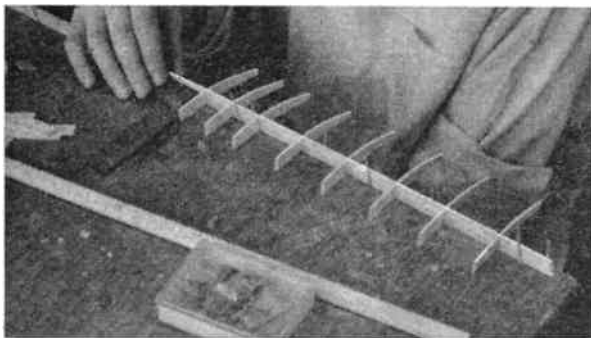
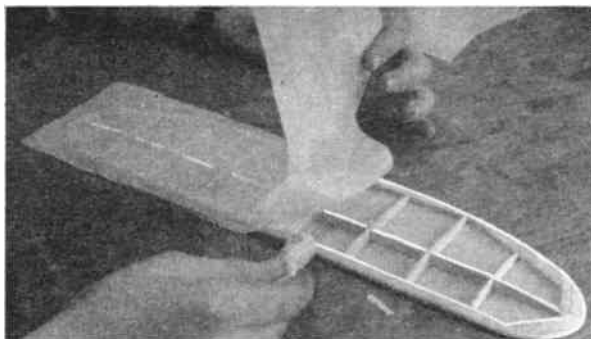

5.—Wing ribs are cemented to spar with their aft ends overhanging the edge of the building board to allow for the undercamber of the ribs. Check with a square.

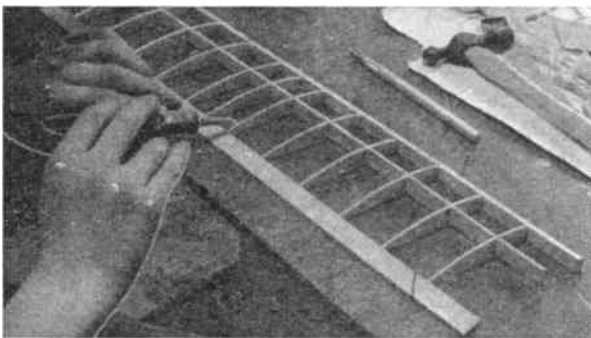

6.—Spar with centre-panel wing ribs attached is pinned to the board and leading and trailing edges are added. Reinforce the junctions of the ribs with the trailing edge with cement.

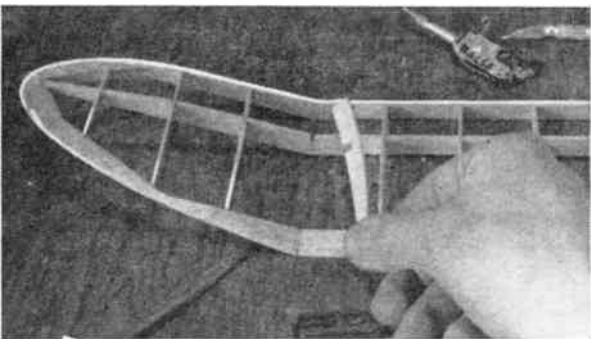

7.—Dihedral-keepers in place at the outer wing panel joints—ready to accept the final rib.

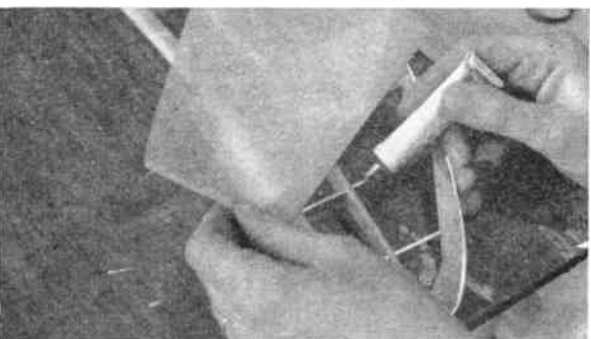

8.—Cover the underside of the wing first, starting with an outer panel and working from joint to tip.

spar slot to allow for the thickness of the plywood.

Finally trim the leading edges and wing tips with glasspaper and cover the centre ribs with sheet balsa as indicated. Note that the grain of this balsa covering should run along the width of the sheet, i.e. towards the wing tips.

Covering of the surfaces comes next. White or coloured Japanese tissue is used. Cover both sides of the fin and underfin, using tube tissue paste such as 'O-My'. This is clean and easy to apply if used reasonably sparingly. Trim the edges on one side with a razor blade and

paste over the raw edges before attempting the covering of a second side. Cover the underside of the tailplane first, making sure that the grain of the tissue runs from leading edges to trailing edge. Top and bottom surfaces are each covered with a single piece of tissue (Fig. 4) and paste should be applied to the ribs as well as the surrounding edges.

When the paste has thoroughly set spray the surfaces on both sides with water and allow to dry. Then give them a thin, even coat of banana oil. To complete, cement the fin in a central position on the fuselage, making sure

that it is perfectly upright, and cement the underfin to the bottom of the fuselage.

Cover the wing in a similar way, but this time use three pieces of tissue for the underside—one for the centre panel and one for each of the tip panels—and the same for the top surface. When applying the paper start at one end of each wing panel (Fig. 8) and work, bay by bay between the ribs, until complete. Water spray and when dry, apply two coats of cellulose shrinking dope.

The next article will deal with the rigging, trimming and flying of the 'Hobby Soarer'.

# CHEMISTRY

## AT HOME

**S**TANNOUS chloride is common enough in home laboratories whereas stannic chloride is seldom seen. As it is easy to prepare stannic chloride from metallic tin, which is also a usual stock item, a new field of experiment can be reached and other stannic compounds be prepared. It will be interesting, too, to compare the reactions of stannic tin with those you may already have done with stannous tin.

Anhydrous stannic chloride is prepared by acting on tin with chlorine. It consists of a colourless fuming liquid. The inconvenience of using large volumes of harmful chlorine in the home laboratory is avoided by adopting another method which gives us a solution of stannic chloride. Since a solution is the essential requirement for the experiments, this is the best method to adopt.

Put 5 grams of granulated tin in a flask, add 25 c.c. of strong hydrochloric acid and 10 drops of strong nitric acid.

## STANNIC CHLORIDE EXPERIMENTS

If any of the acid comes in contact with the skin, at once flush it off with water and dab on a paste of sodium bicarbonate and water. Clamp the flask on a sand bath and attach a cork carrying a long glass tube to the flask neck (see diagram) to carry away inflammable hydrogen which is given off during the reaction. Hydrogen, being so much lighter than air, is safely carried away.

Warm the sand bath gently until all the tin is dissolved. Black flocculent insoluble matter which appears should be ignored. This consists of impurities in the tin. Filter the solution into a large evaporating basin and add 5 c.c. of strong nitric acid. The colourless solution turns yellow. Evaporate on the sand bath to about half the original bulk. During the evaporation a sudden gas evolution takes place lasting some seconds. The gas consists of oxides of nitrogen and because these are harmful if breathed in any quantity, the evaporation should be conducted either in a draught cupboard or in the open air.

Let the solution cool so as to have a glimpse of hydrated stannic chloride. This appears as minute white crystals. Now dilute the solution and crystals to 150 c.c. and you have your stannic chloride solution for experiments.

The first striking difference between stannous and stannic chloride may be seen in the case of the sulphides. Pass hydrogen sulphide through a few c.c. of each of the chlorides. Stannous chloride gives a chocolate brown precipitate,

whereas stannic chloride gives a yellow to yellowish-brown precipitate.

The precipitate given by stannic chloride consists of stannic sulphide, but usually contains some stannic hydroxide. To prepare a specimen, pass hydrogen sulphide through a larger volume of the solution, say 30 c.c., in the open air, for some time and then allow the liquid to stand a few hours. If then the fetid odour of hydrogen sulphide has disappeared, pass in more of the gas. If on the other hand the liquid still smells of it, the precipitate may be filtered off and washed thoroughly on the filter with water until

Tin in the stannic state forms a hydroxide, namely, stannic hydroxide. Put about 30 c.c. of stannic chloride solution into a beaker and add little by little a solution of sodium hydroxide until a drop of the mixture turns red litmus paper blue. It is important not to overshoot this point or the gelatinous white precipitate of stannic hydroxide produced initially will redissolve in the excess alkali, forming sodium stannate.

Owing to the bulky nature of the precipitate, washing on the filter is troublesome unless a very large funnel and paper are used. The best way to free it from soluble sodium chloride also formed in the reaction is to wash it by decantation in a large bottle, such as a winchester fitted with a siphon, as has been illustrated and described in past articles. When one wash water is shown to be free from all but traces of chlorine by a few c.c. of it giving no white precipitate of silver chloride with silver nitrate, the precipitate may be filtered off and dried either on a tile or in a not too hot domestic oven.

### Polishing powder

If you heat a little of this to redness for about half an hour the hydroxide parts with combined water and leaves a white residue of tin dioxide. Under the name of putty powder this compound is used for certain types of polishing. It is also used for producing the familiar opal glass of cosmetic and fish paste jars as well as for opal electric bulbs. More interesting still is that its occurrence as the mineral cassiterite first brought the British Isles into prominence. Seafaring merchants in ancient times came to Britain to trade goods for Cornish tin ore. These merchants, in fact, knew our islands as the Tin Isles.

Although stannic hydroxide is a basic substance, that is, it is capable of forming salts with acids, it also acts as an acid, forming stannates. Substances which act as both base and acid are termed amphoteric.

One of the stannates has industrial importance. This is sodium stannate. Dyers know its solution in water as 'preparing salt', and use it as a mordant on fabrics to fix colours which would otherwise come out in the wash. The brilliant scarlets produced with cochineal are

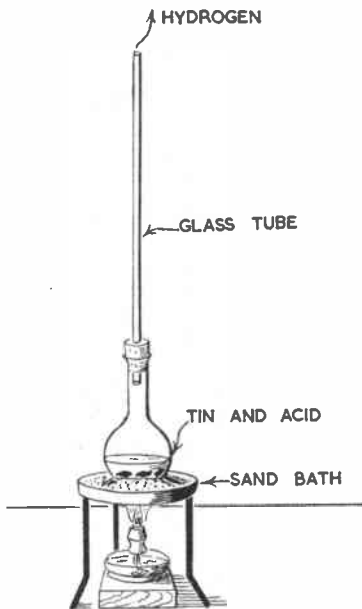

*The safety device in the stannic chloride preparation*

one wash water no longer gives a precipitate with a few drops of silver nitrate solution. Open out the filter paper on to a porous tile and let the substance dry. It darkens on drying.

Stannic sulphide dissolves in alkaline sulphides, producing solutions of thio-stannates of the respective alkalis. To try out the reaction add drop by drop ammonium sulphide solution to some stannic chloride solution in a test tube. At first yellow stannic sulphide is precipitated, but dissolves by progressive addition of ammonium sulphide.



# NOVEL SHELF DISPENSER

THIS is a push-button age and here is a unit that conforms, is functional and will grace the most modern of kitchens.

Most kept-in-stock foodstuffs are still best stored in air-tight tins; in fact, any ironmonger can offer you a set of six or more metal containers brightly coloured and labelled 'Sugar', 'Salt', 'Currants', etc. They help that tidy-kitchen look and deserve a better location than the window sill or the food cabinet top.

This made-to-measure unit also has a novel, push-button device. Further, it enables a row of canisters to be housed in the minimum of shelf space — no small factor these days. With the push-button device no space is needed between the canisters to allow finger grip and they are never found to be in anything but an orderly row.

Square-shaped canisters are best for the unit. You can make your own with, say, six identical tins painted in gay, contemporary colours. Needless to say, they should be clean tins.

First, measure the length of the row of tins placed side by side and touching one another. Then add  $\frac{3}{4}$  in. and this will give you the required length of the shelves. Wood or plywood,  $\frac{1}{2}$  in. thick, should be used for the shelves.

Next, measure across the base of the tins and add on  $1\frac{1}{2}$  in. This will give you the required shelf width.

Along the back edge of the shelf cut a series of slots,  $\frac{3}{4}$  in. in width and  $1\frac{1}{2}$  in. long, to correspond with the number of canisters to be used. Site the slots so that each one comes opposite the centre of the placed canisters.

Then make a corresponding number of pegs to fit the slots,  $\frac{3}{4}$  in. square and 6 in. long. Through the pegs, at centre points, drill  $\frac{1}{4}$  in. holes and then thread the pegs on to a length of dowelling,  $\frac{1}{4}$  in. diameter and 2 in. longer than the shelf length. The pegs should be able to rotate easily on the dowelling. That completes the mechanism for the unit.

Next, cut a matching top shelf of the same dimensions as the bottom shelf but without the slots. Then cut the two shaped end pieces of  $\frac{1}{2}$  in. thick wood. Before fixing these in place, the two free ends of the dowelling must fit into drilled holes made in these end pieces. As shown, the dowelling runs immediately underneath the slots cut in the lower shelf, so it is quite an easy task to mark off the position of these holes in the end pieces. The pegs must, of course, be placed in position in their respective slots, before the two end pieces with their dowelling bearings are fitted.

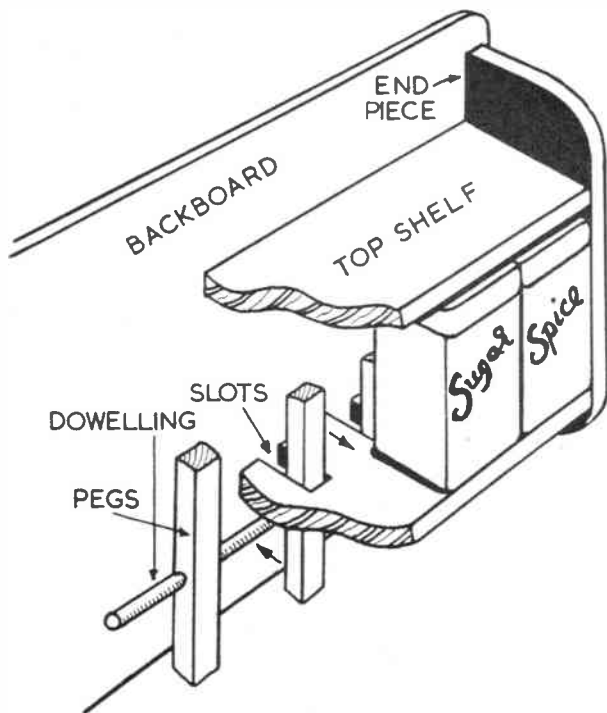

Finally, cut a slightly oversize sheet of  $\frac{1}{4}$  in. plywood as a back board and affix it to the shelves and end pieces by screwing through from the back of the plywood.

In operation, to obtain the canister required, simply push in the peg im-

mediately below it, when the canister will shoot forward, allowing it to be easily gripped with the finger tips.

The pegs can, of course, be numbered or identified with the canisters by painting in different matching colours.

(E.C.)

● Continued from page 24

## Stannic Chloride Experiments

died by first mordanting the cloth with sodium stannate.

To prepare sodium stannate, first prepare some more stannic hydroxide and to the washed but undried precipitate in a beaker add little by little a solution of sodium hydroxide until a little stannic hydroxide remains undissolved. Filter the solution and evaporate it to dryness on the water bath. Sodium stannate remains in the evaporating basin.

Though sodium stannate is soluble in water, many stannates are not and may be prepared by double decomposition. An interesting example is copper stannate, for it has been used as a green pigment. Dissolve some sodium stannate in water and add copper sulphate solution. Double decomposition occurs

with production of soluble sodium sulphate and insoluble copper stannate. When further addition of copper sulphate solution occasions no further precipitate, filter off the copper stannate and wash it well on the filter until one wash water no longer gives a white precipitate with strontium nitrate solution (showing soluble sodium sulphate to have been completely removed). The purified copper stannate may now be dried either on a tile or in the oven.

Rub up a little of it with weak gum water on a glass sheet with a pliable spatula until it sounds smooth and free from gritty noise as the spatula passes over it. By using it as an ordinary water colour, you will see its possibilities as a pleasantly tinted pigment.

(L.A.F.)

# MODES OF TRANSPORT

## 'HANSOM C

LAMP  
CONSTRUCTION

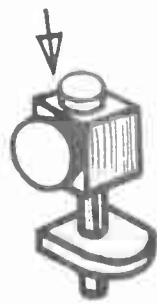

ROUND OFF  
SHAFTS



MADE FROM  
ODD  
PIECES  
OF  
WOOD

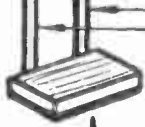

WIRE



G



WIRE

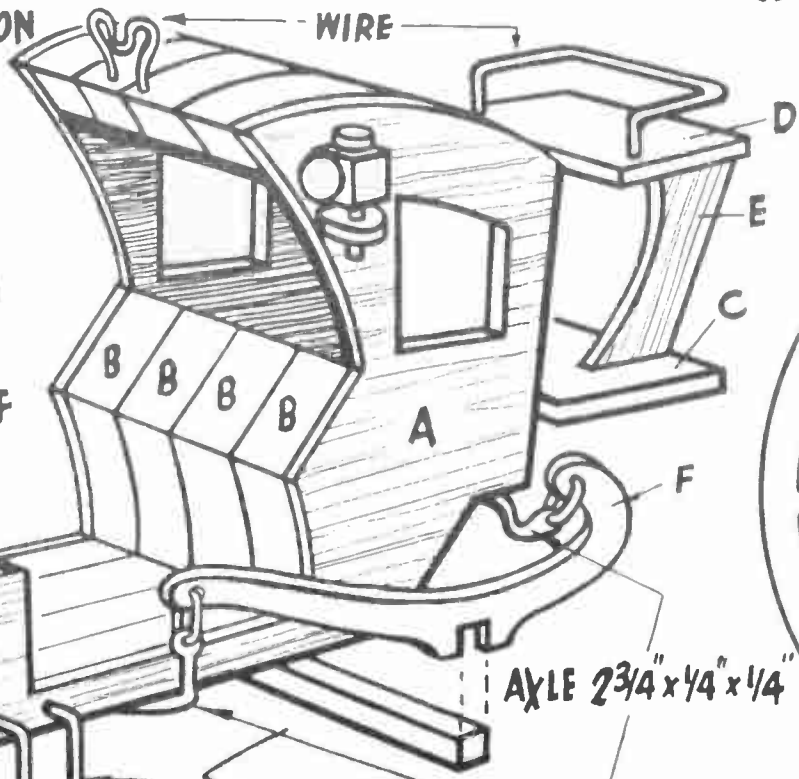

AXLE  $2\frac{3}{4}$ " x  $\frac{1}{4}$ " x  $\frac{1}{4}$ "

MAKE FROM WIRE  
AND TIN

FURTHER DETAILS MAY  
BE OBTAINED FROM  
REFERENCE LIBRARIES  
ENCYCLOPEDIAS, ETC.

WHEEL  
CUT T  
3/16"

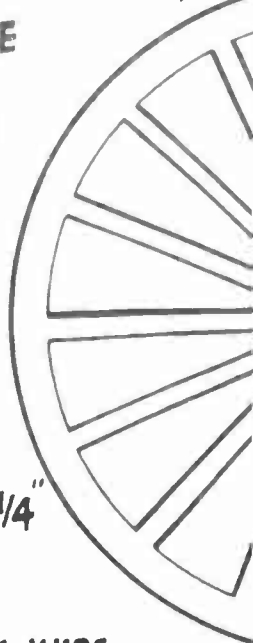

**CAB'**

HEELS  
TWO  
6 IN.

PIECE C  
CUT ONE  
3/16"

PIECE D  
CUT ONE  
3/16 IN.

PIECE E. ONE 3/16"

PIECE G  
CUT ONE  
3/16 IN.

PIECES B.  
CUT FOUR  
1/2 IN.

PIECES F.  
CUT TWO 3/16 IN.

PIECES A  
CUT TWO  
3/16"

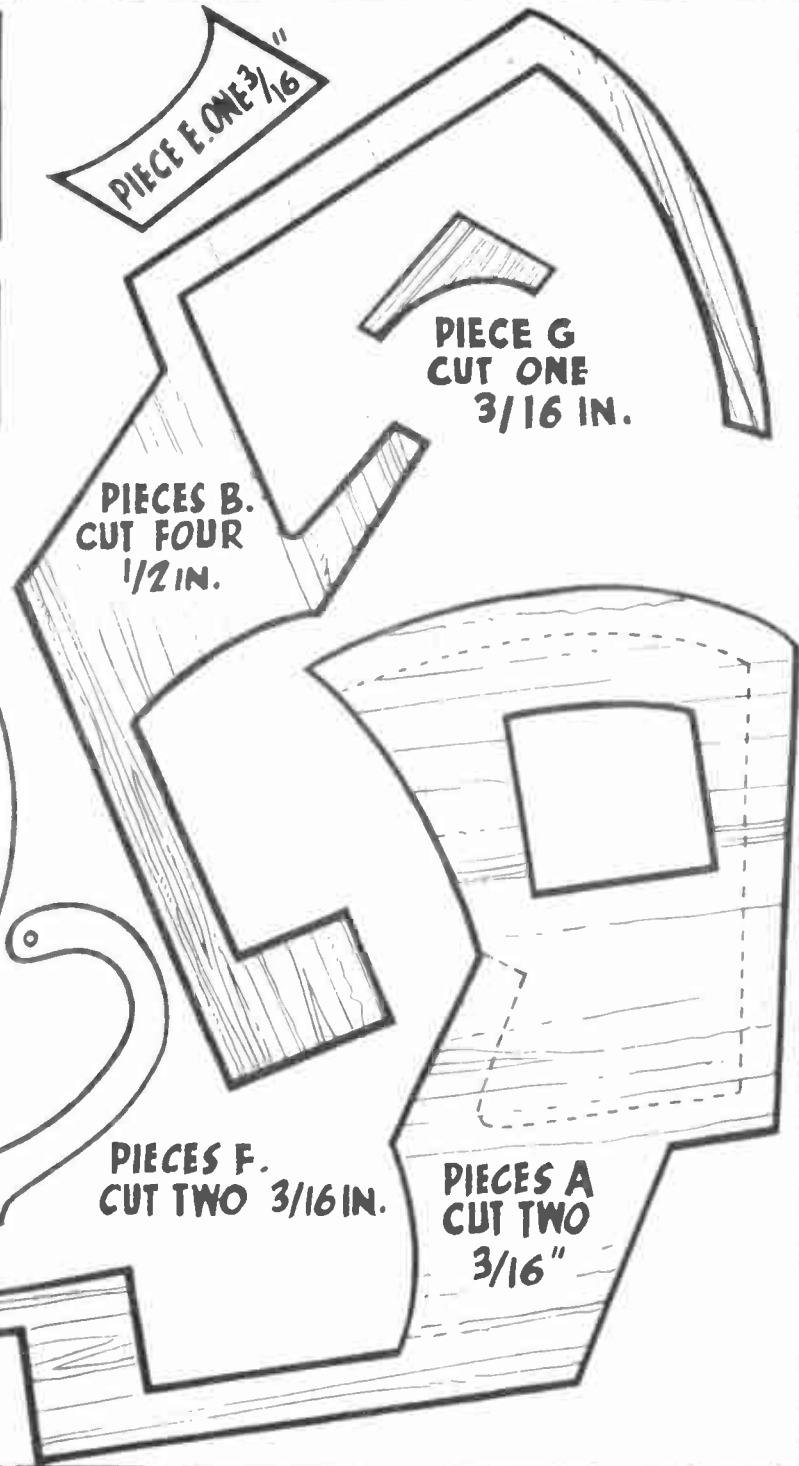
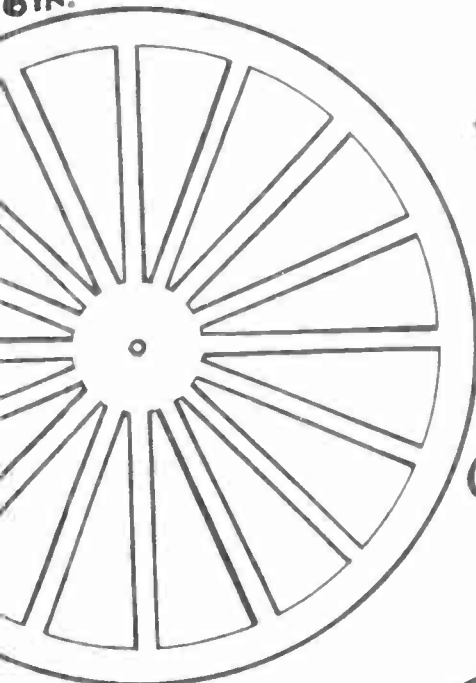

For perfect prints

# USING THE STEP WEDGE

IN previous issues we have endeavoured to emphasize the importance of correct negative exposure and the matching of the negative with the best type of paper, the object being high quality prints. When we arrive at the final process of making the print, we are again confronted with the problem of correct exposure.

There are many ways of determining the exposure time for a print and perhaps the commonest method is by

*By S. H. Longbottom*

making what we term a test strip. A strip of paper is laid on the enlarger baseboard and exposed for a different set of regular periods. For example, an exposure of five seconds is given to the whole strip of paper. We then take a piece of card to cover all the strip except for about 1 in., and expose for another five seconds, repeating the process until the strip has been exposed for 5, 10, 15, 20 or more seconds, ultimately selecting the exposure considered the best. There is also the method of exposure by doubling the previous time, i.e., 5, 10, 20, 40 seconds, etc, but this requires a second test as previously mentioned.

## Cheap accessory

Another way of testing exposure time is by means of a photometer, an optical instrument which compares and measures light of unknown intensity, which is transmitted by the negative, with a standard light source. There are various types on the market but most are too

expensive for the average worker. A rather cheaper, and simpler, accessory is a step wedge negative costing about 5/- and made in different forms by several manufacturers. The most satisfactory aid in this field is probably the Focal Enlarging Chart which not only includes a step wedge for measuring exposures but also a calculator which converts stops, speeds and paper; there is also a fine focusing negative which is a considerable help.

The essential part of this technique is the step wedge negative which is placed on a piece of paper after the picture negative has been placed in the enlarger and focused to the required size of the enlargement. This test strip is then given a fixed exposure of, say, 15, 30 or 60 seconds according to the strength of the

lamp, density of the negative or type of paper, and developed in the normal manner for a fixed period of two minutes. The wedge bears ten different fields and one of these should show the correct exposure for the whole print, this being calculated from the special disc on the chart, and it should be noted that the exposure can be calculated to within one second.

## Extremely accurate

It will be seen that the step wedge not only replaces the usual type of test strip, avoiding errors in timing, but also the more expensive photometer, yet will be found extremely accurate. The main point to remember is that when using a paper with a surface other than glossy it is essential to blot away any surplus moisture before selecting the field. You will recall that we have mentioned the fact that textured surfaces always appear brighter while in a wet condition, and it is most important to remove surplus water if we are to make a correct valuation. Once this basic test has been made, the calculator will provide the exposure time for a different degree of enlargement, without making further tests, and there is also a scale of speed numbers for changing from one paper to another.

At the same time we may mention that while it is not intended for the purpose, we can also use the step wedge to obtain an indication of the paper grade. You will remember that in a previous issue we mentioned that every paper bears an exposure scale, that is,

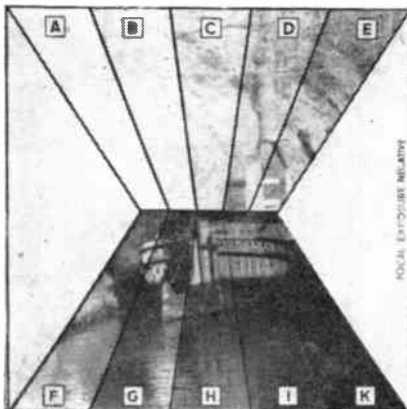
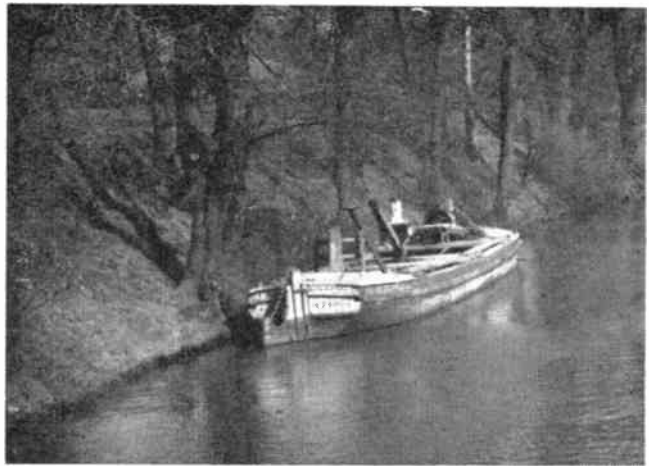
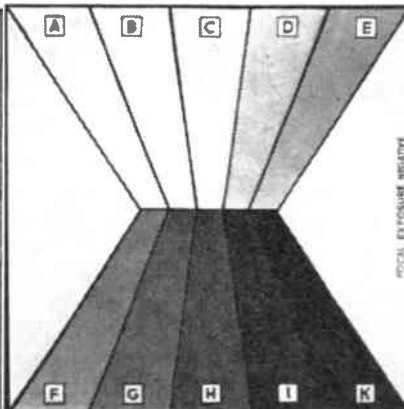

Fig. 1



World Radio History  
Fig. 2  
28

● Continued on page 29

# THE 'LUCKY SEVEN' CARD TRICK

THE number seven is supposed by some to be a lucky number while others credit it with an air of mystery. Whether this is true or not we can use the number for a neat card trick introducing patter while manipulating the cards such as 'there are seven days of the week, seven seas, seven wonders of the world...' and so on.

By 'Mystifier'

While you are thus talking, a pack of cards is produced and seven cards laid out in the shape of a figure seven as shown in our diagram, that is, there are three at the top and four for the downstroke.

A member of the audience is asked to select any card in the downstroke and the remaining three are returned to the pack. Now someone is asked to select one of the cards in the top horizontal row of three. This card is turned over and the value observed, cards to equal the number of the pips shown being dealt out on top of the card but face downwards. Supposing it was the ten of clubs, ten are dealt out; or the Jack of Hearts calling for eleven. Note that the Queen counts 12, the King counts 13, and the ace counts 1 only.

Another face down card in the horizontal row is then selected and a similar operation takes place. Finally, there is only one remaining card which you may turn over, counting out the number of cards. During these operations you may comment on the cards as they are revealed, counting out aloud the requisite number, and finally you may say that we have not yet come across a seven. With this you should turn up the first selected card in the vertical row, and strangely enough it will be revealed as a seven!

It would be an odd coincidence — and you may say this — if any of the other cards were sevens, and sure enough by turning up the piles of those dealt it will be found that the bottom one of each is indeed a seven.

You will appreciate that there has been a little preparation before starting the trick and will recall that the first card selected must have been a seven for no other cards have been placed on top. But how did the sevens arrive at the base of the other three stacks? The following describes the method used to perform this little trick with every success.

First of all the four sevens are taken out of the pack and placed together at the top. When shaping the figure seven on the table these top four cards must compose the vertical down-stroke. This is clearly shown in the diagram, so whichever one is selected is bound to be a seven. The values of the other cards on the horizontal row are not important, but you will want to know how the other sevens find their way to the bottom of the piles.

You will recall that one seven is actually selected in the downstroke and

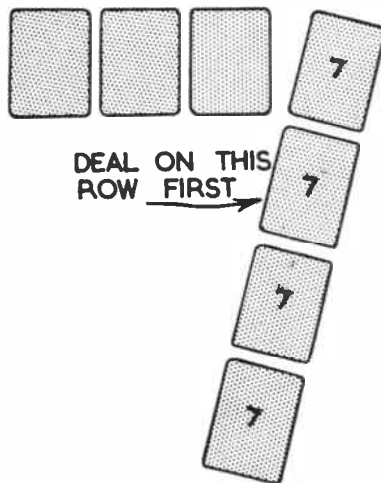

left on the table. That accounts for one of the sevens. Now while talking, pick up one of the other three, placing on

top of the pack, then place the full pack on another seven, and repeating the latter procedure exactly for the third and last card. This method of picking up the cards looks quite natural and a little haphazard, and is quite confusing to the audience for they are totally unaware of what is to happen.

You now have one seven-pip at the top of the pack and two at the bottom. When one of the cards on the horizontal row is turned over and you start dealing out, that top seven becomes the bottom one of the pile. All you have to do is to bring another seven from the bottom to the top and this can be done with a quick, yet smooth, action while talking. If the cards are held in the left hand the little finger can edge the bottom card forward a little and then it can be quickly transferred to the top without detection.

With the next dealing, you transfer this second seven-pip to the bottom of the new pile and the same routine is followed for the final dealing. So you may now be quite sure that the seven-pips have been directed where you want them and you are ready for the finale. Turn up the seven-pip that was in the original downstroke, make your remarks about the mystery of the number and then turn up the little piles in turn.

This trick is almost self-working, but you should practice sliding off the bottom card as neatly as possible so that you do not attract attention. You will find this easier than imagined and the best time to complete the transfer from bottom to top is perhaps after dealing out the requisite number.

● Continued from page 28

## Using the Step Wedge

the number of tones of grey between black and white. If the step wedge is laid on a plain piece of paper — without a negative in the enlarger — and a short exposure made, the number of test fields can be counted. If there are 8 steps between black and white, the paper is normal; if six to seven, it is hard, and if soft, there will be the full ten steps. In this way it is possible to compare the exposure scales of papers made by different manufacturers, for in practice we often find that the normal grade by one maker is softer than the same grade of another.

It will be seen, therefore, that there are several advantages of employing this inexpensive aid, the most important of

which are that it is cheaper, quicker, more accurate and simpler than either the test strip or photometer.

Fig. 2 shows the original test strip made for the picture, and from which field G in Fig. 1 was considered to be the best. In this instance bromide paper was used, and since this is rather fast, an exposure of fifteen seconds was made with a development time of 1½ minutes. After using the calculator, an exposure of 7 seconds was found necessary for this development time, giving the final picture as shown. Fig. 2 also shows how the step wedge has been used as a test for the paper grade, indicating seven clear steps between black and white, starting with field C.

# A 'SHOE POLISH' FINISH

**A** SATIN, waxed finish was once very popular for wood but was replaced by the introduction of french polish during the nineteenth century. At the same time, the housewife still uses wax preparations to maintain a high gloss on her furniture in much the same way as we clean our shoes. And when mass production of furniture became the practice the slower hand french polishing method was replaced by a cellulose finish applied by high pressure sprays.

Whether the latter is entirely satisfactory is a debatable point for the sprayed finish is subject to chipping, and this cannot be said of either wax or french polishing. Consequently, we now see more and more furniture being treated to the satin smooth finish of wax, and nearly all the smaller pieces of wood-ware are so treated.

The amateur will find that wax polishing is easier than french polishing and it can be renewed as desired; in fact the more often it is rubbed with a cloth the better the finish, while small pieces of work can be treated with little delay. The only objection which can be made against this finish is that it is liable to absorb dust which works into the grain, yet by sealing the pores of the wood with an application of french polish this can be avoided.

You may either stain the work with one of the recognised mediums, or apply the staining along with a first coat of polish. If a stain is used it is always advisable to fix this with one or two thin coats of french polish, otherwise the turpentine in the shoe polish may remove patches of stain. Alternatively, you may apply two coats of french polish to the wood to seal the pores and then proceed with the shoe polish, and we should also mention that this idea of giving a preliminary bodying up makes the task of burnishing much easier.

The only thing to remember is not to apply french polish after a coat of wax. When a really light finish is required it is important to use a light coloured french polish, but it is quite unnecessary to apply a filler of any description since the wax acts in this manner, being rubbed into the pores by subsequent applications.

Now let us look at the normal shoe polishes available. It is best to select a high quality, reliable brand of polish, for the best are made from beeswax.

Much depends on the shade required, and no harm will be done by a few tests on waste pieces of wood, but it should be fairly obvious that we can mix any of the colours to a desired tint. Black polish will be found very useful

*The wax finish described in this article by H. Mann can be applied with good effect to this design for a lady's sewing companion, which when closed can be used as a small table and makes an admirable piece of quality furniture.*

**Hobbies Kit No. 3278** for making the sewing companion includes planed wood panels and easily fitted contemporary legs and is available from all branches, etc., or by post, price 65/-

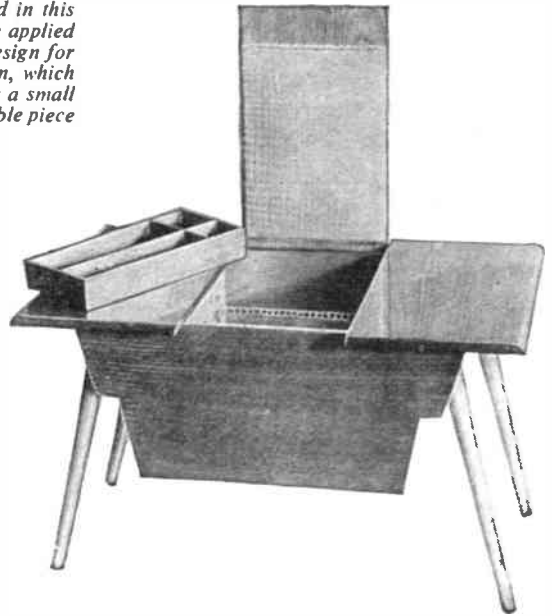

for darkening any colour and for producing a rich, antique effect — but care should be taken to ensure thorough mixing and blending.

First of all you should take a little of the basic colour, stirring in a few drops of genuine American turpentine (not white spirit substitute) and a few drops of refined petrol, that is, lighter fuel. The latter aids evaporation while the turpentine thins the mixture and eases spreading. This foundation colour should not be too thin but easy to apply with rag or brush, and you will find it quite a simple matter to add black or ox-blood in small quantities to brown to produce the required shade. If an antique finish is required, that is, the tone being darker at the sides and corners than in the centre, a little more black should be added accordingly for these parts.

A shoe brush will be found ideal for making the first application, especially if it has fairly stiff bristles, working with and across the grain to ensure even distribution.

After the first application the work should be laid aside for as long as possible, since burnishing cannot be attempted until the turpentine has evaporated. Then brush up the work with a softer brush, finishing with a cloth.

This first application may produce a

patchy spread of polish, in fact it may be expected if the primer of french polish is absorbed more in some parts than others, but this is corrected by a second application, using a rather stiffer wax applied sparingly with a rag. Allow time to dry as before, then give a thorough brushing.

If you wish to experiment by making your own polishes, all that is required is some beeswax, turpentine and petrol. You are warned not to melt these materials over a gas ring, since there is danger of fire from the naked flame. The best way is to place the wax in some vessel contained in a larger bowl of hot water until the wax is melted. The wax may be shredded to speed the process, adding the turpentine and stirring in when the wax has melted. Petrol may also be added at this time if desired. The following recipes will be ample for most needs:—

Dark polish — raw beeswax and turpentine.

Light polish — bleached beeswax and turpentine.

Antique polish — raw beeswax, lamp black and turpentine.

A very light-toned wax polish can be made by using paraffin wax and turpentine instead of beeswax, but it should be noted that the results are not always quite so good.





## Veteran Car Plaques *FOR THE ENTHUSIAST*

Make a set of six wall plaques showing authentic replicas of Veteran cars. These are something new to the Sculptorcraft range of Plastic Moulds. They can be used many times over.

*Write for illustrated leaflet, enclosing 3d. stamp*



**Sculptorcraft**



**SEAMER PRODUCTS (SCULPTORCRAFT) LTD, 23/27 EASTBOURNE STREET, HULL**

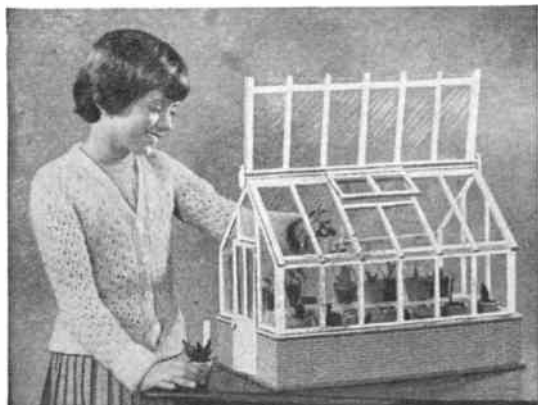

## MINIATURE GREENHOUSE

*A really practical model for the home*

For growing cacti, succulents, miniature trees, seedlings, etc., and can be used as a propagating frame.

### JUST LIKE DAD'S!

You can make this ideal showpiece from Hobbies Kit No. 3300, which contains all wood, materials, etc., and 12 sets of pots and saucers. Hinged roof, window, door. 18 ins. x 12 ins. x 13 ins. high. Only a few simple tools needed in construction.

Kits from Hobbies branches, stockists or post free (see coupon). **39/6**

**ALL-THE-YEAR-ROUND INTEREST**

To HOBBIES LTD., Dept. 991, Dereham, Norfolk

Please send Kit No. 3300 for making Miniature Greenhouse.

I enclose P.O. for 39/6.

Name .....

Address .....

.....  
 .....

# A 'NATURAL' WALL PICTURE

THERE are many possibilities open to the collector of Moths and Butterflies when mounting his specimens. The usual method, of course, is to fix them in neat rows in glass-topped cases and these in turn can become drawers to form a cabinet.

This is the scientific approach to the study of Lepidoptera, each specimen being neatly labelled with all information concerning its species. There is a time, however, when a variation of this lay-out would be appreciated and here is just the thing.

*By A. F. Taylor*

One or more carefully selected specimens neatly arranged with natural surroundings and mounted to form a picture is the idea we have in mind. This not only shows off your choice specimens but also forms a fascinating picture to adorn your wall and charm your friends.

A fairly substantial board is needed for the backboard and this forms the foundation on which to mount your specimens and their appropriate surroundings. In order to preserve this lay-out it is covered with a sheet of glass held in place just clear of the specimens by a suitable moulding.

The size will depend to a certain extent on the number of specimens to be shown but measurements given in the diagrams can be considered a fair average. Alterations can be made to suit individual requirements or where the picture is to fit into a specified position.

A piece of  $\frac{1}{2}$  in. hardboard or plyboard is right for the backboard. The overall size of  $12\frac{1}{2}$  ins. long and 6 ins. wide will make a well-proportioned picture. Reference to Fig. 1 shows how to cut the board — the top takes the form of the fore part of a butterfly or moth while the bottom shows the two rear wings and body.

The rectangular centre portion will need careful preparation in readiness for mounting the specimens. The ideal background for most types is a pale green or blue, although for some of the lighter moths it is advisable to adopt a much darker colour so as to form greater contrast.

Background colour can be painted on, or a sheet of paper stuck down. A matt surface is better for this purpose than a shiny one, which is liable to create unnatural reflections. Decide first the kind of specimens you are going to mount, together with their appropriate surroundings; then you can choose a background to harmonise.

## A grass setting

Grasses form one of the most artistic and natural objects for moth or butterfly pictures and when dried these are ideal for our purpose. We must not forget however that there are certain plants which we can use. The teasel is an excellent example, and when carefully



dried and mounted can be very attractive.

They may be fixed flat on to the backboard but a much better appearance is achieved by letting them stand out, even if it is only by a small amount. A small strip of wood at the base drilled to take the stalks is quite suitable for this purpose, or for a more natural rugged appearance try shaping a piece of modelling clay or similar material.

Short pins are used when mounting the moths or butterflies so that the distance between back and glass can be kept to a minimum. When mounting your specimens set them out as naturally as you can.

Having got a nicely arranged picture it is necessary to preserve it by covering with a glass held at the correct distance with an appropriate moulding.

The framing can be made up as a unit and then added to the backboard or each of the four sides fixed separately. The shape of the moulding is given in Fig. 2 — it is  $\frac{3}{4}$  in. deep and  $\frac{1}{2}$  in. wide and the rebate to take the glass is cut  $\frac{1}{8}$  in. each way. A thin capping to hold the glass in place is  $\frac{1}{8}$  in. wide and about  $\frac{1}{2}$  in. thick, and the pieces are cut to the same lengths as the moulding, i.e. two pieces 9 ins. for the sides and two pieces 6 ins. for top and bottom. Mitre the corners and glue in position.

The moulding can be finished off by painting, or if it is an attractive hardwood then french polish or varnish is suitable. A hole for hanging will complete the job.

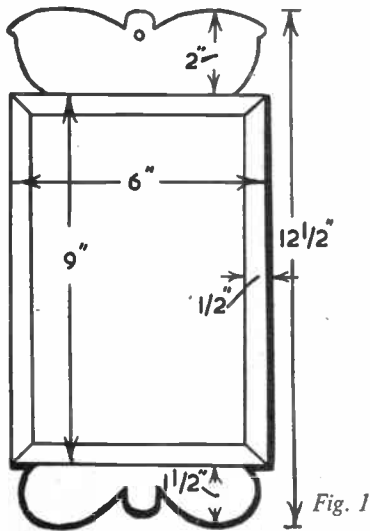

Fig. 1

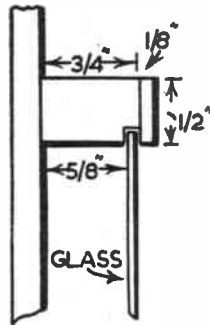

Fig. 2

# Brilliant Postcard Enlargements

## JUMBO ENLARGERS



Now you can make enlargements from your negatives easily and inexpensively. The JUMBO ENLARGERS make postcard size prints on ordinary bromide paper. There is nothing to adjust, no focusing is required. And they are as easy to operate as an ordinary printing frame. Each model has a strong steel body finished in blue and grey Polychrome enamel.

Model No. 1 for 2 1/4" x 3 1/4" negatives £2.4.9.

Model No. 2 for 35 mm. negatives £2.4.9.



FOR CONFIDENCE  
IN PHOTOGRAPHY

## KITS for OLD TIME SHIPS

Hobbies range of Ship Models includes Elizabeth Jonas, Cutty Sark, Victory, Mayflower, etc. Complete kits of wood, sail material, guns, pulleys, cord, etc., with full-size patterns of parts and planed wood ready to cut out, shape and construct. A fascinating pastime.

Ask for free illustrated list at Hobbies Branches or from Hobbies Limited, Dept. 991, Dereham, Norfolk.

LET  
★ **'Plasticine'**  
HELP YOU DO-IT-YOURSELF Regd. Trade Mark  
Harbutt's Plasticine Ltd, Bathampton, Bath

## Webley AIR PISTOLS

High Accuracy  
and Hitting Power  
Perfect Balance  
Robust Construction



Send  
for  
Catalogue

WEBLEY & SCOTT LTD.

34 PARK LANE, HANDSWORTH, BIRMINGHAM 21

## Too good to miss!

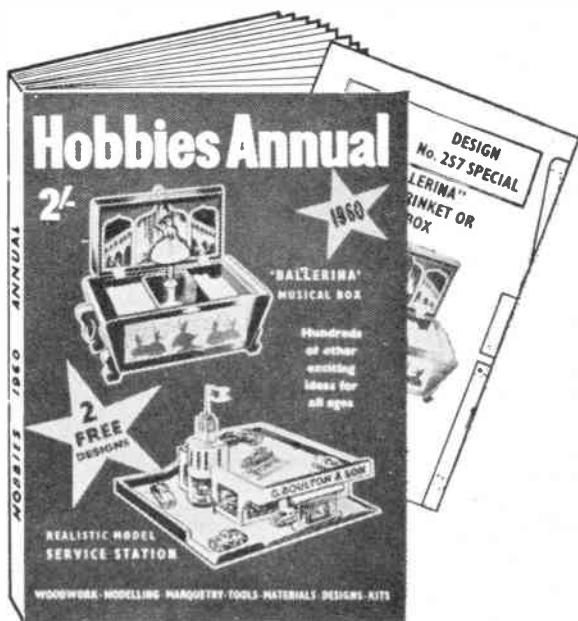

## The Annual You MUST Have

The big-value Handbook for the woodworker, handyman, modeller and handicraft worker. 168 pages full of interesting projects — and ONLY 2/-. TWO FREE DESIGNS WITH EACH COPY

Charming Ballerina Musical Box.  
Model Service Station for the modern lad.

Projects include:

- ★ Animated Toys
- ★ Trailer for Tricycle
- ★ Bathroom Drip Dryer
- ★ Blanket Chest
- ★ Coloured Marquetry Picture
- ★ Standard Lamp
- ★ Modern Clocks
- ★ Model, etc., etc.

From Hobbies branches, stockists, newsagents, bookstalls, etc. or send NOW for your copy by post (6d. extra).

To Hobbies Ltd., Dept. 991, Dereham, Norfolk.

Please send ..... copy/copies Hobbies 1960 Annual (2/6 each, post free). P.O. for ..... enclosed.

Name .....

Address .....

.....

.....



So—a man of resource— he took ESCORT'S quick Course

—And now he's got partners galore!

Can't afford private lessons? Learn ballroom dancing at home! Send for exciting booklet *Dance Escort* - FREE to readers of *Hobbies* - which explains the dynamic SURE STEP system. Just send name and address to:

**ESCORT DANCE INSTRUCTORS**  
Studio H26 Harrogate  
(or Rock'n'roll Course — send 4/6 P.O., or OLD TIME Course 8/6 or CHA-CHA Course 5/6)

**TRANSISTORS**, Germanium Crystals, Headphones, etc. Lists and diagrams free. Germanium Diodes with three crystal set circuits 1/- Postage 3d. P.R.S.(H). 33 Bourne Gardens, London, E.4.

**LEARN RADIO and ELECTRONICS** the NEW practical way! Very latest system of experimenting with and building radio apparatus — 'as you learn'. FREE brochure from — Dept. HW10, Radiostructor, 46 Market Place, Reading, Berks.

**INTRODUCTIONS** to new friends; home and Overseas. — V.C.C., 34 Honeywell Road, S.W.11.

**Refund if not worth double !**



**TV TABLE & EXTRA LARGE RECORD CABINET**

Not only sand polished but also sprayed light or medium WAL-NUT tone. NOTE—ROOMY BOOK CASES AT BOTH ENDS — one converts to Magazine Rack by insertion of sloping panel provided, as illustrated. Amazing offer — 59/6, carr. 6/6 or sent for £1. Balance 6 monthly payments 8/-, plus carr. A well-built contemporary piece of furniture to solve your record problem and also ideal as stand for TV, Radio or Record Player. 30" x 15" x 24" high. Modern sliding doors. Roomy interior, partitioned for classifications, holds up to 200 records (upright for perfect condition). Entirely of seasoned timber. Detachable legs. SEND quickly. LISTS, FURNITURE.

SEND FOR OUR FREE ILLUSTRATED CATALOGUE OF BINOCULARS (EVERY KNOWN MAGNIFICATION), RINGS, WATCHES, FURNITURE, ETC. ALL AVAILABLE ON THE EASIEST OF TERMS

**H**HEADQUARTER & **G**ENERAL SUPPLIES LTD.  
(HOBW/84) 196-200 Coldharbour Lane, Loughboro Junc., London, S.E.5. Open Sat.

**BUILD YOUR OWN HI-FI** at home! At last for reasonable cost — the chance to make your own quality HI-FI audio equipment and to gain the knowledge to service and maintain it. FREE brochure from — Dept. HW20, Radiostructor, 46 Market Place, Reading, Berks.

**100 DIFFERENT stamps free!** Request 3d. upwards discount approvals. — Bush 53 Newlyn Way, Parkstone, Dorset.

**STAMPS FREE** — Empire Packet including Pictorials and Victorians with approvals. — Robert J. Peck, 7A Kemp Road, Bournemouth.

Completely new 54 page Edition  
**WHERE'S THAT CAR FROM ?**  
Price 1/- (Postage 4d.)  
of all Booksellers  
or  
**RALEIGH PRESS, Exmouth, Devon**

**MAKE A MUSICAL BOX** for as little as 21/-. New kits and tunes available. Movements 13/- post free. Please send 3d. stamp for free illustrated catalogue. — The Swisscross Co., Dept. B, 202 Tulse Hill, London, S.W.2.

**EXTRA CHEQUES** from writing. Send for 'Ideas for Writers' (free). Scores of suggestions for beginners and others. Typewriter unnecessary. — Writers' Ring (H.W.), 5 Edmund Street, Birmingham 3.

**GIANTS, Triangles, Pictorials, etc.** — 100 Free. Request Approvals. Postage — Salter, 42 North Road, Rotherham.

**Yours**  
for  
only  
8/6d.  
(Post 1/3)



**Safeguard your copies**  
of **'HOBBIES WEEKLY'**  
The amazing 'EASIBINDER' (Pat.) makes it simple

With the new *EASIBINDER*, specially prepared for *Hobbies*, you can bind each copy of *Hobbies Weekly* as you get it, turning your favourite magazine into a permanent, easily-consulted library of immense value, and avoiding the delay and despair occasioned when copies are accidentally mislaid or destroyed. Carefully finished in black leather-cloth and gold-blocked on the spine, each binder is strong, serviceable and neat. It will hold two complete volumes (52 copies) and costs only 8/6. Each copy of the magazine is quickly inserted by means of a flexible steel wire, and can easily be removed if necessary. Easy-to-follow instructions with each *EASIBINDER*. Get one today and take care of your copies of *Hobbies Weekly*.

**NOTE** From the issue April 10th, 1957, there is a slight difference in the size of the magazine, and two sizes of *Easibinders* are available. Type A is for binding issues published before April 10th and Type B is for those printed subsequently. To avoid confusion, when ordering, please indicate clearly the type of *Easibinder* required. Indices for each completed volume 1/- each post free.

☆ One 'EASIBINDER' holds two volumes (52 copies)  
☆ Easy to use  
**Post today**



To: **HOBBIES LTD., Dept. 991 Dereham, Norfolk.**  
**PLEASE SUPPLY ..... EASIBINDERS**  
(Type ..... ) at 8/6 each (post each 1/3).

NAME.....  
ADDRESS.....  
P.O. for.....  
enclosed.....  
WorldRadioHistory

Present for Dad

# DECORATIVE PIPE RACK

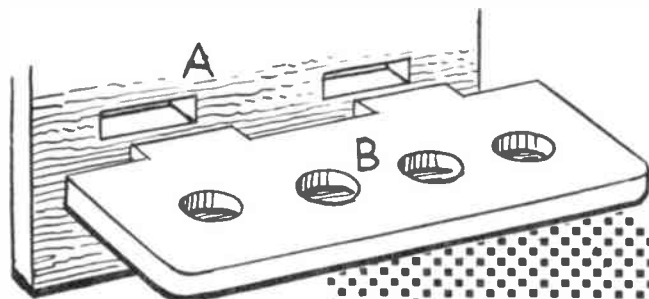

CUT one piece A and one piece B from  $\frac{1}{4}$  in. wood. Glue piece B to A in the position shown by the dotted lines. Clean up with fine grade glasspaper making sure that all traces of glue have been removed.

Finish off by staining and polishing or by painting with high gloss enamel.

(M.p.)

USE YOUR  
FRETSAW

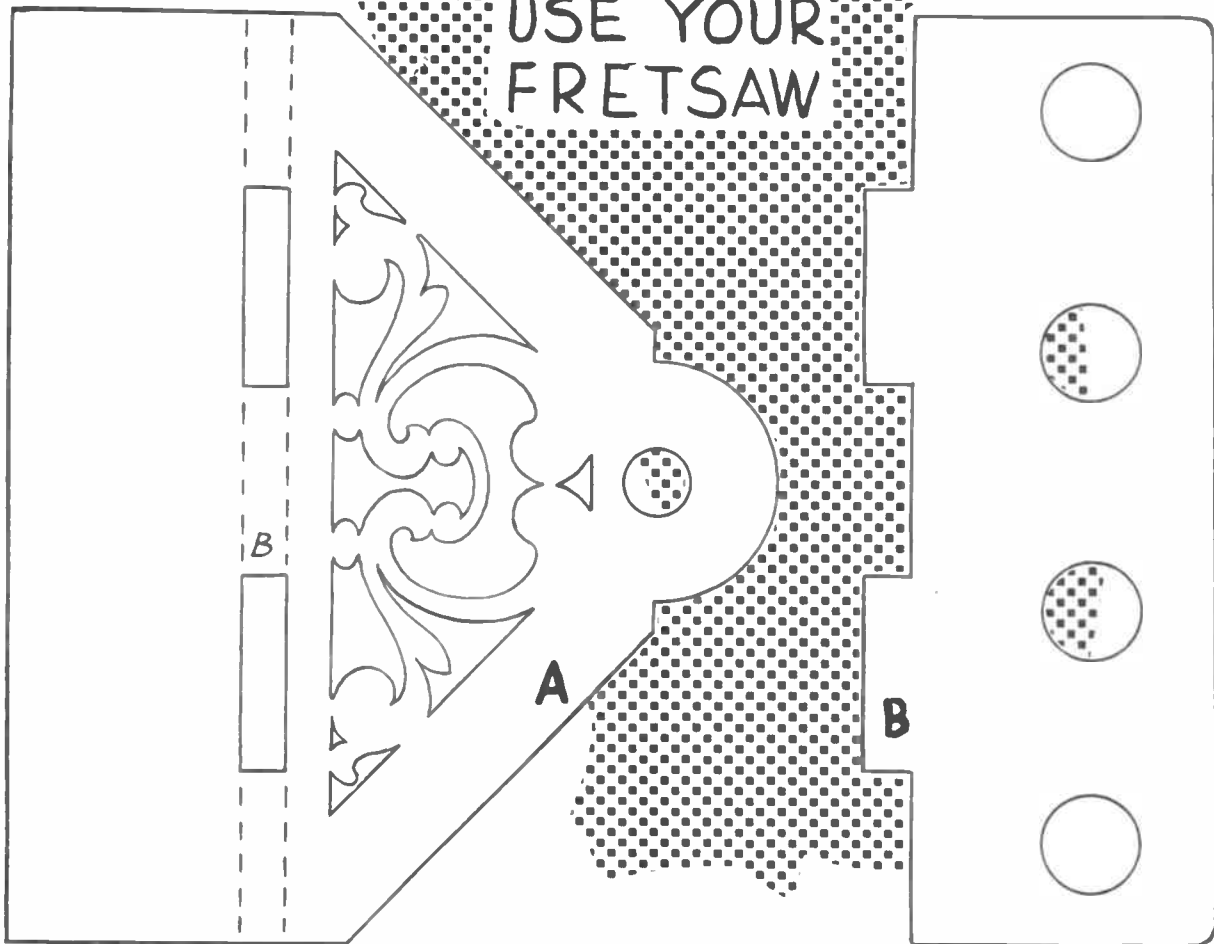

Whatever your speciality

You'll get a far better finish—far quicker—

with **NEW FORMULA**  
**HUMBROL**  
**PLASTIC ENAMEL**

**NEW FORMULA**  
**HUMBROL**  
**PLASTIC ENAMEL**

is available in 34 colours—  
matt and gloss

$\frac{1}{2}$  oz tins 8d. Sizes up to  $\frac{1}{2}$  pint  
Handy multiple painting kits 3/- 12/11  
from all good model shops and  
hardware stores.



Specially formulated for the exacting standards of professional model makers, new formula Humbrol gives a superlatively fine finish to wood, metal, perspex, polystyrene, pottery, aircraft tissue and paper.

- *dual purpose: replaces colour dope*
- *dries in one hour*
- *lead free in most colours*
- *proof to diesel fuel*
- *brushes on easier*
- *consistently matching shades*
- *long lasting*

AIRCRAFT  
SHIPS  
GALLEONS  
CARS  
TRAINS  
ARCHITECTURE  
PUPPETS  
MACHINERY  
HANDICRAFTS

**HUMBROL**

A product of the paints division,  
**THE HUMBER OIL COMPANY LTD.**

MARFLEET · HULL · ENGLAND