

# HOBBIES WEEKLY

MARCH 25th 1959

VOL. 127

NUMBER 3308

## IN THIS ISSUE

	Page
Plant Stand . . . . .	401
Broomstick Novelties . . . . .	402
Two handy Painting Outfits . . . . .	402
Making up the Modern Plant Stand- Puzzlepic . . . . .	403
Do your own Cistern Repairs . . . . .	404
The Balancing Bird . . . . .	405
Model 'Mushroom-type' Lamp . . . . .	406
Playtime with a Swing . . . . .	407
A Vice for Sharpening Saws . . . . .	408
A Home-made Loudspeaker . . . . .	409
Choosing Camp Equipment . . . . .	410
Collectors' Club . . . . .	412
Home-made Toffees . . . . .	414
Patterns for A 'Kitten' Thermometer . . . . .	415



All correspondence should be addressed to the Editor, Hobbies Weekly, Dereham, Norfolk



*FREE design  
inside for you  
to make this  
charming piece  
of furniture*

## PLANT STAND

*Easy to make  
for the  
modern home*

401

FOR ALL HOME CRAFTSMEN  
Over 60 years of 'Do-it-Yourself'

World Radio History

4<sup>1</sup>/<sub>2</sub><sup>ID</sup>

# BROOMSTICK NOVELTIES

WITH a little ingenuity, ordinary broomsticks can be adapted to make useful and decorative articles for the home.

## Clothes airer

A useful and space-saving clothes airer, which can be hung from the ceiling when it is needed, is easy to make, as seen in Fig. 1. A broomstick is drilled to take six 2ft. lengths of  $\frac{1}{2}$ in. dowelling. These are glued into place at right angles to each other to leave space between them for the hanging of clothes. A hook is screwed into one end of the broomstick, and another into the ceiling, making sure that it is screwed into a joist and not into the plaster alone. Make a pilot hole first with a darning needle to find the joist.

## Hanging indoor garden

'Hanging Gardens' look effective at a window, above bookshelves, or in a hall. One broomstick by itself, or two or three can be used. Use tumbler-holders to take the plant pots, one screwed to the lower end of the broomstick, and another half way up, on the opposite side of the stick (see Fig. 2). Use hooks to hang the fitting from the ceiling or top of the window frame. Paint the broomsticks matt black, grey or white for the best effect.

## A wall light

An unusual wall light can be made by screwing a lamp-holder to the top of a broomstick and fitting a plain white bell-shaped shade facing upwards (Fig. 3). Four decorative scrolls are made from lampshade wire and screwed into place, a small loop being made in each scroll at its lower end for this purpose. A hook and eye holds the fitting to the skirting board at its lower end, and a length of heavy silk cord passed through a hole three-quarters way up the broomstick holds it at an angle to the wall. The flex should run up the inner face of the broomstick; plastic twin flex, neatly stapled, is the least noticeable.

## Standard and table lamps

An inexpensive standard lamp is simple to make, using a broomstick in a round wooden base, with the shaft of the lamp finished in a tightly wound spiral of rope, which is fixed in place and painted (Fig. 4). Use a plastic lamp holder of the kind usually sold for fixing in the necks of bottles. This type has a long fixing screw which can be

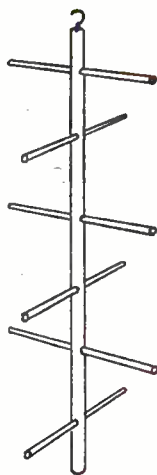

Fig. 1



Fig. 2

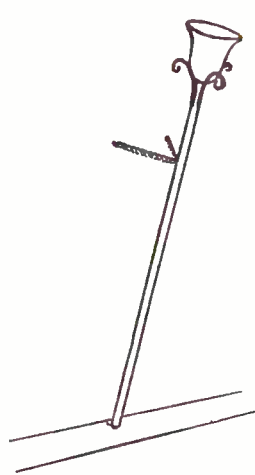

Fig. 3



Fig. 4

'Broomstick' projects described in this article

fitted into a hole drilled in the top of the shank. The rope covering of the lamp also hides the flex, which is run up the side of the broomstick before the rope is fixed in position. Use a length of clothes line for this. After 'whipping' the end with string to prevent it fraying, use a nail to tack it to the bottom of the shaft, and using glue liberally, wind the rope round in a spiral, covering only a

few inches at a time. Keep the rope as tight as possible, and finish it off at the top with a binding of string. Several coats of paint will be needed to give the rope a hard firm finish. To complete the nautical effect, felt shapes of ships' wheels can be fixed to the shade. A table lamp to match can be made in the same way, using a 1ft. length of broomstick. (A.L.)

## Two handy Painting Outfits

THIS brightly coloured economy pack is an attractive outfit consisting of eight plastic containers of Humbrol Art Oil Enamel colours (including gold and aluminium), one of thinners, and one of flattening agent; brush; mixing palettes; mixing instructions and colour guides.

The enamel is quick drying, inter-mixable, and ideal for painting plastics, wood, metal, glass and pottery. The outfit is erected by the purchaser into a 3-D stand (as illustrated) and costs 3/-.

Also introduced is the Humbrol Scenic Enamel Painting Kit. A new 'all-in-one' outfit for the landscape painter; it can be used for painting pictures or miniature scenes, and contains the range of twelve Humbrol scenic enamels, five mixing palettes, painting brush, and illustrated directions. The paint is of the jellied type which does not spill and needs no stirring; giving

excellent results on metal, plastics, wood, glass and all kinds of plaster, hardboard or canvas. Without any mixing being needed, these enamels provide maximum realism in texture and colour. Individual jars are available as replacements and the kit complete costs 12/11d.

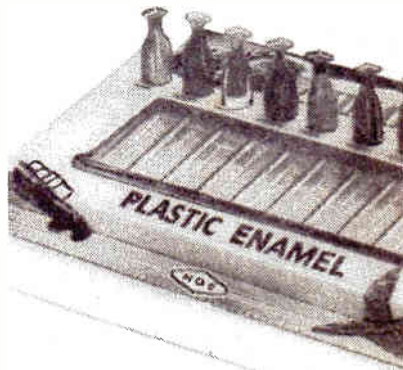



# MAKING UP THE MODERN PLANT STAND

(Illustrated on front page)

VERY simple in construction, this handsome plant stand makes an elegant showpiece for the modern home. The window bay makes an ideal setting, and it would also look very well in the hall. Handles are provided for ease of carrying around and changing its situation as desired.

The trough measures 30ins. long by 7ins. wide, and is supported on 15in. contemporary style legs, giving an overall height of 21ins. It is designed to be filled with house plants bearing decorative foliage which can be interspersed with plants of the trailing kind, as shown in our illustration on the front page. Plants are stood in pots in the stand on containers to catch excess water, and individual plants can be changed around and substituted as occasion arises.

It will be seen that shapes for the ends (B) and handles (E and F) of the trough, are shown full size on the design sheet. Dimensions of other parts of the trough assembly are given on the design sheet and in Fig. 1.

In Hobbies kit there are three furniture panels measuring 36ins. by 6ins. by  $\frac{1}{2}$ in. To economize in wood, the parts should be transferred to these panels as follows: on the first panel, the front and one end; on the second panel, the back and one end; on the third panel, the floor and front rail.

Parts which go to make up the handles are cut from waste wood from the third panel. The cutting of panels 1 and 2 is, of course, identical, and these parts should be cut out and assembled before starting on the third panel, because a certain amount of checking will have to be done before cutting out the floor.

The cut-out shapes of the front and back are identical, and made with a fretsaw. Glue and screw the front and back and two ends together, or nail if preferred, noting that the ends go between the back and front (Fig. 2).

The floor (C) goes inside the bottom of the trough thus far assembled, and must therefore be chamfered all round to give a nice fit (Fig. 2). Allowance for this chamfer must be made when cutting out the floor. Chamfer with a plane or Surform tool, taking off a little at a time and constantly checking to ensure a good fit before finally fixing in place.

The contemporary legs, as supplied in Hobbies kit, are very simple to fit, the legs themselves screwing into blocks

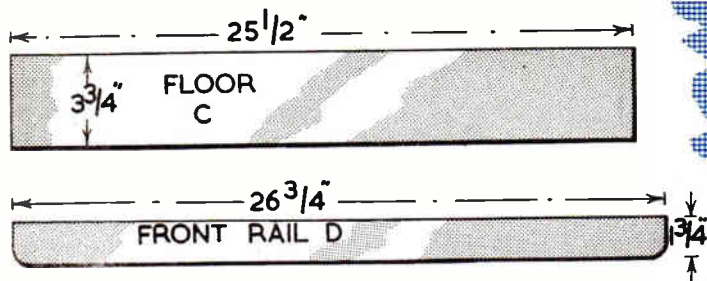

Fig. 1

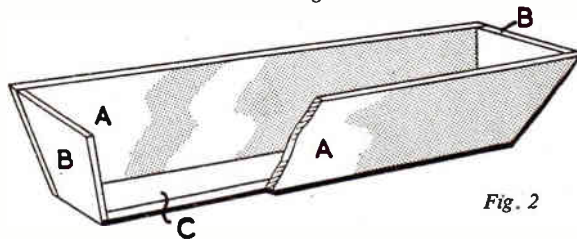

Fig. 2

which are fixed to the underside of the trough. These blocks are screwed side by side so that the legs when screwed in will splay outwards (see end view on design sheet). Note that the back legs will be the outside of each pair and are inset  $2\frac{1}{2}$ ins. as shown on design sheet.

The rail (D) conceals the leg blocks from the front view and is screwed or pinned direct to the blocks of the inside legs which come level with the front. Chamfer the top of the rail neatly to a point where it meets piece (A).

Each handle consists of one piece (F) and one piece (E), which are glued together as shown on the design sheet and screwed one on each end of the trough.

To show up the plant foliage to the

The charming plant stand can be made up for only 27/6 with Hobbies Kit No. 3308 containing panels of wood and four contemporary legs. Kits from branches or Hobbies Ltd, Dereham, Norfolk (carriage 2/9 extra).

best advantage, the trough should be painted in a pastel shade, such as pale green, or cream. Clean up the plant trough thoroughly with glasspaper, and fill all nail and screw holes and the grain of the wood. For a good finish, give an undercoat and two top coats of gloss or enamel paint.

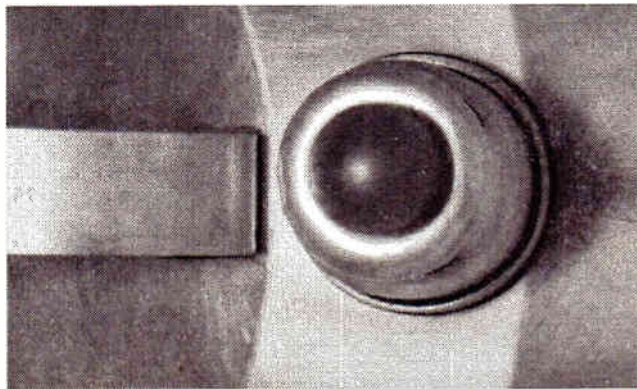

PUZZLEPIC—What is it? See page 410

# Do your own Cistern Repairs

**D**RIBBLES and drips from water cisterns can be annoying. Moreover they are often the cause of a freeze-up in the pipes. Most people can change the washer on a tap and successfully stop a drip. The reason is obvious — the tap handle can be tightened by hand pressure until the drip stops.

With a lavatory cistern the pressure of the washer on the valve face to stop the inflow of water is controlled mechanically — hence when the layman replaces a washer in a cistern and the water still drips out through the overflow pipe, he is at a loss to understand it. It is all caused by a little nick inside, as will be explained later.

First, how does a cistern valve operate? The cross section shown in Fig. 1 illustrates the various components. The water enters from the feed pipe on the right, and into the cistern through the outlet, as shown. The mouth of the water inlet reduces to a hole approximately  $\frac{1}{8}$  in., where it is controlled and

shut off by the pressure of a rubber washer on to the valve inlet face.

The washer is held in the front of a plunger that enters the free end of the valve. Connected to the plunger is an arm carrying the floating ball inside the cistern. By means of a pawl attached to the end of the ball arm and locating into a keyway slot in the plunger, the rubber washer is pushed against the valve face as the floating ball rises with the incoming water and is adjusted so that when the water has reached a certain level it is shut off by the pressure of the washer on the valve face. The ball arm pivots on an axle, usually a split pin.

It will be seen, therefore, that if the valve face is damaged and is not exactly level, the rubber washer cannot make a complete seal, and then you get a drip. The valve face is usually damaged in the first instance by a hard particle of matter which, although minute, adheres to the valve face. In time the pressure of

the washer on this foreign matter forms a hollow or a nick on the valve face. You can go on changing the washers until you are blue in the face and still the water will drip.

*By E. Capper*

The damage is illustrated in Fig. 2. Also, shown here, for the absolute novice, are the two parts of the plunger. The head piece unscrews to allow access to reach the washer for re-changing.

The first signs of a damaged valve face is usually a slight fizzing sound after the water appears to have finished entering the cistern. Remove the plunger from the valve and examine it — first turning off the water supply, of course. If the circular indentation caused by the washer's everyday working on the valve face is clean and unbroken, then a new washer is all that you need to fit. If, however, the circle is not complete, as shown in Fig. 2, then the valve face is damaged.

Check it still further. Insert your little finger into the valve mouth (the end occupied by the plunger); with your finger nail, scrape over the surface of the valve face. You will soon locate any nick in the face, if there is one.

## Remove nick

The nick must be removed if you want the cistern to operate correctly again. You can purchase a tool for the job, called a re-seating tool, from your ironmonger. Its shank is held in a drill chuck, a guiding pin locates into the narrow mouth of the water inlet hole and when the tool is rotated a cutting edge runs over the face of the valve, re-facing it flat and clean. It is important that only the minimum of the valve face is removed — just sufficient to remove the nick and nothing else.

A hand-operated tool can also be purchased. It has the same guiding pin and cutter but the end of the shank is T-shaped and is rotated by hand.

You can reface the valve seating with a  $\frac{1}{8}$  in. drill bit as shown in Fig. 3. Hold the valve in the vice and gently rotate a drill bit until the nick is removed. Very light pressure combined with quick rotation gives the best results. Finish off with emery cloth. Push a wad of the cloth on to the valve face and rotate it with a short length of dowelling.

Another alternative is to cut a saw-cut across a short length of  $\frac{1}{8}$  in. bar and into it insert a snapped-off piece of a

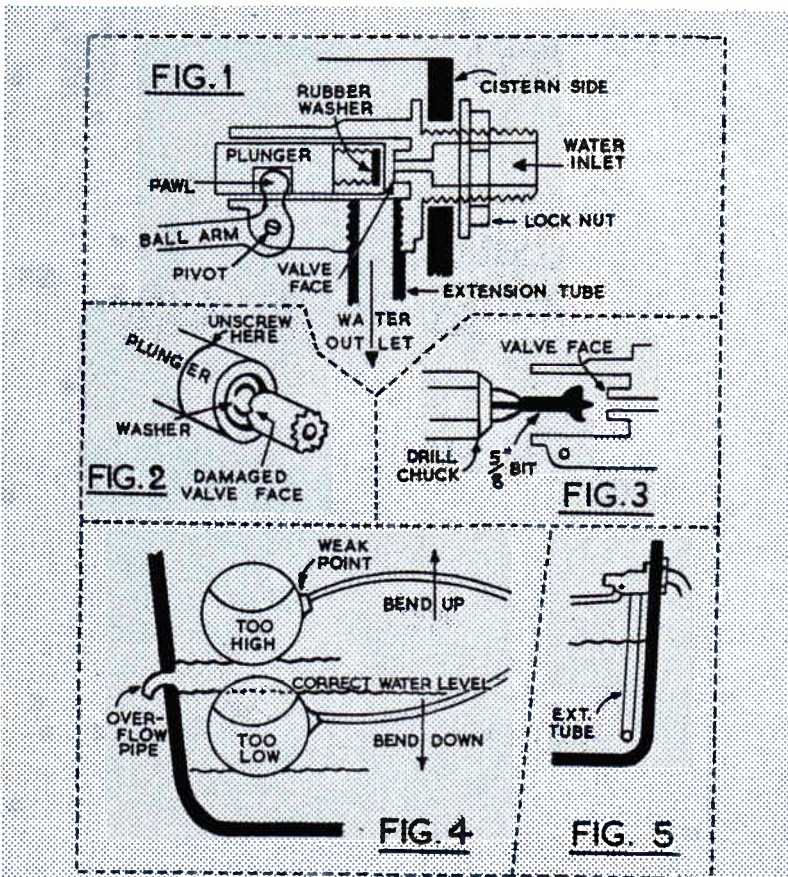



hacksaw blade, so that the blade piece is at right-angles to the bar. Set the blade piece back from the front of the bar so that some of the bar can enter the small water inlet hole to act as a guide piece. Hold the other end of the bar in a drill chuck and use the tool in the same manner as the bought job. The serrated edge of the blade piece is not used against the valve face; use the opposite edge.

You will, of course, have to remove the entire valve from the cistern to do the repairs. This is not difficult provided you use care. Hold the feed pipe firm as you unscrew its union nut so that it does not shift. When replacing the valve after the repairs, make sure that any pipe packing, such as hessian, string or flax (used to make the seal drip-proof) is carefully replaced.

As explained before, the water level in the cistern is controlled by a hollow, floating ball. You will probably find, after you have repaired the valve, that the water level will need adjusting via the ball.

Fig. 4 shows the adjustment procedure. If the water level in the cistern prevents the flush from operating correctly, the water level is too low. To correct it the ball arm should be bent slightly downwards. If the water level is too high and spilling into the overflow pipe, the ball arm should be bent upwards, as shown.

#### Correct water level

You should aim at a water level after the cistern is filled and shut off, of approximately one inch below the level of the overflow pipe exit. Do be careful when bending the arm for there is a weak spot where the arm is soldered to the ball. Do not, therefore, hold the ball with one hand and bend the ball arm with the other. Instead, hold the complete arm with one hand and bend it with the other.

At this point it is wise to check the ball itself. Carefully unscrew it from its union with the arm. It should be quite light in weight. Shake it; if you can hear

water swishing about inside, the ball is punctured at some spot. The hole must be found and covered by a small dab of solder, otherwise your ball will not float correctly and fulfil its function.

You will, of course, have to remove the offending water from inside the ball. You may even have to make another tiny hole in order to force the water out. The main thing is that the water is removed and the ball made watertight again.

The cistern should now be working correctly. Or is it very noisy when it is refilling? To correct this, fit an extension tube as shown in Fig. 5. It is a standard fitting purchased from any plumber's dealer and the water outlet hole is already tapped with a thread to take the tube. It is surprising how very few of these extension-tubes are fitted to cisterns, even nowadays.

The tube should reach to within  $\frac{1}{2}$  in. of the cistern bottom. If it is short, make up the deficit by adding on a length of rubber tubing.

## The Balancing Bird

**B**ALANCING toys are always popular with children, especially when they are in the shape of some well known bird or animal. Here, then, is an amusing toy that never grows tired — it will not lie down, but goes on rocking with the slightest touch.

The secret of the balancing lies in the formation of the base, which contains a piece of lead carefully hidden away.

It is not necessary to stick to the design shown, and many others may be tried out provided the balance is maintained. A little experimenting will soon show how to obtain this.

Too much top weight should be avoided in the finished model, but when making a new design it is best to start with a heavy top and gradually cut it away until the correct balancing movement is obtained.

In order to ensure success the base should be carefully cut to a perfect half-circle and well smoothed to provide a true rocking surface.

Most types of hardwood will possess the quality required for this purpose, and among these oak, beech, walnut and mahogany are all suitable, will work easily, and give a good finish. Thickness is not important, but about  $\frac{3}{8}$  in. is to be favoured, being quite strong enough, yet not too clumsy.

The body of the bird is cut from a piece 6 ins. long and  $2\frac{1}{2}$  ins. wide, while the short side support is 3 ins. long and  $2\frac{1}{2}$  ins. wide. Cut slots in each to the

exact width of the wood, so as to ensure a nice fit; that in the bird being 2 ins. long, while that in the short piece is only 1 in.

These two pieces are then glued together, and at the same time four right-angled corner pieces are fixed in position. Make these 2 ins. long,  $\frac{1}{2}$  in. wide at the bottom, and tapering to a point at the top.

When the glue is thoroughly dry,

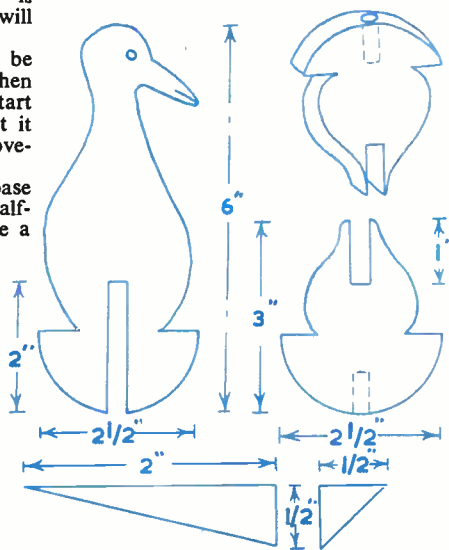

drill a hole in the base, and fill this with lead. The best way to do this is to cut a number of circles of sheet lead just a shade larger than the hole, and hammer them in one at a time with a punch made from a piece of dowel rod.

Leave a space at the bottom for a disc of wood to be glued in, which, when finished off flush, will not be noticed.

After well glasspapering, the model can be finished in a variety of ways. A good wood for instance would look well if just varnished or french polished. It would, however, be more attractive to children if painted in gay colours with oil paint or cellulose enamel. (A.F.T.)

Enhance your layout

# Model 'Mushroom-type' Lamp

**N**EARLY every new petrol filling station or similar building requiring a diffused low level lighting system installs 'mushroom' type lamps fitted on top of steel columns about 10 ft. high. Miniature lamps, as shown in Fig. 1, can easily be made and will add considerably to any model requiring this type of lighting.

wire about  $\frac{1}{8}$  in. outside diameter down the centre of the tube, bend over slot, force down, leaving  $1\frac{1}{4}$  ins. exposed. Bend to shape as shown.

By C. Franklin

$\frac{1}{4}$  in. and fix bulb in position with an impact glue. Place this section over the three arms on the post and glue in position leaving the metal rods and a short section of the insulated wire protruding just sufficiently for the leads from the bulb to be soldered, one to a rod and the other to the insulated wire.

The second disc is now placed on top

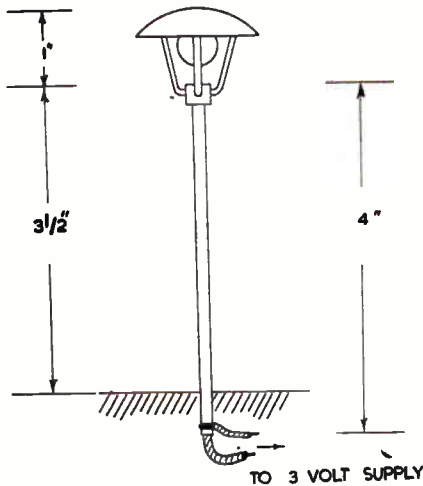

Fig. 1

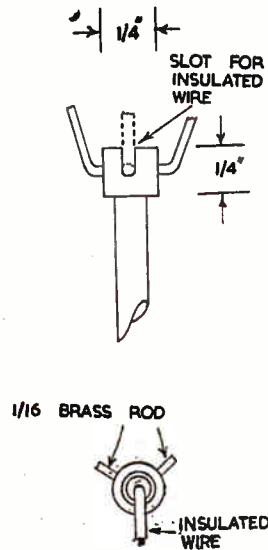

Fig. 2

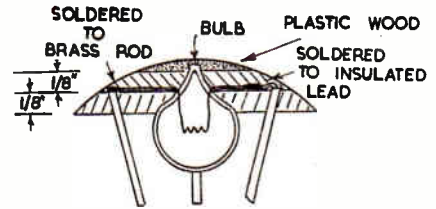

Fig. 3

The main shaft consists of a 4 in. length of  $\frac{1}{8}$  in. diameter copper or brass tube. A  $\frac{1}{4}$  in. diameter collar  $\frac{1}{4}$  in. long is soldered to the top end. This collar is cut from a  $\frac{1}{4}$  in. diameter brass bar and a  $\frac{1}{8}$  in. diameter hole is drilled down the centre. If an old electric light socket is available it may be found that a piece cut off the base of one of the brass plungers will make the collar and it is already drilled. Clean the collar and end of the tube and solder together. One of the easiest ways of soldering this type of joint is to smear both parts when clean with Fryolux solder paint, and when in position fuse in a bunsen flame or gas jet.

Mark off the position for 3 holes equally spaced round the centre of the collar and bore through to the centre of the column with a  $\frac{1}{16}$  in. drill. With a small saw, cut a slot down from the top to one of the holes as shown in Fig. 2.

In the other two holes solder two 1 in. lengths of brass rod,  $\frac{1}{16}$  in. diameter, and bend as shown in Fig. 1. Thread a length of plastic covered single strand electric

The bulb is prepared from an ordinary flash lamp bulb. Carefully crush with a pair of side-cutting pliers the insulation at the base and nip off the soldered bead. Gently chip away inside insulating material until the glass bulb is loose. Release the soldered connection at the top of the brass section with a hot iron, and withdraw the glass bulb with its two leads. If possible try this out first by using a burnt-out bulb.

## The 'Mushroom' fitting

From  $\frac{1}{4}$  in. thick hardboard cut two circles  $1\frac{1}{8}$  ins. in diameter, and shape into a dome as shown in Fig. 3. This can best be done by drilling a  $\frac{1}{8}$  in. hole in the centre and clamping both pieces together with a suitable nut and bolt. Fixing a hand drill in a vice, place the bolt in the chuck and spin, shaping the hardboard with suitable files.

Drill three  $\frac{1}{16}$  in. diameter holes in the lowest circle of hardboard as shown in Fig. 3. Enlarge the centre hole to about

and some of the material chased out so that a good joint is made. Glue in position. The top of the bulb will most likely just protrude through the upper disc and this can be covered with plastic wood and the dome shaped off.

## Assembly and finishing

The bottom of the column can be glued to the base board of the model or two nuts fitted, after a suitable thread has been cut on the column. The insulated wire must be connected up to a 2 or 3 volt electricity supply, the return being taken to the outside of the post.

Finally paint a suitable colour and if the top of the dome is picked out in a pale contrasting colour it will look most effective. The surface of the bulb should be painted a matt white.

# PLAYTIME WITH A SWING

**R**IGID and safe, this child's garden swing can be easily made in a few hours at a cost of something less than £3.

Spruce or deal 4ins. by 3ins. is used for the main structure, which is stable enough in itself to obviate any permanent ground fixing. This feature, which renders the unit mobile, together with the footboards incorporated in the design, eliminate wear and tear on lawns. However, if the height of the uprights is increased from 7ft. 6ins. to 9ft. (which is optional), it may be necessary to peg the base runners as shown in Fig. 1. Mortises 2ins. by 1in. are cut through the ends to accept

mortises, if required, with mallet and chisel. On the broad face of each, 12ins. from each end, cut recesses 3ins. wide by 1in. deep to accept a neat fit for the two cross members, which are both 3ft. 8ins. long. Fix these in place with woodscrews 3ins. long. Between the cross members screw a centre member 5ft. 6ins. long. This is butt-joined and fixed on edge.

Twelve 6ins. wide tongue-and-groove boards each 4ft. long fastened with galvanised nails on the cross members and centre member form the footboards.

Cut two uprights 7ft. 6ins. long. Make slots in the top ends 2ins. wide by 3ins. deep, and drill two  $\frac{1}{2}$ in. diameter holes in each of the bottom ends. Also mark the positions of similar holes in the middle of the base runners by scribing through the holes in the uprights while the latter are held in a vertical position. Drill the runners  $\frac{1}{2}$ in. diameter and fix the uprights in position with  $\frac{1}{2}$ in. Whitworth bolts having a plain length of 6ins. Use washers under the heads and nuts and, when spannered up, turn over the bolt ends with the ball end of a hammer.

Cut the top cross member 4ft. 6ins. long with a tenon on each end 3ins. long by



2ins. wide to fit the fork ends of the uprights. Drill two  $\frac{1}{2}$ in. diameter holes 18ins. apart, centrally disposed, through the top of the member. Fix it in place with 2in. woodscrews and screw home four lengths of 3ins. by  $\frac{1}{2}$ in. straps (Figs. 1 and 2).

*By Gordon Allen*

Four pieces of 4ins. by 3ins. timber, each 6ft. 6ins. long, form the diagonal stays. Lay the upright and base section on its side, mark off the angle of the stay-ends in pencil, cut and then drill the bottom ends for  $\frac{1}{2}$ in. bolts. Drill the base runners to suit, and bolt the stays in place as before. Woodscrew the top ends of the stays to the uprights. Cut the four gusset plates (Fig. 3) from  $\frac{1}{2}$ in. ply and screw in place as shown in Fig. 1.

Cut the seat of the swing, which measures 22ins. by 9ins., from 1in. thick deal. Drill two holes  $\frac{1}{2}$ in. in diameter 18ins. apart, on the centre line.

Ordinary  $\frac{1}{2}$ in. fine-weave rope can be used for suspending the chair, and this is passed through the holes in the seat and knotted, and is secured above the holes in the cross member again with oversize knots. Chains fixed to  $\frac{1}{2}$ in. ring bolts in the seat and in the cross member provide another method of suspension.

The method illustrated in Fig. 1, possibly the safest, shows suspension rods made from  $\frac{1}{2}$ in. diameter black iron rod (formed into rings at the ends) which are fastened to short lengths of chain. The chains in turn are fastened to ring bolts in the cross member, while the rod loops at the bottom ends engage with ring bolts fastened to the seat.

Ring bolts and chains can be bought from most large ironmongers, and rods from garages. If forming the loops on the rods proves too complicated for you (it can be done by hammering the ends round a metal tube clamped in a vice), the local blacksmith will do the job for a shilling or so.

Treat the entire woodworking with wood preservative or paint in the usual way.

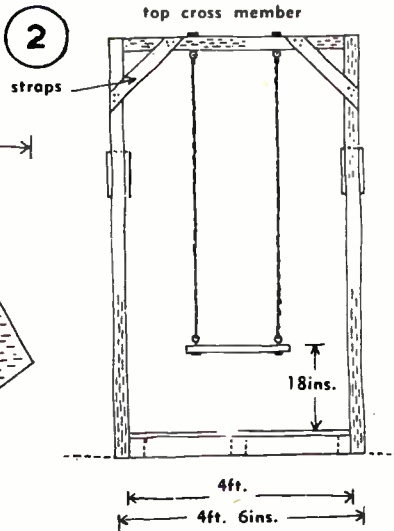
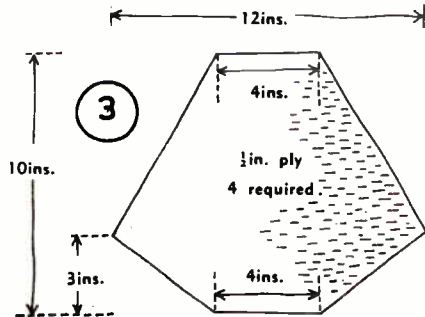
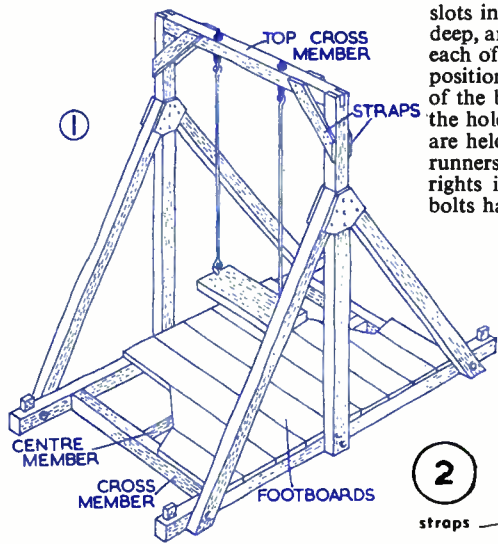

pointed hardwood pegs which are driven into place.

Start by making the base. Cut two 8ft. lengths of wood and add the



# A Vice for Sharpening Saws

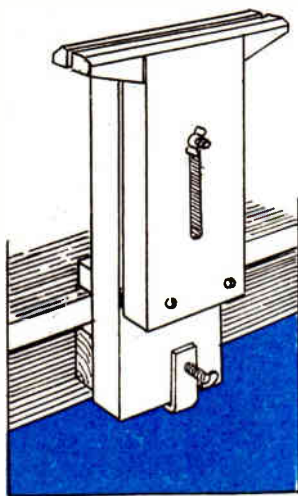

**M**OST handyman use a saw at some time or another, and the ability to sharpen it oneself can prove a useful and economical asset. Apart from the necessary saw file, and a tool for setting the teeth of the saw, a vice to hold the saw in convenient position for the job is necessary. Such a vice is illustrated here, and is quite easy to make. It is designed to be held in the vice of any carpenter's bench, or be fixed to a kitchen type table.

*By W. J. Ellson*

A front and side view of the vice is given in Fig. 1. The body part (A) and cheek (B) are cut from 1in. thick wood, preferably of hardwood. Cut to sizes given and plane up. On part (B) run a pencil line down the centre, and mark spots (C) and (D). Place (A) and (B) together, and cramp up tightly, keeping both parts in their correct positions. With a  $\frac{1}{16}$ in. boring bit, bore holes through both, then saw out the intervening wood between them to leave a slot in which a screw bolt can move as required. Now separate the parts.

For the vice grips (E) cut two pieces of 1in. square wood to length given. These are to be jointed to the top ends of parts (A) and (B) in such manner that they project on the inner face sides of (A) and (B) just  $\frac{1}{16}$ in. To effect this, rebate the tops of both as shown in the slightly enlarged side view (F) in Fig. 2.

Each of the grips (E) has a  $\frac{1}{16}$ in. deep groove cut out, as at (H) and can then be screwed across in position. At the bottom end of (B) a rebate  $\frac{1}{16}$ in. deep is cut, into which a 4in. piece of  $\frac{1}{16}$ in. by 1in. hardwood is screwed and glued. On body part (A) where shown in Fig. 1, a groove of the same dimensions as the rebate is also cut and a second piece of  $\frac{1}{16}$ in. by 1in. wood glued in. The side view (G) Fig. 2, shows both these in place at top and bottom of the cheek of the vice. The side view of both body and cheek in Fig. 1 will make this part of the work quite clear.

The outstanding ends of the vice grips (E) are tapered off as seen, and it will be of some advantage when sharpening a saw, if a chamfer is planed off the outer top edges of these grips, especially if the saw is lowered in the vice to show as little as possible of the blade, and to deaden the rather irritating screech the file makes when doing its work.

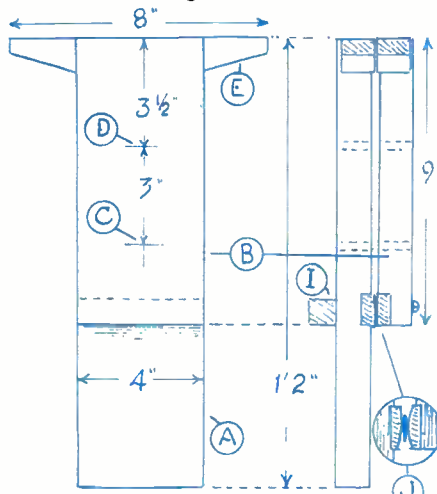

Fig. 1

At the back of the vice a strip of wood is screwed across at (I) in Fig. 1. This rests upon the table when the vice is fixed to it, and prevents side movement. The vice cheek (B) is now fitted to the body part by two round-headed screws, these being driven in at the lower end, and penetrating the hardwood strips fixed there. The meeting face sides of these latter parts are very slightly curved, and brass washers sandwiched between them through which the screw will enter. These details are shown enlarged at (J).

When fixing the vice to a kitchen table, a packing piece will be needed to take up the space between vice and

## CUTTING LIST

Part A.		14ins. by 4ins. by 1in.
Part B.		9ins. by 4ins. by 1in.
Grips E.	(2).	8ins. by 1in. by 1in.
Spacing strips.	(2).	4ins. by 1in. by $\frac{1}{16}$ in.
Back rest. I.		4ins. by 1in. by 1in.

1 screw bolt,  $\frac{1}{16}$ in. by 3ins., with wing nut and washer.  
1 mild steel 4in. cramp.

table rail. This can be cut from any odd piece available. A common mild steel cramp, fitted where shown in the general view of the article, should hold it securely in position.

A few hints on filing a saw may be helpful. Before sharpening, any setting of the teeth necessary should be done with a handset. Run a file lightly along the sides of the teeth, then bend with the handset each alternate tooth sideways, bending only the tips. Then set the saw

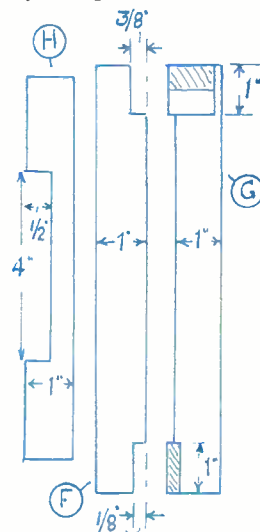

Fig. 2

in the vice, handle to the right, and sharpen each alternate tooth with the file. Keep the file to the same rake or angle, the handle of the file being inclined towards the handle of the saw. A study of the bevel of the teeth will aid in holding the file to its best position. File only enough to sharpen each tooth.

Reverse the saw in the vice, then sharpen the rest of the teeth to complete the job. A certain knack is naturally required for success, and this should be acquired by a little practice, preferably on an old saw, with not too small teeth.



# A HOME-MADE LOUDSPEAKER

**A** LOUDSPEAKER suitable for small battery receivers or transistor sets can be made from a surplus balanced armature unit, or earphone insert. When a cone is added, results are similar to those which were obtained with the balanced armature cone speakers often used some years ago.

The speaker is not satisfactory with a mains receiver, because it will be overloaded by very powerful signals. As a result, the armature strikes the pole pieces, causing an unpleasant sound. The speaker should not be operated at such high volume, but will handle the output of an average battery receiver.

## Earpiece unit

As usually supplied, these have a small projecting threaded rod, locked to the earphone diaphragm by means of small nuts. These nuts should be loosened, so that a larger cone, of stout paper or thin card, can be added.

The speaker cone may be 6 ins. to 12 ins. in diameter, and is made by drawing a circle, and cutting from the perimeter to the centre. A section is cut out, as shown, for the metal cones in Fig. 1. The edges are then overlapped and glued. A little experimenting with various materials is worth while. Stout drawing paper can be used, or any other fairly light, strong material. The cones of old type speakers of this kind were sometimes of quite thin paper, afterwards doped or varnished for stiffening.

The paper speaker cone is held between two metal cones, cut from thin, light metal, as shown in Fig. 1. Here, the projecting rod of the unit is shown enlarged, to clarify the method of fixing the speaker cone between the metal cones.

When the speaker has been found to work properly, a little varnish may be painted round the nuts, washers, metal cones and speaker cone, so that vibration will not make these come loose.

## Cabinet

A fairly shallow cabinet is required, as shown in Fig. 2. It must be large enough to clear the speaker cone, and should have a circular aperture in the front, a little smaller than the diameter of the cone.

The unit is mounted on a strip of plywood about 3 ins. wide, a hole being cut for this purpose. The two leads issuing from the unit may be taken to a pair of terminals, for wiring up the finished speaker.

The supporting strip must be screwed in position as shown, so that the speaker cone rests lightly against the front of the cabinet. Too much pressure must be avoided, or the armature will be pressed back into contact with the magnet, resulting in rattling and poor volume.

## Using the speaker

The ordinary medium impedance type of unit can be connected directly to the output sockets of a transistor set or small battery receiver. The positive lead should be taken to the H.T. circuit, with

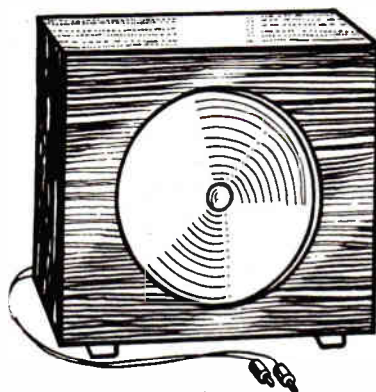

battery sets. With transistor receivers, the negative lead is taken to battery negative. Prolonged running with the leads wrongly connected will eventually weaken the unit magnet.

## By 'Radio Mech'

The volume and tone should be similar to that from a small moving coil speaker. If not, too much pressure on the cone may be preventing the armature moving freely. A very weak cone, or one of very thick, heavy card, will also reduce volume.

An ordinary earphone, not of the balanced armature type, can be used in a similar manner. So that the speaker cone can be attached, a small bolt should be soldered to the centre of the phone diaphragm. Other constructional details can then be as already described, this bolt being used to mount the paper cone, etc. Quite good results can be obtained, though volume is somewhat less than achieved with the balanced armature unit.

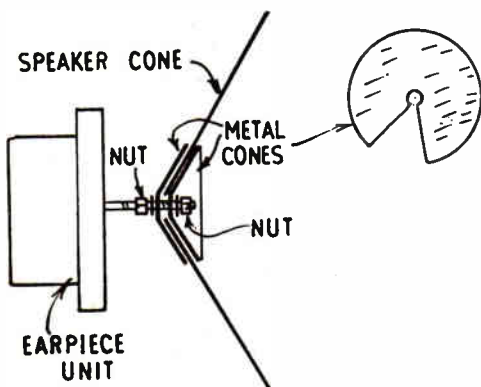

Fig. 1—How cone is fitted

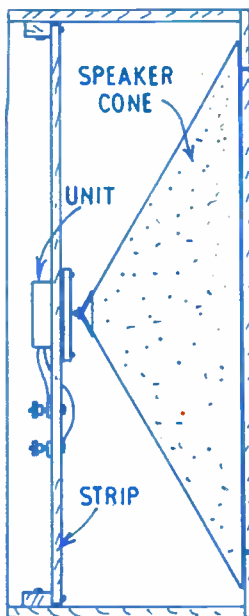

Fig. 2—Mounting the unit

Next week's issue will contain patterns for a charming display rack for cacti; also details for making a handy table for greenhouse work and other handyman projects. Make sure of your copy.

# CHOOSING CAMP EQUIPMENT

**T**HERE is plenty of camping equipment available, ranging from heavy army surplus gear to ultralightweight items for the real enthusiast. Prices vary tremendously, and the beginner may be bewildered by the things he is offered.

The most important item is the tent. If most of your camping is to be in one place, then a heavy canvas is advisable. The heavier grades are very durable and will stand up to bad weather for a long time, but if you want to be mobile and carry your tent on your back, on a cycle or in a canoe, you need something much lighter. Usually it is most convenient to have a tent for two. If there are four in the party it is better to have two tents than one big one. One tent makes too big a load. Get a coloured tent. Apart from being less likely to be disfigured by dirt, the colouring indicates proofing. Unproofed canvas will keep rain out, but if it is packed wet it will soon suffer from mildew. Of course, no tent should be left packed wet for long.

There are many shapes of tents, but the beginner will find it best to start with a ridge tent. The cheapest tents have no walls, but this reduces the amount of useful floor space (A). A tent without walls, 6ft. wide, is only equal to one with walls about 4ft. 6ins. wide (B). Do not get too short a tent. A length of 6ft. may seem plenty, but remember that you have to get your kit in with you and you may wriggle about in your sleep and finish up with wet kit or bedding in the morning — 7ft. is much better.

Even a proofed canvas will start dripping if it is rubbed during rain. A very light fabric will spray in heavy rain. It is because of these two things that fly

sheets are used. They add to the expense and you can camp quite well without one, but if you have no flysheet do not choose too light a fabric, and do not choose a tent that is very low as you would be certain to touch it.

A groundsheet is very important.

---

## By Will Atkins

---

You can get them to fit the tent, but at first it is probably best to have one for each camper. In the past, rubberised fabric was the usual material, but there are some plastic fabrics now which will last longer and are not affected by oil and grease. You must have a good groundsheet — sleeping on one that lets the damp through is a sure start for rheumatism.

When it comes to packing, it is your bedding which has the greatest effect on the bulk of your kit. It is air that keeps you warm in bed. Two fluffy blankets will trap more air and keep you warmer than three heavy army blankets.

However, blankets are bulky and a sleeping bag is worth having. A bag made of blanket material is of little use. What you should aim to get is a quilt type. The cheapest are filled with kapok, which is a vegetable fibre, but a kapok bag will not compress very much. It is better to have feather filling. The best is of down only and one of these bags which packs into a roll about 8ins. diameter and length will open to a bag which will fit a man and keep him warm. In between are other bags with other grades of feather filling.

Camping gives you an appetite and you want proper cooking arrangements. Simplest is a fire and this is very attractive, but when you are mobile and want to prepare meals in many different places it can be slow. On some camp sites fires are not permitted. Spirit stoves are simple and cheap to buy, but they are probably the dearest to run. In any case they are unsuitable for large meals. Pressure stoves of the Primus type are well-tried and popular. For portability you can get small stoves, but it is probably best to make sure that even if the container is small the burner is full-size. Small burners are easily affected by draughts. Choose a roarer burner, not a so-called 'silent', which is difficult to keep going in the open air. Paraffin is probably the cheapest fuel for cooking, but if it leaks or spills it is messy. Petrol is cleaner and easier to get anywhere, and quite safe in a stove designed for it. There are several small gas cookers available. The cheapest has a throw-away container. They are convenient to use, but more costly to run than pressure stoves.

The best cooking gear for a pair of campers is a canteen such as the 'Gilwell', with a couple of cooking pots and a frying pan, which nest together. Get aluminium rather than tinfoil. It will last very much longer. There is much attractive and cheap plasticware available, and it is best to get plastic plates and mug. A few plastic containers for sugar, tea, butter and similar things are worth having.

At first you can use cutlery from home, and your ordinary washing gear and other toilet articles will do for camp, but as you progress you may buy many of these things in lightweight and more compact forms.

How you carry the equipment depends on the type of camping. If your kit is being taken by car or rail, an ordinary round kit bag is as good as anything (C). If you are hiking, a proper rucksack (D) is better than an army pack. The pack is meant to go above other equipment and it does not ride well alone. If you are cycling, it is very tiring to have your kit on your back. The best arrangement is to have a rear carrier with pannier bags (E), then the weight is kept low. For canoeing it is best to divide your kit up into many small bags. Cooking gear and similar things may go loose in the canoe. Bedding and clothing should go in waterproof bags tied twice at the neck (F).

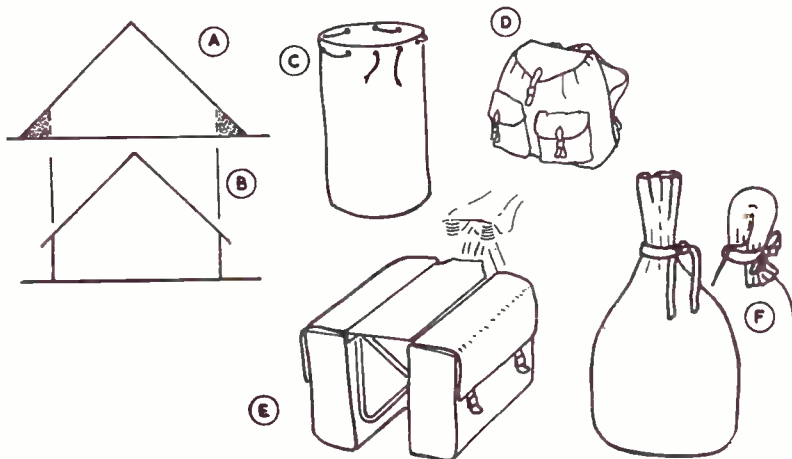

**PUZZLEPIC** — Our unusual-angle photograph on page 403 is the whistle of a whistling kettle.



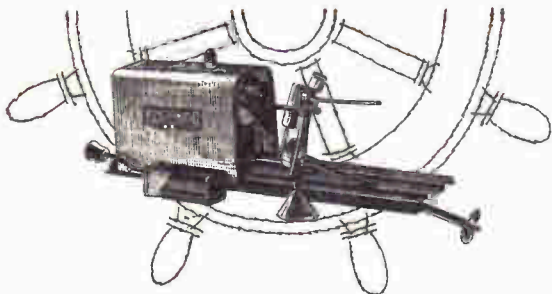

a model **STEAM** marine engine

**OF HIGHEST QUALITY, AND PERFORMANCE**

This latest addition to the famous range of "Mamod" model steam engines is the ideal power unit for model boats, with a length of 20" and over. An extremely lively unit with many refinements including chromium plated windshield, heat insulation and a complete lubrication system. Price 45/- including P.T.



MALINS (ENGINEERS) LTD. 25-31, CAMDEN STREET, BIRMINGHAM, 1.

# TOBY JUGS

BY **Sculptorcraft**

Make these 18th- and 19th-century characters simply - easily with Sculptorcraft Moulds. These miniatures are collectors' pieces and are welcomed ornaments. Illustrated are two made from the range of individual moulds that are available. Send for full list of moulds and characters.



**HAPPY JACK**  
A typical example associated with this period

**GREEDY TOM**  
Humorous portrayal of this particular character.



SEAMER PRODUCTS (SCULPTORCRAFT) LTD  
23/27 EASTBOURNE STREET, HULL

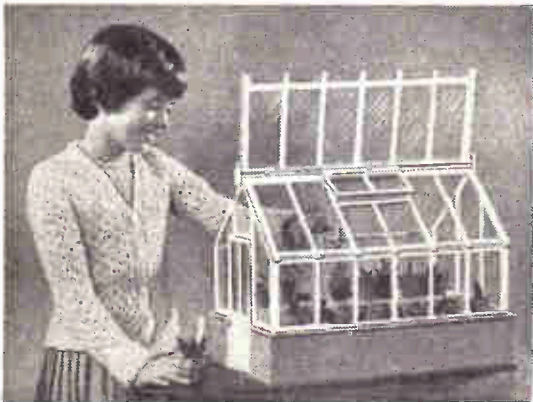

## MINIATURE GREENHOUSE

*A really practical model for the home*

For growing cacti, succulents, miniature trees, seedlings, etc., and can be used as a propagating frame.

### JUST LIKE DAD'S!

You can make this ideal showpiece from Hobbies Kit No. 3300, which contains all wood, materials, etc., and 12 sets of pots and saucers. Hinged roof, window, door. 18 ins. x 12 ins. x 13 ins. high. Only a few simple tools needed in construction.

Kits from Hobbies branches, stockists or post free (see coupon). **39/6**

**ALL-THE-YEAR-ROUND INTEREST**

To HOBBIES LTD., Dept. 99, Dereham, Norfolk

Please send Kit No. 3300 for making Miniature Greenhouse,  
I enclose P.O. for 39/6.

Name .....

Address .....

.....  
.....

**T**HERE is much in Norway to interest us. Its length is 1,100 miles. At its widest part it is 250 miles, narrowing down towards the North to only 25 miles. In area, it is twice the size of England and Wales. On the North it is bounded by the Arctic Ocean; on the West by the Atlantic; on the South by the Skagerrak; on the East by Sweden and Russia.

The whole of Norway is mountainous. To the North are the Kjollen-fjelle. More inland, towards the South, is the Dovrefjeld, and the Hardanger-fjeld. In this district is Jostedal, the largest glacier in Europe, covering an area of 600 square miles. The passes along these mountains are dangerous.

'Stamps 1938. Tourist Propaganda Pictorials — set of 3 — 5d. used'.



The valleys of Norway are peculiar. In other countries they are made of level plains, bordered by sloping mountain sides. But Norwegian valleys are simply rents and chasms between the lofty rugged cliffs that rise up on every side on the coast. The sea finds its way into these chasms between the various mountain sides, and forms the fjords, which stretch all along the coast.

The only important lake is Mjøsa. Its area is 200 square miles. It is 400ft. above sea level.

The Glomma, 350 miles long, is the largest river.

There are many islands off the coast. The Lofoten group is the largest. These islands are the centre of the Norwegian fisheries. You can see the codfish spread out to dry on the shore, or stacked up in the distance, looking uncommonly like haystacks.

'Stamps 1943. 10 öre green — Fishing Station — 10d. mint. 20 öre red — Mountain Scenery — 10d. mint'.

The people are very much like the Swedes. They are fond of singing and dancing.



What strikes one as curious in Norway, is that during the summer months there is no night at all. At midnight it is quite light, even in Oslo. And if you go northwards to Hammerfest, the sun does not set at all. You can see it up in the heavens, circling round the North Pole all night long, and bathing the sea with a flood of golden rosy light charming to behold.

## NORWAY — *By R.L.C.*

The best time to visit Oslo, the capital' is in winter, when the fjord is frozen, for then it is the most cheerful place on earth.

For many years Norway and Denmark were united, and Norway flew the

Danish flag, the Dannebrog — a white cross upon a red field. In the early part of the 19th century the National Arms — the golden lion rampant, crowned, and holding the battle-axe of St. Olav (Norway's patron Saint who died in 1030) — were placed in the canton, and in 1821 the Arms were omitted and a blue cross was superimposed on the white one. Sweden and Norway were united from 1814 to 1905, and for a part of that time the Swedish colours were incorporated in the flag. With the dissolution of the Union, the use of the old flag was resumed.

Norwegian stamps, mostly pictorial, are well worth thematic consideration. Pen-friend] addresses are available on request to the Editor, Hobbies Weekly, Dereham, Norfolk. But please enclose return postage.

## AUTOGRAPH PROTECTION

**A**FTER a few simple rules have been observed, there are many ways of keeping and preserving a collection of autographs.

The less a document is tampered with, the better. If a small repair will stop further tearing of a document, by all means make the repair with good library paste and a piece of paper of similar age and colouring. A piece of transparent tape may fill in a tiny gap. A popular method with expert repairers is 'silking' a document, or covering a page with a very fine layer of silk gauze. This method may be practical when a crumbled document must be pieced together, but it should never be used on documents which are in nearly first-class condition. Silking tends to cut the clarity of a document, but it is a means of rescuing otherwise 'lost' documents from oblivion. Generally, minor repairs, if skilfully executed, improve and enhance the appearance of an autograph.

A collection should also have plenty of room in which to 'breathe'. Paper,

unlike gold, is quite sensitive. It must have air in order to remain in good condition.

Extremes should be avoided — particularly extremes of heat and moisture. Excessive heat tends to dry out a document and make it extremely brittle, even though the quality of the paper originally was excellent. Equally as damaging as heat is excessive moisture, which causes documents to mildew or even to become waterstained.

A good method of keeping a collection is to enclose the autographs in cellulose acetate envelopes mounted in loose-leaf notebooks.

Probably the most common method is the use of ordinary file folders. As these accommodate all but the largest documents, they afford excellent protection.

Keith Davies of 10 Elgin Road, Sutton, Surrey, has a fine autograph collection which includes film stars, Cabinet Ministers, military heroes, etc. He would like pen-friend correspondence from any part of the world.



### BUYING OR SELLING?

Classified advertisements on this page are accepted at a cost of 6d. per word prepaid. Use of a Box No. is 1/- extra. Send P.O. with advertisement to *Hobbies Weekly*, Advert. Dept., Dereham, Norfolk. Rates for display advertising on application.

**STAMPS FREE** — Empire Packet including Spicorials and Victorians with approvals. — Robert J. Peck, 7A Kemp Road, Bournemouth.

**KUKLOS ANNUAL.** Indispensable cyclists handbook. Tours, resthouses, money-saving hints, 3/- post free. — Burrow, Publishers, 2 Imperial House, Cheltenham.

**MODELS.** You can make lasting stone-hard models with Sankey's Pyruma Plastic Cement. Supplied in tins by Ironmongers, Hardwaremen and Builders' Merchants. Ask for instruction leaflet.

**MAKE A MUSICAL BOX** as little as 2/11/-. New kits and tunes available. Movements 13/- post free. Please send 3d. stamp for free illustrated catalogue. — The Swisscross Co., Dept. B, 202 Tuise Hill, London, S.W.2.

## HOW TO STOP SMOKING

and permanently overcome that ceaseless craving for tobacco. Save money, safeguard health. Send stamp for details of the world-famous inexpensive Stanley Treatment for tobacco habit.

THE STANLEY INSTITUTE LTD Dept. 30  
12 Bridewell Place, London E.C.4



THIS IS THE USEFUL MODEL. Naval telescope: powerful day and night lenses, modern micrometer, automatic non-extending range focus apparatus. Splendid object lens. Approx. 15ins. in length. Picks out object with clarity and precision at many miles' range. Scientific instrument. COST WELL OVER £20 TO MAKE. Buy one! It is a real investment. Made by famous instrumental makers. Only 25/-. Post & pack., 2/6. Approx. wgt. 5 lb. FREE LISTS BINOCULARS, TELESCOPES, TENTS, CAMPING EQUIPMENT, SLEEPING BAGS, WATCHES, JEWELLERY. TERMS.



This is an amazing offer for the youngsters. Size 13 ft. x 5 ft. 4 in. high x 5 ft 6 in. width, approx. Light Biscuit colour. The genuine U.S.A. Army tropical command. Unissued. All you have to do is to supply your own poles — two broomsticks or bamboo canes. We supply the metal pegs. This is a fantastic offer at a ridiculous price. Send 10/11, plus post. 2/1, for yours. No more to pay. LISTS, TENTS. Headquarter & General Supplies Ltd. (HOBW/55), 196-200 Coldharbour Lane Loughboro Junc., London, S.E.6 Open Sat.

100 DIFFERENT stamps free! Request 4d. upwards discount approvals. — Bush, 53 Newlyn Way, Parkstone, Dorset.

**WHEELS.** (Hardwood and Rubber Tyred Metal). Cot, Pram and Doll's House Fittings and Papers, Beads, Transfers, Prints and other accessories. Stamp for new lists. (Trade supplied.) New address — JOYDEN CO., 91 Peplins Way, Brookmans Park, Herts.

**MEN/WOMEN** with spare time, required for Mnew simple weaving work. For details, send S.A.E. — Dept. 4, Weava Products, 10 Shelley Rd., Worthing.

**SOUVENIR MAKERS** — we supply transfers for your goods. Mottoes, crests, town names, etc. Large range. List and samples 1/-. — (Dept. H.) Axon, Jersey, C.I.

**DO IT YOURSELF** — real electro-plating at home. For full instructions send 10/- and S.A.E. to Dept. H.W., 'The Meadows', Caistor Rd., Market Rasen, Lincs.

**FREE** — Homeworkers' opportunities. S.A.E. Staffs. — Esprey, 29 Newmans Grove, Rugeley, Staffs.

**EARN** extra money at home. 3d. stamp brings full details, without obligation. — Newdale, 25a Heys Road, Thongsbridge, Huddersfield.

### MAKE EXTRA MONEY AT HOME

London's latest fashions. Most people would like the chance to get to London to choose their new clothes. If you become a spare time agent for FREEMANS, you can save yourself this journey. In FREEMANS 4,000 item catalogue you will find something for everybody. All goods on approval and on credit terms, and generous commission on all your friends' and relations' purchases. Write to Dept. 258G, FREEMANS (LONDON, S.W.9) LTD., Lavender House, London, S.W.9.

## APPARATUS & CHEMICALS

For your experiments. Let us help you equip a HOME LABORATORY

Beakers, Crucibles, Flasks, Funnels  
Gas Jars, Test Tubes, etc.

Booklets:  
(including postage)

'Experiments' 1/2  
'Formulas' 1/2  
'Home Chemistry' 2/10  
New edition

Send 3d. Stamp for latest PRICE LIST

A. N. BECK & SONS (Dept. H.W.)  
60 Stoke Newington High Street, London, N.16



## STICK TO SECCOTINE



Sole Manufacturers —

McCAW, STEVENSON & ORR LTD., BELFAST

A new book which will give you a wealth of novel suggestions

## CERAMIC PAINTING MADE EASY

by Gertrud Derendinger

68 pages, large format (8 1/2" x 12"), with illustrations of 216 hand-painted ceramic objects and 26 pages of designs. Retail price 20/-. The text contains in a concentrated form, numerous practical hints showing how to avoid mistakes which would otherwise appear only after firing. The book is particularly remarkable for the variety of its contents. A gay series of elegant animal and flower motifs alternates with modern abstract designs. This work, which has also appeared in German, French and Italian, is already achieving large sales in 19 countries. Obtainable in all good Ceramic Supply Shops or direct from the publisher. (On advance payment, post-free despatch from the publisher.)

R.I.A. Publisher, Wynigenstr. 15, Burgdorf, Switzerland

## YOU CAN BECOME A HANDICRAFTS INSTRUCTOR

EXPERIENCE NOT ESSENTIAL

Men who enjoy making things in wood or metal can turn their hobby into a permanent and interesting Career. Short hours, long holidays and security in a job you would really enjoy, can be yours if you become a Handicrafts instructor. Let us send details of the easiest and quickest way to get the necessary qualification.

We guarantee "NO PASS — NO FEE"

If you would like to know about our unique method of preparing you for one of these appointments, write today, and we will send you our informative 144 page Handbook—free and without obligation. Mark your letters "Handicrafts Instructor".

BRITISH INSTITUTE OF ENGINEERING TECHNOLOGY **BIET**

595 College House, Wright's Lane  
Kensington, London, W.8

# HOME-MADE TOFFEE

**M**AKING sweets at home? Ridiculous, when the shops are full of every variety! Yet fortunes in sweet-making started in the kitchen and there are wealthy people today who enjoy splendid dividends from money made by their parents, and with their own childish help, when the toffee pan was their only asset.

Daintily packed home-made sweets will always sell, for they appeal to all who believe in home cooking, and who are tired of mass production.

Be workmanlike and get a few tools which will help to make your sweets look professional and pleasing.

---

By G. Keighley

---

There are many such aids on the market, and they vary in size and efficiency. A walk round a hardware store will soon introduce you to these gadgets, and your own taste and fancy can guide your choice. Candy bars, sweet rings or moulds, a caramel marker for marking toffees and caramels, a sugar thermometer, a spatula, a palette knife and some good kitchen scissors, are all good buys before you start.

I would urge the sugar thermometer as a must, because it is better to be scientific and accurate. When using this thermometer, stand it first in hot water for several minutes and then plunge gently into the boiling syrup. This is important to avoid cracking.

And last, but not least, if you are to sell your sweets, a real belief in their goodness and in their quality of ingredients should be part of your sales talk. Our Grandmothers believed so much in the healing properties of butter, honey, treacle and brown sugar, and in the glories of spices and natural perfumes. These form the basis of most home-made confections and have proved their worth for simple remedies.

For making toffee you will need to follow certain rules, then the rest is simple and the variety endless.

1. You will need an iron sheet or asbestos mat over the gas or electric hot-plate to avoid burnt toffee.
2. Sugar must be well dissolved over a gentle heat before being allowed to come to the boil.
3. Avoid stirring whilst boiling except in certain recipe directions.
4. Brittle toffee must boil to 290°F. Extra brittle to 300°F but this is exceptional.
5. Never let toffee boil beyond 300°F.

Here are a few favoured recipes:

## PINEAPPLE TOFFEE

- 1 teacupful finely chopped pineapple chunks
- 1 lb. castor sugar
- $\frac{1}{2}$  teacupful milk
- 1 tablespoonful lemon juice
- 4 tablespoonfuls golden syrup.

Put sugar and milk in pan on the stove. Stir till quite hot. Add golden syrup. Bring to boil. Add pineapple and lemon juice. Boil mixture quickly for 10 minutes, stirring all the time. Remove from stove. Cool for 5 minutes. Beat thoroughly till it begins to set. Pour into well-greased tin. When cold cut into neat squares.

## WALNUT TOFFEE

This is always a favourite.

- $\frac{1}{2}$  lb. chopped walnuts
- $\frac{1}{2}$  lb. brown sugar
- 2 oz. butter
- juice of half a lemon.

Warm sugar and butter slowly to liquid state. Increase heat and simmer until dark gold — 290°F. (or brittle when sample is dropped in cold water). Remove from heat. Add lemon juice and chopped walnuts. Stir well to mix. Pour

into lightly buttered tin. When partly set mark with knife and divide when cold.

## GINGER AND NUT TOFFEE

- 1 lb. granulated sugar
- $\frac{1}{4}$  lb. butter
- 2 tablespoonfuls golden syrup
- 2 tablespoonfuls cream or milk
- 2 oz. ginger chips finely shredded
- 2 oz. any chopped nuts.

Melt butter and sugar slowly in pan. Add syrup and cream. Boil till soft ball stage — sample tested in water remains soft.

Stir in ginger and nuts. Remove from fire. Pour into mould or buttered tin. Mark into size when half cold.

## TOFFEE APPLES

These are a good selling line for bazaars and garden parties. Their appeal never dims.

- 1 lb. Demerara sugar
- 2 oz. butter
- 1 dessertspoonful glucose
- $1\frac{1}{4}$  gills of water

Small selected eating apples and sufficient small wooden sticks, skewers or cocktail sticks.

Dissolve sugar very slowly in water at back of stove.

Add butter and glucose. Boil to crisp stage.

Wipe and dry apples, remove stalks and insert sticks.

Dip each apple quickly in toffee mixture — put to dry on well oiled slab. Repeat process when cold if a thicker coating is desired.

The success of selling your toffees depends largely on their presentation. A sticky mass in a paper bag will not be in demand, but nowadays you can obtain a variety of attractive plastic wrappings and waxed sweet cases. Small boxes filled with a mixture of these will be popular and their preparation will keep you busy once your friends have tasted them.

## WOOD BENCH VICE

A strong hardwood vice which can be screwed to the work bench. A real serviceable tool, well made, and fitted with hardwood screws, 12ins. long.

From branches or:  
**HOBBIES LTD.,**  
Dereham, Norfolk



Price 7/6 (Post. 1/6)

## HEAR ALL CONTINENTS With H.A.C. Short-Wave Receivers

Suppliers for over 18 years of radio S-W Receivers of quality.  
One-Valve Kit, Price 25/- Two-Valve Kit, Price 50/-  
Improved designs with Denco coils. All kits complete with all components, accessories and full instructions. Before ordering, call and inspect a demonstration receiver, or send stamped addressed envelope for descriptive catalogue.  
\*H.A.C.\* Short-Wave Products (Dept. 22), 11 Old Bond Street, London, W.1



# A 'KITTEEN' THERMOMETER

## Full-size Patterns

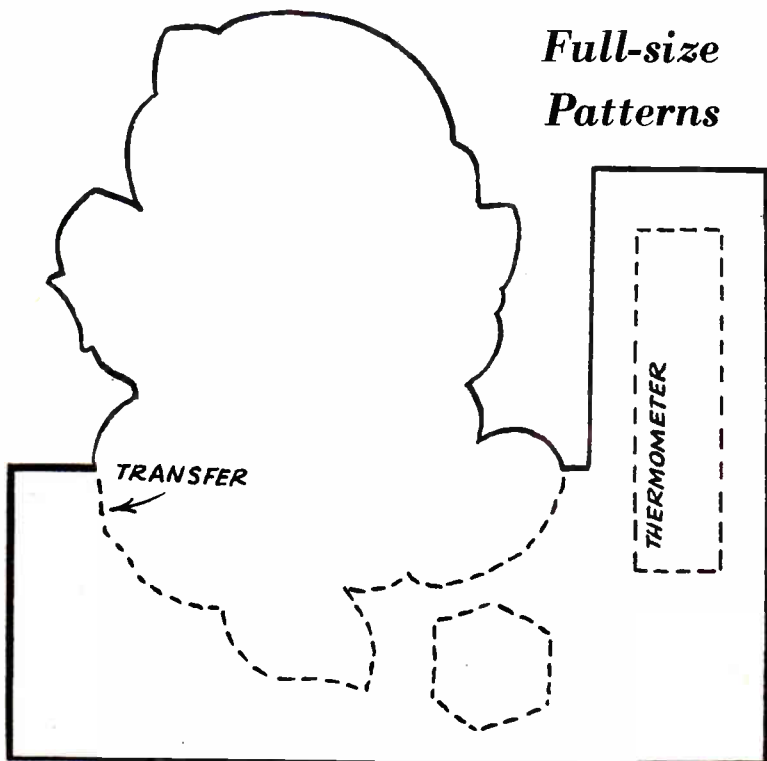

**D**ECORATIVE transfers may be used to make lovely gifts as shown on this page. A 'Fuzzy Kitten' set, No. 223, provides four attractive kittens which can each be used for a novel thermometer setting. Pieces of  $\frac{3}{8}$  in. plywood about 4ins. square are painted white and the transfers put on, leaving room for a small thermometer. Cut out roughly to the shape shown with a Hobbies fretsaw and paint the edges white.

Provide a hinged strut at back or a piece of grooved moulding for support.

Thermometers and transfers may be obtained from Hobbies Ltd Dereham Norfolk. Transfers 2/3 set (postage 3d), thermometers, No. 5016 price 1/6 (postage 4½d.) (M.p.)

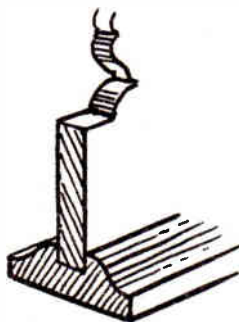
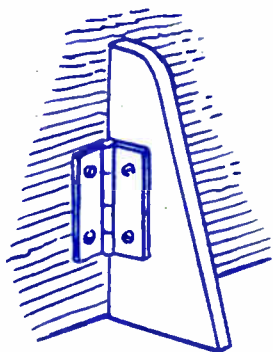
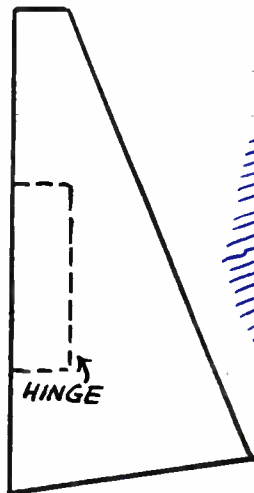

No.48 b GROOVED  
MOULDING

**CUT OUT  
WITH A  
FRETSAW**

# Paddle Your Own Canoe



... and make  
it with the  
aid of  
full-size  
plans from



## BUILDING COSTS FROM ABOUT £7

These plans contain all the information needed to build the canoe and its accessories. The main frames and other shaped parts are drawn full size for tracing direct on to the wood. There are plenty of constructional diagrams, with step-by-step instructions, and a detailed material list. Accessory instructions include the making of paddle, spray cover, trolley, rudder, sailing gear, etc.

All of these canoes are of the decked kayak type and are primarily paddling craft, but sail is useful as an auxiliary and can add to the fun of canoeing. If sailing capabilities are particularly required, PBK 20 is the best selection.

A canvas canoe can be built by the novice with limited equipment, and the average handyman can complete the job in about 40 hours. The structure consists of widely-spaced laths on cross frames, covered with a fabric skin. There are no difficult joints or awkward work. Plywood skinned canoes need more skill and a larger tool kit.

Building costs range from about £7 (for the PBK 10). We do not supply materials for building, but addresses of firms who do so are included with the plans.

### DETAILS OF PLANS AVAILABLE

#### RIGID CANVAS-COVERED

**PBK 10.** Single seat, 11 ft. long, 28 in. beam, normal max. load 300 lb. The shortest satisfactory canoe. Economical in size and building costs. Room for lightweight kit.

Price 11/-

**PBK 14.** A roomy single for the big man, or a two-seater for an adult and child, or two young people. 14 ft. long, 29 in. beam, normal max. load 500 lb. Popular tourer.

Price 12/6

**PBK 15.** Single seat, 14 ft. 6 in. long, 26 in. beam, normal max. load 400 lb. The enthusiast's fast touring craft. Safe and stable. Suitable for any waters.

Price 12/6

**PBK 20.** Two-seat, 15 ft. long, 32 in. beam, normal max. load 600 lb. Stable and seaworthy. Easily paddled and a good performer under sail. Popular with scouts and youth clubs.

Price 12/6

#### RIGID PLYWOOD-SKINNED

**PBK 16.** Two-seater. 16 ft. long, 32 in. beam, normal max. load 700 lb. Flat-bottomed. Safe and robust. Popular for local hire on sea and river. May be left afloat. Price 12/6

#### FOLDING

**PBK 24.** Single seat, 11 ft. long, 28 in. beam, normal max. load 300 lb. Similar lines to PBK 10 but longer cockpit. Only canoe which packs into one bag small enough to go on bus.

Price 12/6

*From branches or direct (post 9d. extra)*

**HOBBIES LTD** (Dept 99) Dereham, Norfolk



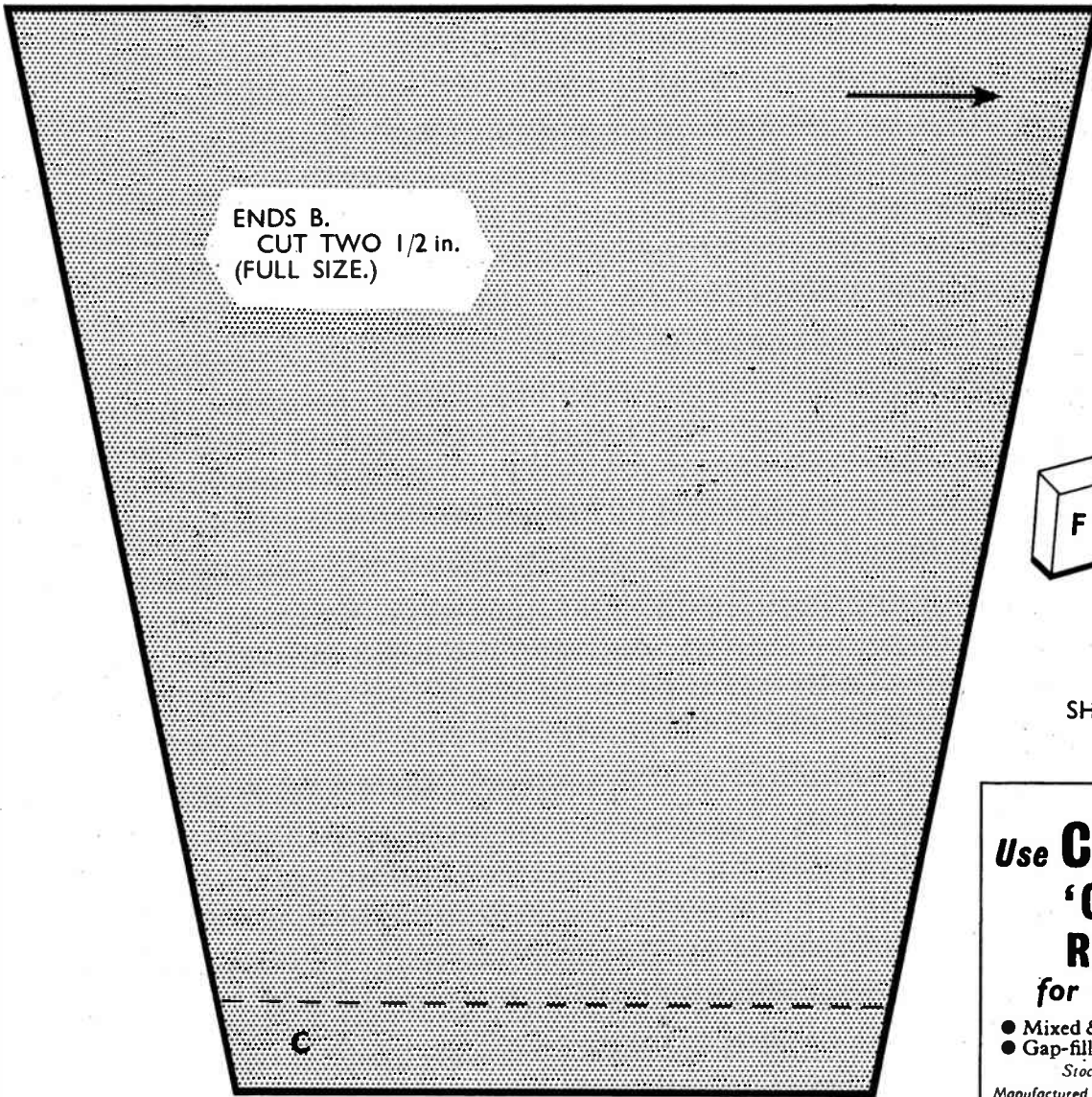

SIZE—  
21 ins. HIGH.  
29½ ins. WIDE.

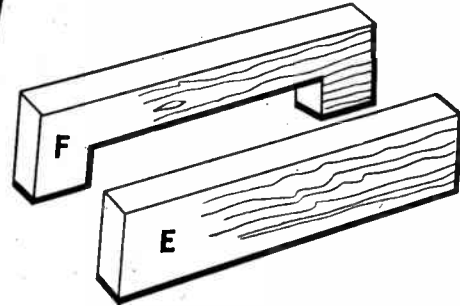

SHOWING CONSTRUCTION  
OF HANDLE.

Use **CASCAMITE**  
‘One Shot’  
Resin Glue  
for all Wood Gluing



- Mixed & use cold
- Waterproof type
- Gap-filling and non-staining

Obtainable in  
3½-oz.; 7-oz.  
and 18-oz. tins

Stocked by: Ironmongers, Builders' Merchants, etc.

Manufactured by:

**LEICESTER, LOVELL & CO. LTD.** North Baddesley, Southam

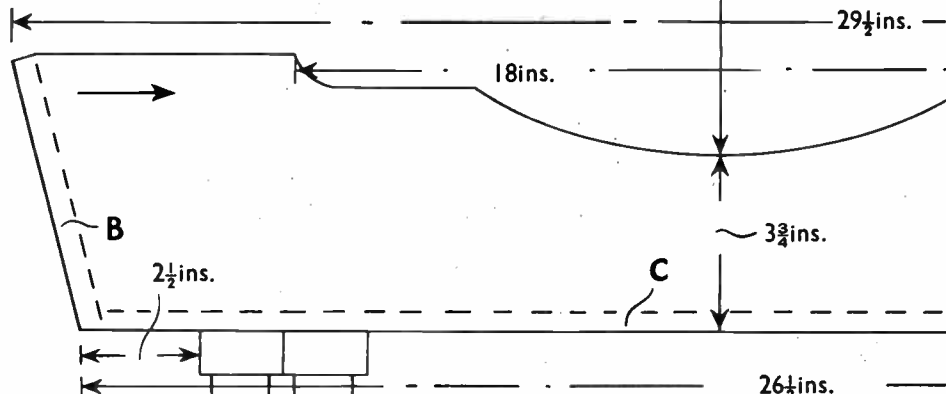
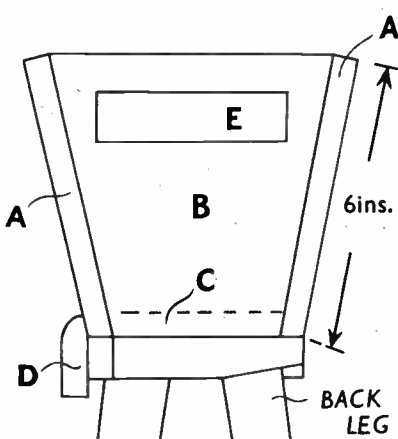
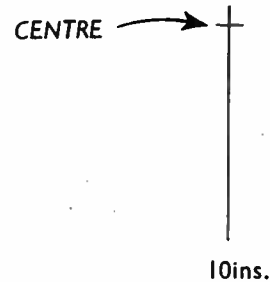
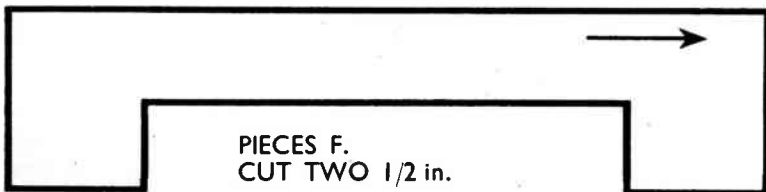

END



# A CONTEMPORARY PLANT STAND

SIZE—  
21 ins. HIGH.  
29½ ins. WIDE.

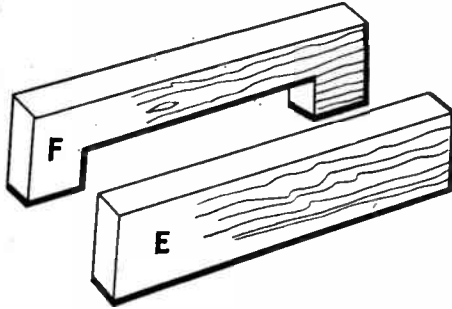

SHOWING CONSTRUCTION OF HANDLE.



Use **CASCAMITE**  
‘One Shot’  
Resin Glue  
for all Wood Gluing



- Mixed & use cold
- Waterproof type
- Gap-filling and non-staining

Obtainable in:  
3½-oz., 7-oz.  
and 18-oz tins.

Stocked by: Ironmongers, Builders' Merchants, etc.

Manufactured by:

**LEICESTER, LOVELL & CO. LTD.** North Baddesley, Southampton

PANELS OF WOOD REQUIRED FOR THIS DESIGN

## THREE R8

A KIT OF MATERIALS FOR MAKING THIS DESIGN IS SUPPLIED BY HOBBIES LIMITED DEREHAM, NORFOLK. PRICE ON APPLICATION.

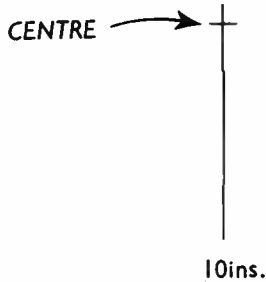

THE ARROWS INDICATE DIRECTION OF GRAIN OF WOOD.

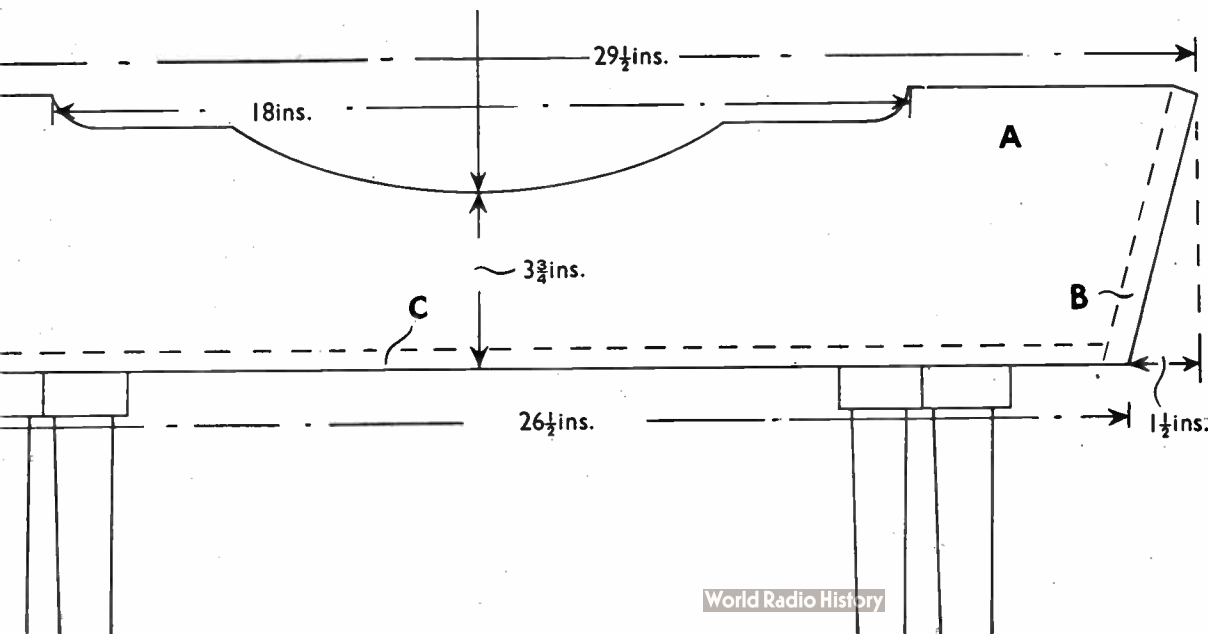

PIECES E. CUT TWO  
1/2 in.





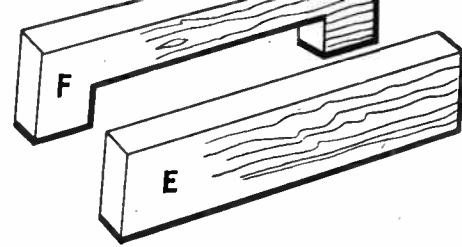
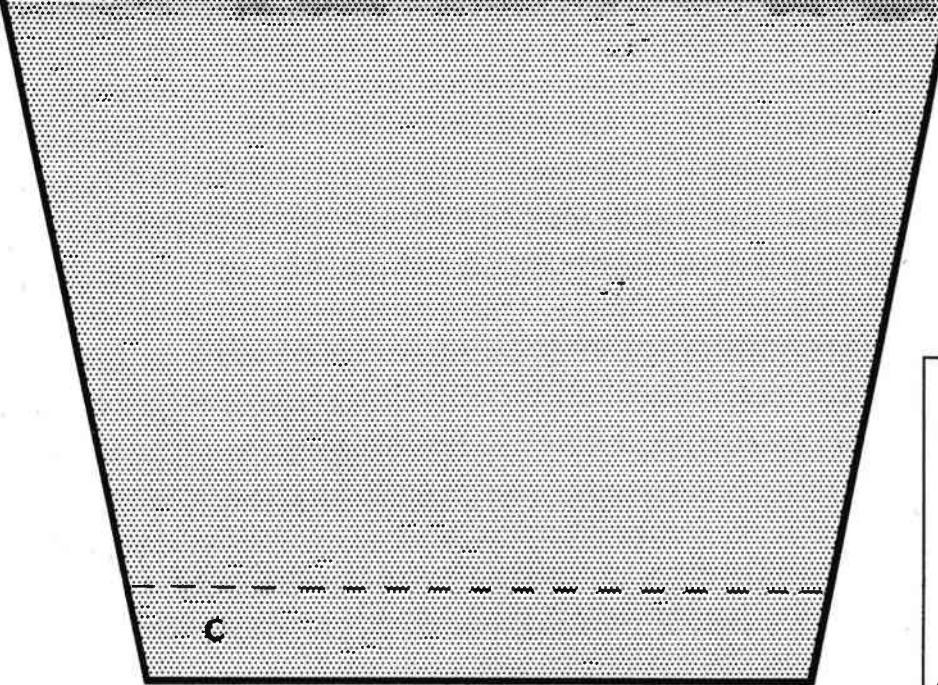

SHOWING CONSTRUCTION OF HANDLE.

Use **CASCAMITE**  
 'One Shot'  
 Resin Glue  
 for all Wood Gluing



- Mixed & use cold
- Waterproof type
- Gap-filling and non-staining

Obtainable in 3½-oz., 7-oz. and 18-oz. tins

Stocked by: Ironmongers, Builders' Merchants, etc.

Manufactured by:

**LEICESTER, LOVELL & CO. LTD.** North Baddesley, Southampton

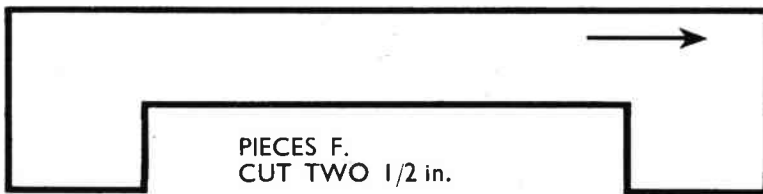

CENTRE →

10ins.

G

29½ins.

18ins.

3¾ins.

2½ins.

26½ins.

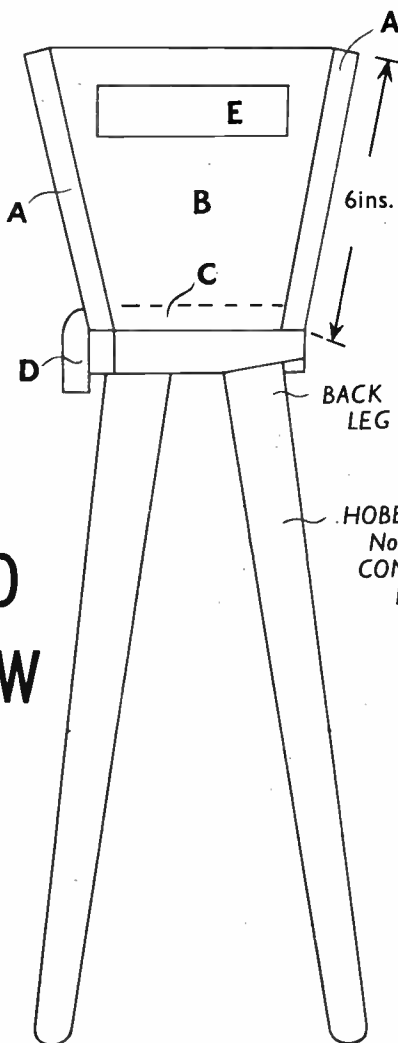

END VIEW

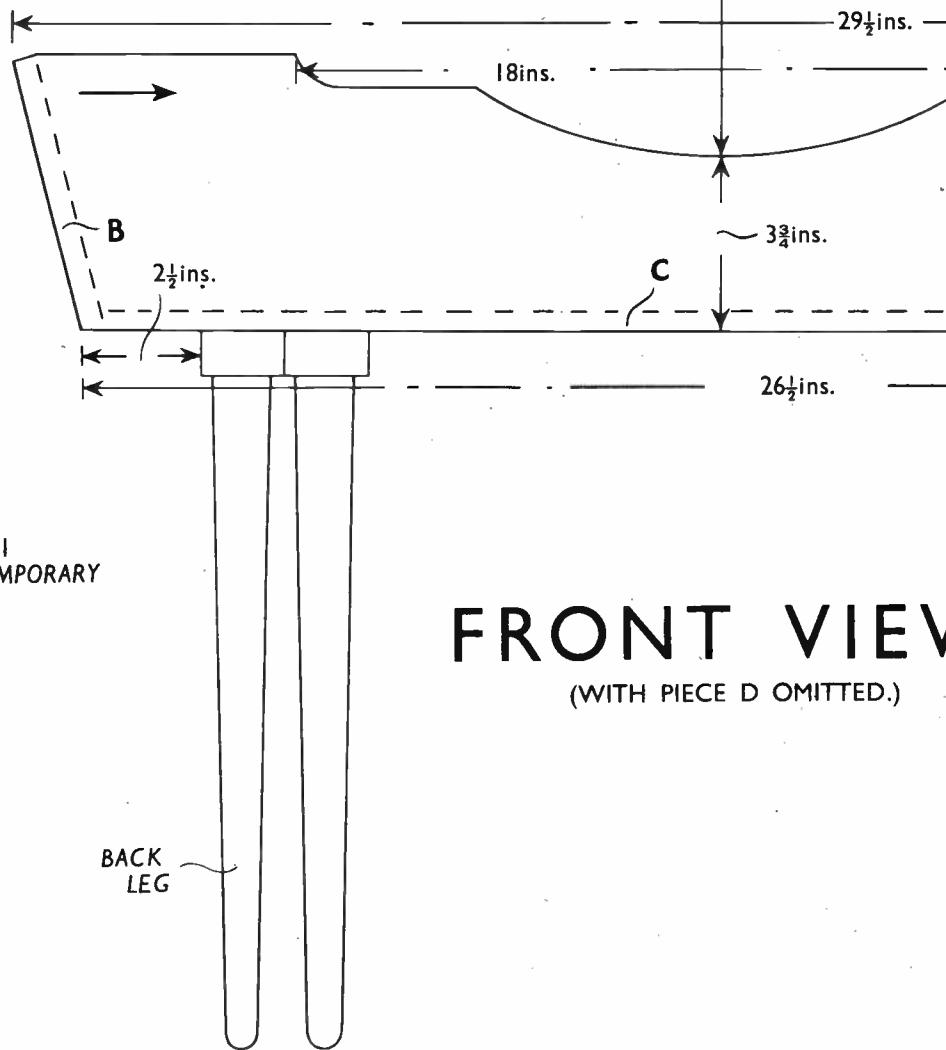

FRONT VIEW  
 (WITH PIECE D OMITTED.)

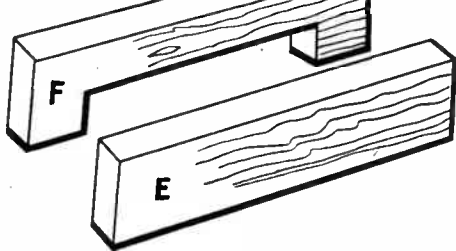

SHOWING CONSTRUCTION OF HANDLE.



Use **CASCAMITE**  
**'One Shot'**  
**Resin Glue**  
 for all Wood Gluing



- Mixed & use cold
- Waterproof type
- Gap-filling and non-staining

Obtainable in:  
 3½-oz.; 7-oz.  
 and 18-oz tins.

Stocked by: Ironmongers, Builders' Merchants, etc.

Manufactured by:

**LEICESTER, LOVELL & CO. LTD.** North Baddesley. Southampton

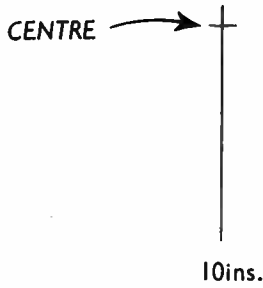

THE ARROWS INDICATE DIRECTION OF GRAIN OF WOOD.

PANELS OF WOOD REQUIRED FOR THIS DESIGN

**THREE R8**

A KIT OF MATERIALS FOR MAKING THIS DESIGN IS SUPPLIED BY HOBBIES LIMITED DEREHAM, NORFOLK.

PRICE ON APPLICATION.

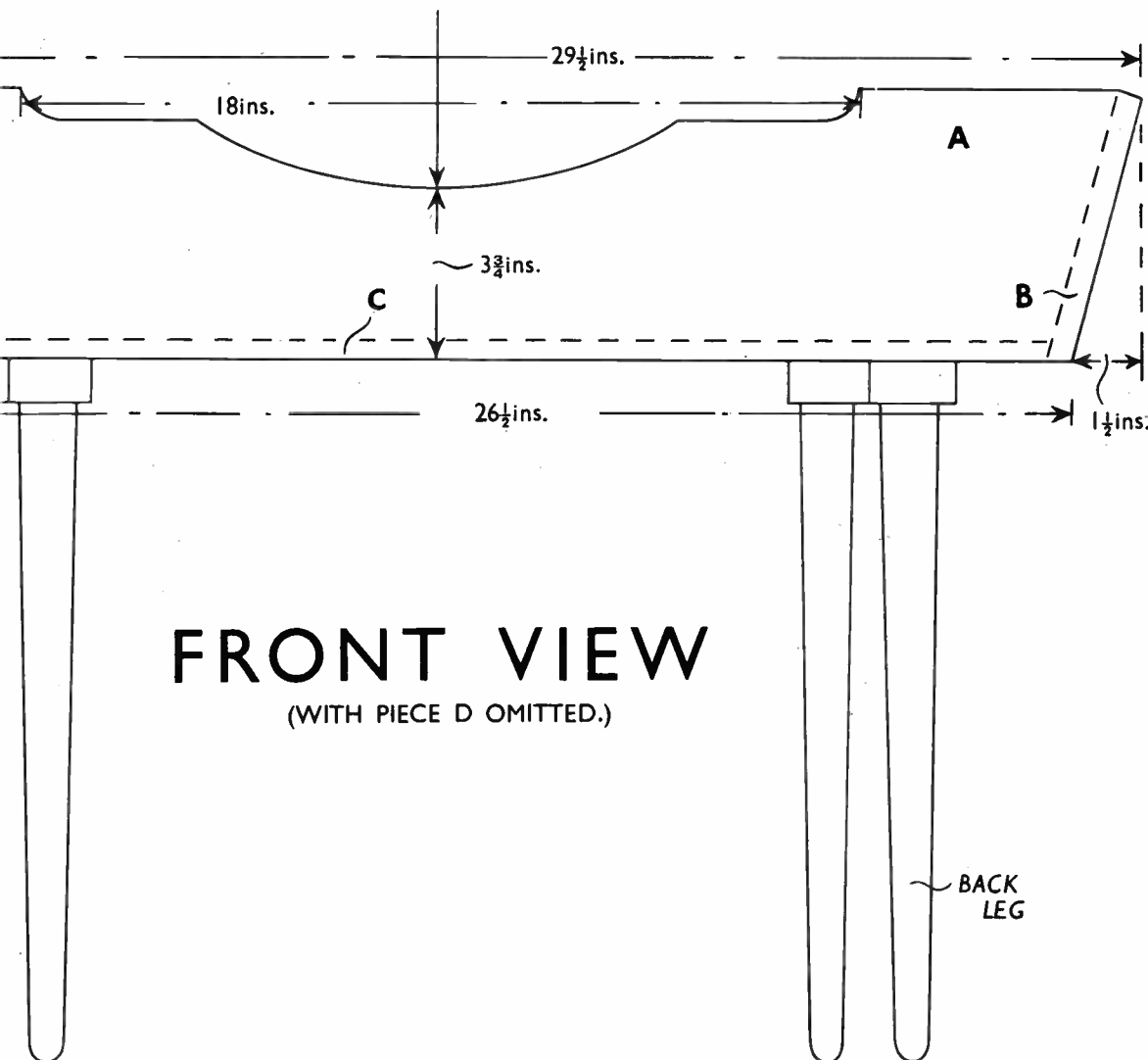

**FRONT VIEW**  
 (WITH PIECE D OMITTED.)

PIECES E.  
 CUT TWO  
 1/2 in.

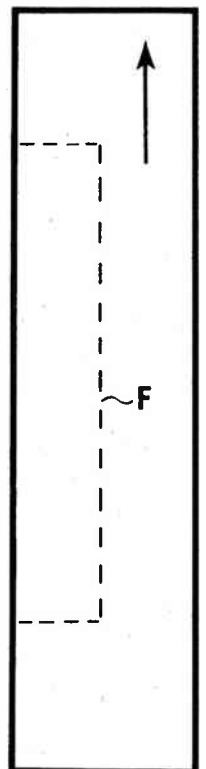

PRINTED IN ENGLAND