

HOBBIES WEEKLY

JANUARY 15th 1958

VOL. 125

NUMBER 3246

IN THIS ISSUE

| | Page |
|-------------------------------------|------|
| The Popular Three | 257 |
| A Multiform Toy | 258 |
| This is Taxidermy | 259 |
| Table and Bookrack | 261 |
| Simplified Bookbinding | 262 |
| Hints Around the House | 263 |
| Space Ship and Launcher | 264 |
| The Mill at Sunset | 265 |
| Bottle-opening Made Easy | 266 |
| Aircraft Spotting | 268 |
| Pattern for Fretsaw Inlay | 271 |



All correspondence should be addressed to the Editor, Hobbies Weekly, Dereham, Norfolk

★ **FREE** ★
*Design
inside*

EASY FRETWORK PROJECTS

THESE three projects have been specially designed for the beginner in fretwork. They consist of a trinket box, watchstand, and matchbox holder — three popular subjects which can be made up as useful novelties. The cutting outlines are very simple and construction is straightforward. Cut-out lettering has been introduced in the match-holder project, and the worker

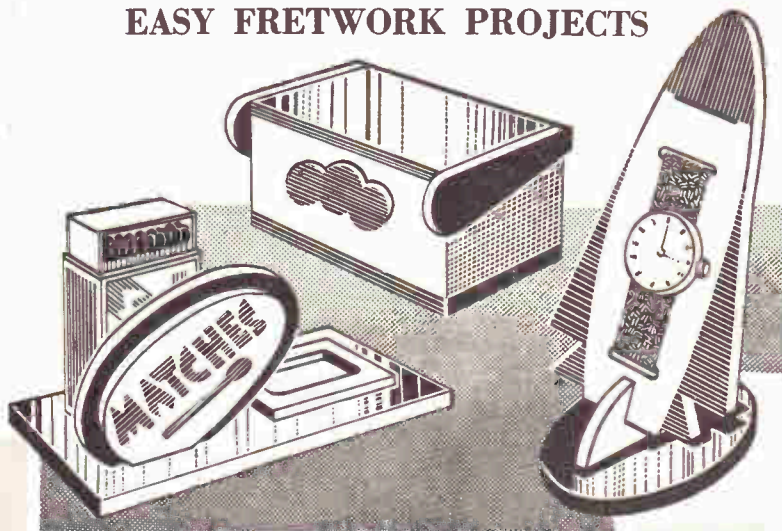

THE POPULAR THREE

might like to try his hand at this, remembering that in this type of work it is advisable to cut the interior frets of piece B before cutting the outline.

All the parts for the three subjects are shown full size on the design sheet, and the thicknesses of wood for each part are clearly marked. By observing all the usual rules when cutting, such as keeping

the saw upright, there is no reason why even the beginner should not make an excellent job of these three articles.

The first objective is to transfer the outlines of the various parts, which go to make each design, on to the chosen thicknesses of wood. This is done by placing carbon paper between the design and wood and marking through with a

sharp pencil. If it is desired to preserve the design for further use, it may be advisable to first trace the outlines on to tracing paper and use this for transferring by carbon paper to the wood.

Make sure to arrange the pieces on the wood so as to obtain the most

Continued on page 258

A MULTIFORM TOY

By
T. S.

Richmond

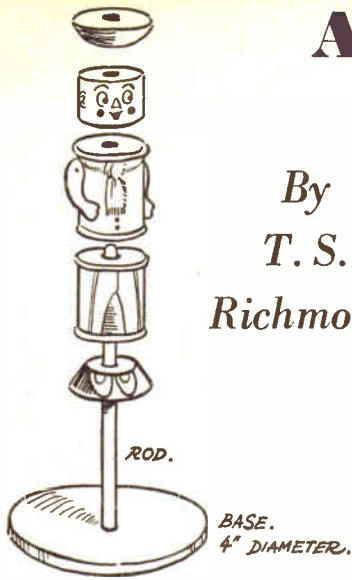

THIS multiform plaything made up from oddments of wood, dowel rod and used cotton-reels will give junior many happy hours taking it apart and assembling it again.

First cut the round base from $\frac{1}{2}$ in. thick wood. Smooth with glasspaper and drill out the centre hole. Cut a 6 in. length of dowel from $\frac{1}{8}$ in. stock. Glue the rod firmly into the base and round off the top end smooth. Paint base a gay colour, but not the dowel stem.

Copy the shapes given over 1 in. squares and cut these out of a panel or from oddments of wood of a suitable thickness. Glasspaper smooth all sharp edges and corners and paint in a variety of bright colours.

Cotton Reel Man

To make up the parts for the Cotton Reel Man obtain three discarded reels. Mother or sister may be able to oblige here. Cut top and bottom from one reel and shape as shown for the hat and the feet. The centre part is used as the face. Use a whole reel for the body and glue or pin on two wooden arms. The third reel of course is for the legs, and these must be painted to represent trousers or a skirt for the comic figure. Glasspaper all parts of cut reels before painting. A suggested key to painting would be: Hat blue. Face pink with brown or black hair. Red or blue coat to body. Flower pattern for skirt or grey with black stripe for trousers. Paint in shoes over black surround. When dry, the figure is assembled on the stem. A box can be provided for housing the toy and set of coloured shapes.

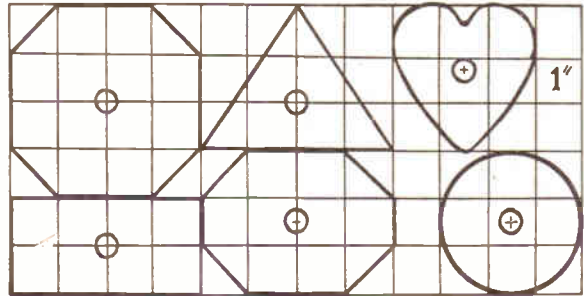

Continued from page 257

The Popular Three

economical cutting from each panel, and particularly note the placing of the shapes according to the grain of wood, which is indicated by arrows.

When the outlines have been transferred to the wood, cut out each shape with a fretsaw and clean up thoroughly with glasspaper.

The step by step construction of each project is clearly given on the design sheet, whilst reference to Figs. 1 and 2 will give further help in making up the watchstand and trinket box respectively. The pieces are added in their various stages by gluing. Note the slots to take

the hinges on one of the pieces B in the trinket box (also shown in Fig. 2.)

Finishing is left to individual taste. This can be by staining and polishing, or application of clear lacquer. Other workers may prefer to paint. On the quality of the finish will depend to a great extent the appearance of the article, so take pains at this stage and do not rush your work.

Kit No. 3246 contains all the wood and materials for making these three projects. Obtainable from branches or Hobbies Ltd., Dereham, Norfolk, price 5/6 (post free).

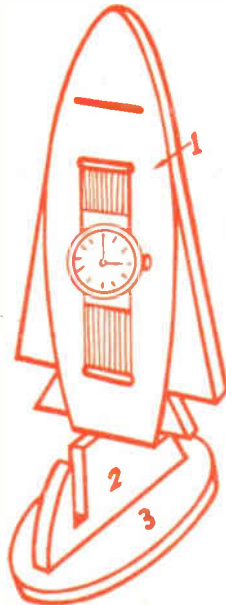

Fig. 1

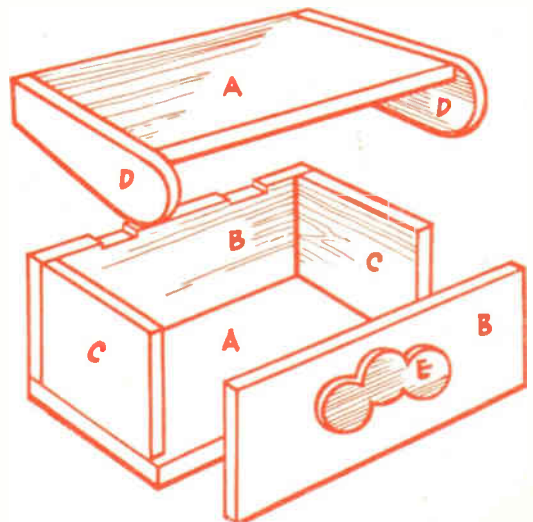

Fig. 2

For the amateur

THIS IS TAXIDERMISTRY

DEFINED by at least one authority as 'the art of preparing and stuffing the skins of animals', taxidermy is well within the scope of the average keen amateur. Additionally, birds, fish, and reptiles may be tackled with equal confidence by the nature-lover anxious to preserve and mount notable specimens.

While the tools and other material requirements for this fascinating pastime are few and simple — namely, an ordinary efficient pocket knife with a large and a small blade, together with a

Commercial preparations of preserving soaps and powders are readily obtainable in made-up form from local taxidermists' and naturalists' stores, as

By C. L. Marriner

are glass eyes in every conceivable size, shape and colour. However, for those who prefer to see the job through on their own, here are a couple of recommended recipes for a preserving soap and powder.

To a pan of boiling water add 3 parts of whiting to 1 part of finely shredded white curd soap, in the proportions of 1 oz. of the latter to every pint of water, and place the whole on a low heat to simmer gently. Then, when the mixture has thickened to the consistency of a stiffly-running paste, and while it is still hot, stir in 3 parts of chloride of lime. Set aside to get cold and top off with 2 parts of tincture of musk, again vigorously whisking the contents of the pan together before pouring it off into an efficiently sealed jar. The preserving powder, on the other hand, consists simply of a smooth blend of 1 part of saltpetre to 4 parts of burnt alum, also stored in an airtight container.

Mention of the squirrel, quite the most popular and appealing of all the many small woodland creatures which lend themselves to taxidermy, leads us naturally to its selection for a detailed description of the correct procedure for skinning, scraping, stretching, manipulating, preserving, modelling and mounting animals in general. So now let us, first, place our specimen face-up on a convenient-sized board (Fig. 2) pre-drilled to take the four attachment strings for the limbs, secure it in position (Fig. 1), and open up the stomach. This is best accomplished with the aid of the large blade in your pocket knife, the incision being commenced centrally under the breast bone and extending well down into the lower abdomen. After which the loose flaps must be pulled apart and each secured with a bent pin attached to a couple of nails with short lengths of string (Figs. 1 and 3).

The skinning

As soon as the specimen has been properly 'gutted', we may then proceed direct to the skinning — an operation which is far more terrifying in prospect than in fact! So let us tackle the job resolutely even, if with extreme care, and see how the task is accomplished step by step.

Commence by working out the hind legs until the large joint of each is sufficiently exposed to ensure clean severance at the knuckle. Now ease the skin off the lower half of the torso, and from the root of the tail withdraw the plug of flesh and small bones. At this stage the skin resembles nothing so much as a furry pullover and should be stripped off the remainder of the body like a child being divested of its woolly outer garment.

Expose each fore leg along the length of its fleshy ham and surgically disjoint as freshly described for the hind-quarters. Draw the pelt up clear of the neck and sever the head from the naked torso, afterwards carefully peeling the skull (attached to the delicate membrane at the inner extremities of the mouth and nasal passages, which, together with the ligaments at the roots of the ears, must be handled with extra caution if irreparable damage is not to result from the involuntary piercing of any of these vital features) and removing in the process all trace of the brain, adhering flesh, and both of the eyes.

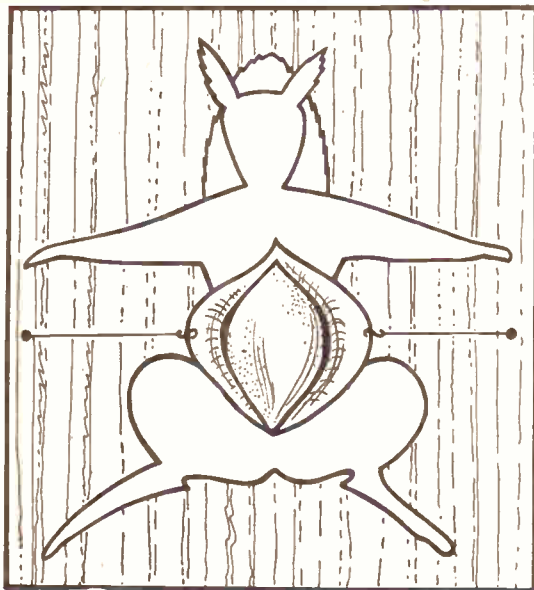

Fig. 1

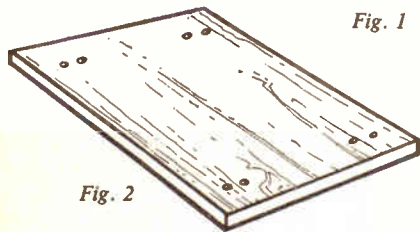

Fig. 2



Fig. 3

suitable honing stone, small scissors, a light hammer, long-nosed pliers incorporating a wire-cutting device, a small triangular file, odds and ends of iron wire, a supply of bead eyes (plain and coloured), thin string, strong thread, tow and cottonwool, clay, wire nails, pins, camphor, and an effective preserving soap.

Assuming that the several ingredients are to be mixed in ratio to a single pint of water, the quantity of preserving soap which results should prove sufficient to deal adequately with quite a number of small animals, such as squirrels. This applies equally to the preserving powder when it is prepared in the proportions of $\frac{1}{4}$ oz. of saltpetre to one of burnt alum.

Having thus obtained the skin of your specimen intact, the next thing is to ensure that it is well and truly cured before finally stuffing it and mounting it. So now turn the whole thing inside out and go over the hairless surface with a scraper. This may sound tedious, but it is essential that every minute scrap of flesh and fatty residue be got rid of, even to that which probably clings to the remaining leg bones. After which the cleaned-up surface of the skin must be given a thorough going over with the preserving soap, applied and meticulously worked in with the aid of a suitable small brush.

Drying period

Keep at it until you are quite satisfied with the results of your efforts — after all, the lasting qualities of the finished product are in the making at this stage — then return the skin to its normal state of fur-side out and hang it in a warm dry room for two or three days.

During this so-called drying period, while the preserving soap is doing its job, the process may — and, indeed, should — be materially assisted by regular and frequent stretching and manipulation of the otherwise stiffening pelt to keep it soft and supple. Then, with the skin turned inside out once more, the treated surface should be given a final clean-up with the aid of a blunt knife, and a liberal application of the preserving powder administered — and again worked in to the best of your ability.

The stuffing

Before you actually start to stuff the now satisfactorily prepared skin, see that you have handy a pair of matching bead eyes of the correct size, shape and colour, an ample supply of powdered camphor, and a strong solution composed of camphor dissolved in turpentine. Then, with the latter, saturate a lump of tow and proceed to pack the skull; afterwards replacing the lost flesh from the outer surface of this with a sort of clay skin. Mould it on as dry as practicable, striving to reproduce as accurately as you are able the original contours of the flesh-encased skull, and place the whole on one side to set hard.

This done, it will now be necessary to fit the skull back into the skin of the head, where previously, in their sockets, the bead eyes should have been realistically substituted for the original. Any discrepancies — which are almost inevitable due to a number of factors over which one has no control — between the outside contours of the skull, and those of the head-skin are simply remedied by rubbing down the high spots on the clay or building up the undesirable depressions with cottonwool manoeuvred into position with a blunt wire.

Strong iron wire, of the desired length and appropriately curved, will serve admirably as a substitute for the animal's backbone; but first wrap it in tow, stoutly bound and roughly shaped to resemble the discarded torso (Fig. 4). From the top end of this false body a short length of the stiffening wire, sharply pointed, should be left protruding — thus a strong joint twist body and head will be ensured when the latter is forced up inside the skull (Fig. 5). A secondary wire stiffener — again of a suitable length, sharply pointed at each extremity, inserted at the root of the tail and caused to run the entire distance of the tough central cartilage — effectively anchors the false body by having its opposite end jammed solidly into the stuffing of same (Fig. 5).

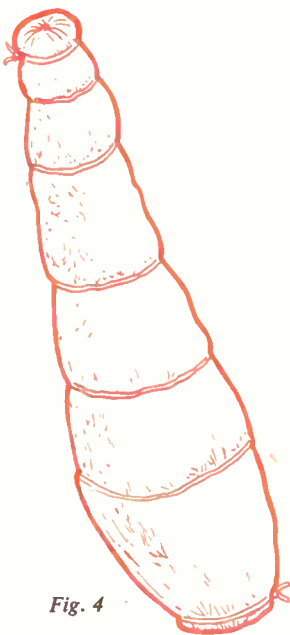

Fig. 4

each fore paw — perhaps to hold securely in place an acorn supposedly cupped in the hands of the finished model (Fig. 5).

Which brings us nearly to the end of the task; for once the stiffening wires have been strategically positioned throughout the body, and each firmly hooked into the appropriate area of the main stuffing, all that remains to be done before finally sewing up the hole in the stomach is to pack out the skin all round with cottonwool heavily laced with powdered camphor.

On your ability to reproduce faithfully the original contours of your specimen by adding to or subtracting from this supplementary stuffing — not to mention the arrangement of the limbs, the set of the head, the up-sweep

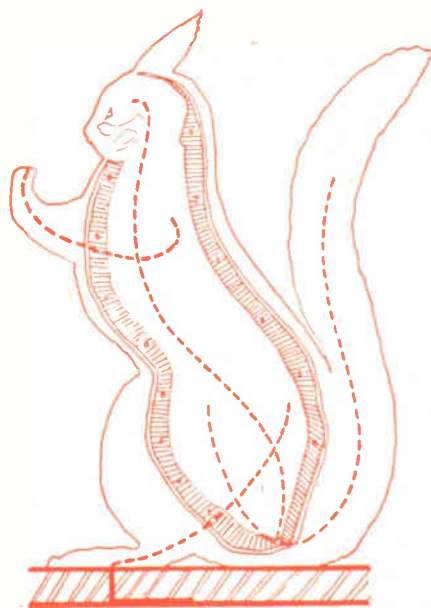

Fig. 5

It will be necessary also to give individual support to all four limbs, except that — taking the hindquarters first — the appropriate wire stiffener enters the sole of the foot in question, passes centrally along the length of the adjoining leg and ends deep in the tow body (Fig. 5). Leave at least 2ins. of wire protruding from the bottom of each foot; and complete this stage of the stuffing by inserting in the loose skin of each leg the small bones previously taken from it, thoroughly scoured, and now encased in clay moulded to the shape of the limb.

Treat the fore legs in exactly the same manner, but in this instance only a very short length of wire need be allowed to project from the palm of

of the tail, and, indeed, the stance of the body in general — will depend the successful outcome or otherwise of the whole venture.

Equally important is the choice of a suitable stand. This may take practically any form from a piece of ordinary timber, rough-cut or prepared, to a bark-covered log of reasonable proportions, or even a gnarled limb cut from a tree — with a single branch sticking out at an angle on one side — rooted in a solid base. But, perhaps, the simpler the better for a start — a plain board, say, 6ins. long by 4½ins. wide by ½in. thick.

Having cut to size and shape such a board, the next step is to drill across it centrally a couple of conveniently-

● Continued on page 266

Out of the ordinary

TABLE AND BOOKRACK

MATERIAL REQUIRED

Ring. $\frac{3}{4}$ in. plywood 1ft. 6ins. by 3ft.
Stand. 1in. by 4ins. by 4ft.
Book Supports. 3 panels. N.D.8.
Bendable Plywood. 9ins. by 24ins.

Described by
W. J. Ellson

TO readers who may desire something out of the ordinary in the furniture line, this unconventional table and bookrack design may appeal.

The construction is simplified, and is quite within the scope of most woodworkers. A front elevation is illustrated in Fig. 1 and a side elevation is shown in Fig. 2 with suitable dimensions. The circular body work consists of two rings of $\frac{3}{4}$ in. plywood, separated by spacing strips, the edges being covered with bendable plywood. The radii of these

strips, lettered D and E, and should be nailed under a centre line, drawn across the rings. They will project inwards just over 1in. and form the supports to which the table top (one of the circular pieces sawn from the rings) will subsequently be screwed. Well countersunk holes for these screws should be made in the spaces before fixing them to the rings, it being a rather difficult job to do afterwards.

A strip, or strips of bendable plywood, 4ins. wide will be needed to cover the rings. As this material can be bought in strips, 9ins. wide and 24ins. long from

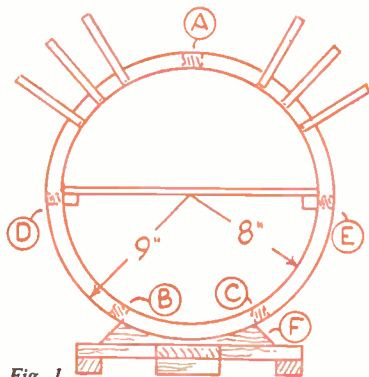
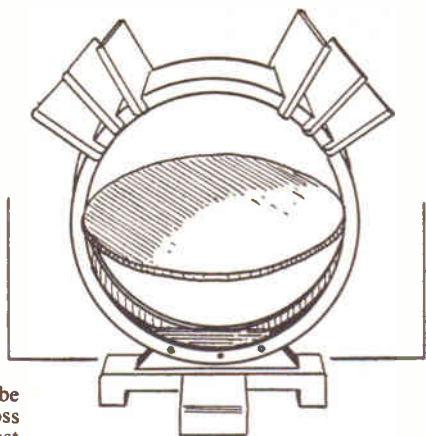

Fig. 1

rings are given in Fig. 1 and should be struck on the plywood. If a pair of compasses capable of such radii is not available, a competent substitute can be made up with a strip of wood, having a nail one end for a pivot and holes at the required distances from the nail for a pencil to enter.

Having cut these rings, and be careful to keep the fretblade upright when doing so, prepare three spacing strips of $\frac{3}{4}$ in. square wood, 3 $\frac{1}{2}$ ins. long. These are nailed across the rings at points A, B and C. Use 1in. oval nails and punch the heads well down, afterwards stopping the holes level. Spaces B and C, by the way, should be 8 $\frac{1}{2}$ ins. apart, measuring across the outer rim.

From 1in. thick wood, cut two pieces to size at G, Fig. 3. These are the spacing

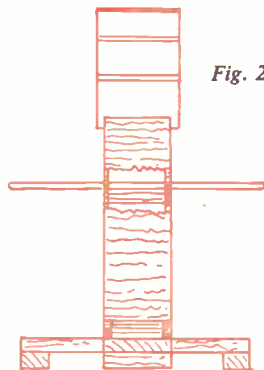

Fig. 2

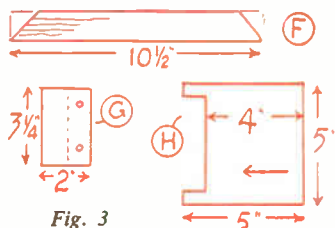

Fig. 3

Hobbies, two strips of the required width can be cut from it, and should be sufficient to cover the distance from spacer B, round the rings, ending at spacer C. If a trifle short, however, a piece of the 1in. strip left over can be glued on to cover the gap. Fix the plywood with glue and panel pins.

To hold the rings to the stand, a piece of 1in. thick wood, of the length given at F in Fig. 3 and 3 $\frac{1}{2}$ ins. wide is cut. The ends of this are cut to 45 degrees, and then it should fit between the rings. Bolt up against spacers B and C, as in the front elevation of the table. The fit being satisfactory, the stand can be prepared.

This is seen in both Figs. 1 and 2, and consists of two pieces of 1in. by 4in. wood, halved together at rightangles. The ends are thickened underneath by 1 $\frac{1}{2}$ in. wide strips of 1in. wood, glued on. The sharp edges at the upper ends of the stand should be neatly rounded off with rasp and glasspaper. Glue and screw part F to the stand, then screw the rings to F, these last screws being of the roundheaded variety.

The circular table top, after having its edge smoothed with a vigorous rubbing with glasspaper, is screwed in place, the screw being driven in through the spacers beneath. It may be found more convenient to fix the table top in place before screwing the rings to the stand.

For the book supports at the top, cut six from $\frac{3}{4}$ in. wood, to the dimensions given at H in Fig. 3. The grain of the wood must run in the direction indicated by the arrow. This is important. The length of the cut-outs at the bottom of the book supports should nominally be 4ins, but as slight inaccuracies will occur, measure the actual width of the body-work across the plywood, as a tight fit is essential.

The two inner supports are fixed at an angle of about 60 degrees from the vertical. The remainder at spaces of 1 $\frac{1}{2}$ ins. apart. Fix with glue and a panel pin through the side pieces that fit up against the rings. Glasspaper the work, and finish with stain and polish to match existing furniture, or apply a coat or two of lacquer.

Simplified Bookbinding

YOU can bind any paper-backed exercise, or similar book quite easily without the necessity of elaborate equipment in the form of presses and guillotines. So bound, the books assume an attractive appearance and with these substantial covers may be used as notebooks for future reference.

By *S. H. Longbottom*

First of all the outer paper cover is removed but the usual wire staples are retained in position since these will hold the leaves together during the next stage. The outer cover may be replaced by a sheet of pastel paper or strong drawing paper cut to the same size as the leaves, and the reason for this will be seen later when the pages are attached to the covers. Now open out the leaves until you come to the centre pages where three holes are made with

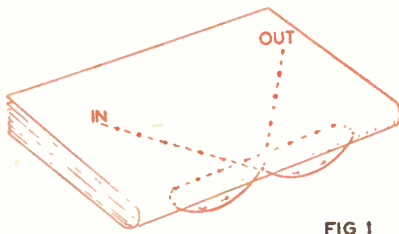

FIG 1

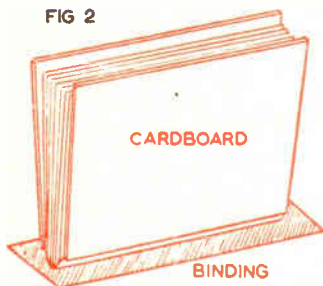

FIG 2

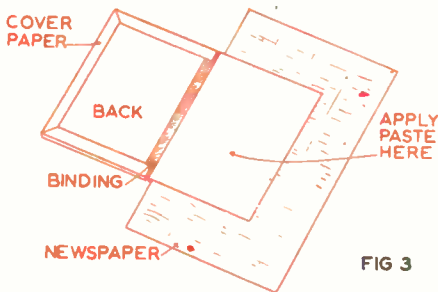

FIG 3

a bradawl to ease the operation of sewing. If the book is large it may be better to make two pairs of three holes, but this is left to your own discretion.

Reference to Fig. 1 will reveal the method of sewing the leaves together. Make one hole in the centre and the other two equidistant on either side. Take some strong, white thread and with the aid of a needle, push through the centre hole to the back. Pull the thread through, but leaving some surplus

behind for tying later. Take the needle through the next outer hole, carrying the thread forward inside the leaves to the other hole at the end and push the needle through. Sewing is completed by inserting the needle at the centre hole again and pulling the thread through. The two ends of the thread are firmly tied together and having completed this the original staples may be removed.

We now require two pieces of stout cardboard for the covers, measuring at least $\frac{1}{2}$ in. deeper to protect the edges of the leaves but approximately $\frac{1}{4}$ in. less in width so that the spine will hinge quite freely. Cut out the cardboard with a sharp knife, using a set square to check the corners, finally placing on the leaves as a test for size.

The covers are fastened together by

gluing on a 3 in. strip of linen book-binding material and any suitable colour may be used. If you will now refer to Fig. 2 you will see that the boards are narrower than the leaves and a test is being made to determine the exact width of the strip which is afterwards glued to the two cardboard covers. Remember to allow one inch at each end for turning inside.

The next step concerns the covering of the cardboard with some kind of

fancy paper as shown in the photograph. You have a wide choice of this type of material at the handicrafts stores, for there are numerous designs, qualities and colours. Your choice may perhaps depend on the type of book you are making and if the book is expected to last it is wiser to select a durable paper. Note that the paper is attached to one side only and does not entirely cover the binding strip, 1 to 1½ ins. of this remaining uncovered. Where the two join there should be a clean straight line of paper, parallel to the spine, so it is essential to be extremely careful with the trimming. It is most important that the two lines are parallel. Perhaps you can imagine the effect if the covering paper was only a little out of true!

Use spatterwork

The paper cover is folded over the back of the card and neatly mitred as shown in Fig. 3. Paste all over the paper and see that it is perfectly flat and uncreased before laying under a weight to dry. Incidentally, in our issue of 22nd May 1957, a method of preparing patterned papers by spatterwork was described and one of these could be used for the covering paper. Try to avoid soiling the cover paper with the paste or by using a dirty duster for smoothing down.

Binding is now almost completed and the last stage in the process is the fixing of the leaves to the outer cover. This is done by pasting the outer cover of the leaves and attaching to the inside of the covers, so you may now appreciate the reason for advising a stronger sheet of drawing paper.

To prevent any paste from soiling the other leaves it is best to lay a sheet of newspaper under the fly leaf to be pasted as shown in figure 3. You may then apply

●Continued on page 263

HINTS AROUND THE HOUSE

THE following hints may be found helpful to the home handyman when carrying out odd jobs around the house.

When cleaning out or repairing the inside of any electric appliance always disconnect the power first by removing the plug from the socket. Do not rely on just switching off the electricity, because this does not guarantee the maximum amount of safety.

Many handymen, nowadays, have small circular saws in their workshops to assist them with their work. These power saws should be used with extreme care. When cutting small sections of timber, always push the last inch or so through the saw with a piece of scrap wood and not with your fingers.

An old toothbrush is a useful item to keep handy in your workshop. You will find it to be an ideal tool when oiling small mechanisms, etc., for the bristles can get into many an awkward corner.

When replacing a broken cord on a sliding sash window it is advisable to use proper sash cord for the job. Many people make-do by using a length of ordinary clothes line, but this is not satisfactory, as clothes line is not strong enough to stand up to the continual strain.

Before inserting wood dowels always form a small saw cut the full length of the dowel to allow any surplus glue to escape with ease. If this is not done, then the hydraulic pressure set up when the dowel is being inserted could easily split the timber and spoil your work. (See diagram)

When carrying out repairs on a pitched roof which is tiled or slated always lay a ladder on the roof surface in order to distribute your weight over a larger area. Failure to do this is not only dangerous, but is also likely to cause damage to the slates or tiles.

Care with your paint brush

Many people, when they are painting, have a habit of stirring the paint with their paint brush. This practice is not to be recommended, as it results in the bristles becoming twisted and eventually ruins the brush.

Folding rules, sometimes become dull and unreadable as a result of continual use. However, if they are rubbed over frequently with a little linseed oil they will remain in good condition for a much longer period.

When fixing on a new shaft to a household broom many people drive an

ordinary nail through the broom head to secure the new shaft in position. This should never be done because the nail is often difficult to remove if desired at a later date. It is much better to use a wood screw for this purpose.

Cork is often a difficult material to cut especially if neat, sharp edges and corners are required. Good results, however, can be obtained by using a sharp knife which should be continually dipped into warm water while cutting.

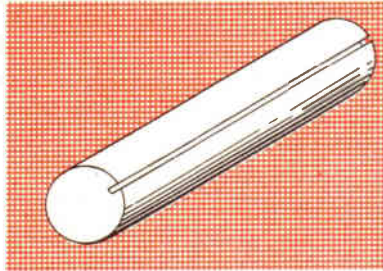

If you intend burning off some old paintwork indoors with a blowlamp, then do ensure that the burning paint droppings don't fall on your unprotected floor coverings, otherwise they will cause some nasty scorch marks.

When making holes in walls to receive wood plugs, the usual method is to use a plugging chisel and a hammer. A more efficient way, however, of doing this job is to use a masonry drill. These drills are much harder than ordinary drills and are specially designed for boring through masonry,

brickwork and tiles, and can be used either with a hand or power driven boring tool.

Many people believe that hacksaw blades are reversible and that they can be attached to the hacksaw frame either way. This is not so. The teeth, though small, have a definite slope, and the blade should be inserted so that they slope away from the handle.

The poor time-keeping of many wall clocks can often be attributed to the walls being out of plumb. When choosing positions, therefore, always make sure beforehand that the walls are plumb.

When setting mouse traps around the house it is advisable to wear gloves when handling the traps to avoid leaving a 'human' smell which the mice can detect. Also, give the traps a wash after every kill to get rid of any smell from the dead mice.

Home-made rubber bands

It's a good plan to keep an old inner bicycle tube in your workshop. The next time you have a use for some strong rubber bands, then all you have to do is to cut off a few portions from the inner tube. Larger bands may be obtained by cutting the sections diagonally.

When purchasing electric light bulbs do remember that the amount of service you get from the bulbs largely depends on getting ones to suit the voltage available. A bulb having a lower voltage than the circuit will give a brighter light, but will burn out more quickly.

(F.K.)

●Continued from page 262

Simplified Bookbinding

a thin coating of strong paste right to the edges without fear of it spreading where it is unwanted. See that the leaves are pushed well to the centre of the spine—you may test this before pasting—turn back the page, smoothing down with a soft, clean duster. The same process is repeated for the other cover, when the whole may be left under a weight to dry.

If the pages bear ruled lines, take care that they are not inserted upside down. The wider margin should be at the top when opening. Use strong but thinly

coated adhesives for quick drying without warping and don't forget to use old newspapers for pasting and keeping the books clean.

Books bound as described are extremely useful for all manner of things such as recipe books, address books and for reference in general. The stouter backs ensure a much longer life while attractive covers make them easily recognized. If you wish, a label may be added for printing a title according to the ultimate use of the book.

WE are on the threshold of space travel. The subject of science fiction writers, comic-strip artists and modern toy designers of yesterday has become the actuality of tomorrow.

On February 29th, 1956, I had published in *Hobbies Weekly*, number 3148, my article and diagrams for making a lightweight rocket with elastic-powered control tower. Many readers, no doubt,

By *T. Richmond*

made up this toy, and, perhaps, some 'space-minded' boy is still getting plenty of fun out of one built specially for him.

To keep abreast of the times, and realising the many new readers to this journal eager to 'have a go' at making something novel and constructive themselves, I am contributing a further Space Rocket toy.

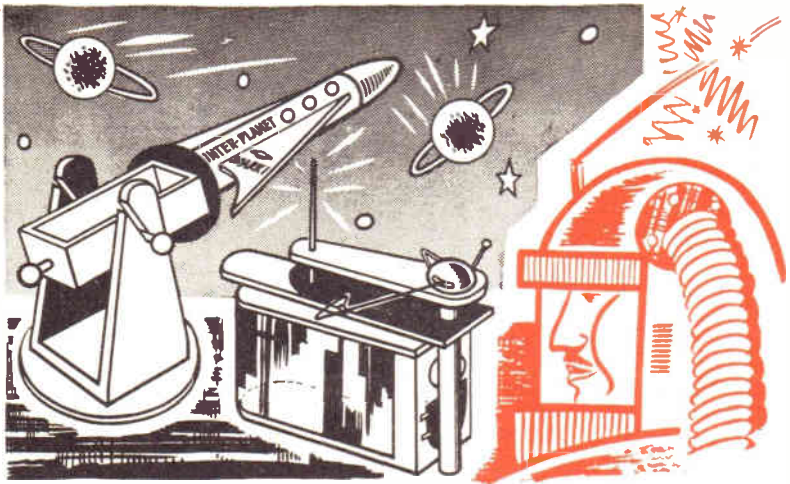

SPACE SHIP AND LAUNCHER

Unlike its predecessor which was of simple design, this project, whilst still easy to build by the toy maker, goes a little further in scope, with its revolving and elevated Launching Station, authentic light-weight Rocket Space Ship, and the addition, if preferred, of an easy-to-assemble 'Space Port'.

Launching Station

Commence work on the Launching Station, which comprises two sloping side uprights screwed to base piece. The latter has a hole through the centre, so that it can be revolved around a wood screw passed through into the larger round base.

Next make up the 'breach' through which passes the plunger rod. The ¼in. dowel-rod plunger is best passed through the holes into the two ends of the breach while it is being glued to make sure it will run easily when the coiled spring and the striker and wood ball handles are added.

Two short lengths of dowel, are glued into the holes drilled centrally through the breach sides, and these can also have wood balls or beads glued at the ends. The pivot rods slot into the uprights of the launching station and the breach assembly can thus be taken apart for easy storage.

With the dowel-rod plunger in position, glue on the round 'Launching Platform' disc which holds the 'Rocket Barrel' as shown at (X) on diagram. The barrel can be a card tube or discarded cotton reel, as preferred. It serves as a holder for the 'Rocket' tube, which is held until released by the plunger. When the coiled wire spring has been

firmly fixed to the rod, the striker ball is added.

From a 5½ins. by 4½ins. piece of card (postcard thickness), mark out the positions of the fins. Make two or three fins from thin card or balsa wood and glue these to the rectangle. Glue two edges of the card to form a tube for the space rocket. The nose of the ship is cut

could be arranged inside before fixing. A 'Radar' top mobile unit is made up with half a ball and bits of wire. Paint all units in gay colours. The toy maker may like to make also a target at which the rocket will be fired, and this can take the form of a cut-out disc of wood with holes cut in it large enough to accept the rocket. These holes arranged for scoring should be appropriately given the names of the major planets: Earth, Moon, Mercury, Mars, Venus, Jupiter. A balloon 'Moon' target suspended from the ceiling would also serve as an effective target for space games.

A carefully made and painted model as suggested here will surely make any boy happy for a long time to come.

ILLUSTRATIONS ON OPPOSITE PAGE

and shaped from a block of balsa wood and glued in place. A rubber or sponge tip could be added for safety in use. Cement inside the tube at a suitable depth at which the plunger will strike, a table-tennis ball or round wood disc. Brush a coat of shellac over the hull to seal the wood and apply aluminium paint over the ship to give it an authentic metallic finish.

Space Port

A 'Space Port' can be made up as shown, and this, together with the launching platform, can be realistically arranged on a suitable base board. Sizes of pieces for making up the port are: (A) 5ins. by 2ins. Cut two and glue to end piece (D), which is size 3½ins. by 2ins. (B) 7ins. by 2½ins. (C) 5ins. by 2½ins. Taper and shape pieces as shown. Glue and pin transparent material around pieces (A). Control gear, etc.,

★
 ★
 ★ **SOLUTION TO** ★
 ★ **CHRISTMAS** ★
 ★ **COMPETITION** ★
 ★
 ★ How many of the 20 items did you ★
 ★ get correct in our Christmas compe- ★
 ★ tion? This is the official solution to ★
 ★ the posers set. Winners have been ★
 ★ notified and prizes dispatched. ★
 ★

- | | |
|-----------------------|---------------------------|
| ★ 1. Crown | ★ 11. Vice |
| ★ 2. Marleyfilm | ★ 12. Aircraft kits |
| ★ 3. Sculptorcraft | ★ 13. Glass |
| ★ 4. Gem | ★ 14. Dowel |
| ★ 5. Musical movement | ★ 15. Guitar |
| ★ 6. Easibinder | ★ 16. Lathe |
| ★ 7. Mitre box | ★ 17. Revenge |
| ★ 8. Galleon | ★ 18. Compasses |
| ★ 9. Tools | ★ 19. Mighty midget motor |
| ★ 10. Cramp | ★ 20. Surform |
| ★ | ★ |
| ★ | ★ |
- ★

Charming picture in wood

THE MILL AT SUNSET

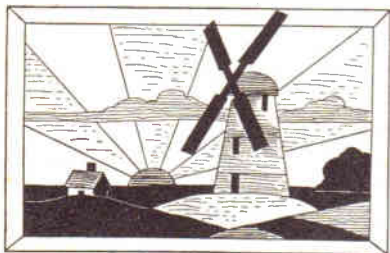

DELIGHTFUL pictures can be made from four No. 1 Inlay panels costing 4/3 from Hobbies Ltd., Dereham, Norfolk. These pictures in wood are easy to make with a fretsaw and the subject is specially designed for the young beginner who is using a fretsaw for the first time.

The panels measure 10½ ins. by 7½ ins. and it is possible to get six good pictures from them. The design should be traced

and transferred to the light panel. You can obtain one design with the grain and two if you position the picture across the grain.

The guide sheet for this picture is on page 271

If you wish to make six pictures, cut the panels in half, and using the four appropriate pieces, pin them together with the marked piece on top. They should be pinned round the edges in the waste wood shaded red and pinned right through to a piece of waste ½ in. wood. Space the pins about ½ in. apart.

Make a drill hole at (X) and insert the fretsaw blade. Do not cut round the outline until last, but cut out one piece at a time, commencing with piece (A), then on to piece (B), then piece (C),

and so on.

When the whole picture has been cut, assemble the pieces in the right order in the same way as a jigsaw puzzle. You will, of course, have enough pieces for four pictures, but one set will be useless since the sky will be dark, two will be quite good, and one will be like the original shown here. Thus, by using the rest of the panels, it is possible to get six pictures in all.

For your guidance in sorting the woods the letters are keyed as follows: L = Light; ML = Medium Light; MD = Medium Dark; D = Dark.

When all the pieces are glued in place on the backboard of ½ in. plywood they are glasspapered down smooth and polished with white wax polish. Small hangers can be screwed to the back.

A leaflet, "Making Pictures in Wood", is obtainable free on request from the Editor. Please enclose s.a.e. for reply. (M.p.)

Details for making the Space Toy

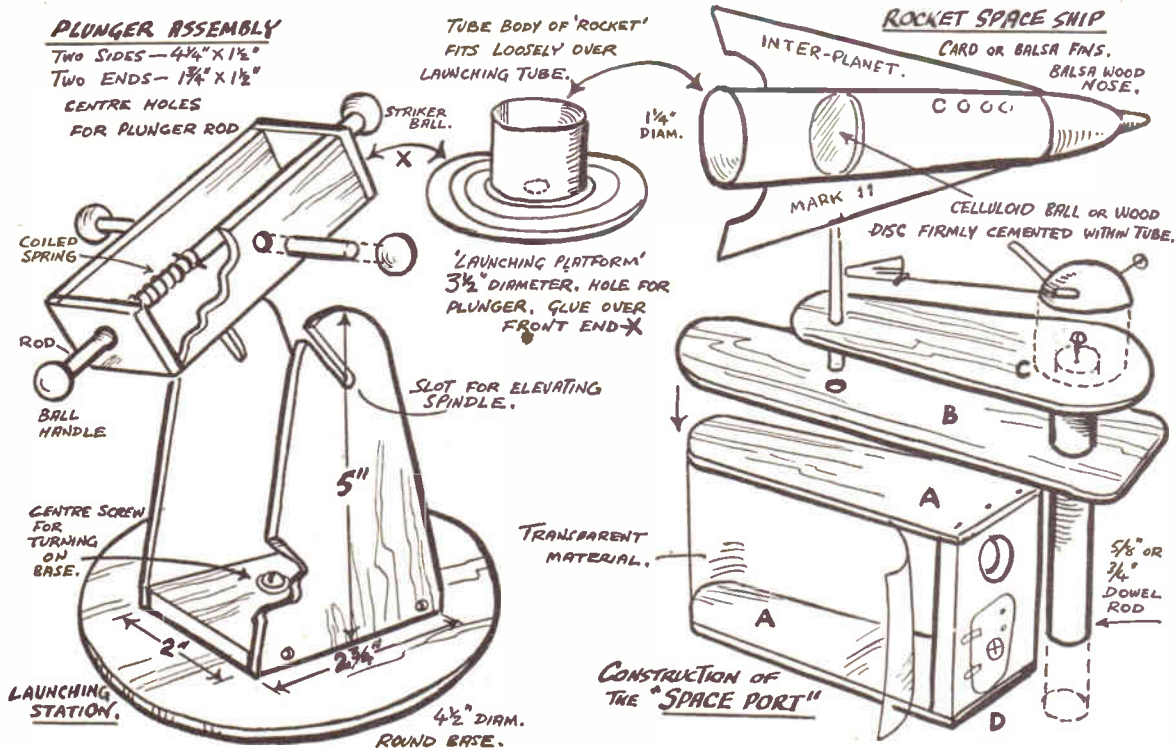

BOTTLE-OPENING MADE EASY

OPENING tight screw-top bottles or jars is often a difficult and tiresome operation, especially if the liquid has caused the metal ring to rust or corrode.

When bottling fruit, etc., it is necessary to see that the cap is screwed

By A. F. Taylor

down tightly, so that no air can enter to start fermentation. For both opening and closing screw caps in an efficient manner the gadget described here will do the job extremely well.

It is designed to fit the ordinary 'Kilner' fruit preserving jar which measures 3½ ins. diameter, but by means of an easily made adapter it can also be used on much smaller bottles and jars. These include coffee, ketchup and salad cream tops and most of the fruit cordial bottles, measuring from 1 in. to 1½ ins. Any other unusual sizes can easily be catered for by making a suitable adapter for them.

The gadget is really a very large pair of pliers with rough jaws which will grip the metal screw cap while it is levered anti-clockwise or clockwise as the case may be.

There will be a very considerable pressure exerted when in operation, therefore a really hardwood should be selected for making it. Oak or beech are two suitable English woods, while there are many tough foreign woods available now.

The base of the instrument (A) is cut from a piece 14 ins. long, 6½ ins. wide and 1 in. thick. The actual shape is not important, but should be somewhat near to that shown with parts rounded off where extra strength is needed.

To hold the cap securely we have two rough edged grips (CC) arranged at an angle to taper off slightly, and the pressure lever (D) also rough edged, which forces the cap on to grips (CC).

For the grips (CC) cut two pieces of hardwood 4½ ins. long and 1 in. square. The rough part consists of a piece of hacksaw blade let into the blocks, and for this an old worn one will be better for the purpose than a new one.

Using a very narrow saw, make a saw cut along the edge of each block and about half way down. It must be very narrow, so that the hacksaw blade fits tightly, and must be hammered in.

Remember to put a piece of wood over the teeth when doing so, otherwise they will get damaged. The hacksaw teeth

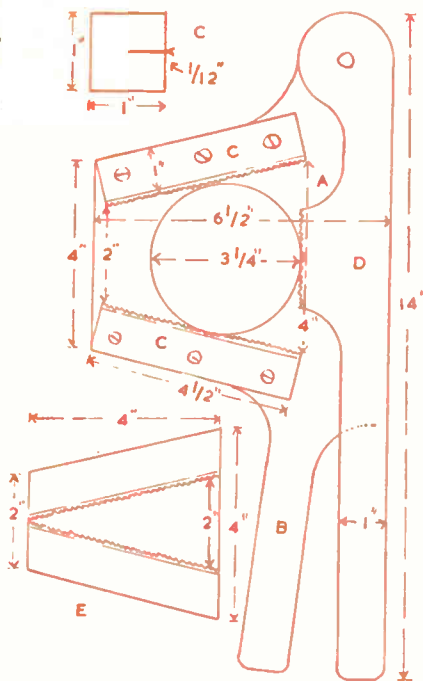

need only project about 1/12 in., as shown in the small sketch of (C).

Glue and screw these two grips firmly

to the base, and three screws in each will not be too much.

The pressure bar (D) is 14 ins. long and 1 in. thick, with a 2 in. circle at the pivot end for added strength. Make the handle end 1 in. square, and round off the edges for easier working. Another piece of hacksaw blade is let into this lever in the same way as that adopted for the other two grips, but it need only be 2 ins. long.

Quite a large amount of pressure will be exerted with the instrument, therefore the pivot of the pressure bar must be fairly substantial and fixed firmly into the baseboard. A ½ in. bolt will not be too large, and if the base is tapped to take this with a lock nut screwed on the end, it should withstand any amount of pressure and do the job efficiently.

The handle at (B) can have another piece of wood fixed on to the base to line up with the pressure lever if desired, but this is not absolutely necessary.

The adapter to take smaller screw caps is shown at (E). Make up two grips exactly as before with hacksaw blades, but they are fastened on to a piece of sheet metal. Be sure to keep the angle the same, so that they fit into the larger jaws of the main instrument snugly.

With the instrument, together with its adapter, it should be possible to deal with all screw caps up to about 4 ins. diameter. A coat of paint to match the other tools and appliances of the cook will make it worthy to take its place in the kitchen, but if it has been made of an attractive hardwood, then a coat of varnish will suffice to preserve it.

● Continued from page 260

This is Taxidermy

spaced holes to take the two securing wires left projecting from the soles of your specimen's feet. Then turn the stand over, and on the reverse side, carve out twin slots each approximately 1½ ins. long.

Before actually mounting the specimen, however, the board must be stained and varnished or polished. Alternatively, it could be quite effectively rough-cast — which means simply that the wood is thinly-coated with glue and sprinkled with sand. But in either case the stand will have to be set aside to dry.

To mount the specimen, insert the securing wires in the holes provided and clench over the surplus at right angles to lie flat in the slots cut into the underside

of the stand. A scrap of baize large enough to cover the base, and glued over the slots, will not only help to retain the wires, but also effectively prevent damage to even the most highly polished surfaces.

Now to the final clean-up. First, go very carefully over the fur with a wad soaked in a cleansing fluid, such as benzoline. Then give the specimen a fine dusting with plaster of paris, afterwards beating out the surplus with a light switch. Finally, with a very fine comb, and, possibly, an eyebrow brush, carefully restore the natural lay of the fur — not forgetting to arrange the tail hairs, ear tufts, and feeler whiskers to the best advantage.

A NEW HOBBY . . . you must try PICTORIAL WINDOW LEADING with **DECRA-LED**

This fascinating craft of making beautiful stained glass windows is now simplified. No glass to cut, no joints to solder. It will give you hours of creative pleasure . . . and profit!

The NEW PICTORIAL WINDOW LEADING KIT contains - lead, cement, five colours brush, working designs (24" x 18") and full instructions. Choice of Galleon, Castle, Bridge or Dutch Boy scenes. Price 10/- complete (Plus 1/6 postage).

Obtain your kit now—full details of all Decra-Led Products and name of nearest stockist from sole makers.

NORTH WESTERN LEAD CO., LTD., Dept. 1,
Junction Street, Hyde, Cheshire Tel.: Hyde 2003
Trade Enquiries Invited



HEAR ALL CONTINENTS With H.A.C. Short-Wave Receivers

Suppliers for over 18 years of Radio S-W Receivers of quality.
One-Valve Kit, Price 25/- Two-Valve Kit, Price 50/-
Improved designs with Denco coils. All kits complete with all components, accessories and full instructions. Before ordering, call and inspect a demonstration receiver, or send stamped addressing envelope for descriptive catalogue.

'H.A.C.' Short-Wave Products (Dept. 22), 11 Old Bond Street, London, W.1

BE TALLER

in 12 days or money back. New gland and spinal discovery increases height 2 to 5 inches. 'I have gained 4½ inches in height. My weight increased from 9-stone 4-lb. to 10-stone 3½-lb.'—P.D. 'Increased 3 inches.'—H.G. Guaranteed harmless. Full course 10/6 (or \$1.50). Air mail 16/3. Details 2d. Sent under plain cover. **J. H. MORLEY**, 28 (H/176) Dean Rd. London, N.W.2. Practical Courses, all subjects. List free.

It's a better job with

Croid

the world's strongest glues



POLYSTIK
P.V.A. adhesive. Polythene bottle 2/6.
12 oz. Jar 12/6.



AERO
Hot glue of great strength. Tins 1/6 to 46/-.



UNIVERSAL
General-purpose liquid glue. Tubes 1/2, tins 2/10.



FABREX
For fabrics, carpets, leather. Polythene bottle 3/6 and 6/-.

TRY FRETSAW INLAY

Marquetry the EASY Way!

IF you like marquetry work, you MUST try Fretsaw Inlay. It has many advantages over knife inlay work with veneers, and is easier, yet the results are equal to the finest marquetry work! Using a fretsaw, all the pieces are cut at once—and must fit perfectly. You get THREE good pictures from four pieces of wood—quite a consideration when you are making pictures for sale—and all are cut at the same time. There's no mess and no bother with Fretsaw Inlay. The kits illustrated are complete with four selected ¼ in. panels of different coloured woods, ½ in. backing board and strip-wood for border. The overall size of a finished picture as illustrated is 14ins. x 10ins. There are also kits for trays inlaid in the same way and using larger panels of wood. Get Hobbies free pamphlet and learn more about Fretsaw Inlay. You'll be surprised how easy it is to create masterpieces in wood!

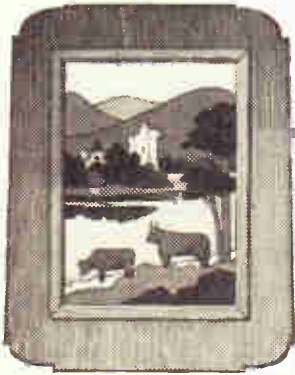

'Kilchurn Castle' (Kit No. 3008)
New designs for Fretsaw Inlay are published from time to time in this magazine. Make sure not to miss them.



'The Bridge' (Kit No. 3016)



To HOBBIES LTD., Dept. 99, Dereham, Norfolk

Please send me the items I have marked thus X.

FREE copy of 'Making Pictures in Wood'

KIT 3008 9/6, post free

KIT 3016 9/6, post free

I enclose **NAME**
P.O. for
ADDRESS

AIRCRAFT SPOTTING

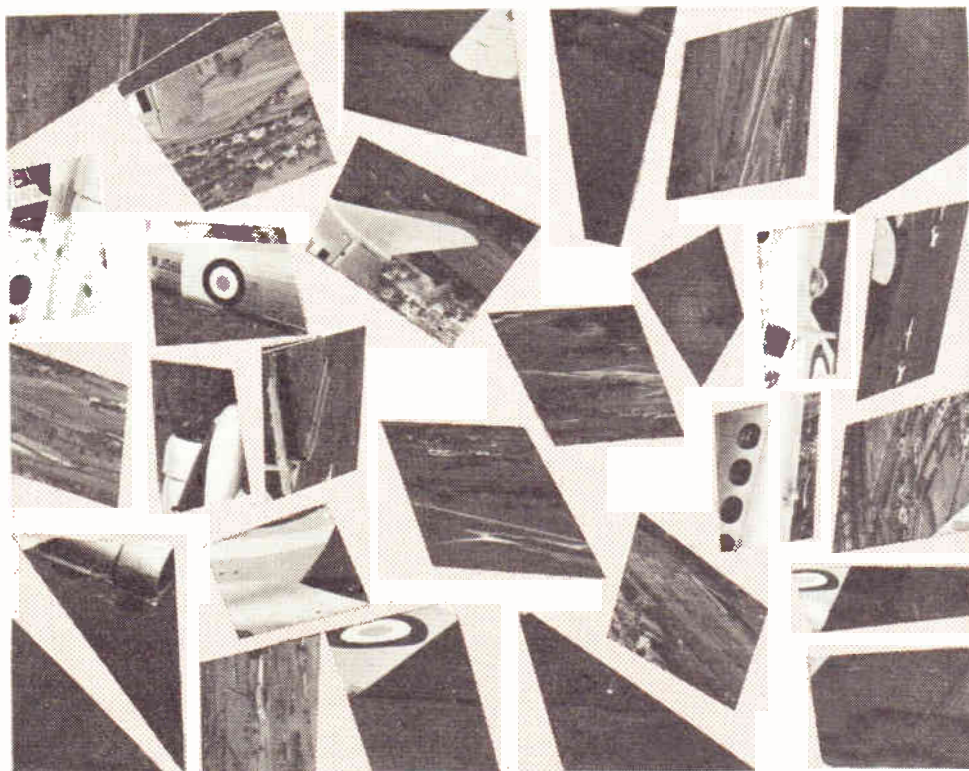

MOUNT the picture, cut out the parts, and fit them together to form a picture of an aircraft which was one of the most successful ever produced. Since the prototype made its first flight in 1934, it has been manufactured in thousands, first of all for coastal reconnaissance duties and later for training purposes. Throughout its long and exceptionally useful life, it was called upon to fill a wide variety of roles and many specialised versions were

By G. Allen

evolved which, although they differed in details of interior layout and operational equipment, still retained the essential characteristics which made the type famous.

Production of the aeroplane was wound up in 1952 when the last aircraft was handed over to the R.A.F. on May 27th — the 11,020th to be built. The

foundations for this gigantic total were laid twenty years ago when a peak output of 130 machines a month was reached. Of the total number of aircraft, 2,882 were built in Canada by Federal Aircraft Ltd., a company formed specially for the manufacture of this type.

The first squadron to receive these machines was No. 48 stationed at Manston, and the first was delivered to them in 1936. Though it is as a trainer that the aeroplane is best known to pilots of the present generation, it was not until 1939 that orders were first placed for this particular variant.

On the other hand, it did have an important and dangerous, if brief, operational career, and several 'kills' were credited to it.

It was a rather sad occasion when production terminated, but with the progress of aviation this was unavoidable. However, she has left behind her something more than a memory — it is the nickname 'Faithful Annie', the old

maid-of-all-work who 'did' for the boys of the Royal Air Force.

Speaking at a ceremony on May 27th, 1952 held to commemorate the handing over of the last machine to the R.A.F., these words were spoken: 'Annie's life isn't yet over by a long chalk, and if she goes on for another nine years, she will equal the record of the 504 which, as a glider tug, concluded twenty-six years of service in 1940.

Can you name the aeroplane? Answer next week.

★★★★★★★★★★★★★★★★★★
 ★ Next week's issue will contain ★
 ★ patterns for making a toy pedal ★
 ★ cyclist and instructions for a read- ★
 ★ ing lamp on which your models ★
 ★ can be displayed to good effect. ★
 ★ MAKE SURE OF YOUR COPY ★
 ★ ★★★★★★★★★★★★★★★★★★★

Yours
for
only
8/6d.

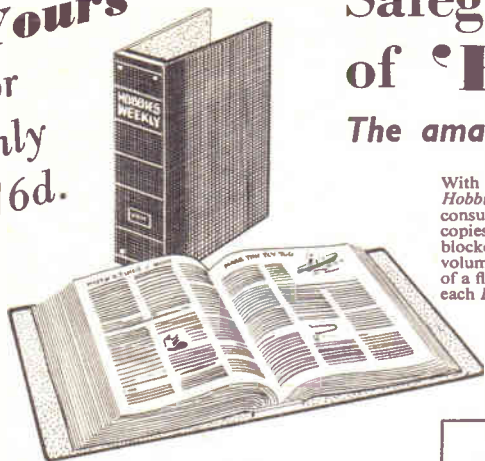

Safeguard your copies of 'HOBBIES WEEKLY'

The amazing 'EASIBINDER' (Pat.) makes it simple

With the new *EASIBINDER*, specially prepared for Hobbies, you can bind each copy of *Hobbies Weekly* as you get it, turning your favourite magazine into a permanent, easily-consulted library of immense value, and avoiding the delay and despair occasioned when copies are accidentally mislaid or destroyed. Carefully finished in black leather-cloth and gold-blocked on the spine, each binder is strong, serviceable and neat. It will hold two complete volumes (52 copies) and costs only 8/6. Each copy of the magazine is quickly inserted by means of a flexible steel wire, and can easily be removed if necessary. Easy-to-follow instructions with each *EASIBINDER*. Get one today and take care of your copies of *Hobbies Weekly*.

NOTE From the issue April 10th, 1957, there is a slight difference in the size of the magazine, and two sizes of *Easibinders* are available. Type A is for binding issues published before April 10th and Type B is for those printed subsequently. To avoid confusion, when ordering, please indicate clearly the type of *Easibinder* required. Indices for each completed volume 1/- each post free.

☆ One 'EASIBINDER'
holds two volumes
(52 copies)

☆ Easy to use

Post today



To: HOBBIES LTD., Dept. 99, Dereham,
Norfolk.

PLEASE SUPPLY EASIBINDERS
(Type) at 8/6 each.

NAME

ADDRESS

P.O. for

enclosed

NEW!

THE PRACTICAL WAY

of learning RADIO • TELEVISION • ELECTRONICS
AMATEUR S.W. RADIO • MECHANICS
PHOTOGRAPHY • CARPENTRY, etc., etc.

COMPLETE EXPERIMENTAL COURSES IN SCIENCE AND TECHNOLOGY

NEW—Completely up-to-date method of giving instruction in a wide range of technical subjects specially designed and arranged for self study at home under the skilled guidance of our teachers.

NEW—Experimental outfits and lesson manuals sent on enrolment remain the student's property. Tutor allotted to each student for personal and individual tuition throughout the course.

In radio and television courses, specially prepared components are supplied which teach the basic electronic circuits (amplifiers, oscillators, detectors, etc.) and lead, by easy stages, to the complete design and servicing of modern radio and T/V equipment.

If you are studying for an examination, wanting a new hobby, commencing a career in industry or running your own part-time business, these practical courses are ideal and may be yours for moderate cost.

Fill in the coupon to-day for a free Brochure. There is no obligation whatsoever. **COURSES FROM 15/- PER MONTH**

SUBJECTS INCLUDE:—

Radio • Electronics • Television Equipment • Mechanics
Chemistry • Photography • Electricity • Woodwork • Electrical
Wiring • Draughtsmanship • Art • Short Wave Radio • Oscilloscope
also many other Home Study Courses without equipment.



- Courses with equipment enable you to design, construct and service.
- 2-stage radio equipment
- 3-stage T.R.F. circuits
- Television equipment
- Workshop Test Panel
- Oscilloscope
- 5 valve 3-waveband superhet circuit

POST THIS TODAY

E.M.I. INSTITUTES, Dept. 31X, London, W.4

NAME AGE
(if under 21)

ADDRESS

I am interested in the following subject(s) with/without equipment



BLOCK
CAPS
PLEASE

(We shall not worry you with personal visits).

15/1/58 IC85

EMI INSTITUTES

The only Home Study College run by a World-wide industrial organisation.

—Part of "His Master's Voice", Marconiophone, etc. etc.

MISCELLANEOUS ADVERTISEMENTS

Advertisements are inserted at the rate of 6d. per word prepaid. Name and address are counted, but initials or groups, such as C.O.D. or £14/1/9, are accepted as one word. The charge for the use of a Box No. is 1/- extra. Small display advertisements on this page are charged at the rate of £1/12/6 per single-column inch. Postal Order or Cheque must accompany the order and advertisements will be inserted in the earliest possible issue. Orders can be sent either to Hobbies Weekly, Advert. Dept., Dereham, Norfolk, or Temple House, Tallis St., London, E.C.4. Other space rates on request.

MAKE A RADIO

NO SOLDERING—only a screwdriver and pliers required. Easy-to-follow building instructions **FREE** with each kit. Send stamped address envelope for further details.

"WINNER" CRYSTAL SET. Only 6 screws to fit. Can be built in an hour. **STANDARD** kit, 15/6 post free. **DE-LUXE** kit, complete with high-grade headphones, aerial wire, etc., makes ideal present, £2 post free.

"CONQUEROR" 1-VALVE SET. Receives 20 to 30 stations, 15 screws only to fit. **STANDARD** kit, with valve and batteries, £2/2/- post free. **DE-LUXE** kit, complete with high-grade headphones, aerial wire, etc., 66/6 post free.

"CONQUEROR" 2-VALVE SET. For loud-speaker reception. **STANDARD** kit, £4/5/- post free, loudspeaker £1/4/- extra. **DE-LUXE** kit, £5/12/6 complete.

HEADPHONES, 4,000 ohm, 18/-; or higher grade, 21/- post free.

Send your order to:

BLANCHARD'S RADIO

(Dept. HD7)

13 Gainford Gardens, Manchester, 10

I went to a dance to find a girl friend—



—but my dancing didn't make girls 'friendly'!

—till a pal told me the secret of Escort's Sure Step System



Now I'm no longer lonely—



—the girls know my steps are sure!

Learn ballroom dancing at home! Send for exciting **FREE** booklet "Dance Escort", which explains the miraculous **SURE STEP** system. Cut out this advt., enclose 3d. stamp, name and address, and post to:

ESCORT DANCE INSTRUCTORS
Studio H4, Harrogate

BRASS, COPPER, DURAL, ALUMINIUM, BRONZE

ROD, BAR, SHEET, TUBE, STRIP, WIRE
3,000 STANDARD STOCK SIZES

No Quantity too small List on Application

H. ROLLET & Co. Ltd.
6 CHESHAM PLACE, LONDON, S.W.1

Also at
Liverpool, Manchester, Leeds, Birmingham

HARDHITTING ACCURATE



Webley AIR PISTOLS

AIR RIFLES · ACCESSORIES

Write for Catalogue

WEBLEY & SCOTT Ltd., 166 WEAMAN ST., BIRMINGHAM, ENGLAND

HOBBIES BRANCHES

- LONDON**
- 78a New Oxford Street, W.C.1 (Phone MUSEUM 2975)
- 87 Old Broad Street, E.C.2 (LONDON Wall 4375)
- 81 Streatham Hill, S.W.2 (TULSE Hill 8796)
- GLASGOW**—326 Argyle Street (Phone CENTRAL 5042)
- MANCHESTER**—10 Piccadilly (Phone CENTRAL 1787)
- BIRMINGHAM**—100a Dale End
- SHEFFIELD**—4 St. Paul's Parade (Phone 26071)
- LEEDS**—10 Queen Victoria Street (Phone 28639)
- HULL**—10 Paragon Square
- SOUTHAMPTON**—134 High St. (Below Bar)
- BRISTOL**—65 Fairfax Street
- NEWCASTLE**—42 Dean Street Newcastle-on-Tyne 1
- GRIMSBY**—88 Victoria Street

WHEELS (Hardwood and Rubber Tyred Metal), Cot, Pram and Doll's House Fittings and Papers, Beads, Transfers, Prints and other accessories. Stamp per new lists. (Trade supplied.) New address — **JOYDEN CO.** 91 Peplins Way, Brookmans Park, Herts.

BECOME trained chiropodist. Quick postal practical. — **GRADUATE SCHOOLS,** 48a Abbey Street, Accrington.

"PAINTSPRAYING" HANDBOOK. Covers Car, Industrial & Flock Spraying, 3/6, post 4d. Catalogue of our Cellulose and Paints and all Allied Sundries 3d. — **Leonard Brooks Ltd.,** 81 Oak Road, Harold Wood, Essex.

MODELS. You can make lasting stone-hard models with Sankey's Pyrama Plastic Cement. Supplied in tins by Ironmongers, Hardwaremen and Builders' Merchants. Ask for instruction leaflet.

LEARN it as you do it — we provide practical equipment combined with instruction in Radio, Television, Electricity, Mechanics, Chemistry, Photography, etc. — Write for full details to **E.M.I. Institutes, Dept. HW47, London, W.4.**

KUKLOS ANNUAL. Indispensable cyclists' handbook. Tours, resthouses, money-saving hints, 3/- post free. — **Burrow, Publishers,** 2 Imperial House, Cheltenham.

MATCHBOX crystal receiver parts and instructions, 3/6. Reception guaranteed. — Write **BCM/ALEXTONE, London, W.C.1.**

MAKE a **MUSICAL BOX** for as little as 21/6. New kits and tunes available. Movements 14/9 post free. Please send 3d. stamp for free illustrated catalogue. — **The Swisscross Co., Dept. B., 116 Winifred Road, Coulsdon, Surrey.**

50 ITALIAN stamps free, to approval applicants enclosing postage. — **Miller,** 95 Bollington Road, Heaton Chapel, Stockport.

1000 YARD DRUMS Assault Cable WIRE



TERRIFIC BREAKING POINT

Genuine Combat field service telephone communication wire on a drum. Rustless, PVC covered. Uses include fencing gardens and fields, baling goods and heavy parcels, tough suspension lines for all purposes. Use instead of roping — neater, stronger, almost everlasting. Fixes almost anything. An essential article to have around. 1,000 yard drum, terrific breaking point: 9/6. Carr. 3/6. Case of 6 carr. free. Gov. surplus article cost pounds to make, our price is cheaper than string!

Complete transmitting and Receiving apparatus for two persons.

From a few yards to a mile Normal telephone strength. No batteries or electricity — it just works! Send 12/11, post 2/1. Ready for use in 5 mins. Lists, Binoculars, Watches, Tents, Terms.

Headquarter & General Supplies Ltd. (HOBW/9.) 196-200 Coldharbour Lane Loughboro Junc., London, S.E.5 Open Sat.

HOW TO STOP SMOKING

and permanently overcome that ceaseless craving for tobacco. Save money, safeguard health. Send stamp for details of the world-famous inexpensive Stanley Treatment for tobacco habit

THE STANLEY INSTITUTE LTD (Dept. 30)
12 Bridewell Place, London E.C.4

GENUINE Swiss Musical Movements. The best and largest selection of tunes in the country; lowest prices 16/3 each. Genuine Thorens Movements, 22/9 each. All guaranteed P. & P. 9d. extra on all orders. — **Richardson & Forder, H.W. 5 Chapel Place, White Hart Lane, London, N.17.**

STAMPS FREE — Empire Packet including Spectaculars and Victorians with approvals. — **Robert J. Peck, 7A Kemp Road, Bournemouth.**

100 DIFFERENT stamps free! Request 4d. upwards discount approval. — **Bush,** 53 Newlyn Way, Parkstone, Dorset.

100 AMERICAN Home-Money-Making methods' (Illustrated). Now available Britain, 3/9 post free. — **World Bureau Publications, Suir Road, Dublin 3.**

WOOD MITRE BLOCK



Price 3/3

This 9in. block is handy for cutting mitres on any small work — moulding, edgings, etc. Made of selected hardwood with right angle and 45° slots for the small tenon saw

From branches or:

HOBBIES LTD., DEREHAM, NORFOLK

FRETSAW UNLAY

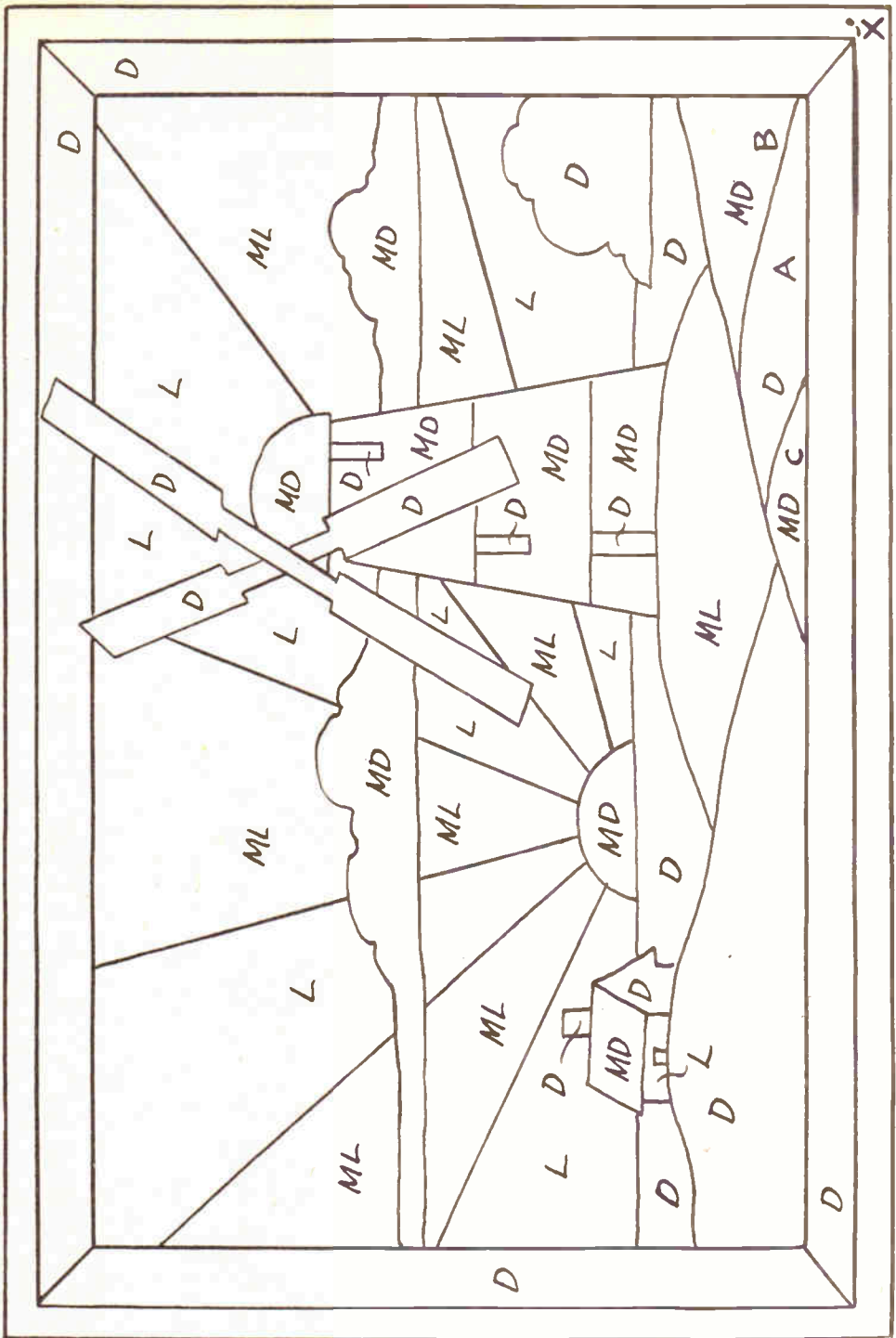

Use this guide pattern for making the 'Mill at Sunset' scene described on page 265

FOR A FIRST-CLASS MODEL . . .

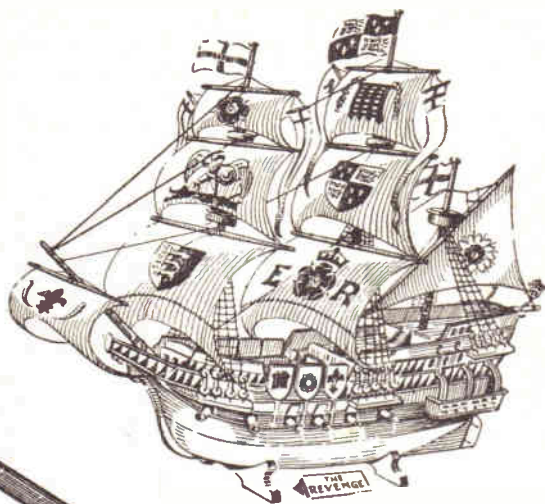
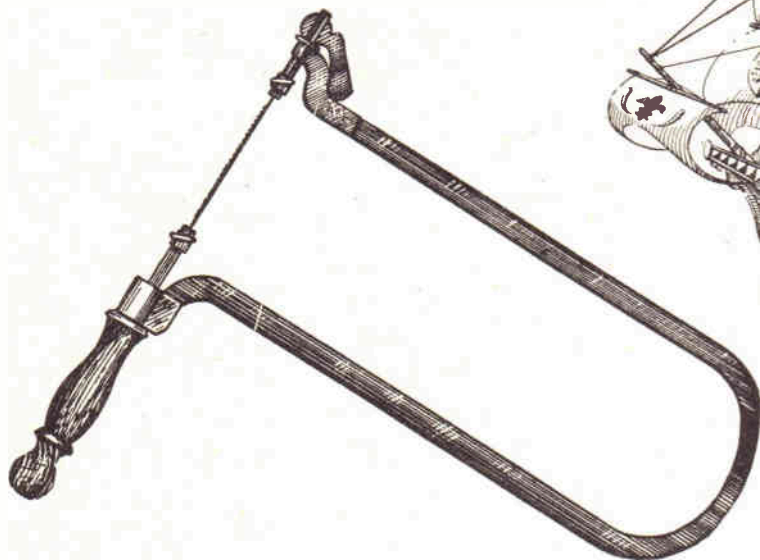

**. . . Use a
First-Class
Tool . . .**

MADE BY . . .



WITH the fretsaw you take the hard work out of model making. It cuts the pieces in less than half the time taken by any other method; it cuts cleanly and accurately; in fact it has no substitute. And when you are not model making you will find it equally useful for light woodwork and those 101 odd jobs you have to do about the house. Cuts wood, light metal, leather, plastics, etc.

Get yours now and join the ranks of real model craftsmen. But remember - insist on Hobbies or you may be disappointed. Prices from 5/- . The saw illustrated is our famous 14in. Lever Frame, price 16/-.

From Stores and Ironmongers everywhere, Hobbies Branches, or post-free from Dept. 99, Hobbies Ltd., Dereham, Norfolk. Free booklet on request.

DEREHAM, NORFOLK

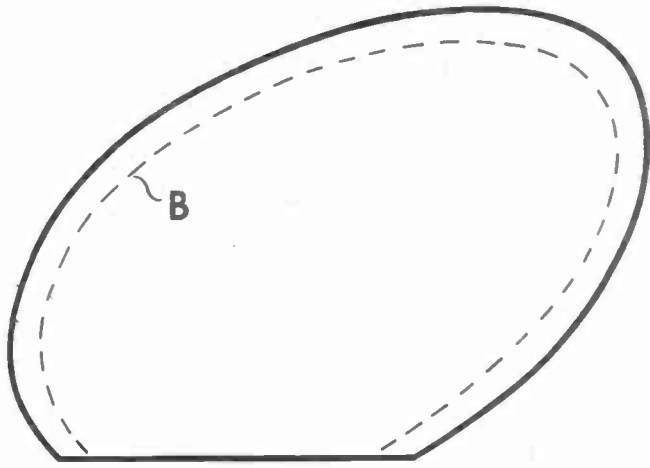

PIECE A. CUT ONE 1/4 in.

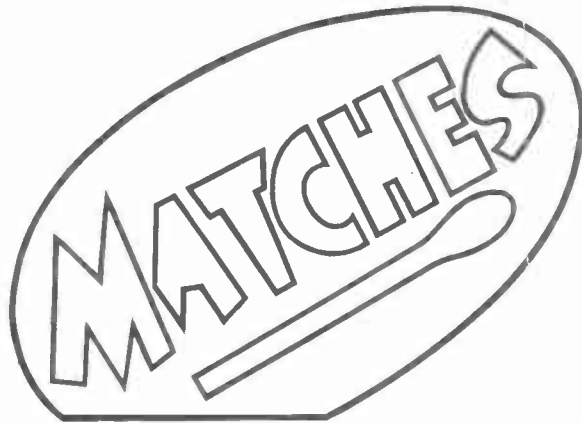

PIECE B. CUT ONE 1/8 in.

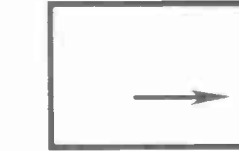

PIECES D. CUT TWO
PIECE E. CUT ONE
GLUE TOGETHER

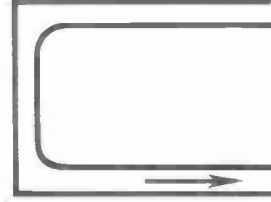

PIECE F. CUT ONE

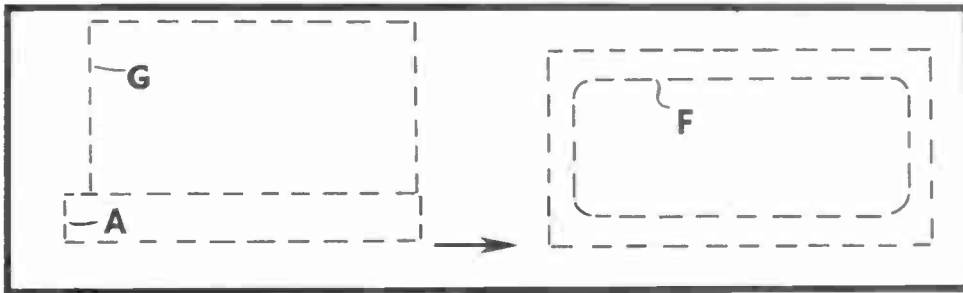

PIECE C. CUT ONE 1/4 in.

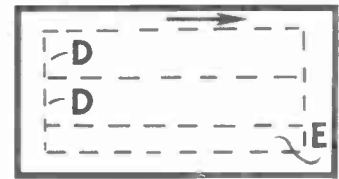

PIECE G. CUT ONE 1/8 in.

THE ARROWS
INDICATE
DIRECTION OF
GRAIN OF WOOD.

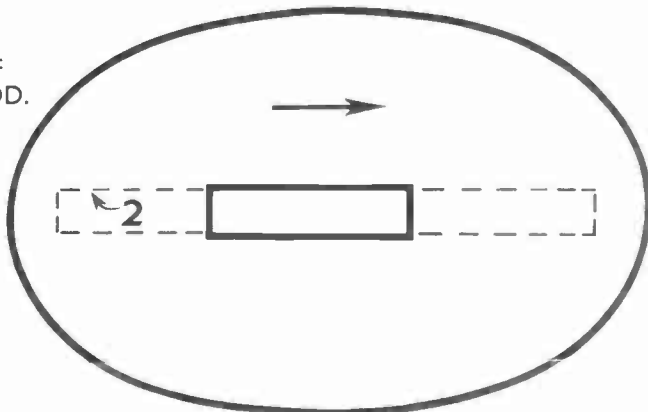

PIECE 3. CUT ONE 1/4 in.

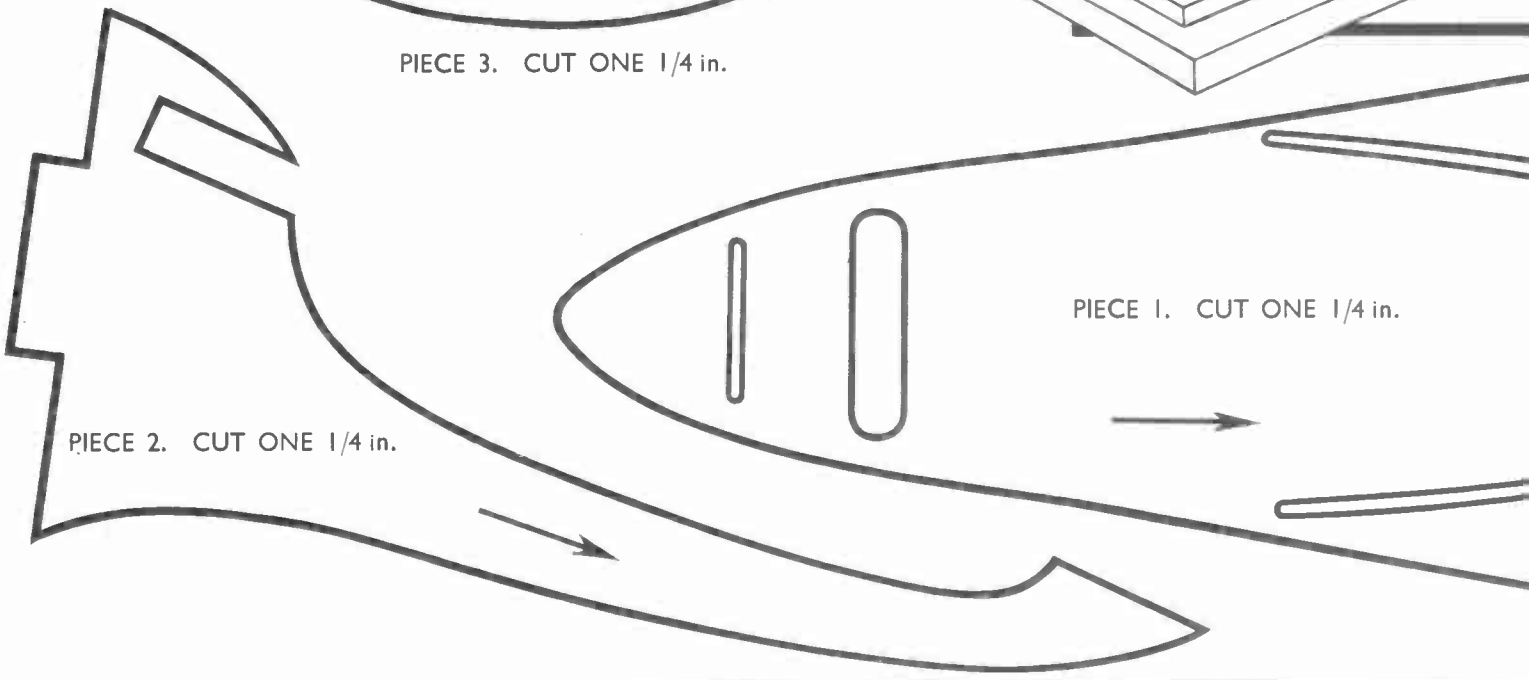
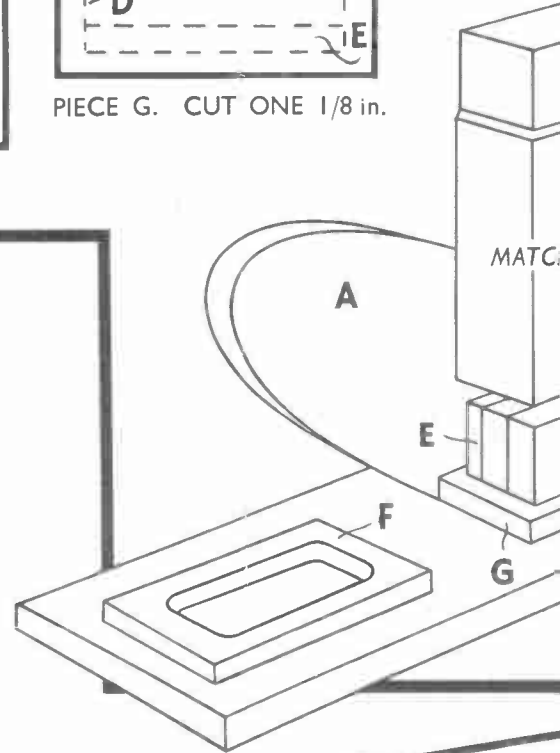

PIECE 1. CUT ONE 1/4 in.

PIECE 2. CUT ONE 1/4 in.

CUT FROM ONE PIECE ONLY.



DESIGN

No. 3246

THE POPULAR THREE

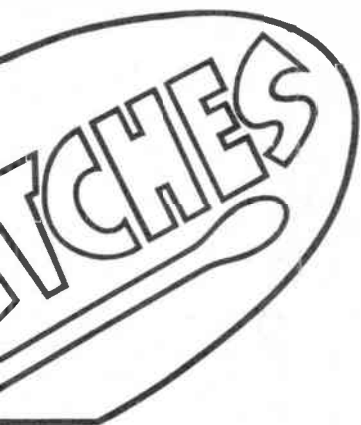

ONE 1/8 in.

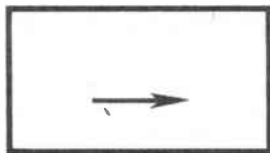

PIECES D. CUT TWO 1/4 in.
PIECE E. CUT ONE 1/8 in.
GLUE TOGETHER.

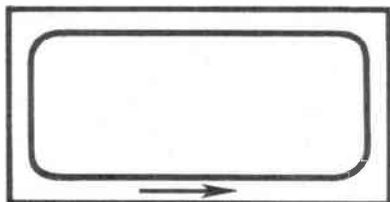

PIECE F. CUT ONE 1/8 in.

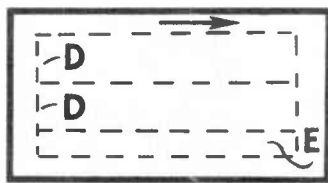

PIECE G. CUT ONE 1/8 in.

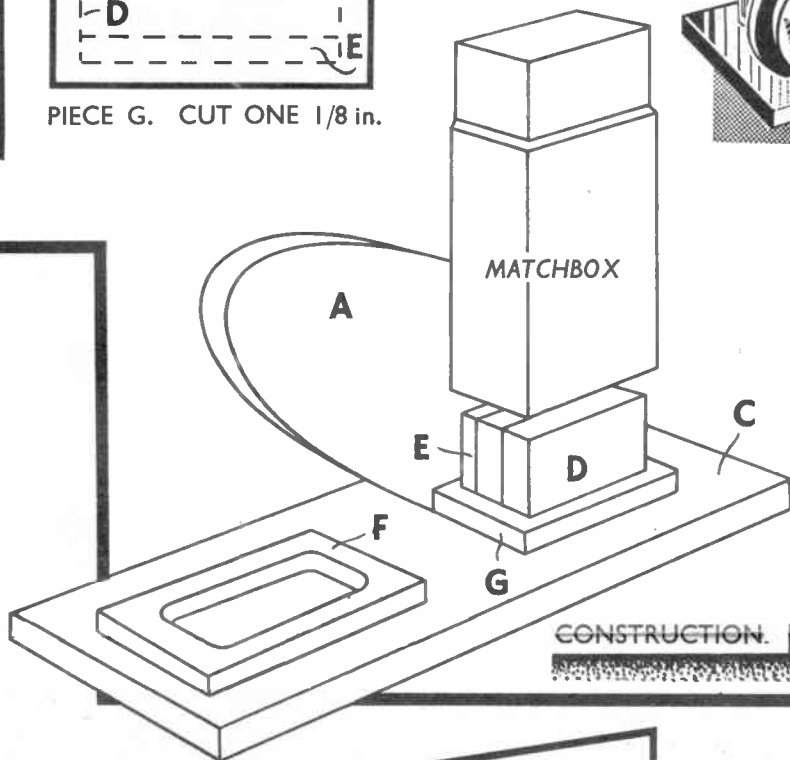
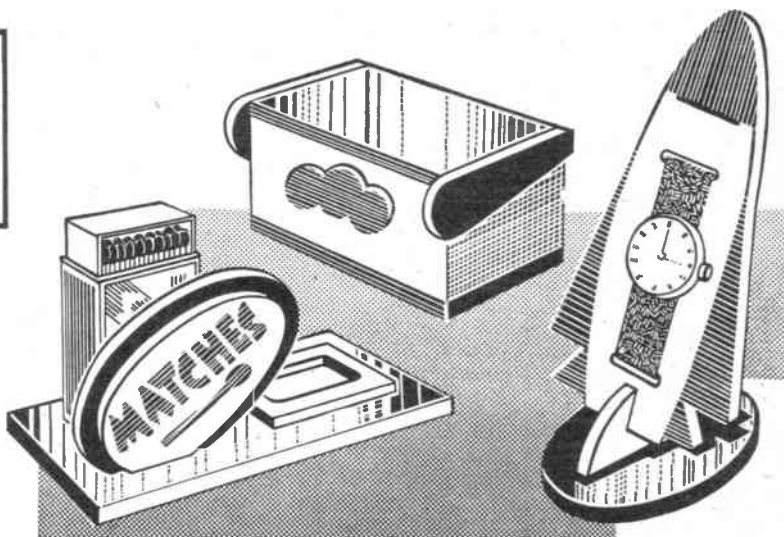

CONSTRUCTION.

PANELS OF WOOD REQUIRED

**ONE H4, ONE G4
ONE G2**

A KIT OF MATERIALS MAY BE
OBTAINED FROM HOBBIES LIMITED
DEREHAM, NORFOLK
PRICE ON APPLICATION

Did You Know

. . . That details of hundreds of designs and kits, chosen from among the best of those produced during the past few years, are given in . . .

HOBBIES Annual

In addition, there is an extensive editorial section full of "how-to-make" articles, a large FREE Design, and a comprehensive catalogue of tools and materials.

The Annual is published each year, and is obtainable from newsagents or Hobbies stockists and Branches, or by post from Hobbies Ltd., Dereham, Norfolk.

PIECE I. CUT ONE 1/4 in.

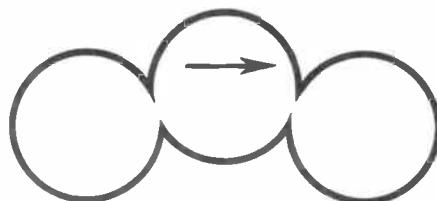
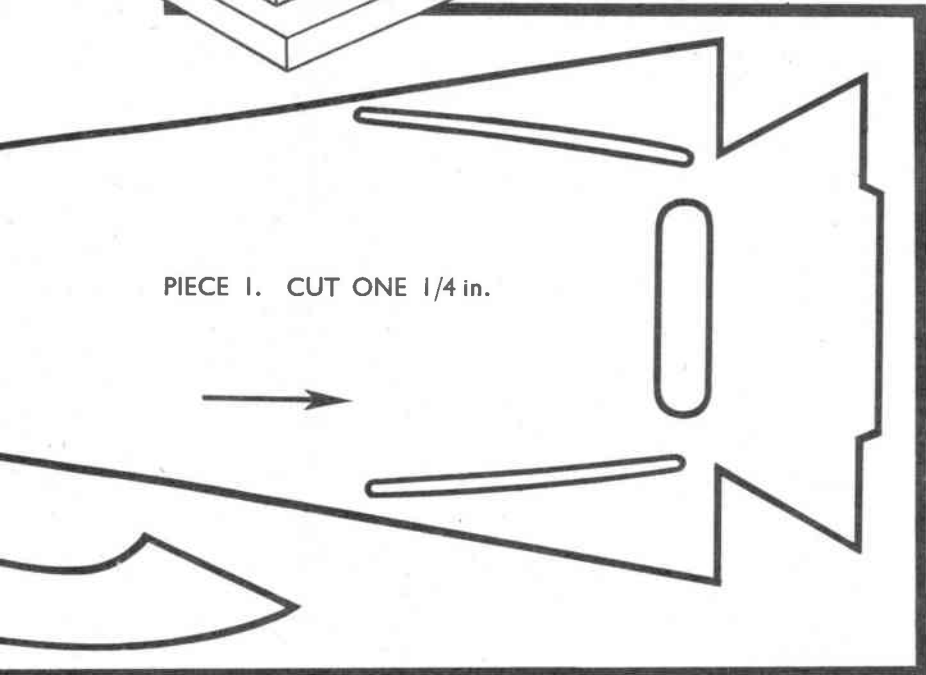

PIECE E. CUT ONE 1/8 in.

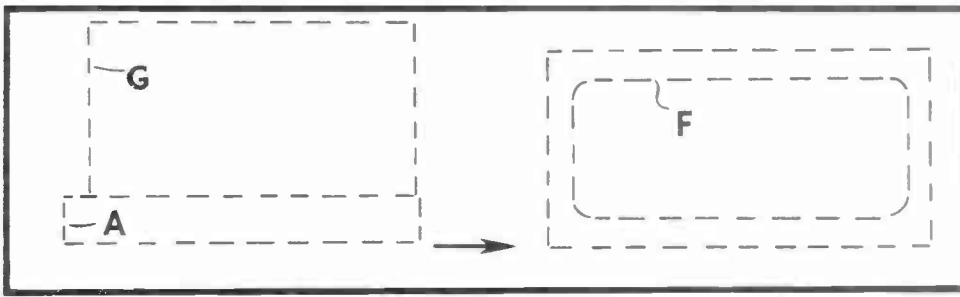

PIECE C. CUT ONE 1/4 in.

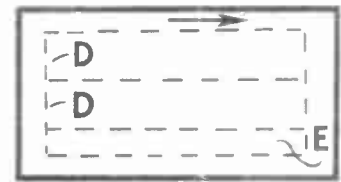

PIECE G. CUT ONE 1/8 in.

THE ARROWS INDICATE DIRECTION OF GRAIN OF WOOD.

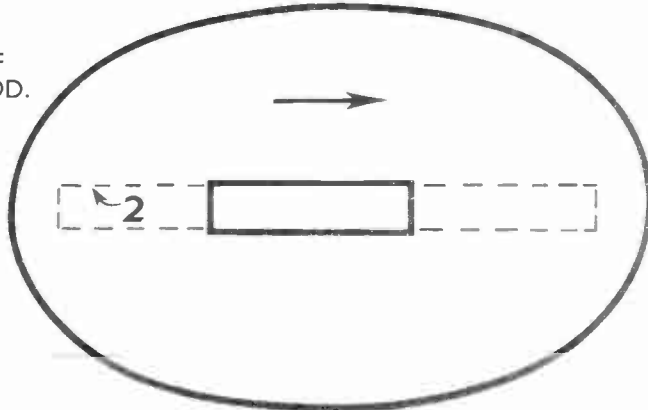

PIECE 3. CUT ONE 1/4 in.

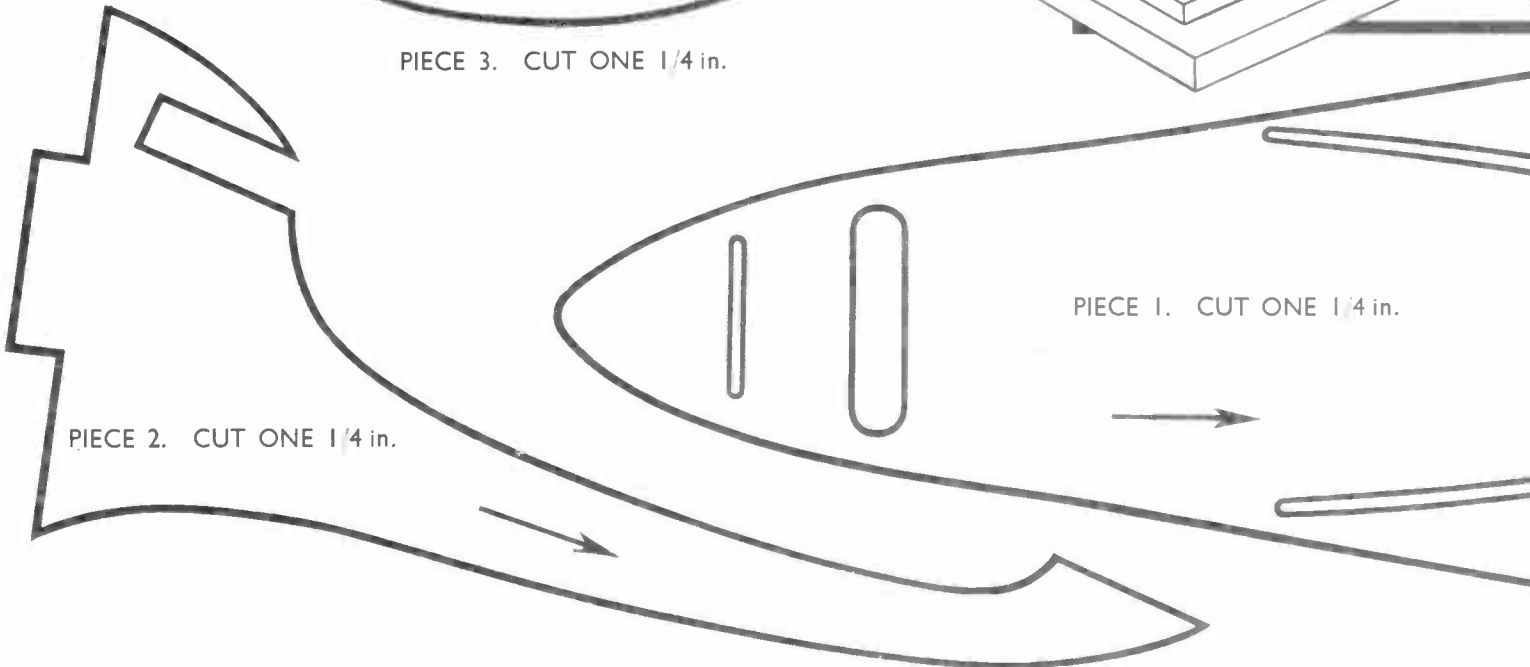
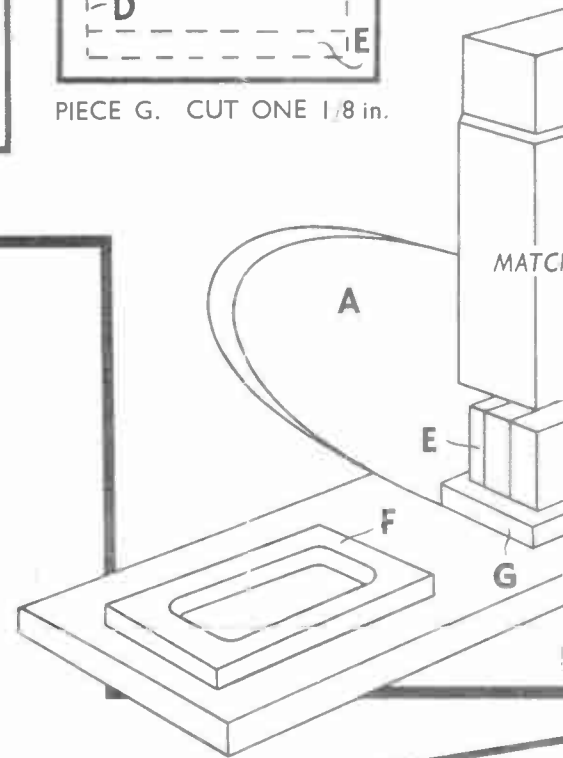

PIECE 1. CUT ONE 1/4 in.

PIECE 2. CUT ONE 1/4 in.

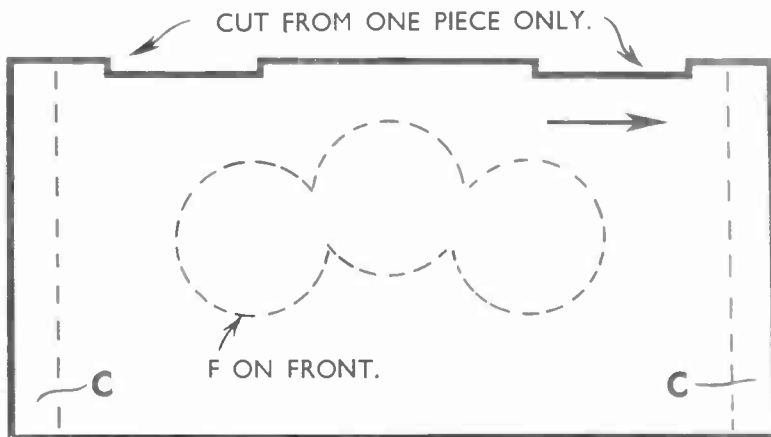

PIECES B. CUT TWO 1/4 in.

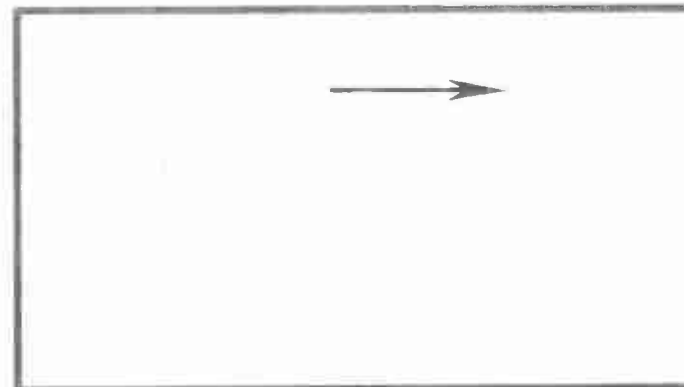

PIECES A. CUT TWO 1/4 in.

ONE 1/8 in.



PIECE F. CUT ONE 1/8 in.

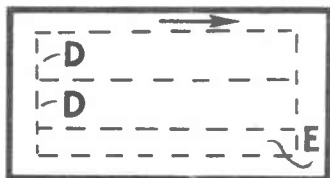

PIECE G. CUT ONE 1/8 in.

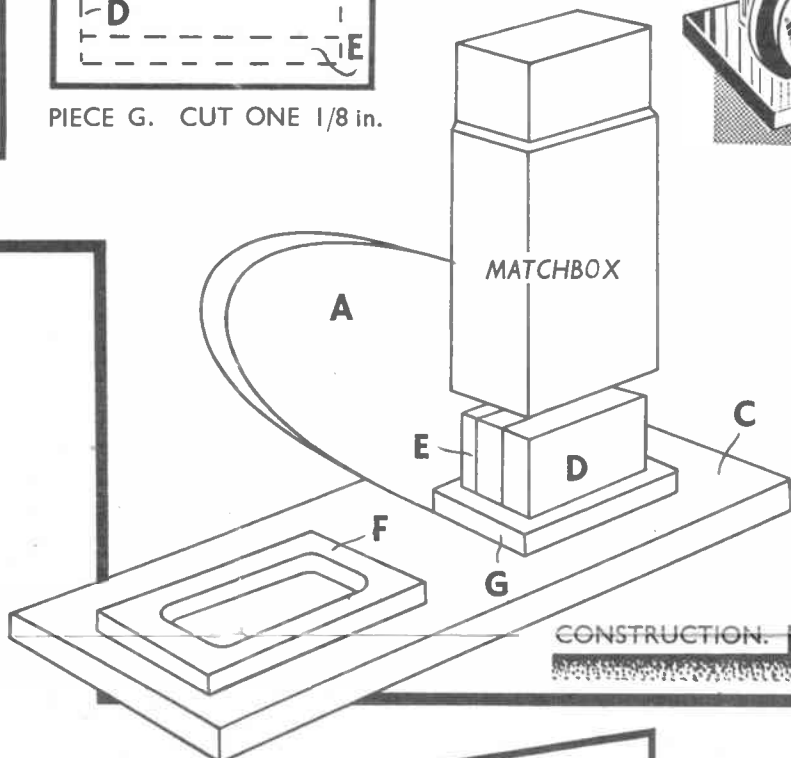
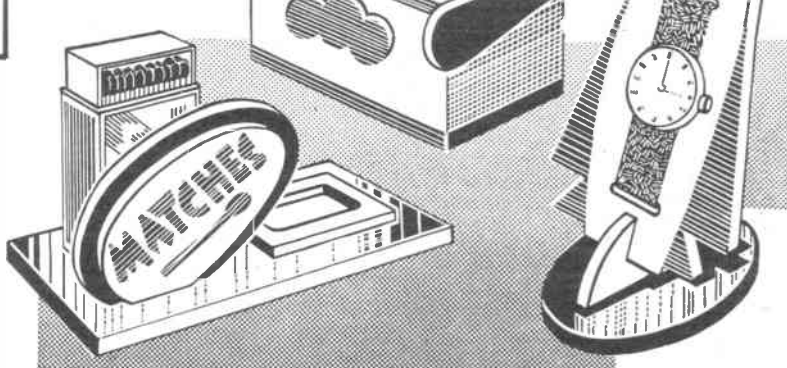

PANELS OF WOOD REQUIRED

ONE H4, ONE G4

ONE G2

A KIT OF MATERIALS MAY BE OBTAINED FROM HOBBIES LIMITED

DEREHAM, NORFOLK

PRICE ON APPLICATION

Did You Know

. . . That details of hundreds of designs and kits, chosen from among the best of those produced during the past few years, are given in . . .

HOBBIES Annual

In addition, there is an extensive editorial section full of "how-to-make" articles, a large FREE Design, and a comprehensive catalogue of tools and materials.

The Annual is published each year, and is obtainable from newsagents or Hobbies stockists and Branches, or by post from Hobbies Ltd., Dereham, Norfolk.

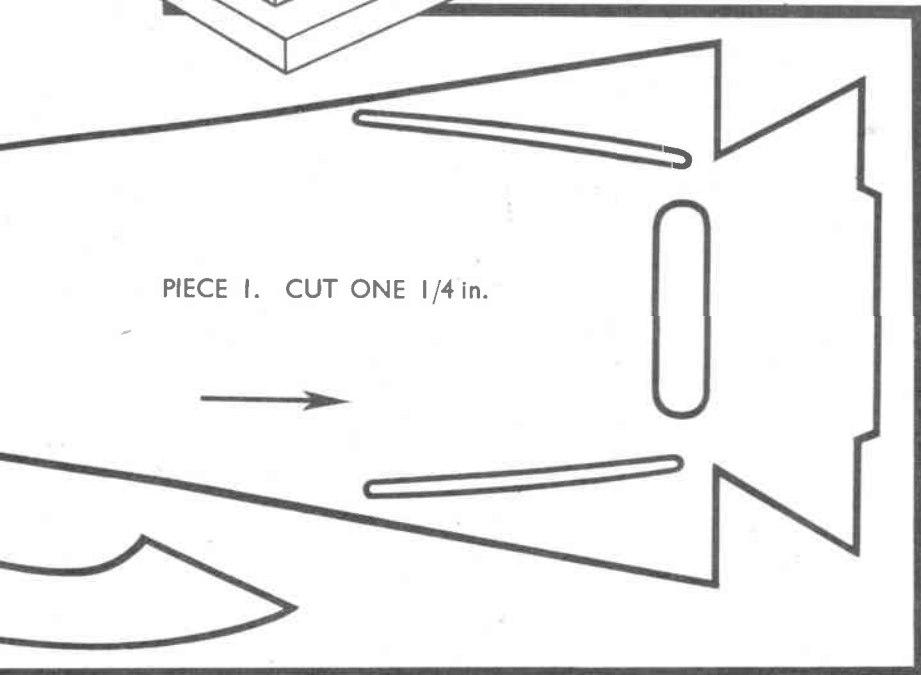

PIECE I. CUT ONE 1/4 in.

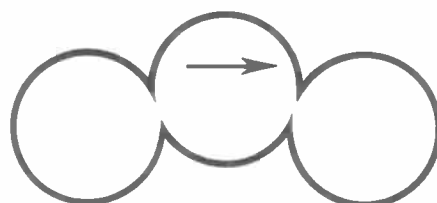

PIECE E. CUT ONE 1/8 in.

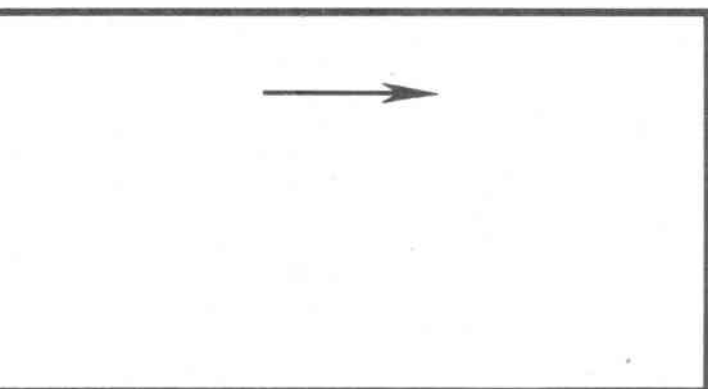

PIECES A. CUT TWO 1/4 in.

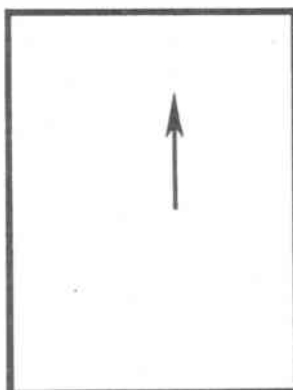

PIECES C. CUT TWO 1/4 in.

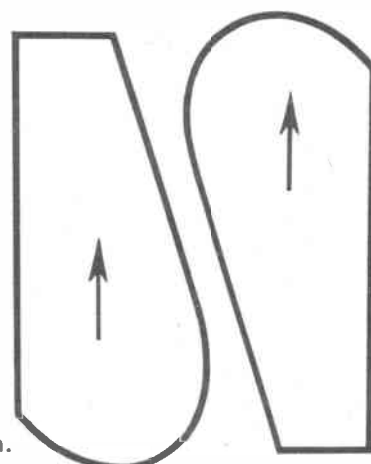

PIECES D. CUT ONE OF EACH 1/4 in.

PRINTED IN ENGLAND.