

# HOBBIES WEEKLY

IN THIS ISSUE

	Page
A 'Treasure Chest' Trinket Box	241
Making an I.F. Signal Generator	242
Jacobean Twist Legs	244
The Care of Oil-Pressure Stoves	245
Make a Useful Scratch Stock	246
Amateur Boat Building	247
Light and Shade in Photography	248
A Utility Wall Cabinet	250
More Random Recipes	252
An Attractive Screen for a Modern Fireplace	255

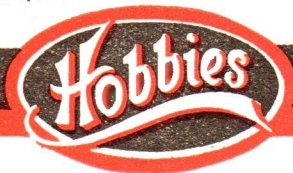

JULY 20th 1955

VOL. 120

NUMBER 3116

*This week's*

## ★ FREE Design Sheet ★

A TRINKET box is a lady's treasure chest—so a trinket box made to this design is quite an appropriate one in which to keep rings, brooches and necklaces, etc.

The heavy metal bands of the old treasure chests are indicated by fretwork overlays, and with careful cutting and finish this makes an ideal article for a place on my lady's dressing-table.

For a start trace off the parts from the design sheet on to their appropriate thicknesses of wood, and cut them out with a fretsaw. Then clean up all the parts with glasspaper.

To assemble the box, take pieces 1, 2, 3 and 4 and glue them together as shown

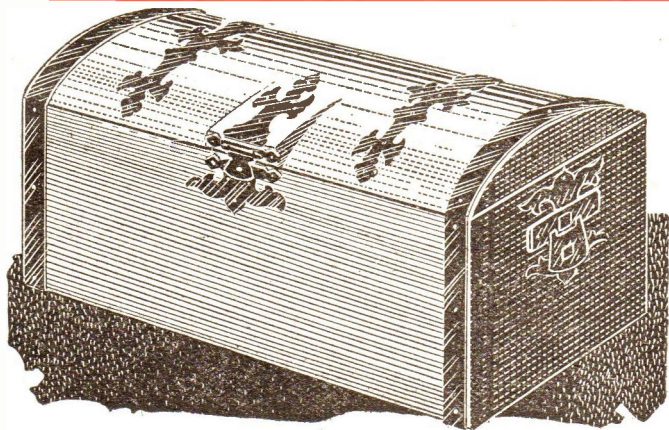

## A 'TREASURE CHEST' TRINKET BOX

in the sketch at the bottom of the design sheet. Note the two recesses in piece 1, which allow the hinges to sit flush.

The lid is a solid piece of wood shaped to section, and this also has recesses cut into the underneath, as will be seen in the hinge-fixing detail. The depth of the hinge recesses are, of course, exaggerated in the details, and they should be cut according to the thickness of the hinges used. All is now ready for the lid to be hinged to the box.

The next step is to pin and glue the overlays in position, and then comes the pinning of the two sections of the catch to the lid and box.

### A KIT FOR 4/11

For making this trinket box you can obtain Kit No. 3116 from any Hobbies branch, or post free from Hobbies Ltd., Dereham, Norfolk, price 4/11

There are two handles—one at each end of the box. These consist of the top portions of a Hobbies No. 6219 catch. The bandings round the edges of the box consist of thin ply cut  $\frac{1}{4}$  in. wide and pinned and glued in position.

The last stage in assembly is to bore holes in the base to take four ball feet, which are then glued in.

For outside finish it is suggested that the box be lightly stained and given two or three coats of brush polish. For effect, the overlays can be painted black or copper colour. The catches can be left in their natural brass or painted to match the overlays.

Workers will have their own ideas on the finish of the interior. Some will line with velvet or other material, and another suitable finish for such an article is velvet spray.

All correspondence should be addressed to The Editor, Hobbies Weekly, Dereham, Norfolk

*For Modellers, Fretworkers  
and Home Craftsmen*



# Making an I.F. Signal Generator

By A. Fraser

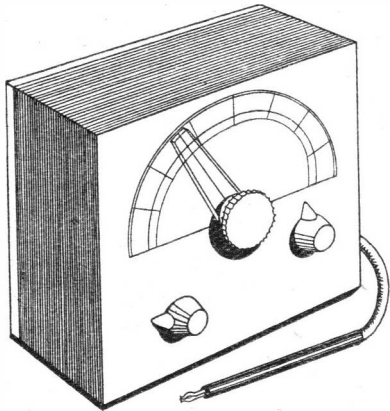

without having to buy expensive generators.

The intermediate frequency tuning can be carried out by using a home-built instrument that is inexpensive and simple to build. What is needed is a generator to produce the desired radio frequency of 465 kilocycles, and to modulate this with an audio frequency

in order to make it discernible to the human ear.

We will describe first the construction of such a generator, and later its application. Only one valve is needed—the small 1S4 valve, easily obtainable on the surplus market. Other valves could be used, such as the 1S5 and 1T4. But all these should have the anode and screen strapped together, so that the valve functions as a triode. The 1S4 does not need to be treated thus, as it is

**M**ANY amateur radio constructors, having built one or two straight T.R.F. sets, are very keen to try their hands at the superhet type. The great stumbling-block, however, is the necessity of alignment, so essential to the superhet. Signal generators designed for this purpose are advertised, but the price of these puts the damper on the aspirations of the would-be constructor.

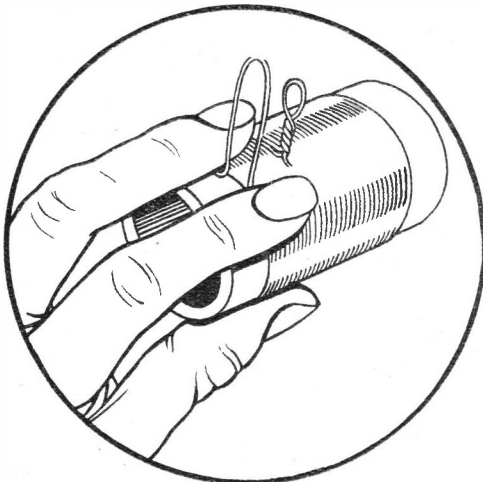

Fig. 1—Tapping the Coil

However, he need not be deterred. The greatest obstacle is the tuning of the intermediate frequency transformers to the proper frequency. (This is usually 465 kilocycles.) If this can be accomplished, then the rest is comparatively easy. The reader can be assured quite definitely that superhets can be built

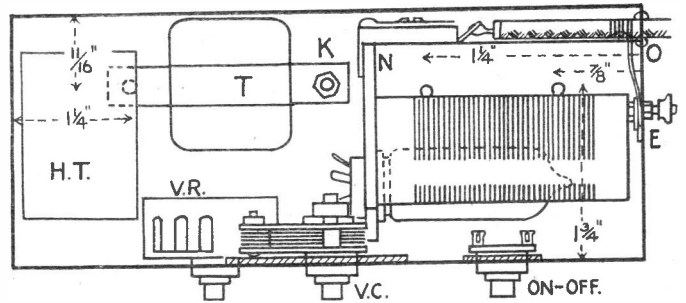
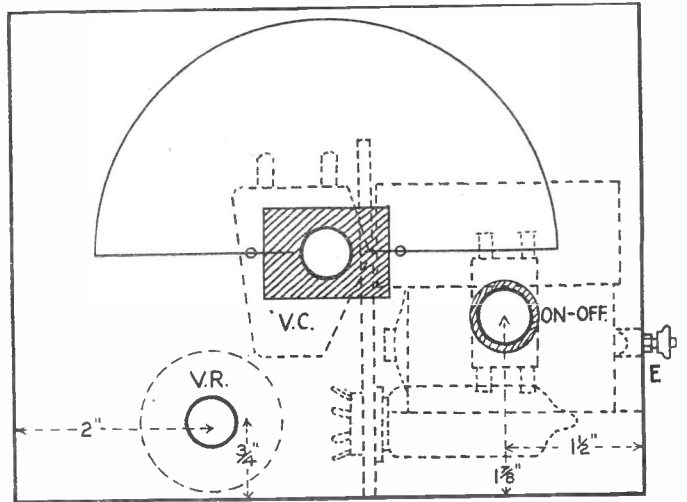

Fig. 3—Front elevation and plan

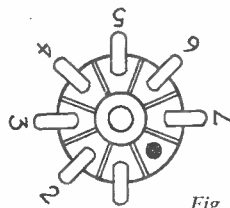

Fig. 4—Valve base

already a triode, so if it can be obtained it is recommended. The HL2 and similar types could be used, but these would need 2 volt filament heating.

The radio frequency (465 kcs.) is generated by a tapped coil, connected between anode and grid of the valve, and tuned by a .0005 variable condenser. This latter could, for cheapness, be merely an ordinary trimmer condenser.

The coil was wound on a paxolin

former  $2\frac{1}{2}$  ins. long and  $1\frac{1}{8}$  ins. in diameter. It consisted of 160 turns of 32 gauge enamelled copper wire, and this occupied  $1\frac{3}{8}$  ins. The coil was tapped half-way down and every  $\frac{1}{8}$  in. after that to make four taps in all (Fig. 1).

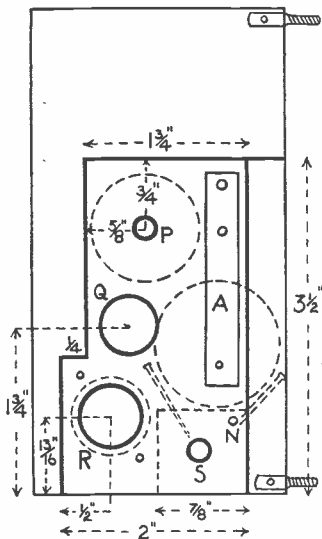

Fig. 2—Panel details

When winding the coil, when a tapping point is reached hold the coils to the former with one hand, and with emery paper rub off about 1 in. of the enamel from the wire yet to be wound on. Then form a loop, like a long inverted 'U', holding the wire firmly, as in Fig. 1, and then twist it four or five times with the free hand, to form a loop. Then proceed with the winding. Make all the tappings like this.

Of course, larger coil-formers and thicker wire can be used, but the number of turns will have to be altered. This former was used as it enabled all the parts to be fitted nicely into an Oxo cube tin (see later).

Note that the enamel is scraped off the wire before the tapped loop is made. Some people leave this until after the loop is made, and the task of removing the enamel is much more difficult.

The audio modulation is injected into the R.F. oscillation through the small inter-valve transformer. The ratio of this can be 3:1. This completes the main components. The condensers and variable resistor are listed in the panel.

The assembly can now be undertaken. It is necessary to screen completely all generators to prevent radiation and confine the output of the instrument solely to the connecting cable. A metal box is indicated and this can conveniently be provided by an Oxo cube

#### COMPONENTS LIST

Coil	(See text).
V.C.	.0005 tuning condenser (solid dielectric).
C1.	.0001 mica condenser.
C2.	.002 condenser (non-inductive).
C3.	30 pfd. trimmer.
V.R.	1 megohm volume control.
S.	On-off switch (insulated).
T.	3:1 intervalve transformer.
V.	1S4 valve (and holder).
H.T.	45 volt battery.
L.T.	1.5 volt cell.

(N.B. It is imperative that both V.R. and S. should be insulated from the front panel.)

paxolin, or it could be plywood. The dotted lines show positions occupied by coil, cell and valve when set up.

Hole P is to accommodate a screw to secure the coil—a piece of wood being fixed in the top of the former for the screw to hold on to. Hole Q is to allow passage for the tapped lead from the coil, and it can be  $\frac{1}{4}$  in. or  $\frac{3}{8}$  in. in diameter. Hole R, for the valveholder, must be  $\frac{5}{8}$  in. in diameter. The small holes on either side are last located by inserting the valveholder and marking the spots. The metal strip can easily be fixed

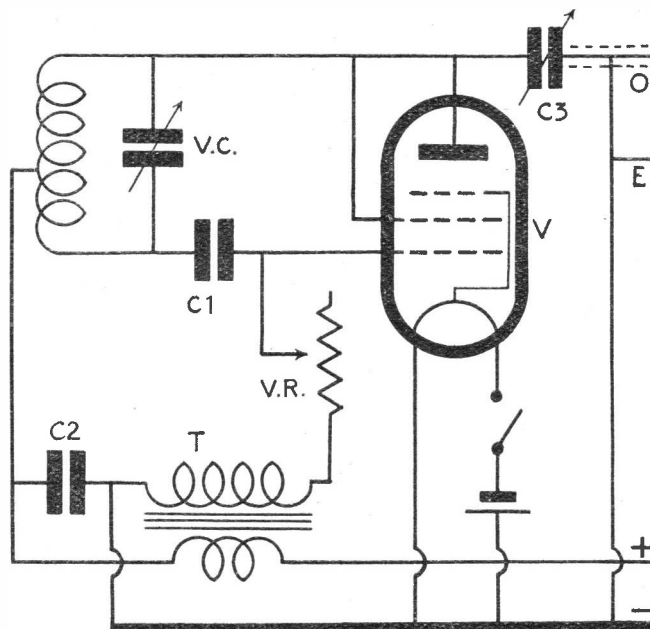

Fig. 5—Theoretical diagram

tin obtainable from any general shop. It measures approximately  $6\frac{5}{8}$  ins. by 5 ins. by  $2\frac{5}{8}$  ins.

It will be noticed from the theoretical diagram that the tuning system is not directly earthed. This means that if an ordinary variable condenser is used, it must not make metallic contact with the metal case. It must be fixed to it by means of an insulating bush. Alternatively, cut out a portion of the front panel of the box (opposite side to the lid) and fix across the opening a piece of paxolin sheet. Small rivets, or nuts and bolts, will secure it. Drill a hole in this, before fixing, to take the condenser screw (usually about  $\frac{3}{8}$  in.). The condenser can then be fitted. It should be the small dielectric type, so as to occupy least space. The particular one employed was a Jackson.

In order to support the coil, valve and low-tension cell, a special panel is made. The shape and dimensions of this are given in Fig. 2. This is of  $\frac{1}{8}$  in. thick

with rivets, and can be  $\frac{1}{4}$  in. or  $\frac{3}{8}$  in. strip brass, and it must be bored at the lower end to allow the switch lead to be soldered on before attachment to the panel. It must also be bent to give a spring effect, to establish good contact with the cell.

The panel is maintained in position by a piece of wooden spar  $\frac{7}{8}$  in. square and  $2\frac{3}{8}$  ins. long. The L.T. cell rests on this, and to cradle it, four panel pins are driven into the spar at an angle. (See illustrations.) The spar is fixed to the panel by a screw through hole S. Later on, the whole assembly with coil, etc., attached, is secured to the bottom of the box by two screws into the base of the spar. The small hole N, near the bottom corner of the paxolin panel, will be used to secure the output trimmer (C3).

This article will be concluded in next week's issue

Try your hand at making

# JACOBEBAN TWIST LEGS

JACOBEBAN twist legs as used for chairs and tables are extremely popular, but expense probably deters some people from using them when building their furniture. There is no reason, however, why you should not try to do the job yourself, and provided that time is no object, it can be accomplished quite easily.

The method described in this article was worked out by the writer during the war when it was impossible to obtain the goods ready-made. It may be the same as that used by the old craftsmen when making the original twists during the latter end of the seventeenth century.

## Few Tools Required

The process is very simple and the tools required are few in number: it would, in fact, be possible to make a perfect twist with the aid of only a pen-knife and a piece of glasspaper.

Oak is, undoubtedly, the correct wood to use for making the Jacobean twist, but you can, of course, employ any hardwood that takes your fancy. The craftsmen of the period always used oak, probably because it was grown extensively in this country and was easy to obtain.

It is essential that straight-grained wood free from knots is used, and to start with do not pick a piece that is too tough. Unless you have a length of wood that is quite round you will have to plane up a piece, and particular care is needed in order to produce a perfect cylinder.

The next step is to determine the 'pitch' of the spiral and set it out correctly. The pitch is the distance between each turn of the spiral, just as the distance between each thread will determine the pitch of a screw.

With the Jacobean twist the pitch is usually about the same as the diameter of the leg. Therefore, if the diameter is 2ins., then the distance from each turn of the spiral will be 2ins. The pitch is sometimes altered to produce a variation from this more or less standard version and a lengthening of the pitch tends to make the spiral more graceful, especially in the smaller sizes.

Marking out is very important and needs to be done most carefully. Unless this is accurate the resulting spiral may be very poor, indeed, and also be a great waste of time.

Having got the wood perfectly round, proceed to set it out as follows. Draw a line along its length, and on this the marks which determine the pitch must be made. Fig. 1 clearly shows how to do the marking out.

says *A. F. Taylor*

First draw the line A, then draw a circle round each end as at B and C. These mark the start and finish of the spiral and for a standard twist the distance between each should be

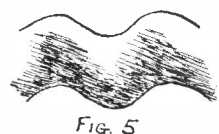
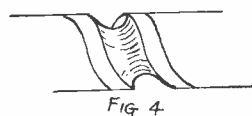
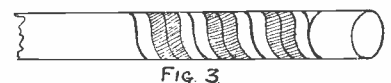
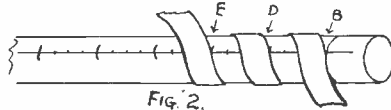
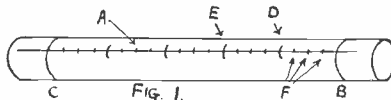

multiples of the diameter. For instance, if the diameter of the leg is 2ins., a distance of 12ins. will allow for six complete spirals. Fig. 1 has been set out for five spirals as shown at D, E, etc.

Each of the spaces B to D, D to E, and so on to C, must be divided into four equal parts to enable the spirals to be marked out correctly.

The next job of marking these spirals may appear a little difficult, but once you have grasped the idea it is really very simple. Take a long strip of stout paper or thin card about 1in. wide, one side of which must be perfectly straight. Coil this round the circular bar so that it cuts through each division B, D, E, etc., as shown in Fig. 2. When the card is lying nice and flat and perfectly even, place a pin at each end to hold it quite tight and then mark along the straight edge of the card with a pencil.

Now move the card along the bar, and make three more spirals from the sub-divisions F (Fig. 1). The result will be as shown in Fig. 3, and the shaded

part in the centre of each is that portion of the spiral which is to be cut out.

Having finished the marking-out correctly, we can now proceed with the actual cutting, and for this the tools needed are two or three gouges of different curves and a half-round file for smoothing off.

Commence by cutting along the centre line of the shaded part in Fig. 3. A saw-cut may be made here, but with a nice sharp gouge the job can be completed very efficiently without using any other tools. The depth of the cut will be governed by the use to which it is to be put. For light work the spiral can be cut deeper than would be required if it is to bear some considerable weight. For most general purposes, however, about one-fifth of the full diameter can be cut away without any great weakening.

## Even Curve

Do the cutting slowly as any wood taken out cannot be replaced, and try to keep the curve as even as possible. Fig. 4 gives an idea of the first cutting, and when this stage has been reached, the two sharp edges at the top of the groove must be rounded off. Turning the gouge over will do this, but a little more care is necessary with the tool used in this position.

A half-round file can now be used to even up the grooves and this is followed up with glasspaper, finishing off with the finest grade. The spiral should now appear as in Fig. 5.

The proper way to finish each end is by gradually decreasing the depth of the groove until it disappears altogether on the surface at the line B shown in Figs. 1 and 2.

When building tables and stools with four legs it is usual to have two left-hand twists and two right-hand, but they can all go the same way if desired. To make the opposite twist it is only necessary to coil the card round the bar in the other direction to that shown in Fig. 2, and mark out in the same manner.

In this article we have been describing how to make a Jacobean twist from a round bar, but quite a lot of furniture is built with legs having a square portion at the top and near the bottom where the bars are fixed. Although a little more care is needed to make this type, it is not at all difficult.

After planing the bar square, mark off the portion to receive the twist and proceed to make this round. With a lathe this is soon done, but there are other ways to obtain a reasonably round job.

● Continued on page 247

Some useful information about

# The Care of Oil-Pressure Stoves

THE oil-pressure stove is an essential item of equipment for camping and similar activities, and nothing is more annoying in these circumstances than a stove that gives indifferent performance.

A difficulty that many campers seem to encounter is in the correct ignition of these stoves. It is absolutely essential that the burner is sufficiently pre-heated to vaporise the paraffin within same, and failure to do so will result in a 'flare-up' of smoky flame which will quickly choke the jet. The usual method of pre-heating the burner is by means of methylated spirit placed within a small bowl beneath the burner, which is ignited and allowed to burn away. Insufficient spirits, especially in the open air, is the usual reason for the burner being insufficiently heated, and often two bowls of spirit are necessary to obtain a satisfactory start.

## Shield from the Wind

Where the conditions are windy, it is essential to shield the lamp during this pre-heating period on the leeward side of the tent or behind a convenient bush. The best procedure, of course, is to be forearmed against this eventuality by providing a tin box—a biscuit tin is ideal—in which the lamp can be placed with safety. Several small holes should be made around the lower part of the box to ensure sufficient air reaching the burner, and if the box is rather small, one side should be cut away to give access to the lamp. The cut-away side should, of course, face away from the wind.

It is a false economy to use cheap paraffin in a pressure stove, for it tends to give a smoky flame and under these circumstances will tend to clog the jet. If the jet is clogged or partially so, it should be cleared with the special prickers as supplied by the makers of the lamp. Do not use needles or pins, etc., otherwise the jet orifice will be enlarged and the jet will have to be replaced. If it ever becomes necessary to remove or replace the jet, it should be removed by a special jet key, as being placed in an inaccessible position, it may be impossible to remove with an ordinary spanner. If a replacement jet is necessary, always obtain the same number jet as the original. The number is usually stamped either on the top of the jet or on the key flats. It may be difficult to see at first, due to the accumulation of burnt oil, etc., but a wipe over with a clean cloth should soon reveal same.

When putting oil in the stove, do not

By *E. S. Brown*

fill further than two-thirds, and always use a filter to trap any foreign matter that may otherwise clog the jet.

Failure to pump air into the oil reservoir is almost always due to the leather washer perishing and becoming

easily replaced by unscrewing the burner unit with a suitable spanner, removing the old washer and replacing with the new. The old washer may be somewhat difficult to remove, as it may have hardened and jammed in the burner screw recess in the top of the oil reservoir. In these circumstances, a small screwdriver or similar tool, carefully inserted beneath the edge of the washer, will enable it to be levered up and off. When replacing the burner after installing a new washer, do not overtighten, otherwise the surface of the washer may be damaged.

Minute air-leaks in the reservoir are

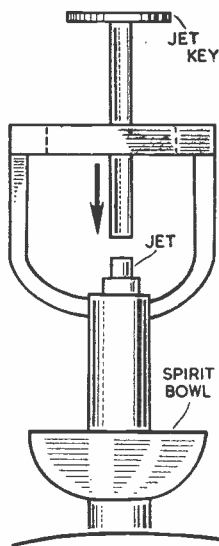

*Procedure for removing jet*

hard through the heat of the lamp. The pump plunger should be removed by unscrewing the knurled collar at the top, and the plunger assembly removed. The washer is then removed by unscrewing the small retaining nut on the end of the plunger-rod. Previous to replacing the new washer, it should be well oiled or greased, and then replaced on the plunger with the cup-side downwards and the retaining nut screwed and tightened back into position. With a new washer, there may be some slight difficulty in reinserting into the pump cylinder. This can be done by squeezing in the cup-sides of the washer with the fingers, then inserting by applying pressure on the top of the plunger together with a screwing motion. By continuing the pressure, the plunger will go fully home, and the knurled collar replaced.

Failure for the lamp to hold air is often due to a leaky washer beneath the burner and also to air-leak within the oil reservoir itself. The washer is quite

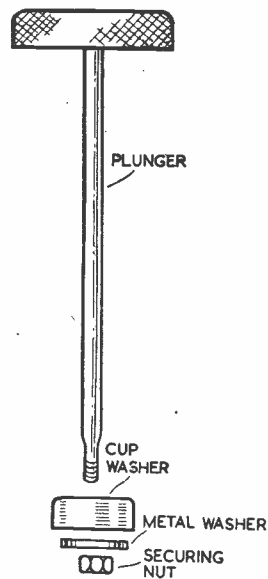

*The correct assembly of the pump plunger*

sometimes very difficult to find. The best method is to empty the oil, place a finger over the jet orifice and give several strokes with the pump. The lamp is then placed in a bucket of water, still retaining the finger over the jet, and any air-leaks will show themselves by a stream of escaping air bubbles. The most usual place is around the pump cylinder where it joins to the reservoir, as it is subject to considerable strain by the pumping action. Another place where leakages are liable to occur is the burner union on the reservoir, which may have become strained through overtightening the burner. Undoubtedly

the most difficult leaks to discover are those caused through pin-holes in the metal. Stoves that have seen much service are somewhat prone to these, due to a slight acid content in the paraffin causing a corrosive action on the brass metal.

### Clean Thoroughly

The places where the air-leaks occur should be most thoroughly cleaned of any dirt and paraffin. Some stoves are also lacquered to preserve their bright appearance, and this should be removed for a suitable distance around the repair. A heavy soldering-bit will be necessary to ensure sufficient heat to sweat the solder in to the repair, for the brass reservoir of the stove, being a good heat conductor, will quickly cool a small iron and so make an unsatisfactory job of the repair. In those instances where a heavy soldering-bit is not available, the damaged areas of the reservoir should be heated with a blow-lamp or over a gas jet. It should not be made too hot, approximately the temperature of boiling water is correct, and it will ensure that the soldering-bit retains sufficient heat to complete the job satisfactorily. If it is necessary to heat the area around the pump cylinder, the

plunger assembly should be withdrawn, otherwise the washer will be adversely affected by the application of local heat.

Although most handymen are conversant with soldering technique, a few notes in this particular instance may not be amiss. Having cleaned the damaged place, a non-corrosive flux, either paste or liquid, is applied. The soldering-bit is brought to the correct temperature (this is indicated by the flame which is heating it taking on a green hue) and the iron well tinned by rubbing quickly on a piece of cloth, then dipping into the flux and rubbing a piece of solder, the end of which is covered with flux, well over the end of the iron. The iron and solder are then transferred to the repair; retaining the iron in position until the solder melts and runs into the damaged parts, the soldering-bit is then moved slowly along, applying solder as required, until the repair is completed. For all soldering jobs such as these, tinsman's solder should be used, as it is free-flowing under quite moderate temperatures.

### Cause of Failure

Failure to make a good repair can be attributed in most instances to an insufficiently heated or too small solder-

ing-bit, or to a repair that has not been thoroughly cleaned, and if difficulty is experienced, it is highly probable that the cause for it lies there.

The atomiser on the 'roarer' type of stove usually consists of a small cast-iron plate which rests on the burner assembly by means of three lugs. When handling the stove, care should be taken to avoid the atomiser falling off and breaking. The lugs are especially vulnerable in this respect.

### Keep Holes Clear

With the silent type of stove, the flame diffuser or spreader usually consists of a cone-shaped steel pressing which fits over the top of the burner. The holes in the pressing should always be kept clear, and if the metal should show signs of burning or distortion, a replacement should be made.

When the stove is not in use, it is a good idea to wrap round the burner assembly a clean, non-fluffy cloth to prevent the ingress of dust, etc., while the air-release valve should be left open, otherwise with the change in temperature and atmospheric conditions, if there is any paraffin left in the stove, it might rise and seep from the jet, and cover the stove and its surroundings with oil.

## FROM SCRAP MATERIALS

# Make a Useful Scratch Stock

By Keith John

A HOME-MADE tool invaluable for moulding edges in decoration, cutting beads, etc., is the scratch stock. It is very easily made from scrap materials, so cost is negligible.

Materials required are a piece of hardwood (preferably beech)  $4\frac{1}{2}$  ins. by  $1\frac{1}{2}$  ins. by 1 in., a  $1\frac{3}{16}$  in. bolt with washer and wing-nut, and pieces of an old saw blade (a broken bandsaw is excellent).

Plane the beech to  $4\frac{1}{2}$  ins. by  $1\frac{3}{8}$  ins. by  $\frac{3}{4}$  in. and then cut out a piece  $2\frac{1}{2}$  ins. by

$\frac{3}{4}$  in. as shown in Fig. 1. A saw cut should then be made down the centre of the arm (A-B). This kerf is to take the cutters. Next, a  $\frac{3}{16}$  in. hole should be bored through (A-B) in the position shown to take the bolt. Insert the bolt and carefully draw round the hexagonal head. Remove the bolt and chisel out

and on each end is filed a different shape. This shape is quite a personal choice and no hard rules are laid down. Two are suggested in the drawing.

The cutter is then slotted in the saw kerf, its position adjusted and the wing nut tightened. The scratch stock is then used exactly as a marking gauge is used, the side (X at Fig. 3) being pressed tightly against the edge of the wood and the scratch stock moved steadily backwards and forwards until the final moulding is achieved. The finished tool is shown ready for use in Fig. 3.

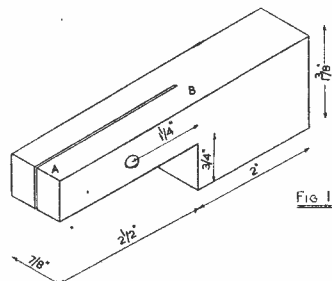

FIG. 1

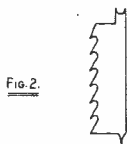

FIG. 2

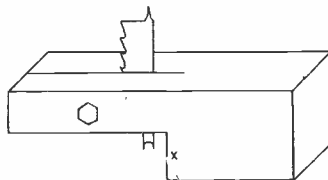

FIG. 3

this hexagon until the head of the bolt is housed in the stock, the outside of the bolt-head being flush with the surface of the wood.

A washer and wing nut are then applied to the opposite side and any surplus threadings on the bolt can be sawn off.

The cutters are made as in Fig. 2. Approximately 2 ins. of blade is used,

### ANY OTHERS?

Since the announcement that 'Hobbies Weekly' will celebrate its Diamond Jubilee of publication on Oct. 19th this year we have heard from a Birmingham reader that he has taken the magazine from its first issue — throughout the 60 years. This record obviously cannot be beaten, but we wonder if there are any other readers who can claim the same length of readership?

# AMATEUR BOAT BUILDING

PREVIOUS articles in this series have laid stress on the selection of the type of boat best suited to your individual needs and pocket. Actually, building a boat entirely single-handed is a pretty tall order. There are certain parts of the construction where you will almost certainly need some help, such as pulling the gunwales and chines round to shape and fitting and screwing the ply skin panels down over the frame. Hence building a small craft is an ideal 'group' project, especially for younger enthusiasts where the group leader or similar officer can supervise the whole thing.

## Not Impossible

On the other hand, if you do want to start entirely on your own bat and you can handle tools competently, don't think that the situation is impossible. Father, an elder brother or even the next-door neighbour will probably be only too pleased to help—once the plan has received parental approval. Once you get started you will be surprised how many of your friends do turn up out of curiosity to see what is going on and stop to lend a hand out of sheer interest. So in this respect you will probably never lack for 'labour' assistance.

Young men of sixteen to eighteen have built *Cadets* and similar small craft—and most of them have turned out quite well. It is unlikely that anyone younger than this would have either the necessary ability or the cash to undertake the job. Yet boys have shown that they can sail *Cadets* quite well from the beginning of their teenage—so if you are in that category and feel the urge to do something about it, it seems just the case for persuading father.

Of course, it is a great advantage if the would-be yachtsman can already swim well. There is little excuse nowadays for boys not being able to swim—most schools offer facilities for learning during the summer term and every big town has its public baths.

Swim or not, the golden rule with all boats—and even more so with small craft—is, never take chances. Sailing boats can overturn, especially if badly handled. Nobody is going to be an expert without learning the practical way how to handle the craft, so the idea is to make everything as safe as possible from the start.

For instance, it is a sensible precaution to wear a life-jacket when sailing in a strong breeze or choppy water, whether you can swim or not

## By R. H. Warring

and also whether or not you are quite competent at handling the craft. When learning, of course, you would *not* try to sail when the weather is bad—or would you? Some beginners are foolish enough to try and more often than not put someone else to a lot of trouble fishing them out of the water, righting their boat and towing them back.

Note that I said 'righting the boat'. Sailing dinghies of the type I have been writing of do not sink. About the worst that can happen is that they go right over on their side, fill with water and lie there, waterlogged and useless. Cling on and you will float with her. With a little more experience you will be able to right her again, bail out and continue sailing. If you want even more buoyancy in the waterlogged position, air-filled flotation bags will provide the answer.

With a non-sailing dinghy the risk of overturning is almost negligible, provided reasonable precautions are observed. Hard chine and 'slabsided' hulls common with amateur construction are strongly resistant to rolling. Hence you can step or stand to one side without 'upsetting the boat', or change places with equal ease when afloat. But the wise small-craft 'skipper' still usually insists on one person only moving about at a time.

## Practice Needed

Seamanship is largely experience. You can read about it in books. You can listen to old sailors talking. In the end it is practice—and still more practice. Operating our 14ft. runabout for the first time on a fast tidal river we clipped the stern of an adjacent boat coming in to land—due to a misjudgment of tide and wind drift. No damage was done to either craft—only to our dignity! But having learnt that lesson we *practised*

it—round and back for a dozen trial landings. 'Circuits and bumps', they would have called it, if we had been piloting an aeroplane, but there were no more 'bumps' after that.

Ideally, small craft should have an alternative form of propulsion, especially operating in tidal waters. It is nice to know, for instance, that if your motor 'conks', out come the oars or paddles; and you can maintain steerage way, at least. Being relatively light, small craft drift quite rapidly in a strong wind when they have lost way. Oars on a 'general purpose' dinghy fitted with rowlocks will easily keep you out of trouble. On a runabout type, where no rowlocks are fitted, paddles are just as effective. One person paddling from one side (first one way, then the other) can keep her under control. Two people paddling, one each side, can shift a 14ft. light-weight hull along at walking pace. Paddles, too, can come in very handy for manoeuvring at close quarters with the engine dead, or even in place of the reverse gear, absent on outboard motors.

## A Last Word

Finally, never ignore local advice. Having completed your 'apprenticeship' as an amateur boat builder and got your craft on the water you are just starting your apprenticeship in sailing and handling her. For a beginning, you probably won't even know how to tie her up. Accept all advice given at this early stage—and be grateful for any experienced help you can get. The thrill of boating can be marred by unfortunate incidents at the early stages, when it may even seem that you have wasted a lot of time and money on the venture. Never make the same mistake twice, and go on learning all the time. You'll soon find yourself a competent 'skipper' with your second period of apprenticeship past.

● Continued from page 244

## Jacobean Twist Legs

A small plane held on the skew will remove some of the centre portion, while a chisel and spokeshave used carefully will cut off the remaining parts. Final cleaning up with a file should produce a surface practically equal to the machine-finished article.

Very little practice should soon enable you to produce a really first-class

article, and there is great satisfaction in having achieved this, especially now that there is so much inferior work being thrown on to the market. Start with a small experimental twist which, if satisfactory, can be turned into a candlestick, after which you will be ready to tackle a set of legs for a chair, stool or table.

*E. G. Gaze explains the importance of.*

# Light and Shade in Photography

WHEN you click your camera shutter a chemical reaction takes place in the sensitised emulsion of your film which, when developed and fixed and washed, gives you your 'negative' image—in effect, you have 'painted with light'. The basis of photography is the making use of light; expose in a completely darkened room with a normally sensitised film

itself, mild 'fogging', appearing on the negative as a lowering of tonal contrast values, is not so often suspected—until you have tried the remedy. And the remedy is a lens-hood.

A lens-hood acts like a blinker to the lens, like shading your eyes in a strong light to see a subject better—it shields the lens from side-light and prevents reflections inside the lens from stray

terrific amount of actinic light is being poured towards your lens quite apart from that falling upon, and reflected by, your subject itself—here a lens-hood is indispensable to avoid light 'flare' on the negative image. But use a lens-hood at all times—into or out of the sun: you will find the overall contrast tone of your negatives improved.

At early morning or late evening the sun hangs low in the sky—then it throws longer shadows, glances along buildings and roof-tops and vegetation, and reveals their texture. At noon, at its zenith, it illuminates generally with a bright flatness—shadows are almost non-existent, or short and 'hard'.

For purely record purposes, when an even distribution of light is helpful, then

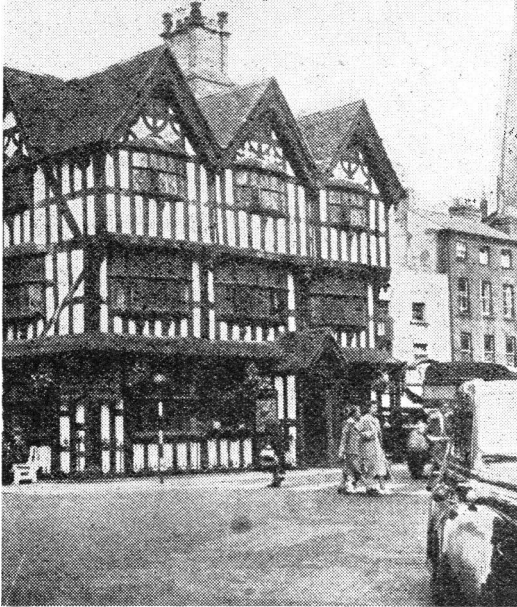

*Fig. 1 (Left)—Uniformity of bright high sun — lack of shadows*



*Fig. 2—Shadows accentuate the effect of sunlight and break up otherwise uniform foreground*

and there is no image recorded, none to record—for complete darkness or blackness is the absence of light.

But light by itself is not enough to 'paint' with: expose a sheet of film outside your camera to daylight and you will record light in an overall 'negative' blackness to give a final 'white', blank print—in other words, 'light' is recorded but no image. It is the camera lens, focused on the scene before you, which records the 'light' image on to the sensitised film—whether you use a pin-hole lens or the carefully computed and constructed ordinary camera lens.

It follows that only the 'light' reflecting image of your subject must fall upon the sensitive film emulsion—any other source of light will cause an exposure effect not part of the scene. Thus, faulty bellows, letting light leak into the camera body, cause dark streaks or general foggy patches on the negative according to the amount and position of the leaks. But, apart from such light leakages in the camera body

light striking it at an angle. Any such light reaching the lens and not coming directly from the subject is unnecessary to form the image of the subject, causes slight 'fogging' and lowers the subject-image contrast. A lens-hood should be an ever-present—and used—part of your equipment. Your camera dealer will have a wide selection, and will help you to choose one suitable for your own particular camera.

Another point about a lens-hood. If you are 'shooting' right into the sun, and even if the sun is high in the sky, a

high-noon paints your picture for you. But, if you want texture of rough stonework, roundness to tree trunks and columns, the play of light and shade—then avoid the high, blazing sun and wait for the softer evening light with its luminous, longer shadows. Or—if you are made that way—get up early in the morning and add early mist and soft ground haze as atmosphere to the scene!

Remember, you are 'painting with light'—and light itself paints a different picture of every scene through the day



and the seasons. Don't be content to say, 'Ah, the sun's shining—let's take a photograph': no—pick your scene, pick your time of day to give light and shade and texture, and your final print will be alive with more atmosphere. A uniformly and brightly-lit scene may record 'brightly', but softening shadow contrasts and texture serve to accentuate brightness itself and to give warmth. You show brightness better by having shadows, ranging from soft to deep.

### Lack of Interest

A photograph taken on a dull, cloudy day will differ from one taken in the glare of the high-noon sun: the second will have more 'brightness' and clarity of detail, yes—but both will share an almost uniform light level over the scene. And uniformity makes for lack of interest and atmosphere. So search not just for light, but for light *and* shade—the shadows to accentuate the very warmth of the light.

The photograph shown in Fig. 1 was taken in a high sun on a cloudless day: bright and clear, but with a uniformity of tone contrast that makes for drabness despite the bright day. Fig. 2 was taken with the sun lower in the heavens when long shadows were thrown: doesn't it have more atmosphere of sunlight, of a warm sunny day than the other?

Exposure speeds? Whether you use a photo-electric cell type, a visual extinction type or one of the soundly computed tables giving exposure data for any normal scene under normal conditions—let experience be your main guide. Experience, based on the constant use of your particular meter, experience in assessing high-light and shadow effect, experience in visualising the scene you wish to 'paint'—always it is experience based on understanding use of your tools that counts. For this reason it is useful to keep exposure records of your photographs and learn from them.

And now a few tips.

### Against the Light Shots

Against the light means extreme contrasts—deep shadows and brilliant high-lights. To expose for the shadows will burn out all detail in the high-lights; to expose merely for the high-lights will mean blackness in the shadow areas of your final print, no shadow detail at all. You must decide what effect you want, or balance between the two extremes. With a very low sun, as at evening, detail is not missed greatly in the shadows and you capture the effect of luminosity in the sky better with a dark ground-level foreground leading to the sky. With a high sun a balance often gives most natural results—a balance between high-light and shadow reading of your meter, not too much



Fig. 3—Against the light with a high sun

development and judicious shading in the final enlargement. But how to take a meter reading directly into the sun? However small an 'acceptance' angle your meter has, there is too much light pouring towards you for the meter to select your subject in an open scene: here it is useful to take a reading with your *back* to the subject, the meter pointing to your front, and then allow up to four times the indicated exposure. With a fairly high sun using this method gives good results, printable on normal grade paper without difficulty (see Fig. 3).

### Accentuating Brightness

Often, with the sun not too high in the sky, it is possible to increase sunlight effect by purposely including a deeper shadow area—such as thrown by a tree or house or wall. In open or street scenes this also serves the useful purpose of breaking up the otherwise uniformly and brightly-lit foreground. And a blank foreground is seldom pleasing on the eye in a monochrome print—and, remember, you are 'painting with light' in a step series of tones ranging from black to white, and colour is absent. In the original scene colour itself may give interest to an otherwise uniform foreground, but the same uniformity—without shadow effect introduced—may well deaden the foreground in your final print. So, don't be afraid to look for shadows and make use of them (Fig. 2).

Semi-posed snaps of the family out

of doors are often better if taken with sunlight diffused behind slight cloud. With soft cloud the lighting is less harsh. Direct, bright sunlight on the face of your subject will almost certainly cause screwed-up eyes—not a happy likeness or one showing enjoyment of welcome sunshine!

### Light-reflecting Scenes

Some subjects reflect much more light than others—beach and water and snow scenes. Too much exposure here will burn out the sparkle of detail in the high-lights—if in doubt use a smaller 'stop' or next faster speed and don't over-develop. But, again, experience based on your own results will teach you more than hours of reading 'advice'—as in most things, doing is the finest way of learning.

Should you think the term 'painting with light' too fanciful, then visit some of the first-class photographic exhibitions held often by camera clubs throughout the country—there you will find not mere mechanical 'records' made and conceived mechanically, but pictures in the true sense: pictures painted with light.

Learn and understand the use of your tools—camera, exposure meter or table, development and enlargement control—standardise with one type of film, developer and printing paper, until you know what it will produce. Then forget the mechanical aids, and cultivate the visual sense of what you are aiming to do—to 'paint with light'.

# A UTILITY WALL CABINET

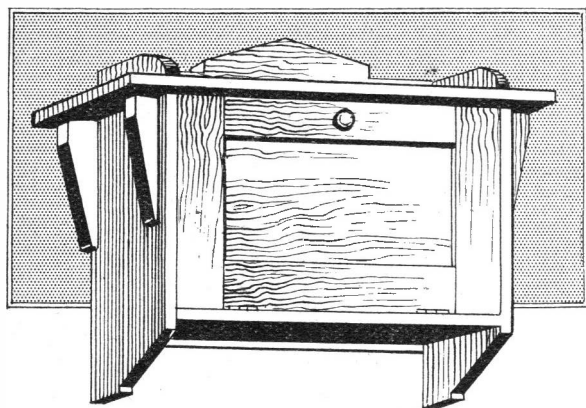

**T**HE illustration shows a construction which would be found useful in many ways. It would serve as a medicine cabinet or as a handy store for stationery, with plenty of space for reserve supplies of ink and other necessary materials.

Overall the cabinet measures 21ins. wide, 16ins. high and 6ins. from front to back. The space inside measures 15ins. by 10½ins. by nearly 5ins., and the door, which falls forward, is hinged to the floor of the cabinet, two small-link chains fixed inside keep the door in a horizontal position when open.

The various parts of the cabinet are shown in the front view Fig. 1, and in the side view Fig. 2, and here useful measurements are included for the setting out and assembly. The two sides (A) are each 13ins. by 5ins. by ½in. thick, and the simple shaping at the lower ends can be set out from Fig. 2, and cut with the fretsaw. The floor (B) is 15ins. by 5ins. by ½in., and is a plain rectangular

cut from pieces measuring 6ins. by 1½ins. by ½in. A shaped pediment rail (E) is fixed along the top, the simple shaping being set out from the details in Fig. 1. Two plain ends (F) 4½ins. by

Dust is excluded from the cabinet, and the plywood back further strengthened, by adding fillets of wood round the inside, as shown at (G) and (H) in Figs. 3 and 4. Glue and ⅜in. brads will make a good and secure fixing.

The door of the cabinet consists of a piece of ¼in. plywood cut exactly to the measurements of the opening, and faced with four rails of ⅜in. thick wood cut square at the ends and glued and screwed from the back of the panel of plywood. Take care to cut the vertical rails 'full', so that they may be cleaned off neatly and evenly along the outside edges later on. The method of laying and fixing the rails is given in Fig. 5. A pair of 1½ins. brass hinges will be recessed into the lower edge of the door and screwed to the ⅜in. rails and to the top of the floor.

A knob or a plain wood block handle may be added and fixed to the door, the wood block having a screw put through from the inside to make a secure fixing.

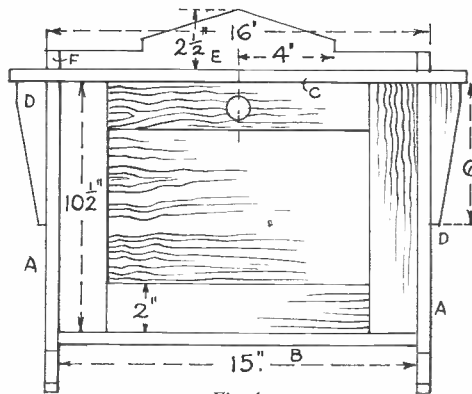

Fig. 1

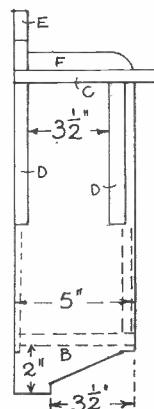

Fig. 2

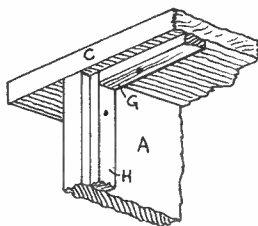

Fig. 3

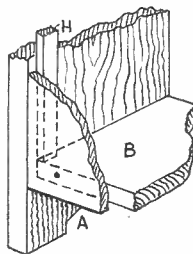

Fig. 4

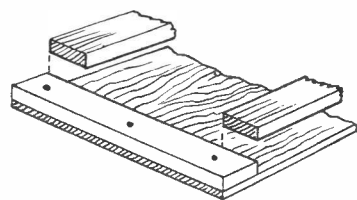

Fig. 5

piece and secured to the sides by two countersunk screws at each end. The top (C) forms a useful shelf and measures 19ins. by 6ins. by ½in. It is fixed by screws to the sides, and is strengthened by four angle brackets (D) glued and screwed as shown. These brackets are

¾in. by ½in. are added and glued on.

The back of the cabinet is of ¼in. plywood cut with square angles to size 15ins. wide and 11½ins. high. It is firmly screwed to the back edge of the floor (Figs. 2 and 4).

Wood bearers may be added to the inside face of the sides of the cabinet as a support for a shelf. If the cabinet is built from deal wood or other soft wood, it may be painted a suitable art shade after a thorough cleaning with coarse and fine glasspaper. (S.W.C.)

## THE PICADOR PUP

Save ground space with this modern, multi-purpose tool. PICADOR PUP comprises a wood-turning lathe, a rise and fall, fully tilting circular saw, a hooded grindstone with drill sharpening attachment, together with sanding and drilling attachments also. It GRINDS, including Twist Drill Grinding, TURNS, SAWS wood, plastic, or soft metals. SANDS and DRILLS for you. PICADOR PUP is small, compact, hardy, and motor-driven. Cash £6.15.0 or 25/- deposit and 6 monthly payments of £1. Leaflet free.

THE MOST VERSATILE TOOL EVER!

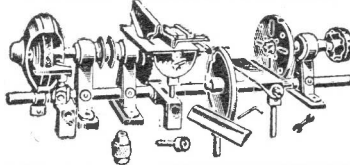

## PHILISHAVE

14 DAYS' FREE TRIAL

Try the wonderful Philishave Electric Dry Shaver FREE for 14 days. Send only 5/- deposit (returnable if not satisfied). Two shaving heads with two 6-bladed cutters have unique rotary action which genuinely shaves — doesn't just snip at the hairs. Result — better quicker shave. Operates 110/250 volts. A.C./D.C. £19.3 cash less your deposit. Or 5/- deposit can be first payment, followed by 8 monthly payments of £1. 12 months' guarantee.

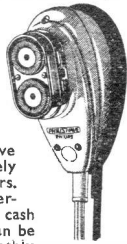

Try the Viceroy V-ten free for 14 days. The aristocrat of electric shavers, made by Rolls Razors. Voltage switch changes from 90/250 volts A.C./D.C. Guaranteed one year. Cash price £9.17.8 or send only 5/- deposit (returnable if not satisfied), then 15/- after 14 days' trial, balance in 8 monthly payments of 24/-.

## VICEROY V-TEN

ONLY 5/- DEPOSIT

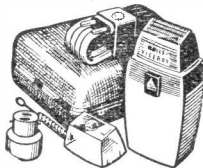

Leaflet of this and other Shavers free.

## ELECTRIC PAINT STRIPPER

4/- DEPOSIT

and  
4 monthly  
payments of  
7/6

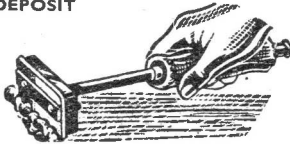

Old paint peels off like magic with the Horvell electric paint stripper. Easy, even strokes remove paint, varnish, etc. Four-sided blade for angles and corners. A.C./D.C.—state actual voltage. Cash 30/-, P & P 1/-. Extra flex 1/- a yard. Spare element 5/6. Leaflet free.

This U.50

## BLACK & DECKER KIT

for ONLY £1 deposit

With this Kit you can clean, buff, burnish, grind and drill. Comprises Sander, Polisher Rubber pad, Lambswool bonnet, 3 sanding discs, one 1/2" chuck, Allen key, wax and polish. Cash £9.17.6 or £1 deposit and 8 monthly payments of 25/-. With chuck, becomes all-purpose drill. Can also be used as driving unit for lathe and saw attachments. Fully suppressed. State your actual voltage.



## ELECTRIC PAINT SPRAYER

Cash 75/-. Or 4/- deposit and 6 monthly payments of 13/6

for 4/- deposit



Paint easily, evenly, twice as fast with the Burgess Electric Sprayer. Sprays paint, varnish, etc. Complete with sturdy glass container, flex, nozzles for ceiling spraying and extra nozzle discs for different liquids. A.C.—state your actual voltage. Fully guaranteed. Leaflet free.

DRILL FASTER  
With a  
Black & Decker  
ELECTRIC DRILL



DEPOSIT

A first-class tool, the Black & Decker U-1 Portable Electric Drill saves hours on home and workshop jobs. Drills wood, steel, brick, etc. Steel capacity up to 1/2". Also drives sanding discs, polisher pads, etc. Weighs 3 3/8 lb. Fully suppressed. £5.19.6 or 12/- deposit and 6 monthly payments of £1. Sent on receipt of the deposit. A.C./D.C. motor, voltages 110 to 250. State your actual voltage.

BARGAIN DISTRIBUTORS (Dept. 124), 5 Silver Street, Luton



For speedy fixing

**SPEEDFIX**  
SELF-ADHESIVE Tape

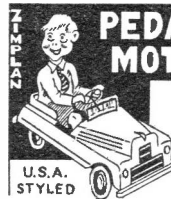

## PEDAL POWER MOTOR CAR

U.S.A. STYLED

A HOLIDAY TOY FOR CHILDREN 2-6 START TO MAKE THIS MOTOR CAR NOW. METAL PARTS AND WHEELS AVAILABLE

PLAN, INSTRUCTIONS & LIST 2/6 post free.

ILLUSTRATED LIST For Toy Makers

with easy plans of DOLL'S HOUSE, DOLL'S COT and TOY CRANE, 9d. post free



## ZIMPLAN

PEDAL TRACTOR

Easy to make. Set of Plans and list of available metal parts 1/6 post free



**ZIMPLAN 182, WARE RD. HODDESDON**

No. 4 'Home-Craft'

## MARQUETRY OUTFIT

Two Designs in One Box—

Make which you like!

BASEBOARD 12x10 PICTURE 10x8 1/2

Complete Kit 19/9 By Post 1/- extra

STOCKED BY ALL HOBBIES BRANCHES

Midland Marquetry Co. Ltd., 187a Plains Road, Nottingham



**G**ARDENING readers will welcome a home-made insecticidal spray. This is quickly and easily prepared. The requirements are: Green soft soap 1 ounce; kerosene (burning paraffin) 1 fluid ounce; hot water 1 pint. Dissolve the soap in the water and let it cool. Pour it into a bottle, add the kerosene and shake well until the latter has emulsified. The spray is then ready for use.

This preparation can be stored indefinitely in corked bottles. The emulsion separates slightly on standing, but quickly redisperses on shaking.

**ANTI-FREEZING LIQUIDS**—Cheap anti-freezing liquids for car radiators can be made from solutions of various salts, but these are not recommended, since encrustation and sometimes corrosion occur. The most useful substance for the purpose is ethylene glycol. This is mixed with an equal volume of water for use. Glycerine and water in the same proportions may also be used. In both cases small additions of water should be made to maintain the original level in the radiator as evaporation occurs.

**PORTABLE GUM**—It is often convenient to have a piece of solid gum to carry about for sticking together papers and so forth. To make it, heat gelatine with one-quarter its weight of brown sugar in a water-bath and add small quantities of boiling water until both have dissolved. It is important to use only as much water as is necessary for solution. Pour out the solution on to a small tin pie dish to a depth of about  $\frac{1}{4}$  in. When the mixture has cooled and set, cut it into convenient sized pieces. For use, simply moisten one end of the piece and apply to the paper.

**MARBLE CEMENT**—Broken marble ornaments can be repaired by using a mixture of: Carnauba wax 7 grams; rosin 2 grams; silica powder 16 grams. Melt the wax and rosin over as low a flame as practicable and then stir in the silica. The cement should be used hot and the marble previously heated gradually in the oven. Press the marble pieces together, bind them and leave till cold.

**GRASS KILLER**—Grass growing in the nicks of brick and stone paths, and which is so tedious to remove, can be killed by means of the solution: Calcium chloride  $1\frac{1}{2}$  pounds; water  $\frac{1}{2}$  gallon. A cheap technical grade of calcium chloride, such as the fused flakes, can be used. Naturally, a dry spell should be chosen for its application, otherwise rain will carry the solution down into the subsoil and vitiate its effect.

**FUNGICIDE**—Persistent fungus growths will yield to a mixture of: Flowers of sulphur 19 parts; aluminium hydroxide 1 part, both by weight. The powders

## More Random Recipes

may be mixed by shaking them in a tin. Simply dust the preparation over the fungus. In place of aluminium hydroxide, a similar proportion of any of the following may be used: aluminium sulphate, zinc oxide, zinc sulphate. These should, of course, also be in powder form.

**IMITATION JAPANESE LACQUER**—Oriental lacquered wood-ware can be well imitated with readily available materials. All we need are methylated spirit, shellac and sealing wax. The different colours are, of course, produced by using different coloured sealing wax. The basic formula is: Methylated spirit 37 c.c.; pale shellac 18 grams; sealing wax 1 to 4.5 grams. To make the lacquer, crush the sealing wax into coarse powder and place this in a closed bottle with the shellac and meths. Shake occasionally until an even lacquer results.

**AEROPLANE DOPE**—The advantages of a skin of very low inflammability for the fabric wings of model aeroplanes are obvious. Instead of a nitrocellulose skin, which is highly inflammable, use is made of cellulose acetate. As 'Celanese' silk consists of cellulose acetate, worn-out garments of this material may be employed, provided they are clean and white. The formula consists of: Acetone 30 c.c.; benzene 30 c.c.; technical methyl alcohol 20 c.c.; diacetone alcohol 10 c.c.; cellulose acetate 7.5 grams; triphenyl phosphate 2.5 grams.

Mix the first four ingredients in a bottle and then add the cellulose acetate. Close the bottle and shake occasionally until the latter has dispersed. Add the triphenyl phosphate and shake until it has dissolved. Any insoluble matter can be removed by allowing it to settle and then decanting. If the dope is needed at once it can be filtered through cotton cloth.

It should be noted that the solvents in this preparation are inflammable. Consequently, it should be brushed or sprayed only in absence of naked flames. When the dope has dried on the wings the fire danger is over.

**CLEAR LACQUER TINTING**—By means of iodine, shellac type lacquers can be tinted from yellow right through intermediate shades to ruby red. These shades are fast to light. Iodine crystals, not the tincture, must be used. By dissolving 0.25 gram in 1 pint of lacquer the yellow is obtained; 6.25 grams per pint gives the ruby red. Quantities between these two limits give the intermediate shades.

**PAINTING GALVANISED IRON**—New galvanised sheeting is rarely so amenable

to paint as plain iron or wood. The tendency to shed its paint prematurely can be obviated. If time is no object, the best thing to do is to let the sheeting weather for a few months and before applying paint to wash well with water and allow to dry.

If you wish to paint at once, there are several pre-painting treatments available. The surface can be scrubbed with vinegar, allowed to dry and given a dry brushing. Scrubbing with soap and water, washing and drying is another method. Good results may also be attained by first swabbing the surface with benzine, allowing to dry and then applying a solution of 1 ounce of copper sulphate in 5 pints of water; let the solution dry on and then clean the surface by dry brushing.

**IMPROVED WHITEWASH**—A formula which gives a good appearance and which at the same time does not readily brush or wash off contains: Quicklime 2 pounds; whiting  $1\frac{1}{2}$  pounds; salt 14 ounces; brown sugar 10 ounces.

Slack the lime with about a gallon of water, crushing down lumps. When cold, strain off any large particles and make up to 2 gallons with water. Stir in the whiting, then the salt and finally the sugar. The resultant whitewash may be thinned a little further to give greater fluidity. For wood, brush on two coats; on stone or brick, three coats. (L.A.F.)

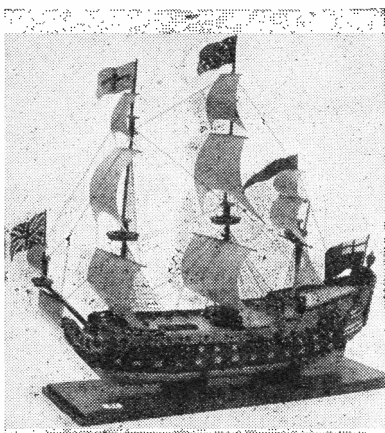

This grand model of the 'Royal Prince', made by W. Barnes of Wilmslow, was awarded the Hobbies Trophy for the best entry made from Hobbies kits at the 7th Northern Models Exhibition

## MORE FUN FROM YOUR RAILWAY!

Get the most from your railway by reading, each month, the leading magazine for the Average Enthusiast, large, lavishly illustrated, and packed full of practical articles on all aspects of the hobby.

With The **RAILWAY MODELLER**

1/6 Monthly 1/8 post paid

Layout Plans No. 1 1/3 No. 2 1/3

Scenic Modelling 1/9

The Railway Modeller Model Railway 6d.

Dept. H.W.  
Pecoway  
Station Rd.  
Seaton, Devon

## HEAR ALL CONTINENTS With H.A.C. Short-Wave Receivers.

Suppliers for over 18 years of Radio S-W Receivers of quality.

One-Valve Kit, Price 25/- Two-Valve Kit, Price 50/-

Improved designs with Denco coils. All kits complete with all components, accessories and full instructions. Before ordering, call and inspect a demonstration receiver, or send stamped addressed envelope for descriptive catalogue.

'H.A.C.' Short-Wave Products (Dept. 22), 11 Old Bond Street, London, W.1

## BETALLER

in 12 days or money back. New gland and spinal discovery increases height 2 to 5 inches. 'I have gained 4 1/2 inches in height. My weight increased from 9-stone 4-lb. to 10-stone 3 1/2-lb.'—P.D. 'Increased 3 inches.'—H.G. Guaranteed harmless. Full course 10/- (or \$1.50). Air Mail 16/3. Details 1/3d. Sent under plain cover. J. H. MORLEY, 28 (H/146) Dean Rd., London, N.W.2. Practical Courses, all subjects. List free.

### A MODEL-MAKER'S 'MUST'!

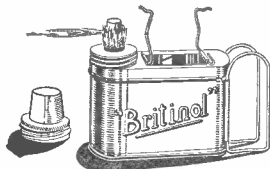

The 'BRITINOL' Spirit Blowlamp Gives a 3—4 inch flame from methylated spirit, is ideal for all soldering jobs, and heats a small iron rapidly. Completely automatic in action, no pumping necessary. Price 7/- from Hobbies or Halfords shops, or in case of difficulty, from: **BI-METALS (Britinol) LTD.,** St. Mary's Works, Bridge Road London, N.9

### GENUINE SWISS Musical Movements

Limited Quantity 17/- each, plus 9d. post/pkg.

Richardson & Forder, 5 Chapel Place, White Hart Lane, London, N.17

**A GRAND BOOK FOR ALL THE FAMILY.** The "Kaylee Year Book of Bright Ideas". A really helpful guide to home planning, decoration, Hobbies, toys, etc. Showing famous Kaylee Transfers in brilliant colours, and most effective uses. From "Hobbies" stockists or direct.

**KAYLEE TRANSFERS** Postage 3d.  
**LTD., (HW) Long Eaton, Nottingham**

## NEW! EXPERIMENTAL KITS

### LEARN THE PRACTICAL WAY

Here is home study of the most effective kind under expert tutors. There is no better way of studying for an examination, starting a new hobby or for a career in industry. These special courses comprise the most modern methods of postal tuition, combined with a Practical Kit of parts (which remains your property).

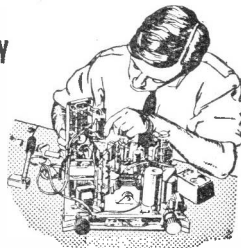

### COURSES FROM 15/- A MONTH

**COURSES WITH PRACTICAL EQUIPMENT INCLUDE: Radio, Television, Mechanics, Electricity, Chemistry, Photography, Carpentry; also Draughtsmanship, Commercial Art, Amateur S.W. Radio, Languages, etc.**

### POST THIS COUPON TODAY

For FREE brochure write: E.M.I. INSTITUTES, Dept. 31X, Grove Park Road, London, W.4.

SUBJECT(S) OF INTEREST.....

NAME.....

ADDRESS.....

20/7/55.....

IC51A

**E.M.I. INSTITUTES**

The only Postal College which is part of a world-wide Industrial Organisation

**SHORTHAND** in 1 week. Test lesson, 2 1/2. Sstamp.—Dutton's (HB/SV), 93 Gt. Russell St., London, W.C.1.

**BUILD** your own T/V and learn about its operation, maintenance and servicing. Qualified engineer-tutor available whilst you are learning and building. Free Brochure from—E.M.I. Institutes, Dept. HW.58, London, W.4. (Associated with H.M.V.)

**MODELS.** You can make lasting stone-hard models with Sankey's Pyramu Plastic Cement. Supplied in tins by Ironmongers, Hardwaremen and Builders' Merchants. Ask for instruction leaflet.

**TOY CASTING MOULDS.** Soldiers, sailors, airmen, etc. 1,000 varieties from 3/- each. Rubber moulding compound for flexible moulds, granulated ready for use. 8/6 per lb. Aluminium moulds for plaster work. S.A.E. for list. Catalogue 9d.—F. W. Nuthall, 69 St. Mark's Road, Hanwell, London, W.7.

**STAMPS FREE**—Empire Packet including Spictorials and Victorians with approvals.—Robert J. Peck, 7A Kemp Road, Bournemouth.

**DOLL'S HOUSE** fittings and papers. Send D.S.A.E. for list. Doll's House plan, special, send 2/6. Trade supplied.—Zimplan, 88 Ware Road, Hoddesdon.

**MAGIC** Jumping Card and wonderful Catalogue 1/-.—DeHempsey, 363 Sandycombe, Kew Gardens, Surrey.

## Get WISE!

GET THE 1955 MAMMOTH 10/- ONLY

### GADGETS ANNUAL

AND FIND OUT

### HOW TO MAKE

OVER 350 NOVEL AND PRACTICAL DEVICES AND GADGETS FOR CARAVAN - HOME - WORKSHOP - OFFICE - HOBBY - MAGIC - PUZZLES - TOYS - GIFTS - MODELS - MONEY SAVING IDEAS - SALEABLE INVENTIONS.

● THIS MASSIVE VOLUME — PRINTED ON SOLID CARD — PROFUSELY ILLUSTRATED — AND BEAUTIFULLY BOUND ON PATENT OPEN-FLAT HINGES — IS LITERALLY PACKED WITH INGENUOUS IDEAS.

The radio and over 60 famous journals have praised this WONDERFUL annual, and The Sunday Graphic said: "This is the very book thousands have been waiting for." The Sunday Dispatch was equally enthusiastic.

● GET YOUR PERSONAL COPY TODAY! The price is 10/- only, post paid. Send to—**HOME MADE GADGETS MAGAZINE** 26 Swan House, Kingsbury, London, N.W.9.

● NOTE: We now have a stock of the famous "SEVENACE" seven-in-one combination pocket knife—26/- only. It has two blades, gimlet, all-purpose punch, corkscrew, screwdriver, and all-purpose saw! A HAND-MADE LUXURY COMBINATION KNIFE. Export Model.

**K.G. VI** UNUSED at face. Colonials and foreign stamps on approval.—Pawson, 5 Wensley Avenue, Hull.

**PERFORATION** gauge and 50 stamps free to all approval applicants enclosing 24d. stamp.—Cliffe West (A1), 61 Wynyard Road, Sheffield, 6.

**SPECIAL offer**—50 different stamps, plus Mint packet of British Empire Pictorials, to applicants for my approvals.—P. E. Bentham, 40 Little Glen Rd., Blaby, Leicester.

**100 DIFFERENT** stamps free! Request 1d. upwards discount approvals, wants lists welcomed.—Bush, 53 Newlyn Way, Parkstone, Dorset.

**FILM** Star postcards. Lists free.—International Filmcard Club, 120 Bournbrook, Birmingham, 29.

**\* GREAT CAMPING OFFER \***



**RIDGE TENT** SENT FOR 4/-

BRAND NEW de luxe 'Safety' Tent. All colours. Complete. Ideal Cyclists.

Camper's. Length 7 ft. 3 in. sleeping base x 4 ft. 6 in. wide x 3 ft. 6 in. high x 12 in. walls, all approx. Weight 3½ lb. £2.15s. or 4/- deposit and 6/- monthly. With fly-sheet £4 2s. 6d. or 10/- deposit and 9/9 monthly. Both carr. 1/6. Don't delay, send now.

**GERMAN PRISMEX BINOCULARS**

**6 LENSES x 40 mm.**

**COATED LENSES**  
Popular Squat Model

**NO DEPOSIT**



Cash Price 69/6

These 6 lenses x 40 mm. for wide field viewing represent the finest value for German Prismex Binoculars. Size 5¼" x 4¼", Bending Bar for eye adjustment, with centre focus. Splendid magnification with real 3D viewing. Clear Bloomed lenses, wide angle. Ideal for sports and holiday use, day and night lenses. Lightweight model. With case lanyard and leather straps. **NO DEPOSIT.** Send only 2/6 for packing & reg., etc. 7 days approval, if satisfactory send 4/6, then 8 payments of 9/- within 8 months. **CASH PRICE 69/6. SEND FOR LIEBERMAN & GORTZ CATALOGUE CONTAINING EVERY KNOWN BINOCULAR MAGNIFICATION. LISTS, TERMS.**

Headquarter & General Supplies Ltd. HOBWX/61, 196/200 Coldharbour Lane, Loughboro Junction, London, S.E.5. Open Sat., 1 p.m. Wed.

**SWISS** musical movements, 14/6.—Artistic Clock Supply Co., 17a New Oxford Street, London, W.C.1.

**200 ALL DIFFERENT** free, genuine offer. S.A.E. for approvals. — W. Self, 36 Fairfield, Boro' Green, Kent.

**FREE**—25 different China, including airmails.—G. F. Bryan, 226 Cateswell Road, Birmingham, 11.

**PRINCESS ELIZABETH** stamp album gratis approvals. Postage 3d.—Neave, 5 Surrendale Place, Paddington, W.9.

**STOP SMOKING** in 3 days or money back. Safe, pleasant, permanent. The only scientific way. **No Will Power necessary.** 'Conquered the habit in 2½ days'.—F.C. 'Within 2 days I was free from the tobacco habit'.—W.G. 'Was a smoker for 2 years and broke the habit in 2 days'.—F.N. 'I used to smoke 20 a day . . . now I have no desire to smoke'.—J.M. Recommended by 'Health and Efficiency Magazine'. Complete course 6/6 (or £1.00 bill). Details 1/4d. stamp. Sent under plain cover. **NATURE REMEDIES, 28 (H/145) Dean Road, London, N.W.2.** Established 1928

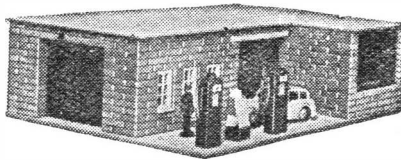

**YOU can build this GARAGE**

WITH

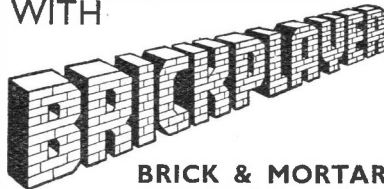

**BRICK & MORTAR BUILDING KIT**

It enables you to build Houses, Inns, Railway Stations, Signal Boxes, or from your own imagination. All railway models will fit 'O' gauge scale. Buildings can be permanent or dismantled by merely soaking in water and the bricks used again and again.

**To all owners of BRICKPLAYER KIT 3**

If you want to convert your Kit 3 into Kit 4, which enables you to build six additional models, ask your dealer for Accessory Outfit 3A at 25/6.

**BRICKPLAYER KITS AT 25/6 AND 47/6 ARE AVAILABLE FROM GOOD TOYSHOPS, HOBBY SHOPS, AND DEPARTMENTAL STORES**

If your dealer cannot supply, write for address of nearest stockist to:

**J. W. SPEAR & SONS LTD.**  
(Dept. H) ENFIELD MIDDLESEX

**A** NUMBER of Bound Volumes of 'Hobbies Weekly' each consisting of 26 issues, for sale. Price 7/6 each. These date back to Vol. 1 and in this form prove an excellent reference library for modellers and handymen. Apply, with postal order, to the Editor, 'Hobbies Weekly', Dereham, Norfolk.

**A** APPROVALS 25 a 1d. upwards. Customer writes—'I have never had any approvals like these; value and condition excellent.'—Jeffreys, 2 Bay View, Craigmoun, Port Talbot.

**M**ARQUETRY for sale—pictures in coloured veneers. London and seaside views. Write—E. Foreman, 157 Cathall Rd., Leytonstone, London, E.11.

**T**RANSFER graining paper—oaks, walnuts; 5 samples 1/-; complete range, 3/-; roll, 16/10.—H. Decano Co., 20 Clarendon Rd., Jersey.

**STAMPS FREE!!** Twenty unused (2½d.).—G. H. Barnett, Limington, Somerset.

**STOP SMOKING!!** Quick Guaranteed remedy. Free Testing Sample!!—Triumph Remedies (H3), Exeter.

**'PAINTSPRAYING' HANDBOOK** (1954 Ed.). Covers Car, Industrial & Flock Spraying. 3/6, post free, including catalogue of our Cellulose and Synthetic Paints and all Allied Sundries and Plant Hire.—Leonard Brooks Ltd., 81 Oak Road, Harold Wood, Essex.

**EARN £££'s WEEKLY** in Sparetime. Hundreds of tested ways. Details free.—S.P. Ltd., 28(HB) Dean Rd., London, N.W.2.

**SWISS MUSICAL** Mechanism for cigarette boxes, etc., 18/- post free. S.A.E. for illustration and list of tunes available.—Dept. HW, Metwood Accessories, Church St., Wolverton, Bucks. (Trade supplied.)

**HOBBIES BRANCHES**

**LONDON**

78a New Oxford Street, W.C.1  
(Phone MUSEum 2975)

87 Old Broad Street, E.C.2  
(LONDON Wall 4375)

81 Streattham Hill, S.W.2  
(TULse Hill 8796)

GLASGOW—326 Argyle Street  
(Phone CENTRAL 5042)

MANCHESTER—10 Piccadilly  
(Phone CENTRAL 1787)

BIRMINGHAM—14 Bull Ring  
SHEFFIELD—4 St. Paul's Parade  
(Phone 26071)

LEEDS—10 Queen Victoria Street  
(Phone 28639)

HULL—10 Paragon Square  
(Phone 32959)

SOUTHAMPTON—25 Bernard St.

BRISTOL—30 Narrow Wine Street  
(Phone 23744)

**A** MERICAN MAGAZINE Subscriptions. One year Popular Mechanics 32/-. Popular Science 31/6. Homecraftsman 16/6. Homecraft 18/-. Deltagram 10/6. Free booklet quoting others.—Willen Ltd. (Dept. 57), 101 Fleet St., London, E.C.4.

**P**LYWOOD: large sizes, 14 lbs. 10/- delivered (Express) C.W.O.—H. Leader (1920), Gosford St., Middlesbrough.

**P**LYWOOD — **HARDBOARD** — at amazing low prices. Send S.A.E. for samples and prices to — N. Gerver, 10 Mare Street, Hackney, London, E.8.

**A**LL COMPONENTS with instructions for A slide-coil crystal set, tunes 200-550 metres; 3/9 post free.—Bailey's, 44 Stanley St., C. Oldham.

**25 STAMPS** free, request approvals.—Broadway Stamps, 80 Broadway Grove, Worcester.

**GOVERNMENT SURPLUS BARGAINS.** Inter-room Telephones, comprising 2 self-energised microphone/receivers and approx. 6yds. flex (may be extended if desired). No Batteries needed. Nothing to wear out. Complete 9/6, post 6d. Motors, Transformers, Switches, etc. 3d. stamps for illustrated list. **Miligan's, 24 Harford Street, Liverpool, 3.** Money Back Guarantee.

# An Attractive Screen for a Modern Fireplace

By  
Stanley  
Turnbull

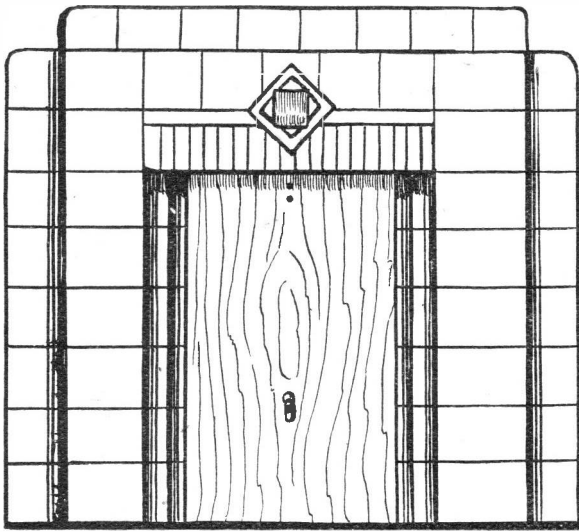

When ready for putting into position as a screen, fix a small hook near the bottom of the front; this will make for easy handling. The screen should fix quite securely and will need a little lift upwards to push it into place, so that the top strut holds the cover firmly. The hook is almost a necessity for removing the cover which will need a forward pull from the bottom to allow the top strut to move backwards in the chimney and come out of position.

The sketches indicate the simplicity with which the screen may be made, and also suggest ideas for linoleum designs.

## Use Your Fretsaw

A local handicraft shop will be able to supply materials and cut the wood to your exact sizes, or even easier still is to

**T**HE attraction of a modern fireplace, with its coloured tiled or simple wood surround, is often completely marred when a fireless sooty mouth gapes out into the room. Unfortunately, ordinary firescreens seldom offer sufficient cover and so often they look quite out of place in a modern home.

The following suggestions offer an inexpensive alternative which will delight with its pleasing effectiveness.

## Cut Plywood to Fit

After measuring the aperture of your fireplace, cut a piece of plywood or similar material to fit snugly as a cover over it. Remember, if your fireplace has a 'well' type of hearth you may have to up-end or remove the fire grid or fret that closes in the bottom of the basket on which the fire normally burns to enable you to fit the plywood cover exactly. A piece of lath or batten about 4ins. long has now to be fixed in the middle back top edge of the cover (Fig. 1). This will extend into the chimney and act as a catchment to hold your plywood cover in position.

The screen itself can be most effectively decorated with odd scraps of linoleum that might tone or contrast with your floor covering. With a little thought and ingenuity you might contrive designs that will use even the smallest scrap of linoleum remaining after fitting a floor covering in another part of the house.

If you fix your linoleum design to the plywood by means of tapestry nails, these themselves can be worked into quite a pleasant pattern. Failing the use of nails, glue or one of the many varied types of adhesive now on the

market can be used to position your lino scraps. As an alternative to the linoleum cuttings, wallpaper similar to that used in your room's decor might be pasted on the plywood cover. Failing that, the cover could be painted or even distempered to suit your colour scheme.

A charming mottled or marbled

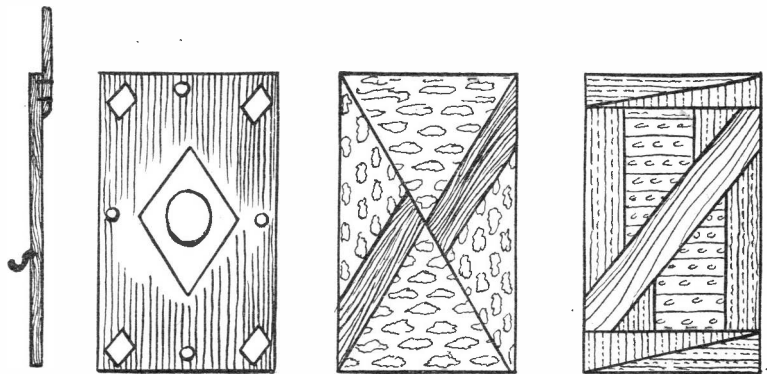

Fig. 1

Three suggestions for designs

effect can be achieved by first painting thick streaks of contrasting colours from top to bottom of the board, then, while the paint is still wet, lay the board flat and gently pour a small amount of turpentine on to it. Quickly turn the board into an upright position, so that the turpentine can run from top to bottom and merge the hard edges of the painted streaks, and then lay the board flat again to dry. Be sure, of course, to do all of this painting in a place where drops of paint cannot spoil any floor-covering, etc.

use your fretsaw on an old tea chest; probably you would get enough good plywood from a tea chest to make four such screen covers.

## Labour-saving Too

One thing is quite certain. Once you have fitted one of the screens in the way suggested, you will be most anxious to fit all your fireplaces with them for the summer months. Falls of soot will not spoil your hearth, so, apart from its attractiveness, such a screen is also labour-saving.

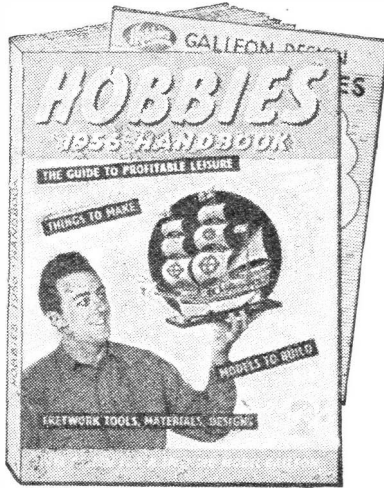

# COMING OUT JULY 30th

152 pages packed with interest for the handyman, modeller and home craftsman — all for 2/-  
**FREE DESIGN for a model galleon**

Stripwood Toy Making

Jigsaw Puzzle Cutting

Coloured Marquetry Picture and Instructions

Modern Furniture Patterns

**CATALOGUE OF HOBBIES FAMOUS TOOLS AND KITS, Etc., Etc.**  
*Make sure of a copy and place an order with your newsagent, Hobbies branch or stockist NOW. Or send 2/3 P.O. to Hobbies Ltd., Dept. 99, Dereham, Norfolk, for a post-free delivery.*

## 'RECORD' PRODUCTS

AVAILABLE ON THE 'LAFCO'  
EASY-PAYMENT SCHEME

(Minimum order 60/-.) To save space we show only the Cash Price. To calculate deposit required add 1/10th to the price shown and divide by 9. (Balance payable by 8 monthly payments of the same amount.)

**Mechanics' Vices.** No. 00=22/-, No. 0=24/-, 1=30/-, 2=42/-, 3=55/-, 4=64/-, 5=78/-, 6=100/-, 7=125/-, 1=42/-, No. 00S=31/6, 0S=34/-, 1S=42/6, 2S=58/-, 3S=76/-, 4S=86/-, 5S=105/-, 6S=129/-, 7S=154/-, 8S=171/-.

**Fitters' Vices (Quick Grip).** No. 21=73/6, 21S=93/-, 22=88/-, 22S=110/-, 23=106/-, 23S=130/-, 24=122/-, 24S=151/-, 25=142/-, 25S=175/-.

**Auto Vice.** No. 74=90/-.

**Table Vice.** No. 80=26/6.

**Woodworkers' Vices.** No. 52=52/6, 52½=71/-, 53=78/-, 52A=57/-, 52½A=76/-, 53A=84/-, 52P=50/-, 52½P=66/-, 53P=72/-, 50=18/-, 51=22/-, 55=32/6.

'RECORD' Cramps also supplied.

'RECORD' Planes as follows:—O3=33/6, O4=34/-, O4½=40/-, O5=42/-, O5½=47/6, O6=53/-, O7=63/-, O8=75/-, O3-S5=33/6, O4-S5, etc., all as above.

O9½=21/6, O10=59/6, O10½=55/-, O20=72/-, O41=32/-, O42=44/-, O43=27/6, O44=47/6, O50=91/6, O71=40/-, O73=60/-, O75=8/-, O76=18/-, O77A=30/6, O78=30/-, O102=8/6, O110=13/6, O120=16/-, O130=16/6, O220=16/-, 311=53/-, Multi Plane 405=173/-.

**CORONET TOOL CO.'S PRODUCTS AVAILABLE** as follows:

(a) Lathe (HC1) with 2ft. 6in. bed complete with centres, etc., £8/17/- cash or 21/8 deposit and 8 monthly payments of 21/8. (b) With 3ft. bed (HC2), £10/4/- cash or 24/11 deposit and 8 monthly payments of 24/11.

Others available. State your requirements.

DESK 197

**LAFCO COMPOUNDS LIMITED**

3 CORBETTS PASSAGE, ROTHERHITHE NEW ROAD,  
BERMONDSEY, S.E.16 BERmondsey 4341/2/3

## HURRY! HURRY! HURRY!

Get your kits NOW for these grand working models

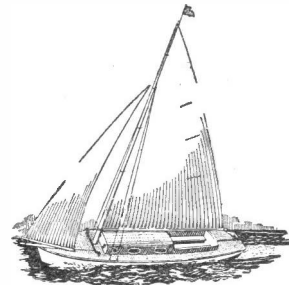

15 in. Model Yacht  
Kit No. 3104

(all fittings, including sails)

Sails perfectly and a real bargain for

**14/3**

20in. Motor Launch  
Kit No. 3096

(including motor and propeller unit)

**36/6**



Obtain your kit now from your Hobbies branch or stockist or direct, post free, from:

**HOBBIES LTD. (Dept. 99)**  
Dereham, Norfolk





DESIGN

No. 3116

# A NOVELTY TRINKET BOX TREASURE CHEST

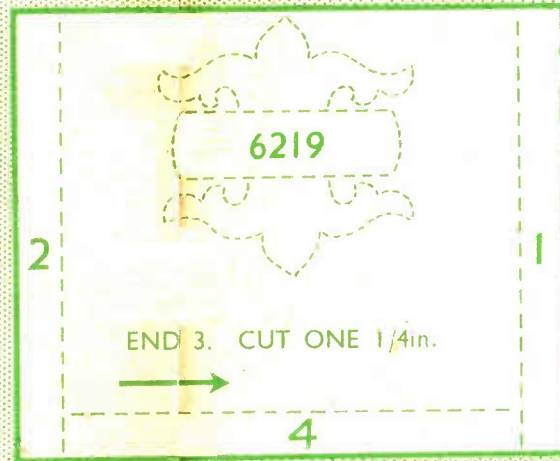
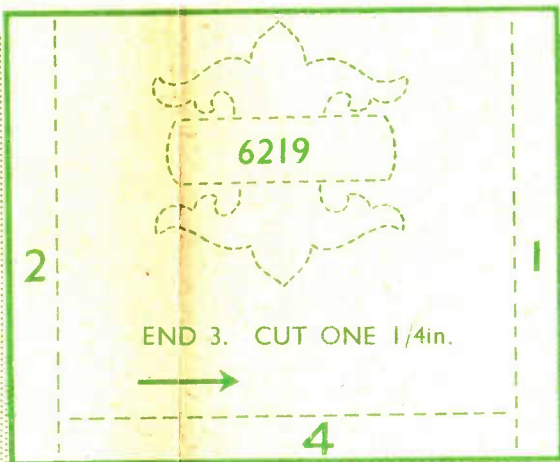

SIZE  $5\frac{1}{2}$ ins. LONG.  
 $2\frac{7}{8}$ ins. WIDE.

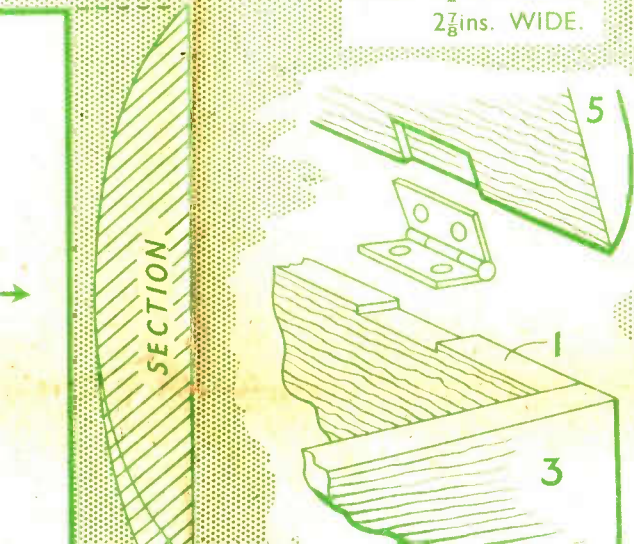

### Materials required for this design

**WOOD** One piece 12ins. x 5 1/2ins. x 4ins. (Hobbies Q4)  
 One piece 8ins. x 3ins. x 3/4in.  
 One piece 11ins. x 4ins. x 1mm. (Hobbies P.P.M.)

### FITTINGS

One pair 1 1/2in. light brass hinges  
 One box catch 1 1/4ins. long (Hobbies No. 6218)  
 Two box catches 1in. long (top portion only) Hobbies No. 6219  
 Four ball feet 1 1/2in. diam. (Hobbies No. 14)

A complete kit of the above materials can be obtained from  
**HOBBIES LTD., DEREHAM, NORFOLK**

## Glue it with **Croid**

**Universal Glue** for use cold straight from the tube or tin from 1/- each.

**Aero Glue** in the Home Outfit or in tins from 1/3 each for quicker setting.

# Glue it with **Croid**

**Universal Glue** for use cold straight from the tube or tin from 1/- each.

**Aero Glue** in the Home Outfit or in tins from 1/3 each for quicker setting.

Available from all branches of Hobbies Ltd.

SECTION

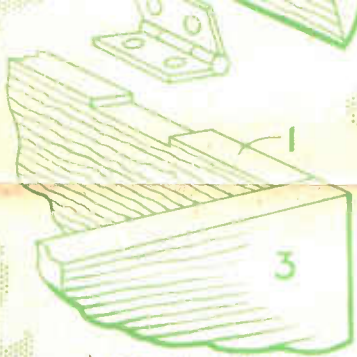

DETAIL SHOWING HOW HINGE IS FIXED.

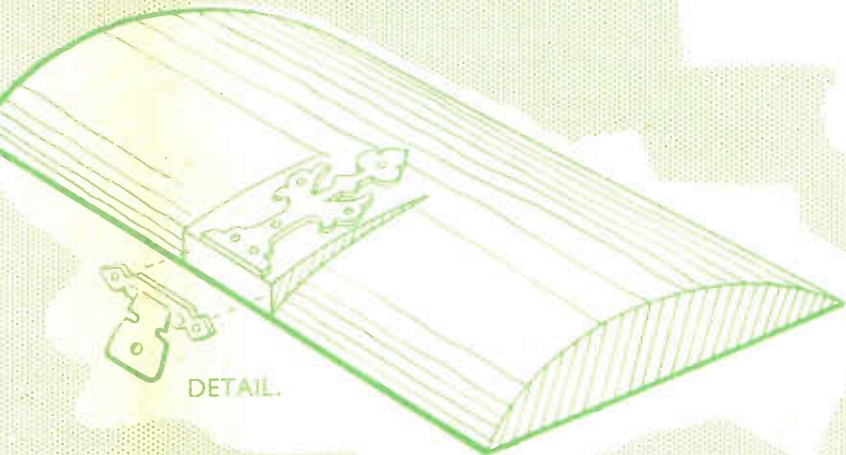

DETAIL.



BALL FEET.  
FOUR REQUIRED.

**A JOB FOR THE FRETSAW**

PIECES. CUT EACH FROM WOOD OR CARDBOARD.

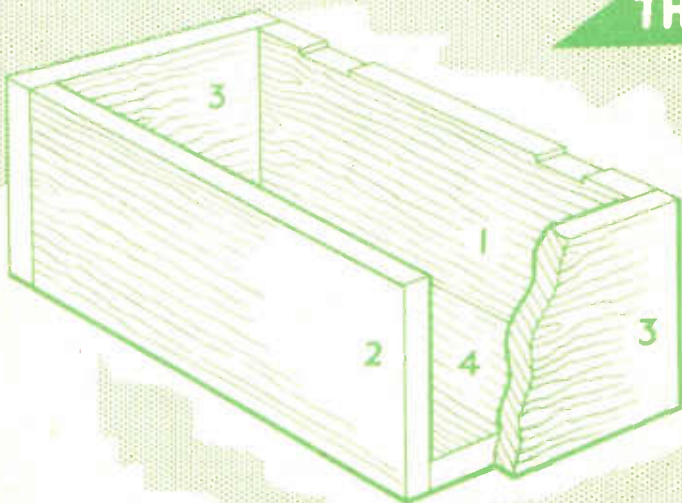

THE ARROWS INDICATE DIRECTION OF GRAIN OF WOOD.

PRINTED IN ENGLAND.

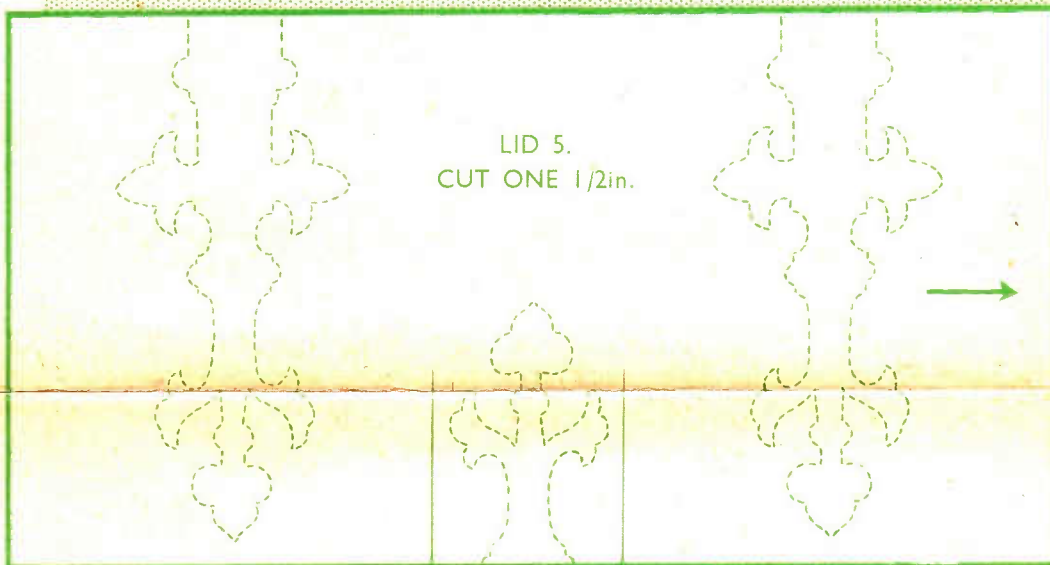
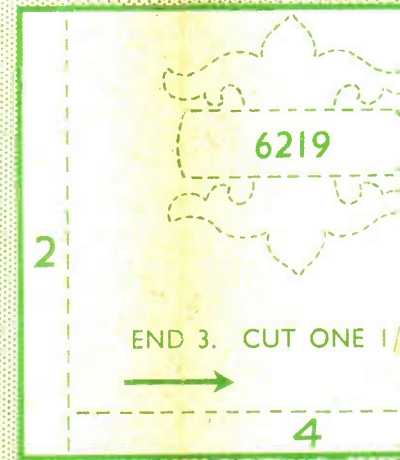
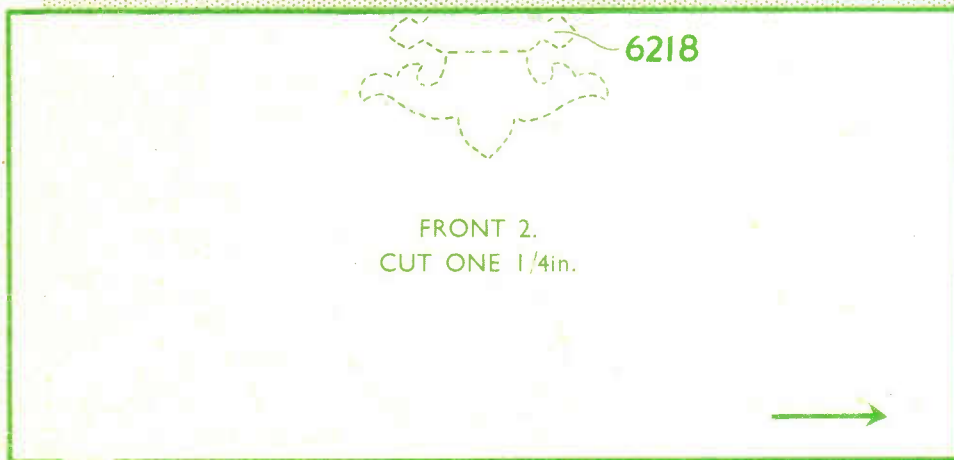
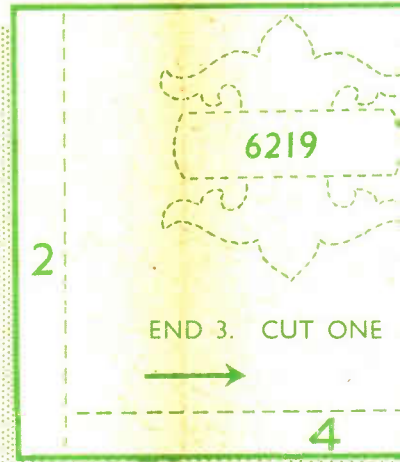

SIZE

DE

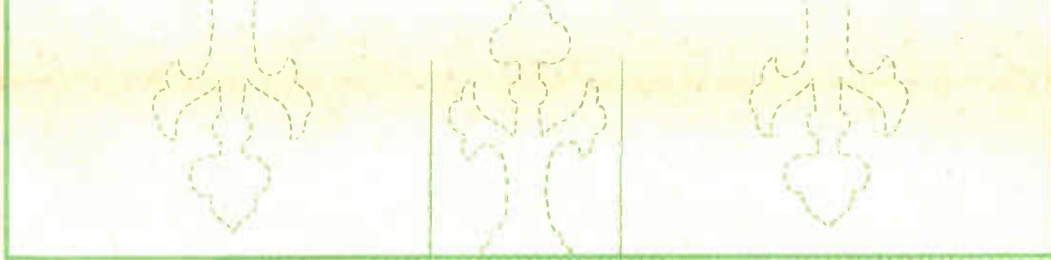

FLOOR 4. CUT ONE 1/4in.

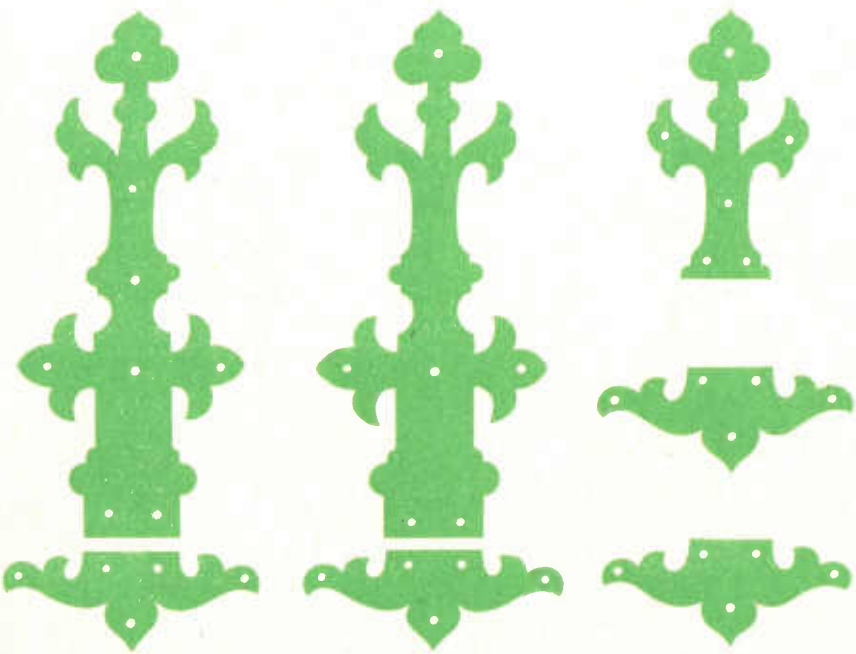
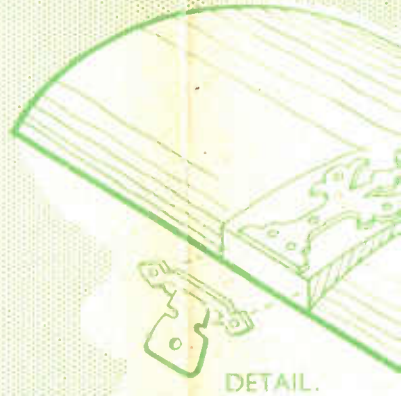
HINGE PLATES. CUT ONE OF EACH FROM THIN PLYWOOD OR THIN CARD.

