

Hobbies

WEEKLY

CONTENTS

	Page
Tea Waggon - - -	1
Cabinet Cone Speaker -	3
Library Book Holder -	4
Useful Cabinet - - -	5
A Hectograph - - -	6
Hints and Tips - - -	6
Glass Cutting - - -	7
Home-made Cements -	7
House Water System -	8
Corner Cupboard - - -	9
Hiking Pleasures - - -	10
Camera Flashlight Unit	11
Renewing Sash Cords -	12
Stamp Collecting - - -	13

PATTERN SHEET FOR A
MEDAL CABINET

April 5th, 1950

Price Fourpence

Vol. 110 No. 2840

THIS is a welcome article of furniture in any home, saving time and much trotting about, carrying tea and dinner things from kitchen to dining room. It is provided with an extra deep lower tray, so if the waggon is used for conveying tea things from the house to the garden, when the weather permits such a pleasure as an open air meal, then there is little danger of the extra jolting tipping crockery over.

For the construction, oak or beechwood is an excellent wood to employ, but if unobtainable a good quality deal will make a satisfactory article. The

A USEFUL SMALL TEA WAGGON

work is not difficult, the necessary mortise and tenon joints being of the simplest. It is just an ordinary piece of household carpentry, quite within the scope of the average woodworker.

General dimensions will be found in the front view of the waggon, Fig. 1 and the side view, Fig. 2. Cut the four legs from wood $1\frac{1}{2}$ ins. square, lay them on the bench, side by side, and square lines across for the mortises necessary for the rails.

Rails

The top rails are from 1 in. wide wood, the tenons being $\frac{3}{4}$ in. and $\frac{3}{4}$ in. long. The lower rails are 3 ins. wide at the ends and $4\frac{1}{2}$ ins. wide at the sides. All these rails are cut from wood $\frac{3}{4}$ in. thick.

Having squared the lines across, gauge lines for the mortises, $\frac{3}{4}$ in. apart, exactly central along the legs. When the rails are cut from the $\frac{3}{4}$ in. wood, the tenons of the lower ones will be as follows. The end rails have two, each 1 in. long, and separated by $\frac{3}{4}$ in. at the centre. The side rails have three tenons, each 1 in. wide, and separated by a distance of $\frac{3}{4}$ in. between each, the top tenon being $\frac{1}{4}$ in. from the top of the rail. Fig. 2 shows these details to help make the above clear.

Leg Joints

The mortises in the legs must be marked as to length to suit these tenons naturally, and can then be chiselled out to a depth of $\frac{3}{4}$ in. Try for fit, and when satisfactory, mitre the ends of the tenons so they can meet in the mortises. A too close meeting between the mitred ends is not desirable, as glue may get between, in fact will, and prevent the joints closing up tightly. Leave a trifling space between them, as at (A).

Now glue all the joints and knock

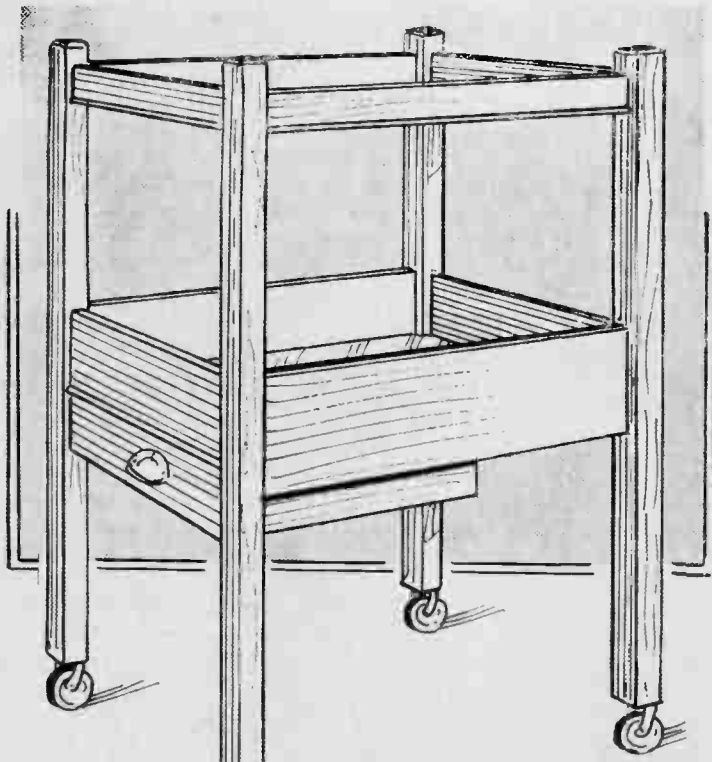

All correspondence should be addressed to The Editor, Hobbies Weekly, Dereham, Norfolk.

them well home. Leave for awhile for the glue to get hard, then the bottoms of both trays can be fitted on. These bottoms can be cut from $\frac{1}{2}$ in. plywood, or possibly a good quality of substitute boarding would suit as well.

Top Tray

For the top tray cut a rectangle 1ft. 8 $\frac{1}{2}$ ins. long and 1ft. 4 $\frac{1}{2}$ ins. wide. At each corner saw out a $\frac{7}{8}$ in. square to clear the legs. Glasspaper the edges of the tray bottom to a smooth curve and fix to the under edges of the rails with slide and small screws.

The bottom of the lower tray requires a piece of plywood the same length as the top one, but only 1ft. 3 $\frac{1}{2}$ ins. wide. The corner pieces to be sawn out measure $\frac{7}{8}$ in. by $\frac{7}{8}$ in. Fix in similarly to the top one, but as the side edges butt up

The drawer is a useful adjunct to the article, most handy for cutlery and table linen. It can be any length within the capacity of the waggon, but 12 ins. to 15 ins. will probably be considered

WOOD

Legs (4)— $\frac{1}{2}$ in. square and 2ft. 4 ins. long.
For upper rails— $\frac{1}{2}$ in. by 1 in. by 7ft. run.
For lower rails— $\frac{1}{2}$ in. by 3 ins. 3ft. run.
For ditto, $\frac{1}{2}$ in. by 4 $\frac{1}{2}$ ins. 4ft. run.
Wood for drawer— $\frac{1}{2}$ in. by 3 ins. 7ft. with one piece 3 $\frac{1}{2}$ ins. wide for drawer front.
Plywood for bottoms, etc., as detailed in article.

enough. It is of simple construction, as shown at (B) in Fig. 4. The sides and ends are 3 ins. wide and cut from $\frac{3}{4}$ in. thick wood.

The bottom can be of plywood,

plough plane can do the job easily, but without it a good plan is to saw the wood to the required depth for the groove with the ordinary tenon saw, using a strip of wood, cramped up against the cutting lines, as a guide. Level the bottom of the grooves with glasspaper folded round a strip of wood, to nearly fit the groove. These grooves will slide along runners, fixed to the lower rails, beneath the tray bottom.

Runners

Prepare the runners from two strips of wood, $\frac{3}{4}$ in. thick and 1 in. wide, with $\frac{1}{2}$ in. wide strips of $\frac{3}{4}$ in. fretwood screwed to them. These latter strips are the actual runners. They should be just the length to fit between the legs, as in

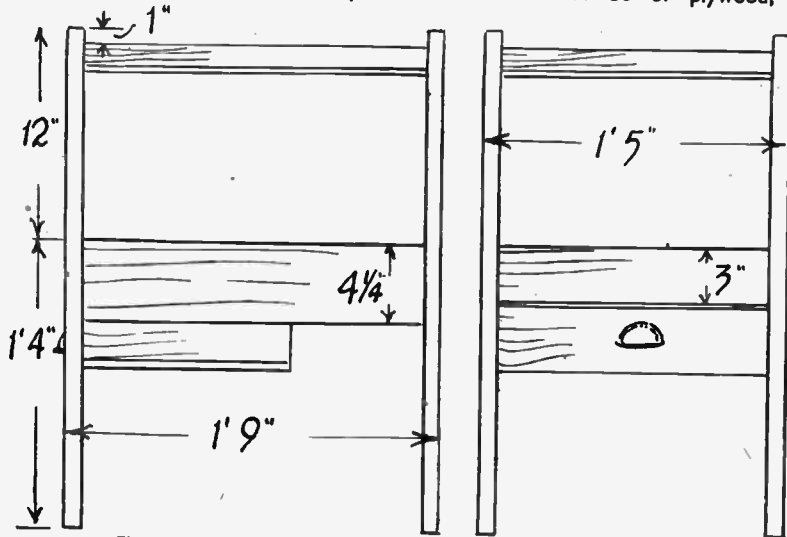

Fig. 1—Side view showing trays

Fig. 2—End view showing drawer pull

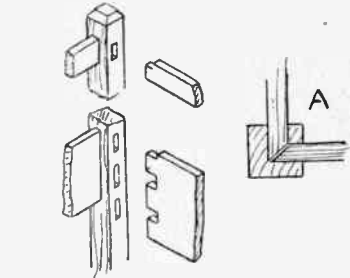

Fig. 3—Details of some joints

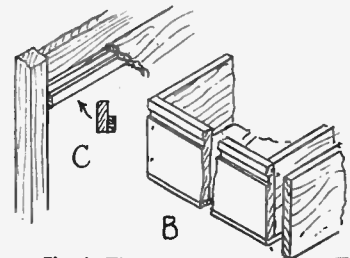

Fig. 4—The drawer and runners

against the rails, gluing and screwing can only be done to the under edges of the end rails. This, of course, will be apparent before fixing. Make a close joint at the sides as any gap will look ugly, and also allow dust and crumbs to work through into the drawer beneath. Finish the tops of the legs by bevelling.

screwed on, or nailed or glued. Before fixing the parts of the drawer together, take the sides and cut a groove $\frac{3}{8}$ in. deep and $\frac{1}{2}$ in. wide in each, the grooves being exactly $\frac{1}{2}$ in. down from the top.

Take care in cutting the grooves to get them truly level from end to end of the drawer sides. Those readers who own a

detail (C). Fix with glue and nails, and glue the top edges, as these will butt against the bottom of the tray above and support it. Finish the drawer with a facing of $\frac{3}{4}$ in. wood, and the whole article with stain and varnish. A 'pull' for the drawer and castors for the legs will complete.

Cone Cabinet (Continued from page 3)

edges may be held together with small paper fasteners or glue.

The cone should not be made too deep or there will not be sufficient space to accommodate it. If it stands about 2 ins. high when placed on a table in a flat position this will do nicely. Its overall diameter should enable it completely to cover the cabinet cut-out when in position, the edge resting against the wood as shown in Fig. 2.

Fixing the Cone

It is possible to secure the cone directly between the locknuts, but this will prove very weak and unreliable. Two cone-shaped washers should, therefore, be made from thin tin by cutting to the shape shown in Fig. 1 and bending the edges together. A small hole is

made at the centre of each washer.

The washers are placed one inside and one outside the paper cone, holding it securely. As a final measure the locknuts, washers, and centre of the cone may be painted with varnish or glue and allowed to dry to ensure that vibration does not loosen the parts.

The strip of wood holding the unit is now screwed in such a position that the cone rests lightly against the front of the cabinet.

Results to Expect

The speaker should click loudly if connected to a small dry battery. If it does not, then the windings of the bobbin or leads to the terminals should be examined.

Excellent reproduction should be

obtained from small 2 or 3 valve battery-operated receivers. The output from 1 valvers is naturally limited, but signals should be loud enough for all words to be clearly audible, and this should also be so with a good crystal set used in an area where one or more local stations are well received.

When connecting to a battery set, take the positive speaker lead to H.T. positive and negative lead to output valve anode. Do not operate the speaker for any length of time with these leads reversed or the unit may become slightly demagnetised. In the unlikely event of reproduction being unsatisfactory, examine the unit as described to assure that the cone is not forcing the armature back against the magnet poles, thus preventing vibration.

How the amateur radio constructor can make an efficient CABINET CONE SPEAKER

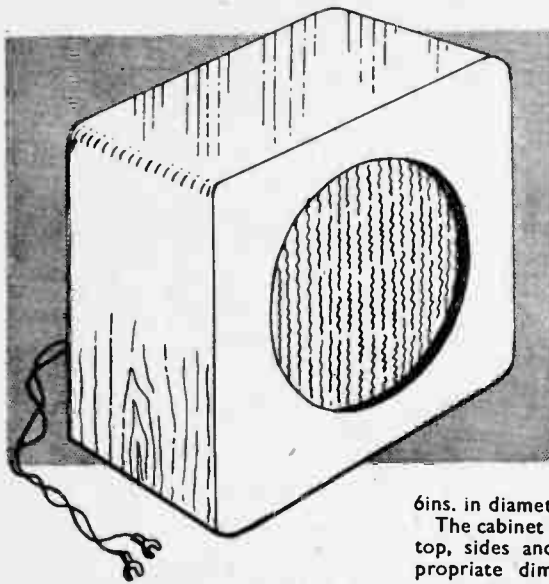

READY-MADE moving coil speakers are fairly expensive, but the constructor who has a small battery-operated receiver can make a suitable speaker very cheaply. Such a speaker can give good results and many listeners hearing it in action would fail to distinguish between it and a ready-made speaker. The quality of reproduction on both speech and music is good; the speaker is sensitive so that it will give quite a good output with small receivers, and it can deliver ample volume for ordinary purposes.

It is not suitable for mains-operated receivers because the windings cannot handle the heavy current taken by the output valves of such sets. But even with a mains receiver it can be used for extension purposes, coupled by means of a condenser so no direct current flows through the windings.

The Unit

The speaker is made up round a permanent magnet balanced-armature unit such as used in balanced-armature high and medium impedance headphones. This may be obtained at a very moderate price (about 2/-) from many stores, or the constructor who has an unused pair of phones to hand may adapt one of the earpieces.

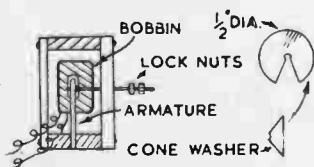

Fig. 1—The unit and cone centre

Though it would be possible to make up such a unit the cost would considerably exceed that of a ready-made unit, even if a suitable permanent magnet and other parts could be obtained. It is, therefore, best to buy this section of the speaker ready-made.

Cabinet Details

The cabinet, which is essential for proper reproduction and also serves to support the parts, can be made up from $\frac{1}{2}$ in. thick wood, with 3-ply for the front. The front itself may be about 8 ins. by 8 ins., with a circular cut-out 6 ins. in diameter for the speaker cone.

The cabinet is about 4 ins. deep and the top, sides and bottom cut out to appropriate dimensions. In Fig. 2 the measurements given assume the use of $\frac{1}{2}$ in. thick wood for bottom and sides, with $\frac{1}{2}$ in. wood for the top, the pieces being so arranged that the minimum number of joints are visible.

The parts should be nailed or screwed securely together. In addition, a strip of $\frac{1}{2}$ in. thick wood 7 ins. long and about 3 ins. wide will be required to support the speaker unit. This strip is screwed to two small blocks which are also screwed to the inside of the cabinet. Nailing or gluing is not recommended here as a little adjustment may be necessary to ensure that the cone comes right up to the cabinet front.

Cabinet Finish

After thorough glasspapering, the cabinet may be varnished, and if a good finish is obtained the final appearance of the speaker will be satisfying. If desired, four small feet (the rubber ones obtainable from the popular stores are suitable) may be added.

The inside of the circular front cut-out may be covered with a piece of thin silk or similar material, glued in place and stretched tightly. Alternatively, if the cone itself is to be made from coloured

material the finish will be quite satisfactory even if the cut-out is left uncovered. With moving-coil speakers some such covering is essential to keep dust from the speech-coil gap, but with this type of speaker this point does not arise.

Mounting the Unit

Most of the units mentioned will appear similar to Fig. 1, when removed from the case. A spindle projects from the armature, and two small lock-nuts will be used to hold the cone in place. As it is absolutely essential that the armature comes centrally between the poles of the magnet, this should be checked, and the armature bent slightly if necessary. If the armature rests against one pole reproduction will be weak and rattling may mar the results obtained.

The unit is mounted on the strip shown in Fig. 2, the armature spindle passing through a fairly large clearance hole (say, about $\frac{1}{2}$ in. in diameter). It is fixed by two or more small bolts from the front and it should be quite secure and so arranged that the spindle does not foul the wood.

Two leads will be found issuing from the bobbin, and the polarity of these should be noted and taken to two terminals situated at any convenient point on the strip. Leads from the receiver can then come to these terminals, and this will ensure that the fine wires from the bobbin are not pulled away.

Making the Cone

It is quite easy to experiment with different materials for this, and reproduction will be influenced slightly by the thickness and stiffness of the material used. Very thin cardboard is suitable, or very stout drawing paper. The best material will be found employed as covers to some large catalogues, being a type of very stout, strong paper of a fairly pliable nature.

A circle about 7 $\frac{1}{2}$ ins. in diameter is drawn on the paper to be used and the shape is cut out. Afterwards remove a narrow segment running right to the centre and draw the edges one over the other so that a cone is formed. The

(Continued foot of page 2)

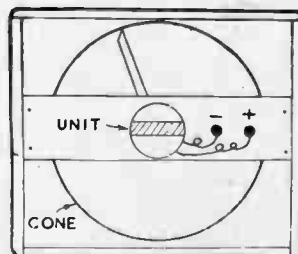

Fig. 2—Internal arrangement of the cabinet

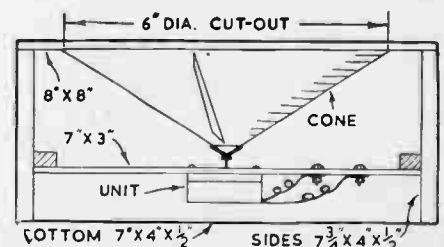
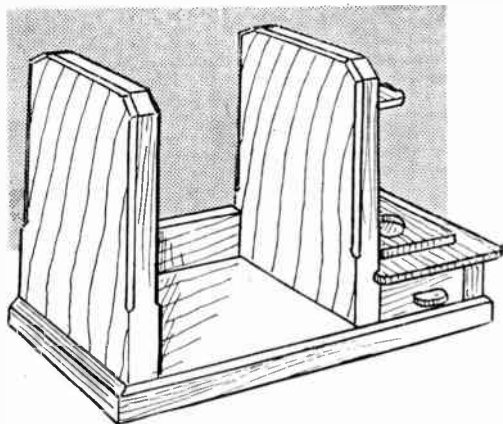

Fig. 3—Back view of speaker

Those who are neat and tidy will make this LIBRARY BOOK HOLDER



DOUBTLESS many readers enjoy the benefits of their County or Town Library, and it would be a good idea to make up the special book holder illustrated, to house them and keep the volumes separate from the home books in their possession. By so doing, no confusion arises, and the borrowed books are taken better care of than when lying about the house.

Included in this particular design of book holder are a pipe rack and a small drawer, the latter being a handy little receptacle for holding library tickets not in use at the time. For making this article it is suggested that readers use the wood from a grocer's box, if they can obtain one suitable for such purpose.

A Box for the Wood

Quite a good box is one used for imported apples, etc., as it has substantial end pieces of $\frac{3}{8}$ in. wood, and two sides of $\frac{1}{8}$ in. wood, all of a quality good enough for the work. In the absence of such a box, the article can be made from a 2ft. 6in. length of $\frac{3}{8}$ in. by 8in. deal, and two panels of $\frac{1}{8}$ in. fretwood, one 7ins. by 14ins., and the other 4ins. by 7ins.

Some of the parts of the holder are shown in Fig. 1, (A) being the base, (B) the sides of the book portion and (C) the side of the drawer portion of it. Cut the base to dimensions given, and run the smoothing plane over the surface, or give it a good rub over with glasspaper, according to the condition of the wood.

The Joints

On this mark off the three mortises shown, positioning them at the centres. Make these $1\frac{1}{2}$ ins. long and $\frac{3}{8}$ in. wide, or whatever thickness the wood may be. The mortises are not cut right through but made $\frac{3}{8}$ in. deep. They can be cut out easily enough with a sharp chisel.

Saw out the bookcase sides (B), making the tenons to suit the mortises in the base, of course. In one (the

middle one), cut out the piece shown, $\frac{1}{8}$ in. or $\frac{1}{4}$ in. according to the thickness of the thin wood used, to leave space for the low back rail at the rear, which prevents the books being pushed off the case.

In the end side part, rebate for this rear piece, so that it can sink in without showing a cut edge. The opposite end piece (C), forming one side of the drawer opening, is now cut, and is similarly rebated at the back. Saw out this part with the grain of the wood running across the narrow part, not length-

wise.

Try these parts for fit, and if satisfactory, glue in the middle one and the short end one, leaving the other for a bit. The edges of the base should be neatly bevelled off, level with the bookcase sides, a job best done before gluing the latter in position, naturally.

Back Rail

At this stage cut a $1\frac{1}{2}$ in. wide strip of the thinner wood, for the back rail, cutting it long enough to extend between the sides. Glue the remaining sides in, and then the back rail, nailing the latter as well.

The side pieces, by the way, can be left with a square edge, but an improvement, worth the little trouble involved, is a chamfer worked along the edges, and stopped about 2ins. from the base. This is shown in the general view, and if intended to be carried out, is best done before the sides are glued in.

A top piece, to cover in the drawer opening, is cut from the thin wood to the size given in Fig. 3 (G). This is glued over and nailed where it butts against the middle side piece, or a better neater fitting obtained at this part by grooving the side piece for it, as in detail (D) in Fig. 2. Cut a second piece of the thin wood, about $\frac{1}{4}$ in. less length and width.

Bowl Rest

On this bore a pair of $1\frac{1}{2}$ in. holes through, say, 1in. apart, for the bowls of the pipes to rest in, and glue the piece to the top part (G), where shown by dotted lines, after (G) is glued in position.

For the mouthpieces of the pipes to

rest in, cut a piece of wood to size (H), in Fig. 3, this time from slightly thicker stuff, say, $\frac{3}{8}$ in. or $\frac{1}{2}$ in. Saw out the slots shown, seeing they come directly over the centres of the holes in (G) and fix it with glue and two screws about 1in. down from the top of the middle side piece. All that now remains is the drawer.

Making the Drawer

This is drawn at (E) in Fig. 2. Its size will be that of the drawer opening, of course, and its depth the same. Construction is simple but neat. Cut the front from the thicker wood, and the rest from the thinner wood, or fretwood as may be necessary. The front is rebated for the drawer sides to fit in. The end piece is cut narrower than the sides, as the bottom is to be nailed to it.

Fit the end across not quite at the back, say, about $\frac{1}{8}$ in. from it. Cut a

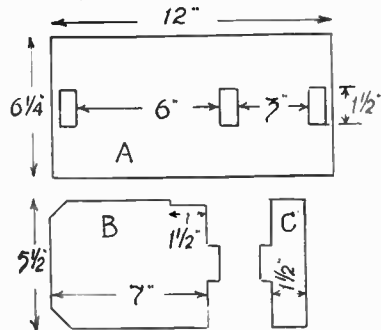

Fig. 1—Main part dimensions

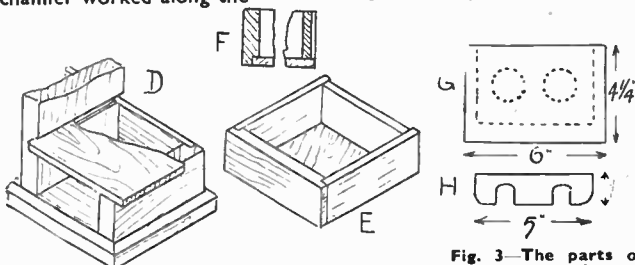

Fig. 2—The end and drawer construction

Fig. 3—The parts of the pipe holder

rebate in the front for the drawer bottom to fit in, and glue and nail all together. Detail (F) shows how the bottom fits in, it is all very simple.

Fit a small wood pull to the drawer front, then clean up with glasspaper and finish the work either with stain and varnish, or a pleasingly coloured enamel. With boxwood the enamel would be best.

In any case it is advisable to add two coats of paint—the first a flat grey colour to form a priming coat and allowed to harden before the second is added.

If stain is applied let get it perfectly dry before you add the varnish over it. A clear hard varnish should be applied, in a warm room.

Keep your sawblades, screws, and sundries in this USEFUL CABINET

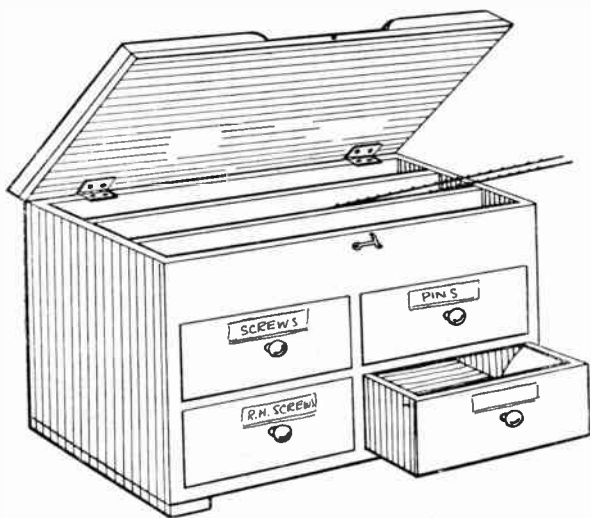

NOW that the light evenings are approaching, many readers will, no doubt, spend a short time in the garden and then finish off with any jobs of fretwork that may be on hand. It is most annoying when only a short time is at your disposal, to find the fretsaw blades are missing, or that the particular size screws you need have been mislaid. It is to avoid this that the neat little box, shown in the illustration, has been designed.

It has shallow compartments in the top for various grades of fretsaws. Three are shown, but, of course, this depends upon the number of sizes that you use. We have provided four little drawers suitable for screws and fretpins.

Extra Partitions

If four is insufficient we suggest that you glue in a centre partition, dividing, say, two or three of the small drawers in two. Alternatively the ends of the box could be made deeper and two or even four more drawers added.

Round the edge of the lid are glued

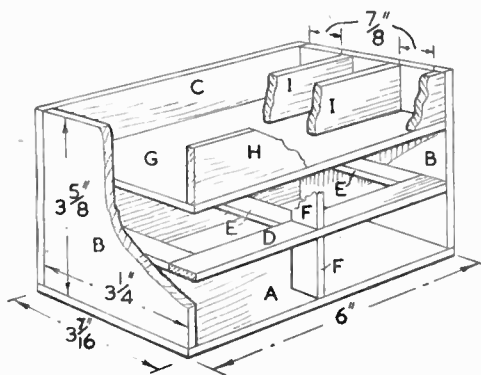

Fig. 1—Cut-away construction view of box

fillets forming a tray which will be most useful for sorting odd nails or screws or for containing them when using a certain number for a particular piece of work. It will be noted in the detail in Fig. 2 that a gap has been left in the front edging fillets just mentioned.

This makes the handling simple, as the contents of the 'tray' can be easily counted and drawn forward as necessary. It may be pointed out, too, that these fillets greatly strengthen the lid,

preventing it from warping.

In Fig. 1 we have a diagram of the box, with various parts broken away to show the construction. Assembly is quite straightforward, and since most parts are lettered and sizes given, further details are unnecessary. It is suggested, however, that the measurements are checked from time to time as work proceeds. This applies more especially to such parts as the interior rails and partitions where, perhaps, the difference in thickness of wood might cause a misfit.

General Assembly

The base (A), the two sides (B), and the back (C) are the first parts to cut and glue up. Take note how the sides (B) fall flush with the front edge of base (A). The front rail (D), and the drawer runners (E) and the uprights (F) are next carefully inserted. The floor (G) of the fretsaw compartment is just a plain piece with the front upright rail (H) glued on.

The partitions (I) are next cut out and glued in position. The lid is the same size as the base (A) and a detail of this is shown in Fig. 2. The inset shows the method of hinging. The hinges are first screwed to the lid, and recesses afterwards made in the

back deep enough to contain the two flaps of the hinges.

This ensures the lid fits flat and even along the top of the box. The edging fillets may be neatly mitred at the corners or they may be simply butted, as shown in the sketch.

Drawer Construction

A detail of the construction of the drawers is given in Fig. 3. The dimensions for all parts of the drawer are given 'full' which allows for rubbing down all round after gluing up, thus ensuring a good fit.

Note how the back of the drawer (L) is kept in a little way along the sides. This is for strength only—so the fret-pins which help to strengthen it are not pulled out with the weight of nails or screws behind it. Note, too, the extra strengthening piece (L) behind (M), the drawer front.

The drawers should each be glued up and glasspapered before the pins are inserted. Each drawer should be numbered during construction so it retains its original and proper place.

Finally, a hook and a pin or round-head screw should be added, the position being shown in Fig. 2. Small knobs can be added to the drawers as shown in the picture of the finished box. Feet can be added, too, if desired; they will add to the appearance considerably. They can be cut from waste wood in the form of small blocks glued to the corners or a strip can be glued the whole way along as shown.

Finishing

The whole box can be suitably coloured with two coats of quick drying enamel or simply stained and varnished. Take care that the varnish or enamel does not come in contact with the drawer sides or runners. If any is accidentally smeared on, it should be wiped off at once before it has time to dry. The addition of small neatly printed labels pasted on the drawers and saw compartments will complete this very useful little box.

One of the principal points in its construction, it should be noted, is to get the edges of all parts cut dead straight or they will not make a satisfactory joint when glued.

The small tenon saw is the best tool to ensure this, and of course pencil lines should be marked out as a guide. Use a rule or pair of dividers to test measurement.

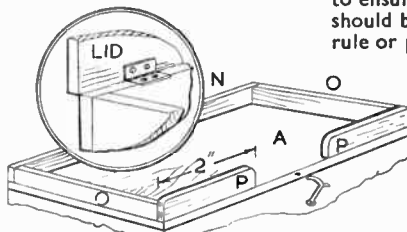

Fig. 2—Detail of tray and lid fixing

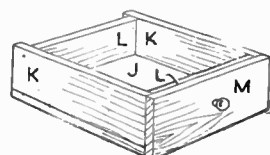

Fig. 3—Drawer construction

How a handy duplicator can be made by using A HECTOGRAPH

A HECTOGRAPH is a very convenient and dependable duplicator which is of particular value to club secretaries, schools, etc. The gelatine type of hectograph is probably superior to the paste or putty type, as it enables a considerably greater number of impressions to be taken which are also of better definition.

To make the gelatine hectograph, soak 3ozs. of pale glue in its own bulk of water until the glue is reduced to a thick and viscous jelly. This process will take upwards of twenty-four hours or so. This time, however, can be appreciably reduced by using pearl or seed glue.

The Jelly Mixture

When the glue is reduced to a jelly, gently warm and stir in 8ozs. of glycerine and 12 drops of oil of cloves to prevent the mixture from turning mouldy. After thoroughly stirring, the mixture should be poured into a shallow dish or tray, approximately 12ins. square by $\frac{1}{2}$ in. deep and placed on a level surface to set.

It is probable that when the mixture is set, many air-bubbles will be evident upon the surface. In this case, the surface should be lightly rubbed over with a damp cloth until the bubbles are removed, and gently reheated until the mixture becomes fluid. It is then placed aside to set.

In Use

To operate the hectograph, the surface is lightly rubbed over with a damp sponge or cloth and the written master sheet gently applied. The master sheet must be gently rubbed from the centre outwards to ensure perfect contact with the hectograph surface, and left in position for a few minutes. When the sheet is removed, an exact impression in reverse will be found upon the glue surface.

Copies are made by placing sheets of paper on the hectograph surface, gently rubbing with the hand, then carefully removing. A considerable number of copies can be made, and as the work proceeds the paper should be left progressively longer in contact with the hectograph surface, to ensure uniform impressions.

Cleaning the Jelly

When sufficient copies have been made, the surface of the hectograph should be cleaned with warm water and a sponge until all imprints have been removed, then remelted and allowed to set. It is probable that after considerable use the mixture may become slightly impregnated with ink. A little powdered whiting should be added which will effectively absorb all ink stains.

Suitable duplicating ink may be obtained from stationery stores, etc., but if the reader prefers to make his

own, the following formula is very suitable. $1\frac{1}{2}$ ozs. of methylated spirit, $2\frac{1}{2}$ ozs. water and $3\frac{1}{2}$ ozs. of pure glycerine are warmed and $\frac{1}{2}$ oz. of methyl green added. The mixture is stirred until thoroughly amalgamated, then is stored for future use in a tightly corked bottle.

Another Form

Another convenient form of hectograph duplicator can be made by reducing 2ozs. of pure gelatine to a jelly with the addition of a little cold water, then adding 4ozs. of glycerine and 2ozs. of water which has been previously warmed. The admixture is then thoroughly stirred and six drops of oil of cloves added for preservative properties.

While still warm, the mixture is very liberally applied to one side of a sheet of duplicating paper which is then placed aside to dry. Duplication is carried out by laying the prepared sheet on a level surface, slightly dampening the surface of same with a sponge, then pressing the master sheet in contact to take the

impression. After a few minutes, the master sheet is removed, and duplication is carried out in the normal way.

Dampen Paper

It is advisable, however, to dampen slightly the copy paper before duplicating, as this enables clearer copies to be made. The duplicated sheets should be placed aside on a level surface to dry out before being used.

In this system of hectograph duplicating, the prepared surface of the paper cannot be renewed after use and must be thrown away. This method of duplication, although extremely convenient, is not so reliable as the glue type previously described, and the number of copies that can be made is strictly limited, due to the extreme thinness of the prepared surface.

When the master sheet has been written, the pen should be well washed in warm water to remove any surplus ink which may otherwise dry and clog the nib.

Handyman Hints and Tips

A Grease Gun

THE barrel from an automatic pencil can be made into a small size grease gun, suitable for lubricating delicate

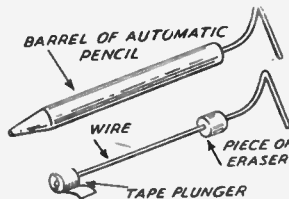

machinery or models. A plunger is made by wrapping a stiff piece of wire with friction tape to the correct diameter and the illustrations show how the whole thing is completed.

Stand Frame Support

HERE is a simple tip which may be useful to those who want to make a support for a stand frame or picture.

Take two pieces of wood — one $\frac{1}{2}$ in. by $\frac{1}{2}$ in., and the other $\frac{1}{2}$ in. by the required length and cut and fit them as shown in sketch. Pin carefully through edges to provide a simple hinge.

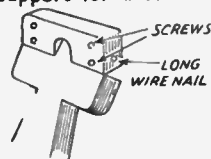

floor, it is difficult to fix it to the floor. Consequently, it slips when one is treading. To avoid this, tie a piece of rope to one leg of the machine, pass it behind your stool or chair, and fix to the other end a strong wire hook and hook it round the other leg. It then prevents the machine from moving when working.

Chemistry Apparatus

IN making improvised chemistry apparatus, it is sometimes necessary to have a ring on your stand. Those

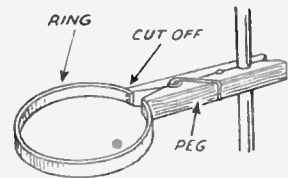

made of tinplate from meat paste jars do very well if fixed to a clothes peg. Cut off about $\frac{1}{2}$ in. of one end and open out the big clip at rightangles to the ring. Clip this in and add glue if necessary.

Tinning An Iron

UNLESS the tip of the soldering iron is coated with a silvery covering of solder, it will not solder properly. To tin it, it should be got red hot and put on a stone, such as a doorstep, and each of the faces filed. Then heat again and dip into some Fluxite and stroke the tip with a stick of solder. An evenly applied thin deposit which reaches to about $\frac{1}{16}$ in. from the tip is required.

Fretmachine Tip

WHEN using a fretmachine in a shed or garage which has a concrete

How to undertake glazing and GLASS CUTTING

AN elementary knowledge of glass cutting and glazing is extremely useful to every householder. Replacements can be made at a small fraction of the cost of having the work done by a professional glazier and, what is often of greater importance, there is no inconvenient and possibly disastrous delay.

Sold by Weight

Sheet glass is produced by a rolling process. Different thicknesses are made and are known by their weight in ounces per square foot—15ozs. to 21ozs. being the most common. The price, of course, varies with the quality and the thickness of the glass.

For domestic use, 'window' glass is required, but for greenhouses, cold frames, etc., 'horticultural' glass can be substituted, as it is considerably cheaper and is quite satisfactory.

Cutting

Glass can be cut with a glazier's diamond or, alternatively, with a wheel-type glass cutter. A diamond is the best of all, but a reliable wheel glass cutter is quite good enough for all ordinary work. Typical examples of the two types are shown in Fig. 1.

The glass, if being puttled in place, should be cut $\frac{1}{4}$ in. shorter and $\frac{1}{4}$ in. narrower than the space into which it is to be fixed. This is to allow room for it

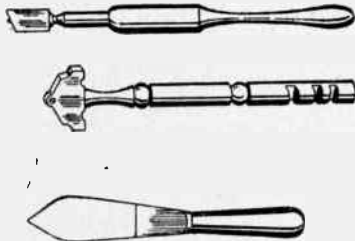

Fig. 1—Two types of glass cutter and a putty knife

to be bedded down in the putty, since, if it is too tight, it will crack.

Successful glass cutting is largely a question of knack and confidence which can soon be acquired if a little practice is obtained by first cutting up some odd scraps of glass.

Marking the Cut

The novice will probably find it an advantage to mark the position of his cut on the glass with a piece of chalk and then to use a straightedge as a guide for the glass cutter. It will not be necessary to draw a line but only to make a mark at each end and place the straightedge on the two marks.

The method of holding a glass-cutter is shown in Fig. 2. The cutter should be pressed on to the glass just sufficiently hard to make it 'bite' on the surface and

then the cut made. On no account should a second cut be made over the first one because, if the two cuts coincide, it will tend to take the edge off the glass-cutter and, if they do not, the glass will nearly always break away from the line.

When the cut has been made the glass should be held as shown in Fig. 3 and

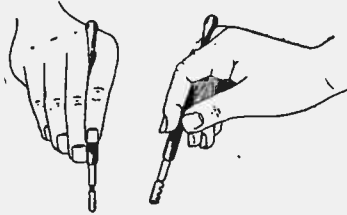

Fig. 2—How to hold the cutter

then a slight upward pressure exerted by the fingers. This will result in the glass breaking along the cut line.

Glazing

If a broken pane is being replaced the first job will be to remove all the broken glass and then all the old putty.

The new putty must be worked up

well, in order to break down any lumps, and then a strip of it pressed into the rebate where the glass is being fitted. Next the glass is gradually pressed into place and a glazier's sprig, or a small brad, driven into the side re-

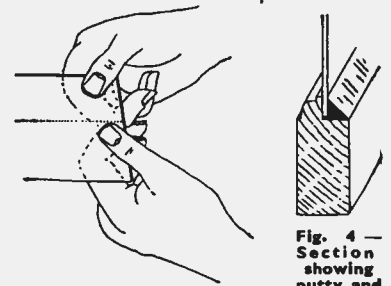

Fig. 3—Breaking the glass

bates to hold the glass firmly in position.

A strip of putty should now be rolled up in the hands and pressed into the corner where the glass meets the frame on the outside. The surface of the putty is then bevelled off with a putty knife. A diagram showing a putty knife is in Fig. 1 and the glass puttled in place is shown in Fig. 4.

More Home-Made Cements

Self-adhesive Tape Dressing

TAPE may be made adhesive for surgical or other purposes by dressing the surface with a mixture of litharge 1 part, lard 1 part, olive oil 1 part and water 2 parts. Alternatively lead acetate 6 parts and soft soap 10 parts, with sufficient water may be used. To either of the above recipes 4 parts of crushed rosin may be added if desired, but it must first be solved in either alcohol, methylated spirits, ether, oil of turpentine or hot olive oil. It could be first dissolved in the olive oil which forms one ingredient of the first recipe above before the complete mixture is made up.

Cellophane Gum

ORINARY adhesives are not permanently satisfactory when used for sticking cellophane sheet, but if an adhesive is made up of 2 parts of gum arabic dissolved in 5 parts of water, and a further 3 parts of glycerine added to the mixture, a strong and permanent joint can be made with its use.

Good Office or Domestic Paste

DISSOLVE 1 teaspoonful of powdered alum (aluminium sulphate) in 1 quart of cold water and stir in enough wheat flour to make a thick even cream; finally stirring in a teaspoonful of finely-powdered rosin and adding a

cupful of boiling water. Give a good final stirring, pour into a wide-mouthed bottle and add a few drops of oil of cloves to stop mouldiness occurring.

Quick-drying Paste

AGOOD all-round paste with quick-drying qualities may be made easily by either mixing 100 parts of wheat flour paste with 5 parts of dextrine ('British gum'), or by mixing equal parts of flour paste and scotch glue.

Bill-posters' Paste

FORMULA No. 1. Half a quartern of wheat or rye flour is beaten with a little cold water, and into the paste so formed, boiling water is slowly added, stirring and crushing the lumps meanwhile. A tablespoonful of powdered alum should then be added to act as a preservative. Cold water may be added as required to thin the paste.

Formula No. 2. Powdered gum tragacanth made into a paste with water in the proportions of 1 part tragacanth to 10 parts water, makes a paste which may also be thinned with cold water.

Formula No. 3. A concentrated bill-poster's paste may be made by mixing a little common starch with 5 or 6 times its weight of boiling water, stirring vigorously till it forms a thick jelly. This may be thinned with a little warm water if necessary.

The summer months are ideal for overhauling the HOUSE WATER SYSTEM

LAST summer when visiting a friend the writer stayed for a few days at his house and found the water system was in a depressing state of disrepair. Taps dripped and whistled even when fully turned off, wash basins emptied painfully slowly, and overflow pipes spouted at frequent intervals. This state of affairs must have been going on for months, but it took only a short time to put the system in order again.

If your taps drip, it is a sign that new washers are needed. Get a supply of these from a hardware store and specify whether they are for hot or cold water taps. Different sizes of taps need different sized washers, so lay in an assortment of sizes.

Off at the Main

Turn off the water at the main, and turn 'on' the tap to its fullest extent. If the tap has an outer hood or cover, remove this first. If it will not unscrew by hand, use a wrench or pair of pliers, but protect the metal from damage with a piece of wood or leather.

Lift up this cover, and underneath you will see a hexagonal nut. Unscrew this with a spanner, holding the nozzle of the tap firmly with your free hand. Unscrew the spindle completely and you will see the loose 'jumper', to which is attached the washer. The jumper fits into a recess at the bottom of the spindle. The washer of a leaky tap will be badly worn. Remove it by unscrewing the nut underneath, and replace it with a new washer of suitable size, enlarging the centre hole if necessary.

On some types of jumper the washer cannot be replaced like this, and the

whole jumper must be renewed, but the assembly only costs a small sum.

The operation of re-washing a hot-water tap is similar, but in most houses there is no easy way of stopping the flow of water through the tap. The pressure in the taps, however, is not great, and you can prevent any splashing by covering the tap with a cloth while unscrewing the spindle. Do the job when the water in the cistern is not very warm.

Should water squirt up the side of the spindle when a tap is running, the packing needs attention. Above the hexagonal nut on the spindle there is a rounded collar with a milled edge. Unscrew this. Inside, there should be a quantity of soft string used as packing, so replace this, or add further packing. Rub the string with Vaseline and wind it round the spindle, ramming it down into the cavity.

Overflow pipes which spurt water when they should not, tell you that there is trouble in the ball-float mechanism in the cistern. The idea of this float is to cut off the flow of water when it has reached a certain height in the tank. Try bending down slightly the arm which holds the float: this will ensure a quicker cut-off.

A Punctured Float

Should this fail, the trouble may be a punctured float. Unscrew it and shake it to test if there is water inside. If so, locate the puncture, enlarge the hole slightly to remove the water, and solder up. Renew the float if it is extensively damaged.

If water will not drain away quickly from the wash bowl or sink, examine the top of the waste pipe for debris, and

remove this with a knitting needle or nail. Pipes which have an S bend often become clogged at this point. There is usually a screw plug at the bend. Place a bucket or bowl underneath, and unscrew this plug. The offending debris should fall out, but it may require helping with a long piece of wire.

Design for a Medal Holder

Complete Kit (No. 2840) is supplied for the Medal Holder Design with this issue for 6/5 at any Hobbies Branch, or 7/2 from Hobbies Ltd., Dereham, Norfolk.

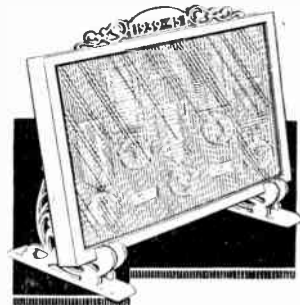

If water drips from the screw plug when fully tightened, cut a new washer from a piece of leather or rubber. If waste-pipe plugs do not keep water from leaking away, replace them. Measure the diameter of the plug hole with a tape measure, and ask for that size of plug.

Sometimes the S hooks at either end of the chain attaching the plug to the bath or bowl become opened out, and so becomes detached. Pinch the opened ends a little closer with pliers or pincers.

Hot Water Leakage

Much fuel is wasted if heat is allowed to leak from the hot water system. Bind all hot water pipes with felt or sacking to keep in the heat. Stop up any air leaks from the cistern cupboard with felt or putty. Stuff sacks between the cistern and the wall to provide insulation, but do not use old woollen clothes, as these harbour moths.

Perhaps you have had some bursts this winter. Bursts are caused by the freezing of the water in the pipe. When water freezes it expands suddenly and makes the pipe crack open. It is not until the thaw sets in that water flows out through the crack.

Prevention is much better than cure. Cover your pipes where possible with felt, sacking or straw, so that bursts are reduced to a minimum in the hard frosts of the winter. Everyone seems to want a plumber at the same time!

A Useful Motor for Models

WE have recently been pleased to test the little motor shown here and can recommend it for attaching to small models, particularly as it requires nothing more than a No. 8 battery for its source of current.

The efficiency of an electric motor is dependent on the proportion of the electrical energy put into it which is wasted by friction, windage and electrical and magnetic losses. For very small motors the efficiency rapidly decreases with the size, and the chief reason for this has been found to be the rapid increase of 'iron losses' with increasing speed. This position has been tackled in a radical manner by the inventors of the 'Mighty Midget' Motor, whose design incorporates no rapidly revolving iron parts.

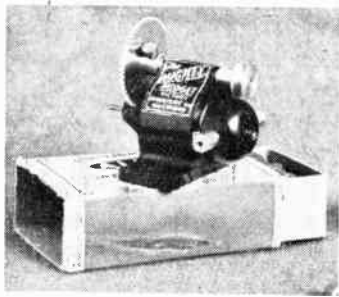

In this design the armature windings are made upon a hollow cylindrical plastic former, which is firmly mounted on a small gauge steel spindle, and within the former a soft iron core is mounted on the spindle in such a way that it is free to revolve. In practice, when current is passing through the motor, the windings and spindle revolve rapidly, while the 'floating core' revolves very much more slowly. There are thus no 'iron losses'. The motor is totally enclosed in a neat plastic case, the drive being normally applied from a small pinion on the spindle to a large brass gear-wheel which, with a 6½ to 1 reduction, gives a practical final driving speed. The firm offering this motor has appeared in our advertising pages or can be obtained on request.

Carpentry and marquetry combine to make an attractive CORNER CUPBOARD

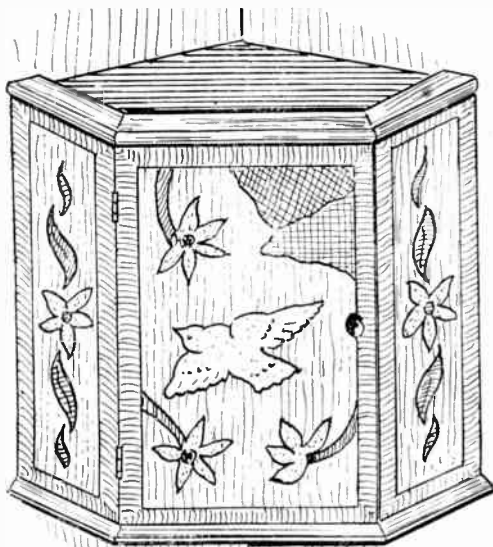

A NICE neat little cupboard this, just the thing for storing small articles out of the way, medicine bottles, and such like things. It is primarily intended for a display of simple marquetrie decoration, but can just as well be made plain, and be subsequently stained and polished.

The general construction is plainly shown in Fig. 1. The carcase is made up of $\frac{3}{4}$ in. thick deal, with $\frac{1}{2}$ in. thick better class wood for side panels and door. Fretwood will do for the latter parts, especially if the marquetrie decoration is to be used, as deal is not suitable as a foundation for the craft.

The Carcase

Get out the sides of the cupboard, making one $6\frac{1}{2}$ ins. and the other $6\frac{3}{4}$ ins., as in plan, Fig. 2. Glue and nail these parts at rightangles, as shown by the dotted lines in plan. To set out the top and bottom parts of the cupboard, cut two $6\frac{3}{4}$ in. squares of the deal, and saw across to make the shape given in Fig. 2. Glue these to the sides.

The addition of a small shelf, as seen in Fig. 1, is entirely optional. Such a shelf can be useful, but should not occupy too much of the space if the cupboard is intended for medicine, or there may be insufficient room for them to stand upright.

Two front side panels and a door will now be needed. These should be cut from the $\frac{1}{2}$ in. fretwood mentioned. The side ones are cut 3 ins. wide, and the door $6\frac{1}{2}$ ins. wide, heights the same as the cupboard. Fit the panels with

round-headed screws at top and bottom (one is shown in position at (A) in Fig. 1) only for subsequent easy removal.

The inner edges of the panels should be planed to an angle of $67\frac{1}{2}$ degrees (see Fig. 3 (C)) and be fitted to the flat side parts of top and bottom pieces of the cupboard. There will probably be a little surplus to be planed off the outer edges of the panels afterwards to make them level with the sides.

The side edges of the door are similarly bevelled, and should be planed a nice, but not too close fit between. The door can now be neatly hinged, using $\frac{3}{4}$ in. by $\frac{1}{2}$ in. brass hinges.

A strip of the deal 1 in. wide should be bevelled at one edge, and cut into three pieces to form a cornice at the top of the cupboard. These should be accurately joined at the angles, as at (C) in Fig. 3, and overhang the edges by $\frac{1}{2}$ in., as in detail (B). Glue and nail in position. Similar strips are also fitted to the bottom of the cupboard, but the edges of these, instead of being bevelled, are neatly rounded off.

Plain Sides

If the marquetrie decoration referred to is not desired, the side panels are removed, the edges touching the sides, and top and bottom of the cupboard glued, and then rescrewed in place. The work needs a thorough glasspapering, and then can be stained and polished. A small cupboard catch is fitted, and a pair of the brass wall plates screwed to the back of the cupboard, for hanging it in position.

For marquetrie decoration, the panels and door are removed. A simple design for these is given at Fig. 4 drawn over 1 in. squares. Copy these full size on thin white paper. Now a word about the design. The absence of intricate scrolls and curves may be noticed, but it should be mentioned at once that these have been purposely omitted, as such

delicate work is fit only for the more practical hand at the craft.

Marquetrie Work

This marquetrie is intended for the beginner, who having read the preceding articles on the subject thinks he would like to make something useful as a start. In the articles mentioned all the necessary information for carrying out the work has already been detailed and, therefore, needs no repetition here.

Readers must choose their own selection of wood for cutting, as it is useless nowadays to say that each portion must be cut in mahogany, others in walnut, and so on. Use must be made of whatever variety of veneers the reader may be able to get together.

The side panels, when decorated, should be put under pressure straight away, and when finished, screwed and glued in position at once, in case they warp. The door should be veneered on its inner surface as well as its outer one, to keep it flat. When preparing the wood for gluing the marquetrie on, tooth the inner surface of the door at the same time. Before applying the marquetrie, cut a sheet of veneer to the size of the door, and lay it ready to hand.

Directly the marquetrie is laid, turn the door over and glue the back, then lay the veneer on and clamp up the

(Continued foot of page 10)

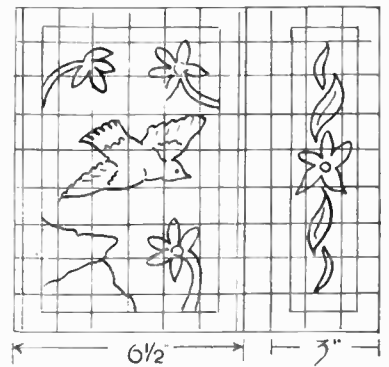

Fig. 4—Decoration for the inlaid marquetrie

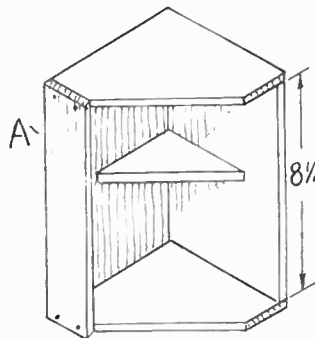

Fig. 1—Cupboard construction

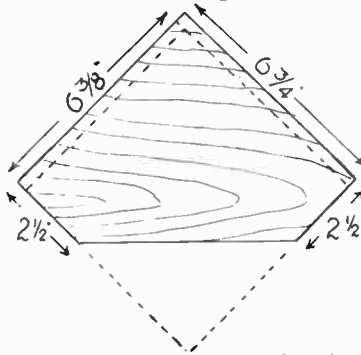

Fig. 2—Shape of top and bottom

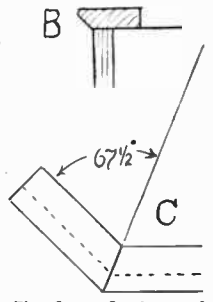

Fig. 3—Angle and chamfer of edging

Training and preparation are needed to enjoy HIKING PLEASURES

MANY readers will now be looking forward to the spring, with its longer and brighter days, and its opportunities for getting out-of-doors. Of recent years hiking has become increasingly popular, which is not surprising, for it is good fun. There is no happier or more interesting way of spending a week-end than tramping.

Longer holidays, as Easter, Whitsuntide and Summer, come into the scheme—a scheme worth considering; for in no other form of week-ending or holidaying do you get such big value for so little cash.

How to Begin

This hiking, however, must be trained for if you are to obtain the best out of it. You cannot expect to walk away on a cross-country ramble or a week-end among the hills, straight from an office desk or an indoor job. It just does not make sense. Walking over footpaths and moorland tracks, rough and stony, is different to the city pavements, or hopping a 'bus.

Therefore, having taken a wise decision to do a lot of hiking this year, get prepared. Start easy by taking short walks around home. If living in a town, get a 'bus out into the country, and with the aid of a local map, make a sort of circular route for a few miles and back to the bus stop again.

Extend the mileage as you gain your walking legs, and your muscles get limbered up. This way you harden yourself and in time find no difficulty in doing twenty or even thirty miles in a day.

Think of your Feet

You can not avoid thinking of your feet, even if you try not to do so, for the hiker travels on his own 'under standings'. Feet must be kept in condition, therefore the question of boots and shoes suitable for the job is an important one.

Nailed boots are recommended, with stout leather soles studded with treble hob nails. See your special hiking footwear are a good fit, and comfortable. Get them broken in before undertaking a long tour. Keep boots—and shoes, if you prefer the latter—soft and easy by oiling them or giving them a good soaking with dubbin, well rubbed in the leather.

This will render them easy to wear and also make them waterproof, for you may have to splash through rivulets, negotiate boggy hollows, or tramp home in the rain. Potholes, ruts, and hollows hold the water after rain, and they cannot always be avoided. Therefore, sound footwear is essential.

Whilst in training—and after—always inspect your feet at the end of the day. If you discover tender spots or blisters, treat them with a little boric ointment. A good notion is to rub Vaseline over your toes and heels prior to putting on your socks or stockings.

Another preventative is to smear the inside of the feet of same with plain yellow soap, wetted. Watch out for any corns, and treat them with one of the various mediums sold by the chemist.

A Steady Pace

Keep to a steady pace, especially in hilly surroundings. Do not start off with a rush, and do not take too many short rests. When you feel you are really in need of a breather park yourself for twenty minutes or half-an-hour. Take longer for your lunch break.

When crossing moors keep to the tracks and paths, even if they are not the shortest cut. The longest way round is frequently the easiest and quickest. That short cut across a stretch of moorland is often the more tiring and takes you longer to do by the time you have negotiated patches of bog or skirted rocks and found a spot where you can wade some burn or beck.

If you have to descend a steep slope, it is better to zig-zag down it than to make a bee-line down. The same applies to going up as well. Watch your step where the ground is littered with stones and boulders, or rutted with potholes.

Maps

Part of your training will consist of learning to use a map. Buy the Ordnance Survey Maps with scale of one inch to one mile, and study same carefully. Important to note is the scale, which, of course, helps you to gauge the mileage from place to place. In the margin of an O.S. sheet the scale is drawn for us—five miles of it—so that we fix it firmly in our minds, and can roughly estimate by eye the distance between any two points on the map.

Brown lines running all over the map denote the contours, and connect all

points of the same height. They are shown at distances, which, between the separate lines, denote every 50ft. of height. The closer these brown contour lines the steeper the ground; where they are widely spaced the slopes are gentle.

Therefore from examining these lines you get an idea of the kind of ground you will have to cover on your hike. With a little practice you can quickly obtain a knowledge of the type of countryside by simply glancing at the contour lines.

Study your maps, and learn how to use them to advantage before you set off on a long walking tour in strange country. The map is the hiker's companion and guide.

The Compass

Another thing you may find useful as you develop your hiking stunts is a compass. Here again, you need to gain a little knowledge in its use before committing yourself to a wide stretch of moorland or hill country. If you are not sure of the route you must take, a compass will help you considerably. Should you get lost a compass will prove a friend indeed.

Practise the art of recognising the landscape on the map, and then with the aid of the compass check your position with landmarks around you. When crossing a moor it is wise at the start to note such landmarks as the nearest village or hamlet, farmstead, or keeper's cottage.

Then, should a mist come down you will know which way to turn to seek shelter. But even a compass is little help in a thick Scotch mist, which is always dreaded by wayfarers out upon the moors or mountains. Practice with map and compass during your training period is to be recommended. It will not be time wasted.

During this probationary period—before you set off on your first long hikes—learn all you can. The best kind of clothing; the handiest rucksack or haversack; whether you can travel better with the aid of a stick; map-reading, etc. All these must be thought about and tried out. Then, when the great day comes, you can set out on your journey with full confidence.

The warm weather of summer has not yet arrived, so you must be clothed accordingly at present to prevent colds or chills.

Corner Cupboard—(Continued from page 9)

door in the press at once. Leave for at least 24 hours before removing from the press.

Glasspaper the edges of the door to make it an easy fit in its opening, and it will be as well to lightly glasspaper the sharp edges of the veneer, in case they

catch as the door is opened or shut, and so tend to splinter or break away.

Finish the work with putting in such lines and marks as the design may necessitate, waterproof drawing ink would do for this, then polish the whole surface, outer surface, of course, with a

clear polish, or apply two coats of copal varnish to finish off. A thin coat of size can be painted over beforehand. This will help to fill the grain of the wood, and prevent the ink used to mark the details from running.

How the amateur photographer can make and operate A FLASHGUN UNIT

MANY amateur photographers are under the impression that flash-bulb photography is the prerogative of professionals, and that lack of skill, complexity of apparatus and cost, preclude this particular branch of photography from the amateur.

Nothing could, of course, be further from the truth. Indeed, under certain conditions, flash-bulb photography gives more assured and dependable results than natural light, due to the consistency of the light actinism. This is especially so when photography is attempted in dull and unfavourable conditions, when the result is often foredoomed to failure.

With the aid of the flash-gun, however, one is independent of the source

easily plugged into the sockets provided in the front of the camera.

To adapt the box camera for flash-gun operation is quite simple. A glance at Fig. 1 shows the arrangement to complete the electrical circuit. The two wires (A and B) are connected respectively to a non-movable part of the shutter (C) and to a simple brass contact (D). Fig. 3 A shows the shape and position of the contact. When the shutter trigger (Fig. 3 B) is depressed in taking the photograph, electrical contact is made, which ignites the flash-bulb in its holder. (Fig. 3 C) shows the trigger at rest at the limit of its travel.

Connections

To enable the necessary connections to be made, the front part of the camera will have to be removed. With most box cameras this is not very difficult, as it merely means the removal of a few screws or nails and carefully lifting the front out of position.

The brass contact, Fig. 1 D is constructed from thin springy brass and is screwed into position with one or two small brass screws. The correct position is approximately midway between the extreme limits of travel of the trigger, but it is best to check for the correct position as follows.

Slowly depress the trigger, stopping any further travel immediately the shutter actuates. The contact should then be screwed into position, just making contact with the trigger in the position indicated.

If the action of the shutter is sluggish, it may well be that the position of the trigger is considerably past the midway position before the shutter actuates. In this case, when taking flash photographs, it must be remembered to only depress the trigger. The upward movement would fire the flash-bulb too early to be effective.

Two wander-plug sockets are fitted into the front end of the camera and the



The Complete Flashgun Unit.

connecting wires (A and B, Fig. 1) are attached to them. The camera front is then carefully refixed, observing that the connecting wires do not foul or obstruct the shutter mechanism in any way.

The Torch Needed

A fairly large tubular pattern torch is next required, and a $\frac{1}{8}$ in. hole drilled in the casing as near the reflector as possible. A length of heavy flex is required, and one end is pulled through the hole and secured against any accidental pulling by making a knot on the inside. Leave about 2 ins. of free end to make the necessary connection.

One wire is then soldered to the underside of the reflector, and the other to a convenient part of the torch casing (Fig. 2 A). Two wander plugs are then connected to the other end of the flex.

The glass is removed from the front part of the torch and an old motor headlamp reflector is obtained (Fig. 2 B).



Taken with the unit, screened light, and portrait attachment

and quality of the existing light, while a further and valued advantage is that the operator can direct the flash-gun to the best advantage.

Flash-bulbs are absolutely safe and dependable in action and for this reason are to be preferred to the use of flash-light powder, especially when indoor photography is attempted. A commercial flash-gun is a fairly expensive component, however, and its price may be a deterrent to the average amateur photographer. The total cost of the unit described is very modest, indeed. The design is both simple and foolproof and will afford its user many interesting and unusual photographs.

Camera Adaption

Although the following article deals with the conversion of a simple film box camera to flash-gun synchronisation, the actual flash-gun unit can be operated manually with any camera. As many modern cameras are fitted with integral flash mechanism, the unit can be quite

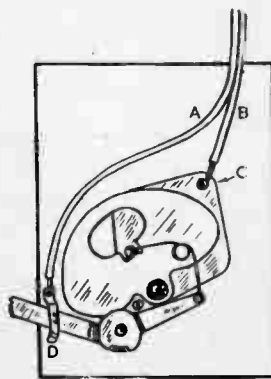

Fig. 1—The electrical circuit

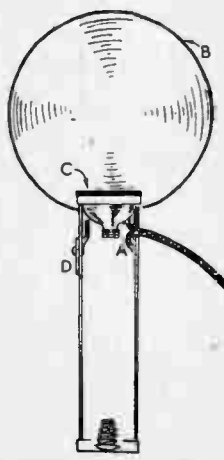

Fig. 2—Section of torch case

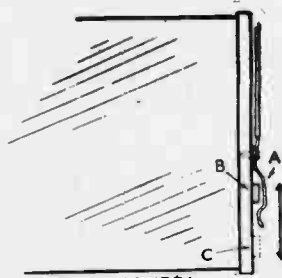

Fig. 3—Side view of parts

A suitable reflector can be obtained at a nominal cost from any car-breaker's yard. The external diameter of the torch should be measured, a suitably-sized hole drilled in the reflector and the torch soldered into position.

Should the reflector be in a poor condition, as is likely, two or three coats of good quality white enamel can be applied to the interior. A pleasing and effective appearance can also be had by enamelling the exterior a pastel green.

A thin strip of insulating tape should be applied around the rim of the torch front (Fig. 2 C) to prevent a metal-to-metal contact being accidentally made with the flash-bulb socket whilst being screwed into position. Should this occur, the lamp will be prematurely fired, due to the completion of the circuit. The torch switch (Fig. 2 D) is left intact for manual operation when required.

The type of flash-bulb that is required is a M.E.S. or Miniature Edison Screw, which has the same screw fitting as that of an ordinary torch bulb. The 'baby' size of flash-bulb will be powerful enough for all ordinary photographs,

such as indoor work and close-ups, etc., but for more ambitious work demanding a stronger source of light, the normal size bulb will be found satisfactory in every way.

When taking 'close-ups' there is a possibility of overexposure occurring due to the intense and concentrated nature of the light. This can be countered by stopping-down the camera, or by placing the flash-gun at a little distance from the subject, or by a combination of both. If an overexposure has occurred, one can, of course, always use a chemical reducer to correct matters, but it is best to take a little trouble to obtain the correct exposure.

To operate the flash-gun, a normal torch battery is inserted in the torch case, and the flash-bulb screwed into position. The wander-plugs should be placed in their sockets prior to the screwing in of the bulb, as otherwise, should they make accidental contact together, the circuit will be completed and the bulb prematurely discharged. The flash-gun may be held in the hand or placed upon a level surface.

The disadvantage of holding the flash-gun in the hand is that the light is all frontal, and tends to give the photograph a flatness, which can be observed in many press photographs. Therefore, if possible, and the length of flex permits, place the flash-gun slightly on the side of the subject. In this way, dull or flat photographs are avoided.

Another failing of flash-bulb photography is the staring eyes and the casting of deep contrasty shadows in portraiture. This can be overcome by suspending a muslin sheet between the flash and the sitter.

When using the flash-gun, it must be correctly positioned, the subject aligned in the view-finder, then the shutter depressed in a decisive movement. Upon the action of the shutter, an intense momentary flash of light will occur, and the proposed photograph will be taken.

The fitting of the synchroniser does not in any way prevent the camera from being normally used, as this can be effected by the removal of the flash-gun connecting plugs.

The home handyman should know the possibility of RENEWING SASH CORDS

READERS who have the sliding sash type of window in their houses will, sooner or later, be confronted with the problem of a broken sash cord. The replacement of a broken cord is not at all difficult if the method described here is followed. It may seem a little awkward on the first occasion,

is, should be removed. The bead is only held in place by brads and can be levered out with the aid of a screwdriver or a narrow chisel. When this bead is out the sash can be removed from the window frame.

The Bead Edge

In some examples of this type of window the bottom sash is kept in place by a bead screwed flat on to the window frame. In this case, the bead on the same side as the broken cord will have to be unscrewed in order to remove the sash.

It will now be seen that the sash cord is nailed in a shallow groove cut in the upper part of the sash and the broken end must next be removed from the groove.

In the side of the window frame is an opening, termed a 'pocket'. This opening is filled with a long strip of wood, nearly as wide as the groove in which the sash slides, and is simply made a tight fit so that it can easily be levered out with the aid of a chisel.

After the strip has been removed the top of the weight will be visible and this should now be taken out and the broken cord removed.

Fixing the New Cord

First of all the new cord must be fitted in the window frame. A simple way of doing this is to tie a small piece of chain or a tiny scrap of lead to a piece of string and then to pass this over the pulley at the top of the frame.

The weight will be sufficient to take the string down the inside of the window frame and, once it is in place,

the end of the string can be tied to the new sash cord and the cord pulled into place, starting from the top and bringing it out through the pocket at the bottom.

The lower end of the cord must next be tied to the weight, the weight replaced in the frame, and then the strip of wood put back in the opening.

The cord must now be cut to the correct length. This can be found by pulling the weight nearly to the top of the frame and then cutting the cord about 9ins. below the lower rail of the top sash.

The end of the cord is next put in the groove in the sash and nailed in place similarly to the one that was previously

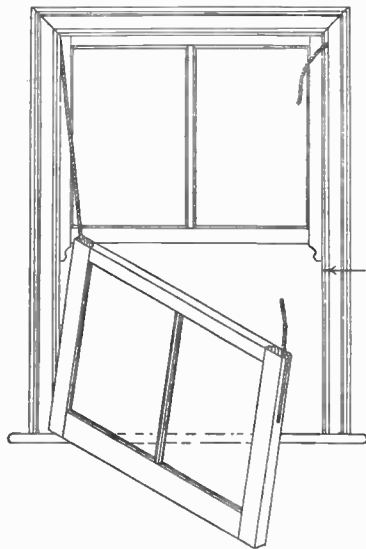

Bottom sash removed to reveal right-hand pocket

but such experience will make further attempts quite straightforward.

First of all the bead on the side of the window frame, where the broken cord

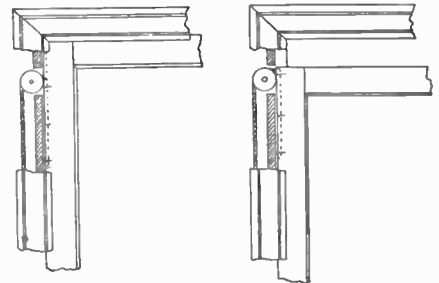

Correct position of cord on a top sash

Result of fixing the cord too tight

removed. The sash can now be put back in the window frame and the bead again fixed in the groove so as to keep the sash in place.

If the broken cord is attached to the top sash it will be necessary to first remove the lower sash, then the bead between the two sashes, and proceed as just described.



WHAT YOU SHOULD OMIT

ONE of the most difficult things that the beginner—or the old collector either for that matter—has to do is to exclude items which appear to be stamps but which are afterwards found out to be something else. Quite a number of labels are so beautifully printed that they appear to be specimens of some merit. Conversely, some of the stamps which are genuine are so crudely made that one might be excused for thinking they should not find a place in the stamp album.

As we remarked a little while ago, a postage stamp collection should not contain anything but adhesive stamps.



Revenue and Postal

That makes it quite clear that printed stationery stamps—such as the embossed stamps on the stamped envelopes one buys at the post office and also the stamps that are printed on the post-cards—should not be placed in.

In Great Britain we have to pay twopence every time we give a receipt for an amount over £2 and this amount is normally paid by sticking on a postage stamp for that value and defacing it by writing over the stamp our name and the date.

In this way we convert it from a postage stamp into an Inland Revenue stamp. The twopence we have paid will not be used in any way for the payment of postage so you see the stamp is no longer a postage stamp.



An essay for an air stamp

There is, however, an exception to this and the first illustration of the pair of stamps should make this clear. Both stamps are printed for inland revenue purposes, but between 1867 and 1881 it was permissible for one to use this type of stamp for letters.

One of the stamps in the illustration has, obviously, been used in this way, for it has a quite distinct postmark. The figures 405 show the area in which it was used. The other has writing on it,

showing it was used for a receipt.

Then again there are excise stamps that must be avoided. Canadian excise stamps seem to be very common now, but they have no place in the stamp album. Neither have the stamps which used to be stuck over the corks of medicine bottles; they are only placed there as a method of paying the patent medicine duty.

Legal Fees

Nearly all legal documents require a fee and this is very frequently collected by means of a stamp. The value depends on the document. Generally this has to be sent away and the stamp is embossed on the document. Such embossed stamps do not carry any postal privileges so they have to stay outside, however tempting it may be to have a stamp valued pounds.

Rhodesia in 1890 issued stamps with a face value up to £10. As you can imagine only a few of these high values were used for actual postal purposes, most of them were used for inland revenue payments. Postal specimens are quite valuable but the fiscally used have no value to speak of. Unfortunately, most of the high value stamps of this set that one comes across are of the lesser use and consequently of little value.

Christmas Labels

Christmas has just passed and most probably a number of you received parcels with 'Christmassy' labels on them such as are sold for charitable purposes or as a fund for giving treats to poor children. Such stamps (they are very frequently in the form of stamps) should not, however, go in the collection unless they have been purchased from postal authorities and carry the right to defray the cost of postage. Do not confuse these labels with the Christmas Charity stamps from such places as New Zealand or Switzerland.

The next illustration is an essay for a British Air Stamp printed at the International Stamp Exhibition held at London in 1923. It was on sale rather as a memento of the occasion. For the normal stamp collector it has no value but for the collector of Air Mail stamps—particularly if the collector goes in for the history of Air Mails—then it is quite an interesting item to have.

An Air Trophy

Another type of stamp which cannot be placed in a proper stamp collection is the type illustrated next—the Lundy Island stamp; this is rather a curious example, because this stamp does up to a point carry postage rights with it, but only postage right for a short distance and for a certain direction. On Lundy

Island, which is nearly 20 miles off the coast of Devonshire (the stamp shows quite clearly where the island is situated); there are very few people indeed on the island and consequently postal services have not always been quite as good as on the mainland.

In 1935 an 'Air Mail Service' was started between Lundy and Barnstaple and for letters to be taken by air they had to have special stamps attached. These stamps only had value for the air passage between the island and the mainland. After that the mail had to go by ordinary route. Consequently they had to have ordinary stamps as well as the special air stamps. This air service was held up by the outbreak of the war in 1939.

Telegraph Stamps

Telegraph stamps should not go in the same album as the ordinary postage stamps. In countries which have different stamps for telegrams, then it is quite easy to separate the two. But in Great Britain, where we have the same stamps for the two purposes, then telegraph and postage stamps are virtually the same. Though, generally speaking, the post office does not allow the stamps which are on telegrams to get into collectors hands.

Some countries have the same stamps,



Lundy Island Air Stamp

but they have a different method of cancelling. For example, Spain punches a hole right through the stamp so no one is likely to want any of their telegraph stamps.

If you are in any doubt whether a stamp should go in the album, why not put it into a tin or an envelope and then when you have the opportunity ask a more advanced collector to tell you what you should do? You will save yourself the disagreeable task of taking stamps out of the album, because they are not really collectable specimens.

Look out for an article shortly, dealing with the great International Stamp Exhibition being held in London next month.

MISCELLANEOUS ADVERTISEMENTS

The advertisements are inserted at the rate of 3d. per word prepaid. Name and address are counted, but initials or groups, such as E.P.S. or £1/11/6 are accepted as one word. Postal Order and Stamps must accompany the order and advertisements will be inserted in the earliest issue. Announcements of fretwork goods or those shown in Hobbies Handbook are not accepted. Orders can be sent either to Hobbies Weekly, Advert. Dept., Dereham, Norfolk, or Temple House, Temple Avenue, London, E.C.4

MAKE £1 an hour, genuine home employment. Full instructions, 3/-.—R. Lowes, Rectory Terr., Simonburn, Hexham, Northnd.

APPLICANTS for approvals sending 6d. receive special album 8ins. x 6½ins., 60 quadrille pages.—Goddard, 41 Kimberley Road, Bournemouth.

STAMPS—Send stamp for approvals. Choose your own free gift. Packets, sets and single stamps.—H. W. Harman, 6 St. Patrick's Road, Coventry.

SEND S.A.E. for particulars of well paid homework.—Box 18, C/O 41 Wade St., Lichfield.

STAMP bargains are found in my Approvals. Applicants receive surprise 20 stamps. Without approvals, 1/-.—S. H. Fleming, Glyn Avenue, Colwyn Bay.

K EEN stamp collectors want Selby's Approvals. S.A.E.—Selby, 66 Donnington Road, London, N.W.10.

P LANS for railway and ship modellers. We have hundreds of accurate, full size drawings available. 24 p. catalogue, 6d.—Skinley, 132 High Street, Southend-on-Sea, Essex.

STAMPS from ½d. each, on 7 days approval. Please state if Foreign or Empire are wanted.—Box 22, Hobbies Weekly, Dereham, Norfolk.

P ERFORATION gauge free. To all applicants for our approvals. Ideal for beginners and medium collectors. Send S.A.E. for trial selection.—Box No. 33, Hobbies Weekly, Dereham, Norfolk.

E NLARGE your drawings mechanically with the 'Perfect' pantograph. Oak with metal fittings. With instructions, 6/6 posted.—G. F. Rhead, Thurston End, Hawkedon, Suffolk.

FREE, Free! 25 fine stamps to all requesting approvals.—Howes, 685 Bath Rd., Hounslow, Middx.

FREE—stamps catalogued 5/- to applicants for ½d. approvals.—Cox, 17 Stoneleigh Park Road, Ewell.

L ONELY? Join Friendship Circle. Details, 7½d.—Secretary, 34 Honeywell Road, London, S.W.11.

1,000 World stamps, 3/9. Bargain catalogue free.—Whitby, Godshill, Fordingbridge, Hants.

R EQUEST stamp approvals. Receive small album, stamps, hinges, free. Postage 6d.—A. M. Day, 73 Thornton Gate, Cleveleys.

STAMPS FREE!! Twenty unused (2½d.).—G. H. Barnett, Limington, Somerset.

P ENNY Black and Sir Rowland Hill on stamp of Cuba, absolutely free. Request approvals.—Hubert Rajski, 21c Thornes Road, Wakefield.

A USTRALIAN U.P.U. and other large Colonials free to approval applicants.—P. R. Cox, 32 Wadley Road, Leytonstone, E.11.

C IGARETTE cards—Bargain list.—Louis George, 11 Friars Street, Ipswich. Established 1908.

H EADPHONES type DLR 5 with lead, H4/9; super quality type DLR1 with double metal head band and lead, 6/6; both types suitable for crystal sets. Aluminium telescopic dinghy masts, 15ins. closed, opens to 9ft., ideal for fishing rods, tent poles, etc., 5/6. 4½ volt twin coil buzzers, 2/6. Crystal set kits complete with phones and instructions, 12/6. All items 6d. postage. Send S.A.E. for free list and morse code alphabet.—J. Hallett, 19 Upper Richmond Road, London, S.W.15.

40 DIFFERENT stamps free, including Silver Jubilee, Coronation, Pakistan, etc. Send 3d. postage and request approvals.—J. F. Smith, 60 Boyne Road, London, S.E.13.

O FFERS invited for the manufacture of magnetic draughts, etc., to prov. patent 2655/50, or for purchase of patent rights.—Osborne, 4 Esher Rd., Esher, Surrey.

100 DIFFERENT stamps free (including triangular and pictorials), to approval applicants enclosing postage.—N. Johnson (Dept. H), 19 Hillside, Slough, Bucks.

500 COLLECTORS' duplicates, 2/6. Amazing variety.—Belfields, Stour Hill, Quarry Bank, Staffs.

P ERSONS required to fill vacancies in our out-work department. Write—Dept. 11, Empire Co., 117 Nottingham Road, Loughborough.

300 SUPER stamps. Many large pictorials, 2/-.—Rummins, 25 Pendennis Park, Brislington, Bristol.

A RAWAK stamp free with approvals.—Wilfred's, 5 Half-way-tree Road, Kingston, Jamaica, B.W.I.

A RTIFICIAL marble powder. Entirely new plastic for casting bookends, ashtrays, wall vases, etc. Easy to use—simply mix with water; sets granite hard with scintillating crystalline structure. Resistant to heat, impervious to water. Any type of veining and colour obtainable. Synthetic Rubber Moulds. Liquid preparation for making permanent, elastic moulds for repetition casting plaster plaques, etc. Very simple system. Write for details.—Karlena Art Stone Co., 26 Whitelaw Road, Chorlton-cum-Hardy, Manchester

FULL OF INTEREST the TWO books

"WHERE'S THAT CAR FROM?"

and

"POPULAR CARS"

(40 Illustrations)

6d each

from all Booksellers and Stationers

Ralegh Press, Exmouth.

4-in-1 ARMY JACK KNIVES!

The real Soldier's Knife as supplied to the fighting troops. Fine for model making and every hobby. Very solid construction with bright stainless steel blade, spike, screwdriver, can opener and carrying loop. Your kit's not complete without it. Write for one today! Cash with order (Add 6d postage)

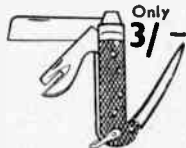

SCOTT & REED LTD
DEPT. 29 1-5, JERMYN STREET, S.W.1.



BRANCHES

LONDON

78a New Oxford St., W.C.1
(Phone MUSEum 2975)

87 Old Broad Street, E.C.2
(LONDON Wall 4375)

117 Walworth Road, S.E.17

GLASGOW

326 Argyle Street
(Phone CENTral 5042)

Head Office & Factories—HOBBIES LTD., DEREHAM, NORFOLK

MANCHESTER

10 Piccadilly
(Phone CENTral 1787)

BIRMINGHAM

14 Bull Ring

SHEFFIELD

4 St. Paul's Parade

LEEDS

10 Queen Victoria Street
(Phone 28639)

HULL

10 Paragon Square

SOUTHAMPTON

25 Bernard Street

BRISTOL

30 Narrow Wine Street
(Phone 23744)

TRIANGULAR DUTCH free



SEND NOW
to the Windsor Stamp
Co. for this really
magnificent Triangular
Stamp of HOLLAND
(Netherlands),
which we will
send to you—
**ABSOLUTELY
FREE.**

This very lovely stamp depicts Pallas Athene (Minerva), and was issued in 1936 to Commemorate the 300th Anniversary of Utrecht University. It is a stamp that every collector wants, and you can have one from us to improve and add interest to your collection, **ABSOLUTELY FREE.** Just send 3d. stamps for postages and lists, ask to see an Approval selection (no obligation to purchase any), and ask for **TRIANGULAR DUTCH STAMP FREE.**
WINDSOR STAMP CO. (Dept. 12) Uckfield, Sussex

ALL ABOUT FRETWORK

by W. F. Chambers
(Editor of Hobbies Weekly)

The book for all fretwork enthusiasts

Bound in paper covers, **2/6** net.

Or there is a cloth bound edition at **5/-** net.

Obtainable from all booksellers, branches of Hobbies, or from the publishers :

VAWSE & WILES (London) LTD.
356/358 KILBURN HIGH ROAD, LONDON, N.W.6



BRITFIX BALSA CEMENT

★ The ideal transparent cement for Balsa Ply Wood, Hard Woods, and Plastics, combining rapid drying with utmost tenacity.

Remember
**STICK BY
BRITFIX**

Small Tube
Now
4½d.

Large Tube
7d.

THE HUMBER OIL CO. LTD., HULL

YOU CAN BECOME A HANDICRAFTS INSTRUCTOR

Experience not essential

Men who enjoy making things in wood or metal can turn their hobby into a well-paid, permanent and interesting Career. Short hours, long holidays, and security in a job you would really enjoy, can be yours if you become a Handicrafts Instructor. Let us send details of the easiest and quickest way to get the necessary qualification.

We definitely guarantee
"NO PASS—NO FEE"

If you would like to know about our unique method of preparing you for one of these excellent appointments, write today and we will send you our informative 176-page Handbook—free and without obligation. Mark your letters 'Handicrafts Instructor'.

**BRITISH INSTITUTE OF
ENGINEERING TECHNOLOGY**

595 Shakespeare House,
Stratford Place, London, W.1

BIET

Double Protection with Yours FOR 15/- TENT

OR CASH PRICE
£3-9-6 PLUS 1/6 POSTAGE
MAKE ASSURANCE DOUBLY SURE

This **PARA** Ridge Tent comes to you with an inner tent plus a separate fly sheet. Absolutely portable outfit in Valise complete with all accessories. Popular size 5ft. 6ins. by 7ft. 3ins. along wall 4ft. 6ins. wide 3ft. 6ins. high. New wall, brand new. Yours for 15/-: 6 monthly payments of 9/9. Without fly sheet. 9/6 deposit. 6 monthly payments of 8/-. **EX-GOVERNMENT SOLID LEATHER HAND SEWN BOOTS 12/6** postage etc. 1/3. Boys, Ladies and Mens with small fittings, finest quality brand new solid leather Boots represent the finest value ever. No stronger Boot was ever made. Sizes 3 up to 7½. Also Mens 11 to 13 same price.



GREAT SURPLUS OFFER "PARATROOP" BINOCULARS

7 oz. Crystal-Clear Lenses. Ideal holiday, sporting events. 42/6. W.D. model, full size, £3 10/-. Very Special 6-Lens Achromatic Model, £5 19/6. Both complete in case, &c. All post 1/-

Other **TENTS, MARQUEES, TELESCOPES**, etc. Terms. Send for list. **HEADQUARTER & GENERAL SUPPLIES LTD., (Dept. HOB),** 196-200, Coldharbour Lane, Loughborough Junc., London, S.E.5
Open all Saturday. Closed 1 p.m. Wednesday.

**THIS 35" STRIP
PROJECTOR GIVES YOU
YOUR OWN
FILM SHOW
IN
YOUR OWN
HOME**

TRANSFORMER
MODEL
REMAINS
ONLY
BATTERY
MODEL
18/6 EACH
12/6 COMPLETE
READY TO USE

**START THIS
FASCINATING
NEW HOBBY**

LATEST INCLUDE

Dick Barton Strikes Back. Bertram Mills Circus, 1950. Mills v. Maxim Fight (Actual K.O. Blows). Laurel & Hardy—Blockheads. Famous Footballers. England at Sport, 1949. Buffalo Bill Rides Again. All 6d. per packet.

ASK AT YOUR LOCAL STORE FOR THESE EXCITING FILMS AND REMEMBER—IT'S THE ACTUAL REAL FILM.
Fowden Films & Optical Service, 2 Hastings St., Luton.

YOUR GUIDE TO BETTER BOX CAMERA photography



Your Guide to Better Box Camera Photography is a booklet you should have if you want to know how to get first-rate pictures with a box camera. It is published this month. Another helpful booklet, "Camera Tips for Everyone", is specially written for the young amateur. Both are profusely illustrated.

Available at your nearest photographic dealer, or, in case of difficulty direct from the publishers. (Write for latest illustrated catalogue of photobooks).



FountainPress
46-47 Chancery Lane, W. C. 2.



DOLL'S HOUSE

How to make in a simplified step-by-step manner a desirable four room Doll's House with electric light and separate garage if required

ALL MATERIAL EASILY OBTAINABLE

Send a 2/6 P.O. now for complete Plan and instructions Doll's House Paper and Doors and Windows, which open, are available. S.A.E. for list.

TRADE INQUIRIES INVITED

**ZIMPLAN 88 WARE ROAD
HODDESDON, HERTS.**

Photography is

FUN

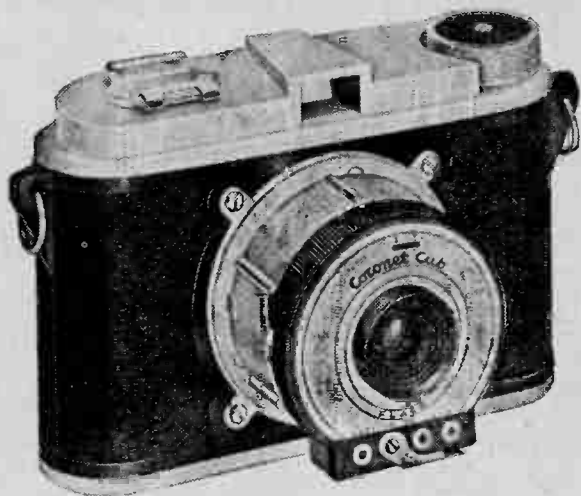

with a **Coronet Cub** camera

Here is a camera you can easily afford yourself and be justly proud to own. With a Coronet Cub you can depend on really first class results, it makes photography so easy—no complicated adjustments or involved calculations. It is straight forward 'shooting' every time. A special feature: it is Flash Synchronised, takes professional indoor pictures.

FREE!

Write for the Free booklet 'PHOTOGRAPHY IS FUN'. It tells you how easy and absorbing photography can be as a hobby with Coronet Cameras and Dufay Film.

Always ask for
DUFAY
NON-FLAM SAFETY
FILM
on sale everywhere



The Standard Coronet
Cub.

£3 13 10

(Including Purchase Tax).

BUY YOURSELF A

Coronet

CAMERA

DUFAY-CHROMEX LTD. / DEPT. P.1. ELSTREE HERTS

Telephone Elstree 1733



COLD water GLUES

supersede this

Most hobbies require Glue—"CASCO" fills the bill for either new work or repairs. It is an absolute necessity for the Modelmaker for Fretwork, Toy-making, etc. Easy to mix in cold water Casco is simple to use and almost impervious to heat and moisture. "CASCO" Grade "A" is the world-famous Casein Cold Water Glue manufactured in Great Britain, Australia, U.S.A. and Scandinavian countries. Conforms to MODERN BRITISH STANDARDS SPECIFICATION 1444, TYPE A.

Stocked by Ironmongers, Builders' Merchants, Hardware Stores, etc.



DISTRIBUTORS:

Gt. Britain: *Charles Cleeve & Co. Ltd.*
45 Gt. Peter St., London, S.W.1.

Eire: *C. B. Waller, 60 Middle Abbey St., Dublin*
M. J. Galligan, 16 Oliver Plunkett St., Cork

FREE! Send for literature and Free Sample to the manufacturers

LEICESTER, LOVELL & CO. LTD.
(Dept. HW), NORTH BADDESLEY, SOUTHAMPTON

NICOTEXIT

The Guaranteed Smoking Deterrent

- ★ Positively Stops Smoking Immediately.
- ★ Purchase Price Refunded if it Fails.
- ★ One Bottle is sufficient to establish control of smoking in any form.

5/6 PER BOTTLE
POST FREE

Obtainable only by post from the Sole
Concessionaires for Great Britain
THE NICOTEXIT COMPANY
(Dept. B.6.)
62, High St., Croydon, Surrey

THE HOBBIES No. 2 CORNER CRAMP

Accurate and Strong. Useful for gluing up corners. Lasts a lifetime.

Cast metal construction. To take any work up to 4ins. wide. Just the tool for gluing up picture frames and all mitre joints. Once used you will never be without one.

It Costs
ONLY
17/6



From any Hobbies Branch or (Post 9d.) from Hobbies Ltd., Dereham, Norfolk.

Hobbies

WEEKLY

CONTENTS

	Page
A Trailer Caravan	- 17
A Fireplace Screen	- 19
Hanging Wall Pocket	- 20
Tripolar Motor	- 21
Simple Bookplates	- 22
A Games Box	- 23
Novelty Trick Butterfly	- 24
An Alarm Clock Light	25
Manners in Hiking	- 26
Leatherwork	- 27
Signal Box Patterns	- 28
Model Signal Box	- 29

April 12th, 1950

Price Fourpence

Vol. 110 No. 2841

How the amateur handyman can make a TRAILER CARAVAN

THERE are many ways of making a trailer caravan and there are several things which decide the way in which it shall be made. First there is the matter of how much cash is to be spent. Then there is the question of total weight. Thirdly, there is how much accommodation will be needed.

This article describes the making of a simple two-berth camping trailer which can be towed up hill and down dale by

any popular 8 h.p. car. The usefulness of this trailer can, of course, be increased by making use of a small tent, thus providing accommodation for two adults and two children.

Chassis Obtainable

The details from which these notes were written, were collected a few years ago when the writer made a similar caravan, using materials purchased chiefly from the car breakers;

new materials being then unobtainable. It is now possible to obtain all the required materials, including aluminium sheeting, ash bends, canvas, plywood, or/and compressed board, metal mouldings and channel iron. The Editor can, if necessary, put you in touch with a firm supplying the chassis.

Firms who specialize in caravan equipment offer comprehensive lists of these materials and in addition, fittings for windows, doors, wheels, ball hitches

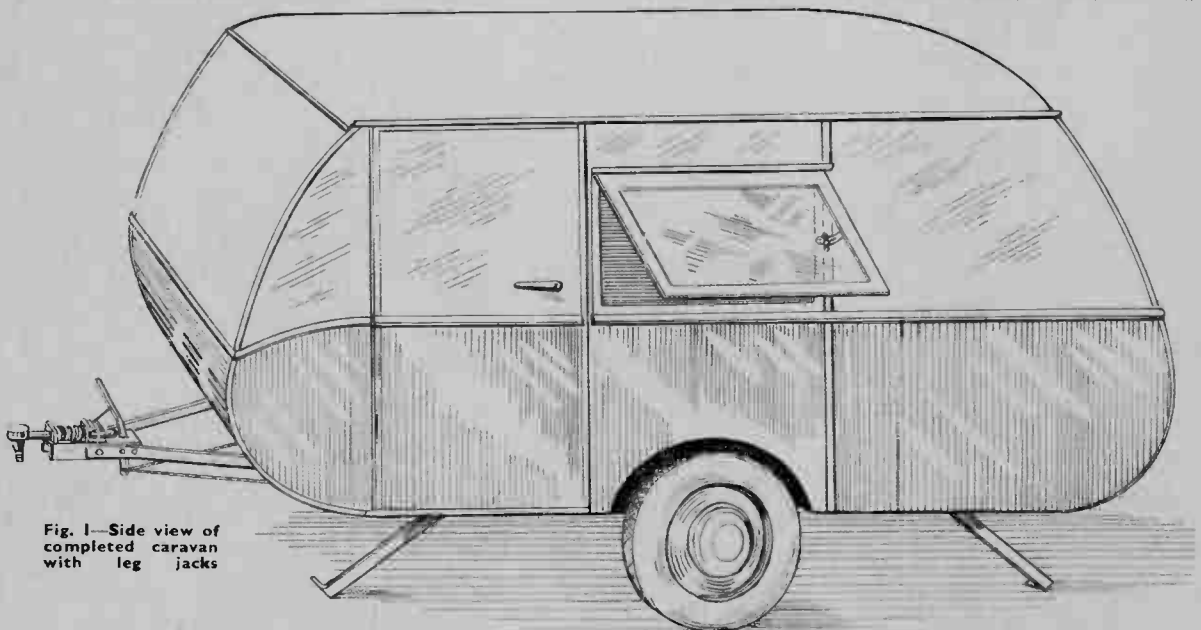

Fig. 1—Side view of completed caravan with leg jacks

All correspondence should be addressed to The Editor, Hobbies Weekly, Dereham, Norfolk.

and interior fittings. However, how much is bought, and how much is made, will depend, as already mentioned, on the available cash, and—we might include—the time limit, the facilities, and the skill of the reader.

The construction details need not be strictly adhered to, as the information is given as the basic conception into which the reader can introduce his own ideas according to the facilities and materials to hand.

The Chassis

The chassis is of very simple con-

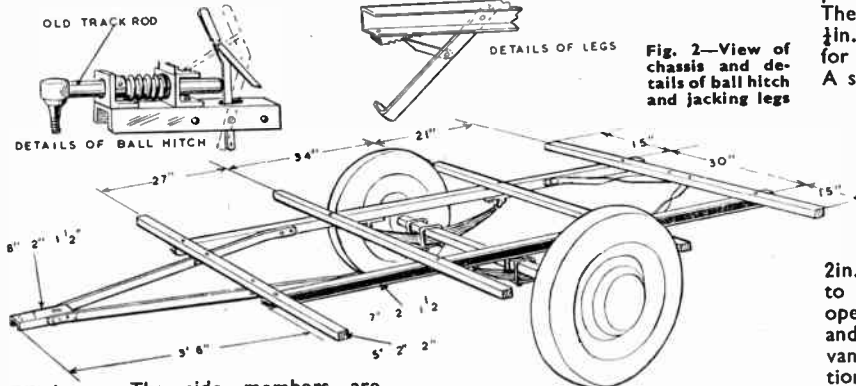

Fig. 2—View of chassis and details of ball hitch and jacking legs

struction. The side members are channel iron 2ins. by 1½ins., to which are bolted four 5ft. lengths of hardwood, preferably ash. Two braces of 1½ins. by ¾in. flat iron are fitted to the rear, being bolted to the sides and the rear cross member with ½in. bolts. The front of the chassis is braced by taking the two sides of the tow bar from just in front of the wheel springs, where they are bolted to the side members, and secured to the front cross member.

These can be made of 1½in. angle iron or 1½in. by ¾in. flat iron. To the front end of these two pieces is bolted a length of 2in. by 1½in. channel iron approximately 8ins. long, suitably drilled for the ball hitch, and drilled and slotted for the brake lever.

If it is decided to make the body detachable from the chassis, a length of 1½in. angle iron should be bolted across and under the front and rear of the side members. The four wooden cross members can then be counted as part of the body and they need not be bolted to the chassis until after the body has been built on to them.

When the intermediate cross members are spaced out, it should be borne in mind that the wheels are fitted slightly to the rear of the chassis in order to throw the weight to the front and make for easy riding. Also the ash bends for the wheel arches are usually listed at 16ins. inside radius.

Making the Jacks

Four legs or jacks will be needed and there are many ways of making these. Pieces of 2in. by 2in. timber hinged to the side members complete with some form of adjustment for uneven ground, would serve quite well. Flat iron 1½ins. by ¾in. fitted up as shown would be better.

This scheme could be improved upon following the lines of those on the market, although for such a light vehicle, anything elaborate is unnecessary and would only add to the weight and cost. Whichever way they are made, some form of clip must be fitted to hold them in the up position. This can be arranged by using flat spring steel bent to form a clip and bolted under the side members.

Wheels and Axle

Special axles complete with wheels are listed in the catalogues, but these are

generally expensive (£25 to £30), so if one has the facilities for making a set up, a great saving in cost can be made. Quite good axles complete with wheels can sometimes be purchased from the car breakers, being either a light car front or rear axle.

If a car rear axle is used it should be lightened as much as possible and the brakes should be overhauled. When using a front axle, the stubs will have to be fixed to prevent the wheels steering. This can be done by bolting suitable

if one is in the engineering business, a simple arrangement can be made as illustrated. The car breaker is again visited, this time for a lorry type track rod of 1in. to 1½ins. diameter and complete with ball end. The rod is sawn off to a suitable length (approximately 8ins.). A 2in. length of 2in. by 2in. angle iron and a 2in. length of 2in. by 2in. channel iron are then drilled to take the track rod and for the fixing bolts.

The track rod is fitted with a shafting collar and both are drilled to take a ½in. bolt. The piece of channel iron is fitted with a brake rack consisting of a piece of grooved steel welded in position. The brake lever is made from ¾in. by ¾in. flat steel. This is fitted with a sprag for holding the brake on when parking. A stout spring is used to take up the shock at override, the assembly being built up as shown.

Body Framework

The body framework is constructed chiefly of 1½in. by 1in. ash, with 2ins. by 1in. for the door jambs. These are fitted with the 2in. sides to the front and rear in order to eliminate spring when the door is opened and closed. Additional stringers and down posts can be fitted if the caravan is to be used under arduous conditions. The framework illustrated is suitable for general conditions and the frame can be made stronger by fitting corner strengthening pieces at every convenient point. These can be made of either wood or metal.

The size of the body shown has an overall length of approximately 9ft., the front and rear ash bends being about 18ins. deep. The width is approximately 5ft. The body can, of course, be made larger within the scope of the chassis.

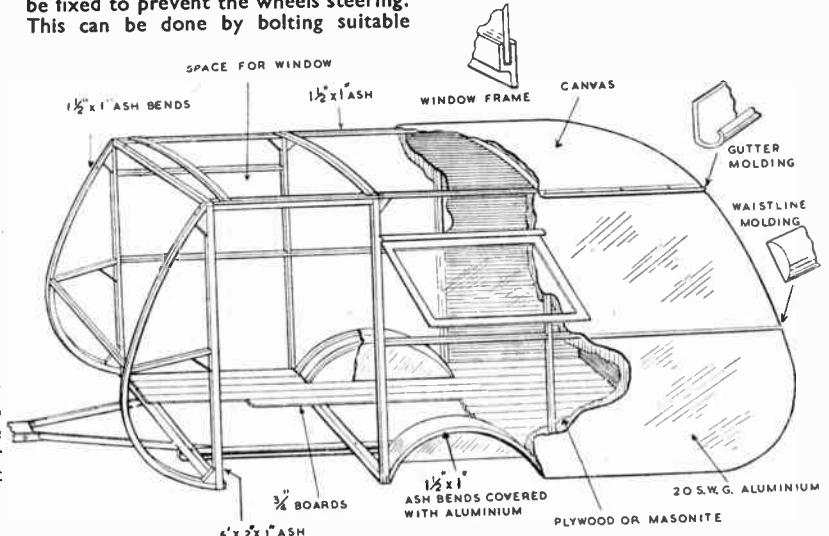

Fig. 3—Showing construction of framework and broken view of metal and outside covering

plates each side of the axle contacting each wheel hub.

The Ball Hitch

Ball hitches, complete with brake levers, can be bought for about £4, but

The size shown allows for 6ft. by 3ft. to 4ft. bunk space (with the second bunk in position), 5ft. by 15ins. cupboard space at the front, and about 5ft. by 20ins. for the cooking equipment and cooking space.

(To be Continued)

A useful piece of carpentry to undertake is this FIRE-PLACE SCREEN

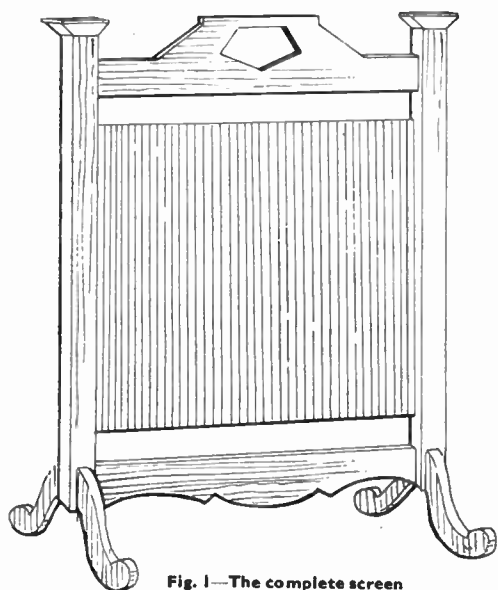

Fig. 1—The complete screen

WE illustrate in Fig. 1 an artistic fire-place screen of good proportions and dimensions to suit almost any hearth and fireplace. This is just the sort of job for the home craftsman who has command of his tools and can work up simple mortise and tenon joints and do ordinary plain carpentry.

The screen consists of a simple frame of some such wood as mahogany, beech or oak and fitted with shaped feet so it stands firmly in the hearth in an upright position. Now, the filling of the centre part of the frame may be carried out in one or two ways.

First, it may, perhaps, be fitted with a plywood panel upon which some mitred pieces of beading or moulding may be fixed. The beading should be pre-designed to form a pleasing panel pattern, with the centre filled with an overlay of raised wood carried out in some contrasting colour stain.

Secondly, the opening of the frame could be filled with a folk-weave fabric held top and bottom by cross pieces of turned rod, as shown in the details here. A wool-work panel upon a suitable backing fabric would also look well and show off to perfection the skill of one or more of the female of the family.

At Fig. 2 we see the front view of the frame or stand, giving the main dimensions to which the various rails, etc., are to be cut. The main uprights (A) of the frame may be 1in. square in section, and the cross rails (B) and (C) framed with mortise and tenon joints into them. In the enlarged detail (Fig. 7) the actual mortises and tenons are shown of both rails, drawn apart to simplify the constructional working.

The tenons should be cut the full depth of the rails— $\frac{1}{2}$ in. long by $\frac{1}{8}$ in. wide. The mortises in the uprights must be carefully marked out and cut to fit the tenons. The shaped legs (D) which are framed into the lower ends of the uprights should next be prepared and glued in firmly.

The Legs

The pattern for the legs is shown in Fig. 6. The lines which are ruled across this illustration are represented to be 1in. apart. Some care should be taken in preparing the full-size pattern for these legs, and it will be a good plan to make up a thin wooden pattern or template first, from which all four legs can be afterwards marked.

Note how the tenon will be set out at the top end of the leg. Each tenon should be $\frac{1}{2}$ in. wide and $\frac{3}{8}$ in. deep to meet in the centre of the uprights (A). The detail, Fig. 7, shows the leg tenon ready to be inserted into its mortise.

In marking out the legs care should be taken to see the grain of the wood runs with the shape of the legs as far as possible; note this on detail Fig. 6. A useful

cross section showing how the rail (C) and the legs (D) meet in the centre of the upright (A) is given in Fig. 8.

Figs. 4, 5 and 6 simply show the patterns for the shaped parts of the cross rails and legs. Allowance must be also made for the extending tenons at the ends. It should be explained that the top rail (B) is $4\frac{1}{2}$ ins. wide at the centre, and that rail (C) is 2ins. wide.

The work having been thus far carried out, the parts of the screen which have been framed up should be cleaned and fitted together temporarily. It will be necessary to cut small tenons—called 'stub tenons', which should be $\frac{1}{2}$ in. long at the top ends of uprights (A) for fixing on the shaped wood caps (E). Four holes must be bored also in the inside faces of the uprights to take the ends of the turned wood rods as (F) in Fig. 7 and in Fig. 2.

Fig. 3 shows an end view of the stand and shows that the above rods do not project through the uprights (A). The holes may be $\frac{1}{2}$ in. or $\frac{3}{8}$ in. diameter to suit the section of turned rod used. The holes may be bored to a depth of $\frac{1}{2}$ in. or $\frac{3}{4}$ in. The work may now be finally glued up and held where possible by clamps until the glue has hardened. It will be a good plan to fix the legs into the uprights first, after which the cross rails are fixed.

The wooden caps (E) should next be prepared and glued firmly to the top of the uprights. Each cap is 3ins. square by $\frac{1}{2}$ in. thick, the underside edges being chamfered or otherwise shaped.

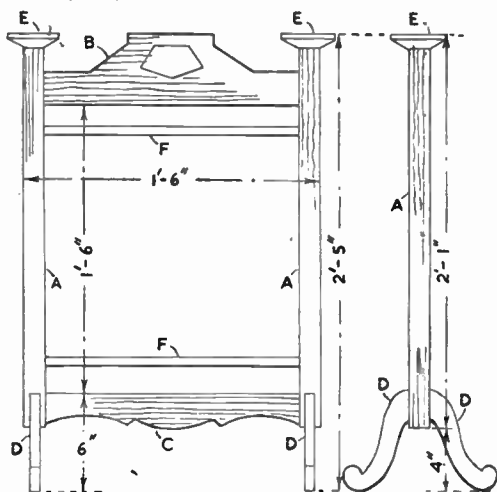

Fig. 2—Front view showing all parts Fig. 3—Side view

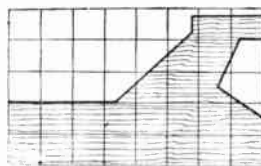

Fig. 4—Half shape of top

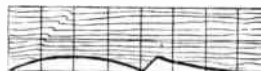

Fig. 5—Lower rail shape

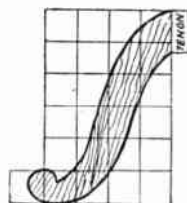

Fig. 6—Outline of feet

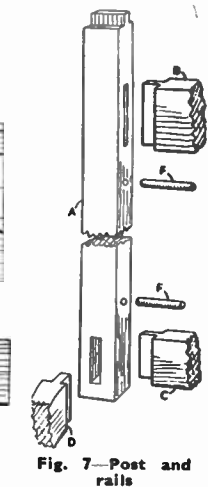

Fig. 7—Post and rails

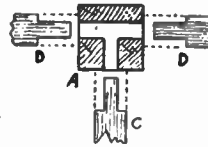
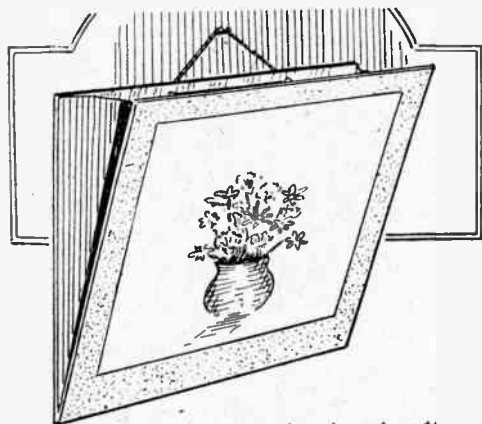

Fig. 8—How parts fit

A useful holder for bills, letters, notes, etc., is found in this HANGING POCKET



FOR a change from woodwork and model making, the useful little article illustrated might find favour. It is made to hang from the wall, and hold odd letters, papers, what you will that is light. A general handy article to help keep the home tidy.

For material, all that is required are one of those artistic almanacs of last year's date, a cardboard box from the grocer and a small piece of strong linen or lining material. Not an expensive collection. Should it happen that no suitable almanac is available, then plain cardboard can be substituted, and decoration supplied with a coloured picture or other means, depending on the artistic ability of the reader.

Picture Decoration

Most homes can, however, find the almanac, and so make good use of a pretty picture which is too often thrown away through lack of not knowing any use to put it too.

Fig. 1 shows a suggested size, the dimensions being given only when no almanac is available. Otherwise the dimensions of Fig. 1 should be the same as those of the almanac to be made use of. Cut two of Fig. 1 and cut, from plain or

coloured paper, two to the same size, plus 1in. extra at sides and top, as indicated by the dotted lines.

Snip these at the top corners, paste them, and rub well down to the cardboard. Turn over and press down at the back. See the corners are neatly folded and the whole free from creases.

From the linen or lining material mentioned, cut two gussets to the shape at (A) in Fig. 2. Width at top and bottom are given, the length will be the same width at Fig. 1, or whatever the almanac measures, plus $\frac{1}{2}$ in. at top and 1in. at bottom. The $\frac{1}{2}$ in. at top is folded over and either glued or stitched down.

Now fold and press down 1in. each side, as shown by dotted lines, to crease the material, and so mark it, for these parts are to be glued to the cardboard back and front pieces of the pocket. As

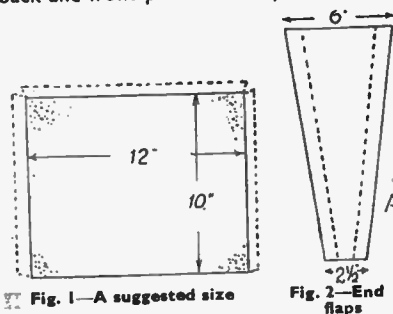

Fig. 1—A suggested size

Fig. 2—End flaps

stated they act as gussets, forming the pocket of the paper holder.

Glue one side first, and rub well down to the cardboard. Ordinary glue will serve for the job, freshly made and not too thick. Leave for an hour or so, then fold the gussets inside, place the second piece of cardboard under, and with the whole in position, glue the remaining part of each gusset to the bottom cardboard.

At the bottom of the extra 1in. of the gussets will stick out, cut off one half and glue the other half over the joint. Between the gussets glue a 1in. wide strip of the material along to finish joining the halves of the pocket together, at the bottom.

The detail sketch (B) in Fig. 2 will show the foregoing details and make all

clear, though there is nothing really difficult about the job to grasp. The cardboard side of the pocket should now be able to open out, and should be left open for an hour or two to better ensure that they do not stick together. Gluing can be rather a sticky job, not to say a messy one, especially when the stuff gets on the fingers or the glue pot is knocked over.

It is always a good plan to let the glue pot stand in a small saucepan of hot water, a piece of cardboard being placed under the saucepan to protect the table. It is then unlikely to be easily upset. Protect the surface of the table itself with an old newspaper, and after gluing anything, tear the soiled newspaper away and so leave a clean surface for gluing the next part upon. With the above precautions a much less messy job results.

Fitting the Pocket

The pocket, as we can now call it, should be turned over, what will be the back part now uppermost. Cut a sheet of the coloured paper, already used for the inside of the pocket, a shade less than the dimensions of the cardboard,

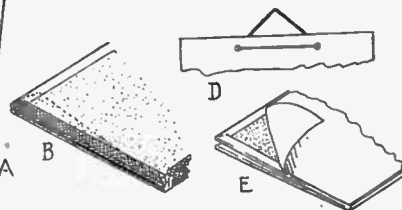

Fig. 3—Hanging and fixing details

and paste this over the back to hide the edges of the gussets and bottom hinge, as seen at (E) Fig. 3.

Now turn right side up, take the almanac, date pad removed, of course, glue about 1in. or a little more round the edges, and stick well down to the cardboard. Place a box, or something flat and rather weighty on top and leave for a few hours for the paste and glue to set.

For Hanging

For suspension purposes, punch two holes in the back of the pocket, about 5ins. apart, or less if the dimensions of the pocket are less than those given in Fig. 1. Through these holes thread a short length of any strong fancy cord that the household can furnish, knot the ends and draw up, as at (D).

A suitable brass-headed nail or cup hook, is better for suspending the pocket than an ordinary nail. Not only does it look neater but holds the pocket more firmly, so that the withdrawal of papers, etc., will not pull the pocket off the wall. Or you can cover the front with a third piece of card, a panel of paper and a picture as shown above.



BRANCHES

LONDON
78a New Oxford St., W.C.1
(Phone MUSeum 2975)
87 Old Broad Street, E.C.2
(LONdon Wall 4375)
117 Watling Road, S.E.17

GLASGOW
326 Argyle Street
(Phone CENTral 5042)

MANCHESTER
10 Piccadilly
(Phone CENTral 1787)

BIRMINGHAM
14 Bull Ring

SHEFFIELD
4 St. Paul's Parade

LEEDS
10 Queen Victoria Street
(Phone 28639)

HULL
10 Paragon Square

SOUTHAMPTON
25 Bernard Street

BRISTOL
30 Narrow Wine Street
(Phone 23744)

Head Office & Factories—HOBBIES LTD., DEREHAM, NORFOLK

Amateur electricians may like to try their hand at A TRIPOLAR MOTOR

AN electric motor with three poles on the armature is a little more difficult to construct than one with only two poles, but has the advantage that it is always self-starting. With a two-pole armature a motor will not start when the current is switched on if the poles are in the dead-centre position, though it will run satisfactorily when the armature is turned from this position.

The motor described here has three poles and will always start itself when current is switched on. The field coil is wound (e.g., not permanent magnet) and consequently the motor will operate from alternative current such as supplied by a small mains transformer. It will also run from dry battery or accumulator.

Making the Armature

The armature has three iron poles spaced at 120 degree intervals round an axle and this part may be made up as shown at (A) in Fig. 1. Each of the poles is a small iron bolt (which may be obtained from an ironmonger's) with the shank sawn off. Dimensions can naturally vary considerably, but it is suggested each pole be $\frac{3}{4}$ in. long. A disc of scrap wood about $1\frac{1}{2}$ ins. in diameter is also cut.

After assuring each of the pole pieces is of the same length and filing to correct any errors, the inner ends of the pieces should be tinned in preparation for soldering to the axle. File the ends and shanks of the pieces bright and smear with soldering flux; afterwards heat with a spirit lamp or large iron until the solder flows freely on to the pole pieces. Treat

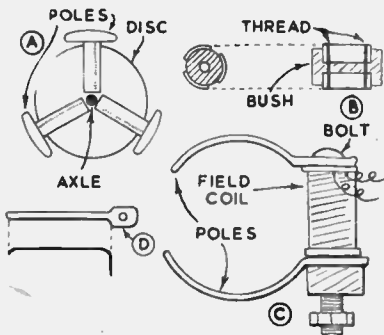

Fig. 1—How the parts are made

the centre of the axle in the same way.

The three poles should now be arranged as shown in Fig. 1, and may be secured to the disc with staples. Also have the axle in position projecting through a hole in the disc and support the whole on blocks so that the axle is vertical.

Plenty of solder should now be applied to the axle and inner ends of the pole pieces and melted on with a large iron which is really hot. When a good

joint has been obtained and the solder has set, the wooden disc is discarded.

The commutator is shown at (B) and consists of three segments of metal on an insulating centre bush. The latter has a central hole which is a tight push fit on the armature axle.

Bushing

The bush may consist of ebonite, wood, or similar material. A long strip of glued paper about $\frac{1}{2}$ in. wide wound tightly round the axle is also suitable. The three metal segments may be bent from thin metal or a short length of brass or copper tubing can be sawn into three to form the sections.

The segments are held in place by binding with varnished thread and then setting aside to dry. A clear space is left between the bindings; here the brushes will run.

The brushes are shown at (D) in Fig. 1. They are cut from thin brass or similar metal and have a small hole so that they can be screwed to the wooden base of the finished motor. Remove any rough edges on brushes or commutator segments with a file. Friction will be reduced if the overall diameter of the commutator is not larger than necessary— $\frac{1}{2}$ in. in diameter is a convenient size.

Making the Field Coil

The completed coil with poles is shown at (C). Actually, the motor will run well if the poles are flat, but it is an advantage to curve them as shown if possible, as this strengthens the magnetic effect between field and armature. Each pole consists of a strip of iron about $\frac{3}{4}$ in. wide and 2ins. long, secured by a fourth iron bolt as illustrated.

A cardboard washer is placed on the inside of each of the poles to keep the wire which will be wound on away from the metal. For the same reason a layer of insulating tape or thick paper is wound round the bolt.

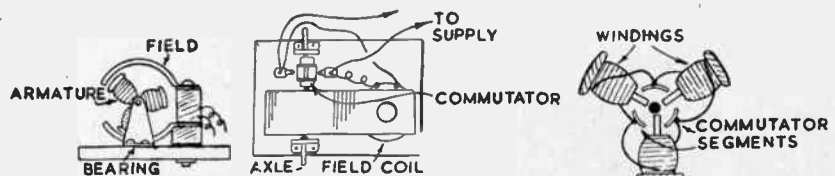

Fig. 2—Side view of motor Fig. 3—Top view showing connections Fig. 4—Armature winding

The armature turns within the poles of the field coil, as shown in Fig. 2. The smaller the gap between armature poles and field poles the better, but, naturally, the poles must not foul each other as the armature rotates.

Bearings cut from fairly stout metal and screwed to the baseboard support the armature axle, and sideways movement is prevented by washers. The field coil is mounted by means of the large iron bolt, a small block being placed

under the lower pole as shown.

It is essential that the armature is wound in the correct manner or one pole may endeavour to cause rotation in the opposite direction to the other two and the motor will only run at low speed and possess little power.

Each pole should be wound in such a way that, looking at it from its free end, all the turns upon it are in the same direction as the turns upon each other pole, when looking at them from their free ends. This is shown in Fig. 4 and no difficulty should arise if the armature is held in one hand and each pole wound in the same direction with the other.

Wiring

The wire should be wound quite tightly, and as many turns as space permits should be put on. Approximately the same number of turns should be used on each pole to avoid vibration. The outside ends of each winding may be secured by raising the wire and passing the end under the previous turn, afterwards pulling tight.

The ends of the windings should be soldered to the commutator segments in the manner shown in Fig. 4. The commutator is a push fit on the axle, but a little free wire should be left so that it can be rotated slightly in relation to the armature poles in order to obtain the best running position.

Field Winding

This consists of one simple coil of wire as shown at (C) in Fig. 1, as many turns as possible being put on. If the wire is wound carefully in layers, maximum efficiency will be obtained.

The ends of this winding are taken to the screws securing the brushes, and the leads to the battery or other source of supply also come from these points, as shown in Fig. 3. If it is desired to reverse the direction in which the finished motor runs, this can be accomplished by

reversing the ends of the field coil.

Double cotton covered wire is best as there is less chance of a short circuit to any metal parts than is so with enamel covered wire. However, the latter is perfectly satisfactory if tape or thick paper is placed between the winding and the armature poles so that the enamel insulation is not scratched off and a short circuit caused.

(Continued foot of page 22)

Prevent the irritating loss of your books by MAKING A BOOK PLATE

YOU have probably allowed people to borrow some of your books, and waited in vain for their return; maybe you have been at fault yourself and forgotten to return borrowed books. But a book will go astray less easily if it contains the owner's book-plate. This consists of a label which is stuck inside the cover of a book, and



Fig. 1—Cutting the lettering white

contains the Latin words 'Ex Libris', meaning 'from the books of', and the owner's name or initials. Very often some design is incorporated, too, and the initials may be in the form of a monogram.

Wood or Lino Cut

You can supply your books with book-plates printed from a wood or lino block. Cutting the block is fascinating work, and many interesting effects can be obtained. To make a wood block, you need a piece of smooth, close-grained wood, such as cherry, birch or holly. A convenient size is 4ins. by 3ins. and any suitable thickness. The smaller the block, within reason, the better.

Square up the block, smooth the

edges, then plane and glasspaper one face until a perfectly flat surface is obtained. Next, prepare the design that you wish to use. The illustrations show ideas for book-plates which are very effective, though simple to produce. Do not go in for complicated designs for they are difficult to cut, and often print badly.

White on Black

Fig. 1 shows the effect produced when the wood is cut from the inside of the letters, so that they print white. This is the easier method. In Fig. 2 the wood has been cut away from between the letters, giving black letters on a white background.

Use tracing paper or thin drawing paper, and carefully draw the design on to this, using a soft lead pencil. Make the framework first by pencilling round the block.

Shade the parts you wish to appear black in the print. Then turn the tracing paper face downwards on to the wood, and 'rub off' the design with a pencil. Be careful not to move the paper during this operation. When you remove the tracing paper there will be the design on the wood in reverse—as seen through a mirror.

Cutting

The next stage is to cut out the white parts of the block. Use a razor blade, cutting round the edges of the letters. For straight pieces, use a ruler, preferably a steel one. Be careful not to over-shoot the mark when cutting, as even the small cut made by a razor blade may show when printing takes place.

Now remove the wood from between the razor cuts. Any convenient tool will do for this—a narrow chisel, or even a sharp pen-knife. There is no need to cut very deeply, just go below the surface of the wood. When all the

cutting-out has been done, trim off the ragged edges with the razor blade.

The Printing

Now for the printing. Do not make the mistake of printing directly into a book. Make your prints on paper, then stick the paper, cut to size, inside the cover.

Experiment, if possible, with different types of paper in order to obtain the best results. Duplicator ink is very good, especially if used on a semi-absorbent paper. You are not restricted to black, of course, for inks can be obtained in various colours. Use a felt pad for inking the block, or alternatively,

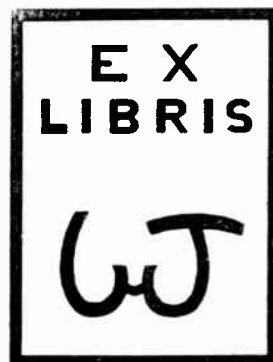

Fig. 2—With block lettering

brush the ink on, applying thinly and evenly.

The process of cutting the block is similar if lino is used, but this is easier to cut, and more complicated designs are possible. For convenience, the lino block should be glued or tacked to a piece of wood.

Now watch the difference a book-plate makes in bringing your precious books home to roost!

A Tripolar Motor—(Continued from page 21)

After the motor has been finished and operates satisfactorily, it will prove helpful to give all the windings a coating with varnish. When dry, this will hold all turns secure. For a 3 to 6 volt dry battery supply 26 S.W.G. wire is suitable. This is also satisfactory for a small transformer. If a 2 volt accumulator is used, then 24 S.W.G. wire will be more suitable.

Actually, the wire gauge may be varied within large limits, but the following points should be noted. For maximum power, a fairly heavy current must flow and thin wire cannot, therefore, be used. But if economy of operation is desirable and low power only is required, a thinner wire may be used, up to 32 S.W.G. proving suitable for 4 to 6 volts. Further economy may also be obtained by connecting the brushes and field in series, instead of in

parallel, as shown, but this reduces power in the same way as using thinner wires.

Obtaining Best Running

For the motor to run at its best, the brushes should make good contact with the commutator, but not press too hard. The commutator must be in a correct position relative to the armature poles

so that each pole receives an alteration in the direction of the current flowing from the brushes as the pole passes the ends of the field coil magnet.

The simplest way of assuring this is to stop the motor and turn the bush a few degrees at a time on the axle. When the correct position is found, the motor will run at maximum speed and no further adjustment is necessary.

For driving models a very small gear or pulley wheel should be used on the motor axle so that a fairly high reduction ratio is obtained. Without this the speed at which the motor runs will be reduced and in consequence it will not develop much power.

For battery operation a permanent horseshoe magnet may be substituted for the field magnet. The motor will not then work from a mains transformer, however.

Index for Vol. 109

Apart from being essential when you get your Hobbies Bound an Index is always useful for reference when you are wanting something to make or do. Volume 109 was completed with the last issue in March and an Index for the previous six months is available from the Editor for 1/- post free

Know where they are by keeping them in A GAMES BOX

WHEN it's time for a game it is a great advantage to be able to produce the cards or pieces immediately, and to know that they will not prove to be 'one short'. The Games Box illustrated keeps safely together in one neat box all the necessary pieces for a variety of games. It also provides an interesting little piece of work to make up, with ordinary fretwork tools and a few odd pieces of wood.

The reader will, naturally, wish to vary the arrangements to suit the game he favours, and this is quite a simple matter. The outfit illustrated provides playing board and compartment for draughtsmen or chessmen, for cards and trump indicator; a score pad and place for pencils, and a pegging board, and leaves plenty of space for holding darts, dice, and anything else the owner may wish to be taken care of.

Suitable Sizes

The exact size is not important, so before deciding on the actual dimensions, it is best to consider what material is available and whether it is intended to incorporate a draughts board already in the reader's possession.

In other cases the measurements given will be found quite suitable. They allow for wood of $\frac{1}{4}$ in. thickness, and do not

sides, and add the base. Now cut out the four lids, the two narrower from one piece of wood and the two wider from another. Fit them so when they lie temporarily in the bottom of the box, with a piece of the wood to be used for the partitions placed between them, they just touch it.

While the lids are in this position, mark the exact places for all four partitions, then remove the lids and glue or screw the partitions into place. Doing the work in this order makes quite certain that the lids will fit nicely, no matter what thickness the wood happens to be. They rest on corner pieces each cut the thickness of the lid shorter than the width of the partitions. When in place the lids are thus just flush with the top of the partitions.

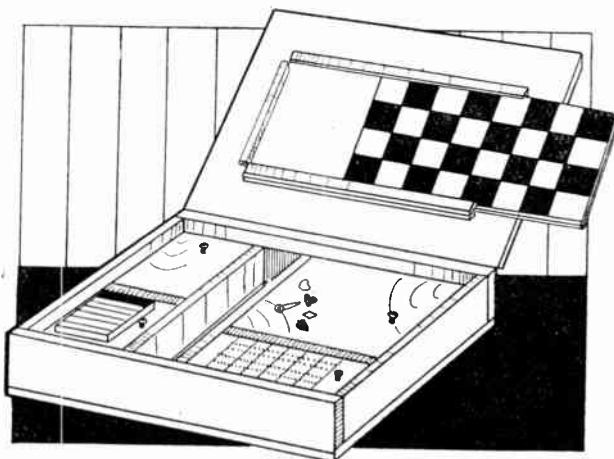

Showing the box open with its various compartments

plan to mark each sixth hole with a horizontal line drawn right across the board, as this guides the eye when pegging and prevents any over-enthusiastic scorer from making 'accidental' mistakes in his position!

If a score pad of the right size is not available, a slightly larger one can be cut down with razor blade or sharp knife and a straight edge. The last page or backing card is glued to the top of the lid later on, when whatever finish chosen has been added.

For the trump indicator the four suits can be either neatly painted on to the lid, or if (as usually happens), a few odd cards are around from some incomplete pack, the four designs can be cut from these and neatly glued into position. The pointer is made from a small strip of brass or other thin sheet metal, held into position with a small screw.

Four little knobs are screwed to the lids, to complete this part of the work. They need to be very short in height, in order not to prevent the lid from closing. Alternatively, four short pieces of dowelling, about $\frac{1}{4}$ in. diameter, glued into holes neatly bored with the brace, will do just as well. If the top of each piece is rounded off, this looks even neater than the bought knobs.

The Draughts Board

To make a folding draughts board, procure two pieces of stout cardboard and cut them to identical size, the length of each piece double the width. Lay them side by side with the long edges touching, and glue down this joint a piece of gummed paper or tape. When this is dry, fold up the cards book-wise and glue another strip over the back edges.

(Continued foot of page 24)

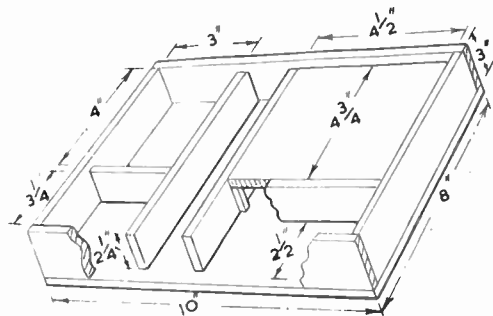

Details of sizes and construction of main box portion

necessitate any pieces larger than can usually be found among the handyman's oddsands. A draughts or chess board of special size to suit the box can be easily made up from cardboard. In fact, the complete outfit could be made up from stout cardboard if reinforced with wooden corner strips and carefully glued together.

Construction

The lid and bottom, which are identical, require the two largest pieces of material, and plywood is the most suitable. Another piece a little smaller is needed if the design on the lid is to take the form of an overlay. The ends of the box and the two main partitions are the same length, but the two partitions are cut $\frac{1}{4}$ in. narrower, as shown.

Glue or neatly screw together the four

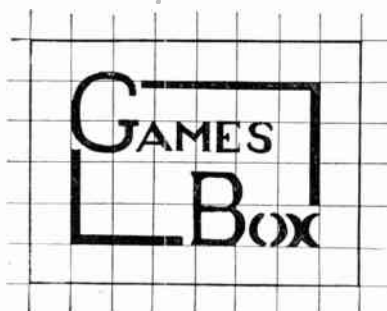

A suitable name lay-out for the lid

The Lids

It will be seen that one of the lids carries the pegging board, one the score pad, and one a trump indicator. The holes in the pegging board can be made with a drill, but the board should be drawn out first to ensure the holes being in straight lines. It is also a good

CUTTING LIST

(for wood of $\frac{1}{4}$ in. thickness)

- 2 pieces 10 ins. by 8 ins. Lid and Bottom.
- 2 pieces 10 ins. by 3 ins. Sides.
- 2 pieces 7 $\frac{1}{2}$ ins. by 3 ins. Ends.
- 2 pieces 7 $\frac{1}{2}$ ins. by 2 $\frac{1}{2}$ ins. Partitions.
- 1 piece 3 ins. by 2 $\frac{1}{2}$ ins. Partition.
- 1 piece 4 $\frac{1}{2}$ ins. by 2 $\frac{1}{2}$ ins. Partition.
- 1 piece 4 ins. by 3 ins. Cards Box lid.
- 1 piece 3 $\frac{1}{2}$ ins. by 3 ins. Score Pad lid.
- 1 piece 4 $\frac{1}{2}$ ins. by 4 $\frac{1}{2}$ ins. Draughts Box lid.
- 1 piece 4 $\frac{1}{2}$ ins. by 2 $\frac{1}{2}$ ins. Pegging Board lid.
- 1 piece 8 ins. by 6 ins. Overlay.

Amuse and entertain your friends with this BUTTERFLY NOVELTY

HERE is a timely little novelty for the youngsters—and, of course, the not so young—with which to cause a bit of harmless fun. If made correctly this 'demon butterfly' should rise to a height of several feet as soon as the harmless-looking folder is opened by the unsuspecting victim. Whether the desired effect will be achieved depends upon the thickness of paper used—the heavier the paper the shorter the distance the butterfly will rise.

Materials Needed

The only materials needed are an envelope of moderate thickness, a large-size paper-clip (or piece of wire just over 4ins. long), a small elastic band, two little beads, a sliver of wood and a few inches of fine wire. Where can you get the thin wire from? You will find two excellent strands inside any pipe-cleaner.

Begin by cutting out the wing shapes from the face of the envelope and place it near to hand. Take your paper-clip and straighten it out, removing the kinks with the aid of a small pair of pliers. This wire will be over 4ins. long. Mark it at the middle and twist the wire

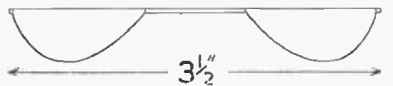
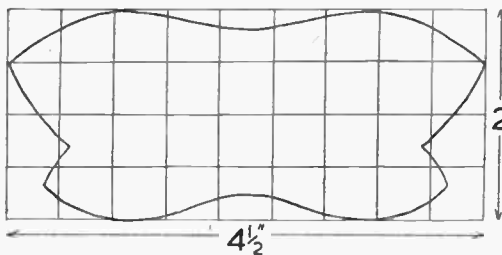

Outline of the butterfly in $\frac{1}{2}$ in. squares, with propeller shape

completely round so that you have a small, circular loop in the middle of the wire. Press the loop flat and, with the pliers still gripping firmly, bend down the two ends of the wire to form a pair of shoulders (see detail illustration).

This may appear complicated before you try it but is really not as difficult as it

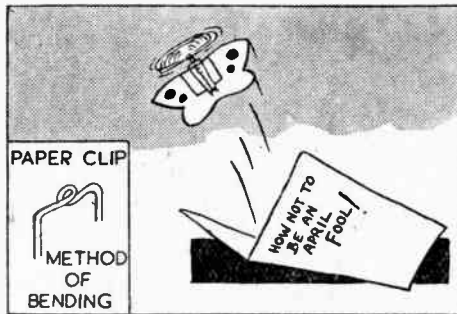

looks. To finish with the paper-clip (we may as well still call it one), just bend up the ends, taking in as little as possible. These will be necessary to hold the end of the elastic band firmly.

Fitting the Elastic

Take the elastic, a band that will fit loosely along the length of the wire braces, and loop it round the ends of the wire as can be seen in Fig. 2. Now press home the bent ends so the elastic is held in place firmly enough to resist the tension when it is wound up.

The next thing is to get the paper-clip fixed to the wings. This can be done with a piece of sticky-backed paper or with a touch of stronger glue. You will have to hold the elastic band out of your way—unfortunately the band has to be put on before the paper-clip is fixed, otherwise it would be a ticklish job.

Press the paper firmly down all round the wire and leave it until it is perfectly dry before working on it again. You can be removing the fine wire from the pipe cleaner while you are waiting.

Take your sliver of wood, pare it down as thin as you can, so it will be fairly pliable, and cut it to a length of $3\frac{1}{2}$ ins. This is for the airscrew shown in the bottom part of Fig. 1. Shape out the two pieces of paper to glue in place at the ends; get them fixed, winding them once around the stick for security.

Coming back to the wings. Take hold of the loose end of your elastic and wrap one end of the pipe cleaner wire around it. Pass the other end of the wire through the loop you made in the paper-clip. Slide the two beads down it so they rest on the loop. Now wrap the other end of your fine wire around the middle of the piece of wood, drawing all the parts together as you do so. Then break off the excess wire.

It will be noticed that the paper on the ends of the air-screw overlap the wings. The wood should be bent from the middle until these parts are clear. The wire binding will prevent the wood from breaking at this point. The butterfly is now complete but, in addition, it

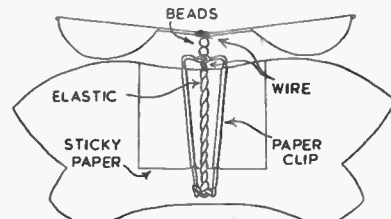

Showing mechanism in position

could be decorated in either brightly painted colours or with pieces of coloured paper, cut in circles and stuck on to the wings.

How to Use

To put the joke into operation hold the wings in one hand and wind up the airscrew with one finger until the elastic is as taut as you can get it. It can be placed inside the cover of a book and left lying around the house, but if you wish it would be easy to hand it to somebody personally.

For this purpose you could prepare a stiff cardboard cover with some kind of a title written on the outside. As long as the cover is held shut it is impossible for the butterfly to jump out.

The card should be neatly folded in half and can be kept in the pocket with a rubber band around it.

Games Box—(Continued from page 23)

Now glue a sheet of stiff paper over each flat surface, and when dry, rule up one or both surfaces and paint black the alternate squares. You will need to divide the board into eight equal divisions in each direction, to leave two clear rows between the two sets of 12 draughtsmen when arranged at the start of the game.

The folded board is held on to the inner side of the lid of the box by

rebates of thin wood or cardboard. The simplest way of doing this is to build up each length with two pieces, the one $\frac{1}{2}$ in. wider than the other. Glue another piece at the end, in the opposite direction, to form a stop when the board is pushed in.

Finishing Off

The ruled design gives a simple suggestion for the lid, but the reader

with artistic ability can, of course, embellish this to suit himself. In fact he might prefer to paint the design on to the lid, which gives still further scope for suitable ornament.

Finally fix the lid to the box with two neat hinges, and a small fastener at the front, and finish off with stain, varnish or paint, according to preference and the wood used. See you have the whole thing clean, neat and attractive in appearance.

How to fix battery and electrical connections for ALARM CLOCK LIGHTING

WHEN we have to be 'up in the morning early' most of us need to rely upon an alarm clock. And when its bell rouses us from our slumbers have you noticed how often we knock over the clock (and sometimes other things, too) in our sleepy fumbling to lay our hands on it in the dark?

The little electrical arrangement shown obviates all that, by automatically lighting up the clock when the alarm goes off. It can be adapted to all the usual types of clockwork alarm, and needs only a torch battery and bulb, some small pieces of wood, and one or two of the screws and pieces of wire that every handyman has amongst his oddsands, or can procure easily for a few pence.

Method of Mechanism

Alarm clocks are all very similar in principle but differ widely in their actual design. For this reason no actual measurements are given. But the method of fixing up the light is clearly shown and the reader with an electrical turn of mind will have no difficulty in making each piece to suit his particular clock.

Briefly, the electrical contact breaker is so arranged that the circuit is closed by the first forward movement of the striker when the clock starts to ring. It stays closed whilst we open our eyes, perceive the time by the illuminated clock face, and switch off the alarm and

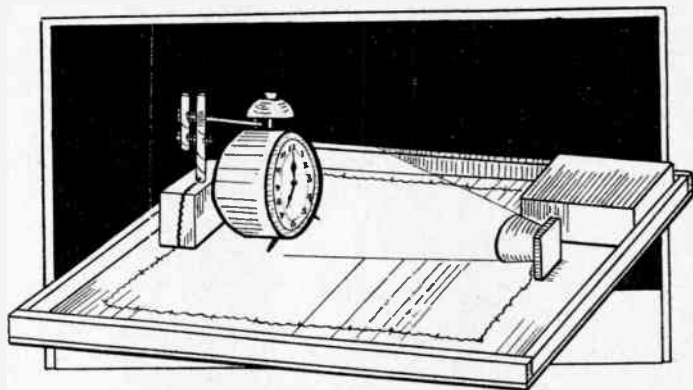

fixed and one movable. Bore the block about $\frac{1}{4}$ in. deep to take the fixed dowel. The movable piece is held to the other by a nut and bolt, with washer between the two dowels as shown.

At the top end of the movable piece drill a hole to take a brass screw about $2\frac{1}{2}$ ins. long which, when in position, will project up to the striker on the alarm clock. The wiring of the circuit runs up these two dowels, and is closed when the brass screw is pushed forward to touch the bared wire on the fixed dowel.

A little careful adjusting of the bolt

the bell, and is close up to the striker. In some cases the bell on the clock has to be wound back a little higher, to give more space between bell and clock case.

Whatever kind of clock is used, it must be held firmly in the tray, so it does not move when the alarm rings. If the clock has legs, these can fit into holes drilled for them in the baseboard. A square or rectangular clock can be held in place by neat strips screwed to the base.

Inside Bells

Clocks that have the striker inside the clock need a little different treatment. The principle is usually the same—a little gong striking either on to the inside of the case or (if this is of wood or bakelite) on to a little bell or strip of metal put in for that purpose. Since this type of clock needs a small hole to be drilled in the side of the case, it is best to allow the clock to run down before commencing operations.

Then take the movement out of the case if this can be done easily. If not, drill the required hole from a sideways position, so the drillings do not fall into the 'works'. Take care also not to let the bit slip right in, but pull up as soon as it is through the case. Choose the position for this hole carefully, as near to the striker as can be arranged.

Usually, less cutting of the case is necessary if an 'end on' push is adopted. Fig. 3 shows such an arrangement. In this case the contact maker will, of course, stand beside the clock, and not behind it as in the method shown for clocks with outside bells. Then only one small hole is needed in the clock-case, through which a short piece of dowel, of the same diameter as the hole, will slide.

This dowel is pushed outwards slightly by the striker, when it moves forward towards the side of the case or

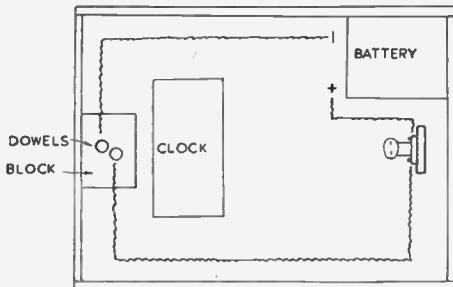

Fig. 1—Lay-out of board and wiring

the light. The clock, light and battery are all held in a small tray, as shown at Fig. 1, though the clock can be lifted out for use independently whenever it is so required.

For the base itself, a small board or piece of plywood is needed, with narrow strips to make it into a tray if desired, although these are not essential. The only other wood required are some small pieces for the battery case, a block to stand behind the clock, and a foot or so of dowelling.

The Contact Makers

The drawing at Fig. 2 shows the general principle for clocks with an outside bell. The contact maker consists of two pieces of dowelling, one

that holds these two dowels together is necessary, so the movable piece is loose enough to move forward and touch the other when pushed by the striker, but tight enough to stay in that position until the light is required to be switched off. Later on, when the final touches have been added, put a second nut on the bolt and lock it down on to the first after the exact degree of tightness has been obtained. This will prevent the first nut from working looser with the to and fro movement of the dowel.

Fix Firmly

Get the exact height of the brass screw by varying the depth that the fixed dowel enters the block. It should be such that the screw projects under

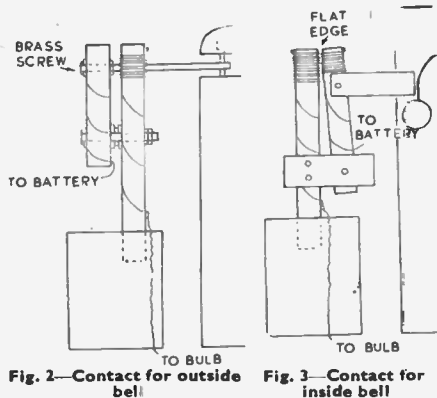

Fig. 2—Contact for outside bell

Fig. 3—Contact for inside bell

bell. The other end of the dowel fits loosely to a second dowel, and from there the arrangement is very similar to the outside-bell method, except that both parts of the contact maker consist of wire-covered dowel.

It will also be noted that the two vertical dowels are not bolted together but are both held to a small piece of plywood near the block. The fixed dowel has two screws through it, and the movable piece one. Here again the joints need to be loose enough to allow of movement but tight enough to hold the electrical contact as long as is required.

Before wiring the movable vertical dowel, flatten one edge a little as shown, so that a broader surface is given for the bared wires to meet. The little dowel that projects through the side of the

clock case needs to work smoothly, and it usually means bending the striker a little to arrange that it touches this dowel when it moves forward.

The Light

Screw a bulb holder to a small piece of wood, and fix the wood in a vertical position into the base board, as shown. Make a little hood for the bulb, to direct the light on to the clock, of thin sheet metal, paper or cardboard, and fix it to the lamp base with screws or gummed paper as most convenient. Three small pieces of wood make a vase for the battery, screwed to the base board from underneath.

Wiring is quite simple and is shown at Fig. 1. The most important place is at the top of each dowel, where contact is

made. When the wire itself is to make the contacting surface, bare it for a few inches, fix the end with a small screw into the dowel, then wind the wire round the dowel, each strand touching the next for about $\frac{1}{2}$ in.

This makes a good broad surface for the contact, and after that the wire can be left covered and simply twisted round the remainder of the dowel in any way most convenient. A small screw at the point where the wire leaves the dowel prevents the wire from moving.

When all is ready, a trial with the clock can be made, and little adjustments in the position and movement of the contact-makers attended to. Then finish off with stain, paint or enamel, to match the clock that is going to be used with it.

Some suggestions of countryside code and manners in HINTS FOR HIKERS

MANY of our readers this Spring may be taking up the grand outdoor pastime of hiking, or rambling if you prefer it. We have heard it said that 'A little of the countryside goes to the head of the city youth', who is intoxicated, as it were, by the changed surroundings and the freedom of the open air.

Whilst this may be true, it is only the few hooligan-minded folk who behave foolishly when hiking, and the great majority are well-behaved and sensible. If you are a beginner, take your cue from them. You can learn a lot by joining a ramblers' club, and going along with the experienced ones.

Courtesy by All

Perhaps it is needless to thrust lessons in deportment upon the common-sense hiker. But, perhaps, it is not irrelevant to point out that there is a sort of 'countryside code' which new-comers should follow. Lack of good manners and boorishness are to be deplored at all times.

Country dwellers usually welcome hikers who come out to enjoy the open air, and it is only right that we should extend to them courtesy and consideration. Do not regard the countryman from the point of view of the cartoonist—as an ignoramus chewing a straw whilst lolling over the pig-sty door.

He is intelligent enough, we can assure you, and in these days especially is as wideawake as any townsman. So give him credit for that, and treat him accordingly. Then you will get on fine with him.

Farmers have complained quite a lot about the thoughtlessness of hikers who ignore the 'Please shut this gate' notice. Do not add to the number of the thoughtless. Leaving a gate open or unfastened is almost a crime in the country, for cattle, sheep and horses are apt to stray, or to enter a field and

damage crops growing there. Frequently trouble is caused by animals straying on to the roads, and taking the farmer's valuable time in rounding them up.

Good Manners

Good manners cost nothing. Rowdy parties invading a quiet country village on a Sunday especially are not looked upon as being a blessing. Rural folk resent such ill manners; there is just a minority who forget themselves.

Here are a few unwritten 'laws' that the beginner should conform to when rambling.

Keep to the footpath when crossing a field, especially where crops are growing. Avoid trampling in mowing grass.

Do not invade private grounds. Do not enter woods or coverts unless there are public rights of way. Where woods and country parklands are kindly thrown open to the public, be thoughtful and leave no litter behind if you pause there for a haversack lunch. Do no damage to trees or shrubs.

If you have occasion to light a fire to boil a kettle for making a cup of tea on moor or heath—or other spot, for that matter—make sure that the embers are thoroughly stamped out before proceeding on your way.

Do not throw away cigarette ends that are still alight; stub them out with your finger and thumb. Do not drop a lighted match into the grass, heather, or undergrowth.

Litter Fiends

Alas! Litter fiends are still with us.

**Be sure to read
our advertisement
pages for some
practical offers**

Not always is it the hiker who transgresses; motorists on country roads are not blameless. Do not copy their example.

The litter fiend is often just thoughtless. He—or she—just dumps a cigarette carton or a bit of sandwich wrapping paper by the wayside, and thinks it matters not at all. Well, it does. Who wants to see the countryside disfigured with such stuff? It is as easy to put it in your haversack and carry it home to burn it, as it was to bring it along.

The outdoor picnic is always an enjoyable meal. When you have finished, collect all paper bags, wrappings, empty tins, and scraps left over, and either take the litter away with you, or destroy it in some way. Put a match to that which will burn, but do not set the hedgerow or bracken on fire, and make sure no embers are left to smoulder. Or you can push it down a rabbit burrow or similar place where it cannot blow about.

No River Pollution

Get rid of your litter in some way, but do not dump it in a stream. For, though even many country people seem to regard any brook or river as a convenient dumping place for rubbish, set them a better example.

Remember, farmers and others living on the banks may have to depend upon the water for use. Besides, who likes to see a clear stream littered with sardine tins, rotting cartons, paper and other rubbish?

Wherever you go on your hikes, stick to a code of good manners and correct behaviour. Think at it like this—'I should resent people coming into my garden or yard and upsetting my flowers and making a mess of the place. Therefore, I will not be like that when in the country, but will be as considerate when walking across fields, through farmyards, in the woods, and by the stream, as if it were my own property!' Thoughtless and ill-behaved hikers only get a bad name for hikers in general.

You can make many delightful and useful things in LEATHERWORK

LEATHERWORK does not only mean the modelling of a picture on leather, but entails the making up of an article in the manner suitable to the material. The most important thing to remember is that the article should be of good workmanship and should serve the purpose for which it is intended. Great care should be taken to see that the corners are square and that the edges are straight or a bag, or other article will not close properly, and the gussets or pockets will not fit the main piece of leather.

Always plan an article in paper, cutting out the pieces to see they fit one another. The pattern can then be placed on the leather, drawn round with the tracer and the lines cut against a ruler. If the pieces are ready cut it is always as well to see that they are square before making the article as in wholesale cutting, the work is sometimes careless.

Matters of Design

When selecting a design care should be taken that it is the right size for the space to be filled, allowing for at least $\frac{1}{4}$ in. for the thong edge around the article. Measure carefully to see the design is straight or exactly in the middle if it is intended to be so.

Always work on a clean piece of paper and keep the leather wrapped up when not in use. Have clean hands, as grease marks are not easily removed and those places will not take stain. A small piece of paper can be placed under the hand whilst modelling. Wet the leather all over the first time as the colour will change—subsequently it is only necessary to damp the piece to be worked on. Leather must be kept damp but not really wet or it will stretch badly and never regain its normal size, leaving puckers in the surface.

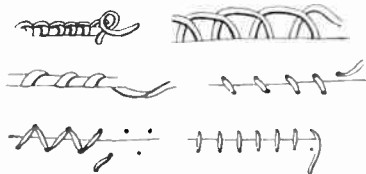

Some examples of thonging

Good craftsmanship means considering the nature of the material and working in a manner suitable to that medium. Leather is strong and meant for hard and long wear. It is, therefore, sensible to use leather thongs for joining the pieces and strengthening the edges rather than to machine these with cotton that will wear out long before the leather.

The same thing applies to lining. Many people line bags or other articles with silk or cotton material. This is quite

suitable in the machine-made article such as a bag made in very thin leather which will generally only last for a few months wear. But the leather used in this work is heavier and with a thin leather lining and thonging for joining the pieces, it will last for years.

When a lining is used, cut out the two pieces, paste them together with flour paste and leave under a flat surface to dry before using. If stiffening is used, such as cardboard for a photo frame or writing case cover this should be cut smaller than the leather to allow for thonging, and pasted to the leather and allowed to dry under pressure.

It is as well to write down the order of procedure if working for the first time, so some important point is not forgotten. If the work is started from the cutting stage, work as follows. Plan the article in paper; cut to pattern; sew pockets to lining or pieces together to form pockets; trace on and model design; measure for punching; punch holes; stain leather; stain leather for thong-cut thongs; polish the pieces; and finally make up the article.

Stuff the article with a wad of paper when giving the final polish, or sometimes inner pockets or purses will leave a mark from the pressure made from polishing. If press studs are not available, it is as well to plan some other means of fastening, such as a tongue through a slot or a band across a flap.

Tools You Need

Tools needed for leatherwork are shown in the drawing and detailed as follows. Tracer: a pointed instrument for pressing a design through paper on to the leather which has been previously damped. Modeller: a flat, round-headed tool for pressing down the leather round or on the design. Ball-head tool: for raising the leather by pushing up from the back to throw parts of the design in higher relief. Edge tool: dividers for making lines at the edge of leather or for measuring punch holes. Edge thinner: a narrow blade for paring the edges if two or more are to be sewn or thonged together. One edge of the tool rests on the table and the other on the leather edge. Thinning knife: a sharp blade for thinning the inside of leather where a fold is needed. The knife is held rather flat against the surface and pushed with sharp strokes forward. If a ruck occurs, the paring

must be done from the opposite direction. Practise is needed in this operation, as it is very easy to cut right through the leather. Stitch marker: a wheel with points for marking holes along a ruled line for stitching.

Punch: a spring punch to be used by pressure in the hands. Extra heads are available of different sizes, but an

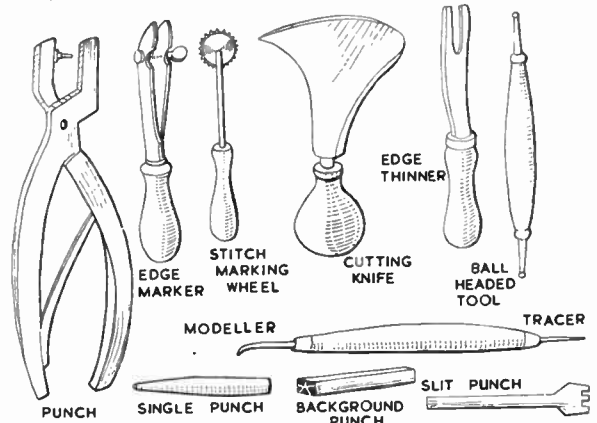

A selection of the tools necessary to the leatherwork

eight-hole wheel punch is best for the work and quicker. Slit punch: flat three-pronged blades for making slits instead of holes to be used by hammering through the leather. This method is more difficult but neater than the round hole thonging. Background punches are stamps in various sizes for decorating borders or the backgrounds of geometrical designs. Awl, Ruler, Set-square: all these tools can be substituted by home-made gadgets. Excellent work has been done with a large nail file, filed off flat or a knitting needle for a modeller. A very successful slit punch was made from a nail filed to a sharp flat edge, while background stamps have been made from screws with a design filed out on the head and the screw end put into a wooden handle.

Tracing

Select a design that suits and fits the piece of leather to be decorated. Damp the leather and place the paper over it and with the tracer press over the lines in the same way as a drawing on tracing paper. Keep the lines as unbroken as possible. Do not press too hard or the paper will tear off and the surface of the leather will be cut.

Redamp the leather and with the modeller press down the leather round the design. The tool should be held like a pencil with the side of the blade against the line of the design. Steady the tool by putting the first finger of the other hand against the handle. This will also prevent the finger nails from digging

into the leather if the other hand is left free.

Take long sweeping strokes from right to left and if the leather puckers repeat in the opposite direction. Do not take the strokes too far away from the outside of the design or press so hard that the surface becomes bruised or shiny or it will not take a stain easily or evenly. The design can be well raised in this manner and those with drawing ability will be able to add lines to give the design more character. To throw up some parts into higher relief, such as the petal of a flower, the ball-headed tool is used.

Relief Work

Damp the leather and rest it on the table. With the tool held straight, gently press up the leather from the back with circular movements under the parts that need more rounding. Do not overdo this pressing, as high-relief is not in very good taste and is likely to stretch the leather so much that it will need padding at the back to keep it from denting in again. It will be necessary to go round the design with the modeller again as the lines will be pushed out by the ball-headed tool.

To make the design stand out more clearly the background can be matted with the tracer by damping the leather and making dots all round the design. Gradually fill in the space to the edges or

only to a certain distance round the design. The matting will also cover a badly bruised background.

Geometrical Patterns

For those who do not wish to make a pictorial design, a very good effect and one suitable to leather can be produced by simple line borders or criss-cross in diamonds or squares over a cover. This should be planned on paper first and the guiding points pressed through before the lines are ruled.

The background punches can be used at the intersecting points of these lines or evenly in the squares to make a repeat pattern. This tool should be used with a hammer. The leather can also be decorated in a simple pattern all over by crosses or scales if care is taken that the marks are even and of the same size.

Hand Sewing

For pockets and purses and for extra tongues for fastening, a hand-made stitch with wax thread is more satisfactory than machining. Mark the hole along a line with a stitch-marking wheel. Prick holes right through these marks with the awl. Grip the pieces between the knees.

Thread two needles on one piece of waxed cotton and push one through the first hole and pull the cotton until half lies on either side. Insert needle No. 1,

in the second hole and pull until half the cotton is through, catch the loop made on the little finger. Push needle No. 2 through the second hole and when the same amount of cotton is through to the other side, let go the loop of the first and pull with both hands evenly. This ensures even stitches. If pockets are to be sewn together, the first stitch must go over the edge and in through the first hole again.

Staining and Painting

Fast dyes are used for staining articles made in leather. The dyes should be mixed with cold water; about one teaspoonful of dye to one pint of water. If a strong solution is mixed it can be kept in a large bottle and diluted when necessary. The dye must be well stirred so every grain is dissolved before using. These colours can be mixed if the pure colour is not suitable. Always mix enough dye to stain all the pieces of an article as it is not always easy to get the same depth of colour the second time.

Damp the leather all over, and with a piece of waste or cotton wool dipped in the stain, rub over the leather with circular movements, starting from the top corner. Work quickly and press evenly, as the harder the pressure, the darker the stain becomes. If the first coat has not produced the desired effect, repeat all over before the leather dries.

(To be Continued)

Scale Patterns for OO or O Gauge Signal Box

(Seq opposite page)



A scale diagram is given on opposite page for this MODEL SIGNAL BOX

THERE are many methods of building a signal box in OO scale, of which probably the simplest is that using cardboard, which is folded and glued together as already described in an article which appeared in *HOBBIES WEEKLY* for December 15th, 1948. But when construction is undertaken in O gauge, this material is far too frail, and wood must be used.

For OO Gauge

The making of a signal cabin in wood involves a fair amount of skill, if it is to be used for housing the levers, and it is essential that the structure is at once neat and strong. The main structural difficulties are created by the large amount of glazed surfaces, and the smallness of the window mullions.

The scale diagram shows a normal representative of the combined brick and timber structures used by many railways and will house a frame of about nine levers. The diagram is reproduced full-size for OO scale, but for O gauge construction, each measurement must be divided by four and multiplied by seven; the ratio between the two scales being as four is to seven.

To get the lever-frame into the building, it is necessary that some portion is removable or hinged. Or again, the lower brickwork portion may be made up complete with the lever-frame and screwed to the model railway baseboard. The latter scheme is a very convenient one for making and fitting the levers. Some readers may, however, feel that the rather unreal spectacle of lifting off the upper portion of the box every time a lever has to be worked, is a disadvantage.

Removable Back Wall

Another idea is that of making the back wall of the box either hinged or entirely detachable, or completely absent. Yet another method is that of making the entire building separate from the lever-frame, building it to drop into place over the latter after all the connections to the points and signals have been made.

As this last method of construction enables the operator to get at the levers without the necessity of weakening the structure, the model to be described will be built along these lines.

It will be appreciated that a prototype cabin is a two-story building, of which the upper story is occupied by the levers and the lower by the locking gear and other paraphernalia. In our model, however, the lever-frame is screwed to the railway baseboard which is in effect the ground floor. Its levers—being greatly over-scale—project through the floor of the upper story. Therefore, this floor must have a

rectangle cut in its centre to accommodate the lever-frame.

The upper floor is placed at the same level as that of the outside stair landing, and it may be either fixed to the frame or—for strength—to the cabin walls; the latter being made from $\frac{1}{4}$ in. stuff.

It is a matter for individual taste whether the sides and ends of the structure are bevelled at each end to produce an invisible joint at each corner. Or whether the sides are made longer by twice the thickness of the wood used, and glued and pinned direct to the ends. The latter method, though much easier, shows a joint at each corner when the model is viewed from either end, but this is of no importance if the box is being covered with brick-paper.

The front wall should be cut out to the inclusive size of all three window-sashes. It should have rebated pieces of $\frac{1}{4}$ in. square wood glued along its whole length above and below the line of windows to retain the glass in place behind the opening. In this respect it is important that the glass must be left free to move in the slots, otherwise it will soon crack.

Door Opening

The end wall of the building in which the window and door are shown, is treated in exactly the same way as the front wall. An extra hole is cut for the door, behind which a piece of $\frac{1}{4}$ in. wood may be glued after being scribed with a knitting-needle vertically to represent the matchboarding of a plain 'ledged' door. Alternatively, the door may be cut from card or $\frac{1}{4}$ in. plywood and glazed in its two upper panels.

On some signal boxes, access to the locking-frame is by means of a trap-door in the upper floor. If desired, however, another door through the end wall may be made below and to the right of the upstairs door, thereby giving apparent access to the ground floor.

Roof Fitting

The roof is made from $\frac{1}{4}$ in. wood, being rebated at the gable at each end to take the ornaments, and having the weather-boards fitted under its ends, slightly back from each edge. It is a good plan to bevel off the edges of the roof boards, so the roof does not appear too thick where it can be seen. More model buildings are ruined in appearance



A guide for building and painting the model

through over-scale thickness of roofs than, perhaps, by any other error.

The front portion of the roof and its ridge should be fixed to the walls, but the back portion, together with the upper part of the chimney should be made removable. Blocks are glued inside the roof at its edges to prevent its slipping down. The lower part of the chimney can be glued inside the back wall if desired.

As the sashes and lights of the window are too small to be cut in wood, they may be painted on the back of the glass or cut out in thin white Bristol-board and stuck on the latter.

A plinth of stripwood should be glued all round the base of the cabin, and another strip at the upper floor level to represent a 'string-course'. A further strip of slightly thicker material will serve as a sill along the front side and door end walls.

As to the stairway, this is made up from stripwood and may be placed on either side of the box, the door being transposed to suit.

Painting the Model

As to the type of finish for the signal box. It may be matt painted a brick-red up to the stringing course. Above that that point is green, with the sashes picked out in cream: or brickpaper—either blue or red brick—pasted below the stringer course and paint above.

If brickpaper is not being used, it will be found advantageous to scribe brickwork on the walls before they are assembled or glazed. A blunt knitting-needle is used for the purpose in preference to a knife edge, which merely cuts a line, rather than making a depression in the wood.

The hand-rail round the front wall and half-end wall is made from a piece of No. 18 S.W.G. wire, being painted black; as, incidentally, is the chimney above the roof.

BE Taller. Quickly! Safely! Privately! No appliances—no tablets—no dieting. Details, 6d. stamp.—Malcolm Ross, Height Specialist, BCM/HYTE, London, W.C.1.

MODELS. You can make lasting stone-hard models with Sankey's Pyrama Plastic Cement. Supplied in tins by Ironmongers, Hardwaremen and Builders' Merchants. Ask for instruction leaflet.

TRANSFERS for decorating toys, trays, furniture, fancy goods. List and samples free. Flowers, pixies, dogs, nursery rhymes.—H. Axon Harrison, Jersey.

PRESSED Metal Wheels, 1½ ins., 1/3; 2 ins., 1/9 per dozen. Or in stove-enamel finish red, green or blue at 6d. per dozen extra. Tax included. Post paid.—The Joyden Toy Co., 193 Chase Side, London, N.14.

DOLL'S House fittings and papers; send S.A.E. for list. Doll's House plan special; send 2/6. Trade supplied.—Zimplan, 88 Ware Road, Hoddesdon.

CONSTRUCTIONAL Kits, 4mm and 7mm scale Lories. Also large range spare parts from which to build to your own design. Price lists, 1d.—Wilson's Lories Ltd., Dept. H., 1/6 Gt. Winchester Street, London, E.C.2.

100,000 Government surplus bargains. Sponge rubber strip, approximately 18ft. x 1½ ins. x ¼ in., 2/-, post 9d. Aluminium rivets, approximately 1lb. assorted, 2/6, post 6d. Warning lights, red, suit models, cycle rear lights, etc., 6d., post 3d. Ammeters, 0-25 moving iron, 5/-, post 6d. 16-bank switches (16 separate snap-action switches in one panel), 7/11, post 9d. Hundreds of other bargains. Send 3d. stamp and S.A.E. for new comprehensive list.—Milligan's, 24 Harford Street, Liverpool, 3.

£5 to £20 weekly earned at home, running your own Mail Order business. Details, 1d.—Stebbing Publications Ltd., (HB) Naphill, High Wycombe.

HARDWOOD Wheels, 2 ins., 1/-; 3 ins., 2/- per set of four. Tax included. Post paid. Other sizes available.—The Joyden Toy Co., 193 Chase Side, London, N.14.

PLYWOOD offcuts. Birch and Gaboon in various thicknesses. Handy sized parcels for the cabinet, toy, model maker, and all handicrafts. Parcels made up in £1 and 10/- lots. Carriage paid. Send P.O. to Reeves, Plywood and Timber Merchant, 33 Front Street, Monkseaton, Whitley Bay. Tel. W.B.4677. Due to exceptional demand we cannot promise delivery under eight days.

FURNISH that Doll's House with the latest model furniture, glassware, food and accessories. List, 8d.—Sutton Models, Billericay.

ENGRAVING on Perspex. Send drawing and S.A.E. for quotation.—Geo. Cleaver, 50 Windsor Road, London, N.W.2.

LONELY? Then write Secretary U.C.C., 5B.B. Hay St., Braughing, Herts. Genuine. Est. 1905.

BE Taller in 14 days or money back. Details, 1d.—Stebbing System, 28 (HB) Dean Road, London, N.W.2.

HOME watch and clock repair outfit. Includes watchmaker's eyeglass, tweezers, screwdrivers, oilers, brush, oil, plus explanatory booklet fully illustrated. In container. Skill unnecessary. Invaluable for all fine work, 12/9 inclusive.—D. Bolster (Dept. A.), 5A Station Parade, Ashford, Middx.

HOME Movies, 9-5 film library, projectors, films, in great variety. Sale cheap; stamp lists.—Wayland, 223 Longley Road, Tooting, S.W.17.

FASCINATING and profitable hobby, casting ornaments, toys, etc. You can easily make these yourself. Paints, brushes and all accessories. Illustrated catalogue of 700 moulds, plus latest list of rubber moulds, with instructions, 9d., post free.—Cock of North Moulds (H), 140 Hollings Road, Bradford.

BLUSHING, shyness, nerves, self-consciousness, fears, ended. Details under plain cover, 1d.—Stebbing Treatment, 28 (HB) Dean Road, London, N.W.2.

STAINING and Polishing by Charles Hayward. A comprehensive guide for those who desire a professional finish. Illustrated, 7/10 posted.—Quadrant Books (Dept. 4), 17 Quadrant Arcade, Regent Street, London, W.1.

AMERICAN Magazines post free for one year. Popular Mechanics, 32/-; Popular Science, 28/6; Mechanix Illustrated, 22/6; Popular Homecraft, 18/-. Stamp for full list of others.—Willen Ltd. (Dept. 57), 101 Fleet Street, London, E.C.4.

ENTER the Juneero National Model Making Competition. Cash and kit prizes to the value of £150. Send now for details or see the Juneero Annual, 1/-, from all Juneero Dealers or 1/2 post free from Juneero Ltd., Boreham Wood, Herts.

PLYWOOD. New selected, 27 x 19 x ¾ in., 7 for 20/-; Veneered Oak, 6 for 30/-; 20 x 20 x ¾ in., 9 for 20/-; Veneered Oak, 7 for 29/9; see list (2d.) for other veneered panels. B.C. Pine Ply, 17 x 7 x ¾ in., 24 for 16/-; Parana Pine Ply, 17 x 6 ½ x ¾ in., 48 for 16/-; all post paid C.O.D. Box Bottoms, 18 x 16 x ¾ in. Birch, 8 for 20/-; Teak, 5 for 20/-. Pine Lids, 39 x 17 x 1 ½ ins., 10/- each, one side clean; Ex W.D. Stretchers, very good condition, 10/- each. All sent carriage forward cash with order.—H2/JDD. Storage, 71 Northcross Road, S.E.22.

PERSONS required make fancy goods at home. Write for details.—Melton Manufacturing Co., Southgate Street, Leicester.

ABSOLUTELY free! 50 different request British Colonial approvals. Large discount given. Postage extra.—Walton (HO), 163 Burnage Lane, Manchester, 19.

PERSPEX flat sheets, clear and 17 colours, cut to shape. Corrugated Perspex rooflights. Aluminium sheeting. Mouldings. Plastic Panelling.—Henry Moat & Son Ltd., Atom Works, Newcastle, 1.

2 ½ ins. PRESSED Metal Wheels, 2/- dozen; 8/6 half gross; 15/- gross. Enamelled red or blue, 6d. dozen extra. Hardwood, pressed metal, metal disc wheels, Doll's House windows, doors, papers. Catalogues, 6d.—Jasons, 135 Nags Head Road, Enfield, Middlesex.

KALEIDOSCOPES. Fascinating novelty for all ages. Ingenious optical creation of ever-changing colour designs. Endless variety. 2/6 post free.—'Stymit', Dept. H., 1/6 Gt. Winchester Street, London, E.C.2.

COLLECTORS' delight—my world-famous Oxford approvals. Generous discount and free packet with each selection. Postage please.—Frank Kennedy, 37 Juxon Street, Oxford.

RUG hand loom blue prints. Easy Rweave, 3/6; Lancashire type, 1/6.—Hodgkinson Bros., Meopham Green, Kent.

40 DIFFERENT stamps free, including Silver Wedding, U.P.U., Victory, Silver Jubilee, Coronation, Pakistan, etc. Send 3d. postage and request approvals.—J. F. Smith, 60 Boyne Road, London, S.E.13.

SELBY for stamps. 50 Norway, 2/6; 50 Ecuador, 4/6. S.A.E. for catalogue.—66 Donnington Road, London, N.W.10.

FREE, Free! 25 fine stamps, to all requesting approvals.—Howes, 685 Bath Rd., Hounslow, Middx.

ENLARGE your drawings mechanically with the 'Perfect' pantograph. Oak with metal fitments. With instructions, 6/6 posted.—G. F. Rhead, Thurston End, Hawkedon, Suffolk.

FREE—stamps catalogued 5/- to applicants for ¼ d. approvals.—Cox, 17 Stoneleigh Park Road, Ewell.

LONELY? Join Friendship Circle. Details, 7 ½ d.—Secretary, 34 Honeywell Road, London, S.W.11.

1,000 World stamps, 3/9. Bargain catalogue free.—Whitby, Godshill, Fordingbridge, Hants.

REQUEST stamp approvals. Receive small album, stamps, hinges, free. Postage 6d.—A. M. Day, 73 Thornton Gate, Cleveleys.

STAMPS—foreign or Colonial on approval. Send 2 ½ d. stamp. Join my wonderful dividend scheme.—Norman Martin, SCC. San., Milford, Surrey.

WANTED—Coronation and Lord Mayor's Coach designs.—Oxley, 38 Primrose Hill Rd., Huddersfield.

STAMPS FREE!! Twenty unused (2 ½ d.).—G. H. Barnett, Limington, Somerset.

MOTOR bench fretsaw. The Hobbies Marvel. Just plug in to your lighting circuit and switch on. Particulars from Ironmongers, Hobbies Branches or Hobbies Ltd., Dereham, Norfolk.

THE STEPPING STONES TO SUCCESS!

Don't hesitate about your future! Go forward, confident that The Bennett College will see you through to a sound position in any career you choose. The Bennett College methods are individual. There's a friendly personal touch that encourages quick progress and makes for early efficiency. Take the first important step NOW and fill in the coupon below.

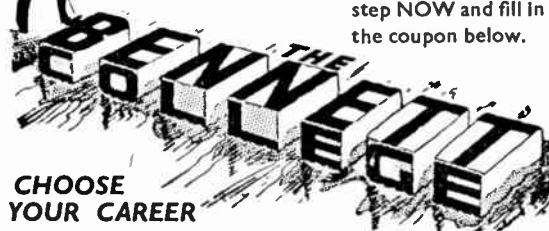

CHOOSE YOUR CAREER

- | | | |
|--|------------------------------------|--------------------------------------|
| Accountancy Exams. | General Education | Road Making and |
| Aviation (Engineering and Wireless) | G.P.O. Eng. Dept. | Maintenance |
| Book keeping. | Heating and Ventilation | Salesmanship |
| Accountancy, and Modern Business Methods | Institute of Housing Engineers | Sanitation |
| Building, Architecture, and Clerk of Works (A.R.I.B.A. Exams.) | Journalism | School Attendance Officer |
| Cambridge Senior School Certificate | Languages | Secretarial Exams. |
| Carpentry and Joinery | Mathematics | Sheet Metal Work |
| Chemistry | Matriculation | Shipbuilding |
| Civil Engineering | Metallurgy | Shorthand (Pitman's) |
| Civil Service | Mining, All Subjects | Short Story Writing |
| All Commercial Subjects | Naval Architecture | Surveying |
| Commercial Art | Novel Writing | Motor Engineering (R.I.C.S. Exams.) |
| Common Prelim. E.J.E.B. | Plastics | Teachers of Handicrafts |
| Draughtsmanship, All Branches | Play Writing | Telecommunications (City and Guilds) |
| Engineering, All branches, Sub-branches and Exams. | Police, Special Course | Television |
| | Press Tool Work | Transport Inst. Examinations |
| | Pumps and Pumping Machinery | Viewers, Gaugers, Inspectors |
| | Quantity Surveying | Weights and Measures Inspectors |
| | Inst. of Quantity Surveyors Exams. | Wireless Telegraphy and Telephony |
| | Radio Service Engineering | |

If you do not see your requirements above, write to us on any subject. Full particulars free.

COUPON. CUT THIS OUT

IF YOU ATTEND TO THIS NOW IT MAY MAKE A WONDERFUL DIFFERENCE TO YOUR FUTURE.

TO DEPT. 62
THE BENNETT COLLEGE LTD.
SHEFFIELD, ENGLAND.

Please send me (free of charge)

Particulars of.....
Your private advice.....
about.....

(Cross out line which does not apply.)

PLEASE WRITE IN BLOCK LETTERS

Name.....
Address.....
12.4.50.....



YOU CAN BECOME A HANDICRAFTS INSTRUCTOR

Experience not essential

Men who enjoy making things in wood or metal can turn their hobby into a well-paid, permanent and interesting Career. Short hours, long holidays, and security in a job you would really enjoy, can be yours if you become a Handicrafts Instructor. Let us send details of the easiest and quickest way to get the necessary qualification.

We definitely guarantee "NO PASS — NO FEE"

If you would like to know about our unique method of preparing you for one of these excellent appointments, write today and we will send you our informative 176-page Handbook—free and without obligation. Mark your letters 'Handicrafts Instructor'.

BRITISH INSTITUTE OF ENGINEERING TECHNOLOGY

BIET

595 Shakespeare House
Stratford Place, London, W.1

NICOTEXIT

The Guaranteed Smoking Deterrent

- ★ Positively Stops Smoking Immediately.
- ★ Purchase Price Refunded if it Fails.
- ★ One Bottle is sufficient to establish control of smoking in any form.

5/6 PER BOTTLE POST FREE

Obtainable only by post from the Sole Concessionaires for Great Britain
THE NICOTEXIT COMPANY
(Dept. B.6.)
62, High St., Croydon, Surrey

AT LAST—The Perfect Precision Cutter

MULTICRAFT

with the 4 in 1 PAK-A-WAY BLADES

The ideal Tool for every Hobbyist and craftsman. 4 Sheffield steel blades housed in handle. Interchanged in a moment. A shape for every job. From all good Hardware, Art and Hobby Shops.

5/- including 4 blades. Clip 4d. extra.

Send for leaflet and name of your nearest dealer to:

MULTICRAFT TOOLS
29 BOLSOVER STREET, LONDON, W.1

Trade Enquiries Invited

WEBLEY

AIR PISTOLS



Marvellously accurate for target practice.

No licence required to purchase.

Senior Mark 1

Junior Webley Air Rifle

Write for List. **WEBLEY & SCOTT LTD.,**
166 WEAMAN STREET, BIRMINGHAM, Eng.

BE STRONG

I Guarantee, as a Builder of Men for 22 years, to give you 10 to 25 inches more Muscle in 30 days—or money back. Full details of famous 4-in-1 Course, recommended by 'Health & Strength' since 1928, sent under plain cover on receipt of 1d. stamp. **Lionel Stebbing Institute (HB/12),** 28 Dean Road, London, N.W.2. Established 1928.

For Perfectly GLUED JOINTS

—follow modern professional practice. Use Croid. Scientifically prepared and supplied ready mixed, CROID is REAL Glue at its best and strongest. It gives you the same high strength every time you use it, avoiding messy preparation and uncertainty. Croid AERO Glue is a hot glue for deep penetration; Croid Universal In tubes for lighter work.



CROID LTD., IMPERIAL HOUSE, KINGSWAY, LONDON, W.C.2



OVER 3,000
ex-R.A.F. Apprentices
have reached commissioned rank



So may you — one day.

If you are chosen to be an R.A.F.

Apprentice you will be trained for a skilled trade, and continue your general education. You will have far more opportunities for sport than most boys. You will be well fed and cared for, and receive good pocket money. And you may end up not only with a commission — but with a flying commission.

Send the coupon. It will not commit you to anything. It may lead to great things.

TO: — AIR MINISTRY, DEPT. HS.44B,
VICTORY HOUSE, KINGSWAY, LONDON, W.C.2.

I am between 15 and 17½. Please send details of R.A.F. Apprenticeships.

NAME _____

ADDRESS _____



Printed by BALDING & MANSELL, LTD., London and Wisbech, and Published for the Proprietors, HOBBIES LTD., by HORACE MARSHALL & SON, LTD., Temple House, Talis Street, E.C.4. Sole Agents for Australia and New Zealand: Gordon & Gotch (A'sia) Ltd. For South Africa: Central News Agency Ltd. Registered for transmission by Canadian Magazine Post.

A MODEL REPAIR
OUTFIT IN THE
PALM OF YOUR HAND

TO SEAL AND MEND
AS WELL AS ASSIST
IN CONSTRUCTION

"DUREX" Tape-it!

STICKS AT A
TOUCH

SEALS WITHOUT
MOISTENING

TRANSPARENT
AS GLASS

A broken 'plane wing, a damaged kite, a cracked doll—they're all put right in a jiffy with "DUREX" Cellulose Tape. Clean and easy to handle, it sticks at a touch, is as transparent as glass and is the handiest thing in the home for mounting snaps, for sticking parcels, repairing torn books and every other sticking job

Trade Enquiries:
Durex Abrasives Ltd., Birmingham 6

"DUREX" Cellulose TAPE

Has every Sealing job TAPED

Modelmakers, Hobbyists, Craftsmen

there is something of interest
to everyone of you in

MODEL-CRAFT MAGAZINE

JUST OUT

Number 13

Volume 3

Contents include:

Why do I make models?

by K. N. Harris

Origin of the Junk and

Sampan

by James Hornell

The Vertical Method

of Yacht Hull Con-

struction

by Bernard Reeve

Flags on Ship Models

(Part IV. Naval Flags
and Codes)

by Alec Purves

A West Midland Loco

Yard

by Edward Beal

Magnetic Miniatures

Issued quarterly. Price 1/- or 4/6 a year post free with Modelcraft List. If you have not yet seen this informative little magazine send 6d. for a backnumber.

MODEL-CRAFT LIST 1950

Price 1/-, lists over 600 plans, plan books, kits, accessories and cut-outs and includes a 1/- refund voucher for use in purchasing Modelcraft goods.

MODEL-CRAFT Ltd. 77 (F) Grosvenor Rd.,
LONDON, S.W.1

Hobbies

WEEKLY

CONTENTS

	Page
A Rabbit Hutch	- 33
Editor's Notebook	- 34
Novel Book-ends	- 35
Stationery Cabinet	- 36
Fretted Decorations	- 37
Photography	- 39
Straight 3 Radio Set	- 41
Stone Garden Images	- 42
International Stamp Exhibition	- 43
A Trailer Caravan	- 44
Metal Photo Stand	- 45

GIFT DESIGN FOR TWO
NOVELTY SWINGING
BIRD TOYS

April 19th, 1950

Price Fourpence

Vol. 110 No. 2842

A SUBSTANTIAL piece of work, this, which no reader need be ashamed for his friends to see. It is of generous capacity, large enough for a pair of rabbits and their litter. Provided with legs it will stand firm in all weathers, alternatively the legs can be omitted and the hutch supported on brackets, screwed to the walls of shed or house, as preferred.

If rabbits are to keep healthy they should be housed warm and dry, and even the tyro at rabbit keeping will appreciate the difference between living in a hutch of this description, and one knocked up from a grocer's box.

Main Framework

A front and side elevation are given in Fig. 1. From these drawings general dimensions can be taken. Should the rabbits be of the large breed, it may be

an advantage to extend the length of the hutch to 3ft. 6ins.; other dimensions can still stand.

Fig. 2 shows a view of the construction. The sides and bottom will be made up of two boards, joined together. Wood of $\frac{3}{4}$ in. for preference, $\frac{1}{2}$ in. if thicker stuff is not available. These thicknesses apply to all parts except those stated further on.

The sides are joined by a 1in. square fillet across the bottom, on the inside,

this fillet being raised from the bottom edge just enough to allow the floor of the hutch to be screwed to it and be level underneath. In other words, if the floor is of $\frac{3}{4}$ in. wood, then the fillets will also be $\frac{3}{4}$ in. up from the bottom.

Centre Partition

It will be seen from the drawings that the top edges of the sides slope towards the rear. Across the top of the hutch a 1in. by 2in. batten is nailed at the front and a 1in. square one at the back.

Between these, a fillet is screwed across each side to keep the boards together. All these will be seen in Fig. 2.

At 12ins. from the left side, two vertical strips of wood are to be nailed between the top rails and the floor of the hutch, to which the partition will be nailed. The front one is of 1in. by 2in. wood; the back one of 1in. square wood.

These are nailed to a line (shown by a dash and dotted one) just 12ins. from the left side. As the rear one is half the width of the front one, the partition can be nailed to the former and will then butt up against the front one, leaving room for a fillet of wood, which can be nailed to the front

A STANDING RABBIT HUTCH

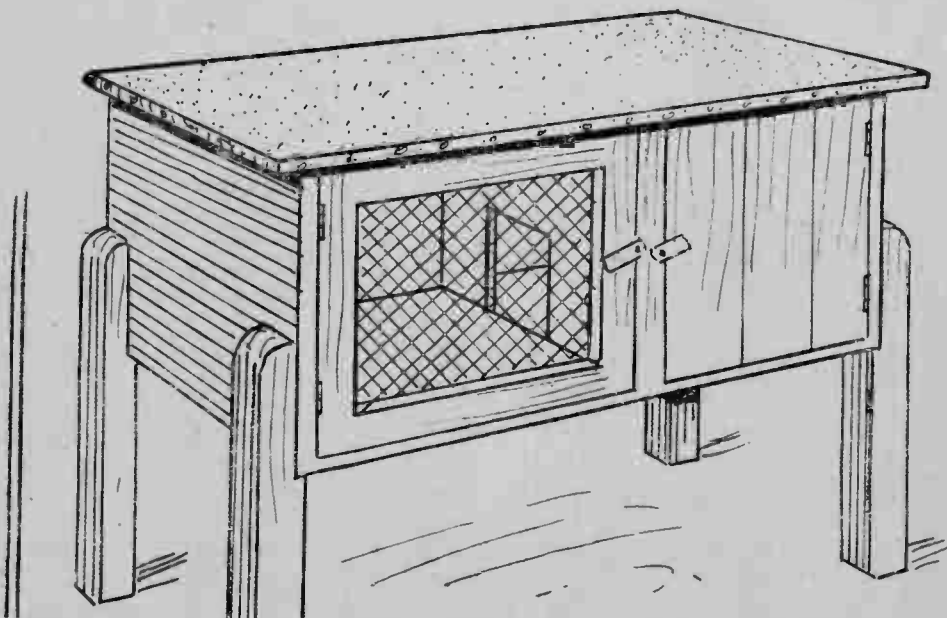

All correspondence should be addressed to The Editor, Hobbies Weekly, Dereham, Norfolk.

vertical and the partition nailed to that.

Partition Wall

In Fig. 2 the partition is shown partly cut away to reveal this. The partition could very conveniently be cut from plywood, and should be 1in. less in length than the depth of the hutch.

In this saw out an opening for the rabbits to enter, one about 6ins. wide and 8ins. high will suit quite well. If the partition is made up of two thinner boards, joined together, the hole should have a fillet nailed each side to prevent the boards breaking apart where the hole is cut.

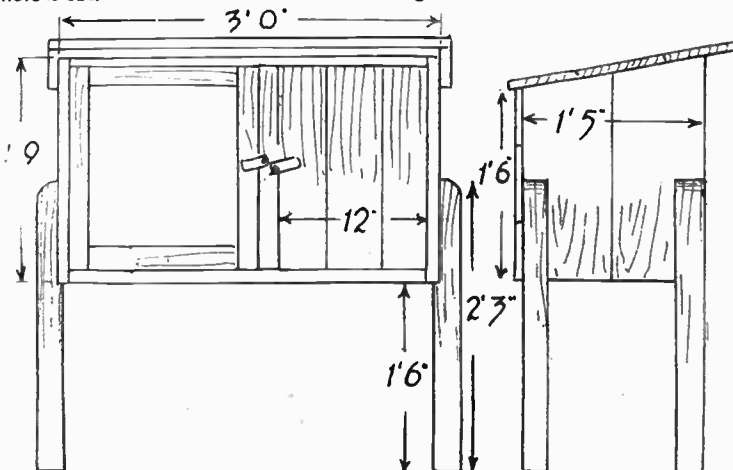

Fig. 1—Front and side elevation giving dimensions of main parts

The roof boards can now be nailed over. Let them extend beyond the back and sides by 1½ins., and over the front 4ins. Wood not thicker than ½in. will suit very well here, thicker stuff not being necessary. Boards for the back of the hutch, similar wood to the roof boards, can now be cut, but will be fixed on after the legs are fitted, supposing legs are decided upon.

These legs should be of substantial timber, say, 2in. square wood, or even a bit stouter. Cut them to the length given in Fig. 1, and those parts to be screwed to the sides of the hutch should be reduced in thickness by ¼in., as in Fig. 2. Fix the legs to the hutch with iron screws, from the inside, well countersunk. The back of the hutch can then be nailed in place.

Two doors are required. That of the keeping apartment is composed of boards, nailed to rear battens. To keep out unwanted draughts the boards should be, if possible, of tongued and grooved kind. Otherwise it would be as

or iron battens to the centre vertical strip of wood. Round off the top corners of the legs and clean up the work. The whole can then be painted or given a coat of creosote. In either case it is as

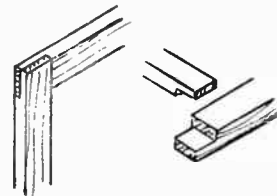

Fig. 3—Corner joints to use

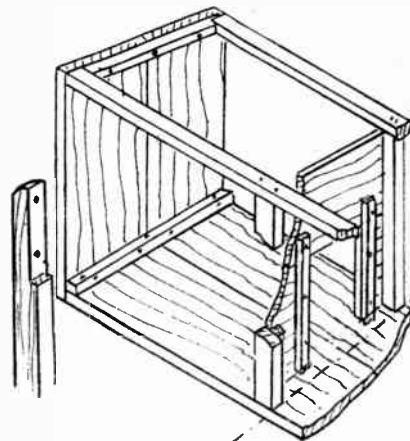

Fig. 2—Interior constructional details

well to glue them edge to edge. Make them a close fit.

Fixing the Doors

The other door is made as a frame of 1in. by 2in. wood, joined together at the corners with a simple halved joint, as in Fig. 3. Glue and nail these joints. Fit both doors with 1½in. iron butt hinges, and to keep the doors closed, add wood

well to creosote the roof boards.

The final job is to cover the roof with roofing felt. This should be laid over, pulled flat and be well nailed to the edges of the roof. The framed door of the hutch should be covered on the inside with 1in. wire mesh netting. See no sharp cut ends of this wire stick out inside the hutch for the rabbits to scratch themselves on.

From the Editor's Notebook—

THE suggestion for commencing to make a collection of orange wrappers may not seem opportune just now, but over a course of years it may prove interesting and worth while. When oranges were so plentiful and cheap before the war there were those who did collect the paper wrappers, and I find Mr. A. Sandiford of Pembridge, Herefordshire, has enjoyed it for over 50 years. Being a fruiterer he had a big advantage, of course, but since 1892—when he started—he has amassed a collection of many hundreds—pasted neatly in several volumes. One wrapper from Italy shows the monument erected in honour of King Umberto I. Printed on another is a sketch of the contemporary bicycle, with pedals on the front wheel, and supported by a cherubic infant waving a bunch of lemons. A prim young lady holding a tennis racket, and what

must have been the first aeroplane reminds us of early progress in customs and inventions.

ANOTHER collector has gone in for having as many military medals as he can. But he cannot wear them all because he now has about 320—collected during the past nine years. There can be a great deal of historical interest in them because the inscription gives the campaign concerned, which can lead to finding matter in reference books so to build up a fascinating story. At least it has proved a fascinating hobby to Mr. B. E. Hawkins of Wylds Lane, Worcester.

EIGHTEEN months ago, three men in a Bolton office pulled out their cigarette cases (says *The Bolton Evening News*), and found that, between them,

they had nine different brands of cigarettes. They put one of each variety into a box, and that was the beginning of a hobby which is not only unusual, but which must have its temptations in these times of cigarette shortages. Nevertheless, they have now a collection of 135 different brands, which includes, in addition to the many English varieties, cigarettes from Russia, Eire, the Channel Islands and, of course, America. They include the familiar 'Camel' and 'Lucky Strike', but there are also 'Escudo de luxe', 'Tassie de luxe', 'Fleur de Roi', '12 o'clock', and the Irish 'Sweet Afton' and 'Tantivy'.

DON'T forget an Index to Volume 109, which ended last month can now be obtained for 1/- post free from my office.

The Editor

A few "bits and pieces" can be easily converted into NOVEL HOUSE BOOK-ENDS

It is amazing how well Book-ends look if made up into some form of a house. All sorts of cottages, log huts or more pretentious finishes can be used, but if a house of some sort is depicted, the effect always seems to be good. A design of the sort is given here.

To make, first cut the base (a) from $\frac{1}{4}$ in. plywood if possible 4 ins. by 5 ins., also the vertical pieces (b) for the end, 5 ins. by 5 ins. This latter can be of thinner material. To go over the back vertical cut the two simple fir trees (c) from $\frac{1}{4}$ in. plywood which can readily be made with a fretsaw.

The Back

The back fits to the base (at a true right-angle please) by three or four small screws, and the fir trees are placed in front as indicated. They can be held by glue and if desired one or two virtually headless gimps.

It is best to 'finish' the ends in parts, as they are put together. The vertical piece should, therefore, be well glass-

the windows, paint in complete rectangle with white first and when dry, outline with black and suggest the curve of the curtains in black also. This, it will be found, gives quite a good vivid effect.

The Roof

For the roof, mix a minute drop of black with a little white on a tin lid will do, which will give a grey. Paint the roof with this and then suggest tiles with black lines.

The chimney is a short rectangle of wood cut as shown and is simply glued to the roof or one side of the stop can be taken off and the chimney fastened by a screw up from below. Before fitting it is given a coat of red, but will be really too small to bother about suggesting brickwork.

Complete, the house is placed before the fir trees and its position pencilled on the base. Paint the base green and when dry mark in the path

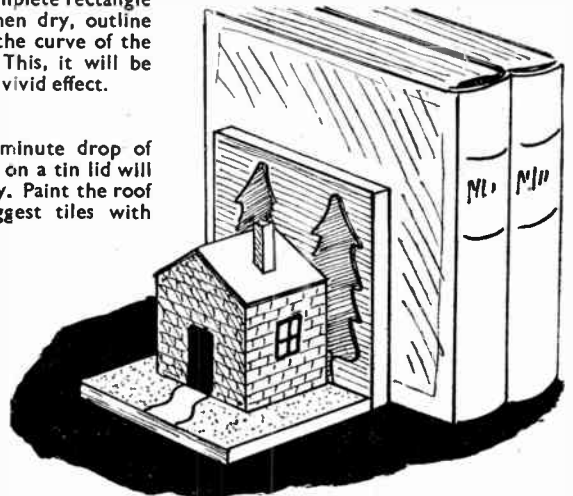

case be drawn on thin card and coloured, and then be glued in the desired position, the items being put under pressure while they dry out. The main thing when attaching paper is to glue the wood well in addition to the back of the paper and then let everything dry under a weight of some kind.

With care, a paper finish like this can be given a coat of clear varnish to obtain the gloss that is given by the direct painting method.

The general surround, too, if desired, can be finished with sand sprinkled over a coat of glue before painting. Indeed, the whole design lends itself to quite a number of interesting variations in the hands of the imaginative craftsman.

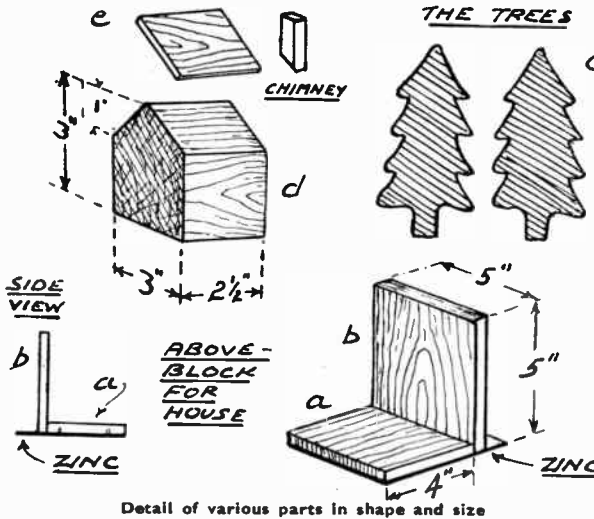

Detail of various parts in shape and size

papered and smoothed and given a coat of blue enamel. The fir trees are then painted dark green and secured in position; by working this way cleaner colouring is obtained.

The Wooden House

Now make the house (d) from a block of wood 3 ins. by 3 ins. by 2 $\frac{1}{2}$ ins., bevelled at the top for 1 in. down and with two rectangles of plywood (e) placed on the slope and allowed to overhang at the eaves a trifle.

Colour the whole house, except the roof, pillar-box red and allow to dry. Now pencil in lightly the brick courses as shown and line them in with white enamel, using a fine brush. The door is put in as a black rectangle. Then make

The Book-end is now complete and the aim has been to give a bright, rather novel-looking article. Of course, a companion is necessary and work can be lessened by making the pair as much as possible together. Thus, the fir trees could be cut two at a time, while, when using a colour for the one end, the same colour could be applied to the corresponding part on the other.

The painting on of the brick courses and tiles is the most effective, but the finish can be quickly put on by pasting brickpaper or stone-paper to the sides, and a roof tiling paper on the sloping top.

Coloured Additions

The window and door must in this

Patterns for Two Swinging Toys

This week's gift sheet contains patterns for two novelty swinging bird toys. A kit of wood (No. 2842) is obtainable for both for 3/6 from

Hobbies Branches or (with 9d. extra) by post from Hobbies Ltd. Dereham, Norfolk.



A modern type with practical uses is this simple STATIONERY CABINET

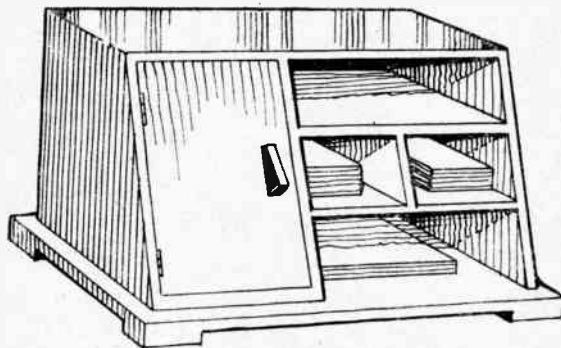

Fig. 1 - The door cabinet and open shelves clearly shown

OUR illustration (Fig. 1) shows an attractive form of stationery cabinet with enclosed cabinet combined. The four-compartment stationery cabinet is of useful size, and the whole is of simple and practical construction.

A plain and easily understood diagram of the construction of the cabinet is

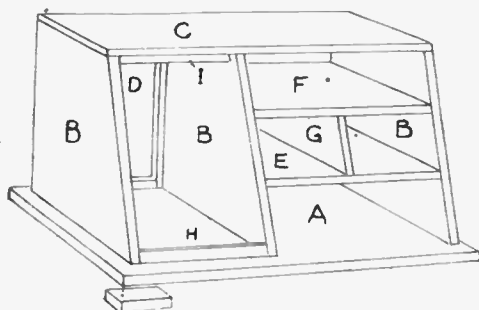

Fig. 2 - Showing general construction of framework

given in Fig. 2, where (A) is the base which must be squared up accurately from a piece of $\frac{3}{4}$ in. stuff. The sides and mid partition (B) should be tenoned into the base, and the plan, Fig. 3, gives the measurements for setting out the three mortises.

As pieces (B) are intended to be $\frac{3}{4}$ in. thick, the mortises should be set out to this width, but when the cutting with the fretsaw is being done, the saw should be kept to the inside of the line. Thus when later the pieces (B) are inserted into their mortises, a tight and secure fit is assured. Four oblong blocks are glued at the corners prepared from $\frac{3}{4}$ in. stuff 2 ins. by 1 in.

Some care must be taken in setting out the three uprights (B) to the outline given in Fig. 4. If the base and its mortises have been prepared as mentioned, then the tenons should be carefully checked for length from these before the cutting actually takes place. Glue the parts together and check the angles inside with a set square or a metal try square.

Next cut and fix the top (C). This is

also of $\frac{3}{4}$ in. wood, and it can be secured with countersunk brass screws.

If a jointed fixing is desired between the uprights and the top (C), open mortises can be cut, as the enlarged detail Fig. 5 shows. This makes a very stiff and firm fixing, but a particularly clean-cut joint must be aimed at if neatness of appearance is a consideration.

The backing to the cabinets may be in two pieces if desired and fixed to each opening by means of small fillets of wood $\frac{3}{4}$ in. by $\frac{1}{4}$ in. glued round inside, as seen in Fig. 6, which is a rear view of one of the cabinets. The back boards will thus fall flush with the back edges of the uprights.

On the other hand, for simplicity sake, the back may be formed from one board carried right across and still fixed

Or, again, the two pieces (E) and (F) may be shallow-grooved, as seen in Fig. 7, and partition (G) finally slid between the two after they are fixed in place. Small rails (H) and (I) are next prepared from $\frac{3}{4}$ in. by $\frac{3}{4}$ in. stuff 6 ins. long, and glued as seen in Fig. 2.

The lower one must be planed to a chamfer to fit the floor (A), the top surface running at a right angle to the sloping front so the door will rest between the sides, and at the same time open accurately along the top edge of fillet (H). Fillet (I) is really intended for the door to rest against, and so must be dropped back the thickness of the door from the front edges of the top (C), and the sides (B) (see enlarged detail Fig. 5).

The Door

The door is made from a piece of $\frac{3}{4}$ in. stuff, and careful measurements should be taken direct from the opening, so as to get a good fit. Brass hinges about $\frac{3}{4}$ in. or 1 in. long should be used, and recesses cut in the edge of the door to receive the two flaps of the hinges.

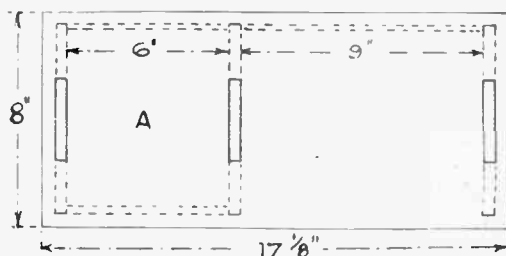

Fig. 3 - How to mark out the base

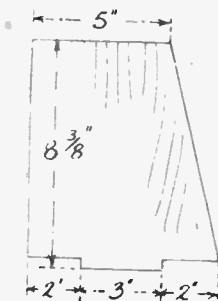

Fig. 4 - End shapes

to fillets on the inside of the ends, and nailed or screwed to the back edge of the middle upright. The latter, it will be understood, must be the thickness of the actual backing board less in width from back to front.

Shelves

The shelves (E) and (F) are next measured and fitted. They may be of $\frac{3}{4}$ in. stuff as desired and glued to bearing fillets put along inside the end (B) and the mid partition. The dividing partition (G) may be previously glued and pinned to (E) and (F) before these latter are actually slid into place between the uprights.

Trim off evenly and neatly along the lower edge of the door where it meets the rail (H).

The wood should receive a good glasspapering and a dusting before the stain is applied. A very simple finish to the wood would be a coating of good varnish applied quickly and evenly in a well heated room, so the varnish may run freely. Or you may be able to obtain a bright glossy surface with french polish after the staining.

A modern-type handle for opening the door may be cut from a piece of spare $\frac{3}{4}$ in. wood and glued in place. A screw, perhaps, run in from behind the door will make a secure fixing.



Fig. 5 - Door stop rail

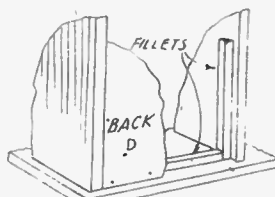

Fig. 6 - Backing holders

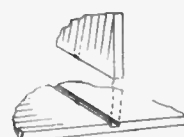

Fig. 7 Grooved upright

How design parts can add to articles as simple FRETTED DECORATIONS

MOST readers will have accumulated a supply of designs, and wonder sometimes whether they are worth keeping, in view of the fact that it will probably be impossible for them to make all the articles therefrom. How many, however, realise that there are other possibilities of their use besides the actual completion of the whole article for which they are intended.

The use of at least a portion of the design can be made in a pleasing and attractive manner by utilising part of them for other subjects. This is where the selection of the designs on hand will

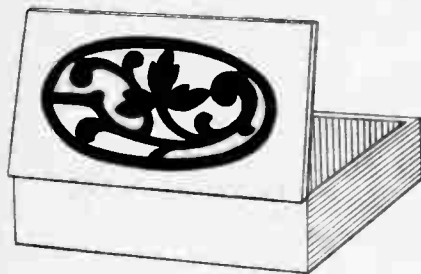

Fig. 1—A simple addition to a box lid

be applicable to the purpose in hand. The suggestions given here are the ideas and, no doubt, the ingenuity of readers will enable them to utilise their own work, even if not in the actual pattern mentioned.

Pattern Parts

For instance, the lid of an ordinary box can be decorated with a pattern such as you see at Fig. 1. This simple pattern is, you will note, an all-round one. That is, it does not face one particular direction so that it forms an attractive addition



Fig. 2—A clock fret



Fig. 3—Figures can be introduced as attractive features

come in to some good purpose, and it is certainly unwise to throw away or dispose of them at all.

The suggestions which follow show a number of instances which if not arising at the moment, may be brought into effect at some time or other, and the idea of using these frets should always be borne in mind. It may be that you have a number of home articles which would look very much more attractive if they had a single piece of fret on the front, top or side.

When you think of it, a plain box can be very greatly improved, for instance, by the addition of a little ornamentation, even if you are not going to complete the whole thing in fretwork. A large flat surface of wood can be relieved either in one place or two or three by the adding of a simple and attractive fret design.

From other Designs

We do not mean to cover the whole of the panels concerned, but merely to add a little decoration which will break up the otherwise flat surface. There are a number of occasions on which these designs can be used, and the suggestions following are taken from some illustrated in the Handbook.

They need not, however, be followed definitely although, of course, they provide suitable subjects, and the designs mentioned can always be obtained. It may be on the other hand, that you have amongst your own collection of designs, certain fretted portions which would be just as ap-

whichever way you look at it.

On the other hand, a clock front such as shown at Fig. 2 could very well have either the fretted decoration shown, or could be provided with a figure or outline which is in a definite direction. The figure of the Dutch girl is an example of what can be added if you wish, to a clock front, and this one is taken from Design No. 2458.

Use of Figure Features

If you have a longer clock, you could add the girl at one end and the boy (from the same design) at the other, as a simple outline and as illustrated in Fig. 3. The patterns of these particular figures are about 5½ ins. high and, of course, you must have a suitable clock or similar piece of work on which they would not look too large. In every case, the proportion should be satisfactory, so that the actual fret does not appear to 'overlap' the main article. On the other hand, it must not be too small and look ridiculous when in place. Searching through your designs and measuring them up, can be quite a happy job preparatory to their actual cutting.

Pattern Parts

Again, the pattern shown at Fig. 4 is a simple one, and here you have two portions of Design 2732 where the parts are used above and below a mirror on what would otherwise be a very plain ground. The simple portion at the top is actually the overlay of the Chinese Casket Design, and as you see,

has been reversed to be more in keeping with the subject.

The little rail below (at Fig. 4) is really only a portion of another part of the pattern, and is an illustration of how small parts can be made suitable for other purposes. The pattern itself is cut short at each end as shown by the shaded piece in the detail, and this is added below the mirror to finish it off at the bottom.

This suggestion, of course, can be carried further by seeing what simple portion of an otherwise larger design

could be utilised for the fretted pieces mentioned, and if taken away from a larger subject can frequently be utilised as small pieces for decoration. There are all manner of things you can incorporate in this way. A glance through the designs in the Handbook or in your own collection, will soon prove productive of results if you bear these matters in mind.

Seasonal Additions

At Christmas time, for instance, if you are making a gift, there are several patterns on which the subject of holly is incorporated. In others, there are various attractive little figures of birds and animals, and even outlines of people themselves which could be incorporated. If the friend to whom you are proposing to give the piece of work is fond of dogs, then there are several of these which could be utilised and the three illustrated at Fig. 5 are taken from Design 238 Special. They can be cut to the outline, suitably painted or carved, and then glued in place on the actual subject taken in hand.

Again, there are a number of hand-some carved decorations, or you could incorporate some with a piece of laurel or a leaf effect which will be very pleasing. For instance, if you are making a plain photo frame of a friend who is now dead, the wording 'In Memoriam' from Design 2606 could well be added, and if you wish, a small portion of the laurel pattern on that same design.

None of these frets should be cut in

thick wood, and generally speaking, the thinner they are, the more attractive they will appear. If you can get the millimetre plywood this is excellent, or failing that, $\frac{1}{16}$ in. wood is suitable. In cutting such thin material, however, you must be careful that no breakages occur.

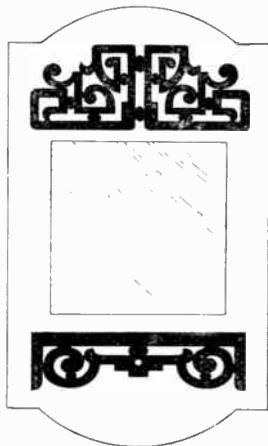

Fig. 4—A fretted decoration cut to fit a frame

For this reason, therefore, it is a good plan to pin the wood to a thicker piece so you have a more solid substance to operate. Watch the direction of the grain so it runs the longest way of the wood, and provides the greatest strength to the material.

Another plan is to sandwich the thin material between two other boards, as this reduces the likelihood of the pattern jumping and getting broken. In cutting such fine work do remember to hold the wood firmly to the table, and with the fingers as close as is feasible to the blade itself.

Hold Work Close

Beginners particularly, have an unfortunate habit of holding the wood rather loosely. In consequence, the saw may catch into the board and lift it and so either break the wood or the fretsaw, or both. There is no need to be afraid of the fretsaw blade if you hold the work very firmly to the cutting table and turn it carefully.

Do not try to force the blade through the material at too fast a rate. Keep the up and down motion of the fretsaw steady and fairly rapid. It is not the actual pressure forward which enables the work to be done quickly, but rather the rapid motion of the blade and a reasonably slow travel into the wood itself.

If you see a professional carpenter, for instance, using a handsaw, he is not driving it hard into the material, but letting it cut its own way through the wood by the teeth biting into the grain. This is the same motion which is required in the fret-cutting rather than an

attempt to force the blade through too quickly and so run the risk of breakage.

Interior Work First

A good plan, too, in these small frets is to do all the interior work before cutting the outside line. This provides a larger piece of board to operate upon, and also reduces the likelihood of the parts being broken where you have to hold the smaller and more delicate pieces. When the part has been cut it should, of course, be cleaned up thoroughly with glasspaper. Do not forget to turn it over and clean the reverse side to take away any slight saw burr which may be there. Keep the work flat on the bench and also use the glasspaper on a block of wood to keep that flat also. Be careful that the edges of the glasspaper do not tear into the pattern.

same colour as the background. The decoration will probably look better if it is a different shade. If the background is dark, then the overlay can be left reasonably light. If, on the other hand, the background is light, then the overlay could be stained fairly dark.

How to Glue

In gluing, remember to apply the adhesive thinly all over the back of the fret so it is firmly fixed in place. You can do this best by rubbing the glue on with the tip of the finger, having it warm enough to make liquid. The glue should be applied very thinly, and care taken not to rub it over the side so that an unsightly edging of it shows when put in place. Have the position marked in one or two places with pencil so that you can lay the overlay direct in place when the



Fig. 5—Three pleasing dog figures cut from a design pattern

A Gluing Frame

As mentioned, your last cutting operation was round the outer edge of the fretself. Do this in one complete movement if you can, as this will provide a frame into which the fret can be relaid for the glasspaper operation. The outer frame is thus the same height as the fret itself, and will help to hold the whole thing flat and firm while the glasspapering is being undertaken.

The actual cleaned work when ready to be put on the background, should be looked at searchingly to see that everything is correct. Any little corners which want taking out, should be completed either with a file or with a fretsaw before satisfaction is assured.

Then, too, of course, you may want to stain the actual overlay before fitting it in place. This staining need not be to the

glue has been added.

Lifting Delicate Parts

The delicate frets can be lifted by means of strong pins or on the point of an awl, laid down straight in place, where they should be, and then held firmly. Put a piece of thin paper over the whole thing, and weight the part down with a pile of books or something similar. Leave until the whole thing has set, then take away the paper covering. If any of it has happened to stick you must, of course, clean off carefully with a sharp knife or small piece of glasspaper.

These suggestions for the use of frets are well worth bearing in mind, for they provide a change of job and one which can be done reasonably quickly with the knowledge they will add considerably to the piece of work when completed.



BRANCHES

LONDON

78a New Oxford St., W.C.1
(Phone MUSEum 2975)

87 Old Broad Street, E.C.2
(LONDON Wall 4375)

117 Walworth Road, S.E.17

GLASGOW

326 Argyle Street
(Phone CENTral 5042)

Head Office & Factories—HOBBIES LTD., DEREHAM, NORFOLK

MANCHESTER

10 Piccadilly
(Phone CENTral 1787)

BIRMINGHAM

14 Bull Ring

SHEFFIELD

4 St. Paul's Parade

LEEDS

10 Queen Victoria Street
(Phone 28639)

HULL

10 Paragon Square

SOUTHAMPTON

25 Bernard Street

BRISTOL

30 Narrow Wine Street
(Phone 23744)

Making the most of the first spool of the season in PHOTOGRAPHY

WHAT an extremely interesting month April is for almost everyone and everything! We all realise that nature re-awakens, the spring flowers very plainly illustrate this, as do the birds with their songs and their busy 'business' of nesting. The same revival is also very evident in human beings. Somehow or other, with the coming of Easter, we feel that we must shake ourselves and throw off the lethargic state that has prevailed throughout the winter months and start thinking about the happy and active times in front of us.

Open-air Sports

Cricket, tennis, cycling, hiking and many other sports are beginning to attract attention. To most photographers Easter means the opening of another season of camera work out of doors and from now on it is safe to assume that every week-end till the end of September, thousands of films will be exposed and new batches of negatives will be added to our collections.

It is to be hoped that every reader of *Hobbies Weekly* has taken the advice and made an excursion during March to their local dealers of photographic material and so secured two or three spools of film. If this was left till the Thursday before Good Friday, then it is doubtful whether those amateurs had any chance of making exposures during the holiday. Because the manufacturers are still unable to give the dealers a full stock or all that they require, although there are signs that bigger supplies will be forthcoming this year. It is a good plan to seek more spools when you have loaded your last one into the camera. Do not wait until that has been completely exhausted.

Choose a Subject

Most old timers of amateur photography will agree that April is the month when it seems difficult to concentrate on any one particular subject. Everywhere appears to be so fresh again, places that appeared so ordinary and commonplace a few weeks ago now present a different appearance. The lighting is so soft, trees are looking fresh and are not so full of leaves, and the flowers simply shout requests to be taken. In fact opportunities for some really artistic and pictorial studies are everywhere.

If, then, you have this in mind, you can be positively certain that even a short walk in the fields or along by the river will provide a variety of scenes or subjects that should give you excellent results for some very pleasant evenings' work in the darkroom in developing and printing.

It would be unwise not to give a note of warning regarding exposure. April

light is very much inclined to vary. It can be very good at about 11 o'clock and by 12 o'clock have changed very considerably. The morning can be just right, but what a change takes place after midday. And, of course, the order can just as easily be reversed with the morning light poor and the afternoon up to about 4 o'clock fairly good.

Occasionally, slight mist is experienced in the early part of the day, but this need not be considered altogether a deterrent, for it can be very helpful in some landscape work. As, for instance, when taking a group of stately elms, oaks,

to develop the film? The writer hopes that most readers have bought a developing tank and intended to use it for this particular film.

Well, if the exposures were correct, then by developing in the tank every one of the results should be perfect. Even if one or two were under or over-exposed, the resulting negatives will still be the best that can be obtained from those exposures. Of course, it cannot be expected that a perfect negative can be obtained from a faulty exposure, but, in order to prevent further errors it is necessary that incorrectly exposed

A picture study of Chilham on the Pilgrim Way

The exposure was at 11 o'clock in April, using an H.P.3 film, with 2X filter at F11—1/25 exposure



beeches and similar trees where the sun every now and then manages to break through the mist.

Points to Note

Do not be too close to the group. With an open space in the foreground and the combination of mist, sun and trees there is the making of a picture. Try to calculate the correct exposure time, for otherwise the result will not be up to your expectation. You will probably find that a fairly large stop will give a better rendering.

What about the April showers? Here again is something that should give you food for thought if you are really anxious to get a picture out of the ordinary. If you are still tramping along a country road and are out for tree studies watch the effect of the rain on the leaves. It might be well worth while to wait a few minutes till the sun makes its way through the clouds and shines on those leaves.

Perhaps, if you happen to be in a public highway, the reflections on the wet pavement might intrigue you. Select a suitable spot where both foreground and background are helpful, then wait for one or two persons to come along with umbrellas up. Naturally you should be under shelter in a doorway, with camera set ready to make the shot.

Such are examples of the type of exposures likely to make up the eight or a dozen of your spool. There may not be two very similar, so how do you propose

negatives should receive correct development. This is just what yours will get if the whole film is developed by the time and tank method.

Protect Your Negatives

Before discussing the question of printing from those particular negatives, will you take this piece of advice and so protect them from being scratched or damaged in some other way? Place each one in a separate small envelope; the type can be bought at any stationers shop for a few pence per hundred. On one side of the envelope write the title of the negative, the date it was taken, the stop and exposure time and the time of day if you like, also the developer. If you intend to keep a register, then give it a number, which should be boldly marked in the top left or right hand corner of the envelope.

The reverse side should be kept plain, but ready for all data connected with the printing processes, etc. It is very doubtful whether anyone has ever regretted spending these few minutes in this way. It is a most satisfactory manner in which to preserve the negatives and it enables one to find any particular film in a few seconds if the envelopes are eventually stored in numerical order in a box.

It is correct to assume that only a few amateurs of the present generation are familiar with P.O.P. printing. This is a process that was used by everyone at the end of last and the beginning of this century, but as the paper is presumably

still manufactured and mention has recently been made of it in some advertisements, it will not be altogether out of place briefly to explain it.

Daylight Printing

P.O.P. means Printing-out-paper. A negative is placed in a printing frame, plain side to the glass, and a sheet of the paper is laid face downwards to the negative and the frame clamped. It is then placed in a window where daylight can reach it and printing is gradual, according to the strength of the daylight.

When the stage is reached which shows that the printing is rather too much the paper is removed to a Toning, or a Toning and Fixing, bath for completion. The result is quite a pleasing colour, almost approaching a Sepia, and, if the operation has been properly done, it is permanent. Try to get a packet of paper and make the experiment.

Contact Printing

In these times, however, Gaslight, or as it is best termed, Contact and Bromide printing papers are almost exclusively used by amateurs making their own prints and it is about these that it is advisable to give a few hints. They are both 'developable' papers which means that exposures have to be made in a darkened room, using either an orange or a red light. This does not necessitate a 'pukka' darkroom, however. A warm kitchen, bathroom or even the dining room, if it can be commandeered and the other members of the family do not mind vacating it.

Contact Papers can be obtained in all standard sizes and in various grades and surfaces. The chemicals required are a packet of Metol-Quinol developer and a tin of Acid-fixing. You will, of course, have to have a couple of shallow dishes. Small pie-dishes will answer if you can borrow them and clean them after use. A glass measure and the lamp will also be essential.

How to Print

Printing is as follows. Switch off or black out all white light. Open the packet of paper and remove one sheet. Then put the packet in a drawer or box away from any light which may eventually be switched on. Place the sheet face downwards on a negative which you have already decided to print and which is in position in the frame.

Now place the frame about 12ins. from the illuminant which can be electric, gas or even a paraffin lamp. The exposure time depends on the strength of the light, distance from light, speed of the paper and the density of the negative. You can make the first three factors 'standard' and for the fourth you will be well advised to sort your negatives into three groups, i.e., thin, normal and dense.

For a normal negative and using electric light at a distance of 12ins., give about six seconds for a 40-watt lamp, the same for incandescent gas, and 30 seconds for a duplex-paraffin lamp. You will find that the packet of Metol-

Quinol makes four ounces of solution for contact papers, which should be sufficient for making approximately 3 dozen prints, 3½ by 2½, in one evening.

Washing and Fixing

When the paper has been exposed, place it in one of the dishes and gently pour the developer over it, avoiding air-bells. The image should appear very quickly and be complete in about 1½ minutes. It should then be rinsed quickly under the tap and placed face downwards in the fixing bath. It must be completely submerged and remain there for at least ten to fifteen minutes.

Prints that are under or over-exposed are either too pale or too dark. Only by securing the correct exposure can you expect to get really good results, so it is up to you to judge the density of each negative and keep a record of the time when you are satisfied you have scored the best result possible.

Bromide Work

It is only possible to deal briefly with bromide printing in this chapter. The operation is very similar, indeed, to gaslight. The same chemicals and apparatus and the same lighting, are used, but it must be noted and recognised that all grades of bromide papers are very much faster than any gaslight paper. It follows then that less time is required for exposure, but this would make the process rather difficult of control. So, instead of giving less time, place the printing frame at a distance of 4ft. from the white light (40-watt lamp) and count 10 seconds for a normal negative.

A little practice will soon make you expert at printing and it is hoped that you will, by following these hints, have some excellent results from the 'mixed grill' of April exposures. Bromide paper will be dealt with more fully in an article on enlarging.



A Practical aid to Learning History

MINIATURE Roman Villas, Georgian mansions, mud huts and igloos are being made in a building which stands on the site of an old Tottenham London castle where Robert Bruce, the spider-watcher, once lived. Soon any school in Middlesex will be able to borrow these models for a county council grant of £750 will make it possible to expand Bruce Castle Museum's visual-aid lending scheme which has previously been limited to Tottenham and certain other districts. A wide variety of museum exhibits will be used

to illustrate such subjects as history, geography and general science. At present the collection available for this purpose includes 10,000 pictures, more than 100 models and about 6,000 natural history specimens. The picture here shows Mr. H. J. Warren the museum technician at work making small parts for some of the models. And, of course, much of his work is done with the aid of a Hobbies Gem Fretmachine—another example of the many uses to which this versatile machine can be put.



(Photographs—Topical Press)



The International Exhibition

IN 1940 there would have been, had it not to be abandoned owing to the War, a Stamp Centenary Exhibition from the 6th to the 11th May. That was the centenary of the introduction of the penny postage in Great Britain, and on the front of the prospectus was printed a reproduction of the famous 'Penny Black'.

The Exhibition (May 6th to 13th) which is to take place this year next month is to a great extent following on the postponement of that one. Obviously, however, one cannot in 1950 commemorate the centenary of something which appeared in 1840.

Souvenirs

As this exhibition is called an international exhibition it has been decided to commemorate, not only the stamps of the British Colonies, but also some from abroad. And as 1850 saw the issue of four noted stamps it is proposed to have reproductions of these in colour for sale as souvenirs. The stamps are:—New South Wales, Sydney View 1d. gooseberry red; Victoria 2d. deep lilac; Austria 9 ks. blue; and Spain 6c. black.

The Exhibition is to be held in the Great Room, Grosvenor House, London, and those of our readers who can possibly manage it should visit the Exhibition. They will see many stamps which otherwise they will have little opportunity of seeing. Also they will see how the expert studies his stamps and writes up his collection.

They need not fear, however, they will see only items as far from them as the stars, for there are classes for juniors and seniors and even one for Boy Scouts only.

The Chairman

The Chairman of the Exhibition is Sir John Wilson, Bart. He is the President of the Royal Philatelic Society and also the Keeper of His Majesty King George VI's philatelic collection. Sir John was Chairman of the 1940 Exhibition which was only held in a simplified form at Lancaster House in aid of the Duke of Gloucester's Red Cross and St. John's Fund.

Readers should realise some of the organisation which lies behind the success of an exhibition of this size. For instance in many countries a representative or commissioner has been appointed who is prepared to answer questions for their own countrymen. In some cases they are prepared to take charge of the entries for the exhibition and to bring them to London themselves. The United States, for example, has three representatives, so she is well catered for.

Many firms will be having stands at the exhibition. Naturally there will be more British firms than foreign, though The United States of America, Canada, Paris, Brussels, Torino (Italy) and Basle all appear in the addresses of firms which have taken space. Those who are able to go will be able to see all the latest that concerns the hobby, be it albums, literature or gadgets, whether they come from Gt. Britain, Europe or America.

Accommodation

One very friendly section which is being developed for this exhibition. Those who live within reasonable reach of the building and who can possibly do so are being asked to accommodate a visitor. They are being asked what they can do, such as bed and breakfast, or complete board residence, and at the same time they are asked to state which side of the hobby most interests them. They will then be put in touch with someone who has similar tastes.

Considering the fact that the British Industries Fair will be on at the same time, it is probable that hotel accommodation will be very difficult, so the service projected will be very valuable.

Guides for Parties

Guides are also being arranged to take charge of parties such as School or

Youth Club groups. As there are something like 900 frames to see, it is quite certain that a lot of time will be saved if one can be shown those items which interest most without having to spend a lot of time looking at items which have less appeal.

First of all one can see prestamp items which have been arranged by the Postal History Society. Then one has a chance of seeing stamps of the whole world, but obviously only those who are able to spend more than one day can hope to see all these.

Royal Collection

Certain it is that everyone will wish to see the 48 pages from the Royal Collection garnered by the late King George V and also the exhibits that H.M. King George VI has graciously permitted to be put on view.

It is expected that the daily attendance will be as high as 8,000. This should show that the intention of the organisers is to interest more than the expert, and none should be afraid that the exhibition has nothing for them.

We cannot all be philatelists, we may not have the money to buy books, write letters, and go to meetings, but when we have the opportunity of being put on to the correct path, then we should take it, and a shilling or two expended on entry fee is money well spent.

A Realistic Farm-yard Model

HERE is a picture of a realistic and complete Farm-yard as made by one of our enthusiastic readers Mr. T. A. Brown of 28 Quicks Rd., Wimbledon, London, S.W.19, and one of which he can justly be proud. The cottage is lighted by electricity, 13 fields are partitioned by brick walls and all doors are made to open. The whole lay-out occupies a space of 4ft. by 3ft. and included are stables, pigsty, poultry run, barn, cowshed, etc., complete with ploughed fields, meadows and even a duck pond. This, as Mr. Brown says, just shows what can be done with a fretsaw. That is, of course, if you add an ingenious and clever mind, and the ability to draw, cut and paint the parts needed. No doubt the idea may prove of service to other readers, and we must, at the same time, congratulate Mr. Brown on his novel and attractive piece of work.

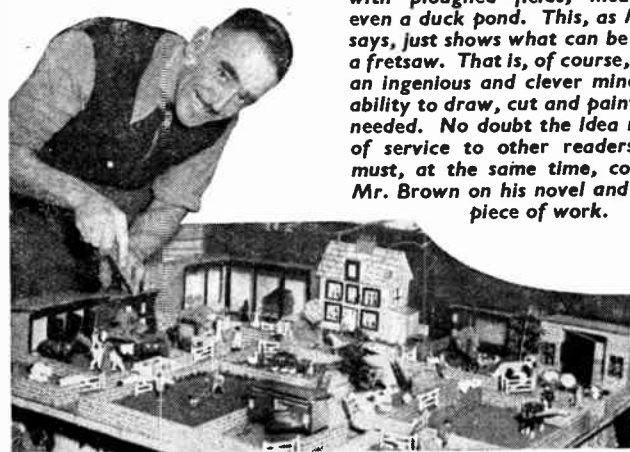

Photograph by Wimbledon Boro. News.

Concluding details for the handyman constructing A TRAILER CARAVAN

HERE are the concluding details for the Trailer Caravan illustrated in last week's issue, when we also gave particulars of chassis and general framework.

During the daytime when the second bunk forms the backrest, the floor space is increased to allow for a folding table, this being attached to the near side wall. The first bunk is used for storing the bedding, and an air bed or mattress is used on the top in the daytime, to form a comfortable seat.

Wardrobe Space

A wardrobe can be fitted to the near side at the rear, extending along the side for about 20ins. Sufficient space will have to be left for when the second bunk is down, and it should be remembered, that the weight must be kept slightly to the front of the axle, otherwise tail wobble will be experienced when on the road.

Lap joints can be used in most instances, but where three lengths meet such as on the top corners, the down post can be butt-jointed, the strength being obtained from the glued and screwed corner pieces or metal plates. The roof bends are screwed in position. A wooden strip of 1in. by $\frac{1}{2}$ in. should be screwed to the door jamb to form a door stop. The waistline rail is dipped at the front to give a streamline effect to the vehicle; this, of course, is optional.

The wheel arches should be let into the chassis cross members and the down posts should be notched to form ledge joints. The panelling will strengthen the body considerably, but this must not be relied on to keep the thing together. When corner pieces are fitted they should not protrude inside or outside of the framework, so that the panelling is a straightforward job.

Window Frames

Window frames can be made in wood or metal or bought complete ready for fitting. If wood is used, it is an easy matter to rabbet the pieces to the section shown. The corners should be mortised and tenoned and pegged. Before the last side is fitted, the glass should be slipped into position, interposing a thin layer of rubber or Bostik B between the glass and the wood.

Metal frames can be made with a similar section either in extruded aluminium, the corners secured with small countersunk screws, or the sections can be made by riveting together suitably-bent sheet steel. In each case the glass should be sealed in with rubber or Bostik. Ordinary window hinges are screwed or riveted to the top side, and a house type catch can be fitted to the bottom.

If preferred, the type of fastener shown can be used. Two of these will be

needed for each window. After the body panels have been fitted, a drip ledge should be screwed in position just above the window. This can take the form of a length of gutter moulding, inverted or anything similar.

The Floor

The floor is made of $\frac{3}{4}$ in. boards nailed, or preferably screwed to the ash cross members. Since good timber is hard to obtain, rough stuff will do for this job, as it can be later covered with lino. The boards should be carefully fitted round the wheel arches.

Panelling

The outside panelling is of aluminium sheet about 20 S.W.G. The pieces are cut to length and fixed to the frame with $\frac{1}{2}$ in. sprigs. The outside faces of the wheel arches are covered in a similar manner. Half-round moulding is fitted to the side joints and screwed to the framework with $\frac{3}{4}$ in. screws.

Threequarter moulding is used over the front and rear corners; this will be found to bend quite easily. A thin layer of Bostik B between the faces will make the job watertight. The lengths of moulding which go up to the roof should not be fitted until after the roof has been covered.

The inside panelling is of $\frac{1}{2}$ in. thick Masonite or similar pressed board, this being cheaper than plywood and serving just as well. The panels are fixed with $\frac{1}{2}$ in. sprigs and the joints covered with slats of soft wood about $\frac{1}{2}$ in. by $\frac{1}{4}$ in.

venient point at the front of the caravan.

The roof is covered with $\frac{1}{2}$ in. thick pressed board such as Masonite, and finally covered with canvas. The Masonite board should be jointed along the ash bends and where it joins on to the sides it should be carefully rounded off with a file. When it is assured that there are no sharp edges, the canvas should be tried in position to make sure that it is large enough. The Masonite is then treated with a waterproofing agent such as Bostik C.

While this is still wet, the canvas should be fitted and made secure. It should be tacked to the centre of one side top rail then pulled taut from the opposite side and tacked. The front and rear should be treated in a similar manner. Then work round the caravan, stretching and tacking until the canvas is secured all round and free from creases.

The edges should then be trimmed off with a sharp knife and the guttering screwed in position along both sides, interposing a thin layer of Bostik B to form a watertight joint. A length of half-round moulding should be screwed along the front and rear in line with the guttering.

The Door

The construction of the door takes the form of a rectangular frame of $1\frac{1}{2}$ in. by 1in. ash, with a cross piece in line with the waistline. Lap joints will suffice at the corners. If one is enthusiastic, however, mortise and tenon

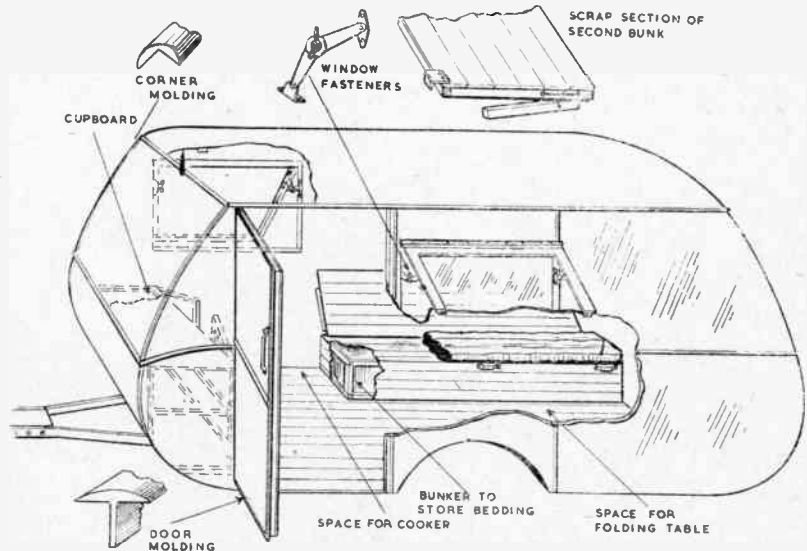

Fig. 4—Cut-away view showing interior fittings and spaces

The wheel arches should be covered with sheet steel about 20 S.W.G. thick. Before the roof and front are lined the wires should be fitted for the roof light, connecting up to a plug at some con-

joints might be considered a better job. The aluminium covering can be turned over round the door frame and finished off by edging with the special moulding shown in the drawing.

As an alternative, the edges of the aluminium can be doubled and allowed to protrude about $\frac{1}{2}$ in. over the frame.

The inside of the door is covered with $\frac{1}{2}$ in. pressed board. Before the inside panel is fixed, the door lock should be fitted. A car type lock is suitable where the key fits in the end of the handle. These can often be purchased quite cheaply from the car breakers. A suitable catch plate should be screwed to the door jamb. Coach type hinges can be purchased second-hand or ordinary door hinges can be used. Some form of door stop should be fitted to prevent the door handle denting the front panel of the caravan.

Internal Fittings

The cupboard is made from a light frame of 1 in. square soft wood covered with plywood or pressed board. The top can be finally covered with American cloth or white enamel sheet metal. Shelves, compartments and hooks are fitted to suit one's requirements. There should be facilities provided for storing the pots and pans while travelling. The cupboard is screwed to the body

frame and fitted with two doors, a handle and ball catch.

The fixed bunker is made of 1 $\frac{1}{2}$ in. by 1 in. soft wood frame 6 ft. by 20 ins. wide by 18 ins. high. The sides are covered with pressed board or matchboard, and the sides should extend above the framework to take the thickness of the top. If pressed board is used for the sides, it must be strengthened round the top with wooden strips.

The top should be strong enough to support several sitting people. It can be made either of $\frac{3}{4}$ in. matchboarding on an 1 in. square frame with two intermediate cross pieces, or with a plywood covering and extra cross pieces. A hand slot should be cut in the top to make for easy removal.

Second Bunk

The second bunk is just a covered frame the same as for the first bunk. This is fitted with three folding legs as shown in the drawing. It also has three hooks equally spaced along the side as shown. These fit into brackets which are screwed on to the first bunk. Safety catches should be fitted to the legs to

prevent them folding under when in use.

Whether a wardrobe is fitted or not depends on requirements. One can make do with a rail screwed to the roof to take coat-hangers. The folding table is simply a piece of plywood on a light frame, hinged to the side of the caravan. The table legs are also hinged.

Finishing

The inside should be painted with a priming paint and finished with hard gloss enamel in light shades. Hooks and wires should be fitted for curtains, and a mirror should be fitted over the window. Combined roof lights and switches can sometimes be bought from the car breakers, this saves fitting a separate switch.

The outside should be primed and finished off with enamel to suit the taste. The brakes should be connected up to the brake lever, and a special bar made to fit across the rear of the car in place of the bumper bar. This will need a bracket in the centre to fit the ball joint taper on the hitch.

Your Caravan is now ready to occupy!

Everyday material can be used to make this PHOTO STAND IN METAL

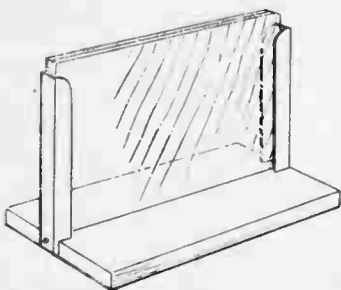

THIS photo stand has the double attraction of being simple to make and also effective when made. It can be made from tin-plate, thin copper or brass, the original being of copper sheet of 24 gauge. The actual width and height of the base and uprights can be made to suit the particular photograph in mind and, therefore, have been left out of the drawings.

Suitable Material

If the reader decides to make it out of tin-plate then it can be made from any large milk tin. It should be painted or enamelled to suit the reader's own taste. If made of copper or brass it should be polished and then covered with either a thin coat of lacquer or varnish, or even a little of the clear nail varnish used by the reader's lady friends.

Begin by setting out the three pieces required on to the particular metal being used. It will be easier to see the markings if the metal is covered with a light film of whitening paste. If this is

done the parts can be marked out with a sharp pencil. Using a pencil has the advantage that if a mistake is made it can be rubbed out, but if the marking is done with a metal scribe it may leave scratches that would be difficult to remove.

Cutting the Parts

Having marked the parts, the next step is to cut them out. Scissors will cut the tin-plate but proper 'snips' will be needed to cut the copper or brass. Care should be taken in the cutting to keep a little away from the finished line. This is filed off, using a fine file and finally using very fine emery paper to take the 'burr' off the edges.

The next thing to do is to bend the parts to shape. This is not very difficult, but it is as well to anneal the copper or brass before doing so. This is done by

back, as in the sketch. Take care to form a neat joint at the corners. These corners should be soft-soldered in the case of tin-plate and if possible silver-soldered with copper or brass, although soft solder will do.

Forming the uprights is easy if the reader has a folding bar $\frac{1}{4}$ in. thick, but if not, any piece of $\frac{1}{4}$ in. metal will do. Failing that, a piece of very hard wood a $\frac{1}{4}$ in. thick and about $\frac{1}{2}$ in. wide will do, and should be bent as in the sketch. All bending should be done with a mallet, not with a hammer, unless a piece of wood is placed between the hammer head and the work.

Assembly

Now to fix them together. They can be soldered (hard or soft solder) or soldered and riveted. If riveted it is as well to solder them in place while the

$\frac{1}{4}$ in.

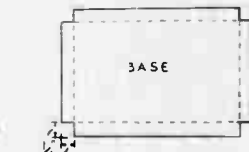

Shape of parts needed

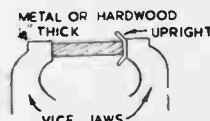

Use of a vice

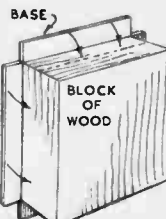

Bending the base

getting the metal red hot and dropping it into water; it will be found that the metal is now much softer and easier to work.

To make the base, bend at the dotted lines with a block of hardwood at the

hole is drilled for the rivet. The rivet should be of the metal used for the work in the case of the brass or copper. If the whole is lacquered, as suggested, it will not need cleaning (only dusting) which will mean a lot to the lady of the house.

PROMOTION

WITH INCREASED PAY

That is what the younger generation are seeking—Promotion, and more money. How to get it is the big question. There's only ONE certain way and that's by systematic training such as the I.C.S. have given to millions and are giving today to tens of thousands of ambitious young men striving to add to their earning power.

Find out how the I.C.S. can help YOU. We teach a wide range of subjects. Here are some of them:

Accountancy	Commercial Art	Radio Servicing
Advertising	Commercial Training	Salesmanship
Architecture	Coal Mining	Sales Management
Building	Draughtsmanship	Sanitary Eng.
Business Management	Electrical Eng.	Structural Eng.
Carpentry and Joinery	Mechanical Eng.	Surveying
Chemical Engineering	Motor Engineering	Works Management
Civil Engineering	Radio Engineering	

LETTERS AFTER YOUR NAME

Do you wish to put 'letters after your name' that will give you recognized professional status of great and life-long value? I.C.S. students have won brilliant successes in various Technical, Commercial, Professional, Civil Service, and other Examinations, including the following:

<i>Technical Exams:</i>	Home Office Mining	C. Inst. Accts.
R.I.B. Accts.	M.O.T. Certif.	C. Inst. Secs.
Inst. of Builders	B. Inst. Radio	Corp. Inst. Secs.
Inst. Civil Eng.	P.M.G.	Inst. Book-keepers
C. & G. Elec.	C. & G. Wireless	Inc. Sales Managers
Inst. Fire Eng.	R.A.F. Wireless	U.C.T.A. in Sales
Inst. Marine Eng.	I.I.A. Foremanship	Matric.—London,
Inst. Mech. Eng.		Durham, Wales
I.M.E. for Bldg. Insp.	<i>Commercial and Edu.</i>	University Entr.
Inst. Municipal Eng.	<i>Exams.</i>	School Certif.
Inst. Struct. Eng.	Advertising Assoc.	Coll. of Precepts
R.I.C. Surveyors	I.I.P. Advertising	

I.C.S. Examination students are coached until successful and all Instruction Manuals and Textbooks are supplied to them free.

International Correspondence Schools Ltd.

(Dept. H.B.2) International Buildings, Kingsway, London, W.C.2



This pocket EXPOSURE CALCULATOR will help you to get really good bright photographs.

A quick, simple and remarkably accurate exposure calculator. Works equally well in summer or winter. By 'dialling' the time of day, subject, weather and film speed the exact exposure for any lens aperture is instantly indicated. Strongly made in white ivory with clear black and red figures. Provision is made for filters.

Photographic Dealers everywhere sell these Johnson Calculators.

PRICE **2/6**

JOHNSONS OF HENDON LTD., LONDON, N.W.4

BOYS!

your chance to GET ON!

If you are over 14 and under 16 here is a golden opportunity. For three years you can enjoy all the amenities of a fine boarding School, entirely without cost to you or your parents. You will be well boarded, fed, clothed and cared for and paid while you learn to handle modern tools and equipment with skill and precision. Your training over, you will be ready to take your place in one of the Army's crack Technical Corps with every chance of quick promotion to Warrant Officer and opportunities of reaching Commissioned Rank. Don't waste this chance. Send the coupon NOW for Free Booklet and date of next Entry Exam.

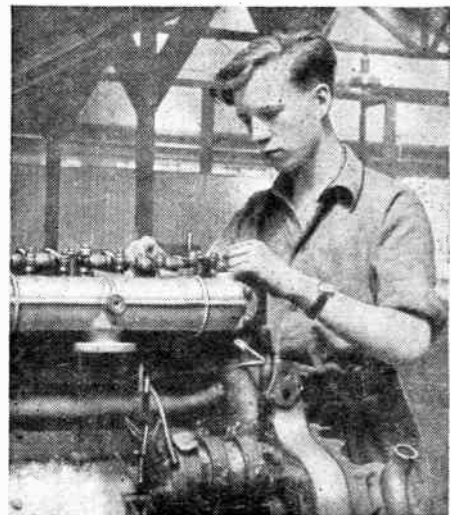

DETAILS FREE Send this coupon Entries for the next Examination must be in by 31st May

Commandant, ARMY APPRENTICES' SCHOOL, Arborfield, Berkshire • Commandant, ARMY APPRENTICES' SCHOOL, Chepstow, Monmouthshire
 Commandant, ARMY APPRENTICES' SCHOOL, Harrogate, Yorkshire • Commandant, ARMY CATERING CORPS CENTRE, Aldershot, Hampshire

Post to whichever of these addresses is nearest to you, or to War Office, A.G.10, London.

Please send me details of Army Apprentice School training and conditions of entry

NAME

ADDRESS

FREE!

2 NEW JUNEERO DESIGN SHEETS

NOW READY! Straight from our designers desk are two magnificent new design sheets—one for a realistic working model OIL DERRICK, another for a Coal Mining Pithead Gear, constructed with Juneero equipment and accessories. The Oil Derrick design sheets, covering 8 pages, are given FREE with the March Juneero News* obtainable from your Juneero dealer at 6d., or 7d. post free from Juneero Ltd.

*This issue of JUNEERO NEWS will be quickly snapped up by thousands of Juneero Fans. Make sure of your copy now, and the May issue which will contain FREE Pithead Gear Design Sheets.

Have you your JUNEERO ANNUAL yet? Given FREE with each copy are Design Sheets enabling you to make a smashing working model Bulldozer. Hurry! Buy a copy to-day from your Juneero dealer 1/-, or 1/2 post free from Juneero Ltd.



JUNEERO

STIRLING CORNER - BOREHAM WOOD
HERTS

YOU CAN BECOME A HANDICRAFTS INSTRUCTOR

Experience not essential

Men who enjoy making things in wood or metal can turn their hobby into a well-paid, permanent and interesting Career. Short hours, long holidays, and security in a job you would really enjoy, can be yours if you become a Handicrafts Instructor. Let us send details of the easiest and quickest way to get the necessary qualification.

**We definitely guarantee
"NO PASS—NO FEE"**

If you would like to know about our unique method of preparing you for one of these excellent appointments, write today, and we will send you our informative 175-page Handbook—free and without obligation. Mark your letters "Handicrafts Instructor".

BRITISH INSTITUTE OF
ENGINEERING TECHNOLOGY

595 Shakespeare House
Stratford Place, London, W.1

BIET

NICOTEXIT

The Guaranteed Smoking Deterrent

- ★ Positively Stops Smoking Immediately.
- ★ Purchase Price Refunded if it Falls.
- ★ One Bottle is sufficient to establish control of smoking in any form.

5/6 PER BOTTLE
POST FREE

Obtainable only by post from the Sole
Concessionaires for Great Britain
THE NICOTEXIT COMPANY
(Dept. B.6.)
62, High St., Croydon, Surrey

EXTRA CASH IN SPARE TIME



A fascinating way of earning extra cash in spare time from odd pieces of lead. Small Outlay—Large Profits. Sample mould 3/6d. Casting moulds, deep-cut and ordinary type Aeroplanes. Soldiers, Farm and Wild Animals, Cars, etc. Stamped envelope for full list. Illustrated Catalogue 9d.

MASTERCRAFT MOULDS
69, ST. MARKS ROAD, HANWELL, LONDON, W.7

BE A MASTER OF JU-JITSU



Amazing new methods show you how to 'get tough' and make any attacker helpless with lightning speed—or money back. The Morley Rapid Ju-Jitsu Course teaches you all the knock out blows, shows you how to throw a stronger man helpless to the ground, gives absolute mastery. Develops body, gives self confidence. You can acquire this devastating weapon in a few weeks. For br th sexes. Complete fighting system, 10/- (or 5/1.00 bill and 40 cents in stamps).

Details 1d.—**JOHN J. MORLEY (H/82)**, Terry House, Naphill, High Wycombe, England. *Established 1936*

Double Protection with **FLY-SHEET**
Yours FOR **15/- TENT**
OR CASH PRICE
£3-9-6 PLUS 1/6 POSTAGE
MAKE ASSURANCE DOUBLY SURE

This **PARA Ridge Tent** comes to you with an inner tent plus a separate fly-sheet. Absolutely portable outfit in Valise complete with all accessories. Popular size 5ft. 6ins. along ridge. 7ft. 3ins. along wall, 4ft. 6ins. wide, 3ft. 6ins. high. 12in. walls. Brand new. Yours for 15/- deposit; cash price £3 9s. 6d. post etc. 1/6 Without flysheet 7/6 de. posit cash price £2 12s. 6d. post 1/-
BELL TENTS, £8 15s. 0d. complete, carriage 5/-. Or deposit 20/-
ESTUARY TENTS, 6ft. 6ins. long, 6ft. wide, 6ft. high, Cash Price £7 7s. 0d. carriage etc., 5/-. Deposit 22/6, all balance over 6 months.

GREAT SURPLUS OFFER "PARATROOP" BINOCULARS



7 oz. Crystal-Clear Lenses. Ideal holiday, sporting events. 42/6. W.D. model, full size, £3 10/-. Very Special 6-Lens Achromatic Model, £5 19/6. Both complete in case, &c. All post 1/-. Other models.

Other **TENTS, MARQUEES, TELESCOPES**, etc. Terms. Send for list.
HEADQUARTER & GENERAL SUPPLIES LTD., (Dept. HOB), 196-200, Coldharbour Lane Loughborough Junc., London, S.E.5
Open all Saturday. Closed 1 p.m. Wednesday.

Don't hard labour it!

Spray it with the TRIGGA Spray Gun. It works off your vacuum cleaner. Switch on, press the trigger and you can paint or distemper a room, stain a floor, creosote the fence, spray away garden pests. Amateurs get professional results with the easy trigger control. The TRIGGA will last a lifetime: the saving in paint brushes will more than repay the initial cost.



*It works off
your vacuum
cleaner*

TRADE ENQUIRIES
INVITED

SPRAY IT with the

TRIGGA SPRAY GUN

Write for free leaflet No. 18

THE IDEAL SPRAY GUN CO., 1 CRAVEN PARK
LONDON, N. W. 10 Telephone: ELGar 6754



All aboard for Hong Kong!

"Yes, that was us off to join the Far East Fleet for a while. We had a whale of a time . . . and during manoeuvres we got a pat on the back for the slick team-work in our carrier. But you can't go wrong on a happy ship like ours . . . I'd hate to leave her—and so say all the lads. I started as a Leading Seaman aboard her—now when I come home next time it will be 'How do, Petty Officer Roberts . . .'"

For full details of how to join and descriptive booklet 'Here is the Navy,' write to THE DIRECTOR OF NAVAL RECRUITING, Dept. A/37, ADMIRALTY, LONDON, S.W. 1.



Make the **ROYAL NAVY**
your career

Printed by BALDING & MANSELL, LTD., London and Wisbech, and Published for the Proprietors, HOBBIES LTD., by HORACE MARSHALL & SON, LTD. Temple House, Tallis Street, F.C.4. Sole Agents for Australia and New Zealand: Gordon & Gotch (A'sia) Ltd. For South Africa: Central News Agency Ltd. Registered for transmission by Canadian Magazine Post.

The bristles

won't

come out!

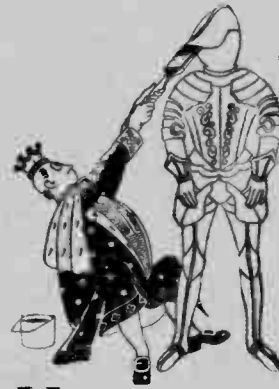

Harris

the paint brush with a name to its handle



There are 3 grades of Harris Brushes. "Junior" good. "Standard" better. "Super" best.

L. G. HARRIS & COMPANY LIMITED, STOKES PRIOR, WORCESTERSHIRE



*Get this book
- make these
MODELS*

HOUSES · SHIPS · ASHTRAYS · BOOKENDS
SIGNAL CABINS · RAILWAY STATIONS
AIRPORTS · DOCKS · RELIEF MAPS · PLAQUES
MODEL FURNITURE · INKSTANDS · PAPER
WEIGHTS · MODEL FIGURES & ANIMALS etc.

SIMPLE TO HANDLE · INEXPENSIVE

The Instruction Book illustrated tells you how to make such models as above, without special tools or skill, in Sankey's "Pyrum" Plastic Cement. This material, modelled while plastic, dries or bakes to stone-hardness, ready for painting according to instructions. Obtainable at local ironmongers, hobbies shops and art material dealers.

Get Instruction Book by sending 4d. in stamps to the address below



Dept. 3

J. H. SANKEY & SON, L.P.

W L F O R D

Est. 1857

E S E X

Hobbies

WEEKLY

CONTENTS

	Page
Metal Garden Wheelbarrow	49
Craftsman's Notes	50
A Batteryless Receiver	51
Turned Wooden Bowls	52
Decorating Glassware	53
Garden Furniture Tips	54
An Oil Trailer Model	55
Small Upright Table	56
The Home Aquarium	57
New Books to Read	59
Oil Bowser Patterns	61

April 26th, 1950

Price Fourpence

Vol. 110 No. 2843

A Handyman can make this useful garden METAL WHEELBARROW

EVERYONE with a garden needs a wheelbarrow at some time or other. The expense of buying one may seriously affect the household budget, so the easiest way to get over the difficulty is to make one yourself. Wooden wheelbarrows are out of the question these days; they are heavy and the right kind of timber is almost impossible to get.

The modern wheelbarrow is made of metal and this article describes in non-technical language how to make it. Anyone not used to working in metals need not be afraid to tackle this job, as it is all so simple if the following instructions are carefully carried out.

Tools and Materials

The only tools required are those usually found in any ordinary home workshop, comprising a hacksaw, wheelbrace and drills, tinsmith's snips, a vice, hammer, cold chisels and spanners. The list of the materials that will be required is given in the panel here-with.

The materials specified can, of course, be modified to suit the supply situation. For instance, if tube is hard to get, flat iron can be used in places as a substitute. Any suitable type of wheel can be used and the size need not be as stated, providing sufficient space is left for it when constructing the frame. The wheel bearing blocks are fitted so the wheel can be taken out any time without taking the barrow to pieces.

As will be seen from the list of materials, the framework is made from

tubing. The two main side members are 1in. diameter, electrical conduit tubing being quite strong enough. An easy method of bending the two pieces, is to drill an 1½in. diameter hole in a hefty piece of timber such as an old railway sleeper. Place the tube through the hole up to the first bend, and lever on the tube to obtain the correct shape.

Each piece is bent in four places as shown on the drawing. No fixed dimensions are given for the bends, as these can be made to suit the individual and the type of wheel used. It will, of course, be necessary to have the two 24in. straight portions to take the body. The wheel ends are flattened to ac-

commodate the wheel bearings, which are drilled in position for the 1½in. diameter fixing bolts.

All the other tubing which makes up the framework, is ½in. diameter. The pieces are sawn to length, flattened at the ends where necessary, drilled ½in. clearance and the ends bent as shown in the drawings. It will be noticed that the pieces are in pairs with the exception of the two body cross pieces.

Making the Body

The body is made from 20 S.W.G. galvanized sheet steel, which can be bought from most of the larger town ironmongers. The top edges are

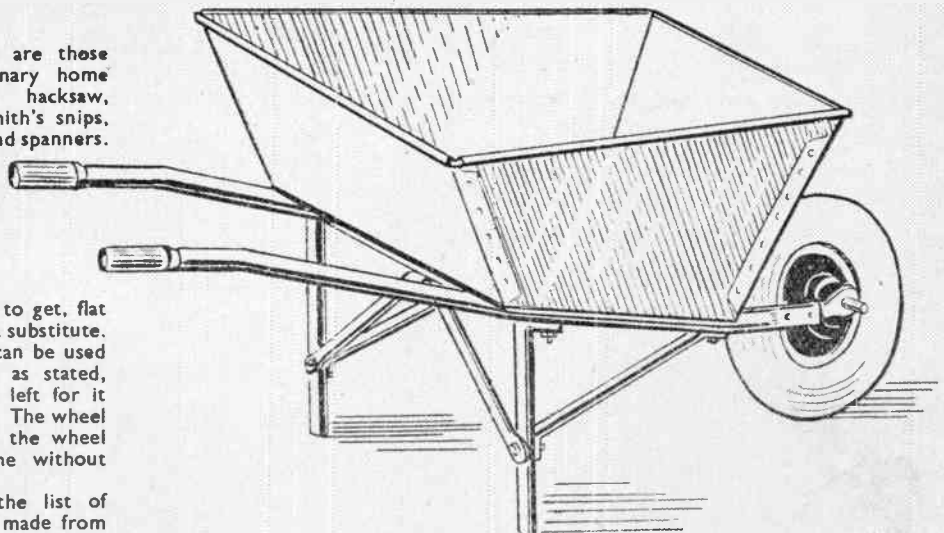

All correspondence should be addressed to The Editor, Hobbies Weekly, Dereham, Norfolk.

strengthened with $\frac{1}{8}$ in. galvanized wire. Mark out the 3ft. by 2ft. piece which is to form the bottom and sides, and cut to shape with tinsmith's snips. The dotted lines on the drawings show where the bends are made to form the shape of the bottom and to take the $\frac{1}{8}$ in. wire. The edge bends on all the three pieces should be made $\frac{1}{2}$ in. from the edge.

MATERIALS

Flat galvanized steel, 20 S.W.G.—
 One sheet—3ft. by 2ft.
 One sheet—2ft. by 2ft.
 Conduit tubing—
 $\frac{1}{2}$ in. diameter, 2 lengths—4ft. 3ins.
 $\frac{1}{2}$ in. diameter, 2 lengths—1ft. 6ins.
 $\frac{1}{2}$ in. diameter, 1 length—1ft. 5ins.
 $\frac{1}{2}$ in. diameter, 2 lengths—1ft. 4ins.
 $\frac{1}{2}$ in. diameter, 2 lengths—1ft. 1in.
 $\frac{1}{2}$ in. diameter, 1 length—1ins.
 Wheel—1ft. 4ins. diameter
 Steel for wheel bearings—
 2 pieces—4ins. by $\frac{1}{2}$ in. by $\frac{1}{2}$ in.
 Rivets— $\frac{1}{2}$ in. by $\frac{1}{2}$ in.—36
 Nuts and bolts—
 $\frac{1}{2}$ in. diameter, 1in. long—4 off
 $\frac{1}{2}$ in. diameter, 1 $\frac{1}{2}$ ins. long—7 off
 Wire— $\frac{1}{8}$ in. diameter, galvanized, 7ft.
 Cycle handle bar grips—one pair

The front and rear pieces are cut as shown, having $\frac{1}{2}$ in. square pieces cut from each corner. Before bending any of the pieces, drill the holes for the rivets. Mark out down the sides and along the bottom of the front and rear pieces and drill for the $\frac{1}{8}$ in. diameter rivets. The holes should be about .200in. diameter, and should be spaced out as shown on the drawings.

Correct Positioning

These holes must match up with those in the 3ft. by 2ft. piece, and to ensure this, the two pieces should be placed in their respective positions on the 3ft. by 2ft. piece and the positions of the matching holes marked with a scriber.

The top edges of all the pieces are then bent outwards to take the wire stiffener. If the pieces are placed in turn on a flat bench, the edges can be knocked up against a piece of hard wood chamfered

to $\frac{1}{8}$ in. on the edge. The bends should be left sufficiently open to allow the wire to be fitted later.

The Bends

The bends to form the bottom and sides can be made by placing the strip of wood along where the bend is to be made, standing on the wood and pulling up on the metal. The bends can be finished off with a mallet. Finally, make the bends for the lap joints, using the same strip of hardwood.

The next step is to rivet the pieces together. The overlaps are best on the outside. This leaves a clean interior which is better for cleaning and shovelling. It does not matter much where one

When all the rivets have been fitted the strengthening wire should be bent to shape. The ends are butt jointed and this should come on the side likely to get least strain, i.e., the side nearest the handles. Press the wire up into the top bent over edges and clinch it here and there with a pair of pliers. Finish off by knocking the metal round the wire with a mallet or light hammer, holding the work in suitable positions up to a wooden block on the bench.

Finishing

When the body is finished, place it in position on the frame to mark the bottom for the four fixing bolts. Drill four $\frac{1}{2}$ in. clearance holes and secure the

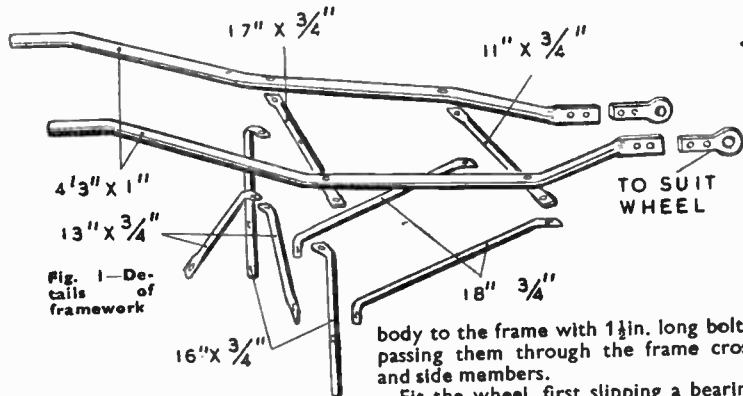

starts riveting. If any of the holes do not match up after the first few rivets have been fitted, they should be opened out with the drill.

Make sure the rivets are not too long; they should protrude about $\frac{1}{2}$ in. before peening. Copper or brass rivets are most suitable as these are easy to work and quite strong enough. A solid object should be held against the head of each rivet as it is peened over. This can take the form of a hammer or a piece of round bar.

body to the frame with $1\frac{1}{2}$ in. long bolts, passing them through the frame cross and side members.

Fit the wheel, first slipping a bearing block (previously shaped and drilled to suit the wheel), over each end of the axle and push the blocks into the flattened ends of the side members. Make secure with four 1in. long $\frac{1}{2}$ in. bolts and nuts.

All that remains is to fit the handle grips, a spot of oil on the axle, and the barrow is ready to use. The prototype from which this article was written has been in use for over ten years and is still capable of carrying loads of more than 1 cwt.

Fashions in Pastimes

HOW fashions change. Not so long ago spotting trains was all the vogue. Then came car numbers. Now it seems that empty cigarette packets are in big demand, and soon, no doubt, something different will be experiencing a boom.

It often happens that different pastimes are taken up just to be in the fashion, many of the new participants regarding them as a temporary sideline to their usual hobbies. There are, however, numbers of enthusiasts to whom these 'hobbies of the moment' are neither new nor temporary.

This wave in collecting cigarette packets, for instance. These cartons are so varied and interesting—and new designs occasionally appear—that they cannot have escaped the attention of serious collectors, and I imagine that some extensive first-collections could be produced by specialists in this line.

Their near relation, the match box, certainly has a good following. Phi-

lumenists (match box cover collectors) are sometimes also interested in the matches themselves, of which I was surprised to learn, there are as many as a hundred different varieties.

Novelties for Youngsters

WITH the aid of a camera one or two interesting presents can be made for the youngsters. The ideas mentioned here are not in any way elaborate, but it is often the case that simple home-made toys are the ones most appreciated.

One suggestion is to make a set of picture snap cards, say, about fifty cards on paper $3\frac{1}{2}$ in. by $2\frac{1}{2}$ in. or thereabouts. This is a convenient size to handle, and if desired they could be mounted on thin card to make them stronger, trimming it evenly. About a dozen pictures of different animals or scenes that can be quickly recognized should be chosen, and four or five duplicate prints made from each. The recipients will know how to play this old-established game.

Another idea, perhaps more difficult

to make but worth trying if you have film to spare, is to take two or three dozen pictures of the youngster in slightly different attitudes, so the finished series is almost like a cinema film. Then make a print from each, but use a larger sheet of paper to leave an ample blank margin of 1in. or more on the left.

Put all the prints in sequence, with flexible cover at top and bottom, and bind together with staples or thread at the left-hand edge. For quiet amusement such albums were quite popular with kiddies at one time. By flicking the pages quickly with the thumb they get the impression of movement in the photographs.

Then, of course, there are photographic jig-saw puzzles, made by gluing an enlargement to a piece of fretwood and cutting into small irregular pieces with the fretsaw. It may be preferable to cut two at a time, clamping the two boards firmly together with the pictures inside.

The Craftsman

The new type of detector is introduced into this BATTERYLESS RECEIVER

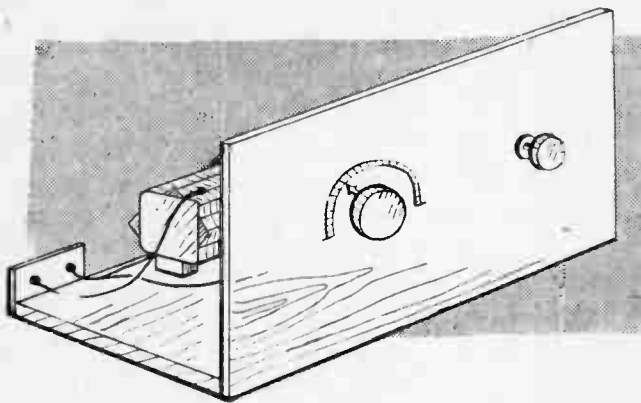

The Tuning Coil is wound in a manner which enables the clips to be attached easily, and is also very efficient. The turns are of bare tinned-copper wire, and the former is ribbed. Ready-made ribbed ebonite formers of suitable size may readily be purchased, or a former can be made up, as shown in Fig. 3.

The centre block of wood is 3ins. by 3ins. and about 8ins. long. The corners may be rounded slightly. Four triangular-shaped pieces are glued along, as shown. Those on the sides and top are the same length as the former, while the bottom strip is a little shorter so that two small blocks of wood may be used to mount the finished coil on the baseboard.

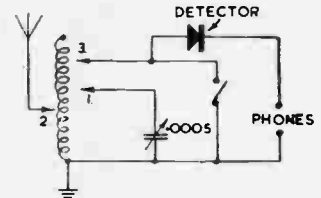

Fig. 1—The theoretical circuit

SMALL receivers that require no batteries or other power supplies to operate them are popular because they are cheap to build, cost nothing to run, and are always ready for use whenever required. The simplest receiver of this type is the crystal set, but by making use of one of the new types of detector developed during the war the inconveniences associated with crystal detectors can be overcome.

This receiver uses such a detector, which is sensitive and almost everlasting, and it is merely necessary to switch the set on, when required, instead of adjusting a catswhisker or similar arrangement and searching for a sensitive spot on a crystal.

Results to Expect

In many areas an indoor aerial along two or more walls of the room near the ceiling will give ample volume and such an aerial may be of any thin insulated wire. With an outdoor aerial there will be additional signal pick-up and louder results will naturally be obtained, which is particularly desirable if more distant stations are to be received.

The very best type of aerial is one which is fairly long (say, 60ft. or so), as high as possible, and clear of surrounding buildings. With such an aerial the headphones should be heard operating quite clearly even if laid on the table, and tests show that after dark it is quite possible to receive continental stations at fair earphone strength.

Whatever type of aerial is used, an earth is desirable and its absence will severely reduce volume. The earth lead

should go to any metal object buried in damp soil outside the house. Proper metal spikes are obtainable, or wire-netting or disused metal containers or sheets of any kind can be used.

Selectivity Problems

The usual fault with receivers of this type is lack of selectivity (or sharpness) in tuning, which results in stations being received together. This has been overcome, and maximum volume assured, by making use of a tapped coil.

The usual lack of selectivity arises because of the damping imposed on the

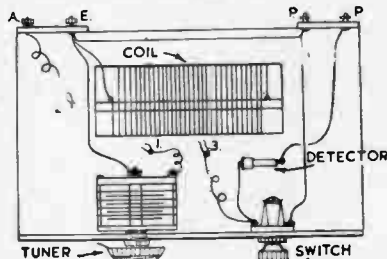

Fig. 2—Complete wiring diagram

tuned circuit by the aerial and detector, and this can be reduced by tapping either aerial or detector down the coil. This is done by means of the clips 2 and 3 shown in Figs. 1 and 2.

The nearer these clips are placed towards the earthed end of the coil the sharper does tuning become. Some loss of volume also arises, and, therefore, a compromise between selectivity and volume has to be made.

With a very long aerial clip 2 may be quite close the earthed end of the coil; a short aerial will allow more turns to be brought in, however.

The settings of the clips are in no way critical and a few moments' spent in experimenting will immediately show how results are influenced.



Fig. 4—The detector mounting

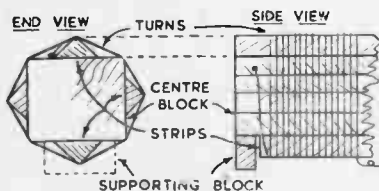

Fig. 3—Making the coil

An air-spaced tuning condenser is best, though a solid-dielectric one specially intended for tuning will also give very good results. A capacity of about .0005 mfd. is most suitable. The condenser may be fitted with a dial, knob with pointer, or so on according to the parts available.

Any small on-off switch is suitable. It should be noted that its function will be the reverse of what is usual. That is, when the switch is in the 'Off' position the receiver will be 'On', and vice versa. When the set is switched off no currents can flow in the detector or phones, but the set is ready for immediate use when the switch is operated.

Constructional Details

All connections are shown in Fig. 2 and no difficulty should arise. The clips are placed on small lengths of flex; they may be purchased from the popular stores, or devised from paper clips or scrap metal strips. The four terminals at the back are mounted on insulated strips and are for Aerial, Earth, and Phones.

A baseboard about 9ins. by 5ins. will

be of ample size, and a panel cut from 3-ply to similar dimensions is suitable.

The clips should go on the turns easily at a point where the latter are raised from the former.

Notes on Operation

To begin with, all the clips may be placed very near together near the right-hand end of the coil (Fig. 2). Upon tuning, stations should be heard, and the effect of moving the clips can then be noted.

As clip 2 is moved to the left along the coil tuning will become more sharp. (Re-tuning will be necessary as this clip is moved). Moving clip 3 to the left will also sharpen up tuning. Moving clip 1 to the left will decrease the minimum wavelength tuned. As a guide, about 70 or 80 turns will be required in circuit for most medium wave stations. The best position for clip 2 depends upon the aerial system and reception conditions.

Some short wave stations may be received when conditions are favourable if the clips are placed about 5 to 10 turns from the earthed end of the coil. But on

these wavelengths conditions vary from hour to hour, and also according to the season of the year.

To assure that proper volume is obtained it is necessary to remember that ordinary medium or high-resistance headphones should be used, not the low-resistance types.

Higher Wave Lengths

If it is desired to tune to higher wavelengths, then the number of turns on the coil must be increased. This may be done by using a longer former, by putting the turns closer together, or by winding a loading coil of thin insulated wire, with turns closely side by side, at one end of the spaced winding. If the tuning condenser is wholly closed and some desired station has not been reached, then turns should be added.

If, on the other hand, the condenser is opened and the wavelength is still too high, then clip 1 should be moved to reduce the number of turns. The clips may be left in one position, once set, ordinary tuning being carried out by means of the condenser.

Scrap pieces of wood and two methods of making A TURNED WOODEN BOWL

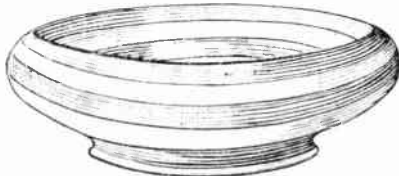

Made by the first method explained

ALTHOUGH at first sight this bowl may appear beyond the scope of the amateur lathe worker, it is not as hard as it seems. There are three methods of doing the job, the method depending both upon the skill and taste of the maker and upon the material available. Throughout the whole process the work is not taken off the wooden faceplate, although the whole may be taken off the headstock, that is metal faceplate with the wooden one still screwed to it as in the sketch.

The first thing to do is to prepare a piece for the base. This must be in one piece (marked C in sketch). Shape this roughly circular before fixing to the wooden face plate, placing a piece of thick paper between it and the faceplate (see sketch). This will enable you to get the work off easily when finished. In all three methods the basepiece is in one.

The Base

The base piece can now be turned to size and at the same time faced up ready for the fixing of the next 'course'. If method (1) is being used, the courses will be already cut and only need gluing in place, each course

is faced up before the next one is placed in position and at the same time can be roughed out to the approximate shape.

Gluing

The greatest snag with this 'course' turning is waiting for the glue to set between turning one course and setting the other. This can be speeded up by using one of the synthetic glues that will set in times varying from half an hour to ten minutes. However, the maker will not usually be in such a desperate hurry that he cannot wait a few hours. If good cake glue is used, the next course can be fixed inside of two or three hours.

With method (1) the separate courses should be of different coloured woods. It also means that definite sizes are required to make the 'rings', whereas in the other two methods, any odd pieces

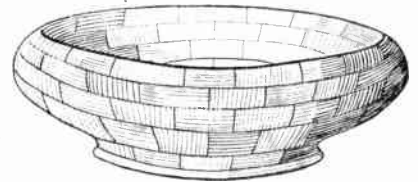

A small block method of making

can be used. Even the courses need not be of the same colour or wood throughout.

Carry on building up the courses and facing up until the required size is reached. Now, with carefully sharpened tools, finish off the bowl inside and outside. Finally finish off with glass-paper from medium to very fine.

Polish

The author finished his with a lump of bees wax held to the work while turning. Then a very coarse piece of sacking is held against the work (still rotating) and with gradually increasing pressure, the heat generated caused by the friction will melt the wax and it will be absorbed into the wood. If the pressure is kept up for a short time it will produce an excellent polish on the surface.

When satisfied with the finish, gently ease the whole job off the wooden face plate with a wide thin chisel. Clean up the under base and glue a piece of felt on to the bottom to prevent marking polished tables, etc.

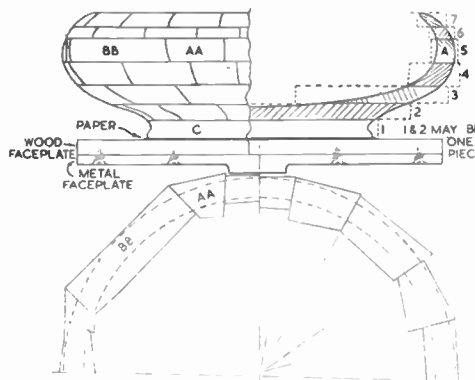

Details of construction with sections through

There is nothing really difficult in the hobby of DECORATING GLASS

MOST handicraft workers have admired the handpainting which is sometimes seen on glassware; it looks so attractive and dainty that it makes an instant appeal. Unfortunately, it also looks so very difficult that few hobbyists are bold enough to try their hand at the craft.

Surprisingly enough, in many ways it is much simpler to decorate glassware than it is to paint the illustration in a child's painting book. It is one of the few crafts where mistakes can be rectified as soon as they occur. And, possibly one of its chief attractions, it requires little in the way of equipment.

Colour and Patience

Even those folks who possess little flair for drawing or painting will find it a comparatively simple matter to turn out professional-looking work from the start. All that is needed are an eye for colour, a little patience, and the ability to apply colour within prescribed limits.

So much for the personal equipment required. The material list is no less accommodating. Your first concern must be the type of colour which you propose to use for your work. Water-colours are useless since they will not 'take' on glass. Artists' oil-paints may be employed, but only on those articles (vases, cosmetic jars, trinkets, etc.) which do not have to be washed very frequently.

Suitable Paints

If washed too often, especially in hot water with the addition of soda or a washing powder, your painted decoration will very quickly strip away from the smooth glass surface. There may actually be quite a number of craftworkers who have become thoroughly discouraged with the craft through having employed a colouring agent which was totally unsuitable for application to glass.

Fortunately, enterprising manufacturers have placed on the market certain art-colours which have been expressly produced for the purpose of providing a durable decoration on glassware. Of the several varieties on the market they may be divided into two groups: opaque and transparent. Both can be used to produce decorated articles of glassware which are the acme of daintiness.

Where to Get Them

An enquiry at any large artists' stockists or handicraft shop should assist you in your choice of colouring media. You will find that these glass-painting colours are quite inexpensive—particularly so when you remember the number of articles which can be decorated from a few tubes or jars. If you cannot obtain locally the Editor can



give you suitable addresses.

Some thought must also be given to your choice of brush for this work. You will find it a false economy to buy cheap bristle brushes. Sable or squirrel hair are best for the job. Once you have acquired good brushes take care of them. If thoroughly cleaned and dried after use they will give lasting service.

The Glass to Use

And now a word about the glassware itself, and its preparation. Various items of glassware are in plentiful supply these days and may be obtained quite cheaply at any of our larger stores. Glass that has already been cut or moulded does not lend itself to the addition of handpainted decoration so well as do simpler articles of plain glassware. Not only does the latter offer by far the better surface for this form of craftwork; it also has the added advantage of being much less expensive.

To begin with it would, perhaps, be best if you try your hand on an old tumbler or even a jam-jar. Remember, even if you make mistakes, they can be removed immediately by means of a matchstick wrapped round with cotton-wool and dipped in a little turpentine.

What to Paint

As confidence is gained, however, the craftworker will, no doubt, begin to think in terms of producing attractive gifts or work for sale. He will possibly graduate to articles such as tumblers, wine-glasses, jugs, carafes, decanters, preserve dishes, etc., after he has served his apprenticeship on jam-jars.

The size and shape of the glass article which you propose to decorate will, obviously, be the chief deciding factor in your choice of a suitable design. At the same time, however, some thought may have to be given to the use for which the article is subsequently intended. While if the friend or relative for whom the finished work is intended has any keen favouritism so far as colour or choice of motif goes, these must also be counted as deciding factors.

Simple Subjects

Fortunately, the craft offers unlimited

scope for originality. There appears to be little limit to the type of design which it is possible to employ. Glassware intended for festive use (tumblers, liqueur and cocktail glasses, etc.) may well be given gay, sporting motifs: horses, dogs, huntsmen, dancers, figures from carnival and pantomime. Nursery rhyme characters, galleons, birds, etc., may all be used to good effect, whilst for those forms of glassware which need a more sober decoration, any form of floral pattern will stand you in good stead.

Copying Pictures

Naturally, we cannot all be such good artists that we are able to take brush in hand and execute an attractive design on glass without an outline of some sort to work from. But there is nothing to stop us cutting a suitable illustration from a magazine or a greeting card, or an embroidery pattern, and pasting this into position on the inside of our glass article.

Thus, with a clear outline to work to, it becomes a simple copying exercise to charge our brush with the correct colours and apply them to the outside of the glass immediately over the pattern beneath. When your work is complete, remove the illustration from the glass vessel and even your closest friends will be astonished by your recently acquired artistic ability.

Before commencing to apply your colours to the glass, however, you must ensure that the glass is perfectly clean and free from grease. After washing in warm, soapy water, polish with a soft cloth and a small quantity of turps or methylated spirit.

Now let us assume that you have decided to decorate a tumbler with four small bluebirds (see the right-hand tumbler in the accompanying photograph). First cut a piece of drawing-paper to shape so that it will fit neatly inside the tumbler and then trace the outline of your motif in the appropriate positions on the paper pattern. Place this developed design inside the tumbler and arrange your colours in readiness.

(Continued foot of page 55)

Prepare for comfort and safety by reading these GARDEN FURNITURE TIPS

WE shall now be getting out the deck-chairs and wicker chairs and tables to enjoy all the hours we can spare in the sunshine. Garden furniture and those odd chairs we use can all do with a little renovation and some of this work you can do in the shed or under the verandah.

Outdoor seats of the open type can be treated with a good preservative such as Solignum. If you do this now it will dry well out before you start to use the articles. Why not change the colour? You can get it in green, purple, red, dark brown and brilliant red. A shade of green will add to the charm of the garden. Be sure to use the exterior

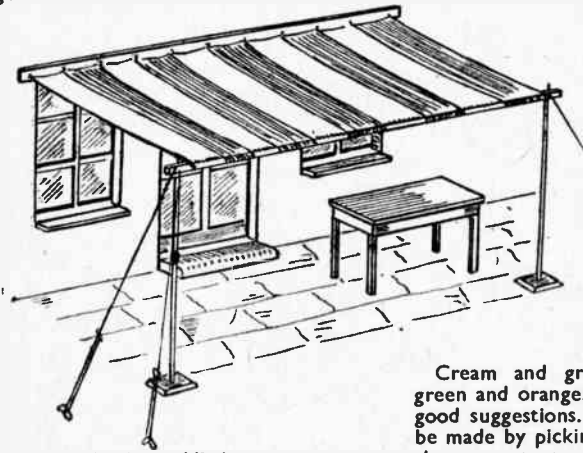

A simple sun blind

quality. Two coats give a deeper effect than one; two will probably obliterate the original colour also, if this is what you want.

Deck Chair Attention

Deck chairs are a very expensive item and they can be made to look new with very little expense. If you do intend to replace the canvas, then remove this at the start. New canvas is in good supply now and cut to the required size. If you wish to wash the old ones, provided they are not perished, they can be laundered in the usual way.

You can also save the wear and tear by fastening the new section to the best of the old section and fitting on like a roller towel. Strain of the person on the canvas is thus halved.

Be sure to remove all old tacks. To fix, turn in one raw edge and fasten to the top bar, then draw right round the bar and down to the seat. This will give it a 'bind' on the top bar. Do the same at the bottom. The framework you will be able to paint quite easily without the canvas on. Be sure that edges are painted without leaving ridges of paint.

Rustic furniture may get rickety, but a short brace piece will soon put this

right. Iron angle brackets will also be a good safeguard against further collapse. Hammocks, tables and adjustable chairs often develop a squeak in the joints but a little oil will put this right. Only use it where it is essential, as too much oil will overlap and risk spoiling clothes.

Wood and Wicker Chairs

Teak garden chairs will look much better when cleaned down with a solution of ½oz. of copper sulphate solution to a gallon of water. This cleans them and prevents damage from insects for a very long time.

Wicker can be cleaned in several ways. If a little soiled, a solution of salt and water will improve it. It is a good plan to renovate wicker furniture which you do not want in the house for outdoor living. It is less prone to damage and the effects of the weather, and it is light to carry around. Left in its creamy white it is also quite attractive, but you can clean this and change the colour by using bright shades of enamel.

Cream and green, red and silver, green and orange, red and black are all good suggestions. Other contrasts can be made by picking out certain parts of the woven texture. Very effective is the scheme whereby the chair is painted a light yellow and allowed to dry. Over this a bright green is whisked and rubbed off partly whilst wet with a dry cloth, which gives a very original effect.

Most wicker will respond to a good soaking and wash down with the garden hose before painting. Finish off with a stout scrubbing brush to get the grease out of the crevices. Dry in the sun or you can even tie them on the clothes line to dry. This is the best way for quick drying. Gay upholstery is more than welcome for these and cretonnes are delightful.

If the children are to be out in the garden quite a lot, they will most certainly want a number of articles carted in and out. There will be books, toys, plastic china and so on. Have a look

round for one of those old tin travelling trunks with the two handles on each end. They are sold and picked up at the local second-hand shop. Clean one down and give a coat of bright green paint. Two thin ones are better than one thick, especially if the trunk may be dented. Store all the outdoor items in this.

A seat can be provided by one or two of the ex-army biscuit mattresses now advertised. Or, if you wish, a panel of wallboard can be placed on the top to form a table for meals. Fix 1in. square quartering battens at each end to hold it on.

A Trolley

For large assemblies in the garden there is much work in taking the china and crocks in before and after meals. The writer made a dinner waggon with 1in. square wood on the same lines as the normal ones but, perhaps, not so well finished. To this he added the 6in. rubber-tyred wheels sold at most toy and model shops. The large wheels are necessary to cover rough ground.

We cannot all afford a tent and, perhaps, we want to keep well up to the house. A very inexpensive and practical little sun blind can be made by getting some striped deck chair canvas and making a shade about 8ft. long and 6ft. wide.

A batten is fitted to the wall with hooks and rings and placed on the canvas. A strip of wood or iron pipe can be fitted to the edge. Screw-hooks in the ends of this will fit on to two upright broom handles, which should stand on 4in. squares of wood to hold in position. Fix and maintain in place with ordinary guy ropes and adjusters.

Although it may seem early in the season to undertake these suggestions, it is surprising how soon summer will be here. Then we shall want to make use of these articles for the garden, only to find there is much repair and renovation needed. Look into the matter now therefore so you can enjoy their comfort and use later. (132)



BRANCHES

LONDON
78a New Oxford St., W.C.1
(Phone MUSeum 2975)
87 Old Broad Street, E.C.2
(LONDON Wall 4375)
117 Walworth Road, S.E.17

GLASGOW

326 Argyle Street
(Phone CENTral 5042)

Head Office & Factories—HOBBIES LTD., DEREHAM, NORFOLK

MANCHESTER

10 Piccadilly
(Phone CENTral 1787)

BIRMINGHAM

14 Bull Ring
SHEFFIELD
4 St. Paul's Parade

LEEDS

10 Queen Victoria Street
(Phone 28639)

HULL

10 Paragon Square

SOUTHAMPTON

25 Bernard Street

BRISTOL

30 Narrow Wine Street
(Phone 23744)

An additional model to our miniatures is this realistic OIL BOWSER TRAILER



THE oil trailer illustrated is a sturdy little vehicle and simple to make from oddments of wood and card. Wheels are the $\frac{3}{4}$ in. solid model aircraft type. The model is intended as an addition to the others already published in this series. Patterns are full size on page 61.

The first part to make is the frame for taking the structure. Make this from $\frac{1}{8}$ in. by $\frac{1}{2}$ in. wood and $3\frac{1}{2}$ ins. long, and round the ends off as shown in Fig. 2. Two cross bearers are needed $1\frac{1}{2}$ ins. in length from $\frac{1}{2}$ in. by $\frac{1}{2}$ in. material. Along the centre is another bar at least $\frac{1}{2}$ in. wide to take the sump heads as shown in Fig. 5, and also to allow the wheels to pivot on the front axle.

Wheel Assembly

In Fig. 2 you will see the side view of the wheel lay-out. These vehicles have what is known as 'torsion' bar assemblies which can be made from $\frac{1}{8}$ in. dowel rod. Two of them are shown crossways at the sides of the top of the wheel. They go across the frame underneath. The back axle is $1\frac{1}{2}$ ins. long by $\frac{1}{2}$ in. by $\frac{1}{8}$ in.

Another bar comes from base of frame to the back axle and is $1\frac{1}{2}$ ins. long. The front unit is made to turn and is shown in Fig. 3, the long cross sections being $1\frac{1}{2}$ ins. and side cross sections $\frac{1}{2}$ in. Another piece is fitted along the centre

on the top and made from $\frac{1}{8}$ in. by $\frac{1}{2}$ in. flat. On this the framework turns.

Now make the framework, from thick card (see Fig. 4), shaped as shown and $1\frac{1}{2}$ ins. long by $1\frac{1}{2}$ ins. wide. It will fit on the front of the turning unit. Card can be used but you should reinforce this with thin $\frac{1}{2}$ in. strip. It will be a good plan to assemble all this part first and see it is in order, stands

level and works from side to side.

The next part is a panel of $\frac{1}{2}$ in. wood 4 ins. by $1\frac{1}{2}$ ins. All round this is fitted a thick cardboard covering, measuring 4 ins. by $1\frac{1}{2}$ ins. Note the cut-out which should be $\frac{1}{2}$ in. at the corners and $\frac{1}{2}$ in. at the narrowest part. Cross strips of wood inside will help to keep it firm when glued. Note the dotted lines for this.

Former Sections

Now cut out three sections in $\frac{1}{2}$ in. wood measuring $1\frac{1}{2}$ ins. across and $\frac{1}{2}$ in. high and half-round in shape. Fix these as shown in Fig. 6 with strips each side to hold them straight. These are the formers for the tank casing. Make the casing with tin with sloped ends and bend this over the formers. Fix down on each side and then add a strip of wood $\frac{1}{8}$ in. wide to the top of the flat panel, thus holding the tanking down.

To finish off, add two ends to fit and two small tool boxes: about $\frac{1}{2}$ in. long by $\frac{1}{8}$ in. by $\frac{1}{2}$ in. at the front (see Fig. 7). On one side you will find two round drum objects made from $\frac{1}{8}$ in. dowels and $\frac{1}{2}$ in. high. These are also shown in Fig. 7 and two more of these are also fitted to the centre cross-bar underneath the chassis framework. A double section of card $\frac{1}{2}$ in. wide at the top is added to each end (see Fig. 7).

This completes the tank itself, but a dome piece is rounded from $\frac{1}{8}$ in. dowel

and placed on top centrally. Add a $\frac{1}{2}$ in. wide cardboard strip. At the rear end fix a piece of $\frac{1}{8}$ in. dowel $\frac{1}{2}$ in. high is fitted and neatly moulded round with plastic wood (see Fig. 8). A cross piece of $\frac{1}{8}$ in. dowel, $\frac{1}{2}$ in. wide is next pinned to this.

Pipe Feeder

You must now attach a length of $\frac{1}{2}$ in. dowel rod 4 ins. long. At the top end fix a 1in. length of valve rubber, $\frac{1}{2}$ in. on the rod and the other half off; another $\frac{1}{2}$ in. piece should be fitted at the base. Also, right at base fix a piece of wood $\frac{1}{2}$ in. long by $\frac{1}{2}$ in. wide and $\frac{1}{2}$ in. thick. Into this fix a bent pin to hold the twin

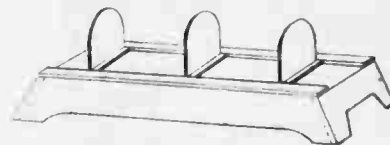

Fig. 6—Framework for tank cover

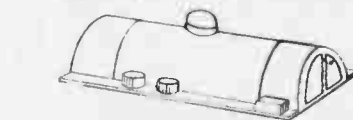

Fig. 7—Cover and ends in place



Fig. 8—The petrol pipe and wooden stand

hoses which can be made from thick thread.

All you need now is a wood support shaped as seen in Fig. 8, this being $\frac{1}{2}$ in. high and shaped and moulded with plastic wood. On this is fitted a bent pin to take the bar.

To help the builder the idea of this is to allow the oil to be pumped up to the bombers at a considerable height. The bar is sprung and balanced by the weight at base. Paint the completed model in grey or olive green.

Decorating Glass—(Continued from foot of page 53)

The underparts of the birds may be in white or yellow. Charge your brush with the desired colour and paint this part in on each of the small motifs. Now cleanse your brush and charge it with blue. Work round the tumbler, filling in the remainder of the birds.

Gaining Speed

Clean the brush again and finish the design with a few black lines to show the eyes, wings and tail-feathers. With a little practise you will find it possible to work at such speed that the decoration of a complete set of tumblers in this manner can easily be accomplished in a spare hour or so.

Here is a word of warning, though. This is such an absorbing craft that when practising it, there is a natural tendency to hold the work too close. Avoid this as much as possible, otherwise your breath will condense on the surface of the glass and possibly prevent the film of colour from taking effectively on the article.

Or for Plastic

Glass-painting colours are equally as effective on plastic and provide an excellent medium for the decoration of nursery-ware. Since it is impossible to work from a pattern gummed on the inside of a plastic article (unless it is

made from one of the transparent materials) it will be necessary to trace the outline on the outer surface of the article with the use of carbon paper. Filling in this outline then becomes as simple as the method employed on glass.

The Best Colours

Light or bright colours are always more successful on glass. Greens should tend to be more of a yellowish hue than a bluish one. And colours such as mauve and purple should contain plenty of red. Transparent colours produce a very pleasing 'fragile' effect that enhances all floral designs. Opaque colours are ideal for animals and figures.

An interesting home carpentry job is to make this SMALL UPRIGHT TABLE

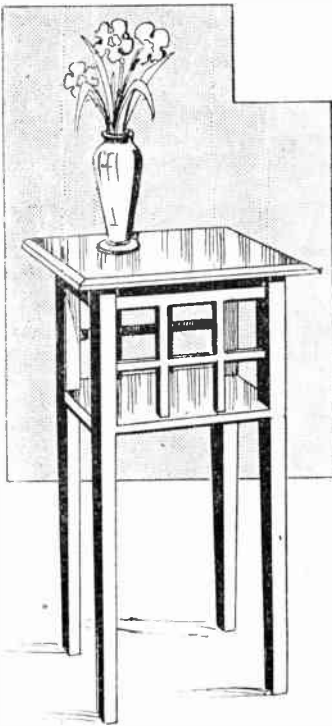

Fig. 1—A handsome little table.

THE neat little hall or side table which we show in Fig. 1 should, for preference, be made of oak, but mahogany or beech or one of the other hardwoods would answer well. There are the usual tapered legs connected at the top by cross rails.

The following is a list of the material which will be required to make the table. The dimensions given are finished sizes, so allowance should be made for planing and cleaning up.

Four legs (A) 2ft. 5½ins. long, by 1½ins. square. These are tapered slightly from the foot upwards to a height of 1ft. 7½ins., that is, to the underside of the shelf, see Fig. 3. Four cross rails (B) 12ins. long by 1in. deep by ½in. thick. Shelf (C) 12½ins. square, by ½in. thick. Two rails (D) 10½ins. long, and four 9ins. long, by ½in. square. Top (E) 18ins. square, by ½in. thick. This top has a wide chamfer worked round its top edge to lighten its appearance and add to its effect.

Construction Details

In making the table you will be greatly helped by the details given at Figs. 2 to 7. These clearly show the method of construction, and also give the principal dimensions. Figs. 2 and 3 show two side views of the table; Fig. 4 shows the method of framing the parts together; Fig. 5 explains the

joints between the legs and the cross rails; Fig. 6 shows how the small side rails are notched or halved together; and Fig. 7 how the top is secured to the side rails by means of shaped glued blocks pressed well into the angle.

In making the table the first operation will be to plane up the legs and the cross rails, and to frame them together. The side rails are mortised and tenoned into the legs, as shown in Figs. 4 and 5, and the mortises and tenons should be set out with the marking gauge and try square or a set square.

The Joints

The tenons are level with the outer edges of the cross rails, they are ¾in. wide, and are haunched down ¼in. from the top edges to give rigidity to the finished joint. The mortises are set ¼in. in from the outer edges of the legs, and are cut to correspond with the tenons.

The mortises are cut from each side of the legs until they meet in the middle, and the ends of the tenons must be mitred to meet in the mortises, as shown in the plan at Fig. 5.

The shelf (C) should next be framed into the legs; it is notched over the legs, and is stub-tenoned into them, as shown at Fig. 4. The tenons which are formed at the ends of the shelf are ¾in. long by ¾in. wide, and care must be taken to cut these tenons so they will be in a line with the small rails which are framed between the shelf, the side rails and the legs, as given in the detail in Fig. 4. The small rails at the sides are then framed together, and let into the shelf, top rails and the legs.

Assembly

The rails are notched together, as shown at Fig. 6, this work being carefully done with the small-toothed tenon saw or even the fretsaw, and cleaned out with a ¼in. chisel. The ends of the rails

are simply let into or housed into the shelf side rails and legs.

This stage in the construction having been reached it will be a good plan to clean all the woodwork, finally test it for fit and then glue it together. It should, perhaps, have been mentioned that the legs are tapered to ¾in. square on the floor and carefully cleaned up with scraper and glasspaper.

In fixing the framework together, first fix the small rails together and well glue them. They are then fixed into the shelf and side rails, and the shelf, the cross rails and the small rails are then fixed into the legs. The joints should be secured with glue, and this should be carefully and sparingly applied to keep a clean joint. The work should be cramped up until the glue has thoroughly hardened.

Table Top

The top of the table is next prepared and fixed in position. Take care to keep an equal margin all round from the side rails. The glued blocks are seen in Fig. 7. If the top is fixed by screws, these should be well countersunk and run into the rails underneath, the heads of the screws being finally filled up level with a plastic wood filler or a paste made of glue and sawdust.

At completion, the surface must be well cleaned with coarse and fine glasspaper. The work may be french polished or stained and waxed, according to the variety of wood which has been used.

The undersides should, of course, also be treated like the rest.

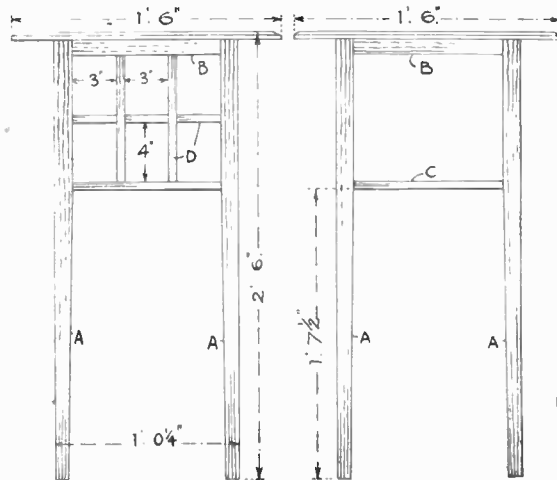

Figs. 2 and 3—Side and end elevations with lettered parts mentioned

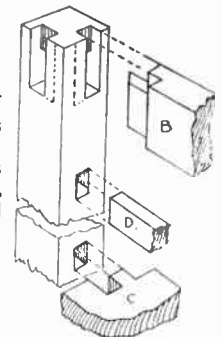

Fig. 4—Framing joints

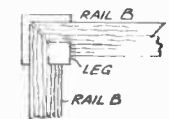

Fig. 5—Corner joints

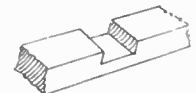

Fig. 6—Rail halving

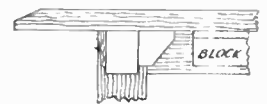

Fig. 7—Section of top fixing

There need be little cost for stock and upkeep of THE HOME AQUARIUM

In an earlier issue we gave particulars of how to make an aquarium—here are details how to stock it and keep it fresh at very little cost. If goldfish in the familiar glass globes could speak, what would they say? They have little room to swim, and often they are gasping at the surface trying to breathe air because the water is stale. Even when they are provided with fresh water it is straight from the tap and a lot colder than that previously in the globe, so that they are chilled.

They either eat a monotonous dried food out of a packet or have their little world filled with all kinds of unsuitable mush from their human owner's table. Altogether they would not seem to have much to be happy about.

Copy Nature

Goldfish, contrary to popular belief, will stand more ill-treatment than most other kinds of fish. If, for instance, you try to keep river or pond fish in the same conditions, they speedily die.

Yet, by carefully copying nature's methods, you can stock an aquarium with fish and plants you can collect yourself. Once you understand their needs and have satisfied them, they will give no more trouble than an unfortunate goldfish in a globe. A few minutes attention each day is enough to give you interesting pets in conditions so like their natural pond that they will live for

a long time, and be the envy of your friends.

No doubt you have seen ponds and ditches in the country in which the water, although not moving, as in a stream, is clear and fresh-looking. This, then, is the condition you want in your aquarium.

Fish and Weed

In such a natural pond, you will probably see only a few small fish, but you will see a lot of water-weed. The reason for this is that the fish and plants act together in a natural balance.

Fish breathe water, but their gills only take oxygen out of the air which has soaked into the water. They breathe out carbon dioxide and this is absorbed by the plants which in turn give off oxygen for the fish. In your aquarium, therefore, you will need water plants to make the same sort of exchange.

If you already have an aquarium, you must decide how many and how large your fish may be to keep this balance of nature. An inch of fish to a gallon of water is a useful rule. Another thing to remember is that the larger the surface area, the more air will soak into the water for your fish to use.

A Suitable Container

If you decide to make a small aquarium from instructions given in a previous issue of this magazine, ideal measurements would be 2ft. long by

1ft. by 1ft. This would allow you to put in 3ins. of materials for your plants to root in, to have 6ins. of water (with 2 sq. ft. of surface) and to allow 3ins. above water level to keep your fish from jumping out.

This aquarium would hold 1 cubic ft. of water, which is approximately 6 gallons. With its large surface area it would be ample for three 2in. fish, two 3in. or one 6in. fish to live naturally in it.

Some Necessary Plants

Having made your aquarium on these lines, you must next obtain plants for it. You may buy these, but it is quite easy to look for them yourself the next time you are in the country. Plants such as watercress and rushes which grow partly above the surface of the water are not very much good. Lilies and other plants with floating leaves should also be avoided, because they reduce the useful surface area of your water.

The ideal is to select as many different kinds of submerged water plants as you can. Rooted specimens are best, of course, but most sorts will soon produce roots if 2ins. or 3ins. of their cut ends are buried. All these may not be happy in your aquarium and they should be planted for at least a month before you put in any fish. Those that rot away may then be removed and the remainder will have rooted firmly, so the fish cannot pull them out.

A Sandy Foundation

The best planting medium for the bottom of your aquarium is river sand. Dirt from your garden may foul the water and harm the fish. Sand from the seashore, builders' sand or small gravel can be used but should be washed in several lots of hot water and given a good soaking to remove salt or anything else which may be harmful.

The most suitable water is that from a natural pool containing fish and plants. Next best is clear river water. But rain or tap water will do quite well.

The best place for an aquarium indoors is near a window which gets a little sunlight to keep your plants growing. Too much sun will make your water unhealthily warm and cause green slime (algæ) to cover glass and plants and even colour the water. Curtains or a sheet of cardboard should be provided if necessary.

Ready for Fish

While your plants are becoming established, you must watch for any which die and also clear away single rotting leaves. Then, when all is ready, you may look for your fish.

Goldfish of the ordinary sort or of fantastic shapes and colours may be bought, but it is much more fun to catch your own. Small fish such as you

A Model Open-Air Theatre

HERE is another practical instance of co-operation in model making, such as we are always recommending. It is a model of a suggested open-air theatre which Torquay hopes to have some time. The realistic work was the result of the idea of a local architect, and carried out by his staff. The lay-out follows the suggested site in Kings Drive, with the Spanish Barn in the background. The model includes the spacious amphitheatre with seating capacity for an audience of 1,000 people.



Photo—Torquay Times

will probably need are plentiful. Those from a pond, ditch or canal are better than those from running water, for they will be used to the conditions you have made ready for them. A net on a stick—and, perhaps, a pair of wellingtons—will be sufficient equipment.

Habits to Watch

Minnows are shy and fast moving. Loach are slow and spend a lot of their time hiding under stones at the bottom of shallow streams, so that once they are disturbed, they can even be caught with the hands. Small eels can also be discovered under stones—but catch them with the net for they bite. Sticklebacks are the smallest fish of all. They are easy to catch and, perhaps, the most interesting.

Most small fish seem to lose the urge to breed in confinement, but sticklebacks caught in early spring will usually proceed to do so. There are two kinds of stickleback, the 3-spined and the 10-spined, the former the most common. Both build nests, the 3-spined on the bottom and the 10-spined in a fork of plants.

The male 3-spined stickleback is a gorgeous little fellow at mating time. Normally a drab colour, he seems to glow—so bright is his orange 'courting suit'—as he sets about building the nest with leaves and twiggy bits. If you catch a few of these little fish you will soon recognise him. The female, too, should be easy to spot, for she will be swollen with eggs.

Fighters

Not more than one male and one or two females should be put in an aquarium in spring unless it is large. Two males will fight furiously, biting and inflicting wounds on each other with their sharp spines, often to the death. Holding a mirror in front of one of these aggressive little gentlemen is enough to send him into a furious rage. He is the one who protects the eggs after they have been laid. It is a good plan even to remove the female after she has done her part.

Interesting Dwellers

Besides fish, frogs and newts are interesting aquarium dwellers. These, however, live as much on land as in water and should be provided with some kind of island. Newts are more attractive in appearance and can be found in or around many ponds in large numbers. They depend to some extent for safety on their uncanny ability to keep still.

Like frogs they grow from tadpoles, which at first have gills so they breathe water like fish, but later these disappear and they come to the surface to breathe at intervals. Unless your aquarium is very large, sticklebacks and newts should be kept separate at breeding time.

Newts eat their own eggs and also those of fish, and the stickleback, though so much smaller—will spend his time driving them away instead of

attending to his nest, his wife and his eggs as he should.

Suitable Foods

You can, if you wish, feed your fish with prepared foods from a pet shop. But, being wild creatures, they will thrive better if you are able to give them a selection of their natural foods. Cyclops and water-fleas—tiny, transparent things about the size of a pin head—are relished by all fish. They are present in most ponds. Indeed, you can sometimes see them moving like a cloud in the shallow water. A fine net will often catch hundreds at a time.

Small worms, cut up into short lengths for newts or chopped for

get too close to it, and you must be careful not to harm them.

If your fish should be hurt through fighting or any other cause, they are liable to get a kind of white mould growing on the wound. This can be treated by lifting the fish out of water, laying it on a wet flannel and very gently wiping the affected part with a very weak solution of water and permanganate of potash.

Such treatment should, of course, be performed as speedily as possible and the fish returned to its natural element. This condition, and the other numerous diseases which attack fish, are not likely, however, to appear at all if you start off with a balance between fish and plants,

Fretframe Cover

GET an old stocking and cut and stitch it as shown. At the top, hold it together with two press studs. It is easily made and is good as it keeps a fretsaw free from rust, and clean and tidy when not in use. The diagram shows the stocking holder clearly.

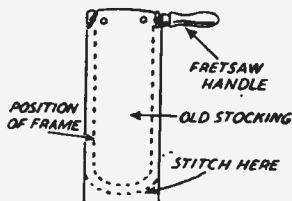

Vice Handle Noise

HERE is a simple way to stop vice handle from making a noise, and for protecting the hands. All you need is two rubber bands from lemonade stoppers. Put one band at each end of vice handle as shown in diagram.

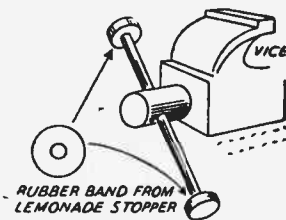

sticklebacks and other small fish, are excellent and nourishing. Small maggots and grubs and some soft-skinned water insects will also usually be devoured eagerly. Flies—small ones for small fish—can be given for variety. Some kinds of fish will also pull leaves off the plants to eat. Shop fish foods are best given only as a supplementary diet to these.

Cleanliness in your aquarium is most necessary. Dirt breeds disease anywhere, but in the little, balanced world of your fish it can be a killer. All scraps of foods which are not eaten should be taken out before they start to decay.

A glass tube—which can be bought from most chemists—will be useful here. Place a finger over one end. Put the other end into the water and near the little piece of rubbish. Take away your finger and the water will rush up into the tube, taking the rubbish with it, and you can easily lift it out.

Cleaning the Glass

No matter what you do, the sunlight will eventually make the glass sides of the aquarium green with algae. Although harmless to your fish, this will spoil your view and can best be removed with a little bundle of cloth tied on the end of a stick. A razor blade on a stick will remove any stubborn patches, but your fish, if aggressive or curious, may

feed your fish properly and spend a minute or two daily on maintenance, keeping strict cleanliness.

This, as you may imagine, is scarcely work, for you will be rewarded by having a perfect little 'pond' in your own home filled with fish which will become quite tame in time.

Some Additions

Useful additions to your aquarium are a wooden stand to enable the glass tank to be easily lifted, and a sheet of glass, raised by slips or pieces of wood, to form a dust cover above it. Dust is always present in a room and, to keep the surface of the water clear, a sheet of newspaper, cut to size, should be placed on the surface and taken off. It will take the surface film with it.

Although the water will not need to be changed, it will be necessary from time to time to 'top-up' the water level. This water should be kept near the aquarium for a few hours before use, so that there is no possibility of it chilling your fish.

Such fish as tiny sticklebacks may seem a small start, but keeping them in the way suggested here, is an interesting experience from which you can learn much. Many people who now keep and breed beautiful and valuable tropical fish started in some such small way.

Books to Read!

A review of interesting books for craftsmen which have been recently published. Obtainable through newsgents or booksellers or direct from the publishers mentioned.

Carpentry and Joinery

by M. T. Telling

THere is probably no greater joy than working in wood, by the craftsman who loves his job, and employs skill, enthusiasm, and imagination in undertaking it. Few other materials can offer such a diverse range of opportunity; with few other materials can beauty, and practical usefulness be combined. So many of our readers know the joy of using wood that it serves as a life long hobby and craft of pleasure. Some of our younger readers are persuaded by it to take up carpentry as a career, and add their pleasure to a remunerative background. There is much to learn and one never ceases to find new ways, means and results, no matter to what age one lives. This book is one of a technical building series and deals with the subject in such a comprehensive manner that it covers the needs of the Intermediate Examination of the London City and Guilds. And that is certainly a good standard for the beginner to endeavour to attain! Carpentry and joinery deals with the commercial side as needed by the professional artist and the elementary and very necessary instructions, illustrations and examples provide a background knowledge which would be an asset and a money-making ability on any age or sphere.

Published by Sir Isaac Pitman & Sons Ltd., Parker Street, Kingsway, London, W.C.2—Price 8/6

Woodwork and Toymaking

by Benjamin T. Richards

THE previous book dealt with the serious side of woodworking as necessary for earning a living. This one shows the pleasure of woodwork in making all kinds of toys and similar novelties. A book on this subject is frequently requested by readers, and very often for use in schools or nurseries. Here is one we can thoroughly recommend. Not only for the clear, concise and comprehensive manner of presentation, but the wide range of suggestions it offers and the complete instruction given on the subject. Whether you work alone or in a group this book tells you how to start, what tools and materials you need, and then offers dozens of suggestions of things to make and practical instruction how to make them. There are static toys, mechanical toys, wheeled toys, model toys, novelties—all reasonably simple to make, assemble and paint. Photographs show the attractiveness of the completed toy, whilst line drawings and detailed in-

structions provide all you need know how to go to work to make them for yourself—or as gifts for some little friends.

Published by G. Bell and Sons Ltd., York House, Portugal Street, London, W.C.2—Price 6/-

The Practical Electrical Reference Book

A LITTLE thought soon makes us realize how electricity is entering more and more into every phase of our modern life. What enormous strides have been made in knowledge and practical use, even in the last ten or fifteen years. The manuals on the subject published 20 years ago are hopelessly out of date. This book, however, is the most concise and helpful up-to-date reference book which can appeal to anyone seriously interested in the subject and anxious to have a thorough knowledge of its many sides. These books of Odhams Press are always wonderfully well done, and amazing value for money. In this, for instance you have 384 pages, and over 500 illustrations dealing with no less than 36 sections. The contributions are by nearly 30 authors who are recognized specialists on the technical side with which they deal. For practising or student electrical engineers the book is a veritable mine of information. Its chapters cover, apart from general subjects, such needs as electricity in mines, lifts and escalators, refrigeration, cinema equipment, electricity in agri-

culture and so on. Diagrams and tabulated details add largely to its usefulness. Published by Odhams Press Ltd., 67/68 Long Acre, London, W.C.2—Price 9/6

Teach Yourself Commercial Art

by H. Cutner

THESE 'Teach Yourself' Books are now extended to cover a wide range of subjects and have become popular and practical text books on matters of interest to a wide range of readers. They are of uniform size and style, with a distinctive yellow dust cover, so that a very useful reference library can be built up by collecting and keeping them for the many occasions on which they come in useful. There is, perhaps, an urge in most of us to draw, but usually a lack of knowledge of elementary rules which prevent us improving a natural aptitude. The manner in which a few lines may be drawn can make all the difference, whilst knowing light and shade, composition, production methods, etc., can produce a surprising and pleasing effect. Commercial art is entirely different in appeal and demand from 'fine' art and specializes in drawings or paintings for publicity purposes—showcards, posters, advertisements, etc. The subjects covered can be as wide as in normal art, but their presentation demands a different technique which is worth studying as much for the pleasure as the possibility of payment. The clear type printing of the book is equalled by

Dust Collector

CUT a small hollow rubber ball in half, and attach to the handle as

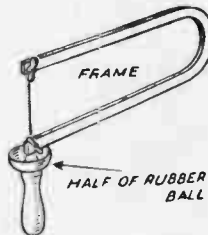

shown in the picture. It will collect the dust as you carry on the work. Do not have the ball too large.

Tiny Model Masts

IN small model ships, use needles for masts. Besides being stronger than wood, the 'eyes' come in very useful when you are rigging her, for you are able to thread the cotton, or whatever

you are using, through them from one end of the boat to the other. You will, of course, have to use a smaller needle at the back than at the front.

Side Wings For 'Gem'

TO provide simple wings for large work on a machine, obtain a fairly stout board, 1/2 in. by 2 ft. 6 ins. wide. Cut it as shown and then remove the block of wood that supports the cutting table.

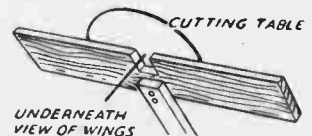

Insert the board, putting the screws back through cutting table and board afterwards. The board will be just below level of cutting table, but pieces of 1/4 in. wood may be glued to bring the board level.

MISCELLANEOUS ADVERTISEMENTS

BE Taller. Quickly! Safely! Privately! No appliances—no tablets—no dieting. Details, 6d. stamp.—Malcolm Ross, Height Specialist, BCM/HYTE, London, W.C.1.

MODELS. You can make lasting stone-hard models with Sankey's Pyrama Plastic Cement. Supplied in tins by Ironmongers, Hardwaremen and Builders' Merchants. Ask for instruction leaflet.

TRANSFERS for decorating toys, trays, furniture, fancy goods. List and samples free. Flowers, pixies, dogs, nursery rhymes.—H. Axon Harrison, Jersey.

LEARN Shorthand by May 26th (1 hour's study nightly). 1st lesson, 2½d. stamp.—Duttons (Dept. HB), 92 Gt. Russell St., London, W.C.1.

RUBBER Tyred Metal Disc Wheels finished in red, green or blue enamel. 2ins., 2/6; 3ins., 3/- per set of four. Post paid. Other sizes available up to 9ins.—The Joyden Toy Co., 193 Chase Side, London, N.14.

DOLL'S House fittings and papers; send S.A.E. for list. Doll's House plan special; send 2/6. Trade supplied.—Zimplan, 88 Ware Road, Hoddesdon.

CONSTRUCTIONAL Kits, 4mm and 7mm scale Lorries. Also large range spare parts from which to build to your own design. Price lists, 1d.—Wilson's Lorries Ltd., Dept. H., 1/6 Gt. Winchester Street, London, E.C.2.

100,000 Government surplus bargains for hobbyists. Perspex strip, 3ft. x 1in., 10/- per doz., post 1/4. Tool or instrument boxes, metal, 12ins. x 7ins. x 6ins., 1/6, post 9d. (many other types in stock). Sponge rubber strip, approx. 18ft. x 1½ins. x ½in., 2/-, post 9d. Aluminium rivets, handy boxes approx. 1lb. assorted, 2/6, post 6d. 20in. flexible drives, 3/6, post 9d. Hundreds of other interesting bargains. Send 3d. stamp and S.A.E. for new illustrated list.—Milligan's, 24 Harford Street, Liverpool, 3.

WHHEELS for toys, and other accessories. Full lists will be sent on application to The Joyden Toy Co., 193 Chase Side, London, N.14.

LONELY? Then write Secretary U.C.C., 5B.B. Hay St., Braughing, Herts. Genuine. Est. 1905.

PLYWOOD offcuts. Birch and Gaboon in various thicknesses, handy sized parcels for the cabinet, toy, model maker and all handicrafts. Parcels made up in £1 and 10/- lots. Carriage paid. Send P.O. to Reeves, Plywood and Timber Merchant, 33 Front Street, Monkseaton, Whitley Bay. Tel. W.B. 4677. Due to exceptional demand we cannot promise delivery under eight days.

£5 to £20 weekly earned at home, running your own Mail Order business. Details, 1d.—Stebbing Publications Ltd., (HB) Naphill, High Wycombe.

HOME watch and clock repair outfit. Includes watchmaker's eyeglass, tweezers, screwdrivers, oilers, brush, oil, plus explanatory booklet fully illustrated. In container. Skill unnecessary. Invaluable for all fine work, 12/9 inclusive.—D. Bolster (Dept. A.), 5A Station Parade, Ashford, Middx.

FURNISH that Doll's House with the latest model furniture, glassware, food and accessories. List, 8d.—Sutton Models, Billericay.

FASCINATING and profitable hobby, casting ornaments, toys, etc. You can easily make these yourself. Paints, brushes and all accessories. Illustrated catalogue of 700 Moulds, plus latest list of Rubber Moulds with instructions, 9d., post free.—Cock of North Moulds (H), 140 Hollings Road, Bradford.

BE taller in 14 days or money back, Bdetails, 1d.—Stebbing System, 28 (HB) Dean Road, London, N.W.2.

AMERICAN Magazines post free for one year. Popular Mechanics, 32/-; Popular Science, 28/6; Mechanix Illustrated, 22/6; Popular Homecraft, 18/-. Stamp for full list of others.—Willen Ltd. (Dept. 57), 101 Fleet Street, London, E.C.4.

ENTER the Juneero National Model Making Competition. Cash and kit prizes to the value of £150. Send now for details or see the Juneero Annual, 1/-, from all Juneero Dealers, or 1/2 post free from Juneero Ltd., Boreham Wood, Herts.

PLYWOOD, new selected, 27 x 19 x ¾in., 7 for 20/-; Veneered Oak, 6 for 30/-; 20 x 20 x ¾in., 9 for 20/-; Veneered Oak, 7 for 29/9. See list (2d.) for other veneered panels. B.C. Pine Ply, 17 x 7 x ½in., 24 for 16/-; Parana Pine Ply, 17 x 6½ x ½in., 48 for 16/-; all post paid C.O.D. Box Bottoms, 18 x 16 x ¾in., Birch, 8 for 20/-; Teak, 5 for 20/- Pine Lids, 39 x 17 x 1½ins., 10/- ea.; one side clean. Ex W.D. Stretchers, very good condition, 10/- ea. All sent carr. for. cash with order.—H2/JDD. Storage, 71 Northcross Road, S.E.22.

BLUSHING, shyness, nerves, self-consciousness, fears, ended. Details under plain cover, 1d.—Stebbing Treatment, 28 (HB) Dean Road, London, N.W.2.

PERSONS required make fancy goods at home. Write for details.—Melton Manufacturing Co., Southgate Street, Leicester.

ENGRAVING on Perspex; send drawing and S.A.E. for quotation.—Geo. Cleaver, 50 Windsor Road, London, N.W.2.

PRIME imported recessed hardwood wheels, 2½ins. diameter, 3/- dozen; 14/- half gross; 26/6 gross. Post free. Pressed metal, hardwood and metal disc wheels, doll's House windows, doors, papers, catalogues, 6d.—Jasons, 135 Nags Head Road, Ponders End, Middlesex.

HOBBY plaster casting, with Flexi-mould.—Dohm Ltd., 167 Victoria Street, London, S.W.1.

STAMPS free—Empire packet including Pictorials and Victorians free to approval applicants.—Robert J. Peck, 7A Kemp Road, Bournemouth, Hants.

500 COLLECTORS' duplicates, 2/6. Amazing variety.—Belfields, Stour Hill, Quarry Bank, Staffs.

PERSONS required to fill vacancies in our out-work department. Write—Dept. 11, Empire Co., 117 Nottingham Road, Loughborough.

(Continued on page 62)

PRIZEWINNERS of the BRICKPLAYER COMPETITION 1950

1st PRIZE £10 : 10 : 0.
C. P. Scott, Bradfield College, Bradfield, Berks.

2nd PRIZE £5 : 5 : 0
H. P. Rang, 17 Hampstead Hill Gardens, London, N.W.3.

3rd PRIZE each £3 : 3 : 0.
P. Severn, Greenacres, Linkswood Road, Burnham, Bucks.

P. A. Allinson, 65 Anson Street, Monton, Eccles, Manchester.

Phil. Phillips, 34 Grove Way, Monks Park, Wembley, Middx.

CONSOLATION PRIZES.

- Colin A. Volk, 5 Edenhurst, Oak Hill Road, Sevenoaks, Kent.
- T. Squires, 10 Ludlow Avenue, Luton, Beds.
- E. J. Jeffs, 11 North View, Eastcote, Pinner, Middx.
- Michael Tod, Pinegrove Farm, Llanwrenarth Citra, Abergavenny, Mon.
- J. C. W. Cope, Mervyn, West Road, Congleton, Cheshire.
- Douglas Hannah, The Glen, Elderslie, Renfrewshire.
- Graham Leeke, 8 Rockhampton Road, South Croydon, Surrey.
- J. C. Simmons, c/o Miss E. M. Bynoe, 70 Strawberry Vale, Twickenham, Middx.
- T. R. Bryce, Broadleeze Farm, Cricklade, Wilts.
- M. J. Sample, Elvington, York.
- L. J. Kottling, 196 Longlands Road, Sidcup, Kent.

Entries for the next Brickplayer Competition must be submitted between 1st January and 28th February, 1951.

Brickplayer Kits at approximately 23/10d. and 44/- and extra accessories are available from good toyshops and departmental stores.

If your dealer cannot supply, write for address of nearest stockist to:

J. W. SPEAR & SONS LTD.
Dept. H, ENFIELD, MIDDX.

the excellence of the varied illustrations, examples throughout being given to elucidate further the point being made. The book covers the progressive stages of the art—from the necessary equipment, through methods, layout type faces, lettering to technique, colour work, photography, posters, etc. Even if the reader is not proposing to take up the work as a career, the book is most helpful to the amateur who likes to do local work of showcards, bills, price cards, etc.—which can be quite a profitable sideline hobby for the art craftsman.

Published by The English Universities Press Ltd., Warwick Square, London, E.C.4—Price 4/6

Leatherwork

by F. J. Christopher

ALTHOUGH only of pocket size there are packed into its 108 pages as much information and suggestions as might well have filled a much larger volume. The hobby of leatherwork is again becoming as popular as in pre-war days and once the extreme shortage of tools and materials has passed, we have no doubt it will be more enjoyed than ever. The book deals with all branches of the work, progressively and in detail, with many helpful clear drawings. The author knows his subject thoroughly and gives constructive instruction clearly and concisely, travelling from one operation to the next as the work proceeds and builds up. Commencing with simple examples, the craftsman gradually improves his work and undertakes more elaborate subjects, but all the time they are practical articles he can use for himself as on the home or as gifts to his

friends. Each chapter is provided with an index-like heading which makes a useful and easy reference to any point which may arise in the mind whilst work is in hand. This forms a very practical addition to the subjects dealt with.

Published by W. & G. Foyle Ltd., 119/125 Charing Cross Road, London, W.C.2—Price 2/6

Brumas

by Elizabeth Armistead and Edwin Landsler

VERY topical and delightful book of pictures of that popular little animal, the Polar Bear Cub, which was so much in the public eye recently. A variety of pictures have been published, but the authors hit on the brilliant idea of stringing them together to form a pleasing little adventure story. The photographs of the endearing little cub were specially taken and form delightful studies to young or old. The pictures are beautifully printed on art paper and the sequence story of the cub and mother at play, sleeping, going to look for father bear and finally at rest after the adventure make a human story in book form of unusual interest and pleasure. Obviously a book to give a kiddie as an excuse to enjoy it yourself!

Published by Britannicus Ltd., 3 Henrietta Street, London, W.C.2—Price 3/6.

Simple Electrical Experiments

by C. E. Page

SO many of our readers like to 'dabble' in electricity, we know they will find enormous interest in a book such as this. Its author is a contributor to the pages of Hobbies Weekly, so you

may be sure he is an expert, and able to offer suggestions of interesting things to make and do. Every experiment is easy to undertake, and no elaborate apparatus is required. There are no highly technical matters involved, so the amateur can with confidence undertake the suggestions and be delighted with the amazing and intriguing results which will be forthcoming. Having graduated through the book successfully the reader can undertake practical pieces of apparatus for use, such as a simple electric dynamo or a table microphone.

Published by Percival Marshall and Co. Ltd., 23 Great Queen Street, London, W.C.2—Price 3/-

Stamp Collecting for Boys and Girls

by L. N. & M. Williams

READERS frequently write us stating their intention of commencing the hobby of stamp collecting and asking our advice. Here is a book we could certainly recommend any of them—even if they are beyond the boy or girl age. It is a book intended for the beginner, and is essentially written in simple language, profusely illustrated with pictures, all equally well printed. Stamp collecting is too often taken up in a haphazard manner, and the mistakes and pitfalls encountered often create an early loss of enthusiasm. Those troubles are prevented by a correct procedure and knowledge—both of which are thoroughly dealt with in this recently published book.

Published by The English Universities Press Ltd., Saint Paul's House, Warwick Square, London, E.C.4—Price 5/-

Full size patterns for OIL BOWSER TRAILER

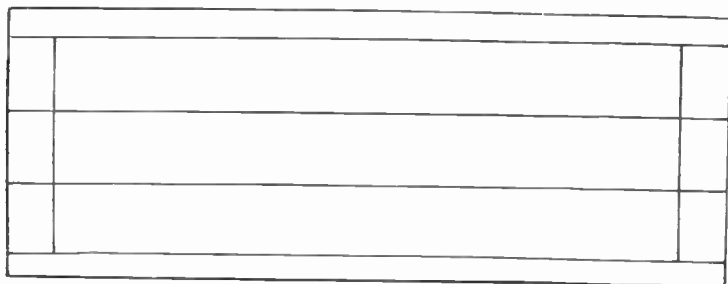

Fig. 1—Plan of main floor of chassis portion

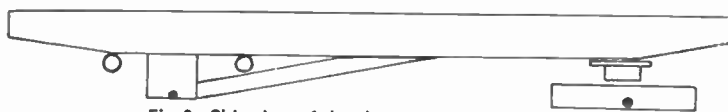

Fig. 2—Side view of chassis showing wheel holders

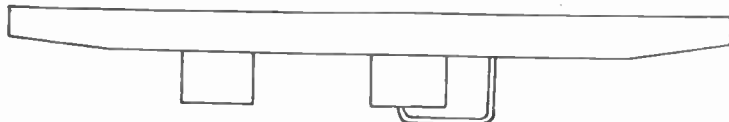

Fig. 7—Showing end view of tool boxes under chassis

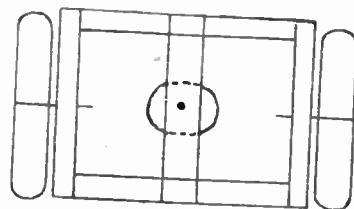

Fig. 3—Plan of front wheel suspension

See page 55

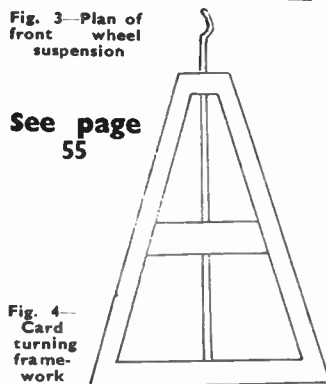

Fig. 4—Card turning frame-work

Photography is FUN

with a *Coronet* 12.20 Camera

Here is a camera you can easily afford yourself and be justly proud to own. With a *Coronet* 12.20 Box camera you can depend on really first class results; it makes photography so easy—no complicated adjustments or involved calculations. It is straight forward 'shooting' every time. It's inexpensive, robustly made and thoroughly reliable—the ideal hobby camera.

A DUFAY
PRODUCT



The *Coronet*
12.20 Box Camera
£1 13 9
(including Purchase Tax).

FREE!

Write for the Free booklet 'PHOTOGRAPHY IS FUN'. It tells you how easy and absorbing photography can be as a hobby with *Coronet* Cameras and Dufay Film.

Always ask for
DUFAY
NON-FLAM SAFETY
FILM
on sale everywhere



Coronet

CAMERA

BUY YOURSELF A

DUFAY-CHROMEX LTD. DEPT. P.2. ELSTREE HERTS Telephone Elstree 1733

YOU CAN BECOME A HANDICRAFTS INSTRUCTOR

Experience not essential

Men who enjoy making things in wood or metal can turn their hobby into a well-paid, permanent and interesting Career. Short hours, long holidays, and security in a job you would really enjoy, can be yours if you become a Handicrafts Instructor. Let us send details of the easiest and quickest way to get the necessary qualification.

We definitely guarantee

"NO PASS — NO FEE"

If you would like to know about our unique method of preparing you for one of these excellent appointments, write today and we will send you our informative 176-page Handbook—free and without obligation. Mark your letters 'Handicrafts Instructor'.

BRITISH INSTITUTE OF ENGINEERING TECHNOLOGY

BIET

595 Shakespeare House
Stratford Place, London, W.1

AMAZING Ex. Govt BARGAIN SIGNAL LAMP

In stout double-compartment water-proof steel case.

- 3½-inch lamp, for day or night use.
 - Swivel base with metal screw-in stand.
 - Viewfinder and reflector.
 - Morse key-board. Fully wired, fitted to folding lid.
 - Adaptable as car, motor cycle or studio spot light and numerous other uses.
- Spare bulbs 1/6 each.

7/6
POST 1/6

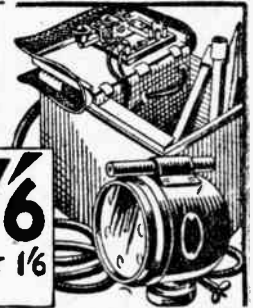

Write for illustrated lists.

PRIDE & CLARKE LTD.

Dept. P.W., 158, STOCKWELL RD., S.W.9. Phone: BRlxton 6251

Miscellaneous Advertisements—(Continued from page 60)

KALEIDOSCOPIES. Fascinating novelty for all ages. Ingenious optical creation of ever-changing colour designs. Endless variety. 2/6 post free.—'Stymit', Dept. H., 1/6 Gt. Winchester Street, London, E.C.2.

40 DIFFERENT stamps free, including Silver Wedding, U.P.U., Victory, Silver Jubilee, Coronation, Pakistan, etc. Send 3d. postage and request approvals.—J. F. Smith, 60 Boyne Road, London, S.E.13.

PERSPEX flat sheets, clear and 17 colours, cut to shape, corrugated Perspex rooflights. Aluminium Sheet- ing. Mouldings. Plastic Panelling.—Henry Moat & Son Ltd., Atom Works, Newcastle, 1.

COLLECTORS' delight—my world famous Oxford approvals. Generous discount and free packet with each selection. Postage please.—Frank Kennedy, 37 Juxon Street, Oxford.

MAKE 5/- an hour, genuine home employment. Full instructions, 3/.—R. Lowes, Rectory Terr., Simonburn, Hexham, Northnd.

SEND S.A.E. for particulars of well-paid homework.—Box 18, C/O 41 Wade St., Lichfield.

SELBY for stamps. 50 Norway, 2/6; 50 Ecuador, 4/6. S.A.E. for catalogue.—66 Donnington Road, London, N.W.10.

1,000 WHOLE world stamps, 3/9; 500, 2/3.—Whitby, Godshill, Fordingbridge, Hants.

PLANS for railway and ship modellers. We have hundreds of accurate, full size drawings available. 24 p. catalogue, 6d.—Skinley, 132 High Street, Southend-on-Sea, Essex.

LOVELY? Join Friendship Circle. Details, 7½d.—Secretary, 34 Honeywell Road, London, S.W.11.

REQUEST stamp approvals. Receive small album, stamps, hinges, free. Postage 6d.—A. M. Day, 73 Thornton Gate, Cleveleys.

100 DIFFERENT stamps free (including triangular and pictorials), to approval applicants enclosing postage.—N. Johnson (Dept. H), 19 Hillside, Slough, Bucks.

THE STEPPING STONES TO SUCCESS!

Don't hesitate about your future! Go forward, confident that The Bennett College will see you through to a sound position in any career you choose. The Bennett College methods are individual. There's a friendly personal touch that encourages quick progress and makes for early efficiency. Take the first important step NOW and fill in the coupon below.



CHOOSE YOUR CAREER

- | | | |
|---|--|--|
| Accountancy Exams. | General Education | Road Making and |
| Aviation (Engineer-
Ing and Wireless) | G.P.O. Eng. Dept. | Maintenance |
| Book keeping, Ac-
countancy, and
Modern Business
Methods | Heating and Vent-
ilating | Salesmanship |
| Building, Architec-
ture, and Clerk of
Works (A.R.I.B.A.
Exams.) | Institute of Housing
Institute of Municipal
Engineers | Sanitation |
| Cambridge Senior
School Certificate | Journalism | School Attendance
Officer |
| Carpentry and
Joinery | Languages | Secretarial Exams. |
| Chemistry | Mathematics | Sheet Metal Work |
| Civil Engineering | Matriculation | Shipbuilding |
| Civil Service | Mining. All Subjects | Shorthand
(Pitman's) |
| All Commercial
Subjects | Motor Engineering | Short Story Writing |
| Commercial Art
Common Prelim.
E.J.E.B. | Naval Architecture | Surveying
(R.I.C.S. Exams.) |
| Draughtsmanship,
All Branches | Novel Writing | Teachers of Handi-
crafts |
| Engineering,
All branches, Sub-
jects and Exams. | Plastics | Telecommuni-
cations (City and
Guilds) |
| | Play Writing | Television |
| | Police, Special
Course | Transport Inst. |
| | Press Tool Work | Examinations |
| | Pumps and Pumping
Machinery | Viewers, Gaugers,
Inspectors |
| | Quantity Surveying
—Inst. of Quantity
Surveyors Exams. | Weights and Mea-
sures Inspectors |
| | Radio Service En-
gineering | Wireless Telegraphy
and Telephony |

If you do not see your requirements above, write to us on any subject. Full particulars free.

COUPON. CUT THIS OUT
IF YOU ATTEND TO THIS NOW
IT MAY MAKE A WONDERFUL
DIFFERENCE TO YOUR FUTURE.



**TO DEPT. 62
THE BENNETT COLLEGE LTD.
SHEFFIELD, ENGLAND.**

Please send me (free of charge)

Particulars of.....
Your private advice.....
about.....

(Cross out line
which does not
apply.)

PLEASE WRITE IN BLOCK LETTERS

Name.....
Address.....
26.4.50.....

WOLF ELECTRIC SOLDERGUNS

**OFF-STRAIGHT EASY-GRIP HANDLE
PERFECT CONTROL
QUICKER HEAT-UP
LOCALISED HEAT
LOW CURRENT CONSUMPTION
MAINTAINS CORRECT HEAT
A MODEL FOR EVERY PURPOSE**

Write for FREE illustrated technical literature with full descriptions of each model, its range of applications, and the features which make these fine Wolf solderguns the best value ever offered.

From all leading tool merchants and factors

Showing at B.I.F. **STAND c603**
(Castle Bromwich)

**WOLF ELECTRIC TOOLS LTD.,
HANGER LANE, LONDON, W.5.**
Telephone: PERIVALE 5631-4

BRITFIX

BALSA CEMENT

★ The ideal transparent cement for Balsa Ply Wood, Hard Woods, and Plastics, combining rapid drying with utmost tenacity.

Remember
**STICK BY
BRITFIX**

THE HUMBER OIL CO. LTD., HULL

Small Tube Now 4d.
Large Tube 7d.

REFILL YOUR OWN BALL PEN for 3d.
KIT INCLUDES SUFFICIENT INK FOR 15 AVERAGE REFILLS AND QUICK EASY INSTRUCTIONS COST ONLY 3/8 POST FREE. AVAILABLE IN BLUE, RED, MAUVE, GREEN AND BLACK FROM
J. WILFORD, 1 VESPER GATE DRIVE, LEEDS 5

RADIO is the hobby with the future. Start learning by making this crystal set. D5 Coil with complete constructional drawings for crystal set, 5/-. Also includes simple circuits for one-, two-, and three-valve receivers. Full kit of parts as illustrated, 15/-. Assembled ready to play, 18/-. All parts supplied separately. Receives stations on long and medium waves.

**HILLFIELDS RADIO,
BURNHAM RD., WHITLEY, COVENTRY**

EVERY DAY

Bind tool handles with Sellotape to stop splinters and blisters. Gives a good grip—keeps handles clean.



YOU'LL NEED



Use Sellotape for fixing labels 'for keeps' on tins of screws and nails etc.—then you can spot the tin you want at a glance.

SELLOTAPE

Whatever your hobby—Sellotape can help. It's self-adhesive, sticks at a touch, leaves no mark on wood or metal. Get some today—

BUT INSIST UPON SELLOTAPE

Stocked by all good Stationers



CASCO

COLD water GLUES



Most hobbies require Glue—“CASCO” fills the bill for either new work or repairs. It is an absolute necessity for the Modelmaker for Fretwork, Toymaking, etc. Easy to mix in cold water Casco is simple to use and almost impervious to heat and moisture. “CASCO” Grade “A” is the world-famous Casein Cold Water Glue manufactured in Great Britain, Australia, U.S.A. and Scandinavian countries. Conforms to MODERN BRITISH STANDARDS SPECIFICATION 1444, TYPE A.

Stocked by Ironmongers, Builders' Merchants, Hardware Stores, etc.

DISTRIBUTORS:

Gt. Britain: *Charles Green & Co. Ltd.*
45, Gt. Peter St., London, S.W.1.

Ire: *G. B. Waller, 60 Middle Abbey St., Dublin*
M. J. Galvin, 16 Oliver Plunkett St., Cork

FREE! Send for literature and Free Sample to the manufacturers
LEICESTER, LOVELL & CO. LTD.
(Dept. HW), NORTH BADDESLEY, SOUTHAMPTON



For every purpose in the small home workshop . . . use a BROOK 'CUB' $\frac{1}{4}$ h.p. motor. Single or split phase.

Electric Motors from 0.25 to 200 H.P.



EMRESS WORKS HUDDERSFIELD I.H.M.149

MYFORD LATHES

turn LEISURE into PLEASURE



QUALITY MACHINES AT LOW COST

ML7 (Metal Working) Heavy Duty Bench Lathe. — Also available on Cabinet Stand—3 $\frac{1}{2}$ ins. by 20 ins. (10 in. swing in gap), complete with motor drive unit and fully guarded at no extra cost. For £39 17s. 6d. you can buy the finest Lathe in its class. Over 50 accessories designed for the ML7 ensure complete versatility and adaptability.

ML8 (Woodworking) Lathe. 8 in. swing-over bed, 30 ins. between centres. Attachments include Saw Table, Disc Sander, Compound Slide. A quality Lathe with a high reputation. Ideal for the home workshop. Turns—Saws—Planes—Sands—Grooves and Polishes. Price (including Drive Unit and Motor Pulley, Prong Centre, Cup Centre and Face-plate) £16 12s. 6d.

We invite you to write for further details.

MYFORD ENGINEERING COMPANY LIMITED
BEESTON, NOTTINGHAM - Phone: 54222 (3 lines)