

Hobbies

WEEKLY

CONTENTS

	Page
Kitchen Cabinet	- - 265
Stylish Bird Table	- - 267
Window Pelmet	- - 268
A Weatherhouse	- - 269
Extending Aerials	- - 270
Ornamental Pistols	- - 271
Timber Selection	- - 272
Recent Stamp Issues	- - 273
Model Railway Tracks	274

SUPPLEMENT DESIGN
FOR NOVEL SMOKER'S
TABLE LAMP

September 7th, 1949

Price Threepence

Vol. 108 No. 2810

THIS cabinet will make a fine and useful piece of furniture for the home. It is a simple constructional piece of woodwork, with nothing difficult to contend with, with as much economy in timber as possible. Except where otherwise stated, the material

A KITCHEN CABINET

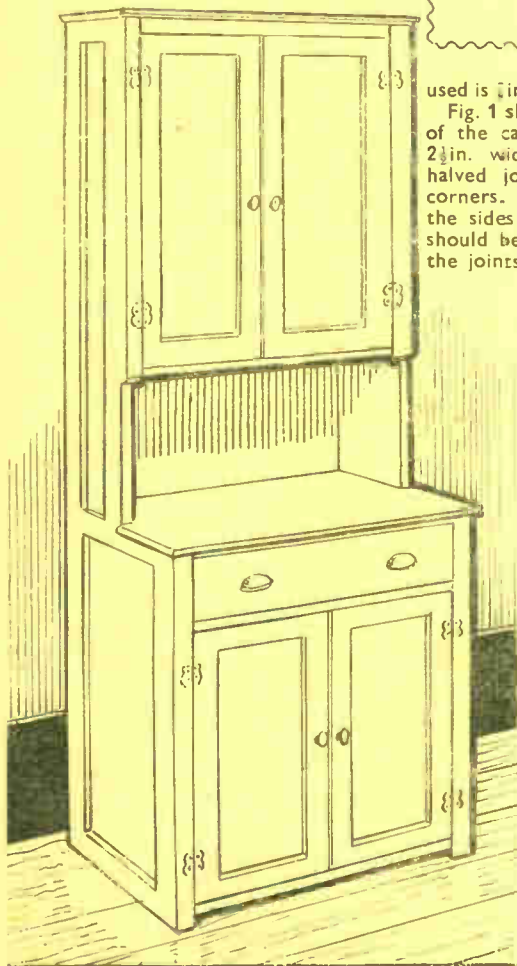

used is $\frac{1}{2}$ in. thick deal board.

Fig. 1 shows a side and front elevation of the carcass. It is framed up from $2\frac{1}{2}$ in. wide strips of wood, a simple halved joint being employed for the corners. It should be noted here that the sides are made as a pair, this fact should be borne in mind when cutting the joints and if you, for example, cut away from the inside when sawing the verticals, and from the outside when sawing the rails, you will not go wrong. Glue and nail the joints on the inside and cover both sides with three-ply or plywood substitute.

Trim up the edges, then on the front ones glue and nail 2 in. wide strips of the wood, as at A and B. These are attached to the front edges to overlap on the inside, making L shape in fact. The sides are now to be joined by the shelves, cross rails, and bottom. Details of these are shown in Fig. 2. The bottom is cut to the full depth of the cabinet, plus the strips B, and to the length given in Fig. 1. To save repetition the length given applies to all the shelves and cross rails.

Two pieces of the board will be glued together to make up the depth and the

bottom is screwed to wood fillets, the fillets themselves being screwed across the sides of the cabinet at the bottom, as at C. Pieces must be sawn out from each corner of this bottom to clear the edge strips at B.

Across the top, two 2 in. wide strips of the wood are screwed across, as at D. The front one of these also is notched at the outside corners to clear strips, A. Countersink the screws that fix them, so that they sink in the wood quite level.

Table Fixing

Across the wide part of the cabinet, where the table top and drawer come, two 2 in. wide rails are similarly fitted across, as shown at E, being 5 ins. apart. Level with the upper one of these, 1 in. wide strips are nailed across each side, extending to the back. The table top, afterwards, is screwed to these.

Level with the drawer rail are two $1\frac{1}{2}$ in. strips, nailed across. These act as the drawer runners, and should be quite level with the rail. To ensure this, the strips are provided with a $\frac{3}{4}$ in. tenon on their front edges, a suitable groove for them being chiselled out of the rails, as shown at E1.

When the rail is fixed across, the side runners are then glued into the rails and only need nailing to the sides, at the rear ends. A second strip of wood, E2, is glued to the runners to fill the space level with the drawer opening. It is important that the runners be level, both sides, to ensure a smooth passage for the drawer.

A good plan to observe here is to cut

the drawer front, and use it as a guide, both to fixing the rail across at its proper distance below the table top rail, and getting the runners quite level, by laying it across, at back and front, and butting both rails and runners up to it while nailing.

Now cut and fit the shelf across at the bottom of strips, A. This shelf, of course, forms the bottom of the upper cupboard of the cabinet. It extends, like the bottom of the cabinet, the full depth, i.e., 10ins. plus the thickness of

on, either plywood or the substitute board being employed as convenient. It would be really better here if a thin matchboarding could be used as a back, but use the material you can get.

Finish off the carcase with a length of moulding or just a planed strip, nailed across the sides and front, to hide the cut edges of the top, and also the screw heads, as at G. It will form a simple cornice and make a suitable addition to the top of the cabinet.

nails in the drawer sides slightly below the surface, and glasspaper the drawer to a nice sliding fit in its opening.

The cupboard doors, both at top and bottom, are not halved together like the sides of the cabinet, as the cut edges of the joints would look unsightly when the doors were opened. Instead they can be mortised and tenoned in the usual way, or joined at the corners with the lap dovetail joint, shown in Fig. 5.

This is quite easy to make, and is

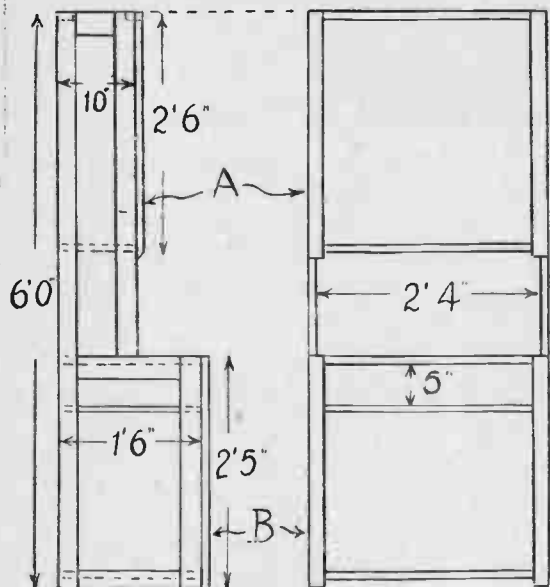

Fig. 1 - Side and front elevation

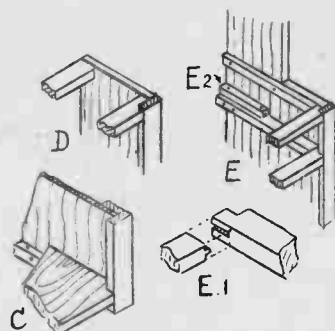

Fig. 2 Cross rail joints to sides

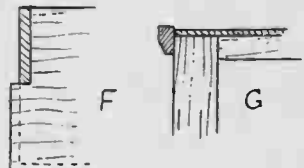

Fig. 3 - The table top

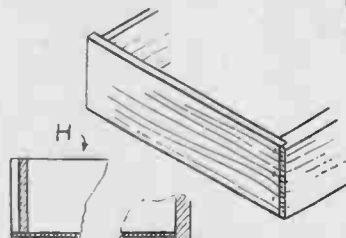

Fig. 4 Construction of drawer

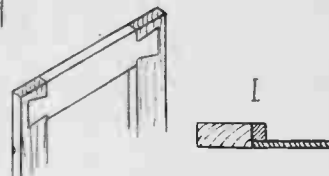

Fig. 5 Door joint and section showing panel

the strips, and is similarly fixed with screws to a fillet across the sides. This screwing, by the way, should be done from below, not above the shelves and bottom.

The table top, composed of solid boards, glued together, is cut large enough to extend over the front and sides about $\frac{1}{2}$ in. Pieces are sawn out at each side to allow this top to enter between and come to the back edge, as in detail F, in Fig. 3. Fix the top in place with screws, driven in underneath, through the cross rail and side strips, and neatly round off the extending edges.

The top of the cabinet is covered over with the plywood, and the back nailed

The construction of the drawer will be seen in Fig. 4. Make the front of $\frac{3}{4}$ in. board and rebate its end edges to receive the sides. These should be cut from thinner wood, say, $\frac{1}{2}$ in. Make the depth of the drawer the same as that of the cabinet, the front will then lie flush.

The back of the drawer is placed $\frac{1}{2}$ in. short of the back edges of the sides, and reaches only to the drawer bottom, the latter being nailed to it. A part sectional view, H, shows other details of its construction. The bottom is nailed to a $\frac{1}{2}$ in. square fillet, the fillets themselves being glued and nailed to the sides and front of the drawer. Note that the side fillets extend only to the back of the drawer, not the full depth. Punch the

similar to the common halved joint, but being cut short of the full width of the framing shows no cross grained edges. Stuff $2\frac{1}{2}$ ins. wide is used for the doors, the same width, in fact, as the carcase framing.

The panels can be cut from plywood or the substitute board mentioned before. These panels are fitted in the doors flush, being nailed and glued to fillets, fixed in the frames, as in detail, I. Finish the woodwork with two shelves to the upper cupboard, and one to the lower one. The shelves are the full depth of the cabinet, less the strips, A and B, as the doors will butt against them.

The doors can be hinged with ordinary brass butts, or the flat type of hinge screwed to the front can be employed. These look quite well, and are easy to fit. Pulls to the drawers, and suitable catches to the doors will complete. The cabinet should be stained walnut or oak, and finished with clear copal varnish.

Bird Table—(Continued from page 267)

the inside surfaces before the roof slopes are put on. Two pieces of board $\frac{1}{2}$ in. thick should be chosen for the roof, and one edge of each planed to a chamfer to fit along the top. The lower edges may be left square.

Nail the boards to the gable ends, allowing an equal overhang each end. Take care to bore the holes for the nails to prevent subsequent splitting. The roof boards should be well coated with the preservative, and if desired the exposed upper surfaces could be covered with a piece of roofing felt cut neatly to the shape of the roof. Allow, say, $\frac{1}{2}$ in. overhang at gable ends and at eaves and

closely nail with galvanized tacks of flat-headed nails. This covering, however, should be done after the brackets are added underneath the table.

The outline for these brackets is shown at C in Fig. 6, and drawn out and made in a similar way to the curved uprights at B. The recess at one end of the bracket is to fit on to the batten of the table. The other end is cut to the correct slope to fit against the post where it is nailed securely.

The ideal method, of course, would be to let this end into a shallow recess cut $\frac{1}{2}$ in. or $\frac{3}{4}$ in. into the post. Four of these brackets could be used with advantage

both for strength and appearance sake. Take care to nail all the parts thoroughly, gluing additional blocks and adding nails wherever possible.

If the table is required to be carried and placed in different parts of the garden, then cross feet could be made of flat wood halved together and four struts or shaping supports added between these and the main post.

If a painted finish is desired, instead of creosote or other preservative, then the whole of the wood should be given a coating of red lead priming, followed by two coats of ordinary paint allowed to harden between each application.

Add to the attraction of your garden by building A STYLISH BIRD TABLE

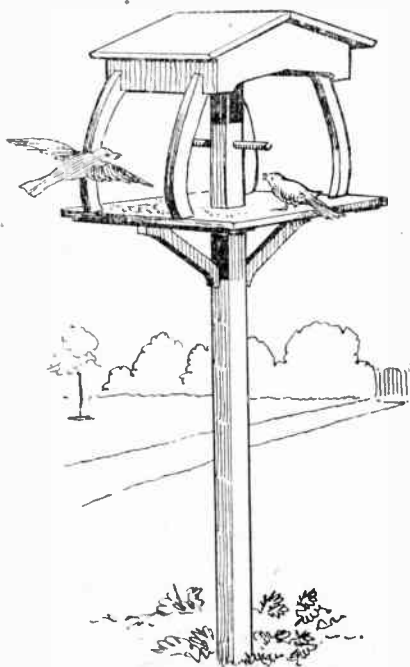

NOW is the time to put in hand the making of a bird table ready for our feathered friends to feed from during the late Autumn and the winter months. The instructions and details given here are for a table that is, perhaps, stylish and a little out-of-the-ordinary in actual character.

Instead of the steep-pitched gable roof so common with the usual run of bird tables, we make a departure, and suggest a shallow-pitch roof with a deep skirting beneath and having gracefully curved supports for the feeding table under. The illustration, Fig. 1, shows clearly the idea and design of the finished table, which should stand about 5ft. to 5ft. 6ins. above the ground.

If an oak or pitch-pine post is used it

should be 2ins. square, but if possible a 3in. post tapered upwards to 2ins. at the table level would look much better. It would, indeed, repay the little extra cost of the wood and the time and work in the setting out.

Post Top

The two illustrations in Fig. 2 show a front and a side view of the table. There are certain measurements when assembling the table, and positions of all the parts. A plain post is shown here and the only extra work needed to be done upon it is the cutting of the slot at the top to receive the ridge piece below the roof. There is also the shaping of the top of the post each side of the slot to the same angle or slope of the roof.

Allowance must be made when purchasing the post for that part which is to be sunk into the ground. It will be found that 18ins. to 20ins. will be sufficient and this should be either tarred or creosoted before it is covered in. A hole for a perch should be made in the post also, as shown, 9ins. down from the top of the post and a piece of round rod driven in.

Roof Frame

The next part to make will be the top frame supporting the roof. This is shown in Fig. 4 with all necessary measurements given to make it simple in drawing out on the wood. As all parts are $\frac{1}{2}$ in. thick, with the exception of the ridge piece, which is of $\frac{3}{4}$ in. wood, the cutting can be done with the fretsaw and either nails or screws used as fixing.

The ridge piece (A) and shown broken through, in Fig. 4, is rather an important number, as it takes a certain amount of the weight of the whole, until the brackets are added and fixed underneath the floor or feeding table. So, care must be taken to make a strong job of the nailing of this ridge piece to the gable ends. Take care to get the frame square, and if any stiffening is

required, this can be done by nailing some angle blocks in the inside corners.

The feeding table will be the next piece to make. It consists of three pieces of $\frac{1}{2}$ in. grooved and tongued matchboard 15ins. long and held by two battens underneath, each measuring 14ins. by 2ins., as Fig. 5 shows. The battens are put $\frac{1}{2}$ in. back from the edges of the table, with the fixing nails driven well in and clenched over. Screws, of course, would be preferable to nails here. A square hole must be cut in the middle board to fit the post.

The outline for the four shaped supports is shown in Fig. 6, at B. The inch squares may be drawn direct on the $\frac{3}{4}$ in. wood, and the outline then made by

CUTTING LIST

- 1 Post about 7ft. 6ins. long by 2ins. square.
- Top Frame—2 pieces 11ins. by 5ins. by $\frac{1}{2}$ in.
- Top Frame—2 pieces 10ins. by 3ins. by $\frac{1}{2}$ in.
- Roof Slopes—2 pieces 12ins. by 7ins. by $\frac{1}{2}$ in.
- Ridge Piece—1 piece 10ins. by 1 $\frac{1}{2}$ ins. by $\frac{3}{4}$ in.
- Uprights—1 piece 11ins. by 7ins. by $\frac{1}{2}$ in.
- Table—3 pieces 15ins. by 5ins. by $\frac{1}{2}$ in.
- Table Battens—2 pieces 14ins. by 2ins. by $\frac{1}{2}$ in.
- Brackets—1 piece 7ins. by 4ins. by $\frac{3}{4}$ in.

following the line through each square. Note the recess at the top of the piece which fits on to the frame $\frac{1}{2}$ in. inwards from the ends, as shown in the side view in Fig. 2. When one support has been outlined and the wood cut, the other three may be marked out by drawing round it in pencil.

Screws should be used for fixing the supports to the frame—two to each upright. A single sloping screw will fasten the foot of each upright to the table, as the dotted lines in Fig. 2 (front view) show.

The whole top is now ready for placing in position over the post, and after this is done, the creosote or other wood preservative should be brushed all over

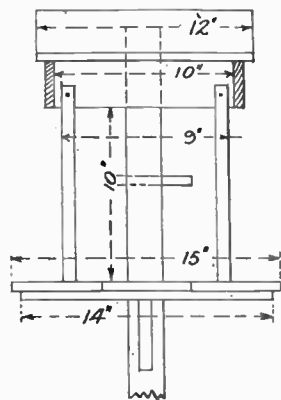

Fig. 2—Side and front view with helpful dimensions

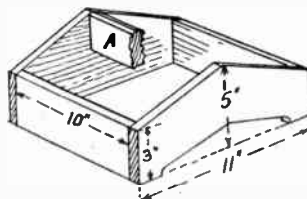
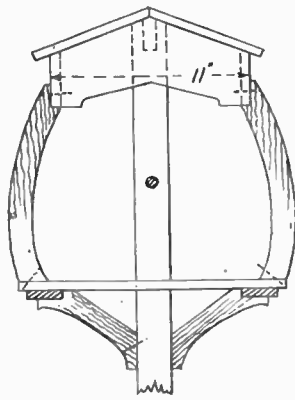

Fig. 4—Details of roof portion

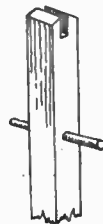

Fig. 2—Top of post

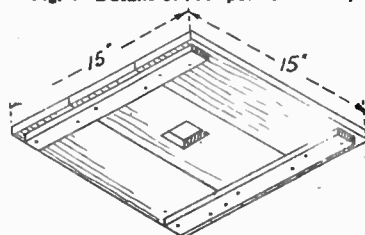

Fig. 5—Underview of feeding table

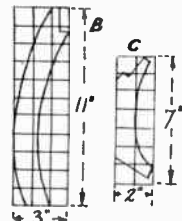

Fig. 6—Arm shapes

(Continued on page 266)

The top of windows can be completed by adding wooden WINDOW PELMETS

PELMETS are now becoming very popular. They are those boards which go across the tops of windows to hide the curtain rings and poles and generally give the casement a neat and finished appearance. They are not hard to put up and as their constructing and fitting comes right into the province of the home handyman, you should try adorning your windows in this way. There is no doubt about it that these boards greatly improve most casements

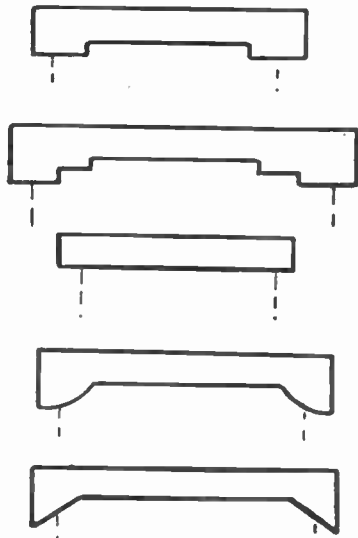

Fig. 1—Suggested alternative shapes of pelmets

and the time taken on them is time well spent.

Three-plywood is the best material from which to make these window additions. It should be used in as big lengths as possible, but joints can be put in by placing a shallow but wide baton at the back to which the adjoining edges are secured. Carefully brought together with each section having a vertical and truly-cut end, the connections are quite invisible from a little distance, especially after staining or painting.

Measurements and Shape

With regard to the making and fitting, the length of the desired pelmet must first be carefully measured. An overlap of 6 ins. to 1 ft. should be allowed on to the wall at either end and a design for the lower edge decided upon. Here there is a good choice and some suitable outlines are shown at Fig. 1.

For the present-day small-size window the board must not be very deep—a too deep pelmet tends to look clumsy—but, of course, it must be deep enough to screen the top of the curtain. A few

tests with a sheet of card or stiff paper will soon give some idea of the correct depth for the window in question.

Square ends are the simplest to cut, but circular ones look very well. Also under certain conditions a straight equal-depth board right across looks well. It all depends on the shape of the window. Tall narrow casements appear best with just the straight board, as this takes off the height. Wide kinds require some sort of relief at either side in the form of semi-circles or larger rectangles.

Plain or Ornamented

The surface of the completed board can be left plain or relieved with beading of one type or another (Fig. 2). This can go along the lower edge, or be made to divide the entire length into panels of one size or another and using beading this way it can be employed to help further in concealing joints in the wood. However the board is finished, this must all be done on the ground, so the pelmet goes up as one complete piece with no further constructional work necessary.

Having everything completed on the ground—now comes the question of fitting. Again, this depends on the type of woodwork there is around the window. When wood extends along the top of the window opening out to a level with the walls (as it does in most modern small houses—see inset, Fig. 3) the board can be attached straight to this with screws at intervals.

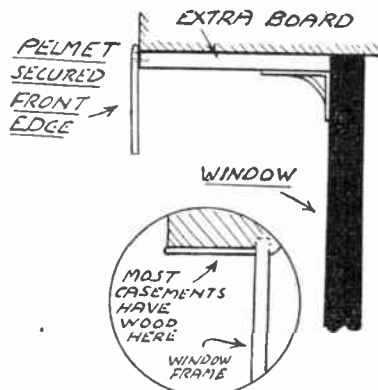

Fig. 3—Section showing fixing to window

Fastened thus the board lies very snugly and in a perfectly vertical position, as the ends are pressing against the wall. Should the window be wide, any tendency to warp at the middle can be counteracted by putting in a plain angle iron from the top wood of the window opening to the back of the pelmet.

Angle Irons

Some window apertures have wood at the side but none on top. The pelmet is then held by angle irons at each end. Should the opening be shaped on plaster only, then it is best to bring the pelmet out over the wall a little at the top and as usual at the sides. Several points in the

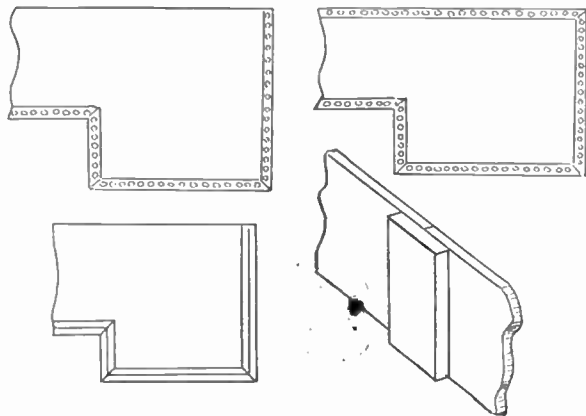

Fig. 2—Moulded edges, and a detail of the joint

plaster are then plugged with wood to take screws which makes quite a satisfactory way of holding.

Another way of securing a pelmet if the window opening is shallow and made of plaster only is to put in a horizontal board against the top (as Fig. 3), held in position by angle irons fastened to the window frames. The pelmet board is then secured to the outer edge of this.

All this may sound rather complicated, but it is really quite simple when you have the pelmet made and the window before you from which the particular method of fastening at once becomes obvious.

Care in Fitting

In undertaking this work you must pay particular attention to your measurements, otherwise you will have "gaping" ends which show the light through and look quite unsightly. When you begin, too, note that where any windows are the same size you can standardize the work as much as possible and cut out several similar boards at the same time.

Test your work as you go along, too, to ensure a good fit before completing the job and finally fixing in place.

There will be an additional number of pages soon!



SOME RECENT NEW ISSUES

WELL, we have started upon another new philatelic season—for although a number of people maintain their enthusiasm throughout the twelve months of the year, there are many who put their stamps away during the summer months, presumably the calls of the tennis court, cricket pitch, golf course or garden are louder and longer than those of the stamp album.

Still now that the new season has started let us commence it by having a look back to see about some of the recent issues of stamps which will have escaped the notice of those who retire temporarily from the collector's fray.

Silver Wedding

Naturally, we shall start with the stamps that have been issued by our own country and her colonies. The particular issue is, of course, the Silver Wedding stamps. At the time they were contemplated we added our voice to the complaint about the high values—now we can see the effect!

Only those with very long purses, indeed, have been able to benefit by these stamps which have gone up in value tremendously. The £1 British stamp is now about 30/- and the stamps from the Colonies which when issued cost just over £40 are now worth £60.

But it is not very likely that many of us will have paid the cost price, and still less likely that many of us will be able to pay the increased value.

In October we are to have the Universal Postal Union commemoratives; it is the 75th anniversary of that union. The cost of the full sets from the Colonies will be just over £7. How many will get those remains to be seen—those

who could afford the Silver Wedding stamps will do so, of course. It seems that others will probably argue that they have not been able to purchase all the stamps, so what is the use of buying these?

Australia and Canada

During the last year Australia has issued three stamps. The first one is illustrated here, commemorating William J. Farrer. He was a man who had been concerned with the breeding of wheat and also the study of the diseases which affect this most important plant. Another botanist was also remembered—namely the late Sir Frederick Von Muller. A third stamp which has come from 'down under' was that issued to celebrate the Pan Pacific Scout Jamboree.

Canada has had two issues, the first to celebrate the first hundred years of responsible government. One shows a picture of the Parliament Buildings at Ottawa, the other commemorates the amalgamation of Newfoundland with Canada. Both of them are large stamps and the second shows a picture of Cabot's ship the *Matthew*.

Readers who get stamps from the Falkland Islands must take care in the future, because she has just issued two changed stamps. The 2½d. when first issued showed a picture of a flock of

These were issued in connection with the silver jubilee of the Accession of H.H. the Ameer of Bahawalpur. Seeing these illustrations it is hardly necessary to look up on the map to see where Bahawalpur is. Yes on the banks of the River Sutlej, a tributary of the R. Indus.

The U.S.A.

It is almost impossible to note all the stamps that have been issued by the United States of America. They are bringing out so many, but here are a few of the notable ones. A portrait of a lady is found on one, 'Juliette Gordon Low' by name, who was the founder of the Girl Scouts of the U.S.A. Another bears the portrait of a man with fire engines on either side of him. On one side an engine of the 1648 variety, while on the other there is the 1948 counter-part. The name of the man is Peter Stuyvesant. Two stamps bear scenes of pioneers, The Swedish Pioneer Centennial stamp and the other the Fort Kearney-Nebraska Commemorative.

Ceylon very early in the year produced two stamps—a 4c. and a 5c. Then in April two more of the same design. The 4c. shows the Lion Flag of the Dominion and so does the 15c., but the latter stamp is slightly bigger than the 4c. The 5c. and the 25c. both give portraits of The Hon. D. S. Senanayake, the Prime Minister of Ceylon.



Australian Wheat Export



Silver Jubilee of H.H. Amer



Bermuda remembers 'Perot' Stamps

sheep, but this value now has a view similar to that of the old 4d., namely an 'Upland Goose'. The new 6d. stamp is of the same design as the old but the colour has been changed. You will remember a little while ago the 1d., 2d., and 3d. were also changed. So you certainly have to keep a sharp look out.

Bahawalpur

There are four values to a new set from Bahawalpur. They are only low values and as the illustrations are rather intriguing they should be well worth spending a matter of sixpence to have them. There is an irrigation tank, a sheaf of wheat, a sprig of cotton plant and, as the illustration shows, a 'Sahiwal Bull'.

South Africa has just given us a pair, one in English and the other in Afrikaans as usual. The 1½d. value shows the immigrant ship the *Wanderer* anchored at Port Natal. It is issued to commemorate the arrival of the British Immigrants to Natal in 1849.

The third illustration shows one of the new Bermuda stamps, which gives a picture of another stamp—a 'Perot' stamp as it is called. The first issued in the island was a hand stamp which the postmaster signed each time it was applied. His name was W. B. Perot—hence the name given to this stamp. By the way, a Perot would cost about £700 now. This issue reminds us of the Mauritius set which came out a little while ago—which showed one of the rare 'Post-Office Mauritius' stamps.



Smoker's Table Lamp No. 2810. Kit for making this novelty from Hobbies Branches for 47. Post free 5/6 from Hobbies Ltd., Dereham, Norfolk.

The use of different line fixing will cause alterations to MODEL RAILWAY TRACKS

UP to the present, to make a model railway look as realistic as possible it has been the aim of most enthusiasts to lay it with "scale-model track" which gives a line that looks exactly like the real thing. This track is made up of correctly scaled "bull-headed" rails with scale model chairs, keys and sleepers, as shown in section herewith at A, and certainly looks very real.

In the near future, however, this make-up will no longer be "scale model" of track used in England. For British Railways have decided to go over to the flat-bottomed rail as its standard. Indeed, a good mileage has already been laid in this new product. New to these islands, that is, for practically every foreign country employs the flat-bottomed or Vignoles rail.

Inverted T Type

The rail is of an inverted T-section (just the opposite to the rails of 100 years ago, which were of an upright T-section) the foot or flange resting on the sleepers. It was designed in its original form by Charles Vignoles (an Englishman, despite his French name), and it has certainly found favour in every part of the world bar here. But for some reason up to the present time the authorities in England have never liked it.

Even when it was being used on the huge trans-continental routes of America we looked on it with some scorn. All right for pioneer tracks and railways that must be quickly laid, but not good enough for the Mother country! And so with a feeling that our permanent way beat all the world we kept to our

Hot Plate Marks

I HAVE a dining room table—walnut finish, which has collected white stains due to a hot dish being placed on it, and am anxious to remove them. (S.B.—Dublin).

TO remove the marks made by the hot dishes on the polished surface of your table, make up a pad of clean rags, moisten with camphorated oil and rub on until the marks disappear. It is as well to slightly dampen the pad with spirit of camphor and rub over again gently. Follow this up with a clean rag moistened with common vinegar to remove the oil.

Leaky Cape Seams

I HAVE a new cycle cape which leaks at the seams. Is there any way of stopping this? (R.P.—Purton).

YOU could stop the leaking by treating with linseed oil, working

"chairs", keys and bull-headed rail and relegated the few flat-bottomed rails which did appear in England to contractor's lines and clay-pit tramways.

Engineers abroad, however, were developing the Vignoles rail, and suddenly we awoke to the fact that railways overseas were making a flat-bottomed track that scored on every point over the English many-piece make-up.

It was 50 per cent stiffer vertically and no less than 136 per cent stiffer in a sideways direction than our lines. Also it ran smoother, was easier to lay, and gave a better road for heavy locomotives. In fact, all the old objections to the track (from our point of view) no longer existed.

We said the bottom flange dug into the sleepers. Well, this had been stopped by slipping a plate between the rail and the wood, so distributing the weight. We said the spikes that held down the rail would be pulled out easily, but screw bolts are now used. Indeed, we said quite a lot of other things about the Vignoles track that do not apply in the least to the modern version of it.

So the British Railways Executive have decided to adopt it as standard for English railways and the conversion is at present under way.

Easier to Handle

Now this is good news for model railwayists, as flat-bottom rail is much easier to model realistically than the "bull-head-with-chairs" type. It is

the oil well into the seams with a suitable brush. Afterwards hang the cape up in a dry airy spot until the treated parts are thoroughly dry. If there are places where the seams have come unstuck altogether, you might try fastening them down by cross-stitching neatly with well-waxed thread, afterwards pressing the parts with a warm flat iron to force the wax into the holes and into the seam, thus stopping the leaking.

Fixing Glass

IS there anything on the market for sticking glass? I would like to fix the tray of a cut-glass cruet set. (F.B.—Leicester).

FOR cementing the broken glass, you can use either Lion cement or Rawplug Durafix, both being excellent for the purpose, and allowing the article to be washed in warm water.

easier to lay and is much more solid when down, and model trains run better on it.

Miniature flat-bottomed rails can already be supplied in small lots by certain firms of model engineers, being made to go with foreign models. There is no doubt, however that the scale Vignoles rail will at once now be put into production and appear cheaply and

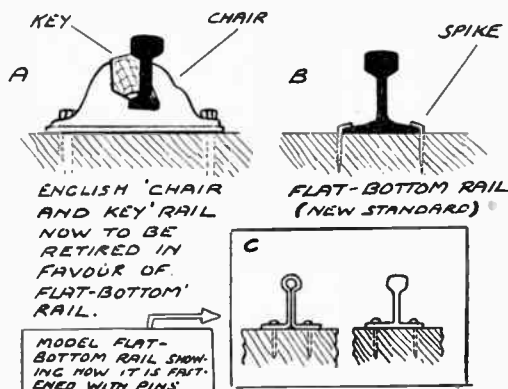

Details showing difference between old and new types

in quantity.

Older Vignoles rail is held with a "dog" or spike, one on either side at each sleeper, as diagram (B), and in the early days these were just driven home with an ordinary sledge hammer. In good model Vignoles track these spikes are faithfully reproduced, but in cheaper varieties and in the smaller scales, like Gauge O, it is the practice to hold the rail by a series of pins going through holes in the bottom flange to the sleeper, see Fig. C.

This makes a very realistic finish, the pin heads suggesting the spikes. The fact that they do not come round the outside of the rail as does a spike is absolutely unnoticed. The pins, which are sold by model dealers, are very easy to insert.

Changeover

Chairless sleepers look bad on present model tracks, but a few spikeless sleepers on model Vignoles track are not noticeable. All of which helps quick and yet realistic laying.

Readers who live in some districts are also fortunate, for lengths of track have already been laid with flat-bottom rail, so they will be able to go and see just exactly how it looks. There will also be 463 more miles of the rail by the end of 1949.

If you are travelling, too, and the train suddenly starts to run very smoothly with rather a different sound on the joints, look out, for it is probable you are passing over one of the new stretches. Oh, yes, it is going to mean definitely smoother running for real trains as well as model.

MODEL CONSTRUCTIONAL KITS

that are well known for quality and low price

AIRYDA MODEL AIRCRAFT



B161 Luton Major

Include both flying and non-flying types; sizes and prices to suit all Modellers. Each kit complete with plan, building instructions and all necessary parts.

ANORNA MODEL BUILDINGS



A1 Bungalow

This range of Model Buildings includes shops, houses, factories, railway buildings, etc., which are all designed to 4 mm. scale suitable for OO gauge Model Railway lay-outs, etc.

AQUILA MODEL SHIPS & BOATS



C200 Waterlily

This series includes Motor Launches, Cabin Cruisers, Motor Yachts, Cross Channel Steamers, etc. Sizes range from 20ins. to 39ins. in length; and prices from 18/- to 62/6.

Full particulars can be obtained from your local dealer, or write enclosing 4d. in stamps for fully illustrated price list to:

MODELLERS SUPPLY LTD.
ASPLEY, HUDDERSFIELD

The Modelcraft PLANBOOKS

The 'Modelcraft' planbooks are justly famous as being the most complete and lucid instruction books of their kind. They are copiously illustrated and include the 'working drawing' as well as instructional diagrams and text.

MODEL OIL ENGINE

2/2 POST FREE

An entirely new model engineering technique has been evolved for making this model. Only tools that are in every home and materials that are always to hand are needed. The model runs on air.

A SIMPLE MODEL LOOM

2/8 POST FREE

There is something deeply satisfying in handling a device you have made yourself which also does something. Ties, scarves, table mats, etc., can be made on this home-made loom which is also a faithful model of the crofters' type of loom.

MAKE-A-CLOCK

3/9 POST FREE

Most people would tell you that an "ordinary man", without fine tools and much skill and experience can't make a clock. Well, the "Flipclock" is different! Many have been made on the kitchen table with the help of this plan book.

BUILDING A GALLEON

13/- POST FREE

This book has become a classic and is now known to model-makers the world over. Plans for the Golden Hind, the ship in which Drake sailed round the world, are included.

★ Many other planbooks are included in the *Modelcraft Complete List for 1949, which, for 1/- post free or from your model shop, lists over 600 items.*

MODEL CRAFT LTD.
 77 (F) Grosvenor Rd., London, S.W.1

1,014 Decorations
 —including the V.C. and G.C.
 have been won by
Ex-R.A.F. APPRENTICES

That shows you the sort of stuff R.A.F. Apprentices are made of! That's why they are hand-picked from the keenest, brightest, most ambitious boys.

They are given a fine technical training and all-round education at what is probably the most-advanced "air School" in the world—and enjoy opportunities for sport unequalled by many public schools.

* You'd like to be one of them? Then send in the coupon—without obligation.

TO: AIR MINISTRY,
 INFORMATION BUREAU, (DEPT. HS25Z) KINGSWAY, LONDON, W.C.

Please send details of R.A.F. Apprenticeships (age limits 15 to 17½).

NAME _____

ADDRESS _____

FOR A REAL Professional FINISH

'FINISH' is the true test of craftsmanship. It's easy to impart a real professional 'finish' to woodwork and furniture you make at home with "COLRON" WOOD DYE—the finest stain for all practical purposes.

One coat of "COLRON" is all that is required to emphasise the natural beauty of the wood grain. No smears—no 'overlaps'—no trouble. Leave from two to three hours, burnish with rough dry cloth and you have a perfect base for french polishing or for waxing with "RONUK" FLOOR POLISH.

COLRON WOOD DYES

12 SHADES—ALL SIZES

Write for colour guide and full details to:
RONUK LTD. (Dept. 62) Portslade, Sussex

ALL ABOUT FRETWORK

by W. F. Chambers
(Editor of Hobbies Weekly)

The book for all fretwork enthusiasts

Bound in paper covers, **2/6** net.

Or there is a cloth bound edition at **5/-** net.

Obtainable from all booksellers, branches of Hobbies, or from the publishers:

VAWSER & WILES (London) LTD.
356/358 KILBURN HIGH ROAD, LONDON, N.W.6

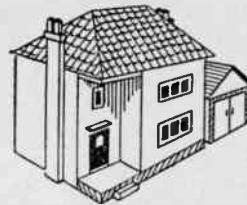

DOLL'S HOUSE

How to make in a simplified step-by-step manner a desirable four room Doll's House with electric light and separate garage if required

ALL MATERIALS EASILY OBTAINABLE

Send a 2/6 P.O. now for complete Plan and Instructions. Doll's House Paper and Doors and Windows, which open, are available. Send S.A.E. for list.

TRADE INQUIRIES INVITED

ZIMPLAN 88 WARE ROAD
HODDESDON, HERTS.

BLACK MOURNING AIR FREE



ABSOLUTELY FREE. We will send YOU this super Free Gift of HUNGARY and RUSSIA stamps **ABSOLUTELY FREE** to improve YOUR collection. The HUNGARY is a black Mourning Stamp in memory of Stephen Horthy, killed in a plane crash, and shows horsemen in sky over planes. The RUSSIAN is an interesting Revolution issue depicting a Soldier. To obtain these send us 3d. stamps for post and List, ask for Hungary and Russia Free Gift and a selection of stamps on Approval (no obligation to purchase any). Send to

WINDSOR STAMP Co. (DEPT. 12) Uckfield, Sussex

USEFUL PUBLICATIONS

Expand your interest in Life, by reading the Literature of Life

GUIDE TO RAPID WEALTH. Most famous opportunity book published since the war: Mail Order, its wonderful possibilities, yet only small capital required. How 15/- made £12! Tested money making plans. Spare-time employments. Formulas for fortunes. For the alert—a goldmine; will remould your life. New edition handsomely bound ... 10/-

HYPNOTISM. Mystic art that charms and fascinates, 25 lessons... 2/3

TEN BEST FISH BAIT SECRETS. Fish bite like hungry wolves... 2/3

SIMPLE DECORATIVE LATHE WORK. Well printed, illustrated. Unrepeatable offer ... 2/9

TURNING FOR BEGINNERS. As above, 128 pages, illustrated 2/9

FAMOUS SPECIALIST'S HAIR RESTORER TONIC COURSES. For baldness, thin and falling hair, complete, 3/- All books, etc., post free.

SPEEDWELL" (Publishers), Albert St., Lockwood, Huddersfield

BRITFIX BALSA CEMENT



★ The ideal transparent cement for Balsa Ply Wood, Hard Woods, and Plastics, combining rapid drying with utmost tenacity.

Remember
**STICK BY
BRITFIX**

Large tube
7d.

Small tube
(with special
long nozzle)
5d.

THE HUMBER OIL CO. LTD., HULL



Whatever your soldering job, in your home or workshop, you will prefer to use Ersin Multicore Solder. No extra flux is required. Multicore is the simple and precision method of making sound soldered joints for all household purposes. Just apply it simultaneously with the soldering iron; the three cores automatically provide correct proportions of flux to solder.

6
d.
CARTON
Shown above

WORKSHOP SIZES 4/10 - 6/9 each.
MULTICORE SOLDERS LTD.
McHler House, Albemarle Street, London, W.1
Tel.: REGENT 1411

EX ARMY BELL TENTS £5. 15. 0.

GENUINE EX-RAILWAY AND SHIP HEAVYWEIGHT
TARPAULINS

Guaranteed Waterproof

70 sq. ft. 20/-, 2 for 39/-, 4 for 77/6. 140 sq. ft. £2 10s. 280 sq. ft. £5, approx. 360 sq. ft. £6, approx. 720 sq. ft. £12. Medium or lightweight if desired. All include carriage. **CAMPING EQUIPMENT**, in Stock. Send 1d. for list.



GREAT SURPLUS OFFER
**PARATROOP
BINOCULARS**

Compact, 7 oz. Crystal-clear lenses. Ideal holiday, sporting events, 40s. 6d. W.D. model, full-size, in case, leather slings, £3 10s. Very special 6-lens achromatic model, £5 19s. 6d., complete in case, etc. All post 1s.

TELESCOPES AND BINOCULARS. H.P. terms can be arranged.
HEADQUARTER & GENERAL SUPPLIES LTD., H.O.B.
196-200 Coldharbour Lane, Loughborough Junction, London S.E.5.

SUPPLEMENT TO HOBBIES No. 2810.

PIPE RACK AND ELECTRIC TABLE LAMP COMBINED

THE ARROWS INDICATE THE DIRECTION OF GRAIN OF WOOD.

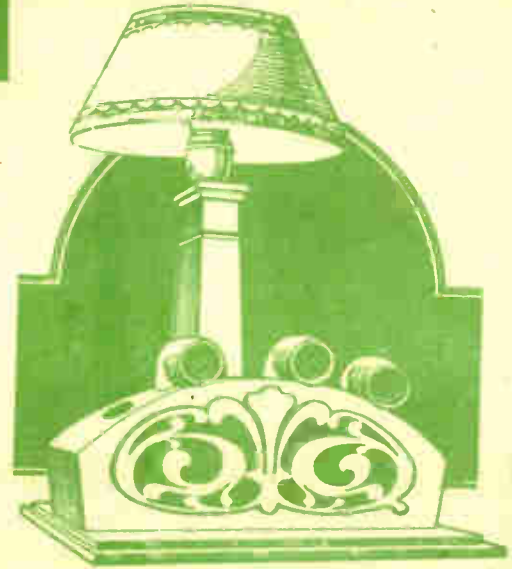

PANELS OF WOOD REQUIRED FOR THIS DESIGN

TWO G3, FOUR G4, ONE G2, ONE PPM

Materials for making this design are supplied by HOBBIES LIMITED, Dereham, Norfolk. Price on application.



ALLOW FOR TRIM

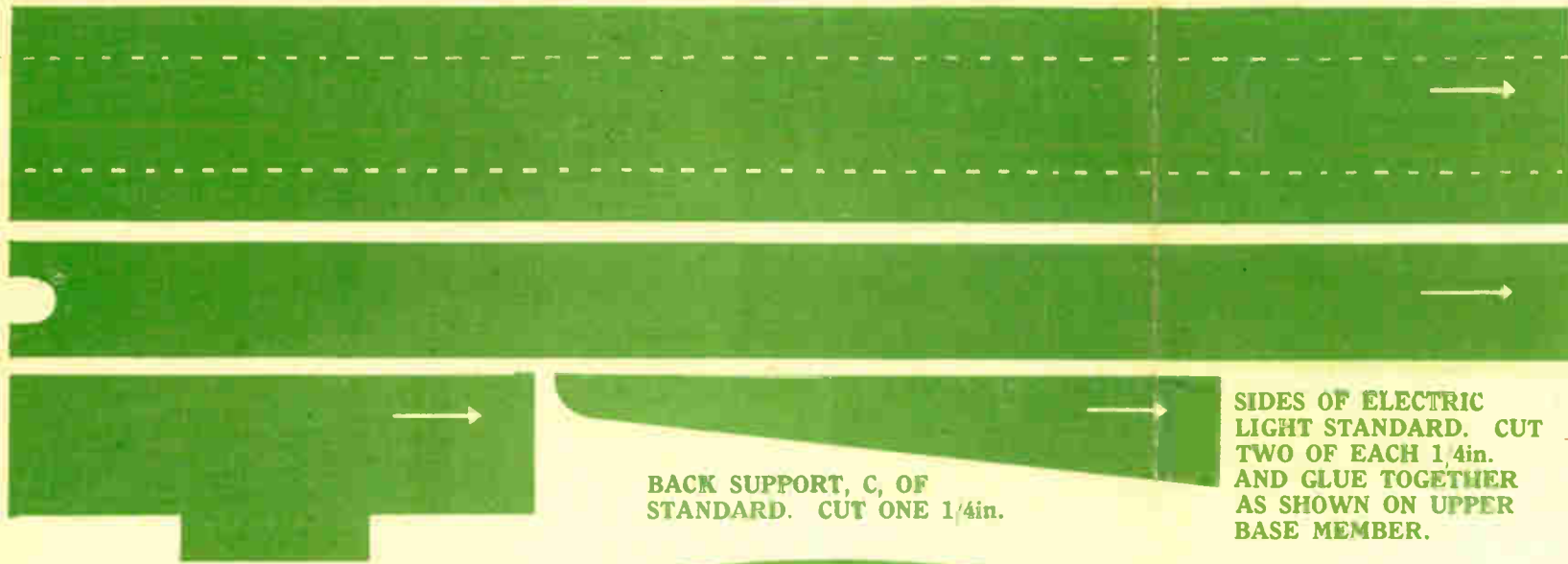

SIDES OF ELECTRIC LIGHT STANDARD. CUT TWO OF EACH 1/4in. AND GLUE TOGETHER AS SHOWN ON UPPER BASE MEMBER.

BACK SUPPORT, C, OF STANDARD. CUT ONE 1/4in.

PARTITIONS B OF RACK. CUT FOUR 1/4in.

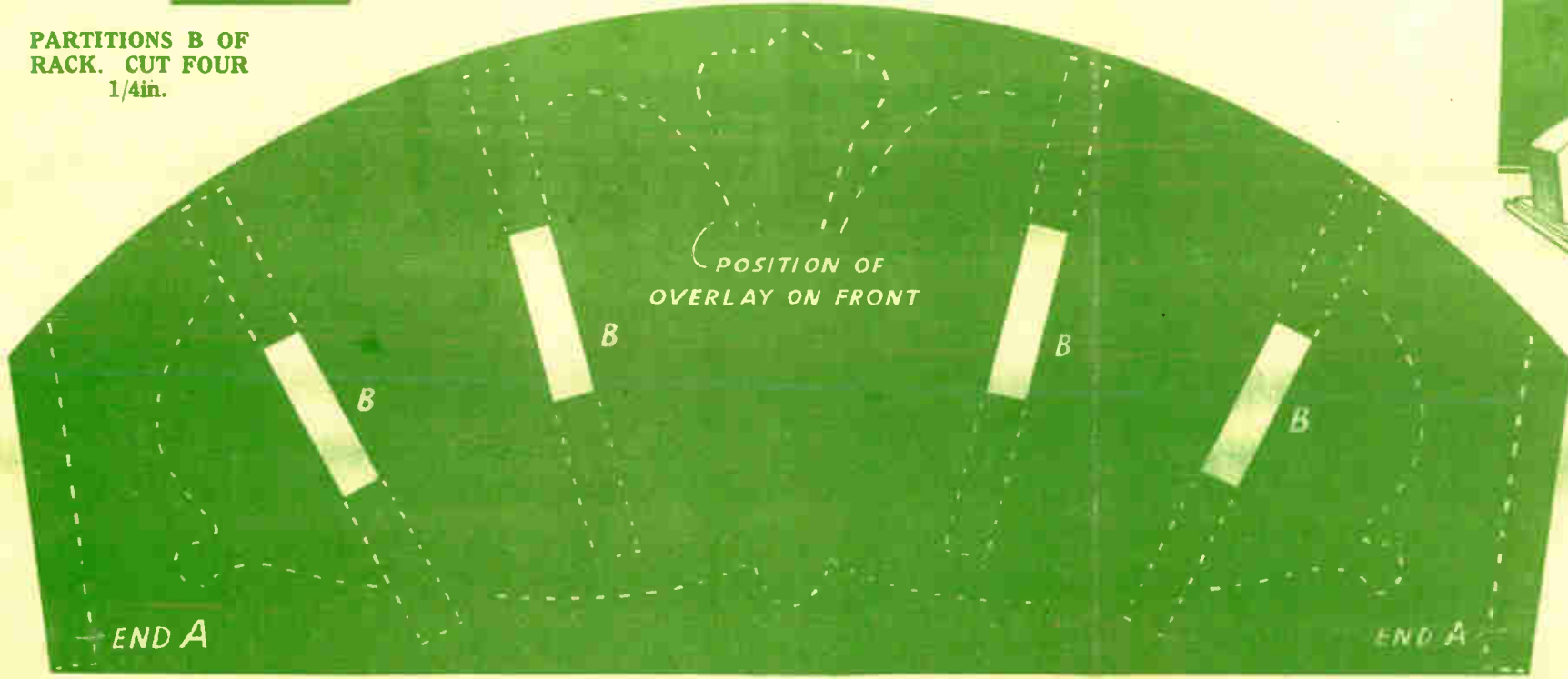

POSITION OF OVERLAY ON FRONT

END A

END A

BACK OF RACK. CUT ONE 1/4in. ALSO FRONT OF RACK. CUT ONE TO OBTAIN CURVE

BACK SUPPORT

TABLE PIPE RACK AND LAMP

THIS attractive piece of work can easily be made with a fretsaw and a few tools, and would make an ideal gift for any pipe smoker. In addition to the practical rack for holding the pipes, there is the electric lamp standard behind, to make the whole thing a useful article to have handy when sitting reading or writing.

The main parts are cut in $\frac{1}{2}$ in. and $\frac{3}{16}$ in. wood with $\frac{1}{8}$ in. fretted overlay on the front, and the rounded curve of the pipe rack itself in thin bendable plywood. There is no need to paste all the patterns down to the wood, because they can be measured up and marked out, or traced through carbon paper direct to the boards themselves. The curve of the back and top should, if possible, be marked with the compasses to ensure a steady line. The fretted overlay can be pasted down, and then glasspapered off after the part has been cut out with the fretsaw.

Interior Partitions

The interior of the box frame is fitted with cross partitions so that the pipe stems do not hang against each other whilst a small rectangle cut in the upper base allows extra long pipes to be used without trouble. The position of the main parts is shown on the pattern of the upper base, and these dotted lines should be clearly noted.

The box frame with its curved top is made up of four pieces. The back and front are alike, except that the former

has the slots, B, cut in at the points shown. The four small partition pieces must next be cut and glued into the back. The two end pieces, A, are next glued between the back and the front, with a little glue added to the other end of the partition pieces so that the whole thing is fixed solid.

Note that the ends, A, slope slightly outwards to come flush with the ends of the back. The top end will project above, but this can be shaped down afterwards with a rasp and file, so it has the same curve as the back and front.

Fixing to Base

This box frame is glued to the upper base, coming centrally between the ends and set back $\frac{1}{2}$ in. from the straight front edge. The exact position is shown by the dotted lines on the pattern of the base itself. If necessary you could, of course, add some flat-headed screws through from the underside into the edge of the uprights. The whole thing can next be glued to the lower base which leaves a $\frac{3}{16}$ in. projection all round.

The top of the pipe rack box is covered in with a strip of thin plywood in which four holes are cut to accommodate the pipe stems. This piece is $10\frac{1}{2}$ ins. long and $1\frac{1}{2}$ ins. wide. A better plan is to cut it a little larger than this, then, when you have glued it to the edges of the box top, you can afterwards trim off any projecting pieces to bring the whole to a neat joint.

The electric standard pillar is a tall

hollow box glued behind the back, in the position shown by the dotted lines of the pattern of the base. Of the two sides of the pillar, one has a little semicircular hole cut to accommodate the flex, the two narrow sides are glued between the wide ones, leaving a hollow tube through which the flex can be drawn.

Cover Piece

The top is covered by a two-piece cap. Of this the $1\frac{1}{2}$ in. square cap is glued on first, and then the 2in. square cap above it. The latter has its upper edge rounded as shown in the section. A hole is drilled through both pieces, the diameter of the threaded portion of the electric fitting which will be screwed or fixed in.

The illustration of the finished article shows the lamp standard tapering, which adds considerably to the finished effect. To get this, you should glasspaper the part top to bottom, taking off more of the former and fading out at the latter. It must, of course, be done before the capping pieces are added, and before the whole thing is glued to the base.

The finished rim shown on the picture, can be painted on in two colours about 1in. below the capping itself. If you are proposing to stain and polish the article, this should be done before the overlay is added. The overlay, of course, is cut from $\frac{1}{2}$ in. wood and glued to the front in a central position. If the box has been polished beforehand, you must scrape some away to allow the glue to hold efficiently.

AND EXCLUDING THE
MORTISES B.

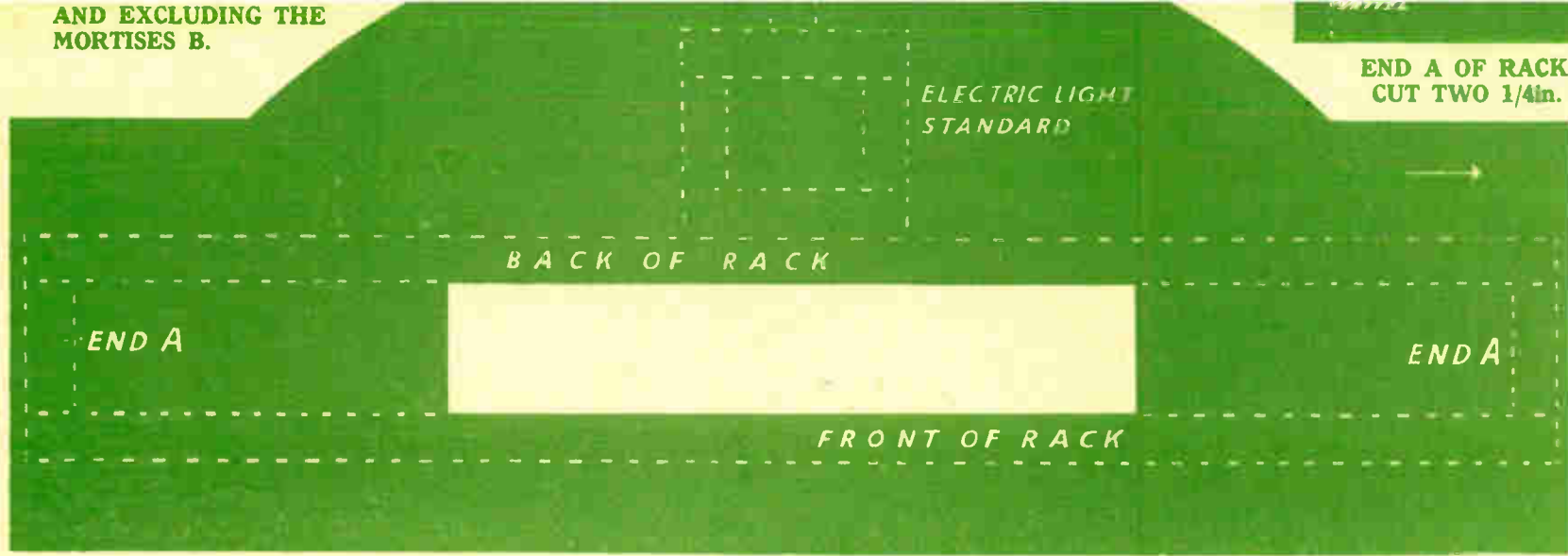

BASE.
UPPER MEMBER.
CUT ONE 3/16in.

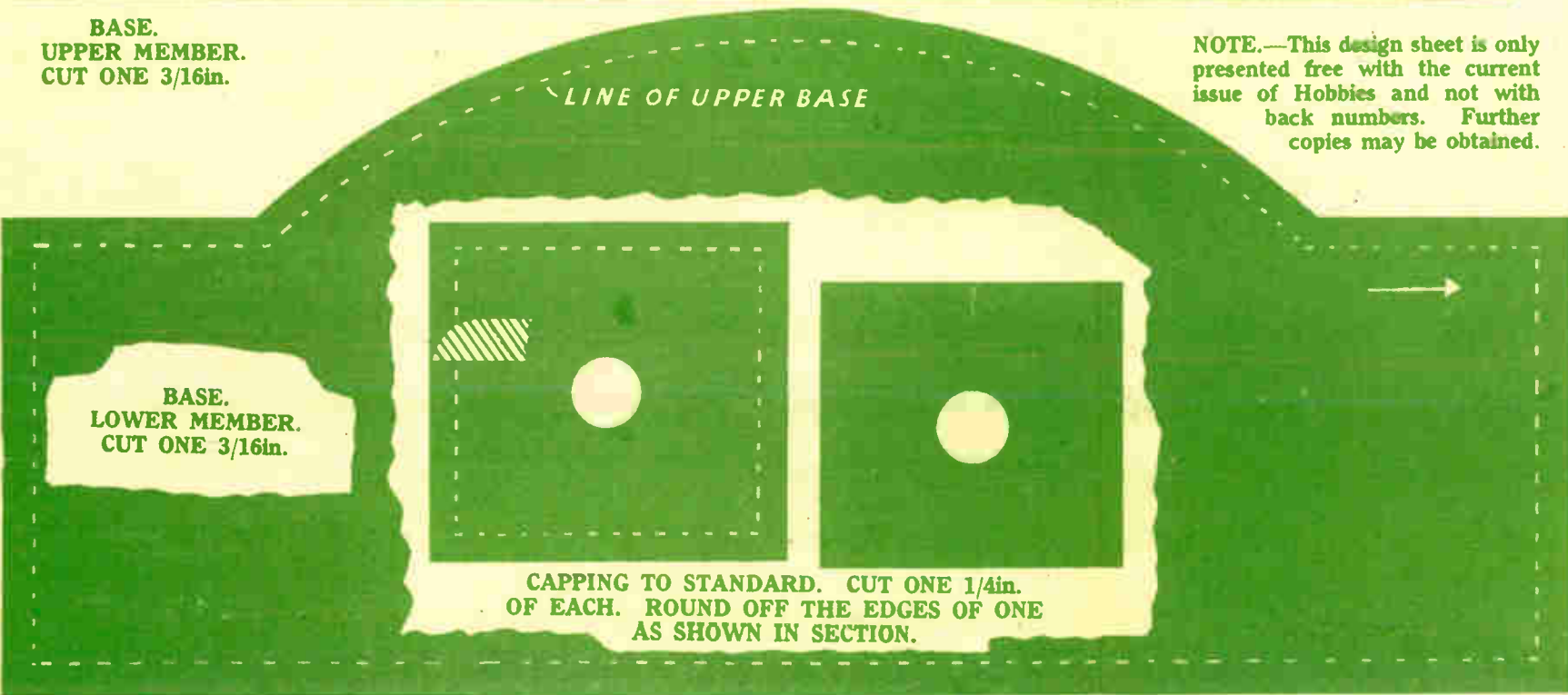

NOTE.—This design sheet is only presented free with the current issue of Hobbies and not with back numbers. Further copies may be obtained.



OVERLAY.
CUT ONE 1/8in.

PRINTED IN ENGLAND.

