

Hobbies

WEEKLY

July 5th, 1944

Price Twopence

Vol. 98 No. 2542

Good looks and usefulness in this ORNAMENTAL DUCK POND

DUCKS, unlike hens and chickens are hardy and easier to keep. They do not need to be kept so dry and warm, but unless the natural habits of the birds are considered, ducks cannot thrive properly.

It is wrong, as every amateur poultry-breeder knows, to keep ducks confined like other fowl. The birds

like plenty of freedom and water. A pond should be available, and it is chiefly because of the lack of a pond that many folk—who love duck eggs and flesh—cannot rear them.

If space for a small pond is available in, say, a back garden, a pond can be easily made. The design, in fact, ought to please all those desirous of making a garden pool only. Sand, cement, old rubble and broken tiles, are used in the construction.

Picking the Site

The site should be well chosen. If possible, the pond should be situated above ground level, such as on a flat bank, so that an outlet pipe can be incorporated to facilitate the draining of the pond which should take place frequently.

Having selected the site, consider the size of pond it will permit. The pond at Fig. 1 is situated on the back lawn of a house. A good, useful size of pond is one measuring 8ft. by 5ft. with a depth of 12ins. or more. That is the inside sizes. If the decorative surround is wanted, it must be allowed for.

Incidentally, any size, or shape of pond can be made, according to individual needs or available materials being either circular, oblong, octagon, or diamond shape. The constructional method to be outlined will apply to them; so your pond site will determine the size and shape only.

Marking out and Trenching

Assuming you wish to make the size and style of garden pond shown, complete with sloping runway and crazy paving border, stake off a space 9ft. by 6ft., with an 18in. marginal allowance all round. Tie a guide line (a piece of cord) around the ground stakes.

Now, using a square-ended 6in. wide spade, make a series of deep cuts in line with the guide cord. After doing so, line off an 18in. space at one end, cut the soil, then make a 3in. trench (see Fig. 2), this measuring 6ft. by 18ins.

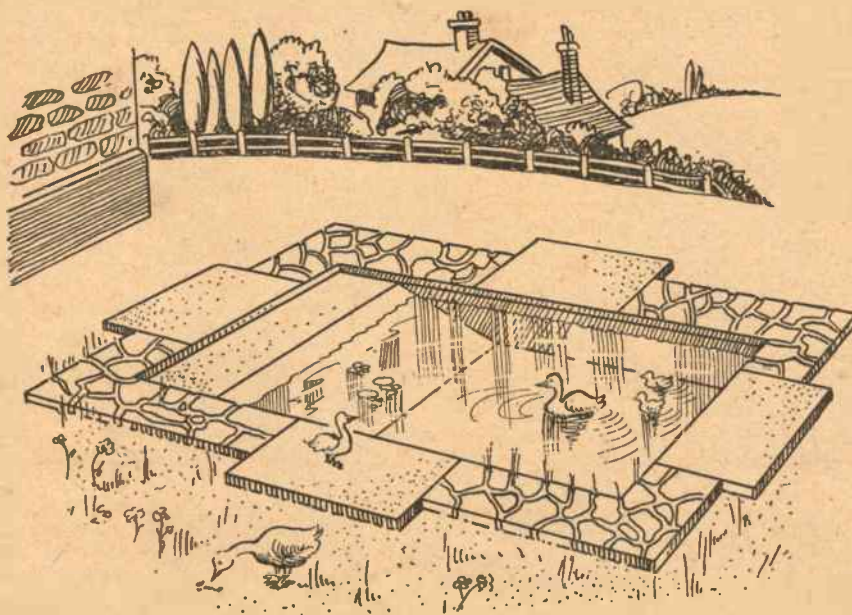

Fig. 1—An ornamental pond put to excellent war-time use in the garden

Proceed by staking off an inner space 7ft. by 5ft. The soil is cut in line with the guide cord. Remove the guide line and stakes of wood, then carefully trench the ground to a depth of 15ins., working between the outer and inner line of spade cut. One end (where already trenched to a depth of 3ins.) is not touched.

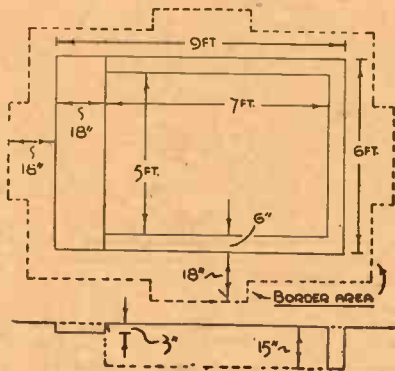

Fig. 2—First stage to set out site with dimensions and depths as shown

sectional and top view at Fig. 5. There is no need to wait on this cemented part to dry.

Border Work

Proceed with the work of adding a border to the pond. In the design shown at Fig. 1, four complete paving stones are used. These are

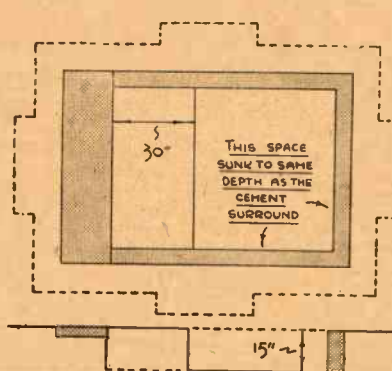

Fig. 3—Second stage shows trenching filled with stony cement, slope marked and pond dug

the crazy paving border, as such will contrast attractively. Like the cement flags, the pieces of tile are laid on a mortar foundation, the spaces and fissures being filled with the same material.

The face edging resting on the cement walls of the pond need to be smoothed off neatly with the trowel. Now, as it is made, the pond is completed. But, in order to prevent the likelihood of the water level rising through heavy rain-storms and thus overflowing, a small brick surround could be added, using a single row of 9in. by 4in. by 3in. building brick (see Fig. 6).

Reason for Runway

No doubt you may be wondering at the inclusion of a sloping runway. This, it should be explained, is for the convenience of little ducklings, and even the older ducks.

The water level to be maintained is the top of the slope. When, as during the hot, summer months, there is a loss of water due to evaporation, the ducklings can easily waddle up the runway.

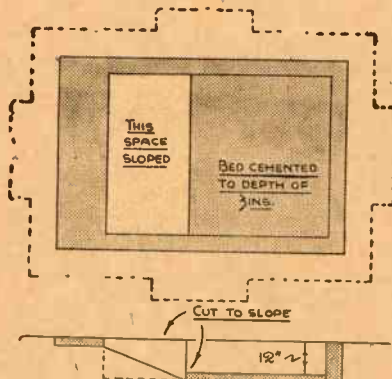

Fig. 4—The bed is cemented and one end sloped to top as shown

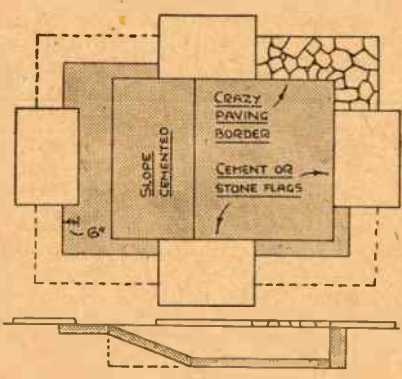

Fig. 5—Next the slope is cemented and surface paving begun

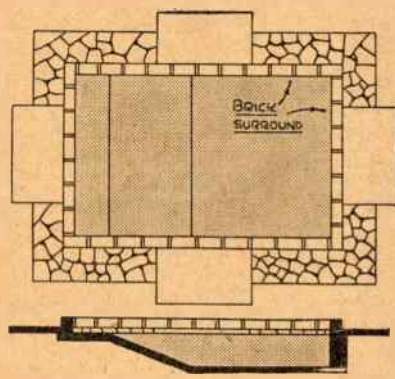

Fig. 6—Plan of completed pond, showing single brick surround and section for depth

At this juncture, the trenching is filled with a mixture of cement and stones. Use 1 part of cement to 2 parts of sand and 1 part of stones. The mixture is poured into the trenching and levelled off with the surface. Leave further excavation of the soil for some days ahead, or at least, until the cement has set. Do not, by the way, have the mixture of cement too sloppy, nor should the stones be rather large and heavy.

Large stones sink to the bottom of the trenching. Keep them small, breaking up large ones, if necessary. Broken tiles, bricks, pebbles, etc., can be used.

The Pond Bed

When the "walls" of the pond has hardened, the bed can be excavated, doing so to a depth of 15ins. (see Fig. 3). The bed is then cemented to a depth of 3ins. and allowed to set.

The remaining flat space is then sloped, as shown at Fig. 4, then cemented, as can be seen by the

laid on a foundation of mortar, flush with the edge of the pool. Note that one slab, at the sloping runway, is kept inwards 6ins. (see Fig. 5).

Paving flags are a grey colour; if unobtainable, they could be made from cement, using a wooden mould. If used, broken yard tiles, which differ greatly in colour, can be used to make

Prior to filling the pond with water, the bottom should be sprinkled with pebbles, stones and soil. If possible, use spring water. Ordinary tap water is, as you know, hard, containing a slight percentage of lime. Spring water, or rain water, is softer and ducks, being regular drinkers, are more used to it.

For Decoration Only

If the pond is made solely for decoration in the garden, various plants, such as water-lilies, Fabiola, Venusta, Chrysantha, Odorata alba, etc., can be planted. The pond bed is partly filled with a loamy soil, covered with a layer of tiny stones or pebbles.

If tap water is used, do not introduce plants or animal life until it has stood for a few days to get aerated and warmed. It is usual to wash out newly-made ponds with diluted permanganate of potash, as this chemical neutralizes the poisonous elements in the concrete.

CIGARETTE BOX DESIGN

Design No. 2542 presented with this issue. Parcel of planed wood 2/10 or from Hobbies Ltd., Dereham, Norfolk, for 3/5.



Add to your garden attraction with this OUTDOOR PLANT BOX

THE plant box shown here would make an interesting piece of garden carpentry. A plant box requires to be well and strongly made to stand up to exposure in all weathers.

Almost any class of wood is suitable. We know, of course, that teak or oak are ideal woods for the job but they are now difficult to procure and we must therefore fall back on elm or even ordinary pine.

The latter wood if well chosen and thoroughly coated with creosote or other preservative should last for a very long time, especially if a fresh application of this be added every springtime.

The size of our box overall is 14ins. square by 15ins. high, which conveniently takes an earthenware pot up to 10ins. in diameter. The framework of the box consists of four legs, each 2ins. square. Tenoned into them are the eight rails as shown in the side view Fig. 1.

Marking Out

This diagram gives the measurements for marking out the spaces for the rails, while the enlarged detail Fig. 2 shows how the tenons are cut.

There are two methods of finishing the top of the box. In one, the legs may stand up beyond the edges of the top rails (Fig. 2), or the legs may be flush with the rails (Fig. 3). The rails and the end grain of the legs in the latter case are protected by a mitred capping.

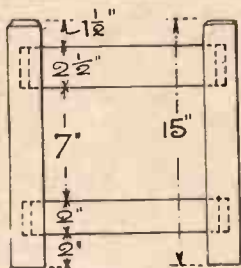

Fig. 1—Rails and legs.

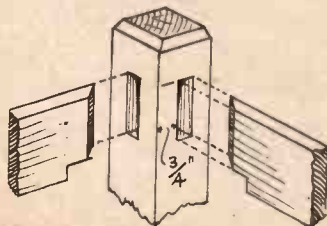

Fig. 2—Rail fixing joint

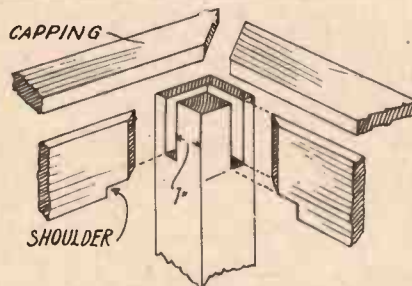

Fig. 3—Top rail and capping mitres.

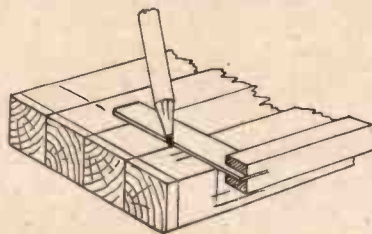

Fig. 4—Marking four legs at once.

In the first method the capping pieces are cut square at the ends and fit between the legs being nailed to the cross rails.

Accuracy is essential in marking out the positions of the mortises on the legs, for if this is not attended to then it is quite likely that the box will not stand evenly, or will finish up with its panels being square.

Leg Lengths

The proper way of assuring this accuracy is to set out all the legs, after these have been squared up properly, so that they stand level at one end as in the detail Fig. 4. Then mark down the various measurements from the top end and draw lines across all four legs with the aid of the try square.

All four faces of the legs should be treated thus and the actual widths of the mortises and their marginal widths also carefully set out. The chisel and mallet do the rest. Notice in both diagrams (Figs. 2 and 3) the rails meet at a mitre midway in the leg. It is therefore necessary to carry through the mortises from each face until they meet. (see Fig. 3).

If the leg mortises are opened as Fig. 3 then the inside width or margin should be 1in. as indicated, to give sufficient strength at this part while fixing the rails.

If, however, Fig. 2 method is adopted then the inside margin need be only 3/4in. This gives more

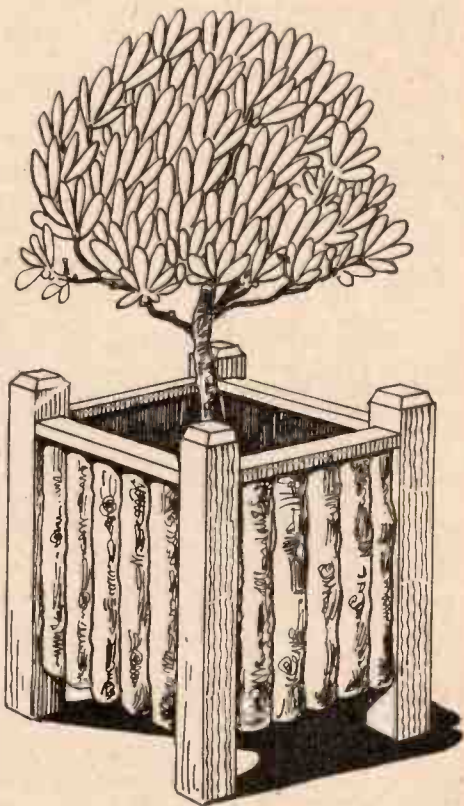

width on the outside for nailing on the upright rustic panelling.

Whichever method is chosen, the legs are set out 10ins. apart and the measurements for the rails taken accordingly, always allowing of course for the projecting tenons into the legs themselves.

Rail fixing

All eight rails will be the same length and the measurement between the shoulders shown will be 10ins. Having cut the tenons and their ends to a mitre of 45° see they fit the mortises before finally driving the rails into the legs.

Dowel-pins made from a hard wood about 3/4in. diameter are bored for and driven through the leg and through the tenon as fixing.

The capping rails are 2ins. wide by 3/4in. thick, fitted between the legs or mitred accurately as the case may be, before being nailed to the rails beneath.

The inside and the outside of the whole framework should now be given the preservative coating suggested and time should be given for this to dry into the wood before the side panels are added.

The final article for the handyman on POLISHING WOOD

WE dealt in our previous article (in the issue of June 14th) with the preparation of wood in the filling and staining stages. Now we come to the process of finishing it finally, to produce the highly polished surface which is often required.

The easiest way of doing this, of course, is by giving the whole thing a coat of varnish, but this is never so professional on its appearance as the French polished finish. The

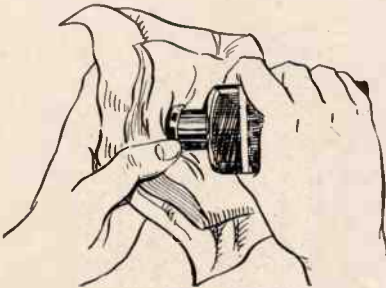

The polish applied inside the rubber

varnish itself is applied with a brush and should never be done in an atmosphere where the temperature is low. A warm room is most satisfactory, and a flat, soft brush should be used.

One of the troubles to be looked for is a peculiar appearance which is called "bloom." This is caused by moisture collecting on the surface when the varnish is dry, and can best be avoided by finishing the work as early in the day as possible in order to allow it to dry before the moisture of the atmosphere settles upon it.

Beware of Dust

Another cause of trouble is dust, and although it may not be visible when the work is being done, it will probably be there all the same, and reveal itself when the work is dry by a number of speckled spots appearing on the finished coating. Be careful, therefore, to have the atmosphere as still as possible.

Take care not to shuffle about a lot, and raise dust from there. If you are likely to do this you can, of course, lay the dust by sprinkling the floor with a little water.

The varnish is applied with a steady up and down motion, then crossed with a very slight pressure and finally finished again up and down in the same direction. Do not apply it too thickly or you will get a nasty treacly result. The varnish itself, of course, flows something like enamel, and produces a level surface for itself.

Too much should not be put on at once, nor should there be necessity for several coats. Two or three applications may be necessary, but the first one should be definitely rubbed down quite smooth before the following ones are applied.

Troubles of Varnishing

On the face of it, varnishing seems simple, but there are a large number of faults which will be found to arise, and which will prove disheartening to the beginner. In addition to the "bloom" which we have mentioned, there is blistering, cracking, pitting, specks, streakiness, and so on. If you are going to undertake a large amount of work of this character, it is as well to study the question and be able to deal with these faults.

To produce a smooth, highly polished surface on wood, the most popular method is that of French polishing. And here again, some experiment should be made on a spare board before actually beginning the work.

Special polishes are made for the amateur to use, which cuts out many of the processes indulged in by the professional. The polish, of course, is much thinner than varnish, and instead of being applied with the brush is put on with a rubber. This should be a piece of clean linen wrapped around wadding which should be smooth and soft. The shape of a useful rubber was shown with our previous article.

Care with the Rubber

You must remember, however, that once this pad has been left to get dry, it is impossible to use again. It gets quite hard and would only scratch the surface if re-used. Have all your work, therefore, ready for the polishing, so you may complete it as far as possible at one operation.

Polish is applied to the rubber, and then with a circular motion put on to the work. Do not let the pad stop on the work, but keep it going

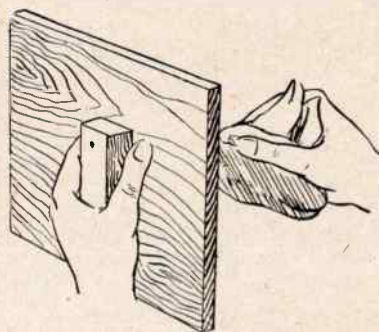

A temporary handhold to the work

round and round and finish near an edge where you can slide off without apparent effort. The illustration herewith shows how you can cover a plain board in this way.

Hints in Use

Do not put too much polish on to the pad at first, and do not press it too hard on to the wood. Keep a reasonably light pressure working so as to cover the whole surface as quickly and evenly as possible.

The rubber itself which is loaded with polish, has the pad inside the outer covering. The covering itself is wrapped around the wet pad so the polish squeezes through on to the work in the operation on the board.

Wood in its natural state will absorb a considerable amount of



Applying varnish or polish with a brush

polish, and for this reason is best filled as was dealt with in the previous chapter. This will body up the grain and so prevent the polish being soaked up.

The first coat rubbed on may not, in any case, produce a highly glossy surface, and it should be left for some hours before a second one is applied.

Circular Movement

The same operation of a circular movement is used, keeping an even pressure and covering all the work as required. The finish to the surface largely depends on the wood itself, on the amount of polish it has taken, and on the 'glossy finish which is produced.

The rubbing can be continued until you get a surface such as required, but even then it may disappear slightly after a time. To get a perfectly smooth surface you can rub the first coat down slightly with a very fine glasspaper.

Take care not to scratch the polish itself, but merely render the wood with a flat instead of a glossy face. Dust the wood thoroughly before recommencing and then carry on with the polishing as before.

The edges of fretted work can be dealt with very carefully by means of a brush. The same brush can be used too on shaped parts like moulding or awkward corners. As in the case of varnishing, the work should be done in a warm room. Remember, too, not to touch it after polish has been applied or the grease of the fingers will mark the work very unsatisfactorily.

Re-polishing

If you happen to have polished or varnished a piece where it has not gone satisfactorily you may want to remove it and start again. This can be done by one of the solvents you can probably obtain from a hardware store or by soaking a piece

of rag in methalated spirits and applying this to the surface of the work.

The spirit will dissolve the body which may then be scraped off. The surface will have to be kept wet with spirit by frequent application of a soaked rag. The wood, of course, must be left for some time before re-used, and even then must be given a rubbing of glasspaper to



A comfortable and effective rubber

get the surface perfectly smooth.

It may seem a little difficult to hold the work for polishing, but there is always a method which a little ingenuity will provide. For instance, you can drive in a screw hook on the

back of the board to form a handle. You can put nails through a board and so hold the work on to their projecting ends on the bench.

You can fit a strip of wood to the edge of a piece of moulding to form a handle, or two bench stops can be screwed into the bench against which the work is held during the process.

Box Support

Or again, if you are doing a frame box, you can nail a projecting strip of wood to stick out beyond the end of the bench and hang the box on it as a support whilst the polish is drying, or during the actual work.

As mentioned previously the first attempt at polishing should be made on a piece of waste wood so that you can get the "feel" of it before doing the actual job. Do not be disheartened if the first experience is unsatisfactory. Try again and you may find that you have dropped into the way of doing it quite easily.



Improving Varnish

I VARNISHED my door and put the varnish on too thickly; it ran and is terrible looking. Could you help me out in any way? (A.W.—Co. Down).

YOU can remove the excess varnish on the door by vigorous action with coarse glasspaper of the kind known as "wet and dry." Keep it well moistened with water while rubbing the varnish. This is to stop the varnish heating and lifting or spoiling the paint and graining beneath it. It is a tedious but effective method, and you can do it a little at a time. The only possible alternative is to use a caustic "paint remover," but this will more than likely spoil the graining.

Fixing a Weathervane

FOR some time I have been trying to make and set up a weathervane in my garden. It seems to me that there must be some physical law governing the exact position for the bearing upon which the cock turns to the wind (G.W.—Norwich).

THE fundamental law governing the position of the vertical axis or pivot of any weathervane, is that the area in square inches of the surface of the leading part of the vane (no matter what its shape) multiplied by the distance from the centre of gravity of that area—to the vertical axis (in inches) shall be less than that of the following part, similarly

calculated. Conveniently, the following part (or tail) may be $\frac{3}{5}$, and the leading $\frac{2}{5}$, but there is no hard and fast rule about this; it affects the speed of action of the vane, and is affected by the amount of friction in the bearings.

An Electric Guitar

PLEASE supply me with any information as to making an electric guitar. (G.M.—Newcastle-on-Tyne).

THE term "electric guitar" is colloquially applied to a variety of musical instruments, and we cannot decide from your letter to which of them you refer. In the simplest form, a loudspeaker trumpet is firmly attached to a hole in the sounding board and to some extent amplifies and alters the normal tone. In another form, a single string is stretched across a small microphone in the sound board, which has a loudspeaker trumpet and diaphragm energised by the induced currents from the microphone. A development of this idea consists in the use of a battery or other source of power to actuate the microphone and loudspeaker, and to amplify the sounds.

Bunsen Blast Furnace

I WISH to construct a blast furnace and have a suitable bunsen, but unfortunately gas is not available. (T.O'N.—Co. Dublin).

THE only practicable way of making a bunsen burner when

Extracts from some of the answers we have sent to readers recently, which may also be of interest and service to others.

gas is not available, it to use a blow-lamp burning paraffin oil. The lamp should be bought ready-made, not home constructed. Carbide or acetylene gas is *not* suitable. Calor gas is a proprietary product; it is obtained in steel cylinders under high pressure, but can be used for the purposes of a bunsen burner. It cannot be made at home.

Arrow Points

I AM making a bow and arrow, but cannot think of a way of putting points on the arrows. (P.P.—Bridport).

THE regulation "pile" or point for an arrow consists of a cylindrical metal tubular portion, into which the shaft fits, and a steel point. If a metal turning lathe is available such "piles" could be turned and bored from the solid, but if such a tool is not to hand, a simple tubular ferrule could be fitted to the shaft and a sharpened nail driven into the end of the shaft, the projecting part of the nail being about $\frac{1}{4}$ in. long and filed to a sharp point. Another method is to cut a piece of tinfoil to a wedge shape, roll it up to form a long tapered cone or "extinguisher," and solder a nail into the point thereof and also solder the joint in the piece of tinfoil. All the foregoing are preferably fixed to the shaft by first carefully fitting the shaft to the "pile," and then fixing it with Le Pages glue smeared over the shaft end and having a few turns of cotton wrapped around the moist glue, and then forcing the "pile" on with a twisting motion.

How to use an earpiece to make a practical SMALL LOUDSPEAKER



Fig. 1—Extension loudspeaker which can also be used as microphone

MOST mains-operated and battery-operated wireless sets are provided with extension loudspeaker sockets. This permits, of course, an extra loudspeaker to be worked in another room.

The horn, or amplifier, is the first part to make. It is best made from thin, stiff, ticket-card, this being obtainable at almost any art shop. Card about 1/32in. thick is ideal stuff, including a thinner variety that resembles ordinary post-cards. Both are not flabby, yet bend easily.

The horn, you see, must be firm in structure, otherwise it will not "amplify" the sound to any degree. Therefore, as much depends on its structure, take care and patience—use only the material suggested; it may be unwise to make use of a substitute.

Setting out the Parts

With pencil, compasses and set-square, mark out the quadrant-shaped body piece detailed at Fig. 2. The 1/4in. wide joining tab must not be creased or scored; just rule a line along for guidance. Note the size of the joining tabs to be cut at the corner of the shape; the top, or outer, tabs are 1/4in. long. It is a matter of ruling the curved line and then snipping the card with the scissors.

Having done that, smear tube glue along the joining tab and bend the card into a poke-shape so the other end goes on top, even with the tab all along. In order that you may be able to press the glued ends together at the "point" of the poke, a piece of 1/8in. dowelling, or a pencil, should be inserted through the work and held beneath the joint.

Top and bottom "stiffening" pieces have to be adhered to the body

of the horn, as shown at Fig. 3. These parts are detailed at Fig. 2. You need two of each of the shapes shown. To mark them on the card, simply scribe the diameters stated.

To provide fixing tabs in the smaller end pieces, make four cuts in the centre with a sharp penknife, or with a 1/4in. wood chisel. The fixing tabs in the larger end pieces are made by first cutting out the centres; the inner edge of the rings thus formed are serrated, as shown, with the scissors.

Bend the pointed tabs upwards in one ring, as shown, then having turned out the tabs at the wide end of the horn, turn the work downwards on the table and glue the ring to the horn (see Fig.

3). The other ring, it will be observed, has its pointed tabs fitting to the inside of the horn, being fixed on from the opposite side.

Finishing the Horn

Have the wide end of the horn sitting on a flat surface. Press both rings neatly together so the horn tabs are flattened neatly between them. A small, flat stick should be pushed around the edging, much in the way that you might press the brim of a hat with a smoothing iron.

The Bottom Ends

The bottom end of the horn is the smaller end. One end piece is "opened" in the centre by pushing a finger through. It is glued over the point of the horn level with the bending line of the tabs provided. These tabs are then glued and bent over on the end piece and pressed flat. The second end piece has its pointed tabs glued *within* the point of the horn, the flange going on top of the other

end flange, as can be seen in the diagram on the left.

The diagram on the right shows a thickening ring built up from three rings of card. One could use a piece of 1/4in. plywood, or 1/16in. stuff. The rings are, of course, cut 1 1/2ins. diam., with a 1/4in. hole in the centre. When the horn has been glued together, set it aside to dry; make sure that all joining tabs are properly adhered.

Making the Base

A suitable base for the reproducer, i.e., the ear-phonc, is now made. It could be made out of a solid block of wood, but for convenience and simplicity, we show how it can be built up from separate parts.

The top piece, detailed at Fig. 4, is cut from 1/4in. wood. The 1 1/2in. hole to be cut in it is to take the back of the ear-phonc casing. As it must be a neat, tight fit, measure your own phonc and find the exact diameter required. Two terminal holes must be made in the top piece, the position being indicated by the measurements.

Now, the block on which the top rests could be prepared from a solid piece of wood measuring 1 1/2ins. long by 2 1/2ins. wide by 2 3/4ins. deep. However, two triangular-shaped side pieces are cut from 1/4in. wood to the size indicated by the dotted lines at Fig. 4. To shape the centre piece, ignore the dotted lines. The centre piece is cut from a piece of 1 1/2in. square wood.

Glue the sides to the centre block, then add the top piece (see constructional view at Fig. 5). The bottom is added, this being cut to the size and shape detailed at Fig. 6, using 1/4in. wood. The fore edge of the top piece requires to be cut to a suitable bevel so the block rests flatly on the bottom. The bottom, by the way, should only be screwed to the work,

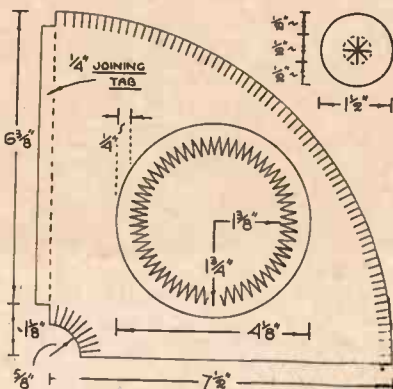

Fig. 2—How to cut the card trumpet parts

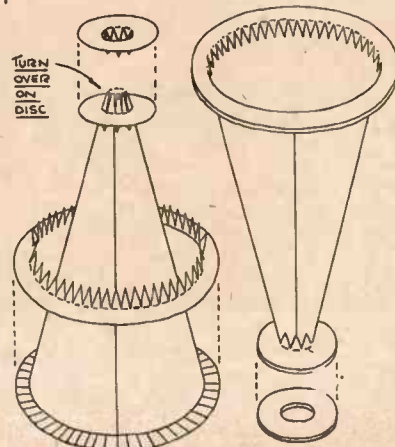

Fig. 3—Constructional details of horn

as you might need to remove it at some time.

The horn now only remains to be

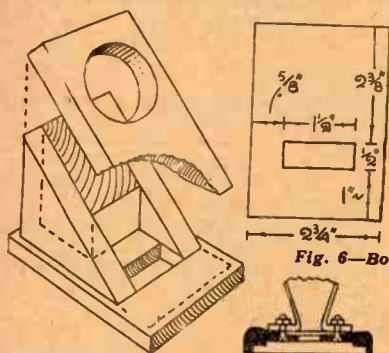

Fig. 6—Bottom parts

Fig. 5 (above)—
Flowing construction
of base

Fig. 7 (right)—
Section of earphone
and view showing
drill holes



affixed to the phone. To do so, unscrew the cover, then drill three holes in it (refer to Fig. 7) for three small bolts having flat heads. It is essential that the bolts are brass and flat-headed. Iron is apt to interfere with the diaphragm in the phone, whilst the bolt heads, unless counter-

sunk in the cover (see sectional view at Fig. 7) will also interfere with it.

Having drilled and countersunk the three holes in the ear-phone cover, set the horn on top and pencil the

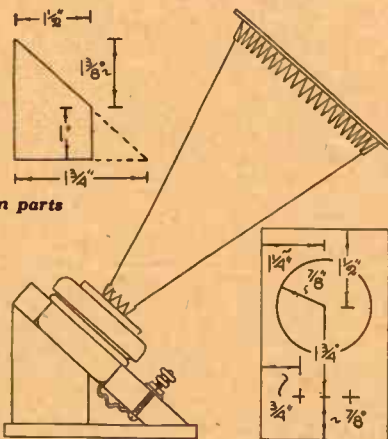

Fig. 4—Side elevation and detail of base top

hole positions on the bottom. Pierce, or drill, suitable holes in same and bolt (or screw) the horn to the cover.

The horn, at this stage, should be given three coats of shellac varnish

or polish. Ebony black is an ideal colour. The outside should be given three separate coats, the inside requiring a single coat only. The polish helps to stiffen the amplifier a great deal, thereby improving its amplification power.

Connecting the Phone

The old connections in the phone must be removed, replacing same with two new, thin, flexible wires. These wires, as can be seen at Fig. 4, are brought along to the heads of the terminals and connected to them. It may be necessary to remove the bottom piece of the base.

In conclusion, the miniature model makes a really fine type of microphone. The horn, of course, catches sounds very easily and these sounds converge upon the diaphragm in a concentrated form and are thus more effective in producing "sound vibration" on the diaphragm. The permanent magnet twin coils behind the diaphragm are affected as a result, and stronger, electrical impulses are set up.

No battery is required. The loud-speak-cum-microphone provides its own electrical energy, the same as a pick-up. As a temporary article, in either instance, you could not wish for any better.

The handyman should know the meaning of common ELECTRICAL ABBREVIATIONS

THE beginner interested in electricity is often "stumped" in respect to many electrical terms given as abbreviations. What, for instance, does "M.E.S." mean? This abbreviation frequently occurs in instructions for making novelties, etc., which require flashlamp bulbs and fittings.

M.E.S. stands for Miniature Edison Screw. Thus, instead of

referring to a bulb for a flashlamp as a flashlamp bulb, we should call it an M.E.S. bulb, this also applying to the holders. More often we get abbreviations written without any full stops, such as MES, which is rather confusing, to the amateur electrician, at least.

Readers interested in radio (wireless) may find it difficult to "read" a simple circuit layout on account of the "united" abbreviation letters.

The matter set out in the panel will, therefore, be greatly appreciated for reference purposes.

Naturally, space does not permit a full text of the terms used in electrical engineering. Those given are the terms most frequently used and which, incidentally, can be a big drawback if one is not conversant with the meaning of them. To our knowledge, such abbreviations do not appear in ordinary dictionaries.

TYPES OF WIRES USED

B and S—Brown and Sharpe's gauge.
B/D or Brd—Braided wire.
BWC—Birmingham wire gauge.
DCC—Double cotton-covered wire.
DIR—Wire double-lapped with pure rubber.
DPC—Double paper-covered wire.
DPR—Double-lapped pure rubber-covered wire.
DSC—Double silk-covered wire.
DWC—Double white silk-covered wire.
HD—Hard-drawn copper wire.
HC—High-conductivity wire.
SCC—Single cotton-covered wire.
SD—Soft-drawn copper wire.
SIR—Wire with single rubber lapping.
SSC—Single silk-covered wire.
SWG—Standard wire gauge.
TCC—Triple cotton-covered wire.
TPC—Triple paper-covered wire.

GB—Grid Bias (battery).
HT—High tension (battery).
IFT—Intermediate-frequency transformer
LS—Loudspeaker.
LT—Low tension (battery).
MA—Mains aerial.
MC—Moving coil (loudspeaker).
P or PC—Padding condenser.
Pen.—Pentode (valve).
PM—Permanent magnet.
PU—Pick-up.
R—Resistance (or resistor).
S or Sw.—Switch.
Spk.—Loudspeaker.
T or TC—Trimming condenser.
TI—Tuning indicator.
Tri.—Triode (valve).
Trans.—Transformer.
V—Valve.
VR—Variable resistor.
VC—Variable choke.
WC—Wave-change (switch).

Amp.—Ampere.
AVC—Automatic volume control.
Cgf.—Grid-to-cathode capacity.
cps.—Cycles per second.
CR—Cathode ray.
CW—Continuous wave.
DC—Direct current.
EMF.—Electro-motive force.
FM—Frequency modulation.
FR—Field resistance.
HF—High frequency.
ICW—Interrupted continuous wave.
kcs.—Kilocycles.
L—Inductance.
M/a or ma—Milliamperes.
mc.—Megacycle.
mfd.—Microfarad (or microfarads).
osc.—Oscillator.
Pfd.—Pico-farad.
RCC—Resistance-capacity coupled.
Rec.—Rectifier.
RF—Radio frequency.
SG—Screen grid.
SW—Short wave.
Sync.—Synchronising.
TRF—Tuned radio-frequency.
USW—Ultra short wave.
v.—Volt.
X's—Atmospherics.

ELECTRICAL COMPONENTS USED

A or AB—Aerial.
C—Condenser (or capacity).
EHT—Extra high tension (battery).
ES—Extension speaker.

GENERAL TERMS USED

AC—Alternating current.
AC-DC—All mains.
AF—Audio frequency (or low frequency).
AFC—Automatic frequency control.

MISCELLANEOUS ADVERTISEMENTS, etc.

The advertisements are inserted at the rate of 3d. per word or group of letters prepaid. Postal Order and Stamps must accompany the order, and the advertisements will be inserted in the earliest issue. Fretwork goods or those shown in Hobbies Handbook not accepted. Orders can be sent to Hobbies Weekly, Advertisement Dept., as below.

10 MINT PICTORIALS, album, perforation gauge, watermark detector, 2/3.—Ahdown, 164 Woodward Road, Dagenham.

15 FREE STAMPS, and Bargain approvals.—Brett, 16 Heathway Court, London, N.W.3.

TOYS—Make them yourself from oddments. Range of assorted, fascinating, popular designs with full instructions 2/6d. only, post free. You will be delighted.—Harrod, 10, Beaconsfield Road, Maidstone.

LONELY? Join Friendship Circle. Details 6d.—Secretary, 34 Honeywell Road, London, S.W.11.

SET U.S.A. DEFENCE STAMPS FREE to all sending 2½d. for Approvals.—Ramsey, 168 Legsbay Av., Grimsby.

STAMPS FREE! Twenty unused (2½d.).—G. H. Barnett, Limington, Somerset.

24 ATTRACTIVE SETS available 7 to 10 stamps. Send shilling and choose sample set. Australia, New Zealand, Czechoslovakia, Greece, Poland, Luxembourg, Mozambique, South African War.—A. E. Marsden, 33 Belsize Square, London, N.W.3.

FREE!! 25 KG. VI. Request Approvals (2½d.).—H. Thompson, 21, Springbridge, Road, London, W.5.

BE TALLER! Quickly! Safely! Privately! No Appliances—No Tablets—No Dieting. Details, 6d. stamp.—Malcolm Ross, Height Specialist, BM/HYTE, London, W.C.1

LONELY? Then write Secretary U.C.C., 5B.B. Hay St., Braughing, Herts. Genuine. Est. 1905.

MODELS: you can make lasting stone-hard models with Sankey's Pyruma Plastic Cement. Supplied in tins by Ironmongers, Hardwaremen, and Builders' Merchants. Ask for Instruction leaflet.

APPROVALS on request.—A. Warrington, Letham, Bearsden, Glasgow.

MODELS of Naval Ships and Aeroplanes to build in wood. Full patterns and instructions. Send 2d. for leaflet.—Hobbies Ltd., Dereham.

MODEL Working Gun Patterns No. 228 Special. Made in wood, with automatic action. Design, price 9d. Complete parcel of wood, 7/4 post free.—Hobbies Ltd., Dereham, Norfolk.

OO GAUGE RAILWAY. Designs in making an Engine Shed, Signal Box, Footbridge, Railway Station, Fencing, etc., 10d. the set, post free.—Hobbies Ltd., Dereham.

HOBBIES still make Fretwork Outfits and some tools, but owing to war needs supplies are short and immediate delivery cannot be guaranteed. Make enquiries before you order. Hobbies Ltd., Dereham.

S.W.A. FREE



This very attractive **SOUTH WEST AFRICA** stamp can be yours, **ABSOLUTELY FREE.** It is a very difficult stamp to get nowadays; was issued in 1931 by the government of **SOUTH WEST AFRICA**; is printed in two colours and shows a peculiar African bird. This bird is a large Bustard and is known as a "Gum Peacock" because it feeds on mimosa gum, as well as grasshoppers. The design at the sides of the stamp is comprised of the bird's footmarks.

YOU can get this scarce and interesting stamp from us **ABSOLUTELY FREE.** It will add value and interest to your collection and be the envy of your friends. All you have to do to get it is (1) Ask for **FREE S.W.A. STAMP**; (2) Ask for Approvals and Price Lists; (3) Write clearly your name and full address; (4) Place 3d. in stamps (to cover cost of Lists and postage to you of the Approvals and the Free S.W.A. stamp) inside your letter and post it to:—

WINDSOR STAMP CO. (Dept. 12), UCKFIELD, SUSSEX.



A MODEL IN PYRUMA

Made for the Daily Express by Brian Adnams, this model is stone hard and in natural colour. It was modelled in plastic Pyruma, air-dried, sized and painted with poster colour. Pyruma Plastic Cement, in air-tight tins, is obtainable from Ironmongers, Hardwaremen, Hobbies Shops, Basset-Lowke Depots, and many Art Material Dealers from 1/3 a tin.

ILLUSTRATED INSTRUCTION SHEET

J. H. SANKEY & SON, LTD.

ILFORD

Est. 1857

ESSEX.



MAKE FRIENDS ALL OVER THE WORLD

The first step towards true international friendship is a common language. **ESPERANTO** is the international, auxiliary language already spoken in over a hundred countries. Start learning it straight away, and do your share towards a better post-war world.

A correspondence course costs only 5/- including textbook and correction of exercises

Write for full particulars to:

BRITISH ESPERANTO ASSOCIATION INC.
Dept. H.9 - Heronsgate - Rickmansworth - Herts.

THE ARROWS INDICATE THE DIRECTION OF GRAIN OF WOOD.

CHAMFER



RAIL L CUT ONE



INSIDE GUIDE 4. CUT TWO.

MOVING FRONT F. CUT ONE.



CHAMFER

3 5/8"

BLOWING FLOOR. CUT ONE TO LENGTH SHOWN.

CHAMFER



BRACKET K. CUT TWO.

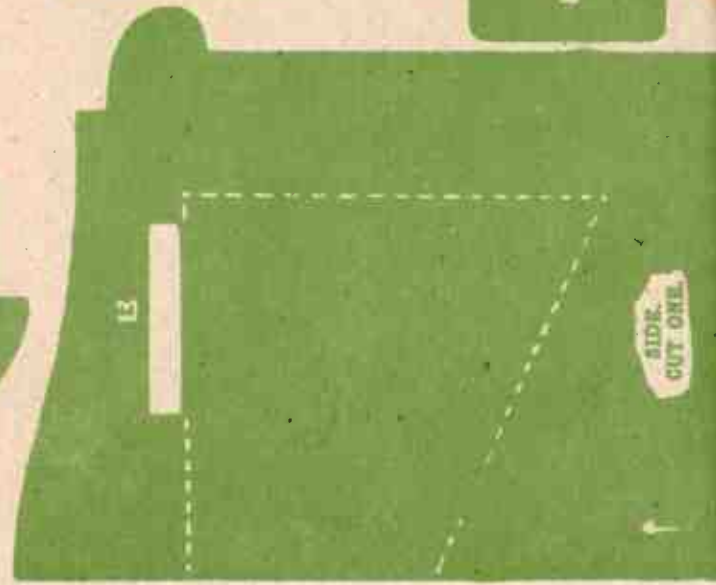

B

SIDE. CUT ONE.



RAIL E. CUT ONE.

CHAMFER

SECTIONAL DIAGRAM SHOWING CONSTRUCTION WITH FRONT DOWN.



B

KNOB

CUT ROUND ON THIS LINE ON THE LINE TO FORM DOOR.

HINGE



TOP. CUT ONE.



RAIL G. CUT ONE AND CHAMFER

THIS RAIL IS TO BE GLUED TO FRONT F.



KNOB. CUT ONE.



A

POSITION OF INSIDE GUIDE TO BE GLUED IN.



RAIL I

BRACKET K

K

FRONT E. CUT ONE.

RAIL J
CUT ONE

RAIL L
CUT ONE

CHAMFER

CHAMFER

3 5"

SLOPING FLOOR.
CUT ONE
TO LENGTH
AS SHOWN.

CHAMFER

CHAMFER

HINGE

BEHIND THIS LINE
IS FRONT DOOR.

KINGS

RAIL G.
CUT ONE
AND CHAMFER.

BE GLUED TO FRONT P.

RAIL I

RAIL K

Hobbies

DESIGN

No. 2542
E. T. 4A.

SUPPLEMENT TO HOBBIES No. 2542.

AUTOMATIC CIGARETTE

BOX

MADE TO HANG ON WALL

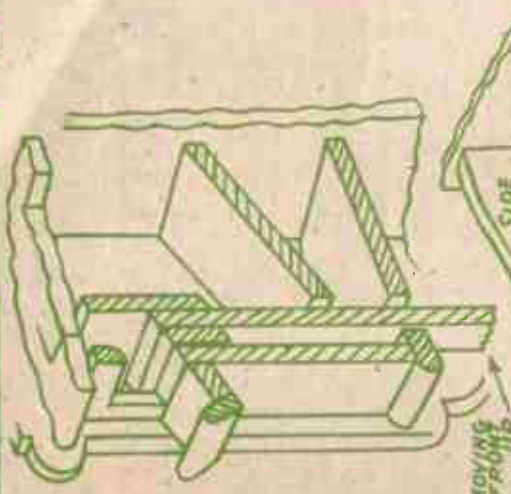

MOVING FRONT

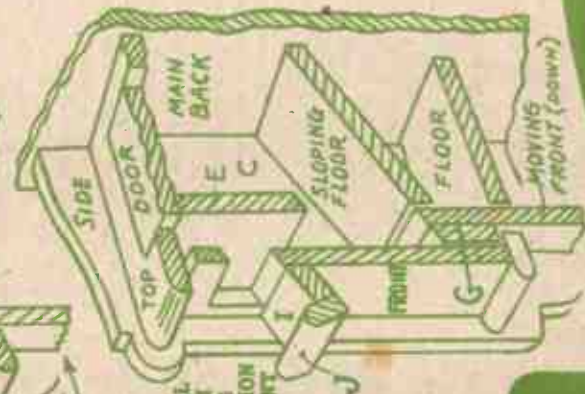

SECTIONAL DIAGRAM SHOWING CONSTRUCTION WITH FRONT DOWN.

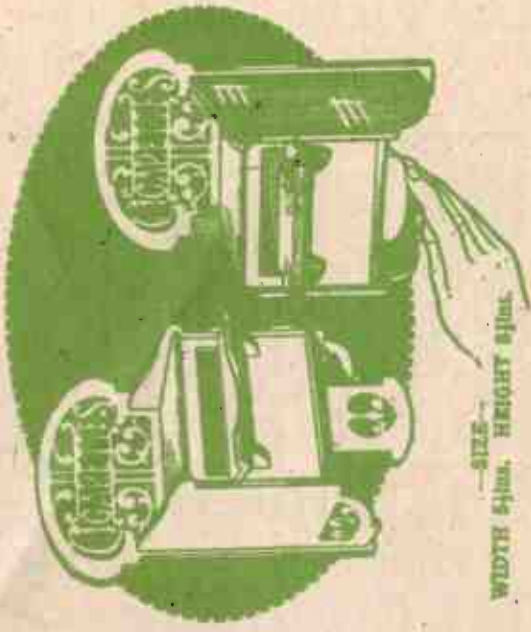

—SIZE—
WIDTH 5 1/2 IN., HEIGHT 5 IN.

PANELS OF WOOD REQUIRED FOR THIS DESIGN

TWO H3

This price is shown in Hobbies Weekly, July 5th 1944, but is subject to revision. See the current edition of Hobbies Handbook, or write for prices to Hobbies Limited, Dereham, Norfolk.



TOP

NOTE:— This design sheet is only granted free with the current issue of Hobbies.



SIDE.
CUT ONE.

KNOB.
CUT ONE.

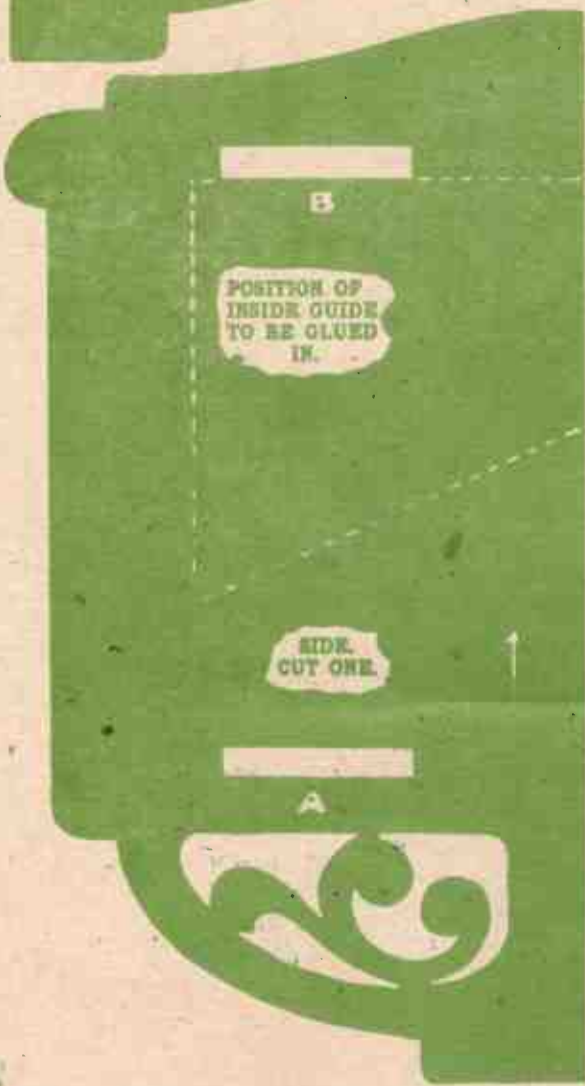

POSITION OF
INSIDE GUIDE
TO BE GLUED
IN.

SIDE.
CUT ONE.



RAIL E.
CUT ONE.

CHAMFER



CUT ROUND
ON THIS LINE
TO FORM DOOR.

HINGE



TOP.
CUT ONE.



RAIL G.
CUT ONE
AND CHAMFER.

THIS RAIL IS TO BE GLUED TO FRONT F.



RAIL E

BRACKET K

FRONT H.
CUT ONE.



FLOOR.
CUT ONE. CUT THROUGH
ON LINES XX AND GLUE
ON THE FRONT PIECE AFTER
THE MOVING FRONT F HAS
BEEN LAID IN POSITION IN
THE SLOT.

SLOT

ROUND OFF THIS EDGE



SECTIONAL
DIAGRAM
SHOWING
CONSTRUCTION
WITH FRONT
DOWN.

CHAMFER

CHAMFER

CHAMFER

HINGE

BOUND THIS LINE FORM DOOR.

KNOB

OF ONE.

RAIL G. CUT ONE AND CHAMFER.

BE GLUED TO FRONT F.

RAIL I

K

FRONT H. CUT ONE.

FLOOR. CUT ONE. CUT THROUGH LINES XX AND GLUE THE FRONT PIECE AFTER MOVING FRONT F HAS BEEN LAID IN POSITION IN THE SLOT.

SLOT

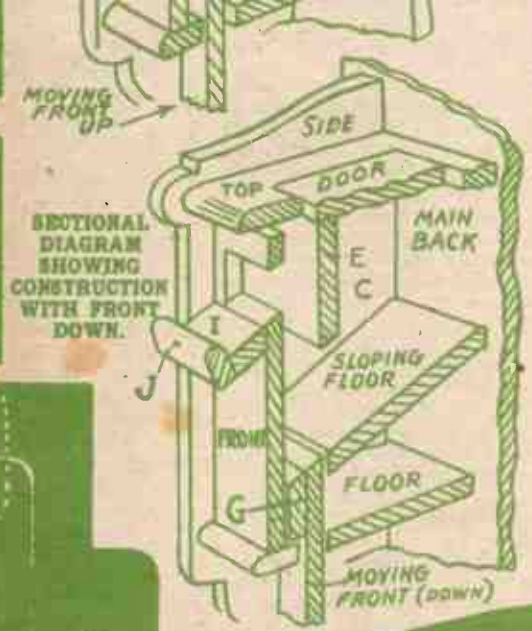

PANELS OF WOOD REQUIRED FOR THIS DESIGN

TWO H3

The price is shown in Hobbies Weekly, July 5th 1944, but is subject to revision. See the current edition of Hobbies Handbook, or write for price to Hobbies Limited, Dereham, Norfolk.



AUTOMATIC CIGARETTE BOX

THE model which can be cut in fretwood from the patterns on the other side of the sheet is of different style from any we have published previously, but is equally ingenious and attractive in its working. The cigarettes are held in the container which forms the main box, and when the drop portion seen below the front is lifted, a cigarette comes through the slot and rolls into the little receiving trough ready to be extracted.

As often as this piece is raised, so a cigarette is automatically delivered. All the parts are cut from 3/16in. wood, and those patterns which are shown to plain outline should be just marked out direct to the boards concerned.

In the case of the sloping floor, the length is 3 3/8 ins. extended in the direction shown by the arrows. The patterns with the fretted portions are the only ones which really need fastening down, and even then some marks should be made on the board to indicate where adjoining pieces have to be glued or fixed so that this is obvious after the pattern remains have been cleaned away.

The mechanism and interior should be built carefully, taking pains to see that the moving parts particularly are correct. Edges must be straight and smooth, and any chamfered portion cut to the shaded section shown on each piece.

It is best to make the two sides, top and interior of the box first, and then to fix it finally to the main back in the position shown by the dotted lines. Measure the parts up carefully before fixing so that they are correctly placed and everything is working smoothly before finally adding this back.

First of all, get the two sides, the top and the floor and front. Cut the parts carefully and study the cut-away diagrams of the two details on the sheet. The top has a centre panel cut from it to provide the door, and this can be hinged either with the fancy metal hinges, or by a simple piece of tape along the back. A little odd knob can be glued on to the centre front where shown.

The floor is first cut as one piece, and then a strip cut off the front on the line marked X. Then cut the rebate piece shown as the slot, and make this deep enough to allow the moving front to slide easily in it.

Fit the top and the floor into the sides by means of the tenons at A and B. Now add the moving front F and notice that its top edge must be chamfered to slope forward. This top edge has also the rail G glued on, and the chamfer continued through the whole thickness. You can see it in the detail in place.

When this sliding front has been laid in position, glue on the strip of the floor which was previously cut away after rounding off the front edge. The moving piece is thus held in place but allowed to slide up and down.

To each side, coming immediately under the top and in line with the back edge, is the guide piece C. Notice the dotted lines on the pattern of the side giving the exact position. Between these two guide pieces across the front the piece lettered E is glued. The top edge of it acts as a stop to prevent the door falling inwards. This piece E forms the backboard for the moving front.

A sloping floor is next added to force the cigarettes to roll forward for delivery. Its two long edges are chamfered to a shaded section so it will lie flat against the main

back and against the back of the moving front portion. You can see it in position in the detail.

This floor is glued below the side guide pieces, and can also be stiffened up from beneath with little strips if necessary. Try the movement of the sliding piece now to ensure satisfactory movement, and if necessary add the graphite from a pencil down any edges which have a tendency to stick.

The front can be added after its little trough has been glued on. This is made of the rail I and the front stop rail J. The back edge of the rail I must be planed to a chamfer to form the slope, and notice also that the edge of the opening in the front must be similarly angled off before gluing the trough piece in place. You can see this also in the detail. Two little segment brackets K help to hold the trough piece in place. They are glued into the angle 1/4 in. inwards from each end of the front.

When the whole front is satisfactory, it is carefully glued between the sides, floor and top. In fixing, apply the glue very thinly and see it does not ooze out behind to affect the movement of the sliding piece. Little headless nails can be driven through the sides to keep it upright.

Test the moving parts before finally fixing this front, to ensure there is just room for the slide piece to run comfortably. The whole of the main portion is now complete, and can be fixed as a box on to the main back.

This part has had its lettering and fretted portions cut, and a drill hole or two made from behind to indicate the position of the sides, top and floor. When the whole lot is glued together, small screws or panel pins can be driven in to stiffen the whole thing up.