

# Hobbies

## WEEKLY

June 7th. 1944

Price Twopence

Vol. 98. No. 2538

WITH exception of a few bars of thin metal, the pram shown is an all-wood affair, constructed to use up small cuttings. The pram sizes are moderate, but if a doll's pram is wanted, all dimensions shown can be reduced by half. Wheels can be plain discs, with thin hub pieces glued on at each side, instead of being spoked as detailed.

It will be noticed from the elevations at Fig. 2 that the body of the pram is not mounted on springs. If springing is a feature desired, it is possible to fit four steel bicycle saddle springs, these being about 3ins. long. It means making the axle supports 3ins. less in height.

## A UTILITY MODEL DOLL'S PRAM

As you know, bicycle saddle springs are affixed by bolts and nuts. Therefore, it is a comparatively simple matter to incorporate them in the chassis work. The wheels, by the way, although made from wood, with dowelling for spokes, are strong and lasting. They are a fixture on their

metal axles, the latter revolving in the support prongs.

### The Body Sides

The body sides are built up from pieces of  $\frac{1}{2}$ in. wood to the size and shape shown at Fig. 3. The pieces are best doweled together, using  $\frac{1}{8}$ in. diameter dowelling. Prepare both sides identical. The canopy railing is then made.

The railing consists of a slanting rail 19ins. long by  $1\frac{1}{2}$ ins. wide, with a top piece 9ins. by the same width as can be seen. The top rail is doweled to the top part of the body shape, with the end half-checked for the slanting rail.

The latter is half-checked, too, at the top (see inset detail). In order to have the slant rail flush against the interior side of the body shapes, its position is marked with a pencil across the work, and the work pencilled over it for half-checking as detailed.

### Assembly of Body

Having glued and screwed the canopy parts to the sides, all joints are levelled off with a smoothing plane. It is best, of course, not to cut the lower corners away from the body ends until the last.

Now the full width of the body should not be less than 15ins., that is, by inside measurement. Therefore, you will require several pieces of  $\frac{1}{2}$ in. stuff 15ins. long (or longer, if desired) by various widths.

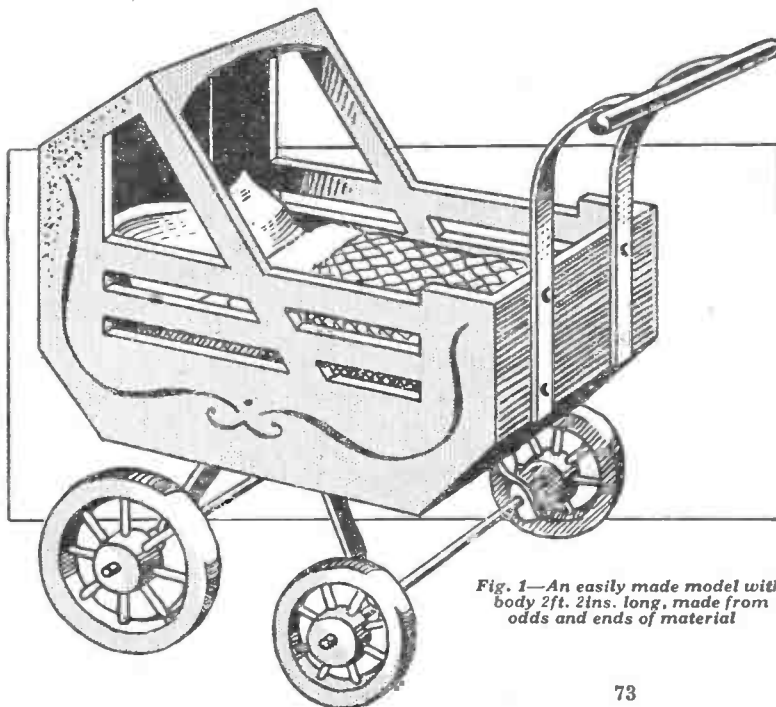

Fig. 1.—An easily made model with body 2ft. 2ins. long, made from odds and ends of material

These pieces are nailed between the sides to be flush at the edges and ends. A canopy "arch" piece (stiffened inside with angle blocks) is fitted at the front as indicated by the end view and illustration.

The leading wheels are 10ins. diameter, with the trailing wheels

rod;  $\frac{3}{8}$ in. diameter curtain rod can also be used. The axles must be a forced fit into the wheels; one wheel can be affixed on at this juncture on each axle.

#### Axle Supports

The axle supports like the pram

To keep the wheels suitably apart from the axle supports, divide the washers at each wheel with a wrapping of insulation tape. In regard to the pram handle, the two supports are drilled, then bent to shape and bolted on. The handle could be a piece of broomstick slotted to fit over the ends of the supports.

To prevent the handle coming off,

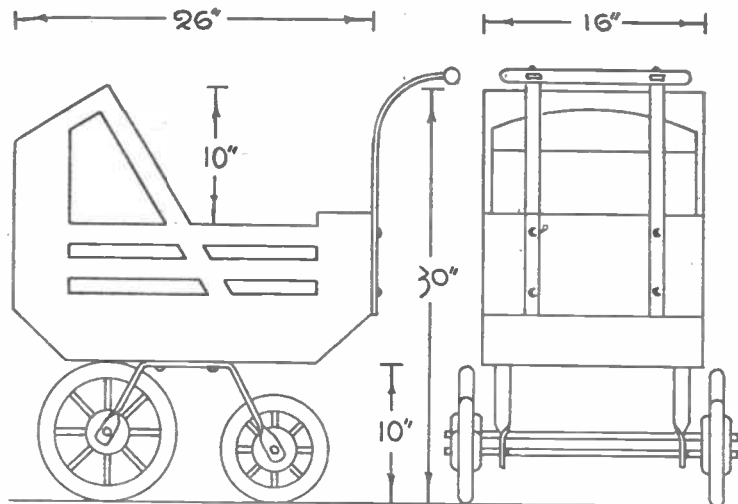

Fig. 2—Side view, with end elevations and helpful dimensions

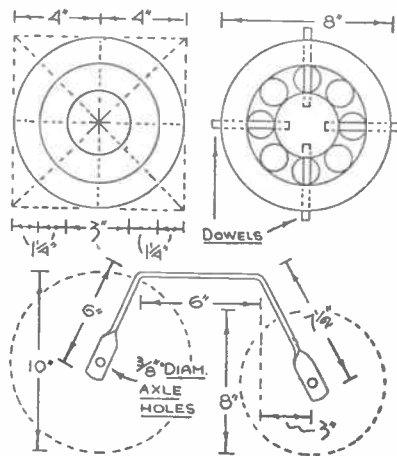

Fig. 4—Wheel discs marked out with sizes of metal undercarriage support

10ins. diameter, so four suitable squares of  $\frac{3}{4}$ in. thick wood are needed.

#### Wheel Construction

Scribe the rim and hub lines, then mark off the spoke guide lines, these being the dotted lines shown at Fig. 4. When you have done this, cut the wood to shape with a keyhole saw, or bow-saw, to make four plain discs.

The guide lines for the spokes are, when the circumference edges are spokeshaved, brought across the edge (use a set-square) and centred. Fit a  $\frac{3}{8}$ in. dowel bit in the brace and proceed to bore the spoke holes. The depth of these holes are  $\frac{3}{8}$ in. or  $\frac{1}{2}$ in. in the hubs.

Trueness in boring the holes is very necessary. When bored, select the smaller wheel discs and, fitting a  $1\frac{1}{4}$ in. centre bit in the brace, bore eight holes through the discs between the rims and the hubs as you can see.

#### Fitting the Spokes

The eight dowel spokes are then glued into the discs (we show only four in the diagram for clearness) and the waste wood between the spokes cut away with a chisel. All four wheels are made much in the same way. You might have to use a smaller centre bit and bore extra holes in respect to the larger wheels.

The hubs are faced on both sides with  $\frac{1}{2}$ in. thick  $\frac{3}{8}$ in. diameter capping pieces. The axle holes are then bored truly, the diameter depending on the thickness of the metal axles. One could possibly make use of round steel carpet rod or pick up mild steel

handle supports are made from mild steel bar (or anything similar) about 1in. wide by  $\frac{3}{16}$ in. (or less) thick. For the wheel supports two pieces  $19\frac{1}{2}$ ins. are wanted.

Bend to shape as shown at Fig. 4. A twist is put on at the ends, using a couple of sash cramps or one clamp and a bench vice. Bolt and axle holes are then drilled.

If  $\frac{3}{8}$ in. rod is used for axles, do not attempt to bore  $\frac{3}{8}$ in. axle holes in the supports right away. Make  $\frac{1}{2}$ in. holes first, then use a  $\frac{3}{8}$ in. drill. Such holes will be easier drilled.

Mount the supports truly in line on the bottom of the body keeping them inwards from the side about one inch (see end view). Prior to fitting the axles, slip on a couple of suitable metal washers. When the axles are inserted through the supports, slip on another couple of washers, then fix on the wheels.

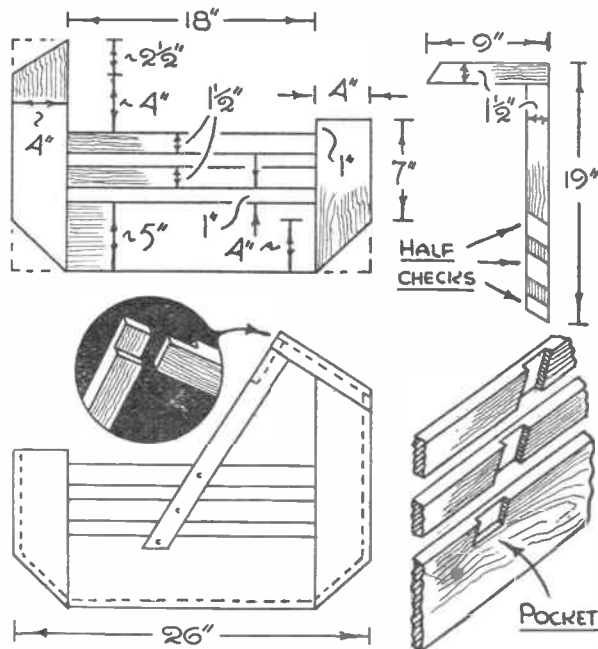

Fig. 3—Body work, showing use of comparatively small pieces

small holes could be drilled through the ends for the entry of roundhead screws. For a finish, give the body work, including the wheels, a couple of coats of dark blue enamel paint. The metal parts are black enamelled and the inside of the pram is given a coat of blue paint. When dry, apply oil to the wheel bearings.

# An easy-to-make elastic-driven realistic MODEL MOTOR BOAT

HERE is an interesting little motor boat to make up and run on a calm pond or lake. It is fairly simple to make, being bluff at the bow and therefore more like a surf boat. This method of building cuts out a lot of shaping which would otherwise have to be done with a boat having pointed bows and a shaped keel.

Our boat measures 14 ins. long, is  $3\frac{1}{2}$  ins. wide at the bow and  $2\frac{1}{2}$  ins. at the stern. These sizes make for a very workable model, not too small to handle comfortably and at the same time not unwieldy to act under the power suggested for it.

A good general idea of the boat can be gained from Fig. 1, which shows a side view complete and a plan beneath. The hull tapers both ways towards the stern making a speedy little craft in appearance, and the cabin too makes an interesting and attractive addition.

## Deck Outline

The sectional diagram in Fig. 2 shows the construction of the hull, while the squared diagram above this makes for simplicity in drawing out the true outline of the side of the hull.

To get the exact shape of the hull parts, draw out the deck first, as the

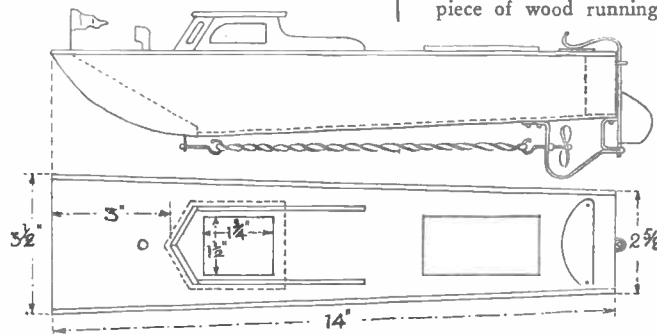
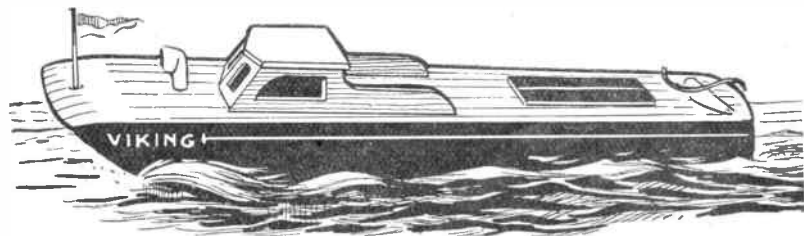

Fig. 1—Side view and plan, with dimensions

other parts can then be shaped up from this quite conveniently. Draw the shape of the deck on to  $\frac{1}{4}$  in. thick wood according to the measurements given in Fig. 1. Cut this round with the fretsaw and smooth up the edges with glasspaper.

Next prepare the stern block from a piece of  $\frac{1}{4}$  in. wood,  $2\frac{1}{2}$  ins. long and  $1\frac{1}{2}$  ins. wide. With the aid of the deck board as template, mark out the keel board or bottom of the boat.

This board is exactly the same shape as the deck but only  $10\frac{1}{2}$  ins. long from the stern, and it is  $\frac{1}{4}$  in. less in width. Glue and screw the keel



board to the stern block and then add two fixing fillets about  $\frac{3}{8}$  in. by  $\frac{1}{4}$  in. in section to the board as shown in the sectional diagram in Fig. 2. Use waterproof or marine glue for all the fixing of the wood parts.

## Hull Sides

Next prepare the two sides of the boat. These are  $\frac{1}{4}$  in. thick and cut to the outline shown in Fig. 2. By ruling  $1\frac{1}{2}$  in. squares over one of the pieces and adding the thick line as shown, the true shape may be had. This is then cut with the fretsaw, the second side being obtained by drawing round it.

Brush some glue on to the keel board and the fixing fillets and then lay on the sides weighting these carefully until the glue has hardened.

The bow block is next made, and this is shaped up from a piece of pine or deal  $\frac{1}{4}$  in. thick,  $3\frac{1}{2}$  ins. long by  $4\frac{1}{2}$  ins. wide. By having the grain of this piece of wood running crosswise as

outside surfaces of the boat must receive a good glasspapering to remove all grease and glue, and any cracks that remain should be puttied up.

At least three coats of paint should be well brushed on and allowed to dry before the hull is tested in water.

## The Cabin

The cabin is formed from  $\frac{1}{4}$  in. wood, and the four pieces which make up the sides are fixed to the deck and partially enclose the opening cut in the latter as figured in the plan, Fig. 1.

Cut all the pieces of the cabin accurately with the fretsaw, and clean off the bevels and angles with coarse and fine glasspaper. Cut a roof from  $\frac{1}{4}$  in. stuff as shown, to the measurements in the top diagram in Fig. 3, and glue and pin it on with fine brass fretpins. Round off all the edges before finally varnishing it.

The deck should be varnished also,  
(Continued foot of next page)

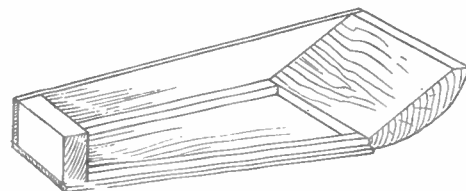

Fig. 2—Shape and construction of hull

shown, the shaping of the front curved face is simplified. Mark the taper of this bow block carefully using the deck as a template.

Fit the block in place, easing and cleaning away the wood as necessary to get a perfect fit between sides and keel board. Small gluing blocks can be added between the bow block and the sides of the boat for additional strength. The whole weight, however, should be reduced and kept down to a minimum.

The inside of the hull should be thoroughly painted before the deck is finally glued and screwed on. The

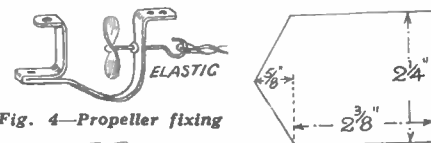

Fig. 4—Propeller fixing

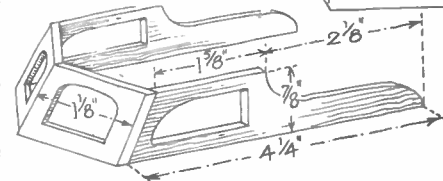

Fig. 3—Raised deck screen details



# Add to the realism of the training with these A.R.P. LECTURE FIGURES

A LOT of lecturing is being carried out at the moment by instructors in the new Fire Guard organisation, and all are on the look-out for anything that will bring variety and perhaps a little humour into the matter they have to put over.

Here then, is an idea used with

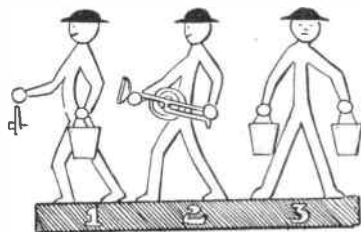

The figures carrying their correct pieces of equipment

considerable success by a Cheshire Training Officer to drive home certain points and introduce a shade of light relief into his special talk on the stirrup pump and stirrup-pump team.

The quaint figures shown in the diagrams represent the full stirrup-pump team of three persons and the "model," cut out of wood, hangs on a blackboard or other suitable place, to be referred to as the description of each member and his duties is reached.

## Hanging Equipment

The novelty of the whole scheme, however, lies in the fact that the hands are drawing-pins upon which the lecturer hangs, as the talk proceeds, the various items of equipment that each member should carry. The colouring is simple but vivid and the "cut-out" never fails to catch and hold the attention of the class.

Now with regard to construction, obviously the figures can be made in any size desired but the lecturer in question had adopted 1ft. 3ins. in length by 10ins. high. This gives a

"cut-out" that can be seen quite well by the usual audience.

Three-ply wood is used, base and figures being cut as one. Care should be taken by anyone making the model in the placing of the hands as they are all in particular positions to hold certain items and show clearly what they are holding. How this can be done is illustrated at fig. 1.

## Hung on Pins

Thus No. 1 has the axe hanging well away from his body to be plainly seen, while the hands of No. 2 are designed so the pump will lie nicely across the drawing pins and No. 3 is so positioned that it can be observed by all that he is carrying two buckets.

The items of equipment are shown in Fig. 2, being an axe, three buckets, and a stirrup pump. The axe and buckets have a thin wire loop just attached as shown but the pump lies on the pins of No. 2. Pillar-box red is used for the buckets, while the pump is painted black.

The curve of the handle is only lined in, no attempt being made to

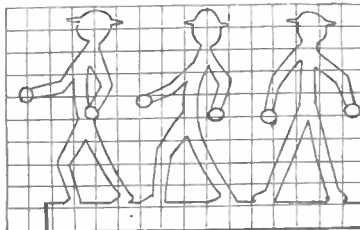

Squared diagram of figure shapes

cut out the hand space. The hose is blackened string of suitable diameter dipped in glue and coiled as realistically as possible against the further side. The division between the barrel and the stirrup can be cut out but this is not absolutely essential.

When everything is cut out and rough edges trimmed away undertake the general colouring. The figures are painted yellow (to stand out well against anything dark). The hats

may just be darkened in or may be painted the regulation white with the appropriate markings, or as much as would be showing in a side view, put on with a fine brush. The base is black with the team numbers in white. The "1," "2" and "3" should be put on in a very bold and

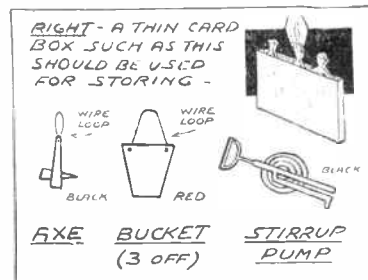

Fig. 2—Shape of equipment pieces

clear manner. Lastly, put in the drawing pins.

Faces are, of course, the merest suggestion of features effected with the small brush and a little black paint. Colour of equipment is as shown—i.e., buckets, pillar-box red; pump, lined in black; and the axe black. Leave the wire loops bright. The model is hung on a board, etc., by means of a loop of wire at the back of the central figure.

## Wider Application

Finally the model has a wider use than as outlined here, for it can be employed to illustrate the equipment that should be carried by a "damping down" party. It could also be used to demonstrate any of the various parties throughout A.R.P. and C.D. organisations that operate in groups of three.

The model is best kept and carried about in a thin card box as shown. Such carriers are readily made but at one time they were used extensively for putting photographic and similar materials through the post.

## Motor Boat—(Continued from previous page)

but before doing this, line it up with a hard pencil to represent planking deck lines being about 3/16in. apart.

We have dealt often in these pages with the method of propulsion by elastic, so that what we show and describe here will not come altogether new to most of our readers. Little need really be said as the complete outfit in Fig. 1 explains the method, while the independent diagram, Fig. 4, shows how the propeller frame is made.

Needless to say the hook and its connection at the bow must be sturdy and well made to take the strain from

the elastic when this is fully twisted.

The propeller frame, Fig. 4, is made from strip brass, a piece 5½ to 6ins. being sufficient for bending and angling up as shown. Drill the holes carefully, and do not weaken the brass by having the holes larger than necessary.

Solder the propeller to a stout wire stem bent up to form a hook for the elastic, and solder on also a stout conical washer to keep the propeller properly spaced in its frame.

Two or four strands of elastic may

be used according to the section of stuff adapted for the work. Put a little grease or oil on the conical washer of the propeller from time to time to keep it free running, and when the boat is taken from the water dry off the elastic and rub on a little french chalk.

A rudder may be made from stout wire to which a thin metal (tinned) or brass plate has been soldered. Shape the top of the rudder wire to come down over the stern and to slide upon a shaped deck plate as shown on the plan in Fig. 1.

# It will pay you to read and remember these points on FRET MACHINE CARE

**I**N these days, those of us who own fretmachines must certainly take greater care of them than usual. It pays to give them an overhaul every now and then, and to watch out for any worn parts, or those which may be becoming worn.

This question of spare parts is always a difficult one now, in that no firm can make spares or have them in stock in the same quantity they did formerly. In consequence, it is no use waiting until a part breaks before ordering, because the likelihood is that it may be some time before replacement comes through.

## Watch Worn Parts

Some parts, of course, are easily replaced, but where it is a question of castings or metal pressings, these are only undertaken periodically. If they happen to be out of stock at the time, then you will have to wait until the next consignment is made.

For this reason, keep a watchful eye on your machine to see if anything is becoming worn and likely to require replacement within a comparatively short time. The little wooden pitman is apt to wear a larger hole under the cutting table as it is used more and more. You will therefore do well to have a spare part in hand.

The same applies to the long wooden arm of the treadle in connection to the driving wheel. The hole may become larger than originally and sooner or later the part will require replacement.

## Makeshift

If, too, you find that when a part is ordered it may be some time before it can be replaced, then you must use a little ingenuity in providing a substitute to form a temporary repair.

Special wing-nuts may not be available, but even an ordinary square or hexagonal nut can be made to serve the purpose for the time being. It is a shame to be without

the use of your machine because you cannot get the actual piece required and do not take the trouble to think of a makeshift until the other part comes through.

## Careful Usage

One of the causes of breakage is, of course, rough usage, and in this connection some workers allow their machine to be badly handled, pushed about just anyhow. This must not be done now, and care should be taken that the machine is put away with due thought so that other things do not fall on it or anything be thrown near it likely to break it.

A good idea, indeed, is to get some suitable framework covering. If you put the machine in a cupboard, then have it under a wide shelf so there is no likelihood of damage being done to it by falling articles. After use, of course, you should always clean away the dust, and particularly the sawdust which may have accumulated on the working portions under the table.

## Oil Running Parts

Naturally, you will keep the machine in good condition with oil. Most of the trouble of worn parts, particularly in those which move, is in the lack of oil and the consequent increase of friction. It is not the flooding of the part which is required, but merely a thin film which should cover the moving pieces and work into the running parts.

Be careful to see the oil does not run off to the driving belt or into the grooves along which it works. If you do, it will only create slip, for the latter will not grip properly on to an oiled surface.

It may be, too, that you are wasting a lot of energy with a slack belt and becoming annoyed because it will not drive properly. This can easily be overcome by shortening the belt. Take it off the driving wheel and then lever up the ends of the little metal clip which holds the

two ends together.

## Renewing the Belt

Take one end of the belt away and cut off about  $\frac{1}{4}$  in. of it. With a fine awl drive a hole through the fresh end of the belt. Put the clip through this hole and bend over with pliers, then replace the whole thing on the driving wheel and the pulley wheels and you should have a very

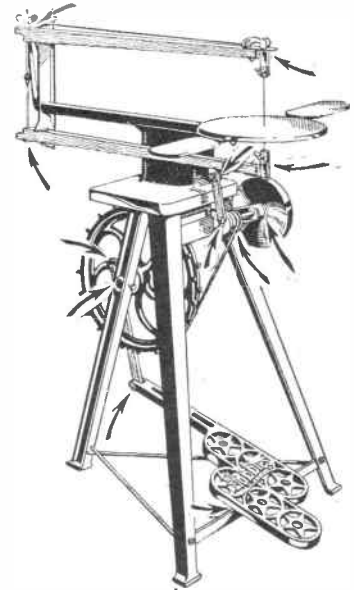

*The arrows indicate the parts of an A1 machine which occasionally need oil*

much improved action.

## Preventing Slip

If you find the machine is inclined to slip along the floor when in use, this all creates shake and liability to damage. Put a stop in the floor, if you can, to rest the back leg against.

A reduction of the noise of treadling can also be brought about by a thick pad of material, such as a piece of motor tyre or thick baize, or lino being fitted under each leg. Be sure to get each the same thickness.

If you have the machine in a permanent place for use, then it should be screwed down firmly to the floor by means of the holes and slots provided in the feet of the machine. A dust cover should also be provided for the whole machine if it stands anywhere where that trouble is likely to accrue.

As we said at the beginning, machines are valuable and becoming scarce, so that every owner will do well to take note of these hints and ensure that his own machine does not suffer from lack of a little attention.

## Our free design for an attractive BOOKSTAND

The Design (No. 2538) presented free with this week's issue is for this easy-to-build Bookstand and Drawer compartment for which complete patterns and instructions are provided. Hobbies Ltd. also supply a parcel of planed wood, in the correct thicknesses, for 8/5 or sent post free for 9/- from Hobbies Ltd., Dereham, Norfolk.

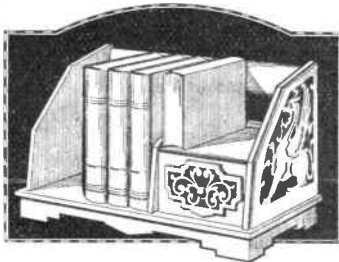

# Lighten the loads of the housewife by making A SHOPPING CARRIER

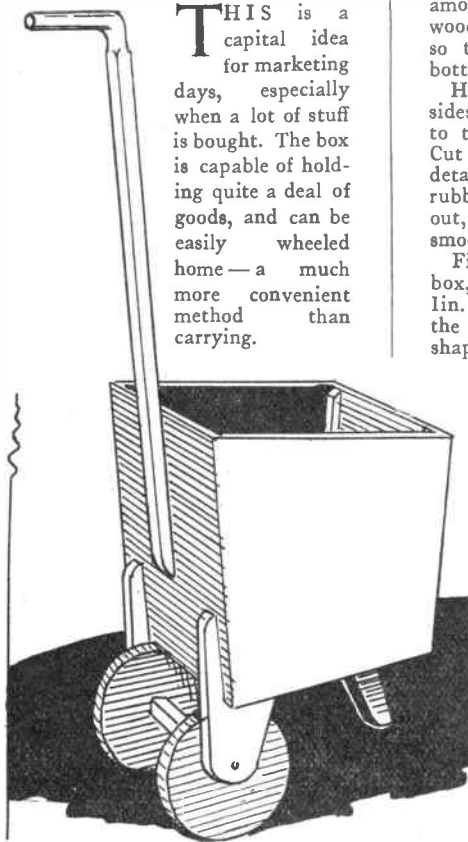

**T**HIS is a capital idea for marketing days, especially when a lot of stuff is bought. The box is capable of holding quite a deal of goods, and can be easily wheeled home—a much more convenient method than carrying.

amount equal to the thickness of wood used for the bottom of the box, so that space will be left for the bottom to fit well in.

Having fixed the fillets, screw the sides of the box to the ends, screwing to the fillets it will be understood. Cut the bottom and nail it in, as in detail, Fig. 2. Give the whole a good rubbing with glasspaper, inside and out, especially the edge, and leave all smooth and no splinters anywhere.

Fig. 3 shows the other parts of the box, except the handle. Drawn over lin. squares are the axle brackets and the leg. Cut two of the brackets to shape and note that those parts of the brackets which fit against the back end of the box are cut to a slope like the box end itself.

It will be wise to lay the brackets against the box in the position they will occupy when fixed, and mark the slope by drawing a pencil along the edge of the box. The axle holes are bored to fit a 4in. wire nail, as to be used for axle pins.

One leg only will be required. This should be cut from wood about lin. thick and is to be fixed to the bottom of the box, in the centre near the front, as will be judged from the general view. Fix it with one or two screws, driven into it from the bottom of the box.

Next to the brackets, in the illustration, Fig. 3, is shown the wheel, two of which are required. These are plain discs of 3in. to lin. wood, and should be cut out accurately. In the centre cut 3/4in. sq. holes for the axle.

## Wheel Fixing

It is important to cut these holes exactly over the centre of the wheels, to run true. Rasp the edges level all round, then slightly round off. Finish with file and glasspaper.

Now fix the axle brackets to the box with screws, where shown, about

3/4in. in from the sides. Fix with one screw through into the back and one through the bottom into the bracket. The axle is a piece of 3/4in. or lin. sq. wood, long enough to be a loose fit between the brackets.

It is shown, or at least part of it, below the wheel in Fig. 3. At each end of the axle cut a 3/4in. sq. tenon to fit the mortise slots in the wheel. Cut these tenons about 3/4in. longer than the thickness of the wheels, then the latter will not be likely to scrape against the inside of the brackets as they turn.

Glue the wheels on, and in the exact centre of the ends drive in a 4in. wire nail, half-way. Cut the nails short to leave pins about lin. long; these are the axle pins. Remove one of the brackets and slip the axle in position, then re-screw the bracket in place.

## The Handle

The handle can be an old curved top walking stick, just screwed to the back end of the box, or one can be made from 3/4in. sq. wood for the purpose. To make the handle, cut the wood into two pieces, one for the stick and one for the hand grip, as in Fig. 4. Fix them together with a dowel joint, well glued.

A mild steel screw dowel would serve well here, or just the ordinary wood dowel. Near the bottom, a piece 3/4in. thick is cut away; this reduced end is screwed to the back end of the box.

Carefully shape up the top part, as shown at A, to make it comfortable to grip. The box can be completed with a coat of stain and varnish, or paint, as preferred. If painted green, with the inside of the box white, a nice result will ensue.

The box itself should be preferably of light construction, say, 3/4in. thick wood. If a box is already available, knock it carefully apart and plane the wood smooth.

The sides of the box are shown in Fig. 1, suggested dimensions only, as the box can be made much larger if thought necessary. The ends, not shown, are the same height and 10ins. wide. To the ends screw 3/4in. by lin. fillets each side, level with the edges.

The fillets do not reach to the bottom edge but are cut short by an

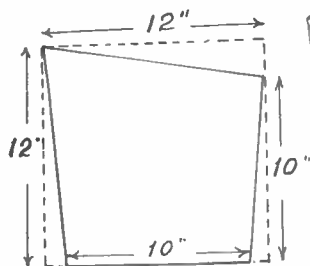

Fig. 1—Outline of box side

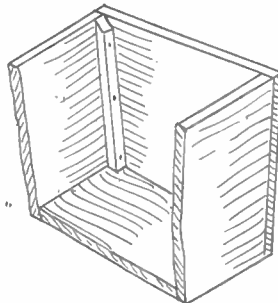

Fig. 2—Showing box construction

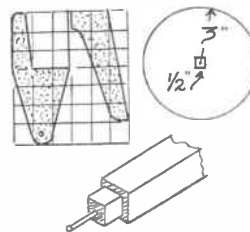

Fig. 3—Brackets, axles and wheels

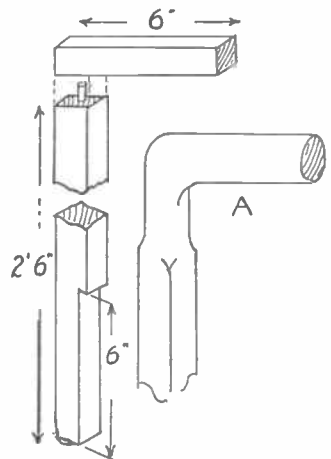

Fig. 4—Details of handle shaping



# How to utilize present-day materials to make pleasing WALL FINISHES

"I'M sick looking at that wallpaper," someone in your household has probably said for the past four years, since the war began. But, the most we can do these days is to distemper over existing wallpaper or paint the wall a suitable colour.

Here is a new way to treat kitchen and scullery walls—modern and striking. And although this article is confined to kitchens and sculleries, it would be a comparative easy matter to apply the treatment to other walls in the house.

## How to Begin

We shall deal with the kitchen first. The usual height of the surrounding walls is 8ft. 6ins. To mark off the frieze near the ceiling, there may be a picture moulding or probably just a paper border, the latter giving the frieze a depth of 14ins. as shown at Fig. 1.

If the wall is minus a frieze, i.e., papered from ceiling to skirting (and this is very rare), no moulding or bordering need be added, because it is difficult to make a pure, clear white frieze, unless white-coloured paper is pasted around the walls. Pattern designs in wallpaper "show" up plainly after being distempered or whitewashed, especially after the first, or second, coat.

If the wallpaper stretches right up to the ceiling, and if a white frieze is wanted, there is no need to go to the expense (and trouble) of buying picture moulding—which is hard to obtain, in any case—and fitting it up.

The best alternative is to buy an ogee-type of moulding strip, this

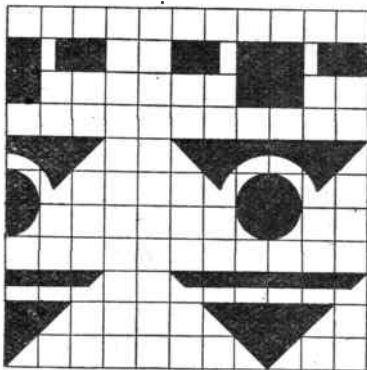

Fig. 2—Three simple border stencils plotted in  $\frac{1}{2}$  in. squares

being printed realistically on paper, and paste it around the walls. A fancy, cut-out paper border could go beneath to add to the general effect, as shown at Fig. 1, although a real picture moulding is indicated in the drawing.

Before adding the picture moulding strip and the border, however, the depth of the proposed frieze should be chalked off, or pencilled. One may mark the guide lines with the aid of a straight-edged lath of wood or tick off the depth at the corners, stretch a chalked string from the marks and, by pulling the string outwards from the wall slightly and releasing it sharply, mark a straight line that way.

When marked off, the ceiling—if flaky and patchy—is dusted with a dry brush, then whitewashed, including the marked-off frieze. The remaining part of the wall is then distempered a bright colour, such as cream or tangerine.

When applying the distemper, load the brush and, starting from the lefthand side of the wall, run it side-wise along the frieze line for about 18ins., then applying the colouring in downward sweeps to the skirting.

Having applied the horizontal topmost stroke, always block the width in with downwards strokes, following which another top stroke is made, the width filled in and so on until the wall is distempered.

## A Central Rail

Instead of having the wall one colour with exception of the white frieze, a modern innovation is to have a "waist" border portion and colour it to contrast with the top part. The waist half should not be more than 40ins. high, as shown. If the top half is cream, the bottom half could be tangerine. If the top is tangerine, the bottom could be light green; red, purple, or blue shades are not too pleasing.

In order to divide the two colours the "join" is covered with an  $1\frac{1}{2}$  in. wide brown-coloured moulding paper strip, this being pasted on when the distemper is dry. By the way, make sure you do not have the paper "moulding" adhered upside down.

An "embossing" is usually printed on the moulding strip and this should face the skirting. Regarding the latter and the picture rail (if the latter is wood), both should be painted a brown colour, the same as the door entrances and interior side of the doors.

## Treatment for Sculleries

Scullery walls should not be distempered. They should be painted, using a flat, oil paint of suitable colour, such as cream or yellow.

The walls can, as a result, be washed down with a cloth when they become dusty and greasy (assuming much cooking is done in the scullery). One cannot do so when the walls are merely distempered.

Some people prefer to apply an enamel (high-gloss) brand of paint. This is advisable, if it can be obtained, but you might prefer to follow the scheme devised (and tried) by the

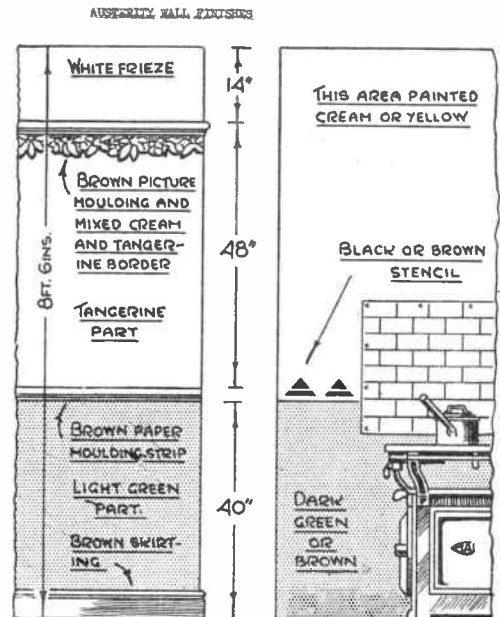

Fig. 1—suggested colour scheme for kitchen and scullery

writer. This scheme is designed to cut out as much expense as possible and also to prevent less washing and cleaning for the housewife, and yet make the scullery up-to-date and tidy in appearance.

Having whitewashed the ceiling, or distempered it a buff colour, a waist half is divided off 40ins. high, as shown. The walls are painted to the dividing line, using a thin oil paint. When this dries into the wall, give a second coat.

This applies to the waist of the wall, but dark green or brown oil paint should be used. This paint will dry dull and flat. As you will not be using a bordering strip of moulding paper, the waist line must be neat and straight. That is why the top half should be painted first; the line can be straightened out with the darker paint.

## A Stencilled Border

When the paint has dried, the whole effect can be considerably improved by adding a stencilled border, part of which is shown in the

Illustration of part of the scullery wall. Stencils are easily made, and three simple, useful designs are provided at Fig. 2.

The shapes are plotted in  $\frac{1}{4}$  in. squares. So, it is only necessary to select one design, mark out the squares on a piece of thin cardboard, such as ticket card, then work in the stencil shape. The black portions are the pieces to be cut from the stencil plate (card), using a ruler and sharp-pointed penknife.

In the drawings of the three stencils, we show one complete design, with an exact half shape. You will require both in the one strip of card the half shape being used as a guide in judging the distance each "impression" should be apart on the wall, this being 1 in.

The impressions are made about 1 in. above the waist line on the wall. A thin, black (or brown) oil paint can be used in making the impressions. If a proper stencil brush is not available, the next best thing is an old shaving brush, with the bristles cut short, or one may use one end of a small boot polish brush, or an old, trimmed paint brush.

#### Applying the Stencilling

Having the stencil plate held in position against the wall, put a small quantity of black (or brown) paint on the bristles of the brush, rub the brush in circles on a scrap piece of card to spread the paint into the bristles, then daub them over the stencil until the "open" shapes are well covered with paint. To prevent running, the stencilling brush must

not be over-loaded with paint. A "dry" brush is the wisest—and safest—thing.

As soon as one impression is made, apply another and so on until the wall is surrounded. If the brush daubing is slow work, try rubbing it over the stencil plate in small circles.

The stencilling cannot be rushed. It must be done neatly, because it is the first thing that catches the eye. It is a job worth doing and taking your time over, and having it thoroughly executed, the final operation is to give the whole painted area of the wall a coating of clear varnish. This takes the dullness away and also preserves the paint. Each year, if necessary, it is only essential to wash the wall and give it a fresh coat of clear varnish to brighten it up.

## MISCELLANEOUS ADVERTISEMENTS, etc.

The advertisements are inserted at the rate of 3d. per word or group of letters prepaid. Postal Order and Stamps must accompany the order, and the advertisements will be inserted in the earliest issue. Fretwork goods or those shown in Hobbies Handbook not accepted. Orders can be sent to Hobbies Weekly, Advertisement Dept., as below.

**BE TALLER !!** Quickly !! Safely !! Privately !! No Appliances—No Tablets—No Dieting. Details, 6d. stamp.—Malcolm Ross, Height Specialist, BM/HYTE, London W.C.1.

**HOW I TOURED THE WORLD ON NOTHING.** by Walter Buchler (with pen and camera), 1/6. **THE ART OF SCALE MODEL AIRCRAFT BUILDING.** by V. J. F. Woodason, Price 4/11. Cloth 8/6. "In this book the author has produced the most complete and accurate account of solid model making yet published. It is to be heartily recommended to the expert and to the beginner, and to those only interested in aircraft recognition instruction.—"The Aeroplane." **MONEY IN EXPORTS,** 10/6. (Trading in Many Lands-41). For Press Reviews send 1d. stamp. Our Giftware Dept. is interested in all manner of articles and curios suitable as gifts. — USEFUL PUBLICATIONS, 37, Aldwych, W.C.2.

**LONELY ?** Then write Secretary U.C.C., 5B.B. Hay St., Braughing, Herts. Genuine. Est.1905.

**MODELS:** you can make lasting stone-hard models with Sankey's Pyruma Plastic Cement. Supplied in tins by Ironmongers, Hardwaremen, and Builders' Merchants. Ask for Instruction leaflet.

**TOYS.** Send for range of popular designs with instructions. Simple to make from scrap materials. 2/6 only post free.—Harrod, 10 Beaconsfield Road, Maidstone.

**LONELY ?** Join Friendship Circle. Details 6d.—Secretary, 34 Honeywell Road, London, S.W.11.

**SET "Royal Visit" Canada Free.** Request approvals. — Woods, Riverview, Beaulah St., Gaywood, King's Lynn, Norfolk.

**SPECIAL ANNIVERSARY FREE GIFT** to all applicants for our approvals. Postage please.—Austin Bros. Approval Service, 20, Fulford Rd., West Ewell, Surrey.

**APPROVALS** on request.—Warrington, Letham, Bearsden, Glasgow.

**STAMPS FREE !!** Twenty Unused (2 $\frac{1}{2}$ d.)—G. H. Barnett, Limington, Somerset.

**10 MINT PICTORIALS,** album, perforation gauge, watermark detector, 2/3.—Ahdown, 164, Woodward Road, Dagenham.

**INTERESTED IN STAMPS ?** — Write 32 North Street, Goolle.

**CHERRY WOOD PIPES,** easily made, good profits, unlimited market. Clear diagrams and instructions plus the secret of the C.W. perfume. 3/6, materials stocked.—H. Barham, Hilltop, Bradmore Green, Coulsdon, Surrey.

**SECONDHAND MOULDS** for making soldiers in battledress, planes, farm animals, wild animals, racing car, which runs on wheels, from 7/- each. Stamped addressed envelope for list.—15 Rosemary Gardens, Mortlake, London, S.W.14.

## MAORI LANDING PACKET FREE



Get this attractive stamp from us **FREE—ABSOLUTELY FREE.** It is very handsomely designed and depicts the landing from native boats on the shores of New Zealand of the native Maoris about the year 1350, and was issued by NEW ZEALAND in 1940 to commemorate one hundred years of British Sovereignty. A most interesting stamp which every collector should have.

In addition we will also include in this **FREE MAORI PACKET** a few more interesting stamps from such countries as **HOLLAND, BELGIUM and GERMANY.** All you have to do is (1) Ask for **FREE MAORI PACKET;** (2) Ask for Approvals and Price Lists; (3) Write clearly your name and full address; (4) Place 3d. in stamps (to cover cost of Lists and postage to you of Gift and Approvals) inside your letter and post to: **WINDSOR STAMP CO. (Dept. 12), UCKFIELD, SUSSEX**



## Books of Designs

Simple designs for everyday subjects to cut from small pieces of wood. Brackets, pipe racks, boxes, frames, calendars, etc. All printed full size ready to paste down.

### FOUR BOOKS

A and B Books have 20 Designs each. Books C and D each contain 14 Designs of larger subjects.

1/6 each, postage 1d.

**HOBBIES LIMITED, DEREHAM & BRANCHES**





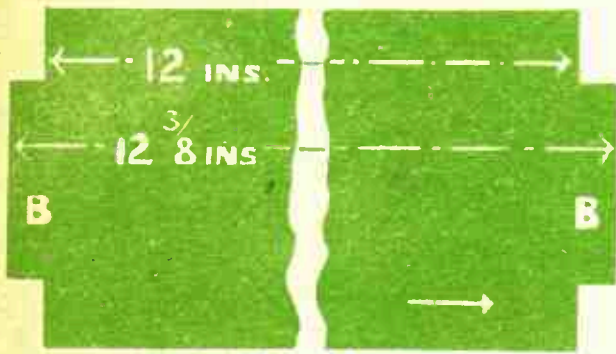

UPPER BACK RAIL. CUT ONE TO LENGTH SHOWN 3 16in.

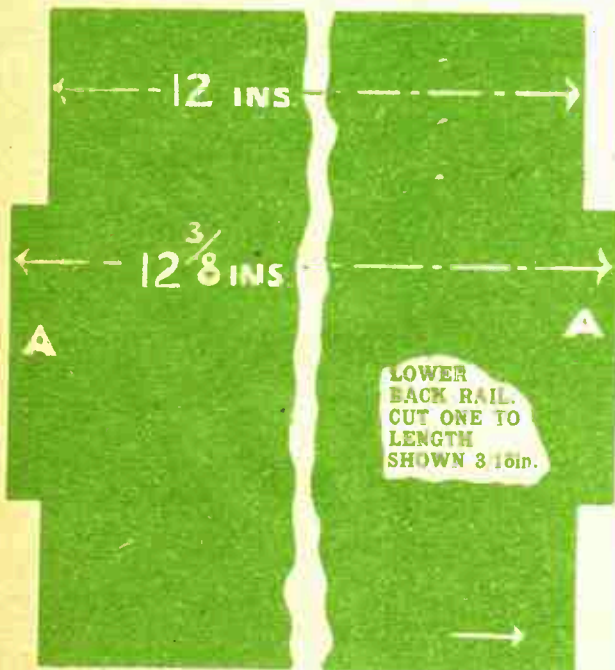

LOWER BACK RAIL. CUT ONE TO LENGTH SHOWN 3 16in.

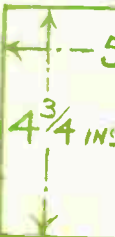
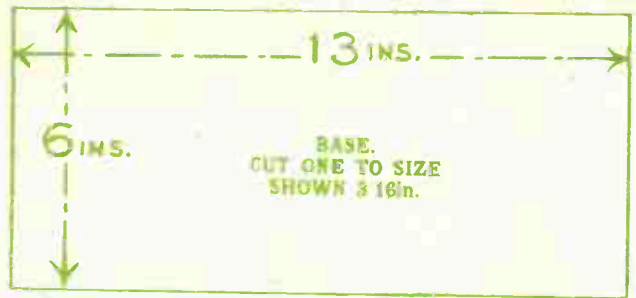

SHelf DRAWER ONE TO 3 16

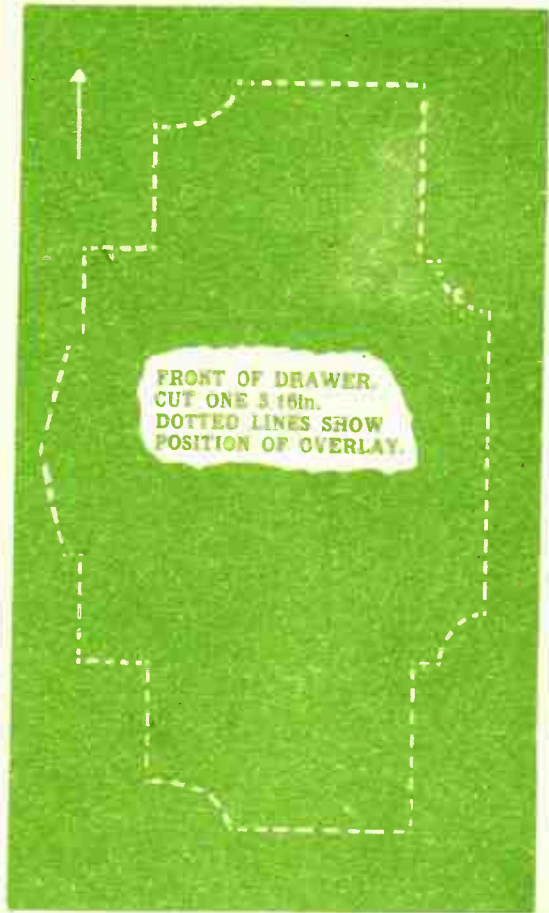

FRONT OF DRAWER. CUT ONE 3 16in. DOTTED LINES SHOW POSITION OF OVERLAY.



BASE, FRONT RAIL. CUT ONE 3 16in. THE BACK RAIL. CUT ONE 3 16in. BUT PLAIN AND NO FROTS



BASE, END. CUT TWO 3 16in.

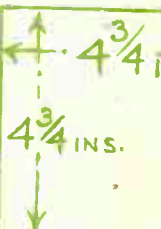

NOTE.—This design sheet is only presented free with the current issue of Hobbies and not with back numbers. Further copies may be obtained.

INS. →

SIZE  
3in.

THE ARROWS INDICATE  
THE DIRECTION OF GRAIN  
OF WOOD.



DESIGN

No.  
2538  
7.6.44

SUPPLEMENT TO HOBBIES No. 2538.

BOOK SHELF WITH DRAWER

PANELS OF WOOD REQUIRED  
FOR THIS DESIGN

FIVE H3 ONE H2

The price is shown in Hobbies Weekly, June 7th, 1944, but is subject to revision. See the current edition of Hobbies Handbook, or write for price to Hobbies Limited, Dereham, Norfolk.

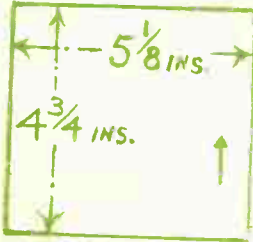
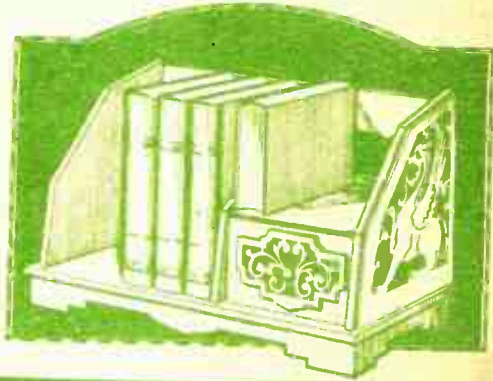

SHELF ABOVE  
DRAWER. CUT  
ONE TO SIZE  
3 16in.

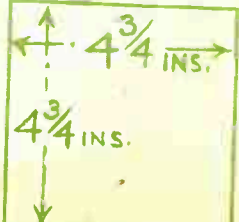
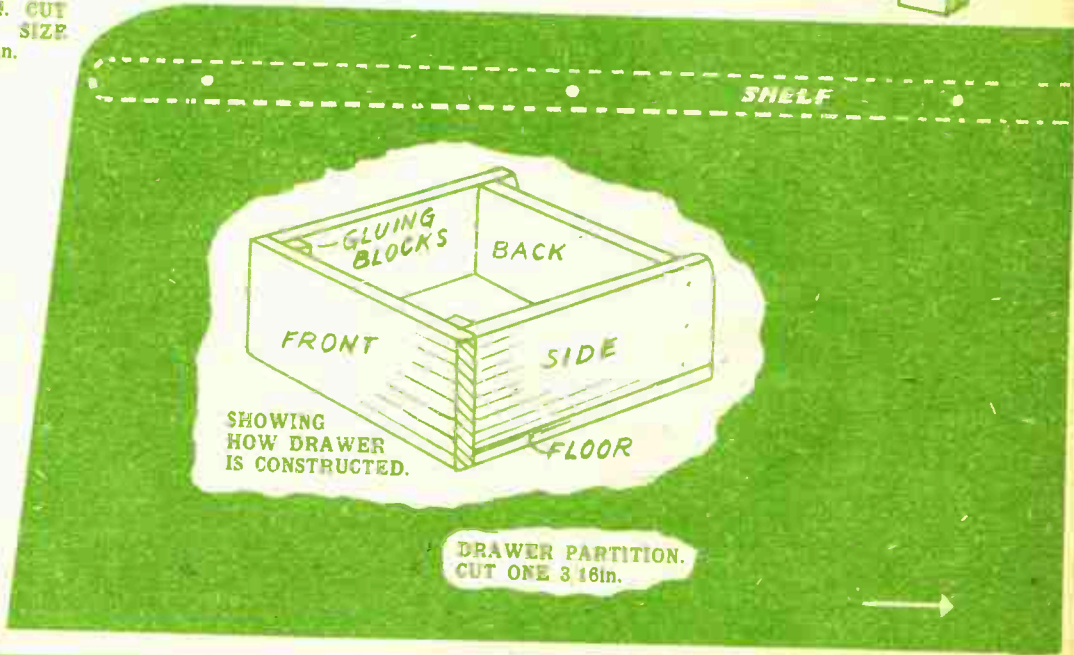

FLOOR OF  
DRAWER.  
CUT ONE  
TO SIZE  
SHOWN  
3 16in.



LOWER  
BACK RAIL.  
CUT ONE TO  
LENGTH  
SHOWN 3 1/8 in.

BASE, FRONT RAIL.  
CUT ONE 3 1/8 in. THE  
BACK RAIL. CUT ONE  
3 1/8 in. BUT PLAIN AND  
NO GROOVE

BASE, END.  
CUT TWO  
3 1/8 in.

NOTE—This design sheet is only presented free with the current issue of Hobbies and not with back numbers. Further copies may be obtained.

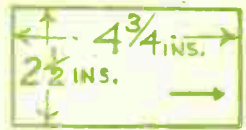
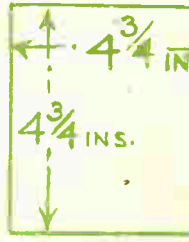

DRAWER SIDE. CUT TWO TO SIZE SHOWN 3 1/8 in.

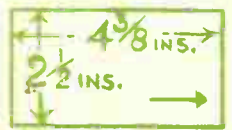

DRAWER BACK. CUT ONE TO SIZE SHOWN 3 1/8 in.

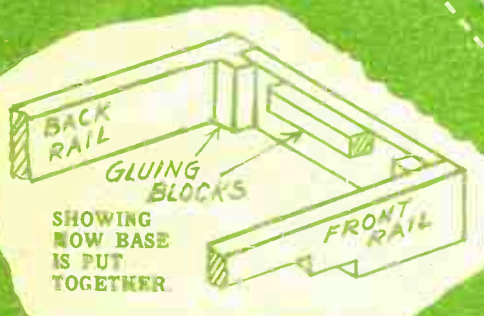

END UPRIGHT.  
CUT TWO 3 1/8 in.

Line of Overlay.  
To be glued to End.



FRONT  
SIDE  
FLOOR  
SHOWING HOW DRAWER IS CONSTRUCTED.

DRAWER PARTITION.  
CUT ONE 3 16in.

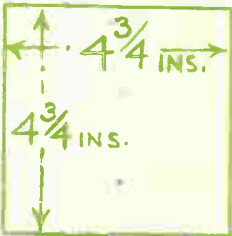

FLOOR OF DRAWER.  
CUT ONE TO SIZE SHOWN 3 16in.

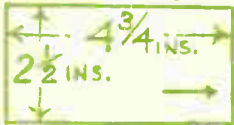

DRAWER SIDE. CUT TWO TO SIZE SHOWN 3 16in.

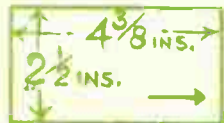

DRAWER BACK. CUT ONE TO SIZE SHOWN 3 16in.



END OVERLAY.  
CUT TWO 1 8in.

# BOOK SHELF with Drawer

**S**TUDY the patterns on the design sheet before you commence cutting them out, in order to realise where each part comes. Wherever possible, mark all sizes direct on to the wood, but in other cases paste the design down. This applies particularly to the fretted ends and the end upright, which are of unusual shape.

In drawing out the pieces with the projecting joints A and B, get them correct and test all with the component parts in which they fit. The base, shelf and drawer parts are shown to scale, and must be extended carefully to full dimensions.

Cut out all parts with the fretsaw and clean up thoroughly with glass-paper. Construction is straightforward, and where butt joints only are provided, angle blocks of waste wood should be glued in as shown in the details. This particularly applies to the under-rails below the base, and to the inside of the drawer.

## First Erection

On the base, erect the two ends and the two back cross rails. The former will be set inwards slightly from the actual ends of the base, and the actual distance will be fixed by the length of the cross rails. The widest rail is at the bottom at A and the upper one, of the narrower one fitting into the joints, at B.

Measure off the distances along the back, and then between the front edges of the end parts to ensure that the latter parts are at right angles. The ends can be screwed as well as glued if you take particular care in getting the screws home without splitting the wood.

The end overlays of thinner material can be added later, but it is worth noting that they are glued to the extreme back edge in order to cover the joints of the rails. They will not then come to the extreme front edge of the ends, but be set back about  $\frac{1}{2}$  in.

## Marking the Drawer

The drawer should be made up next, and the detail shows how it is done. The two sides and back are actually glued on the floor, but the front is put over the edges of all to cover them. Notice the back is set inwards a little and gluing blocks are added inside the front to stiffen the corners. Be sure to get the drawer perfectly square, otherwise it will not slide comfortably in its partition.

When completed it should be used to mark off the distance of the upright partition piece. Lay the drawer inside the end and pencil a line along the base at its edge. Pencil another line along the upright back vertically. You thus have the position of the partition which is glued and can also be screwed to the floor and back rail.

## Drawer Cover

The top of the drawer is provided by a shelf, the front edge of which is rounded and set back slightly from the partition. By placing the drawer in position, you can get the height of this horizontal shelf. Mark it off in pencil first. Take the drawer away, and then fix the horizontal piece in place with glue.

A couple of screws can also be run through the back edge and through the partition piece to strengthen if desired. Be sure that the drawer

runs in and out of the compartment easily. If it does not at first, glass-paper the necessary portion down so it does not stick in use.

The front of the drawer can be decorated by the fretted panel of  $\frac{1}{2}$  in. wood as shown, and finally a little knob is driven through the centre to form a grip.

## Bottom Rails

On the underside of the base there is yet to fix the rails lifting it from the table. The back rail can be a plain rectangle of wood, but the front is provided with a little ornamental cut as are the ends. In fixing together the ends, go between the back and front rails, and all must be carefully butted up to each other and to the base itself.

Be sure to get the upper edges flat for the glue to hold, and provide further strength by adding blocking pieces in the corners and on the underside of the base itself. In placing the rails in position you will notice that they are all set back slightly from the edge of the base, and you must arrange for the projection to be the same all the way round.

As the whole weight of the article in use will be on these rails, it is very important to get them quite strong and binding together, as well as to the base itself.

The gluing blocks previously mentioned should have therefore been put all round and glued, of course, firmly into the right angles of the various corners.  $\frac{1}{2}$  in. square blocking strips can be used, or if you have them, the plain triangular strips are better, being less unsightly.