

Hobbies

WEEKLY

July 28th, 1943

Price Twopence

Vol. 96. No. 2493

A NON-FLYING MODEL JET-PROPELLED PLANE

THIS week we give our model aircraft enthusiasts something really astonishing in the way of aeroplanes. It is a model of the type of planes we may be seeing in the future, having been based (from meagre details available) on an actual jet-propelled machine designed by an Italian, Signor Secondo Campini, in 1941.

The new "rocket" type of aeroplane is due to thermal-jet propulsion. Air is fed, via the nose of the machine to motor-driven air compressors housed in the main wings. The same air, released at terrific pressure, issues from the tail jet at sufficient force to send the aeroplane forward into the air.

Thermal-jet propulsion thus opens up tremendous possibilities in aviation. The thermal power units can be serviced with ordinary motor-car spirit, paraffin oil, etc. Although still in the elementary stages, the C.C.2. has proved that jet-propelled aircraft is practical, having—during a test flight—flown from Milan to Rome in November, 1941, a distance of 168 miles.

A model of such an aeroplane is, undoubtedly worth making and adding to your collection.

Making the Fuselage

Full size patterns of the necessary parts are provided on cover iv of this

issue. It will be seen that the fuselage is built from five shaped layers of wood having a thickness of $\frac{1}{8}$ in. and $\frac{1}{4}$ in. respectively, as stated on each pattern.

When cut out, the shapes are glued neatly together, with the $\frac{1}{4}$ in. side and cover pieces to the outside of the $\frac{1}{8}$ in. centre piece (see Fig. 2). As the main wing goes through a slot in the

Alternatively, separate wings could be cut out, with a $\frac{1}{4}$ in. tenon, or root, for the mortises cut in the side cover pieces only. This suggestion may save troublesome fitting owing to slight inaccuracy in assembling the fuselage. A complete main wing ensures that it will be dead straight at both sides.

The top and underside of the fuse-

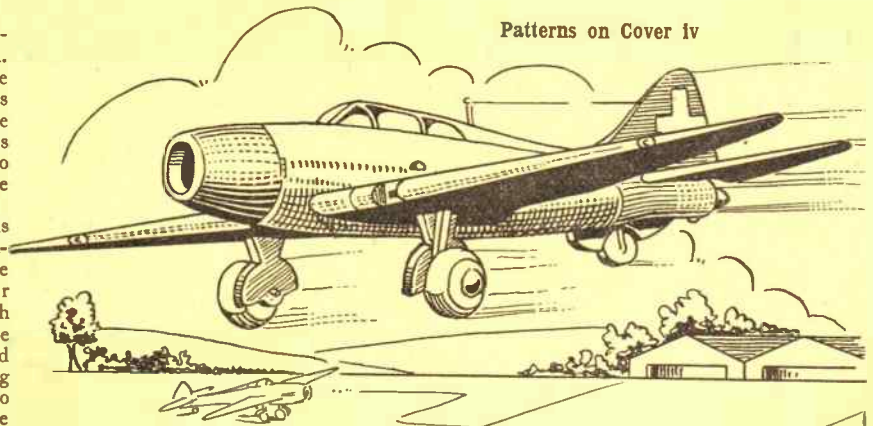

fuselage in a complete form, it is advisable to see that the slots cut in the fuselage parts are assembled in true alignment; you can ensure this by gluing the parts together over a piece of wood measuring 3 ins. by 2 $\frac{1}{4}$ ins. by $\frac{1}{4}$ in. This can be withdrawn when the glue has set.

lage is shaped to the contour indicated by the dotted lines at Fig. 2. The penknife will remove most of the waste, but in order to ensure that the "nose" is done properly, the nose piece should be cut out, bevelled as sectioned, then glued in place, which means levelling off the front end.

Letters to the Editor should be addressed to Hobbies Weekly, Dereham, Norfolk. Address orders for goods to Hobbies Limited.

Helpful half-sections of the fuselage body-shaping is shown at Fig. 4. There is really no need to make and use suitable templates. Once you get started, the shaping can be easily judged by the eye. The top plan view at Fig. 3 will be helpful in shaping the cabin.

Special care must be taken in shaping and preparing the tail end of the fuselage. A "seat" has to be cut for the tail wing, as shown by the drawing at Fig. 3. Notice, too, how the air-jet stub end is neatly rounded, the diameter being $\frac{3}{16}$ in.

Drill a $\frac{3}{16}$ in. hole $\frac{1}{2}$ in. deep in the air-jet stub, then countersink the rim of the hole slightly. The hole is then



Fig. 2—The boards of the fuselage, from above, glued together

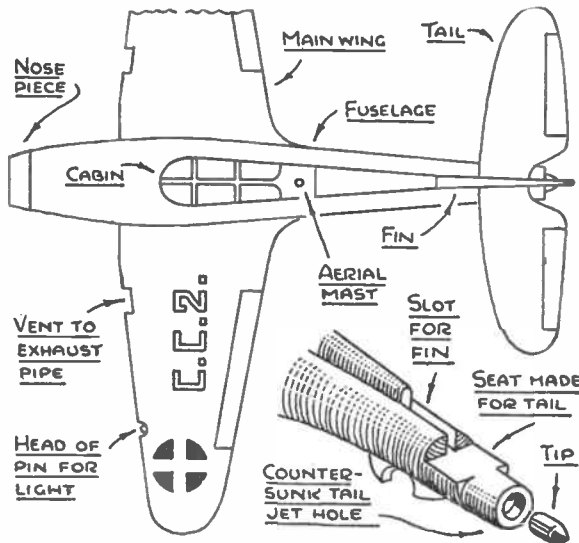

Fig. 3—Looking down on the plane, and a detail of fuselage rear

"tipped" with a piece of $\frac{3}{16}$ in. dowel rod shaped like a tiny bullet; its point projects about $\frac{1}{4}$ in. or so.

Fitting the Wings

The main wing is cut out completely (we only show half of it on the pattern page, the same as the tail wing) from $\frac{1}{2}$ in. wood. A bevel is made on the underside $\frac{3}{16}$ ins. from the wing tips, as clearly shown by the frontal view at Fig. 5.

You will see how the wings are "sloped" on the surface side by the side view at Fig. 4. This sloping is best done with a sharp penknife, using the smallest blade, if any. A half-round file, or cabinet wood file, will be a big aid in rasping the shaping smooth and neat.

To prevent an ugly joint in the fuselage slot, it is advisable to insert the wing temporarily in place and draw a pencil mark around it so you will know how far to carve in at the curvature in the wings. When neatly

carved and glasspapered, glue the wing in position, then glasspaper the joint to even it up with the side shape of the fuselage.

The tail wing is cut from $\frac{1}{2}$ in. wood and shaped to the section shown at Fig. 4. Glue and pin it on its seat, then make the fin and adhere it on top in its slot. The streamline "cowling" from the cabin is glasspapered level with the fin.

The Undercarriage

The wheel leg pieces are cut from $\frac{1}{2}$ in. wood and assembled together, as a right and left, in the manner shown on the pattern page. The wheels are cut from $\frac{1}{2}$ in. stuff, following which the edges are rounded over, as shown. Round-head brass nails serve to "axle" the wheels to the legs, the heads giving the appearance of "domed" hubs; by the way, the wheels must be free to turn on the nails.

alike, so just cut out a wheel, round its edge, then make a small wire "fork" for it as depicted on the pattern page, the fork ends being inserted in a hole made in the "guard" in the centre (see side view).

Finishing Details

Simple navigation lights can be suggested by the heads of large pins. The leading lights are red and green, whereas the tail light is white or yellow. The exhaust pipe air vents in the leading edge of the main wing are made with a bradawl.

A plain pin serves as an aerial mast. A piece of thread or fine wire (a strand of fine coil wire or copper wire from flexible cotton-covered cable) serves as an aerial.

Foot louvres, or grips, can be cut in the sides of the fuselage with a small gouge, just beneath the cabin windows, as shown by the side view of the model. Alternatively, these additions could be painted on.

Regarding the nose of the model, the small $\frac{1}{2}$ in. square hole in the centre of same could be deeply

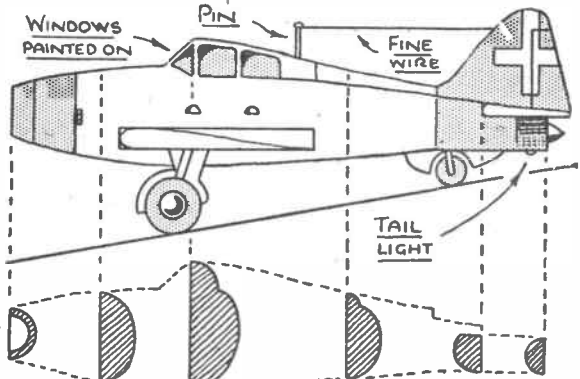

Fig. 4—A side view with sections showing shape

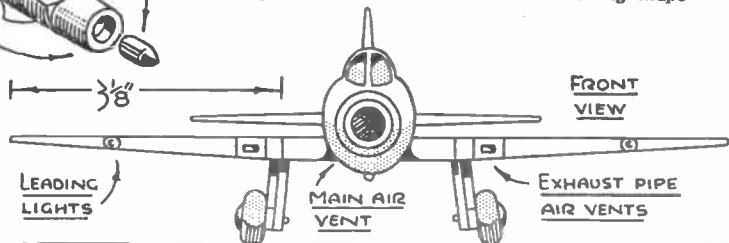

Fig. 5—Front view with helpful details

The position of the wheels can be judged from Fig. 5. It is only necessary to make a suitable hole (for the tenon on each wheel leg) at the underside of the wing, using a sharp bradawl or suitable drill. The legs are then attached to "splay" outwards slightly.

So far as we can judge, taking into consideration the velocity of an air-propelled machine, the tail skid wheel is either housed in a streamlined guard or else it, like the front wheels, is retractable in a suitable housing. We are of the opinion that the former principle is more likely.

In any case, both methods look

countersunk or else drilled $\frac{1}{2}$ in. deep with a $\frac{3}{16}$ in. twist drill. The nose rim is, as you will notice, rounded over nicely.

The most adequate way to finish off the work is to coat it all over with a flat, light grey paint. When dry, the nose and tail end is painted a darker shade of grey, including the underside of the wings.

The wheels could be black, including the "air vent" at the nose of the model and the "tip" at the rear end. The identification markings are painted on with white paint, whereas the lines on the wings and fins could be black.

For saving time and trouble in collection make these SALVAGE HOLDERS

WHEN salvage is sorted, ready for collection, much time and expense are saved to the authorities, and incidentally much more valuable scrap saved from spoiling. Two different designs of salvage holders are shown each having its own special appeal to the householder. Both are of the simplest descriptions and equally worth the little trouble of making.

The smaller one on the left, is a plain wooden box, with a tray to lift out, not unlike the household box of well known design. A section through it is given in Fig. 1. The dimensions are merely suggestive, but will be helpful if the box is to be made.

Ready-made Boxes

Some readers, however, may have a wooden box already in their possession, which can be utilised for the purpose. If a box has to be made, lin. thick deal should be used if possible to ensure a strong affair. A plain nailed joint will suffice.

The tray is made of a size to fit easily in the box, and can well be divided by a middle partition.

About 3ins. down on opposite sides of the box, bore a $\frac{3}{4}$ in. hole through. These are for a rope handle, convenient for carrying the box about. Slip the ends of the rope through the holes from the outside and knot them on the inside. These knots will prevent the tray from falling down too far in the box.

A Sighting Hole

In one side, approximately where shown, bore out a 2in. hole so that the collector can see that something is in the box as well as in the tray. Normally the collector will see this for himself, doubtless, but the sight hole will make doubly sure.

It is a good plan to nail or screw, a small square of wood at each corner of the box, underneath, to act as feet keeping the bottom of the box from a wet floor, or pavement. Give

the whole a good clean up with glasspaper, and if so inclined paint it. The word "salvage" painted on provides a finishing touch.

It is suggested that paper and rags be stored in the box and

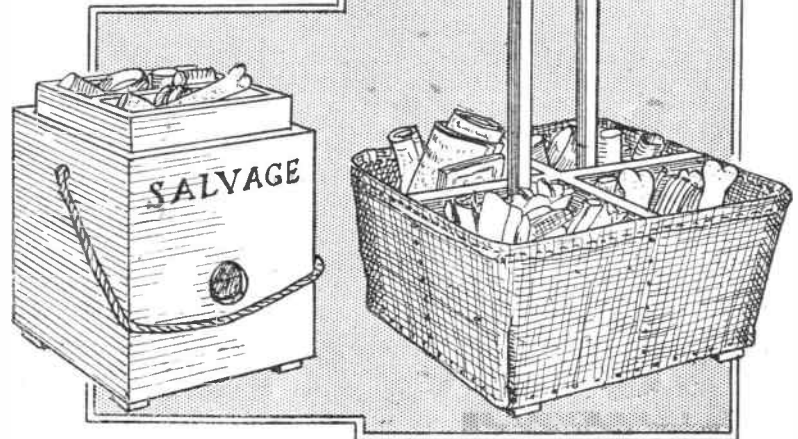

metal and bones in the tray. The box can be divided into two compartments by a division piece, like the tray, if a piece of wood to spare is available, but need not be considered essential as after all paper and rags do not mix or spoil each other.

A Larger Carrier

The larger salvage holder, shown on the right, needs less wood to make, and holding more salvage may be preferable. Its construction is very simple.

Fig. 2, shows this construction plainly. First make up a square board for the bottom, of two boards nailed to battens underneath. Then cut the two cross pieces from a length of board, say 8ins. wide, and slot them in the centre as shown, so that they fit together forming right angled divisions. Note, the top edges of these are longer than the bottom edges so as to give play to the outside covering.

Fit together and firmly nail, or screw to the bottom boards. For the handle supports cut two lengths of lin. square wood to 20ins. long or thereabouts—no reason to be particular about this—and nail to the divisions about 4ins. apart. Then a strip of wood is nailed between them near the top for a handle.

Another Handle

A more comfortable handle can be made with a little trouble, as shown in Fig. 4 which may be preferable if the holder is to be carried about much. It is an 8in. length of 3in. wide wood of the same thickness as that used for the cross divisions.

In this bore a couple of lin. holes, 2ins. apart, and saw out the intervening wood to leave a space for the fingers to enter. Nail this between the handle supports.

The outer covering of the holder can be a strip of stout canvas, calico,

(Continued foot of next page)

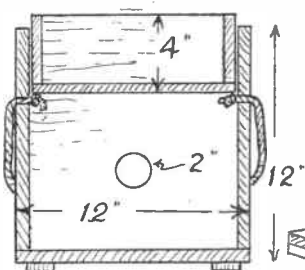

Fig. 1—Section of the smaller box

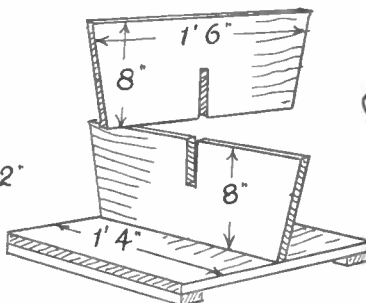

Fig. 2—Fixing partition to base

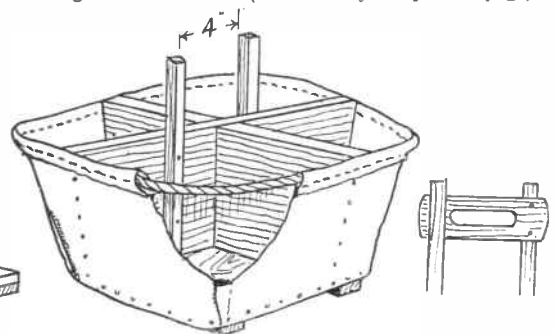

Fig. 3—Cut-away showing construction

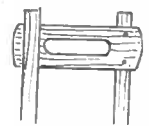

Fig. 4—Handle detail

A Doll's House will be more realistic with these MINIATURE FITTINGS

AN interesting addition can be made to the sets of furniture in our previous articles by making three novel items, namely, a sideboard, wireless cabinet and a standard lamp. Here again, just odd blocks of wood will be needed and some scraps of strong cardboard. Other oddments can be collected from friends.

For the sideboard, make a block of wood, lin. square by $2\frac{1}{2}$ ins. long and for the wireless cabinet another block lin. on all sides. For the lamp you will require a half of a spool-shaped cotton reel.

That completes all the woodwork, so if you intend to make up several sets, plan out your wood and get all the cutting up finished with. This will help you to be able to work on the remaining jobs inside the house during the dark and cold nights.

Sideboard Parts

In Fig. 1 is shown the shape of the front and two sides of the sideboard which should be cut as shown and scored on the dark lines. Tack this firmly to the block and the sideboard is now mounted and taking shape.

In Fig. 2 you will see the top is slightly larger than the block to allow a neat overlap when fitted in place. When fixing this, prop the wooden block on another block of wood so you do not crush down on the card-

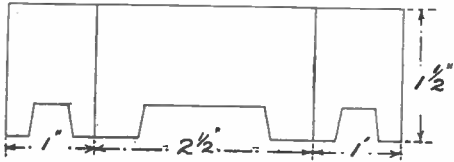

Fig. 1—Sideboard front and sides in one piece

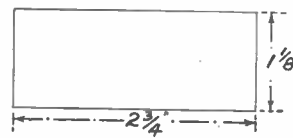

Fig. 2—The sideboard top

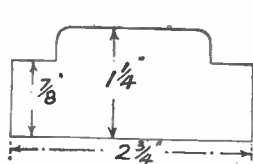

Fig. 3—The back shape

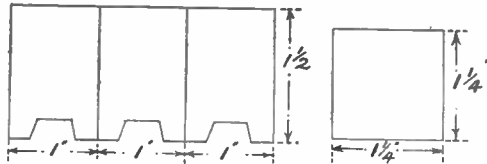
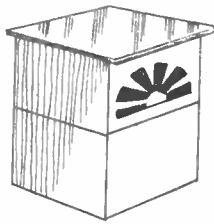
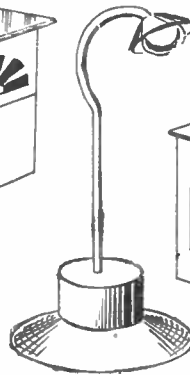

Fig. 4—Two pieces forming the wireless cabinet



Wireless Cabinet



Standard Lamp

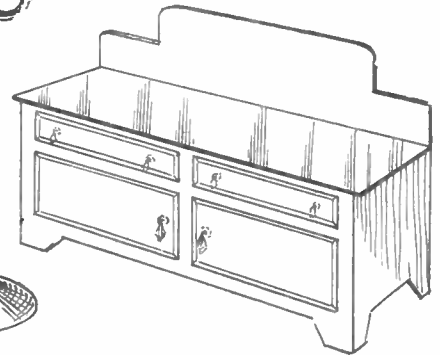

A Model Sideboard

board legs. Fig. 3 shows you the simple shape of the back, which should overlap on the back of the wooden block.

Now you have the piece made and ready for completion. If you have any $\frac{1}{4}$ in. by $\frac{1}{4}$ in. Hobbies stripwood, glue this round just above the cut-away sections as shown in the drawing of the finished article. Cover the sideboard with wood-grained paper or you could colour it with poster colours marking in drawers and doors in black.

Add a Mirror

The back of the sideboard can be made any shape you like and changed in each set if you wish to create variety. A neat mirror from silver paper could be let in.

A thin runner cut from a bright piece of fabric will make an ideal

finish and so will coloured beads to represent bowls and vases if you tack them carefully in place with large pins. Choose your beads well and you will be very pleased with your handiwork.

The wireless is quite simple by cutting the cardboard shape as shown in sketch (Fig. 4). Here again the beading as suggested before could be used. The top section is also a little larger and will allow for an overlap. Your design can be of your own choice and varied in each set. A bead of suitable design will soon put a very effective touch to this novelty.

The Lamp

The standard lamp will not require a great effort to make as the worker will notice that the reel, cut in half forms the base. A button mould, inverted, on the top of reel, would greatly improve the finish.

The hole in reel should be plugged and a piece of strong iron wire inserted and shaped as shown to make the stand. A large round white or coloured bead on the end of the wire will complete this article. Finish off with bright paints.

Space does not permit too much explanation, but any keen worker will improve on these ideas. Collect the material, plan the work, choose suitable shades and trimmings and you will fill a very much needed want.

Salvage Holders—(Continued from previous page)

or other suitable material available. A piece of strong sacking would also serve, though sacking is not very attractive to look at. Cut it about 12 ins. wide and 6 ft. long.

If the material is not so long, sew two or more bits together to make the length. Fold over 1 in. of the top edge and stitch to form a hem. Insert a length of sash cord, or thin rope, in this hem during the stitching.

The covering should now have its

ends sewn together and be passed over the cross divisions to which it is tacked. Get the fullness evenly spaced. The surplus at the bottom should be turned back to make a double thickness and then be tacked to the edge of the bottom boards. Any fullness there (and there will be some), should be folded in at each corner and tacked together. The detail, Fig. 3 shows these points and also the rope in the hem.

Readers who have some wood to spare can make the outer covering of boards for a stronger piece of work.

This can be added with or without the canvas, but in any case the canvas must be as strong as possible with glue and screws added. This will prevent damage in any rough handling when in use.

The material used in the making of these containers need not be new but it should certainly be strong.

A handy, simple job is to make a CLOTHES AIRER

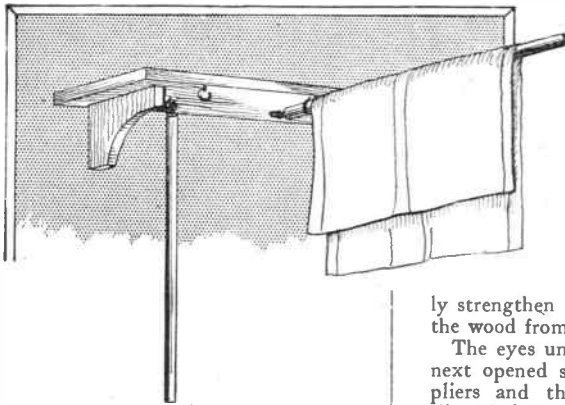

in, have a tendency to split, fine brass wire may be bound round and finished off neatly.

Or again, if a piece of brass tubing about the same diameter as the rods can be obtained, then cut off short pieces of this and drive on the ends of the rods. These ferrules will certainly strengthen the ends and prevent the wood from splitting.

The eyes underneath the shelf are next opened slightly with a pair of pliers and those on the rods then slipped in, after which the former lot are again closed.

Fixing the Rod

It only remains now to bore holes in the underside of the shelf and about $\frac{1}{2}$ in. from the edge exactly in line with those at the back. In these holes screw in some hooks in size large enough for the rods to rest in just as shown in the diagram Fig. 1. It will now be seen that when the rods are not in use they can be unhooked and allowed to hang free as in Fig. 2.

Another form of rod is shown in Fig. 3 where round rods perhaps are unobtainable. To take the place of the rods, splines of wood about $1\frac{1}{2}$ ins. by $\frac{3}{4}$ in. in section are adopted, and are hung below the shelf by means of wire staples, and supported similarly by wire hooks.

The staples and hooks will be spaced out in a similar manner to that previously described, one leg of the former being bent down to facilitate threading through the splines when these are being prepared for fixing to the shelf.

The round rods or the splines, whichever are used,

MOST homes today may require some sort of handy rack where articles may be hung for drying or airing. The kitchen is generally chosen for convenience, and one may often see improvised lines running sometimes from dresser to mantel in cobweb fashion.

The purpose of this article is to show how a more permanent and certainly more sightly form of airer can be made. The diagrams included here are practically self explanatory, but a brief description of the work entailed in making will not be out of place.

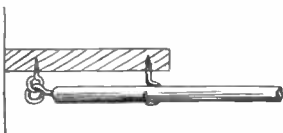

Fig. 1—Section of shelf showing hooks and rod

The fitting consists of a shelf supported in the usual manner by brackets held firmly to the wall. It may so happen that there is already a shelf which can be used for the purpose. In this event it may perhaps just require strengthening by the addition of an extra wall fixing plate or an additional bracket.

The Under-shelf Eyes

Underneath the shelf a number of stout iron eyes are run in at distances of about 6 ins. or 8 ins. apart and about $1\frac{1}{2}$ ins. distant from the wall.

Now get a number, which will depend of course on the length of the shelf and the number of eyes that have been used, of lengths of round dowelling about 24 ins. or 30 ins. long and in one end bore for and screw in similar iron eyes as those already used under the shelf.

As a precaution in case the ends of the rods, where the eyes are screwed

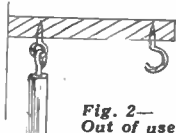

Fig. 2—Out of use

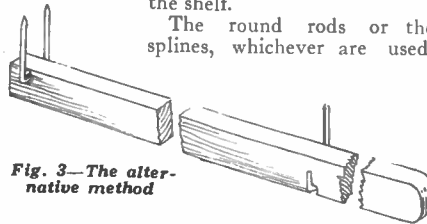

Fig. 3—The alternative method

would be well if coated with white enamel or paint. The shelf and brackets also, if they be new fittings, might also be painted.

You must remember, in making a piece of work like this, that the wood has to stand up to varying temperatures. Damp and cold clothes will be hung and allowed to heat and dry. Therefore, use only wood which is well seasoned.

The Editor's Notebook

THE death has occurred at Heathfield, Sussex, of Mr. Bertram Mainwaring, whose photograph had appeared in numerous leading newspapers and periodicals and in films in connection with his unusual hobby of making wooden dolls and figures out of used cotton reels. These he sold in aid of local charities and raised considerable sums.

WHAT do you think is the record sum raised by model making for charities? I knew of some amazing sums but was absolutely staggered when I heard that Provost-Sergeant Doig of Shoreham, Sussex, had managed no less than £20,000 for charity by making scale model ships for exhibition and sale.

IF you are a capable model maker be proud of it. And talk about it. You never know where it leads. Making models can be a real joy to you, and also be a profitable occupation as well. Repairs are often wanted by other people who own model ships. They do not know in the ordinary way, where to get such work done. Few shops could undertake them but would be glad to know of somebody who could do it for them. An advertisement occasionally, in the local paper could tell readers you were able to repair models at reasonable cost. Even if orders do not pour in at once, they will come along gradually and spasmodically. So let your ability be known by a little judicious publicity. But remember, above all, what I said in the first sentence—"if you are a capable model worker." You must be good at it, patient and painstaking with attention to accurate detail.

AS I say, one never knows where such a job leads. I know of a Southampton lad, who has been crippled since his birth and yet, is a very keen and able worker. He started with a penknife, but the British Legion supplied some Hobbies tools for his use. He has been able to make splendid repairs to a model ship for a lady, who had failed to get the work done in London. One of his ships, too, is now in the possession of Admiral Jellicoe's grandson. That famous Admiral was, of course, responsible for the British Fleet in home waters at the Battle of Jutland in the last war.

The Editor

Make yourself a real handyman by doing those ODD JOBS AT HOME

FIBRE carpets for kitchens and bedrooms are, like most other household items, very scarce and expensive. These generally measure 1½ yards long by 1 yard wide. They usually begin to "fray" at the side edges, for these edges get kicked up and curled a lot with the feet. The protective linen banding at the ends, moreover, becomes worn away and the woven fibre shows signs of unravelling.

When such carpets are not worth trying to fix, do not, as we used to do, throw them away or burn them. It is easy to make two or three small door mats from a single carpet, complete with fringe at the sides! These handy little fibre mats readily replace the usual oilcloth type.

Simply cut the mats to a size which suits your requirements, with a ¼ in. allowance at the sides for the fringing. When cut to width, unravel the continuous fibre ¼ ins. at the sides. This results in leaving plain fringe lengths of the fibre which, in couples, are tied together and straightened out. If desired, every alternate double strands could be tied together. Alternatively, the unravelling sides could be protected by attaching a linen band over the edges in the original manner.

Stiff Letter Boxes

Most postmen (or is it postwomen?) suffer from sore fingers and knuckles on the account of stiff letter-box flaps. Apart from the difficulty of "thrusting" mail through the slot, the packets get crumpled. So, you will please both yourself and the mail carrier by oiling the flap of the letter-box, including its spring.

Being near dampness, the spring is bound to be rusty and grates against the flap. If the spring is too strong, try and slacken it by unwinding it a few turns. The application of oil should, however, remedy matters.

Felting Corrugated Roofs

If you possess a shed roofed with corrugated sheeting that has become rusty and leaky, do not attempt to cover it with a roofing felt in its present state. If possible, the zinc sheeting should be first covered with mortar or sand and cement mixed.

Only the hollows in the sheeting need to be filled up. Spread the cement on with a trowel and allow it

to dry hard prior to fixing on the roofing felt on top. If desired, one could merely give the cemented roof a couple of coats of tar paint. However, there is a chance of heat and dampness having effect on the tar and cement. It is a good, cheap way of repairing the leaky roof if roofing felt is not obtainable, nevertheless.

Felt, if used, must be supported all over. It would be a good idea to tar the corrugated sheeting, then lay the felt over it and press it well down into the hollows. All overlaps should be joined by smearing with the tar paint. Give the felt a surface coat of the same paint afterwards to make it absolutely waterproof all over.

Unsteady Gate Posts

Gate posts that are rotted in the ground and are thus unsteady can be strengthened by driving flat stakes of wood into the ground beside them. Drive four stakes at the four sides of the posts. Three stakes, or even two, would help a lot. The supporting stakes must be allowed to remain above the ground level by 6 ins. or so. Drive screws through the projection of the stakes into the wooden gate posts. Point one end of the stakes so they will go more easily into the ground, further, the stakes should be coated with creosote to preserve them against damp and dry-rot.

Sun Blister on Paint Work

Nothing looks more unsightly than sun-blistered painted doors. It is worse looking if new paint is applied over the blisters which have chipped away. Far better to try to even up the blistered

surface by scraping it and glasspapering it smoothly as much as possible. The doors will look all the better for the fresh coat of paint.

An oil paint should be used on out-door articles, such as sheds, garden gates, yard doors, back doors, etc. If a bright finish is wanted for, say, a front door, it can be coated with a suitable varnish after the oil paint has dried.

Hole in Window Panes

Window panes are often broken by marbles or small stones. The latter are frequently thrown up from the ground by a heavy, rubber-tyred vehicle which may pass by if the house is situated near a main road.

The remedy is to patch up the hole with discs of Cellophane paper, gluing a disc to the outside and the inside of the pane. It saves time, money and labour.



**FOR A
REAL
Professional
'FINISH'**

'FINISH' is the true test of craftsmanship. It's easy to impart a real professional 'finish' to woodwork and furniture you make at home with "COLRON" WOOD DYE—the finest stain for all practical purposes.

One coat of "COLRON" is all that is required to emphasise the natural beauty of the wood grain. No smears—no 'overlaps'—no trouble! Leave from two to three hours, burnish with a rough dry cloth and you have a perfect base for french polishing or for waxing with "RONUK" FLOOR POLISH.

**COLRON WOOD
DYES**

8 SHADES—ALL SIZES—8d. UPWARDS

Write for colour guide and full details to:
RONUK LTD. Dept. 62 Portslade, Sussex

Look out next week for a large free Design Chart for making a splendid Model Fort

Even if you cannot buy them you can make a BAKING BOARD & ROLLER

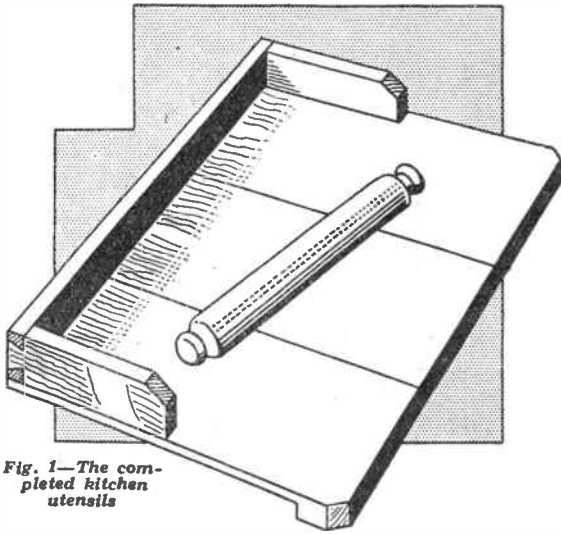

Fig. 1—The completed kitchen utensils

THE best way to ensure that your mother, housekeeper, wife or sister will try to bake bread is to make a suitable baking board, complete with a rolling-pin. A simple design is presented at Fig. 1, the board and rolling pin being made from light margarine boxes which are still being made up by the distributors.

In any case, a baking board is easily constructed from any sort of wood. The board could be merely an 18in. square, no surround being absolutely necessary. As for the rolling-pin, one could make it from a length of 1½in. or 1¾in. curtain pole, but more about it later on.

At the moment, to make the board illustrated, you need the three box bottom pieces shown at Fig. 2, the size of which is 14½ins. by about 5/16in. thick. With a smoothing plane, clean one side of these boards and straighten the joining edges.

The Surround

Set the three boards edge to edge on a flat surface and glue the edges. Turn the boards upside down, by the way, so ½in. long corrugated fasteners can be hammered across the joins. The fasteners will draw the board tightly together and help to make a sound piece of work.

To keep the board straight at the front edge and add to its firmness, a lath of wood 2ins. long by 1½ins. wide by ½in. thick is glued and screwed to the underside. The lath serves a double purpose, keeping the board firm and engaging with the front edge of the table so it (the board) does not shift about when the dough is kneaded or rolled out.

The surround attached at the back

and halfway at the ends is cut from ¾in. wood or ¾in. thick stuff. The 7in. long pieces are first scribed at the ends with a marking gauge set to the thickness of the wood. When the shoulder lines are marked, cut a dovetail on the ends with a tenon saw.

Scribe the same shoulder lines on the ends of the back surround piece, this being 21ins. long. Set the dovetail pins on the ends and, with a fine-pointed pencil, mark out the pin shape. Be sure to mark each end piece A and B to avoid confusion.

Dovetail Joints

The receiving dovetails are cut by first cutting down the lines, then by chiselling away the waste at the centre of the shoulder line, doing so from both sides. Simply set the chisel on the lines and hammer upon it (with a mallet), the waste being removed by cutting (splitting) the wood away in layers endwise.

Alternatively, you could merely butt-join the surround together by gluing and nailing. When made up, set the work on the board and drive nails or screws into it from the bottom.

Cut away the sharp corners from the ends of the side arms and the front and corners as shown. Glasspaper all other sharp edges smooth, including the surface of the board.

The Rolling-pin

There are several ways in which the rolling-pin can be made. The easiest method is to obtain a 15in. long piece of old curtain pole about 1½ins. in diameter. When scraped and cleanly glasspapered, a couple of "knobs" are shaped on it at the ends, using a rasp and glasspaper.

Instead of actually shaping the knobs, you could screw a couple of old wooden door knobs to the ends, as shown by the second drawing at Fig. 4. There is really no great need for end knobs; they merely

give the roller a good appearance

To build up a good rolling-pin, you need four pieces of wood about 12ins. long by 1½ins. wide by ½in. thick. Have the edges planed dead square, straight and true. The laths are then glued together in the manner shown by the sectional end view at Fig. 3.

No Nails

Do not use nails to hold the laths together, for when the glue has set, the wood is rounded over as indicated by the dotted lines. Prior to rounding it, however, you need two 6in. long pieces of ¾in. dowelling, same being glued and inserted in the "core" of the rolling-pin piece to project 3ins. or 2½ins.

Round over the ends of these dowel handle grips. If you want the roller to work on a free spindle insert an 18in. length of ¾in. dowelling in its centre. The dowel must be free to turn easily in the roller, so reduce it if found necessary by planing and glasspapering.

To keep it projecting evenly at each end, cut out two 1½in. washers from ½in. wood. The spindle hole in these must be a tight fit over the spindle. Force them on the ends of the spindle and glue them so there is a little bit of side play.

When the spindle ends are held in the hands, the roller will be free to revolve over the board. Many cooks prefer this kind of roller to the "solid" type. That, however, is really a personal matter and one that is decided according to available materials.

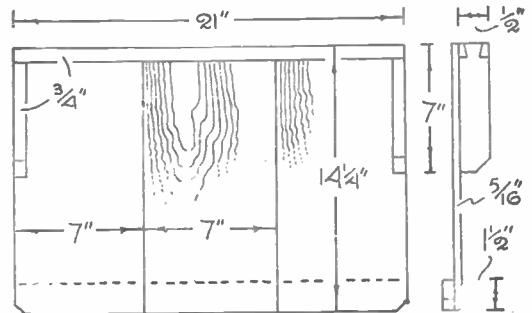

Fig. 2—Top view of board with side elevation

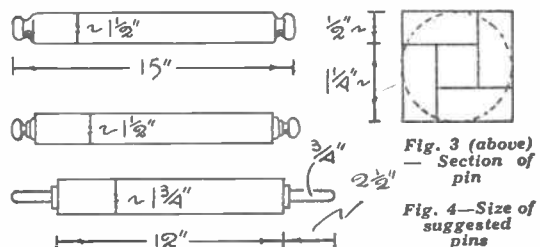
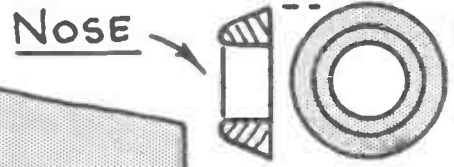
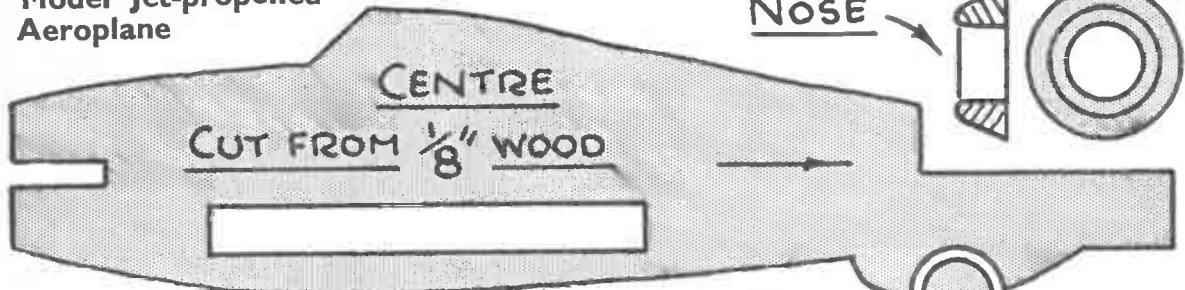

Fig. 3 (above) - Section of pin

Fig. 4—Size of suggested pins

**Model Jet-propelled
Aeroplane**



See
page 129

