

Hobbies

WEEKLY

February 10th, 1943

Price Twopence

Vol. 95. No. 2469

A KIDDY'S TEA TROLLEY

“OH, I am so glad to see you, Mrs. Jones,” says little Lady Make-believe. “You are just in time for a cup of tea.” And Mrs. Jones, of course, stays for tea. How children—especially little girls—love to imitate the grown-ups!

You can be sure, therefore, that the novel, simple tea trolley described herewith will add a lot more realism to Lady Make-believe's imagination. The tiny tea set will never get peace!

Only a few pieces of light wood are required to make the trolley. But, even though the trolley is small, its design and construction could be applied in making a large trolley for “grown-up” use. It is just a matter of size. The ordinary height is about 30ins., the width 14ins. to 16ins., the length being 24ins. to 30ins. No change in the thickness of the wood or size of the wheels should be made, unless preferred.

Top Construction

The top frame work should be constructed first. It is made from 1in. square lengths of deal. Note how the ends are checked into the side pieces (see Fig. 3). The depth of the checks is $\frac{1}{2}$ in. deep.

You can do without checking, by

the way, and merely cut the end pieces to the inside length (10ins. long) and nail them between the side pieces. The checking is suggested to keep the parts held squarely. If adopted, the length of the end pieces will be 10 $\frac{1}{2}$ ins.

The side pieces are cut so a “lug” is provided at the projecting end to

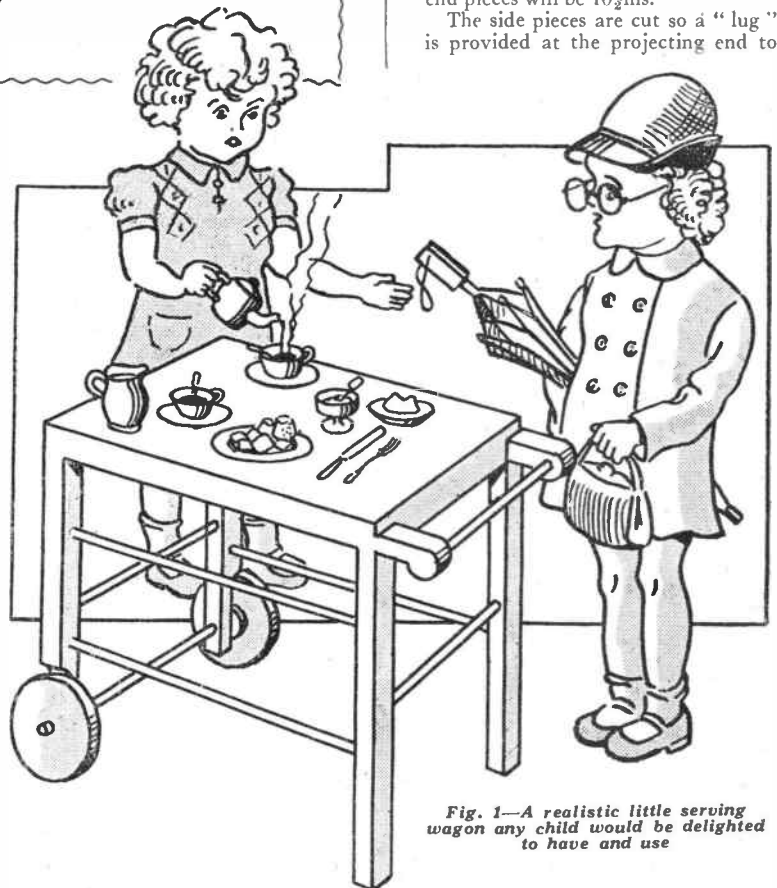

Fig. 1—A realistic little serving wagon any child would be delighted to have and use

allow for a $\frac{1}{2}$ in. dowel handle rail. The lugs are formed by gluing a short piece of wood to the end, then when dry, cutting the lug to shape, the diameter being first scribed with the compasses.

The dowel hole is $\frac{1}{2}$ in. in diameter and $\frac{1}{2}$ in. deep. It is advisable to bore the hole prior to cutting the lug shape. No need to use a keyhole saw in order to cut the lugs to shape; the shaping can be done with a wood chisel, paring the waste away piece by piece.

The dowel rail length is 11 ins. It is glued in the lug holes first, following which the end pieces are attached between the sides.

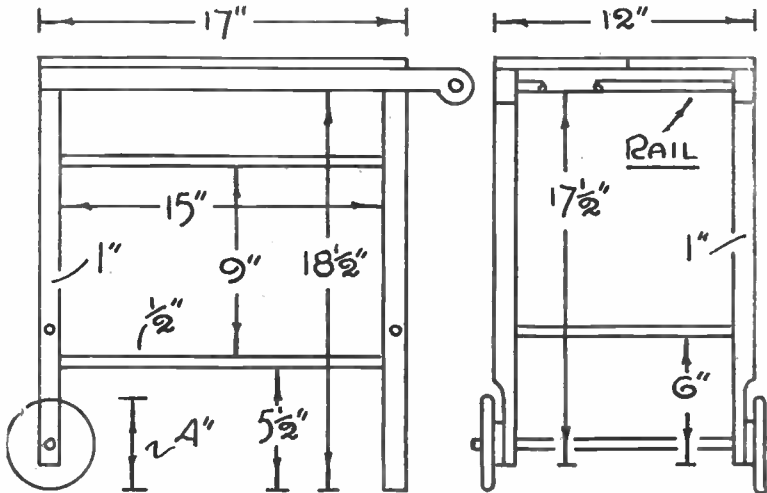

Fig. 2—A side view and end elevation giving helpful dimensions

As you can see, the legs differ in length and shape. The rear legs are $18\frac{1}{2}$ ins. long by 1 in. square. The front legs are $17\frac{1}{2}$ ins. long by the same thickness. To allow for the hub disc of the wheels, one side of the front legs are cut (checked) by half, i.e., $\frac{1}{2}$ in. deep, the length being about 4 ins. or so.

The Legs

The leg sides must be bored for the $\frac{1}{2}$ in. dowel rails. The views at Fig. 2 show you the position of the dowels at the sides and ends. If desired, the topmost side rails can be dispensed with. In the event of not being able to obtain $\frac{1}{2}$ in. dowel, $\frac{1}{4}$ in. square strips could be run off a suitable length of $\frac{1}{2}$ in. board, the edges being rounded with a smoothing plane and then glasspapered smooth.

Attach the side rails first. The length of these is, of course, 16 ins., the extra 1 in. being taken up by the depth of the holes in the legs.

Fitting the Top

Having inserted the end rails between the legs, the top framing is fixed on top, using oval nails of suitable length. It is wise to bore the nail holes with a bradawl so as to prevent any chance of the wood

splitting. Keep the leg tops flush at the corners of the framing.

Now, the top of the trolley can be either a plain piece of wood 17 ins. long by 12 ins. wide by $\frac{1}{2}$ in. thick which is merely nailed flush on top of the frame work. On the other hand, you could check it at the corners so it fits beneath the top framing, the sides and ends of the latter thus forming an adequate "tray" or well.

Hiding the Joints

By fixing the top down on the framing, it hides the joints in the wood. So, you can have it one way or the other, as you think best. Should you make a neat joining job in the frame

For an axle, you need a piece of $\frac{1}{2}$ in. dowelling 15 ins. long. Glue the hub disc to the wheel discs, then attach one wheel to one end of the axle so that $\frac{1}{2}$ in. of the latter projects.

The wheel is glued on the axle, the latter revolving in the holes bored in the trolley legs. Therefore, insert the axle, then glue on the other wheels. Allow a small amount of side play to ensure freedom for the wheels.

Incidentally, seeing that you have been told to bore $\frac{1}{2}$ in. holes in the legs for a $\frac{1}{2}$ in. dowel axle, the holes are just too tight, so you can enlarge them slightly by wrapping coarse glasspaper around a piece of $\frac{3}{4}$ in. dowelling (a pencil would serve) and twisting the "file" in the holes. The enlarging is done smooth, thus assuring that the axle will revolve smoothly.

The Finish

To complete the toy, it should be given one coat of Jacobean oak varnish stain. If required, apply a second coat. This is a quick way to finish the trolley, but if you desire a better finish—particularly if you have made a full-size trolley—that really adds a professional touch, then stain and polish the wood a mahogany colour.

Light oak always looks favourable on tea trolleys. It seems to look cleaner. If you have no stains or polish, but some enamel paint in the house, this, so far as the trolley is

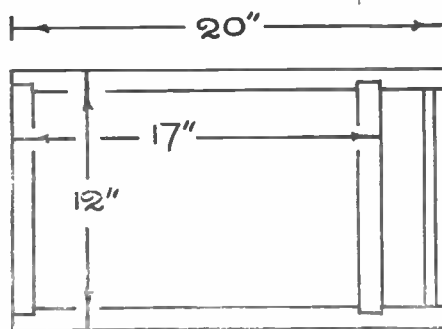

Fig. 3—A top view of the railing

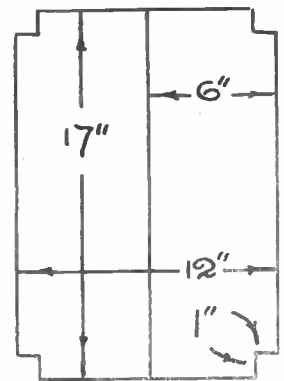

Fig. 4—Alternative method in which top can be cut

work, we see no reason why the shallow tray should not be included. The board for the top is made from two pieces of wood 6 ins. wide, should you be unable to find a piece of the width required.

Do not think of dowelling the pieces together. Simply plane the edges true, then glue them together, pressing out excess glue by rubbing the edges together until they become fixed; this is known as "rub joining."

The Wheels

To make the wheels, cut out two 4 in. diam. discs from $\frac{1}{2}$ in. wood, including two hub discs about 2 ins. in diameter. Drill a $\frac{1}{2}$ in. hole in the centre of the wheels and hubs.

concerned, could be used. The trolley would not look out of place, if you coloured it a bright blue, or green or even red. Children like bright colours, so instead of one colour only, the wheels and rails could be done a contrasting colour.

When painting the axle, take care not to run too much paint into the axle holes. Brush sparingly, using an almost "dry" brush. Otherwise, of course, the paint will cause the toy to squeak and trundle along stiffly.

Bear in mind during the construction, too, that the article will ultimately come in for rough usage. Make it as strong as possible, and use screws which give added strength.

Full-size Figure Patterns on Cover iv, so you can make A MODEL CIRCUS

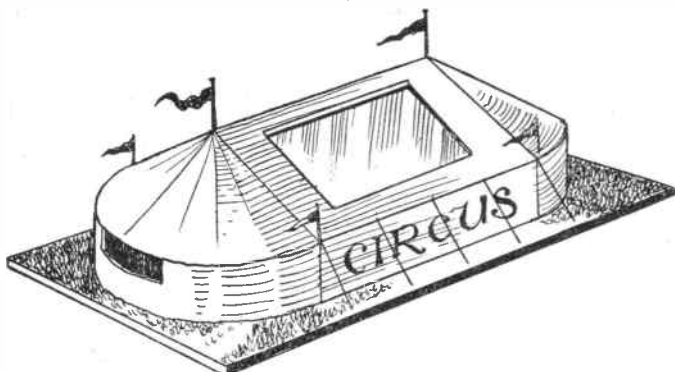

WE are giving particulars for making from wood and cardboard a circus, the general idea of which can be gained from the sketches. There is the usual "big-tops" or large tent with rounded ends and ropes and flags complete.

At one end there is to be an open panel through which one can look and view the interior. Here, arranged about the ground, are stand-up circus figures consisting of elephants, clowns, etc.

Figures Inside

The interior of the tent is lighted by having two oblong panels in the flat sides of the roof. These are covered with thin coloured tissue paper so when the model is held up towards the light a striking effect of illumination is given.

The tent stands upon a base consisting of pieces of stout cardboard stiffened with pieces of wood round its edges.

On Cover iv are given several

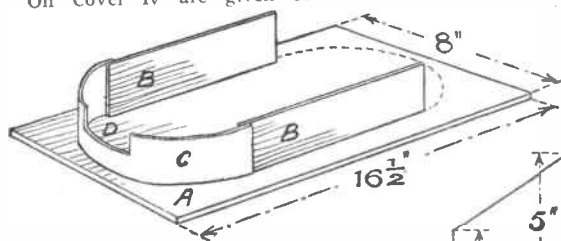

Fig. 1—Base and tent sides

figures in outline which may be either stuck down to card and cut round with scissors, or stuck to thin wood, say, $\frac{1}{8}$ in. thick, and supported by wood bases so they stand up.

Having, then, described the circus, we give a few instructions on how it should be made. The base measures $16\frac{1}{2}$ ins. long by 8 ins. wide. It should, when complete, be stiff and not liable to buckle or sag.

Of course, if a piece of, say, $\frac{3}{16}$ in. plywood could be obtained for the

base it would be much better than card.

The tent is shown at Fig. 1. These are two sides B of, say, $\frac{3}{16}$ in. wood each measuring $9\frac{1}{4}$ ins. by $2\frac{1}{2}$ ins. and they must be firmly fixed to the base with screws and glued blocking fillets inside. To the ends of these uprights are fixed the rounded ends of the tents and in Fig. 1 the nearside end is shown as C.

The length of these pieces is best gauged by first cutting a strip of thin card measuring $2\frac{1}{2}$ ins. wide and bending it round to a line making a true semi-circle from the ends of the uprights B.

In one of the curved ends there will be an oblong cut out measuring about 4 ins. by $1\frac{1}{4}$ ins. (as D in Fig. 1). The opposite end, of course, will be solid.

The whole roof of the tent will be made from thin card and Fig. 2 shows how it is marked out and cut ready for shaping up and gluing together. The two centre or straight portions of the roof are made from a piece of card measuring $9\frac{1}{4}$ ins. long by $8\frac{1}{4}$ ins. wide. Two $\frac{1}{4}$ in. wide borders

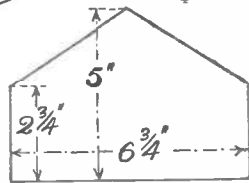

Fig. 3—Details of one end

are marked off along the wide edges shown by the dotted lines and a line drawn down its centre ready for creasing and bending.

Two panels of the card are then cut away and over each will be pasted,

inside, the coloured tissue paper. One panel should be slightly larger than the other to afford sufficient space to get the hand in when change of "performers" is required. Score the dotted lines lightly with a pocket-knife and bend ready for gluing to the uprights.

To form the conical ends of the tent two pieces of the card will be wanted, measuring 7 ins. by $4\frac{1}{4}$ ins. Describe the arc shown with a pair of compasses to a $\frac{1}{4}$ in. radius. Then

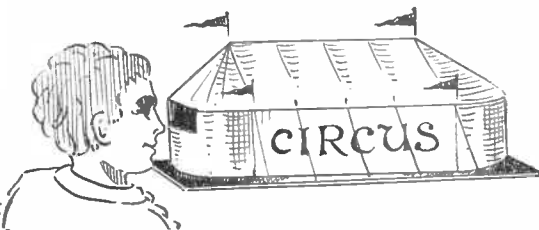

set across this the length of 7 ins. as shown. This will be found to provide the exact shaped pieces to fit the circle of card at the end and to conform to the proper slope of the roof where this latter is angled up.

Gluing Tabs

In the diagram, Fig. 2, the two gluing tabs are shown as F and G for attaching to the roof sections. Tab F in the diagram is already glued in place while tab G is waiting to be brought round and connected up.

Both ends of the tent will be similarly done while a card template cut to the outline of Fig. 3 will be temporarily held in place, say, in the middle of the tent until the glue has hardened in all positions.

Small tabs of ordinary linen tape about $\frac{1}{4}$ in. square will be found useful for strengthening the creased portions and to make the connections between roof and curved ends.

To form the tent poles on which in our sketch the large flags are seen flying, two pieces of $\frac{1}{8}$ in. round rod should be used. Cut small holes

(Continued on page 162)

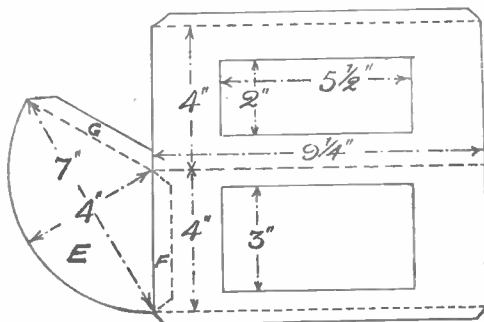

Fig. 2—The roof and end slopes, showing gluing tabs

How to develop your own films successfully in HOME PHOTOGRAPHY

IN the last article you were told something of the theory of exposure and developing and how they were very closely linked in the making of a perfect negative. In this instalment we want to go with you into your kitchen or bathroom and let you develop a film while we look on.

It is not an expensive process. You will of course, have to buy some developer and some fixing salts and it will be as well if you use one of the most familiar developers. Azol costs 2/3 for a 3-ounce bottle which is sufficient for about two dozen spools of film. We also advise using acid fixing. One 8-ounce tin costs 1/- and makes 60 ounces of solution for quite a number of films.

Apparatus Needed

You will wonder what apparatus you will require. Well, you will want a red light and, perhaps, you can buy a piece of ruby glass that will fit into your bicycle lamp. If you cannot do this then get a small lamp complete with a piece of ruby, orange and clear glass. It should not cost very much and will last for years.

What about other apparatus? If you do not want to spend any more money for the present you can start off by using a couple of pie or pudding dishes. They will serve your purpose very well indeed but do, please, see they are thoroughly washed before you put them back in their proper place.

How to Measure

You will eventually feel that you must have a measuring glass. But do you know that the average tumbler holds half-a-pint of water, which is ten ounces? And, perhaps, you do not know that a standard table-spoon holds one ounce; a dessert-spoon half-ounce and a teaspoon quarter-ounce of liquid. Take a note of those measurements for you will find them useful.

Will you want scales? No, for you can measure the acid fixing powder from the tin which is fitted with a cup lid. This cup holds two ounces of the powder; the quantity required for making up 15 ounces of fixing solution for films.

Tables and Temperature

You will first turn to the Azol development tables to see how long to leave the film in the solution. It is an Ilford H.P.3 make and is included in Group 5 of the tables that group wants 9½ minutes at a temperature of 65° F.

This is the average temperature

of tap water during the summer months but in the winter there is a variation. Therefore, it may be necessary to add a little hot water to bring it up to 65° F, which is the best temperature at which to keep the solutions when developing. The bathroom thermometer will help you to get the right degree.

Cleanliness Essential

Cleanliness is a habit which every photographer must practise. There are two outstanding reasons for the habit. First, the presence of dirt or dust on sensitized material or on dishes or benches will inevitably leave its mark; secondly, all developing solutions will stain wood, porcelain, linoleum or carpets. Therefore, if you want to leave the scullery or bathroom free from stain you must place some paper or old material over the table or bench, and avoid dropping any solution on the floor or into the bath.

If you are intending to work over the bath or sink be sure to have a supply of water in them while you are working. This will take up any stray drops of developer and completely dilute them so that the staining property is lost.

Having made your developer by pouring one ounce into 24 ounces of water turn it into one of the dishes and proceed to make the fixing bath. Take particular note in which dish this solution is placed. Turn out all white light and put on the red one. Get your spool of film and start removing the cover paper, unrolling until you come to the film.

Some films are fastened to the cover at this end and in that case remove the fastening and continue unwinding. Ignore the paper and look after the film. When you reach the end you will no doubt find that this end is

gummed to the paper. Unstick it and let the paper with the reel fall to the floor and take hold of the film in both hands, one at each end.

Developing Operations

It is quite a good plan to pass the film through clean water for a few seconds before developing, to prevent air-bells. Now take note of the time and by holding one hand fairly high over the dish and the other almost in the developer you will form a loop of the film.

Allow it to fall into the developer and pass it through by lifting the one and dropping the other hand alternatively. This is known, by the way, as the see-saw method of developing a film. Keep hold of each end and continue the action regularly for 9½ minutes.

At the end of this your film will be correctly developed and you should transfer it to the fixing bath. Continue the same see-saw action for the first three or four minutes and then you may drop the film into the dish. Make sure it is covered completely with the solution, and every few seconds gently draw it upwards

(Continued foot of opposite page)

The Black-out is an ideal time for doing this

You have often wanted to make some more prints from those snaps you took last summer. Why not do it now? With some Azol, that simple one-solution developer (it only needs the addition of water) you can make beautifully bright prints on

AZOL

*is the developer
to use. It brings
out the detail.*

gaslight paper. Azol is so simple to use and you don't have to mess up the bathroom—or wherever you work—with a lot of other chemicals. Just Azol and, of course, the acid-fixing to make up the hypo bath. If you haven't tried Azol send for our trial set. You'll never know what splendid results it gives until you've used it yourself. Azol is jolly good, too, for developing films.

Special Trial Offer :

For 2/3 P.O. Johnsons will send you post free (G.B. only) a trial set of Chemicals, including 1-oz. bottle of AZOL, to develop eight spools 2½in. by 3½in., 4-oz. tin ACID-FIXING, making 30-60 ozs. solution, one packet AMIDOL DEVELOPER, enough for 2 to 3 doz. bromide or contact "gaslight" prints.

Address : Hobbies Dept.

JOHNSON & SONS Manufacturing Chemists Ltd., HENDON, N.W.4

A noise to frighten away the birds is made by a GARDEN BIRD RATTLE

THIS bird windmill which will make a noise when revolving is quite a good piece of equipment to scare birds in the garden. It is not difficult to make and requires very little timber.

To make the body, square up one edge of a piece of wood such as pine and smooth the surface to about 15ins. by 4½ins. by ¾in. Cover one side with 1in. square and transfer the design of the bird from the drawing Fig. 1.

Saw out the design round the back lower edge and top of bill. Bore a ¼in. hole through the body at the centre of balance.

Now cut out the two ¾in. thick blocks (Fig. 2) 2ins. in diameter. Bore a ¼in. hole half way through and a 5/16in. hole the rest of the way.

Then nail on the block in the position shown at Fig. 3. The larger hole is next to the body and covers the hole in the body. Apply a coat of white

paint and when dry glasspaper smooth and enamel as indicated.

For the wings, square up one edge of each of the two pieces of wood 10½ins. by 4ins. by ¼in. Transfer the wing design (Fig. 4) on the surface and saw out.

Then round off the leading edges and wing tips and bevel one side of each wing as shown in the drawing.

Wing Blocks

To make the wings flange blocks cut a piece of pine 3½ins. by 1½ins. by 1½ins. and mark off two lines 1¼ins. from each end of the block as shown at Fig. 5. Draw a diagonal on the surface between the two centre lines, find the centre of the ends and draw a 1in. circle. Then bore a 5/16in. hole half way into each end of the block.

Saw the block on the diagonal (Fig. 6) and with a sharp knife carve the flange from the diagonal to the circle as shown at Fig. 7.

Drill a 1/16in. hole through the round, ¾in. from the end. Cut a piece of 5/16in. dowel 5½ins. long and glue and nail the wings on to the flanges. Get the acute angle of the wings on to the flanges to the length of the wing.

Fixing a Wing

Carve the bevelled end of the flanges to blend into the design of the wing end and fix one wing on the dowel pin. Finish the wings and flanges the same as the body but use blue enamel for the final coat.

Up till now there is only one wing and flange fixed to the dowel. To assemble, temporarily, put the wing with the dowel pin through the body of the bird. Then slip the other wing in position.

Find the centre of balance on the under side of the bird and mark it. Drill a hole about 1/64 in. larger than the diameter of the post bearing into the body of the bird at the centre of balance and toward the centre of the axle hole.

To the Post

Then cut a square piece of birch ½in. by ½in. and chamfer all edges ¼in. Select a long wire nail, about 4ins. for the post bearing and drill a hole a shade smaller than the diameter of the nail and 1½ins. into one end of the birch. Force the nail into the post, cut off the head and enamel the post black.

Reassemble the bird with washers on the post bearings and wing bearings. Now balance the wings. With someone carefully holding the assembly drill the second hole through the flange block and through the dowel.

Fasten the second wing securely with a nail. The birch post is socketed into a ground post which sets the rattle at the required height (Fig. 3).

It is just the thing to make now in readiness for the birds' arrival.

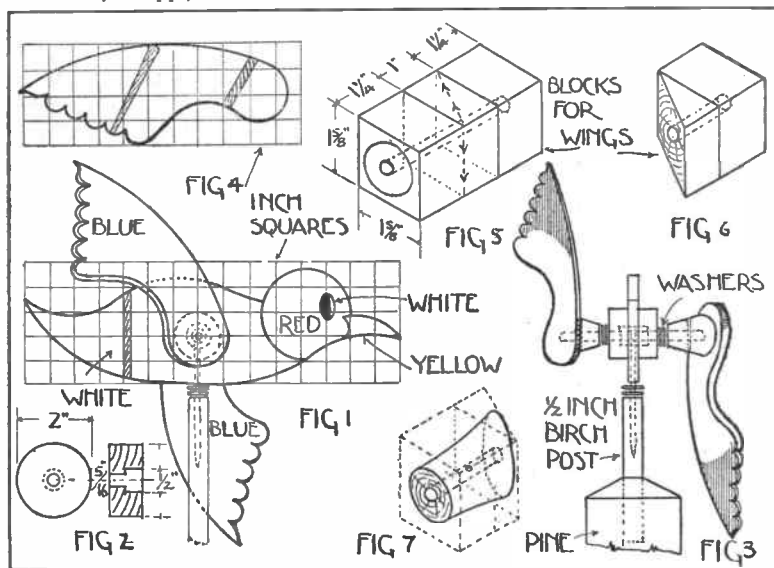

Photography—(Continued from previous page)

and downwards to enable fresh solution to get at it.

At the end of another four minutes you can turn on the white light and this will enable you to examine your first attempt at processing your own film. It will undoubtedly give you a thrill when you see what a fine set of negatives you have got.

Final Washing

But do not be too keen on examining the film while it is wet. It is

fully fixed when all the grey cloudiness has disappeared from the back of the film, and every part looks black. Then place it in a dish for its final washing. If running water is used half-an-hour will be sufficient but if this is impossible give it at least six changes of water each lasting about six minutes.

Then the film should be hung in a dry place free from dust. If possible pin to a shelf in the bathroom where it can remain undisturbed

through the night. Do not forget to pour the solutions into bottles for future use, but be sure that the bottles are full and stoppered.

When the film is dry it should be cut into its sections and each negative placed in its own envelope. This in turn should have a record of its contents marked clearly on the outside. Never keep negatives lying about or in your pocket book for they are easily damaged by rubbing and they finger mark very readily.

A Free Pattern Sheet for a useful HAT AND COAT RACK will be given away with next week's issue

Just blocks of wood and cardboard form simple MINIATURE FURNITURE

At the moment dolls, soft toys and animals are being made up by the W.V.S. and other classes for the hospitals and day nurseries. One type of article which is very much appreciated and which is not forthcoming is strong hard wearing miniature furniture.

If made up on the lines suggested in this article there should be a good sale for these apart from their value as toys for younger sisters. Only very small oddments of wood are needed and a few pieces of strong cardboard for the surrounds.

A Complete Suite

Each set could consist of four small chairs, two settees, and a table. You will note that all complicated bits and pieces are left out so they will stand rough treatment.

In the sketching is shown the main cardboard sections for the three items. In the case of the chairs and the settees, one strip only is made. This is scored down the thickly marked line which will enable it to bend round the prepared wooden block and held by glue and a tack on each side.

For this part, try and get good strong cardboard with a firm surface so that the glue, when applied, will not sink in too much.

Blocks of Wood

Any odd wood will do to form the main part of the chair or settee as shown. For the chairs, make the block a cube with 1in. sides and for the settees 1in. by 2ins. The base of the table is 1in. by 3ins. Clean these off nicely and prepare the cardboards.

If you are mass producing these sets, then estimate how many blocks you have so you may finish with the woodwork part in one operation.

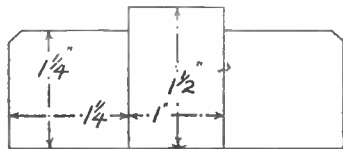

Cardboard for small chair

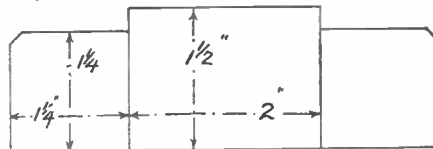

Shape of cardboard for the settee

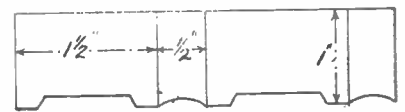

The undersection of the table

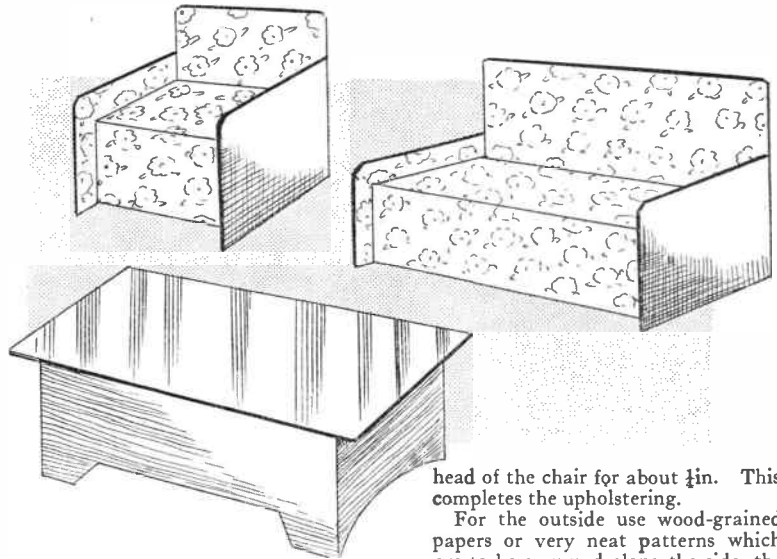

In the case of the table, the four-sectioned cardboard folds round the wooden block and thus forms the legs and under section all in one. The top of the table could be cut from plywood if you have it and should measure about 4 1/2 ins. by 2 1/2 ins. The same measurements will apply if you have to make the tops from cardboard but see that this is of a strong type.

Imitation Upholstery

Now for the upholstering. Collect some brightly shaded fabrics but not with too much pile as this will only fill up the seat and spoil the effect. Also, avoid the use of large patterned fabrics which will overshadow the chair and make them look too gaudy.

The fabric should be cut wide enough to fit inside the cardboard sides of the chair along the seat and up the back being carried over the back and

head of the chair for about 1/4 in. This completes the upholstering.

For the outside use wood-grained papers or very neat patterns which are to be gummed along the side, the back and on to the opposite side. Trim away the surplus material cutting it so that the upholstered part shows for the 1/4 in. at the top.

The covering of the settees is done in exactly the same way only the width will be in proportion to the size of the seat.

Table Mats

In the case of the table, cover the stand section with wood-grained paper before fitting the top. In covering the table top this should be done before fitting to the base and should overlap well on the edges.

Although, with the use of odd materials one cannot give definite measurements, approximate ideas are given in the sketches and the worker can make up his own sizes but must keep them proportionate.

If you are making sets up for sale, then mount up on a sheet of cardboard which should be covered with some type of fancy paper. Oddments of pile fabric are effective.

Model Circus—(Continued from page 159)

at the apex of the roof slopes and push the rod through fixing the ends with glue.

Brightly coloured flags can be made from the tissue paper, while for the stay ropes each side of the tent, fine string could be used with wire staples at the ground and glued tabs at the top.

Mention has been made regarding the making of the figures or performers but a tip must be remembered regarding their arrangement in the tent. Viewed from the end of the tent through the "spy-hole," all the figures should be seen at one time. So some of them will therefore have to be placed at an angle.

The figures may be coloured with water-colour or crayon, but the best result would be got by outlining the figures on to the wood and then colouring them up in matt enamels.

The groundwork round the tent should be painted green and represent grass while inside the tent the ground should be painted yellow ochre.

Final instructions for completing in wood a WORKING ELECTRO-MAGNET CRANE

WE can now complete the work commenced last week and finish this splendid model. New readers will have to obtain a copy before beginning.

Fit the handle to the winding drum spindle. The handle is merely a disc of wood with a piece of $\frac{1}{4}$ in. dowel glued near its edge (the disc is shown at Fig. 9). When gluing the disc to the spindle, keep it fairly close to the side of the cabin so the winding is done somewhat stiffly.

This is to do away with a ratchet wheel and pawl. The stiffness should "hold" up most weights without the cord unwinding. If this should result a wire or cord loop can be affixed to the side of the cabin for putting over the handle of the winding drum.

The hook is made from a strong hairpin or paper clip. Make the "eye" first, then thread on a wooden or glass bead, then bend the "hook" portion. A length of strong black thread is tied to the "eye" of the hook, the other end going to the winding drum.

Now, to make the electro-magnet coil, obtain a 2 in. by $\frac{3}{16}$ in. iron

machine bolt with nut. File and drill a hole in the end of the bolt as shown at Fig. 9. Cut two discs from $\frac{1}{8}$ in. wood to the size shown at Fig. 3, drilling a tiny hole near the central hole in one of the discs.

Screw the other disc on the bolt, right up to the head, then screw on the other disc. A strip of thin



Fig. 8—Half-view of the under base

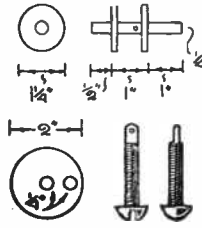

Fig. 9—Winding drum details, with bolt

paper is wrapped around the bolt between the discs and glued. The paper, while serving to insulate the wire from the bolt, also ensures neater winding.

To wind on the wire, obtain some coil stuff, enamelled or otherwise,

and thread one end through the hole in the end disc. Leave about one foot of wire projecting, then proceed to wind the wire around the bolt, four layers of wire (windings) sufficing.

Final Work

The last layer—the fourth—brings the wire near to the tiny hole in the end disc again. Thread the rest of the wire through it and cut it the same length as the first end of the wire.

The wires are twisted together neatly near the disc and loosely along the rest of the length (see side view). Hook the electro-magnet to the hook of the crane. Bare the ends of the wire leading from the magnet coil and fix them to the terminal bolts.

This completes the work. For a finish, apply a thin coat of enamel paint to the cabin and bases. If desired the whole of the model could be painted in this one colour, but it will look much nicer if the crane arm, the winding handle and electro-magnet parts, hook, etc., are enamelled black.

Leave the enamel to harden thoroughly, of course, before using.

From the Editor's Notebook—

THE release of Malta from constant bombing attack is reflected in my mail bag. I am delighted to be hearing more regularly now from some of the staunch readers in the island and to know that in spite of everything they are still enthusiastic readers of Hobbies whenever they can get it. One of the sad reflections is obtained from the requests for back numbers which apparently have failed to reach their destination "owing to enemy action."

ANOTHER Hobbies Club has been formed—at Cockermouth in Cumberland and it appears to have made a flying start with success. The organiser is Harry Bowman of 9 Main Street, Cockermouth, and the secretary Sewell Bell. The present H.Q. is at All Saints School, open every Monday night 7.30 to 9.30. This is the first club of its nature in the district, and a great success. During the first six weeks some 50 to 60 models had been made with the Club numbering about 30 members. There is a sub. of 6d. per month. After the first month a competition was held for the best model, being judged by the Sub-Editor of the local paper. The competition was won by Maurice Sumpton, a boy of 15 who had never

made a model plane before joining the Club. More boys over the age of 12 are wanted as members and those who wish to join should call on the Club Night.

MODEL making can certainly cover some unusual subjects and can frequently be made to individual tastes and requirements. For instance, a replica in miniature made to scale, of Moses' Sanctuary constructed in the Wilderness by the Children of Israel has been completed by a Nottingham man—F. K. Winterton of Rosslyn Drive. It was made for instructional purposes and has taken nearly two years to reproduce.

MOST readers know our model design for a model of St. Paul's Cathedral and many have made it up. But I wonder how many have counted the number of parts. Candidly, I have not, but I am interested to find out that someone has. John Elford of Gilfach Bargoed (which is in South Wales) reports that his model is made up of 2,700 pieces. I should not have imagined that number, but he may have included the five lamps, etc., with which the interior is fitted.

I SUPPOSE this craze for big numbers gets hold of certain people, because I have also recently been shown a photograph of a model Spitfire in its skeleton state. It had no fabric covering but was made from 3,000 matches and nothing else. The queer craft was actually on view at an Arts and Crafts Exhibition at Ilford, although I am not sure whether it was counted as an "art" or "craft"

THIS model however can be beaten by one which contained no less than 30,000 matches! Needless to say it was completed before the present scarcity. The model is a realistic reproduction of York Minster and like that historic edifice, came near to being bombed flat when the owner's house was damaged some time ago. It was made by Fred Marsdin of Snaith, near Goole, and having survived the blitz has since raised money for the Red Cross and Pontefract Infirmary. Now, can anyone produce a model of over 30,000 matches? I want the record if I can! At one time, you know, there used to be a Match Collectors Club, but this was in the happy days when matches were so plentiful you could afford to waste them.

The Editor

Set of simple cut-out
**STATUETTE CIRCUS
ANIMALS AND FIGURES**

See details on page 159

