

HiFi

1959

YEAR BOOK

SPECIAL TAPE EDITION

QUAD

for the
closest
approach
to the
original sound

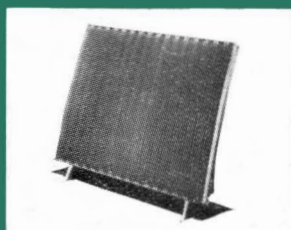
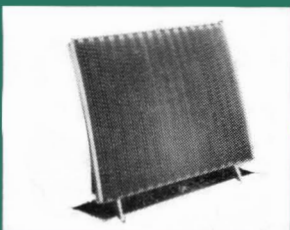
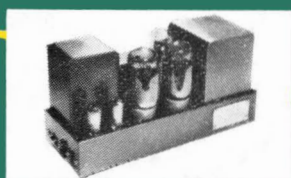
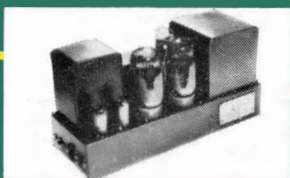

ACOUSTICAL MANUFACTURING CO. LTD. HUNTINGDON, HUNTS.

**PICKUPS • AMPLIFIERS • SPEAKERS •
MOTORS • TUNERS • TAPE RECORDERS**

10/6

Hi-Fi Year Book

— 1959 Edition —

Editor - - MILES HENSLOW



Published by:

MILES HENSLOW PUBLICATIONS LIMITED,
99 MORTIMER STREET - - LONDON, W.1

INDEX

	<i>Page</i>
Pictorial Feature	
Precision-made Pickups	5
Transcription Motors	
<i>By Stanley Kelly</i>	15
Motor Units <i>DIRECTORY</i> ...	17
Pickups and Styli	
The Progress and the Future	
<i>By Stanley Kelly</i>	21
Pickups and Accessories <i>DIRECTORY</i> ...	23
Amplifiers and Pre-Amplifiers	
A Survey of Current Trends	
<i>By George W. Tillett</i>	33
Amplifiers <i>DIRECTORY</i> ...	43
The BBC's FM Service <i>MAP</i> ...	72
Radio Tuners	
An Introduction	71
FM and AM Tuners <i>DIRECTORY</i> ...	73
Impulse Tests for Speakers	
<i>By J. Somerset Murray</i>	83
Loudspeakers—"Domestic and Hi-Fi"	
<i>By Ralph West</i>	88
Speakers and Enclosures <i>DIRECTORY</i> ...	89
Recorders, "Hi-Fi and Domestic"	119
Tape Recorders <i>DIRECTORIES</i>	
(a) Professional and Semi-Professional	121
(b) Tape Decks	125
(c) General Purpose and Domestic	127
(d) Battery Operated Portables	142
(e) Mixers, Amplifiers and Accessories	143
How to Use Your Microphone	
<i>By John Borwick</i>	151
Microphones <i>DIRECTORY</i> ...	155
Home Construction	
An Introduction	161
Constructors' Kits <i>DIRECTORY</i> ...	162
Hi-Fi Dealers <i>DIRECTORY</i> ...	169
Advertisers' Index	167

INTRODUCTION

IN offering our readers this Fourth Edition of "Hi-Fi Year Book", we feel that several points should be made; and this, therefore, is more than the customary "introduction". In 1956, when we published the first edition, the industry as a whole was beginning to expand; and largely on account of the first London Audio Fair, thousands of new enthusiasts found a hobby in "Hi-Fi". In the early part of that year there were relatively few *Hi-Fi Dealers*, and an enormous amount of public buying was done by post. Our own post-bag in this editorial office, with its hundreds of letters from readers of *Hi-Fi News*, was largely made up of requests for specific information about what to buy, what not to buy, and how best to spend a given amount of money.

It was because of this need for information—already an obvious urgency—that *Hi-Fi Year Book* was planned. The editorial policy of the book was intentionally strict, in so far as it was possible to outline the term *hi-fi*, on account of the importance of maintaining the very standards implied by the term.

"Hi-Fi" and "Audio"

Bearing in mind those still very important standards, three things have happened since that first edition was published. First, and inevitably, the truly hi-fi products from the factories of a hard core of real enthusiasts have been joined by a hundred-and-one new products, in every classification, from a score of manufacturers who have become interested in the industry. Second, the tape recorder has demanded the attention of the general public; and this instrument, as a legitimate unit in the chain of sound reproduction, is now represented by dozens of models. Finally, within the past 12 months, the impact of stereo has rocked the industry, and in some cases the confidence of the buying public.

Editorial policy, both with *Hi-Fi News* and this *Year Book*, has been far from easy as a result of the above three factors. It is a simple matter to give a publication a high-toned tag, but quite another matter to ensure that its use is justified. It was, therefore,

with the interests of our readership in first place, that we decided upon the more liberal policy of the greatest possible coverage of products. This change of policy was also influenced by the fact that *Hi-Fi Year Book* has become accepted as the annual reference book for dealers and distributors, both at home and abroad. Arbitrary selectivity would therefore be both an impertinence and a cause of irritation, when considering the needs of sellers and buyers. On the contrary, the more representative the coverage, the better the liaison that is possible between all sides of the industry.

A Buyer's Guide

In a nutshell, then, "Hi-Fi Year Book (1959 edition)" offers the buyer the most complete possible guide to *all* audio products, from the miniature tape recorder to the most costly and advanced high fidelity apparatus. It is a regrettable fact that not all manufacturers' specifications are the conservative statements that they should be; however, it is dodging no responsibility to state that this factor is outside the scope of *Hi-Fi Year Book*—which is, and must be, no more than a guide book compiled from data and statements received from manufacturers. It is not a review journal. It is to be hoped most sincerely that—with the good co-operation of the now many Hi-Fi Dealers, and an increasing knowledge on the part of the buying public—the "Manufacturer's Specification" will rapidly become a more trustworthy statement, and that it will cease to be used (as is current practice) in inflated form as an advertising gimmick.

The discerning reader—and buyer—will know at once, from a quick appraisal of the facts, what is true hi-fi and what is not. The less well-informed reader (who is more deserving of guidance) must always bear in mind what has so often been repeated—that quality costs money, and that there is no short-cut to high fidelity.

Outlay

There are many readers who would like highest fidelity of sound reproduction, but who know full well that it is out of reach, on

account of cost. Their choice is a difficult one, from the really vast amount of equipment that is now available. To give any form of hard and fast guidance in this book is quite impossible; but one of the most reliable yardsticks will always be "*a modest specification at a moderate price*". There are, of course, obvious signposts to follow. For instance, *lp* discs (stereo or mono), at £2 each, deserve nothing but the best pickups for playing them. To apply pinch-penny tactics here is to risk destroying all traces of hi-fi on a hundred discs for the price of a dozen.

Quality

On the subject of amplifiers—one of the widest fields of choice—a thousand words could easily be written, advising upon the many points involved; but there is one very good line of guidance to remember; namely, that an amplifier is a simple piece of electronics to design, and that only through cheese-paring on vital components, or sloppy construction, should a bad product result. High power output, low distortion, extended frequency response, etc., are the items in the maker's spec. which should be reflected in the price. To look for the ultimate in these factors, and to expect them for minimum cost, is to look for trouble—because they are the very things which, *in combination* (which is important) cost money to achieve.

On the subject of speakers, little need be said here: a short introductory article in the

appropriate section of the book should prove adequate. The position today is exactly as it was five years ago. There are definite limitations, set by speakers of different size and design, which automatically "place" the product in or outside the realms of true hi-fi; and here again price often plays a decisive part. Outside these realms, there are many grades of "good" and "very good" which will adequately serve the needs of enthusiasts, according to their whims.

Tape and Hi-Fi

Tape recorders, too, are dealt with on this basis in the introductory chapter of that subject. With the exception of the least pretentious, there are few recorders which cannot lay claim to a place in the hi-fi scheme of things, for the very good reason that they can be used for the collection of material, and chosen accordingly. It goes without saying that the final hi-fi application—*tape facilities for replay through high fidelity equipment*—should be with a deck and electronics that are no less worthy than the rest of the set-up.

★

In conclusion, we hope that this edition of *Hi-Fi Year Book* will prove itself useful to readers, dealers and manufacturers alike. Though every care has been taken in the compilation and presentation of the data supplied by manufacturers, no responsibility can be accepted for errors or omissions.

'WATCHMAKERS' PRECISION IN PICKUP MANUFACTURE

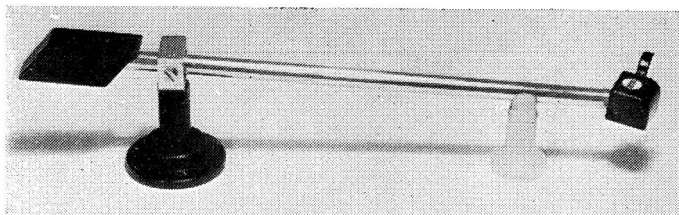

In April 1958 the first pre-production models of the long-awaited Decca ffs pickup were available for test. Number two of these, pictured above, was used in the "Hi-Fi News" demonstration room at the Audio Fair of that year. Many months of exacting work, numerous modifications in the light of experience, and all the usual teething troubles lay between the above and the quantity production run, which has at last reached hundreds per week . . . for hi-fi enthusiasts the world over.

THE *lp* disc is a precision-made product. It is an accepted fact among knowledgeable people that the full and faithful reproduction of the high quality of its recorded signal has, until quite recently, been beyond the capabilities of all but a comparative few. With the advent of stereo, the *lp* disc made yet another great advance, and so set the perfectionists an even harder task in their search for really high fidelity reproduction. The technical "bottleneck", which has always stood in the way of the disc user, is the pickup. There is a vast gulf between the quality of music, as enjoyed by the multitudes, and the near-perfect reproduction of all that a disc contains; and the difference lies almost entirely in the respective abilities of pickups to trace the signal. It is an unfortunate fact that, in many cases, a pickup which does not do its intended job properly is simultaneously degrading the quality of the discs on which it is being used; and it is therefore a good thing that stereo has made its extra demands upon pickups, because it has set the pickup makers to work with a new set of standards to achieve.

For the sake of his discs alone, the wise record collector will not be satisfied with anything but the best: the true hi-fi enthusiast knows that, in terms of quality, he is wasting his time (let alone his money) on anything else.

First in the field with a new precision-made pickup was *Decca*—not altogether surprising, since that company's earlier experiments with recording and reproduction by the high frequency "carrier" system had involved several years of work upon pickups which could trace accurately up to 30 Kc/s! The following pages of pictures show some of the delicate work which goes into the production of the *ffs* stereo pickup. Though pole pieces and certain other parts are machined to fine limits on large machines, the workers on the assembly lines rely upon tweezers, magnifiers and small but highly accurate jigs—and nimble fingers. Microscopes are part of the stock-in-trade of the benches. Every part, and every sub-assembly, is individually checked. Inspection is ruthless, and every pickup undergoes final playing tests, with measurements of output, before it is passed for sale.



1. Tie-back loop of fine Terylene to prevent forward stylus movement.

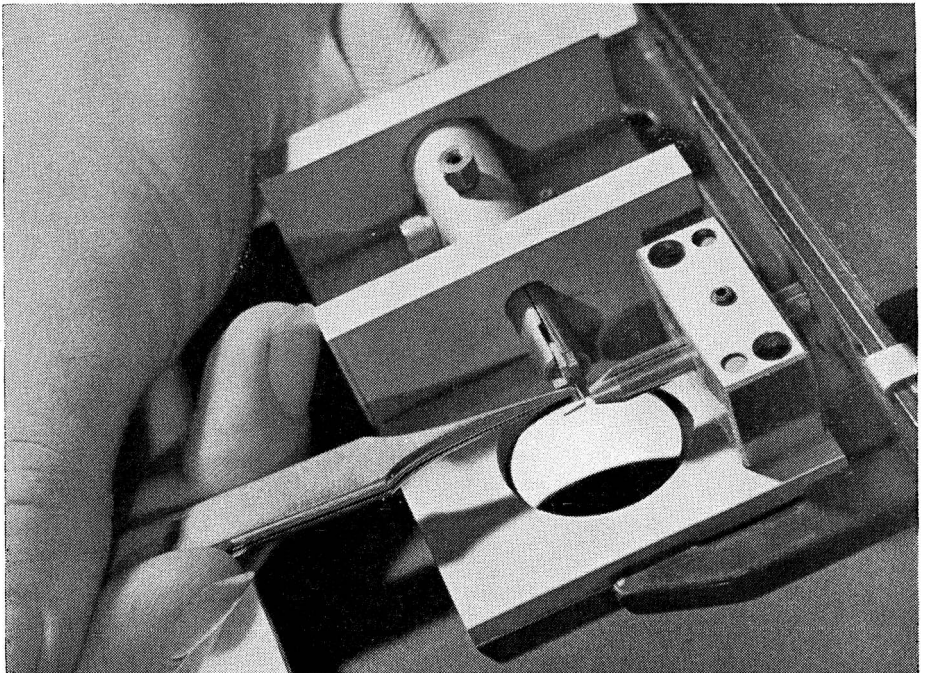

2. Stylus holder and clamp plates being positioned for optical check under microscope.

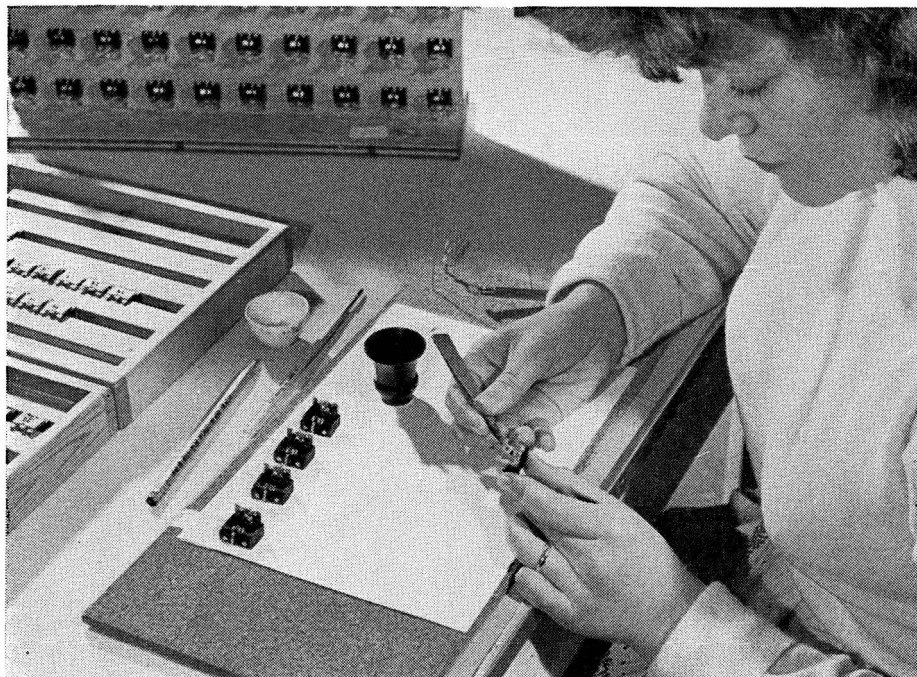

3. The "lateral" coil (for mono discs) is centralised and cemented into position.

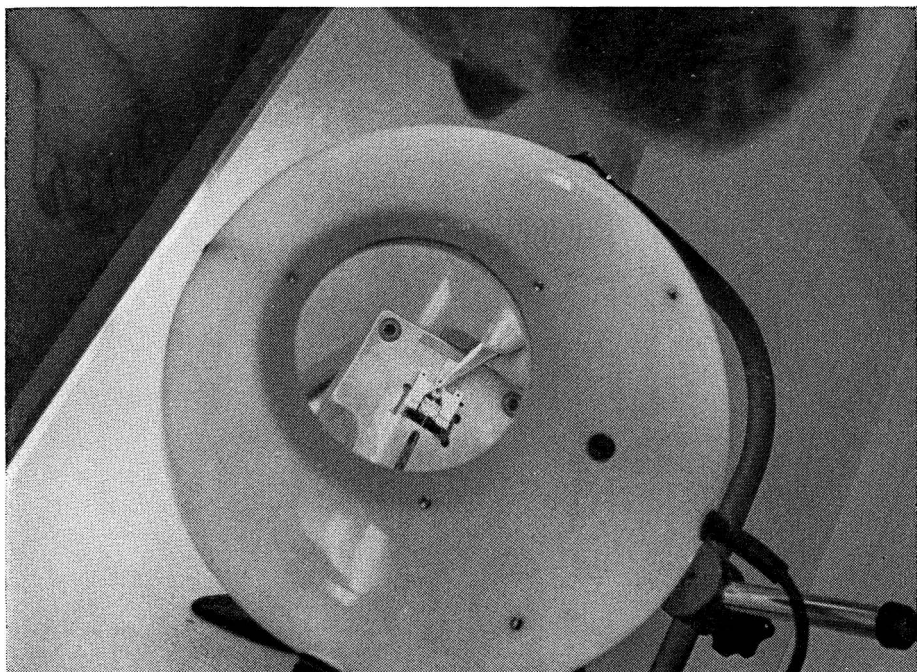

4. With magnifier and tweezers, the Terylene Tie-back loop is positioned round the stylus tip.

final head wiring



5. *The previous four photos show some of the really delicate stages in the manufacture of the "ffss" pickup. The bobbin of Terylene in fig. 1 is sufficient for many thousands of tie-back loops. Stainless steel wire (only 0.0016 diameter) was originally tried for this vital part, but Terylene proved better. The stylus itself is so small that 80 of them weigh no more than a British 3d. postage stamp. When all these tiny parts have been placed in position, the final wiring up (above) is done—with miniature iron and tweezers.*

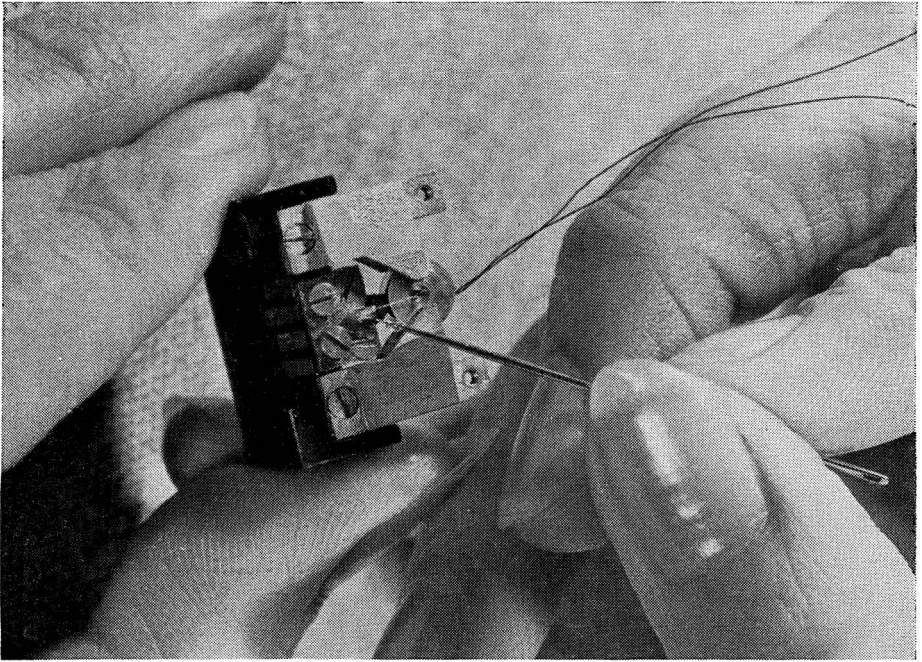

6. *Cementing Damping Block in position. Note Terylene Tie-back thread and lateral coil.*

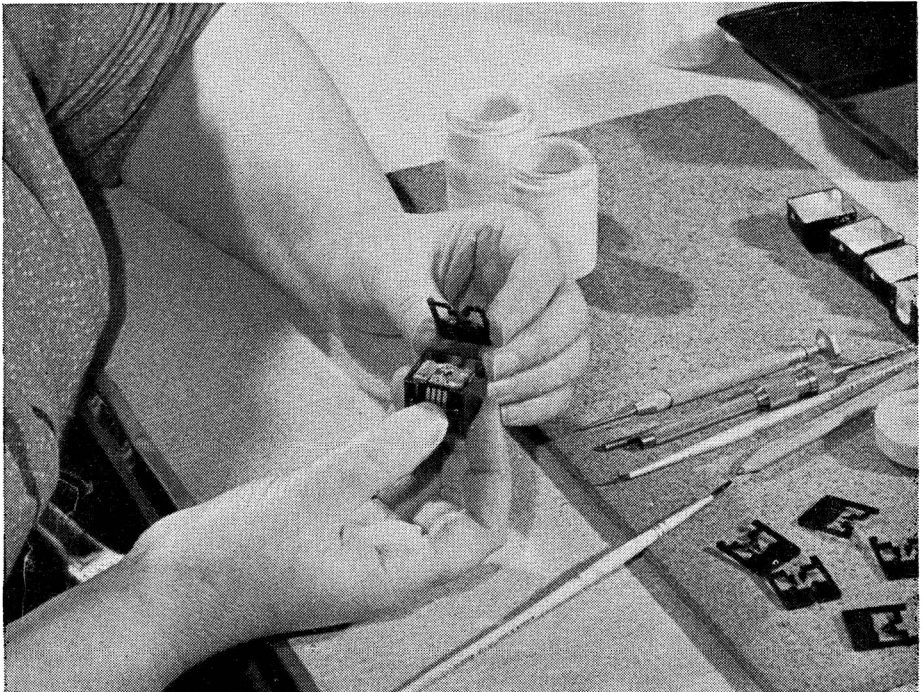

7. *The wiring completed, the pickup is given its cover and bottom shield.*

head magnetising

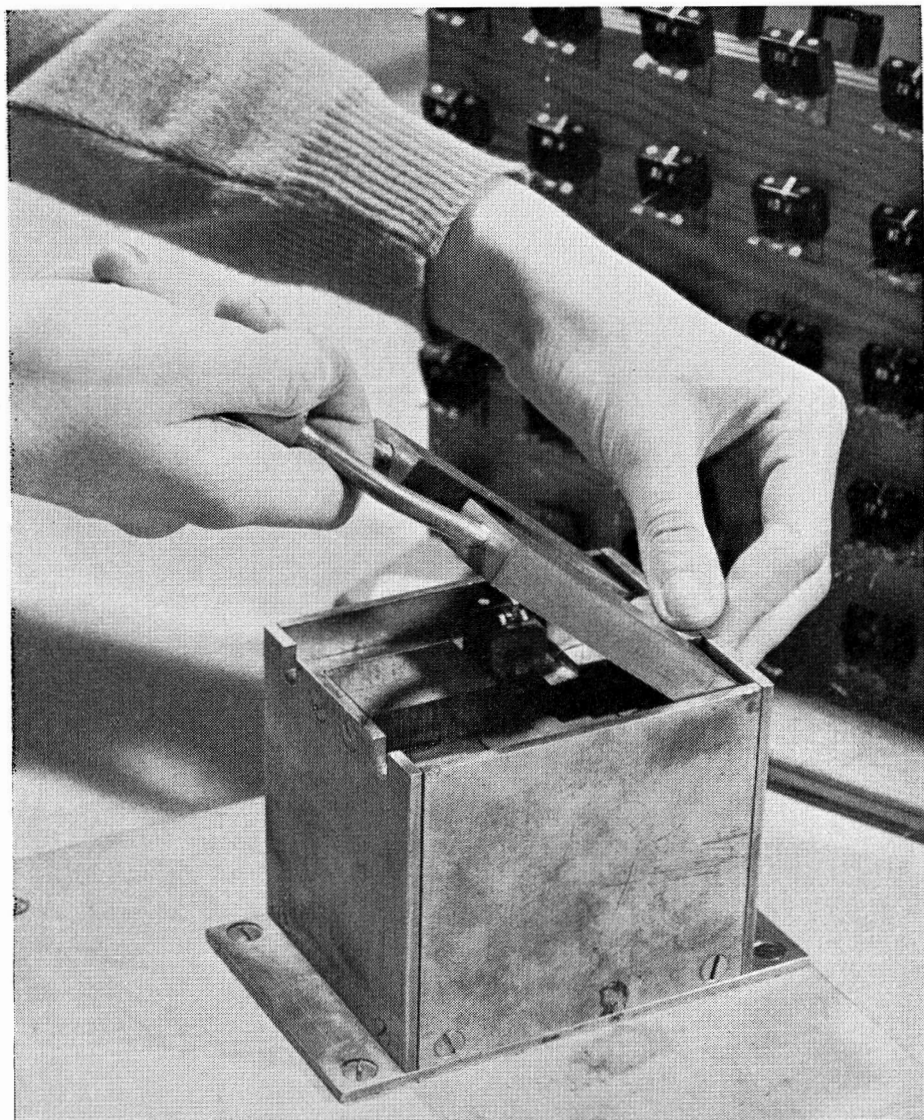

8. *When completely assembled the pickup heads are almost ready for their electrical tests. Only one very important operation remains—magnetisation. A powerful permanent magnet, built into a specially made jig, makes this job a very simple one. The pickup head is placed in position, and the hinged “lid” of the jig is closed. The future magnet of the pickup becomes momentarily a part of the magnet circuit, and when the jig is opened a few seconds later its magnet is of the required strength.*

arm assembly



9. Meanwhile, on another assembly line, the pickup arms are prepared. Each ffs stereo/mono pickup is matched to its individual arm, and tested with it, so the tracking weight is correct to a fraction of a gramme—and is fixed that way! Arm manufacture, though involving larger pieces, is just as precise. Here the pivot is being pressed into position. Ball races have to be fitted. The arm has to be wired—and damped. The next two photos show two further stages of assembly.



10. Here, the wire is inserted, the contact plate added, and the lifting handle fitted.



11. Final stages of arm assembly include the fitting of pillar and mounting flange.

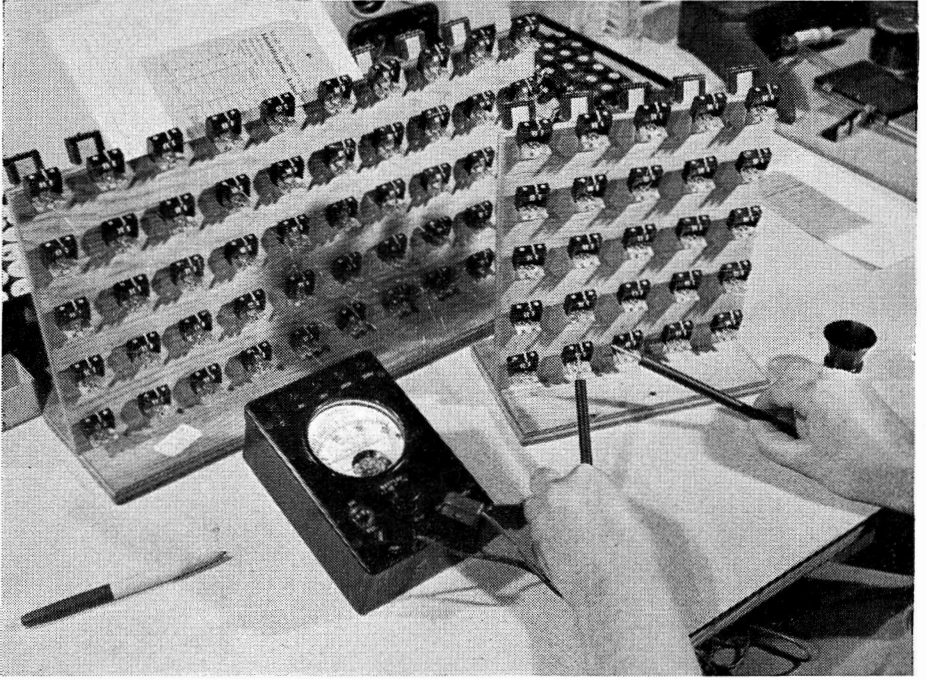

12. Many tests are made during assembly. Here, the lateral coil is tested for continuity.



13. This instrument tests the insulation and electrical continuity of the complete head.

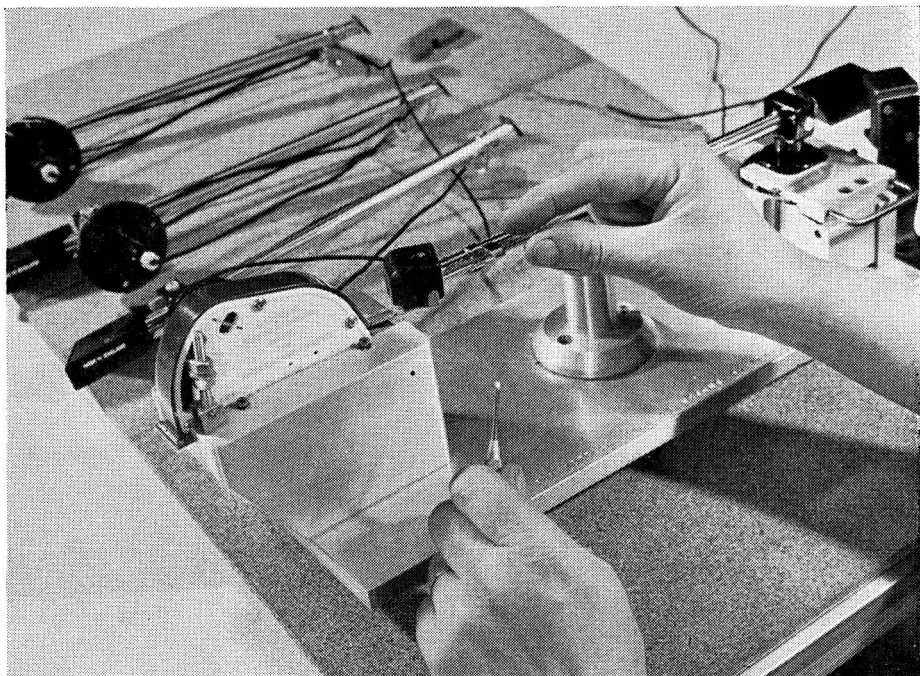

14. *With counterweight fitted, the pickup assembly is balanced for correct playing weight.*



15. *Final tests. With C.R.O. and meter the output from a test disc is measured.*

TRANSCRIPTION MOTORS

AN INTRODUCTION

by Stanley Kelly

ALTHOUGH in the United Kingdom there are probably 40 or 50 manufacturers of high fidelity amplifiers, and almost a like number of speaker systems, the manufacturers of transcription turntables and high fidelity pickups can be counted on the fingers of one hand. The reason for this is not far to seek. The mechanical limits required in the production of these two products are far closer than in the rest of the reproducing chain and, with the ever-increasing stringency of requirements, these limits are now approaching those used in the watchmaking industry. Another reason is the very large capital expenditure for tools, jigs and fixtures, etc.

Only Two New Models

The introduction of completely new transcription turntables therefore tend to be few and far between. In the past three years, only two completely new units have been introduced. They are the **Garrard 4.H.F.** and the **Goldring Lenco GL60**. In the Garrard unit, considerable effort has been expended into producing a medium-priced turntable which, whilst not quite in the "301" class, is considerably better than the domestic units. The Goldring Lenco GL60 made its appearance at the Northern Audio Fair, and is fitted with a new tone arm wired for stereo, and a cast aluminium turntable. All the other units listed in the Directory (with the exception of the imported **Thorens**) are substantially the same as last year, but with the inevitable improvements which, when

they come to light, are automatically fitted on well-established lines.

New Requirements

One thing that stereo-on-disc has taught us is the stringent requirement of minimum vertical rumble. The vertical sensitivity of monaural pickups is reduced as much as possible in the design stages, principally to avoid distortion in the high frequency region due to hill-and-dale effect. Any vertical rumble component present in the motor is thus reduced. With stereo cartridges (in which the sensitivity in a vertical direction is the same as lateral), vertical rumble must be reduced or eliminated at the source, and the attention of the gramophone motor manufacturer has been directed towards this end during the past 18 months. These desirable results have been achieved by attention to detail rather than any basic new discoveries. In general, the motor proper is balanced in two planes, and the mechanical d-coupling between the prime mover and the turntable has also been improved. Additionally, improvements in the main bearing, trueness and balance of the turntable have played their part.

How about Two Speeds only?

Now, with the production of 78 *rpm* records coming to a close, and 16 2/3 *rpm* thank goodness, not having made their appearance, perhaps some enterprising manufacturer will produce a two-speed-only turn-

table in the next year. This will be a boon to many people who are buying hi-fi equipment for the first time, and who will not want to be cluttered up with the old shellac noise generators. And the saving in production cost could then be passed on to the customer, or used to improve the quality of the product.

At the same time, we can find very little

fault with the modern transcription turntable, and provided that the user always remembers to switch the turntable off with its own controls—thus disengaging the idler, rather than using the amplifier power switch—he can expect a trouble-free life of at least as long as the other components of the system.

S. K.

HISTORICAL FLASHBACK

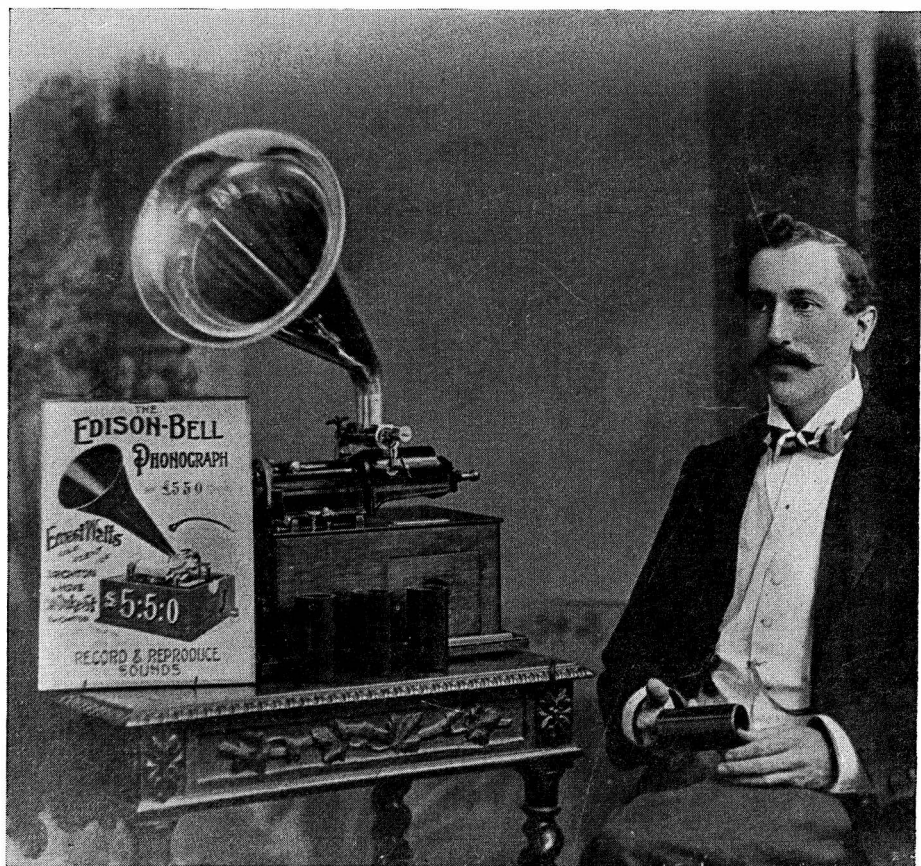

● Readers of *Hi-Fi News*, Number One, will remember this picture—as will those who recall the first edition of *Hi-Fi Year Book*. It now makes a fitting tail-piece to Stanley Kelly's introductory remarks to the short directory of Motor Units, spanning the gap of nearly sixty years. In 1902, this Edison Bell instrument represented the last word in "high-figh". The price, clearly marked, £5. 5. 0. It both recorded and replayed. The demonstrator is Ernest Watts, father of Cecil Watts, who is so well known the world over for his work on behalf of quality from disc.

DIRECTORY OF MOTOR UNITS

★Important Note—No mention is made of record-changers in the following directory. The list is confined to motor units of transcription quality only. The products listed below can be recommended, and conform to the requirements necessary for high-quality sound reproduction.

Collaro Limited, Ripple Works, By-Pass Road, Barking, Essex. Tel.: Rippleway 5533. Cables: Korllaro Telex, Barking.

Transcription Unit, Model 4T200. Four speeds. Complete with pickup arm and "Studio P" head with turnover cartridge.

Plays discs up to 16-in. diameter. Price £13 16s. 6d. (U.K. purchase tax £5 6s. 6d.).

Transcription Unit Model 4TR200, specification as for 4T200 but without the arm and pickup. Price £10 15s. (U.K. purchase tax £4 3s.).



Collaro 4T200 transcription motor

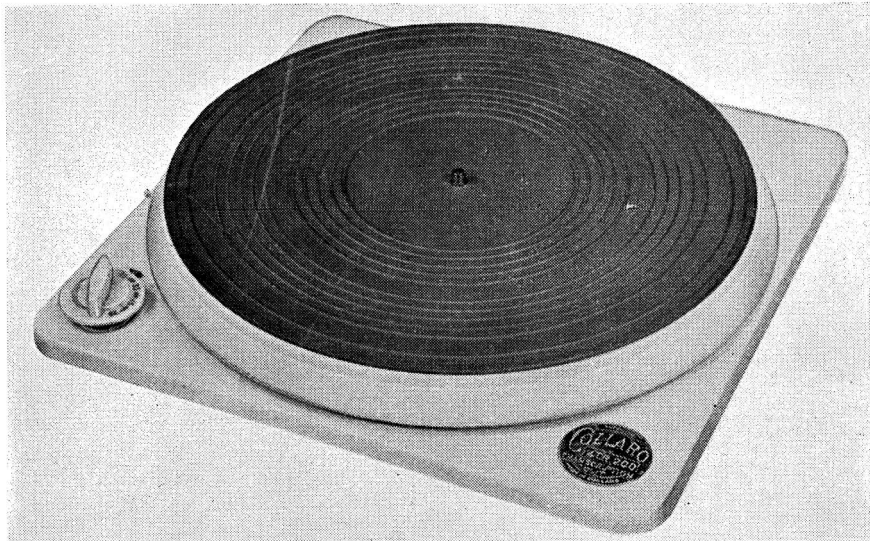

Collaro 4TR200 transcription motor

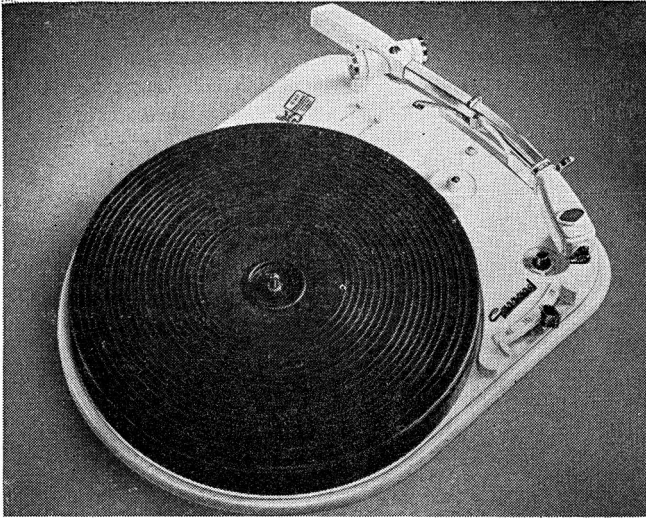

Garrard 4HF. Four speed record player complete with pickup arm. 12-inch pressed steel turntable. Rheostat speed control $\pm 3\%$. Automatic stop may be disconnected. Price with GC8 cartridge £13 19s. (U.K. purchase tax £5 8s. 10d.), with GMC5 cartridge, £19 19s. (plus £7 15s. 7d.)

★

Garrard Engineering & Manufacturing Co. Ltd., Swindon, Wiltshire, England. Tel.: Swindon 5381. Cables: Garrard, Swindon.

Goldring Manufacturing Co. (Great Britain) Ltd., 486/488 High Road, Leytonstone, London, E.11. Tel.: Leytonstone 8343.

Model 301 Transcription Motor. Three speeds. Variable speed adjustment. Price £19 (U.K. purchase tax £7 8s. 3d.).

Lenco Transcription Unit GL58. Infinitely variable speed adjustment, with preselected stops for 16, 33 $\frac{1}{3}$, 45, and 78 r.p.m. Groove location arm lowers pickup on to record as on/off is operated. Fitted with G.60 arm. Price £15 (U.K. purchase tax £5 17s.).

Stroboscopic Turntable, extra cost, £1 3s. 6d. (U.K. purchase tax 9s. 2d.).

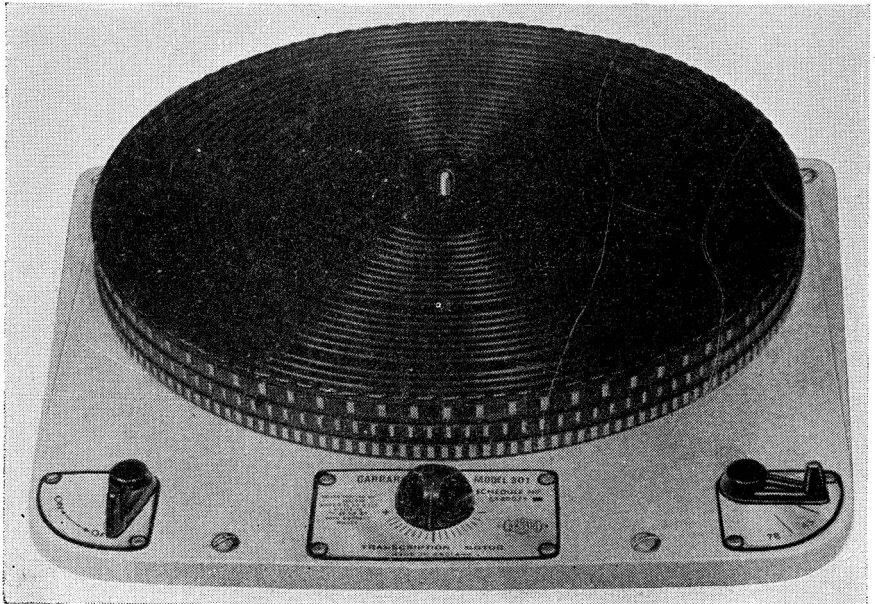

Garrard Model 301 with stroboscopic turntable

Lenco Transcription Unit GL60. Non-ferrous turntable, weight 8 lb. Infinitely variable speed adjustment. Groove location arm. Massive centre spindle on nylon thrust bearing. Fitted with G.60 arm. Price £20 17s. (U.K. purchase tax £8 2s. 8d.).

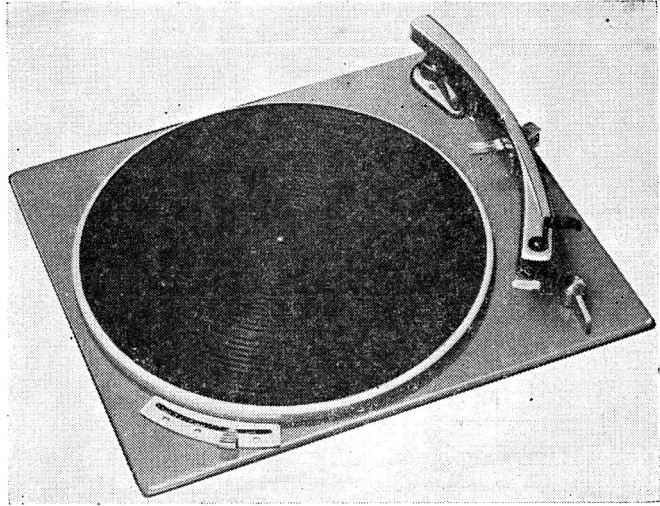

★

Philips Electrical Limited, Century House, Shaftesbury Avenue, W.C.2. Tel.: Gerrard 7777. Cables: Phillamps.

AG2005. High Fidelity Record Player. Three speeds, 33 $\frac{1}{3}$, 45 and 78 r.p.m. Built-in stroboscopic indicator and speed control. Price £18 3s. 10d. (U.K. purchase tax £7 0s. 2d.).

★

A. R. Sugden & Co. (Engineers) Ltd., Market Street, Brighouse, Yorkshire. Tel.: Brighouse 2142. Cables: Connoisseur, Brighouse.

Connoisseur Transcription Motor. Three speeds. With variable speed adjustment. Price £20 10s. (U.K. purchase tax £8 15s. 3d.)

Connoisseur Transcription Motor Type B. Similar to the original model above, but incorporating a large stroboscopic disc beneath the turntable, viewed through a mirror with an internal light source. Precision ground revolving shafts run in nylon graphite bearings, which are adjustable to maintain full accuracy throughout the life of the unit. Price £20 10s. (U.K. purchase tax £8 15s. 3d.).

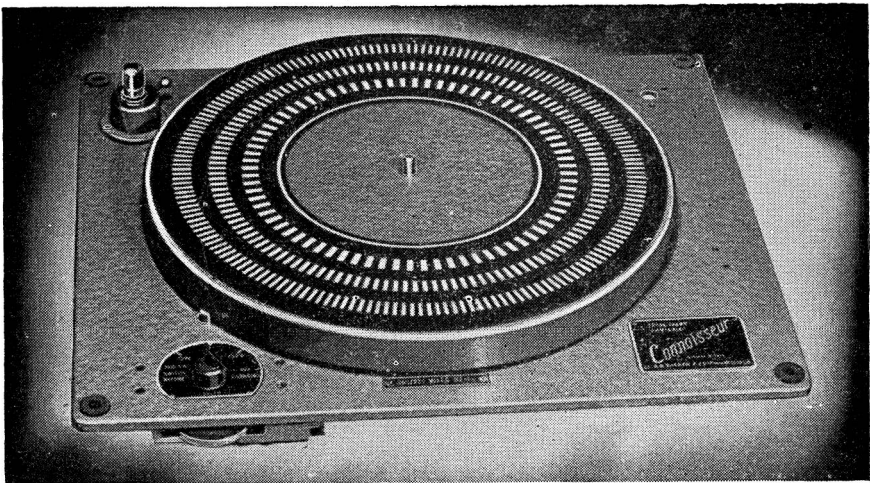

Connoisseur transcription motor

Thorens. Distributed in the U.K. by Thompson, Diamond & Butcher Ltd., 5-9 University Street, London, W.C.1. Tel.: Euston 3494.

Thorens TD124 Transcription Turntable. Four speeds with "OFF" position of selector switch between each speed. Eddy current speed control $\pm 3\%$. Built-in stroboscope for four speeds at 50 and 60 c/s. Price £37 17s. 3d. (U.K. purchase tax £14 10s.)

Woollett Sound and Wireless Equipment, Wells Park Road, London, S.E.26. Tel.: Forest Hill 2527.

3-speed Transcription Motor Unit, fitted with accessory container. Price £17 17s. (U.K. purchase tax £7 2s. 5d.).

4-speed Transcription Motor Unit, with variable speed adjustment providing 8% variations on 78 and 3% on $16\frac{2}{3}$, $33\frac{1}{3}$ and 45 r.p.m. Will accommodate any pickup on baseplate. Price as 3-speed model.

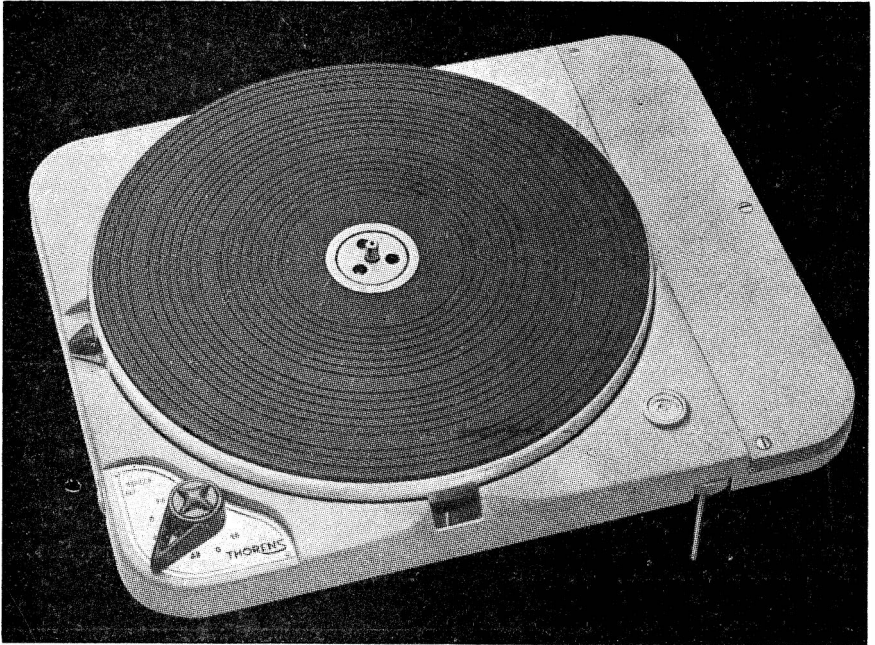

Thorens TD 124 Transcription Turntable

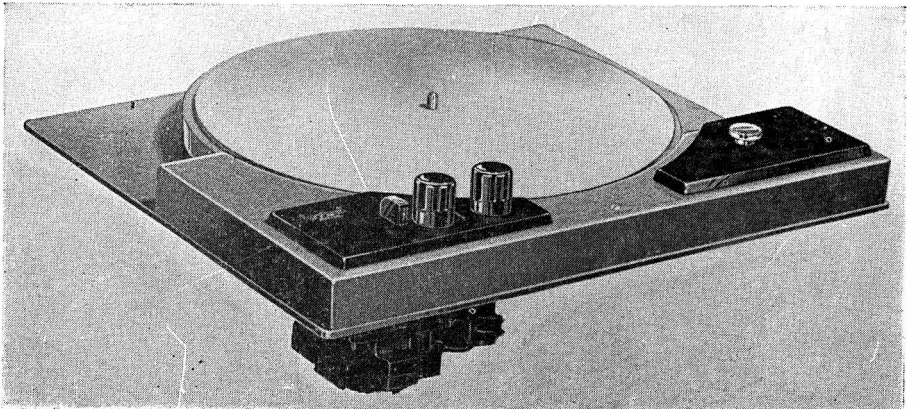

Woollett 3-speed transcription motor

PICK-UPS & STYLI

THE PROGRESS AND THE FUTURE

by Stanley Kelly

1958 will go down in history as the first year of stereo—at least in so far as pickups are concerned. During the past twelve months, not one British monaural cartridge has made its appearance. All manufacturers have been concentrating on producing stereo cartridges, the majority of which are completely compatible for use on normal monaural long playing records.

The January issue of *Hi-Fi News* tabulated twelve pickups which were generally available to the British public, as of October 1958. Of these, eight were crystal and four were magnetic. The crystal cartridges were high output "corrected" types, giving an average modulation of about 0.25 volt from normal stereo records. These cartridges are eminently suitable for the medium-price stereo amplifiers which have also been produced during the past year. The frequency response is reasonably flat from 40 c/s to 10 Kc/s. The cross-talk is generally about 15 to 18 dB, and it usually deteriorates at the high frequency end of the band; but under domestic listening conditions this is not very serious. The playing weights are of the order of 5 to 7 grams, and to reduce the effect of stylus loading (and hence increased wear) the stylus radius is made to measure 0.7 thou. With the exception of the Philips cartridge, sapphire is fitted as standard, although diamond styli are available at extra cost for all cartridges.

Magnetic Cartridges—Stereo Only

The magnetic cartridges are stereo only, and they track at between 3 and 4 grams; diamond stylus is fitted as standard, and has a nominal half-thou radius. The frequency response and cross-talk are all generally better than in the case of the crystal car-

tridges, but this is offset by a considerably lower output; all magnetic units require a high gain pre-amplifier.

Since the list was compiled, a number of new cartridges have made their appearance. These are the *E-V* ceramic stereo, the *Sonotone* ceramic stereo, and a new magnetic stereo by *Elac* which is distributed in this country by *Burne-Jones*. No further information is available on any of these cartridges which have not yet been tested in our laboratories.

Faults of the Early Products

The first stereo cartridges were rushed on to the market a year ago; they were very much rough and ready products, and the design philosophy of monaural cartridges was very much in evidence. Generally, the dynamic mass and stiffness was too great, and in order to get the cartridges to track correctly, the playing weights were considerably increased above optimum, which resulted in excessive record attrition. This was very much apparent at demonstrations given at last year's *Audio Fair*, but in the majority of cases the manufacturers have learnt a salutary lesson, and most present-day cartridges can count on a stylus life and, concomitantly, record life, of at least three times that of the products offered twelve months ago. However, it cannot be over-emphasised that, because of the small radius of the stylus (which is dictated by minimum distortion requirements), the stylus and record wear is considerably greater for a given playing weight when referred to the normal monaural records.

Investigations during the past twelve months have indicated that with a half-thou

stylus a maximum playing weight of 3 to 4 grams is mandatory, and with a 0.7 thou stylus the absolute maximum should be 5 grams. This is not always achieved, and in cartridges fitted to record changers (because of the mechanical requirements of mechanisms, etc.), it is the exception rather than the rule. At the same time, where sapphire styli are used, *they must be changed at least four times as frequently* as the normal one thou stylus (used on a monaural record) with an equivalent type of pickup at the same playing weight.

New Arms are Awaited

We are still awaiting new tone arms which have been specifically designed for stereo; at present stereo cartridges are fitted to arms the majority of which have been designed several years ago, and which, by any stretch of imagination cannot be considered ideal for stereo. One of the biggest difficulties with stereo cartridges is the static displacement of the stylus, due to side-thrust; this is a function of overhang and offset angle. It has been noted on wear tests, that the wear does tend to be more on one side of the stylus than on the other. In marginal cases, where the cartridge tends to be stiff, there is a greater tendency for the pickup to jump, because of this overhang. In the case of magnetic cartridges, its effect is reduced, and in some cases nullified, by using completely magnetically balanced systems; but in bad cases the distortion can be heard. The ideal, of course, is a parallel tracking device with absolutely zero friction, and one in which the total effective mass is of the order of 30 grams. It has not yet been produced.

Motor Rumble

Motor rumble is still rearing its ugly head, especially where the loudspeaker system has adequate low frequency response. The Americans have introduced a "vertical modulation eliminator" which is for use with crystal pickups, and which consists of a resistance (usually of the order of 100,000 ohms to half a megohm) connected across the two output terminals of the cartridge. The value must be determined by an experiment. What happens is that at low frequencies the impedance of the crystals increases, and more energy is shunted from one crystal

element to the other. The result is a considerable decrease in vertical modulation sensitivity, and therefore decreased motor rumble. The trick is to obtain the right value of shunting resistance which eliminates the motor rumble, and at the same time does not unduly curtail the low frequency response.

In magnetic cartridges, the major trouble is due to induced hum from the motor. In a lot of cases, experiment will be well repaid by varying the position of the pickup until minimum induced hum is found.

Finally, whilst perfection has most certainly not been achieved in 1958, very substantial progress has been made in cartridge design, and 1959 will most certainly be another major stereo year. To newcomers to the field, the best advice we can offer is to buy the best stereo cartridge which can be afforded, even though at this stage they only contemplate using a monaural system. The stereo cartridge, when correctly connected, will give at least equivalent results for monaural records, and, theoretically at least, tracing distortion should be less because of the smaller radius of the stylus. Also, intermodulation distortion due to *hill-and-dale* effect should be considerably reduced, if not completely eliminated.

Cleanliness Essential

We would earnestly advise all audiophiles to take particular care in keeping their records scrupulously clean and well "de-staffed". Experiments which we have performed over the past twelve months show that an increase in stylus and record life *of at least times four* can be obtained if the records are cleaned either during playing (such as with a "*Dustbug*") or immediately prior to each performance.

Last year we suggested that owners of "steam monaural systems" need not be over-distressed with the advent of stereophony. Our prognostications this year are along the same lines. With the exception of the *Decca* pickup, generally the stereo cartridges are inferior as regards frequency response and tracking capabilities to their equivalent monaural units. 1959 will probably see the balance somewhat redressed, but it must be remembered that monaural cartridges have a lead of 25 years over stereo, and it must take some time before this balance can be redressed. S.K.

DIRECTORY OF PICKUPS AND ARMS

★ In the abridged specifications of this directory, the following abbreviations are used for economy of space: **S.r.u.**—Stylus can be replaced by user; **D.p.**—Downward pressure of stylus; **Cms**—centimetres per second.
 ■ Denotes Stereo Equipment

Bang & Olufsen, Struer, Denmark. Sole U.K. importers: Avey Electric Ltd., Ayron Road, South Ockendon, Essex. Tel: South Ockendon 3444.

Orthophonic balanced 8-pole variable reluctance pickup. Available as single stylus or dual stylus. Sapphire or diamond. Output voltage l.p. 100 mV; 78 200 mV. Range 20-16,000 c/s. D.p.: l.p. 5-7 gm.; 78 9-12 gm. Load imp. 10-100 K. Price: from £1 (U.K. purchase tax 8s. 3d.) single sapphire to £3 8s. 2d. (£1 7s. 3d.) dual diamond.

★

Burne-Jones & Company Ltd., 18 Brunswick Road, Sutton, Surrey. Tel: Vigilant 5050. Cables: Burjomag, Sutton.

B.J. C/12. Plug-in crystal head. Low mass cantilever stylus. S.r.u. Output voltages: l.p. $\frac{1}{2}$ v; 78 1v. Range 20-17,000c/s. D.p. 4-8 gm. High imp. Price £1 12s. 6d. (U.K. purchase tax 13s.) Diamonds available.

■ **B.J. Stereo Cartridge.** Non-magnetic. Diamond stylus approx. $\frac{1}{2}$ thou. Output voltage 200 mV. Range 30-12,000 c/s. D.p. 4-7 gm. Load imp. 2 Megohms. Price £5 5s. (U.K. purchase tax £2 2s.)

■ **B.J.-ELAC 200.** Magnetic stereo cartridge. Diamond stylus 0.5-0.7 thou. Output voltage 2 mV per channel. Range 40-12,000 c/s. D.p. 4-6 gm. Load imp. 1,500 ohms. Price £14 12s. 6d. (U.K. purchase tax £5 17s.)

■ **B.J.-ELAC 300.** Magnetic stereo cartridge. Diamond stylus 0.5-0.6 thou. Output voltage 2 mV per channel. Crosstalk better than 25 dB at 1,000 c/s, and 14 dB at 15 Kc/s. Range 40-15,000 c/s \pm 2 dB. D.p. 4-6 gm. Load imp. 1,500 ohms. Price £17 5s. (U.K. purchase tax £6 18s.)

B.J. TAN/II arm. Designed to overcome "tracking error," this model incorporates "point contact" bearings and a height adjusting ring. Price £3 3s. (U.K. purchase tax £1 5s. 3d.)

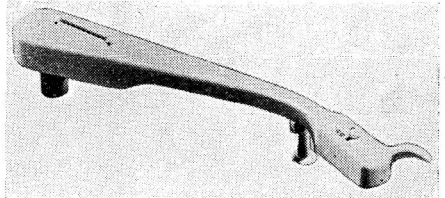

B. & O. Short pickup arm

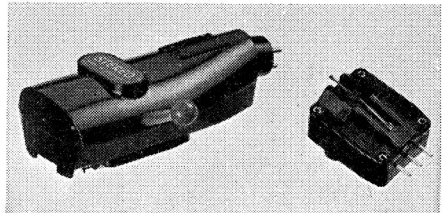

B.J. Head and Stereo cartridge

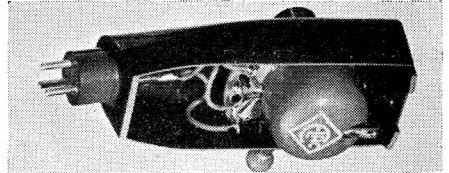

B.J. Elac 300

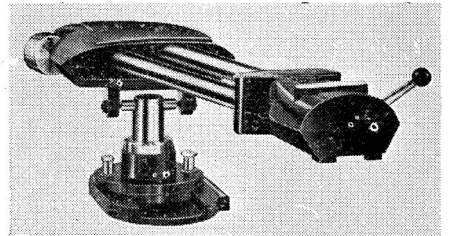

B.J. Super 90 arm

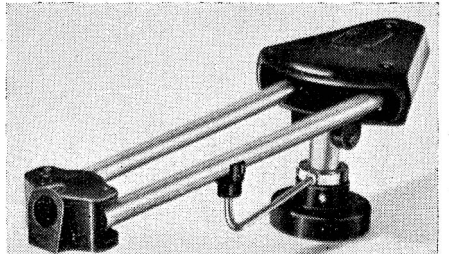

B.J. TAN/II arm

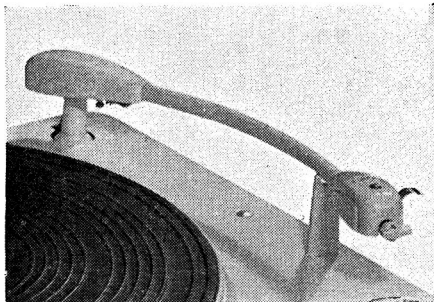

Collaro Transcription arm

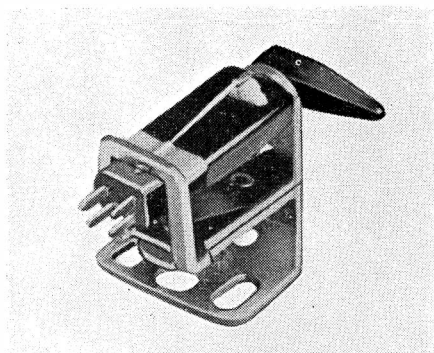

Collaro Stereo Type C

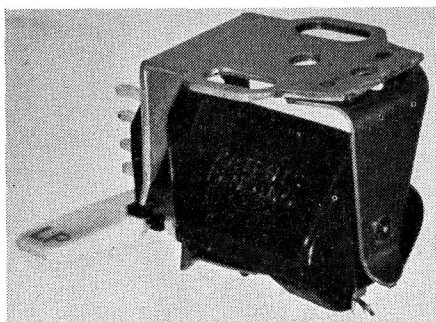

Acostereo 73-1

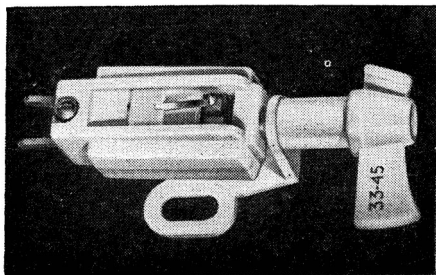

Acos "GP 67-1"

B.J. Super 90 Mk II pickup arm. Two models. 12 in. and 16 in. Price (including two plug-in-shells to carry standard cartridges) Super 90/12 in. £11 11s. (U.K. purchase tax £4 12s. 5d.); Super 90/16 in. £12 5s. (U.K. purchase tax £4 18s.)

B.J. plug-in shell for holding cartridges. Price 17s. 3d. (U.K. purchase tax 6s. 11d.)

★

Collaro Ltd., Ripple Works, By-pass Road, Barking, Essex. Tel.: Rippleway 5533. Cables: Korllaro. Telex: Barking 28748.

“**Studio Transcription**” TX88. Turnover crystal cartridge. Output voltage: l.p. 125 mV/cm/sec. at 1 Kc/s. Range 50-20,000 c/s. Load imp. 1 megohm. Price with 2 sapphire styli, £1 15s. (U.K. purchase tax 13s. 6d.)

■ “**Studio**” Stereophonic “**Type C**”. Turnover ceramic cartridge. Output voltage 50mV. Price £2 5s. (U.K. purchase tax 17s. 4d.)

Studio transcription arm to play up to 16-in. records, suitable for turnover type cartridges. Price complete with “**Transcription**” cartridge £3 17s. 6d. (U.K. purchase tax £1 9s. 11d.)

★

Cosmocord Ltd., Eleanor Cross Road, Waltham Cross, Herts. Tel.: Waltham Cross 5206. Cables Cosmocord, Waltham Cross.

Acos GP65-1. Turnover crystal cartridge. Output voltage: l.p. 160 mV/cm/sec. Range 40-12,000 c/s, substantially flat. D.p. 8-10 gm. Load imp. 2 Megohms. Price £1 10s. (U.K. purchase tax 11s. 7d.) Diamonds available.

Acos GP65-3. High output version.

Acos “The Black Shadow.” Complete arm and slide-on l.p. head. Output voltage: l.p. 30 mV/cm/sec. Range 40-16,000 c/s. ± 3 dB. D.p. 4-6 gm. Load imp. 100K ohms or higher. Diamond stylus fitted. Price complete £4 17s. 2d. (U.K. purchase tax £1 17s. 6d.) 78 heads available.

Acos GP67-1. Turnover crystal cartridge. output voltage 200 mV. Load imp. 2 Megohms. Range 30-14,000 c/s. D.p. 5-7 gm. Price £1 10s. (U.K. purchase tax 11s. 7d.)

■ **Acostereo 71-5.** L.p. only. $\frac{1}{2}$ thou. stylus. Output voltage 140 mV. Load imp. 2 Megohms. Range 40-12,000 c/s. D.p.

3-4 gm. Price with diamond £2 (U.K. purchase tax 15s. 5d.)

■ **Acostereo 73-1.** Turnover crystal stereo/standard. Output voltage l.p. 150 mV. Load imp. 2 Megohms. Range 40-12,000 c/s. D.p. 3-4 gm. Price with sapphire £2 (U.K. purchase tax 15s. 5d.), diamond £4 8s. (U.K. purchase tax £1 13s.)

★

Decca Radio and Television Ltd., 9 Albert Embankment, S.E.11. Tel.: Reliance 8111.

■ **Decca FFSS.** Magnetic stereo with slide-on head. Diamond $\frac{1}{2}$ thou. stylus. Output voltage 1.4 mV stereo, 1 mV monaural. Range 30-15,000 c/s \pm 2 dB. D.p. 3.5 gm. Load imp. 50,000 ohms. Price £15 16s. 6d. (U.K. purchase tax £6 3s. 6d.)

★

Elac. Electroacoustic GmbH, Kiel. Distributed in the U.K. by Thermionic Products, Ltd., Hythe, Southampton. Tel.: Hythe 3265/7. Cables: Technico.

Miratwin MST 2. Variable reluctance turnover cartridge. Output voltages at 10 cm/sec: l.p. 55 mV; 78, 45 mV. Range 20-30,000 c/s, up to 19,000 c/s \pm 2 dB. D.p. 4-6 gm. Load imp. 68,000 ohms. Price, with 2 sapphires, £4 10s. (U.K. purchase tax £1 17s. 9d.) Diamonds available.

Miratwin MST1. Single version of MST2 for l.p. only. Output voltage 55 mV at 10 cm/sec. Price with sapphire stylus £3 10s. (U.K. purchase tax £1 9s. 5d.) With diamond £6 0s. 9d. (U.K. purchase tax £2 10s. 9d.)

■ **Stereotwin STS 200D.** Variable reluctance cartridge. Diamond stylus 0.7 thou. Output voltage 2v. Range 30-15,000 c/s \pm 5 dB. D.p. 4-6 gm. Load imp. 47,000 ohms. Price £14 (U.K. purchase tax £5 17s. 7d.)

■ **Stereotwin STS 300D.** Variable reluctance cartridge. Diamond stylus $\frac{1}{2}$ thou. Output voltage 1.5v. Range 30-15,000 c/s \pm 3 dB. D.p. 4-6 gm. Load imp. 47,000 ohms. Price (provisional) £18 plus purchase tax £7 11s. 2d.

★

Expert Gramophones Ltd., 39-41 New Oxford Street, London, W.C.1. Tel.: Covent Garden 2156.

Pickup and arm. Hard steel-pointed pivots for vertical and horizontal movements. Adjustments for tracking and stylus pressure.



Acos "Black Shadow"

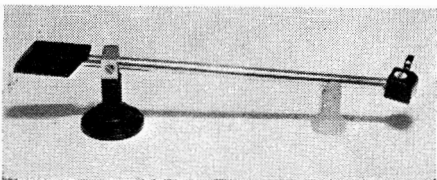

Decca FFSS Stereo pickup

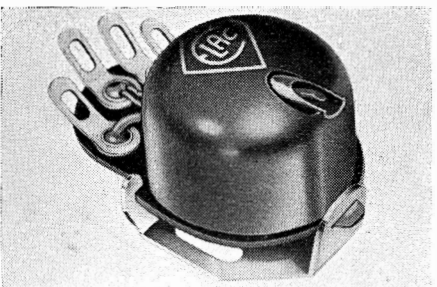

Elac Stereotwin STS/200D



Elac Miratwin MST1

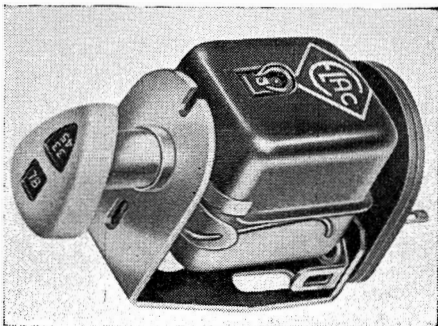

Elac Miratwin MST2

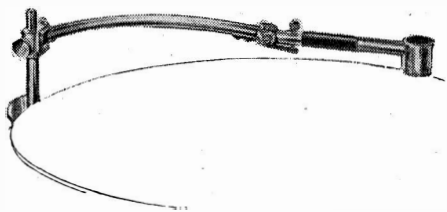

Expert arm and head

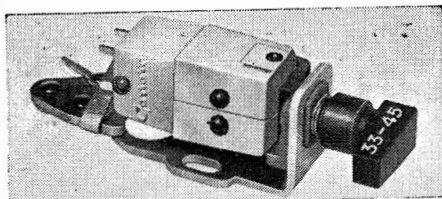

Garrard "G.M.C.5" cartridge

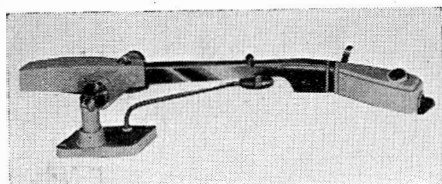

Garrard "TPA 12" pickup arm

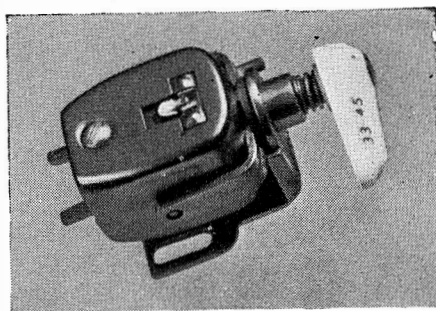

Goldring "600" cartridge

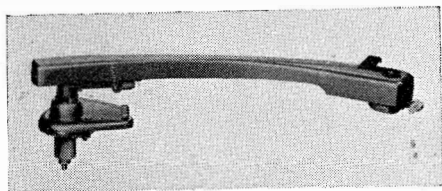

Goldring G60 pickup arm

Moving coil pickup head. Also sold as separate plug-in head. Diamond stylus for l.p. and 78, also thorn for 78. Output voltages: l.p. 60 mV; 78, 80 mV (both at transformer secondary). Range 40-18,000 c/s \pm 1 dB (diamond stylus). D.p. adjustable down to 3 gm. Load impedance 10 ohms (pickup only), transformer secondary impedance 250,000 ohms. Price, complete with diamond, £11 5s. (U.K. purchase tax £4 14s. 6d.); plug-in head, diamond £9 (U.K. purchase tax £3 15s. 7d.); thorn £7 (U.K. purchase tax £2 18s. 10d.); transformer £2 15s.

★

The Garrard Engineering & Manufacturing Co. Ltd., Newcastle Street, Swindon, Wilts. Tel.: Swindon 5381. Cables: Garrard, Swindon. Telex: 44-316.

G.M.C.5. turnover moving coil cartridge. Separate coils attached to each stylus. Fitted with diamond l.p. and sapphire 78 styli. Output voltages with TP.1 transformer: l.p. 0.008v; 78 0.03v. Range 20-16,000 c/s. D.p. 5 gm. Load imp. 0.5 Megohm min. across transformer. Price, inc. transformer, £6 18s. (U.K. purchase tax £2 13s. 10d.)

TPA.12 Transcription pickup arm with plug-in moulding to take almost all makes of cartridge. Price £3 7s. 6d. (U.K. purchase tax £1 6s. 4d.)

★

Goldring Manufacturing Co. (Great Britain) Ltd., 486/488 High Road, Leytonstone, E.11. Tel.: Leytonstone 8343. Cables: Echovox London.

"600." Variable reluctance turnover cartridge $\frac{1}{2}$ in. centre. mounting holes s.r.u. Diamond stylus for l.p. sapphire for 78. Output voltage 3.2 mV/cm/sec. Range 20-21,000 c/s \pm 2 dB. D.p. 7 gm. Load imp. 68,000 ohms. Price £8 8s. (U.K. purchase tax £3 5s. 6d.)

"580." Variable reluctance turnover cartridge. Diamond stylus for l.p. sapphire for 78. Output voltage 3.2 mV. Range 20-18,000 c/s. D.p. 6-7 gm. Load imp. 68,000 ohms. Price £4 4s. (U.K. purchase tax £1 12s. 9d.)

■ **"700."** Magnetic cartridge for stereo. Diamond stylus $\frac{1}{2}$ thou. Output voltage 1 mV. Range 30-12 Kc/s. D.p. 4 gm. Load imp. 50,000 ohms per channel. Price £7 7s. (U.K. purchase tax £2 17s. 4d.)

■**G60.** Transcription arm wired for stereo. Incorporates new slide-in head that will accommodate most cartridges. Height adjustable and d.p. variable from 2 gm upwards. Price £3 (U.K. purchase tax £1 3s. 5d.)

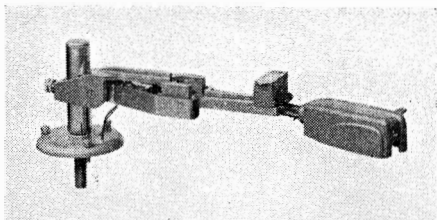

Goldring TR1 pickup arm

TR.1 and **TR.2** transcription pickup arms. TR.1 12 in., TR.2 16 in. Counter-balance weight adjustment from 2-12 gm. Adjustable height, ball races throughout. Price, TR.1, £8 8s. (U.K. purchase tax £3 5s. 6d.); TR.2, £9 9s. (U.K. purchase tax £3 13s. 9d.)

★

H. J. Leak & Co. Ltd., 57/59 Brunel Road, East Acton, London, W.3. Tel.: Shepherds Bush 1173. Cables: Sinusoidal, Ealux, London.

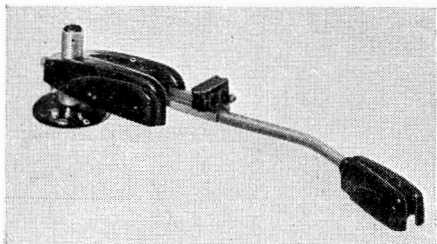

Goldring TR.2 pickup arm

Dynamic pickup Mk. II. Moving coil, interchangeable heads, both with diamond stylus. Output voltages: l.p. and 78, 8 mV (at transformer secondary). Range 40-20,000 c/s ± 1 dB. D.p. l.p. 3 gm, 78, 5 gm. Load imp. 50,000-100,000 ohms. Price, with two heads, £16 (U.K. purchase tax £5 19s. 9d.)

★

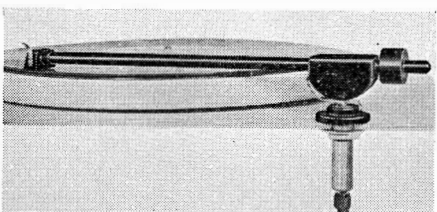

Leak Dynamic arm and head

The Long Playing Record Library Ltd., Squires Gate, Station Approach, Blackpool.

Mackie Parallel Tracking Arm. Designed to eliminate tracking error and side pressure wear on disc and stylus. Groove cueing scale and pickup lowering device. Total moving mass 35-40 gm, depending on cartridge used. Two models available. Standard, which will fit most gramophones, price £12 12s. inc. purchase tax. Transcription, which occupies 20 in. length and 5 in. height, price £18 18s. inc. purchase tax.

★

The Lowther Manufacturing Co., Lowther House, St. Mark's Road, Bromley, Kent. Tel.: Ravensbourne 5225. Cables: Lowther, Bromley.

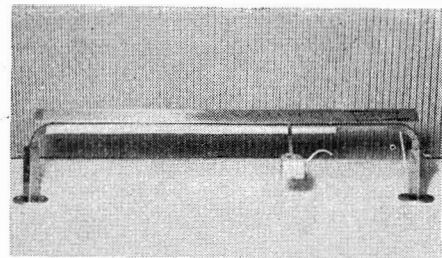

Mackie Transcription arm

L.P. pickup. Moving coil fixed head. Output voltage 10 mV. Range 20-20,000 c/s ± 2 dB. D.p. 4-6 gm. Imp. 25 ohms. Price with sapphire stylus £5 10s. (U.K. purchase tax £2 3s. 10d.); with diamond stylus £12 10s. (U.K. purchase tax £4 19s. 9d.)

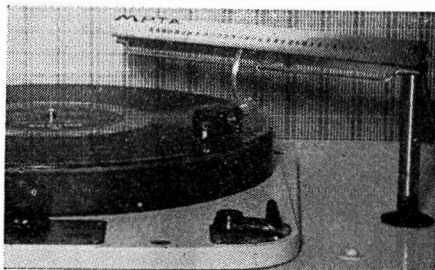

Mackie Standard arm

78 pickup. Moving coil fixed head. Output voltage 18 mV. Range 20-20,000 c/s ± 2 dB. D.p. 6 gm. Imp. 25 ohms. Price, same as for L.P.

■**In preparation:** a stereo moving-coil.

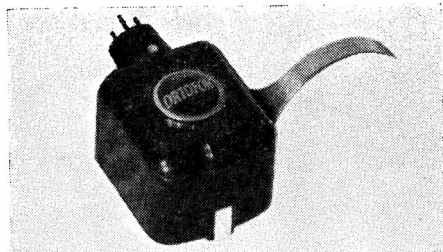

Ortofon Type C Head

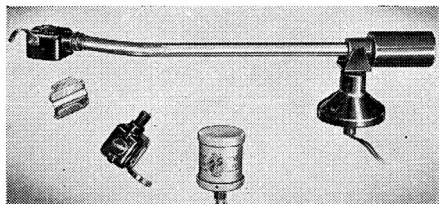

Ortofon pickup head, arm and transformer

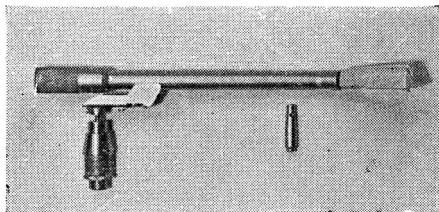

Philips "Magnetodynamic" arm and head

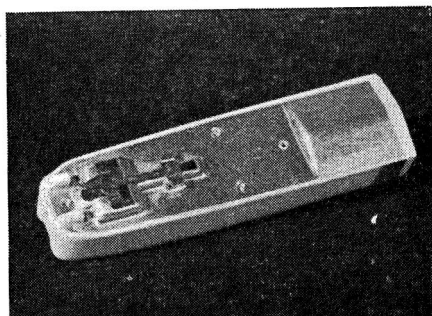

Philips AG.3060 stereo cartridge

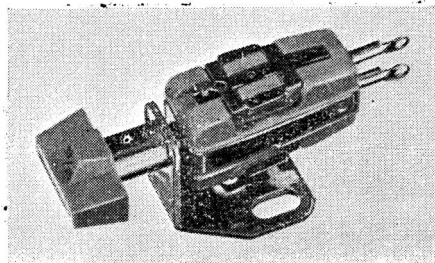

Ronette TX88 cartridge

Ortofon, Fonofilm Industri A/S. Copenhagen. Distributed in the U.K. by Technical Suppliers Ltd., Hudson House, 63 Goldhawk Road, London, W.12. Tel.: Shepherds Bush 2581. Cables: Teknika, London.

Type A. Moving coil. Exchangeable heads with vertical coils. Diamond stylus. Output voltage l.p. 0.5 mV/cm/sec. Range 20-20,000 c/s \pm 2 dB. D.p. 5-6 gm. Load imp. 2 ohms (transformer required). Price £7 5s. (U.K. purchase tax £2 8s. 8d.)

Type C. Moving coil as above. Diamond stylus. Output voltage l.p. 0.3 mV/cm/sec. Range linear 20-20,000 c/s. D.p. 3-5 gm. Load imp. 2 ohms (transformer required). Price £13 (U.K. purchase tax £5 5s. 2d.)

Transformer for use with above pickups. Price £2 7s. 6d.

■ **Type SCG.** Magnetic stereo pickup. Diamond stylus approx. 0.7 thou. Output voltage 0.5 mV. Range 20-20,000 c/s. D.p. 3-5 gm. Load imp. 2.5 ohms. Price £24 (U.K. purchase tax £9 14s. 1d.)

SK 212. Pickup arm with adjustable playing weight. Price £4 15s. (U.K. purchase tax £1 18s. 5d.)

■ **SSM 212.** Pickup arm for stereo cartridges. Playing weight adjustable from 0 to 12 gm. Price £10 (U.K. purchase tax £4 0s. 11d.).

★

Philips Electrical Limited, Century House, Shaftesbury Avenue, W.C.2. Tel.: Gerrard 7777. Cables: Phillamps.

AG.3025. Crystal head fitted with diamond stylus. Output voltage approx. 0.5v. Load imp. 500,000 ohms. Price £3 0s. 7d. (U.K. purchase tax £1 3s. 5d.)

NG.5400 Magnetodynamic. Arm and moving magnet l.p. head fitted with diamond stylus. Output voltage approx. 25 mV. Range substantially linear 20-20,000 c/s. D.p. 0-10 gm. Load imp. 68,000-100,000 ohms. Price complete £14 8s. (U.K. purchase tax £5 11s.)

■ **AG.3060.** Crystal stereo pickup. Diamond stylus. Output voltage 120 mV. D.p. 4-6 gm. Load imp. 470,000 ohms per channel. Price £4. Sapphire version also available.

■ **NG.5400/S.** Transcription arm fitted with crystal stereo pickup (Type AG 3060). Micrometer adjustment of playing weight

and height variable. Diamond stylus. Output voltage 0.5v per channel. Range 30-12,000 c/s. D.p. 4-6 gm. Load imp. $\frac{1}{2}$ Megohm per channel. Price £11 15s. (U.K. purchase tax £4 10s. 6d.)

★

Ronette. Sole U.K. Importers: Trianon Electric Limited, 95 Cobbold Road, London, N.W.10. Tel.: Willesden 2116.

■ **TX88.** Turnover crystal cartridge. Low effective mass. Output voltage: l.p. 125 mV/cm/sec. at 1 Kc/s. Response 50-20,000 c/s. Load impedance 1 Megohm. Clip in styli for easy replacement. Price with two sapphire styli £1 15s. (U.K. purchase tax 13s. 6d.)

■ **OV.** Stereo/OV turnover crystal cartridge. Sapphire styli. Output voltage 160 mV. Range 50-12,000 c/s. D.p. 5 gm. Load imp. 1 Megohm. Price £3 (U.K. purchase tax £1 3s. 5d.)

■ **Binofluid BF40.** Crystal stereo cartridge. Details as above. Price £2 10s. (U.K. purchase tax 19s. 6d.)

■ **Fonofluid/Binofluid.** Arm and stereo pickup complete. Sapphire stylus. Output voltage 160 mV. Range 50-12,000 c/s. Load imp. 1 Megohm. Price £6 (U.K. purchase tax £2 6s. 10d.)

★

F. & H. Schumann, GmbH. Sole U.K. importers: G. A. Stanley Palmer Ltd., Maxwell House, Arundel Street, London, W.C.2. Tel.: Temple Bar 3721/3.

A range of crystal pickups, including the Schumann-Merula stereo cartridge Type STK490.

★

A. R. Sugden & Co. (Engineering) Ltd., Market Street, Brighouse, Yorkshire. Tel.: Brighouse 2142. Cables: Connoisseur, Brighouse.

Connoisseur super lightweight Mk. II pickup. Interchangeable heads, moving iron. Output voltages: l.p. 15 mV; 78 25 mV. Range 30-20,000 c/s \pm 2 dB. D.p.: l.p. 4 gm; 78 8 gm. Load imp. 10,000 ohms. Price, complete with one head and diamond stylus, £8 19s. (U.K. purchase tax £3 16s. 6d.); with sapphire stylus £5 17s. (U.K. purchase tax £2 10s.); head only with diamond stylus £6 12s. (U.K. purchase tax £2 16s. 5d.);

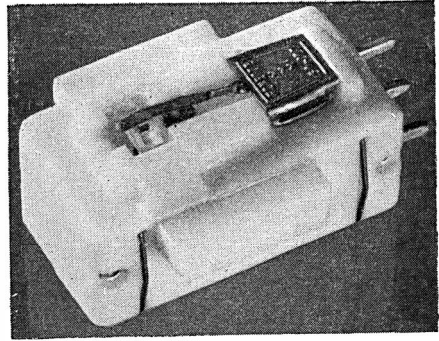

Ronette Binofluid BF40

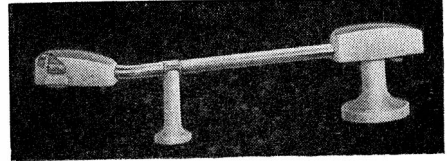

Ronette arm and pickup

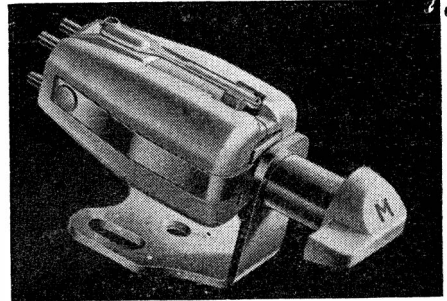

Schumann-Merula Stereo cartridge

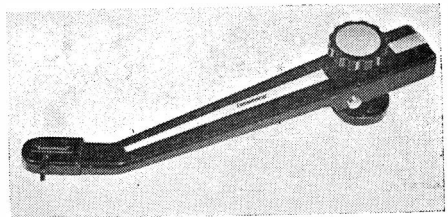

Connoisseur Stereo CSI

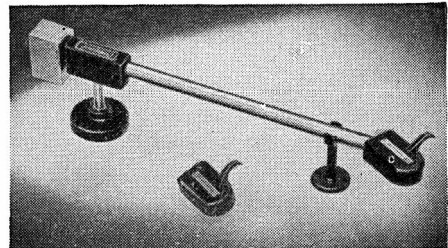

Connoisseur Super Lightweight Mk. II

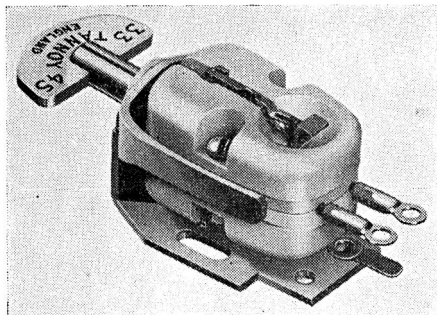

Tannoy "Variluctance" turnover cartridge

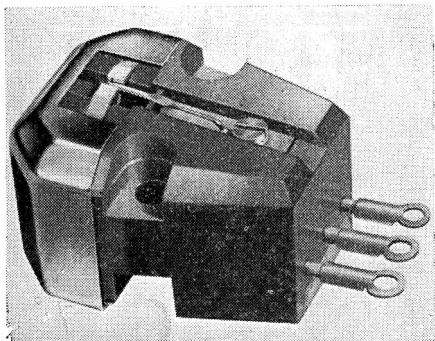

Tannoy Stereo Varitwin

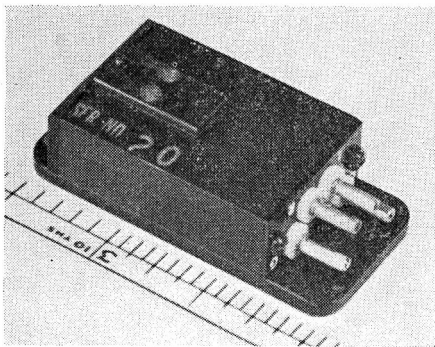

Prototype Westrex Stereo pickup

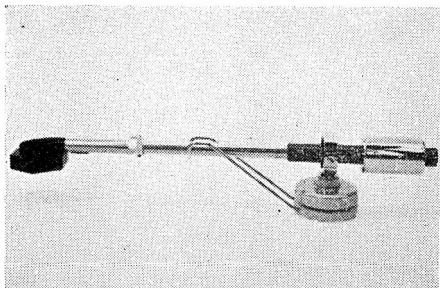

Woollett pickup arm and head

with sapphire stylus £3 10s. (U.K. purchase tax £1 9s. 11d.)

■ **Connoisseur CS.1.** Arm and stereo pickup complete. Diamond stylus $\frac{1}{2}$ thou. Output voltage 7 mV. Range 20-16,000 c/s ± 2 dB. D.p. 4-5 gm. Load imp. 50,000 ohms. Price £9 (U.K. purchase tax £3 16s. 11d.)

★

Tannoy Products Ltd., West Norwood, London, S.E.27. Tel.: Gipsy Hill 1131. Cables: Tannoy, London.

Variluctance turnover cartridge. S.r.u. Output voltages: l.p. 10-12 mV; 78 18-20 mV. Range 20-16,000 c/s ± 2 dB. D.p. 5-6 gm. Load imp. 50,000 ohms. Price, with 2 diamonds, £12 (U.K. purchase tax £4 17s.); with 1 diamond and 1 sapphire £9 10s. (U.K. purchase tax £3 16s.); with 2 sapphires £7 (U.K. purchase tax £2 16s. 7d.).

Single stylus version of Variluctance for l.p. also available. Price with diamond, £6 15s. (U.K. purchase tax £2 14s. 7d.)

■ **Vari-Twin.** Magnetic stereo cartridge. Diamond stylus $\frac{1}{2}$ thou. Output voltage 7 mV per channel. Range 30-15,000 c/s ± 1.5 dB. D.p. 4 gm. Load imp. 100,000 ohms. Price £9 19s. (U.K. purchase tax £4 0s. 5d.)

★

Westrex Co. Ltd., Liberty House, Regent Street, London, W.1. Tel.: Regent 1001. Cables: Westelcal, Norphone, London.

■ **In preparation:** 10A Stereodisk pickup cartridge, twin moving coil, stereo or single track. Diamond stylus. D.p. 6 gm.

★

Woollett Sound & Wireless Equipment, Wells Park Road, London, S.E.26. Tel.: Forest 2527.

■ **Stereo Pickup.** Arm and moving-coil pickup complete. Diamond stylus 0.7 thou. Output voltage approx. 7 mV. D.p. 4 gm. Load imp. 100,000 ohms. Price £21 (U.K. purchase tax £5 11s. 8d.).

Single channel pickup. Arm and moving-coil pickup complete, or available with interchangeable heads. Diamond stylus. Output voltage: l.p. 10 mV; 78 8 mV. D.p. 4 gm. Range 20-18,000 c/s. Load imp. 100,000 ohms. Price £15 0s. 8d. (U.K. purchase tax £4 11s. 10d.)

ACCESSORIES

Auriol (Guildford) Ltd., 63 Shepherds Lane, Guildford, Surrey. Tel.: Guildford 66712.

Auriol Pickup Control. This unit eliminates accidental damage to the record by the stylus, the control provides air cushioned lowering and positive vertical lifting and lowering of the stylus. The supporting arm is serrated and calibrated for accurate positioning of the stylus at any pre-selected position within 1-2 microgrooves. Three cursors are provided to mark starting positions and an indexing clip is supplied to suit any specified pickup arm. U.K. price £3 3s., inc. purchase tax. Export price £2 15s.

Auriol Pickup Control Mk. II. This is dimensionally similar to the above but the arm will swing clear of the turntable to allow its use with the Autochanger/Manual player units. U.K. price £4 0s. 6d., inc. purchase tax. Export price £3 7s. 6d.

★

Burne-Jones & Co. Ltd., 18 Brunswick Road, Sutton, Surrey. Tel.: Vigilant 5050. Cables: Burjomag, Sutton.

Counterweight Unit. The addition of this unit to a B.J. pickup arm permits speed and accuracy in weight compensation. The unit may be attached with or without standard weights supplied, and produces a total point pressure variation of approximately 4 gm. Price 12s. (U.K. purchase tax 4s. 10d.)

B.J./Acos Adaptor. This has been designed to accommodate Acos slide-on heads to the B.J. range of arms and those arms using standard 3-pin plug-in head fixing. Price 10s. (U.K. purchase tax 4s.)

Alignment Protractor. For measuring the tracking accuracy of all pickup assemblies. Made in plastic ivoryine. Price 7s.

★

The Garrard Engineering & Manfg. Co. Ltd., Newcastle Street, Swindon, Wilts. Tel.: Swindon 5381. Cables: Garrard, Swindon.

S.P.G.2. Stylus pressure gauge, also includes a spirit level for checking the level of the turntable. Price 18s. 9d. (U.K. purchase tax 7s. 4d.)



Auriol pickup control

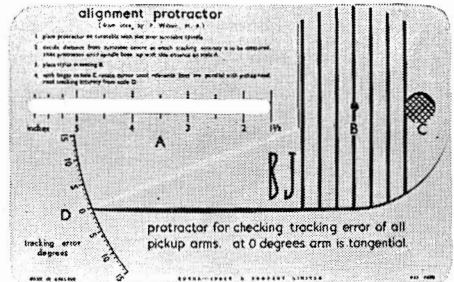

B.J. alignment protractor

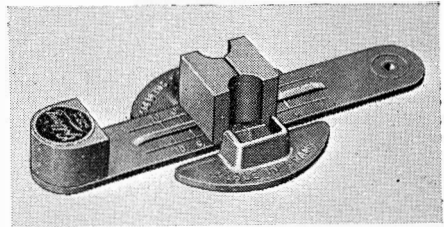

The Goldring STB1



Left, the Rimington Clendisc, available in two sizes. Right, the Fredorec cleaning pad.

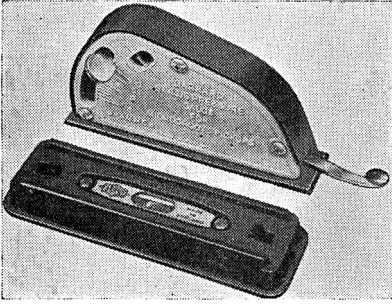

Garrard S.P.G.2

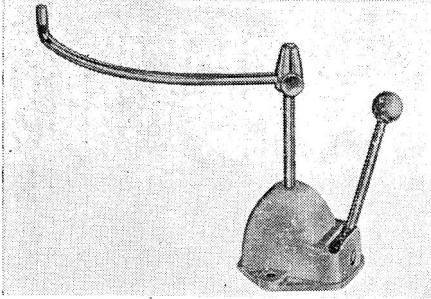

Thermionic Microlift

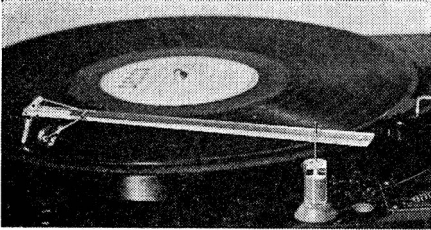

The Dust Bug

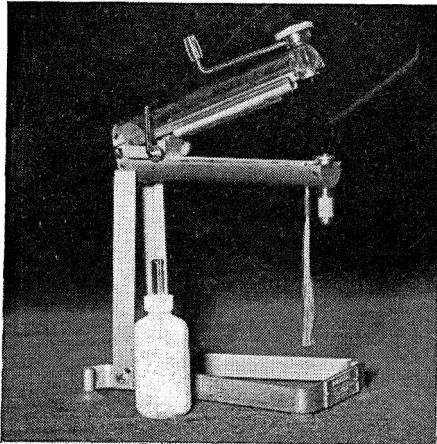

The Parastat

Goldring Manufacturing Co. (Great Britain) Ltd., 486/488 High Road, Leytonstone, E.11. Tel.: Leytonstone 8343. Cables: Echovox, London.

Anti-static Cleaning Pad. Removes dust from records and is fitted with a detachable brush for keeping stylus clean. Price 4s. 6d. (U.K. purchase tax 1s. 9d.)

STB.1. Stylus balance, a simple yet accurate gauge which operates at record level. Stylus pressure is read directly in grams off the calibrated scale. Price 3s. 6d. (U.K. purchase tax 1s. 5d.)

★

Rimington van Wyck Ltd., 42 Cranbourn Street, London, W.C.2. Tel.: Gerrard 1171.

Clendisc. An anti-static cleaner and preserver for all l.p. records, also suitable for 78s. Price 3s. 9d. and 6s.

Fredorec. A cleaning pad for removing dirt from all records. When used with Clendisc forms a perfect combination for record care. Price inc. purchase tax 3s. 2d.

★

Thermionic Products Ltd., Hythe, Southampton. Tel.: Hythe 3265/7. Cables: Technico.

Microlift. A device for raising and lowering a manual pickup arm at any point on the record for minimising risk of damage either to record or stylus through handshake. Easy to fit to any back-pivoted pickup. It does not hinder record handling by overlapping the turntable. Price 21s. (U.K. purchase tax 8s. 10d.)

★

Cecil E. Watts Ltd., Darby House, Sunbury-on-Thames, Middx.

The "Dust Bug." Claimed to be the most efficient method of removing all static and dust from records as they are played. Instantly fitted, suitable for all types of records. Record quality is improved, surface noise and wear reduced. Price 17s. 6d. (U.K. purchase tax 7s.) Note: A model suitable for use on autochangers is produced in co-operation with Cosmocord Ltd.

The "Parastat." For cleaning both sides of an l.p. disc simultaneously and making it inert to all static charges. Principally for trade use. Price Mk. II £18 10s. (U.K. purchase tax £7 8s.)

AMPLIFIERS AND PRE-AMPLIFIERS

By G. W. Tillett

LAST year in the "Hi-Fi Year Book", I commented on the fact that there was a definite trend towards the self-contained type of amplifier—that is, the combined amplifier and pre-amplifier, or control unit, housed in one case. Two unit amplifiers are still the most popular, because they are more adaptable, and they permit mounting in any type of cabinet, allowing the main unit containing the heavy transformers and output valves to be placed in the best position for ventilation. Nevertheless the trend towards the self-contained unit continues, and the past year has seen further examples of this type of presentation. Such products have come from *Pilot*, *Stereosound*, *Heathkit*, *Pye*, *Jason*, *Sound Sales*, *W&N*, etc. All these are stereo amplifiers, and it must be said right away that the problems associated with the design of Hi-Fi equipment will still be the same with stereo equipment—plus a few more. The same standards associated with single channel Hi-Fi should apply to two channel Hi-Fi. It is a complete fallacy to suppose that Hi-Fi stereo reproduction can be had with inferior equipment; in fact Hi-Fi single channel reproduction will be found superior to poorer quality stereo, once the novelty has worn off.

In addition to the accepted requirements for distortion, frequency range, etc., the following are the extra problems which face designers of stereo amplifiers. The two channels must have a similar frequency response at all settings of all controls—preferably within 2 dB above 300 c/s; a balance control must be provided, to control the relative gain without appreciably affecting frequency response; means must be provided to reverse the channel relationship; switching must be provided, so as effectively to parallel the two channels for monophonic use; and with the more expensive amplifiers the gain and signal-to-noise must be adequate to cope with low output magnetic pickups. Add to this the necessity of keeping cross-talk to a reasonable minimum, plus the fact that most of these requirements are made more difficult to achieve by putting two amplifiers in one small case, and it will be realised that designers have not had a very easy time. How are they tackling these problems?

There is no doubt that multiple valves such as the ECF80 and ECL82 have proved a considerable help. Originally developed for television purposes, the ECL82 is a triode-pentode, two of which used in push-pull are capable of giving some 8 watts

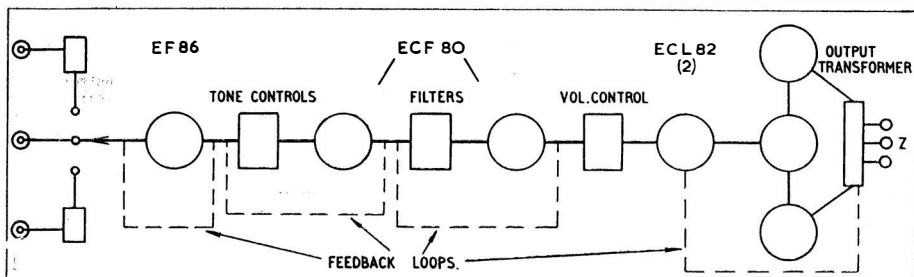

Fig. 1.—One channel of a stereo amplifier (Heathkit S88) showing feedback arrangements.

output, with the two triode sections available as phase-splitter and AF stage. Rather more feedback is necessary to reduce distortion to comparable figures obtainable with valves of the EL84 class, and dissipation must be

EL84's plus extra triodes, and the latter employing the EL34 single end output stages, as used in the monophonic version which was described in the 1958 Year Book.

The Large Amplifiers

Coming now to the larger amplifiers (i.e. those comprising two units, and having rather higher power outputs) we find the basic difference from the single channel versions—apart from purely stereo modifications—is the provision of higher gain pre-amplifiers, rendered necessary by the introduction of the high quality magnetic pickups such as the *Tannoy*, *Goldring* and *Decca* with outputs around 5mV. The *Leak* pre-amplifier uses two EF86's per channel, and follows the basic circuit of the original "Point One," but here the second EF86 is pentode connected, instead of triode, to give the extra gain required.

Quad—Orthotone—Dulci

The *Quad 22* again has a very similar circuit to the single channel *Quad*, but the gain has been increased considerably. A comparative newcomer to the hi-fi scene is the *Orthotone* made by Scientific and Technical Developments, a subsidiary firm of Clarke and Smith Ltd., who have specialised in radio equipment for educational purposes. The *Orthotone 399* pre-amplifier is notable for the "Bridged T" high pass or rumble filter employed (see fig. 2). Three EF86's are employed in each channel. An even more ambitious pre-amplifier is the *Stereo 8* made by *Dulci*, which employs no less than four EF86's per channel. Features of this unit are input sockets permitting direct connection to tape heads with compensation for both 7½ i/s and 15 i/s tape, three-position filters, and separate hum balance controls for each channel.

Chapman—BTH—Astronic

The *Chapman 305* has two EF86's plus three ECC83 double triodes, and can be used with a 8 plus 8 watt amplifier, or with

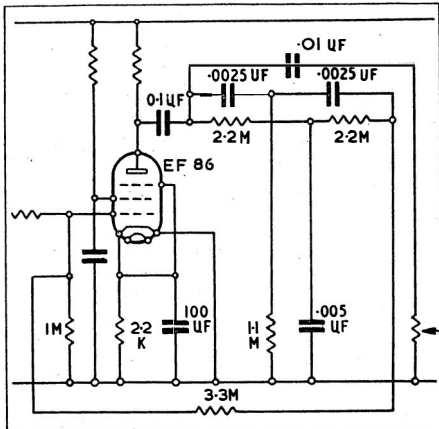

Fig. 2.—Example of "bridged T" filter (Orthotone).

kept within the maker's limit; but using two in an Ultra-Linear circuit, with 20% screen taps, it is possible to obtain 6 watts output with a total harmonic distortion of less than 0.1% if 20 to 26 dB feedback is used.

Fig. 1 shows a block diagram of a typical arrangement (*Heathkit S.88*). For the sake of clarity only one channel is depicted. Similar circuits are used by the *W & N* and *Pilot*, but both these amplifiers use a ECC83 instead of a ECF80 for V2. The ECF80 is another triode-pentode also developed originally for television purposes, but now finding applications in audio amplifiers. The *Pamphonic 3,000* and *Stereosound "Milan"* also have ECL82 output stages, but they omit the EF86 input valve because they are designed to be used with crystal pickups. Two notable exceptions to the foregoing are provided by the *Jason J2/10* and the *Pye Stereo Mozart*, the former using

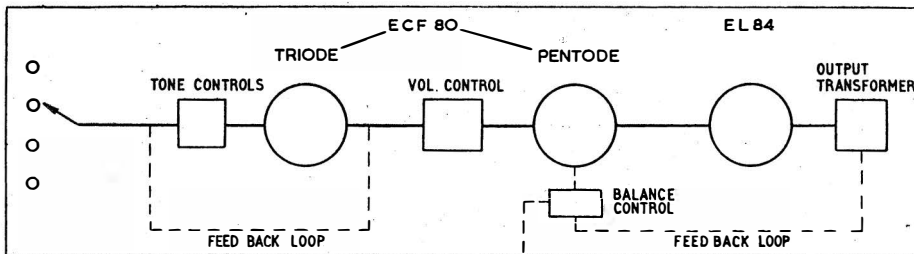

Fig. 3.—Block diagram of one ultra-linear channel of Jason JSA-2 amplifier.

two of the larger "type 205" units, which have a power output of some 25 to 30 watts each. The new *BTH* stereo pre-amplifier has a similar appearance to its monophonic version, the only difference being the inclusion of two additional slide switches for function switching and rumble filter. However, the circuit is very different; each channel now comprises two EF86's, and the main amplifiers use two EL84's with a single ECC83 in each stage. The variable filter has been omitted, and its place is taken by a balance

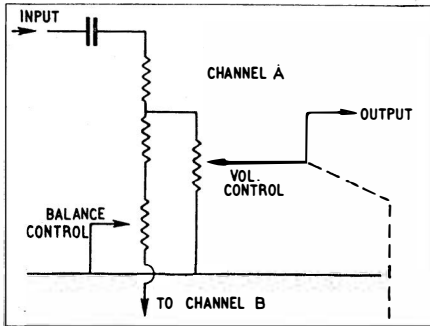

Fig. 4.—Balance control—Pye Mozart.

control. Another pre-amplifier having a switched rumble filter is the *Astronic A1434*, which has a presence lift switch—an unusual feature these days. This unit uses concentric controls instead of the more generally preferred ganged type.

Transistorised Inputs

Three amplifiers use transistor input stages—*Sound Sales*, *Walgain* and *Lowther*; but it is not known whether they are suitable for high impedance pickups.

Main amplifiers for the most part follow a conventional pattern of EF86, ECC83 cathode-coupled phase splitter, and an Ultra-Linear output stage with two EL84's, but a number of firms including *Sound Sales*, *Lowther*, *Rogers* and *Leak* offer a choice between this type and larger units using EL34's or similar valves.

Small, Self-contained Amplifiers

Right at the other end of the scale are the smallest, self-contained amplifiers giving a modest 3 to 4 watts per channel. These are eminently suitable for use in small rooms, and will give very acceptable results if reasonably efficient speakers are used. A block diagram of a typical arrangement is shown in fig. 3, this is the *Jason JSA2*, but a very similar circuit is used by the *Heathkit*

S33, which also has an Ultra-Linear output stage. Another example is the *CQ "twin 4,"* which employs a ECC83 instead of a ECF80 triode-pentode. A single EL84 can give an output of some 2.5 to 3 watts at a distortion as low as 0.3%, provided that a high amount of feedback is used, with an adequate output transformer.

Dual Control Units

Many people find the solution to the problem of buying new equipment for stereo in adaptors, which may incorporate an amplifier and dual control unit, such as the *Armstrong*, which can operate with an existing amplifier. Alternatively, *Sound Sales* make an adaptor unit which is self-powered, but which has separate balance controls to permit its use with amplifiers having widely different sensitivities. The main drawback to both these excellent units is the fact that they can only be used with high output pickups, such as crystal or ceramic types. Actually, many amplifiers have sensitivities too low to permit operation direct from tape heads and low output pickups; consequently a number of head or sub-amplifiers have made their appearance. These include the *Cape*, *Heathkit*, *CQ*, *Walgain*, and *Lowther*—the last three of which use transistors.

Stereo Balance

Balance Controls. Most stereo amplifiers incorporate a balance control, but before examining the various methods employed,

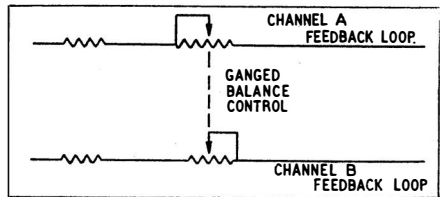

Fig. 5.—Balance control—Pamphonic 3000.

it would be as well to list a number of factors rendering such a control necessary. Starting from the reproduction itself, and working back along the chain, we have: (a) The acoustics of the listening room. (b) The two loudspeaker systems. (c) The two amplifiers. (d) The pickup. (e) The recording or transmission. The first two will normally vary only slightly and the amplifiers should be matched within 2 dB at any setting of the controls. This was quite difficult to achieve, prior to the introduction of close matched ganged controls by *Morganite*, and it meant the use of switched banks of matched high

stability resistors (as many as 88 in a pre-amplifier!).

Pickups and Discs

What about pickups? As might be expected, the expensive magnetic types are accurately matched within 1 or 2 dB, but crystal and ceramic types are another story. The best of these are rated within 4 dB, but some deviate as much as 6 dB, although they are showing signs of improving—in that respect at least.

Finally we come to the records themselves. It is a fact that early recordings—both

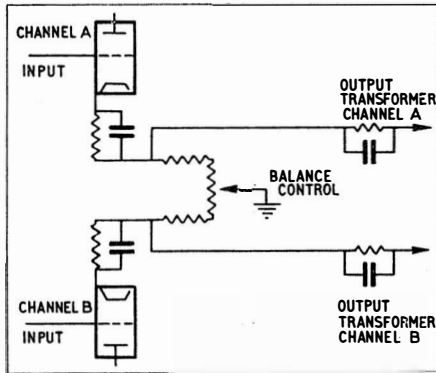

Fig. 6.—Balance control—Heathkit S88 and Jason J 10.

British and American—were not always well balanced; and even these days the odd one or two still require some adjustment to the balance control in order to get the best from them.

Channel Variation

Summing it up, then, it is easy to see that a total channel variation of 6–8 dB at least is necessary (less if separate pre-set input controls are fitted). This is either achieved by reducing the gain of one amplifier by some 3 dB, and by varying the gain of the other by 6 dB (i.e. plus and minus 3 dB) or, alternatively, a more efficient system is used whereby the gain of one amplifier is increased as that of the other is decreased. This latter method is adopted by *Pye* in the stereo “Mozart” and is shown in fig. 4. Here the control is in a grid circuit. Fig. 5 shows a balance control in a feedback loop as used in the *Pamphonic* 3000; it will be seen that a twin ganged control is employed. Fig. 6 shows a similar circuit used by the *Heathkit* S88 and the *Jason* J2/10, but with a single

control only. Provided that criteria of stability and distortion can be met, there are advantages in incorporating a balance control in the feedback loop—one being the absence of “Miller” effect, which can cause serious high frequency unbalance when a balance control is in a grid circuit.

The *Quad* 22 balance control is effectively in a feedback loop but in this case it is in the input stages of the pre-amplifier. The *Stereosound* amplifier has an unusual and ingenious balancing arrangement, using a neon relaxation oscillator to generate a signal which gives what is termed “aural balancing”. A later model carries this a stage further by making use of a magic eye to indicate visual balance (see fig. 7.) Here is how it works: The switch S3 and S4 parallel the two inputs to the amplifier and connect the common input terminal to an audio source (6v. A.C.). The signal from this is passed through each amplifier, and presented across each tertiary winding A and B. The amplitude of the signals across each tertiary winding is adjusted by the settings of the respective volume controls VC1 and VC2. Due to the fact that the tertiary windings are opposing, there will be minimum voltage between their terminals when the amplifiers are adjusted to give equal gain. The resultant signal voltage across the tertiary windings is passed for rectification to D.C. through the OA81 diode and then to the EM 84 magic eye.

Magic Eye Methods

In practice it is claimed that as the amplifiers are approaching balance there is a very pronounced “dip” in the voltage applied to the magic eye thus providing a very good indication. The circuit shown is that of two single end amplifiers but the same basic circuit will be used with larger push-pull versions. It will be realised that this method of balance only balances the amplifier; whilst it is true that a frequency record could be used to take care of the pickup this still leaves the speaker system, the listening room and the recordings themselves.

Crosstalk

Great pains were taken in the design of many early stereo amplifiers so as to prevent crosstalk between channels; screened leads, metal shields and boxes were used unsparingly—until it was realised that most of these precautions were really unnecessary. For two reasons, one—channel separation could be achieved fairly simply by means of

sensible layout, and two—channel separation figures of 60 to 70 dB were not needed. In the present state of the art, even the finest pickups (ditto the recordings) cannot achieve a channel separation greater than 10 dB at 10 Kc/s, and 20 dB at 500 c/s. This is not as serious as it seems, because it can easily be proved that a 6 dB increase in signal applied to one speaker in a stereo system will have the effect of completely moving the sound image over to one side.

Channel Separation

There is no doubt that a complete system separation of 14 dB for the frequency range 300 c/s to 10 Kc/s is adequate, but as far as the amplifier is concerned it must be stressed that this figure refers to ordinary crosstalk, and *not* to intermodulation of one channel by the other. A typical crosstalk figure for a self-contained amplifier would be around 40–50 dB at 300 c/s, dropping to about 35 dB at 10 Kc/s. Since most crosstalk is caused by stray capacitive coupling it will obviously tend to increase at the higher frequencies. Anode-to-anode, or grid-to-grid couplings are not usually important unless the circuits concerned are of high impedance. What is likely to prove much more serious is the coupling of a high level circuit of one channel with a low level circuit of the other.

Switch to “Mono”

For monophonic use, the two amplifiers of a stereo system are usually paralleled in

some manner. I say “usually” because in one or two amplifiers one channel is switched off when not required for stereo purposes. Some amplifiers (including the *Heathkit S88*, *Leak*, and *CQ*) simply switch the inputs together. The *Jason 10* and *Pye Mozart* switch at a point following the volume control; whilst the *Pilot*, *Quad*, and *Dulci* switch before the control.

Channel Reversing

Provision for reversing the channel relationship is usually in the same part of the circuit, but there are one or two exceptions where reversing is effected at the speaker terminals. The *W & N* and *Jason 10* have a phasing switch, so that the phase of one channel can be reversed; this is particularly useful when playing non-standard tapes;

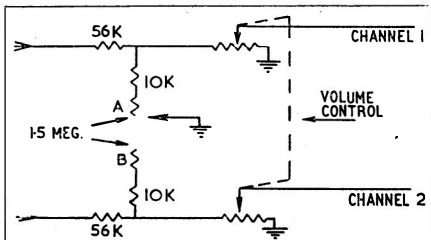

Fig. 8.—Balance control circuit—Bogen 212.

but as far as records are concerned, once the correct phase has been found, subsequent changing would be unlikely to be required as records are standardised. It may not be

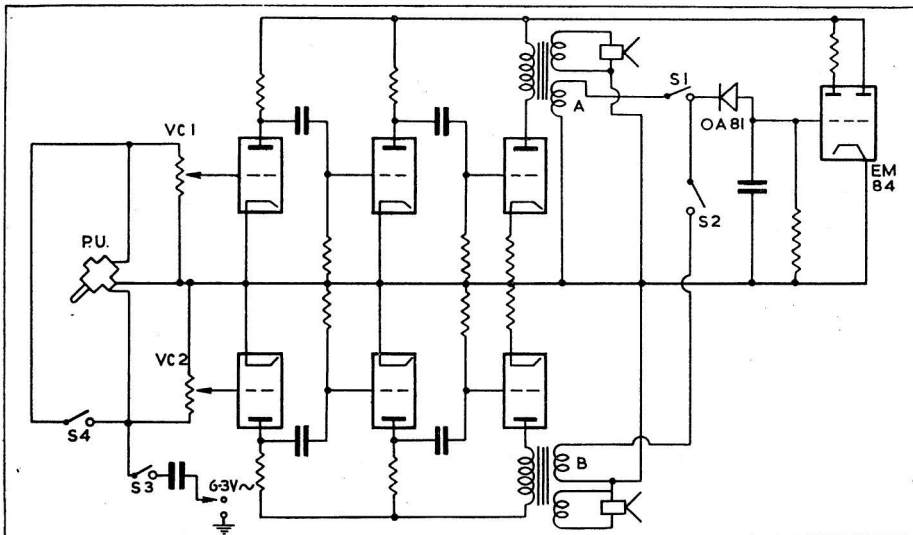

Fig. 7.—The use of a magic eye for balance, as in the latest Stereosound amplifier.

inappropriate to mention here that much of the effect known as "hole in the middle" is due to incorrect phasing somewhere in the system. It can usually be quickly remedied by reversing one pair of speaker leads.

Continental Practice

In other countries on the Continent—particularly in Germany—stereo amplifier design has followed a similar pattern to our own with a possibly greater emphasis on self-contained units; and probably more attention has been given to styling and presentation. The *Telewatt* "Nova" uses 5 ECC83's and 4 ECL82's and its frequency range and distortion compares quite favourably with its British equivalents. Other amplifiers made by *Telewatt* include a 2.5 plus 2.5 watt, and a 12 plus 12 watt. In

magnetic and crystal pickups; 24 equalisation positions; volume and loudness controls; rumble and muting filter (?) output meter, etc., etc.—all this and an "Acoustic probe" as well! Whether this last item is intended to check the neighbours' reactions to the 160 watts peak is not stated.

. . . and Modesty

Among the amplifiers with more modest ratings are *Fisher, Harmon-Kardon, Madison-Fielding, Sherwood and Bell*. The majority of American amplifiers still use triode input stages, with the attendant disadvantages due to "Miller effect", but there is a definite trend towards using valves of the EF86 type for low level input stages. Balance controls, generally speaking, differ little from those used here, one variation is a split type used by the *Bogen 212* (see fig. 8). The control is in effect two separate 1.5 megohm elements in one case, and it can be seen that the gain of either channel can be reduced without affecting the other. As a point of interest, this particular amplifier makes use of the pentode amplifying stage operating on the "starved current" principle, which involves the use of a high value anode resistor, and low screen voltage, to give a very high gain. It was used in this country by the Mullard 3 watt amplifier, but has never become really popular—probably because the high frequency response is inherently poor.

Balance by 2 Volume Controls

The *Madison-Fielding 320* amplifier does not have a balance control, and the gain of each channel is adjusted by means of two separate volume controls. Visual balance is indicated by a magic eye using a somewhat similar method to the one used by the British *Stereosound*. Fig. 9 shows the details. A and B are taken from the anodes of one output valve in each channel, and a switch is provided to inject a 120 c/s signal to the input of the amplifiers and the volume controls are adjusted so that the shadows on the magic eye are equal. The two 100 K controls are calibrated in watts, and so enable the power output to be indicated. This may indeed be useful, but the balancing system itself is open to the same objections as the *Stereosound*—viz. that it can only balance the amplifier, and it assumes that the speaker system and the two pickup elements are accurately matched.

An unusual phase-reversal circuit is shown in fig. 10; this is used by the Scott 130. When the switch is at "Normal", the

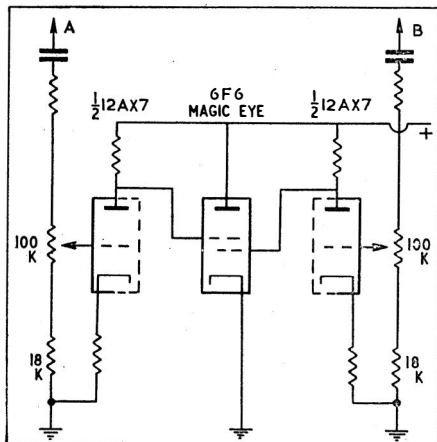

Fig. 9.—*Madison-Fielding 320, Visual balance.*

general, amplifiers in Germany still tend to use smaller amounts of negative feedback than is customary in this country; and because of the popularity of crystal pickups, most of these amplifiers have fairly low sensitivity.

The American Power Complex . . .

Turning to America, there is no possible doubt that the self-contained amplifier is still gaining in popularity; and power outputs are still high, judged by our standards. Many amplifiers are rated at 40, 60 and even 100 watts combined output. Some of these are very elaborate indeed, and boast impressive arrays of knobs and push-buttons likely to deter all but the most hardened "audiophile". For example, consider these specifications: 80 watts output; 160 watts peak; inputs for radio, tape, TV, microphone,

signal is taken direct, but when the switch is at "Reverse" the signal is taken through the triode valve, thus changing phase in the process. The resistor feedback network reduces the gain to unity. Many American amplifiers have what is known as a phantom or centre channel; this is achieved by mixing part of the left and right channels, and is intended to be fed to a centre speaker so as to remove the "hole in the middle" effect.

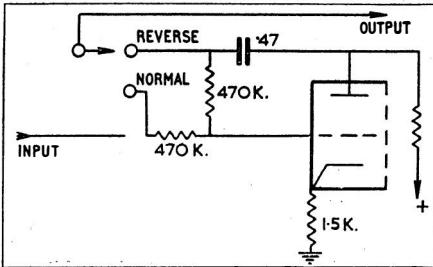

Fig. 10.—Phase reversal circuit—Scott.

As has been previously stated this effect is often due to incorrect phasing, but it must be admitted that it is also an effect produced by some exaggerated stereo records that were a feature of the early days of stereo. This type of artificial third channel might provide an improvement, but it is obviously not the real answer.

Stereo Adaptors

Stereo adaptors are more popular in America than they are in this country, the simplest consisting basically of a ganged

volume control, balance control, reversing switch and input switching. These units are intended for use with two monophonic installations—either between the signal sources and the pre-amplifiers, or between the pre-amplifiers and the main power amplifiers. Examples of these adaptors are made by *Marantz*, *G. E. Scott* and *Dynakit*. The last named is a kit, as its name implies, and it differs from the others by including a "blend" control which mixes the two channels, and at full rotation puts them in parallel. Another kit, marketed by *Knight*, is intended for use in the speaker circuits and incorporates low impedance volume and balance controls. One advantage of this type of unit is the fact that quite long leads can be used and it can form a remote control from one's chair-side.

Single-End-Push-Pull

Not strictly Hi-Fi, but certainly one of the most interesting stereo circuits to come from America, is the one developed by *RCA* for an economically priced system. This is a combined single-end-push-pull amplifier. Part of the circuit is shown in the diagram fig. 11. Two conventional single-end stages are used for stereo, and the two are combined in an ingenious manner to form a push-pull output stage for single channel operation. On the right channel the feedback is taken from the tap on the output transformer, and injected into the cathode of V3a: on the left channel the feedback is also taken from a tapping, but because it is reversed in

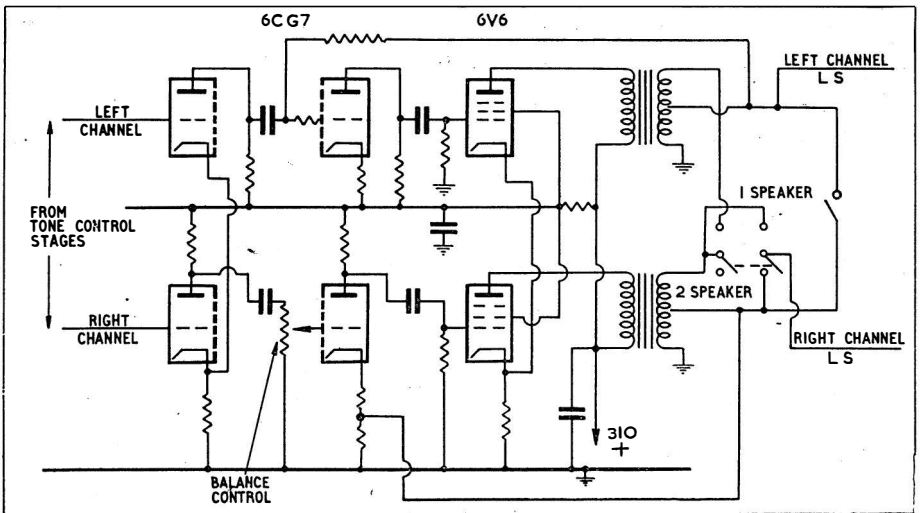

Fig. 11.—Stereo circuitry from America. Single-end and output stages in push-pull.

SUM AND DIFFERENCE STEREO

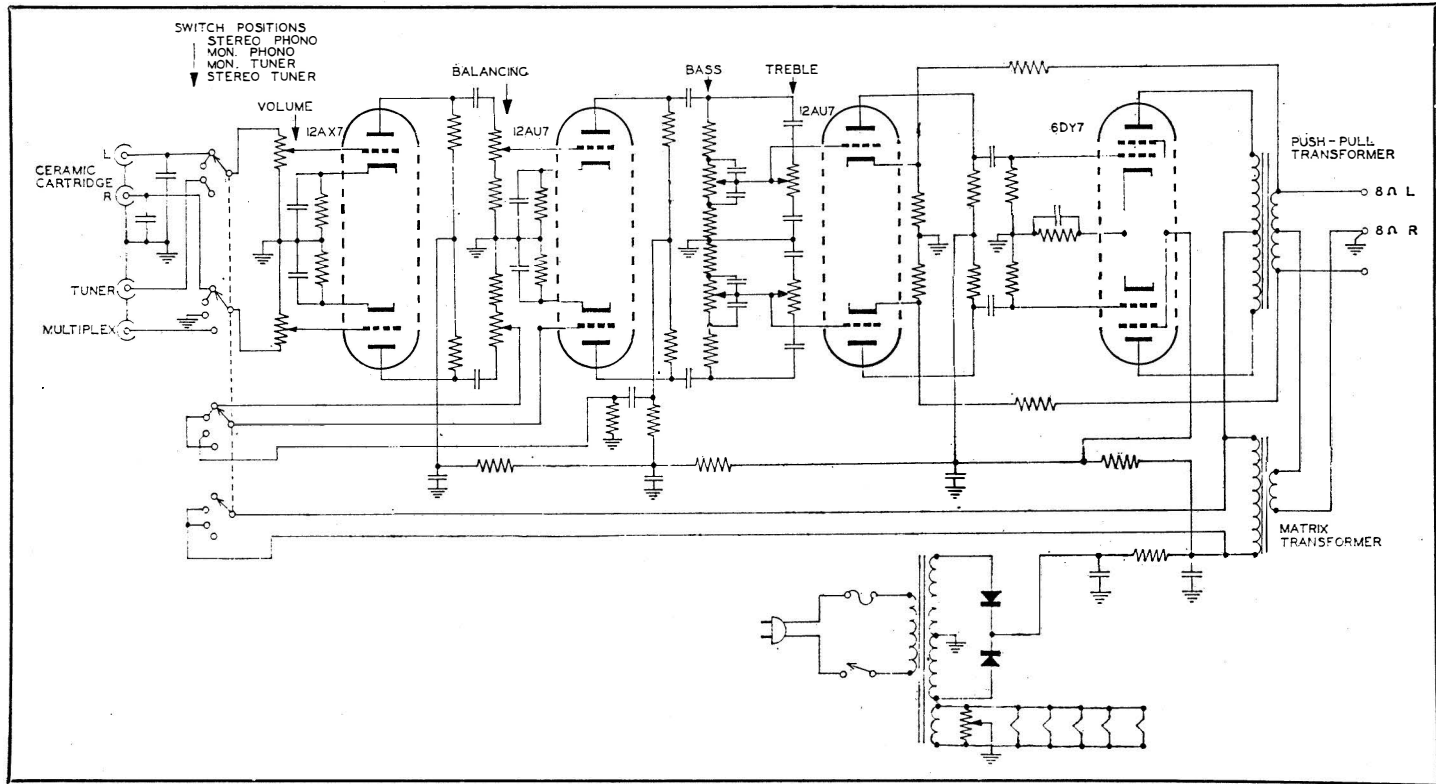

Fig. 14.—This complete circuit, from the American Columbia Laboratories, and developed and used by American Heathkit, shows the arrangement by which the sum and the difference of a stereo signal are handled separately and re-united at the output transformers.

polarity with respect to the grid of V3b, it is injected at this point to effect correct feedback. When the amplifier is used for monophonic reproduction, the output circuits are connected together by the switch S1b so as to effect push-pull operation. When switch S2 is in the *one-speaker* position, and no speaker is connected to the left channel output, both amplifiers are properly matched to the single speaker, and the amplifier is always in the push-pull condition, regardless of the position of the setting of S1b. Obviously the distortion—particularly second harmonic—is higher when the amplifier is functioning as two single-end stages, but for this application it was apparently not considered too serious. The actual figures quoted are—push-pull 0.7% at 6 watts, single end (combined) 1.5% for 6 watts.

Printed Circuits

The last few months have seen a great increase in the use of printed circuits, and already they are used in nearly half the British amplifiers. Recent correspondence in a trade journal indicates that there is still considerable opposition to their use, although it must be stated that the criticism was mainly based on their use in television sets—which, by the nature of things, are not nearly as reliable as high fidelity amplifiers. Provided that printed boards are used where they definitely have an advantage, and provided that due care is paid to possible servicing requirements, then there is no reason why, eventually, the majority of amplifiers should not use printed boards in some form or another.

Transistors

I cannot report the same progress in the sphere of transistors, however; and although three British amplifiers use transistor input stages, I feel that it will be some time before they are more universally adopted for this application. One drawback is that it is extremely difficult to design an economic transistor input stage having low noise and a high impedance necessary to match the low output magnetic pickups. Consequently, it looks as if the EF86 will more than hold its own for some time to come.

A Future for Ceramics?

Whether high quality ceramic pickups will out the crystal types remains to be seen; already *Connoisseur* have announced details of a miniature ceramic pickup giving some 20mV output, which should challenge the

expensive magnetic types. Nevertheless, I think the trend towards high gain amplifiers will continue.

“Phantom” Telephony

The next few months may see the appearance of twin-channel single amplifiers. This apparent impossibility is based on what telephone engineers call the “phantom” line. This is how it works; imagine a two-wire telephone system AA connected at both ends to transformers, the centre-taps of which are returned to earth via the windings of a second pair of transformers, as shown in fig. 12. The balanced windings are unaffected, one side swinging positive, and the other side swinging negative; but a signal at T3 will

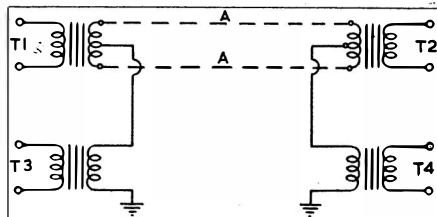

Fig. 12.—The “Phantom Line” principle.

appear at T4 without interaction with the other information carried by the main system. In other words, a balanced two-wire circuit can carry an additional unbalanced line between the two lines and earth.

The diagram shown in fig. 13 shows a similar circuit using valves; a signal applied

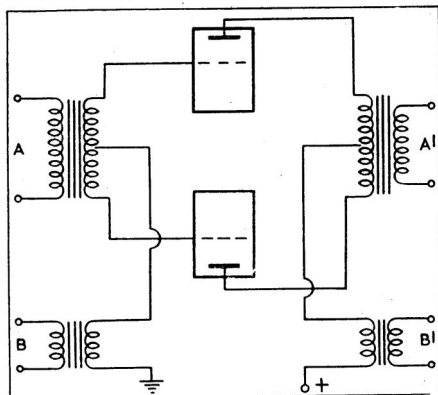

Fig. 13.—Push-pull stage to handle two signals.

to the winding A will drive the two grids in opposition so that the stage will operate in a conventional push-pull fashion, and a signal will appear at the winding A1; and since the anode currents are balanced, there will be no output from B1. A signal applied to the

winding B will drive both grids equally, and the anode currents will be in the same

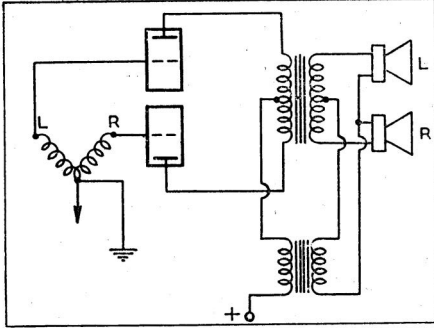

fig. 15.—Stereo pickup connected to sum-and-difference amplifier.

direction, resulting in parallel operation; so there will be an output from B1 but not at A1. Such a push-pull stage is capable of handling two independent signals with very little interaction, but its chief defect arises

from the fact the push-pull channel would be superior, to the parallel channel, in respect of distortion and handling power. This is a serious disadvantage, but one that can be overcome if the sum-and-difference technique is employed. In other words, the sum of the two stereo signals is fed to the push-pull channel, and the difference (which is a much smaller signal) is fed to the parallel side.

Sum and Difference Connections

Fig. 15 shows how a stereo pickup is connected to a sum-and-difference amplifier. The two coils are connected so as to give a reverse phase output to that normally used. The two separate stereo channels are re-constituted by the appropriate interconnection of the output transformers. The system described is due to the *Columbia Laboratories* of America, and fig. 14 shows a practical circuit developed with their co-operation by the *Heathkit* company in America.

DIRECTORY OF AMPLIFIERS & CONTROL UNITS

★ The following abbreviations are used in this directory section: H.D.—Harmonic Distortion; <—less than; H and N—Hum and Noise; P.a.t.—Power supplies available for tuner; R.M.S.—root mean square; N.L.—Noise level; Sel.—Selector switch; ■—Stereo equipment.

Acoustical Manufacturing Co. Ltd., St. Peter's Road, Huntingdon, Hunts. Tel.: H'don 361 and 574. Cables: Acoustical.

Quad II Q.C. II Control Unit. Inputs: radio/tape 100 mV; mic. 1.5 mV; gram. to suit pickup. Treble, bass, vol. and on/off, filter slope. Switch filter 5, 7, 10 Kc/s and "out." Tape record socket, switched playback socket. H.D. <0.1%. H and N —70 dB. Size $10\frac{1}{2} \times 3\frac{1}{2} \times 6\frac{1}{2}$ ins. To operate with Quad II power amp or similar. Price £19 10s.

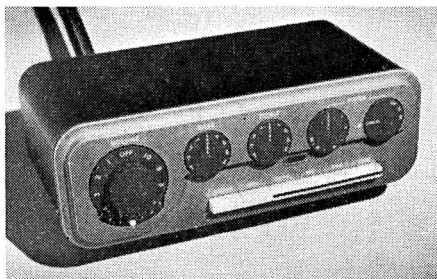

Quad 22 Control Unit

■ **Quad 22 Control unit.** Inputs: Radio/tape 70 mV @ 100 K; mic 1.5 mV @ 100 K; pickup dependent on adaptor unit used, Vol. and on/off, bass, treble, filter slope, filter switch 5, 7, and 10 Kc/s. Push-button selection of channels, mono/stereo, and record equalisation. H.D. <0.1%. H and N —70 dB total, P.a.t. 330 v 35 mA each tuner, 6.3v 3 amps. Size $10\frac{1}{2} \times 3\frac{1}{2} \times 6$ ins. Price to be advised. To operate with QUAD II amplifiers. Price £25.



Quad II Amplifier. 15 watts. Dist. total 3rd harmonic and higher. <0.18% at 12 watts. Input for spec. output 1.4v. RMS for 15 watts. Response 20-20,000 c/s. ± 0.2 dB; 10-50,000 ± 5 dB. Feedback incorporated in original ultra-linear arrangement. N.L. —80 dB at 15 watts. Out. imp. 7 and 15 ohms. Output KT66's. Original combined anode/screen current circuit. Size $13 \times 4\frac{3}{4} \times 6\frac{1}{2}$ ins. To operate with QCII control unit. Price £22 10s.

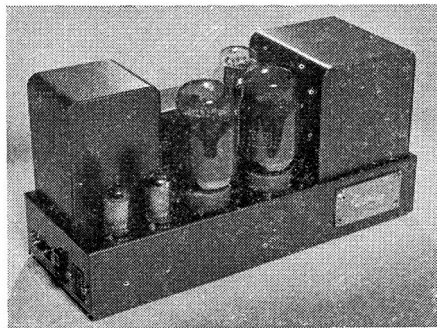

Quad II control unit and amplifier

★

Altbass Ltd., Percy Road, Aylestone Park, Leicester. Tel.: Leicester 31616. Cables: Altbass, Leicester.

"High Fidelity 510" Control Unit. Inputs: tape/radio 100 mV; P/U (l.p.) 50 mV; P/U (78) 60 mV; mic. 10 mV. 5 pos. sel., treble, bass, vol. and on/off. Tape replay socket. H.D. 0.15%. H and N —64 dB mic.; —71 dB on other inputs. Size $10 \times 3\frac{1}{2} \times 4\frac{1}{4}$ ins. Price £8 8s. Sold only with 510 power amp.



Altbass 510 control unit

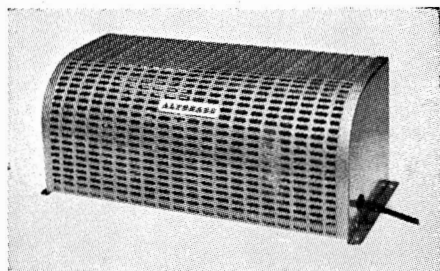

Altobass 510 amplifier

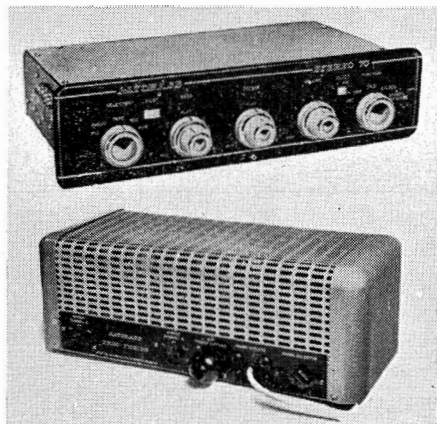

Altobass Stereo 70 C/U and Twin 12 amp.



Altobass Seventy control unit

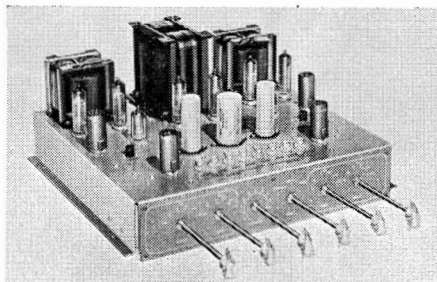

Airmec combined stereo amplifier

“**High Fidelity 510**” Amplifier. 10 watts nom., 11 watts max. Dist. 0.1% (10 watts. at 400 c.p.s.). Input for spec. output 40 mV. Response 15-20,000 c/s. ± 0.6 dB. Feedback — 20.5 dB. N.L. — 78 dB relative to 10 watts. Out. imp. 3.75 or 15 ohms. Output EL84's. Ultra-linear. Size $13\frac{1}{2} \times 5\frac{1}{2} \times 5\frac{1}{2}$ ins. Price £15 15s.

Altobass Seventy Control Unit. Inputs: Pickup 4 and 50 mV; Radio 250 mV; Tape 5 and 250 mV; Aux. 50 mV. 6-position sel., bass, treble, volume and on/off, switched high pass filter 100 c/s, switched low pass filter 5.5 Kc/s. H.D. 0.015%. H and N Tape — 52 dB, others — 56 dB. Size $10\frac{3}{8} \times 4 \times 4\frac{1}{2}$ ins. Price £16 16s. To operate with Altobass 510.

■ **Altobass Stereo 70 Control Unit.** Inputs: pickup 4 mV; radio 220 mV; tape 3 mV; mic. 5 mV; aux. 100 mV. 5-position sel., bass, treble, volume, function switch and on/off. H.D. 0.015%. H and N — 54 dB. Rumble filter. Size $13\frac{1}{2} \times 7 \times 3\frac{1}{2}$ ins. Price £24 3s. To operate with Altobass Twin Twelve.

■ **Altobass Twin-Twelve Stereo Amplifier.** 10 watts each channel, 12 watts max. Dist. 0.1% at 10 watts. Input for spec. output 150 mV. Response 20-20,000 c/s ± 0.5 dB. 20 dB feedback. N.L. — 78 dB relative to 10 watts. Out. imp. 4, 8, and 16 ohms. Output EL84's. Ultra-linear. Size $14\frac{1}{2} \times 7 \times 6\frac{3}{4}$ ins. Price £30 9s. To operate with Altobass Stereo 70 Control Unit.

■ **Altobass Twin II Amplifier and Control Unit** Inputs: 200 mV for 2 watts per channel. 3-position sel., dual-concentric volume and frequency controls with on/off switch. H and N — 56 dB referred to 2 watts. Size: Main amp. $9 \times 6 \times 5\frac{1}{2}$ ins. Control Unit $5 \times 3 \times 4\frac{1}{2}$ ins. Price £16 16s. complete.

■ **In preparation: Altobass Twin 7 Amplifier** an integrated stereo amplifier with an output of 7 watts per channel.

★

Airmec Limited. High Wycombe, Bucks. Tel.: High Wycombe 2060.

■ **Airmec Stereo Amplifier and Control Unit.** 10 watts per channel. Distortion $< 0.2\%$. Response 20-20,000 c/s ± 0.5 dB. H. and N. — 70 dB. Aut. inp. 3.75 and 15 ohms. Inputs: pickup 1 20 mV at 100 K, pickup

2 400 mV at 1 M ohm, tape and radio 100 mV at 220 K. Selector switch, bass, treble, volume. P.a.t. 320 v at 60 mA, 6.3 volts at 4 amps. Chassis size $16\frac{1}{2} \times 15\frac{1}{4} \times 7\frac{1}{2}$ ins. 5-inch long control spindles. Price £33 10s.

★

Armstrong Wireless & Television Co., Warters Road, Holloway, N.7. Tel.: North 3213/4.

Mk. II Control Unit. Inputs: radio 80 mV; tape 80 mV; mic. 4 mV; gram. (4) 8-1200 mV. 4 pos. input switch; 6 pos. equaliser; treble, bass, vol. and on/off; 6 pos. switched filter. Switched tape input. H.D. 0.05% at 1,000 c/s. at 180 mV. H and N better than — 60 dB. Rumble filter. P.a.t. 320v at 35 mA; 6.3 at 2A. Size $5\frac{1}{4} \times 9\frac{3}{4} \times 5\frac{1}{4}$ ins. To operate with A10 Mk. II power amp. Price £10 10s.

PCU 21 Stereo Control Unit. Inputs: Radio 180 mV, Tape 500 mV, Gram 1,000 and 280 mV, and 180 mV stereo, 3-position sel., function, bass, treble, balance, volume. H.D. 0.5%. H and N — 66 dB. Size $13 \times 4\frac{1}{2} \times 2\frac{1}{2}$ ins. Price £9 15s. To operate with amplifier A 6.

RF125T. Tuner/Control Unit. Inputs: radio, gram. 1.1 volts or 280 mV. Tuning, volume, bass, treble, wave change, on/off. Size $15 \times 9\frac{3}{4} \times 9\frac{1}{4}$ ins. Price £22 10s. (U.K. purchase tax £9).

A10 Mk. II. 10 watts nominal, 20 watts max. Dist. 0.1%. Input for spec. output 400 mV for 10 watts. Response 15-30,000 c/s. ± 1 dB. Feedback 28 dB. N.L. better than — 80 dB. Out. imp. 1, 3, $7\frac{1}{2}$ and 15 ohms. Output EL34's. Ultra-linear. Size $14 \times 18\frac{1}{2} \times 6\frac{1}{2}$ ins. To operate with Mk. II control unit. Price £21 10s.

A6. 6 watts. Dist. 0.5%. Input. for spec. output 700 mV. Response 15-35,000 c/s ± 2 dB. Feedback 14 dB. N.L. — 70 dB. Out. imp. 3, $7\frac{1}{2}$, and 15 ohms. Output ECL82's. Size $13 \times 3\frac{1}{2} \times 5$ ins. Price £9 17s. 6d. To operate with PCU21 Control Unit.

In preparation: Stereo pre-amplifier PCU27, designed for low output pickups and repro. from tape playback head.

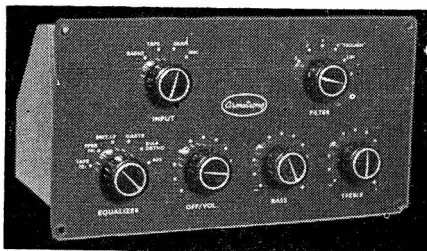

Armstrong A10 Mk II C/U and amplifier

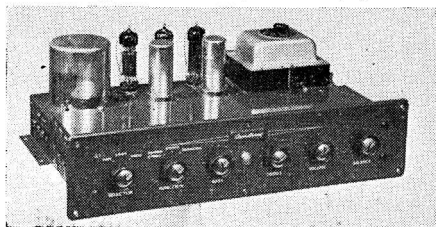

Armstrong PCU 21 C/U and A6 amplifier

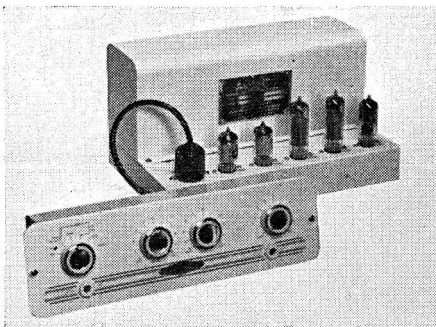

Astronic A1332 control unit and A1333 amp.

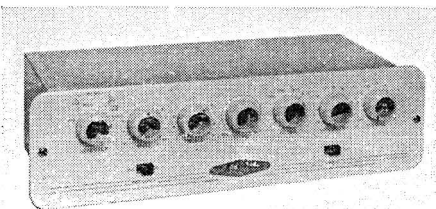

Astronic A1432 control unit

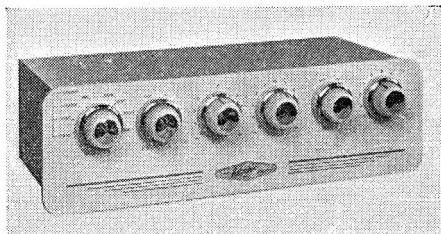

Astronic A1434 stereo control unit

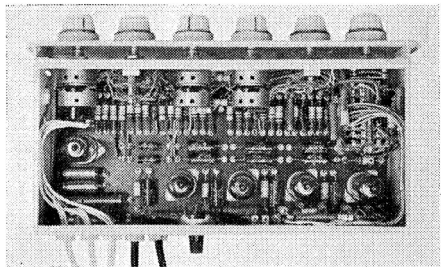

Astronic A1434 with top cover removed

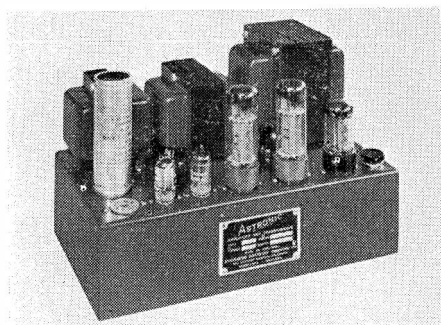

Astronic Atlas A1440 amplifier

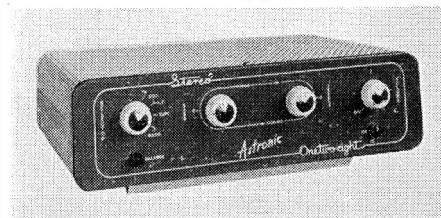

Astronic A1444 complete stereo amplifier

Associated Electronic Engineers Ltd., 10 Dalston Gardens, Stanmore, Middx. Tel: Wordsworth 4474/5/6. Cables: Astronic, Stanmore.

Astronic A1332 Control Unit. Inputs: mic. 20 mV; gram. A.E.S., FFRR, NARTB 10-20 mV; radio/tape 220 mV. 6 pos. sel., treble, bass, vol. and on/off, gram. input attenuator. Tape record and playback

socket. H and N — 70 dB. Size $12 \times 3\frac{3}{8} \times 1\frac{7}{8}$ ins. To operate with A1333 power amp. Price £9 10s. 6d.

Astronic A1432 Control Unit. Inputs: mic. 20 mV; radio 120 mV; P/U 4 mV or 20 mV; tape (C.C.I.R.) 1-2 mV. 6 pos. sel. (3 record equal.), treble, bass, vol. on/off. Filter 5, 7, 10 Kc/s. Slope 6-30 dB/octave. Loudness — 18 dB max. Presence + 6 dB, 2-3 Kc/s. Rumble filter. Variable P/U attenuator. Socket for direct replay from tape head. H.D. not measurable. H and N — 65 dB. Size $11\frac{1}{2} \times 3\frac{1}{2} \times 5\frac{1}{4}$ ins. To operate with A1333 or A1440 amplifiers. Price £21 19s.

Astronic A1333 Amplifier. 10 watts nom., 13 watts max. Dist. 0.1% at 10 watts. Input for spec. output 0.33v R.M.S. Response 20-20,000 c/s. ± 0.5 dB. Feedback 18 dB N.L. — 72 dB. Out. imp. $3\frac{3}{4}$, $7\frac{1}{2}$ and 15 ohms. Output N709's or EL84's. Ultra-linear. Size $11\frac{1}{2} \times 6\frac{1}{4} \times 6$ ins. To operate with A1332 control unit. Price £18 19s. 6d.

■ **Astronic A1434 Stereo Control Unit.** Inputs, single channel: tape 1-2 mV; l.p. (Int.) 4 mV; radio 120 mV; mic. 20 mV; aux. 120 mV. Stereo inputs for tape, P/U and radio same sensitivities. 8 pos. sel., bass, treble, vol., on/off, rumble filter, presence switch, channel balance (pre-set). Dist. negligible. H and N — 65 dB. Size $11\frac{1}{2} \times 3\frac{1}{2} \times 6$ ins. To operate with amplifiers A1333 Mk. I and Mk. II or A1440. Price £22 5s.

■ **Astronic A1444. Combined Stereo Unit.** 4 watts. Dist. 2%. Inputs: radio, tape and LP discs. 150 mV; 78 discs. 350 mV. 4-position sel., bass, treble, volume and on/off. Out. imp. 3 and 15 ohms. Size $11\frac{1}{2} \times 8\frac{3}{4} \times 3\frac{1}{4}$ ins. Price £24 3s.

Atlas A1440. 20 watts nominal, 35 watts max. Dist. 0.1%. Input for spec. output 0.25 volts. Response 20-20,000 c/s ± 5 dB. Feedback 30 dB. N.L. — 85. Out. imp. $3\frac{3}{4}$, $7\frac{1}{2}$ and 15 ohms. Output EL34's. Ultra-linear. Size $13 \times 7\frac{1}{4} \times 8\frac{1}{2}$ ins. Price £37 16s. To operate with amplifiers A1332, A1432, and A1434.

★

Beam-Echo Ltd., 13 South Molton Street, London, W.1. Tel.: Mayfair 1039. Cables: Hibeam, London.

Avantic DL7 Control Unit. Inputs: P.U.1 4-6 mV; P.U.2 40-60 mV; P.U.3 55 mV; tuner 1 100 mV; tuner 2 500 mV; aux. 1 2 mV;

aux. 2 20 mV; tape 100 mV. 8 pos. sel., treble, bass, vol. and on/off, loudness. Switched filter 5, 10 and 20 Kc/s. 3-pos. monitor/record switch. Tape record and playback sockets. H.D. <0.1% for 200 mV and <0.2% for 2.0v. H and N, radio and tape — 64 dB; pickup — 53 to — 56 dB; aux. 1 — 45 dB. Roll-off freq. 40 c/s. Slope 12 dB/octave. P.a.t. 200 v at 30 mA, 6.3v at 2.5 A. Size 11 × 4 × 7 ins. Price £22.

Avantic DL7-35 Amplifier. 30 watts nom., 45/60 watts max. Dist. <0.05% at 20 watts, >0.1% at 27 watts. Input for spec. output 220 mV. Response 5-30,000 c/s. ± 0 dB, 2-100,000 c/s. ± 1 dB ref. 1,000 c/s. Feedback 30 dB. N.L. — 84 dB at 20 watts. Out. imp. 4, 8, and 16 ohms, switched. Output EL34's. Ultra-linear. Size 14½ × 9 × 8½ ins. Price £33. Complete with control unit £55.

■ **Avantic SP21. Stereo Control Unit.** Inputs: Tuner 100 and 250 mV; tape 100 mV; pickup 5 and 50 mV; Aux. 250 mV. 6 position sel., bass, treble, volume, loudness, function switch, filter. Rumble filter. Size 15 × 9 × 4 ins. Price £28 10s. To operate with Avantic DL7-35.

■ **Avantic SPA11.** 7 watts per channel, 10 watts peak. Dist. <1%. Inputs: tuner and tape 100 mV; gram 650 mV. Response 40-15,000 c/s ± 1 dB. Out. imp. 4, 8 and 16 ohms. Output ECL82's. Size 14½ × 4 × 8½ ins. Price £29 8s.

■ **Avantic SPA21.** 12 watts per channel, 20 watts peak. Dist. 0.1%. Min. input 4 mV from tape head. Response 40-15,000 c/s ± 0.5 dB. Out. imp. 4, 8 and 16 ohms. Output EL84's. Size 15 × 14 × 4 ins. Price £48 10s.

★

B.K. Partners Ltd., 229 Regent Street, London, W.1. Tel.: Regent 7363.

Audio Plan Control Unit. Inputs for P/U and radio. 5 pos. sel. (4 record equal). H.D. 0.25%. H and N — 75 dB. Panel size 9½ × 3½ ins. To operate with Audio Plan power amp.

Audio Plan Amplifier Mk. I. 6 watts nom., 8.5 watts peak. Dist. 0.25%. Input for spec. output 40 mV. Response linear 30-100,000 c/s. at 3 watts. N.L. — 75 dB. Out. imp. 3 and 15 ohms. Output ECL82's. Size 11½ × 4 × 4½ ins. Price with control unit £18.

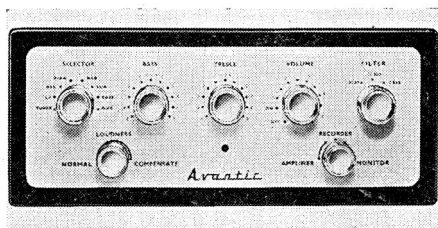

Avantic DL7-35 control unit

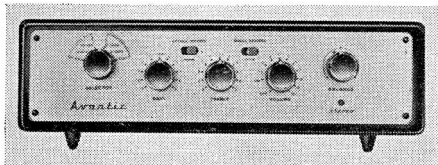

Avantic SPA11 complete stereo amplifier

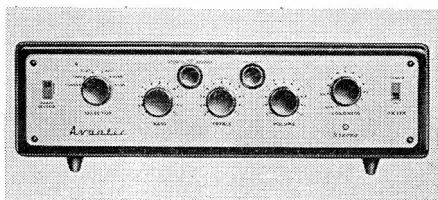

Avantic SPA21 complete stereo amplifier

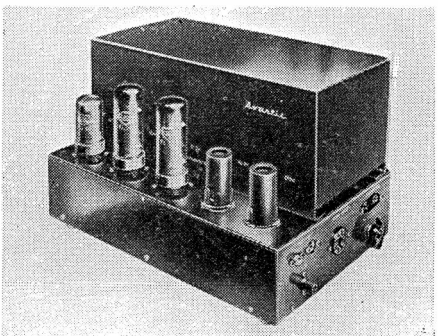

Avantic DL7-35 amplifier

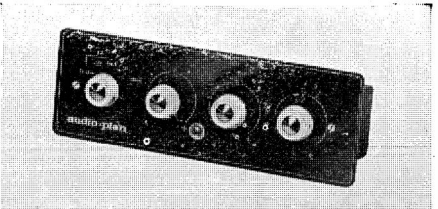

B.K. Audio Plan control unit

Audio Plan Amplifier Mk. II. As Mk. I, but with aux. power for tuners, etc., H.T. at 30 mA and 6.3v at 2A L.T. Price with control unit £19 15s.

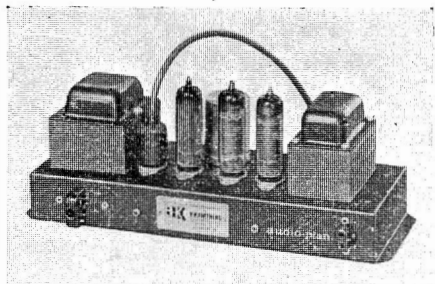

B.K. Partners "Audio Plan" amplifier



B.K. Partners P.205 stereo control unit

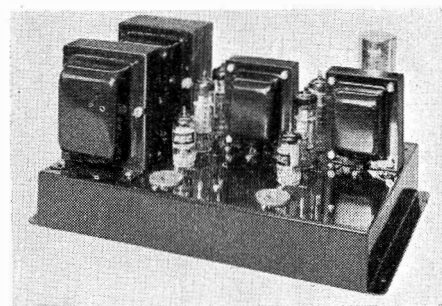

B.K. Partners A205 stereo amplifier

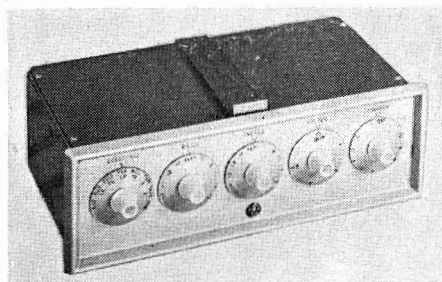

BTH Mk I control unit

■ **P205 Stereo Pre-amplifier.** Inputs: tape 2 mV; pickup 3 and 120 mV; radio 120 mV; mic. 20 mV; Aux. 120 mV. 8-position sel., treble, bass, presence. H and N. — 65 dB. Rumble filter. P.a.t. 230 volts, 35 mA. Size $11\frac{1}{2} \times 3\frac{1}{2} \times 6$ ins. To operate with amplifier A205. Price complete £42 10s.

■ **A205 Twin Channel Amplifier.** 5 watts per channel, 7 watts peak. Dist. <0.2%. Input for 5 watts 300 mV. Response 30-25,000 c/s ± 1 dB. Feedback 15 dB. N.L. — 70 dB. Out. imp. $3\frac{3}{4}$, $7\frac{1}{2}$ and 15 ohms. Output ECL82's Ultra-linear. Size $12 \times 8 \times 6$ ins. Price £42 10s. See P.205 above.

★

BTH Sound Equipment Ltd., Crown House, Aldwych, London, W.C.2. Tel.: Temple Bar 8040. Cables: Soundequi, Lesquare, London.

Hi-Fi Control Unit Mk. 1. Inputs: Mic. 5 mV; tape head 5 mV; pickup 6 and 250 mV; Equalised tape 180 mV; radio 180 mV. 8-position sel., filter, bass, treble, volume and on/off. H.D. <0.05%. H. and N. — 86 dB. Size $10\frac{1}{4} \times 3- \times 5\frac{1}{2}$ ins. Price £17 10s. To operate with BTH Hi-Fi Amplifier, or similar.

Hi-Fi Power Amplifier Mk 1. 20 watts nominal, 30 watts peak. Dist. <0.05%. Input for 20 watts 100 mV. Response 20-20,000 c/s ± 1 dB. Feedback 24 dB. N.L. — 80 dB. Out. imp. 4, 8 and 15 ohms. Output EL34's. Ultra-linear. Size $10\frac{3}{4} \times 5\frac{1}{2} \times 6\frac{3}{4}$ ins. Price £24 10s. To operate with BTH Hi-Fi Pre-amp. or as a pair with BTH Stereo Control Unit.

■ **In preparation:** A Hi-Fi Stereo Control Unit with details as for the Mk 1 above. Price £51 9s. complete with stereo power amplifier (also in preparation).

★

Cape Electrophonics Ltd., 43-45 Shirley High Street, Southampton. Tel.: Southampton 74251.

Cape Audio System. Based on M/S control unit and VL1 amplifier. Interchangeable additive units covering all monaural and stereo applications for radio, gramophone, tape and microphone.

Cape M/S Control Unit. Monaural and stereo inputs for radio, gramophone, tape and microphone plus auxiliary. Bass treble and volume. Monaural and stereo tape record outlets. Prov. price £15.

Cape VL1 Amplifier. 25 watts nom. approx. 40 watts max. Dist. at 1,000 c/s. 0.03% at 15 watts, 0.1% at 25 watts. Over

range 50-10,000 c/s., 0.1% total at 15 watts. Input for 15 watts output, 0.8v R.M.S. Response 10-80,000 c/s. ± 0.5 dB. Feedback external loop 20 dB. N.L. — 85 dB at 25 watts. Out imp. 3.5, 7 and 15 ohms. Output KT66's. Ultra-linear. Choke regulated power supply. Output and driver stages balanced by direct coupled feedback. Size $15\frac{1}{2} \times 8\frac{1}{2} \times 7$ ins. Price £30.

Cape VL2 Amplifier. Second channel amplifier with similar performance to VL1 but with reduced external supplies. Price £25.

Cape Sub Amplifier. Model A. Straight single stage amplifier with gain of 100 pentode connected or 30 triode connected. Price £5. **Model B.** Single stage tape correction amplifier with switch for 15, $7\frac{1}{2}$ and $3\frac{1}{2}$ i/s. Price £5 12s. 6d. **Model C.** Single stage amplifier for ribbon or moving coil microphone with Partridge transformer matching 15, 30, 300 or 600 ohms balanced line. Price £8 10s. **Model D.** Simple two stage no compromise pre-amplifier without tone control or filter. Int. LP, Tape $7\frac{1}{2}$ and radio with selector switch and volume control. Price £9 10s. **Model E.** As type B with additional stage, giving output of up to $\frac{1}{2}$ volt from tape head. Price £9 5s. **Model F.** Straight two stage unit, low noise, for boosting output from stereo pickup or tape head. Price £8 10s.

★

C. T. Chapman (Reproducers) Ltd., Chapel Lane, High Wycombe, Bucks. Tel.: H.W. 2474.

Chapman 205CU Control Unit. 6 inputs from 1.5 mV-100 mV. 6 pos. sel., treble, bass, loudness. 3 pos. roll off, 5, 10 and 20 Kc/s. Tape record and playback jacks, H.D. <0.1%. H and N radio — 64 dB, P/U — 54 dB. Rumble filter, better than 12 dB per octave below 35 c/s. Size $12 \times 2 \times 6$ ins. To operate with power amp 205 or Williamson power amplifier. Price £12.

Chapman 205 Amplifier. 20 watts from 30-20,000 c/s. Dist. <0.05% at 20 watts. Response 2-100,000 c/s. ± 1 dB. Feedback 30 dB. N.L. — 89 dB at 20 watts. Out. imp. 15 ohms. Output EL34's. Ultra-linear. To operate with 205CU. Price £34.

■ **Chapman 305 Stereo Control Unit.** Inputs: Pickup and tape 4.5 mV; radio 100 mV;

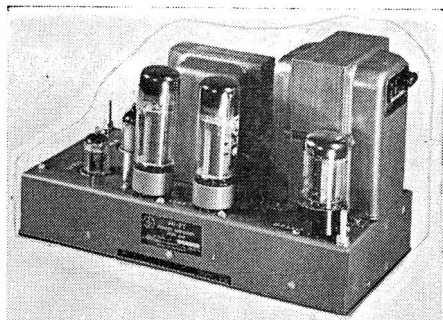

BTH Mk I power amplifier

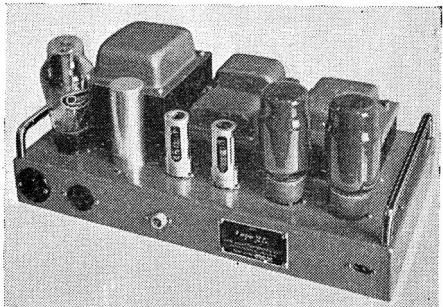

Cape VLP Mk 2 control unit and VLA amplifier

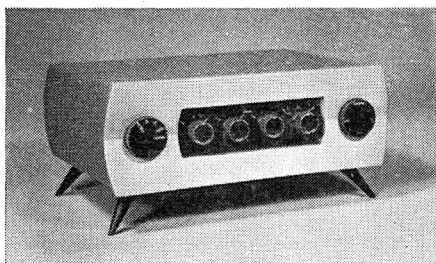

Chapman 105 combined amplifier

Aux. 100 mV. 4 position sel., bass, treble, volume, balance, filter. H.D. <0.1%. H and N — 50 dB. Rumble filter. Size $12 \times 4\frac{1}{2} \times 6\frac{1}{2}$ ins. Price £18 18s. To

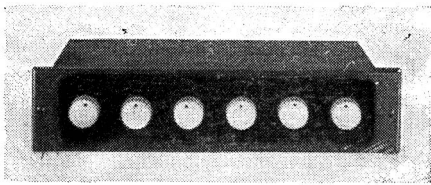

Chapman 205 C/U control unit

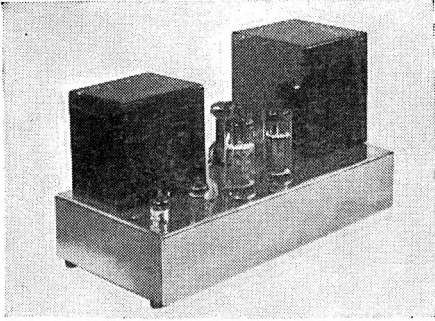

Chapman 205 amplifier

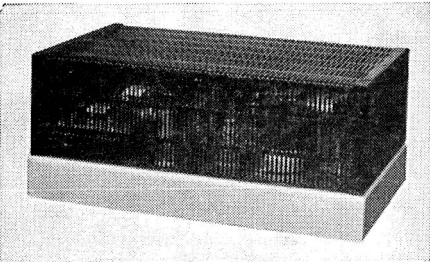

Chapman 305 stereo amplifier

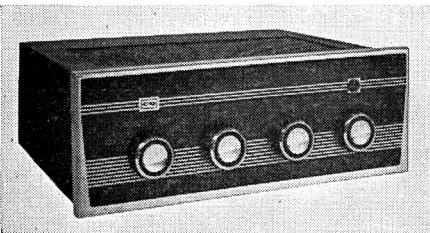

C.Q. combined amplifier

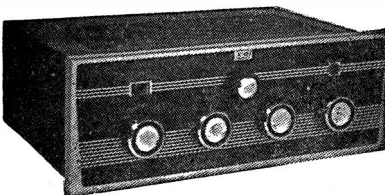

C.Q. Twin Four stereo amplifier

operate with 305 amplifier or 2 × 205 amplifiers.

■ **Chapman 305 Stereo Amplifier.** 8 watts per channel, 15 watts peak. Dist. <0.1%, input for spec. output 350 mV. Response 30-20,000 c/s. ± 0.2 dB. Feedback 10 dB. N.L. — 80 dB. Out. imp. 3 and 15 ohms. Output EL84's. Ultralinear. Size 12 × 7 × 5 ins. Price £21. To operate with 305 pre-amplifier.

Chapman 105 Combined Control Unit and Amplifier. 10 watts nominal, 20 watts peak. Inputs: pickup 10 and 50 mV; radio and tape 100 mV. Selector, bass, treble, filter, loudness control, volume and on/off. Rumble filter. Dist. <0.1%. Response 30-20,000 c/s ± 0.2 dB. N.L. — 80 dB. Out. imp. 3 and 15 ohms. Output EL84's. Ultra-linear. Size 12 × 4½ × 8½ ins. Price £29 18s.

★

C.Q. Audio Ltd., 2 Sarnesfield Road, Enfield, Middx. Tel.: Enfield 8262.

C.Q. 10-watt Combined Control Unit and Amplifier. Inputs: mag. P/U 10 mV; crystal P/U 100 mV; tape 200 mV; radio 200 mV; mic. 2 mV. 6 pos. sel., treble, bass, vol., tape outlet, 1 mW into 600 ohms. H.D. 0.1% at 10 watts. H and N — 80 dB below full output. P.a.t. 2 outlets of 200/240v AC one switched. Output 10 watts nom., 15 watts max. Response 20-25,000 c/s. ± 1 dB. Out. imp. 4, 8 and 16 ohms. Output EL84's. Ultra-linear. Size 11 × 4 × 8 ins. Price £22 15s., or 100/120v A.C. model £23 11s.

■ **Stereo Economy Pre-amplifier.** Input: 3 mV each channel. Master volume control, with pre-set control on each channel. H.D. <0.1%. H and N — 55 dB reference 1 volt. Size 3½ × 3½ × 4½ ins. Price £7 19s. External power supply required.

CQPA10. 10 watts, 15 watts peak. Dist. 0.1%. Input for spec. output 500 mV. Response 10-65,000 c/s ± 1 dB at 1 watt. Feedback 20 dB. N.L. — 75 dB. Out. imp. 4, 8 or 16 ohms. Output EL84's. Ultra-linear. Size 10½ × 3½ × 7 ins. Price £14 14s. Alternative model B for 115 or 230 volts mains £15 15s.

CQPA30. 30 watts, 50 watts peak. Dist. 0.1%. Input for spec. output 500 mV. Response 10-65,000 c/s ± 1 dB at 1 watt. Feedback 26 dB. N.L. — 80 dB. Out. imp.

4, 8 and 16 ohms. Output EL34's. Ultra-linear. Size $12 \times 5 \times 7$ ins. Price to be announced.

■ **CQ Twin Four Stereo Amplifier.** Inputs: pickup 100 mV; tape and radio 300 mV. Power output 3-4 watts. Response 20-25,000 c/s ± 1 dB. Dist. $<0.7\%$ N.L. — 60 dB. Out. imp. 3 and 15 ohms. Size $11 \times 4 \times 3\frac{1}{2}$ ins. Price £22 ls.

★

Dulci Co. Ltd., 97-99 Villiers Road, N.W.2.
Tel.: Willesden 6678/9.

DPA10 Control Unit. Inputs: pickup 6 mV; tape 100 mV; microphone 1.5 mV; radio 100 and 300 mV. 6-position sel., bass, treble, volume and on/off. H.D. $<0.1\%$. H and N — 45 dB. Size $11\frac{1}{4} \times 3 \times 5\frac{1}{4}$ ins. Price £7 7s. To operate with DPA10 amplifier.

DPA10 Power Amplifier. 15 watts nominal. Dist. 0.3%, input for 10 watts 40mV. Response 30-15,000 c/s ± 1 dB. Feedback 26 dB. N.L. — 75 dB. Out. imp. 3-16 ohms. Output EL84's. Ultra-linear. Size $11\frac{1}{2} \times 6 \times 5\frac{1}{2}$ ins. Price £12 12s. To operate with DPA10 Control Unit, Stereo Two, or Stereo Eight.

■ **"Stereo Two" Control Unit.** Inputs: radio and tape 100 mV; pickup adjustable 50 mV to 2 volts. 6-position sel., bass, treble, volume, balance. H.D. $<0.1\%$. H and N — 60 dB. Size $12\frac{1}{2} \times 3\frac{1}{4} \times 5$ ins. Price £9 9s. To operate with two DPA10, or SP44 amplifiers.

■ **"Stereo Eight" Control Unit.** Inputs: mic. and tape 3 mV; radio 100 mV; pickup 4 to 100 mV; tape 100 mV; aux. 50 mV to 2 volts. 6-position sel., bass, treble, filter, balance, function. H.D. $<0.1\%$. H and N — 50 dB. Rumble filter. Size $14\frac{1}{4} \times 4 \times 9\frac{3}{8}$ ins. Price £23 2s. To operate with two DPA10, or SP44 amplifiers.

■ **SP44 Stereo Amplifier.** 4 watts per channel. Dist. $<1\%$. Input for 3 watts, 65 mV. Response 40-25,000 c/s ± 1 dB. Feedback 20 dB. N.L. — 72 dB. Out. imp. 3 and 15 ohms. Output EL84's. Size $11\frac{1}{2} \times 6 \times 5\frac{1}{2}$ ins. Price £12 12s. To operate with "Stereo Two", or "Stereo Eight".

GA4 Combined Amplifier and Control Unit. 4 watts. Dist. $<1\%$. Input for spec. output 40 mV. Response 40-18,000 c/s ± 2 dB. Feedback 20 dB. N.L. — 65 dB. Out. imp.

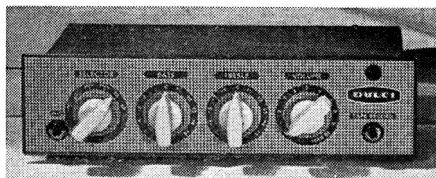

Dulci DPA 10 control unit

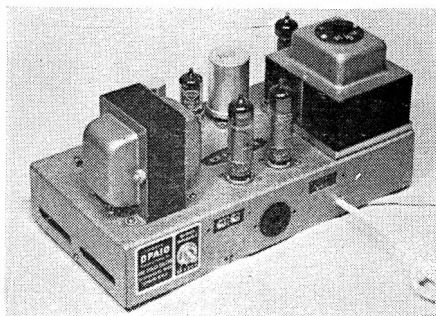

Dulci DPA 10 amplifier

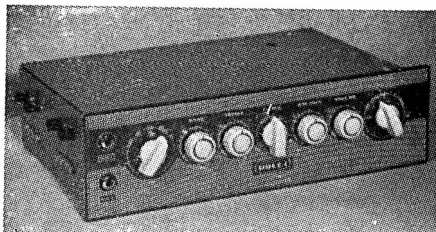

Dulci Stereo Eight control unit

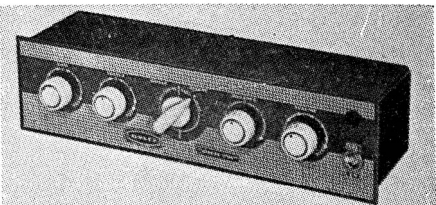

Dulci Stereo Two control unit

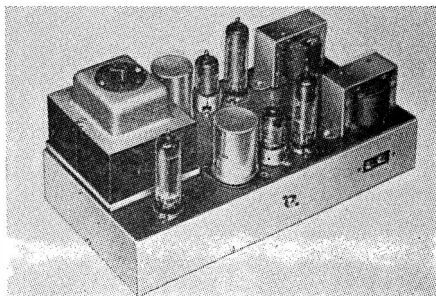

Dulci SP44 Stereo amplifier

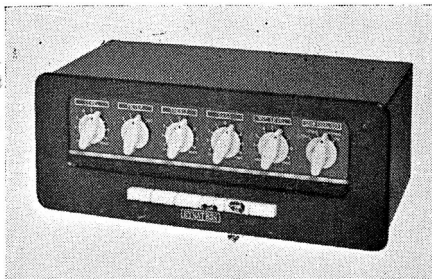

Dynatron TC20 control unit

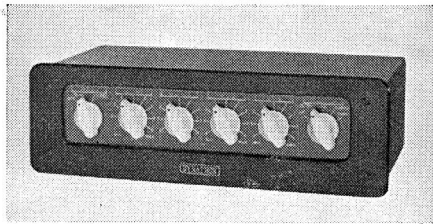

Dynatron TC16CS Stereo control unit

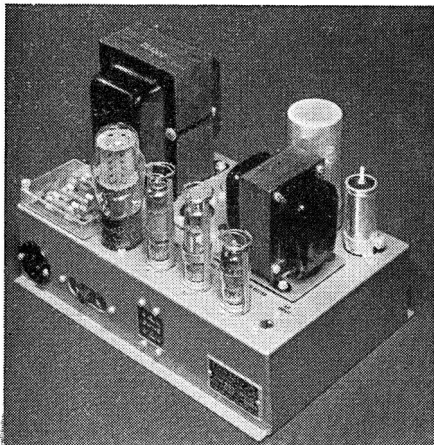

Dynatron LF11 amplifier



Dynatron LF20 amplifier

3 and 15 ohms. Output EL84. Size: Amplifier $14 \times 4\frac{1}{2} \times 5$ ins. Control Unit $6 \times 4 \times 4$ ins. Price £9 9s. complete.

★

Dynatron Radio Limited, Maidenhead Berks.
Tel.: Maidenhead 5151/5.

Dynatron TC15CS Control Unit. Inputs: pickup 6 mV; radio and aux. 100 mV; recording 85 mV. On/off, volume, filter, treble, bass, selector switch. H and N — 50 dB. Rumble filter. Size $3\frac{3}{8} \times 12\frac{1}{2} \times 3\frac{3}{4}$ ins. Price £17 10s. To operate with LF15CS amplifier.

Dynatron TC20CS Control Unit. Inputs: pickup 10 mV; radio, tape and aux. 350 mV; mic. 2 mV. Selector switch, equaliser, mic. level, bass, treble, filter, volume. Size $4\frac{1}{2} \times 12\frac{1}{2} \times 6\frac{3}{4}$ ins. Price £29. To operate with LF20 Amplifier.

■ **Dynatron TC16CS. Stereo Control Unit.** Inputs: pickup 5 or 200 mV; radio 100 mV; tape 6 mV. Off/Dual/Stereo, vol., balance, treble, bass, selector switch. H and N — 50 dB. Rumble filter. Size $12\frac{1}{2} \times 7\frac{3}{4} \times 3\frac{3}{4}$ ins. Price £27. To operate with LF15, LF16, or LF20 amplifiers.

Dynatron LF11 Amplifier. 10 watts max. Input for spec. output 2 volts. Out. imp. $7\frac{1}{2}$ and 15 ohms. Output EL84's. Ultra-linear. Size $7\frac{1}{2} \times 11\frac{1}{4} \times 7\frac{3}{4}$ ins. Price £21.

Dynatron LF16CS and LF15CS Amplifiers. 10 watts undistorted. Input for 10 watts 1 volt. Response 15-30,000 c/s ± 1 dB. Feedback 20 dB. N.L. — 80 dB. Out. imp. $3\frac{1}{2}$ and 15 ohms. Output EL84's. Ultra-linear. Size $7\frac{3}{8} \times 11\frac{3}{8} \times 5\frac{1}{2}$ ins. Price: LF15CS £20 5s., LF16CS £17 10s. (the latter has similar characteristics except that no aux. power outlets are provided). To operate with TC16CS Control Unit.

Dynatron LF20CS Amplifier. 20 watts undistorted. Input for 20 watts 0.8 volts. Response 30-30,000 c/s ± 1 dB. Feedback 30 dB. N.L. — 90 dB. Out. imp. 4, 8 and 16 ohms. Output EL34's. Ultra-linear. Size $8 \times 7\frac{3}{4} \times 12\frac{1}{2}$ ins. Price £29 15s. To operate with TC20 and TC16CS Control Units.

★

Expert Gramophones Ltd., 39-41 New Oxford Street, London, W.C.1. Tel.: Covent Garden 2156.

Expert Control Unit. Input P/U, tape, radio, all 20 mV. 3 pos. sel., vol., bass,

treble filter-variable slope. Tape input socket. H.D. <0.1%. H and N — 60 dB. Attenuation introduced below 20 c/s. P.a.t. from power amp. Size 12 × 3½ × 6 ins. To operate with Expert "Master" and "Standard" or any similar power amp. Price £18.

Expert "Standard" Amplifier. 12 watts nom., 14 watts max. Dist. 0.1%. Input for spec. output 200 mV. Response 20-25,000 c/s. ± 0.5 dB. Feedback 30 dB. N.L. — 80 dB at 8 watts. Out. imp. 15 ohms. Output EL84's. Ultra-linear. Size 12 × 9 × 6½ ins. To operate with Expert control unit or similar. Price £23.

Expert "Master" Amplifier. 20 watts nom., 26 watts max. Dist. 0.07%. Input for spec. output 200 mV. Response 20-30,000 c/s ± 0.5 dB. Feedback 30 dB. N.L. — 85 dB at 20 watts. Out. imp. 15 ohms. Output EL34's. Ultra-linear. Size 12 × 9 × 7½ ins. To operate with Expert control unit or any similar. Price £35.

★

General Electric Co. Ltd., Magnet House, Kingsway, W.C.2. Tel.: Temple Bar 8000. Cables: Polyphase, London.

G.E.C. BCS2417A Control Unit. Inputs: P/U 15 mV; radio 300 mV; tape 7½ mV. 6 pos. sel. (4 gram.), treble, bass, presence, vol. Provision made for easy add. of tape pre-amp stage allowing direct connection to tape playback head. H and N approx. — 66 dB at 12 watts. P.a.t. from BCS2418A power amp. To operate with BCS2418A power amp. and only sold in conjunction with it.

G.E.C. BCS2418A Amplifier. 12 watts nom. Dist. <0.5% at 12 watts. Input for spec. output 120 mV. Response 15-20,000 c/s ± 1 dB. Feedback 22 dB overall. Out. imp. 15 ohms (or 1, 2 or 3 3-5 ohms speakers). Output N709's. Weight 7½ lb. Price, complete with BCS2417A control unit £29 8s.

★

Goodsell Ltd., 40 Gardner Street, Brighton. Tel.: Brighton 26735.

Golden PFA Control Unit. Inputs: pickup 5-7 mV; mic. 5 mV; radio 80 mV. 4 pos. sel., treble, bass, vol. Separate "roll-off" and "turnover" facilities covering all known equalising characteristics. Switched filter 5, 7, 9, 13 Kc/s and "out." Spec. dependent on amp. used. Size 11 × 9 × 3½ ins. To operate with all Goodsell amplifiers. Price £20.

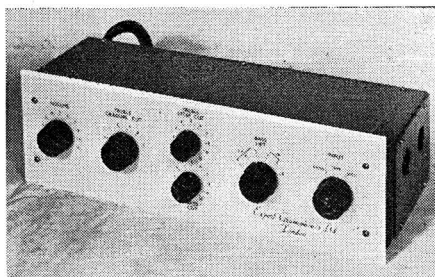

Expert control unit

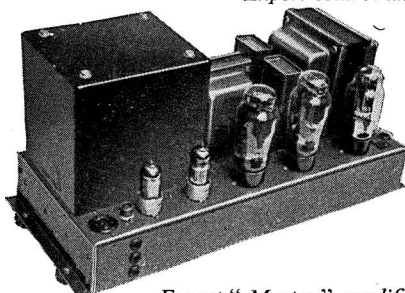

Expert "Master" amplifier

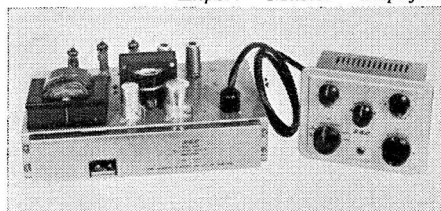

G.E.C. control unit and amplifier

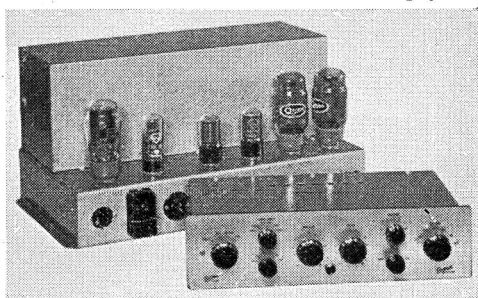

Goodsell PFA control unit and GW50 amplifier

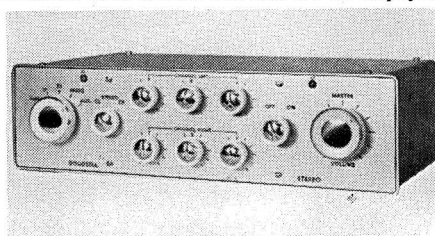

Goodsell Stereo II control unit

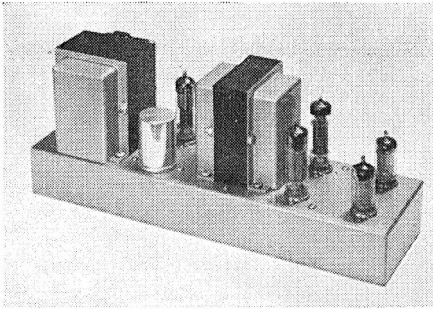

Goodsell MA10 amplifier

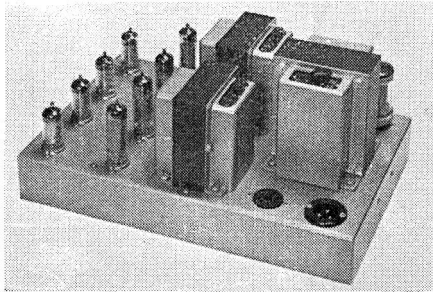

Goodsell MA20 Stereo amplifier

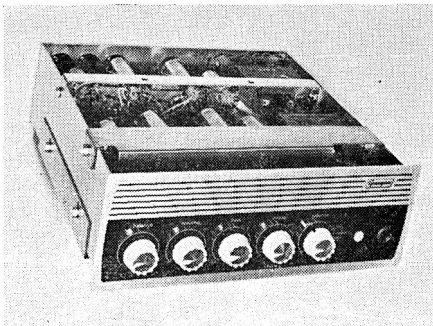

Gramplan 590 combined stereo amplifier

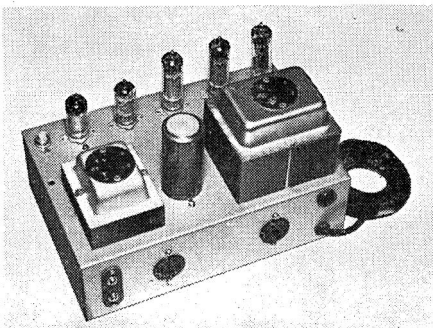

Gramplan 10-15 amplifier

■ **Stereo I Control Unit.** Inputs: pickup 7 mV stereo; radio 150 mV. Selector switch, vol., bass, treble and on/off. H.D. 0.1%. Size 7 × 6 × 4 ins. Price £16 15s.

■ **Stereo II Control Unit.** Inputs: pickup 7 mV stereo; radio 150 mV; tape 3 mV. Selector switch, vol., bass, treble, on/off. H.D. 0.1%. Size 13 × 7½ × 3¾ ins. Price £27 15s.

■ **MA8 Stereo Amplifier.** 3.5 watts per channel. Dist. 0.4%. Input for spec. output 1.5 volts. Response 30-30,000 c/s. Feedback 25 dB. N.L. — 70 dB. Out. imp. 3 and 15 ohms. Output EL84's Ultra-linear. Size 14 × 6 × 6 ins. Price £17. To operate with Stereo I or Stereo II Control Unit.

■ **MA10 Amplifier.** 10 watts. Dist. 0.1%. Input for spec. output 1.5 volts. Response 30-30,000 c/s ± 0.5 dB. Feedback 22 dB. N.L. — 70 dB. Out. imp. 3 or 15 ohms. Output EL84's. Ultra-linear. Size 14 × 5 × 6 ins. Price £18. To operate with Stereo I or Stereo II Control Units.

■ **GW25 Amplifier.** 20 watts. Dist. 0.1% input for spec. output 1.5v. Response 20-100,000 c.p.s. Feedback 20 dB. N.L. better than —75 dB. Out. imp. 3, 8 and 15 ohms. Output KT66's. Ultra-linear. Size 14 × 10 × 7 ins. Weight 35 lb. To operate with PFA control unit. Price £27 10s.

■ **Golden GW50 "Williamson" Amplifier Mk. II.** 40 watts. Dist. <0.1%. Input for spec. output 1.5v. Response 20-100,000 c/s. ± 2 dB. Feedback 20 dB. N.L. —75 dB. Out. imp. 3 or 8 or 15 ohms. Output KT88's. Size 17 × 11½ × 8¾ ins. Weight 54 lb. To operate with PFA control unit. Price from £40 10s.

■ **MA20 Stereo Amplifier.** 10 watts per channel. Details as MA10 above. Price £32 5s.

★

Gramplan Reproducers Ltd., Hanworth Trading Estate. Feltham, Middx. Tel.: Feltham 2657/8/9. Cables: Reamp, Feltham.

■ **Gramplan 582 Control Unit.** Inputs: pick-up 15 mV; radio 200 mV; tape 500 mV. Selector switch, bass, treble, vol. Size 10¼ × 4 × 5½ ins. Price £13. To operate with "Ten Fifteen" Amplifier.

■ **Gramplan 580 Control Unit.** Similar to 582, but for crystal pickups. Sensitivity 600 mV, radio 500 mV. Price £7 10s.

Grampian 10-15 Amplifier. 10 watts nom., 15 watts peak. Dist. 0.1% at 10 watts. Input for spec. output 50 mV. Response 30-20,000 c/s \pm 1 dB. Feedback 20 dB N.L. — 65 dB below full output. Out. imp. 4, 8, 15 ohms. Output EL84's. Ultra-linear. Size 11 \times 7 $\frac{1}{2}$ \times 6 $\frac{1}{2}$ ins. To operate with "580" and/or "582" control unit. Price £17.

■ **Grampian 590 series.** Stereo Control Unit with single channel amplifier and provision for adding a second amplifier for stereo. 7 watts per channel, 10 watts peak. Dist. 1% H. and N.—60 dB. Inputs: pickup 0.5 v at 1 Megohm, tuner and tape 1v at 0.5 Megohm. Sel. switch, balance, bass, treble. Out. imp. 4 and 15 ohms. Size: chassis 10 $\frac{7}{8}$ \times 3 $\frac{7}{8}$ \times 13 ins., wood surround 12 $\frac{1}{2}$ \times 5 $\frac{3}{8}$ \times 13 ins. Price 590/1 (control unit and one 584 amplifier) £20, 590/2 (control unit and two 584 amplifiers) £31, 584 amplifier £10, wood surround £2 2s.

★

Jason Motor & Electronic Co., 3/4 Gt. Chapel Street, London, W.1. Tel.: Gerrard 0273/4.

J10 Combined Control Unit and Power Amplifier. Inputs: mic. 1 mV; tape 0.5 mV; radio 0.5 mV; P/U 10v. and crystal P/U. 6 pos. sel., treble, bass, vol. P.a.t. 270v. at 10 mA, 6.3v at .3A. Output 10 watts nom., 15 watts max. Dist. 0.1%. Response 30-30,000 c/s. \pm 2 dB. N.L. better than 55 dB (mic. input). Out imp. 15 ohms (other imps. to order). Output EL84's. Ultra-linear. Size 15 \times 8 $\frac{1}{4}$ \times 4 $\frac{3}{8}$ ins. Price £22 10s.

■ **JSA2 Combined Stereo Amp. and Control Unit.** Inputs: pickup 70 mV; radio 200 mV; selector switch, bass, treble, vol., balance and phase. H.D. <1%. Rumble filter. 3 watts per channel. Response 25-15,000 c/s \pm 1 dB. Out. imp. 4 and 16 ohms. Size 11 \times 6 $\frac{5}{8}$ \times 8 $\frac{3}{8}$ ins. Price £23 15s.

■ **J2-10 Combined Stereo Amplifier and Control Unit.** Inputs: pickup 5 mV and 100 mV; radio, tape. Selector switch, filter, channel switch, balance, treble, bass, vol. H.D. <0.1%. H and N — 60 dB. Rumble filter. 10 watts per channel. Response 20-20,000 c/s \pm 0.5 dB. Out. imp. 4, 8 and 15 ohms. Ultra-linear. Size 15 \times 4 $\frac{3}{8}$ \times 11 $\frac{1}{2}$ ins. Price £37 10s.

★

H. J. Leak & Co. Ltd., 57-59 Brunel Road, East Acton, London, W.3. Tel.: Shepherds Bush 1173. Cables: Sinusoidal, Ealux, London.

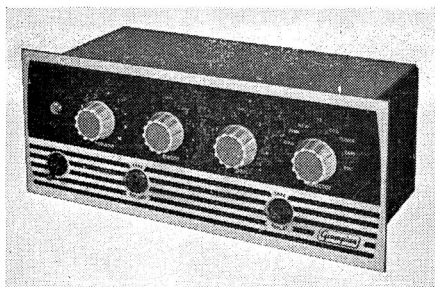

Grampian 582 control unit

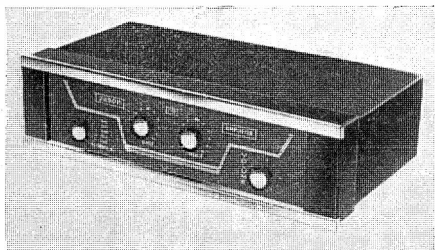

Jason J10 amplifier



Jason J2-10 complete stereo amplifier



Leak "Point One Stereo" control unit

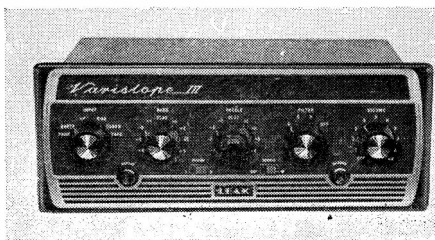

Leak Vari-slope III control unit

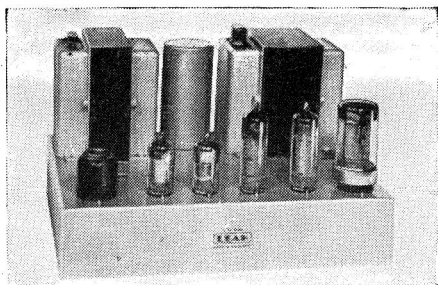

Leak TL/12 plus amplifier

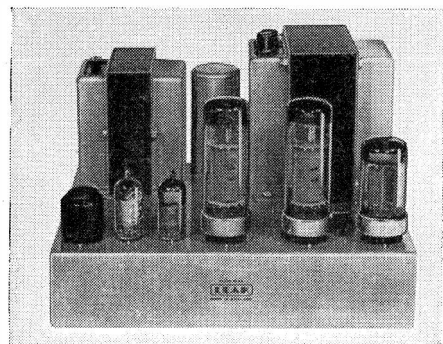

Leak TL/25 plus amplifier

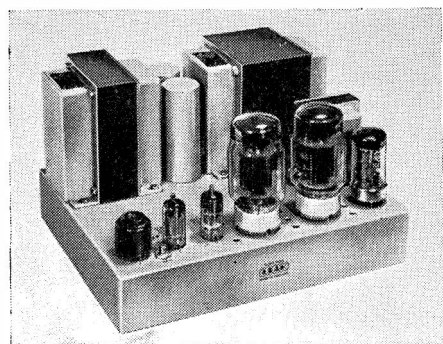

Leak TL/50 plus amplifier

“Point One Plus” Control Unit. Inputs: tape 50 mV or mic. 4 mV; tuner 50 mV; P/U 9.5 mV. 6 pos. sel., 4 record equal, treble, bass, vol., mains on/off. Switch filter 4, 6 and 9 Kc/s. Input level control for P/U, tuner. Tape record and replay sockets on front and rear. H.D. <0.01%. H and N — 66 dB. Size $11\frac{1}{2} \times 4\frac{7}{8} \times 5$ ins. To operate with TL/12 Plus, TL/25 Plus or TL/50 Plus amplifier. Price £12 12s.

“Vari-slope III” Control Unit. Inputs: tape 50 mV or mic. 4 mV; tuner 45 mV; pickup I 9 mV; pickup II 9 mV. 6 pos. sel. and change-over switch for pickup I/pickup II. Treble, bass, vol., mains on/off. Switched low pass filter 5, 7, and 9 Kc/s plus Vari-slope controls. Rumble filter cut in. Input level controls for tuner, pickup I, pickup II. Tape input sockets on front and back panels. H.D. <0.01%. H and N — 66 dB. P.a.t. on TL/12 plus power amp. Size $11\frac{1}{2} \times 4\frac{7}{8} \times 5$ ins. To operate with TL/12 Plus, TL/25 Plus, and TL/50 Plus amp. Price £15 15s.

“Point One” TL/12 Plus Amplifier. 12 watts. Dist. 0.1%. Input for spec. output 125 mV. Response 20-20,000 c/s. ± 0.25 dB. Feedback 26 dB. N.L. — 84 dB. Out. imp. 4, 8 and 16 ohms. Output EL84's. Ultra-linear. Size $10 \times 8 \times 6$ ins. To operate with Vari-slope III or Point One Plus control units. Price £18 18s.

“Point One” TL/25 Plus Amplifier. 25 watts. Dist. 0.1%. Input for spec. output 125 mV. Response 20-20,000 c/s. ± 0.25 dB. Feedback 26 dB. N.L. — 83 dB. Out. imp. 4, 8 and 16 ohms (other imps. to order). Output EL34's. Ultra-linear. Size $10 \times 8 \times 6\frac{3}{4}$ ins. To operate with Vari-slope III or Point One Plus control units. Price £25 4s.

“Point One” TL/50 Plus Amplifier. 50 watts. Dist. 0.1%. Input for spec. output 125 mV. Response 20-20,000 c/s. ± 0.25 dB. Feedback 26 dB. N.L. — 84 dB. Out. imp. 4, 8 and 16 ohms (other imps. to order). Output KT88's. Ultra-linear. Size $11\frac{1}{2} \times 9 \times 6\frac{3}{4}$ ins. To operate with Vari-slope III or Point One Plus control units. Price £33 12s.

■ **“Point One Stereo” Control Unit.** Twin channel inputs for P/U, 5 mV; tuner 50 mV; tape recorder 50 mV; tape head 4 mV; mic. 3.5 mV. Stereo/monaural and rumble switches, balance, treble, bass, vol., mains on/off. Input level controls. Tape sockets for recording. H.D. 0.01% on each channel H and N — 66 dB. To operate with “Point One” stereo 20 amplifier. Price £21.

■ **“Point One” Stereo 20 Amplifier.** 10 watts each channel. Dist. 0.1% on each channel. Input for spec. output 125 mV. Response 20-20,000 c/s. Feedback 24 dB. N.L. — 80 dB. Out. imp. 4, 8 and 16 ohms. Output EL84's. Ultra-linear. To operate with “Point One Stereo” control unit. Price £30 9s.

Lowther Manufacturing Co., Lowther House, St. Mark's Road, Bromley, Kent. Tel.: Ravensbourne 5225. Cables: Lowther, Bromley.

Lowther No. 2 Control Unit. Inputs: mic. 45 mV; P/U 45 mV; radio 100 mV. 4 pos. sel., treble, bass, vol., on/off. Mic./tape input socket. H.D. 0.1% on 1v R.M.S. H and N — 60 dB. Size $10\frac{1}{2} \times 3 \times 3\frac{1}{2}$ ins. To operate with LL10, LL26 and similar power amp. Price £10 10s.

Master Control Unit Mk. II. Inputs: mic., P/U and tape head 3 mV; radio, tape and aux. 100 mV. 6 pos. sel. 5 pos. record equal, treble, bass, vol., on/off. Low pass filter. 18 dB per octave. 35 down to 4 Kc/s. Socket for direct connection to tape playback head. H.D. <0.1%. H and N — 90 dB. Size $10\frac{1}{2} \times 5\frac{1}{2} \times 7\frac{1}{2}$ ins. To operate with LL10, LL26 and similar power amp. Price £24.

Lowther LL15 Amplifier. 15 watts. Dist. <0.1%. Input for spec. output .75v. Response 30-30,000 c/s. ± 1 dB. Feedback 22 dB. N.L. — 80 dB. Out. imp. 16 ohms with adjustment. Output EL34's. "Lowther Linear" (screen and anode feedback). P.a.t. Size $12 \times 9 \times 6\frac{1}{2}$ ins. To operate with MCUI, MCUII or control unit No. 2. Price £27 10s.

Lowther LL26 Amplifier. 16 watts. Dist. <0.1%. Input for spec. output 0.75v. Response 20-60,000 c/s ± 1 dB. Feedback 22 dB. N.L. — 90 dB. Out. imp. 16 ohms with adjustment. Output EL34's. "Lowther Linear." P.a.t. Size $12 \times 12 \times 8\frac{1}{2}$ ins. To operate with MCUII, MCUIII or control unit No. 2. Price £47.

Lowther-Murray Transistor or "Matching" Unit No. 1. Inputs: 5 mV. 5-50 ohms. On/off battery switch only. Imp. matching transistor pre-amp forward gain 100-1. Dist. not measurable at normal output. No hum/noise. Size approx. $3\frac{1}{2} \times 3\frac{1}{2} \times 6$ ins. To operate with any power amp. Price £9 9s.

Lowther-Murray Transistor or "Matching" Unit No. 2. Spec. as for No. 1 but gain 45-1. Size $3\frac{1}{2} \times 3\frac{1}{2} \times 3\frac{1}{2}$ ins. To operate with any power amp. Price £6 6s.

Lowther-Murray Transistor or "Matching" Unit No. 3. Inputs 5 mV, low imp. 5-50 ohms. Imp. matching transistor control unit with corrections for connection to normal "Radio" position. 4 pos. sel. off, R.I.A.A., ffr 78, mic. H.D. nil. H and N no hum,

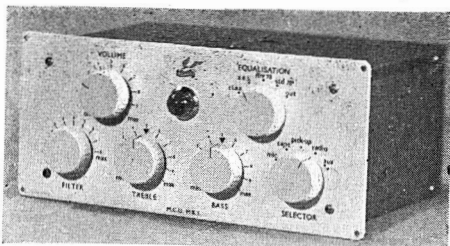

Lowther Master control unit Mk. II

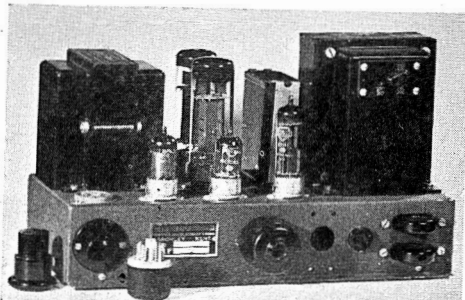

Lowther LL10 amplifier

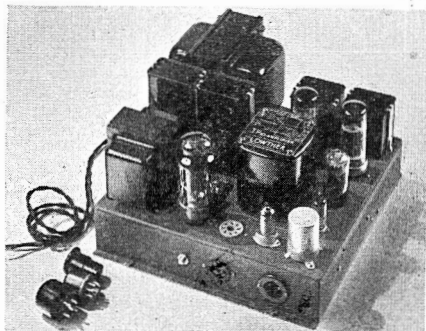

Lowther LL16 amplifier

less noise than record or radio background. Size approx. $3\frac{1}{2} \times 3\frac{1}{2} \times 6$ ins. To operate with any power amp. Price £12 12s.

■ **Lowther S.C.U. Stereo Control Unit.** Input as for Master Control Unit Mk. III. Tape input sockets. H.D. 0.1%. Dual low pass filters. Dual output balanced and balance controls between channels. Size as M.C.U. Mk. III. To operate with LL10S power amp. Price £40.

■ **Lowther LL10S Stereo Amplifier.** 12 watts output on each channel. Dist. 1%. Input for spec. output 0.75v. Response 20-40,000 c/s. ± 1 dB. N.L. — 80 dB. Out. imp. 7.5 or 15 ohms. Output EL34. "Lowther Linear." Size $11 \times 10 \times 8$ ins. To operate with SCU control unit. Price £40.



Pamphonic 1004 amplifier



Pamphonic 3000 stereo amplifier

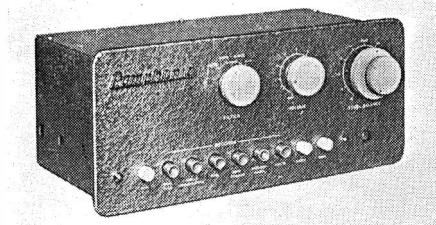

Pamphonic 1002B control unit

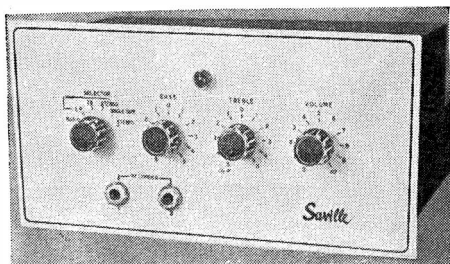

Saville stereo control unit

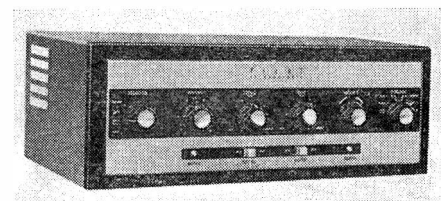

Pilot SHF15 combined stereo amplifier

■ **Lowther LL8S Stereo Amplifier.** 8 watts per channel. Dist. <0.1%. Input for spec. output 0.75 volts. Response 25-20,000 c/s \pm 1 dB. Feedback 22 dB. N.L. — 85 dB. Output EL84's. Ultra-linear. Size 11 \times 10 \times 8 ins. Price £35.

★

Pamphonic Reproducers Ltd., 17 Stratton Street, W.1. Tel: Grosvenor 1926.

1004 Self-contained Control Unit and Power Amp. Separate controls for bass, treble, volume and loudness (contour), and input selection. Plug-in gram, attenuation. 10 watts. Dist. at 1,000 c.p.s., 0.5% at 10 watts. Input voltage for spec. output mic. 2.5 mV; tape/radio 100 mV; P/U 12-15 mV. Response substantially flat 50-50,000 c/s. Feedback 20 dB. N.L. mic. — 53 dB, P/U — 54 dB. Out. imp. 3.5 and 15 ohms. Output 6BW6's. Ultra-linear. Price £26 5s.

1002B Control Unit. Inputs: mic. 2-3 mV, radio/tape 60 mV; P/U 6-8 mV. Push-button sel. 9 pos. (6 gram.). Cut off filter 4, 7, 12 Kc/s and "out." Terminals for tape input. H and N 60 dB below 0.5v. P.a.t. Size 10 $\frac{1}{4}$ \times 4 $\frac{1}{4}$ \times 7 $\frac{1}{4}$ ins. To operate with 2001 power amp. Price £25 4s.

2001A Control Unit. Inputs: 3-120 mV depending on input. 6 pos. sel. Pre-set level control for tape/radio. Cut-off filter at 4, 7, 12 Kc/s and "out." Loudness control. Tape input sockets. H and N 60 dB below 0.5v. P.a.t. To operate with 2001 power amp. Price £12 12s.

2001 Amplifier. 25 watts. Dist. at 1,000 c/s., 0.05% at 15 watts. Input for spec. output 0.5 v. Response substantially flat 2-100,000 c/s. Feedback 28 dB. N.L. 90 dB below full output. Out. imp. 3.75, 6.6, 10, and 15 ohms. Output KT66's. Ultra-linear. To operate with 2001A or 1002B control units. Price £29 8s.

■ **3000 Stereo Amplifier.** 7.5 watts per channel. Dist. 0.5%. Inputs: radio 1 volt; tape 0.5 volts; pickup crystal stereo. Response 50-15,000 c/s. Feedback 20 dB. N.L. — 57 dB. Out. imp. 15 ohms. each channel. Ultra-linear. Size 14 \times 9 $\frac{3}{4}$ \times 4 $\frac{1}{2}$ ins. Price £31 10s.

★

Period High Fidelity Ltd., 28 South Street, London, W.1. Tel.: Grosvenor 4686.

■ **Saville Stereo Control Unit.** Inputs: pick-up 5 and 50 mV; radio 50 mV; tape 3 mV. Selector switch, bass, treble, vol., balance. H.D. 0.1%. H and N — 60 dB. Size $11 \times 5 \times 6\frac{1}{2}$ ins. Price £15. To operate with Saville Twenty or Seven amplifiers.

■ **Saville Stereo Seven Amplifier.** 7 watts per channel, 15 watts max. Dist. 0.2%. Input for spec. output 3 volts. Response 35-20,000 c/s. Feedback 15 dB. N.L. 75 dB. Out. imp. 15 ohms, or to order. Output ECL82's. Ultra-linear. Size $11\frac{1}{8} \times 7\frac{3}{4} \times 6$ ins. Price £33. To operate with Saville Stereo Control Unit.

Saville Twenty Amplifier. 20 watts nominal, 30 watts peak. Dist. 0.1%. Input for spec. output 3 volts. Response 35-30,000 c/s. Feedback 20 dB. N.L. — 85 dB. Out. imp. 15 ohms, or to order. Output EL34's. Ultra-linear. Size $11\frac{1}{8} \times 7\frac{3}{4} \times 8$ ins. Price £27. To operate with Saville Stereo Control Unit.

★

Pilot Radio Limited, High Fidelity Division, Park Royal Road, London, N.W.10. Tel.: Elgar 7353. Cables: Piloset, London.

HFA11 Self-contained Control Unit and Power Amplifier. 5 inputs—magnetic P/U 3/5 mV; crystal P/U 160 mV; radio, aux., tape, 120 mV. 7 pos. sel. (4 record equal.). Switched scratch and rumble filters. Variable treble, bass, loudness and vol. Tape input and output sockets. 10 watts output. Dist. $\pm 0.1\%$ for 8 watts at 1 Kc. Response 20-20,000 c/s. ± 1 dB. Feedback 21 dB. N.L. 80 dB below full output. Out. imp. 3, 8 and 15 ohms. Output EL84's. Ultra-linear. Size $13\frac{3}{8} \times 8\frac{3}{8} \times 5$ ins. Price £25 4s.

HFC12 Control Unit. Inputs: P/U magnetic 3/5 mV and 20 mV; crystal 50 mV; radio 150 mV; tape 150 mV; aux. 3/5 mV. 7 pos. sel. (4 record equal.) treble, bass, vol. Filter 5, 7, 10 Kc/s. and flat, loudness with on/off, muting switch. Tape input and output sockets. Built-in high pass filter. H.D. (with main amp.) 0.1% for 8 watts at 1,000 c/s. H and N 80 dB below full output. Size $13\frac{3}{8} \times 5 \times 5\frac{1}{2}$ ins. Available only with HFA12 amplifier.

HFA12 Amplifier. 12 watts nom. Dist. 0.1% for 8 watts at 1 Kc. Input for spec. output 200 mV. Response 15-50,000 c/s. ± 1 dB. Feedback 22 dB. N.L. 80 dB below full output. Out. imp. 3, 8 and 15 ohms. Output EL84's. Ultra-linear. Size $11\frac{1}{2} \times 6\frac{1}{4} \times 6\frac{3}{4}$ ins. To operate with HFC12 control unit. Price complete system £29 8s.



Pilot HFA11 combined amplifier

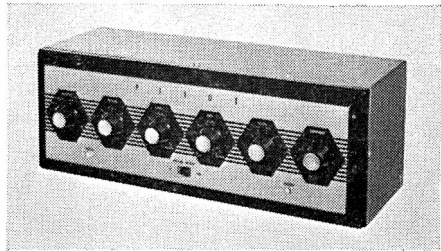

Pilot HFC12 control unit

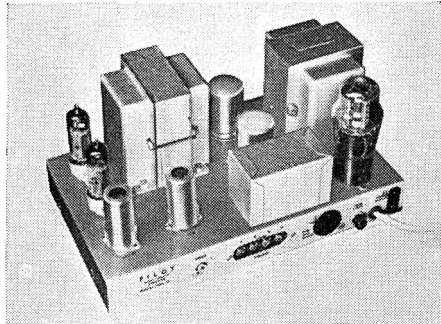

Pilot HFA12 amplifier

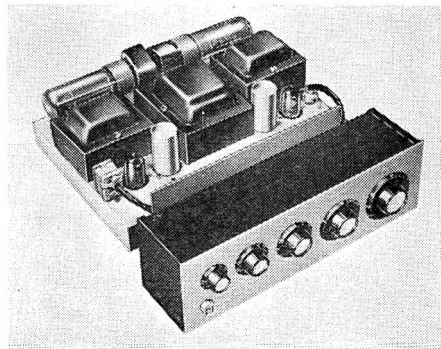

Pye Stereo Mozart combined amplifier

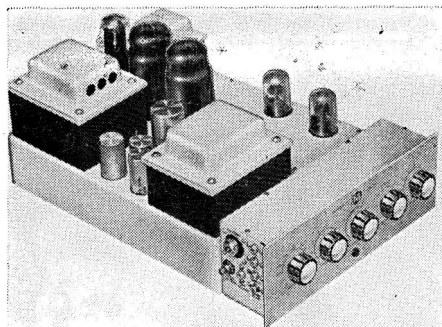

Pye Proctor control unit and Provost amplifier

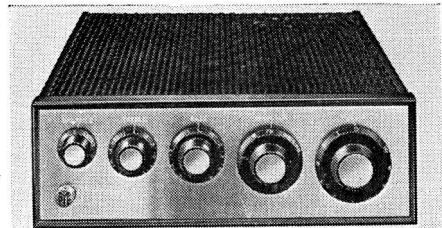

Pye Mozart HF10M

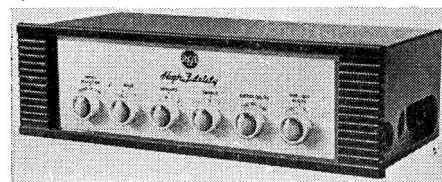

RCA Orthophonic control unit



RCA Orthophonic amplifier

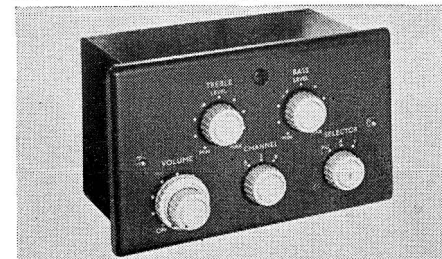

Rogers RD Cadet Stereo control unit

■ **SHF15 Combined Stereo Amplifier and Control Unit.** Inputs: Pickup 3/5 and 16 mV; radio and tape 100 mV; Aux. 5 mV. Selector switch, volume, treble, bass, balance, function switch, filter, Dist. 0.1%. H and N — 60 dB. 7.5 watts per channel. Response 20-20,000 c/s \pm 1 dB. Feedback 20 dB. Out. imp. 3, 8, and 15 ohms. Output ECL82's. Size $13\frac{1}{4} \times 8\frac{1}{2} \times 5$ ins. Price £33 12s.

★

Pye Limited, 65 Fairview Road, London, S.W.16. Tel.: Pollards 9441/2. Cables: Faramarine Souphone, London.

HF10 Mozart Self-contained Control Unit and Power Amplifier. Inputs: tape 100 mV; radio 100 mV; P/U 15, 10 and 10 mV on each of the 3 curves at 1,000 c/s. special compensation for all makes of P/Us. 5 pos. sel., treble, bass, vol., mains on/off, filter at 4, 7, 12 Kc/s. and out. Tape replay socket. H.D. 0.3% at 1,000 c/s. and 9 watts. H and N main amp. — 70 dB; tape, radio — 60 dB; P/U — 55dB. Output 10 watts nom. Response 3-70,000 c/s. \pm 3 dB. Feedback 3 main loops over output stage — 5, 8 and 14 dB. Out. imp. 4, 8 and 15 ohms. Output 1 EL34. Integrated single ended ultra-linear. Size $10\frac{1}{2} \times 3\frac{1}{2} \times 5\frac{1}{2}$ ins. Price £23 2s. Also available in metal case for shelf mounting, HF10M £24 13s. 6d. and mounted in cabinet with provision for motor HFPI £33 12s.

Proctor HF25A Control Unit. HF25AW in cabinet. Inputs: tape 120 mV; radio 120 mV; mic. 3 mV; P/U max. sens. 8 mV dependent on P/U compensator used. 7 pos. sel. (4 gram.), treble, bass, vol. and on/off. Switched filter 4, 7 and 12 Kc/s and "out." Tape input socket. H and N — 60 dB on 0.5v. Size $10\frac{3}{4} \times 4 \times 4$ ins. To operate with HF25 power amp. Price HF25A £12 12s.; HF25AW £17 6s. 6d.

Provost HF25 Amplifier. 25 watts nom., 30 watts max. Dist. 0.3% at 25 watts, 3.0% at 30 watts. Input for spec. output 0.5v. Response 2-160 Kc/s \pm 3 dB. Feedback 26 dB. Variable poss. feedback by means of manual control. N.L. — 90 dB at 25 watts. Out. imp. 3.75, 6.6, 15 and 60 ohms. Output KT66's. Ultra-linear. Size $13\frac{1}{2} \times 10 \times 7$ ins. To operate with HF25A control unit. Price £29 8s.

■ **Mozart Stereo Amplifier and Control Unit. HFS20.** Inputs: Pickup 7 mV; radio and

tape 100 mV. Vol, bass, treble, balance, on/off, selector switch. H and N — 55 dB. 9 watts per channel nominal, 10 watts max. Dist. 0.3%. Response 10-50,000 c/s \pm 2 dB. Feedback 27 dB. Out. imp. 4, 8, and 15 ohms. Output EL34. Size $3\frac{1}{2} \times 10 \times 7\frac{1}{2}$ ins. Price Chassis £35, in metal case £36 15s.

★

RCA Great Britain Ltd., Lincoln Way, Sunbury-on-Thames, Middx. Tel.: Sunbury-on-Thames 3101. Cables: Telex and Tex 28608.

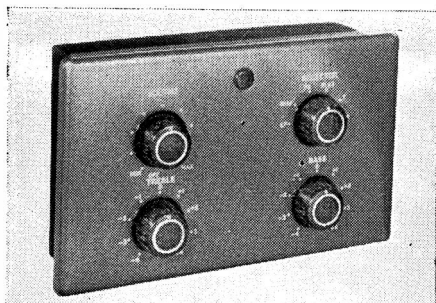

Rogers RD Minor control unit

RCA New Orthophonic Control Unit LMI.32215A. Inputs: mic. 6.5 mV; radio/tape 200 mV; radio/tape 50 mV; P/U (crystal) 300 mV; P/U (magnetic) 11.5-16 mV. 6 pos. sel. (4 gram.), treble, bass, vol. Switched filter 5, 7 and 10 Kc/s. Variable slope control inc. on/off switch, variable to 35 dB per octave. Tape playback. H.D. <0.1% at 700 c/s. at 10 watts. H and N 85 dB below rated output. Rumble filter built in on power amp. LMI.32216A. P.a.t. 395v at 45 mA, 6.3v at 2.5 A. Size $12\frac{1}{2} \times 6\frac{1}{2} \times 3\frac{1}{2}$ ins. To operate with RCA power amp LMI.32261A. Price £16 10s.

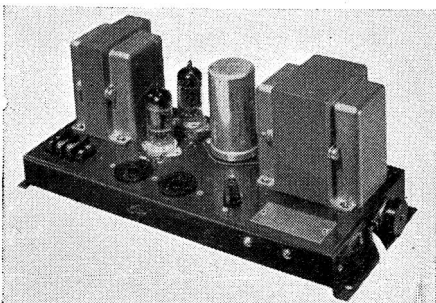

Rogers RD Minor amplifier

RCA New Orthophonic Amplifier LMI.32216A. 20 watts nom., 40 watts max. Dist. at 700 c/s. <0.1% at 10 watts. Input for spec. output 1.2v. Response 20-20,000 c/s. \pm 0.2 dB. Feedback — 40 dB total. N.L. 85 dB below rated output. Out. imp. 4, 7 and 15 ohms. Output KT66's. Improved ultra-linear. Size $16\frac{1}{2} \times 8 \times 7\frac{1}{2}$ ins. To operate with LMI.32215A control unit. Price £24 10s.

★

Rogers Developments (Electronics) Ltd., 4-14 Barmeston Road, Catford, S.E.6. Tel.: Hither Green 7424/4340. Cables: Rodevco, London, S.E.6.

RD Cadet Control Unit. Prov. spec. inputs: tape 200 mV; radio 200 mV; P/U1 comp. 60 mV; P/U1 flat 18 mV; P/U2 comp. 360 mV; P/U2 flat 220 mV. 6 pos. sel., treble, bass, vol. on/off. Tape record and replay sockets. Size $8\frac{1}{2} \times 5\frac{1}{2} \times 2\frac{1}{2}$ ins. To operate with RD Cadet amplifier. Price £7.

RD Junior Mk. II Control Unit. Inputs: tape 20 mV; radio 50 mV; mic. 5 mV; P/U1 5-9 mV; P/U2 40-75 mV. 7 pos. sel. (4 record equal.), treble, bass, vol. on/off.



Rogers RD Junior control unit



Rogers RD Senior control unit

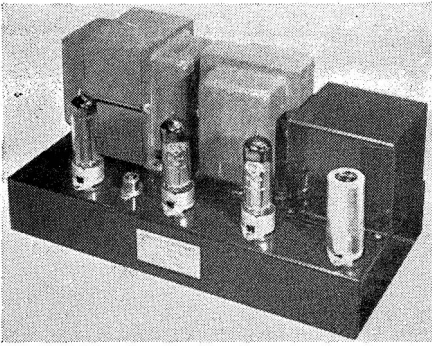

Rogers RD Junior amplifier

Switched filter 4, 5, 7, 9 and 20 Kc/s. Tape record and replay sockets. Size $8\frac{1}{2} \times 5\frac{1}{2} \times 4\frac{7}{8}$ ins. To operate with RD Junior Amplifier. Price £11.

RD Cadet Amplifier. Prov. spec. 5 watts nom., 6 watts max. Intermod. Dist. 3.5% at 4 watts (100 c/s. and 6,000 c/s. mixed 4 to 1). Input voltage for spec. output 600 mV. Response 30-20,000 c/s. ± 0.25 dB. Feedback 14 dB ± 1 dB, 30-20,000 c/s. N.L. — 72 dB below 5 watts. P.a.t. 230v at 35 mA, 6.3v at 2 A. Out. imp. 15 or 3.75 ohms. Output ECL83's. Ultra-linear. Size $11 \times 4\frac{1}{2} \times 4\frac{1}{4}$ ins. To operate with RD Cadet control unit. Price £10 10s.



Rogers RD Junior Stereo control unit

RD Senior Mk. II Amplifier. 20 watts nom., 36 watts peak. Dist. 0.1% at 15 watts. Input for spec. output 1.4v for 20 watts. Response 25-20,000 c/s. ± 0.25 dB. Feedback 25 dB (2 loop). N.L. — 95 dB below 20 watt. Out. imp. 3.75, 7.5 and 15 ohms. P.a.t. 425v at 40 mA, 6.3v at 2 A. Output EL34's. Ultra-linear. Size $13 \times 8 \times 8$ ins. To operate with RD Senior Mk. IV control unit. Price £28.

RD Senior Control Unit Mk. IV. Inputs: radio/mic. 2 mV; radio 100 mV; tape 50 mV; P/U 8-10 mV. 7 pos. sel. (4 record equal.), treble, bass vol. and on/off. Switched filter 5, 7 and 9 Kc/s. Filter slope control 5-30 dB per octave. Tape record 1.5v and replay socket (flat or C.C.I.R. at $7\frac{1}{2}$ i/s.). Rumble filter fixed 12-15 dB fall off below 25 c/s. Size $10\frac{1}{2} \times 5 \times 2\frac{5}{8}$ ins. To operate with RD Senior Mk. II power amp. Price £13 10s.

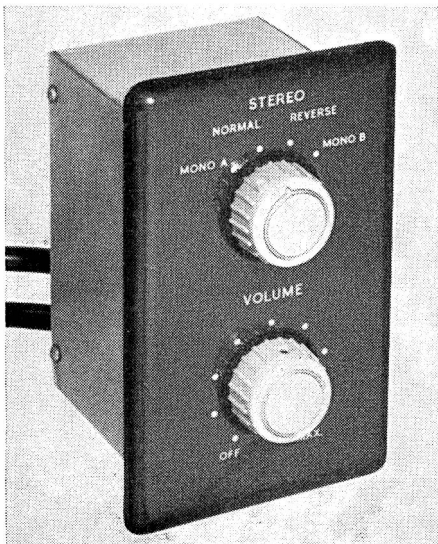

Rogers RD stereo adaptor

RD Junior Amplifier. 10-12 watts nom., 14 watts max. Dist. at 1,000 c/s. 0.12% at 10 watts. Input for spec. output 600 mV RMS for 10 watts. Response 20-30,000 c/s. ± 0.25 dB. Feedback 20 dB. N.L. — 85 dB below 10 watts. P.a.t. 285v at 40 mA, 6.3v at 2.5 A. Out. imp. 2-3, 6-8, 12-16 ohms. Output EL84's. Ultra-linear. Size $11 \times 6 \times 5\frac{1}{4}$ ins. For Junior II control unit. Price £17.

■ **RD Cadet Stereo Control Unit.** Inputs: pickup 50 mV; radio and tape 100 mV. Bass, treble, vol., function switch, selector switch. Size $8\frac{1}{2} \times 5\frac{1}{2} \times 4\frac{7}{8}$ ins. Price £12. To operate with two RD Cadet, Junior, or Senior II amplifiers.

■ **RD Junior Stereo Control Unit.** Inputs: pickup 5 and 50 mV; radio 40 mV; tape 4 mV, mic. 6 mV. Selector switch, vol., bass and treble, filter, function switch. Size $8\frac{1}{2} \times 5\frac{1}{2}$

× 5½ ins. Price £19 10s. To operate with two RD Cadet, Junior, or Senior II amplifiers.

■ **RD Stereo Adaptor.** Designed to couple together two single channel Control Units for stereo operation. Provides ganged vol. control, and function switch. Price £2 10s.

■ **HG88.** Combined stereo amplifier and control unit, 8 watts per channel. Dist 0.5%. H. & N. -55-60 dB. Response 30-60 dB. Response 30-20,000 c/s ± 1 dB. Inputs: pickup 4, 10, 60 and 150 mV at 60K and 1 Megohm, radio and aux. 40 mV, tape 4 mV, mic. 3 mV. Sel. switch, bass, treble, balance, filter, and precision volume control. Out. imp. 3.75 or 15 ohms. Size 15½ × 10½ × 7 ins. Price £37 10s. (case £2 10s.).

LG88. Simplified version of HG88. Price £31 10s.

★

Scientific & Technical Developments Ltd., Melbourne Works, Melbourne Road, Wallington, Surrey. Tel.: Wallington 9252. Cables: Electronic, Wallington.

“**Orthotone**” **STD/448 Control Unit.** Inputs: pickup 10 mV; radio and tape 40 mV; mic. 5 mV. 6-position sel., bass, treble, filter, slope, vol. H.D. <0.1% H and N - 65 dB. Size 11¾ × 4⅝ × 7 ins. Price £19 19s. To operate with STD/373 amplifier. Self powered. Cathode follower output.

“**Orthotone**” **STD/399 Stereo Control Unit.** Inputs: pickup 3 mV; radio and tape 35 mV. 4-position sel., bass, treble, balance, volume, function switch. H.D. <0.1%. H and N - 60 dB. Rumble filter. Size 11¾ × 4⅝ × 7 ins. Price £19 19s. To operate with STD/381, and STD/373 amplifiers.

■ “**Orthotone**” **STD/444 Combined Stereo Amplifier and Control Unit.** Inputs: pickup, radio, and aux. 300 mV. 6-position sel., bass, treble, balance, vol. 2.5 watts per channel. Dist. 0.3%. Out. imp. 15 ohms. H and N - 60 dB. Size 11¾ × 4⅝ × 10 ins. Price £27 6s.

■ “**Orthotone**” **STD/381 Stereo Amplifier.** 10 watts per channel. Dist. 0.1%. Input for spec. output 200 mV. Response 30-20,000 c/s. ± 1 dB. Feedback 26 dB. N.L. - 80 dB. Out. imp. 4, 8, and 16 ohms. Output EL84's. Ultra-linear. Size 8½ × 13 × 6 ins. Price £29 8s. To operate with STD/399 Control Unit.

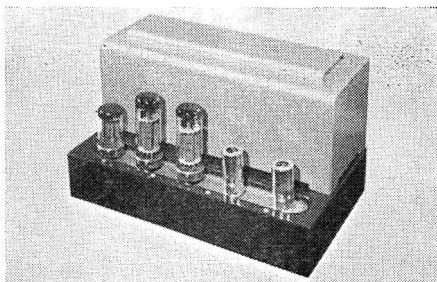

Rogers RD Senior amplifier

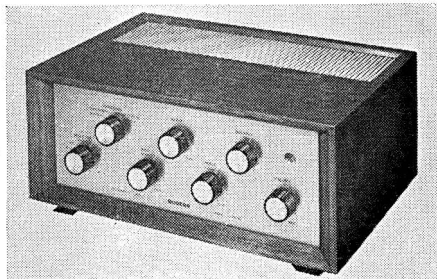

Rogers HG 88

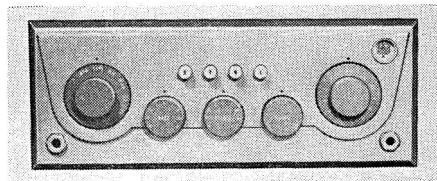

STD Orthotone STD/448 control unit

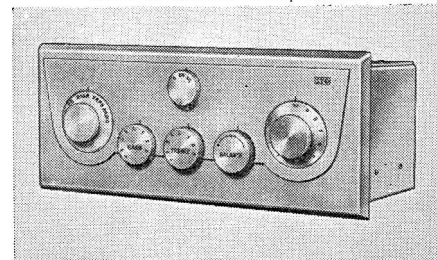

STD Orthotone STD/399 stereo control unit

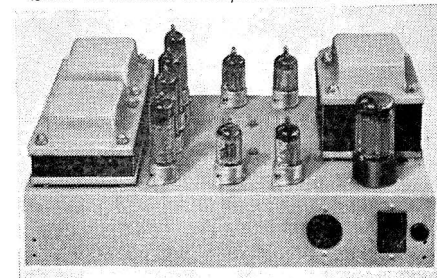

STD Orthotone STD/381 stereo amplifier

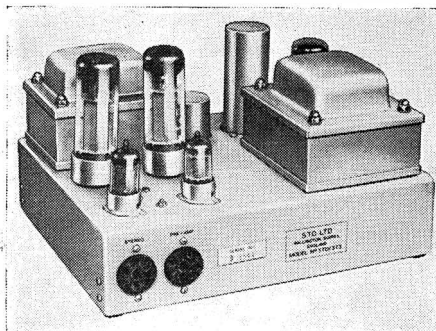

STD Orthotone STD/373 amplifier

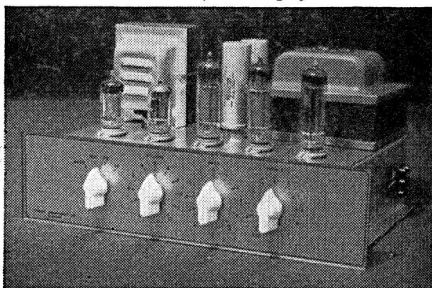

Shirley Jupiter amplifier

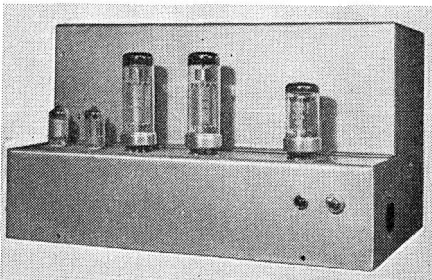

Shirley Mullard 20-watt amplifier

"Orthotone" STD/373 Amplifier. 25 watts. Dist. 0.1%. Input for spec. output 160 mV. Response 20-20,000 c/s. ± 1 dB. Feedback 28 dB. N.L. — 76 dB. Out. imp. 4, 8, and 16 ohms. Output EL34's. Ultra-linear. Size 11 \times 9 \times 6 $\frac{1}{2}$ ins. Price £25 4s. To operate with STD/448 and STD/399 Control Units.

★

Shirley Laboratories Ltd., 3 Prospect Place, Worthing, Sussex. Tel.: Worthing 30536.

Jupiter 3B/1-15E Self-contained Control Unit and Power Amplifier. Inputs: radio, tape, P/U 78 and L.P. Output 15 watts nom. 25 watts max. Input approx. 10 mV for 15 watts. Treble, bass, vol. Response 45-35,000 c/s. ± 1 dB. N.L. — 80 dB.

Dist. 0.2% at 10 watts and 1,000 c/s. Out. imp. 15 ohms or as requested. Output EL84. P.a.t. 250v at 35 mA, 6.3v at 2 A. Size 10 \times 7 \times 6 $\frac{1}{2}$ ins. Price £23 2s.

Jupiter 3B/1-30E Self-contained Control Unit and Power Amplifier. Spec. as for 3B/1-15E except output 30 watts nom., 45 watts max. Response 28-35,000 c/s. ± 1 dB. Output EL34's. Price £33 12s.

Mullard 20-watt Control Unit. Inputs: radio/tape 100 mV; i.p. 4 mV/50 mV; 78 5 mV/60 mV; mic. 1.5 mV. 4 pos. sel., treble, bass, vol., low-pass filter at 5, 10 and 20 Kc/s. High-pass filter at 35 c/s. Sold only with Mullard 20-watt power amp.

Mullard 20-watt Amplifier. 20 watts nom. 35 watts max. Dist. 0.05% at 20 watts. Input for spec. output 220 mV. Response 30-20,000 c/s. ± 0.5 dB. N.L. — 89 dB. Out. imp. as required. Output EL34's. Ultra-linear. Price complete with control unit £54 12s.

■ **PA 4/86 Stereo Control Unit.** Inputs: pickup 3 and 50 mV; radio 100 mV; tape 3 mV and 0.5 volts, selector switch, bass, treble, volume, balance. H.D. 0.1%. H and N — 58 dB. Price £21 1s. To operate with SF/10 amplifier, or two SB/7-30.

SB/7-30s Amplifier. 20 watts nominal, 35 watts max. Dist. 0.1%. Input for spec. output 2.5 volts. Response 34-40,000 c/s. ± 0.3 dB. N.L. — 80 dB. Out. imp. 15 ohms. Output EL34. Ultra-linear. Size 11 \times 7 $\frac{1}{2}$ \times 8 ins. Price £29 8s. 28 watt version £32 11s. To operate with PA 4/86 Control Unit.

Jupiter SB1-15F Combined Amplifier and Control Unit. Input 2 mV minimum. Dist. 0.2%. 14 watts nominal, 23 watts max. Response 45-35,000 c/s. ± 1 dB. N.L. — 80 dB. Out. imp. 15 ohms or to order. Size 10 \times 7 \times 6 $\frac{1}{2}$ ins. Price £23 2s.

■ **SF/10 Combined Stereo Amplifier and Control Unit.** 12 watts per channel, 18 watts peak. Dist. 0.1%. Control Unit similar details to PA 4/86 above. Price complete £46 4s.

★

H. L. Smith & Co. Ltd., 287/289 Edgware Road, London, W.2. Tel.: Paddington 5891/7595.

Cooper-Smith Mk. II Control Unit. Inputs: radio 100 mV; P/U 3 mV; mic. 1.5 mV;

tape 100 mV. 6 pos. sel. (3 record equal.), treble, bass, vol. on/off. Switch filter 6, 8 and 10 Kc/s. Co-axial tape replay switch. H.D. 0.1% or less at 1,000 c/s. H and N — 80 dB. Rumble filter 12 dB cut at 30 c/s. Size $10 \times 3\frac{1}{2} \times 6\frac{1}{2}$ ins. To operate with B.P.1 power amp. Price in kit form £8 3s. Assembled and tested £11 3s.

Cooper-Smith B.P.I. 10 watts nom., 12 watts max. Dist. 0.15% or better at 10 watts. Input for spec. output approx. 1.9 V. Response 20-30,000 c/s. ± 1 dB. Feedback 18 dB. N.L. 90 dB below max. output. Out. imp. 3.75 and 15 ohms. Output 6BQ5's or EL84's. Ultra-linear. Size $12 \times 7 \times 7\frac{1}{2}$ ins. To operate with Cooper-Smith Mk. II control unit. Price in kit form £12 12s. Assembled and tested £14 17s.

"Prodigy" Combined Amplifier and Control Unit. Inputs: pickup 8 mV; radio and tape 100 mV, 6 watts, 9 watts max. Dist. 0.2%. Response 30-25,000 c/s. ± 1 dB. Feedback 15 dB. N.L. — 70 dB. Out. imp. $3\frac{1}{2}$, $7\frac{1}{2}$, and 15 ohms. Output ECL82's. Ultra-linear. Size $10\frac{1}{2} \times 7 \times 5\frac{1}{2}$ ins. Price Kit £13 7s. 6d. Assembled and tested £16 16s.

★

Sound Sales Ltd., Works and Acoustic Laboratories, West Street, Farnham, Surrey. Tel.: Farnham 6461-2-3. Cables: Sounsense.

A-Z Wide Range Control Unit Mk. III. Inputs: pickup 5 and 50 mV; radio 50 mV; mic. 1 mV. 8-position sel., bass, treble, presence. H.D. 0.06% H and N — 80 dB. Rumble filter. P.a.t. 250v @ 40 mA. Size $11\frac{1}{4} \times 4\frac{3}{8} \times 5\frac{1}{2}$ ins. To operate with Mk. III Amplifier, and not sold separately.

A-Z Mk. III Amplifier. 10 watts nominal, 13.5 watts max. Dist. 0.06%. Input for 10 watts — 18 dB ref. 1 volt. Response 12-27,000 c/s. ± 1 dB. Feedback 22 dB. N.L. — 80 dB. Out. imp. 3, 6, 15, and 30 ohms. Output EL84's. Ultra-linear. Size $10\frac{1}{4} \times 7\frac{1}{8} \times 6$ ins. To operate with Mk. III Control Unit. Price complete £25. Amplifier only £17.

A-Z Twin Twenty Stereo Control Unit. Inputs: pickup 5 mV and 100 mV; radio 3 @ 30 mV; tape 14 and 125 mV; mic. 1.4 mV. 11-position sel., balance, bass, treble, presence. Size $11\frac{1}{4} \times 4\frac{3}{8} \times 9\frac{1}{2}$ ins. Price £20.

A-Z Wide Range Stereo Control Unit. Details as for Twin Twenty above but with additional Transistor stage to increase

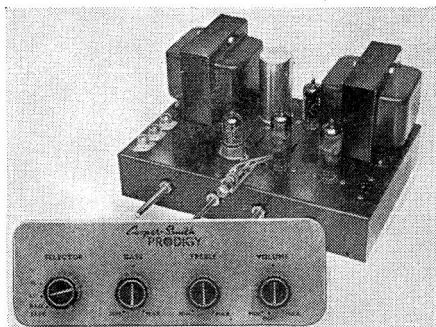

Cooper-Smith Prodigy control unit and amplifier

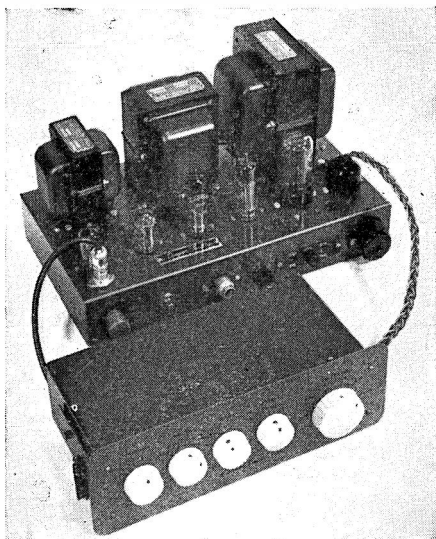

Cooper-Smith control unit and amplifier

sensitivity to 0.80 mV for pickup, and 80 mV for P/U and tape head. Size $11\frac{1}{4} \times 4\frac{3}{8} \times 9\frac{1}{2}$ ins. Price £26.

A-Z Twin Twenty Stereo Amplifier. 10 watts per channel, 13.5 watts peak. Dist. 0.065%. Input for spec. output 0.1 volts per channel. Response 20-20,000 c/s. flat. N.L. — 80 dB. Out. imp. 3, 8, and 15 ohms. Output EL84's. Ultra-linear. Size $12\frac{1}{2} \times 10 \times 6\frac{1}{2}$ ins. Price £30. To operate with Twin Twenty Control Unit, or A-Z Wide Range Control Unit, or Stereo Converter.

A-Z Stereo Converter. Inputs: pickup 45 and 70 mV; radio 3 inputs @ 45 mV; tape 45 and 55 mV. 8-position sel., bass, treble, presence, volume, balance. Rumble filter. Size $11\frac{1}{4} \times 4\frac{3}{8} \times 5\frac{1}{2}$ ins. Price £17 10s. Designed to operate with any existing am-

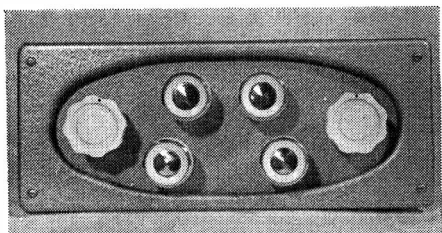

Sound Sales Tri-Channel control unit

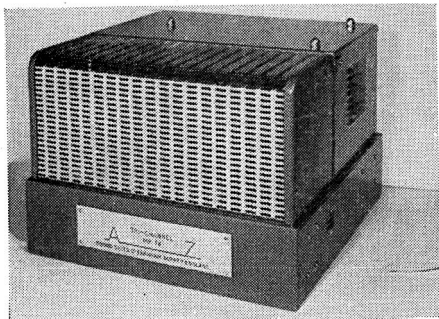

Sound Sales Tri-Channel amplifier

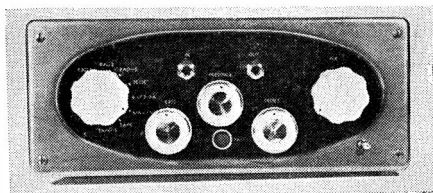

Sound Sales Mk. 3 control unit

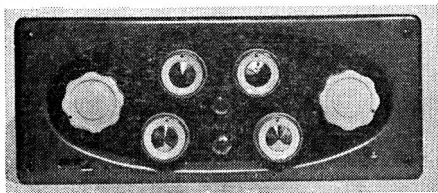

Sound Sales A-Z Twin Twenty control unit

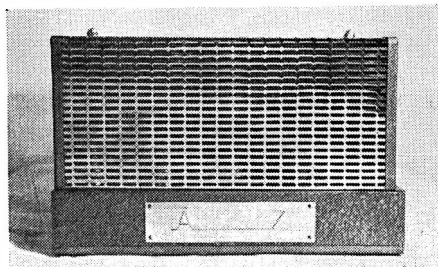

Sound Sales A-Z Senior Mk. II amplifier

plifiers for conversion to stereo. Supplied less power pack, with 1 Mk. III Amplifier at £34.

A-Z Senior Control Unit with transistor input. Inputs: mic. 1 mV; radio 100 mV; tape 250 mV; tape 1 mV (from head) C.C.I.R. and N.A.R.T.B.; P/U variable 1-100 mV. 11 pos. sel. (5 record equal.), treble, bass, vol., presence control, switched filter, 2 pos. and cut combined with variable slope. Tape recording in all positions, also jacks for portable recorders. Specially designed for use with M.C. pickups or tape-head without necessity of transformers. Size $11 \times 4\frac{1}{2} \times 6$ ins. Sold only with A-Z Senior power amp.

Tri-Channel Control Unit with transistor input. Inputs: mic. 1 mV; radio 100 mV; tape (from recorder) 250 mV; tape (from head, C.C.I.R. and N.A.R.T.B.) 1 mV; P/U variable 1-100 mV. 11 pos. sel. (5 record equal.). Presence, middle channel response; treble, top channel response; bass, bass channel response. Infinitely variable electronic crossover system, controlling 3 separate amplifying channels to appropriate speakers via master vol. control. Switched filter. Tape recording in all positions also jacks for portable recorders. H and N better than — 80 dB. Dist. not measurable at normal output. Size $11\frac{1}{2} \times 4\frac{3}{8} \times 6$ ins. Sold only with Tri-channel amp. and speaker enclosure.

Tri-Channel Amplifier Mk. V. Bass 20-30 watts, mid channel 8-12 watts, treble channel 4 watts. Total undistorted output approx. 45 watts. Dist. 0.05%. Response infinitely variable on 3 channels. N.L. better than — 80 dB. Output LN309, EL84, EL34 Ultra-linear. Size $18 \times 10 \times 8\frac{3}{8}$ ins. Price complete with control unit and tri-channel speaker enclosure £125.

■ **Tri-channel Stereo Control Unit and Tri-channel Stereo Amplifier.** Designed for stereophonic or monaural reproduction using 2 Tri-channel main amps. and 2 labyrinth speakers. Stereo to monaural changeover switch, giving parallel or stereo connection. Price complete with control unit, 2 amps and 2 speaker systems £300.

A-Z Senior Mk. II Amplifier. 20 watts nom. 30 watts max. Dist. 0.05% at 20 watts. Response flat 10-30,000 c/s. Feedback 25 dB. N.L. — 80 dB at 20 watts. Out. imp. 3, 6, 15 or 30 ohms. Output EL34's. Ultra-linear. Size $14\frac{1}{4} \times 8\frac{1}{2} \times 8\frac{1}{2}$ ins. Price complete with A-Z Senior control unit £42.

Specto Ltd., Vale Road, Windsor, Berks.
Tel.: Windsor 1241/2. Cables; Specto,
Windsor.

Spectone 5-15 "Eton" Combined Control Unit and Amplifier. 3 pos. sel. Plug-in equalisers for crystal P/U's. 10 watts nom. 15 watts max. Dist. better than 0.3% at 10 watts. Input for spec. output 500 mV. Response 20-20,000 c/s. ± 0.5 dB. Feedback — 26 dB. N.L. — 73 dB on 10 watts. Out. imp. 15 ohms. Output EL84's. Size $14 \times 7 \times 8\frac{1}{2}$ ins. Price £18 18s.

Eton Pre-amp. Available for low output P/U's, etc. Input 40 mV for 500 mV output. H.D. better than 0.1%. H and N — 73 dB. Size $6\frac{1}{4} \times 3\frac{1}{2} \times 1\frac{7}{8}$ ins. Price £4 4s.

Spectone 5-15 "Windsor" Control Unit. Inputs: radio 100 mV; P/U 50 mV; aux. 10 mV. 4 pos. sel., treble, bass, vol. and on/off. H.D. better than 0.15% on all inputs for 40 mV output. H and N — 54 dB on mic., — 73 dB others. Size $10 \times 5 \times 3$ ins. Sold only with the Windsor power amp.

Spectone 5-15 "Windsor" Amplifier. 10 watts nom., 15 watts max. Dist. better than 0.3% at 10 watts. Input for spec. output 40 mV. Response 20-20,000 c/s. ± 0.5 dB. Feedback — 26 dB. N.L. — 73 dB on 10 watts. Out. imp. 15 ohms. Output EL84's. Size $14 \times 7 \times 8\frac{1}{2}$ ins. Price with control unit £24 17s. 6d.

★

A. R. Sugden & Co. (Engineers) Ltd., Market Street, Brighouse, Yorks. Tel.: Brighouse 2142. Cables: Connoisseur, Brighouse.

Connoisseur HQ20 Control Unit. Inputs: radio, tape and P/U 10 mV. 5 pos. record char. switch, treble, bass, vol. Steep slope filter, 5, 7 and 9 Kc/s. Tape input sockets. H.D. at 1,000 c/s. better than 0.1% at 20 watts. H and N with amp 75 dB down on 20 watts. 30 c/s. rumble filter. Size $11\frac{1}{2} \times 4 \times 4\frac{3}{4}$ ins. To operate with HQ20 power amp. Price £16.

Connoisseur HQ20 Amplifier. 20 watts nom., 30 watts max. Dist. better than 0.1% at 20 watts. Input for spec. output 300 mV. Response 20-50,000 c/s. ± 0.5 dB. N.L. — 85 dB at 20 watts. Out imp. 15 ohms. Output EL34's. Ultra-linear. Size $12 \times 8\frac{1}{4} \times 7\frac{1}{2}$ ins. Sold only with control unit. Price £31 10s.

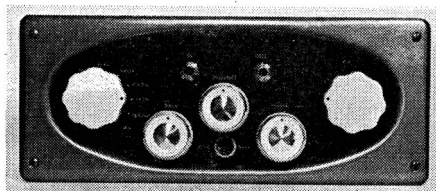

Sound Sales A-Z stereo converter

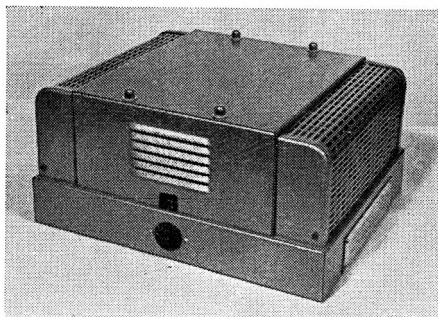

Sound Sales Twin Twenty stereo amplifier

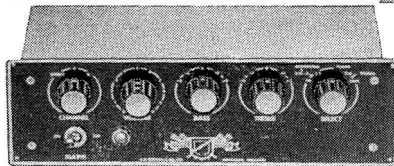
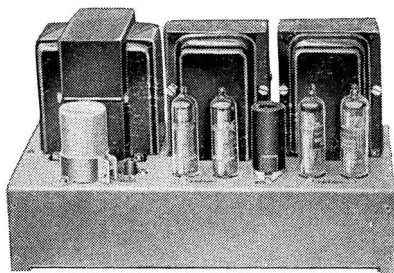

Connoisseur stereo control unit and amplifier

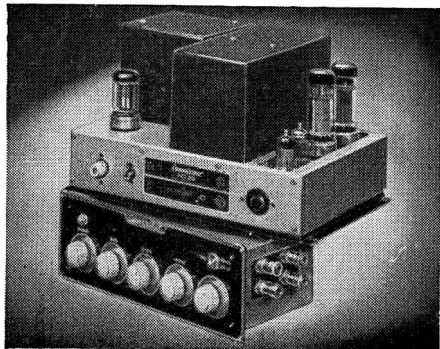

Connoisseur HQ20 control unit and amplifier

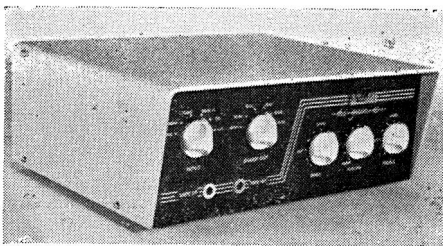

Tannoy Hi-Gain 15 combined amplifier

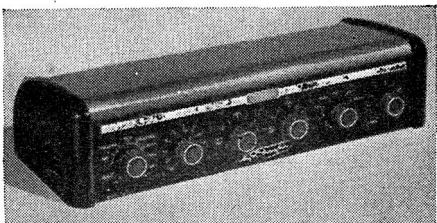

Tannoy Autograph "F" control unit

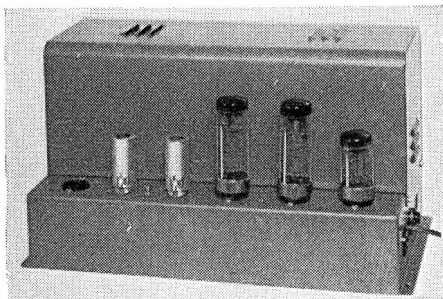

Tannoy 20-watt amplifier

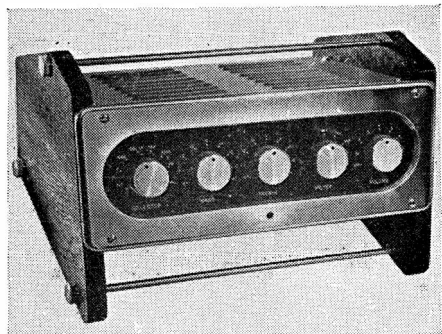

Thermionic TP100CU control unit

■ **Connoisseur Stereo S66 Control Unit.** Inputs: pickup 6 mV; radio and tape 100 mV, 5-position sel., treble switch, vol., channel switch. H.D. < 0.1%. H and N — 60 dB. Rumble filter. Size $10\frac{3}{4} \times 3\frac{1}{4} \times 5\frac{1}{2}$ ins. Price £16 10s. To operate with Stereo S66 Amplifier, or two HQ20.

■ **Connoisseur Stereo S66 Amplifier.** 6 watts per channel, 7.5 watts max. Dist. < 0.3%. Input for spec. output 250 mV. Response 30-20,000 c/s ± 1 dB. Feedback 20 dB. N.L. — 70 dB. Out. imp. 3.5 or 15 ohms. Output ECL82's. Ultra-linear. Size $11\frac{1}{2} \times 5\frac{1}{2} \times 6\frac{3}{4}$ ins. Price £24 10s. To operate with Stereo S66 Control Unit.

★

Tannoy Products Ltd., West Norwood, London, S.E.27. Tel.: Gipsy Hill 1131. Cables: Tannoy, London.

Autograph Type F Control Unit. Inputs: mic. 5 mV; radio 100 mV; tape 100 mV; P/U 5 mV at 1 Kc. 11 pos. sel. (9 record equal.), treble, bass, vol., filter at 4, 5, 7 and 9 Kc/s; slope 6-40 dB per octave. Tape record and replay. H.D. < 0.07%. H and N better than — 70 dB. Rumble filter fixed at 30 dB per octave below 20 c/s. Size $16 \times 7\frac{1}{2} \times 4$ ins. To operate with Tannoy 20-watt power amp. Available for free standing. Price £37 10s. or panel mounting £31.

Tannoy 20-watt Amplifier. 20 watt nom. Dist. 0.07% at 1,000 c/s., 0.1% at 20-20,000 c/s. Input for spec. output 0.4v. Response 20-70,000 c/s. ± 0.1 dB. Feedback damping factor 40. N.L. (unweighted) 90 dB below max. output. Out. imp. 4, 8 or 16 ohms. Output EL39's or KT66, or 6L6G's or 5881's. Ultra-linear. P.a.t. 450v at 50 mA, 6.3v at 1.5 A. Size $15 \times 8\frac{1}{2} \times 8\frac{1}{2}$ ins. To operate with Autograph type F control unit. Price £33 10s.

“**Hi-Gain 15**” **Combined Amplifier and Control Unit.** Inputs: pickup 5 and 10 mV; radio 100 mV; tape 4 and 100mV; mic. 4 mV. Selector switch, vol., bass, treble, filter. 10 watts nominal, 15 watts peak. Intermod. 1%. Response 30-20,000 c/s. Out. imp. 4, 8, and 16 ohms. H and N — 40 dB. Size $12\frac{1}{4} \times 4\frac{3}{4} \times 9\frac{1}{2}$ ins. Price free standing £42, and for panel-mounting £39 18s.

★

Thermionic Products Ltd., Hythe, Southampton. Tel.: Hythe 3265/7. Cables: Technico.

TP100CU Control Unit. Inputs: mic. 50 mV; radio 50 mV; P/U (crystal) 100 mV; P/U (magnetic) average 20 mV. 8 pos. sel. (4 gram.), treble, bass, vol. and optional on/off. Switched filter, 5, 7 Kc/s and “out.” H.D. < 0.1%. H and N — 60 dB for 0.5

output. Rumble filter. P.a.t. 300v at 50 mA; 6.3v at 2.5 A. Size $10\frac{1}{2} \times 7\frac{1}{2} \times 5\frac{1}{2}$ ins. To operate with TP100 power amp. Price £17 14s. (£1 15s. extra for special wooden "Book-End" stand.)

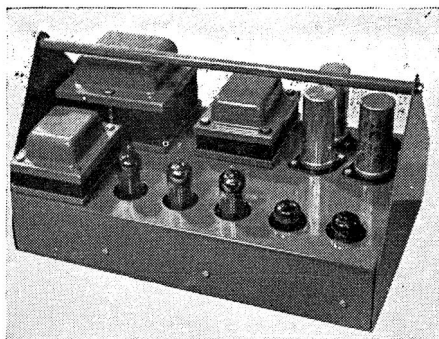

Thermionic TP100 amplifier

TP100 Amplifier. 10 watts. Dist. at 1,000 c/s., $<0.1\%$ at 10 watts. Input for spec. output 0.5v. Response 25-30,000 c/s. ± 0.25 dB. Feedback — 20 dB. N.L. — 95 dB at 10 watts. Out. imp. 3.75 and 15 ohms. Output N709's. Size $11 \times 7 \times 5\frac{1}{2}$ ins. To operate with TP100CU control unit. Price £19 16s. (£1 extra for special carrying tray.).

★

Trix Electrical Company Limited, 1-5 Maple Place, London, W.1. Tel.: Museum 5817. Cables: Trixadio, Wesdo, London.

Trixon T800 Combined Control Unit and Power Amp. Inputs: LP 4 mV; 78 12 mV; radio/tape 100 mV. 3 pos. sel., treble, bass, loudness control (additional bass and treble boost given at low vol. levels). 4 pos. pickup equalisation plug fitted. Tape input socket. H.D. at 1,000 c/s. $<0.5\%$ at 6 watts. H and N better than — 60 dB. Rumble filter 18 dB octave below 30 c/s. P.a.t. 270 v at 20 mA, 6.3v at 1 A. 8 watts nom., 12 watts max. Response 30-15,000 c/s. ± 1.5 dB at 6 watts. Triple-loop feedback. Out. imp. 3, 8 and 15 ohms. Output EL84's. Size $12\frac{1}{2} \times 9\frac{1}{2} \times 5$ ins. Price £33 12s.



Verdik High Gain control unit

★

Verdik Sales Ltd., 139/143 Sydenham Road, Sydenham, London, S.E.26. Tel: Sydenham 3118/9.

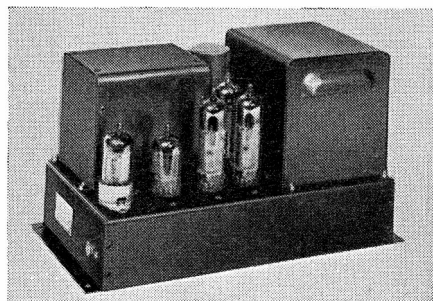

Verdik Quality Ten amplifier

Verdik High Gain Control Unit. Inputs: radio 50 mV; tape 1 mV at 1,000 c/s.; P/U 2.5 mV at 1,000 c/s.; mic. 5 mV. 8 pos. sel. (5 records equal.), treble, bass, vol. on/off. Tape replay sockets. H.D. better than 0.1% H and N. Mic. — 60 dB, other inputs — 20 dB at 10 watts. Rumble filter. Size $10\frac{1}{2} \times 2\frac{3}{4} \times 4\frac{1}{2}$ ins. To operate with Verdik Quality Ten power amp. Price £9 9s.

Verdik Quality Ten Amplifier. 10 watts nom., 12 watts max. Dist. 0.1%. Input for spec. output 50 mV. Response 20-15,000 c/s. ± 1 dB. Feedback 20 dB. N.L. — 75 dB referred to 10 watts. Out. imp. 4, 8 and 16 ohms. Output EL84's. Ultra-linear. P.a.t. 250v at 35 mA, 6.3v at 2 A. Size $10 \times 5\frac{1}{2} \times 5\frac{1}{2}$ ins. To operate with Verdik Standard or High Gain control units. Price £14 14s.

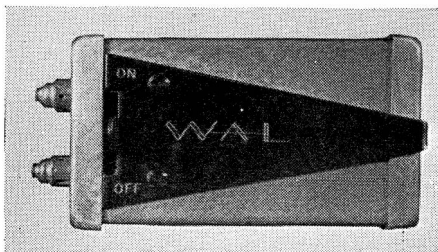

WAL Gain

Wellington Acoustic Laboratories Ltd., All-ways, Kings Lane, Wrecclesham, Farnham, Surrey. Tel: Farnham 6461/4961.

■ **WAL Twin Twenty Stereo Control Unit.** Inputs: stereo pickup 5 mV and 100 mV;

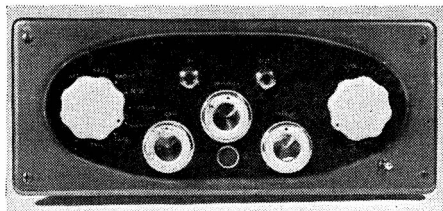

WAL Converter tone control unit

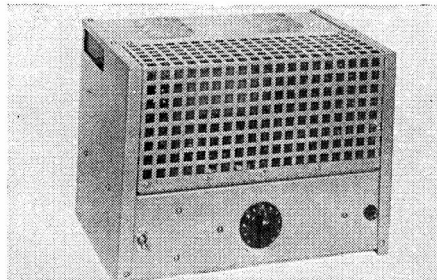

Westrex 2192 amplifier

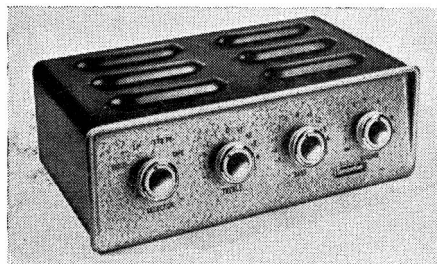

Stentorian WB combined amplifier

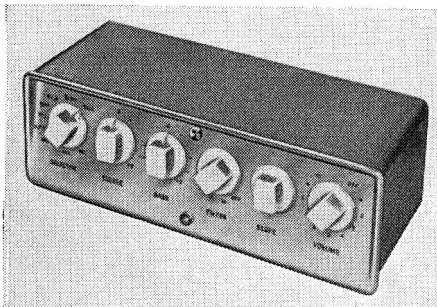

Stentorian WB12 Major control unit

tape 14 and 125 mV; radio 3 @ 30 mV; mic. 1.4 mV. 11-position sel., balance, bass, treble, presence. Size $11\frac{1}{2} \times 4\frac{5}{8} \times 9\frac{1}{2}$ ins. Price £20. To operate with WAL Twin 10 Amplifier.

■ **Wide Range Stereo Control Unit.** Details as Twin Twenty above, but with additional Transistor stage increasing sensitivity to .80

mV for pickups, and 80 mV for P/U and tape head. Price £26.

■ **WAL Stereo Convertor/Control Unit.** Inputs: pickup 45 mV; radio 3 @ 45 mV; tape 45 and 55 mV. 8-position sel., bass, treble, presence, volume, balance. Size $11\frac{1}{4} \times 4\frac{5}{8} \times 5\frac{1}{2}$ ins. Price £17.

■ **WAL Stereo Ten Twin Amplifier.** 5 watts per channel. Dist. 0.1%. Input for spec. output 150 mV. Response 20-20,000 c/s flat. Feedback 15 dB. N.L. — 80 dB. Out. imp. 3 or 15 ohms. Output LN309. Ultra-linear. Size $10\frac{3}{4} \times 7\frac{1}{8} \times 6$ ins. Price £25. To operate with WAL Wide Range, WAL Convertor, or WAL Twin Twenty Control Units.

■ **WAL Gain.** Impedance matching transistor pre-amp, battery operated (3,000-hour life). Noise and distortion too low to measure, gain better than 100. Suitable for use with low output P/U or for direct connection to tape head. For use with any amplifier. Size $3\frac{5}{8} \times 2\frac{1}{8} \times 2\frac{1}{8}$ ins. Price £5.

★

Westrex Company Ltd., Liberty House, Regent Street, London, W.1. Tel.: Regent 1001. Cables: Westelcol, Norphone, London.

■ **2192 Amplifier.** 30 watts. Dist. 0.1%. Size $12 \times 9 \times 8\frac{1}{2}$ ins. Designed primarily for use with the Westrex 2241 Loudspeaker Assembly. Price £49.

■ **In preparation.** 20 watt stereo amplifier using sum and difference principles in a single channel circuit.

★

Whiteley Electrical Radio Co. Ltd., Victoria Street, Mansfield, Notts. Tel: Mansfield 1762/3/4/5. Cables: Whitebon, Mansfield.

■ **Stentorian WB12 Standard Control Unit.** Inputs 50 mV. 6 pos. sel. (3 gram.), treble, bass, vol. Tape/Radio input socket. H and N — 70 dB at 10 watts. P.a.t. 250v at 50 mA, 6.3v at 1.5 A. Size $9 \times 3\frac{1}{8} \times 3\frac{3}{8}$ ins. To operate with WB12 power amp. Price £9.

■ **Stentorian WB12 Major Control Unit.** Inputs: mic. 2.5 mV; P/U 10 mV; radio 100 mV; tape 100 mV; aux. 50 mV. 9 pos. sel. (4 record equal), treble, bass, vol. on/off, switched filter at 5.7 and 11 Kc/s.; filter slope. Tape input socket. H.D. 0.3%. H and N — 70 dB. Size $11\frac{5}{8} \times 4\frac{1}{2} \times 4$ ins. To operate with WB12 power amp. Price £19 10s.

WB12 Amplifier. 12 watts nom., 15 watts max. Dist. at 1,000 c/s. 0.12%. Response 20-20,000 c/s. \pm 0.15 dB. Feedback 25 dB. N.L. — 80 dB at 10 watts. Out. imp. 3 and 15 ohms. Output EL84's. Ultra-linear. Size $10\frac{3}{8} \times 8 \times 7$ ins. To operate with WB Major or Standard control units. Price £18 10s.

■ **WB Stereo Control Unit.** Inputs: pickup 2.5 and 100 mV; radio and tape 50 mV. Selector switch, bass, treble. H.D. 0.2%. H and N — 70 dB. Size $11\frac{3}{4} \times 4 \times 7\frac{1}{2}$ ins. Price £22 15s. To operate with WB8S, or two WB12.

■ **WB8S Stereo Amplifier.** 6-8 watts per channel. Dist. 0.2%. Input for spec. output 650 mV. Response 40-15,000 c/s \pm 0.5 dB. Feedback 20 dB. N.L. — 60 dB. Out. imp. 3 and 15 ohms. Output ECL82's. Ultra-linear. Size $10\frac{7}{8} \times 6\frac{1}{4} \times 10\frac{1}{2}$ ins. Price £23 15s. To operate with WB Stereo Control Unit.

WB8 Combined Amplifier and Control Unit. 6 watts, 8 watts max. Dist. 0.3%. Inputs: pickup 100 mV; radio and tape 50 mV. Response 30-20,000 c/s \pm 2.5 dB. Feedback 15 dB. N.L. — 60 dB. Out. imp. 3 and 15 ohms. Output ECL82. Ultra-linear. Size $11\frac{1}{2} \times 7\frac{1}{2} \times 4$ ins. Price £19 19s.

★

W & N Electronics Ltd., 80/82 Uxbridge Road London, W.13. Tel.: Ealing 4774.

Audiomaster Mk. II and Mk. III Control Units. Inputs: tape, 1.8 mV; P/U 8 mV; mic. 1 mV; tuner 50-200 mV; aux. from 2 mV (flat). 10 pos. sel. (4 record equal.), 3 pos. mic. sel., treble, bass, vol. on/off, loudness switched filter at 5, 7, 9, 12 Kc/s., filter slope, amp/record/monitor switch. Direct replay from tape head, C.C.I.R. or N.A.R.T.B. H.D. better than 0.1% for 200 mV out. H and N 250 mV out, tape and mic. — 45 dB, P/U and aux. — 56 dB, tuner — 65 dB. Roll off frequency comm. 50 c/s. Size $13\frac{3}{4} \times 5\frac{3}{8} \times 8$ ins. To operate with W and N/520 power amp. Price £28 15s.

W & N/520 Amplifier. 20-25 watts nom. 60 watts inst. peak. Dist. 0.05% at 20 watts. Input for spec. output, 220 mV. Response 15-30,000 c/s. \pm 0.5 dB. Feedback 20-26 dB. N.L. better than 85 dB. Out. imp. 4, 8 or 16 ohms. Output EL84. Ultra-linear. Size $12 \times 6\frac{3}{4} \times 8\frac{3}{4}$ ins. To operate with Audiomaster Control Units Mk. I, II or III. Price £30 15s.

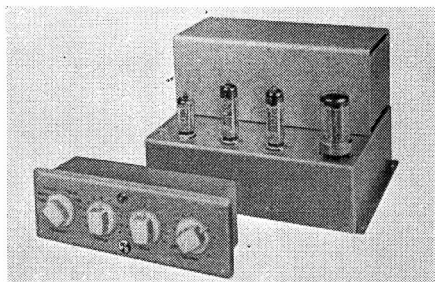

Stentorian WB12 control unit and amplifier



W & N Audiomaster control unit

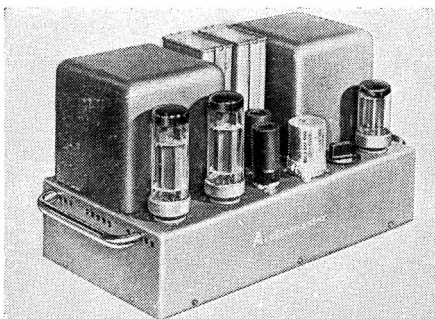

W & N Audiomaster amplifier

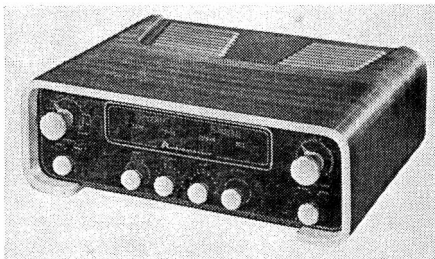

W & N combined stereo amplifier

■ **Audiomaster 8 + 8 Stereo Unit.** 8 watts per channel. Dist. 0.5% at 6 watts, response 40-15,000 \pm 2 dB. Feedback 15 dB. Output ECL82 Ultra linear. Inputs: tape, 3 mV, P.U. 4 mV; mic. 4 mV; tuner, from 20 mV; 8 pos. sel., treble, bass, vol. on/off, balance, phase, function switches. Size $14 \times 5 \times 13$ ins. Price £33 15s. 0d.

RADIO TUNERS

— An Introduction —

THERE are no available statistics about the uses to which people put their hi-fi equipment. There was a time, not so long ago, when it would have been a safe bet to say that discs were the most used programme source. However, as a result of the greatly increased coverage provided by the BBC, the *vhf* FM service must already be a close second—even if it does not already lead—basing the comparison upon listening hours.

Assuming, then, that FM transmissions tie with disc programmes for hi-fi reproduction, this introduction to the following directory section of tuners should start with an important question: “*What sort of an aerial do you use?*”

“Only the Best” is the Rule

With discs, nothing but the best is good enough when it comes to the pickup. The quality of reproduction is primarily governed by the quality of the signal; and the finest amplifying and speaker chain in the world is wasted, if fed with an inferior signal. Similarly, with a radio input, if the signal is not beyond reproach the remainder of the apparatus can do nothing to rectify its shortcomings. In areas of good signal strength it is all too easy to sling up an indoor “T-shaped” aerial. A piece of flex, with its ends untwisted to form the “T”, with arms of approximately the right length, makes a very adequate indoor aerial. The owner of his first FM tuner usually fits this temporary antenna—just to get things working quickly; and he is often so pleased by the resultant quality—which is nearly always so many streets ahead of the Medium Wave quality that he has become acclimated to—that the “temporary hook-up” becomes permanent.

If one lives in a secluded part of the country—free from the interference of ignition noise

from cars, etc.—there is very often nothing to grumble about when such an aerial is used; provided that no one uses a piece of domestic equipment, such as a vacuum cleaner, washing machine, or door-bell, while an important recording is being made; and provided that the one motor-cycle of the week does not arrive at the door. But if one lives in a heavily built-up area—and particularly where there are lifts and office machinery, to say nothing of lighting and power switches, and traffic, there is not the slightest doubt that a proper aerial, mounted as high as possible, and on the side farthest removed from the street, is more than worthwhile. Indeed, to feed a good radio tuner with anything less is to offset the most important advantages that *vhf* radio has to offer.

Advantages from AM

Many hi-fi enthusiasts have both AM and FM tuners for feeding their amplifiers, merely because FM alone cuts off the listener from the outside world. The results obtained from an AM tuner are very rarely so good as those available via FM, simply because all the normal clutter and interference of AM are reproduced in the same way as they are with the domestic receiver. Nevertheless, AM reception, enjoyed via a hi-fi set-up, has considerable advantages over its “domestic radio” or radiogram counterpart. For example, the filter circuits of the hi-fi amplifier, plus the bass and treble lift and cut controls, can do a lot more than is possible with a normal radio’s “volume and tone knobs”; and again, the considerably better components in the tuner itself, and the amplifier, and the well-designed speaker drive unit, with its good enclosure, make the most of what is available from the aerial.

If, having considered these points, it is

considered worthwhile to add AM to the hi-fi rig, it is also worth thinking of a combined AM/FM tuner, of which there are several good makes on the market. The advantage here is that only one item of power drain is called for, against two if separate AM and FM tuners are installed—also, as relatively few pre-amplifiers make provision for two tuner inputs, it is necessary to unplug and plug-in every time a changeover is wanted.

Power Supplies

The question of power supplies should be considered carefully before buying a tuner unit, AM or FM or combination. It is sometimes an advantage to have a self-powered tuner. On the other hand, if "extra power supplies" are available from the amplifier there is no point in not using them, particularly if £.s.d. can be saved with a tuner that does not embody its own power unit.

Nearly every tuner marketed today has an output which is more than adequate for driving even the lowest gain amplifiers. Thus the main points to watch are (a) sensitivity for fringe-area reception, and (b) good selectivity for areas where overlapping services from different regions may cause trouble by interference.

With tuners, as with most items of hi-fi equipment, the problem of housing the unit is of great importance; and for this reason it is well to consider the pros and cons of free-standing models and those which are designed for in-building. Feeder leads of quite reasonable length can be used for connecting tuners to pre-amplifiers; and if

the co-axial cable (usually brown) is painted to room colour, it is often possible to position a self-powered tuner at a convenient point, for mains supply and aerial feeder, well away from the rest of the hi-fi set-up.

Separate Power for Tape

If tape facilities are in mind, with the possible need for power for recording electronics, it is advisable to settle-in-advance for a separate power supply unit for this addition, and not to allow the future addition to cloud the issue of self-powered tuner versus unpowered tuner. Tape electronics will always be happier when working from a separate power source, because the possibility of a varying power drain (through switching on and off of other units) can affect the *bias* and *record* circuitry.

Points to look for

Points well worth considering, when making a choice from the many available tuners, are *Frequency coverage*—for some tuners cater for a larger slice of the band than others, and some users may think it worthwhile to explore the other sections of the band for possible foreign stations, and for the other non-programme transmissions which are radiated; also the item *Quieting* in the maker's specification—for this, as experienced listeners will already know well, is the factor which determines the degree of silence of the background when tuned to weak signals; and, finally, *Drift*—which can be an infuriating fault, but which should not be present in any tuner worthy of the name.

DIRECTORY OF RADIO TUNERS

★ In the abridged specifications of these directory entries the following abbreviations have been used: P.s.n.—Power supply needed; A.F.C.—Automatic frequency control.

Acoustical Manufacturing Co. Ltd., St. Peter's Road, Huntingdon, Hunts. Tel.: Huntingdon 361 and 574. Cables: Acoustical.

F.M. Tuner. Variable tuning. Range 87.5-108 Mc/s. Special double neon display ind. P.s.n. 330v at 27 mA; 6.3v at 1.85 amps. Size $10\frac{1}{2} \times 3\frac{1}{2} \times 6$ ins. Price £21 (U.K. purchase tax £9 9s.).

A.M. Tuner. Variable tuning, DM 70 ind. P.s.n. 330v at 20 mA; 6.3v at 1.2 amps. Size $10\frac{1}{2} \times 3\frac{1}{2} \times 6$ ins. Price £21 (U.K. purchase tax £9 9s.).

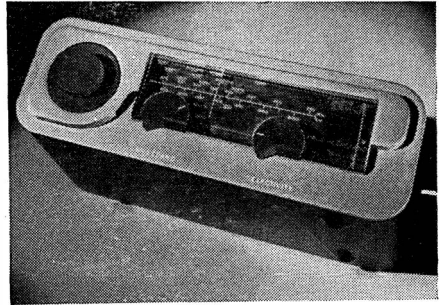

Quad AM tuner

★

Armstrong Wireless & Television Co., Warlters Road, Holloway, London, N.7. Tel.: North 3213/4.

F.M. Tuner FM 61. Dial/permeability tuning. Range 88-108 Mc/s. A.F.C. Ratio disc. Magic eye ind. P.s.n. 220-410v at 35 mA. 6.3v at 2 amps. Size $9\frac{3}{4} \times 5\frac{1}{4} \times 7$ ins. Price £15 15s. (U.K. purchase tax £6 6s.)

A.M./F.M. Tuner ST3. Variable tuning. Range 87-108 Mc/s, 187-570 and 1,053-2,000 metres. A.F.C. Ratio disc. Magic eye ind. Self-powered. Size $13\frac{1}{4} \times 7\frac{3}{4} \times 8\frac{1}{2}$ ins. Price £20 5s. (U.K. purchase tax £8 2s.)

BS 125T. A.M. Tuner/Control Unit combined. Bandsread tuning on 11, 13, 16, 19, 25, and 31 metre bands. General coverage 15-43, 43-150, 190-550 metres. Magic eye ind. P.s.n. 250v 30 mA; 6.3v 2.6 amps. Size $15 \times 9\frac{3}{4} \times 9\frac{1}{4}$ ins. Price £31 10s. (U.K. purchase tax £12 12s.)

RF 125T. Home market version of above, covering 13-550 metres in four bands, plus Long Waveband.

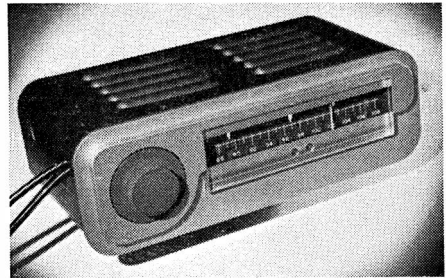

Quad FM tuner

★

Beam-Echo Ltd., 13 South Molton Street, London, W.1. Tel.: Mayfair 1039. Cables: Hibeam, London.

Avantic BM 611. A.M./F.M. Tuner, variable tuning. Range 88-108 Mc/s, 545-1,600 Kc/s. A.F.C. Foster-Seeley disc. Magic eye ind. Self-powered. Size $14\frac{1}{8} \times 10 \times 4\frac{1}{2}$ ins. Price to be advised.

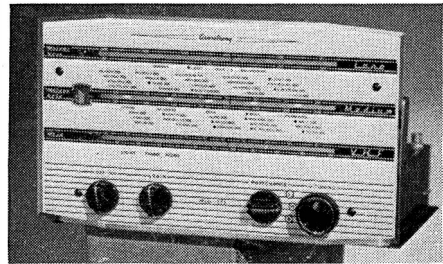

Armstrong AM/FM ST3



Armstrong FM61

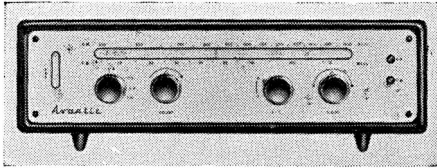

Avantic BM611 AM/FM

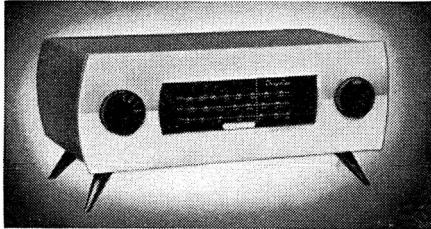

Chapman FM95



Chapman FM91

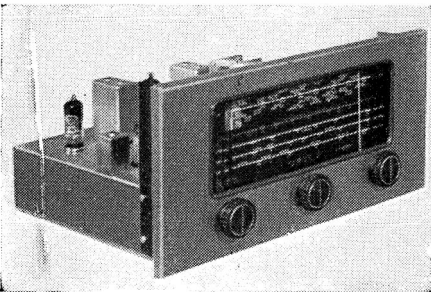

Chapman SSE/FM

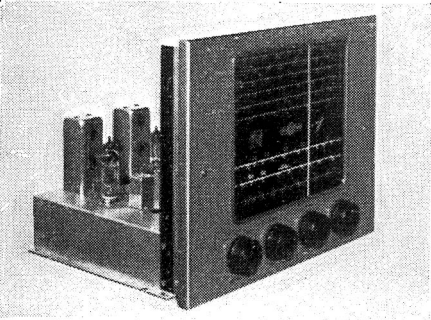

Chapman S6BS

Avantic BM 612. A.M./F.M. Tuner. Variable tuning. Range (F.M.), 88-108 Mc/s; (A.M.) 545-1600 Kc/s A.F.C. Foster-Seeley disc. Magic eye and neon ind. Self-powered. Multiplex output available for binaural or stereo reception. Sensitivity F.M., $2\mu\text{v}$ for 20 dB quieting. Size $14 \times 4\frac{7}{8} \times 8\frac{1}{2}$ ins. Type A 100-125v AC; Type B 200-250v AC; Type C at slightly higher cost 100-250v AC. All 40-60 c/s. Price to be advised.

★

C. T. Chapman (Reproducers) Ltd., Chapel Lane, High Wycombe, Bucks. Tel.: High Wycombe 2474.

F.M. Tuner FM80. Switched. Range 87.5-100 Mc/s A.F.C. Wide Band ratio det. P.s.n. 250v at 40 mA; 6.3 v at 2A. Size $9 \times 4\frac{1}{4} \times 5\frac{3}{8}$ ins. Price £15 15s. (U.K. purchase tax £6 6s.)

F.M. Tuner FM91. Free tuned. Range 87.5-100 Mc/s or 88-108 Mc/s A.F.C. Wide band radio det. Bright Line tuning ind. P.s.n. 250v at 40 mA; 6.3v at 2A or self-powered. Size $12 \times 4\frac{1}{8} \times 6\frac{1}{4}$ ins. Price £17 5s. 1d. (U.K. purchase tax £7 4s. 11d.). Self-powered £20 4s. 11d. (£8 10s. 1d.)

A.M./F.M. Tuner. F.M. 85. Free tuned. Range (F.M.) 87.5-100 Mc/s; (A.M.) 190-550, 800-2,000 metres. Ratio det. plus limiter. Magic eye ind. P.s.n. 250v at 40 mA or self-powered. Size $10\frac{3}{8} \times 6\frac{1}{8} \times 7$ ins. Price £18 9s. 10d. (U.K. purchase tax £7 15s. 2d.). Self-powered £21 9s. (£9)

FM95 A.M./F.M. Tuner. Variable tuning. Range 87.5-100 Mc/s, 195-550 and 800-2,000 metres. A.F.C. Ratio det. EM84 ind. P.s.n. 250v at 30 mA; 6.3v 2 amps. Size $12 \times 4\frac{1}{8} \times 8\frac{1}{2}$ ins. Price £20 1s. 5d. (U.K. purchase tax £8 8s. 7d.) Self-powered version £23 1s. 3d. (£9 13s. 9d.)

A.M./F.M. Tuner S5E/FM. Free tuned. Range (F.M.) 87.5-100 Mc/s or 88-108 Mc/s; (A.M.) 12.5-37, 35-100, 90-250, 190-550 metres. Ratio det. plus limiter. Magic eye tuning ind. P.s.n. 200/250v at 40/50 mA or self-powered. $13\frac{1}{2} \times 6\frac{1}{2} \times 9$ ins. Price £25 2s. 10s. (U.K. purchase tax £10 11s. 2d.) Self-powered £28 1s. 10d. (£11 16s. 2d.)

A.M./F.M. Tuner S5/FM. Free tuned. Range (F.M.) 87.5-100 Mc/s; (A.M.) 16-50, 195-550, 800-2,000 metres. Ratio det. plus limiter. Magic eye tuning ind. P.s.n. 200/250v at 40/50 mA or self-powered. $13\frac{1}{2} \times 6\frac{1}{2} \times 9$ ins. Price as S5E/FM above.

A.M./F.M. S6BS/FM. Free tuned. Range (F.M.) 87.7-108 Mc/s; (A.M.) 6 bandspreads: 11, 13, 16, 19, 25, and 31 metres; also 15-43, 43-140, 175-570 metres wide band ratio det. Magic eye ind. Self-powered. Size $13\frac{3}{4} \times 12\frac{1}{2} \times 11$ ins. Price to be announced.

A.M. Tuner S6E. Free tuned. Range 12.5-37, 35-100, 90-250, 190-550 metres. Otherwise similar to the S6BS. Size $13 \times 8\frac{1}{4} \times 9\frac{3}{8}$ ins. Price £22 10s. (U.K. purchase tax £9) or £27 powered (£10 16s.).

A.M. Tuner S6BS. Free tuned. Range 6 bandspread ranges: 11, 13, 16, 19, 25, and 31 metres. Magic eye ind. P.s.n. 250v at 30/40 mA; 6.3v at $1\frac{1}{2}$ amps, or self-powered. Size $13\frac{3}{4} \times 12\frac{1}{2} \times 11$ ins. Price £33 (U.K. purchase tax £13 4s.) or £37 10s. powered (£15).

★

C.Q. Audio Ltd., 2 Sarnesfield Road, Enfield, Middx. Tel.: Enfield 8262.

F.M. Tuner. Free tuned. Range 88-108 Mc/s. A.F.C. Foster-Seeley disc. Self-powered. Size $10\frac{1}{4} \times 4 \times 6$ ins. Price £19 4s. (U.K. purchase tax £7 15s.)

★

Dulci Co. Ltd., 97/99 Villiers Road, London, N.W.2. Tel.: Willesden 6678/9.

F.M. Tuner. Permeability tuning. Range 87-100 Mc/s. Ratio det. Magic eye ind. Self-powered. Size, front panel $10\frac{1}{2} \times 5\frac{3}{8}$ ins., depth including knobs $7\frac{1}{2}$ ins. Price £12 12s. (U.K. purchase tax £4 18s. 3d.)

A.M./F.M. Tuner H3S. Variable tuning. Range 87-101 Mc/s, 187-540 and 1,100-1,900 metres. Ratio det. Self-powered. Size $12 \times 7\frac{3}{4} \times 9\frac{3}{4}$ ins. Price £21 (U.K. purchase tax £8 3s. 10d.). Note: includes twin audio amplifiers 4 watts per channel.

A.M./F.M. Tuner H4T/2. Variable tuning. Range 87-101 Mc/s, 16-50, 187-540, and 1,100-1,900 metres. Ratio det. Magic eye ind. Self-powered. Size $12\frac{1}{2} \times 6\frac{1}{4} \times 10$ ins. Price £17 19s. (U.K. purchase tax £7)

★

Dynatron Radio Ltd., Maidenhead, Berks. Tel.: Maidenhead 5151/5.

F.M. Tuner. FM2 LV and FM2 HV. Switched tuning. Range 88-100 Mc/s. A.F.C. control approx. ± 300 Kc/s. Foster-

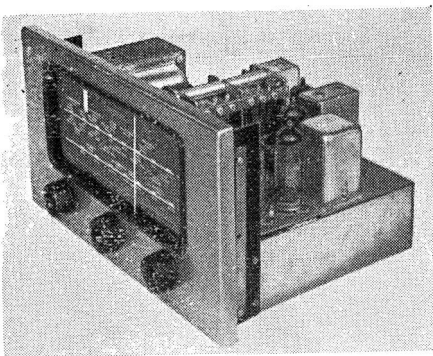

Chapman FM85

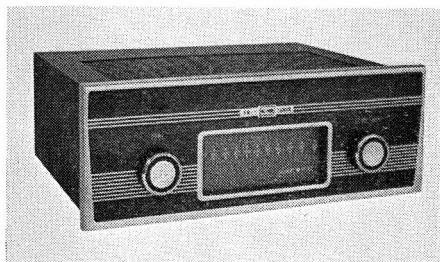

CQ Audio FM

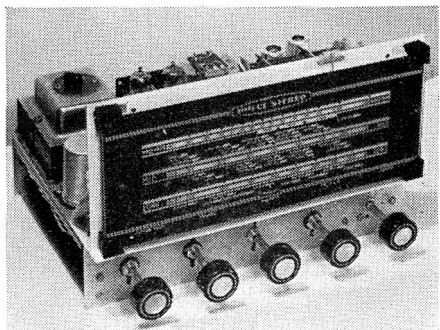

Dulci H3S

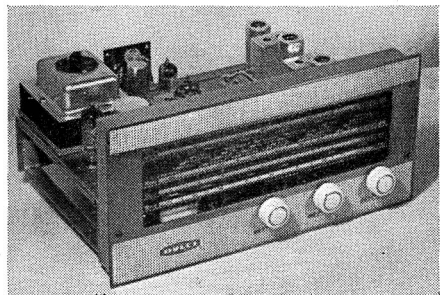

Dulci H4T/2

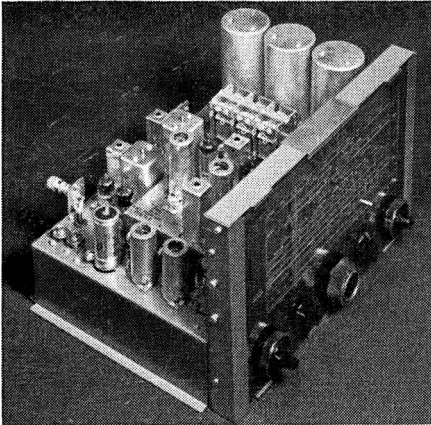

Dynatron T10A

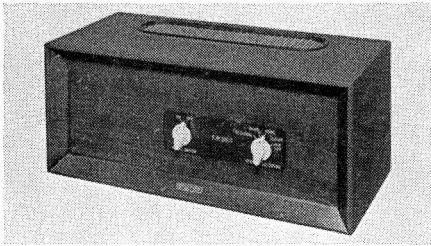

Dynatron FM5P2

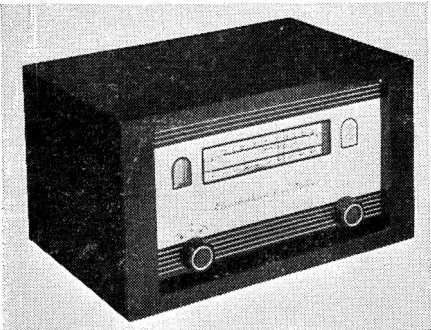

Elizabethan FM tuner

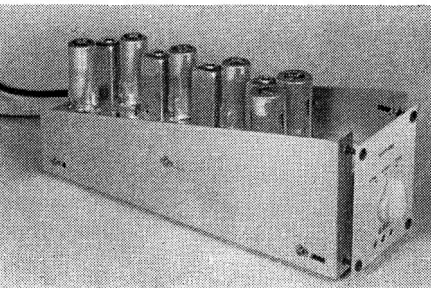

G.E.C. BCS 1352

Seeley disc. P.s.n. 250v at 45 mA; 6.3v at 2.5 amps. Size $5\frac{1}{2} \times 6\frac{1}{2} \times 5\frac{1}{2}$ ins. Price—FM2 LV £18; FM2 HV £21 (U.K. purchase tax—FM2 LV £7 0s. 6d.; FM2 HV £8 3s. 9d.).

A.M./F.M. Tuner T.11. Variable tuning. Range 88-108 Mc/s, 860-2,000, 200-500, 60-150, and 15-43 metres. Ratio det. EM84 ind. Size $7\frac{1}{2} \times 11\frac{1}{4} \times 7\frac{3}{8}$ ins. Price £43 (U.K. purchase tax £16 15s. 6d.).

Ether Pathfinder A.M./F.M. Tuner T10A. Tuning, variable condenser (A.M.). Permeability (F.M.). Range (F.M.) 88-108 Mc/s, (A.M.) LW 800-2,000 metres, M.W. 190-550 metres, SW1 13-48 Mc/s, SW2 48-160 Mc/s. Ratio det. Magic eye ind. P.s.n. 250v at 60 mA, 6.3v at 3 amps. Size $8\frac{3}{4} \times 14 \times 10\frac{5}{8}$ ins. Price £47 9s. 9d. (U.K. purchase tax £18 10s. 3d.)

F.M. Tuner FM5P2. Switched tuning. Range 88-110 Mc/s. A.F.C. Foster-Seeley disc. Self-powered. Size $16 \times 8 \times 7\frac{1}{4}$ ins. Price £28 14s. (U.K. purchase tax £11 1s.)

Ether Marshal A.M. Tuner T139. 5 wavebands, 10-30, 28-80, 80-200, 200-580, 800-2,200. Ratio det. Magic eye ind. Own separate amplifier. Size $8\frac{1}{4} \times 14 \times 10\frac{5}{8}$ ins. Price complete with amplifier £131 6s. 5d. (U.K. purchase tax £51 4s. 3d.)

★

EAP (Tape Recorders) Ltd., Bridge Close, Oldchurch Road, Romford, Essex. Tel.: Romford 62366-7.

Elizabethan F.M. Tuner. Manual tuning. Range 81-105 Mc/s. Ratio det. Magic eye ind. Self-powered. Price £16 16s. including purchase tax.

★

General Electric Co. Ltd., Magnet House, Kingsway, W.C.2. Tel.: Temple Bar 8000. Cables: Polyphase, London.

VHF/F.M. Tuner. BCS 1352. Switched tuning. Range 88-98 Mc/s. A.F.C. Foster-Seeley disc. P.s.n. 150v at 20 mA; 6.3v at 1.8 amps. Power pack available (Cat. No. BCS 1351). Price Tuner only £20 9s. 5d.; power unit £6 5s. (U.K. purchase tax tuner only £7 17s. 7d.).

★

Goodsell Ltd., Gardner Street, Brighton, Sussex. Tel.: Brighton 26735.

F.M. Tuner. FMT601. Perm. tuning. Range 85-100 Mc/s. Ratio det. Magic eye

ind. P.s.n. 250v at 25 mA. Size 11 × 8 × 8 ins. Price not yet fixed.

★

Grampian Reproducers Ltd., 19 Hanworth Trading Estate, Feltham, Middx. Tel.: Feltham 2657. Cables: Reamp, Feltham.

F.M. Tuner 571. Free tuned. Range 85-98 Mc/s. Ratio det. Magic eye ind. P.s.n. 300v at 35/40 mA, 6.3v at 2.5 amps. Size 10½ × 5½ × 6¼ ins. Price £17 10s. (U.K. purchase tax £7 1s. 6d.)

★

Jason Motor & Electronic Co., 3/4 Gt. Chapel Street, London, W.1. Tel.: Gerrard 0273/4.

Prefect F.M. Tuner. Switched incremental inductance tuning. Range 88-95 Mc/s. A.F.C. Foster-Seeley disc. Sensitivity 80μv for 40 dB quieting. P.s.n. 220-270v at 30-40 mA, 6.3v at 2 mA. Size 4½ × 4¾ × 6 ins. Price £11 5s. (U.K. purchase tax £4 7s. 9d.)

F.M. Tuner FMS2. Switched incremental inductance tuning. Range 88-105 Mc/s. A.F.C. Foster-Seeley disc. Sensitivity 15μv for 40 dB quieting. Self-powered. Size 8½ × 8¼ × 4¾ ins. Price £17 5s. (U.K. purchase tax £6 14s. 6d.)

A.M./F.M. Tuner AM/FMS2. 3 gang condenser (M.W.). Switched incremental inductance (F.M.). Range (F.M.) 88-108 Mc/s. (A.M.) 186-565 metres. A.F.C. Foster-Seeley disc. Magic eye ind. (A.M.). Sensitivity 2μv for 40 dB quieting. Self-powered. Size 15 × 8¼ × 4¾ ins. Price £22 16s. (U.K. purchase tax £8 15s. 8d.)

A.M./F.M. Tuner AM/FM2. Variable capacitor 3 gang tuning, A.M. and F.M. Range (F.M.) 88-108 Mc/s. (A.M.) 180-565 metres with variable selectivity. A.F.C. Foster-Seeley disc. Magic eye ind. Sensitivity for 20 dB quieting, F.M. 2μv, A.M. 10μv. Self-powered. Size 15 × 8¼ × 4¾ ins. Price £33 (U.K. purchase tax £12 17s. 5d.)

F.M. Tuner FMT3. Variable tuning. Range 88-108 Mc/s. A.F.C. Foster-Seeley disc. Self-powered. Size 11¼ × 6⅞ × 4¾ ins. 15μv for 40 dB quieting. Price £17 5s. (U.K. purchase tax £6 14s. 6d.)

F.M. and A.M./TV Sound Tuner JTV. Switched turret tuning. Range 88-96 Mc/s. plus all Television channels. Ratio det. Magic eye ind. Self-powered. Size 11¼ × 6⅞ × 4¾ ins. 80μv for 40 dB quieting. Price £19 4s. (U.K. purchase tax £7 9s. 10d.)

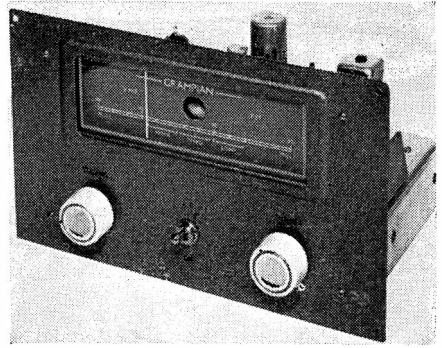

Grampian FM 571

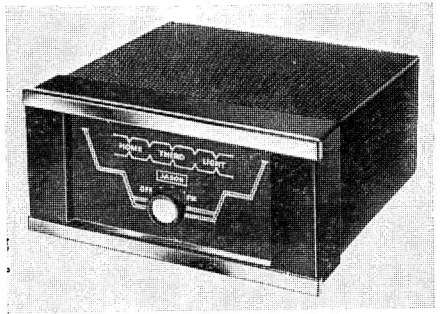

Jason FMS2

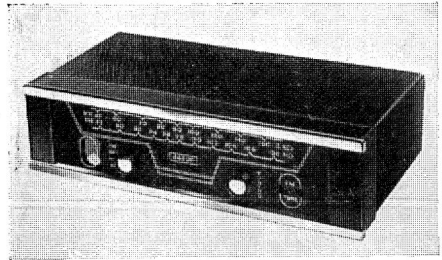

Jason AM/FM2



Jason AM/FMS2

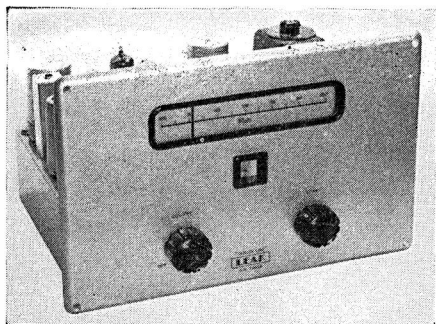

Leak FM "Trough-line" tuner

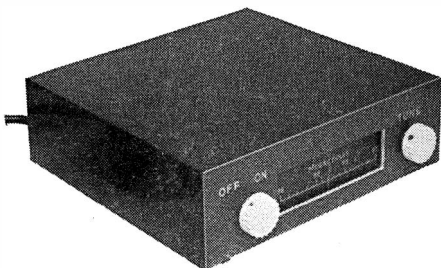

"Sterling" FM tuner

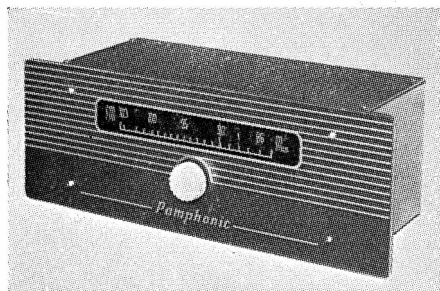

Pamphonic 640 FM tuner

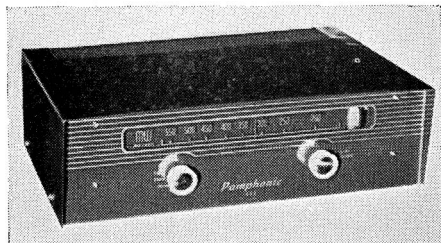

Pamphonic 645 FM/AM tuner

H. J. Leak & Co., Ltd., 57/59 Brunel Road, East Acton, London, W.3. Tel.: Shepherds Bush 1173. Cables. Sinusoidal, Ealux, London.

F.M. Tuner, Trough-Line. Variable tuning. Range 88-100 Mc/s. A.F.C.

Foster-Seeley disc. Original magic eye ind. circuit accurate to 2 Kc/s. Self-powered. Size $10\frac{1}{2} \times 7 \times 7$ ins. Price £25 (U.K. purchase tax £10 10s.)

★

The Lowther Manufacturing Co., Lowther House, St. Mark's Road, Bromley, Kent. Tel.: Ravensbourne 5225. Cables: Lowther.

F.M. Tuner Mk. III. Twin gang tuning, horizontal scale. Range 87.5-100 Mc/s. A.F.C. Foster-Seeley disc. Press button ind. 50 c/s injection. Self-powered. Size $13\frac{1}{4} \times 5\frac{1}{2} \times 5$ ins. Price £24 10s. (U.K. purchase tax £9 15s. 6d.)

F.M. Tuner Mk. IV. Variable tuning. Range 87.5-100 Mc/s. A.F.C. Foster-Seeley disc. Press button ind. P.s.n. 250v 30 mA; 6.3v 2 amps. Size $10\frac{1}{4} \times 4\frac{1}{2} \times 7$ ins. Price £22 (U.K. purchase tax £8 15s. 7d.)

A.M. Tuner DT/5. Ganged condenser, band spread tuning. Range 12-30, 30-90, 90-200, 195-550 metres. "S" meter ind. P.s.n. 250v at 30 mA; 6.3v at 2.75 amps. Size $12 \times 10\frac{1}{2} \times 12$ ins. Price £33 (U.K. purchase tax £13 3s. 4d.)

★

S. E. Opperman Ltd., Stirling Corner, Boreham Wood, Herts. Tel.: Elstree 2021.

Sterling F.M. Tuner. Variable permeability tuning. Range 86-100 Mc/s. Ratio det. Self-powered. Size $7\frac{1}{2} \times 7\frac{1}{2} \times 2\frac{1}{2}$ ins. Price including purchase tax in U.K. £13 13s.

★

Pamphonic Reproducers Ltd., 17 Stratton Street, London, W.1. Tel.: Grosvenor 1926.

640 F.M. Tuner. Variable tuning. Range 86-103 Mc/s. Ratio sel. Magic eye ind. P.s.n. 200v at 30 mA, 6.3v at 2 amps. Size (panel) $9\frac{3}{8} \times 3\frac{1}{2}$ ins. Price £15 (U.K. purchase tax £5 15s. 6d.)

645 F.M./A.M. Tuner. Switched F.M., variable A.M. Range (F.M.) 86-103 Mc/s. (A.M.) 185-565 metres. A.F.C. Foster-Seeley disc. Magic eye ind. Sensitivity F.M., $15\mu\text{v}$ for 40 dB quieting. Self-powered. Size $13 \times 10\frac{1}{2} \times 4\frac{1}{2}$ ins. Price £21 13s. 2d. (U.K. purchase tax £8 6s. 10d.)

★

Period High Fidelity Ltd., 28 South Street, London, W.1. Tel.: Grosvenor 4686.

Saville F.M. Tuner. Variable tuning.

Magic eye ind. Cathode follower output.
Price £24 (U.K. purchase tax £10 16s.).

★

Pye Ltd., 65 Fairview Road, London, S.W.16.
Tel.: Pollards 9441/2. Cables: Faramarine,
Souphone, London.

A.M./F.M. Tuner, HFT.111 W. 2 chassis forms. Horizontal and vertical scale. Permeability tuning. Range (F.M.) 87.1 100 Mc/s. (A.M.) 183-564; 956-1,910 metres. Foster-Seeley disc. Magic eye ind. Self-powered. Size $15 \times 8\frac{1}{2} \times 9$ ins. Price £26 10s. 8d., chassis form £21 19s. 8d. (U.K. purchase tax £10 4s. 4d., chassis, £8 9s. 4d.)

F.M. Tuner Mozart HFT. 108. Variable tuning. Range 88-108 Mc/s. A.F.C. Foster-Seeley disc. Self-powered. Size $10\frac{1}{2} \times 3\frac{3}{8} \times 5$ ins. Price £16 13s. 7d. (U.K. purchase tax £6 8s. 5d.), chassis only, or in metal case £18 3s. 11d. (£7 0s. 1d.)

★

RCA Great Britain Ltd., Lincoln Way, Windmill Road, Sunbury-on-Thames, Middlesex. Tel.: Sunbury 3101. Cables: Telex and Tex 8608.

F.M. Tuner LMI 32230B. Continuously variable tuning. Range 87.5-108 Mc/s (full international F.M. broadcast band). A.F.C. Ratio det. 6 AL7 electron ray tuning ind. P.s.n. 230-390v at 40 mA (adjustable tapings); 6.3v at 2.25 amps. Size $12\frac{7}{8} \times 6\frac{1}{2} \times 3\frac{7}{8}$ ins. Price £17 5s. 4d. (U.K. purchase tax £6 14s. 8d.)

Power Unit LMI 32283. For supplying power for radio-tuners or tape units. Power available 290 or 230 volts at 45 mA D.C. and 6.4 volts at 2.25 amps A.C. To run from 110/120, 150, 200/255 volts, 50 or 60 c/s. Intended for use with R.C.A. Supersensitive Tuner LMI 32230B. Price £4.

★

Rogers Developments (Electronics) Ltd., "Rodevco Works," 4-14 Barmeston Road, Catford, S.E.6. Tel.: Hither Green 7424/4340. Cables: Rodevco, London.

R.D. Junior F.M. Tuner. Variable inductance tuning. Range 87-107.5 Mc/s. A.F.C. Foster-Seeley disc. Tuning ind. centre-zero meter (optional extra). Sensitivity for full limiting, $10\mu\text{v}$. P.s.n. 270v at 38 mA, 6.3v at 2.3 A or self-powered. Size $9 \times 5\frac{3}{8} \times 8\frac{3}{8}$

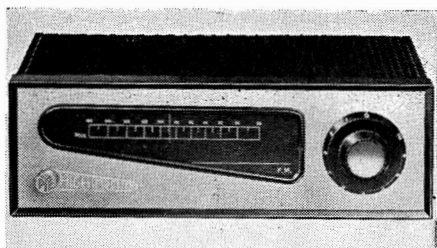

Pye Mozart HFT 108

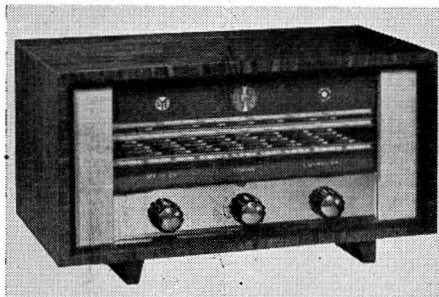

Pye FM/AM tuner

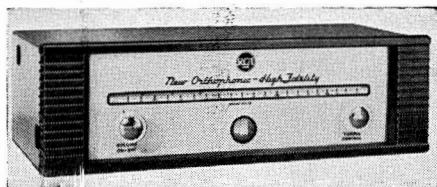

RCA FM tuner

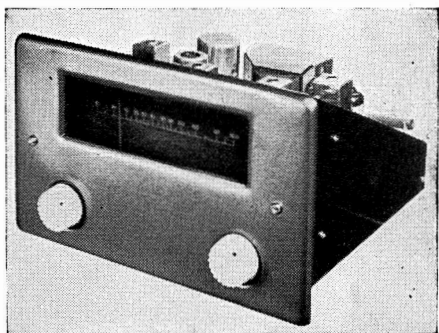

Rogers R.D. Junior FM tuner

ins. Price £16 11s. (U.K. tax £6 1s. 9d.) or £18 5s. 6d. powered (£7 13s. 6d.)

F.M. Tuner R.D. Junior Switched. Switched tuning. Range 87-96 Mc/s. A.F.C. Foster-Seeley disc. P.s.n. 250v 35 mA; 6.3v 1.7 amps. Size $9 \times 5\frac{3}{8} \times 5\frac{3}{8}$ ins. Price £11 5s. (U.K. purchase tax £4 12s. 2d.)

Scientific & Technical Developments Ltd.,
Melbourne Road, Wallington, Surrey. Tel.:
Wal. 9252. Cables: Electronic, Wallington.

F.M. Tuner Orthotone STD/374. Switched tuning. Range 86-96 Mc/s. or as required. A.F.C. Ratio det. P.s.n. 180-250v 40 mA; 6.3v 2.5 amps. Size $11\frac{3}{4} \times 4\frac{3}{8} \times 5\frac{1}{2}$ ins. Price £16 13s. 7d. (U.K. purchase tax £6 8s. 5d.)

F.M. Tuner Orthotone STD/445. Self-powered version of above. Price £19 14s. 3d. (U.K. purchase tax £7 11s. 9d.)

★

Shirley Laboratories Ltd., 3 Prospect Place, Worthing, Sussex. Tel.: Worthing 30536.

F.M. Tuner R/6. Variable tuning. Standard range. Ratio det. Magic eye ind. P.s.n. 200-300v 30 mA; 6.3v 2.5 amps. Price £22 1s. (U.K. purchase tax £8 16s. 6d.)

★

Sound Sales Ltd., Works and Acoustic Laboratories, West Street, Farnham, Surrey. Tel.: Farnham 6461/2/3. Cables: Sounsense, Farnham.

A-Z F.M. Synchrolock Unit Mk. IV 108. Variable twin gang tuning. Range 87.5-108 Mc/s. A.F.C. Foster-Seeley disc. Magic eye ind. Self-powered. Size $11\frac{1}{8} \times 4\frac{1}{2} \times 6\frac{1}{2}$ ins. Price £22 (U.K. purchase tax £8 9s. 5d.)

★

Technical Suppliers Ltd., Hudson House, 63 Goldhawk Road, London, W.12. Tel.: Shepherds Bush 2581/4794.

F.M. Tuner Mk. III International Model. Variable permeability tuning. Range 88-108 Mc/s. Ratio det. Magic eye ind. Self-powered. Size $10\frac{3}{8} \times 7 \times 5\frac{3}{8}$ ins. Price £13 13s. (U.K. purchase tax £5 5s.)

★

Whiteley Electrical Radio Co. Ltd., Victoria Street, Mansfield, Nottinghamshire. Tel.: Mansfield 1762-5. Cables: Whitebon, Mansfield.

W/B Stentorian F.M. Tuner Mk. II. Variable permeability tuning. Range 88-108 Mc/s. Foster-Seeley disc. P.s.n. 200-240v at 45 mA, 6.3v at 2 amps. Size $11\frac{3}{4} \times 4 \times 7\frac{1}{2}$ ins. Price £16 2s. 5d. (U.K. purchase tax £6 19s. 7d.)

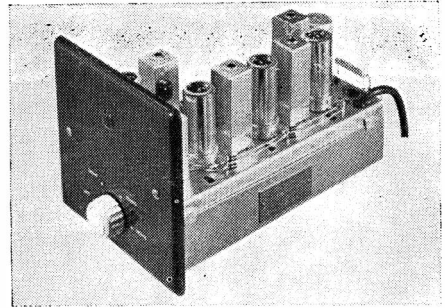

Rogers Junior Switched

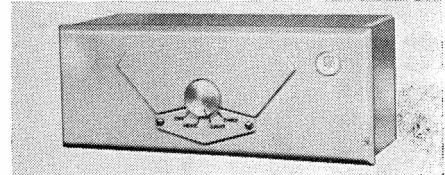

S.T.D. Orthotone STD/374

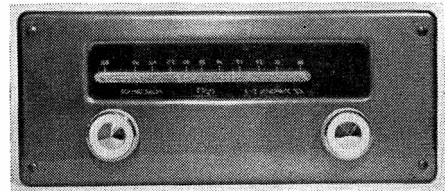

Sound Sales Synchrolock Mk. IV

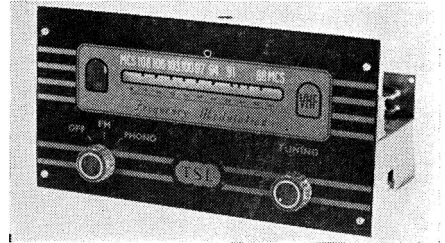

T.S.L. F.M. tuner, Mk. III



W/B Stentorian F.M. tuner

IMPULSE TESTS FOR LOUDSPEAKERS

By J. Somerset Murray

One of the most difficult things, in the whole art of sound reproduction is to measure the performance of a loudspeaker. While I would not go so far as to say that a perfectly reliable method will never be developed, I think most people will agree with me that the existing methods, using microphones and an-echoic rooms, have their limitations. The impression one gets of the performance of a loudspeaker depends very much on the liveness or deadness of the listening room; the two elements, the room and the loudspeaker, must be taken together if the effect is to be valid as an assessment of the value of any particular design. Only the ear can do this to-day.

When experiment becomes too difficult to interpret there is an excellent reason for sitting down and re-examining the problem, so as to try to break down the question into smaller pieces, each of which can be shown to be valid in its own right; and so in time to build up a structure which can stand the test of criticism. We still have a long way to go, but I feel that this is a good time to tell you about one step in that direction that I have made use of since 1953, when it was first applied in the development of the TPI. The idea is to shock the transducer into motion and to examine the subsequent movements as the shock subsides.

Using the Moving Coil as a Microphone

This idea has been used before, by Dr. N. W. McLachlan, who used a microphone to pick up the acoustic waves from a moving coil speaker when it had been excited by the discharge of a condenser through it. My improvement was to use the moving coil itself as the microphone, and to obtain records

of the reflections which must occur when the outgoing radiated wave meets a discontinuity in the medium. The first successful use of this method determined the neck resonance of the Voigt twin cone diaphragm, with its aluminium coil—a very important point in the design of a wide range unit since, if this is too low, there will be no top above this resonance, and the design will fail. As will be obvious, no microphone method can possibly give this information.

LF Characteristics

I have recently applied the same principle to the examination of the low frequency characteristics of enclosures, employing a sine-squared pulse of wider shape, so as to cut out the small discontinuities from the trace, and to leave the major low frequency echoes discernible. This has the advantage that the room is not involved in any way, since the shock has not reached the room-walls before the echoes in the enclosure have finished. The experiments about to be described combine the "sonar" method with the microphone.

The Wide Range Electrostatic

In the last two or three years we have seen two important advances in the art of sound reproduction. Both these will have a lasting effect on the critical appreciation of loudspeaker designs, and which must from now on be considered whenever the design of a loudspeaker is to be undertaken. The first, in time and in importance, is the emergence of the first wide range electrostatic speaker, the *Quad*. Critical ears (the "golden-ear brigade") have accepted this as the logical development of sound, scientific principles

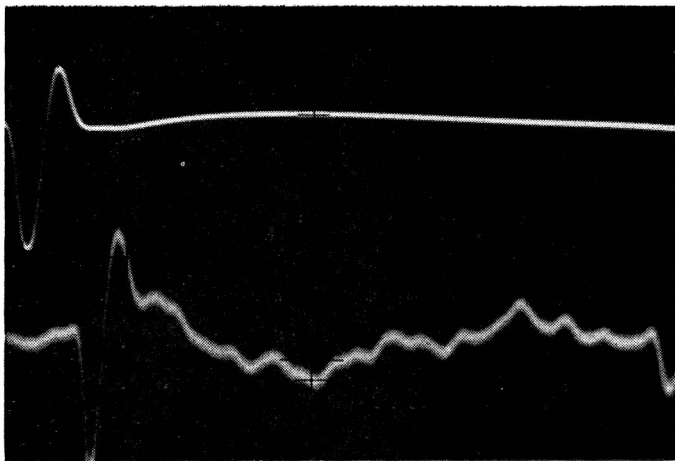

FIG. 1

The actual current passed through the speaker coil (upper trace) compared with the output of a ribbon microphone placed three feet in front. A very low level has been used here to illustrate the pulse shape. Screen width 20 milliseconds.

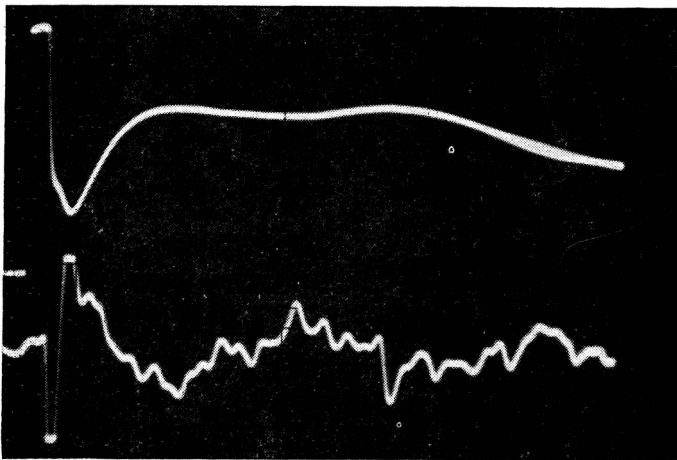

FIG. 2

A repetition of fig. 1, but with the input considerably stepped up and limited by a window. The screen width has been slowed to 32 milliseconds, and a pressure microphone was substituted for the ribbon.

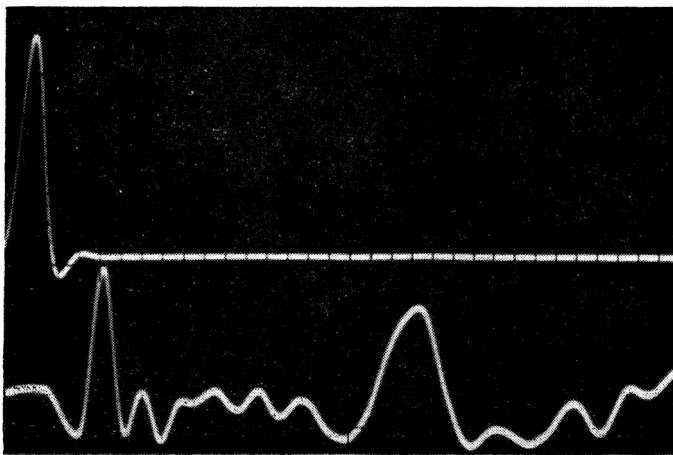

FIG. 3

Impulse applied to the TP1 loudspeaker, which produces front and back radiation of high and low frequencies respectively. Two microphones were employed and the signals adjusted to illustrate timing rather than the relative levels (or phase).

successfully carried out. I have never heard an adverse opinion on this speaker from any person whose ears I respect.

The *Quad*, because it is such an advance on the older techniques, sounds different. The difference can be explained very simply: a dipole operating directly in the medium in which it is to radiate, sees no discontinuities; and it follows that there will be no reflections or multiple paths which cause the ear to receive the same impulse more than once. This very simple fact explains the complete absence of colouration of the signal, which has till now seemed inevitable to ears accustomed to enclosures developed during the last twenty years.

The Infinite Baffle

Progress, alas, is not always forward, and we have to go back to the infinite baffle, or the open baffle, to re-discover this single impulse type of reproduction. Both the earlier methods, the infinite baffle and the open baffle, had their own difficulties, which are still with them, and which caused them to be dropped when the vented baffle came along. But the vented baffle is the result of the sine-wave approach to acoustic design, and fails in most of its objectives when the input is not sinusoidal.

The second advance is the arrival, in various forms, of stereo. If, by "stereo" we mean point localising two channel reproduction, we must admit that doubled images detract noticeably from the accuracy, and increase the mental effort involved in listening to it. Unless there is complete mastery of the technique, listening to stereo will remain in the regions of the gimmick, wonderful when it occasionally comes off, but, like early colour films, the interest will remain in the wonders of the technique, and detract from the artistic merits of the performance. The artistic merit of the idea will not emerge until the technique is mastered and forgotten by the user. On both counts the sign posts point to single impulse types of reproducer for the future.

The Impulse Method

Since the excitation of all possible mode of vibration of a loudspeaker at once would make interpretation impossible, the impulse is limited in frequency from a low value, ideally d.c. to an upper limit determined at will by the operator. This is achieved by making the pulse an approximation to a sine-squared pulse by means of a filter network. The shape is shown in the Y2, (lower) traces in Figures 1 and 2. This is the voltage

applied to an amplifier feeding the loudspeaker being tested.

The current that actually passes through the speaker is shown in the top trace of fig. 1. There is a slight overshoot on the down stroke due to the low frequency cut off of the amplifier. All the traces shown have this waveform as the actual exciting pulse in the coil, or in the primary of the driving transformer of the electrostatic.

Fig. 1 is, in fact, the input to the *Quad*, at a very low level, to illustrate the shape of this pulse. Normally the input is much higher, and the driving pulse is limited by a window. This enables much higher gains to be employed in the examination of the after trace, but we shall come to that later. The Y1 track of fig. 1 is reproduced accurately by the Y2 track, which shows the voltage developed by a ribbon microphone placed about three feet in front of the diaphragm. The reproduced pulse is super-imposed on a background of room clutter, caused by the repetition frequency of the pulse. For future technique, a single shot time base, and one pulse only, would give a clearer picture; but that kind of time base is not found on simple equipment. The main point is that it shows a clear similarity between the driving current and the reproduced sound velocity near the diaphragm. The exposure had to be kept short because of interference from cars outside the house.

Pulse Width and Time

The width of the pulse, at half height, is very nearly one millisecond; and the width of the screen is about twenty milliseconds. After the current pulse on Y1, there is a very slight curvature in the trace, due to the reverse effect of the diaphragm acting as a microphone and also, perhaps, due to some time constants inside the *Quad* itself. These are again shown on a magnified scale in fig. 2, where the input has been stepped up considerably, and both the driving pulse and the reproduced pulse have been limited by windows. This picture is the "odd-man out" in the series, as it is the only one at this slower time base speed, of about 32 milliseconds for the screen width. Another difference is that a pressure microphone was used slightly closer to the diaphragm.

Tests of the TP1

The next picture, fig. 3, shows, on the 20 millisecond time base, the effect of the impulse when it is applied to the TP1. This loudspeaker makes use of both sides of the diaphragm in an acoustic cross-over system—

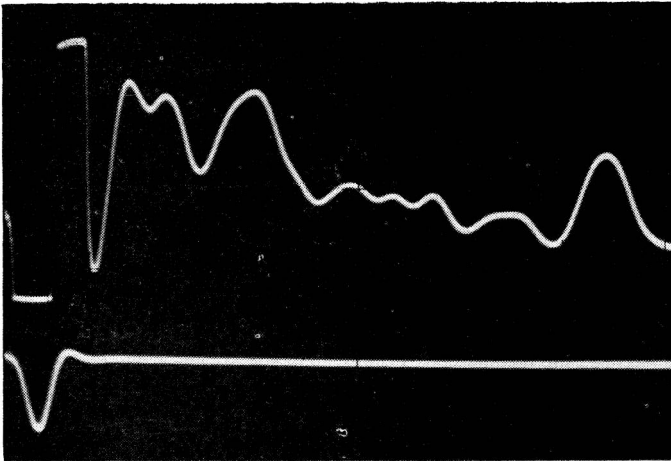

FIG. 4

The pulse (on Y2) and the echoes produced on the coil. The pulse itself is heavily clipped to show the rest of the information more clearly. The large wave on the right corresponds to the reflection from the horn mouth, delayed 16 milliseconds.

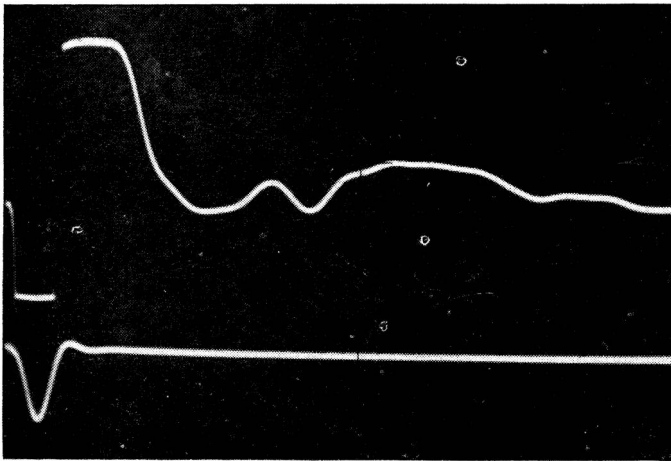

FIG. 5

A similar diaphragm to that of fig. 4, but in a new form of enclosure. Back radiation is eliminated and therefore coloration due to reflections is very small. Those which do appear can be associated with disturbances in the impedance/frequency characteristic.

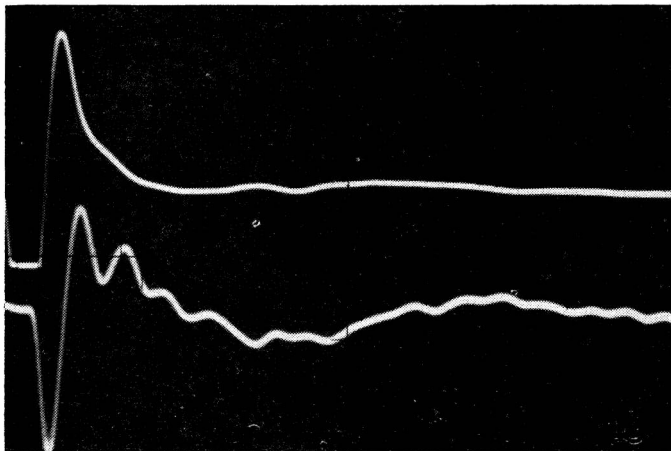

FIG. 6

Showing the echo trace of fig. 5 as Y1 on a less magnified scale. Y2 is the ribbon microphone output for a 1 foot distance, and shows a prominent overshoot which indicates a discontinuity some 13 inches away from the diaphragm.

the front, radiating the middle and top, and the back acting as the diaphragm in a very low frequency throat chamber, throat and horn assembly, the division of the frequency band into two parts being accomplished by the selection of the volume of the throat chamber, in relation to the mass of the diaphragm and associated air. The area of the throat determines the acoustic damping of the throat chamber/diaphragm cross-over frequency, and the length and expansion rate of the horn settle the bass cut-off. The idea has at least one enormous virtue: it delivers its output with very low excursions of the diaphragm.

Doppler Distortion

This virtually eliminates Doppler distortion and non-linearity, due to large bass excursions into a fringing magnetic flux. The pulse was a little short to pass efficiently down the low frequency channel, and to illustrate the effect of a slightly wider pulse, two microphones were used, and the gain of the low frequency pickup was adjusted to give a clear picture of the timing of the pulse. It must not be taken as a picture of the relative levels.

Microphone Arrangements

As the use of two microphones was necessary to eliminate room clutter, by having one near each opening, the phase of the microphones was arbitrary and in fig. 3, they were deliberately put out of phase to make the two acoustic pulses the same way up in the picture.

In fig. 3 Y1 is the signal voltage pulse, and Y2 is the microphone output. It shows quite clearly the two pulses separated by 8.2 milliseconds (measured at the leading edges) and the broadening of the later pulse, due to the filtering action of the cross-over in the throat chamber. Had the pulse been slower, equivalent to a wave of about 200 c/s, the two would have been of equal level and equal height, and at lower frequencies still, the later one would have been the larger.

Time Separation

Considered as a reproducing system, the two divisions of the spectrum are separated in time by about 8 milliseconds. Now this does not appreciably matter in large orchestral works where the orchestra itself has a depth from front to back of twenty or thirty feet, but a single cello ten feet thick from

front to back could prove disturbing to accurate point-localising stereo.

Horn Mouth Reflections

Fig. 4 shows the pulse voltage on Y2, and the echo picture from the coil due to the various folds in the bass horn, and the reflection from the horn mouth. This is the large wave at the right of the picture, and it occurs 16 milliseconds late on the current pulse, because it has to traverse the full length of the horn twice. The shape is that of the pulse filtered twice by the cross-over (acoustic) in the throat chamber. The other reflections correspond to the folds in the low frequency horn. Again, it should be emphasized that the magnitude of these reflections is very small: the driving current pulse, seen on the left, has been enormously clipped by the window; and the residue of the picture expanded to give its information distinctly.

A New form of Enclosure

The next picture fig. 5, shows an exactly similar diaphragm at the same scale of magnification as fig. 4, in a completely new form of enclosure. In this enclosure the front is, as usual, a direct radiator, but the back is presented with what is in effect an infinitely long tube. No radiation comes from the back, and the colouration due to reflections is extremely small, as can be seen from the very small irregularities in the echo picture. It is interesting to confirm that the irregularities shown can be associated with disturbances in the impedance frequency characteristic. I feel that the use of this form of echo picture, when adjustments are to be made to eliminate irregularities, is of great value since the effect of any change is immediately visible on the picture, and quite critical adjustment is possible, which would be quite out of court if it all had to be done with impedance curves. I have actually carried out the damping of the box used for figs. 5 and 6 by both methods, and the resultant impedance characteristics were indistinguishable. Y2 on fig. 5 is the same as Y2 in fig. 4.

The use of a Ribbon Microphone

Fig. 6. This has Y1, the echo curve of fig. 5 on a more realistic scale. Y2 shows the ribbon microphone response to the usual millisecond impulse, the microphone being fairly close to the diaphragm at about one foot. This shows one prominent overshoot just after the real one due to the amplifier, and it has a correlation with a change of

slope in the echo curve just above it. All the rest of the lower trace is room clutter, and compares with the Y2 trace in fig. 1. The conclusion from this picture is that there is still one more discontinuity to locate in the box. The picture also tells one where to look. The disturbance returns to the diaphragm 2.2 milliseconds after the pulse. It is thus 1.1 milliseconds away, or about 13 or 13½ inches from the diaphragm.

The Lower trace in fig. 6 should be compared with the driving current as shown in fig. 1 top trace. I think you will agree that the resemblance, apart from the one remaining discontinuity, is quite remarkable. None of the wriggles are due to faults in the diaphragm itself. The drive unit was tested separately to make sure of this before the rest of the work was done. The low frequency component in the room clutter is due to the height of the ceiling.

The performance of the new box on stereo is highly satisfactory, but of course its power

handling capacity is very much less than the same diaphragm in the TP1. There seems to be an artistic compromise in every design problem connected with loudspeakers. They are in fact quite maddening! To paraphrase the old song, anything you do to them is either illegal or immoral—or you lose your top! Perhaps this description of the uses of impulse testing will help towards longer and saner lives among the designers of air moving equipment.

Footnote: the new box, whose performance is illustrated in figs. 5 and 6, is based on the complete principle of which a part was foreshadowed in the design of the *Mozart* "Companion Loudspeaker." It is in fact a column type, 3 feet 10 inches high.

The photographs illustrating this article were all taken on the editorial *Cossor* Double beam Oscilloscope (model 1071K) and were the first time this interesting animal had been used in anger!

LOUDSPEAKERS — "DOMESTIC & HI-FI"

By Ralph West

Because of the stereo interest, there is a marked demand for high class loudspeakers of small size. Some of these are quite expensive, very well made, and have remarkably smooth responses. The bass response is remarkable for the cabinet size, but it is always lacking at the lowest frequencies. Used with bass boost they still fail to reach the performance of a full-sized loudspeaker. One can slacken off a violin string till it vibrates at the double-bass frequency, but however hard it is played, it won't sound like a double bass! Double basses, timpani, pedal-organ pipes are all rather big and if the same effect could be obtained with smaller devices, it would have been done long ago.

Omission of these very lowest frequencies takes something subtle out of the music whether it be monophonic or stereo. Listening becomes definitely less restful, as well as less satisfying. Stereo, too, loses something subtle—the "feel" of the auditorium in which the performance is taking place. Most musical performances are indoors, usually in very specially designed halls. We listen to orchestra (or whatever it is) *plus* auditorium. Good stereo signals contain these various sounds, some of which are of very low frequency. Full realism can only be produced if the *full* frequency range from *both* speakers is possible. Then and only then

can it really be called high fidelity reproduction.

A pair of loudspeakers are by no means wasted on monophonic signals. Most people who have installed stereo, use both speakers all the time. Large orchestral items are considerably improved as the layout in the writer's opinion goes half of the way to stereo by providing sound coming to the ear from various directions. It has been called "semi stereo". There need be no fear of a soprano soloist having a mouth 12 in. wide—unless two bad and different speakers are used! The effect is *one* soloist somewhere beyond the space between the speakers, and completely dissociated from them—a desirable thing. The results are noticeably smoother, too, as one is listening to the average of two loudspeakers. When the two speakers sound and "feel" right with monophonic signals, they will most probably be right for stereo too.

Identical speakers are not essential, merely desirable. Differences in the two locations usually unbalance them anyway.

With limited resources, it is probably better to get one really good full range loudspeaker and run a smaller cheaper one with it for the time being. Later on it can have a proper partner. Roll on that day! **R.L.W.**

SPEAKERS & ENCLOSURES—Directory

● This directory is divided into two parts. **Part 1** deals with the range of drive units which, by makers' specifications, are within the Hi-Fi classification. **Part 2** deals with complete enclosures. These, as a general rule, embody the drive units of Part 1. For economy of space the following abbreviations are used: v.c.i.—voice coil impedance; r.c.f.—recommended crossover frequency (and in Part 2) Rec.—recommended units; Height by Width by Depth are the order of printed dimensions.

PART I—DRIVE UNITS

Richard Allan Radio Ltd., Baffle House, Taylor Street, Batley. Tel.: Batley 1123/1308/4033. Cables: Acoustics Batley.

Golden Eight. 8 in. Paper cone and surround. Voice coil 1 in. Gap flux 12,000 gauss. Total flux 48,000 maxwells. H.C. 5 watts. v.c.i. 15 ohms. F.R. 60-10,000 c/s. Price £2 10s. 0d. (U.K. purchase tax 19s. 4d.)

Golden Ten. 10 in. Paper cone. Foam surround. Voice coil 1½ in. Gap flux 14,000 gauss. Total flux 82,000 maxwells. H.C. 10 watts. v.c.i. 15 ohms. F.R. 40-5,000 or 40-9,000 c/s. r.c.f. 5,000 c/s. Price £5 12s. (U.K. purchase tax £2 3s. 2d.)

Bronze Ten. 10 in. Paper cone. Foam surround. Voice coil 1½ in. Gap flux 12,500 gauss. Total flux 73,000 Maxwells. H.C. 8 watts. v.c.i. 15 ohms. F.R. 40-5,000 or 40-9,000 c/s. Price £4 17s. (U.K. purchase tax £1 17s. 4d.)

Golden Twelve. 12 in. Paper cone. Foam surround. Voice coil 2 in. Gap flux 14,000 gauss. Total flux 182,000 maxwells. H.C. 15 watts. v.c.i. 15 ohms. F.R. 25-15,000 c/s. r.c.f. 1,100 c/s. Price £12 12s.

410T. Tweeter. 4 in. Paper cone and surround. Voice coil ⅝ in. Gap flux 10,000 gauss. Total flux 15,000 maxwells. H.C. 3 watts. v.c.i. 15 ohms. F.R. 2,000-17,000 c/s. r.c.f. 5,000 c/s. Price £1 5s. (U.K. purchase tax 9s. 8d.)

★

Altobass Ltd., Percy Road, Aylestone Park, Leicester. Tel.: Leicester 31616. Cables: Altobass, Leicester.

2000. Dual Concentric. 12 in. Moulded paper cone, corrugated surround (L.F.). Duralumin pressure tweeter. Voice coil 1¾ in. (L.F.), 1 in. (H.F.). Gap flux (L.F.) 8,000 (H.F.) 13,000 gauss. Total flux (L.F.) 90,000

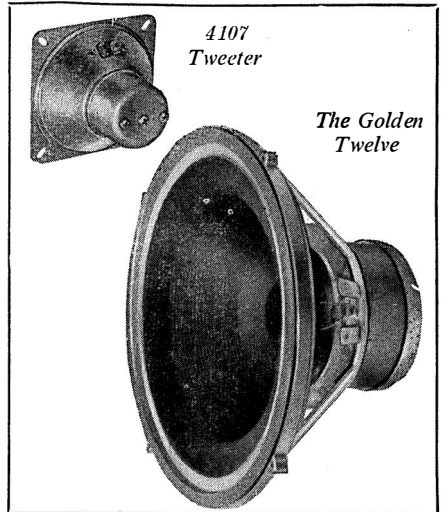

Richard Allen Drive Units

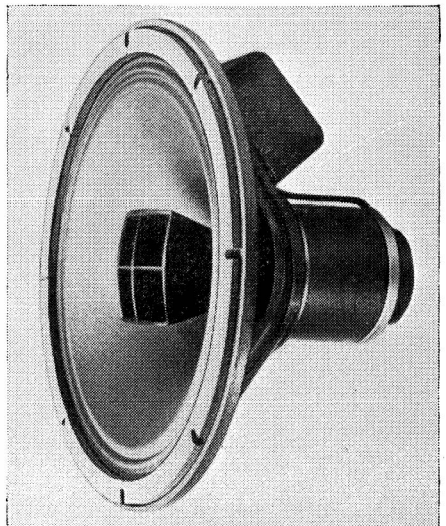

Altobass 2000

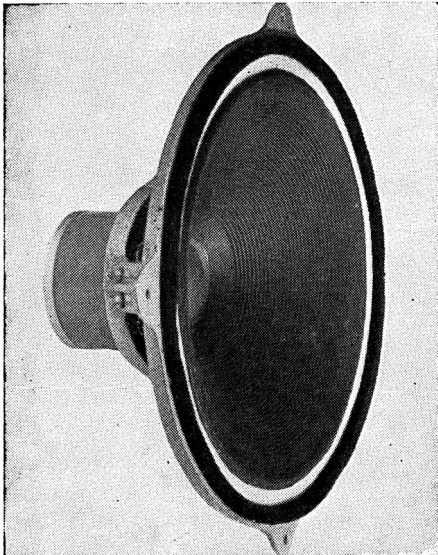

Bakers Selhurst 15-in./CS Auditorium

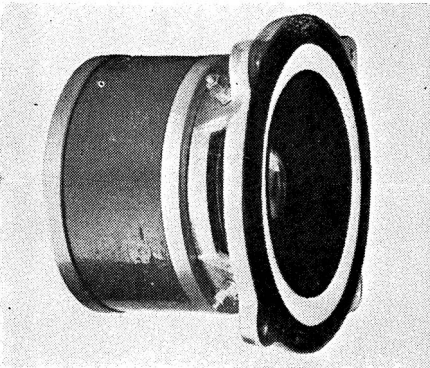

Bakers Selhurst Ultrasonic

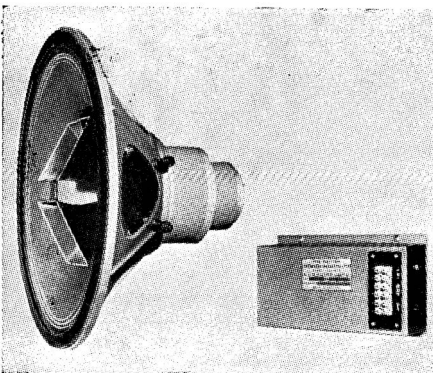

BTH K10A and crossover

(H.F.) 50,000 maxwells. H.C. 10 watts. v.c.i. 10 ohms. F.R. 30-20,000 c/s. Built-in crossover at 1,200 c/s. Price £17 17s.

★

Bakers "Selhurst" Radio, 24 Dingwall Road, Croydon, Surrey. Tel.: Croydon 2271/2.

Junior de-luxe 8-in. fibre cone, bakelized apex. Foam surround. Voice coil 1 in. Gap flux 18,000 gauss. H.C. 8 watts. v.c.i. 15 ohms. F.R. 35-20,000 c/s. Price £8 4s. 3d.

Junior Special. Spec. as for Junior de-luxe, but with aluminium voice coil and drive giving increased response and peak handling capacity. Price £9.

12-in. de-luxe fibre curvilinear cone, bakelised apex. Foam surround. Voice coil 1½ in. Gap flux 15,000 gauss. H.C. 15 watts. v.c.i. 3 or 15 ohms. F.R. 20-17,000 c/s. Price £9 15s.

12-in. Ultra de-luxe fibre curvilinear cone, bakelised apex. Foam surround. Voice coil 1½ in. Gap flux 17,000 gauss. Peak H.C. 20 watts. v.c.i. 15 ohms. F.R. 18-20,000 c/s. Price £11 7s. 6d.

Ultra Twelve 12-in. fibre curvilinear cone, bakelised apex. Foam surround. Voice coil 1½ in. Gap flux 17,000 gauss. Aluminium voice coil and drive. H.C. 20 watts v.c.i. 15 ohms. F.R. 20-25,000 c/s. Price £17 10s.

15-in./CS Auditorium. Fibre cone, bakelised apex. Foam surround. Voice coil 2 in. Gap flux 17,000 gauss. H.C. 15 watts. v.c.i. 8 or 15 ohms. F.R. 20-13,000 c/s. r.c.f. 5,000 c/s. Price £18.

Ultrasonic 3¼-in. bakelised cone. Foam surround. Voice coil 1 in. (aluminium). Gap flux 18,000 gauss. H.C. 12 watts above 1,000 c/s. v.c.i. 15 ohms. F.R. 1,000-25,000 c/s. r.c.f. 1,600 or 3,000 c/s. or by 3µF condenser. Price £7 10s.

★

Beam-Echo Ltd., 13 South Molton Street, London W.1. Tel.: Mayfair 1039. Cables: Hibeam, London.

Avantic PXD. 33. 15 in. Paper cone, foam suspension. Voice coil 3 in. Gap flux 15,000 gauss. Total flux 180,000 maxwells. H.C. 25 watts. v.c.i. 15 ohms. F.R. 20-1,000 c/s. r.c.f. 400 c/s. Price £28.

B.T.H. Sound Equipment Ltd., Crown House, Aldwych, London, W.C.2. Tel.: Temple Bar 8040. Cables: Soundequi, Lesquare, London.

B.T.H. 12A. 12 in. Paper cone. Fabric surround. Voice coil $1\frac{1}{2}$ in. Gap flux 14,400 gauss. Total flux 122,000 Maxwells. H.C. 18 watts. v.c.i. 15 ohms. F.R. 50-10,000 c/s. Price £14.

B.T.H. 12B. 12 in. Paper cone. Foam surround. Voice coil $1\frac{1}{2}$ in. Gap flux 14,400 gauss. Total flux 122,000 maxwells. H.C. 12 watts. v.c.i. 15 ohms. F.R. 40-10,000 c/s. Price £14 14s.

B.T.H. DC12 Dual Concentric. 12 in. Paper cone. Fabric surround. Voice coils (L.F.) $1\frac{1}{2}$ in. (H.F.) 1.56 in. Gap flux (L.F.) 10,000 gauss (H.F.) 13,000 gauss. Total flux (L.F.) 85,000 maxwells (H.F.) 49,000 maxwells. H.C. 15 watts. v.c.i. 15 ohms. F.R. 50-14,000 c/s. Built-in crossover 1,500 c/s. Price £25.

B.T.H. 18A. 18 in. Paper cone. Fabric surround. Voice coil $2\frac{1}{2}$ in. Gap flux 15,000 gauss. Total flux 376,000 Maxwells. H.C. 40 watts. v.c.i. 10 ohms. F.R. 30-9,000 c/s. r.c.f. 500 c/s. Price £41.

B.T.H. 18B. Details as above, but Felt surround. R.F. 20-9,000 c/s.

B.T.H. 18C. 18 in. Paper cone. Fabric surround. Voice coil $2\frac{1}{2}$ in. Gap flux 11,800 gauss. Total flux 215,000 maxwells. H.C. 30 watts. v.c.i. 10 ohms. F.R. 30-9,000 c/s. r.c.f. 500 c/s. Price £25.

B.T.H. K10A. Dual Concentric. 18 in. Paper cone. Felt surround. Voice coils (L.F.) $2\frac{1}{2}$ in. (H.F.) 1.56 in. Gap flux (L.F.) 14,300 (H.F.) 16,700 gauss. Total flux (L.F.) 285,000 (H.F.) 63,000 maxwells. H.C. 25 watts. v.c.i. 10 ohms. F.R. 30-17,000 c/s. Built-in filter 1,700 c/s. Price £48.

★

C.Q. Audio Ltd., 2 Sarnesfield Road, Enfield, Middx. Tel.: Enfield 8262.

LS.95. 9 × 5 in. elliptical paper cone, corrugated surround. Voice coil $\frac{7}{8}$ in. Total flux 11,000 maxwells. H.C. 6 watts v.c.i. 15 ohms. F.R. 40-9,000 c/s. r.c.f. 4,000 c/s. Price £3 10s. (U.K. purchase tax £1 7s. 6d.).

LS 4/H.F. Unit. 4 in. paper cone, corrugated surround. H.C. 6 watts. v.c.i. 15 ohms. F.R. 3,000-20,000 c/s. r.c.f. approx. 4,000 c/s; 6 μ F condenser recommended when used with LS.95.

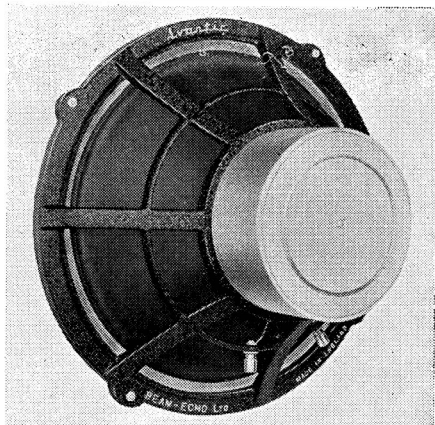

Avantic PXD33

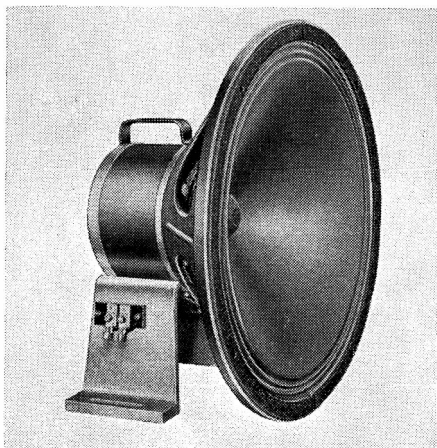

BTH Type 18A

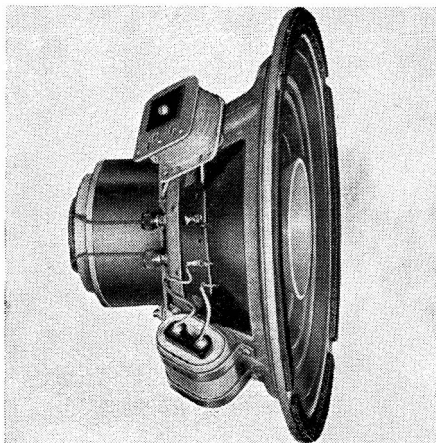

BTH Type DC12

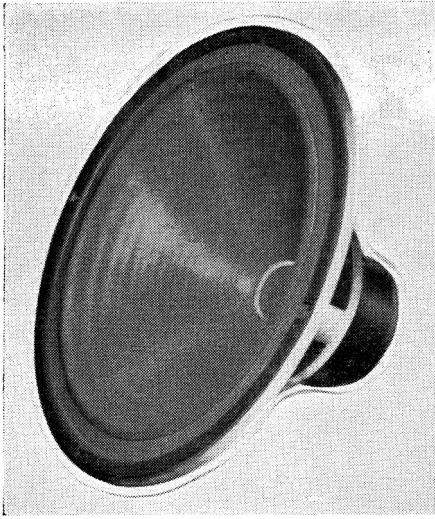

Duode 12D

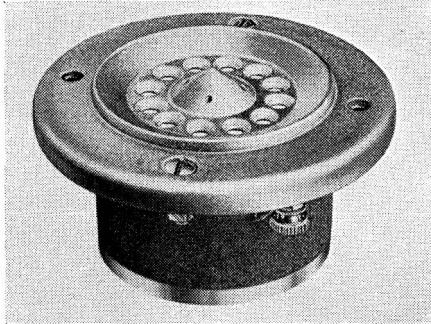

Fane 301 HF unit

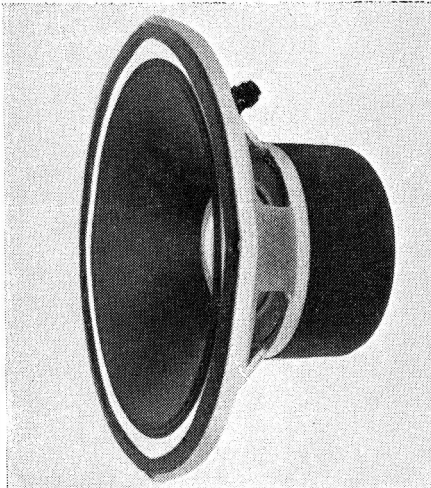

Fane H.D. 121A

Duode Ltd., BCM/Duode, London, W.C.1.

Duode 12E. 12-in. Linen moulded cone. Foamed plastic surround. Voice coil 1.5 in. Gap flux 17,000 gauss. Total flux 190,000 lines. H.C. 30-15 watts. v.c.i. 15-8-5 ohms. F.R. 20-16,000 c/s. Price £15.

Duode 12D. 12-in. Linen moulded cone. Foamed plastic surround. Voice coil 1.5 in. Gap flux 14,500 gauss. Total flux 130,000 lines. H.C. 15 watts. v.c.i. 30-15-8-5 ohms. F.R. 20-16,000 c/s. Price £12.

★

Fane Acoustics Ltd., 1 Wellington Street, Batley, Yorks. Tel.: Batley 1578. Cables: Fane, Batley.

Fane H.D. 121. 12 in. Paper cone. Foam surround. Voice coil 2 in. Gap flux 12,000 gauss. Total flux 160,000 maxwells. H.C. 20 watts. v.c.i. 15 ohms. F.R. 30-5,000 c/s. r.c.f. 2,000 c/s. Price £9.

Fane H.D. 121A. Details as above, but aluminium voice coil. F.R. 30-10,000 c/s. r.c.f. 5,000 c/s. Price £9 9s.

Fane 301 High Frequency Unit. Aluminium cone. Voice coil $\frac{3}{4}$ in. Gap flux 17,000 gauss. H.C. 12 watts. v.c.i. 15 ohms. F.R. 1,500-17,000 c/s. r.c.f. 2,000 c/s. Price £3 15s.

★

General Electric Co. Ltd., Magnet House, Kingsway, W.C.2. Tel.: Temple Bar 8000. Cables: Polyphase, London.

Metal Cone Speaker. BCS1851. 8-in. Duralumin cone. P.V.C. surround. Voice coil 1 in. Gap flux 13,500 gauss. Total flux 53,400 maxwells. H.C. 12 watts. v.c.i. 4.1 ohms at 400 c/s. F.R. 30-20,000 c/s. Price £6 13s. 7d. (U.K. purchase tax £2 11s. 5d.)

BCS1852 Presence Unit. Miniature metallised pressure diaphragm. Surround integral with diaphragm. Overall dia. $1\frac{1}{8}$ in. Voice coil $\frac{3}{4}$ in. Gap flux 10,500 gauss. Total flux 26,000 maxwells. H.C. 3 watts max. v.c.i. 15 ohms. F.R. 1,000-15,000 c/s. Price £3 19s. 6d. including condenser and mounting components.

BCS 1853. High Flux Presence Unit. Miniature metallised diaphragm. H.C. 12 watts max. v.c.i. 15 ohms. F.R. 1,500-13,000 level. r.c.f. 1,500 c/s. Price £6 10s.

Goodmans Industries Ltd., Axiom Works.
Wembley, Middx. Tel.: Wembley 1200,
Cables: Goodaxiom, Wembley.

Axiette. 8-in. Paper cone. Plastic treated surround. Voice coil 1 in. (2.5 cms). Gap flux 15,000 gauss. H.C. 6 watts. v.c.i. 3 ohms or 15 ohms. F.R. 40-15,000 c/s. Price £5 (U.K. purchase tax £1 18s. 6d.).

Axiom 80. 9½ in. Paper cone, free edge surround. Voice coil 1 in. (2.5 cms). Gap flux 17,000 gauss. Total flux 62,600 maxwells. H.C. 6 watts. v.c.i. 15 ohms. F.R. 20-20,000 c/s. Price £17 10s. (U.K. purchase tax £6 14s. 9d.)

Audiom 60. 12-in. Paper cone. Paper surround. Voice coil 1½ in. Gap flux 14,000 gauss. Total flux 158,000 maxwells. H.C. 15 watts. v.c.i. 15 ohms. F.R. up to 7,000 c/s. r.c.f. 750 c/s. when used as bass speaker in multi-speaker systems. Price £9 12s. 9d.

Audiom 70. 12-in. Paper cone. Paper surround. Voice coil 1½ in. (4.4 cms). Gap flux 17,500 gauss. Total flux 195,000 maxwells. H.C. 20 watts. v.c.i. 15 ohms. F.R. up to 7,000 c/s. r.c.f. 750 c/s. when used as bass speaker in multi-speaker systems. Price £15 2s.

Axiom 300. 12 in. Twin diaphragm, paper cone. Plastic treated surround. Voice coil 1½ in. Gap flux 14,000 gauss. Total flux 158,000 maxwells. H.C. 15 watts. v.c.i. 15 ohms. F.R. 30-16,000 c/s. Built-in mechanical crossover network at 5,000 c/s. Price £11 5s, 9d.

Axiom 400. 12 in. Twin diaphragm, paper cone. Plastic treated surround. Voice coil 1½ in. Gap flux 17,500 gauss. Total flux 195,000 maxwells. H.C. 20 watts. v.c.i. 15 ohms. F.R. 30-16,000 c/s. Built-in mechanical crossover network at 5,000 c/s. Price £16 1s.

Audiom 80. 15-in. Paper cone. Paper surround. Voice coil 2 in. (5 cms). Gap flux 14,500 gauss. Total flux 215,000 maxwells. H.C. 25 watts. v.c.i. 15 ohms. F.R. up to 7,000 c/f. 750 c/s. when used as bass speaker in multi-speaker systems. Price £22 10s.

Trebax. Horn-loaded pressure Tweeter. Aluminium diaphragm. Voice coil 1 in. H.C. suitable for inclusion in systems of up to 25 watts. v.c.i. 15 ohms at 10 Kc/s. F.R. 2,500-16,000 c/s. r.c.f. 5 Kc/s. Price £6 4s.

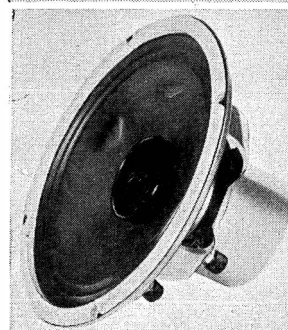
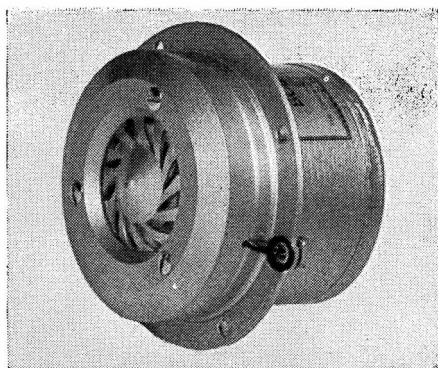

G.E.C. High Flux Presence unit

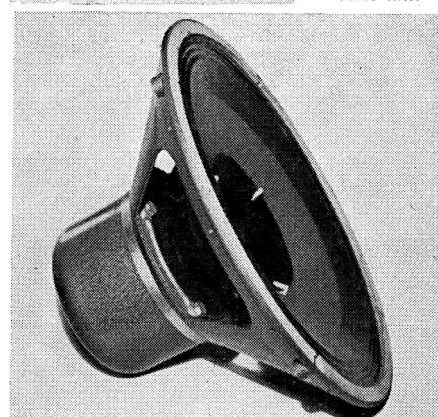

G.E.C. Metal cone unit

Goodmans Axiom 300

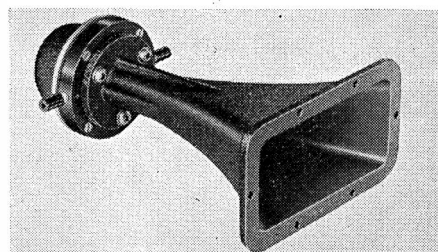

Goodmans Midax 650

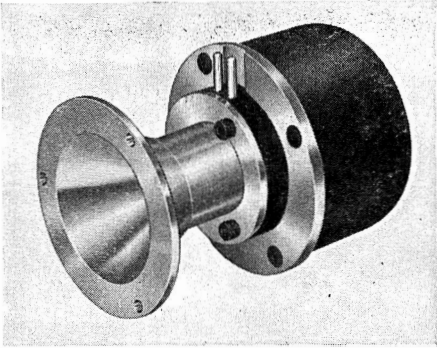

Goodmans Trebax

Midax 650. Horn loaded pressure unit. Resin impregnated linen diaphragm. Voice coil $1\frac{1}{2}$ in. H.C. suitable for systems up to 25 watts. v.c.i. 15 ohms. F.R. 650-8,000 c/s. r.c.f. 950 and 5,000 c/s. Price £9 10s.

★

Grampian Reproducers Ltd., Hanworth Trading Estate, Middx. Tel.: Feltham 2657/8/9. Cables: Reamp, Feltham.

Grampian 1255/15. 12-in. Paper impregnated cone and surround. Voice coil $1\frac{1}{4}$ in. Gap flux 14,500 gauss. Total flux 130,500 maxwells. H.C. 10 watts. v.c.i. 15 ohms. F.R. 35-15,000 c/s. Price £9.

★

The Lowther Manufacturing Co., Lowther House, St. Mark's Road, Bromley, Kent. Tel.: Ravensbourne 5225. Cables: Lowther, Bromley.

P.M.6. 6-in. Selected paper cone. Plastic surround. Voice coil 39 mm. Gap flux 17,500 gauss. Total flux 196,000 maxwells. H.C. 6 watts. v.c.i. 15 ohms. F.R. 20-18,000 c/s. Price £18 18s.

P.M.2. Mk. I. 6 in. Selected paper cone. Plastic surround. Voice coil 39 mm. Gap flux 21,000 lines per sq. cm. Total flux 281,000 maxwells. H.C. 6 watts. v.c.i. 15 ohms. F.R. 20-20,000 c/s. Price £30.

P.M.2 Mk. II. 6 in. Selected paper cone. Plastic foam surround. Voice coil 39 mm. Gap flux 23,000 gauss. Total flux 350,000 maxwells. H.C. 6 watts. v.c.i. 15 ohms. F.R. 22-20,000 c/s. Price £40.

P.M.3. 6-in. selected paper cone. Plastic surround. Voice coil 39 mm. Gap flux 22,000 gauss. Total flux 307,750 maxwells. H.C. 6 watts. v.c.i. 15 ohms. F.R. 20-20,000 c/s. Not sold separately from enclosure type T.P.1.

P.M.4. 6-in. Selected paper cone. Plastic surround. Voice coil 39 mm. Gap flux 24,500 gauss. Total flux 385,000 maxwells. H.C. 6 watts. v.c.i. 15 ohms. F.R. 20-25,000 c/s. Price £48.

★

Philips Electrical Ltd., Century House, Shaftesbury Avenue, W.C.2. Tel.: Gerrard 7777. Cables; Phillamps, London.

9710. 8 in. Paper cone corrugated surrounds. Voice coil 1 in. Gap flux 8,000

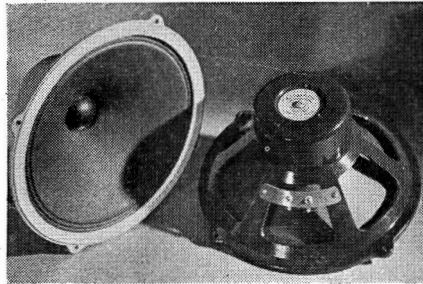

Grampian 1255/15

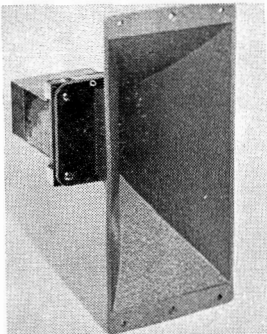

*Kelly
Ribbon
Tweeter
Mk. II*

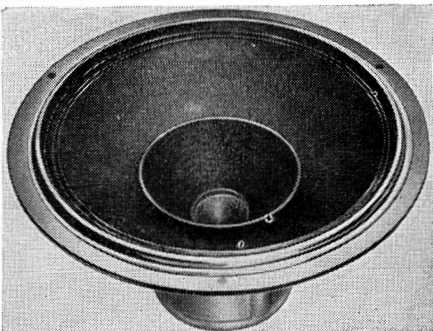

Philips 9762M 12-in. dual cone

gauss. Total flux 97,000 maxwells. H.C. 10 watts. v.c.i. 7 ohms. F.R. 40-10,000 c/s. r.c.f. 500-1,000 c/s. Price £4 8s. 5d. (U.K. purchase tax £1 14s. 1d.).

9710 M. 8-in. Dual cone. Paper corrugated surround. Voice coil 1 in. Gap flux 8,000 gauss. Total flux 97,000 maxwells. H.C. 10 watts. v.c.i. 7 ohms. F.R. 40-18,000 c/s. r.c.f. 500-1,000 c/s. Price £4 18s. 7d. (U.K. purchase tax £1 17s. 11d.)

9762. 12-in. Paper cone. Corrugated surround. Voice coil 1½ in. Gap flux 11,000 gauss. Total flux 134,000 maxwells. H.C. 20 watts. v.c.i. 7 ohms. F.R. 40-10,000 c/s. r.c.f. 500-1,000 c/s. Price £10.

9762M. 12-in. Dual cone. Paper. Corrugated surround. Voice coil 1½ in. Gap flux 11,000 gauss. Total flux 134,000 maxwells. H.C. 20 watts v.c.i. 7 ohms. F.R. 40-18,000 c/s. Price £10 10s.

★

Rola Celestion Ltd., Ferry Works, Thames Ditton, Surrey. Tel.: Emberbrook 3402-6.

Colaudio 1550. 15 in. Paper cone. Foam surround. Voice coils (L.F.) 3 in. (H.F.) ¾ in. Gap flux (L.F.) 12,500 (H.F.) 14,500 gauss. Total flux (L.F.) 290,000 (H.F.) 73,500 maxwells. H.C. 25 watts. v.c.i. 15 ohms. F.R. 30-15,000 c/s. For use with 3K50 coupling unit. Price £32 10s. Coupling unit £2 19s. 6d.

★

Romagna Reproducers Ltd., 2 Sarnesfield Road, Enfield, Middx. Tel.: Enfield 8717.

Kelly Ribbon H.F. Speaker Mark 2. Aluminium foil ribbon. Catenodal horn, mouth 8 × 4 in. H.C. 10 watts max. v.c.i. 15 or 3.5 ohms. F.R. 1,500-25,000 c/s. Price £10 10s.

★

Sound Sales Ltd., Works and Acoustic Laboratories, West Street, Farnham, Surrey. England. Tel.: Farnham 6461/2/3. Cables: Sounsense.

Dual Suspension Auditorium. Models A and B. 12-in. paper cone. Very flexible velvet surround plus dual suspension spider. Voice coil working in 0.06 in. by ¼ in. deep gap, maximum effective travel ⅜ in. Gap flux

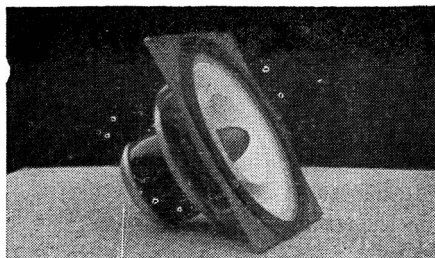

Lowther P.M.6

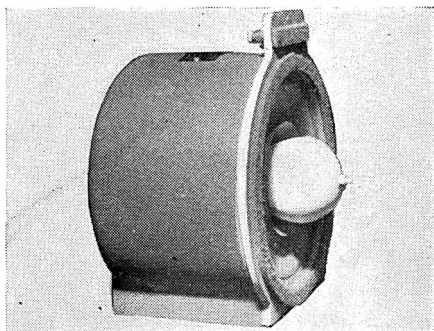

Lowther P.M.3

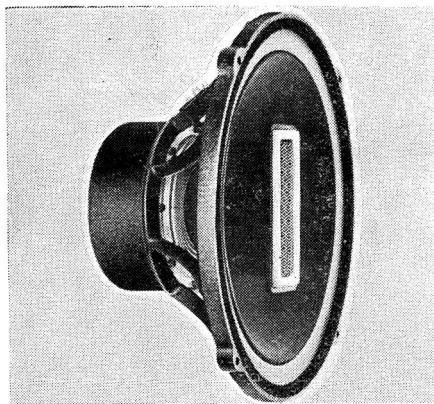

Rola Celestion Colaudio 1550

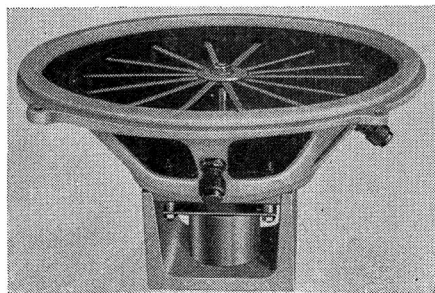

Sound Sales Dual Suspension Auditorium



Tannoy Monitor "Fifteen"

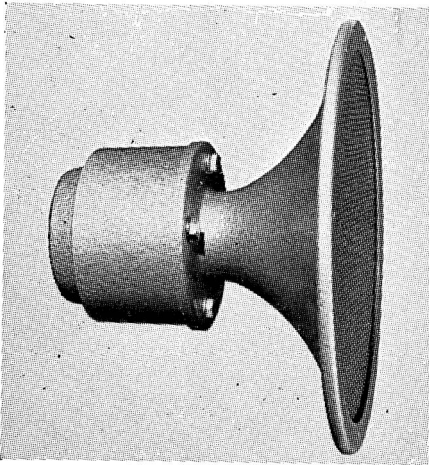

Tannoy H.F. unit

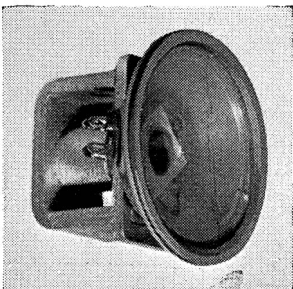

*TSL-Lorenz
LPH65
Tweeter*

10,600 gauss. Total flux 95,000 maxwells. H.C. 12 watts in suitable enclosure. v.c.i. model A 15 ohms; model B 3 ohms. F.R. 30-13,500 c/s. with suitable mounting. r.c.f. about 3,000 c/s. Price £9 13s. 4d.

★

Tannoy Products Ltd., West Norwood, London, S.E.27. Tel.: Gipsy Hill 1131. Cables: Tannoy, London.

12-in. Low Frequency Unit. Moulded fibre cone. Plastic treated surround. Voice coil 2 in. Gap flux 10,000 gauss. H.C. 15 watts. v.c.i. 15 ohms. F.R. 35-4,000 c/s. r.c.f. 1,700 c/s. Price £14 14s.

15-in. Low Frequency Unit. Moulded fibre cone. Plastic treated surround. Voice coil 2 in. Gap flux 12,000 gauss. H.C. 25 watts. v.c.i. 15 ohms. F.R. 30-3,000 c/s. r.c.f. 1,000 c/s. Price £21 10s.

Direct radiator. 12-in moulded fibre cone. Plastic treated surround. Voice coil 2 in. Gap flux 14,000 gauss. H.C. 15 watts. v.c.i. 20 ohms. F.R. 40-16,000 c/s. Price £14 14s.

High Frequency Speaker Unit. Horn loaded plastic coated light alloy diaphragm. Voice coil 2 in. Gap flux 15,000 gauss. H.C. 20 watts above 1,000 c/s. v.c.i. 15 ohms. F.R. 1,000-20,000 c/s. r.c.f. 1,000 c/s. Price £18.

Monitor "Twelve". 12 in. Moulded fibre cone. Plastic treated surround. Voice coils (H.F. and L.F.) 2 in. Gap flux (L.F.) 11,500 (H.F.) 15,000 gauss. H.C. 30 watts. F.R. 25-20,000 c/s. r.c.f. 1,700 c/s. Price £30 15s.

Monitor "Fifteen". 15 in. Moulded fibre cone. Plastic treated surround. Voice coils (L.F. and H.F.) 2 in. Gap flux (L.F.) 13,500 (H.F.) 18,000 gauss. H.C. 50 watts. F.R. 23-20,000 c/s. r.c.f. 1,000 c/s. Price £37 10s.

★

Technical Suppliers Ltd., Hudson House, 63 Goldhawk Road, London, W.12. Tel.: Shepherds Bush 2581/4794.

TSL-Lorenz. LP. 215. 8-in Reinforced paper cone. Permaflex surround. Voice coil 1 in. H.C. 8 watts, peak load 12 watts. v.i.c. 4.5 ohms. F.R. 35-12,000 c/s. Price £4 19s. 6d. (U.K. purchase tax £1 18s. 4d.)

LP. 312-2. 12-in. Reinforced ribbed paper cone. Permaflex surround. Voice coil $\frac{1}{2}$ in. H.C. 25 watts. (Peak rating in suitable enclosure 40 watts.) c.c.i. 15 ohms. F.R. 20 to above 17,000 with 2 type LPH 65 treble speakers in a fitted bridge assembly. r.c.f. 3,000-5,000 c/s. Price £14 19s. 6d.

TSL-Lorenz Tweeter LPH 65. $2\frac{3}{4}$ in. Special plastic cone. Plastic surround. Voice coil $\frac{1}{2}$ in. H.C. 2 watts (H.F. only). v.c.i. 5.5 ohms. F.R. 2,000 to above 17,000 c/s. r.c.f. 3,000-5,000 c/s. Price £1 8s. 6d. (U.K., purchase tax 11s.)

★

Vitavox Ltd., Westmoreland Road, London, N.W.9. Tel.: Colindale 8671. Cables: Vitavox, Hyde, London.

Duplex Coaxial DU 120. 12-in and 3-in. Paper and polyester film cones and surround. Voice coil (L.F.) 1.75 in., (H.F.) 0.65 in. gap flux (L.F.) 14,000, (H.F.) 12,000 gauss. Total flux (L.F.) 160,000, (H.F.) 15,000 maxwells. H.C. 15 watts. v.c.i. 15 ohms. F.R. 40-15,000 c/s. nominal. Price £19 10s.

AK.120. 12 in. Paper cone. Paper surround. Voice coil 1.78 in. Gap flux 14,000 gauss. Total flux 160,000 maxwells. H.C. 15 watts. v.c.i. 15 ohms. F.R. 40-12,000 c/s. r.c.f. 1,000 c/s. Price £14.

K15/40. 15 in. Paper cone. Paper surround. Voice coil 2.25 in. Gap flux 14,000 gauss. Total flux 260,000 maxwells. H.C. 40 watts. v.c.i. 15 ohms. F.R. 40-10,000 c/s. r.c.f. 500 c/s. Price £25.

★

Westrex Co. Ltd., Coles Green Road, London, N.W.2. Tel.: Gladstone 5401/8, Cables: Westelcol, Norphone, London.

20/80 Low Frequency Unit. 15-in paper cone with damped surround and spider. Voice coil 3 in. of edgewound copper ribbon. Gap flux 13,200 gauss. v.c.i. 16 ohms. H.C. 30 watts. F.R. up to 800 c/s. r.c.f. 675 c/s. Price £33 15s.

High Frequency Unit, with acoustilens coupling unit. Horn loaded. Alloy dome on 3-in. voice coil of edgewound aluminium ribbon. Gap flux 17,500 gauss. H.C. above 500 c/s. up to 30 watts. F.R. 500 to over 15,000 c/s. r.c.f. 675 c/s. Speaker includes horn and acoustic lens giving necessary dispersion. Price complete with horn and lens £69 17s.

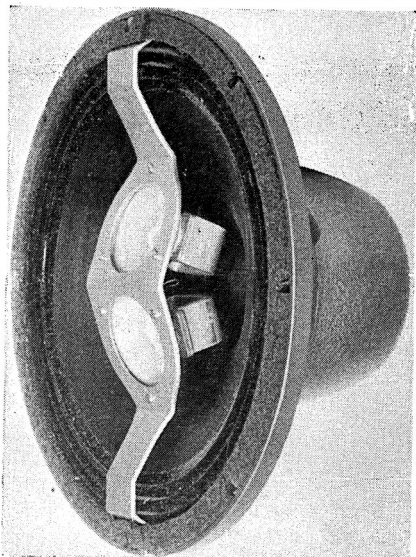

TSL-Lorenz LP312-2



Vitavox DU120 Duplex

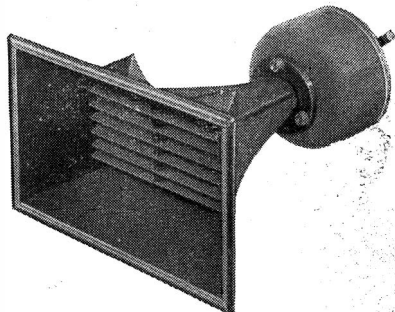

Westrex H.F. unit

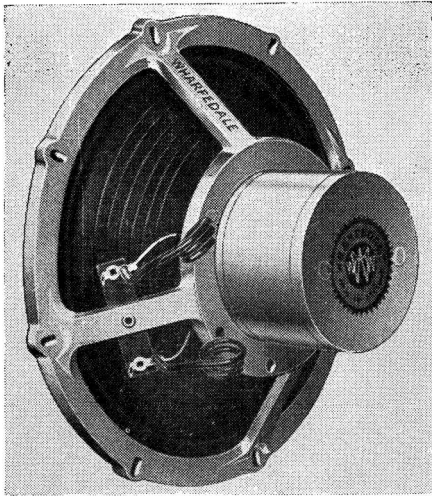

Wharfedale Super 8

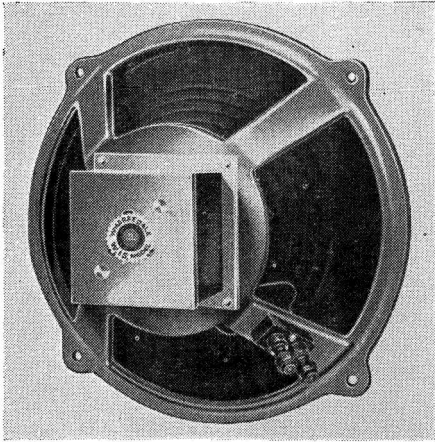

Wharfedale W15/FS

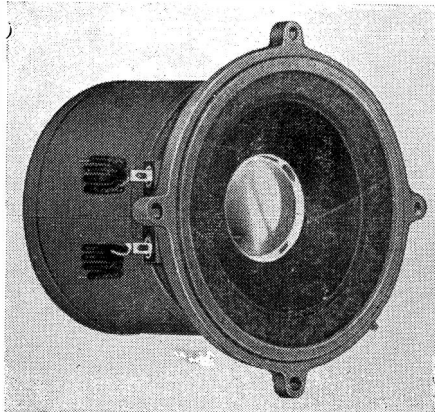

Wharfedale Super 3

Wharfedale Wireless Works Ltd., Idle, Bradford. Tel.: Idle 1235-6. Cables: Wharfedale, Idle, Bradford.

8-in. Bronze/FS/AL. Paper cone. Foam plastic surround. Voice coil 1 in. (aluminium). Gap flux 10,500 gauss. Total flux 41,500 maxwells. H.C. 4 watts. v.c.i. 2-3 ohms or 10-15 ohms. F.R. 40-12,000 c/s. Price £3 5s. (U.K. purchase tax £1 6s.)

Super 8. 8-in. Paper cone. Surround, paper corrugations. Voice coil 1 in. Gap flux 14,500 gauss. Total flux 60,000 maxwells. H.C. 6 watts. v.c.i. 2-3 or 12-15 ohms. F.R. 50-12,000 c/s. r.c.f. 1,000 c/s. Price £4 10s. (U.K. purchase tax £1 15s. 11d.)

Super 8/FS. 8-in. Paper cone. Foam plastic surround. Voice coil 1 in. Gap flux 14,500 gauss. Total flux 60,000 maxwells. H.C. 5 watts. v.c.i. 2-3 or 12-15 ohms. F.R. 40-12,000 c/s. Price £5. (U.K. purchase tax £1 19s. 11d.)

Super 8/FS/AL. 8 in. Paper cone. Foam plastic surround. Aluminium voice coil, 1 in. Gap flux 14,500 gauss. Total flux 60,000 maxwells. H.C. 4 watts. v.c.i. 2-3 or 10-15 ohms. F.R. 40-14,000 c/s. Price £5 5s. (U.K. purchase tax £2 1s. 11d.)

10-in. Bronze/FSB. Paper cone with bakelised apex. Foam plastic surround. Voice coil 1 in. Gap flux 10,500 gauss. Total flux 41,500 maxwells. H.C. 6 watts. v.c.i. 2-3 or 12-15 ohms. F.R. 30-10,000 c/s. Price £3 19s. 6d. (U.K. purchase tax £1 11s. 9d.)

Golden/FSB. 10-in. Paper cone with bakelised apex. Foam plastic surround. Voice coil 1 in. Gap flux 14,500 gauss. Total flux 60,000 maxwells. H.C. 8 watts. v.c.i. 2-3 or 12-15 ohms. F.R. 30-12,000 c/s. Price £6 5s. (U.K. purchase tax £2 9s. 11d.)

W10/FSB. 10-in. Paper cone with bakelised apex and aluminium dome. Foam plastic surround. Voice coil 1 in. Gap flux 16,000 gauss. Total flux 84,000 maxwells. H.C. 10 watts. v.c.i. 2-3 or 12-15 ohms. F.R. 30-14,000 c/s. Price £9 7s. 6d. (U.K. purchase tax £3 14s. 10d.)

W12/FS. 12-in. Paper cone with bakelised apex. Foam plastic surround. Voice coil 1½ in. Gap flux 13,000 gauss. Total flux 145,000 maxwells. H.C. 12 watts. v.c.i. 12-15 ohms. F.R. 30-10,000 c/s. Price £10 5s.

Super 12/FS/AL. 12-in. Paper cone with bakelised apex. Foam plastic surround. Voice coil $1\frac{1}{2}$ in. (aluminium). Gap flux 17,000 gauss. Total flux 190,000 maxwells. H.C. 12 watts. v.c.i. 12-15 ohms. F.R. 30-14,000 c/s. Price £17 10s.

W 15/FS. 15-in. Paper cone. Foam plastic surround. Voice coil 2 in. Gap flux 13,500 gauss. Total flux 180,000 maxwells. H.C. 15 watts. v.c.i. 12-15 ohms. F.R. 20-2,000 c/s. r.c.f. 800 c/s. Price £17 10s.

Super 3. 3-in. Bakelised paper cone with aluminium dome. Foam plastic surround. Voice coil 1 in. (aluminium). Gap flux 14,500 gauss. Total flux 60,000 maxwells. H.C. 6 watts above 1,000 c/s. v.c.i. 2-3 or 8-15 ohms. F.R. 3,000-20,000 c/s. r.c.f. 4,000 c/s. Price £5. (U.K. purchase tax £1 19s. 11d.)

8/145. 8 in. Paper cone. Foam surround. Voice coil 1 in. (aluminium). Gap flux 14,500 gauss. Total flux 60,000 maxwells. H.C. 4 watts. v.c.i. 2-3 or 10-15 ohms. F.R. 40-14,000 c/s. Price £5 5s. (U.K. purchase tax £2 1s. 11d.)

Coaxial 12. (L.F.) 12 in. (H.F.) 2 in. Paper cone. Foam surround. Voice coils (L.F.) $1\frac{1}{2}$ in. (H.F.) 1 in. Gap flux (L.F.) 14,000. (H.F.) 13,200 gauss. Total flux (L.F.) 155,000 (H.F.) 44,000 maxwells. H.C. 15 watts. v.c.i. 12-15 ohms only. F.R. 25-20,000 c/s. Price £25.

★

Messrs. Whiteley Electrical Radio Co. Ltd., Victoria Street, Mansfield, Notts. Tel: Mansfield 1762-5. Cables: Whitebon. Mansfield.

Stentorian HF.812. 8-in. Composite (paper and cambric) cone. Cambric surround. Voice coil 1 in. Gap flux 12,000 gauss. Total flux 47,400 maxwells. H.C. 5 watts. v.c.i. universal (3, 7.5 and 15 ohms). F.R. 50-12,000 c/s. Price £2 19s. 6d. (U.K. purchase tax £1 4s.)

H.F.816. 8-in. Composite (paper and cambric) cone. Cambric surround. Voice coil 1 in. Gap flux 16,000 gauss. Total flux 63,000 maxwells. H.C. 6 watts. v.c.i. universal 3 ohms, 7.5 ohms and 15 ohms. F.R. 50-14,000 c/s. Price £4 17s. 7. (U.K. purchase tax £1 19s. 5d.)

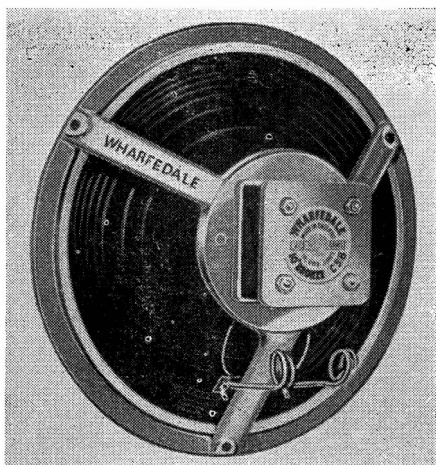

Wharfedale Bronze/FSB

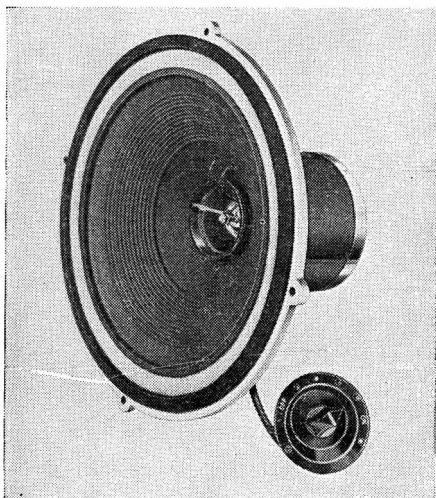

Wharfedale Coaxial 12

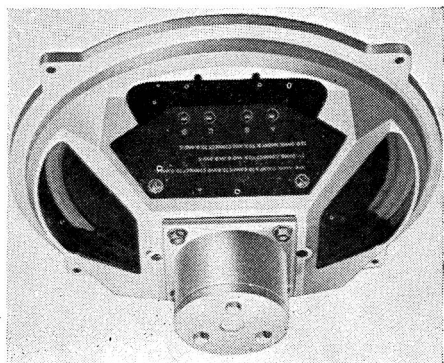

Whiteley HF 1012

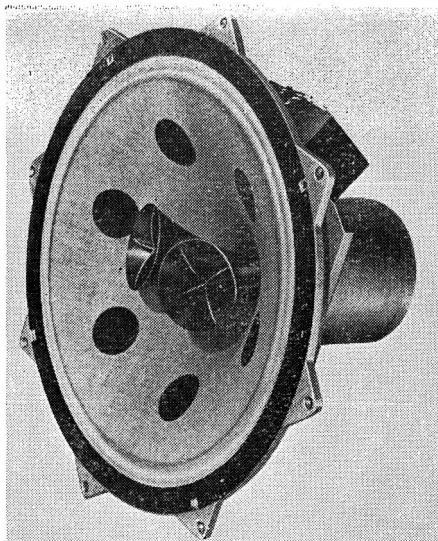

Whiteley 15-in. Concentric Duplex

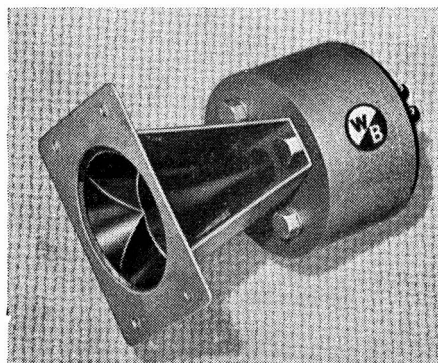

Whiteley T12 tweeter

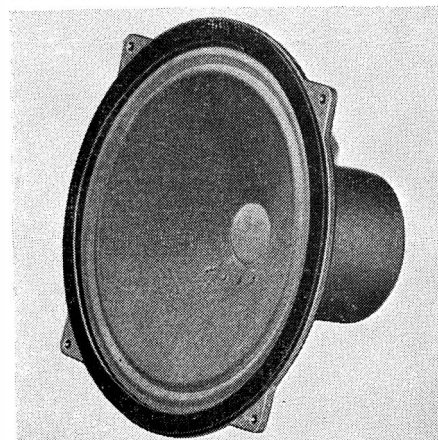

Whiteley H.F. 816 8-in.

H.F.817. 8 in. Paper cone. Cambric surround. Voice coil 1 in. Gap flux 17,000 gauss. Total flux 67,000 maxwells. H.C. 10 watts in cabinet. v.c.i. 15 ohms. F.R. 60-22,000 c/s. Price £8 2s. (U.K. purchase tax £3 5s. 6d.)

HF.912. 9-in. Composite (paper and cambric) cone. Cambric surround. Voice coil 1 in. Gap flux 12,000 gauss. Total flux 47,400 maxwells. H.C. 7 watts. v.c.i. universal (3, 7.5 and 15 ohms). F.R. 40-13,000 c/s. Price £3 3s. (U.K. purchase tax £1 5s. 6d.)

HF.1012. 10-in. Composite (paper and cambric) cone. Cambric surround. Voice coil 1 in. Gap flux 12,000 gauss. Total flux 47,400 maxwells. H.C. 10 watts. v.c.i. universal 3 ohms, 7.5 ohms and 15 ohms. F.R. 30-14,000 c/s. Price £3 11s. (U.K. purchase tax £1 8s. 9d.)

HF.1016. 10-in. Composite paper and cambric cone. Cambric surround. Voice coil 1 in. Gap flux 16,000 gauss. Total flux 63,000 maxwells. H.C. 10 watts. v.c.i. 3, 7.5 and 15 ohms. F.R. 30-15,000 c/s. Price £5 13s. 11d. (U.K. purchase tax £2 6s. 1d.)

10-in. Concentric Duplex. Composite (paper and cambric) cone. Cambric surround. Voice coil 1 in. Gap flux (L.F.) 12,000 (H.F.) 13,000 gauss. Total flux 47,400 maxwells. H.C. 10 watts. v.c.i. 15 ohms. F.R. 30-14,000 c/s. r.c.f. 3,000 c/s built-in. Price £9 3s. 9d. (U.K. purchase tax £3 14s. 3d.)

HF.1214. 12-in. Composite (paper and cambric) cone. Cambric surround. Voice coil 1.5 in. Gap flux 14,000 gauss. Total flux 106,000 maxwells. H.C. 15 watts. v.c.i. 15 ohms. F.R. 25-14,000 c/s. r.c.f. 1,500-3,000 c/s. Price £9 15s. 6d.

12-in. Concentric Duplex. Composite (paper and cambric) cone. Cambric surround. Voice coil 1½ in. Gap flux (L.F.) 14,000 (H.F.) 17,000 gauss. Total flux 220,000 maxwells. H.C. 15 watts. v.c.i. 15 ohms. F.R. 25-17,000 c/s. r.c.f. 3,000 c/s. built-in. Price £25.

15-in. Concentric Duplex. Composite paper and cambric cone. Cambric surround. Voice coil 2 in. Gap flux (L.F.) 14,000 (H.F.) 17,000 gauss. Total flux 350,000 maxwells. H.C. 25 watts. v.c.i. 15 ohms. F.R. 20-18,000 c/s. r.c.f. 3,000 c/s. built-in. Price £40 3s.

HF.1514. 15-in. Composite (paper and cambric) cone. Cambric surround. Voice coil 2 in. Gap flux 14,000 gauss. Total flux 178,000 maxwells. H.C. 25 watts. v.c.i 15 ohms. F.R. 25-5,000 c/s. r.c.f. 1,500-3,000 c/s. Price £24 10s.

T.10 Tweeter. Aluminium cone and surround. Voice coil 1 in. Gap flux 14,000 gauss. Total flux 44,000 maxwells. H.C. 5 watts. v.c.i. 15 ohms. F.R. 2,000-14,000 c/s. r.c.f. 3,000 c/s. Price £4 4s.

T.12. Tweeter. Aluminium cone and surround. Voice coil 1.5 in. Gap flux 17,000 gauss. Total flux 110,000 maxwells. H.C. 12 watts. v.c.i. 15 ohms. F.R. 2,000-17,000 c/s. r.c.f. 3,000 c/s. Price £12 12s.

T.816. 8-in. Paper cone and surround. Voice coil 1 in. Gap flux 16,000 gauss. Total flux 63,000 maxwells. H.C. 15 watts. v.c.i. 15 ohms. F.R. 1,500 to 17,000 c/s. r.c.f. 1,500 c/s. Price £4 12s. 7d. (U.K. purchase tax £1 17s. 5d.)

T.359. 3½ in. Paper cone and surround. Voice coil 0.625 in. Gap flux 9,000 gauss. Total flux 14,900 maxwells. H.C. 15 watts with crossover. v.c.i. 5 or 15 ohms. F.R. 3,000-17,000 c/s. r.c.f. 3,000 c/s. Price £1 4s. 11d. (U.K. purchase tax 10s. 1d.)

Acoustic Resistance Units

Goodmans Industries Ltd., Axiom Works Wembley, Middx. Tel.: Wembley 1200
Cables: Goodaxiom, Wembley.

172 ARU Unit. This unit combines both reflex port and acoustic resistance in one complete unit. The port area and resistance are calculated to suit a particular cabinet volume and speaker cone resonance, thus being usable with a variety of cabinet designs and driving units. Price £2 15s. 3d. to £4 4s.

★

Electrostatic Speakers

Acoustical Manufacturing Co. Ltd., St. Peter's Road, Huntingdon, Hunts. Tel.: Huntingdon 361 and 574. Cables: Acoustical.

Quad Electrostatic Loudspeaker. Full range doublet covering 45 c/s to 18 Kc/s. Attenuation outside band asymptotic to 18 dB/8ve. Total integrated radiation at max. output equivalent to 95 phons in rooms of up to 5,000 cu. ft. with average reverberation. Dispersion approx. 70 deg. horizontal; 15 deg. vertical. Impedance 30-15 ohms; 40 c/s to 8 Kc/s falling above 8 Kc/s. Designed for use with standard Quad II Amplifier or equivalent. Suitable for AC supplies 100-120 or 200-250v. 50-60 c/s. Free standing unit requires no enclosure or cabinet. Weight 35 lb. Price £52 complete.

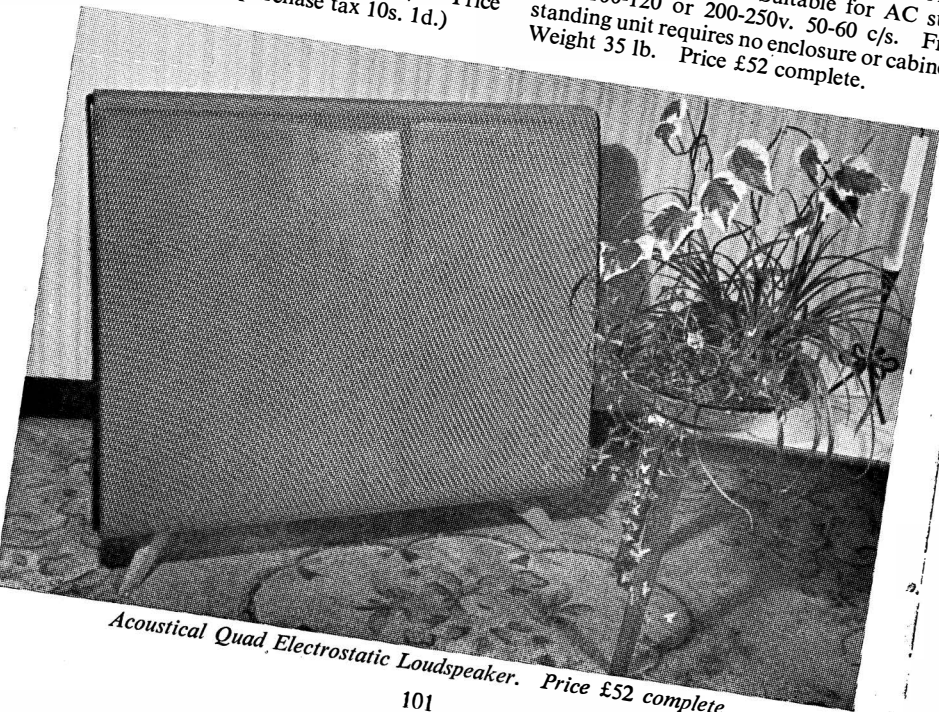

Acoustical Quad Electrostatic Loudspeaker. Price £52 complete

SPEAKERS, PART 2—ENCLOSURES

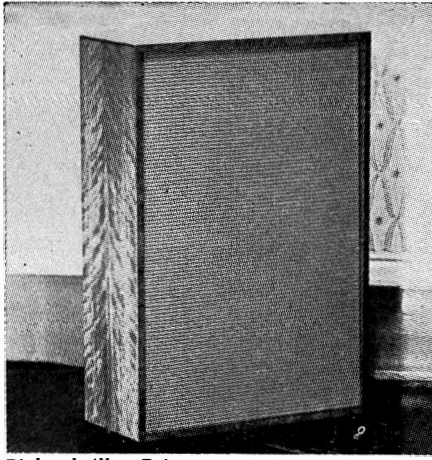

Richard Allan Princess

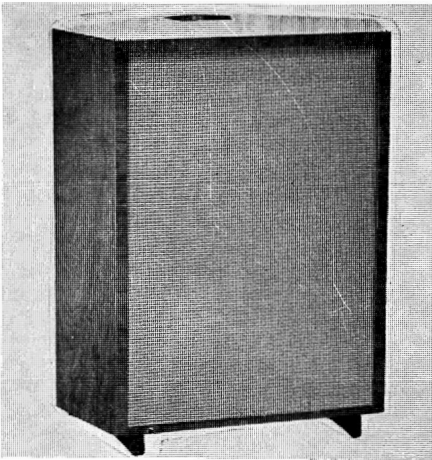

Richard Allan Duchess

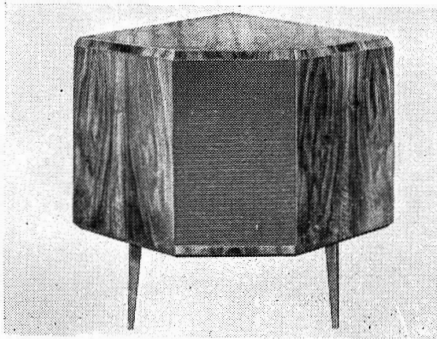

Beam Echo Avantic Mk. 6

Richard Allan Radio Ltd., Baffle House, Taylor Street, Batley, Yorks. Tel.: Batley 1123/1308/4033. Cables: Acoustics, Batley.

Princess. Reflex forward facing unit. Designed for corner location. One 8 in. drive unit. Rec. Golden Eight. Response 60-10,000 c/s. Size 28 × 20 × 12 ins. Weight 28 lb. Price £11 11s.

Duchess. Reflex unit designed for corner location. Upward facing tweeter, forward base. Two drive units. 10 in. bass and 4 in. tweeter. Rec. Golden Ten and 410T. Crossover CN.104. Response 40-17,000 c/s. Size 30 × 25 × 17 ins. Weight 48 lb. Price £15 15s.

Empress. Reflex unit designed for corner location. Upward facing tweeter, forward bass and middle units. Three drive units. 12, 8 and 4 ins. Rec. Golden Twelve, 812, and 410T. Crossover CN.1284. Response 25-17,000 c/s. Size 33 × 31 × 19 ins. Weight 72 lb. Price (complete) £37 16s., (without units) £17 17s.

★

Altobass Ltd., Percy Road, Aylestone Park, Leicester. Tel.: Leicester 31616. Cables: Altobass, Leicester.

Corner Folded Horn, forward facing 12-in. and 10-in. units, upward facing 1-in. tweeter with diffuser.

Bass Reflex Cabinets for Altobass 200. Dual concentric units. Two types for corner position or free standing.

★

Bakers "Selhurst" Radio, 24 Dingwall Road, Croydon, Surrey. Tel.: Croydon 2271/2.

A range of phase-inverter enclosures for single and multi-speaker systems. Prices on application.

★

Beam-Echo Ltd., 713 South Molton Street, London, W.1. Tel.: Mayfair 1039. Cables: Hibeam, London. Showrooms and Sales Office, 8 Eccleston Street, S.W.1. Tel.: Sloane 0695-7.

Avantic L 20. Forward facing reflex enclosure, dual throated ports for corner placing. Three drive units, 12 in. bass, mid-range unit and pressure H.F. unit. Crossover at 400 and 4,000 c/s. Response 20-20,000 c/s. Size 36 × 25 × 18 ins. Price (complete) £47 5s.

Avantic L. 35. Forward facing reflex enclosure, dual throated ports for corner placing. Three drive units, Beam-Echo PXD.33 15 in. bass unit, separate middle and H.F. units. Crossover at 400 and 4,000 c/s. Response 20-20,000 c/s. Size 45 × 33 × 22 ins. Price (complete) £94 10s.

Avantic SL 71. Reflex forward facing unit. Two drive units. 10 × 8 ins. bass, 4 in. treble. Crossover included. Response 50-12,000 c/s. Size 36 × 12½ × 9¾ ins., including legs. Price £17 17s.

Avantic SL 12-21. Reflex forward facing unit. Two drive units. 12 in bass and pressure unit. Crossover included. Response 40-17,000 c/s. Size 38 × 18½ × 15¾ ins. Price £23 2s.

★

B.K. Partners Ltd., 229 Regent Street, London, W.1. Tel.: Regent 7363.

L.P.R. 103. Reflex with acoustic filter. Two drive units, with h.f. upward and l.f. direct radiation. Rec. Wharfedale Bronze 10/FSB and Wharfedale Super 3 tweeter. Crossover through 2 mfd filter condenser and level control. Response 35-18,000 c/s. Size 29½ × 20 × 11 ins. (at base). Price (with rec. units) £24 19s. 8d. (U.K. purchase tax £3 11s. 8d.); without units, £12 8s. 6d.

AP.10 and AP.12. Audio Plan speaker unit. Forward facing reflex, designed to accept 12 or 10 in. units with resonance below 40 c/s., also some H.F. units. Rec. Tannoy 12 in. dual concentric Vitavox DU.120; Wharfedale W.12/FS, Super 12, Bronze 10, etc. Size 24 × 18 × 18½ ins. Weight 42 lb. Price of cabinet only £16 19s. 6d.

Eight 1 Four. Reflex with "Acoustiflex". Forward facing L.F. unit, upward facing H.F. unit. Two drive units. 8 in. bass, 4 in. treble. Rec. B-K 812/4 assembly with crossover. Response 40-16,000 c/s. Size 14½ × 11 × 24 ins. Price (complete) £13 16s. 4d. (without units) £8 10s.

Twelve 2 Four. Reflex with "Acoustiflex". Forward facing with H.F. units at 45 degrees.

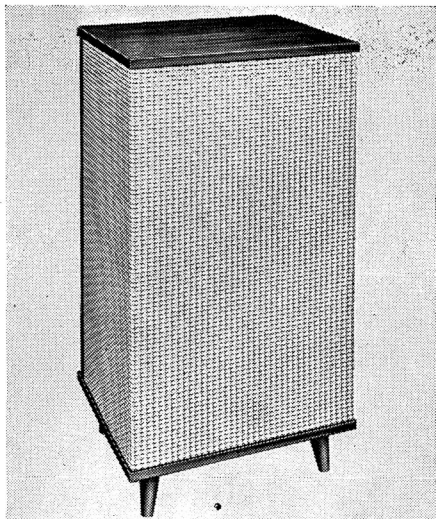

Beam Echo Avantic SL12-21

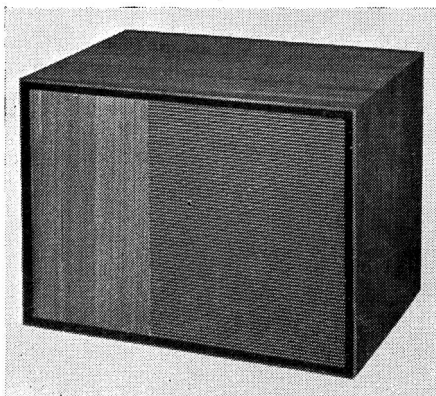

BK Partners AP10



BK Partners Twelve 2 Four

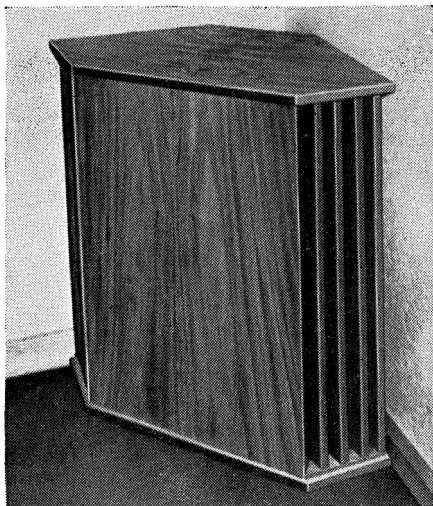

Burne-Jones R-2

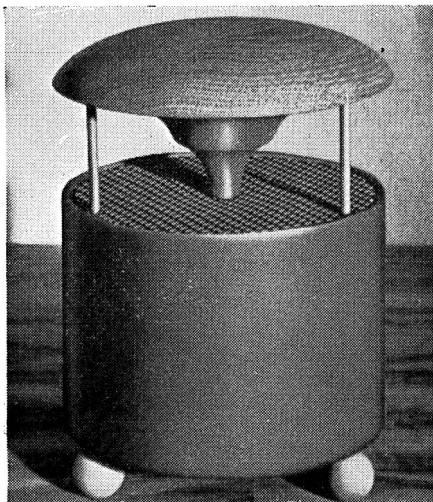

B.J. "Top C"

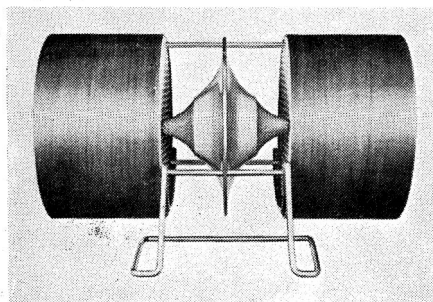

Burne-Jones Treble Twin

Three drive units. Phillips Dual Cone 12 in., and two 4 in. H.F. units. Crossover included. Response 40-16,000 c/s. Size 24 × 29 × 12 ins. including 4½ in. legs. Price £26 10s.

Note: The above is a Sidewall version. There is also a corner version, size 33½ × 27 × 12 ins., including legs. Price £28 10s.

★

Burne-Jones & Co., Ltd., 18 Brunswick Road, Sutton, Surrey. Tel: Vigilant 5050. Cables: Burjomag, Sutton.

B.J. Reproducer Cabinet R-1. Corner horn including reflex loading: a two- or three-speaker system, radiating forwards, also backwards into the corner. Rec. units, Bass units, 10-in. and 8-in. from the Wharfedale and Stentorian ranges, and tweeter if required in space provided. Response with selected units, 30-20,000 c/s. Size 41½ × 35 × 18½ ins. Price of cabinet £26 15s. 6d. including side panels.

B.J. Reproducer Cabinet R-2. A new horn loaded and reflex reproducer complete with 12-in. drive unit. Response 25-15,000 c/s. Price £30 9s.

B.J. Sonetta. Reflex column. Two drive units. 9 in. and 4 in. Crossover included. Response 35-18,000 c/s. Size 26 × 12 × 12 ins. Price £12 7s. 6d. (U.K. purchase tax £4 19s.)

B.J. Top "C" Tweeter. Horn loaded omni-directional. To stand on top of any reproducer. Response 1,000-18,000 c/s. rec. for use with all enclosures. Complete with built-in crossover and balance control. Price £3 15s. (U.K. purchase tax £1 10s.)

B.J. Treble 20. Omnidirectional multi-horn. One 4 in. unit. Crossover built in. Response 1,000-18,000 c/s. Size 6 × 5 ins. Weight 1½ lb. Price £5 5s. (U.K. purchase tax £2 2s.)

B.J. Treble Twin. Omnidirectional horn. Two 4 in. drive units. Crossover included. Response 900-18,000 c/s. Size 9 × 4½ × 6 ins. Weight 2 lb. Price £7 2s. 9d. (U.K. purchase tax £2 17s. 2d.)

★

C.Q. Audio Ltd., 2 Sarnesfield Road, Enfield, Middx. Tel.: Enfield 8262.

Senior "CQ". Controlled "Q" reflex. Forward facing table model, with optional screw-in legs. Wide range 9 × 5 in. elliptical, and 4 in. extended range tweeter. Crossover at 7,000 c/s. Response 35-17,000 c/s. Size 22 × 12 × 13 ins. Weight 22 lb. Price £13 4s. 6d. (U.K. purchase tax £5 3s.).

"Tetraq" treble unit. Two 4 in. tweeters housed in a box with four triangular sides. Range 4,000-20,000 c/s., crossover built in. Price (complete) £4 16s. (U.K. purchase tax £1 19s.).

CQ Junior Enclosure. Controlled "Q" reflex. Forward facing bookshelf model. One drive unit. Response 45-12,000 c/s. Size 17½ × 10 × 9 ins. Weight 10 lb. Price £9 14s. (U.K. Purchase Tax £3 19s.)

CQ Q-Flex. Flexing wall reflex kit for home constructors. Upward facing units with H.F. deflector. (£7 7s.) Three drive units, one 9 × 5 ins., and two 4 ins. Response 40-17,000 c/s. Size 34 × 17½ × 13½ ins. Price £5 5s. (U.K. Purchase Tax £2 2s.)

3-Way Speaker System. Controlled "Q" principle. Four drive units. 12 in. bass; elliptical middle unit semi-horn loaded; two 4 in. tweeters. Size 30 × 20 × 12 ins. Price (provisional) £40 9s. Or De Luxe model using Kelly Mark II Ribbon tweeters. £50 8s.

★

Dynatron Radio Ltd., St. Peter's Road, Furze Platt, Maidenhead, Berks. Tel.: Maidenhead 5151/5.

CLS10. Bass reflex, forward facing. Three drive units. Goodmans 12 in. and two 5 in. treble units. Size 34 × 27½ × 13½ ins. Weight 55 lb. Price £30 9s.

CLS15. As above, but two drive units. Goodmans 12 in. Orlin III and one 5 in. treble unit. Weight 65 lb. Price £35 5s.

CLS20. As CLS15 above, with Goodmans Axiom 150 Mk II and Trebax Treble unit and filter. Price £46 10s.

TLS1. Baffle type, forward facing. Two drive units, 10 × 6 in. elliptical, and 5 in. treble unit. Size 12½ × 19½ × 13 ins. Price £14 14s.

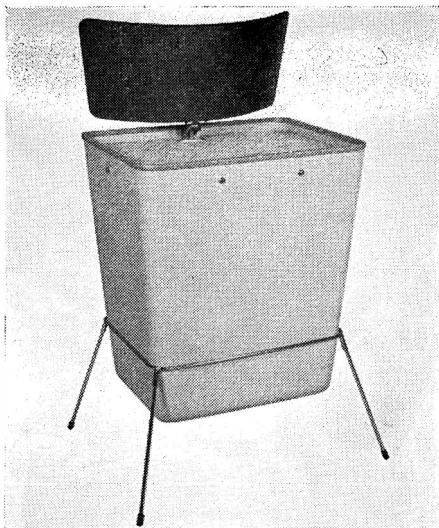

CQ Audio Q-Flex

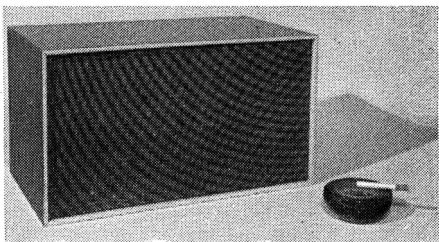

CQ Audio Junior Enclosure



Dynatron CLS10

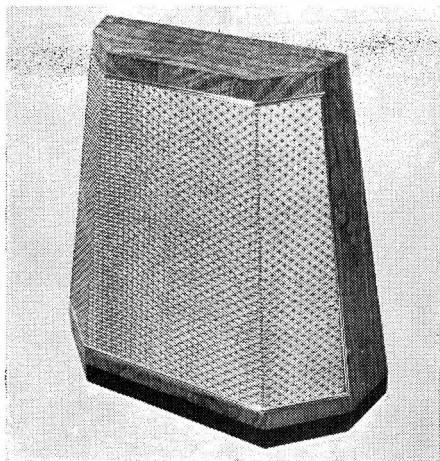

Fane Quartet

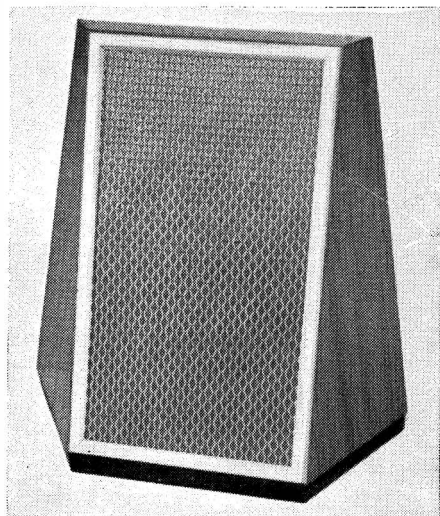

Fane Trio

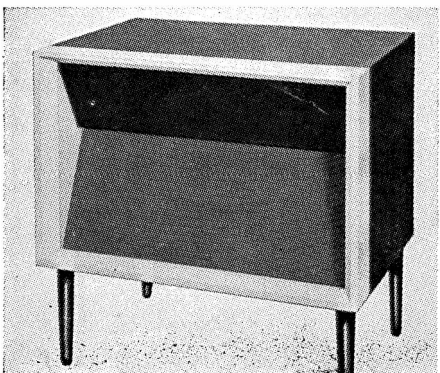

G.E.C. Baby Periphonic

Expert Gramophones Ltd., 39/41 New Oxford Street, London, W.C.1. Tel.: Covent Garden 2156.

"Acoustic Column". Elongated reflex. Vertically mounted 12 in. bass unit and 2½ in. tweeter. Rec. Goodmans 12 in. and Lorenz tweeter. Size 44 × 14 × 14 ins. Price (complete) £33.

"All Range." Corner reflex. Vertically mounted 12 in. unit; horizontally mounted 8 in. unit. Rec. Baker 12 in. and Philips 9710 M. Size 42 × 30 × 23 ins. Price (complete) £65.

Master Speaker. Corner reflex. 15-in. concentric unit, vertically mounted with reflector. 90° distribution. Rec. unit 15-in. Tannoy dual concentric. Crossover 1,000 c/s. Size 60 × 34 × 24 ins. Price (complete) £110; without unit £70.

★

Fane Acoustics Ltd., 1 Wellington Street, Batley, Yorks. Tel.: Batley 1578. Cables: Fane, Batley.

Trio. Cabinet-baffle, forward facing. Three drive units. 12 in., 8 in., and H.F. unit. Fane units rec. Crossover included. Response 40-17,000 c/s. Size 24½ × 24 × 8½ ins. Weight 13 lb. Price £17 10s.

Quartet. Cabinet-baffle, forward facing. Four drive units. 12 in., 8 in., and two H.F. units. Size 25½ × 25½ × 8¾ ins. Weight 32 lb. Price £35. Cabinet only not supplied.

★

General Electric Co., Ltd., Magnet House, Kingsway, London, W.C.2. Tel.: Temple Bar 8000. Cables: Polyphase, London.

Periphonic Cabinet. Model BCS 1869. Double-pipe loaded with periphonic L.S. coupling unit, forward facing. Two metal-cone type units 8-in. nominal, with 4 presence units, 2 front and one each side. Special crossover network and auto-transformers for 15 ohms input. Response 30-15,000 c/s. Size 42 × 15 × 36 ins. Price complete, less metal cone units £98.

Baby Periphonic BCS 1870. Periphonic coupling, forward facing. Two metal cone 8 in. bass units, with two presence units. Response 40-15,000 c/s. Size 21 × 22 × 14¾ ins. Weight 42 lb. Price, cabinet only, £13.

Octagonal Periphonic BCS 1872. Periphonic with pipe loading. Forward facing. Two metal cone 8 in. bass, and one or two presence units. Response 30-15,000 c/s. Size 30 × 20 × 14½ ins. Weight 38 lb. Price cabinet only, £17 10s.

★

Goodmans Industries Ltd., Axiom Works, Wembley, Middlesex, England. Tel: Wembley 1200. Cables: Goodaxiom, Wembley.

Stereophonic Bowl Unit S.23. Contains special 6 in. drive unit, and filter. Response with filter 300-15,000 c/s. Size 6¾ × 8½ ins. Price £17 6s. 6d. Without filter £8 8s.

Axiette Corner Reflex. Supplied ready to assemble. One 8 in. drive unit. Rec. Axiette. Response 40-15,000 c/s. Size 25½ × 26½ × 18½ ins. Price, without unit, £14 1s. 6d.

I.B.3. Infinite Baffle, forward facing. Three drive units. 12 in. Bass, horn-loaded mid-range, and horn-loaded H.F. units. Crossovers included at 950 and 5,000 c/s. Response 35-16,000 c/s. Size 14¼ × 24 × 12¼ ins. Only supplied as complete system. Price £59 17s.

A range of loudspeaker systems is produced complete in enclosures; fitted with one, two, three or four drive units. These enclosures employ friction loading using acoustical resistance units and are normally supplied complete. Write for a copy "High Fidelity Loudspeaker Manual" which gives latest details and prices of the range.

★

Grampian Reproducers Ltd., Hanworth, Trading Estate, Feltham, Middlesex, England. Tel.: Feltham 2657. Cables: Reamp Feltham.

Grampian WS8. Totally enclosed, forward facing. Fitted with 8-inch drive unit. Handling capacity 7 watts. Size 23 × 12 × 12 ins. Shaped for corner or wall position. Price £16 16s. (including Purchase Tax), legs extra £1 10s.

Grampian RB12. Forward facing reflex, shaped for corner or wall position. One 12-in. unit. Grampian rec. 1255/15. Size 31 × 22 × 16 ins. Weight 60 lb. Price (complete) £25; without unit £16.

The above cabinet also available in kit form, for user assembly. All woodwork fully machined and drilled; ready to assemble stain and polish. Complete with mesh material, screws, glue, etc., £11.

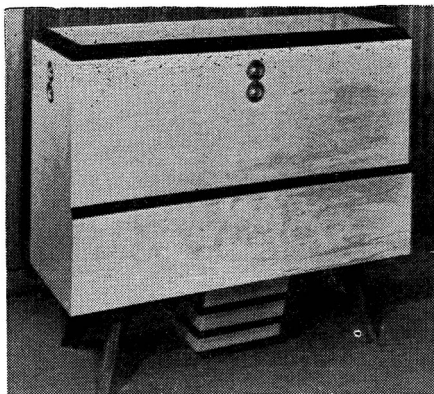

G.E.C. Periphonic Enclosure

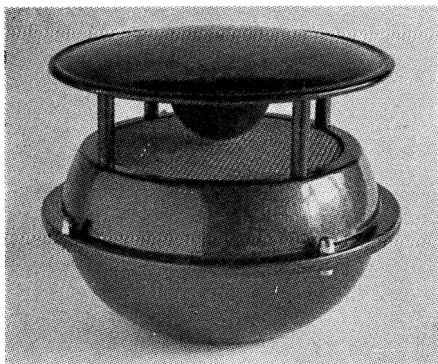

Goodmans Stereophonic Bowl

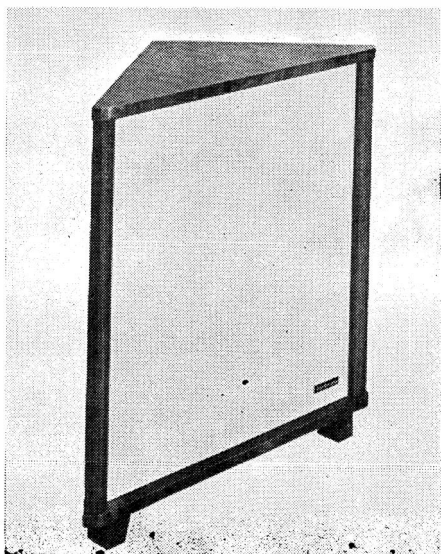

Goodmans Axiette Enclosure Kit



Grampian WS8

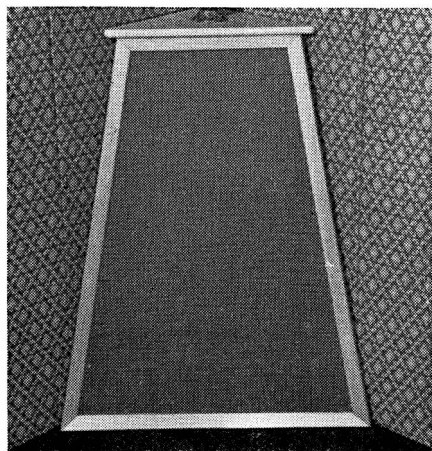

Lektra Gazelle

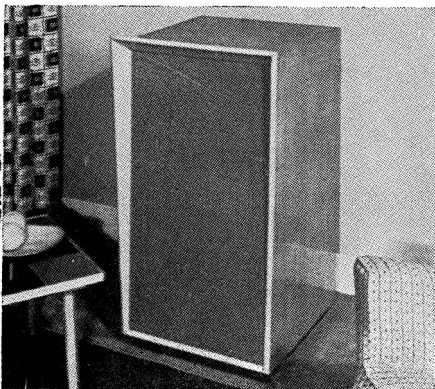

Musicraft F.E.H.

Lektra Products, 118 Gordon Road, London, W.13.

Gazelle. Reflex corner kit. One 8 or 10 in. unit, and one tweeter. Size $30 \times 23\frac{1}{2} \times 12\frac{1}{2}$ in. Weight 20 lb. Price £6 6s.

Mayfair. Reflex corner kit. One 10 or 12 in. unit, and one tweeter. Size $36 \times 28 \times 16\frac{1}{2}$ ins. Weight 30 lb. Price £9 9s.

★

Lockwood & Co. (Woodworkers) Ltd., 67 Lowlands Road, Harrow, Middlesex, England. Tel.: Byron 3704.

LE.1. Reflex, forward facing. Suitable for 15 in. dual concentric unit, or 3-way combination. Size $44 \times 24 \times 17\frac{1}{2}$ ins. Concealed castors. Price £38 10s.

LE.2, 3, and 4. These have a similar outward appearance and design to the LE.1 above, but are progressively smaller in dimension and price, and are suitable for smaller speaker systems. The smallest, LE.4, is $27\frac{1}{2} \times 17\frac{1}{2} \times 12\frac{1}{2}$ ins. Price £15 15s.

★

Lowther Manufacturing Co., Lowther House, St. Mark's Road, Bromley, Kent, England. Tel.: Ravensbourne 5225. Cables: Lowther, Bromley.

Corner Reproducer TP1. Folded bass horn/direct h.f. horn type. One specially designed 6-in. pressure unit PM3. Acoustical crossover. Response 40-20,000 c/s. Size $47 \times 32 \times 31$ ins. from corner. Weight 70 lb. Price of standard Model A £96. Model B £106.

Corner Horn Model PW2. Horn and bass chamber type, with front of diaphragm horn loaded down to 250 c/s, rear bass chamber down to 40 c/s. One 6-in. or 8-in. unit. Rec. Lowther PM6 or PM2 Mk. 1. Response 40-18,000 c/s. Size 60×15 ins., corner to front face. Weight 60 lb. Price £34 10s.

Acousta Cabinet. Models FH/V, FH/H. Folded horn type, forward facing, with rear folded horn. Vertical on plinth, or horizontal on 12-in. legs. One unit, 6-in. or 8-in. Rec. Lowther PM6. Response 60-17,000 c/s. Size $30 \times 18 \times 15$ ins. Weight 45 lb. Price without unit £18 18s., walnut, oak, mahogany.

This enclosure is also available in a "Do-it-yourself" kit form. Price £14 14s. ex works.

Audiovector. Compound horn. 180 deg. compound upward facing mid- and high-frequency horn with rear folded horn. One 8 in. unit. Range 30-20,000 c/s. Size approx. 26 × 30 × 18 ins. Price approx. £50.

★

M.S.S. Recording Co. Ltd., Colnbrook, Bucks., England. Tel.: Colnbrook 2431. Cables: Emessco.

Model LSX/1. Reflex forward facing. Cabinet on walnut pedestal. One 8-in. unit. Response 40-15,000 c/s. Size 34 × 17 × 10½ ins. Price £25.

★

Musicraft, 20/22 High Street, Southall, Middx., England. (Branches at 13 King Street, Richmond, Surrey and 80/82 Uxbridge Road, Ealing, London, W.13). Tel.: Southall 3828.

F.E.H. Enclosure. Folded exponential horn type, forward facing. Two units, 8-in. and 3-in. Rec. Goodmans "Axiette" and Wharfedale Super 3. Crossover 4/5,000 c/s. Response 30-17,000 c/s. Size 36 × 20 × 20 ins. Price (complete) £40 19s.

★

Pamphonic Reproducers Ltd., 17 Stratton Street, London, W.1. Tel.: Grosvenor 1926.

Victor Senior. Two units. Bass, 15-in. treble 6-in. elliptical. Response 30-15,000 c/s. Crossover 1,000 c/s. Price £45.

Victor Junior. Two units. Bass 12-in., treble 6-in. elliptical. Response 35-12,000 c/s. Price £30.

S.1 Stereo. Cabinet type, forward facing. Elliptical 10 × 6 in. concentric cone unit. Size 15 × 12 × 11 ins. Price £10 12s. 5d. (U.K. purchase tax £4 1s. 7d.).

★

Pilot Radio Ltd., High Fidelity Div., Park Royal Road, London, N.W.10. Tel.: Elgar 7353. Cables: Piloset, Harles. London.

HFS 14. Corner reflex. Forward facing with bass and treble diffusion ports. One 12 in. unit with foam surround fitted. Range 30-16,000 c/s. Size 36 × 21 × 14 ins. Weight 31 lb. Price £29 8s.

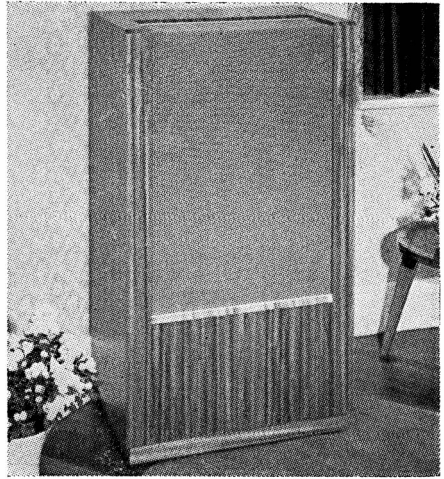

Lockwood LE1 reflex

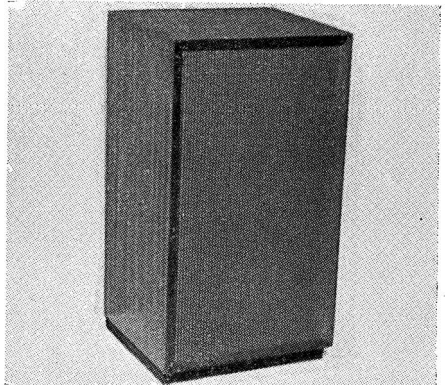

Lowther Acousta cabinet

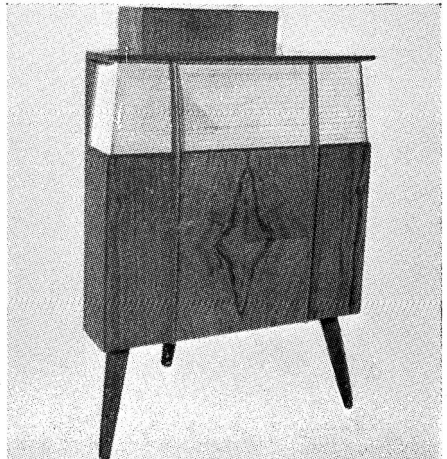

Lowther TP1



Pye Mozart HF10BS.

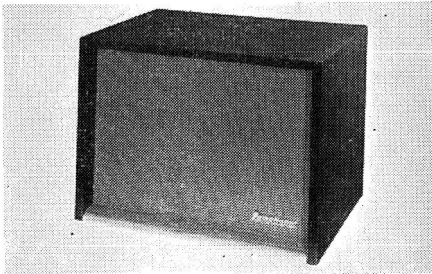

Pamphonic S1

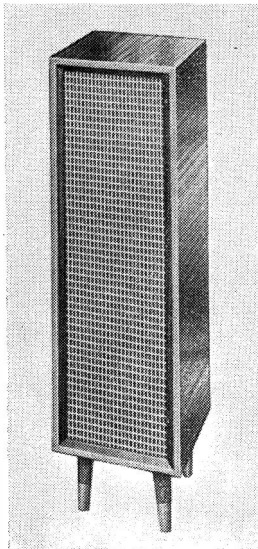

*Beam-Echo
Avantic SL71*

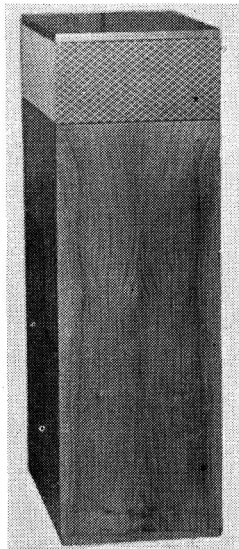

*Expert Gramophones
Acoustic Column*

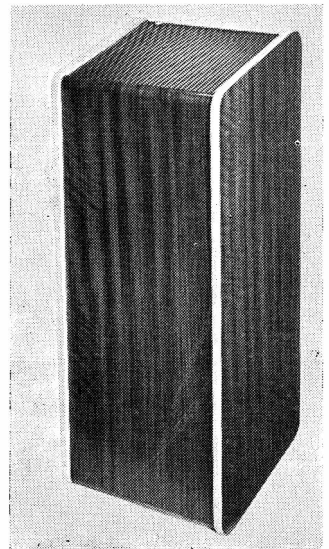

*Rogers Development 1284 3-way
system*

Pye Limited, 65 Fairview Road, London, S.W.16. Tel: Pollards 9441/2. Cables: Faramarine Souphone, London.

Enclosure HF12SMT. Reflex type, with forward facing unit. 12-in. unit and 4-in. tweeter, co-axially mounted. Response 30-15,000 c/s. Size $31 \times 20\frac{1}{2} \times 14\frac{1}{2}$ ins. Weight $79\frac{1}{2}$ lb. Price £33 12s.

Mozart Companion HF.10 BS. Folded duct bookcase loudspeaker. Two drive units. 8 in. bass and 4 in. H.F. Crossover frequency 7,000 c/s. Response 60-15,000 c/s ± 4 dB. Size $11\frac{1}{2} \times 25 \times 10\frac{1}{2}$ ins. Weight $22\frac{1}{2}$ lb. Price £22 1s. Legs £2 2s. extra.

De-Luxe HF.25 SCA. Reflex corner speaker, forward facing. With A.R.U. Three drive units. 15 in., 8 \times 6 in. elliptical, and 4 in. tweeter. Crossovers 1,500 and 7,000 c/s. Size $38\frac{1}{2} \times 28 \times 19$ ins. Weight 90 lb. Price £57 15s.

★

RCA Great Britain Ltd., Lincoln Way, Sunbury-on-Thames, Middlesex, England. Tel.: Sunbury 3101. Cables: telex and tex, 28608.

Panoramic Multiple Speaker System. Models LM1 32245F (walnut) and LM1 32245E (light oak). Ported bass reflex. Forward facing, screw-in legs. Three m. coil

units. 15-in. and two 2½-in. Crossover 2,000 c/s. Response 29-20,000 c/s. Price £56 11s. Size 32 × 25 × 16 ins. Weight 136 lb.

★

Rogers Developments (Electronics) Ltd., 4-14 Barmeston Road, Catford, London, S.E.6. Tel.: Hither Green 7424/4340. Cables: Rodevco, London, S.E.6.

RD Junior Corner Horn. Folded exponential horn, designed to use room's corner walls as part of horn. Diffused treble. One 8-in. unit. Rec. Goodmans "Axiette," Wharfedale Super 8 FS/AL, or Lowther PM6. Response 35-16,000/20,000 c/s (top limit dependent upon unit fitted). Size 36 × 32 × 25 ins. Price without unit £18 17s. 6d., plus optional pair of side panels £3 10s. Price with PM6 unit less panels £37 15s. 6d.

1284. 3-way column speaker. Three drive units. 12, 8 and 4 ins. Crossovers included. Response 35-17,000 c/s adjustable. Size 37 × 15 × 14 ins. Price £26 10s.

84. 2-way damped reflex loudspeaker system. Two drive units, 8-in. and 4-in. with adjustable vol. control. Impedance 5 ohms. Response 45-15,000 c/s. Size 28 × 12 × 12 ins. Price inc. Purchase Tax £18 18s.

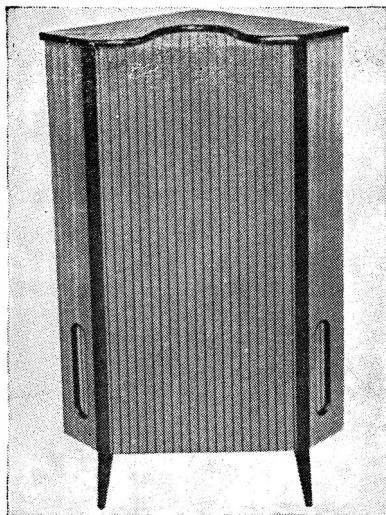

Pilot HFS14

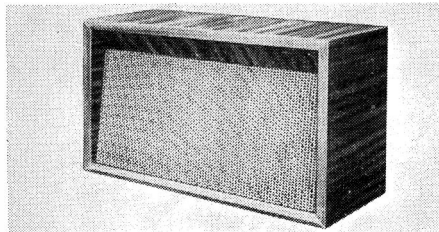

Orthotone STD/418

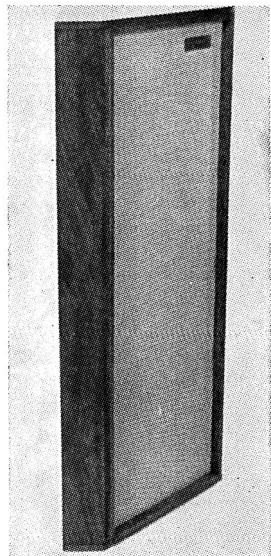

*Tannoy Products
Chatsworth*

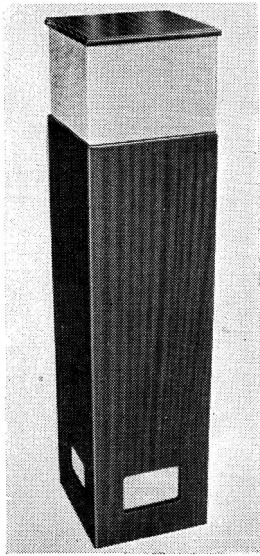

*Whiteley Electrical
Stentorian WB Column*

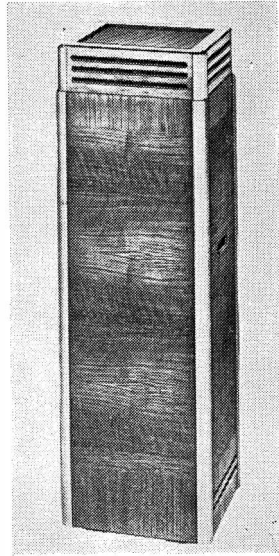

*Wharfedale Wireless
Column eight*

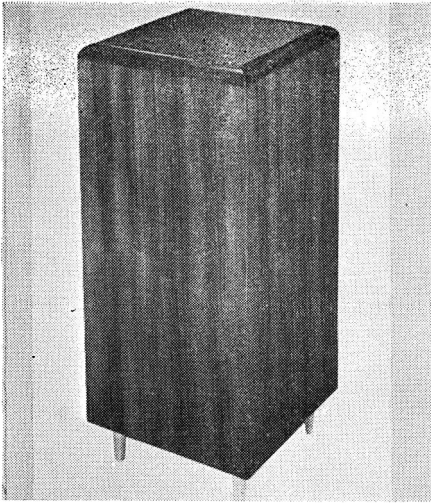

Rogers 84 2 speaker system

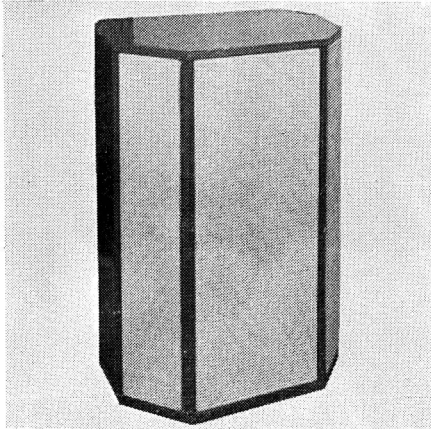

Orthophonic STD/415

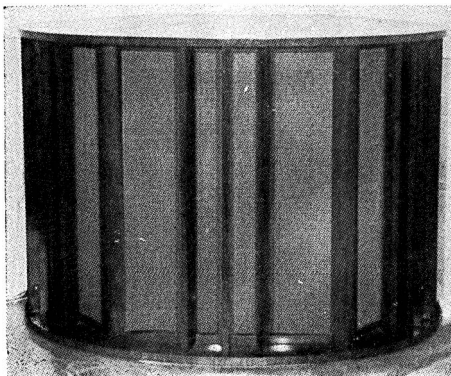

Sound Sales Tri-Channel

Scientific & Technical Developments Ltd., Melbourne Works, Melbourne Road, Wallington, Surrey. Tel.: Wal. 9252. Cables: Electronic, Wallington.

“**Orthotone**” STD/418. Reflex bookshelf speaker. One 8 in. drive unit. Rec. Goodmans “Axiette”. Response 60-15,000 c/s. Size 13 × 23 × 12 ins. Price without unit £10 10s. Legs £1 15s. extra.

“**Orthotone**” STD/415. Octagonal reflex enclosure. Forward-facing 1 or 2 8 in. drive units. Rec. Goodmans “Axiette” or G.E.C. Metal Cone with Presence Unit. Response 30-15,000 c/s. Size 30 × 20 × 15 ins. Price, without units. £19 19s.

“**Orthotone**” STD/417. Octagonal Enclosure. Forward facing. Two drive units. 12 in. and tweeter. Size 35 × 24½ × 15 ins. Price, without units, £26 5s.

★

Sound Sales Ltd., Works and Acoustic Laboratories, West Street, Farnham, Surrey. England. Tel.: Farnham 6461. Cables: Sounsense.

Phase Inverter Speaker. Model A, 15 ohms. Model B, 3 ohms. Reflex type. Ported cabinet for forward facing, inc. treble diffuser. 12 watt handling. 12-in. Sound Sales dual suspension auditorium unit. Response 30-13,500 c/s. Size 29 × 14 × 18½ ins. Weight 44 lb. Price £20 10s. complete.

Tri-Channel Mk. 5. Special labyrinth construction, reflex. Distribution over 90° arc. Three 12-in. Sound Sales Auditorium units, and one electrostatic tweeter. Response 25-27,000 c/s when used with associated amplifiers. (This equipment is sold complete. Refer to amplifier section). Size 43 × 31 × 35 ins. Weight 202 lb. Price, including amplifiers and tone control unit, complete, £125.

★

Tannoy Products Ltd., West Norwood, London, S.E.27. Tel.: Gipsy Hill 1131. Cables: Tannoy, London.

Canterbury. Reflex, with forward facing unit, dual throated ports, for corner placing. One 12-in. dual concentric unit, or direct radiator. Size 37 × 25 × 17 ins. Price, with dual concentric, £57 15s.; with direct radiator, £43 15s.

Lansdown. Reflex. Forward facing unit, dual throated ports. For side wall placing. One 12-in. dual concentric unit. Response 30-20,000 c/s. Size 32 × 36 × 17 ins. Price £75.

York. Reflex. Forward facing unit, dual throated ports, for corner placing. 12-in. or 15-in. dual concentric unit. Response 35-20,000 c/s. Size 45½ × 32 × 22½ ins. Price, with 12-in. unit, £66; with 15-in. £75.

G.R.F. Folded horn. Rear horn loaded, forward facing unit, for corner. One 15-in. dual concentric unit. Response 20-20,000 c/s. Size 48 × 38 × 29 ins. Price £122.

Guy R. Fountain Autograph. Folded horn. Front and rear horn-loaded unit, forward facing for corner placing. 15-in. dual concentric unit. Response 20-20,000 c/s. Size 58½ × 43 × 26½ ins. Price £165.

Chatsworth. Aperiodic enclosure. Tannoy 12 in. dual concentric drive unit. Response 50-20,000 c/s ± 3 dB. Size 39 × 19 × 12 ins. Price (complete) £49 15s.

★

Tele-clinic (Sales & Service) Ltd., 36 Brick Street, Warrington, Lancs. Tel.: Warrington 33179.

“Normanda.” Free standing reflex type with folded horn midrange unit. Three speakers, 12 in. bass, midrange pressure unit and 2½ in. tweeter. Crossover 1,000 c/s. Size 33 × 26 × 18 ins. 3 in. pedestal. Weight 110 lb. Price £63.

★

Trix Electrical Co. Ltd., 1-5 Maple Place, London, W.1. Tel.: Museum 5817. Cables: Trixradio, Wesdo, London.

Triple Unit Assembly, comprises 12-in. bass reproducer, 6 × 4 in. elliptical and 4-in. tweeter mounted in corner console cabinet. Response 40-12,000 c/s. Size 22 × 16 ins. × 32 ins. high. Price, complete, £28 7s.

★

James Turner, Little Barn, Arford, Headley, Hampshire. Tel.: Headley Down 2335.

“Brearcliffe 12.” Corner reflex. Designed to accommodate most drive units up to 12 in. Provision for tweeter. Size 36 × 21 × 13½ ins. Price of cabinet £18 18s.

“Brearcliffe 15.” Similar to above, but designed for two units up to 15 in. Size 39 × 27 × 17 ins. Price £24 3s.

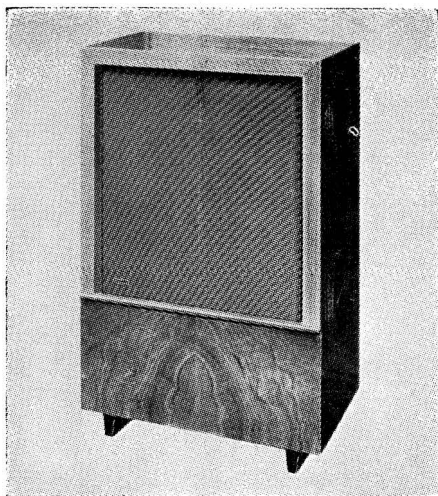

The Wharfedale AF 12

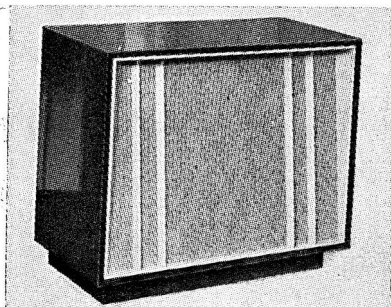

Tele-Clinic “Normanda”

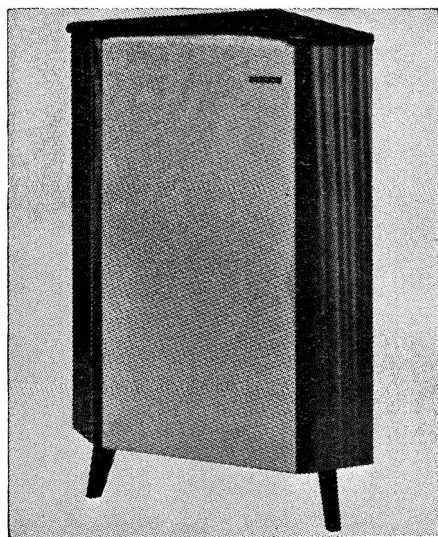

“Brearcliffe” Enclosure

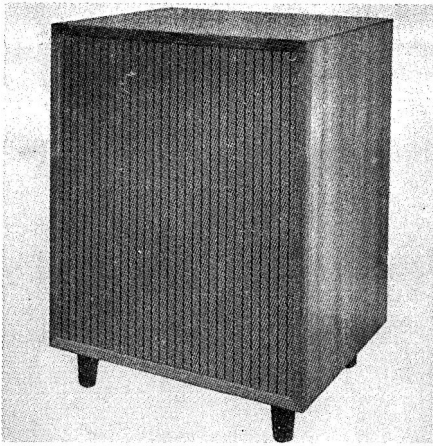

Vitavox Hallmark



Wal Duo-Reflex

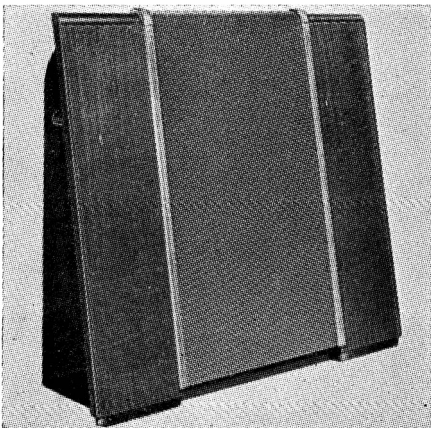

Wharfedale SFB/3

Vitavox Ltd., Westmoreland Road, London, N.W.9. Tel.: Colindale 8671. Cables: Vitavox, Hyde, London.

Vitavox Hallmark. Forward facing reflex, with port underneath. One 12-inch unit. Rec. Vitavox DU120 or AK120. Size Model 351: $27\frac{1}{2} \times 20 \times 16\frac{1}{2}$ ins. Available as horizontal (Lowboy) or vertical (Tallboy) system. Price complete, £42 in Walnut or Oak, £45 in Teak.

Klipschorn. Double channel horn. Folded L.F. horn, forward facing H.F. horn. 2 drive units: 15-in. L.F., pressure type H.F. Crossover at 500 c/s. Response 30-15,000 c/s. Size $50 \times 30 \times 27$ ins. Weight 210 lb. Price, with specified units, £165.

★

Wellington Acoustic Laboratories Ltd., Allways, Kings Lane, Wrecclesham, Farnham, Surrey. Tel.: Farnham 6461/4961.

WAL Duo-Reflex Speaker. Forward facing reflex enclosure. Incorporating 12-in. bass unit with foam surround and H.F. pressure tweeter. Built-in crossover unit. Response 30-13,500 c/s. Size $33 \times 18 \times 14$ ins. Weight 55 lb. Price £27. Available as a matched pair for stereo £52.

★

Westrex Company Ltd., Coles Green Road, London, N.W.2. Tel.: Gladstone 5401/8. Cables: Westelcol, Norphone, London.

Acoustilens 20/80 High Fidelity System. Large reinforced 1-in. ply reflex housing own (15 in.) 20/80 low frequency unit and horn loaded high frequency unit with acoustic lens. Crossover 675 c/s. Response below 30 c/s.—above 15,000 c/s. Size $44 \times 33 \times 19\frac{1}{2}$ ins. Weight approx. 160 lb. Price, complete with units and crossover, £169.

2241. High efficiency 2-way loudspeaker of unusually large handling capacity. Incorporates Westrex 20/80 L.F. and Westrex H.F. Acoustilens Units. Price on application.

In preparation. A stereo loudspeaker system employing two H.F. units and one L.F. unit for association with a sum and difference amplifier.

★

Wharfedale Wireless Works Ltd., Idle, Bradford. Tel.: Idle 1235-6. Cables: Wharfedel, Idle, Bradford.

RJ-8. Damped reflex. Forward facing. One 8 in. drive unit. Rec. Super 8/FS/AL; 8 in. Bronze FS/AL. Response 60-14,000 c/s. Size $24\frac{1}{2} \times 11 \times 10\frac{1}{2}$ ins. Weight $16\frac{1}{2}$ lb. Price, without unit, £11 10s.

PST/8. Damped reflex, forward facing. One 8 in. drive unit. Rec. Super 8/FS/AL or 8 in. bronze FS/AL. Response 60-14,000 c/s. Size 24 × 12 × 12 ins. Weight 17 lb. Price, without unit, £7 10s. whitewood, or £10 10s. veneered and polished.

Column Eight. Reflex column with acoustic filter and conical diffuser for upward facing 8 in. unit. Rec. 8/145, Super 8/FS/AL or 8 in. bronze FS/AL. Response 40-14,000 c/s, depending on unit. Size 44 × 14 × 12 ins. Weight 34½ lb. Price, without unit, £21 15s.

AF/12. Reflex with acoustic filter, forward facing. One 12 in. drive unit. Rec. Coaxial 12, Super 12/FS/AL, W12/FS. Response 30-20,000 c/s with Coaxial 12. Size 36½ × 23 × 14½ ins. Weight 61 lb. Price £24 10s. (Whitewood £20).

AF/10. Forward facing reflex with acoustic filter. One 10-in. unit. Rec. 10-in. Bronze/FSB, Golden/FSB, W10/FSB. Response 40-10,000 or 14,000 c/s depending on unit fitted. Size 30 × 17 × 10½ ins. Weight 35 lb. Price, without units, £15 15s.

SFB/3. Sandfilled baffle. 3 drive units. 12 and 10-in. units facing forwards. 3-in. H.F. unit facing upwards for omni-directional treble distribution. Response 30-20,000 c/s. Size 34 × 31 × 12 ins. Weight 64 lb. Price, with units, £39 10s. (not sold separately).

“Omni-directional” 3-speaker corner system. Sand-filled reflex enclosure, bass unit facing forward, separate mid range and treble units facing upward. 15-in., 8-in., and 3-in. units. Rec. W15/FS, Super 8/FS, Super 3. Response 20-20,000 c/s. Size 48 × 34 ins. Weight 160 lb. Price, with specified units, £73 10s.; sandfilled panel only, £31; twin treble cabinet, £8 15s.

Super 3 Cabinet. Open baffle, facing upward to house 1 Super 3. Crossover 5,000 c/s. Response 5,000-20,000 c/s. Size 8 × 6 × 5 ins. Weight 1¾ lb. less unit. Price £4 10s. (for 8/15 ohm speakers); £5 (for 2/3 ohm speakers).

W2. Two-speaker system, incorporating WLS/12 and Super 5 with vol. control. Crossover 1,000 c/s. Size 23½ × 14 × 12 ins. Price veneered, complete £29 10s.

W3. Three-speaker system, incorporating WLS/12; a 5-in. bronze, and Super 3. Separate vol. controls for the two H.F. units. Crossover 1,000 c/s. Size 28 × 14 × 12 ins. Price veneered, complete £39 10s.

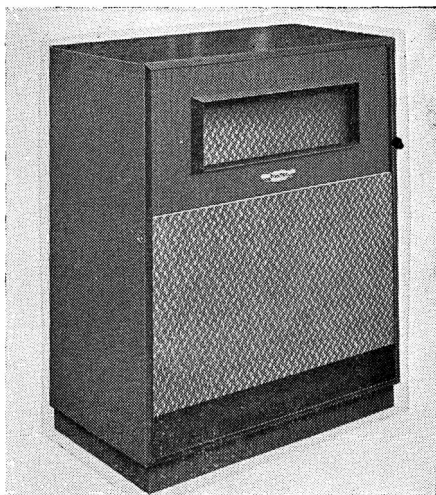

Westrex Acoustilens 20/80

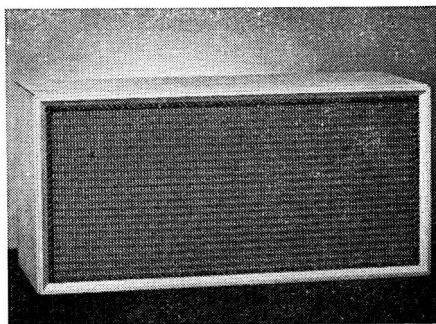

Wharfedale PST/8

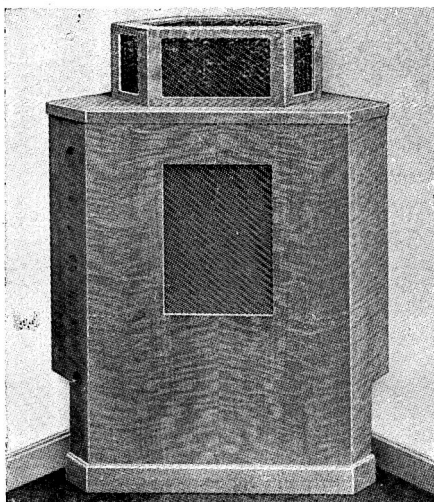

Wharfedale “Omni-Directional”

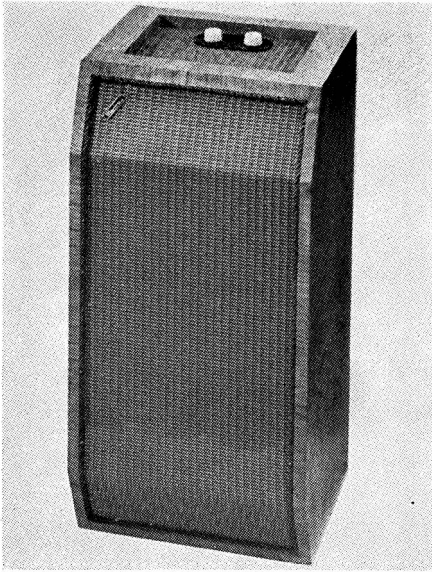

Wharfedale W3

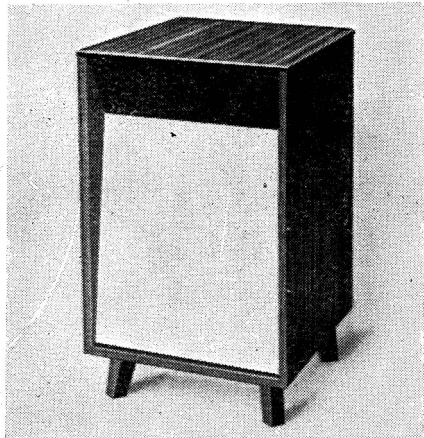

Stentorian "Prelude" Major

W4. Four-speaker system, incorporating WLS/12, two 5 in. bronze, and Super 3. H.F. units are arranged for omni-directional radiation and have independent mid and treble vol. controls. Size 35 × 24 × 13 ins. Price veneered, complete £49 10s.

★

Whiteley Electrical Radio Co., Ltd., Victoria Street, Mansfield, Notts. Tel.: Mansfield 1762/3/4/5. Cables: Whitebon, Mansfield.

Stentorian Corner Console. Infinite baffle. 1 8-in. unit. Rec. HF812. Response

50-12,000 c/s. Size 26 × 17 × 7½ ins. Price, with specified unit, £8 9s. 6d. (U.K. purchase tax £1 4s.); without unit, £5 10s.

Stentorian Junior Console. Bass reflex for corner position. 1 or 2 drive units. Rec. HF816 or HF1012 with T10 tweeter, if required. Crossover 3,000 c/s. Response HF816, 50-14,000 c/s; HF1012 and T10 30-14,000 c/s. Size 33 × 22½ × 28½ ins. Price, with HF816, £14 6s. 7d. (U.K. purchase tax, £1 19s. 5d.); with HF1012 and T10, £18 14s. (U.K. purchase tax £1 8s. 9d.); without units, £9 9s.

Stentorian Standard Console. Forward facing bass reflex. 1 or 2 drive units. Rec. HF1012 or HF1214 with T10 or T12, if required. Crossover 3,000 c/s. Response with HF1012 and T10 30-14,000 c/s; with HF1214 and T12 25-17,000 c/s. Size 32 × 22 × 16 ins. Price, with HF1012 and T10, £19 15s. (U.K. purchase tax £1 8s. 9d.); with HF1214 and T12, £34 7s. 6d.; without units £10 10s.

Stentorian Senior Corner Console. Bass reflex for corner position. 10-in. or 12-in. drive unit with tweeter, if required. Crossover 3,000 c/s. Response with HF1012 and T10 30-14,000 c/s; with HF1214 and T12 25-17,000 c/s. Size 35 × 30 × 19 ins. Price, with HF1012 and T10, £20 16s. (U.K. purchase tax £1 8s. 9d.); with HF1214 and T12, £35 8s. 6d.; without units, £11 11s.

Stentorian "Prelude." Bass reflex for corner position. One 8 in. or 10 in. unit with provision for tweeter. Rec. HF812, HF816, or HF1012 and T10. Crossover at 3,000 c/s. Response depending on unit used. Size 33 × 21 × 17 ins. Weight 23¾ lb. Price, without units, £10 10s. Model also available for free standing, otherwise as above. Size 33 × 19 × 19½ ins. Weight 27½ lb. Price £11 11s.

Stentorian Sloping Dual Front. Tweeter housing, reversible, either forward or rear facing. One 8-in. unit. Rec. T816. Response 1,000-17,000 c/s. Size 13 × 10½ × 7½ ins. Price, with unit, £8 10s. 1d. (U.K. purchase tax £1 17s. 5d.); without unit, £3 17s. 6d.

Stentorian Prelude Major. Reflex, forward facing. One or two 10 or 12 in. drive units. Rec. HF1214 and T10. Response 30-17,000 c/s. Size 35 × 20 × 33 ins. Price (complete) £45; without units £25.

Stentorian Prelude Horn Loaded. Folded horn, forward facing. One 8 in. drive unit. Rec. HF817. Response 60-22,000 c/s. Size $35 \times 10\frac{1}{2} \times 16\frac{1}{2}$ ins. Price (complete) £27 2s. (U.K. purchase tax £3 5s. 6d.). Price, without units, £19.

Stentorian Junior Column. Reflex upward facing omni-directional. One 6 in. unit. Rec. HF610. Response 100-11,000 c/s. Size $36 \times 9 \times 9$ ins. Price (complete) £11 17s. 7d. (U.K. purchase tax 15s. 5d.). Price, without unit, £9 16s. 6d.

Stentorian Senior Column. Reflex upward facing omni-directional. One 8 in. unit. Rec. HF816. Response 60-14,000 c/s. Size $57 \times 13\frac{1}{2} \times 13\frac{1}{2}$ ins. Price (complete) £23 15s. 7d. (U.K. purchase tax £1 19s. 5d.). Price, without unit, £18 18s.

Stentorian Stentereo. Infinite baffle. Corner speaker, forward facing. Two drive units 8 in. and 5 in. Rec. HF812 or HF810 with S.510. Crossover 1,500 c/s. Response 100-12,000 c/s. Size $22 \times 12\frac{1}{2} \times 10$ ins. Price (complete) £13 0s. 8d. (U.K. purchase tax, £1 11s. 7d.). Price, without units, £7 10s.

Note: All units for the above may be supplied separately.

CROSSOVERS, ETC.

Richard Allan Radio Ltd., "Baffle House," Taylor Street, Batley. Tel.: Batley 1123/1308/4033. Cables: Acoustics, Batley.

CN.104 Crossover Unit. A two way half section parallel network. Crossover frequency 5,000 c/s. All terminations 15 ohms. Price £2 2s.

CN.1284. Crossover Unit. A three way crossover with main crossover operating from half wave parallel network and subsidiary crossover capacity fed. Crossover frequencies 1,100 and 5,000 c/s. All terminations 15 ohms. Price £6 5s.

★

Goodmans Industries Ltd., Axiom Works, Wembley, Middx. Tel.: Wembley 1200. Cables: Goodaxiom, Wembley.

X0/5000-Crossover Unit. A 2-way half-section crossover network, operating at 5,000 c/s. All terminations 15 ohms. Price £1 19s.

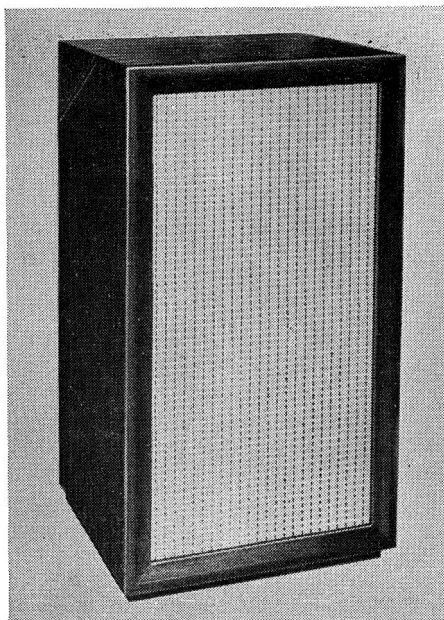

Stentorian "Prelude" Horn Loaded

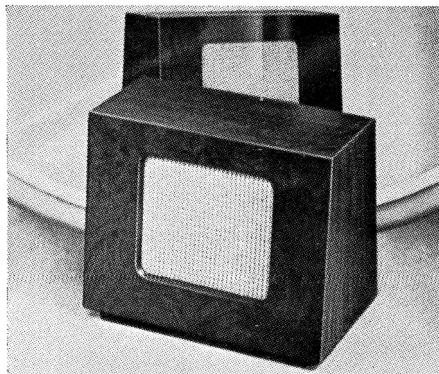

Stentorian Sloping Dual Front

X0/750-Crossover Unit. A 2-way, half-section, crossover network, operating at 750 c/s. All terminations 15 ohms. Price £5 10s. 9d.

X0/950/5000. Crossover Network. A multiple crossover network comprising four half section L.C. filters. Crossover frequencies are 950 c/s and 5,000 c/s. All attenuation rates are 12 dB/octave. All terminations 15 ohms. Price £7 0s. 6d.

Romagna Reproducers, 2 Sarnesfield Road, Enfield, Middlesex. Tel.: ENField 8717.

CO/1/15. Crossover Network. 3 Kc crossover frequency for 15 ohm loudspeakers and amplifiers. Balance control fitted, $\frac{1}{2}$ section networks giving 12 dB/octave cutoff. Minimum insertion loss 1 dB in pass band. Potted in cast aluminium case. Price £3 3s.

CO/1/3.5. Crossover Network. As CO/1/15, but with 3.5/5 ohm impedance. Price £3 3s.

CO/2/15. Crossover Network. As CO/1/15, but with 1,500 c/s crossover frequency. Price £3 3s.

CO/2/3.5. Crossover Network. As CO/2/15, but with 3.5/5 ohm impedance. Price £3 3s.

CO/BK. Crossover Network. $\frac{1}{4}$ section network. Coil is tapped to give two values of crossover—1,500 c/s and 3 Kc, and can be switched out of circuit. Price £1 11s. 6d.

★

Technical Suppliers Ltd., Hudson House, 63 Goldhawk Road, London, W.12. Tel.: Shepherds Bush 2581/4794.

HP1 Crossover Unit. A $\frac{1}{4}$ -section crossover specially designed for use with TSL Lorenz LP312-2 speaker system, crossover at 5,000 c/s. Price £2 2s.

★

Westrex Co. Ltd., Coles Green Road, London, N.W.2. Tel.: Gladstone 5401/8. Cables: Westelcol, Norphone, London.

Dividing Network. Constant impedance parallel network, using two L-type filter sections, low and high pass, crossover at 675 c/s. For any impedance 16-24 ohms. Price £13 10s. 6d.

★

Wharfedale Wireless Works Ltd., Idle, Bradford, Yorks. Tel.: Idle 1235-6. Cables: Wharfedel, Idle, Bradford.

Loudspeaker Separators. $\frac{1}{4}$ -section type. Operating at 1,000 or 3,000 c/s. 8 units available to cover from 2-16 ohms impedance. Slope 5 dB/octave. Size $7 \times 4 \times 3\frac{3}{4}$ ins. Weight 2-2 $\frac{1}{2}$ lb. Max. input 30 watts. Price from £2 11s. to £4 17s. 6d. depending on type.

HS/CR3/2. $\frac{1}{2}$ -section 3-way separator unit with crossover at 800 and 5,000 c/s. Max.

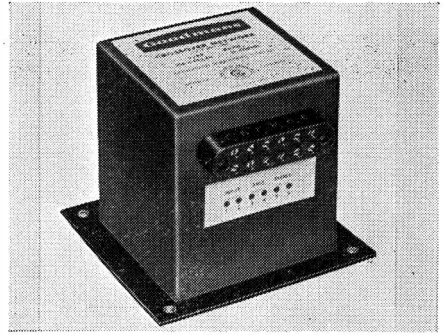

Goodmans XO750 crossover

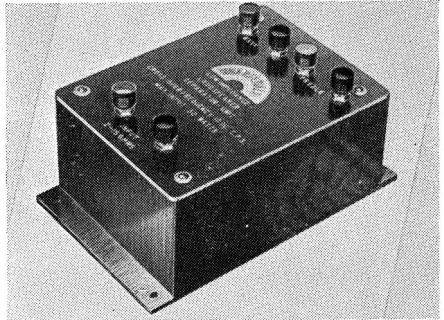

Wharfedale 1/4 section separator

input 30 watts. Slope 12 dB/octave. Size $9 \times 6 \times 5$ ins. Weight 6 $\frac{1}{2}$ lb. 2 models. 2-6 ohms. Price £11; 7-16 ohms, Price £8 10s. Also available with crossover at 400 and 5,000 c/s. 7-16 ohms only. Price £10.

WMT1 Matching Transformer. Auto transformer for matching 10-16 ohms or 7-9 ohms speakers to sets with 2-5 ohms output or vice versa. Response 20-15,000 c/s \pm 1 dB. Handling capacity 15 watts. Can also match speakers of different imps. to crossover unit in 2 or 3 speaker systems. Size $2\frac{7}{8} \times 2\frac{3}{4} \times 2\frac{3}{4}$ ins. Weight 12 $\frac{1}{2}$ oz. Price 13s. 6d.

★

Whiteley Electrical Radio Co. Ltd., Victoria Street, Mansfield, Notts. Tel.: Mansfield 1762-5. Cables: Whitebon, Mansfield.

CX 500. Crossover Unit. A 2-way half-section crossover network operating at 500 c/s. All terminations 15 ohms. Price £1 6s.

CX 1500. Crossover Unit. As CX 500, but operating at 1,500 c/s. Price £1 18s. 3d.

CX 3000. Crossover Unit. As CX 1500, but operating at 3,000 c/s. Price £1 10s.

TAPE RECORDERS

— AN INTRODUCTION —

THIS edition of *Hi-Fi Year Book* carries a greatly enlarged section devoted to tape recorders, and in the following pages there are details, makers' specifications and prices of over 200 models and accessories. As mentioned in the opening introductory article on page 3, these products are by no means hi-fi products in the true meaning of the word, and it must be clearly understood that their inclusion in *Hi-Fi Year Book* does not constitute any such implication. In order to clarify this position as much as possible, the following section has been divided into sub-headings to take in (a) *Professional and Semi-Professional recorders*, (b) *Tape Decks*, to which high quality electronics can be added, (c) *General Purpose and "Domestic" recorders*, and (d) *Small Portables and Midgets*.

Mention does Not Imply Recommendation

This classification of recorders does not automatically imply that instruments listed under, say "*GP & Domestic*", are unsuitable for hi-fi use; indeed, there are several recorders in the "*GP*" category that are of exceptionally good quality. It should also be noted by intending purchasers that any recorder—provided that it is based upon a good deck—can be used to advantage with existing hi-fi equipment, *if provision is made, via co-axial socket, for taking off the replay signal direct from the head*, thus by-passing the electronics of the portable, which cannot possibly measure up to the standards of good hi-fi equipment.

During the past twelve months or so, tape has been put to increasing use by enthusiasts as a programme source—both for mono and stereo reproduction. There are now several catalogues of recorded tapes available in this country, and these tapes are recorded to the CCIR characteristic at a speed of $7\frac{1}{2}$ i/s. Provided that these tapes are replayed via a

good deck, and through a CCIR correction network, extremely high quality reproduction can be achieved from them. Many of the hi-fi pre-amplifiers now on the market make provision for a tape input, and this tape input is followed (in the inbuilt electronics) by such a correction network. If the pre-amplifier does not include a tape input point, it is good practice to build up the weak tape signal by means of a small sub-amplifier (see *Caper Electrophonics* and other entries in the *Amplifier Directory* section), with correction network incorporated, and then to feed this output into a suitable point on the pre-amp which is affected only by treble, bass and filter controls—not by disc correction points.

More recently, and particularly since the introduction of the new BBC programme "*Sound*" on Network Three, enthusiasts have been turning their attention to the making of Sound Effect tapes—electro-phonetic music; and for this purpose several decks can be employed, for dubbing, superimposing, etc. And for this purpose also, good quality domestic recorders can play a useful part. Midget recorders, too, are being used by an increasing number of people for "catching outside effects" and making on-the-spot recordings which are beyond the scope of mains-driven portables. Users of tape are learning to edit, cut and re-record; and as a result of all this activity the importance of tape in the hi-fi field is growing rapidly.

Look for Quality

In the final choice, of course, it must be left to the purchaser to decide how to spend his money; and once again we commend the axiom "Quality costs Money". You can rarely get the former without being prepared to lay out sufficient to ensure it.

Mixers, tape accessories, etc., are dealt with under appropriate sections in the

following directories. Microphones, closely allied to Tape Recorders, are listed separately; and this directory section is preceded by its own introductory article on the use of the microphone.

Plan for Tape

As with most hobbies involving equipment, "Tape" can be an expensive addition to the hi-fi set-up; and it is therefore advisable to plan well ahead. The hi-fi enthusiast who knows that his requirements will be limited to the replay of tapes—stereo or mono—need only make sure of buying a really good deck to cover two speeds of $7\frac{1}{2}$ and $3\frac{3}{4}$ i/s. If his pre-amplifier is of sufficient gain to accept and handle the signal direct from the tape head, this deck purchase may well be the final outlay—except, perhaps, a stereo head to replace mono; and of course a de-fluxer for keeping the heads demagnetised.

Stereo Recording, too?

Enthusiasm has a habit of spreading its tentacles, however; and it will be surprising if many of the absolutely determined "replay only" enthusiasts manage to keep off the more fascinating process of recording—and (though possibly fewer of them) of recording stereo; and in this connection it is well to remember that the BBC's stereo broadcasts may not *always* be experimental! This opens up the possibility of (first) a record amplifier, and a second record amplifier for the second channel. But all this can spread from the same initial deck.

Those who are interested in making up tape loops, and even short programmes of electrophonic music, must similarly have a good deck; but they will also need a recorder

of good quality; and a second and possibly less pretentious recorder—perhaps bought initially for home entertainment—may well find its place in the scheme of things.

For serious work; and indeed for nothing less than average quality, two heads are the minimum—*erase* and *record/replay*. For more interesting work, three heads are better; so space on the deck (or on the deck of the recorder) can be an asset for fitting a *monitor* head at some later stage. With this device, recording only is done with the first head, and *all* replays can be taken off the monitor head, thus leaving the erase and record heads permanently in circuit with the recording electronics, and using the monitor (replay) head permanently connected to the input point on the pre-amp.

Tape versus Disc

The argument on "Tape or Disc" still continues, and is likely to continue for some time. All discs do, of course, stem from tape masters; and, therefore, given tape equipment of *really* professional (and hence really expensive) quality, results from tape can equal or surpass results from disc. But with all but the highest grade tape equipment the disc must score in comparison—because the signal which has been put on disc, from tape, has been put there by means of the finest electronics; and to take the signal from the disc only requires the use of a good pickup, intelligently handled. Nevertheless, it must also be remembered that a well handled tape signal can easily be better than a signal from a disc which has been mauled—which happens all too often—first by an inferior pickup, and then by unworthy electronics.

DIRECTORY OF TAPE RECORDERS

* The abbreviations used for the specifications in this directory are as follows: **Fr**—frequency response; **i/s**—inches per second; **P.s.n.**—Power supply needed; **<**, better than; **M.E.**—Magic eye; **W. & F.**—Wow and flutter; **S-N**—signal to noise ratio ■—Stereo equipment

PROFESSIONAL and SEMI-PROFESSIONAL

Bradmatic Ltd., Station Road, Aston, Birmingham 6. Tel.: East 2881-2. Cables: Bradmatic, Birmingham.

Bradmatic Console. Models 25, 35, 45. Semi-prof. recorders less output stage. $7\frac{1}{2}$ and $3\frac{3}{4}$ i/s. 3 motors. $10\frac{1}{2}$ -in. N.A.B. spools. F.r.: $7\frac{1}{2}$ i/s, 40-15,000 c/s; $3\frac{3}{4}$ i/s, 40-7,500 c/s, both ± 4 dB V.U. level meter. Size $35 \times 27 \times 25$ ins. P.s.n. 230v 50 c/s or 110v 60 c/s. Price, Model 25 (fitted with type 10/7A amp.) £173; Model 35 (fitted with type 10/7AM amp.) £175; Model 45 (fitted with type W/7 AS amp.) £190.

■ **Bradmatic Console Model 45.** Deck and pre-amp. Model 5D tape deck. 3 motors. $7\frac{1}{2}$ and $3\frac{3}{4}$ i/s. $10\frac{1}{2}$ -in. spools. Response 40-15,000 c/s ± 4 dB. Size $35 \times 27 \times 25$ ins. P.s.n. 110v, 60 c/s or 230v, 50 c/s. Price £190.

The above models are available with full track or stereophonic heads to special order. Prices on application.

✱

EMI Sales & Service Ltd., Hayes, Middx. Tel.: Southall 2468. Cables: Emiservice, London.

E.M.I. Model TR51. Prof. transportable recorder. Four types: A, 15 and $7\frac{1}{2}$ i/s full track; C, 15 and $7\frac{1}{2}$ i/s half track; B, $7\frac{1}{2}$ and $3\frac{3}{4}$ i/s full track; D, $7\frac{1}{2}$ and $3\frac{3}{4}$ i/s half track. 1 motor $8\frac{1}{4}$ -in. or 7-in. spools. F.r.: 15 i/s, 50-15,000 c/s. V.U. level meter. Size $13\frac{1}{4} \times 18 \times 17$ ins. Weight 59 lb. Price £105.

E.M.I. Model TR90. Prof. recorder for rack mounting or as a console on transportable trolley. 30 and 15 i/s or 15 and $7\frac{1}{2}$ or $7\frac{1}{2}$ and $3\frac{3}{4}$ i/s. 4 motors. $10\frac{1}{2}$ -in. spools. F.r.: 15 i/s, 50-15,000 c/s; $7\frac{1}{2}$ i/s, 50-10,000 c/s; $3\frac{3}{4}$ i/s, 50-6,000 c/s. All ± 2 dB. V.U. meter level ind. or peak programme meter. Size (transportable version) 2 cases $14\frac{1}{2} \times 20 \times 16\frac{1}{2}$ ins. Weight 80 and 58 lb.



Bradmatic Console



EMI TR51 recorder

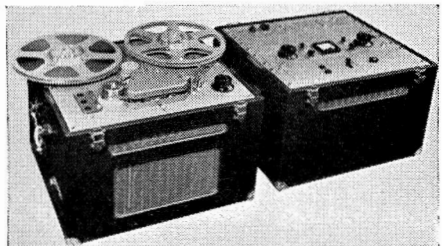

EMI TR90 in transportable form

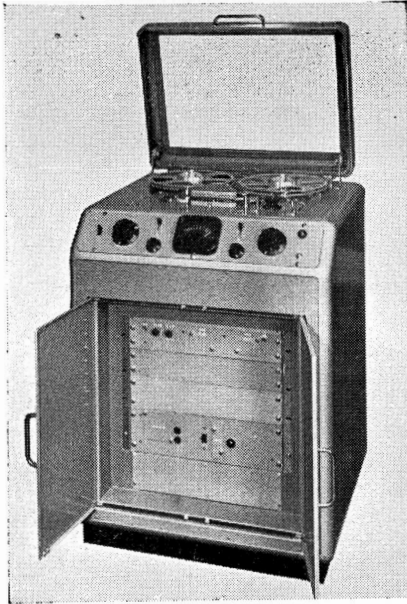

EMITR90 In console form (above)

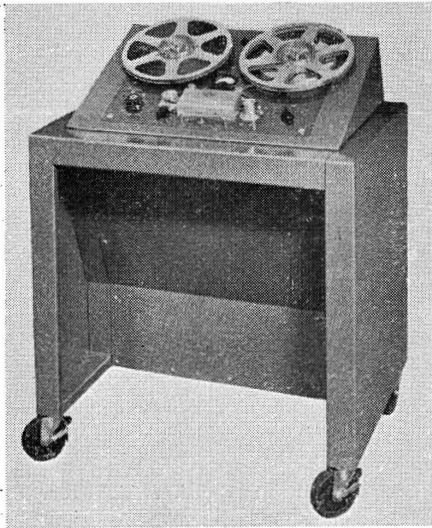

Leever-Rich Series E No. E141K

British Ferrograph Recorder Co. Ltd., 131 Sloane Street, S.W.1. Tel.: Sloane 1510. Cables: Britferro, Knights.

Ferrograph 4A/N and 4A/H. Complete portable recorder. Any two adjacent speeds from $1\frac{7}{8}$ to 15 i/s. 3 motors. $8\frac{1}{2}$ -in. spools. F.R. 15 i/s, 40-15,000 c/s ± 2 dB; $7\frac{1}{2}$ i/s, 40-12,000 c/s ± 3 dB, 50-10,000 c/s ± 2 dB;

$3\frac{3}{4}$ i/s, 50-6,000 c/s ± 3 dB. Sustained peak signal level meter. Space under the head cover for additional plug-in head for monitoring, lower track working stereo playback or American dual stereo standard. Size $18\frac{1}{2} \times 17\frac{1}{2} \times 9\frac{3}{4}$ ins. Weight 50 lbs. Prices, 4 A/N ($7\frac{1}{2}$ and $3\frac{3}{4}$ i/s) £85 1s.; 4 A/H (15 and $7\frac{1}{2}$ i/s) £90 6s.

4 AN/CON and 4 AH/CON. Versions of above for console fitting, same price.

■ **Ferrograph 4 S/N and 4 S/H** as models 4 A/N and 4 A/H, but with stereo replay heads fitted. With the Stereo-ad unit suitable for the replay of stereo tapes. Prices 4 SN/CON £92 8s., 4 SH/CON £97 13s.

■ **Ferrograph Stereo 88.** A complete 2-channel recorder/reproducer. For tape speeds of $7\frac{1}{2}$ and 15 i/s. Switched input meter enables levels of both channels to be balanced. Output of each channel on playback approx. 2 millivolts across 600 ohms. Can also be used for monaural record/replay. Price £110 5s.

★

Leever-Rich Equipment Ltd., 78b Hampstead Road, London, N.W.1. Tel.: Euston 1481. Cables: Leemag. London.

Model E. No. ER141K. Prof. reproducer console. 15 and $7\frac{1}{2}$ i/s. 3 motors. $11\frac{1}{2}$ -in. spools. F.r.: 15 i/s, 50-15,000 c/s; $7\frac{1}{2}$ i/s, 50-10,000 c/s, both ± 2 dB on C.C.I.R. test tape. Size $30 \times 22 \times 36\frac{1}{2}$ ins. Weight 162 lb. Price £440.

Model E. No. E141R. Complete rack mounting prof. recorder. 15 and $7\frac{1}{2}$ i/s. 3 motors. $11\frac{1}{2}$ -in. spools. F.r.: 15 i/s, 50-15,000 c/s; $7\frac{1}{2}$ i/s, 50-10,000 c/s, both ± 2 dB. V.U. level meter. Size $19 \times 17\frac{1}{2} \times 9$ ins. Weight 50 lb. Price £420.

Model E. No. E121P. Prof. portable recorder. Spec. as for E141R. In two cases, $20 \times 17 \times 11\frac{1}{2}$ ins. and $15 \times 18 \times 10$ ins. Weight 79 lb. Price £550.

Model E. No. E141K. Prof. network recorder console. Spec. as for E141R. Size $30 \times 22 \times 36\frac{1}{2}$ ins. Weight 185 lb. (approx.). Price £545.

Model C. Model C621P. Prof. portable recorder. 15 i/s. 3 motors. $9\frac{1}{2}$ -in. spools. F.r.: 50-15,000 c/s ± 2 dB. V.U. level meter. Size $13 \times 18 \times 10$ ins. Weight

73 lb. P.s.n. 12v battery or auxiliary mains unit. Price £420.

Model DB. No. DB221P. Prof. portable recorder. Spec. as for C621P but in two cases, $13 \times 18 \times 10$ ins. and $16 \times 20 \times 11\frac{1}{4}$ ins. Total weight 74 lb. P.s.n. as C621P. Price £500.

Model CS. No. CS621P. Syncropulse recorder, for magnetic recording in sync. with cameras, etc. Spec. as for C621P. In two cases both $13 \times 18 \times 10$ ins. Total weight 73 lb. P.s.n. as C621P. Price £525.

■ **Model E. No. ED.142P.** Complete portable dual channel recorder. 3 motors. 15 and $7\frac{1}{2}$ i/s. Monitoring off tape, separate V.U. Meter, unit amp. L.R. and H.R. Mic. or line inputs. 11 $\frac{1}{2}$ -in. spools. Response at 15 i/s, 50-15,000 c/s ± 2 dB. Size 2 cases $16 \times 20 \times 11$ ins. Total weight 80 lb. Price £620.

★

Multimusic Ltd., Mayland Avenue, Hemel Hempstead, Herts. Tel.: Boxmoor 3636. Cables: Multimusic, Hemel Hempstead.

“400”. Prof. tape deck, record amp. and pre-amp. (3 units) continuously variable speeds from $3\frac{1}{2}$ to 8 i/s. 3 motors. 8 $\frac{1}{4}$ -in. spools. F.r.: $7\frac{1}{2}$ i/s, 50-10,000 c/s ± 2 dB; 45-12,000 c/s ± 3 dB. S-N \leftarrow 45 dB unweighted. W. and F., \leftarrow 0.2% RMS. Outlet from pre-amp. stage. Meter level ind. Neon lit. stroboscope. Separate record and replay amps. Size: deck, $17\frac{1}{4} \times 13\frac{3}{4} \times 7\frac{1}{2}$ in.; Amplifier, $13\frac{1}{4} \times 6\frac{1}{2} \times 3\frac{1}{2}$ ins., power pack, $11 \times 5 \times 5$ ins. Price £88 4s.

“500”. Complete prof. recorder. Spec. as for model 400, but incorporating output stage and loudspeaker in portable case $21 \times 14\frac{1}{2} \times 10\frac{1}{4}$ ins. Weight 50 lb. Price £98 14s.

■ “540”. Conversion unit comprises stereo head, playback amplifier and power pack to convert model 500 for stereo reproduction of tape and discs. Price, £81 18s.

■ “470”. Prof. stereo tape deck and record/replay amps. (3 units). Deck as for Model 400. Size, deck $17\frac{1}{4} \times 13\frac{3}{4} \times 7\frac{1}{2}$ ins., Amps each $13\frac{1}{4} \times 6\frac{1}{2} \times 3\frac{1}{2}$ ins. Total weight 60 lb. Price £145 19s.

■ “570”. Complete prof. stereo and monaural recorder. Spec. as for 470, but contained in one case $29 \times 14\frac{1}{2} \times 12\frac{1}{2}$ ins. Weight 70 lb. complete with two monitor loudspeakers. Price £156 9s.

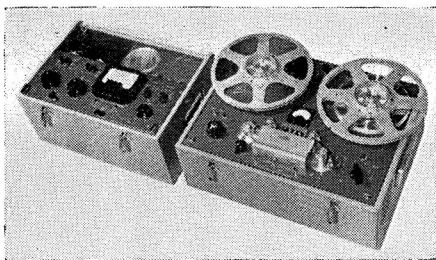

Leever-Rich Series E No. E121P

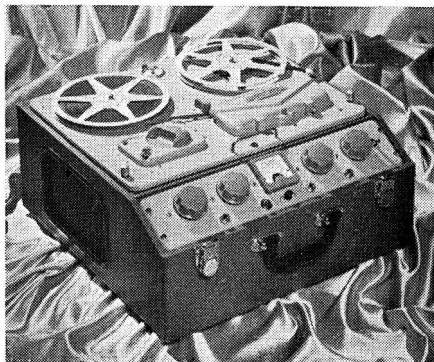

Ferrograph Model 4A/N

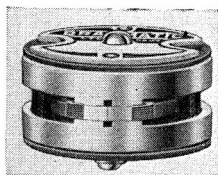

Bradmatic sound head without fixing stem

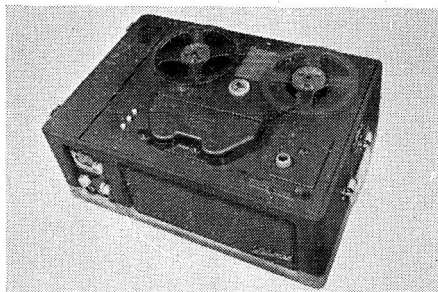

Reflectograph 500

Tandberg – Sole U.K. distributors, **Technical Suppliers Ltd.,** Hudson House, 63 Goldhawk Road, London, W.12. Tel.: Shepherds Bush 2581, 4794. Cables: Teknika, London.

■ **Tandberg “5”.** Complete semi-pro. portable recorder. Record/replay stereo and monaural on 2 or 4 tracks. $7\frac{1}{2}$, $3\frac{3}{4}$ and $1\frac{1}{8}$ i/s. One motor. 7-in. spools. F.r.:

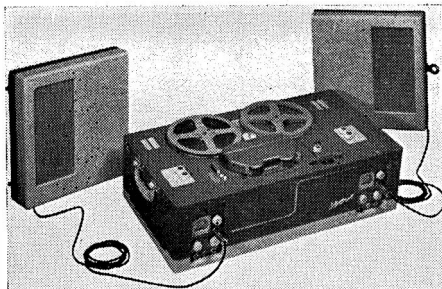

Multimusic "570" Stereocorder



Tandberg "Model 5"

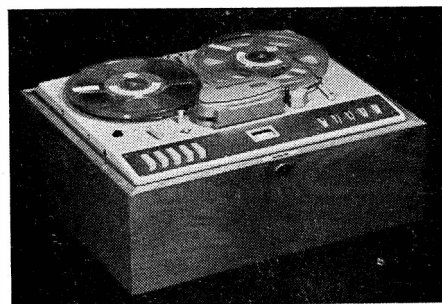

Telefunken M23

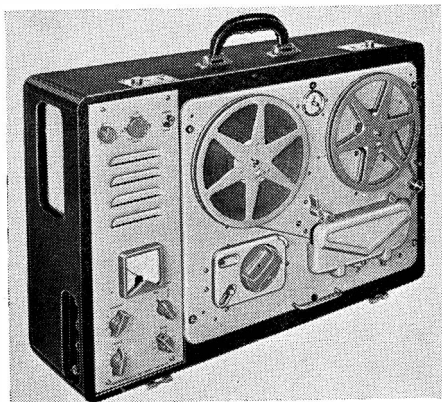

Vortexion WVA semi-professional portable

30-18,000 c/s at $7\frac{1}{2}$ i/s; 30-12,000 c/s at $3\frac{3}{4}$ i/s; 30-6,500 c/s at $1\frac{7}{8}$ i/s, all ± 3 dB. S-N, < -55 dB unweighted; W. and F. $< 0.15\%$ combined at $7\frac{1}{2}$ i/s. M.E. level ind. Facility for direct playing of stereo tapes or discs through built-in balanced stereo amplifier. 4 watts output each channel. Size $11\frac{1}{2} \times 15 \times 6\frac{1}{4}$ ins. Weight 27 lb. Price £130 4s.

■ **Stereo Add-on recording unit.** Converts Model 5 to a portable stereo recorder either 2 or 4 track. M.E. level ind. S-N < -55 dB unweighted. Size $9 \times 6\frac{1}{4} \times 2\frac{1}{4}$ ins. Weight $2\frac{1}{2}$ lb. Price £17.

★

Telefunken – Sole U.K. distributors, **Welme Corporation Ltd.**, 147 Strand, London, W.C.2. Tel.: Temple Bar 3357. Cables: Welmcors London.

M23. Small Studio Recorder. $7\frac{1}{2}$ and $3\frac{3}{4}$ i/s. 3 motors. 9-in. spools. F.r.: 20-16,000 c/s ± 3 dB at $7\frac{1}{2}$ i/s, 20-13,000 c/s ± 3 dB at $3\frac{3}{4}$ i/s. S-N < 46 dB. W. and F. $\pm 1.5\%$ at $7\frac{1}{2}$ i/s; $< \pm 3\%$ at $3\frac{3}{4}$ i/s. Moving coil level ind. Mixing 4 inputs. Output 1 volt, 600 ohms imp. Separate record and playback amps. Automatic stop at end of tape, tension controlled. Full monitoring. Interchangeable heads, 3 fitted. Price, chassis only, £140, in wooden cabinet, £150.

In Preparation.

Fully portable version with output stage and 4 loudspeakers. Price £180.

■ **Stereo supplement** with interchangeable heads assemblies and pre-amplifiers for stereo recording and playback. Price not fixed.

★

Vortexion Ltd., 257/236 The Broadway, Wimbledon, London, S.W.19. Tel.: Liberty 6242/3. Cables: Vortex, Wimbledon.

Model WVA. Complete semi-pro. portable recorder 15 and $7\frac{1}{2}$ i/s or $7\frac{1}{2}$ and $3\frac{3}{4}$ i/s. Wright and Weaire deck. 3 motors. $8\frac{1}{4}$ -in. spools. F.r.: 30-17,000 c/s ± 3 dB at 15 i/s; 30-15,000 c/s ± 3 dB at $7\frac{1}{2}$ i/s. S-N < 50 dB unweighted. W. and F., $< 0.2\%$. Meter level ind. ■ Provision for fitting stereo head with direct connection. Loads $7\mu V$ mic. Weight 49 lb. Price £93 13s. (£5 extra for 15 i/s).

Model WVB. Spec. as for WVA, but with extra monitor head and amplifier fitted ■ provision for fitting of stereo head. Price, £110 3s. (£5 extra for 15 i/s).

DECKS—GENERAL PURPOSE and SEMI-PROFESSIONAL

Birmingham Sound Reproducers Ltd., Monarch Works, Powke Lane, Old Hill, Staffs. Tel.: Cradley Heath 69272.

B.S.R. Monardeck TDI. G.P. deck. $3\frac{3}{4}$ i/s. One motor. $5\frac{3}{4}$ -in. spools. F.r.: with good amplifier equalisation 30-10,000 c/s ± 3 dB. 2 heads. W. & F., 0.5% RMS. Size $13 \times 8\frac{3}{4}$ ins. Price not announced.

★

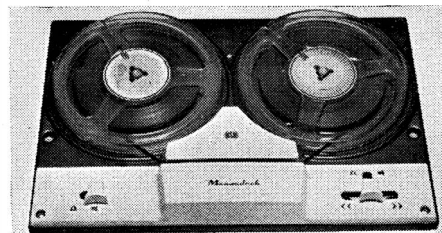

B.S.R. Monardeck TDI

Bradmatic Ltd., Station Road, Aston, Birmingham, 6. Tel.: East 2881-2. Cables: Bradmatic, Birmingham.

Bradmaster. Models 5B, 5CS, 5CD, 5D Semi-prof. tape deck. $7\frac{1}{2}$ and $3\frac{3}{4}$ i/s. 3 motors. Model 5B 7-in. spools; 5CS and 5CL $9\frac{3}{8}$ -in. spools; 5D $10\frac{1}{2}$ -in. N.A.B. spools. F.r.: $7\frac{1}{2}$ i/s, 40-15,000 c/s; $3\frac{3}{4}$ i/s, 40-7,500 c/s, both ± 4 dB (dependent on amp. used). Size and weight dependent on model. Price 5B £42; 5CS £45 10s.; 5CL £47 10s.; 5D £50. ■ Available with full track or stereophonic heads to special order. Prices on application.

★

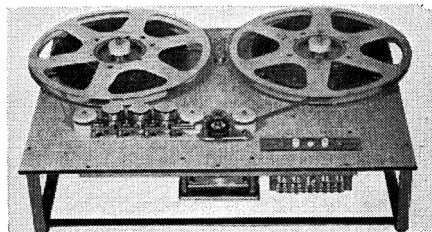

Bradmatic Model 5D deck

Brenell Engineering Co. Ltd., 1a Doughty Street, London, W.C.1. Tel.: Holborn 7358.

Mark 5. G.P. tape deck. 15, $7\frac{1}{2}$, $3\frac{3}{4}$ and $1\frac{7}{8}$ i/s. 3 motors. $8\frac{1}{4}$ in. spools. W. and F. $<0.2\%$ at $7\frac{1}{2}$ i/s. accommodates up to four heads. Size $15 \times 11\frac{1}{2} \times 5$ ins. Weight 16 lb. Price £29 8s.

★

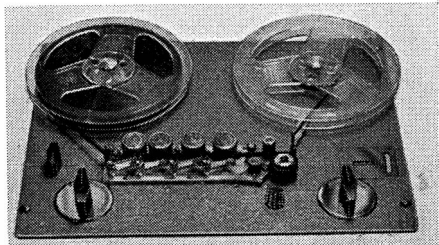

Brenell Mk. 5 tape deck

Collaro Ltd., Ripple Works, By-Pass Road, Barking, Essex. Tel.: Rippleway 5533. Cables: Kabarro. Telex, Barking.

Collaro Mk. IV. G.P. tape deck. 15, $7\frac{1}{2}$ and $3\frac{3}{4}$ i/s ± 3 dB with record/playback equalisation, 4 heads. W. and F., not greater than 0.15% at $7\frac{1}{2}$ i/s. Direct use of second track without removing the spools. Size $13 \times 11\frac{1}{2} \times 5\frac{1}{2}$ ins. Weight 16 $\frac{1}{2}$ lb. Price £25.

Collaro Studio. G.P. tape deck $7\frac{1}{2}$, $3\frac{3}{4}$ and $1\frac{7}{8}$ i/s. 3 motors. 7 or $5\frac{3}{4}$ -in. spools. F.r.: up to 12,000 c/s ± 3 dB at $7\frac{1}{2}$ with record/playback equalisation 2 heads. Price not announced.

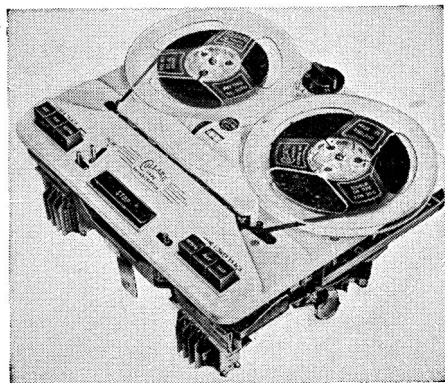

Collaro Mk. IV tape deck

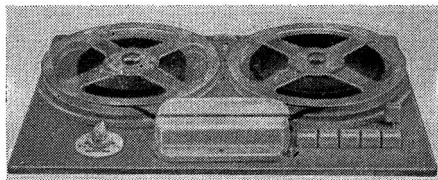

Motek K9

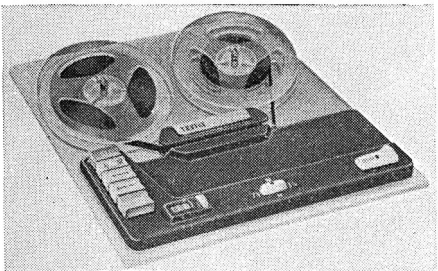

Truvox Mk. VI Deck

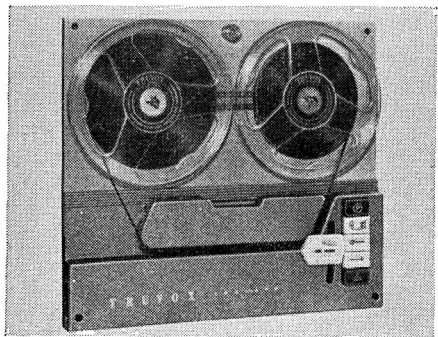

Truvox Mk. IV Deck

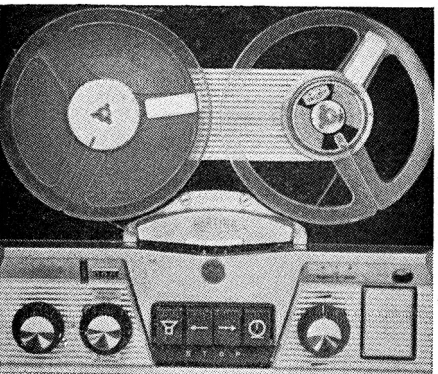

Harting HM5SD

Harting - Sole U.K. distributors, Technical Suppliers Ltd., Hudson House, 63 Goldhawk Road, London, W.12. Tel.: Shepherds Bush 2581, 4794. Cables: Teknika, London.

■Harting HM5SD. G.P. tape deck for monaural and stereophonic use. $7\frac{1}{2}$ and $3\frac{3}{4}$. One motor. 7-in. spools. F.r.: 30-20,000 c/s ± 2 dB at $7\frac{1}{2}$ i/s; 30-16,000 c/s ± 2 dB at $3\frac{3}{4}$ i/s. W. and F. $<0.1\%$. Size $15 \times 12 \times 6$ ins. Weight 19 lb. Price £44 2s.

★

Modern Techniques, Wedmore Street, London N.19. Tel.: Archway 3114.

Motek K9. G.P. tape deck. $7\frac{1}{2}$, $3\frac{3}{4}$, $1\frac{1}{8}$ i/s. 3 motors. 7-in. spools. F.r.: approx 50-10,000 c/s at $7\frac{1}{2}$ depending on amplifier used. W. and F. $<0.2\%$ at $7\frac{1}{2}$ i/s. 2 heads. High imp. record head. Size 15×11 ins. Price £22 1s.

★

Tape Recorders (Electronics) Ltd., 784-788 High Road, Tottenham London, N.17. Tel.: Tottenham 0811. Cables; Taperec, London.

Sound 333. Miniature tape deck $2\frac{1}{2}$ i/s. One motor. 4-in. spools. Push button control. Size $10 \times 8 \times 3$ ins. Price to be announced.

★

Truvox Ltd., Neasden Lane, London, N.W.10. Tel.: Gladstone 6455. Cables: Truvoxeng.

Mark IV. G.P. tape deck. $7\frac{1}{2}$ and $3\frac{3}{4}$ i/s. 3 motors. 7-in. spools. F.r.: 50-12,000 c/s at $7\frac{1}{2}$ i/s. 100-7,000 c/s at $3\frac{3}{4}$ i/s, both ± 3 dB. W. and F., 0.2% at $7\frac{1}{2}$ i/s. Size $14\frac{1}{2} \times 12\frac{3}{4} \times 7\frac{1}{2}$ ins. Weight $14\frac{1}{2}$ lb. Price £27 6s. with timing scale; £30 9s. with 3-digit counter.

Mark VI. G.P. tape deck, a restyled version of the Mark IV. F.r.: 30-15,000 c/s at $7\frac{1}{2}$; 30-9,000 c/s at $3\frac{3}{4}$ i/s. Size $14\frac{1}{2} \times 13 \times 4\frac{3}{4}$. Weight $13\frac{3}{4}$ lb. Price £26 5s.

■Fitted with stereo head. £40 19s.

★

Wright & Weaire Ltd., 131 Sloane Street, London, S.W.1. Tel.: Sloane 2214. Cables: Writewed, Knights.

Wearite Models 4A, 4B, 4C. Semi-pro. tape deck. $3\frac{3}{4}$ and $7\frac{1}{2}$ i/s. Also available $7\frac{1}{2}$ and 15 i/s, 4AH, 4BH, 4CH. 3 motors. $8\frac{1}{4}$ -in. spools. W. and F., 0.2% at $7\frac{1}{2}$ i/s. Size $16\frac{1}{2} \times 13 \times 7$ ins. Weight 18 lb. 4A standard monaural record/replay. Price £36 10s. 4AH £41 10s. 4B monaural record/replay plus monitor head. Price £41 10s. 4BH, £46 10s. 4C Industrial dual track. Price £46 10s. 4CH, £51 10s.

■Models 4SN, 4SH. Monaural record replay plus stereo replay. Price, 4SN, £43 17s.; 4SH, £48 17s. Model 88 Stereo record replay, full track erase. Price £51 10s.

GENERAL PURPOSE and DOMESTIC RECORDERS

Abbey Radiogram Manufacturing Co., 813 Green Lanes, London, N.21. Tel.: Laburnam 7315.

Sovereign. G.P. Portable recorder. Collaro deck. F.R. 15 i/s, 50-15,000 c/s \pm 3 dB; $7\frac{1}{2}$ i/s, 50-12,000 c/s; $3\frac{3}{4}$ i/s, 50-7,000 c/s \pm 3 dB. W and F, 0.15%. M.E. level ind. Monitoring of input signal through speaker. Mixing of inputs. Screw-in legs available. Size, $18\frac{1}{2} \times 13\frac{3}{4} \times 9\frac{1}{2}$ ins. Weight 38 lbs. Price, with tape and mic., £50 8s. Legs £2 2s.

★

Apparatus & Instrument Co. Ltd., Atco House, Vineyard Path, Mortlake High Street, London, S.W.14. Tel.: Prospect 2202.

Selectophone. G.P. portable recorder. $7\frac{7}{8}$, $4\frac{9}{10}$ and $3\frac{3}{8}$ i/s corresponding with a capstan speed of 78, 45 and $33\frac{1}{3}$ r/m. One motor. A 35 mm strip of tape is housed in a cassette shaped like a book. There are 70 tracks on each tape, transfer is automatic. 3 lengths of tape are available. A. gives 70-150 mins; B. 120-278 mins; C. 155-360 mins. depending on speed used. F.R. $7\frac{7}{8}$ i/s, 40-12,000 c/s \pm 2 dB. A turntable and pickup are available that plug directly into the recorder. Straight through amp. M.E. level ind. Size, $16\frac{1}{2} \times 11\frac{3}{4} \times 6\frac{1}{2}$ ins. Weight 30 lbs. Price, with tape A, £79 16s.

★

Baird Television, Camp Bird House, Dover Street, London, W.1. Tel.: Hyde Park 8292.

In Preparation

G.P. portable tape recorder ready August/September.

★

Connaught (Tape Recorder) Ltd., 3-4 Berners Street, London, W.1. Tel.: Flaxman 6575/6

Console. G.P. recorder. Harting deck. F.R.: 30-16,000 c/s \pm 2 dB at $3\frac{3}{4}$ i/s. M.E. bar type level ind. Outlet for pre-amp stage. 10 watts output. Mounted in a pressure controlled cabinet housing 12 in. drive unit and 2 tweeters. 5 inputs. Price, with tape and moving coil mic., £125.

★

Brenell Engineering Co. Ltd., la Doughty Street, London, W.C.1. Tel.: Holborn 7358.

Three Star. G.P. portable recorder. $7\frac{1}{2}$, $3\frac{3}{4}$ and $1\frac{7}{8}$ i/s. 1 motor. 7-in. spools.



Connaught Console



Brenell Three Star

F.R. $7\frac{1}{2}$ i/s, 60-10,000 c/s \pm 3 dB; $3\frac{3}{4}$ i/s, 60-6,000 c/s \pm 3 dB; $1\frac{7}{8}$ i/s, 60-3,000 c/s \pm 3 dB. S-N, < -40 dB. W and F, $< 0.2\%$ at $7\frac{1}{2}$ i/s. M.E. level ind. Outlet from pre-amp. stage. Straight through amplifier. Adaptable for Stereo. Headphone monitoring. Size $15 \times 15 \times 7$ ins. Weight 30 lbs. Price, with tape and mic., £60 18s.

Mark 5. G.P. portable recorder. 15, $7\frac{1}{2}$, $3\frac{3}{4}$ and $1\frac{7}{8}$ i/s. 3 motors. $8\frac{1}{4}$ -in. spools. F.R. 15 i/s, 50-14,000 c/s; $7\frac{1}{2}$ i/s, 60-10,000 c/s; $3\frac{3}{4}$ i/s, 60-6,000 c/s; $1\frac{7}{8}$ i/s, 60-3,000 c/s, all \pm 3 dB. S-N — .40 dB. W and F.

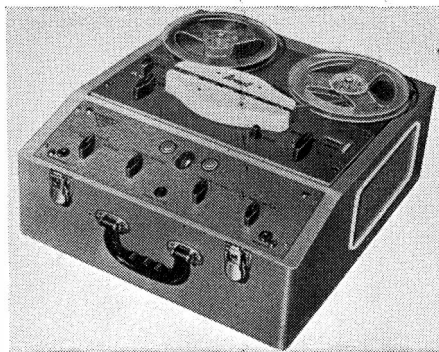

Brenell Mk. 5 portable

<0.2% at 7½ i/s. M.E. level ind. Monitoring by headphones. Straight through amp. Easily adapted for stereo. Size 18 × 16 × 8 ins. Weight 39 lbs. Price with tape £67 4s.

■ **Brenell Stereo record and replay.** Mk. 5 deck, 15, 7½, 3¾ and 17½ i/s. Two Mk. 5 amps. F.R. as Mk. 5 portable. Mounted in special rack 17½ × 16½ × 11 ins. Weight 43 lbs. No speakers. Price £93 16s.

★

Clarke and Smith Manufacturing Co. Ltd., Melbourne Works, Wallington, Surrey. Tel.: Wallington 9252-3. Cables: Electronic, Wallington.



Clarke & Smith STR/4

Model CTR/4. G.P. portable recorder. Collaro deck. F.R. 15 i/s, 50-16,000 c/s; 7½ i/s, 50-12,000 c/s; 3¾ i/s, 50-7,000 c/s. S-N < -45 dB. M.E. level ind. 6 watts output. Monitoring by headphones. Power supply available to power mixer unit or FM tuner. Stout wooden case. Size 10 × 18½ × 15½ ins. Weight 48 lbs. Price, with tape and mic., £68 5s.

Model STR/4. G.P. portable recorder. Wright and Weaire deck. F.R. 7½ i/s, 50-11,000 c/s ± 3 dB; 3¾ i/s, 50-5,000 c/s ± 3 dB. S-N, -50 dB. M.E. level ind. 4½ watts output. Monitoring by headphones. Oak case. Size 18 × 14½ × 10 ins. Weight 48 lbs. Price, with tape and mic., £93 9s.

★

Dulci Co. Ltd., 97/99 Villiers Road, London, N.W.2. Tel.: Willesden 6678/9.

Dulci-Harting. G.P. tape deck and pre-amp. Harting deck. 7½ and 3¾ i/s motor. 7-in. spools. F.R. 7½ i/s, 30-15,000 c/s ± 2 dB; 3¾ i/s, 30-10,000 c/s ± 3 dB. Size 16 × 13 ins. Price £57 15s.

★

E.A.P. (Tape Recorders) Ltd., Bridge Close, Oldchurch Road, Romford, Essex. Tel.: Romford 62366-7. Cables: Elizabethan, Romford.

Elizabethan Essex. G.P. portable recorder. Collaro deck. F.R. 15 i/s, 50-16,000 c/s; 7½ i/s, 50-12,000 i/s; 3¾ i/s, 50-7,000 c/s. M.E. level ind. S-N, < -40 dB. W and F, <0.1%. Output from pre-amp. stage. Mixing on both inputs. Monitoring. Straight-through amp. 6 watts output. Size 19½ × 15 × 9½ ins. Weight 45 lbs. Price, with 1,800 ft. tape, £68 5s.

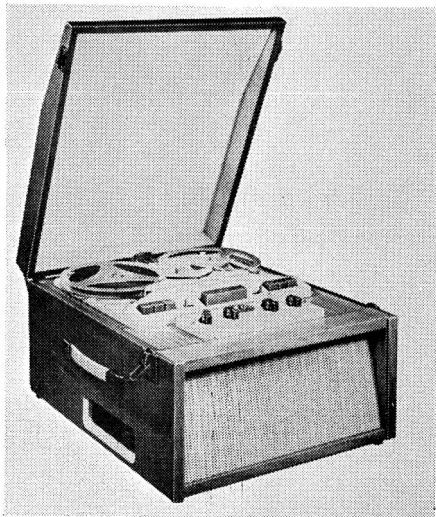

Clarke & Smith CTR/4

Elizabethan Mayfair. Console version of the Essex. Provision for FM tuner. Price, with 1,800 ft. tape, £75 12s.

Elizabethan Escort. G.P. portable recorder. Motek deck. F.R. $7\frac{1}{2}$ i/s. 60-12,000 c/s; $3\frac{3}{4}$ i/s, 60-8,000 c/s; $1\frac{7}{8}$ i/s, 60,4-000 c/s. M.E. level ind. S-N, < -40 dB. W and F, $< 0.2\%$. Output from pre-amp stage. Mixing on both inputs. Superimposing. Monitoring. Size $14 \times 11\frac{1}{2} \times 6\frac{3}{4}$ ins. Weight 23 lbs. Price, with tape and mic., £47 5s.

Elizabethan Bandbox. Miniature portable. $3\frac{3}{4}$ and $1\frac{7}{8}$ i/s. One motor, $3\frac{1}{2}$ -in. spools. F.R. up to 6,000 c/s at $3\frac{3}{4}$ i/s and up to 3,500 c/s at $1\frac{7}{8}$ i/s. M.E. level ind. S-N, < -40 dB, W and F $< 0.2\%$ @ $3\frac{3}{4}$ i/s. Output from pre-amp. stage. Mixing of inputs. Monitoring. Size $10\frac{1}{2} \times 9 \times 6$ ins. Weight 12 lbs. Price, with tape and mic., £30 9s.

★

EMI Sales & Service Ltd., Blyth Road, Hayes, Middx. Tel.: Southall 2468. Cables: Emiservice, London. Telex, Emiglobe 2-2417.

■EMI "Stereosonic" Tape Deck. Pre-amp. and control unit. Model 3035. 1 motor. $7\frac{1}{2}$ i/s. Input for single channel tape records, discs and 2 aux. inputs. 7-in. spools. C.C.I.R. spec. Response 40-10,000 c/s ± 3 dB. Deck size $17 \times 11\frac{1}{2} \times 13\frac{1}{2}$ ins. Control unit $16 \times 4 \times 4$ ins. Bass, treble and vol. controls give combined control on both amp. circuits.

★

Grundig (Gt. Britain) Ltd., Newlands Park, Sydenham, S.E.26. Tel.: Sydenham 2211 Showroom: 39-41 New Oxford Street, W.C.1. Cables: Grundig, London. Telex: 22054.

TK20. G.P. portable recorder. $3\frac{3}{4}$ i/s. One motor. $5\frac{3}{4}$ -in. spools. F.R. 60-10,000 c/s $+ 5 - 4$ dB. S-N, < -45 dB. W and F, $< \pm 0.2\%$. Bar type M.E. level ind. Output from pre-amp. stage. Auto stop at end of tape. Size $13\frac{3}{4} \times 12\frac{1}{2} \times 7$ ins. Weight 20 lbs. Price, with tape and mic., £54 12s.

TK25. G.P. portable recorder. $3\frac{3}{4}$ and $1\frac{7}{8}$ i/s. One motor. $5\frac{3}{4}$ -in. spools. F.R. $3\frac{3}{4}$ i/s. 60-15,000 c/s ± 3 dB; $1\frac{7}{8}$ i/s, 60-8,000 c/s ± 3 dB. S-N, < -45 dB. W and F, $3\frac{3}{4}$ i/s, $< \pm 0.25\%$, $1\frac{7}{8}$ i/s, $< 0.4\%$. Bar type

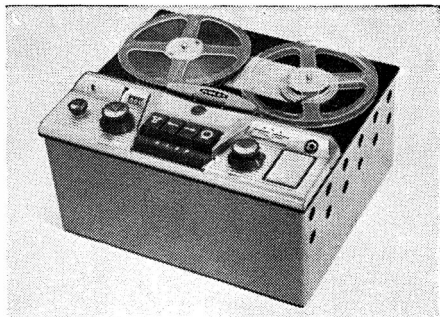

Dulci-Harting unit



Elizabethan Essex

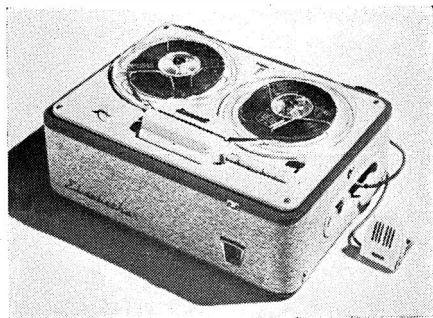

E.A.P. Elizabethan Escort

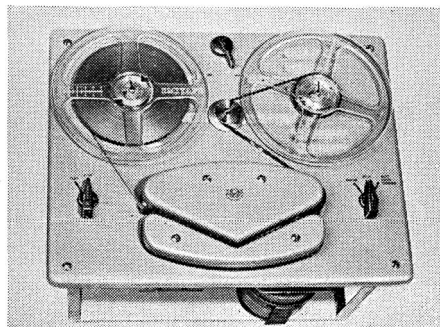

EMI Stereosonic deck Model 3035



Grundig TK20

M.E. level ind. Output from pre-amp. stage. Input fading control. Superimposing. Size $14 \times 12\frac{1}{2} \times 7\frac{1}{2}$ ins. Weight 25 lbs. Price, with tape and mic., £65 2s.

TK30. G.P. portable recorder. $7\frac{1}{2}$ and $3\frac{3}{4}$ i/s. One motor. 7-in. spools. F.R. $7\frac{1}{2}$ i/s, 50-15,000 c/s ± 3 dB; $3\frac{3}{4}$ i/s, 50-10,000 c/s ± 3 dB. S-N, < -43 dB. W and F, $7\frac{1}{2}$ i/s, $< 0.2\%$; $3\frac{3}{4}$ i/s, $< \pm 0.25\%$. Bar type M.E. level ind. Output from pre-amp. stage. Superimposing. Autostop at end of tape. Remote control facilities. Size $18 \times 18 \times 11\frac{1}{2}$ ins. Weight 31 lbs. Price, with tape, £75 12s.



Grundig TK35

TK35. G.P. portable recorder. $7\frac{1}{2}$, $3\frac{3}{4}$ and $1\frac{7}{8}$ i/s. One motor. 7-in. spools. F.R. $7\frac{1}{2}$ i/s, 50-18,000 c/s ± 3 dB; $3\frac{3}{4}$ i/s, 50-14,000 c/s ± 3 dB; $1\frac{7}{8}$ i/s, 100-8,000 c/s ± 3 dB. S-N, < -43 dB. W and F, $7\frac{1}{2}$ i/s $< \pm 0.2\%$, $3\frac{3}{4}$ i/s $- 0.25\%$, $1\frac{7}{8}$ i/s $- 0.4\%$. Output from pre-amp. stage. Superimposing, autostop, remote control facilities. Bar type M.E. level ind. Size $17 \times 16\frac{3}{4} \times 9\frac{1}{2}$ ins. Weight 34 lbs. Price, with tape, £86 2s.

TK830/3D. G.P. portable recorder. $7\frac{1}{2}$ and $3\frac{3}{4}$ i/s. 1 motor. 7-in. spools. F.R. $7\frac{1}{2}$ i/s, 40-15,000 c/s ± 3 dB; $3\frac{3}{4}$ i/s, 50-10,000 c/s ± 3 dB. Automatic stop foils at end of tape. Track change without spool reversal. Provision for remote control. Outlet from pre-amp. stage. M.E. level ind. Size $19\frac{1}{4} \times 8 \times 10\frac{1}{2}$ ins. Weight 46 lbs. Price, with tape, £105.

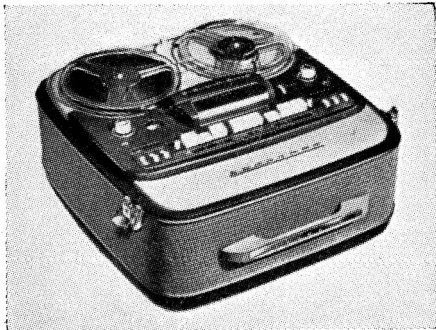

Grundig TK830/3D

TM20. Deck mechanism with pre-amp. stage. $3\frac{3}{4}$ i/s. One motor. $5\frac{3}{4}$ -in. spools. F.R. 60-10,000 c/s $+ 5 - 4$ dB. S-N, -45 dB. W and F, $\pm 0.2\%$. Bar type M.E. level ind. Size $12\frac{1}{2} \times 9\frac{1}{2} \times 6$ ins. Price £46 4s.

★

Hatfield Radio, 28 Stroud Green Road, London, N.4. Tel.: Archway 1593.

Viking. G.P. portable recorder. Motek deck. F.R. $7\frac{1}{2}$ i/s, 50-11,000 c/s ± 3 dB. S-N, < -45 dB. M.E. level ind. Outlet from pre-amp. stage. Superimposing. Monitoring by headphones from erase head. Size $16 \times 14\frac{1}{2} \times 8$ ins. Weight 34 lbs. Price, with tape and mic., £48 6s.

★

Kurland Recording Systems Ltd., Tilly's Lane, High Street, Staines, Middx.

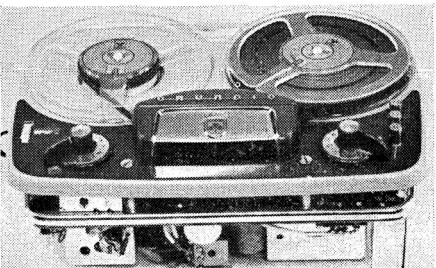

Grundig TM20

TR7m. G.P. portable recorder. Collar deck. F.R. 15 i/s, 40-15,000 c/s; $7\frac{1}{2}$ i/s,

50-12,000 c/s; $3\frac{1}{2}$ i/s, 50-9,000 c/s; S-N — 40 dB. W and F, $<0.1\%$. M.E. level ind. Built in mixer. Size $15\frac{1}{2} \times 15\frac{1}{2} \times 7\frac{1}{2}$ ins. Weight 35 lbs. Price, with tape and mic., £58 16s.

★

Lee Products (Great Britain) Ltd., Longford Street, London, N.W.1. Tel.: Euston 5754.

Elpico TR350. G.P. portable recorder. Collaro deck. Mixing facilities. M.E. level ind. Can be converted to a consolette by the fitting of legs. Size $16 \times 17 \times 9$ ins. Weight 35 lb. Price, with legs, tape and crystal mic., £59 17s.

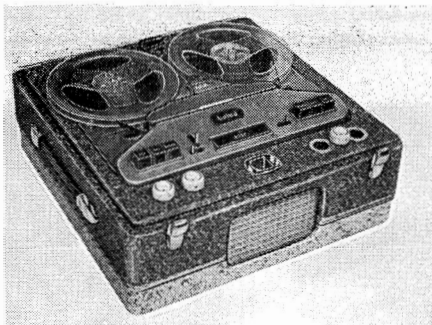

Kurland TR7m

Geloso TR175. Miniature G.P. portable recorder. $3\frac{3}{4}$ and $1\frac{7}{8}$ i/s. $3\frac{1}{2}$ in. spools. F.R.: 80-6,000 c/s at $3\frac{3}{4}$ i/s. 2 watts output. M.E. level ind. Size $10 \times 5\frac{1}{2} \times 6$ ins. Weight $7\frac{1}{2}$ lb. Price, with tape and mic., £39 18s.

★

Magnafon Ltd., 3 Baggally Street, London, E.3. Tel.: Advance 3112.

Courier. G.P. portable recorder. Motek deck. F.R. $7\frac{1}{2}$ i/s, 50-10,000 c/s ± 3 dB; $3\frac{3}{4}$ i/s, 50-6,500 c/s ± 3 dB; $1\frac{7}{8}$ i/s, 50-4,000 c/s ± 3 dB. S-N, < -40 dB unweighted. W and F, $<0.1\%$ at $7\frac{1}{2}$ i/s. M.E. level ind. Mixing on mic., radio and gram inputs. Separate controls. Outlet from pre-amp. stage. Weight 28 lbs. Price, with tape and mic., £51 9s.

★

M.S.S. Recording Co. Ltd., Colnbrook, Bucks. Tel.: Colnbrook 2431. Cables: Emesco.

Model CMR/DE. G.P. recorder. $7\frac{1}{2}$ and $3\frac{3}{4}$ i/s. 3 motors. $8\frac{1}{2}$ -in. spools. F.R.: $3\frac{3}{4}$ i/s, 100-7,500 c/s. ± 3 dB; $7\frac{1}{2}$ i/s, 60-10,000 c/s. ± 5 dB; flat 100-7,000 c/s. Level meter. Size $36 \times 28 \times 18$ ins. Weight 110 lb. Price £140; F.M. tuner available at an extra £25.

★

Normende, Bremen. U.K. Distributors: TAK Continental Importers, Stone, Staffs. Tel.: Stone 260.

Normende Titan. G.P. portable recorder. $7\frac{1}{2}$ and $3\frac{3}{4}$ i/s. 3 motors. 7-in. spools. F.R. $7\frac{1}{2}$, 50-18,000 c/s; $3\frac{3}{4}$, 50-13,000 c/s. Bar type M.E. level ind. Size $16\frac{1}{2} \times 8 \times 15$ ins. Weight 33 lbs. Price, with tape and mic., £91 9s.

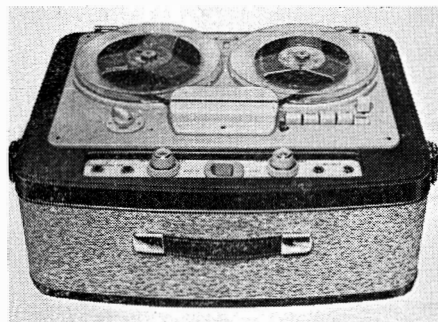

Magnafon Courier

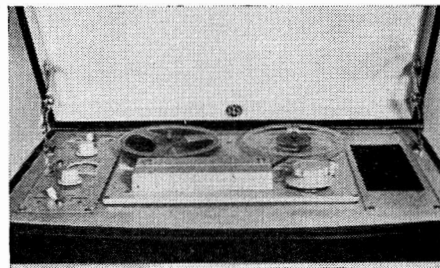

M.S.S. CMR/DE

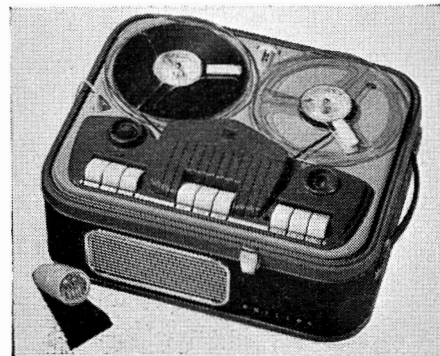

Philips AG8108G

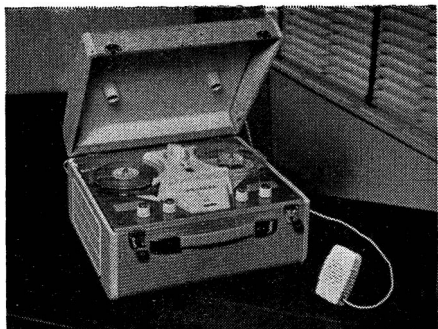

Philips EL3527

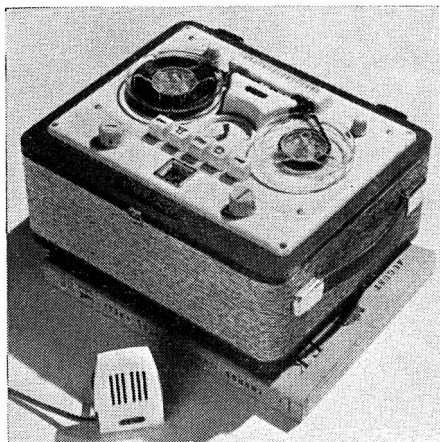

EAP Elizabethan Bandbox



EAP Elizabethan Mayfair

Philips Electrical Ltd., Century House, Shaftesbury Avenue, London, W.C.2. Tel.: Gerrard 7777. Cables: Phillamps, London.

EL.3527. G.P. portable recorder. $3\frac{3}{4}$ i/s. One motor. 5-in. spools. F.R. 50-10,000 c/s. S-N, $<- 40$ dB. W and F, $<0.2\%$. M.E. level ind. Mixing. High imp. output. Size $14 \times 13 \times 7\frac{1}{2}$ ins. Weight 21 lbs. Price, with tape and mic., £40 19s.

AG.8108G. G.P. portable recorder. $7\frac{1}{2}$, $3\frac{3}{4}$ and $1\frac{7}{8}$ i/s. One motor. 7-in spools. F.R. $7\frac{1}{2}$ i/s, 50-18,000 c/s ± 3 dB; $3\frac{3}{4}$ i/s, 50-12,000 c/s ± 3 dB. $1\frac{7}{8}$ i/s, 50-6,000 c/s. S-N, $<- 45$ dB. W and F, $7\frac{1}{2}$ i/s $<0.2\%$; $3\frac{3}{4}$ i/s, $<0.3\%$. M.E. level ind. Auto stop. Monitoring by headphones. High imp. output. Size $15\frac{3}{4} \times 13 \times 8$ ins. Weight 30 lbs. Price, with tape and moving coil mic., £65 2s.

★

Phillips & Bonson Ltd., Imperial House, Dominion Street, Moorgate, London, E.C.2. Tel.: Monarch 5481.

President. G.P. portable recorder using the Truvox Mk. IV deck. Straight through amp. headphone monitoring. M.E. level ind. Size $22 \times 14 \times 9$ ins. Weight 35 lb. Price, with timing scale, £57 15s. De Luxe model with 3 digit counter £65 2s.

★



Lee Products Elpico TR350

Reps. (Tape Recorders) Ltd., 118 Park Road North, South Acton, London, W.3. Tel.: Acorn 4141.

R.20. G.P. portable recorder. Collaro tape deck. F.R. 15 i/s, 40-17,000 c/s; 7½ i/s, 50-10,000 c/s; 3¾ i/s, 60-6,000 c/s all ± 3 dB. Meter level ind. Size 16½ × 16 × 9¾ ins. Weight 43 lbs. Price, with crystal mic., stand and spool of tape, £65 2s.

R.30, as above, but with 2 in. meter level ind. Price £69 6s.

R.40. G.P. portable recorder. Collaro tape deck. F.R. 15 i/s, 40-20,000 c/s; 7½ i/s, 50-12,000 c/s; 3¾ i/s, 60-6,000 c/s. 10 W peak output. M.E. level ind. Size 16½ × 9¾ × 16 ins. Weight 44 lbs. Price, with crystal mic. and tape, £73 10s.

★

Radio Gramophone Development Co. Ltd., Eastern Avenue West, Romford, Essex. Tel.: Romford 45991.

RGD Mark 107. G.P. portable recorder. 7½ and 3¾ i/s. One motor. 7-in. spools. F.r.: 30-18,000 c/s at 7½ i/s; 40-13,000 c/s at 3¾ i/s. S-N, — 45 dB, W. and F. 0.3% at 3¾, 0.1% at 7½. Direct connection to replay head. Connection for remote control. M.E. level ind. 4 watts output. Straight through amp. Size 16½ × 13 × 8 ins. Weight 29 lb. Price £72 9s.

★

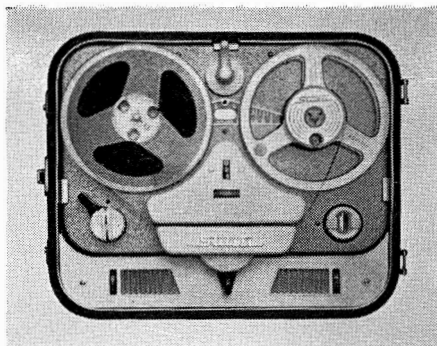

Stuzzi Mambo

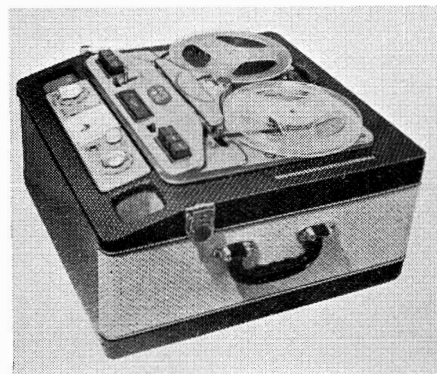

Reps R30



Abbey Sovereign



WyndSOR Dauphin



RGD Mk. 107

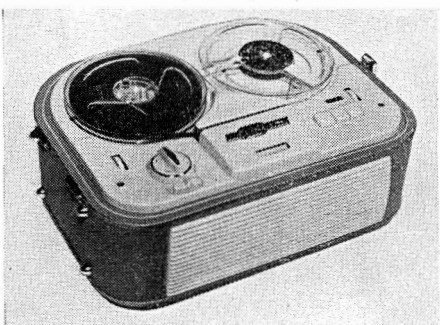

Perth-Saja Standard Mk. 40



Perth-Saja Standard Twin Mk. 45

Regentone Radio & Television Ltd., Eastern Avenue West, Romford, Essex. Tel.: 45991.

RT50. G.P. portable recorder. Motek deck. Twin neon lamps give recording level ind. F.r.: 60-10,000 c/s at $7\frac{1}{2}$, 60-6,000 c/s at $3\frac{3}{4}$, 60-3,500 c/s at $1\frac{7}{8}$, all ± 6 dB. S-N. — 45 dB. W. & F., 0.2% at $7\frac{1}{2}$ i/s; 0.3% at $3\frac{3}{4}$ i/s. Size $17 \times 14 \times 7\frac{1}{2}$ ins. Weight 24 lb. Price, with tape and crystal mic., £57 15s.

★

Saja (West Germany) Sole U.K. Distributors, **Perth Radios Ltd.,** Martin House, 39-47 East Road, London, N.1. Tel.: Clerkenwell 2413.

Perth-Saja Mk. 40. G.P. portable recorder. $3\frac{3}{4}$ i/s. One motor. $5\frac{1}{4}$ -in. spools. F.R. 50-12,000 c/s. Bar type M.E. level ind. Output from pre-amp. stage. Size $14 \times 10\frac{1}{2} \times 6$ ins. Weight approx. $17\frac{1}{2}$ lbs. Price £47 5s.

Perth Saja Mk. 5. G.P. portable recorder. $7\frac{1}{2}$ and $3\frac{3}{4}$ i/s. One motor. $5\frac{1}{4}$ -in. spools. F.R. $7\frac{1}{2}$ i/s, 50-16,000 c/s; $3\frac{3}{4}$ i/s, 50-12,000 c/s. M.E. level ind. Outlet from pre-amp. stage. Superimposing. Size $15\frac{3}{4} \times 12\frac{1}{2} \times 7$ ins. Price, with mic. and tape, £58 16s.

In Preparation.

Perth-Saja Mk. 45. G.P. portable recorder. Speeds of $3\frac{3}{4}$ and $1\frac{7}{8}$ i/s.

★

Henri Selmer & Co. Ltd., 114 Charing Cross Road, London, W.C.2. Tel : Temple Bar 0444. Cables: Selmaton, West, Cent.

Saba. G.P. portable recorder. $7\frac{1}{2}$ and $3\frac{3}{4}$ i/s. 2 motors. 7-in. spools. F.R. $7\frac{1}{2}$ i/s, 30-20,000 c/s; $3\frac{3}{4}$ i/s, 40-16,000 c/s. W and F, $7\frac{1}{2}$ i/s $\pm 0.2\%$; $3\frac{3}{4}$ i/s $\pm 0.4\%$. Bar type M.E. level ind. Automatic stop and reversal at end of tape. Straight through amp. Outlet from pre-amp. stage. Superimposing. Provision for remote control. Size $17\frac{1}{2} \times 8\frac{1}{2} \times 17\frac{1}{2}$ ins. Weight $37\frac{1}{2}$ lbs. Price, with tape, £93 9s.

Simon Sound Service Ltd., 48 George Street, London, W.1. Tel : Welbeck 2371. Cables: Simsale, London.

Simon SP/4. Automatic. Complete semi-prof. portable recorder $7\frac{1}{2}$ and $3\frac{3}{4}$ i/s. 1 synchronous motor. 7-in. spools. F.R. $7\frac{1}{2}$ i/s, 30-12,000 c/s ± 3 dB. ref. 1,000 c/s, $3\frac{3}{4}$ i/s, 30-7,000 c/s ± 3 dB. M.E. level ind. S-N, < -52 dB. ref. to 10W output. W and F, $< 0.2\%$

peak to peak. Automatic reversal at end of tape, 3 way mixing. Monitoring, push-pull oscillator. 10 watts output, 0.5% distortion. Independent tone controls. Provision for remote control. Size $16\frac{1}{2} \times 14\frac{3}{4} \times 10\frac{1}{2}$ ins. Weight 48 lbs. Price, with tape, £99 15s.

★

Sonomag Ltd., 2 St. Michael's Road, London, S.W.9. Tel.: Brixton 5441.

Society. G.P. portable recorder. Motek deck. M.E. level ind. Price, with tape and mic., £48 6s.

Classic. G.P. portable recorder. Collaro deck. M.E. level ind. Price, with mic. and tape, £56 14s.

Continental. As Classic, but with two colour polka dot finish. Price, with mic. and tape, £58 16s.

Concerto. G.P. portable recorder. Collaro deck. M.E. level ind. Two replay speakers. Price, with tape and mic., £69 6s.

Elon JC20. G.P. portable recorder. Collaro deck. M.E. level ind. Price, with tape and mic., £68 5s.

Adaptatape. Collaro deck with pre-amp. stage. M.E. level ind. Price, with power supply, £39 18s.

★

Specto Ltd., Vale Road, Windsor, Berks. Tel.: Windsor 1241/2. Cables: Specto, Windsor.

Spectone 151. G.P. portable recorder. Collaro deck. F.R. 15 i/s, 30-16,000 c/s (to C.C.I.R. spec.); $7\frac{1}{2}$ i/s, 30-12,000 c/s (to C.C.I.R. spec.); $3\frac{3}{4}$ i/s, 40-6,000 c/s, all ± 3 dB. Level meter. Size $18\frac{1}{2} \times 16 \times 11\frac{3}{4}$ ins. Weight 50 lbs. Price, with mic., £79 16s.

Spectone 161. G.P. portable recorder. Collaro deck. F.R. 15 i/s, 50-16,000 c/s; $7\frac{1}{2}$ i/s, 50-12,000 c/s; $3\frac{3}{4}$ i/s, 50-8,000 c/s. M.E. level ind. Mixing. Superimposing. Outlet from pre-amp. stage. S-N < -45 dB below full peak output. W and F, 0.15%. Size $15\frac{1}{2} \times 15\frac{3}{4} \times 8\frac{1}{4}$ ins. Weight 36 lbs. Price, with mic., £51 9s.

■ **Spectone 123.** Complete stereophonic and single track reproducer. 3 motors. $7\frac{1}{2}$ i/s. Provision is made for feeding an external crystal pickup or radio tuner unit into one or both amps., and for fitting a transcription



Saja Twin De-Luxe Mk. 5



Saba

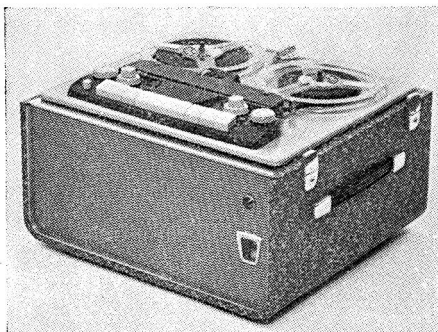

Simon SP/4

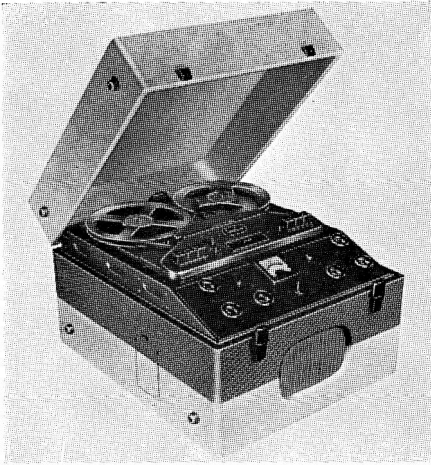

Spectone 151

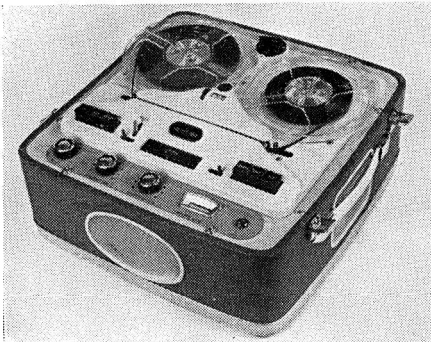

Spectone 161



Stella Model ST450

motor and FM tuner. 7-in. spools. Response C.C.I.R. spec. 50-12,000 c/s \pm 1.5 dB. Size 44 \times 25 \times 3 $\frac{1}{2}$ ins. Price £210.

■ **Spectone 129.** Complete reproducer. 3 motors. 7 $\frac{1}{2}$ i/s. 7-in. spools. Facilities: $\frac{1}{2}$ track record and replay plus twin track replay for stereo. Complete mixing on 3 input channels. Size 32 $\frac{1}{2}$ \times 22 $\frac{3}{4}$ \times 22 $\frac{1}{2}$ ins. Price £183 15s.

★

Stuzzi. Sole U.K. distributors, **Recording Devices Ltd.**, 95 Villiers Road, London, N.W.2. Tel.: Willesden 6678.

Stuzzi Mambo 368W. G.P. portable recorder. 3 $\frac{3}{4}$ i/s. One motor. 5 $\frac{3}{4}$ -in. spools. F.R. 50-12,500 \pm 3 dB. S-N, <— 40 dB. W and F, <0.2%. Outlet from pre-amp. stage. Automatic motor transit lock. Size 13 $\frac{1}{2}$ \times 10 $\frac{1}{2}$ \times 6 $\frac{3}{4}$ ins. Weight 19 lbs. Price, with tape and mic., £40 19s.

★

Stella Radio & Television Co. Ltd., Astra House, 121/3 Shaftesbury Avenue, London, W.C.2. Tel.: Gerrard 7086.

ST451. G.P. portable recorder. 3 $\frac{3}{4}$ i/s. One motor. 5 in spools. F.r.: 60-9,000 c/s. M.E. level ind. Mixing. Straight through amp. Output from pre-amp. stage. Size 13 $\frac{3}{4}$ \times 12 $\frac{1}{2}$ \times 7 ins. Weight 21 lb. Price, with tape and crystal mic., £42. 3 digit counter extra.

ST450. G.P. portable recorder. 7 $\frac{1}{2}$, 3 $\frac{3}{4}$ and 1 $\frac{7}{8}$ i/s. One motor. 2-in. spools. F.r.: 50-18,000 c/s at 7 $\frac{1}{2}$; 50-12,000 c/s at 3 $\frac{3}{4}$; 50-6,000 c/s at 1 $\frac{7}{8}$ i/s. M.E. level ind. Mixing. Straight through amp. Output from pre-amp. stage. Monitoring by headphones. Automatic stop at end of tape. Size 16 $\frac{1}{2}$ \times 14 \times 8 ins. Weight 30 lb. Price, with tape and moving coil mic., £66 3s.

★

John Street (Manufacturers) Ltd., Falcon Works, 71-73 Beacon Road, Lewisham, London, S.E.13. Tel.: Lee Green 3391.

Falcon T30. G.P. portable recorder using the Collaro deck. Mixing on 3 inputs. Monitoring straight-through amp. Size 18 \times 14 \times 9 ins. Weight 35 lb. Price £47 5s.

Symphony Amplifiers Ltd., 16 Kings College Road, London, N.W.3. Tel.: Primrose 3314.

Symphony. G.P. table recorder. Truvox Mk. IV deck with Truvok type K amplifier, $7\frac{1}{2}$ and $3\frac{3}{4}$ i/s. F.R. to C.C.I.R. spec. ± 3 dB. S-N, — 45 dB at 4 watts. W and F. $<0.2\%$. M.E. level ind. Output from pre-amp. stage. Mounted in Record Housing Nordyke cabinet, choice of 3 finishes. Size $20 \times 14 \times 16$ ins. Weight 42 lbs. Price £56 14s. Portable version available.

★

Tape Recorders (Electronics) Ltd., 784-788 High Road, Tottenham, London, N.17. Tel.: Tottenham 0811-3. Cables: Taperec, London.

Sound Belle 333. G.P. miniature recorder. $2\frac{1}{2}$ i/s avge. One motor. $4\frac{1}{2}$ -in. spools. M.E. level ind. Straight-through amp. Output from pre-amp. stage. Size $10 \times 8 \times 5$ ins. Weight 11 lbs. Price, with L.P. tape and crystal mic., £27 6s.

Sound 444. G.P. portable recorder. Collaro deck. F.R. 15 i/s, 90-14,000 c/s ± 3 dB; $7\frac{1}{2}$ i/s, 90-11,000 c/s ± 3 dB; $3\frac{3}{4}$ i/s, 90-5,500 c/s ± 3 dB. W and F, $<-0.1\%$. M.E. level ind. Output from pre-amp. stage. Size $14\frac{1}{4} \times 15 \times 8$ ins. Weight 31 lbs. Price, with tape and crystal mic. £47 5s.

Sound 555. G.P. portable recorder. Collaro deck. F.R. 15 i/s, 90-14,000 c/s ± 3 dB; $7\frac{1}{2}$ i/s, 90-11,000 c/s ± 3 dB; $3\frac{3}{4}$ i/s, 90-5,500 c/s ± 3 dB. W and F, $<0.1\%$. M.E. level ind. Output from pre-amp. stage. Size $19\frac{1}{2} \times 13 \times 9$ ins. Weight 35 lbs. Price, with l.p. tape, stethoset for monitoring and dynamic mic., £68 5s.

★

Taplin-Hirst & Co., 22 Coram Street, London W.C.1. Tel.: Terminus 4741.

Balmoral Standard Plus. G.P. portable recorder. Collaro deck. F.R. 15 i/s, 40-16,000 c/s ± 3 dB; $7\frac{1}{2}$ i/s, 40-12,000 c/s ± 3 dB; $3\frac{3}{4}$ i/s, 50-8,000 c/s. S-N <-46 dB at 2 watts. W and F, 0.15% at $7\frac{1}{2}$ i/s. M.E. level ind. Separate record and replay amps. Monitoring through main speaker. Output from pre-amp. stage. Size $16 \times 14\frac{1}{2} \times 7\frac{3}{4}$ ins. Weight 34 lbs. Price with tape and mic., £54 12s.

Balmoral Deluxe. G.P. portable recorder. Spec. as for standard, but with manual speed correction switch. Superimposition. Price with tape and Acos Mic-39, £66 3s.



Stella Model ST451



Sound Belle 333



Sound 444



Taplin-Hurst Balmoral

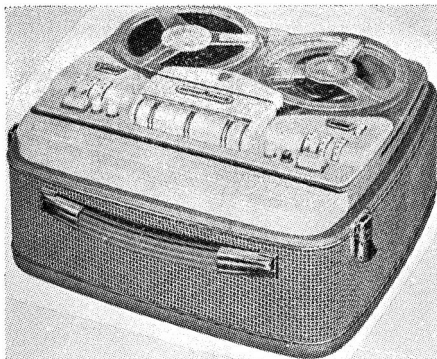

Normandie Titan

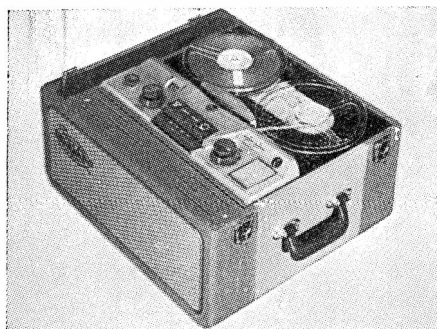

Harting HM5

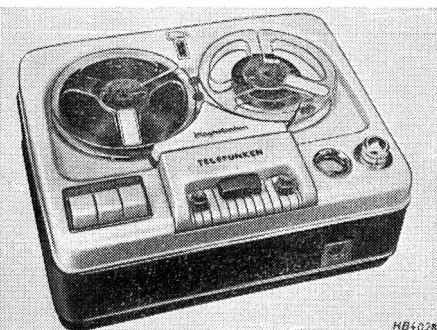

Telefunken 75T

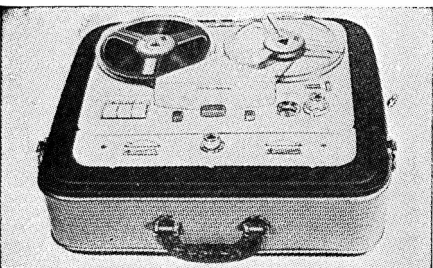

Telefunken Model 85

Technical Suppliers Ltd., Hudson House, 63 Goldhawk Road, London, W.12. Tel.: Shepherds Bush 2581 and 4794. Cables: Teknika, London.

Elektron EMG 9/2. G.P. portable recorder. $3\frac{3}{4}$ i/s. One motor. $5\frac{1}{2}$ -in. spools, F.R. 30-16,000 c/s ± 3 dB. S-N, < -50 dB. W and F, $< 0.12\%$. M.E. level ind. Size $13 \times 10\frac{1}{2} \times 6\frac{1}{2}$ ins. Weight $17\frac{1}{2}$ lbs. Price, with tape and mic., £49 17s. 6d.

Harting HM5M. G.P. portable recorder. $7\frac{1}{2}$ and $3\frac{3}{4}$ i/s. One motor. 7-in. spools. F.R. $7\frac{1}{2}$ i/s, 30-20,000 c/s ± 2 dB; $3\frac{3}{4}$ i/s, 30-16,000 c/s ± 2 dB. S-N, < -55 dB. W and F, $< 0.06\%$. M.E. level ind. Outlet from pre-amp. stage. Telefunken heads. Size $12\frac{3}{4} \times 15\frac{1}{2} \times 8\frac{1}{2}$ ins. Weight $37\frac{1}{2}$ lbs. Price, with tape, £86 2s.

■ **Harting HM5S.** Specification as model HM5M, but with the added facility of stereo playback. Price £99 15s.

★

Telefunken - Sole U.K. distributors, **Welmecc Corporation Ltd.**, 147 Strand, London, W.C.2. Tel.: Temple Bar 3357. Cables: Welmeccor, London.

75K. G.P. portable recorder. $3\frac{3}{4}$ and $1\frac{7}{8}$ i/s. One motor. 5-in. spools. F.r.: 60-16,000 c/s ± 3 dB at $3\frac{3}{4}$ i/s; 60-9,000 c/s ± 3 dB at $1\frac{7}{8}$ i/s. W. and F. 0.4% at $3\frac{3}{4}$ i/s. S-N, > 40 dB. M.E. level ind. Automatic stop at end of tape by foils. Connections for synchronised control of automatic slide projector. Superimposing. Connection of remote control. Output from pre-amp. stage. Size $6\frac{1}{4} \times 12\frac{1}{2} \times 12\frac{1}{2}$ ins. Weight 21 lb. Price, with tape, £52 10s. Also available with accessory compartment, £60 7s.

75T. A table model with no carrying case or loudspeaker, but a power stage with output of 2.5 watts 4.5 ohms. Size $5\frac{1}{2} \times 9\frac{1}{4} \times 12\frac{1}{2}$ ins. Weight $16\frac{1}{4}$ lb. Price £47 5s.

85K. G.P. portable recorder. $7\frac{1}{2}$ and $3\frac{3}{4}$ i/s. One motor. 7-in. spools. F.r.: 30-20,000 c/s ± 3 dB at $7\frac{1}{2}$ i/s; 30-15,000 c/s ± 3 dB at $3\frac{3}{4}$ i/s. S-N, > 50 dB. W. and F. $< \pm 0.2\%$ at $7\frac{1}{2}$ i/s; $< \pm 0.4\%$ at $3\frac{3}{4}$ i/s. M.E. level ind. Outlet from pre-amp. stage. Straight through amp. 3 watts output. Superimposing. Automatic stop at end of tape by foils. Monitoring by earphones. Provision for remote stop/start. Built-in splicing device. Size $7\frac{3}{4} \times 17\frac{3}{4} \times 16\frac{1}{4}$ ins. Weight 33 lb. Price £78 15s.

85KL as model 85K, but with 6 watts push-pull output. Price £82 19s.

85T. Table version. No carrying case, output stage or loudspeakers. Output from pre-amp. 1.2-2 volts. Price £66 3s.

■ **85K Stereo** G.P. portable recorder. Single track record/replay with stereo replay, spec. as for single track model. Price £117 12s.

85T. Stereo. Table model. Single track record/replay and Stereo replay. Spec. as for single track model. Price £99 15s.

★

Truvox Ltd., Neasden Lane, London, N.W.10
Tel.: Gladstone 6455. Cables: Truvoxeng.

R.2. G.P. portable recorder. $7\frac{1}{2}$ and $3\frac{3}{4}$ i/s. 3 motors. 7-in. spools. F.R. $7\frac{1}{2}$ i/s, 50-12,000 c/s ± 3 dB; $3\frac{3}{4}$ i/s, 60-9,000 c/s ± 3 dB. S-N, -45 dB. W and F, <0.2%. M.E. level ind. Outlet from pre-amp. stage. Size $15 \times 14 \times 8\frac{1}{2}$ ins. Weight 37 lbs. Price, with tape and crystal mic., £61 19s.

■ **Twin-set.** G.P. portable, stereo replay and record, one R2 with stereo head and matching unit containing loudspeaker and amplifier. Price £115 10s.

★

Tutor-Tape Co., 70 Brewer Street, London, W.1. Tel.: Gerrard 3376. Cables: Tutape, London.

The Tutor. G.P. portable recorder. Collar deck. F.r.: 50-21,000 c/s at 15 i/s; 50-10,000 c/s at $7\frac{1}{2}$ i/s; 50-6,000 c/s at $3\frac{3}{4}$ i/s. 5.7 watts output. Monitoring by headphones. Size $17\frac{1}{4} \times 15\frac{1}{4} \times 7\frac{3}{4}$ ins. Weight 36 lb. Price, with tape and crystal mic., £66 3s.

★

Verdik Sales Ltd., 139/143 Sydenham Road, London, S.E.26. Tel.: Sydenham 3118.

S.1. G.P. portable recorder. $7\frac{1}{2}$ and $3\frac{3}{4}$ i/s. 3 motors. 7-in. spools. F.R. $7\frac{1}{2}$ i/s, 50-10,000 c/s ± 3 dB, 40-12,000 c/s ± 5 dB; $3\frac{3}{4}$ i/s, 50-9,000 c/s ± 3 dB. S-N, -45 dB ref. to $2\frac{1}{2}$ W. W and F, $7\frac{1}{2}$ i/s, 0.2%; $3\frac{3}{4}$ i/s, 0.3%. M.E. level ind. Separate monitor head, separate record and replay amps. Size $15\frac{1}{4} \times 14\frac{1}{2} \times 7\frac{1}{2}$ ins. Weight 33 lbs. Price, with tape and crystal mic., £47 5s.



Telefunken 75K



Truvox R2

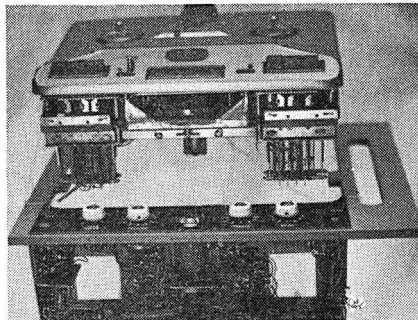

The Tutor Tape "Tutor"

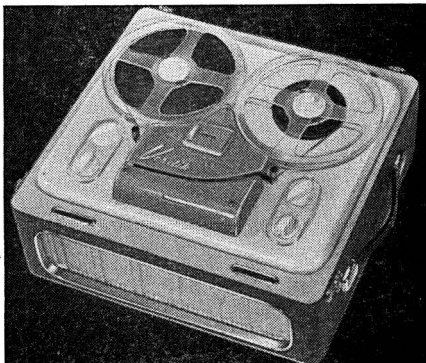

The Verdik S1



Veritone Venus Portable



Veritone Venus Console

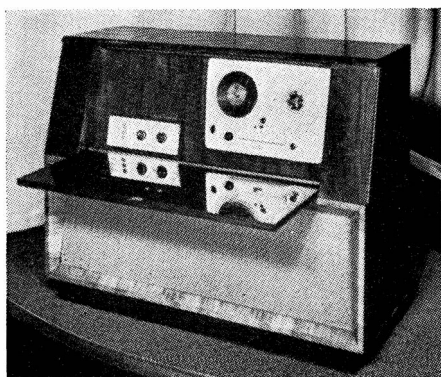

Walter "1000"

Veritone Ltd., Avenue Parade, London, N.21.
Tel.: Laburnum 6641/2.

Venus Portable. G.P. recorder. Verdik deck. $7\frac{1}{2}$ and $3\frac{3}{4}$ i/s. F.R. $7\frac{1}{2}$ i/s, 40-12,000 c/s ± 3 dB; $3\frac{3}{4}$ i/s, 40-8,000 c/s ± 3 dB. S-N, -45 dB. W and F, $<0.2\%$. M.E. level ind. Outlet from pre-amp. stage. 3 heads, separate record and playback amps. Direct monitoring. Size $17\frac{1}{4} \times 15\frac{1}{2} \times 7\frac{1}{2}$ ins. Weight 35 lbs. Price, with tape and Acos. mic.-39, £60 18s.

Venus Console. G.P. recorder. Verdik deck. Spec. as for portable provision for in-built FM tuner. Size $24\frac{3}{4} \times 17 \times 29$ ins. (inc. legs $17\frac{1}{2}$ ins.). Weight 50 lbs. Price £69 6s.

★

Walter Instruments Ltd., Garth Road, Morden, Surrey. Tel.: Derwent 4421.
Cables: Walinst. Morden.

"101" Miniature portable recorder. $3\frac{3}{4}$ i/s. One motor. 5-in. spools. F.R. 60-7,000 c/s. S-N, -40 dB. W and F, 0.35%. M.E. level ind. Size $11\frac{3}{4} \times 11 \times 6\frac{1}{2}$ ins. Weight 17 lbs. Price, with tape and crystal mic., £30 9s.

"303" De Luxe. G.P. portable recorder. $7\frac{1}{2}$ and $3\frac{3}{4}$ i/s. One motor. 7-in. spools. F.R. $7\frac{1}{2}$ i/s, 40-12,000 c/s; $3\frac{3}{4}$ i/s, 40-7,000 c/s. S-N, -40 dB. W and F, 0.35% at $3\frac{3}{4}$ i/s. M.E. level ind. Outlet from pre-amp. stage, telephone attachment, provision for ciné strob. Size $14 \times 11 \times 8\frac{1}{2}$ ins. Weight 19 $\frac{1}{2}$ lbs. Price, with tape and crystal mic., £44 2s.

"505". G.P. portable recorder. $7\frac{1}{2}$ and $3\frac{3}{4}$ i/s. One motor. 7-in. spools. F.R. $7\frac{1}{2}$ i/s, 40-14,000 c/s; $3\frac{3}{4}$ i/s, 40-7,000 c/s. S-N, -40 dB. W and F, 0.2% at $7\frac{1}{2}$; 0.35% at $3\frac{3}{4}$ i/s. M.E. level ind., Superimposing, Provision for ciné strob., remote control, straight-through amp. Telephone attachment. Outlet from pre-amp. stage. Size

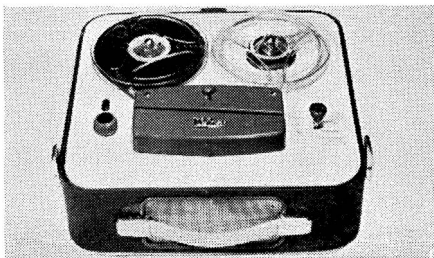

Walter "101"

16½ × 12½ × 8 ins. Weight 23 lbs. Price, with tape and crystal mic., £59 17s.

“1000”. G.P. Console recorder. Walter Mk. II deck. 7½ and 3¾ i/s. One motor. 7-in. spools. F.R. 40-14,000 c/s at 7½ i/s. S-N, <— 50 dB. W and F, 0.2% at 7½ i/s. 10 watts output. M.E. level ind. Straight through amplifier. Provision for fitting of FM tuner. 5 replay speakers. Size 33 × 41 × 17 ins. Walnut veneer finish. Price, with tape and mic., £136 10s.

★

Winston Electronics Ltd., Govett Ave., Shepperton, Middx. Tel.: Walton 6321. Cables: Winston, Shepperton.

Thoroughbred. G.P. portable recorder. Collaro deck. F.R. 15 i/s, 50-16,000 c/s; 7½ i/s, 50-12,000 c/s; 3¾ i/s, 50-7,000 c/s. W and F, 0.1%. M.E. level ind. Mixing. 3 loudspeakers. Output from pre-amp. stage. Size 17 × 15½ × 9¼ ins. Weight 48 lbs. Price, with tape and mic., £72 9s.

★

Wyndson Recording Co. Ltd., (inc. Magnetic Recording Co.) 2 Bellevue Road, Friern Barnet, London, N.11. Tel.: Enterprise 2226/7. Cables: Wyndreco.

Wyndson Dauphin. G.P. console recorder. Harting tape deck with extra monitor head fitted. F.R. 7½ i/s, 50-15,000 c/s; 3¾ i/s, 50-8,000 c/s, both ± 3 dB. M.E. level ind. Size 21 × 16½ × 16¼ ins. On legs supplied. 30 ins. high. Price, with tape and mic., £93 9s.

Wyndson Viscount. G.P. portable recorder. Collaro deck. Mk IV. F.R. 7½ i/s, 50-12,000 c/s. M.E. level ind. Monitoring; speaker mounted in detachable lid. Size 15½ × 14¼ × 10½ ins. high with lid in position, 5¾ ins. deep without lid. Price, with tape and mic., £51 9s.



Wyndson Viscount



Walter 303 De-Luxe

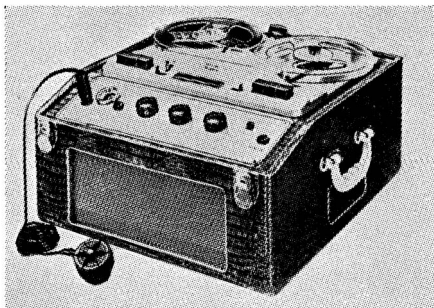

Winstone "Thoroughbred"



Walter "505"

BATTERY OPERATED PORTABLES



EMI L/2 battery driven portable

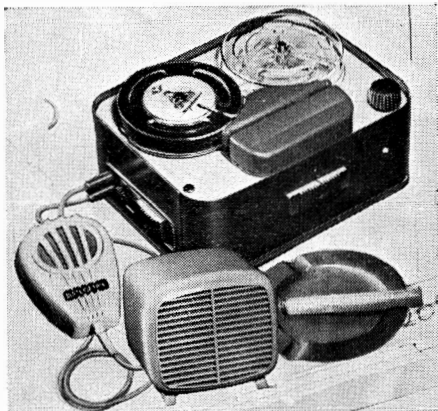

GBC Phonotrix

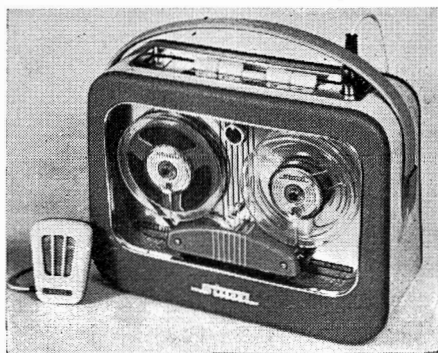

Stuzzi Magnette 671B

Challen Instrument Co., Hamelton Works, 179a Hamelton Road, West Norwood, London, S.E.27. Tel.: Gipsy Hill 4381.

Minivox. Miniature battery portable. $1\frac{7}{8}$ i/s 3 motors. $3\frac{1}{4}$ -in. spools. M.E. level ind. 3 batteries; life, given average use, over 3 months. 250 mW output. Size $10 \times 7 \times 5$ ins. Weight 9 lb. Price, with tape and mic., standard model £35 14s. De Luxe model approx. £38 17s.

★

EMI Sales & Service Ltd., Hayes, Middx Tel.: Southall 2468. Cables: Emiservice, London.

E.M.I. Model L/2. Prof. battery operated portable recorder. 2 types: L/2A $3\frac{3}{4}$ i/s; L/2B $7\frac{1}{2}$ i/s. 1 motor. 5-in. spools. F.r.: $7\frac{1}{2}$ i/s, 50-7,000 c/s; $3\frac{3}{4}$ i/s, 50-3,000 c/s. Level meter. Size $14 \times 8 \times 7$ ins. Weight with batteries, $14\frac{1}{2}$ lb. Powered by, ten U2's or 2LP type 1.5v cells, and two B101 type 67.5v H.T. batteries. Price £102 18s.

★

Fi-Cord Ltd., 40a Dover Street, London, W.1. Tel.: Hyde Park 3448. Cables: Fi-Cord London.

Mark 1A. Miniature battery portable. $7\frac{1}{2}$ and $1\frac{7}{8}$ i/s. One motor. $3\frac{1}{4}$ -in. spools. F.r.: 50-12,000 c/s ± 3 dB at $7\frac{1}{2}$ i/s. W. and F. 0.4%. S-N, — 35 dB. M.E. bar type level ind. Outlet from pre-amp. stage. Rechargeable batteries, price includes a charger. Mic. incorporates stop/start switch. Battery life, $1\frac{1}{2}$ -2 hrs. at $7\frac{1}{2}$ i/s; 3-3 $\frac{1}{2}$ hrs. at $1\frac{7}{8}$ i/s. Size $9\frac{5}{8} \times 5 \times 2\frac{3}{4}$ ins. Weight $4\frac{1}{2}$ lb. Price, with tape, batteries and mic., £61 19s.

★

GBC Electronic Industries Ltd., 119 Edgware Road, Park West, London, W.2. Tel.: Ambassador 2872.

Phonotrix. Battery portable. $1\frac{7}{8}$ i/s 3-in. spools. Separate loudspeaker. Powered by four U2 batteries. Size $10\frac{1}{2} \times 4\frac{1}{2} \times 3\frac{1}{2}$ ins. Weight $5\frac{1}{2}$ lb. Price, with tape and mic., £27 6s. Mains converter, £4 4s.

Livingston Laboratories Ltd., Retcar Street, London, N.19. Tel.: Archway 6251.

Nagra III B. Prof. battery portable recorder. 15, $7\frac{1}{2}$ and $3\frac{3}{4}$ i/s. One motor. $5\frac{1}{2}$ -in. spools, or $7\frac{1}{2}$ -in. with lid open. F.r.: 30-15,000 c/s ± 1 dB at 15 i/s; 30-12,000 c/s ± 1.5 dB at $7\frac{1}{2}$ i/s; 50-7,000 c/s ± 3 dB at $3\frac{3}{4}$ i/s. S-N — 52 dB at $7\frac{1}{2}$ i/s. W. and F. 0.2% at $7\frac{1}{2}$ i/s. Meter level ind. Batteries, twelve 1.5v torch batteries, life approx. 20 hours. On alkaline accumulators, approx. 70 hours life. Mixing on the 3 inputs. 3 heads. Monitor speaker, outlet from pre-amp. stage. Size $8\frac{3}{4} \times 12\frac{1}{2} \times 4\frac{1}{4}$ ins. Weight approx. $15\frac{1}{2}$ lb. Price £270.

★

Stuzzi - Sole U.K. distributors, Recording Devices, 95 Villiers Road, London, N.W.2. Tel.: Willesden 6678.

Magnette 671B. Miniature battery portable. $3\frac{3}{4}$ and $1\frac{7}{8}$ i/s. 2 motors. 4-in. spools. F.r.: 80-9,000 c/s at $3\frac{3}{4}$ i/s; 80-4,500 c/s at $1\frac{7}{8}$ i/s. W. and F., 0.25% at $3\frac{3}{4}$ i/s;



Fi-Cord Mk. 1A

0.35% at $1\frac{7}{8}$ i/s. S-N, — 45 dB. M.E. bar type, level ind. Outlet from pre-amp. stage. Powered by four standard torch batteries; life, 30-100 hours depending on type of use. Battery indicators. Size $11 \times 4\frac{1}{2} \times 8$ ins. Weight 8 lb. Price, with tape and mic., £72 9s.

TAPE AMPLIFIERS AND MIXER UNITS

Associated Electronic Engineers Ltd., 10 Dalston Gardens, Stanmore, Middx. Tel.: Wordsworth 4474/5/6. Cables: Astronic, Stanmore.

Astronic A.1446. 6 channel electronic mixer unit. Designed for 5 low impedance sources each 10/30 ohms, 0.5 mV; 1 high impedance source 250K ohms, 0.2 volts. There are four output sockets supplying 0.7 volts into 600 ohms. A master Gain fader is incorporated, and each channel has an indicator lamp to show which sources have been faded up. A.C. mains required. Size $9 \times 11 \times 8\frac{1}{2}$ ins. Price £58 10s.

★

Brenell Engineering Co. Ltd., 1A Doughty Street, London, W.C.1. Tel.: Chancery 5809/Holborn 7358.

T.P.2. Tape pre-amp. Inputs: Mic. 2.5 mV, radio/P.U. 250 mV. Frequency correction for 15, $7\frac{1}{2}$ and $3\frac{3}{4}$ i/s. F.r.: 15 i/s., 50-14,000 c/s.; $7\frac{1}{2}$ i/s., 60-10,000 c/s.; $3\frac{3}{4}$ i/s., 60-5,000 c/s., all ± 3 dB. Facilities include head demagnetising, monitoring, auxiliary power switch. Output

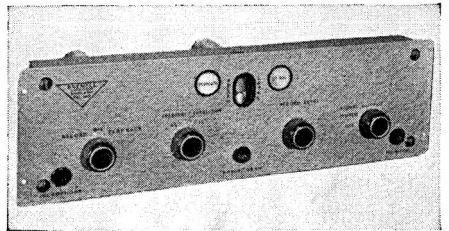

Brenell TP2

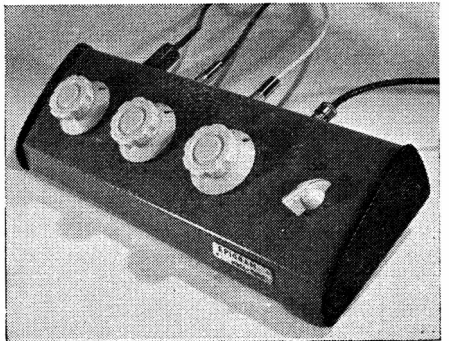

Penco Products Mix/39

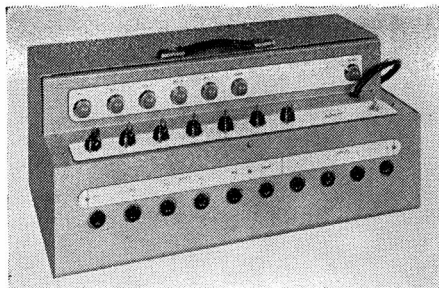

Astronic A.1446

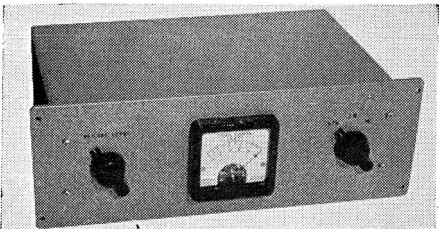

Cape VLT



Grundig G.M.U.3

approx. 1v at source, input of 50,000 ohms. P.s.m. 300v at 40mA, 6.3v at 1.5 amps. Size panel 15 × 4½ × 5 ins. Price £17 17s.

P.U.2. Power unit for use with T.P.2 when main equipment extra power supply is inadequate. Price £4 18s.

Brenell Mixer Unit. 3 channel unit. For best results high impedance sources such as crystal microphones and pickups are recommended. There are 4 sockets for jack plugs for the three inputs and the output lead, each input having a volume control. Price £2 18s.

★

B.T.H. Sound Equipment Ltd., Crown House, Aldwych, London, W.C.2. Tel.: Temple Bar 8040. Cables: Soundequi, Lesquare, London.

In preparation: 4 channel electronic mixer unit primarily for low impedance microphones. Cathode follower output.

Cape Electrophonics Ltd., 43-45 Shirley High Street, Southampton. Tel.: Southampton 74251.

Cape VLT. Tape Unit for use with Cape Audio System. Replay amplifier. Gain approx. ×30 giving overall sensitivity with VLP of 0.6 mV at 15 i.p.s. and 1 mV at 7½ i.p.s. Recording amp. 18 dB feedback. Parallel T network in feedback loop adjustable for 3 tape speeds. Peak signal level meter. Oscillator low distortion circuit, p.s.n. 430v and 6.3v. Size 9 × 6 × 3 ins. Weight 3¼ lb. Price £25 (see amplifier directory).

★

C.Q. Audio Ltd., 2 Sarnesfield Road, Enfield, Middx. Tel.: Enfield 8262.

Tape pre-amplifier. Provides facilities for stereo record/replay with a maximum output of 2 volts. Independent pre-set gain controls. Push-pull erase and bias oscillator included. Price to be announced.

★

Grundig (Gt. Britain) Ltd., Newlands Park, Sydenham, S.E.26. Tel.: Sydenham 2211. Showroom: 39-41 New Oxford Street, London, W.C.1. Tel.: Covent Garden 2995. Cables: Grundig London. Telex 22054.

G.M.U.3. Four channel mixer and pre-amp. Inputs: Mic. 1, 1.2 mV, 100 K ohms; Mic. 2, 4 mV, 100 K ohms. Polarised 100v D.C. Mic. 3 as Mic. 2. Channel (radio/P.U.). 300 mV, 500 K ohms. Out. imp. approx. 1,000 ohms. Magic eye level ind. Output level 65 mV. Mains-powered. Price £16 16s.

★

Jason Motor & Electronic Co., 3/4 Gt. Chapel Street, London, W.1. Tel.: Gerrard 0273/4.

J.S.M./1. Record and replay tape unit. Recording input 100 mV. Push-pull oscillator. Variable bias control. Magic-eye indicator. Replay amplifier produces 0.5 volts from 7 mV programme peak. Size 15 × 8¼ × 4¾ ins. Price £37 10s.

★

Kenton Laboratories Ltd., 4 Tottenham Mews, London, W.1. Tel.: Museum 8105.

Kenton Mixer Unit Mk. I. 4 inputs. Channels 3 and 4 are of low sensitivity for high output tuner or pre-amp, 50,000 ohms.

1 and 2 are of high sensitivity for low output mic. or pickup 100,000 ohms: These channels are amplified + 20 dB to match output from channels 3 and 4. Output impedance 50,000 ohms. Pilot light. Self-powered. Size $8 \times 3\frac{1}{2} \times 5$ ins. Price £10 15s.

★

The Lowther Manufacturing Co., St. Mark's Road, Bromley, Kent. Tel.: Ravensbourne 5225. Cables: Lowther, Bromley.

Tape B and E Unit, No. 1. Tape Record unit for bias voltage and record level metered control with playback pre-amp, for direct head connection. Switch to allow meter setting of bias voltage to suit head or tape. P.s.n. 250v at 30 mA; 6.3v at 3 amps. Price £25.

Companion Supply Unit No. 2. H.T. and L.T. power supply suitable to power radio tuners. Preamp and tape bias amplifier. Output 250v at 40 mA, 6.3v at 3 A. Price £5 10s.

★

Lustraphone Ltd., St. George's Works, Regents Park Road, London, N.W.1. Tel.: Primrose 8844. Cables: Lustraphon London.

M.U.577. Transistor mixer unit. Inputs: 1 and 2 are unbalanced and are suitable for low imp. mics. (line or high imps. to order). 2 and 3 are high imp. and suitable for radio or P/U. Output is balanced to match that from 1 and 2. F.r. substantially flat 50-14,000 c/s. Power by mercury cell with 1,000 hours life. Alternative input and output impedances to specification. Price, standard model, £22.

M.U.483. 3 Channel unit. Input impedance 20 ohms each channel, or to order. Output impedance 20 ohms or to order. Standard jack plugs supplied. Size $13 \times 5 \times 5$ ins. Price £13 13s.

★

M.S.S. Recording Co., Ltd., Colnbrook, Bucks. Tel.: Colnbrook 2431. Cables: Emesso.

4 M 2 or 2 ML. Microphone mixing and control unit. Up to 4 mics. or line, P/U and 2 mics. Microphone switching and level control. Output sockets for 600 ohm line and headphone monitor. 4 input sockets. H.D. at 1 mW 1,000 c/s. tone, is 0.25%. H and N at normal output level on 1 mW signal to noise ratio 60 dB. Size $14\frac{1}{2} \times 12 \times 7$ ins. Price £50.

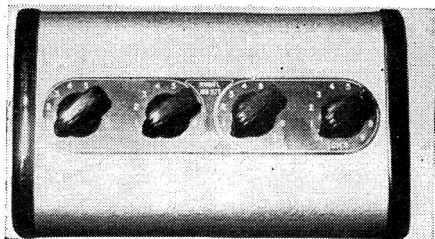

Lustraphone MU577



Spectone Electronic Mixer

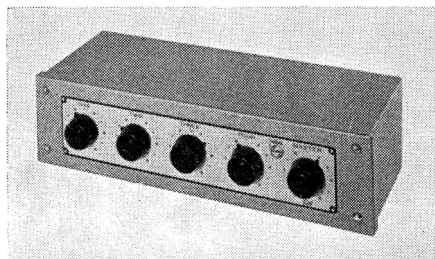

Philips ET1039 Mixer

RA/50. Amplifier for recording and playback. 50 watts. Dist. 2.5% at 50 watts. Input for spec. output 1v. Response 30-15,000 c/s. ± 2 dB. Feedback 12 dB. N.L. — 80 dB at full output. Out. imp. RA50/1 1,800 ohms; RA50/2 200 ohms; RA50/3 15 ohms. Output EL37's. Size $19 \times 14 \times 8$ ins. Power available for pre-amp. Price £70.

★

Penco Products, 36 Coniston Road, Kings Langley, Herts. Tel.: Kings Langley 3134. Cables: Penco, Kings Langley.

Epigram Mix/3. 3 channel unit. Incorporates 3 transistors and is designed for 2 low impedance 15/30 ohms and one high impedance input. Power derived from 4 volt Mercury Cell. Output is high impedance. Price £19 19s.

Epigram Mix/35. Details as above except that 5 transistors are included giving extra gain, e.g. to by-pass input stage of recorder. Price £26 5s. Specials to order.

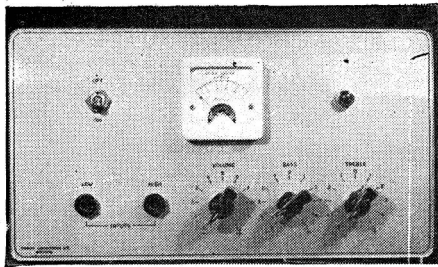

Shirley TWA/15

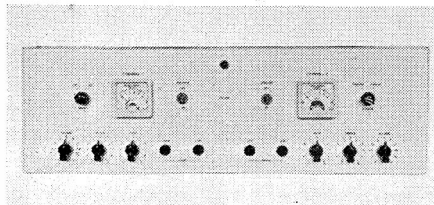

Shirley TWA/1515

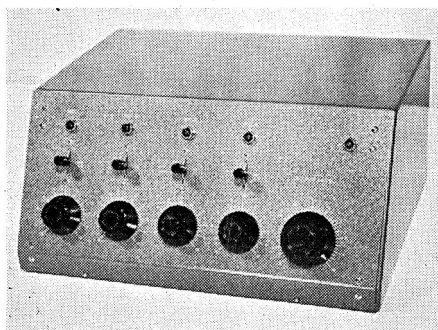

MSS 4M2 4-Channel Mixer

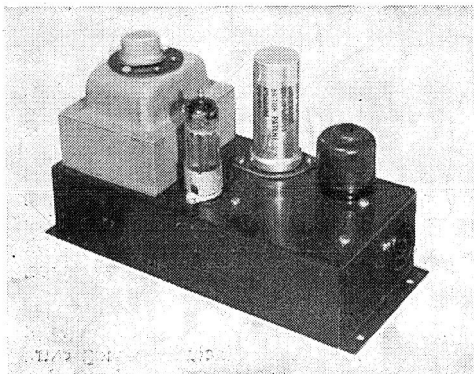

Rogers Power Pack

Philips Electrical Ltd., Century House, Shaftesbury Avenue, London, W.C.2. Tel.: Gerrard 7777. Cables: Phillamps, London.

Philips ET.1039. 4 channel unit. Each input is designed for a microphone of 50/600 ohms impedance and includes a transformer. The output voltage is approximately 90 mV and is cathode follower. A master gain control is included and mains supply is required. Size $12 \times 6\frac{1}{2} \times 3$ ins. Price £36.

Philips EL.3989. 4 channel unit. Incorporating 4 separate potentiometers. Price £4 4s.

★

Rogers Developments (Electronics) Ltd., "Rodevco Works," 4-14 Barmeston Road, Catford, S.E.6. Tel.: Hither Green 7424. Cables: Rodevco, London.

General Purpose Power Pack. Suitable for tape units and radio tuners. Output 250v at 45 mA, 6.3v at 2.5A. Size $7\frac{1}{2} \times 3 \times 5$ ins. Price £4 5s.

★

Shirley Laboratories Ltd., 3 Prospect Place, Worthing, Sussex. Tel.: Worthing 30536.

TW/PA2. Recording amplifier for use with high quality power amplifier. Inputs: 1.5 mV. and 60 mV. Bias and erase oscillator. Full corrections. Valve voltmeter modulation level ind. For use with Wearite tape deck, can be supplied to order for any deck. Size $10 \times 5\frac{1}{2} \times 5\frac{1}{2}$ ins. P.s.n. from main amp. or power pack can be supplied at £6 16s. 6d. Price £31 10s.

TW/CT. Tape amplifier for use with Collaro tape deck. F.r.: as recorder, 50-12,000 c/s.; as amplifier 50-16,000 c/s. Bass and treble boost and cut. Magic eye level ind. Output $3\frac{1}{2}$ watts. Inputs 1.5 mV and 40 mV. Price on application.

TWA/15. Tape amplifier for use with most tape decks, also for use with pickup or radio. Inputs: 1-1.5 mV and 40 mV. Output: 15 watts, 20 watts peak. F.r.: as recorder 50-12,000 c/s. as reproducing and gram amp. 20-40,000 c/s. Bass and treble boost and cut. H and N 85 dB down. Valve-Voltmeter level ind. power supply on separate chassis. Price £47 5s.

■ **TWA/1515.** Complete stereo record and replay amplifier. Output 15 watts continuous, 25 watts peak on each channel.

Inputs: 1.5 mV and 50 mV. Bass and treble boost and cut. Level indicated by separate sustained peak-reading valve volt-meters. Power supply and oscillator on separate chassis. F.r.: 40-30,000 as ordinary amp.; 40-15,000 as recording amp. Size: control unit $23 \times 7\frac{1}{2} \times 7$ ins. Power unit $10 \times 8 \times 7\frac{1}{2}$ ins. Price £100 16s.

■ **TW/PA22.** A two-channel version of the TW/PA2. Price on application.

★

Sound News Productions, 10 Clifford Street, New Bond Street, London, W.1.

Unimixer 1. 3 channel unit. Channels 1 and 2 have duplicate sockets for low or high impedance microphones—30 ohms or 400 K ohms. Recommended load impedance not less than 500 K ohms. Price £9 9s.

Unimixer 2. 3 channel unit. Inputs as above but high impedance is 5 M ohms in channels 1 and 2. Power supply needed 200/300 volts D.C. at 5 mA, 6.3v at 0.3 amps. Special connectors available to obtain power supplies direct from Ferrograph or Vortexion recorders without any alteration. Price £15 15s.

★

Sound Sales Ltd., Works and Acoustic Laboratories, West Street, Farnham, Surrey. Tel.: Farnham 6461-2-3. Cables: Sounsense.

A-Z General Purpose Power Pack for supplying additional units beyond the scope of the main amplifier. Output 250v at 35 mA, 6.3v at 2 A. Size $11\frac{1}{4} \times 4\frac{1}{2} \times 4\frac{1}{2}$ ins. Price £5 10s.

A-Z Precord Unit. Designed for use with Wearite, Truvox or Collaro tape deck. Self-powered. Inputs: mic. or radio/pickup. Sel. switch for record and replay. Green and red ind. lights give add. visual check. Calibrated recording level indicator. Equalisation for $3\frac{3}{4}$, $7\frac{1}{2}$ and 15 i.p.s. C.C.I.R. and N.A.R.T.B. characteristics. Variable bias control. Record level gain control. Size $11\frac{1}{4} \times 9\frac{1}{2} \times 4\frac{3}{4}$ ins. Price £30.

★

Specto Ltd., Vale Road, Windsor, Berks. Tel.: Windsor 1241. Cables: Specto, Windsor.

Spectone Electronic Mixer. 142 and 142A. Inputs: radio 100 mV; mic. 1.5 mV; P.U.1 6 mV; P.U.2 50 mV. Output 0.5v. P.U.1 can be used as second mic. input. F.r.: radio 20-20,000 c/s. ± 0.5 dB; mic. 25-20,000 c/s. ± 0.5 dB. H and N P/U — 53



Masterlink M2A

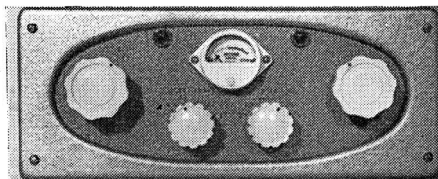

Sound Sales A-Z Precord



Sound News Production Unimixer

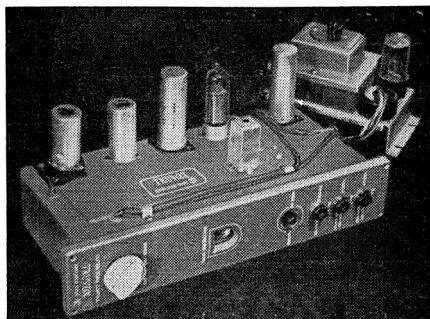

Truvox Type K recording amplifier

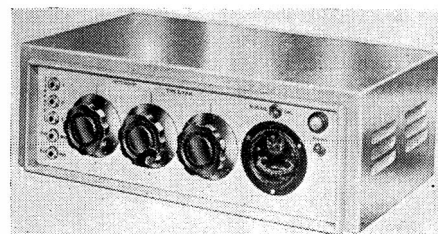

Vortexion 3-way Mixer

dB. P.s.n. model 142, 200-300v at 5 mA; 6.3v at 12 amps. Model 142A, self-powered. Size panel $12\frac{1}{4} \times 5\frac{1}{4}$ ins. Casing $11\frac{1}{4} \times 4\frac{1}{4} \times 4\frac{1}{4}$ ins. Price: 142, £17 17s.; 142A, £22 1s.

★

Technical Suppliers Ltd., Hudson House, 63 Goldhawk Road, London, W.12. Tel.: Shepherds Bush 2581/4794. Cables: Teknica London.

3 channel mixer unit. Designed for high impedance inputs. Jack plug sockets fitted. Size $4\frac{1}{2} \times 3\frac{3}{8} \times 4\frac{1}{2}$ ins. Price £2 2s.

★

Tele-Radio (1943) Ltd., 189 Edgware Road, London, W.2. Tel.: Paddington 4455.

Masterlink M2A. Tape pre-amp originally for Wearite series of deck, suitable for Reflectograph, Collaro and Brenell decks. 2 units, pre-amp and oscillator and separate power supply. Switched inputs for mic., 1.2 mV and radio/P.U., 100 mV. Meter indicates bias, rec. signal, P/B signal. F.r.: 30-20,000 c/s. ± 1 dB. Oscillator cut-out facility for deck connection. Switched equalisation for $3\frac{3}{4}$, $7\frac{1}{2}$ and 15 i.p.s. Low imp. output approx. 200 mV. C.C.I.R. adjustment pre-set. Size $12 \times 6 \times 8$ ins. Price £28 7s.

★

Truvox Ltd., Neasden Lane, London, N.W.10. Tel.: Gladstone 6455. Cables: Truvoxeng.

Type "K" Recording Amp. Inputs: 1 megohm at 1-2 mV; $\frac{1}{2}$ megohm at 0.5v. Vol. and on/off. Record/replay switch. Tone control. High imp. output. H and N

— 45 dB. Output 4 watts. Primarily for Truvox tape deck. Price £19 19s.

★

Vortexion Ltd., 257/263 The Broadway, Wimbledon. Tel.: Liberty 6242/3. Cables: Vortexion, Wimble, London.

3-channel Prof. Mixer. Built-in mu-metal shielded input transformer, hermetically sealed controls, screened mains transformer. Output 1m/watt, 600 ohm balanced or unbalanced. Peak programme meter calibrated zero level ± 12 to ± 20 dB. Size $18\frac{1}{2} \times 10\frac{1}{2} \times 6$ ins. Price on request.

4-channel Prof. Mixer. For 30-50 ohm mic. balanced line or other imps. to order, heavy mu-metal shielded transformers, hermetically sealed controls. Outputs $\frac{1}{2}$ v on more than 20,000 ohms or 600 ohm, 1 mV. Has own screened power pack for AC mains. Similar 12 way is also available. Size $18\frac{1}{2} \times 10\frac{1}{2} \times 6$ ins. Price £40 8s. 6d. 600 ohm output extra.

★

W & N Electronics Ltd., 80/82 Uxbridge Road, London, W.13. Tel.: Ealing 4774.

In preparation

Audiomaster Mk. 1-3. Semi-professional recording amp supplying constant current for direct supply to tape head and erase and bias supply. For use with any high grade tape deck. Correction at $3\frac{3}{4}$, $7\frac{1}{2}$ and 15 i.p.s. 30 i.p.s. can be supplied to order. F.r.: 15 i.p.s. 50-14,000 c/s.; $7\frac{1}{2}$ i.p.s. 50-10,000 c/s.; $3\frac{3}{4}$ i.p.s. 50-5,000 c/s. All ± 2 dB. Oscillograph cathode ray tube or meter level ind. Size $8 \times 5\frac{1}{8} \times 8$ ins. Price not available.

TAPE ACCESSORIES and COMPONENTS

Bradmatic Ltd., Station Road, Aston, Birmingham, 6. Tel.: East 2881/2. Cables: Bradmatic, Birmingham.

A range of twin track high impedance sound heads, single hole fixing, pole pieces are cylindrically ground flush with caps. Screening cans available.

Type 5 RP. Combined record/replay head 0-0004 in. gap. Price £3 5s.

Type 6 RP. Super fidelity record/replay head 0-0002 in. gap. Price £3 15s.

Type 5R. Record only 0-0007 in. gap. Price £3 5s.

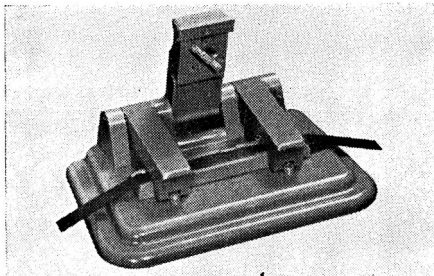

The Sonocolour tape splicer, price 32s. 6d., distributed by Tape Recorder (Electronics) Ltd.

Type 5E. Erase head. Price £3 5s.

Full track versions of the above are also available.

■ **Type ST-RP.** Stereo record/replay head. Price with screen can, without fixing stem, £6.

■ **Type 2 TK-RPC.** Stereo record/replay head, super fidelity. Price £17 10s.

★

EAP (Tape Recorders) Ltd., Bridge Close, Oldchurch Road, Romford, Essex. Tel.: Romford 62366/7.

Elizabethan Stethoset Headphones. Lightweight, high impedance. Price £3 13s. 6d.

Elizabethan Radio/P.U. Connecting Lead. 3 yards of low loss screened cable fitted with British Standard jack plug and coaxial plug. Price 15s.

★

EMI Sales & Service Ltd., Blyth Road, Hayes, Middx. Tel.: Southall 2468. Cables: Emiservice, London. Telex: 2-2417.

Emitape Jointing Compound. AP35 for C.A. base tape. AP77 for P.V.C. base tape. A jointing fluid for making permanent welded joints in magnetic tape. Price 7s. 6d. per bottle.

Emitape Jointing Tape. AP103. Adhesive jointing tape for simple and quick splicing and editing of magnetic tape. Price 7s. 6d. per reel.

Emitape P.V.C. Editing and Marker Tapes. A range of six coloured tapes to enable colour code reference to be inserted in a reel of recorded tape for quick editing and indexing purposes. AP38/1 white; AP38/2 red; AP38/3 yellow; AP38/4 blue; AP38/5 orange; AP38/6 green. Price 4s. 6d. per reel.

Emitape Plastic Tape Spools in cartons, all standard sizes available. Price: 3 in. and 3½ in. 3s.; 5 in. and 5½ in. 4s. 6d.; 7 in. 5s.

Emitape Jointing Block and Cutter. Type AP46. For splicing and editing tape. The tape location channel gives perfect alignment to the tape and the cutter is of non-magnetic material. Price 17s. 6d.

Emitape Non-magnetic Scissors. Type AP39. Made of non-ferrous metal, the scissors may be used for splicing magnetic tape without risk of magnetising, so ensuring a completely noiseless join. Price 16s.

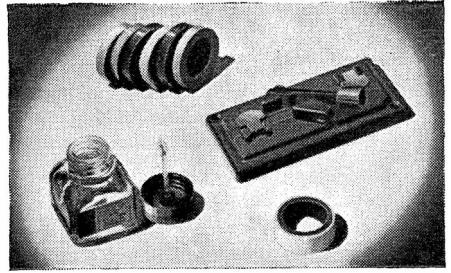

E.M.I. tape accessories

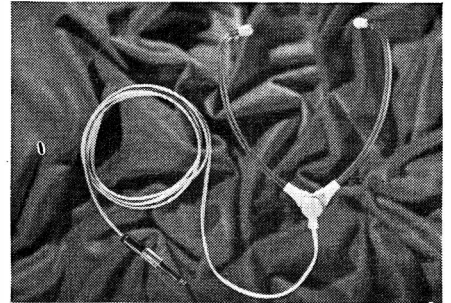

Sound Stethoset

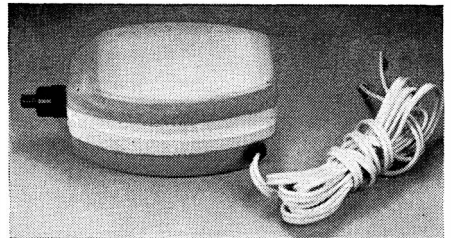

Osmabet "Instant" Bulk Eraser

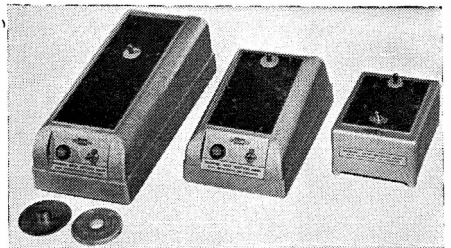

Leavers-Rich Lee Raser

Leavers-Rich Equipment Ltd., 78b Hampstead Road, London, N.W.1. Tel.: Euston 1481. Cables: Leemag, London.

LeeRaser. Junior ER30A; Standard ER31B; Senior ER32B. Ultra rapid demagnetisers for spools of tape and accessories. Price £6 5s.; £9 10s.; £15.

Multicore Solders Ltd., Multicore Works, Hemel Hempstead, Herts. Tel.: Boxmoor 3636.

The "Bib" Tape Splicer. This splicer enables the tape to be jointed easily and to be edited to the accuracy of a syllable. Supplied complete with razor cutter and mounted on flock-covered panel. Price 18s. 6d.

★

Osmabet Ltd., 14 Hillside Road, Tottenham, N.15.

Instant Bulk Eraser. Operates from A.C. mains to provide rapid and complete eraser of tapes prior to making quality recordings. Price £1 7s. 6d.

★

Sound Developments, 9 Osborne Road, Kingston-upon-Thames.

Editape. Tape splicing block with machined groove to hold the tape, and accurate 45° slot for cutting. Price 7s. 6d.

★

Simon Sound Service Ltd., 48 George Street, London, W.1. Tel.: Welbeck 2371. Cables: Simsale, London.

Simon Remote Control Unit. Operates with Simon SP/4 recorder to give start, stop and track change from up to 25 feet distance. Price complete with cable and plug £3 3s.

Stethoscope Head Set. Operates from ext. L/S socket for monitoring. Price with plug £2 12s. 6d.

★

Tape Recorders (Electronics) Ltd., 784/788 High Road, Tottenham, London, N.17. Tel.: Tottenham 0811. Cables: Taperec.

Sound Stethoset. Lightweight headphones. Impedance 50 ohms. Weight 1¼ oz. Price complete with lead and screened plug £2 10s.

★

Truvox Ltd., Neasden Lane, London, N.W.10. Tel.: Gladstone 6455. Cables: Truvoxeng.

TR2049. Stereophonic Head. Stacked heads with safety gap for ¼ in. tape. Azimuth adjustment incorporated—will directly replace Truvox ½-track heads. Response 50-15,000 c/s ± 3 dB with suitable amp. Impedance 50,000 ohms at 10 Kc/s. Cross talk better than 45 dB. Price £14 10s.

Telephone attachment, for recording 2-way telephone conversations. Price £2 2s.

Headphones, for use with any recorder with low imp. output socket. Price £3 3s.

A.M. Radio Jacks. Price Standard (M.W. only) £2 10s. (U.K. purchase tax £1 2s.).

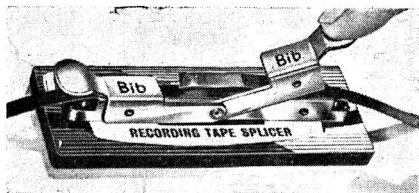

Multicore "Bib" tape splicer

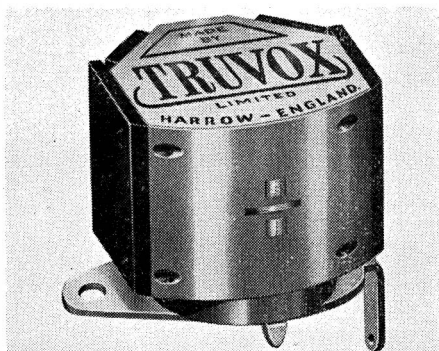

Truvox TR2049 Stereo Head

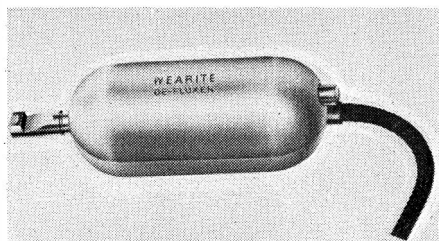

Wearite Defluxer

Wellington Acoustic Laboratories Ltd., Allways, Kings Lane, Wrecclesham, Farnham, Surrey. Tel.: Farnham 6461/4961.

WAL Tape Eraser. A mains operated tape demagnetiser, accommodates from 5 to 10 in. reels, push button operated. Erases both tracks in a few seconds. Available for 200-250v, 50 c/s. or 110-125v, 60 c/s. Price £7 18s. 6d.

★

Wright & Weaire Ltd., 131 Sloane Street, London, S.W.1. Tel.: Sloane 2214. Cables: Writewea, Knights.

★

Wearite Defluxer. For depolarising heads of tape recorders and players. It ensures maximum signal/noise ratio from any tape recorder and protects recorded tapes from cumulative background noise and the gradual attenuation of the higher frequencies. Price £2 10s.

HOW TO USE YOUR MICROPHONE

THE relative merits of crystal, moving-coil, ribbon, and condenser microphones, may be summarised as follows: crystal microphones are inexpensive and produce a large output voltage for direct connection to the "high impedance" input socket. However, long leads cannot usually be employed.

Moving-coil microphones are most versatile, being robust and suitable for use with long extension leads. They need a step-up transformer, which may be built into the microphone, or incorporated in a low impedance input socket on the recorder.

Ribbon microphones have similar impedances to moving-coils. They are not

suitable for outdoor use, but usually have a figure-of-eight directivity pattern which is extremely useful in music recording. Condenser microphones resemble the crystal type being high impedance and requiring a short cable. They also need a supply of D.C. voltage to polarise the plates.

When choosing from the above types it is important to check their suitability for the particular recorder. Advice on the technique of microphone balance is much more difficult to come by. However, a series of articles was devoted to this in *Hi-Fi News* during February to May, 1958, and a number of suggestions are given below in diagrams.

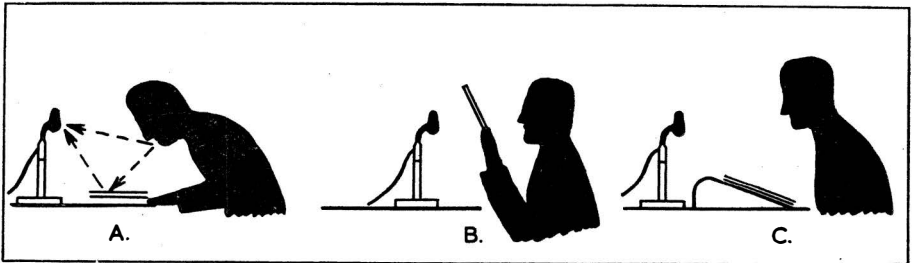

Speech Balance. When using a table stand it is important to speak directly at the microphone. The illustration shows A the way in which distortion can arise due to sounds arriving at the microphone by two paths—direct and reflected; B holding the script in front of the microphone cuts off high frequencies; C is the correct position.

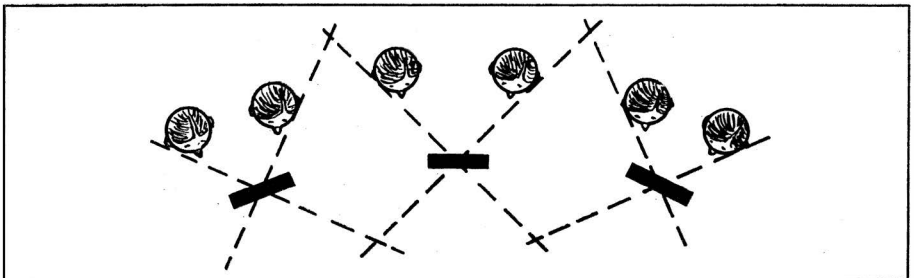

Platform discussions, brains trusts, etc. A single microphone will rarely be satisfactory. Using a number of microphones it is necessary to guard against interference effects which occur if any source is picked up on two microphones. Use directional microphones, such as ribbons, angled so as to cover the speakers individually as shown.

for pianos, singers and ensembles

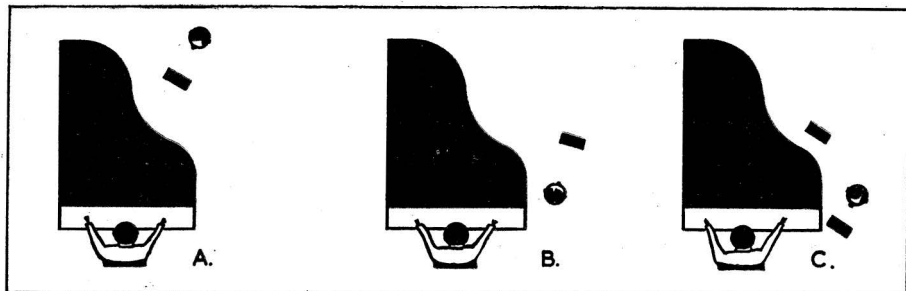

Singer or solo instrument with piano accompaniment. Of the three arrangements shown, A is a split balance which allows the singer and pianist to keep in visual contact, but is inflexible as regards choice of microphone height, etc.; B permits more rearrangement; C shows the use of two microphones. An upright piano may be employed in any of these layouts.

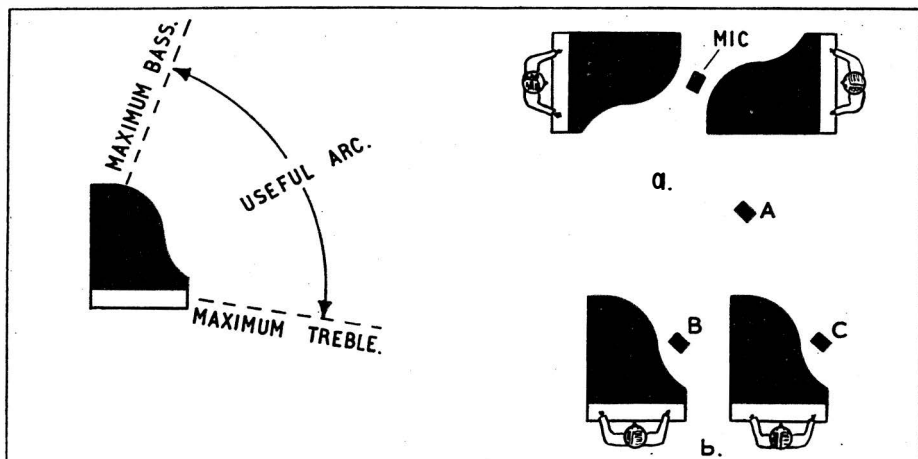

Grand piano. The left hand drawing shows the useful arc in which a good frequency response may be expected. Increased treble is found towards the keyboard end, and increased bass towards the tail end. The best distance for the microphone varies from 1 foot for dance music to 12 feet or more for a serious piano recital. Two possible arrangements for two pianos are shown on the right.

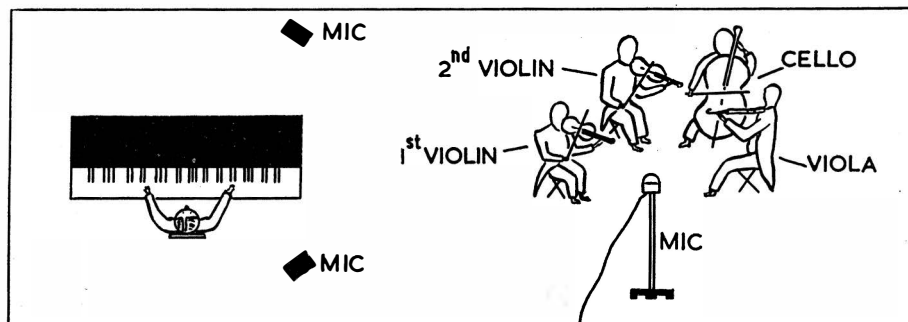

Upright piano (left). Microphone should favour treble. String Quartet (right).

—symphonic works with soloists and choruses

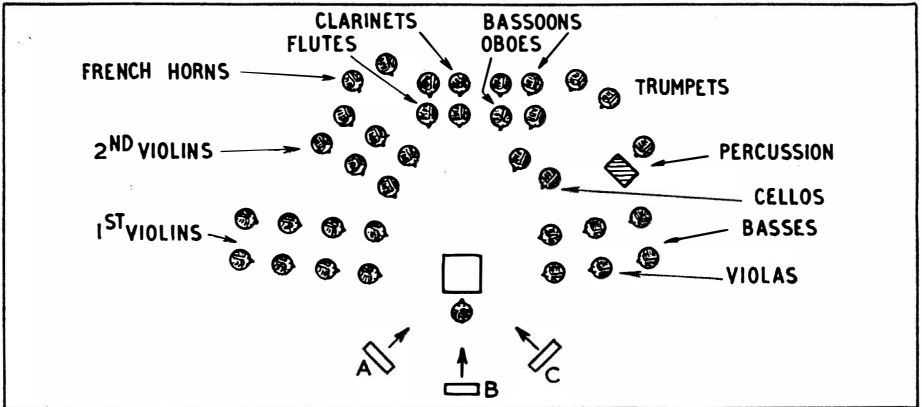

Orchestral balance. Using a single microphone has the advantage of preserving the internal balance of the orchestra. The drawing shows, by way of an example, the layout of a “small” orchestra. Of the three microphone positions, A and C favour the violins—which is often necessary—A by its proximity to them and C by its angle.

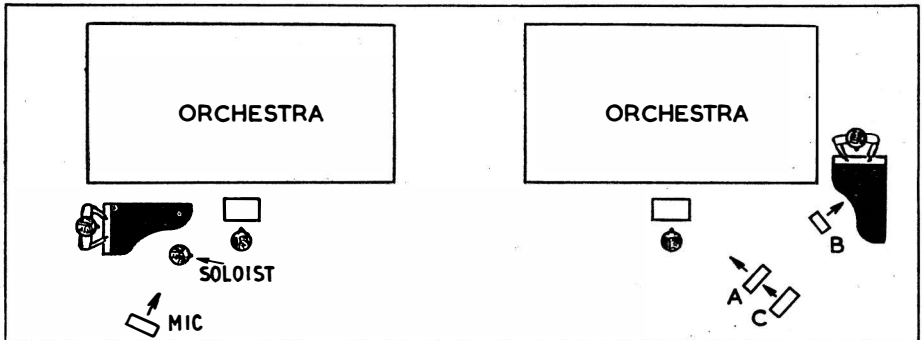

The Concerto. The left hand drawing uses a single microphone. On the right a separate piano microphone has caused the orchestral microphone to be moved nearer (from C to A) to allow for the extra reverberant sound picked up by B.

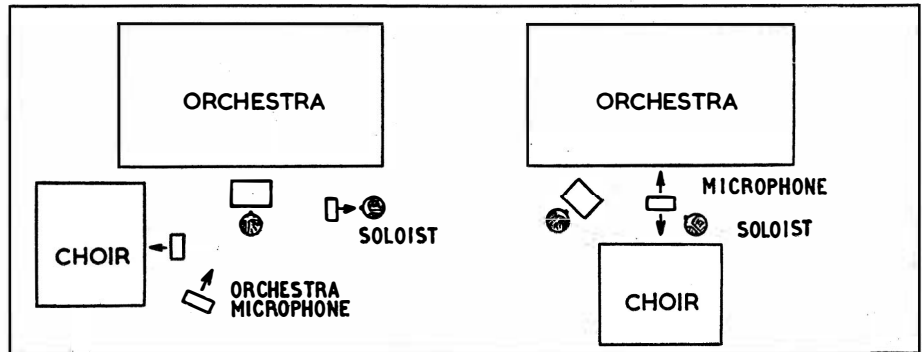

Orchestra, Choir, and Soloists. If there is no audience to be considered, special positions may be taken up as shown. The left hand layout uses three microphones, and the right hand a single bi-directional microphone.

—all singers with orchestra—and jazz

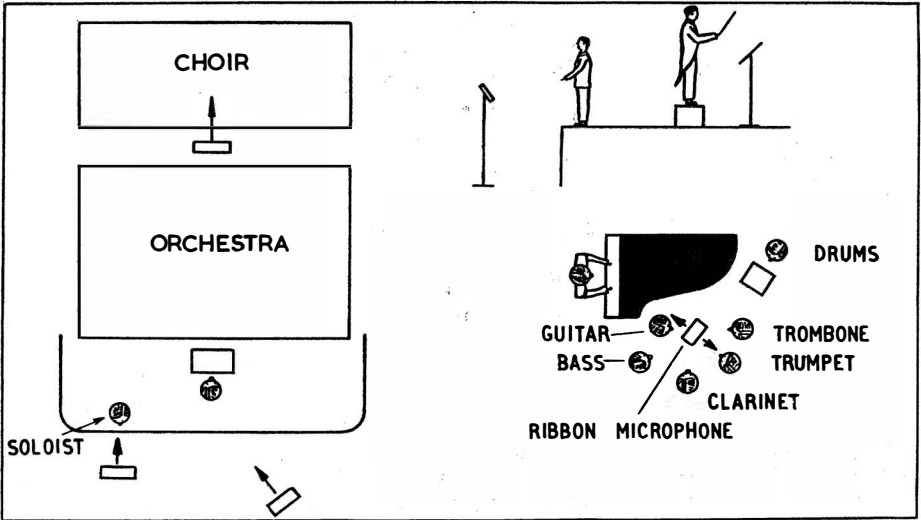

Orchestral Concert (left). When recording or relaying a live performance with an audience, it is not possible to take liberties with the positioning of artistes, as on the previous page. A compromise balance may be necessary, with a choir microphone, and a soloist's microphone angled as shown (top right). A possible jazz band balance, using a single ribbon (bottom right).

In ideal acoustic conditions, placing microphones is largely a matter of layout. The voices and musical instruments, which all radiate in a directional manner, must be arranged so that the microphone "sees" them to good advantage, and their relative perspectives will be a function of the microphone's polar diagram—circle, figure-of-eight, or cardioid—and its distance from each player.

Unfortunately, the acoustics of a room or studio are often far from ideal, and the sound is modified accordingly. The direct sounds travelling from the source to the microphone are reinforced by multiple reflections from the walls and other surfaces, reaching an equilibrium intensity when the rate of energy loss by absorption equals the rate of supply. A good comparison is the rise of the temperature of a room when a radiator is switched on. The temperature settles down to steady state conditions when the rate of losing heat through doors, etc., equals the radiation rate, and switching off the radiator will be followed by a more or less gradual fall in temperature. Similarly, sounds take a measurable time to die away when the source ceases vibrating. This dying away period is called the Reverberation Time, and is the most important single factor in room acoustics, affecting as it does not only the

build up and decay of sounds, but the maximum intensity reached.

What the best degree of reverberation is for various types of performance will always be partly a matter of personal taste. It is desirable to achieve adequate volume of tone and at the same time good definition, but these two desiderata are in opposition, the former calling for a gradual, and the latter a rapid decay of sounds.

It is often part of the art of microphone balance to disguise the acoustics of the studio, and we might define Apparent Reverberation as the degree of liveliness appearing on the sounds as reproduced from the loudspeaker. A considerable variation in Apparent Reverberation is obtained, for example, by simply altering the microphone distance. This ability to alter the apparent acoustics by suitable choice of microphone distance can often be turned to good account, but it introduces a corresponding restriction on microphone balance in general.

In the case of a large orchestra, for example, the back row instruments may be as much as 30 feet farther from the microphone than the first desks of violins. Bringing a front microphone nearer than about 30 feet from the fiddles would, therefore, cause too steep a rise in relative liveliness from front to back of the orchestra.

DIRECTORY OF MICROPHONES

★In these abridged specifications, the following abbreviations are used: **Source imp.**—microphone source impedance. **Rec. load imp.**—recommended load impedance, and Sensitivity is given in dB with reference to 1 volt/dyne/cm², unless otherwise stated.

AKG (Akustische und Kino-Geräte Ges. m.b.H.) Sole U.K. suppliers, **Politechna (London) Ltd.**, 357 Euston Road, London, N.W.1. Tel.: Euston 5851-3. Cables: Polindust, London.

D9. Moving coil. Response 80-10,000 c/s. Source imp. 200 ohms and 50 K ohms. Fitted with collapsible stand and 5 ft. screened cable. Price £4 19s.

D11. Moving coil with cardioid directional pattern. Response 80-12,000 c/s. Source imp. 200 ohms or 50 K ohms. Fitted with screw-on table stand and 5 ft. screened cable. Price £5 6s. (low imp.) and £5 12s. (high imp.).

D19. Moving coil with cardioid directional pattern and bass cut switch. Response 40-16,000 c/s. Source imp. 200 ohms or 50 K ohms. Price £19 10s. (low imp.) and £22 (high imp.).

★

Collaro Ltd., Ripple Works, By-Pass Road, Barking, Essex. Tel.: Rippleway 5533. Cables: Korllaro-Telex-Barking 28748.

Studio Crystal. Response 50-10,000 c/s. Sensitivity 1.8 mV/U.B. Source imp. 1,500 P.F. Rec. load imp. 5 megohm. 6-ft. cable. Tel. jack plug. Price £2 5s.

★

Cosmocord Limited, Eleanor Cross Road, Waltham Cross, Herts. Tel.: Waltham Cross 5206. Cables: Cosmocord, Waltham Cross.

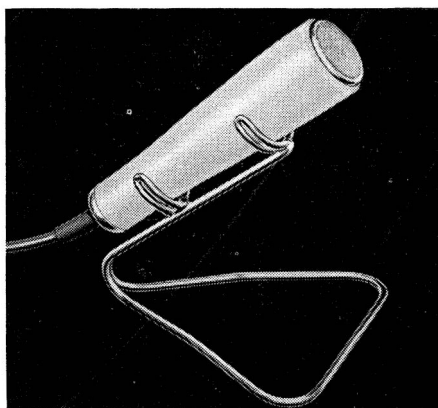

Acos Mic 39-1 crystal

Acos Mic. 39-1. Crystal. Response 40-15,000 c/s \pm 6 dB. Sensitivity — 60 dB. Source imp. equals capacity of 800 pF. Rec. load imp. not less than 4.7 megohm. 8-ft. cable. Desk or floor stand, adaptor available. Price £5 5s.

Acos Mic. 40. Crystal. Response 40-6,000 c/s. Sensitivity — 50 dB. Source imp. equals capacity of 2,000 pF. Rec. load imp. not less than 4.7 megohm. 6-ft. cable. Foldaway desk stand. Price £1 15s.

★

Film Industries Ltd., 90 Belsize Lane, N.W.3. Tel.: Hampstead 9632/3. Cables: Troosound, Haver.

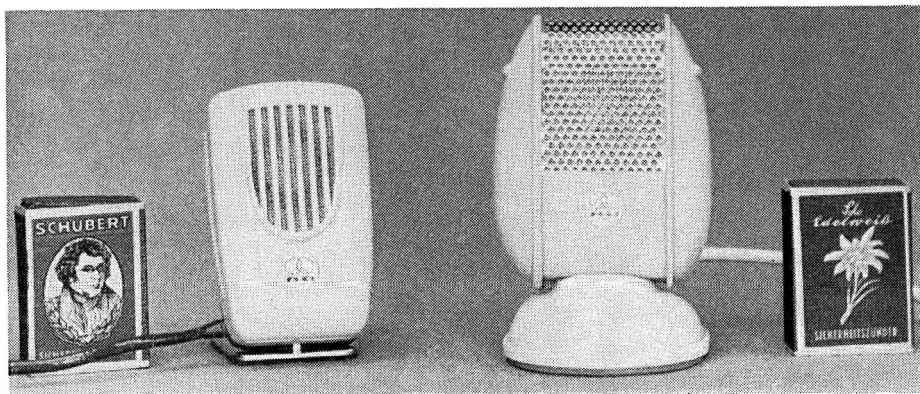

AKG, D9 left and D11 moving coil microphones

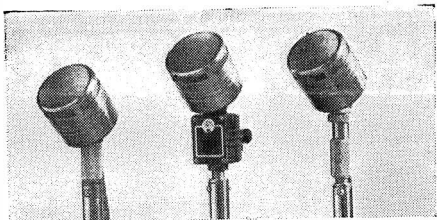

Trix G7871 Models A, B and C

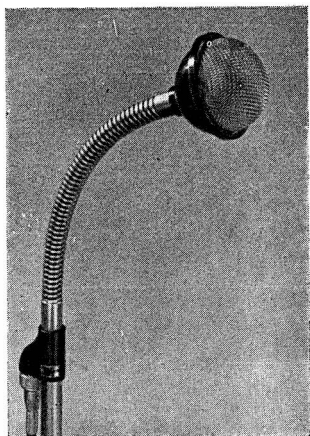

Ronette 088F crystal

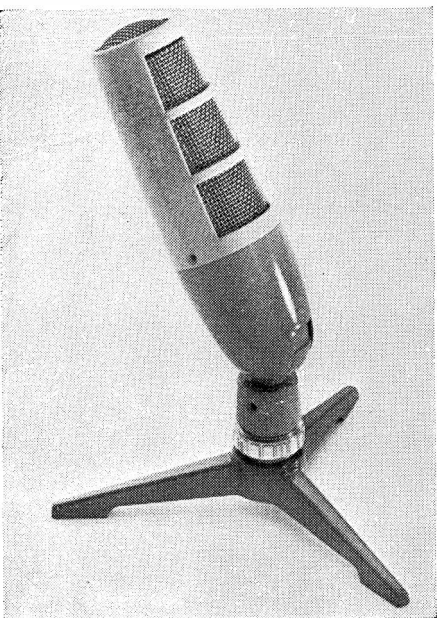

The Simon Cadenza

M.7. Moving coil. Response 80-9,000 c/s. Source imp. 30 ohms. 6-ft. twin screened cable standard, other lengths if required. Table, desk and floor stands available. Price £6 5s.

M.8. Ribbon Response 40-14,000 c/s. Standard source imp. 30 ohms with inbuilt transformer. Other impedances up to 170 K/ohms available 12-ft. twin screened cable standard, other lengths if required. Table, desk and floor stands available. Price £8 15s.



General Electric Co. Ltd., Magnet House, Kingsway, London, W.C.2. Tel.: Temple Bar 8000. Cables: Polyphase, London.

G.E.C. Studio Ribbon Microphone BCS2372S. Response 50-14,000 c/s ± 1 dB. Sensitivity — 79 dB @ 250 ohms. Built-in trans. "captive head" terminals at rear. Price £19 19s.

BCS 2249A. Floor stand suitable for above mics. BCS2246A table stand. BCS2255 "Boom" studio stand.

BCS 2378. Ribbon. Response 50-8,000 c/s. ± 2.5 dB. Impedance 30 ohms. Includes rotary ON/OFF switch, transformer, and length of screened cable. Price £10 5s.

BCS 2384. Moving coil. Response substantially flat 200-10,000 c/s. Impedance 25-30 ohms. Price £8 18s. 6d.



Grampian Reproducers Ltd., Hanworth Trading Estate, Feltham, Middx. Tel.: Feltham 2657/8. Cables; Reamp, Feltham.

DP4/H. Moving coil. Response 50-15,000 c/s. Sensitivity — 52 dB, — 70 dB, — 86 dB, for high, medium and low impedance. 50,000, 600, and 25 ohms. Tubular case. Price, including holder and lead, £9.



Lustraphone Ltd., St. Georges Works, Regents Park Road, N.W.1. Tel.: Primrose 8844. Cables: Lustraphon, London.

LX55 Crystal. Response 30-8,000 c/s. High source imp. 9-ft. cable. Price £2 10s.

Lustrette LD/61 Series. Moving coil. Response 70-12,000 c/s. Source imp. low, line and high. Built-in trans. when required. 9-ft. cable. Price £3 7s. 6d.

Master C51. Moving coil. Response 50-8,000 c/s. Source imp. low, line and high. Built-in trans. for line and high. 3-pin moulded mic. plug. Stand as required. Price, low, £5 5s.; line and high, £5 15s. 6d.

Master C48 and C48/S with Switch. Moving coil. Response 50-8,000 c/s. Source imp. 20 ohms. 3-pin moulded mic. plug. 6-ft. cable. Price, C48, £6 6s.; C48/S, £7 7s.

Hand Pencil LfV/H59. Moving coil. Response 150-14,000 c/s. Source imp. low, line and high. Built-in trans. for line and high. 20-ft. cable for low and line. 9-ft. for high. Price £8 8s.

Full-Vision LfV/59. Moving coil. Response 150-14,000 c/s. Source imp. low, line and high. Built-in trans. for line and high. 20-ft. cable with low and line. 9-ft. with high. Stand as required. Price £8 18s. 6d

Master TH59/SB. Moving coil with switch. Response 150-14,000 c/s. Sensitivity — 88 dB @ 25 ohms, — 75 dB @ 600 ohms, and — 54 dB @ 50,000 ohms. Transformer as required. Price £8 18s. 6d.

Master VR53. Ribbon velocity. Response substantially flat to 14,000 c/s. Source imp. low, line and high. Built-in trans. 3-pin moulded mic. plug. 6-ft. cable. Stand as required. Price £9 19s. 6d.

Ribbonette VR/64. Ribbon. Response, substantially maintained up to 13,000 c/s. Source imp. low, line and high. Built-in transformer. 20-ft. cable for low and line. 9-ft. for high. Table base. Price £7 17s. 6d.

Stereomic VR/65. Dual head ribbon. Response 50-13,000 c/s. Sensitivity Stereo — 90 dB @ 20 ohms. Source imp. 2 × 20 ohms or 2 × 300 ohms. Internal transformer. Price £31 10s.

Lapel Mic. LP/62. Electro-Magnetic. Response, substantially maintained up to 6,000 c/s. Source imp. 30 and 1,000 ohms. 6-ft. cable. Price £3 7s. 6d.

DI 59/B.S. Moving coil. Response, substantially flat from 150-14,000 c/s. Source imp., low. 6-ft. cable. Price £11 11s.

Velodyne VC52/THSB. Noise cancelling moving coil with switch. Response rising to 1,700 c/s, flat to 3,500 c/s then falling. Source imp. 25 ohms or as required. Transformer as necessary. Price £8 18s. 6d.

★

RCA Great Britain Limited, Lincoln Way, Windmill Road, Sunbury-on-Thames, Middlesex. Tel.: Sunbury-on-Thames 3101. Cables: RCA, London. Telex: 28608.

Varacoustic LMI. 6203C. Ribbon. Response 60-10,000 c/s. Source imp. 50, 250 and 600 ohms. 30-ft., 2-conductor shielded cable. Stand as required. Price £22 10s.



RCA LMI 6203C

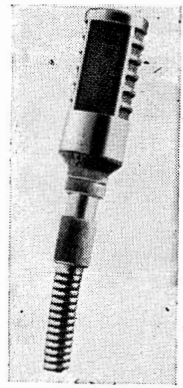

Film Industries M8



Shumann-Merula crystal mics., distributed in U.K. by Stanley Palmer



Lustraphone Ribbonette VR/64

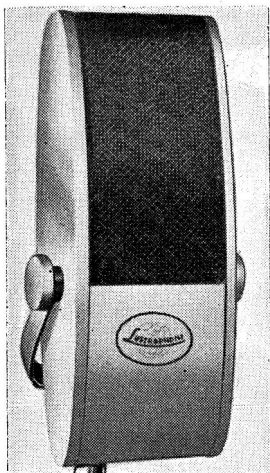

*Lustrophone
VR 53 Ribbon
Velocity micro-
phone*

LMI 6204C. Ribbon. Response 60-10,000 c/s. Source imp. 40,000 ohms. 30-ft., 2-conductor shielded cable. Stand as required. Price £22 10s.

★

Ronette, Sole U.K. Importers: Trianon-Electric Limited, 95 Cobbold Road, London, N.W.10. Tel.: Willesden 2116 and 3696.

Ronette. 19 different crystal microphones. Response according to type from 50-10,000 c/s to 20-16,000 c/s. Source imp. 200 ohms. Rec. load imp. 5 megohms. Supplied with or without transformers. 9-ft. cable. Price range from £2 10s. to £17 10s. Desk stand DS5 £1 7s. 6d.

★

Simon Sound Service Ltd., 48 George Street, Portman Square, W.1. Tel.: Welbeck 2371. Cables; Simsale, London.

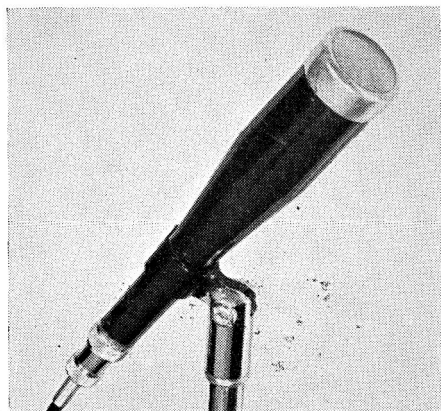

Grampian DP4/H moving coil

Cadenza Ribbon. Response 50-12,000 c/s. Sensitivity, high impedance — 58 dB, low impedance — 93 dB, or with suitable line transformer — 58 dB. Source imp. 30 ohms and 80 K/ohms. Price £8 18s. 6d.; with tripod desk stand and 11-ft. cable £10 10s.

★

Standard Telephones & Cables Ltd., Cannaught House, Aldwych, London, W.C.2. Tel.: Holborn 8765. Telex: London 202385. Cables: Relay, London.

4021. Spherical omnidirectional moving coil. Flat response 30-12,000 c/s. Impedance 30 ohms. Sensitivity — 80 dB. Price £21.

4032. Moving coil hand microphone. Flat response 40-10,000 c/s. Impedance 30 ohms. Sensitivity — 78 dB. Windshield available. Price £18.

4033. Cardioid microphone. Moving coil and ribbon elements which can be used individually or in combination. Flat response 40-10,000 c/s. Impedance 50 ohms. Sensitivity — 80 dB. Front to back ratio 15 to 20 dB. Price £46 10s.

4035. Moving coil. As 4032 above, but for stand mounting. Price £18 10s.

4037. Moving coil unobtrusive "Pencil" microphone. Flat response 40-12,000 c/s. Impedance 30 ohms. Sensitivity — 84 dB. Price £20.

4038. Studio ribbon microphone. Accurate figure-of-eight polar response. Flat response 30-15,000 c/s. Impedance 30 ohms. Sensitivity — 85 dB. Non-linear distortion 0.1%. Controlled transient response. Price £38 10s.

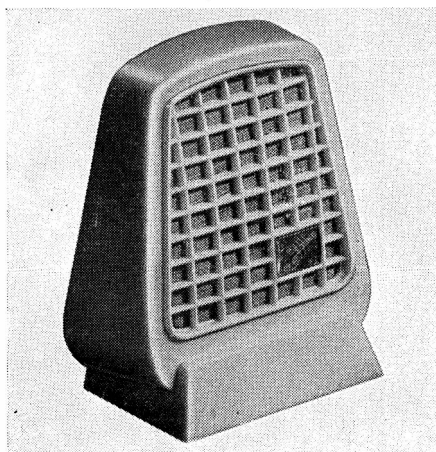

Sound M1 crystal

4104. Commentator's lip microphone. High degree of noise cancellation. Flat response 70-10,000 c/s. Impedance 30 ohms. Output — 82 dB ref. 1v for 10 dynes/cm². Price on application.

4105. Cardioid moving coil. Flat response 100-10,000 c/s. Impedance 30 ohms. Sensitivity — 82 dB. Front to back ratio 15 to 20 dB. Price £20.

★

Tape Recorders (Electronics) Ltd., 784-8 High Road, Tottenham, London, N.17. Tel.: Tottenham 0811. Cables: Taperec, London.

Sound M1. Crystal hand mic. Response 20-16,000 c/s ± 15 dB. Rec. load imp. 1-5 megohm. 8-ft. screened cable and screened jack plug. Price £2 15s.

Sound M2. Moving coil. Impedance from built-in transformer 80,000 ohms. 8-ft. screened cable and screened jack plug. Price £5 12s. 6d.

★

Trix Electrical Company Limited, 1-5 Maple Place, London, W.1. Tel.: Museum 5817. Cables: Trixadio, Wesdo, London.

G7871. 3 models A, B, C. Moving coil. Response 50-8,000 c/s. Source imp. 30 ohms. G7871/A 18-ft. cable. G7871/B no cable 2-pin plug. G.7871/C 18-ft. cable. 3-pin locking type plug. Stand as required. Price A £7 10s.; B £8 8s.; C £9 9s.

G7822. 2 models B, C. Ribbon. Response 50-10,000 c/s. Source imp. 30 ohms. G7822/B 2-pin plug, no cable. G7822/C

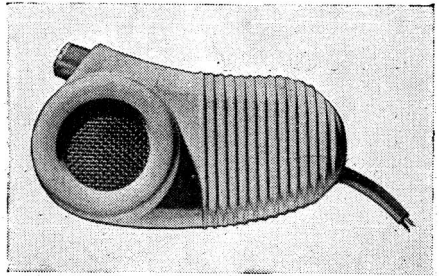

Vitavox B50 moving coil

18-ft. cable, 3-pin locking type plug. Stand as required. Price B £12 10s.; C £11.

Various types of floor and desk stands available, also flexible stems and hand grips.

★

Vitavox Limited, Westmoreland Road, London, N.W.9. Tel.: Colindale 8671. Cables: Vitavox, Hyde, London.

B50. Moving coil. Response 60-8,000 c/s. Sensitivity — 85 dB. Source imp. 25 ohms. 6-ft. cable. Price £6 10s.

B51. Crystal. Response 60-8,000 c/s. Sensitivity — 50 dB. Source imp. 1 megohm. 6-ft. cable. Price £5 10s.

B52. Moving coil. Response 60-8,000 c/s. Sensitivity — 85 dB. Source imp. 600/100,000 ohms. Built-in transformer. 6-ft. cable. Price £7 10s.

Type A. Moving coil. Response 60-8,000 c/s. Sensitivity — 82 dB. Source imp. 25 ohms. Rec. load imp. 25 ohms. Desk, table or pedestal stands. Price £9 9s.

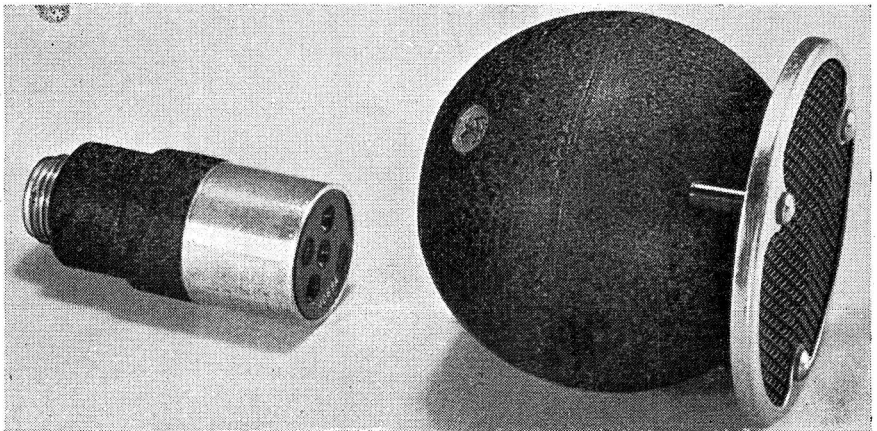

The STC 4021 moving coil, known as the ball and biscuit.

historical flashback

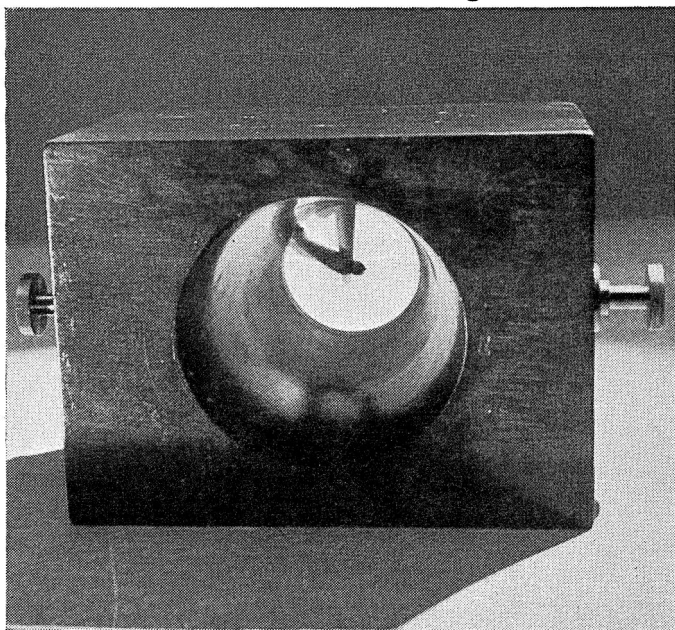

In 1861, Reis built this very simple microphone, known as the Reis Transmitter. The photograph shows the speaking end. The diaphragm can be seen at the distant end of the tapering channel.

microphones of a century ago

The Reis Transmitter, viewed from the opposite end, showing the extremely simple construction and method of connection. The pressure of contact between reed and diaphragm was adjustable by means of the small thumbscrew.

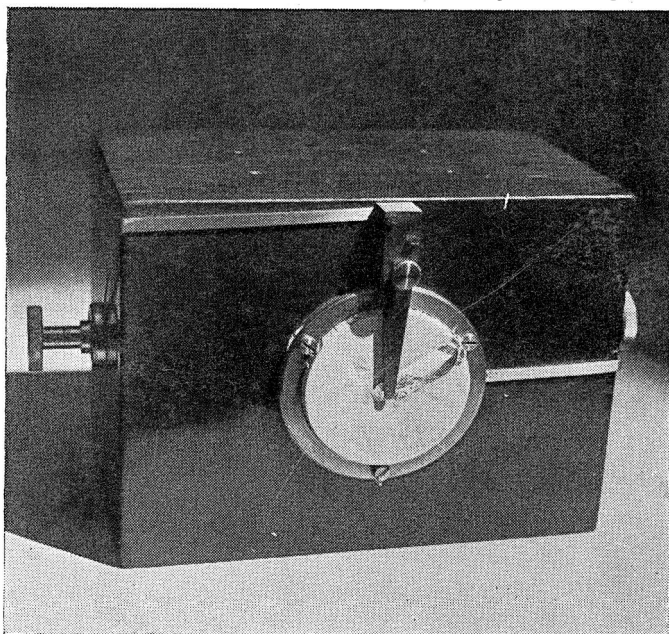

Photos by courtesy of the Postmaster-General

“DO-IT-YOURSELF”

An Introduction

IN the world of radio, home construction was a popular hobby even before the first British broadcasts, and enthusiasm has never waned. It was therefore inevitable that many hi-fi enthusiasts would pounce upon it. Home construction offers an even greater reward than the satisfaction of “having made it”—for it brings with it a valuable knowledge of the equipment in use.

Three Degrees

There are three main sub-headings in the “do-it-yourself” field. First, and most advanced, is the art of designing the circuit and building up completely from that point. Second, and midway, is the opportunity offered (as in *Hi-Fi News*) for building up from circuit and point-to-point wiring diagrams—and from pre-determined parts lists. Finally, there is the simplest method—construction from a kit of parts and a step-

by-step working manual. So good are some of these manuals (e.g. *Cossor* and *Heathkit*) that a complete novice can produce an amplifier, radio, or test meter and—given only an ability to solder properly, and to use simple tools intelligently—be reasonably sure of “first time results”.

Get the Right Tools First

Only a few words of advice are offered. Buy a set of tools, and practice with them. *Henley* 25 watt iron; *Bib* wire strippers; miniature vice; hand drill with 4BA and 6BA clearance drills; screwdrivers; set of “BA” spanners; long-nosed pliers; small square nosed ditto; side cutters with slightly pointed blades. Buck and Ryan of Edgware Road have a note of the tools required as listed in *Hi-Fi News*.

A final word. Check every step in construction, as it is made.

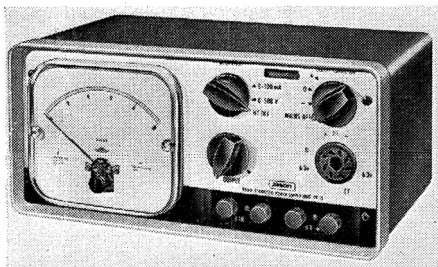

It is an interesting sign of the times that the catalogue of “Do-it-Yourself” kits has grown from one or two in 1958 to about three dozen in 1959. And, furthermore, these kits cover numerous items of test equipment. Illustrated above are two items from the Jason range of apparatus—Left, the PP 10 M stabilised power pack, and Right, the Crystal Calibrator CC 10.



Cossor Instruments Ltd., Cossor House, Highbury Grove, London, N.5. Tel.: Canonbury 1234. Cables: Cossor, London.

1044K. Valve voltmeter kit. Ranges A.C. volts 1.5, 5, 15, 50, 150, 500 and 1,500 volts R.M.S., full scale; 4, 14, 40, 140, 400, 1,400 and 4,000 volts peak-to-peak, full scale. D.C. volts 1.5, 5, 15, 50, 150, 500 and 1,500 volts full scale. Ohms 1, 10, 100, 1,000, 10K, 100K, 1 Megohm. Measures 0.1 ohm to 1,000 Megohms with internal battery. Size $9\frac{1}{2} \times 5 \times 4\frac{3}{4}$ ins. Price £15 12s. 6d. Assembled £22 5s.

1045K. Single-beam Oscilloscope kit. Printed circuits. 4-inch tube. Y amplifier sensitivity 50 mV/cm, response 5 c/s to 3 Mc/s (30% down), rise-time 0.12 microsec. X amplifier sensitivity 0.75 V/cm, response 2 c/s to 275 Kc/s (30% down), rise time 1.4 microsec. Intensity modulation. 1 volt calibration source built in. Size $14\frac{3}{4} \times 9 \times 18\frac{1}{2}$ ins. Weight 18 lb. Price £35. Assembled £45 2s. 6d.

1071K. Double-beam Oscilloscope kit. Printed circuits. 4-inch tube. Two Y channels, each sensitivities 0.5, 1.5, 5, 15 and 50 V/cm, response D.C. to 3 Mc/s (30% down), rise time 0.12 microsec. Pre-amplifier on Y giving sensitivities down to 5 mV/cm. X amplifier sensitivity 0.5 V/cm, response 0.5 c/s to 300 Kc/s (30% down), rise time 1.2 microsec. Intensity modulation.

10V, 1V and 10mV calibration built in. Size $15 \times 9 \times 18\frac{1}{2}$ ins. Weight $20\frac{1}{2}$ lb. Price £49 17s. 6d. Assembled £60 10s.

Heathkit. Manufactured by Daystrom Ltd., 900 Southgate Street, Gloucester, England.



Heathkit Stereo amplifier SP8

S-88. Stereo amplifier kit. 8 watts per channel. Distortion 0.1%. Stability better than 10 dB. Response 30–20,000 c/s ± 2 dB. Inputs: pickup 20 mV, radio 200 mV, tape 400 mV. Push-button sel., bass, treble, filter, balance and reversing switch. Size $13\frac{1}{2} \times 5\frac{1}{2} \times 9\frac{1}{2}$ ins. Price £25 5s. 6d.

S-33. Stereo amplifier kit. 3 watts per channel. Distortion 0.3%. Input 100 mV at 1 Megohm. Bass, treble, balance, volume. Price £11 8s.

HEATHKIT—(continued)

SSU-1. Speaker system kit. Comprises 8 in. and 4 in. matched drive units, and ducted-port bass reflex cabinet. Frequency 40–16,000 c/s \pm 5 dB, crossover frequency 3,000 c/s. Imp. 15 ohms. Size $23 \times 11\frac{1}{2} \times 11\frac{3}{8}$ ins. Price complete £11 16s., without legs, £10 9s.

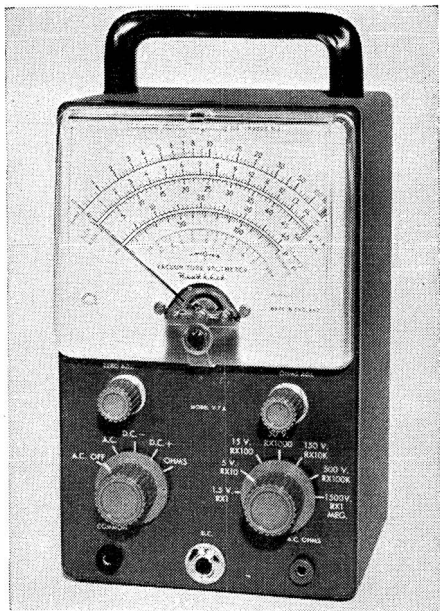

Heathkit Valve Voltmeter V-7A

V-7A. Valve Voltmeter Kit. Printed circuit. Measures A.C. volts (0–1.5, 5, 15, 50, 150, 500, 1,500) R.M.S., A.C. volts (0–4, 14, 40, 140, 400, 1,400, 4,000). Peak-to-peak, D.C. volts (0–1.5, 5, 15, 50, 150, 500, 1,500). Ohms (with 10 ohms centre) \times 1, 10, 100, 1,000, 10K, 100K, 1 Meg. 0.1 ohms to 1,000 Megohms with internal battery. Input resistance 11 Megohms. Meter 200 micro-amps. full scale deflection. Accuracy \pm 3% full scale. Price £13.

O-12U. General purpose oscilloscope Kit. 5 in. flat face C.R. tube. Printed circuits. Vertical bandwidth 3 c/s to 5 Mc/s. Built-in 1 volt calibrator. "Y" sensitivity 10 mV R.M.S. per cm. "X" sensitivity 0.12V R.M.S. per cm. Phasing control. Z-axis modulation. Price £34 15s.

New Items for Home Constructors are published regularly in *Hi-Fi News*.

"Hi-Fi News" Constructional Units

The following apparatus, with one exception, was designed for *Hi-Fi News* by H. Lewis York, of Cape Electrophonics Ltd. The Hi-Fi Tuner was designed for *Hi-Fi News* by Geoffrey Blundell, of Jason. All this equipment is available, ready built and tested, by the Companies concerned.

Stereo Pre-amplifier. Twin circuits with ganged volume and tone controls. Produces 1.5 volts r.m.s., when fed direct from tape head. C.C.I.R. $7\frac{1}{2}$ i/s, and R.I.A.A. fine groove frequency correction. Distortion less than 0.1%. High pass filter 30 c/s. Originally described in *Hi-Fi News* February, March and April 1958. Reprint SP1, price 3s.

Hi-Fi Tuner. Switched Turret tuning to cover 88–96 Mc/s FM and all Television channels. Ratio det. Magic eye ind. Self-powered. Originally described in *Hi-Fi News* September 1958. Reprint SP2, Price 2s. 6d.

Other Constructional Units were described in *Hi-Fi News* as follows:—Tape Sub-amplifier—July 1957, Level Indicator—August 1957, Oscillator—September 1957, Recording Amplifier—October 1957, 10-watt Amplifier—May 1958, 5-watt Amplifier—June 1958, 5-watt Stereo Amplifier—July 1958, Valve Voltmeter—November 1958, 10-watt Stereo Amplifier—December 1958, AF Signal Generator—January 1959, Decca Corner Speaker Enclosure—March 1959, Stereo Sub-amp. for low sensitivity pickups—April 1959.

* * *

Jason Motor and Electronic Co., 3/4 Gt. Chapel Street, London, W.1. Tel.: Gerrard 0273/4.

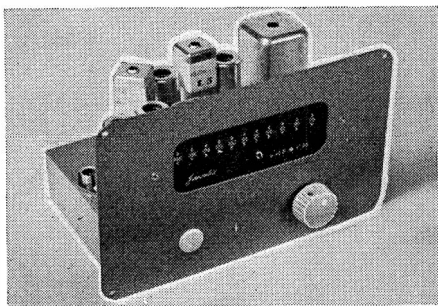

Jason FMT 1 FM Tuner

F.M.T.1 Standard F.M. tuner kit. The original kit has been built successfully by many thousands of constructors. 4 valves only are used, giving an aerial sensitivity of

JASON KIT—(continued)

better than 100 microvolts. A Ratio detector is combined with a limiter for low distortion and good noise rejection. Price without valves and power supply £5 5s. Power Pack kit £2 1s. 9d.

F.M.T.2. This is the same unit as the F.M.T.1. but built into a shelf mounting case. Price, less valves, but with power supply £7 3s.

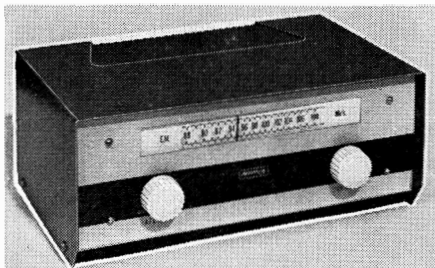

Jason FM Tuner, FMT 3

F.M.T.3. A fringe FM tuner with automatic frequency control. Two limiters combat the effects of aeroplane flutter and car interference. Price with case but less seven valves required, £8 5s.

Mercury switched tuner kit. This has a similar specification as the F.M.T.3. Switched tuning makes this an ideal unit for local programme listening. One control tunes all three programmes simultaneously. A front end is supplied ready built and tested with valves. Price, less three further valves required, £9.

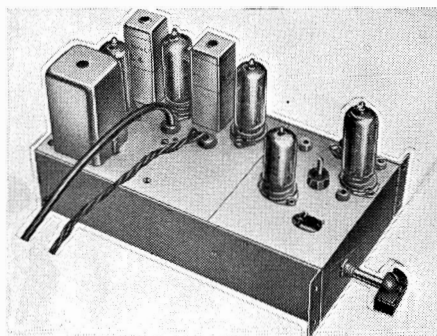

Jason "Mercury" Switched Tuner

TV Sound and F.M. tuner kit, J.T.V. Introduced a few months ago this self-powered tuner has proved very popular and early in 1959 was still the only TV Sound tuner available. Without such a unit tape

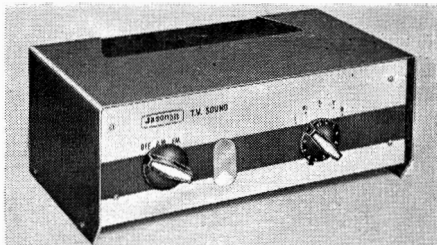

Jason TV Sound and FM Tuner, JTV

recording of TV Sound is hazardous due to the live chassis usually found in modern TV sets. Potentially good quality of TV Sound justifies the use of this tuner with a High-Fidelity amplifying system. The J.T.V. kit matches the JSA2 and J2-10 kit and costs £12 19s., less four valves required. The front end is supplied ready built and tested with two valves.

Argonaut AM/FM tuner. For the more experienced constructor this unit offers a good sensitivity FM tuner combined with AM reception. Price with power supply as a complete tuner, but less the valves required, 10 guineas.

Stereo Amplifier Kits

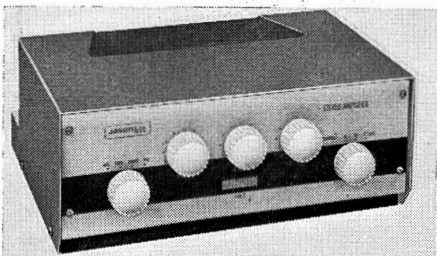

Jason Stereo Amplifier JSA2

J2-10 kit. The output of this amplifier is 10 watts per channel down to 25 c/s with unconditional stability. The input sensitivity is 5 mV to suit such pickups as the *Decca*, *Tannoy*, *Elac* and *Goldring*. The signal to noise ratio is better than 50 dB on the pickup channel and better than 60 dB on other inputs. The front panel controls include a 12 dB per octave filter channel switching and stereo balance. A speaker phase switch simplifies the initial setting up. Price of the kit with twelve valves required £26 19s.

J.S.A.2. Three watt amplifier kit. Three watts per channel are available from this simple kit which gives good results from such stereo pickups as the *Ronette* and

Acos. 18 dB of feed-back is applied to the pentode section of the first amplifier which is an ECF80 while the triode section is used in the tone control circuit. Stereo balance control gives 5 dB variation each way. Price £13 19s. including all valves.

JSP2. Stereo pre-amplifier. A new design which will be available shortly features sufficient gain for tape heads and low output magnetic pickups. The output voltage of 2v is sufficient to drive any type of power amplifier. There is a built-in steep cut rumble filter. Price with five valves required £13 19s.

J4-4 stereo pre-amplifier. Designed for *Hi-Fi News* by H. Lewis Yorke. This was the first design to appear in this market. Price £16 10d. less the eight EF86 valves required.

Test Instrument Kits

EM10 Valve Voltmeter. The heart of this instrument is a four valve bridge circuit which was first published in *Wireless World*. The feed-back employed reduces the gain to unity but results in a very high input impedance low errors, and very small zero drift. Attention has been given to the diode probe circuits so that an accuracy of 3% is maintained on the lowest ranges. The input resistance on the 1, 5 and 10 volt D.C. ranges is extremely high being above 1,000 M ohm and on other ranges is 100 M ohm. The performance of this kit is as good as the most expensive valve voltmeter and considerably better than any other kit. A large clear 4½ in. scale meter completes this unit which is mounted in the standard case measuring 11½ in. × 5¼ in. × 6½ in. deep. A cast surround protects the front of the instrument. Price £18 10s. Kit £23 built.



Jason Audio Generator AG10

AG10 Audio Generator. A capacity tuned Wien bridge covers from 10 c/s to 100 Kc/s with excellent stability and low distortion while the output is held constant within 1 dB. Output impedance is 600 ohm from a cathode follower and the Attenuator uses

resistors of 1% accuracy. The rise time on square waves is better than 2 microseconds. Price kit £12 10s. Built £15 2s. 6d.

AA10 Audio Attenuator. Nine slide switches give the following attenuation. 40 dB, 20 dB, 20 dB, 10 dB, 10 dB, 5 dB, 2 dB, 2 dB, 1 dB, while the tenth switch allows the addition of a 600 ohm termination resistor. Resistors of 1% accuracy are used. The case measures 13 in. long × 2¼ in. wide × 1 in. high. Price kit £5 5s. Built £6 18s.

CC10 Crystal Calibrator. The exact frequency of a generator may be found by connecting the output to this crystal calibrator when the self-contained audio section and loudspeaker allow marker pips to be heard directly. These marker pips are generated at 10 Mc/s, 1 Mc/s, 100 Kc/s and 10 Kc/s so that generators in the range of 10 Kc/s to 250 Mc/s may be checked. The basic accuracy of .01% comes from a 1 Mc/s crystal oscillator. Price kit £14 10s. Built £18 19s.

P.P.10M Stabilized Power Packs. (240v at 80 mA) and **P.P.20M** (300v at 175 mA). A cascade amplifier feeds a series regulator valve giving a low output impedance of less than 1 ohm which is maintained over the voltage range of 250-350v in the case of the P.P.20M and 250-300 in the case of the P.P.10M. Prices P.P.20M kit £22 10s. Built £27 15s. P.P.10M kit £19. Built £23 15s.

OG10 Oscilloscope. This simple but excellent 2½ in. Oscilloscope has a sensitivity of 10 mV/cm with a bandwidth of 2 c/s-2 Mc/s. Sweep linearity is good and push-pull amplifiers are used on both X and Y. Price kit £19 10s.

OG20 Oscilloscope. A 1 in. ray tube gives a remarkably detailed indication. The time base covers from 30 c/s to 10 Kc/s while the amplifier has a sensitivity of 25 mV/cm and a bandwidth of 10 c/s to 50 Kc/s. Provisional price £12 19s.

W11 Wobbulator. This unit used in conjunction with the Oscilloscope OG10 or OG20 allows frequency response curves to be shown. It is suitable for all IF and RF alignment in TV and radio tuners. 50 c/s sound wave is used for scanning while the return trace is blanked to provide a reference base line. Price kit £12 10s.

Various other Test Equipment kits will appear in 1959, such as an Audio Power Meter, Inter-Modulation Distortion Meter and a Millivolt Meter with a wide bandwidth.

HI-FI YEAR BOOK 1960 EDITION

— IMPORTANT NOTES —

THE preparation of the 1960 Edition of *Hi-Fi Year Book* began as this current edition went to Press. Throughout the next 12 months, data has to be collected from manufacturers, distributors, Hi-Fi dealers and overseas companies. This next edition will, it is hoped, embody several new and valuable features to make it of special interest and use, to sellers and buyers alike, the world over. In order to achieve this objective, assistance and co-operation is sought from all quarters, as follows:

READERS

REGULAR readers of *Hi-Fi Year Book*, whose names are on our mailing list, will help us considerably by notifying any address changes as they occur (and no matter how often!). Postcards, addressed as below, and headed on the reverse **IN BLOCK CAPITALS**, “**Address Change**”, followed by the name and address, will be filed in our mailing department. Order forms will then be sent out in good time.

HI-FI DEALERS

HI-FI dealers are invited to send in similar postcards, headed on the reverse *HI-FI DEALER*, followed by the address and telephone number. Two qualifications are necessary for inclusion in the directory (1) Facilities for good, comparative demonstrations (2) Comprehensive stocks of good quality equipment carried.

MANUFACTURERS

MANUFACTURERS are requested to send regular details of new equipment as they go into production, together with photographs as they become available. Any modifications to current equipment, and any withdrawals of equipment from production, should also be sent to the address below, in order to save both buyers and makers from unnecessary correspondence at a later date.

HI-FI YEAR BOOK : 99 MORTIMER STREET : LONDON, W.1

ADVERTISERS' INDEX

	Page		Page
ACOUSTICAL MANUFACTURING CO. LTD.	Cover	LUSTRAPHONE LTD.	231
ALTOBASS LTD.	213	LLOYD & KEYWORTH LTD	188
ARMSTRONG WIRELESS & TELEVISION CO. LTD.	238	MODERN ELECTRICS (RETAIL) LTD.	210
BEAM ECHO LTD.	224 & 225	MUSICRAFT	226
B.K. PARTNERS LTD	196 & 197	MULTIMUSIC LTD.	192
BRADMATIC LTD	211	MSS RECORDING CO. LTD.	209
BRENELL ENGINEERING CO LTD.	217	PHILIPS ELECTRICAL LTD.	204
BROADWAY RADIO	237	PYE LTD.	219
BURNE-JONES	179	QUALITY MART	182
BTH SOUND EQUIPMENT LTD.	203	RARE RECORDS LTD.	233
CAPE ELECTROPHONICS LTD.	183	RICHARD ALLAN RADIO LTD.	184
C. T. CHAPMAN (REPRODUCERS) LTD.	221	RIMINGTON VAN WYCK	186
THOMPSON, DIAMOND & BUTCHER LTD.	178	ROGERS DEVELOPMENTS (ELECTRONICS) LTD.	195
COSMOCORD LTD.	218	ROMAGNA REPRODUCERS LTD.	175
C.Q. AUDIO LTD.	176	SOUND SALES LTD.	227
THE DULCI CO. LTD.	228	STANDARD TELEPHONES & CABLES LTD.	229
"DUST BUG"	232	SCIENTIFIC & TECHNICAL DEVELOPMENTS LTD.	181
E.A.P. (TAPE RECORDERS) LTD.	220	SIMON SOUND SERVICE LTD.	208
E.M.I. SALES & SERVICE LTD.	206 & 207	A. R. SUGDEN & CO. (ENGINEERS) LTD.	189
GARRARD ENGINEERING & MANUFACTURING CO. LTD.	191	SYPHA SOUND SALES LTD.	200
GOLDRING MANUFACTURING CO.	202	TRIANON ELECTRIC LTD.	235
GOODMANS INDUSTRIES LTD.	194	TECHNICAL SUPPLIERS LTD.	239
GOODSELL LTD.	177	VITAVOX LTD.	193
H. C. HARRIDGE	180	VORTEXION LTD.	201
HIGH FIDELITY DEVELOPMENTS LTD.	214	WEBB'S RADIO	205
HEATHKIT (DAYSTROM LTD.)	236	WELLINGTON ACOUSTIC LABORATORIES LTD.	230
ALFRED IMHOF LTD.	198	WELMEC CORPORATION LTD.	212
JASON MOTOR & ELECTRONIC CO.	199	WESTREX CO. LTD.	215
LARGS OF HOLBORN	234	WESTWOOD OF OXFORD	172
LASKY'S (HARROW ROAD) LTD.	222	WHARFEDALE WIRELESS WORKS LTD.	216
H. J. LEAK & CO. LTD.	190	WHITELEY ELECTRICAL RADIO CO. LTD.	223
THE LOWTHER MANUFACTURING CO.	174	W. & N. ELECTRONICS LTD.	185

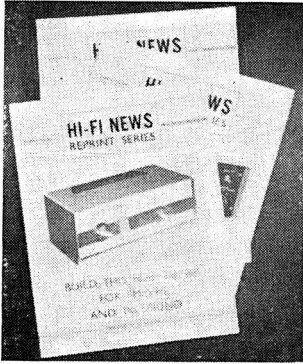

HI-FI NEWS REPRINTS

DURING the past eighteen months or so *Hi-Fi News* has published numerous constructional features. It is the policy of the publishers to make these available in reprint form, and two are already on sale, as detailed opposite. Among reprints to be published shortly are "A Tape Replay and Record Unit", and the series of "Amplifiers for Stereo Use".

- ★ **SP1.** Build this High Fidelity Stereo Pre-Amplifier.

Price: 3/6 post free.

- ★ **SP2.** Build this Hi-Fi Tuner for FM/VHF and TV Sound.

Price: 3/- post free.

HI-FI BOOKS

ALSO in preparation is a series of "Hi-Fi Books", the first titles of which are to be published shortly. These books will be in the same format as this "Hi-Fi Year Book", and will cover all aspects of sound recording and reproduction. Full details of these books, and their publication dates will be given in *Hi-Fi News*, but the publishers will be pleased to mail details of each title, as it becomes available. Post cards, addressed as below, and bearing the sender's name and address in block letters (nothing further needed) will ensure inclusion on this regular mailing list. A short list of provisional titles is given below:

- **HI-FI FOR BEGINNERS**
 - **A SURVEY OF STEREO**
 - **TAPE RECORDERS AND MICROPHONES**
 - **AMPLIFIERS AND PRE-AMPLIFIERS**
 - **HI-FI SPEAKERS**

————— HI-FI BOOKS —————

CLASSICAL RECORD NEWS LIMITED

99 MORTIMER STREET · LONDON · W.1

DIRECTORY OF HI-FI DEALERS

IMPORTANT NOTE: The following list is of shops where stocks of equipment are believed to be kept, and where facilities for demonstration exist. It is not necessarily a complete list, and we invite new dealers to submit details for future publications.

LONDON AREA

BERRYS (SHORT WAVES) LTD., 25 High Holborn, W.C.1

B.K. PARTNERS LTD., 229 Regent Street, W.1

THE CHELSEA RECORD CENTRE, 203 Kings Road, S.W.3

CITY SALES & EXCHANGE LTD., 93 Fleet Street, E.C.4
ELECTRONICS (FLEET ST.) LTD., 152/3 Fleet Street, E.C.4

B. B. EVANS, 148-162 Kilburn High Road, N.W.6

C. C. GOODWIN LTD., 7 The Broadway, Wood Green, N.22

GRAMOPHONE EXCHANGE LTD., 80-82 Wardour Street, W.1

H. C. HARRIDGE, 8 Moor Street, Cambridge Circus, W.1

HARRODS LTD., Knightsbridge, S.W.1

H.M.V., 363 Oxford Street, W.1

HOLLEY'S, 315 Camberwell Road, S.E.5

ALFRED IMHOF, 112 New Oxford Street, W.1

LARG & SONS LTD., Hanover House, 76/77 High Holborn, W.C.1

LEE ELECTRONICS, 400 Edgware Road, W.2

JOHN LEWIS & CO. LTD., Oxford Street, W.1

LEWIS RADIO, 120 Green Lanes, Palmers Green, N.13

MAGNEGRAPH, 1 Hanway Place, W.1

MIRASOUND, 31 Watling Street, E.C.4

MODERN ELECTRICS LTD., 164 Charing Cross Road, W.C.2

MUSIC IN THE HOME, 100 Queensway, W.2

MUSICRAFT, 80-82 Uxbridge Road, Ealing, W.13

NEWBURY RADIO, 305 Romford Road, Forest Gate, E.7

PETER JONES, Sloane Square, S.W.1

QUALITY MART, 8 Dartmouth Park Avenue, N.W.5

RADIO CENTRE, 33 Tottenham Court Road, W.1

RIMINGTON VAN WYCK LTD., 42-43 Cranbourn Street, W.C.2

SELFRIDGES LTD., Oxford Street, W.1

H. L. SMITH & CO. LTD., 287-9 Edgware Road, W.2

A. L. STAMFORD, 98 Weymouth Terrace, E.2

STANWOOD RADIO LTD., Service Dept., 715 High Road, Leyton, E.10

TELE-RADIO (1943) LTD., 189 Edgware Road, W.2

JOHN TRAPP LTD., 371 Green Lanes, Palmers Green, N.13; 15 Crouch End Broadway, N.8

TROUGHTON & YOUNG LTD., 143 Knightsbridge, S.W.1

WEBBS RADIO, 14 Soho Street, W.1

BANGOR

MELODY HOUSE, High Street

BATH (SOMERSET)

C. MILSOM & SON, North Gate

BIRKENHEAD

JAMES MCKENZIE LTD., 27/29 Grange Road West

BIRMINGHAM

GRIFFIN RADIO LTD., 122 Bristol Street, B'ham, 5

HOLLICK & TAYLOR, 16 Grosvenor Road, Handsworth Wood, B'ham, 20

JEWKS & CO., 293 Broad Street, Birmingham, 1

WALKER BROS, 27 Temple Row, Birmingham, 2

C. H. YOUNG, 110 Dale End, Birmingham, 4

BLACKPOOL

F. BENFELL LTD., 17 Cheapside

BOURNEMOUTH (HANTS)

NATIONAL RADIO SUPPLIES, 66 Holdenhurst Road

RONALDSON, 205 Seabourne Road, Southbourn

BRADFORD

BROWN, MUFF & CO. LTD., 55 Margaret Street

SUPER RADIO CO. LTD., Baker Street, 1

BRADSHAWGATE

HARKER & HOWARTH, 7 The Arcade

BRIGHTON (SUSSEX)

JOHN KING (FILMS) LTD., East Street

LANES, 11 Gardner Street

LYON & HALL, 92 Western Road

BRISTOL (SOMERSET)

AUDIO BRISTOL, Park Street Avenue

BRISTOL & WEST RECORDING SERVICES LTD., 6 Park Row

RECORD CENTRES (BRISTOL) LTD., 5 Denmark Street, Centre 1

BURY ST. EDMUNDS (SUFFOLK)

LEESONS PHOTOGRAPHIC LTD., Opposite the Abbeygate

CAMBRIDGE

ADAMS & DELLAR LTD., 66 Regent Street

K.P. CAMERA SHOP, 12a Kings Parade

H. GEE, Esq., 94a Mill Road

G. P. REECE, 1-2 Peas Hill

UNIVERSITY RECORDINGS, 16 Burleigh Place

CANTERBURY

GOULDENS, 36 High Street

CARDIFF

J. GOUGH & CO. LTD., 148-154 North Road

KENNARD RADIO DEPT., Corner Richmond Road and Crwys Road

CHELTENHAM (GLOS.)

CAVENDISH HOUSE (CHELTENHAM) LTD.

RAY ELECTRICAL, 287 High Street

RECORD NEWS



“ . . . Without any doubt the finest and most reliable review paper of its kind anywhere in the world.”

PRICE 1/6 MONTHLY

● “Record News” is produced by the same editorial office as this “Year Book” and both “Hi-Fi News” and “The Tape Recorder”. We think you will like it. Send 6d. stamp for specimen copy. Annual subscription for 12 numbers, 21/- (U.S.A. \$3.00) or with annual index 24/- (U.S.A. \$3.50), posted to any address in the world.

— RECORD NEWS —
99 MORTIMER STREET · LONDON · W.1

CHESTERFIELD (DERBYSHIRE)

BLACKS RADIO STORES LTD., 55 Lower Pavement

CHICHESTER (SUSSEX)

STORRY'S, 83 North Street

COTTINGHAM (YORKSHIRE)

G. JOHNSON, 29 Thwait Street

COVENTRYELECTRONIC SERVICES, 110 Gosford Street
RADIO EXPERIMENTAL PRODS., 33 Much Park Street
R.E.S. (COVENTRY) LTD., 128 Far Gosford Street**CREWE**

MILLER & PALIN LTD., Odeon Buildings, 11 Delmar St.

CROYDON (SURREY)CLASSIC ELECTRICAL CO. LTD., 352-364 Lower
Addiscombe Road**DARLINGTON**

PALMERS, 3 East Street

DERBYDALTON & SON LTD., 11 London Road
DIXONS (DERBY) LTD., Strand Arcade
VICTOR BUCKLAND LTD., 37-39 London Road**DORKING**

THE HIGH FIDELITY CENTRE, 61 West Street

DUDLEY (WORCS)RADIO TELEVISION SERVICE, 214 High Street
J. P. WHITTAKER & SON, 214 High Street**DUNDEE**LARG & SONS (DUNDEE) LTD., 16-24 Whitehall
Street**EASTBOURNE**

MODERN TECHNICAL SERVICES, 71 Seaside Road

EDINBURGHACOUSTIC PRODUCTS, 54 Elm Row
W. JEFFREY & SON LTD., Audio House, 23 Earl Grey
Street.JEFFREYS OF LEITH, Market House, Tolbooth Wynd, 6
J. NICHOLSON, 1 Haddington Place**EXETER**

FILDEWS, 99 Fore Street

FARNHAM (SURREY)

THE RECORD SHOP, 26/27 Downing Street

GLASGOW

J. KERR, 262 Woodlands Road, C.3

GRIMSBY (LINCS)CHARLES PERRITT LTD., 242 Freeman Street
FRED W. WOOD LTD., 24a Bull Ring**GUILDFORD**

J. A. TOWNSEND LTD., 5 Tunsgate

HALIFAXT. FAWTHROP, 17 Rawson Street
D. R. SMITH, 44b Pellon Lane**HAMPTON HILL (MIDDX)**

MELFORD RADIO, 58 Windmill Road; & 181 High St.

HANLEY (STAFFS)

HI-FI SOUND EQUIPMENT, 116 Birches Head Road

HARROGATE

JOSEPH NICHOLSON, 13 Montpelier Parade

HIGH WYCOMBE (BUCKS)

M. W. KEEN, The Chantry Studio, Paul's Row

HUDDERSFIELDGORDON ROBERTS, Yorkshire Sound Centre,
5 Outcote Bank
J. WOOD & SONS LTD., 67 New Street**HULL**

EAST HULL RADIO & RECORDS, 27 Holderness Road

IPSWICH (SUFFOLK)

R.C.S., Fore Street

KEIGHLEY (YORKS)

J. S. RAMSBOTTOM & CO. LTD., Cooke Lane

KIDDERMINSTER

F. W. LONG, 14 Mill Street

KINGSTON-ON-THAMES (Surrey)R. K. APPLEBY, 5 Crown Passage
JOHN GRENFELL, 48 Surbiton Road**LEATHERHEAD (SURREY)**

MAURICE RICHARDS LTD., Radio House, The Crescent

LEEDSVALLANCE & DAVISON LTD., 144 Briggate
P.W.B. AUDIO, 41 Call Lane**LEICESTER**G. W. COWLING LTD., 26 Belvoir Street
DALTON & SONS LTD., 76 Granby Street
LEICESTER CO-OPERATIVE SOCIETY LTD., High Street**LEIGH (LANCS.)**

MELODY HOUSE, Market Street

LIVERPOOL

BEAVER RADIO LTD., 60-62 Whitechape

LUTON (BEDS)COVENTRY RADIO, 189 Dunstable Road
S. FARMER & CO., 2 Wellington Street.**MACCLESFIELD (CHESHIRE)**

HI-FI HOUSE, 123 Chestergate

MAIDSTONE (KENT)

HIGH FIDELITY (MAIDSTONE) LTD., 57 King Street

MANCHESTERFORSYTH BROS. LTD., 126/8 Deansgate
HIGH FIDELITY DEVELOPMENTS LTD., 8 Deansgate
HIMES & ADDISON, 37 John Dalton Street, Albert
Square, 2NORTHERN ELECTRONIC COMPONENTS, 227b
Oxford Road

RARE RECORDS LTD., 4 Oxford Station Approach

MIDDLESBROUGHAUSTIN KYME LTD., 67 Corporation Road
PALMERS, 106 Newport Road**MITCHAM (SURREY)**

HOME RADIO (MITCHAM) LTD., 187 London Road

MONTROSE

LARG & SONS (DUNDEE) LTD., 135 High Street

NEWCASTLE-ON-TYNEHAYMARKET RADIO, 10b Haymarket
PAYNE & HORNSBY, 3 Andrews House, Gallow Gate

We are agents and distributors for the famous **AVANTIC** equipment, which can be seen and heard in our

**DEMONSTRATION
ROOM**



**FOR
YOUR**

HI - FI

WESTWOOD

STEREOPHONIC AMPLIFIERS

Avantic SPA11 combined amplifier and control unit (7 watts each channel) **£29 8 0**
 Avantic SPA21, as above but 12 watts each channel **£48 10 0**
 A full range of Standard amplifiers always in stock including Armstrong, Leak, Tripletone, R.D., Quad, W.B.

TUNERS

Armstrong "Jubilee" Chassis, AM/FM 87-108 Mc/s Medium and Long. Tape Record and Playback facilities A.F.C. on F.M. Two Compensated P.U. Inputs, Bass and Treble Controls ... **£30 9 0**
 Armstrong Stereo "12". Specification similar to Jubilee but has 6 watts Push-Pull Output on each channel and Tape Record and Playback facilities, and Pickup Inputs for Stereo and Monaural **£38 17 0**
 Armstrong AF105. 10 watts Output. F.M. 88-108 Mc/s A.M. Short Wave 16-50 and 50-120 meters M.W. 180-525 M. L.W. 1000-1800 M. **£37 0 0**
 Full details of the above and all Armstrong products available on request.
 F.M. TUNERS BY AVANTIC, ARMSTRONG, LEAK, QUAD, JASON, etc.

TRANSCRIPTION MOTORS

Garrard 301 **£26 8 3**
 Connoisseur, Lenco, etc.
 Other Garrard Units include:—
 Model 4HF with GC8 Cartridge **£19 7 10**
 Model 4HF with GCS10 Stereo **£19 17 7**
 Model TA/Mk.II **£9 15 8**

**46 GEORGE STREET
OXFORD**

TAPE RECORDERS

We are THE area Agents for Reflectograph, Brenell, Telefunken.
 Brenell Tape Decks and Amplifiers can be purchased separately.

RECORDING TAPES

Basf and E.M.I.—Marker and Splicing Tapes, Jointing Compounds.

MICROPHONES

Ribbon—Moving Coil, Crystal—Floor and Table Stands—Transformers.

SPEAKERS AND ENCLOSURES

Avantic SL12-21. 15 w. **£23 2 0**
 Brearcliff. Corner Enclosure **£18 18 0**
 Tannoy Dual Concentric 12" and 15" with Crossover. Prices from **£30 15 0**
 Goodmans Axiom 300 **£11 5 9**
 W/B HF10/12 **£4 19 9**
 W/B HF10/16 **£8 0 0**
 Tweeters, attenuators, Crossover Units. All types of Avantic, Goodmans and W/B Cabinets available.

TRANSCRIPTION ARMS

TPA12 with GMC5 Cartridge **£14 2 6**
 TPA12 with GCS10 Cartridge **£6 5 6**
 TPA12 Arm only **£4 4 5**
 All other makes and Stereo Cartridges available.
 EDDYSTONE Communication Receivers
 Prices from **£34 16 0**

**PHONE
OXFORD 47783**

NEWTON ABBOT

D. O. H. COLES LTD., 13 Courtenay Street

NORTHAMPTON

CRYER'S, 222/224 Wellingborough Road

NOTTINGHAM

NOTTINGHAM TAPE RECORDERS LTD., Burton Street

ALEX OWEN, 51 Carrington Street

NUNEATON

T. & F. HAMMONDS, 2 & 4 Lister Street, Attleborough

OXFORD

HORNS, 6 South Parade

LOWE & OLIVER, Ship Street

L. WESTWOOD, 46 George Street

PERTH

LARG & SONS (DUNDEE) LTD., 7 County Place

PETERBOROUGH

CAMPKIN'S (formerly Camera & Cine Centre), 14 Long Causeway

ROY SPACKMAN, Cowgate

PLYMOUTH

ALBERT E. FORD, 7 George Street

M. JONES & CO. LTD., 84 Embankment Road

PORTSMOUTH (HANTS)

ERNEST WYATT, 10 Queens Road

READING

BARNES & AVIS, 35 London Street

HERBERT & LASCELLES LTD., 22-25 St. Mary's Butts; 31 Friar Street; 59 Oxford Road

HICKIES, 153 Friar Street

RICHMOND (SURREY)

MUSICRAFT, 13 King Street

SALISBURY (WILTS)

J. F. SUTTON, 89 Crane Street

SHEFFIELD

PHILIP CANN, 4 Dixon Lane

SLOUGH (BUCKS.)

HICKIES, 35 High Street

SOLIHULL (WARWICKS.)

H. C. HOLLOWAY, 2 High Street

SOUTHALL (MIDDX)

MUSICRAFT, 20-22 High Street

SOUTHAMPTON

MOXHAM'S LTD., 96 St. Mary's Road

J. F. SUTTON, 421 Shirley Road

SOUTHPORT (LANCS)

ALDRIDGES (MUSIC) LTD., 14-16 Houghton Street

STOKE-ON-TRENT

HIGH FIDELITY SOUND EQUIPMENT, 116 Birches Head Road, Hanley

SUNDERLAND

ROSE BROS., 5 Blandford Street

SUNNINGDALE (BERKS)

PACKS RADIO

SUTTON (SURREY)

SHINNERS, High Street

THORNTON HEATH (SURREY)

NUSOUND RECORDING CO., 3-8 Brigstock Parade, London Road

TRURO

EDMUND FORD, 9 Pydar Street.

TUNBRIDGE WELLS (KENT)

GOULDEN & CURRY, 59-61 High Street

PERCY POWELL LTD., 54 High Street

WALSALL (STAFFS)

H. TAYLOR & SON, Bridge Street

WARRINGTON (LANCS)

WESTERN SOUND RECORDINGS, 11 Wilson Patten Street

WESTHOUGHTON (LANCS)

"MAXTONE", 19 Market Street

WIGAN

R. H. COOK, 281 Billinge Road, Pemberton

MELODY HOUSE, 43 Hallgate

WOLVERHAMPTON (STAFFS)

FENWICKS, Great Brickkiln Street

PODMORE LTD., 19 Merridale Road

VOLTIC RADIO, Queen's Arcade

WORCESTER

JOHNSONS, 46 Friar Street

WORTHING (SUSSEX)

BARNES & SPICER, 4 Connaught Buildings, Chapel Rd.

BOWER & WILKINS LTD., 1 Becket Buildings, Littlehampton Road

J. W. MANSFIELD LTD., 8/10 Liverpool Road

WREXHAM

HIGH FIDELITY DEVELOPMENTS LTD., P.O. Stores Garden Village



-towards perfection-

tuner units
a.m. — f.m.

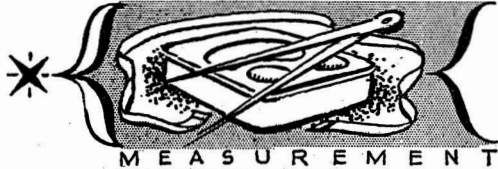

M E A S U R E M E N T

transistor
pre-amplifiers



S P E C I F I C A T I O N

pick-ups

equaliser and
control units



M U S I C I A N

power amplifiers

loudspeaker
drive units for
horn loading



L I S T E N E R

loudspeakers for
monitoring or
laboratory

— *from every point of view*

the greatest range of instruments on offer
for professional or amateur requirements

The Lowther Corner Reproducer type T.P.I. is the most outstanding electro-dynamic acoustic development of our time.

THE LOWTHER MANUFACTURING COMPANY
LOWTHER HOUSE : ST. MARK'S ROAD : BROMLEY : KENT

Telephone : RAVensbourne 5225

FOR THE BEST POSSIBLE REPRODUCTION OF UPPER FREQUENCIES

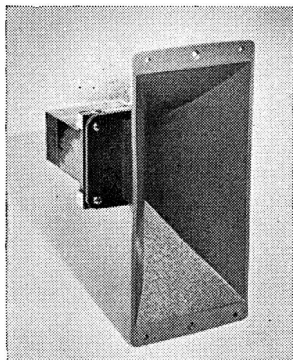

"I know of no other tweeter on the market which I should prefer."

Mr. Percy Wilson, Gramophone, July 1958

In the Kelly Ribbon Loudspeaker Mk. II, a 2-micron aluminium ribbon, supported on milar film, moves in an intense magnetic field. The technique ensures both uniformity of response to the energy applied and relatively great mechanical strength. The result is an instrument of remarkably smooth response and robustness (see curve below). The specially designed catenoidal horn provides ideal distribution of frequencies above 1.5 K/cs. The built-in low-loss matching transformer is available for 3.5 or 15 ohms inputs. Intended for adding to any loudspeaker system to improve high-note response, the Kelly Ribbon Loudspeaker Mk. II gives added quality to stereo that is positively outstanding.

KELLY RIBBON LOUDSPEAKER Mk. II

- Response—2,500 to 25,000 c/s
- Power capacity—10 watts peak
- Dynamic mass—8 milligrams
- With built-in matching transformer

10 GNS.

From your hi-fi stockist.
Please write us in case of difficulty. Leaflet on request.

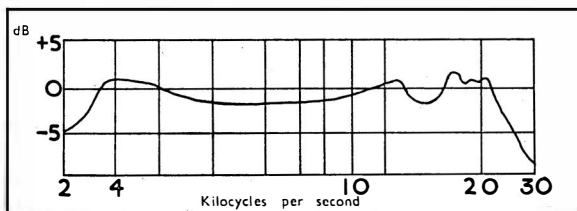

KELLY CROSSOVER NETWORK CO/1/15

For operation from 15 ohms output and 15 ohm bass unit up to 12 watts loading together with Kelly Ribbon Loudspeaker Mk. II. A balancing potentiometer is incorporated and the unit is potted in Araldite Resin and housed within a cast metal case.

£3 . 3 . 0

ROMAGNA REPRODUCERS

2 SARNESFIELD ROAD, ENFIELD, MIDDLESEX, ENGLAND

Telephone: ENfield 8717

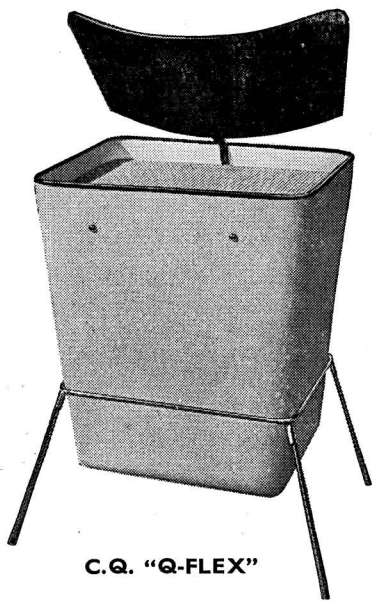

C.Q. "Q-FLEX"

CQ JUNIOR

REPRODUCER

Impedance 15 ohms.
Weight 10 lb. (4.5 kilos)
Matching Transformer
for 3, 5, 8 or 15 ohms.
available

Now after two years further experience and development an even smaller speaker has emerged. The frequency range is 45 to 12,000 c/s and the power handling 4 watts continuously or 8-10 watts speech or music. Dimensions are 17" x 9½" x 10". A genuine "bookcase" speaker. Four sides are veneered and polished so that it can be mounted either vertically or horizontally.

Senior FULL RANGE REPRODUCER
NOW ALSO AVAILABLE IN KIT
FORM

"We... had no doubts as to its superiority. It stood comparison with much more expensive combinations."—*The Gramophone*

Q-Flex SPEAKER KIT.
A new concept in
enclosure design.

"We much prefer it to that which is obtainable with speakers of the small box type."—*The Gramophone*

Tetraq Omni-Directional
Tweeter Unit

The increase in source size was immediately obvious and very pleasant too."

CQ-3 A new wide range high
performance 3-way
speaker system employ-
ing a 12" bass unit, 985 Mid-frequency
unit and two miniature Tweeters.

"THE Q-FLEX LOUDSPEAKER"
by A. R. Neve.

An outline of the flexing wall principle with performance graphs and constructional details. From your dealer or bookseller 3s.

Post free 3s. 6d.

Whether converting your single channel to stereo or starting fresh, CQ amplifiers provide the finest performance at moderate price

- C.Q. TWIN FOUR** Combined Stereo amplifier and preamp.
- C.Q. TEN-FIFTEEN** Single Channel Combined amplifier and preamp.
- C.Q. TWIN P.U. PREAMP.** Pickup Preamp. conversion unit.
- C.Q. "TAPEHEART"** Stereo Record-Replay and oscillator unit.
- C.Q. POWER AMPLIFIER** Single 10-15 watt Basic Power Amplifier.

Write for full details to:— Sole Trade Distributors: **TECHNICAL SUPPLIERS LTD.,**
63 Goldhawk Road, London, W.12. Or direct to: **C.Q. AUDIO LTD.,** Bush Fair,
Harlow, Essex.



**new
products
from . . .**

Goodsell

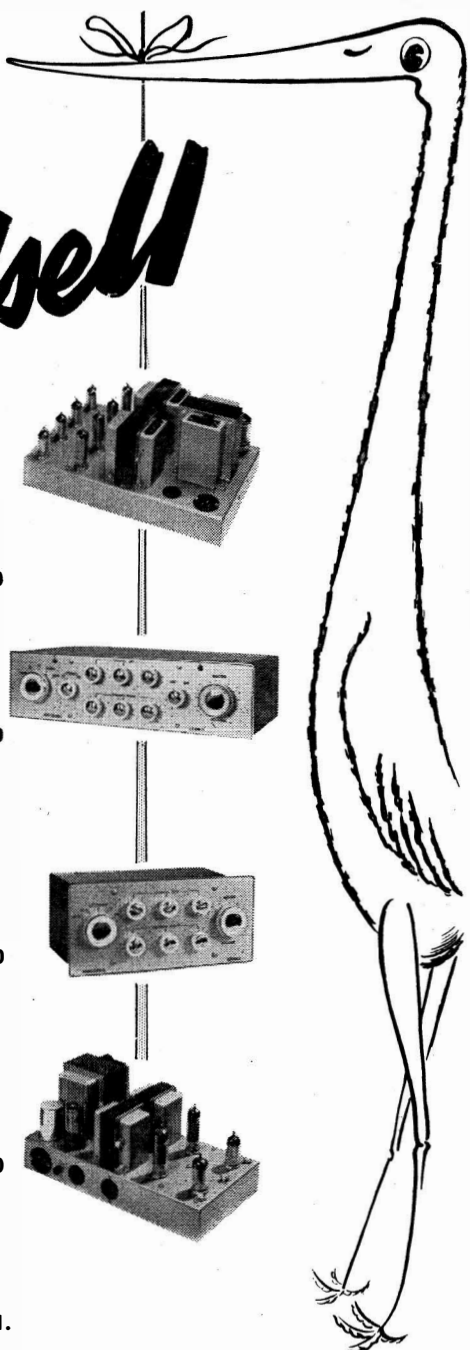

**MA20
STEREO AMPLIFIER**

A compact unit comprising two circuits on a common chassis using one mains transformer and giving 10 watts per channel.

£32 5 0

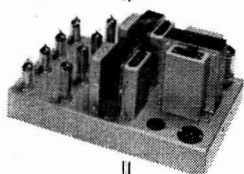

**STEREO II
TONE CONTROL**

A de luxe unit giving highest possible quality of reproduction with minimum noise and "break through." Affords full R.I.A.A. correction for records and C.C.I.R. correction for tapes.

£27 15 0

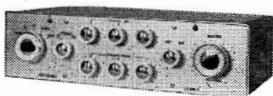

**STEREO I
TONE CONTROL**

Independent control of Bass, Treble and Volume for each channel.

£16 5 0

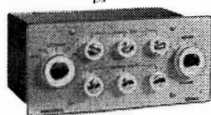

**MA8
STEREO AMPLIFIER**

An excellent stereo unit of very compact design at an extremely realistic price.

£16 10 0

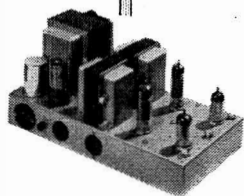

Write for details to

GOODSELL LTD.

40 Gardner Street, Brighton, 1.

Telephone: Brighton 26735

THOMPSON, DIAMOND & BUTCHER LTD.

5-9 UNIVERSITY STREET, LONDON, W.C.1 Phone EUSton 3494

Manufacturers of Monaural and Stereophonic Record Reproducers
"Convertogram", "Meritone", "New World", "National", "Lamplifier".

The Leading Distributors of High Fidelity Equipment.

Showroom Facilities for Dealers.

New Season's Trade Hi-Fi Catalogue available May/June

AMPLIFIERS and TUNERS

Leak
Quad
Rogers
R.C.A.
Avantic
Chapman
C.Q.
Dulci

LOUD SPEAKERS

Wharfedale
Goodmans
W.B.
C.Q.
Fane
Kelly
Lowther

TAPE RECORDERS

Brenell
Elizabethan
Grundig
Stella
Stuzzi
Truvox
Walters
etc., etc

TRANSCRIPTION MOTORS

Connoisseur
Collaro
Garrard
Lenco
Thorens

PICKUPS and CARTRIDGES

Acos
B.J.
Decca
Elac
Garrard
Goldring
Leak
Ortofon
Philips

TAPES

Emitape
Scotch Boy
B.A.S.F.
Mastertape

SUNDRIES

All Styli
(Sapphires and
Diamonds),
Pressure Gau ges,
Record Cleaning
Units, etc., etc.

FOR THE MOST COMPREHENSIVE STOCKS and PROMPTTEST SUPPLIES

YOU CAN RELY UPON

THOMPSON, DIAMOND & BUTCHER LTD.
LONDON W.C.1

BJ WORLD'S MOST ADVANCED PRODUCTS

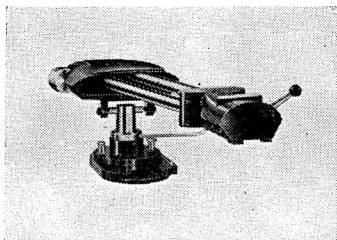

SUPER 90 MK II

B-J ELAC
200 & 300
STEREO CARTRIDGES

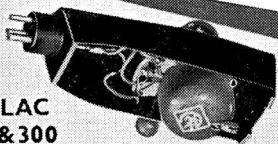

B-J
STEREO CARTRIDGE
(CRYSTAL)

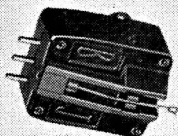

B-J COUNTER
WEIGHT
UNIT



BJ
TAN II
ARM

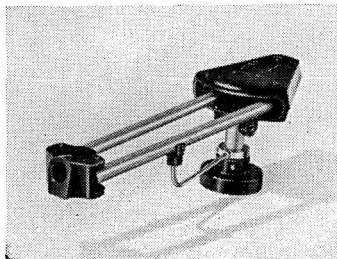

BJ TANGENT ARMS

have all the advantages of swinging type arms yet none of the limitations, since the patented BJ principle overcomes *tracking error*.

BJ CARTRIDGES (magnetic and crystal) meet the superlative standards set by the BJ arms.

BJ SONETTA REPRODUCER and unique treble units are accepted by the Council of Industrial Design where appearance and performance are of first importance, a tribute to their technical and artistic excellence.

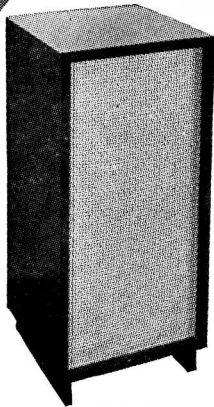

SONETTA

BJ ARMS OVERCOME TRACKING ERROR

TOP 'C'
TWEETER



TREBLE 20

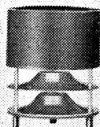

TREBLE TWIN

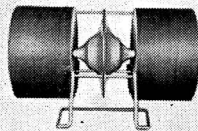

BURNE-JONES

18, BRUNSWICK ROAD : SUTTON : SURREY : ENGLAND

STEREO
or
MONAURAL ?

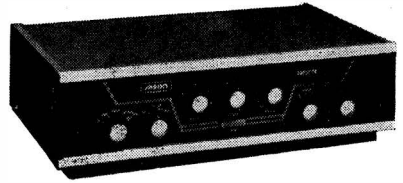

Comparative demonstrations any time of

RECORD REPRODUCERS
and
TAPE RECORDERS

Always in Stock

ROGERS Amplifiers and speakers and tuners

QUAD Electrostatic speaker and equipment

LEAK Amplifiers

JASON Tuners and amplifiers

WHARFEDALE & GOODMAN SPEAKERS

ALL THE BEST TAPE RECORDERS



Your unwanted equipment taken in part exchange



H. C. HARRIDGE
8 MOOR STREET, CAMBRIDGE CIRCUS W.I

Telephone: GERrard 7108

Open daily except Thursday.

Late night Friday.

'ORTHOTONE'

HIGH FIDELITY

ELEGANT STYLING

PRECISE ENGINEERING

**LOUDSPEAKER SYSTEMS
AND ENCLOSURES**

**EQUIPMENT CABINETS
AND CONSOLES
OF ORIGINAL DESIGN**

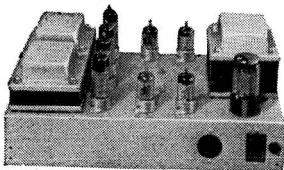
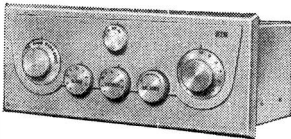
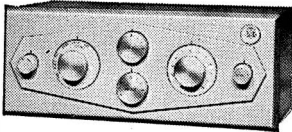

Stereo amplifiers-integrated, control and power units.

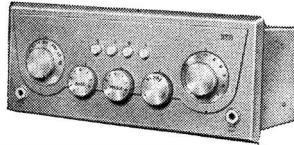

Single-channel self-powered pre-amplifiers, and power amplifiers.

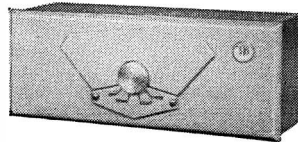
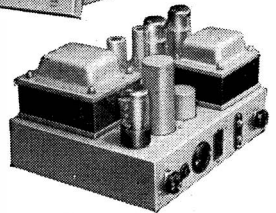

Radio tuner units with and without power supply.

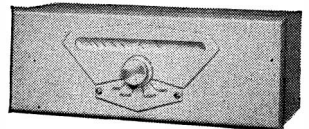

Please write or telephone to attend a demonstration

SCIENTIFIC & TECHNICAL DEVELOPMENTS LTD.
MELBOURNE WORKS - MELBOURNE ROAD - WALLINGTON
SURREY
Tel.: WALLINGTON 9252 (10 lines)



Heard about the Q.M. Record Service? You simply order your record and it is promptly delivered in *factory-fresh condition*. Each record is unplayed but carefully inspected by us, **PARASTAT TREATED**, and packed in a polythene bag. L.P.s and 45s — post free (except single 45s). Overseas costs only 4/5ths of home prices.

...looking for the perfect system ?

There is of course a different answer for everyone—the main thing is that *your* high fidelity system should suit your ear, your home and your pocket at one fell swoop !

A word of warning, however—it is only too easy to spend a lot of money on hi-fi equipment. Only the expert knowledge you get at Q.M. can help you to choose items that combine to good effect. A letter or, better still, a visit to Q.M. can give you the kind of advice that makes *sound* sense about any of the equipment shown in Hi-Fi Year Book.

Incidentally, we are adept at answering difficult export problems.

Quality Mart

AUDIO HOUSE

8 Dartmouth Park Avenue,
London, N.W.5 GULliver 1131

Our showroom is open for demonstrations daily 9.30-6. Friday 1.30-9. Closed Monday.

Only 20 minutes from Charing Cross by Northern Underground or Buses 27, 134, 137 to Tufnell Park Station.

The Cape VLI Amplifier

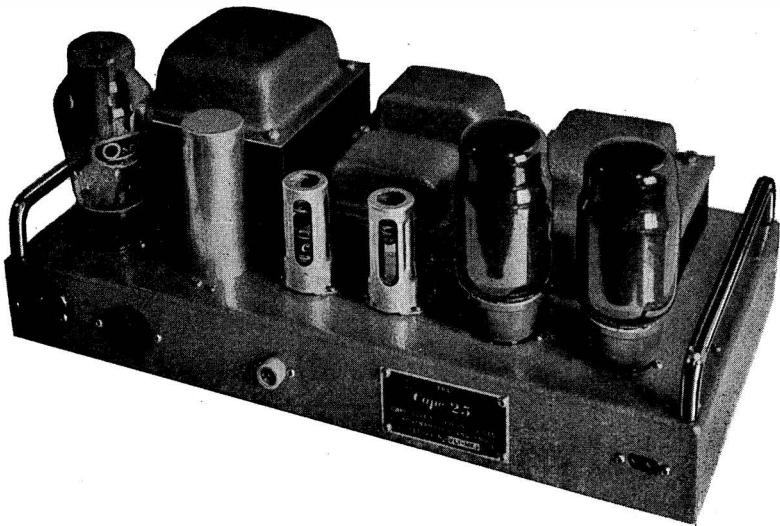

Designed by Mr. H. Lewis York, the Cape VLI amplifier has received world-wide acclaim for its high standard of performance and utter reliability. Mr. G. Tillett, in the *Hi-Fi News Review* said "the amplifier with its generous power supply and high output with the minimum of distortion is really superb". The VLI is being used more and more by laboratories and recording studios and is suitable for the highest quality monaural or stereo installations in the home. A full range of associated units is available from the makers.

CAPE ELECTROPHONICS LTD.

43-45, Shirley High Street, Southampton

Telephone 74251

**HIGH FIDELITY
SPEAKERS AND
ENCLOSURES BY**

Richard Allan

**THE
GOLDEN
EIGHT**



Features:—

8" diameter.
1" centre pole.
48,000 Maxwells.
5 watts max. peak input.
60 to 10,000 c.p.s.
14 oz. Alcomax 11 magnet.

Price £2 10s.
Plus Tax

Features:—

10" diameter.
1½" centre pole.
82,000 Maxwells.
10 watts max. peak input.
40 to 9,000 c.p.s.
2 lb. Alcomax 11 magnet.

**THE
GOLDEN
TEN**

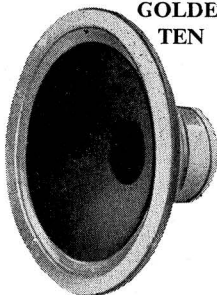

Price £5 12s. Plus Tax
FOAM SURROUND

Price £5 5s. Plus Tax
STANDARD
SURROUND

Features:—

12" diameter. 2" centre pole.
182,000 Maxwells.
15 watts max. peak input.
25 to 5,000 c.p.s.
4¼ lb. Alcomax 11 magnet.

Price £12 12s. Tax Free

**THE
GOLDEN
TWELVE**

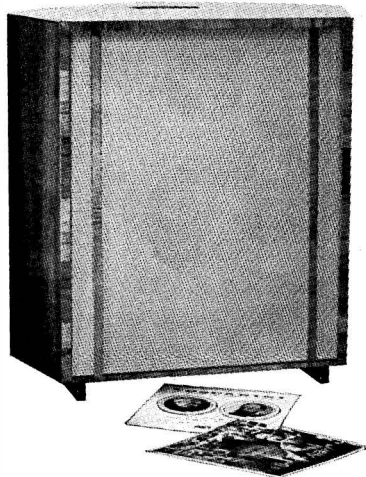
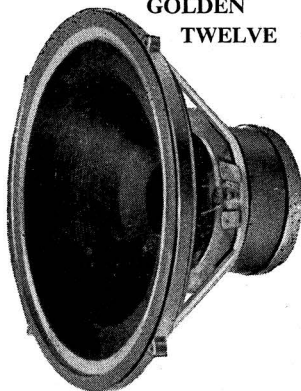

The
"EMPRESS"
enclosure

One of the range of Richard Allan High Fidelity enclosures, the "EMPRESS" is recommended for the most critical listener. It is a three unit system and has a frequency coverage from 25 to 17,000 c.p.s.

Price £37 16s. Complete
Tax Free

For details of these and other High Fidelity products write to:
Richard Allan Radio Ltd., Batley, Yorks.

Audiomaster

Styled

and engineered

for those who demand the best

Audiomaster Stereo Amplifier

From any point of view, the Audiomaster Stereo Hi-Fi amplifier offers the finest value it's possible to find.

Attractive appearance and beautifully finished housing make it just as suitable for table-top use or for fitting into a bookshelf or room divider as for horizontal panel mounting in existing cabinets.

Never before in this price range has it been possible to include such features as: suitability for either crystal or magnetic pickups, facilities for playing direct from tape head and twin microphone inputs for special stereophonic effects.

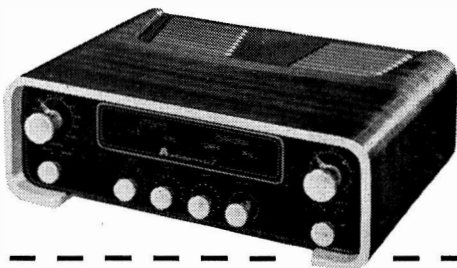

Audiomaster Monaural Amplifier



The finest monaural amplifier ever made. A galaxy of features and facilities include direct replay to C.C.I.R. and N.A.R.T.B. characteristics from any high quality tape head without a separate stage of pre-amplification.

Audiomaster Tape Adaptor

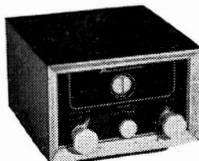

A complete tape amplifier with separate playback section enabling full advantage to be taken of decks provided with a monitoring head.

... and NOW the Audiomaster Stereo Unit



Offering all the advantages previously obtainable only in the highest price range, the new stereo amplifier incorporated in this equipment gives the fantastic output of 30 watts per channel with a harmonic distortion of 0.1 per cent. (a figure well below that detectable by the average human ear). Complementary equipment includes recording amplifier with cathode ray tube monitoring facility. Wearite Stereo tape deck, Connoisseur turntable, Decca Stereo pickup, Chapman AM/FM tuner and twin, matching free standing speakers.

See Audiomaster at your dealers now or write for details to:—

W. & N. ELECTRONICS LTD.

80-82 Uxbridge Road, Ealing, W.13

Telephone: EALing 4774



CLENDISC – Anti - Static
Cleaner and Preserver

3/9 & 6/- per bottle

FREDOREC
RECORD PAD

3/2 (inc. tax)

See Prescription

AVAILABLE FROM ALL GOOD
RECORD SHOPS OR DIRECT . . .

1950 was a great year for the Gramophone. It saw the birth in this country of L.P. Records and the introduction of CLENDISC—still the finest formula for keeping them clean. After all these years, CLENDISC is the most effective and safest medium for keeping your records in pristine condition. It has powerful anti-static properties and used in conjunction with the now-familiar FREDOREC PAD in accordance with the “prescription” above, it will keep your records in mint condition, improve reproduction and reduce surface noise. CLENDISC is also a wonderful tonic for your 78 Records. Time has proved that CLENDISC and the FREDOREC PAD are indispensable accessories to every discerning record-lover. Use your FREDOREC PAD every time you play a Record !

RIMINGTON VAN WYCK

SPECIALISTS IN LONG-PLAYING RECORDS AND EQUIPMENT FOR THEIR REPRODUCTION

42 Cranbourn Street, London, W.C.2 - - GERard 1171

the **DECCA ffs*** **PICK-UP**

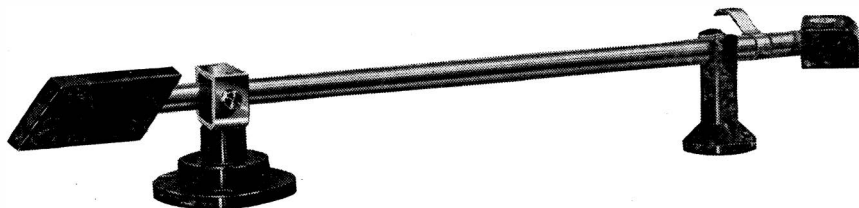

undoubtedly the finest in
the world for both stereo and
mono microgroove discs

- low amplitude and intermodulation distortion
- accurate tracking even of inner groove high frequency transients
- negligible cross-talk
- less than 1 milligram tip mass
- 0.0005/75" radius diamond stylus
- negligible record wear



* ffs — full frequency stereophonic sound

*"... on present facts this Decca cartridge is the ne plus ultra
of stereo cartridges."* (The Gramophone)

"It deserves everything good that can be said about it." (Hi-Fi News)

*"It is highly recommended without reservation or qualification
of any kind."* (Record News and Stereo Disc)

DECCA RADIO & TELEVISION

DECCA HOUSE ALBERT EMBANKMENT LONDON SE11

Stereo or Monaural— Which Shall I Buy?

That is the question you may possibly be asking yourself—perhaps we can help you. Many people visiting us for the first time have expressed surprise at the very large selection of High Fidelity Equipment and Tape Recorders that we can offer, and we are told that we are quite the most interesting and helpful Hi-Fi shop in Surrey and Hampshire.

We feel in all modesty that they have some justification for this because:

We do stock most of the good High Fidelity Equipment and Tape Recorders listed in this Hi-Fi Year Book, together with a large range of Cabinets. We also design and make cabinets to customers' requirements.

We have a cheerful, helpful staff to advise you with your purchases and problems. You can compare the merits of any combination of Amplifier, Speaker, Pickup, and V.H.F. Tuner in our demonstration room.

We are not a large organisation, but we want to please you, the customer, and we offer a personal service backed by sound advice, and a reputation for scrupulously fair dealing. We do not only want to sell you the equipment—we want to give you service and to help you to get the best out of it.

If you are interested in High Fidelity Equipment it will pay you to visit our showrooms in Farnham. If you are unable to do this, our representative will be pleased to call at your home to discuss the installation of any sound equipment.

Lloyd & Keyworth Ltd.
The Record Shop
26/27 Downing Street, Farnham, Surrey
Telephone 5534

“ QUALITY, RELIABILITY, AND SERVICE ”

Hours of Business—9 a.m. to 6 p.m.; Wednesday—9 a.m. to 1 p.m.

STEREO SOUND SUPREME

by *Connoisseur*

THE RESULT OF FOUR YEARS PROGRESSIVE DEVELOPMENT

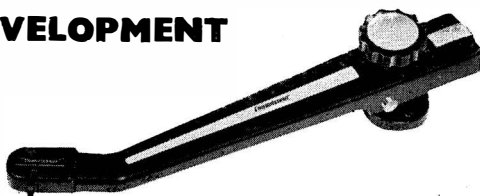

THE STEREO PICKUP

For playing 45/45 records. Miniature ceramic type with replaceable diamond stylus. Constant velocity output approximately 20 mV from each channel. Frequency range 20 to 16,000 cycles. Channel separation 20/25 dBs.

STEREOPHONIC AMPLIFIER AND PRE-AMPLIFIER

Twin channel amplifier and pre-amplifier for reproducing monaural and stereophonic sound from disc, radio and compensated tape. Ultra linear push-pull output giving 7.5 watts peak from each channel.

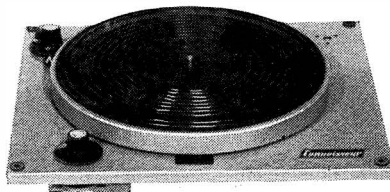

VARIABLE 3-SPEED MOTOR TYPE B

Operates at 33 $\frac{1}{3}$, 45 and 78 r.p.m. Non-ferrous turntable. **Built-in large stroboscope with internal light source.** Precision ground and lapped spindles. Adjustable nylon graphite bearings. Synchronous motor.

A. R. SUGDEN & CO. (ENGINEERS) LTD.,
MARKET STREET, BRIGHOUSE, YORKSHIRE

Is your amplifier good enough for broadcasting and recording?

State here

yes
or
no

If NO we will send you full particulars of our amplifiers.

If YES we will make sure we have your name on our mailing list for details of our new stereo amplifiers and future products.

NAME

ADDRESS

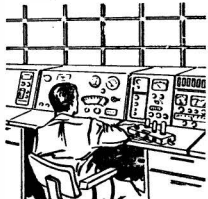

Leak Amplifiers were the first in the world to be marketed with a distortion content as low as 0.1%; a claim received with incredulity in 1945; but which was subsequently confirmed by the National Physical Laboratory and has since become an accepted world-wide standard.

LEAK amplifiers are the choice of professional engineers such as the B.B.C. (over 500 delivered), the South African Broadcasting Corporation (600), I.T.V. and many other Commonwealth and overseas broadcasting and TV systems, who use them for transmitting and/or monitoring (quality checking the broadcasts to which you listen).

Also many of the gramophone records you buy are cut via LEAK amplifiers. This acceptance by professional audio engineers has led to a demand for Leak equipment from music-lovers throughout the world.

From long experience and by extreme attention to design details during development work on the pre-production models, we enable our craftsmen to achieve a high output per man-hour. The labour costs thus saved offset the increased costs incurred for high-grade materials, components and finishes, and this together with quantity production (made possible only by a world-wide market) explains how quality products may be sold at reasonable prices.

LEAK

The first name
in High Fidelity
since 1934

H. J. LEAK & CO. LTD., BRUNEL ROAD,
WESTWAY FACTORY ESTATE,
LONDON, W.3, ENGLAND

Telegrams: Sinusoidal Ealux London
Telephone: SHEpherds Bush 1173/4/5. Cables: Sinusoidal, London

Ask your dealer for a demonstration of
LEAK equipment including the NEW POINT
ONE STEREO pre-amplifier and STEREO
20" power amplifier.

For **40** years

the World's Widest range of Gramophone Equipment

301 TRANSCRIPTION MOTOR

This motor has a 6 lb. accurately balanced die cast aluminium turntable. It is of the shaded pole induction type, is in heavy cast casing and is magnetically screened. The precise speed can be obtained by means of the eddy current brake. It is used by the B.B.C. and many broadcasting stations throughout the world.



High Fidelity ...

TPA 12 TRANSCRIPTION PICK-UP ARM

This pickup arm has been designed to comply with the latest requirements for monaural and stereophonic record reproduction. The pick-up head is offset, the angle of which was carefully calculated to give the minimum tracking error. Its length allows for records up to 16" diameter to be played. The plug-in pickup head will house most types of pick-up cartridges. The height and stylus pressure are readily adjustable. It is elegantly styled and finished in an attractive combination of Ivory, Chrome and Red.

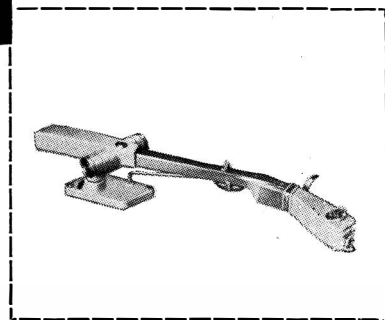

4 HF

This unit has been designed to meet the demand for a high quality single record player at a reasonable price. A 12" diameter formed turntable weighing 4 lbs. has been incorporated.

Speed variation on all four speeds of plus or minus 3% is obtainable by means of an electrical speed control. Provision is made for disengaging the automatic stop if so desired.

The TPA.12 Transcription pick-up arm is incorporated on the unit plate.

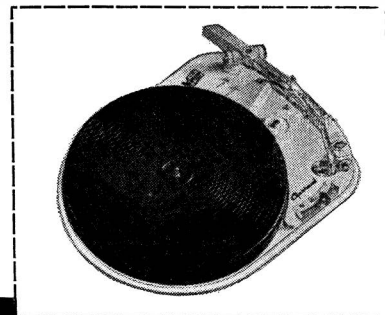

Garrard

THE GARRARD ENGINEERING & MANUFACTURING CO. LTD., SWINDON, WILTS.



Introducing the **new**

Reflectograph STEREOCORDER model 570

The unique self-contained, transportable recorder incorporating separate record and playback stacked (in line) heads, separate record and playback amplifiers and Goodmans monitor loudspeakers. It *records* and *plays back* tapes . . .

STEREOPHONICALLY MONOPHONICALLY TWO-CHANNEL

Permitting superimposition on one track and reproduces stereo records from a stereo pick-up through the high quality amplifiers.

BRIEF SPECIFICATION:

Case in pigskin and luxan hide colours with loudspeakers fitted in dual-section lid. Reflectograph exclusive variable speed deck 8-3½ i.p.s.

Neon-lit stroboscope showing precise speeds of 7½ and 3¾ i.p.s. Three Garrard motors. Push button and lever controls, including "inching" facility. Provision for 8¼" reels. Clock-type tape position indicator. Bib tape splicer.

Full tape width erase head (switchable). 45 db separation between each track of playback head, allowing interference free reproduction of one track of a two-track tape. Two pairs of separate record and playback amplifiers. Each pair

having 3 watts undistorted output to CCIR response.

Tape/Input switch providing instant comparison between input signal and signal recorded on tape. Treble and bass tone cut controls. Two input and two output sockets. Peak level record meter. Complete with two 10 ft. speaker leads, two screened plugs, splicing tape, demonstration stereo tape and tape reel. Price 149 gns.

FOR THE TECHNICAL MAN—

Dimensions: 31" long x 14½" wide x 11½" high: Weight 70 lbs. Frequency Response: ± 2 dB. 50—10,000 c/s: ± 3 dB. 45—12,000 c/s. Overall Response: Strictly to C.C.I.R. recommended specifications. Signal to Noise Ratio: Better than—45 dB. (unweighted, including hum). Output from

Playback Pre-amplifier: 200mV. R.M.S. Inputs to Record Amplifier (High Impedance): Microphone 1mV.: Radio or pick-up 50-200mV. —for maximum record level. "Wow" and "Flutter": Better than 0.2% R.M.S. as measured on the G.B.-Kalee-Flutter Meter.

ONE YEAR'S FREE MAINTENANCE: All Reflectographs are guaranteed for one year (including valves) . . . available throughout U.K. Service undertaken immediately by Engineers of the E.M.I. Company, Home Maintenance Ltd. Annual Service Contract available for 20 years subsequent for small annual fee.



Model 570
Price: 149 gns

Please write for fully descriptive literature of Model 570, Reflectograph Model 500 and name and address of the nearest retailer.

MULTIMUSIC LTD, MAYLANDS AVENUE,
HEMEL HEMPSTEAD, HERTS. TEL: BOXMOOR 3636

Introducing . . . the entirely new . . .
Integrated Line

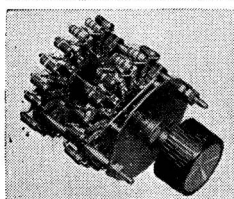
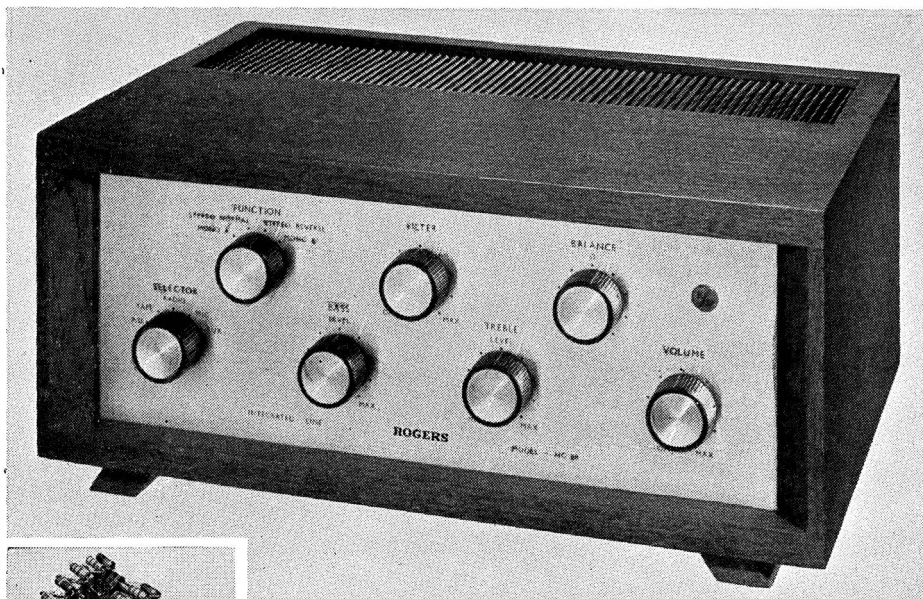

The most critical design feature of any Stereo Amplifier is the volume control. The volume control fitted to the Model HG88 is unique in that instead of the customary carbon potentiometer, a two bank 18-way selector wired with 5% resistors is employed. This form of control ensures that stable accurate stereo balance is maintained at all volume settings, within $\pm \frac{1}{2}$ dB in this case, and avoids the difficulties associated with carbon potentiometers when used for stereo. As far as we know this feature is exclusive to the Model HG88.

First of an entirely new range of Integrated Equipment, the Model HG88 Stereo Amplifier sets standards for performance, flexibility and styling which will be difficult to equal. No less than ten inputs provide for every possible programme source, including low output stereo pickups and direct replay from tape heads. Seven panel controls ensure optimum results whatever the programme material or listening conditions, additional pre-set controls facilitates the matching of associated equipment. Materials and workmanship are of the highest standard giving long-term reliability. Styling represents a completely fresh approach to this important aspect of design, the result blending with any furnishing scheme. Hear the HG88, study the specification, examine the workmanship; in every respect you will find it an outstanding example of high fidelity equipment.

SEE AND HEAR THE NEW

MODEL HG88

STEREO AMPLIFIER
 £37 . 10 . 0 (case £2 . 10 . 0)

Illustrated Literature dealing with the new Integrated Line may be had free, and post free, on request.

Trade and Export inquiries invited :

ROGERS DEVELOPMENTS (ELECTRONICS) LTD.

"RODEVCO WORKS", 4-14 BARMESTON ROAD, CATFORD, LONDON, S.E.6 - Hither Green 7424/4340

“ How much
does a good
Loudspeaker System cost ? ”

eight -1- four

LOUDSPEAKER
ENCLOSURE

incorporating

ACOUSTIFLEX

(prov. patent)

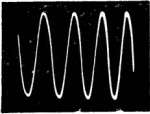
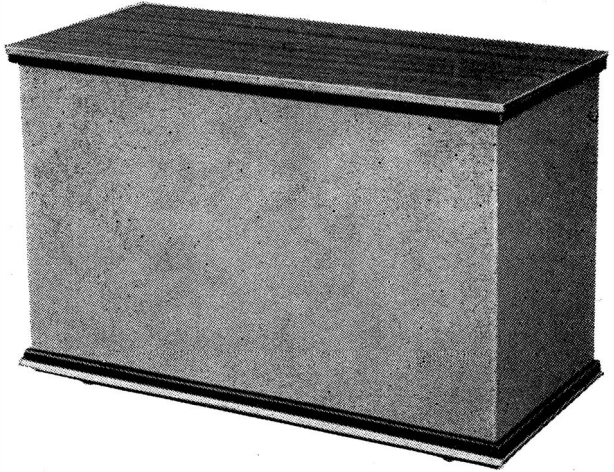

Waveform of output
from speaker cone,
50c/s, 2 watts, using
recommended units.

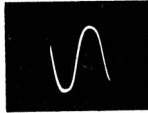

Waveform of output
from Acoustiflex, 40
c/s, 2 watts, using
recommended units.

That's a question we often hear. If you want the ultimate it can cost you three figures. On the other hand, sacrificing a little of the specification can save you more than two-thirds of this cost. Take the Eight-1-Four for instance. Here's an enclosure that is neat and compact with

the distinctive elegance of design you expect with BK cabinets. We've spent a great deal of thought on the Eight-1-Four and the result is an enclosure that sounds—and looks—as good as many three times its price. Don't take our word for it, we would rather you heard it for yourself!

Recommended drive units: High Flux, low resonance 8-inch, flux density 12,000 lines; total flux 48,000 lines; power rating 6 watts; and 4-inch Tweeter, flux density 10,000 lines; plastic foam suspension; response 2 Kc/s–16 Kc/s, with Kelly designed parallel quarter section filter network. Natural Walnut or Sapele veneers.

Price ? — it's no secret
call at your local dealers now
... you'll be surprised
... and delighted

BK

PARTNERS LTD.

229 Regent Street, London, W.1
(Entrance in Hanover Street)
Tel.: REGent 7363

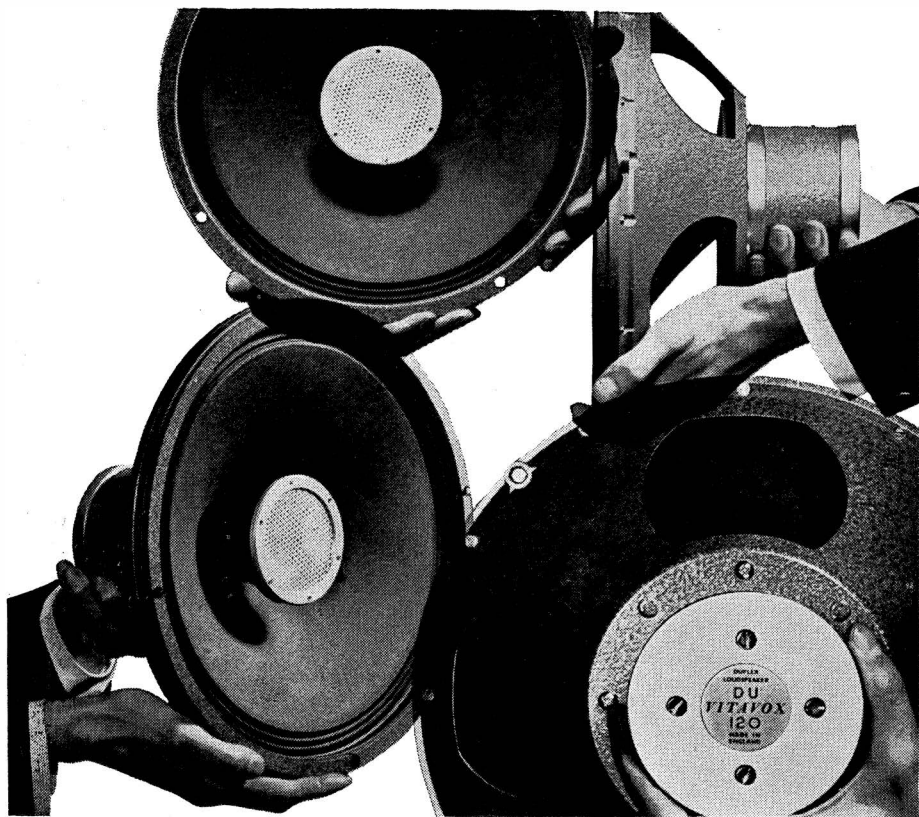

from all angles . . .

... THIS IS A FINE LOUDSPEAKER

- ★ Duplex design
- ★ Full range reproduction
- ★ Purpose-built tweeter
- ★ Heavy duty woofer
- ★ Generous magnet design
- ★ Plasticised cone surround
- ★ Dust-excluding construction
- ★ Low fundamental resonance
- ★ Smooth cross-over
- ★ Replaceable cone
- ★ Die-cast chassis
- ★ Instrument finish

VITAVOX *DU120 DUPLEX COAXIAL*
FULL RANGE
LOUDSPEAKER

VITAVOX LIMITED • Westmoreland Road, London, N.W.9 • Telephone: colindale 8671

GOODMANS for High Fidelity

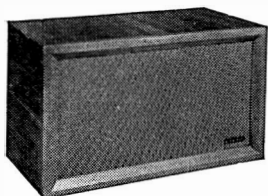

Model IB3

Measures only 24" x 12½" x 14½" high, yet contains a full size 25-watt 3 way High Fidelity Loudspeaker System. Specification and performance outclass most systems three times its size.

Frequency range: 35 c/s—16,000 c/s. **Bass:** (35 c/s to 950 c/s) 12" unique triple suspension, pneumatic air control. **22 lb. magnet system.**

Mid range: (950 c/s—5 Kc/s) Pressure driven horn loaded unit.

High Frequency: (5 Kc/s—16 Kc/s) Pressure driven horn loaded unit. Separate external L-pad controls for mid-range and high frequency units. Multiple crossover network. Walnut veneered, hard wax polished enclosure.

Axiom 300

The most advanced twin radiator 12" high fidelity loudspeaker produced. Provides smoother and more extended response than previously achieved by this type of unit.

Frequency response 30—16,000 c/s. **Power handling capacity** 15 watts. Enclosure volume required, 7,800 cubic inches, with Acoustic Resistance Unit loading. (ARU. 172).

STEREOPHONIC SOUND Two IB3 reproducers are ideal for use with the best stereophonic equipment, and form a very compact system. Two AXIOM 300 units, properly housed, will also provide outstanding performance, but with greater space requirements.

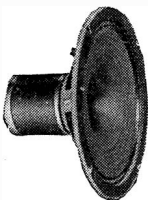

Axiette

The AXIETTE is an 8" Full Range (40 c/s—15,000 c/s.) High Fidelity Loudspeaker which has achieved World-wide popularity because of its impressive performance, mod st space requirements, and sensible price. It is exceptionally versatile. In addition to its main application as a full range unit, it may also be employed in multiple systems as a high-frequency unit, a mid-range unit, or it can combine both functions in one.

For domestic Stereophonic installations, two Axiettes constitute a logical and highly satisfactory choice, and occupy a total floor space of less than 2½ square feet when mounted in reflex enclosures. The overall performance of the Axiette is so exceptionally smooth and well controlled that it compares very favourably with larger units; and is thus perfectly suitable for use as the second channel unit when one channel is already catered for by an existing good High Fidelity loudspeaker system.

SPECIFICATION

Frequency Range: 40 c/s.-15,000 c/s.
Fundamental Resonance: 65 c/s.
Power Handling Capacity: 6 watts.
Flux Density: 15,000 gauss on 1" dia. pole.
Impedance: 3 or 15 ohms.

Goodmans High Fidelity Loudspeaker Manual, which contains full information on Goodmans High Fidelity products, free on request.

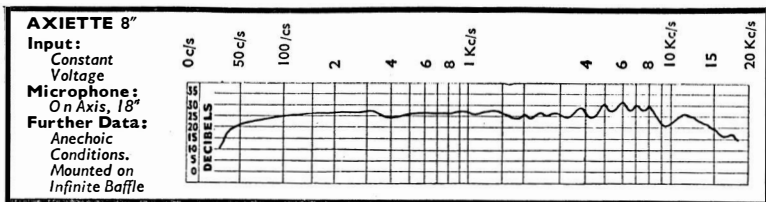

GOODMANS

GOODMANS INDUSTRIES, LIMITED
 AXIOM WORKS, WEMBLEY, MIDDLESEX
 Wembley 1200 (8 lines) Grams: Goodaxiom, Wembley, England

Europe's largest
 Manufacturers and
 the World's largest
 Exporters of High
 Fidelity Loudspeakers

"It looks so right in this room"



twelve -2- four

LOUDSPEAKER SYSTEM

Incorporating

ACOUSTIFLEX

(prov. patent)

'Looks so right'—we almost expect this compliment for BK cabinets, but then we do take a great deal of care in their design to ensure their harmonious blending with almost any room style.

'Yes—and sounds even better'—thanks to ACOUSTIFLEX. A new, unique method of loading which, together with the main unit and two special H.F. units fitted with foam surround give an extremely high and well-balanced quality of reproduction with wide angle coverage, making the 'twelve-2-four' ideal for stereo or monaural reproduction.

"Yes—
and sounds even better"

The extremely low cost—perhaps a third of that you might expect for a system of this quality—is due to the entirely new method of design and construction.

The 'Twelve-2-Four' employs as the main unit the Philips 9762M High Fidelity Loudspeaker, a 12" Dual Cone Drive Unit of wide response and very low frequency resonance.

Write for full details and leaflet to :

BK

PARTNERS LTD.

229 Regent Street, London, W.1
(Entrance in Hanover Street)
Tel.: REGent 7363

more people buy hi-fi equipment from IMHOFS than from any other store

and here are the reasons why!

WIDEST CHOICE—EASIEST CHOICE

You'll find every worthwhile new development in sound reproduction at Imhofs first. Europe's finest selection of audio equipment is here on permanent demonstration. The unique Imhof Comparator (coupled 4,000 different hi-fi combinations) simplifies the problem of selection.

STEREO, OF COURSE

Relax and judge for yourself the merits of various available systems in conditions closely resembling those in your own home.

LONGEST EXPERIENCE—BEST ADVICE

We were the first store in Britain to sell gramophones. Our expert sales staff are not only widely experienced in every aspect of sound reproduction, but are in constant touch with manufacturers and are thus qualified to give the best technical advice.

GENEROUS PART-EXCHANGE FACILITIES

We will take, in part-exchange for hi-fi equipment, any radio, TV, player, gramophone or other musical reproducer, irrespective of age or condition.

PLUS SERVICE

Second Floor for Service Shop. Minor repairs put right while you wait—extensive range of spares and accessories.

EXCLUSIVE CABINETS

Created by some of Britain's foremost designers, our exclusive ranges of elegant cabinets and hi-fi unit furniture have been exhibited at the Design Centre, and chosen for display in exhibitions of Good Design all over Europe and in the U.S.A.

FREE DELIVERY ANYWHERE IN GREAT BRITAIN

We also guarantee safe, swift delivery to any address in the world.

You are cordially invited to pay an early visit to our showrooms and see for yourself our extensive stocks and unrivalled demonstration facilities. Or write for copy of "This Year of Hi-Fi 1959" Imhofs guide to greater listening pleasure.

IMHOFS

EUROPE'S LEADING HI-FI STORE

Alfred Imhof Limited (Dept. HYB), 112-116 New Oxford Street, London, W.C.1 MUSEum 7878

Jason

amplifiers and tuners

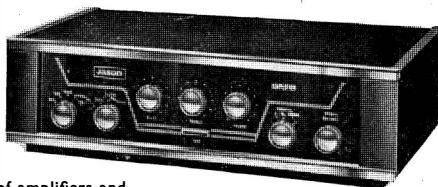

In the Jason Matching Equipment series of amplifiers and tuners, all models are self-powered and uniformly styled for shelf-mounting. Stereo amplifiers in the range may be used for single-channel reproduction, change-over being effected by the front-panel channel selector switch. They are equipped to operate from radio, microphone, tape pre-amp. as well as all types of standard stereo and single-channel pickups. The radio input may be from any of five tuners in the matching equipment series. These tuners provide reception from A.M., F.M. and T.V. Sound according to the Jason model selected. Literature on request.

Jason

Constructors' Kits

TEST EQUIPMENT

Jason designs include kits for oscilloscope, valve voltmeter, audio generator, wobblator, etc., etc. Assembled models also available. Literature on request.

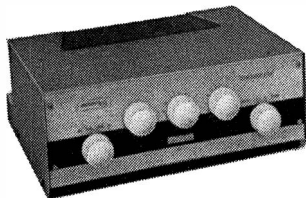

A number of designs are offered to provide choice of stereophonic amplifiers and pre-amps as well as F.M. and F.M./A.M. tuning units. A T.V. Sound/F.M. Tuner design is also available. Building is straightforward and well within the scope of anyone capable of using simple household tools. Fully detailed instructions are included for each model, and the Jason service department is always available if ever required. Jason kits are sold through dealer's everywhere. Literature on request.

THE JASON MOTOR & ELECTRONIC CO., 3 (AC) Gt. Chapel St., Oxford St., London, W.1

GERrard
0273/4

BRITISH DESIGNED TO HIGH TECHNICAL STANDARDS

FREE!

40 page catalogue

For tape recorders or HI-FI, YOU MUST SEE this unique new catalogue from the Tape Recorder Centre. 40 illustrated pages, free of charge, giving details of all makes of tape recorders, accessories and Hi-Fi equipment. The most comprehensive catalogue of its kind, listing over 150 items. All orders over £30 on no Interest Terms.



<i>TAPE RECORDERS</i>	<i>HI-FI EQUIPMENT, MICROPHONES, SPEAKERS, ETC.</i>	
GRUNDIG		CONNOISSEUR
ELIZABETHAN		GOLDRING
FERROGRAPH	LEAK	T.S.L.
VORTEXION	QUAD	STIRLING TUNERS
WALTER	ROGERS	ACOS
BRENELL	ARMSTRONG	LUSTRAPHONE
REFLECTOGRAPH	DULCI	ELPICO-GELOSIO
SIMON	JASON	SIMON-CADENZA
TANDBERG	PAMPHONIC	RESLO
HARTING	AVANTIC	RECORD HOUSING
TELEFUNKEN	W. B. STENTORIAN	LINEAR
PHILIPS	GOODMANS	TANNOY
SPECTONE	C.Q.	ORTOFON
VERDIK	WHARFEDALE	R.C.A.
VERITONE	ELAC	LOWTHER
STUZZI-MAGNETTE	B.J.	
FI-CORD	GARRARD	
TRUVOX		
BAIRD		
MAGNAFON		
KURLAND		
REPS		
REVOX		
WYNDSOR		

TAPE
EMITAPE
SCOTCH BOY
BASF
GRUNDIG
TELEFUNKEN
AGFA
ELPICO
SOUNDRITE

*All Accessories,
tapes, etc. by
return of post.
All makes in
stock.*

Choose with confidence from the leading Specialists in the country:

THE TAPE RECORDER CENTRE

SYPHA SOUND SALES LTD. (DEPT. HY)
75, GRAND PARADE, HARRINGAY, LONDON, N.4 STAmford Hill 1146

Vortexion

All models now have provision for Stereo or for easy conversion at a later date.

Conversion units are also available. The regular models are retained with additions and improvements.

Our high standard which has made these recorders famous, resulting in their being chosen for the foremost musical centre in this country, has been maintained.

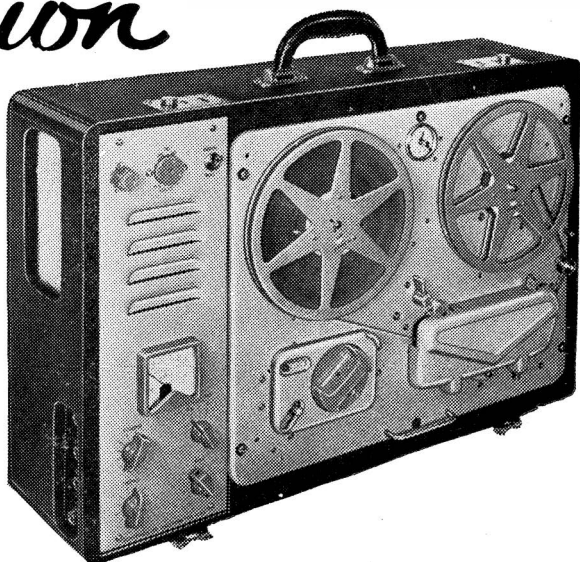

TWELVE-CHANNEL ELECTRONIC MIXER

This is similar to the 4-channel, but is fitted with 12 hermetically sealed controls, 12 balanced line microphone transformers potted in mu-metal boxes, and a mains transformer also potted in mu-metal. All components which can affect noise are tested and selected before insertion. It is supplied in standard steel case or 7 inch rack panel.

30/50 WATT AMPLIFIER

Gives 30 watts continuous signal and 50 watts peak Audio. With voice coil feedback distortion is under 0.1%, and when arranged for tertiary feedback and 100 volt line it is under 0.15%. The hum and noise is better than -85 dB referred to 30 watt.

It is available in our standard steel case with Baxendale tone controls and up to 4 mixed inputs, which may be balanced line 30 ohm microphones or equalised P.U.s to choice.

120/200 WATT AMPLIFIER

Will deliver 120 watts continuous signal and over 200 watts peak Audio. It is completely stable with any type of load and may be used to drive motors or other devices to over 120 watts at frequencies from 20,000 down to 30 cps in standard form or other frequencies to order. The distortion is less than 0.2% and the noise level -95 dB. A floating series parallel output is provided for 100-120 v. or 200-240 v. and this cool running amplifier occupies $12\frac{1}{4}$ inches of standard rack space by 11 inches deep. Weight 60 lb.

VORTEXION LIMITED

257/263, The Broadway, Wimbledon, London, S.W.19.

Telephones: LIBerty 2814 and 6242-3

Telegrams: "Vortexion, Wimble, London"

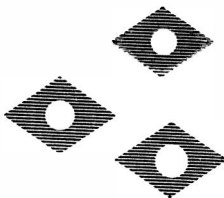

ONE NAME

**TWO FINE TRANSCRIPTION UNITS
THREE FINE CARTRIDGES**

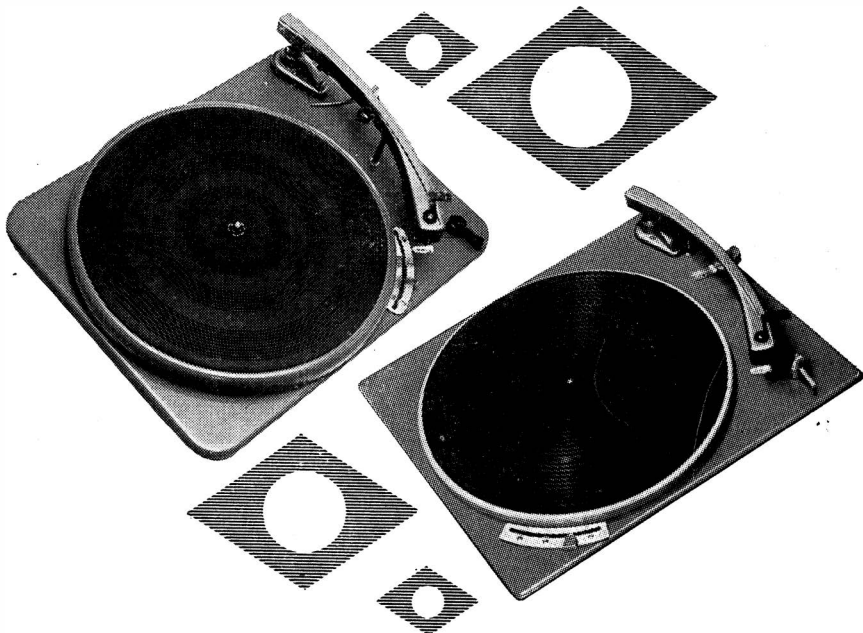

GL 58 Transcription Unit, with arm

The extremely popular Goldring-Lenco unit with the unique vertical drive system, continuously variable speed control, and pick-up lowering device. For Stereo and Monaural reproduction. Fitted with the new Goldring G.60 fully adjustable transcription arm incorporating the unique nylon slide-in platform.

GL 60 Transcription Unit, with arm

The new de luxe Goldring-Lenco unit with die-cast non-magnetic 8 lb. turntable. Drive similar to the GL 58. Continuously variable speed control, and pick-up lowering device. For Stereo or Monaural reproduction. Fitted with the new Goldring G.60 fully adjustable transcription arm incorporating the unique nylon slide-in platform.

The G.60 transcription arm as fitted to these models is available separately for conversion of previous Goldring-Lenco units to stereo operation.

600
CARTRIDGE

The established variable reluctance turn-over cartridge for high quality monaural reproduction. Diamond stylus for LP sapphire stylus for 78 rpm.

580
CARTRIDGE

Similar to the "600" but with sapphire stylus for LP & 78 rpm.

700
STEREO CARTRIDGE

The new variable reluctance Stereo cartridge, with 0.0005" tip radius diamond stylus.

The name is

Goldring

Goldring Manufacturing Co.
(Gt. Britain) Ltd.,
486 High Rd., Leytonstone, E.11.
Leytonstone 8343

HI-FI

BTH EXPERIENCE
BRINGS OUT THE BEST
IN SOUND REPRODUCTION

CONTROL PANEL

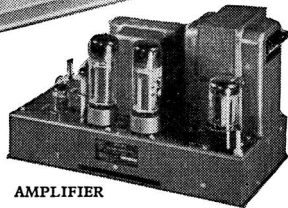
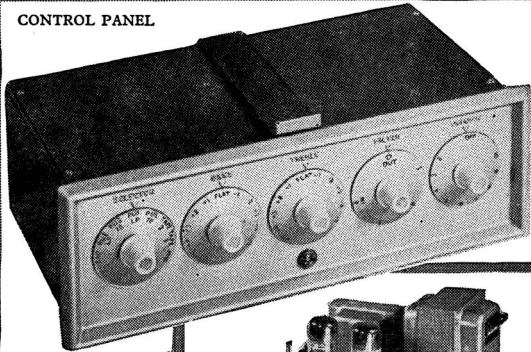

AMPLIFIER



The most brilliant disc or tape recording is wasted unless it can be brilliantly reproduced. The thousands of Hi-Fi enthusiasts who visited the 1958 Radio Show were most impressed by the results achieved with the new BTH equipment. Designed by Mr. James Moir, M.I.E.E., the control unit and amplifier give entirely new standards of stereophonic or single-channel reproduction. Behind this achievement is 30 years' BTH experience in building the highest quality sound reproduction equipment for cinemas and public buildings. At the Festival of Britain in 1951, it was BTH who first introduced the public to stereophonic sound.

These features are unique

Infinitely-variable cut-off constant-slope filter provides the best adjustment for individual records or radio programmes. High sensitivity inputs available for direct connection to tape head or pick-up without the need for additional pre-amplifiers. Separate low sensitivity inputs for disc or tape also provided. Printed circuits ensure reliability and negligible background noise. Output is 20 watts with very low harmonic and intermodulation distortion at full power. Built-in compensation for disc and tape recording characteristics is automatically selected by the input switch. The amplifier covers the entire audio frequency range and has separate bass and treble controls.

A range of matching loudspeakers is also available.

Send for Descriptive Literature

Control Panel and Amplifier £42 AVAILABLE DIRECT FROM STOCK

HEAR IT—AND YOU'LL CHOOSE BTH

BTH SOUND EQUIPMENT LTD
CROWN HOUSE, ALDWYCH, LONDON, W.C.2

A5313



For Hi-Fi



say
PHILIPS

High Fidelity means faithful reproduction — reproduction of the full range of the sound recorded. To get freedom from the mechanical noise produced by ordinary record-playing equipment, Hi-Fi reproduction requires special top-quality equipment — Philips equipment, like the exclusive Philips Magneto-dynamic pickup Model NG5400 and the superb Philips motor and turntable unit Model AG2009.

Model AG2009 (*Made in Holland*)
Philips new 4-speed Hi-Fi Record Player Unit with variable speed control $\pm 2\%$. Dual stylus pickup and adjustable playing weight. Pickup lifting and lowering device. Stereo head, optional extra. Price **10 gns.** tax paid.

Model NG5400
is Philips 'Magneto-dynamic' pickup with transcription arm, using a diamond stylus, adjustable weight, high sensitivity pickup with ferroxdure movement flat response from 20-20000 cycles. **19 gns.** tax paid.
Transcription Arm with Stereo crystal pickup head 15½ gns. tax paid.

PHILIPS MAKE OTHER FIRST-CLASS HI-FI UNITS, TOO !



PHILIPS ELECTRICAL LTD

CENTURY HOUSE · SHAFTSBURY AVENUE · LONDON, W.C.2.

(PR2532)

*All roads
lead to*

How to get there. From Tottenham Court Road Tube Station go westward along Oxford Street, Soho Street is the first on the left.

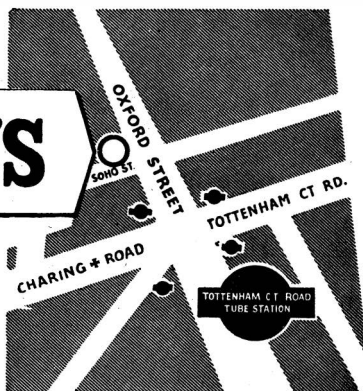

London's Hi-Fi Centre

You'll find everybody at Webb's to be cheerful and helpful—without any high pressure sales talk.

You make your choice—at ease and

in comfort—in our demonstration room where facilities for instant comparison of amplifiers, speakers, pickups and motors, etc., becomes a pleasure, not a chore.

● **AMPLIFIERS by**

ACOUSTICAL	R.C.A.
ROGERS	LEAK
ARMSTRONG	B.T.H.

● **SPEAKERS by**

GOODMANS	WESTREX
VITAVOX	W.B.
TANNOY	C.Q.
WHARFEDALE	

● **F.M. & A.M. RADIO UNITS by**

ACOUSTICAL	CHAPMAN
ARMSTRONG	JASON

● **PICK-UPS & MOTORS by**

COLLARO	CONNOISSEUR
TANNOY	EXPERT
GARRARD	LEAK



Come in and chat about your Hi-Fi problem now



14 SOHO STREET, OXFORD STREET, LONDON, W.1

Telephone: GERrard 2089 and 7803

Shop hours: 9 a.m. to 5.30 p.m. (7 p.m. Thursday), 9 a.m. to 1 p.m. Saturdays

—the basis of perfection

in recording



For some years now the 'masters' of most LP records have been made on the same standard .0015 in. base Emitape that you buy . . . Proved technical superiority and durability of PVC recording tape—make Emitape the choice of world-famous companies like "H.M.V.," Columbia, Parlophone—for recording all the greatest artists of our day . . . For the same reason, the B.B.C., Independent Television and broadcasting authorities all over the world use hundreds of millions of feet of Emitape every year; it is equally in demand in the fields of industry and science. Backed by E.M.I.'s unique experience in sound recording—over 60 years—and manufactured in the largest and most modern magnetic tape factory in Europe.

Emitape

the magnetic
recording tape
with the highest
technical
standards

- * High sensitivity
- * Low noise level
- * Low 'print through' factor
- * Anti-static
- * Freedom from curl and stretch

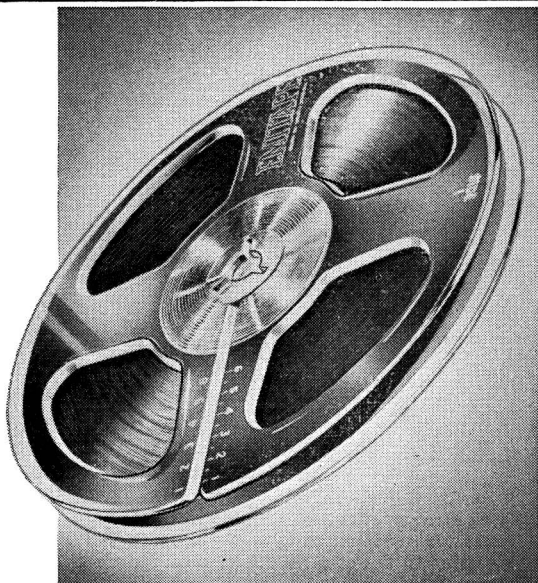

"88" GENERAL PURPOSE

"99" LONG PLAY

Type No.	Title	Size	Length Approx.	Price
88/3	"Message"	3" dia.	175'	7.6.
99/3		3" dia.	250'	9.6.
88/3N		3½" dia.	175'	7.6.
99/3N		3½" dia.	250'	9.6.
*88/6	"Junior"	5" dia.	600'	1. 1.0.
*99/9		5" dia.	850'	1. 8.0.
*88/9	"Continental"	5½" dia.	850'	1. 8.0.
*99/12		5½" dia.	1200'	1.15.0.
*88/12	"Standard"	7" dia.	1200'	1.15.0.
*99/18		7" dia.	1800'	2.10.0.
88/18	"Professional"	8½" dia.	1750'	2.17.6.
99/24		8½" dia.	2400'	3.12.6.

*Also available in EMICASE—2s. 6d. extra

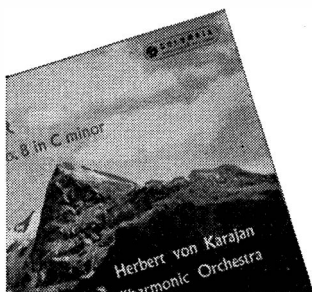

Emicase

now available separately!

the polystyrene container that solves tape storage problems, protects spools from dust and allows easy identification of leader tapes.

7"-4s. 0d.; 5½"-3s. 6d.; 5"-3s. 6d.

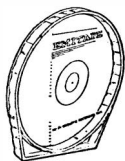

for those who want something more

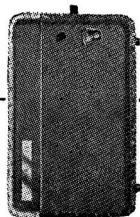

Never before has all this been brought together in a portable tape recorder.

Performance of a high order combined with a range of features, many of them exclusive to Simon, enormously increase its value to the connoisseur of recorded sound.

Look at its elegant styling, listen to it at your local dealer—you'll decide that this is the recorder for you.

these figures

Frequency response
at $7\frac{1}{2}$ i.p.s. 30-15,000 c.p.s. ± 3 dB (ref. to 1 Kc)
at $3\frac{3}{4}$ i.p.s. 30-7,000 c.p.s. ± 3 dB
Wow and flutter content—
better than 0.2% peak to peak
Output—10 watts push-pull

... and these features

- SIMON AUTOMATIC DECK**
fully 'push-button-controlled'
- AUTOMATIC TAPE REVERSAL**
without touching controls
- 3-WAY MIXING FACILITIES**
on both record and playback
- BASS AND TREBLE LIFT AND CUT**
with independent controls
- HIGH QUALITY MONITORING**
Paired base and treble loudspeaker units
- 10 WATTS OUTPUT**
from ultra-linear push-pull amplifier
- PUSH-PULL OSCILLATOR**
for noise and hum suppression
- ACCIDENTAL ERASURE PREVENTION**
by special record 'safety button'

combined in the new

simon S.P. 4

incorporating the new Simon fully automatic tape deck

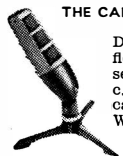

THE CADENZA RIBBON MICROPHONE

Dual impedance head for flexibility in use; output sensibly flat between 50-12000 c.p.s. In handsome presentation case: head only 8½ gns. With tripod desk stand 10 gns.

REMOTE CONTROL UNIT

Electrically operated, gives push-button control at any practical distance. (Stop/Start and track change on either Record or Playback.) Size $1\frac{1}{2}'' \times 2\frac{1}{2}'' \times 3\frac{1}{2}''$. With 25 ft. of cable 3 gns.

95 GNS.

Your Simon Dealer would be pleased to arrange H.P. terms

Choose Simon for Sound

Send now for leaflet (R 59) on the Simon S.P.4.

SIMON SOUND SERVICE LTD

46-50 George Street, Portman Square, London W.1.

TA 2121



➤ HIGH TOP RESPONSE

The ability to capture and reproduce sounds of extremely high register—even beyond the limits of human hearing, that is what is meant by High Top Response. This the bat can do—and so can Mastertape, recording and playing back every sound with the utmost clarity, in a way that must be heard to be believed. High top response also means that Mastertape can record efficiently at lower speeds with maximum possible brilliance.

MASTERTAPE IN THE NEWS! Mastertape is now supplied for use with the British Communications Corporation Mars Recorder in service with the United States Air Force.



Attractive, ideal tape storage. Stoutly bound book containers in red, black and gold, with transfer numerals, holding two 7 in. reels of tape. Price 7/6. Bookrack to hold six books, 17/6. Set of six books and rack 62/6.

Mastertape

MAGNETIC RECORDING TAPE BY
MSS RECORDING CO. LTD. Colnbrook, Bucks.
Telephone: Colnbrook 2431.

Showroom and Studio

21, Bloomsbury Street, London, W.C.1.
Telephone: MUSEum 1600.

AVANTIC
B.J.
BRENELL
C.Q.
CHAPMAN
COLLARO
CONNOISSEUR
COSMOCORD
DECCA

EQUIPMENT FOR TAPE, DISC & RADIO

MODERN ELECTRICS (RETAIL) LTD.

DULCI
ELAC
ELIZABETHAN
FERROGRAPH
G.E.C.
GARRARD
GOLDRING
GOODMANS
GRAMPIAN
GRUNDIG
JASON
KELLY
LEAK
LENCO
LUSTRAPHONE
ORTOFON
PAMPHONIC
PHILIPS
PILOT
QUAD
REFLECTOGRAPH
RESLO
ROGERS
RONETTE
TANNOY
TRUVOX
VITAVOX
W.B.
WHARFEDALE

*We send the best of
Britain's Hi-Fi
everywhere*

Our service reaches to every part of the world, and extensive selections of our up-to-the-minute stocks appear regularly in our advertisements each month in "Hi-Fi News", "The Gramophone", "Wireless World", etc. If you cannot call, send us your enquiries without obligation. Whatever you order, no matter how small or how large, it is given prompt and personal attention at all times.

MODERN ELECTRICS (RETAIL) LTD.

164 CHARING CROSS ROAD, LONDON, W.C.2

(Three shops from Tottenham Court Road Stn. Und.)

Telephone: TEM 7587 and COV 1703 Cables: MODCHAREX, LONDON

Where Quality Counts—

Your Choice is

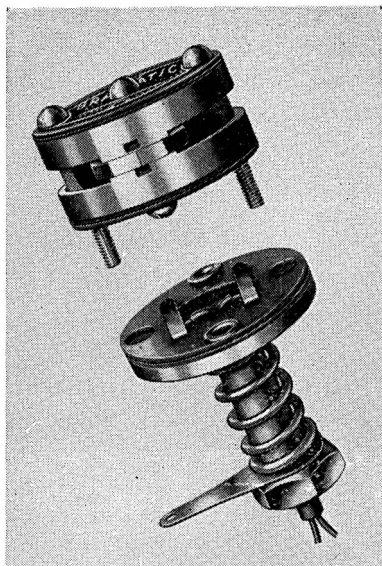

BRADMATIC SOUND HEAD SHOWING
DETACHABLE HEAD AND STANDARD
SPRING TYPE FIXING STEM



MAGNETIC SOUND HEADS

Half-Track Heads	
Type 5RP (Record/Play)	£3.5.0
Type 6RP (Record/Play)	£3.15.0
Type 5R (Record)	£3.5.0
Type 5E (Erase)	£3.5.0
Type 2TK-RPC	Stereophonic head £17.10.0

Screening cans to suit.

Type ST/RPB Stereo Head complete
in own can (without fixing stem)
£6.0.0

AMPLIFIERS

The Bradmatic Type 10 amplifiers give PROFESSIONAL RESULTS AT 7½ INCHES PER SECOND. They have an overall frequency response of 30-15,000 cycles within 4 db. at 7½ i.p.s. with a signal-to-noise ratio of 50 dbs. unweighted. The type 107/A is designed for normal half-track monaural record and play-back and the type 107/AS is monaural half-track record and stereophonic playback for reproducing "Stereophonic tapes" with optimum results. These amplifiers are specially designed for use with Bradmatic Model 5 Tape Desks.

TAPE DESKS

All desks fitted with three motors, two tape speeds, servo braking and push button control. Tape Desks available:

Model 5b (to take 7in. reels) £42 0 0
Model 5c (to take 9½in. reels) £47 10 0
Model 5d (to take 10½in. reels) £50 0 0

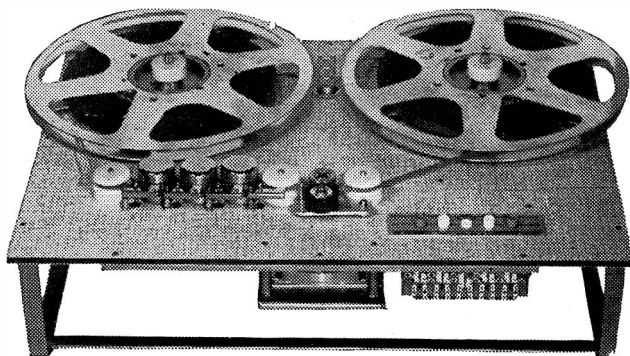

Model 5D Tape Desk

Send for lists.

BRADMATIC LIMITED

STATION ROAD, WITTON LANE, BIRMINGHAM, 6

Telephone: EAST 2881-2

Telegrams: BRADMATIC, BIRMINGHAM

Here is a Genuine

HI-FI

SPECIFICATION!

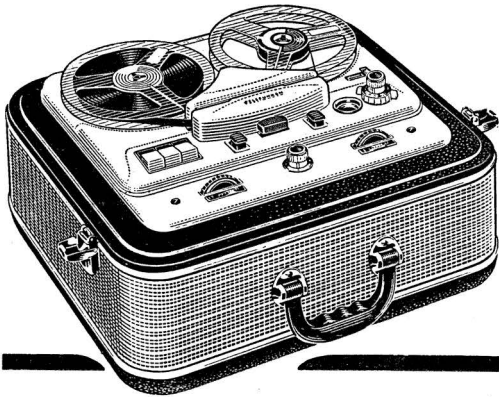

SPECIAL TELEFUNKEN STEREO MODELS

KL 785 T Stereo—for use with HI-FI equipment
95 Gns.*

KL 85 K Stereo—portable model complete in case
112 Gns.

*Comprehensive literature is available, giving full details
of all Telefunken models and accessories.*

TELEFUNKEN
The originators of tape recording

Sole U.K. Distributors:—

WELMEC CORPORATION LTD

147 Strand, London, WC2

Telephone: [TE]Mple Bar 3357

- **FREQUENCY RANGE** guaranteed by individual certificate for each machine.
30–20,000 cycles/sec. at $7\frac{1}{2}$ i.p.s. ± 3 dB and
30–15,000 cycles/sec. at $3\frac{3}{4}$ i.p.s.
- DC heated pre-amplifier valves eliminate all hum and background noise.
- Two matched loudspeakers give a quality and tone equal to first-class HI-FI radio.
- Separately controlled L.F. amplifier with treble and bass controls, permits use as straight-through amplifier, and allows incoming signals to be monitored.
- Fast forward and rewind in 1 min. 55 secs. with three digit counter to pinpoint any position.
- Tape splicing groove incorporated.
- Input selector switch for radio, microphone and gramophone.
- Five press-button controls for recording, stop, play back, recording interlock and trick button, quick stop.
- Automatic tape tension control.
- Double screened motor.
- Connections for monitoring earphones, remote control, start-stop remote control, extension speaker, etc.
- Volume control. Separate bass and treble controls.

TELEFUNKEN KL 85 K (portable) 75 Gns.*

TELEFUNKEN KL 85 T (Table Model) 63 Gns.*

TELEFUNKEN KL 85 KL (Specification as above but with push-pull 6 watts output stage) 79 Gns.*

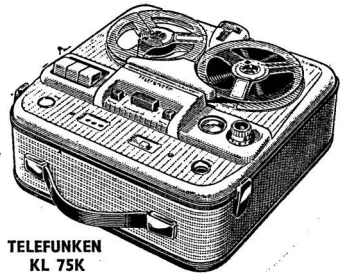

**TELEFUNKEN
KL 75K**

THE TELEFUNKEN KL75K has two speeds with frequency response from 60–16,000 at $3\frac{3}{4}$ i.p.s. and 60–10,000 at $1\frac{1}{2}$ i.p.s. giving over 4 hours playing time on one Telefunken DP Tape. In lightweight Styrol case (weight 20 lb.), has push-button controls and finely adjusted magnetic heads specially aligned to give maximum fidelity at low speeds.

The modulator control for Radio and Mike are combined in one control with facilities for remote control allowing for use as a dictating machine.

TELEFUNKEN Model KL 75 K as above
50 Gns.*

TELEFUNKEN KL 75 T Table Model
45 Gns.*

* All prices excluding microphone—extra from 5 Gns.

ALTOBASS

HIGH FIDELITY
EQUIPMENT

for faithful reproduction of concert hall quality



510 PRE-AMPLIFIER

A single stage unit for use with crystal pickups.

8 gns.

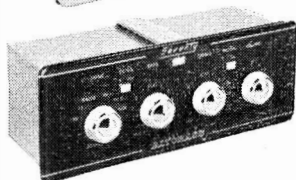

Seventy PRE-AMPLIFIER

A high gain unit for use with any type of pickup. May be fed direct from a tape head.

16 gns.

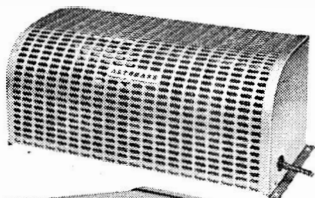

510 POWER AMPLIFIER

Suitable for use with either of the above pre-amplifiers. Power output 10 watts 0.1 per cent. distortion.

15 gns.

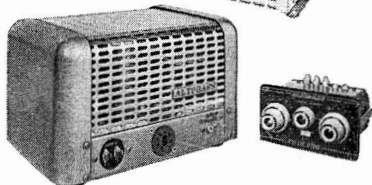

TWIN-TWO STEREO AMPLIFIER

A simple, inexpensive system for stereophonic reproduction of very good quality.

16 gns.

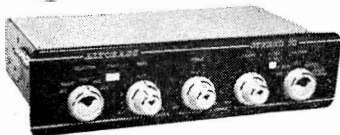

STEREO 70 PRE-AMPLIFIER

A most comprehensive amplifier system for the reproduction of stereo discs and tapes. Suitable for use with any type of stereo pickup.

23 gns.

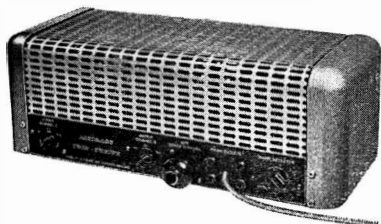

TWIN-TWELVE POWER AMPLIFIER

A stereo amplifier unit, incorporating two 12 watt power amplifiers on a common chassis. For use with the Stereo 70 pre-amplifier.

29 gns.

ALTOBASS LIMITED · PERCY ROAD · LEICESTER · ENGLAND

NORTH WALES
WREXHAM 2472



MANCHESTER
DEA 3825

The North's Sound Reproduction Specialists

HIRE PURCHASE
AT
LOWEST
RATES

After you have perused the pages of this Year Book let us assist in finalising your choice of equipment—we can deliver, install and provide AFTER SALES SERVICE.

PERSONAL
EXPORT
FREE OF TAX
QUICK SERVICE

ALL LEADING MAKES STOCKED



**THREE
FLOORS
PROVIDING
EVERYTHING
IN
SOUND**

- Grnd. Floor . . . TAPE RECORDERS
and STEREOGRAMS etc.
- Lr. Grnd. Floor . GRAMOPHONE RECORDS
BOOKS and ACCESSORIES
- Basement HI-FI and STEREO
EQUIPMENT also
DEMONSTRATION ROOMS
- Basement (Rear) . SERVICE DEPT.
and CABINET SECTION

HIGH FIDELITY DEVELOPMENTS LTD.
Home Music Shop · 8 DEANSGATE
MANCHESTER

Next to Grosvenor Hotel

Near to Exchange Station



**A loudspeaker system
of unique performance
remarkable in its ability
to keep faith with the sound
it reproduces**

ACOUSTILENS 20/80

Regd. TRADE MARK



*Available for inspection and demonstration at most
retailers of really high fidelity equipment
throughout the country*

Name and address of your nearest supplier on application to:

WESTREX COMPANY LTD • LIBERTY HOUSE • REGENT STREET • LONDON, W.1 • REGENT 1001

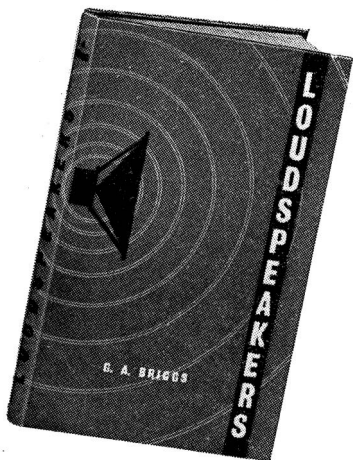

THREE “SOUND” CLASSICS

Which are a “must” for the sound reproduction enthusiast and music lover. G. A. Briggs is the versatile author of these interesting and entertaining books.

LOUDSPEAKERS

5th edition. 336 pages. 230 illustrations. Standard reference work on loudspeakers. 31 Chapters including :—Reminiscences—Frequency Responses—Directional and Phase Effects—Baffles, Cabinets and Horns—Electrostatic Speakers—Stereo—Audio Fairs and Concert Halls. Sales to date over 50,000.

PRICE 19s. 6d. (20s. 9d. Post Free)

SOUND REPRODUCTION

3rd edition, fourth impression, 368 pages, 315 illustrations. Chapters on Resonances—Cabinets—Room acoustics—Response curves with Oscillograms—Crossover networks—Recording Systems—Records—Pickups, etc. Total sales exceed 35,000.

PRICE 17s. 6d. (18s. 6d. Post Free)

PIANOS, PIANISTS and SONICS

A book for sound enthusiasts and music lovers written in G. A. Briggs' entertaining style. Chapters on piano history and construction—Harmonic analysis—Touch—Tone—Tuning, etc. 192 pages, 102 illustrations.

PRICE 10s. 6d. (11s. Post Free)

Sold by radio dealers and bookshops



Wharfedale
WIRELESS WORKS LTD
IDLE BRADFORD YORKS

Published by

Wharfedale Wireless Works Ltd.

Telephone: Idle 1235/6

Grams: “Wharfedel” Idle Bradford

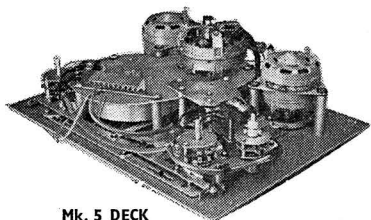

Mk. 5 DECK

4 operating speeds. 4 heads can be fitted. $8\frac{1}{2}$ in. reels accommodated. 3 independent motors. Instant stop without spillage. Two switches only for simple control, etc.

Tape deck with provision for extra heads **28 gns.**

Complete record/playback amplifier with power unit **£24**

Stereo/Rec. Playback (including mounting rack) **£93 16 0**

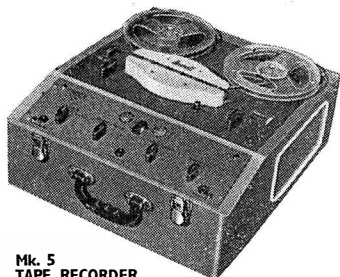

Mk. 5 TAPE RECORDER

Incorporating the Mk. 5 deck with all its outstanding features. Its unit construction makes internal inspection, lubrication and adjustment a matter of minutes.

Including 1,200 ft. of tape **64 gns.**



3 STAR PORTABLE

Smart appearance, brilliant performance, fine engineering at a price within the reach of almost everyone. Approved by the Council of Industrial Design.

Including 1,200 ft. of tape, spool and microphone **58 gns.**

The Famous **BRENELL** Range— each model with exceptional features!

Versatility—realism—precision engineering at its best. Tape recording equipment made by Brenell is the outcome of nearly 10 years' research and manufacturing experience. There's no doubt the Brenell Deck and recorders present outstanding possibilities for the hi-fi enthusiast. It is interesting to note all Brenell models may be converted to stereophonic use.

Full details of all models are available on request from sole manufacturers.

Brenell

PERFORMANCE
IS TRUE TO LIFE
PERFORMANCE

BRENELL ENGINEERING CO. LTD.

1a Doughty Street, London, W.C.1

Telephone: CHA 5809 and HOL 7358

ACOStereo

The ACOStereo cartridges now in production are amongst the first and finest in the world. This remarkable range plays an important part in stereophonic reproduction of the highest standard at a reasonable cost.

Beyond a doubt Acos are doing things in styli, both in conventional and in stereophonic sound reproduction.

 **progress**

STEREOPHONIC AND MONOPHONIC
CARTRIDGES AND EQUIPMENT

PICKUPS · STYLI · MICROPHONES

DUST BUGS FOR AUTO-CHANGERS (*see also
Cecil E. Watts' announcement on page 232*).

COSMOCORD LTD., Waltham Cross, Herts.
Telephone Waltham Cross 5206

Take an outstanding amplifier...double it... and you have the finest instrument of its kind available today

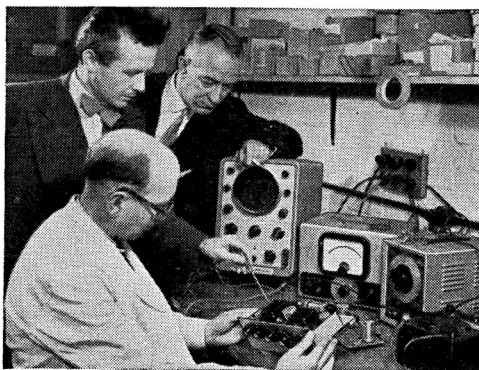

The new Pye Mozart Double 10-watt Stereo Amplifier Model HFS20. This outstanding new stereo amplifier is mounted on a chassis only a few inches deeper than the original single-channel Mozart amplifier. Available in a metal case as a combined Amplifier and Pre-Amplifier or in chassis form as a separate Amplifier and Pre-Amplifier with three feet of linking cable. Control panel is identical in size and finish to the Mozart FM Tuner.

Making high fidelity equipment is a specialist business calling for knowledge and techniques of the highest order. The Pye High Fidelity Division is a completely separate and self-contained organisation. Meticulous attention is paid to every detail. Exacting performance tests are carried out at every stage. Hand-finishing is by experts. The result is a range of instruments which are among the finest available in their power ratings.



TECHNICAL SPECIFICATION PER CHANNEL

PRE AMPLIFIER

Sensitivities: P.U. 7 mV. Tape 100 mV. Radio 100 mV.
Tape record output 300 mV at above specified input sensitivities.

Hum and Noise: P.U. —55 db. Tape —60 db.
Radio —60 db.

Frequency Response: Tape 20 to 20000 cycles $\pm 1\frac{1}{2}$ db.
Radio 20 to 20000 cycles $\pm 1\frac{1}{2}$ db.
P.U. Within $1\frac{1}{2}$ db of published replay curves.

Channel Separation: between —40 db and —50 db overall.

Controls: Volume: Continuously variable.
Bass: +10 db to —15 db at 50 cycles.
Treble: +10 db to —15 db at 10000 cycles.
Balance: Variation of 6 db per channel.
Illuminated Push/Push on/off switch.

Selector Switch: (5 Position) Tape. Radio.
78 (all 78 records). L.P.O. (Pre 1955 recordings).
L.P.N. (Recordings to R.I.A.A.)

Output: 0.2 V into 100 K.

Pick-up matching: by "Dialomatic" compensation.

MAIN AMPLIFIER

Sensitivity: 0.2 V.

Output: 10 watts per channel.

Distortion: 0.3% total harmonic at 9 watts.

L.F. Power Output: 8 watts at 40 cps.

Loudspeaker Impedance: 4, 8 and 15 ohms
(with phase reverse switch).

Damping Factor: 30

Hum and Noise: —70 db with 100 K input impedance.

Frequency Response: 10 —50,000 cycles ± 2 db.

Negative Feedback: 27 db (in 3 loops).

Total Power Consumption: 110 vA.

Mains: 200 V to 250 V AC 50 cycles. 110 V to 120 V AC 60 cycles (Export model).



HIGH FIDELITY SYSTEMS

HIGH FIDELITY DIVISION • FAIRVIEW ROAD

LONDON • S.W.16

LOOK! MY BANDBOX



29 GNS

including microphone,
tape and accessories

My new Elizabethan Bandbox. It's the smallest, finest, neatest recorder in the world. Just look at my Bandbox: it's as small and as neat as my model bag, and even I can lift it with a finger. Just listen to my Bandbox: sounds nice! My boy friend says the specification is wonderful for the price. It's got two speeds, 3½" and 1½" (the only two-speed recorder at this price). The loudspeaker is oval, 7" x 4". There are clever push-buttons (and even I can work them).

There's an external monitoring sprocket, or something, and a dial position clock and you can turn knobs to change the sound. You can record two things at once. And there's a full-size 6-valve circus and four magnifier stages and I just love my Bandbox.

You'll love it, too, and *your* boyfriend can jolly well buy you one.

He'll find it at all the better dealers.

Elizabethan

Other Elizabethan models:

MAYFAIR

Setting a new trend in Hi-Fi equipment for the discriminating home. An exquisite Consolette, combining all the features of the Essex. Together with the Elizabethan FM Tuner, the Mayfair is a handsome and complete Tape-Radio reproducer.

Microphone as for Essex **72 GNS**

ESSEX

A superb recorder. Three speeds, mixing, dual-track with immediate change-over. 6-watt ultra-linear amplifier, three matched speakers.

Ribbon microphone 7½ gns **65 GNS**
Crystal microphone 5 gns

ESCORT

The brilliant popular recorder. Three speeds, 6½ hours playing time, mixing superimposing and monitoring. Light weight and handsome.

Including microphone **45 GNS**

Chapman on your high fidelity equipment shows that it has been designed and made to a standard of excellence reflected in its continual reliable performance year after year.

- ★ **The finest British components**
- ★ **Fully tropicalised throughout**
- ★ **Use of sound design techniques**
- ★ **Stringent quality control and testing**
- ★ **Always up to specifications**

These are some of the reasons why the original high performance is maintained so constantly, and why CHAPMAN equipment is used by the discriminating listener throughout the world.

In fact, for those initially prepared to spend a little more, the result is an outstanding long term investment.

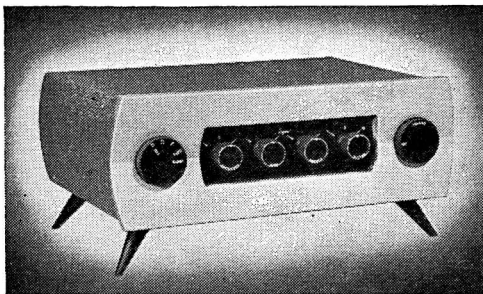

**STEREO
305
Control Unit**

Full details from your hi-fi dealer or :

C. T. CHAPMAN (REPRODUCERS) LTD.
Chapel Lane, High Wycombe, Buckinghamshire

Telephone: High Wycombe 2474

LASKY'S RADIO

THE LARGEST STOCKS OF STEREO AND HI-FI EQUIPMENT

"in the heart of London's West End"

*Photo shows
a section
of our
Demon-
stration
Studio.*

*If unable to
call, write
us. Our
Technical
and Mail
Order
Depts. are
at your
service.*

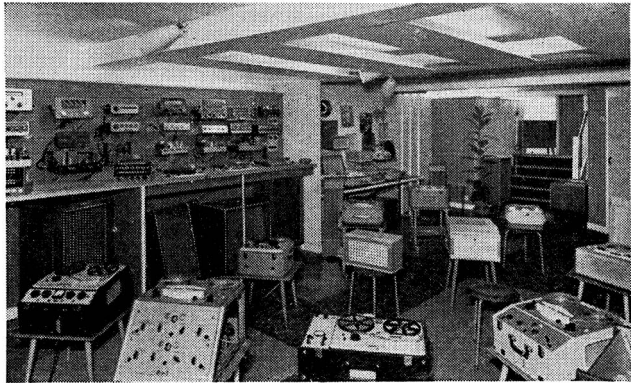

- ★ AMPLIFIERS
- ★ CONTROL UNITS
- ★ PICKUPS
- ★ LOUDSPEAKERS
- ★ SPEAKER SYSTEMS
- ★ RECORD PLAYERS
- ★ AUTOCHANGERS
- ★ TRANSCRIPTION
TURNTABLES
- ★ AM/FM TUNERS
- ★ TAPE DECKS
- ★ TAPE RECORDERS
- ★ MICROPHONES
- ★ CABINETS & SPEAKER
ENCLOSURES

*Listen to the latest
monaural and
stereophonic
equipment in the
comfort of our
DEMONSTRATION
STUDIO*

The most satisfactory way of choosing your equipment, or adding to it, is to listen to, compare and judge a comprehensive range of leading makes and types. Our Studio provides unique facilities for doing so and our specialist staff will be pleased to assist you with their up-to-the-minute knowledge of high fidelity technicalities. If unable to call send for our special Hi-Fi Catalogue post free.

EASIEST HIRE PURCHASE. Deposit and monthly terms to suit your personal requirements.

*Open all day Saturday
Early Closing Thursday*

LASKY'S (HARROW RD.) LTD.
42 TOTTENHAM COURT ROAD, LONDON, W.1
Nearest Station: Goudge Street MUSEum 2605
also 370, HARROW ROAD, PADDINGTON ROAD, W.9 CUN 1979

Stentorian

HIGH FIDELITY AT REALISTIC COST

The items illustrated are representative of the wide range of W.B. Hi Fi equipment. A noteworthy recent addition is the "Stentereo" Stereophonic Speaker System embodying many novel features. Our experience in sound reproduction covers 33 years: such a background is a guarantee of quality. Full details of all W.B. products will gladly be sent on request.

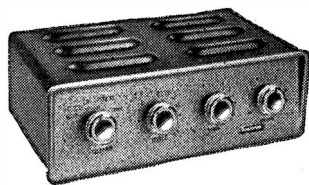

W.B.8 Amplifier £19.19.0.



Stentorian V.H.F. Tuner £23.2.0.

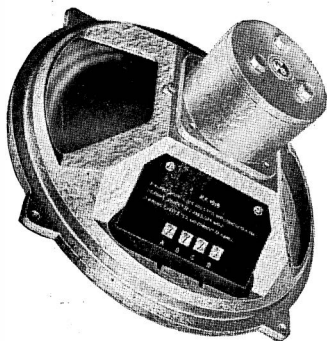

Stentorian Cambric Cone Hi-Fi Units.
The famous H.F.1016 at £8.0.0.
Others from £1.6.9.

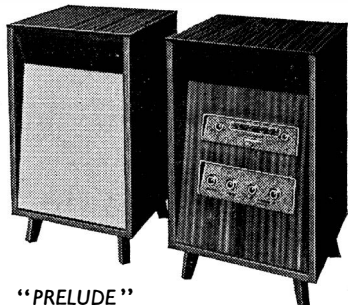

"PRELUDE"
ready-to-assemble cabinets in striped sapele from £9.19.6 to £13.13.0.

Ready-to-assemble cabinets in polished walnut from £5.10.0 to £16.16.0.

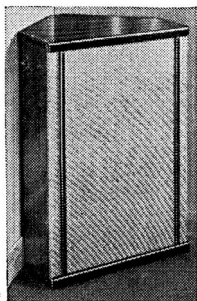

Prelude Horn-Loaded Cabinet
£19.10.0.

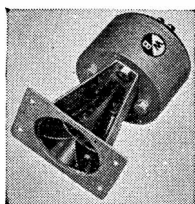

Tweeter Units from 35/- to £12.12.0.

HF. 817
Speaker
£11.17.6.

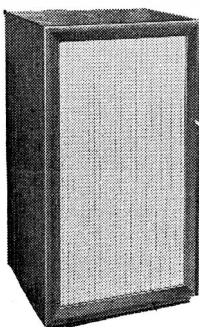

Stentorian
Extension
Speakers
from 63/-.

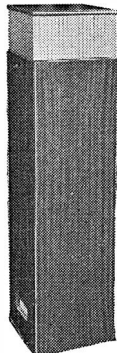

COLUMN LOUDSPEAKERS
Cabinet for H.F.816. Unit £18.18.0.
Cabinet for H.F.610 Unit £9.19.6.

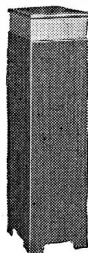

WHITELEY ELECTRICAL RADIO CO. LTD • MANSFIELD • NOTTS

W.B.110

Telephone: MANSFIELD 1762-5

PUSH-PULL STEREO

ALL *Avantia* AMPLIFIERS HAVE PUSH-PULL

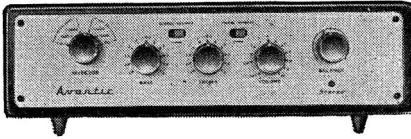

SPA11

This is a complete twin-channel amplifier with combined pre-amplifier control unit capable of delivering a peak power output of 10 watts on each channel. It is attractively styled and built to an exceptionally high standard of workmanship.

28 gns.

SPA21

Similarly styled to the SPA11, this complete twin-channel amplifier with combined pre-amplifier control unit is capable of delivering a peak power output of 20 watts on each channel. It is sufficiently sensitive to operate directly from a high impedance tape reproducing head.

£48. 10s.

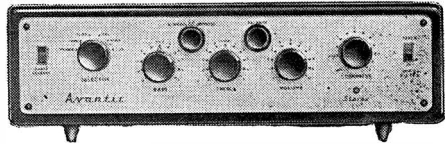

DL7-35

For three years, this power amplifier has maintained its reputation as the finest obtainable. Ultra-linear output stage delivers 54 watts peak power. £33. Can be supplied with single-channel at £22, or SP21 stereophonic pre-amplifier at £28. 10s. The SP21 is identical in frontal appearance to the SPA21.

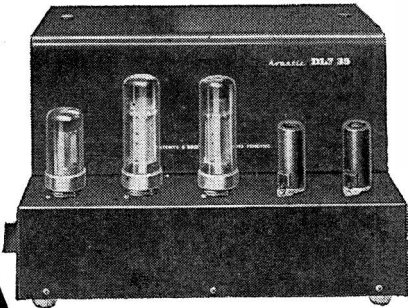

Avantia

PHONIC SOUND

OUTPUT STAGES FOR EACH CHANNEL

SL71

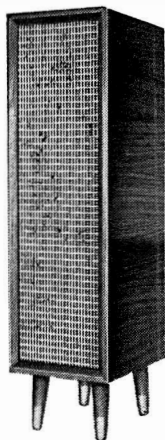

A neat loudspeaker enclosure which is ideal for stereophonic reproduction in small rooms and is recommended for use with the SPA11 amplifier. Separate low and high frequency units give a frequency range from 55c/s. to 15kc/s. The five-inch legs are detachable. Matt medium walnut finish. 17 gns. incl. tax.

SL12-21

This loudspeaker enclosure is recommended for use with the SPA21 amplifier. It contains a 12-inch diameter loudspeaker and a high frequency pressure unit which combine to give a frequency range from 40c/s. to 17kc/s. Medium matt walnut finish. 22 gns.

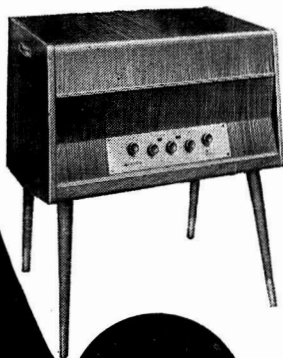
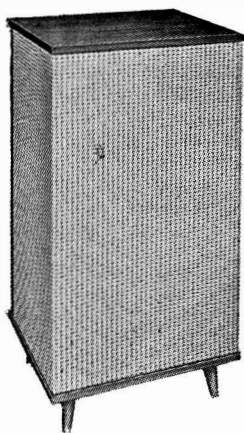

JUNIOR GLYNDEBOURNE

An elegant, solidly built cabinet finished in contrasting walnut and mahogany veneers which is designed to house the SPA11 or SPA21 amplifiers. Space is provided for a radio tuner unit. £49. 7s. with SPA11 amplifier fitted.

Avanti

Musicraft



FOR

Sound Perfection

IN HOME ENTERTAINMENT



EALING:

80-82 Uxbridge Road, Ealing, W.13

Tel: EAL 6995

RICHMOND:

13 King Street, Richmond, Surrey

Tel: RIC 6798

SOUTHALL:

20-22 High Street, Southall, Middx.

Tel: SOU 3828

Experts' Choice
in a world of sound



We are Designers and Manufacturers plus a Sales Organisation enjoying World markets. Since 1931 my team and I have devoted our specialised plant to the production of Amplifiers, Transformers, Chokes, Chassis and Loudspeakers right down to the magnet, in order to maintain Laboratory perfection. The claim "Experts Choice" in a world of sound is substantiated by the number of Amplifiers supplied to the B.B.C., Education Authorities, Sound Publications and Music Lovers. It is endorsed by the Council of Industrial Design who selected our 108 m/c Synchrolock F.M. Unit for display at the Design Centre. *We now proudly present our A-Z Twin 20 Stereo Amplifiers* for your greater enjoyment in the appreciation of sound.

R. N. Wellington, *Managing Director*

SOUND SALES LTD.

**WORKS AND ACOUSTICS LABORATORIES
 WEST STREET, FARNHAM, SURREY**

Farnham 6461/2/3

Positively no connection with any firm using the word Sound.

U.S.A. - Canada - New Zealand - Paris - Italy - Singapore

Links in the chain of our successes!

DULCI

A high gain precision instrument to professional standards. Incorporating every facility for high quality Monaural and Stereophonic reproduction. Price £23 2 0

Also available "Stereo Two" Pre-amplifier, a high grade Stereo/Monaural instrument for use with Crystal pickups Tuners and compensated tape. Price £9 9 0

Both Pre-amplifiers are designed to work with either twin power amplifiers below.

'STEREO TWO' PRE-AMPLIFIER



DPA10/2

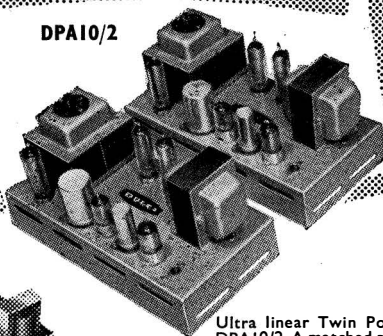

Ultra linear Twin Power Amplifiers for Stereo. Model DPA10/2. A matched pair, 10-15 watts each, for professional or domestic use. Price per pair £25 4 0

Model SP44. A twin channel Stereo Power Amplifier on one Chassis 8 watts (4 watts each). £12 12 0

Full details with advice on the choice of Stereophonic equipment can be sent on request.

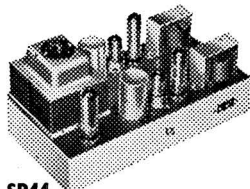

SP44 TWIN (Stereo) POWER AMPLIFIER

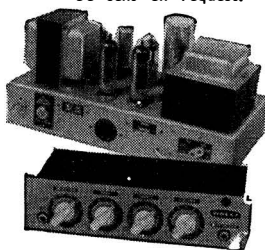

DPA10 AND PRE-AMPLIFIER

GA4 HIGH FIDELITY AMPLIFIER

High Fidelity Ultra Linear Power Amplifier Model DPA10, 10-15 watts laboratory design for professional or domestic use.

DPA10 only £12 12 0

With Pre-amplifier £19 19 0

Also available GA4 4 watt power amplifier and control panel. £9 9 0

Model H4T2 self-powered AM/FM Tuner (4 bands magic eye tuning and audio stage with feedback). £24 19 0 inc. P.T.

Write for literature dealing with our full range of Amplifiers, Tape Units, Tuners and Radiogram Chassis.

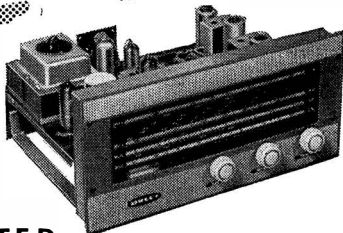

THE DULCI COMPANY LIMITED

97-99 Villiers Rd., London N.W.2

Tel: Willesden 6678/9



High Quality microphones

Often the least considered link in the electronic chain, the microphone is an important factor if the highest quality sound reproduction is to be achieved. Any initial loss of quality can never be regained in the amplifying equipment however good it may be.

S.T.C. microphones are precision made instruments utilising the finest materials and techniques and will satisfy the most fanatical Hi-fi enthusiast for high quality reproduction of speech and music.

*The microphones
you see on television*

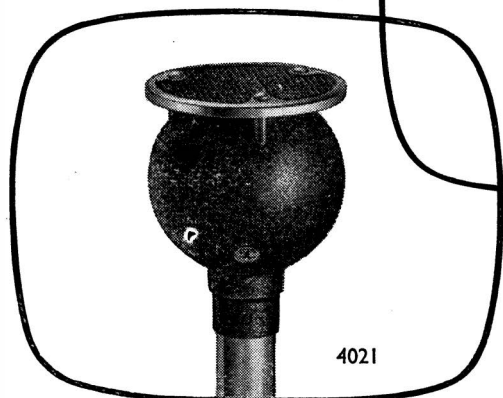

4021

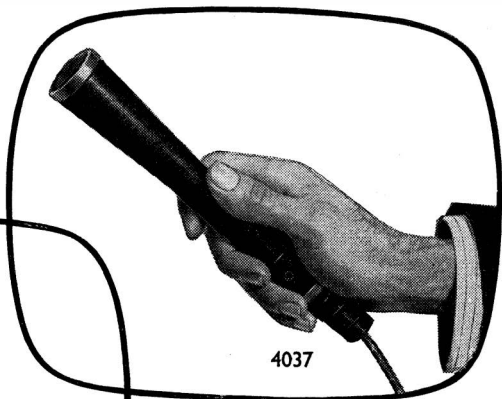

4037

4021

Moving coil microphone

Firmly established for high-quality studio work and acoustical measurement.

4038

Ribbon microphone

One of the world's best, and specially suitable for the reproduction of music.

4037

Moving coil microphone

Light-weight. Unobtrusive appearance. High-fidelity, omni-directional polar response.

OTHER MICROPHONES IN THE RANGE:

- 4032 Hand Microphone
- 4035 General Purpose Microphone
- 4105 Cardioid Microphone
- 4033 Cardioid Microphone
- 4104 Commentator's Lip Microphone

Each S.T.C. microphone is individually tested to a very exacting specification over the whole range of its performance.



Standard Telephones and Cables Limited

PUBLIC ADDRESS DEPARTMENT

CONNAUGHT HOUSE - ALDWYCH - LONDON - W.C.2.

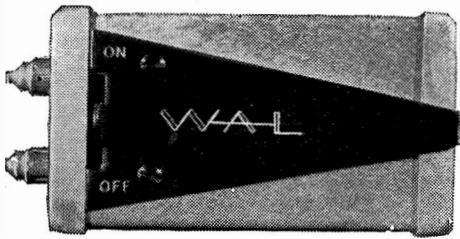

THE WAL Gain Transistor Pre-Amplifier

Transistor Pre-Amplifier, high gain low noise. Excellent with Quad, Sound Sales, Leak, Rogers, etc. Amplifiers . . . Ortofon, Expert, Garrard or Leak, etc. Supplied with connection instructions, phono plugs, screened lead. £5. Size 3½" + phone plugs × 2½" square.
 "... I would never again dream of using an input transformer".

P. Wilson, M.A., *Gramophone*, June 58

THE WAL Mono/Stereo Ten

Stereo, that is, Hi Fi Stereo. Neat Duo-Chassis, 10 w. output, available with Standard Tone Control Unit, £42, or Wide Range Tone Control Unit, £51. Export model 110 v. 60 cps. also available. Send for latest technical leaflet.

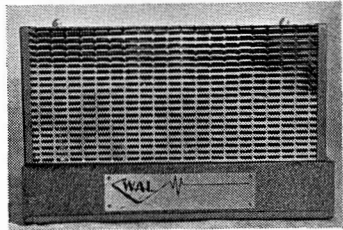
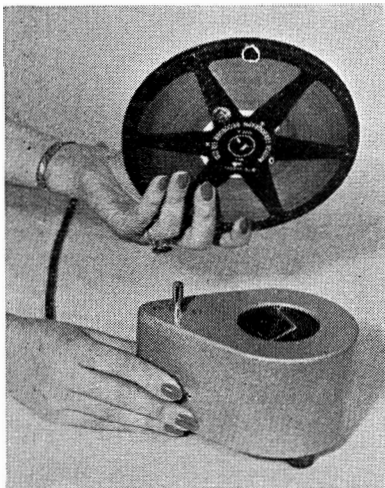
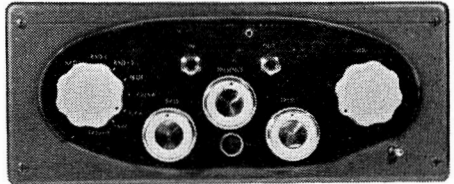

THE WAL Tape Eraser

The Professional Eraser wipes both tracks clean at one and the same time. Two models available 230 v. 50 cps, 110 v. 60 cps. £7 18s. 6d. Size 6½" × 4½" × 3½".
 "... WAL is to be congratulated for the neat design of this Tape Eraser which will accommodate 5, 7, 8½ or 10" reels of tape and will wipe these clean in about 30 seconds".
 D. Aldous, G.R.R., Sept. 58.

THE WAL Duo-Reflex

Chosen by Art and Industry. Laboratory built incorporating foam surround 12" speaker, crossover unit, H.F. pressure tweeter. A technically designed cabinet that is also an attractive piece of furniture. Size 33" high × 18" wide × 14" deep. Single Speaker complete £27, Stereo Pair, £52.
 "... For above all it's a realist".

P. Wilson, M.A., *Gramophone*, Oct. 58.



Ask your dealer for details of WAL Products.

Export inquiries welcomed by our Export Division.

WELLINGTON ACOUSTIC LABORATORIES LTD.

KINGS LANE, WRECCLESHAM, FARNHAM, SURREY

(Farnham 6461 & 4961)

PARIS

NEW YORK

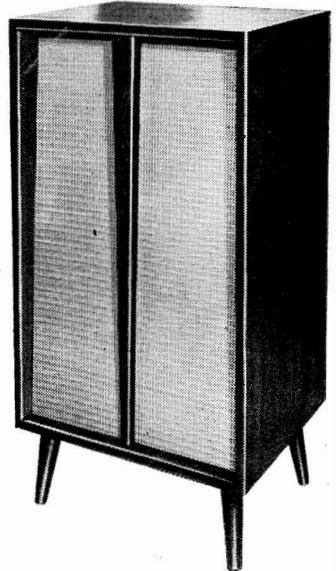

FOR QUALITY REPRODUCTION

WITH



LUSTRAPHONE LTD. design and make microphones for all recording requirements. Models range from the ever-popular "Lustrette" Moving Coil Microphone at 67s. 6d. to the "Stereomic" stereophonic Microphone at 30 gns. The company also specialises in the production of transistorised equipment and accessories for use with their many types of microphones.

British in design, materials and manufacture



MODEL VR/64

MODEL VR/64

Bi-directional ribbon velocity microphone with triple blast screening. Even response from 40 to 14,000 c/s. In high, line and low impedances. With base and swivel mount.

£7 17 6

MODEL MU.557

Transistorised 4-channel mixer. Takes two high and two low impedance inputs. High impedance output to recorder or amplifier. Self-powered by 1,000 hour miniature mercury cell. Other impedance arrangements available.

£22 0 0

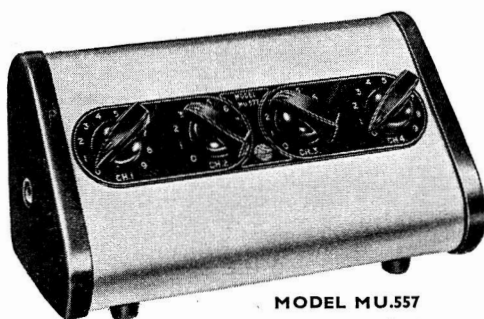

MODEL MU.557

Details of Lustraphone Microphones and equipment gladly sent on request. Please mention the 1959 Hi-Fi Year Book.

LUSTRAPHONE LTD.

ST. GEORGE'S WORKS,
REGENT'S PARK ROAD, LONDON, N.W.1
Telephone: PRImrose 8844

PROVED

The finest method for cleaning records.
Already over 200,000 enthusiastic users

All Static and Dust completely
removed from Your Records as
they are played

THE

“Dust Bug”

AUTOMATIC GRAMOPHONE
RECORD CLEANER

PATENT APPLIED FOR

Instantly Fitted. Suitable for all
Types of Record. Quality Im-
proved. Surface Noise and Wear
Reduced.

STANDARD MODEL FOR TRANSCRIPTION
AND SINGLE RECORD PLAYERS.

PRICE
REDUCED 17/6 (Plus 7/-
purchase tax)

From Your Dealer, or

CECIL E. WATTS LTD.
(Sound Recording and Reproduction)

Darby House, Sunbury-on-Thames, Middx.

AUTOMATIC RECORD CHANGERS

Ask your dealer for

THE NEW

AGOS CHANGER MODEL

“Dust Bug”

FITS THE PICKUP ARM
providing

**AUTOMATIC RECORD CLEANING
WHILE CHANGER IS IN OPERATION**

(without affecting stylus pressure)

CHANGER MODEL 17/6 (Plus 7/-
PRICE purchase tax)

Manufactured by

COSMOCORD LTD.

Eleanor Cross Road, Waltham Cross, Herts.

The PARASTAT

(Regd.)

TREATMENT FOR L.P. RECORDS (PATENTS APPLIED FOR)

Buy where there is a “Parastat” service — Used by dealers who have the
customer’s interests at heart

This Machine serves three main
purposes in the handling of all types
of Gramophone Records.

1. It cleans simultaneously both sides
of the entire surface of the record
(including the label), and removes every
particle of dust or foreign matter from
the grooves in less than ten seconds.

2. Renders the record permanently
inert to all Static charges induced by
any means, leaving no trace on either
groove or record surface.

3. Reduces the coefficient of friction
between stylus and groove wall at all
points of violent acceleration reducing
tracing distortion wear and surface
noise.

CECIL E. WATTS LTD. - DARBY HOUSE - SUNBURY-ON-THAMES - MIDDLESEX



WHEN IN MANCHESTER

*... visit the
North's largest
stockist of
high-fidelity
equipment*

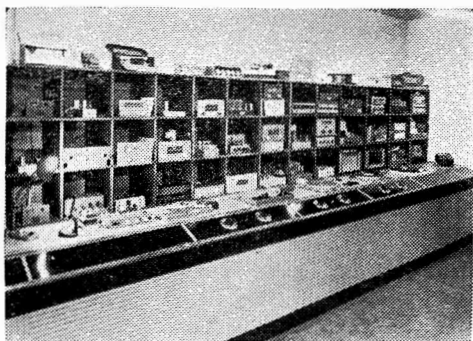

S T E R E O

*... realism
at realistic
prices*

*... the most
comprehensive
and up-to-date
stocks*

All leading makes of stereo and single channel amplifiers stocked and demonstrated without appointment or obligation. Speakers, AM and FM tuners, transcription turntables, equipment, speaker and record cabinets, styli (sapphire and diamond), on show in our special demonstration room. Hire purchase facilities available.

CALL, WRITE OR PHONE
RARE RECORDS LTD.
5/7 BARTON SQ., ST. ANN'S SQ.,
(Between St. Ann's Square and Deansgate)
MANCHESTER, 2.
DEAnsgate 3265/6

Our comfortable
and attractive
audio demonstration
showroom.



"TAILARGRAM"

Tailor - made Radio - Gramophone

The unique Tailargram service is the new way of obtaining both high fidelity equipment *and* the cabinets for housing it that will be the pride of the housewife and the delight of the music-lover.

Perhaps you are thinking of choosing ready-made cabinets? We stock all leading makes, traditional and contemporary. Or, if you like, we will make your cabinets to measure, it will cost very little more.

By using the Tailargram Service you will ensure perfect music from furniture that really fits *your* home.

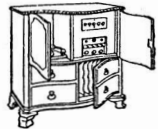
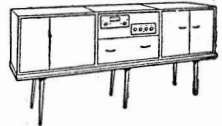

for High Fidelity

Largs OF HOLBORN

Near Holborn Tube Station.
Buses 7a, 8, 22, 23, 25, pass
the door.

76-77 HIGH HOLBORN, LONDON, W.C.1 CHAncery 2626

DaL59HFYB



MICROPHONES, PICK UPS
and
STEREOPHONIC PICK UPS

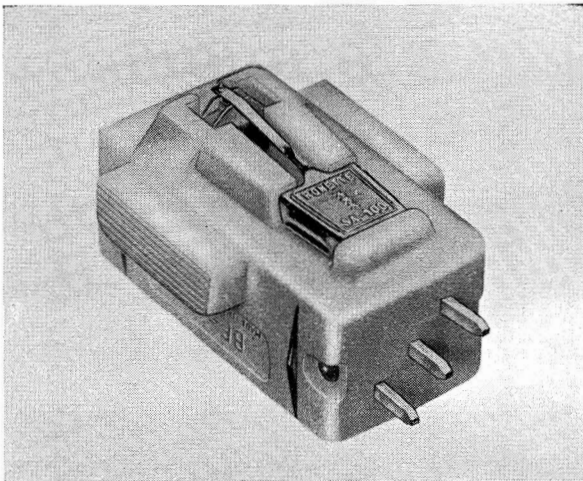

Sole distributors for Gt. Britain

TRIANON ELECTRIC LTD.

95 COBBOLD ROAD · LONDON · N.W.10

Tel: Willesden 3696 & 2116

Heathkit

THE WORLD'S FINEST ELECTRONIC KIT SETS

HI-FI STEREO AMPLIFIER

This elegant model in two-tone grey with golden surround and relief includes four-position filters; ganged

controls; three-position matching switch; press-button selection; balance control; STEREO and MONAURAL inputs for Radio, Gram and Tape Recorders. With 52-page Instruction Manual and large wall Pictorials giving easy step-by-step instruction suitable to permit construction even by absolute beginners.



Model S.88

MODELS-33. A high quality amplifier designed specifically for those with moderate means who want the benefit of stereo sound at the lowest possible price. It comprises two—3 watt channels each with 3 stage amplifiers having distortion factor of 0.3 per cent. at 2.5 watts per channel. In elegant metal cabinet suitable for open display or mounting in existing cabinet.

NEW! MODEL USP-1 STEREO PRE-AMPLIFIER.

This meets a long-felt need. It is a compact low-noise two channel pre-amplifier enabling amplifiers of moderate gain and input to be used with low output high fidelity pickups such as that of Decca. It uses two EF86's and has switched inputs for microphone, tape and gram, stereo and monaural.

SPEAKER SYSTEMS. These include book-case system with legs optional for pedestal use on floor. It comprises two loudspeakers (bass and treble unit with balance control). Ideal for stereo, especially where rooms are not exceptionally large.

Other kit-sets include Transistor portable radio, "Ham" transmitter, 5 in. oscilloscope and other test gear, e.g. valve voltmeter, audio generator.

We are continually adding to our range, why not write to us for details— and, remember, in buying direct from us you save money and get expert service.

DAYSTROM LTD. DEPARTMENT H.Y.
GLOUCESTER, ENGLAND

A MEMBER OF THE DAYSTROM GROUP

Manufacturers of

THE LARGEST SELLING ELECTRONIC KIT-SETS IN THE WORLD

HIGH FIDELITY

(In all senses of the phrase!)

You will do better at your

NORTH KENT

HI-FI CENTRE

for HIGH GRADE EQUIPMENT, BOTH TAPE AND
DISC, BY ALL LEADING MANUFACTURERS.

for INDIVIDUAL AND COMPARATIVE
DEMONSTRATIONS

for INTERESTED PERSONAL SERVICE

for YOUR COMPLETE MUSICAL SATISFACTION

HOURS OF BUSINESS

Monday	9.00 a.m. — 6.00 p.m.	Thursday	9.00 a.m. — 6.00 p.m.
Tuesday	9.00 a.m. — 6.00 p.m.	Friday	9.00 a.m. — 8.00 p.m.
Wednesday	9.00 a.m. — 1.00 p.m.	Saturday	9.00 a.m. — 6.00 p.m.

or at other times by appointment

Call or phone

BROADWAY RADIO

228 BROADWAY, BEXLEYHEATH, KENT

Telephone: Bexleyheath 4186

an

Armstrong

achievement

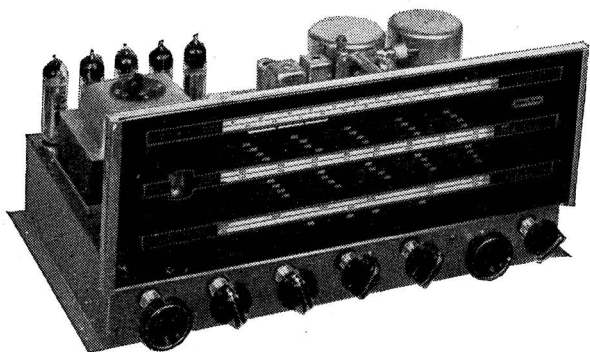

PRICE
37 gns.
TAX PAID

STEREO-TWELVE MODEL

- ★ STEREO and MONAURAL RECORD
REPRODUCTION
- ★ VHF/FM and AM TUNERS
- ★ STEREO and MONAURAL TAPE RECORD
and PLAYBACK FACILITIES

ALL ON ONE CHASSIS

Send for descriptive literature of the Stereo-Twelve and of other models in our range which includes High Fidelity Amplifiers both stereo and monaural, AM/FM and FM Tuners, Bandsread Shortwave and R.F. Tuners, Complete stereo and monaural Chassis

ARMSTRONG WIRELESS & TELEVISION CO. LTD.

Walters Road, Holloway, London, N.7

TECHNICAL SUPPLIERS LIMITED

Announce their 1959 Programme of HIGH-FIDELITY TAPE RECORDER EQUIPMENT

This consists of:

- 1. HARTING HM5M MONOPHONIC TAPE RECORDER.** Speeds of $7\frac{1}{2}$ " and $3\frac{3}{4}$ " with extended frequency range of 30 to 20,000 cps. **Price 82 gns.**
- 2. HARTING HM5S STEREOPHONIC TAPE RECORDER** with identical characteristics to above with extra facility for stereo playback. **Price 95 gns.**
- 3. HARTING HM5SD STEREOPHONIC TAPE DECK** for the home constructor and high-fidelity market. Facilities for monophonic and stereophonic recording and playback.

SPECIFICATION

Frequency response—30 to 20 kc/s within +2 dB at $7\frac{1}{2}$ i.p.s.

Playing Time—Up to 4 hours at $3\frac{3}{4}$ i.p.s.

Wow and Flutter—Better than .1 of 1 per cent.

Signal to Noise Ratio—Better than 55 dB unweighted.

Reel Size—7 in.

Price complete 42 gns.

This specification also applies to items 1 and 2 above.

- 4. TANDBERG QUADRUPLE 4-track Model 5**—the only available 4-track stereo recorder with facilities for recording and playback both monophonic and stereophonic. Three speeds— $7\frac{1}{2}$, $3\frac{3}{4}$ and $1\frac{7}{8}$ i.p.s. Frequency response 30–18,000 cps. Double the playing and recording time of any other machine. Facilities for 4 tracks of monaural recording or 2 tracks of stereo recording. Supplied complete with built-in stereo amplifiers. Facilities for playback of stereo discs. The world's most versatile machine. **Price 124 gns.**
- 5. TANDBERG STEREO ADD-ON UNIT** enables any stereo model Tandberg to be converted for stereo recording, and with modifications can be used for converting any recorder fitted with stereo recording and playback heads so that full $\frac{1}{2}$ -track recording facilities are available. **Price £17**
- 6. ELEKTRON EMG9/2 PORTABLE TAPE RECORDER.** Lightweight, portable, high fidelity, single speed of $3\frac{3}{4}$ i.p.s. with recording and playback facilities giving response of 30 to 16,000 i.p.s. Uses $5\frac{3}{4}$ " reels with a maximum playing time of 3 hours. **Price 47½ gns.**
- 7. TAPE MASTER MIXER UNIT**—this enables three different inputs to be balanced at any predetermined level, either separately or jointly, and to be fed to any tape recorder or amplifier which only has facilities for single level inputs. **Price 2 gns.**

Messrs. Technical Suppliers Ltd. are now distributing the whole range of high fidelity products manufactured by C.Q. Audio Ltd. These include the C.Q. range of reproducers, 10 watt extreme low distortion monaural Amplifier, twin 4 watt Stereo Amplifier, FM tuner, Tetraq high frequency reproducer, and the world famous Q: Flex speaker enclosure kit.

Comprehensive catalogues with full technical specifications available on request. Supplied through all wholesalers. In case of difficulty write to:

TECHNICAL SUPPLIERS LIMITED

HUDSON HOUSE, 63 GOLDHAWK ROAD, LONDON, W.12

Telephone: SHEpherds Bush 2581/4794

Telegrams—Home: TEKNIKA LONDON. Overseas: TEKNIKA.

a fine start



for a fine magazine

the
TAPE
RECORDER

● From the same editorial office as 'Hi-Fi Year Book', 'Record News' and 'Hi-Fi News', this new magazine, 'The Tape Recorder' got off with a flying start in February 1959. Within three numbers its sale had climbed to 20,000 copies monthly. We confidently recommend it to everyone interested in "tape". On sale everywhere, price 1/6d. Annual subscriptions 21/- for 12 numbers (U.S.A. \$3.00) or 24/- with annual index (U.S.A. \$3.25) from the publishers:

MILES HENSLOW PUBLICATIONS
99 MORTIMER STREET - LONDON - W.1

FOR THE SOUND ENTHUSIAST

★ 'Hi-Fi News' is the leading British monthly journal for all Hi-Fi enthusiasts. Finely produced, and profusely illustrated, it brings you all the latest news and reviews in the most interesting and comprehensive form. 2/- MONTHLY



★ 'Hi-Fi News' is on sale at all the leading bookshops, news stands and Hi-Fi dealers throughout the world. Overseas retailers are invited to write for agencies.

Published Monthly by

CLASSICAL RECORD NEWS LIMITED
99 MORTIMER STREET, LONDON, W.1.