

STILL
£2.30

H
i
-
F
i
-
F
i
W
O
R
L
D

H
i
-
F
i



W **O** **R** **L** **D**

JANUARY 1998 £2.30

For the love of music

BUDGET DYNAMITE



**THE BEST LOUDSPEAKERS
UNDER £150**

EXCLUSIVE
PHILIPS
CDR 870
REWRITABLE
CD RECORDER



**£4000 CHRISTMAS
COMPETITION**
**EVERYTHING
REVIEWED MUST BE
WON**

ISSN 0961-7663



9 770961 766062



The best things in life cost quite a bit, actually.

Music is one of life's great pleasures. But like caviar and Champagne, the best never comes cheap.

Take KEF's legendary Reference Series. We set out to create loudspeakers of unrivalled acoustic transparency - and in the pursuit of perfection, price is a secondary consideration.

Nothing is allowed to compromise the purity of the recorded signal. High-order crossovers are computer matched for seamless integration. Internal wiring is oxygen-free copper, soldered by hand. The baffles are mineral filled and contoured to minimise edge diffractions. And before it leaves the craftsmen who build it, every loudspeaker is rigorously tested against a calibrated laboratory reference system.

Hence the flawless response. The astonishing lucidity. The consummate musicality. Technical supremacy in a Savile Row suit.

Actually, they don't seem expensive at all.



Reference Series



MERRY CHRISTMAS FROM HI-FI WORLD

BIG WIN PAGE

If your wallet's feeling the strain of Christmas shopping already, then save your pennies and get your system sorted out with some of the great components we're giving away in this issue. Just turn to page 34 to find out how to enter.

JPW ML510 loudspeakers	£129.99
Mission 731 Pro loudspeakers	£139.90
Eltax Liberty 3+ loudspeakers	£149.99
Tannoy Mercury m2 loudspeakers	£139.90
Mordaunt-Short MS101 Pearl loudspeakers	£149.99
Kenwood DM-9090 MiniDisc recorder	£549.95
Roksan Ojan 3 loudspeakers	£1000
Musical Fidelity X-Pre/X-A50 amplifiers	£199.99/£499.99 pair
DPA White Slink interconnect	£75.00
Pentacore Plain Soft Copper interconnect	£74.95
Prowire Silver interconnect	£59.99
Statmat CD mat (10 off)	£199.50
Licon Contact Enhancer (2 off)	£60.00
GATE Troughline Stereo Decoder	£335
Philips CDR 870 CD-R/CD-RW recorder	£499.99
GRAND TOTAL	£4264.13

IN THE FEBRUARY ISSUE

Here are some of the superb products we hope to bring you in our February issue:

£180-£220 CD PLAYER GROUP TEST

With so many budget CD players on sale, it's a veritable minefield out there for the first time buyer. We look at five new models from Marantz, Technics, Denon, Kenwood and Yamaha to see just how good CD players at around £200 have become.

LP LAUNDERING

If you have a big record collection and want to keep it in pristine condition, find out about the best ways to look after

your cherished vinyl and make it last for years to come.

ETALON PREAMPLI PRE AND AMPLI POWER AMPS

They may not be a household name in this country but the Hungarian company Etalon is making a splash across Europe. We take a listen to the Preampli/Ampli combination to find out why.

B&W CDM7 LOUDSPEAKERS

After reviewing the stylish B&W CDM1 stand mounters in September we

couldn't resist having a listen to their new big brothers, the floor standing CDM7s. Will the Kevlar mid/bass and metal-dome tweeter combination work as well in the CDM7s as it did in the CDM1s?

PINK TRIANGLE LITAUROL CD PLAYER

We bring you the first review of Pink Triangle's £2000 flagship one-box CD player. Can it live up to the high standards set by PT's previous digital components?

AUDIO PUBLISHING LTD
64 CASTELLAIN ROAD,
MAIDA VALE,
LONDON W9 1EX.

CONTACT NUMBERS

10am - 6pm
Tel: 0171-289 3533
Fax: 0171-289 5620

Email: edit@hi-fiworld.co.uk
Individual queries cannot
be answered by telephone.

MAIL ORDER

Tel: 0171-266 0461
(24 hour answerphone)

SUBSCRIPTIONS

See page 97 or our web
site: www.hi-fiworld.co.uk
for details.

Editor

Jon Marks

Assistant Editor
Ketan Bharadia

Contributors

David Price
Douglas Floyd-
Douglass
Dominic Todd
Leo Lam

Music Reviewers

Peter Herring
Simon Hopkins
Jon Clarke
Simon Cooke
Sara Davis
Leon Palmer

Production Editor

Designer
Lynne Ross

Advertising

Designer
Faiza Chunara

Photography

David Noble

Advertising Manager

Caroline Knott
Tel: 01 245 443555

Sales Advertising manager

Stef Jakeman

Marketing Manager

Amanda Sweeney

Technician

Nick Lucas

Accounts

Ken Heath

Publisher

Noel Keywood

Distributed by:
Marketforce Ltd, 245
Tottenham Court Road,
London, W1P 0AU
Tel: 0171 261 5555

Printed by:

Southernprint, Poole, Dorset.
Tel: 01202 622226

All unsolicited submissions are
made at the owners risk. We
accept no responsibility for such
submissions, nor do we undertake
to return them.

No material may be reproduced
from this magazine without the
publisher's written permission.
© Audio Publishing Ltd

ABC
NATIONAL ASSOCIATION
CONSUMER PRESS

THIS MONTH'S REVIEWS

AMPLIFIERS

MUSICAL FIDELITY X-PRE AND X-A50 MONOBLOCKS

37

Can valves and transistors live in harmony? Dominic Todd thinks so after listening to Musical Fidelity's new valve/solid-state line-level X-Pre pre-amp and matching 50watt monoblocs, the X-A50s.



COMPACT DISC

PHILIPS CDR 870 CD RECORDER 28

At last, after years of opposition from the music industry, audiophiles have a high-grade digital format that can be recorded onto time after time - CD-ReWritable. Ketan Bharadia and Jon Marks test Philips £500 CDR 870 which can burn CD-Rs as well as CD-RWs to find out what the future holds for digital recording.



LOUDSPEAKERS

SUB-£150 LOUDSPEAKER GROUP TEST

12

Five top contenders battle it out for the mantle of best stand mounter under £150. Taking to the field are Tannoy's Mercury m2s, JPW's Millennium 510s, Mordaunt-Short's MS10i Pearls, Eltax's Liberty 3+s and Mission's 731 Pros.

ROKSAN OJAN 3

33

Proving that loudspeakers don't all come in rectangular boxes is the Ojan 3 with its radically-shaped floor standing cabinet and tweeter mounted on a sprung paddle. Ketan Bharadia joins Roksan's 'speaker fanclub.



MINIDISC

KENWOOD DM-9090

65

With CD-RW about to hit the highstreets, MiniDisc, with its lack of pre-recorded MDs, looks to have its work cut out. As Jon Marks discovers though, Kenwood's £500 DM-9090 MD recorder makes a strong case for CD's smaller relative.



WORLD VERDICT



OUTSTANDING - Superb sound, something we'd use ourselves.



GOOD - Has strong merit. Well worth an audition.



ADEQUATE - Mediocre in several areas. May be worth auditioning.



POOR - Seriously flawed. Not worth considering.

NEXT ISSUE**3**

You don't have to wait until next month to find out about the goodies we have on offer - take a look here and all will be revealed.

NEWS**7**

Find out about the fresh new components coming your way and all the latest industry news.

READERS' LETTERS**42**

Six pages of letters and e-mails packed full of system and equipment queries as well as your views and opinions.

HI-FI WORLD LIBRARY**50**

A pair of pages featuring some of the most informative and accessible books available on hi-fi and electronics.

COLUMNS**55, 61, 67, 70**

Words of wisdom and experience from World's men at the cutting edge of hi-fi.

SPECIALIST HI-FI DEALERS**62**

If you're having trouble with your system or fancy an upgrade these are the people who can help.

MEET YOUR MAKER**66**

Problems with your components or just need advice? Call those who know best, the people who make your hi-fi.

HI-FI WORLD KITS**74**

Here you'll find the full range of Hi-Fi World's superb kits, be it pre-amps, power amps or 'speakers.

DIAL-A-DEALER**89**

Planning a system or component change? Have a look here and find your nearest dealer.

MEASURED PERFORMANCE**111**

See how this month's reviewees cope under the spotlight of our technical interrogation.

WORLD BUYING GUIDE**127**

A guide to our favourite components, both past and present.

OLDE WORLDE**125**

Old is gold discovers David Price with Linn's Axis turntable.

READERS' CLASSIFIEDS**135**

Six pages full of second-hand bargains just waiting to spice up your system.

FEATURES

FROM PC TO CD RECORDER**23**

Leo Lam tells you everything you need to know to turn your Personal Computer into a CD recorder with a CD-R drive and Adaptec's Easy CD Creator Deluxe software.

CAPITAL CONNECTIONS**41**

Ketan Bharadia gets wired with three £60-£75 interconnects.

STATMAT AND LICON**53**

Not, it's not some new crime-busting detective duo but two ways to get more out of your system with Ringmat's anti-static Statmat for CDs and DNM's Licon contact enhancer.

CHESTERFIELD HI-FI SHOW**57**

Hi-Fi World was in Chesterfield on October 25th and 26th along with a whole host of other exhibitors. Turn to page 57 for the highlights.

LP ON A BUDGET**78**

While almost a whole generation has grown up listening to CD alone, there are still new audiophiles wanting to go the LP route. David Price explains how, without breaking the bank.

MUSIC

ROCK AND POP**81**

RECORD OF THE MONTH:
The Verve, Urban Hymns

DANCE/AMBIENT**84**

RECORD OF THE MONTH:
LSG, Collected Works

JAZZ REVIEWS**87****CLASSICAL REVIEWS****93**

RECORD OF THE MONTH:
Queen Of Heavenly Virtue, Concertare

COMPETITION - PAGE 34



Santa's smiling this month as we're giving away literally every component reviewed in this issue with over £4000 of prizes.

S
T
I
N
T
E
N
T
I
N
Z
O
O

Clearly superior
home theatre.



A bold claim - until you know the reason.

KEF's patented Uni-Q is intrinsically better suited to home theatre than any other loudspeaker technology. For a start, it creates a far larger listening area. And its characteristic point source effect greatly enhances clarity and definition.

With clear cone Uni-Q drivers throughout, our new Q Series sounds breathtakingly real - and the Q95C centre speaker brings vocals and dialogue to life as never before.

No wonder the Q35 floorstander so convincingly trounced all-comers in What Hi-Fi?'s Supertest. Awarding the ultimate five gold star rating, the review praised its "three dimensional, almost tactile effect" with "hi-fi resolution that's second to none."

Q Series home theatre from KEF. The difference is clear.



Q
SERIES



Sponsors of
VH-1

Take It to the bridge

QUICKSILVER SPEED ON

Valve-amplifier specialists Quicksilver have announced the release of a new monobloc power amplifier called the V4 Monaural. This power amp uses KT88 valves in the output stage, but if required EL34s, 6550s or 6L6s can be substituted. Either way, power output is claimed to be a healthy 120W into 8 ohms. The V4 also offers a chassis-mounted bias meter and individual adjustment of the output valves' bias. Price for a pair of these monoblocs is \$3800.

Quicksilver Audio
 5635 Riggins Court No15,
 Reno,
 Nevada 89502,
 USA
 Tel: (001) 702 825 1514



GREENING HI-FI

On Saturday 25th October, Friends of the Earth called for the UK electrical industry to pay for the collection of waste electrical goods for reuse or recycling. They also called for manufacturers to label products with expected life spans and retailers to offer free extended warranties.

FOE have held demonstrations outside Dixons (the UK's leading electronics retailer) in order to influence discussions on a new European law which could ensure that manufacturers take responsibility for their products from birth to grave. This, FOE claim, will give the industry incentives to make electrical components which are designed for durability, repair, reuse and recycling. REL, known for their subwoofers, already recycle some of their components' internals.

Extended warranties would further encourage manufacturers to make products which are more reliable and easily repairable. Anna Thomas of FOE said, "Throwaway products have a major impact on the natural environment. Precious resources are squandered to make new products, mountains of waste are created during mining, and the manufacturing process pumps out pollution and wastes energy".

Of course, one of the easiest ways to reuse hi-fi is to buy second-hand or upgrade the system you already have with audiophile-grade components.

A FIRM FOUNDATION

British hi-fi manufacturer Myryad have moved upmarket with the introduction of the new MCD 500 CD player. Retailing for £1299.95 this player features a 20-bit Delta-Sigma dual-differential DAC which has a master clock running off its own dedicated power supply.

All the audio stages in the MCD 500 are direct coupled, any residual DC voltage on the output removed by manual adjustment of each channel during production. Myryad say that doing things this way removes the need for sound-degrading DC servos. Power supply design has been a major priority too with no less than 13 separate regulated supplies in the MCD 500.

Myryad Systems
 2 Pipers Wood,
 Waterberry Drive,
 Waterlooville PO7 7XU
 Tel: 01705 265508



Trade winds

The Caspian System by Roksan



ROKSAN

tel: 07000 Roksan
fax: 070001 Roksan
email: info@roksan.co.uk

NEATLY DONE

Neat Acoustics have been hard at work improving their range of loudspeakers. The stand mounting Petites gain a circular Emit ribbon tweeter in place of the previous Tonigen and a modified crossover. Neat say these changes result in a smoother, more extended treble which in turn improves sound staging and tonal colour. Price for a standard black pair is £745 with a £50 premium for the Cherry veneer.

The Mystique and Critique 'speakers have also been revised to take a new tweeter, in this case a 25mm fabric-dome unit. With their realigned crossovers apparently both now have better transparency, presence and timing. The standard Mystique is £575 and the Critique is £385, with Cherry veneer an option.

Neat Acoustics
Unit 17A
Sutton Grove Industrial Estate
Bernard Castle,
Co. Durham DL12 8UJ
Tel: 01033 631021



FOUR BITS MORE

Meridian has upgraded its 508 integrated CD player which first saw the light of day in 1995 by swapping the standard 20-bit DAC for a 24-bit one from Crystal. The 508.24 features balanced outputs and sports a price of £1995. Existing owners of the 508.20 can have their players upgraded to the latest specification at a cost of £395.

Meridian Audio
Stonhill,
Stakeley Meadows,
Huntingdon,
Cambridgeshire PE18 6ED
Tel: 01480 52144



SONNETEER SWELL

Sonneteer have decided to complement their range of line-level integrated amplifiers with the Sedley phono stage for vinyl heads. Cartridge loading and gain are adjustable without removing the lid and there's a warp filter for those with crinkle-cut LPs and reflex loudspeakers. This £399.99 phono stage makes use of a discrete, low-noise differential input stage and an active grounding system fed from a power supply using staggered-value reservoir capacitors.

FTM Marketing
PO Box 163c,
Esher KT10 0YH
Tel: 0181 286 6661



Trade winds

No one night stand



Byron CD player

SONNETEER

Dealers:

The Hi-end, London 0181-8780066 O'Brien Hi-Fi, London 0181 946 1528 London Hi-Fi, 0171 263 1015
 J&A Cameras, Barnstaple 01271 24384 Mike Manning, Yeovil 01935 79361 Omega, Kent 01732 848268
 Replay Chester 01244 401290 B.I.L. Audio, Northumberland 01670 788671 Olivia, Essex 01702 585865
 May Audio, West Yorkshire 01535 632700

Sonneteer. PO Box 163c . Esher . Surrey . KT10 OYH
 tel./fax. 0181 286 6661



audio consultants

TEL/FAX
01244 401290
E-MAIL
replay@dial.pipex.com

Replay is an independent hi-fi specialist based in Chester, we offer a very high standard of service which includes home demonstrations throughout the North West, along with genuine help in choosing or upgrading your hi-fi system. All our customers are seen individually by appointment and our demonstrations are relaxed and informal.

We have a superb range of high quality products from:

ALCHEMIST, AUDIO ANALOGUE, AVI, BLUEPRINT, HEYBROOK, KESWICK, LFD, MISTRAL, NEAT, ORIGIN LIVE, ORTOFON, PINK TRIANGLE, PROJECT, ROKSAN, SONNETEER, TARGET, TRICHORD, TRILOGY, UKD etc.

Amplifiers:

In the December issue of Hi-Fi World, Ketan and Jon reviewed five of the best integrated amplifiers in the £700 bracket. As agents for three of the five products reviewed, we have to say that we broadly concur with the conclusion that the two writers arrived at, the excellent Audio Analogue Pucchi SE is very lucid and transparent and sounds much more refined than it has the right to at this price level! The Sonneteer amplifiers have been favourites of ours for a while now, and it is good to see this company doing so well in the Hi-Fi Press. The Roksan Caspian is a very consistent amplifier that sounds superb from system to system and from disc to disc. It is also very well built and features full remote control. Although not featured in this particular review the LFD Mistral integrated is also worth a mention for its involving and detailed sound. LFD also make a lesser known but, in some aspects, superior integrated amplifier, the Zero, for £550.

Loudspeakers:

The new BluePrint Point One loudspeaker (£1000) from Keswick Audio is a refreshing and distinctive design available in three very attractive finishes (cherry, ash or purpleheart). The Point One is a tall floorstander with, unusually, a rear-firing tweeter. The soundstage produced by this speaker is very lifelike with real scale and height. They are very easy to drive and sound good with the Audio Analogue amplifier or a good valve amplifier. The Pink Triangle Vertical (£990) is still one of our favourite speakers as it offers a quality in the mid range that is un-equalled in its price bracket. It is system and room dependent and does not have massive power handling, but it is capable of stunning results. AVI's new Positron loudspeaker is one of those rare hi-fi products that seem to do nearly everything right! Decent bass extension, lots of detail, outstanding imaging and clarity. For a very reasonable £899, they offer an overall sound that many more expensive boxes cannot approach.

Digital Replay:

The LFD DAC 3 (£3000) is still our reference Digital to Analogue converter, you have to spend a lot more than this to better it. The mid range of this DAC is of true reference quality and stands comparison with even the most expensive converters. It works extremely well with Teac, Trichord or Meracur transports. Trichord have recently improved the Genesis and Revelation CD players and they now sound even further ahead of their rivals. Also new from Trichord is the Clock 3 modification which will literally transform your existing CD player for only £172. If you haven't had a Clock update, you really are missing out on the true potential of your player.

EX Dem and Second Hand Items

Throughout January, we shall be having a massive clearance of dem stock at very good prices. If you would like a copy of the full list of sale stock, call, fax or email on the numbers above and you will receive it in the first week of January. In the meantime, if there is anything we can help you with, we are available from 9.30am-7pm each day.

**For more information on any of these products,
or for any help or advice, please phone, fax or e-mail.**



SOUND
CONNECTIONS

TEL / FAX : 01244 401280
E-mail : sound.connections@dial.pipex.com

MAIL ORDER SUPPLIERS OF QUALITY HI-FI ACCESSORIES



The superb Chord Chorus interconnect is now available for home trial

The importance of cables and accessories is often overlooked when purchasing a hi-fi system. It is very easy to be sceptical about cables because of their apparent high cost or insubstantial appearance, but they can play a major part in achieving the full potential from your system.

We offer a popular HOME TRIAL SERVICE which enables you to evaluate cables in your own system, therefore ensuring you purchase the right cable.

PLEASE TEL / FAX / E-MAIL FOR OUR LATEST PRODUCT AND PRICE LIST

VAN DEN HUL ♦ DNM RESON ♦ SONICLINK ♦ NORDOST ♦ CHORD CO
 XLO ♦ AUDIO QUEST ♦ KIMBER ♦ SENNHEISER ♦ STAX ♦ ORTOFON
 LAT ♦ SUMIKO ♦ LYRA ♦ MICHELL ♦ STANDS UNIQUE ♦ TARGET
 SOUNDSTYLE ♦ TOWNSHEND ♦ IXOS ♦ MUSICAL FIDELITY

52 Green Lane ♦ Great Sutton ♦ South Wirral ♦ Cheshire ♦ L66 4LE

BALANCE OF FORCES

If you've been hankering after an electronic stylus gauge like Technics' famous but extremely rare unit, you can now relax. The Moth group is offering a digital electronic stylus balance from 'The Cartridge Man', Len Gregory. This £185 beastie is housed in a 4in. diameter moulding that contains the strain-gauge mechanism, digital read-out and rechargeable battery. A battery charger is also supplied. The stylus balance is claimed to be accurate to 1/50 gramme over a range of 0-4gms and can be used on all turntables.

Moth Group
10 Dacie Lane,
Wilstead,
Bedford MK45 3HT
Tel: 01234 741152



WELL CONNECTED

Qnect 2 and Qnect 4 are two new interconnects from QED. Both have been designed according to the conclusions reached in QED's own cable-research report, 'Genesis'. As you might expect, the £27 Qnect 2 uses a pair of 99.999% oxygen-free copper conductors twisted together to cancel out noise and interference while the £54 Qnect 4 uses two twisted pairs. High-quality gold-plated phono plugs are fitted as standard.

QED Audio Products
Ridgeway House,
Ridgeway Close,
Lightwater,
Surrey GU18 5XU
Tel: 01276 451166



Trade winds

GOAT ALERT

A box of natural-fibre record brushes was stolen at the recent Chesterfield show from Loricraft Audio's van. These brushes aren't yet available in the shops and should be easy to identify due to the use of goat's hair and a natural Beech wood handle. If you're offered one of these brushes or have any idea as to their whereabouts, Terry O'Sullivan from Loricraft would be pleased to hear from you. There is a reward on offer, so if you have any information please call 01488 72267.

YET MORE UPGRADES

Mordaunt-Short continue to update their range of loudspeakers with two new introductions. The first is the Pearl version of the MS25i floor standers. These sell for £329.99 and now feature a new mica-filled, polypropylene polymer mid/bass cone said to improve efficiency and piston motion in the low and mid-frequencies.

The crossover has been reworked because of the new driver, cabinet volume has been increased and the reflex loading features a revised alignment to give better bass performance. The MS25is are available in Black Ash and Rosewood finishes.

The other arrival joins the Classic range. The MS30i Classic comes wrapped in a real Rosewood veneer and carries a price tag of £599.99. The mid/bass cone uses the same technology as the MS25i Pearl and is allied to Mordaunt-Short's long-lived 25mm aluminium gold-dome tweeter through a minimalist first-order crossover.

Mordaunt-Short
3 Ridgway,
Havant,
Hampshire PO9 1JS
Tel: 01705 407722



Trade winds

TOP TRANSDUCERS

Ketan Bharadia and Jon Marks find out that you can buy true high-fidelity in a loudspeaker for less than £150 with Tannoy's Mercury m2s, Mission's 731 Pros, Mordaunt-Short's MS10i Pearls, JPW's Millennium 510s and Eltax's Liberty 3+s.



When you're a budding audiophile with your sights set on the sort of hi-fi nirvana that comes with a hefty price tag, it can be all too easy to dismiss the budget end of the market. But that would be a shame and a mistake. After a fair stretch of time when the words "budget box" meant boofy bass, high-power, armour-piercing treble and more radiation from the cabinet than from the cones of the drivers, things have changed.

A new generation of small, inexpensive loudspeakers, spearheaded by the likes of Tannoy's Mercury m2s, is being born. The cream of this crop boasts superior drivers, crossovers and cabinets to their predecessors and wouldn't be embarrassed sitting on the end of a source and amp costing many times more than themselves. We actually decided to use Roksan's class-

leading Caspian CD, Ringmat's new Strarmat (which gives smoother treble and a generally cleaner sound from CD, as we discovered on page 53), Roksan's Caspian amplifier and interconnects and 'speaker cables from DNM.

All the loudspeakers in our test here rely on reflex loading to get the most bass from their cabinets. The laws of physics dictate that a small volume will give limited bass, but an experienced designer can tailor the frequency response to give more apparent weight by putting a 2dB-3dB lift in the upper bass: the Tannoy m2s and Mission 731 Pros, for example, showed this trait when we measured them.

Balancing out the bass limits are the traditional benefits of a loudspeaker with relatively small dimensions. Imaging, the way individual members in

a band are 'pictured', is almost always more precise than it is with floor standers, which often have a rather diffuse view of imaging. Cabinet boom, where the walls of the enclosure start to add their own sound to the music, is less too.

One vital piece of equipment you'll need to go with these 'speakers is a decent set of stands - Atacama's SE24s at £70 are a good bet. And if you really want to get the considerable best from our contenders this month, spend some time setting them up. Try not to push any of these loudspeakers right up against a side or rear wall - it can ruin imaging and makes the bass boomy - and make sure each one is the same distance away from the listening position. After that, fire up your system and settle back for some musical delight.

MISSION 731 PROS

THE TECHNOLOGY

The 731 Pros differ from earlier versions of Mission's famous 731 loudspeakers in two main ways. They use the same new 25mm silk-dome tweeter which has sweetened the sound of the rest of the 73 range in place of previous, less polished drivers. Second, they are bi-wireable. The benefits of bi-wiring are well known but two pairs of binding posts on budget 'speakers are a rarity, so this is the first time Mission's entry-level model has been fitted with them.

The little Pros' cabinets are constructed along lines many of Mission's budget loudspeakers have followed. Moulded plastic front and rear baffles are fitted together to sandwich the particle board sides and top and held them rigidly in place. These are the smallest speakers on test at just 320mm by 180mm by 200mm.

SOUND QUALITY

As you might imagine from their small enclosures, the 731 Pros operated best close to a rear wall - ideally around 30cms away - and pointing very slightly inwards towards the listening position. Unlike the other 'speakers on test, toeing-in wasn't essential for crisply-defined imaging.

I set the Missions rolling with Paul Young's *No Parlez* album, which showed the 731 Pros possess quite a strong sonic signature. They have a very sweet, smooth balance with a gentle roll-off in the treble, as our measurements show. This has no doubt been done to compensate for the many bright, often brash budget amplifiers and CD players around. Thankfully, Mission have finely judged this roll-off and the result would complement most systems.

On 'Come Back And Stay', Paul Young's vocals, though lacking the last ounce of detail and projection, were



enjoyably expressive and easy to follow. The Pros made this CD fun to listen to and always managed to sound lively and enthusiastic thanks to their low-mass mid/bass cone.

As I moved on to Choral music in the form of Robert White's *Sacred Music For Choir* the Pros continued to shine. The voices of individual choristers were kept nicely separated and had a believable texture and presence. Thanks to the small frontal area of their cabinets (which reduces the amount of sound reflected off the front baffle) imaging was very good, if not the most tightly focused I've heard. In terms of character the drive units are seamlessly integrated, giving a cohesive, transparent sound.

In an attempt to stretch the 731 Pros I turned to Wagner's *Rienzi*. The dinky Missions passed this test, if not with flying colours, then at least pretty close. They did a fine job of capturing the menacing mood of the piece, the orchestra was accurately laid out and the various sections were easily identifiable. Dynamic range was good,

and even at high volumes with the musicians working hard these 'speakers never sounded out of their depth. In fact, this was the most impressive thing about the 731 Pros - they were always musical, composed and in control, no matter how demanding the music.

Having said that there were some shortcomings. The orchestra was rather small scale and, as mentioned above, detail wasn't a forte. Sound stages weren't especially deep, which is often down to a limited bass output that doesn't relay the spatial clues contained in the lowest octaves. Finally, the Missions can't match 'speakers with larger mid/bass cones for ultimate loudness, though in small to medium sized rooms they should be more than acceptable.

The 731 Pros have an even overall balance suited to all types of music in budget systems. Their strengths are many and include a sweet, smooth sound, great dynamics and a cohesive character. Weaknesses are few, and as an all-rounder the 731 Pros are difficult to beat.

For the best in Hi-Fi

TV

video

and Home Cinema



Before you buy Hi-Fi, TV, Video or Home Cinema, you owe it to yourself to visit Musical Images.

Musical Images is one of the UK's premier Audio Visual retailers. We offer a massive choice of top products, unhurried demonstrations in relaxing lounges, helpful professional advice, and an acclaimed installation service. With four branches within the M25, interest free credit facilities and our unbeatable price promise, a visit to Musical Images could certainly brighten up your life...

- Musical Images is an authorised dealer for over 100 top manufacturers including Sony, Kenwood, Panasonic, Philips, Linn, Yamaha and many, many more
- Twelve demonstration lounges
- Qualified information and advice
- Dedicated design and installation
- Interest free credit facilities**
- Open 7 days a week

We'll match any Authorised Dealer Price*

MUSICAL IMAGES PRICE PROMISE



"Overall 100%" Your Own Home Cinema Magazine.
"Top of the Shops' survey winner: Musical Images."
"London's premier AV place."
Home Entertainment Magazine.



e-mail: sales@musical-images.co.uk



Open Sundays

MUSICAL IMAGES IS AN AUTHORISED MAIN DEALER FOR OVER 100 LEADING MANUFACTURERS

Acoustic Energy	B & W	Cyrus	Infinity	Micromega	Orelle	REL	Sony	Trichord
Aiwa	Barco Projectors	Dall	Jamo	Missison	Panasonic	Rogers	Soundstyle	Tube Technology
Akai	Beyer Dynamic	Definitive	JBL	MIT	Philips	Roksan	Spender	Van den Hul
Alchemist	Bose	Denon	JVC	Mitsubishi	Pink Triangle	Rotel	Stands Unique	Wadia
Alphason	Boston	DPA	KEF	Monitor Audio	Pioneer	Royd	Sumo	Wharfedale
Apollo	Cabletalk	EPOS	Kenwood	Mordaunt-Short	Polk	Ruark	Systemdek	XLO
Arcam	Canon	Exposure	Lexicon	Musical Fidelity	Proac	Samsung	Tannoy Prestige	XTC
Atacama	Carver	GLL	Linn	NAD	Project	Seleco	Target	Yamaha
ATC	Castle	Goldring	Loewe	Nakamichi	Turntables	Projectors	TDL	and Many More
Audio Alchemy	Celestion	Grundig	M&K	Naim	QED	Sennheiser	TEAC	
Audioquest	Cerwin Vega	Harbeth	Marantz	NHT	Quad	Sharp	Technics	
Aura	Chord	Harman Kardon	Meridian	Onkyo	Quadraspire	Shure	Thorens	
AVI	Citation	Heybrook	Michell	Ortofon	RCF Projectors	SME	Toshiba	

*Subject to availability and dealer having stock of offered items. ** Subject to status. Ask for written details. E&OE.

JPW MILLENNIUM 510

THE TECHNOLOGY

Like Tannoy with the Mercury m24, JPW have decided not to build their cabinets with plastic front and rear baffles. Instead, it's a 25mm combination of MDF and particle board for the front and particle board elsewhere.

The mid/bass unit has a 105mm doped-paper cone mounted on a cast-polymer chassis. JPW claim this has the kind of stiffness associated with cast metal chassis without the rattle they can suffer from. The tweeter is a 19mm fabric-dome type complete with ferrofluid cooling to boost power handling. The 510s measure a domestically non-conflicting 330mm high by 195mm wide and 222mm deep.

SOUND QUALITY

The JPWs' frequency response had looked impressively flat so I was expecting a well-balanced performance from these attractive baby boxes. The measurements were borne out in the listening sessions - Eric Bibb and Taj Mahal's vocals were smooth and even on the former's Me To You album. Occupying the top plate of a pair of Atacama SE24 sand-filled stands the 510s spread the music across the breadth of our listening room although they couldn't quite manage to capture the full depth of the band and acoustic. What helped here was positioning the JPWs a fair distance apart (at least six or seven feet) - even though they look as isolated as the two ends of a suspension bridge without a roadway, they need a bit of space and a 20-25-degree toe-in to hit their stride.

Sampling the JPWs arranged in this way with sparser numbers from this album (like 'You're The One') found these 'speakers in their element with a smooth, involving and slightly warm presentation perfect for these Bluesy tunes. The only bars to top marks were a lack of transparency and a sense of slowness to the rhythm that sapped a little of the excitement from the music.

With an HDCD recording of



Schubert's Trio in B-flat major by Opus 3 (fans of HDCD, whose recordings are available from Pentacore, tel. 01924 445039) the 510s' warmth sweetened violin and cello and softened their natural bite to give a sound that was amenable if not particularly detailed. But this is preferable to the kind of ear-bashing you can get from close-mic'd strings through brighter, harsher sounding 'speakers. On the other hand, it is possible to get just as easy-going a rendition with more clarity from some of the 510s' peers.

Many cabinets little larger than a brace of fruit-juice cartons tend to hamstring their drivers due to the fact that small boxes mean small bass. The JPWs, however, squeeze most of the available low octaves out of their enclosure, avoiding thin, weedy orchestras with extended bass, if you can pump a few watts into their voice

coils. Stravinski's Firebird (on a Reference Recordings' HDCD CD) with its thunderous timpani proved the JPWs won't run and hide at the first sign of any signal lower than 100Hz and could keep their head on some heavy-duty crescendos at high levels.

John Cale's Eat/Kiss (music for the films of Andy Warhol) gave the 510s their sternest test. 'Movement 01' (there must have been much pondering on that title) has deep synthesiser notes sitting below a scabbling violin and these have floored many loudspeakers. The JPWs kept a firm grasp on this track instead of turning it into the hi-fi equivalent of mashed potato.

The JPWs have a character as even as their frequency response which will endear them to any genre you care to mention. With greater transparency and a bit more get up and go the 510s could aspire to be the leaders of the pack.

PURE LINEAR STRUCTURED CARBON FIBRE AND CARBON HYBRID CABLES

VLDH

The Wind £19.99/m (Single Strand)

The Second £199.99 0.8m Stereo Phono or XLR

The Revelation £59.99/m (Single Strand)

The First £184.99 0.8m Stereo Phono

van den Hul UK P.O.Box 31 Bishop Auckland DL14 7YX
Tel: 01388 663273

XTC

The Ultimate Listening Experience



PRE-1
POW-1

CDP-1

"Firmly Recommended"
-Hi-Fi News & RR April 97

"It was meant as a reference,
and reference quality it is."
-Hi-Fi World November 96

"...a welcome addition to the
top rank of British audio."
-Gramophone August 97

XTC Information Line
TEL (0181) 810 9388
FAX (0181) 810 9365

MICHELL GYRODEC AND QC POWER SUPPLY

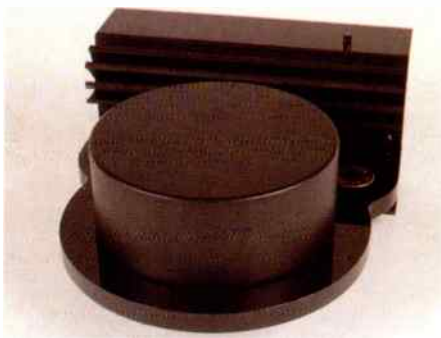

A SYMBOL OF PRECISION



"THE MOST DESIRABLE DECK BELOW £1500"
Ken Kessler - Hi-Fi News & Record Review August '94

Michell Engineering, 2 Theobald Street, Borehamwood, Herts WD6 4SE
Tel:- 081 953 0771

TANNOY MERCURY M2

THE TECHNOLOGY

Recessed into the m2s' 15mm MDF front baffle (the rest of the cabinet is made from 15mm particle board) is a 1in. plastic-dome tweeter. Bass duty falls to a mid/bass driver with a 6.5in. coated-paper cone that's larger than the norm (often 4in.-5in.) and boasts an inverted dust cap. This gives smoother and more extended high frequencies than the standard dome dustcap, whose edges can cause standing waves within the cone itself which show up as a lumpy driver response. The tweeter and mid/bass are linked by a second-order low-pass and second-order high-pass crossover. Bi-wiring has yet to reach the m2s as the single pair of gold-plated terminals testifies. Size-wise the m2s come in at 380mm high by 203mm wide and 270mm deep.

SOUND QUALITY

The Mercury m2s made a bit of a name for themselves back in May 1997. It wasn't difficult to understand why when you saw their relatively large cabinets and chunky mid/bass drivers hooked up to a quality tweeter. By comparison, many inexpensive 'speakers with their lightweight build and small, cheap drivers feel like biscuit boxes. You can also hear the 2s' solidity in a lack of enclosure coloration - OK, there's some blurring across the midrange and bass, but many of the competition come up with a veritable orchestra of honks and quacks.

John Cale's *Eat/Kiss* CD with its thick wash of synthesiser backgrounds underlying strings and vocals can quickly get out of hand unless the 'speaker playing it has a real grip on the sound, as do the Mercury m2s. They separated out the various synth lines and gave drum beats power and extension, never leaving this album sounding anaemic. It took some welly to open up the Tannoys fully (partly because of their well-damped lower bass) but with the volume control in



the right position they really sang, delivering contemplative or aggressive in whatever amounts were called for.

The sound staging abilities of this second pair of m2s will win as many friends as that of the first, with cleanly-recorded Jazz and Classical pieces producing a hallmark acoustic signature. Tonal colour with unprocessed music was just that - colourful. Guitar had a harmonic richness to it while brass was throaty and raw without giving the impression it was being sonically sandpapered by a rough tweeter.

The Reference Recordings HDCD of Stravinski's *Firebird* was a prime example, with its great swathe of an orchestra reaching back behind the rear wall of our listening room. The obvious musical elbow grease of the third movement must have had the instrumentalists reaching to undo collar buttons and cool down. This fiery energy certainly came through the

Tannoys with massive, taut timpani and a tangible tension as the orchestra headed inexorably towards the crescendo. That said, the Tannoys still sounded as if they could have been a touch freer dynamically.

I couldn't resist a quick dip into the waters of heavy-duty Techno with the Chemical Brothers' *'Setting Sun'*. I found that even with a recording as dirty and harsh as this, the Tannoys wouldn't be knocking out the local canine and bat populations with ear-piercing treble. And the depth-charge electronic bass of this single failed to panic the Mercurys into mid/bass driver overload.

The Tannoys have an air of enjoyability and control about them that mirrors their measured performance. Partner them with an amp like Denon's PMA-250SE and a CD player like Kenwood's DP-3080 and your system will be sorted.

*The alphabet according to
Musical Fidelity.*



X10D Class A
Tube Line Stage



X CANS Class A
Tube Headphone Amplifier



X DAC New Technology
HDCD DAC



XLP Low Noise
MC/MM Phone Stage



X PRE Class A
Tube Preamplifier



X PSU Add on Power Supply
for all X Series



X TONE
High Quality Tone Control

MUSICAL FIDELITY

When music matters most

FOR DETAILS OF
A DEALER NEAR YOU,
CONTACT MUSICAL FIDELITY LIMITED,
15-17 OLYMPIC TRADING ESTATE,
FULTON ROAD, WEMBLEY, MIDDLESEX HA9 0TF.
TELEPHONE 0181 900 2866.
World Radio History

MORDAUNT-SHORT MS-10i PEARL

THE TECHNOLOGY

The MS-10i Pearls are the latest version of Mordaunt-Short's long-running budget competitor and feature a host of improvements over their predecessors: the 10i. First, the 130mm injection moulded midbass cone now uses the new version of Mordaunt-Short's MCS (Moulded Cone and Surround) technology. This is claimed to produce a smoother roll-off in the driver's upper response and thus improved integration with the 25mm aluminium gold-dome tweeter. The second change is that the 'speakers are now bi-wireable via a first-order, hard-wired crossover. The reflex loading of the cabinet has also been tweaked to extend bass response. The cabinet itself measures 305mm high by 185mm wide and 212mm deep.



SOUND QUALITY

Experimenting with positioning I found the Pearls sounded best at around 50cms from the rear wall. This is double what M-S recommend but I found that this set-up gave the best compromise in our room as regards tonal balance, bass depth and imaging precision.

Gabrielle's eponymous second album was loaded into the Caspian CD player and evidently suited the little Mordaunts down to the ground. These are true rhythm transducers - if there's even a hint of rhythm around, the M-S10i Pearls will latch on to it and exploit it for every bit of enjoyment it contains. The speed and attack they are capable of brought many of the songs on this album alive. Tracks like 'Forget About The World' and 'Give Me A Little Time' rocked along with a fresh vitality.

No loudspeaker this size is going to give you seismic lows and the Pearls are obviously limited in this respect. Still, the bass they are capable of is solid, powerful and well defined, so unless you've heard the same piece of music

on a 'speaker with a heavier bottom end, you probably won't miss much. Drawbacks? There was a hint of a 'cuppy' coloration on vocals and a slight veiling of fine detail but compared to what the Pearls were doing right it was a more than acceptable trade-off.

Hunting for an Achilles heel I plied the Mordaunts with Wagner's Rienzi. Where there should have been a large acoustic unfortunately there wasn't - that swift but light bass lead to the loss of subtle low-frequency acoustic clues, diminishing the size of the sound. What I was left with was a small-scale, slightly dry presentation which lacked the majesty and imposing presence that this recording has.

Moving on to less demanding works had the Mordaunts sounding more comfortable and enjoyable, their ability of getting to the heart of the music once more to the fore. Imaging, for example, was very precisely focused and located

in a broad, deep sound stage.

Handling the Pop of Paul Young's No Parlez, the 10i Pearls retained their deft touch. This album's typically early-Eighties drum machine rhythms were reproduced with admirable verve. The mood of 'Wherever I Lay My Hat' was superbly conveyed, Paul Young's vocals dripping with emotion - the Pearls were involving enough for me to sing along, a rather scary experience for anyone within earshot.

Mordaunt-Short's 10i Pearls are swift 'speakers that love everything but bass-heavy works. As long as you don't demand Dub Reggae basslines from their small, lightweight mid/bass drivers and you partner them with smooth, warm components, they won't fail to please. They have their flaws but at their best the Mordaunts make listening to music a joy and they possess that rare ability of being able to involve you with ease.

ELTAX LIBERTY 3+

THE TECHNOLOGY

Eltax are certainly not alone in their reliance on drivers from Vifa - the Swedish tweeters and woofers turn up in many a company's loudspeakers. In the Liberty Vifa are represented by a 26mm soft-dome tweeter and a 165mm mid/bass, its cone moulded from NRSC - Non-Resonant Suspension Coupling.

Eltax are certainly not bucking the trend for reflex loading, as the rear-mounted ports (flared at both ends to reduce turbulence) proves. They've also opted for quite a deep cabinet which endows them with a volume of nearly 18litres (380mm high by 205mm wide and 330mm deep). A deeper cabinet like this is theoretically a good idea as it lowers the frequency of reflections off the cabinet's rear wall and reduces the energy of these waves as they have further to travel.

SOUND QUALITY

The Danish company Eltax is relatively unknown in the UK, but as I looked over their new Liberty 3+ stand mounters I had a feeling that this will change soon. Unpacking the loudspeakers I thought there had been some sort of pricing error - these stand mounters looked like they ought to cost at least £100 more than their £150 thanks to their large cabinet and classy Cherry finish.

Before the serious listening started I experimented with positioning and found the best balance when the Liberties were positioned about a metre or so from the rear wall and strongly toed in towards the listening position. In our room they also worked best on heavy sand-filled Atacama SE24 stands as opposed to open-frame types.

'House Of The Rising Sun' by Cyndee (yep, that's Cyndee) Peters kicked things off. Cleanly-recorded, dark and bitter, this song lost little of its anger and sadness through the Eltaxes. Images were tightly focused in a wide, deep sound stage the 'speakers just

disappeared into, so that, closing my eyes, I couldn't pinpoint their location.

One word of warning: the Liberties' presentation errs a little on the bright side even when working with the Roksan Caspian CD/Audio Analogue Puccini SE amplifier. Make sure these 'speakers are partnered with warm, smooth components if this aspect of their sound is not to overshadow everything else they do so competently.

With Wagner's *Rienzi* (played by the Philharmonia Orchestra and conducted by Otto Klemperer), once again the Eltaxes captured the essence of the music, its dark majesty combined with a very real sense of power and menace. Horn sections through the Eltaxes were clear and possessed an attractive brassy rasp which refused to turn harsh and rough even during orchestral crescendos. Another plus point was the way delicate parts of the orchestra like triangles weren't swamped by the more powerful instruments. Dynamics were faithfully tracked and never sounded

strained or compressed. These qualities, together with the Liberties' cohesive nature, kept me listening to this CD far longer than normal.

A change of genre and tack found me spinning Gabrielle's CD to see how the 3+s would cope with more contemporary, up-tempo Pop recordings. Seeing as they're rhythmically adept, the Eltaxes made easy work of the barrage of synthesiser and drum machines on this album and assembled a truly involving performance. There was sufficient punch and slam in the lower frequencies to keep bass-heads happy too. A slight flaw that surfaced was some excessive sharpness and thinness in the treble. Fortunately this wasn't so intrusive it would keep you from lengthy listens to your music collection.

There's no two ways about it, the Liberty 3+s are a lot of loudspeaker for the money. They're musically involving, well built and look classy - what more could you want?



CONCLUSION

It was a close run thing between these five contenders but emerging victorious to carry off the laurels once more were Tannoy's Mercury m2s.



The m2s, clad in their grey or natural wood veneers (which make a refreshing change to the standard Henry Ford black vinyl wrap) are the best all-rounders in the group. They have a bottom end which goes deep given some volume and never loses control.

Matched to the accomplished mid/bass is an equally skilful tweeter that prefers crisp but colourful to hard and aggressive. Our measurements showed an almost imperceptible join between the two drivers which lends the m2s a sense of harmonious integration. Only Mission's 731 Pros, which boast similarly transparent crossovers, came close in this respect.

Tannoy have rustled up a revealing, weighty loudspeaker in the m2 that looks like it will be the budget benchmark for some time to come.

Noting that of the Mervals, and second place were the Eltax Liberty 3+ in closely measured terms, the Eltax Liberty 3+ then came next. Spearheaded by a massive 100W mid/bass unit, accompanied by a pair of elegantly styled tweeters, it gave a measured performance. Eltax's identical Mercury 1500 was the least



of sonic tailoring has resulted in a bright, forward sound with boofy bass. But the Liberty 3+s have a smoother tweeter and tauter bass and manage to stay the right side of the fidelity line with a solid, dynamic sound. As with the m2s, their large mid/bass driver has an easier time of large dynamic swings than the smaller units on the Missions and Mordaunt-Shorts.

The Eltaxes also put their deep cabinets to good use to yield a fair dose of transparency. And they had a speed and rhythm to their presentation that left even the Tannoys a little slow-footed at times.

Mission's tiny 731 Pros come next. Mission's experience and knowledge when it comes to loudspeaker design are obvious from the way they measure - there's the tiniest dip in their response at the crossover point and they have a well-judged gentle roll-down at the top end that will flatter brasher budget sources and amps.



The 731 Pros have a consistency and smoothness that makes them worth their price at any musical genre - they'll happily play the job. Their ability to handle a wide range of input signals, the lack of any major peaks and a lack of deadening dynamic range, meant that they were a very good choice for our measurements. We'd have to say that the 731 Pros are worth the

price. Much more was thought about the Liberty 3+ than the Eltax Liberty 3+ and the Liberty 3+ response was consistent with what we heard. A large dip around the crossover point was visible as the tweeter sounded separate from the mid/bass unit. There was also a general rise in output across the midband and into the treble, which gave the Pearls a slightly

forward character. At least their metal-dome tweeter is smooth and colourful in contrast to many of the hard and clinical units of yore.

Where the Pearls really made a splash was with their pace and dynamics. Here, they were second to none in this group. They possessed a vitality and speed which made music edge-of-the-



seat exciting. Transparency was another of their strengths. If Mordaunt-Short could only add more bass weight and iron out the lumpy response the 10i Pearls might become group leaders.

Last but definitely not least are JPW's ML 510s. These newcomers actually produced a superb measured response that's genuinely ruler-flat. You can hear this as an even balance which allows the JPWs to handle whatever music you throw at them. They also have a smooth warmth akin to the 731 Pros which should again make them a good match for some of the less polished budget amplifiers out there. Their bass was sufficiently extended to flesh out the dynamics of a lot of



With respect to JPW's other offerings, we'd say they should look on their own terms. In many ways, in both of these aspects they were the middle of the road Pearls - although they were made music a chore to listen to. With enhanced clarity and wider dynamics the 510s would be winners. ●

Meridian Digital Theatre™, the real thing.

Adding extra speakers to your audio system will never give you real home theatre and could spoil your music.

Meridian Theatre systems based around our award winning 565 7.1 and 541 Surround sound controllers have been designed from the start to provide the best music and a real home theatre experience.

Starting from our 541 analogue controller you can build towards a Meridian Digital Theatre system, now recognised as the finest in the world.

All Meridian products from our CD players and FM Tuner to the new 586 DVD player work as a matched system controlled from one handset using our own software so you can always be sure to keep pace with new formats as they appear.

DOLBY
DIGITAL

dts



24-bit
PCM

LUCASFILM
THX

BOOTHROYD STUART
MERIDIAN

Meridian Audio Limited

Stonehill, Stukeley Meadows, Huntingdon, PE18 6ED
Tel (0) 1480 434334 Fax (0) 1480 432948

<http://www.meridian-audio.com>

CD-REVOLUTION

Leo Lam, our man with the Personal Computer, ventures out to burn his own CDs.

With all the hype around the launch of DVD (Digital Versatile Disc), the giants in the hi-fi industry seem to have ignored a group which may silently usurp their supremacy - the computer manufacturers. Intel have dipped their toe into the waters of multimedia with the MMX processors, and on the high street there's already software in abundance which can do virtually anything that a hi-fi system can, albeit with lower sound quality.

Personal Computers (PCs) can replay all sorts of media, and now this flexibility is being extended to recording formats, including CD-R (Recordable). By comparison, the audio industry has failed to come up with a high-quality digital recording medium due to protests from the music business, although Philips' CDR 870 CD-R (Recordable) and CD-RW (ReWritable) recorder on p28 could change that. Still, a cheap and easy way to make your own CDs, if you have a PC, is to buy a CD-R drive and the necessary software.

CD-R is not new. Its big brother, CD-Erasable, was successfully developed by Philips back in the Eighties, but under pressure from the IFPI (International Federation of the Phonographic Industry) who feared consumers being able to record digitally would damage record sales, Philips decided not to market CD-E. However, since they're outside the ambit of the IFPI, the computer industry went for the idea and implemented it as a storage medium.

THE TECHNOLOGY

Basically, the CD-R disc is a WORM



Easy CD Creator's title screen greets you as the programme loads from its CD.

What's on offer with Easy CD Creator, including CD Spin Doctor, which removes scratches and clicks from recordings of LPs.



Easy CD Creator's Wizard helps you through the creation of your own CDs.

(Write Once Read Many) recordable CD. It consists of a plastic disc with a reflective layer, usually made out of gold, an organic dye layer and a protective polymer layer. Burning the dye layer with the laser inside a CD recorder creates a non-reflective 'scar' which mimics the pit on a CD. After the recording process, the disc is identical to a normal CD as far as a CD drive or player is concerned.

So, how do you go about turning your PC into a CD-R recorder?

INSTALLATION

I opted for one of Philips' CD-R drives, the CDD2600 together with a SCSI adapter. The software side of things was dealt with by Adaptec's Easy CD Creator Deluxe software.

I had no difficulty fitting the CD-R drive, although a working knowledge of your computer's innards helps. The CDD2600 is a 'plug-and-play' unit that slips into an empty drive bay. There were no system requirements mentioned in the literature but a 120MHz Pentium processor with around 32Mb of RAM should set a reasonable bottom line. A SCSI hard drive is a bonus.

This was how I did it. First, I carefully fitted the SCSI card into the PCI slot. Make sure you earth yourself before doing so because all the components mentioned here are very static sensitive. You can do this by touching the casework of the computer (which is plugged into the wall socket but switched off) before you start installing the various bits. Check and remember the jumper settings on the CD-R drive before slipping it into the bay as well. Don't fix it yet because getting the wires into its socket takes a bit of fiddling, especially if the wiring inside your computer is quite messy.

After this, dig out all the required wires - the power, the SCSI and the analogue audio outputs - for connection to your soundcard. After all the socket handiwork, you can finally secure the drive using all the four screws for stability and secure earthing. Now, put the case of the computer back on and off you go!

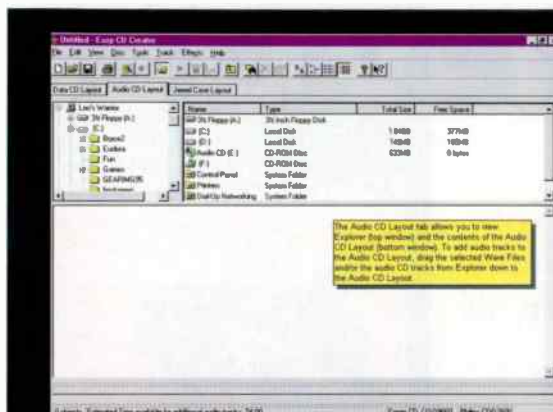

Before you can start filling a CD-R with recordings, you need to access 'Audio CD Layout'.

Once you're in the layout screen, you can listen to the tracks you're recording by clicking on them twice and pressing 'Play'.



THE SOFTWARE

Easy CD Creator Deluxe from Adaptec actually comes with 'AutoPlay': that is, it fires up automatically and gives you a graphic interface as the disc loads in the drive. The graphics were eye-catching and contained a multimedia demonstration of the software which, providing you can remember everything you've just seen, allows you to spin out a new CD immediately after the programme has loaded.

As its name suggested, this program was very easy to use. The Deluxe package that we had was bundled with other programmes which facilitated immensely the copying process. Easy CD Creator had a comprehensive user manual which was written in very precise wording.

BURNING YOUR OWN CD

The procedure for recording a CD is carried out through a friendly interface that makes the process very simple.

When you're composing a compilation CD of music from other CDs, first select 'New CD Layout' from the menu and then click on the 'Audio CD Layout' tab. This allows you to build up the list of tracks that you want to record onto your CD-R. To do this, simply drag and drop the required tracks from the Windows Explorer window where the music CD currently in the computer's CD drive is displayed.

A word of warning though. It really is a slow process if you make a copy from one music CD at a time to the CD-R drive. You can speed the process up a lot if you copy the tracks first onto your

hard disk and then make the recording from there. A friend of mine did it this way and managed to finish his compilation off in 45 minutes.

Once you've sorted out the track listing, select 'Create CD' and the 'CD Creation Setup Settings' box will appear. Here you can choose the speed at which you want the CD to be written, the number of copies you want to burn, etc. Finally, click 'OK' to start the recording.

Unfortunately, when I clicked 'OK' I was greeted by the message 'Error, buffer underrun'. The writing process needs a strictly continuous data stream and, although there was a memory buffer, an external programme, such as a sophisticated screensaver in my case, could draw too much processing time from the processor and force the buffer to 'run out of steam'. This would render the disc totally useless. Switching off the screensaver was the answer and my second disc popped perfectly formed out of the CD-R drive.

VIRTUAL VINYL

For all you vinyl fans, Easy CD Creator Deluxe comes with 'CD Spin Doctor' which you can use to archive your precious records. Spin Doctor is a software-based signal processor that reduces hiss, clicks and pops. All you have to do is plug the output of your pre-amp into your computer's soundcard (whose Analogue-to-Digital Converter will digitise your turntable's output), select Spin Doctor from the Adaptec menu, choose your source and press 'Record'. The software will automatically record the music onto the hard drive as a Windows sound file as long as you have enough memory.

Next, you can drag the resultant sound file into the CD track listing just like recording the tracks from a CD. The Spin Doctor can also automatically equalise the volume of individual tracks if you are recording from different sources like a cassette deck or microphone.

SOUND QUALITY

There were differences between the original CD and the copy, but I had to

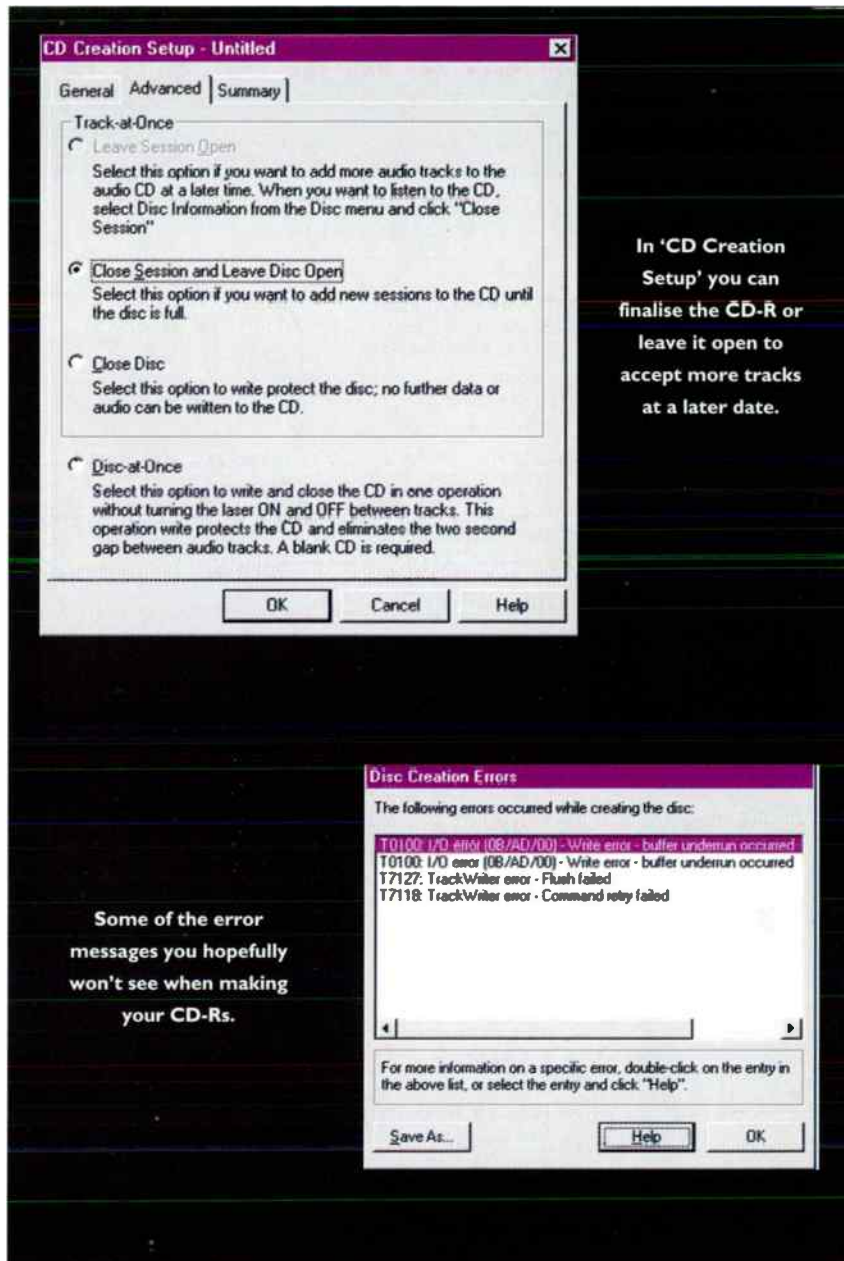

In 'CD Creation Setup' you can finalise the CD-R or leave it open to accept more tracks at a later date.

Some of the error messages you hopefully won't see when making your CD-Rs.

listen hard to find them. The copy generally sounded softer, lacking the punch of the original, and the sound staging and imaging shrunk slightly.

Tonal quality between the two discs was very similar, as was the amount of detail. The bianzhong (ancient Chinese bells the size of a car) in 'Symphony 1997' by Tan Dun sounded extremely convincing on the copy although there was a loss of ambient detail. In spite of the fact that the feeling of size and shape in a recording venue was diminished, it would be churlish to complain considering that a blank CD-R costs around £3.

There's a whole host of computer shops selling CD-Rs, so getting hold of blanks should be as simple as a call to your local supplier. If archiving or compilation making is your goal and you want sound quality better than cassette can offer, £69 spent on Adaptec's Easy CD Creator to go with your PC could be a fine investment ●

Adaptec UK
4 Archipelago,
Lyon Way,
Camberley,
Surrey GU16 5ER
Tel: 01276 854500

30 Branches Nationwide



At Sevenoaks Hi Fi you will find a wide range of products on show with the emphasis on quality combined with unbeatable value for money.

Everything in stock is on display and available for audition in our dedicated Hi Fi and Home Cinema demonstration rooms.

Our friendly and experienced staff will be happy to assist you through every step of your purchase to ensure total listening satisfaction.

Sevenoaks Hi Fi - there is no better place to buy.

Sevenoaks TOP TEN CD Albums only £9.99 each

- The Verve - Urban Hymns
- M People - Fresco
- Elton John - The Big Picture
- Portishead - Portishead
- Texas - White On Blonde
- Sleeper - Pleased to Meet You
- Jimmy Nail - The Best Of...
- Spice Girls - Spice World
- Oasis - Be Here Now
- Eternal - Greatest Hits

Sorry - no other titles available.
Max 3 discs per customer. Offer subject to availability. Personal callers only, E&OE.



30 SEVENOAKS HI FI BRANCHES NATIONWIDE

STOP PRESS
Sevenoaks **Top Ten CD Albums**
only **£9.99** each

- SEVENOAKS
01732 459555
109-113 London Road
- ABERDEEN
01224 587070
491 Union Street
- BEDFORD
01234 272779
29-31 St Peters Street
- BIRMINGHAM
0121 233 2977
12 Queensway Arches,
Livery Street
- BRIGHTON
01273 733338
55 Preston Street
- new BRISTOL
0117 974 3727
92B White Ladies Road,
Clifton
- BURY ST EDMUNDS
01284 753776
47 Churchgate Street
- new CARDIFF
01222 472899
104-106 Albany Road
- CARLISLE
01228 590775
3 Earls Lane
(Next to Bus Depot)
- CHELSEA
0171 352 9466
403 Kings Road, SW10
- CHELTENHAM
01242 241171
24 Pittville Street
- CROYDON
0181 665 1203
373 London Road
- ENFIELD
0181 342 1973
7 Genotin Road
- ESSEX
01376 501733
1 The Grove Centre,
Witham
- GUILDFORD
01483 536666
73b North Street
- HULL
Opening Early 1998



- KINGSTON
(LATE NIGHT THURSDAY)
0181 547 0717
43 Fife Road
- LEEDS
(OPEN SUNDAY)
0113 245 2775
112 Vicar Lane
- MAIDSTONE
(OPEN SUNDAY)
01622 686366
96 Week Street
- new NEWCASTLE
0191 221 2320
19 Newgate Street
- NORWICH
01603 767605
29/29A St Giles Street
- OXFORD
(OPEN SUNDAY)
01865 241773
41 St Clements
- PETERBOROUGH
(LATE NIGHT THURSDAY)
01733 897697
36 Park Road
- new PRESTON
01772 825777
40-41 Lune Street
- READING
0118 959 7768
3 & 4 Kingswalk
- new SHEFFIELD
0114 255 5861
Old Sheffield Savings
Bank, Heeley
- new SOUTHAMPTON
01703 337770
33 London Road
- TUNBRIDGE WELLS
01892 531543
28-30 St Johns Road
- WATFORD
(OPEN SUNDAY)
01923 213533
478 St Albans Road
- WORCESTER
01905 612929
2 Reindeer Court

Mail Order 01732 458985

NAIM AUDIO NOW AVAILABLE IN BEDFORD AND BIRMINGHAM

The renowned range of Naim Audio hi fi separates and loudspeakers is now available in our Bedford and Birmingham branches. To experience the quality of this superb British product please telephone Bedford 01234 272779 or Birmingham 0121 233 2977.

REWRITE THE RULES

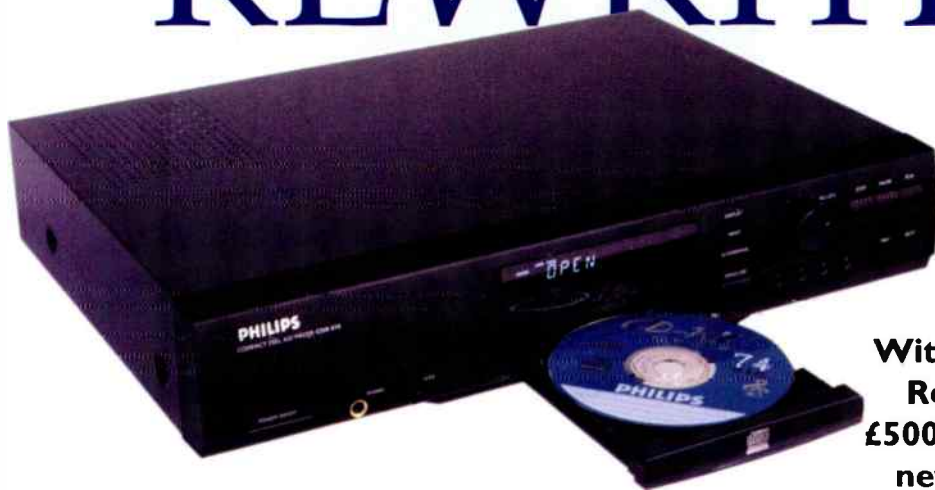

With the release of a combined CD ReWritable/CD-R recorder in the £500 CDR 870, Philips are opening a new chapter in home recording. Is this the recorder of the future?

People have stubbornly refused to buy DAT, then DCC and MD. All the signs are that technology in the home is now so commonplace - even intrusive - that no one wants multiple formats. Buyers are happy enough with CD and appear little interested in getting another box of tricks just for recording purposes.

Philips proposed recordable CD-E (CD-Erasable) in the late 1980s but under pressure from the music industry, especially its own Polygram label, quietly dropped the idea. Afraid that any recordable digital format would lead to rampant piracy the music business has done its best to prevent such technology entering the home.

But times change. Whilst piracy remains an issue, home taping does not. Also, Philips are now doing well in many areas of computing and CD-R - a CD that can be recorded only once - has really taken off. Polygram's many objections to recordable CD now have far less influence upon company policy, we have been told by an internal source. So the company has decided to revive CD-E in the shape of CD-ReWritable (CD-RW).

Meanwhile, CD-R prices have fallen thanks to strong demand from the computer industry and the discs are now going for around £2-£4, making the format a much more attractive

proposition for home recordists, albeit an inflexible one because CD-Rs cannot be erased.

Philips first CD-RW recorder, the CDR 870, records not only erasable CD-RW discs, currently priced at around £12, but less expensive non-erasable CD-R discs as well, which is good news. This is important, because there's another complication for you to consider. The new CD-RW discs have low reflectivity so they won't play on most CD players, only on new Multi-read players that possess a more sensitive read mechanism. So CD-RW discs recorded on the CDR 870 will play on it, but at present on little else until Multi-read players become more widespread. Luckily, CD-R discs have much the same reflectivity as a conventional CD, so anyone wanting to record CDs for the car or a portable will have to record on CD-R discs.

When it comes down to actually making those recordings, the CDR 870 is a breeze to use. Slip into the tray a CD-R or CD-RW (the procedure is the same for both). You then have to select either a digital or analogue input - pressing the Input button toggles between analogue, co-axial digital and optical digital. The only time you won't be able to make a copy is if you're trying to make a digital copy of a digital copy of copyrighted material (!), in

which case the Serial Copyright Management System kicks in to prohibit the process and stop Copyright infringement. To explain this malarkey, you CAN make a perfect digital copy of a commercial (i.e. copyrighted) CD, say for use in your car. But you CANNOT make a further copy from that copy. You can make multiple copies of your own recordings of course - say the dog howling - because you (or the dog) own the copyright and no S.M.C.S. flag will be inserted (unless you have an extremely clever dog).

For analogue recordings, first make sure you're working from the analogue input. Next, hit the button marked Auto/Manual to set track numbering. Once you've started recording, Auto inserts a new track number after a three-second silence in the music, while manual allows you to put one in wherever you choose - simply press Rec on the CDR 870 itself or Track Incr on the remote control. On copyright again, no S.C.M.S. flag can be transferred via analogue, so copies from the first copy are possible.

Pressing Rec for the first time puts the player into Record Standby mode which lets you set the recording level prior to recording. Now get your source playing and turn the Rec Level knob so that as many of the blue segments on the level meter light up

without any of the red (overload) ones lighting up. All that remains is to press Play and start the recording.

Recording from a digital source is even easier. Choose the input then press Rec and Play and start your source, or press CD Sync, which will set the CDR 870 recording as soon as it senses a signal from the source.

Whenever you stop recording, the display will show Update as the player updates its temporary Table Of Contents (TOC). This TOC contains information such as the number of tracks and recording time left (out of a maximum of 74mins). With a temporary TOC, you'll only be able to replay the disc on a CD-R/CD-RW recorder. To make the disc playable on a normal replay-only CD machine, its TOC needs to be made permanent. All you need to do is press Finalize and Rec and in about 2 mins time the permanent TOC will be set.

One thing to bear in mind is when a CD-R has been Finalized you can't record anything else onto it, even if there's spare capacity. The same goes for a CD-RW, although it can be totally erased and will then accept new recordings.

REPLAY

Björk's new album, Homogenic, with its barrage of sequenced drum machines neatly interlinked with numerous weird samples slipped into the Philips. The CDR 870 was evidently at home with the fast beats, showing fine attack and articulation, although the deepest notes were slightly blurred and lacked real slam. Björk's idiosyncratic and expressive vocals hung clearly between the 'speakers and there was sufficient texture and warmth to them to make for a compelling listen. The CDR 870 possesses an attractive smoothness which is very well judged and never spills over into being dull or bland because speed and bite remain good - a difficult balance to strike.

Switching over to the father and son team of Bucky and John Pizzarelli playing their version of 'Stompin' At The Savoy' (on Chesky's Sampler Vol 1) proved engrossing. Both men play seven-string guitars without

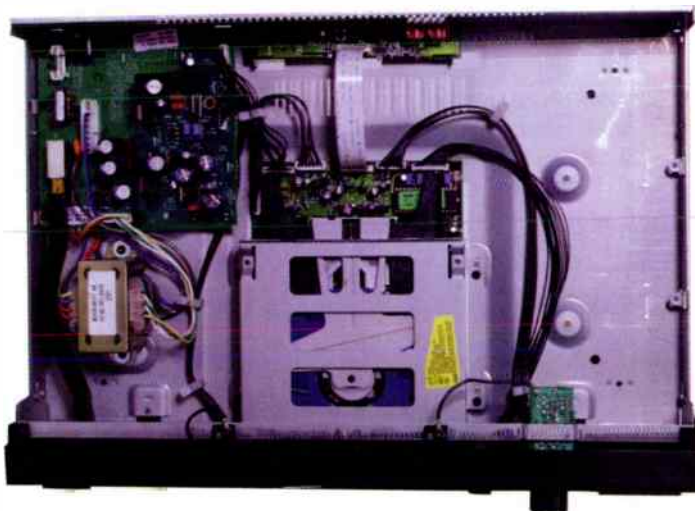

amplification and this gives the piece an incredibly natural feel which the Philips did a good job of conveying.

In playback terms, the CDR 870 acquitted itself well - it's equivalent to the best players at around £250-£300. But the main idea behind this machine is recording rather than replay.

PERFECT RECORDINGS FOREVER?

Listening to Daboa's From The Gekko album as a recording made through the CDR 870's Analogue to Digital Convertors (Philips own SAA7366) from the analogue outputs of Roksan's Caspian CD player, I found it had a fuller, softer sound than the original. Dynamics were more relaxed, which took some of the excitement out of the performance. Subtle detail was also lost and the sense of drive and pace this CD has was reduced, although recordings were still better than on cassette.

Recordings made via the digital input were, unsurprisingly, far closer to the original. With the digital input there were small losses in transparency, dynamics and detail but these would only show up through components costing more than the CDR 870's £500.

So much for differences between original and recording. What about between CD-R and CD-RW? On 'The House Of The Rising Sun' sung by Cyndee Peters the differences were again small. CD-R had a more vivid, dynamic sound and the sense of space around Cyndee's vocals was better. CD-RW countered this by having a

smoother, more controlled presentation which made the double-bass easier to follow. Bells and cymbals had their leading edges rounded off very slightly too.

As a way of putting together compilation discs the CDR 870 looks like a stone cold bargain. After contenders like DAT and MiniDisc have failed to take off because of their non-existent pre-recorded catalogues and opposition from the music business, there is now an affordable rerecordable digital format backed up by the biggest catalogue around.

But what about recordable DVD, you may be thinking? Well, until the wrangling over standards is settled, DVD isn't really relevant. CD-RW alongside CD-R is going to be ruling the roost for quite a while. Nice one, Philips.

Philips CDR 870 £499.99

Philips
420-430 London Road,
Croydon,
Surrey CR9 3QR
Tel: 0181 689 4444

WORLD VERDICT

At its price, the CDR 870 is a bargain sonically and financially.

Measured Performance
see P111



JMLab by FOCAL

GRANDE UTOPIA

"For me, this is truly the ultimate desert - island loudspeaker"
Jack English
Stereofile, Volume 19
No. 5.

Sound Image UK Ltd
52 Milton Road London SW14 8JR
Tel 0181 255 6868 Fax 0181 255 6869

JMLab

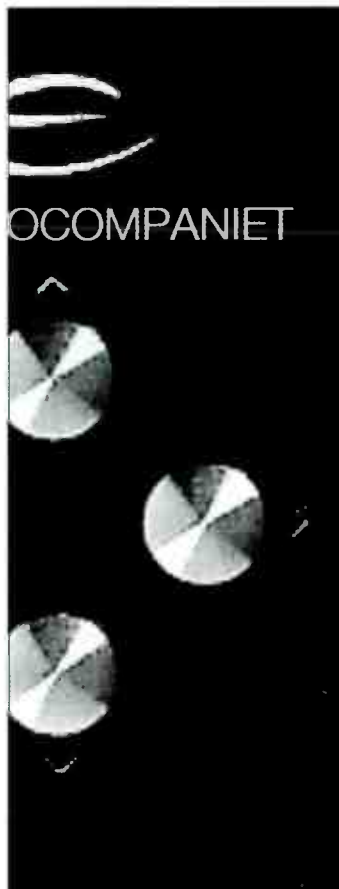

Hi Fi Choice "The **ECI-1** is one of the more important integrated amplifiers out there in hi fi land." Alan Sircom
England June 95

Hi Fi Choice "Electrocompaniet's cheapest amp is the one to beat." Alvin Gold
England May 96

Hi Fi News & Record Review "AW100DMB combined with the EC-4 preamplifier is recommended for amplifier combinations over £2000" Alvin Gold
Nov 96

Prices from £500 ECP-1 phono stage through ECI-2 integrated at £995 to the AW 250 DMB @ £3995

Sound Image UK Ltd
52 Milton Road London SW14 8JR
Tel 0181 255 6868 Fax 0181 255 6869



High End has never been so affordable



* Amplifiers, D/A Converters, CD Players, Tuners and Mini CD's
* Perfect sonic performance combined with stunning good looks.
* Designed by Dr. R. Brown and Prof. M. H. H. H. H.
* Hand built in the UK by world experts
* Prices from £299 to £599
* NEW entry level Midal range



THE ULTIMATE AURAL EXPERIENCE

LFD Audio, Midal House, 23 Clifton Hill, Clifton, Bristol, BS2 9EP, UK
Tel: 01274 432444 Fax: 01274 221009

HORN LOUDSPEAKERS
Klipsch
IMMORTAL SOUND FORESIGHT

Hear KLIPSCH for yourself in:

Bucks - Northwood Audio 01296 28790. Cheshire - Philip Dooley 01625 264666. Cornwall - R J F Audio Visual 01209 710777. Sounds Perfection - 01326 221372. Eire & N. Ireland - Kronos Hi-Fi 01868 748632. Hants - The Audio Gallery 01730 895194. Herts - Radlett Audio 01727 855577. Humberside - ZFB Audio 01472 883722. Hunts - The Hi-Fi Company 01733 341755. Kent - Sounds of Music 01892 547003. Lancs - Orpheus Audio 01257 473175. Leics - Audio World 01162 571414. Notts - John Kirk 01159 252986. Chantrey Audio 01777 870372. Suffolk - Audio Images 01502 582853. Sussex - Heatherdale Audio 01903 872288. W.Mids Fiveways Hi-Fi 0121 455 0667. Worcs - Music Matters 01384 444184. Yorks - The Hi-Fi Studios 01302 781387. London - KJ West One 0171 486 8262. Musical Images 0181 952 5535. Purist Audio 0171 431 7423. The Audio Consultant 0171 380 0866.
UK Distributor -

Midland Radio Supplies, Maypole Lane,
Birmingham B14 4PE.

TECHNICAL DETAILS

Though CD-RW is a new technology as far as domestic audio goes its roots are very much in CD-R which was introduced back in 1991. So to understand how it works let's have a brief look at CD-R first.

The CD-RW disc is very similar in construction to existing CD-R discs, the main difference between the two lies in the material used for the recording layer. CD-R uses an organic cyanine dye coating which is applied over a substrate that contains a tracking groove (called the pre-groove). The pre-groove has a 22.05 kHz analogue signal mechanically imprinted onto it (lateral modulation), frequency modulated by plus or minus 1kHz to record time code and other disc information. The 22.05kHz frequency is used to control the turntable motor speed, while the time code information is used to position the recordings on the disc.

To record, the organic dye coating is heated by the laser beam. Once the intensity of the laser passes a certain threshold (approximately 250 degrees C), the recording layer melts, creating a bump. This is an irreversible process which drastically alters the optical characteristics of the disc. Using this technique, a bump pattern is written on to the flat top of the tracking groove, producing a digital recording.

With CD-RW, there are two main differences. The

reflecting layer is silver. The recording layer consists of silver, indium, antimony and tellurium. It can have two states (phases): low reflectivity and high reflectivity. They are equivalent to a conventional CD's pits and lands. Whereas conventional CD and CD-R have reflectance specifications of 70% minimum for lands and 28% maximum for pits, because of the nature of CD-RW these fall to 8% for the pits and 20% for the lands. These lower reflectance values mean that playback on existing CD players is not guaranteed. Philips claim that only 30% of the machines out there can actually play recorded CD-RWs but they are also not sure which machines are compatible. Compatibility will be ensured in the future as all forthcoming Philips CD players, known as Multi-read players, will be able to read recorded CD-RWs.

The actual CD-RW recording process is as follows. The low reflectivity phase is produced when the laser heats the recording layer rapidly above its melting point of 500-700 degrees. Cooling very quickly, the low reflectivity domain 'freezes'. The high reflectivity phase is caused by the laser heating the recording layer to a lower temperature for a longer time. The life of a CD-RW under this heat treatment is at present claimed to be about 1000 write/erase cycles, though with more development it is expected to increase.

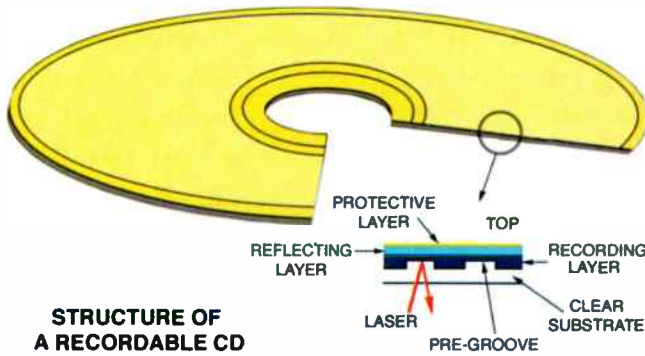

STRUCTURE OF A RECORDABLE CD

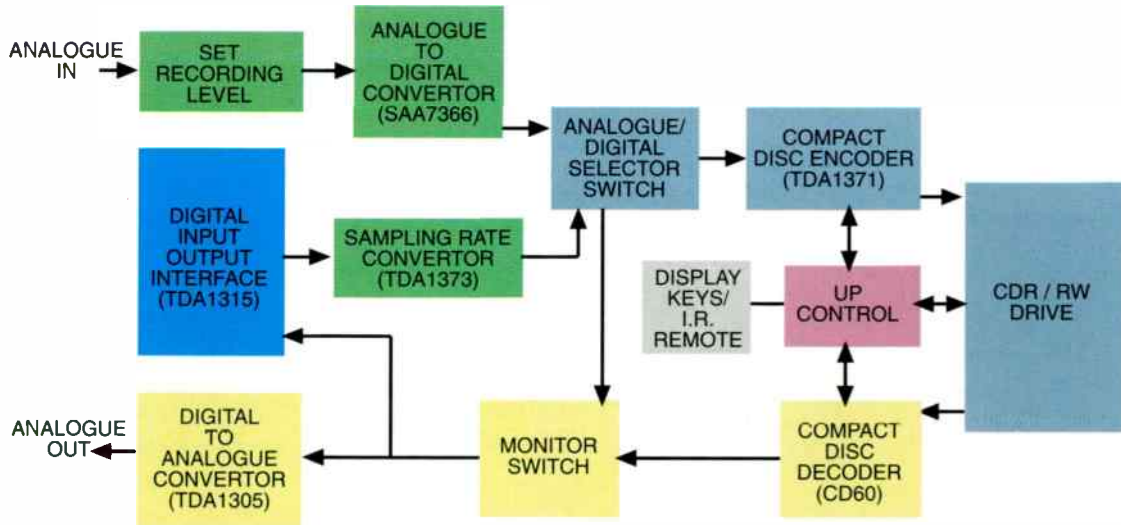

Philips use many of their own silicon chips in this new recorder, including the specialised SAA7366 A/D convertor. Note the Sampling Rate Convertor, TDA 1373, another Philips chip. This accepts input sampling rates between 15kHz and 56kHz, including standard rates of 32kHz (satellite), 44.1kHz (CD replay), 48kHz (DAT replay). For chip details go to: <http://www.semiconductors.philips.com/>

DAC
GEEK

THE GOLD STANDARD

AUDION
EST.1987



"A VOYD REFERENCE TURNTABLE FOR THE MILLENIUM"
THE "ULTIMATE" FROM THE DIGITAL ANALOGUE COMAPANY

"The D.A.C. Was so musical so engaging and so
captivating that you couldn't walk away and leave it"
Audio Quarterly sept '97

"This is probably the richest and fastest-handling
CD player we've heard, at any price."
What Hi-Fi april'97
FIVE ***** STARS

"The player makes you hungrier the more it satisfies"
What Hi-Fi '97

NEWS FLASH
NEW RANGE AND SILVER OUTPUT TRANSFORMERS

ALEMA LTD 103 SOUTH STREET LANCING 01903 750755 / 750756

UNCONVENTIONAL WISDOM

Ketan Bharadia samples Roksan's £1000 Ojan 3 loudspeakers and finds a refreshing mix of unique styling and innovative design.

If there was ever a competition for the manufacturer who picks the most unusual product names, Roksan would surely be the winner. After all, Xerxes, Artemiz and Darius are hardly run of the mill. This tradition is continued in the Ojan 3s which, in line with their name, are hardly 'speakers of standard design.

Loudspeaker manufacturers like rectangular cabinets because they are easy and cheap to make - that's why 99% of all enclosures are built in this shape. But barring a cube, a rectangular box is the worst choice from the point of view of standing waves so Roksan have decided to forget convention and plump for a squat, sloped-back design in the reflex-loaded Ojan 3s.

And that's not the only bit of original thinking in these 'speakers. There's also the tweeter mounted on an MDF 'paddle' which is attached at the base of the front baffle on a curved metal bracket. This decouples the tweeter from the vibration of the mid/bass unit and yields clearer, more focused treble.

Returning to the norm, the Ojan 3s can be mass loaded but Roksan only recommend this if the 'speaker is placed away from a rear wall in a large room. In ours, the best results were achieved with the unloaded Ojans 1.5m from the back wall and toed very slightly inward.

I fired the Roksans up with Tchaikovsky's Pathetique as performed by the Royal Philharmonic Orchestra. This piece opens with double-basses and here the Ojans revealed one of their major strengths by reproducing the deep thrum of these notes with their full weight. The rest of the orchestra wasn't lost in an amorphous mass but came through with great definition and detail.

Sound staging was good, even if, regardless of toe-in, width wasn't as great on this piece as I've heard it from something like the Jamo Concert 8s. Depth was excellent though, as was the focus of individual instruments.

Dynamically the Ojans are hard to fault too - even during full-blooded crescendos, transients were given their full impact and instrumental images didn't blur. Tonally the verdict was slightly lean and crisp, the tweeter having a tendency to sound a little too vivid for its own good.

Unusually, considering the forwardness of the 25mm fabric-dome tweeter, the midrange had a shut-in character which curtailed projection of vocals. Our measurements show two dips in the Roksan's frequency response where the 8in. mid/bass driver has difficulty in reaching high enough to integrate with the tweeter properly.

Moving on to Donna Summer's 'She Works Hard For The Money', the Ojans were revealing enough to show that the production wasn't the best without drawing my attention away from the music. Playing their parts here were the excellent rhythm and timing that make these 'speakers genuinely fun to listen to.

The Ojan 3s remained consistent whatever the music - they were never less than involving and they possess a



rare ability to reproduce bass with real power and rhythm. True, they have a couple of foibles and, in areas like openness and transparency, they're outshone by the competition. But looked at as a whole the Ojan 3s are well worth putting on your shopping list.

Roksan Ojan 3 £899

**Roksan
Stonehill,
Huntingdon,
Cams. PE18 6ED
Tel: 01480 451777**

WORLD VERDICT

Unusual 'speakers with excellent rhythmic capabilities and great bass. Could be more transparent though.

**Measured Performance
see p111**



In our Christmas competition all this month's reviewees are up for grabs.

It's January bonanza time as we maintain a Hi-Fi World competition tradition and offer every component reviewed in the magazine this month as a prize. All 15 items are up for grabs - that's £4200 of

equipment to be won.

It's important that you state your order of preference for the prizes as we will be grading the winners on the quality of their tie breakers and allocating the highest selected prize

available. So winner No1 will get their first choice, winner No2 theirs and so on. Only if a prize has already been selected by someone else will a winner get a prize that isn't their first choice.

COMPETITION ENTRY QUESTIONS

- 1) How many pairs of 'speakers are on offer in this competition?
A. 5 B. 6 C. 7 D. 8
- 2) How much are this month's prizes worth?
A. £500 B. £1000 C. £7000 D. £4200
- 3) Which is the most expensive item on offer?
A. Musical Fidelity X-A50 monoblocs
B. Roksan Ojan 3 loudspeakers
C. Ringmat Statmat
D. DNM Licon
- 4) How many Statmats are being given away?
A. 4 B. 8 C. 13 D. 10
- 5) Which recordable digital formats are represented in the competition?
A. CD-Recordable, CD-ReWritable and MiniDisc
B. Digital Audio Tape
C. Digital Compact Cassette
D. Sony U-matic

TIE BREAKER (obligatory)

Complete the following in less than 30 words

The time is Christmas and Santa is here,
With a prize from World you'll be in good cheer,
Just answer the questions and write your tie breaker,
To win some hi-fi that'll shake your money maker

.....

.....

Name:

Address:

Post Code: Tel No.

Please do not add my name to your mailing list.

PREFERENCES:

- JPW ML510 loudspeakers
- Mission 731 Pro loudspeakers
- Eltax Liberty 3+ loudspeakers
- Tannoy Mercury m2 loudspeakers
- Mordaunt-Short MS10i Pearl loudspeakers
- Kenwood DM-9090 MiniDisc recorder
- Roksan Ojan 3 loudspeakers
- Musical Fidelity X-Pre/X-A50 amplifiers
- DPA White Slink interconnect
- Pentacore Plain Soft Copper interconnect
- Prowire Silver interconnect
- Statmat anti-static CD mat (10 off)
- Licon contact enhancer
- GATE Troughline Decoder
- Philips CDR 870 CD recorder

If you'd like to enter this corking Christmas competition, just answer the questions opposite and complete the tie breaker. Then send in your entry form on the back of a postcard or sealed envelope to reach us before January 7th to:

Hi-Fi World Christmas Competition
Hi-Fi World Magazine,
64 Castellain Road,
Maida Vale,
London W9 1EX

Don't forget to include your name, address and telephone number if possible so that we can contact the winners promptly.

COMPETITION WINNERS

NOVEMBER ISSUE COMPETITION

In November we had a Mistral integrated amp, CD player and phono stage to give away to three lucky winners. And those winners are:

Peter Ash of Hengoed
wins the Mistral amplifier

Mick Page of Birmingham
wins the Mistral phono stage

Patrick breaden of Lewisham
wins the Mistral CD player

Congratulations!

COMPETITION RULES AND CONDITIONS

[1] Only one entry per household. Multiple entries will be automatically disqualified.

[2] In the event of more than one entrant submitting all-correct answers, the winner will be picked from the tie-breaker by the editor. We will endeavour to publish the results in the second issue following the closing date.

[3] Purchase of the magazine is not a precondition of entry

[4] No correspondence will be entered into; the Editor's decision is final.

[5] No employees of Audio Publishing Ltd. or of any companies associated with the production or distribution of the prizes may enter

SUGDEN

HAND CRAFTED ■ FAIT À LA MAIN

PURE CLASS A FROM £599

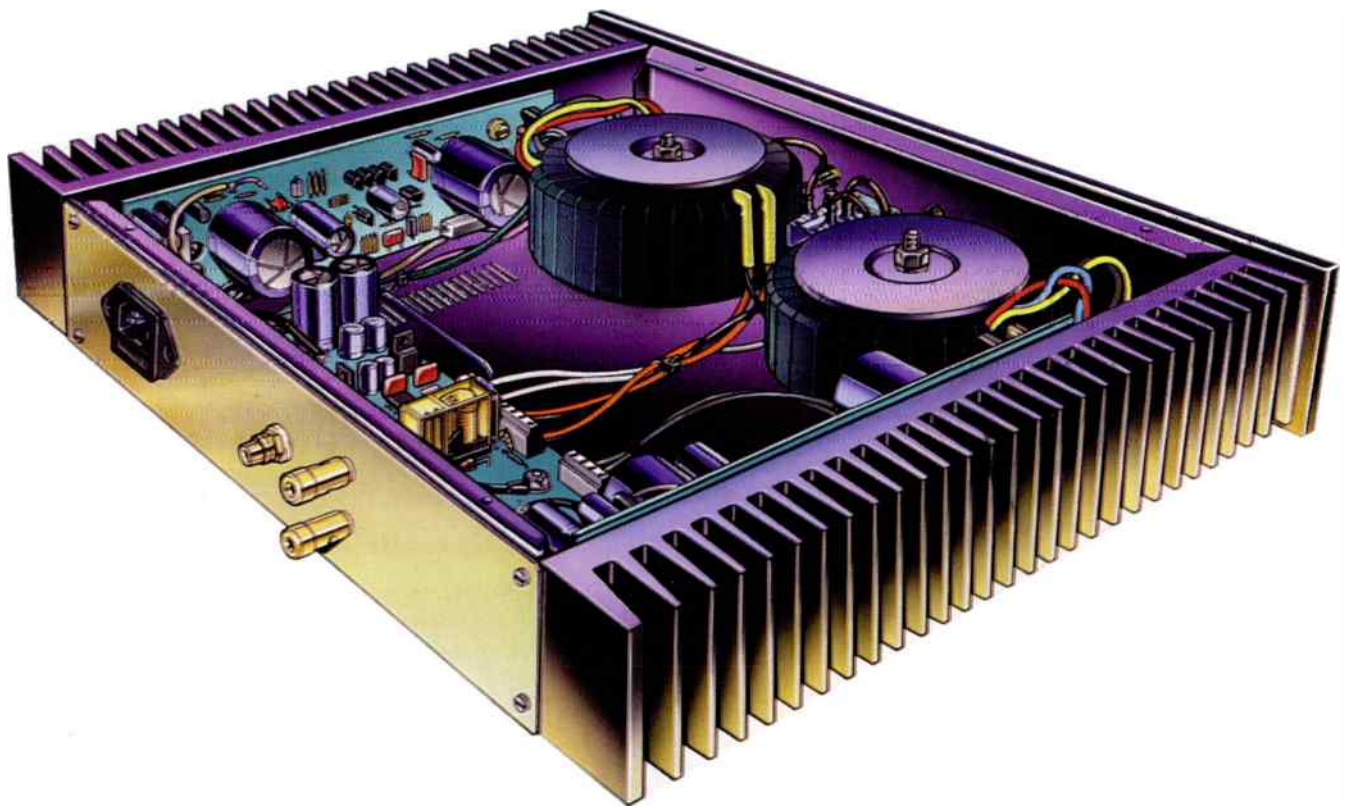

**INDIVIDUALLY HAND CRAFTED
REFERENCE SOUND QUALITY
SENSIBLE RETAIL PRICES
PURE CLASS A OPERATION
THE ORIGINAL AND BEST**

DESIGNERS AND MANUFACTURERS OF REAL AUDIO EQUIPMENT

J.E. SUGDEN & CO.LTD

Valley Works,

Station Lane, Heckmondwike,

West Yorkshire WF16 0NF

Tel: Heckmondwike 01924 404088/9

Fax No: 01924 410069

World Radio History



Dominic Todd finds Musical Fidelity's new X-Pre pre-amp and X-A50 monoblocs have that vital X-factor.

In the beginning there was the Musical Fidelity X-10D buffer, designed to sit between CD player and amp. I must admit I was rather sceptical about its chances at first; the same sonic tricks, aimed at warming up and smoothing out CD's sound, have been tried before - remember the Francinestien? My fears proved unfounded though and the valve-based X-10D, reviewed last month, has proved a great success. Hoping to build on this, Musical Fidelity have produced a whole range of X components, including a couple of DACs, a phono stage, a headphone amp and a pre-amp, all of which follow the same 'hi-fi in a can' styling theme.

Now, step forward the X-A50 monobloc power amps, with their extra-long cases stretched to accommodate a toroidal transformer. Each X-A50 offers 50watts of power from its Class A/B biasing - unlike many other MF amplifiers, these don't

operate in egg-fryingly hot pure Class A. Cooling wouldn't be a problem even if they did as the output transistors use the whole of the casing as a heatsink, form following function with attractive results. The drawback with Class A is its low efficiency (around 25%), which often means much punier output power than the X-A50s' healthy 50watts.

In an attempt to mimic the richness of sound apparent in most Class A amps, the matching X-Pre line-level pre-amp sports a valve output stage. Even with only four inputs, the Pre, like the X-A50s, offers great value for money. I do, however, have a couple of gripes. The first is that the tiny volume and source selector knobs are fiddly in the extreme. The other is that the pre-amp has no On/Off button - fine if the unit can be left on all the time, but as it has a plug-mounted PSU this makes it rather impractical otherwise. Still, the build quality is solid and you can guarantee the threesome will be

noticed by even the most hi-fi illiterate of guests.

The units were linked together with Musical Fidelity's own X-Link 'no nonsense' interconnects and fed from a Cyrus dAD7 CD player. At the other end of the hi-fi chain sat a pair of Celestion SL6s and Mission's 750 LE loudspeakers.

The influence of the pre-amp's valve was immediately apparent. The guitar sounded sweet and mellifluous while still showing realistic definition. Likewise the percussion, which was crisp and spacious thanks to treble that sparkled without resorting to fierceness. Bass weight was good, if not exceptional, but then from a 50watt amp you can't expect thundering subsonics. It's just that after the incisiveness shown by the midrange and treble I had hoped for more.

Where the benefits of going the monobloc route really came to the fore was with sound stage depth and width.

MS

Mordaunt-Short



"The MS20i Pearls are outstanding speakers. The low-end is tight yet well extended, treble is crisp, and the mid-range sounds as open and natural as you could wish. Fast, revealing and seamlessly integrated from top to bottom, ... Get it right, and these are the best speakers £200 can buy."

WHAT HI-FI? October 1997 ★★★★★

A Little Gem

"Standmounters that sound simply huge - the most complete speakers you can get at the price."

WHAT HI-FI? Awards 1997

The MS20i Pearl is a further celebration of Mordaunt-Short's 30th Birthday and, like the MS10i Pearl and the MS25i Pearl, has been born from a lasting dedication towards new technology and a fearless, open-minded approach towards original thinking and innovation. In short, the Pearl Series encapsulates all the ideals that have ensured Mordaunt-Short's success over the last 30 years.

Worthy of the 'Highly Recommended' accolade at the 1997 What Hi-Fi Awards, the MS20i Pearl features a painstakingly developed moulded cone and surround using patented MCS₂ technology to ensure a clean, seamless transition to our acclaimed gold anodised aluminium tweeter. This provides the listener with stunning clarity and detail in both the mid-band and treble. The inclusion of a new, bi-wireable crossover with distributed component resonances reduces signal cross-talk and colouration at the normally troublesome cross-over frequencies, resulting in an impeccably realistic sound-stage image. In addition, the cabinet has been retuned to provide a deeper, cleaner, more forceful bass.

All this translates into a speaker that What Hi-Fi? describes as being "Taut, clean, weighty and above all highly musical", we like to describe it as "A Little Gem".

For your FREE copy of this review and a FREE Mordaunt-Short literature pack, including details on the Music Series i loudspeakers, Home Entertainment loudspeakers, Performance loudspeakers and the V Series loudspeakers, CALL FREE NOW on 0321 506550 (24 hours)

<http://www.mordaunt-short.com>

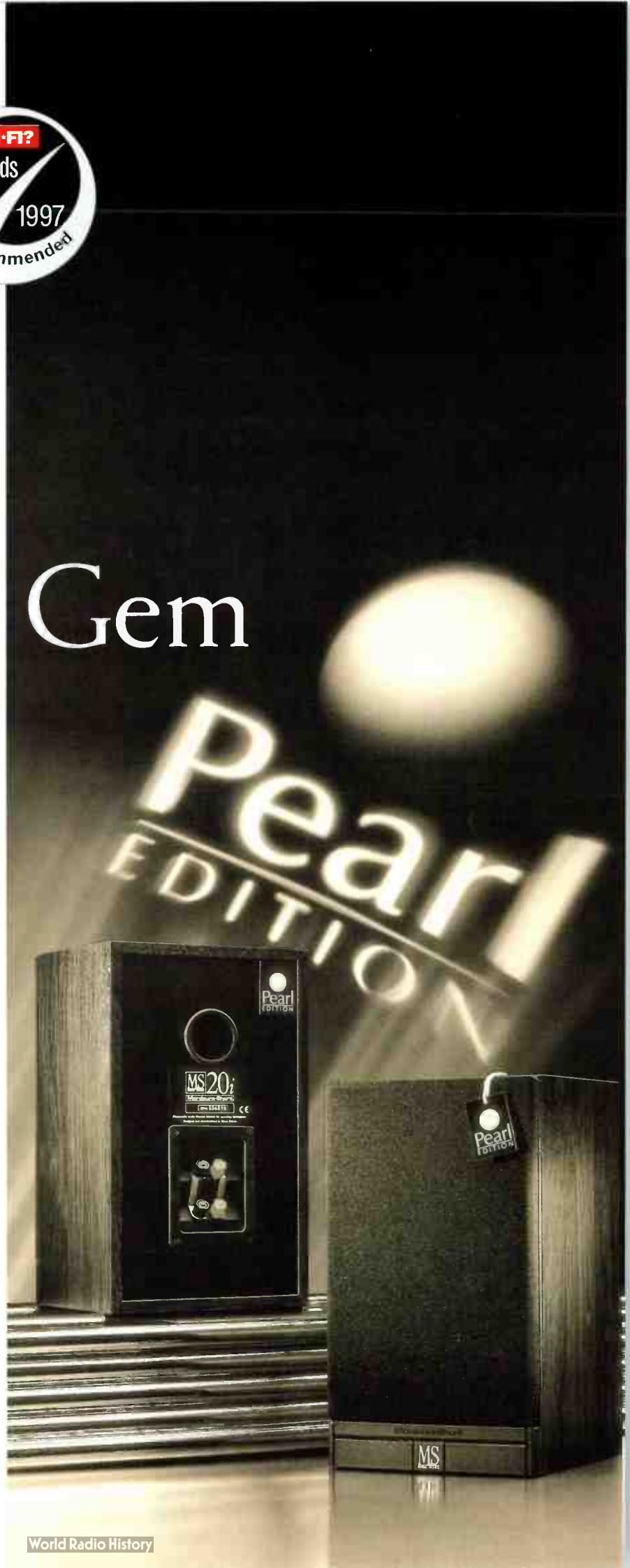

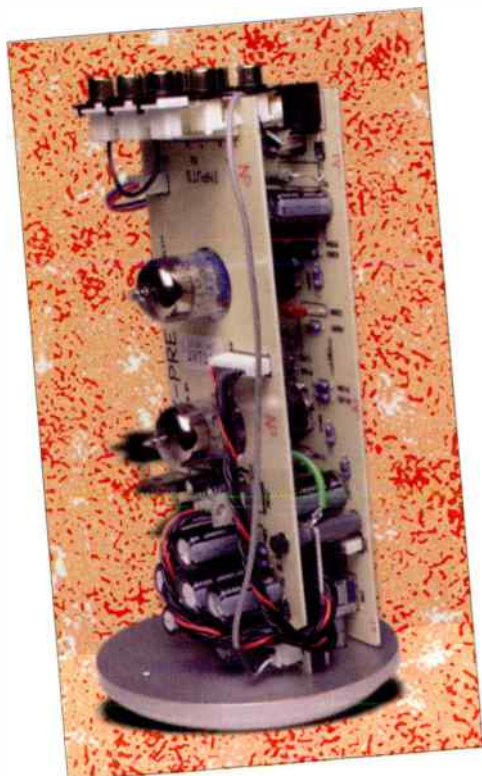

There was a level of openness and instrumental separation that even the best integrated amps struggle to achieve.

A sparse, melancholic backdrop was offered by The Blue Nile's 'Heatwave'. On this track, vocals were not quite as forward as they have been through some of the amplifiers I've heard but the X-Pre/X-A50s still captured the music's sense of weariness. And the smoothness in the upper registers translated into hours of fatigue-free listening.

Moving considerably up-tempo, I rendezvoused with Bobbi Humphrey's Jasper Country Man CD on the Blue Note label. This album's funky bassline has got to come across with its drive and slam intact if it's going to keep you involved. The X-A50s managed this feat, but only just. There was a softness at lower frequencies that reminded me very much of previous Musical Fidelity amps - it actually seems to be something of a company trait. This and a rather lightweight piano sound apart, the rest of the performance was exceptionally good. Flute soared above

the rest of mix, the X-Pre and X-A50s showing off their midrange prowess. Ditto the sound stage, populated with tangible images all the way out to far left and right. And where some competitors trade in a touch of control to broaden their sound stage, the X-A50s kept their cohesion with what is a complex and demanding piece of music.

They provided a similar balance on Mendelssohn's The Hebrides, Op26. There was a little veiling during the introduction and the kettle drum wasn't quite as dynamic as it could have been, but that's splitting very small hairs considering the outlay.

The MFs obviously have a soft spot for strings, with a fluidity and total lack of transistor grain worthy of more exotic designs. The way these amps concentrate more on emotion than analysis doesn't make them a natural choice, if you're interested in every last detail and texture in a Classical piece. As a means of enjoying music they rate very highly at the price because of a combination of

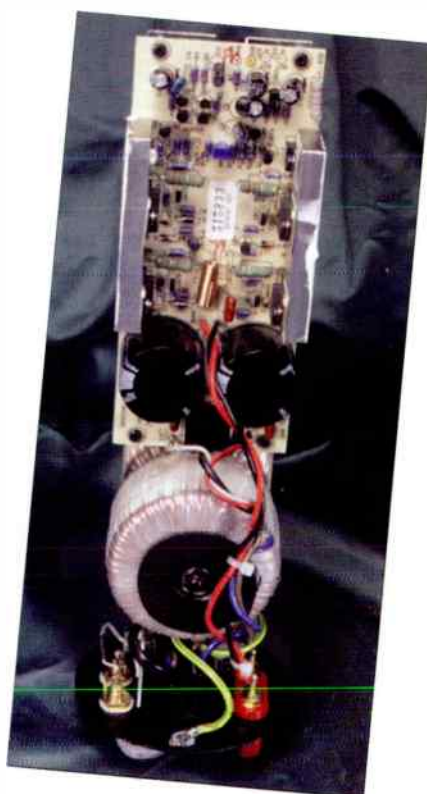

seamlessness and tonal colour.

Michelle Shocked's 'Hello Hopeville' showed the Xs could bop with the best of them. Her vocals were passionate, vivid and smooth, lacking the hardness common to transistor amps. When the guitars let rip, the raw energy was still there - it hadn't been smothered by the gloss that can afflict lesser Class A and valve amps.

A taste of the high end: it's become something of a cliché, I know, but this really does sum up the X-A50 and X-Pre combination. High end in that the styling is eye-catching and, at the same time, practical and solidly constructed. As with the Michell Gyrodek, I can see people being tempted by the X-Pre and X-A50s on the basis of looks, engineering and value alone. Fortunately, again like the Gyrodek, they pull ahead of the crowd in sound quality too. Their even-handed approach and musical fluidity add up to the type of sound that'll have you going through your entire record collection for the first time in months.

There's no such thing as perfection though. The soft bass could cause problems, if partnered with loose sounding 'speakers, so match carefully. These are also not the most revealing and analytical of amps. But if you value involvement over accuracy and match your ancillaries carefully, you'll find the X-Pre and X-A50s simply X-cellent!

X-Pre £199.99
X-A50 £499.99

Musical Fidelity
15-16 Olympic Trading Estate,
Fulton Road,
Wembley,
Middx. HA9 0TF
Tel: 0181 900 2866

WORLD VERDICT ⓄⓄⓄⓄ

Both X-Pre and X-A50s are smooth, sweet and musical performer.

Measured Performance
see p103

STATIC RUINS THE SOUND
FROM YOUR CDS

 **STATMAT**

STOPS THE STATIC

Another
innovative
product
from the
designers of
Ringmat

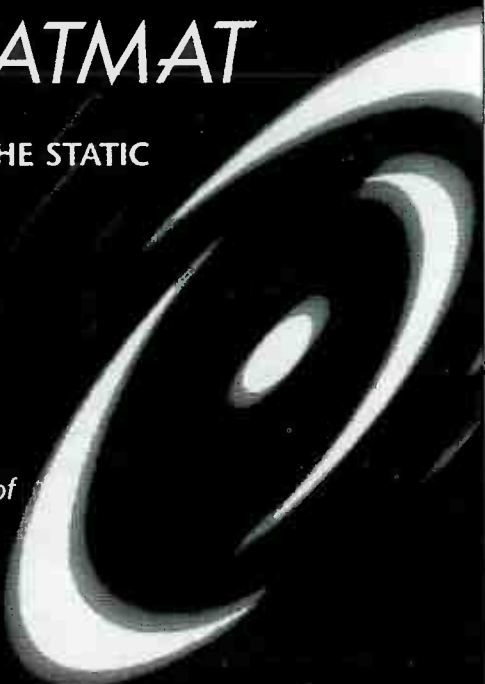

FIRST REVIEWS & CUSTOMER COMMENTS

".. Listening extensively myself, and trying the Statmat effect on others, I now instinctively use the device all the time....Indeed. the Statmat...makes the spoken word more articulate and clearer in inflections (and therefore instrumental sounds too), and gives phrasing and timing in music a more natural, non-fatiguing character...." Christopher Breunig (Hi-Fi News & Record Review, November 1997)

"..It definitely worked. What I heard was impressive...the sound isn't just smoother, sweeter or sharper. Rather, the music itself seems to change, becoming rhythmically more cohesive, and altogether more purposeful and coherent." Jimmy Hughes (Hi-Fi Choice, December 1997)

"Unbelievable how much difference a piece of plastic film can make. Stereo imagery, depth and solidity all improved. I can no longer play a CD without STATMAT!"

Mr A.C. Nottingham

"I'm always a little sceptical of so-called hi-fi tweaks, but in this case both my wife and I were stunned! Your claims are justified, voices were particularly affected, a more natural sound and intonation. Instruments are cleaner and better sorted. Everything sounded more relaxed and fluid. CD has just taken another step forward! Excellent product!"

Mr. N.M. Sleaford

"It works and betters `mats` I've tried so far" Mr R.E. Milton Keynes

STOP THE STATIC WITH

 **STATMAT**

IT'S NEW.....

.....IT'S ONLY £19.95

RINGMAT DEVELOPMENTS

P O BOX 200, Brentwood, Essex, CM15 9FB GB
T +44 (0) 1277 200 210 F +44 (0) 1277 201 225

Also available on mail order. UK p&p £1.95
Outside UK: Total cost £25, incl. p&p

**TAKE A
LOOK AT
THE NEW
CHAMELEON 2**

A genuinely well balanced mix of power, openness and clarity. Superb control and imaging. For a well balanced view of your Hi-Fi sound out the Chameleon 2.



For further details:
The Chord Company,
30a Sarum Business Park,
Portway, Salisbury,
Wiltshire, SP4 6EA.
Tel: 01722 331674
Fax: 01722 411388
WWW.CHORD.CO.UK.



THE CHORD
COMPANY
LIMITED

SOUND

OUT

WIRE WINNERS

If you have £65-£75 to spend on interconnects, where should you invest? Ketan Bharadia reckons DPA, Pentacone and Prowire are three to consider

PENTACONE PLAIN SOFT COPPER £74.95/m



Looking very Christmassy in its chocolate-brown sheathing, the Pentacone boasts some of the best fitting phono plugs I've come across. They made a tight connection without being so tight as to require Arnold Schwarzenegger-type strength to remove them from the sockets.

Sound-wise, this cable is the most dynamic of this group, with transients faster than a speeding bullet even on laid-back songs like Eric Bibb's 'Look Over Yonder'. Bibb's rich voice was well conveyed tonally but sounded a little dry, as did cymbals which were a touch sharp.

The Stockholm Arts Trio playing Schubert's Trio, Op99 once again benefited from swift dynamics, both small and large scale. There was a pleasing immediacy to the sound and instrumental harmonics were well captured. The Pentacone is a hard-hitting, rhythmic cable which can capture the subtlety in music too

Pentacone
4 Cross Bank Road,
Batley,
West Yorkshire
WF17 8PJ
Tel: 01924 445039

PROWIRE SILVER £59.99/m

Just by examining the Prowire's build you'd never guess it's the cheapest interconnect here. It's immaculately finished and has some of the best-engineered connectors I've seen.

This cable has a very different character to the Pentacone. The Stockholm Trio had a smooth, spacious sound, albeit without the level of detail of the Pentacone and DPA. Piano notes flowed well but had their leading edges rounded off and lacked the final degree of attack. Similarly, violins were clear



and precise but also overly sweet.

Moving onto something yellow and soothing I slipped Isaac Hayes' Branded into the CD tray. This album suited the Silver down to the ground, its rich, full basslines carrying plenty of weight but staying tight enough not to sound loose or blurred. Some subtleties of his voice were overlooked and transients didn't quite have the oomph they should have, but overall this cable is pleasant and easy to listen to and good value as well.

Vivanco (Prowire)
Maxted Court,
Maxted Road,
Hemel Hempstead,
Herts. HP2 7BY
Tel: 01442 403020

DPA WHITE SLINK £75/m

To be honest, compared to the other two cables in terms of construction the White Slink is nothing special. Luckily for DPA the Slink sounded excellent. Isaac Hayes' album starts with a series of loud heartbeats and the DPA conjured up impressive weight and definition. Isaac's vocals came across with a great deal of subtlety and detail, making their emotional impact stronger and small accents revealed in the percussion let the music flow that much more convincingly. This is a fast, dynamic cable but it delivers the music with true smoothness.

The Stockholm Trio CD showed the DPA had copious detail retrieval, obvious from the ease with which cello resonances could be heard and piano harmonics made out. It's true that leading edges were slightly softened but this didn't really affect my musical enjoyment. The White Slink never becomes stressed or confused and always sounds musical. What more can you ask for from an interconnect!



DPA Digital
Willowbrook Technical Units,
Crickhowell Road,
St Mellons,
Cardiff CF3 0E1
Tel: 01222 795621

WRITE & WIN WITH HI-FI WORLD!

Every letter we print
wins a superb prize!

Decca record brushes,
Chord Co.
interconnects,
Audio Electronics
books and a
FREE subscription
to Hi-Fi World
for the best letter
of the month!

Please write, fax or

E-mail to

Hi-Fi World Mail
(with prizes)

64 Castellain Rd,

Maida Vale,

London W9 1EX

Fax: 0171 289 5620

E-mail:

edit@hi-fiworld.co.uk



World

COMPLIANCE COMPLICATIONS

I have a problem. Your excellent magazine has enlightened me on many subjects to do with audio - valve amps, 'speakers, turntables to name a few - but in many of your readers' letters regarding cartridges this particular word pops up as part of an answer and yet goes unexplained. Without wanting to sound naïve, exactly what is 'compliance'?

You use it to describe

moving coils (low compliance) and moving magnets (high compliance) but what is it in a cartridge the high or low compliance refers to?

Some tone-arms such as SME's 3009 are suited to high-compliance cartridges whilst others like Rega's RB300 are happy with both types. What is it about a moving coil that makes it unsuitable in some arms?

I've been trying to work this one out for quite a while now but I just can't seem to understand it at all. Chris Webb
Chatham,
Kent.

The stylus at the tip of a cartridge's cantilever is moved from side to side and up and down by the signal cut as a groove in the record's surface. To allow it to move thus the cantilever is usually mounted on some kind of rubber block. Compliance is a measure of how far the stylus is deflected for a given amount of force, and is normally expressed in terms of millionths of a centimetre per dyne (1dyne = 1thousandth of a gramme). If you describe a cartridge as having 'high compliance' that means it does not take much force to deflect the cantilever. A 'low-compliance' cartridge

LETTER OF THE MONTH

MY BOYFRIEND IS AN ALIEN

I read the feature "Going for a Spin" in the Supplement to your November 1997 edition with a mixture of concern and relief - relief that there are others out there as obsessive as my boyfriend and concern that such persons may not entirely be of this world. My boyfriend could yet prove to be an alien.

For months I have looked forward to relaxing in the evening with a glass of wine, accompanied by a soothing melody. But no.

Instead I return to find - oh joy of joys - yet another beige-coloured concrete slab in the living room. Balanced delicately on tip-toe on one such slab have been a variety of objects; currently it's a black tripod from Roksan. Above this

precariously hovers a solid slab of marble bearing - you've guessed it - three more marble slabs each sitting on three independently adjustable padded feet.

In fact there are three separate slabs, each meticulously levelled (and re-levelled every night to prevent distortion caused by subsidence or earth tremor).

One slab bears a Rega RB300 tone-arm (which I was compelled to purchase as a "joint" Christmas present after Slate Audio's advertisement kept appearing, mysteriously, wherever I went). Another slab bears the motor and



If your boyfriend or husband looks like this, you know he's a hi-fi addict.

the final one supports the bearing/platter. I am informed that these bits began life quite innocently in the form of a Planar 3.

I know you're thinking that living with concrete and marble slabs is a small price to pay. I might agree



dMail

on the other hand requires more force to deflect it over the same distance.

High-compliance cartridges tend to work best in low-mass arms and low-compliance cartridges in high-mass arms. When a spring (which is basically the way in which the rubber cantilever mount acts) interacts with a mass (the effective mass of the arm and the mass of the cartridge itself) they will resonate at a particular frequency.

If you combine a low compliance with a low mass you end up with a relatively high resonant frequency which, in the

case of an arm and cartridge on a turntable, would be clearly audible as an over-emphasis of that particular frequency, a bit like reflex loudspeakers can 'boom' if they're put in the corner of a room so they excite one of the room's main resonant modes (see October's Supplement and the review of the Visual Ears room analysis software for more on this).

If you partner high compliance with high mass you get a very low resonant frequency. This puts the resonance outside of the audible range but means that, if your

turntable bounces slowly as you walk across the room, the stylus might jump out of the groove because its resonant frequency coincides with the frequency of your footsteps.

The equation that allows you to calculate resonant frequency from known mass and compliance is: $f=1/2\pi\sqrt{MC}$ where M =mass and C =compliance. A reasonable resonant frequency to aim for is about 12Hz-20Hz as this won't make its presence felt sonically while also avoiding problems when

you're walking around the room. JM

The compliance of a cartridge hinge works in conjunction with the effective mass of the tone-arm to produce a resonance. Warps cluster around 5Hz, floors bounce a little lower in frequency, but the audio band starts at 20Hz (nominally). Ideally, the arm/cartridge resonance should be placed between them at around 12Hz, according to Shure's research.

Also, low-compliance moving coils (MCs) usually have greater damping ... 45

LETTER OF THE MONTH (CONT.)

if that were the end to it.

First came the Blu-tack - little globules everywhere adorning the turntable and gratuitously decorating my most precious records. Then came the cork era. This began with little slices and advanced to a flying saucer known affectionately as a "Ringmat" - yet another expense for me. Apparently I caused the first one to warp when I spilt a drop of coffee on it.

More recently, my precious tone-arm has been given a Frankenstein makeover including a bolt painfully thrust through its delicate limb. This proved only to be an excuse for the return of the Blu-tack which was positioned as a counterbalance. The Blu-tack was, of course, weighed and moulded to precise dimensions - although to the uneducated it may look like any old lump of Blu-tack.

Finally (not!) there is the continual pursuit of the "perfect" needle (currently a Sumiko Bluepoint Special) and the isolation of the power supply which has now been delegated to Mr Val Hallah.

And that is just the record player. I shall not even begin to describe what lurks on the other three concrete slabs or the two five-foot by three-foot monoliths dominating the horizon.

Does anyone know where I can get a marble-coloured spirit level before Christmas? Or, alternatively, a new boyfriend?

Yours in desperation

Catherine Milton
London.

Well, it sounds like your boyfriend is suffering from a condition known as 'audii addictus miserabilis' which, strangely enough, seems to infect only the male of the species. The consequences of contracting this bug can be terrible, causing devastation to bank accounts, decor and untold mental and aesthetic woe for spouses and girlfriends as they are dragged mercilessly around hi-fi dealerships and shows. In fact, as you probably know, the term "hi-fi widow" is often used.

Unfortunately, as far as I'm aware, modern medical science has yet to come up with a cure for this affliction. Ear-plugs and electro-shock therapy (at 240VAC, usually delivered when the sufferer is messing around with the innards of a power amplifier) have thus far proved unsuccessful. You could, of course, try sealing the door to the hi-fi room with Blu-Tack to force your boyfriend into cold turkey (Latin name: *roadrunna frigida*). I hate to have to say it though, but when the sufferer is in such an advanced stage of the bug as your boyfriend (concrete slabs, Blu-Tack), I don't actually think there is a cure.

For a marble-coloured spirit level, try a local stone mason who should be more than happy to assist. On your second question, as my old granny used to say, there's other fish in the sea - go fishing! JM

AUDIO ANALOGUE PUCCINI S.E.

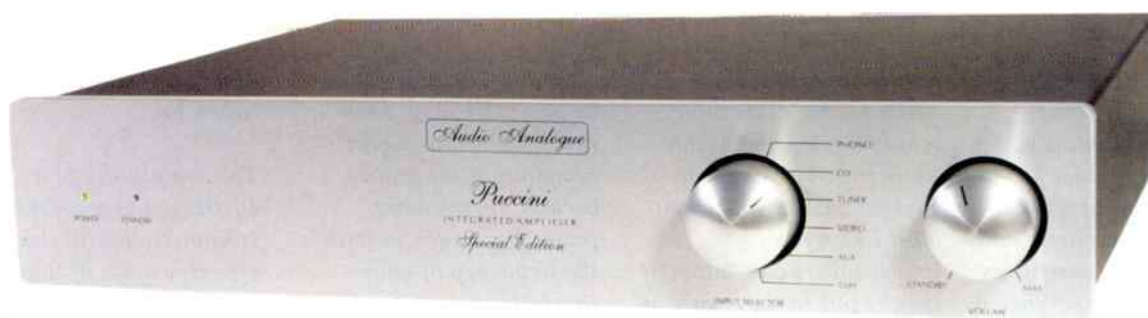

"outstrips the competition at up to £1000"

-Hi Fi World, Sept. 97

That may sound like an outrageous claim for an amplifier that costs just £595. But Hi Fi World were spot on in their judgement. The Audio Analogue Puccini S.E. is indeed a very special amplifier.

Special in the way it's designed and built, with full dual mono-construction, top quality internal components (including built-in MM/MC phono stage) and an absolutely superb finish. As Jon Marks correctly noted: "The Puccini S.E. is very different to just about every sub-£1000 integrated I've come across before".

Special too in the way it sounds. "An addictive mix of fine tonal colour, delicacy, power and involvement" (Hi Fi World's words again). Of course, that's the way a good amplifier should sound, but in reality transistor amps very rarely do. A hard, bright, uninvolved sound is what you usually get at this price level. The Puccini S.E. however is "completely free from transistor grain" with "a depth to its sound stage which leaves other integrations sounding flat". And to emphasise the gulf that separates the Puccini S.E. from the rest Jon Marks pointed to perhaps its most attractive quality: "What it does have which none of the competition do is a lucidity, a see-through transparency combined with control which makes its peers sound quite boxy and forced".

Praise indeed. But fully merited, even if we do say so ourselves. And if that sounds like your kind of amplifier, you won't be disappointed. For more details and the name of your nearest stockist, please contact:

UKD

23 RICHINGS WAY

IVER, SL0 9DA, BUCKS. ENGLAND

TEL: 01753-652669 FAX: 01753-654531



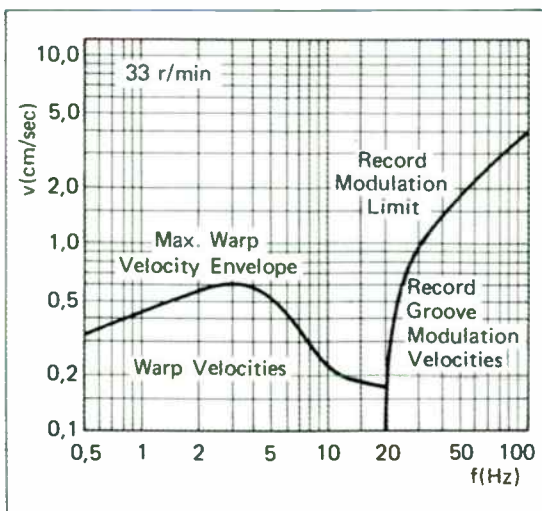

Research into mechanical resonance in record players by Bruel and Kjaer showed 12Hz is a good figure to set arm/cartridge resonance at.

and as a result put more audio energy into an arm. As Garrard first pointed out aeons ago, arm tubes also have a resonance, at around 200Hz. MCs excite this, which induces further coloration. Garrard's solution was to produce the Lab80 rosewood and aluminium sandwich tone-arm, quite a clever solution. However, the ideal solution always was to taper the arm tube, since this not only frustrates ringing but also results in great rigidity and low effective mass. Rega were the first to do this and the RB300 arm is a classic. SME followed with the magnesium Series V and the rolled aluminium 309/312.

So don't get confused by these two 'arm resonances'. The first once dominated audio thinking because of research papers by Shure and Bruel & Kjaer, leading to the low-mass tone-arm craze. I always thought this was a

misunderstanding however, feeling the pipe resonances identified by Garrard had a greater influence upon sound quality, as opposed to warp tracking. Once the RB300 showed this to be the case, low mass ceased to be pursued for its own sake and arm design became more balanced in its objectives. NK

VIVANTE: 0181 977 6600



Once you've got your arm and cartridge sorted out, do the same for your records with a Decca 2+2 brush from Vivante.

PERFECTING MY PLAYER

My present system consists of a Roksan Xerxes turntable with XPS 3.5 power supply, Tabriz zi arm and Denon 304 moving coil cartridge. This front end drives an Audiolab 8000C/P pre/power combination and Rogers LS7t 'speakers which are mounted on Heybrook HBI stands.

Ancillary equipment comprises a Denon DCD-1520 CD player.

I am an unashamed vinyl addict but occasionally use the CD player for more than just background music. To this end I wonder, would I notice a significant improvement, if I installed a DPA Little Bit III DAC and

new Clock 3, digital output board and power supply including fitting.

Alternatively, the Clock 3 and PSU on their own will set you back £132 and £55 respectively.

Another company who can help you out are Technical Wizardry (0378 048188) whose clock



Outboard DACs may improve the sound of old CD players but an upgrade to the player itself can really pay dividends.

used the Denon as a transport?

I'd like to approach the sound from LPs without spending a fortune as the limited use I put CD to hardly warrants such expense.

E. Garrett Hartley Vale, Plymouth.

The DCD-1520 is built very solidly, as were a lot of Eighties CD players. The main problems with its use as a transport given its vintage are its master clock and digital output board - the Denon was designed in the days before the effect of jitter on digital signals was widely understood. If you go ahead and use the Denon unmodified in conjunction with an outboard DAC, you might actually be disappointed.

A couple of companies can carry out these modifications for you - Trichord (01684 573524) who charge £385 for their

upgrade and digital output board will set you back £168.75 and £93.75.

I think you'll actually find that a new master clock on its own will make the Denon a much more enjoyable listen, and if you buy the digital output board after splashing out on something like the DPA, the sound will get even better. JM

Chord Co. Tel: 01722 331674



Get the most from your choice of upgrade with the Chord Company's Cobra 2 interconnects.

If you do not want your e-mail address published, please let us know

edit@hi-fiworld.co.uk



ORIENTAL EXCESS

I will soon be acquiring a Michell Iso HR/Argo HR/Alecto stereo amplification system to partner my Linn LP12/Armageddon/Aro turntable front end. The system points down the main length of my L-shaped listening room, this being a mere 8.5ft. by 11.5ft. A 3ft. by 5ft. area completes the 'L'. My musical tastes are mainly Jazz, Soul, Funk, Reggae, Brazilian and African, and I like a detailed, dynamic and involving sound.

Here in Japan, my chances of getting a good listen to the equipment I would like to hear are slim indeed. Choice is relatively limited and prices are very high. Not only that, but buying hi-fi here is a task made next to impossible by my limited knowledge of Japanese. Your advice will therefore be so much more appreciated and my questions are necessarily quite specific.

What ProAc 'speakers and accompanying stands would you recommend? Would I be limited to something the size of the Response IS Crystals due to my small listening room? To what extent would I have to forego reproduction of real deep bass in this context? Budget is around £1200 (fairly flexible) but the 'speakers can't be more than a foot or so out from the rear or side walls. What others might I consider?

My Sumiko Blue Point Special cartridge is getting on

a bit now and, as I presume the pre-amp must be somehow configured to the cartridge, this may be a good time for an upgrade. I have the Lyra Lydian on my list and it's certainly readily available here. What would you recommend?

Trevor Carty
Trevor_Carty@ringo.net

Whether you forego deep bass depends on how much living room you want left after you've installed your loudspeakers! Option one is, as you say, the ProAcs,



Lyra's Lydian MC cartridge is one of the best around at under £1000 and it's easy to get hold of in its native Japan.

which are a good choice and a proven synergetic match with Michell amplification, but I'd go for Harbeth's HL-P3ES which are the best small 'speakers around, bar none. Unfortunately, they're not ideal for Reggae, but you could always add a small REL subwoofer later for serious low frequencies. For stands use Atacama SE24s or SE16s if you have a Japanese-style apartment with tatami mats.

Alternatively, if you want real bass with less space, Yamaha NS100X

loudspeakers would be superb. With near electrostatic speed and clarity in the mid and treble, and mega bass, they're tops for Reggae and Funk. And although they're big they work great in small spaces, close to walls and at low volumes (as well as at high volumes in clubs).

If you're in Tokyo, try Laox in Akihabara, Audio Union in Minami-Shimokitazawa or Yodobashi Camera in Nishi-Shinjuku (New Keio Line). Don't worry about the language problems, as lots of Japanese hi-fi salesmen suddenly become bi-lingual when there's a potential sale involved! Otherwise, point to what you want demonstrated and say "So re o mi se te, ku da sai" (please show me this). As for cartridges, the Lyra is my absolute fave, but the brighter Audio Technica ART-1 is great and much cheaper. Otherwise, an Ortofon MC30 Supreme would be nice, with its bright, open sound. Good luck. DP

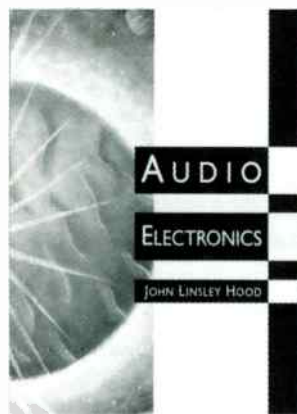

Here's some bed-time reading to accompany a cup of warm sake - John Linsley Hood's Audio Electronics.



UPGRADE ADVISABILITY

I would like to make an upgrade. My system is built from a Rotel RCD-970BX CD player, Rotel RT-940BX tuner, Aura VA 80 amplifier and a pair of B&W 603 loudspeakers. The cables are Wireworld Oasis and Audioquest Indigo 2.

I listen mainly to Jazz, Pop and Classical and want to improve my amplifier. With a budget of £3500 I was considering the Krell KAV300i. Any other suggestions would be welcome. Would it be worth upgrading the cables at the same time?

Arismar Léon Pereira
arismar@br.homeshoppi ng.com.br

Sinking your entire budget into a £3500 amp fronted by sub-£500 sources and backed up by sub-£500 loudspeakers is a recipe for disappointment. You'd be better off spreading your budget over amp, source, 'speakers and cables, if you want to get the biggest sonic improvement.

Roksan's Caspian CD player at £760 (without UK VAT for export, as are the other prices here) would be a good start, followed by Audio Analogue's Bellini pre-amp at £490 and a pair of the matching Donizetti power amps at £405 a piece. You could then round the system out with Roksan's small floorstanders, the Ojan 3X at £850. This would give you a sound far superior to the Krell in combination with such inexpensive partnering

equipment, especially in terms of clout, sound staging and musicality. JM

which pass both tests are Monitor Audio Studio 20s. Whether they sound OK is a

mounters that will gel nicely with your present amps. There are B&W's £600 CDM1s as well. These smart 'speakers impressed us all with their musical and dynamic sound when we heard them back in September. KB

Or how about KEF Q15s. I know they're inexpensive, but they are fundamentally accurate and very sweet, with good bass for their small size. NK



Bi-amping your system with two of Audio Analogue's Donizetti power amplifiers and a Bellini pre-amp is one way to impressive sound quality.

Chord Co. Tel: 01722 331674



Bring your set-up a step closer to completion with the Chord Company's Cobra 2 interconnects.

different matter. The obvious choices (Naim Intros or Credos) are probably just too big/ugly.

Do 'speaker companies not employ style consultants? Not everyone has a barn in which to put their precious hi-fi. Maybe we should go for a good pair of discreet stand mounters? Or even, dare I say it, wall-mounted 'speakers? I'm not going to sacrifice sound quality but I can see my wife's point of view. What should I be auditioning?

Nick Peacock
(e-mail address withheld by request)

The Monitor Audio Studio 20SEs are well over £2000, so unless you have access to a second-hand pair or are willing to really stretch your budget, these 'speakers aren't an option. The most obvious choice for a smallish floor stander at about £1000 is the Epos ES22. Though slightly over-budget at £1185, these would fit your requirements very well and perform even better should you move further up the Naim range of amplifiers.

If these are too expensive don't forget the Epos ES12s at £500 which are compact stand



At £600 B&W's small CDM1 stand mounters are one of the best loudspeakers around at the price.

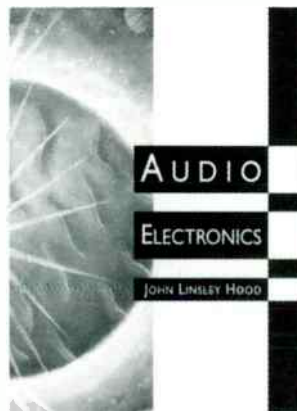

Get stuck into a copy of John Linsley Hood's Audio Electronics and find answers to all your hi-fi questions.

SHINY SHELLACS

I've been happily listening to LPs & CDs via a Linn active Kaber system for several years, but recently my mother died and I now have a collection of 78s in my possession. I've just picked up a Rega Planar 78 to sit alongside my LPI2, and I'm very pleased with the sound. Unfortunately some of the

discs are extremely dirty. Do you have any recommendations for cleaning them, bearing in mind they are considerably heavier and more fragile than the standard LP?

Mick Curtis
mickc@dircon.co.uk

Milty's Permaclean, distributed by Goldring (01284 701101), is the best light-duty cleaner I've used, but with mega-dirty discs Audio Technica's AT6012 kit would be more effective.

But the best solution would be to find somewhere - such as a record shop or hi-fi dealer - with a Keith Monks machine. This would really do the trick. DP

I'd suggest you rub any cleaner on a bare area of shellac first, to see if any chemical component, like Isopropyl alcohol, has a damaging effect. Shellac is a "natural thermoplastic resin derived from the secretions of the Lac beetle (found in India, Thailand and Brazil). 78s comprised "65% slate powder, up to 27% shellac resin, and small amounts of manilla copal, wood resin, carnauba wax, and carbon black." (source: EMI's Hayes On Record book).

SPEAKER SEEKER

I need new 'speakers and my budget is up to about £1000. My old Wharfedale 506s (bless 'em) just aren't up to it any more. I have a Linn LPI2/Lingo/Naim Aro/Dynavector Karat 17D2 and Naim 92/90/Flatcap. I listen to Rock and Pop (especially buzzing guitars), Dance and Classical (mainly choral).

The real problem is that my wife, quite naturally, will only accept 'speakers which (i) look acceptable, and (ii) don't take up too much of our precious floor space. To date the only floorstanders

acoustic solutions

www.acoustic-solutions.co.uk

after a great reception of the eight loudspeaker both at the ramada and chesterfield hifi shows, we provide a list of dealers for the christmas rush

audio grande (leicester) 07000 560668
select audio (london) 0181 986 8788
stow sounds (suffolk) 01449 675060

ASL

'loudspeakers for the audiophile'

acoustic solutions

4a corporation road chelmsford essex cm1 2ar england
telephone +44 (0)1245 25 28 25 facsimile +44 (0)1245 60 80 80
e-mail info@acoustic-solutions.co.uk

AUDIO GRANDE LEICESTER

Stockists for

Audionote, Vaic Sing e-ended Valves and matching Transformers

ART AUDIO

SINGLE ENDED, AMPS
DIABOLO WITH
VV 32B VALVES

"Musically the Amps's hard to touch nothing else in its price league will even get off the starting line in comparison and the combination of attributes likely to leave amps costing many times the price well behind."

Chris Beaching
The Listener (USA)
The Diavolo can also be fitted with the russian 300B as a more economical package for later upgrade

PUSH PULL AMPS
What do the critics say:

QUINTET

The Art Audio gives you music with a sense of rightness that you don't really question but just get on and enjoy. Sweet open and lucid, the music is produced with an easy sense of naturalness which makes long term listening fatigue free and especially rewarding.

Roy Gregory Hi-Fi Choice

TEMPO

I feel that the Art Tempo amplifiers are among the finest valve power amplifiers currently available. The imagery that the Tempos create is vivid, lifelike and full of space and air.

Alan Sircom, Hi-Fi World

CONCERTO

The Concerto is an exceptionally sweet sounding amplifier. By any standards it is smooth, clean and extremely well-balanced, from its deep bass to its high treble, which is endearingly free from brashness and hardness.

Jimmy Hughes, Audiophile

MAESTRO

...they are just so stunningly gorgeous and open to listen to, I can barely imagine anything more alluring.

Noel Keywood, Hi-Fi World

...the Maestro is part of that rare breed of Hi-Fi that makes you forget about the equipment and think about the music. In all, unlike the car, the Maestro lives up to its name

Alan Sircom, Hi-Fi World

AUDIO GRANDE IS AN APPROVED DEALER FOR:

KLIPSCH SPEAKER RANGE - FOR AUDIO & HOME THEATRE

TRICHORD RESEARCH

CLOCK 3 UPGRADES FOR SUPERB PERFORMANCE. CAN BE FITTED TO MOST PLAYERS OR TRANSPORTS (PHONE FOR QUOTE + JIMMY HUGHES REVIEW

REMOTE VOLUME CONTROL ALSO TO PREAMPS (CONTROL FROM YOUR ARMCHAIR!!!) PULSWIRE CABLES ANALOGUE & DIGITAL
NEW ACOUSTIC SOLUTIONS EIGHT NOW AVAILABLE!!!

TEL: 07000 : 56 06 68 FAX: 07000 : 78 48 41
24 HRS MESSENGER & PAGING SERVICE (01399 703036)

AUDIOPHILE 180G VINYL REISSUES

NEW TITLES - THE SAME GREAT SOUND

RECORD OF THE MONTH

THE
OSCAR PETERSON
TRIOS
THE LOST TAPES
MPS 529 096-1



OSCAR PETERSON HAS ALWAYS BEEN A FIRM FAVOURITE WITH AUDIOPHILE AND JAZZ FANS ALIKE. AND THIS NEW SPEAKERS CORNER RELEASE ON THE MPS LABEL MAINTAINS PETERSON'S POSITION AS ONE OF THE GREATEST JAZZ PIANISTS OF HIS GENERATION. NEVER AVAILABLE ON VINYL BEFORE, THIS RECORD COMBINES BRILLIANT MUSICIANSHIP AND GLORIOUS SOUND. MPS 529 096-1. PRICE: £19.95

HERE IS A SELECTION OF OTHER 180G VINYL TITLES

- JIMI HENDRIX: BAND OF GYPSYS (LTD EDITION ANALOGUE VERSION). NEW RELEASE PRICE: £19.95
JIMI HENDRIX: SOUTH SATURN DELTA (MCA 11684) 2LP. NEW RELEASE PRICE: £15.95
STEVE MILLER BAND: GREATEST HITS (DCC LPZ 2028). NEW RELEASE PRICE: £21.95
SONNY CLARK: COOL STRUTTIN (BLUE NOTE BN 1588). PRICE: £21.95
ILLINOIS JACQUET: SELF TITLED (EPIC BA 17033). PRICE: £21.95
DIZZY GILLESPIE REUNION BIG BAND (MPS 21.20682-2). SALE PRICE: £9.95
PACO PENA: FLAMENCO LIVE! (PFS 4237). SALE PRICE: £12.95
BERNARD HERMANN: GREAT HITCHCOCK MOVIE THRILLERS (PFS 4173). SALE PRICE: £12.95
DAVE BRUBECK: TIME OUT (CS 8192). SALE PRICE: £17.95
SONNY ROLLINS: TENOR MADNESS (LPZ 2022). SALE PRICE: £17.95
PATRICIA BARBER: CAFE BLUE (PR 737). PRICE: £19.95
JOHN WILLIAMS: STAR WARS SUITE (KING SAD KJC 9199). NEW RELEASE PRICE: £21.95
PROKOFIEV: LOVE FOR THREE ORANGES (MERCURY LIVING PRESENCE SR 90006). PRICE: £21.95
BARTOK: DIVERTIMENTO (DECCA SXL 6026). NEW RELEASE PRICE: £19.95
ROSSINI: OVERTURES (DECCA SXL 2266). BACK IN STOCK. PRICE: £19.95
BRAHMS: SYMPHONY NO.2 (PHILIPS 835 167). NEW RELEASE PRICE: £19.95
TO ORDER ANY OF THE ABOVE OR TO RECEIVE A COPY OF OUR CURRENT AUDIOPHILE VINYL CATALOGUE, PLEASE CONTACT:

VIVANTE LONDON

UNIT 4, 60 HIGH STREET, HAMPTON WICK, SURREY KT1 4DB
TEL: 0181 977 6600 FAX: 0181 977 4445
EUROPE'S PREMIER AUDIOPHILE MAIL ORDER COMPANY

THE ONLY WAY TO HEAR EXACTLY WHAT THE RECORDING ENGINEER INTENDED

TRANSFIGURATION

Moving Coil
cartridges



SPIRIT



TEMPER

A new generation of unique yokeless cartridges offering musically natural dynamics, transients, harmonic structure, imaging, resolution and presence. The superb Temper is regarded as a world leader - liquid and luxurious from the lowest to the highest frequencies.



The new GRAHAM Mk 2.0 tonearm

The next step forward from the award winning 1.5 with increased dynamics, bass extension, solidity and soundstaging.

Audio
Reference
IMPORT & DISTRIBUTION

For further details contact

Distributors of:

Convergent Audio Technology Amplification and Magnum Dynalab Tuners

Unit 8 Enterprise Park, Slyfield Industrial Estate, Guildford, Surrey GU1 1RB

01483-575344



The ultimate in vinyl accessories - a record-cleaning machine.

Collectors will know it is fragile. Soapy water is more inert chemically, but must be sucked off to lift dirt from the bottom of the groove.

Consider this. Easy CD Creator from Adaptec will allow you to record your fragile 78s to CD. Then you can store them. Better, it has Spin Doctor "that lets users turn scratchy old LPs into crystal clear CDs". It will "clean up scratches,

pops and hisses" (are hisses like sheeps?) Adaptec tell us in their lucid product data. A great price of £69 is no joke though. Surf into www.adaptec.com or fax their UK ops. at 01276 854500 (Camberley, Surrey). NK



Chord Co. Tel: 01722 331674



Get more from your system with a pair of the Chord Company's Cobra 2 interconnects.

QUO VADIS DIGITALIS?

I am on the verge of upgrading my hi-fi system and would appreciate any advice you have to give. My current system is an ageing Rotel RCD-965BX CD player, Arcam Alpha 3 amp, Technics cassette deck and JPW Sonata loudspeakers Blu-Tack'd to sand-filled Target stands. I wish to upgrade my CD player and, possibly, my loudspeakers.

My budget is around £650 and I have come up with the

following two possibilities: a Marantz CD-63 mkII KI-Signature and Mission 750 LE 'speakers. The other possibility is to leave the 'speaker upgrade for the time being and go for a Teac TI transport and Musical Fidelity X-ACT DAC. I am not sure which route would give me the best quality sound - the CD player is going to get a great deal of use and will need to be very well built.

I have a diverse taste in music and favour a sound which has a sparkly treble (though not sharp), natural sounding midband and a fast, tuneful bass (quality is more important to me here than sheer depth).

I find the situation regarding interconnect cables very confusing - there are just so many, quite often with ridiculous prices! I have around £50 to spend on a cable to link the CD to the amp and would value any suggestions.

John May
j.may@macmillan.co.uk

I'd tend to go for the Marantz CD-63 mkII KI-S/Mission 750 LE option. The Marantz is a definite classic (especially now that its price has come down to £400). We've yet to formally review the 750 LEs but first impressions are rather promising thanks to their

silk-dome tweeter and Aerogel mid/bass units.

Another component sitting in our set-up here which will hopefully be featured in next month's issue is Kimber's PBJ interconnect which has a very spacious, transparent sound. This clarity would help to open up the sound of your Arcam amp and give music more dynamism and drive. At £59 for a 50cm pair, they should also just about fit your budget.

After these changes you could swap the Arcam for an Audio Analogue Puccini SE integrated amp at £595 when you're due for the next upgrade. JM

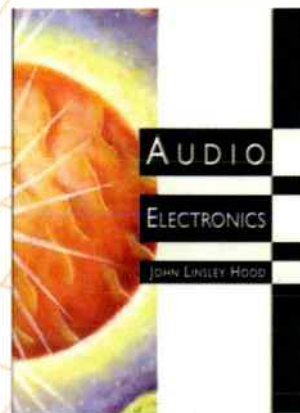

Find out about the inner workings of all those black hi-fi boxes with a copy of Audio Electronics.



Kimber's PBJ interconnects have a very revealing, natural sound that works a treat with capable electronics.

VALVE BOOKS

The Williamson Amplifier -

D.T.N. Williamson. Offers practical advice on how to build and set up the amplifier for best results.

£9.95 + £1 p&p
Code: 1040

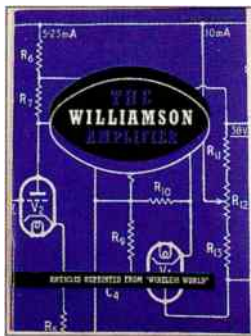

70 Years of Radio Tubes and Valves

- John W. Stokes.

Outlines the evolution of radio receiving tubes and the part they played in the domestic radio receiver. A reference for those

interested in the history and development, and collectors alike.

£19.95 + £2 p&p
Code: 1050

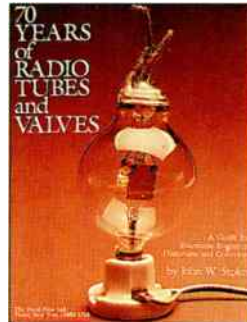

Principles of Electron Tubes - Herbert J. Reich.

A textbook for beginners starting with the basics of how a vacuum tube actually works. Shows how a simple circuit is designed including amplifiers, transformers and power supplies. A must for both enthusiasts and hobbyists.

£27.95 + £2 p&p
Code: 1010

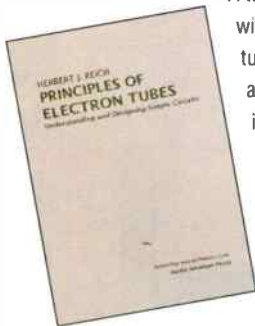

An Approach to Audio Frequency Amplifier Design -

Seventeen circuits from 5 to 1100watts - General Electric Co.

High quality amp. designs using KT66s, KT88s, DA100s etc.

Includes two valve pre-amps complete with phono stages.

£19.95 + £2 p&p

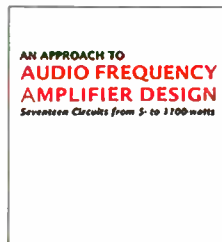

Code: 1020

Mullard Tube Circuits for Audio Amplifiers

- Includes full designs for eleven power and control amps, including 5-20, using valves. Begins with a four chapter tutorial on getting the best sound from valve amplifiers.

£13.95 + £2 p&p
Code: 1030

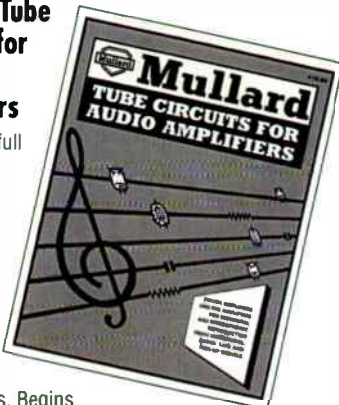

LOUDSPEAKER BOOKS

Electronic Universal Vade-Mecum - Piotr Mikolajczyk & Bohdan Paszkowski.

This Data book comprises 5693 valves divided into 442 groups. A comprehensive book which contains connection details, operating parameters, load lines and example circuits. £49.95 + £6 p&p

Code: 1060



Quick & Easy Transmission Line Speaker Design

- Larry D. Sharp.

Practical approach to designing and building your own transmission line loudspeaker.

Includes design examples, equations and a computer disk (Lotus123) for the maths! £10.95 + £2 p&p

Code: 1130

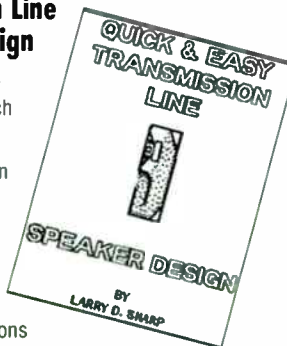

Loudspeakers: The Why and How of Good Reproduction -

G.A. Briggs
An easy to understand book on building loudspeakers, using

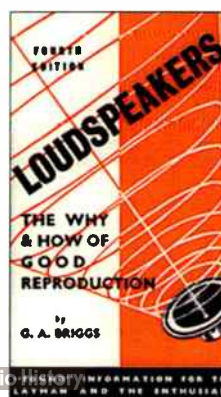

empirical techniques that pre-date computer analysis. Strong recommendation for beginners.

£10.95 + £1 p&p
Code: 1070

Bullock On Boxes

- Robert M. Bullock III.

Using Thiele-Small parameters clearly, it offers lots of helpful tables and graphs to get to grips with the sizing of the box and port of a reflex loudspeaker.

£12.95 + £2

p&p
Code: 1100

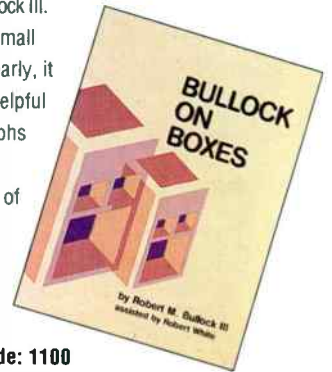

Electrostatic Loudspeaker Design and Construction

- Ronald Wagner.

Step by step guide to the design and construction of a full range electrostatic loudspeaker, including basic operating principles.

Strongly recommended for those wanting to either build, repair and/or restore or who are just interested in electrostatics.

£16.95 + £2 p&p

Code: 1080

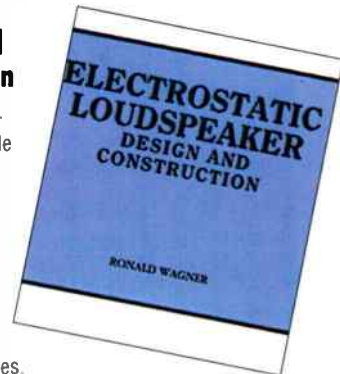

The Loudspeaker Design Cookbook, 5th edition -

Vance Dickason.

This best seller offers up-to-date design information for the home constructor. It uses modern Thiele-Small theory and parameters.

£22.95 + £2 p&p

Code: 1090

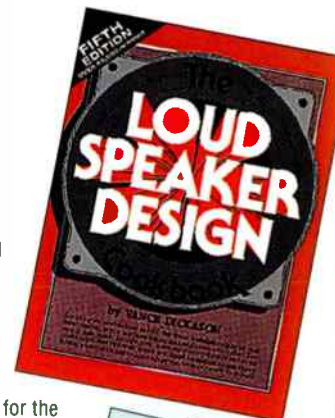

Theory and Design of Loudspeaker Enclosures -

J. E. Benson.

Covers infinite



baffle, reflex, passive radiator etc. in great detail with a highly mathematical approach making it unsuitable for beginners but highly authoritative to experienced designers.

£23.95 + £4 p&p Code: 1140

Acoustics - Leo L. Beranek.

This book ranges from analogous electrical circuits, (important for modelling) to microphones, then loudspeakers (sealed, ported and horn) showing how theory influences practice in drive units. In addition it describes the behaviour of sound in rooms.

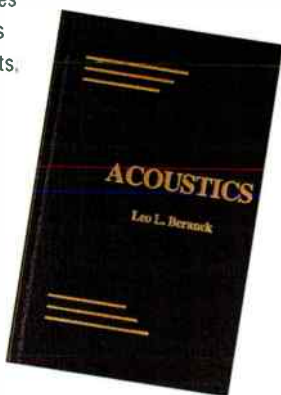

£39.95 + £4 p&p Code: 1120

AUDIO ANTHOLOGIES

Audio Anthologies - When Audio Was Young

Six volumes to collect, covering one of the most exciting and important eras of hi-fi. The Audio Anthologies contain many ground breaking circuits and theory articles of all aspects of hi-fi design. A must for true enthusiasts.

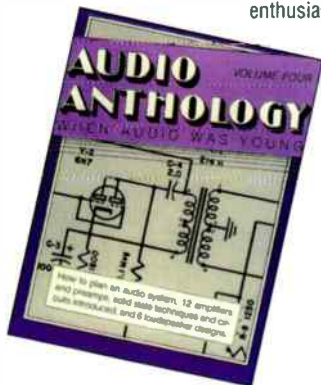

Volume One: May'47 to Dec'49

Contents: 9.5W, 5W and 6.5W 6AS7G amps., 30W 300B amp., valve FM tuning indicator, 30W 211 power amp., cathode follower amp. using 6V6, an adaptation of the Williamson amp., valve phono pre-amp., several horn and reflex loudspeaker designs.

£14.95 + £2 p&p Code: 1150

Volume Two: Jan'50 to Jul'55

Contents: Ultra linear 6L6 design and operation of the Williamson, a direct coupled amp., Williamson type amp using 6A5s, 40W 845 push-pull amp., valve phono and line pre-amps., valves and loudspeaker damping, design and construction of reflex and horn loudspeakers.

£14.95 + £2 p&p Code: 1160

Volume Three: Aug'52 to Jun'55

Contents: Simple valve phono stage, transformerless amplifier using 6082, 20W 5881 amp., 10W 6V6 amp., stereo valve pre-amp., high quality valve phono stage, a pre-amp for the Williamson, low distortion tone control pre-amp., binaural or stereophonic, transistor phono amp., corner horn loudspeaker, concrete horn loudspeaker.

£14.95 + £2 p&p Code: 1170

Volume Four: Jul'55 to Dec'57

Contents: 18W 5881 amp., 4W single-ended tweeter amp., budget 11W amp., versatile bass/treble control, transistor theory, transistor pre-amp., transistor techniques, battery powered transistor phono pre-amp. and loudspeakers explained.

£14.95 + £2 p&p Code: 1180

Volume Five: Jan'58 to Dec'59

Contents: Stereo valve multiplex decoder, 7W EL84 amp., valve active crossover and 20W treble amp/50W bass amp., monaural, binaural,

monophonic and stereophonic explained, heterodyne FM multiplex adapter, transistor pre-amp., 60W EL34 amp., high power audio amps, hi-fi loudspeaker enclosure.

£14.95 + £2 p&p Code: 1190

Volume Six: Jan'60 to Dec'61

Contents: Transistor pre-amps., feedback techniques, the coming of FM stereo, FM multiplex adapters, Tape recorders; distortion, frequency response and noise, 120W 6550 amp., loudspeaker efficiency.

£14.95 + £2 p&p Code: 1200

SOLID STATE ELECTRONICS

The Art of Electronics

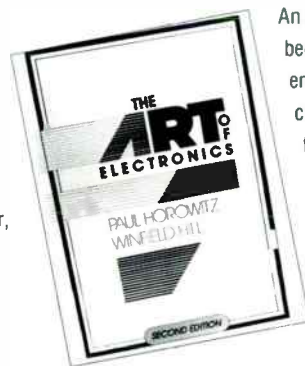

- P. Horowitz & W. Hill. An ideal book for beginner through to engineer. Each chapter takes you from the basic first principles through to full design and practical circuits. **£35.00 + £5.50 p&p. Code: 1210**



For overseas orders, please telephone (+44) 171 289 3533 or fax (+44) 171 289 5620 for postage rates.

P&P rates are for UK only

ORDER FORM

Please Send (Code No.) _____ (enter codes clearly)

I Pay: World Audio Publishing Ltd. £ _____ or debit my Mastercard/Visa card (Card No): _____

Exp date _____ Name _____ Signed _____

Delivery Address: _____

Tel (Day) _____ Please return to: W.A.P. Ltd., 64 Castellain Road, Maida Vale, London W9 1EX, ENGLAND

TEL/FAX: 0171-221-0691 OR 24 HOUR ANSWERING MACHINE: 0171-266-0461 Tick if you do not want to be added to our mailing list

Please contact us for overseas P&P charges. Allow 28 days for delivery. All orders subject to availability. If further space is required please attach separate sheet.

10/12 Chapel Place
Tunbridge Wells, Kent

Sounds Of Music

Tel: 01892 547003
Fax: 01892 547004

LUMLEY L/M I MKII

AUDIO SYNTHESIS ● AUDIO PHYSICS ● APOLLO ● AUDION ● AUDIO NOTE ● AUDIO RESEARCH ● AUDIO ANALOGUE ● ALTIS ANTHEM ● A.V.I ● A.T.C ● ALON ACOUSTIC ENERGY ● ATACAMA B.C.D. ● BASE ● BALANCED AUDIO TECHNOLOGY ● B&W ● BOW ● CONVERGENT AUDIO TECHNOLOGY ● CHORD ● COPLAND ● CADENCE ● COGAN/HALL ● CABLE TALK ● CYMBAL ● C R DEVELOPMENTS ● DUNLAVY ● D.A.C. ● EXPOSURE ● ELECTROCOMPANET ● EIKOS ● F.M.ACOUSTICS ● GENESIS GRAHAM ● GRAFF ● GOERTZ ● GOLDRING ● GERSHMAN ACOUSTICS ● HARBETH ● HELIOS ● INFINITY ● JAMO ● J.M. LABS ● KOETSU ● KRELL ● KEF ● KLIPSCH ● KIMBER ● LUMLEY ● LYRA ● L.A.T. LAVARDIN ● MUSICAL TECHNOLOGY ● M.I.T. ● MAGNUM



● MAGNUM DYNALAB ● MICROMEGA ● MYRYAD ● MARANTZ ● MORDANT SHORT ● MAGNAPLANAR ● MARTIN LOGAN ● MICHELL ● NEAT ● NORDOST ● NOTTINGHAM ANALOGUE ● OPERA ● OPTIMUM ● ORTOFON ● ORELLE ● PROMENADE ● PURIST AUDIO ● PASS ● PRO-AC ● PINK TRIANGLE ● Q.E.D. ● QUAD ● RUARK ● RESTEK ● R.E.L. ● ROKSAN ● ROLAND ● S.M.E. ● SEQUERRA ● SHURE ● SENNHESER ● SOUNDSTYLE ● SONIC FRONTIERS ● SUNFIRE ● SPENDOR ● SONUS-FABER ● STANDS UNIQUE ● TARGET ● TRILOGY ● TANNOY ● TOTEM TALK ● TRANSPARENT ● TRANSFIGURATION ● THETA ● TOWNSHEND ● TRICHORD ● THORENS ● TEAC ● TRIANGLE ● UNISON RESEARCH ● V.A.C ● VON SCHWEIKERT ● WOODSIDE ● WILSON BENESCH ● WADIA ● WILSON AUDIO ● X.T.C ● X.L.O.

'FOR REAL MUSIC LOVERS'

PRICE FOR PRICE - NOTHING ELSE COMES NEAR



1 months trial exchange system

<http://www.sounds-of-music.co.uk>

Free Delivery anywhere



"The improvement...is huge. Brilliant. Absolutely brilliant." Mr Granger, Chelmsford

ReVeel the music in your CDs.

"For the sheer pleasure of music..."

£9.95 direct from

Russ Andrews Accessories Ltd,
Edge Bank House, Skelsmergh, Kendal, Cumbria LA8 9AS
Freephone Orderline: 0800 373467



Buy Direct Feel The Difference As Well As Hear It
AV Supports Hifi Supports Speaker Supports.
X WING REFERENCE FULLY DECOUPLED RACKING SYSTEM

XWing design available in any height configuration

Marble shelves come as standard. Granite and slate also available.

Adjustable spikes under all shelving

Black is the standard finish other colours available

Adjustable feet



PAT Pending

Every shelf is decoupled. Isolation increases level by level.

Machined round aluminium legs improves stability and isolation.

Legs can be anodised (six colours available).

Design completely modular can be split or added to whenever

XWing racks starts from £149.99 + P & P.

The rack shown above has been specially designed for Naim Audio equipment. Have your rack designed for you.

SPECIALIST EQUIPMENT RACKS FOR HIGH END EQUIPMENT
30 day money back guarantee. For FREE Colour Brochure or to Order
Please call or Fax 01904 490184
(Please allow 14 days for delivery)

SOUND IDEAS

Ketan Bharadia and Jon Marks find out how to upgrade your system with Ringmat's Statmat for CDs and DNM's Licon contact enhancer.

RINGMAT STATMAT £19.95

The Compact Disc has enjoyed a lot of tweaking attention with varying and often small degrees of success. There have been green pens, CD refrigeration, disc stabilisers and various cleaners and sprays.

I have to admit I was sceptical when I came across the Statmat as it looks like no more than a thin piece of plastic with a strange pattern printed on it. How could this alter the sound of a CD?

When a CD is played, it revolves at high speed in a closed environment where the air is relatively dry and hot - the drive motor and electronic circuitry generate quite a lot of heat. Over time this combination of spinning and a dry atmosphere builds up electrostatic charges on the surface of the CD. These aren't evenly spread but form low-voltage hotspots randomly distributed over the disc's surface.

Ringmat say these charges rapidly intensify as the CD is played and interfere with the CD player's ability to interpret the digital information coming off the disc, causing phase problems. What the Statmat apparently does is disperse the hot spots and thus eliminate static-induced phase distortions. Well, as they say, the proof's in the pudding. . .

The Statmat actually works rather well. Using it is very simple - just place it on top of the disc the correct way up (This Way Up is helpfully written on the plastic to help you) and play the CD as normal.

The effect the Statmat has on the sound varies in degree from disc to disc

but the biggest change is in the treble, which becomes clearer and more detailed while the rest of the sound gets more dynamic. The bass end firms up a tad too and the sense of rhythm improves.

If you use the Statmat and the sound loses some of its rhythm, Ringmat advise you to try reversing the phase on your CD player or 'speakers as the disc is probably not recorded in absolute phase.

£19.95 for a piece of plastic film may look expensive materially but the sonic changes are well worth the money.

DNM LICON (1 bottle) £30

At £30 for what looks like a perfume sampler bottle DNM is also lagging in the perceived value stakes. Fortunately, like the Statmat, once you've put the contents of this little bottle to work you know your money has been wisely spent.

DNM describe Licon as a kind of 'liquid metal'. It fills in the tiny holes and cracks on the surfaces of conductors and gives a more intimate connection. DNM were necessarily a little vague as to the ingredients that go into Licon because it's subject to patent.

To give your set-up the Licon treatment all you do is spread a drop onto the connector's surface with the applicator built into the bottle's lid, having first cleaned the connection with either isopropyl alcohol (available from chemists like Boots) or a contact cleaner like Kontak. Then put plug back into socket and listen.

The improvements aren't small.

Cleaning and Liconing all the interconnect plugs and amp and source sockets in my system boosted performance quite a way. The sound became more dynamic, spacious and controlled, as well as losing a mild graininess that had previously afflicted the



midrange. The biggest step forward came when I treated my cartridge pins and tags. DNM confirm it's on low-voltage connections like this that Licon works most audibly. They also say that mains plugs and fuses are least affected. This may be true for standard mains cables but I was surprised at the extent to which it enhanced the sound of specialist mains leads like Kimber's PowerKords (see last month's review).

Considering you only need go back to the bottle every six months to reLicon your connections and that a £30 bottle will last for at least four or five treatments unless you splash it on like Henry Cooper, Licon is one of the most cost-effective upgrades around ●

Ringmat Developments
PO Box 200,
Brentwood,
Essex CM15 8QG
Tel: 01277 200210

Virtual Reality Audio Systems (DNM)
PO Box 383,
Brentwood,
Essex CM14 4GB
Tel: 01277 227355



ORANGES & LEMONS

Juicy fruit from London's freshest
hi-fi / home cinema retailer.

Free home installation + credit cards,

0% credit finance available

(subject to status).

ARCAM, B&W, CABLETALK,
CHORD CO, DENON, EPOS, KEF,
MARANTZ, MICROMEGA, NAD,
NAIM, NEAT, QUAD, REGA,
ROKSAN, ROTEL, ROYD, RUARK,
SOUNDSTYLE, STANDS UNIQUE,
YAMAHA

Now in our third tangy year

*THE INNOVATIVE
AUDIO RETAILER*

0171-924 2040

61/63 WEBBS ROAD, CLAPHAM, SW11

Outstanding new products...

We are delighted with these startling new products, and we think they will become the reference for performance at their prices.

dCS Elgar: probably the ultimate 24 bit/96kHz DAC, software upgradeable and future-ready. Versions are used in the BBC and the recording industry.

DNM: The 3C preamp is now available, all we need say for people who know this amazing brand. You don't?

BKS: A ribbon hybrid that is seamless from top to bottom. Open, natural, wonderful!

Customers say we make some of the best sound they have ever heard. Whether it's a complete system or an upgrade we try to give a long-term view, not a quick sale. We are so confident in the products we have chosen that we will gladly do A/B home demonstrations against the competition - anywhere. *Just listen and you'll know.*

CD: Acurus, Audio Synthesis, Classé, dCS, Enlightened Audio Design, Meracus, Orelle, Wadia, XTC.

Vinyl: Basis, Crown Jewel, Graham, Michell, Stratosphere, Sumiko Blue Point Special, Transfiguration.

Amplifiers: Acurus, Audio Sculpture, CAT, Classé, DNM, Lumley, Michell, Orelle, Siemel, Sirius, Soneteer, XTC.

Loudspeakers: Audio Artistry, Audio Physic, BKS, Dunlavy, Ethos, Harbeth, Lumley, Magneplanar, Mirage, NEAT, Totem.

Tuners: Fanfare, Magnum, Dynalab.

Supports: Air Pods, DH Cones, Signal Guard, Vibraplane

The Right Note - Bath

(01225) 874728



DESIGNED BY
GRAHAM NALTY M.A.

15 Derwent Business Centre, Clarke Street, Derby DE1 2BU

Sales Office Hot Line: **07000 SONIC LINK**

Tel: + 44 1332 361 390

Fax: + 44 1332 298 836

pear audio

presents

Shahinian DYNAVECTOR

Stockists and Information from
**Pear Audio Ltd. 7 Prospect Place,
Alnmouth, Northumberland, NE66 2RL**
Tel: **01665 830862** Fax: **01665 830051**

The Sunday Times ran a piece recently accusing the music business of killing off the cassette, contrary to the wishes of the music buyers. Well, of course they're right: there are millions of cassette recorders out there, so there must be plenty of demand. Or must there? Products have lifetimes and once sales start to decay it doesn't stop until there's nothing left but a few hardy collectors mourning the passing of an era.

Much of what the Sunday Times said was both interesting and true, but at heart the most baffling fact they hinted at but didn't quite nail is that the cassette is being killed off by the 'bell curve', not by any retail conspiracy. What seemed like the most

popular electrical item in the world, beaten only by the light bulb?

It seems not. Having now watched the bell curve take its toll first on the LP and now the

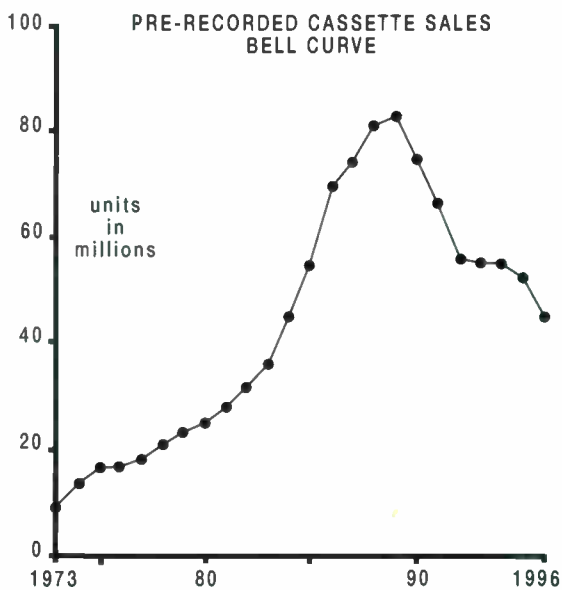

facile comment in the whole piece was in fact the opposite: a retailer said, "The cassette isn't sexy any more".

As a serious-minded engineer I just used to get irritated by this sort of comment - it seems to say little of any practical consequence. Where's an analysis based on a plausible theoretical model, I'd think? Surely we know a bit more about how people react to products? There must be some slightly more useful and profound observation to make about a product that is the second most

cassette I am beginning to realise that there's more to this thing than anyone fully understands. The industry's best marketing men are unable to explain precisely what lies behind the bell curve; it just has to be accepted as a fait accompli. Once products cease to be sexy, they just die - poof! And the cassette is dying on us.

So what's the bell curve? It is the shape a sales graph takes over time - the shape of a bell. When a product comes to market initial sales volumes are low. Then they rise steeply, plateau out and - here's the

Mysteries from Noel Keywood



tough bit - go into terminal decline. No amount of marketing and sprucing up can stop this it seems. Once the rot sets in there's no turning back. Even nasty old retailers and the evil empire of the music business can do little about such a cosmic inevitability.

Why an inanimate product is destined to die like this is the baffling bit. If it works well and satisfies people's needs, then why doesn't it at least bumble along a little? On this I can offer no insight at all. I didn't want to believe it, but just look at the cassette's sales graph. It's a classic bell curve.

Launched back in 1963 for dictation purposes the cassette really didn't catch on until 1980 or thereabouts, when sales crept through 20million. Ironically, it took off after CD was launched (1983) and seemed to go ballistic through the go-go part of

the 1980s. Perhaps it would have enjoyed a few pleasant mid-life years were it not for the recession which turned a gentle roll-over in sales around 1990 into a precipitous fall. You might be interested to know that the recession did not affect the more expensive CD similarly, so this isn't the reason for the compact cassette's demise.

There's no doubt that retailers would prefer to stock just one format and doubtless they have been destocking cassette and perhaps contributing to its decline, as the Sunday Times suggested. But the graph shows quite clearly that the rot set in some time ago, catching even Philips by surprise (they invented the Compact Cassette). The cassette was destined to die I'm afraid to say. It's a simple as that. It got old and just wasn't sexy any more ●

EDITORIAL ASSISTANT REQUIRED

Hi-Fi World is looking for an Editorial Assistant. We need someone with a good knowledge of hi-fi, drawn from experience, plus an ability to write. The office is located in central London. If you think you have the right qualifications and are interested in entering publishing, please send details or your CV to:

Hi-Fi World
64 Castellain Road
Maida Vale
London W9 1EX

or:
Fax: 0171-289-5620
e-mail: edit@hi-fiworld.co.uk

MAKE YOUR REGA SOUND AS GOOD AS A LINN

Fibre-lam plinth kits, Megabearings, power supplies and Rega tonearm rewires from £70 and upwards. There's a lot of potential upgrading in your deck - telephone or e-mail for info pack.

MAKE YOUR LP12 SOUND AS GOOD AS A MANTRA

Fibre-lam subchassis with Megabearing and motor rebuild, power supplies and tonearms from £330 upwards. Manticore Mistral *System Integrity* wired phono stage now available.

MAKE YOUR MANTRA SOUND EVEN BETTER

Take your Mantra up to Magister level. And then spend your money on vinyl. Over 4,000 pre-enjoyed vinyl records in stock from £3 and upwards. Amplifier and CD upgrades a speciality.

MANTICORE AUDIO VISUAL

MAV Shareholders Ltd, The Old Tinsmith's, Shortmead Street, Biggleswade, Bedfordshire, SG18 0AP, United Kingdom

Tel: 01767 318437 Fax: 01767 318462

Visa, Mastercard, Delta, Switch, cheque and wonga taken

E-mail: manticore@dial.pipex.com

Web: <http://dialspace.dial.pipex.com/manticore/>

Trichord Research Limited CD UPGRADE

CLOCK 3

CD PLAYER UPGRADE FROM £132

From the designer of the original Clock 2 upgrade
A new generation of Master Clock
"Significantly better than anything else
I've experienced to date" - Jimmy Hughes.

- * High accuracy (5ppm) low jitter performance master clock.
- * Up to five times reduction in date related jitter
- * Increased transparency, resolution and sound staging
- * Greater dynamics and sheer listening pleasure
- * Can be fitted to most players or transports regardless of price
The level of improvement is just as significant with expensive transports as it is with inexpensive players.

These modifications can be carried out by Trichord Research Ltd, or by your local Trichord dealer. Also available in kit form with instructions for the technically competent.

Remote Volume Controller Upgrade - £65

Major Credit Cards Accepted

Tel: (01684) 573524 Fax: (01684) 577380

73 Church Street, Malvern, Worcs, WR14 2AE

DEFINITIVE AUDIO

Export Tel/Fax 00 44 115 9813562

Tel/Fax 0115 9813562

We have a prestigious reputation for leading edge and innovative audio. We carry a strict selection of only the finest designs and offer a unique system based approach. This has earned international acclaim and established recognised sound quality benchmarks.

Living Voice Auditorium. "I had expected these speakers to be hot on tone and dynamics, since these parameters embody the company's hi-hi philosophy. I wasn't disappointed. Vocals were superb, instrumental timbre was beautifully resolved and any life that could be found in the music was there to walk into.

Consummate performance at an affordable price..." Hi-Fi Choice '97
High sensitivity (94dB/w), outstanding dynamic range, excellent low-level resolution, £1500.

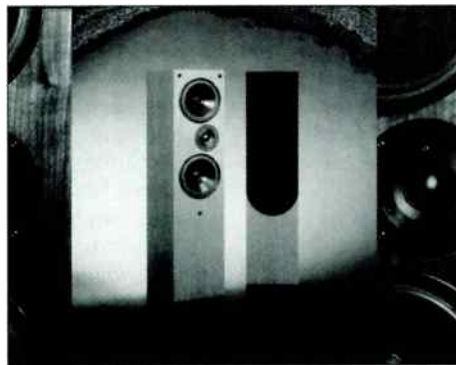

Our products range from modest to exotic, from mainstream to unusual. All are serious.

- Living Voice Airscout, RW24 Bass Bin • Border Patrol • Art Audio •
- SJS Electroacoustics • Wadia • Musical Fidelity • Kelly Transducers • Lowther •
- Nottingham Analogue • Vitavox • Mystic Mat • Musical Shoes • Platter Matter • and more.....

Second Hand Items Include

Art Audio Quintet, Chrome/Gold £1200, Impulse H5 Light Ash £850, Audio Innovation First Audio Mono's £700, Audio Innovation S200 pre £160, S200 power £300, S800 MkII £350, Monarchy M18 DAC £450, Audio Note M2 Line £650, various EQ tables, high end cables and Vitavox drive units.

Amex - VISA - MASTERCARD

CHESTERFIELD

1997

Jon Marks takes you round the highlights of 1997's Chesterfield Hi-Fi Show.

1997's Chesterfield Hi-Fi show turned October 25th and 26th into two days to remember for many a dedicated hi-fi enthusiast, whether an analogue or digital devotee.

Hi-Fi World's hardy touring team of Editor Jon Marks, Assistant Editor Ketan Bharadia and Technician Nick Lucas were on hand in the HFW room to help out with answers to queries and to demonstrate our range of valve amps and 'speakers.



Graham Tricker's Tron valve amps. In the foreground are the line and phono pre-amps with the 211 SE amp to their right.

We certainly weren't the only room to be bristling with warm valves though. Graham Tricker of GT Audio (tel: 01895 833099) was proudly showing off the new Tron Nucleus valve phono and line-level amplifiers backed up by the monstrously heavy (108lbs) 12W Tron 211 single-ended valve power amp. This was lightly loaded by a pair of Avantgarde Acoustic's Duo horn loudspeakers and fronted by a Nottingham Analogue Spacedeck turntable.



Terry O'Sullivan's gorgeous Garrard 501 turntable sporting an SNE Series V tone-arm.



Martin Bastin's Garrard 301 was happily ensconced in his new plinth. The prototype 301/401 power supply is sitting on the rack's bottom shelf.

Vinyl put in another eye-catching appearance in Terry O'Sullivan's Loricraft (tel: 01488 72267) room in the form of his superb Garrard 501 turntable. This beautifully-engineered deck will sell for around £5000 (the price has yet to be finalised) and was sounding worth every penny. Thanks to its long, tightly toleranced main bearing and re-engineered Canadian-sourced motor it was producing some very solid, dynamic and three-dimensional music from the old LP.

The name Garrard was being spoken in Martin Bastin's Black Plastic (tel: 01902 842489) room as well. Martin was putting his new 301/401 plinth through its paces. In his design (£300 for the 9in. arm version and £325 for the 12in.), the motor cage is bolted to the bottom of the plinth to reduce the amount of noise transmitted into the top-plate and on into the record. Also visible below the Croft valve pre-amp is his prototype Garrard power supply, which gave a 301, equipped with Nottingham Analogue's 12in. 'Foot' tone-arm, a smooth, weighty sound.

Flying the flag for the digital brigade were Audio Synthesis (tel: 0115 922 4138) with their awesome looking DAX decoder, packed with audiophile components. There are three toroidal transformers, one for the analogue and two for the digital stages.

Going against the Bitstream grain were the Burr-Brown PCM63PK multi-bit DACs fitted to the DAX. This £2795 decoder was sounding very sweet and spacious. Sitting behind it in the picture is the Passion 8M remote-controlled passive pre-amp with its six inputs and Vishay bulk-foil stepped

SOUNDS PERFECTION

CORNWALL'S NO.1 SPECIALIST RETAILER



SPECIALISTS IN PROVIDING MUSIC IN YOUR HOME
THE FINEST SERVICE WITH FREE ADVICE

WE BRING TO YOU

AMPLIFIERS:- ALCHEMIST, AUDIO-NOTE, MUSICAL FIDELITY,
PARASOUNDS, ROTHWELL, MICHELL & THORENS

TURNABLES:- AUDIO-NOTE, MICHELL, PROJECT, SME, &
THORENS

CD & DAC'S:- ALCHEMIST, AUDIO-NOTE, PARASOUND,
TEACH, TRICHORD & THORENS

SPEAKERS:- ANALYSIS, AUDIO-NOTE, AUDIO SPECTRUM,
BOSTON ACOUSTICS, MONITOR AUDIO, R.E.L. KLIPSH,
TRIANGLE & NOW ATC

CABLES:- CABLE TALK, AUDIO-NOTE, HENLEY, AUDIO QUEST,
PHILOSOPHY & SONIC LINK

CARTRIDGES:- GOLDING, GRADO, ORTOFON, & SHORE

STANDS:- ATACAMA, ELEMENTAL AUDIO,
SOUNDSTYLE, TARGET.

CHRISTMAS SALES

	NEW	MINT 5 YR
AUDIO NOTE ONGAKU (THE ONE & ONLY)	£59,000	£17,500
ANALYSIS OMEGA'S (LATEST SPEC)	£4,500	£3,500
AUDIOLAB 8000 CDM		£995
AUDIONOTE M2 PRE (SIDE ENTRY INPUTS)		£575
MONITOR AUDIO STUDIO 2'S	£695	£395
CASTLE HARLECH'S (BOXED) (8 MONTHS OLD)	£880	£525
TDL SUDIO 1'S (BLACK)	£695	£325

CONTACT NIGEL
AVAILABLE 7 DAYS A WEEK
TEL/FAX 01326 221372
MOBILE 0498 554357



VIBRATION CONTROL PLATFORMS AND THE MODULAR AUDIO SUPPORT SYSTEM

**MUCH MORE THAN JUST A
STAND!**

As a piece of functional furniture the BASE
Racks and platforms together are a work of
art - Dave Wiley, Audiophile Magazine.

It's refreshing to find a complete isolation
system that values aesthetics as highly as it
does sonic benefits -
Mr P M Rodwell, Cornwall.

Thanks!! The improvement is
astounding and after hearing and
trying other audio stands, the performance of
BASE is second to none -
Mr M Slattery, Sussex.

"The Audiophile support brings the sound I hear
at home one step closer to the sounds we
create in the concert hall. Bravo".....Dr. K
Murphy
(Classical Musician)



WORLD VERDICT

OUTSTANDING - Superb
Sound, something we'd use ourselves.

WORLD VERDICT

Great Build and finish, and it
sounds great too.

Audiophile Furniture Ltd
The Square
Forest Row
East Sussex
RH18 5SE.

Audiophile

For more details
and a product
portfolio please
contact:
Tel:01342 826262
Fax:01342 824845

ROCK SOLID

Peak performance acoustic platforms from No Name Acoustics

For the serious audiophile, the search for equipment supports
has been an uncomfortable compromise between style and
effectiveness. For such people their quest is now over.

Using up to five vibration dampening technologies including SoundByte
filled subframes and bearing layers, platforms provide unsurpassed resilience to
vibration and render dramatic sound improvements.

Platforms are styled with simple smooth lines and finished in
one of four colours to complement hi-fi components and the
home environment. (other colours optionally available)

Pretty they may be, but for peak
performance they're better than
placing your equipment on solid rock.

Telephone (0171) 288 1966
e-mail nna@atomic-design.com
www.atomic-design.com/noname

No Name Acoustics

Wood Silver Isolation Yacht

campaign audio design



Getting a better, more involving sound often
means spending a lot of hard earned money.
It's such a waste, because every system can
benefit from our cables and accessories, at a
fraction of the cost of some new "black box".

Here are some of the ways we can help.

We have Linear Crystal Oxygen

Free Copper interconnects (£12.48) up to
High Purity Silver cables (£89.00) and high
definition loudspeaker cables in Silver Plated
Copper or Pure Silver. Our mains cables add
weight, power and scale, and with non-inductive RF filtering (£10.00) and over
voltage protection (£3.00) enhance performance still further. Gold plated AV cables,
both RF (£17.95) and OFC Seart (£19.21), help bring picture quality in line with
NICAM sound resolution.

Valves, capacitors and transistors are all microphonic. They cannot perform
optimally if vibrated. Our set of three brass isolation cones (£5.00) are worth their
weight in gold - revealing low level resolution and dynamics hitherto hidden beneath
electronic noise. We also have a cure for your noisy fridge or central heating motor
(£3.50), enabling you to throw away your big mains noise suppressor, which has
been giving you that "sat upon sound" for years. There's lots we can do to bring you
closer to the emotion and energy of the performance. So confident are we, that we
offer a 14 day money back guarantee.

Ring or write for details:-

CAMPAIGN AUDIO DESIGN
Llandudno Road (HW)
Cardiff CF3 8PG
Tel:- 01222 779401



Trade and International Enquiries Welcome.



The handsome DAX converter from Audio Synthesis. The power supply consists of no fewer than three high-quality toroidal mains transformers.



In GATE's room a 300B single-ended amplifier (bottom right hand) took its signal from the line-level pre-amp to the left which was plugged into a Leak Troughline tuner.

attenuators for £1695.

The silver disc was also spinning alongside the black in Vinyl Demand's (tel: 01425 654545) room, where CD players Model 1 (£1250), 2 (£950) and 3 (£650) from the American company Helios were working to good effect. Helios have a background in digital logic and data processing which has allowed them to develop their own digital electronics for these players. Like many other companies they rely on transports from Philips - the 12.4 mechanism here - but these are totally rebuilt using materials like carbon fibre. The results were very rhythmic working through a system built around Trilogy valve pre and power amps and Audioplan 'speakers.

GATE (01895 833099), the manufacturers of the

audiophile stereo decoder for the Leak Troughline tuner on offer in this month's competition, had a tasty valve system up and running. Fronted by said Leak, decoder and a line-level valve pre-amp, and powered by their 300B single-ended amplifier into a pair of large Posselte loudspeakers there were some airy and open sounds coming from the room.

It was a case of vinyl galore in the main hall where picture discs as well as standard LPs were on sale.

Chesterfield 1997 showed the strong support amongst hi-fi enthusiasts for the LP and quality turntables backed up by capable valve pre and power amplifiers. Digital and solid-state were almost equally well represented with some very natural sounding systems. Hopefully Chesterfield 1998 will prove to be every bit as worthwhile a visit. It's a great show ●



Taking top spot on the rack to the left is VPI's junior turntable with its Sorbothane suspension. In the rack to the right are the three Helios CD players, with Model 1 on the top shelf and Model 3 on the bottom.



Picture this - vinyl enjoyed a very high profile at the show. About 50% of the exhibitors were using turntables as their primary sources.

Vadis

DIRECT OUTPUT

VALVE POWER AMPLIFIERS

The superior musical and sonic qualities of valve power amplifiers are now well established, and many music lovers and professional users have converted (reverted?) from transistor to valve amplification. Currently popular units, from traditional Williamson-based ultra-linear class B designs, to very expensive "high-end" single ended triode amplifiers, depend on a transformer to match the high anode resistance of the output valves to the low impedance of the loudspeaker.



The **Vadis** direct output stage achieves the required low output impedance without a matching transformer, using readily available valves, and giving a very wide bandwidth with low distortion at full power. The clarity and accuracy of reproduction is exceptional, with a lifelike sound stage clearly defined both spatially and musically. Each amplifier is hand built to order, and fully tested before delivery. In addition to traditional black, alternative colour finishes are available on request.

Vadis is a new company, designing and building high quality valve amplifiers in Scotland.

Vadis AMPLIFIERS

Kirkland, 32 Head Street, Beith, Ayrshire KA15 2EU. Tel: 01505 504128

David Price



Remember that skit from Not The Nine O'clock News - the one with Mel and Griff having a laugh at the customer's expense in a hi-fi shop? Well, watch it again these days and it just doesn't ring quite so true. Since the early Eighties most of Britain's hi-fi retail fraternity have cleaned up their act. Dealers are no longer prone to jargon-packed soliloquies about some or other product, and most show a worrying tendency to let customers make up their own minds.

Unfortunately the same can't be said of car audio. Note that I've omitted to use the term 'hi-fi' in the same sentence, because nine times out of ten it's nowhere near fi, let alone high. In-car entertainment (to use its original nomenclature, circa 1977) is, as Arthur Daley would say, "A nice little earner, Terence". As a £250m industry, sales are measured in truck-loads rather than units, and unlike real hi-fi, selling requires little from dealers. Where real hi-fi retailers toil to sell £130 bookshelf 'speakers (bi-wiring them up to buyers' systems in single-'speaker dem rooms, etc.), most in-car audio gets no such attention to detail.

Recently, after the passing of my car's original Pioneer car radio cassette,

I've experienced this firsthand. Out to buy some new music for me motor, I've been little short of appalled at the complete lack of knowledge and commitment shown by most dealers I visited.

Picture the scene. Yours truly enters an impressive

noise.

I head towards the cheapies from Sony, Pioneer and Kenwood. Matey boy switches each one on in turn, cranks up the bass, treble and volume to maximum and searches for a loudness button to complete the job. We're

"Wading past acres of mobile phones, I finally realise I've reached the car section thanks to the strangely distorted low-frequency rasps coming from a small tin can with 'subwoofer' writ large on its front."

looking (from the outside at least) retail establishment. Wading past acres of mobile phones, I finally realise I've reached the car section thanks to the strangely distorted low-frequency rasps coming from a small tin can with 'subwoofer' writ large on its front. "Can I 'elp you, mate?", mutters our man. Judging by what I've just seen I doubt that very much.

Anyway, I say I want a good, basic radio cassette for around 300 notes, including a pair of decent small 'speakers. Funny then that the first thing he demonstrates is an £800 Alpine CD system with a flatulent subwoofer and four 'speakers bigger than my car wheels. I guess he can't have heard me right - not surprising with all that

greeted by the sound of a 40W op-amp being overdriven - not as loud as Motorhead, but no less distorted. The dem consists of hearing each stereo played at '11', proving no more than how gracefully each amplifier clips.

I turn them down to half volume and set the tone controls to off. That's better - now I can actually hear how they sound. Not bad is the answer - the cassette decks are good, and the radios adequately clean and clear, if a touch synthesiser-ish. Unfortunately I get about ten seconds to listen before the guy starts up about the remotes, how many 'speakers they'll drive, whether you can use 'a graphic', etc, etc. Oh well, never mind.

After doing the rounds

of all West London's dealers, I eventually plumped for a Sony XR-4750RDS radio cassette and XS-7303 loudspeakers. Still without a real feel for how it would sound, I set about installing it in my car. The results were fairly impressive. The clean, high-current power from a battery that car audio uses is every hi-fi designer's dream, so at least it's off to a good start - but I still question whether it's hi-fi.

Naturally, I did some experimentation while installing everything, and ended up with a real improvement to the sound. Spectra Dynamics' Foculpods and Deflex panels were used to isolate the stereo from vibration, and more Deflex was applied to the insides of the door skins to deaden the loudspeakers' environment. Finally, the dreadful supplied 'speaker wires were replaced by a few metres of DNM solid core.

The result? A secure, stable sound from the cassette with low wow, flutter and hiss. And pleasant FM stereo too, if not as smooth as the analogue tuner of my 1978 Pioneer. The

'4x35W' amp section is clean, if a little chrome-plated, but an improvement on my Pioneer's five watts of discrete transistor power nonetheless. But the Sony polypropylene coned three-way 'speakers were the best surprise - far superior to the soggy paper Pioneer co-axials I prised from my door panels.

So now it's back to the familiar smells of my trusty Triumph two-seater - Castrol GTX seeping from the rocker gasket, ATF from the diff and the odd splash of anti-freeze leaking from the radiator. Not an ideal environment for my new in-car entertainment, but short of becoming a car hi-fi dealer, I doubt I'll ever be able to afford better!

LONDON



Oxford
01865 785961
Enfield
0181-367 3132
Swindon
01793 538222
Hempstead
0171-794 7848
Cheltenham
01242 583960

Advice & demonstrations, Home Cinema & Multi-Room, Part X e.mail:
hifi@audio-t.co.uk

audio-T

PRICE PROMISE

- We know you won't find better service
- We know you won't find better sound
- But if you find a better deal, let us know and as long as we can verify it we'll be happy to match it.

Gants Hill
0181-518 0915
Basingstoke
01256 324311
Reading
0118-958 5463
Camberley
01276 685597
Brentwood
01277 264730
Interest Free Credit, 3 year guarantee on all hi-fi separates see us at:
www.audio-t.co.uk

Great Value Sound & Vision

SOUTH con't



Best place in town for Hi Fi and Home Cinema

- * Six demonstration rooms
- * All leading brands
- * Interest Free Credit
- * Free Parking
- * Open 10-4 every Sunday

UNILET SOUND & VISION
35 HIGH STREET, NEW MALDEN,
SURREY, KT3 4BY

Tel: 0181 942 9567 Fax: 0181 336 0820

AUDIO CONCEPT

27 BOND STREET, EALING
LONDON W5 5AS
TEL. 081 - 567 8703

AMC, Acoustic Energy, Aura, Audiolab, Audio Innovations, B&O, B&W, Cannon, Castle, Cyrus, Denon, Dual, Evolution, JPW, KEF, Marantz, Micromega, Mission, Monitor audio, Musical Fidelity, NAD, Nakamichi, Onix, Onkyo, Quad, REL, Rogers, Rotel, Systemdek, Target, Teac, Thorens, Van den Hul

10 - 6 pm Mon., Tues., Friday, & Sat.
Late night Thur., closed Wed.

Two demonstration rooms.
Free local delivery and installation.
Repairs and Services

HI-FI EXPERIENCE

Arcam • Audiolab • Audioquest • Bang & Olufsen • Chord • Cyrus • Denon • KEF • Marantz • Meridian • Mission • MF • NAD • Quad • REL • Rotel • Sendor • Tannoy • TDL • Yamaha • Sony.

Award Winning Hi-Fi from stock - Sales or Service - WE CAN HELP

Tel: (0171) 580 3535

Fax: (0171) 436 4733



Britain's Top Specialist Hi-Fi Stores

227 Tottenham Court Road,
London, W1P 0HX.

Send or call for your FREE Magazine and Catalogue BADA Bonded

Stockists of: ARCAM • CREEK • EPOS
HEYBROOK • MICROMEGA • NAIM AUDIO
NEAT • REGA • ROKSAN • ROTEL • ROYD
TEAC • YAMAHA

Infidelity

indecently good hi-fi

9 High Street, Hampton Wick, Kingston upon
Thames, Surrey KT1 4DA. Tel: 081-943 3530
Open Tues - Sat 10.30am - 7.00pm.

SOUTH EAST



Best place in town for Hi Fi and Home Cinema

- * Three demonstration rooms
- * All leading brands
- * Interest Free Credit
- * Good parking facilities
- * Open 10-4 every Sunday

UNILET SOUND & VISION
24-26 UNION STREET, MAIDSTONE ME14 1ED
Tel: 01622 676703 Fax: 01622 676123

specialist hi-fi dealers

This one's worth keeping!

GRAHAMS HI-FI

Hi-Fi-Home Cinema
Multi-Room Installations

0171 226 5500

Grahams Hi-Fi, Canonbury Yard,
190a New North Road, London N1 7BS
Tel: 0171 226 5500 Fax: 0171 359 7620
E-mail: world@grahams.co.uk
Web site: http://www.grahams.co.uk

O'Brien Hi-Fi



AKG, ARCAM, AUDIO TECHNICA,
BEYER, CABLETALK, CHORD,
CREEK, DENON, DENSEN, JECKLIN,
MAXELL, MICHELL, MUSICAL
FIDELITY, NAD, NAIM, ONKYO,
OPERA, QED, ROGERS, ROYD,
RUARK, SENNHEISER, SEQUENCE,
SME, SONNETEER, SONY, TEAC,
THORENS, UNISON RESEARCH

Demonstration Room - Free car parking
Major Credit Cards - Mail Order - Installation Service
Repair facilities - 5 mins walk from Raynes Park BR
60 Durham Rd, West Wimbledon, London SW20 0TW
Tel. (0181)946-1528 Fax (0181)946-0331



INSTANT 0%
FINANCE
AVAILABLE
SERVING LONDON
FROM BATTERSEA

ORANGES & LEMONS

Juicy fruit from London's newest, freshest hi-fi/home cinema retailer. Telephone demonstrations or just pop in. All the usual, i.e. friendly and efficient service, free home installation + credit cards.

THE INNOVATIVE AUDIOVISUAL HI-FI RETAILER. ARCAM, CABLETALK, CHORD CO, DENON, EPOS, MARANTZ, NAD, NAIM, REGA, ROKSAN, ROTEL, ROYD, RUARK, SOUNDSTYLE, STANDS UNIQUE, YAMAHA.

NOW IN OUR THIRD
TANGY YEAR.

0171- 924 2040

61/63 WEBBS ROAD, SW11

Front End Problem?

contact

The Cartridge Man

It doesn't have to cost an arm and a leg to get the best - listen to my Koetsu - and Decca - eater.

Also agents for Croft, Hadcock, Real Music Co, Michell & Moth.

plus cartridge re-tipping service

0181 - 688 6565

SOUTH

SPALDINGS

THE SOUTH EAST'S LEADING HI-FI COMPANY

3 DEM ROOMS A.V.
HOME DEMS., 0% CREDIT
FREE INSTALLATION

LINN . NAIM . QUAD . AUDIO LAB
DENON . MARANTZ . RUARK
MON TO SAT 9.00 to 6.00, TUE 9.00 to 8.00

SEVICE DEPT

325-354 Lower Addiscombe Road, Croydon, Surrey CR0 7AF
Telephone: 0181 654 1231/2040 Facsimile: 0181 655 3922

WORTHING AUDIO

20 Treville Gate, W.Sussex BN11 1UA
(0903) 212133

The friendly shop with the best sound system in the South.
Talk Electronics - Friendly Advice - 3 Year Guarantees
Easy Parking - Open Mon-Sat. 10am-6pm.
Late Night Wed 7.30pm.
Agencies include: Arcam, Exposure, Kinshaw, Naim, Audio, Marantz, Ruark, Audio Technica, Target, Tripod, JPW, TDL, Orelle, and many more.....

audio excellence BADA

WHERE THE MUSIC MATTERS

CHESTER 86-90 Boughton, Chester CH3 5AQ (01244) 345576
PRESTON 131 Friargate Preston, PR1 2EE (01772) 253057

TUESDAY - SATURDAY 9.00 - 5.30
CLOSED MONDAY

NORTH

HI-FI EXPERIENCE

Arcam • Audiolab • Audioquest • Bang & Olufsen • Chord • Cyrus • Denon • KEF • Marantz • Meridian • Mission • MF • NAD • Quad • REL • Rotel • Sendor • Tannoy • TDL • Yamaha • Sony.

Award Winning Hi-Fi from stock - Sales or Service - WE CAN HELP

Tel: (01325) 481418

Fax: (01325) 382982



Britain's Top Specialist Hi-Fi Stores

17 Coniscliffe Road,
Darlington DL3 7EE.

Send or call for your FREE Magazine and Catalogue. BADA Bonded

NORTH (Con't)

THE hi-fi ROOM

50 BRIDGE STREET, MANCHESTER M3 3BN. TELEPHONE: 0161-832 0888/0161-835 1366

An Oasis of Sound

EXCLUSIVE HI-FI AND AUDIO VISUAL SYSTEMS

GLASGOW 0141 248 2857 EDINBURGH 0131 220 0909 NEWCASTLE 0191 230 3600 LEEDS 0113 242 7777

SERIOUS KIT

The finest range of Hi-Fi in the north. Stockists of Audionote, Sugden, Impulse, Pro-Ac, Harbeth, Stemsfort, Target, Noat, Trichord, Systemdek, Lyra, Proceed, SME, Michell, Heart, Keswick etc etc
Open 10-6pm Mon-Fri
10-5pm Sat
10-2pm Sun

Phone: 0161 793 6742
Fax: 0161 727 7042

MIDLANDS



SOUND

ACADEMY

Audio Equipment from leading and specialist brands for you to listen to and choose from.

Tel: 01922 493499/473499

- 3 Hi-Fi Studios
- Home Trials
- Home Cinema Theatre
- Audio Visual Equipment
- Inhouse Service Department
- Mail order available
- Interest Free Credit (On Selected Items APR0% written details on request)

Hi-Fi for those with an eye for Quality



WE ARE HERE

Sharing the ASDA Catchment with ample free parking, 631 High Street, Birmingham, Nr. Walsall, West Midlands

Open 6 Days, 9am - 6pm
Late night Friday

ARCAM AUDIO LAB CHORD NAIM KESWICK AUDIO RESEARCH ALBO-APOLLO AT AUDIO ALCHEMY AUDIO QUEST HAV ROSE BEYER CABLE TALK CHORD COMPANY CYRUS CELESTION DPA EPOS EXPOSURE KEF REFERENCE KEVWOOD MARANTZ MICHELLE MORDAUNT SHORT MERIDIAN MICROMEDIA MISSION BOTH MUSICAL FIDELITY NAKAMICHI ORTOFON PROJECT QUAD ROKSAN ROGERS ROTEL SENNEISER SONY SUNKO SYSTEMDEK TARGET TEL TUBE TECHNOLOGY VAN DEN HUL YAMAHA

MUSIC MATTERS



LATEST ARRIVALS

CHORD SPA3200 & SPM1200B PRE-POWER, MERIDIAN DSP6000 SPEAKER SYSTEM, S65AC-3 SURROUND PROCESSOR, 557 POWER AMP, 510 DIGITAL PROCESSOR AND 566 20-BIT DAC,

ALCHEMIST MAXIM, NEMESIS AND FORSETI AMPLIFIERS, DYNAUDIO RANGE OF SPEAKERS, EPOS ES22, SPENDOR AND PRO-AC SPEAKERS, ROYD SQUIRE & DOUBLET SPEAKERS, QUAD 77 RANGE.....

CLEARANCE & SECOND HAND SALE

OUR VERY SUCCESSFUL SALE NOW MEANS WE HAVE A NEW LIST. PLEASE SEND A N.S.A.E. FOR AN UPDATE OF THE NEW BARGAINS AVAILABLE.

PLEASE NOTE OUR NEW OPENING TIMES
TUESDAY TO SATURDAY 10am TILL 5.30pm,
LATE NIGHT THURSDAY TILL 7pm.

Branches at:

- Birmingham : 363 Hagley Road, Edgbaston, Tel: 0121 429 2811
- Solihull : 93-95 Hobs Moat Road, Tel: 0121 742 0254
- Stourbridge : 156/157 Lower High Street, Tel 01384 444184
~Demonstrations By Appointment~

FRANK HARVEY

Hi-Fi EXCELLENCE

163 Spion Street, Coventry, CV1 3BB Tel : 0203 525200.
Mon to Sat 9.30 till 5.30. Closed Thursday

MUCH MORE THAN HI-FI
WE ARE A BADA DEALER

Audiolab - Audio Alchemy - Arcam - Alphason - Bose - Bang & Olufsen - Celestion - Cyrus - Denon - Dual - Foundation - Kef - Marantz - Monitor Audio - Mission - Musical Fidelity - Nakamichi - Nad - Quad - Rega - Rogers - Rotel - Target - Tripod - Tannoy - Thorens - Van Den Hul - Yamaha

MAILORDER - EXPORT - HOME TRIALS

3 Floors. 3 Dem rooms. 3000 sq feet in the pursuit of Hi-Fi Excellence

CREATIVE AUDIO

9 DOGPOLE, SHREWSBURY, SHROPSHIRE

Tel: (01743) 241924

Closed Mondays

- Comfortable listening rooms
- Home demonstrations available
- Part exchange welcome
- Free home installation
- Interest free credit

Authorised retailer for:

A&R ARCAM, AUDIOLAB, CELESTION, CYRUS, DENON, DUAL, MERIDIAN, MISSION, MONITOR AUDIO, QUAD, REVOLVER, ROKSAN, ROTEL, YAMAHA, EPOS, NAIM, KEF, NAD

THE LEAMINGTON HI-FI COMPANY

THE LEADING HI-FI SPECIALIST

ARCAM AUDIOLAB QUAD MERIDIAN MARANTZ DENON PIONEER YAMAHA NAD MICROMEDIA MISSION KEF CELESTION ATACAMA TECHNICS TRICHORD TEL REL DIOS
SINGLE SPEAKER DEM ROOM WE DO NOT USE ANY COMPARETORS
WE ALSO HAVE FULL DEMONSTRATION OF PROJECTION TV WITH LASERDISC AND FULL PRO LOGIC SYSTEMS
PART EXCHANGE WRLCOMR
PLEASE PHONE OR B.MAIL FOR PRICES
WE HAVE IN STOCK OVER 200 LASERDISCS
CALL FOR OUR LATEST CATALOGUE
THE LEAMINGTON HI-FI COMPANY
23a Regent Street, Leamington Spa, Warwickshire CV32 5EJ
Phone: 01926 85644 Fax: 01926 887488 E-mail: lbrowne@hbcnca.org.uk

WEST & WALES

audio excellence 

WHERE THE MUSIC MATTERS

Bristol	Cardiff
65 Park Street Bristol BS1 5PB (01179) 264975	134/6 Crwys Road Cardiff CF2 4NR (01222) 228565
Gloucester	Swansea
58 Bristol Road Gloucester GL1 5SD (01452) 300046	9 High Street Swansea SA1 1LE (01792) 474608

Exeter
156 Sidwell Street, Exeter, EX4 6RT
(01392) 491194

TUESDAY - SATURDAY 9.00 - 5.30
CLOSED MONDAY



specialist hi-fi dealers

EIRE

Hearing is Believing

CLONEY
Audio
30 years of Excellence

55 Main Street,
Blackrock,
Dublin.

Tel: (01) 2889449/2888477

Open: Tues - Sat 10 am to 6 pm.
Thurs - Fri 10 am to 6 pm.

**Arcam
B&W
AudioLab
Castle
Meridian
Classé
Rega
Marantz
Epos
Naim Audio
Sony
REL**

VALVES & TUBES



CHELMER VALVE COMPANY
for
High Quality Audio Valves

Buy CVC PREMIUM HI-FI valves direct from us.

All valves processed for improved performance.

We also have Stock of MAJOR BRAND types including :MULLARD, GEC, BRIMAR, RCA, GE, etc
130, New London Road, Chelmsford, Essex, CM2 0RG
Tel: 01245 265865 Fax: 01245 490064

SERVICES & CONSULTANTS

STUDER REVOX

SALES, SERVICE, SPARES

SERVICE & REPAIR OF

A77, B77, A700, PR99 &

36 SERIES

HI-FI SPARES TO ORDER

SERVICED MACHINES IN

STOCK

APPROVED CONVERSIONS

E.M.A.S.

TEL: 01246-275479

FAX: 01246 550421

REVOX SERVICE

Fully Guaranteed Service and Repair

Insured Carriage arranged

Free Estimation

Also: Tape Supplies

Second User Reconditioned Machines

Spare Parts orders welcome

Free Advice

Ram Tek

Tel: (0181) 207 6159

Fax: (0181) 953 1118

Kinetic Centre, Theobald Street,
Borehamwood, Herts. WD6 4SE

SERVICES & CONSULTANTS

atv

- Service & Repairs
- Valve & transistor amplifiers
- Vintage valve Radios
- Hi-Fi VCR's
- Valves Tested

ATV SERVICES

LEATHERHEAD

01372 456921

LORICRAFT AUDIO

Required Garrard 301/401, Thorens TD124, Goldring GL75 any condition or any parts from new to completely used

Tel/Fax/Answer phone -
01488 72267

GT AUDIO

GUARANTEED TOP QUALITY REPAIRS AND SERVICING ON ALL TYPES OF VALVE AUDIO EQUIPMENT. SYMPATHETIC UPGRADING CARRIED OUT USING THE FINEST COMPONENTS AVAILABLE.

Also agents For:-CROFT, G.A.T.E., GRAAF, LEAK TROUGHLINE TUNERS, MONRIO, NOTTINGHAM ANALOGUE, POSSELT, UKD OPERA, UNISON RESEARCH, YAMAMURA CHURCHILL ACCESSORIES

TEL: 01895 833099

RESTORATION OF CLASSIC EQUIPMENT

Electronics engineer (Degree/MAES) with over 40 years experience and specialist knowledge of Quad, Radford, Leak, Rogers and Armstrong, etc. Extensive facilities enable original standards with detailed reports of work carried out. Apparatus is demonstrated prior to clients departure. Available 7 days a week. Valve testing a speciality.

Circuit Data of Classic Equipment on offer...

PLEASE ENQUIRE

Electronics Engineer and Consultant

Tel: 0181 504 5467 Woodford, Essex

REPAIR & DIY

TECHNICAL & GENERAL

THE ORIGINAL TURNTABLE SPECIALIST

for the Great Classical Turntable, Arms, Cartridges, Styli

CONNOISSEUR • GARRARD • GOLDRING • LENCO • ORTOFON • SHURE • S.M.E. • THORENS • WATTS

All available Genuine spares and our own re-manufacture of obsolete parts

NO ILLUSORY 'IMPROVEMENT' NO DUBIOUS OR HARMFUL 'MODIFICATIONS'

Cartridges and styli, correct radius diamonds, for early recordings - 78s & Lps

TECHNICAL & GENERAL

P.O.Box 53 Crowborough, East Sussex TN6 2BY

Tel: 01892 65 45 34

REPAIR & DIY



Bored by the sound of your current Hi-Fi system?

The Russ Andrews Solution

Don't change it - upgrade it!

By improving the quality of crucial components and wiring in your equipment you can achieve results that will astound you...and for a fraction of the cost of buying a new model

Our Catalogue contains the definitive selection of the World's best Hi-Fi components.

Our Upgrade Kits provide instructions on how to carry out a vast range of upgrades.

Our Unique after-sales technical support ensures you have access to our expertise should you have any queries.

Give it a new lease of life!

To receive our latest information and upgrading advice - just mail, phone or fax the following address:

Russ Andrews Ltd., Edge Bank House, Kendal, Westmorland LA8 9AS, ENGLAND. Tel: 01539 823247 Fax: 01539 823317

VINYL

Records at Cost

NOW YOU CAN BUY YOUR CDs AT DEALER'S COST PRICE

As a member of the WSL Records at Cost Service you can buy any brand new CD at trade price + postage and a small handling charge from only 50p. Write, phone, fax or e-mail us now and we'll send you full details of the Records at Cost Service and how to join.

WSL P.O. BOX 32 ST. LEONARDS EAST SUSSEX TN38 0UZ

TEL: (01424) 718254 (24 Hours) FAX: (01424) 718262

E-MAIL: WILSONSTEREOLIBRARY@COMPUSERVE.COM

PLUS! WE INVITE YOU TO CASH IN ON A MASSIVE CD WAREHOUSE

CLEARANCE SALE!

TO ADVERTISE IN SPECIALIST HI-FI DEALER SECTION PLEASE PHONE: CAROLINE KNOTT 01245 443555



To Advertise in Hi-Fi World's "Specialist Hi-Fi Dealer" Section Please Telephone Me... Caroline !!! on (01245) 443555

MINI MAGIC?



Do Kenwood have a MiniDisc success on their hands with the DM-9090 recorder, wonders Jon Marks?

Can Kenwood's new £550 DM-9090, with the latest ATRAC 4.5 processing, keep the torch burning for MiniDisc now that CD-RW has arrived?

Like the DM-7090 (reviewed in April '97) it boasts Kenwood's proprietary D.R.I.V.E. (Dynamic Resolution Intensive Vector Enhancement) to smooth low-level waveforms. This should add up to a more atmospheric sound with better sound staging.

Tina Turner's *Simply The Best* compilation managed a fully-formed sound stage with fine depth as well as width. It also had its share of low-down bump and grind rhythm thanks to chunky basslines like those on 'I Can't Stand The Rain'. The Kenwood surprised me with the sheer funkiness of the music it was playing - this was real living-room danceable stuff.

The same drive and pace came through with The Fugees' *The Score* album. Upper bass was taut and hard

while lower bass had a bit of a boost to it that added weight and slam without it booming loosely around the room. That characteristic spaciousness also put in a second appearance.

Now it was time to try recording an analogue signal through the 20-bit D.R.I.V.E. analogue to digital convertor. On Stravinsky's *Firebird* I was greeted by the same kind of atmospheric, involving sound I'd heard with Tina Turner and The Fugees. Dynamically the copy was only a shade slower than the original across most frequencies, a lack of punch and definition in the lower bass stopping the '9090 scoring higher. The sound stage was smaller than the original's too, but the images within it were solid as a rock.

If it's digital copies as opposed to analogue you're after, simply select one of the three digital inputs (two co-axial and one optical) with the Rec Input button then press Rec twice.

Comparing two copies, one analogue and one digital, of the Stravinsky piece, I found the digital version obviously better - it was crisper, more transparent and had more slam as well.

The DM-9090 is one of the best MiniDisc players I've come across, but how would it fare against Philips' CDR 870, especially bearing in mind basic MiniDiscs cost about £4, better sounding ones like Sony's 60min ES about £6?

CD-Rs, which can be burned once only, can be had for £2-£4.

With a copy of the Stravinsky made through exactly the same equipment and cables I have to say the Philips was generally superior. It might not have been as involving as the DM-9090 but it was cleaner, more detailed and more controlled on both analogue and digital recordings. By comparison the Kenwood was rather blurred and fuzzy, although it had a wider range of tonal colour and weightier bass.

Kenwood's DM-9090 is an excellent MiniDisc recorder, whether it's replay or recording in question. It has a smooth, engaging presentation that will make it a lot of MiniDisc friends. As a digital recorder though, it is outstripped by Philips' CDR 870, which happens to be £50 cheaper to boot ●

Kenwood DM-9090 £499.95

Kenwood
Dwight Road,
Watford,
Herts. WD1 8EB
Tel: 01923 816444



WORLD VERDICT

One of the best MD machines to date, but CD-R has the sonic edge.

VINTAGE VIRTUES

by Haden Boardman

Horn loudspeakers are one of those subjects which can raise the heart-beat of dedicated enthusiasts. Problem is, there are so many different kinds of horns, with so many different applications, not all of which are really hi-fi. However, Lowther is a name which has become synonymous with horn loudspeakers, some of which are truly excellent.

Lowther started producing hi-fi amplifiers and tuners in the early 1930s in the large wooden radiogram-style cabinet that was ubiquitous at the time. What was unusual was that the better quality sets did not generally have built-in loudspeakers. The natural partner was the Paul Voigt Corner Horn loudspeaker, and the two items were generally sold together.



The PM4 had such a large magnet assembly it came with a handle to make it easier to lift.

This loudspeaker was an amazing unit, with its small, six-inch full-range cone and very large, powerful electromagnet. Later modifications included fitting a 'whizzer' cone to the centre of the main cone to improve high frequencies and produce a response that extended past 13kHz. Remember, we're talking mid-1930s here, and this kind of specification was ground-breaking at the time.

After the Second World War, Paul Voigt left England, having been almost driven out because of his German name, and eventually settled in Canada, leaving his loudspeaker designs in the hands of Lowther. By the early 1950s the range of 'speakers had progressed to a handful of different models, although the original Voigt Corner Horn remained.

Lowther had done a lot of work on permanent magnets as replacements for mains-energised types - the original Voigt mains-energised units required 42watts of power at 200volts DC to work! So the new PM1 driver retained the same performance as the original Voigt but was easier to use and marked a new era for Lowther.

The American designer Stewart Hegeman then became involved and



produced a new flagship horn known simply as 'The Hegeman'. This relied on the same basic twin-cone driver allied to the new PM4 magnet unit, which has the most unbelievably powerful gap-flux of 24,000Gauss - stronger than anything else I have ever seen.

The Hegeman has a huge monster of a cabinet, four feet tall, four feet wide and two feet deep. It has a folded bass horn to the rear (or, more correctly, underneath) the driver and a plaster-of-Paris midrange and treble horn. I am lucky enough to have picked up one of these and I cannot tell you how much I would give to make a stereo pair - it is a truly awesome loudspeaker.

By the late 1950s stereo was becoming popular, and most of Lowther's models were huge. As a result, the constant-width rear-horn Acousta, built to work with the PM6

One Award, Nine Real Winners

WHAT HI-FI?

Awards

1997
BEST BUY

Available in

9

Real Wood
Veneers

Rosewood
Yew
Walnut
Cherrywood
Mahogany
Natural Oak
Medium Oak
Antique Oak
Black Ash

Severn 2

CASTLE

and PM7 units, was born. These two drivers had physically smaller magnets than the earlier PM1 but, through the use of new materials such as Ticonal, these were actually much more powerful, especially in the PM7 model.

The Acousta cabinet is simple enough in terms of construction. It isn't exactly small or attractively-proportioned by modern standards but it isn't so big a pair won't fit in a modern room. One advantage it does have over more modern loudspeakers is that it often works better situated in a corner - it is not the kind of 'speaker that appreciates sitting in open space. This is basically because its horn mouth is designed to work in conjunction with the wall and floor to effectively increase its size and lower its bass cut-off frequency.

I find the sound of the Lowthers beguiling. They are very efficient - in a cabinet, the PM7 hits over 103dB/watt. A good, clean valve amplifier is the best way of driving Acoustas. Lowther make some rather optimistic claims about power handling which, in reality, is about 15watts. Mind you, that translates into more than 111dB in-room, and that's LOUD! A 'speaker of 83dB/watt



The Acousta's horn mouth is set low so that side walls and floor act to increase its area and so extend bass downwards.

would require in excess of 1kW per channel to go that loud, if it could handle so much power.

The Lowthers' frequency response is hardly ruler flat, but the older the unit is, the smoother it gets. A new drive unit or one freshly repaired will take around three years to run in. This is because the cone is so very light its sound is heavily influenced by the age of the roll surround and spider.

The treble is very directional so you have to sit fully on axis to get the best out of it. When you do, you'll find its quality is excellent, similar to an electrostatic, only more dynamic.

On first audition, a pair of Acoustas may sound flat, lacking in definition and bass-light. The longer you listen though, the more you become aware of just how much there is going on in the music that lesser moving coil

magnets fitted from the early 1980s are not as good as their Alnico counterparts.

Never use Lowther drivers with any transistor amps that have a switch-on 'thud' - the thin, delicate voice-coil wire will fall off the coil former. This can happen more easily than you might think because Lowther wind on the inside of the coil former as well as the outside to obtain maximum efficiency.

Despite their faults, like a slightly boxy sound, the Acoustas are a very enjoyable listen. The fact they're efficient is an added bonus. They are an easy load too (early ones are rated at 15ohms, later black-chassis versions at 8ohms) but have a high average impedance curve. This makes it hard for a low-power amplifier with high output impedance to drive them correctly.



Alnico and ceramic magnets are distinguished by their different shapes. The Alnico on the left is small and bulbous while the ceramic on the right is flatter and larger in diameter.

loudspeakers miss out on. I recently made a recording of a drummer for sampling purposes and playing it back over the Lowthers was a scary experience it was so life-like.

Lowther drivers do have their problems - they are very easily damaged and cost a small fortune to put right. When buying second-hand, unless you have documentary evidence they have been replaced, budget on the foam surrounds being rotten. Even if they look okay, they may still be past their best. Newer units (recognisable for a black chassis) have updated surrounds that do not suffer this but the cones are not as well made in my opinion. Also look out for magnets that have been swapped over - the late ceramic

Steer clear of later MDF Acoustas and the narrow dual-position or corner types which have the driver pointing up at 45degrees. Stick to the pre-1970 plywood incarnations and 'A' (Alnico: aluminium/nickel/cobalt) magnets on either PM6s or PM7s. Also check out the rare PM1 and Audiovector models. Lowther made some impressive valve power amplifiers as well although these are rarer than hens' teeth. Avoid Lowther's early experiments with transistors; like many amps from solid-state's infancy they're not particularly good.

A good pair of Acoustas with PM6As or PM7As will command a price of around £300-£500 and that's money well spent ●

Live music - there's nothing quite like it. Not even the very best, most expensive hi-fi systems can offer quite the same emotion, atmosphere and involvement as a good live performance. Whether the gig you've just been to was acoustic or electric, coming home to your hi-fi is always a bit of a disappointment. As reader Nicholas Davis said in the Letter Of The Month, Nov 1997, hi-fi is 'only a means to an end'. Jon Marks agreed, and I think it is a sentiment that most of us can relate to. There's nothing more pitiful than someone with a system worth thousands of pounds and only a dozen or so 'test discs' deemed worthy of a listen. Get too carried away with the equipment and it's frighteningly easy to wake up one day and find yourself listening to the hi-fi rather than the music.

Yet, as Jon Marks also stated, the point is that many people see music as a means of relaxation rather than a social event. For this reason, the comfort of your own home can be preferable to the possible discomfort and often questionable acoustics of a live event. A very different sound is required, one that is beguiling and soothing rather than one that leaves your ears ringing long after you return home. In short, many home hi-fi systems are deliberately sugary and coloured to aid long-term listening pleasure. But this isn't everyone's concept of good hi-fi. Some manufacturers would rather get as close to a live performance as possible, and the methods used can be quite intriguing.

Loudspeakers are the only part of the hi-fi system whose performance relies heavily on a room's acoustic. Hence it's here we see the most effort being made to create a greater sense of realism of

Fair Views

from
Dominic Todd,
our man in
retailing



sound. Central to the design rationale of several manufacturers is the fact that when attending a live performance, or in everyday life, we hear a mix of both direct and reflected sound. To create a full picture of the acoustic, our brains need

from the front but peek around the rear and rather than finding the customary port hole and binding posts, you'll find another tweeter and maybe a woofer. Again, the idea is to reflect the sound off the rear and side walls, creating a more spacious

living rooms of the UK, however, remains to be seen.

Life-like realism comes in more flavours than expansive sound staging. Many audiophiles are addicted to rhythm above all else. Linn and Naim have built something of a reputation for just such a rhythmic foot-tapping quality from their electronics and loudspeakers.

Another name to look out for, if you're seeking thrills, is Rehdeko. To look at, these transducers appear to be little

more than a pair of 6in. by 4in. in-car drive units slapped into a cheap cabinet. A first listen will also be rather disconcerting, questioning all your assumptions as to how hi-fi should sound. But leave the room and listen from the outside and you could easily be fooled, with smaller scale music at least, into thinking real musicians were in the room. Listen some more and it's not hard to see why Rehdeko, like Naim, have such a loyal following.

Hi-fi that thrills is great, but then so is a system that soothes after a hard day at work. The only real answer is to have a house with at least two or three different hi-fi systems to cater for all your different moods! Oh, and don't forget live music either. Now, where did I leave that lottery ticket?

"Life-like realism comes in more flavours than expansive sound staging. Many audiophiles are addicted to rhythm above all else."

both kinds of sound. Without reflected signals we would be left with an anechoic chamber-style presentation which sounds acoustically 'dead'.

Obviously, in most listening environments there is a certain amount of reflected sound. Some manufacturers, one of the best known being Bose, take this idea one stage further by deliberately bouncing the sound off rear and side walls. This can be done in a variety of ways like placing midrange drive units and tweeters at the side or rear of the loudspeaker cabinets.

With the increasing interest in audio-visual products, bipolar loudspeakers are making something of a comeback; a tepid one mind, but a comeback nonetheless. A bipolar 'speaker usually looks fairly conventional

and less 'boxy' sound. It's the thing to have for rear 'speakers in a home cinema system, so there are plenty of bipolars around from mass-market manufacturers.

You'll also find some of the more esoteric companies, such as Mirage, following the same kind of formula. As with many areas of hi-fi, it's the mid-price area which makes or breaks technologies that dare to be different. I was therefore keen to hear Canadian Paradigm's floor standing bipolar loudspeaker, the Esprit. How did it sound? Well, provided it was sited in a largish room away from the rear wall, there was a sense of scale, and what can only be described as a 'wall of sound', that few 'speakers could match. Whether the design will catch on in the dimensionally-challenged

This man can't
believe what he's
hearing...

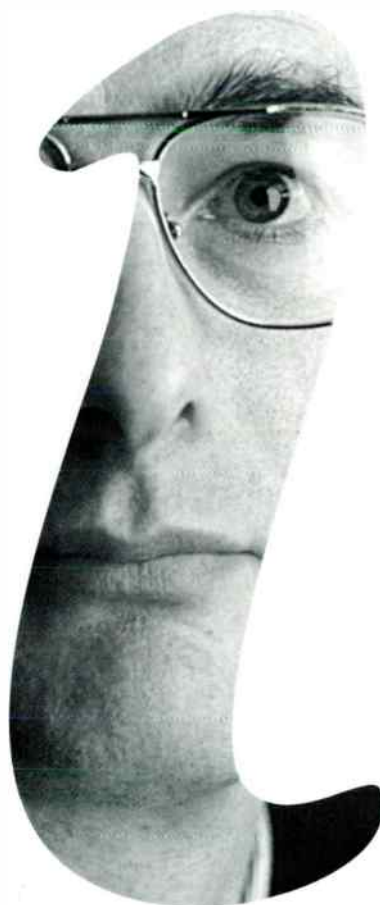



...But it's true.

Peter J Comeau is no ordinary reviewer. As designer of the only product to win the coveted What Hi-fi Best Loudspeaker Award three times in succession, he's generally regarded as the guru of small speakers. With 30 years' experience as a specialist hi-fi retailer, co-founder of a highly respected UK hi-fi manufacturer and one of the 'terrible three' who pioneered subjective reviewing in the staid hi-fi press of the 1970s, his opinion carries formidable weight.

“Percussion is firm and practically floor shaking in its intensity - just a few bars and you are already reaching for your wallet.”

Hi-Fi News & Record Review

“...The 12i marks the baseline performance above which all other speakers should rise. But do they? Do they hell!”

Seasoned hi-fi critics are notoriously hard to impress.

So how come we weren't surprised when Peter J Comeau enthused so fulsomely about our new 12i?

“They sound like a grand's worth of exotic compact,” he wrote in October's Hi-Fi News. “If Celestion can achieve this sort of performance for a miserly figure, why are most of the speakers that arrive on the market so poor in comparison?”

Well, we can't speak for anyone else - but we know what makes the 12i such a remarkable performer.

The smooth, natural-sounding vocals? Celestion's 19mm tweeter, whose neodymium magnet is ferrofluid-cooled for improved power handling.

The phenomenal bass response? 130mm long throw bass drivers, which allow the cone extended movement without removing the HF coil from the magnetic gap where energy is most concentrated.

The acoustic purity and lack of distortion? The use of laser interferometry to tune out the response peaks of conventional speakers. Celestion crossovers to ensure seamlessly smooth transitions. Mounting the drivers and reflex port in a dense one-piece composite baffle to minimise resonance. Cabinets computer-designed to eliminate box coloration.

In the words of the Hi-Fi News lab report, “the horizontal off-axis trace is brilliantly managed.” To the listener, that means the same seductive audio experience wherever you sit in the room.

No wonder the 12i reproduces the most demanding material with such accuracy ▷

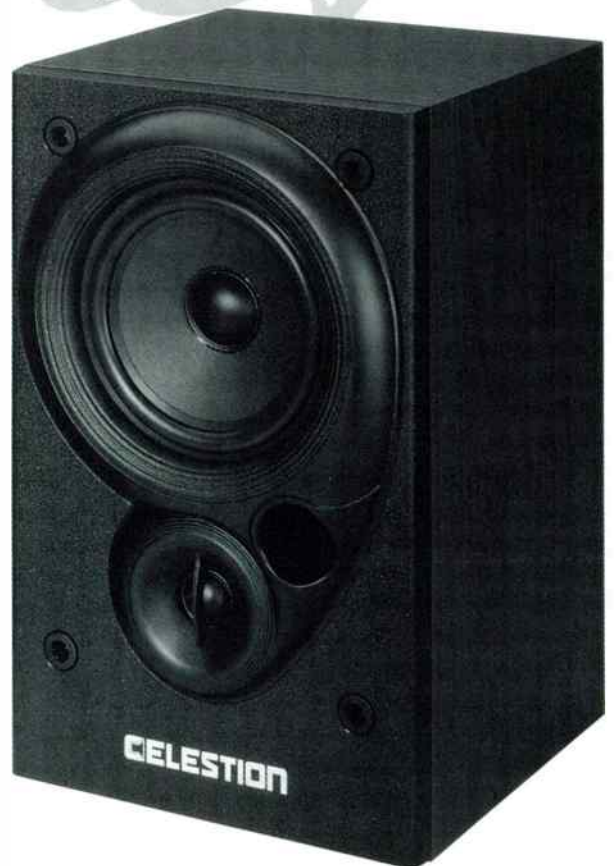

i Series



and emotional depth.
 "The coherence is extraordinary,"
 Peter J Comeau remarks. "That each
 note is so well defined is remarkable
 for a speaker of this class."

Peter concludes "When you
 close your eyes, they (the artists)
 might just as well be in the room
 with you."

That's the ultimate accolade for
 any speaker, irrespective of price.

At only £119, no wonder he
 couldn't believe his ears.

*"Nothing prepares you for the
 sound of this new model. Ask
 listeners to guess the price,
 I guarantee an answer closer to
 £500 than the spare change you
 have to sprinkle on the counter
 to own a pair."*

**...At only £119, no wonder he
 couldn't believe his ears.**

The 12i is available at:

Avon	Bristol	Paul Roberts Hi-Fi	31-33 Gloucester Road, BS7 8AA	01179 429370
Bedfordshire	Bedford	Richard's Audio Visual	4 Greyfriars, MK40 1HP	01234 365185
Berkshire	Windsor	Sonics Hi-Fi Ltd	58-60 Grove Road, SL4 1HS	01753 859721
Cheshire	Cheadle	Audio Council	14 Stockport Road, SK8 2AA	0161 428 7887
	Cheadle	Chester Audio Visual	47 St Werburgh Row, CH1 2DY	01244 320414
	Crewe	Roy Townsend	2-4 Victoria Street, CW1 2HE	01270 213276
	Northwich	Roy Townsend	39 Chester Way, CW9 5JT	01606 43691
	Winsford	Nordis	Queens Parade, CW7 1AE	01606 593205
	Warrington	Warrington Audio Visual	106 Bridge Street, WA1 2BY	01925 636215
Cumbria	Kendal	K. Gardener Ltd	Unit 5, The Westmourland, LA9 4LR	01539 721953
Derbyshire	Chesterfield	E.L. Smith	12 Cavendish Street, S40 1VY	01246 234953
Dorset	Bournemouth	Movement Audio	926 Wimbourne Road, Moordown, BH9 2HH	01202 529988
	Bournemouth	Strouden Park TV	472-476 Castle Lane, BH8 9UD	01202 518323
East Sussex	Hove	Churchers	8 Western Road, BN3 1AE	01273 324616
Essex	Epping	Chew & Osbourne	148 High Street, CM16 4AG	01992 574242
	Saffron Walden	Chew & Osbourne	26 King Street, CB10 1ES	01799 23728
	Southend-on-Sea	Gateshead Ltd	19 The Royals, SS1 1DQ	01702 461634
London	Palmer's Green	Audio Vision	349 Green Lane, N13 4JG	0181 447 8288
	West Hampstead	Audio T	190 West End Lane, NW6 1SQ	0171 794 7848
Hampshire	Andover	KLW Cook	1 The Broadway, ST10 2JF	01264 323573
Hertfordshire	Hitchin	David Orton Audio Visual	6 Bancroft, SG5 1JQ	01462 452248
	St Albans	W. Darby & Co	6 Market Place, AL3 5DG	01727 851596
Humberside	Kingston-Upon-Hull	Nuway Televisions Ltd	149-151 Kingston Road, HU10 6AL	01482 651774
Kent	Canterbury	Canterbury Hi-Fi & Video	50 Burgate, CT1 2HW	01227 765315
Lancashire	Lancaster	Kenneth Gardener	TV House, Parliament Street, LA1 1DQ	01524 39344
	Wigan	Ron Leigh Ltd	49 Mesnes Street, WN1 1QX	01942 244696
Leicestershire	Market Harborough	The Auditorium	27 Adam & Eve Street, LE16 7LT	01858 461460
Middlesex	Edgware	Musical Images	173-175 Station Road, HA8 7JX	0181 951 5864
	Ruislip	TV Allied Service	70-72 Victoria Road, Ruislip Manor, HA4 0AH	01895 632217
Norfolk	Kings Lynn	Martins Hi-Fi	5 High Street, PE30 5AF	01533 761683
	Norwich	Martins Hi-Fi	85-87 Ber Street, NR1 3EY	01603 627010
Northamptonshire	Kettering	Classic Hi-Fi & Video	School Lane, NN16 0DH	01526 310855
	Northampton	Audiocraft	23-25 Deansgate, NN1 1TY	01604 36291
Northern Ireland	Belfast	LRG Sound & Vision	171-175 Albert Bridge Road, BT5 4PS	01232 451381
	Co. Antrim	LRG Sound & Vision	120 Main Street, BT40 1RG	01574 272757
Nottinghamshire	Nottingham	Forum Hi Fi	600-602 Mansfield Road, NG5 2FS	0115 962 2657
Scotland	Aberdeen	Bruce Miller's	363 Union Street, AB9 1EN	01224 592211
	Lanark	Braedale Electronics Ltd	33 St Leonard Street, ML11 7AB	01555 663023
South Yorkshire	Doncaster	Barker & Wigfall Ltd	25 Hallgate, DN1 3NH	01302 323923
Staffordshire	Stafford	Roy Townsend	Sheridan Centre, Gaolgate Street, ST16 2AD	01785 243669
	Stoke	Roy Townsend	Level 2, Lewis Dept. Store, Lamb Street, ST1 1LP	01782 289114
Suffolk	Ipswich	Matthews Ltd	97 Foxhall Road, IP3 8JY	01473 216121
	Ipswich	Eastern Audio	41 Bramford Road, IP3 2LU	01473 217217
	Sudbury	System Sound	91 North Street, CO10 6RE	01787 881816
Warwickshire	Leamington Spa	The Leamington Hi-Fi Co	23A Regent Street, CV32 5EJ	01926 888644
	Rugby	Sounds Expensive	12 Regent Street, CV21 2DF	01788 540772
West Midlands	Solihull	Music Matters	93-95 Hobbs Moat Road, B92 1HJ	0121 742 0254

This does not constitute a full list of dealers. For your nearest Celestion dealer call

Freephone 0800 731 3410

CELESTION

Celestion Consumer Division, Dept HFW18, FREEPOST MA 1332, Eccleston Road, Tovil, Maidstone, Kent, ME15 6QP.

World Radio History

KITS HAVE NEVER

K5881 MkII VALVE AMPLIFIER KIT

A 20watt Class A power amplifier that uses reliable Russian 5881 output valves, a military version of the American 6L6, designed for low distortion audio work.

Now with a super shunt regulated push-pull (SRPP) input stage K5881 offers amazing sound quality. It can be used with a simple passive pre-amp or one of our own pre-amplifiers, and it matches modern loudspeakers well.



MkII with SRPP
input stage!

£395



K5881PSE VALVE AMPLIFIER KIT

An audiophile parallel single ended valve amplifier at an affordable price. K5881PSE uses the reliable Russian 5881 output valve. Its 17watts is enough to drive most loudspeakers, making high-end sound quality and design available to everyone. Can be easily monoblocked to give 32watts.

£650

300B VALVE AMPLIFIER KIT

This is a specialised 28watt amplifier based on the highly linear 300B triode valve. Our 300B runs in Class A, giving one of the most sweet, open and neutral sounds possible today. Matched with good loudspeakers, it is unsurpassed. All parts are included in the kit, except valves since different 300B makes are available.



£850

KLS3 THREE WAY CARBON-FIBRE DRIVER LOUSPEAKER

KLS3 uses extremely light and stiff carbon-fibre cone drive units for a fast, accurate sound. A dedicated 4inch carbon-fibre midrange drive unit provides the clean, smooth and detailed midrange characterised by superb projection. Its high 90dB sensitivity and near flat 8ohm impedance make it one of the easiest loudspeakers to drive. An ideal loudspeaker for high-end valve amplifiers.

Drive Unit & Crossover kit etc £350
Drive Unit Pack £230

KLS4 TWO WAY CARBON-FIBRE DRIVER LOUSPEAKER

A two way standmounter using stagger-tuned reflex loading for good bass, plus light and fast carbon-fibre drivers.

Drive Unit & Crossover kit etc £230
Drive Unit Pack £120

KLS7 TWO WAY CARBON-FIBRE DRIVER FLOORSTANDER

Compact and affordable two way reflex loudspeaker. KLS7's slim dimensions make it easy to accommodate, but it uses top quality

carbon-fibre drivers, so performance isn't compromised. An audiophile bargain.

Drive Unit & Crossover kit etc £195
Drive Unit Pack £110

KLS8 TWO WAY HIGH SENSITIVITY

With a sensitivity of 94dB, KLS8 needs very little power. Its 10in. professional bass driver and horn loaded tweeter give it a BIG sound. Ideal for low power amplifiers. Provides high level listening without fatigue!

Drive Unit & Crossover kit etc £260
Drive Unit Pack £175

BEEN SO GOOD!



£495

KLPP1 VALVE PHONO PREAMPLIFIER

KLPP1 has five line inputs a tape input with monitor, and a unique low noise valve MM/MC phono stage. There is a switchable subsonic filter to prevent output transformers of valve amplifiers saturating. The line stage has gain, so it will drive any power amplifier. Audio grade components are used and many parts are custom made for highest quality. KLPP1 has a super clear sound, sweet and detailed through line and phono inputs.

UPGRADE KITS

K5881 MkII £35

Upgrade your pre November 1996 K5881 amplifier to MkII status for just £35. Includes new 7025 double triode input stage in place of the original EF86 pentode.

KLS3 Gold

NEW! LOW LOW PRICE £330

Upgrade your KLS3s to Gold status. Includes latest oval gold dome piezo tweeter and all components.

KLP1 VALVE LINE PREAMP

The KLP1 line level preamp uses one an elegant cathode follower line drive circuit to give a sound of remarkable clarity and detail. The components are all high quality and include Alps volume control, Sovtek valves, silver plated wire etc. With a gain off x1, it matches our sensitive power amplifiers. Beautifully built, with solid machined alloy fascia and gold anodised knobs, it looks compact and elegant in the home.



£345

Audax HD-3P Gold dome piezo-electric tweeter NEW LOW PRICE!

£130

Beginners - Go for this one and blow your mind!!

NEW!

KLS9 TWO WAY FLOORSTANDER

Here's a storm for you - KLS9, with its BB4 alignment bass cabinet and Audax High Definition Aerogel 8in bass/midrange unit. Designed by Noel Keywood to possess optimal bass damping and a clean step response. Aided by a teensy bit of bass lift, KLS9 really thunders, it will re-arrange your furniture. But it does not waffle, falling silent when there's no bass in the music.

Aided by a high power 1in fabric dome tweeter, KLS9 is detailed, evenly balanced and images superbly. It is an easy 12ohm load and is 88dB sensitive. For amps up to 60W. Easy to build and great for beginners. 93cms high.

Drive units, crossover parts, wool, etc

£230

Drive unit pack

£160

KLS3 Gold Mk II ADVANCED TECHNOLOGY THREE WAY LOUDSPEAKER

KLS3 Gold uses the latest version of Audax's innovative oval gold dome piezo electric tweeter, giving it the sweetest and most extended treble. Married to a 4in. carbon fibre cone midrange driver for neutral and clear reproduction, and a powerful 8in. bass driver for superb depth, this is our top-of-the-line reference 'speaker.

Drive Unit & Crossover kit etc £575

Drive Unit Pack £450



KIMBER KABLE DIRECT

Jon Marks plugs into Kimber PowerKords

"When we auditioned mains cable from Moth and DNM back in June, we found really quite slight improvements to our systems's sound, but not so with the 4TCM. Even as I was walking over to our customary listening spot on the sofa, I could hear better bass definition and extension.

"Treble was also sweeter and there was a clarity that allowed the full acoustic through Jamo's Concert 8 stand mounters to provide a large, holographic sound stage.

"So far, so good, and £73 very well spent.

"...if you wanted to shake a stick at the rhythm, it would now be the size of a telegraph pole.

"Last was a six-foot 8TCM - Kimber say the longer the better with these cables, as RF attenuation increases with length. Now the music coming from the Concert 8s had an addictively natural, organic feel to it. Switching back to normal leads, the sound was still enjoyable but had a hard mid and treble and soggy bass.

"I only hope Russ doesn't want these back, as they're now taken up permanent residence in our system!"



Jon Marks, Mains Maintenance review, Hi-Fi World, Dec 1997

"For the sheer pleasure of music..."



'Phone for a FREE Brochure

**Russ Andrews Accessories Ltd, Edge Bank House, Skelsmergh, Kendal, Cumbria LA8 9AS
Freephone Orderline: 0800 373467**

HEYBROOK

For more information contact:
HEYBROOK HI FI LTD CLEMO ROAD LISKEARD CORNWALL PL14 3NH
TEL: (0)1579 342866 FAX: (0)1579 342833

WARNING

THESE ARE EXPERT KITS, NOT FOR THE INEXPERIENCED. YOU MUST BE ABLE TO SOLDER AND READ A CIRCUIT DIAGRAM. THE VALVE KITS CONTAIN LETHAL VOLTAGES. WE CANNOT BE HELD RESPONSIBLE FOR ANY PROBLEMS ARISING FROM THE CONSTRUCTION OF THESE KITS.

ORDER FORM

Please send your completed order form to: WORLD AUDIO PUBLISHING, 64 Castellain Road, Maida Vale, London W9 1EX

Tel/Fax: 0171 221 0691 or Tel: 0171 289 3533 Fax: 0171 289 5620

240/120 option - delete the voltage NOT required. Valves included except where otherwise stated.

IF YOU WOULD LIKE A DATA SHEET ON ANY OF THE KITS, PLEASE WRITE A 'D' IN THE QTY BOX

WARNING - World Audio Publishing Ltd accept no responsibility for kits, parts or modifications made or supplied by third parties.

DESCRIPTION	ORDER No.	QTY	UK (inc.VAT and P&P)	OVERSEAS (exc.VAT and P&P)
AMPLIFIER KITS				
NEW K5881 MkII 20W push-pull valve amplifier	K5881-K240/120	<input type="checkbox"/>	£395	£350
NEW K5881 MkII Built	K5881-B240/120	<input type="checkbox"/>	£595	£550
K5881PSE 17W single-ended amplifier.....	K5881PSE-K240/120	<input type="checkbox"/>	£650	£555
K5881PSE Built.....	K5881PSE-B240/120.....	<input type="checkbox"/>	£850	£725
300B 28W valve power amplifier (Not inc. Valves).....	300B-K240/120	<input type="checkbox"/>	£850	£725
300B Built.....	300B-B240/120	<input type="checkbox"/>	£1150	£950
KLP1 line level pre-amplifier	KLP1-K240/120	<input type="checkbox"/>	£345	£295
KLP1 Built	KLP1-B240/120	<input type="checkbox"/>	£545	£465
KLPP1 valve phono pre-amplifier	KLPP1-K240/120	<input type="checkbox"/>	£495	£425
KLPP1 Built	KLPP1-B240/120	<input type="checkbox"/>	£695	£595

LOUDSPEAKER KITS

KLS3 3-way carbon-fibre driver floorstanding loudspeaker				
Drive Units + Crossover kit etc	KLS3-C	<input type="checkbox"/>	£350	£300
Drive Units.....	KLS3-D	<input type="checkbox"/>	£230	£200
NEW KLS3 Gold Mk II 3-way carbon-fibre driver floorstanding loudspeaker with piezo tweeter				
Drive Units + Crossover kit etc	KLS3-C	<input type="checkbox"/>	£575	£500
Drive Units.....	KLS3-D	<input type="checkbox"/>	£450	£392
KLS4 2-way carbon fibre driver standmounting loudspeaker				
Drive Units + Crossover kit etc	KLS4-C	<input type="checkbox"/>	£230	£200
Drive Units.....	KLS4-D	<input type="checkbox"/>	£120	£105
KLS7 2-way carbon fibre driver floorstanding loudspeaker				
Drive Units + Crossover kit etc	KLS7-C	<input type="checkbox"/>	£195	£170
Drive Units.....	KLS7-D	<input type="checkbox"/>	£110	£95
KLS8 2-way high sensitivity standmounting loudspeaker				
Drive Units + Crossover kit etc	KLS8-C	<input type="checkbox"/>	£260	£225
Drive Units.....	KLS8-D	<input type="checkbox"/>	£175	£150
NEW KLS9 2-way HDA driver floorstanding loudspeaker				
Drive Units + Crossover kit etc	KLS9-C	<input type="checkbox"/>	£230	£200
Drive Units.....	KLS9-D	<input type="checkbox"/>	£160	£140

AUDAX DRIVE UNITS

Carriage and packing please add £6.00 for one unit or a tweeter pair otherwise add £15.00 for 2-6 units

High Definition Aerogel Drivers

3inch midrange, 93dB	HM100Z0	<input type="checkbox"/>	£35	£30
4inch midrange, 92dB	HM130Z0	<input type="checkbox"/>	£47	£40
6.5inch bass/mid, 91dB.....	HM170Z0	<input type="checkbox"/>	£53	£45
8inch bass, 91dB	HM210Z0	<input type="checkbox"/>	£64	£55
10inch bass, 90dB	PR240Z0	<input type="checkbox"/>	£76	£65

Carbon Fibre Drivers

4inch midrange, 90dB	HM130C0.....	<input type="checkbox"/>	£41	£35
6.5inch bass/mid, 90dB.....	HM170C0.....	<input type="checkbox"/>	£47	£40
8inch bass, 90dB	HM210C0.....	<input type="checkbox"/>	£58	£50

Paper Cone Drivers

10inch paper cone bass, 95dB	PR240M0.....	<input type="checkbox"/>	£67	£55
13inch paper cone bass, 97dB	PR330M0.....	<input type="checkbox"/>	£147	£125

Fabric Dome Tweeters

25mm 92dB for 2 way systems.....	TW025M0	<input type="checkbox"/>	£15	£13
25mm 92dB for 3 way systems.....	TW025M1	<input type="checkbox"/>	£16	£14
25mm horn loaded 97dB.....	PR125T1.....	<input type="checkbox"/>	£25	£21
34mm 93dB - powerful sound.....	TW034X0.....	<input type="checkbox"/>	£26	£22
Oval Gold Piezo electric dome tweeter, 89dB	HD-3P	<input type="checkbox"/>	Now £130	£110

(Please telephone for further details regarding other Audax Drive Units).

NAME: _____

ADDRESS: _____

POST CODE: _____

COUNTRY: _____

TEL. (DAY): _____

CREDIT CARD ORDERS TEL: 0171 266 0461 (24 hours)

I enclose cheque/postal order for £ _____ made payable to

World Audio Publishing Ltd. I wish to pay by Mastercard / Visa.

Please debit my account no:

--	--	--	--	--	--	--	--	--	--	--	--	--	--	--	--	--	--	--	--

Expiry Date: _____

Signature: _____



OVERSEAS PRICES AND DETAILS

Please allow for your own local import taxes (customs duties) and for carriage charges, which must be added to the overseas price. Telephone or Fax for a quote.

METHODS OF PAYMENT
International money order in Sterling, Mastercard or Visa.

PRO-JECT .5 £159

Very much a starter turntable, the Project .5 comes complete with an Ortofon OM10 Moving Magnet cartridge (worth £30) and basic automation - the deck starts revolving when you move the tone-arm over the record. Although a touch rough around the edges, the Pro-ject manages an enjoyably musical performance and represents excellent value for vinyl virgins.



PRO-JECT 1 £199

A proper hi-fi deck, the 1 is completely devoid of facilities, preferring to put the emphasis on sound. Features include a precision bearing supporting a dynamically-balanced alloy platter and a good basic arm with adjustable height - an unusual but highly worthwhile feature. The sound is fast and punchy, with more life and sparkle than its more expensive Rega rival. Factor in the fitted Ortofon 510 cartridge and it's a tempting proposition.



REGA PLANAR 2 £214

Despite fierce competition from Pro-ject, this evergreen remains highly competitive. Cunningly simple, it consists of a black fibreboard plinth into which a decent motor and bearing are set, with a thin glass platter and felt mat on top. The RB250 arm is a remarkably polished performer for the money with decent bearings and a quality, one-piece cast arm tube.

A refined and musical design, the Planar 2 sounds more mature than the Pro-ject 1 but lacks a little of its brio. By absolute standards the 2's rather limited at frequency extremes and has mediocre speed stability but you'd be surprised at how good it can still sound. The 2 has also appeared slightly modified under Akai and NAD 533 guises.

VINYLD

David Price points the cheapest

People who've grown up with CD could be forgiven for not wanting to get with more money than sense? Well, no. There are still plenty of affordable, their clicks, pops and dirty styli, they'll give you more passion, more life, more Vinyl guide, a no-nonsense look at the best budget vinyl hardware. Go on, ge

REGA PLANAR 3 £274

A grown-up version of the Planar 2, this classic deck has sold in vast quantities since its inception way back in 1978. Although it gets an improved plinth, platter and bearing, its most distinguishing feature is the RB300 arm - a budget classic if ever there was one. Given a good cartridge and proper siting on a vibration-free support, the Planar 3 will embarrass many far more expensive CD players. Its civilised yet musical performance is soft and subtle yet detailed and engaging. Although bettered by slightly more expensive separate turntable/arm combinations, as a 'plug in and play' solution it's superb. And it's also the only turntable available in purple - an extra £15 buys you a choice of seven pretty colours!

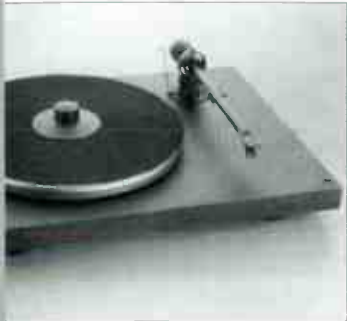

PRO-JECT 2**£299**

A souped-up Pro-ject 1, the 2 has an improved alloy, glass and felt platter and a standard record clamp - usually the province of high-end Michells and SMEs. The tone-arm also gets a few mods, but it still can't really match the Rega RB300.

The sound gains refinement and poise, sounding faster, cleaner and better focused, making the deck a truly enjoyable listen. The cartridge is improved too, with either an Ortofon 520 or an MCI moving coil for those with suitable phono stages. A lot of turntable for very little money.

MICHELL MYCRO **£435**

An unconventional design, the Mycro is basically a palmed-down GyroDec, itself one of the best sub-£1000 turntables. Hand-built from the best materials, it features a sprung sub-chassis on which sits a superb inverted-bearing and heavy acrylic platter, driven by a long rubber belt from a low-noise motor. The base is also acrylic, chosen for its excellent resonance damping properties as much as its striking looks. Numerous armboards are available but the Mycro

usually comes with the ubiquitous Rega for £577.

Sound is very solid, detailed and open with particularly strong stereo imaging. Bass is deep and controlled, if a little dry. Although more cerebral sounding than most, the Mycro is a truly

accomplished budget design and looks superb to boot.

**PRO-JECT 6****£459**

This is value - a three-point suspended sub-chassis deck with a decent arm and groove-tastic Ortofon MC15 Super 2 moving coil for under £500! It's also hard to argue with its alloy and glass platter, icon arm damping and highly adjustable suspension. Sound is strong and musically confident, with real bass and smooth treble - a major step up from the Rega class. The Project isn't quite up there with the Michell and Systemdek, but then it's far cheaper when you remember you need an arm and cartridge for the latter pair. This is the one to go for if you want a top notch, fuss-free turntable package.

DEMAND

Way to high-quality vinyl replay.

vinyl. After all, isn't it the preserve of snobbish, backward-looking old fogeys, £500 turntables on sale that will eat most CD players for breakfast. Despite music than any silver-disc spinner. So we thought we'd give you a Get Going In yourself a turntable, you know you want to!

**ROKSAN RADIUS****£470**

An unusual but attractive deck, the Radius brings some exotic features to the budget end of the market. An independently-sprung sub-chassis does a good job of isolating the deck from its surroundings, while a decent bearing, motor and belt drive give a stable ride for the record.

The Radius comes without an arm, but when partnered with Roksan's excellent £320 Tabriz it gives an impressively fast and dynamic sound. Best used with warm ancillaries, this deck is for those who prefer power and involvement to subtlety and warmth.

SYSTEMDEK 2X2

£500

The 2X2 straddles the gap between budget and high end. Its independently sprung sub-chassis offers near immunity to acoustic feedback, while the expensive acrylic platter is a superb way to support records. Although usually sold with the Rega RB300 arm, various armboards are available and the 2X2 is quite capable of accepting arm designs costing twice its price. Sonically it's one of the best affordable turntables - clean and detailed yet highly musical and dynamic. Bass isn't particularly deep but it's fast and fluent, and the upper midrange and treble are pin-sharp - for the money it's little short of a bargain.



CARTRIDGES

ORTOFON OM10

£29.95

A quality budget cartridge with a smooth, refined, if slightly bass-light sound. Stylus can be easily upgraded to OM20 status, bringing bags of extra detail and polish.



GOLDRING 1042

Beautifully deep, dark, rich analogue sound goes down a treat in Regas and super-decks alike. Secure tracking makes for excellent detail and poise.



PHONO STAGES

QED DISCAVER

£35

Cheap and cheerful starter powered by a mains adapter or direct from a PP3 battery - the latter brings a smoother, cleaner sound. Either way it's a fast, rhythmic performer that will extract plenty of music from inexpensive turntables and cartridges.



ROTEL RQ-970BX

£129

The cheapest serious design, this full-width black box offers a fast and musical sound with a surprising amount of detail - for not much money. Also has a good moving coil input.



LFD MISTRAL PHONO STAGE

£300

The Mistral is a super device with a rich, detailed and rhythmic sound that makes it the best at the price. It's also an excellent upgrade to virtually any integrated amp's internal phono stage, although the switchable Moving Coil stage can be a bit on the hissy side.



INDEX

rock & pop	81
John Clarke	
dance & ambient	84
Sara Davis	
Leon Palmer	
jazz	87
Simon Hopkins	
Simon Cooke	
classical	93
Peter Herring	

Rock and Pop

rock & pop reviews

Jon Clarke



In many ways he is on the same ground as *Blood On The Tracks* though there is nothing here to really compare with 'Tangled Up In Blue'.

What we have in spades here is the Blues. Clever lyrical trickery is out of the window. He's not singing about Captain Ahab and the whale, he's out to expose the worthlessness of his own soul and sing about broken hearts and damaged lives - there's a lot of those about, after all.

This much is clear from the opener, 'Love Sick' where Bob's vocals seem very spooky, crying out the pain of disappointment. The eeriness is more than matched by the later 'Standing In The Doorway' in which he mourns, "Yesterday everything was going too fast, Today it's moving too slow."

This theme continues through 'Million Miles' and 'Tryin' To Get To Heaven' until perhaps the finest chapter in this documented despair, 'Not Dark Yet'. If the song wasn't so tuneful and the voice not so strong and forceful, you'd be forgiven for reaching for the next litre of sourmash.

'Cold Irons Bound', another high-point of the album, reels again with the force of the Blues and boy, can't he do it well.

Towards the end of this assortment Bob slips slightly downhill, giving us the thankfully brief 'Make You Feel My Love' and the lacklustre 'Can't Wait', a loose, Bluesy ballad which makes you think you can.

The last number, 'Highlands', is a rambling sixteen-minute affair in which Bob amusingly sketches out a trip to a Boston diner where he discusses eggs and art with a waitress. Could only have been delivered in a fit of pique! These weak and eccentric moments aside, it is plain to see that the bard is back and bleedin'.

BOB DYLAN
TIME OUT OF MIND
COLUMBIA COL 486936 2

Bob Dylan is unwell and has become a musical Jeffrey Barnard (RIP). We are not talking about the airborne-chicken infection he contracted earlier this year, we're talking the rancour embattling his very soul. But that's OK - the one thing you learn from Dylan is that the more up desolation row he is, the better the quality of his music.

Like its maker, *Time Out Of Mind* is grizzled and mean, and a thankful return to form after years of mediocre output and pointless Willbury travellin'. It also sees him back with old sparring partner Daniel Lanois, producer of his last good album, 1989's *Oh Mercy* which saw him rail against environmental neglect.

It's easy to see what's eating Bob - age, cynicism and the lack of a true love.



THEMELOGY
THE BEST OF JOHN BARRY
SONY 488582 2

It's summer again, you're driving down the King's Road in a convertible E-type, you're wearing an open-necked shirt and a leggy blonde pussycat is sitting beside you. Life is grand and you're part of the scene - the Sixties scene.

At a time like this the natural inclination is to put on a bit of Barry; not the walrus of love, Mr Barry White, but

John Barry, natch.

In terms of stature, the man and his music are legendary. You may not know this, but buy the album and you'll be sitting there going: "Yeah, yeah, yeah - I know this" all the way through.

Responsible for many of the numerous '60s film soundtracks, John

Barry defined a musical generation and was as much a musical icon as Serge Gainsbourg and Burt Bacharach. The reason no one remembers him is his quest to stay out of the public eye. The man was always much quieter and less attention-grabbing than either Bacharach or Gainsbourg.

As soon as you hear the lazy opening beats of The Persuaders theme tune though, you start on a fantastic voyage of self-discovery, with almost no exceptions. Each song is quickly remembered in glorious cinematic scale as the particular film scene jumps to mind. Not only are all the rip-roaring

rock & pop record of the month

THE VERVE
URBAN HYMNS
 HUT CDHUT 45

Only two things have traditionally come from Wigan - piers and rugby hardmen. From now on there is something else - The Verve, who have, with *Urban Hymns*, just made the album of their lives. George Orwell once took the road to Wigan pier. The Verve took the M1 straight down to the capital, where a month ago they blew Oasis off the stage at Earl's Court.

Now completely established in the UK, *Urban Hymns* is definitely in the draw along with Radiohead's *OK Computer* for Album Of The Year. And this comes only two years after vocalist Richard Ashcroft's dissolute lifestyle and tortuous relationship with guitarist and songwriter Nick McCabe led to a breakdown and practically the demise of the group.

Suddenly the tide turned and the band was resurrected in full force with their troubles put behind them. Somehow, out of nowhere they managed to conjure up this juggernaut of an album.

Kicking off with 'Bitter Sweet Symphony', a peach of a song which has already done the rounds and climbed to the top of the charts, we have a classic anthem, in, say, the mode of Massive Attack's sweeping 'Unfinished Sympathy'. It's more complete and gloriously full-bodied than even that though - in fact it's so good there's the danger that it might engulf the rest of the album.

We need not fear. The next few tracks hold their own convincingly enough. You don't have to know the iambic pentameter to realise that the

country-tinged 'Sonnet' is pure poetry. At its core is a strummed acoustic which is picked up and finally carried off in a crescendo of strings, a pattern also used successfully later in their No1 single, 'The Drugs Don't Work' and 'Lucky Man', the album's best track.

As you travel through *Urban Hymns* it becomes increasingly apparent that the Verve are big Stones fans. And, like Primal Scream,

interesting interludes but show The Verve to have a rounded understanding of how Rock music should operate in the '90s. Like Radiohead they can play with the ambient, the dreamy and the heavy and brutal equally to make music which literally soars (above the competition). It's a case of using '60s and '70s Rock sensibilities and blending them in an original format for the modern era. Often it's a spot of quirkiness or a new instrument that serves to change the mood. Often it's just a switch in vocal styles.

At times The Verve sound very Jamesish in feel. Take 'This Time' - all jaunty vocals and funky little beats - Richard does an amazing impersonation of Tim Booth.

Later on, in 'Velvet Morning' we have an almost Neil Diamond sound - but a grumpy, bad tempered Diamond who has got out of the wrong side of the bed. This is a great track which has the wonderful lyric, "If Life was a game, you tried." - the ultimate put-down for you to try out on your flatmates.

The album ends defiantly with 'Come On' which sees



The Verve spoiling for a fight - an immense track which like the Stone Roses' brilliant 'I Am The Resurrection' literally blows you away. It makes the perfect last track.

Urban Hymns fulfils wildly all the promise of their two past albums *A Storm In Heaven* and *A Northern Soul*, and will no doubt represent a great leap forward.

In a distinct contrast to *OK Computer* which is conceived in the ethereal, *Urban Hymns* is of the street. It is positive, lairy and downright dirty. Overall what it offers is anything but a bleak outlook on life. Wigan has never been this pretty ●

especially like Primal Scream, they have a shameless tendency to churn out those famous chunky riffs as if they had exclusive rights. Take the bruising 'Rolling People' - it is never more than a breath away from Mick's mouth and there is also a very distinctly Stones feel in the mellower 'One Day' and indeed 'The Drugs Don't Work'.

Unlike The Primals, however, the results are original and not *Exile On Main Street II*; despite many of the tracks wearing Stones clothing, they are not strait-jacketed by them.

Songs such as 'Catching The Butterfly', 'Neon Wilderness' and 'Weeping Willow' are not just

Bond themes here, from Shirley Bassey's sultry 'Diamonds Are Forever' to Matt Munro's 'From Russia With Love', but there are also those other Bondesque interludes like 'Space March' which are as much JB as his array of life-saving gadgets. Lesser-known gems like 'Wednesday's Child' from The Quiller Memorandum and 'The Ipcress File' will get you reaching for your Walther PPK just as surely.

For my money, however, the inclusion of 'Midnight Cowboy' sends the collection into the realms of the must-buy category.

On the whole John Barry's intriguing collection conjures up an elegance and grandeur in music now sadly long gone. And yes, in an ideal world everyone drives a British-made sports car with leather upholstery, convertible roof and chick to match. Vintage stuff!



BUGGY
HOMOGENIC
ONE LITTLE INDIAN TPLP71CD

Oh strange one, how you entertain!

Less heralded than earlier efforts, stranger, sadder and slower, nonetheless Homogenic still captures that moody, spine-tingling emotional feel so often associated with the little one herself.

With kiss and tells, violent airport outbursts and maniac stalker escapades clearly beginning to take their toll on the Icelandic beauty, she wisely opted for the quiet, secluded life in Southern Spain to record her latest LP. Away from the pressures of life in London high up in the Andalucian mountains her famously eccentric spirit was able to soar once again. Balearic beats didn't come into it, however, and Homogenic has a much more rugged, ice-cold Icelandic feel to it. More appropriately it has that twisted, tragic meandering of a Flamenco singer in full swing. Yes, this is quite a haunted

work of art.

Those happy purchasers of earlier works Debut and the more complex Post will find her latest work less commercial than the first but more digestible than the second. It may be sombre but it is also intimate, intuitive and powerfully emotional.

When she excels, particularly in the flamenco-style 'Hunting', in 'Joga' (a love song for her best friend) and 'Immature', it is because her primal vocals are honed to perfectly match the often complex orchestral arrangements. In terms of grandeur, 'Joga' is probably the best thing she has done since 'Play Dead'.

The music is rich indeed and the ideas typically madcap as you would expect. 'Bachelorette', another highlight, is a demented dream sequence where she envelops her lover in various elemental guises, as water, as a tree and, incredibly, as a path of cinders. Read in this what you will but the imagination cannot be underestimated. Like Dali, one of the most colourful and complex artists of the 20th century, she must be left to rant and ramble.

There are violins all over the shop (most played by her coterie of Icelandic friends with unpronounceable names) and even a touch of harp ('Immature'). The overall effect, however, is a landscape of fairly austere sound, reminiscent of David Sylvian's solo work and, at times, Portishead. There is little of the Poppy commercial humour that bathed Debut (eg, 'Big Time Sensuality') and occasionally Homogenic feels rather cruel and leaden and like a lump of granite, truly monolithic.

Homogenic misfires completely on a couple of tracks; on the dirgey and dreadful 'Pluto' and the experimentally ambitious '5 Years'. The latter fails because it attempts to marry Bjork's voice with a backdrop of what sounds like interrupted radio signals or someone chewing cardboard. In spite of these tracks, this LP is generally a definite '97 classic. Sure, it's an acquired taste, but wasn't her first and very haunting single 'Birthday' with the Sugarcubes? If you are a fan of the Icelandic growls and screeches and hanker for left-field originality this is definitely one for you.

Bjork has had her share of bad times of late and this album is very much tinged with sadness and pain. It marks a return to her anarchic best and should be listened to alone. For this is not the party album of the year, but one for sufferers the world over.



PHOTEK
MODUS OPERANDI
VIRGIN CDJQED 1

Hailing from the North London/Hertfordshire fringes, Rupert Parkes (aka Photek) was getting into Kraftwerk and Tangerine Dream when every kid aspired to be the new George Michael. The legacy of robots hunched over bleepy home computers with their rigid, tinny rhythms is spectacularly brought back to life by Photek.

The concept: a seminal, non-Dance Drum 'n' Bass album. Instead of breakbeats galore, samples and occasional songs with vocals, Photek has plumped for shifting Ambient textures with little in the way of division between tracks.

The android warms up with a whole series of fairly commonplace machine-based rhythms, sparse floating loops and flurries of drums until we finally find a lease of life with title track 'Modus Operandi', and this only because he uses piano, guitar and double-bass for a melodic Acid Jazz blend. The frantic and much more Drum 'n' Bass-inspired 'KJZ' is also good but begs the question, why did we have to wait so long before the energy was found?

Much of this is reminiscent of Bowie and Eno's 'Low'/'Heroes' collaborations from the '70s. It boldly tries to be innovative and dream-like but increasingly ends up like Tangerine Dream's Warsaw Concerts album - ie, a dull album served up in a place you have no desire to be.

Modus Operandi is OK as far as it goes but it could have been so much better. Photek's piece on LTJ Bukem's Logical Progressions compilation, 'Pharaoh', was one of the centrepieces on an album of worthy tracks. Which makes the offering here more than a little disappointing ●

Dance and Ambient

Sara
Davis
&
Leon
Palmer

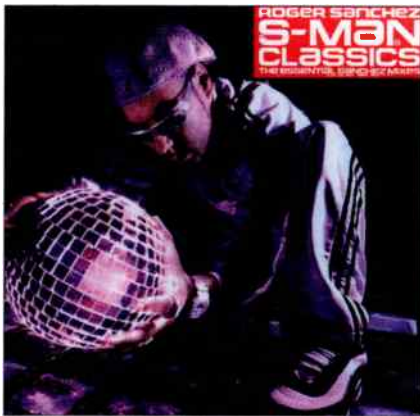

S-MAN CLASSICS
HARMLESS HURTCO 004

Whether you know him better as Roger S, the slick sounding S-Man or simply Sanchez, you'll certainly recognise his tunes. The manic Hispanic from New York has had a prodigious output over the last ten years which have seen him remix and produce some of the greatest House/Garage tracks this side of 1990. Unlike the trademark piano sounds of Frankie Knuckles or the unforgettable Hard Funk of Todd Terry's overworked drum patterns, Roger Sanchez has managed to remain flexible, diverse and happening in his own special way.

The latest compilation to feature him has nothing to do with the Radio One show of the same name but it does boast the renowned personal remixes and productions of some of the biggest names in Dance music plus some creations of his own. The tracks Harmless Recordings have chosen for this compilation reflect their own and Sanchez's Techno diversity. After all, the

labels last smash was with some of Sanchez's mates, Kenny Dope Gonzalez and Lil' Louis Vega, aka 'Masters At Work', the DJs who put the Latin into Latin House.

They have since progressed successfully into the lucrative market of more mainstream Dance, leaving the murky world of the underground scene to artists like Todd Terry and Sanchez.

The album is split into two parts, one disc of 'Ultimate Anthems', a more uplifting collection of jumpy basslines and Garage vocals, and a second of 'Underground Classics', with slightly harder but still amenable music.

For me, this album starts off firing on all 'speakers, gets better, briefly satisfies and then flattens out slightly. The tracks on the first disc, the 'Ultimate Anthems' are very familiar - they're the sort of tunes you pray they'll play to prevent your fair-weather clubbing mates from leaving early. Once they've heard the likes of Incognito's 'Givin' It Up' and Brand New Heavies' 'Midnight At The Oasis' they should be begging for more.

Admittedly Sanchez has to share the glory here with the Acid Jazz bands' supremely groove-packed songs but the mixes are great. No such qualifications for the fabulous vocal moments of 'Take Me Back To Love' by Kathy Sledge. However, after the Garage-drenched version of M People's 'Movin' on Up', the peak of Sanchez's indulgence of the Pop world, we go progressively darker, although seamlessly of course.

Here we're in the acceptable part of the 'underground', a kind of deep and Dubby House, until we arrive, almost full circle at one point during the side,

(the part when your friends start complaining again) at 'Get Hi', a song which seemed to come out under different guises every month at one point during 1996.



**SOUND IN THE EIGHTH
DIMENSION VOL 2**
ASTRALWERKS 44674 2 5

Surfer/designer looking types without shades but exuding relaxed elegance appear too nice to be involved in the Florida beats scene. After all, the sunshine state's only other exports of note have been Murk's funky Garage and hard cops Crocket and Tubbs. But that's OK because the music constructed by the trio of Q-Burns Abstract Message, DJ BMF, Pimp Daddy Nash and friends contains no nastiness whatsoever.

Nicely flipped out somewhere between Trip-Hop and Electronica, Sound In The Eighth Dimension is more

Hip than Trip and gives a cool, if somewhat tame view of a genre where Funk is more important than Pump. The main treats in this selection are memorable for their head-stretching melodies rather than their beats.

Healthily musical without being too out there, Sounds is a lively assortment of the best moments from Florida's answer to the Blue Note Club in London. Unlike the planned chaos prevalent there, this album draws its energy from neat arrangements, simmering landscapes and strong, saturating vocals.

'Shelter' by Lickerish Quartet gently tests the listener's taste buds with some sweet and Trancey Drum 'n' Bass while Q-Burns 'Total Maza' - up-front, up-tempo and beatsey - squeaks its way quickly into the brain. Just when you think you know what these dudes from Florida are trying to do they come up with 'Illadin', a masterful collaboration of Q-Burn and DJ BMF designed to slow you right back down again.

Just to prove they're really up to date the boys and girls of Eighth Dimension pop in a sumptuous Drum 'n' Bass number, 'Listening (I Promise)' near the end complete with psychoactive samples from something out of Buck

Rogers with groovy sax, and sexy vocals. This is a real party stomper that hints for better things to come from Lickerish Quartet.



LARRY HEARD
DANCE 2000
DISTANCE RECORDS

Soulful and chilled-out, Dance 2000 marks the sad departure of one of House music's pioneers, Larry Heard, also known as 'Mr Fingers'. Legend has it that this digit reference stemmed from Larry's talent for, er, swift hand movements during his early days of

synth meddling and fanatical mixing.

Now it seems a digital reference would be more appropriate. After years of production work with the biggest names - Virgin, FFRR and Mercury to name but a few - Larry's giving up the music biz for the less hectic world of computer programming.

Unsurprisingly, Dance 2000 is a slickly-produced slice of mature Chicago House and a fitting close to a great career. Mr Heard is responsible for all compositions, engineering, keyboard improvisation, mixing and computer, synthesiser and drum programming, so this really is the definitive album for fans of the master.

Musically, Dance 2000 blends mellow, refined basslines with haunting melodic chimes, flawlessly mixed to a dinner-party level of sophistication. The conversation goes like this: 'Saga Of The Evil Queen' for a jazzy schmooze with infectious sampling; 'Pleasure Island', if you're feeling like a funk; or 'Dancefloor Seduction' and its subtle acidic touch when it's time for after-dinner mints.

Best kept for grown-ups and special occasions is this album. Mr Fingers' Dance 2000 should be treated like a good bottle of whisky and appreciated for its purity and maturity.

dance & ambient record of the month

LSG

COLLECTED WORKS HOJ CHOONS

Is your record collection cool? Only if your K-L section includes an Oliver Lieb release. Mine was sadly deficient and I was mourning that unfilled gap deeply until this LSG album turned up. Here's a tip; if any of Oliver Lieb's aliases - Spicelab, Ambush, LSG, Paragliders or Arte Bionico - ever come your way in the trusty local record shop, BUY THEM. The same goes for this special release too.

LSG, Collected Works takes tracks from the first two Lieb albums which date back to the late '80s/early '90s, a time of flourishing German

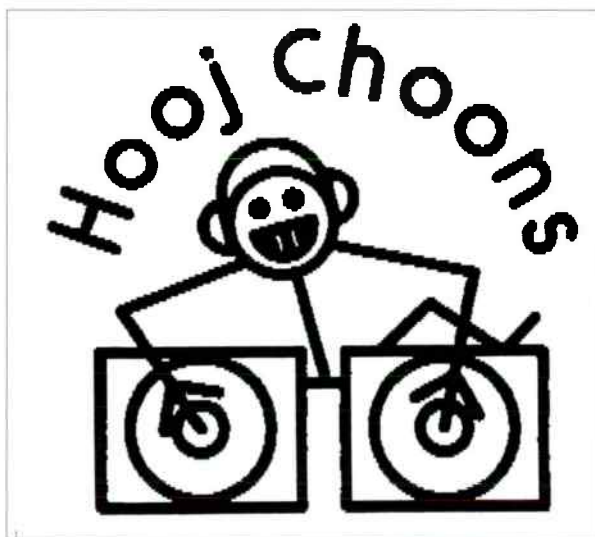

underground Techno. As neither of the original albums were released in the UK back then, Hooj Choons really are offering a gift of an album here which you can't afford to miss (unless you're Christmas skint, of

course).

Sound-wise, Lieb's style has been described as 'skirting the borders between Techno and hard Trance' and 'an exploration across light and dark and all points between'. Both are so true but neither says it all.

Lieb's work is always characterised by a certain 'je ne sais quoi', a natural tunefulness which comes alive through minimal Industrial Trance. Nearly a decade on his music still sounds 100% fresh - the melodic charm of opener 'Fragile Part 2' elevates the album straight to Dance Anthem status. 'Netherworld' puts a strong case for keeping it there: even if you've never heard Lieb before, you'll remember this track from somewhere.

How can I put it? I want to grow dreadlocks and bounce around in a field on LSG's for the rest of my life.

Marston Audio Research Products are now available at:

The Audio File
41 Victoria Road
Cambridge
01223 463015

The Cornflake Shop
37 Windmill Street
London
0171 6410472

River HiFi
24 Clifton Crescent
Dunfries
0187 267048

Heatherdale Audio
302 Finton Road
Finton Valley
Worthing
01903 872288

Audiocom uk
Unit 6 Tindle Ent Cen
Warrant Street
Tenby
Pembrokeshire
01834 842803

Sound Dr. Jules
Swansea
01792 280061

Spectral Sounds
10/14 Station Hill
Chippenham
Wiltshire
01249 654357

Silhouette Series

DIGITAL TO ANALOGUE CONVERTER



AND EXTERNAL POWER SUPPLY UPGRADE
by

MARSTON AUDIO RESEARCH

"Marston Audio Research's Silhouette DAC on its own is really rather good"
"With its optional power supply the good bits get even better"

Hi-Fi World Aug 1997

Digital To Analogue Converter **£650.00 Inclusive**
With External PSU Upgrade **£895.00 Inclusive**

Rediscover the true nature of audio

For further details contact:

Marston Audio Research
17 Queens Avenue
Kings Lynn PE30 5LR
Tel: 01553 772875
e-mail: marston@planetweb.co.uk
www.planetweb.co.uk/marston



THE listening rooms

SALE NOW ON.

RRP SALE

CD PLAYERS

THETA DATA BASIC 2	2300.00	1695.00	D
MICROMEGA STAGE ONE	549.99	379.00	D
MICROMEGA STAGE TWO	699.99	459.00	D
MERIDIAN 203 DAC	-	195.00	S/H
MERIDIAN 506 18 BIT	995.00	695.00	
MERIDIAN 500 TRANSPORT	1245.00	875.00	
MICROMEGA STAGE 4	559.00	422.00	N
MICROMEGA STAGE 5	750.00	527.00	N
MICROMEGA STAGE 6	950.00	667.00	N/D
MICROMEGA DRIVE 2	999.00	699.00	D
MICROMEGA DAC1	699.00	489.00	D
TEAC VRDS 10	-	295.00	S/H

AMPS

QUAD 77 INT	650.00	453.00	1/N
AUDIO RESEARCH CLASSIC 120 POWER AMPS x 2	-	3000.00	S/H
AUDIO RESEARCH LS7	1599.00	1095.00	D
AUDIO RESEARCH D200 POWER AMP	-	1395.00	S/H
AUDIO RESEARCH VT60 VALVE POWER AMP	2645.00	1995.00	D
HARMAN KARDON AVR 30 PRO LOGIC RECEIVER	1000.00	750.00	D
HARMAN KARDON AVP-1A THX PROCESSOR	-	595.00	S/H
BEARD P50 PWR AMP	-	395.00	S/H
AURA AU100 AMP	350.00	219.00	D
ANGSTROM HOME THEATRE DIRECTOR	3495.00	2200.00	D
MICROMEGA TEMPO 1 AMP	699.00	489.00	D

LOUDSPEAKERS

MERIDIAN A500 ROSEWOOD	815.00	599.00	D
MISSION 754 OAK	1498.00	999.00	D
REL STENTOR SUB-WOOFER	-	800.00	S/H
SONUS FABER EXTREMA	-	3500.00	S/H
SLATE STANDS FOR SONUS FABERS (CUSTOM MADE)	-	200.00	
B&W 805	995.00	646.00	D
B&W DM305	349.00	249.00	D
KEF CODA 9	299.00	219.00	D
EPOS ES22	1185.00	999.00	D
APOGEE CENTAUR	-	795.00	S/H
TANNOY 637	499.90	349.90	D
TANNOY 636	419.90	295.00	D
LINN KABERS	-	1000.00	D

TUNERS

QUAD 77 TUNER	699.90	499.00	N
AURA TU50	259.90	179.00	D

VARIOUS HIGH QUALITY CABLES INC. COJELCO, VDH REVELATION, ETC PHONE FOR DETAILS - SUPER PRICES

D=ExDem S/H=Second Hand N=New
161 OLD BROMPTON ROAD, LONDON, SW5 0LJ
TEL: 0171-244 7750 / 59 FAX: 0171 370 0192

Wilmslow Audio

The name in Loudspeakers for over 30 years
We are the UK's largest distributor of replacement drive units and accessories for the trade and DIY speaker builder



A range of 25 DIY loudspeaker kits from £140 - £3800 on demonstration

◆ Crossover design and supply

- ◆ Large range of accessories including Capacitors, Inductors,
- ◆ Resistors, Binding posts, Grille cloths and foams,
- ◆ Ports, Spikes, Cable and much, much more.

Wilmslow Audio Ltd Phone for your free catalogue
50 Main Street Boughton Astley Leicester LE9 6RD
Tel: 01455 286603 Fax: 01455 286605

York... a great place for...

- AE
- Atacama
- Audiolab
- B&W
- Cable Talk
- Copland
- Cyrus
- Harman-Kardon
- JBL
- KEF
- Kenwood
- Krell
- Marantz
- Martin-Logan
- Meridian
- Michell
- Mission
- Monitor Audio
- Musical-Fidelity
- Pickering
- Pink Triangle
- Pioneer
- Quad
- REL
- Rogers
- Rusark
- SME
- Sonus-Faber
- Spendor
- Systemdek
- Tannoy
- TDL
- Thorens
- Yamaha

- Widest choice in the area
- Independent advice
- Qualified staff
- Comfortable dem rooms
- Superb showrooms
- Main road location
- Major car parks nearby
- Insurance estimates
- Over 30yrs experience.
- Service Dept.
- Delivery & installation
- Part Exchange
- Open 10:30-5:30 6 days

Up to 3 yrs.
Interest Free
Credit

deposit only 20% of
£500+ for 12 months
£1500+ for 24 months
£3000+ for 36 months
subject to status



PS. If you're making a special trip it's best to book weekdays.



24 Gillygate, York
Tel. 01904 629659
High Fidelity Specialists est. 1967



AUDIOLAB



The very best in Hi-Fi and Home Cinema...

MARTIN-LOGAN



KRELL

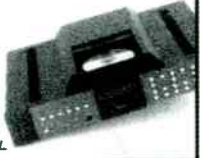

MONITOR-AUDIO



Jazz

Simon Hopkins

Nils Petter Molvaer
Khmer

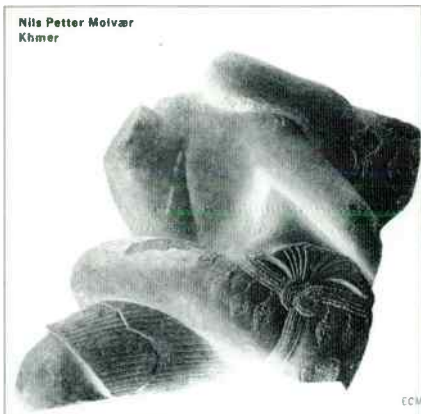

NILS PETTER MOLVAER

KHMER

ECM ECMI 560

Here's a record I've been hoping for from the German Jazz and New Music label ECM for quite some time. The whole notion of electric Jazz has received such a drubbing since the late '70s that, for far too long, it was nigh-on impossible to admit to having ever blissed-out to the likes of the Mahavishnu Orchestra et al. We haven't had those kinds of reservations here, needless to say. Still, it's nice at last to see long-forgotten work from the '70s by Herbie Hancock and Eddie Henderson and even Miles Davis finally getting the respect it's due.

It would be all too easy to think that a label like ECM stood for everything that electric Jazz was categorically not about. Instead it's always been about flawless recordings of almost entirely acoustic performances, a certain Folkish lyricism that absolutely eschews grandstanding (always the chief gripe many had with a lot of Jazz Rock) and minimalist, typographically superb packaging.

But this view of the label's development overlooks certain key records in its repertoire that remain

among Jazz Rock's finest moments, including Julian Priester's *Love, Love and Polarization* and Bernie Maupin's *Jewel In The Lotus*.

These records, and *Love, Love* in particular, represent all that Jazz Rock was at its best, combining oblique sonorities and angular rhythms with ferocious group-improvising: in short, all that should have followed in the wake of Miles' first forays into electric territory, but so rarely did. If these records remain overlooked in any telling of the ECM story, it must be, in part, a deliberate move on the label's part, for these records remain untouched in the label's considerable reissue programme. One wonders, will they ever see the light of day?

The release of this new set by trumpeter Nils Petter Molvaer suggests that maybe they will. For *Khmer*, in many ways, taps into a certain Jazz Rock zeitgeist in that it wilfully combines acoustic and electric instruments with 'ethnic' Folk melodies, long solo and group improvisations and, occasionally, some really fierce noise making in ways that manage to avoid the pitfalls of Fusion's empty gestures. It also, for a lot of the time, works very, very well indeed.

Molvaer, who also contributes guitar, bass, percussion and samples, is ably abetted by a group of rather fine Scandinavian musicians: guitarists Elvind Aarset, Roger Ludvigsen and Morten Molster; drummer Rune Arnesen; samples manipulator Ulf Holand; and, contributing 'sound treatments', Reider Skar.

Now, I'll come clean, only Molvaer is known to me of this lot, but whatever, one look at that line-up gives quite a few clues as to what's going on here. First up, the presence of four guitar players.

The guitar is, of course, the iconic Jazz Rock instrument and has been

responsible for some of the music's finest and most disastrous work (er, say, John McLaughlin and Al Di Meola respectively). Miles Davis himself would regularly deploy two full-on improvising guitar players in his '70s groups.

The guitars here never really deliver quite the ferocity that I'd hoped for, but they add a huge depth of colour and power to the music.

The other point to note is the presence of so much programming. *Khmer* doesn't simply resurrect Jazz Rock tropes, but rather combines them with contemporary, post-Ambient soundscaping technologies. This is something going on elsewhere, in the work of, among others, Bill Laswell, Dave Douglas, Paul Schutze and Rhys Chatham, and this should not come as a surprise. Certain musical ideas introduced to the music in the early '70s have, over the course of the last ten years, started to show overtly in the work of many music makers who came to light in Ambient's wake.

I have to say there are some moments when I really don't think this works, not because it can't but because certain choices being made in the rhythm programming are, frankly, a little hokey for my tastes - just a little too Camden Market, tie-dye New-Age gypsy. But these are more than made up for by some fantastic passages which see Molvaer's blistering trumpet cutting a course through swathes of distorted guitar, clattering percussion and unplaceable electric guitar textures.

The album is accompanied by a 12in. single of mixes from the album by various London-based music-makers on the fringes of the Dance scene, which might give you a clue as to where both ECM and Molvaer want to take this music. It's a bold step for the label, and one with which I hope they stick. I for one eagerly await *Khmer's* follow-up.

Simon Cooke

♪ jazz



VARIOUS ARTISTS
**SWINGIN' JAZZ FOR HIPSTERS
 VOLUME ONE**
 CONCORD CCD-4791

Well, due to the pressure of work and other such matters, it looks as though this will be my last review for these hallowed pages, so I've been rummaging around for something really pyrotechnic; go out with a bang and all that.

Those of you who have seen previous reviews of mine will recall remarks that I've made about the quality of Concord releases, and these CDs are no exception. Despite being compilation albums, all of the tracks are presented with Concord's standard crystal-clear sound and voluminous presence. Unlike other high-quality recordings, these are so well balanced that they will give their best no matter what system they are

played on.

The package itself has the kind of tongue-in-cheek (I hope!) pretentiously hip image reminiscent of times when serious hip meant owning a black beret and conversing in soundbite out-takes from a Top Cat script (Daddy-O!) Not only that but the CD itself is printed to resemble that good old black vinyl stuff. Never mind, if the style isn't your thing, you can throw the inserts away and just enjoy the music, because it really doesn't need anything to support it.

So what is the music? What makes it so hip? Well, it really is all you need to instantly become disgustingly hip in one easy lesson; none of your fly-by-night one-hit wonders here! You get some of the best musicians on Concord (sorry Concord, but there are some good musicians out there that you haven't yet signed) playing some of the greatest jazz around.

Volume One is a twelve-track selection including Mel Torme singing Fagen's 'Walk Between Raindrops', Stephane Grapelli and Martin Taylor on Wonder's 'Isn't She Lovely', Ruby Braff, Scott Hamilton, Dave McKenna and Howard Alden performing Mancini/Mercer's 'Days Of Wine And Roses', and Charlie Byrd playing Jobim/Gimbel/Moraes' 'Girl From Ipanema'. Those are just the highlights and remember, it doesn't cover all the other little gems in here.



VARIOUS ARTISTS
**SWINGIN' JAZZ FOR HIPSTERS
 VOLUME TWO**
 CONCORD CCD-4792

The second album in the set, unlike some sets where a simple idea is spun out for too long, works as well as the first, if not slightly better. Again you get twelve tracks for your hard-earned cash, including Baker/Ellington's 'Mr Gentle And Mr Cool' played by the Ken Peplowski Quintet, Rado/MacDermot/Ragni's 'The Age Of Aquarius' from Brother Jack McDuff's Hammond Organ, and Howard's 'Fly Me To The Moon' played by Monty Alexander.

These two CDs would be excellent for anyone you know who's hip or just throwing a party. In this season for giving, take my advice and put them at the top of your presents list.

Classical

Peter Herring

Romance - and the Romantics: discover the music that gave solace to a lonely, love-struck Catholic queen during her King's darkest hour; and the far-from-dark concertos and symphonic poems of two of the 19th century's early Romantic composers, Felix Mendelssohn and Franz Liszt.

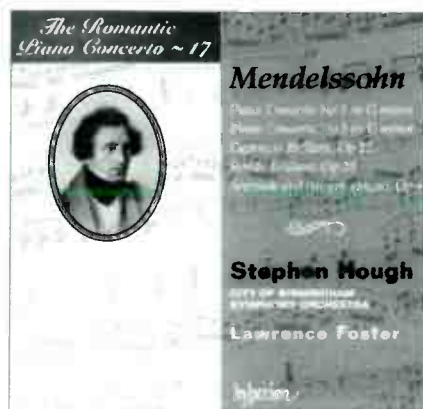

FELIX MENDELSSOHN
Piano Concerto No1 in G minor, Op25/Piano Concerto No2 in D minor, Op40/Capriccio Brilliant in B minor, Op22/Serenade and Allegro giocoso in B minor, Op43
Stephen Hough, piano; City of Birmingham Symphony Orchestra; conductor, Lawrence Foster
HYPERION CDA66969 (DDD/75.13)

Since his famously successful coupling of two concertos by Johann Nepomuk Hummel for the Chandos label back in the Eighties, piano concertos of the early-to-mid Romantic period have provided rich pickings for Stephen Hough - witness his 1996 award-winning recording, this time for Hyperion, of works by the hitherto obscure Franz Xaver Scharwenka and Emil von Sauer.

The name of Felix Mendelssohn is rather better known, but his piano concertos have remained among the most neglected of his major orchestral works. While they may not be in the class of the ever-popular E minor Violin

Concerto, they are never less than engaging and, with a soloist of the quality of Stephen Hough, frequently utterly captivating.

Of the two concertos, the Second in D minor, first performed in Birmingham in 1837 with the composer as soloist, is the more substantial. Its outer movements are reminiscent of Chopin, while the heart-felt adagio has something of the devotional quality of the slow movement of Beethoven's 'Emperor' concerto. Both works, though, are principally distinguished by their pianistic fireworks, with the soloist often required to play at an electrifying speed. Hough clearly relishes the challenge, his fingers dancing through the glittering torrent of notes, and his entire approach to the concertos has a vitality, freshness, delicacy and wit which comes across as exactly right. It is all very persuasive.

In addition to the two concertos, Hyperion generously include three other pieces for piano and orchestra, such as the breath-taking Capriccio Brilliant and Rondo Brilliant, which alone establish Mendelssohn's credentials as a virtuoso in the class of his contemporaries Chopin and Liszt. Unlike the latter, however, Mendelssohn was never one for showmanship and self-glorification, which probably explains his relatively limited output of piano music and its comparative neglect.

This recording does much to redress the balance, with Stephen Hough's dazzling playing nicely complemented by the CBSO under Lawrence Foster, and by a refined and coherent sound from the ever-dependable team of Tony Faulkner and Andrew Keener. At times I thought the

orchestral contribution could have done with a little more projection, but then this very much is Stephen Hough's show.

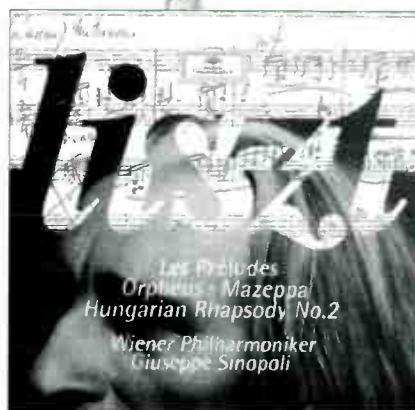

FRANZ LISZT
Symphonic Poems: Les Preludes/Orpheus/Mazeppa/Hungarian Rhapsody No2
Vienna Philharmonic Orchestra; conductor, Giuseppe Sinopoli
DEUTSCHE GRAMMOPHON 453 444-2 (DDD/57.59)

Giuseppe Sinopoli is the most frustrating of conductors, triumphs and 'turkeys' appearing in roughly equal measure. This Liszt programme - unlike his more recent recording of Mahler's *Das Lied von der Erde* - undoubtedly merits inclusion in the first category.

What particularly distinguishes these performances by the Vienna Philharmonic is the grasp of structure that Sinopoli displays - no mean achievement in works that in less secure hands can appear meandering and shapeless. The control displayed



United Electron Tubes

Exclusive European Distributor of PRO-CAP Capacitors and Professional Audio Components Tubes & Transformers
 PRO-CAP Silver Foil Paper in Oil Capacitors. Designed specifically for use in the signal paths of audio amplifiers. These capacitors are superior to any other type at any price. Plastic case, Axial leadouts using OFC, Inner foil denoted by GOLD plated leadout, Outer foil leadout Silver Plated.

SILVER FOIL						PAPER IN OIL					
Value	Voltage DC	Length	Dia	Price £each	5+£each	Value	Voltage DC	Length	Dia	Price £each	5+£each
0.005uf	700 volts	20 mm	8 mm	5.04	4.53	0.1uf	600 volts	40 mm	12 mm	8.32	7.49
0.01uf	700 volts	25 mm	10 mm	5.65	4.91	0.22uf	600 volts	40 mm	15 mm	12.62	11.35
0.02uf	700 volts	25 mm	12 mm	6.00	5.40	0.47uf	600 volts	50 mm	22 mm	18.46	16.61
0.05uf	650 volts	30 mm	12 mm	6.75	6.07	1uf	600 volts	60 mm	30 mm	23.61	21.25

High voltage POLYPROPYLENE Power Supply smoothing capacitors. These capacitors made by PRO-CAP in the USA have been designed for use in medium high voltage power supplies. They offer significant advantages over Electrolytics and all other types including Slit Foil.

HIGH VOLTAGE POLYPROPYLENE CAPACITORS											
Value	Voltage DC	Length	Dia	Price £each	5+£each	Value	Voltage DC	Length	Dia	Price £each	5+£each
20uf	600 volts	95 mm	35 mm	8.70	7.63	100uf	1250 volts	115 mm	103 mm	58.40	53.22
100uf	650 volts	95 mm	65 mm	23.10	20.79	200uf	650 volts	90 mm	103 mm	43.26	39.86

High voltage Metal Film resistors. These resistors offer a very high degree of stability over wide temperature and climatic variations. They will withstand overload conditions without Flame or Mechanical breakdown upto 1,800 volts. Available in three power ratings. Leadouts are OFC GOLD plated.

HIGH VOLTAGE RESISTORS											
Value	Wattage	Price £each	5+£each	Value	Wattage	Price £each	5+£each	Value	Wattage	Price £each	5+£each
1R0 to 1M	one	0.55	0.48	1R0 to 1M	two	0.78	0.71	1R0 to 1M	three	0.94	0.86

High Voltage Chassis Standoffs with 4 mm screw fixing soldering pin is Silver plated. Also PTFE insulated solder terminals, mounts through 4mm hole in chassis inserting pin SILVER Plated nickle. These two components are not available anywhere else in Europe. Made for the US Military to a very high specification. These are the very best solder anchorage points you can buy and are designed for point to point wiring.

CHASSIS STANDOFFS				PTFE INSULATED			
Maximum Voltage	Price £each	10 + £price each		Maximum Voltage	Price £each	10 + £price each	
5,000 volts	0.86	0.72		5,000 volts	0.68	0.57	

We hold a small inventory of original Tubes in addition to supplying the popular types from Svetiana and other sources. All tubes carry standard manufacturers warranty. We do not offer a matching facility as it is difficult if not impossible to match Tubes and give a guarantee as all Tubes will drift out after approximately 30 hours use. However all tubes are tested and graded into Two categories, Grade 1 & Grade 2. This is then reflected in the price. We are always interested in buying tubes. Please fax us with your list for an immediate decision.

GRADE 1					GRADE 2					GRADE 3				
Tube	Make	New	Pull	£ each	Tube	Make	New	Pull	£ each	Tube	Make	New	Pull	£ each
2A3	Chinese	Yes		15.00	2A3	Chinese	Yes		12.00	KT88	GEC	Yes		150.00
300B	Chinese	Yes		42.00	300B	Chinese	Yes		36.00	TT21	GEC	Yes		12.00
STC4-300B	Chinese	Yes		59.00	STC4-300B	Chinese	Yes		52.00	6146B	GE	Yes		16.00
VA300B	Chinese	Yes		50.00	VA300B	Chinese	Yes		47.00	5B255M	STC	Yes		14.00
805	Chinese	Yes		16.00	805	Chinese	Yes		14.00	13E1	STC		Yes	35.00
811A	Chinese	Yes		8.00	811A	Chinese	Yes		7.00	6B4G	VARIOUS	Yes		35.00
845	Chinese	Yes		30.00	845	Chinese	Yes		27.00	6080WA	MULLARD	Yes		12.00
211	Chinese	Yes		26.00	211	Chinese	Yes		22.00	6J5GT	JAN	Yes		6.00
6SN7GT	Chinese	Yes		4.25	6SL7GT	Chinese	Yes		4.75	6SN7GT	JAN	Yes		6.00
SV300B	Svetiana	Yes		90.00	SV300B	Svetiana	Yes		85.00	6SL7GT	MULLARD	Yes		9.00
SV572-3	Svetiana	Yes		68.00	SV572-3	Svetiana	Yes		64.00	CV2492	MULLARD	Yes		7.00
SV572-10	Svetiana	Yes		80.00	SV572-10	Svetiana	Yes		75.00	CV4058	MULLARD	Yes		5.00
SV811-3	Svetiana	Yes		25.00	SV811-3	Svetiana	Yes		23.00	5R4GY	VARIOUS	Yes		8.00
SV811-10	Svetiana	Yes		25.00	SV811-10	Svetiana	Yes		23.00	CV378	MULLARD	Yes		10.00

KITS We are currently working on two kits which we anticipate will be ready for general release by end of December 1997 & Jan 1998 respectively Svetiana SV572-10. The kit comprises 2 outboard power supplies mounted on 2 separate Solid Copper 24 carat Gold Plated chassis. Each power supply is fully Tube stabilized and features 2 X 5U4 rectifiers, 1 x 6C4, 1 x 0A2, Choke, 600uf Polypropylene smoothing capacitors which in turn feed into 2 x 6550 Series Pass Tubes. Each power supply is connected to the Stereo chassis via 2 x umbilical cords. The Amplifier itself is also constructed on a Solid Copper 24 carat Gold Plated chassis and features the following 4 X SV572-10, 7 X 6SN7GT, 2 x Hand Wound Output Transformers. Silver Foil Paper in Oil capacitors and Metal Film resistors throughout. OFC Silver wire and silver solder. Point to Point wiring connections to PTFE insulators with Silver Pin. Kit 2 is a single ended amplifier which shares the same chassis and layout as Kit 1 and is constructed in the same manner. These kits have not been built to a price and no compromise has been made in the sourcing of components. Prices are expected to be £3000 (Kit 1 or Kit 2) + VAT. To see the finished amplifiers and read the review then please see Hi-Fi News Jan 1998

FAX (0044) 01705-474242

TEL (0044) 01705-486050

UET, 9 LANGSTONE AVE., LANGSTONE, HAVANT, HANTS, PO9 1RU, ENGLAND

Classical

here is impressive, the build-up of tension and its ultimate release - as in the climax of *Les Preludes* - superbly handled. For once this best-known of Liszt's symphonic poems, which suffered the misfortune of being adopted as the musical embodiment of Nazi triumphalism, has genuine nobility as well as excitement, and the 'pastoral interlude' is beautifully played.

Les Preludes, its title inspired by the Lamartine poem of the same name, was originally intended to become the overture to a four-movement choral work, *Les Quatres Elements*, but Liszt abandoned this project and revised the piece to become one of the series of symphonic poems on which he 'cut his teeth' as an orchestral composer prior to embarking on such large-scale works as the *Faust* and *Dante Symphonies*.

Mazeppa is cast in the same heroic and colourful mould as *Les Preludes* and, again, Sinopoli's command of the score produces a performance that is both exciting and convincing.

The playing of the Viennese orchestra is outstanding in this evocation of the story of the Polish aristocrat, Ivan Mazeppa, who - as punishment for an illicit liaison - is tied to a wild horse which is driven across the steppes to the Ukraine. Here he is rescued by Cossacks and eventually becomes their warrior leader. Liszt depicts the action in great orchestral colour, right down to the crack of the whip that sets the horse careering on its turbulent ride. It's terrific stuff.

In contrast, *Orpheus* is a gentle hymn to the mythical creator of music, with his traditional instrument, the lyre, represented by harps. Liszt wrote it to preface a performance of Gluck's *Orfeo et Euridice* in Weimar in 1854, a role for which it was well worthy. Here, too, Sinopoli's attention to every nuance of the score, his careful regulation of dynamics, brings its rewards.

These qualities are also evident in

the *Hungarian Rhapsody No2* which supplies a rousing conclusion to the programme. I can guess at the commercial reasons for including this war-horse, and it is splendidly played by the VPO, but how much more valuable the CD would have been for including another of the symphonic poems: *Tasso*, for example. And, unlike the other works on the disc, Sinopoli seems less committed here, for once exhibiting a little too much control. Still, with Liszt's orchestral music conspicuously out-of-fashion at the moment, this issue, recorded with appropriate spaciousness and sumptuousness in the *Großer Saal* of Vienna's *Musikverein*, has to be enthusiastically welcomed.



FRANZ SCHUBERT

Symphony No2 in B flat major, D125/Symphony No3 in D major, D200/Symphony No5 in B flat major, D485
Orchestra of the 18th Century;
conductor, Frans Bruggen
PHILIPS CLASSICS 446 100-2 (DDD/78.04)

This generous coupling of three youthful symphonies by Schubert, all composed between 1815 and 1816 when he was nineteen and twenty years of age, is drawn from concert performances given in The Netherlands

between 1990 and 1995. Despite the time gap, Frans Bruggen's approach to these far-from-immature works is wholly consistent: tempos are brisk and buoyant, sustaining the breezy, invigorating freshness so characteristic of early Schubert, and his precocious mastery of orchestral colour can seldom have been better portrayed than by the period instruments of the *Orchestra of the 18th Century*. Take, for example, the delicious wind solos in the third and fourth movements of the *Second Symphony*.

However, when it comes to authenticity, Bruggen is no straight-laced puritan and one of the joys of these performances is the expressive freedom he allows his players. With the rhythmic precision comes an alluring warmth and charm and a genuine feeling of the emotional breadth that underpins these outwardly care-free compositions.

The balance struck between recreating a 'period' feel and allowing the kind of individual interpretative insights that give any performance its special character seems entirely right, not least in the beguiling and endlessly tuneful *Fifth Symphony*. Here, Bruggen charts a course between the Haydn-esque, the Italianate and the early Romantic to magical effect. I found myself appreciating anew the sheer vitality of this music, and the clarity of line afforded by both the recorded sound and the inner balances of the ensemble allows every finely-spun orchestral strand to be savoured.

Despite the five-year span of the recordings (and the inevitable changes in personnel over that period) the performances have a satisfying consistency. Thirty years ago I came to love the Third and Fifth Symphonies through the infectious ebullience of Beecham's historic HMV recording; now Bruggen has not only reinforced that affection but enriched it ●

Record of the month

QUEEN OF HEAVENLY VIRTUE

Sacred music for Queen Henrietta Maria's chapel in Oxford

Music by **Alessandro Grandi, Francesco Maria Marini, Giovanni Battista Aloisi, Giovanni Rovetta, Tarquinio Merula and Anonymous**
Lynda Sayce, chitarone; Concertare; Jonathan Wainwright, chamber organ and director

ISIS CD023 (DDD/78.42)

'Young girl enters into loveless royal marriage' has a familiar ring to it, except that this particular wedding took place in the 17th century and the bridegroom - King Charles I of England - didn't even bother to turn up for the ceremony (which took place in the cathedral of Notre Dame in Paris). Despite this unpromising start, the King and his French bride, Henrietta Maria, came to fall deeply in love. Unfortunately, this blossoming relationship was rudely upstaged by the English Civil War which saw the Queen - a Catholic - exiled to Holland for her own safety. After seventeen months abroad, Henrietta Maria returned to England in July 1643 and was reunited with her husband who, forced out of London, had set up court - together with his army - in Oxford.

The young Queen did not join Charles I at Christ Church but instead took up residence in the Warden's lodgings at Merton College. She remained there for nine months before the worsening situation forced her to flee to France in April 1644. Charles I held out for another two years until, with Oxford besieged, he escaped under cover of darkness on April 27, 1646.

It is probable that, during her

sojourn at Merton College, Henrietta Maria was permitted to hold Roman Catholic services in the Chapel, and that the music to accompany these services was derived from the large collection of printed music books held by the prominent Royalist Sir Christopher Hatton who, in December 1643, was appointed to the position of Comptroller of the King's Household.

Hatton's household musician, George Jeffreys - a notable composer in his own right - had accompanied him to Oxford and brought with him a quantity of manuscripts of Italian music which he - Jeffreys - had copied in his own hand. The manuscripts contained masses and motets by several of the major

double-edged significance, with the devotional refrains in Marian motets such as O Dulcis Virgo and O Maria Quam Pulchra Es easily interpreted as referring to Oxford's queen as well as the Queen of Heaven. Given that Henrietta Maria was seen as a symbol of hope for the Royalist cause, the line "reparatorum saeculi" (restorer of the world) in O Dulcis Virgo would have had a direct appeal. Many other texts suggest clear parallels between the divinity and the monarchy.

Musically, the research undertaken by Concertare's director, Jonathan Wainwright, into this brief but extraordinary period in the history of music-making at Oxford is more than

justified. The contrasts between the solemnity of the mass movements and the ripely sensuous motets and songs with their often overt eroticism make for seductive listening.

The six voices of Concertare - all ex-Oxford or Cambridge scholars - capture the varying moods of this fascinating music quite beautifully, passionate and plaintive as required. First recording this may be, but the quality of ensemble and the clarity of line suggest a choir rich in experience and confidence.

The voices are skilfully underpinned by instrumental contributions from

chitarone (a form of lute) and chamber organ, and the whole ensemble has been excellently recorded by Edward Horn, appropriately enough in the Chapel of Merton College which, regardless of its historical associations, has the ideal acoustic for this music anyway. The perspectives are natural and the voices firmly focused with precisely the right degree of ambience. And how satisfying it is not to have to struggle to hear the texts. A first from Oxford - and with distinction ●



composers of the time including Alessandro Grandi, sometime deputy to Claudio Monteverdi at St Mark's, Venice. Thus the historical basis for this, the first commercial recording by Concertare, and the predominance of Grandi's music in the programme.

And a well-conceived programme it is, with a selection of sumptuous songs and motets incorporated into the contrastingly sparer setting of mass. Several of the former have a plainly

INTERNET

Visit our site

UPDATED REGULARLY
News; DIY; valve amps/pre-amps; speaker kits; reviews
+ lots more information not published in the magazine.

www.hi-fiworld.co.uk
or Email: edlt@hi-fiworld.co.uk



SUBSCRIBE

★ 1 year's subscription only £25 (£2.09 per issue!), and we mail it to you free. ★ Get to our amazing classified ads first and grab a bargain. ★ Run by dedicated hi-fi engineers and enthusiasts, HI-FI WORLD has become famous for its informative reviews and radical kit designs.

OVERSEAS SUBS RATES

Surface Mail	£38
Airmail Europe	£48
Airmail Middle East & South East Asia	£58
Airmail USA, Canada, Australia, Japan, Korea and China	£68

- Airmail
- Surface mail

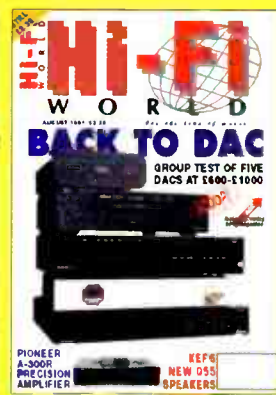

By telephone: Contact Faiza Chunara **Credit card hotline:** (44) 0171 289 3533
Fax: (44) 0171 289 5620 (Please fax form below)
By post: to pay by cheque or postal order send in an envelope marked
 Hi-Fi World, FREEPOST LON3478, LONDON, W9 1BR

HI-FI WORLD SUBSCRIPTION CARD

PLEASE REGISTER ONE YEAR'S SUBSCRIPTION FOR HI-FI WORLD

DEBIT MY MASTERCARD/ACCESS/VISA ACCOUNT NO:

EXPIRY DATE:

SIGNATURE _____

credit AUDIO PUBLISHING LTD the sum of £25.00 (UK ONLY)

NAME _____

ADDRESS _____

DAYTIME _____
 TEL NO _____

HI-FI & AV SYSTEMS

BEST PRICES IN THE UK

STOCKISTS OF ALL LEADING BRANDS

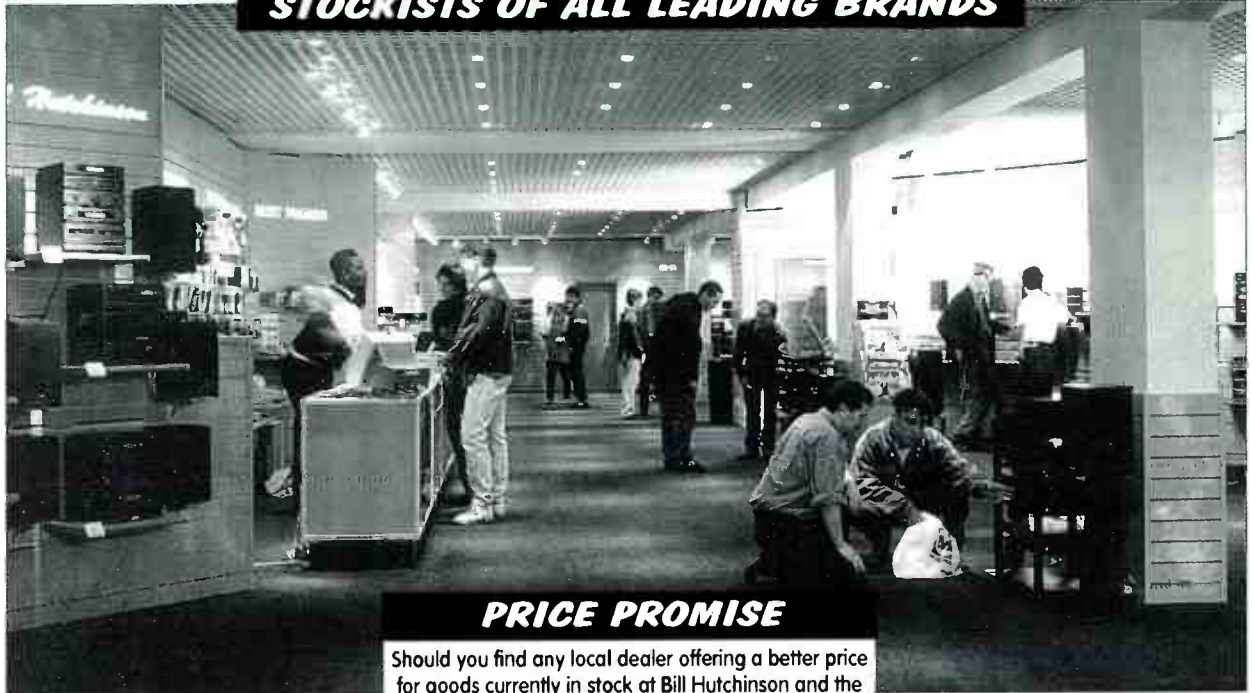

PRICE PROMISE

Should you find any local dealer offering a better price for goods currently in stock at Bill Hutchinson and the alternative quoting retailer, we will better that deal.

5 BILL HUTCHINSON STORES

MANCHESTER

50-52 DEANS GATE
0161-832 1600

LEEDS

26-28 WOODHOUSE LANE
0113-242 7777

NEWCASTLE

87A CLAYTON STREET
0191-230 3600

EDINBURGH

40A QUEENSFERRY ST
0131-220 0909

GLASGOW

43 HOPE STREET
0141-248 285

WHY SO MANY PEOPLE BUY FROM US

- Professional Staff
- Expert and friendly advice
- Home installation available
- Range of finance options available
- Exchange Policy

Dear Customer

My staff and I would like to extend to you the same first class service and friendly advice that is given to our present customers. We pride ourselves in offering first class service, choice and unbeatable value. Should you find a better price locally please inform my staff who will gladly better that deal!

Many thanks to all our loyal customers.

sincerely *Bill*

See in store for our price promise!

- Audio visual specialist
- Extensive Hi-Fi TV/Video range
- Huge selection of mini and micro systems
- Demonstration rooms in every store.

SEE OUR PRESTIGIOUS STORE

THE hi-fi ROOM

50 BRIDGE STREET,
MANCHESTER M3 3BN.
TEL: 0161-832 0888/0161-835 1366

*An Oasis
of Sound*

EXCLUSIVE HI-FI AND
AUDIO VISUAL SYSTEMS

Bill Hutchinson

Hi-Fi • CD • Audio Visual Centre

THE PROFESSIONALS
World Radio History

SEE OUR CLEARANCE CENTRE

HIFIUK

0131-667 2877

43 SOUTH CLERK STREET, EDINBURGH

SCOTLANDS NO.1 CLEARANCE CENTRE

WE SPECIALISE IN END OF LINE EX-DISPL
AND MANUFACTURERS SURPLUS STOCK

UNBEATABLE PRICES ON QUALITY BRANDS

SLATE AUDIO



Linking The Past, Present & Future



THE SPEAKERSTAND®

The best speaker supports in the world.

State of the art in performance and design, custom made to suit any loudspeaker. Solid slate, supremely rigid and totally neutral" (*Slate was chosen after extensive testing on all other stones)

SPEAKER PLATFORMS ISOLATION PLATFORMS TURNTABLE PLATFORMS SHELVING SYSTEMS

"Immaculately finished, sublimely rigid, on a par with the best stands I've used." Ken Kessler, Hi-Fi News R/R. "An astonishing degree of instrumental separation, stable and holographic, with great precision and remarkable poise. The ultimate in high fidelity supports." David Prakel, Hi-Fi Answers. "Superbly finished, the sound quality was considered to be first rate." Martin Colloms, Hi-Fi News R/R. "The sound quality when using the Slate Audio stands proved to be a revelation, something special." Paul Messenger, Hi-Fi Choice. "The finish is excellent, the sound quality magnificent and breathtaking." Tom Bryant, The Telegraph. "The Slate stand is unusual and expensive, but if you are after an exceedingly neutral stand it's the leading contender. This stand offers an exceptionally neutral platform for speakers; highly transparent sound leads to musical performances with real insight." SOUND QUALITY: ■■■■■■ Malcolm Steward Hi-Fi Choice.

SLATE AUDIO GARRARD 301 and 401

The best and most musical record players in the world.

Our researched Solid Marble Plinth System® advances the state of the art and brings the Garrards into the 21st century. All wooden plinths produce unacceptable levels of coloration, microphony and feedback, with poor signal to noise ratios. When dealing with a thoroughbred you must respond with a firm hand, as anybody who has heard the transformation will testify.

No other plinth system can claim to improve the performance of these superb players.

Dear Mr. Soper,

Thanks for sending me the plinth for my Garrard 401. I must confess, that I was a bit sceptical about it. when I ordered one - after all, I bought it, without the possibility of listening to it first. But the results I get are really unbelievable. There is no rumbling, instead deep, deep bass and an authority, I never heard before from my records. And believe me, I tried some of the best turntables around (Linn LP 12, Roksan Xerxes). Now I'm waiting for the forthcoming power-supply. The day I place my order for it, I will do so without being a bit sceptical. Thanks again for a marvellous piece of art.

MR TEILINGNER - AUSTRIA



Nothing sings like a diamond



THE GLASSMAT®

The finest platter mat in the world.

The Glassmat® was developed to improve the performance of the Garrard 301 and 401 record players. However it also gives astonishing results when used on other turntables. So effective is its performance, we have now made it available as a universal replacement mat. In all cases other mats introduce colorations of their own, robbing the music of large amounts of detail and ambience. In order to achieve maximum information retrieval with optimum damping, a hard and unyielding material is required. Glass is ideal in every respect, damping is complete, the playing surface being quite simply sublime. In terms of detail resolution and sheer three dimensional ability, no other mat comes close. But then you still have to consider the absolute clarity, precision and solidity of the presentation. This is the ultimate platter mat.

THE POWERHOUSE OUR QUARTZ REFERENCED GARRARD 301/401 TD124 AND UNIVERSAL POWER SUPPLY. "KILLER" K.K.
THE TABLESTROBE QUARTZ REFERENCED STROBE GUN DESIGNED SPECIFICALLY FOR THE GARRARD 301 AND 401.
THE HANDSTROBE QUARTZ REFERENCED HAND HELD STROBE SUITABLE FOR ANY TURNTABLE WITH SPEED ADJUSTMENT.
STORMFORCE SOLID MARBLE ENCLOSURES® FOR ALL TANNOY DUAL CONCENTRICS. BEWARE ...STRUCTURAL DAMAGE MAY OCCUR!
HUMDINGER ELEVATE YOUR EARLY SME 3009S2 TO 1997 STATUS. BREATHES NEW LIFE INTO A GREAT CLASSIC.
BACKLASH SUPERB SME 3009 & 3012 GOLD PHONO SOCKET CONVERSION. INCLUDING OFC LEADS: BRILLIANT? YES.
BRAZEN UPGRADE YOUR V15III WITH OUR ALLOY RE-BODY AND MICRO RIDGE STYLUS: INSANE? NO.
SOLID MARBLE PLINTH SYSTEMS® ALSO FOR EMT AND THORENS TD124.

SLATE AUDIO GARRARD 301 AND 401 ARE AVAILABLE COMPLETE OR MARBLE PLINTH SYSTEM® ONLY.

SME CELEBRATION ARMS WITH SPECIAL GRAPHICS "SLATE AUDIO 301 OR 401 CELEBRATION" AND "SLATE AUDIO TD124 CELEBRATION" 309 • 312 • IV • V.

THE TONEARM OUR SPECIAL VERSION OF THE FAMOUS REGA RB300, FITTED WITH GOLD PHONOS.

SME 3009S2 (1997 VERSION) A PERFECT MATCH FOR OUR V15III BRAZEN AND THE NEW SHURE V15V x MR. "STILL CRAZY AFTER ALL THESE YEARS".

THE SPIKEKIT SPECIALLY DEVELOPED TO FIT DIRECTLY TO FLOOR STANDING LOUDSPEAKERS OR ANY WOODEN SUPPORT ADJUSTABLE AND VERY SIMPLE TO FIT.

BE BRAVE FACE YOUR FEARS LIVE YOUR DREAMS

SHURE STYLUS PRESSURE GAUGE • GARRARD 301 SWITCH SUPPRESSOR • TURNTABLE SERVICING • GARRARD 301 LEVER SET • GARRARD 301 FIXING BOLT SET
STROBE 013C • GARRARD 401 CONTROL PANEL SET • GARRARD 301 MOTOR PULLEY • FULL RESTORATION OF GARRARDS TO ORIGINAL CONDITION

ALWAYS WANTED, GARRARD 401, GARRARD 301 AND THORENS TD124 RECORD PLAYERS, PLEASE PHONE

47 GEMINI CLOSE, LEIGHTON BUZZARD, BEDS, LU7 8UD.

TEL/FAX: 01525 384174 MOBILE: 0421 624429

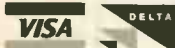

THE**Hi-End**

5 Rocks Lane Barnes
 London SW13 0DB
 Tel: 0181 876 3355
 Fax: 0181 876 3399

**Don't cheat yourself...
 ...Treat yourself
 to the world's finest audio fidelity equipment**

We specialise in:

Audio visual interior design • Multi-room installations • 'Life-style' systems
 Systems from £300 to over £30,000

CLEARANCE BARGAINS

	Was	NOW
AVI S2000 MP Pre-Amp (SH)	£949	£499
AVI S2000 MI Int Amp (SH)	£999	£799
AVI S2000 Reference CD	£1400	£1169
B+W CDM 1	£600	£479
B+W P4	£675	£539
B+W P5	£875	£699
B+W P6	£1095	£875
B+W DM602	£300	£239
Castle Eden (OAK)	£470	£360
Chario Academy one	£1300	£999
Chario Hiper 1000 Tower	£800	£499
Heybrook Heylo	£440	£350
MARANTZ CD 67SE	£299	MASSIVE
MARANTZ CD 63 K.I. SIG	£399	SAVING
MARANTZ CD 17 K.I. SIG	£1099	P.O.A
MICROmega DAC	£749	£599
MICROmega Drive 3	£999	£749
Neat Critique (SH)	£385	£285
Quad 77 CD (Bus)	£700	£595
Quad 77 Pre + Console	£850	£699
Quad 77 Power Amp	£600	£499
Restek Sixtant Pwr Amp	£900	£599
Ruark Broadsword	£900	£599
Roksan Caspian Amp (SH)	£695	£549
Roksan Rok One	£645	£499
TDL RTL 3 II	£400	£249
Teac DTI DAC	£500	£375
Teac TI Transport	£550	£439
Teac V6030S Tape	£550	£439
Thorens TD 180	£199	£145

CYMBOL CDP12



AUDITION THIS AMAZING CDP12 TODAY
£1279 OR £199 deposit 9 X £120
TOTAL PAYABLE £1279.
(Subject to Status)

OTHER FAVOURITES ALL AVAILABLE ON

Meridian 506 CD Player
 £1100.00
 £200 deposit
 6 x £150 Total payable
 £1100.00
 (Subject to status)

Marantz CD17KI CD
 £1099.00
 £199 deposit
 6 x £150 Total payable
 £1099.00
 (Subject to status)

AVI, ALCHEMIST, ANTHEM, BAYER, BOSE, BOULDER, CABLETALK, CASTLE, CHARIO, CITATION, ELECTROCOMPANIET, EXPOSURE, FINAL, GAMMA ACOUSTICS, GENESIS, HEYBROOK, JAMO, KEF, LINN, LUMLEY, MAGNUM DYNALAB, MARANTZ, MCINTOSH, MERIDIAN, MICHELL, MICROMEGA, MYRYAD, PRECIOUS METALS, PROJECT, ORTOFON, QED, QUAD, REVOX, ROKSAN, RUARK, SEQUENCE, SOUNDSTYLE, SONNETEER, SONICLINK, SENNHEISER, SONIC FRONTIERS, SME, STAX, TDL, TEAC, TOTEM, TRICHORD, TANNOY, TARGET, XANTEK

Showroom open 10.00 to 6.00 Monday to Saturday

All Major Credit Cards Accepted • Finance Arranged • 2 Demonstration Rooms

0%

**INTEREST
FREE
CREDIT ***

(available on selected items)

WORLDWIDE MAILORDER SERVICE

From Dublin to Durban, Sheffield to Sydney
we'll ship fully insured within days of you
placing your order. Telephone or Mailorder
Hotline NOW ON + 44 (0)181 - 8780066
(INTEREST FREE CREDIT MAILORDER - UK ONLY)

**THE
Hi-End**



ROKSAN CASPIAN Range NOW AT THE HI END

AVAILABLE ON INTEREST FREE CREDIT 0%
TELEPHONE OUR MAILORDER HOTLINE ON 0181 8780066
FOR DETAILS...SHOP FROM HOME
*REMEMBER WE CAN SUPPLY VIRTUALLY ANY BRAND OF
HI-FI YOU REQUIRE AT THE KEENEST PRICES

INTEREST FREE CREDIT (Subject to status)

NOW DEMONSTRATING

- AVI Pre-amp + Monoblocks - *awesome*
- ANTHEM Integrated/Pre/Power-Amplification - *best of Canadian valves*
- CASTLE SEVERN 2 - *frighteningly good valve*
- CYMBOL - *HDCD at £1299 - Unreal*
- CYMBOL - *New Integrated amp at £499*
- ELECTROCOMPANIET - *Class A Perfection from Norway*
- GAMMA ACOUSTICS RHYTHM - *single ended integrated*
- GENESIS - *Loudspeakers - a refreshing alternative to Wilson Audio*
- GRADIENT - *Loudspeakers from Finland*
- LINN - *LP12, HI-FI + Multi Room solutions*
- MARANTZ - *CD63SE, CD63 K.I.Sig*
- MERIDIAN - *500 Series*
- MAGNUM DYNALAB - *Ultimate reference tuners.*
- MICROMEGA STAGE/DRIVE - *Vinyl like CD - so natural*
- ROKSAN - *Caspian Amp + CD*
- RUARK - *Icon, Sceptre, Broadsword - monitor heaven*
- RESTEK - *The Germans have landed - Challenger II, Concret CD "Battleship hi-fi" - Truly remarkable*
- SONIC FRONTIERS SFCD1 - *HDCD - Heaven*
- SONNETEER CAMPION - *The best*
- SONNETEER ALABASTER - *The best gets better*
- TOTEM Model 1 - *We dare you*
- TOTEM MANI 2 - *Our best loudspeaker*
- TRICHORD - *Revelation and Genesis CD Players*

Roksan Caspian CD

£895.00

£175 deposit

6 x £120 Total payable

£895.00

(Subject to status)

Roksan Caspian Amp

£695.00

£125 deposit

6 x £95 Total payable

£695.00

(Subject to status)

-- STOP PRESS -- -- STOP PRESS -- -- STOP PRESS --

******LIMITED STOCK******

**Ruark Broadsword (Walnut/Black).
Brand New Boxed - Normally £900.00
Yours for only - £599.99**

*** SUBJECT TO STATUS**

0%

FINANCE

Up to 36 Months



0%

FINANCE

Up to 36 Months

OMEGA Electronic Equipment (Europe) Ltd, New Road Business Estate, Ditton, Maidstone, Kent, ME20 6AF

Tel : 01732 848268 (7 Lines) Fax : 01732 848289

- Quality Audio Visual Products.
- 4 Evaluation Suites.
- 0% Finance up to 36 Months.
- Suggested Systems.
- Home Evaluation.
- FREE Installation Service.
- Evening Appointments.
- Ample FREE On-Site Parking.
- Easy Access M20/M25/M2&A2.
- World Wide Mail Order.
- 8.30am to 6.30 pm Mon - Fri.
- 10.00am to 4.00pm Sat.

Please note that Saturday demonstrations after 4pm are available by pre-booking.

SOME OF THE PRODUCTS NOW AVAILABLE FOR DEMONSTRATION:



Musical Fidelity X Series : Whole range from the **X10-D** to the absolutely brilliant **NEW X-A50** mono power amps stocked and on demonstration in our dedicated **X-Suite**. These products have taken the industry by storm and rightly so. Stunning looks and sound to match. You can now own a full **Musical Fidelity** system, based around the **X-Series** with your choice of CD transport & speakers. Whether you are looking for a cost effective upgrade to your existing system, or to purchase a complete new set of upgradable electronics, you owe it to yourself to seriously consider these superb products. Enthused about by the press, even outside of the normal HI-FI publications, these are real objects of desire. You have probably gathered by now that we rate the **X-Series** more than a bit !!

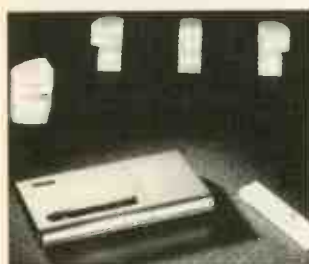

BOSE : Another of our favourite products. **Lifestyle 12** Home Cinema System and **Lifestyle 20** multiplay, dual zone high quality audio systems on permanent demonstration in our dedicated **BOSE Theatre**. Superb sound and vision from these stylish, virtually invisible, user friendly works of art. Full range of **BOSE** products available including the other **Lifestyle** systems and the **Acoustimass** loudspeakers. The performance and pure lifestyle orientated ease of use of these products make them out and out winners. We currently have some very special offers on all **BOSE** products, giving you anything up to a **FREE PC system and 0% finance** !! Call for details and to book the **BOSE Theatre**.



Audio Analogue : **Puccini & Puccini SE** integrated amps, **Bellini** pre and **Donizetti** power amps. You should be familiar with these very, and we mean very classy Italian products by now. The **Puccini SE** recently had a storming review in **Hi-Fi World**, the **Bellini** and **Donizetti** will be equally as well received. Available in both silver and high gloss black finishes, these products are destined to become future classics. We strongly urge you to book your demonstration now. Priced from only **£ 450.00** for the **Puccini** integrated, the range represents unbelievable value in the sound per pound stakes. Another Italian import heading for the Premier League !!



Partington : Speaker stands or works of modern art ? How about both. After 25 years in the audio industry **Partington** have come up with what can only be described as a truly brilliant and revolutionary **NEW** loudspeaker support in the **A7-60**. Will sell by the bucket load on looks alone, but the sound enhancement properties of this support make for something bordering on the spectacular. The **A7-60** should be deemed as an essential purchase for anyone wishing to extract the maximum performance from stand mountable loudspeakers. Forms an incredible sonic and visual statement with the **Townshend SSS** . We have been waiting for a speaker stand like this for ages. Nice one Partington !!

OEE specialise in the supply of quality audio visual products that offer stunning sonic and visual appeal. Call for our full price list & product guide or to book one of our 4 **NEW** evaluation suites. **FREE** UK Mainland delivery on all mail order sales.

*** STOP PRESS *** Sonic Frontiers Anthem CD Multiplayer - Finally available & well worth the wait.

The Prime Source for ...

Anthem, Audio Gem, Audio Analogue, Audiocarpet, Bose, C.A.D., Ergo, Graaf, Jecklin Float, JBL, LFD, LG Electronics, Mistral, Monrio, Musical Fidelity, Neolith, Partington, Precious Metals, Sequence, Sonic Frontiers, Sonic Link, Sonneteer, Stax, Totem, Townshend, Triangle, UKD, Unison Research ...
& other quality audio visual products from around the World.



HEATHERDALE AUDIO LTD.



202 FINDON ROAD, WORTHING, WEST SUSSEX, BN14 0EJ
TEL. 01903-872288 OR (AFTER HOURS) 0860 660001 FAX. 01903-872234
e-mail: heatherdale@hifi-stereo.com http://www.hifi-stereo.com

HEATHERDALE PRE-OWNED GUARANTEED EQUIPMENT
EXPORT FACILITIES AVAILABLE

**FORSSELL AIR REFERENCE CD TRANSPORT AND
DAC ONLY 3 MONTHS OLD** £15650 new offered for £8995

**FORSSELL LTD EDITION AIR REFERENCE TURNTABLE AND
AIR BEARING TONEARM** £4995

KRELL ksa200b Balanced Power Amp £2495

THIEL CS2 2 Loudspeakers MINT £1995

MARK LEVINSON No 26s Pre amplifier £2995

CONRAD JOHNSON Premier 8a mono-blocks £8995

MARK LEVINSON No 29 Power Amplifier £1995

MARK LEVINSON No 39 CD Player MINT £4495

ELECTROCOMPANET 2 Channel Audio Power Amp £295

KRELL KRC 3 remote pre-amp ex-demo £2750

VOYD Standard Turntable, Mint. £1495

B & W Matrix 802 Series IIs £1595

HELIUS Silver wired Tonearm £395

Sonus FABER Fixed Stone/Wood Stands £250

MARK LEVINSON ML3 200 Watt Dual Mono Amp £3195

AUDIO NOTE IO Limited cartridge & PSU £2750

LUXMAN D-500Xs CD Player MINT/BOXED (£3495) £1795

NAKAMICHI ZXL1000 Tape Deck - B&W Serviced £2195

AUDIO NOTE ANS7 Step-up Transformer £3000

ARCAM Alpha 3 Integrated Amp with phono £165

CAMBRIDGE P50 Integrated Amplifiers £75

AUDIO NOTE Kassa Silver Amplifier £1995

MISSION 762 Loudspeakers with stands £250

KEF 104 Loudspeakers £450

AUDIO NOTE M7 Silver Signature pre-amp £7000

LUXMAN T-4 Accutouch CLL AM/FM Tuner £450

MARANTZ CD52 Mk II CD Player £125

ARCAM Delta Black Box II DAC Boxed £175

AUDIO NOTE ANE/SE Loudspeakers silverwired £3995

AUDIO NOTE DAC 4 MINT/Boxed £3995

STUDER A807 Pro. tape recorder MINT £3750

HEYBROOK Quartets & stands Ex Dem(£840) £595

AUDIO RESEARCH LS2b Hybrid Line Pre (£3398) £1995

SOLSTICE AAD speakers with stands £495

TRANSPARENT Ref. interconnect 15' st. pair £1595

GENESIS Model III speakers MINT £2495

JADIS Dely 7 stereo amp. mint £3695

LUXMAN MQ 3600 KT88 stereo power amplifier £1295

SPENDOR SP1 Loudspeakers £250

Q.E.D. Digit Dac & Positron PSU £125

PIONEER PD-A400X Integrated Amplifier £150

LUMLEY Promenade SP1 Loudspeakers (NEW) £250

TECHNICS SLO30 Turntable £125

KISEKI Blackheart Unused/Boxed (£1995) Special Offer £1500

YAMAHA CDX880 CD Player £195

AUDIOLAB 8000C Pre-amplifier £295

MAGNAPLANAR 2a panel Speakers £950

APOGEE Stage speakers with stands £1495

B & W JOHN BOWERS Active 1Speakers £895

MARK LEVINSON 3BS pre-amp ex-demo £4850

ROTEL RCD965BX CD player £195

ALL USED CARTRIDGES ARE CHECKED UNDER A MICROSCOPE BEFORE BEING OFFERED FOR SALE.

VISA - SWITCH - MASTER CARD - AMEX - DINERS CLUB WELCOME.
WE TAKE PART EXCHANGE ON NEW & USED STOCK AND BUY IN FOR CASH

JUST AVAILABLE FULL CELLO SYSTEM
PLEASE ASK FOR DETAILS
EX-DEM EXPOSURE EQUIPMENT AVAILABLE
PLEASE TELEPHONE FOR LIST
MAIN UK DEALERS FOR THIEL SPEAKERS
FOR AN UP-TO-THE-MINUTE LIST VISIT OUR NEW WEB SITE:
<http://www.hifi-stereo.com>

ALPHASON Designs

OVERSEAS DISTRIBUTORS required
for the UK's leading specialist hi-fi and
home entertainment furniture manufacturer.

For further details contact John B.Reddington.
ALPHASON DESIGNS LIMITED
Tel: +44 1189 833523 Fax: +44 1189 833567
E-mail: john.reddington@virgin.net

Silvernote

Ultra High Fidelity Magazine 1 year £25
DIY and Vintage Audio, VISA, MC, AMEX.
Audio Garrad 301, 401,
Origin Live Turntable RB300,
SME 3009, Mission 774, Revox G36,
Studer B62, AKAI GX310D,
Audionote M2 Preamp,
ANS2 Transformer, Lowther Drivers,
Cello Cartridge, Thorens 124.
Tel/Fax 01992 620905 - S. J. Mann

Sound Investment

If you have invested expertise and
money in building up a sound system
to your own unique specifications,
then why compromise with indifferent
housing units?

Fi-Rax offers a new dimension in
audio visual racking - from a range
of standard designs to the flexibility
to custom create a unit to suit your
particular sound system and lifestyle.

- *High quality aluminium construction.
- *Finishes available to your choice.
- *Fully adjustable 6mm glass shelving.
- *Sound isolation on shelving/feet.
- *Custom created to suit your system.
- *Free delivery throughout the UK.

Fi-Rax - a sound investment for those
who want the best from their
equipment.

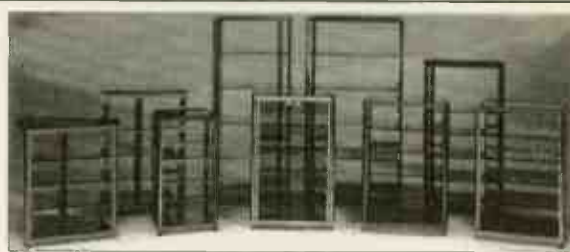

Audio Visual Furniture

For further information or a free brochure contact: JEM Distribution,
Springfield Mills, Spa Street, Ossett Wakefield WF5 0HW.
Tel: 01924 277626 Fax: 01924 270759

Are you making the right connections?

Send for Britain's biggest catalogue of
specialist cable and connections.

All available by mail order.

Phone 0181-942 9124 or clip
the coupon for your Free copy

**CUSTOM CABLE
SERVICE**

PO Box 4007, London SW17 8XG

Please send me your FREE Custom Cable Catalogue

Name _____

Address _____

Postcode _____

NO FURTHER INFORMATION REQUIRED

Send to: Custom Cable Service
PO Box 4007
London SW17 8XG



Audio Note Kit Amplifiers

Power-Amp Kit

The Audio Note Kit One (Illustrated)

Based around the justly famous 300B directly heated triode, we see this kit as the introduction to *real* Audio Amplification, as it covers all the important aspects of design necessary, Single Ended, No-Feedback, Class A, Directly Heated Triode, to become a member of this exclusive club of amplifiers.

Kit One has one 300B per channel running at 420 volts with 75mA current giving 8-9 watts of the cleanest power you will ever hear, the input stage consists of a 6SN7GT with a 5687 double triode driver stage running in SRPP. The power supply is capacitor-choke-capacitor configuration with a 5U4G HT rectifier, the 300B's have a DC filament supply for hum-free operation whilst the other valves are AC heated. Component quality is similar to our Level 2 finished products, **Audio Note** paper in oil signal capacitors, Beyschlag 1 watt 1% metal film resistors, good quality electrolytics (sorry NO Black Gates!) and a simple, attractive stereo chassis in black paintwork. We have several component and cosine for **Kit One**, for details.

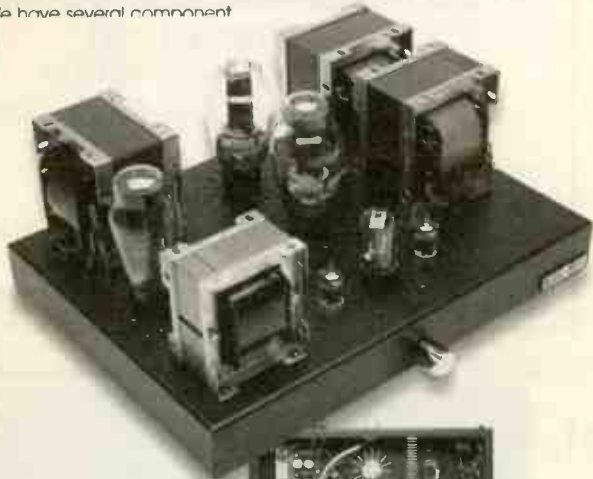

The **Kit One** has recently been awarded the title "The G Audio Barg" by *Twentieth C Dick Osher* in a review. It is just one of many rave reviews, copies of which we can supply on request.

Price: £799 incl. VAT, which includes ALL parts & valves (yes, also the 2 x 300B's needed) but not postage/packing which to UK customers is £12.00.

KIT ONE ORDER CODE: AN-KIT-001

The Audio Note Kit Two

Kit Two features a single 6550 tetrode running in Single-Ended mode, yielding some 12 watts of pure Class A. With a valve rectified HT for the output stage, stereo chassis, and 6SN7GT input and 12AX7/ECC83 SRPP driver stage, componentry and chassis as **Kit One**.

Kit Two costs £599 incl. VAT, includes valves, but not postage/packing.

KIT TWO ORDER CODE: AN-KIT-002

The Audio Note Kit Three

Kit Three features 2 x 300B's per channel running in single-ended parallel yielding 16/17 watts in pure Class A. This kit is on two mono chassis with valve rectified HT supplies, no signal feedback, it uses a 6SN7GT double triode as input valve and a pair of 5687 double triodes running in SRPP as drivers. The **Kit Three** is essentially a mono version of the **Kit One** with double the power, the same component choices and on two chassis' instead of one.

Kit Three costs £1,550 incl. VAT but excluding delivery.

KIT THREE ORDER CODE: AN-KIT-003

The Audio Note Kit Four

The **Kit Four** is really our introduction to valve amplifier kit building, the circuit and power supply being mounted on a single printed circuit board. The high-quality push-pull output and mains transformers are all mounted in a small aluminium chassis covering everything so nobody will be able to see that you have succumbed to the lure of the valve amplifier which is sweeping the world. The circuit consists of two 6V6GT tetrodes running in Push-Pull class A, yielding about 10 watts, driven by a 6SN7GT and a 12AX7/ECC83 input stage. Easy to build, even for the beginner. Visually **Kit Four** matches the **Audio Note** Pre-amplifier shown here but with a single chrome-plated volume control. As with all **Audio Note** kits everything (except solder) is included.

The **Kit Four** costs: £279 incl. VAT but not delivery.

KIT FOUR ORDER CODE: AN-KIT-004

Pre-Amp Kit

The Audio Note Pre-Amplifier Kit (Illustrated)

A complete kit loosely based on the **Audio Note** M7Tube pre-amplifier circuit is now available.

The moving-magnet compatible phono stage consists of a cascode input, with passive RIAA equalisation and anode-follower output using the 12AX7/ECC83. L buffer/amplification for the line inputs consists of an E configured in parallel anode mode. For the power supply rectifier and choke-input filter employed. All circuitry is housed in a non-magnetic aluminium giving the very best sound quality.

Both phono and line stages are built on 'track-less' pcbs allowing easy construction but with the sonic benefits of hard-wiring.

The standard-quality version of the pre-amp kit includes Roederstein polyester film capacitors, Beyschlag 1 watt 1% metal film resistors, Noble open-frame style potentiometers and all pcbs, valves, wire etc. Various component upgrades are available, details upon request.

Cost of The Pre-Amplifier Kit is: £299 incl. VAT but not delivery.

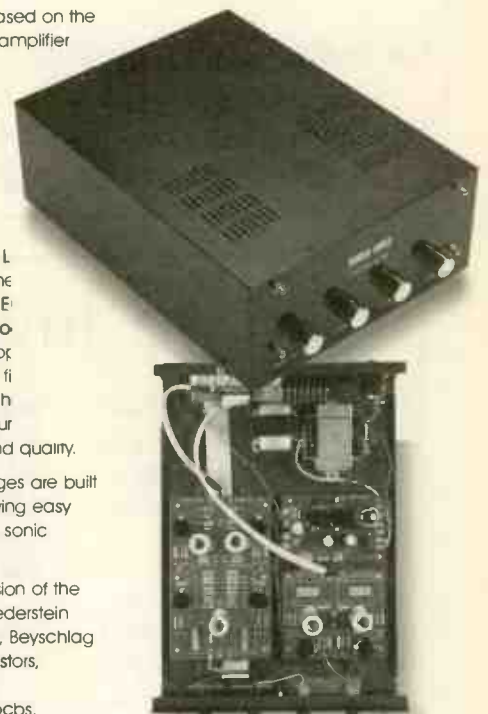

FURTHER INFORMATION IS AVAILABLE FROM:

An
Audio Note

Music's Finest Conductor

Audio Note (UK) Ltd, Unit C, Peacock Industrial Estate
Lyon Close, 125-127 Davigdor Road, Hove, East Sussex BN3 1SG

Tel: +44 (0)1273 220511 Fax: +44 (0)1273 731498

Web: www.audionote.co.uk

FOUNDING SPONSOR
masterprize



TOWERING INFERNO

WHAT ELSE SETS YOUR MUSIC
COLLECTION ALIGHT?

BLOW YOUR MIND
TAKE THE TUBE

GOLDEN DRAGON TUBES ARE AVAILABLE FROM:

P. M. Components
Springhead Enterprise Park
Springhead Road
Gravesend
Kent DA11 8HD
Tel: 01474 560521, Fax 333762,
e-mail: 101650.2424@compuserve.com

DEMAND

vinyl

Premium Discs, Audio Equipment & Accessories

AA 006 ARGENTA BOX SET from ALTO

Six records in original sleeves+bonus45, book and super quality presentation box.

Rodrigo, Falla, Breto, De Falla etc. £160

MCA JIMI HENDRIX (US Imports)

First Rays of the New Rising Sun (2LP) £22.50

Electric Ladyland (2LP) £22.50

Axis-Bold As Love £17.50

Are You Experienced (2LP) £22.50

Band of Gypsies £17.50

Art Pepper-New York Album, So in Love, Intimate £15 All 3 for £40

Decca SXL 2009 Argenta / OSR -Berlioz - Symphonie Fantastique £20

Decca SXL 6136-Kertesz / LSO - Kodaly - Harry Janos Dances Of Galanta £20

We stock a huge range of audiophile vinyl, including the excellent NEW releases from Absolute Analogue!

ANALOGUE PRODUCTIONS REVIVAL · AUDIOQUEST · UK BLUE NOTE · CARDAS RECORDS · 180 gm

HQ · CLASSIC RECORDS · RCA LIVING STEREO · DCC · DECCA SXL / LONDON CS · 180 gm HQ

EMI CLASSICAL · 180 GM HQ · FONE · 180 gm HQ · 2LP BOX SETS · GRAPEVINE · IMPLUSE JAZZ · 180 gm

HQ NEW RELEASES · SUPER ANALOGUE · LINN RECORDS · JAZZ / ROCK · MCA · 180 gm HQ

MOBILE FIDELITY SOUND LABS · PROPRIUS · RCA · SHEFFIELD LABS

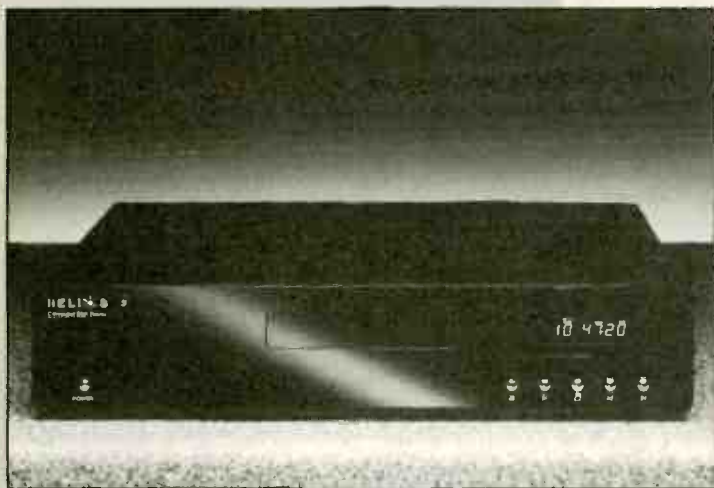

HELIOS CD PLAYERS

New to the UK, The Revolutionary CD players from Helios.

These machines look and feel totally different to the opposition. They sound better too.

On the outside a Metacrylite front panel and Stainless Steel controls combine with a heavily damped chassis to produce a reassuring sense of solidity.

Inside, you'll find a massively rebuilt transport system (Model 1 & 2) with extensive use of Carbon Fibre, and propriety digital electronics, all upgradable between models.

The results speak for themselves. Effortless bass dynamics and a wide open sound stage give music a tremendous sense of presence and involvement.

Impressive beyond their price.

Experience the Helios Solution to CD's problems. From £650 to £1250

VPI HW 19 Jr / RB300 £599

A top quality US record player, the HW 19 Jr offers unbelievable performance for the money. Fully suspended and featuring a solid acrylic platter, the Jr represents unprecedented value - even more so because it can be fully upgraded into the Legendary HW19 MK IV, the top selling analogue front end in the US.

This turntable combination used to cost £850, but we sell it direct to you for £599.

HW 19 Jr Available in Black Oak, Light Oak, or Piano Black lacquer at extra cost.



VPI HW 16-5 Record cleaning machine £399

The HW16-5 has been the benchmark record cleaner since its introduction. Stereophile's Analogue accessory of the year for more years than I can remember, the 16-5 is much more than a luxury - it is essential to protect your valuable investment in vinyl. It also opens huge vistas of gloriously cheap second hand records!

Nobody with a serious interest in vinyl record replay can afford to be without one.

We stock a full compliment of spares and accessories, as well as the professional grade HW 17F, intended for archival and serious audiophile use.

Vinyl Demand import and distribute a huge range of audiophile vinyl as well as analogue replay system and accessories from VPI, Rockport Technologies and Audioplar

Please phone for further information and catalogue of Records (VOL1) and Analogue Equipment and Accessories (VOL2)

★★★★★ What Hi-Fi July 1997

VINYL DEMAND PO Box 1532 Fordingbridge SP6 15B Tel 01425 654545 Fax 01425 65440

"Music is more than a bunch of sine waves"

ORCHID

PRECISION AUDIO

It was in 1822 when Jean Baptiste Joseph Baron De Fourier invented the Fourier transform, the powerful and elegant mathematics which can describe a complex signal such as music in terms of a collection of simple sine waves, and in so doing laid the foundations for the way we now measure the fidelity of a hi-fi component in terms of its 'frequency response'.

But there was always more to the Baron's theory than that, there is the phase response, the forgotten part. And leaving out the phase response provides just half a description. Perhaps nowhere more so than with loudspeakers.

THE PHASE LINKED LOUDSPEAKER
23 Hz - 24 Khz, 117 dB SPL peak, 300W



ORCHID PRECISION AUDIO - THE PHASE LINKED LOUDSPEAKER

So here's the test that nobody shows you, the square wave test. A square wave contains a very rich spectrum of harmonics. If a loudspeaker can reproduce these harmonics without altering either their amplitude or phase, a square wave will be obtained at the microphone. The first photograph is the response of a respected American loudspeaker trying to reproduce a 300 Hz square wave. You could be forgiven for remarking that the output (on the lower trace) looks nothing like the input (on the upper trace). This is phase distortion. If this measurement was of an amplifier, it wouldn't even merit a review.

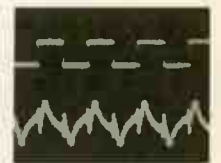

Surprisingly, some manufacturers actually state that loudspeakers are generally incapable of reproducing a square wave, due to all sorts of reasons. We don't feel that way, as the lower photograph shows. With enough care, which we have, this higher level of fidelity can be obtained.

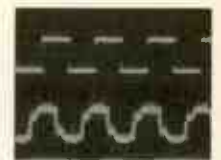

300 Hz TEST PLOTS

But what does it all mean? It means that these loudspeakers reproduce music on a grand scale and preserve all the subtle nuances that contribute to a realistic stereo image, both in width and depth. These loudspeakers are passionate, demanding, and addictive. They fulfil the only criterion left at the high end, that you can just forget about them, be convinced by the music, and not have to work at it. If you would like to know more, write to us at our address below, better yet listen to them at our distributor's and hear real music.

Freq resp: +/- 3dB,
24Hz - 22 Khz
Sensitivity: 90 dB/watt/1M
Impedance: 4 ohms, nom
Min power: 100 watts
Size (inch): 39 x 14 x 15
Price: £5900.00

Dealers:
ZOUCH AUDIO
Ashby De La Zouch, Leics
01530 414128
SOUNDS OF MUSIC
Tunbridge Wells, Kent
01892 547003

AUDIO MASTERS
near Oxford, Oxfordshire
01608 644954
OR CALL US:
01608 684 694

HART

The Home of *Hi-Finesse.*

Hart Audio Kits and factory assembled units use the unique combination of circuit designs by the renowned John Linsley Hood, the very best audiolophile components, and our own engineering expertise, to give you unbeatable performance and unbelievable value for money.

We have always led the field for easy home construction to professional standards, even in the sixties we were using easily assembled printed circuits when Heathkit in America were still using tagboards! Many years of experience and innovation, going back to the early Dinsdale and Bailey classics gives us incomparable design background in the needs of the home constructor. This simply means that building a Hart kit is a real pleasure, resulting in a piece of equipment that not only saves you money but you will be proud to own.

Why not buy the reprints and construction manual for the kit you are interested in to see how easy it is to build your own equipment the HART way. The FULL cost can be credited against your subsequent kit purchase.

'AUDIO DESIGN' 80 WATT POWER AMPLIFIER.



Our John Linsley Hood designed 80 watt Power Amplifier continues to amaze all who listen to it, and it is now finding new friends among speaker manufacturers who use it to show their own products to their best advantage. Its flawless performance is a result of the combination of inspired circuit design and the very best components, specified by the designer. Such innovations as the six rail fully stabilised power supply make great contributions to the overall reproduction quality yet are not found on even the most expensive run-of-the-mill designs in the High St shop window.

We have long known that the delicacy and transparency of sound from this amplifier placed it in the world class and side-by-side comparisons with amplifiers costing five times as much still show small performance advantages, which suggests that even the most expensive amplifiers will only equal rather than exceed, its sound quality. All amplifiers in the range have the same basic quality and the decision about whether to use a preamplifier is governed by the facilities you need. The STANDARD amplifier has switching for up to three inputs, if you need more than this then a preamplifier feeding a SLAVE power amplifier will give you up to seven inputs.

If you would like to hear this incredible amplifier in action then arrange a visit to Wilmslow Audio's new premises at Broughton Astley, near Leicester. Their phone number is 01455 286603, speak to Shaun or Terry.

All amplifiers are available in kit or factory assembled form.

K1100 Complete STANDARD Amplifier Kit	£415.21
A1100 Factory Assembled version	£515.21
K1100S Complete stereo SLAVE Kit	£353.62
A1100S Factory Assembled	£522.22
K1100M MONOBLOC Amplifier Kit	£271.20
A1100M Factory Assembled	£351.20

Super Audiophile (SA) Versions of all the above come with selected audiophile components at an extra cost of only £39.30 per channel. All HART kits are designed for easy home construction to the very highest standards, and can be built by anyone of average manual ability. If you are still not convinced how easy it is to build it yourself with a HART kit you can order the Instruction Manual to read for yourself and we will refund the cost when you buy your kit!

JOHN LINSLEY HOOD 15W SINGLE ENDED CLASS 'A' POWER AMPLIFIER

A design for the experimenter who wants to try and re-create the warmth and purity of sound given by valve amplifiers from the vintage years, without the problems of cost, deterioration and danger associated with trying to use valves today.

It employs the newly re-discovered single-ended circuit configuration to give total freedom from crossover artifacts and to give a sound that is indistinguishable from the famous 'Williamson' design, the undisputed leader of the field, with its triode connected KT66s and all-tin oxide drivers. See our list for full details.

Reprint of Article	£2.50
CM4000 Construction Manual	£5.00

MAINS LEADS & POWER DISTRIBUTION.

All our kits use standard IEC mains leads and these are available for a range of countries. We also stock distribution boxes with IEC sockets to minimise the space needed for power leads. See our lists for details.

"CHIARA" HEADPHONE AMPLIFIER.



Highest quality, purpose designed, 'single ended' class 'A' headphone amplifier for 'stand alone' use or to supplement those many power amplifiers that do not have a headphone facility. Easy installation with special signal link-through feature, the unit uses our 'Andante' Ultra High Quality power supply.

Housed in the neat, black finished, Hart minibox it features the wide frequency response, low-distortion and 'musicality' that one associates with designs from the renowned John Linsley Hood. Volume and balance controls are Alps 'Blue Velvet' components. Very easy to build, or available factory assembled, the kit has very detailed instructions, and comes with Hart audiograde silver solder. A valuable personal listening option and an attractive and harmonious addition to any hi-fi system.

K2100 Complete Standard Kit	£112.50
K2100SA 'Series Audiophile' Kit with selected audiophile components	£115.46
A2100SA 'Series Audiophile', Factory Assembled	£115.46
CM2100 Construction Manual	£2.50

SHUNT FEEDBACK PICKUP PREAMPLIFIER

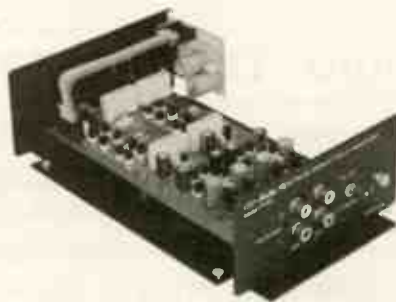

If you want the very best sound out of vinyl discs then you need our high quality preamplifier with Shunt Feedback equalisation. The K1450 also has an advanced front end, specially optimised for low impedance moving coil cartridges as well as moving magnet types. Selected discrete components are used throughout for ultimate sound quality. The combination of John Linsley Hood design, high quality components and an advanced double sided printed circuit board layout make this a product at the leading edge of technology that you will be proud to own. A recent review in "Gramophone" magazine endorsing this view. Bought in kit form our step by step instructions it is very easy and satisfying to assemble, or you can buy a factory assembled version if you wish.

This magnificent kit, comes complete with all parts ready to assemble inside the fully finished 228 x 134 x 63mm case. Comes with full, easy to follow, instructions as well as the Hart Guide to PCB Construction, we even throw in enough Hart Audiograde Silver Solder to construct your kit!

K1450 Complete Kit	£116.58
K1450SA Audiophile Kit	£138.94
A1450SA Factory assembled Audiophile unit	£188.94

"Andante" Linear Technology AUDIOPHILE POWER SUPPLIES



The HART "Andante" series power supplies are specially designed for exacting audio use requiring absolute minimum noise, low hum field and total freedom from mechanical noise.

Utilising linear technology throughout for smoothness and musicality makes it the perfect partner for the above units, or any equipment requiring fully stabilised $\pm 15v$ supplies.

There are two versions, K3550 has 2 $\pm 15v$ supplies and a single 15v for relays etc. K3565 is identical in appearance and has one $\pm 15v$. Both are in cases to match our 'Chiara' Headphone Amplifier and our K1450 'Shunt Feedback' Pickup preamp.	
K3550 Full Supply with all outputs	£94.75
K3565 Power Supply for K1450 or K2100	£84.42
A3550 Factory Assembled Full Supply	£147.25

ALPS "Blue Velvet" PRECISION AUDIO CONTROLS



Now you can throw out those noisy ill-matched carbon pots and replace with the famous Hart exclusive ALPS 'Blue Velvet' range components only used selectively in the very top flight of World class amplifiers. The improvement in track accuracy and matching really is incredible giving better tonal balance between channels and rock solid image stability. Motorised versions have 5v DC motor.

MANUAL POTENTIOMETERS

2-Gang 100K Lin	£15.67
2-Gang 10K, 50K or 100K Log	£16.40
2-Gang 10K Special Balance, zero crosstalk & zero centre loss	£17.48

MOTORISED POTENTIOMETERS

2-Gang 20K Log Volume Control	£26.20
2-Gang 10K RD Special Balance, zero crosstalk and less than 10% loss in centre position	£26.98

ALPS PRECISION SWITCHES.

At long last, switches to match the quality of our Alps pots. These switches not only solve the quality gap but also have features facilitating their use in real audio applications. The "Flex" version having a panel mounting control coupled to a rear mountable switch unit by a 190mm Flex Link. Also available is a motor driven option which, like the pots, can also be operated with its control knob.

HC5520. 4P 4W. Manual Control	£16.73
HC519. 4P 6W Manual	£17.95
HC5545. 8P 5W Flex Switch	£21.60
HC5560. 4P 6W Motorised	£29.80

SOLDERING

The size of modern components makes the right soldering equipment essential for good results. Everything we offer we actually use in our own workshops! See our Lists for the full range.

845-820 XS240 ANTEX 240v 25w Soldering Iron. This is the ideal Multi-purpose iron as the bit is designed to totally surround the element giving the best heat transfer. This excellent design also means that although it is small and handy enough for modern components its heating capacity is better than larger irons of conventional construction. Excellent Value.	£12.43
845-080 ST4 Lightweight Soldering Iron Stand. This has provision for the classic damp sponge for bit wiping.	£3.95

HART SUPER AUDIOGRADE SILVER SOLDER.

Hart Super Audiograde Silver Solder has been specially formulated for the serious audiophile. Not only does it give beautiful easy-to-make joints but it is designed to melt at normal soldering temperatures avoiding the possibility of thermal damage to components or the need for special high temperature irons. A very low residue flux makes perfect joints easy but eliminates the need for board cleaning after assembly.

845-007 3mtrs 22SWG in Hart Mini Tube	£3.90
845-008 100g. Reel Special Valve Grade, 20swg	£12.90
845-009 100g. Precision PCB Grade, 22swg	£14.75
845-110 100g Reel Superfine 24swg for ultra precise control and easy working	£21.45

PRINTED CIRCUIT BOARD SOLDERING PRACTICE KIT.

Unsure whether you can construct a HART kit?, this is your chance to try! Your HART Printed Circuit Board Soldering Practice Kit comes with a range of modern components, a typical Hart quality PCB, a roll of the correct grade of solder and full instructions. It enables the enthusiast who is uncertain of his, or indeed her, ability to put together and solder a printed circuit to try their hand at minimum cost. The instructions explain the right technique and guide even an absolute beginner through the seemingly daunting, but in fact very simple, art of making a good soldered joint. Excellent value for money at only

Super Version with Hart Silver Solder	£6.95
---------------------------------------	-------

LINSLEY-HOOD 400 SERIES SUPER HIGH QUALITY FM TUNER.

This ultra high quality analogue tuner system is the ideal companion to the 80W Audio Design Amplifier in any ultimate hi fi setup, with case size, front plate layout and even control pitches unified for stacking. Like the 80W Audio Design Amplifier this is your route to ultimate performance at incredibly modest cost! Novel circuit features include ready built pre-aligned front end, phase locked loop demodulator with a response down to DC and advanced sample and hold stereo decoder together making a tuner which sounds better than the best of the high-priced exotica but, thanks to HART engineering, remains very easy to build and set up. Since all components are selected by the designer to give the very best sound this tuner is not cheap, but in terms of its sheer sound quality it is incredible value for money.

K400 Complete Kit.	£256.82
RLH8 Reprints of 3 articles covering the FM tuner.	£3.70
CM400 Construction Manual	£4.95

Send for Your FREE copy of our LISTS

All Prices include UK/EC VAT.

Its not what you do, its HOW you do it that counts!

ASM100 ACTIVE SUBWOOFER MODULE



This attractive module consists of a low pass filter and power amplifier ready for you to mount in a suitable sub-woofer cabinet. The combined unit can then be combined with any new or existing hi fi or home cinema speaker system to add in the real bass punch missing from most setups.

The ASM 100 module comes as a ready-to-mount unit on a solid diecast aluminium frame/heat-sink. Input signal can be at line or speaker level for easy system integration. There are three separate stereo inputs at line level and the unit will use any signal presented or mix all inputs to add bass to any signal. The speaker level inputs are used by simply wiring the unit in parallel with the existing speakers to provide them with strong bass support. Crossover frequency can be selected to 50, 100 or 200Hz and the bass level can be adjusted by a front panel control. The 'Green' power supply switches the unit to standby if no signal is present. Drawings are included free for the compact 418 x 380 x 303mm cabinet.

With its powerful 125 watt output and versatile filtering the ASM 100 is the ideal universal active driver module for all subwoofer requirements.

ASM 100 Module, complete with IEC mains lead, instructions and ASM - W20 cabinet drawings. Pt. No. V7000 **£185.29**
 W 200 S 20cm Long Throw Drive unit for use in ASM - W20 cabinet **£36.68**

VISATON HI TOWER SPEAKER KIT



A speaker kit from the VISATON range that really fits the modern idiom, giving a full uncoloured, and highly defined, sound stage combined with unobtrusive elegance that does not look out of place, even in a smaller room. A frequency response from 38-20,000Hz and a power rating of 100W make it easy to drive. The novel arrangement of five high/mid tweeters angled at 45 degrees, creates a really dynamic sound stage with sharply defined sound staging. With its compact 200mm square section it can also be used as ultra high quality main speakers for home cinema applications. The kit includes all drive units, crossovers, terminal blocks and damping materials for you to make a stereo pair of speakers.

LK5961 Kit **£392.42**

EXPERIENCE V20



A real heavyweight performer with a total of no less than five drive units in each cabinet. Together these produce a satisfyingly smooth and wide frequency response. The single tweeter is a special 25mm high-end unit with a double coated fabric dome and ferrofluid for cooling and damping. There are two 13cm mid-range speakers and two 20cm long throw woofers for extended bass.

Nominal Power Rating	180W
Max. Music Power	300W
Impedance	4Ω
Freq. Response	29 - 30,000Hz
Crossover Frequency	450Hz, 3KHz
Mean Sound Pressure	88dB
Box Volume	100Ltr. & 7Ltr.
Size/Height	1,300mm
Width	300mm
Depth	360mm

LK5965 Per Pair **£538.70**

ASM - T20 SUBWOOFER

An easy to build, but very effective, bass reflex cabinet design using the ASM 100 Active Sub-woofer Module and the W200S, high compliance, 8" driver, with its 20mm maximum cone displacement. Easy to incorporate into a modern living environment the size of the cabinet has been kept as small as possible at 418 mm high, 303 mm wide, and 380 mm long. To aid its ease of positioning in the room both the drive unit and the vent are situated on the front of the cabinet. Despite these compact dimensions, and with a volume of only 31Ltrs, the ASM T20 gives up to 106dB with an acoustical cut-off frequency of 25 Hz. The cabinet is made from 19mm MDF, and needs about 8 sq.ft.

W200S 20cm. Long Throw Drive unit. Part No. 9030 **£36.68**



COUPLED CAVITY SUBWOOFER.

An alternative design by David Purton, from his little "Coupled Cavity Handbook", using the same drive unit but requiring a bit more woodwork skill as the speaker is set on a baffle in the middle of the box. The total box size is even smaller than the ASM T20 at only 418 mm high, 303 mm wide, and 344 mm long. Construction Drawing. **£1.50**

SPEAKER DESIGN SOFTWARE

All programs are for IBM or compatible computers.

VISATON SPEAKER PRO 6. Software (PC) for cabinet and crossover design and calculation with full extendable data bank of drive unit parameters with performance curves acquired in tests in VISATON's own anechoic chamber. This is the essential tool that turns you into a speaker designer. Full Version (3") **£45.51**

BASSBOX 5.0 for WINDOWS. Harris Technologies.

This program aids the design of bass enclosures by allowing you to model how a speaker will sound in a variety of boxes and then modelling the maximum loudness of the speaker/box combination. It then helps to calculate the dimensions of the box and port, if vented. Needs Windows 3.1+, DOS 5.0+, 386 or better, 4MB RAM and 44MB hard disk space. With easy-to-use printed manual. Shipping Wt. 450g SOF-BAS **£87.50**

BASS HORN DESIGN. A.L.Senson.

This program, patterned after Brian Smith's tractrix horn design program, calculates dimensions for a catenoid, exponential or hyperbolic bass horn and prints out in less than a minute. Provides mouth and throat areas, back chamber volume, and dimensions to design your enclosure. SOF-HOR **£17.95**

X'OVER 2.0 for WINDOWS. Harris Technologies.

This package helps in the design of two and three way passive dividing networks as well as load compensating circuits and calculates values for first, second, third and fourth order networks. Same computer requirements as above but only needs 1.5MB disk space. SOF-XOV **£27.90**

"QUICK & EASY TRANSMISSION LINE LOUDSPEAKER DESIGN"

Larry D. Sharp. Explanatory booklet plus computer disk that requires Lotus 123, or equivalent spreadsheet software on your machine. 1993. 22pp. 215 x 280. Spiralbound. SOF-QET **£8.95**

REPLACEMENT CASSETTE HEADS.



The excellent performance of modern cassette recorders depends totally on the quality of the R/P head. Even the slightest amount of wear can impair the frequency response and distortion levels. Our HC80 is a top quality head from one of the foremost manufacturers in Japan.

It is easily fitted to most standard stereo recorders (except Sony) and will transform the performance over a worn head. The fact that we buy these in vast quantities enables us to offer them at the amazing price.

HC80 R/P Head, Std Mtg **£11.70**
 Special Offer. 2 for **£17.60**

HRP373 Downstream monitor combi head.

SPECIAL OFFER HALF PRICE **£29.50**
 HQ551A 4-Track R/P **£14.60**
 HQ551S Sony Mount 4-Tr. R/P **£14.90**

REEL TO REEL HEAD 999R 2/4 R/P 110mH **£16.84**

PRECISION DIGITAL Triple Purpose TEST CASSETTE TC1D.

Are you sure your tape recorder is set up to give its best? Our latest triple purpose test cassette checks tape speed, head azimuth and VU level without test equipment. Ideal for machine testing or when fitting new heads. A professional quality, digitally mastered test tape at a price anyone can afford.

TC1D Test Cassette. Our price only. **£9.99.**

CD3 "Stereophile" TEST CD. 27 Tracks for testing loudspeakers and rooms. CDSTPH3 **£8.75**

PROFESSIONAL PHONO AUDIO LEADS



Super High Quality stereo phono to phono audio lead featuring gold plated screened phono plugs with split outer contact shell ensuring positive connection to phono sockets. Plugs have red and black polarity bands. Sky blue multi-strand oxygen free copper cables with independent braided screens give minimum signal loss and crosstalk with maximum musicality at a sensible price. Directional arrows indicate preferred signal direction.

An excellent high quality lead ideal for interconnection between professional audio equipment or for use in high end domestic hi-fi systems. 4ft long **£14.98**

MAKE YOUR OWN AUDIO INTERCONNECTS.

Using our High Quality Audiophile Grade double screened signal cable. Linear crystal oxygen free copper with outside diameter to match our T711G Teflon insulated plugs.

T780-911 Audiophile Signal Cable. Per metre **£3.98**
 T711G Plugs, Red or Black ring **£3.25**
 T711G 10 or more, mixed OK **£2.75**

T780-803 Speaker Cable. 322 x 0.1 OFC. Mtr. **£5.42**
 T780-804 Speaker Cable. 511 x 0.1 OFC. Mtr. **£8.90**

TECHNICAL BOOKSHELF

Bigger Range of Books. Better Prices. No "28 Day" Wait!

New Titles.

"A BEGINNER'S GUIDE TO TUBE AUDIO DESIGN" Bruce Rozenblit. A practical book that does exactly what its title says and takes a modern look at valve amplifier construction. 132pp. ISBN 1-88280-13-3. **£18.20**

"HIGH PERFORMANCE LOUDSPEAKERS" Edn.5. Martin Colloms. Latest edition, just out. A really in-depth coverage of the whole World of speakers and high quality sound reproduction, but entirely readable in style. Just reviewed in "HiFi World". 478pp. ISBN 0-4719-7089-1 **£24.95***

NORMAL STOCK RANGE

"AUDIO ELECTRONICS" John Linsley Hood. **£18.99***

"THE ART OF LINEAR ELECTRONICS." John Linsley Hood **£16.95***

"THE ART OF ELECTRONICS" Horowitz & Hill **£35.00***

"DIGITAL AUDIO AND COMPACT DISC TECHNOLOGY" 3rd.Edn. 0-240 51397 5 **£19.95***

"INTRODUCING DIGITAL AUDIO CD, DAT AND SAMPLING" ISBN 1870776 22 8 **£7.95**

"ACTIVE FILTER COOKBOOK" Don Lancaster **£19.95**

"THE ART OF SOLDERING" 0-85935-324-3 0 **£3.95**

"HOW TO USE OSCILLOSCOPES & OTHER TEST EQUIPMENT" R.A.Penfold. BP267 **£3.50**

"LOUDSPEAKERS; THE WHY AND HOW OF GOOD REPRODUCTION." G.Briggs. 1949. **£8.95**

"THE LS. DESIGN COOKBOOK" Vance Dickason. (5th Edn.) **£22.95**

"ELECTROSTATIC LOUDSPEAKER DESIGN AND CONSTRUCTION" Ronald Wagner BKT6 **£15.95**

"THE ELECTROSTATIC LS. DESIGN COOKBOOK" R. P.Sanders **£24.95***

"BULLOCK ON BOXES" Bullock & White. **£8.99**

"AN INTRODUCTION TO LOUDSPEAKERS & ENCLOSURE DESIGN" V. Capel. BP256 **£3.95**

"LOUDSPEAKERS FOR MUSICIANS" BP297 **£3.95**

"THEORY & DESIGN OF LS. ENCLOSURES" J.E.Benson. **£21.95**

"THE COUPLED CAVITY HANDBOOK" David Purton. **£4.90**

"VISATON. HOME HI FI CATALOGUE." Specifications and Thiele Small Data on all Drive Units **£4.50**

"VISATON. CAR HI FI CATALOGUE." In car guide **£3.50**

"VISATON. CABINET PROPOSALS" Book 1. In GERMAN **£6.50**

"VISATON. CABINET PROPOSALS" Book 2. In GERMAN **£6.50**

"VALVE AMPLIFIERS" Morgan Jones. 1995/6 **£24.50**

"THE VTL BOOK" David Manley 1994. BkVT1. **£17.95**

"MULLARD TUBE CIRCUITS FOR AUDIO AMPLIFIERS" BKAA27. **£11.95**

"THE WILLIAMSON AMPLIFIER" 0-9624-1918-4 **£6.95**

"AN APPROACH TO AUDIO FREQUENCY AMPLIFIER DESIGN" GEC 1957. **£13.95**

"AUDIO ANTHOLOGIES", articles from Audio Engineering. Six volumes covering the days when audio was young and valves were king! BKAA3/1 to 6. Price Each All **£12.95**

"THE RADIOTRON DESIGNERS HANDBOOK" (CD) **£49.00**

"PRINCIPLES OF ELECTRON TUBES" H.D.Reich PH.D **£25.95**

"POWER AMP PROJECTS" Anthology. 1970-1989 **£15.50**

"WORLD TUBE DIRECTORY" 1996-7 Sourcebook **£5.95**

Don't forget, No waiting at HARTI. All listed books are normally in stock! Postage, unless started, only £2 per book, maximum £4.50 for any number, any size! Starred items are heavy books costing £3.50 to send.

Postage for kits and other items is £2 for orders up to £20, orders over £20, post £4.50, Courier £10. We accept all major credit and debit cards, including Switch Diners and Amex.

DEMONSTRATIONS

The ASM 100 and our 80W Power Amplifier Range can be heard at Wilmslow Audio's new premises at Broughton Astley near Leicester. Tel 01455 286603



HARTI ELECTRONIC KITS LTD.
 2 Penylan Mill, OSWESTRY, Shrops. SY10 9AF, UK

24 Hr. ORDERLINE 01691 652894 Fax. 01691 662864

GAMMA ACOUSTICS

GAMMA ACOUSTICS have created a range of products utilising avant-garde technology, but still adhering to traditional principles, despite inevitable change. Creating a balanced interaction between components and design.

We have produced a range of loudspeakers second to none, with one major difference **AFFORDABILITY.**

There is always a price to pay for high performance but using components manufactured for us to our exact standard and bought in vast quantity, gives the customer an uncompromising product at the right price...

EPOCH REFERENCE FIVE LOUDSPEAKER

All enclosures are constructed from 24mm solid M.D.F. Very extensive cross bracing at minimum intervals to give tremendous rigidity. All cabinets are damped with deflex panels to minimise any box colouration and resonance. All drive units are time aligned on a sloping baffle for an excellent phase response, the use of poly-glass cross bonded with two layers of kevlar produces a sandwich of great structural strength yet only two thirds the mass of comparable units. This gives the design overall the sensitivity required for use with ultra-high quality linear single-ended amplifiers, yet the control of other well damped equivalents without the gross drop in sensitivity and impedance fluctuations.

Tel: 01753 526939
Fax: 01753 532262



EPOCH REFERENCE 5 LOUDSPEAKERS

This makes the Epoch at home in the most demanding of applications and yet suitable with even modest equipment. All this from a very conservative sized enclosure offering truly unbelievable control as yet unattainable from small cabinets. Dynamic range, Natural timber, timing agility, transparency and a total lack of colouration are all presented. They are finished in piano-black lacquer, Wild Cherry and Oak. With an unimposing appearance allows the Reference Five to fit into any domestic environment.

SPECIFICATION

CROSSOVER
1% polypropylene capacitors
air-cored inductors
encapsulated in silicone
99.99% silver litz internal
cable used throughout

IMPEDANCE
8 ohms nominal
heavy-duty gold-plated
scorpion binding posts
4mm bi-wire/bi-amp facility

HIGH FREQUENCY
1in polykevlar dome inverted

BASE MIDRANGE
8in polykevlar unit

SENSITIVITY
90db for 1 watt 1 metre

SIZE
H 945mm W 265mm
D 355mm

BASE ALIGNMENT
bass reflex optimum damped

POWER HANDLING
100 Watt r.m.s.

RECOMMENDED PLACEMENT
working range: 200mm—1 m
optimum depending on
room acoustics & ancillary
equipment

PRICE £2999.00

CLEARANCE LIST

	RRP	XD	S/M		RRP	XD	S/M
EAR 859 integrated as new mint	£2250		£750	GEMINI line integrated S. Ended			
Soundlab Dynastat loudspeakers - mint	£4750		£1800	BARGAIN Last one!	£699		£350
Muse Serris II one seven fives mono power				RHYTHM 211/VT4C phono Ex-Demo Marked	£2499		£999
Balance amplifiers mint go well with the	£3999		£1700	RHYTHM LINE Ex review/as new	£2499		£1750
above spk.				AEON MK1 MONOBLOCKS 20Watt S.E. Si			
Transparent Audio Musicwave plus cable 8ft				construction Ex-review new marked	£4999		£2999
speaker pair 1 x 15ft interconnect 1 x 5ft	£1000		£250	Era Std. phono mm preamp New marked new	£999		£399
interconnect.approx				SPACE REFERENCE MKII ex hi-fi show display as new BARGAIN	£7999		£5499
Voyd bl s.p.u. £1870 SME4 Siltech wired £1000 Audionote I.O				Stunning sound/looks			
cartridge £1495 Audioinnovations £1000 M.C.T £349				SPACE 300B	£1999		£999
BARGAIN! All above mint as new £2400				Epoch loudspeakers Ex-demo	£1499		£750
Audionote an2 2 x 5m bi wire spk cable	£380		£190	EPOCH REFERENCE FIVE Ex Ramada			
Base 4 tier iso platform/rack as new mint	£560		£280	display as new!	£2999		£1999
Base 2 tier iso platform/rack as new mint	£300		£180				
Mana sounds table	£300		£180				

Ivy Lodge, 81 Sussex Place, Slough, Royal Berkshire, SL1 1NN, England.



MEASURED PERFORMANCE

LOUDSPEAKERS

JPW MILLENNIUM 510

JPW obviously consider flat response an important criterion; our analysis shows an impressive result in which the ML 510 stays within 1dB limits from 20kHz down to 125Hz, below which output rolls off slowly and smoothly. Lacking any bass peak, the ML 510 is quite well damped and may well sound reticent in its bass delivery unless placed close to a rear wall. My experience is that most people subjectively prefer the emphasis on 'rhythm' that a little peaking produces; see Tannoy and Mission also.

The JPW's impedance curve gyrates in level from 4ohms to 14ohms through the audio band, measuring 6.3ohms overall. Although reactive and not the easiest load, the 'speaker is sensitive at 88dB, so it does not need to be driven hard. About 50watts should be enough for most situations.

This is a well engineered 'speaker, but it will highlight amplifier differences, so audition first. **NK**

Impedance

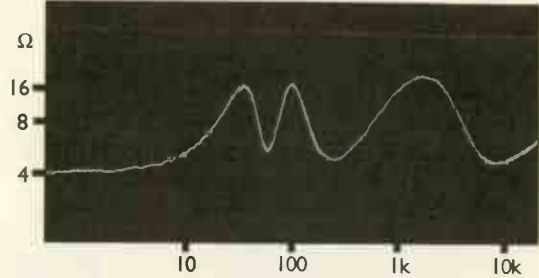

Frequency response

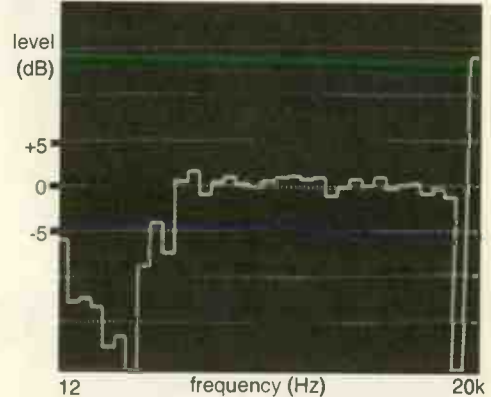

MISSION 731 Pro

With the 731 Pro Mission have adopted our preferred response pattern of a slow downward tilt toward high frequencies. This gives a full-bodied sound, but not one short of detail or clear treble.

Drive unit integration was excellent over a wide frontal angle. Some bass peaking around 150Hz is evident, an effect that will improve bass speed and presence. With healthy output down to 60Hz the little Pro can also deliver wallop, but a rear wall may be needed to make the most of this.

The Missions swing from 4ohms to 30ohms, displaying an overall impedance of 6.3ohms. They will need a bit of driving, producing just 86.5dB SPL from one nominal watt (2.84V), so a powerful amplifier of 60watts or more is best.

As long as a good amplifier is used the small Pros should give a good account of themselves. **NK**

Impedance

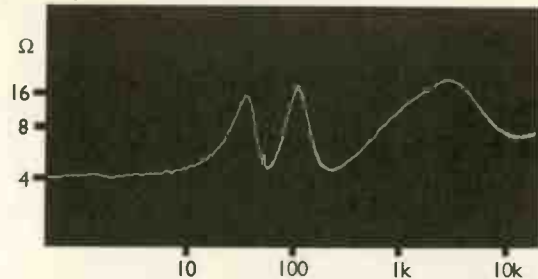

Frequency response

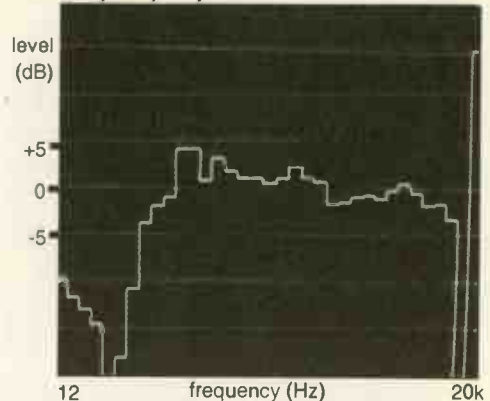

DIY SPEAKER BUILDERS HEAVEN

VISATON speaker kits give unrivalled quality & performance are suitable for enthusiasts of any experience. Home building is a great way to cut the cost of a new speaker system, without losing quality or performance. From the traditional all round speaker, to the top class high-eng systems, home building will allow you to choose your desired finish, so tailoring your new speakers to suit your individual requirements.



All kits are supplied with simple instructions & cabinet dimensions. No soldering is required for the "Alto" series as the crossovers come ready wired & fixed to gold plated connection terminals. The more advanced kits do require some soldering & more advanced woodworking skills.

Cabinets are available either as flat packs or pre-built needing only finishing.

UP-DATED
Catalogue / Price lists
now available !

Supplying.... **DRIVER UNITS**



R.C.L.



ACCESSORIES
In stock

ACCESSORIES
In stock

Port-tubes, grills, spikes, terminals, wadding, crossover boards, binding posts, banana plugs, MKT capacitors, air-cored inductors, resistors, DEFLEX acoustic sheets & cables.

Newly available :

Visaton Ribbon Tweeter

This high-end transducer is capable of very high power handling with maximum efficiency and a linear frequency response and offers excellent value for money.

Help with your own Ideas

At *South Coast Speakers* we want to help you realise your own ideas. We offer a full after-sales service to help with any construction problems & general queries. We can also cater for specific needs with custom projects.

Design Services

1) **Crossover Design :**

Given the parameters of the units that you wish to use we can then supply a Theoretical or Computerised Crossover design, optimising the performance of the desired units

2) **Cabinet Design :**

In order to achieve optimum performance from the bass driver the cabinet must be the correct volume for that driver. Given the parameters of the unit we will supply cabinet dimensions together with port tube length & diameter (if required).

3) **Full Test Service :**

We can fully test your loudspeaker with regard to frequency response, phase and impedance. We can also test driver units & supply you with the Thiele/Small parameters.

Listening Room

At *South Coast Speakers* we have a comfortable listening area modded on the average family living room, giving you, the customer, a realistic idea of how your kit speaker will sound when you have completed construction & plug them in at home. There are 10 kits on demonstration (± 2 from time to time).

Above all we are here to help you. We offer informed & friendly advice so please ask!

SOUTH COAST SPEAKERS LTD.

326, Portswood Rd. Southampton Hampshire SO17 2DT

Tel / Fax : 01703 - 559312

TANNOY MERCURY M2

Much like the Mission 731 Pro, the Tannoy m2 displays a smooth frequency response over a wide frontal angle, indicative of good driver integration. It also has a smooth response with a downward trend toward high frequencies, an absence of crossover suckout ensuring good detailing. A bass peak at 150Hz will emphasise upper bass and make the bass sound speedy. The steady fall in lower bass output suggests strong damping and the probability that a position a foot or two in front of a rear wall may help.

Overall impedance was high at 10ohms, limiting power draw. As a result the m2s were insensitive, giving just 85.5dB SPL for one nominal watt (2.84V) of input, so they will need a powerful amplifier of around 60watts for voltage swing, low current-draw making the most of any driving amplifier. The m2s will be easy on amplifiers as a result.

Tannoy's m2s were well engineered all round, but they will need a powerful amplifier to go loud, even though the power will not be drawn. **NK**

Impedance

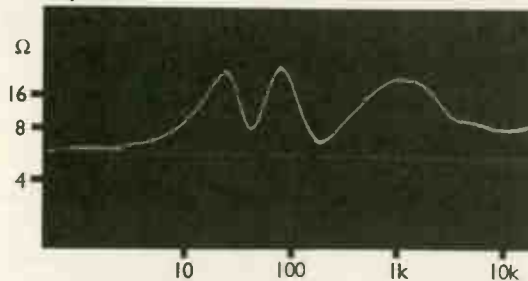

Frequency response

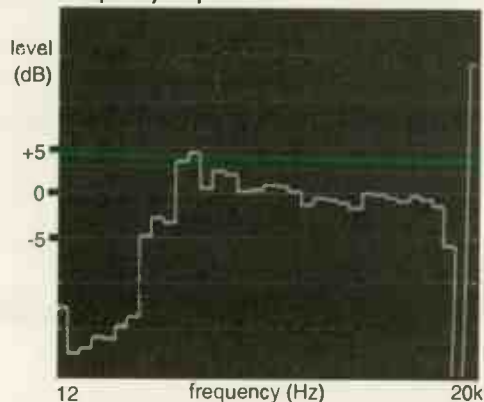

ELTAX LIBERTY 3+

Dominating the Liberty 3+'s response trace are bass and treble peaks, both larger in amplitude than usual. This is a somewhat antiquated 'boom 'n' ting' approach to loudspeaker engineering that will emphasise 'speed' and 'timing' by hardening up wavefronts, albeit artificially.

Drive unit integration was mediocre, a suckout at the crossover frequency (3kHz) appearing above the tweeter axis during measurement. Our analysis shows the integrated forward response, lessening the visual impact of this phenomenon. The treble peak is extreme and will produce an obviously bright sound, likely to square badly with innately bright recordings. Careful auditioning is recommended.

The impedance curve swung massively from a very low 3.6ohms at DC and 200Hz, up to a high 30ohms at 1kHz. There was plenty of reactance in the load and a lot of current-draw at low frequencies, so the Liberty 3+'s need a beefy amplifier and will highlight amplifier differences. Overall impedance measured 5.7ohms and sensitivity a good 87.5dB, so they will go loud easily.

The engineering of these loudspeakers is not especially impressive. **NK**

Impedance

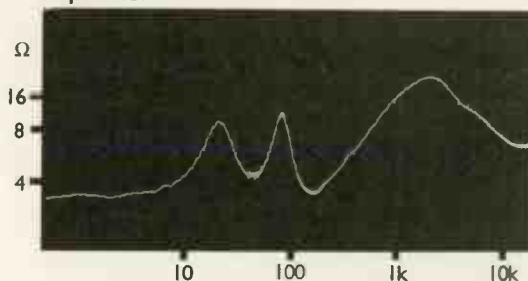

Frequency response

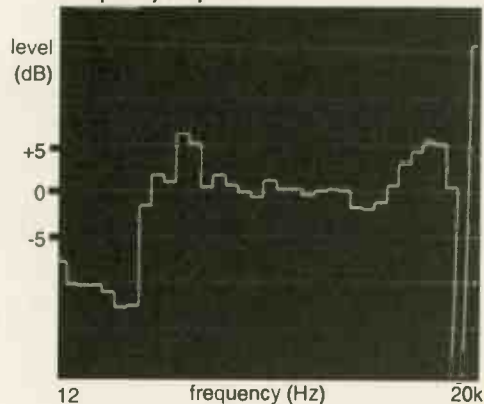

Oxford Audio Consultants HI-FI SPECIALISTS

Our superb service is the same, regardless of price.

NOW DEMONSTRATING

KRELL KPS25 CD PLAYER - THE NEW REFERENCE - MUST BE HEARD
KRELL KAV 3001 INTEGRATED AMPLIFIER!! - now joined by the 300CD/250P
PREAMP AND 250A POWER AMP - incredible value for money -
just ask for a dem

AUDIO RESEARCH - WATCH THIS SPACE - A HOST OF NEW PRODUCTS
FROM THIS DYNAMIC COMPANY

SONUS FABER ELECTA AMATOR 2 - a startling improvement on a classic design
PROAC RESPONSE FIVES - just out and very special
THETA PEARL TRANSPORT & MILES CD PLAYER - SUPERB VALUE FOR
MONEY

STOP PRESS: NEW PRODUCTS FROM PINK TRIANGLE INCL LITAUERAL CD
PLAYER & TARANTELLA TURNTABLE

CABLES & ACCESSORIES from TRANSPARENT, SILTECH, CABLE TALK,
SHAKTI, GMAUDIO, SHUN MOOK, HARMONIX, SOUNDSTYLE, TARGET,
KRELL FBP600 - we now have this awesome powerhouse on permanent
demonstration

AUDIO ANALOGUE PUCCINI/DONIZETTI/BELLINI AMPLIFIERS - staggering
build quality and unrivalled sound

GM AUDIO EQUIPMENT TABLES - THE ELITE - NOW EVEN BETTER
VALUE

WILSON AUDIO CUBS - an astonishing new baby from this top class company !!

MARTIN LOGAN SL3 - still very very good value for money
COPLAND CD266 CD PLAYER - a budget priced cd player from this hugely
impressive company

UNISON RESEARCH SMART 845 MONO BLOCKS - ITALIAN design at its best
with sound to match the looks

MUSICAL FIDELITY X SERIES - a whole range of products incl dacs, phono
stage, headphone amp, preamp, monoblock power amps - AVAILABLE ON SALE

OR RETURN OF COURSE

NEW MINI SYSTEMS FROM TEAC,

DENON AND PIONEER - the ideal Christmas

presents

EX DEM & P/EX BARGAINS

AUDIO RESEARCH V160	£1395	XD
AUDIO RES RCH LS7	£1295	XD
ABOVE COMBINATION (WAS £4000)	£25	XD
AUDIO RESEARCH D200 POWER AMPLIFIER	£1500	SH
EPOS ES11 BIWIRED INC STANDS	£ 325	SH
COPLAND CSA14 AMPLIFIER	£ 895	SH
COPALND CD288 CD PLAYER	£1395	XD
COPLAND CTA501 AMPLIFIER	£1295	SH
APOGEE DIVAS/SUBWOOFERS/KRELL KOVER	£3495	SH
MERIDIAN 208 CD PLAYER	£ 595	SH
MAGNEPLANAR 2.5R SPEAKERS MINT	£ 895	
EXPOSURE XI / XII / SUPER 8	£ 895	SH
KRELL KST100 POWER AMPLIFIER	£1250	SH
KRELL KSL PREAMP WITH PHONO STAGE	£1250	SH
KRELL MDA300 MONOBLOCK POWER AMPS	£3495	SH
PINK TRIANGLE CARDINAL TRANSPORT	£ 500	NEW
PINK TRIANGLE DC POWER SUPPLY FOR DACAPO	£ 750	XD
MICROMEGA 2.1 CD TR-NSPORT	£ 995	SH
MUSICAL FIDELITY A1000	£ 950	XD
MUSICAL E SERIES AMP/CD/TUNER	P.O.A.	
OXFORD CRYSTAL REFERENCE T/TABLE MAHOGANY	£ 995	SH
REGA ELA SPEAKERS	£ 195	SH
ORELLE DA 188 DAC	£ 250	SH
PROAC RESPONSE 2 INCL TARGET 'R' STANDS	£1750	
NAIM 32.5 PREAMP MM BOARDS	£ 195	SH
SPENDOR SP7 SPEAKERS CHERRY	£1495	XD
SD ACOUSTICS SD3 SPEAKERS	£ 175	SH
MICROMEGA STAGE ONE	£ 250	SH
B & W THX SPEAKER SYSTEM EX DEM	£2750	
RCFPROJECTOR WIDESCREEN EXDEM	£3995	XD
AUDIO RESEARCH VTM 120 SE PRIVATE SALE	£3750	
AUDIO SYNTHESIS PASSION	£ 850	
CYRUS 1 AMPLIFIER	£ 125	SH
AUDIO RESEARCH L55 MK 1	£1495	XD
B & W SILVER SIGNATURES INC STANDS	£2750	XD
TUBE TECHNOLOGY UNISYS AMPLIFIER	£ 995	XD
AUDIO RESEARCH L52B MK 2	£1995	XD

0% INTEREST FREE CREDIT

Licensed Credit Broker

Agencies include: Air Tangent, Audiogram, Audio Research, Audio Technica, Auris, B&W, Bose, Cable
Talk, Castle, Denon, Exposé, Harman, JBL, J. B. Labs, Klipsch, J. B. Labs, Koetsu, Krell, Lyras,
Marantz, Martin Logan, Michell, Micromega, Monitor, Musical Fidelity, NAD, Onkyo, Orelle, Orford, Pink
Triangle, Pioneer, Proac, Project, QED, QUAD, REL Subwoofers, Tagers, Rotel, Ruark,
Sennheiser, SME, Sonus Faber, Spendor, Stax, Target, T.D.L., TEAC, Theta, Thorens, Transparent
Cables, Unison Research, van den Hul, Wilson.

TAX-FREE EXPORT SERVICE
MAIL-ORDER AVAILABLE ON MANY ITEMS

Open Mon-Sat 10am-6pm

Oxford Audio Consultants

Oxford Audio Consultants, Cantay House, Park End Street Oxford OX1 1JE
Telephone: Oxford (01865) 790879 Facsimile: Oxford (01865) 791665
E-MAIL: Oxford.Audio@btinternet.com

R.J.F.

HIGH END
AUDIO FOR
DISPOSAL AT
GIVE-AWAY
PRICES!

AUDIO VISUAL

84 PENDARVES STREET, TUCKINGMILL, CAMBORNE
CORNWALL TR14 8NJ 01209 710777

New, Used and X-dem

Acos Lustre arm	£ 90.00	U
Arcam Alpha Plus CD	£249.00	U
Arcam Delta 290 integ. amp	£450.00	U
Arcam Delta 290P power amp	£299.00	U
Audiomeca Kreatura CD transport	£550.00	U
Beyerdynamic DT511 phones	£ 85.00	N
BEL 1001 power amps (pair)	£750.00	U
Exposure XII/XIII pre/power amps	£425.00	U
Grado SR60 phones	£ 60.00	N
Heybrook TT2/Linn Basik LVX	£200.00	U
Kinshaw Overture DAC	£199.00	U
Kinshaw Perception mono-blocks	£999.00	U
Micromega Leader	£249.00	U
Micromega Minium CD	£249.00	N
Micromega Minium system	£750.00	N
Micromega Drive 1/DAC 1	£750.00	N
Proac Studio 100 speakers	£400.00	U
QED Vector Reference Pre-amp	£269.00	N
QED Digit Plus DAC	£150.00	N
Revox B710 II cassette, exceptional cond.	£450.00	U
Revox B780 receiver, exceptional cond.	£750.00	U
Rotel RB971/RC995 pre/power amps	£650.00	N
Rotel RC960 pre amp	£120.00	U
Rotel RT935AX tuner	£130.00	N
Roxan ROK-DA1 DAC	£150.00	U
Sanyo Plus N55 noise reduction system	£300.00	U
Thorens TD126/Alphason/ADC	£450.00	U

AKG, Audio Technica, Bandridge, Beyer Dynamic, Bose, Cerwin Vega, Denon,
Electrocompaniet, goldring, Harman, Impulse, JBL, JB Labs, Klipsch, Musical Technology,
QED, Quad, Rel Acoustics, Rotel, SME, Sugden, TDL, Teac, Thorens, Yamaha, others
please enquire.

Also consult us for your high (or low) end repairs / mods, CD re-clocking, Laser disc AC3
upgrade + more. Valve specialists.
NOW FITTING BORDER PATROL PSU

Now in production: DEMON CABLES, outstanding performance, simply
designed to work, NO FRILLS or BULL. For medium to high end systems.
Money back guarantee. Dealers required.

DEMON SA BASIC	£99.00/m	£79.00/ 1/2m
DEMON SA1	£149.00/m	£129.00/ 1/2m
DEMON SA2	£199.00/m	£179.00/ 1/2m



PROGRESSIVE AUDIO

VISA

Mid-Season Sale of Ex-Dem and Secondhand Equipment

Analysis Epsilon Ribbon Loudspeakers	(£3750)	Sale	£2600
Audio Alchemy DAC 1.2	(£595)	Sale	£375
Chord Electronics LS512A Loudspeakers (Ebony)	(£1679)	Sale	£1200
Parasound P/LD 2000 Preamp	(£1495)	Sale	£1095
VPI HPW 19 MkIII Piano Black Turntable	(£1800)	Sale	£1150
Alon Petit Loudspeakers (walnut)	(£1087)	Sale	£795
Alon 1 Loudspeakers (oak)	(£1616)	Sale	£1200
Chord 800 Power Amp	(£2155)	Sale	£1600
Michell Argo HR Pre-Amp	(£1339)	Sale	£1050
Audio Alchemy Headphone Amp	(£249)	Sale	£199
Beyer 531 Headphones	(£120)	Sale	£85
Stax SR-84 Electret Headphones	(£259)	Sale	£195
Questar QA2 Active Speakers/Stands/ 3M Kimer 4TC	£300	the lot	
4M Set Nordost Red Dawn Speaker Cables (Terminated)	(£929)	Sale	£750
Audio Silver Knight 300B Mono Blocks	(£2495)	Sale	£1750
Roksan Xerxes (Piano Black) Tonearm	S/H		£1200
Audionote Meishu (phono m/m) amplifier	(s/h)		£2250
XTC Pre 1 pre amp - 3 weeks old	(s/h)		£800
Trichord Pulsar 1 DAC	(s/h)		£825
Meridian 200 CD transport	(s/h)		£400
Proac Studio 100 loudspeakers (cherry) 3 weeks old			£550
Technics SE-A1000 and SU-C1000 pre/power combo			£450
SD Acoustics SD3 loudspeakers	(ex dem)		£350
SD Acoustics Alexandra stands for above	(new)		£220
Foundation Designer '600' stands 21 inches tall			£210

New in this month and on permanent dem:-
Audio Synthesis Dax Decade and Desire Decade Tube
Technology CD player.

Call For More Details Or Dem Of New Equipment
(List Available)

All items mint/boxed, Guaranteed as new
(unless S/Hand)

Telephone Medway (Kent) 01634 - 389004 anytime

MORDAUNT-SHORT MS10i

The tweeter of both MS10is was out of phase with the bass/mid unit. We reversed the tweeter connections and the situation improved greatly, although not above the tweeter axis. Using the 'speaker upside down to put the tweeter below the bass/mid, Mission-style, gave the best on-axis integration. Mordaunt-Short could well improve driver integration even with the tweeter connected correctly.

Response was not especially flat, steadily falling bass output suggesting an over-damped arrangement. This gives good downward bass extension, but should be used with wall mounting to avoid a bass-light sound. Our analysis shows results as delivered and (at bottom) results with tweeter in-phase and 'speaker upside down.

The impedance curve was fairly gentle over most of the audio band, hitting a minimum of 5ohms. An overall value of 7ohms was delivered, sensitivity measuring a reasonable 86.5dB sound pressure level from one watt.

Obviously, Mordaunt-Short could usefully spend a little more time developing these 'speakers. **NK**

Impedance

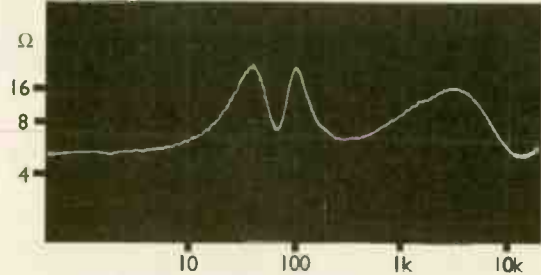

Frequency response

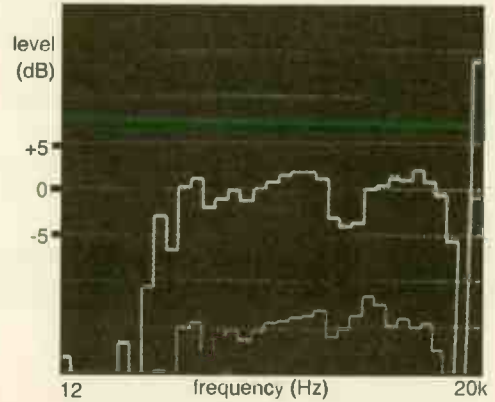

ROKSAN OJAN 3

Although the Ojan 3 displays a flat overall response trend, it suffers a few suckouts and looks ragged as a result. The large cabinet runs flat down to 60Hz and should give weighty bass. Some slight softening of projection and detail is likely from the suckouts, but since these were less below axis, hard-floored rooms may well lessen the effect. The Ojan 3 is basically accurate in its balance though.

A very high impedance of 11.4ohms overall results in a poor sensitivity of 85dB SPL from one nominal watt (2.84V), meaning the Ojan 3s need a powerful amplifier of 60watts or more to go loud. This apart, they are an easy load and will make the most of any amplifier they are partnered with.

Although bettered in measurement by some of the budget 'speakers in our group test, the Ojan 3s measured respectably well. **NK**

Impedance

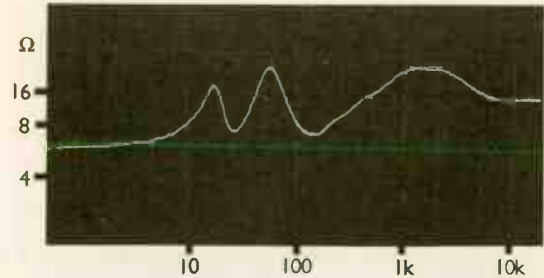

Frequency response

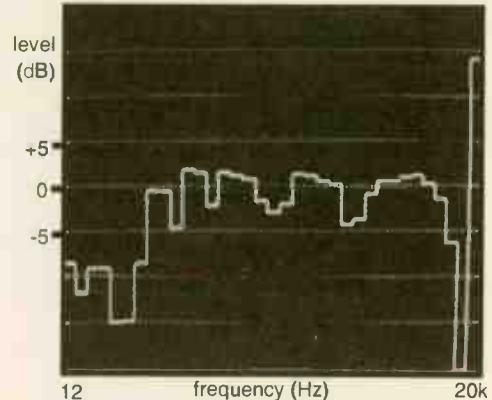

WANTED

HI-FI & accessories

FOR CASH OR EXCHANGE

any make, any age

NOTHING LEGAL REFUSED!

(Official ID with address & signature required from sellers)

MUSIC & VIDEO EXCHANGE

64 Notting Hill Gate, London W11
☎ 0171 792 3474

480 Fulham Rd (Broadway), London SW6
☎ 0171 385 5350

95 Berwick St, Soho, London W1
☎ 0171 434 2939

MVE, Manchester Arndale Centre (near High St entrance) ☎ 0161 839 0677

OPEN 7 DAYS

LARGE SELECTION ON SALE

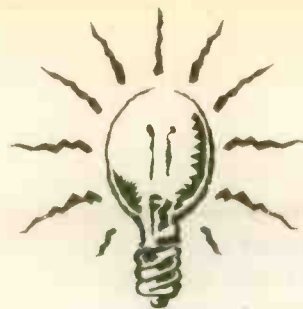

Your guiding light in the hi-fi world

Arcam - Audiolab - Castle - Chario - Denon - Epos
KPF - Linn Hi-Fi - Linn AV51 - Linn Knect
Loewe Televisions - Micromega - Mordaunt Short
Musical Technology - Naim - Primare
Projekt Furniture - QED Systemline - Rega - Rotel

Cymbiosis

Audio & Visual Solutions

6 Hotel Street - Leicester - LE1 5AW
Telephone 0116 262 3754 - Facsimile 0116 262 3758
Opening hours: Mon-Sat 10am-5pm - Sun 11am-4pm

ZeroFeedBack

Audio Consultants
Lincolnshire

01472 883722

- AUTHORISED AGENCIES -
KLIPSCH - TRIANGLE - AUDION - ARION -
SILVER SOUNDS - AUDIOMECA
NOTTINGHAM ANALOGUE

The only way to audition expensive Hi-Fi equipment is in the comfort of your own home. This is precisely what we specialise in, high quality audio in your own home. If your requirements are for vinyl, valves or high efficiency speakers then phone us for a home demonstration. No video, no satellite just pure music.

Hi-Fi with Passion

Business Hours 5pm to 10pm

Talk to Shaun on the above number

Liberty Audiosuite v 2.2

the PC based DOS and WINDOWS audio measurement and analysis system for loudspeaker and electronic circuit development and test

Now includes support for the **Turtle Beach 20 bit Multisound Fiji professional audio DSP soundcard**. (external mic/probe preamp not required with Turtle Beach card)
*** Distortion levels to below 0.003% can now be measured ***

- **HIGHEST CAPABILITY**
MLS, SINEWAVE, PINK and WHITE NOISE
THIRD and SIXTH OCTAVE REAL TIME ANALYSER
DISTORTION ANALYSER, and VISUALISER
THIELE SMALL PARAMETERS, and much more
- **STRAIGHTFORWARD OPERATION**
using the built-in EASY SCRIPTS
- **DOWN-TO-EARTH PRICE**
Obtain the complete system with Software and manual, Probes, Turtle Beach Fiji soundcard, Calibrated mic and cables for **£696.00** excl VAT

for FREE DEMO DISK, contact

Tony Seaford
MARTON MUSIC
phone/fax 01282-773198
e-mail 106505.251@compuserve.com

Full details available on <http://www.libinst.com>

also demonstrated at IPL Acoustics, Westbury, Wilts 01373-823333
Horsham Hi-Fi, Horsham, W Sussex 01403-251587
other locations--please call me

CD PLAYER

PHILIPS CDR 870 COMPACT DISC RECORDER

The measured performance of the CDR 870 is determined by the analogue to digital convertor between input and disc, and the digital to analogue convertor between disc and output. Of the two, the ADC is the more difficult and expensive technology.

I checked to see whether the disc altered the performance of the convertors, assessed in record/pause mode, and found that - surprisingly - it did. The distortion spectrum changed very slightly. Otherwise, Philips' CDR 870 returned the sort of performance typical of CD, with a bit more distortion at peak level - 0.18% against a common value of 0.003% - and also more down through the available dynamic range.

However, although distortion levels were approximately double normal down to -80dB or so, below this the system became more linear, perhaps because of the dithering effect of noise from the input circuits and ADC. Whatever, the CDR 870 still turned in a pretty respectable result in absolute terms and it's interesting to see that at normal music levels (-30dB) our spectrum analysis clearly shows a useful absence of high-order harmonics. That almost puts the

CDR 870 on par with a good valve amp!

Frequency response was flat, although there is just a small emphasis on the midband our analysis reveals. This will push vocals forward just a tad, whilst ensuring bass stays in check and treble doesn't rip.

Out-of-band spurious were barely in evidence and there was little sign of the 22.05kHz motor speed control signal.

Whilst the output meets Philips' standard of 2V maximum (0dB) input sensitivity was 700mV - quite high. Most cassette decks manage 200mV. Don't expect to hook up a Troughline (30mV output) direct. Noise was a little higher than usual but still very low at -93dB. The CDR 870 measured extremely well, showing no major weaknesses or peculiarities. Philips have a good grip on their technologies and the CDR 870

reflects this fact. It's very well engineered.

NK

Frequency response	4Hz-21kHz	
Distortion (%)	left	right
-6dB	0.176	0.184
-30dB	0.04	0.04
-60dB	0.8	0.82
-90dB	30	32
-90dB dithered	2	3
Separation (dB)	left	right
1kHz	98	99
20kHz	91	90
Noise	-93dB	
Output	2V	

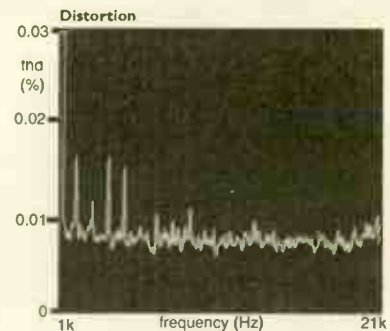
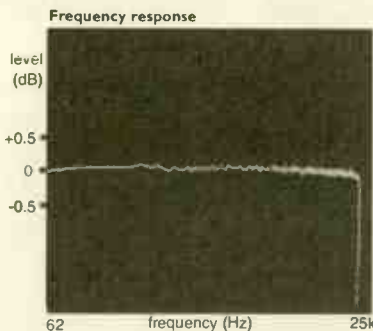

AMPLIFIER

MUSICAL FIDELITY X-PRE AND X-A50

Although small Musical Fidelity's X-A50 turns out plenty of power, producing 55watts into 8ohms and no less than 90watts into 4ohms. That's more than enough to make a modern sensitive loudspeaker go loud.

Frequency response extended from a low 8Hz up to 56kHz, giving good coverage of the audio band, plenty of downward extension promoting good bass. Noise was low at -101dB but this was mainly because sensitivity was low as well at 325mV. Most amplifiers nowadays have 200mV sensitivities, in order to match older tuners and cassette decks that would turn out just 300mV maximum.

Output DC offset measured a low

4mV, which was encouraging. Distortion was minimal at low levels, even at high frequencies - a good sign. A wide spread of harmonics appeared at high output levels but their overall level remained in check, total harmonic distortion measuring a respectable 0.017% in the midband and 0.025% at high frequencies. There may be just the slightest edginess if the amp is pushed hard. Otherwise, the X-A50 and X-Pre are well engineered and will give a smoother sound than competitors with rising high frequency distortion, something this design usefully lacks. **NK**

Power	55watts
CD/tuner/aux.	
Frequency response	8Hz-56kHz

Separation	90dB
Noise	-101dB
Distortion	0.004%
Sensitivity	325mV
DC offset	4mV

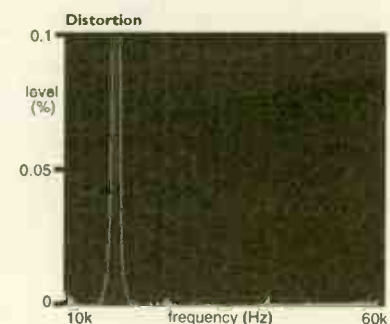

TEL: 01428-651554

P.G. Hi-Fi

FAX: 01428-654592

Buying & Selling Vintage HiFi, Valves, Classical LP Records & Spare Parts.

Quad

- QUAD ESL 57 Electrostatic speakers (pair) £200
- AM2 £30 to £70
- FM1 £10
- QCII £40
- QUAD 33 PRE-AMP in original box £50
- QUAD II amplifiers (pair) no valves dusty and a little rusty £160

Leak

- TL12+ (Pair) £300
- Stereo 20 £250
- TL12.1 (Pair) £1500
- Tuners £40 to £70
- Troughline 3 mono £20
- TL25+ (single) Black £200
- Troughline (very early) LW/MW/SW £60

Decca FFSS

- Cartridge £70 to £100
- S.M.E. 3009 Prototype £100

- Garrard 301 (mint) £250
- Garrard 401 (no mat) £30
- Thorens TD 125 in original box £50

Valves (G.E.C. Mullard etc.)

- KT66, ECC81/2/3, 6SN7GT + Many Others.
- Please Phone For Details.

Most Models Of Leak Mono + Stereo Pre-Amps In Stock.

Spare Parts For Quad + Leak Transformers etc

Vintage Classical LP's Bought and Sold Decca - SXL Columbia - SAX HMV - ASD RCA - SB + LSC + Furtwangler / De Vito Martzy Etc Please Phone or Fax wanted list

Speakers

- Wharfedale W3 (Single) £20
- Tannoy 3LZ (Pair) £250
- Wharfedale W15FS D/Unit (Single) £20
- Wharfedale W15RS D/Unit (Single) £15
- Ferranti M1 Plus D/Unit (1930's) £25
- Lowther TP1 (single) dark oak, original PM3 £550
- Lowther corner acoustas (pair) original PM6 1 drive unit open circuit £400
- Lowther acoustas (pair) rosewood PM6C drivers £300
- Decca deccola corner speakers (Pair) £350

Microphones: various, please phone for details

Wanted

Tannoy Speakers - Lancaster, York, G.R.F. and Autograph.

HICAM

GOOD QUALITY PRE OWNED EQUIPMENT BOUGHT SOLD PX

Amps

	£
Audiolabs 8000 c/p	900
Sony 540e Int.	150
Naim Nap 250	900
Quad 33/303	200
Mark Levinson 28/29	3,700
Pioneer A400	100
Yamaha 401 R.C.	80
Pioneer V.S.P. 200	125
Yamaha DSP 1000	500
Naim 180 Power Amp	750
Naim 135 Mono block	1500
Naim Nac 62 Old Style	250

Turntables

	£
Linn Axis/Akito/K9	250
Rega Planer 2	85

Speaker Stands

	£
Atacama 24	35
Target	35

Tuners

	£
Audfolab 8000 T	500
Sony 730 ES	100
Nad 402	80

Tape Decks

	£
Yamaha K390	80
Denon DRM 10X	80
Denon 800	80
Sony ES 700	100

CD s

	£
Technics 770A	125
Arcam Alpha 5+	225
Proceed T/Dac	2,500

Speakers

	£
Heybrook HB1	150
Kef 100 C/S	175
Kef Celeste	40
Mission 751 Blk	175
Infinity C/S	50
Revolver Purdey Teak	60
JBL Control 1	65
Naim SBL Blk	750
NAD 801 Blk	50
Rega Kytes Blk	125
Roger LS2/2A Blk	150
Linn Keild R/W	550
Apogee Stages	1500
Castle Winchester	850

Mon-Sun 10am - 8pm VISA Switch - Mastercard For further details Phone/FAX 01844 260182 Mobile: 0973 233380

affordable audio

A selection of our ever changing offers for sale (all fully guaranteed)

Equivalent New Price

Sale Price

A selection of our ever changing offers for sale (all fully guaranteed)

Equivalent New Price

Sale Price

A selection of our ever changing offers for sale (all fully guaranteed)

Equivalent New Price

Sale Price

AMPLIFIERS

- Ariston amplifier Int. (I.C.) s/h - 99.95
- Meridian MCA Int. MC phono stage (vgc) s/h - 149.95
- 2 x spare line modules for above (vgc) s/h each 40.00
- Quad 86 pre-amp with remote control station (vgc) s/h 863.00
- Naim NAC 42/WAP 110 pre/power (vgc) s/h - 369.00
- Legend P300 2x200 watts Mosfet power amp (scruffy but mega powerful) s/h - 179.95
- Beard VMI 70 hybrid valve/mosfet Int. s/h 1200.00
- 2 x 70 watts solid mahogany case work (vgc) s/h 350.00
- Microomega Minium Int (mint) s/h 3200.00
- Audio Research D24011 2x240 watts into 4k2 (mint) s/h 140.00
- Arwa 2003 2x40 watt Int. (mint/phonon) s/h 400.00
- Marantz PM 55 2x60 watt Int. (g.c.) s/h 230.00
- Incaseth Claymore Mosfet Int. (mint) s/h - 189.95
- Rega BR10 Int. (mint) s/h 2000.00+
- Quad 405 I power amp (g.c.) s/h - 119.95
- DNH 3A/Primus power supply (MC phono) (mint) s/h 450.00
- A.R. 'The Amplifier' Int. (vgc) s/h 229.95
- Moth Passive Pre/Phono Stage/Power Supply (VGL) s/h - 79.95
- Nytech CTP102 Pre Amp (VGL) s/h - 149.95

TURNTABLES

- Thorens TD 160 BII/SME 3009 F/H Axc Xim MM Cart (vgc) s/h - 159.95
- Thorens TD 166/Arm/A.T. MM (black) (vgc) s/h 430.00
- Thorens TD 320/Arm/Arcam C77 cart. (black) (vgc) s/h 280.00
- Thorens TD 280 IV/Arm/Linn CS cart. (black)(mint) s/h - 149.00
- Walker CS 55/Rega RB250/YMS 2 cart. (g.c.) s/h - 199.95
- Systemdek IIX/ADC ACT/Oriolon MM (vgc) s/h - 299.95
- Systemdek IIX/HELOS Scorpio/Silicon MP-10 cart. (acrylic platter version) (black) (vgc) s/h - 329.95
- Systemdek IIX 900/Rega RB300/Rega Elys MM Cart. (light ash finish) s/h - 169.95
- Origin Live/Syraux PUZ/AT MC Cart. (g.c.) s/h 220.00
- Dual CS 505/Oriolon cart. (vgc) s/h 450.00
- Logic Tempodatum II Arm/Oriolon M20 F.L. Cart. (VGC) s/h - 40.00
- ADC ALT Arm (VGC) s/h 200.00+
- Audio Technica AT 32E moving coil Cartridge (very few hours) (mint) s/h 99.95

LOUDSPEAKERS

- Heybrook HB 1 (Walnut) (vgc) s/h 280.00
- Heybrook HB 51 (stands for above) (mint) s/h - 49.95
- Tannoy 611 inc. ceramic bases/dual concentric drivers (mint/as new) s/h 500.00
- Castie Warwick (black) (mint) s/h 210.00
- Mordants Short M335TH (black) (vgc) to clear s/h - 99.95
- Mordants Short M325TH (black) (scruffy) s/h - 79.95
- Jano Corner 70 (black) (g.c.) s/h 330.00
- Jamo Classic 6 floorstanders (rosewood) (mint) s/h 360.00
- Allison CD7 floorstanders (black) (vgc) s/h 380.00

- Alison (R.A. Labs) Ref 4A (new) (ex.dem) - 170.00
- Leak 200 (original mini Sandwich) (g.c.) s/h - 49.95
- Rogers LS 35A (BBC monitors) inc. stands (g.c.) s/h 699.00
- Tannoy Oxford (walnut) (vgc) s/h - 149.95
- Tannoy Mercury M20 (walnut) (I.C.) s/h - 99.95
- Castle Richmond (walnut) (I.C.) s/h - 59.95
- Quad ESL 57 (Electrostatic) (suspect bass panels) s/h - offers
- Treble panels good (suitable for spares/restoration) s/h 200.00
- Revolver Purdy (black) (vgc) s/h 130.00
- Mission 731 bookshelf (mint) s/h 325.00
- Gale 301 II bi-wire (mint) s/h 300.00
- TDL ATL 2 (black) (g.c.) s/h - 99.95
- A.R. 28 (walnut) (I.C.) s/h 450.00
- EPOSII Monitors in Cherry (mint) s/h 269.95

PRODUCT OF THE MONTH

Infinity Modulus Mini Monitor Loudspeakers In Sexy Piano Black
 Features Emit Ribbon Tweeters (Superb Mid-Band Transparency)
 Bi-Wireable/200 Watts Handling
 In Mint Condition With Dedicated Stands
 Normal Package R.R.P. Yours For
 £1000.00 **£499.95**

CASSETTE DECKS/REEL TO REEL

- Xenmod 5030 3 motor/HX Pro (vgc) s/h 170.00
- Denon DRM 550 (mint) s/h 160.00
- Rotel RD 865/2 2 motor/HX Pro (vgc) s/h - 129.95
- Sony TCR 511 Dolby S etc (mint) s/h 250.00
- Arwa AD WX 717 two motor/8/C/high speed dub. (vgc) s/h 220.00
- Polliester CFW503R twin/auto reverse etc (vgc) s/h 200.00
- Denon DRM 700/3 heads etc (vgc) s/h 250.00

COMPACT DISC PLAYERS

- Philips CD 160 (vgc) s/h - 69.95
- Technics SLP8 remote (g.c.) (old) s/h 479.00
- Arwa X300 Bistream remote (mint) s/h 150.00
- Pioneer PDS 505 'Precision' remote (mint/as new) purchased 16/5/97 s/h 460.00
- Technics SL P5740 remote (mint) s/h 250.00
- Arcam Alpha 5 remote (mint) s/h 450.00
- Philips CD 732 Bistream remote (mint) s/h 140.00
- Denon DCD 1700 remote (massive build) (g.c.) s/h 400.00
- Quad CD 66 remote (vgc) s/h 544.00
- Denon DCD 1700 remote (massive build) (g.c.) s/h 399.00
- Pioneer PD 103 (vgc) s/h - 109.95
- Monarchy DIP Jitter Buster (vgc) s/h 250.00

	£
Musical Fidelity X-DAC (HCD compatible) (mint-as-new) s/h	300.00
NAD 901 pre/processor Dolby Pro-Logic remote (mint) s/h	400.00
Quad PH2 valve tuner FM (mint) s/h	-
Quods sand fill stands (good 'uns) (vgc) s/h	-
Technics ST G 70L digital tuner (good tuner) (vgc) s/h	-
Technics ST G460 digital tuner (vgc) s/h	-
Mission Cyrus tuner (vgc) s/h	-
Quad FM4 tuner (mint) s/h	424.00
Target AER 3 TV equipment table (new) s/h	184.00
Target B5 equipment table (piano black) x2 (new) s/h	203.00
Target LB 5 equipment table (plum) (new) s/h	155.00
Other equipment tables/LS stands in stock s/h	(Please Phone)
Panasonic SL S 159 Disman portable (mint) s/h	89.95
Linn K400 bi-wire cable (some left) hurry! (as new) s/h	10.00 metre
Linn Interconnects (few left) (as new) pair s/h	47.00 stereo
Nytech Active systems: AMP/Active X-over/ARC 101 Speakers (G.C.) s/h	-

WE CURRENTLY HAVE CUSTOMERS LOOKING FOR THE FOLLOWING EQUIPMENT.....IF YOU CAN HELP PLEASE RING

- Original Pink or P.T. II any finish with decent arm
- Ittok or Zeta or Alphonson arms
- Arcam Delta 250 transport
- Quad FM4/Naim Flat Cap
- Quad 44 Pre/405 II (phonon only)
- Late Spec Naim Hi-Cap
- Quad 66 CD
- Beard CA 35 pre-amp
- Cyrus PSX (black or grey)
- Linn Ekos Mk1 or 2
- Pioneer SA-800/SA-9900
- SME 3009 F/M (must be mint)
- Arcam Delta 280 tuner
- Quad 606 II amp
- Epos ES22 (in light cherry)
- Quad ESL 57 (in black and mint)
- Meridian 506 (20 bit only)
- Lesson Tuner (1st chance - but you never know Alan!)

***** GOOD HI-FI SEPARATES WANTED *****

Don't forget we can offer mail order. All major credit cards accepted. Phone anytime with your wants, stock changing daily. All equipment is sold with warranties. We welcome part-exchange on any of the above. Affordable Audio is always keen to buy, (or part-exchange) Good quality Hi-Fi separates in good condition. Especially top British manufacturers products!

Merry Xmas and a happy and prosperous New Year to all our customers, friends and colleagues. From Paul & Paul R

We can also sell your equipment for you on a commission basis. (Lowest rates/best return) (Please phone Paul for details!)

M MIDLAND A AUDIO X EXCHANGE

Suppliers & Installers of High Quality Audio Systems

Roksan - Rega - Michell - D.P.A. - ProAc
Audio Note - Densen- UKD- Orelle - Myriad -
Implulse - Ruark- Mark Levinson

181 Franche Road
KIDDERMINSTER

WORCS
DY11 5AD
Telephone: 01562 822236
Mobile: 0421 605966

Midland Audio Exchange are currently demonstrating the following superb CD players.

Rega Planet CDD player	£ 423.00inc remote
Orelle CD 100e CD player	£ 649.00
Roksan Caspian CD player	£ 895.00
DPA Renaissance CD player	£ 925.00
Monrio Privilege CD player	£ 895.00
Audio Note CD 2 player	£ 999.00
Roksan Attesa CD player	£1595.00
Roksan Attesa 3 box	£2439.00
Mark Levinson No. 39 (now only)	£4999.00

With new CD players from Electrocompaniet and Densen due in shortly, 1998 has got off to a fine beginning.

Also, we have the finest choice in up and coming integrated amplifiers.

Audio Analogue Puccini SE	£ 595.00
Densen Beat 100	£ 650.00
Roksan Caspian	£ 695.00
Orelle SA100	£ 449.00
Audio Note Oto Se (phono)	£1500.00
Electrocompaniet EC1-2	£ 995.00
Densen DM10	£1375.00

If digital is not your bag then choose from our fine selection of Analogue Turntables/Tonearms/Cartridges.

Rega Planar 2 / RB 250
Rega Planar 3 / RB 300
Systemdek 2 x 2 / RB 300
Audio Note ATT 1 / RB 300
Roksan Radius / Tabriz
Roksan Xerxes X / Tabriz
Rega Planar 9 / RB 900
Michell Mycro / RB 300
Michell Gyrodeck / RB 300
Michell Orbe / SME / Graham
Roksan TMS / Artemiz
Audio Note ATT 3 / AN1s / ANV

Cartridges at M.A.X.

Ortofon -	All models stocked
Lyra -	Lydian Clavis DaCapo
Transfiguration -	Spirit, Temper
Sumiko -	All models stocked
Grado -	Signature series
Roksan -	All models stocked
Rega -	All models stocked
Goldring -	10 series
Audio Note -	Most of range in stock

We also pride ourselves in keeping a wide range of phono stages in stock, starting with -

Rotel RHQ 970 BX	£139.00
Henley Designs HMC 50	£199.00
Densen DP 02 Drive	£349.00

S/Hand and Ex Demo Clearance Items - January 1998

	WAS	NOW
Arcam Alpha 6 CD player (6 months old)	599	395
Audio Note M1 phono pre-amp	750	495
Audio Research CL 30 VT power amp	2300	995
Audio Research LS7 preamplifier	1599	1195
Audio Technica OC5 (350 hours)	129	70
Audio Technica OC7 (450 hours)	269	95
Deva Audio 250 integrated (new)	400	275
DPA Enlightenment DAC (ex demo)	825	750
EMT TU2 cartridge (450 hours approx)	695	250
Epos ES14 Inc Stands MK1 black	650	295
JBL L1 2 way monitors (inc stands)	749	299
KEF Q 35 loudspeakers (new)	350	279
Kef Q 55 loudspeakers (new)	499	375
Klark Teknik DN 15 pre amplifier	899	199
Klipsch Heresay Spls.	600	325
Linn LP12/litok (black)/OC7	2000	650
Michell Focus One/Mayware Unipivot	N/A	149
Michell Gyrodek/RB300 (3 months old)	950	750
Michell QC Psu (3 months old)	398	320
Mission Cyrus 780 loudspeakers	200	85
Mission Cyrus 781 (inc stands)	465	199
Mission Cyrus One old style	199	75
Musical Fidelity A1 integrated	299	145
Musical Fidelity Tubalog valve dac	499	195
Naim Audio 42.5/110/pre/power	649	325

Rega EOS	£398.00
Roksan Artexerex X	£395.00
Electrocompaniet ECP1	£495.00
Audio Note Moving Coil Transformers	
AN S1	£349.00
AN S2	£449.00

Always a wide range on Loudspeakers to listen to from, ProAc / Impulse / Audio Note / Roksan / Ruark / Rega / Kef / QLN / JM Labs / Diapaisson and Blueprint.

MAGNUM DYNALAB

The most highly regarded FM tuners are now on permanent demonstration at Midland Audio Exchange. More and more people are now listening to radio as an ultimate source, with stations like Classic FM and Jazz FM providing a huge catalogue of new and old recordings, what better than listening to them on a MAGNUM tuner.

Prices start at:

MAGNUM DYNALAB FT-11	£ 550.00
MAGNUM DYNALAB FT-101	£ 825.00
MAGNUM DYNALAB ETUDE	£1250.00
MAGNUM DYNALAB 108 HYBRID	£4500.00

Recommended Vinyl

Eagles	Hell Freezes Over	£17.90
Ricki Lee Jones	Pop Pop 180 gm	£19.95
Monty Alexander	Live at Montreux 180 gm	£19.95
Cassandra Wilson	New Moon Daughter	£19.95
Ben Harper	Will to Live	£15.90
Van Morrison	Moondance 180 gm	£15.90
Fleetwood Mac	Rumours 180 gm	£15.90
Ry Cooder	Paris Texas 180 gm	£15.90
Art Pepper	Rhythm Section 160 gm	£10.95
Jimi Hendrix	R.U. Experienced	£17.95
Jimi Hendrix	Band of Gypsies	£12.95
Janis Ian	Between the Lines	£10.90
EMI	EMI 100 Year 180 gm	
	(all titles stocked)	£14.90
Beck!	Odelay 180 gm	£12.90
David Bowie	Earthling Limited Edition	£14.90
Tom Petty and the Heartbreakers	She's the One	£11.90
Arthur Louis	(featuring Eric Clapton)	
	Knockin' on Heaven's Door	£11.90
Nina Simone	Sings the Blues 180 gm	£19.95
Miles Davis	Tutu 180 gm	£15.90
Santana	Abraxas 180 gm	£21.95
Mobile Fidelity	Titles/200 gm Special Offer	£19.99
Joan Armatrading	Same 180 gm	£19.95
Jimi Hendrix	First Rays of the New Rising Sun 180 gm	£24.95
Jimi Hendrix	Axis Bold as Love 180 gm	£21.95
Oscar Peterson	We Get Requests	£15.90
DCC 180 gm	Series Virgin Vinyl	£21.95
Miles Davis	Kind of Blue Double 180gm	£38.00
Sergio Mendes and Brasil 66	180 gm	£19.95
Sonny Clark	Cool Struttin' Blue Note 180 gm	£19.95
Ike Quebec	Soul Samba Blue Note 180 gm	£19.95

Naim Audio NAP 110	425	179
QLN Cubic 111 speakers	199	89
QLN Cubic 122 speakers	279	149
QLN Split Field Signatures cherry	1500	1199
Rega Planar 2 (6 months old)	196	139
Rega XEL r/wood	1040	740
Rogers E20 A valve integrated	1230	650
Rogers LS33 & S33 subwoofers	678	425
Rogers LS55 speakers	429	225
Gamma Acoustics Aeon 211 monos	4500	1995
Roksan Xerxes RB300 ATOC5/XPS 3	1055	549
Roksan Caspian amplifiers (2nd quality)	695	550
Roksan DS5/DA2 PSU/Converter	1150	695
Roksan L2.5 preamplifier (silver)	1295	599
Roksan Ojan 3 rosewood speakers 2nd	999	649
Roksan S1.5 power amplifier (silver)	1495	950
Roksan Xerxes various models available from	495	to 995
Roksan Xerxes Tabriz OC 5 XPS 3	1098	795
Roksan Xerxes X black ash XPS 3.5	1695	1095
Roksan Xerxes XPS 3 black ash/RB300	850	495
Rotel RC 970 BX pre amp (new)	175	135
Ruark Equinox light ash	1850	1499
Sugden Symetra Class A mono blocks	1550	995
VP1 TNT Mk 2.5 (new parts fitted)	3995	2995

Midland Audio Exchange are looking for good used British & American HI-FI, cash paid call John Roberts 01562 832236

SERIOUS KIT

EX-DEM - P/X BARGAINS

	NOW	NEW	TYPE
ProAc Studio 100's	£450.00	£700.00	E/D
Pro-Ac Response 1's	£600.00	£900.00	S/H
Pro-Ac Tab 50 (Yew)	£600.00	£679.00	E/D
Pro-Ac Studio 150	£850.00	£1,400.00	E/D
Sugden SDA DAC x 2	£450.00	£795.00	S/H
Sugden A21 PWR x 2	£400.00	£600.00	S/H
Sugden AU51 PWR	£1,100.00	£1,450.00	E/D
Sugden AU51 PRE	£750.00	£995.00	E/D
Sugden Symetra M/B	£950.00	£1,500.00	E/D
Sugden A25INT x 2	£100.00	N/A	S/H
Stemfoort Dac + Transport	£2,600.00	£3,400.00	E/D
Audio Note M2 Phono	£750.00	£1,500.00	E/D
Audio Note Conquest - M/B	£3,800.00	£4,500.00	E/D
Audio Note Meishu Phono	£2,700	£3,250.00	E/D
Trichord Pulsar One Dac	£1,000.00	£1,395.00	E/D
Trichord Genesis	£449.00	£549.00	E/D
Trichord Revelation	£650.00	£799.00	E/D
Neat Petite II	£500.00	£795.00	E/D
Neat Mystique	£350.00	£650.00	E/D
Apogee Duetta	£1,250.00	£5,000	S/H
M/Logan CLSII	£2,000.00	£4,500.00	S/H
Monitor Audio Reds	£400.00	N/A	S/H
Systemdek RM1	£900.00	£1,200.00	E/D
Systemdek RM2	£1,600.00	£2,000.00	E/D

SERIOUS KIT

Agents for

Audio Note - Sugden - Pro-Ac - Harbeth - Neat-Trichord - Systemdek - Lyra - Proceed - Target - Stemfoort - SME - Mitchell - Heart - Keswick and more

By Appointment Only

0161 - 793 6742 / Mobile: 0402 - 367843

Colomor (Electronics) Ltd

170 Goldhawk Road, London W12 8HJ Tel: 0181 743 0899 Fax: 0181 749 3934 EMAIL - giacomelli@colomordemon.co.uk

Celebrating 30 Years 1967 - 1997

Over 6 000 Types of Valves In Stock Please Ask For Quote

£ p	£ p	£ p
ECC81 2.50	EL84 Sovtek 2.50	6L6GC Sylvania 17.50
ECC81 (CV455) 5.85	EL84 Mazda 6.00	6L6GT/C 2.95
ECC81 (CV4024) 8.85	EZ80 2.20	6L6WGA Sylvania 14.10
ECC82 2.90	EZ80 Mullard 7.05	6L6WGB 14.10
ECC82 Bnmar 8.50	EZ81 2.85	6SL7GT 2.75
ECC82 Mullard 9.41	EZ81 Mullard 7.05	6SL7GT Bnmar 9.40
ECC82 (CV4003) Bnmar 11.75	GZ33 Mullard 15.30	6SL7GT USA 5.30
ECC82 (CV4003) Mullard 14.70	GZ34 4.05	6SN7GT 4.20
ECC83 Sovtek 3.90	GZ34 Mullard 17.65	6SN7GT Bnmar 9.40
ECC83 Mullard 11.15	KT66 Matched Pair 61.00	6V6 9.45
ECC85 2.70	KT88 20.95	6V6GT 6.00
ECC85 Mullard 4.70	VT4C-GE 141.00	6V6G 7.65
ECC88 Tesla 2.30	5R4GA 7.20	6X4 2.35
ECC88 Siemens 5.80	5R4GY 6.80	6X4WA 3.85
ECC88 Mullard 11.75	5R4GYB 7.65	12BY7 RCA 9.95
E88CC Telefunken 11.75	5R4WGA 7.65	12BY7A GE 9.95
E88CC Mullard 11.75	5R4WGB 8.40	12E1 STC 15.00
E88CC01 11.75	5R4WGY 8.40	12E1 Black Anode 14.00
E88CC01 Mullard 19.90	5U4G 5.80	12E1 Old Shape 14.00
ECH81 1.90	5U4G Bnmar 7.05	13E1 STC UK 90.00
ECH81 Philips 4.10	5U4GB 8.80	85A2 2.60
ECL82 1.80	5Z4GT 4.20	85A2 Mullard 5.80
ECL82 German 5.30	5Z4GT 2.25	807 USA 4.80
EF86 5.10	5Z4G 7.05	6146 16.25
EF86 Mullard 12.95	6B4G Sylvania 34.00	6336A USA 57.55
EL33/CV1438 Mull 15.00	6B4G Shouldered 41.15	6550A 11.20
EL34 Sovtek 7.10	6BH6 3.05	6550A GE 15.00
EL34B 7.20	6FQ7 11.10	6550A Svetlana 28.35
EL34 GE USA 41.15	6L6G (CV1947) 35.25	6550A Svetlana matched pairs 37.60
EL37 Mullard 35.25	6L6G Colomor 7.50	

Also available

Oil filled block capacitors by TTC Dublin
Suf, luf, 2uf, 4uf all at 600V £7.05 ea
8uf 600V: Suf, 1KV; luf, 1KV:
2uf, 800V; 4uf, 1KV £9.40 ea
8uf, 800V £11.75 ea

Oil filled Transformer, Gardeners
Primary 110 - 240V;
Secondary
250-0-250; 180mA 6.3V, 7A, 5V, 3a
£58.75
Primary 110 240 V
Secondary 215V
175A B.R. 6.4V 5.5A £35.00 +Vat
Primary 110 250V Secondary 400-0-400
75mA 6.3V 5A 6.3V 2.5A 6.3V 500mA
6.3V 300mA 4V 500mA £47.00

Primary 110-240V Secondary 225-0-225V
100mA 6.4V 1A £32.25
Primary 115-250 440V
Secondary 640-0-640V
160mA 330-0-330 225mA £58.75
New Mains Isolation Transformers
250V, 50Hz, 1 to 1.3kVA, 13A fused
Class F, 13A Skt & Plug £112.00 ea
240V Transformer, output 0 18.5V
26V, 29V, 35A & 26V, SA £32.25 ea

Oil filled Chokes by Parmeko/Gardeners
2.5H, 220mA; 2.5H, 350mA; 4.5, 150mA
4.5H, 220mA; 4.5H, 280mA; 5H, 110mA
5H, 200mA; 5H, 250mA;
all at £35.25 ea
5H, 400mA £38.78 ea;

7.5H, 250mA £35.25 ea
10H, 75mA £23.50; 10H, 170mA £38.78 ea
20H, 50mA £35.25 ea
10H, 70mA Resin Filled £23.50
10H, 75mA Varnished £11.75
Other types/values in stock. Send sae for list
1µF, 1KV Axial TCC super metal pack, ceramic end plates, oil
Visconol £4.00 ea
Valve Holders
B7G - unskirted £0.31 ea
B7G - skirted £0.65 ea
B9A - unskirted £0.75 ea
B9A - skirted £1.05 ea
B4 - Paxolin £0.60 ea
B5 - Paxolin £0.60 ea
Octals - ceramic, E F Johnson £4.00 ea
Other types also in stock

Valves Wanted - New & Boxed

KT66 - GEC £40.00 each	4212E - STC, UK £150.00 each
KT88 - GEC £60.00 each	PX25 - £100.00 each
EL34 - Mullard £15.00 each	Globe shaped £60.00 each
EL37 - Mullard £12.00 each	PX4 - £3.50 each
DA30 - GEC £80.00 each	Globe shaped £60.00 each
PT15 £10.00 each	ECC83/EF86 £3.50 each
DA100 - GEC £100.00 each	V503 £100.00 each

Telephone or Fax list for offers. Please quote ref HF
P&P - Orders up to £3.00 @ £1.95, £3.00 - £5.00 @ £2.25, £5.00 - £15.00 @ £2.50, £15.00 - £20.00 @ £3.35, Over £20.00 @ £4.55. Over 2 Kg. at cost.

WANTED
Quad II Amps - up to £150.00 each

VAT included in all prices.
Please ring for availability and price.



SOUND-BYTES

High Density Filler for Speakers and Stands

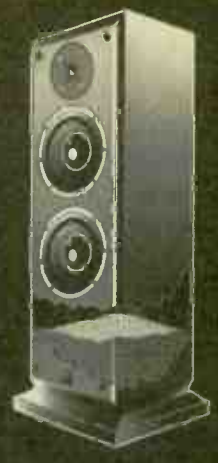

There is no doubt, that for maximum speaker performance, your stands or mass loadable floorstanding speakers must be filled with a suitable mass loading material. Our small diamond shaped steel chips are designed to almost completely eliminate pillar and cabinet resonance that would normally adversely effect speaker performance.

But don't just take our word for it, independent recommendations from the stand and speaker manufacturers listed below speak for themselves as do the glowing reviews from the Hi-Fi press. In addition we have just celebrated a record breaking sales figure of 25 TONNES of material sold throughout the UK over the last 12 months. All these sales and not a single complaint - only letters of thanks from satisfied customers!

FOR MASS LOADING, THERE IS NO SUBSTITUTE!

WHAT THE EXPERTS SAY:

"Not only was the bass tighter and better defined, but midrange became better focused and treble more precise."
 Dominic Baker
 Hi-Fi World

"Listening tests proved conclusively to my mind that SOUND-BYTES are thoroughly effective"
 Jonathan Kettle
 CYBERFi

"It'll improve your unfilled stands, budget or dear"
 Ken Kessler
 Hi-Fi News

RECOMMENDED BY THE FOLLOWING MANUFACTURERS:

APOLLO, ATACAMA AUDIO, B&W, KLH, KUDOS, MISSION, MONITOR AUDIO, PARTINGTON, REVOLVER, RUARK, SOUNDSTYLE, SOUND ORGANISATION, TARGET

AVAILABLE MAIL ORDER FROM

**Colin Mackenzie's
HI-FI-CORNER**

Scotland's No.1
Hi-Fi Company

Tel: 0131 556 7901

ONLY £19.95 + £5.00 P&P

Colin Mackenzie's HI-FI-CORNER

Scotland's No.1
Hi-Fi Company

MAIL ORDER FROM
HI-FI-CORNER SELECT
1 HADDINGTON PL
EDINBURGH
TEL: 0131-556 7901

MORE OUTLETS AT:

52 GORDON STREET
GLASGOW
TEL: 0141-248 2840

121 ROSE STREET
EDINBURGH
TEL: 0131-220 1535

44 COW WYND
FALKIRK
TEL: 01324-629011



PURE
DEAD
BRILLIANT

MISSION 731i
SPEAKERS AT
HALF PRICE!*

*BUY FROM THE OFFICIAL DISTRIBUTOR (see page 4) and use the 2 Year warranty. Offer is for MISSION 731i speakers at HALF PRICE!

- Arcam
- Audiolab
- Audioquest
- Boyer
- Base
- B&W
- Castle
- Celestion
- Denon
- Densen
- Harman
- Keivin Cables
- Kenwood
- Micromega
- Mission
- NAD
- Onkyo
- Panasonic
- REL
- Riark
- Sennheiser
- Sound-Bytes
- Soundstyle
- Tannoy
- Target
- TDL
- Teac
- Technics
- Thorens

THIS GREAT OFFER IS ALSO AVAILABLE
TO SASSENACH'S!

http://www.virtual-publishing/cyberfi/hifishop/



WILMSLOW AUDIO

WATCH THIS SPACE FOR A RADICAL NEW DESIGN!

Wilmslow Audio are known throughout the industry for their high quality self assembly loudspeaker kits, which have been sold for over 30 years to demanding institutions such as Broadcasting companies, Ford Motor Co and the Royal Opera House as well as to the general public. But this is only a small part of their business with the main stay of trading coming from the sales of Drive units and Components to OEMs, Hi-Fi Traders and enthusiastic DIYers. Wilmslow Audio stock a vast range of replacement drive units and are usually able to offer suitable alternatives even if the original manufacturer has long gone out of business. They are the UK stockists for imported drive units from **Dynaudio**, **Morel**, **Peerless** and **Scan-speak** along with British manufactured units from **ATC**, **Coles** and **Volt**. This range of drive units is complimented by an extensive array of high quality components such as **Ansar** polypropylene capacitors, **Volt** air cored inductors, **Puresonic** cables and **Bennic** connectors. All orders for drive units are dispatched via a national carrier and addresses in the UK should receive their goods within 48 hours.



A range of 25 DIY loudspeaker kits from £140 - £3800 on demonstration

- ◆ Crossover design and supply
- ◆ Large range of accessories including Capacitors, Inductors,
 - ◆ Resistors, Binding posts, Grille cloths and foams,
 - ◆ Ports, Spikes, Cable and much, much more.



Wilmslow Audio Ltd
50 Main Street
Boughton Astley
Leicester LE9 6RD

phone for your free catalogue
Tel: 01455 286603
Fax: 01455 286605

INACCESSIBLE ACCESSORIES ~~BY POST~~



cartridges :

denon, goldring, lyra,
ortofon sumiko

***new Lyra Parnassus DC† out now
30% allowance for your old one**

cables :

audioquest, cable talk, chord company,
dnm, heybrook, ixos, kimber, kontak, lfd,
nordost flatline, ortofon, qed, sonic link,
trichord, van den hul, xlo

headphones :

beyer, creek, earmax, grado,
jecklin, sennheiser, stax*

***new stax SR0001 In ear electrostatic
package £279 in stock**



stands :

alphason, apollo, frameworks, heybrook,
sound organisation, something solid,
soundstyle, stands unique, target

accessories :

audioquest, bib, creek,
densen demagic, discwasher,
goldring, ixos, kontak,



THE PISTOL THAT NEUTRALISES STATIC
ZEROSTAT 3

michel, milty, monarchy, moth,
musical fidelity, nordost, pixall, qed,
rms, rata, shure, trichord, *zerostat (it's
back and not just for vinyl!)

**phone, fax or write for
price list / newsletter**

DEALS, DEALS, DEALS

Sequence 300 loudspeakers, black with
Tri-mount stand, (RRP £300) x/d. Brilliant
with a RELI **£225**

Quad II power amplifiers with GEC /
Mullard valves Excellent, with 22 pre-
amplifier, manuals, plug in equalisation
canisters etc. **£675**

Quad 33, 303 + FM3 good condition
boxed **£225**

Audiomeca Damnation CD
transport with Trichord Clock
II & PSU (£1150) s/h
..... **£690**

Michell Argo pre-amplifier
with Hera PSU. S/H (£885)
..... **£495**

Michell Mycro turntable with RB250
arm Perfect, latest spec (£552)
..... x/d **£405**

Michell ISO MC phono stage s/h (£420)
excellent **£225**

Audio Physic Tempo (Mk I) loudspeak-
ers. Black ash X/D perfect (£2000
Tempo II costs £2500) ... x/d **£1475**

EAR 859 integrated SE triode
line level valve amplifier. s/h
(£1800) **£975**

DAX 2 dac. Perfect, boxed
coaxial, AT&T, Toslink + bal-
anced digital inputs
(£2200) **£1695**



hi-fi for grown-ups

DEMONSTRATIONS WITH PLEASURE BUT BY APPOINTMENT PLEASE!

ata audio analogue audiomeca
audio synthesis beyer creek
densen graaf grado harbeth jecklin
lyra michell musical fidelity nva
nordost ortofon qin rogers royd
sequence sugden sumiko teach
thorens trichord unison research
ipswich (01473) 622866
signals martlesham heath
ipswich suffolk IP5 3UA
fax (01473) 631588 email : enq @signals.demon.co.uk
http://www.signals.demon.co.uk

B*****a

"a fine testament to..."

"...breathtaking speed and
transparency at low
frequencies are quite a
prize, and lend the speaker
a superb sense of timing
and the ability to play
bass-heavy material with
delightful agility..."

"...the Virtuoso Gold plays
middle frequencies quite
spectacularly. But in this
case, high and low
frequencies come across
with equal aplomb.
Instead, my attention was
drawn to the fine dynamics
on display..."

"With the finesse of an
electrostatic and the
timing of a Rehdoko, the
B*****a Virtuoso Gold
repays searching out."



-Jason Kennedy, Hi-Fi Choice, June 1997

...horn technology" b

B*****a speakers are designed and manufactured by
Thomas Transducers
White House Hall, Hadlow Road, Tonbridge, Kent TN11 0AJ, UK
T: +44 (0)1732 851408 F: +44 (0)1732 850315

This photo of one of our beautiful pieces
of furniture was taken at midnight and has
not come out too well.
But for a clearer view of our wide range -

the **BEES KNEES**
in storage units for
CDs Videotapes LPs
Books Music Cassettes
Hi-Fis TVs Video Etc Etc

- Send for the Brochure from

Ian Edwards The Old Chapel . 282 Skipton Road
Harrogate . HG1 3HB
Telephone: 01423 500442

MS

Mordaunt Short

<http://www.mordaunt-short.com>

LOUDSPEAKERS



CHELMER VALVE COMPANY

for High Quality Audio Tubes

Everybody in the tube business knows that the justly famous Brand names of yesteryear like BRIMAR, GEC, MULLARD, RCA & TELEFUNKEN Etc. Etc. are scarce and often very expensive.

Although we supply all major brands when available (and have many in stock) our policy is to offer a range of tubes, mostly of current manufacture, the best we can find from factories around the world, which we process specially to suit audio applications. The result - CVC PREMIUM BRAND.

Our special processing includes selection for LOW NOISE, HUM & MICROPHONY and controlled BURN-IN on all power tubes to improve STABILITY and select out tubes with weaknesses Etc.

A selection of CVC PREMIUM Audio Tubes

PRE-AMP TUBES	POWER TUBES	POWER TUBES	SOCKETS ETC.
ECC81 5.00	EL34G 7.50	(continued)	B9A (Chassis or PCB) 1.60
ECC82 5.00	EL34 (TESLA) 8.00	6336A 46.00	B9A (Ch or PCB) G/Plated 3.00
ECC83 5.00	EL34 (Large Dia.) 8.50	6550A 11.00	Octal (Ch. or PCB) 1.80
ECC85 6.00	EL84/6BQ5 4.70	6550WA or WB 13.50	Octal (Ch. or PCB) G/Plated 4.20
ECC88 5.00	EL509/519 13.00	7581A 11.00	4 Pin (For 2A3, 300B etc.) 3.30
ECF82 5.00	E84L/7189A 6.50	807 9.00	4 Pin (For 2A3, 300B etc) 5.00
ECL82 5.00	KT66 9.50	811A 11.00	G/Plated 11.00
ECL86 5.00	KT77 12.00	812A 34.00	4 Pin Jumbo (For 211 etc.) 15.00
EF86 5.50	KT88 (Standard) 12.50	845 30.00	4 Pin Jumbo (For 211 etc.) Gold Plated 3.00
E80F Gold Pin 10.00	KT88 (Gold Special) 21.00		5 Pin (For 807) 4.50
E81CC Gold Pin 6.80	KT88 (Gold Lion Pair) 60.00	RECTIFIER TUBES	7 Pin (For 6C33C-B) 5.00
E82CC Gold Pin 8.00	PL509/519 9.00	EZ80 4.00	9 Pin (For EL, PL509, Ch. or PCB) 2.00
E83CC Gold Pin 7.50	2A3 (4 or 8 Pin) 14.50	EZ81 4.50	Screening Can (For ECC83 etc.) 1.50
E88CC Gold Pin 8.00	211 22.00	GZ32 11.00	Anode Connector (For 807 etc.) 1.70
6EU7 6.00	300B 50.00	GZ33 9.50	Retainer (For 6L6WGC etc.) 2.00
6SL7GT 4.50	6C33C-B 27.00	GZ34 6.50	
5SN7GT 4.50	6L6GC 6.50	GZ37 7.50	
6922 5.20	6L6WGC/5881 8.00	5U4G 5.00	
7025 6.50	6V6GT 5.00	5Y4GT 4.50	
	6080 11.50	5Y3GT 4.00	
	6146B 10.50	5Z4GT 4.50	

and a few "Other Brands" (inc. Scarce types).

5AR4/GZ34 MULLARD 20.00	6B4G RAYTHEON 27.00	6SN7GT BRIMAR 5.50	13E1 STC 110.00
5R4GY RCA, STC 7.00	6BW6 BRIMAR 5.00	12AT7WA MULLARD 5.00	805 CETRON 50.00
5R4WGY CHATHAM USA 10.00	6BX7 GT SYLVANIA 8.50	12AY7 GE-SYLVANIA 7.75	5842A GEC 15.00
5U4GB RCA or GE 12.00	6CG7/6FQ7 SYLVANIA 7.50	12AZ7 GE 7.50	6080W TUNGSTOL 12.50
5Y3WGT SYLVANIA 5.00	6CL6 RCA or GE 5.00	12BH7A GE or RCA 13.00	6550A GE 22.00
6AS7G RCA or SEIMENS 12.00	6CW4 RCA 11.00	12BY7A GE 9.00	6146B GE 17.00
6AU6WC SYLVANIA 3.50	6SL7GT STC 5.50	12E1 STC 12.50	

ALL PRICES IN U.K. POUNDS £

Please note carriage charge extra + VAT (EEC Only) - When ordering state if matching required (add £1.00 per tube).

Payment by CREDIT CARD (ACCESS, VISA, MASTERCARD) or BANKERS DRAFT, TRANSFER or CHEQUE (UK ONLY).

FAX or POST your ORDER - We shall send PROFORMA INVOICE if necessary.

Valve Amplifiers sound better still fitted with CVC PREMIUM Valves!

Chelmer Valve Company, 130 New London Road,
Chelmsford, Essex CM2 0RG. England.

☎ 44 (0)1245 355296 Fax: 44 (0)1245 490064

SECOND COMING

**David Price thinks
Linn's Axis turntable
is a sharp used buy.**



Billed as 'Son of Sondek', Linn's second turntable design, the Axis, always had much to live up to. Launched in 1987 when Compact Disc was finally taking hold, it was Linn's attempt to lure silver-disc purchasers back to vinyl. This meant it had to outperform decent CD players, be easy to set up and use and look good. By any yardstick it succeeded on all three counts.

Its problem was its big brother, which was still held in a kind of reverential awe at that time. Why, said magazine reviewers, bother with an Axis when The Best Turntable In The World was "only" £300 more? This aside, the Axis was a fine piece of kit with many interesting features - some of which actually improved on its much-hyped bigger brother.

For example, its intelligent active power supply not only gave Linnies push-button 45rpm for the first time but varied the power going into the motor depending on the load. Clever stuff - so clever that it appeared on Linn's top Lingo PSU three years later. The other trick was its novel, non-adjustable rubber suspension system, which meant the Axis worked straight out of the box. Unfortunately, for those schooled in the Cult of Linn, this was most uncool, depriving the Axis of a number of Flat Earth brownie points.

Elsewhere, the Axis borrowed a lot from its bigger brother, with the same - albeit less highly specified -

bearing, aluminium platter and felt mat. The plinth was a cheaper affair than the LPI2's but handsome nonetheless, and, together with the brushed satin top plate, it gave the Axis a fresher and more contemporary look than the Sondek.

The original Axis came complete with an LVX+ plus arm for £299 - a modest sum considering the armless Valhalla LPI2 cost over twice that. Unfortunately, since it was a distant relative of the ADC ALTI, the LVX wasn't up to much, being just about capable of tracking a mid-price Moving Magnet. The Akito which replaced it in 1989 was an altogether sturdier design, but still no match for Rega's giant-killing RB300.

Strictly speaking, the Axis was never the best sounding turntable in its price range - the Manticore Mantra lay claim to that mantle - but it was a damn good second. Properly set up with a decent cartridge it still sounds surprisingly good by today's standards. Curiously, its presentation is much closer to Roksan's Xerxes than its big brother, being tight, lean and punchy with no trace of that bass bloom and 'woody' lower midrange coloration that characterises the LPI2. Speed stability is very good too, as are dynamics, and it still has that

quintessentially Linn rhythmic bounce. True, it isn't in the super-deck league, but it's still a significant step up from a Rega Planar 3.

Drawbacks? PSU problems have been known, with stories of mains surges spontaneously starting the motor and cooking the active power supply - the answer is to unplug the deck when not in use. Also, the rubber suspension sometimes goes out of alignment, making it hard to level the deck. Overall though, the Axis is a good design well built.

It makes a great second-hand buy, particularly if you're that strange brand of vinyl junkie who actually wants to listen to music rather than tweak your turntable. Pay between £150 and £250, go for a one-owner example with the original box and chuck the K9 (which it'll inevitably come with) for a Goldring 1042.

Tweak-wise, the news isn't so good. True, you could fit an Ittok or an Ekos, but you'd be a fool to try - the Axis just isn't up to it. Early LVX-fitted decks would benefit from the later Akito arm, but it really isn't worth losing sleep over, especially considering Linn's rather optimistic pricing of the latest Akito III! No, turntable fettlers look elsewhere, the Axis is happiest simply playing music, something it does rather well, and with the absolute minimum of fuss ●

AudioCom (UK)

Suppliers of the World's Finest Components

Catalogue Preview Of Selected Components

Nichicon MUSE KZ Premium Grade Electrolytic's
(Made For Audio Featuring Low Distortion, OFC Wire Lead-Outs)

VALUE (µF)	PRICE(£) 1+	PRICE(£) 5+
25V/100	1.05	0.95
25V/470	2.00	1.85
25V/1000	3.20	3.00

Fully Annealed, Long-Grain Pure Silver Wire 99.99% (4N)

Dia.(mm)	PRICE(£) 1.0Mtr	PRICE(£) 5+ Per Mtr
0.45	3.45	3.22
0.71	5.30	4.72
1.0	8.98	8.05

Sanyo OS-CON SG Electrolytic Capacitors
(Specially Designed For Audio Featuring OFC Leadouts)

VALUE (µF)	PRICE(£) 1+	PRICE(£) 5+
16V/1000	9.20	8.50
16V/470	7.00	6.60
20V/100	4.50	4.20
25V/10	1.60	1.50

Other Lines Include: ALPS Potentiometers, BHC AEROVOX Capacitors, Burr Brown Semi-conductors, Caddock Resistors, Danish Audio Connect CTI Stepped Attenuator, DNM Design Capacitors, Elma Capacitors, I.T. Electronics Air Core & Iron Dust Core Inductors, Linear Technology Voltage Regulators, MIT MultiCap Polystyrene & Polypropylene Capacitors, Sfernice Potentiometers, Vishay Resistors,

Friendly Service . Prompt Dispatch

For a Free copy of our 34 Page 1997 Illustrated Audiophile Parts Catalogue, contact us at:
AudioCom (UK)
Unit 6, Tindle Enterprise Centre, Warren Street, Tenby, Pembrokeshire, SA70 7JY
Tel: (01834) 842803 Fax: (01834) 842804
E-Mail Address: Audiocom@connect-wales.co.uk
(Business Hours: 9:30 to 5:30 from Mon-Fri)

DANISH AUDIO CONNECT

CTI AUDIO ATTENUATOR



Improved sound quality
Improved accuracy
Improved reliability
Improved tracking

THE IDEAL VOLUME CONTROL

In high quality hi-fi and professional audio equipment
Precision attenuator for measuring & test equipment
Passive volume control

5 times shorter signal path
than conventional design
50 MHz bandwidth
Reduced distortion

Available in 10, 20, 50, 100
and 250 kOhm log
Available in versions for
balanced equipment (4 gang)

World-wide sales office

Danish Audio Connect (Thailand) Ltd.
Unit 1501/3 Box Chang Glas Haus Bldg.
1 Sukhumvit Rd. Soi 25
Bangkok 10110, Thailand
Tel: (+66 2) 260 6072
Fax: (+66 2) 260 6071
E-mail: vilodact@loxinfo.co.th

UK distributor

AUDIOCOM
Unit 6 Tindle Enterprise
Centre
Warren Street
Tenby
Pembrokeshire
SA70 7JY
Tel: 01834 842803
Tel/Fax: 01834 842804

International Distributors Welcome

Designed and manufactured in Denmark Audio Connect A/S, Copenhagen

DBF ACOUSTICS

Superior Quality
Audio/Visual
Products

What makes our cables stand out from the rest ?

- An open minded design approach ensures maximum performance.
- Substantial, solid build quality ensures consistent performance.
- Advanced semiconductor technology eliminates noise to reveal low level detail, increase dynamics, and release the emotion in music.

What makes our cables such good value for money ?

- Only available direct from manufacturer - No middle men, and no dealer margin - 14 day money back satisfaction guarantee - No expensive display packaging, we focus your money on the product
- Our extensive range of cables are all hand made to order, and we can make up custom cables to meet your specific requirements.

EXAMPLES

Fathom speaker cable 2m pair gold plated 4mm plugs.....	£ 48.00
Azure gold plated phono-phono 1m.....	£ 49.99
Black Velvet gold plated phono-phono 1m.....	£ 29.99
Black Velvet 2xphono - 4 or Spin DIN 1m.....	£ 29.99
Black Velvet 4xphono - Spin DIN 1m.....	£ 39.99
'Jackson Pyramid' Loudspeakers.....	pair £229.00

When ordering DIN cables please give the required pin configuration and dimensions for phono to DIN

"The Black Velvet's unusually atmospheric sound proved engrossing over the long term. There was great insight into performance thanks to an uncanny retrieval of low level subtleties."
Black Velvet (Noel Keywood - Hi-Fi World January 1997)

"The [Azure] cable is very accurate across the bandwidth. From the highest treble to the deepest bass it has no hidden nasties..."
Azure (Alan Sircom - Home Entertainment Sep/Oct 1997)

Call now for your FREE 20 page catalogue

Credit card facilities
available for fast delivery

P&P £1.50 in UK Mainland, £5.00 International
DBF-Acoustics, 11 Fishers Mead, Puckeridge, WARE, Herts SG11 1SP

24 hour Telephone/FAX: 01920 823 208

MUSONIC STYLI

SPECIALIST MANUFACTURER &
SUPPLIER FOR MORE THAN 40 YEARS

REPLACEMENTS & ORIGINALS

MANY OBSOLETE/78 VERSIONS

PICK-UP CARTRIDGES

RECORD/TAPE/CD ACCESSORIES

WHY NOT TRY US AND HEAR THE
DIFFERENCE !!

For prices tel/fax/e-mail to:-

MUSONIC (UK) LIMITED
Unit 13 Wenta Business Centre Colne Way
Watford Hertfordshire WD2 4ND
Tel: 01923 213344 Fax: 01923 213355
e-mail: musonic@compuserve.com



SIMPLY THE BEST



COMPACT DISC PLAYERS

QUAD 67 second-hand

One of Quad's best products for a long time, the 67 is warmer and smoother than most, yet is highly musical and revealing.

DENON DCD-315 £150

Real hi-fi and real music for a mere £150.

NAD 510 £200

A competent all rounder with lifelike soundstaging and impressive treble clarity.

ARCAM ALPHA 7 £320

This British built player is extremely good value. Upfront, punchy nature suits Techno and Rock.

MARANTZ CD-63MKII KI-S £500

Similar to the CD-63SE but more powerful bass and an all-round smoother sound.

TRICHORD GENESIS £549

Conveys music in a powerful and dramatic fashion. Smooth and sweet, with a good sense of depth. A little soft sounding though.

DPA RENAISSANCE £895

Words cannot describe its infinite variety, but you'll love it or hate it. Highly emotional presentation with not a hint of self-doubt.

ROKSAN CASPIAN £895

The Caspian has a smooth, even sound with some of the clearest treble in the business. Very engaging, dynamic character.

MARANTZ CD-17 KI-S £1300

The Marantz excels in all areas. Without doubt this is one of the most involving CD players on the planet. Build quality is also exemplary.

NAIM CDI £1600

This single box 16-bit player sounds very engaging compared to your average bitstreamer. Has that vital tingle factor of the larger, two-box CDs.

MCINTOSH CDM7009 £2635

A thoroughly inspiring machine. One of the most musical CD players around; sweet, open and detailed.

COMPACT DISC TRANSPORTS

TEAC VDRS-T1 £550

Not as substantially built as its chunky looks suggest, the T1 is nevertheless a good entry-level transport with a warm, expansive sound.

AUDIOLAB 8000CDM £1300

Beautifully built and finished, the CDM is packed with sensible features and performs superbly, day-in day-out.

TEAC P-30 £2500

Cheap it isn't, but then it sounds like a million digital dollars. Nothing short of superb.

CD CONVERTORS

DPA LITTLE BIT III £300

A lot more weight at frequency extremes than the II and far better control. A bargain at £300.

THORENS TDA2000 £700

Used with the TCD2000 as a transport, the TDA2000 produces a sound that is focused, detailed and spacious. Good value.

MARSTON SILHOUETTE £795

With Crystal Semiconductors' 18-bit DAC the Marston produces clean-cut images and a transparent sound stage. Very rhythmic too.

PINK TRIANGLE DA CAPO £1450+

Offers a choice of filter modules, all up there with the best. The Da Capo is superb in many respects, but can sound a touch polite on Rock.

DPA I024 £6000

Proof positive that today's CDs needn't sound CD-like! Uses an in-house discrete convertor, and DPA haven't skimmed on the build either!

TURNTABLES

GARRARD 401 second-hand

In a decent plinth with an arm of SME309 calibre, the 401 has a highly authoritative overall sound with the most solid, expressive bass in the business. Very musical, but treble isn't up to modern standards.

THORENS TD124 second-hand

One of Thorens' best-ever turntables. Needs a modern plinth to give of its best. Duly installed, it's good enough to face off the Garrard 401, swapping some of its bass power for a more delicate, incisive treble.

SYSTEMDEK IIX900/RB250 £330

A fine all rounder and easy to upgrade too. Has more depth and breadth than Rega Planar 3.

PINK TRIANGLE TARANTELLA £575

Not only does the Tarantella have more style than a catwalk full of models, it also combines PT's usual clarity with real authority. The biz.

VPI HW 19 JUNIOR/RB300 £599

With its control and grip on music the Junior never fails to engage. Set-up is a piece of cake and there's a whole range of upgrades on offer too.

MICHELL GYRODEC £800

Stunning looks, build and fine sound. Standard PSU has detailed, architectural, if undynamic sound. With QC PSU, scale and insight kill the competition.

PRO-JECT 6.1SA £999

The Pro-ject places the listener in the best seat in the control room. Outrageous dynamics and a punchy, seriously deep bass. Comes with Sumiko arm and Ortofon MC30 Supreme.

LINN SONDEK LP12 £840 - £1530

Cirkus bearing puts it back up with the best. Superbly beguiling, rhythmic sound that plays Jazz like few others, but lacks the Gyrodec's detail or imaging. You'll forget CDs were ever invented.

PINK TRIANGLE ANNIV. £2495

One of the finest-sounding turntables around, the Anniversary takes the listener nearer the recording studio than almost any other deck. Works with Rega, Linn and SME arms alike.

ROKSAN XERXES X £1295

DSU or XPS 3.5 power supply £150/170 extra. Excellent pitch stability from a new Swiss motor and outboard power supply. Very tight bass, fine dynamics and revealing clarity.

MICHELL ORBE £1950

The Darth Vader of analogue, the Orbe builds on the strengths of the Gyrodec. An ultra-tuneful, expansive sound.

SME MODEL 20 £2495

Including the excellent SME V tonearm, the Model 20 is possibly the last great turntable, unless you've got £11,000 for the Model 30, that is.

tone-arms

REGA RB300 £130

Supremely capable at the price, but not quite humankind's salvation as has been suggested. Detailed, tight, rhythmic sound but tonally rather grey and cold-sounding.

SME 3009SII £375

This Paleolithic device doesn't bother with frequency extremes or detail, but its legendary serviceability makes it a cult in Japan. Oh death, where is thy sting?

SME309 £570

A down-market version of the IV and V with aluminium armtube and detachable headshell. Tight, neutral sound with good tonality, but lacks the IV's pace and precision.

SME V £1235

A masterpiece of precision engineering with a cohesive, ultra-transparent sound.

LINN EKOS £1400

A thunderous battleship of an arm, with a very impressive sound, masses of detail and dynamics, but lacks the SME V's cohesion and musicality.

CARTRIDGES

ORTOFON VMS-2E £10

Warm, full-bodied, punchy and fast. Not to be sniffed at for a tenner. Can be upgraded with a better stylus at a later date.

GOLDRING I012GX £60

An accomplished MM with a solid bass, slightly forward midband and clean transients £20 buys the faster, more dynamic I022GX.

GOLDRING I042 £100

The best moving magnet available. Has an extremely cohesive, weighty sound that's warm but highly involving.

SHURE V15VXMR £295

The Shure produces a warm, dynamic sound which has great detail and impact. Far superior to earlier V15s.

World favourites guide

ORTOFON SUPREMES £225-£450

The MC10, MC20 and MC30 Supremes all offer superb sound and value for money, with a rich, smooth and musical performance.

ORTOFON MC2000 £650

We came across this one in an SME IV on a Garrard 401; it duly gave one of the best results we've ever heard.

ORTOFON ROIIMANN £1000

In a way it's MC2000 meets MC7500 with the tonal strengths and dynamo sound Ortofon put into their moving-coil cartridges.

LYRA LYDIAN £649

A truly musical, sophisticated device that makes most other MCs sound frigid.

VAN DEN HUL MC-10 £840

Fluid bass, finely etched treble and highly tuneful in between. The MC-10 is honey, pure and simple.

ORTOFON MC7500 £2000

Conclusive proof that there's hope for humankind. CD lovers would die if they heard it.

INTEGRATED AMPLIFIERS

NAD 3020 *second-hand*

Classic sweet sounding, punchy budget super-amp with strong phono stage. Able to embarrass many modern budget amps.

NAD 310 £130

A real hi-fi amplifier at a bargain price. Forms the heart of a separates system that will murder any midi system at twenty paces. No phono stage, but you can't have everything at this price.

NAD 312 £200

Smooth, clear and dry. Fine detailing with little to complain about at the price. Good facilities.

ROTEL RA-970BX £250

With its smooth and powerful sound, the Rotel sings a seductive song with all types of music.

AURA VA-80 £280

The VA-80 is superb for the price - it is capable of embarrassing more up-market competition.

PIONEER A-300R PRECISION £299

This is the cooking A-300 tweaked with special components and it shows. Rhythm and detail are first-class and the phono stage isn't far behind.

NAIM NAIT 3 £500

A taste of high-end audio. The most involving, musical design at the price, but low power.

MISSION CYRUS 3 £500

Superb engineering, a solid cast chassis and a clear, spacious sound. Phono stage could be better.

SÖNNETEER CAMPION £579

An amplifier that delivers near studio definition along with exemplary timing. Utterly gripping.

DPA RENAISSANCE £595

Rich and smooth, the Renaissance is one of the sweetest amps around, if lightweight.

AUDIO ANALOGUE PUCCINI SE £595

This superbly made Italian integrated has a lucidity and control which leave the competition at up to £1000 standing. Sound stage depth is unequalled.

AUDION STERLING ETSE £600

Economically but well built single-ended valve amplifier. Wonderful clarity with vocals.

SUGDEN A21a £640

Class A transistor amp. Rich, crisp, deep, tight sound and it images well too. Wonderful.

MERIDIAN 551 £795

Beautifully-built integrated with a sweeter, clearer sound than mid-price alternatives. Plenty of facilities and remote controllable.

UNISON SIMPLY 2 £995

This single-ended valve amplifier is smooth, sweet and open. An extremely musical performer.

UNISON SIMPLY 4 £1495

Sonically similar to the Simply 2, but with more power and control.

McINTOSH MA6800 £3735

The MA6800 not so much plays music as takes control of it, with effortless bass drive and a three-dimensional sound stage.

PRE-AMPLIFIERS

QED DISCSAVER £35

A true bargain that offers a cohesive, musical sound but avoid using it in thin sounding systems.

ROTEL RQ-970BX £130

Superb value entry-level phono stage with audiophile quality components and clear sound.

LFD MISTRAL PHONO STAGE £300

The Mistral has a warmth and involvement that make many more expensive phono stages sound overpriced.

TECHNICS SU-C1000 £350

At its price, this battery powered pre-amp is difficult to beat. Weak points are lightweight build and average phono stage.

DPA DSP200S £495

Not quite the 50S, but there's little to match it at this price if transparency and involvement are your priorities.

AUDIOLAB 8000C £520

Versatile with superb phono input. Can sound sterile, but latest version is much improved.

MICHELL ISO/HERA £530

This phono stage has fine midband and treble detail, with taut bass. The £850 ISO/HR brings more of everything.

AUDIO INNOVATIONS P2 £749

Fantastic bass and super insight make this one of the best phono stages around. One for vinyl lovers.

AUDIOLAB 8000Q £995

Excellent line-level only pre-amp, greatly improves on 8000C with a more fluid, musical sound and greater grip. Remote control.

ROKSAN ARTAXERXES X £950

With the Atessa PSU the Artaxerxes X MM/MC stage still shines. Its fortes are great stage depth, neutrality and tonal colour. Musical too.

MARANTZ MODEL 7 PRE-AMP £3500

A '60s reissue, the Marantz pre-amp still sounds superb. Has a great phono stage.

POWER AMPLIFIERS

QUAD II *second-hand*

Classic valve monoblock with many thousands still in use. Archetypal warm, smooth valve sound, although not the last word in detail or dynamics.

LEAK STEREO 20 *second-hand*

The Stereo 20 can sound impressively up-to-date, although power and detail are ultimately limited.

QUAD 405II *second-hand*

Solidly built, but lifeless sounding, power amp can be substantially improved by a Quad service.

ARCAM ALPHA 9 £400

With 70watts on tap, the 9P will drive most loudspeakers with a spacious and detailed sound. Good bass drive too.

MISSION CYRUS POWER £450

This power amplifier is a real honey. Rich and smooth, but with a firm grip; a fine blend of properties.

ROSE RP190 £495

Used with the partnering pre-amp it gives 70watts of smooth, relaxing sound.

SUGDEN AU41P £530

Extremely competitive at the price with 100W of unusually smooth, full-bodied sound.

SHEARNE PHASE 3 £619

A neutral, highly dynamic and thoroughly exciting amplifier. A sonic bargain.

DPA DPA200S £750

Better than anything else at the price. Not as dry as the 50S.

NAIM NAP180 £900

Partnered with a NAC82, this has classic Naim control, making for a superbly rhythmic presentation. A touch lean for some tastes.

MICHELL ALECTO STEREO £1300

A refined transistor amplifier with valve-like transparency and a full, warm, easy-going sound. The £1800 Alecto monoblocks have rare lucidity and three dimensional realism.

World favourites guide

MERIDIAN 557 £1400

Great control is allied to seductive smoothness. A rare combination of power and delicacy.

MARANTZ MODEL 9 £8000

Authentic reproduction monoblocs still more than cut the sonic mustard. The sound combines grunt with great tonal colour and expressiveness.

TUNERS

LEAK TROUGHLINE second-hand

Our favourite way of listening to the wireless. A deliciously mellifluous sound will have you junking your transistor radio in seconds.

NAD 412 £190

The 412 is remarkably musical and natural sounding. Rich sound and full bass are a rarity.

MISSION CYRUS FM7 £300

Clear and lucid sound puts it up with the best regardless of price. Superb build too.

ROTEL RT990BX £500

High quality Michi-based tuner with a sophisticated, forward sound with great imaging and soundstage. Sensible facilities and remote control.

NAIM NAT03 £500

The NAT03's warm, atmospheric sound is further proof of Naim's proficiency with tuners.

FANFARE FT-1 £1350

In its native US the FT-1 is no mere tuner but a 'broadcast monitor' no less, a task at which it acquits itself well, with a clear and powerful sound.

NAIM NAT01 £1380

This is the best solid-state tuner available bar none. For better radio, go and live in the studio.

CASSETTE DECKS

AIWA AD-S750 £150

Sonically a very decent machine. For the price there's nothing better. Comes fitted with Dolby B, C and S.

KENWOOD KX-3080 £160

A simple deck, but high quality head and transport give an unusually high level of performance at this price. Not to be missed.

YAMAHA KX-580SE £250

The 'Special Edition' tag is more than a marketing gimmick. Sound is solid and clear with Dolby S.

AIWA AD-S950 £300

A stable transport, superb head and Dolby S make the AD-S950 an excellent all rounder.

PIONEER CT-S740S £430

A great piece of engineering from Pioneer, with first rate sound on playback and recording.

NAKAMICHI DR2 £600

Where serious cassette decks start. The DR2 pushes recordings to the limit, remaining unflustered at all times.

NAKAMICHI DR1 £850

Better still than the DR2, with manual head azimuth adjustment to boot.

NAKAMICHI CR7 £1500

Kills every other cassette deck and stamps on their graves.

LOUDSPEAKERS

KEF Q15 £199

These stand mounters offer impressive bass and excellent clarity but need a powerful amplifier to perform at their considerable best.

HEYBROOK HBI S3 £269

Fine tonal resolution through midrange and a smooth and extended treble make the HBI's ideal for Classical/acoustic music. Bass is a little boxy and constrained though.

CELESTION IMPACT 23 £299

A smooth and even handed loudspeaker. Has clear and well extended treble and deep, tight bass. Midrange is focused and pure with plenty of detail and speed.

B&W DM 602 £300

Deep and strong bass, pure, projected and uncoloured midrange. Treble quality a little metallic, but imaging precise. A lively, enjoyable sound.

REL Q-BASS £350

Few subwoofers match the Q-Bass at the price. The tuning controls can be a bit of a fiddle, but once set up the rest is pleasure.

CASTLE EDEN £450

Impressively vice-free 'speakers that offer great transparency and involvement. Unbeatable at the price.

EPOS ES12 £495

Strong, punchy bass is allied to detailed and articulate midrange and treble. Above all, these 'speakers are thoroughly musical.

REL STRATA £500

The Strata subwoofer is not a toy. It offers superb, true hi-fi bass depth and power, and opens up sound stage depth in particular.

MISSION 752 Freedom £600

Use advanced High Definition Aerogel bass/midrange driver and silk dome tweeter. Dynamic, punchy and musical, yet refined like few others are at the price. Not as sweet or soft as the original 752s though.

TANNOY D100 £650

This small dual-concentric loudspeaker produces believable three dimensional imaging.

CASTLE AVON £700

Taut, dry bass and lucid midrange from their carbon fibre driver, but need warm ancillaries to avoid sounding bright.

HARBETH HL-P3ES £799

A fine example of good loudspeaker engineering. The top of the mini-monitor league.

HARBETH HL-K6 £975

Clean, musical and classy - Harbeth have done themselves proud again.

KEF REFERENCE SERIES ONE £995

The KEFs combine pin-point imagery and detail with a smooth and polite balance. Good, agile bass too.

HEYBROOK SEXTET 11 £1129

Heybrook have retained the strengths of the original Sextet, improving on bass extension and smoothness. Treble and imaging still excellent.

MISSION 754 FREEDOM 5 £1299

The 754 Freedom 5 has a highly articulate and informative sound with fine imaging and tight, deep bass extension. Uses silk dome tweeter, HDA midrange and 8in woofer.

JAMO CONCERT 8 £1500

With their inch-thick cabinets and fabulous drive units, the Concert 8s are the most transparent stand mounters around. They don't suffer poor sources gladly though.

EPOS ES25 £1505

Epos' best. Combines near-uncoloured tonality with characteristic fireworks in the rhythm department. Superb by any other name.

SPENDOR SP7/I £1970

This big Spendor is very appealing thanks to its lucid sound and valve-friendly load.

TANNOY AMS8 £2700

Bold sounding professional active monitor with solid bass, clearly focused midrange and delicious treble. Built-in amplification.

QUAD ESL-63 £2860

A reference against which all other loudspeakers are judged, the '63s have superb imaging qualities and genuine transparency. Earlier ESL model is a fine second-hand buy.

KEF REFERENCE SERIES FOUR £3099

Superb bass and near-electrostatic soundstaging make these involving loudspeakers a reference to others. Need a strong amplifier though.

JBL S2600 £3500

Smooth, detailed and spacious with great dynamics and fine imaging. Capable of producing a superb performance when used in a big room.

TANNOY WESTMINSTER ROYAL £10,000

An incredibly dynamic, detailed full-range horn design with a rich sound. Its high sensitivity predisposes it to valve amplification.

MINIDISC PLAYERS

SONY MDS-JE500 £300

An impressive sound and unmatched convenience make this MiniDisc player an excellent buy.

KENWOOD DM-7090 £500

Both replay and recording quality are superb through this Kenwood. Nakamichi owners should start getting worried - at last there's competition.

THE MIDLANDS
BEST USED
EQUIPMENT
SPECIALIST



QUALITY USED
EQUIPMENT,
BOUGHT, SOLD,
PART EXCHANGE

ALL EQUIPMENT
TESTED AND
GUARANTEED

URGENTLY REQUIRED
LINN, NAIM,
MERIDIAN, QUAD,
CASH WAITING

AUTUMN CLEARANCE ITEMS

	CD's			NEW	OUR PRICE
Naim CDS				£4000	£2295
Micromega Duo + Duo Pro DAC				£3200	£1195
Quad 66				£600	£295
Meridian 506 20 Bit + MSR				£1100	£795
Meridian 563 DAC				£800	£395
AMPS					
Quad 66 Pre + Remote				£678	£395
Quad 606 Power				£650	£395
Musical Fidelity F15				£2000	£995
Musical Fidelity F22				£1000	£495
Naim 42.5				£N/A	£145
Naim 110				£N/A	£195
Naim Hi Cap				£700	£295
Naim Nait Mk1				£N/A	£145
Naim 92 + MM				£550	£345
Naim 90				£450	£295
Naim Flat Cap				£340	£225
Naim 32				£N/A	£145
SPEAKERS					
Naim IBL				£1000	£395
Naim SBL				£2000	£1200
Linn Kans + Stands				£N/A	£195
Linn Tukans Rosewood				£600	£295
Linn Kabers Rosewood				£2500	£1195
Linn Kabers Black				£2000	£495
Linn Isobarick Walnut + Stands				£3300	£495
Linn Tune Box Active X Over				£450	£195
Meridian DSP 600 Digital					
Active Speakers Rosewood				£3000	£1495
TDL Studio 1M Rosewood + Stands				£1000	£495
TURNTABLES					
Linn LP12 + Ekos	£2800	£795	Yamaha 590	£350	£145
Linn LP12 + LVV + A+RP6£N/A£195			Yamaha 390	£300	£95
Linn Ekos Full Report	£1500	£695			
From Linn, New Bearings etc			TUNERS		
Linn Akito	£500	£175	Meridian 204	£450	£245
Roksan Xerxes + Artemiz	£N/A	£795	Quad 66 FM	£575	£295
+ ATOC9 + Roksan Table			Quad FM3	£N/A	£95
Linn Basik + Akito + K5	£N/A	£195			

ODD'S 'N' SODS

Various tables, cables etc Ring For Details

OPEN MON-SUN
10.00 TO 8.00

RING FOR FURTHER DETAILS
TEL 0121-783-8227



BorderPatrol

Valve Amplifier Power Supply Upgrade £595.00

Off board valve rectified, choke input filter power supply for Valve Amplifiers. This upgrade reduces distortion, increases resolution and strengthens bass performance and dynamics. If you like the sound of your valve amplifier but would like to tighten the bass and strengthen the overall dynamics this is what you need. Versions available to suit everything from vintage Leaks to modern Audio Innovations, Audio Note and Art Audio designs. If you are unsure about the suitability for your amp please telephone us.

'In every instance the Border Patrol effect was nothing short of a transformation. Bass solidified, imaging became significantly more three-dimensional and substantial, and the power supplied amp made the regular version sound, quite literally, a mess.'

'With the Border Patrol back on the music regained its composure: instruments not only sounded more natural and realistic, but seemed much more musically coherent. In many respects it was like taking the good things about transistor amps and adding them to the natural strengths of valves - a remarkable blend.'

...Jason Kennedy Hi-Fi Choice April 97

Call us for A/B with/without demonstrations of the BorderPatrol effect

BorderPatrol Tel/Fax Brighton 01273 276716

Watford Valves

3 Ryall Close Bricket Wood,
St Albans Herts AL2 3TS
Phone: 01923 893270
Fax: 01923 679207

SPECIAL OFFERS

FREE MATCHING* NO MINIMUM ORDER REQUIRED

300B SOVTEK excellent detail & bass outstanding £65 now £59 each

A.R. and Lumley Owners

6550 A JAN G.E. USA meets military spec mil-E-I superb £30 now £24 each

QUAD II OWNERS

KT66/7581A PHILIPS USA, the best replacement ~~£20~~ now £18 each

GZ32 New old stock ~~£15~~ now £10 each

EF86 SIEMENS and TELSA ~~£9~~ now £8 each

LEAK & RADFORD OWNERS

E34L TESLA BLUE GLASS widest frequency response ~~£12~~ now £10 each

EL34WXT SOVTEK increased spec best yet from Sovtek ~~£7~~ now £6 each

EL84 JAN PHILIPS USA a true audio EL84 ~~£12~~ now £10 each

ECC81	PHILIPS	£4.50
ECC82	PHILIPS	£4.50
E83CC	SIEMENS	£10.00
EL519	E.I.	£10.00
PL519	E.I.	£10.00
PCC88	PHILIPS	£3.00
6SL7WGT	PHILIPS	£7.00
6SN7WGTA	PHILIPS	£7.00
5687WB	PHILIPS	£5.00
5842WA	RAYTHEON	£6.00
6550C	SVETLANA	£16.00
6922	SOVTEK	£3.00

KT66 GEC ORIGINAL limited supply matched pairs p.o.a.

*** OPEN 7 DAYS A WEEK 9AM-9PM* PROFESSIONAL ADVICE***

Fast & Efficient mail order service. All valves are new, boxed and guaranteed.

Prices exclude VAT and carriage.



Garrard™

The Phoenix rises..... The first new high-end Garrard turntable for 25 years is unveiled by Loricraft Audio, licencees of the Garrard name and trademark. The Garrard 501 is a classic idler-wheel turntable that continues the design philosophy of the original firm.



Also launched are a new range of Garrard turntable accessories. A unique new "Natural Fibre" record brush evolved during research for the Loricraft record cleaner, "the world's finest vinyl cleaning machine".

The Garrard "SoundStage" turntable support platform was developed with the help of a leading materials company. The entire structure works to damp vibration and pull the best from any vinyl player or other equipment.

Loricraft also offer the Garrard improved power supply, originally developed for the 501. This is now available for all Garrard and other fine turntables.

The Legend Continues....

Garrard products are on demonstration at **Byworth Music Farnham, Surrey 01 252-710910** and **Audible Elegance Hernebay, Kent 01 227-742928**

For further information contact:

LORICRAFT AUDIO,
1 BIG LANE,
GOOSE GREEN, LAMBOURN,
BERKSHIRE, RG17 8XQ
01488 - 72267

TELEPHONE ENQUIRES: 8:30 - 4:00 PM MON-FRI
TECHNICAL HELPLINE: TUESDAY & THURSDAY

definitive audio

USED AND EX-DEMONSTRATION EQUIPMENT FOR SALE

	Offer Price	List Price
Source Components:		
Theta Data Basic CD transport	£995	(£2000)
EAS DSP 7000 Series III DAC	£1250	(£2495)
Monarchy DIP Jitterbuster	£125	(£250)
Voyd turntable/SME V (AudioNote silver wired)/Goldring 1040	£1600	(£3250)
Amplification:		
Border Patrol 300B SE single-ended power amp (ex-dem, black and chrome)	£1750	(£2500)
Audio Innovations 2nd Audio mono-blocks (latest spec, new valves throughout)	£1200	(£3250)
Audio Innovations L2 (new valves)	£375	(£750)
Audio Innovations L1	£225	(£375)
Audio Innovations S200 pre-amp	£250	(£350)
Naim NAC 42	offers	
Loudspeakers:		
Snell type E loudspeakers with Pirate stands	£850	(£1500)
Snell type K loudspeakers with Pirate stands	£375	(£750)
Cables:		
Transparent MusicWave Plus 4.5 bi-wire set	£350	(£750)
Audio Note AN-SPx silver speaker cable (Two 3m sets)	£1000	(£2750)
Transparent Music Link Plus interconnect (Three 1m pieces)	£125	(£199)
Silteck HF8 digital interconnect (1/2m set)	£175	(£300)
Headphones:		
Stax Lambda Signature + SRDX Pro Energiser	£400	(£850)
Jecklin Float ELS + PS2 electrostatics	£195	(£400)

Tel/Fax: Brighton 01273 276716

diverse vinyl

12 Upper Dock Street Newport Gwent NP9 1DF. 9am-5.30pm Mon-Sat.
Internet site <http://www.diverse-music.co.uk>
phone/fax 01633 259661 / 256261 E Mail :- sales@diverse-music.cfx.co.uk
-Mastercard - Visa- Catalogues available -Amex-Switch-JCB-

WEA 180gm Reissues Phase 2

America	Greatest Hits	£14.90
Bob Jarmes/D Sanborn	Double Vision	£14.90
Doobie Brothers	Stampede	£14.90
Eric Clapton	Journeymen	£14.90
James Taylor	Greatest Hits	£14.90
Joni Mitchell	Blue	£14.90
Little Feat	Waiting For Columbus	£14.90
Phil Collins	Face Value	£14.90
Prince	Purple Rain	£14.90
Quincy Jones	Back On The Block	£14.90

New And Forthcoming Releases

2Pac	R U Still Down(Remember Me)	£11.90
Art Blakey	Buhaina - Reissue	£9.50
Black Grape	Stupid Stupid Stupid	£10.90
Junior Kimbrough	All Night Long/Most Things	each £8.90
Metalheadz	Platinum Breaks 2	£14.90
Metallica	Reload	£12.90
Moby	I Like To Score	£9.90
R L Burnside	Too Bad Jim - Reissue	£8.90
Royal Trux	Single Live Unreleased	£15.90

Current And Recent Releases

Adam F	Colours	£15.90
Bryan Maclean - ex Love	Ifyoubelievein (Fancub issue)	£27.90
Cassandra Wilson	New Moon Daughter - 2 LP	£17.90
Cure	Galore - Singles 1987-1997	£11.90
Dave Brubeck	Jazz Goes To College	£6.90
Duke Ellington	Blues In Orbit	£6.90
Duke Ellington	Uptown	£6.90
Gilby Clarke	The Hangover	£9.90
Green Day	Nimrod	£14.90
John Scofield	Still Warm	£8.90
M People	Fresco	£9.90
Ozric Tentacles	Curious Corn	£12.50
Patti Smith	Peace And Noise	£9.90
Pere Ubu	Modern Dance	£8.90
Richard/Linda Thompson	Shoot Out The Lights	£7.90
Rickie Lee Jones	Firewalker - import 12"	£6.90
Scott Walker	Tilt	£10.90
Spice Girls	Spiceworld	£12.50
Widhearts	Endless Nameless	£9.90

All The Staff At Diverse (Mark John Kevin And Paul)
Wish All Our Customers A Happy Turntable Christmas

P and P £1.00 1st LP additional LPs 50p each (max £3.50)



DREAM SYSTEMS: WE MAKE

CYRUS GETS SERIOUS WITH MICRO SYSTEMS

FROM AS LITTLE AS
£72.90
PER MONTH

While some customers can be attracted to the appearance of many mainstream mini and micro systems, they are quickly won over by a demonstration of the sheer musical superiority of these diminutive Cyrus components.

As beautifully constructed as anything on the market, this superb Cyrus and Mission line-up provides an exquisite system for anyone looking for legitimate hi-fi performance but with the minimum impact on their domestic decor.

The system offers a stylish and genuinely sophisticated quality of reproduction with all types of music that is likely to satisfy its owners for many years to come.

Call in for a demonstration and find out about our unbeatable trade-up offers.

CYRUS 111i Amplifier	£598
CYRUS PSX-R Power Supply	£328
CYRUS daD3Q CD Player	£898
Mission 752F	£578

TOTAL £2402

PART-EXCHANGE (example) or Deposit	£602
BALANCE	£1800*

INTEREST FREE PAYMENTS 12 X £150

***OR DEFER PAYMENT
90 DAYS THEN 3YEARS AT
JUST £16.82 PER WEEK**

WE MAKE IT EASY!

With 0% Finance available on all **NEW and USED HI-FI and Audio-Visual Purchases**

THE ULTIMATE INNOVATIVE TRADITIONALISTS

FROM AS LITTLE AS
£81.00
PER MONTH

No hi-fi manufacturer can claim to have a more significant history of innovation than Quad, and this latest system continues that tradition, offering both exceptional sound quality and outstanding value.

Judging by demand for older Quad equipment through our own 'second user' store, we would guess that Quad offers the best 'investment' potential amongst hi-fi products, and owners of older Quad equipment will be pleased to know that because of the demand through our 'Trading Station' we always offer exceptionally generous part-exchange allowances against Quad hi-fi of any vintage when you up-grade to the wonderful Quad 77 system.

QUAD 77 Control Amplifier	£849
QUAD 77 CD Player	£699
QUAD 77 Tuner	£699
Quad 10i Speakers	£599

TOTAL £2846

PART-EXCHANGE (example) or Deposit	£846
BALANCE	£2000*

INTEREST FREE PAYMENTS 12 X £167

***OR DEFER PAYMENT
90 DAYS THEN 3YEARS AT
JUST £18.69 PER WEEK**

TRADE-IN YOUR HI-FI

Generous allowances for your carefully used hi-fi equipment plus a **'CASH-IN-HAND'** facility.

FOR MANY OF US VINYL STILL RULES!

FROM AS LITTLE AS
£89.91
PER MONTH

There is still something so beguiling about the quality of vinyl that even now, some fifteen years after the introduction of digital sound, many of us treasure our LPs more than ever. You know that old saying "you don't know what you've got until you lose it!"

If you're no longer playing your old albums, or if you've replaced your collection with CDs, it's worth knowing that we have a high demand for quality used turntables - so whatever you do, talk to us - please don't throw it away! But, if you're a 'vinyl junkie' you'll want to speak with kindred spirits.

So this is our recommended 'Re-start System' for anyone with a dominant collection of the beautiful black stuff!

PINK TRIANGLE TARANTELLA With Rega RB300 & Grado	£795
COPLAND CSA 14 Amplifier	£1199
SONUS FABER Concertino Spkrs	£599
SONUS FABER Speaker Stands	£290

TOTAL £2883

PART-EX (Example) or Deposit	£663
BALANCE	£2220*

INTEREST FREE PAYMENTS 12 X £185

***OR DEFER PAYMENT
90 DAYS THEN 3YEARS AT
JUST £20.75 PER WEEK**

WE'LL BUY YOUR HI-FI

Instant Cash offered for Used and Vintage hi-fi equipment. Complete systems always wanted.

WHEN IT'S RIGHT YOU KNOW IT'S RIGHT!

FROM AS LITTLE AS
£91.53
PER MONTH

There's little we can say about Audiolab and Monitor Audio that isn't already well known. Other than that they are near neighbours of ours in a concentration of top-name manufacturers in the hi-fi hotbed that is Cambridgeshire.

We have brought the two companies even closer in this highly recommended system to demonstrate how bi-amping a superb two-way speaker creates a soundstage of amazing scale and precision.

We can commend Audiolab and Monitor Audio, not only for such obvious sonic qualities (achieved within 'sensible' budgets) but also for their outstanding engineering as well as the cosmetic finish which enhances the sheer desirability of all their award winning components.

AUDIOLAB 8000CD CD player	£999
AUDIOLAB 8000LX Pre amp	£469
AUDIOLAB 8000SX Pwr amp	£549
MONITOR AUDIO Studio 12 Floorstanding Speakers	£999

TOTAL £3016

PART-EX (Example) or Deposit	£756
BALANCE	£2260*

INTEREST FREE PAYMENTS 12 X £188

***OR DEFER PAYMENT
90 DAYS THEN 3YEARS AT
JUST £21.12 PER WEEK**

WE'LL SELL YOUR HI-FI

Let us help you get **THE BEST PRICE** for your old hi-fi by selling it for you on a commission basis.

ARCAM ♦ ARION ♦ AUDIOLAB ♦ AUDIO RESEARCH ♦ AVI ♦ BOWERS & WILKIN ♦ CASTLE ♦ CERWIN VEGA ♦ COPLAND ♦ CYRUS ♦ MICHELL ♦ MISSION ♦ MONITOR AUDIO ♦ MUSICAL FIDELITY ♦ NAIM ♦ PINK TRIANGLE ♦ PIONEER ♦ PRO-AC ♦ QUAD ♦ REGA

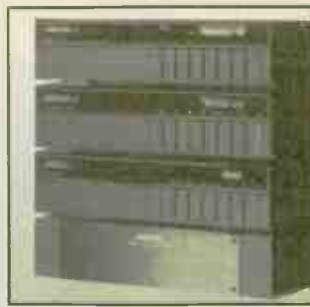
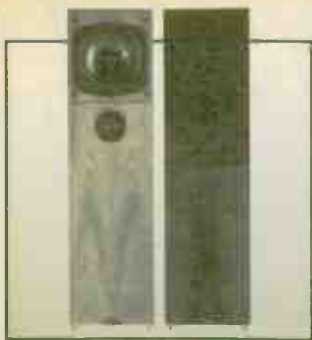

THEM A FINANCIAL REALITY

NAIM THAT TUNE IN ONE!

FROM AS LITTLE AS
£128.79
PER MONTH

If you're after that 'toe-tappin', 'finger poppin', 'hand clappin', 'thigh slappin', sound experience - simply call in and listen! We'll demonstrate Naim, a company that places a convincing emphasis on the value of true system synergy. For a growing number of our customers, Naim reproduces music the way they like it, and we'll place a bet that when you listen, you'll probably discover that you do too! A complete Naim system starts from around £2,300 which you can build incrementally to a staggering £30,000! What's more, if you'd like a personal endorsement, we can tell you that some of our people have chosen to spend their own 'hard-earned' on complete Naim systems. We can't say fairer than that!

NAIM CD2 CD Player	£2000
NAIM 102 Pre-amp	£1050
NAIM 180 Power amp	£1060
NAIM Credo Speakers	£1060
TOTAL	£5170
PART-EXCHANGE (example)	
or Deposit	£1990
BALANCE	£3180*
INTEREST FREE PAYMENTS 12 X	£265

***OR DEFER PAYMENT 90 DAYS THEN THREE YEARS AT JUST £29.72 PER WEEK**

VALVE & SOLID STATE - BEST OF BOTH WORLDS?

FROM AS LITTLE AS
£324.00
PER MONTH

No dogma here! While different technologies provide different solutions to achieving state-of-the-art sound reproduction, The Hi-Fi Company will always provide an appropriately wide choice of top quality equipment for your personal assessment. Audio Research have earned a global reputation with their highly sophisticated vacuum-tube amplifiers which, with the help of their new CD player in this system, produce an utterly convincing portrayal of all types of music. Add the ProAc Response 2.5 loudspeakers and, in our view, these rare devices help this system create the transparent sound of electrostatics with the sheer power that only superior cabinet speakers can achieve.

AUDIO RESEARCH CD2	
CD player	£3399
AUDIO RESEARCH LS9 Pre	£1949
AUDIO RESEARCH VT50 Pwr	£2895
PRO-AC RESPONSE 2.5	£2700
TOTAL	£10,943
PART-EX (Example) or Deposit	£2943
BALANCE	£8000*
INTEREST FREE PAYMENTS 12 X	£667

***OR DEFER PAYMENT 90 DAYS THEN 3 YEARS AT JUST £74.77 PER WEEK**

KRELL CLASS A POWER DRIVES MARTIN LOGAN

FROM AS LITTLE AS
£364.50
PER MONTH

For many years we have delighted in the transparency of electrostatic speakers, but never more than when driven by hugely powerful Class A amps. Electrostatics really open up to Krell amplifiers, enhancing their clarity with a three dimensionality which can be eerily real in some instances. With well recorded discs one can feel as if it's possible to walk right through a literally transparent soundstage to mingle with the musicians in your own living room! Any system offering this level of performance usually deserves a home demonstration and if that is something you would like to experience for yourself, please contact us and we will be delighted to make the arrangements for you. The system is of course on dem in store.

KRELL KAV300CD CD player	£3549
KRELL KAV250P Pre amp	£1999
KRELL KAV250A Pwr amp	£3195
MARTIN LOGAN CLS11	£4555
TOTAL	£13,298
PART-EX (Example) or Deposit	£4298
BALANCE	£9000*
INTEREST FREE PAYMENTS 12 X	£750

***OR DEFER PAYMENT 90 DAYS THEN 3 YEARS AT JUST £84.12 PER WEEK**

MULTI-CHANNEL EXPERTISE IS HARD TO FIND

FROM AS LITTLE AS
£405.00
PER MONTH

Digital technology which leads the way in audio-visual systems and there's no doubt that Meridian of Cambridgeshire are world leaders in the design of state-of-the-art multi-channel sound equipment. With our own extensive expertise in home-cinema installations at all budget levels, we have to place this system as perhaps offering the perfect combination of hi-fi pedigree and sonic performance with genuine up-to-the-minute audio-visual compatibility. If you are serious about creating a multi-channel 'home cinema' and hi-fi system, this is the ultimate installation.

MERIDIAN 500 CD Transport	£1245
MERIDIAN 518 Processor	£925
MERIDIAN 519 RF Demod	£450
MERIDIAN 562V Dig Control	£995
MERIDIAN 565-7.1	
S/S Decoder with AC3/DTS	£2850
MERIDIAN DSP 5000	
Digital spkrs Rosewood (2 pairs)	£6920
TOTAL	£13,385
PART-EX (Example) or Deposit	£3385
BALANCE	£10,000*
INTEREST FREE PAYMENTS 12 X	£833

***OR DEFER PAYMENT 90 DAYS THEN 3 YEARS AT JUST £93.46 PER WEEK**

All Systems Guaranteed for Three Years

The HiFi Company

Nobody Values Your Hi-Fi More

THE HI-FI COMPANY 35 - 42 COWGATE PETERBOROUGH PE1 1LZ Tel: (01733) 341755 Fax: (01733) 358141

DENON ♦ EPOS ♦ GRAAF ♦ K&L ♦ KRELL ♦ LEXICON ♦ LINN ♦ MAGNAPAN ♦ MARANTZ ♦ MARTIN LOGAN ♦ M&K ♦ MERIDIAN ♦ ROGERS ♦ SME ♦ SONUS FABER ♦ SPENDOR ♦ TEAC ♦ TECHNICS ♦ UNISON ♦ WILSON ♦ WILSON BENESCH ♦ YAMAHA

FOR THE LARGEST RANGE OF QUALITY USED HI-FI IN THE COUNTRY PLEASE SEE OUR 'TRADING STATION' ADVERTISEMENT OVERLEAF

WANTED

TOP QUALITY HI-FI

We urgently require all types of hi-fi equipment, classic and modern.

INSTANT CASH

OR COMMISSION SALES

Phone (01733) 555514 for full details.

PART EXCHANGE

Nobody Values Your Hi-Fi More - that's our Promise!

BUY BACK PROMISE

Unbeatable 'Buy-Back' GUARANTEED on any future up-grade!

THE FINEST SELECTION OF USED HI-FI IN THE COUNTRY - GUARANTEED!

TURNABLES / ARMS

Akai APB21 (Rega) RB200	£169	£99
Dual CS505		£80
Grado tonearm		£498
Goldring Lenco (78sl)		£75
Heybrook TT2 / Linn LVX / Grado MT+		£248
Linn Axis / K9	£425	£298
Linn LP12 (Afr)		
Zeta/Koetsu Silver Onyx	£2500	£995
Linn LP12 Akito / Lingo	£2200	£995
Linn LP12 Afrosomia / Valhalla		£500
Linn LP12/Ekos/ Troika	£3000	£1298
Logic Tempo / RB300		£198
Manticore Mantra / Magician		
+ MBP6 pwr sup / Ort MC3000		£1198
Pink Triangle Export c/w 250 GTI	£900	£597
Rega 9 / Exact / Mint	£1750	£948
Rega Planet / Acos Lustre		£120
Revolver / Helius Scorpion / P77		£299
The Head MC Transformer	£500	£295
Thorens TD160 S + Mission Arm		£120
The Voyd Turntable (Incl Reference external power supply	£2800	£1298
Voyd 0.5 c/w SMEV (Silver wired)	£5300	£3250

NO MORE LPs?

We always require Enthusiast Quality **TURNABLES**

AMPLIFIERS - SOLID STATE

Albany AP4 Pre	£350	£227
Alchemist Kraken Pre	£395	£288
Arcam Delta 90 (Int)	£500	£268
Arcam Delta 290 (Int)		£375
Audiolab 8000M (X2) ExD£1600		£1125
Audiolab PPA (Phono stage)	£1100	£798
Audio Research D200 Power - 200 wpc	£3250	£2257
BGW 202 (Control/Pre)		£275
Burmester 846 Line Stage		£695
Classe Audio 3D Pre	£1320	£695
C J Sonographe FET (Pre)	£1250	£495
Counterpoint Solid 1 Pwr	£1495	£795
Counterpoint SA20 Pwr	£3000	£1398
Creek CAS4040 Integrated	£225	£144
Cyrus I (Integrated)	£395	£195
Cyrus II / PSX		£395
Cyrus Straight Line	£398	£298
Cyrus PSX R (As new)	£328	£248
DPA 200S Pre/Power	£1250	£875
DPA Renaissance Intgrtd	£595	£477
DPA DSP200 Line Pre	£499	£397
DPA 50S Power	£1500	£895
Finestra EC (Inc mains filter)		£795

TRADING STATION

35 Cowgate Peterborough
(01733) 555514
FAX (01733) 358141

Jeff Rowland Consumate Pre	£5500	£2798
Kinshaw Overture Integrated	£435	£294
Krell Ref KR5BP (6 component balanced pre)		£3995
Krell KSA100S	£5843	£3997
Lecson AC1/AP1 (Circa 1975)		£295
Lentek (Design Award)	£784	£398
Linn LK1 / 280 Pre/Pwr	£1300	£698
LFD LSB + PA2 (Pre/Pwr)	£3800	£1798
Meridian 603 Digital Pre	£1750	£754
Musical Fidelity A200	£800	£425
Musical Fidelity A120	£549	£345
Musical Fidelity F18 (Pwr)	£4000	£1998
Musical Fidelity F22 Pre	£995	£697
Naim 42 Pre		£195
Naim 180 Power	£1095	£798
Naim 160 (Old style)		£495
Naim 250 (Old style - late)	£1655	£895
NVA AP30 (Integrated)	£350	£228
Nytech CP122 / CPA602	£700	£325
OCM 500 Power amp	£2750	£1698
QED C300/P300	£675	£378
Quad 405 Selection From just		£195
Rappaport Pre 2 (Pre)		£295
Rega Elex	£398	£248
Sugden A48 (Circa 1976)		£128
Sumo Athena (Pre) & 9 (Pwr)		£995
Tornado 1/ Hurricane 1	£995	£828
Thorens TTP2000 Mk1 Pre	£499	£397
Thorens TTA2000 Pwr (35w)	£599	£477
Threshold S300 (pwr)	£5500	
£1950 Yamaha A970 (New)	£800	£507
YBA 2 (Pre)	£1700	£878

VALVE AMPLIFIERS

Arion Electra Integrated	£1400	£875
Audio Alchemy Vac-In-The-Box Phono/Pre	£249	£197
Audio Innovations 1st Audio (7.5watt heated triode)	£1700	£695
Audio Research SP11 Mk1 (Revalvd & Serviced)	£4995	£1798
Audio Research SP11Mk 2		£1998
Audio Research BLI Cntr	£888	£587
Audio Research V70 Pwr	£4480	£2487
Audio Research LS15 Line Pre	£3199	£2497
Audio Research LS5 Mk1 Line Pre	£5295	£3997
Avantlc SPA II Vintage valves		£188
Croft Series V Power	£555	£357
Croft Micro Pre / V Pwr	£1400	£704
Dynaco ST120 (Classic ower amp circa 1976)		£328
Golida SG-502	£950	£698
Graaf 5050 Power	£2150	£1657
Graaf WFB 2 Pre	£1195	£897
Grant G100 (3 box MC / Pre / Pwr)	£2200	£998
Papworth Audio TVA50	£1950	£998
PM Components MPL1 Pre plus		
2 x Mp211 Power amps	£5000	£2507
Sonic Frontiers SFM160 (Mono's)	£5495	£2498

CD PLAYERS / DACS

Arcam Alpha 1	£320	£195
Arcam Alpha 6	£500	£354
Arcam Delta 270CD	£800	£447
Arcam Delta 70 /Black Box 3		£675
Arcam Black Box 5 DAC		£295
Acoustic Prec Eikos (New)	£1850	£1448
Audio Alchemy DACMAN	£149	£117
Audio Alchemy DAC-IN-THE-BOX	£229	£177
Audio Alchemy Digital Encoding Engine V1.1	£399	£297
Audio Alchemy DTI Plus	£249	£197
Audio Alchemy ACD2 Plyr	£490	£397
Audiolab 8000 Trans/DAC	£2200	£1500
DPA Renaissance DAC	£569	£395
DPA Renaissance CD Plyr	£950	£757
Kinshaw Overture DAC	£235	£147
Krell SBP64X DAC (1991)		£2998
Marantz SD 35		£75
Marantz CD65 MkII		£100
Meridian 602/606 Trans/DAC	£3350	£1498
Meridian 508CD Mk1	£1685	£1187
Micromega Stage 4 CD	£600	£397
Micromega Duo (2 box)	£2299	£1198
Micromega Stage 5 CD	£750	£597
Micromega Stage 6 CD	£950	£747
Mission dad 7000		£195
Monarchy DIP Jitterbuster	£245	£197
Musical Fidelity Diglog		£195
Musical Fidelity Tubalog	£500	£368
Musical Fidelity E600	£600	£428
NAD 5220		£90
Parasound DAC-1000	£795	£528
Pink Triangle Ordinal DAC	£995	£578
Pioneer PD7700	£250	£187
Pioneer PDS901 (Silver)		£250
Pioneer PD9700	£450	£254
Proceed PDT1 / PDP1	£3490	£1690
Rotel RCD 945		£125
Sony CDP2700 (balanced)	£995	£395
Technics SL-PS 770A	£250	£155
Theta TLC Jitter Buster	£229	£177

TAPE DECKS / TUNERS

Avantlc BM611 Valve Tuner		
Circa 1960 (no decoder)		£148
Braun 301 Tuner		£125
Creek T40	£199	£125
Cyrus Tuner	£399	£268
Marantz SD55 3 hd / 2 mtr	£400	£195
Nakamichi CR2	£495	£298
Nakamichi 680ZX	£600	£398
Revox A77 1/4 track 3 ³ / ₄ & 7 ¹ / ₂		£495
Pioneer CT70R 3 head (Silver)		£150
Revox B215	£1950	£658
Rotel RT850L tuner		£100
Sugden T48 tuner (Circa 1976)		£95
Teac / Tascam 3220 1/2 t- 7 ¹ / ₂ /15		£595
Teac B700	£860	£628
Uher 4200 / PSU / Service Manual		£698
Yamaha KX530	£125	
Yamaha KXW282 Twinmini	£260	£168
Yamaha KX480 mint	£200	£138

LOUDSPEAKERS

Acoustat Model X (valve amps)		£1498
Acoustic Energy AE1	£799	£549
Apogee Caliper Signature (Marked)	£4000	£1508
Apogee Centaur Minor		£1345
Castle Howard Mk2	£1200	£947
Carver Silver Signature	£2200	£1498
Celestion 300 (Rosewood)		£1095
DCM Time Windows		£495
Epos ES22	£1185	£987
Gale 301 (Black)		£165
Harbeth HL4 + Stands	£1000	£398
Harbeth HL Compact 7	£1499	£1197
Harbeth HL K6		£1049
Impulse H6 (Horns)		£878
Impulse H7	£799	£497
KEF 103/4	£1195	£595
KEF 103/4	£1295	£694
KEF 104/2 (Teak)	£1495	£795
KEF 70s (Surrounds)		£299
KEF LS5/1a (BBC Monitors.1960's)		£495
Leak Sandwich (Originals)		£148
Lentek Monitors		£400
Linn Kan II (Inc stands)	£650	£395
Linn Kelidh (Walnut)	£750	£598
Linn Kaber (marked)	£2200	£998
Linn Isobarik (Active)		£1250
Magnaplanar SMG-A		£498
Martin Logan Aerius (Blk)	£2200	£1650
Meridian M30 (Active)		£578
Meridian M2500 Active Sub	£1595	£1297
Mission 753F		£798
Mission 754F		£1498
Mission 754F (Oak) Ex-dem		£1198
Monitor Audio R352 (Teak)	£395	£248
Monitor Audio MA800 (Rose)	£795	£395
Mordaunt Short MS737 with Decca Ribbon Tweater	£500	£175
Musical Fidelity MC2		£295
Nalm Intro (Ex-dem/Black)	£660	£580
Note Perfect Virtuoso	£2750	£1497
Note Perfect Concert	£2450	£1297
Pink Triangle Ventrical	£896	£597
ProAc Response 2	£1700	£998
Quad ESL63 (Brown)	£3500	£1695
Quad ESL63 Afro/black	£3450	£2447
Quad fit Gradient SW63		
Subwoofer system	£1750	£1247
Rogers Studio 3 (Black)	£495	£348
Rogers LS-4 (Black)		£185
Royd Coniston	£249	£120
Royd Minstrel (Black)	£260	£185
Ruark Templar 2	£559	£395
Sonus Faber Electa Amator Mk1	£3293	£2497
Spendor SP1		£549
Spendor BCIII (Teak)		£495
Tangent RS2 + Stands	£400	£225
Tannoy 637 Profile	£575	£450
Tannoy Devon (12" drivers)	£795	£348
Thiel CS1.2	£1100	£645
Townsend Glastonbury	£1700	£854
Wilson Witt Mk1	£8888	£6887

TRADING STATION

The HiFi Company

ESTABLISHED 1974

PRIVATE CLASSIFIED ADS

Six pages of great bargains !!



Dealers must not advertise in the Private Classified section. Monthly consecutive insertions will be considered Trade advertising. The Publisher reserves the right to judge submissions

ARCAM DELTA 170.2 CD transport and Black Box 2, with interconnects and remote control. Excellent condition, boxed, manuals, £400. Tel: 01908 615 305 (home), 01908 653 634 (work) (Milton Keynes) (Jan)

LINN EKOS Mk1 tonearm, mint and boxed £475. NYA 3 box set - P80/A60/Phono 1. Excellent condition £375. Wanted: Naim Armageddon + Mana amp stand. Tel: 0181 871 0424 (SW London) (Jan)

LINN MAJIK I integrated amplifier with MM/MC phono stage. Brand new condition, boxed etc £370 ono. Tel: 01285 652 649 (Cirencester, Gloucestershire) (Jan)

KRELL KC100 cartridge retipped by Van den Hul £450. Musical Fidelity 3A pre-amp, 1 pair MA50 power amps £400. Oracle Alexandria Mk IV turntable, piano black £495. Naim Snaps power supply £50. Tel: 0410 275 149 anytime (Jan)

AKAI 4000D reel to reel £110. Target TTW2 wall stand £45. Target 2 x 1 1/2 equipment table £40. Linn K9 c/w extra stylus 10 hours use £55, QED 200 cable 4 x 6m £36. Tel: 01484 864 962 (Jan)

LEAK SYSTEM. Delta 75 receiver, Delta turntable and Sandwich 600 speakers. Owner from new, still used. Excellent condition. All instruction books and registration cards! £200 ono. Tel: 01253 395 784 (Jan)

MERIDIAN 551 & 209 remote £475. Meridian 555 power amp £425. £850 together. Great bi-amped. Meridian 208 CD player £1100. Transcriptors Hyd. Ref. Helius arm £250. Wanted: Lecson amps and pre-amp. Tel: 01226 710 605 (Jan)

SAGE AUDIO Supermos 250 power amp (2 monoblocks) £600. With pre-amp and separate phono stage £200 and spare Supermos 500 power module (compatible with Supermos £250) All pure Class A to full power. Is this the ultimate amp? Tel: 0141 578 1205 (Glasgow) (Jan)

SONNETER CAMPION amplifier, boxed as new £380 ono. Rotel phono amp RQ 970BX £65, boxed. Sale due to upgrading. Tel: 01546 603 592 evenings (Jan)

AUDIOLAB 8000M monoblock pair, only 9 months old. As new, perfect condition. Incompatible upgrade forces sale. Boxes, manuals, guarantee £500 saving on new! Bargain £1100. Tel: Peter 0121 706 6658 (Birmingham) (Jan)

ROGERS E40A valve amp. 40 watts per channel. Unused, boxed, current model new price £1800. Only £950. Rogers LS55 speakers, as new condition £275. Tel: Day 0181 771 7350. Eves 0973 320 252 (Jan)

MONITOR AUDIO speakers 703 PMC. Black ash £600. Epos speakers ES22, light cherry £850. Both 6 months old and in immaculate condition. Tel: John 01425 628 064 daytime. 01202 516 289 evenings and weekends (Jan)

MAGNEPLANAR SMGA speakers black upgraded x-overs spiked stands £350. Arcam Black Box 5 DAC £279 ono. Wanted: Technics U205CMK3 cartridge, AR P/C/E/ 77 MG/Stilton bodied cartridge any condition. Tel: 01209 613 733 (Jan)

LINN KEILIDH Loudspeakers (black) bases £400. Two Linn LK100 poweramps, each £350, both £625. Linn Pretek preamp £120. DPA TI transport + Bigger Bit 2 £650. Teac KT3133 flywheel tuner £30. JVC KD-D35 cassette £30. Together £1600. Bargain. All boxes, instructions. Tel: Ken 0121 353 7627 evenings (Birmingham) (Jan)

ROGERS LS6 Black ash speakers, superb sound (no space in new location) mint, boxed £175 inc. 24 hour carriage UK. Target iT2, mint £25. Target TT3, mint £30. Tel: Joanne 01889 582 688 daytime (Jan)

LINN LP12/Aro/MC10 Supreme £900. Linn Kairn (phono) £600. Dynavecator 17D2 £225. Audion valve phono stage, hardly used £200. Audionote transformer AN S2 £150. Tel: 0115 972 4161 (Jan)

NAIM CD3 12 months old, mint condition, boxed £600. Chord Company Cobra 5 pin DIN to 2 phono, 1 metre £20. Leak Truspeed MkII turntable. Perfect working order. Mint condition £75 Tel: 01295 261 166 (Jan)

ATC ACTIVE 100 speakers £4200, Quad 66 pre amp £440, Teac P500/D500 CD player £700. Exposure 15 amp £350, Yamaha CX2/MX2 pre pwr amp £675. Tel: 01977 643 629 (Jan)

LINN LP12, Cirkus bearing, Akiko, K9, Lingo power supply, Alfiro finish £750 ono. CD player considered for exchange. Naim 42.5 pre £50. Tel: 01689 827 572 (Kent, SE London)(Ans/Ph Hixon) (Jan)

AUDIOLAB SILVER Night 300B monobloc valve power amps and Audion Premier 2 box preamp with phono stage £2000 ono. Roksan DPI CD transport and DSD Decode 1 DAC £650 Tel: 01403 711 778 (Jan)

RUARK TALISMAN MkII, dark walnut, excellent all rounder, £400. Sony 561E CD player, excellent with valves £120. Tel: 0161 437 5819 eves (Jan)

CROFT SERIES 3 OTL power amp £650. Audiolab 8000A amp MkII £300. Nakamichi CR-3E tapedeck £350. Marantz CD-6SDX £150. Manicore Mantra TT, Alphason Opel arm, Audio Technica ATC OS cartridge £450. Pioneer F656 tuner £120. Tel: 01507 463 917 (Jan)

NAKAMICHI TAPE Deck wanted, only tidy examples considered. Tel: 01462 653 567 (M.F. England) (Jan)

ION NEXUS SP1 pre amplifier with X-PAK2 power supply, moving coil phono input £250. Tel: 01244 345 461 (Chester) (Jan)

NAIM 32-55 (Naim serviced) MC and 2 x CD boards. NAP 90 power (dealers guarantee) All traditional style and boxed. NA 24 interconnect. Naim speaker cable £495 ono. Money back guarantee. Tel: 01202 481 386 (Jan)

FOR SALE Systemdek IIXE, walnut veneer, acrylic platter, Helius Scorpio arm, Roksan Chorus, Black cartridge. Excellent combination £250 ovo. Arcam Delta 70.2 CD player plus Sorbothane feet, box, manuals, good condition £175 ono. Tel: 01256 476 060 (Jan)

QUAD ELECTROSTATICS EL557. Good condition, wonderful sound £300. B&W DM610 loudspeakers £125. AR Legend turntable with RB250 & Ortofon S10 £150. Thorens TD150 without arm £25. Tel: Mike 01248 681 602 (Jan)

LINN KLOUT power amplifier, 160 watts per channel. 1 year old, with maker's guarantee. Supplied with box. Will demonstrate. As new. To buy now £2400. Bargain at £1200. Tel: 01992 460 831 (Jan)

AUDIOLAB 8000Q £600. Boxed, 18 months low level use, remote control, two pre-amp outputs. Tel: Peter 0181 294 1340 daytime (London, Eltham SE9) (Jan)

QUAD ELS 57 with MAF stands £395, JPW P.I. light oak with Atarama 24" stands £140. Cambridge CD4 and DacMagic 2i £175. Troughline Stereo £80. Tel: 01455 558 426 (Leicester) (Jan)

QUAD FM4 tuner, brown, with switched DX filter, original spec in 'Wide', £250. Single Optimus Pro LX5 speaker (with Lineaum tweeter; identical to Tandy Genex Pro LX5) £60. Tel: 01751 432 656 (Jan)

A HI-FI CLASSIC for £600. Pink Triangle PT Two (serviced by Pink) in black plinth with Helius Orion arm (silver wired) and PSU. Tel: 01252 715 031 (Surrey) (Jan)

LINN SONDEK LP12 turntable 1983. Unused, still in box. Unwanted gift £200 ono. Tel: 0115 943 8005 (Jan)

NAIM 72/180 Pre/Power amp £995. 2 x 5m Naim speaker cable £25. Tel: 01992 578 964 (Epping) (Jan)

LUMLEY ST 70 triode switchable, mint, boxed, bargain £875. Grant G100 AMS 100 watt valve monoblocks, boxed £695. Audio Innovations First Audio new 2A3 valves, mint, boxed £675. Swap or exchange for interesting equipment. Tel: 0121 784 8765 (Jan)

MICHAELSON AUDIO Odysseus integrated valve amplifier, 45 watts p/c. Superb sound quality. Boxed, mint, cost £1000. Accept £525. Sony S570ES tuner, boxed, mint £90. Tel: 01432 275 203 (Hereford) (Jan)

HADCOCK GH228 Super arm with Uni-lift and damping fluid. Excellent condition. Boxed £70. Entre-1 moving coil cartridge. Little stylus wear. Boxed £20. Tel: 01228 44398 (evenings) (Jan)

QUAD II's SPARE KT66 valves £400. Quad 44 £150. Quad AM3 & FM2 valve tuners. These are hybrids with independent power supplies. Offers. Quad 303 £90. Wanted Quad 606 Mk2. Tel: 012258 52271 (Jan)

AVI S2000MI integrated amplifier. 100 watts per channel. Complete with remote control. 15 months old. Excellent condition £500. Tel: 01256 461 453 (Basingstoke) (Jan)

SYSTEMDEK SYSTEMS 93Is speakers in walnut. Mint condition £160. Tel: 01633 667 346 (Jan)

SPENDOR SPI/2 speakers with M.A.F. stands (£1500) £550 for a very quick sale. Phone anytime day or night. Tel: 0181 531 5979 (Jan)

MERIDIAN 566 DAC. Latest, 20 bit version, boxed, instructions & digital interconnect. As new, cost £1090. Sell for £700. Tel: 01285 862 564 daytime. (Jan)

AUDIO SYNTHESIS Passion. All Vishay (£795) £240. Woodside ISA230 line amp (£1000) £445. Neat Critiques (£325) £175. Granite speaker stands, 18" high £65. Tel: 01707 891 974 (Herts) (Jan)

RUARK ACCOLADE Loudspeakers. Dynaudio low, mid and high drivers. In dark walnut. 'Soundbytes' filled, each speaker weighs 70 kgs. Effortless dynamic presentation. £2750 new, asking £1750. Tel: 01296 437 314 (Aylesbury) (Jan)

CLASSIC VINYL: Early Roksan Xerxes Artemiz AT OC9 (new) can be upgraded to latest spec. Black, vgc, little use. Naim NAC 42-5 (MC) Hi-Cap. NAP 110, MS20 speakers NAC-5 cables. Soundorg tables. Mini forces sale! Sensible offers. Tel: 01326 319 626 (Cornwall) (Jan)

RUARK EQUINOXES £990: Crusader II £895. consider P/Ex for ATC 10 or AVI Neutrons. AVI 2000 MM 150W monoblock power amps £750. Tel: 01092 536 919 (W. Kent) (Jan)

DPA ENLIGHTMENT DAC + 'Power' mains filter and Slink mains lead for sale. Immaculate, boxed, manual and run-in with manufacturers warranty £640 ono (£950 new) Tel: 01934 813 666 (Nr Bristol) (Jan)

WANTED LINN Powertek power amplifier. Demo working if possible. Tel: Mike 01708 726 403 (Ans-phone) (Essex, E. London) (Jan)

NAIM 72 PRE-AMP, with M/M boards, boxed as new £425, no offers. Tel: 01635 40242 (Newbury/Berks) (Jan)

CASTLE HOWARD S2 loudspeakers in natural oak £750. B&W CDM1's in red ash with Kudos stands £500. Exposure XV Super, moving mag £500. Marantz CD-63 Kl Signature £325. Cyrus FM7 £200. Nordost Flatline, bi-wire £160. Between 12-18 months old, with boxes. Tel: 0976 241 713 (Blackburn) (Jan)

BRAND NEW untouched equipment for sale. Proac Response ISC speakers (ebony) with Target R1 stands, new £1720, asking £1375. Theta Pearl CD transport, new £1450, asking £1175. Audio Technica ATOC9 cartridge £200. Tel: 01924 290 749 (Jan)

classified ads

THE EMPORIUM

28 St Nicholas Street, Diss, Norfolk IP22 3LR
Tel/Fax: 01379 650744

FOR SALE

CD & DAC's

MICROMEGA Microdac	£200
KEWWOOD DP-K9000 transport	£200
ARCAM ALPHA PLUS	£200
MICROMEGA Stage one	£275
ROKSAN DAC 1	£200
AUDIO ALPHENY 11 OF MISSION DAC S	£180
MERIDIAN 506 88 bit stereo reloaded	£550
PINK TRIANGLE OA CAPO 18 bit CD + DACs	£850/1007/£925
MERIDIAN 200 TRANSPORT/203 DAC CD + DACs	£650

WANTED: CD Transports + Good DAC's

VALVE-AMPS

AUDIO REFERENCE Pre-amp	£450
GAMMA RHYTHM 211 Single Ended	£1250
AUDIO INNOVATIONS Second Audios with new matched Octet of Golden Dragon 243 pair	£1100
STEREO HOLLAND 510 with parallel + Parallel transformers	£1200
AUDIO RESEARCH CLASSIC 30	£1200
ADGERS CADET / HG88	£1000/£1500
COUNTERPOINT SA7 valve pre with high level input	£400
MELOS 222 Two box Vankee high end valve pre-amp, awesomely dynamic MC input.	£1200
BEARD P100 MK2 Power amp, the big black ugly beast, buy it first then tell the wife!	£550
AUDIO RESEARCH D70	£900
CONCORDANT EXHILIRANT (line level only)	£400
HEART 300B single ended monoblocks 1/2 price	£1100
LEAK TL12+ gold very good	£150
Orange Pre Amp	£350
Gamma Gemini single ended integrated	£350
LEAK STEREO 20 Excellent	£250
AUDIO INNOVATIONS Triode Monoblocks 604g Push Pull on old 900 series chassis often called list	£600
AUDIO Mono	£600
CROTT SUPER MICRO/V PRE/POWER	£400
AUDIO NOTE CONQUEROR 300B Stereo	£1000
Beard P35 II power amp	£550
Audio Icomatocast III II	£300

WANT TO GO VALVE? RING FOR HELP

LOUDSPEAKERS

VOIGT DOMESTIC COAXIAL HORNS with LOWTHER PH2A	£2500
QUAD ELECTROSTATICS ESL 63 Black with stands 5 years old	£1350 pair
TDL Studio 3's	£500
CASTLE CHESTERS	£300
TANNOT CHATSWORTH RT with 12" Monitor	£450
THIEL ES 1.2	£550
LOWTHER PH6A original alnico magnets, serviced, pair	£250
QUAD ELECTROSTATICS good used pair	£400
LINN KELEIDON spiked floor standing speakers	£400
TANNOT Easterbury/Tork/GRF. Pairs	POA
LOWTHER TPI Original Type A Pair	£2000
HETROOX Quartets	£375
PROAC Response 1's*	£550
SOUNDLAB DVNSTAT	£3600 new only £1000*

Linn L4100 black based high	£3000
Thorn Boe Active Crossover	£150
TOL ATL 2 Transmisson line small/footstander	£1400
Linn Kallers Active with Tune Box	£1400

WANTED: Pro-Ac, LS3a, TANNOT 15" + 12" MONS, FABEA, MARTIN LOGAN, QUAD, IONOFANE, VOIGT ENERGOIZED DRIVERS, PIZ HE25, HIIFI LARFITA

TURNTABLES/CARTRIDGES

SME 3009 II	£40
VOYD with split phase PSU, Audionote Arm	£1200
HETROOX T12	£175
Denon 103	£50
LINN ASAR MC	£500
WANTED: GYRODECK, SME20, ORBE, SHEIV, V, 3012, NAIM ARO, DECENT MC's, LINN LP12, ITTDX, EKOS ARO	

FOR SALE

LINN KARAN WITH BRILLIANT P.S.U.	£900
LINN LR200 / Spark	£450
LINN 6000 tri-wire cable 2x5.5 metres	£75
MICHEL Argon HX/HERA/ALECTO Monoblocks	£2400
HUMBLE French Pre-amp with mm phono + separate pass.	£450
Naim Mini 2	£250
MARAKICHI 700 Tritracer	£200
QUAD 606 1/II	£325/£425
MUSICAL FIDELITY Pre-amp 8	£200
SUGDEN A8BII	£100
LINN LK1 Preamp ELLA's no leads hence	£190
QUAD 33 pre-amp	£75
REVIN LABS Absolute Zero line pre + MC stage (pair)	£250
MUSICAL FIDELITY E100, Shiny + Very Phallic.	£400
LEAR TAUGHLIN STEARO	£100
QUAD 33/303 (pair)	£150
INTEGRATED CLAYMORE	£140
YAMAHA CR-1000 Tuner Amp - wooden sleeved beastie	£200
QUAD 34, 44, 405, 306	£200 each
Naim 72 pre with MC board	£450
AUDIO INNOVATIONS Passive Pre	£100
RADFORD SC24/SPASO	£200
MISSION CYRUS Pre/Power	£400
AVI Pre + 2 Monoblocks	£900
Naim 72/140 new style with phono	£900
Naim NAT 02 Tuner	£500
MARAKICHI 600 tatty but serviced	£100
MARAKICHI RX 302 unidirectional tweets cassette around	£300
MARAKICHI 480 2x	£200
ALPHASON ATLAS PSU	£150
ALPHASON SONATA TURNTABLE with Atlas pmu & HA100 MCs Arm	£550
ROGTSU black	£250
AEYEX A77 2 track 33/4, 71/2 ips with NAB adaptors	£275

VINTAGE

Quad QCI	£40
Quad 22 Totally Rebuilt	POA
Quad 4 pair original valves	£500
Leak Stereo 20 + Vardolico Stereo	

WANTED ALL YOUR VINTAGE GEAR

PHONE WITH THE PHILE YOU WANT OR WE CAN MAKE YOU AN OFFER. ALSO GOOD USED EQUIPMENT WANTED

ALON & LOW POWERED VALVES AMPS

Regular readers will know that I am not a great fan of low powered valve amps because they are generally incapable of driving real world speakers. But there are a lot out there and a recent experience with an A.I. 500 and the Alon 1 speakers showed a remarkable synergy and some amazing bass that astounded everyone. Alon are now also producing a new range of speakers specifically for valve amplifiers, of which the Lotus at £2750 is the first and now available in the UK. Two more new items worth investigating are the AVI CDII CD player at £900 and the ATC A7 Bookshelf and Tower speakers at £750 and £1200 respectively, so that with the AVI Integrated at £1000 and the AVI Positron speakers at £900 it is now possible to buy these superb systems for between £2650 and £3100

SALE OF EX-DEMO (X) / P.E. EQUIPMENT

	NEW	SALE
AUDIO INNOVATIONS S800 ANNIVERSARY POWER		
AMP + BORDER PATROL POWER SUPPLY	£2000	£1000
DALI 104 MS FLOORSTANDERS (MODIFIED)	£650	£350
HORNING AGATHON SIGNATURE BRONZE (OAK)	£2800	£1400
X CELESTION KINGSTONS + STANDS	£2500	£1800
LFD MC2 PHONO STAGE	£1500	£700
AUDIOPLAN KONTRAPUNCT SPEAKERS (BL)	£N/A	£500
AUDIO INNOVATIONS 1000 VALVE PHONO PRE	£1500	£700
DENON DP3000 D/D TURNTABLE + SME 3009	£N/A	£250
ROKSAN XERXES + SME 3009 S/2 + 1022	£1200	£550
BEARD BB101 (SEPARATE P.SUPPLY) 50W/CH INTEGRATED	£2500	£1200

V'audio Hi-Fi Consultants

36 Druid Hill, Stoke Bishop, Bristol BS9 1EJ
Tel / Fax: 0117 968 6005



MANTRA AUDIO

CARTRIDGE SELECTION	NEW	EX	REPLACEMENT STYLII	
Audio Technica			Audio ATN 95 E, ATN 110E	£13*
AT 95 E	£21		Arcam PN7	£48
AT 110 E	£25		Technical ATN 450 E	£33*
AT OC 9	£280	£210	ADC XLM Mk III	£13.50
Denon			Akai AN 5, AN 60	£9
DL 304	£190	£160	AN2, AN 70	£11
Goldring			Dual DN 145 E, DN 165 E	£13.50
1012 GX	£70		Goldring G800 Super E	£13.50
1022 GX	£90		D 12 GX (for 1000 Series)	£46*
1042	£105		D 42 (for 1042)	£70*
Eroica (LX or H)	£100	£65	JVC DT 55, DT 60	£9
Elite	£187	£122	National EPS 24 CS, P 30 D, P 33 D	£9
Excel VX	£446	£360	Ortofon FF 15 E II, VMS 20 E II, OM 20 510	£13.50
Grado			Pioneer PN 210, PN 220, PN 240	£9
Prestige Black	£44	£134	Shure N 75 C, SC 35 C,	£9
Prestige Gold	£134		N 75 ED T2, N 75 EJ T2	£11
Ortofon			N 95 ED, N 95 EJ, N 75 3 (78)	£13.50
510	£32		VN 35 E	£16.50
MC 15 Super II	£120	£102	N 95 HE, N 97 HE, VN 35 HE	£22
MC 25 FL	£210	£178	Sony ND 142 G, ND 150 G, ND 155 G	£9
MC 10 Supreme	£263	£224	CN234	£11
MC 20 Supreme	£330	£280		
MC 30 Supreme	£392	£333		
Rohmann	£725	£645		
Shure				
V 15 V XMR	£265			

EX - Exchange price against any type of moving coil cartridge

Visit our Website at
<http://www.mantra-audio.co.uk>
For full selection and technical data

MAIL ORDER (1-10 DAYS) PRICES (INC D&P) ARE BEST WE CAN OFFER THROUGHOUT THE UK & MAINLAND EUROPE - ALL ITEMS CARRY FULL MANUFACTURERS GUARANTEE - PLEASE NOTE WE DO NOT ACCEPT CREDIT CARDS - OVERSEAS CUSTOMERS PLEASE ADD £5.00 TO ORDERS OVER £50 IN VALUE TO COVER INSURANCE

Tel/Fax (01757) 288652 e-mail: enquiry@mantra-audio.co.uk

MANTRA AUDIO (HFW), 22 GARTH AVENUE, NORTH DUFFIELD, SELBY, NORTH YORKS YO8 7RP

Q.T.A. SYSTEMS -

DESIGNS ENGINEERED FOR EXCELLENCE WITH:-

- POLYPROP CAPS
- AIR CORED COILS
- HI-TEC DRIVERS
- TOP GRADE COMPONENTS

- CABINETS INCLUDED WITH OPTIONS ON FINISH
- NOTES AND SPECIFICATIONS COMPREHENSIVE INSTRUCTIONS
- AVAILABLE AS COMPLETED UNITS WITH STANDARD OR EXOTIC VENEERS
- DISCRETE COMPONENTS CUSTOM MACHINING SMALL PANELS, JOINTS & CUT-OUTS

FOR FURTHER DETAILS:-

Q.T.A. Systems

2 Wheatsheaf Way
Linton - Cambs CB1 6XB
Tel: 01223 891091

Hi-Fi World Classified Ads



PRIVATE

VALVE AMPS, Dynaco Stereo 70, rare S.T.D. 381 Stereo, matched pair gold Leak TL12 plus, Stereo 20, Rogers Cadets, Luxman LX33. All lovely condition. Wanted: Sound Sales triode amp. Tel: 01364 72153 (Jan)

FOR SALE: Leak Troughline 3 stereo tuner £100, Williamson amp (pair KT66's) £150, GL68 + arm £25, ARI9B speakers £30, Wharfedale panel speaker £40, Hacker VHF Herald radio £20, Phase Linear model 330 pre amp £50, Hi-Fi Year book 1976 £5, Quad mono preamp £5, Chapman valve tuner £20, Vortexion power amp £25. Tel: 01661 852 874. New/used valves for sale. Send SAE to: A. Cavender, 288 Hexham Road, Throckley, Northumberland, NE15 9QX (Jan)

THORENS TD105 turntable, with SME 111S arm and Shure V15V/MR cartridge, immaculate condition £160. Target TTS stand £40. JVC A1 turntable with Shure cartridge £20. Tel: 01245 442 052 (Chelmsford) (Jan)

WANTED: I.A.S. 811 1/4 wave horn loudspeakers. Demonstration essential. Will collect. Tel: John 0181 452 0053 (Jan)

POSSELT ALBATROSS horn loaded speakers. 6 ohm, 91dB. Black finish £1500. Buyer collects. Tel: 01423 536 692 (Jan)

ZETA TONEARM, VDH, S/wired £650. 'Gold Bug Briar' MC cartridge £450. Both items recently rebuilt by 'The Cartridge Man' and still need to be run in. Perfect condition. Tel: 0181 688 6656 (Jan)

AUDIO ALCHEMY DITB: Theta TLC Jitter-Buster £145 each. Flatline bi-wire speaker cable, plugs, 2x4M £125. Sound Organisation 3 shell cable £45. Pair B&W P4 speakers, plinths £495. Tel: 01908 510 852 (Jan)

TEAC TI CD Transport, 6 months old, immaculate £400. Wanted: SME 309 tonearm, Cambridge CD3 and Kelly ribbon tweeters with transformers. Tel: 01780 764 149 anytime. Can deliver/collect. (Jan)

GARRARD 401 Chassis in excellent condition. Includes manual, test certificate and cutting template. Also includes incomplete SME 52 arm £150. Tel: 01727 761 908 (Jan)

ARCAM BLACK Box 2 DAC £150. JRI49 loudspeakers £100. Leak Troughline 3, overhauled by G.T. £200. Maplin Millenium amplifier monoblocks £180. Tel: 0121 427 8810 (Jan)

NAIM PRE-POWER Amplifiers, 32.5-140 (140 new circuitry by Naim) Snaic cable, 2x4 1/2 metres A5 speaker cable, Chord Cobra interconnect £525. Epos 14 speakers bi-wirable + stands £350 ono. Tel: Roy 01444 241 472 (Sussex) (Jan)

ONITOR AUDIO Studio 20SE (black ash) £1400. Harman Kardon AYP1a THX Dolby surround sound processor £1200. Kef 100 centre speaker £150. Marantz PM60 power amplifiers (3 for sale) £120 each. All in immaculate condition, manuals and boxed. Tel: Tony 0370 48 45 44 (day) or 01905 723 396 (evenings) Worcester (Jan)

NAIM WANTED: NAC 52 Supercap, CDS, DBL speakers. Tel: 0171 371 5497, 0385 315 550. Fax: 0171 371 5842 (Jan)

NEAT PETITE Speakers £300, Slate Audio stands for Neat Petite £179. Linn Sara speakers with stands £300. Musical Fidelity MYT Mark 3 pre amp £450. Tel: 01132 621 383 (Jan)

MERIDIAN 201 Pre-amplifier (boxed with manual) with Meridian M2 active loudspeakers in rosewood, with Meridian stands. All in excellent condition £525. Tel: 01234 711 657 (North Bucks) (Jan)

LINN LP12 Turntable, walnut. Valhalla, armboard & springs upgrade (unused 2 years) boxed. Black (rare) Ittok II, K18 (25 hours) Excellent condition £500 ovno. Tel: 01933 680 245 (Finedon, Northants) (Jan)

AUDIOLAB 8000T Tuner. As new, boxed. £395. Tel: 01884 259 637 (Devon) (Jan)

QUAD GRADIENT Crossover £700 each. Two available, both as new. Tel: 0171 257 6384 or 0956 338 103 (North London) (Jan)

AUDIONOTE AN-R Speaker cable, 4 metres bi-wired £80, single £40. Military spec interconnect cable, silver plated CD to DAC £25. Speaker stands 2ft tall, 4" steel box, top plates 8" x 9", stainless spikes, solid high mass, sand filled, built for Proac Studio 100 £80. Tel: 0161 928 1158 or 0161 929 6620 after 5pm (Jan)

NAIM CD 3 CD player, excellent sound, full of detail, has vital tingle factor. 2 x 4 metres Naim Nac 5, 1 Chord Company interconnect. £675. Tel: 01992 718 406 after 5pm (Jan)

LINN AXIS/Akito/K9. Dealer set up. Includes extras £225. NAD 402 tuner under guarantee. Includes expensive interconnects £95. Both mint. Also speaker cables and connector bargains. Wanted: Lingo. Tel: 01772 791 147 (Jan)

T-YAC LINE Level integrated stereo valve amplifier. 50 watts per channel, Class A from KT88 output valves. As new £500. Tel: 01795 536 269 (Jan)

QUAD SYSTEM, comprises 44 control unit, 2 x 405 Mk1 power amps. Configured for bi-amp operation. FM4 tuner. All in classic bronze finish. Boxes, manuals, all in good condition with pedestal stand £500. Tel: 0161 688 0152 after 7pm (Jan)

HEADROOM HEADPHONE amp with More Power unit, image processor, one of the best £230. Tannoy DS00, rosewood £750; 3 Seismic Sinks £80 each. Sony CD-Player 337 ES, huge and heavy £80, 4 pairs of Cable Talk Monitor 2 interconnects £25 each. Naim NAC 5, 4 x 5m £50. Tel: Michael 0171 937 7935 (Jan)

VINTAGE QUAD Electrostatic speaker. Quad twin amplifiers. Quad control unit. Quad FM tuner. Quad AM tuner. Garrard 401 with SME tone arm complete in cabinet. Offers. Tel: 01483 503 154 (Jan)

ROYD PRIOR speakers in walnut. Unmarked condition. Tel: 01908 510 838 (Milton Keynes) (Jan)

QUAD ESL63 (1988) £1500. Quad CD77 (grey) £650. Quad FM4 £275. Quad 44 (grey) £250. Quad 306 £350. Linn Keilidh active system, complete (new & guaranteed) £2250. Revox B77 high speed 1/2 track £650. Arcam Alpha 8 (unused) £290. Naim 72/140 (very latest) £900. Tel: 01952 502 097 (Jan)

QUAD ESL 57's, rebuilt with new internal wiring, components and new dust covers, on good quality stands. Superb sound, audition essential to appreciate £500. Tel: 01780 764 149 anytime (Jan)

XLO 4.1 DIGITAL leads .5 and .75 metre. XLO 1.1 analogue interconnects .5 metre. Nutrik Profi analogue interconnect .75 metre. Meridian 562 D-A converter, plus others Tel: 01865 450 822 (Oxford) (Jan)

QUAD 34 303 as new in boxes + books and cables £200. Thorens TD 160 Mk4 with SME 3009 arm and Shure ML 140 HE cartridge as new £165. Tel: Steve 01203 544 626 (Jan)

SONUS FABER Grand Piano's, brand new, £1750. Concerto's with stands £850. LPI2 Valhala/Syrinx PU2 £475. Hafler DH200 power amp £350. Leak Troughline Stereo 30 + console £200. Luxman T88R tuner £100. Audio Alchemy DDE v1.0/Power Station 2 £350. All 'spot on'. Tel: 01273 607 068 (Jan)

QUAD 77 Carbon amp mint £450 ono. Linn Sondek black ash, Ekos MkII, Lingo, Karma, boxed, new lid, bargain £1500. Acoustic Energy AEI's, new drivers, gloss black, dedicated stands £650. Linn Kabers, black ash, mint £600. Atacama SE 24's £45. Tel: Jules 01792 280 061 (Jan)

MARTIN BASTIN Garrard 301, Tim de Paravicini 'H-bracket', beautiful cherry, SME 3009/II serviced, rewired with vdl tone arm leads, SME FD200 fluid damper. Pickering XV15/625E cartridge spare styli. Superb sound and looks. Cost £1055. Price £575. Tel: 01203 713 501 eves (Jan)

QUAD COMPLETE valve stereo system. Quad 11/22/FM1 w. decoder/ESL in mint condition. Very late ESL's ca. 1979. Tuner and ESL recently serviced by Quad. Very pleasant system. Price £895. Very heavy, spiked MAF stands for ESL and spare new GEC KT66 valves also available. Tel: 01203 713 501 eves (Jan)

GARRARD 301 chassis. Mint to very good condition. Greased bearings: Silver Grey £350, Cream £250. Oiled bearings: Cream £150-175. SME 3009 and 3012 arms £50-75 & £175 respectively. Shure V15II £35. Garrard 401/Decca FFS5 in teak plinth £150. Tel: 01203 713 501 eves (Jan)

LEAK STEREO 20 gold as new and in collectable condition £350. Leak TL12+ gold pair, almost original condition and with Leak preamp £195. Leak Troughline 3 stereo £50. Garrard 401 chassis as new £105. Tel: 01203 713 501 eves (Jan)

COMPLETE QUAD valve based stereo system comprising of Quad 11/22/FM1 (no decoder)/ESL (bronze). Very good condition and sound. Price £755. Tel: 01203 713 501 eves. (Jan)

REGA 9, Exact cartridge, immaculate £1000. Teac YRDS 10 SE £600. Exposure Super 15 MM £600. Epos ES12's, light cherry, with stands £470. Record storage rack, holds 675 LP's £100. Tel: 0385 765 727 (Jan)

MICROMEGA STAGE 1 £270. DPA Little Bit Three £230. Pioneer Laser Disc player 1950 £300. DPA integrated amp £350. Creek T40 tuner £120. Tel: 0385 765 727 (Jan)

EPOS ES25's, Black £1100. Marantz CD63SE £250. Audio Alchemy D.I.T.B. £140. Rogers Studio 3's, rosewood with stands £300. Five tier custom design rack, glass shelves £125. Tel: 0181 311 8986 (Jan)

QUAD FM4, silver fascia, mint and boxed with manual £250. Stax Lambda Nova Basic, mint and boxed £300. Meridian MSR remote £40. JBL L20T monitors with Foundation stands £170. Tel: 01793 526 796 (Jan)

MISSION 752F Speakers, boxed as new £385 ono. Arcam Alpha 5 Plus CD player £240 ono. Tel: Yusuf on (Mobile) 0976 233 994 or (home) 01293 530 254 (Jan)

WADIA 8/15 Transport/DAC, digital volume control, mint, boxed £2995 (£7500 new). Jeff Rowland Model SSE balanced, Kimber Silver wired, latest TZ spec, mint, crated £2450 (£7500 new) Tel: 01449 676 335 (Jan)

NAIM NAC 72K, Hi-Cap, NAP 250 £1600. NAP 140 £400. All vgc new style, boxed. Tel: P. Allen 01903 893 352 (W. Sussex) (Jan)

B&W CDM2 Loudspeakers. Absolutely mint condition £220. Atacama stands, 21 inch, mint £40. Tel: 01494 525 618 (Jan)

AUDIO INNOVATIONS Series 200 separates, ideal introduction to valve amplification, EL84 output stage, quality MM phono stage, new valves, mint condition £470. Quad 22 with stereo cables £50. Tel: 01834 860 681 (Jan)

MARANTZ CD 10, cost £1250, sell £700 ono. Stemmfort/Sugden SF100 amplifier, cost £850, sell £600 ono. ProAc Response One's (special finish - Burr Oak) cost £1200, sell £800. Target stands, cost £350, sell £175 ono. Target 'TS' stand with solid marble shelving, cost £375, sell £175. All units are immaculate with original packing and boxes. Tel: 0131 228 9501 (Jan)

MUSICAL FIDELITY 3A pre-amp £250. Arcam Alpha 5 Plus CD & amp £330. Thorens TD160-Super £150. 2 Nakamichi c/deck £275 & £225. Audiolab 8000-DAC £450. All in excellent condition (instruction manuals) KEF 104/2 or 105/3 rosewood speaker wanted. Tel: 0121 326 8083 (Birmingham) (Jan)

ARCAM POWER amplifier £280. 4 months old. Tannoy M20 speakers + JPW MS2 Epos style stands £60 immaculate, very clean deep bass. Albarry AP3 pre-amp £70. Tel: Martin 0171 690 9445 (Jan)

PINK TRIANGLE Anniversary, SME V, mint £1750. Sonus Faber Minima Amators, iron wood stands, mint £1600. Copland CS14 integrated amp, 1 yr old, mint £800. Audio Innovations 500 integrated amp £400 ono. Tel: 01937 725 089 after 6pm. Mobile 0976 241 092 (Jan)

NAKAMICHI CASSETTE Decks. 582/581/480 £300/200/120. Aiwa 6900 c/deck £150. Power amp NAD 902 new £150. Russian valve amp new £500. Luxman L-3 amp/T-112 tuner £180, Trio KT-1000 tuner £300. Tel: 01494 721 274 (Amersham, Bucks) (Jan)

classified ads



Y.F. & Associates
Sales and Service

MAKE AND MODEL	TYPE		WAS	NOW
ARCAM ALPHA	CD PLAYER	S HAND		£150.00
BANG & OLUFSEN CENTRUY BEOSOUND		EX DEM	£1075.00	£950.00
CASTLE HOWARD (YEW)	LOUDSPEAKERS	EX DEM	£1400.00	£1000.00
CELESTION CS 8's	LOUDSPEAKERS	NEW	£500.00	£275.00
CELESTION 9's	LOUDSPEAKERS	EX DEM	£289.00	£175.00
DENON D-77	MINI SYSTEM	EX DEM	£650.00	£500.00
KEF CODA 9	LOUDSPEAKERS	EX DEM	£300.00	£250.00
MERIDIAN 500	CD TRANSPORT	EX DEM	£1245.00	£950.00
MERIDIAN 508 20 BIT	CD PLAYER	EX DEM	£1695.00	£1200.00
MERIDIAN 541	PROCESSOR	EX DEM	£1095.00	£895.00
MERIDIAN 565	PROCESSOR	EX DEM	£2250.00	£1500.00
MERIDIAN 565 + AC-3	PROCESSOR	EX DEM	£2750.00	£2250.00
MERIDIAN 566	DAC	EX DEM	£1095.00	£699.00
MISSION 7331	LOUDSPEAKER	EX DEM	£300.00	£200.00
MUSICAL FIDELITY A1	AMPLIFIER	S HAND	£500.00	£325.00
PIONEER CLD D925	LASERDISC PLAYER	NEW	£800.00	£600.00
QUAD 77 + SYSTEM REMOTE	PRE AMPLIFIER	NEW	£849.95	£650.00
QUAD 77	POWER AMPLIFIER	NEW	£599.95	£425.00
SONY MDS 302	MINI DISC RECORDER	NEW	£500.00	£200.00
TDL RTL 3'S	LOUDSPEAKERS	EX DEM	£400.00	£250.00
TANNOY 628	LOUDSPEAKERS	NEW	£150.00	£100.00
TANNOY 631 SE	LOUDSPEAKERS	EX DEM	£170.00	£140.00
TANNOY 632 +	LOUDSPEAKERS	EX DEM	£200.00	£160.00
TANNOY 635 +	LOUDSPEAKERS	EX DEM	£450.00	£375.00
TANNOY 636 + PLINTHS	LOUDSPEAKERS	EX DEM	£450.00	£250.00
YAMAHA AX 490	AMPLIFIER	NEW	£249.00	£200.00
YAMAHA AX 592	AMPLIFIER	NEW	£279.95	£225.00
YAMAHA DSPA 2070	PROLOGIC AMPLIFIER	NEW	£1100.00	£600.00
YAMAHA DSPA 990	PROLOGIC AMPLIFIER	NEW	£900.00	£500.00
YAMAHA DSPA 590	PROLOGIC AMPLIFIER	EX DEM	£350.00	£250.00
YAMAHA DSPE 390	PROCESSOR	EX DEM	£250.00	£150.00
YAMAHA DSPE 200	PROCESSOR	EX DEM	£300.00	£150.00

STAR BUY OF THE MONTH 'MERIDIAN 565 PROCESSOR + AC-3' £2250

All items are in perfect condition and fully guaranteed

SUPER SAVER SYSTEM OFFER:

ROTEL RA 920	AMPLIFIER	NEW	£100.00
YAMAHA CDX 390	CD PLAYER	NEW	£130.00
KEF CODA 7	LOUDSPEAKERS	NEW	£130.00
	TOTAL SYSTEM PRICE		£300.00

MAIL ORDER SERVICES MAJOR CREDIT CARDS ACCEPTED
CALL 01788 540772 - OR WRITE TO 12 REGENT STREET, RUGBY, WARWICKSHIRE

ANOTHER BIG HIT!

Following in the path of the original and extremely well received Assemblage DAC-1, the DAC-2 appears to be another big hit with customers and reviewers alike. The DAC-2 builds on the strengths of the original DAC-1, with its dual Burr-Brown PCM 1702 20 bit DACs, Crystal CS8412 input receiver, toroidal power transformer and Analog Devices based output stage, but adds HDCD capability with the PMD-100 digital filter chip, an extra co-ax digital input on a BNC jack, a phase invert switch, three more power supply regulation stages with greatly increased power supply capacitance, and improved parts quality in the analog output stage. The best news is that all these improvements come with a very small price, the DAC-2 digital processor kit is \$499.00 U.S.! Of course, the DAC-2 also comes with our 30 day satisfaction guarantee, two year limited warranty, AND our assembly guarantee, (If you can't get it to work, we will!).

For those of you with the upgrade bug, we also have a parts upgrade kit available for the DAC-2. This kit includes Caddock resistors and MultiCap capacitors for the analog output stage, Kimber silver and Illuminati hook-up wire, EAR and Soundcoat isolation and damping materials, Linear Technology voltage regulators, and more parts that make a significant improvement in the performance of the stock DAC-2. The parts upgrade kit is available at a special package price of \$149.00, which makes it even more good news!

For more information on any of our products, please call, write, Fax or E-mail us and we will be happy to assist you.

THE PARTS CONNECTION
A DIVISION OF SONIC FRONTIERS INC



2790 Brighton Road, Oakville, Ontario, Canada L6H 5T4

Telephone (905) 829-5858 Facsimile (905) 829-5388

E-Mail: TPC@sonicfrontiers.com

Audible Elegance



WINTER SPECIAL PRICES

ART AUDIO QUINTET MONOBLOCKS (CHROME/GOLD)	£2095.00
BEAM ECHO DL7-35 MONOBLOCKS	£2500.00
GAMMA ACOUSTICS GEMINI LINE INTEGRATED	£ 450.00
GAMMA ACOUSTICS RHYTHM PHONO	£1100.00
GAMMA ACOUSTICS AEON MONOBLOCKS	£2995.00
TUBE TECHNOLOGY SYNERGY PRE POWER	£3995.00
TUBE TECHNOLOGY UNISIS POWER	£1195.00
TUBE TECHNOLOGY PROPHET PRE AMP	£1250.00

Art Audio - Alchemist - Beam Echo - Bravura - Gamma Acoustics - Loricraft Audio/Garrard - JM Labs Speakers - Klipsch - Monrio - Nottingham Analogue - Ortofon - Project Turntables - Sovereign Valves - Target - Trichord Research - Tube Technology

"Audible Elegance are now pleased to be associated with Cary Audio Design"

01227 742928 0976 402779

Ashcroft Bishopstone Lane Herne Bay Kent CT6 6RP

EX DEMONSTRATION EQUIPMENT

	NEW	SALE
Audio Alchemy DDE v3.0 DAC (inc Power Station 3)	£900	£675
Cyrus Dacmaster D/A Converter	£950	£395
Epos ES12 Loudspeaker (Dark Cherry inc stands)	£600	£495
Epos ES25 Loudspeakers (Walnut)	£1655	£1095
Exposure 17/18 Pre/Power Amplifier	£1700	£1495
ProAc Studio 250 Loudspeakers (Cherry)	£2249	£1995
Rega EL8 Loudspeakers (Black)	£298	£219
REL Q50 Active Subwoofer	£395	£319
Rotel RC970/RB970 Pre/Power Amp	£395	£329
Micromega Drive 1 CD Transport	£700	£495
Trichord Genesis CD Player (inc isolation base)	£700	£450
Yamaha DSP-E390 Pro-Logic Processor	£250	£165
Yamaha RXV 590RDS Pro-Logic Receiver	£450	£325

QUALITY USED EQUIPMENT

Audiolab 8000C Pre Amplifier	£580	£395
Cyrus XPA Power Amplifier	£298	£225
Sony MDP850D Laser Disk Player	£700	£275
Spendor BC1 Loudspeakers (Teak)	N/A	£349

SPECIAL PURCHASE NEW BOXED EQUIPMENT

Micromega Minium Amplifier	£400	£319
Micromega Minium CD Player	£400	£319
Yamaha DPS A590 Pro Logic Amp	£350	£275

Now in stock at
The Powerplant

The new Audiolab Power Amps
8000SX 8000PX 8000MX
£550 £850 £1800 (Pair)

The new Cyrus MR3
Multiroom Amp

THE

powerplant

66/67 Upper North Street Brighton BN1 3FL

Tele: 01273 775978 Fax: 01273 748419

Email: email@powerplant.co.uk

ATC, AVI, Audiolab, Arcam, B&O, B&W, Cyrus, Exposure, KEF, Linn, Micromega, Marantz, Mission, Mark Levinson, Pro Ac, Proseed, Rega, Roksan, Stax, Trichord and other quality equipment.

Mail order and Worldwide Export service available

Hi-Fi World Classified Ads

SPECIAL
INTERNET
OFFER SEE
PAGE 144 FOR
DETAILS

PRIVATE

LEAK TROUGHLINE II with Tim Paravacini HFV decoder. Both aligned by Leak time served tuner specialist. £325 for this distinguished equipment. Tel: 01203 679 165 (Jan)

ARCAM 5 CD Player £130 ono mint condition. Marantz SD4511 cassette player £90 ono. Audio Innovation Alto amplifier £130 ono. Both little used. Tel: 01934 624 404 (Jan)

LINN/NAIM; Black LP12, Cirkus, Naim Armageddon, Ekos, Klyde (£3650), recently serviced £1550, NAC 82 £1300; Hi-Cap £450; NAP 250 £950; SBL's, black, passive £1050. All mint, boxed. Tel: Jon 0131 226 2279 evenings, 0131 650 2920 days. (Jan)

PINK TRIANGLE Da Capo DAC with 1307 filter (Analoguey). Tremendous bass and detail. Very good condition, boxed. Bargain at £595 ono. Tel/Message John 01865 862 745 (Oxon) anytime (Jan)

LOWTHER ACOUSTAS with PM6A drive units £395 QLN Splitfield Signature speakers and stands, less than 12 months old £800. Sony CD101 Compact Disc player with remote, boxed, offers. Tel: 01332 875 828 (Jan)

NAIM AUDIO Nair3 £350, Nair3R remote £500, 92/90.3 £550, 92R/90.3 remote £750. HiCap unused £550, Nap250 new style £900, old style £600, Credo cherry £650, mostly boxed as new. Tel: 0181 995 6451 (Jan)

CASTLE/EPOS. Howard S2, mahogany, cost £1200, boxed, mint, £650. Avon rosewood, cost £850, boxed, virtually unused £550. ES22, light cherry, cost £1100, boxed mint £690. Tel: 0181 995 6451 (Jan)

WANTED: AUDIO Synthesis DAX II. For Sale: Very rare Quad I amplifier, circa 1948 with matching preamp. Quad mono preamp with Quad II amplifier. Mono FM tuner. Leak Troughline II tuner, Sugden Connoisseur 3 speed variable deck. Garrard 401 SME 5009 V15, 2 Goodmans Axiom 300's. Sensible offers. Tel: 01745 331 681 (Jan)

FOR SALE: Garrard 301 'Lockwood' plinth/cover, SME 3009/Denon 110, original instructions, perfect £250. Target PSW1 shelf to suit Garrard £30. Wanted: Mana wall shelf. Tel: 0151 632 3790 (Wirral) (Jan)

WANTED: QUAD 67 CD Player. Tel: 0181 529 3930 (Jan)

MONITOR AUDIO R852 MD speakers, walnut finish, little used, immaculate condition, boxed with manual £200. Can demonstrate. Tel: 01282 450 471 (Jan)

NAKAMICHI CR3E Cassette deck. Recently serviced. Excellent condition. Still the best! £150. Meridian 500/563. Mint, boxed with manuals. Cost £2050, accept £1195. Tel: Paul 01733 892 261 (Jan)

PROCEED CD Drive transport. Proceed DAP DAC with HDCD filter (by Mark Levinson) £1600 each. Earmax valve h/phone amp £295. Sennheiser HD 580 Jubilee phnnes £100. HD 535 phnnes £50. All mint/boxed. No offers. Tel: 0181 367 9738 (Jan)

THORENS TD 160B SME Arm £150. Quad 33 pre-amp £50. Tel: 01603 810 904 (Norwich) (Jan)

SNELL TYPE K Loudspeakers. The originals. One of the world's most amazing small speakers. Ultra transparent. Highly efficient and stupidly loud. £200. Tel: 01608 684 694 eves. (Jan)

LINN MIMIK CD Player, over 3 years manufacturers warranty remaining. Best selling player in its class. Mint. boxed £600 (£875) Dual CS505 record deck £80 ono. Both £640. Tel: 01904 627 437 (Jan)

CHORD CPA 2200 SPM600, new, boxed £2900. Yan den Hul The First, The Second (balanced), The Wind. All new £450. Tel: Dave 0171 209 1468 (Jan)

LINN ITTOK With Karma cartridge £150. Large quantity of valves. Some very old, includes KT88, GZ34, EL34, EF86, E88CC, KT61 etc. £200 the lot. Tel: 01794 516 910 Romsley (Jan)

EPOS ES 11 (walnut) matching stands mint boxed £300. Celestion Ditton 15XR new HF units, vgc £60. Wanted: Monitor Audio MA4 speakers. Tel: 0116 273 6676 (Leic) after 6pm (Jan)

LUMLEY REFERENCE 70 Valve amplifier £1200. Audio Research LS3 preamp £1100. Troughline stereo tuner £75. Quad valve FM2 £50. Studio 12 decoder £20. Quad 303 £80. Tandberg TCD 440A cassette £75. Tel: 01279 832 883 (Jan)

NAKAMICHI BX300 3 head, dual capstan, pitch control, mint condition, recent Nakamichi service £350. Audio Alchemy DDEV 1.1/Power Station Two/DST (£820 new) £400. Pioneer PD9700 mint £250. Tel: 0171 286 3841 evenings (Jan)

QUAD ESL 57 Electrostatic speakers. Bronze, manual, Quad serviced, unmarked mint condition £375. Quad 33, 303, FM3 boxed, manuals, recent Quad service, mint condition £250. Tel: 01639 641 043 (Jan)

LINN SONDEK LP12 with Linn Akito arm, Linn K18 MK2 stylus. Mission 751 speakers & Aura Evaluation VA 100 MK2 amplifier. Price £1200 No offers, all to be sold as one unit. Tel: 03788 44413 day, 01604 402 856 evenings (Jan)

NAIM HI-CAP New style, boxed, perfect £450. Tel: 01675 442 567 (Jan)

ARCAM ALPHA CD Player £150. Mission CD DAC full differential bistream converter £120. Naim NAC 32 pre-amp £100. Quad FM2 £60. Creek 4140 S2 amplifier £80. Revolver turntable, Mission arm, Shure cartridge £100. Canon 550 speakers £150. Above as new. Tel: 0181 406 4460 (Croydon) (Jan)

PM COMPONENTS VAA-70 MkII Valve power amp, volume control allows CD direct, 20W/channel. This kit amplifier was built and tested by PM. Was £250. Now £220 due to timewaster (£300 new as kit) Tel: Robbie 01332 831 416 (evening) (Derby) (Jan)

AUDIONOTE 'OTO' Integrated valve amp, MM phono £525 ono. TDL 0.75m speakers, walnut with floor plinths £425 ono (£825 new). Both mint, upgrading. Tel: Bob 01420 544 962 (Hants) (Jan)

ENSEMBLE REFERENCE Silver loudspeakers, Superb sound and imaging. Mint condition, barely 6 months old. Reason for sale: upgrading to Primadonnas. RRP £4500, £2250. Tel: Chris 01892 824 651 eves or 0370 920 040 anytime (Jan)

SUGDEN AU41C Preamp and AU41P poweramp £450. AU48A Class A/B 50W amp £50, DT48 tuner £50. ProAc Super Tablette bookshelf speakers with custom Target stands £300. Tel: 0171 372 3650 after 7pm (Jan)

MICROMEGA STAGE 2 CD player £350, Shearne Phase 2 Mk2 Int amplifier £375, Rogers Studio 1A loudspeakers £350, Nec AV271 surround sound processor £100. All very good condition. Tel: 01225 790 620 (Wilts) (Jan)

COUNTERPOINT SA220 Power amp, hybrid valve/mosfet, 220 watts per channel and rated deep, deep down to 1 ohm and will drive any speaker without fuss & nonsense. Just re-valved, manuals, boxed, superb £1195 (£3200) Tel: 01733 310 819 (day) 01733 892 228 (eve) (Jan)

NAIM NAC 92.3 pre amp £300. DPA Renaissance CD player, as new £750 boxed etc. Marston Audio Silhouette DAC, new £600. XLO Type 0.1 interconnect 1 mtr (rrp £180) £100 as new. XLO Type 1 interconnect 1 mtr (rrp £275) £190 as new. Black Sixteen seven foot 6" £180. ATC SCM 280's mint on stands £800. Tel: Jules 01792 280 061 (Jan)

FOR SALE, Sugden AU41P power amp 100wch, mint boxed £390. Mission 753 black ash, excellent, boxed £350. Tel: 01371 850 665 (Essex) (Jan)

PINK TRIANGLE PT00 with outboard power supply, superb Alphason Delta tonearm and several quality unused cartridges, with Sound Organisation table only £395 for quick sale. Tel: 0171 730 1614 daytime (Jan)

AUDIO RESEARCH Pre-amp SP8 MkII boxed, mint £900 ono. Leak Stereo 20 amplifier, mint condition dark grey £285. Tel: 0181 946 8179 (Jan)

WILSON WATT III, Puppy II's £7000, Martyn Logan CLS II's £2200, AR CL120's £3750, Transparent Music Wave Ultra SC £1100. All first owner, mint condition. Tel: 0171 495 1220 (Jan)

KRELL KSA505 £2000 (£3800) KRC2 £2200 (£4200). Theta Data Basic transport £1000 (£2000). Theta Pro Prime 2 DAC £1000 (£1800). Monitor Audio Studio 50 special finish £2250 (£5000). All immaculate condition. Tel: 01797 253 073 (East Sussex) (Jan)

MANA ACOUSTICS Sound Shelf, boxed and in Al condition £120. Tel: 01904 490796 (York) (Jan)

BILL BEARD BB101 remote control line level valve amplifier. Beautiful two box design, finished in wood and brass. Very desirable and in pristine condition. Boxed. Tel: 01443 685 492 (Jan)

CHORD COMPANY Flatline Gold 2 x 5m twin bi-wire speaker cables £75. (Less than half price). Tel: Paul 01603 261 358 (Jan)

ACOUSTIC PRECISION 'EIKOS' CD player, 4 months old £1400. Mordaunt Short Performance 860 speakers, brand new £1480. Avondale Naim 140's £700 pair. Tel: Mike 01633 430 036 (Jan)

LINN SONDEK LP12 (walnut), Lingo, Cirkus, Ekos II, OC7. Absolutely mint £1400 or sensible offer. Full active Linn Kaber system. Interested? Ring for details, may split. Tel: 01787 462 940 (N. Essex) (Jan)

HITACHI DA-1000 CD Player wanted. Service manual and similar upright players will also be of interest. Tel: 01582 419 154 (Luton) (Jan)

NAIM NAC 72 Pre-amp, NAP 140 power amp, N & K phonoboards (all boxed) £700. Royd Abbot speakers, immaculate condition £350. Tel: 01282 439 334 (Jan)

WANTED: MISSION Cyrus II or SL integrated amplifiers. Metal cased versions. Must be in good condition and perfect working order. Cyrus III's also considered. Tel: 0181 452 1452 (evenings) (Jan)

FOR SALE: Technics SL-1000 MkII turntable with Technics plinth (original heavy version). Modifications include high-grade regulators, Cerafine and Nichicon PSU caps. Comes with SME and Technics armboards. Superb sound, £650. Wanted: Kenwood LOZA integrated, Sony TA-N88B power amp and Technics SST-1 speakers. Tel: Jon 0181 992 8952 (Jan)

QUAD ELECTROSTATICS, ESL 57, bronze, 1979, serial numbers 47630 and 47631. Good condition, instruction booklets, original boxes and invoice. Unsuitable for new house. History for £250. Tel: 01635 46312 evenings (Newbury) (Feb)

NAIM 250 x 3 Hi-Cap, Naxo 3/6, 72 - 32.5, Linn Isobariks, latest spec, external crossovers, panel stands, Linn Ekos, Linn Lingo, Linn Arkiv. All mint, mostly boxed. Also Rega 3. Tel: 0114 248 6493 (Feb)

QUAD 33/303 overhauled by Quad, converted to phono by Academy Sound. Superb sound quality. Vgc, manuals, boxes £295. Tel: 01903 247 779 (Sussex) (Feb)

QUAD 22 MONO Blocks rebuilt with many new parts, new valves, EL34 outputs. Two tone colour, crimson base, original grey top. Super sound quality. Some spare valves. £495 cash. Buyer collects. Tel: 01903 247 779 (Feb)

NAKAMICHI DRI Perfect condition. Only 25 hours use. I would like it to go to someone who will use and appreciate it! £500 ono. Tel: 0161 718 8135 (Feb)

NAIM CLASSIC Silver edged 32.5 (upgraded 72), Hi-Cap and 250 power amp. Immaculate condition £1000 ono. Tel: 01443 405 347 (Mid Glam) (Feb)

HEYBROOK QUARTETS, Walnut, 90dB £280. Upgrading. Tel: 0161 247 5365 office hours, ask for Tony (Feb)

WANTED: LEAK Stereo '70' amplifier and Stereofetic tuner, must be in mint condition throughout with original boxes and instruction leaflets. Tel: Peter 01273 583 675 before 7pm (Feb)

H.F.A. SPEAKERS T.L. B139 bass, B110 mid, T27 tweeter, STC 4001 super. Finished in rosewood formica, black grills £225 ono. Monitor Audio R852 MD speakers with 25" stands (all black) £200 ono. Tel: 01992 576 533 (Essex) (Feb)

AUDIOLAB 8000M Monoblocks, two pairs, 1996 spec, perfect condition, fully boxed and documented. £995 per pair (£1600), both pairs £1900 (£3200). Tel: 01225 777 367 ext 3223 (work); 0850 792 927 (mobile) anytime, ask for John (Feb)

Celect Audio

Suppliers of quality pre-owned Hi-Fi

AMPLIFIERS/PRE AMPLIFIERS

Hafner DH101 pre-amplifier.Ex condition	£95	Musical Fidelity Ma65s mono*2	£450
NVA A40 Power amplifier. Boxed. Ex cond	£125	Sugden A25B Intergrated amp	£180
Quad 405/1 power amplifier.	£180	Sugden P51 power amplifier	£150
Quad 405/2 power amplifier	£220	Sugden C51 pre-amplifier	£100
Quad 606	£400	Dnm 2A pre-amp & power supply	£400
Quad 306 power amplifier	£200	Dnm 2A pre-amp & 2 power supplies	£500
Quad 66 pre-amplifier.	£450	Roksan L2 pre amp & Dsu power supply	£600
Quad 44 pre-amplifier	£250	Jeff Rowland model one power amplifier	£1500

SPEAKERS

Rogers Ls1.boxed	£80	Musical technology Harrier in black	£160
Rogers ls7T in black	£220	Triangle Titus in black.Ex dem.Boxed.	£300
Kef 101/2 in rosewood.Boxed.	£295	Origin Live Conqueror in rosewood.	£700
Triangle comete in blackboxed	£300	Spendor Bc1s & stands	£250
Celestion 5000 & stands.Boxed.Ribbon	£300	Harbeth HL4 speakers + stands	£250
Volante in cherry.Boxed.	£400		

OTHER TIEMS

Qed digit + Positron power supply	£160	Micro seiki Electrostatic	
-----------------------------------	------	---------------------------	--

TRANSLUCENT INTERCONNECT CABLE

99.99% pure silver conductors	Balanced	Quality gold plated RCA plugs
Half metre terminated £80.00	1 metre terminated £80.00	Add £20.00 per additional half metre

WANTED URGENTLY

Quality used HiFi equipment. Collection can be arranged
Part exchange welcome.

Special introductory offer. (For month of November only)

1 metre **TRANSLUCENT** interconnect £60.00 Half metre **TRANSLUCENT** interconnect £50.00
Please quote special price when ordering.

**Unit 2, 61 Aylestone Drive, Aylestone
Leicester.LE2 8QE.
Tel 0116 2248250 Fax 0116 2835821**

Papworth Audio Technology

For many years we have supplied our superb range of hand crafted audio equipment to the ultra discerning high end markets in Asia and Scandinavia.

We are now bringing our products to those in Britain who appreciate True High Fidelity coupled with seriously good build quality.

M100 Monobloc



One of the most popular products in the range, the M100 Monobloc will drive the most difficult 'speakers with ease

Available soon, the stunning new MVH-200 Integrated. This hybrid tube-mosfet amplifier brings you all the benefits of Papworth's legendary quality at a surprisingly affordable price.

Papworth Audio Technology
All U.K. Sales and enquiries to Colin Berresford
01744 604578 (Tel/Fax)

CLASSIQUE SOUNDS (LEICESTER) TEL: 0116 2835821 **VINTAGE HIFI & VALVE SPECIALIST FAX: 0116 2835821**

FOR SALE.PRE/POWER AMPLIFIERS(VALVE)

Musical fidelity F22 Valve pre-amplifier,with phono	£ 695	Radford MA50 amplifiers. Pair	
Ray Lumley M100 amplifiers Kt88s	£1099	Pair Ray Lumley M75 amplifiers Kt88s	£ 999
Matched pair Leak TL10s	£ 500	Matched pair Leak TL12+ amplifiers	£ 500
Matched pair Rogers Junior amplifiers	£ 350	Pair Quad 1s Scruffy condition	£ 300
Rogers Junior stereo power amplifier	£ 350	Pair Rogers cadet monos	£ 200
Rogers Cadet 2 Pre/power amplifier	£ 150	Rogers cadet 3 pre/power amplifiers	£ 100
Single Leak TL10 amplifier	£ 225	Single Leak TL12+ amplifier	£ 150
Leak Stereo 20 power amplifier.serviced	£ 350	Clarke + Smith HV10 intergrated amplifier	£ 150
Audio Innovations First Audio amplifier	£ 700	Audio Innovations s/RID 2 box pre-amplifier	£ 250
Rogers Cadet 3 power amp Needs service	£ 50	Rogers Cadet 2 power amp Mains transformer gone	£ 25
Quad 22 pre-amplifier	£ 50	Audio innovations s/200 power amplifier	£ 275
Leak point one stereo pre amplifier	£ 40	Leak Variotlope stereo pre-amplifier	£ 50
Quad 33 pre-amplifier good condition	£ 75	Quad 303 power amplifier good condition	£ 125
Quad 44 pre-amplifier ex cond. Boxed	£250	Quad 405/2 amplifier ex condition	£ 225
Quad 50E. Pair	£250	Quad 405/1 amplifier good condition	£ 175

TURNTABLES

Garrard 301/401s. price Varies on condition	EPOA	Thorens 124. Various prices and condition	EPOA
---	------	---	------

SPEAKERS

Snell J2 loudspeakers	£300	Quad Electrostatic ev157s Several in stock	
EPOA		Tannoy Ardens in walnut	£ 600 Pair
B&W DM170 Electrostatic / hybrid speakers	£ 300	Pair B&W DM170 Electrostatic / hybrid speakers	£ 400
Pair IMF TLS80 transmission line speakers	£ 250	Pair Radford studio 270/50 loudspeakers	£ 450
scruffy Lowther cabinets	£ 50	Pair Lowther Accouta Loudspeakers	£ 450
		Single Lowther dual positon	£ 300

OTHER ITEMS

SME 3009 tonearms. Various	£60	Quad fm3 tuner. Excellent condition	£75
Leak Troughline 2 and 3 tuners. mopno	£75	Leak Troughline 2 stereo	£100
Quad rack & pedestal for 66/30/66 pre-amp	£100	Audio Note MC step up transformer	£200
Lowther PM3A drive units Half Lowther price	£600	Pair Lowther PM3C drive units Half Lowther price	£300

TRANSLUCENT SILVER INTERCONNECT CABLE

99.99% pure silver conductors	Balanced	Quality gold plated RCA plugs
	1 metre terminated £80.00	Add £20.00 per additional half metre

7 DAY MONEY BACK GUARANTEE IF NOT BETTER THAN EXISTING CABLE. (Restrictions of price or quality)

99.99% PURE SILVER WIRE@ ONLY £4.95 METRE

NEW EARPHONES/EQUIPMENT

EAR 834p mm/m. Phono stage with volume control £499 EAR 834p Phono stage. MM only. No volume control £349
EAR 834L Line only valve pre-amplifier. Probably the best valve pre-amplifier under £1000. Amazing value only £450
501/401/24 POWER SUPPLIES & PLINTHS
Power supplies. Amazing value at only £100 each Plinths & £175.00(unfinished) or £275.00(finished) Very heavy
Leak replacement output/mains transformers. Supplied and fitted from only £90.00

REPAIR AND SERVICE ON ESL 57s

Repair of damaged treble or base panel including dust covers. £95 EHT units £28 Full service EPOA

WANTED (bring for best price)

Vintage/modern valve HiFi equipment & valves to include:
LEAK,QUAD,RADFORD,ROGERS,DECCA,LOWTHER,GARRARD,TANNOY,VITAVOX,VORTEXION, CROFT,EAR,LUMLEY,AUDIONOTE,THORENS,ART AUDIO,GEC,MULLARD,OSRAM,BRIMAR,ETC

CLASSIQUE SOUNDS TEL/FAX 0116 2835821 OR 0802 213740 (MOBILE)
CLASSIQUE HOUSE, 61 AYLESTONE DRIVE, AYLESTONE, LEICESTER, LE2 8QE

IAN HARRISON HI-FI

TEL: 01283 702875

9am- 9pm

INCLUDING SUNDAYS

HIFI AT DISCOUNT PRICES. FREE NATIONWIDE DELIVERY

TRADE IN YOUR OLD MOVING COIL CARTRIDGE & SAVE UP TO 45% OFF THE RRP.

CARTRIDGES & STYL	TONEARMS	CASSETTE DECKS	COMPACT DISC
DENON SHURE AUDIO TECHNICA GOLDRING AUDIOQUEST TRANSFIGURATION LONDON (DECCA) ARCAM STANTON GRADO B & O TECHNICS ROKSAN VAN DEN HUL ORTOFON	ROKSAN SME MOTH ZETA	PIONEER TEAC SONY DENON YAMAHA MARANTZ TASCAM	PIONEER TEAC SONY DENON YAMAHA MARANTZ QUAD PHILIPS CREEK
	TURNTABLES		TUNERS
	SME TECHNICS STRATOSPHERE & OTHERS	DAT PIONEER TEAC TASCAM SONY FOSTEX	SONY DENON PIONEER YAMAHA MARANTZ QUAD PHILIPS
LOUDSPEAKERS	HIFI FURNITURE	MINI DISC	AMPLIFIERS
HARBETH ATC QUAD SONY ROYD	APOLLO SOUND STYLE PROJECT SOUND ORGANISATION	SONY CDR PIONEER	QUAD DENON MARANTZ PIONEER YAMAHA MARANTZ PHILIPS & OTHERS
HEADPHONES	CABLES	REEL-REEL	
SENNHEISER BEYER SONY AKG GRADO AUDIO-TECHNICA	SONIC LINK AUDIOQUEST AUDIO-TECHNICA VAN DEN HUL GOLDRING QED	STUDER TASCAM	
			*ALL GOODS ARE BRAND NEW & BOXED WITH FULL U.K. GUARANTEES. NO EX/DEM OR EX DISPLAY GOODS. NO GREY IMPORTS.
TEST CASSETTES TEST CD'S TEST RECORD DEMO CD'S	BLANK TAPES / DISCS	ACCESSORIES	
*PHONE OR WRITE FOR DETAILS	TDK SONY MAXELL BASE 353	DISHWASHER MAXELL SONY ANTIFERRENE MAXVAV PIVOTELLI	

PLEASE PHONE TO CONFIRM PRICE & AVAILABILITY PRIOR TO ORDERING. GOODS ARE NOT SUPPLIED ON APPROVAL. SORRY, NO GENERAL CATALOGUES. PLEASE PHONE OR WRITE FOR SPECIFIC REVIEWS, BROCHURES OR PRICES.

MAIL ORDER ONLY FROM: IAN HARRISON, 7 MILL HILL, REPTON, DERBY, DE65 6GO. TEL: 01283 702875. 9am - 9pm INCLUDING SUNDAYS.

Hi-Fi World Classified Ads

SPECIAL
INTERNET
OFFER SEE
PAGE 146 FOR
DETAILS

PRIVATE

FOR SALE: Pioneer PDS703 CD £135, Sugden A21-9 amp £425, Sugden SDA-1 DAC £450, Monarchy 'DIP' super drive £145. Wanted: Mana Soundframes, Target R2 stands, Kimber BTC cables. Tel: 0411 316 586 or 0181 521 0843 (Feb)

PINK TRIANGLE 22 Bit filter £80. Beyer DT531 headphones and HFN amp £90. Audioquest Diamond 0.5m £150. VdH The First 1.0m £100, 0.6m £70. VdH CS12 4x5m £120. Aiwa AD810 £90. Tel: 01592 772 806 (Feb)

LEAK TL12.1 BBC version. Rare collectors items. Used by BBC as amps for monitor speakers hence natural broadcast quality sound. Best offer over £1500 secures. Tel: 01423 536 692 (Feb)

AUDIO INNOVATIONS Series 300 £190, Edison 18 line valve amp (built by Audion) £190. Audion Phono Stage (2 box) £145. Evolution Audio Single Ended transistor amp £295. REL Sub-woofer unopened, unwanted, Marantz CD67 player unopened, unwanted £220. Tel: 0370 435 952 (Feb)

MUSICAL FIDELITY A1000, Marantz CD10, Pioneer PD75, Meridian 606 DAC, Kef 103/4, Kef 104, Cambridge Audio R50's, Reference speakers, Leak Sandwich, (all boxed/mint) Kef Carltons, Ditton 25's. Tel: 01992 718 265 (Feb)

WANTED: PICK-UP arm, unipivot type, required for London Gold cartridge. Tel: 01208 821 394 (Cornwall) (Feb)

INFINITY RS III A speakers, free standing oak cabinets, twin 10 inch bass drivers, 'Emir' electrostatic tweeters. Bargain at £650 (new price £2500) due to house moving. Tel: 01922 479 034 (Bloxwich, West Midlands) (Feb)

CYRUS PRE & PSX-R + Cyrus power & PSX-R for sale, approx 1 year old. Excellent sound & condition. Will not split. Genuine reason for sale £1000 ono. Cost £1800. Tel: 01582 826 528 (Feb)

MISSION 753 (rosewood) £425. 2 x Cyrus II amplifiers (both boxed with manuals) £175 and £150 or £300 the pair. Quad 606 II (boxed, 18 months) £425. Ruark Talisman II (walnut, mint) £425. Tel: 01132 824 428 (3 mins M1/M62 intersection) (Feb)

RUARK TALISMAN II (walnut, mint, 16 months) £425. Quad 606 II (boxed, 18 months) £425. Denon DCD 1500 Mk II (mint, cost £500) £150, Mission DAC 5 (mint, cost £300) £100. Marantz CO63SE (mint) £195. Tel: 01132 824 428 (3 mins M1/M62 intersection) (Feb)

TRIANGLE TE60 Class A integrated amp. Smooth yet powerful Vgc £250 (£700 new) Harman Kardon HK6550 amp, LS200 Kevlar speakers, stands and Audioquest cable (20m) £295 (£810 new). Tel: 0117 9246 297 (Feb)

FOR SALE: Conrad Johnson PV10 AL (Special Edition) pre amp. Improvement over standard PV10 easily heard (£1300 new) £885. Tel: 01886 821 577 (Feb)

CELESTION DITTON 66 speakers, re-wired, new cones by Celestion, excellent condition £325. 2 metre pair transparent speaker cable c/w spades/plugs £79. For details Tel: Paul Allen 0115 981 7814 (work) (Feb)

CASTLE HOWARD Speakers, dark oak, upgraded by Rata, mint £525, Chord SPM 800 power amp £850. Quad 66 pre (upgraded) remote and tuner £725. Tel: 01803 855 321 (South Devon) (Feb)

LOWTHER. PAIR of original Lowther PM6 drive units, good condition but need re-coning. £100 or best offer. Please Tel: 0191 273 8827 (Feb)

LINN LP12 Motor unit with 1996 mechanical upgrade, motor & Valhalla £375. Ringmat 330 XLR £20. Tel: 01664 822 648 (Melton Mowbray) (Feb)

EPOS ESII + Dedicated stands. Good condition £250 ono. Various speaker cables, Linn, Naim, Ortofon. Phone for details. Tel: Neil Hughes (Home) 01744 600 639 (Work) 01695 577 123 (mobile) 0468 898 979 (Feb)

CLEAR OUT: Linn Kan 2 speakers (free stands) £225. Polk LS/FX speakers (surround dipoles) £300. Pioneer 3 head cassette deck £75. Rappaport pre amplifier (separate power supply) £100. Tel: 01292 441 544 Weekends (Feb)

LINN KEILDHMS With Kli-Stone plinths and 8m of K-400 bi-wire cable (£1000) £495. Chameleon Ruby power amp (£1000) £395. Will sell both for £695 for very quick sale. Tel: 0121 705 4859 (Feb)

MAGNAPLANAR MGIC Panel speakers, true audiophile speakers, big but they produce a beautiful soundstage £450. Quad 3/4/405.2 pre/power amps, excellent condition £325. Tel: Geoff 01222 (Cardiff) 891 314 or 0802 183 240 (Feb)

RADFORD MONITOR Loudspeakers, mint condition, wood unmarked, excellent bass. Will sell reluctantly due to space problems. Good offer secures. Ex. working order Quad tuner £30. Tel: 0131 661 5427 (Feb)

JOLIDA SJ-502A Int amp. extra tube, Teac P-700 CD transport, Cambridge Dac Magic II (fully modified), Tara Prism digital cable, Audioquest power cord. All £1100 (cost £1800) Tel: 0181 364 5687 (Feb)

LINN AXIS Turntable, Akito tonearm, K9 cartridge, ex. condition £280. Other cartridges available - offers. Wanted: Conrad Johnson pre-amp (phono) PV10A or similar. Also Linn Lingo PSU. Tel: 0121 353 1286 (Sutton Coldfield) (Feb)

CELESTION SL600Si speakers with DLP 600 and Kudos Lead filled stands £550. Rotel Michi RHT10 tuner £450. Theta TLC 1115. Goliath PSU for TLC £100. Sony Minidisc recorders MS30/MS37 £150 each. Cables: VdH First pairs 0.8m £85, 0.6m £70, Digital 470, Versalabs Wood Block £50. Tel: 0181 871 2345 evenings (Feb)

SNELL TYPE K Speakers, excellent condition, boxed, black ash £225 ono. Stands available. Also possibly for sale, Nakamichi Tri-Tracer 1000: Offers. Tel: James 01865 728 938 (Oxford/London) (Feb)

CYRUS 2 AMPLIFIER £200. Harbeth HL MkII monitors £350. B&W DM110 monitors, Apollo stands £100. Wharfedale 504 speakers, Partington stands £120. Marantz CD65 MkII SE CD player £195. A&R HA10 head-amp, offers. Tel: 0181 818 4492 (Guildford) (Feb)

MARANTZ CD12 Limited Edition CD player for sale. As new condition, excellent sound, learning remote control, very high end transport and DAC. Cost £3000 when new. Sell for only £1400. Rotel RB-10 Michi power amplifier, very high quality power amplifier, excellent sound, cost £2300 when new, 200 watts RMS. Sell for only £1000. Tel: 01275 333 020 or 0467 234 218 (Bristol) (Feb)

MACKINTOSH MC60 (1962) valve monoblocks - offers. Meridian 208 CD/Pre-amp £595 ono. (new £1350) Quad 44/405 MkII pre/power amps £355, may split. Quad 306 power amp £155. Croft valve pre-amp £170. Tel: 01746 764 984 (Feb)

COLLECTORS ITEMS: QUAD 22 amp £75, Revox G36 tape recorder in case, excellent condition but noisy output stage £85. Ferrograph Logic 7 tape recorder, good condition, playback only, used for editing £75. Also Dual CS 505-4 turntable plus Audio Technica cartridge. Excellent, boxed with manual £60. £250 for the lot. Buyer collects. Tel: 01222 617 767 (Cardiff) (Feb)

KLIPSCH CHORUS Speakers, excellent condition £900 ono. Tel: 0171 790 3404 or 0468 362 087 (Feb)

AUDIOLAB 8000S Amp. 6 months old, boxed, clear transparent sound £529. Audioquest Quartz 2 analogue interconnect £60. Tel: 0115 952 1820 (Feb)

ORACLE ALEXANDRA Mk3, SME309, ATOCS, Mana Soundframe £750. Fons Mk1 3 speed, Rega RB250, OM10-78 stylus £100. Tel: 0181 554 6199 (Feb)

ORIGINAL DIRECT Cut vinyl disc, 'Thelma Houston' 'I've Got The Music In Me'. Serious offers invited. Collectors item. Other direct cut/supercut records available, i.e. Beatles Abbey Road. Tel: 01227 360452 (Feb/1)

AUDIO INNOVATIONS 2nd Audio amps L2 pre PI phono, Alto CD, perfect condition, downsizing hence reluctant sale £1700. Consider exchange for smaller high-end system. Tel: 01460 72545 (Somerset) (Feb/1)

ROKSAN XERXES (Walnut) turntable, Rega RB300 arm, Audio Technica OCS cartridge plus XPS3 & DSU power supply. Excellent condition, with box £525. Tel: 01299 271 266 eves (West Midlands) (Feb/1)

MUSICAL FIDELITY F-19 Poweramp, 9 months old, 2 x 300 watts RMS. Cost new £4000, asking £2200. Tel: 01296 437 314 eves (Aylesbury) (Feb)

LEAK STEREO 20, completely rebuilt £250. Leak TL12 Plus gold monoblocks, 3 available £150 each. Varislope Stereo pre-amp £40, Mono £20. Leak TLSO plus (GEC KT88's) £250. Leak Troughline 3, spotless condition £100. Tel: 01633 422 559 (Feb)

GARRARD 401, excellent £110. Lowther FM Mk2 tuner £65. Tannoy units, LSU/HF 12, one 'Silver', one 'Red' £100 each. Quad 2 monoblocks, completely rebuilt £350 pair. Leak Stereo 30, pristine £40, Stereo 70 £50, Delta 30 £25. Tel: 01633 422 559 (Feb)

MERIDIAN 518 Processor. As new, boxed £600. Silurian, high end, silver screened digital cable, 1m, £60. Tel: Gerry Hassell 0181 751 3771 or 0181 890 3302 (business hours) (Feb)

COUNTERPOINT DA10a/DAI 1a combo. Latest spec, high-end 20 bit DAC & transport. HDCD, JAC anti-jitter board etc. Black/silver finish. Half price - both items as new, boxed. DAC £1000. Transport £800. Siltech digital cables, 1m £100, 0.5m £65. Tel: Gerry Hassell 0181 751 3771 or 0181 890 3302 (business hours) (Feb)

B&W MATRIX 804 speakers. Superb sound £895. Naim Nait 3 amp £375. Sony CD X222ES £225 ono. All in excellent condition. P/X considered. Tel: 01225 404 431 (Feb)

AUDIO INNOVATIONS Series 800 Anniversary power amp with Border Patrol power supply £1300, new. Audio Note ANJ speakers £600. Little Pink Triangle turntable, Rega RB300 arm/Grace cartridge £300. Tel: 01903 731 646 (Feb)

DPA 2 x 200S stereo power amps. Can be bridged for mono operation. £350 or as a pair £650. DPA Enlightenment drive with Deltran £350. Tel: 01724 710 547 (Lincs) (Feb)

MANA 5 TIER Stand inc 1 ref top & 2 soundstages £1100. Pioneer Precision CD player inc. Acoustic Precision base support £425. Neat Mystique floor standers £395. Trichord Pulsewire I/C 2 pairs 1/2 mtr and 1 mtr £145. Flatline speaker cable 2 x 4 mtr 4 soldered banana plugs at each end £120. Tel: Paul 0181 205 3264 or Paul.I@virgin.net (Feb)

NAIM 62/140 Amplifiers. New style, mint condition, boxed £600. SNAPS power supply £100. Tel: 01638 668 299 (Newmarket) (Feb)

CHARIO ACADEMY speakers. Solid walnut curved edges. Stunning looks and sound. 12 months old. Boxed with instructions. Can demonstrate. Cost £1400. Sold complete with Target 'K' Series sandfilled stands for £800. Tel: 0181 642 6470 eves, 0831 163 784 day. (Surrey) (Feb)

LINN ISOBARIKS (panel stands) SM6233, black, upgraded tweeters £775 excellent condition; Sony Walkman Professional £120; Target AER4TV table £50. DAT 120m tapes £2. Tel: 01622 858 085 (Feb/1)

AUDIOLAB 8000S £480. Meridian 551/MC board + MSR £550. Meridian 200 transport £350 + 203 DAC7 £250. Shahinian Arc speakers £800. Tel: 01703 345 188 after 6pm. (Hants) (Feb)

LINN LP12 walnut, Ittok LVIII arm, Ortofon MC10 supreme cartridge vgc £550. Alphason turntable stand (grey) £50. Ruark Templar speakers, rosewood £225 (boxed). Tel: 01223 360 313 (Feb)

QUAD 33/303 and FM in perfect working order in original packing with manuals. Soundcraftman 10 octave sound equaliser. Rogers matched pair Studio I speakers in teak. Would sell separately. Offers Cash. Buyer collects. Tel: 01206 32 3327 (Colchester) (Feb)

QUAD 606 Power amplifier, pre-amplifier, FM tuner and control panel with original boxes and instruction booklets. £1100 ono. Tel: 01274 814 231 (Feb)

EXPOSURE VII (Dual) pre-amp with two VI psu's. Absolutely mint but old style cases hence only £250. Also Linn Klyde M/C cartridge. 24 months light use £75. 01942 818 752 (Feb)

more CHOICE

AGENTS FOR:
 ACOUSTIC ENERGY, ALON, ATC, BOULDER, BRYSTON, C.A.T., CHORD,
 FORSELL, GAMMA, GRAHAM, LUMLEY, ROCKPORT, SME,
 SOUNDSTYLE, STRAIGHT WIRE, TARGET, TOTEM, TRICHORD,
 TRILOGY, van den Hul, VPI, XLO and many more.

- generous part exchange
- your equipment purchased
- show room/dem room
- trade in policy • all credit card inc. Amex
- mail order • export service
- the hi-fi exchange

SOME OF OUR CURRENT SECOND HAND STOCK

POWER AMPLIFIERS

Audio Research D125 balanced	Mint	S/H£1995.00
Audio Research H300 monoblocks	Mint	S/H£4995.00
Jadis JAS00 monoblocks	Mint	S/H£7995.00
Jeff Rowland Model 3 monoblocks	Mint	S/H£2395.00
Lumley Ref 120 monoblocks	Mint	S/H£1695.00
Conrad Johnson MF 2300	Mint	S/H£1995.00
Audio Research V 1 60	Mint	S/H£2495.00
Jadis DA 30 integrated	Mint	S/H£2995.00
Art Audio Quintet	Mint	S/H£995.00
Albarry PPI	Mint	S/H£295.00
Conrad Johnson Prem 8a	Mint	S/H£7995.00
Boulder 500 AE	Mint	S/H£2995.00
Melos 402 Monoblocks	As New	£4950.00
LFD PA/LSI	Mint	S/H£895.00
Audio Research D79/SP10 mk II	Mint	S/H£P.O.A.
Krell KSA 50 S	Mint	S/H£2495.00
Audio Research D400	Mint	S/H£2500.00
Musical Fidelity F15	Mint	S/H£1095.00
Beard P35	Mint	S/H£595.00
Krell KSA 300S	Mint	S/H£5995.00
Alchemist Kraken Monos & Pre-amp	Mint	S/H£895.00
NVA 80 Monoblocks & P50 Pre-amp	Mint	S/H£995.00
Bryston4	F	S/H£995.00
4 x Chameleon Ruby Power Amps	Mint	S/H£595.00
Each or	£995.00	Pair
Musical Fidelity PI 80 & CRPS	Mint	S/H£895.00
Krell KSA 1 00 mkII		£1595.00
Krell KSL Pre-amp	Mint	S/H£1095.00
Meridian 557	As New	£1050.00
Audion Golden Nights	Mint	S/H£2250.00
Audio Innovations S500 Integrated	Mint	S/H£495.00
Merridian 505 Monoblocks	As New	£1195.00
Muse 175 mk II 175W Monoblocks	Mint	S/H£2250.00
Krell KSA 80	Mint	S/H£1595.00
Mark Levinson ML 2 Monoblock	Mint	S/H£2795.00
Krell KSA 100 mkII	Mint	S/H£1495.00

PRE AMPLIFIERS

Musical Fidelity MVT	Mint	S/H£595.00
MC Cormack TLC-1	As New	£695.00
Tesserac Tala	Mint	S/H£795.00
Jeff Rowland Consumate & Phono	Mint	S/H£4995.00
DNM 3A & Twin Pack	Mint	S/H£750.00
Boulder LSAE	X-Dem	£2250.00
Audio Research LS7	Mint	S/H£1395.00
Naim Mac 52/ Supercap	Mint	S/H£250.00
Conrad Johnson Prem 7B	Mint	S/H£5995.00
Exposure IX professional power supply	Mint	S/H£795.00
Exposure V Active Xover	Mint	S/H£495.00
Naim Mac 52/ Supercap	Mint	S/H£3495.00
McCormack Micro Line Drive	As New	£395.00
Mod Squad Line Drive	Mint	S/H£250.00
Linn Kaim (SMP5) Phono	Mint	S/H£925.00
Krell PAM 3 Pre amp	Mint	S/H£1295.00

SPEAKERS

Alon V Mark One	X-Dem	£1995.00
Infinity IRS Beta	Mint	S/H£4995.00
Apogee Scintilla	Mint	S/H£895.00
Ensemble PAI Silver - bi wire	As New	£1995.00
Duntech Crown Princes	Mint	S/H£1995.00
B&W Silver sig & Stnds	Mint	S/H£3995.00
Apogee Caliper	Mint	S/H£795.00
Alon IV mk II	Mint	S/H£2495.00
Ruark Icon & Stands	Mint	S/H£295.00
Musical Fidelity MCS	Mint	S/H£395.00
Snell III's	Mint	S/H£695.00
Sonus Minima Anators & Ironwood Stds	Mint	S/H£1395.00
Martin Logan CLS IIZ & Kinergetic	Mint	S/H£5995.00

Subwoofer		
Magneplanar SMG 3	Mint	S/X£ 895.00
Dalquist DQ12	Mint	S/X£ 595.00
Sonus Faber Extrema + Stnds	Mint	S/X£ 4250.00
Spendor SP2/2	Mint	S/X£ 395.00
EPOS ES II & Stnds	Mint	S/X£ 395.00
Monitor Audio 700 PMC	Mint	S/H£450.00
Martin Logan Sequel II	Mint	S/X£ 1595.00
Royd Sapphire	Mint	S/X£ 195.00
Westlake HRI (Retail £20,000)	Mint	S/X£ 6995.00
Alon Phalanx	Mint	S/X£12000.00
B & W P6	Mint	S/H£695.00
Acoustic Energy AEI & Stands	Mint	S/H£695.00
Monitor Audio Studio 20SE & Plinth	Mint	S/H£1495.00
SD Acoustics SDI	Mint	S/X£1200.00
Rogers LS35A	Mint	S/H£350.00
Proac Response 4	Mint	SIX£ 7995.00
Soundlab Dynastat	Mint	S/X£ 2500.00

CD PLAYERS & DACS

Wadia I6	As New	£ 4750.00
Krell Studio 2	Mint	S/H£ 1595.00
Mission Cyrus Discmaster	Mint	S/H£ 595.00
Krell SBP 64X	Mint	S/H£ 3500.00
P.S. Audio Ultralink	Mint	S/H£ 895.00
M C Cormack DAC-1	Mint	S/H£ 695.00
Wadia 22/26	As New	p.a
EAD 9000 Series III HDDC	Mint	S/H£ 4500.00
Balanced/Gold		
Acuphase DP70	Mint	S/H£2250.00
Acuphase DP90/91	Mint	S/H£9950.00
Mark Levinson 30.S/31.S	Mint	S/H£14995.00
Forsell Air Ref Transport mk II	Mint	S/H£8995.00
Forsell Air Ref dac		
Wadia x 64.4 dac	Mint	S/H£1995.00
Pink Triangle da Capo 1307	Mint	S/H£ 695.00
Linn Kank Numeric & Remote	Mint	S/H£1795.00
EAD 1000 Transport	Mint	S/H£500.00
Marantz CD80	Mint	S/H£395.00
Rotel 965 BX	Mint	S/H£250.00
Theta TLC	Mint	S/H£ 695.00
DPA PDM 2 Silver Wired	As New	£995.00
Meridian 500 Transport	As New	£995.00
Meridian 566 20 bit Dac	As New	£ 895.00
Audio Alchemy Transport	Mint	S/H£ 495.00
Micromega Stage 1	Mint	S/H£ 295.00
Theta Progeny	Mint	S/H£ 750.00

TURNTABLES/ANALOGUE VARIOUS

Basis Ovation	As New	£ 3495.00
Pierre Lurme JV/SL5	Mint	S/H£ 2250.00
Koetsu Urushi	Mint	S/H£ 1295.00
Kuzma Stabi/ Stogi reference	Mint	S/H£ 1495.00
Linx Tuner	Mint	S/H£ 295.00
YPI TMT Wheaton III	Mint	S/H£ 1995.00
Pierre Lurme JV Sowerth mkIII	Mint	S/H£ 2250.00
Musical Fidelity TI Tuner	Mint	S/H£ 195.00
Musical Fidelity KT Tuner	Mint	S/H£ 495.00
Audio Technica ART 1	Mint	S/H£ 595.00
TNT mk III & Lid	Mint	S/H£ 3995.00
Clear Audio Gamma 24 CT Gold Coils	As New	£495.00
Stax SR Gamma Pro & SRMX Pro Energiser	Mint	S/H£ 595.00
Meridian 504 Tuner	As New	£525.00
Technics SPO mkII full opsidium plinth	Mint	S/H£1200.00
TMT 4 & Flywheel Air Suspension	As New	£4500.00
Forsell Air Force One	As New	£11995.00
Kiseki Agat Ruby	Mint	S/H£ 1495.00

CHOICE
 10am-8pm
 7 days by appt.

Tel 0181 392 1959
 0181 392 1963
 Fax 0181 392 1994
 E-Mail: Choice_Hi Fi@msn.com

BETTER OFF DEAD

no vibrations dead sounds perfect

Fit FOCULPODS

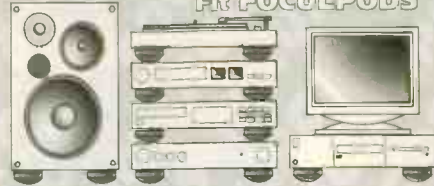

WHAT THE PRESS HAVE TO SAY

...I thought they worked very well on some low-cost CD players I had Knocking About...

Hi-Fi Choice
 July 1995

FOCULPODS & POLIPODS are high performance vibration absorbing supports designed to be placed under Compact Disc Players, Turntables, Amplifiers, Loudspeakers and all other Audio & Video equipment. Designed using computer modelling techniques the spherical surface provides even contact and uniform energy distribution

4 FOCULPODS will support a maximum of 20 Kilos

NEW

POLIPODS

Designed to support a pair of bookshelf speakers or 2 items of lightweight Hi-Fi equipment



50 mm dia. x 20 mm



40 mm dia. x 14 mm

£14.95

per pack 4
 available from most good Hi-Fi dealers

4 POLIPODS will support a maximum of 5 Kilos

WHAT THE PRESS HAVE TO SAY

...We found they worked best with CD players, allowing the transport to run more smoothly to give a more open and natural sound, and better stereo imaging...

WHAT HI-FI - 1996

£14.95 per pack 8-
YES 8!!
 available from most good Hi-Fi dealers

For a **FREE** information pack and details of other products from **SPECTRA DYNAMICS**

Tel (01745) 360070 Fax (01745) 360086

Unit A1, Ffordr Derwen Industrial Estate, Rhyll, Denbighshire, LL18 2YR

DEFLEX[®] By SPECTRA Dynamics

Deflex material is a specially formulated low resilience polymer with exceptional shock absorbing properties. Loosely grouped molecules within the material rub together and transfer vibrations into heat. In its soft form the material has a texture similar to plasticine but with a high memory characteristic. The mechanical properties of the material guarantee to reduce unwanted noise



You need at least 2 Deflex panels for a pair of small bookshelf speakers, 4 panels for a pair of Tannoy 6's and at least 6 panels for larger cabinets



Once you have gained access to the inside of the cabinet, remove foam and/or wool damping from the inside of the speaker (if fitted)



Place the flexible Deflex panel thru the speaker cut-out and stick to the inside of the cabinet using the recommended adhesive

DEFLEX ACOUSTIC PANELS

The simplest and most cost effective way to upgrade your existing system

Deflex panels seemed to give greater tightness and control, improved internal clarity and pitch definition - all without deadening the sound in any way

the result was sharper imaging, wider dynamic and a more natural sound

CHOICE VERDICT

Sound Quality ■■■■■
 Value for money ■■■■■

a marked improvement was obvious from the first few bars of RFM's Automatic for the people album

But one thing for sure - the Deflex panels are no gimmick! They work

PANEL PRICES

Standard Panel	£7.95	(28cm x 21cm)
Medium Panel	£6.95	(28cm x 18cm)
Small Panel	£5.95	(24cm x 13cm)
Sub-Woofler Panel	£14.95	(34cm diameter)
Adhesive	£3.50	Delivery £5.00

"The only world acclaimed flexible acoustic damping pad for lining loudspeakers" (UK PATENT N° GBPT 227700B)

For a **FREE** comprehensive information pack & details of other products from **SPECTRA DYNAMICS**

Tel. (01745) 360070
 Fax. (01745) 360086

Unit A1, Ffordr Derwen Industrial Estate, Rhyll, Denbighshire, LL18 2YR, UK

Hi-Fi World Classified Ads



PRIVATE

SONUS FABER Minima Amator speakers, brand new, still boxed with full guarantee. Never used. Unwanted gift! £1150 ono. Tel: 01753 681 912 or 0973 333 145 (Feb)

AUDIOLAB 8000Q amp £650. Audiolab 8000P power amp £450. Audiolab 8000CDM £650. DPA Enlightenment DAC £550. Rotel R-T990BX tuner £350. Makamichi DR-1 tape deck £450. Project 6.15 record deck with Ortofon MC30 Supreme £450. Pace M551000 satellite receiver £150. JVC HR-S5500EK S-VHS video recorder £250. Tel: 01296 398 166 (Feb)

RUARK SABRE loudspeakers in unmarked condition and walnut veneer £195 ono. Exposure loudspeaker cable. Two 8m lengths £30 ono. Tel: 01502 716 197 (Feb)

NAIM O2 TUNER (new) Linn Pretek, 2 Powerteks, Keilidh speakers (new), Meridian 200 CD player, 203 DAC, Nakamichi cassette deck 2, Target stand. All excellent condition. Offers. Tel: 01794 523 746 (Feb)

PROAC STUDIO 100 speakers with Target R1 stands. Both in excellent condition. (£980 new for pair) Selling for £595 ono the pair. Tel: 01780 764 149 (Feb)

NAIM CD3.5 £700. NAC 102, NAP 180 £1350 (£2110). Epos ES11 £230 (mah.) SoundStyle rack £100 (£220). May split. Tel: Colin 01293 416 022 (Feb)

MISSION 752 Freedom (rosewood) Mint condition £430. Marantz CD63 KI Signature, mint condition £275. Arcam 6+ amp vgc £140. All boxed and instructions. Tel: 01508 499 586 after 4pm (Norfolk) (Feb)

MAGNAPLANAR MG1Cs £650. Quality monoblocs (prototypes) £350. Rega Planet CD + remote, boxed as new £375. MacIntosh MC 2100 power amp + power supply £700. Musical Fidelity XLP, boxed as new £100. Linn LP12 Valhalla/Syrinx PU2/Rega Flys £500. All vgc. Tel: 01273 607 068 (Feb)

MUSICAL FIDELITY M.Y.X. pre-amp, 4 line + MM/MC phono stage, mini, boxed, cost £2300 new. Accept £695. Musical Fidelity P180 power amp £450. M.F. P270 MkII £695. Pink Triangle Da Capo DAC 22 bit and 1307 filters £695. Tel: 01634 387 686 (Feb)

SPENDORS SPI 001270/1 boxed perfect £250 or XC. Philips Motional F/B L5541 £65. Thorens 125, plinth, 3009, v15 £120. Revox Mint 791 tangential £175. Quad FM4 mint boxed Charcoal No. 018246 £225. 5m remote for Teac R/R £25. Sony auto rev TC-V7 vgc £40. Sony MC XL55 Pro boxed, mint. Tel: 01392 860 182 (Feb)

GAMMA AEON 211/VT4C valve monoblock silver amplifiers (£5000) Class A single ended £2195 ono. May P/X. Marantz CD-10 £495. (others) Tel: 01225 480 990 (Feb/1)

PINK TRIANGLE Pip2 pre-amp battery PSU MC stage, superb (£4000) £1150. Audio Synthesis DAX2 AT&T as new (£2100) £1450. Sonus Faber Amator speakers with slate stands (£3600) £1850. Avondale VI power-amp (£1250) £550. Naim 62 Avondale 6 channel PSU £650. Lowther Acousta speakers PM6 original re-coned £225. Meridian M2 active speakers, stands, cables and pre-amp £400. All mint and boxed. Tel: 01274 426 103 (Feb)

QUAD 63 ELECTROSTATIC speakers £1100. Quad 66 pre amp £440. Teac P2 DAC £800. Kef 104/2 Raymond Cooke Special speakers £850. Yamaha CX2/MX2 pre pwr amp £675. Tel: 01977 643 629 (Feb)

NAIM DBL's (Active/Passive) £3000. 6 tier Target stand X2 £350. Linn LP12 turntable £500. Naim Aro £500. Naim Prefix £195. Naim Hi-Cap £400. Lyra Parnassus £1100. Linn Lingo £350. Mana Reference/Mini Mana £250. Naim CDS £2750. Naim S2/Supercap £3500. Naim NAP 135 X2 £2000. Tel: 0171 801 0905 or 0385 575 643 (Feb)

BBC L55/12A Monitors, new, boxed, half price £600. Stands £50. Scopex dual beam scope + manual £75. Fluke 8024A digital multimeter + temp. probe + manual £65. Lowther PM6 drive unit £45. Tel: 01303 258 961 (Feb)

SYSTEMDEK HIXE 900, Acrylic platter, metal armboard, RB300/Goldring 1020GX cartridge. Nice condition £350 ono. Sony Pro Walkman, leather case, cables, boxed, nice condition £150 ono. Tel: 0114 272 7969 day, 0114 233 5413 eve. (Feb)

NAIM NAC 42 £90 ono. Brand new Marantz CD 67 £180. Quad 77 Int. amp, carbon £450. Acoustic Energy AE1's, new drivers, gloss black cabs, dedicated stands £650. Denon DNS 810 cass deck £140. DPA Enlightenment drive DAC, 6 months old £950. Tel: Jules 01792 280 061 (Jan/1)

MERIDIAN 263 Delta Sigma DAC plus Ixos 105 digital interconnect £225. Denon DRM 510 tape deck £80 ono. DCD 960 CD £125 ono. All boxed and mint. Tel: 0171 739 2659 or 0850 088 434 (Feb)

QUAD QA12P (1948/51), actual one photographed for 'Audio Audio' book, plus matching Quad HR1 tuner. Both in excellent original condition, serious offers only. 2 Avo Mk3 valve testers, offers. Tel: 01550 777 336 (Feb)

ART AUDIO Tempos Class A triode monoblocks 30W, new £2700, £1200 ono. Ruark Accolades, top of the range tri-wireable new £2700, £1200 ono. Silver Seven interconnect one metre £95. Canare speaker cable, two 3.5 metre tri-wire lengths £70. Tel: Chris 0181 993 2006 (Feb)

QUICK SILVER valve monoblocks GEC KT88 100wpc (£3500) £1175. Quick Silver valve pre-amp MC phono (£2200) £725. Naim 42 with Avondale PSU £450. Radford Woodside WSCD2 CD player Trichord Clock2 (£1100 + £176) £450. Audio Synthesis Silverblue 2.5m £185. Oracal Delphi turntable Helius Scorpio arm Onix PSU £550. Mitchell Hydrolic Reference turntable Linn arm and cartridge £250. All mint and boxed. Tel: 01274 428 170 (Feb)

QUAD 77 CD (mains) £600. 77 pre & system controller £550. 77 Stereo power amp £400. All grey Nextel. Tel: 01733 551 881 (Feb)

NAIM NAXO 3-6 Crossover, new style, boxed, never used, currently located at a house in Guildford. List price £676. Will sell for £400. Tel: Ireland 01 285 3860 (Feb)

NAIM NACS2 and Supercap power supply, one year old but good as new. Unusual reason for sale. £3250 Tel: 01635 866 004 (Feb)

SURROUND SOUND System (separates) high quality, boxed as new, mint. Sale due to bereavement. Denon, Rotel, Kenwood, Monitor, Celestion, Target, TV cables. Cost £2500, accept £1500. Details Tel: Charles 01398 323 406 - 01823 324 811 (Somerset/Devon) (Feb)

THORENS 155 Mk II turntable with ADC cartridge, two Mordaunt Short M5600 mahogany speakers (Decca ribbon tweeter, Celestion 10" woofer), Akai GCX320D cassette deck. Best offer accepted. Tel: 01491 612 521 (Feb)

PINK TRIANGLE LPT (Blue Nextel/Black Plinth) - RB300 arm - Roksan Corus Black (low hours) All excellent. Tel: Gregory 0181 981 6195. E.Mail:Hugoshouse@compuserve.com (Feb/1)

AKAI GX-4000DB, reel to reel tape deck wanted in good condition (or for spares) Willing to pay up to £200 in cash. Tel: 01925 822 897 (Feb)

NAIM 82 £1350, 3 x Hi Caps £400 each. Naxo 2/4 X-over £300. All new style. 2 x NAP 250 serviced & matched, old style £650 each. Avondale 42 preamp with CD input & power supply £300. All perfect c/w boxes & manuals. Tel: 01527 401 954 (Feb)

FOR SALE: PT Two, RB250, boxed, excellent £350 ovno. Linn Basik, Akito, K6, boxed, excellent £175. RB300 silver wired by Audio Synthesis on Linn board £110 ovno. Tel: 0191 226 0174 (Feb/1)

TECHNICS SLP1200 CD player as in November 97 Hi-Fi World, page 47. Complete boxed £375 ono. Tel: Lyn 01302 321 066 (Doncaster) (Feb)

NAIM 140 Power amp £400. Audiolab 8000T tuner £395. Wanted: Naim 250 power amp. Tel: 01884 259 637 (Devon) (Feb)

MUSICAL FIDELITY T1 Tuner £80. Linn Valhalla PSU board for LP12 £55 (with 4S adaptor). Tel: 01522 694 871 (Lincoln) (Feb)

AUDIO ALCHEMY DUS3 transport with £350 Trichord mods £550, SD1E speakers just run in new £2950, £1800, Zeta Vdh tonearm and recapped Kneissl Red Signature £800, old style SD1 speakers £450. All mint, any demo. Tel: 01734 611 918 after 7pm (Feb/1)

NEW VALVE Amplifiers using classis Mullard 5-20 circuit with modern high-quality components. Tesla/Sovtek valves, 25 watts per channel. Monobloc pair £250, single-chassis dual mono £300 Tel: 0181 427 1378 (Harrow) (Feb)

WANTED: QUAD 66 Pre amp with remote, Quad 66 tuner, Quad 67 CD. Must be mint. Also ELS 63's Tel: 01453 764 734 (Feb)

XTC PRE 1, pre amplifier, lacquer black, remote control, superb performer, highly reviewed, 3 months old, boxed, as new, cost £1250, sell £800. Tel: 01634 365 153 (Kent) (Feb)

REGA ELA Loudspeakers (black) 12 months old. Immaculate condition. Five years warranty remaining, only £400. Also Soundstyle 4 shelf rack blue/black marble effect £200. Tel: 01253 884 023 (Blackpool) (Feb/1)

TANNOY CHATSWORTH Speakers 12" Monitor Gold, in mint condition £375. Tel: 01829 782 115 Evenings (Cheshire) (Feb)

QUAD ESL 63 with MAF stands. Black grilles, rosewood finish. Mint condition, boxed as new. Reluctant sale due to recent move £1500. Tel: 01772 315 723 (Feb)

QUAD EQUIPMENT stand, designed to house Quad 66 series, cost new £240, as new will accept £120. Mint condition. Tel: 01903 750 962 (W. Sussex) (Jan)

CELESTION SL600 speakers, grey, excellent condition, boxed £250. Also Meridian 203 DAC £200. Tel: 01793 490 597 after 5pm (Jan)

CELESTION SL65 Speakers, walnut finish, with Celestion stands, immaculate condition, original box, manual and test certificates £275. Tel: 01623 27974 (Mansfield) (Jan)

AUDIOLAB 8000M Monoblocs (3). Two are 5 months old, one is 3 months old. Boxed, paperwork, immaculate! £550 each. Tel: 01794 830 111 (days) 01703 769 175 (evenings) Ask for Alex (Jan)

QUAD ELS pair 1960s bronze grilles, with cables & GFD stands £450, also Blaupunkt 'Florenz' 20350 4-band 3-speaker table radio 1962, offers, buyer collects, East London. Tel: 0181 989 4251 (Jan)

FOR SALE: A hi-fi system, which includes Naim-NAP 250 power supply, 2 Hi-Caps, NAC82 preamplifier, NACD2 compact disc player, 2 SBL speakers (latest models), 1 Nakamichi DR1 cassette player, 1 Rotel stereo tuner, 1 Linn Sondek record deck + Ittok arm. Price £5000. Tel: 01454 419 157 (Jan)

ROSE RV-235 valve pre-amp £300. Audion Sterling valve power amp £350. Buyer collects. Tel: 01529 460 016 (Lincs) (Feb/1)

WANTED: E.M.I. TR90 tape recorder. Someone must have one! Will collect. Tel: 01580 830 558 (Feb)

TANNOY III LZ £200. Moving coil pre pre-amps, QED £15, Lentek £25. Wharfedale Super 8/F5/AL drivers in cabinets £30. Rogers Junior single monoblock £80. Akai 4000D £90. Tel: 01705 839 809 (Hants) (Jan)

MARANTZ CD63 MKII CD player £135. Naim Nair 3 amplifier £400. Both mint, boxed etc, 18 months old. Tel: 01904 690 222 daytime (York) (Jan)

APOGEE DUETTA Signatures full range ribbon speakers. Mint condition incl boxes & manual £1950. Symo speaker cable 2 pairs of 2.5m £225 a pair. Meridian 566 20-bit DAC £500. Meridian 518 digital pre-amp/jitterbuster £600. Tel: 0171 281 0821 (Jan)

IMPULSE H2 Loudspeakers. Ultra-sensitive (95dB) ideal partners for low output valve amplifiers. Beautiful condition, black finish. A bargain at £1700. Tel: Mark 01252 845 128 (Fleet, Hampshire) (Jan)

KEF Q55 loudspeakers, amazing imaging, 6 months old £375 (£500 new). NAD 3020A amplifier £50. Rega RB250 £50. Quad 33 £40. Quad 303 (damaged channel) £30. Tel: 01403 264 517 after 6pm (Jan)

LINN KAN Mk1 speaker in immaculate rosewood finish £150. Tel: 01258 450 503 (weekends only) (Jan)

71 HIGH STREET,
NEW MALDEN,
SURREY, KT3 4BT.
ENGLAND.
TEL: 0181 336 0012
FAX: 0181 336 2703



0% CREDIT
(SUBJECT TO STATUS)

2 DEMONSTRATION ROOMS
FREE PARKING
WIDE RANGE OF PRODUCTS
OPEN 9.00-6.00 MON -SAT



USA ESOTERIA

JBL ESC550
LIFESTYLE WALL/FLAT MOUNT
DOLBY SURROUND CONSOLE
INCLUDING CD & TUNER WITH FULL SPEAKER
SYSTEM INCLUDING SUB WOOFER
"SIMPLY BRILLIANT"

MUSICAL FIDELITY
X - SERIES
THE COMPLETE RANGE
OF THIS OUTSTANDINGLY
GOOD VALUE EQUIPMENT
IS HERE!

MARANTZ REFERENCE
CD17/K.I. CD PLAYERS
PM17 AMPLIFIER
ST17 TUNER
INCREDIBLE BUILD &
SOUND QUALITY



U.K. ESOTERIA



UNIQUELY ON DEMONSTRATION

TEAC REF 500/300
HIGH QUALITY MIDI
COMPONENT SYSTEMS WITH HI-FI SEPERATES
SOUND QUALITY

EXCLUSIVE AREA DEALERSHIP FOR...

- ATC ● AURA ● AVI ● B&W ● CASTLE ●
- CHORD ● H/K ● JAMO CONCERT ● LINN ●
- MARK LEVINSON ● MUSICAL FIDELITY ●
- PROCEED ● PROJECT ● PIONEER
- PRECISION ● TEAC ● PLUS:

ALCHEMIST, CABLE TALK, DPA, EXPOSURE, HARBETH,
JBL, MARANTZ, MICHELL, MCINTOSH, NORDOST,
PRECIOUS METALS, REL, RUARK, SENNHEISER, SONIC
LINK, SYSTEMDEK, TANNOY, TDL, AND MANY MORE



GENUINE BARGAINS AVAILABLE ON CLEARANCE ITEMS, 'PHONE FOR DETAILS' NEW MALDEN EXIT (A2403) ON A3 NEAR KINGSTON UPON THAMES

**ORIGIN LIVE MODIFICATION FOR
THE REGA RB250 & RB300**

If you are the proud owner of one of these two arms why not turbocharge it into the league of super arms with the Origin live structural modification:- £75 inc post & packing. Rewiring with silver litz cable is also offered at an additional £70.

"I have to say the Rega modifications turn the arm into a real Giant killer" Hi Fi WORLD SUPPLEMENT NOV 97

CROSS SECTION OF ARM END

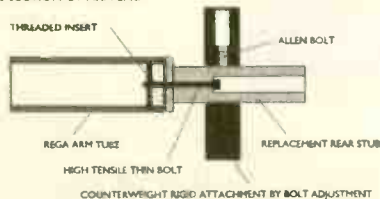

ORIGIN LIVE TURNTABLE KITS
Standard & Ultra

Now you can save money and build your own high performance dock. The standard kit version is offered at £125, and the ultra version at £249. Both decks come with a full set of drawings and guidance instructions. The kit allows for your creativity or there are optional parts that will enable you to assemble a tried and tested design within 2-4 hours.

"With all these goodies in place, the standard would give turntables at the £1200-£1400 mark a hard time." HI-FI WORLD SUPPLEMENT NOV 97

For further information contact:-

**Origin Live, 87 Chessel Crescent, Bitterne,
Southampton, SO19 4BT**

Tel: 01703 578877 / 442183 Fax: 01703 398905

**AUDIO
ILLUSION**

23 Langley Broom
Langley Berkshire SL3 8NB
TEL: (01753) 542761 : FAX: (01753) 772532
OPENING HOURS:
10am - 8pm Monday - Saturday (By appointment)

★ **CABLES
GALORE
AND A
WHOLE
LOT MORE**

* Mail Order Service * Export Facilities : * All Major Credit Cards Accepted

PRICES NEVER TO BE REPEATED

BARGAIN OF THE MONTH

MARK LEVINSON No. 27.5 Power Amplifier
Still under Warranty, as new - **SAVE £2,200** - call now
Cost New £5,400 Sale Price £3,200***

		NEW	SALE
Audio Research LS22 Linestage Preamplifier	A few hours use	£4300	£3150
Mark Levinson No. 27.5 Power Amplifier -			
	Still under warranty - As new -	S/Hand	£5400
	Little use - As new		£4800
Alchemist "The Alchemist" 200wpc Power Amplifier			£2995
Infinity IRS Sigma Ribbon Hybrid Loudspeakers -	A few hours use -	As new	£6800
Mirage:-			
M-290 2-Way Audiophile Compact Monitors		Ex. Demo	£ 400
M-1090h 2-Way, 4 Driver Bipolar Radiators	As New	S/Hand	£1300
M1-si 3-Way, 6-Driver Bipolar Loudspeakers - the Ultimate		As New	£6800
M5-si 2-Way, 4-Driver Bipolar Radiators		Ex. Demo	£2000
BPS-150 Active 150w Bipolar Subwoofer (Piano black)	As New	S/Hand	£ 800
Transparent Cables			
AES 1.0M Balanced Digital Interconnect		Ex. Demo	£ 300
BM1P 1.0M Balanced Interconnect		Ex. Demo	£ 430
MWP 6.0M Speaker Cable (2 pairs available - price per pair)		Ex. Demo	£ 712
TW 3.3M Speaker Cable		Ex. Demo	£ 130
Siltech Cables			
HF8 0.5M 75 ohm Digital Interconnect		Ex. Demo	£ 100
HF8 1.0M 75 ohm Digital Interconnect		Ex. Demo	£ 230

Information available on the following :-

acurus

Classe Audio : Enlightened Audio Designs :

EUPHONIA ISOLATION DEVICES

RENAISSANCE AUDIO

KORA : MIRAGE

For your nearest stockist contact: AUDIO ILLUSION

Hi-Fi World Classified Ads



PRIVATE

SENSIBLE OFFERS For enthusiasts clear out. Quad FM1 tuner. Braun 510 receiver. Akai 4000DB tape deck. Leak TL 12.1 valve amp. Akai CR80DS 8 track player/recorder. All excellent condition. Tel: 01472 870 367 (Jan)

UHER CR240 Stereo recorder, Uher 4000 Report C, 1960's models. Sale to best offer. Tel: 0181 903 6188. Email: handmade_paper_co@compuserve.com (Jan/1)

MUSICAL FIDELITY A120 integrated amplifier, very fine sound quality, boxed, as new £210 ono. Tel: 01562 710 850 (W.Mids) (Jan)

REL STORM active subwoofer. A superb bass playing instrument for hi-fi/audio visual. Brand new & full warranty. Half price £350. Tel: 01702 421 304 (Jan)

KEF 103/4 Reference Series (rosewood) Cost £1300. Bargain £600. Yamaha stereo cassette deck TC-800GL, special wedge shape design. Collectors item £100. Both mint condition. Spendors BCI teak, perfect £200. Tel: 01708 767 478 (Romford) (Feb)

NAKAMICHI DR3 10 hours use £199. ProAc Super Tablettes inc Target stands, vgc £350. Meridian 204 tuner £249. Quad 306, vgc £190. Yamaha E200 Dolby Pro Logic processor, vgc £149. Tel: 01293 886 205 (evenings) Sussex (Feb)

LINN CD and active crossover. Linn Karik 3 CD player, 9 months old £1350. Active electronic crossover for Isobarik £500 ono. Tel: 01753 851 429 (Feb)

WANTED: REVOX Pre-amp, equaliser, timer for B77. W.H.Y. Tel: 01923 443 490 (Feb)
NAIM SUPERCAP 3 months old, for use with 52 pre-amp, 82, pre-amp or Super Naxo £1500. Tel: 01767 317 166 (Feb)

PAIR DENON 6600A Monoblock power amplifiers. Excellent with Isobariks or similar hard to drive loudspeakers. 260W into 8 ohms, 450W into 4 ohms. Spare pair boxed £500. Tel: 01455 233 017 (Feb)

SYSTEM FOR Sale. Arcam 250 Delta transport, Pink Triangle Da Capo DAC, DPA 200S pre amp, 2 x DPA 200S power amps, Magnaplanar 1.4 loudspeakers. £2100. Tel: Andy 01708 732 850 (Jan/1)

PAIR UNISON Research Smart 845 monoblocks. Superb sound. Mint condition, hardly used. Boxed. Upgrade necessitates sale. Demonstration, and delivery may be possible. £2300. Tel: 01666 504 550 (weekend) or 01772 853 658 (work) (Feb/1)

REGA KYTE Speakers, virtually new, hardly ever used £130. Stands available too. Tel: 01623 871 950 (Jan)

LP12 (BLACK). Cirkus, Lingo, Tramalin, Aro, Arkiv, spare Klyde, Naim 82, two Flatcaps, 180, Kabers, Mana Six shelf, Arcam Alpha Five CD. Excellent condition. Offers for the lot. Tel: 01706 828 294 or 0402 180 652 (Jan)

ORIGINAL LEAK Sandwich speakers. Black grills, 12 inch Sound Organisation stands £90. Moth record deck, Mission arm, Shure cartridge £40. Meridian 103 Pwr amps, 3 box £60. Tel: 01765 600 450 (N. Yorks) (Jan)

ROTEL RCD965BK, Micromega Microdac, Linn Intek, Tannoy 609's, Target stands, quality interconnects, bi-wired (cost £1500), boxed, mint £600. Tel: 01282 817 143 (Lancs) (Feb)

MUST SELL Highest offer secures. Neat Petite II, new, unopened. Mark Levinson MLI preamp. Studer A725 CD Fisher valves FM200B tuner, AC280 monoblocks, Grado Signature. Low hours. Tel/Fax: 01642 649 702 (Jan)

EXPERIMENTORS CLEAROUT. Custom built equipment offers. Audionote M7 phono, line stages, Naim S2 M.C. stage, rebuilt Naim NAP120 300VA x 2, Dual mono P.S.U. etc. Luxman line level transformers. Tel/Fax: 01642 649 702 (Jan)

NAKAMICHI BX2, Cassette deck £200. Meridian 200-203 CD £630. Thorens TD160 Super turntable complete £140. Creek 4140 S2 amplifier £80. Linn Index speakers £100. Mission DAC3 CD digital converter £110. Quad FM3 £80. Meridian 101 pre-amp £80. All new condition. Tel: 0181 681 1054 (Croydon) (Jan)

DPA 200S Pre power, boxed, just serviced £600. Roksan Caspian integrated amp, boxed £500. Soundstyle x100 5 glass stand £100. 2 x DPA. The Power mains filters £50 each. Tel: 0181 654 9850 (Croydon) (Jan)

NAIM GEAR (New style) - CDS £2200, NACS2 £3300, NAP250 £1000, NAT01 £900, LP12 Lingo, Ekos, Arkiv £1200, Nakamichi CR7 £1100, Marantz CD10 £400. Two Rotel Dolby units £100. All mint. Tel: 01473 610 434 (Ipswich) (Feb)

CLASSE AUDIO DR6 preamplifier, boxed in very good condition £1100. Theta Pro Basic III DAC (upgradeable). Boxed in mint condition £1300. Townshend Seismic Sink (2). Small size, for supporting Meridian sized components. £50 each. XLO Signature balanced interconnect, 1 1/2m £400. Tel: 01502 724 251 (Feb)

MILLER & KREISFL Solid walnut 'Volkswooler' and satellite loudspeakers £700 ono. Recently serviced and very rare original. Cost \$1800. Tel: Sushi 0171 602 3822 (Jan/1)

ROGERS STUDIO Ones and Threes with stands £250 each. KEF Reference Ones £750 Guaranteed. AEI's £250. All boxed mint. Rogers Cadet pre/power £50. Top kit, bottom prices! Tel: 01332 200 495 (Jan)

REVOX A77 4 track recorder. Couple of hours use after £800 overhaul. Selling due to illness £400 ono. Quad mono tuner £35. Phone 0181 893 4650 (Jan)

VINTAGE FOUR triode amplifiers using Px4s Dynatron/Vortexion etc. STC triode amplifier similar to Western Electric OPT 4043c. Pye HF 5/8s. Tannoy 12/15 Lancasters. GEC/BBC amplifiers. Offers. No idiots/canvassers. Tel: 0171 349 9675 or 0958 607 613 (Jan)

NAKAMICHI 1000ZXL cassette deck £1995. Nakamichi OMS-4E CD player £145. Nakamichi Case pre amp £225. Meridian Mod 226 power amp £95. Cambridge C100 pre-amp £135. KEF centre speaker Mod 100 £135. Tel: 01923 442 210 (Jan)

TDL STUDIO I Speakers, walnut, immaculate £450 incl stands, and Naim cables, boxed. Tel: 01494 727 504 (Feb/1)

MOTH 30 SERIES, 40W monoblocks £350. Moth Leyline black interconnects £75. Tel: 01933 356 086 (Northamptonshire) (Feb)

ARCAM ALPHA 6 CD player £350. Arcam Alpha 6 plus amplifier £220. Kef Coda 9 loudspeakers £160. Audioquest Ruby interconnect £45. 2 Cabletalk professional interconnects £50 each. Tel: 01489 570 990 (Feb)

MISSION DADS/DACS £250. Naim NAC 62 £220 (new style) NAP 140 £425 (new style). Ruark Talisman II (black) £425. All in excellent condition. Tel: 01642 824 429 (Cleveland)(Feb)

FOR SALE: 1940s/60s. Tannoy 15" bass unit low frequency £250. Tannoy monitors 10" pair £250. Goodmans corner speaker £450. Soundsale speakers £450. Various 1940s triode amplifiers using PX4s/PX25s. Tel: 0171 349 9675 or 0958 607 613 (Jan)

TRADE ADVERTISERS

NAIM / LINN / MANA
BUY / SELL ALL ITEMS
e.g. 52, CDS, SCAP, SNAXO, HICAP, NAXO, 135, 250, SBL, IBL, 180, 140, 72, 32, MANA etc
TEL: BOB 01382 819 732 (Dec)

SEE THE New Neat Acoustics range and compare with Castle, Mission etc. Fire them up with Audiolab or Arcam or DPA etc. All at Audio File Objective, 37 Tower Centre, Hoddesdon, Herts, on The North London, Essex borders. Free parking. Hi-Fi Purchased. Tel: 01992 478 666 (Jan)

TECHNICS SP10 £380, Studer A710 £500. Studer A80 £750. Studer B62 £650. Revox B77 HS £600. Studer B67 £500. Studer A725 £450. Revox C278 £1600, EMT 948 £650. Tel: 0246 275 479 (Jan)

IMMORTAL COILS has a new phone/fax no: 01480 289 730. ACTIVE CROSSOVERS designed and built to your exact requirements. ACTIVE CROSSOVERS for the RUARK range now in stock. (Jan)

BUY-SELL-EXCHANGE. Vintage wireless and classical audio. Repairs, spares, restoration, modification to all valve equipment. Quad II, Leaks etc. Visit us for collectable audio gifts. 17 Bell Street, NW1 5BY. Tel: 0171 258 3448 Fax 0171 258 3449 (Feb)

GARRARD 301's and 401's for sale. All in excellent condition from £130 each. Also 'SME' 3009 arms from £60 each. Tel: (0044) 01705 486050. Fax: (0044) 01705 474242 (Jan)

MIRAGE BI-POLAR Speakers, ex-dem offers. M1090i's (£1295) £995. MC2 Centre Channel (£449) £379. MBS2 monitors (£599) £479. BPS 150 sub woofer (£759) £629. M5si (£1995) £1695. All with full warranty. Tel: 01628 440 637 (Jan)

THEATERMASTER, FABULOUS 24ct Gold AC3/DAC/Preamp. RRP £7500 (£5000) Matching LD/CD T8000 transport RRP £4995 (£3500) Both are ex-dem and extremely rare with full warranty. Tel: 01628 440 637 (Jan)

VENEERING SERVICE for DIY Speakers and Plinths. Your choice of veneer. High Quality work Guaranteed. Good Prices. Also Hardwood decor panels for Amps etc. Tel: P & J Design on 01424 715 692 (Jan)

HALCYON SYSTEMS Class A Mono-Bloc Amplifier 60 watt £495 ea. Passive Pre-Amplifier £299 ea. Two Way Horn Loaded Loudspeaker, Horn Loaded A.B.R. System Bi-Wireable £599 pair. Necromancer Two Way Ported Loudspeaker With Ribbon Tweeter Bi-Wireable £899 pair. Tel/Fax 01903 716 209 (Apr)

COPPER SHIELDING
CD 'Roof': RF interference and casing vibration cut dramatically.
Also damping pads, component shields and sheet copper for DIY.
SAE To:
Kopperae, PO Box 6884, Dundee, DD5 1YB
E-Mail: wkopp@traynet.co.uk (Feb/1)

NEAT PETITES MkII with ribbon tweeter £339. Neat Mystiques £399. DPA 200S preamp £299. All Xdisplay. Audiolab 8000C + 8000P with six months warranty £899. Others available. Hi-Fi Purchased. Objective Audio 01279 426 647 or 0973 452 368 (Jan)

WANTED - EARLY HI-FI
LOUDSPEAKERS
Tannoy, Lowther, Parmeko, Voigt, Vitavox, RCA WE etc
TURNTABLES
Garrard, BBC301, EMT SHE, Ortofon, Decca, etc.
VALVE AMPLIFIERS
AEI, EMI, Leak, Rogers, PYE- Quad, WE etc
AUDIO VALVES
DA30, KT66, KT88, PX4, PX25, PP3/350, WE300
CLEAR CRYSTAL SYSTEMS
John Petrie-Baker
Tel: 0171 328 9275

classified ads

HI-FI WORLD CLASSIFIED ADS ORDER FORM

Dealers must not advertise in the Private Classified section. Monthly consecutive insertions will be considered Trade advertising. The Publisher reserves the right to judge submissions

Hi-Fi WORLD CLASSIFIED ADS ORDER FORM

Please type or write your advertisement copy in block capitals. Use a separate sheet of paper and return with this completed form.

SPECIAL OFFER FOR DECEMBER 1997 ONLY. BOOK A PRIVATE OR TRADE CLASSIFIED AD. AND GET ONE MONTH'S FREE INTERNET AD. OFFER ENDS DECEMBER 31st 1997

RATES

Maximum length per advert is 30 words, each additional word is 50p extra. Telephone and model numbers are treated as one word.

MAGAZINE & INTERNET

- Private with Free Internet £10.00 per month
 Private, Boxed with Free Internet £15.00 per month
 Trade with Free Internet £10.00 per month
 Trade, Boxed with Free Internet £15.00 per month

PLEASE TICK HERE IF YOU DO NOT WANT YOUR FREE INTERNET ADVERT

Name _____
 Address _____

 Post code _____ Daytime Tel. No _____

I enclose cheque/postal order for £ _____ Made payable to Audio Publishing Ltd.

Please debit my VISA/MASTERCARD card No. Expiry Date _____



For office use only
 Ref _____ JAN98

Send this form together with your payment to:
Hi-Fi World Classified Ads., Audio Publishing Ltd.,
64 Castellain Road, London, W9 1EX

DEADLINE FOR FEBRUARY 1998 ISSUE IS TUESDAY 9TH DECEMBER 1997

ADVERTISERS INDEX

Affordable Audio	118	Gretton Audio	52	Omega Electrical	102	Spectra Dynamics	142
Alama	32	Hart Electronic		Oranges & Lemons	54	Sugden	36
Alphason	103	Kits	108, 109	Orchid Precision		Thomas Transducers	123
AP Electronics	54	Heatherdale	103	Audio	107	Trichord	56
Apollo Cables	126	Heybrook	76	Origin Live	144	Try Me & See	100, 101
Audible Experience	138	Hi-Fi Co (The)	132, 133	Oxford Audio		U.E.T	94
Audio Com	126	Hi-Fi Corner	121	Consultants	114	UKD	44
Audio Grande	48	Hicam	118	P.G. Hi-Fi	118	Vadis Amplifiers	60
Audio Illusions	144	Ian Edwards	123	Papworth	140	van den Hul	16
Audio Reference	48	Ian Harrison	140	Pear Audio	54	Vickers Hi-Fi	86
Audiophile Furniture	58	Jem Distribution	103	Power Plant (The)	138	Vinyl Demand	106
Bill Hutchinson	98	Kef	71, 72, 73	Progressive Audio	114	Vivante	48
C.A.D.	58	LFD Audio	30	Q.T.A.	136	Watford Valves	130
Castle Acoustics	68	Listening Rooms	86	R.J.F.	114	Wilmslow Audio	86, 122
Celestion	IFC, 6	Loricraft	131	Replay Audio	10	Zero Feedback	116
Central Audio	130	Manticore Audio	56	Right Note	54		
Chelmer Valve Co	124	Mantra Audio	136	Ringmat	40	Supplement	
Choice Hi-Fi	142	Marston Audio	86	Roksan	8	Art Audio	20
Chord Co (The)	40	Marton Music	116	Russ Andrews	52, 76	B&W	OBC
Classique Sounds	140	Meridian	22	Serious Kit	120	Creek Audio	14
Colomor Electronics	120	Michell Engineering	16	Sevenoaks	26, 27	Doug Brady Hi-Fi	IBC
Custom Cables	103	Midland Audio		Signals	123	Etalon	14
Cymbiosis	116	Exchange	119	Silvernote	103	Glass Audio	20
Definitive	56	Midland Radio		Slate Audio	99	Hi-Fi Curiosity Shop	20
Definitive Audio		Supplies	30	Sonic Frontiers	138	Michael Stevens	
(Brighton)	130, 131	Mission	BC	Sonneteer - F.T.M.	10	& Pttrs	18
Diverse Music	131	Mordaunt-Short	38, 123	Sound Image	30	Mike Manning	14
Emporium (The)	136	Musical Fidelity	18	Sounds Expensive	138	Pink Triangle	IFC
Gamma Acoustics	110	Musical Images	14	Sounds Of Music	52	Roksan	10
General Trading CO	116	Musonic Ltd	126	Sounds Perfection	58	Sevenoaks	11, 24
Grandix	144	No Name Acoustics	58	Southcoast Speakers	112	Zen Audio	6

advertisers index classified ads



THE
**HI-FI
SHOW**
97
1049 First Floor
Ramada Hotel
Heathrow
11th-14th
September 1997



Perhaps it is the most important thing in the valve audio field.

VA5300B



Shenzhen Valve Audio Lab is the leading designer and manufacturer in China of the tube amplifier hi-fi system. Manufacturing since 80', we now have more than 30 models, including JD(Deluxe Series), MP(Middle Price Series) and VAA(SKD Form Series), among others. OEM and ODM projects have been successfully offered to overseas buyers. Superb quality, competitive prices and excellent service are assured. Form A and C/O certificate available. OEMs and ODMs are welcome.

Why its sound so pure?--Improved material and wonderful design
How to get higher power? --Higher emission and greater anode dissipation
Why its lifetime so long?--Lower anode temperature and greater cathode emission

It is well known that improvements on quality always originate from the upgraded materials in today's technology field. The success of VA-5300B depends on the new graphite anode, new gold grid and new cathode with greater emission. This improved cathode design allows an anode current of up to 150mA as self biased. The anode of VA-5300B made of fine graphite can undergo greatly increased anode dissipation, up to 80W (the standard 300B is only 40W). This anode runs at lower temperature on the same condition with the standard 300B and the graphite anode has lower thermal expansion. In the test, this VA-5300B can last at least 2-3 times the lifetime of iron anode 300B. Duo to its greater stability of μ Gm, and the gold grid wrie which reduces the emission of secondary electrons, this VA-5300B has fascinating sound!

Valve manufacturer : O&J Enterprises Co.,Ltd.
Amplifier manufacturer : ShenZhen Valve Audio Lab.
General export agency : China National Electronics Imp./Exp. Valve Audio Connexion
Address : International Electronics Building, Yingbin Road, Changsha, Hunan 410011, P.R.China
Tel: +86(731)442-8169 Fax : +86(731)445-6999
E-mail : ValveArt @ public cs. hn. cn.

MISSION

CYRUS

DAD3



"It's hard not to be impressed by the sheer levels of detail it unearths..."
"The DAD3 is a bit special."
"Cyrus DAD3Q - Astonishing scale, presence, detail and plenty of power."
"The Q-mod is just too good to miss." ★★★★★

What Hi-Fi? April 1997

Straight Line



"Frankly, this one makes some of its minimalist competition look overpriced." ★★★★★

What Hi-Fi? April 1997

750 LE

"Perfectly adapted to their task, they deliver an extremely fine sound for very reasonable money" ★★★★★

What Hi-Fi? September 1997

The Best System of '97

Cyrus DAD3
Cyrus Straight Line
Mission 750 LE

WHAT HI-FI?

Awards

The year's best hi-fi
1997

For your nearest dealer please call:
Mission Group, Huntingdon, PE18 6ED, England.

Tel: 01480 451777 Fax: 01480 432777 email: info@mission.co.uk <http://www.mission.co.uk>

World Radio History