

**£2.00**  
There's no other choice!

# Hi-Fi WORLD

AUGUST 1995 £2.00 *For the love of music*

**PINK TRIANGLE  
VENTRICLE  
LOUDSPEAKER**

**SCOOP!**

## **NEW AUDIOPHILE 514 CD PLAYER FROM NAD**

**SUPPLEMENT NO. 16  
(overseas - inside)  
free with this issue.**

**SCOOP!**

## **BASS POWER - REL'S STADIUM II SUBWOOFER**

**UNISON SIMPLY TWO  
VALVE AMPLIFIER -  
AFFORDABLE  
SINGLE-ENDED**

**COMPETITION - WIN A MERTDIAN  
HI-FI SYSTEM WORTH £2500**

**Exercise your senses at the  
London Sound  
Vision Show  
22nd - 24th  
September  
1995**



# MISSION

Seven  
three

**B**  
one

**What else can  
we say....?**



1994/95



Mission 731

# This Month's World

Too many of the valve amplifiers that reach us are crudely engineered. Beneath the veneer of a sexy chassis (!) they rely on copycat circuits hooked up to cheap output transformers. Buyers are being taken in. A well engineered valve amplifier is something very special, but there are few around. You'll find one of the few on p42.

- NAD enter the budget CD battlefield with their new big gun, the 514. Champions of budget esoterica, they face off Marantz. Will the CD63SE win again, or have NAD got a killer on their hands? See p13.
- Linn's LP12 is one of the world's most famous turntables. It's still good enough to bruise the competition. On p36 we bring you one of the most comprehensive Sondek features going.
- People love being moved by their hi-fi. REL subwoofers do just that. Their latest ground shaker appears on p27.
- Getting hi-fi from an old 1960s dictation medium like cassette is wringing blood from a stone. TEAC do it better than most, as their top V-8030S model testifies on p29.

**W**e thought the valve revival was small time - a minor tributary of interest alongside the main stream of audio. But perhaps not. Now the music business are turning on to them; Pink Floyd's new Pulse album uses valves in its mastering.

Couple this with a serious appreciation in the Far East and you have an increasingly valuable worldwide market.

This resurgence isn't passing unnoticed - everywhere. Western Electric of the USA are restarting 300B production. The Russians are already well in there, as are the Chinese of course.

The tributary is growing into a river.

*Noel Keywood, Editor*

## SHOW! SHOW! SHOW!

Hear our DIY kit designs at the London Sound & Vision Show, Cumberland Hotel, Marble Arch, London. It's a great venue for real hi-fi, held from 21st-24th September 1995 (the same time as Live 95, so you can go to both). We'll be there, with a stand and a room.

### TEST EQUIPMENT



- Hi-Fi World has its own advanced test laboratory and acoustically treated listening room. No other hi-fi magazine has the benefit of such facilities.
- Hi-Fi World has a dedicated in-house team of experienced listeners, and uses selected freelance professionals. We review thoroughly by extensive auditioning, rather than by quick-fire group listening tests.
- Hi-Fi World's engineering team designs a wide range of products in-house. We export kits, parts and built-up products around the world, delighting buyers in far flung corners of the globe. No other hi-fi magazine is so expert and dedicated.

### LISTENING ROOM (TREATED BY RPG ACOUSTIC TOOLS)



Distributed by:  
COMAG, Tavistock Road, West  
Drayton, Middlesex, UB7 7QE  
Tel: 01895 444055

Origination by:  
Ashford Scanning, 2 Norfolk Drive,  
Fairwood Industrial Park,  
Ashford, Kent TN23 2FB  
Tel: 01233 622042

Printed by:  
Southernprint, Poole, Dorset.  
Tel: 01202 622226

All unsolicited submissions are made  
at the owners risk. We accept no  
responsibility for such submissions,  
nor do we undertake to return them.

No material may be reproduced  
from this magazine without  
the publisher's written permission.  
© Audio Publishing Ltd

Editor  
**Noel Keywood**  
Assistant Editor  
**Dominic Baker**  
Production Editor  
**Ferewini T. Michael**  
General Manager  
**Mark Winfield**  
Marketing Manager  
**Jon Dolan**  
Advertising Executives  
**Caroline Knott**  
Design Engineer  
**Andy Grove**  
Technical Assistant  
**Nick Lucas**

Contributors  
**Eric Braithwaite**  
**Richard Brice**  
**Jon Clarke**  
**Giovanni Dadomo**  
**Peter Herring**  
**Simon Hopkins**  
**Dominic Todd**  
  
**CONTACT NUMBERS**  
10 am - 6pm  
Tel: 0171-289 3533  
Fax: 0171-289 5620  
Individual queries cannot be  
answered by telephone.

**MAIL ORDER**  
Tel: 0171-266 0461  
(24 hour answerphone)  
  
**SUBSCRIPTIONS**  
see page 68 for details

**AUDIO PUBLISHING LTD**  
64 CASTELLAIN ROAD,  
MAIDA VALE,  
LONDON W9 1EX.

**ABC**  
CONSUMER PRESS

## AMPLIFIERS

### ALCHEMIST FORSETI 23

All that glisters is not gold, but Alchemist's latest pre/power combination is a gem, finds Eric Braithwaite.

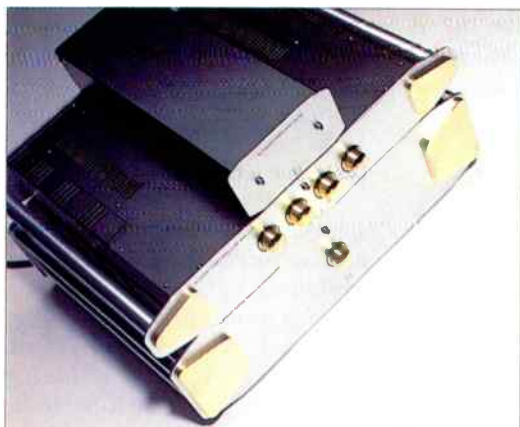

### UNISON SIMPLY TWO 42

Amidst a sea of black boxed solid-state mediocrity is a fine sounding tube amplifier adorned in wood. Douglas Floyd-Douglass gives it a listen.

### SONY TA-F446E 49

David Price auditions Sony's latest entry into the super-competitive world of budget transistor integrations.

## COMPACT DISC

### NAD 514 13

Does NAD's new no-nonsense 514 CD player slay the all-conquering Marantz CD-63SE? Dominic Todd finds out.

### MARANTZ CD-16 20

Dominic Baker is seduced by the smooth, unassuming sound of Marantz's £1400 CD player.



### AUDIO ALCHEMY DDE 1.1 32

The long awaited replacement to AA's first "Digital Decoding Engine" gets an extensive audition from David Price.

## LOUDSPEAKERS

### PINK TRIANGLE VENTRICLE 18

The unusual appellation isn't the only thing interesting about Pink's new high end loudspeaker, finds Noel Keywood.

### REL STADIUM 2 27

Dominic Baker listens to REL's latest wall cracking, teeth rattling, low frequency generator.



### NHT 1.3 50

With 'Focused Image Geometry', these American loudspeakers seem to have plenty to offer the budget-conscious buyer. Douglas Floyd-Douglass takes a listen.

### NEAR SOUNDMAST 57

Cunningly disguised as tall, black gate posts, New England Audio Research show that high end A/V 'speakers can make the grade. Douglas Floyd-Douglass sets his video.

## CASSETTE

### TEAC V-8030S 29

After months of mediocrity, Douglas Floyd-Douglass has finally found a deck to be reckoned with, even if it is a tad expensive.

## TUNER

### HARMAN KARDON TU-930 35

Airwave surfer Eric Braithwaite is impressed by Harman's latest entry to the budget tuner battleground.

## WORLD VERDICT

●●●●● **OUTSTANDING** - Superb sound, something we'd use ourselves.

●●●● **GOOD** - Has strong merit. Well worth an audition.

●●● **ADEQUATE** - Mediocre in vital areas. May be worth auditioning.

● **POOR** - Seriously flawed. Not worth considering.

## REGULARS

- NEWS** 7
- LETTERS** 44  
You expound on issues that concern us all.
- QUERIES** 55  
The team get to grips with your hi-fi problems.
- COLUMNS** 63, 64, 69, 71, 72  
Comment, criticism and overviews.
- NEXT ISSUE** 60  
September's *Hi-Fi World* is jam-packed with the latest, greatest products from across the globe.
- COMPETITION** 66  
Win yourself an instant upgrade!
- SUBSCRIPTIONS** 68  
No more tedious trips to the newsagent - and you'll have the pick of the classifieds. What other reason for subscribing do you need?
- SPECIALIST HI-FI DEALERS** 77  
These dealers offer expert advice and service.
- MEET YOUR MAKER** 81  
Who makes what and how to get in touch.
- WORLD AUDIO DESIGN** 82  
A range of high performance kits for those who keep soldering on.
- DIAL-A-DEALER** 89  
Who sells what, and how to get in touch.
- HI-FI WORLD LIBRARY** 98  
An essential collection of highly readable titles.
- ACCESSORIES** 101  
Keep that system in the best of health.
- MEASURED PERFORMANCE SECTION** 105  
Noel and Dominic heat up the HP3561A.
- READERS' CLASSIFIEDS** 135  
Looking for that bargain Sondek - *Hi-Fi World* classifieds are the place.
- ADVERTISER'S INDEX** 146

## FEATURES

- LP12 FEATURE** 36  
David Price brings you the definitive article on Linn's venerable LP12 turntable, complete with an introduction from the ever-ebullient Ivor Tiefenbrun.
- READER'S SYSTEM** 40  
John Murt invites us home to peruse his enviable collection of vintage hi-fi.
- TWEAKY CORNER** 65  
David Price and Dominic Baker listen to cables from Chord, Connections and MPI.

## DIY SUPPLEMENT

This month's FREE *Hi-Fi World* DIY Supplement includes a unique design for an open baffle midrange, three-way loudspeaker. It uses Audax High Definition Aerogel drivers and their special oval gold dome piezo electric tweeter. There's also letters, news, and much more!

## MUSIC

Some excellent new releases for your perusal.

### ROCK RECORD OF THE MONTH:

Paul Weller: Stanley Road

### CLASSICAL RECORD OF THE MONTH:

Beethoven: Symphony No5 in C minor Op67, Symphony No7 in A major Op92, Vienna Philharmonic; Carlos Kleiber

**ROCK AND POP** 73

**JAZZ** 86

**CLASSICAL** 93

## COMPETITION

Win a stunning Meridian system worth £2500, including 506 CD player 551 amplifier an A500 loudspeakers!



# CONTENTS

# One of life's more rewarding decisions.



## KEF Reference Series

If only all decisions in life were as straightforward as this.

The fact is that if you want the purest sound and the most uncompromising specification, it simply has to be New KEF Reference.

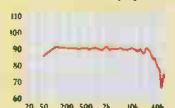

Every speaker must match our engineers' 'reference' prototype to an almost unbelievable

tolerance of 0.5 decibels. This means you can be sure that the sound KEF created will be recreated in your home. Exactly.

Our breakthrough Uni-Q® technology delivers an astonishing stereo image, its unique point source design, with the tweeter at the exact acoustic centre of the mid-range cone, lets you visualise the precise location of every performer on the stage. What's more, because of Uni-Q's smooth, even dispersion you'll hear that incredible realism throughout the room. From speakers this good you'd expect outstanding

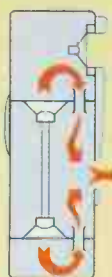

bass performance. With KEF's famous 'coupled cavity' bass system, now further improved with interports, you get it. We go to similar extremes in perfecting every detail.

Some you can't see, like Oxygen-Free Copper internal wiring or magnetic shielding (vital in Home Theatre). Some you can - sumptuously veneered cabinets with heavily gold-plated feet and terminals, for example.

In other words, each pair of Reference speakers is as close to perfection as KEF can make it.

When you know you can choose the best, would you willingly settle for anything less?



The experience of sound

## KEF Reference Series Authorised Dealers

ABERDEEN	Holburn HiFi	01224 686713
BISHOP STORTFORD	Audio File	01279 506576
BLOXWICH	Sound Academy	01922 473499
BOURNEMOUTH	Suttons Hi-Fi	01202 555512
BRISTOL	Radford HiFi <i>(near office)</i>	01172 428247
CARDIFF	Audio Excellence <i>(near office)</i>	01222 228565
CHANDLER'S FORD	Hampshire Audio	01703 252827
CHELTENHAM	Sevenoaks HiFi	01242 241171
CONGLETON	Congleton HiFi	01260 297544
COVENTRY	Frank Harvey HiFi	01203 525200
EDGBASTON	Music Matters	0121 4292811
GODSTONE	Surrey HiFi	01883 744755
GUILDFORD	P J HiFi	01483 504801
HEREFORD	English Audio	01432 355081
KINGS LYNN	Martins HiFi	01553 761683
KNUTSFORD	Wilmslow Audio	01565 650605
LEEDS	Audio Projects	01132 304565
LONDON NW6	Studio 99	0171 624 8855
LONDON W1	HiFi Experience	0171 500 3535
LONDON W1	K J Leisuresound	0171 486 8262
LONDON W5	Audio Concept	0181 567 8703
MAIDSTONE	Speakers Corner	01622 677773
NEW MALDEN	Unilet Audio	0181 942 9567
NEWCASTLE	J G Windows	0191 2321356
NORWICH	Martins HiFi	01603 627010
NOTTINGHAM	Nottingham HiFi	01159 706919
OTLEY	Aston Audio	01626 582704
PETERBOROUGH	The HiFi Company	01733 341755
PORTSMOUTH	Jeffries HiFi	01705 663604
SALISBURY	Salisbury HiFi	01722 322169
SHEFFIELD	Sound With Style	01142 737893
SHREWSBURY	Creative Audio	01743 241924
SOLIHULL	Music Matters	0121 742 0254
SOUTH CROYDON	Zebra	0181 688 2491
ST LEONARDS	Adams & Jarrett	01424 437165
WORCESTER	Sevenoaks HiFi	01905 612929
WORTHING	Phase 3 HiFi	01903 245577

### IF YOUR TOWN ISN'T LISTED PLEASE CONTACT:

KEF AUDIO (UK) LIMITED, ECCLESTON ROAD,  
TOVIL, MAIDSTONE, KENT ME15 6QP.  
TELEPHONE (01622) 672261.

## THE KING IS DEAD!

Retailing for £199.95, the NAD 510 replaces the much loved budget 501 CD player. Gone are superfluties like remote control and in are a number of improvements including shorter analogue signal paths with better shielding from RF interference.

All secondary circuits including transport, servos, and display drivers, have been relegated to separate circuit boards, and separate power regulators for digital and analogue sections ensure proper electrical isolation.

The 510 sports a Bitstream single bit convertor with a 5 pole filter in the analogue stage using high grade components, which NAD claim results in "an unparalleled open and rich sound that is commonly only available from more expensive machines". We wait with interest!

**NAD Building**  
**401-405 Nether Street**  
**London N3 1QG**  
**☎ 0181 343 3240**



## WHARFEDALE EMPOWER YOU

Wharfedale's new Valdus range signals the company's return to its traditional stomping ground - conventional loudspeakers high on value for money. High efficiency means they can be used with modestly powered budget amplifiers. They feature five new driver designs, including a plastic dome tweeter mated to an elliptical horn, claimed to aid dispersion. Commendably simple crossover networks are used, complete with electronic protection for tweeters.

Finished in traditional English black vinyl wrap, the five models range from the 2-way bookshelf Valdus 100 at £89.95 to the 3-way floorstanding 500, priced at £299.95.

**Wharfedale International**  
**Sandles Way,**  
**Crossgates,**  
**Leeds LS15 8AL**  
**☎ 0113 2601222**



# HEAR HOW THE LINN KARIK IS THE SONDEK FOR CD



## Scotland:

Aberdeen	The Audio Suite	01224 625635	Aldridge	Musical Approach	01922 57926	Basingstoke	Audio T	01256 24311
Montrose	Robert Ritchie Hi-Fi	01674 673765	Royal Leamington Spa	House of Music	01926 881500	Guildford	PJ Hi-Fi	01483 504801
Edinburgh	Russ Andrews Hi-Fi	0131 557 1672	Leicester	Listen Inn	0116 2623754	Ashford	Soundcraft	01233 624441
	In HiFi Ltd	0131 225 8854	Northampton	Listen Inn	01604 37871	East Grinstead	Audio Designs	01342 314569
Glasgow	Stereo Stereo	0141 248 4079	Nottingham	Nottingham Hi-Fi	0115 9786919	Dover	Smye-Rumsby Ltd	01304 201525
Kilmarnock	Laser Audio	01563 40292	Worcester	West Midlands Audio	01905 458046	Brighton	Jeffries	01273 609431
						Eastbourne	Jeffries Hi-Fi	01323 731336
						Portsmouth	Jeffries Hi-Fi	01705 663604

## Northern Ireland:

Belfast Lyric Hi-Fi 01232 381296

## Northern England:

Carlisle Peter Tyson 01228 46756  
 Newcastle Newcastle Hi-Fi 0191 285 7179  
 Leeds Audio Projects Ltd 0113 2304565  
 Image Hi-Fi 0113 2789374  
 Hull Sound with Style 01482 222771  
 Oldham Audio Counsel 0161 633 2602  
 Cheadle Audio Counsel 0161 428 7887  
 Doncaster Sound with Style 01302 321421  
 Rotherham Moorgate Acoustics 01709 370666  
 Liverpool Better Hi-Fi 0151 227 5007  
 Warrington Chris Brooks Audio 01925 261212  
 Sheffield Moorgate Acoustics 0114 2756048  
 Sound with Style 0114 2737893  
 Congleton Congleton Hi-Fi 01260 297544  
 York Sound Organisation 01904 627108

## Central England:

Birmingham Griffin Audio 0121 692 1359  
 Stafford Musical Approach 01785 55154  
 Cambridge The Audio File 01223 68305  
 University Audio 01223 354237

## Southern England:

Banbury Overture Ltd 01295 272158  
 Bishops Stortford The Audio File 01279 506576  
 Chelmsford Rayleigh Hi-Fi 01245 265245  
 Oxford Audio T 01865 65961  
 Rayleigh Rayleigh Hi-Fi 01268 779762  
 Southend-on-Sea Rayleigh Hi-Fi 01702 435255  
 Uxbridge Uxbridge Audio 01895 230404  
 Chalfont St Giles Dallas Audio Ltd 01494 874366  
 Enfield Audio T 0181 367 3132  
 Ilford Audio T 0181 518 0915  
 High Wycombe Sound Gallery 01494 531682  
 London N1 Grahams Hi-Fi Ltd 0171 226 5500  
 London NW6 Audio T 0171 794 7848  
 London SE1 The Conran Shop Contracts 0171 357 7703  
 London SE13 Billy Vee 0181 318 5755  
 London SW1 Harrods 0171 730 1234 x 3392  
 London SW5 The Listening Rooms 0171 244 7750  
 London SW7 Kraft 0171 581 8877  
 London W1 Son et Lumiere 0171 580 9059  
 London W4 Uxbridge Audio 0181 742 3444  
 Windsor Radfords 01753 856931  
 Swindon Audio T 01793 538222  
 Kingston-upon-Thames Infidelity 0181 943 3530  
 Croydon Spaldings Hi-Fi 0181 654 1231

## Wales:

Swansea Audio Excellence 01792 474608  
 Cardiff Audio Excellence 01222 228565

## Southern Ireland:

Dublin Dublin Hi-Fi 00 353 147 852 05

## South West England:

Cheltenham Audio T 01242 583960  
 Gloucester Audio Excellence 01452 300046  
 Bristol Audio Excellence 0117 9264975  
 Bath Radford's Ltd 01255 446245  
 Bournemouth Suttons Hi-Fi 01202 555512

**LINN HI-FI**  
*music for life™*

**Linn Customer Services**  
**Freecall: 0500 888909**

**LINN HI-FI is sold world-wide through more than 300 specialist hi-fi retailers**  
**LINN HI-FI Retailers are different. They are all independent businesses. Each has its own distinct personality.**  
**Linn Products Limited, Floors Road, Waterfoot, Glasgow, G76 0EP, Scotland, UK.**

Telephone: 0141 307 7777 Facsimile: 0141 644 4262



This microprocessor controlled device also features full remote control with 'intelligent' programming to improve ease of use. It comes with an external power supply in the form of Power Station One for £449.95, or with the superior Power Station Three for £649.95.

**Path Premier,  
Unit 2, Desborough Park Road,  
High Wycombe  
Bucks HP12 3BG  
☎ 01494 441736**

## RADLETT MOVE

Radlett Audio, formerly of 141 Watling Rd, Radlett, Herts, has moved to new premises at 9 Holywell Hill, St. Albans, Herts AL1 1EU. The new telephone number is 01727 855577.

## U.S. HI-FI ON THE UP

Figures just released from the US Electronic Industries Association showing factory sales of audio equipment have interesting parallels with their British equivalents.

The overall picture is one of quiet optimism in the States at present, with total sales up over 12% in the year to date 1994. As with the UK, the most buoyant area is audio systems - the realm of minis and micros - which saw an improvement of 16.3%. Portable audio sales including CD portables and "boomboxes" (ghettoblasters to you and I) are also up 12.3%.

In the real hi-fi sector, separates sales - including America's healthy roster of expensive high-end equipment - have risen by a modest 3.1%. Like Britain, separates have been bolstered by audio/visual receivers and "home theater 'speakers", which are individually up a whopping 78% over 1993. But unlike our domestic market, the States seems to be eating up high-end A/V products, so for Americans at least, adding a couple of extra speakers to your cheapo mini-system just isn't real cinema sound.

## AMERICA'S LOVE AFFAIR WITH COMPACT DISC CONTINUES

If you're in the US music business, you've got much to smile about right now, as sales records are being broken as surely as Americans think it's always raining in Britain. Annual shipments of pre-recorded music and videos exceeded \$12 billion in 1994, a record 20% increase over 1993, meaning 1.1 billion CDs, cassettes, LPs and music videos were sold last year.

Opinions voiced in the latest RIAA journal include BMG Distribution president Pete Jones' belief that much of this growth is thanks to more buyer-friendly retail outlets with 'listening stations'. Linda Ury Greenberg of Sony Music believes "this growth has obviously been fuelled by the phenomenal success of Compact Disc, which continues to represent the largest and fastest growing format in the market".

## SUMMER McINTOSH

Although not terribly visible in the UK, McIntosh are stalwarts of the international superfi scene, with a reputation for excellent build. Their new glass fronted MCD7009 is no exception, boasting a TEAC-style VRDS transport with aluminium die-cast disc turntable. It also features a Bitstream Dual differential DAC per channel, with a 20bit 8 times oversampling digital filter. The MCD7009 is also quite 'affordable' by McIntosh standards, at a trifling £2395.

**MPI Electronic,  
13 Western Road,  
Guildford GU2 6AU**

## NO PRE-VIOUS CONNECTIONS

Resembling some kind of laboratory measuring instrument, Audio Alchemy's new Digital Line Controller is their first all-analogue product. This 4 input line-level preamp sports LEDs to indicate input selection and a pair of two-digit displays showing left and right gain in decibels.



# AUDIOVECTOR



You may be forgiven for thinking that the best solution for a speaker design is the commonly found, easy to manufacture, rectangular box. Not so.

The asymmetric cabinet used with all **AUDIOVECTOR** speakers is an example of the finest engineering and visual design.

- non parallel sides reduce standing waves
  - ultra-rigid front panels
  - quality crossover and high sensitivity
  - exceptional design
- = more clarity, articulate bass
  - = better transient response, greater dynamics
  - = easy load for amplifier
  - = unrivalled depth of sound stage and imaging

In technical terms, the absence of parallel surfaces means there are no standing waves. This results in less distortion, higher sensitivity and a cleaner sound. In layman's terms this means an involving and enjoyable sound...

...but if you have heard the **AUDIOVECTOR** speakers you would know this.

AUDIOVECTOR 2X Black Ash .....	£850	AUDIOVECTOR 5 Cuba .....	£2500
AUDIOVECTOR 3X Cuba .....	£1500	AUDIOVECTOR 5 Black Ash .....	£2500
AUDIOVECTOR 3X Black Ash .....	£1500	AUDIOVECTOR 6 Black Piano .....	£4600

For more information and demonstration, contact:.

The Chord Company Ltd., 30a Sarum Business Park, Portway, Salisbury, Wiltshire SP4 6EA. Tel: 01722 331674 Fax: 01722 411388

Distributors of Audiovector speakers for F3/LYD, Meinungsgade 8, D2, DK-2200 Copenhagen N, Denmark. Tel: 01 39 60 60

## TEAC DAT SHADES MD



At this rate TEAC are going to get the *Hi-Fi World* gong for most diligent Japanese company of all time. If you so much as blink, you'll miss their latest product release, so eyelids were duly prized open for the

announcement of their R9 DAT recorder.

The R9 is an interesting move in the face of so much down-market action by Philips and Sony with DCC and MiniDisc respectively. Retailing at £1195.95, it reinforces the trend of DAT as the choice of recording professionals and affluent home recordists.

Underlining this, the R9's busy front panel bears a certain resemblance to TASCAM 'pro' products. A 'shuttle dial' provides video editing-style search facilities, full remote control is standard and the deck features separate one-bit A/D and D/A convertors for each channel. As per usual, UK buyers can have this 9.3kg monster in any colour they like as long as its black.

**TEAC UK Ltd.,**  
5 Marlin House,  
The Croxley Centre,  
Watford,  
Herts WD1 8YA  
☎ 01923 819630

## JAPANESE YEN FOR LESS

To revive their becalmed economy, the Japanese government is investing billions of yen in much needed public works programmes, while the electronics giants are heavily restructuring themselves in the face of an unstoppable yen (at the height of the 'bubble economy' in 1990 £1 bought 295 yen, now it commands just 130).

After several years of losses, many large electronics companies are showing modest returns to profitability, with JVC announcing total sales up to 541,000 million yen. Posting a 1,000 million yen profit for fiscal 1994 against a 20,000 million yen loss the previous year, things are looking better. Japanese corporate austerity measures mean JVC shareholders are being asked to make sacrifices, with yearly dividends for fiscal 1994 suspended.

Audio sales grew as strongly as video, up 5%. The area of greatest growth was "Information-related" product lines up 25%, while "Entertainment" dropped 11%. JVC say favourable business in Asian markets has supported the sales increases.

## COMPACT KEVLAR

B&W's new CDM1 and CDM2 standmount loudspeakers continue the company's amplifier-friendly form by using high quality Kevlar bass/mid drivers.

The first Compact Digital Monitor retails for £599.95 and is a reflex loaded design boasting a healthy 88dB sensitivity figure. The second comes rear reflex-loaded with the same 165mm Kevlar driver, in a smaller box. Both feature a removable port bung which enables listeners to tune the 'speakers to their rooms. Both models offer a choice of real wood veneers in Black or Red Ash.

**B&W UK,**  
Marlborough Road,  
Lancing,  
West Sussex BN15 8TR  
☎ 01903 750750

## SOUND DISPERSION

Confirming our suspicions about the burgeoning audiophile music software market, Audiophile International have just been made exclusive distributors for Cisco Music. This means they are now handling famous labels like King Super Analogue, Aelos and DCC Compact Classics, as well as being mail order distributors for the famous Mobile Fidelity Sound Labs series of remasters.

**Audiophile International**  
☎ 01276 855578.

## SNEAKY KUDOS IS BRILLIANT!

Hot from Ivor T's cameo appearance in *The Mail on Sunday* as "the vinyl expert", Linn announce the Kudos tuner, which comes as a Sneaky module to fit into the Wakonda preamp or Majik-1 integrated for £349, or as a stand-alone unit for £549.

The Kudos is said to provide a standard of performance "close" to the flagship Kremlin tuner, prompting Linn to call it "astounding value for money", even if they do say so themselves! The Kudos sports FM and AM, 50 presets, variable Threshold and Selectivity, plus an infra-red remote control.

**Linn Products Ltd.**  
Floors Road, Waterfoot,  
Eaglesham  
Glasgow G76 0EP  
☎ 0141 307 7777





**Goes  
Green!**

# Watch Out!



*Incredible Range of Branded Products  
Must Be Cleared At Appetising Prices  
Over The Next Few Weeks!  
(Display & Ex-Demo Items\*)*

\* Subject to availability. Some items only one off's. Green Star offers not available with other promotions. E. & O. E.

**Ring us last on our GreenLine  
0181-952 5535**

**You Decide • We Provide  
The Powerhouse of Choice**

**6 Dedicated Hi-Fi & Audio Visual Demo Rooms  
Main Authorised Dealer for over 100 Manufacturers**

W/SW London

**Musical Images  
45 High Street  
Hounslow, Midd'x  
TW3 1RH  
Tel: 0181 569 5802  
Fax: 0181 569 6353**

Central London

**Musical Images  
18 Monmouth Street  
Covent Garden,  
London WC2H 9HB  
Tel: 0171 497 1346  
Fax: 0171 497 9205**

N/NW London

**Musical Images  
173 Station Road  
Edgware, Midd'x  
HA8 7JX  
Tel: 0181 952 5535  
Fax: 0181 951 5864**

# HIT IN THE MIDDLE

Since NAD discontinued their Monitor range just over a year ago, they have been left without a suitable CD player to compete in the closely fought mid-range CD player market. Especially galling for NAD has been the success rivals have had with such machines. The Rotel RCD970 (£350), Marantz CD-63SE

(£350) and the Arcam Alpha One (£300) are three examples that spring to mind. Now NAD are set to make the task of choosing between these machines

Will NAD's new 514 CD player be a mid-market hit?  
Dominic Todd  
Reviews



**SPECTRA**  
Dynamics

# DEFLEX<sup>®</sup> acoustic PANELS

The simplest and most cost effective way to upgrade your existing system

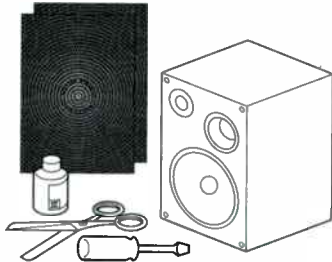

You need at least 2 Deflex panels for a pair of small bookshelf speakers, 4 panels for a pair of Tannoy 6's, and at least 6 panels for larger cabinets

Once you have gained access to the inside of the cabinet, remove foam and/or wool damping from the inside of the speaker (if fitted)

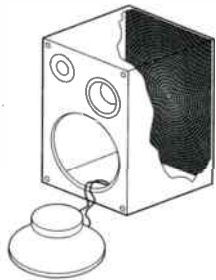

Place the flexible Deflex panel thru' the speaker cut-out and stick to the inside of the cabinet using the recommended adhesive

Now sit back and listen to the extra detail in sound, and far less distortion when played loud



## What the experts have to say...

"...a marked improvement was obvious from the first few bars of REM's *Automatic for the people* album..."  
Hi-Fi News & Record Review - March 1994

"...Deflex panels seemed to give greater tightness and control, improved internal clarity, and pitch definition - all without deadening the sound in any way..."  
Audiophile - January 1994

"...the result was sharper imaging, wider dynamics and a more natural sound..."

### CHOICE VERDICT

Sound Quality       
Value for money       
Hi-Fi Choice - January 1994

"...But one things for sure - the Deflex panels are no gimmick. They work..."  
Audio Video - November 1994

Standard Panel £7.95 (28cm x 21cm)  
Sub-Woofer Panel £11.95 (34cm diameter)  
Adhesive £3.50 Delivery £4.00

For a **FREE** information pack and details of other products from **SPECTRA DYNAMICS**

Tel (01745) 571600 Fax (01745) 570194

Talarogoch Trading Estate, Meliden Road, Dyserth, Clwyd LL18 6DD, United Kingdom.

DISTRIBUTORS WORLDWIDE: U.K. Tel. (01625) 500507 - Fax. (01625) 500508; Australia Tel. (03) 429 2199 - Fax. (03) 429 9909; Austria Tel/Fax 43 7472 61529; Belgium Tel/Fax 09 357 4937; Bermuda Tel 809 292 3125 Fax 809 295 8379; Canada Tel 514 691 2584 - Fax 514 692 9990; C. P. Rep. Tel. 02 442148 - Fax 02 464001; France Tel 78 95 04 82 - Fax 78 50 76 35; Germany Tel 01 246 6576 - Fax 01 246 6713; Holland Tel 076 715010; Hong Kong Tel (852) 898 8111; Fax (852) 558 0073; Israel Tel 3 924 7524 - Fax 3 924 7279; Fax 3 540 7438; New Zealand Tel/Fax 0-9-849-8108; Norway Tel 0469 1937 - Fax 755 25335; Portugal Tel/Fax (01) 295 72 77; Fax (01) 295 72 77; Singapore Tel 021 439 8450 - Fax 021 439 8451; S. Africa Tel 021 439 8450 - Fax 021 439 8451; Spain Tel 34 3 265 82 10 - Fax 34 3 265 77 94; Sweden Tel 0660 560 30 - Fax 0660 561 01; Switzerland Tel/Fax 61 361 64 66; U.S.A. Tel 415 669 7181 - Fax 415 669 7558; U.S.A. Tel 608 831 3433 - Fax 608 831 3771

## campaign audio design

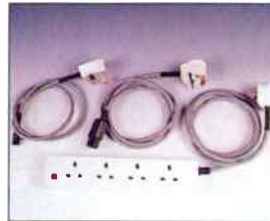

Getting a better, more involving, sound often means spending a lot of hard earned money. It's such a waste, because every system can benefit from our cables and accessories, at a fraction of the cost of some new "black box". Here are some of the ways we can help.

We have Oxygen Free Copper interconnects (£12.48) up to Pure Silver cables (£120.00) and high definition loudspeaker cables in Silver plated Copper or Pure Silver. Our main cables add weight, power and scale. Non inductive RF filtering (£10.00) and over voltage protection (£3.00) enhance performance still further. Gold plated AV cables, both RF (£19.95) and Scart (£23.52), help bring picture quality in line with NICAM sound resolution.

Valves, capacitors and transistors are all microphonic, they cannot perform optimally if vibrated. Our set of three Brass Isolation cones (£6.50) are worth their weight in gold - revealing low level resolution and dynamics hitherto hidden beneath electronic noise. We also have a cure for your noisy fridge or central heating motor (£3.50), enabling you to throw away your big mains noise suppressor, which has been giving you that "sat upon sound" for years.

There's lots we can do to bring you closer to the emotion and energy of the performance. So confident are we, that we offer a 14 day money back guarantee.

Ring or write for details:-

**CAMPAIGN AUDIO DESIGN**  
Llandudno Road (HW)  
Cardiff CF3 8PG  
Tel:- 01222 779401

Trade and International Enquiries Welcome.

## Wonderful Range of High Quality Transmission Line Hi-Fi Loudspeakers



P52	Mahogany Veneered	£399.95
P62	Mahogany Veneered	£499.95
P82	Mahogany Veneered	£599.95

Impedance .... 8 ohms  
Systems Transmission Line Two Way Ported Reflex  
Applications : Single-wired, Bi-wired, Bi-amplified  
Binding post terminals two pairs Gold plated and colour coded  
Bass / midrange driver Polypropylene cone  
Treble soft dome tweeter  
Crossover : 2nd order high and low pass at 4kHz  
Enclosure ; 19mm MDF  
As standard finish : Rich red Mahogany wood veneer or White Gloss

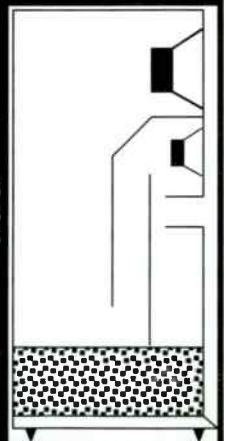

Internal details of transmission line and lead shots

For other models and finishes phone:



**Elvins Acoustic Technology**  
MANUFACTURERS OF HIGH QUALITY AUDIO PRODUCTS

12 BRETT ROAD LONDON E8 1JP UK  
TEL: 0181-986 8455 FAX: 0181-985 7285

even more difficult than before, with the introduction of the 514 priced at £349.95.

There are no real surprises on either the aesthetic or technical front. As always, NAD have created their latest CD player through evolution. The remote control 514 follows on from the old Monitor range in being 44cm (rather than 42cm) wide. The plain aesthetics and excellent ergonomics are just what you'd expect from NAD, but the chunky build quality (set off by the metal front plate) is a worthwhile step up from cheaper NAD players.

Technically, NAD use a Sony transport with a Japanese MASH convertor. In this case, it's an 18-bit device married to a 5-pole filter in the analogue stage. Attention has been paid to power supplies and output stages. The 514 uses AD712 output op. amps. instead of the ubiquitous NE5532, plus quality components, and it avoids series capacitors.

No review of a CD player at this price range can be complete without comparison to the player of the moment - the Marantz CD-63SE. So, with both machines plugged into my system the listening began. The first CD loaded into the NAD was "Maxinquaye" by Tricky, a good test of the 514's ability in handling deep processed bass and psychedelic instrumentation. The NAD had no trouble in conveying the deepest bass notes with conviction and weight. In the manner of the CD-63SE it made sense of events, leaving the listener to concentrate on the music itself, rather than the machine relaying it.

Vocals had good presence, and a lack of "glare" that allowed comfortable listening at high levels. Against the Marantz it was ultimately smoother and more refined but seemed slightly veiled next to the '63SEs class leading transparency. Having said that, the 514 couldn't be

called compressed or particularly reticent in its portrayal of dynamic contrasts. It's just not quite as effervescent, and hence involving, as the Marantz.

Fairport Convention's "Red Tide" and "The Islands", tracks from their latest CD, emphasised the subtle differences between the two machines. The NAD produced excellent separation between instruments, even during the loudest passages. However, the vocals were slightly "thin" sounding next to the rounded 63SE. Drums could also sound boxy at times, although guitar and violin timbre were of a very high order for a machine at this price.

The 514 lacked some of the Marantz's energy, although it easily matched its ability to depict the atmosphere of music - especially important on "The Islands" track. The NAD could become slightly "breathless" with the lowest frequencies though. Although both players reproduced this album to a very high standard, the 63SE just seemed to offer a little more. More transparency, more depth, and a little more body to vocals. It didn't all go the Marantz's way, however. The 514 wasn't quite as sibilant as the 63SE although, once again, the differences were marginal.

Changing musical tack once again, Holst's "Planets" was the next CD used. The most striking initial difference between the two players wasn't so much sonic, as operational. Whereas the NAD graciously swept through the entire, admittedly rather battered disc, the Marantz skipped, jumped and eventually gave up the fight altogether by stopping the disc. In the past I've found Philips lasers not quite as tolerant as others, and this still seems to be the case today. It's something worth considering if many of your CDs are worse for wear.

The actual sonic differences between the two machines were very slight. That is to say they were both

excellent. The NAD brought out the subtle fluttering violins at the beginning of "Mars", and offered enough drama and tension to capture my attention. Once again, though, the Marantz had a tad more attack and less veiling. A brief listen to Elvis Costello's "Ship Building" highlighted a lack of solidity to piano notes with the NAD. That having been said, neither player suffered from the lightweight sound of machines at this price range a few years ago (and cheaper players today). The NAD proved supremely relaxing to listen to, and free from any distracting foibles.

You've probably guessed by now that the Marantz CD-63SE is still the best player at its price range in my opinion. However, don't for one minute think the NAD is out of its depth here. Far from it, in fact. For two machines using such completely different technology, the resulting sound was remarkably similar in many ways. Most notably in the ability to really involve the listener in the music. The NAD was also slightly less rough around the edges at times, and possessed class-leading instrument separation during loud and difficult passages. Combine this with its fine build quality, sensible blend of facilities and understated styling, and the 514 becomes a real force to be reckoned with. If you've already tried the CD-63SE and found it too strident, then the NAD 514 is the next best thing ●

**NAD 514**

**£349.95**

**NAD Marketing Ltd.,  
NAD Building,  
401-405 Nether Street,  
Finchley,  
London N3 1QG  
☎ 0181 343 3240**

#### WORLD VERDICT

Great sound - one of the best value CD players around.

**Measured Performance  
see p105-113**

*“The NAD proved  
supremely relaxing to  
listen to.”*

Analogue lovers... **SME**



Our world renowned precision pick-up arms and turntables await you.

Sales and service enquiries to:

SME LTD • STEYNING • SUSSEX • BN44 3GY • ENGLAND  
 ☎01903 814321      ☎01903 814269

## Art Audio MAESTRO

*"They are just so stunningly gorgeous and open to listen to, I can barely imagine anything more alluring"*

NK Hi-Fi World, June '91

Valve amplifiers from £750 to £4150 Cables from £27 to £1700

Select Audio  
Glasgow (041) 226 4268

Doncaster Hi-Fi Studios  
Sunnyfields (0302) 731387

Paul Green Hi-Fi  
Bath, Avon  
(0225) 316197

Hazelmere Audio  
High Wycombe, Bucks  
(0494) 437892

Audio Venture  
Banbury, Oxon (0295) 261863

The Hi-Fi Consultants  
London (071) 380 0866  
Evenings (071) 482 0003

Audible Difference  
Diss, Norfolk  
(0850) 983233 or  
(0379) 740227

K.A.I. (UK) Ltd  
Folkstone (0303) 245005

The Hi-Fi Consultants  
Nottingham (0602) 232450

Impulse Audio Consultants  
Westcliff-on-sea, Essex  
(0831) 616426 or 0374 277736

Sound Academy  
Bloxwich, West Midlands  
(0922) 473499

New A4 brochure containing full details of our amplifier and silver cable range contact

Art Audio (UK) Ltd., 130 Main Street, Calverton,  
Nottingham, NG14 6LU  
England UK  
Tel. 0602 - 653604  
Fax 0602 - 637795

# Studio One

We are flexible with our opening times

117-119 HAMMERSMITH ROAD  
LONDON, W14 0QH.

Tel: 0171 371 3037

Fax: 0171 371 1790

We are open Mon-Sat 9.30 -6.30



## "END OF TERM SALE"

PHONE US FOR THESE ITEMS PRICES  
EX-DEMO NEWLY BOXED.

MUSICAL FIDELITY E600 CD PLAYER  
 MUSICAL FIDELITY E500 TUNER  
 KINSHAW OVERTURE PRE-AMP  
 KINSHAW OVERTURE POWER-AMP  
 KINSHAW INTEGRATED AMPLIFIER  
 MARANTZ CD10 PLAYER  
 HEYBROOK HEYSTACK SPEAKERS  
 TANNOY 636 SPEAKERS  
 POLK 3000 SUBWOOFER SYSTEM  
 KEF Q50 SPEAKERS  
 HEYBROOK HB1 MKIII SPEAKERS  
 SPENDOR BBC MODIFIED S20 SPEAKERS  
 PROJECT 7 AMP  
 PROJECT 6.1 TURNTABLE

# fuller's audio



*combining innovation with classic design*

fuller's audio      01702 612116

20 Tunbridge Road, Southend-on-Sea, Essex SS2 6LT

*You take your music seriously  
 You have a fine collection,  
 the best audio components  
 but....*

**it still doesn't sound right.**

did you know?

Many people underestimate the  
effect that room

## acoustics

have on the way your music sounds.  
Acoustic Tools are the most cost-effective and  
permanent audio upgrade you'll ever need

# RPG

as easy as ABC

As used by Hi Fi World, Peter Gabriel,  
Decca and lots of other people,  
who like you take their music seriously.

RPG Europe Ltd.,  
Unit G, Smarden Business Estate, Monks Hill,  
Smarden, Kent TN27 8Qj. Tel: 01233 770291  
EAR Audio Consultants Tel: 01732 763 046



# Great tracking

Ortofon is famed the world over for the tracking capability of its cartridges. Cartridges which will breathe new life into a cherished LP collection, divulging detail as never before.

The cartridge is always the key factor in the reproduction of music from records and Ortofon has dedicated nearly 50 years to the manufacture of the finest pick-ups possible. Enjoying constant critical acclaim along the way.

So if you want to bring more out of your records than ever imagined, an Ortofon Cartridge will have you hot on the scent.



**500 Series**  
Moving magnet  
cartridges from £30-£100



**MC Series**  
Moving coil cartridges  
from £80-£110



**Q Series**  
Moving coil cartridges  
from £140-£500



**1000 Series**  
Moving coil cartridges  
from £800-£1500

## ortofon

Ortofon (UK) Limited, Chiltern Hill, Chalfont St Peter, Bucks SL9 9UG.

Tel: 0753 889949.



**RUARK**  
*A Stroke of Genius*

For further information on the range of loudspeaker systems Ruark will send you the latest brochure, a copy of Press Cuttings and authorised dealer list.  
RUARK ACOUSTICS, Dept. HFW, 59 Tailor's Court, Temple Farm Industrial Estate, Southend on Sea, Essex SS2 5TH.  
Telephone: (01702) 601410. Fax: (01702) 601414

# Heart Stopper

**L**orita Grahame changed my mind about these 'speakers. The deliciously smooth delivery of her vocals, ringing with studio reverb, coloured for deliberate artifice, yet forceful and vibrant, answered a subconscious question: what is it about these speakers that's so good? It is a fabulously smooth, gorgeously revealing midband that can deliver female vocals with a sense of disarming naturals. Arena II came over beautifully; I realised Pink Triangle's 'speakers have a certain magic.

Not that there's much magic in their name: ventricle is a chamber in the heart - yeech!

Before I'd played Colourbox, the 'speakers had me intrigued, but undecided. They've a clean yet sweet and fluid midband, but couldn't place images with metric precision. Within an inch or so perhaps, but not down to a millimetre. Yet apparently contrary to this, violin sections of Chicago's Symphony Orchestra busily hovered with convincing life and body in Scheherazade. So many 'speakers make violins sound coarse, and often congealed into an amorphous mass too, because they fall into the critical break-up/crossover region between midrange and treble drive units. The Pink's benefit here by having a ribbon tweeter and a small, well damped treated-paper midrange cone.

Unfortunately, the midrange unit Pink use is barely able to reach up to meet this tweeter, leaving a shallow but broad midrange dip in the frequency

response. I detected this immediately, noticing a softness and lack of midrange bite. And although massed orchestral violins were handled wonderfully, the 'speaker - almost paradoxically it would appear - muted Samuel Magad's solo violin in the opening sequences of Scheherazade. It was withdrawn on the sound stage and a little vague in image position in comparison to the Heybrook Sextets, for example. Images gelled best at high-ish volume; the Pink's came over as a little warm and mellifluous at low listening levels, in my view.

Another apparently contradictory feature of these 'speakers is that although basically warm sounding, they could on occasion display a bright edge. CDs with a lot of treble energy excited the tweeter peak; Steve Earle's close-miked, steel-string guitar cut like a switchblade, his "sixty-seven Chevy, she's old and sleek and black" hissed with sibilant fricatives.

Pink Triangle are, like us, great respecters of the Quad Electrostatic. What they have attempted, with the Ventracles, is to capture its glorious midrange properties of transparency and smoothness. In this they've been successful. At reasonable volume the speakers revealed a rich palette of tonal colour and contrasts, and it was this that told me Lorita Grahame had never sounded so real. Differences between violin and viola, clarinet and oboe were resolved clearly, where other speakers can impose a uniformity of colour that acts to mask such differences.

**Pink Triangle's Ventricle loudspeaker produce a little flutter - in Noel's heart!**



The Pinks use a tiddly four-inch bass/midrange driver. Small bass drivers like this work hard for a living and, pushed hard, get into a tizzy. I quickly found its limitations, the copious bass of Eddie Reader's eponymously named album imposing obvious strain, kick drum farting, bass guitar wallowing at high volume. Measurement revealed extremely low sensitivity of 81dB, so an amplifier of at least 40watts is needed for moderate listening levels, yet the small bass driver will not deliver high volume. Our 100W Audiolab monoblocks quickly taxed their strengths, so for most listening I used an Aura VA-80 (50watts), reined back.

All the same, at moderate levels the Ventricle has healthy low-end output, giving them a warm, fulsome balance that brought body and dimension to orchestra and band alike. The Boo Radley's reggae bass line of Upon a 9th and Fairchild strode along cleanly, exhibiting a little softness, but without overhang, and the expansive production of Jackie Leven's Call Mother a Lonely Field filled our listening room beautifully. If you want to appreciate the rich, resonant tones of a baladeer like Leven, I'd have to say the Pinks are as good as any - and better than most.

The Ventricle loudspeakers have properties few others approach and many of us sat quite entranced at times - but they don't go loud. These 'speakers are for 'refined listening', shall I say, in small to medium rooms. ●

**Pink Triangle Ventricle** £896

**Pink Triangle Projects,**  
4 Brunswick Villas, Camberwell,  
London SE5 7RR  
☎ 01753 789789

#### WORLD VERDICT

Smooth and refined. Some listeners will find them captivating.

**Measured Performance**  
see p105-113

**E**xternally, Marantz's CD-16 looks like any other Japanese CD player. Its moulded plastic fascia, thin steel top cover and neatly located control buttons and display would be equally at home on a £300 player. So what makes the CD-16 so special that Marantz feel it deserves a retail price of £1399.90?

The first clue comes as you lift it from its box. The CD-16 is a heavyweight player, weighing in at around 13kg. Looking underneath to remove the transit bolts it becomes more obvious where much of its weight comes from. The CD-16 is built on a thick slab of copper, with copper sides and rear. Copper is used because

of its non-magnetic properties, which stops eddy currents disturbing signal purity. This shows real attention to detail and a level of dedication rarely seen in Japanese products bound for this country.

Inside the flow of copper continues, with plates screening critical areas such as the power supply, which has

# BALANCED OUTPUT

**Marantz's top-end CD-16 Compact Disc player neither giveth nor taketh away, finds Dominic Baker.**



separately regulated sections for digital and analogue electronics. The control board, which controls the transport and decodes the signal from the laser into a digital bitstream, is separate from the analogue output board, where two TDA1547 (DAC-7) one bit converters run in differential mode. These in turn feed Marantz's Hyper Dynamic Amp Modules (HDAMs). The majority of the components are high quality surface mount devices, with a few conventional leaded components scattered amongst them. The transport resting neatly amidst all this is the die-cast CDM-4MD, which although several generations older than the CDM-9 and 12 transports, Marantz feel gives a better performance.

## SOUND QUALITY

Where most CD players have some area of their performance that you can pinpoint, like a brightness to the treble, a coarseness to the midrange or a strong bass, the CD-16 displays little character of its own. There is nothing about its sound which stands out, which initially leaves you a little unimpressed. Players with bass lift, bright treble or other traits sound more immediately impressive. The Marantz has none of this, remaining extremely neutral, smooth and reserved in its performance.

Marantz's own CD-63SE, some £1050 less, initially sounds clearer, faster and more detailed, until after several albums you realise that the CD-16 is doing everything the '63 is, only without making such a fuss about it. The '63 has all the glitter and shine of a star performer, but the CD-16 is a more subtle, mature artist uninterested in playing to the gallery.

I had been living with the CD-16 for several weeks before its real strengths dawned on me. I was unsure

about it for a long time, finding it exceptionally smooth and fluid, detailed and pure, but it never surprised me like other players can. Sitting back and

*“The '63 has all the glitter and shine of a star performer, but the CD-16 is a more subtle, mature artist uninterested in playing to the gallery.”*

relaxing, concentrating on music rather than the player's sonic abilities, it struck me how consistent the CD-16's performance was. It plays disc after disc without exaggerating any part of a performance. An extremely natural sounding player, it resolves terrific amounts of detail, but without ever drawing attention to itself.

All too often, especially as a reviewer, you find yourself listening for the subjective qualities of a system, rather than the music itself. The CD-16 has an uncanny knack of allowing you to forget the hi-fi and concentrate on the music. Indeed after a while you forget it's even there. Belly's 'Judas my Heart', from their King album, enjoyed a wide open acoustic, with superb detail resolution, drawing you deep into the music. Vocals were especially smooth and free from coarseness or grit, flowing majestically from the 'speakers.

This super smoothness helped Salvatore Accardo's violin create a deliciously open and clear performance, which was tonally superb. Slight changes in pitch and the complex harmonic structure were captured without being overstated, to create a realistic and neutral performance. Although only a simple piece, this *foné* recording of I violini di Cremona demonstrated the CD-16's ability to resolve tremendous detail

and produce the atmosphere around a piece which makes a performance complete.

With more complex pieces the CD-16 continued unflustered. This super-competent player remained unflustered by the multi tracked, heavily produced The The album *Mind Bomb*, with all its effects and complex interleaving. With a wide sound stage, images tightly focused, its coherence made sense out of a recording which trips up most players.

## CONCLUSION

Against discrete designs from Pink Triangle and DPA, the CD-16 loses little, which came as a surprise. The only appreciable difference is slightly more compressed stage depth and less low level detail but this is an area where most CD players are weak anyway. The CD-16 is very musical, never slipping up whatever material it's asked to play. There are more characterful players around that impress more in a demonstration, but they tend to favour particular styles of presentation. The CD-16 is one of the most universally consistent players around, bringing a level of musicality to all styles of music that will provide years of long term enjoyment ●

Marantz CD-16 £1399.90

Marantz Audio (UK),  
15/16 Saxon Way Industrial Estate,  
Moor Lane,  
Harmondsworth,  
Middx UB7 0LW.  
☎ 01753 680868

### WORLD VERDICT ●●●●●

Highly capable yet self-effacing player with an endearingly neutral balance.

Measured Performance  
see p105-113



## AUDIO ILLUSION

23 Langley Broom  
Langley Berkshire SL3 8NB  
(2 mins June. 5 off the M4)  
TEL: (01753) 542761; (0860) 665662  
10am-10pm Mon-Sat By Appointment  
Sundays by Arrangement

- Free Installation
- Home Demos. By Appointment
- Mail Order Service
- Dedicated Listening Room
- Export Facilities
- Part Exchange
- All Major Credit Cards Accepted
- Credit Facilities Subject to Status

AGENCIES:  
Air Tangent; Apogee; Audio Alchemy; Audio Research; Classe; Copland;  
Davidson Roth; Densen; Earmax; Jadis; Keotso; Krell; Lineaum; Martin Logan;  
Micro Seiki; Mirage; Morel; Musical Fidelity; PS Audio; Sonus Faber; Sumiko;  
Theta; Target; Wilson; Puresonic; Siltech & Transparent Cables; WBT

### NEW!!!

\* Musical Fidelity E10 Electra Amplifier 40w  
R.R.P. ....£299.95  
Sale Price .....£249.00

*This is a Limited Offer while stocks last!!!*

### SECONDHAND and EX. DEMONSTRATION BARGAINS

Audio Alchemy Dac-in-the Box (£199)	Mint	£145
Audiomeca J1 Turntable with SL5 Arm and Koetsu Urushi (£6,800)	Mint	£2,950
Musical Fidelity FC D Player (£1,500)	Ex. Demo	£1,095
Audio Research LS7 Linstage PreAmp (£1,555)	Ex. Demo	£1,250
Classe 30 Remote Preamp Balanced (£1,370)	Ex. Demo	£1,095
Classe 70 Power Amp 70w Balanced (£1,400)	Ex. Demo	£1,095
(Classe 30 and Classe 70 sold as a pair)	Sp. Price	£1,995
Krell KSA 100 Poweramp 100w Class A	Mint	£1,495
Krell KSL Linstage Fully Balanced (£2,300)	Mint	£1,395
Levinson 38S PreAmp (£6,495)	Mint	£4,495
Audiolab 8000A Integrated Amp 60w (£500)	Mint	£350
Musical Fidelity E10 Electra Amp 40w (£300)	Ex. Demo	£225
Apogee Centaurs, Slate/Black (£2,300)	Mint	£895



## sound investment

If you have invested expertise and money in building up a sound system to your own unique specifications, then why compromise with indifferent housing units?

Fi-Rax offers a new dimension in audio visual racking - from a range of standard designs to the flexibility to custom create a unit to suit your particular sound system and lifestyle.

- High quality aluminium construction.
- Finishes available to your choice.
- Fully adjustable 6mm glass shelving.
- Sound isolation on shelving/feet.
- Custom created to suit your system.
- Free delivery throughout the UK.

Fi-Rax - a sound investment for those who want the best from their equipment.



### Audio Visual Furniture

For further information or a free brochure contact:

JEM Distribution, Springfield Mills, Spa Street,

Ossett Wakefield WF5 0HW.

Tel: 01924 277626 Fax: 01924 270759

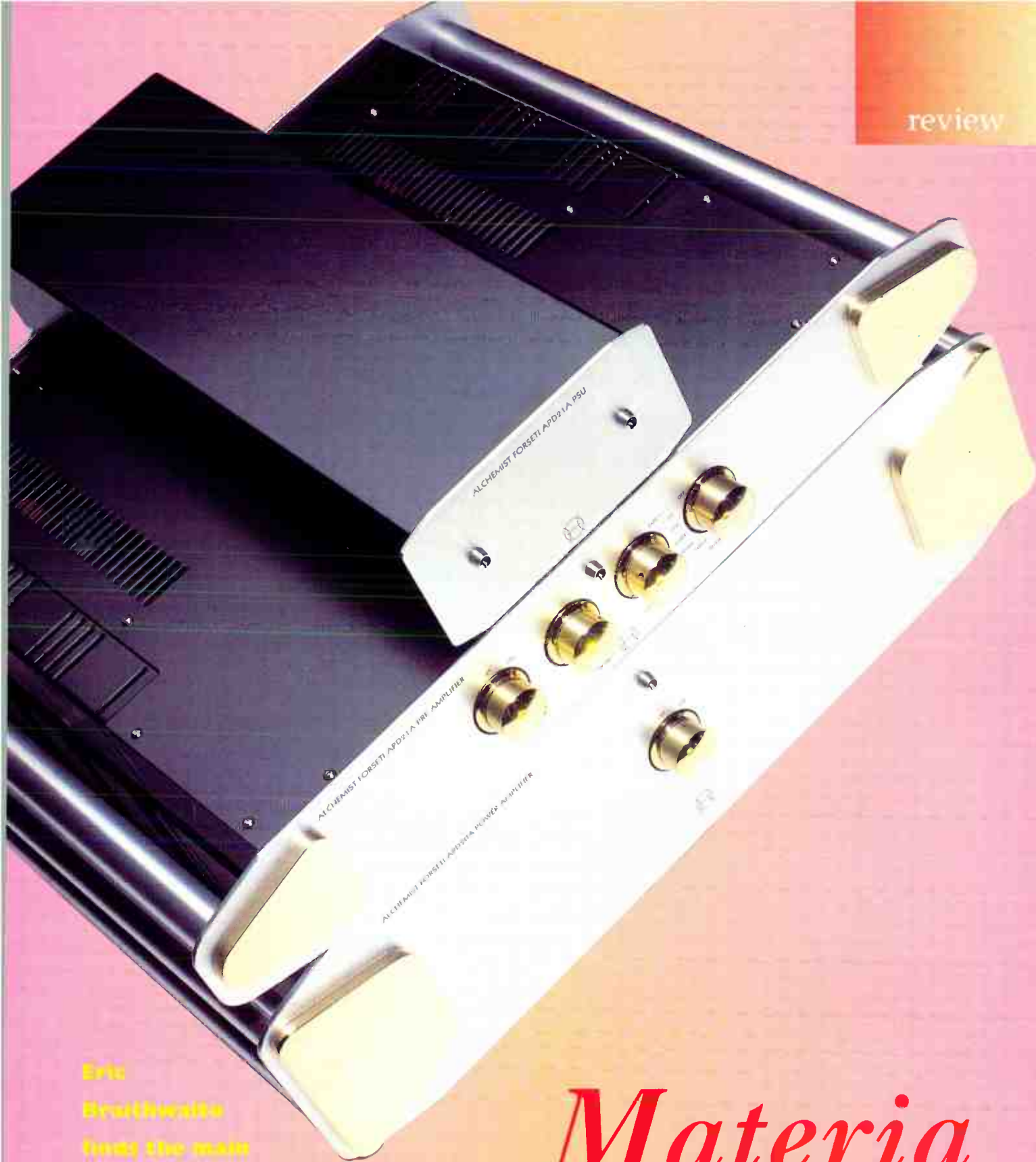

Erto  
Brouillette  
finds the main  
element in  
Alchemist's Forseti  
pre-power amplifier  
combination is music.

# *Materia Prima*

**M**uswell Hill in North London is home to Alchemist, as well as the infamous

Hillbillies. It must be the lingering radiations in the air from the old Ally Pally nearby that influences them.

Connections with Norse mythology are more obscure, but it's there with the name Forseti.

September 1995



# exercise your senses

at the

## London Sound & Vision Show

Where the leading names will be demonstrating  
their best Hi-Fi and Home Cinema systems

**Absolute Sounds, Alphason Designs, Arcam, Arion Acoustics, Audiolab,**  
**Aura, Beyer Dynamic, Mission, Carver, Cyrus, Linn Products, B&W, Nakamichi, Solid,**  
**Naim Audio, JPW Loudspeakers, Chord Company, Kronos, Apogee, Audiomeca,**  
**Audioplan, Boston Acoustics, Copland, Meridian, Shark Cable, Puresonic, Revolver,**  
**Mana Acoustics, Cerwin Vega, Cable Talk, SD Acoustics, Technics, TDL, Projekt Furniture,**  
**REL, Goldring Products, Soundstyle, Tech-Link, Target Audio, Veda Products**

The Cumberland Hotel  
Marble Arch London W1  
Friday 22nd September 2-7pm  
Saturday 23rd 10am - 6pm  
Sunday 24th 10 - 5pm  
Trade only Thursday and Friday am

For more information contact:  
London Sound & Vision Show,  
St. Ives, Cambs. PE17 4PR

World Radio History





Well, actually, that's guesswork. I give up! For all I know, it could be the name of a Sicilian motorbike.

Come to think of it, there is a touch of Motoguzzi about this twosome. Both pre and power have aluminium grab-handles either side, stretching front to rear towel-rail style. In front, a brushed aluminium finish fascia is highlighted in gold; the control knobs are gold too, and even the indicator lights are amber.

Hefty power amplifiers sometimes glisten on the outside but sound leaden when wired up to a pair of speakers. Not the Forseti however. It has a drive and nervous energy that is instantly attractive, with the dynamic ability to reproduce an acoustic instrument as though the real thing is in the room, instead of being a recorded toy, Blur's 'This is a Law' being a prime example, though the Hammond organ sounded rather subdued.

Hope Sandoval on 'Into Dust', sounded crisper and brighter, even on the edge of fierce. The Alchemist pairing was certainly transparent enough to cast a keen eye on background goings on. It also surprised me with the two quite different acoustics on Miles Davis' 'In a Silent Way/It's About That Time', displaying the difference in dynamic range between them with digital-counter precision.

With a recording of Beethoven's Eighth, there was likewise a strong sense of depth and spaciousness, and the essential feeling of air around performers; du Pre's cello in the classic EMI Elgar concerto recording was lush and full-flavoured.

However, switching to a Michell Argo HR preamp suggested that the Forseti power amp came out of the Alchemist's alembic with a rather higher number of carats than the preamp. Villa-Lobos' Choros No 7 is a strange, wild, dancing and shimmering mix of rhythms and instruments (scored for flute, oboe, clarinet, alto sax, bassoon,



violin, cello and tam-tam). With Forsetis together, it had a nervous, edge-of-the-seat energy and a strong sense of fore-and-aft space. Taking my mind off the

exceptionally quick-witted rhythm however, it became clear that the tapestry of the various instruments had its threads somewhat too close together. Plugging in the Argo, suddenly the bassoon's lower notes became richer and firmer, while violin, sax and flute when playing

together could be more clearly discerned as separate textural strands in the score.

There was obviously something of a clever balancing act going on here, because though the Argo-pre/Forseti-power coupling had slightly softer dynamics and less space around the back than the pairing as delivered, it had a richer tonal colour in the bottom half of the instrumental spectrum. Here we go with yet another hi-fi paradox: the Forsetis together had the excitement and Brazilian verve that would have a parrot doing a polka, while the Argo/Forseti had a truer, wider and

subtler rainbow of tonal feathers.

The Forseti power amplifier is true gold: near enough a piece of straight wire, with plenty of dynamic range - and strongly recommended. A spot of experimentation with preamplifiers is recommended, according to the flexibility of the purse. In other words, Alchemist's Forseti pre/power is a fair enough crock of gold for the price, but the power amplifier is beyond rubies ●

Alchemist Forseti preamp £870  
power amp £1250

Alchemist Products  
4 Rosebery Mews,  
Muswell Hill,  
London N10 2LG  
☎ 0181 883 3008

*“The Forsetis together had the excitement and Brazilian verve that would have a parrot doing a polka.”*

**WORLD VERDICT**



Outstanding power amp is hindered by a merely competent preamp. Well worth auditioning.

**Measured Performance**  
see p105-113



MODEL: DEFINITION D700

EXPERIENCE THE SCALE, EXCITEMENT AND IMPACT OF LIVE MUSIC  
WITH THE 'DEFINITION' SERIES FROM TANNOY

**TANNOY**

BROCHURE HOTLINE: 01236 425407

TANNOY LIMITED, ROSEHALL INDUSTRIAL ESTATE, COATBRIDGE, STRATHCLYDE ML5 4TF, SCOTLAND. TEL: 01236 420199, FAX: 01236 428230



# SUB-STANTIAL

**Dominic Baker powers up REL's latest subwoofer, the Stadium II.**

**W**ith the £1225 Stadium II subwoofer, REL are catering for the serious audiophile who craves true full-range sound. Don't confuse it with downmarket contenders in the A/V subwoofer market, where the emphasis is on volume rather than quality, with resonant boxes, poor drivers and weak amplifiers all disguising the original signal under a powerful wave of waffle and boom.

The REL Stadium II features an amplifier improved since the already very good Mark I version, a top quality high power Volt bass unit, and an even thicker and heavier cabinet. These

improvements amount to lower distortion and colouration, giving the Stadium II even tighter, cleaner bass with true definition. Put simply, it plays music - something that curiously evades so many of its competitors. The Stadium II uses REL's traditional coarse/fine roll-off controls which set the upper frequency limit, and an overall gain control. I have yet to come across a better system than this, allowing it to be matched very effectively with a wide range of loudspeakers.

As expected, when properly set up the Stadium added an extra dimension

to everything played. Without drawing attention to itself it plumbed the depths, revealing bass lines and subsonic detail most loudspeakers completely miss. After living with a subwoofer or 'speaker capable of revealing all of this extra information, it's hard to imagine being without it. It is surprising how much detail those last few Hz carry, and how strong their effect is on a performance.

Even with recordings that aren't blessed with much subsonic information, the REL still brought about a great improvement. Blur's Parklife has firm, punchy upper bass lines, but little real depth. On most loudspeakers you can hear the small cone punching away frantically lending much of its own character to the sound, but with the REL installed a sense of control and ease takes over. A small cone has trouble producing low bass; it is on its limit where distortion rises and cabinet effects are strong. The REL is just cruising here, giving a natural but resolute performance with detail and dynamics aplenty.

So this new sub is a worthy upgrade to any system, making performances truly complete and adding a sense of realism to music that any serious audiophile shouldn't ignore. If you want true full range sound, you really must audition the REL Stadium II ●

**REL Stadium II**

**£995**

**Harman International Industries Ltd.  
Unit 2,  
Borehamwood Industrial Park  
Rowley Lane,  
Borehamwood,  
Herts WD6 5PZ  
☎ 0181 207 5050**

## WORLD VERDICT

Excellent bass performance means the Stadium II is definitely not a toy.

**Measured Performance  
see p105-113**

# "SIMPLY SENSATIONAL"

- Ken Kessler, Hi-Fi News

Once in a while a new product comes along which is destined to become a modern classic. The Simply Two is just such a product. Already nominated for the prestigious USA 'Gold Note' award for the best tube amplifier 1995, the Simply Two offers vintage valve sound encased in the luxury of real wood. Its elegantly understated looks tell you that here is an amplifier whose vocation is, simply, to make music an enjoyable experience.

And its single-ended, pure Class A design gives the kind of sound which will put a smile on the face of any music lover.

As the illustrious Hi-Fi reviewer put it: *"For those of us with a lust for music, a craving for luxury and limited funds, the Simply Two is simply sensational".*



For full details on the Unison Research Simply Two integrated amplifier (£995), Simply Four (£1495), or the amazing 'Smart 845' monoblocks (£2995), contact:

## U.K. DISTRIBUTION

23 RICHINGS WAY, IVER, BUCKS. SL0 9DA

TEL: 01753-652669 FAX: 01753-654531

Simply Two is exclusively on demonstration at the following carefully selected UKD specialists:

London: Hi Fi Confidential (0171 233 0774)

Kent/S.E. London: Progressive Audio (01634 389004)

Backs/Herts: G.T. Audio (01895 833099)

Sussex/Surrey: Horsham Hi Fi (01403 251587)

S. Midlands: Audio Insight (01908 561551)

N. Midlands: Nott'm Analogue (01773 762947)

E. Midlands: Encore! (01664 823282)

N. Wales: Acton Gate Audio (01978 364500)

West Country: Audio by Development (01984 623100)

Yorkshire: Hi Fi Studios (01302 781387)



# PRO LOGIC

If you had just woken up after a decade of suspended animation, you'd be forgiven for wondering 'where have all the cassette decks gone?' Compact cassette's falling sales are making themselves conspicuous in the hi-fi field, and it's getting harder to find a decent cassette deck. Sure, you

**TEAC's V-8030S is built for those with professional demands from their cassette deck, Douglas Floyd-Douglass finds.**

can get serious-looking confections from other major Japanese manufacturers for considerably less

than this TEAC's £649.95 price tag, but they're built down to a price, to put it politely.

Distributors clears stock, export-  
discount **50%** or more

# HIGH END SALE

## WELL TEMPERED

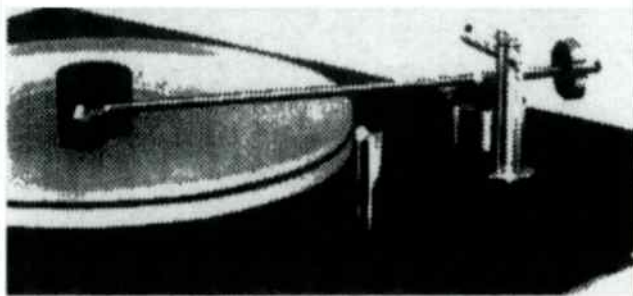

Record Player,  
Classic, Signature

export price from

# £590

## AUDIO RESEARCH

DAC1, SP9, SP15,  
D250, MkIIS, M300 MkII,  
Classic 150

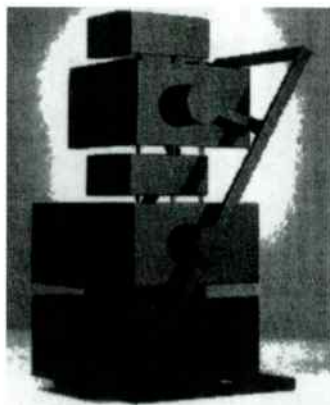

## GOLDMUND

Studietto, ST4, T5, Cartridge,  
Mimesis amplifier series,  
Super-Dialogue, Apologue  
(picture)

## KOETSU

MLC1, JC1, ML3, HQD-  
system (2xML6A,  
2xLNC2, 6xML2,  
2xHartley/Quad/Decca-  
array)

## MARK LEVINSON

MLC1, JC1, ML6, HQD-  
system (2xML6A, 2xLNC2,  
6xML2,  
2xHartley/Quad/Decca-array)

Also: **Berning,  
Breuer, Cotter,  
Eureka, Fidelity  
Research, Linn,  
Moersch....**  
**Call for catalogue!**

Glotta AB, phone +46 8345251, fax +46 8346533

# GT AUDIO



## "SIMPLY TWO"

HAVE YOU EVER WONDERED WHAT AN EXCEPTIONAL SINGLE ENDED AMPLIFIER CAN DO FOR YOUR SYSTEM? THEN YOU OUGHT TO HEAR THE UNISON RESEARCH "SIMPLY TWO". THIS JEWEL OF AN AMPLIFIER NOT ONLY SOUNDS SIMPLY STUNNING, BUT IS EXQUISITELY BUILT AND FINISHED IN REAL ITALIAN WOOD. IT HAS ALREADY BEEN CLASSED ALONG SIDE ONE OF THE ALL TIME CLASSIC AMPLIFIERS "THE MARANTZ PM4": KEN KESSLER'S REVIEW SIMPLY STATED (Hi-Fi News & Record Review March 1994) "THE SIMPLY TWO IS VINTAGE TUBE SOUND ENCASED IN REAL WOOD"

FOR A DEMONSTRATION OF THE SIMPLY TWO OR ANY OF THE UNISON RESEARCH AMPLIFIERS, CALL *GRAHAM TRICKER* WHO IS COVERING LONDON AND THE BUCKINGHAMSHIRE, HERTFORDSHIRE AREA.

**TELEPHONE/FAX:- 01895 833099**

AGENTS FOR CROFT, NOTTINGHAM ANALOGUE, POSSELT LOUDSPEAKERS, UKD OPERA LOUDSPEAKERS, MONRID, MONARCHY AUDIO, BEARD, XLO, GROOVE TUBES, GOLD AERO, TOWNSEND, UNISON RESEARCH, MARTIN BASTIN PRODUCTS, GT AUDIO CABLES.

DEMONSTRATIONS BY APPOINTMENT ONLY

## MIDLAND AND NORTH OF ENGLAND

FED UP WITH RUNNING  
IN CIRCLES, WE WILL  
HELP YOU FIND WHAT  
YOUR EARS ARE  
LOOKING FOR.



*For the Best in Hi-Fi*

## UNISON SIMPLY TWO



When it comes to unaggressive, punchy, detailed, spacious, natural presentation, the new Unison Simply Two is **The Canine's Testes!** (Whatever your speakers' efficiency) (See review in this issue.)

## TEAC V8030S CASSETTE DECK



We guarantee you won't be able to spot a recording made on this machine from the original, .. If you can **we will give you £20!!** £ for £, spec for spec these decks cannot be beaten (See review in this issue.)

## NEW REL STORM

We are REL subwoofer stockists (the only serious way to add quality bass.) (See review in this issue.)

For a chat about quality hi-fi phone Jeff, Neil or Lesley on Doncaster

# 01302 781387

The V-8030S is a veritable Rolls Royce of a machine, with substantial build and more facilities than you'll probably ever need, including Dolby S. Although to TEAC's credit, with the exception of remote control and music search facilities, most are actually designed to help you, and it, get the best from whatever formulation you care to place in its gilded cassette compartment.

Most useful is its off-tape monitoring facility,

meaning you can monitor your recordings in real time in direct comparison to your source. Add to this variable bias and calibration, independently applied to each channel, and you have a cassette

recorder which is compatible with most types of tape and more than capable of getting the best out of them.

The V-8030S has four internal motors that individually operate the transport mechanism, power loading, capstan and reel drives. There is comprehensive vibration protection in the chassis, feet and casing. The cassette door is made of 6mm thick aluminium, said to further reduce vibration. The transport mechanism is mounted on an internal sub-chassis, and judging by the results, this really works - it's faultless.

In use, the TEAC had no hidden surprises, but although clean and commendably linear, it lacked the innate musicality of a Nakamichi. My listening started with Sheffield Labs' pre-recorded cassette of 'James Newton Howard' and friends, which had a warm, solid synth bass line and crisp (never harsh) treble detail in the percussion. The Beatles' 'Nowhere Man' was brought to life by the V-8030S. It was like being at EMI's studios thirty years ago! The characteristic George Martin 'vocal pan to the right' had John and Paul sitting comfortably within hand's reach. The bass line was clear and well supported by the strummed rhythm guitar. 'Drive My

Car' sounded equally good, the cowbell and snare adding solid presence. Guitar and piano sounded atmospheric, and transient chords cut forwards. The life-like backing vocals filled out the whole sound, in what is by any standards an 'old' recording. This deck certainly makes you listen to the music.

Sade's 'Diamond Life' sounded excellent, with the detail and attack of CD and a pleasant analogue feel. Even the intonation of the skin drums could be clearly heard.

*“Sade's 'Diamond Life' sounded excellent, with the detail and attack of CD and a pleasant analogue feel.”*

Latin percussion, maracas and bongos were played with rhythm and zest, and sounded just as good. Sade's vocal was beautifully preserved, and well supported by the tenor sax's

gentle breeze. Pre-recorded on chrome cassette and Dolby B, playback response extended right up giving excellent treble quality. In short, TEAC's V-8030S proved its ability with pre-recorded cassettes, almost matching my own Nakamichi Tri-Tracer.

This machine presents a rich variety of recording options, possessing Dolby B, C and S noise reduction, plus the ability to tune-in ferric, chrome and metal tapes. On ferric (normal) tape, results with TDK AR were particularly good. High input levels of +4 were easily achieved and even with no Dolby a perfectly acceptable signal-to-noise ratio could be achieved. However, pulling record level back to +2 maximum to avoid treble overload, and switching in Dolby S (which also has overload prevention) gave near perfect results with TDK AR - uncanny. Bias did have to be pulled right back though. I tried TDK AD, but this was less successful, sounding muddled.

Chrome tape (TDK SA), although quieter, was less impressive, losing impact and attack. The overall recorded result at a decent level (+3dB) sounded mildly distorted and splashy in the treble. Sound at 0dB was good, but hiss

was more audible. Dolby S helped, but did not save the day.

The TEAC V-8030S worked a treat on metal tape (TDK MA), with strong preservation of detail and was capable of huge input levels (+8dB) with Dolby S in and almost as much with Dolby B - great for car stereo recordings.

Dolby B noise reduction did, however, introduce some treble roll-off at 10kHz, sounding muffled and losing detail. Dolby C was even worse, sounding compressed and not natural at all. These two systems did not seem properly set up. This sort of thing doesn't happen on a Nakamichi. I assume that TEAC included Dolby C purely for compatibility with previously encoded Dolby C cassettes. The TEAC monitor circuits had a slight colouration effect, sounding a little compressed. Via headphones, sound quality was excellent.

The Teac V-8030S is a solidly built, good all-round performer. It relies upon Dolby S to avoid the need for a head of Nakamichi performance standards, whilst incorporating a better transport than similarly priced Naks. It doesn't possess the replay response and Dolby tracking accuracy of a Nakamichi, which is disappointing. All the same, here's a top deck that's wonderful to use and gives superb results, for those who want the best from cassette ●

**TEAC V-8030S**

**£649.95**

**TEAC UK Ltd.,  
5 Marlin House,  
The Croxley Centre,  
Watford.  
Herts WD1 8YA  
☎ 01923 819630**

#### WORLD VERDICT

One of the highest quality Dolby S decks available, well built and easy to use. Very serious.

**Measured Performance  
see p105-113**

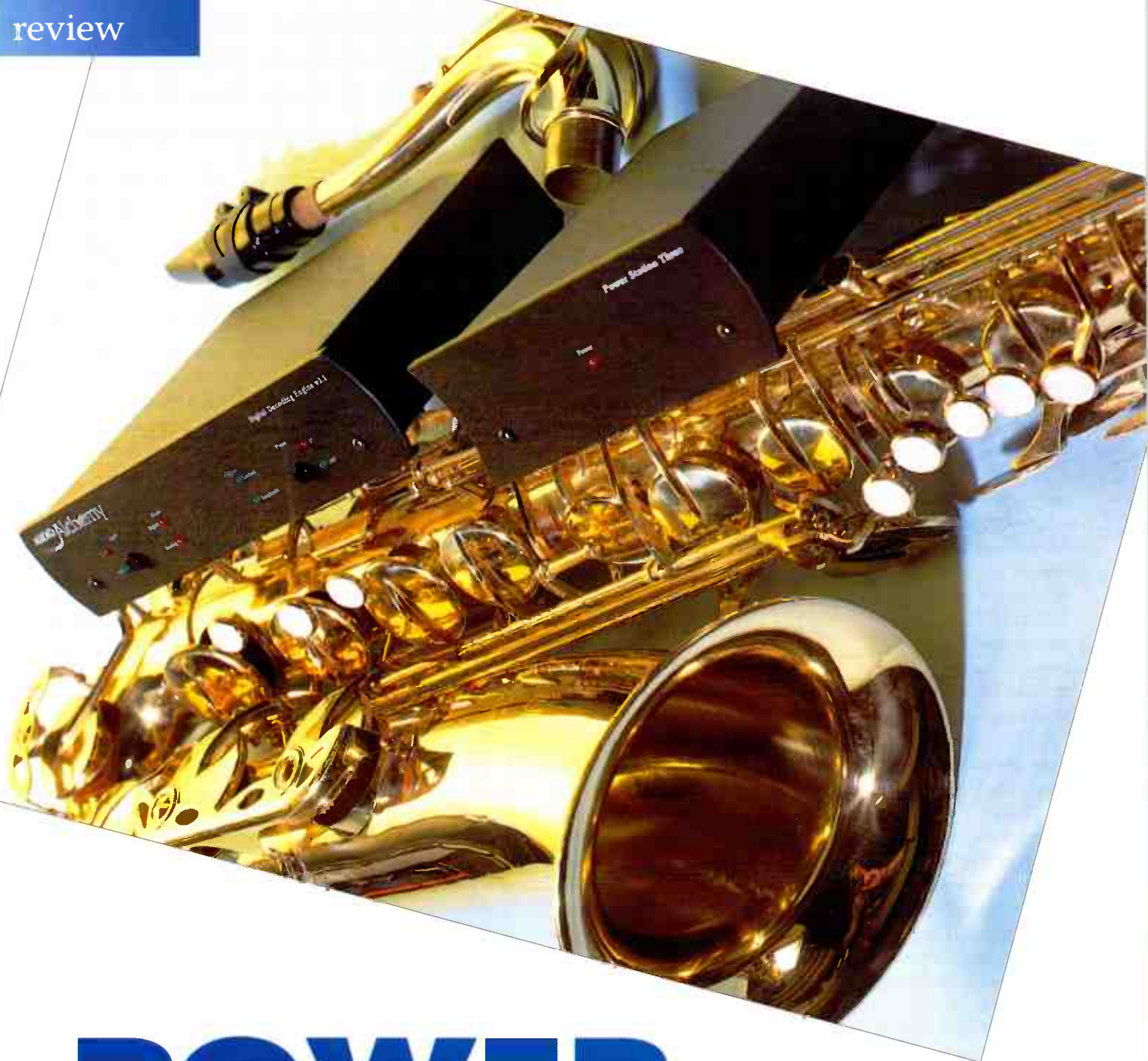

# POWER DAC

**Audio Alchemy's latest Digital Decoding Engine v1.1 CD convertor needs extra PS3 power to give its best, finds David Price.**

**B**ack when William Jefferson Clinton was a wide-eyed Arkansas governor, Audio Alchemy appeared from relative obscurity to launch their Digital Decoding Engine v1.0. Recently they've consolidated their range with some



interesting new designs aimed fairly and squarely at audiophiles on a budget, the DDE v1.1 being the latest. It sports various improvements, including a simpler circuit design with a built in DTI-type jitter reduction stage, low distortion op-amps and discrete components in the Class A analogue output stage.

To confuse matters, their latest convertor comes with a variety of different power supply permutations. In the States, \$459 buys you a DDE complete with cooking external PSU.

An extra \$79 buys you the Power Station One (PS1), claimed to improve bass and imaging. Fortunately, British buyers get the PS1 thrown in as standard with the DDE for £399.95. Also available is the Power Station Three for \$259, which delivers more juice and includes additional filtering to remove RF and digital line noise. Bundled with the latest DDE, this package costs £599.95. As UK prices aren't appreciably more than Stateside ones, it suggests importers Path Premier mean business.

Prospective DDE purchasers most likely own a fair-to-middling budget CD player. With this in mind, we decided to pit the DDE against a certain well-regarded, similarly priced integrated player, rather than another convertor. No prizes for guessing the chosen reference - after countless requests I finally managed to wrest a Marantz CD-63SE from the Editor's system.

After the obligatory warm up period the first listening tests centred around which type of digital connection to use. Both optical and electrical coaxial have their devotees, but it seems to me it's a case of what you lose on the roundabouts, you gain on the swings. After much listening, and contemplation of the political ramifications of such a major decision, I chose the Kontak Link 505 coaxial that was supplied by Path. While the optical input was marginally smoother, electrical wire gave a brighter, bigger sound with an appreciably larger soundstage.

The Power Station One'd DDE

wasn't terribly impressive against the Marantz's internal convertor. Although different, much scratching of heads went on about whether it was better. With Oasis' 'Slide Away', the Marantz gave a tidy, orderly presentation with the slightest hint of richness in the upper mid and treble, but the DDE sounded a touch uncouth and raucous.

*“Moving to Miles Davis' Kind of Blue, the DDE/PS3 set up a deeper, wider acoustic, with stronger, more airy bass.”*

Soundstaging was slightly improved over the Marantz, with lead guitars further forward and more space around vocals, but I remained unsure as to whether this extra air was down to added brightness or true detail resolution. Certainly the DDE rendered cymbals splashier than the Marantz, which remained smoother with no less grip or control. With £400 to spend on either the DDE/PS1 or an integrated player, I'd go for the latter providing it had 'CD-63SE' written on the front. But as the Marantz is so good for £350, the DDE doesn't come off too badly.

However, with Power Station Three connected up things looked decidedly different. Back with Oasis, the DDE took a step up, bettering the Marantz in many ways. That expansive soundstage had tightened up appreciably, with far better stage depth and detail resolution. Tonally, the DDE remained on the bright side, but with less splash you could hear cymbal texture better. Timing was also improved, with notes starting and stopping faster than the Marantz, which was gently smoothing attack transients.

Moving to Miles Davis' Kind of Blue, the DDE/PS3 set up a deeper, wider acoustic, with stronger, more airy bass. Trumpet was further back in the stage, but more tightly located, with its phrasing better carried. The Marantz countered this with a pleasing smoothness to brass which the Audio Alchemy just couldn't deliver. True, it sounded slightly veiled in the upper mid

in comparison, but the extra tonal colour and smoothness made up for many failings. The DDE was incisive and slightly more detailed, but the Marantz was ultimately more satisfying.

The picture continued with Young Marble Giants' 'N.I.T.A.', the Audio Alchemy bringing more air to this early Rough Trade recording, as well as revealing more tape hiss. Yet the Marantz just got on with the music, rendering guitars less scratchy and Alison Statton's voice smoother and more silky. The BBC Symphony Orchestra, conducted by Andrew Davis, playing Berlioz's Symphonie Fantastique enjoyed more warmth from the Marantz too. Although the DDE caught the atmospheric feel of Tokyo's Hitomi Kinen Kodo hall better, imaging wider and giving better body to cellos, there was the slightest tinge of glare to strings which the Marantz avoided.

So, driven by Power Station One, the DDE's not quite up there with the Marantz. However, it will still breathe new life into a tired £300 player, and is considerably better than cheaper options like Cambridge's DacMagic. The strength of Audio Alchemy's DDE 1.1 is its upgradeability. The trump card is the Power Station Three, which transforms it into a serious combatant. Although it may sound too sharp for some tastes, when used in a dull system it'll reward with star quality from your silver discs ●

**Audio Alchemy DDE 1.1 £399.95**

**Audio Alchemy DDE 1.1&PS3 £599.95**

**Path Premier**

**Unit 2, Desborough Industrial Estate,**

**Desborough Park Road, High**

**Wycombe, Bucks HP12 3BG**

**☎ 01494 441736**

#### WORLD VERDICT

Well presented, lively sounding DAC that comes into its own with power supply PS3.

**Measured Performance**  
see p105-113



## (R)EVOLUTIONARY

**David Price looks at Linn's classic Sondek LP12 turntable. Designer and founder of Linn, Ivor Tiefenbrun, recalls its beginnings.**

**T**he Linn Sondek's twenty-two year life has seen it denounced, but also celebrated as symbolising everything good about the vinyl disc. Even today it provokes strong reactions. For some the LP12 is the last word in analogue, while others think Linn's hype exceeds the deck's capabilities. One thing's for sure: it's never been abandoned by controversy.

Cast your mind back to the mid-seventies, when the wisdom of the day

held that loudspeakers were the most important part of the system. The turntable, people thought, simply had to revolve accurately at  $33 \frac{1}{3}$  rpm without rumbling. Duly, decks that measured well, like the Pioneer PL12D and Technics' direct-drive SL110, made great inroads into the British market.

In this climate, Ivor Tiefenbrun launched the Linn LP12, and became the first to argue something that's now accepted as common-sense - the source

crucially influences a system's performance. As Linn's only product at the time was a source component, many saw his reasoning as a clever line in self promotion and said so with no lack of candour. However, using the "Garbage In Garbage Out" analogy from the computer industry, Linn took on the audio establishment by demonstrating that without a decent source, the rest of the system had little chance of success.

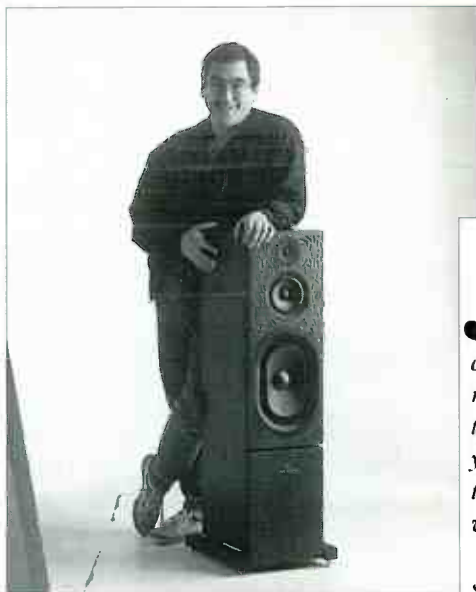

The hi-fi press took to this view and by the late seventies they were spreading the word with evangelical zeal. Linn's source-first philosophy became accepted so completely that magazines started recommending the LP12 for use even with budget ancillaries. Reviewers insisted that even with a £69 NAD amplifier and £50 KEF 'speakers, the £295 LP12 would work wonders!

Never ones to rest on their laurels, Linn consolidated the LP12's success with a series of retrofitable upgrades such as *Nirvana*, a package of improved suspension components, and the quartz-controlled *Valhalla* power supply. The late seventies introduction of the *Ittok* tonearm and *Asak* cartridge gave buyers their first chance to own a complete Linn front end. The *Ittok*, named after its Japanese designer Mr. Ito, soon established itself as one of the best tonearms around. Like the *Sondek*, it ran counter to current engineering wisdom. Eschewing the low-mass-is-best approach epitomised at the time by SME, it featured battleship construction and finely toleranced bearings which made for a tight, fast sound.

The advent of Compact Disc in 1983 saw the first real challenge to its reign. Although the LP12's sonics were well ahead, the silver devil nevertheless threw its failings into sharp relief. Imaging was vague and the lower midband coloured compared to "pure, perfect" digital sound. Linn responded with an improved bearing and a stiffer armboard, bringing greater focus and clarity. By the late eighties, CD was mounting a more serious challenge which Linn responded to with the *Lingo* power supply, while the new *Ekos* tonearm built on the *Ittok*'s strengths.

*Just over twenty-six years ago, when I got married, I bought my first hi-fi system. I noticed that the sound I heard through headphones altered when the 'speakers were switched off, so I placed the turntable outside the room, closed the door and immediately gained substantially improved performance. I realised that the output from the loudspeakers was interfering with the turntable system. A discussion with a friend involved with Decca for many years and familiar with every aspect of audio engineering, quickly convinced me the task of retrieving the fine information from a record groove was a challenge vastly beyond my expectations or previous understanding.*

*In the closed-loop record cutting process, movement between the cutting stylus and the acetate faithfully captures all relative motion occasioned by the music signal, but the playback process is an open loop with enormous scope for the loss of valuable music information.*

*These observations led me to the notion that the turntable, as the platform for the recordarm/cartridge combination, was the major determinant of the information that could be faithfully retrieved from a record.*

*With invaluable input from my late father who was skilled in bearing design, and by employing the precision engineering skills and expertise that still exists at Castle Precision Engineering, the company my father founded, I developed and built a turntable which retrieved more information from the record. It also maintained more constant and stable rotational velocity and its operation was not only unprecedentedly quiet, but far less susceptible to external influences.*

*The idea that the quality of hi-fi systems was ultimately constrained by source quality offended anyone who believed that loudspeakers were the crucial components, the view at the time. Far from seeing the hierarchy of the system following its signal path from source to listener, most people believed the loudspeaker at the end of the chain was the most influential component. Fortunately for me, some open minded people were prepared to listen for themselves and make up their own mind, so some retailers were excited by the prospect of selling a product that could improve any system and give people more pleasure from their record collections. The question was how to sell such an advantage. It seemed obvious that the best way was to simply demonstrate the difference by comparison and let people hear for themselves what an LP12 would do to the sound quality of a system.*

*The pursuit of simplicity and innovation led to the continuous improvement of the LP12 as our knowledge grew. These values, standards and techniques enabled customers to upgrade their LP12 whenever they wished. This all helped to set Linn on a path that has made it, to those who use and enjoy our products, a cherished marque. The Linn *Sondek* LP12 has become, through many metamorphoses, a classic product that still excites the most discriminating customers over a quarter of a century after the first prototype sang its first song.*

*I appreciate the opportunity of introducing this feature on the Linn *Sondek* LP12 to Hi-Fi World readers. The values that built its reputation and give its owners such pleasure persist in everything we do, but as I have always said, you should be the judge. All you have to do is listen and decide for yourself!*

Ivor Tiefenbrun

Most recently, the *Cirkus* bearing introduced a couple of years ago brought even sharper focus and more stable imaging.

Nowadays, the *Sondek* is no longer the undisputed king. But many believe

its innate musicality, for which it was always famous, is still unsurpassed. As worldwide sales show, the *Sondek* has done no end of good for British hi-fi, bolstering this country's reputation as a key player on the global hi-fi stage.



## SOUND QUALITY

With a Klyde moving coil cartridge fitted, Linn's £1138 'entry-level' LP12 Basik/Akito arm sounds impressive in the best sense of the word. Bass is deep and warm, while the upper regions exhibit the LP12's hallmark smoothness and cohesion. Sound staging is significantly better than pre-Cirkus models. Images have satisfying solidity and body, and stage depth, always an LP12 strong point, is better than ever. Hi-fi aspects aside, the deck's strength has always been in the timing department. Here, the Basik LP12 has a real grip on rhythms, working the old magic with the ability to make music sound like a group of real musicians playing together.

On the downside, there's a flattening of dynamics, down to the Akito arm, which makes for a smooth presentation that won't pin you to your seat. Tonally, upper bass is slightly coloured compared to rivals, but this isn't necessarily a bad thing in the right system. Although timing also lacks the mechanical precision of the equivalent Michell Gyrodec, the Linn still manages to sound rhythmically more involving.

Allowing Linn Products to divest you of £2926 gets you the ultimate Sondek, complete with external Lingo power supply providing switchable speeds, the latest version of the Ekos arm with uprated bearings, and Trampolin base, which provides an extra degree of decoupling from surroundings. Our review model was also fitted with Linn's *tour de force* moving coil, the Arkiv.

This incarnation represents the pinnacle of development for this venerable turntable. Simply put, this LP12 is one of the smoothest, most civilised sounding hi-fi components

going. Its great refinement and poise shouldn't be confused with blandness - today's top LP12 is a lithe, dynamic device indeed.

This LP12's most immediate improvement over the entry-level version is stage depth. Although slightly smaller on the horizontal plane between the speakers, it goes far further back and projects forward better. Images come into greater focus, underlining how much the Sondek has improved since the Cirkus bearing.

Indeed, the way music hangs back from the 'speakers lends the deck grace that many will find endearing. Unlike the Gyrodec or Garrard 401, its musical presentation doesn't grab you by force or detail, but by a beguiling subtlety. Those schooled on raucous CD players might find it anticlimactic at first, but give it time and the Sondek will pull you in and keep you.

Suitably warmed up, this LP12 gave one of the best renditions of Lou Donaldson's 'Alligator Bogaloo' I've heard, instruments located with pin-sharp precision in an expansive acoustic. Rhythm was sublime, capturing the stop-go feeling furnished by the overlay of solos on the constant beat. George Benson's guitar was striking, showing gripping counterpoint with Leo Morris' machine gun snare work.

This LP12 really puts the cat amongst the super-deck pigeons at low frequencies. While the Garrard 401 has a slight edge in the solidity stakes, LP12 bass emotes like no other, with a grasp on dynamics and detail which superbly underpins proceedings higher up. It was also considerably superior to the entry-level Sondek, with a supremely tactile delivery totally independent of events in the upper registers.

The Sondek remains a damn fine turntable that can teach newer rivals a thing or two. Like all top decks, the LP12's strengths predispose it to particular types of music. In this guise, with the extra detail and delicacy of touch brought by the Ekos and Arkiv, its talents are honed for classical and jazz music. But its abiding talent with any disc you care to play is its tunefulness and musicality. Despite all the changes, this is one thing that's stayed the same.



## GETTING THE BEST FROM YOUR LP12

- Linn recommend placement on a rigid wall shelf. Otherwise use a level, rigid coffee table or dedicated equipment support such as a Mana, Audiotech or Sound Organisation.
- Pressing up and down on the point between the spindle and the arm bearing should see the suspension bouncing cleanly with no sideways movement. Sideways ambling means a dealer service beckons.
- Periodically clean the belt, inner platter and drive capstan with isopropyl alcohol. Ensure the belt's smoother side faces inwards. Replace if there are any signs of wear. Use a different belt with the 45RPM adapter.
- Use Duraglit or better still, Kontak to ensure all mains connections are clean.
- Disabling the LED or trying different types of felt mat are for inveterate time wasters only.



## BUYING

The rule is the newer the better. An original 1974 model costs £699.50 to bring up to the latest specification, whereas a brand new LP12 starts at £784 plus base, so you'd have to find a pretty cheap example for this to be a cost-effective way of doing things.

To upgrade a 1974 LP12 to 1995 spec:

CIRKUS KIT	£299
MOTOR	£63
PLINTH	£157.50
TOP PLATE	£105.00
LABOUR [3hrs@£25/hr]	£75
<b>TOTAL</b>	<b>£699.50</b>

Ensure there are no scuff marks where the outer platter has fouled the top plate. This suggests it's been transported or moved without removing the inner platter, which can damage the expensive main bearing. Pull the inner platter out and check there's no scoring of the spindle, and that reasonably clean oil drips down. Like car engines, Linn bearings don't like running dry or with black treacle. Suspension bounce isn't critical as it can be remedied with a new set of springs and grommets, costing about £25 and fitted by a dealer.

## USED PRICE GUIDE

**£2500** - Last year's Cirkus LP12 with Lingo power supply, Trampolin, Ekos, and Archiv cartridge.

**£1200** - Recent Valhalla Cirkus LP12 with Ekos arm and K18.

**£700** - Three year old pre-Cirkus Valhalla LP12 with Ittok LVIII and K9.

**£500** - Late eighties braced plinth Valhalla LP12 with Akito and K9.

**£350** - Early eighties pre-braced plinth Valhalla LP12 with LVX+ and Basik cartridge.

**£200** - Antique pre-Valhalla LP12 with SME 3009S2.

## NEW PRICE GUIDE

LP12 LINGO	£1414.00
LP12 VALHALLA	£933.00
LP12 BASIK	£784.00
CIRKUS upgrade	£299.00
TRAMPOLIN base	£115.00
SOLID base	£55.00

## TONEARMS

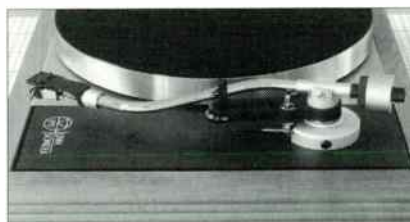

### LINN BASIK [s/h] £50

LVV (illustrated) is cheap and cheerful. Less crude, straight-pipe LVX has detachable headshell. LVX+ has better bearings and fixed headshell.

### LINN AKITO £299

Far superior to the LVX+, the Akito is an excellent entry-level arm but not quite up to Rega's RB300.

### LINN ITTOK LVII/III [s/h] £150-300

The newer the better, although early Scottish-built black LVIIIs have their devotees. Super-rare 12" version collectable but won't fit LP12. The original superarm can still sound impressive.

### LINN EKOS £1397

For many the King. Super clean, whiz-bang impressive sound, but lacks Naim ARO's cohesion. Latest models have retrofittable higher tolerated bearings.

### NAIM ARO £963

For many the ultimate partner to a Sondek. Lacks the fireworks of the Ekos, but brings a beguiling cohesion.

### REGA RB300 £130

Dry, analytical sound counters the LP12's bloom nicely. Clear midband but dynamics and frequency extremes behind Ittok standards. Won't fit braced-plinth LP12s without surgery.

### SME SERIES IV/V £850-1232

These superb arms don't seem to work synergistically on the Sondek, and their weight gives the suspension a hard time.

### LP12 DEVELOPMENT [serial no.]

**1993** [90582]

Cirkus upgrade fitted as standard.

**1992** [88950]

Improved top plate fixing.

**1991** [87672]

LP12 called LP12 Basik, with option of Valhalla or Lingo power supplies.

45 adapter standard with Basik and Valhalla versions. Trampolin suspended base board option.

[87672]

Solid base board replaces hardboard.

Valhalla [87047]

Lingo [87206]

Motor thrust pad cap fitted.

**1990**

Lingo power supply option available.

**1989** [81000]

Harder suspension grommets fitted.

[79700]

Motor thrust pad changed.

**1987** [79160]

New MDF armboard.

[70,000]

Improved bearing. Change to black oil.

Suspension springs improved.

**1986**

Suspension springs improved.

**1984** [54,000]

Subchassis strengthening bar epoxy glued instead of spot welded.

[53,000]

Enlarged plinth corner bracing.

**1982** [38,000]

Valhalla power supply standard.

**1981** [32,800]

Nirvana mechanical components.

**1979** [27,000]

Lid and hinges changed.

**1978** [23,000]

Top plate modified.

**1974** [2,000]

Main bearing liner changed.

Subchassis strengthened

Motor control and mains switch changed.

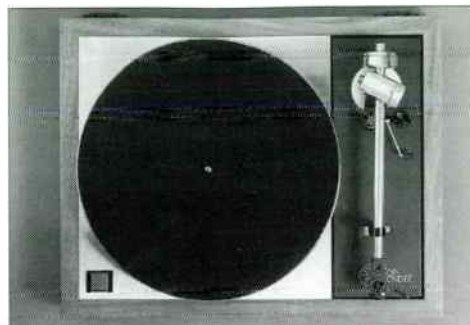

Linn Products ☎ 0141 644 5111

# VINTAGE

**John Murt takes you down under to see his remarkable collection of classic valve audio from the fifties and sixties.**



Custom console housing a BBC Garrard 301/SME3012, Leak Stereo 20 power amp, Troughline II FM tuner and Varislope stereo preamp.

combination playing through a highly original Leak Stereo 20 and Varislope III stereo preamp.

The 'speakers are a pair of Audax 2-way studio M10s, capable of remarkable results. I prefer modern 'speakers mainly because of low coloration, smoother frequency response and more accurate representation than fifties designs. I do possess older speakers including Quad ELS, Karlson 'Distributed Constants' coupler, Goodmans 80's, 60's etc., but for everyday use I come back to more modern designs. The Leak/Audax/Garrard system is also supported by an original Leak Troughline FM tuner, fired up every morning.

This system affords me many hours of enjoyable listening. Although not as sought after in Britain as down here because of its lower price, it still offers very good performance. I use a dedicated multi-band, high gain antenna

**V**alve amplification has been a passion of mine since the late sixties. At school in Northcote, Auckland, New Zealand, hi-fi was very expensive to a fifth former on limited pocket money. So with the help of a school friend, some gutted parts and about ten pounds, I cut my teeth on a Mullard 10-10 design, using EL84 pentodes in push-pull to obtain around 15 to 17 watts a side.

The rest of the system comprised the very first Garrard SP25 mkl (I lusted after a Garrard 401 with SME3012, but who didn't), a Jensen dual-cone guitar speaker in a modified cabinet with another 12" dual concentric driver, probably a Rola or MSP from Australia, in a similar open baffle box. How did it sound when playing the Supremes' Greatest Hits? Fantastic!

Now I live in North East Australia in a popular holiday spot close to Noosa, where the weather averages around 23°, and summer temperatures reach

the low 30s. My collection of early hi-fi covers Quad, Leak, Radford, McIntosh, Scott, Fisher, Lux, Pye (English), Rogers, Dynaco, Thorens, Garrard and Altec - about 55 valve amplifiers in total. My current interest is directly heated triode technology and my main directly-heated triode amps are Lux 300Bs which support single-ended 300B tubes in the output. They sound wonderfully fast and clean, with a midrange presence that is sheer heaven - and they look superb!

My current listening room measures 12'x18' which will suffice until my dedicated 'music' room is complete. I have two main areas of interest in hi-fi, vintage hi-fi which allows me to enjoy my 78s, and more modern designs. My vintage system comprises a restored broadcast console with a Garrard 301/SME 3012/Shure 44

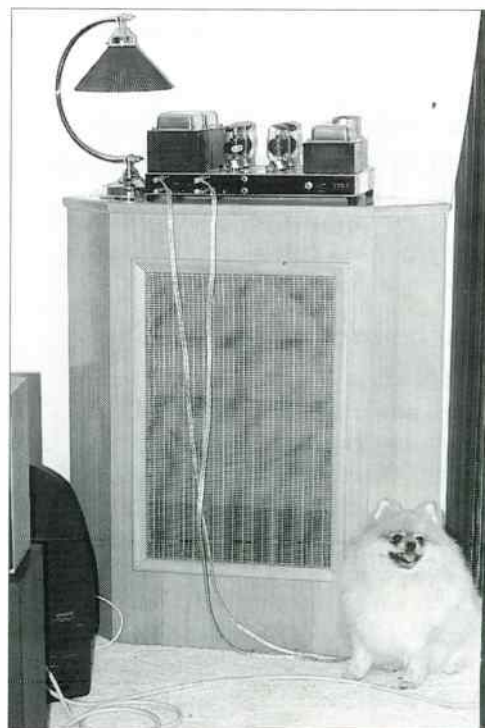

BTH horn loudspeaker with 15" dual cone driver with Austin Michaelson TVA-1 70W amplifier atop. Below, Toby the Pomerian guards against marauding CD players.

# VANTAGEPOINT



**Brunswick Radiogram (circa 1930s) with Brown horn 'speaker.**

that picks up two local FM stations and a couple from Brisbane (over 130km away). The Leak Varislope III is a much underrated stereo valve preamp, offering a wide range of inputs including two phono inputs (both 3.5mV), a tuner input (50mV), microphone input (2mV) and tape head (3mV), with sensitivity quoted at 3.5mV for an input impedance that varies from 50,000 to 100,000ohms.

The Varislope III, as with earlier Varislopes, is configured with RIAA equalisation and NARTB for pre-1955 LPs, USA 78s, LP (post 1955) and 78OE (old European). Although not up to today's standards as preamps go, it offers a warm, lucid midrange and is a reliable performer. The Leak Troughline II tuner is on every day for several hours. Although only mono, it is very satisfying. It lacks a little high end brightness but is remarkably dynamic and midrange fidelity is hard to beat.

Another favourite amplifier of mine is the Quad II/22 combination. The

Quad 22 preamp offers the most comprehensive range of equalisation settings for 78 cartridges and is a delight to use. It is in original condition, as I prefer my equipment to be as good as possible.

One of the enduring features that Harold Leak had the foresight to provide was primary voltage selections from 200-250Vac. It's not unusual for Australian voltage to run from 210 to 260Vac. I have heard of cases when it has been as high as 280Vac. Combine that with soaring temperature in the mid to high thirties in Queensland and you have a recipe for catastrophic transformer melt down.

That brings me to my favourite small power amplifier, the Leak Stereo 20, finished in light bronze and offering similar performance to the earlier TL-12s. Firstly, it consumes only 105 watts at rated output, even on warm days it runs only lukewarm. Ideal for servicing, it has two virtually vertical circuits comprising a 3 stage triple loop feedback design, for which Leak claim 26dB of negative feedback over the complete amplifier. A low noise, high gain triode (12AX7) feeds into a second stage double-triode phase splitter, which in turn feeds two push-pull

output valves arranged in what Leak call 'distributed-load' condition (ultra-linear). Leak used grain oriented steel in the cores of both the output transformers and the mains transformer. The EL84 (6BQ5) was primarily a 9 pin miniature to replace the 6V6 and when configured in the right circuit is very satisfying. This is why modern amplifiers like the Beard PB100 that employs six EL84s in push-pull parallel sound very good.

Although I possess a pair of TL50s and a couple of Stereo 60 power amps, I have much affection for this Stereo 20. The circuit is maintained very much to the original, if a resistor or capacitor needs replacing it is with a low noise metal type or quality WIMA. The Varislope stereo preamp is also pretty well original with just a few coupling and leaking bypass caps replaced.

I am presently looking for Leak TL-12 mono blocks, Radford STA-15 mono blocks, and Lux 3045s. If you would like to contact me, please write to PO Box 814, Tewantin, Queensland 4565, Australia. You can also phone or fax me on (006) 61 074 491 601.

*John Murt is an associate member of the Institute of Radio and Electronic Engineers (Australia) and Founder President of the Wireless and Vintage Sound Society of Queensland ●*

**Custom console with Quad 22 preamp, and Quad AM and FM3 tuners. On top sit a Lux solid-state tuner, a rare Scott 330-C stereo valve tuner, and a new fangled 'transistor'.**



**E**xuding style with a finish that would do Ferrari proud, this little Italian glower is belissimo with an *antipasto* price tag. Here is real value for money with no compromise. The £995 Unison Simply Two is

adorned with real wood (not veneer) on a black steel case with neatly punched-out vents. Mirrored stainless steel forms the base from where the EL34 valves rise tellingly, suggesting an inherent sweetness of tone.

This is a carefully designed amplifier with much attention to detail. The speaker binding posts are solid and of the type you would expect on amplifiers costing at least twice as much. All inputs and outputs are gold-plated and

# SIMPLY BETTER

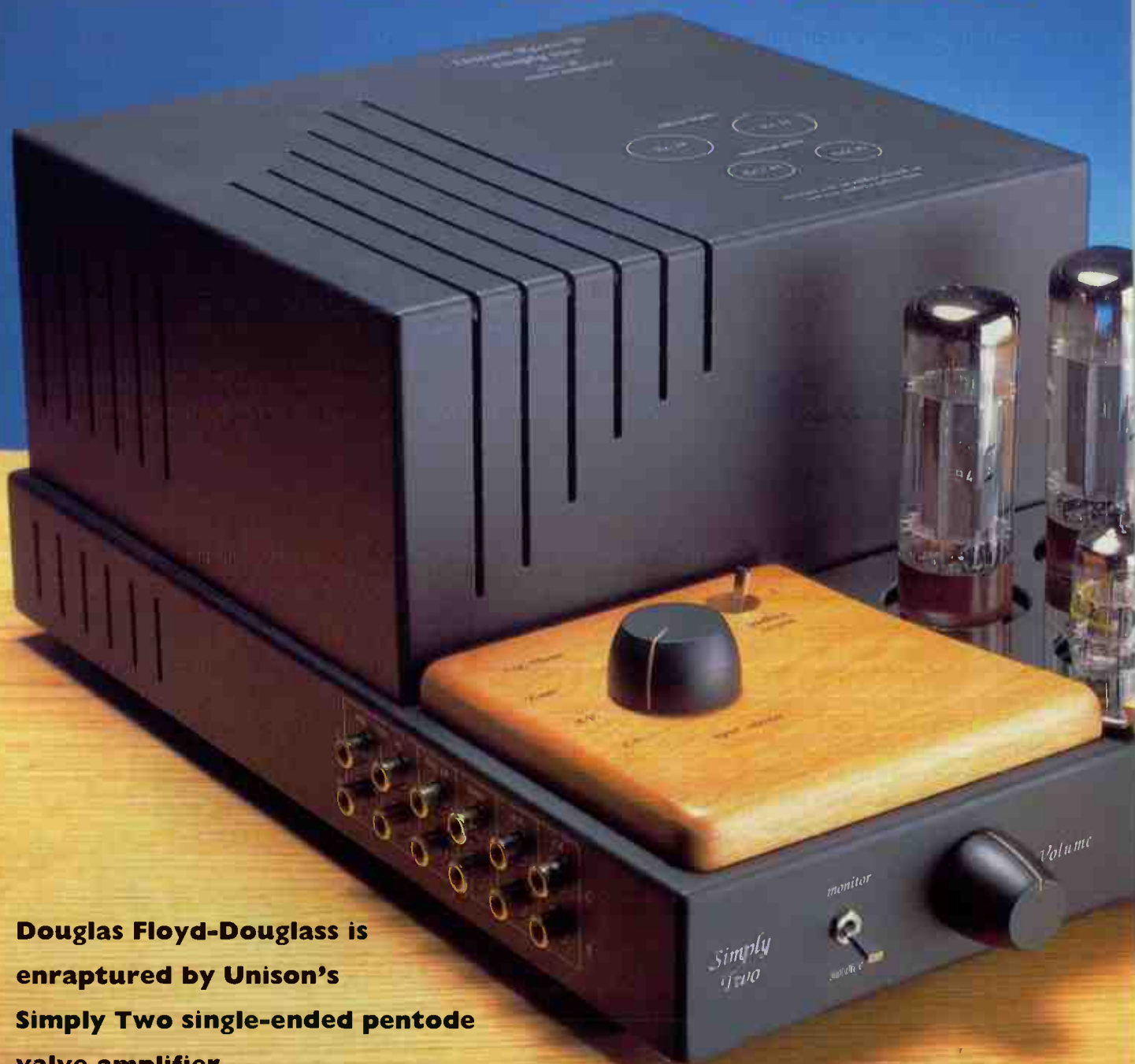

**Douglas Floyd-Douglass is enraptured by Unison's Simply Two single-ended pentode valve amplifier.**



securely mounted. The rotary volume control is smooth and matches the styling well, but the selector control is rather squidgy, and doesn't click into source with much conviction. By all accounts this small single-ended 12watt valve amplifier is very good looking, unpretentious and is a noble step in the right direction. Congratulations Unison.

Little Feat's 'Last Record' yielded superb transients and a smoothness which my ears greeted with joy. Clarity was good and consistent throughout the frequency range. Cymbals rang true with fabulous harmonic overtones and superb decay. Drums were presented with natural attack and soft presence, allowing the warmth of the bass guitar to sit comfortably at the helm of the mix.

The Simply Two can handle dynamics with extraordinary dexterity. The drum solo in 'One Love Stand' was tight and fast, with the stereo image projecting well into the room. Subtle little sound treats like the Fender Rhodes and Latin percussion rose almost as if by magic to the surface of a most convincing sound stage. In 'Long Distance Love' the balance between

bass and vocals was particularly well defined, again suggesting excellent dynamic control. The acoustic guitar was well detailed and natural sounding - a treat.

Paul Barrere's fine lead vocal was strong, and due to the natural affinity the Simply Two has for music, the charismatic gospel backing vocals shone through with real life. The bass on this album is often performed on a lower than usual scale, making it really deep. The Simply Two was not particularly tight, but it did keep control at all times.

Talking Heads' live version of 'Psycho Killer' on 'Stop Making Sense' had a marvellous sense of space, and the sound of the crowd was particularly convincing. The Unison design is extremely musical and so compatible with a variety of styles. Even in the vocal extremes, where David Byrne really strains, the Simply Two maintained its composure with sufficient headroom to produce a flawless performance. More evidence that twelve watts of good Class A valve amplifier can sound really great, can be found in the 'gated' snare drum at the end of the track. As the only electronically enhanced sound on a predominantly acoustic backdrop, the snare produced a peak of at least two to three decibels, which the Unison handled with relative ease.

Tchaikovsky's Pathetique, sensitively conducted by (Sir?) Yehudi Menuhin sounded magnificent. It is a work of contrasting deep melancholy and ecstatic jubilation. These emotions were perfectly translated by the Simply Two and the genius of this great Russian composer was clearly portrayed in this autobiographical work. From the first solo bassoon (which eerily warns of the impending crescendo) to the soft woodwind and strings, the Simply Two performed like a virtuoso. The overall sound was so open and uncluttered you could literally zoom in on single instruments amidst full orchestral or band performance, which I found most impressive.

I was so enveloped in the music that I was startled a few minutes later when an inconsiderate motorcyclist roared by, temporarily marring the sound

stage! Nonetheless, this is what *real* hi-fi is all about, sound electronic design delivering natural musical reproduction.

The only disappointment was that solo piano tended to break up quite early. This meant that Chopin's (unaccompanied) scherzo in B minor had to be played at a much lower level than of a standard grand piano. The piano's tone was excellent however, with fine balance between attack, decay and harmonic detail. With a bit more level, it could sound really fantastic.

Alan Parsons Project's 'Old and Wise' is a reminder of real music production with the engineering polish gained only from years of experience. His recordings are a pleasure to listen to on any sound system and this was no exception. The string section was soft and evenly spread in the sound stage, allowing the essential, but often missed church organ to be heard clearly. The saxophone solo soared through the finale in a triumph of musical arrangement and valve reproduction. Even at higher levels, despite a slight bass roll-off, treble remained clear and undistorted.

This is a fine example of a perfect transition in the audio chain from recording studio to listening room. Afterwards, I found myself breathing a really deep sigh - a combination of both pleasure and relaxation, like you do when an exceptional orchestral performance comes to a satisfying end. I want one. But then again, I may have to settle for Simply Two. ●

**Unison Research Simply Two £995**

**U.K. Distribution,  
23 Riching Way,  
Iver,  
Bucks. SL0 9DA  
☎ 01753 652669**

**WORLD VERDICT** ●●●●

Good circuit design and a highly musical performance make this a top quality amplifier.

**Measured Performance  
see p105-113**



# World



## DECODED MESSAGE

Thank you for publishing the article on the Studio 12 Stereo Decoder. I am sure it will spark off a few enthusiasts: unearth that old mono tuner that has been mouldering in the loft, garage, etc!

There were a lot of good FM tuners designed and built in the golden era of valve hi-fi and they deserve a better fate than lying in some forgotten corner. The Troughline gets all the kudos of course, but a lot of other famous, but now forgotten marques run it very close for performance.

One thing in the article I didn't expect was Dominic's defence of the decoder built into the Troughline Stereo. This decoder to my ears always sounded 'phasey' and lacking in a solid central image. I'm a great fan of the thermionic valve, but can't find any enthusiasm for the old germanium transistors used in the decoder section of the Troughline Stereo. I have actually supplied a number of decoders to Troughline owners who were not happy with their stereo version. Likewise with the early Quad decoder - the one in the metal cage that fastened on the rear of the Quad FM tuner.

I have experimented with valve decoders and at the moment have a prototype built by a retired friend of mine who used to be design engineer for a famous radio and audio company. The prototype uses an ECF80 and an ECC82 as the active elements. Sadly, separation and general performance aren't up to modern standards.

One valve decoder I like

is the one fitted as standard by Fisher in their 500C and 800C receivers, an excellent design using three ECC83s. Having said that, it still can't beat a modern, dedicated chip design.

Finally, a few comments on the Leak Troughline. Firstly, don't have one realigned without first checking the components, particularly the higher value resistors. Often, changing a few wayward resistors can bring the tuner back into alignment. I have known resistors in a Troughline almost double in value!

Secondly, if those flimsy AFC and LOCAL/DISTANT switches are a problem, wire them out of circuit, choosing either position of the switch to suit your preference. I say this because they are not easily replaced, as they are fastened by a rivet moulded into the fascia plate.

Thirdly, regarding connection to a decoder, I prefer to take the output from the tuner, immediately after the discriminator. In the stereo version the output from the built-in decoder comes after the cathode follower stage. An unnecessary stage in my view, best eliminated.

**Stan Halfyard,  
Studio 12,  
St. Ives,  
Cornwall.**

*Yes, the decoder isn't the world's best. However, we still find the Troughline so outperforms everything else that weaknesses seem academic. NK*

## ROB'S RESPONSE

I read with a great deal of interest and pleasure *Hi-Fi*

*World's* review on the Renaissance CD player (June 1995). I am pleased it generates much scratching of heads as to whether its outstanding and unusual musical performance was accurate or some kind of euphonic manifestation. To some extent the issue of accuracy does not matter. If the CD player sounds musical and involving with a sense of life and body, then it is immaterial whether it is accurate or not.

However, I maintain the CD player is giving an accurate rendition simply because there has been no conscious attempt during the design of the player to generate euphonic colourations. Indeed, my whole design philosophy is

to make products as transparent as possible. This enables you to hear the subtle cues that go into converting a mere rendition into an involving musical event.

All the observations made about the sound of the unit are fully explicable and are mostly a function of the DX processor. For example, the outstanding sound stage reproduction is down to the extremely simple analogue section of the DX processor with only two passive components and the op-amp in the direct signal path.

The rhythmic abilities, timbral variation, rhythm and pitch reproduction qualities are due to the

## Letter of

### MIDI-OCRE ASPIRATIONS

You express bewilderment at the low audio aspirations of "the average Briton". My experience as a lucky chap who can afford to indulge in hi-fi extravagance suggests that:

[1] People value variety of sources highly. They would dismiss a £300 CD-based system compared to a similarly priced midi because the latter has four sources.

[2] Convenience is paramount to buyers. They hate the process of mixing and matching

components, feeling they have better things to do, and like the option of having one big box to cover their audio needs. We're in the Big Mac culture!

[3] Proper hi-fi retailers can be excellent, but also eccentric, snobbish, patronising - you name it. I believe the real hi-fi world is constantly undermined by duff retailers. Why else do people go for the impersonal approach of the likes of Argos?

[4] Quality hi-fi looks awful. Most people regard audio systems as a necessary but evil

*Send your letters to Hi-Fi World Letter Page,*

# writes

filtering structure of the processor as it

has a lack of phase intermodulation distortion. The instrument separation, lack of modulation and purity is down to an elimination of amplitude modulation effects.

The above three defects are not exposed by traditional measurements which explains why it measures relatively poorly but sounds very transparent. Also, no other DAC in the world has been designed with any of these features as a design principle. This is why the DX processor sounds so unique compared to any other CD player or DAC available today.

Noel's "problem" - that

the DPA tends to suppress noise and nastiness of relatively poor quality recordings - is again explicable. Most special problems of noise and scratches are caused by modulation of the instrument you are trying to hear. If it becomes difficult for the brain to separate individual instruments out, then noise and other distortions become subjectively much more prominent.

This is the irony of the situation, that better detail resolution and transparency allow the brain to ignore noise and distortions, giving a more musical event.

**Robert Watts,**  
**DPA Digital,**  
**Cardiff.**

## THE CLOSEST APPROACH TO WHAT?

I was interested to read a letter from a correspondent commenting on the need for hi-fi systems to provide "realistic reproduction" and would like to make a couple of points.

If, as I suspect was the case with the letter, we are considering so-called classical music, we are considering acoustic instruments which rely on oscillating strings, vibrating air, resonating wood etc. to create the original sound. To expect a simple mechanical device to recreate this with realism after the acoustic signal has passed through an electronic chain is being a little optimistic. What we can best hope for is a sound we subjectively believe to be accurate and real.

There is no way in my humble opinion that a cone, diaphragm or whatever, horn loaded or not, can

accurately reproduce the subtleties of a violin string, trumpet or a triangle. The crucial word here is subjective. At the end of the day we can tune our systems to sound as close to the real thing as we can manage.

A different system exists for electronic instruments and the bulk of my listening is to electronic ambient or rock music. What is the realistic sound of a synthesiser? What does an electric guitar really sound like? Go to a gig and you will hear the instruments played through an excruciatingly loud PA system with a tonal balance governed by the size of the audience, the whims of the guy on the mixing desk and what have you.

However, there is a good chance that a so-called live recording will be taken off the mixing desk before it ever gets to the PA. So does this truly reflect the sound

continued on page 47...

## the Month

intrusion on their living rooms, and so a nearly invisible micro system gains approval. When manufacturers produce compact, pleasing components, they will gain wider appeal.

[5] People think their ears won't do justice to a 'proper' system. My dad, God bless him, isn't going to waste money on nuances he can't hear, is he?

[6] Finally and most importantly, people see music as a lifestyle accessory, not an essential. They want dinner party background music, Take That for the kids and naff

Greatest Hits compilations to remind them of their youth.

However we all know there's a huge world they are missing, and with luck, the promotion of real hi-fi might open a few ears to the inspirational effect of music.

**Mike Henning**  
**Hants.**

*Thanks for keeping our feet on the ground with your summary of today's outlook. These simple but crucial views tend to escape most of the industry, including us.*  
**NK**

64, Castellain Road, Maida Vale, London W9 1EX.

## WIN HI-FI WORLD INTERCONNECT CABLES

### OR PERFECT PITCH'S FRANCINSTIEN CD

#### ENHANCER

The writer of the most interesting or funniest letter will receive a choice of either: a free set of Hi-Fi World's silver plated copper interconnect cables, worth £69.95, or a Francinstien CD convertor enhancer worth £150.





# Richer Sounds Reference Products



"Engaging and very musical ...smooth, yet expressive and detailed...enthralling sound"

- *What Hi-Fi?* - Nov 93

**WHAT HI-FI?** Value ★★★★★

Teac VRDS 10 - £649.95

Were £769.95, Save £120

## 1/2 PRICE

"The Mission has a crisp, dynamic, emotionally charged and exciting sound."

- *What Hi-Fi?* - May 93

**WHAT HI-FI?** Value ★★★★★

Mission Dac 5 - £149.95 RRP £299.95



"Succeeds in projecting a marvellous sense of space, air and delicacy... listeners were utterly charmed by the Alto's unforced and thoroughly natural presentation." - *Hi-Fi Choice* - June 94

**WHAT HI-FI?** Verdict ★★★★★

Alto Amplifier (Black)- £299.95

Chrome version also available just £329.95

HI-FI CHOICE



"Superb value...sounds way beyond its price ...a definite digital bargain."

- *What Hi-Fi?* - July 95

**WHAT HI-FI?** Verdict ★★★★★

Cambridge Audio CD4 - £149.95



"Knockout sound - joke price... stupendous value for money..."

If you've a CD player with a suitable digital output that you want to upgrade, buy this!"

- *What Hi-Fi?* - Dec 94

**WHAT HI-FI?** Verdict ★★★★★

Cambridge Audio Dac Magic - £149.95

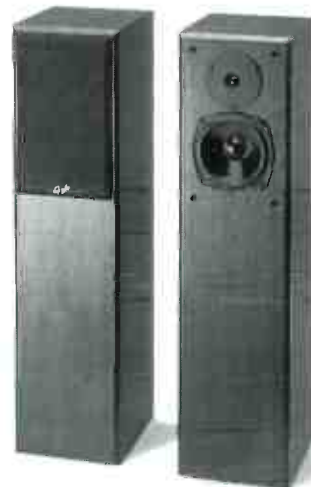

"miraculous for the money... they're worth five stars per speaker at least... these speakers quickly redefine any notion of what £200 will buy you... In the market for a £200 pair of speakers? Buy the Gales... Sit back...Enjoy"

- *What Hi-Fi?* - July 95

**WHAT HI-FI?** Verdict ★★★★★

Gale 4 (pair) - £199.95

With any products purchased from our reference range at our normal in-store prices, you may claim\* 15% of the purchase value in FREE INTERCONNECTS OR SPEAKER CABLE (eg: purchase Teac VRDS 10 - current price £649.95 and claim £97.50 worth of interconnects or speaker cable FREE!). \*Sorry this offer cannot be used in conjunction with any other current offer/promotion.

We are using our enormous buying power to deal with factories/manufacturers direct. This allows us to cut out the typical middleman distributor (together with their chunk of profit). Elsewhere in Europe these products can cost over 50% more! - we pass this huge saving onto you. Factory direct products are only available in our 23 stores nationwide.



FREEPHONE 0500 10 11 12 for your latest copy of our 52 page catalogue-branch list

.... continued from page 45

of the concert and is it therefore realistic? Should we who listen to amplified instruments throw away our hi-fi products and install a JBL/Crown PA system or a row of Marshall cabs to achieve true realism? This is a subjective thing. Have a PA if you want and the neighbours don't mind, or use a low power valve amp with super-sensitive horns, or whatever.

Perhaps the key thing is this: whatever you listen to music on, if you like it, it's OK. After all, we listen for enjoyment, don't we?

**Peter Withers  
Pershore,  
Worcs.**

### BLIND PREJUDICE

I have been a regular reader of all UK hi-fi magazines for many years: the good, the erratic and the short-lived. I even read with caution and derive some entertainment from Mr Nazir's magazine, the huge selling *What Hi-Fi?*

The viewpoint expressed by you in "dB on the level" (*Hi-Fi World* April '95) does not specify which journal's blind listening tests have given you the hump. By being so dismissive of blind listening tests, using such terms as "short cuts" and "fallacy" and not being specific as to whose blind listening tests you find "absurd", it may lead the reader to think of the notable blind listening tests conducted by Mr Paul Miller for *Hi-Fi Choice*. Was this your intention? If so I have point to the failings in your article.

It can be seen from long term reading that Mr Miller's panel is made from regulars taken from the industry obviously chosen for their ability to hear differences and their knowledge of what hi-fi can sound like. They all know each other, which makes for a relaxed

atmosphere, and the music used is consistently the same over the last five years, played through a familiar reference system based around DPA amps and Audionote E 'speakers. Unlike your claim that only response errors can be picked upon, Mr Miller's panels have been able to not only discern multi-bit sound from low bit, but family sounds (Marantz, Rotel, DAC-7, etc.). Would you agree this is impressive?

And Mr Miller's exhaustive and comprehensive technical specification testing, which to us readers is easily understood and with which direct correlation can be found with the blind listening panels' findings. We can check the specification compatibility, for example the single-ended Philips DAC7-equipped CD players being run at the lower 256 rather than 384 oversampling rate. With a remarkably consistent plot in Mr Miller's graphs showing a vast rise in ultrasonic noise, it's become an easily identifiable fingerprint for such types of CD players (Philips and Marantz being two obvious examples). Pretty handy for us readers to know at a glance if our amps are wide or band-limited, whether our systems are swamped with this noise, wouldn't you agree? Having checked for technical compatibility, readers can refer to the panel's findings, which frequently pick up on "those underlying properties that might be more influential in the long term".

Your view that subjective tests still reign supreme is true probably only because it's easier than organising a panel of regular listeners, stripping down the equipment, lab testing it and putting it back together again. I shall continue to seek an overall view of specific equipment based on information gained from all

techniques, objective and subjective from my select group of journalists, and yes, you are one of them. But for this reader, Mr Paul Miller is a true star and his methods faultless, wouldn't you agree?

**John Slevin,  
Stockwell,  
London.**

*We were generalising, but our views reflect concerns widely expressed by others. I have participated in and have run group listening tests in the past. In my view, even when set up with care, they are of dubious value, imposing unrealistic listening conditions. In particular they provide far too short an exposure in oft compromised conditions with an absurdly curtailed selection of music. Wildly conflicting views often surface, which must be homogenised for the sake of apparent harmony. Otherwise, as a freelance, you are then faced with telling the magazine the listening test was inconclusive, whereupon they'll find someone who'll make it conclusive.*

*Many people in the industry refuse to participate in these affairs, including myself. I had to leave one session where seven one-minute excerpts of music were put through each loudspeaker. Let's look at how this comes about.*

*You have to 'phone and book a useful number of listeners, around 4-6. Getting them all into one place at one time is difficult. You get one shot at this; a second take isn't practical. Consequently, there's pressure to review as many items as possible, so a large-ish group is tested, up to ten. You have six hours at most, giving 36 minutes per item. In fact, this is generous - and*

*not all of it is prime listening time. There are interruptions, discussions, change over time, tea, etc. Around 20 minutes per item is about normal.*

*So we are now assessing a piece of equipment in twenty minutes. With eight musical excerpts (four Classical/four Rock) that's 2.5 minute excerpts - not even one whole music track. If it's a blind test, then 'speakers cannot be optimally positioned.*

*This basic analysis shows just how unrealistic blind/group tests are and why we reject them. NK*

### IGNORANCE IS BLISS

My views on the growth of midi sales, as opposed to proper hi-fi is simple. The British public is woefully ignorant about the performance and simplicity of separates and prefers this state of bliss to having to think and make choices about what is really available. It's easy to buy a black box with lots of buttons and flashing lights with a couple of 'speakers. It is easy to handle, looks good and the noise from the 'speakers will shake the floor. But quality of sound seems to be a complete unknown to many who expect a complete system for £150. I have to admit that until 1981 I was as ignorant and anyone else until I bought a friend's Hitachi system and began to read *What Hi-Fi?* when I gradually changed my opinion and system, and then became really brave and bought my first soldering iron and began DIYing.

I think the only way to reverse the trend is for the industry to scrape enough cash together for effective advertising, mimicking car advertising on television, as

continued on page 53...

The Synergy was designed for maximum pleasure minimum fuss.

All on one chassis it incorporates a remote controlled dual mono preamplifier (housed 2" from the inputs) and a dual mono power amplifier developing 150 watts per channel of smooth detailed muscle, plus an On Board Bias Control for easy and accurate tube maintenance.

Attention to detail and sonic integrity is achieved with no less than 14 circuit boards and all control circuitry is non-interactive utilizing

its own power supplies.

Even the remote volume is achieved using a separate gear box and motor together with a high quality attenuator.

Our build quality is of the utmost highest standard and we stand by it, offering a 10 year guarantee on our products.

Described here are only a few features of the Synergy, for a complete discussion and audition of this and our other remarkable products please contact us for your nearest dealer and colour brochure.

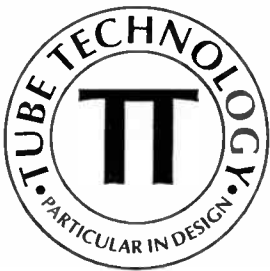

Tube Technology, Foxhills Farm, Longcross Road, Ottershaw, Surrey, KT16 ODN, England.

Tel: 01932 873444 ~ Fax: 01932 873012  
All Tube Technology amplifiers are designed and manufactured in England.

From the moment you hear The Synergy...

you realize that its unique styling is a major contribution to it's musical performance.

### *Sold Aero*

The Synergy is shown here fitted with Gold Aero tubes from the USA. These are high grade, audiophile vacuum tubes which have attained world class respect for thier sonic qualities. Now available in the UK via Tube Technology & their selected dealers.

Please enquire for a tube list & brochure.

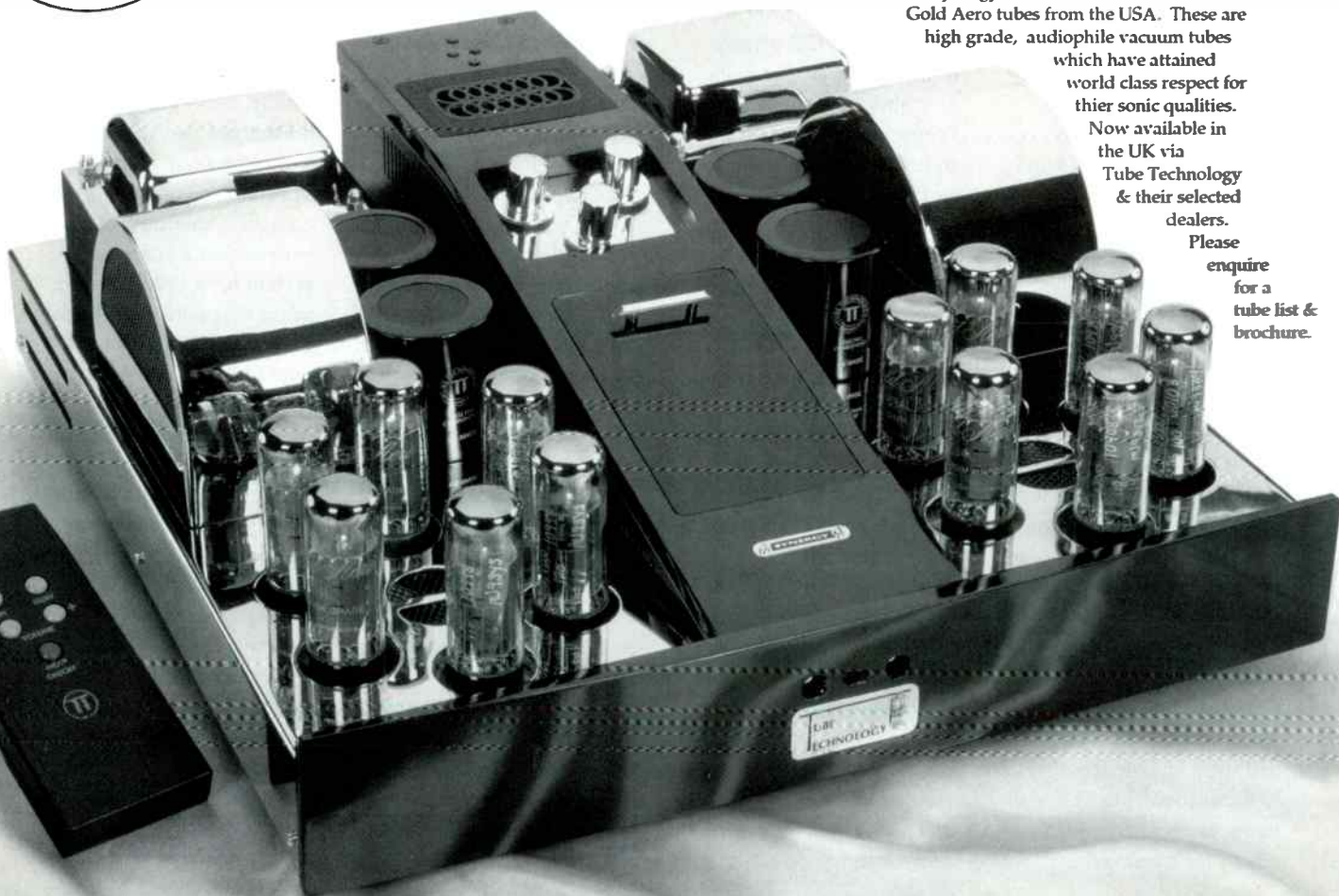

**B**uoyed by the combination of British kudos and a strong Yen, the likes of Aura and NAD are making inroads into the Japanese domestic market, believe it or not. While not quite in the same league as Sony or Panasonic, they've given the Japanese major manufacturers added impetus to compete not just on price, but quality too.

So here's Sony's new £250 TAF446E amplifier pitted against one of our own major league players: the Aura VA-80. With an Audiolab CD transport/PT Da Capo feeding the Aura, and a pair of Mission 752s on the other end, the Aura gave a wonderfully large, expansive sound. I'd forgotten. So impressed, I didn't rate the Sony's chances. "Answer that and stay in fashion", I thought.

It did, bringing more atmosphere and detail to the soundstage, throwing out cymbals at the back of the mix that the VA-80 had missed. Tracey Thorn's unmistakable voice had greater emotion, her intonation better carried.

So what's the drawback, you ask? Well, it pains me to say, but solid-state mid-band glare reared its ugly head. Yes, the Sony is bright, and a touch hard. Rim shots were tighter and faster than those from the Aura, but also rather more tinny and transistorised. All the same, the Sony's not beyond redemption; if it's partnered sensibly this won't be a problem.

With Siouxsie and the Banshees' 'Hyena', the Aura delivered an emotional performance, tonally balanced with deep bass and sweet treble. The Sony changed the presentation, having more air in its slightly larger acoustic, and a good degree more depth too. But although nowhere near as bad as your average Jap. tranny amp., which has more grain than a health food shop, strummed guitar strings and percussion were a touch too prominent for me.

The Sony also possesses a curious form of bass, one that seems common at this end of the market. There's certainly plenty of low frequency information - more than you'd expect at the price - and it's also quite tuneful.

## It's a ?

**Yes, it is a Sony, but is it a winner too? David Price pits Sony's new TAF446E amplifier against hot competition.**

But it seems to have a cardboard quality that just doesn't sound right. In this respect, Sony could learn a trick or two from NAD.

And finally, the phono stage. Japanese amplifiers have never been famous for the importance they attach to getting this right, but the TAF446E seems the exception that proves the rule. Whilst not quite an EAR834P, it was nevertheless good enough to let our Linn LP12/Ekos/Archiv stick two fingers up at the Audiolab/Da Capo CD system that sat opposite. Noise was very low and the TAF446E proved smoother but just as dynamic from LP through its phono stage as it did with silver disc.

Which would I have of the Aura and Sony? I think I'd still buy British. The TAF446E is very capable - up with the best in many ways - but the Aura's silky,

self-effacing presentation wins the day for this reviewer. You may not feel the same; this amplifier has great definition, so ignore it at your peril ●

**Sony TAF446E** £250

**Sony Consumer Products Ltd.,  
Sony House,  
South Street, Staines,  
Middx. TW18 4PF  
☎ 01602 251517**

### WORLD VERDICT

Bright, clear and detailed, but needs a touch more refinement to prevail.

**Measured Performance  
see p105-113**

# NOW HEAR THIS!



**Douglas Floyd-Douglass listens attentively to N.H.T.'s latest standmount loudspeakers.**

**N**HT, an American company, was founded in 1986 by two consumer electronics veterans. The £389 model I.3A is a two-way loudspeaker based on NHT's 'Focused Image Geometry', which basically means that they angle the baffle



by 21 degrees so that the drivers fire inwards. This is intended to direct sound toward the listener, away from reflective room boundaries and give a more focused image. The angled front baffle also helps to minimise internal standing waves, giving less colouration.

The cabinets are rigid and well finished in a piano black effect material called Nevamar, which is scratch resistant. I mounted the I.3s on 22inch stands, approximately 3feet away from the side and rear walls. As NHT rightly point

out, experimentation yields the best results when positioning, and time spent doing just that with the I.3s is a good investment.

Jackie Leven's "Call Mother a Lonely Field" was introduced by a dynamic and resounding snare drum, and a fine neutral balance of background strings. The bar scene was atmospheric, and the chanting of 'Danny Boy' reminiscent of the probable pub-on-the-loch from where it originated. Lead vocals were rich and the supporting backing vocals smooth through the whole range.

Hi-hat and cymbal definition benefited from the fast response of the

I.3s in the mid-high frequencies, sounding crisp and metallic. The mandolin and guitar were well balanced, and conjured up more authentic Gaelic imagery, creating a real sense of atmosphere in front of my seat. On 'Crazy' the acoustic guitar had super detail, with clear harmonic overtones. Vocal harmonies sounded natural and unrestrained, and combined with distant strings gave rise to a realistically deep sound stage. This translated into a good feel for the music, one which I found endearing.

NHT's 'Focused Image Geometry' is reasonably effective, the I.3s projecting a dominant central image. Solo instruments - as in Bach's cello suites - were realistically focused and well placed in the sound stage. However, with larger orchestral pieces the music seemed confined, failing to extend beyond the 'speakers. The actual 'sound' of the cello was tonally accurate, but the natural decay of acoustic instruments does occur prematurely. The initial transient grabs you, but then harmonics fade rapidly.

The I.3s do well at producing a good scale of music for their size, but are really best suited to smaller rooms, where they sound extremely good, if still on the drier side of neutral. Despite being designed as an independent full range system, a good sub bass would do them the world of good, adding richness.

I decided to give the I.3s the 'Radio Kaos' treatment next. In full blown digital audio, Roger Waters' law-breaking sound engineering places great demands on any system. The I.3s rose to the occasion, welcoming the genius of a great contemporary composer and the accompanying sound wizardry with open arms. Vocals were crisp and central, with exciting sound-bites popping out all over the place. The synth flute revealed a stereo pan-effect, which I had not heard before. On 'Powers That Be', the bottom end was tight and powerful. The guitar 'scrape', which has a fairly high peak, was dealt with smoothly, and without any break-up or edge.

'Four Minutes' reached wide out past the 'speakers, with unnervingly

realistic vocals and the ringing telephone (off-axis and to the left), prompted me to automatically reach out and answer it. The guitar in 'Tide is Turning' is supported by warm strings and a homogenous blend of engineering and reproduction. The vocal delays can be heard clearly above the programme material, adding a pleasing ambience and fresh balance. This confirmed my hidden suspicion that the I.3s were probably intended/designed to deal with more digitally refined music programme.

Female vocals from Eddie Reader's 'Patience of Angels' had clinical accuracy, and me thinking I was in a control room, rather than in *Hi-Fi World's* listening room. The I.3s do sound like near field monitors a lot of the time. NHT have certainly succeeded in dealing with internal LF energy (standing waves). The detailed and clean midrange is a good example of this. The 'Focused Image Geometry' seems to work, but does produce a projected and focused characteristic, rather than a warm and more welcoming sound.

I would like to hear the I.3s with a well matched subwoofer as they are just too small to fill many larger rooms with sound, especially at lower frequencies. The I.3s do have a commendable lack of distortion and are capable of handling a good deal of power. They are also more than capable of delivering a lot of music for their size and price. For the budget conscious or those aspirant audiophiles wishing to impress with their first real system, these 'speakers are it ●

#### NHT I.3A

£389

Sound Dept.,

33 Beaumont Street,

Oxford OX1 2NP

☎ 01865 516800

#### WORLD VERDICT



Very clean, crisp sounding 'speakers best suited to smaller rooms.

Measured Performance  
see p105-113

# PROJECT

*State of the Art Analogue*



Best Turntables  
under £1000



Vinyl replay  
systems from  
£145

Ortofon (UK) Limited  
Chiltern Hill,  
Chalfont St. Peter,  
Bucks, SL9 9UG  
Tel: 0753 889949

.... continued from page 47

well as magazines.

Hi-fi seems in the grip of nostalgia, with valve amplifiers resurrected all over the place and turntables too. Only loudspeakers have avoided this trend, apparently, because they appear to be improving all the time, and offer better value for money over their predecessors.

Transistor amplifiers sadly seem so complicated, expensive and swamped with feedback to achieve really good sound that valve amplifiers begin to look better value for money, despite using more electricity per watt and having a poorer measured performance.

Surely there must be something badly wrong when war-time technology is superior to present-day offerings? What happened to our Victorian confidence that the future can only get better? Did the marketing men steal it by selling inferior goods, or was it accountants' cost cutting?

**A. Proctor  
Scunthorpe.**

*I think midi systems and their ilk are serious threats to the hi-fi industry, because in the present economic climate at least, the town ain't big enough for both of us. As you point out, this means large PR offensives to hit casual Saturday afternoon buyers. I thoroughly applaud BADA's campaign for "real hi-fi", but am worried that the hi-fi press isn't pulling its weight.*

*In the early eighties the scourge of civilisation was the "music centre". To its credit What Hi-Fi? spent much time and energy pointing out how inferior they were to equivalently priced separates. Now, both What Hi-Fi? and Hi-Fi*

*Choice show a curious interest in the modern equivalent - the cheap and nasty micro/mini/midi system.*

*Entry-level hi-fi mags should be fiercely arguing the case for real hi-fi, because if they don't, they'll usher in their own demise - and everybody else's. As they're so good at tabloid front page headlines, may I suggest "Stunning Separates Murder Midi!" for the next issue of What Hi-Fi? We live in hope. DP*

### **DRIVING AUNTIE'S BABY**

I was interested to read in your April edition a letter from Martin Swain looking for a suitable amp to partner the L53/5a speaker. I have been through a similar odyssey over the past 8 years trying various amps including the Cyrus I Mr. Swain has.

I now own a Radford STA15 which I restored myself and I find it the perfect partner for this speaker, possibly because valves tame their lispy treble, but perhaps more likely because you can match the amp's output impedance to that of the speakers. LS3/5as were originally 15 ohm, but modifications in the late eighties dropped this to around 11.

The comparatively low output of this amplifier (115 watts) can drive these inefficient speakers to loud enough levels for me, via a passive pot with no gain!

When restoring the Radford I actually removed the impedance selector and hard wired it through on the 16 ohm taps as I decided that the only speakers I was likely to use were the L53/5a and the original Quad ESL.

It's worth the trek as I have yet to find a speaker I prefer. Volumes have been written about this design, but I think it says something

that while 50,000 pairs have been shipped throughout the world and four suppliers are still producing them under license (KEF, Rogers, Harbeth and Spendor). Not bad for a product that came out twenty years ago!

**Jonathan Ives  
Fleet,  
Hants.**

### **ANOTHER TYPE OF CROSSOVER**

Why is Simon Hopkins reviewing records under a "Jazz" heading? Is it because he can't find a more relevant category for the ambient and thrash music (i.e. burbled) he seems to favour?

As a suggestion, you might institute a new "Engineering" review section, which should then give proper credit for the noises on these discs; perhaps also syndicating the feature to be carried by other publications, such as *What Hearing Aid* and *The Frisby Society* journal.

**J McDermott,  
Maidenhead.**

*I don't know, jazz these days just ain't the same as when Louis and Ella used to do it, is it? Full of all these young upstarts with synthesisers who don't know one end of a tenor sax from the other. Bring back national service, that's what I say! DP*

### **GRASS' AND THE OTHER SIDE**

May I tell you about the best hi-fi I've ever heard? It consisted of a Pink Triangle Anniversary with SME IV arm and Ortofon MC3000 cartridge, Michell ISO, Croft Super Micro III/V and a pair of Audioplan Kontrapunkts. And it sounded effortlessly smooth and dynamic with fantastic imagery.

The thinking behind my own system is broadly similar, except the front-end is somewhat more humble. It

consists of a PT One (the poor man's Anniversary?) and a Roksan Corus Black mounted in a late model Ittok.

I feel it is time to replace the cartridge after two and a half years, but what with? How can I even approach the architectural image quality of my ideal system, which I can't even afford to stretch to the Ortofon MC15 Super II/EAR 834P combination you reviewed so favourably recently is out of the question. Perhaps the idea is designed to remain just that for the foreseeable future, something to believe in but not necessarily attainable.

**Chris Moorhouse,  
Sheffield.**

### **INTERFERING WITH THE MAINS**

Equipment supports, 'speaker cables and interconnects all play an important part in obtaining audio nirvana. But many may not realise that the mains supply can be a major culprit for preventing us getting there. Last year I started buying HFW and noticed Campaign Audio Design's offer on mains cables. I sent off for a Conqueror mains lead to use with my amplifier but remained sceptical. However, its effect was nothing short of remarkable. For the first time I could actually sit down and become pleasantly engulfed in music. I have since had my CD player modified to accept an IEC mains socket and have bought a 4-way mains distribution block, incorporating RFI filtering and VDRs.

For anyone who may be interested, my system is as follows: Sony X77ES CD player on 40lb marble slab, Audiolab 8000A amplifier and Linn Kan 'speakers on Linn stands with LK20 interconnect.

**J.M. Willis  
London.**

IT'S CURTAINS  
FOR THE  
COMPETITION



ALCHEMIST  
AXIOM

RRP: £299.95

ELEMENTAL AUDIO

For full details of products and stockists: 0181- 883 3008

Distributor clears stock, export-  
discount **50%** or more

# HIGH END SALE

## WELL TEMPERED

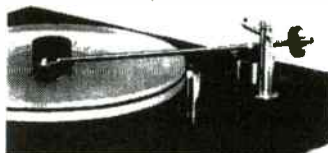

Record Player,  
Classic, Signature **£590**

export price from

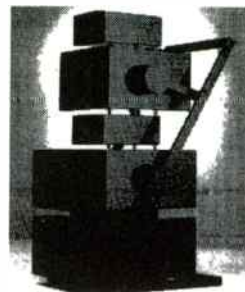

**GOLDMUND**  
Studietto, ST4, T5,  
Cartridge, Mimesis amplifier  
series, Super-Dialogue,  
Apologue (picture)

## AUDIO RESEARCH

DAC1, SP9, SP15, D250 MkIIS,  
M300 MkII, Classic150

**KOETSU** Black, Rosewood  
Signature, Onyx Signature

## MARK LEVINSON

MLC1, JC1, ML6, HQD-system  
(2xML6A, 2xLNC2, 6xML2,  
2xHartley/Quad/Decca-array)

Also: **Berning, Bruer,  
Cotter, Eureka, Fidelity  
Research, Linn,  
Moersch...**

**Call for catalogue!**

Glotta AB, phone +46 8345251, fax +46 8346533

# Recital

RIVETING EXHILARATING UPLIFTING  
CAPTIVATING MOVING INSPIRING



*Lumley*



The Lumley monitor LM2 is  
a Loudspeaker of rare  
quality, combining tangible  
imaging, real world  
dynamics and accurate tonal  
balance

These speakers work superbly with a wide range of amplification,  
including: Adyton, AVI, Boulder, CAT, Counterpoint, Densen,  
Lumley Reference, Musical Fidelity, Orelle and Trilogy.

CALL US ON: 0171-731 0340  
10 TIL 6, MONDAY TO SATURDAY

289 NEW KINGS ROAD,  
FULHAM, LONDON SW6 4RE

## Loricraft Audio

Specialists in Garrard, Thorens and SME.

### PSU II Power Supply

Now in its second year of production PSU II mkII is a power supply that mimics a perfect mains supply, allowing Garrard 301/401 TD124 to be used anywhere in the world, and was developed as a result of our more technically minded customers requiring a more advanced PSU over our successful active PSU I. Whilst PSU I cleans and reshapes the incoming wave from PSU II generates a low distortion wave from which is both voltage and frequency stable. PSU II can also be used with CD players pre amps and tuners.

PSU I £149.00 PSU II £400.00

Supply and service of Garrard, Thorens, and other high quality turntables using genuine and newly manufactured part to original specifications.

Also manufacturers of the world finest Plinth for Garrard 301/401 Thorens TD124 now with 5mm covers and finest hinges if required.

Loricraft PRC 1 Record Cleaning machine as used by the professionals. Please send for details.

Loricraft Garrard 401s with SME arms and record cleaning machines are in use with recording studios and record dealers.

*J.M. O'Sullivan*

4 Big Lane, Goose Green Lambourn,  
Berks RG16 7XQ

• New 1995 catalogue available •

Fax /  
Ansaphone: **01488 72267**

Suppliers of Art Audio Amplifiers, Goldring, Ortofon, & SME

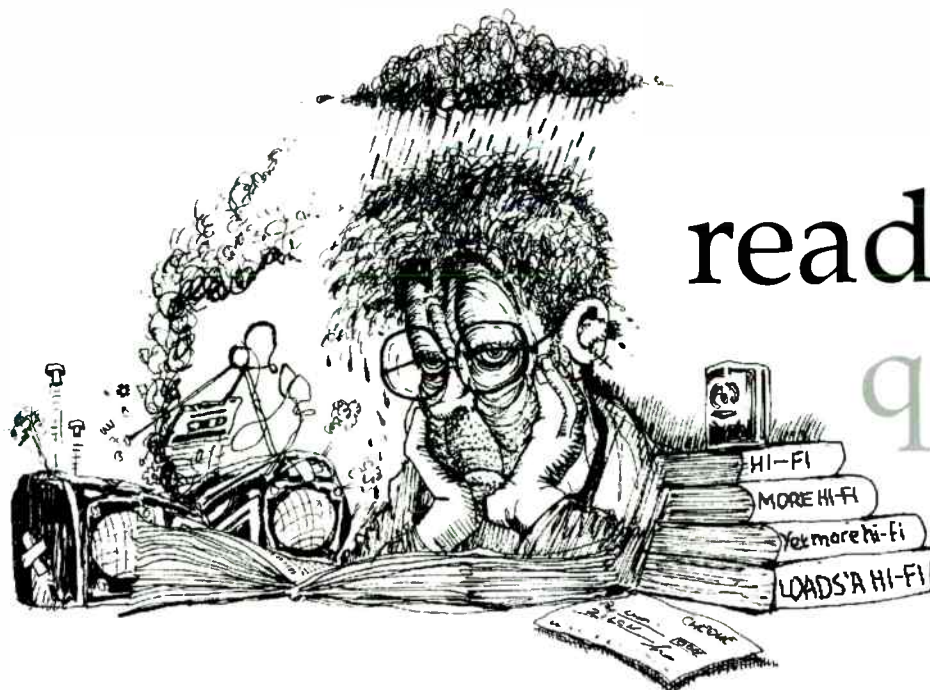

# readers' queries

## LAST OF THE INCAS

My system comprises a Michell Gyrodec/Alphason Xenon/Audio Technica ATF3 with standard Gyropower power supply, Incatech Claymore amplifier and Tannoy DC2000 'speakers, using Target supports and Naim NAC04 'speaker cable.

The amplifier has given up the ghost, so I'm looking to replace it. I initially want to spend around £500 and then another £700 or so at a later date. I was thinking in terms of an Audiolab 8000A, with an additional 8000P power amp to be purchased later. Would this give me the tight, punchy sound I'm after?

**Simon King,  
Stroud.**

*The Audiolab is great value, but in absolute sound terms the Naim Nait 3 betters it in my view. With your budget, why not consider this route: buy a Nait 3 for £600 including MC stage, and when funds permit, for £16 your Naim dealer will re-configure it to a preamp. As the Nait 3's power amp section is actually a NAP90, you can then buy another for £415 and bi-amp them. This will give you plenty of power, with an easy upgrade path. You could then invest in a Flat-Cap power supply for*

**Write in with your problems to Hi-Fi World, 64 Castellain Road, Maida Vale, London W9 1EX.**

**Our panel of experts will endeavour to solve them, or at least offer some practical advice.**

*£299 as a final upgrade (famous last words), or have the Nait 3 converted back to an integrated amp which you could sell, and use the proceeds to buy a better Naim preamp.*

*Confused? I'm sure your local dealer will assist. Meanwhile you should consider a QC power supply for the Gyrodec. It's probably the most cost-effective upgrade you can make to your system, and will bring substantial improvements to the system as a whole. DP*

## TILL DEATH US DO PART!

I want to purchase a second hi-fi system but am bemused

by the vast array of equipment available. I've had only one system before, purchased 25 years ago, comprising B&O 1000 receiver and turntable and Celestion Ditton 15 'speakers. The B&O finally ended its days last year and I now have a Luxman 707.11 amplifier and Sony ST-A3L tuner purchased second-hand from a friend, which I use with a Sony TC152 tape deck.

This works fine but I want a new system in the top room of the house (Victorian gable-end) which is to be a retreat. I am thinking of Castle Chesters and a Nakamichi DR2 tape deck, and possibly a second-hand Quad amplifier and tuner, but not the new 77 as it is too expensive and I can't cope with 'remote control'.

I suppose my ears are now tuned to the Celestions' sound, as I like a warm, rich, mellow, full sound with depth, resonance and articulation, especially with human voice. My choice in music is catholic: liturgical, symphonic, early music, string quartets and some folk and rock, but my main love is modern jazz and jazz vocal.

I have a treasured record collection and also need a new turntable to go with this new system. I had thought of

a Rega Planar 3. More importantly I am a keen Radio 3 listener (although it's hard to be keen about Radio 3 these days) and would be recording from the radio, so the tuner is a crucial item.

Your suggestions would be much appreciated. I am not into upgrading, so this system would be it for the rest of my life, hopefully.

**Shirley Hillier,  
Bradford.**

*What a tall order! You're not very specific about your budget, but assuming you want to dabble in used equipment, here goes!*

*The excellent Rega Planar 3 is a little analytical for some tastes, but this can be assuaged by partnering with a Goldring 1042 cartridge. Tracking at 1.7gms, you'll find this top moving magnet sensibly robust, but its high tracking ability will preserve your records.*

*As far as amplification is concerned, you could look around for a second-hand Quad 34 preamp and partner it with an early (hence cheaper) 606 power amp, which has a satisfyingly sumptuous, well-upholstered presentation. The partnering FM4 tuner is the obvious choice of*

radio, although the NAD 402 is a nice, warm sounding design at a more affordable price.

For 'speakers, the Castles you mention suit the bill admirably, but consider the big, warm Heybrook Heystak also, which sounds good with jazz.

The Nakamichi DR2 cassette deck is of course a must - almost compulsory if you want long, reliable service, coupled with

genuinely high quality.

Cables again depend on your budget, but Chord Company's Flatline is an excellent value product. DP

The Sugden A21a also works extremely well with the Castle Chesters and has an excellent phono stage too, so will serve your records well. On the subject of records, the Planar 3 is getting long in the tooth now; also try

auditioning one of the more modern Pro-ject turntable packages which all come with fine Ortofon MC cartridges, giving a super performance and top value. DB

Yes, but bear in mind that if you bounce one of these superb moving coils, bending the stylus, you must get buy a factory replacement, which costs serious money (£100+). I suspect this represents a

level of commitment you'd find excessive. Like all moving magnet cartridges the Goldring 1000 Series have user replaceable styli and, because they are made in Britain by a long established and reputable company, spares are available and are likely to remain so. NK

Continued on page 61...

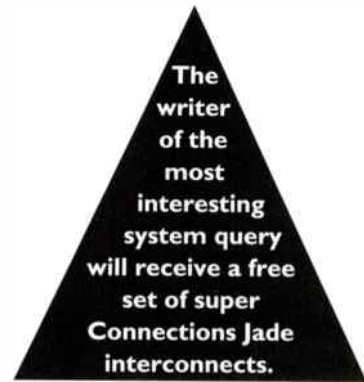
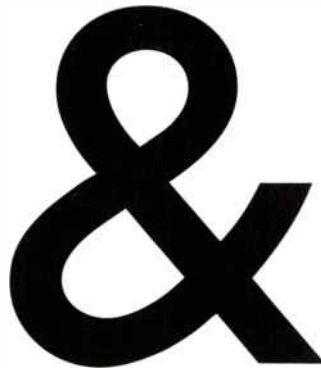

The writer of the most interesting system query will receive a free set of super Connections Jade interconnects.

**A CONNOISSEUR OF VINTAGE**

My system comprises an Arcam Alpha 3 amp, Denon DRS-610 tape and a Marantz CD52 II with Mission 760i 'speakers, in my front room approximately 12' by 12'. It is great, I thoroughly enjoy the sound. This cost about £700.

From a junk shop several years ago I purchased a 'radiogram' which was really a professionally built cabinet holding a Trio KA2000A amplifier, 1000A tuner and a turntable with no visible name. However underneath the turntable is a sticker with the legend Type BD2, A.R. Sugden and Co. Ltd, Brighouse, Yorkshire.

The pulley has a plastic

cover with Connoisseur printed on it. Underneath are the numbers 23556 and EW in felt pen. The tonearm is 11" long with no name on the cartridge. The 'speakers have no visible ID and are not even a pair.

It sounds superb and goes very loud and cost me £25. Is it worth re-housing in smaller purpose built containers, or is it worth spending money on a better turntable?

**B.A. Morgan Gwynedd.**

Your turntable is a Connoisseur BD2, a belt drive design from the early seventies, sold by A.R.Sugden (not to be confused with his brother J.E.Sugden, the amplifier

manufacturer). The tonearm fitted to all BD2s was Connoisseur's own SAU2.

The turntable was a good budget design of its day, competitive with best-selling Japanese designs like the Pioneer PL12D or Trio KD1033. In 1972 it retailed for £23 for the chassis, or £32 with a plinth and cover. (As a gauge, the standard entry-level Garrard SP25 Mk III was £13, the 401 cost £32 as a chassis only and the PL12 was £41 complete.) Your Trio amp was also a good budget design in its day, retailing for around £30 and offering 16W RMS per channel.

As far as re-housing

the components goes, it's up to you. I suspect the system has a big, warm, fruity sound with plenty of tonal colour that makes it nice to listen to. However, on the second-hand market it's worth very little, so if you like the sound as it is, why not just enjoy it? For the sake of your records though, I'd buy a new cartridge, such as the Ortofon VMS2E or Stanton 500AL, both of which can work in 'robust' tonearms at higher tracking weights. DP

Yep, and get a decent pair of budget speakers as well, like Celestion 1s or Goodmans Maxims. NK

o f t h e M o n t h



# TIED TO THE MAST

**Audio bachelor  
about-town Douglas  
Floyd-Douglass  
contemplates life  
with N.E.A.R.'s  
Soundmast  
loudspeaker.**

**N**ew England Audio Resource lay claim to being "The Leader in Metal Speaker Technology." N.E.A.R. have an in-house design and manufacturing facility which they say allows them to make superior components. All their tweeter and

woofer models use metal alloy cone materials. N.E.A.R. has eliminated the centering 'spider' which they say is the single most distorting mechanical factor in a loudspeaker. They have replaced this with a solution called MLS, 'Magnetic Liquid Suspension', which is

said to have no non-linearities, no distortions and no noise. A bold claim indeed.

The Mast is N.E.A.R.'s current flagship home theatre floorstander. Four foot tall, yet narrow at the waist, they are gracefully high-tech in

# PREPARE TO BE BLOWN AWAY

“Dead good speakers”

Mr. GR Hudson, Hampshire, on the *Beretta*

“Astonishing performance and value.  
A surefire success”

Mr. D Mclean, Surrey, on the *Purdey*

“a range that aims to blast away  
established sharp-shooters in the  
£100 to £250 corral”

Malcolm Steward, Hi-Fi Choice  
on the *Revolver Purdey, Colt and Beretta Loudspeakers*

“Revolver’s reliability is so good  
that we are placing a 10 year guarantee  
on all our loudspeakers”

Ray Nugent, RAM UK Ltd.

REVOLVER

by

*Ram*



appearance. Standard piano black high-gloss tops and bottoms are well finished and add an air of quality. The Soundmast is equipped with two 5 1/4 inch woofers with MLS and a single 1.1 inch concave titanium tweeter. The cabinet design incorporates multiple cross bracing and has a large tuning chamber - all evidence that we are about to hear something that has taken a lot of planning to meet the variety of home musical and audiovisual needs.

The Soundmasts are labelled 'left' and 'right' on their bases, suggesting an optimal L/R configuration. In this instance, the concave tweeters face inwards. They have sufficient dispersion to cover a wide horizontal range and yet also enough directivity to ensure crisp speech intelligibility.

Within the first few notes of Bob James' 'Maputo' the bass was immediately impressive, suggesting the designers have succeeded in creating a first rate enclosure to complement their driver design. Percussion was precise and fast and the overall dynamic of the presentation was convincing. An example of this is the duet of Marcus Miller (bass) and Steve Gadd (drums) on 'More than Friends'. Here, two of the world's finest session/jazz musicians are seriously getting their musical rocks off, and yet the subtlety of the guitar riffs are never marred by the powerful, rudimentary drum patterns. Keyboards were smooth and transparent, while Al Jarreau's voice was like honey over the supremely laid-back orchestral string arrangement.

The ambience that the Masts conjure up is really quite remarkable: one might be forgiven for thinking they secretly contain a couple of advanced DSP chips! 'Caroline' from Fleetwood Mac's *Tango in the Night* sounded refreshing and upbeat. The air the Masts shift seems directed at the legs, and would go down a treat after dinner or any impromptu dance opportunity. Horizontal imaging was good, with floor toms rolling hard to the right, ending in a solid thud. The triangle which characterises this track was prominent, rising out of the percussion. Treble detail, or 'clarity' as some would call it, could sometimes be overwhelming to

the point where some may find it distracting, especially as soundstage depth is somewhat compromised. Whilst such intensity isn't unmusical, it could make frequency extremes appear limited, whether imagined or real. There's evidence of this on pieces where treble roll off is quite noticeable, in the lack of decay of quieter acoustic instruments such as harpsichord, cello, and violins.

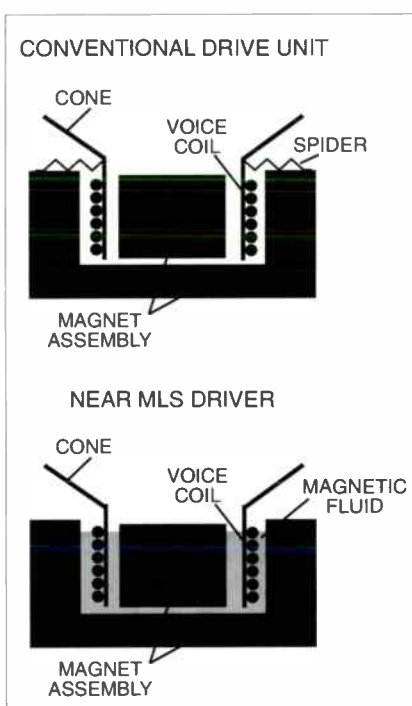

Classical guitar on 'Family Man' was realistic with fast, open attack. On 'Welcome to the Room', the soundstage gave an almost live feel to the listening room. Backing vocals seemed to originate from way behind the Masts, while the lead was pleasantly upfront. 'Isn't it Midnight' is a great rock production, full of soundbites that do justice to the imaging abilities of the Masts. The low male voice rises hauntingly out of the mix at points when you least expect it, while the sustained Les Paul guitar, so characteristically Fleetwood Mac, is treated to an authentic and extended lie in. The musical activity never seems to clutter or become tonally distorted, even in busy arrangements.

The choir of King's College, Cambridge, under the baton of Stephen

Cleobury, sounded majestic, with the space and depth of the cathedral well preserved. Organ sound was particularly good, due to the Masts' undeniable ability to handle low frequencies with style. Solo voices were well projected and had spine tingling reverberation. The atmosphere was a commendable testimony to the presentation of choral recording, which is often difficult to portray.

Marcello's oboe concerto was warm and relaxing, the depth of the Masts adding authority to the performance. The light and airy oboe had a good sense of timing and feel, while separation of orchestral parts was complemented by the wide soundstage.

N.E.A.R have succeeded in developing an A/V loudspeaker that can truly call itself hi-fi. The N.E.A.R Soundmasts would be equally at home delivering an authentic bone-crushing blow from Stallone as they would a chamber recital. This in itself is an achievement. As with all good loudspeakers, they have a distinct personality of their own. If you get on with their sound characteristics, you invariably end up living with them. Indeed, if you like them that much, you marry them. As for me, I'm an audio bachelor, still in search of that elusive loudspeaker that truly sounds like the 'real thing'. It's a sunny Friday afternoon and I'm off to enjoy a cold beer on the Thames, listening to a live gig. Well at least it's one step closer to the real thing!

**N.E.A.R. Soundmast** £1199

**MPI Electronics**  
13 Weston Road,  
Guildford,  
Surrey GU2 6AU.  
☎ 01483 454993

#### WORLD VERDICT

An interesting, musical 'speaker that's good value even at this price point.

**Measured Performance**  
see p105-113

# IN THE SEPTEMBER ISSUE

With the nights getting longer, how better to spend them than relaxing to music and reading the latest issue of *Hi-Fi World*. We'll bring you all of the latest news from the industry, features, readers' letters and queries, a super competition, reviews on the latest equipment and more. Here's just some of what the September issue hopes to bring.



## **McINTOSH MA6800 AMPLIFIER**

Weighing in at around 40kilos this monster integrated amplifier from the States certainly packs some punch. With 150watts on tap and a peak current capability of 55amps, it's an integrated with the power to impress.

## **CASTLE SEVERN LOUDSPEAKERS**

One of the first of a new breed of Castle, the Severn loudspeakers use a recently developed 130mm injection moulded bass driver with a 25mm polyamide tweeter. The Severns are a reflex design, their slim and elegant cabinets graced with real wood veneer.

## **DPA DIGITAL LITTLE BIT III CD CONVERTOR**

With an expected retail price of around £300, the new Little Bit III will be the most affordable discrete design CD convertor available. Could this change the face of CD as we know it?

## **TEAC A-BX10 AMPLIFIER**

TEAC have taken the minimalist approach with their new £999 integrated amplifier. Aimed at the audiophile, the A-BX10 claims 100watts output and a low feedback circuit philosophy. We ask whether it measures up to the best of British.

## **COMPETITION - WIN REL SUBWOOFERS AND ADD SOME DEPTH TO YOUR SYSTEM**

For September's fabulous competition we're giving away a REL Stadium II subwoofer as first prize and a Strata subwoofer for the first runner up. Both are guaranteed to add an extra dimension to your system, with fast, deep and powerful bass.

*Hi-Fi World* is still only £2, but with more editorial than most rivals. With the most enthusiastic and expert editorial team in hi-fi journalism, can you afford to miss it? Make sure you don't by filling in this order form and handing it to your newsagent.



Please reserve/deliver\* *Hi-Fi World* on a regular basis, commencing with the next issue, until further notice.

Name: \_\_\_\_\_

Address \_\_\_\_\_  
\_\_\_\_\_  
\_\_\_\_\_

Signed: \_\_\_\_\_ Date: \_\_\_\_\_

• Delete as appropriate

Distributed to the news  
trade by

**COMAG**  
MAGAZINE MARKETING

.... Continued from page 56

## THE BOTTOM LINE

I have recently purchased a pair of Spendor SA2 'speakers and am delighted with them. They represent a considerable improvement over the Leak 3030s I was using before which were good in the midrange, but dreadfully inefficient and undynamic.

The rest of my system consists of a Logic DM101 turntable, Hadcock Unipivot arm and Ortofon FF15E cartridge, Mission Cyrus 2 amp and NAD 5420.

My main source is vinyl and I was wondering whether upgrading the cartridge would be sensible. I'm not too sure how good the Cyrus' phono stage is, but cannot get a head amp because I have no spare line inputs on the amp. Is it possible to bypass the phono stage and have it turned into a line stage to be used with a head amp?

**M. Watchman  
Sheffield.**

*Modifying your Cyrus in the manner you suggest doesn't sound a good idea to me, as it makes it hard to resell, and isn't really the root cause of your system's problems.*

*The first thing you should consider is the turntable itself, which was an excellent deck in its day, but that was a long time ago.*

*If you're happy with the Logic, consider having it serviced and fitting a new arm such as a Rega RB250. Contact Manticore Audio Visual on 01585 583653 who do a good range of spares for the DM101, including belts and springs. They'll also be able to advise about arm-boards, and arm fitting.*

*The other option on a budget is a second-hand Linn Axis, preferably with Akito tonearm, or a*

*Manticore Mantra/RB300 of several years vintage. Ironically, the latter sounds richer and more Linn Sondek-like, while the baby Linn is lithier and more neutral. With either the Logic or the Manticore I'd go for an Ortofon MC15 Super II, and I'd put a Goldring G1042 in an Axis. DP*

## ROOM REFLECTIONS

I read your recent article on loudspeaker positioning with interest, as I live in a modern house with low ceilings.

From where I sit, the distance to my 'speakers is greater than from the top of my 'speakers to the ceiling (even though they face across the room).

As you predicted, the stereo image improves when I sit closer to the 'speakers. However I don't want to move them as they produce the best bass about 10cm from the rear wall, and my wife won't let me have the settee in the middle of the lounge.

Would a lower, upward firing floorstander like the Townshend Sir David be better, or would an efficient panel 'speaker help? My system comprises Ruark Talismans, Beard BB100, with Rock/Moth/Goldring I022GX turntable and Teac VRDS 10 CD player.

**David Kelly  
Cambridge.**

*If you are pleased with your Ruark Talismans, there is no need to change them. You have identified a 'sweet spot' by what you describe as a position where the stereo image is best. This position is also where the direct signal is at its strongest. The Talismans (which are fine loudspeakers in my opinion) are designed to be angled slightly upwards. A low ceiling such as yours may be subject to strong high frequency*

*reflections. You may also have strong reflections off the rear, and possibly side walls as well.*

*The mirror test (HFW Nov '94) describes an accurate method of locating primary and secondary room reflections from room boundaries and surfaces which are responsible for the anomalies you are experiencing. With low ceilings you need to minimise strong treble reflections. The sound may be unbalanced because treble is a few dB up (louder) due to reflections from the immediate boundaries and room furnishings.*

*In small areas, an area of optimal diffusion (amplitude of original signal is not diminished, and energy is evenly distributed across the frequency spectrum) is most desirable; that is to say, preserving the integrity of the original music whilst allowing the room to create a natural, supportive acoustical environment around it. Once you have located these points of reflection, you have a number of options to improve the acoustical characteristics of your listening room:*

**1. Install professional acoustical materials to control these reflections**

*and optimise your sweet spot through maximum diffusion.*

**2. Use home made materials.** Carpet and egg boxes in various states of disguise can be quite effective, placed on the located spectral reflection points. (It should be noted that if you have excessive treble, absorptive surfaces are most effective.) Where detail and power is required, cardboard egg boxes are best. If a combination is required, back the boxes with insulation material. The sound will improve remarkably.

**3. Where the above options are not possible, use your intuition, a bit of experimentation and careful listening to create the ideal blend of a home and music listening room.** Large plants, strategically placed, can be useful diffusers. Tapestries can be effective HF absorbers. (Careful! Too much will leave the room sounding dull.) The thicker the depth and surface area, the more bass will be absorbed. Paintings can be used as reflectors when glass covered. DF-D

## NAIM CHANGE FOR QUAD

As a keen hi-fi enthusiast I

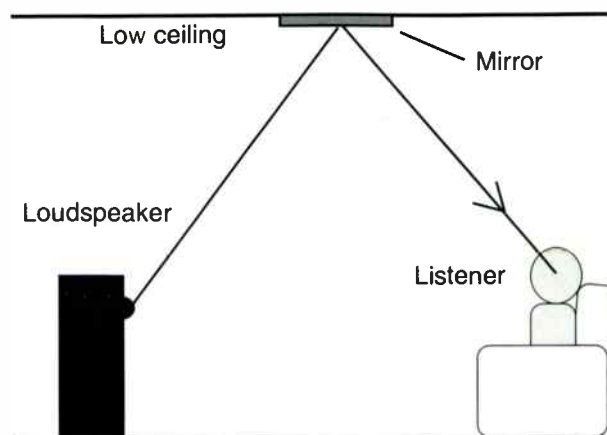

Treat sound as light: find image of 'speaker in mirror and install sound diffuser at that position.

have at long last managed to afford some high end equipment. I used to have an Arcam Alpha 3 amplifier with Philips CD and Tannoy M20 speakers, Rega Planar 3 turntable, Denon 260L tuner and a Marantz cassette deck. Various hi-fi magazines were perused and a good dealer was selected (Sound Organisation, London). I chose to audition and buy Naim equipment. I decided on a combination of 72 pre amp, 140 power amp, Hi-Cap, NAC5 and CD3 together with a Super Bias cartridge.

I took the equipment home, rigged the system up and began to listen. Imagine my disappointment when I heard hiss. My wife also commented on the noise level. She normally professes not to notice any difference in the sound and thinks that I waste my money on purchasing equipment. I had the equipment for a few months, during which time I made several calls to the dealer who told me there was possible RF interference causing the problem. I was advised to disconnect all the front end components and check for hiss. No change. The dealer agreed to swap the Naim equipment after trying out another 72 and Hi-Cap with no change.

I auditioned a Quad 66 preamp and 306 power amp which is now with me together with a Nakamichi DR3. The Quad is not displeasing and more bass response is elicited from the ELA's with no hiss, but I do not feel that the Quad sound is as precise as the Naim. I would like to know if I can improve on this - with a 606/2 power amp perhaps?

As a humble non-technical punter I'm at the mercy of hi-fi magazines recommending equipment and reputable dealers. Why are these most annoying defects in a system not mentioned in reviews?  
**M. D. Aitkins**

**Laindon West,  
Essex.**

*Baffled by this, we 'phoned your dealer, The Sound Organisation and Naim, as well as Son et Lumiere for general tests and advice, since they too have Naim and Rega and like to help out with such queries (you are ex-directory and supplied no 'phone number).*

*The Sound Organisation, sell the 72 preamp with the 140 power amplifier and Elsas quite regularly (as do Son et Lumiere) and neither have received complaints about hiss. They confirmed that your Naim*

*quiet room. Even then, on LP, disc surface noise would swamp this hiss. Son et Lumiere confirmed this.*

*Feeling that you are unusually sensitive to hiss, The Sound Organisation say they felt obliged to offer you a quieter power amplifier (you apparently complained about power amp hiss, since volume was at zero, they told us).*

*Unfortunately, some confusion may have arisen from the advice you received that you should "disconnect all the front end components and check for hiss". If you do this, the phono stage in*

*should point out, is input stage hiss, whilst with volume at zero you hear power amp hiss - and I'm not really certain which you were suffering. However, since power amp hiss is very low, I suspect the former.*

*Naim checked and rechecked and told us they could only hear hiss with their ears against the Ela tweeter and certainly not at a normal listening distance.*

*These days hiss is inaudible through low sensitivity/gain CD/tuner/aux inputs, at normal volume and listening distances. You can just hear some hiss from the tweeter, but only 12in away or less. This, however, is of no importance. If you want near-silence from your Rega Bias, either an NAD, Audiolab or a Linn preamp are alternatives to the Quad, since all have class-leading hiss levels, assuming it is input hiss you are hearing.*

*We only criticise phono hiss when it is high enough not to be swamped by disc surface noise. Otherwise, criticism becomes academic and it can be counter-productive.*

*I hope all this isn't too confusing (input hiss, output hiss, equivalent input noise and gain are confusingly interactive parameters) and will give you some idea of what to expect, why, and the consequences. If you are still not happy, contact Naim direct on 01722-332266, or Alester Kells at Son et Lumiere on 0171-580-9059.*

*Oh, and finally Alester made the point that you must use 3.5m or more of pNaim NAC A5 loudspeaker cable with your 140 to load its output or it might not be happy.  
NK*

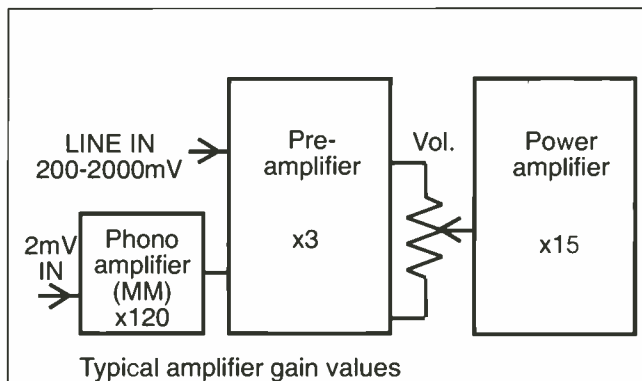

**Sources of hiss.** Here are the gain levels found in a typical hi-fi amplifier. The hiss you hear comes mainly from the first active device (valve or transistor) amplified by the gain of the following stages. For example, if the first stage has a gain of thirty and an intrinsic hiss (equivalent input noise) level of 1µV (one millionth of a volt), it will throw out 30µV of hiss. If the next device is twice as noisy (say), producing 2µV of hiss, hiss from the first stage will still be x15 greater. This example shows that 'input hiss' usually swamps everything else. That's why hiss usually comes from the front of an amplifier and goes up and down with volume.

In our example, input hiss of the power amp. is amplified 15 times, that of the preamplifier 45times (3x15), but that of the phono stage (MM) no less than 5,400 (120x3x45) times! This is why phono stages are hissier than line stages (ignoring source noise). Moving coil cartridges need ten times more gain (i.e. x54,000 in all), so they're even hissier.

Naim amplifiers have an unusually high line input sensitivity of 70mV, three times normal, so with volume at maximum they will produce more hiss. However, this is an unrealistic situation. In use you'll simply turn volume lower, reducing hiss to the same level of any other amplifier.

*amplifier was working normally and that there was only the slightest amount of hiss, inaudible at a normal listening distance unless, perhaps, you listen in a deathly*

*particular will hiss like crazy, the only possible explanation for being able to hear hiss four feet away. Phono stages must be loaded by a cartridge to work properly. This, I*

The concrete loudspeaker cabinet is one of hi-fi's barmier ideas. It recirculates in the collective consciousness of enthusiasts like an endless tape loop carrying a demented message. Was it those concrete caissons, known as Mulberry Harbours, used in the D-Day landings of World War 2 that started this off? They were an unlikely idea that just about worked, leaving powerful images of strength, longevity and immovability - just like concrete loudspeakers.

Trouble is, whilst immovability had its plus points in resisting assault by channel gales and Nazi bombardment, things aren't so turbulent in the average British home. At least, not as far as I'm aware.

I suppose for those whose homes are a battlefield, the concrete cabinet is a great idea. You can shelter in them when a raid is on, can't you? But then, you might ask yourself why the missus got like this in the first place - perhaps it was merely the sight of concrete cabinets that did it.

Anyway, this totally daft idea has settled upon us like a mystery virus from outer space. The logic is that wooden cabinets thrum, producing a wooden sound, and that concrete, as evidenced in motorway bridges and such like - quite apart from Mulberry Harbours - obviously doesn't. Ergo, what's good for motorways must be good for loudspeakers - a leap in logic that, well, defies logic. The final result is an object so heavy and coarse of finish it brings all the worst properties of Stonehenge into your living room.

That's assuming you can get them in there of course. Coles do a nice line in mobile cranes that are of some use to those with an upstairs room fitted with a convenient

kaleidoscope

Reflections  
from Noel  
Keywood



skylight. Otherwise, you'll need to read a few accounts of how they built the Pyramids to sort out the mechanics and logistics of this little exercise. Just remember that chopping down the street's Plane trees to make rollers, as they did in 2000 B.C., won't make you popular with the local council.

Concrete cabinets don't thrum. I can confirm this from experience, because I've heard a few in my time. So what? There are other, subtler problems that cancel this out. Just building the things in the first place is so messy and difficult, labour costs alone make the whole exercise uneconomic.

*“Concrete loudspeakers are a daft idea, although if you throw them into the sea they do make passable Mulberry harbours.”*

Mass production means hiring a fleet of cement lorries and a team of navvies, neither of which fit in with most production managers' ideas of heaven. Concrete loudspeakers steadfastly refuse to lend themselves to mass production, potentially consigning their over-ambitious but thoughtless designers to a lifetime's toil with a

trowel. This is why new models consistently have a short lifespan.

The final nail in the concrete coffin lies in the last but least considered part of the whole crazy scheme: delivery. Everyone forgets about delivery charges. Parcellforce don't possess Scammel low loaders, so you have to 'phone Bovingdon Camp and catch them on an off day when their Chieftains are being serviced. Contact the M.O.D. for a quote. This will prove my point.

Add up the cost of tackling these hidden difficulties and it becomes apparent there's no money left for drive units, not to mention decent ones. So in go a

pair of the cheapest imaginable and that's that: the heaviest and worst sounding speaker in the world. Concrete loudspeakers are a daft idea, although if you throw them into the sea they do make passable Mulberry harbours.

★ ★ ★

Let's look at an alternative idea which I think is completely sane,

but everyone else believes to be totally daft: a loudspeaker without a cabinet. The Quad ESL-63 is the best example, but Gilbert Briggs (founder of Wharfedale) and his chums experimented with conventional drive units mounted on open baffles back in the fifties, in an attempt to get rid of cabinet colourations and echoes. Nobody has said much about such speakers ever since, it appears to me. The big surprise is that an open baffle can produce deeper, higher quality bass than a cabinet. I thank Gordon Bank, chief designer at Celestion for this one. Until I heard the Celestion SL-6000 open dipole subwoofer I would never have believed it, although room positioning is critical. So a full range open baffle 'speaker is not only possible, but of potentially higher quality than a box design too.

We hope to get around to revealing much more about this complex subject in a future issue. In the meantime, Dominic has come up with a practical, space efficient arrangement of reflex bass cabinet and open dipole midrange/treble. It offers most of the advantages, but none of the disadvantages of a full range open-baffle. There's great elegance in this 'speaker's apparent simplicity ●

**H**appily, my decision to include my email address at the bottom of the last few articles has started to produce some active feedback from readers interested in the Maximalist Preamplifier series. There seems to be great interest too in the information on the project which I have made available on the World Wide Web.

Emailed suggestions have included the addition of a processing loop so that a surround encoder might be switched into, or out of, circuit. This is a very topical point with the proliferation of A/V set-ups, so I'll try to pick up on this in a future article. Martin Leach (martin@apnix.demon.co.uk) kindly pointed out that I omitted values on the circuit included in the July issue. My mistake, sorry. They are as follows: Top Boost Control, 18K lin; Top Cut control, 1K lin; Bass Boost control, 10K log; Bass Cut control, 100K log.

Neil Sumner (100541.3367@compuserve.com) complained that his Sony Minidisc only provides an optical digital interface

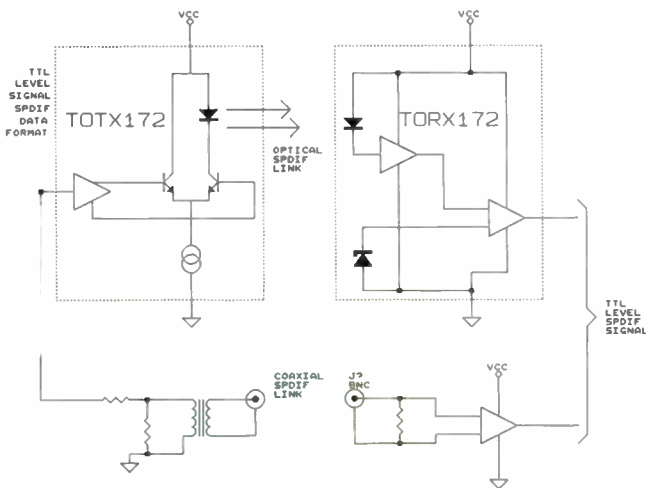

and therefore, in order to enjoy the digital "tape-loop" on the Maximalist preamp, he would need to include an optical send and return. Fortunately this is not a complicated problem to solve and the

# recorded message

Left by  
*Richard Brice*



circuit diagram below illustrates simple applications information for the Toshiba optical transmitter and receiver devices employed in the optical "TOSLink".

I feel however that I ought to justify what was a tacit decision on my part (and consequently may appear an apparent oversight!) in omitting optical interfacing on the Maximalist Preamplifier. As I have mentioned before in these pages, in many ways an optical link seems to be the ideal solution for joining two pieces of digital audio equipment together. Obviously a link that has

no electrical contact cannot introduce ground-loop hum problems. Also, because the bandwidth of an optical link is so high, it would appear from a superficial inspection that an optical link would

provide the very fastest (therefore "cleanest") signal path possible. However the optical TOSLink is widely regarded as sounding a little less crisp than its coaxial electrical counterpart.

There are a number of possible reasons for this. In the first place, the speed of the link is compromised by the relatively slow light emitting diode transmitter and photo-transistor receiver housed within the connector shells. Secondly, cheap optical fibres which allow the optical signal more than one direct path between transmitter and receiver ("multimodes"), causes a temporal smearing of audio pulses, resulting in an effect known as modal dispersion. This can cause a degree of timing instability in digital audio circuits (jitter) which can affect sound quality.

The only advantage the optical link confers therefore, is its inherent freedom from ground-path induced interference signals such as hum and r.f. noise. Yet at digital audio frequencies ground isolation, if it is required, is much better obtained by means of a transformer. And, as anyone who has been following this series knows, I have preached the benefits of transformers for digital signals from the start. Incidentally, if you want to modify a piece of

equipment with an optical interface to include SPDIF coaxial output, I designed a modification for this which was published in *Hi-Fi World* September 1993. I'll also place that design on my Web pages for easy reference.

Neil Sumner also asked, "Did you know that the Soundblaster AW32 has an SPDIF digital output on the board?" The answer is, yes I did. The I/F is SPDIF format at TTL level so, provided the appropriate electrical transformations are made, this feature allows for the intriguing possibility of a direct digital output from the Soundblaster.

All the articles so far published about the Maximalist Preamplifier, as well as a whole host of other information, is available on-line by visiting my Electric Perception WWW home page at URL, <http://www.demon.co.uk/epercept/>. You can leave messages and comments for me there or, alternatively, at CompuServe ID 100601,1614 or via email 100601.1614@compuserve.com. I've tried to make sure I have replied to all your enquiries and suggestions but it's quite a task, so if you think I'm ignoring you, I'm not. Finally, I've considered providing the HTML files of the Web pages on floppy disc to save on phone bills. Does anyone think this is a good idea?

# TOTALLY WIRED

**David Price and Dominic Baker return to tweaky corner to test some interesting cables.**



## CHORD COMPANY FLATLINE

At £73 for a 3m pair, Flatline Gold is the basic mono-wired version. They sound substantially cleaner and crisper than our budget reference QED 79 strand (of which there's also a flat version), but they should do considering the price difference. I was extremely impressed with the clarity and speed of Flatline Gold, together with its lack of grain and mush. In a sense, this cable is as inconspicuous sonically as it is visually.

Moving up to bi-wirable Flatline Twin at £120 for a 3m stereo pair brought further rewards, with more space around instruments and a general increase in effortlessness and poise. Whether it's worth the extra £50 or so depends on you and your system. Mono-wired Gold is such a good starting point that many will find it all they need before going crazy on ten awesome sounding metres of silver Blue Heaven at £1,182!

**The Chord Company**  
30a Sarum Business Park  
Portway,  
Salisbury,  
Wiltshire SP4 6EA  
☎ 01722 331674



## CONNECTIONS JADE

Connections' Jade is intended as an affordable upgrade to the standard patch lead supplied with most equipment which, if you are still using it, may be limiting the performance of your prized equipment quite considerably. Jade is made from a good quality 7 x 0.2mm cable, and silver soldered to reasonable quality gold plated phono sockets.

Replacing the thin patch leads I had deliberately placed between CD player and preamplifier with the Jade, the sound grew considerably. There was better body through the midrange, stronger bass lines and a finer, more focused treble. Also notable was the way the Jade relaxed the whole sound. Before it had sounded pinched and constrained, but now it took on a greater sense of ease. This level of improvement is well worthwhile, especially when all it costs is £21/m.

**Connections UK**  
49 Bishops Road,  
Peterborough,  
Cambridgeshire.  
PE1 5AP  
☎ 01733 897379

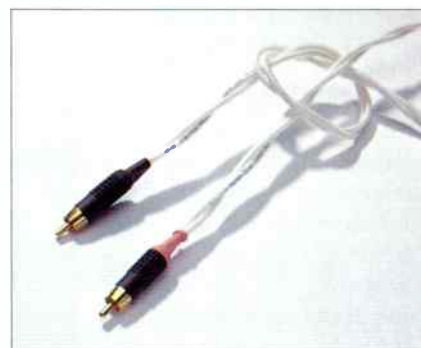

## PRECIOUS METALS SILVER

At £200/m for the Silver Signal 200 interconnect and £100/m for the bi-wire Silver Loudspeaker 240 'speaker cables, these certainly are precious metals. Made from a special silver alloy and fitted with solderless plugs for best signal purity, their construction is unique.

Both Precious Metal interconnects and 'speaker cables share a similar character. Like van den Hul's carbon fibre cables, they display a natural, sweet balance, but with a brighter tone. They also combine warmth with a crispness and precision that is beguiling to listen to. Particularly impressive was the way they coped with female vocals and strings through the upper midrange, an area where any hint of coarseness or grain is quickly recognisable. With these cables though, there was a super smoothness to the sound, clear and open and well projected, but never hard.

The Precious Metal cables come into their own in a top-end, well balanced system, where their supremely neutral character does little to colour the sound. With a blend of crispness and sweetness, they are well worth searching out, if you've got a deep wallet.

**Picture The Sound**  
13 Weston Road, Guildford,  
Surrey GU2 6AU  
☎ 01483 454991

**T**his month's super competition prizes come from Meridian's stylish 500 series. We're offering a complete CD-based system which is fully remote controlled, has a top class sound, and is worth £2500. The system comprises the latest 506 CD player, 551 integrated amplifier and A500 loudspeakers, all finished to the impeccably high standard you'd expect from one of the country's leading hi-fi specialists. Also included in the prize is Meridian's 500 series remote control, which allows complete control of this dream system from the comfort of your favourite armchair.

Meridian's stylish 506 CD player uses Crystal's CS4328 convertor chip, known for its sweet and musical properties. The 506 has a lean and detailed sound, one that brings great insight to music. Its delicate, warm treble never offends, which compliments CD very nicely indeed, for it never sounds aggressive or sharp.

This player is partnered with their 551 integrated amplifier, whose smooth powerful sound placed it "up with the best integrations under £1000" when Dominic Baker reviewed it in the May '95 issue of *Hi-Fi World*. The 55watt 551 has six inputs, five for line level sources and one for an optional MM/MC phono stage. All inputs have adjustable sensitivity, so they can be matched to a wide range of equipment.

Both the CD player and amplifier are remote controllable, and if you have the 500 series remote control, which Meridian have generously included in this prize, the whole system and all of its features can be



# WIN A FABULOUS £2500 MERIDIAN SYSTEM!



activated from your listening chair.

Completing this excellent system are the A500 loudspeakers. With high sensitivity from their light, doped paper drivers they have a fast and detailed sound. Their silk dome tweeter is tonally neutral, helping to ensure highs are always sweet and open. These 'speakers are a three-way design, combining this tweeter with two 6.5inch drivers, one for bass/midrange frequencies, and one to add extra power low down.

So if you're looking for a top class system that's stylish and has the luxury of full remote control, don't miss this one. All you have to do to enter the competition is simply complete the questions and tie breaker opposite.

Please send your entry on a POSTCARD, or the back of a SEALED ENVELOPE, and completed in block capitals, to arrive no later than 4th AUGUST 1995 to:

**MERIDIAN SYSTEM COMPETITION**  
**Hi-Fi World Magazine,**  
**64 Castellain Road,**  
**Maida Vale,**  
**London W9 1EX.**

**COMPETITION ENTRY QUESTIONS**

*Cut out and affix to the back of a sealed envelope*

- 1) Meridian's 506 CD player uses which convertor chip?
 

A. Burr Brown PCM63	B. Philips DAC-7
C. Crystal CS4328	D. Analogue Devices 1867
  
- 2) How powerful is the Meridian 551 integrated amplifier?
 

A. 5watts	B. 55watts
C. 551watts	D. 51watts
  
- 3) What material is used in the tweeter dome of the Meridian A500 loudspeakers?
 

A. Paper	B. Plastic
C. Velvet	D. Silk
  
- 4) What feature does the Meridian 500 series system in this competition offer?
 

A. Full remote control	B. Built-in alarm clock
C. Voice activated control	D. CD autochanger

**TIE BREAKER (obligatory)**

Lazy bones will Rock 'n' Roll  
 To a Meridian system with remote control  
 Discs will spin, cones vibrate  
 Raising the idle and prostrate

.....  
 .....  
 .....

Name: .....

Address: .....

.....  
 .....

Post Code: ..... Tel No. ....

Please do not add my name to your mailing list.

**COMPETITION RULES AND CONDITIONS OF ENTRY**

- [1] Only one entry per household will be accepted. Multiple entries will be automatically disqualified.
- [2] In the event of more than one entrant submitting all correct answers, the winner will be picked from the tie-breaker by the editor. Will will endeavour to publish the results in the September 1995 issue. Purchase of the magazine is not a precondition to entry.
- [3] No correspondence about this competition will be entered into and the editor's decision is final.
- [4] No employees of Audio Publishing Ltd. or any companies associated with production or distribution of the prizes may enter.

Don't forget to include your name, address and a telephone number so that we can contact the winners promptly.

Your name and address may be added to our mailing list only.

If you would prefer not to receive details of new products or special offers from us alone please tick the box. Hi-Fi World magazine is published by Audio Publishing Ltd.

**JUNE ISSUE**  
**COMPETITION - WIN A**  
**COMPLETE LINN**  
**SYSTEM WORTH**  
**£2400**

The Winner of Linn System is  
 Paul Hensby from London

# Subscriptions

## 12 ISSUES FOR ONLY £22 (UK only)

### HI-FI WORLD SUBSCRIPTION FORM

Please debit my VISA/ACCESS Card No:

--	--	--	--	--	--	--	--	--	--	--	--	--	--	--	--	--	--	--	--	--

Please send me the next 12 issues of Hi-Fi

World, starting with the -----issue.

Expiry Date: 

--	--	--	--

I enclose my cheque/postal order for £22  
(UK only) made payable to **Audio Publishing Ltd.**

Signature: -----

Name -----

Address -----

-----  
-----  
-----  
-----

Send to: **Audio Publishing Ltd.**,  
64 Castellain Road,  
Maida Vale, London W9 1EX.  
Tel: 0171-266 0461

Overseas subscription rates.

Surface Mail: £29.

Airmail: £42 Europe, £52 Middle East,

Hong Kong, Singapore & Malaysia,

£62 USA & Canada, Australia, Japan,

Korea & China.

Airmail

Surface Mail (tick as appropriate)



Daytime Tel No:-----

07/95 E&OE

## Back Issues

### HI-FI WORLD BACK ISSUES ORDER FORM

Please tick the box next to the issue(s) you wish to order

- |   |  |
|---|--|
| <input type="checkbox"/> October 1993    £3.00  | <input type="checkbox"/> September 1994    £3.00 |
| <input type="checkbox"/> January 1994    £3.00  | <input type="checkbox"/> October 1994    £3.00   |
| <input type="checkbox"/> February 1994    £3.00 | <input type="checkbox"/> November 1994    £3.00  |
| <input type="checkbox"/> March 1994    £3.00    | <input type="checkbox"/> December 1994    £3.00  |
| <input type="checkbox"/> April 1994    £3.00    | <input type="checkbox"/> January 1995    £3.00   |
| <input type="checkbox"/> May 1994    £3.00      | <input type="checkbox"/> February 1995    £3.00  |
| <input type="checkbox"/> June 1994    £3.00     | <input type="checkbox"/> April 1995    £3.00     |
| <input type="checkbox"/> August 1994    £3.00   |  |

I enclose cheque/PO for £ -----made payable to **Audio Publishing Ltd.**

I wish to pay by Visa/Access (orders for 4 copies or more only), please debit my account no:

--	--	--	--	--	--	--	--	--	--	--	--	--	--	--	--	--	--	--	--	--

Expiry date: 

--	--	--	--

Signature: -----

Name -----

Total no of issues ordered -----

Address -----

Total price -----

- Your name and address may be added to our mailing list only.  
If you would prefer not to receive details of new products or special offers please tick box.  
Hi-Fi World magazine is published by Audio Publishing Ltd.

Post Code -----Tel:-----

07/95 **Please allow 28 days for delivery**

Please send completed order form together with your cheque/PO to:  
**AUDIO PUBLISHING LTD.**, 64 Castellain Road, Maida Vale,  
London W9 1EX.

Unfortunately, all issues prior to October 1993 are completely sold out, but subsequent issues, as listed below are available for £3.00 including postage and packing in the UK. Overseas please add £1.00 per copy (surface mail).

I would like to use my column this month to mention a couple of products I have been using over the last few months. The first is the Stereo decoder supplied by Studio 12, and originally reviewed in *Hi-Fi World* Supplement No. 15. Stan Halfyard of Studio 12 has since made a couple of modifications which have resulted in greatly improved performance. The second is an interesting turntable stand from Acoustic Artists, which is radically different in its design.

## dB on the level

### Dominic Baker



#### STUDIO 12 DECODER

Shortly after reviewing this stereo decoder, which can be plugged into the MPX outputs of any tuner to provide a full stereo signal, Stan of Studio 12 wrote to me suggesting some improvements. I found the original decoder a little dry; the lovely, big enveloping bass lines that set the Leak Troughline I was using apart from mass market designs being restricted. I also found the midrange a little more compressed, losing that natural, close miked atmosphere of the studio that the Troughline captures so successfully.

Stan had spent some time after these comments working on ideas to improve performance, and I must say that what he came up with is very successful indeed. If you aren't already the owner of one of Studio 12's decoders, these modifications are now standard with the kit and built modules. For those of you who are already using one, here's a brief description of the simple modifications.

You might like to do the modifications in two parts, as I did, curious about how each tweak affected the sound. The first modification is to remove the coupling capacitor between the MPX input socket and the potentiometer, direct coupling the MPX input to the decoder module. At the same time as this change the potentiometer to a

1M $\Omega$  type.

Listening straight after this modification, the sound was noticeably clearer and sweeter. Midrange seemed better focused, with images firmer between the 'speakers, and less distortion on weak signals.

The second stage is to increase the two 0.1 $\mu$ F output coupling capacitors to 10 $\mu$ F. Plugging the module back in, I was surprised at how much this improved bass quality. The old Troughline warmth and depth was back, bass lines full and free flowing.

Switching between the decoder and the Troughline's own decoder there was now less of a difference. Whereas before the decoder had made the sound harder, drier and more compressed through midrange and treble, now much of the Troughline's sweet and atmospheric character was retained. But better still, the decoder was now giving a tighter focus to vocals, and although bass lost a touch of warmth, it now had better dynamics, speed and punch. This combined with the greater precision brought throughout the frequency range by the first modification, now makes the Studio 12 decoder in its latest guise even better value than before. I'm now considering a better potentiometer and a sprinkling of Solen polypropylene capacitors as its next upgrade. The Studio 12 decoder should definitely be auditioned by

anyone using a vintage tuner with MPX outputs. Apart from being a simple and fun project to build, its performance is now top class.

#### ACOUSTIC ARTISTS

This is a turntable stand for those of you who have the patience to get the very best from your record deck. I always find it fascinating how half a screw turn of adjustment can make such a large difference to a top flight turntable. Now Acoustic Artists have made a stand that demands similar tuning to get the very best from it, and it works.

Acoustic Artists have paid particular attention to preventing resonances within the structure of the table. The three legs the whole structure stands on are set at different angles and the glass sub-table and main supporting surface both sit on four spikes which are deliberately placed so as not to be symmetrical. Finally, from the centre of the triangle formed by the three legs there's a weight attached by a spring, which can be moved up and down to tune any remaining resonances out of the table.

After around two hours setting up the Acoustic Artists table with a Pink Triangle Anniversary/SME V/Lyra Lydian combination, I was thoroughly relieved when straight away there was a strong difference to my standard square welded table. It's best to

get a friend to help you tune the mass on the spring while you sit listening carefully. You should be able to find an exact point where the whole sound snaps into focus, images tightly defined.

Once this lengthy set up procedure is complete though, there's a radical and worthwhile difference compared to standard tables. The most noticeable difference is the brighter, more natural tone strings take on. Although I hadn't noticed before, my old table sounded distinctly muffled compared to the Acoustic Artists, which was brighter and crisper throughout the frequency range. Bass lines had even better punch and the whole image between the 'speakers more solidity, both areas where the Pink is certainly no slouch anyway.

The Acoustic Artists isn't the most elegant table to look at, and certainly isn't cheap at £640. But if you're using a top turntable it gets the very best from it. Providing you've got large amounts of cash with no home to go to, it's a worthwhile upgrade. The difference it made was akin to having a worn cartridge that's starting to lose resolution, replaced by a brand spanking new one.

Studio 12  
 ☎ 01736 798393  
 Acoustic Artists  
 ☎ 0151 734 2753

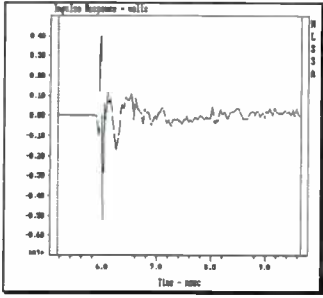

# AUDIO TEST AND DESIGN SOFTWARE FOR THE PC

MLSSA - Industry standard dual domain audio band analyser employing advanced MLS techniques. Full length card. Version 9.0 now available

LEAP - Advanced loudspeaker cabinet and crossover design

LMS - Economical PC based audio measurement. Full length card, includes mic.

NEW: FILTERCAD - Active filter design under Windows

pcRTA - PC based Real Time Analyser

ALSO: Calsod - Loudspeaker and crossover designer

IVIE - High quality measurement microphones

Outline - Automatic loudspeaker turntable.



**Call NOW! for more information and prices**

The Studio, Unit 21, Riverside Workshops,  
28 Park Street, London SE1 9EQ

Tel: 0171 403 3808 Fax: 0171 403 0957

## *Cheshire's premier Hi-Fi and Home Cinema specialists*

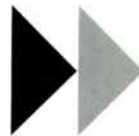

*Come and sample the finest selection  
of Hi-Fi and home cinema equipment in one of  
our luxuriously appointed listening rooms.*

1/1A Duke St Congleton Cheshire CW12 1AP

**01260 297544**

LINN ▶ ARCAM ▶ KEF ▶ YAMAHA  
DENON ▶ CANON ▶ NAD ▶ B&W

One aspect of hi-fi that never ceases to amaze me is how some people can spend hundreds (or even thousands) of pounds on a hi-fi, and never have it set up properly. This is especially the case with turntables, as they are often set up in the customer's home by the dealer and then simply left until something breaks. Yet with a little care, a good turntable can last for decades, and often end up costing less to keep than C.D. players and cassette decks which eventually (or quite soon in some cases) need expensive new lasers or transport overhauls. Of course, not having your turntable set up properly not only effects longevity, but sound quality too. With this in mind, here are a few pointers to ensure you are getting the most from your turntable.

Placement and support are the first factors to look at. Ideally, the deck should be placed on a dedicated turntable stand or at the top of a hi-fi shelving unit. Try to place the support on the most stable and level section of the floor. If the floor's completely shot, or space is tight then try a custom wall support. Once you've found the best position for the support, ensure the shelf is perfectly level, using a spirit level (most shelves are adjustable, and spiked feet are an additional means of levelling). With the support now secure and level, you might like to try some of the isolation units on the market. Although these may not necessarily suit all turntables, they can reduce motor noise and improve sound quality through isolation from vibrations travelling up the support. The most effective ones worth

# Fair Views

- from Dominic  
Todd, our man in  
Scarborough



looking at are from Mana, Townsend, and Reference Imports new Air Pod system, which offers total isolation via magnets.

If your deck features adjustable suspension, check it is level and not sagging on one side. Generally, it's best to run the platter as close to the plinth as possible, without it scraping. Make sure you allow for the extra weight of the record when making this adjustment. Adjustment is usually made via three Allen bolts (or similar). While making these

*“With a little care, a good turntable can last for decades, and often end up costing less to keep than C.D. players.”*

adjustments, ensure that the arm wire isn't snagging in the suspension, and that it has free movement across its arc. Next, check the belt is taut and hasn't gone sticky. If it has, or it goes riding up the pulley, it's usually time for a change. Clean the pulley and the inner rim of the platter (in other words, the path of the belt),

using methylated spirit or something similar.

That's the main part of the turntable set up. Next comes the arm. First check it's securely mounted (you'd be surprised how many decks I see with loose arms). Then check the arm height. It should be level when playing a record. You may find the height is no longer correct if you've recently fitted a new mat such as the Ringmat. If it's not quite right, then you can either adjust it with the built-in adjuster, or use spacers or large washers, placed between the arm and plinth, to build the height up.

The cartridge should be aligned using a specific alignment gauge. Be careful not to knock the cantilever, which hangs below the body when making this adjustment. Clean the stylus using a proper stylus cleaning brush (either electronic or manual), and check the condition using a mirror. If this is inconvenient, it's usually possible to tell when a stylus is on its last legs simply by listening. If the sound breaks up at high frequencies (Mary Black's vocals are a good test), then it's usually time for replacement.

If you fit a completely new cartridge, ensure the four connecting leads are fitted the correct way round. If the cables are

the wrong way round, you may still get sound out, but it will sound distant and muffled.

Tracking weight and anti-skating can sometimes be knocked out of adjustment over time. The weight is found at the rear of the arm tube, and is usually adjustable via a screw thread, friction lock, or Allen bolt. The weight should balance out the weight of the cartridge. Then, extra weight is dialled in according to the cartridge manufacturer's specifications. There are scales available which make the whole process a lot simpler. Next set the anti-skating. This is usually found on the base of the arm, or it could be a very small weight suspended on a piece of nylon. If it's a dial type adjustment, simply set it to the same reading as the main weight (i.e. if the cartridge required a weight of 2 grams, set the anti-skating to 2). Adjustments without markings are usually made via trial and error. Generally though, a middle setting will be equivalent to between 1.5 and 2 grams.

Follow these simple steps periodically and you'll find that not only will you get good service from your turntable, but you'll also be giving your records a fighting chance to show just what they're capable of ●

When the final Triumph sports car rolled off BL's production line in 1981, many car enthusiasts shed a tear. As the last mass production British two seater, it seemed the end of a golden age of motoring epitomised by legendary marques such as MG, Riley, and Austin Healey.

The way forward, thought BL and its competitors, was the "hot hatch". Cheap, fast and easy to drive - perfect for modern motoring conditions. Thus began the eighties love affair with the GTi, signposting the decade's fresh, efficient approach to the business of having fun on Britain's roads. But as sales soared and the roads swelled with hatchbacks bedecked in go-faster graphics, something strange started happening.

Almost overnight, a plethora of "classic" car magazines appeared on the nation's news-stands, celebrating the inexpensive joys of 'practical classics' that readers of all mechanical persuasions (both the competent and the not so) had restored. Why on earth, amidst the thrusting, go-getting arriviste eighties, would anyone bother with rusting, sixties relics?

*"Quality modern valve designs shouldn't be viewed as the audio equivalent of the flat capped Home Counties' MG brigade."*

The reason was something that took mass manufacturers a long time to grasp, and one with resonances for the hi-fi industry too: true car enthusiasts were disparaged by the cynicism major makers were showing with their superannuated shopping trolleys. Many 'classics' were more satisfying to drive and own than the

new breed of hatchback. And it wasn't all down to affluent old fogeys with too much cash to shake a walking stick at. Often, buyers of sixties machinery were too young to even remember their pride and joy in production. Instead, they wanted character cars, not the motoring equivalent of hi-fi's bestickered black box, the hatchback.

So the classic car scene was partly a reaction to a lack of tempting modern hardware. Despite the corporate marketing muscle of major manufacturers trying to persuade people of the allure of their computer-designed tin boxes, demand for classics only relented when

manufacturers started offering affordable, individualistic, specialist products once more.

Hi-fi is subject to similar market dynamics. There's a parallel between the GTi and the generic Japanese hi-fi separate. Both are sometimes little more than older, unremarkable designs in modern packaging. Both are reliable, easy to use

and require the minimum of dedication or specialist knowledge from their owners. Of course, these are positive attributes, but they don't necessarily confer lasting happiness, automotive or audio. Real hi-fi is an *active* leisure pursuit. Audiophiles want products to enthuse about, covet, maintain, modify, tune or improve. And in the absence of modern, innovative designs many have started looking to the past.

Funny how times change. In the eighties, valves were seen as anachronistic as old sports cars: warm, woolly and wet. This misapprehension was partly down to the likes of the Quad II, whose sound epitomised the gentlemanly euphony of fifties designs, and partly because of a complete lack of understanding about how valve amplifiers work. Reviewers of the flat earth disposition showed little knowledge and interest, using quintessentially eighties', hard-to-drive 'speakers with which most valve amps struggle. Was it any wonder that Leak Stereo 20s wheezed and groaned under the load of a pair of Linn Saras?

But the nineties' valve revival has led to greater care being taken to match 'speakers to amplifiers. The old orthodoxy of power sapping multi-element crossovers, mini-monitors tuned for bass extension rather than sensitivity and sponge-like

cheap driver materials is on the way out. This in turn makes it much easier for valve amps to perform as intended.

But it's not all love and peace on the thermionic front. *Hi-Fi World's* patronage of all things warm and glowing has proved rather a double edged sword. Although we've identified music lovers with a focused, hands-on approach to hi-fi, we've also rather opened up a can of worms. In the same way that age maketh not the Hillman Hunter a classic car, being valved doesn't make an amplifier a classic design. And now unscrupulous souls are rehashing obsolete sixties circuits, sticking them in fancy cases and selling them on that valve 'authenticity' cachet.

So if you're auditioning amplifiers that glow in the dark with a view to buying, don't make allowances for them. A decent modern valve design like the WAD 300B, which I've come across only quite recently, is smooth, yet so fast and dynamic it will have you running for cover.

Quality *modern* valve designs shouldn't be viewed as the audio equivalent of the flat capped Home Counties' MG brigade - it's not just a nostalgia thing. Like a lot of us, I'm looking forward to the day when the first modern mass-produced British valve amp rolls off the production line!

# audiophilia

David  
Price



# The Music Pages

Giovanni Dadomo

It's a long time since I've seen this much fun. The music is so good, the lyrics are so good, the album is so good, it's a real joy to listen to. The music is so good, the lyrics are so good, the album is so good, it's a real joy to listen to. The music is so good, the lyrics are so good, the album is so good, it's a real joy to listen to.

**INDEX**

**RECORD REVIEWS**

Rock & Pop ..... 73  
 Punk & Hardcore ..... 73  
 Hip-Hop ..... 73  
 Soul & Funk ..... 73

**CLASSICS**

Classical Music ..... 73



**VARIOUS ARTISTS**  
**Tank Girl O.S.T.**  
 ELEKTRA 7559-61760-2

● Cult comic becomes cult movie sensation? Not being Jonathon Woss or Liz Hurley, I haven't yet sampled the delights (?) of the cinema translation of the grooviest band designee (that's French for comic, not being flash - well just a bit - just hate repeating words too esoteric to be comfortable *thisclosetogether*) this side of 'Ranxerox', but as soundtracks go this is a well

above average effort. This may well have something, perhaps everything, to do with the fact that like *Natural Born Killers*, it was put together by a musician, namely Courtney Love-Cobain. All of which can't help but point to the disc's weirdest moments which occur when Love's own band Hole's cut is immediately followed by 'Bomb', an item which sounds very, very, much like Nirvana. But here's the rub - the group hail not from grunge capital of the world Seattle, but the rather more mundane Shepherd's Bush. Mind you, the Who came off them very same streets. Not to mention the rather awesome Hammersmith Gorillas. (The dementoid lead Gorilla Josse Hector is treading the necessarily humble boards again, and should be seen at least once - a Great British Rock Eccentric, no exaggeration).

Anyway, back to La Love's inspired Tank Girl long-player. Your mis-spent earnings will grab you a nab of Devo's remarkably evergreen 'Girl U Want', L7's feisty 'Shove', not to mention the Magnificent Bastards - a name guaranteed to ask for trouble if ever

there was one - with 'Mockingbird Girl'. Perhaps the most stupendous track is Joan Jett and Paul Westerberg (was not he in Devo too, or was it The Residents? Forgiven, either way).

Anyhow, said duet takes place alongside the eminently inestimable Joan Jett, who has solidified her career without the benefit of silicone or hyperbole - good on yer, chook! The last cut may well be the deepest, redolent with all the anger, passion and verbal dextrousness that only the singular Ice-T can muster. It's what you Girls out there, tank top wearing or not, might call a real ball-buster. *Oi, me pobres cojones!* (That's Spanish for "Ouch!", in case you were wondering.)



### SCOTT WALKER

#### Tilt

FONTANA 526 859-2

● My first serious girlfriend, a postman's daughter name of June Eaton - where are you now, you were beautiful then and always will be - was fanatical about The Walker Brothers. I loved Scott's hair more than the massive ballads he and his nominal siblings turned out courtesy of pro song-scribblers like Burt Bacharach, Hal David and so on. But then a miracle happened - the Bros split and Scott went solo, discovered the genius of Jacques Brel, and went on to record a quartet of superb LPs.

True, some of his originals were word-wise a tad trite - 'Plastic Palace People', 'The Amorous Adventures Of Humphrey Plugg'? Do us a favour Mr Engel (that's his given name, for those who didn't know - presumably because it sounded fashionably British at the time). Still, he became a legend and an inspiration to generations that followed - Marc Almond, Julian Cope, even Pulp's Jarvis Cocker I'll wager. He had a splendid three-octave range, and was blessed with arrangers of true brilliance,

Wally Scott to name but one.

But then he got all existential, moved to Amsterdam, or so the legend goes, and promptly vanished off the pop firmament for a decade. The Walkers reunited in the early seventies and made an electro-style pop LP that spawned a classic single in 'No Regrets'. Scott promptly vanished for another decade or so before putting out the idiosyncratic (or to some, crap) *Climate Of Hunter*. That was about ten years ago too. So now, ho, ho, ho, comes *Tilt*, a disc as unique and unclassifiable as Nico's *Marble Index* and as likely to be as slowly-but-surely influential as time goes by. Take it slow and easy, this man has a voice that can still shatter hearts and a rare and special musical imagination. Let's hope it's not a decade until the next one. And, Scott, why not get John Cale to produce the next one? A marriage made in Heaven that would surely be.

PS By the way, Mr. Engel's lyrics are miles better than of yore, catch only the clever-clever boxing metaphors on, er, the song with the boxing references.



### THE LAST POETS

#### Holy Terror

RYKODISC RCD 10319

● The Last Poets must take most of the blame for the Rap Music phenomenon. I don't mean that with disrespect - quite the opposite: they almost single-handedly took a passing fad - a bad Allen Ginsberg-styled poet accompanying his bull-spoor with an equally malodorous bongo-player for backing. It's the sort of thing movie buffs will recall from early Roger Corman epics featuring the obligatory Beatnik scene - all girls in Juliette Greco shades and polo necks, all boys in badly-adhered goatees, berets and regulation black polos.

The Last Poets made their big crossover via a track on the Jagger film

*Performance*, and titles such as 'Wake Up Niggers (Or We're All Through)' were to inspire generations of black singer/writer/poets (not to mention a few white ones) from Gil Scott-Heron to everyone in the current crop, including all the Ices Baskin-Robbins never made (and Mr Vanilla, you definitely ain't on the list, sweetie). They're still as essential, relevant and PC as anyone under the rising sun. Dig, badass.

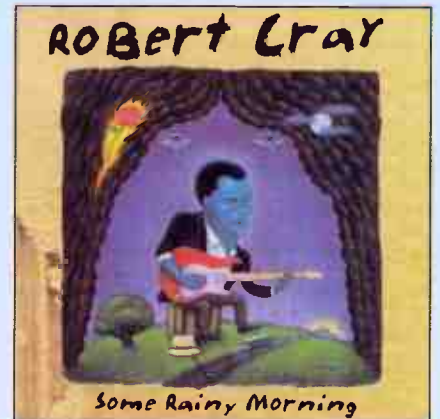

### ROBERT CRAY

#### Some Rainy Morning

MERCURY 526 928-2

● Apart from startling second and third LPs, Robert Cray's later career has been a trifle topsy-turvy to say the least. Here at long last sees the *New King Of The Blues* back with a blistering disc. All the familiar concerns are present - love found, lost, crossed, and so on and so forth - but delivered with Cray's distinguished bravura and fire, be it on the vocal or guitar fronts. He's still the best of the new breed and whether you've never heard the word or given up on the bird, 'Some Rainy Morning' is as good as any place to join the Cray Fan Club.





**PAUL WELLER**  
**Stanley Road**  
 GO! DISCS 828-691-2

● It's the name of the street he was born in, so we're told, and probably the best original title this side of The Kinks' Muswell Hillbillies. Me, I was raised in Northdown Street, not half a mile from Shane 'The Original Pogue' McGowan, and Steve Thingummy, co-founder of the late but eminently venerable Palace Pictures. Anyhow, I've always been of the opinion that Weller mk I (of The Jam) just happened to be one of the foremost song writers of his generation - particularly as he'd just about quit his teens and was turning out titles as strong as 'Going Underground'. 'A Town Called Malice' and 'Start!', combining social issues with great tunes even more frequently than their oft-admitted forefathers The Who. But then to this warped little mind at least, Weller took a brave but somewhat iffy turnaround with *The Style*

Council. For this vet soulboy's tastes at least, it all too often sounded like Weller's new mentor was the by now sadly beleaguered Curtis Mayfield. And whereas Weller was well 'ard as Peter T's own bespoken son, another Mayfield he certainly wasn't.

Paul's first solo effort went by like the proverbial fart in a hurricane, but 'Wildwood' put him back on front covers and smacked the charts heavy on the noggin. So too will 'Stanley Road', a deft blend of the rocky and olde English parochial. Why did I keep thinking of Traffic's epochal "getting it together in the country" period, 'Mr. Fantasy' onwards? Well, if it isn't Stevie Winwood on guest vocals! I don't think even the aforementioned Mr. Townsend was ever afforded that accolade.

Tracks to open your lugs wide, one and all - what that fat Oirish geezer would call "a cracker". Lazarus doesn't stand a living chance alongside Weller's resurrection shuffle. Take my word for it.

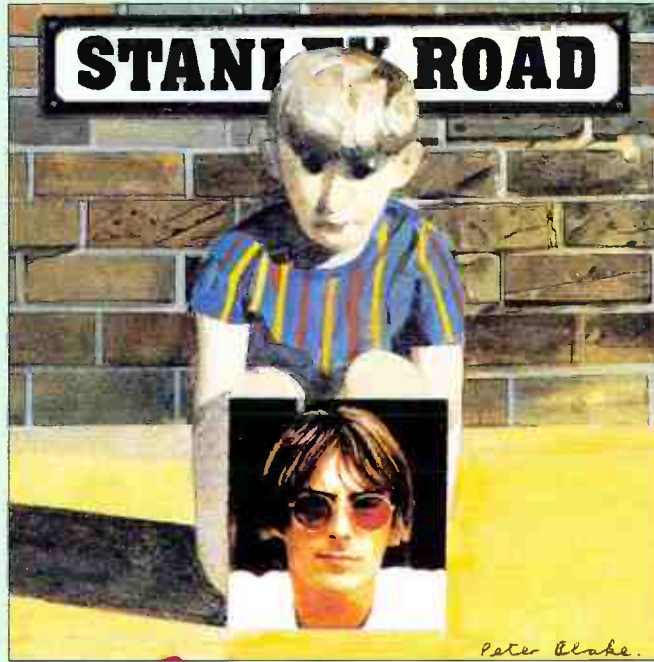

Rock & Pop.

*Jon Clarke*

**BJÖRK**  
**Post**  
 ONE LITTLE INDIAN TPLP5 CD

● Bjork's second solo effort, following her highly acclaimed Debut of two years ago, is a step away from commercialism and a stride into a more industrial sound. And where there's some solid chart material in the guise of 'Army of Me' and 'Hyperballad', there's a much larger slice of experimentation, perhaps part-influenced by collaborations with Tricky in the studio, reminiscent of the young lady's Sugarcube days. Despite a weird, downbeat feel, within sit some

magical and highly original moments, epitomised up by 'Blow A Fuse' with its *Sound Of Music*-style build up and aggressive chorus.

The industrial spine of the album

begins with the single 'Army of Me' and follows on into 'Enjoy', a grinding, repetitive tale of sadness and woe, and then into 'I Miss You'. There's also a heavy string and orchestral influence on particularly audible on 'Isobel' and 'You've Been Flirting Again', both tracks leaving a warmer feel.

But overall you get the impression of an embittered Bjork, revealing a newer, serious side - one that may claw her nearer to the icy peaks of pop credibility, but lose her some of her teenage fanclub. Her sense of fun is still however in evidence on 'Hyperballad' where we have Bjork at her brilliant old best. An intriguing, almost bitter release, with a fine balance of hard-edged, often beautifully delivered tracks.





## David Price



**KRAFTWERK**  
**Man Machine**  
EMI 74603928

**KRAFTWERK**  
**Computer World**  
EMI 74604024

gaze to the embryonic information superhighway with 1981's *Computer World*. By now they'd taken to appearing live with identical dummy replicas of themselves, their presence only discernible when previously motionless figures suddenly started playing Casio calculators hard-wired into their Kling Klang mobile studio! A sight to behold, these theatrics made them an instant cult among the electro cognoscenti and brought untold music and fashion press column inches.



**KILLING JOKE**  
**Wilful Days**  
VIRGIN CDOVD440

● Post-punk ancients Killing Joke continue on the war path in 1995, as Jaz and fellow jokers release the interesting, but hardly essential *Wilful Days*. Like Stevie Wonder in the world of soul, on the punk scene Killing Joke are rather a spent force, their crown long stolen by bands like the Ramones, the Mission and SMASH. This compilation of 13 out-takes, B-sides, dance versions and extended mixes has both their high and (very) low points. While special moments like 'Eighties' and 'Love Like Blood' sound as good as ever today, others just go to show how a well-oiled machine can go rusty and break down. While it's great to reminisce on 'Sun Goes Down' and 'Follow The Leader', half these tracks are poor and would be unlikely to make a Best Of Killing Joke Volume II.

● Fueled by a shell-shocked music press desperate to jettison its prog-rock credentials, the mid-seventies British music scene momentarily found itself dominated by punk. But as The Clash unleashed their smash-the-system polemics, changes were afoot abroad that were (arguably) to have more impact on today's pop music. Kraftwerk had just released *Trans-Europe Express*, a journey through the "elegance and decadence" of post-war Europe. Something of a transitional long player, it saw the group honing the formula for which they'd later become famous. Gone was the convoluted experimentalism of earlier work, and in its place a new economy of style, culminating in 1979's *Man Machine*.

An epic Fritz Lang-esque trip through some imaginary futurescape, *MM* is most famous for 'The Model', whose unconcerned, deadpan vocals and stripped-down electronics brought Kraftwerk their only UK Number One to date. The Bauhaus-inspired cover and modernist celebration of a future 'Metropolis' concerned some who saw it as flirting with fascist imagery. This was well wide of the mark - it was more of a classical European reply to the might of all-powerful American disco, which had the dance scene all to itself until then. After *Man Machine*, electronic music would never be the same.

Having worked their way through terrestrial and space travel with *Autobahn*, *Trans-Europe Express* and *Man Machine*, Kraftwerk shifted their

The dramatic title track, built around heavy electronic percussion underpinning an impassive "business, numbers, money, people" refrain, suited the live shows just fine. But the German version, featuring Ralf Hutter's vocal intoning the mantric "Interpol and Deutsche Bank, FBI and Scotland Yard have information on you" chant, again upset concerned liberal types worried about the power computers conferred on government. For them, Kraftwerk's engagement with the new 'information society' all seemed a touch too wide-eyed and uncritical. Although this meant a frostier than expected reaction at home, the group's wry smiles weren't missed in Britain, where the synth-blues of 'Computer Love' and proto-hip-hop beats of 'Numbers' made it their greatest success to date.

Brimming with vintage analogue electronics, classic tunes and a resolutely internationalist outlook, many regard *Computer World* as Kraftwerk's finest forty minutes. Indeed, if you live and breathe techno, there's no way you won't already have heard vast tracts of this album sampled into the delirium house and hip hop, from Afrika Bambaata to The Shamen, or cut-and-pasted across countless nineties ambient soundscapes.

*Rock + Pop.*

# Specialist Hi-Fi Dealers

## BADA DEALERS COME HIGHLY RECOMMENDED



Hear the difference.

### VOX MAGAZINE:

"You can be confident that BADA members are reputable, financially sound businesses which will sell you hi-fi in a professional manner."

### HOMES & GARDENS:

"A tried and tested way of finding trustworthy dealers ... BADA whose members are specialist Hi-Fi Dealers."

### GRAMOPHONE:

"Over 100 member shops ... from Aberdeen to Plymouth ... Helping customers to identify, clarify and satisfy their needs through the demonstration of suitable hi-fi products."

BRITISH AUDIO DEALERS ASSOCIATION



## LOOK FOR THE BADA LOGO WHEN YOU CHOOSE YOUR REAL HI-FI DEALER

Write for a FREE Fact Sheet, BADA benefits and full members list to P.O. Box 229, London N1 7UU. Tel: 0171 226 4044 Fax: 0171 359 7620

### SOUTH

## THE SOUND GALLERY

### BUCKINGHAMSHIRE'S PREMIER HI-FI DEALER

Arcam, Denon, Linn Products, Naim Audio, Meridian, Rotel, Yamaha, NAD, Quad, Tripod, Nakamichi, Rega, Creek, Epos, Mordaunt Short, Celestion, Marantz, Mission, Cyrus, etc. ...

65 Castle Street, High Wycombe, Buckinghamshire.  
Open Monday - Saturday  
0494 531682 / 464670

### SOUTH

## TECHNICAL & GENERAL

THE ORIGINAL TURNTABLE SPECIALIST for the Great Classical Turntable, Arms, Cartridges, Styli  
CONNOISSEUR • GARRARD • GOLDRING • LENCO • ORTOFON • SHURE • S.M.E • THORENS • WATTS

All available Genuine spares and our own re-manufacture obsolete parts  
Servicing and Overhuls, to original technical specifications.

NO ILLUSORY 'IMPROVEMENT' NO DUBIOUS OR HARMFUL 'MODIFICATIONS'  
Remedial Services available

Cartridge and styli, correct radius diamond, for early recording - 78s & Lps

### TECHNICAL & GENERAL

P.O.Box 53 Crowborough, East Sussex TN6 2BY  
Tel: 0892 65 45 34

### LONDON & SOUTH EAST

## SURREY HIFI

45 HIGH STREET GODSTONE SURREY RH9 8LS  
GODSTONE (01883) 744755

YAMAHA MUSICAL FIDELITY  
QUAD • JPW  
AUDIOLAB • BOSE  
REL • TDL • KEF  
TUBE TECHNOLOGY  
TANNOY • DENON  
NAKAMICHI  
THORENS • TARGET  
MARANTZ • MICHELL  
SENNHEISER  
BEYER HEADPHONES  
SOUND STYLE  
VAN DEN HUL CABLES  
CABLE TALK

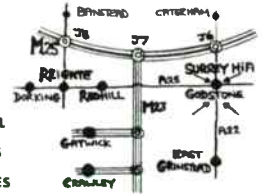

For the great sound of sound :

### The Comflake Shop

37 Windmill Street London W1P 1HH  
071 631 0472 Fax. 071 436 7165

We stock ATC, Arcam, Meridian, Naim, Rega, Royde, Roksan, AVI, Monitor Audio, DNM: as well as offering a marvellous mail-order worldwide service • Crunch •

## Sussex Surplus

Original Mullard GEC Valves  
for sale & wanted for cash

Sussex Surplus  
13 Station Road, Horsham, West Sussex.  
Tel: 0403 251302



79/81 Fairfax Road  
Swiss Cottage  
London NW6 4DY  
071 624 8855/6  
Mon-Fri 10-7 Sat 10-6



7 ST. PANCRAS,  
CHICHESTER,  
WEST SUSSEX  
CLOSED ALL DAY  
MONDAY  
Tel: (0243) 776402

Appointed stockists of: A+R Cambridge, Castle Acoustic, Creek, Dual, Goldring, Linn Products, Monitor Audio, Naim, Nakamichi, Quad, Rega, Rogers, Royd Audio, Spondor

### LONDON & SOUTH EAST

## AUDIO CONCEPT

27 BOND STREET, EALING  
LONDON W5 5AS  
TEL. 081 - 567 8703

AMC, Acoustic Energy, Aura, Audiolab, Audio Innovations, B&O, B&W, Cannon, Castle, Cyrus, Denon, Dual, Evolution, JPW, KEF, Marantz, Micromega, Mission, Monitor audio, Musical Fidelity, NAD, Nakamichi, Onix, Onkyo, Quad, REL, Rogers, Rotel, Systemdek, Target, Teac, Thorens, Van den Hul.

10 - 6 pm Mon., Tues., Friday, & Sat.  
Late night Thur., closed Wed.

Two demonstration rooms.  
Free local delivery and installation.  
Repairs and Services



THE INNOVATIVE  
AUDIO AND VISUAL  
HI-FI RETAILER  
SERVING LONDON  
FROM BATTERSEA

ORANGES  
& LEMONS  
071- 924 2040/3665  
61/63 WEBBS ROAD, SW11

## Front End Problem?

### contact - The Cartridge Man

It doesn't have to cost an arm and a leg to get the best - listen to my koetsu - and Decca - eater.

Also agents for croft, sugden, Thorens, Pentachord Speakers & Nottingham Analogue.

plus cartridge re-tipping service  
081 - 688 6565

## WORTHING AUDIO

20 Treville Gate, W.Sussex. BN11 1UA  
(0903) 212133

The friendly shop with the best sound system in the South, Friendly advice  
• 3yr guarantees • easy parking  
Open Mon.-Sat. 10am-6pm Late night Wed. 7.30pm  
Agencies include: Arcam, Exposure, Kinshaw, Naim Audio, Marantz, Ruark, Audio Technica, Target, Tripod, JPW, TDL, Orelle, and many more....

audio innovations audison audio note audiqueford chord company cambridge  
audio design densen ear helms heybrook impuse iras jostlin  
research kinshaw lyra michel morel moth musical techn  
manit ortofon perris kume quadmeqa project qed  
sugden sumiko teac triangle trichard van den  
works  
tripos projekt mat sound organisation target  
hans audison audio note audison  
densen ear helms heybrook  
kinshaw lyra morel  
perris kume quadmeqa  
teac  
voigt  
atracama target  
audiocassette chord company  
helms heybrook iras impuse  
manit ortofon perris kume quadmeqa project qed royd  
research sumiko teac triangle trichard van den hul voyd  
sound organisation target alphonson  
audiocassette audison audio note well done reading so far (and so small)  
signals stocks a wide range of valve transistor analogue and digital products. we  
offer home delivery/tutorials and proper service. ...the people. positive reviews.



ipswich  
01473 622866

## "One of the 5 best hi-fi shops in the world"

### GRAHAMS HI-FI

Canonbury Yard, 190A New North Road  
London N1 7BS, ☎ 071-226 5500  
Ring for a chat, an appointment and a map!



Stockists of: ARCAM • CREEK • EPOS  
HEYBROOK • MICROMEGA • NAIM AUDIO  
NEAT • REGA • ROKSAN • ROTEL • ROYD  
TEAC • YAMAHA

## Infidelity

indecently good hi-fi

9 High Street, Hampton Wick, Kingston upon  
Thames, Surrey KT1 4DA. Tel: 081-943 3530  
Open Tues - Sat 10.30am - 7.00pm.

# Specialist Hi-Fi Dealers

## LONDON & SOUTH EAST

**Near Norwich  
Norfolk**  
Tel. (0508) 570829



**Basically Sound of Norfolk**  
STOCKISTS OF LEADING HI-FI

Arcam, Naim, Audiolab, Audio Innovations, Epos, Denon, Nakamichi, Acoustic Energy, Heybrook, Micromega, Rotel, Royd, TDL, The Chord Company, Sound Style etc...

**STATION SOUNDS**  
W O R T H I N G  
FOR A SELECTION OF VALVE AMPLIFIERS AND OTHER OLDER QUALITY EQUIPMENT

Valve amplifiers (combos and hi-fi) overhauled at sensible rates.  
Audio Note speakers and used Audio Innovations amplifiers stocked  
Valve and other equipment always wanted.

**Mike Pointer 0903 239980** (including Fax)  
DOWN PLATFORM WORTHING STATION SUSSEX

**Lockwood Audio**

THE  
Authorized **TANNOY** Specialist

SPARES AND REPAIRS

DEALERS IN VINTAGE AND USED EQUIPMENT AND RECORDS

 Callers welcome by appointment   
Imperial Studios Maxwell Road  
Borehamwood Herts. WD6 1WE  
Phone: +44(0)181 - 207 4472  
Fax: +44(0)181 - 207 5283

## LONDON & SOUTH EAST

*the powerplant*

**BRIGHTON'S LEADING HI-FI SHOP**  
Cyrus, Roksan, Micromega, Audionote, Audiolab, Rega, Arcam, Exposure, Aura, Epos, Thiel, Ryark, Rotel, Marantz and other fine equipment.

**66 Upper North Street, Brighton**  
Telephone 0273 775978

**The Hi-Fi Shop**  
GUILDFORD'S SPECIALIST SINCE 1950

We are at:  
3 BRIDGE STREET, GUILDFORD  
(By the traffic lights, next door to Alfred Marks)  
0483 548001 • 0483 304756  
Access • Visa • Switch  
Open Monday-Saturday 9am-6pm (later by appointment)

 *Best place in town for Hi-Fi and Home Cinema*

**UNILET SOUND & VISION**  
35 High Street, New Malden, Surrey KT3 4BN  
Tel 0181 942 9567 Fax: 0181 336 0820

- ★ Six superb demonstration rooms
- ★ Interest Free Credit
- ★ all Leading Brands
- ★ OPEN SUNDAYS

## MIDLANDS

*Branches at:*

- 363 Hagley Road, Edgbaston, Birmingham Tel: 0121 429 2811
- 93-95 Hobs Moat Road, Solihull Tel: 0121 742 0254
- 156/157 Lower High Street, Stourbridge Tel 01384 444184

- DEMONSTRATIONS BY APPOINTMENT -

**MUSIC MATTERS**



*JUST ARRIVED....*

DPA RENAISSANCE CD + ENLIGHTENMENT DAC, TEAC VRDS-T1 + T1 DAC, B&W CDM1 & 2 & P SERIES, CYRUS PRE-POWER DENSEN DM10 & BEAT, HEYBROOK QUARTET & SEXTET'S, AUDIOLAB 8000Q, RUARK EQUINOX, PINK TRIANGLE CARDINAL, DACAPO & ANNIVERSARY TURNTABLE, etc...

 INTEREST FREE (for Ltd period)  
APR 0% Written details on request.  
Licensed Credit Broker. Switch Card accepted.

**OPENING TIMES**  
TUESDAY TO SATURDAY  
10.30 TO 6PM, LATE NIGHT FRIDAYS  
TILL 8PM.  
CLOSED MONDAY.

**EX-DEM AND SECOND-HAND CLEARANCE SALE AT EDGBASTON STORE**

## MIDLANDS



**Spaldings**  
ESTABLISHED IN SOUND

☎ 081-654 1231/2040  
352/4 LOWER ADDISCOMBE RD., CROYDON, SURREY

**FRANK HARVEY**  
Hi-Fi EXCELLENCE

163 Spon Street, Coventry, CV1 3BB Tel : 0203 525200.  
Mon to Sat 9.30 till 5.30. Closed Thursday

**MUCH MORE THAN HI-FI**  
WE ARE A **BADA DEALER** MAILORDER - EXPORT - HOME TRIALS

Audiolab • Audio Alchemy • Arcam • Alphason • Bose • Bang & Olufsen • Celestion • Cyrus • Denon • Dual • Foundation • Kel • Marantz • Monitor Audio • Mission • Musical Fidelity • Nakamichi • Nad • Quad • Rega • Rogers • Rotel • Target • Tmpod • Tannoy • Thorens • Van Den Hul • Yamaha

**3 Floors, 3 Dem rooms, 3000 sq feet in the pursuit of Hi-Fi Excellence**



**AUDIO EQUIPMENT FROM LEADING AND SPECIALIST BRANDS ON TWO FLOORS FOR YOU TO LISTEN AND CHOOSE FROM**

**SOUND ACADEMY**

 Quality, Clarity, Expertise... and that's just the service!

- 3 Demonstration Rooms
- Home Trials
- Home Cinema - Instore Demonstration Theatre
- Audio Visual Equipment
- Evening Demonstrations by appointment
- Inhouse Service Department
- Mail Order Available
- Interest Free Credit on Selected Items (Apr. 0% - Written details on request)

Hi-Fi for the Beginner, the Enthusiast and the Audiophile Telephone (0922) 493499/473499

ACUSTIC ENERGY • ARCAM • ALEMA • AUDIO LAB • APOLLO • A.T. • AUDIO ALCHEMY • AUDIO QUEST • BAW • BUSE • BEYER • CABLE TALK • CHORD COMPANY • CHORD • CYRUS • CELESTION • DBA • EPOS • EXPOSURE • INFINITY JPW • KEF REFERENCE • KENWOOD • MARANTZ • MICHELI • MONITOR AUDIO • MONSTER • MORDAUNT SHURI • MERIDIAN • MICROMEGA • MISSION • MOTU • MUSICAL FIDELITY • NAKAMICHI • ORTOFON • PROJECT • QUAD • ROKSAN • ROGERS • ROTEL • SENNHEISER • SONY • SPENDUR • SUIMIKO • SYSTEMDEK • TARGET • TDL • THORENS • TRIANGLE • TUBE TECHNOLOGY • VAN DEN HUL • VANDERSTEEN • YAMAHA • YBA

Sharing the ASDA Carpark with ample free parking.  
Off High Street, Bloxwich, Nr. Walsall, West Midlands  
Near M6 Jnc. 10 & 11  
Open 6 Days, 9am - 6pm  
Late night Friday



# Specialist Hi-Fi Dealers

## MIDLANDS

### WELL ENGINEERED PRODUCTS FOR ACCURATE SOUND REPRODUCTION FROM:

Arcam, ATC, Audioquest, Audio Technica, AVI, Beyer, Cable Talk, Castle, Chord, CRD (Valve), Denon, Dual, Klipsch, Michell, Nakamichi, Ortofon, QED, Quad, Revox, Sennheiser, Sequence Design, S.M.E., Sponder, Target, TDK, TDL, Thorens, Triology (valve) etc., Keith Monks Record Cleaning Machine.

### FIVE WAYS HI-FIDELITY LTD (Est. 1972)

12 Islington Row Edgbaston, Birmingham B15 1LD  
0121-435 0667 (closed Mondays)

## CREATIVE AUDIO

9 DOGPOLE, SHREWSBURY,  
SHROPSHIRE

Tel: (01743) 241924

Closed Mondays

- Comfortable listening rooms
- Home demonstrations available
- Part exchange welcome
- Free home installation
- Interest free credit

Authorised retailer for:

A&R ARCAM, AUDIOLAB,  
CELESTION, CYRUS, DENON, DUAL,  
MERIDIAN, MISSION, MONITOR AUDIO,  
QUAD, REVOLVER, ROKSAN, ROTEL,  
YAMAHA, EPOS, NAIM, KEF, NAD

## WEST & WALES

### V AUDIO

Tel: 0117 95686005

36 Druid Hill  
Stoke Bishop

ATC, AVI, Acoustic Energy, Audio Innovations, Alon, Audiomeca, Audio Technica, AMC, Analogue Electronics, Cadence Valve, Chord Amps, Electrocompaniet, Exposure, Goldring, Harman Kardon, Heybrook, Jamo, LFD, Lyra, Ortofon, Perception, Pink Triangle, Ruark, Michell, REL, Sansui, SME (inc. 20A), Sonic Link, Stax, Sugden, Sumiko, Townshend, Triangle, Wagia.

Demos by appointment only. Home trial facilities.  
Free installations. Servicing facilities.  
We are not a shop.

## ENGLISH audio

### CYRUS CENTRE

PINK TRIANGLE-AUDION-SYSTEMDEK-HEYBROOK-MICHI-KEF-REFERENCE-MICROMEGA-NAKAMICHI-CHORD-ARCAM-ROGERS-NAD-ROTEL-DENON-TANNOY-MARANTZ-MISSION-STAX-DUAL-TDL-JPW-EXPOSURE-YAMAHA-JOHN SHEARNE-AND OTHERS

Free installation. Credit facilities: Service department

Mon - Sat 9.30 - 5.30

37 Whitecross Road, Hereford. HR4 0DE

## EIRE

• REL • Audiolab • Arcam • B&W •

A Passion for Excellence

**CLONEY**  
*Audio*  
for those who demand the best

55 Main St Blackrock

Tel: 2889449 • 288477

Open: Tue-Sat 10AM-6PM. Thur/Fri 'till 9PM

• EAR • Classé • Meridian • TDL •

• Naim • Castle • Epos • Technics

• Audioquest • Pink Triangle • Rega

## SCOTLAND

ANCRUM  
ELECTRONICS

YOUR LOCAL HI-FI SHOP

PIONEER, TECHNICS, PROLOGIC AMPS + LASER

DISC FOR HOME ENTERTAINMENT

TEL: (01382) 480030

39 GRAY ST., BROUGHTY FERRY DUNDEE

## OVERSEAS



Get on our list -  
to get closer to this list.

• MIT MultiCap • Wonder Cap • Kimber Kap • Solo • Hovland MusiCap  
• Solen • Siemens • Wima • Holco • Rel-Cap • Dralonic • IRC • Allen-Bradley  
• Jensen • Resista • Vishay • Caddock • Mills • Matsushita • TKD • Noble  
• Cardas • Kimber Kable • van den Hul • Discovery • Audioquest • MIT  
• Alps • Bourns • Shalco • Elma • Electroswitch • Nichicon • Gold Aero • RAM  
• Mallory • Panasonic HFQ • Nichicon • Elna • New Old Stock • Ruby Tubes  
• UltraAnalog • Burr-Brown • Crystal • Linear Technology • Analog Devices  
• Edison Price • International Rectifier • Hitachi • Motorola • UCC  
• MagnQuest • Sonic Frontiers • Pearl • Tube Sockets • WBT • Neutrik  
• Sound Coat • Curcio Audio Engineering • Assemblage and other kits

And it's growing and growing. To order The Parts Connection 1995 Catalog & Resource Guide, send £7 and mailing information. You'll also receive a Discount Coupon worth \$10 off a purchase over \$100 or \$25 off a purchase over \$250\* as well as The Broadboard bulletin to keep you updated on our latest news, information and growth spurts.

\*or \$10 US, or credit card information  
\*discount coupon values are in US Dollars



**THE PARTS CONNECTION**  
A DIVISION OF SONIC FRONTIERS INC

2790 Brighton Road, Oakville  
Ontario, Canada L6H 5T4

Toll Free Order Line

1-800-769-0747

(U.S. & Canada only)

Tel (905) 829-5858

Fax (905) 829-5388



## HOW TO SAVE £100 ON YOUR HI-FI

Choosing the right Hi-fi and saving money is a difficult task, make it easy on yourself.

To get your copy of "Guide to Buying Hi-fi" just telephone

**FREEPHONE 0800 373039**

We will send you one Free of Charge together with our Fact Pack and see how you can save £100 on recommended Hi-fi Systems.

## Active Audio

12 Osmaston Rd. 29 Market Street. 95 Stafford Street.  
The Spot. Tamworth Hanley.  
Derby Staffs. Stoke-on-Trent.  
Tel: 0332 380385 Tel: 08273 53355 Tel: 0782 214994

## WEST & WALES

audio excellence **3ADA**  
THE ULTIMATE IN SOUND ADVICE

WHERE THE MUSIC MATTERS

### Bristol

65 Park Street  
Bristol BS1 5PB  
(01179) 264975

### Cardiff

134/6 Crwys Road  
Cardiff CF2 4NR  
(01222) 228565

### Gloucester

58 Bristol Road  
Gloucester GL1 5SD  
(01452) 300046

### Swansea

9 High Street  
Swansea SA1 1LE  
(01792) 474608

TUESDAY - SATURDAY 9.00 - 5.30  
CLOSED MONDAY

## NORTH

HI-FI YOU  
CAN'T  
AFFORD  
not to listen to

EQUIPMENT BY ABSOLUTE SOUNDS,  
AUDIO INNOVATIONS, SUGDEN, IMPULSE, MICHELL, ROKSAN,  
PINK TRIANGLE, ACCUPHASE, THIEL, COUNTERPOINT, SONIC  
FRONTIERS, TRICHORD RESEARCH ETC.  
By appointment only

**SERIOUS KIT**

061-707 4823

## ACTION GATE AUDIO

4 Ruabon Road, Wrexham, Clwyd LL13 7PB  
Tel: (01978) 364500

Yamaha Cinema DSP Specialist

AMC, MARANTZ, MISSION, MUSICAL  
FIDELITY, QUAD, REGA, ROTEL, TANNOY,  
ETC.

Family business ask for Chris or Mike.

## • SOUNDS AROUND •

NEW & USED HIFI

Professional Service Repairs and  
Accessories

146A Clarendon Park Road, Leicester

Telephone : 0533 702442

# Specialist Hi-Fi Dealers

## REPAIRS/DIY

### GT AUDIO

Specialises in the repair of all types of audio equipment (including valve). All work is guaranteed and carried out to the highest standard.

Tel: 0895 833099

### THE Service Specialists

From early VALVES [we'll happily re-align your HRO!] to the latest DIGITAL LASERDISC .....  
 REVOX • TEAC • QUAD • ROGERS • RADFORD • TRESHAM • KENWOOD • ALTOBASS • TASCAM • PIONEER (LASERDISC & HI-FI) YAMAHA etc.  
 Our facilities are already used by Broadcasters, Recording Studios & leading Manufacturers.  
 If you've a quality-equipment problem .... call us today

AUDIO LABORATORIES (LEEDS)  
 0113 2440378



Russ Andrews Ltd.  
 Edge Bank House, Skelsmergh, Kendal,  
 Westmorland, LA8 9AS, ENGLAND  
 Tel: 01539 823247 Fax: 01539 823317

If you like the Hi-Fi equipment you have but want a better performance, don't change it -

#### UPGRADE IT!

You can build better than you can buy and we offer kits, parts and instructions for anything from simple component upgrades to complete rebuilds, plus kits to build high end equipment from scratch.

#### New Upgrading Service.

If you are doubtful of the prospect of taking the lid off your prized possession, send it to us and we can do the upgrade for you. We will advise on feasibility and cost before starting work and upgrade to the level of performance you require and can afford. We have a secure, low cost collection and delivery service within the UK.

Upgrades to: Audio Research, Celestion, KEF, Krell, Linn, Morantz, Meridian, Noim Nytech, Pioneer, Quad, Leak, Radford, Rotel etc....

To receive your copy of our 1994/95 catalogue and a £5 discount voucher usable on your first order over £50, just mail, phone or fax the address above, together with £3 or \$5US or your credit card information.

### RESTORATION OF CLASSIC EQUIPMENT

SUITABLY QUALIFIED ELECTRONICS ENGINEER (DEGREE/MAES) WITH OVER 40 YEARS EXPERIENCE AND SPECIALIST KNOWLEDGE OF QUAD, RADFORD, LEAK, ROGERS, AND ARMSTRONG, ETC. EXTENSIVE WORKSHOP FACILITIES ENABLE ORIGINAL STANDARDS ACCOMPANIED BY DETAILED REPORTS OF WORK CARRIED OUT. CLIENTS WILL HEAR THEIR APPARATUS DEMONSTRATED PRIOR TO THEIR DEPARTURE. AVAILABLE 7 DAYS PER WEEK

CIRCUIT DATA ON OFFER (SEND SAE FOR LIST)  
 TEL 0181 504 5467 WOODFORD, ESSEX

Sowler Transformers  
 EA Sowlers Ltd  
 PO Box 36  
 Ipswich IP1 2EL  
 0473 219390/252794

Output and mains transformers for GEC KT88 circuits.  
 Can also make any other transformer to order. Send SA for lists and data.

## SERVICES & CONSULTANTS

### LORICRAFT AUDIO

Required Garrard 301/401, Thorens TD124, Goldring GL75 any condition or any parts from new to completely used

Tel/Fax/Answer phone -  
 01488 72267

## VALVES/TUBES

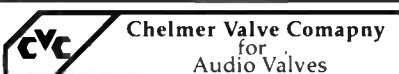

Buy CVC PREMIUM Hi-Fi valves direct from us. All valves processed for improved performance. We also have Stock of MAJOR BRAND types including :MULLARD, GEC, BRIMAR, RCA, GE, etc  
 130, New London Road, Chelmsford, Essex, CM2 0RG  
 Tel: 01245 265865 Fax: 01245 490064

### SOVTEK VALVES

6550WA. 6L6WGC/5881. EL34G.  
 12AX7WB/7025. EF86/6267

Over 1000 different types of valves stocked S.A.E. for list DEPT. HFW

Wilson Valves, 28 Banks Ave, Golcar,  
 Huddersfield, West Yorks, HD7 4LZ.  
 Tel: 0484 654650/420774 Fax:0484 655699

Mail order only, Visa etc.

## SERVICES & CONSULTANTS

### REVOX SERVICE

A77, B77 PR99

For fully guaranteed professional service and repairs, call RamTek.

Tel: (081) 207 6159. Fax: (081) 953 1118  
 Suite 33, Kinetic Centre, Theobald Street,  
 Borehamwood, Herts WD6 4SE

### R. J. F.

#### AUDIO VISUAL

Tel: 01209 612260 Fax: 01209 710777

A.K.G., Audio Innovations, Audio Analysis, Atacama, Audio Mech, Audionote, Audioquest, Audio Technica, Beyer, Cable Talk, Denon, Foundation, Goldring, Harman Kardon, Impluse, JBL, JPW, Klipsch, Micromega, Monitor Audio, Musical Fidelity, NAD, Nakamichi, Onkyo, Ortofon, Preception, Project, QED, S.D. Acoustics, SME, Sonic Link, Soundstyle, Sugden, Target, TDL, Teac, Triangle, Trichord, Vivanco

## MUSIC

### CD SELECTIONS

The UK's leading suppliers of bargain CDs and music for your free catalogue contact

CD SELECTIONS  
 PO BOX 1011  
 DORCHESTER DORSET D12 7YG  
 Tel. 0305 848 725

## Hi-Fi World Specialist Dealer Directory Order

Book 12 Months For A 30% Discount!! Or 6 Months For A 20% Discount.

I wish to be included in Hi-Fi World's Specialist Dealer Directory

starting the ..... issue for a total of ..... insertions.

Please find enclosed my artwork/copy details.

I wish to book ..... column centimetres at £12.50 per col. cm.

Name .....

Company .....

Address .....

Postcode .....

Telephone No.....

Please return to:

Hi-Fi World, 64 Castellain Road, London W9 1EX

# Meet-Your-Maker

A reference guide to Britain's Manufacturers and Distributors.

**ACOUSTIC ENERGY**, 3a Alexandra Road, London W13 0NP. Tel: 0181 840 6305. Acoustic Energy manufacture the award winning Reference Series AE1 and AE2 loudspeakers and the new Aegis Series Model 1, all of which feature the unique AE metal cone drive units. The AE distribution division offers superb high end products from WADIA, GRYPHON, ENSEMBLE and TARA LABS.

**ALCHEMIST PRODUCTS**, 4 Rosebury Mews, London N10 2LG. Call us for a list of our dealers in many areas including:- London, Kent, Hampshire, Wilts, Milton Keynes and N. Ireland and for product information on the Kraken, Freya, Bragi, Odin, Genesis and more Tel: 0181 883 3008

**ALEMA UK LTD.**, 25 Montifore Road, Hove, BN3 1RD. Tel: 01273 202637. Audion \* Edison \* Andersson \* (Trade enquiries welcome for our newly extended range).

**APPOLLO**, The UK based designers and manufacturers of high quality speaker stands and equipment racks have now added to their comprehensive range a modular system ideal for housing audio visual products and CD storage. Please send for our free brochure to Zenith Crown Ltd. Tipton Rd, Dudley, West Midlands, DY14 Tel: 0121 520 5070. Fax: 0121 522 2055. - All export trade enquiries welcome.

**ARCAM**, Pembroke Ave, Denny Industrial Centre, Waterbeach, Cambridge, CB5 9PB. Tel: 01223 440964 or Fax: 01223 863384. Manufacturers of the Delta 290 Amplifier and the Delta 280 Digital FM Tuner. The two together produce a sound that has been described as 'subtle and intriguing' and that provide 'real clout' - discover this for yourself. For information on not only these products but also the Arcam CD Players, Speakers, Cassette Decks etc., Phone or write in to request a brochure - The pleasure is all yours!

**ATACAMA AUDIO SUPPORTS** from Sambell Engineering Ltd. We are the sole manufacturers of the 'SE' range of speaker stands, consisting of an 8", 12", 16", 20" and the award winning 24" high stand. Also three specialist models for the Tannoy sixes Loudspeakers.

**AUDIONOTE CD**, Unit 1, Block C, Hove Business Ctr. Fonthill Road, Hove BN3 6HA. Tel: 01273 220511. Audionote supply a range of very high quality and very expensive audiophile components including valve output transformers.

**AUDIO SYNTHESIS**, 99 Lapwing Lane, Manchester. M20 0UT. Tel: 0161 434 0126. Audiophile design, development and distribution. Please contact us for details of: PASSION the passive controller everyone's talking about. SILVERBLUE pure silver interconnect cable and the ultra analog based dac - DSM.

**BANDRIDGE LTD** are the premier suppliers of quality audio and video leads, connectors and speaker cables in the UK. In addition to probably the widest range available, including PROFI GOLD, SUPER GOLD and SUPER +, offering a level of quality that meets the needs of the most exacting specification. Bandridge of London Ltd. Premier House, Deer Park Road, Wimbledon SW19 0181 543 3633.

**CA8LE TALK** PO Box 413, Woking, Surrey, GU22 8YZ. Telephone 01483 750667. Fax 01344 360866. Designers and manufacturers of British made high quality, value for money, interconnect and speaker cables. Phone or fax for a free full colour brochure on our What Hi-Fi? 5 star rated products

**CAMPAIGN AUDIO DESIGN**, Llandudno Road, Cardiff CF3 8PG. Tel: 01222 779 401. Supplies / manufactures mailorder high purity silver interconnects, loudspeaker cables, internal wires and bespoke mains cables. Generous two week trial period.

**CANFORD AUDIO PLC**, Crowther Road, Washington, Tyne & Wear, NE38 0BW. UK Sales 091 415 0205 Admn 0191 417 0057. Fax 0191 416 0392 UK's leading manufacturer and distributor of professional audio equipment 9000+ products are detailed in a bi-annual catalogue which is available free of charge to professional users. Next day deliveries when possible.

**CHDRD ELECTRONICS**, 3 Bower Mount Road, Maidstone, Kent. Tel: 01622 764874 Audition the

Chord SPM 1200 at any of the following branches: Doug Brady HiFi - Liverpool / Leeds / London / Cheshire, Audio Reflections - Leeds, Music Matters - West Midlands and many others. Please call us for details.

**CREEK AUDIO LTD** 2 Bellevue Road, Friern Barnet, London N11 3ES. Tel: 0181 361 4133. Fax: 0181 361 4136. Manufacturers of the 4240 Integrated Amp, P42 and A42 Pre/Power Amps, CD42 CD Player. Please write for further details.

The Exultant Power Amp fitted to Quad II Hardware.

**DBS AUDIO**, PO Box 91, Bury St. Edmunds, Suffolk, IP3 0NF. Tel: 01284 828926. Fax: 01284 828026. The DBS6 loudspeaker kit, as designed by Dave Berriman and featured in Hi-Fi News Feb/Mar 92, is still available - only from DBS Audio. To find out what these comprise, cost and how to order plus any other information on DBS products please telephone, fax or write in to the above address and numbers.

**D H M DESIGN**, - BUNDEE CD REPAIR PROTECTION SYSTEM - Tried and tested on Tomorrow's World. Repairs and protects over 50 CD's, even those scrubbed with steel wool. Effective for all laserdisc formats including CD ROM, MiniDisc and CDI. RRP £14.95. Why buy a new one when you can clean, repair and protect fifty? Contact David Mather for details of your nearest stockist or distributor. Export enquiries welcome. DHM Design Ltd, Studio 6, Bentinck Court, Bentinck Road, West Drayton, Middlesex. UB7 7RG Tel: 01895 449559 Fax: 01895 420540

**ECA DISTRIBUTION**: For the "naturally neutral" chain. Nothing added; nothing taken away. The VISTA line-amp; The LECTERN S power-amp and the SERVO A.2 speakers. Resulting from their own Research and Development, the ECA Design Team provides a "super-symmetry" circuit with the barest minimum of wiring in the amps vacuum impregnated air-coils in the custom-made midrange unit for the speakers. P.O.Box 3023 London NW2 7RW. Tel: 0181 830 5128

**IAN EDWARDS**, The Old Chapel, 282 Skipton Road, Harrogate, Yorks. Tel: 01423 500442. Somebody Somewhere must make better storage units for CDs, Music, LPs, HiFi, Books, etc. than Ian Edwards. BUT until he appears, why not send for the brochure showing a selection of HAND MADE units. To do this please send 3 x 2nd class stamps.

**E J JORDAN DESIGNS**, The Oak, Manor Bier, nr Tenby, S Pembrokeshire, SA70 8QR. Tel: 01834 871 209. or Fax: 01834 871 770. Curvilinear metal cones loud speakers were first developed by Ted Jordan in 1963. EJ Jordan Designs are now World leaders in foil cone technology. First and foremost.

**ELECTROFLUIDICS**, 27 Fournier Street Spitalfields London E1 6QE Tel: 0171 247 0813. Makers of the acclaimed Sonolith loudspeaker series and Monolith 20/20 cable. Mineral polymer enclosures, controlled - flexure alloy - coned drive units, ultra - low impedance wide - band feeds: extraordinary clarity, control and resolution.

**ELYTON ELECTRONICS** (Yuetone), c/o Don Fordy Ltd., 4 Abertawe House, Ystrad Road, Swansea, SA5 4JS. Tel: 01792 - 588862 or Fax: 01792 - 588865. Elytone Electronics (formerly Yuetone Industrial) are Taiwanese OEM manufacturers of high quality Loudspeaker Crossover Networks and associated components. Don Fordy Ltd. are the UK agents for Elytone.

**EMF**, 2a Bellevue Road, Friern, Barnet, N11 3ES. Tel: 0181 361 6734. Manufacturer of Sequel 50w integrated amplifier and the Crystal D2A converter Amplifier and DAC. Please write in for details.

**FALCON ACOUSTICS LTD.**, Tabor House, Norwich Road, Mulbarton, Norwich, Norfolk, NR14 8JT. Tel: (01508) 78272. U.K. distributors of FOCAL drive units and SOLEN (chateauroux) polypropylene capacitors and the largest injector manufacturer in the U.K. Comprehensive range of DIY Speaker Parts and Kits, Sub-Bass and Electronic Filters. "Everything but the wood"

**FULLERS AUDIO**, 20 Tunbridge Road, Southend on Sea, Essex SS2 6LT. Tel: 01702 612116. Fuller's audio produce a range of innovative

products. Amplification - a10 a single ended class A semiconductor power amplifier - £1200, b70 a mosfet power amplifier of high standard - £599, prel and prel + matching pre-amplifiers - £599/£649, geni phono stage for mm and mc cartridges £299. Loudspeakers - Pharoah system, upgradable from 1 pair of cabinets to 3 pairs for truly extended bass, passive/active options £649-£2499 Sphinx a 3 way floor standing unit £849, Sultan H.E., 98dB sensitivity £439, matching Sub Woofer £559, Sultan, 91.5dB sensitivity £309.

**F & S TRADING LTD**, 31 Brooks Road, Sutton Coldfield, West Midlands B72 1HP Tel: 0121 321 3357. "Single-ended amplifiers"

**J E SUGDEN & CO LTD.**, Valley Works, Station Lane, Heckmondwike, West Yorkshire, WF16 0NF. Tel: 01924 404088. Manufacturers of hand crafted audio products. "A world of Music". Call or write in for information on our SDA-1 Digital to Analogue Converter, SD1-I CD Player, A21a Class 'A' Amplifier, A25B Integrated Amplifier, A48 Integrated Amplifier, Au51c Pre Amplifier, Au51p Power Amplifier and more.

**JORDAN WATTS ACOUSTICS LTD**, Cyntra Place, 201 Mare Street, Hackney, London E8 3QE. Tel: 0181 985 1646. Jordan Watts Acoustics for Sight AND SOUND.

**KESWICK AUDIO RESEARCH**, 54 Coach Road, Outwood, Wakefield, W Yorks, WF1 3EX. Tel/Fax 01924 870606. "I'd say that the Figaro is the best miniature speaker I have heard" Audiophile March 1993. Write in or call for details on our full product range and your nearest stockist.

**KRONDS DISTRIBUTION**, 35 Farlough Road, Dungannon, N. Ireland. BT714 DU. Tel: 01868 748632. Fax: 01868 448281. Kronos is the UK distributor of some of the finest Hi Fi products in Europe. These include Audiomeca digital products and turntables; Lieder silver speaker and interconnect cables; Pro-Ject turn-ables and amplifiers; Triangle speakers and electronics; and YBA amplifiers. We also handle Frameworks equipment tables; Arion valve amplifiers and mains filters and Essex Audio digital products from the UK. Please telephone or write for product details and dealer lists.

**LANGREX SUPPLIES LTD**, 1, Mayo Road, Croyden, Surrey. CR0 2QP. Tel: 0181 684 1166. Fax: 0181 684 3056. We are one of the largest stockists and distributors of electronic valves, tubes and semiconductor in the UK. Over 6,000 types in stock. We specialise in obsolete types including original UK and USA made audio valves. Telephone or fax for an immediate quotation.

**LINN PRODUCTS LTD**, Floors Road, Waterfoot, Glasgow, G76 0EP. Scotland. Customer Helpline 0500 888909. LINN HI-FI faithfully captures the source signal, nurturing and protecting it through every stage of the playback chain. All you have to do is listen to decide for yourself how good a sound you want. Call the LINN Customer Helpline free for further information on LINN HI-FI and LINN RECORDS, or to find your nearest retailer.

**LORICRAFT AUDIO**, 4 Big Lane, Goose Green, Lambour, Berks. RG16 7SQ. Tel: 01488 72267. Specialist restoration of 301's and 401's using genuine spares and re-manufactured parts to original pristine standards in our newly built work shops designed primarily for these purposes.

**MAY AUDIT MARKETING U.K. LTD.** 83 Main Street, Burley in Wharfedale, North Yorkshire. LS21 7BU. Tel: 01943 864930. Distributors of High Quality audio products from Duson Electronics, Totem Loudspeakers, Jecklin Float Headphones and quality recordings from Proprius, Prophone, Opus, MAP and Swedish Society. IF ITS MUSIC YOU LOVE, TELEPHONE OR WRITE FOR LITERATURE.

**MICHELL**, 2 Theobald Street, Boreham Wood, Herts, WD6 4SE. For full information on our full range of excellent products including the Gyrodec. Alecto, Iso, Argo and others please telephone us on 0181 953 0771. Michell - Symbol of Precision  
**PLATFDRM 7** high density marble ISOLATION PLATFORMS for all makes of equipment RACKS/STANDS an elegant way to UPGRADE. Improves clarity, better BASS control. 3 Abbots Drive, N. Wembley, Middlesex HA0 3SB TEL: 0181

904 2646 Also NEALGAR DISTRIBUTION TEL/FAX 01296 24756

**QUANTUM AUDIO LTD**, PO Box 26, 1 Oliphant Drive, Kilmarnock KA3 7JA. Tel: 01563 71122 Fax 0563 71133. Quantum's craftsmen produce the £899.99 MINSTREL 30 Watt, Ultra Linear, zero feedback correction, integrated, line level, valve amplifier. Don't buy any old fashioned valve amplifier before hearing the unique improvements modern technology provides to valve sounds. AAn audition will immediately convince the listener of the Minstrel's superiority.

**SELECT SYSTEMS (PERFECT PITCH MUSIC)**, Hanworth Trading Estate, Hampton Road West, Feltham, Middlesex, TW13 6DH. Tel: 0181 893 8662. Fax: 0181 893 4318. We manufacture the Francinstien CD enhancement system, The Oacua DAC and Perfect Digital and Analogue interconnects. Perfect Pitch also provide freelance design, manufacture, prototyping and test, also valve and solidstate specials. Trade enquiries welcome.

**REL ACOUSTICS**, Unit 2, New Street, Bridgend Ind Est. Bridgend, Mid Glamorgan, CF31 3UD. UK. Tel: 01656 768 777. international +44 656 768 777. Fax: 01656 766 093. international. +44 656 766 093. The UK's only specialist sub-bass speaker manufacturer. "The only one that works". Get your dealer to give you a home demo and find out what the fuss is all about.

**REL. HARMAN AUDIO**, Unit 2, Borehamwood Ind. Park, Rowley Lane, Borehamwood, Herts. WD6 5PZ. Tel: 0181 207 5050, Fax 0181 207 4572. Sub Base Systems - Rel Strata, Stadium, Stentor, Studio

**RICHARD ALLAN AUDIO**, Bradford Road, Gomersal, Cleckheaton, W Yorks. BD19 4AZ. Tel: 01274 872442. Fax 01274 869935. Manufacturers of very high quality loudspeaker enclosures and drive units. Examples being the £270 RA8 series 2 as supplied to the BBC and the 5" reviewed Minette 2 at £120.

**SEQUENCE DESIGN LTD**, 83 Main Street, Burley-in-Wharfedale, Yorkshire. LS29 7BU. Tel: 071 495 0775. Fax 0171 495 0281. Slim loudspeakers which stand close to a wall or hang like pictures. "Likely to cause a glint in the audiophile's eye" (Audiophile); "the answer to a prayer....a bargain in the extreme" (HiFi News). Available with light or dark grilles and various solid wood finishes. From £199.95 a pair. Call or write in for an information kit and reviews re-prints.

**SHEARNE AUDIO**, PO Box 22, Stevenage, Herts. SG2 8HF. Tel: 01438740953. Following the success of John Shearn's Phase 1 pre power combination, (reviewed in HFV), is the phase2 reviewed earlier in HFV and listed as a world favourite. Having many of the design features of the phase 1 R.R.P. £549, 50 wpc and same finish as Phase 1 pre-power. Also, option of phono stage for phase 2 mm £65 mc £75

**TARGET AUDIO PRODUCTS PLC**, Britannia House, Leagrave Road, Luton, LU3 1RJ. The Audio equipment, rack and speaker stand specialist. For information on our products please telephone or write.

**TRICHORD RESEARCH LIMITED** Following on from the highly acclaimed CD clock oscillator modifications the Pulsar Series One digital to analogue converter. This unique design is part multibit and part bitstream to give absolute linearity over an extremely wide dynamic range. Switchable between 18 or 20 bit resolution this converter will become the standard for CD replay. For details telephone (0684)573524

**WILMSLDW AUDIO LTD**, Wellington Close, Parkgate Trading Est. Knutsford, Cheshire, WA16 8DX. Tel: 01565 650605. Extensive range of drive units and over 30 different designs of self-assembly kits. Everything required for the loudspeaker builder and four dem rooms to listen to the kits in built-up form.

## REPAIRS & DIY

**SOUNDS ARDUND**, 146A Clarendon Park Road, Leicester. Tel: 01533 702442. New and used Hi-Fi. Professional service repairs and accessories.

# KITS HAVE NEVER BEEN SO GOOD!

**NEW - KLPP1**

**£495**



KLPP1 has five line inputs, a tape input with monitor, and a unique low noise valve MM/MC phono stage. There is a switchable subsonic filter to prevent output transformers of valve amplifiers saturating. The line stage has gain, so it will drive any power amplifier. Audio grade components are used and many parts are custom made for highest quality. KLPP1 has a super clear sound, sweet and detailed through line and phono inputs.

The World Audio Design range of kits are engineered like no others. Features of World Audio Design valve amplifiers include:

- Pure Class A working
- 4/8/16Ω taps for optimum speaker matching
- Custom designed transformers for unrivalled performance.
- Audiophile components
- Choke regulated power supplies
- Can be easily monoblocked for double power
- Welded steel chassis
- Hard wearing 'baked on' powder coat finish



**300B VALVE AMP KIT £850**

This is a specialised 28watt amplifier based on the highly linear 300B triode valve. Our 300B runs in Class A, giving one of the most sweet, open and neutral sounds possible today. It is so linear it can be used without feedback, but feedback can be switched in for difficult loads. Matched with good loudspeakers, it is unsurpassed. Can be monoblocked for 60watts.

All parts are included in the kit, except valves since different 300B makes are available.



**K588 I PSE KIT £650**

An audiophile parallel-single-ended valve amplifier at an affordable price. K588 I PSE uses the reliable Russian 588I output valve in parallel-single-ended mode for outstanding detail and atmosphere. It produces 17watts enough to drive most loudspeakers, making high-end sound quality and design available to everyone. Can be easily monoblocked to give 32watts.

**K588 I KIT £395**

A superb, Class A, 20watt stereo power amplifier that uses the Russian 588I output valve, a military version of the American 6L6, designed for low distortion audio work.

Designed for long life, low running costs and excellent sound quality, K588 I is sensitive enough to be used with a simple passive pre-amp. or our own line-drive pre-amp, and it matches modern loudspeakers well.



 **World Audio**  
*design*

**Tel: 0171 289 3533**



### 4W SINGLE-ENDED VALVE AMP KIT £385

The 4W Single-Ended amplifier kit is a line level integrated amplifier. It comes with three line level inputs and a tape output. High quality components are used throughout, including polypropylene signal capacitors, Alps volume control, custom C&K gold plated selector switch etc. Valves are included.



### KLPI VALVE LINE PREAMPLIFIER £345

Newly updated with an extra line input and output for bi-amping or subwoofer connection, the line level preamplifier uses one of the simplest and most elegant circuits to give a sound with remarkable clarity and detail. The components are all high quality and include Military Spec, Russian valves, Alps potentiometer, polypropylene signal capacitors, silver plated copper wire etc.



### THREE WAY CARBON-FIBRE DRIVER LOUDSPEAKER

KLS3 uses extremely light and stiff carbon fibre cone drive units for a fast and accurate sound. A dedicated 4inch carbon fibre midrange drive unit provides the cleanest, smoothest and most detailed midrange characterised by superb projection.

KLS3 has been engineered to get the best from your amplifier, be it valve, solid state, single-ended or zero feedback. Its high 90dB sensitivity and near flat 8Ω impedance make it one of the easiest loudspeakers to drive.

Drive Unit & Crossover kit etc £350  
 Drive Unit Pack £230  
 Built £1500

### KLS4 TWO WAY CARBON-FIBRE DRIVER LOUDSPEAKER

Drive Unit & Crossover kit etc £230  
 Drive Unit Pack £120

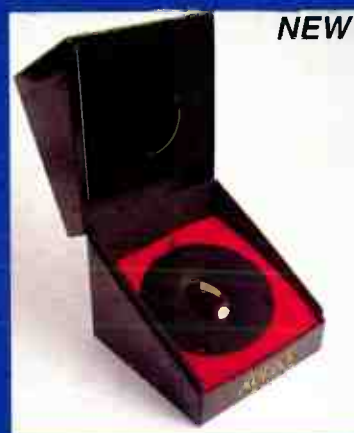

### HD-P3 OVAL GOLD DOME PIEZO ELECTRIC TWEETER £225

This special new tweeter from Audax gives exceptional clarity and detail - use with HM100Z0 high definition aerogel midrange unit on an open baffle (design available) for the ultimate in transparency.

### HIGH TECH AUDAX DRIVE UNITS

The 1994 range of Audax drive units sees many modern high tech materials and technologies that would normally be unavailable to the home constructor. We offer a small range of the highest quality drivers, including High Definition Aerogel (HDA) units, carbon fibre and three superb soft dome tweeters. Sadly there isn't enough room to print the specs, but if you are interested in any of the following drivers, please ask us for a detailed spec sheet.

#### Audax Drive Units:

##### CAST CHASSIS UNITS

	3inch mid	4 inch mid	6.5inch bass/mid	8inch bass
HDA	HM100Z0	HM130Z0	HM170Z0	HM210Z0
CARBON FIBRE		HM130C0	HM170C0	HM210C0

##### FABRIC DOME TWEETERS

TW025M0 (25mm 92dB suitable for 2-way systems)

TW025M1 (25mm 92dB suitable for 3-way systems)

TW034X0 (34mm 93dB a large dome with powerful sound)

OVAL GOLD DOME TWEETER HP-P3 (comes complete with crossover. Works extremely well with HM100Z0 giving ultra flat response from 400Hz to 20kHz.)

### CLASS A 36W SOLID STATE MONOBLOCKS

A pure Class A transistor design offering superb clarity and transparency. The Class A monoblocks use special new super grade audio transistors. They are extremely fast and linear, giving a super measured performance without the need of high levels for feedback.

Circuit board + output transistors £129.40



**World Audio**  
*design*

Tel: 0171 289 3533

### DEMONSTRATIONS!!

World Audio Design Products are on demonstration at:

**Hi-Fi Confidential**  
 34 Buckingham Palace Rd,  
 Victoria,  
 London.  
 Tel: Luigi on  
 0171-233-0774

**Horsham Hi-Fi**  
 28 Queensway,  
 Horsham,  
 W. Sussex.  
 Tel: Jeff on  
 01403-251587

World Radio History See page 85 for order form...

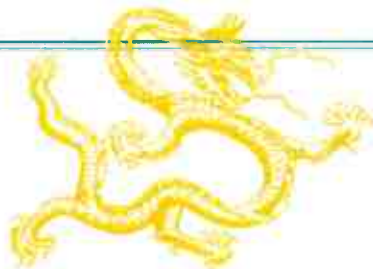

# Golden Dragon

## RETAIL PRICE LIST

Golden Dragon Pre-Amplifier Tubes	Singles
6AQ8/ECC85	£6.50
12AT7A/E81CC/ECC81	£6.95
12AU7A/E82CC/ECC82	£6.95
12AX7A/E88CC/ECC83	£6.95
6DJ8/E88CC/ECC88	£10.95
6SN7GT/ECC33	£8.95

## Special Quality Golden Dragon Pre-Amplifier Tubes

Special Quality Golden Dragon Pre-Amplifier Tubes	Singles
E81CC-01 Gold Pins Low Microphony Low Noise	£10.50
E82CC-01 Gold Pins Low Microphony Low Noise	£10.50
E83CC-01 Gold Pins Low Microphony Low Noise	£9.50
E88CC-01 Gold Pins Low Microphony Low Noise	£14.50

## Golden Dragon Triodes

	Singles	Pairs	Quads
2A3 4PIN	£22.50	£50.00	£100.00
2A3 OCTAL	£22.50	£50.00	£100.00
211	£28.50	£60.00	£120.00
811A	£11.50	£25.00	£50.00
845	£36.50	£75.00	£150.00
805	£36.50	£75.00	£150.00

## Golden Dragon 300B Range

	Singles	Pairs	Quads
300B Super	£79.00	£160.00	£320.00
4.300B	£84.00	£170.00	£340.00
4.300BLX Super	£124.00	£250.00	£500.00

Please enquire of any tube types not listed. We have an inventory of over 2,500 different types in stock.

## Golden Dragon Power Tubes

	Pairs	Quads	Octets
EL34/6CA7	£25.00	£50.00	£100.00
E34L	£29.95	£60.00	£120.00
EL84	£8.95	£19.00	£38.00
E84L	£12.50	£25.00	£50.00
6L6WGB/5881	£25.00	£50.00	£100.00
KT66	£25.95	£52.00	£104.00
KT88 (New Design)	£57.95	£116.00	£232.00
KT88 Super (Laminated)	£67.95	£136.00	£272.00
6L6GC	£19.95	£40.00	£80.00
6550A	£42.95	£86.00	£172.00
6550A Special (Gold Plated)	£64.95	£130.00	£260.00
50CA10	£84.95	£170.00	£340.00
807	£25.00	£50.00	£100.00

## Ceramic Sockets and Hardware

	Standard	Gold Plated
Locking 4 Pin (300B etc.)	£6.95	£15.00
4 Pin UX4 (300B etc.)	£2.5	£3.50
Jumbo (211 etc.)	£12.50	£25.00
Octal Chassis (EL34 etc.)	£1.25	£3.50
Octal PCB (EL34 etc.)	£1.25	£3.50
B9A Chassis (pre amp)	£1.25	£2.50
B9A PCB (pre amp)	£1.25	£2.50
Screening Can & Skirt (pre amp)		£8.50
Damping Can (pre amp)		£4.50
Power Valve Retainer (EL34 etc.)		£5.50

## Golden Dragon

NEW

KT66 Super

KT90

KT90 LX

274B

350B

NEW

£65.00 pair

£65.00 pair

£75.00 pair

£14.50 each

£29.95 pair

Carriage charge £2.50 on any U.K order. Cash with order or Visa - Mastercard accepted. 24 Hour Answerphone Service.

We have a vast range of tubes available from manufacturers all over the world including rare and vintage types. A 70 page booklet of valves available is updated monthly and can be provided at a cost of £2.50 per copy including U.K postage or you may telephone our Sales Desk for a prompt quotation. Prices exclude VAT. Please add VAT at 17.5%.

## A selection from our stock of over 2,500 different audio quality valves. Please enquire for items not listed

ECC81	BRIMAR	4.50	M8162/ECC81	MULLARD	8.50	6550A	TEONEX	12.50
ECC82	GE	4.50	M8137/ECC83	MULLARD	24.00	12AT6	BRIMAR	2.50
ECL82	TEONEX	3.50	0A2WA	TEONEX	4.50	12AV6	RCA	2.50
ECC83	TEONEX	3.50	PCC88	BRIMAR	3.50	12BA6	WESTINGHOUSE	3.50
ECC85	TEONEX	3.50	PL36	MAZDA	3.50	12BH7A	USA	12.00
ECC88	TEONEX	4.50	PL519	THORN	5.95	12E1	STC	15.00
ECC88	BRIMAR	4.50	TT100	GEC	65.00	13D3	BRIMAR	6.50
ECF82	RCA	3.50	U19	GEC	8.50	85A2	MULLARD	6.50
ECL86	TEONEX	3.50	UCC85	MULLARD	3.50	300B	TEONEX	50.00
EF86	TEONEX	4.50	2A3	TEONEX	15.00	807	TEONEX	6.50
EF804S	TELEFUNKEN	36.00	5Y3WGTA	SYLVANIA	4.50	1625	RCA	6.50
EL34	TEONEX	6.50	5V4G	BRIMAR	3.50	5687	USA	6.50
EL86	MULLARD	4.50	6AG7	RCA	3.50	5814A	GE	5.50
EL504	TEONEX	3.50	6A7G	RCA	8.50	5881	USSR	6.50
EL519	PHILIPS	15.00	6B4G	TEONEX	29.50	6072A	USA	8.95
GZ32	MULLARD	8.50	6C8G	RCA	3.50	6146B	TEONEX	8.50
GZ37	MULLARD	4.50	6K7G	RCA	3.50	6158	BRIMAR	6.50
GZ34	TEONEX	5.50	6L6GC	TEONEX	4.50	6189	SYLVANIA	4.95
G237	GEC	5.50	6SN7GT	TEONEX	4.50	6189W	GE	5.95
KT66	TEONEX	6.50	6V6G	RCA	6.50	6201	GE	6.50
KT88	TEONEX	12.50	6V6GT	TEONEX	4.50	6463	UNITED	7.50
M8136/ECC82	MULLARD	8.50	6X4	TEONEX	4.50	6870	BRIMAR	11.50

## EXPORT WELCOME CARRIAGE AT COST

P.M. COMPONENTS LTD., Springhead Enterprise Park, Springhead Road, Gravesend, Kent DA11 8HD, England  
Sales Desk Tel: 01474 560521. Fax: 01474 333762

**WARNING**

THESE ARE EXPERT KITS, NOT FOR THE INEXPERIENCED. YOU MUST BE ABLE TO SOLDER AND READ A CIRCUIT DIAGRAM. THE VALVE KITS CONTAIN LETHAL VOLTAGES. WE CANNOT BE HELD RESPONSIBLE FOR ANY ERRORS ARISING FROM THE CONSTRUCTION OF THE KITS.

**ORDER FORM**

Please send your completed order form to: WORLD AUDIO DESIGN, 64 Castellain Road, Maida Vale, London W9 1EX  
Tel: 071 289 3533 Fax: 071 289 5620

240/120 option - delete the voltage NOT required. Valves included except where stated.

**IF YOU WOULD LIKE A DATA SHEET ON ANY OF THE KITS, PLEASE WRITE A 'D' IN THE QTY BOX CONCERNED**

'BUILT' - we can supply the amplifiers built up and tested by an approved service, for safety and guaranteed performance to specification.

**WARNING - World Audio Design Ltd will accept no responsibility for kits, parts or modifications made or supplied by third parties and based on our designs.**

DESCRIPTION	ORDER No.	QTY	UK (inc VAT& carriage)	OVERSEAS. (net)
<b>4W single-ended integrated</b>				
KIT	4WSE-K240/120	<input type="text"/>	£385	£330
transformer set	4WSE-TR240/120	<input type="text"/>	£190	£150
<b>K588I 20W budget valve amplifier</b>				
KIT	K588I-K240/120	<input type="text"/>	£395	£350
BUILT	K588I-B240/120	<input type="text"/>	£595	£550
transformer set	K588I-TR240/120	<input type="text"/>	£220	£180
<b>K588IPSE 17W budget valve amplifier</b>				
KIT	K588IPSE-K240/120	<input type="text"/>	£650	£555
BUILT	K588IPSE-B240/120	<input type="text"/>	£850	£725
transformer set	K588IPSE-TR240/120	<input type="text"/>	£340	£290
<b>300B 28W specialised valve amplifier (prices do not include valves)</b>				
KIT	300B-K240/120	<input type="text"/>	£850	£725
BUILT	300B-B240/120	<input type="text"/>	£1150	£950
transformer set	300B-TR240/120	<input type="text"/>	£430	£370
<b>KLPI line level preamplifier</b>				
KIT	KLPI-K240/120	<input type="text"/>	£345	£295
BUILT	KLPI-B240/120	<input type="text"/>	£545	£465
<b>KLPP1 full valve phono preamplifier</b>				
KIT	KLPP1-K240/120	<input type="text"/>	£495	£425
BUILT	KLPP1-B240/120	<input type="text"/>	£695	£595
<b>KLS3 3-way carbon fibre driver floorstanding loudspeaker</b>				
Drive Units + Crossover kit etc	KLS3-C	<input type="text"/>	£350	£300
Drive Units	KLS3-D	<input type="text"/>	£230	£200
<b>KLS4 2-way carbon fibre driver standmounting loudspeaker</b>				
Drive units + Crossover kit etc	KLS4-C	<input type="text"/>	£230	£200
<b>AUDAX DRIVE UNITS (P&amp;P Extra, please add £5.75 for individual units or tweeters, otherwise add £10)</b>				
<b>High Definition Aerogel</b>				
3inch midrange	HM100Z0	<input type="text"/>	£35	£30
4inch midrange	HM130Z0	<input type="text"/>	£45	£40
6.5inch bass/mid	HM170Z0	<input type="text"/>	£50	£45
8inch bass	HM210Z0	<input type="text"/>	£60	£55
<b>Carbon Fibre</b>				
4inch midrange	HM130C0	<input type="text"/>	£40	£35
6.5inch bass/mid	HM170C0	<input type="text"/>	£45	£40
8inch bass	HM210C0	<input type="text"/>	£55	£50
<b>Fabric Dome Tweeters</b>				
25mm 92dB for 2-way systems	TW025M0	<input type="text"/>	£15	£13
25mm 92dB for 3-way systems	TW025M1	<input type="text"/>	£16	£14
34mm 93dB - powerful sound	TW034X0	<input type="text"/>	£25	£22
Oval Gold Piezo electric dome tweeter	HD-P3	<input type="text"/>	£225	£195

NAME: \_\_\_\_\_  
ADDRESS: \_\_\_\_\_  
\_\_\_\_\_  
\_\_\_\_\_

I enclose cheque/postal order for £ \_\_\_\_\_  
made payable to **World Audio design Ltd.**  
I wish to pay by Access/Visa. Debit my account no:

POST CODE: \_\_\_\_\_ TEL: \_\_\_\_\_

Expiry date:

**CREDIT CARD ORDERS TELEPHONE 071 - 266 0461 (24 HOURS)**

Signature .....



**OVERSEAS PRICES AND DETAILS**

All our kits can be supplied overseas excluding the European Community, free of UK tax (VAT). However, allow for your own local import taxes (customs duties) and for carriage charges, which must be added to our net price. Surface mail is slow (1-4 weeks) but inexpensive; airmail is fast (up to 7 days) but more expensive. We recommend couriers like UPS for speed and door-to-door service. We package overseas orders securely.

**METHODS OF PAYMENT**

International money order in Sterling, Visa, Mastercard/Access, Local Currency at agreed exchange rate by registered mail. Payment in advance. Contact us for details.  
**CONTACT: RICHARD JOHNSON** London, England.  
PHONE (9.30am-6pm) 071-289-3533  
ANSWERPHONE (24hrs) 071-266-0461  
FAX (24hrs) 071-289-5620



**With phenomenal work from John Zorn and Painkiller and various other great shakers taking so much space of late, dozens of fine jazz releases have almost slipped through the net, so here's a dash through some other recent must-haves.**

## *Simon Hopkins*



**JOHN PATTON QUARTET**  
**Minor Swing**  
DIW 896

● Organist John Patton was a legendary Blue Note regular in the sixties. Here he enjoys a welcome reappearance in stellar contemporary company. Zorn contributes wailing, crying alto, further proving he's one monster jazz altoist. Guitarist and Henry Threadgill sideman Ed Cherry flits from funky comping to lyrical, post-Jim Hall soloing, and drummer Kenny

Wollesen - Joey Baron's stand-in on the live version of the Masada group - drives proceedings along in a fiercely swinging manner. The music they create together is great jazz-blues, at once inventive and cerebral yet earthy, street music for the knowing and the hip.

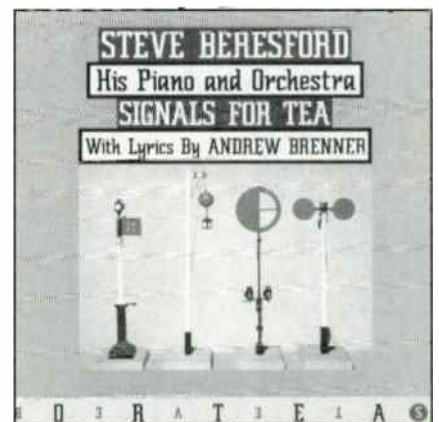

**STEVE BERESFORD - HIS PIANO AND ORCHESTRA**  
**Signals for Tea**  
AVANT AVAN039

● Zorn and Wollesen make up two fifths of this group, alongside fellow Masada men trumpeter Dave Douglas and bassist Greg Cohen. All answer to Brit improv man Steve Beresford ("the best fucking musician in Europe" according to Zorn) who here ditches his usual assortment of ancient clapped-out toys, arcane devices and general junk in

favour of a joanna and his voicebox.

The group work their way through a series of mildly jazzy tea dances whose tunes are Beresford's and whose feisty, ironic and witty lyrics ("Air after breathing, tasting of lung/Songs after singing, tasting of sung") are the work of Andrew Brenner. Considering this is the Masada group with a key figure of European improv, Signals couldn't be more unexpected, but it's a thoroughly charming, committed and utterly unpretentious album. A little record, for sure, but totally addictive.

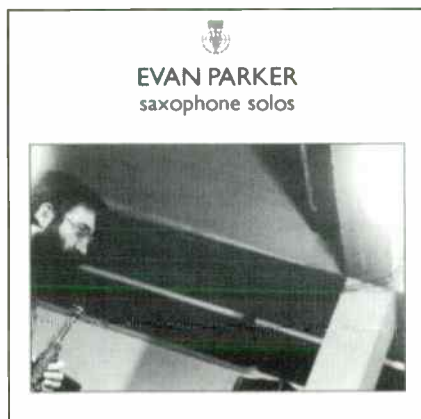

**EVAN PARKER**  
**Saxophone Solos**  
CHRONOSCOPE CPE 2002-2

● A world away and twenty years ago, another star of free improv single-handedly reinvented the possibilities of solo sax improvising. Saxophone Solos brings together long-unavailable recordings of some of Parker's earliest solo performances, recorded live in the studio in the summer and autumn of 1975.

Parker is of course one of the world's most remarkable musicians, one who's created or appropriated whole new technical strategies to extend his personal vision - multi-phonics, circular breathing and the simultaneous playing of two or more independent melodic lines chief among them. There's no question that while his solo records are undoubtedly a difficult listen, he nevertheless remains the most important improvising sax player since his hero, John Coltrane.

What makes this record essential is that we hear the very beginnings of Parker's ongoing solo project, and the style to emerge is still largely inchoate (witness that the endless wall of notes which now characterises Parker's current soloing is less in evidence than long, slow phrases and indefinitely-held single notes). Respect to Chronoscope

for this, their second release (the previous, the Spontaneous music Ensemble's Karyobin was another lost classic of British free jazz and equally essential). Long may they run.

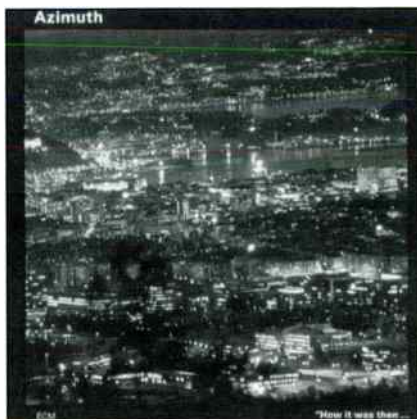

**AZIMUTH**  
**How It Was Then**  
ECM 523820-2

● Karyobin featured four other singular talents alongside Parker, among them English trumpeter and flugelhorn player Kenny Wheeler. Wheeler actually couldn't have followed a different musical path from Parker if he'd tried, however (although both still appear together in straighter "jazz" conditions than either normally inhabits).

No group has showcased Wheeler's playing more effectively than Azimuth, although it nearly didn't feature him at all. Pianist John Taylor and singer Norma Winstone had originally come together in the late seventies to work out Taylor's thoughts on a minimalist music which might serve as a platform for a more romantic, lyrical improvising. ECM main man and producer Manfred Eicher suggested the addition of Wheeler, and Bob's-your-uncle, Azimuth: one of the most outstanding and enduring groups in European jazz.

How It Was Then is the group's first new release in over five years. Gone are the synths and organ of previous records, but the sonic world conjured up from a piano, trumpet, flugelhorn and a human voice (and what a voice Norma Winstone has) is remarkable. This is gorgeous, ceaselessly exploring stuff - highly recommended.

**GOD**  
**Appeal To Human Greed**  
BIG CAT ABB79XCD

● Last year, London-based industrial-jazz collective God turned in The

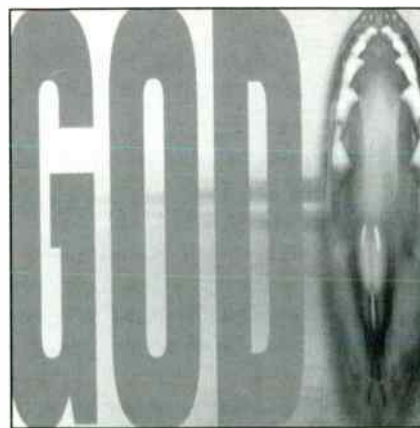

Anatomy of Addiction, their fourth album, and one of the overlooked albums of the year regardless of genre. The brainchild of saxophonist, vocalist, sample manipulator and producer Kevin Martin, God are without doubt one of the finest groups in Europe, a musical alternative history where Miles Davis' and Herbie Hancock's psychedelic seventies albums have replaced Led Zeppelin and Deep Purple in the hearts of every would-be rocker on the planet, and where the baby of Can, Neu, Faust and sundry art rock worthies haven't been thrown out with the bathwater of prog rock the minute punk arrived. Or something like that.

Anatomy was their most stripped-down outing to date, with the sound of the group's expansive line-up - tenor sax, two guitars, alto sax, electric viola, double bass, two bass guitars, percussion and drums - at once pummelled into hard rock riff madness and dubbed-out beyond the wildest imaginings of any HM freaks I care to think of. (In fairness God, and Martin's other projects - among them Techno Animal and the criminally-overlooked Ice - are part of a larger movement in UK music where rock musicians are taking the tools and techniques of dub, techno and rap and making them their own. Termed by some "post-rock", this is a "movement" which certainly ain't going to go away, but if God are one of the groups in this music's vanguard, they stand out from many of their fellows with a double debt to the legacies of hard rock and electric jazz).

Appeal to Human Greed nods even further in the direction of dance music's cannibalistic methodology by presenting four songs from Anatomy of Addiction all radically remixed by a pretty unlikely collection of knob twiddlers. 'Gold Teeth', the album's opener, is also its biggest blast; US hip hoppers New Kingdom have stripped out just about everything but the bass and Martin's growled berating from the original track and slapped under them a mad hip hop beat played on clay drums and Tibetan

bells. The effect is like a drunkard walking in on a hip hop sound system, wrestling the mic from the DJ and turning mad MC.

Martin's long-time collaborator, guitarist Justin Broadrick (who played throughout Anatomy and is Martin's partner in sampladelic ambient dub-hoppers Techno Animal, but is undoubtedly best known as leader of famed Midlands industrial thrash outfit Godflesh) has taken the album's already stomping 'On All Fours' and impossibly, made it even harder.

Elsewhere, New York bassist, producer, bandleader and all-round New Music god Bill Laswell has mixed 'Bloodstream' into a downtowner's take on 'Eugene'-period Floyd. A brooding, malevolent ambient opening builds to a crashing psychedelic burn-out. Martin, ably assisted by fellow saxman Alex Buess of Swiss avant-jazz monsters 16/17, has also remixed 'Bloodstream'; 'Peckinpah Mix' says it all. And My Bloody Valentine's shoe-gazing guitar god-turned jungle explorer Kevin Shields out-psychedelics them all with a remix of 'Tunnel' which is for my money the album's stand-out track.

As rock music gasps its last breath, the music business is beset by revisionists who insist that any viable musical future has to look to its former glories to survive. I give you Blur, Suede, Pulp, the New Wave of the New Wave (hah!), the mod revival, the glam revival, the bloody Paul Weller revival. What the rock establishment ignores at its peril is that there's a generation of musicians whose tastes are broader than any other previous generation's. These musicians are as much influenced by, say Sun Ra or Miles Davis or John Coltrane as they are by Hendrix or the Floyd, and gratefully take on the mixological exploits of all dance music's wayward children, without giving a hoot for the pointless raging arguments over the "sterile" use of studio technology versus the corporeality of "live" rock music.

By surrendering their work to the remixing whims of others, God add yet another dimension to their already heady mixture of psychedelic and free jazz, industrial rock, thrash and dub, and offer another way forward for all these musics. Superb, shocking, essential.

*Jazz*

## Simon Cooke

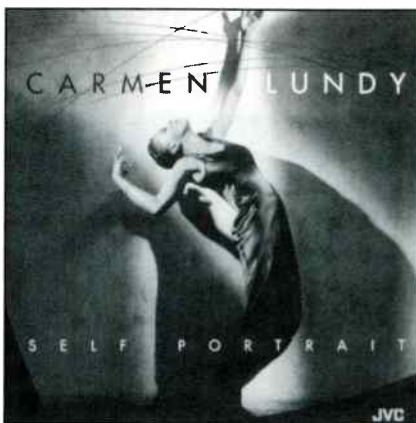

**CARMEN LUNDY**  
**Self Portrait**  
JVC-2047-2

● Although most tracks here are written by Lundy, many run beyond her vocal range, especially into the lower octaves where her voice breaks up, at least on this recording. This technique is often used in jazz, but to overuse it makes it look like neither Lundy nor her producers are aware of her vocal limits. Nevertheless, as MOR orchestrated jazz goes, it isn't bad, keeping the band well back - a touch too far, since they don't really seem to image properly - and choking any schmaltz early.

There's a curious texture to this recording, not gritty and raunchy but granular, at odds with the smoothness required of this kind of music. If it had more energy, the music would wear it better, but this is easy listening territory where challenge is an anathema to the listener, and sounds like a mix of artist and technical team which does neither justice, a pity because Lundy's control and emotion warrants a wider audience.

**ERNIE WATTS**  
**Unity**  
JVC-2046-2

● Anyone recalling my comments about Steve Swallow's 'Real Book' last year will be able to second-guess my opinion of this CD when I say he's here doing the honours on electric bass. Ditto with my past comments about Jack DeJohnette on drums. Piano is provided by Geri Allen, but this is a five-piece with a difference; two bass voices with Eddie Gomez on acoustic partnering Swallow. Although given the spotlight on one track, Oscar Pattiford's 'Tricotism', they mesh well with the other players the whole way through.

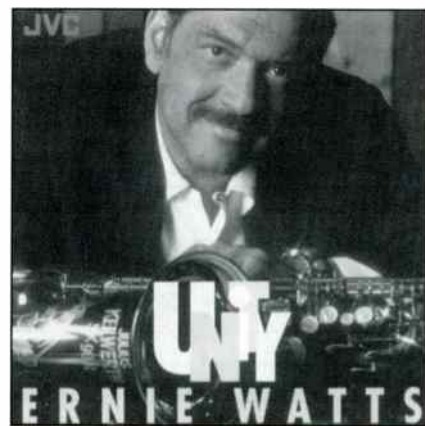

That said, this CD is about Watts' tenor sax, a voice tempered by long service in big bands, and it shows. He's not nearly so up-front as many players who have fronted small bands from an early age, and he plays with careful phrasing, emotion and swing, rather than raw energy.

This CD suffers less graininess than Carmen Lundy's, but still doesn't cut the mustard acoustically compared with a good Linn, Naim or Concord recording. It has neither the presence of the former nor the clarity of the latter, but shows JVC's 20 bit super coding to be an acceptable compromise and better than the quality of 'Self Portrait' would have you believe. Seek out and enjoy!

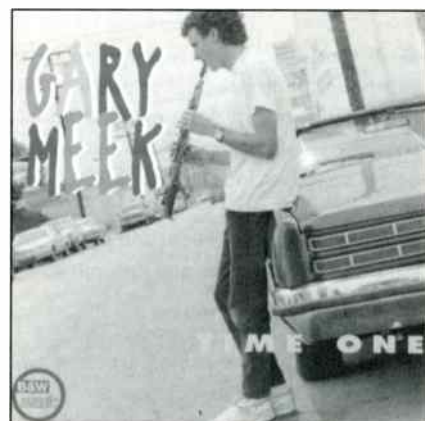

**GARY MEEK**  
**Time One**  
BW057

● Reviewing 'Finding One's Self' on B&W last month was a revelation for me, but they've surpassed even that high standard this time. It's a good recording of Latin-laced mainstream sounds, passably well played and well recorded. My only quibble is that it's pretty derivative territory done better before by the likes of Zubop, but where they let humour pervade their work, Meek applies an artisan's methodical approach to add a more contemplative feeling, without weighing it down too far.

# Hi-Fi World Dial-a-Dealer

## AVON

**AUDIO EXCELLENCE** 65 Park Street, Bristol BS1 5PB. Tel. 01179 264975 Fax 01179 251327 All that's best in hi-fi carefully selected and demonstrated by friendly knowledgeable staff, at prices to suit all budgets. Delivery and installation, home dems, part exchange, in house workshops, full credit facilities with interest free on selected items. Tuesday - Saturday 9.00 - 5.30. Closed Monday.

**PAUL GREEN HI-FI LTD.** Kensington Showrooms, London Road, Bath. Tel. (01225) 316197. Musical Fidelity, Krell, Creek Rogers, Quad, Cusl. car park. Best selection in the West.

**VAUDIO**, 36 Druid Hill, Stoke Bishop, Bristol, BS9 1EJ. Tel. 01272 686005. ATC, Acoustic Energy, Ruark, AVI, Exposure, Pink Triangle, Wadia, Audio Innovations, SME (incl 20A), Chord Amps, Michell, AMC, Analogue Electronics, Cadenace Valve, Jamo, LFD, REL, Sansui, Sonic Link, Stax, Townsend, Audio Technica, Goldring, Ltra, Ortofon, Sumiko. Demos by appt only. home trial facilities, free install. service facilities.

**THE RIGHT NOTE**, We specialise throughout the West Country and Wales in giving advice and demonstrations in your own home, where you can best judge the benefits. Your long-term satisfaction is our aim. Brands stocked for their excellent sound (not just a passing review), their reliability and suppliers' back-up: Lumley Reference (amps and speakers), Michell, Orelle, CAT, Stratosphere, Graaham, Magnum Dynalab, Transfiguration, NEAT, Sequence, Cogan Hall, Silver sounds, MAF, Atacama Air Pods etc... Tel: 01225 874728 and 01426 315092

## BEDFORDSHIRE

**TECHNOSOUND LTD.** 79 West Street, Dunstable, Beds. Tel: 01582 663297 - See our main entry under Bucks.

**RICHARD'S AUDIO VISUAL**, 4 Greyfriars Bedford. Tel: 01234 365165. Stockists of: Arcam, Audio Innovations, Audioquest, Aura, Beyer, B&W, Bose, Celestion, Cyrus Denon, Heybrook, Marantz, Mission, Moth, Musical Fidelity Nakamichi, Ortofon, Pioneer, Pro-Ject, Rotel, Royd, Ruark, Sennheiser, Systemdek, Target, Thorens, Van den Hul & more! Expert friendly service: Listening room. Pioneer Reference Point. Visa / Access.

## BERKSHIRE

**NEWBURY AUDIO**, 2 Weavers Walk, Northbrook Street, Newbury, Berks, RG13 1A1. Tel. 01635 33929. Linn, Creek, Epos, Denon, Nakamichi, Shahinian, Marantz, Micromega, JPW, Ruark. Single speaker dem room. Appt. necessary. Home trial facilities, free install. service dept. late appts. Access/Visa, interest free credit subject to status. 6 days 9.30am - 6.00pm.

**ASTLEY AUDIO**, Wallingford, 01491 839305. See our entry under OXFORDSHIRE

**AUDIO ILLUSION** 23 Langley Broom, Langley, Berks, SL3 8NB. (2 mins. Junc 5 off the M4). Ample free parking. Tel. (01753) 542761. Fax: (01753) 772532. Air Tangent: Apogee: Audio Alchemy: Audio Research: Classe: Copland: Davidson Roth: Densen: Earmax: Jadis: Koetsu: Krell: Lineaum: Martin Logan: Micro Seiki: Mirage: Moret: Musical Fidelity: PS Audio: Sonus Faber: Sumiko: Target: Theta: Wilson: Puresonic, Siltech and Transparent Cables: WBT. 10.00AM-10.00PM Monday - Saturday (by appointment), Sundays by arrangement. Dedicated listening room, Home demonstrations, Free installations, Part exchange, Mail order service, All major credit cards accepted. Credit facilities available. We can tailor a system at a price you can afford - for friendly expert advice give us a call. For a current list of Second hand and Ex. Demo bargains see our monthly ad.

## BUCKS

**D.L. CHITTENDEN LIMITED**, 59-61 The Broadway, Chesham, Bucks, HP5 1BX. (Opposite Boots). Tel: 01494 784441. Philips, Denon, Kenwood, Canon Audio, Koss, Wharfedale, Mitsubishi, Target, Grundig, QED, Mordaunt-Short, Toshiba, Dolby Pro-Logic Systems, Nicam TV and Video, Surround Sound, AV Systems. Showroom Demonstrations from expert and friendly staff. No appointments necessary. Service Department. Credit facilities available. Open 8.30 to 5.30 Mon-Sat.

**AUDIO INSIGHT** - 53 Wolverton Rd, Slony Stratford, Milton Keynes, Bucks - 01908 561551 - See our main entry under Technosound.

**DEJAC HI-FI Consultants**, 21 the Broadway, Old Amersham, Bucks, HP7 0HL. Tel. (01494) 433173. AMC, Arcam, Bose, Meridian, Quad, Denon, NAD, Tannoy, Mission, TDL, 2 dem rooms, Appts necessary. Free installation, Tricity finance, Instant credit, open 9.30-5.30 pm, including Saturdays.

**NORTHWOOD AUDIO** 11, 98 Cambridge St, Aylesbury, Bucks HP20 1BA. Tel. 01296 28790 (A/P). Selected sounds from Alchemist, Aura, Boston, B & W, Cabeltack, Castle, Celestion, Denon, Exposure, Gyrodec, Harman Kardon, Heybrook, Marantz, Micromega, Monitor Audio, Moth, NAD, Nakamichi, Rose, Rotel, Royd, Ruark, Systemdek, Tannoy, TDL, Thorens etc ect. Expert orders welcome. 2 Dem rooms. Credit facilities available.

**TECHNOSOUND LTD.** 7 Granville Square, Willen, Milton Keynes. MK15 9JL. Tel: 01908 604949, Audiophile Hi-Fi Specialists. All major brands stocked from Arcam to Yamaha. Demonstration facilities and expert advice. Mon-Sat 9.30 - 5.30 late night Friday. Credit Cards accepted. Finance available.

## CAMBRIDGE

**CAMBRIDGE HI-FI**, 1-3 Hawthorne Way, Chesterton, Cambs. CB4 1AT. Tel. 01223 67773. Kenwood, Pioneer, Ariston, Kef, Technics, Yamaha, Marantz, B&W, AR, Mordaunt-Short, Bose. Single speaker dem room. Tues-Sat 9.30-5.30pm. Closed Monday. Free install. service dept. Vis/Access credit facilities.

**UNIVERSITY AUDIO**, 1-2 Peas Hill, Cambridge. 01223 354237. Mission-Cyrus, Arcam, Rotel, Denon, Meridian, Ruark, ATC, AVI, Quad, Linn, £ dems, 1 single speaker. Home trial, free install, Service Dept. VISA, ACCESS, AMEX, Credit Terms. Open 9-5.30

## CHESHIRE

**CONGLETON HI-FI**, 1/1A Duke St, Congleton, Cheshire CW12 1AP. (01260) 297544. Arcam, B&W, Denon, Epos, Kef Reference, Linn, NAD, Nakamichi, Onix, Royd, Target, Yamaha, etc. Superbly appointed single speaker demo facilities. No appointment necessary, home trials, free installation. 2 year guarantee on all equipment. Access, Visa, Amex, all usual credit facilities. Open Mon-Sat 9.30-6pm.

**SWIFT HI-FI**, St. Annes Parade, Wilmslow. 01625 526213. Aura, B&W, Denon, Kenwood, Marantz, Nad, Pioneer, Rotel, Systemdek, Tannoy, Revolver, J.P.W., M. Short, Mission, Celestion, Technics, Audiolab, Castle. Open 9.30-6. Dem room. No pressure. BADA member.

**THE HI-FI SHOWROOMS**, 12A West Str, Congleton, Cheshire (01260) 280017, 1 Stanley St, Leek (01533) 383780, Celestion, Creek, Exposure, Royd, Naim Audio, Musical Fidelity, Project, Rotel, Ruark, Tannoy, Technics, 5 Dem Rooms, No appts nec, Home trial, Free install, Service dept. Access, Visa, Lombard Tricity. Open 9-5.30. Closed Wed.

**HALE HI-FI**, 2 Bold St, Hale Road, Altringham, Cheshire WA14 2ER. Tel: 0161 929 0834. Open Mon - Sat 10am-6pm & later by appointment. Specialising in equipment by: Naim, Quad, Royd, Nad, Denon plus selected others. Large range of quality accessories. On site service department. Installation & delivery. Home demonstrations a pleasure

**ASTON AUDIO**, 4 West Street, Alderley Edge, Cheshire. Tel: 01625 582704. Products include: Bang & Olufsen, Arcam, Audiolab, B&W, Cyrus, Denon, Epos, Meridian, Micromega, MF Mission, Nakamichi, Quad, Rotel, TDL & other leading brands. Demonstration Rooms, Installation Service, Interest Free Credit. Access, Visa. Open Mon-Sat

**CHRIS BROOKS AUDIO**, 29 Gaskell Street, Stockton Heath, Warrington, Cheshire. WA4 2UN. Tel (01925) 261212. Tues-Sat 10.00-6.00. 2 dem-rooms. credit facilities. All credit cards. Established 1978. Total absence of bulls\*\*t.

**PRACTICAL HI-FI**, 88 Bridge Street, Warrington, WA1 2RF. Tel: 01925 632179. See our main entry under Preston, Lancs.

**THE AUDIO COUNSEL**, 14 Stockport Road, Cheadle, Cheshire. Tel (0161) 428 7887 and 12 Shaw Road, Oldham, Manchester OL1 3LQ Tel (0161) 633 2602. Linn, Arcam, Naim, Audio Research, Martin Logan, Yamaha, Creek, Nakamichi, Denon, JPW, Marantz, Royd, Lexicon, 3 dem rooms, free install, VISA/ACCESS Full multi-room and A.V. installation 10:00 - 5:30pm Mon-Sat, till 8:00 Thursday.

**NORMAN AUDIO LTD.** 106 Victoria Street Crew 21J Telford. Tel: 01270 211091 Fax: 01270 250794 See main ad also under Lancs. for our agencies

**CHRIS BROOKS AUDIO**, 29 Gaskell Street, Stockton Heath, Warrington, Cheshire. WA4 2UN. Tel (01925) 261212. Tues-Sat 10.00-6.00. 2 dem-rooms. credit facilities. All credit cards. Established 1978. Total absence of bulls\*\*t.

## CLEVELAND

**GILSON AUDIO LTD.** 172 Borough Rd., Middlesbrough. (01642) 248793. Micromega, Exposure, Arcam, Mission, Cyrus, Denon, Marantz, Rotel, Pioneer, Audiolab, Tannoy. Demonstration facilities in main shop and one demonstration room. Appointments necessary. Home trial facilities. Free installation on request. Service department. Access, Visa, H.P. 10-5-6 days.

## CORNWALL

**RJF AUDIO VISUAL**, 84 Pendarves Street, Tucking Mill, Camborne, Cornwall, TR14 8NJ. 01209 710777/612260. Audio Analysis, Audio Innovations, JBL, Teac, TDL, Monitor Audio, Musical Fidelity, NAD, Nakamichi, B&W, SME, Micromega, Pink Triangle, Pro-ject, Perception, Suggden, Harman Kardon, Triangle. Integral dem/showroom and special home dems. Appts nec, home trial, free install, service dept. All cards Switch and Transax. Open Mon-Sat 9.30-5.30.

## COUNTY DURHAM

**HI-FI EXCHANGE DARLINGTON**, 30a Larchfield Street, Darlington, County Durham. The North's only used Hi-Fi Specialist. Hear our Quad, Naim, Oracle, Neat, Thorens etc. Separate Dem Room. 3 months warranty on all systems. Full range of leading Japanese make Technics, Sony etc. Tel: 01325 463007

## CUMBRIA

**MISONS SOUND & VISION**, Viaduct House, Victoria Viaduct, Carlisle, CA3 8EZ. Tel (01228) 22620. Bang & Olufsen, B & W, Castle, Sonic Link, Quad, NAD, Yamaha, Sony, Rotel, Demo Suite. No appts nec. Home trial facilities. Free installation. Service Department 9- 5.30 Mon - Frid, Thurs 9-1, Sat 9 - 5.

**PETER TYSON**, 6 Abbey Street, Carlisle, Cumbria, CA3 8TX. 'Cumbria's premiere hi-fi centre'. Part exchange welcome. (01228) 46756. Linn, Musical Fidelity, Cyrus, Marantz, Denon, Philips, Nakamichi, Technics, Pioneer, Creek and more. Dem Rooms. Demos without obligation. Home trial. Free installation. In-house service dept. Access, Visa, HP. 9-5.30pm

**PRACTICAL HI-FI**, 106 English Street, Carlisle, CA3 8ND Tel: 01228 44792 See our main entry under Lancster.

## DEVON

**THE HI-FI ATTIC**, 58 New George St., Plymouth, Devon. PL1 1RR. 01752 669511. We stock most leading brands including Linn, Arcam, Denon, Pioneer, Musical Fidelity amongst others, and have an expert enthusiastic staff. Premises include attractive hi-fi and home cinema demonstration rooms. We offer free installation and credit facilities (written details on request) also a fully equipped service department. We can also provide a mail order service for all your LaserDisc requirements. We accept Visa, Access, Amex.

**UPTON ELECTRONICS**, 31 Torquay Road, Paignton, Devon. TQ3 3DT. Tel: 01803 551329. Pioneer Reference Point Dealer. Denon, Sony, Technics, Harmon-Kardon, Orelle, Kinshaw, Creek, Quad, Audio-Innovations, Target, Tannoy, Mordaunt-Short, Castle, TDL, Ruark, JPW, Royd, Project, Monitor-Audio, Micromega, Chord, van den Hul, Jamo. Full range of accessories etc. Demonstration room. Home Demos, free delivery and installation, own in-house service dept. AAccess, Visa, Amex. Credit facilities 9.00 - 5.30, 9.00 - 1.00 Wed.

## DERBY

**STRAO TRADITIONAL AUDIO**, 29 Meadowfield, Whaleybridge, nr Buxton, Derbyshire. SK12 7AX. Tel. 01663 733383. We construct custom made reproductions of classic 1950's loudspeaker enclosure designs using authentic blueprints. These have never been bettered for valve amplification. Requests for specific designs considered and researched. Superb new speaker units from Richard Allan and Lowther are used.

**ACTIVE AUDIO**, 12, Osmaston Street, The Spot, Derby. Tel: 01332 380385. Fax: 0332 385185. We have three studios including a dedicated Audio Visual studio for the demonstration of quality equipment from the largest range in the Midlands. Open six days per week. Own service department. Free local delivery, home trial facility. Current special offers and buyers fact pack and quotation on request.

## DORSET

**SUTTONS HI-FI**, 18 Westover Road, Bournemouth, Hants. Tel. 01202 555512. Arcam, Audiolab, Audiotechnica, Chord, Celestion, Denon, Infinity, Kef Reference, Linn, Mission, NAD, Qed, Rotel, Rel, Sennheiser, Sony, Target, Yamaha and others. 2 listening rooms. Home Cinema Free delivery and installation. Home demonstrations. Open Mon-Sat 9.00-5.30. BADA Member. Two year guarantee on Hi-Fi.

## ESSEX

**AUDIO T**, 442-444 Cranbrook Road, Gants Hill, Ilford. (0181) 518-0915. Great Value on Aiwa, Arcam, Audiolab, Cyrus, Denon, Kenwood, Li-n., Marantz, Meridian, Mission, Micromega, Rotel, Sony, Technics, Yamaha & more. Tues/Thur/Fri 10-7. Wed/Sat 9.30-5.30. 3 year Hi-Fi guarantee. 30 day free upgrades. PX. Selected Interest Free Credit. 2 listening rooms. Home Cinema. BADA Bonded.

**BRENTWOOD HI FIDELITY**, 2 Ingrave Road, Brentwood, Essex. CM15 8AT. Tel: 01277 221210. Aura, Audio Innovations, Castle, Chord, Crimson, Denon, ONM, E.A.R., Impulse, Marantz, Mission, Micromega, NAD, Pink Triangle, Project, QUAD, Ruark, Rehder, Shearne Audio, Systemdek, Tannoy, TDL, Thue Audio Single speaker dem rooms, home trials, dems and installations. Mon-Sat 9.30-5.30. Access, Visa, service facilities. Simply THE place to visit if you're serious about music.

**RAYLEIGH HI-FI**, Chelmsford, 216 Moulsham St. 01245 265245. RAYLEIGH HI-FI, Rayleigh, 44a High Street. 01268 779762. RAYLEIGH HI-FI, Southend, 132/4 London Rd. 0702 435255. Over 21 years experience of supplying the best. The best dealer, the best Hi-Fi equipment, the best service\* Carefully selected Hi-Fi

from: Arcam, Audiolab, Cyrus, Denon, Epos, Linn, Meridian, Mission, Naim, Nakamichi, Quad, Rega, Roksan, etc. etc. 3 years guarantee on Hi-Fi systems. 0% credit facilities.

**COLVILLE HI-FI - RHYTHMS 8**, Market Square, South Woodham Ferrers, Chelmsford, Essex, CM3 5XA. Tel: (01245) 325125/Fax: (01245) 328748 Products: Yamaha/Marantz/Musical Fidelity /Tannoy/Mordaunt Short/Td/Toshiba/Cable Talk/Usos/Alphason/Sennheiser/Pioneer & More. Tv/Video, Cinema Sound, Friendly Advice, Dem Rooms. See It Hear It And Believe It At Rhythms - For Beautiful Sound & Vision Without The Blues!

## GLOUCESTERSHIRE

**AUDIO EXCELLENCE**, 58 Bristol Road, Gloucester, GL1 5SD. Tel. 01452 300046 Fax. 0452 310680. All that's best in hi-fi carefully selected and demonstrated by friendly knowledgeable staff, at prices to suit all budgets. Delivery and installation, home dems, part exchange, in house workshops, full credit facilities with interest free on selected items. Tuesday - Saturday 9.00 - 5.30. Closed Monday.

**AUDIO T**, 40-42 Albion Street, Cheltenham. (01242) 583960. Great Hi-Fi on Aiwa, Arcam, Audiolab, Denon, Linn, Marantz, Meridian, Micromega, Mission, NAD, Nakamichi, Pioneer, Quad, Rotel, Sony, Technics, Yamaha & many more. Tues-Fri 9.30-6, Sat 9.30-5.30. 3 year Hi-Fi guarantee. 30 day free upgrades. Home demonstrations. Part exchange. Selected Interest Free Credit. Listening room. BADA Bonded.

**THE RIGHT NOTE** - Bath for specialist advice and home demonstrations. See Avon.

## HAMPSHIRE

**AUDIO GALLERY**, Near Petersfield, Hampshire. Mana, Castle, Alchemist, Albarry, Audio Innovations, Wadia, Deltac, Tube Technology, Denon, Pioneer, Alphason, Tripod, Nad, Teac, Audio Alchemy, Kipsch, AMC, Proac, JPW, Moth, Pink Triangle. Mail order cabinets supplied to order in any size, wood & hand painted finishes, stone-granite-marble shelving. For a demonstration with home comforts call us for an appointment on: 01730 895194.

**HOPKINS HI FI**, 'FOR THE BEST SEAT IN THE HOUSE' experience home cinema sound with Technics, Denon and Kenwood. Award winning products. Now on demo at HOPKINS HI-FI. 38-40 Fratton Road, Portsmouth, Hants, PO1 5BX. Tel. 01705 822 155, Fax. 0705 830 753

**AUDIO T**, 4 Feathers Lane, Basingstoke. (01256) 24311. Great Value on Aiwa, Arcam, Audiolab, Cyrus, Denon, Linn, Marantz, Micromega, Mission, Naim, Nakamichi, Sony, Technics, Yamaha & many more. Tues-Sat 9-5.30. 3 year Hi-Fi guarantee. Free delivery & installation. 30 day free upgrades. Home demonstrations. PX. Selected Interest Free Credit. Listening room. BADA Bonded.

## HEREFORDSHIRE

**ENGLISH AUDIO**, 37 Whitecross Road, Hereford, HR4 0DG. (01432) 355081. Arcam, Audion, Audio Technica, Castle, Celestion, Cyrus, Denon, Exposure, Heybrook, JPW, Kar, Kef, Marantz, Michi, Micromega, Mission, Moth, NAD, Nakamichi, Pink Triangle, Polk, Rel, Rogers, Rotel, Ruark, John Shearman, SME, Stax, Sueden, Systemdek, Tannoy, TDL, Yamaha. Single speaker dem room, home trial facilities, free installation, service dept. Access/Visa, Credit arranged. Open Mon-Sat. 9.30-5.30pm BADA members.

## HERTFORDSHIRE

**DAVID ORTON AUDIO VISUAL**, 6-8 Bancroft, Hitchin, Herts. Tel: 01462 - 452248. Mission, Cyrus, Denon, Pioneer, Marantz, Aura, Kenwood, Rotel, Ruark, Celestion, JVC, Polk and many more. Open Mon-Sat 9.30-5.30. All major credit cards accepted. Finance available. (See our main advert pg 106).

**DYNAMICS**, Welwyn, Herts - Europe's largest stockist of ex-dem and second hand equipment. High End Audio - Bought, Sold or Exchanged. Many items in stock (see our main ad pg. 128). Efficient servicing Dept. All items guaranteed. All major credit cards accepted. Please telephone 01438 - 714038 for appointment.

**GO SPEL MUSIC AUDIO**, 32a High Street, Kington, Herefordshire, HR5 3JH. (01544) 230254. Alphason, Allison, Revolver, Luxman, Yamaha, QED Audio, Systemline

**STUDIO 82**, 82 High Street, Harpenden, Herts AL5 2SP. 01582 764246. Fax 0582 467022. ATC/AVI, Arcam, Aura, Audiolab, B&D, Denon, Epos, Mission, Cyrus, Naim Audio, Nakamichi, Quad, NAD etc. Quiet single speaker dem room. Appts nec. Home trial, free installation. Service dept. Visa, Access and finance terms. 9-5.30 (Mon-Sat) Closed Weds.

**THE AUDIO FILE**, 27 Hockerill St., Bishop's Stortford, Herts, CM23 2DH. Tel: 01279 506576. Fax: 0279 506638. Linn, Naim, Roksan, Quad, Rega, Mission, Arcam, ProAc, Marantz, Sony etc. 4 dem rooms, installation service. Min 3 year warranty, 0%, BADA.

# Hi-Fi World Dial-a-Dealer

**REVOX Service & Repairs**, Suite 10, Smugock Business Centre, Lye Lane, Brickeworth, Herts. AL2 3UG. Tel 01923 893711. Seventeen years experience, ex-Bauch. Authorised agents for Revox products, sales and spares. All repairs carried out are guaranteed. Fast turnaround. Any enquiries telephone: 01923 893711.

**RADLET AUDIO**, 9 Holywell Hill, St. Albans, Herts, AL1 1EU. Tel. 01727 855577. Mark Levinson, Proceed, Proac, Tube Technology, Teac, Audiolab, Stax, ATC, Audio Alchemy, EAR, Sumiko, Quad, JBL, Denon, Creek, Michell, Micromega, XLO, Alchemist, B&W, Ruark, LFD and many others. Home trial facilities, free installation. Service Dept., Visa/Access, Open 9.30 - 5.30 Mon - Sat.

## HUMBERSIDE

**Zen Audio** George Street Hull Tel. 01482 587397. "Comfortable listening rooms. Home dems. Free installations. Agencies include: Audiolab, Audio Innovations, Aura, Audion, Denon, DNM, D.P.A., Cable Talk, Heybrook, JPW, Kar, Neat Petite, Micromega, Michell, Harmon Kardon, Impulse, Ruark, Rotel, Ruyk, Sugden and many more."

## KENT

**JOHN MARLEY HI-FI CENTRES**, 2 Station Road, West Canterbury. (01227)769329. Also at Dover - 01304 207562. Arcam, Audiolab, Aura, B&W, Heybrook, JPW, Proac, Pioneer, Rotel, Ruark, Tannoy, Technics. Dem rooms and home trial facilities. Mon-Sat, 9-5.30 clos. Thurs. Free install. Credit to £1,000. Access, Visa and credit charge. Service Dept.

**KIMBERLEY HI-FI**, 193 Broadway, Bexleyheath, Kent. Tel 0181 3043272. Pioneer, Technics, Kenwood, Marantz, Denon, NAD, Aiwa, Tannoy, Mission, Rotel, Wharfedale, Castle. Separate dem room, no apt necessary, free installation, service dept, instant credit facilities. no early closing.

**V.J. HI-FI**, 29 Guildhall St. Folkstone Kent Tel: 01303-256860. Stockists of: Mission, Tannoy, J.B.L., Pioneer, Philips, Aiwa, Marantz, Musical Fidelity, Quad, Yamaha, Denon and much more besides. Full audio and home cinema demonstration facilities. Fully bonded BADA members. Interest free credit available (subject to status). Open Mon-Sat 9:00-6:00

**V.J. HI-FI**, 119 High St Margate Kent Tel: 01843-226977. Stockists of: Mission, Cyrus, Quad, Tannoy, J.B.L., Sound Effects Range, Musical Fidelity Yamaha, Denon Meridian, Sunn Style and Target Equipment Racks. Full audio and home cinema demonstration facilities. Fully bonded BADA members. Interest free credit available (subject to status) Open Mon-Sat 9:00-5:30

**THE WESTGATE HI-FI**, 2 Station Road West, Canterbury, Kent. 01227 769329. Suppliers of quality hi-fi equipment including: Arcam, Akai, Aura, B&W, Denon, Jamo, JPW, Mordaunt Short, NAD, Panasonic, ProAc, Quad, Rotel, RuArk, TDL, Technics, Tannoy. Part exchange. Listening room. Service and repairs. Credit facilities. Access/Visa. Open 6 days 9-5.30.

**DOVER HI-FI**, 43 High Street, Dover. Tel: Dover 207562. Suppliers of quality hi-fi equipment including: Arcam, Akai, Aura, B&W, Denon, Jamo, JPW, Mordaunt Short, NAD, Panasonic, ProAc, Quad, Rotel, RuArk, TDL, Technics, Tannoy. Part exchange. Listening room. Service and repairs. Credit facilities. Access/Visa. Open 6 days 9-5.30.

**ELECTRICAL DISCOUNT CENTRE, EDC**, 138 pelham Road Gravesend, Kent DA11 0JH. Tel: 01474 569601. Pioneer, Marantz, Technics, Akai, JVC, Jamo.

**ELECTRICAL DISCOUNT CENTRE, EDC**, 109 The Broadway Bexley Heath Kent DA6 7JH. TEL: 0181 298 7880. Pioneer, Marantz, Technics, Akai, JVC, Jamo.

## LANCASHIRE

**MARTON MUSIC**, 5 Masterson Ave, Read, Burnley BB12 7PL. Tel: 01282 773198. Demonstrations of stereo and A/V systems in large comfortable lounge using equipment from AVI, ATC, RUARK, YAMAHA, MARANTZ, SEQUENCE, plus a range of custom built speakers, including Transmission Lines; home demo's encouraged before buying, free installation when required. Agent for LIBERTY INSTRUMENTS IMP/m and AUDIO SUITE loudspeaker testing systems. Ring anytime for appointment, free advice or chat... we never close.

**ORPHEUS AUDIO (HOME DEMONSTRATION SPECIALIST)** - for a "Musical" system tailor-made (sonically and visually) to your Home requirements. Arion Acoustics (Valves), Audiomeca, Audio Alchemy, Audio Synthesis, Audio Valve Amplification, Burmeister, Kinshaw, Lieder, Ortofon, Pro-ject, QED, Teac, Triangle, YBA, Orpheus Audio, please tel: 01257 426100 or Fax: 0257 473175 for appointment.

**PRACTICAL HI-FI**, 43 Friargate, Preston. Tel: 01772 883958. The audio visual specialist, expert advice, instant demonstrations, best prices, instant free credit, part exchange welcome. Extended warranty. Stockists of Yamaha, Kenwood, Denon, Sony, Technics, Onkyo, Marantz, Pioneer, Mission, Kef, Jamo, Celestion, B&W. Also stockists of LaserDiscs.

**PRACTICAL HI-FI**, 84 Penny Street, Lancaster, LA1 1XN Tel: 01524 39657 - See our main entry under Lancaster.

**PRACTICAL HI-FI**, 33/35 Knowsley Street, Bolton, Lancs Tel: 01204 395789 - See our main entry under Lancaster.

**PRACTICAL HI-FI**, 10 Preston New Road, Blackburn, BB2 1AW Tel: 01254 691104. See our main entry under Lancaster

**PRACTICAL HI-FI**, 81 Whitegate Drive, Blackpool, FY3 9DA Tel: 01253 300599. See our main entry under Lancaster.

**NORMAN AUDIO**, 131 Friargate, Preston, Lancashire, PR1 2EE. Tel. 0772 253057. Fax. 0772 562731. Marantz, Pioneer, Yamaha, Audiolab, Arcam, Mission, Cyrus, B & W, Kef. Send for your catalogue. Home cinema dem room plus three sales areas. No apt necessary, free install. service dept. instant credit subject to status. Open 9.30-5.30, late night Wed-8pm.

## LEICESTER

**LISTENING INN**, 6 Hotel Street, Leicester. Tel. 01533 623754. fax. 0533 623758. Arcam, Audiolab, Cable Talk, Chord Co, Creek, Denon, Epos, Heybrook, Kef, Linn, Micromega, Nakamichi, Onix, Rotel, Royd, 4 Dem Rooms. Open 10.00-5.30 (Six days).

**ENCORE!** Nr. Melton Mowbray. Tel. 01664 823282. Sugden, Densen, Tube Technology, Ruark, UKD Opera, Keswick Audio Research and Fi-Rax. As you can see from our agencies, we are open-minded and able to present diverse options for your appraisal. Unbiased and unhurried demonstrations by appointment incl. evenings and weekends.

## LINCOLNSHIRE

**BOSTON HI-FI CENTRE**, 65a Wide Bargate, John Adams Way, Boston, Lincs PE21 6SG. Tel. 01205 365477. Quad, Nakamichi, Arcam, Marantz, NAD, Castle, Tannoy, Rogers etc. Separate demonstration studio inc. home cinema. Free installation. Access, Visa, Tues-Sat 9-5 pm.

**COTTAGE AUDIO**, 17 Bridge Street, Saxilby, Nr Lincoln. LN1 2PZ. Tel: (01522) 702834. Evenings: (01522) 696708. ATC, AVI, Chord amplifiers, Harbeth, LFD, Michell, Drigin Live, Kinshaw, QED, Royd, Sansui, Sequence, Something solid, Sonic Link, etc. Demonstration rooms. Home Trial facilities. Free installations and above all a personal, friendly service.

**STAMFORD HI-FI CENTRE** - 9 Red Lion Square, Stamford, Lincs. PE9 2AL. (01780) 62128. Pioneer, Technics, Cyrus, Mission, Rotel, NAD, Yamaha, Kenwood, Marantz, Quad plus all major speaker manufacturers. Expert Advice, Comparator demonstrations, part-exchange HiFi purchased for cash. No appts necessary. Home trial facility, free installation. Service Dept. Mastercard, Visa and credit charge. Mon-Sat 9-5.30 pm. Closed Thursdays.

## LONDON

**ANALOG AUDIO**, 849 High Road, Finchly, N12. (0181) 445 3267 For friendly service and advice. AR, AKG, Allison, AT, Cerwin, Vega, Denon, Dual, Harmon Kardon, Jamo, Infinity, Marantz, NAD, Pioneer, Rotel, Revolver, Sonab, Teac, Thorens, Tannoy, Wharfedale, Yamaha. Speaker cables and accessories. Free installation. service

**AUDIO CONCEPT**, 27 Bond Street, Ealing, W5 5AS. Tel: (0181) 567 8703. Acoustic Energy, Audiolab, Aura, B&O, B&W, Boston Acoustics, Canon, Castle, Denon, Dual, Evolution, Infinity, JPW, KEF, Marantz, Mission, Monitor Audio, Musical Fidelity, NAD, Nakamichi, Onix, Quad, Revox, Rogers, Rotel, Systemdek, Target, Teac, Thorens, Van den Hul. Two dem rooms. Interest free credit, free local delivery & installation, service department. "Hi-Fi Specialists without the attitude"

**AUDIO T**, 190 West End Lane, West Hampstead. (0171) 794-7848. Great Value on Aiwa, Arcam, Audiolab, B&W, Denon, Linn, Marantz, Meridian, Micromega, Mission, Nakamichi, Rotel, Sony, Technics, Yamaha & many more. Tues-Sat 10-6 Late Thurs until 8.00. 3 year Hi-Fi guarantee. 30 day free upgrades. Home demonstrations. PX. Selected Interest Free Credit. 2 listening rooms. BADA Bonded.

**THE CARTRIDGE MAN** - Front end problems? It doesn't have to cost an arm and a leg to get the best listen to my Koetsu and - Decca - Eater. Also agents for Croft, Sugden, Thorens, Pentachord Speakers and Notts Analogue. (Plus a cartridge re-tipping service. Tel. 0181 688 6565.

**GOLF ELECTRONICS**, 311 Kentish Town Road, NW5 2TJ Tel 0171 482 2518. Fax 071 284 3381. Authorised dealers for: Sony, Pansonic, Aiwa, Aakai, Mitsubishi, Philips, Grundig, Bose. We carry an extensive range of hardware from Walkmans to camcorders, including a wide range of TV and video equipment. Free local delivery & installation on selected items. Open 10-6 Mon-Sat. We regularly have special offers on different products. A visit to GOLF ELECTRONICS could save you ££££

**HIFI & COMPONENTS**, 84 Battersea Rise, London, SW11 1EH. (0171) 223 1110. Denon, Tannoy, NAD, Rotel, Bose, Dual, QED, Wharfedale, Jamo, Celestion, Kenwood, Ortofon, Infinity, Shure, to name but a few! Established over 29 yrs. Appts necessary. Service dept. 10-6 (closed Weds)

**HIFI EXPERIENCE**, 227 Tottenham Court Road, London W11. 0171 580 3535. Arcam, Audiolab, Mission, Cyrus, Quad, Celestion, Kef, Meridian, Rogers, Tannoy, Yamaha, TDL, Thorens, Marantz, Nakamichi, Musical Fidelity and many more. Open 10.00-7.00 Mon-Fri. 9-6 on Sat. Service dept, Credit facilities, delivery and free installation.

**KAMLA ELECTRONICS**, 251 Tottenham Court Road, London W1P 9AD. Telephone. 0171 323 2747. Fax. 071 637 2690. Acoustic Research, Aiwa, Akai, Albarry, Alchemist, Alphason, Audio Alchemy, Audio Innovations, Audio Technica, Audioquest, Aura, Audiostatic, B&W, Cerwin Vega, Conrad Johnson, CopenHagen, Furukawa, Goldring, Infinity, IXOS, JPW, JVC, KEF, Kenwood, Kuzma, Lynwood, Maxwell, Micromega, Mitsubishi, Monster, Mordaunt Short, Moth, Nakamichi, Oracle, Ortofon, Panasonic, Pioneer, Project, QED, Rotel, Ruark, Sansui, Stax, TDK, and many more!!

**K J WEST ONE**, 26 New Cavendish St., London W1M 7LH. 0171 486 8262/63. Fax 071 487 3452. Two hi-fi & two home cinema dem studios. Appts pref. Home trial. Installation by arrangement. Service dept. Major credit cards. Interest free credit on selected items. Major brands stocked: Arcam, Audio Alchemy, Audio Innovations, Audion, Aura, Audiolab, Audio Research, B&W, Chord, DPA, Epos, Harman Kardon, Impulse, Krell, Martin Logan, Meridian, Michell, Musical Fidelity, Nakamichi, Nitty Gritty, Orelle, Pink, ProAc, Quad, Rel, Roksan, Sonus Faber, Stax, Tannoy, Theta, Trichord. Open 6 days.

**CONNECTIONS**, 13 John Prince's Street, London W1M 9AH. Tel. 0181 348 5676. Dealers in: Absolute, Audio Note, Audioquest, Deltac, Harmonix, Kimber, Mandrake, MIT, Siltech, Symo, Van den Hul, WBT and others.

**THE LISTENING ROOMS**, 161 Old Brompton Road, London SW5 0LJ. (0171) 244 7750/59. Fax (071) 370 0192. Linn, Quad, Meridian, Nakamichi, Arcam, Audiolab, Acoustic Energy, SME, Audio Research, Krell, Wadia, Theta, Apogee, Martin Logan, Pioneer, Tannoy, Systemdek, Stax, Pink Triangle, Michell, Monitor Audio, Yamaha, Marantz, Kef, Bose, Celestion, Epos, Mission, Denon, Neat Petite. Mon-Sat 10-6pm.

**THE CORNFLAKE SHOP**, 37 Windmill Street London W1P 1HH. Tel.(0171) 631 0472 Fax (0171) 436 7165. Tues-Sat 10-6, Thurs 10-7. The specialists for the highest quality of sound, for one room or many more. Full advice & installation service available. Multiroom specialists & worldwide mail

order service. Brands carried include: ATC, AVI, Rega, Naim, Mark Levinson/Proceed Royd, and many more.....

**MUSICAL IMAGES**, 173 Station Road, Edgware, Middlesex. Tel. (0181) 952 5535 - See advert under Middlesex for more information.

**MUSICAL IMAGES**, 45 High Street, Hounslow, Middlesex. Tel.(0181) 569 5802. See advert under Middlesex for more information.

**AUDIO T**, 190 West End Lane, West Hampstead, London, NW3 1SQ. (0171) 794 7848. Fax (071) 431 3570. Great Hi-Fi from Adcom, Arcam, Audiolab, B&W, Denon, Epos, Marantz, Meridian, Michell, Mission, Philips, Rotel, Proac, Micromega, Nakamichi, Yamaha, & many more. Mon-Sat 10-6. 3 year guarantee on Hi-Fi. Free delivery & installation. 30 day free upgrade scheme. Home demonstrations. Part exchange. 2 listening rooms. BADA Bonded.

**ORANGES & LEMONS**, 61-63 Webbs Road, Battersea, SW11. Tel: 0171-924 2040. Juicy fruit from London's newest, freshest Hi-Fi/Home Cinema retailer. Telephone demonstrations, or just up in. All the usual ie. friendly and efficient service, free home installation, credit cards, 0% credit finance available, plus...all the very best from Audio Vector, Cable Talk, Chord Co, Denon, Epos, Mission, NAD, Naim, Rega, Roksan, Rotel, Royd, Ruark, Soundstyle, Stands Uno and more.

**ZEBRA**, 18-24 Brighton Road, South Croydon. Tel: 0181-688 2093. The UK's First and Finest Home Cinema Store. 3 Demonstration Rooms. Laser Disc CRT and Projection TV Centre. Many brands stocked including Arcam, Audiolab, Meridian, Lexicon, Kef, Pioneer, Rotel, Yamaha, REL and Panasonic. Mon-Sat 9.30-6.00pm. All major credit cards accepted. Finance available. Evening demonstrations by appointment.

**SELECT AUDIO**, London for Mirage, VPI, Ortofon cartridges, Mark Levinson, Jeff Rowland, Proceed, Sumiko Transfiguration, Magnepan, Lyra plus more, 3 single speakers Listening room by appointment only. Tel: 0181 986 8788. 10-7pm closed wednesday.

**RECITAL**, 289 New Kings Road, London SW6 4RE Tel 0171-731 0340. To unlock the potential in your music collection hear it through one of our carefully chosen hi-fi systems. equipment by: Adyton, Alchemist, Arion, ATC, Audio Alchemy, Audiomeca, Audio Physic, AVI, Boulder, Cat, Celestion, Choro, Chord Co, CRD, Densen, Graham, Harman, Heybrook, Lumley, Michell, Micromega, Musical Fidelity, NAD, Orelle, Ortofon, Ruark, Triangle, Trilogy.

## GREATER MANCHESTER

**THE AUDIO COUNSEL**, 12 Shaw Road, Oldham, Manchester OL1 3LQ Tel (0161) 633 2602 and 14 Stockport Road, Cheadle, Cheshire. Tel (0161) 428 7887. Linn, Arcam, Naim, Audio Research, Martin Logan, Yamaha, Creek, Nakamichi, Denon, JPW, Marantz, Royd, Lexicon, 3 dem rooms, free install. VISA/ACCESS Full multi-room and A.V. installation 10:00 - 5:30pm Mon-Sat, till 8:00 Thursday.

**ORPHEUS AUDIO (HOME DEMONSTRATION SPECIALIST)** - for a "Musical" system tailor-made (sonically and visually) to

## TO FIND YOUR AREA Use our COLOUR REFERENCE



To Advertise in this section, please contact Hi-Fi World Sales Dept on:

0171 289 3533



# Hi-Fi World Dial-a-Dealer

**your** Home requirements. Arion Acoustics (Valves), Audiomeca, Audio Alchemy, Audio Synthesis, Audio Valve Amplification, Burmeister, Kinshaw, Lieder, Drifon, Pro-ject, QED, Teac, Triangle, YBA, Drpheus Audio, please Tel: 01257 426100 or Fax: 0257 473175 for appointment. See our main Advert under Lancashire Area

**PRACTICAL HI-FI** 65 Bridge Street, Manchester M3 3BQ Tel: 0161 839 8869 See our main entry under Lancaster

**BILL HUTCHINSON HI-FI, 50-52 Deansgate, Manchester M3 2FE.** (0161) 8321600. For the largest selection of HiFi and audio visual equipment in the North West. Specialist A.V. demonstrations of the highest quality. Best prices guaranteed. Minimum 2 year warranty and an optional 5 yr guarantee available. Instant credit and mail order service on offer throughout the U.K. Pioneer, Denon, Kenwood, Yamaha, Technics, Marantz, Mission, Tannoy plus many more.

## MIDDLESEX

**PURE SOUND/THE AUDIO ROOM.** We specialise in high quality valve and solid state amplification, with matching quality speakers and signal source components, and we cover London and the South East. Call us for a personal demonstration of some of the finest equipment around. We offer too many brands to list here but they include Audio Note, Arion Acoustics, Audio Innovations, Lumley, Impulse, Townsend, Pink Triangle, Audiomeca, XLO, Micromega, Frameworks. 01784 458176/0181 893 4485

**AUDIO T, 159A Chase Side, Enfield.** (0181) 367-3132. Great Hi-Fi from Arcam, Audioblab, Cyrus, Denon, Linn, Marantz, Meridian, Micromega, Mission, Rotel, Yamaha and many more. Mon-Fri 10-6. Sat 9.30-5.30. 3 year Hi-Fi guarantee. Free delivery & installation. 30 day free upgrades. Home demonstrations. PX. Selected Interest Free. 2 Listening Rooms. Home Cinema Specialists. BADA Bonded.

**MUSICAL IMAGES, 45 High Street, Hounslow, Middlesex.** Tel:(0181) 569 5802. Fax. (081) 569 6353.

**MUSICAL IMAGES, 173 Station Road, Edgware, Middlesex.** Tel. (0181) 952 5535. Fax. (081) 952 5535. Most brands available - see full page advert. Interest free credit, ask for details. Demo rooms. Repairs & Service. Sunday opening - Open all week. A Home Cinema Specialist. Mail order. Part exchange.

**AUDIO T, 159a Chase Side, Enfield.** (0181) 367-3132. Great Value on Aiwa, Arcam, Audioblab, Celestion, Cyrus, Denon, Linn, Marantz, Meridian, Micromega, Mission, NAO, Nakamichi, Rotel, Sony, Yamaha & many more. Tues-Fri 9.30-6. Sat 9.30-5.30. 3 year Hi-Fi guarantee. 30 day free upgrades. PX. Selected Interest Free. 2 listening rooms. Home Cinema specialists. BADA Bonded.

## NORFOLK

**PROTECT-A-DISC, Unit 4, Elvin Way, Sweetbriar Industrial Estate, Norwich, NR3 2BB.** Tel: 01603 482193. Producers and suppliers of finest quality card record and CD sleeves with taped edges, poly-lined or unlined, mailers and crumfords etc. Please send SAE for full current price list. Trade enquiries welcomed. Tel: 01603 482193.

## NORTHAMPTON

**THE AUDIO SHOP, 6 Hill Street, Raunds, Northants, NN9 6NN.** Tel: 01933 622325. Rotel, Denon, Marantz, Philips, Kinshaw, Moth, Pro-ject, Royd, TDL, JPW, Bose, Wharfedale, Goldring, Ortofon, Chord Co., Van Den Hul, Audioquest, QED, Sound Org., Beyer, Sennheiser, etc. Service dept., Home Demos., Free Installation, Easy Parking, Open 9.30am to 5.30pm (closed Wednesdays).

**LISTEN INN, 32 Gold Street, Northants NN1 1RS.** Tel: 01604 37871. Fax 0604 601430. Naim, Linn, Rega, Audiolab, Arcam, Cyrus, Royd, Nakamichi, Mission, Denon, Rotel, Nad, Heybrook, Marantz, Chord Co. etc. etc., Open 10.00 - 5.30 (Closed Thurs)

**THE AUDIO SHOP, Hi-Fi Specialists.** Appointed stockists of: Ariston, Creek, Denon, Dual, Goodmans, JPW, Mordaunt-Short, Rotel, Royd, Tannoy, 6 Hill Street, Raunds, Northamptonshire. Tel:- 01933 622325

## NOTTINGHAMSHIRE

**PETER ELLIS AUDIO, 29 KIRKGATE NEWARK NOTTS NG24 1AD** TEL 01636 704571. C astle. Arcam, Sugden, Tannoy, T.D.L., Musical Fidelity, Heybrook, Mordaunt Short, Teac, Marantz, Stemmfort, Yamaha, Denon, + more - Demo room, P-ex. Service Dept. free installation. Access, Visa, Amex, Switch. Mon - Sat 9.00-5.30 closed Thurs pm.

**CHANNY AUDIO, 18-18a Eldon Street, Tuxford, Nr Newark, Notts, NG22 0LH.** Tel: 01777 870372. Pink Triangle, OPA, Rotel/Michi, Micromega, NVA, Alchemis, Michell, Monitor Audio, Lumley, SME, Audion, and much more ! Three dem

rooms, home trial, free installation, service department. Access & Visa, credit facilities, Mail order. Mon-Sat 9.30-6.00, Sun and evenings home dem by appointment.

**NOTTINGHAM HI-FI CENTRE, 120-122 Allreton Road, Nottingham.** Tel:- 01602 786919. Over 25 years experience, superb demo rooms, extensive range, free parking. Mon-Sat 9-5.30

## OXFORDSHIRE

**AUDIO T, 19 Old High Street, Headington, Oxford (01865) 65961.** Great Value on Aiwa, Arcam, Audioblab, Cyrus, Denon, Linn, Marantz, Meridian, Micromega, Mission, NAD, Pioneer, Rotel, Sony, Technics, Yamaha & more. Tues-Fri 10-6. Sat 9.30-5.30. Thurs until 8.00. 3 year Hi-Fi guarantee. 30 day free upgrades. PX. Selected Interest Free. 2 listening rooms. Home Cinema. BADA Bonded.

**OVERTURE HI-FI, 3 Church Lane, Banbury, Oxfordshire.** Tel: 01295 272158. Consult the experts for the best advice on matters Audio. Choose from Arcam, Audioquest, Bose, Denon, Epos, Heybrook, Kef, Linn, Mission, Naim, Nakamichi, Quad, Yamaha. 2 to 5 year warranty. Installation specialists. Superb demonstration facilities. Open six days. Members of the Guild of Master Craftsmen and BADA.

**WESTWOOD & MASON, 46 George Street, Oxford.** Tel. 01865 247783. Creek, Marantz, Naim, Arcam, Rotel, Rega, Epos, Tannoy, Mission, Nakamichi, Denon, Aiwa, Quad, Yamaha, Monitor Audio. Open 9.30-5.00pm. Dem room. Closed Thursdays.

**ASTLEY AUDIO LTD, 3 Marketplace, Wallingford (3 miles from Berkshire border).** 01491 839305. Aura, B&W, Technics, Panasonic, Pioneer, Kenwood, Sony, Yamaha, Denon, Dual, Marantz, Mission, Tannoy. 1 listening room. Home trial, free installation. Service department. Access, Visa, Amex. Dinners. Instant credit. Tues-Fri 9-5.30, Sat 9-5. Records & CDs stocked.

## SHROPSHIRE

**AVON HI-FI, 12 Barker Street, Shrewsbury, Shropshire, SY1 1QJ.** Tel. 01743 355166. Aiwa, Beyer-Dynamic, NAD, Quad, B&W, Mordaunt-Short, Kenwood, Bose, Nakamichi, Onkyo, Teac, Sennheiser. Dem room. Home trial. Free install. Service dept. Access/Visa. £1,000 instant credit. Mon, Tues, Wed, Fri, Sat 9 - 5.30.

**SHROPSHIRE HI-FI, St Michael Street, Shrewsbury, Shrops.** SY1 2ES. Tel. 01743 232065. Stockists of Musical Fidelity, Mordaunt Short, Sony, Kenwood, Pioneer, Rotel, Denon, B&W, Proac. Audio Visual. Products available. Open 9.30 - 5.30pm Mon-Sat.

**MO SHROPSHIRE AUDIO, 24 Peveril Bank, Oawley, Telford TF4 2BU (01952) 502097.** Pink Triangle, T.D.L., Marantz, Denon, JPW, Ortofon, Project, Yamaha, Ruark, Royd, Michell, Musical Fidelity, Yamaha, Target (Tables, Speaker Stands, best prices). Free Delivery nationwide. Good Discounts with no p/x. Surround sound specialist. Home demonstrations a pleasure. 0% finance.

**W. Owen Est 1901 58 Market Street Oakengates Telford Shropshir Tel. 01952 613818.** "Audio/Video specialists. Pioneer, Reference Piont, Kenwood, Sony, Akai, B & W, Bose. Dolby Pro-Logic Specialist- 16:9 screens in stock. Free installations and home deliveries."

## SOMERSET

**MIKE MANNING AUDIO, 110 Middle Street, Yeovil, Somerset, BA20 1NE.** Tel (01935) 79361. Fax. (0935) 32923. Mobile (0850) 325965. Naim, Roksan, Pink Triangle, A&R (Arcam) ATC, AVI, NAO, Pioneer, Rotel, Denon, Teac, Onyx, Mission, Rega, Marantz, Royd, Heybrook etc. Dedicated listening lounge, for relaxed and unpressured demonstrations. Appts not usually nec, but best to phone first. Home trial facilities on request, free installation, service department. Instant credit, Access & Visa etc. 9-5.30, closed Mondays.

## STAFFORDSHIRE

**ACTIVE AUDIO, 95, Stafford Street, Hanley, Stoke-on-Trent.** Staffs. Tel: 01782 214994. Fax: 0782 283346. We have four studios including a dedicated Audio Visual studio for the demonstration of quality equipment from the largest range in the Midlands. Open six days per week. Own service department. Free local delivery, home trial facility. Current special offers and buyers fact pack and quotation service on request.

**ACTIVE AUDIO, 29, Market Street, Tamworth, Staffs.** Tel: 01827 53955. Fax: 0827 59513. We have two studios including a dedicated Audio Visual studio for the demonstration of quality equipment from the largest range in the Midlands. Open six days per week. Own service department. Free local delivery, home trial facility. Current special offers and buyers fact pack and quotation service on request.

## SUFFOLK

**AUDIO IMAGES, 7 All Saints Road, Pakefield, South Lowestoft, Suffolk, NR33 6JL.** Tel/fax: 01502 582853. Quad, Triangle, Arcam, Castle, Rotel, Moth, JPW, Sugden, Mission, Project, Denon, Yamaha surround sound. Audio Innovations, plus the amazing RDTHWELL range. Separate dem room, no appts nec. 10-30 Tues-Thurs, 7pm Fri, 6pm Sat.

**SIGNALS Martlesham Heath, Ipswich, Tel:(01473) 622866** see display advertisement for brands. Turntables, high end CD drives/DAC's as well as integrated players, valve and solid state amplification, wide range of cables and loudspeakers. Home demonstrations/equipment trial service. Please telephone for directions and to book appointment.

**BURY AUDIO, 47 Churchgate Street, Bury St Edmunds, Suffolk, IP33 1RG.** Tel. 01284 724337. Arcam, Audio Alchemy, Heybrook, Marantz, Michell, Meridian, Nakamichi, Pink Triangle, Quad, Rotel, Sonus Faber, Stax., Tube Technology., Single speaker dem room. Free install. Credit facilities. Mon-Sat 9.30-6.00, closed Wed. Evening dems by appointment.

**EASTERN AUDIO, 41 Bramford Road, Ipswich, Tel. 01473 217 217.** Fax 0473. 215705. Quad, Arcam, Audioblab, Meridian, Mission, Denon, Rotel, Marantz, NAD, Sony, Rogers, Nakamichi, Systemdek, Technics, Celestion, B&W, Tannoy, Morel Thorens and Top Tape. Also stock a wide range of accessories. usual credit facilities. A BADA dealer.

**ANGLIA AUDIO Dedicated to top quality HiFi since 1971.** Near Berton Bury St Edmunds IP30 9AZ. Quality systems built to your specification. Telephone (01359)270212. Open 9-6 closed Thursday. Open other times by appointment and evening dems can be arranged

## SURREY

**SPALDINGS HI-FI, 352-4 Lower Addiscombe Rd., Croydon, Surrey.** 0181 654 1231/2040. 3 dem rooms and home dem. Free installation/credit. Linn, Naim, Quad, Arcam, Audioblab, Mission, Denon, Tannoy, Marantz, Ruark. Mon-Sat 9-6, Tues 9-8, Closed Wed. Service dept.

**PJ HI-FI, The HiFi Shop, 3 Bridge Street, Guildford, Surrey GU1 4RY.** Tel:(01483) 504801. 9-6 Mon-Sat, Linn, Meridian, Rega, Arcam, Quad, Revox, Musical Fidelity, Rotel, NAD, Nakamichi, Marantz, KEF, Reference etc.

**ROGERS HI-FI, 13 Bridge Street, Guildford, Surrey, (01483)61049.** Aiwa, Creek, Denon, Qual, JPW, Marantz, Onix, Pioneer, Systemdek, Ruark, Tannoy, Teac. Dem facilities available, no appts necessary, free installation, service dept. Access/Visa. Instant credit upto £1,000 subject to status. Monday-Saturday, 9.30-6pm, later by appt.

**SURREY HI-FI, 45 High Street, Godstone, Surrey, RH9 8LS.** (01883) 744755. Specialist HiFi outlet, demonstration room and parking available. Quad, Audioblab, TDL, Tube Technology, Rel Acoustics, Nakamichi, Kef, Thorens, Musical Fidelity, Van Den Hul cables, Bose, Sennheiser, Beyer headphones, Marantz, Onon, Michell, Van den Hul, Musical Fidelity, Tannoy, Target, JPW. Single speaker dem rooms. Free installation service dept. Access /Visa /Mastercard. Open 9-6pm. Closed all day Wednesday.

## SUSSEX (EAST)

**THE POWERPLANT "Brighton's Leading HiFi Shop". 66 North Street, Brighton, Tel. 01273 775978.** Comfortable listening rooms. Knowledgeable and approachable staff. Roksan, Micromega, Exposure, Audioblab, Epos, Rotel, Marantz, Cyrus, Regal, Arcam, Mission and more.

**WORTHING AUDIO, 20 Treville Gate, W Sussex, BN11 1VA.** Tel 01903 212133. "The friendly shop with the best sound systems in the South". Friendly advice, 3 yr guarantees, easy parking, open Mon-Sat 9-6pm. Late night Wed. Arcam, Exposure, Naim Audio, Marantz, Ruark, Restek, Clear Audio, Audio Technica, Target, Tripod, Sennheiser, AR and many more.

**CHURCHERS HI-FI, 154 Montague St. Worthing, Sussex.** BN11 3HH. Tel. 01903 821595. All major well known brands of Hi-Fi stocked. Please call for details.

**HEATHERDALE AUDIO LTD, 202 Findon Road, Worthing, Sussex.** Tel:- 01903 827288 or 01860 660001 eves. Three comfortable demonstration lounges where you can audition; Audionote, Krell, Audio Research, Klipsch, Martin Logan, Apogee, Sonus Faber, Theta, S.M.E. Coptland, Voyd, Magneplanar, E.M.F., Lumley Reference, Creek, Rotel, Heybrook, Clearaudio. Phone for used stock list. 'We are the South Coast's Premier Hi-Fi Specialist'

## SUSSEX (WEST)

**CHICHESTER HI-FI, 7 St Pancras, Chichester, W Sussex.** PO19 1SJ. Tel. 01243 776402. Linn, Naim, Rega, Creek Nakamichi, A&R, Denon, Roksa, Epos, JPW, Ruark, Rotel, Quad, Spondor. Evening appts available.

**CRAWLEY AUDIO, 1 Silkin, Dalton Close, Broadfield, Crawley, West Sussex.** Tel: 01293 531190. Mob: 01860-911640. RCA "Living Voice" Recordings, Alchemis Burmeister, Manhattan Acustik, German Physiks, Chord Co, Cable Talk, Systemdek, Gravis Subwoofer, WAD, Apollo, CAD, Drifon, Fullers Audio, Lonicraft (Garrard) SME, Denon cartridges, Pole Audio, Atacama, Magneplanar. Purpose Built Dem Rooms, Home Dems available. Part Exchange, Credit Cards Accepted.

**HORSHAM HI-FI, 28 Queensway, Horsham, West Sussex.** Tel 01403 251587/0831 418619. Suppliers of quality audio equipment including Magneplanar Loudspeakers, TEAC VRDS CD Players, Michell Turntables and amplification, Opera Loudspeakers, Unison Research Single Ended valve amplifiers, VRR valve amplifiers World Audio products, Audio Technica, Gravis active subwoofers, Fanfare Broadcast quality tuners. Comfortable demonstration room, home trial facility. Free installation. Part exchanges welcome. Servicing and repairs. Open mon-sat 10am - 7pm.

## TYNE & WEAR

**BILL HUTCHINSON HI-FI, 87a, Castle Street, Newcastle-Upon-Tyne, (0191) 230 3600.** For the largest selection of HiFi and audio visual equipment in the North East. Specialist A.V. demonstrations of the highest quality. Best prices guaranteed. Minimum 2 year warranty and an optional 5 yr guarantee available. Instant credit and mail order service on offer throughout the U.K. Pioneer, Denon, Kenwood, Yamaha, Technics, Marantz, Mission, Tannoy plus many more.

## WARWICKSHIRE

**SOUNDS EXPENSIVE 12 Regent St. Rugby, Warwks CV21 2DF.** Tel: 01788 540772. Agents for: Arcam, Audioblab, Aiwa, Castle, Celestion, Cyrus, Denon, Dual, Kef, Heybrook, Mission, Marantz, Meridian, Mordaunt-Short, NAD, Quad, Rotel, Tannoy, TDL, Yamaha & many more. @ year warranty on all hi-fi separates. 2 Demonstration rooms, Home Trials, All Major Credit Cards Accepted, Mail Order Welcome. Ring Now For Keenest Prices. Open Monday - Saturday 9-5.30. If We Haven't Got It It's Probably Not Worth Having.

## WEST MIDLANDS

**MIOLANO VALVE HI-FI, Specialising in true fidelity systems** built around valve amplification: Audio 3008 Silver Nights, Audio Innovations, Impulse, Audio Note, KAL, Townsend Audio, Ortofon, Voyd, Micromega, Edison, Stax, Apollo, Dynavector, Seismic Sink, Valves. Home demonstrations and part exchange. Also vintage: Leak, Quad, Croft, Radford, etc. Flexible opening 7 days. 'phone Gary 0121 722 2317.

**MUSIC MATTERS, 351 Hagley Road, Edgbaston, Birmingham, B17 8DL.** Tel 0121 429 2811. Roksan, Nakamichi, Arcam, Audioblab, Kenwood, DPA, Tannoy, Royd, Heybrook, Michell, Panosica, Aura, Celestion, Musical Fidelity, Mission/Cyrus, Meridian, Kef, Monitor Audio, Pink Triangle, Ruark, Epos, Exposure, Pioneer and many, many more! 2 single speaker dem rooms. Appts necessary. Home trial facilities and free install. Service dept. Access/Visa/instant credit upto £1,000. Interest free credit available also. Tues - Thurs 10.30-6pm, Friday 10.30-8.00pm, Saturday 10.00-5.30pm. Check out the new branch in Solihull - Phil works there so it can't be bad! 0121 742 0254

**COVENTRY HI-FI, 126, Church Lane (off Walsgrave Road), Coventry, CV2 4AJ.** Tel: 01203 440529. Quad sales & service agent, Pioneer Reference Point, Kenwood, Aiwa, T.D.L. B&W, Tannoy etc. Private listening room, 2 year guarantee on all new hi-fi. Open 9.30-5.30 Mon-Sat Closed Thursday.

**ELMOON AUDIO, Tel 0121 784 8765.** Reference Imports Lumley, Alon etc. Esoteric Audio Research 834 integrated on demonstration. Home demonstration can be arranged. Top part exchange prices. Lots of used bargains. Quad, Leak, etc. Valves and valve testers, new GEC KT66s available.

**FIVEWAYS HI-FIDELITY LTD, 12 Inlington Row, Edgbaston, Birmingham, B15 1LQ.** 0121 4550667. Arcam, ATC, Audioquest, Audio Technica, AVI, Beyer, Cable Talk, Castle, Chord, CRO (Valve), Denon, Qual, Klipsch, Michell, Nakamichi, Ortofon, QED, Quad, Revox, Sennheiser, Sequense Design, SME, Spondor, Target, TOK, TOL, Thorens, Trilogy (Valve) etc. Keith Monks Record Cleaning Machine. Closed Mondays.

**SOUND ACADEMY, The ultimate experience for those seeking HiFi.** Ac. Arcam, Audioblab, AudioQuest, B&W, Bose, Chord, Cyrus, Cable talk, OPA, Epos, Kef, Marantz, Meridian, Mission, Mus. Fid, Nakamichi, Ortofon, Project, Quad, Roksan, Tube Tech, Rotel, Micromega, KAR, Kenwood, Lexicon, Cannon, Celestion, Beyer & more. 3 single speaker dem. room on two floors incl. A/V Cinema. Open 6 days a week. Mon-Sat. All major credit cards taken. Part exchange, enquiries welcome. Just off the high Street, Blaxhock, Walsall, W. Midlands. Tel. 01922 493499. (ample free parking)

# Hi-Fi World Dial-a-Dealer

**AMADEUS SOUND & VISION**, 10 Boldmere Road, Sutton Coldfield, West Midlands, Tel. 0121 354 2311. Audio Innovations, B&D, Castle, QED, Wharfedale. Single speaker demo, appts preferred, service available, installations, B&D link install, home trials, Access/Visa, interest free credit available subject to status. 9.30-6.00pm 6 days.

**GRIFFIN AUDIO**, 94 Bristol St., Birmingham, Tel. 0121 622 2230/0121 692 1359. Tues-Sat 10 a.m.-6 p.m. Enjoy music at home with a system from Griffin Audio. We demonstrate and install the very best hi-fi, with systems from £500 to £25,000. Ask for Bob, Tim or Alex. Linn, Naim, Shalinian, Quad, Arcam, Rega, Denon, Marantz, Rotel.

**ELECTRO CENTRE**, 244 Soho Rd. Handsworth, Birmingham. Tel. 0121 554 1878. Full range of HiFi: Pioneer, Technics, Kenwood, JVC, Sony, Aiwa, Akai. "Guaranteed the lowest prices in the UK". 24hr Mail Order facility available.

## WILTSHIRE

**AUDIO T**, 60 Fleet Street, Swindon. (01793) 538222. Great Value from Aiwa, Arcam, Audiolab, Denon, Linn, Marantz, Meridian, Micromega, Mission, NAD, Naim, Nakamichi, Rotel, Sony, Technics, Yamaha & many more. Tues-Sat 9.30-6. 3 year Hi-Fi guarantee. Free delivery & installation. 30 day free upgrades. Home demonstrations. PX. Selected Interest Free Credit. 2 listening rooms. Home Cinema specialists. BADA Bonded.

**P.R. SOUNDS** 58 Castle Street, Trowbridge, Wilts BA14 8AU Tel: 01225 777799. Authorised dealer for Pioneer, Technics, Marantz, Kenwood, Mission, J&M and many more. Cinema Sound Specialists with Listening Room. "For all that's best in Hi-Fi at a Price you can afford" Open Mon-Sat 9-6 Credit Cards accepted. Finance available.

## WORCESTERSHIRE

**LYNDES AUDIO**, 01527-873766. Exclusive Midlands Audio Synthesis Dealer, Audio Physic, Adyton, Essex Audio, LFD, Sequence Design Wall Speakers, Harman Kardon, JBL, REL, etc. Specialist Engineering Dept. offers Custom Design and Up-grades, all Kits etc., built to Customers requirements. Open Tues.-Sat. 10am-5pm. Evenings by appointment.

**SPAINS HI-FI 2 & 2a** New rd, Bromsgate Worcs Tel: 01527 872460. Aura, Apollo, Audioquest, B&W, Denon, Harman Kardon, JBL, JVC, Kef, Kenwood, Marantz, Mission, NAD, Nakamichi, Onkyo, Pioneer, QED, REL, Revolver, Rotel, Sennheiser, Sony, Tannoy, Thorens, etc. 2 Demonstration Rooms, Home Cinema Specialists, 0% Finance available on selected products. Part Exchange welcome, on site service dept; wide range of television, video, mini systems etc. in stock.

**COLDRAMA HI-FI**, 27 Kingfisher Walk, Kingsfisher Centre, Redditch, Worcs B97 4EY (0527) 597260. Aura, NAD, Onkyo, Kenwood, Denon, TDL, Polk Audio, B&W, Tannoy. Full Pro-logic products. In-store integrated dem facilities. No appts required, service dept. Access, Visa. Open 9-5.30, closed Thursdays.

## WEST MIDLANDS

**WEST MIDLANDS AUDIO**, 158 Ombersly Road, Worcester WR3 7HA. Tel 01905 458046. Fax. 0905 457585. Naim, Rega, Rotel, Marantz, Nakamichi, NAD, Audiolab, Roksan, Meridian, B&W, Audio Research, Krell, Martin Logan, Arcam. 9-5.30 Mon-Sat, eve's by appt only. Free

## YORKSHIRE (SOUTH)

**HIFI STUDIO'S**, Sunnyfields, Doncaster, Tel 0302 781387 TDL, Sugden, ProAc, Ruark, Teac, Impulse, Systemdek, Alphason, Target, Albarry, Heybrook, Monitor Audio, JPW, Totem, Harbeth, Keswick Audio Research, Michell Engineering, AMC (CD and Valves), CR Developments(Valves), Art Audio (Valves), Rel Acoustics, Projekt, Origin Live, Dual, Yamaha plus home Cinema pro-logic dems. Listening room demo's. Home trial, free install, licensed credit broker, 2 yr guarantee on all equipment, service available, Access/Visa. 10-8pm 6 days. "phone for further information and free fact pack."

**TRC HIFI**, 3 Kings Cross Street, Halifax, HX1 (01422) 366832. Agents for Kenwood, Denon, Castle, Rotel. Demonstrations and advice a pleasure. Call at any time to audition some of the best HiFi and pro-logic systems. Delivering and installation free within 20 miles. "The family firm where the customer matters most."

## YORKSHIRE (NORTH)

**AUDIO CLINIC**, 22 Lord Mayors Walk, Yorks, YO3 7HA. Tel. (01904) 646309. Revox- Ded- Audio Innovations-Allison-Celestion-Yamaha-Teac-Revolver-JPW-Kenwood-Bose-Thorens-Mission-Snell-B&W-Heco-Cannon-NAD-JVC-Musical Fidelity-Wharfedale-Micromega-Ruark-Heybrook.

Surround sound and demo rooms, free installation, Service Dept. Credit facilities on request. Access, Visa, Open 10am - 5pm 6 days a week.

**HARRDGGATE HI-FI** 15 Commercial Str, Harrogate, N Yorks. (01423) 504274. One of the best ranges of quality hi-fi in the North of England including: Lumley valve amplification, Audio Research, Musical Fidelity, Martin Logan, Sonus Faber, Castle, Orelle, Michell, Ruark, Stax, Copland, Tannoy, NAD, Alchemist, Onkyo, Rotel, Marantz, Quad ESL, Lexicon, Project, Silversounds, Cogan Hall, DNM. Home cinemadems. Home dems (appts not always req'd). Service Dept. All major credit cards accepted. Credit facilities available. Open 10-6pm. Why? Because music matters.

**THE SOUND ORGANISATION (YORK)** 2b Gillygate, York, YO3 Tel. (01904)627108. Linn, Meridian, Micromega, Naim, Rega, Arcam, Creek, Nakamichi, Mission, Denon, Epos, Royd, Rotel. 3 single speaker dem rooms, appts. preferred, home trial facilities, free install, service dept. Credit facilities on request. Access/Visa. 10.00am-5.30pm. Tues-Sat. Sony dealer award nominated '86, '87 and '88.

**VICKERS HIFI**, 24 Gillygate, York. (01904) 629659. Audio Innovations, A, E, Audiolab, Beyer, Harmon Kardon, JBL, Kef, Kenwood, Marantz, Michell, Mission, Monitor Audio, Mordant Short, Pickering, Pink Triangle, Pioneer, Quad, Rogers, Systemdek, Tannoy, Technics, Heybrook, TDL, Thorens, Dual and lots more. Dem Rooms 4. (3 by appointment). Superb showrooms. 2 yr guarantee on all hiFi products. Appts. as above. Home trial facilities, free install. service dept. Qualified and experienced staff, over 25 yrs experience. 12 mths interest free credit. 10.30-5.30 Mon-Sat.

**CLARITY HI-FI: PHONE MIKE ON 01723 503432.** Friendly polite new business, free estimates / advice, no vat. All work guaranteed specialist in Repairs, Servicing, all makes including Valve Equipment. Audio upgrades V.C.R.S. All work considered. Plugs, sockets, tapes, headphones, microphones etc. Brand names like Q.E.D. / Goldring / Demion / Audio Quest / etc. To find out more feel free to phone between 9.00 am / 9.00 pm Mon to Sat.

## YORKSHIRE (WEST)

**BILL HUTCHINSON HIFI**, 26-28 Woodhouse Lane, Leeds (01532) 427777. For the largest selection of HiFi and audio visual equipment in the Yorkshire. Specialist A.V. demonstrations of the highest quality. Best prices guaranteed. Minimum 2 year warranty and an optional 5 yr guarantee available. Instant credit and mail order service on offer throughout the U.K. Pioneer, Denon, Kenwood, Yamaha, Technics, Marantz, Mission, Tannoy plus many more.

**HUDDERSFIELD HI-FI CENTRE**, 4 Cross Church St, Huddersfield. (01484) 544668. B&W, Cyrus, Kenwood, Denon, Rotel, Arcam, Musical Fidelity, Quad, Audio Lab, Marantz, Mission, ect. Dem facilities - appointment reqd. Mon-Sat 9-5.30, Thurs 9-8. Closed Wed. Free installation, credit facilities. Access, Visa.

**AUDIO PROJECTS**, 45 Headingley Lane, Leeds. Tel: 01532 304565. A&R, Audiolab, Creek, Heybrook, Linn, Musical Fidelity, Naim, Quad, Rega, etc. Free installation, home trial, 2 year warranty, appts preferred. Tues-Fri 9.30-6, Sat 2.30 - 5.30.

**ASTON AUDIO**, 19 Crossgate, Otley, Leeds. LS21 1AA 01943 467689. Products: Naim, Arcam, Audiolab, Cyrus, Denon, Epos, Meridian, Micromega, MF, Mission, Nakamichi, Quad, Rotel, TDL & other leading brands. Demonstration Rooms, Installation Service, Interest Free Credit. Access, Visa, Open Tues - Sat.

## SCOTLAND

### EDINBURGH

**BILL HUTCHINSON HIFI**, 43 South Clark Street, Edinburgh. (0131) 667 2877. For the largest selection of HiFi and audio visual equipment in Lothian Specialist A.V. demonstrations of the highest quality. Best prices guaranteed. Minimum 2 year warranty and an optional 5 yr guarantee available. Instant credit and mail order service on offer throughout the U.K. Pioneer, Denon, Kenwood, Yamaha, Technics, Marantz, Mission, Tannoy plus many more.

**MUSIC MILL** - 72 Newhaven Road, Edinburgh EH6 5GG. Tel: 0131 555 3963. Stockists of Micromega, Proac, Audio Innovations, Lumley Reference, Tube Technology, ONM, B&W, Systemdek, Nottingham Analogue, Nakamichi, Rehdeko, Qali, Crinson, Harmon Kardon, Goldring, DPA, Royd, Alchemist, Beyer Dynamic. Mon-Sat 10-6.00 pm by appt. Closed Wednesdays. All Major Credit Cards Accepted. Contact Fraser or Mark

## \*ABERDEEN

**HDLBURN HI-FI**, 441 Holburn Street, Aberdeen. Tel: 01224 585713. Arcam, Audiolab, B&W, Celestion, Denon, Dual, Epos, Heybrook, ION, Kenwood, Creek, Marantz, Meridian, Mission, Cyrus, M.S., NAD, Nakamichi, Pioneer, QED, Quad, Revox, Rotel, Ruark, Tannoy, Technics, Wharfedale, Yamaha. 9.30-5.30 Mon-Sat.

**HI-FI EXCELLENCE**, Hi-Fi innovators & product designers with 15 years experience. Very much in the business for the music. Musical Fidelity key dealer. Largest Rotel retailer in the area. Particularly keen to make the buying of Hi-Fi a fun experience. Situated in the West End away from the bustle of the City centre - the perfect environment to enjoy quality Hi-Fi. Full time service engineer. Open Mon-Tues 10-6, Wed 10-1, Thurs 10-7, Sat 10-5 or later by appointment. Hi-Fi Excellence, 293 Union Grove, Aberdeen. Tel: 01224 322520

## AYRSHIRE

**LASER AUDIO**, Now at new premises : 1 St Mamock Place, Kilmarnock KA1 1DT. Tel: 01563 40292. Audiolab, Aiwa, Celestion, Cyrus, Denon, Dual, Marantz, Mission, Philips, Pioneer Systemdek and Tannoy, 2 demonstration rooms, AV dem room. Appointments preferred, home trial facilities. Free installation, service facilities. Access, Visa and written credit. Open Tues- Fri 10-5.30 Sat 9.30-5.30.

**THE SOUND FOUNDATION**, 22 Nelson St., Kilmarnock, Ayrshire. KA1 1BA 01563 74185 Agents for Sugdon, Pink Triangle, Micromega, Audio Innovations, Harman Kardon, Castle, Revolver, Michell. Single speaker dem. room. Home dems. & delivery installation service available. Full credit facilities available. For more info, phone Kevin. Be Different Pay Us a Visit.

## GLASGOW

**HI-FI MATTERS**, 272 St Vincent Street, Glasgow G25RL. Call Garry or Ewan on 0141 226 2400 for unbiased advice based on over 25 years experience in tailoring systems to individuals needs. Agencies include: Audio Innovations, Arcam, Shearpe, Roksan, JPW, Aura, Heybrook, Michell, Minstral, REL, Systemdek, Impulse, Marantz & Rogers. Open 10-6, six days a week.

**STEREO STEREO**, 278 St Vincent Street, Glasgow, Scotland. Tel 0141 248 4079. Closed Tuesdays. Installations throughout Scotland. Credit facilities available.

**BILL HUTCHINSON HIFI**, 43 Hope Street, Glasgow, (0141) 248 2857. For the largest selection of HiFi and audio visual equipment in South West, Scotland Specialist A.V. demonstrations of the highest quality. Best prices guaranteed. Minimum 2 year warranty and an optional 5 year guarantee available. Instant credit and mail order service on offer throughout the U.K. Pioneer, Denon, Kenwood, Yamaha, Technics, Marantz, Mission, Tannoy plus many more.

**STEREO STEREO** 278 St Vincent Street, Glasgow. Tel: 0140 248 4079 E mail Stereo @ six. compulink.co.uk We will supply the most musical sound for your budget and if you take the time to visit us we will take the time to return the compliment with free installation of your chosen equipment. Open 10-6.00pm closed Sunday, Tuesday Installation Nation-wide interest free credit available

## INVERNESS

**THE MUSIC TANTON**, 49 Church Street, Inverness, IV 1DR. Tel: 01463 225523. Beyer Dynamic, Celestion, Denon, Jamo, Kef, Kenwood, Mission, Marantz, Musical Fidelity, Pioneer, Rotel, Sony. Listening room, service department, free local delivery, part exchange, full range of credit facilities.

## IRELAND

### DUBLIN

**CLOMEY AUDIO**, 55 Main Street, Blackrock, Co Dublin, Tel. 288949/2888477 Fax. 2834887. Products include: Arcam, Classe, Philips, Rogers, Epos, B&W, Naim Audio, Meridian and others. Open Tues/Sat 10am-6pm. Thurs/Fri 'till 9pm Closed Mondays.

**PETER DAND & CO LTD**, 111 Clonskeagh Road, Dublin 6. Tel. 0103531 2694433. Products include: B&D, Quad, KEF, Thorens, TEAC & many more! 2 demonstration rooms and 2 year guarantee.

## BELFAST

**LYRIC HIFI**, 163 Stanmills Road, Belfast (01232) 381296. Linn, Naim, Rega, Arcam, Denon, Rotel and more. Mon-Sat, 10.00-6.00pm. Late night Thurs.

**ZEUS AUDIO**, 6 Hope Street, Belfast, (01232) 332522. Audio Innovations, Pink Triangle, Roksan, Marantz, Celestion, Meridian and more. Mon-Sat 10.00-5.30pm. Late night Thursday.

## COUNTY DOWN

**ASTON AUDIO**, Unit 8, Kings Road Shopping Centre, Kings Road, Belfast. (01232) 402220. Akai, Technics, JVC, Samsung, Toshiba, Panasonic and many more. Demos. Open Mon-Fri 10-8pm Sat 10-5pm.

## LONDONDERRY

**ZEUS AUDIO**, 23a Kingsgate Street, Coltraine, BT52 4LB. Tel. (01265) 56634. Marantz, Mission Cyrus, Aiwa, Akai, Alphason, Sony, Pink Triangle, Celestion, Rotel. Mon-Sat 10-5.30pm. Closed Thurs.

## WALES

### NORTH WALES

**ACTON GATE AUDIO**, 4 Ruabon Road, Wrexham, North Wales. Tel:01978 364 500. Audio Visual Specialists. Aiwa, Arcam, AMC, Bose, B&W, Beard, Canon, Celestion, Castle, Cyrus, Jamo, Marantz, Michell, Mission, Mordaunt Short, Musical Fidelity, NAD, Nakamichi, Micromega, QUAD, Radford, Rotel, Rogers, Rega, Ruark, Spendor, Tannoy, Thorens, Wharfedale, UKD, Yamaha, DSP Club Member, Demo Room, installation service. Easy Parking and Motorway access. All major credit cards accepted. 9.30 - 5.30 daily. Closed Weds pm.

**ELECTRO TRADER**, 19 Colwyn Crescent, Rhos on Sea, Colwyn Bay, Chwyd, Wales, LL28 4RN. (01492) 548932. NOW APPOINTED SUGDEN DEALER FOR THE NORTH WEST. Rotel, Yamaha, NAD, Harman, Kardon, Teac, Alphason, Heco, Infinity, KEF, JBL, Sugden, Tannoy, Rotel Michi, Haybrook, Acoustic Research, RLarc and Soundstyle tri-pod racks etc. Dem room appts. preferred. Home trial. Free install. Access, Visa, Open 9.30 - 1.00, 2.00 - 5.30 Mon-Sat.

### GLAMORGAN (SOUTH)

**AUDIO EXCELLENCE**, 134-6 Crwys Road Cardiff CF2 4NR. Tel. 01222 228565 Fax. 0222398201. All that's best in hi-fi carefully selected and demonstrated by friendly knowledgeable staff, at prices to suit all budgets. Delivery and installation, home dems, part exchange, in house workshops, full credit facilities with interest free on selected items. Tuesday - Saturday 9.00 - 5.30. Closed monday.

### GLAMORGAN (WEST)

**AUDIO EXCELLENCE** 9 High Street, Swansea, SA1 1LE. Tel. 01792 474608 Fax. 0792 645087. All that's best in hi-fi carefully selected and demonstrated by friendly knowledgeable staff, at prices to suit all budgets. Delivery and installation, home dems, part exchange, in house workshops, full credit facilities with interest free on selected items. Tuesday - Saturday 9.00 - 5.30. Closed monday.

## GWYNEDD

**TOP TAPE**, 1 Crystal Way, Elmgrove Road, Harrow, Middlesex, HA1 2RJ. Tel: 0181 427 1404. The UK's oldest and largest Tape Mail Order Service. TDK, Maxell, Sony, Ampex audio cassettes plus Fujii, JVC, Konica, Memorex, Scotch & TDK video tapes. Send for complete list of latest prices and offers including Video 8, VHS-C, S-VHS, DAT, MiniDisc and Open Reel and tape accessories including Alliso. Local Dealer Listing available. Telephone orders on 081 427 1404 Mastercard, Visa & Switch accepted.

TO ADVERTISE IN THIS SECTION FOR ONLY £10.00 PER MONTH CALL HI-FI WORLD ADVERTISING SALES ON 0171 289 3533

*Peter Herring*

**It's sensational stuff: virtuoso fiddling from Italy, wrap-around Wagner from America, organ opulence from France (via Scotland) and most sensational of all, how Deutsche Grammophon have re-invented the LP (purely for promotional purposes, of course!)**



**PIETRO ANTONIO LOCATELLI  
L'Arte del Violino Op3 (12  
Concerti per violino con 24  
Capricci ad libitum)**

Elizabeth Wallfisch, violin; The Raglan Baroque Players; director, Nicholas Kraemer

**HYPERION CDA66721-3 (3 CD SET)  
(DDD/213.06)**

● This is the kind of thing that Hyperion does supremely well: the polished and persuasive presentation of attractive but not necessarily well-known music and invariably in an irresistibly collectable package. So it is with L'Arte del Violino of the Italian composer and virtuoso, Pietro Antonio Locatelli, one of the most influential musical publications of the early eighteenth century.

Locatelli was born in Bergamo in 1695 and after sixteen years spent there moved to Rome in 1711 ostensibly to receive lessons from the established violin master, Arcangelo Corelli. However, it is doubtful if Locatelli even met Corelli and his tutor was most probably the violinist and composer, Giuseppe Valentini. He also worked alongside Valentini as a musician in the employ of the Caetani family.

In 1723, Locatelli left Rome to embark on a career as a travelling virtuoso and entertained the courts at Mantua, Munich, Dresden, Berlin and Kassel. He also visited Venice where he encountered the Venetian patrician, Gerolamo Michiel Lini, and subsequently dedicated L'Arte del Violino to this appreciative gentleman. Locatelli also wrote of his music being performed in a liturgical context and there is evidence that instrumental music was played

during certain sections of the Mass: the Epistle (Gradual), the Elevation of the Host and during Communion. It is tempting to imagine the flamboyant Locatelli, whose temperament and personality apparently matched his explosive violin playing, delighting the assembled congregation during services at St Mark's but sadly no evidence exists to suggest it ever occurred. What is known, however, is that after six years 'on the road', Locatelli settled in Amsterdam, residing there until his death in 1764.

The title, L'Arte del Violino, suggests some kind of musical textbook of purely pedagogic interest, let me hastily correct that impression. The score consists of twelve concertos for solo violin, strings and continuo, with the added spice of a 'capriccio' - a kind of cadenza - inserted into the first and last movements. Naturally, the concertos are principally showcases for the violinist and, between them, they explore more-or-less the full range of the instrument's technical possibilities. The soloist's technique is tested to its limit with double-stopping, polyphonic writing, trills and exceptionally difficult bowing, and in the main all at fast tempos.

However, L'Arte del Violino isn't solely about technique and virtuoso display, it is also highly enjoyable, spirited music in its own right. A knowledge of the complexities of violin playing is not a prerequisite to being entertained by these scintillating concertos, here played with dazzling skill and élan by the Australian-born soloist, Elizabeth Wallfisch, and her colleagues in the Raglan Baroque Players. Ms Wallfisch plays with the

The wheel has come full circle. Do you recall how a decade ago we were being informed that black vinyl had been consigned to the dustbin of history and that those who persisted in advocating its virtues, Canute-fashion, would be lost in the tide of technology? And now look what's happened: the marketing people who declared the LP to be dead-and-buried have suddenly discovered that it has a cachet which CDs, for all their qualities, still haven't managed to capture.

But what to do to cater for this continuing appeal? Your factories cannot return to producing LPs, but they can make CDs that look like them. And that's precisely what Deutsche Grammophon's new 'Originals' series has done. The booklet covers reproduce the famous 'yellow label' LP covers and, most bizarrely, the 'information' side of the CD is designed to look like a five-inch version of a twelve-inch LP, i.e. black with a centre label.

The temptation is to dismiss this as an idea dreamed up by the DG marketing department after an especially good lunch in one of Hamburg's finest eateries, but you can't because, putting the gimmickry to one side, the label is using this series to reissue some of the very finest performances from its back catalogue, and offer

exceptionally good value into the bargain. However crass the presentation, the content simply cannot be ignored. Someone in DG has made some inspired selections: Kempff playing Beethoven (both the sonatas and the concertos); Jochum's Bruckner; Gilels' Brahms; Rostropovich in Dvorak; Anda and Fricsay collaborating in the Bartok concertos; Abbado conducting Prokofiev. All eminently desirable, but for me one reissue stood out from the rest, now twenty years old and on LP one of Deutsche Grammophon's greatest achievements.

**LUDWIG VAN BEETHOVEN**  
**Symphony No5 in C minor**  
**Op67**  
**Symphony No7 in A Major**  
**Op92**

Vienna Philharmonic Orchestra;  
 conductor, Carlos Kleiber  
 DEUTSCHE GRAMMOPHON 447 400-2  
 (ADD/72.08)

● Chances are you have the nine Beethoven symphonies in your collection and, in works such as the 'Eroica' and the Ninth you may well have alternative versions. It may take some effort to persuade you of the value of investing in another

performance of the Seventh, let alone the Fifth. But Carlos Kleiber's are, to use an over-worked but wholly appropriate phrase, in a class of their own.

Kleiber is one of music's most enigmatic figures. Unlike many of his contemporaries, he exhibits no desire to flood the catalogue with recordings. In the world dominated by the ubiquitous and, it has to be added, the utilitarian, he remains a specialist. Even now at the age of sixty-five, his recordings can almost be counted on the fingers of two hands. For Deutsche Grammophon, he recorded five operas: Verdi's 'La Traviata', Weber's 'Der Freischütz', Johann Strauss' 'Die Fledermaus' and most memorably perhaps, Wagner's 'Tristan and Isolde'. On video only, he conducted Richard Strauss' 'Der Rosenkavalier'. Kleiber's orchestral recordings are fewer still: a gripping interpretation of Brahms' Fourth Symphony, two superb Schubert symphonies (the Third and the Eighth), and two symphonies of Beethoven. Both Beethoven performances were taped in the fine acoustic of the Musikvereinsaal in Vienna, the Fifth in March and April of 1974, and the Seventh in November 1975 and January 1976. They were released on two separate LPs, without 'fillups', and this was unchanged in their first CD

confidence of someone who has come to appreciate the delights of this music over the years (she founded the Locatelli Trio in 1989) but for whom it still holds a certain wonderment. You'll listen in open-mouthed amazement at some of the playing here.

The recording, which is enhanced by a superb sound balance, with natural perspectives and timbres (all credit to the production team of Antony Howell and Martin Compton) also benefits from having access to the most up-to-date historical background material to Locatelli's music, in the shape of some recently-discovered cadenzas to the concertos written by the Mainz-based virtuoso Gottfried Dominicus Reber in 1743. As I remarked at the outset, it all

contributes to a typically satisfying and rewarding Hyperion issue.



**RICHARD WAGNER**  
**Die Meistersinger von**  
**Nürnberg - Prelude to Act**  
**One/Rienzi - Overture/A Faust**  
**Overture/Der Fliegende**  
**Höllander - Overture/Tristan**  
**und Isolde - Prelude and**

**Liebestod/Tannhäuser -**  
**Overture**  
 Cincinatti Symphony Orchestra;  
 conductor, Jesús López-Cobos  
 TELARC CD-80379 (DDD/76.55)

● By far the most entertaining programme in Channel Four's 'Wagnermania' season saw the composer's great-grandson, a remarkably lucid and balanced character in comparison to some of the others who surfaced in the programmes, perform a refreshingly unbuttoned assessment of his illustrious antecedent's glorious contribution to music, and his decidedly less glorious personality. You could sympathise with his heartfelt desire to blow up the grandiose statue of his great-grandfather which had haunted him since childhood, and admire the frankness with which he described the Wagner 'shrine', Bayreuth, as no more than a dull, bourgeois German town. Wagner Junior was also fairly dismissive of a great-

*Classical*

incarnation, which was also at full-price. This led the authors of the 1988 edition of the *Penguin Guide to Compact Discs* to describe the reissues as 'uneconomic' and they encouraged DG to find 'fillers' for the discs. Unfortunately, Carlos Kleiber is not the sort of conductor who drops by the studio to tape a couple of overtures or whatever as makeweights. Now though, DG have done the obvious and combined the two performances on one mid-price CD, offering a package which no critic could carp about.

But what makes these Beethoven performances so special? It is perhaps best summed-up by saying that, where other conductors feel they have to conduct the Beethoven symphonies, Kleiber passionately wanted to record these two works. It's surely no coincidence that they are two of the most dramatic and spirited of the nine symphonies.

From the first familiar four notes of the Fifth Symphony it is strikingly clear this is no routine performance. The momentum and the energy are sustained throughout, and the effect is

electrifying. With incisive and brilliant playing from the Vienna Philharmonic, Kleiber succeeds in producing a performance possessed of a freshness which would have seemed impossible in this work twenty years ago, let alone today when the catalogue is replete with polished but pedestrian



recordings of this work. As he did two decades ago, Kleiber forcibly reminds me that it is not Beethoven's Fifth that has become predictable, only the majority of its performances.

The Seventh is an equally edge-of-the-seat experience, but the effect is not achieved through exaggerated gestures and over-dramatisation. Instead Carlos Kleiber underlines the rhythmic vitality which led no less than Richard Wagner to describe this symphony as the 'apotheosis of the dance' and, as in the Fifth, he fully exploits the potent contrasts within the score. The result is thrilling but in no way superficial, and how the newly minted sound brings out the detail of this sharply etched performance. The VPO's playing in the final allegro con brio, incidentally, is quite breathtaking.

While DG's cunning presentation ploy will not persuade me to part with the original real LPs (we're talking serious nostalgia here), I have to admit these fresh transfers are remarkably clean and transparent. DG call it 'original image bit-processing'; I can only add that whatever it is, it does a good job. The result is one of the most desirable reissues of this or any other year, and an essential addition to any collection of the Beethoven symphonies.

granddad Richard's work, citing 'Tristan und Isolde' as his one lasting contribution to musical progress - all good, provocative stuff, and a good antidote to those luminaries who neatly side-stepped the question of Wagner's moral and political baggage.

I only mention this because this magnificent new recording from Telarc reminded me just how stirring and seductive Wagner's music can be, whether it be the melting beauty of Tristan or the puff-chested pride of Meistersinger. And there are those including, I would suspect the composer's aforementioned great-grandson who find a decent selection of famous orchestral excerpts quite sufficient and would rather not become embroiled in the sub-text of the Ring cycle, or the hidden fascist agenda of Parsifal.

Here, the very fine Cincinatti orchestra and its conductor offer a generous programme, one distinguished

by its inclusion of the rarely heard overture to Wagner's projected symphony based on Goethe's 'Faust'. The symphony was never completed but the overture survives to offer a tantalising glimpse of what might have been. Jesús López-Cobos is at his best here, as he is in lovingly-played Prelude and Liebestod from Tristan; but in the Rienzi overture he is too po-faced and ponderous - there is joy as well as devout solemnity here. The overture to Meistersinger also has a somewhat heavy tread, rather as if those taking part in the singers' procession had just returned from a particularly heavy session at the bierkeller.

However, Lopez-Cobos whips up a fair old storm for Der Fliegende Holländer, and the Tannhauser overture supplies a majestic conclusion. Both are superbly played, and those seeking a sound quality to match the splendour of this music will not be disappointed. This is the 'Telarc' sound at its richest and

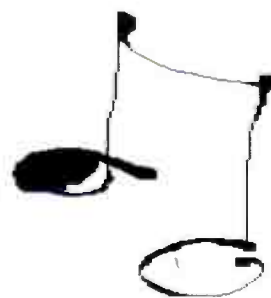

fullest, with a towering range and broad soundstage (though I was not entirely convinced by the 'surround sound' claim 'three dimensional surround sound listening experience using two ordinary stereo speakers' as Telarc describe it - but this could well be valid in other listening circumstances). However, though a 'big' sound, this is not an unsubtle one, and anyone can enjoy the orchestral detail and colour which were the utterly uncontroversial aspects of Wagner's music.

**Introducing the Riverside 4040 Valve Amplifier...**

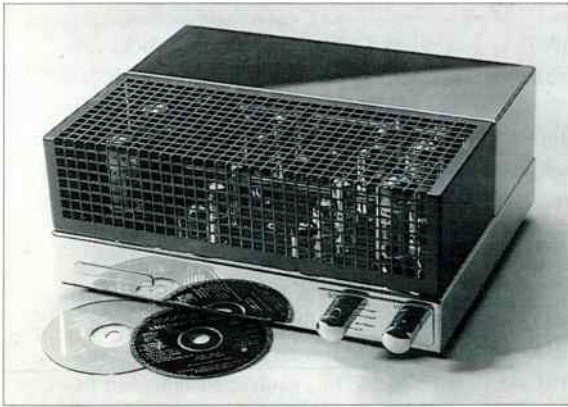

**The Riverside 4040 brings high-end features - in kit form:**

- Integrated amplifier with dual mono configuration with a generous 40W rms of valve sound per channel.
- Mirror finish stainless steel chassis with gold plated audio connectors.
- Quality British made transformers and tested valves.

The kit comes with a "guaranteed to work" promise and a full parts warranty.

Kit price £780 including delivery (in UK) and VAT; or send £3 for the 18 page construction manual.

The Riverside 4040 is also available fully assembled and tested, with a two year warranty, at £995 including delivery (in UK) and VAT.

**Phone or fax Cambridge (01223) 501997 (7 days, 24 hours) for further information.**

*Technical specifications:*

*Dual mono construction, 40W rms per channel using McIntosh output topology, 8Ω and 4Ω outputs, 240/230V input, five line level inputs, monitor output, 13Hz to 20kHz bandwidth.*

**Riverside Audio (Cambridge) Limited,  
18 Riverside, Cambridge CB5 8HL.**

# PERFECTION IS A PASSION



"...PASSION took over the reference position... substantially ahead of the best active line pre-amps. PASSION's switched, discrete attenuator is clearly more accurate, more dynamic and transparent than the pot alternative. When audio products are as good as this, there is little more to say, save to endorse them with a firm recommendation... Now better still in all Vishay mode with a record score of 37".

*Review of PASSION - Martin Colloms  
HiFi News April '93 and November '94*

Audio Synthesis, 99 Lapwing Lane, Manchester, M20 0UT, U.K.  
Tel: 0161 434 0126 & 01159 224138 Fax: 01159 258431



## HEYBROOK HEYSTAK – feel the dynamics and excitement of your music

Please send me details of the Heybrook Heystak.

Name ..... Address .....

HEYBROOK HI-FI LTD, ESTOVER INDUSTRIAL ESTATE, PLYMOUTH PL6 7PL  
TEL: 01752 731313 FAX: 01752 733954



New range includes:	4240 Integrated Amp	£249
	P42 Pre-Amplifier	£249
	A42 50W Power Amp	£249
	CD 42 CD Player	£499
	OBH-8 Phono Pre-Amplifier	£99

Over the last 12 years Creek Audio has designed and constructed Hi-Fi equipment for thousands of enthusiasts. Now that it is once again an independent company the story is set to continue, with a new range of equipment designed for the nineties.

For further information and list of stockists

Phone 081-361 4133 or send coupon to:

**CREEK AUDIO LTD, 2 BELLEVUE ROAD, FRIERN BARNET, LONDON N11 3ES**

Name ..... Address .....

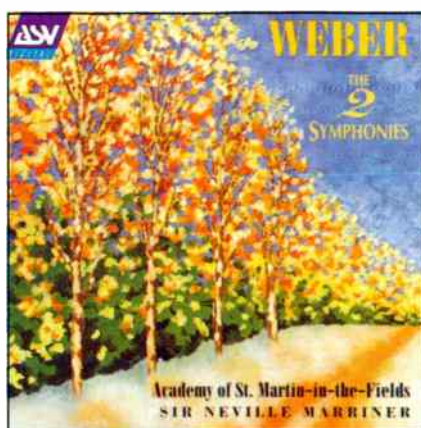

**CARL MARIA VON WEBER**  
**Symphony No 1 in C Major**  
**Op19/Symphony No 2 in C**  
**Major J5 I**

Academy of St Martin-in-the-Fields;  
 conductor Sir Neville Marriner  
 ASV DIGITAL CD DCA15 (DDD/43.36)

● When you read that Weber's only two symphonies were written within a few months of each other at the age of twenty, and that apparently he felt no further urge to return to the form, expectation does not run high. Yet these two works composed during the winter of 1804-1807 are not at all short on quality and offer much pleasure and a fair few surprises. In style, they are more akin to the high spirits of the youthful Schubert than to the iconoclastic Beethoven whose 'Eroica' had appeared just eighteen months earlier. There are also many Haydn-esque elements which is hardly surprising as Haydn was the favourite composer of Weber's employer at this time, Duke Eugen von Wurttemberg-Ols. The Duke was also an accomplished oboist, and the delectable oboe solos of the symphonies' slow movements were no doubt composed with this knowledge firmly in mind!

Both symphonies consist of the conventional four movements and unusually both are in C Major. The first Symphony opens with an energetic *allaegro con fuoco* reminiscent in many ways of the dramatic, fantastic world of Weber's operas. A stately *andante*, clothed in sumptuous orchestral colour is followed by an elegant and witty scherzo and a spirited and tuneful *presto finale*.

Weber completed this First Symphony on January 2, 1807; three weeks later, he started work on the Second and completed it a week later. The opening is less hectic than its predecessor and leads into a rapt and unashamedly romantic *adagio*. After a sunny third movement. minuet, the lyrical *presto*-dominated by an

infectious melody reminiscent of Schubert - brings the work to a rousing conclusion.

While not 'library' works, Weber's youthful Symphonies give pleasurable, undemanding and lively listening, and these performances by the ASMF can be warmly recommended, even if competition in the current catalogue is pretty much non-existent. The playing is characterised by some crisp string articulation and beautiful phrasing, especially from the woodwinds. Marriner's tempos are appropriately brisk and the recording is well-defined and weighty, if a little one-dimensional; pity about the short timing, though, on the 1982 Mike Sheedy/Abbey Road production. It would have added to the attractions to have the ASMF in a couple of the popular Weber overtures.



**FRENCH ROMANTIC ORGAN**  
**MUSIC**

Simon Bertram, organ  
 UNICORN-KANCHANA SOUVENIR  
 SERIES UKCD2070 (DDD/69.26)

● Subtitled 'From Saint-Clotilde to the Sacre-Coeur', Simon Bertram's recital is a tour of the organ lofts of the great churches of Paris and its environs, except that just one instrument is employed on this musical journey, the relatively new Rieger organ of St Giles Cathedral in Edinburgh. Built by Rieger Orgelbau of Austria, the instrument was dedicated in May 1992, along with the newly reglazed south transept window which had been bricked up at the beginning of the Second World War. The organ therefore enjoys a much more splendid setting than its predecessor and, as the Edinburgh born Simon Bertram demonstrates, has a sound to match.

The tradition of organist-composers at major churches within France is a long and fruitful one. The programme here embraces over a century of music, from Charles Tournemire's

extraordinary Choral Improvisation *sur le Victimae Pascali*, to *The Embrace of Fire*, a Biblically-inspired three-movement piece by the forty-year-old Lebanese-born Naji Hakim, who studied in Paris under Jean Langlais. Hakim's work, which in 1986 won him a prestigious award in the United States, is compelling, full of exotic, mysterious sonorities and displaying a consummate mastery of organ technique.

Simon Bertram includes two pieces by Jehan Alain, brother of the well-known organist, Marie-Claire Alain. Born in 1911, Jehan Alain was never to fulfil his true potential as a composer. He had but a handful of masterpieces to his name when he was tragically killed in action in 1940. *Litanies*, completed in 1937, remains Alain's best known work, a clemonic whirlwind of driving rhythmic patterns which resolve themselves in a dramatic final cadence.

Jehan Langlais succeeded Charles Tournemire as the organist of the Basilica of Sainte-Clotilde and went on to hold the post for forty-two years. And, like Tournemire, Langlais used his time there to make a substantial contribution to the canon of French organ music. Simon Bertram plays three of Langlais' finest works, including the *Chant Heroique*, which was dedicated to the memory of Jehan Alain. The *Chant de Paix*, also from the *Neuf Pieces* of 1943, is an altogether simpler and more tranquil offering, but no less affecting in its quiet plaintiveness.

Another famous resident of the organ loft at Saint-Clotilde, a nineteenth-century Gothic-style church in the heart of Paris, was Belgian Cesar Franck, and it was the church's magnificent Cavaille-Coll organ which inspired some of his finest composition, including the majestic *Priere*. Simon Bertram concludes this wide-ranging programme with another of the tributes to Jehan Alain by his fellow composer-organists, Maurice Durufle's *Prelude and Fugue sur le nom Alain*. By transposing the letters A-L-A-I-N into musical notes, Durufle obtained the theme for both the prelude and fugue, A-D-A-A-F, and then proceeded to develop it into a wonderful composition of which Alain himself would have been proud.

Simon Bertram shows kinship with the French repertoire in his playing, and the recording both produced and engineered by Henry Mitton, is stunning in its detail, range and truthfulness. Perhaps this excellent partnership can be persuaded to explore this 'French connection' still further - there's a wealth of wonderful music out there.

# WORLD LIBRARY

**NEW NEW NEW NEW NEW NEW NEW NEW NEW NEW NEW**

## NEW VALVE BOOKS

### PRINCIPLES OF ELECTRON TUBES, by Herbert J. Reich

£29.95

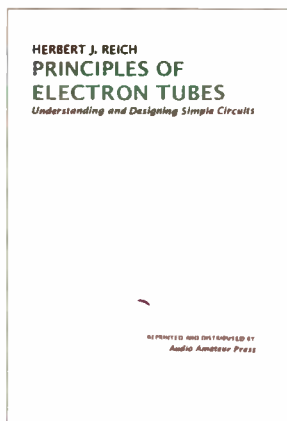

Principles of Electron Tubes first appeared in 1941 as a textbook for beginners studying valves for the first time. The book starts with the basics of how a vacuum tube actually works, including how construction and materials effect performance. Once this basic understanding is in place, Herbert Reich goes on to explain the principles of the simple diode valve, the triode and multi-grid valves. Familiar with the various valve types and their operating principles, the book continues to show how a simple circuit is designed and on to amplifiers, transformers and power supplies. A must for budding valve enthusiasts and an invaluable reference for hobbyists.

### 70 YEARS OF RADIO TUBES AND VALVES, by John W. Stokes

£19.95

New Zealand author John Stokes, with over fifty years experience, outlines the evolution of radio receiving tubes and the part they played in the domestic radio

receiver in this beautifully illustrated (B&W) book. An ideal reference for those interested in the history and development of valves and for collectors alike.

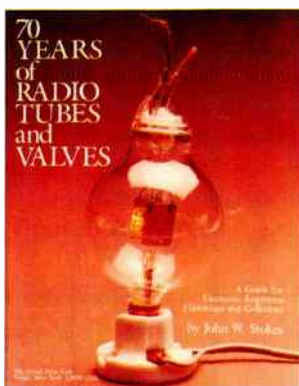

### ELECTRONIC UNIVERSAL VADE-MECUM, by Piotr Mikolajczyk & Bohdan Paszkowski

£49.95

This sizeable data book contains no fewer than 5693 valves divided into 442 groups. It contains connection details, operating parameters, load lines, example circuits and more making it one of the most comprehensive reference books we've seen, although there are some omissions, such as 300B and 211 valves.

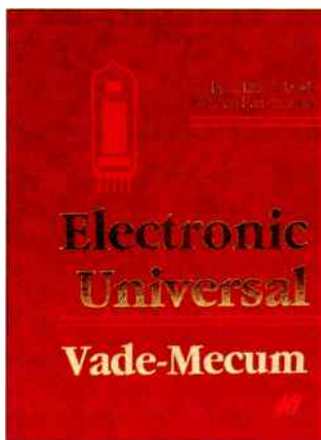

## LOUDSPEAKER BOOKS

### BULLOCK ON BOXES, by Robert M. Bullock

£12.95

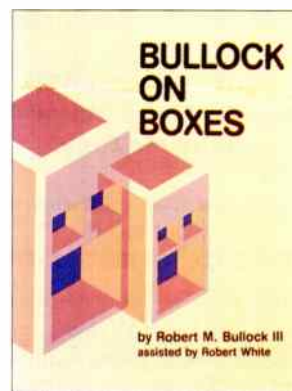

This book relies on manipulation of Thiele-Small parameters (supplied with all drive units) to optimise reflex box design, but with a calculator and at high school level. With lots of helpful tables and graphs, this straightforward book is every beginners best bet for getting to grips with sizing the box and port of a reflex loudspeaker.

### ACOUSTICS, by Leo L. Beranek

£39.95

From analogous electrical circuits important for modelling, the author moves through to microphones then loudspeakers. He covers design factors, showing how theory influences practice in drive units. Loudspeaker enclosure types covered include sealed, ported and horn. The behaviour of sound in rooms, very important for hi-fi, is also covered extremely well here.

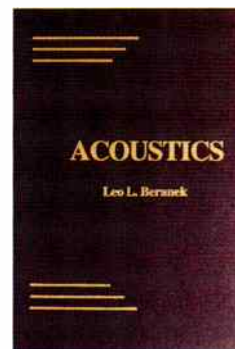

### QUICK & EASY TRANSMISSION LINE SPEAKER DESIGN by Larry D. Sharp

£10.95

A practical approach to designing and building your own transmission line loudspeaker. Covers the background theory, but is very practical in approach. Design examples and equations, even a computer package to run under Lotus 123 which takes care of the maths.

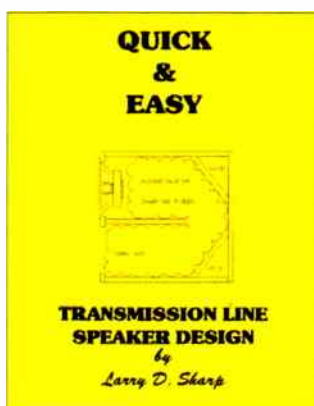

### THEORY AND DESIGN OF LOUSPEAKER ENCLOSURES by J. E. Benson

£23.95

This book covers loudspeaker enclosure design; infinite baffle, reflex, passive radiator etc in great detail, with a highly mathematical approach, making it unsuitable for beginners, but highly authoritative to experienced designers with a good foundation in acoustics.

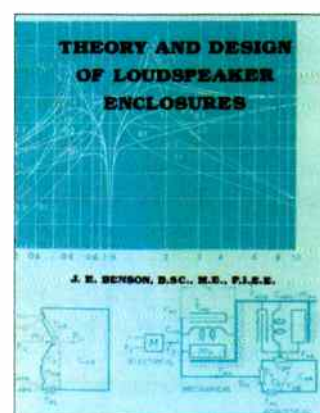



# Hi-Fi World WORLD LIBRARY

## SOLID STATE ELECTRONICS

### THE ART OF ELECTRONICS, by P. Horowitz and W. Hill. £35

The definitive electronics book. The Art of Electronics is an ideal book for the beginner through to the engineer. Written in easy to understand English, each chapter takes you from basic first principles through to full design exercises and practical circuits.

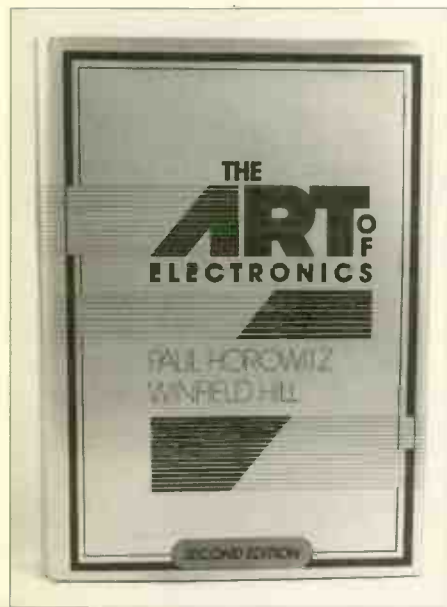

### THE ART OF LINEAR ELECTRONICS, by J. Linsley- Hood. £16.95

Concentrates specifically on analogue electronics for audio and goes into detail on obscure topics like the drawbacks of feedback, as well as its advantages. Covers mainly solid state but also includes valves. A must for serious enthusiasts and budding designers.

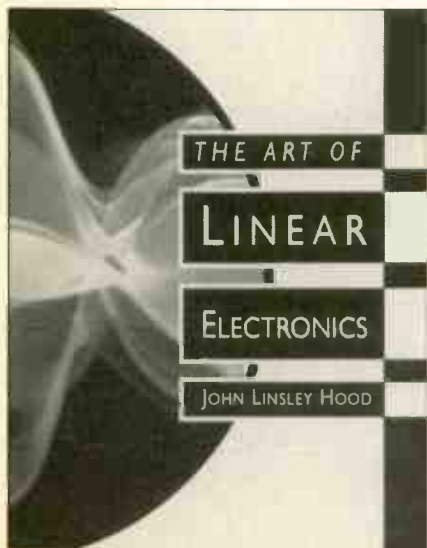

## AUDIO ANTHOLOGIES

### Audio Anthologies - When Audio Was Young

There are five volumes of the Audio Anthologies, listed below with a brief description and guide to their contents. They cover one of the most exciting and important eras of hi-fi, from the end of the second world war, through the introduction of stereo, magnetic recording, binaural recording and the FM Multiplex decoder. They contain many ground breaking circuits and theory covering all aspects of hi-fi design. A must for valve enthusiasts.

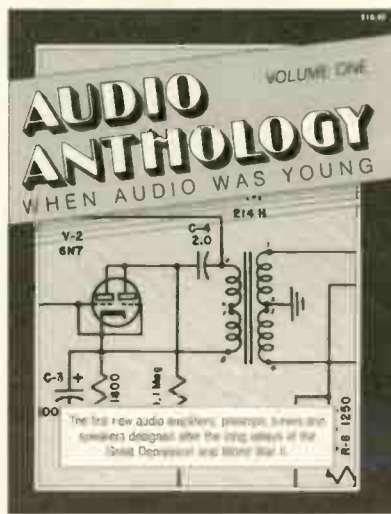

### Volume One - May 1947 to December 1949

The first new audio amplifiers, tuners and speakers designed after the long delays of the Great Depression and World War II.

**Summary of Contents:** 9.5watt, 5watt and 6.5 watt 6AS7G amplifiers, 30watt 300B amplifier, valve FM tuning indicator, 30watt 211 power amplifier, cathode follower amplifier using 6V6, an adaptation of the Williamson amplifier, valve phono preamplifier, several horn and reflex loudspeaker designs and much more.

### Volume Two - January 1950 to July 1952

More great amplifiers, preamps, loudspeaker designs, and the first glimmer of the stereo revolution plus magnetic recording aids.

**Summary of Contents:** Ultra linear 6L6 design and operation of the Williamson, a direct coupled amplifier, Williamson type amplifier using 6A5s, 40watt 845 push-pull amplifier, valve phono and line preamps, valves and loudspeaker damping, design and construction of reflex and horn loudspeakers.

### Volume Three - August 1952 to June 1955

Seven power amplifiers, eighteen preamps, twelve loudspeaker designs, including four horn types and binaural recording techniques.

**Summary of Contents:** Simple valve phono stage, transformerless amplifier using 6082, 20watt 5881 amplifier, 10watt 6V6 amplifier, stereo valve preamp, high quality valve phono stage, a preamp for the Williamson, low distortion tone control preamp, binaural or stereophonic, transistor phono amp, corner horn loudspeaker, concrete horn loudspeaker.

### Volume Four - July 1955 to December 1957

How to plan an audio system, twelve amplifiers and preamps, solid state techniques and circuits introduced and six loudspeaker designs.

**Summary of Contents:** 18watt 5881 amplifier, 4watt single-ended tweeter amplifier, budget 11 watt amplifier, versatile bass/treble control, transistor theory, transistor preamp, transistor techniques, battery powered transistor phono preamp, loudspeakers explained.

### Volume Five - January 1958 to December 1959

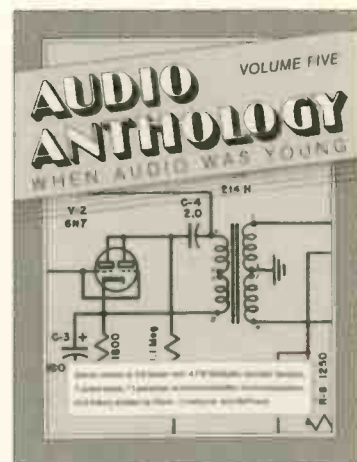

Stereo comes to full flower with four FM Multiplex decoder designs, seven power amps, eleven preamps, a commercial killer, five loudspeakers, and theory articles by Olson, Crowhurst and McProud.

**Summary of Contents:** Stereo valve multiplex decoder, 7watt EL84 amplifier, valve active crossover and 20watt treble amp/50watt bass amp., monaural, binaural, monophonic and stereophonic explained, heterodyne FM multiplex adapter, transistor preamp, 60watt EL34 amplifier, high power audio amplifiers, hi-fi loudspeaker enclosure.

Price  
All five for

£14.95each  
£69.95

# WORLD LIBRARY

## VALVE BOOKS

**AN APPROACH TO AUDIO FREQUENCY AMPLIFIER DESIGN, seventeen circuits from 5 to 1100watts. General Electric Co. £19.95**

Seventeen high quality amplifier designs from the Research Laboratories of the General Electric Company (UK). Designs range from 5 to 100watts, using KT66s, KT88s, DA100s, etc. Also includes two valve pre-amplifiers complete with valve phono stages.



**MULLARD TUBE CIRCUITS FOR AUDIO AMPLIFIERS. £13.95**  
First published in 1959 by Mullard, this book includes full designs for eleven power and control amplifiers, including the 5-20, using valves. This book begins with a four-chapter tutorial on getting the best sound from valve amplifiers.

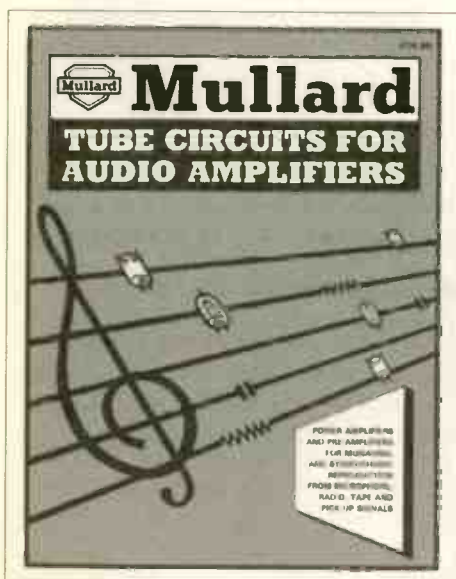

**THE WILLIAMSON AMPLIFIER, by D. T. N. Williamson. £9.95**

In April 1947, Williamson's valve power amplifier become an overnight success. The author takes you deep into his design decisions and offers practical advice on how to build the amplifier and set it up for best performance.

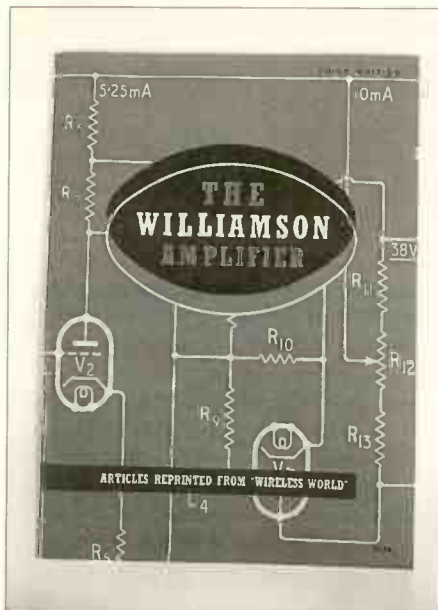

## LOUDSPEAKERS

**LOUDSPEAKERS: THE WHY AND HOW OF GOOD REPRODUCTION, by G. A. Briggs. £10.95**

A popular and easy to understand book on building loudspeakers, using empirical techniques that pre-date computer analysis. A fine grounding, written by a manufacturer with first hand experience - recommended for beginners.

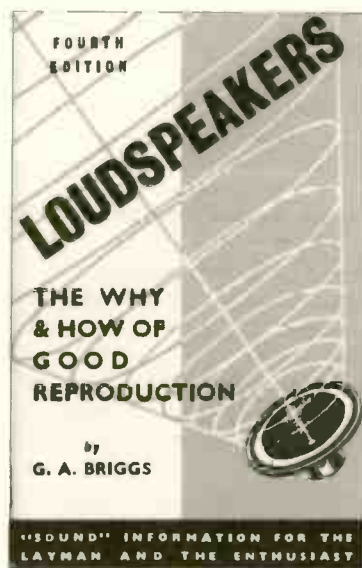

**ELECTROSTATIC LOUDSPEAKER DESIGN AND CONSTRUCTION, by Ronald Wagner. £19.95**

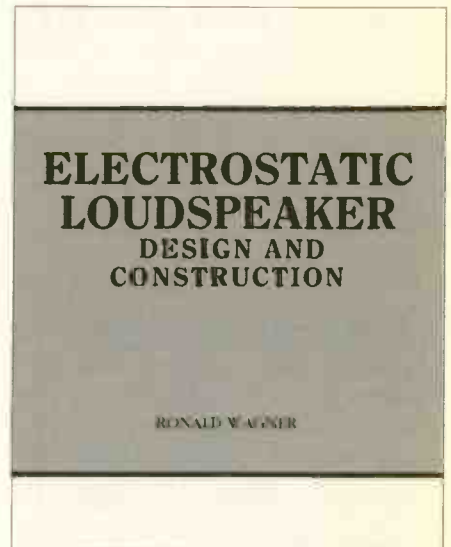

This book takes you step by step through the design and construction of a full range electrostatic loudspeaker, including the basic operating principles behind electrostatics. Whether you intend to build your own electrostatic, repair and restore a vintage electrostatic or are just interested in the principles behind electrostatics, this book is a must.

**THE LOUDSPEAKER DESIGN COOKBOOK, by Vance Dickason. £23.75**

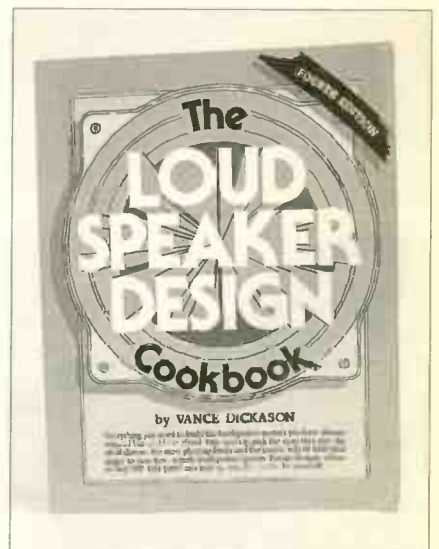

This best selling book in the field of loudspeakers offers good, up-to-date practical design information for the home constructor. Like today's manufacturers it uses modern Thiele Small theory and parameters.



# SLATE AUDIO



## HI-FI Design & Cable Services



### THE SPEAKERSTAND

*The best speaker supports in the world.*

State of the art in both performance and design. custom made to suit any loudspeaker. solid slate, supremely rigid and totally stable.

"Immaculately finished, sublimely rigid, on a par with the best stands I've used." Ken Kessler, Hi-Fi News R/R. "An astonishing degree of instrumental separation, stable and holographic, with great precision and remarkable poise. The ultimate in high fidelity supports." David Praker, Hi-Fi Answers. "Superbly finished, the sound quality was considered to be first rate." Martin Colloms, Hi-Fi News R/R. "The sound quality when using the Slate Audio stands proved to be a revelation, something special." Paul Messenger, Hi-Fi Choice. "The finish is excellent, the sound quality magnificent and breathtaking." Tom Bryant, The Telegraph. "The Slate stand is unusual and expensive, but if you are after an exceedingly neutral stand it's the leading contender. This stand offers an exceptionally neutral platform for speakers; highly transparent sound leads to musical performances with real insight." SOUND QUALITY: ■■■■■ Malcolm Steward Hi-Fi Choice.

### SLATE AUDIO GARRARD 301 and 401

*The most musical record players in the world.*

Our researched Solid Marble Plinth System® advances the state of the art and brings the Garrards into the 21<sup>st</sup> century. All wooden plinths produce unacceptable levels of coloration, microphony and feedback, with poor signal to noise ratios. When dealing with a thoroughbred you must respond with a firm hand, as anybody who has heard the transformation will testify.

Dear Mr. Soper,

Thanks for sending me the plinth for my Garrard 401. I must confess, that I was a bit sceptical about it, when I ordered one - after all, I bought it, without the possibility of listening to it first. But the results I get are really unbelievable. There is no rumbling, instead deep, deep bass and an authority, I never heard before from my records. And believe me, I tried some of the best turntables around (Linn LP 12, Roksan Xerxes). Now I'm waiting for the forthcoming power-supply. The day I place my order for it, I will do so without being a bit sceptical. Thanks again for a marvellous piece of art.

MR TEILINGNER - AUSTRIA



*Better than a . . .*



### THE GLASSMAT

*The finest platter mat in the world.*

The Glassmat was developed to improve the performance of the Garrard 301 and 401 record players. However it also gives astonishing results when used on other turntables. So effective is its performance, we have now made it available as a universal replacement mat. In all cases other mats introduce colorations of their own, robbing the music of large amounts of detail and ambience. In order to achieve maximum information retrieval with optimum damping, a hard and unyielding material is required. Glass is ideal in every respect, damping is complete, the playing surface being quite simply sublime. In terms of detail resolution and sheer three dimensional ability, no other mat comes close. But then you still have to consider the absolute clarity, precision and solidity of the presentation. This is the ultimate platter mat.

£65.00 PLUS £3.50 FREIGHT.

### ARRIVING SOON THE ULTIMATE GARRARD 301/401 POWER SUPPLY

Slate Audio make the best loudspeaker stands in the world, we are able to demonstrate this and prove that a correctly engineered support is not merely an accessory. Having established ourselves as world leaders in stand design, we have now turned our attention to other areas of interest. We continue to apply the same strict design principles to all of the projects that we take on. We believe in quality products that people will want to own not just for their performance, but also for their aesthetic appeal. Our insistence on perfection is reflected in all the products that we make. We make no apologies for boasting that our reputation is now legendary.

SLATE AUDIO GARRARD 301 AND 401 AVAILABLE COMPLETE OR MARBLE PLINTH SYSTEM® ONLY.

SME/GARRARD 301 AND 401 CELEBRATION ARMS WITH SPECIAL GRAPHICS "GARRARD 301 OR 401 CELEBRATION" 309 £597.00 • 312 £694.00 • IV £869.00 • V £1295.00.

THE TONEARM OUR SPECIAL VERSION OF THE FAMOUS REGA RB300, FITTED WITH GOLD PHONOS £155.00 + £3.50 FREIGHT.

THE SPIKEKIT SPECIALLY DEVELOPED TO FIT DIRECTLY TO FLOOR STANDING LOUDSPEAKERS OR ANY WOODEN SUPPORT ADJUSTABLE AND VERY SIMPLE TO FIT £25.00.

GOLD PHONOS (PAIR) £9.50 • GOLD BANANA PLUGS (FOUR) £8.00 • SORBOTHANE BIG FEET (FOUR) £48.00 • SORBOTHANE CO FEET (FOUR) £30.00 • SORBOTHANE SHEET (6"x6") £15.00 • SHURE STYLUS PRESSURE GAUGE £18.95 • GARRARD 301 SWITCH SUPPRESSOR £7.50 • TURNTABLE SERVICE £65.00.

**FOR INFORMATION, SALES OR DEMONSTRATIONS, SPEAK TO PETER SOPER**

**47 GEMINI CLOSE, LEIGHTON BUZZARD, BEDS, LU7 8UD. TEL: 01525 384174**

# Try me & see

U.K.'s No.1 Specialist  
Mail Order Company

## For the very best deal on any Hi-Fi, Home Cinema, A/V unit

- including all Award Winners!

- Try me & see is Britain's first dedicated Hi-Fi mail order company
- 1000s of satisfied customers nationwide

"...  
What choice, what advice,  
what knowledge.  
Wow! What next?"



"...  
I'm so delighted, that  
words fail me. Thank goodness  
I contacted you."



- Over half of our business is recommended or repeat
- You phoned the rest, now try the best!

# AMAZING PRICES GUARANTEED!

... you'll get first-class  
**service  
savings  
and support**

You can always buy from us with the complete confidence that we will never let you down.  
We always put our customers first and constantly upgrade and update our systems in order to improve our service.

### OUR COMMITMENT TO YOU

- ✓ To supply budget, regular and esoteric equipment.
- ✓ To deliver, insured, anywhere in the world within one week\* - or your money back!
- ✓ To accept cheque, cash or major credit/debit cards.
- ✓ To offer a comprehensive warranty on all goods.
- ✓ FREE collection (within 24 hours) and delivery of repairs.
- ✓ To offer extended warranties up to 5 years.

\* Subject to stock availability

If you are SERIOUS about  
buying hi-fi, phone

**(0181) 563 0003**

**NOW!**

Fax (0181) 563 0300

"... no  
hesitation in recommending  
you to my friends"



...We will be opening a new showroom soon...

**Try Me & See Ltd, 5 Rocks Lane, Barnes, London SW13 0DB**

World Radio History



# Sussex Surplus

13 STATION ROAD, HORSHAM, WEST SUSSEX RH13 5EZ

Telephone: (0403) 251302 Fax: (0403) 270339

Test Equipment • Components • Accessories  
Electromechanical • Mechanical • Engineering

### VALVES

65N7 U.S.A.	£5 ea
300B CHINA	£50 ea
EL34 CHINA	£10 ea
KT66 CHINA	£10 ea
KT88 CHINA	£20 ea
KT100 CHINA	£25 ea
EL34 MULLARD	£27 ea
GZ34 MULLARD	£15 ea
GZ37 MULLARD	£7 ea
GZ33 BULBOUS	£13 ea
EL84 MULLARD	£7 ea
ECC32 MULLARD	£12 ea
GZ32 MULLARD	£15 ea
EF86 MULLARD	£8 ea
ECC81 MULLARD	£6 ea
ECC82 MULLARD	£8 ea
ECC83 MULLARD	£10 ea
E88CC MULLARD	£10 ea
EF37A MULLARD	£8 ea
6080 VARIOUS	£10 ea
A2900 G.E.C.	£20 ea
EM34 MULLARD	£10 ea
ECC88 FOREIGN	£4 ea

### OIL FILLED CHOKES

16H 80MA	£15
10H 180MA	£20
10H 75MA	£15
10H 250MA	£30
10H 350MA	£35
50H 50MA	£15
1H 300MA	£15
16H 120MA	£20
16H 150MA	£25
5H 200MA	£15
20H 120MA	£20

### OIL/PAPER CAPACITORS

.1UF 1500V	£8
1UF 600V	£6
2UF 600V	£6
4UF 600V	£6
8UF 600V	£8
8UF 800V	£10
8UF 1000V	£12
8UF 1500V	£30
4UF 1000V	£12

4UF 800V	£12
2UF 1000V	£10
.25UF 1000V	£8
.5UF 1000V	£8

### OIL FILLED H.T. TRANSFORMERS

PRIMARY 10/0/110/200/220/240	SILVER PLATED, P.T.F.E.
SECONDARY 325-0-325 200MA	COVERED WIRE VARIOUS
5V 3A	£35ea SIZES AND COLOURS 50p PER MTR
PRIMARY 10/0/200/220/240	AVO CT160 VALVE TESTER,
SECONDARY 325-0-325 250MA	WITH DATA BOOK TESTED
300-0-300 100MA	BUT NOT CALIBRATED £99 ea £35 EA
PRIMARY 200/210/220/230/240/250	£5 POSTAGE TO BE ADDED TO
SECONDARY 250-0-250 50MA	UK ORDERS.
6.3V 1A	£25 ea VAT AT 17.5% TO BE ADDED
	OVERSEAS POSTAGE AT COST.
	TO TOTAL AMOUNT ORDERED.
PRIMARY 230V ONLY	
SECONDARY 310-0-310 160MA	
6.3V 1A/6.3V 3A/6.3V 4A	
5V 3A	£40 EA

**MANTRA AUDIO** • CARTRIDGES AND STYLUS  
• MAIL ORDER DIRECT 1-10 DAYS  
• COMPETITIVE PRICE (nc P&P)

MAKE	MODEL	CARTRIDGE	STYLUS	W.S.S. QUALITY DIAMOND STYLUS	PRICE
Arcam	C77 C77 Uq	N/A	N/A	ADC QLM 30, R0 3/4	£8.00
	E77, E77 Mg	N/A	N/A	R20 XE, QLM, 34/36, XLM III	£12.50
	P77, P77 Mg	N/A	N/A	AN 5/1130/60/8745	£8.00
Audio Technica	AT 95E	£21.00	£12.50	AN 2/50/70/70/4932/8743	£10.00
	AT 110 E	£26.50	£16.00	AKAL RS 33/35/38/84/85/90	£8.00
	AT 450E	£57.00	£34.00	BSR ST 14/15/16/17/19/21	£3.00
	AT OC3	£92.00	£64.00*	Dual ON 145/155/165/E, DN 149 S	£12.50
	AT OC 5	£125.00	£90.00*	Goldring G800/820/850 (D110/D120/D130)	£8.00
	AT OC9	£216.00	£150.00*	G800 Sup E, G800 - 78pm	£12.50
Denon	DL 110	£65.00	£52.00*	Hltachi DS-ST 7/12/14/15/26/30/35/102	£8.00
	DL 160	£85.00	£68.00*	DS-ST 5/16/23/24/25/55/103/104	£10.00
	DL 304	£180.00	£155.00*	DT 33/35/36/45/55/60/65, DT Z1 S	£8.00
Goldring	ELECTRA 100E	£24.00	£16.00	Kenwood N 47/48/51/53/60/61/63/66/72	£8.00
	1012 GX	£58.00	£29.00	(Tri) N 36/37/43/45/56/59/62/67/69/71	£10.00
	1022 GX	£76.00	£38.00	National EPS 23/24/25/30/33/51 CS/27/0 D	£8.00
	1042	£94.00	£49.00	(Technics) EPS 43/52/75/76/ STSD, P30/33 D	£12.50
	EROICA (LX/H)	£90.00	£60.00*	P30 E (Upgrade), EPS 205/207 E	£12.50
				FF 15/MS 10/20 EL, OMAF 20	£8.00
				GP 371/400/780/400 I/III	£10.00
				GP 330/370/401/401 II/412 II	£10.00
				PN 210/220/240/K65/250T/295T	£8.00
				SN 27/28/29/33/34/37/41/50/80/101	£8.00
				ST 80/100/15J/66/613	£8.00
				ST G 8/9/10, ST 28/29/35/37/40 D	£8.00
				STY 104/111/116/117/118/123/124	£8.00
				N 75-6/C/G/N 91 G.S.S 35 C	£8.00
				N 44 E N 70 E/J, N 75 ED/EJ T2	£10.00
				N 55 E, N 95 ED/EJ, N 97/105 ED	£12.50
				VN 15E, VN 35E (V 15 IIIE)	£15.00
				ND 133/134/142/150/155/200 G	£8.00
				ND 115/143/148/153/220/250 G	£10.00
				N 53/55/60 DY, N 62/292, N 71/290	£8.00
					£8.00

REDISCOVER SOME OF OUR BEST SELLING UPGRADE YOUR CARTRIDGE FOR A FASTER SWITCH

MAKE	MODEL	CARTRIDGE	STYLUS	W.S.S. QUALITY DIAMOND STYLUS	PRICE
Nagaoka	MP11	N/A	£13.50	Sanyo (Fisher) ST G 8/9/10, ST 28/29/35/37/40 D	£8.00
	MP 11 Boron	N/A	£26.00	STY 104/111/116/117/118/123/124	£8.00
	TS 10	N/A	£20.00	N 75-6/C/G/N 91 G.S.S 35 C	£8.00
Ortofon	OM10, OMP 5E	£16.00	£14.00	N 44 E N 70 E/J, N 75 ED/EJ T2	£10.00
	OM 78 (Stylus)	£16.00	£26.00	N 55 E, N 95 ED/EJ, N 97/105 ED	£12.50
	OM10, OMP10	£25.00	£18.00	VN 15E, VN 35E (V 15 IIIE)	£15.00
	OM20	£63.00	£35.00	ND 133/134/142/150/155/200 G	£8.00
	OM30	£81.00	£60.00	ND 115/143/148/153/220/250 G	£10.00
	OM N CLUB 6	£31.50	£19.00	N 53/55/60 DY, N 62/292, N 71/290	£8.00
	510	£31.50	£21.00		
	520	£54.00	£40.00		
	530	£85.00	£63.00		
	540	£112.00	£85.00		
	MC1 Turbo	£58.00	£45.00*		
	MC3 Turbo	£112.00	£85.00*		
	MC 10 Super	£85.00	£65.00*		
	MC 15 Super	£112.00	£85.00*		
	MC 10 Supreme	£234.00	£186.00*		
	MC 20 Supreme	£340.00	£255.00*		
	MC 30 Supreme	£425.00	£319.00*		
Shure	VN 35 MR (V15 I)	£68.00	£68.00		
	VN 45 MR (V15 IV)	£90.00	£90.00		
	V15 V MR	N/A	£130.00		
Stanton	500 AL Disco	£30.00	£18.00		
	680 ALX Disco	£44.00	£32.00		
	680 ELX Disco	£54.00	£39.00		

Exchange any MC ★★ ★★ Over 500 stylus type stocked ★★ ★★ Tel (01757) 288652

All above items UK supplied/UK guarantee - No grey imports

MANTRA AUDIO (HFV), 22 GARTH AVENUE, NORTH DUFFIELD, SELBY, NORTH YORKS YO8 7RP

## Harrogate Hi-Fi Centre

15, Commercial Street, Harrogate,  
North Yorkshire HG1 1UB  
Tel: 01423 504274

We Currently Have On Demonstration One Of The Finest Selections Of Top-Flight Loudspeakers, Valve Amplifiers And Solid State Equipment In The North Of England...

### Loudspeakers

Lumley Monitor 2 - Authoritative Reference Loudspeakers  
Martin Logan Aeries - The Electrostatic With Attitude!  
Opera Callas II - Smooth And Articulate, With Solid Cabinets  
Lumley Reference 3.5 - One Of Our Best Sellers. Find Out Why!  
Celestion SL-600si - Aerospace Technology In A Loudspeaker!

### Amplification

Lumley ST-40 Stereo 40 Watt Valve Amp In Chrome £999.00  
Lumley ST-70 Stereo 70 Watt Valve Amp- Stunning £1950.00  
Lumley 120 Monoblocks - Yes, 120 Watts From Valves! £3350.00

### Solid State Equipment

Musical Fidelity E-10 New Budget Integrated Amplifier £299.00  
Musical Fidelity E-100.. You'd Think It's A Pre-Power £599.00  
Musical Fidelity A-1000 Still One Of The Best Trannies £1399.00

### New! On Demonstration Now

Alchemist Forsetti.. Kinshaw Perception Range.. NAD 208s..  
Lexicon & Onkyo DSPs.. Silver Sounds Cables.. Air Pods.. Chord Flatline.. Orelle CD-10T.. Beyer DT100-911

### And More REAL HiFi From

Sonus Faber- Castle- Michelle- Tannoy- NAD- Alchemist- Stax  
Rotel- Copland- Lexicon- Marantz- Onkyo- Celestion- DNM

# MEASURED PERFORMANCE

It's important to measure products to assess performance, find explanations of sound quality and warn of peculiarities or faults. Only Hi-Fi World has an advanced in-house laboratory with digital signal analysis for this purpose. In conjunction with this facility we assess sound quality in our own acoustically treated listening room. We measure most products reviewed. Here's a simple guide on our test results.

## LOUDSPEAKERS

Smooth, flat frequency response is important to ensure a balanced sound. Look carefully at overall trends; rising treble will give a bright sound, falling treble a dull sound. A rise through the midrange normally corresponds with good projection.

High sensitivity (better than 86dB) means less power is needed for a certain volume, meaning a low power amp. can be used.

The impedance curve tells us how easy loudspeakers are to drive. Low or wildly varying impedance is bad; a flat impedance around 8Ω is good.

## CD PLAYERS

Even small trends in frequency response of CD players can affect their subjective balance. Generally, those with a gently rolled off treble and, more rarely, a rising bass will sound best. Rising treble can

produce a sharp sound.

The distortion plot we show is taken at -30dB, to represent a typical music signal. High distortion at this level, combined with rising treble, can result in a harsh sound. Yet other effects have to be considered, especially low level linearity, which we also test for, including -90dB signals with dither applied.

## AMPLIFIERS

Distortion from solid state amplifiers should be no more than around 0.2%. Even order (2nd, 4th, 6th etc) distortion is aurally innocuous, but odd order (3rd, 5th, 7th etc) distortion makes for a glassy, hard sound, or grittiness.

Frequency response can be band limited, with bass and treble rolled off just out of the ear's range, or wideband. Each has its own characteristics. Small wideband response variations colour tonal balance.

Power output is easy to understand: the higher the figure, the louder it will go. Just make sure there's enough power output to drive any loudspeakers you intend to use.

## TUNERS

Frequency response, as always, says much about tonal balance and character traits, like peaky treble (due to a mis-matched MPX filter). Distortion and channel separation need to be less than 0.3%

(according to harmonic structure) and better than 25dB.

Hiss level must be lower than -70dB for Radio 3 silences to be just that - silent. And full quieting, the strength of aerial signal needed for optimum results, should be around 1mV or less

Selectivity, the ability to separate stations under the most difficult conditions should be better than 60dB and sensitivity better than 30μV on stereo.

## CASSETTE DECKS

Replay performance is measured to IEC 94 Standards using IEC test tapes. This ensures that recordings made on a machine transfer to a car player, personal stereo or another domestic recorder properly, as well as ensuring optimum results with commercially prerecorded tapes. Look for a quoted replay response of 40Hz-10kHz, no more than 1% speed error and hiss in the replay amps lower than -58dB.

Recording quality considers frequency response, bias variation, head performance and alignment. Frequency response should stretch from 40Hz-15kHz or so. Head overload (MOL315) must be above 0dB, reaching around +4dB for good results.

From the transport mechanism look for less than 0.15% wow or flutter. Overall (DIN weighted) wow and flutter should be no more than 0.1% or so.

# TUNER

## HARMAN KARDON TU-930

The TU-930 has a frequency response judiciously rolled-off above 12kHz, giving a softer, easier sound than designs possessing treble lift (of any degree). Denon and Technics have both learnt about this, if not others, who engineer for "detail" in the sound I suspect, getting unpleasant brightness too - but not Harman.

Distortion was higher than that of rivals, but not disastrously so. Channel separation on stereo proved good right across the audio band and unwanted outputs above 15kHz minimal due to good pilot/sub-carrier filtering. At -69dB, hiss wasn't as low as hoped and will just be audible during Radio 3 silences, if at no other time.

Audio output was very high at 1.5V and full quieting satisfactory at 1mV and above. With normal sensitivity and very high selectivity, the TU-930 proved well engineered. NK

## TEST RESULTS

Frequency response	10Hz-12kHz	Sensitivity	
Stereo separation	42dB	mono	2μV
Distortion (50% mod.)	0.7%	stereo	30μV
Hiss (CCR)	-69dB	signal strength meter	none
Signal for minimum hiss	1mV		
Selectivity (at 0.4MHz)	80dB		

Distortion

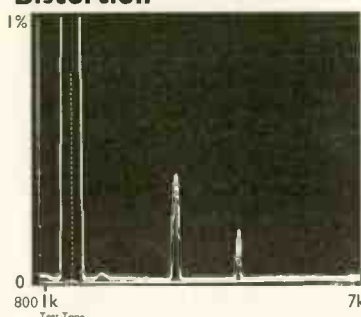

Frequency Response

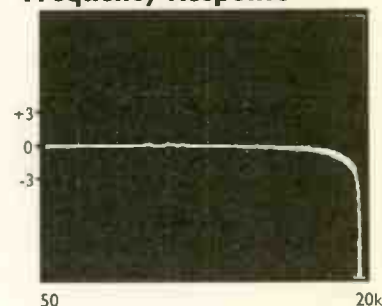

Continued on page 107

# Peter TYSON

The NAME you can TRUST

6 ABBEY STREET, CARLISLE, CUMBRIA CA3 8TX  
TELEPHONE: 01228 46756

**We stock and demonstrate  
the full range of LINN  
Products and Systems  
including Multiroom.**

Our Other Brands  
Include:

Arcam, Mission,  
Marantz,  
Micromega,  
Revolver, Technics,  
Denon, Kenwood  
and Much More



**PART EXCHANGE  
WELCOME. 0%  
CREDIT  
AVAILABLE**

## SERIOUS KIT

21, ALGERNON ST., MONTON, ECCLES,  
MANCHESTER, M30 9QA.  
0161-707 4823

NEWSLETTER NO. 4

O.K. O.K. so Audio Note make the best sounding valve amps, of course there is the question as to whose transistor amps work best? We may have led you readers out there, to believe that at Serious Kit we only stock Audio Note products. Not so! In fact we've been promoting and selling another of "Britain's best kept secrets" since we started. I do of course refer to the excellent products of Yorkshires very own J.E Sugden & Co.

Here we have a range of products that are designed and hand made by a dedicated team of music lovers. There are amplifiers from £300 (inclusive of m.m phone stage) through to the remote Optima series of amps and CD player, right up to the AU51 series of "professional level" line pre-amp & power amp. there is also a Pro-CD range (also with the AU51 label).

However, me being me, I'll talk to you about my own personal favourite from this most under-estimated manufacturer.

The much loved (by Hi-Fi World) A21a integrated amplifier is also one of my own most loved amps under £1000. this little gem runs @ 25w per channel class 'A' and sell @ a mere £700 including m.m. and or m.c. phono board. However it is also available as line level only at a mere £629 inc. VAT.

It runs really hot, and sounds very sweet and open. Transparency is its middle name. Although not the worlds most powerful amplifier, by carefully matching the loudspeakers (Impulse/Pro-Ac/Keswick Audio). One can reach more than enough S.P.L., for all but the largest of rooms. So, why pay more? Many of you won't have to, as the A21a is in my opinion the class leader, on a plateau of its own!

Of course if you have already made a speaker purchase and have something that requires good current delivery or major voltage swing, you must shortlist the AU51 power-amp. here is a beast in wolf's clothing. delicate yet muscular, tonally neutral but enthralling, open and involving. What comes close @ £1295. Search me, this amplifier has seen off more than one or two of the so called "American heavy weights". It's natural partner is of course the AU51 line pre-amp @ £900. Here we have as over engineered pre-amp as you've seen. The switches are all super quality as is the volume control. Naturally all inputs and outputs are gold-plated phono, and all internal signal wire is silver. This combination works especially well with "difficult" loudspeakers like Electrostatics, call for a demo and experience

the "emotional factor".

Sugden also produce a range of digital products. Before you spend a load of hard earned cash on a DAC you should definitely check out the SDA-1. Another personal favourite @ £750, there ain't much at twice the price that comes close. It is so un-digital in its presentation, so un-analytical but detailed. The SDA-1 is one of those products that makes a mockery of many so called "STATE OF THE ART" products costing many times more. Another bargain from Yorkshire.

Most of our digital customers over the last few months have wanted to spend around the £1000 mark for their CD replay requirements. Most of them had been disappointed by the many "recommended by the mags" products previously auditioned. All of them were sent home with an SDT-1 integrated player for home audition. All of them purchased SDT-1 CD players. Quite remarkable really when the "under-dog" product leaves the biggest positive impression. Of course there is no "black magic" in the SDT-1, just lots of top quality components. The standard Philips 7220 filter, but used in conjunction with the TDA 1541 'crown' pedigree DAC chip. Very few manufacturers use this version of the TDA 154.1, because it is expensive, however in usual Sugden style they bring it to all Audiophiles and music lovers in a fully integrated player for a mere £995.00.

If you want a CD player that thinks its a record player, audition this one. It'll become a way of life!

Remember, audio reproduction is not about product hype, or blessed products sent from above. It is simply engineering. True, some engineering is more effective than others.

Call us soon, and let us engineer a music system for you.

As ever, wishing you a musical month ahead, till next time.

Kind regards

David W. Speirs

(PROPRIETOR)

STOCKISTS OF THE WORLD'S FINEST AUDIO EQUIPMENT:  
ABSOLUTE SOUNDS, AUDIO NOTE, AUDIO INNOVATIONS, MICHELL,  
LYRA, J.E. SUGDEN, PRO-AC, IMPULSE, VOYD, WILSON BENESCH,  
ORTOFON, KINSHAW, KESWICK AUDIO, STAX, ROKSAN ETC ETC



# AMPLIFIERS

## ALCHEMIST FORSETI

The Forseti APD20A power amplifier is unusually powerful, delivering 145watts into 8ohms and 225watts into 4ohms, so it is meant for big speakers and rooms. It runs quite hot, suggesting strong bias into Class A.

Bandwidth was adequately wide, measuring 9Hz to 30kHz, -1dB, some band limiting being used at high frequencies, generally a wise thing to avoid transient distortions.

Although harmonic distortion was low overall, not exceeding 0.1% (full output, 10kHz) I noticed harmonic patterns changed as signal level rose - not the best of phenomena to encounter, since distortion will be modulated by signal level. Feedback does tend to create this effect, although it isn't usually so noticeable. In areas like this only listening tests can decide whether they may be consequential or not. Noise and channel separation were satisfactory.

The Alchemist measured well. It is a powerful amplifier, but strong Class A working may well provide good low level performance. **NK**

### TEST RESULTS

Power	145watts
CD/tuner/aux.	
Frequency response	9Hz-30kHz
Separation	82dB
Noise	-103dB
Distortion	0.01%
Sensitivity	300mV
dc offset	-16/10mV

### Distortion

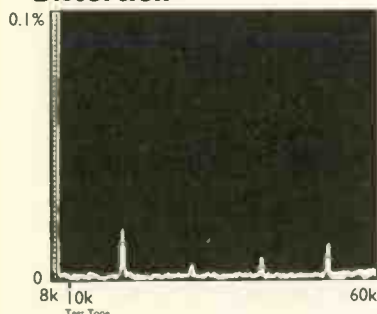

## SONY TA-F446E

The TA-F446E offers plenty of power: 55watts into 8ohms and no less than 80watts into a low 4ohm load. That's enough to make most 'speakers go very loud, especially today's more sensitive designs, so the Sony has plenty of grunt.

Distortion was all but unmeasurable,

hovering around 0.004%, third-harmonic only, at all frequencies and power levels. With a satisfactory bandwidth of 10Hz-63kHz (-1dB) and high sensitivity of 150mV, the line inputs offer good results.

Finding the phono stages measured unusually well, and similarly between MM and MC - a rare thing in Japanese amps where design philosophy hardly exists - I opened up the case and found an all discrete phono stage section - rare indeed. These days silicon chips reign unopposed, so I wonder where Sony found the designer. All figures for disc - both MM and MC - were very good. My only minor gripe is that MM bass rolls off slowly but MC bass rises slowly, differences between the two amounting to 0.7dB or so at around 80Hz. I'm not sure anyone will notice, but I don't like to see bass fall in this part of the phono spectrum. MC in particular was unusually sensitive, so it will accept high quality MCs, and it was quiet too - a serious design.

The TA-F466E is powerful, well engineered and has very good MM and MC phono stages. It is one of the better designs of its type. **NK**

### TEST RESULTS

Power	55watts
CD/tuner/aux.	
Frequency response	10Hz-63kHz
Separation	71dB
Noise	90dB
Distortion	0.004%
Sensitivity	150mV
D.C. offset	26/28mV
Disc (MM)	
Frequency response	30Hz-71kHz
Separation	57dB
Noise	87dB
Distortion	0.004%
Sensitivity	2.4mV
Overload	150mV

Disc (MC)	
Frequency response	20Hz-42kHz

### Distortion

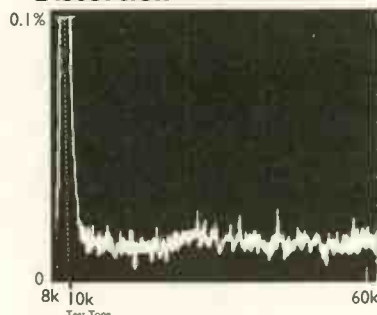

Separation	40dB
Noise	68dB
Distortion	0.004%
Sensitivity	0.15mV
Overload	10mV

## UNISON SIMPLY TWO

By using just one valve in inefficient single-ended mode the Simply 2 is necessarily limited in power output, producing just 8watts. That's roughly what's expected.

Overload (clipping) was gentle and progressive, and also symmetrical - good signs on a low power amplifier that will almost certainly be run into peak-clip. I noticed in particular a fairly benign distortion spectrum with, as expected from our own experience, more innocuous second harmonic in low feedback mode. Increasing feedback produced better distortion figures - 1.4% instead of 1.8% at 1watt output - but worse distortion. Interestingly, there was no increase in distortion at high frequencies.

Bandwidth was adequate at both feedback levels (13Hz-33kHz, -1dB worst case) and full output was delivered at 10kHz - very encouraging. Too many valve amps don't manage this important prerequisite. The Simply 2 proved better engineered than most of the modern S.E. breed and I'd expect it to deliver the sort of qualities expected from a such a design. **NK**

### TEST RESULTS

Power	8watts
CD/tuner/aux.	
Frequency response	10Hz-40kHz
Separation	71dB
Noise	96dB
Distortion	1.5%

### Distortion

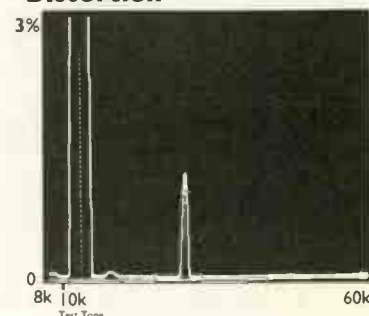

Continued on page 109

## hi Best prices for new, xdem & s/h equipment *fi*

Jadis DEFY 7	as new	£3500	KEF Koda	as new	£89
Jadis JA500 (re-valued, semi-rod)	mint s/h	£10895	SD Acoustics S03	as new	£295
NRG 201 S	mint s/h	£2750	Sonus Faber Extremas + std	mint s/h	£4250
Krell KSA 100 mül	mint s/h	£1695	Sonus Faber Minima Amators	mint s/h	£1200
Jadis JA30	mint s/h	£2250	Audio Static ES 100	mint s/h	£1795
Cadence M2/M2A2	x-dem	£1750	Soundlab A3	mint s/h	£4995
Goldmund Miramis 3	mint s/h	£2600	Rolsan Darius	mint s/h	£795
Tesseract Tamp 60 ref. monoblocks	x-dem	£3995	Ret Strata	as new	£395
LFD PA1/L51	mint s/h	£995	ATC SCM 20T	x-dem	£1895
Meridian 605 monoblocks	as new	£1495	Neat Petite	mint s/h	£350
Jeff Rowland Model 3	mint s/h	£2750	Epos ES II + std	mint s/h	£295
Jeff Rowland Model 1	mint s/h	£1495	Linn kabars	mint s/h	£795
Audio Innovations 2nd/L2	mint s/h	£1995	Spemán SP9/1	as new	£2600
Lumley Reference 120	mint s/h	£1795	Martin Logan CLS II	mint s/h	£1495
Copland CTA 401	as new	£995	Linn KAN + stds	vgc	£275
Jadis JP 80 mc	as new	£7995			
Electrocommel AW100/EC3	as new	£1995	Audio Research DAC1	mint s/h	£1495
Linn LK 100	as new	£350	P.S. Audio Ultralink	mint s/h	£1250
Albany 408	x-dem	£395	Meridian 206 Delta Sigma	mint s/h	£595
Albany 1008	x-dem	£650	Micromega Trio transport	as new	£1895
Musical Fidelity F15/F22	mint s/h	£2250	Naim CD1	mint s/h	£1200
Cilittos pre/amp	mint s/h	£3995	Wadia 16	as new	£5995
Naim 82 pre	as new	£1395	Accuphase DP70	mint s/h	£2995
Naim 250 pwr	as new	£1195	Renox H2	as new	£595
Naim Hi CAP	as new	£450	Wadia 15 D to A	x-dem	£2250
Classe DR6 Line/phono	as new	£2500	Meridian 263	mint s/h	£275
Sonic Frontiers SFL-1	mint s/h	£695	Micromega Stage 2	x-dem	£495
Tesseract Tali Ref pre	x-dem	£3995	Rolsan Dp2 mül	x-dem	£995
Burmester 808 phono/line	mint s/h	£2500	Arcam Alpha 5	mint s/h	£295
Audio Research SP9	mint s/h	£795	Meridian 200/263	mint s/h	£750
Audio Research LS3	as new	£1200	Deron DCD S1	mint s/h	£3750
Mark Levinson No 28	mint s/h	£1895			
Proceed pre-amp	as new	£1595	Audiomeca Romance/Romeo	mint s/h	£895
Arcam Zeta One	as new	£750	Piere Lume J1/SME V	mint s/h	£1995
Audio Synthesizer Passion	mint s/h	£350	Graham 1.5 (two tubes)	mint s/h	£1295
Albany API	as new	£295	Alphason Sonata HR100 MCS		
Naim NAP 180	mint s/h	£750	Atlas Power Supply	mint s/h	£1295
Trilogy 958 monoblocks	mint s/h	£1800	VP1 TNT mül	mint s/h	£2250
Creek 4240	mint s/h	£175	Oracle Delphi midV	mint s/h	£795
Pioneer A400 GTE	mint s/h	£225	Koetsu Red	as new	£495
			Audio Note I/O	as new	£895
Naim SBL's (latest spec)	as new	£1395	Wilberst Sigma Genesis	as new	£295
Quad ESL 63	mint s/h	£1895	Emminent Technology ET II	mint s/h	£750
TDL ref Monitors	mint s/h	£1895	Piere Lume J1/Sowther Tri-Quartz	mint s/h	£1795
Impulse H2	mint s/h	£1495	Kinshaw Perception phono stage	mint s/h	£295
Apogee Caliper sig	mint s/h	£1595	LFD MC1 phono stage	mint s/h	£395
Apogee Diva +Dax	mint s/h	£4995	Retel Michi RHQ 10	mint s/h	£595
Apogee Stage	mint s/h	£1495	Alphason HR 100 mcs	mint s/h	£350
Magneplanar 2.5R	mint s/h	£995	Linn Ittok LVII black	mint s/h	£250
Magneplanar SHiGa	mint s/h	£350	Nakamichi DR1	as new	£495
Sonus Faber Guadri	as new	£4495	VPI Record Cleaning M/C	poa	
Infinity IRS Beta	mint s/h	£4995	Slax ST Sigma Pro/SRM-TI	as new	£1795
ATC SCM100 passive	vgc	£1895	Tube Energizer		

**MINT S/H** - Second hand as good an example as we've seen anywhere  
**AS NEW** - Typically less than 4 months old in new condition  
**X-DEM** - Typically 'as new' but may be older  
**G.C.V.G.C** - In perfect working condition but may be marked

## hi CHOICE *fi*

(0181) 392 1959

(0181) 392 1994 phone/fax

Equipment bought or part exchanged  
 Full demonstration facility - by appointment  
 Major credit cards accepted  
 9.30am - 8.00pm 7 days

## STILL CAN'T FIND WHAT YOU'RE LOOKING FOR .... TRY

## The Hi-Fi Exchange

The Hi-Fi Exchange is a new and unique service that allows you to buy and sell equipment using our sophisticated data base.

Please call 0181 392 1963  
for details.

## ENGLISH audio

### SALE OF EX-DEM EQUIPMENT

	WAS	NOW
KEF Reference 3 (Rosewood)	£2500	£1995
Musical Fidelity F15/F22	£3000	£1995
Orelle CD480	£400	£290
Micromega Microdrive/Variodac	£1400	£700
Micromega Stage I	£500	£390
Micromega Stage II	£650	£490
Micromega Stage III	£850	£650
NAD 906	£500	£390
TDL Point 75 (Walnut)	£750	£490
KAR Volante (Black)	£550	£440
Pink Triangle Export (Nat Ash)	£950	£690
Heybrook Sextets (Black/Burr)	£1130	£790
Sugden AU41 Pre/Power (M/C)	£1250	£990
Rotel Michi RH1 10	£895	£695
Rotel Michi RHA 10	£995	£795
Rotel Michi RHB 10	£1650	£1290
Exposure 15 Integrated (M/M)	£725	£590
Exposure 20 Integrated (Line)	£625	£490
Exposure 17/18 Pre/Power (M/C)	£1525	£1100
Audion Silver Nights (Push/Pull)	£2000	£1500
Mission 753 (Rosewood)	£800	£640
Polk RM3000	£800	£500
Tannoy D500 (Walnut)	£1470	£990

### SECONDHAND

Apogee Centours (Black)	£800
Linn LP12/Ittok/Cirkus/Trampolin	£800
Musical Fidelity MA50 (pair)	£350
Sugden A21a Integrated	£350
Pink Triangle Ordinal (18 bit)	£600
Arcam Delta 110.S	£300
Magnum A40 Power Amp	£400
Quad FM4 Tuner	£200
Heybrook Quartets + Stands (Black/Burr)	£600

  **37 WHITECROSS ROAD HEREFORD HR4 0DE**  
**TEL. 01432 355081 FAX. 01432 354302**



## CABLE TALK

BRITISH  
MADE

★★★★★ Rated interconnects and speaker cables are available from your local specialist dealer.

.....STOP PRESS.....STOP PRESS .....STOP PRESS.

"Talk 3's great sound quality and value for money"  
 (Dec '92 WHAT HI-FI?)

Can now be obtained in a convenient bi-wire format at £4.50 per metre.

Please Telephone 01252 373434 Fax 01252 371818  
 For Further Information

## THE EMPORIUM

28 St. Nicholas Street, Diss, Norfolk.  
 TEL (01379) 650744 FAX (01379) 641932  
 Open MON - SAT 11.00am - 5.30pm

### ANY DECENT HI-FI BOUGHT FOR CASH

FOR SALE			
LINN LP12/ITTOCK K9	£450	KEF 105/2	£450
SYSTEMDECK IIX 900/TABRIZ/1012	£250	MONITOR AUDIO, STUDIO 15 PIANO BLACK	£850
QUAD 33/405	£200	ROKSAN XERXES/KUZMA STOGI (SILVER WIRED)	
DECCA FFSS ARM	£30	KOETSU RED	£900
SME 3009 II IMPROVED	£75	MAGNEPLANAR 1.4 (GREAT WITH VALVE AMPS)	£700
QUAD 22/II/II PROFESSIONALLY RESPRAYED	£400	MUSICAL FIDELITY DR THOMAS AMP	
ROGERS CADET III PRE POWER	£100	(AUDNDALL-MOD) AVONDALE-MOD	£275
GOODSELL MA 10 MONOBLOCKS (EL84)	£150 PAIR	MC TRANSFORMER (FUPEX)	£75
ROGERS HG88/II	£75	SUMO ATHENA PRE-AMP	£200
LEAK TL12 + PAIR	£350	NAKAMICHI 550	£150
LEAK TL25+ PAIR	£400	ARISTON RD40-LIN BASIK PLUS	£100
LEAK TL10 PAIR	£400	MARTIN LOGAN CLFI	£2000

# CD PLAYERS

## AUDIO ALCHEMY DDE VI.1

We tested two samples of the DDE 1.1, the first measuring poorly enough to suggest a small fault. The second sample was a lot better in many areas, but still retained many of the first sample's quirks. Distortion is high right across the board, being more than ten times higher than the best at -30dB, a level picked to represent a typical music signal, as can be seen in the plot below. On top of this the DDE 1.1 showed high noise out of band, the noise floor being nearly higher than the fundamental signal between 70-80kHz.

Frequency response was very well engineered though, being very flat and smooth with just a gentle roll off above 10kHz, which should smooth the subjective balance.

Elsewhere things measured normally enough, the only area worth mentioning being the higher than standard output of 2.67V. The DDE 1.1 will sound louder in a demonstration against a competitor adhering to the Philips 2V standard, but this extra output does give a little extra room for passive preamplifiers. **DB**

### TEST RESULTS

Frequency response	4Hz-21.2kHz	
Distortion (%)		
-6dB	0.007	0.008
-30dB	0.060	0.070
-60dB	1.20	1.50
-90dB	74	83
-90dB dithered	-	-
Separation (dB)	left	right
1kHz	95	96
20kHz	71	73
Noise		-102dB
with emphasis		-102dB
Dynamic range		101.7dB
Output		2.67V

### Distortion

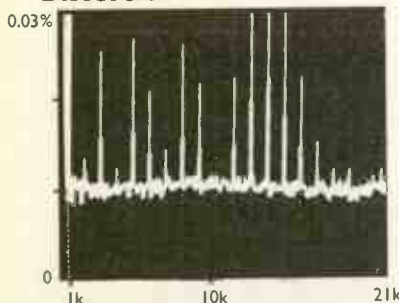

### Frequency Response

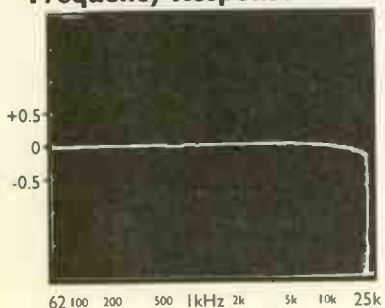

## NAD 514

The frequency response of the new NAD 514 CD player is nicely engineered, having gentle treble roll-off to prevent sharpness, and a slight lift towards lower frequencies. Although only subtle, this should ensure solid bass and a smooth balance through midrange and treble.

Distortion is a little higher than the best at -30dB, a level picked to represent typical music signal level. The best get as low as the NAD at 0.018%. It displayed a small amount of innocuous 2nd harmonic, and some scattered higher order distortion too.

Elsewhere the 514 measures competently, having low noise, a healthy dynamic range of 110dB, and good output at 2.2V. **DB**

### TEST RESULTS

Frequency response	4Hz-21kHz	
Distortion (%)		
-6dB	0.007	0.007
-30dB	0.018	0.018
-60dB	0.46	0.47
-90dB	25.2	25.7
-90dB dithered	5	8
Separation (dB)	left	right
1kHz	119	115
20kHz	99	99
Noise		106dB
with emphasis		108dB
Dynamic range		110dB
Output		2.2V

### Distortion

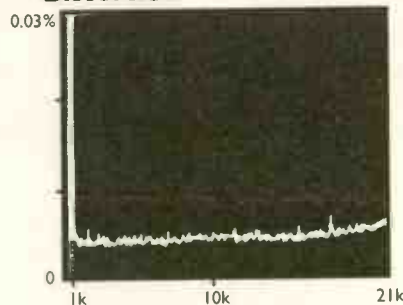

### Frequency Response

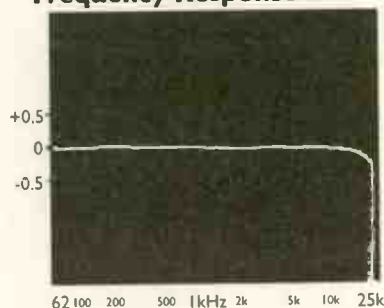

## MARANTZ CD-16

The Marantz is one of the best, if not the best CD player we have measured for a long time. Previously, Pink Triangle's Ordinal has set the standard for others to beat with a flat frequency response and super low distortion. The Marantz CD-16 has a similarly smooth response, with treble above 10kHz just falling a fraction; never a bad thing with CD.

Distortion is extremely low right across the board, with not a single harmonic visible at -30dB, a signal picked to represent typical music level. I'd expect the CD-16 to sound very clean and free from grain or sharpness as a result.

At -60dB distortion is still extremely low, at 0.36%, which gives rise to a wide dynamic range of 111dB (EIAJ test). Separation is wide, noise very low, and output spot on the Philips standard at 2V. This impressive set of test results shows fine engineering. **DB**

### TEST RESULTS

Frequency response	4Hz-21.3kHz	
Distortion (%)		
-6dB	0.005	0.006
-30dB	0.005	0.005
-60dB	0.36	0.36
-90dB	27.8	27.9
-90dB dithered	6.3	5.9
Separation (dB)	left	right
1kHz	128	127
20kHz	104	105
Noise		-104dB
with emphasis		-105dB
Dynamic range		111dB
Output		2.0V

### Distortion

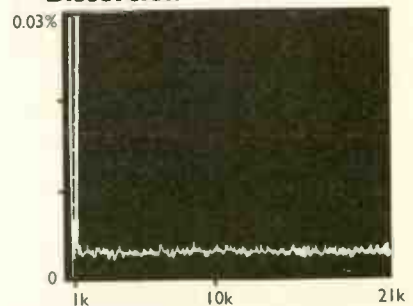

### Frequency Response

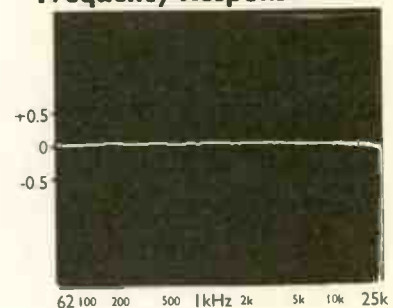

Continued on page 111

# GENUINE HI-FI

# sale

YOU MAY PLACE ORDERS 7 DAYS - A WEEK

Save Up To 50%

Hi-Fi Confidential welcomes you...

100'S OF ITEMS REDUCED

### AMPLIFIERS

COMPANY	MODEL	DESCRIPTION	OUR PRICE	COMPANY	MODEL	DESCRIPTION	OUR PRICE
ALCHEMIST	APD-3	FRAYA PRE-AMP	599	KINSHAW	PERCEPTION	PHONO CENTRE	479
ALCHEMIST	APD-4	BRAGI PHONO STAGE	299	LUMBLY REFERENCE	ST-70	Power Amp	1799
ALCHEMIST	APD-6	KARKEN INTG	279	LUMBLY REFERENCE	ST-40	Power Amp	899
ALCHEMIST	APD-7	KARKEN PRE	250	MUSICAL FIDELITY	E-199	INT AMP	539
AUDIO INNOVATIONS	L1	LINE PRE AMP	269	MUSICAL FIDELITY	E-200	INT AMP	539
AUDIO INNOVATIONS	L2	LINE PRE AMP	629	MUSICAL FIDELITY	E-300	Power amplifier	629
AUDIO INNOVATIONS	SERIES 200	Power amplifier	429	ONIX	OA31-M	Amplifier	279
AUDIO INNOVATIONS	SERIES 800	Power amplifier	769	ORELLE	SD101/SP101	PRE & POWER AMPS	550
AUDIO INNOVATIONS	SERIES 1000	Power amplifier	1349	PIONEER	A-300X	INTG AMP	180
AUDIO INNOVATIONS	SERIES 300	INT AMP	449	ROTEL	RA-930AX	INTG AMP	299
AUDIO INNOVATIONS	CLASSIC 25	INT AMP	809	ROTEL	RA-935BX	INTG AMP	175
AUDIO INNOVATIONS	ALTO	INT AMP	299	ROTEL	RA-940BX	INTG AMP	195
AURA	VA-50 CROME	INT AMP	229	ROTEL	RB-970BX	Power amplifier	175
AURA	VA-100	INT AMP	229	ROTEL	RB-956AX	Amplifier	250
AURA	VA-80	INT AMP	259	ROTEL MICH	RHC-10	Passive Pre Amp	599
AURA	DSP-200S	PHONO AMP	449	ROTEL MICH	RHC-10	Phono equaliser	695
DPA	DSP-200S	PRE AMP	449	ROTEL MICH	RHB-10	Power amplifier	1199
DPA	DPA-200S	Power amplifier	676	ROTEL MICH	TOTAL SYSTEM		2400
JOHN SHEARNE	PHASE 2	INT AMP	469	SUGDEN	A-48B	INT AMP	529

### CD PLAYERS

COMPANY	MODEL	OUR PRICE	COMPANY	MODEL	OUR PRICE
AURA	CD 50 Black	329	PHILIPS	CD930	159
MARANTZ	CD 53	POA	PHILIPS	CD940	179
MARANTZ	CD 63	POA	PIONEER	PDS 703	239
MARANTZ	CD 63SE	POA	ROTEL	RCD 945 AX	190
MICROMEGA	STAGE 1	449	ROTEL	RCD 955	200
MICROMEGA	STAGE 2	599	ROTEL	RCD 965	250
MICROMEGA	STAGE 3	799	TEAC	VRDS-10	729
MUSICAL FIDELITY	E 600	539	TEAC	VRD-7	569
ORELLE	CD 480	329	TEAC	VRDS-T1	479
ORELLE	CD 160.2	549	YAMAHA	CDX-580	195
ORELLE	CD 260.2	699	YAMAHA	CDX-860	229
ORELLE	CD 10.T	649			

### SPEAKERS

COMPANY	MODEL	OUR PRICE	COMPANY	MODEL	OUR PRICE
CASTLE	YORK	599	SPENDOR	SP 2/3	825
CASTLE	CHESTER	299	SPENDOR	SP 1/2	1099
HARBETH	LS 5/12A	525	SYSTEM	935	329
DYNAUDIO	CONTOR 1.8	1139	UKD	CALLAS MAH	675
DYNAUDIO	AUDIENCE 15	1550	UKD	CALLAS WAL	775
DYNAUDIO	AUDIENCE 5	950	UKD	OPERA PRIMA	399
MONITOR AUDIO	MA202	350			
MONITOR AUDIO	MONITOR 9 GOLD II	389			
ORELLE	ORATOR	229			
ROYD	SAPPHIRE 2	550			
ROYD	ABBOT	220			

### MULTI CD PLAYERS

COMPANY	MODEL	OUR PRICE
TECHNICS	SLPD 667	159
YAMAHA	CDC-645	239

...Complete Home Cinema Equipment Available..Cassette Decks & Turntables On Sale...

Mail, Telephone & Fax Orders Welcome

24Hrs Delivery

FREE Carriage Insurance



EASY Parking, Easy Access from Victoria Tube & Main Line Stations

34 Buckingham Palace Road, London SW1W 0RR

# HI-FI

CONFIDENTIAL

0171 630 1127

0171 233 7225

FAX: 0171 233 7226

1 Minute from Victoria Station

8 am - 10 pm 7 Days - a - Week

© Media Marketing & Design 1995 Tel (0181) 6579547

## R. J. F.

### AUDIO VISUAL

ANALYSIS AUDIOMECH TRICHORD  
PERCEPTION SME MCINTOSH (ETC)  
CORNWALL'S PREMIER DEALER  
FOR SALE

SME 20 V ARM ORTOFON MC 7500 (MINT, 100HR'S USE) EX DEM	£4250
ROKSAN XERXES, ARTEMIZ, SHIRAZ , ARTAXERXES	£1425
ROKSAN PRE L2	£595
ROKSAN POWER S1	£845
ACCUPHASE C200 P-300 PRE/POWER	£1495
TDL MONITORS	£975

**"CLOCK THIS"**

UPGRADE YOUR PLAYER'S TRANSPORTS WITH CLOCK MODIFICATION. CLOCK MOD'S FROM £80.00.

CONTACT NIGEL OR RUSSELL FOR FURTHER INFORMATION

RUSSELL J.FLETCHER  
PENDARVES STREET, TUCKINGMILL,  
CAMBORNE, CORNWALL TR14 8NJ  
Tel: 01209 612260 Fax: 01209 711939



## X-DEM + S/H EQUIPMENT SALE

### LOUDSPEAKERS

ATC SCM 20'S (TEAK).....	£750
B&W 805 MATRIX (BLK).....	£675
ACOUSTIC ENERGY AE2 + STANDS.....	£775
EPOS ES14 (BLK) + STANDS.....	£450
TANNOY G15'S (FLOORSTANDERS) BLK...£450	
NEAT PETITES (BLK)).....	£395
HEYBROOK HBI S3 (BLK) + STANDS.....	£200
ENSEMBLE PRIMADONNAS (BLK).....	£3000
(VERY RARE ) + VARIOUS STANDS FROM....	£30

### AMPLIFIERS

AUDIOLAB 8000C 8000P.....	£500
MAGNUM P200 PRE + A50 POWER AMP MONOBLOCKS x 4 (340WPC).....	£1950
(NEW £4500)	
PIONEER A400 GTE.....	£225
NAD 302 AS NEW.....	£115

# 0181 - 948 5568

# LOUDSPEAKERS

## NEAR SOUNDMAST

Near's Soundmast loudspeakers show reasonable integration through the midrange, but above and below this things get a little lumpy. Treble level falls above 8kHz and below 800Hz there is a dip which may subjectively "thin" male vocals. A peak at 250Hz will add speed and punch. The Soundmasts are likely to have quite a distinct character.

At 85dB measured at 1m with a nominal watt (2.83V) pink noise signal, they are of average sensitivity. Impedance is just a fraction under  $8\Omega$  too, so the Soundmasts will be easy enough to drive by most modern amplifiers. I'd recommend 30watts or more for best results. **DB**

Frequency Response

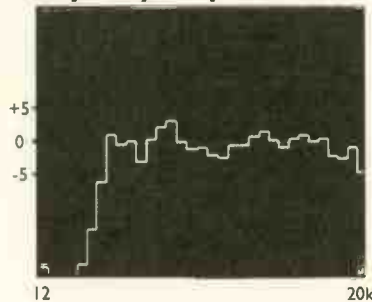

Impedance

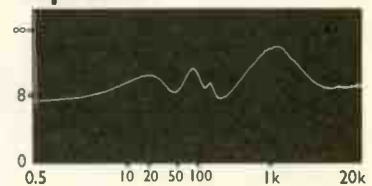

## PINK TRIANGLE VENTRICLE

The Ventricle peaks in the upper bass, whilst lower bass steadily falls away, although the peaking helps maintain output down to 63Hz (-6dB) - a normal value. All the same, subjectively, upper bass will dominate.

Midband output was smooth and even, but almost inevitably, the driver used cannot reach up high enough to integrate smoothly to the ribbon tweeter (few do), resulting in a -2dB suckout above 3kHz, an effect that will suppress detail, but aid perceived smoothness.

When the tweeter cuts in (6kHz) treble output lifts, peaking by +2dB at 16kHz. This will cause some treble sharpness or 'thinness'.

Sensitivity was very low at 81dB, partly due to a high overall impedance of 12ohms.

At least 40watts will be needed for decent volume, although too much will also overdrive the small bass unit. A strong dive in impedance above 5kHz means low output impedance amps are technically the best match (solid-state or high-feedback valve designs). **NK**

Impedance

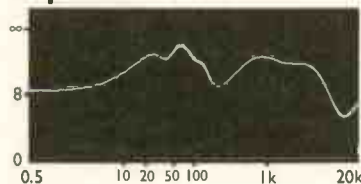

Frequency Response



## NHT 1.3A

The NHT 1.3As are very well engineered in some areas, but are a little unfortunate in others. Their response is commendably flat and smooth, showing fine treble extension and super crossover alignment. But below 500Hz or so output falls off by -3dB, which will tend to give them a light and thin balance with little bass power. So although they have a very well engineered response, they are likely to be bass light in practice unless used close to a wall.

Sensitivity of the NHT 1.3As was very low, measuring 83.5dB at 1m for a nominal watt (2.83V) pink noise signal. They will need an amplifier capable of delivering a lot of volts if you like your music loud or have a large room. Their impedance curve is very smooth, lifting gently through the midrange.

They will present a very easy load to an amplifier in this respect, being mainly resistive and with a high overall  $9\Omega$  impedance value.

The NHTs are well engineered in many respects, but will have light bass unless close to a wall and they need a powerful amplifier (50W min.) for decent levels. **DB**

Impedance

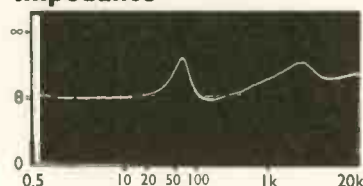

Frequency Response

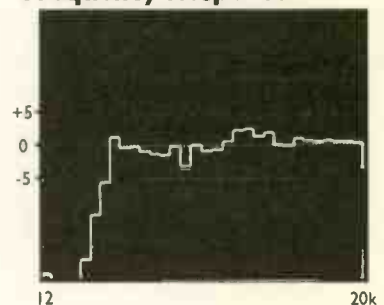

# Francinstien

STEREO ENHANCEMENT SYSTEM



## Try the CD Filter with a difference in your own home

When we listen to music, both the high and low frequency sounds help our brains to paint a 3 dimensional stereo picture. But when we listen to CD, the high and low pictures do not perfectly realign. With their clinically clean electronics, CD players lack the beneficial, subtle signal handling of analogue equipment which can actually "re-converge" the two stereo images. So creating the convincing illusion that is the hallmark of good analogue systems.

**Francinstien**, designed by Hi-Fi World columnist Richard Brice, breathes life into digital stereo. By simulating the best aspects of analogue equipment, it restores the sense of depth - and even height - to digital recordings. And it does it without introducing any of analogue's vices!

Simply plug **Francinstien** between your CD player and pre-amplifier (or integrated amplifier) and you can have your cake and eat it. Analogue imaging and "involvement" with the clarity and "bite" of digital. But you don't have to believe us because you can try **Francinstien** on home trial.

*"It's a gentle elegant effect - and a very even one...One simply becomes more aware of the music."*  
— **Eric Braithwaite** - Hi-Fi World

*"CDs sounded better defined, the soundstage having a more definite shape. It was as if there was more air around each strand in the mix, allowing you to hear it more distinctly, more separately...I didn't immediately want to switch the CD player off and relax with some LPs, instead I went on to make further explorations of my CD collection"*  
— **Andrew Cartmel** - Hi-Fi Choice

Let the **Francinstien** improve the audio quality and stereo imaging of your system. To send you a demonstration unit we require either cheque or credit card payment for £7.00, to cover postage and administration. If you wish to purchase a **Francinstien** please call us and £7.00 will be deducted from the total price of £150 inc. VAT. However, if you do not wish to keep the **Francinstien** then simply return the unit to us within 10 days.

Title: \_\_\_\_\_ First Name: \_\_\_\_\_ Surname: \_\_\_\_\_

Address: \_\_\_\_\_ Post Code: \_\_\_\_\_

Francinstien unit for home demonstration  Further information on Perfect Pitch Music products

Credit card payment — I authorise you to debit my credit card account for the cost of goods despatched.

Visa  Mastercard  Tick one box

Credit card number: \_\_\_\_\_ Credit card expiry date: \_\_\_\_\_

N.B Goods will be despatched only if the above address is the cardholder's address.

Cardholder's signature: \_\_\_\_\_ Date: \_\_\_\_\_

VISA

MasterCard



Perfect Pitch Music is a trademark of Select systems™

Select Systems Ltd. Dept. HFW/8 Hanworth Trading Estate Hampton Road West Feltham Middx. TW13 6DH

Tel: +44 (0)181-893-8662 Fax: +44 (0)181-893-4318

World Radio History

# LOUDSPEAKERS

## REL STADIUM II

The two plots show the Stadium II with its filter controls at either extreme, rolling into the main loudspeakers between 90-150Hz, combined with the output from the large downward firing reflex port.

Although the response isn't as smooth as with some of the previous REL subwoofers we've measured, it does extend extremely low, port output being just -6dB down at around 14Hz! This is very low, low enough for the longest organ pipe to be reproduced with enough power to send you and your neighbours across the room. Ultimately though, bass quality is a very subjective thing, and can only be assessed after extensive listening. **DB**

Frequency Response

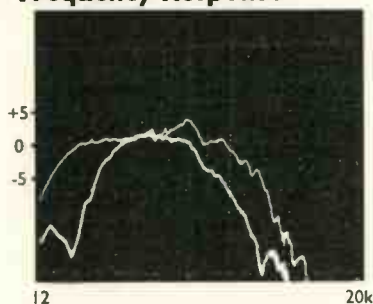

With the controls set to minimum the Stadium rolls off at 90Hz.

Frequency Response

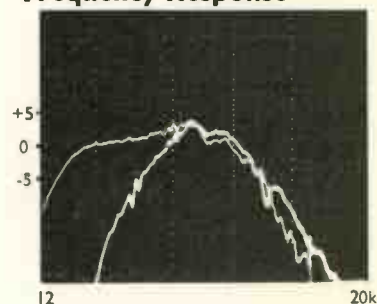

maximum setting roll-off is at 150Hz.

# CASSETTE TAPES

## TEAC V-8030S

The replay amplifiers were quiet, and replay speed correct, but slight head adjustment (azimuth) error caused a little high treble roll-off. This will make many pre-recorded tapes sound a little muted in their treble with Dolby B applied (which amplifies such error). At these price levels it is worth having head alignment tweaked by an engineer.

The head has, in itself, a wonderfully flat frequency response from 20Hz to 20kHz, as our analysis with the new IECIV Primary Reference Tape shows. Better, much the same result was achieved with quality ferrics and chromes, although I was surprised that bias had to be cranked back near to minimum to accommodate TDK AR. At the other end of the scale however, Teac had taken into account the need for variable metal bias and accommodation of TDK MA-XG. Here, though, came a big disappointment: the head's overload ceiling (MOL315) was just +2dB onto TDK MA and +4 onto MA-XG. Any 3-head Nakamichi manages +6 or more, even without the benefit of Dolby HX Pro to support treble with high bias levels. The V-8030S was a disappointment in this respect, but it has Dolby S, which itself possesses overload prevention (companding). Head finish was superb though; I've rarely seen such steady output at 20kHz from cassette.

Also superb was the transport, in absolutely every area. I measured flutter, but found it was being produced by the Maxell

Vertex cassette. TDK MA-XG eliminated this, giving the low modulation-noise/flutter floor seen in our analysis. The unusually clean test tone spike at right has no capstan wow 'shoulders'; wow was minimal at 0.03%. There was no drift either. This was a superb result.

Dolby C did not provide full hiss reduction benefit, but I imagine most people will use B with pre-recordeds and S when recording, both of which worked properly.

In all areas except head overload, the V-8030S worked superbly. It should be seen as a top line Dolby S model, not as a bare-knuckle Nakamichi rival, which it is not. **NK**

## TEST RESULTS

### REPLAY (pre-recorded tapes)

Frequency response (-2dB) 30Hz-15kHz  
Speed accuracy 0%  
Hiss (70uS, Dolby out) -61dB

### RECORDING (blank tapes)

Frequency response (IEC Primary Refs.)  
ferric (IECI) 20Hz-20kHz  
chrome (IECII) 20Hz-20kHz  
metal (IECIV) 20Hz-20kHz  
Separation (1kHz) 42dB  
Distortion (315H) 1.4%  
Hiss (70uS, Dolby out) -56.6dB  
Speed variations (DIN total) 0.04%  
Flutter energy (3-3.13kHz) -42dB  
MOLSAT (IEC Refs) 315/10k

EC I (ferric)  
IECII (chrome)  
IECIV (metal)

2.8dB/-4.5dB  
1.5dB/-5dB  
2dB/0dB

Frequency Response

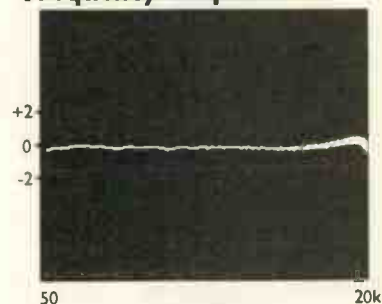

Speed Stability

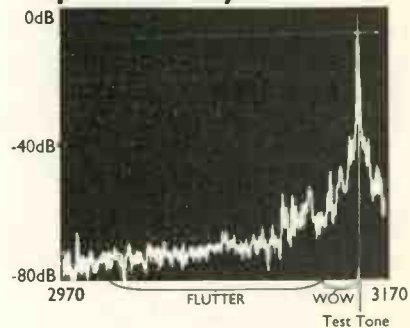



THE INNOVATIVE  
AUDIO/VISUAL  
HI-FI RETAILER  
SERVING LONDON  
FROM BATTERSEA

# ORANGE & LEMONS

Juicy fruit from London's newest, freshest hi-fi/home cinema retailer. Telephone for demonstrations or just pop in. All the usual, i.e friendly and efficient service, free home installation + credit cards, 0% credit finance available.

CABLETALK, CHORD CO, DENON, EPOS, MISSION, NAD, NAIM, REGA, ROKSAN, ROTEL, ROYD, RUARK, SOUNDSTYLE, STANDS UNIQUE, with more to come.

THE INNOVATIVE  
AUDIO/VISUAL RETAILER

0171 - 924 2040

61/63 WEBBS ROAD, SW11

# BE JUDGE AND JURY TRY

# BASE



**LISTEN TO SOMEONE THAT DID!**

*"The Audiophile support system has released another octave from the bass output of my turntable and added transparency and a more natural feel to the treble of all components. As a classical musician, being a hifi enthusiast can be a frustrating business. The added sense of musicality and involvement gained from the Audiophile support brings the sound I hear at home one step closer to the sounds we create in the concert hall. Bravo!" .....Dr. K Murphy*

ISOLATION PLATFORMS FOR AUDIO EQUIPMENT

**Audiophile Furniture Limited 01342 826262**

THE SQUARE FOREST ROW EAST SUSSEX RH18 5ES

**Wilmslow  
Audio**



As any discerning sound engineer will tell you, the ATC SCM50 and 100 are the ultimate in accurate low distortion professional monitoring. But what they may not know is that self assembly versions based on these classic monitors are now available from the UK's leading speaker kit supplier, Wilmslow Audio, at a fraction of the ready built price. ATC and Wilmslow Audio have worked very closely on the cabinet and crossover design to ensure that the completed kit lives up to the very high standards associated with the ATC name. As with all Wilmslow products, the ATCK50 and K100 kits come complete with precision machined cabinet panels, crossovers, and all necessary hardware, including

factory matched ATC drivers. Cabinet parts are machined from high grade MDF for easy assembly and consistent acoustic performance. ATC's MK I Tri-Amp Pack systems are available as an option if required.

- The Result . . .**
- *Stunning accuracy and clarity*
  - *Clean well damped bass*
  - *Smooth detailed treble*
  - *Totally transparent mid range*
  - *No overdraft!!!*

If you aspire to the unrivalled quality of ATC monitoring, but are working to a tight budget, contact Stephen Leigh who will be pleased to tell you exactly how economical these kits are. ATCK50s and 100s are on demonstration by appointment.

Wilmslow Audio Limited, Wellington Close, Parkgate Trading Estate, Knutsford, Cheshire, WA16 8DX, England. Tel: (0565) 650605 Fax: (0565) 650080

**SELECT AUDIO  
LONDON**

for

**MIRAGE VPI**

**ORTOFON CARTRIDGES**

**MARK LEVINSON**

**JEFF ROWLAND**

**PROCEED**

**SUMIKO TRANSFIGURATION**

**MAGNEPAN**

**LYRA AUDION AUDIO MECCA**

**TRIANGLE**

**"Plus more"**

3 Single Speaker listening rooms  
by Appointment only

**0181 986 8788**

10-7pm closed Wednesday





**griffin**  
audio

1955  
TO  
1995

## "COME AND LISTEN TO THE WORLD'S FINEST HI-FI,

INCLUDING THE LINN KARIK CD  
PLAYER. WHETHER YOU'RE  
LOOKING FOR HI-FI,  
HOME THEATRE, OR  
MULTI-ROOM  
SYSTEM, YOU'LL  
BE THRILLED"



94 BRISTOL STREET  
BIRMINGHAM  
B5 7AH  
**0121 692 1359**  
Tues-Sat 10am-6pm

# VRR

VALVE HI - FI



### "ADUR"

Monoblock Amplifiers

Hand-wired — without PCBs!

Single-Ended  
or Push-Pull  
Triode or Pentode  
but always  
Class A<sub>1</sub>

\*

\*  
for  
further  
information  
please telephone  
Worthing  
(01903) 501158

# FREE Audio Catalogue

That Will Change  
The Way You Buy Hifi

Inside the new RDL  
catalogue you'll discover:

- The secret to picking the right speakers.
- Why your home is the only place to test audio equipment.
- How to get more audio for your money.
- How to buy home theatre systems.
- Why the reviewers say RDL offers superior audio equipment at unbelievably low prices.



Buying from RDL is easy and risk free with our **100%** "no strings attached" money back guarantee.

Roy Allison, President and Chief Designer of RDL Acoustics has put together two new, superb ranges of speakers to fit every situation at prices well below normal shop retails.

**FREE**  
32 pg.  
AUDIO  
catalogue

Order your free catalogue, call:

**0484 603333**

or fax on 0484 607774

**RDL**  
ACOUSTICS

20 Cleveland Way, Shelley  
Huddersfield, HD8 8NQ

# Oxford Audio Consultants

## HI-FI SPECIALISTS



Our superb service is the same, regardless of price.

**A STUNNING NEW FLOOR STANDING SPEAKER FROM WILSON AUDIO**

- the next best thing to System 5s - must be heard!!

## NOW DEMONSTRATING

AUDIO ALCHEMY VAC PHONO STAGE – brilliant value!!  
 MARTIN LOGAN SL3 – the new SEQUEL replacement - a stunning advance  
 THETA TLC anti-jitter device – you've heard about it now try it for yourself - sale or return  
 TUBE TECHNOLOGY UNISYS/SYNERGY – gorgeous glowing valvest  
 KRELL KAS 2 REFERENCE POWER AMPS – we're lost for words!!  
 MICHELL ORBE TURNTABLE – superb value for money  
 THETA PROBASIC 3 – A WINNER  
 AUDIO RESEARCH LS7/VT 60 – a snip at the price!  
 WILSON SYSTEM 5 – quite simply state of the art  
 SONUS FABER LOUDSPEAKERS – we love them all!  
 B & W 'P' SERIES – superb sound and finish  
 G.M. AUDIO EQUIPMENT TABLES – the ULTIMATE hi-fi table  
 ROTEL RC/RA970 pre/power  
 MICROMEGA STAGE CD PLAYERS and the NEW AMP and TUNER!  
 QUAD 77 SERIES – a big step forward  
 MUSICAL FIDELITY ELEKTRA SERIES – now even better value  
 REL SUBWOOFERS – redefined our ideas about subwoofers  
 B & W THX SPEAKER SYSTEM on dem now  
 PINK TRIANGLE DACAPO/DC/ORDINAL/CARDINAL  
 RUARK EQUINOX – a big, bold sound from a small box  
 LYRA CLAVIS DA CAPO – even better in Mk2 and only £395  
 SPENDOR SP3/2  
 DENON AVC2800 A/V AMP  
 MARANTZ CD16  
 FULL RANGE OF TRANSPARENT CABLES including ULTRA

## EX DEM & P/EX BARGAINS

QUAD CD 67 PLAYER £575  
 QUAD 34/306 AMPLIFIERS £475  
 MICROMEGA STAGE 3 EX DEM £750  
 APOGEE CENTAUR MINORS £750  
 MAGNEPLANAR MG3.3 AS NEW £2250  
 KRELL MD20 CD TRANSPORT MINT £2495  
 HEYBROOK INTEGRA AMP £395 (\$550)  
 PIONEER CTS810S CASSETTE DECK £295  
 YAMAHA CDX 560 CD PLAYER £125  
 ROTEL RX850AL RECEIVER £100  
 AUDIO RESEARCH LS5 PREAMPLIFIER £2995 (£5290)  
 CHORD SPM1400B MONOBLOCK POWER AMPS PIANO BLACK £345  
 RAM OSIRIS LOUDSPEAKERS £250  
 COPLAND CTA401 EX DEM £995  
 ORELLE CD 480 CD PLAYER EX DEM £299  
 AUDIO RESEARCH SP9 MK3 EX DEM £1995  
 DPA 1024 D/A CONVERTER £3495  
 NAIM 82 PREAMP AS NEW £1295  
 HICAP POWER SUPPLY £350  
 NAIM 250 POWER AMP £950  
 EPOS E11 SPEAKERS £295



Please ask for details or our current list  
 Agencies include: Aura, Accuphase, Acoustic Energy, Air Tangent, Apogee, Audio Alchemy, Audio Research, Audio Technica, B&W, Castle, Cable Talk, Classe, Copland, Denon, DPA, Dual, Goldring, Harmonix, Heybrook, Koetsu, Jadis, Krell, Lyra, Mandrake, Marantz, Martin Logan, Michell, Micromega, Music Fidelity, NAD, Nakamichi, Onix, Orelle, Ortofon, Pink Triangle, Pioneer, Proceed, Projekt, PS Audio, QED, Quad, REL Subwoofer, Rogers, Roksan, Rotel, Ruark, Seismic Sink, Sennheiser, Slate Audio, SME, Sonus Faber, Stax, Target, TDL, Teac, Theta, Thorens, Transparent Cables, Van den Hul, Wadia, Wilson

TAX-FREE EXPORT SERVICE  
 MAIL-ORDER AVAILABLE ON MANY ITEMS  
 Open Mon-Sat 10am-6pm

# Oxford Audio Consultants

Oxford Audio Consultants, Cantay House, Park End Street OX1 1JE  
 Telephone: Oxford (01865) 790879 Facsimile: Oxford (01865) 791665

## Inaccessible accessories by post.

If you can't get to us, we'll get our accessories to you.

CARTRIDGES: Arcam, Audio Technica, Denon, Dynavector, Goldring, Lyra, Ortofon, Sumiko. CABLES: Audioquest, Cable Talk, Goertz, Heybrook, Ixos, Kimber, Kontak, LFD, Monster, Ortofon, Precious Metals, QED, Sonic Link, Van den Hull, XLO. STANDS: Alphason, Apollo, Atacama, Sound Organisation, Sounds Style, Stands Unique, Target. HEADPHONES: Beyer, Sennheiser, Stax. ACCESSORIES: Audio Technica, Audioquest, BIB, Discwasher, Goldring, Hunt, Ixos, Kontak, Last, Michell, Milty, Moth, Nagoaka, Pixall, QED, Shure, Townshend. Plus a full range of quality equipment available.

PLUS A FULL RANGE OF QUALITY EQUIPMENT AVAILABLE. SEE OUR MAIN ADVERTISEMENT.



**BURY AUDIO**

TEL 01284 724337

MOBILE 0802 206761

47 CHURCHGATE STREET,  
 BURY ST. EDMUNDS,  
 SUFFOLK IP33 1RG.



Prop: M & P Pay  
 Tel: (01723) 503432

GET A FRESH SOUND FROM YOUR EXISTING HI-FI



**CLARITY HI-FI**

HIGH-FI SYSTEM UPGRADES

BRAND NAMES: QED, GOLDRING, DEMION, ARCAM, ETC...



45a Dean Road  
 Scarborough  
 N. Yorks YO12 7SN

Friendly business with free estimates and advice  
 Specialist in repair and servicing all makes including Valve  
 Equipment, CD, Laser. Alignment: Upgrades all work  
 considered. Professional Multimedia equipment Accessories  
 include Cables, Plug, Sockets ... to find out more - feel free to  
 phone anytime between 9am-9pm Mon-Sat

# WANTED!!!

## (Triode Tubes)

DA30, PX25, 4300A/B, Ed,  
 ADI, RS237, WE300B,  
 274A/B ETC.

## (Turn Tables)

Garrard 301

EMT 927

With replacement parts

# TRIODE SUPPLY JAPAN

FAX: 81-44-511-3492

TEL: 81-44-511-6343

1-101 227 Kasimada Saiwaiku  
 Kawasakisi Kanagawaken Japan

# LINDLEY TYSON



*'Untwisting all the chains that tie the hidden soul of harmony'*  
MILTON

LINDLEY TYSON offer a choice of valve and transistor amplification. The customer is able to choose a complete valve or solid state system and any combination of either technology.

The High Definition Electrostatic Transducers (HDEST) are also available for the ultimate in 'loudspeaker' performance and design. Choices of solid hardwood finishes are available.

We also offer an upgrade and restoration service for vintage valve equipment ( Quad, Leak, Radford etc ).

LINDLEY TYSON offer a unique alternative to volume manufactured designs. We design, build and test each product to meet the individual requirements of our customers. This ensures the highest possible standard of performance and satisfaction.

The cost of owning our custom designed equipment is often lower than expected. Please call for details.

LINDLEY TYSON - Bespoke Audio Engineering.

☎ 01775 722346 or ☎ 01522 695542

## WOMEN

who hate Hi-Fi, CDs,  
LPs etc LOVE Ian's Furniture



This unit holds 1120 CDs  
£1892 Georgian Style

Why not make her happy?

Send for his Brochure (3 - 2nd class stamps please)  
to: Ian Edwards, The Old Chapel, 282 Skipton Rd,  
Harrogate, HE1 3HP  
Tel: 01423 500442

ARCAM  
CABLE TALK  
CELESTION  
DYNAUDIO  
MARANTZ  
MISSION  
NAD  
PARTINGTON  
PINK  
TRIANGLE  
QED  
RESTEK  
SYSTEMDEK  
TDL  
TRIPOD  
YAMAHA

### WE OFFER

- ★ Home demonstrations (the only way really)
- ★ Free installation on all hi-fi systems
- ★ 2 Year Guarantee
- ★ Single speaker demonstration room
- ★ All cables terminated using silver solder for highest quality signal path

**TDL RTL 2 OWNERS**  
Improve the sound of your system with  
our own newly developed, spiked stand  
**ONLY £19.95** RING FOR DETAILS  
★★★★ **WHAT HI-FI?**

PERFORMANCE SYSTEMS + HI-FI

KENT'S  
LEADING  
SPECIALIST

5 London Road, Riverhead, Sevenoaks, Kent. Tel: 01732 740425

# KLIPSCH<sup>®</sup>

HORN LOUDSPEAKERS

IMMORTAL SOUND FORESIGHT

Hear KLIPSCH for yourself in: Avon 0934 520248/0272 686005. Bucks 0296 28790. Cheshire 0925 828900. Cornwall 0209 612260. Hants 0730 895194. Herts 0923 856497. Kent 0303 256860. London (W1) 071 486 8262. (NW3) 071 431 7423. (NW6) 071 794 7848. Middx 081 892 7613. N. Ireland 0232 403634. Northants 0604 37871. Notts/Lincs 0777 870372. Oxon 0865 247783. Scotland 0381 620655. Suffolk 0284 724337. Sussex 0903 872288. Wales 0978 364500/0745 343060. W. Mids 021 429 2811/455 0667/742 0254/354 2311, 0203 525200. Worcs 0384 444184. Yorks 0302 781387. UK Distributor 021 430 7817

# THE LISTENING ROOMS LTD

## SALE BARGAINS

	LIST		SALES PRICE
KRELL K.S.A. 100s	5843.00	D	3799.00
*KRELL K.S.L.2	3331.00	D	1995.00
* as above but including phono board			2395.00
AUDIO RESEARCH LS3	1695.00	D	1349.00
APOGEE STAGE	3000.00	D	1295.00
CLASSÉ DR10	2299.00	D	1295.00
CLASSÉ DR4	1735.00	D	1295.00
MARTIN LOGAN QUEST	4998.00	D	3998.00
WADIA DAC 12	1530.00	D	1079.00
ORELLE CD10T TRANSPORT	799.00	D	519.95
ORELLE CD480 CD	399.95	D	269.00
REL STUDIO SUBWOOFER	2995.00	D (mint)	1995.00
AUDIO RESEARCH SP9 mkII		S/H	895.00
KRELL PAM7 PRE/AMP		S/H	795.00
KRELL KSA 505 P/AMP	3690.00	D	2767.00
MARTIN LOGAN SEQUEL		S/H	895.00
MUSICAL FIDELITY P270II		S/H	495.00
FANFARE FT1 REMOTE TUNER(BALANCED OPTION)			
STEREOPHILE RECOMMENDED		S/H	495.00
PIONEER CTS 8305 3H. CASS/DECK	499.00	NEW	419.00
DELTEC LITTLE BIT DAC (BOXED V.G.C)		D	150.00
LINX POWER AMP			295.00
THETA DATA BASIC TRANSPORT	199.00	S/H (mint)	1499.00
THETA COBALT ONE	699.00	S/H (mint)	499.00
CLASSE 70/30 PRE/POWER AMPS	2769.00	S/H (mint)	1590.00

D - EX-DEMO  
S/H SECONDHAND



THE listening rooms

161 Old Brimpton Rd. London SW5 0LJ Tel: 0171-244 7750/59 Fax: 0171 370 0192

# AMADEUS SOUND & VISION

Audio Innovations,  
Aura,  
Bang & Olufsen,  
Castle Acoustics,  
Micromega, Marantz,  
Musical Fidelity,  
NAD, Pioneer,  
Quad, Spondor,  
Technics

10 BOLDMERE ROAD  
SUTTON GOLDFIELD,  
WEST MIDLANDS  
Tel: 021 -354 2311

# Encore!

• AUDIO CONSULTANTS •

TEL. MELTON MOWBRAY 01664 823282

superb sound and style from:  
SUGDEN DENSON UNISON  
TUBE TECHNOLOGY RUARK  
UKD OPERA KESWICK AUDIO

EVENINGS/WEEKENDS HOME DEMO  
BY APPOINTMENT



Get on our list -  
to get closer to this list.

• MIT MultiCap • Wonder Cap • Kimber Kap • Solo • Hovland MusiCap • Solen • Siemens  
• Wima • Holco • Rel-Cap • Draloric • IRC • Allen-Bradley • Jensen • Resista • Vishay • Mills  
• Caddock • Matsushita • TKD • Noble • Cardas • Kimber Kable • van den Hul • Discovery  
• Audioquest • MIT • Alps • Bourns • Shalco • Elma • Electroschick • Nichicon • Gold Aero  
• RAM • Mallory • Panasonic HFQ • Nichicon • Elna • N.O.S. • Ruby Tubes • UltraAnalog  
• Burr-Brown • Crystal • Linear Technology • Analog Devices • Edison Price • Motorola • UCC  
• International Rectifier • Hitachi • MagneQuest • Sonic Frontiers • Pearl • Tube Sockets  
• WBT • Neutrik • Sound Coat • Curcio Audio Engineering • Assemblage and other kits

And it's growing and growing. To order The Parts Connection 1995 Catalog & Resource Guide, send £7 and mailing information. You'll also receive a Discount Coupon worth \$10 off a purchase over \$100 or \$25 off a purchase over \$250\* as well as The Breadboard bulletin to keep you updated on our latest news, information and growth spurts.

\*or \$10 US. or credit card information  
\*catalogue discounts are in US Dollars

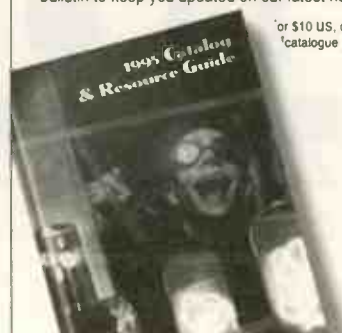

THE PARTS CONNECTION<sup>®</sup>

A DIVISION OF SONIC FRONTIERS INC

2790 Brighton Road, Oakville  
Ontario, Canada L6H 5T4

Toll Free Order Line 1-800-769-0747  
(U.S. & Canada only)

Tel (905) 829-5858 Fax (905) 829-5388



# SOUND-BYTES

high density filler material for hi-fi speaker stands

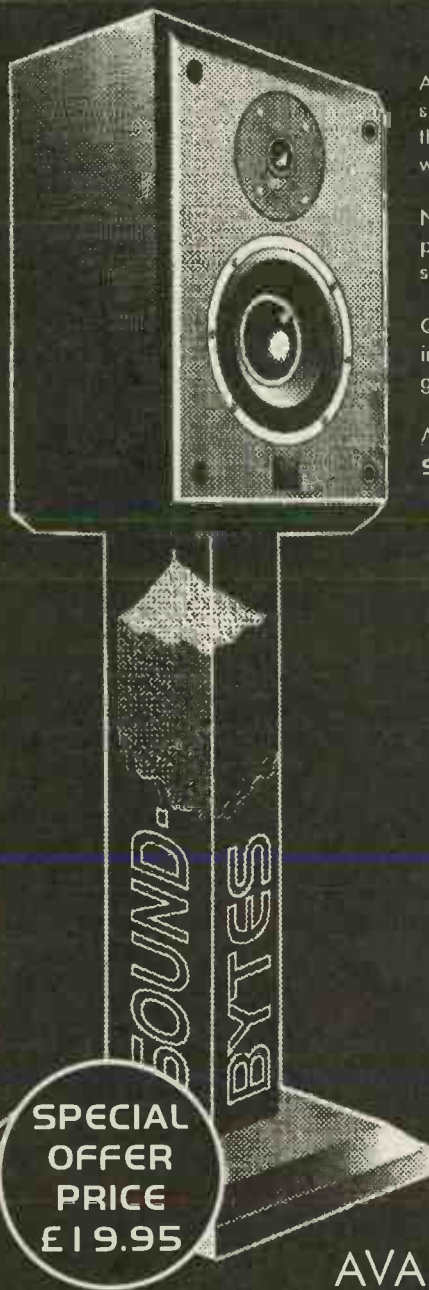

As any hi-fi specialist will tell you, to get the maximum benefit from your loud-speaker / speaker stand combination, you should fill your stands with a suitable material. Until now, the most common medium has been sand or a sand-based alternative. The other option was lead-shot that, although very dense, is extremely expensive and difficult to source.

Now available to fill this gap are **SOUND-BYTES**, uniquely shaped steel chips that once poured into the speaker stand, effectively provide a solid steel core within. This makes the stand an extremely dense heavy platform, ideal for getting the best out of your speaker system.

Once your stands are filled, you will immediately notice an improvement in lower frequencies, in the form of a much tighter, punchier bass response - a welcome enhancement for the generally smaller cabinets and woofers of stand-mounted speakers.

Available in 4 litre tubs of approximately 20Kgs in weight, each tub will provide enough **SOUND-BYTES** to adequately fill most commonly available speaker stands.

- interlocking steel delta-shaped bytes
- superb value for money
- superb sound isolation
- suitable for support tables
- very nearly the full density of lead
- four times the density of sand
- suitable for all hollow speaker stands
- suitable for many floor-standing speakers

RECOMMENDED BY SOME OF THE UK'S LEADING STAND AND LOUDSPEAKER MANUFACTURERS...



*a stroke of genius*



**Atacama Audio**

AVAILABLE MAIL ORDER FROM

**Quality Suppliers of:**

- Technics • Denon
- Mission • Arcam
- Wharfedale • Nad
- Micromega • Onkyo

52 Gordon Street,  
Glasgow  
0141 248 2840

42-44 Cow Wynd  
Falkirk  
01324 629011

INSTANT CREDIT  
AVAILABLE (Subject to Status)  
5 Years Guarantee on all Loudspeakers

**Colin Mackenzies's  
HI-FI-CORNER**

Scotland's No.1  
HI-FI Company

**0131 556 7901**

Carriage £5.00 Allow 14 Days Delivery.

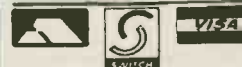

- Harman/Kardon
- Kenwood • Tannoy
- Audiolab • Target
- Aiwa • Cyrus • TDL
- and other leading makes

121 Rose Street,  
Edinburgh  
0131 220 1535

1 Haddington Pl,  
Edinburgh  
0131 556 7901

# 180

Audiophile International Presents

## Pure Virgin Vinyl LP's

Analogue Pressings By DCC

DCC Compact Classics presents landmark reproductions of classic music performances on pure analogue 180gm virgin vinyl LP's

Remastered from the original master tapes on all-tube playback machine and lacquer cutter. Plating of the lacquers is done the same day as cutting, using a slow, low-temperature bath to minimize groove echo and loss of high frequency information.

Pressings are made with the recently-developed HQ180+ process which produces a super-flat extra heavy virgin vinyl disc of unmatched sound quality

DCC is a company name and does NOT stand for Digital Compact Cassette



### ELTON JOHN

#### Madman Across The Water

This landmark 1971 release is considered one of Elton John's greatest works containing his finest melodies and Bernie Taupin's finest lyrics. This 180gm LP pressing has enhanced warmth, detail and clarity. Mastered from the original stereo master tape, hit songs include "Tiny Dancer", "Razor Face" and "Holiday Inn".



### RAY CHARLES & BETTY CARTER

#### Ray Charles & Betty Carter

The charms of Ray Charles and Betty Carter are evident on this 1961 landmark album. The arrangements of Marty Paich's big band vary from lush to raucous, with a sumptuous string section evident. Carter's vocal is brilliantly accompanied by Charles on piano. Tracks include "Baby It's Cold Outside", "People Will Say We're In Love" "It Takes Two To Tango"

RELEASE DATE JUNE 95 \* RETAIL PRICE £25

Available To Order Now From Audiophile International

Retail Visa / Access Call 01276 855578

24 Hour Fax 01276 855580

Wholesale inquiries welcome 01276 855530

Our catalogue free with every £20 order. Postage and Packaging £3 first LP 75p per additional

### AVAILABLE IN JULY 95 THE BEACH BOYS

#### Pet Sounds

This 1966 release is now considered to be the most innovative and influential American album ever released in the '60s. Many regard 'Pet Sounds' as the American 'Sgt. Peppers'. This milestone album also contains many of The Beach Boys classics: "Wouldn't It Be Nice", "God Only Knows", and the radio classic, "Here Today". Mastered from the original unequalised full-track masters.

### SAM 'LIGHTNIN' HOPKINS

#### Blues Hoot

This once in a lifetime pairing of blues legends; Hopkins, McGhee and Terry took place at the Ash Grove in Los Angeles in August 1961. The Blues revival began in earnest when this great album was released. This is the first-ever release of "Blues Hoot" that utilizes the recently discovered original first-generation stereo master tapes. Tracks include "Big Car Blues", "Coffee House Blues".

### SONNY ROLLINS

#### Saxophone Colossus

This 'Prestige Recording' from 1956 is considered Sonny Rollin's finest effort ever! One of the pivotal recordings in bringing about the widespread acceptance of the modern jazz saxophone as a major instrument in jazz. Rollins displays humour, gentleness and a delicate feeling for beauty unsurpassed in recorded jazz. Features: St. Thomas", "You Don't Know What Love Is", "Stroke Rode".

Audiophile International Presents

## More HQ Vinyl LP's

### RECOMMENDED VINYL LPs

TORI AMOS - Under The Pink	£12
JACKSON BROWNE - I'm Alive	£12
JOHN COLTRANE - Blue Train	£12
THE CRANBERRIES - No Need To Argue	£9
THE CRANBERRIES - Everybody Else Is Doing It...	£9
MILES DAVIS - Kind Of Blue - Analogue U.S. Import	£10
THOMAS DOLBY - Alien Ate My Buick	£8
ELASTICA - Elastica	£9
ENYA - Celts	£12
STAN GETZ - Voyage	£15
RICKIE LEE JONES - Rickie Lee Jones	£12
DANIEL LANOIS - For The Beauty Of Wynona	£12
BOB MARLEY & THE WAILERS - Natural Mystic - New Release	£9
NIRVANA - Unplugged In New York - U.S. Import	£12
PINK FLOYD - Wish You Were Here - U.S. Import	£12
PINK FLOYD - Pulse - New Release	£12
Stunning 4LP deluxe box set containing a 52 page colour book	£44
PORTISHEAD - Dummy	£9
PULP FICTION - Sound Track - U.S. Import	£10
TEENAGE FANCLUB - Grand Prix	£9
BLUR - Parklife	£10

### MOBILE FIDELITY SOUND LABS

#### 200gm HQ Vinyl Pressings

<b>BUY ANY 2 SINGLE LPs @ £22 BUY ANY 5 SINGLE LPs @ £21</b>	
MUDDY WATERS - Folk Singer - <i>Stunning</i>	£25
PINK FLOYD - Atom Heart Mother	£25
ALAN PARSONS PROJECT - Tales Of Mystery...	£25
THE MODERN JAZZ QUARTET - The Modern Jazz Quartet	£25
MODERN JAZZ QUARTET - Blues At Carnegie	£25
STAN GETZ & JOAO GILBERTO - Getz/Gilberto	£25
TRAFFIC - Low Spark Of High Heeled Boys	£25
JOHN HIATT - Bring The Family	£25
QUEEN - The Game	£25
JEAN MICHELL JARRE - Oxygene - <i>Classic</i>	£25
DUKE ELLINGTON - Anatomy Of A Murder	£25
THE MOODY BLUES - On The Threshold Of A Dream	£25
DAVE BRUBECK - We're All Together Again	£25
THE ALLMAN BROTHERS BAND - Brothers & Sisters	£25
COLLINS, CRAY & COPELAND - Showdown!	£25
EMERSON, LAKE & PALMER - Trilogy	£25
WOODY HERMAN - The Fourth Herd	£25
ERIC CLAPTON - Eric Clapton	£25
BOB MARLEY - Exodus	£25
JOHN MELLENCAMP - Lonesome Jubilee	£25
JOE COCKER - Sheffield Steel	£25
HANK CRAWFORD - Soul Of The Ballad New	£25
TODD RUNDGREN - Something / Anything 2LP set	£37
ALBERT COLLINS - Cold Snap - <i>New</i>	£25
JEAN MICHELL JARRE - Equinoxe - <i>New</i>	£25
THE MODERN JAZZ QUARTET - At Music Inn Vol. 2	£25
U2 - The Unforgettable Fire - <i>New Release</i>	£25

### CLASSIC RECORDS - VERVE JAZZ

#### 180gm HQ Vinyl Pressings

ELLA FITZGERALD - Clap Hands, Here Comes Charlie	£25
DUKE ELLINGTON & JOHNNY HODGES - Back To Back	£25
COLEMAN HAWKINS ENCOUNTERS BEN WEBSTER	£25
BILLIE HOLIDAY - Songs For Distingue Lovers	£25
DUKE ELLINGTON & JOHNNY HODGES - Side By Side	£25
ELLA FITZGERALD - Let No Man Write My Epitaph	£25

### VISIT US AT THE HI-FI SHOW

Ramada Hotel, Heathrow, September 7 - 10  
Ground Floor, Bays 3 & 5, as you walk in.  
Gold CDs, New and Used Vinyl LPs

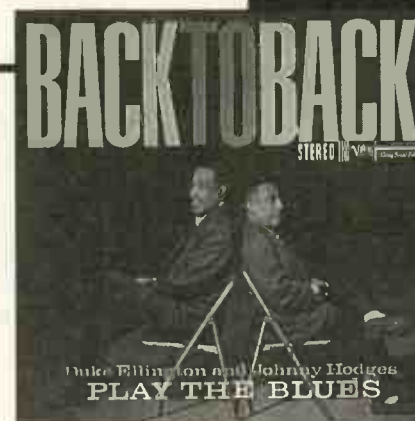
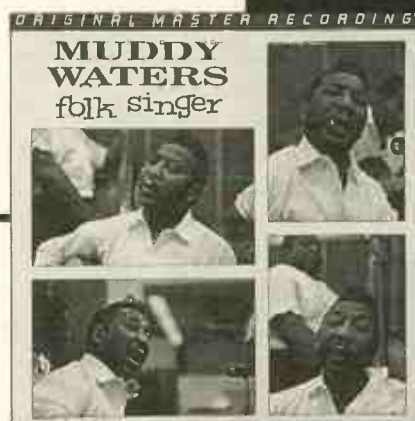

P.O. Box 303, Chobham, Surrey, GU24 8RX. For our 70 page glossy yearly catalogue send £3 in postage stamps or 5 International Response Coupons, you will join our data base and receive free monthly update catalogues containing new releases and used LPs. Free catalogue with every £20 order from this advert, U.K. postage £3 first LP 75p per additional, £2 first CD 50p per additional, we send every U.K. order First Class Recorded Superpacked. Overseas customers please call.

# Audiophile International

### Worldwide Mail Order

Retail Orders 01276 855578  
Fax 24 Hours 01276 855580  
Wholesale 01276 855530

**HEATHERDALE AUDIO LTD.**

202 Findon Road, Worthing, West Sussex. BN14 0EJ  
Tel. 01903-872288 or 0860 660001 (after hours) Fax 01903-872234

This months pre-owned bargains:

Oracle Delphi Mk.3 with PSU New SME309	£1,395	Diamond Acoustic Ref. 2s inc. stands	£995
Oracle Delphi Mk.3 with PSU/no arm	£795	Lumley 120 monoblocks	
Audionote M7 tube (with phono) pre-amp	£6,500	(switchable)	£2,795
£6,500		Nakamichi 1000 ZXL fully serviced (rare)	£2,500
Audionote Neiro (silver) Ex-demo	£6,950	Magnepan SMGb speakers (new)	£790
Audionote Ongaku Ex-demo	£27,500	Audio Research D400 amp (ex demo)	£4,750
Musical Fidelity P180 p/amp & psu	£695	Audio Innovations 1000	
Audio Innovations 800		MC transformer	£250
MC transformer	£120	Meridian 105 monoblocks/101	
Linn LP12	£395	pre-amp	£495
Wadia X 32 DAC	£795	Tanberg TD20A 7.5/15 ips reel to reel	£395
Sony 702 DAC	£795	Thorens TD 150/S.M.E./Shure V15 111	£275
Linn LP12/SME/Ort.MC20 cartridge	£595	Theta Cobalt DAC (ex demo)	£575
Audionote ANJ speakers, from;	£650	Clearaudio turntable/arm & cartridge	£2,995
Apogee Centaur Minor loudspeakers	£995	Nakamichi Dragon cassette deck	£1,250
Pioneer CT 93 Reference Cass deck	£550	B & W 802 Matrix speakers (walnut)	£1,495
Klipfch La-Scala speakers	£1,495	Musical Fidelity A100 int amp.	£295

MAIN DEALERS FOR QUAD.  
VISA SWITCH MASTER CARD WELCOME.  
WE TAKE PART EXCHANGE ON NEW & USED STOCK

MARTIN LOGAN, ROTEL, THETA, BASIS, C.A.T

CLEARAUDIO, LUMLEY REFERENCE, KRELL, LUMLEY MONITOR, MAGNUM/DYNALAB

QUAD, HEYBROOK, VOYD, KLIPSCH, APOGEE, COPLAND, SONUS FABER, AUDIONOTE,



**Cooke International  
SUPPLIER OF QUALITY USED  
TEST INSTRUMENTS**

ANALYSERS, BRIDGES, CALIBRATORS, VOLTMETRES,  
GENERATORS, OSCILLOSCOPES, POWER METERS, ETC.  
**ALWAYS AVAILABLE**

ORIGINAL SERVICE MANUALS FOR SALE  
COPIES ALSO AVAILABLE

EXPORT, TRADE AND U.K. ENQUIRIES WELCOME,  
SEND LARGE "A3" S.A.E. + 50P POSTAGE FOR LISTS  
OF EQUIPMENT AND MANUALS.

ALL PRICES EXCLUDE VAT AND CARRIAGE  
DISCOUNT FOR BULK ORDERS SHIPPING ARRANGED

OPEN MONDAY-FRIDAY 9AM-5PM

**Cooke International**  
ELECTRONIC TEST & MEASURING INSTRUMENTS  
Unit Four, Fordingbridge Site, Main Road, Barnham, Bognor  
Regis, West Sussex, PO22 0EB

Tel: (+44) 01243 545111/2 Fax: (+44) 01243 542457

TEST EQUIPMENT & ACCESSORIES PURCHASED

**Are you making the  
right connections?**

Send for Britain's biggest catalogue of  
specialist cable and connections.

All available by mail order.

Phone 0181-9429124 or clip  
the coupon for your Free copy.

**CUSTOM CABLE  
SERVICE**

PO Box 4007, London SW17 8XG

Please send me your FREE Custom Cable Catalogue

Name \_\_\_\_\_

Address \_\_\_\_\_

Postcode \_\_\_\_\_

NO FURTHER INFORMATION REQUIRED

Send to: Custom Cable Service  
PO Box 4007  
London SW17 8XG



HFW/8/95

**AUDIO BY DEVELOPMENT  
SOMERSET  
TEL/FAX 01984 623100**

Agencies: • AUDIO INNOVATIONS • IMPULSE • SNEI.I. • SYSTEMDEK •  
SME • JPW • MOTH • DYNOVECTOR • GOLDRING • ECA • UKD  
CALLAS • WELL-TEMPERED • PAD SUPPORT FURNITURE • ORELLE •  
REL • QLN LOUDSPEAKERS • UNISON RESEARCH • AUDIONOTE •

AUDIO BY DEVELOPMENT is situated in the heart of Somerset and serves both U.K. and International Customers. We offer you the opportunity to hear some of the best audio equipment currently available. We pride ourselves in assembling systems that will truly convince whatever your budget. Our service is second to none offering friendly professional advice, extended home dems, free expert installation, excellent 'trade in' offers and appointment times to suit you.

If you yearn for a taste of the 'high end' but have a budget that threatens to restrict your upgrades, then might we suggest you investigate the excellent performance of the new 'Orelle products including their superb DAC 180 convertor and CD 100 player. Both products now being demonstrated.

THIS MONTH'S SALE STOCK

	WAS	NOW
Fuller Audio Sultan Loudspeakers - mint	(400)	150
Audionote IO II Cartridge - very low hours	(1350)	595
TOCA 22 Watts S.E. Amplifier - unused	(2000)	995
TOCA 50 Watts S.E. Amplifier - devastating sound	(6000)	1995
Meridian 203 D to A Converter - mint	N/A	249
Leak Troughline II Tuner - as new	N/A	195
Audio Innovations Series 200 power - unused	(500)	275
Audio Innovations Alto Integrated Amp - unused	(329)	225
Audio Innovations Second Audio 2A3 Triode Poweramps - ex dem, very low hours	(3000)	1595
Biwire Set Audionote A.N.B. Speaker cable 2 x 3 meters	(295)	150
Rock Reference Turntable		1950
Rock III Turntable		500
EAR 802 Preamplifier		1000
Helius Sirius II Loudspeakers - excellent cond.		950
Linn LP12 Turntable with ITTOK tonearm - mint N/A		550
Voyd Valdi Turntable with HELIUS tonearm	N/A	595
Audio Innovations T2 Stepup transformer	(350)	200
Rega Planar 3 Turntable - mint	N/A	175
JPW AP2 Loudspeaker -ex dem light oak	(199)	149

ALSO LARGE SELECTION OF NEW, DELETED AND MINT CONDITION  
VINYL LP'S ALWAYS IN STOCK - LATEST LIST NOW AVAILABLE

PLEASE RING WITH YOUR ENQUIRIES OR FOR FURTHER INFORMATION ON ALL OUR PRODUCTS  
REQUEST OUR LATEST NEWS

AUDIO BY DEVELOPMENT, ROTTON ROW, WIVELISCOMBE, SOMERSET TA4 2NB



# AUDIO ARTS PRESENTS AUDIO NOTE

*Sometimes dealers just don't understand the difference. If you want to hear music at its best, come to AUDIO ARTS and audition the fabulous range of AUDIO NOTE products.*

*Don't believe the hype! Good hi-fi (sorry) music (!!) is available at affordable prices.*

*Thanks for taking the time to read this.*

*Give us a ring 0181 893 4485 ask to speak to Paul.*

*FOR FURTHER INFORMATION PLEASE TELEPHONE  
0181 - 893 4485*

*AUDIO ARTS FOR REAL MUSIC*

## SERIOUS KIT

21, ALGERNON ST., MONTON, ECCLES,  
MANCHESTER, M30 9QA.  
0161-707 4823

### The Serious Kit Summer System Review!

As ever, at Serious Kit, we take one aspect of a hi-fi system and take it very seriously indeed! I of course refer to that elusive condition of TOTAL SYNERGY.

So many systems that we come across should simply have never been put together. Pre-amps from one manufacturer that will not "drive" power amps from another. Speakers that are unsuited by tonal character to cartridges or digital front ends! It makes us wonder if some "dealers" actually care about the music, let alone the customer!

Here lies the beauty of a Serious Kit system. Every component works with the next in the audio chain, dynamically, rhythmically, electrically and totally sonically! (Wow. wot a lot of ly's)

For instance, one of our favourite (and a few recent customer's) systems has been the incredible SUGDEN SDT-1 @£995 CD player, running into the AUDIONOTE OTO S.E. which then plays into the AUDIONOTE 'J' speakers.

At a touch over £3,000 including stands and cables, the gauntlet is thrown to find a more musical system. In terms of transparency, 3-D imagery, tonal "rightness" intimacy of performance, I ask the question 'Is there anything better costing 50% more?' I fear not. Here is a system that works, magically and majestically. Vivid instruments and voices appear in mid-air, hung between the speakers, under the speakers. Yes it is possible to demonstrate "surround sound" using only 2 loudspeakers. Call for a dem, if you don't believe me.

It is Serious Kit policy not to stock "flavour of the month" products, but rather to build systems that synergise long term. Our products tend to have a long shelf life, rather than a "this year's model" attitude. All too often an expensive product appears, lasts a production life of 12 months and is replaced by the same thing "with a go fast stripe". This renders your model as out of date, with a very low re-sale or trade in value! Not the way forward.

This is one of the beauties of dealing with a carefully chosen hard-core

of manufacturers and distributors. Rather than deal with "everyone" and be a "jack of all trades but master of none". Serious Kit only deals with the smaller hand-crafted manufacturers. The end result being less of an overall selection of products. The up-side, being able to string the pearls together to form something magnificent! Specialist systems for music lovers seeking something out of the ordinary! It has to be said, that an awful lot of equipment being offered as serious hi-fi, simply is not. It takes a lot more than a nice box, and clever advertising campaigns to produce music from the black or silver disc. I feel that a complete change in the audio industry is taking place. Fads come and go, only a hand-ful of products carry on, gathering momentum as they go. These products are manufactured by companies who put the music first and the hype last.

Put simply, there is Serious Kit available, but hi-fi not necessarily at the local High St. and seldom offered by the hifi chain stores that offer "amazing hi-fi value".

Real HiFi, real musical reproduction is here, probably under your nose! Call me to audition a serious audio system at your convenience! I don't think you'll find better advice, or sound quality anywhere, so treat yourself today!

As ever, happily listening, thanx for reading the blurb!

Kind regards

David W. Speirs  
(PROPRIETOR)

STOCKISTS OF THE WORLD'S FINEST AUDIO EQUIPMENT:  
ABSOLUTE SOUNDS, AUDIO NOTE, AUDIO INNOVATIONS,  
MICHELL, LYRA, J.E. SUGDEN, PRO-AC, IMPULSE, VOYD, WILSON  
BENESCH, ORTOFON, KINSHAW, KESWICK AUDIO, STAX, ROKSAN  
ETC. ETC.



# Winners

Voted for by the press, the trade and YOU the British public!

The British Federation of Audio Awards



**MISSION 731**  
Best Loudspeaker under £300

*A superb budget loudspeaker for under £130*



Winners of this prize are available in a quality range of the shop opposite

**MISSION 753**

Winner Loudspeaker over £300

*Another award to add to the collection*



**ARCAM XETA ONE**

Best Home Cinema Amp



*Home cinema amp with a musical pedigree*



**CYRUS III** Best amplifier over £300

*European Amplifier of the Year '95/'96*



**AUDIOLAB 8000T** Best Tuner



*Why not use the cash you were going to spend on a less expensive tuner as the down payment for the best?*



**ARCAM ALPHA 5 PLUS CD**

Best CD Player under £500

*The best selling UK made CD Player*



AWARDS

# Where to find your nearest stockist



- 1 HI-FI CORNER GLASGOW 0141 248 2840
- 2 JAMES KERR GLASGOW 0141 332 0988
- 3 HI-FI CORNER EDINBURGH 0131 220 1535
- 4 HI-FI CORNER EDINBURGH 0131 657 7901
- 5 HI-FI CORNER FALKIRK 01324 620011
- 6 CLONEY AUDIO BLACKROCK 01288 8477

- 7 ASTON AUDIO ALDERLEY EDGE 01625 582704
- 8 ASTON AUDIO LEEOS 01943 467689
- 9 AUDIO T OXFORD 01865 65961
- 10 AUDIO T SWINOOD 01793 538222
- 11 AUDIOT CHELTENHAM 01242 583960
- 12 AUDIO T ENFIELD 0181 367 3132
- 13 AUDIO T W. HAMPSTEAD 0171 794 7848
- 14 AUDIO T ILFORD 0181 518 0915
- 15 AUDIO T BASINGSTOKE 01256 24311
- 16 AUDIO DESIGNS E.GRINSTEAD 01342 314569
- 17 CREATIVE AUDIO SHREWSBURY 01743 241924
- 18 FRANK HARVEY HI-FI COVENTRY 01203 525200
- 19 HI-FI EXPERIENCE LONDON W1 0171 580 3535
- 20 HI-FI EXPERIENCE DARLINGTON 01325 481418
- 21 LINTONE AUDIO GATESHEAD 0191 477 4167
- 22 LINTONE AUDIO GATESHEAD 0191 460 0999
- 23 LINTONE AUDIO NEWCASTLE-UPON-TYNE 0191 232 3994
- 24 MARTINS HI-FI NORWICH 01603 627010
- 25 MARTINS HI-FI KINGS LYNN 01553 761683
- 26 MUSIC MATTERS HI-FI EGOBASTON 0121 429 2811
- 27 MUSIC MATTERS HI-FI SOLIHULL 0121 742 0254

- 28 MUSIC MATTERS HI-FI STOURBRIDGE 01384 444 184
- 29 NORMAN AUDIO PRESTON 01772 253 057
- 30 NORMAN AUDIO BLACKPOOL 01253 295661
- 31 RAOFORDS BRISTOL 0117 944 1010
- 32 RAOFORDS WINOSOR 01753 856 931
- 33 RAOFORDS EXETER 01392 218895
- 34 RAOFORDS BATH 01225 446245
- 35 RAOFORDS CARDIFF 01222 398121
- 36 RAOFORDS TORQUAY 01803 326723
- 37 RAOFORDS PLYMOUTH 01752 226011
- 38 RAOFORDS DXFORD 01865 511241
- 39 RAYLEIGH HI-FI CHELMSFORD 01245 265245
- 40 RAYLEIGH HI-FI RAYLEIGH 01268 779762
- 41 RAYLEIGH HI-FI SOUTHERN-DN-SEA 01702 435255
- 42 THE AUDIOFILE BISHOPS STORTFORD 01279 506576
- 43 THE AUDIOFILE CAMBRIDGE 01223 368305
- 44 THE POWERPLANT BRIGHTON 01273 775978



Credit facilities are variable. Please ask for written details

For further information contact:

Mission Group, Huntingdon, PE18 6ED Tel: 01480 451777 Fax: 01480 432777  
 Arcam, Denny Industrial Centre, Waterbeach, Cambridge, CB5 9PB Tel: 01223 440964 Fax: 01223 863384  
 World Radio Hi-Fi, 200 Business Park, Huntingdon, PE18 6XY Tel: 01480 52521 Fax: 01480 52159

CHORD, ATC, AVI, HARBETH, ROYD,

**BUYING OR SELLING?  
THEN USE OUR DATABASE!**

LFD, MICHELL, ORIGIN LIVE, KINSHAW,

Apogee	Centaurus Minor loudspeakers (b/ash)	£750
ATC	SCM 50A loudspeakers (black)	£2,850
ATC	SCM 50A loudspeakers (walnut)	£3,995
AVI	S2000MD dac	£375
B&W	801 loudspeakers no acoustic hood 8/ash	£1500ono
Chord	SPM 1000B stereo power amplifier	£1,500
Harmon Kardon	655 int amp 40 wpc	£150
Kimber	Cable	£100
Kinshaw	Overture integrated amp	£295
Kinshaw	Perception preamp	£350
LFD Audio	MMO phono stage mm/mc	£299
Linn	Kaber loudspeakers	£700
Linn	Kaim preamp (phono socket model)	£700
Linn	LK100 power amp	£325
Lumley	75wpc monoblocks (pair) new valves	£520
Meridian	201 preamp mm/me stage	£299
Meridian	203 dac	£250
Musical Fidelity	A100 integrated amplifier	£250
Noim	NAT01 tuner	£900
Origin Live	OL2 loudspeakers (black ash)	£450
Origin Live	OL1 loudspeakers (black ash)	£350
QED	Digit	£95
Quad	606 mk1 power amp (green)	£400
Royd	A7 series II loudspeakers (b/ash)	£75
Royd	Abbot loudspeakers (walnut)	£450
Royd	Minstrel loudspeakers (grey)	£175
Sansui	AV2000 DSP Pro Logic A/V amp	£499
Sequence	Model 30 loudspeakers (dark)	£150
Sequence	Model 30 loudspeakers (light)	£160
Sony	715 CDP CD player as new	£195
Spendor	SP/3 loudspeakers in walnut	£600
Target	Open Frame 20" stands	£35
Target	Single column 22" stands	£65
Thorens	166 mk VI turntable & AT95 Cartridge	£199

*Cottage Audio*

17 Bridge Street, Saxilby, Nr. Lincoln. LN1 2PZ  
Tel/Fax (01522) 702834

DELPH, QED, PROJECT, THORENS

SANSUI, SEQUENCE, SONIC LINK,

**CLASSIQUE SOUNDS (LEICESTER)**

**WANTED**

ALL CLASSIC VINTAGE VALVE HIFI EQPT.

<b>PRICES PAID. UP-TO:</b>	EMT	£400
	ROGERS CADET 2/3	£50
QUAD 11/22	ROGERS HG88 MK1/2/3	£70
QUAD 33/303	ROGERS JUNIOR/MASTER	£100
QUAD ELECTROSTATIC SPKRS	RADFORD STA 12	£200
QUAD 405/34/44	RADFORD STA 15/SC22	£250
QUAD 606	RADFORD STA 25/SC22	£200
LEAK STEREO 20	RADFORD MA 15	£200
LEAK TL10/12+	RADFORD MA 25	£200
LEAK STEREO 50/60	RADFORD MA 50	£225
LEAK TL25	AVANTIC DL7/35	£175
LEAK TL12.1	AVANTIC SPA11/21	£50
LEAK TROUGHLINE 2/3	RCA NEW ORTHOTHONIC	£125
GARRARD 301	LOWTHER VALVE AMPLIFIERS	£100
GARRARD 401	LOWTHER SPEAKERS	£150
THORENS 124	TANNOY SPEAKERS	£400

**OTHER CLASSIC HI-FI EQUIPMENT ALSO WANTED. IE**

SCOTT, DYNAVECTOR, DYNACO, MC'INTOSH, BEARD, CROFT, LUXMAN, EAR, MICHAELSON AND AUSTIN, ETC. RING FOR PRICE PAID.

MODERN VALVE AMPLIFIERS ALSO PURCHASED FOR CASH. IE CROFT, CONCORDAUNT, AUDIO RESEARCH, CONRAD JOHNSON, LUMLEY ETC. AUDIO VALVES WANTED. IE MULLARD, GEC, BRIMAR, OSRAM ETC.

**£15.00 PAID FOR HIFI YEAR BOOKS.**

NON WORKING VINTAGE VALVE HI-FI EQUIPMENT ALSO PURCHASED.

CLASSIQUE SOUNDS, CLASSIQUE HOUSE, 61 AYLESTONE DRIVE, LEICESTER LE2 8QE. TEL/FAX UK + 0116 2835821 OR 0802 213740 (MOBILE)

*Gramex  
Audio*

**DAN  
DULEY**

**SECONDHAND QUALITY HI-FI.  
CUSTOM BUILT EQUIPMENT AND ACCESSORIES.  
KITS BUILT TO ANY SPECIFICATION.**

**NEW IN THIS MONTH:-**

LINN SONDEK WITH VALLHALLA BOARD AND LVX FOR £400

SOME OLD VALVE RADIOS AT £40 TO £80, TWO 401 CHASSIS UNITS AT £120 AND £95 AND VARIOUS AMPLIFIERS FROM LEAK NAD TRIO NAIM SUGDEN ETC.

ORIGINAL QUAD SLEEVE FOR 33/FM3 £50, THORENS TD124(II) WITH SME III £250 AND VARIOUS GRUNGE AMPS & TUNERS THAT WERE TAKEN IN P/EXCHANGE TO BE DISPOSED OF AT VERY GOOD PRICES!

WE SPECIALISE IN THE REPLAY OF "78" RPM RECORDS ETC.

DON'T FORGET OUR UNRIVALLED SELECTION OF SECONDHAND LP&CD.

HELPFUL ADVICE ALWAYS AVAILABLE, DROP IN FOR A CHAT.

**25 LOWER MARSH, LONDON SE1 7AJ**

**WE ARE ADJACENT TO WATERLOO MAINLINE STATION.**

**TEL 0171 401 3830 FAX 0171 928 3999**

**OPENING HOURS ARE TUES. TO SATURDAY, 12:30 TO 18:30**

**SECOND HAND QUALITY HI-FI ALWAYS REQUIRED, ESPECIALLY VALVE EQUIPMENT, WORKING OR NOT.**

# WOLLATON A • U • D • I • O

THE MONARCHY

## DIP

Digital Interface Processor

The DIP will improve your CD transport by removing jitter

Phone for further information  
and copies of reviews

Please see 5 star  
review in April issue of  
**WHAT HI-FI?**

Wollaton Audio  
134 Parkside, Wollaton, Nottingham, NG8 2NP  
Tel/Fax (0115) 928 4147

## CLASSIQUE SOUNDS (LEICESTER) FOR SALE

### TURNABLES.

GARRARD 301	FROM £150.00	LINN AXIS/AKTO/K9	£275.00
GARRARD 401	FROM £125.00	STD 305M/SME	£125.00
THORENS 124	FROM £200.00	THORENS 125/SME	£150.00
THORENS TD160S, BOXED	£175.00	THORENS 160S/MISSION 774	£175.00
THORENS TD160/MAYWARE	£175.00	LOGIC DM101/ARM. TO CLEAR	£149.00

### AMPLIFIERS.

QUAD 11s. CONCORDAUNT/MOD	£450.00	QUAD 11s. VARIOUS FROM	£350.00
LEAK STEREO20s. FROM	£250.00	LEAK TL12+vs. PAIR FROM	£350.00
RADFORD STA15/25 FROM	£450.00	ARMSTRONG A6s+PRE-AMP	£225.00
ROGERS HG88 INTEGRATED	£175.00	AUDIO INNOVATIONS S/500	£495.00
VICEROY STEREO SCOPE	£195.00	QUAD 33/303	£195.00
NVA PRE/POWER AMPLIFIER	£395.00	BEARD P100.100W/CH	£795.00
ARMSTRONG A48 MK1. BOXED	£149.00	ARMSTRONG A28. MINT	£149.00
QUAD 608MK2.10 MONTHS OLD	£499.00	GRANT G50A 45 W/CH. MINT	£495.00

### PRE-AMPLIFIERS.

QUAD 22	£50.00	QUAD 66 10MONTHS OLD	£599.00
LEAK VARIOSLOPE STEREO	£50.00	LEAK POINT 1. MONO	£20.00
ALBARRY DMP1+P/SUPPLY	£195.00	GRANT G100 P/AMP MINT	£395.00

### SPEAKERS

QUAD ELECTROSTATICS BNZE	£495.00	QUAD ELECTROSTATICS BLACK	£450.00
--------------------------	---------	---------------------------	---------

### TUNERS.

LEAK TROUGHLINE 2	£75.00	LEAK TROUGHLINE 3 STEREO	£150.00
ROGERS MK 3 VALVE + DECODER	£99.00	QUAD FM1	£40.00
PYE MOZART MINT BOXED	£100.00	RADFORD MATCHES SC22	£100.00

### OTHER ITEMS

REVOX G36 VALVE EX COND	£350.00	PIONEER SX1250 180W/CH	£99.00
301/401 POWER SUPPLY 100V	£99.00	301/401CORK MATS	£5.00

### VINTAGE VALVE AMPLIFIER FULL REBUILDS

FROM £100.00 ADD £20.00 FOR SAME DAY SERVICE. APPT ONLY

#### TRANSLUCENT.

#### PURE SILVER INTERCONNECT

HALF METRE TERMINATED £59.99 (PAIR) C/W QUALITY GOLD PLATED PHONOS  
ONE METRE TERMINATED £79.99 (PAIR) C/W QUALITY GOLD PLATED PHONOS  
EACH ADDITIONAL HALF METRE ADD £20.00 P+P £2.20

CLASSIC HI-FI AND MODERN QUALITY, HI-FI ALWAYS WANTED FOR CASH.

TEL/FAX PAUL GREENFIELD UK + (0116) 2835821 DR 0802 213740 (MOBILE) ANY-TIME  
CLASSIQUE SOUNDS. CLASSIQUE HOUSE, 61 AYLESTONE DRIVE, AYLESTONE, LEICESTER. LE2 8QE

## FOR SALE

Akai 400DB open reel recorder	£100
Audio Research D70/II tube poweramp	£800
Croft MICRO, latest version, save £200	£300
Denon DRM22 cassette deck	£50
SME3009/II, tone arm	£50
Linn LP12, SME3009/II imp	£175
Linn LP12, Lingo, Ekos, OC9	£1,100
Marantz CD12, L.E. two box machine	£1,200
Mission DAD7000 CD player	£50
Pioneer SX747, 4ch receiver	£75
Quad FM4 stereo tuner	£200
Quad FM3 stereo tuner	£100
Quad 33/303 pre-power	£185
Quad 33 preamp	£65
Quad 303 poweramp	£150
Quad II power amplifiers (pair)	£350
Quad FM/ISD (matches 33)	£100
Radford STA15/III, SC22, FMT2	£500
Radford STA25/III	£450
Sony ESPRIT TAN900, 200W monoblocks	£800
Tandberg TD20A, open reel, quarter track	£300
Tannoy "WESTMINSTER", horn speakers	£3,000
Thorens TD124, chassis only	£120
Walker CJ58, SME3009/III	£75
UHER 4000 report, just the machine	£50

Telephone: **01 942 25 75 25**

Facsimile: 01 942 525 861 Mobile: 0585 476 574

E-Mail: h.boardman@bbcnc.org.uk

M.A.C., P.O.Box 67, WIGAN,  
Lancashire WN2 3AG England

Part Exchange/Credit cards/Quick Delivery  
Quality Equipment bought for CASH

## PHASE 3 HIFI

213 - 215 Tarring Road, Worthing

West Sussex BN11 4HW Telephone (01903) 245577

Fax. (01903) 505824

## SUMMER BARGAINS!!

TANNOY D500	1360.00	M.F. PREAMP	130.00
ADCOM GCA 510	150.00	MERIDIAN 207*	375.00
MOTH 30 RIAA	150.00	LEXICON CP2*	695.00
MOTH 100VA PS.	119.00	MERIDIAN 204	400.00
MOTH 30 40W	259.00	SD SD3/STANDS	650.00
NAD 502	200.00	MOREL 704	750.00
MARANTZ CD63	200.00	CELESTION 7 Mk11	200.00
MARANTZ CD63SE	300.00	MARANTZ PM 53	179.00
M. F. TEMPEST	100.00	YAMAHA E1000	599.00
M.F. TYPHOON	200.00		

Delivered U.K. Mainland 48 hours, F.O.C. Visa, Access and Switch  
accepted. Products marked \* are pre used bargains. All other  
products are EXDEM.



PHASE 3 HIFI

(01903) 245577



# Studio One

We are flexible with our opening times

117-119 HAMMERSMITH ROAD  
LONDON, W14 0QH.  
Tel: 0171 371 3037  
Fax: 0171 371 1790  
We are open Mon-Sat 9.30 -6.30



## "END OF TERM SALE"

PHONE US FOR THESE ITEMS PRICES  
EX-DEMO NEWLY BOXED.

MUSICAL FIDELITY E600 CD PLAYER  
MUSICAL FIDELITY E500 TUNER  
KINSHAW OVERTURE PRE-AMP  
KINSHAW OVERTURE POWER-AMP  
KINSHAW INTEGRATED AMPLIFIER  
MARANTZ CD10 PLAYER  
HEYBROOK HEYSTACK SPEAKERS  
TANNOY 636 SPEAKERS  
POLK 3000 SUBWOOFER SYSTEM  
KEF Q50 SPEAKERS  
HEYBROOK HB1 MKIII SPEAKERS  
SPENDOR BBC MODIFIED S20 SPEAKERS  
PROJECT 7 AMP  
PROJECT 6.1 TURNTABLE



Don't let your  
**LISTENING ROOM**  
spoil his performance.

With the help of

*Room Acoustics Services*  
you can achieve near concert hall realism,  
in harmony with your home decor.

Full details, reviews etc, of our computerised postal  
Hi-Fi room acoustics consultancy available from:-

### ROOM ACOUSTICS SERVICES

3, Queen Elizabeth Way, BARTON-upon-HUMBER,  
South Humberside, DN18 6AJ. Tel: (01652) 635523

## WANTED

- SERIOUS SOUNDS  
AT  
SENSIBLE PRICES -

## NORTHWOOD AUDIO

TELEGRAPH: 01296 28790

REWARDS: DEAD OR ALIVE FROM

98 Cambridge Street

Aylesbury

FOR THE ULTIMATE SPECIALIST EXPERIENCE



The MANA  
Reference 5-tier  
Amplifier Stand  
with Sound Stage

For information on MANA products please contact:  
MANA ACOUSTICS, 59 Jubilee Close, Pinner, Middx. HA5 3TB. Tel/fax 081-429 0118



Aural Pleasures for Audiophiles at...

THE SOUND GALLERY

65 Castle Street, High Wycombe, Bucks HP13 6RN 01-494 531682



## Helen Koczur

HiFi - TV - Video - Home Cinema  
Specialists & Consultants

HiFi & Home Cinema Specialist - inc THX.

Stockists of - Harman Kardon, Onkyo, Teac,  
Canon, JBL, KEF, B&W, Nakamichi, Tannoy  
inc Definition Range etc.

Home Delivery & Installation  
Two Dem rooms  
Free Parking.

Open Mon, Wed, Thur, Fri 9.00am - 5.30pm  
Sat 9.00am - 5.00pm  
Sundays by Appointment  
Closed Tuesday.

Helen Koczur  
161, Yorkshire Street, Rochdale,  
Lancashire OL12 0DR  
Telephone: 01706 42107  
Facsimile: 01706 711989

## KEF CONSTRUCTOR SERIES

## Wilmslow Audio

KEF Uni-Q Technology, the unique KEF driver design that delivers a sharply focused sound stage throughout a room, is now available to the home constructor.

KEF's Constructor Series of loudspeaker drive units and dividing networks, may be used in systems of your own design, or by following the KEF kit plans below:

**KEF Kit 60** - A two-way bookshelf/stand-mounted loudspeaker using a single 8" Uni-Q drive unit in a compact 18 litre reflex loaded enclosure. The DN60 dividing network allows bi-wiring/bi-amping.

**KEF Kit 80** - An 8" Auxiliary Bass Radiator augments the output of the main 8" Uni-Q driver used with a DN80 bi-wireable dividing network. This is a floorstanding loudspeaker with exceptional bass response.

**KEF Kit 90** - An 8" dedicated bass unit, 8" Uni-Q and DN90 bi-wireable dividing network give this three way floorstander extended bass output down to 35 Hz (-6dB).

KEF have designed a range of drive units and dividing networks which, with simple D.I.Y skills, can be transformed into State-of-the-Art loudspeakers capable of giving years of truly high-fidelity performance.

Kit	60	70	80
Boxed	£215	280	370
Total	£290	370	460

Free DIY speaker catalogue  
export £3.50

Dept. HFW  
Wellington Close, Parkgate Industrial  
Estate,  
Knutsford, Cheshire WA16 8XL  
Tel: 01565 650605  
Fax: 01565 650080

Open Tuesdays to Saturdays  
4 demonstration rooms



**KEF Kit 60**  
2-way bookshelf/  
stand-mounted



**KEF Kit 80**  
2-way floorstanding



ACCESS VISA  
AMEX

**KEF Kit 90**  
3-way floorstanding

# Audio Note

## AUDIO NOTE AUDIO COMPONENTS PRICES LIST

The increase in all things single-ended, especially the trade loss-feedback variety, is now so great that even the mainstream valve manufacturers are about to follow suit, so if you are looking for a single-ended product beware of the false prophet, who speaks of things he did not believe in, until he becomes financially expedient or downright necessary to have a single-ended amplifier in the programme. So whether you are building a single-ended amplifier yourself or having to buy a manufactured single-ended product, please remember that it was **AUDIO NOTE**, who, in the face of the usual industry hype about continual "progress", brought the technology to the attention of press, public and general audio industry alike, not because it would lead a quick buck to the purse, but because we firmly believe that it is a superior way of amplifying any music signal, and therefore deserves to be resurrected as the preferred technology for anyone who wants the genuine aesthetics and beauty of real music reproduced in their home.

Now that we stand on the boundary of this, the brave "new" world of 1920's circuitry, we note with interest the number of manufacturers who have manufactured valve amplifiers for many years, but who only now have "discovered" the value of single-ended, and who in the past have been the strongest proponents of the high power "high quality" valve amplifier, watch them, as they now, for commercial gain embrace the world of high loudspeaker efficiency and single-ended triode amplification and then draw your own conclusions about their sincerity and competence in overall knowledge of the technology of **AUDIO NOTE**. We were first and remains the last word in sonic quality if you appreciate these things.

To enhance your ability to design and manufacture your own special version of any of the single-ended circuits being discussed, whether old or new, we will continue to expand on what is already the most extensive range of ultra high quality components that the discerning "do-it-yourself" valve amplifier enthusiast can use to construct any single-ended (or share on you!) push pull amplifier, whether triode or pentode. All these parts are used in various models of the manufactured line of **AUDIO NOTE** amplifiers. These components include mostly specially made items like ceramic valve bases with either silver or gold plated pins, paper in oil aluminium foil signal capacitors, copper & silver foil signal capacitors, Black Gate graphite electrolytic capacitors, acorn/corvette-free silver solder, copper and silver wired audio output transformers, non-magnetic tantalum resistors, non-magnetic RGA and speaker terminals, valves and many other useful bits and pieces for upgrading old or constructing new valve amplifiers.

All prices are excluding UK VAT at 17.5%, which, if you live inside the EC, UK VAT will be added to your purchase, after the addition of postage and packing costs.

We accept **VISA, Mastercard, Access, Diners, and Amex.** To pay this way, we will need your address, card no., with start and expiry dates, you can also pay by bankers draft, Euro cheque or cheques drawn on a UK bank account. Please note that there is a minimum charge on credit card transactions of £20.00.

Delivery is normally about 14 days from receipt of cleared funds, but please allow up to 60 days for some items, if not stock at the time of order. If any of you reading this have possession of any books which contain information relevant to the subject of **AUDIO NOTE** Design and which would be useful to share with others, please let us know either by fax or telephone, there is an award of £20.00 (payable in valves or other bits, post free) to anybody who sends us a book which contains useful information about valve amplifier design or theory.

## CIRCUITS, VALVE DATA & BASIC TECHNICAL INFORMATION.

If you would like some suggestions which to base a future project around then we shall be happy to provide you with a circuit pack containing good circuit ideas like **ONGAKU**, **KEGON/KASSAI**, **KEIRO**, **GAKU-DN** plus several other power amplifier circuits and the **M7TUBE** pre-amplifier, which is the best pre-amplifier circuit we have come across. Just send a stamped self addressed A4 size envelope, together with 5.00 pounds in small denomination UK stamps or if you live outside the UK US\$ 15.00 in \$ bills will do, please do not send Bankers Drafts in US\$, International Response Coupons or International money orders, as they cost more to cash than their value.

We have a large number of requests for the circuits of the **AUDIO NOTE** valve amplifiers, like OTD Phone SE, MiPhone, MiSARU, SORO etc, and since we (unlike the majority of our talented competitors) do not have any knowledge in this department, are only too pleased to help a friend the envelope of anyone in this much maligned field, we shall be happy to send you any existing or prospective competitor, one of more circuit diagrams, they cost £5.00 each or you can buy for a single all phone in the UK, for £20.00 (\$50.00), or all line-inlet amplifiers for £25.00, all pre-amplifiers for £20.00 (\$35.00), or simply a complete circuit pack or £2.00, (\$8.00) All can be paid either by credit card, cash, bankers draft or cheque drawn on a UK bank, the cost includes postage.

We can also supply a set of data sheets for the most commonly used valves, ECC82, ECC83, 622, 12AY7, 6072A, 7025, 72AK7, 6AR5, 6CC6, 6X4, 6SN7, 300B, 211V7A, 6L5, EL34, 6AR5, 2A3, 6X4, 5U4G, G2345A, 6BM8, 6BM8S, 6V6GT, 6L6G, 5881, 6BE6, 6CT6, 6BE6. Again send a stamped self addressed A4 size envelope together with £4.00 in small denomination stamps or if outside the UK another US\$ 15.00 will suffice.

Since nothing really exists which gives a reasonable background to the subject of valve amplifier design, if you Adams and I have written and assembled a number of articles and a tract from old books which give some background to the subject, do not expect to become an instant a part, but it will serve as a useful reference, for the beginner as well as the more advanced, we have expanded this info-pack to include even more useful information, so if you have already bought the old pack, just send UK or US\$ 5.00. For the full pack a small charge is required to meet £7.00, and a full denomination stamp with a stamped self addressed envelope, or £2.00, the UK, please send US\$ 25.00.

We do accept a UK cheque or bankers draft in Sterling for the above charges as well, just convert the US\$ amounts to Pounds \$1.70 to the Pound, after you have rounded up to nearest \$5.00.

## SOUND PRACTICES.

If you are seriously interested in the subject of valve amplifier design, without the usual prevaricating notions of what is "good" amplifier design and technology (the traditional view, which has brought us the blessings of the transistor amplifier, has obviously disqualified itself quite monumentally), then **SOUND PRACTICES** is the magazine to read, here you will find articles about design parameters, DIY articles for amplifiers and speakers, reviews of new and old. In other words the very subjects that none of the self-serving advertising led traditional press will touch as they do not enhance the business of their normal advertisers. You may buy **SOUND PRACTICES** from us at £5.00 per copy (there are currently 5 issues available) or by subscription from **SOUND PRACTICES** P.O. Box 180552, Austin, TX 78718, USA. A regular market world bargain, and there are practically none of those in **AUDIO NOTE**. With enough subscription support **SOUND PRACTICES** may just bring about the "sound practices" that the hi-fi industry has abandoned for so long. So get a subscription!

By the time you read this **SOUND PRACTICES** issue 8 should be here, so the should keep you off the street for the next weekend! Buy a copy for £5.00 + postage for self addressed envelope with order if you live in the UK, contains the following articles, **Blue Thunder - DIY TAD and Focal Horn System** from Zurich, **The Louther-Voigt Legacy**, **Join The Club**, **Louther Clubs** by Joe Roberts, **The Reichert 300B Amplifier**, by none other than Herb Reichert!, **Homebrew Gallery**, **Photos of Readers Projects and Systems**, **Reinventing Old Triodes**, **New Russian Triodes**, **A Screen Drive Driver Stage**, **A Cathode Follow/Bridge Amplifier**, and much more!

Each good and informative reading as usual, again £5.00 + an A4 size stamped self addressed envelope if you live in the UK or US\$ 10.00 and a self addressed envelope if you live abroad.

## POSITIVE FEEDBACK.

This is one type of feedback that we are not entirely against! Positive feedback is the club name for the Oregon Triode Society with aspirations towards greatness, not unlike the great underground magazines of the 1970's it is a quarterly publication of zany, controversial commentary, by in-house writers, members as well as various industry doyens on the subjects of music, audio technology and the quest for musical satisfaction, I for one, think it is an excellent read and provides a good alternative view to most of the established press, which tends to view the world in the context of what new products is available right now, without giving much perspective backwards. Positive Feedback latest issue is just off the press and is available at £8.00 per issue.

## COMPLETE KITS.

At the current moment the following kits are under development, and should be available during 1994, the sequence of introduction may be different from the number, we have the **KIT THREE** available for shipment now. **KIT TWO** 6550 single-ended, 15 watts Class A, on a stereo chassis, expected cost £599.00 incl. Vat. Delivery currently unknown due to unavailability of Soviet 6550W, it can be any other without valve for £570.00. **KIT THREE** 300B parallel single-ended, mono chassis, 16.17 watts Class A, cost £1,450.00 incl. Vat. **KIT FOUR** 6V6 push pull, 10 watts Class A, stereo chassis, expected cost £199.00 incl. Vat. delivery May 1995. **KIT FIVE** 211 single-ended, 15 watts Class A, mono chassis, expected cost £2,250.00 incl. Vat. delivery October 1995. We hope!

**KIT SIX** 300B single-ended, 7/8 watts Class A, stereo chassis, expected cost

£499.00 including valves and Vat. This will be our "entry point" or "gateway" to single-ended triode bliss or rock and roll. If you prefer. Expected available June 1995.

If you are in doubt as to whether a kit project is suitable for you, we suggest you spend £10.00 on buying the instructions for the **KIT ONE**, single 300B single-ended, this will give you a good idea whether a kit project is for you. If you decide to buy a kit then the £10.00 will be refunded against the cost of the kit. As the other kits become available their instruction manuals will also be available at £10.00 each. We have the Kit One instructions available in English and Italian.

## AUDIO NOTE OUTPUT TRANSFORMERS

We are in the process of building up four separate ranges of **AUDIO NOTE** output transformers, in order to offer the best possible outputs at different price points, they will fall into four categories:

A) Economy range, where the price/quality relationship is carefully calculated to ensure audio quality in a compact package, initially we will only be offering 3 single ended output transformers in this range, push-pull outputs are under development, but do not expect to see any on this side of August 1995.

B) Mid-price range, which are the output transformers already on offer, we have made a couple of additions to this range, since the last issue.

C) High Quality range, this will be a range of double C-core outputs for single-ended circuits exclusively, no push-pull outputs will be offered, unless demand requires it. Again 3 offerings initially.

D) Super High Quality range, all-silver wired outputs of the best possible quality, when I say best possible, I do not mean to say that these silver output transformers are the best available silicon steel laminations, they are made in Japan, they aren't, but then again they do not carry the price tag either!

The quality criteria for Group A are 20Hz to 20KHz -1 to -1.5dB, they are E core with silicon steel laminations and are supplied with frames and solder tabs which will allow good audio quality at the cost. The main cost saving being the use of a smaller core, specified to be the actual power rating, rather than over specifying by 50 or 100%, as we do on Group B, the winding quality and copper wire is the same.

Group B are typically 20Hz to 40KHz minus 1.5dB, E core with high quality silicon steel laminations, wound with oxygen-free copper wire and supplied with either bell-end or frames always with flying leads.

Group C are typically 12Hz to 70KHz minus 1.5dB, silicon steel double C-core made from the best available silicon steel laminations, these outputs will compare more favourably with the best available types from days gone by and from other current sources like Partridge, Tang, Tamura etc.

Group D use **AUDIO NOTE** silver wire, I say, I mean you???

## Specifications.

PP = Push-Pull, PPP = Parallel Push-Pull, SE = Single-ended, PSE = Single-ended Parallel, UL, signalises 43% ultra linear taps, as a general rule we do not condone the use of UL taps, as we consider these detrimental to sound quality. \*\*

Dynaco replacements are indicated for Class A operation, with the main consideration given to maximum dynamic power transfer and minimum distortion, rather than maintaining steady state sine- or square wave conditions. All our single-ended output transformers are airgapped, and the maximum standing current allowed before saturation is shown in column 5.

All our output transformers are tested to simulation levels of minimum 3,000 volts, all 211/6A5 outputs are insulated to 5kV flash, every transformer is tested to this level of insulation.

We generally over specify our transformers by 50% power in Push-Pull (which means that a transformer stated as 25 watts will allow about 35-38 watt peaks), our single-ended outputs are generally over specified by 100%, which means that they will instantaneously allow peaks of double the given maximum power through undistorted, this is necessary due to the better clipping behaviour of the single-ended stage.

We do not give any further technical information on our output transformers, as we do not wish to take part in technical competitions, our products are designed to criticize which are and will be understood once they are listened to!

In addition to the output transformers offered below, we offer a design service, where we can supply almost any requirement for wideband transformers, whether for microphones, moving coil cartridges, line input, phase splitter, interstages, driver or power output, we design and manufacture prototypes in-house, the cost for the paper design is £200.00, prototype cost is calculated on a per case basis. We can also produce production quantities.

Sizes are given as Width/Height/Depth, where depth is the depth of the coil itself and width is the length of the core.

## AUDIO NOTE PAPER IN OIL SIGNAL CAPACITORS

These handmade signal capacitors are sonically superior to any of the plastic or other paper types we have come across. If you have never experienced the difference that a really good paper/roll capacitor can make in a valve amplifier, then you really should try! Our specially made paper caps have a life colour, lack of harshness and evenness of dynamic behaviour across the frequency range, which is guaranteed to brighten up your day! Recommended as replacements in old and new valve amplifiers alike (and even the odd transistor amplifier), and essential for DIT projects in line with environmental standards, all **AUDIO NOTE** paper oil capacitors contain only non-toxic, biodegradable vegetable oil.

Our paper is specially treated and impregnated by a method that enhances longevity and sound quality, to ensure optimum performance all round. As you will see, we are slowly incorporating solid 99.99% pure silver leadouts on this range of paper oil capacitors as well, in common with the copper and silver foil types. There

## AUDIO NOTE AUDIO QUALITY OUTPUT TRANSFORMERS

Group A	Max. CL A Power	Prim.-Sec. Imp.	Size/Weight	Max. Current	Price Ex. UK VAT
Single ended Outputs					
Recommended Valve					
300B/2A3/6B4G	15 watts	2K5 - 4/8 Ohms	80 x 67 x 68 mm	90mA SE	44.50
801A/V12/845	20 watts	6K - 4/8 Ohms	100mA SE	73.50	
300B/2A3/6B4G	20 watts	1K25 - 4/8 Ohms	150mA PSE	84.50	
Group B					
Recommended Valve					
EL84/6CL6/6V6	20 watts	2K6 - 4/8 Ohms	117 x 96 x 90 mm	110mA PSE	87.00
300B/2A3/6B4G	25 watts	2K5 - 4/8 Ohms	117 x 96 x 90 mm	90mA SE	91.00
EL34/6CA7	30 watts	1K5 - 4/8 Ohms	115 x 98 x 95 mm	180mA B PSE	113.00
7A3/6W6	30 watts	1K25 - 4/8 Ohms	98 x 82 x 95 mm	130mA SE	113.00
211V7A-C45	30 watts	2K1 - 4/8 Ohms	115 x 98 x 95 mm	140mA PSE	106.00
211V7A-C45	50 watts	1K6 - 4/8 Ohms	117 x 98 x 100 mm	150mA SE	114.00
6L5	50 watts	1K25 - 4/8 Ohms	112 x 134 x 150 mm	150mA SE	124.00
845	50 watts	2K5 - 4/8 Ohms	135 x 115 x 125 mm	180mA PSE	151.00
211V7A-C45	50 watts	2K5 - 4/8 Ohms	137 x 114 x 130 mm	180mA SE	172.00
6L6	75 watts	3K - 4/8 Ohms	137 x 115 x 145 mm	240mA PSE	237.00
EL34/6W6/6K7B	20 watts	3K - 4/8 Ohms	117 x 98 x 92 mm	130mA SE	104.00
300B/2A3/6B4G	25 watts	2K5 - 4/8/16 Ohms	117 x 98 x 90 mm	90mA SE	102.50
6L6G	30 watts	3K - 4/8 Ohms	115 x 98 x 95 mm	140mA SE	107.00
NEW SE Product					
6550K7B8	60 watts	2K3 - 4/8 Ohms		110mA PSE	123.00
Group B					
Push/Pull Circuits					
300B/2A3/6B4G	15 watts	8K - 4/8 Ohms	80 x 67 x 68 mm	PP	42.00
EL34/6L5/6B9V	25 watts	6K - 4/8 Ohms	88 x 73 x 80 mm	PP	59.00
2A3/6B4G/300B	30 watts	3K - 4/8 Ohms	88 x 75 x 80 mm	PP	63.00
KT88/6550	50 watts	6K5 - 4/8 Ohms	108 x 91 x 92 mm	PP	72.00
EL34/6T6/5881	50 watts	3K - 4/8 Ohms	98 x 82 x 83 mm	PPP	74.00
845	50 watts	6K8 - 4/8 Ohms	108 x 91 x 90 mm	PP	114.00
KT88/6550	60 watts	4K3 - 4/8/16 Ohms	125 x 100 x 113 mm	L/L	111.00*
KT88/6550	100 watts	2K2 - 4/8/16 Ohms	150 x 147 x 118 mm	L/L PP/PPP	134.00*
Group C					
Single-ended only					
300B/2A3/6B4G	25 watts	2K5 - 4/8/16 Ohms	90mA SE	360.00	
211V7A-C45	50 watts	1K6 - 4/8/16 Ohms	165 x 148 x 140 mm	150mA SE	410.00
300B	50 watts	1K25 - 4/8/16 Ohms	165 x 110 x 138 mm	180mA PSE	396.00
Group D					
Pure Silver Wired Outputs					
300B/2A3/6B4G	25 watts	2K5 - 4/8 Ohms	117 x 96 x 90 mm	90mA SE	1,645.00
211V7A-C45	50 watts	1K6 - 4/8 Ohms	112 x 134 x 150 mm	150mA SE	1,975.00

The **AUDIO NOTE** silver wired outputs listed here are designed and made in the UK, we can supply the **AUDIO NOTE** Japan manufactured outputs for the **ONGAKU**, **KAGERI**, **GAKU-DN** or the **KEGON**, but they are exceptionally expensive, as you would expect from items that take upwards from 100 hours each to make. For example an output transformer for an **ONGAKU** costs £18,500.00.

Value	Size	Price Ex. UK Vat
0.5uF/400mA		18.00
1uF/100mA		14.00
3uF/250mA for ONGAKU/KEGON		21.00
5uF/150mA		31.00
5uF/400mA		21.00
10uF/25mA	63 x 74 x 76 mm	26.00
10uF/200mA	96 x 65 x 83 mm	33.00
20V/500mA	68 x 36 x 58 mm	24.00

Other values can be supplied to order, ask for quote

## AUDIO NOTE CHOKES & INDUCTORS.

Value	Size	Price Ex. UK Vat
0.5uF/400mA		18.00
1uF/100mA		14.00
3uF/250mA for ONGAKU/KEGON		21.00
5uF/150mA		31.00
5uF/400mA		21.00
10uF/25mA	63 x 74 x 76 mm	26.00
10uF/200mA	96 x 65 x 83 mm	33.00
20V/500mA	68 x 36 x 58 mm	24.00

Other values can be supplied to order, ask for quote

## AUDIO NOTE MAINS TRANSFORMERS.

This range relates to our finished products, mains transformers are notoriously difficult items to offer as the number of permutations of HT and Heater voltages are almost endless. We have added mains transformers for making replicas of the **KASSAI** and **ONGAKU**, as there has been considerable call for these, likewise we are preparing mains transformers for the **WE91** described in **Sound Practices** issue 1, we shall continue to expand the range as opportunities and our experience with your requirements improve.

Primary Voltages	Secondary HT Windings	Secondary Heater Windings	Price Ex. UK Vat
0v/100v/110v/120v	0v - 230v at 350mA	0v-12.6v at 1 Amp	34.00
0v/220v/230v/240v	0v - 230v at 350mA	3.15v-0v-3.15v at 4 Amp	41.00
120v/110v/100v/0v	0v - 230v at 350mA	0v-12.6v at 1 Amp	34.00
0v/100v/110v/120v	0v - 230v at 350mA	8.1v - 0v - 8.1v at 1 Amp	46.00
120v/110v/100v/0v	0v - 230v at 350mA	12.6v - 0v at 1.5A	46.00
100v/110v/120v	0v - 230v at 350mA	6.3v - 0v at 600mA	
			for M7TUBE Pre-amp with 50mA choke input filter
0v/100v/110v/120v	0v - 290v at 40mA	12.6v-0v at 1.5A	25.00
0v/100v/110v/120v	0v - 290v at 40mA	0v - 6.3v at 300mA	
0v/100v/110v/120v	0v - 290v at 40mA	3.15v-0v-3.15v at 4.5 Amp	72.00
0v/100v/110v/120v	0v - 290v at 40mA	12.6v at 1.5 Amp	32.00
120v/110v/100v/0v	0v - 920v at 160mA	0 - 10v at 4 Amp, 0v-8.3v at 1.5A, 0v - 5v at 2.5A	98.00
120v/110v/100v/0v	150v-150v at 50mA	1.5A, 0v - 5v at 2.5A	86.70
120v/110v/100v/0v	390v-0v-390v at 200mA	3.15v-0v-3.15v at 1.2 Amp, 7v at 3A, 7v at 3A, 5v at 2A	
120v/110v/100v/0v	170v at 50mA	3.15v-0v-3.15v at 2.5A, 7.0v-0v-7.0v at 2A, 7.0v-0v at 3A	95.60
120v/110v/100v/0v	425v-0v-425v at 200mA	12.6v-0v at 50mA, 7.0v-0v at 2A	
120v/110v/100v/0v	3.15v-0v-3.15v at 750mA	12.6v-0v at 50mA, 7.0v-0v at 3A, 7.0v-0v at 3A, 5v - 0v at 2A	107.00
100v/110v/120v	390v-0v-390v at 200mA	3.15v-0v-3.15v at 1.2A	For KASSAI replica
120v/110v/100v/0v	380v - 0v 380v at 200mA	150v-0v at 150mA, 10v-0v at 3.25A, 10v-0v at 3.25A, 5v - 0v at 3A, 5v - 0v at 3A, 5v - 0v at 3A, 5v - 0v at 3A	137.00
100v/110v/120v		8.3v - 0v at 1.25A	For ONGAKU replica

We also have a mains transformer/choke kit for the **WE91** power amplifier as shown in **Sound Practices**, this combined with our single-ended output transformers with 300hm primary impedance will make a very fine replica of this classic amplifier total cost £420.40 per set.

We now also have the facility to make any mains transformer to your specification, as long as you offer minimum 2 per cent, they can be supplied with soldertags, flying leads, frames or bell-ends. Ask for quote

On a more general note, it is important to understand the specialised nature of the design and manufacture of transformers for audio equipment, in most industrial applications the main criteria are cost, weight or longevity, an audio mains transformer also has to have good regulation under load, must run cool and generate no mechanical noise or vibration, produce no excessive stray magnetic fields etc, etc, a pretty tall order, when one considers that the cost also has to be reasonable. So no matter where you order your mains transformer remember that if it should conform to the above criteria, so specify them when you order. As a general rule we do not recommend potted transformers, as all listening tests have shown these to sound less clear, than unpotted equivalents!

are several new values available, including the 2.2mF/5



0.8mm	ML	31.75
1mm	ML	36.75

The above listed silver wires are suitable for inductors for speaker crossovers, both active and passive, or for internal wiring in tonearms, amplifiers etc.

**AUDIO NOTE Coax Interconnect Cables:**

Type/Colour code	Construction/Price per Stereo Meter Ex. UK Vat.
AN-A	symmetrical 58 copper litz coax 15.32
AN-C	symmetrical 09HC copper litz coax 29.29
AN-S	dark grey/yellow stripe symmetrical 99.99% silver litz coax 84.75
AN-V	silver grey/yellow stripe symmetrical 99.99% silver litz coax 152.35
AN-Vs	silver grey litz coax 382.98

It is recommended to use the internal twin filter wires in the AUDIO NOTE Coax as internal wiring cable; this is what we do in amplifiers like the ONGAUK MT7tube etc.

**AUDIO NOTE Speaker & Wiring Cables.**

Type/Colour code	Construction	Price per Mono Meter Ex. UK Vat.
AN-D	orange or red single conductor 6m copper speaker wiring	6.85
AN-B	blue white writing double strand, screened 6N litz speaker wire	12.34
AN-L	blue black writing double strand, screened 6N litz speaker wire	25.11
AN-SP	single core 15 strand 99.99% litz silver speaker wire 106.38	
AN-SPs	single core 20 strand 99.99% litz silver speaker wire 382.98	

**PTE Insulated Silver Plated Copper Wires.**

We can also provide interconnect wiring wires for hard wiring circuits, these PTE insulated silver plated copper wires are 19 strand of 0.15 mm wire and come in brown, black, blue, red, green, orange, violet, white and red/white they cost £1.60 per meter in any colour.

**AUDIO NOTE HIGH QUALITY STEPPED ATTENUATORS & SWITCHES.**

These handmade attenuators and switches are manufactured by a friend of Mr. Kondo of AUDIO NOTE and represent the best available volume control and switches you can use in your pre-amplifier; the attenuator is 48 steps and with silver/rhodium plated contacts/banana made with an array of tantalum film resistors. The switches feature silver plated contacts and still cleaning action.

Type	Value	Price Ex. UK Vat.
Stereo Potentiometer/Attenuator	100kOhms	221.75
Stereo Potentiometer/Attenuator	500kOhms	237.75
2 Channel switch	6 - way adjustable	98.75
4 Channel switch	6 - way adjustable	124.75

**AUDIO NOTE HIGH QUALITY CERAMIC VOLTAGE BUSES.**

All of our voltage buses are of the highest possible quality, made from stellite and using the best metal parts from alloys which retain their spring tension around the vane on for longer. They are recommended as upgrades to most old vane amplifiers and should be an essential part of any DIY project.

Type	Mounting	Plating Price Ex. UK Vat.
4-pin UK for 300B/2A3/801A	Chassis	8.25
4-pin UK for 300B/2A3/801A	Nickel	7.25
4-pin UK WE-type for 300B/2A3/801A	Chassis/Silver	14.75
4-pin UK WE-type with bayonet mounting	Chassis	48.95

Type	Value	Price Ex. UK Vat.
4-pin Jumbo 4 for 11A7/4C/845	Chassis with bayonet Silver/chrome	159.95
5-pin UVS for 807	Chassis	9.75
7-pin B7 for 6X4, 6A2	PCB	8.15
7-pin B7 for 6X4, 6A2	PCB	7.85
7-pin B7 for 6X4, 6A2	Chassis from above	6.75
7-pin B7 for 6X4, 6A2	Chassis from above	7.95
8-pin UBK for EL34, 6S50, 5U4G, 6Z54, 6L6, etc.	Chassis/Silver	5.65
8-pin UBK for EL34, 6S50, 5U4G, 6Z54, 6L6, etc.	Chassis/Gold	8.85
9-pin B9 for ECC83, ECC88, 5687, 6350, etc.	PCB/Silver	3.85
9-pin B9 for ECC83, ECC88, 5687, 6350, etc.	PCB/Gold	5.75
9-pin B9 for ECC83, ECC88, 5687, 6350, etc.	Chassis from above/Silver	4.45
9-pin B9A for ECC83, ECC88, 5687, 6350, etc.	Chassis from above/Gold/6.75	
9-pin B9A for ECC83, ECC88, 5687, 6350, etc.	Chassis from below/Silver/4.95	
9-pin B9A for ECC83, ECC88, 5687, 6350, etc.	Chassis from below/Gold/7.15	

Type	Value	Price Ex. UK Vat.
4-pin UK for 300B/2A3/801A	Chassis	8.25
4-pin UK for 300B/2A3/801A	Nickel	7.25
4-pin UK WE-type for 300B/2A3/801A	Chassis/Silver	14.75

You may want to start your project with less overall cost, and for this purpose we can offer the following "industrial grade" ceramic voltage buses:

Industrial Grade Valve Bases:	Mounting	Price Ex. UK Vat.
8-pin for EL34, 6S50, 5U4G, 6L6, 6G	Chassis with bracket	1.45
9-pin for ECC83, ECC88, 5687, 6350	Chassis with shroud	1.85

**AUDIO NOTE CERAMIC STAND-OFFS.**

In most handwired vane power amplifiers it is frequently difficult to get the HT and heater rails properly suspended and separated, safely and neatly from the chassis; this especially applies when building amplifiers using the really high voltage directly heated triodes like 211, V74, C, 845, 849, 304T, 0A100 etc. When planning design like this, it is important to incorporate suitable stand-off from the start, and the AUDIO NOTE stand-offs are more or less mandatory in that context. They are screw-in type with stellite inductor and either a wrap-around turned "head" on the single wire version or separated socket slots on the multi wire version.

Type No.	Height	Solder Connection	Chassis Fixing	Price Ex. UK Vat.
AN-421	1 25.5 mm	Wrap round	Screw in bolt	1.41
AN-422	1 17.4 mm	Wrap round	Screw in bolt	1.41
AN-423	1 22.6 mm	Solder slot	Screw in	1.41
AN452	2 Adjustable		Dual bolt screw-in	2.42
AN453	3 Adjustable		Dual bolt screw-in	3.05
AN-455	5 Adjustable		Dual bolt screw-in	4.04
AN-458	8 Adjustable		Dual bolt screw-in	5.79
AN-460	10 Adjustable		Dual bolt screw-in	7.31
AN-476	6 25mm/45mm	Solder slots	Screw in bolts	5.35
AN-479	9 25mm/65mm	Solder slots	Screw in bolts	7.53

**AUDIO NOTE SELECTED AUDIO VALVES.**

Our valves are selected from the best available sources and are tested to the same stringent standards that we apply in the production of our own amplifiers; they fall into two categories: standard production items and rare, mostly NOS (New Old Stock) valves which are no longer in production. We have compiled a special list of the NOS items, which is available against a stamped self addressed envelope if you live outside the UK; you should be aware that the valves on this list are NOT cheap, but we have stock of original GE, RCA and United Electronics 211, both standard versions and reinforced force type; 845 Westinghouse, V125V1010V, V162/801A, WE300B, STC400A, Mullard GZ34/CV1377, Tungoil 5U4G (best sounding 5U4G I have ever heard!), Chialam SR4WGY and many others.

Standard Stock Items:	Type	Price Ex. UK Vat.
ECC83S/12AX7W/7025	double triode	2.95
E88CC/6Z50/807A/7308	double triode	3.95
E88B/6Z50/807A/7308	double triode	5.95
6SN7GT	double triode	17.75
6X4	double triode	2.65
5687WA	double triode	8.75
6350VA	double triode	6.75
EL84/805	small power pentode	1.55
EL84/805VA	small power pentode spec version	4.51
6V6GT	small power pentode	2.45
6X4	medium power diode	8.25
6BE6/12AT6/DLW30Z	medium power triode	4.51
6CA7/EL34 Fat Buff	power triode	8.85
EL34G	power pentode	6.45
6550/6T8	large power triode	12.45
8C23	powerful regulator, indirectly heated triode	24.65
845/6080	strong regulator, indirectly heated triode	8.45
2A3 4 000	directly heated small power triode	17.95
300B	directly heated power triode	57.95
VA1C/V308	2500V 1/2" pin triode	29.01
5U4G	HT-rectifier	3.25
5Y3GT	HT-rectifier	2.25
5V4GT	HT-rectifier	2.25
GZ34/AR4	HT-rectifier	8.75
6X4	HT-rectifier very good for pre-amplifiers; 7-pin base	2.65
6X5	HT-rectifier, for pre-amplifiers & power amplifier front-ends; UXB base	2.65

Please note: our 300B's are manufactured in China by Gold Dragon / Shengsheng. We are filled in those under seal and condition to performers somewhat more stringent than otherwise done. We do not stock outages as good as original WE 300B's or STC 400A's, nor do they carry the same premium price, please consider the following, unless you have absolutely torn of money or you happen to have them in your attic, do not consider original 300B's. It is in most cases far better to invest the money in more permanent features of the amplifier project, like better output transformers, better signal cables or resistors or the various valve options, but nevertheless very good sounding. A pair of original WE 300B's cost at least £1,200.00 on a good day, and in terms of an overall price compromise, you can get some fabulous sounding passive for the difference in cost between a pair of Chinese 300B's and the original WE's, and in many cases the impedance in sound quality is greater than the WE 300B's will continue. ADO the contribution to sound is permanent, consider that when you plan your project.

**RESISTORS**

We endeavour to stock the entire E12 range of all the different makes of resistors that we stock, except the very lowest Ohmic values, which are extremely costly; as a rule we do not stock below 10 Ohms or above 3MΩ. Whilst we attempt to fill every single E12 value in stock, that cannot be guaranteed, especially on the Helvetic and tantalum film resistors can be very long leaded; however, since most are used in our production of finished products, there will generally be stock available within 4 weeks.

**BEYSCHLAG**

We offer three quality levels of resistor quality, all are 1%, starting with the Beyschlag Metallfilm, which are silver magnetics; also the best majority of other metal film resistors, but nevertheless very good sounding, as used in all our UK-made amplifiers up to and including quality level 3. The MESHUP/PA, 300B no-feedback triode amplifiers.

Resistor Type	Value	Price Ex. UK Vat.
Beyschlag 1 watt, 1% resistors up to 500kOhm	£1.10	
Beyschlag 1 watt, 1% resistors up to 500kOhm	£1.10	
Beyschlag 1 watt, 1% resistors up to 500kOhm	£1.10	

**SHIMOKI TANTALUM FILM RESISTORS.**

These resistors are made especially for us by a major manufacturer. They are available in a 1 watt range which becomes an exclusive range for AUDIO NOTE, we consider this to be a major breakthrough since without a reasonable range of values at the 1 watt rating it is pretty difficult to get the very best out of the best circuit. As with most handmade specialist items, which covers most of the best film resistors can be quite rare, as we are prepared to wait for the value we need in stock.

**AUDIO NOTE 1 WATT TANTALUM FILM RESISTORS.**

Up to now the tantalum film resistors have been extremely difficult to get however, after much persuasion and against a mid-run quantity guarantee from AUDIO NOTE UK, the manufacturers have agreed to widen the range of 1/2 watt and reintroduce the 1 watt range which becomes an exclusive range for AUDIO NOTE, we consider this to be a major breakthrough since without a reasonable range of values at the 1 watt rating it is pretty difficult to get the very best out of the best circuit. As with most handmade specialist items, which covers most of the best film resistors can be quite rare, as we are prepared to wait for the value we need in stock.

**POTENTIOMETERS.**

Best available from sound quality - price viewpoint, made by Noble in Japan. High quality conductive plastic film.

Volume Controls	Construction	Price Ex. UK Vat.
100kOhm Stereo	Frame type PCB mounted	3.95
100kOhm Mono	Encapsulated type PCB mounted	15.65
100kOhm Stereo	Large Encapsulated, high quality	107.45

**BALANCE CONTROLS**

100kOhm Stereo	Construction	Price Ex. UK Vat.
100kOhm Stereo <td>Encapsulated type PCB mounted</td> <td>32.25</td>	Encapsulated type PCB mounted	32.25
100kOhm Mono <td>Large Encapsulated</td> <td>156.65</td>	Large Encapsulated	156.65
100kOhm Stereo <td>Large Encapsulated, high quality</td> <td>107.45</td>	Large Encapsulated, high quality	107.45

**HIGH TANTALUM WIREWOUND RESISTORS.**

As a new item we shall start offering a range of 2 - 15 watt wirewound resistors, which will be starting with small range expanding that we go along with the moment the following is available, all these resistors are 5% tolerance and glazed.

Wattage	Value	Tolerance	Price Ex. UK Vat.
6 watt	47R	5%	0.86
6 watt	100R	5%	0.86
6 watt	470R	5%	0.86
6 watt	1K	5%	0.86
6 watt	2K	5%	0.86
6 watt	15K	5%	1.32
6 watt	20K	5%	1.32
6 watt	100K	5%	1.24
6 watt	150K	5%	1.24
9 watt	1K	5%	1.24

**BLACK GATE ELECTRON TRANSFER, HIGH PERFORMANCE, GRAPHITE FOIL CAPACITORS.**

Firstly, I would like to categorically state that any, resistor or capacitor that is unavailable or discontinued are totally unusable, malicious and incorrect. AUDIO NOTE is currently the sole source in Europe that holds any significant range of values in stock, we use literally 1000's in production, as we were the first company to realize the tremendous benefits that Black Gate capacitors offer, and we are the only high-end audio company in the world to incorporate Black Gate capacitors consistently in our finished products. There are vendors in the audio parts that promise a guaranteed improvement when replacing practically any other part, but this is what the BLACK GATE capacitors actually do. Exchanging any electrolytic capacitor anywhere in the circuit of an amplifier or in the crossover of a speaker will greatly improve sound quality. We are working on some guidelines as to how, when and which types of Black Gates to use in different circuits; the first such technical guideline is available now and is called "Improving your CD-Player" and can be obtained by sending a stamped addressed envelope to us requesting this leaflet. All AUDIO NOTE Level 2 Signature products use Black Gate Electron Transfer in critical signal/power supply junctions.

**BLACK GATE CAPACITORS**

It is very important to note that all Black Gate capacitors take time to charge-up as well as time to be in circuit, depending on type and application this "maturing" time can be between 100 and 300 hours, Black Gate call this the "idling process" - see enclosed list of available values. We feel, however, that this process takes longer, or available!

We are about to stock the entire range of values on the enclosed list, so a separate price list is attached to the list of Black Gate programme available. Ask us to send you this list as it is too long for an advertisement or to incorporate in our standard component list, therefore it is not included in full. Again, as always, we appreciate a stamped self addressed envelope. It greatly influences the expediency this and.

**IMPORTANT NOTICE**

PLEASE NOTE, THE PRICE LIST FOR BLACK GATE CAPACITORS IS A GUIDELINE ONLY. DUE TO THE CONTINUOUS STRENGTHENING OF THE JAPANESE YEN, IT IS IMPOSSIBLE TO PRINT UP-TO-DATE PRICES MONTHLY, SO ASK FOR PRICE WHEN YOU ORDER.

Value	Voltage	BG Type	Suggested Use	Price Ex. UK Vat.
47mf	25 volt	PK	Anywhere	1.85
100mf	25 volt	PK	Anywhere	1.75
0.1mf	50 volt	PK	Anywhere	1.75
0.1mf	50 volt	PK	Anywhere	1.75
2.2mf	50 volt	PK	Anywhere	1.23
3.3mf	50 volt	PK	Anywhere	1.38
4.7mf	50 volt	PK	Anywhere	1.87
10mf	50 volt	PK	Anywhere	1.68
22mf	50 volt	PK	Anywhere	2.68
22mf	16 volt	SK-type	Anywhere	2.82
33mf	16 volt	SK-type	Anywhere	3.42
47mf	16 volt	SK-type	Anywhere	4.11
33mf	16 volt	SK-type	Anywhere	6.68
10mf	50 volt	Standard	Anywhere	2.97
4.7mf	50 volt	Standard	Anywhere	4.41
10mf	50 volt	Standard	Anywhere	4.73
100mf	50 volt	Standard	Anywhere	5.47
220mf	50 volt	Standard	Anywhere	10.41
10mf	100 volt	Standard	Anywhere	3.71

47mf	100 volt	Standard	Anywhere	6.31
100mf	100 volt	Standard	Anywhere	8.54
220mf	100 volt	Standard	Anywhere	22.18
100mf	16 volt	Standard	Anywhere	8.22
100mf	50 volt	Standard	Anywhere	24.55
220mf	16 volt	Standard	Anywhere	6.35
470mf	16 volt	Standard	Anywhere	6.35
220mf	50 volt	Standard	Anywhere	13.45
1000mf	50 volt	Standard	Anywhere	234.65
470mf	16 volt	Standard	Anywhere	14.25
47mf + 47mf	500v-550v surge	SKz-Type	PSU filter capacitor	85.95
100mf + 100mf	500v-550v surge	SKz-Type	PSU filter capacitor	101.95
100mf	500v-550v surge	SKz-Type	PSU filter capacitor	72.75
220mf + 220mf	350v-400v surge	SKz-Type	PSU filter capacitor	92.65
100mf + 100mf	350v-400v surge	SKz-Type	PSU filter capacitor	75.35
22mf	35v	VK-Type	Decoupling or filter capacitor	18.95
150mf	35v	VK-Type	PSU filter capacitor	41.23
47mf	16 volt	FK-Type	Ultra low ESR version comparable to film caps	7.15
100mf	16 volt	FK-Type	Ultra low ESR version comparable to film caps	13.71
220mf	16 volt	FK-Type	Ultra low ESR version comparable to film caps	9.95
100mf	25 volt	FK-Type	As above	14.28
220mf	25 volt	FK-Type	As above	21.43
100mf	50 volt	FK-Type	As above	15.71
100mf	50 volt	FK-Type	As above use anywhere	58.71
220mf	35 volt	FK-Type	As above use anywhere	55.71
220mf	63 volt	FK-Type	As above use anywhere	101.43
100mf	100 volt	FK-Type	As above use anywhere	32.85
2.2mf	50 volt	C-Type	For circuits with DC potential difference	2.07
4.7mf	50 volt	C-Type	For circuits with DC potential difference	3.35
6.8mf	50 volt	Bipolar	For loudspeaker crossover networks	12.65
10mf	50 volt	Bipolar	As above	18.85
22mf	50 volt	Bipolar	As above	23.95
47mf	50 volt	Bipolar	As above	36.95
100mf	50 volt	Bipolar	As above	46.65
220mf	8.3 volt	BG-N Type	For super low noise PSU's	12.35
100mf	16 volt	BG-N Type	For super low noise PSU's	24.65
470mf	16 volt	BG-N Type	As above	28.95
470mf	35 volt	BG-N Type	As above	210.45
50mf	50 volt	BG-N Type	As above	5.45
10mf	50 volt	BG-N Type	As above	6.65
10mf	50 volt	BG-N Type	As above	7.55
47mf	50 volt	BG-N Type	As above	13.75
100mf	50 volt	BG-N Type	As above	20.35
100mf	50 volt	BG-N Type	As above	99.95
220mf	100 volt	BG-N Type	As above	423.35

**UK NOTE KIT THREE Chassis, mid steel**

You have to specify when you order whether you want Chassis 2 for pre-amplifier or power amplifier use; the pre-amplifier has inputs on the top of the cover, the power amplifier has many more ventilation holes, top and side; if you want a PCB with the input sockets included with the pre-amplifier cover add £19.75 to the cost of the chassis and remember to specify this when you order. Please note that no copper pre-amplifier lid is currently available for Chassis 2. From time to time we will have more damaged or scratched chassis's if you are not bothered about the finish or general appearance or you intend to refinish the chassis anyway you can have one of these for 50% of the above price; though you should know, so acquire if this is of interest.

Chassis 1 Aluminium	Size	Price Ex. UK Vat.
Chassis 1 Aluminium	437 x 396 x 125 mm	£34.50
Chassis 2 Copper	294 x 396 x 125 mm	£99.50
Chassis 2 Copper	437 x 396 x 125 mm	£188.50
Chassis 2 Copper	294 x 396 x 125 mm	£165.00

**AUDIO NOTE COMPLETE KITS.**

As mentioned above, we are developing a range of complete kits to give those of you who have the ability, but do not have the time to develop a project from the ground up to speak, in order to be able to offer the best available quality - price relationship; the kits we offer will be good basic circuits with no-frills power supplies and components that have input volume controls to allow use of a single source, UK CD-player direct in.

**UK NOTE KIT FOUR**

Based around the justly famous 300B directly heated triode, we see the kit as the introduction to real audio Amplification, as it covers all the important aspects of design: negative Single-Ended, No-Feedback, Class A, Directly Heated Triode, to become a member of this exclusive club of amplifiers.

**UK NOTE KIT FIVE**

The KR One has 300B per channel running at 420 volts with 75mA current giving 91.0 watts of the cleanest, most musical, most powerful sound you can get. It consists of a 6SN7GT with a 5687 double triode driver stage running in SRPP. The power stage is a capacitor-choke-coupled with a 5U4HT rectifier; the heaters are AC heated. Component quality is similar to our Level 2 finished products. AUDIO NOTE paper in oil signal capacitors, Beyschlag 1 watt 1% metallfilm resistors, good quality electrolytics (except AC Black Gates) and a simple attractive stereo chassis in grey paintwork. Prototyping cover is included. Price £199.00 incl. Vat. which includes all valves (yes, also the 2 300B needed) but not postpacking which to UK customers is @12.00 top cover is £99.00 extra. The KR One is available in black.

**UK NOTE KIT TWO**

Kit Two features a simple 6550VA Sovtek tetraode running in Single-Ended mode, yielding some 17 watts of pure Class A, valve rectified HT for the output stage, stereo chassis, and 6SN7GT input and 5614A/ECC82 SRPP driver stage; component and chassis kit only. Kit Two is currently unavailable due to the lack of supply of Sovtek 6550VA's, we can offer it without valves for £570.00 incl. UK Vat. If used with Chinese 6550VA no claims for faults in power supply or output transformers will be accepted. Price £399.00 incl. Vat. Includes valves, but not postpacking, cover is extra at £99.00.

**UK NOTE KIT THREE**

Kit Three features 2 x 300B per channel running in single-ended parallel yielding 1617 watts in pure Class A, 845 litz on two mono chassis' with valve rectified HT supplies, no signal feedback, it uses a 6SN7GT double triode input valve and a pair of 5687 double triodes running in SRPP as drivers. The KIT THREE is essentially a mono version of the KIT ONE with double the power, the same component choices and all two chassis' instead of one. The KIT THREE costs £1,350.00 incl. Vat. is available now.

**UK NOTE KIT FOUR**

The KIT FOUR is really our introduction to valve amplifier kit building; circuit and power supply mounted on one simple printed circuit board, with two OTT - type push-pull output transformers all mounted in a single P1SE type chassis, covering everything, so nobody will be able to see that you have succumbed to the lure of the valve amplifier, which is swamping the world. The circuit consists of two 6V6GT tetraodes running in Push-Pull Class A, yielding about 10 watts; driver by a 6SN7GT and a ECC83 input stage. Easy to build, even for the beginner. The KIT FOUR costs £199.00 and is available from May 1995.

**PRE-AMPLIFIER KIT**

A kit based on the AUDIO NOTE MT7tube pre-amplifier circuit is under development; it will be offered in three-four versions, with the best version using cheaper valves expected cost £299.00 incl

## Richard's Audio Visual

Stockists of  
 Arcam, Audio Innovations, Audioquest, Aura,  
 Beyer, B&W, Bose, Celestion, Cyrus, Denon,  
 Marantz, Mission, Moth, Musical Fidelity,



Nakamichi, Ortofon, Pioneer, Pro-ject, Rotel,  
 Royd, Ruark, Sennheiser, Systemdek, Target,  
 Thorens, Van den Hul & more!

Expert friendly service: Listening room  
 Pioneer Reference Point  
 4 Greyfriars, Bedford

**Tel: 01234 365165**

## diverse vinyl

est 1988

12 Upper Dock Street Newport Gwent NP9 1DF  
 phone/fax 01633 259661 P&P £1.00 per order  
 A vinyl service aiming to cover the whole music spectrum  
 Catalogues available shortly

### Recent Releases

Bjork	Post	£7.90
Chemical Brothers	Exit Planet Dust	£11.50
Dire Straits	Live At The BBC	£8.90
Future Sound London	ISDN	£11.50
Gary Moore	Blues For Greeny	£8.90
Incognito	100 degrees and rising	£9.90
Marillion	Afraid Of Sunlight	£8.50
Neil Young	Mirror Ball	£9.90
Paul Brady	Spirits Colliding	£8.90
Paul Weller	Stanley Road	£8.50
Pink Floyd	Pulse-4lp set (expected 10/7)	£37.90
PJ Harvey	To Bring You MY Love	£8.90
Reef	Replenish	£9.90
Rod Stewart	Spanner In The Works	£9.90
Teenage Fanclub	Grand Prix	£7.90
Therapy	Infemal Love	£8.90
Tindersticks	2nd Album	£9.90
Van Morrison	Days Like This	£8.90
Zion Train	Home Grown fantasy	£7.90

### Stock Selection

Buffalo Springfield	Anthology (2lp German)	£17.90
Captain Beefheart	Clear Spot	£8.90
Crædance Clearwater	Cosmos Factory	£7.50
Rycooder	Paris Texas	£6.50
Elvis Costello	Armed Forces	£7.50
Leonard Cohen	Song Of	£8.90
Doors	In Concert (3lp German)	£29.50
Bob Dylan	Bootleg Series 5lp set	£25.00
David Gilmour	David Gilmour	£8.90
Genesis	Lamb Lies Down	£17.50
Rolling Stones	Let It Bleed/Aftermath (US)	£10.90
Smiths	Queen Is Dead 10"	£8.50
Bruce Springsteen	Born To Run	£8.30
Television	Marquee Moon	£5.90
Tom Waits	Blue Valentine	£9.90
Neil Young	Zuma	£9.30
Mary Chapin Carpenter	Come On Come On	£9.90
Al Green	Lets Stay Together/green lp	£9.90
Issac Hayes	Shaft 2lp	£11.50
Otis Redding	Otis Blue	£6.50
<b>Labels</b>		
ECM	Lots Available ask for list	£10.50
Blue Note	UK reissues and some Jap	
Impulse-Coltrane	Gatefold Reissues - 3 titles	£14.90

## THE RECORD SHOP

42 FIFE ROAD  
 KINGSTON-UPON-  
 THAMES  
 SURREY  
 KT1 1SU  
 TEL: 0181-546 3880  
 FAX: 01372 360996  
 EST. 1968

SPECIALIST IN NEW VINYL  
 RECORDS

### PLEASE NOTE CHANGE OF ADDRESS

- Neil Young - Mirror Ball 13.99  
 (2 LP set from the main man, featuring Pearl Jam)  
 Various - Verve Talking, Roots of Jazz 11.99  
 (2 LP - 27 tracks with Wes Montgomery, Donald Byrd,  
 Jimmy Smith, Milt Jackson, Cal Tjader, Stan Getz ....)  
 Van Morrison - Days Like These 9.99  
 (Brand new album, Bit of a Stunner!)  
 Bjork - Post 9.49  
 (Long awaited 2nd LP, and worth it too, from what we have  
 heard so far)  
 Bon Jovi - These Days 11.49  
 (2 LP all brand new staff!)  
 Primus - Take From The Punch Bowl 10.49  
 (new album from San Francisco's finest wacky 3 Piece.  
 Martin's favourite LP at the moment)  
 Dusty Springfield - A Very Fine Love 11.49  
 Soul Asylum - Let Your Dim Light Shine 11.49  
 Michael Jackson - History 21.49  
 (3 LPs, 15 old tracks, 15 new tracks)  
 Pink Floyd - Pulse 39.99  
 (4 LP set from recent tour. Extra track on the vinyl  
 (We Still Think!) + Book. Will finally see light of the  
 day mid-July)

### A FEW YOU MIGHT HAVE MISSED

- Blur - Leisure 6.99  
 Blur - Parklife 9.99  
 Blur - Modern Life Is Rubbish 9.99  
 Pulp - His 'n' Hers 9.99  
 Radiohead - The Bends 9.99  
 Oasis - Definitely Maybe (2 LP) - 10.49  
 Boo Radleys - Wake Up! 9.49  
 Elastica - Elastica 8.99  
 Super Grass - I Should Coco 9.99

### BACK IN STOCK

- Jay Hawks - Tomorrow The Green Grass 10.99  
 Victoria Williams - Loose 10.49  
 (One of the finest album of last year)  
 Esquivle - Space-Age Bachelor Pad Music 10.99  
 (U.S. Import, mega big cheese LP - Volume II  
 Expected soon - Reaches the parts of your Hi-Fi that other  
 records just don't reach!)

Mary Coughlin - Love For Sale 8.99

### Blue Note Connoisseur series @ 9.99

- Ike Quebec - Heavy Soul  
 Lee Morgan - Lee Way  
 Grant Green - Green Street  
 Grachan Moncur III - Some Other Stuff  
 Jackie Mclean - Destination Out!  
 Basra - Pete La Roca

### POSTAGE & PACKING

- Single Album £2.00 +50p for subsequent Album(s)  
 Double Album £2.50 +£1.00 for subsequent Album(s)  
 THEREAFTER, WE DON'T SKIMP ON THE PACKING - AND ALL LPS  
 ARE POSTED WITH POLY-LINED INNER SLEEVES

SO PICK UP THE PHONE AND ASK FOR TIM OR MARTIN  
 (SECOND HAND VINYL ALSO AVAILABLE)

**ACCESS/VISA WELCOME**



## Vacuum Tubes for Audio Are Back!

*Glass Audio* brings together yesterday's tube with today's improved components, voltage control, and the exciting new Soviet tubes, to make smooth sound in your livingroom possible again!

# YES!

Please send my first issue of *Glass Audio*. I'll pay just \$45.00 for six issues (1 year); \$80.00 for 12 issues (2 years) of the best information on tubes to be found anywhere. I understand that my satisfaction is guaranteed!

Name \_\_\_\_\_

Street & Number \_\_\_\_\_

City \_\_\_\_\_ Postal Code \_\_\_\_\_

Country \_\_\_\_\_ REMIT IN US \$ DRAWN ON A US BANK ONLY. PRICE GOOD THROUGH DECEMBER 31, 1995.

We Accept MC/VISA.

## Glass Audio

PO Box 176, Dept. HFWS, Peterborough, NH 03458-0176 USA  
Phone: (603) 924-9464 or FAX 24 hours a day (603) 924-9467

## IMMORTAL COILS

ACTIVE CROSSOVER CONVERSIONS

UPGRADES & MODIFICATION inc.  
BI/TRI WIRING

MOST LOUDSPEAKERS CATERED FOR

31 St. Johns Close, Needingworth,  
Huntingdon, Cambs, PE17 3TT

**0 1 4 8 0 4 9 7 7 3 0**

## Audio Physics

PROFESSIONAL DESIGNERS AND SUPPLIERS OF  
COST EFFECTIVE UPGRADE SERVICES INCLUDING:

- The CLEANLINE range of modifications to Naim Hi Cap and Snaps power supplies. Also an expanding range of upgrades to most other high quality audio equipment. e.g. better power supplies, precision clocking.
- COMPUTER AIDED DESIGN service for your special requirements. eg active crossovers, passive pre-amps.
- A build & test service for your kits, prototypes and one offs. Specialists in the IMP LOUDSPEAKER TESTING KIT.

Call Geoff Mead on 01895 637846 for details

# Audiophonics

1995

3 Meldone Close, Surbiton,  
Surrey KT5 9HQ, England.

Email: info@apnix.demon.co.uk

Tel ++(0)181 390 6480

'C' Series:  
Phase Coherent  
Point Source  
Spheroidal  
Loudspeakers  
in Marble.

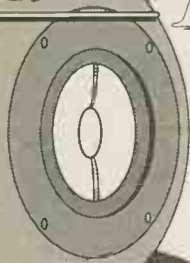

The 'C' loudspeakers have a clarity and detail normally only associated with electrostatics. The 200 mm dia. nonresonant enclosure is carved from a single stone block & specially shaped to minimise diffraction distortion. The 50 mm metal cone driver covers 100 Hz to 22 KHz.

### Loudspeakers.

CA50. Sphere - 30W @ 8 ohms.

FBX150. Bass - 200W @ 4 ohms.

(Bass extension with a pair of 150 mm metal cone drivers. Stone plinth and top.)

Please send this coupon for further details.

Name: .....

Address: .....

.....

.....

.....Post Code.....

Tel..... 9506

*The Art of Sound Reproduction.*

# WE'VE ONLY JUST BEGUN

**AUDIO**Alchemy

**A**udio Alchemy is renowned for its low cost high performance products. Audio Alchemy has in the past redefined high-end sound quality at the lowest possible price. Our new model program began with DAC-IN-THE-BOX, which is the world's most affordable high performance D to A Converter. Over the next twelve months we will be launching our new and innovative products, which will immediately establish themselves as best in class.



DAC-IN-THE-BOX is the most cost effective upgrade to improve the sound quality of your CD Player.

- ▶ Two Digital inputs - Coaxial and Optical.
- ▶ Auto Switching for inputs.
- ▶ Comes complete with a separate high current Power Station One power supply.



The Data Stream Transceiver is the world's first all powered digital Interconnect system. A new level of performance is now available to anyone that has a separate transport and DAC.

- ▶ Includes separate send and receive modules with external power supply.
- ▶ Dual inputs coaxial and Toslink.



The Audio Alchemy Digital Line Controller is the company's first full Remote Control Line Level Pre Amplifier. The DLC can be easily expanded to work with any and all future audio/video components.

- ▶ Volume and balance control via Remote Control.
- ▶ Front mounted dual seven segment LED display, calibrated in decibels
- ▶ Four line inputs, upgradable for future video switching.
- ▶ Comes complete with a separate high current Power Station One power supply.

Please send information on your Audio Alchemy products to:

**PATH**  
*Premier*

Path Premier, unit 2, Desborough Industrial Park,  
Desborough Park Road, High Wycombe, Bucks. HP12 3BG.  
Tel: 0494 441736, Fax: 0494 461209

# Classified Ads

For details on how to place a Classified Advertisement, please see page 146

FOR SALE SD ACOUSTICS SD1 Mk2. Very good condition £650 o.n.o. Tel: 0121 622 2230 or 0121 692 1359, from 10.00 – 6.00.

AUDIOLAB 8000A amplifier, bought January 1994 60 w.p.c., perfect working order, unmarked case, £300.00. Tel: 01246 419269 (Chesterford).

NAIM SBLs, EXCELLENT condition, £1,000; 72 Pre-amp, £400; Flatcap, brand new, £280; Mana Reference table, £250; Linn LP12, Aro, Dynavector XXII, offers. Tel: (01234) 341943, evenings, weekends.

KEF 107s MINT CONDITION; superb sound. New (£3,999) bargain at £2,000, with boxes. Musical Fidelity P270.2 and MVT mint both £1,600, with boxes. Tel: 01703 511038 (after 5pm); 01703 766856.

MICHELL SYNCRO, Alphason Xenon tonearm, Audio Technica ATF5. Le Cartridge. Fully boxed with spares, absolutely mint £295. Alphason HR1005 tonearm. Boxed, mint condition £195. Tel: 01642-246939 (Giles).

NAIM NAC72, NAP140 new style Hi-Cap power supply mint, boxed with heads £1,100 o.n.o. Tel: 0181 508 8932

RELUCTANT SALE: LFD LS2 pre-amplifier (£1,599) £695 o.n.o. LFD PA2 power amplifier (£1,599) £695 o.n.o. Both £1,200 in V.G.C. Spondor SP20 speakers mint £279 o.n.o. Other equipment, enquire John (01603) 38752.

TANDBERG 2060L receiver TCD440A cassette deck, TD20A reel-to-reel with numerous tapes (some unused), pair of Shure Unidyn B microphones. £650. Tandberg C.D. player 3015A £300. Mayware Unipivot tonearm £25. Everything mint and boxed. Tel: 01482 666313.

LINN LP12 (BLACK), Valhalla, Iittok LVII, AT03 MC cartridge, spare Asak 45 adaptor, mint all boxed £550 – Arcam Alpha 'Five' tuner 8 months old, under warranty mint, boxed £150. Tel: 01782 774321

MERIDIAN 203 DAC7 converter mint, boxed. £235. XLO digital cable (transport to DAC) (thrashes Video Z) half metre, gold plugs. £45. Tel: John (01865) 862745.

MERIDIAN MCA1 component amplifier (CD tape, MM MC 35 wpc), 2 x MPA1 power amplifiers – 200 wpc. £650. Also available Yamaha RX300 receiver, Technics SL7 turntable. Offers? Oxon Tel: (01869) 277525.

REVOX B77 – £500, B750 amp – £250, B760 tuner – £450 mint condition with manuals, take £1,100 the lot including Revox stacker unit. Sansui AU-999 70+70W rms amp £250, Sansui TU-7700 tuner £150, Pioneer CT-F1000 3 head cassette deck £250 Tannoy Arden speakers (15" concentric drive units) resplendent! £650. Tel: 01483 725643 (Woking).

EXPOSURE VI/VII/Super VIII amps £500. Naim 42.5/110 amps, Linn Kans, stands, Chord cables £425. DPA PDM1 Series2 DAC £225. Arcam Alpha CD £185. All excellent condition. Tel: 01206 272314.

FOR SALE. P.S. AUDIO 4.6 preamp £625. Audio Technica OC 30 cartridge £150. Omega turntable with Omega Point One arm and Accuphase AC2 cartridge £800. Omega Point Two arm £300. Decca London Gold and Silver cartridges £50 each. Tel: 01342 712653 / 0181 399 6308.

MUSICAL FIDELITY CDT valve CD player as new, boxed £385. Cartridges. ATOCS £60, AT24 £50, Ortofon MC10 Super £20, all VGC. Pair Musical Fidelity MC2 speakers, modified £80. Pair JWS speakers £50. Tel: 01474 704382 (N. Kent).

EXPOSURE VII PRE-AMP, VI power supply and IV power amp, plus all Exposure interconnects. Old style cases hence only £500 the lot. Tel: 01942 818752.

PETER SANHEN, PS AUDIO 1.5 pre-amplifier. Very rare (only 30 manufactured) but highly regarded by reviewers. Unusual design concepts. Complete with MC phono stage, in excellent condition. Cost new £2,350, will accept £1,100. Tel: 0181 291 1744.

ARCAM DELTA transport and Black Box 2, as new condition with Sorbothane feet: £325. Tel: 01224 589471 after 6pm.

LINN KAN MKII speakers (Black) with Atacama SE24 stands. Excellent condition demonstration possible. £200.00. No offers. Tel: 0171-606 0888 or 0181-665 6183.

MARANTZ CLASS A monoblock power amplifiers with Marantz SC22 matching pre-amp. Boxed as new. Fantastic mid range. See Ken Kessler review. New cost £3,000. Sacrifice at £1,500. Tel: 01633 400546.

GARRARD 301 ON PLINTH, SME 3009 fixed, Shure M95, £140. Tequipment Double Beam Oscilloscope, Model D43, valve, £120. Rogers early valve amp, mono, pre-amp, £30. Tel: 01843-832926, (Margate).

YAMAHA NS-1000 monitor loudspeakers, black finish. Including three column Target stands, mint condition £450.00. Tel: 01502-563750 (Suffolk).

QUAD ESL-63 electrostatic loudspeakers. Wanted privately. Tel: 01643 821137.

ARCAM DELTA 290 integrated amplifier. One year old, box and instructions, V.G.C., upgrade forces sale. £295 o.n.o. Tel: 01494-762055 (Bucks).

ENTHUSIASTS CLEAROUT! Rare valve amps from Leak (various), Lowther, Pye, Quad etc. Quad ELS, Spondor BC1s. Thorens TD125. AVO 160 valve tester. Various valves (including unused GEC KT88). For details: 01364 72153.

IMPLUSE H6 SPEAKERS as new, £950 ono. Koetsu Rosewood cartridge (older long-bodied model) £150. Audio Technica ATOCS MC cartridge (light use) £65. Cranfield Rock Turntable – offers. Ring 0181-989 6434 or work 0171-412 7410.

LEAK TROUGHLINE stereo tuner for sale £120. Leak Troughline FM3 mono tuner (easily converted) for sale £95. Goldring GL75 Transcription deck with arm and Shure M75 cartridge £35. Tel: 01705 358502.

PIONEER PD95 – mint condition – top end of CD player £1,400 ono. Evenings 0202 510304.

ROCK TURNTABLE. Excalibur arm, plinth/lid, excellent, boxed, demonstrated, £850 ono. Decca Garrott cartridge, believed unused, may be examined under microscope, £175 ono. Ideal vinyl revival combination! Tel: (01728) 685633 (Suffolk, delivery possible).

ARCAM ALPHA and CD player. Boxed. Excellent condition. £200 ono. Alan 01737-556631 day; 01306-888527 evenings.

LINN ARKIV cartridge. Supplied/fitted by Grahams. Approx. 500 hours use; perfect. Genuine reason for sale; up-graded. £200. Tel: 0181-546 4768 after 7pm.

LEAK TL25 plus amplifiers £100 the pair; Leak Troughline stereo tuner £130; Armstrong integrated valve stereo amplifier Model 222 £50. Tel: 01702 202556.

APOGEE DIVAS (list £12,980) £3,850. Krell KRS200 Amps four 200 watts Class 'A' mono-blocks (list £12,000 each) £4,250 each or £15,000 all 4; KRS pre-amp 6 components (list £11,500) £3,950; Krell MDI CD (list £6,500) £2,500; Krell 64 SBP Reference DAC (list £9,900) £3,500. All mint/ unblemished and little used with original packing etc. Tel: 0945 63077.

AUDIOLAB 8000A MKII amplifier 1994 Model, superb sound and condition, boxed as new £300.00. Tel: Worthing 01903 205994 after 5.30pm.

FOR SALE: LINN LP12 (black)/Iittok LVIII (arm)/Karma (cartridge)/Nexus (loudspeakers) on stands (grey). 1988 spec. used for less than 10 hours (honest). Quick sale at £900. Buyer collects. London 0171-607 4642 between 6-10 pm please.

LOWTHER BICOR 200/2 horn speakers, mint condition, mahogany. £475. Audio Innovations series 1000 valve monoblocks, new £1,500 accept £875. Kudos S100 stands, new £300 accept £100 Tel: 01432 275203.

ACCUPHASE, ACCUPHASE! Yes Accuphase! Accuphase power amplifier (Pss), Accuphase pre-amplifier (C200), and Leak TL12+s for sale. Serious offers invited. No dealers please! Contact Tim 0171-205 2329.

QUAD FM4 £225 Denon DL304 MC cartridge, one year's careful use £75. Tel: Cheltenham 01242 231766.

SPENDOR BCI new reflex ports and binding post £250 o.n.o. Heybrook HBI £150. ProAc Studio 1 Mk2 £375. Rogers LS5 £115. KEF Carltons (floorstanding) £150. Tel: 0634 377339.

MUSICAL FIDELITY MC2 (Mk1) speakers plus stands £200. Leak Troughline 3 stereo tuner, serviced and new decoder by GT Audio £190. Leak Delta tuner £50. Tel: 0181-521 3239 evenings.

ART AUDIO VPI valve pre-amp. Only 180 hours use. £230 for quick sale. Two 3 metre lengths origin live speaker cable. Rather cumbersome £35. Tel: 0181-203 2120.

QUAD ESL loudspeakers, black grille, boxed, serviced £375. TEAC compact disc player – VRDS-10 £500. AVI S2000 MD D.A.C. £350 ono. AVI S2000 MP pre amp £475 ono. Tel: St. Albans 01727 835625.

RADFORD STA 15 requires attention to one channel £135. Radford SC2 valve pre-amp £65. Exposure 7 pre-amp and power supply £150. Van den Hul MCI cartridge, little used £250. Tel: 01252 311266 (Surrey).

ACOUSTAT SPECTRA 1100 electrostatic hybrids. Excellent sound. Cost £1,300, sell £500. Mod Squad Line Drive, high quality, passive £200. Serious enquiries only please. Tel: 01843 584030 (Thawet) after 6pm.

PAIR ORIGINAL "Williamson" triode valve amps. Old and very ugly but rebuilt with Holco resistors and Sidereal capacitors £425. Tatty pair Quad Electrostatic speakers £150. Tel: 01903 715191.

MERIDIAN M3 Active speakers, in walnut with Meridian 101 pre-amp. Excellent condition R425. Tel: 01432 265768 (day) 01568 797394 (evenings/weekends).

ENTHUSIAST'S CLEAROUT – Marantz CD63SE; Rogers LS7 speakers; Target HJ15 stands; Mission PCM II; Mission DAD 7000R; Technics SL7 deck; NAD one speakers; AKAI SSI Quadrophonic decoder; Dual CS505, plus other items. Tel: 0121-350 9230.

OFFERS WANTED for Technics – stereo cassette deck 671, tuner ST 9600; integrated amp SU 6600; D Drive turntable SL 1310; speakers SB 6000. All in black. Tel: (01292) 264152.

ROKSAN XERXES, fitted with Tabriz "Zi" tonearm and Linn K18. XPS 2 power supply. Recently serviced and updated with new Blobs. Finished in black and fully boxed, £500. Tel: 01977 552813

CADENCE VALVE pre-amp, MC and MM phono inputs, CD, tuner and AV inputs, excellent condition, £400 ono. Tel: 01264 361778

NAKAMICHI 1000 ZXL recorder £1,900, also a 6822X £350. Selection of valve amps, Leak, Roger, Quad, Radford, B.T.H. Revox, Fisher. Leak tuners. B & W DM2a DM3. Rogers LS/35A speakers. Tel: 01903 239980.

REVOX EVOLUTION system, amp, tuner, CD player, very futuristic looking, fantastic sound. Pair Royd Minstrel speakers, Oppolo stand, Van den Hul cables, in excellent condition. £1,200 o.n.o. Tel 0945 63856 (Cams.)

# Windsor

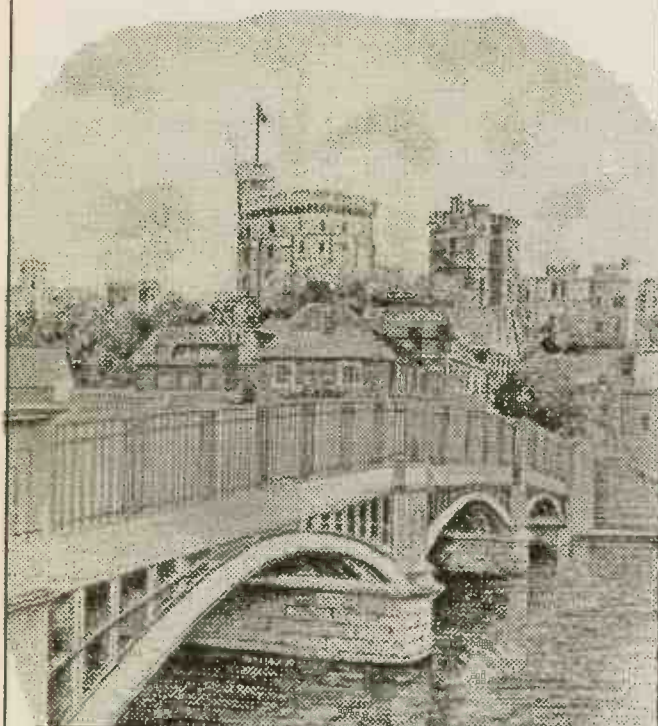

## Sale of Ex-Display and Demonstration HiFi equipment

Model	was	Now
Audiolab 8000A Amp	480	379
Audiolab 8000C Preamp	460	379
Epos ES11 + Stands	550	399
JPW AP2 Spkrs	200	139
Denon DRM 710 Tape	260	189
Denon 1290 CD	330	219
Pioneer A300X Amp	229	149
Rotel 920 Amp	150	89
Marantz CD52 2SE	300	189
Shahinian ARC Speakers	1675	995
Shahinian Obelisk	2490	1595
Pioneer Impresso Mini	750	595

### ALSO

Rotel 965 CD Player	300	229
Sony S505ES Tuner	250	189
Sony 611 Cassette	300	249
Mission 780SE	240	189
Rotel 930 Tuner	175	139
Naim SBL	1708	P.O.A

## RADFORDS

*Sound Advice · Perfect Vision*

43 King Edward Court, Windsor.

**Tel 01753 856931**

## #1-77 SHACK

Your equipment wanted!

**BEST PRICES PAID!**

Tel/Fax. 0181- 255 0274

Trilogy Monoblocks	mint	£1995	Kef 105/3	new	£1350
Lumley 120s	ex-dem	£1995	Lumley LM21	ex-dem	£1999
Lumley ST70	ex-dem	£1550	Linn Isobariks active crossover	vgc	£1350
Second Audios	mint	£1799	Conrad Johnson PV10	ex-dem	£999
Audio Note Meishu	ex-dem	£1995	Counterpoint DAII	ex-dem	£1350
Audion 300B Monos	mint	£1550	Naim CDI	mint	£1150
Copland CSA14	mint	£699	Audiomeca Mephisto	ex-dem	£1800
Muse 100	ex-dem	£999	Audiomeca Kreatura	ex-dem	£999
Deltac 50s power amps			YBA CD2	ex-dem	£1899
pre and phono stage	vgc	£1200	Teac VRDS10	mint	£550
Krell KSA100	mint	£1495	Micromega Duo Pro	ex-dem	£1250
YBA3 Power	ex-dem	£899	Theta Data Basic	mint	£1700
Triangle Alion	ex-dem	£699	Teac P1	vgc	£1350
Kelvin Labs M60 Monos	vgc	£799	Counterpoint DA10		
Exposure 17	mint	£450	UA Chip	ex-dem	£2250
Exposure 18	mint	£450	Pink Triangle Ordinal	mint	£650
Mark Levinson 27.5	mint	£3500	Audio Note DAC2	ex-dem	£799
Mark Levinson 28	mint	£2400	AudioPlan Kontrast	mint	£1250
YBA Pre2	ex-dem	£999	Grant G200	S/H	£1495
Audio Innovations L2	mint	£450	Audio Research D200	mint	£1750
Sonus Faber Electa	mint	£1200	Audio Research SP14	mint	£1750
Sonus Faber Amators	mint	£1699	Roksan Pre/Power		£1450
Impulse H2	ex-dem	£1699	Counterpoint SA3000	S/H	£999
Impulse H6	ex-dem	£899	DNM 3B	S/H	£750
Triangle Scalens	ex-dem	£499	PS Audio Lambada	mint	£1650
Triangle Alicante	ex-dem	£699	PS Audio Ultralink		£1350
Triangle Titus	ex-dem	£150	Audiomeca J1		£1400
Krell KSA200	vgc	£2150	Audiomeca J1 SL5		£1700
Quad ESL63	mint	£1499	Burmester 838		£750
SD1	new	£1250	Exposure Monoblocks	S/H	£799
Mirage MS1s	new	£4450	Audio Research LS3	mint	£1250
SD5	new	£999			

**THE APEX 100 SERIES SOUND EXPERIENCE**



**FEATURING**  
**PASSIVE CROSSOVERS**  
**ACTIVE CROSSOVERS**  
**ALUMINIUM CONES**  
**WOOD VENEERS**  
**OFC CABLING**  
**STANDS**

**Q.T.A. SYSTEMS**  
 2 WHEATSHEAF WAY · LINTON  
 CAMBRIDGESHIRE · CB1 6XB  
 TEL: 01223 891091

WANTED: AUDIOLAB 8000C + P. Tel: John 0191-266 2292 work; 0191-265 3353 home.

NAIM NAPI 60 + Cerafines NAC32 + P.S.U. £395, Epos ES14, Spondor B.C1, Audioplan Konzept, 92dB designed for valves! Revox G36 half track, high speed, Thorens TD124II, Meridian 206D.S., ADI.S.E. Valve monoblocks. Tel: 01642 559543.

SPENDOR SPI/2 six months old £750 or exchange for Magnepan SMGB speakers, Leak Stereo 20 amp £200. Sony CDP103 CD player £100. Phone 0181-531 5979.

KEF Q60 Uni-Q loudspeakers, 2 years remaining on warranty, £250. DPA PDMI series 2 DAC, £190 ono. Atacama SE20 sand-filled speaker stands (20-inch), £40. All boxed/as new. Tel: 01279-416041 (answerphone).

MUSICAL FIDELITY MX pre-amp, external PSU, mint, boxed £550 (£1,500 new) P270 power amplifier, mint, boxed £695 (£1,500 new). May P/EX with American pre-power amplifiers. Tel: (01449) 676335.

MARANTZ CD85, QED Opto Digit, DAC, quality leads. Excellent £250.00. Linn Klyde cartridge £250.00. Linn Trampolin, base board £50.00. Tonestand, T/table, CD table £40.00. Tel: 01502 714730. Suffolk.

LINN LP12 ITTOK arm Audio Technica OC30 cartridge. Cirkused immaculate condition £600. Equinox moving coil head amp cost new £900, £290 immaculate. Tel: 0116 2813534 evenings; 0116 2780936 day (Leicester).

MAGNEPLANAR SMGA-LE. Superb condition in light oak. Original packing. Can deliver £375 ono. Wanted Quad 405II x four B+W Matrix 801 (latest spec., not Black Ash). Tel: 01423 521303.

MAGNERPLANAR I.4 panel speakers, 14 months old £1,200 new, bargain £600. KEF 103/4 speakers, 5 months old £1,200 new, bargain £900. Phone Luton 0582 582540; evenings 0582 582 540.

MERIDIAN 200 transport with Trichord Clock modification. Very good condition. £300. Tel: 01592 772806 (Fife).

GARRARD 401 plus instruction manual and template, plinth, cover, Audio-Technica 1005 II arm £85. Goodmans max amp tuner £20. Tel: 01933-312919 (Northants).

NAIM 72 PRE AMPLIFIER mint condition and boxed £395.00. Linn K400 speaker cable - 2 x 7 metre lengths £80.00. Tel: 01275-543447 after 6pm (Bristol area).

OUTSTANDING ION NEXUS active system comprising of four mono power amps, SPI pre amp, X-PAK 2 power supply, JCI active speakers with stands, including Linn cable, Isolda interconnects. £1,500 (originally over £4,000). Roksan Xerxes latest spec., Kuzma Stogi arm, ATOC9 cartridge plus Roksan table. All as new £800. Telford 01952 502097.

TEAC A7300RX 7.5/15 ips reel-reel 2-track master recorder and many accessories, as new. Ideal for high quality analogue rec/playback, or live recording using integral mixing desk and optional dbx noise reduction system. Phone for full details. Also Roxan Corus Black, little used £45 ono. Tel: 01624-673396.

NAIM 72/180 £1,200. LP12/Pink Linnk/Ittok/Clyde £1,000. EPOS ES14 £350 will part ex for: old style Naim pre power. Rega 3/Dunlop. Epos ES II. Tel: 0226 764749.

HARMAN-KARDON 6800 amplifier. Three years old. £375 (cost £800). Denon 101 M.C. cartridge. £50. (As new). Cosmocho 78 pick-up (takes Thorns). £10. Tel: 01249 812565.

ROGERS STUDIO 3, Walnut, boxed and mint (£500) £330 ovno. Pioneer car equaliser, EQ6010, Din (£200) £120 ovno. Also boxed and mint. Call Phil 01208 75376 (Cornwall).

WANTED: PRIVATE BUYER requires pair of Tannoy Monitor Gold Lancasters. Must be good condition. Also require Fidelity Research concern for Garrard 401. Tel: 01883 723317 (Surrey).

QUAD ESL 63s, under four years old, very light use, black, boxed and in absolutely mint condition - £1,495. Tel: 01252 844248 (Hampshire).

TEAC P500 transport, Quad 306 power amps x 2, TDL Studio 1s plus stands, Mission Isoplat. All in VGC. £1,100 ono. Tel: 01752 350528 evenings.

ARCAM DELTA 170/3 C.D. transport/Black Box 5 Combination with Sync lock facility inc. Audioquest Video Z cable) £575. Tara Labs. Quantum C.D. £25. Interconnect cable MTR. £25. Tel: Malcolm 0483 275389.

EXPOSURE MONO-BLOCKS VIII Reg. Available through up-grade. Superb dynamics, versatile "Sound for all seasons". Good condition, boxed. £750 ono. Tel: 0181-341 7037 evenings.

LEAK TL12 POINT I wanted by enthusiast. Domestic, open frame transformer type. Must be in good working order. Decent price paid for right one. Tel: 01643 702739. Ask for Steve.

LUMLEY REFERENCE M120 valve mono-block amps, 15 months old, mint condition, cost new £3,200, quick sale £1,450 o.n.o. Audio Alchemy, DDT VI.1 (transport), DDC VI.1 (D.A.C.), with extended digital processor, digital transmission interface, power station 2, transport Trichord clock modification, one year old cost £2,200.00 quick sale £1,095.00 o.n.o.. Please phone 0181-574 2961.

FOR SALE: SONY MDR 1000 headphones, mint. Cost £180, now £110. Phone: 01772 315723.

ALPHASON HR 100 MCS tonearm £550 new; 14 months old £300.00. Can demonstrate on Garrard 401. Tel: 0121-357 6533 after 6.00pm. Tel: 0121-446 4545 ext. 3272 work. Mike.

MITCHELL GYRODEC wanted. For Sale: Leak Stereo 50, gold plated valve holders, Holco and Kimbers fitted. All internal wiring solid silver £450. Garrard 401 £90. Tel: Alan 01661 852874.

NAIM AUDIO NAIT 2, mint condition, limited edition. £230.00 o.n.o. Tel: (01222) 700208 (Cardiff) after 6pm.

AUDIO INNOVATIONS Second Audio triodes £1,500, L2 line pre-amp £500, Impluse H2 speakers light oak £1,400, Rel Stadium subwoofer £500, Mana Reference table £150, Target four shelf rack £50, Target two shelf wall support £25. All perfect and boxed. Tel: 01425 470907 Ringwood, Hants.

TANNOY BERKLEYS 15" Dual Concentric speakers fitted with Tannoy Synchronise. £450. No offers. Rotel RCD 865 C.D. player £95. Tel: 01342 843149.

NETCALC SOFTWARE £50, 4mH (10A?) Choke £5, pairs KEF B200A, DN13, T27A £50, B200G, T33A £50, ILP 20W Class 'A' Modules £30, Audax HM13OCO £40, TW 025M0 £30. Tel: 01895 633486.

ONE PAIR of REGA Kyte loudspeakers, six months old, excellent condition, lifetime guarantee, boxed £170.00 ono. Tel: 01403 253873.

EMPIRE 2000 OR 4000 Series M.M. cartridge wanted - stylus unimportant. Phone Warrington 01925-659744.

QUAD FM3/33/303. Boxed, with circuit diagrams and manuals. All in excellent condition. Can demonstrate. £225. Tel: 01359-242513.

PIONEER A400 £145. Linn Axis - Basik Plus - K9 £225. Philips remote C.D. 850 £50. Aiwa ADF 360 cassette £25. All in excellent condition. East Sussex. Tel: 01797 253073.

QUAD II and 22 amp. Just re-valved and serviced recently, excellent condition, £360. Scott C222 valve amp. £250. Wanted!! Wanted!! 2 X Goodmans Axiom 300 (pay £250), 2X Axiom 400 (pay £280), 2X Lowther PM4A (pay £480), Partridge output transformers. Tel: (0191) 4778213 after 6pm.

MILLENIUM 30 watt ultralinear valve amplifiers, monoblocs £175 each, stereo (single Chassis), up-rated power supply, LC smoothing, £400. Williamson 30 watt monoblocs, KT88s, Sowter transformers, £225 each. Tel: 0181-427 1378 (Harrow).

AUDIO INNOVATIONS 500 integrated valve amplifier 25 w.p.c. Perfect. Few months old only, up-grading to monoblocks. Cost £1,000, £500 o.n.o. Thomas: 01582 765871.

WANTED: MARANTZ C.D. 94, Sony ES. 337/338/555/+ matching E.S. tuner. Any Naim or Quad equipment Gyrodec/L.P.12 and any good quality arm. Tel: 0114 248 6493

TDL STUDIO 3 transmission lines with TDL frame stands, in walnut, £750. Denon POA 6600 monoblocks, 250wpc, £650. Together £1,300. All in excellent condition. Tel: 01296 24903 (evenings) 01494 545253 (work). Aylesbury.

ACOUSTIC ENERGY AE3 with dedicated AE stands £750, Albarry M1008 Mk 2 mono-blocks with AP4 pre-amplifier, latest grey finish and spec. £750 no offers or timewasters. York: 01904-763157.

LINN. 280S/SPARKS and Aktiv crossover for Isobariks wanted. Phone Arnold Johannesburg, South Africa. (01027) 11-4215843 day, (01027) 11-8222638 eve. Fax (01027) 11-4213632. Payment and shipping no problem.

ACOUSTIC ENERGY AE2 speakers - externally bonded to plate glass and wrapped in lead sheet (removable) £350. REL Strata sub-woofer - externally bonded to plate glass £200. Can be auctioned but due to weight buyer must collect. Tel: 01834 812963 - West Wales.

NAIM NAC72 PREAMP, immaculate, boxed, as new, with input boards for CD player and Troika cartridge, £375. Can deliver UK. Upgrading to NAC52! Wanted: Hi Cap. Tel: 01734 771130 Day/Even.

ARCAM DELTA 170/3 and Black Box 5 £500. Meridian 200 transport and Mission DAC 7 £650. Rega ELA loudspeakers £330. EPOS ES14 and stands £275. Marantz CD 63 sealed box £185. Possible P/EX. Telford: 01952 502097.

PINK TRIANGLE Da Capo with DC battery power supply. Mint condition 19 months old. £2,130 (new (£3,150) may consider splitting. Tel: 01284 769985 (Suffolk).

QUAD 34, MINT CONDITION, boxed, £195. Quad 306, mint condition, boxed £175. Linn Nexus loudspeakers, Linn stands, Cable Talk 3 bi-wire cable, mint condition £275. Tel: (01295) 250 000.

NAIM NAXO 3/6 active crossover. New style case. £250.00. Phone Mike: 01895 440602, Mobile: 0860 155521.

SONUS FABER MINUETTOS, mint £725, Fidelity Research FRI MK2 cartridge £30, Quad storage rack (grey) for 66 series £30. Tel: 01603 714528 evenings, before 9.30pm.

MERIDIAN 601 DSP pre amp. Meridian 602 transport C.D. Meridian 605 mono amps. All mint condition with remote £3,750.00 the lot. Tel: 01527 543442.

LINN SONDEK LP12, Basik arm, A.T. headshell and A&R P77 cartridge. Rosewood finish with black smoke lid £250 ono. Tel: 01332 834339.

NAIM/LINN Buy/Sell: 52, CDS, 250, 135, 140, ARO etc. Tel: Bob 0382 819732.

AUDIO TECHNICA OC9 cartridges. Brand new guaranteed £180.00 Naim 42.5 NAP90 £450. Heybrook HBI MKIII mint, boxed etc. £180.00 Deltec DPA 50s mint condition £530.00 ono. Wanted: Cyrus 2 PSX. Cyrus tuner. Tel: Jules on 01792 280061.

we've produced  
 naturally musical loudspeakers  
 which have been  
 critically acclaimed

**S Y S T Y M**  
 LOUDSPEAKERS

So what turns the critics on ?

The answer is simple. The ability of Hi-fi products to reproduce any musical event. That's the already established reputation of successive SYSTYM products, including our award winning SYSTEMDEK turntables. In loudspeakers it means carefully selected drive units, in combination with precision acoustic design to produce the basic SYSTYM criteria, then on to seemingly endless auditioning and fine tuning for listening perfection. The result ensures a detailed and precise natural soundstage and it is little wonder that the music is so real and that the critics climb aboard.

for further details contact

SYSTEMDEK LTD 34 KYLE ROAD IRVINE SCOTLAND KA12 8LD TEL:(01294) 271251 FAX:(01294) 277095

"WOW, THIS IS A REAL PEACH....!"

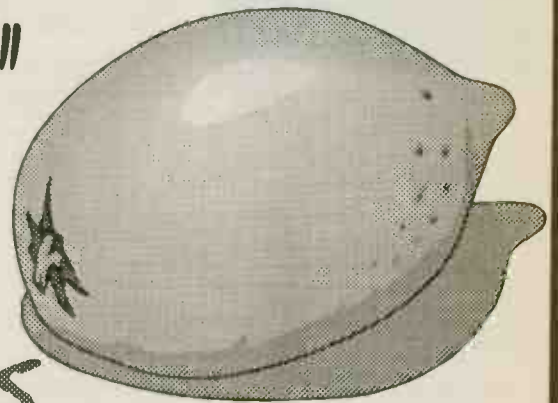

get serious

TRUST YOUR EARS

*the hi-fi specialists* **mike manning** audio

Branches at:

**YEOVIL**  
 110, Middle Street  
 Yeovil  
 Somerset  
 0935-79361

and:

**BOURNEMOUTH**  
 128, Poole Road  
 Westbourne  
 Bournemouth  
 01202-751522

CLOSED MONDAYS CLOSED MONDAYS CLOSED MONDAYS CLOSED MONDAYS CLOSED MONDAYS CLOSED MONDAYS CLOSED MONDAYS

- Demonstrating Real Hi-Fi from -  
 Naim Audio - Sugden - Arcam - AVI - Rega - Roksan - ATC - Rotel - Pink Triangle - TEAC - Audio  
 Alchemy - Mission - Heybrook - Marantz - Musical Fidelity - Epos - Shalinian - LYRA - Royd  
 Nakamichi - Denon - Aura - NAD - Pioneer - Kinshaw - Onix - Chord - Cable Talk  
 Not all products stocked at both shops

INTEREST FREE CREDIT 0% INTEREST FREE CREDIT



LINN KARIK £1,095, Numerik £795, Kabers black £925, Kaber Aktiv cards £525. Linn Keltiks walnut £2,695. Tel: 01582 456137 evenings or weekends.

AUDIO INNOVATIONS Series 1,000 MKII, 50 watt Class 'A' monoblocks, re-valved with groove tubes; also Pearl Valve coolers (worth £400.00), including original valve set, £1,095.00. Audio Note M2 valve, line, pre amp, £675.00. All one year old, great sound, excellent condition, boxed. Tel: (01635) 42278 (Berkshire).

NAIM 72/HICAP Naim Naxo 2-4/ Hicap Naim SBLs. LPI2/ARO/Circus/ Armadon/Dynavec. All new style 24 - 36 months old. Boxed. Will split. Phone for details. Tel David: 01674 672582 after 5pm.

CONRAD JOHNSON PVI0A pre amp (Line and MM/MC). Boxed, as new, 7 months old. £795. Tel: 01628 789360 evenings or weekends.

REVOX B260 FM tuner two aerial. Inputs 60 pre sets £720. North Bucks: 01908 376966.

FOR SALE: Superb turntable: Mentor Reference, plus specially selected Zeta with Van Den Hul cable. Offers? Trilogy monoblocks, magical, six months old, £2,300 (£3,000 new). Phone: 0181 340 9941.

JOHN SHEARNE PHASE II. High class integrated amp. Six months old £360.00. Rotel BX 990 200 W.P.C. amp £300.00. Meridian 215 phono stage, boxed £70.00. Tel: 01226 710605 South Yorks.

WANTED: KEF 104 AB speakers. Will collect and pay an excellent price for a mint pair. Tel: Doncaster 01302 724384.

WOODSIDE STA35 "Radford Renaissance" valve power amp (1992) highly upgraded £500. (Cost new £1,350). Impulse H7 horn speakers (compact floor standers) black £450. Tel: 01278 786180 (Somerset).

RADFORD MA15 - Mk.II amplifiers (pair), Quad-II amplifiers (pair), Rogers Cadet III integrated (pair), Quad - 33/303/FM3 in afromosia case, Tannoy Little Reds Monitors (pair): offers. Wanted, pair or Quad ESL 63s. Don 0181-881 3790.

LINN KLOUT power amp, boxed £1,300.00. Tel: 0161 - 456 1024.

LINN BASIK Plus arms x 2. Both near mint £50 each. Koetsu Black, £50. Nagaoka MP II Boron, Stilton solid body £40. Audio Technica AT30HE moving coil £25. Tel: 01582 792543,

LINN SONDEK LPI2, Valhalla power supply, Ittok arm, Linn K9 cartridge, VGC £375. Also Audiomaster ML52 speakers £25. Tel: St. Albans (01727) 853600 (evenings).

NAIM NAT02 tuner, new style, immaculate condition, superb sound. Costs £950 new, will accept £650. Tel: 0171 700 0876.

EAR834P VALVE phono stage. Volume control. Stereo/mono switch. Approx 8 months old and 30 hours use. £280. Reason for sale? Going for KLPP1! Tel: Yeovil (01935) 706163.

**GOLD PLATED E.A.R. 509 MKII monoblock valve 100w power amps £1,450. Croft Mega-Micro 2-box valve pre-amp £750. amp combination £2,000 but will split. ProAc Response 1 speakers £550. Tel: 01664 823282.**

QUAD ELECTROSTATIC loudspeakers. Black, with custom stands, original wooden feet, quality cable, manuals and Quad boxes. Good condition, will demonstrate. Best offer over £200. London NW3. Tel: 0171-722 2736 (evenings).

QUAD 606 POWER AMP £325 ono, Quad 306 power amp £175.00, Sendor BCI loudspeaker, C/W sendor stands £125.00. Tel: Martin (01526) 347793, Lincs.

CABLES FOR SALE. Cabletalk Reference 1 metre £80 ono. Cabletalk Professional 1 metre £65 ono. 0.5 metre £45 ono. Wanted cheap Revox H208 remote. Tel: (01734) 875964.

LEAK TROUGHLINE tuner £60. Hi Fi World design Horn loaded speakers £200.00 ono. Leak Stereo 70 £50. Leak Stereofetic tuner £20. Tandberg Huldra 8, offers. Mission 774 tonearm £40. Tel: Plymouth (01752) 491924.

AUDIOLAB 8000C two 8000P stereo power amps - 12 months old £1,100 Arcam 170 (Trichord Mod) and Black Box £350. Soundstyle Tripod support light blue £150 (five shelves) Technics Slimline tuner £25.00 or £1,400 complete (cost price in excess of £3,000). Phone: 01734 773077 evenings.

WANTED ONE LEAK TL12+, gold coloured preferred. One with a faulty mains transformer will be acceptable. Tel: Plymouth (01752) 491924.

FOR SALE: MARANTZ CD 94 MKII, excellent condition. Cost new £899. £395 ovno. Marantz CDA 94, excellent condition. Cost new £899. £375 ovno. Contact Sunday or Monday day or any evening. Tel: 01908 605617.

CHAPMAN MODEL 305 valve power amplifier. EL84s, ECC83s, Partridge transformers, etc. Early valve Audiophile product. Cost £700, best offer secures. May PFX quality record deck. Plymouth (01752) 691095.

TOWNSHEND ROCK with Excalibur arm and Anex power supply. £450.00. Apogee Stage speakers, taupe and walnut finish £800. Tel: 01962 860004.

JAZZ LOVERS! 26 Original 10" LPs, by Glenn Miller, Harry James etc. £10 each, also various 12" LPS. Please ring for list, may swap for decent DAC. Preston (01772) 252126

NAIM ACTIVE SYSTEM, NAC 82, Naxo, 2xNAP 250, Hi-Cap (all new style). Hi-Cap (old style), NA SBL 'speakers. £5,995.00 ono. May split. Tel: (0191) 4166866 after 6pm/ weekends (Washington, Tyne & Wear).

LINN, ITTOK, LINGO, Audio Innovations 200 p/pwr, Audio Research LSI, pre Croft 3R power, P.S. Audio phono stage, various arms and cartridges, Hi Cap/Lingo Pwr supplies, Naim 32/140 - 32.5/250 Stax Lambda Signature inc. valve engrsr Quad F.M.4. Tel: (0114) 2486493.

**WANTED ONIX power supply for Onix turntable (12 volt AC), any condition. Tel: 01324 714752**

LINN KANS. MKII stands, black. £165. Gale 301s £95. Arcam Delta 70.3 CD perfect, guaranteed. £350. NVA amps: P60MC/PSU/A60. Mint. £350. Carriage £10/item. Wanted: Saras, NVA speakers. Tel: (0191) 4141852.

SONY TAE 1000 ESD Pro-Logic preamp with learning remote, £450. Hafler DH 120 mosfet power amps, £200 each. JBL control 4312 loudspeakers - studio quality with amazing bass, high sensitivity (91dB) £550. Linn Axis/Akito and Black Chorus, £350 ono. All excellent condition. Tel: 0117 9853943.

KOETSU ROSEWOOD - VDH upgrade, will require re-tip (£150) soon - £150. Classic valve head-amp £150. Burmester 785 pre-amp polished brass finish, excellent condition inc. original packing and manual £250. Reviews available. Tel: 01924 (Wakefield) 279281.

ARCAM TWO PLUS loudspeakers (black ash) £150. Myst TMA 3 amp £130. Exposure speaker cable 2 x 4 metres (terminated) £20. Wanted: Naim Snaps. Tel: James: 01280 813037/0585 457092.

HIGH-END CABLES Half Price! XLO Signature 5.1 speaker cable, 6 feet length £800. XLO CD to DAC digital interconnect, Signature 4.1, 0.5 metre length £100. Madrigal HP interconnect, 1.5 metre length £150.00. Tel: 0181-291 1744.

MUSICAL FIDELITY F22/15 pre/ power amplifiers. Mint. £2,195 ovno. Tesseract TAHA/TAPA head amplifier and power supply. Mint. Cost £1,800 - accept £800 ono. Roksan Tabriz arm - £95 ono. Tel: 0181-949 6723 evenings.

BOSE 901 SPEAKERS with Equaliser £185. Tel: (01834) 812963.

RADFORD RENAISSANCE series valve amplifiers (by Woodside Electronics) 5C25 pre-amp with moving magnet input (£950) £400; STA 35 power amp £1,320) £500. Both excellent condition and revalved late 1994. Tel: 01843 592542 (Kent).

SYSTEMDEK IIX turntable with arm, mint £160. Audio Technica OC9 MC cartridge, new £140. Denon 304 cartridge £50. Dynavec M.C. Step-up transformer £50. Rega RB250 arm £45. Tel: (01634) 387686. Kent.

QUAD 34 control unit; 306 power amp; FM4 tuner £720 ono. Tel: Nottingham (0115) 973 4358.

LINN LPI2 Valhalla, Ittok LVII. Klyde and Circus upgrade November 1993. Very little used since owner enjoys CD. Full service history. £900. Dave Billinge (01705) 293 646 (Portsmouth).

NAIM 82 pre-amp, including phono boards and remote, £1,500. Naim C.D.i. £1,375. Both as new, boxed. Naim 135 Monobloc power-amps, old-case style but immaculate condition, boxed. £1,400 o.v.n.o. Tel: 0161-928 8464.

SONY TAF 540E amplifier built specially for British market, solid, heavily built, minimalist design, genuine 90 W.P.C.. Will drive any 8ohm speakers M/M M/C phono stage, boxed, manual, two years old, £110 (£250). Tel: 01268 479 744.

QAD ESL - 63 speakers, dark brown, excellent condition, £1,200. Tel: (01622) 832356 (Marden, Kent).

MARANTZ CD10 compact disc player £650. Audiolab 8000T tuner £450. New. Boxed. Will demonstrate. Tel: 0181-949 7809 (Kingston).

GARRARD 401, SME 3009/11 in substantial plinth. Very good condition, deck unmarked. £175. Tel: 0181-747 4764.

REGA PLANAR 2 with AT110E cartridge boxed £95; Linn Ittok LVII with Linn K18 cartridge £195 boxed; Target (28 inch) speaker stands £40 all in excellent condition. Tel: 01257 263403 (Lancs).

NAIM NAXO 3/6 new style, active crossover, V.G.C. £285. Meridian 105 Monoblocks 100 watts/channel V.G.C. £265 o.n.o. Meridian 101B pre-amp for above £75 o.n.o. or the pair for £300. Creek T40 tuner £75 o.n.o. Wanted: Kimber Cable 4TC and 8TC. Bognor Regis (01243) 262235.

**LINN HI-FI: Karik III (3 months old) £1,095; Kairn (inc. brilliant) £950; Klout £1,195; Kabers (passive, polymer stands) £795; Kaber Aktiv Modules £475; LPI2 (Valhalla, Circus) £495; Ekos £795; Klyde £195. Mostly 12-18 months old. Tel: (01922) 640737.**

# definitive audio nottingham

Tel/Fax +44 (0)1159- 813562

Import/Export

## SECOND HAND EQUIPMENT

# Denote full warranty	Price	RRP
SME 3009 II Improved - Boxed, perfect	# £100	
SME Model 20 Boxed/Unused - available immediately	# £2650	£2950
Save £300 and avoid waiting		
SME IV Tonearm - Boxed, unused - Save £100	# £768	£868.56
Sony 29" SVA 2942 Dolby Pro Logic TV - New, Boxed	# £880	£1000
Yamaha DSP A2070 - Boxed, unused x 3	# £950	£1100
Yamaha NSE 80 Centre Channel speaker - new, boxed	# £150	£200
Bose 901 Vi speaker system (2 prs), boxed, unused inc. eq+stand#	£1450	£1650
Pioneer CLD 2950 Laser disc players x 3, boxed, unused	# £600	£700
Sony MHC 7900 AV Mini system x 2, boxed, unused	# £1200	£1500
Snell All Mahogany - Excellent condition	# £1700	£4500
Audio Innovations 1st Audio 1 7/2w Triode - ex dem	# £800	£1555
lowther Acousta - New PM6A drive units - excellent cabinets	£390	
Orange Valve pre amp	£400	
EMT 930 St. Turntable + eq. + tonearm	£1600	
Micromega Solo - Excellent condition	# £650	£1500
Moth Series 30 phono/passive/power	£350	£590
Helius Scorpio - needs attention x 2 each	£50	£190
Helius Aurum Tonearm	£130	£300
Helius Aurius II Tonearm	£190	£400
Souther Linear Tracking arm	£400	£1300
Croft pre amp - super mcro	£150	
Sony 715 CD player - 30 hours use - HiFi Choice Best Buy	# £180	£250
4 Vitavox AK127 Alnico Drive Units. Each	# £150	£300
Audio Innovations 200 pre power	# £400	£850
Audion 300B Silver Night (p/p) 2 pairs	# £1250	£2000

All prices exclude carriage. Delivery worldwide.

Phone or fax direct +44 (0)1159-813562

Definitive Audio serves the first time purchaser and the seasoned audiophile with the same high level of care and interest. Our aim is long term customer satisfaction. We achieve this with quality impartial advice, quality back up and service, and a genuine interest in your needs. We have an established reputation for achieving sound quality benchmarks with innovation. We have an extensive range of carefully selected agencies. We are open Mon-Fri 9.30-6.30. sat 10.00-1.30. Visa/mastercard/Amex. Deliveries nationwide and worldwide. Extensive second hand stock. Components from £10.00 to £75.000. call for more information.

Tel/Fax (0)115 9813562

**LIVING VOICE** - Large domestic horn loudspeaker applications. Beautiful furniture, elegant design precision engineering. The finest sound quality available. 2 models Tone Scout and Air Partner from £7,500 to £20,000

**HORNING** - Danish loudspeaker systems with beautiful cabinet work and artful acoustic engineering. High sensitivity and even, easy load, £2,000 to £10,000

**DALI 104MS** - 93/94dB/W floorstanders. 'Hi-Fi Choice August 95 5 Star review' an underlying sonic beauty which far surpasses many sleeker rivals ... an uncanny ability to suck you into the musical experience.' £650.00. An audiophile bargain.

**WADIA** - The most intelligently and completely designed digital source components currently available. Models 23, 21 and 16.

**MDNARCHYAUDIO** - A selection of excellent digital products including the model M18 DAC and the DIP. The latter is used between the transport and DAC, providing excellent improvements to the dynamics, band width and coherence. The better the existing components, the greater the improvement.

**MICROMEGA** - Upgradable digital source components from £550 to £1750.

**AUDIO INNOVATIONS - AUDIO NOTE - BORDER PATROL** - An extensive range of high quality valve amplification.

**VOYD** - After 10 years in the market place, this turntable design still represents the most intelligent choice of analogue source component.

**XLD** - Digital interconnects. **LIVING VOICE** analogue interconnects. tonearms from SME, Wilson benesch and Rega, Cartridges from Ortofon, Lyra, EMT, Goldring. Digital from Audio Alchemy

**LOWTHER** - Full range of drive units always available PM4, PM2, PM6, PM7, (Alnico) usually in stock. Enclosure drawings £29.00 - Mini Acousta, Acousta, TP1 (Audio Vector Auditorium £39.00)

## MANTICORE MAKE MORE MUSIC

Turntable Servicing all makes please ring for details.

### ARISTON - LOGIC - THORENS SPARES

Arm rewiring - Manticore standard cable	£80.00
Arm rewiring - Van den Hul. Isoda	£160.00
Arm rewiring - Cardas	£160.00
Silver plated mains cable with IEC socket	£50.00
Aerolam equipment support	£54.00
Fibrelam equipment support - superior performance	£130.00
Mantra replacement belt - supplied in twos	£22.00
Logic DM101 belt - supplied in twos	£22.00
Logic DM101 spring sets	£23.00
Rega arm spacers - polished aluminium 1mm increments	£11.00
Impex motor, pulley and PCB	£90.00
Manticore Jazz turntable - choice of tonearms	POA
Manticore Magister with 12" Magician	£3,800.00
Manticore Mantra turntable - the classic - no arm	£495.00
Manticore Musician tonearm	£395.00
Manticore Magician tonearm	£695.00
Manticore 12" Magician tonearm	£795.00
<i>Part-ex available against all other tonearms</i>	
MB5i off-board power supply "suits most decks"	£290.00
MB6 off-board power supply	£490.00
Motor rebuild	£150.00
RIAA and preamplifier "system Integrity wiring"	£690.00
Active crossovers and AV amplifier	POA

Please telephone or write for more information and a copy of Mumbo Jumbo



## MANTICORE AUDIO VISUAL

MAV Shareholders Ltd.  
The Courtyard, 56c Shortmead Street,  
Biggleswade, Beds. SG18 0AP  
Tel: 01767 318437 (office) and 0585 583653 (mobile)

## •SALE•SALE•SALE•

IAN HARRISON HI-FI  
TEL: 01283 702875

SENNHEISER	BEYER	AUDIO TECHNICA
HEV70 EPOA	DT911 EPOA	
HE60 EPOA	DT901 EPOA	
HD580P EPOA		AT-OC9 EPOA
HD585 EPOA	IRS890 EPOA	AT-OC5 EPOA
HD1000 EPOA	IRS790 EPOA	ATH811 EPOA
HD29 EPOA	DT811 EPOA	ATH610P EPOA
ORPHEUS EPOA	DT801 EPOA	ATH90811 EPOA
IS850 EPOA	DT511 EPOA	
IS650 EPOA	DT431 EPOA	KOSS
IS450 EPOA	DT 311 EPOA	ESP960 EPOA
OTHER MODELS EPOA	OTHER MODELS EPOA	OTHER MODELS EPOA
NAKAMICHI	TEAC	ANWA
DRAGON EPOA	V7010 EPOA	XKS9000 DR1
DR1 EPOA	V8000S EPOA	XKS7000 EPOA
DR2 EPOA	R9000S EPOA	
DR3 EPOA	VRDS-7 EPOA	
OTHER MODELS EPOA	VRDS-10 EPOA	SONY
	VRDS-20 EPOA	
MODELS EPOA	X-1 EPOA	DTC60ES EPOA
	X-1S EPOA	TC007 EPOA
		PCM2300 EPOA
		PCM2700 EPOA
STAX	LYRA	EPOA
OUAD	OED	
CD67	DIGIT	MARANTZ
77 EPOA		
86 EPOA	DIGIFLEX EPOA	CD63 EPOA
806 EPOA	DAC PACK EPOA	CD53 EPOA
34 EPOA	DIGIT REF EPOA	CD52 EPOA
FM4 EPOA	POSTRONE EPOA	SD63 EPOA
FM66 EPOA	AMPS EPOA	SD63 EPOA
ESL-63 EPOA	OPTIFLEX EPOA	SD415 EPOA
		ST53 EPOA
		ST40L EPOA
DENON	SHURE	
DL 304 EPOA	VNSMR EPOA	PM700AV EPOA
DL110 EPOA	OTHER	PM53 EPOA
DL103D EPOA	STYLJ EPOA	PM43 EPOA
DL180 EPOA	ME97HE EPOA	PM32 EPOA
I also supply		
Kuzma, Benz-Micro, & Conrad Johnson.	TTR117 EPOA	SR82 EPOA
	TEST EPOA	SR73 EPOA
	RECORD	SR63 EPOA
		SR53 EPOA

### CARTRIDGES

I SUPPLY: AUDIO TECHNICA, ORTOFON, DENON, DYNVECTOR, LYRA, SHURE, GOLDRING ARCAM & STANTON. TRADE IN YOUR OLD MOVING COIL(S); ANY MAKE, ANY CONDITION AND SAVE UP TO 45% OFF THE NORMAL SELLING PRICE!! NO OLD MOVING COIL? DON'T WORRY, JUST PHONE.

### HI FI FURNITURE

I SUPPLY: APOLLO, SOUND ORGANISATION, SOUND FACTORY TRIPOD, SOUNDSTYLE. PLEASE PHONE OR WRITE FOR BROCHURES & PRICES.

### CABLES

I SUPPLY: AUDIOQUEST, SONIC LINK, QED & GOLDRING.

### TEST CASSETTES AND CDs

I SUPPLY MY OWN REAL TIME, INDIVIDUALLY MASTERED RANGE OF AUDIO TEST CASSETTES FROM £5-£20. THE MULTI-PURPOSE TEST CASSETTE TESTS: DOLBY LEVEL, AZIMUTH, REPLAY FREQUENCY RESPONSE (30Hz-15KHz), DOLBY B/C TRACKING & TAPE SPEED. AVAILABLE IN 120us & 70us eq VERSIONS. £20 POST FREE.

I ALSO SUPPLY DENON TEST CD'S INCLUDING THE AUDIO TECHNICAL TEST CD, £12 POST FREE.

### BLANK TAPES & ACCESSORIES

I SUPPLY: TDK, MAXELL, SONY, JVC, SCOTCH, AMPEX, BASF, KUNICA, FANASONIC, FUJI, DISCWASHER, AUDIOQUEST, GOLDRING

### PLEASE NOTE

ALL GOODS ARE BRAND NEW WITH FULL U.K. GUARANTEES. NO EX-DEM EQUIPMENT. INSURED DELIVERY IS £5. CARTRIDGES ARE POST FREE. PLEASE PHONE PRIOR TO ORDERING TO CONFIRM PRICE & AVAILABILITY. MAIL ORDER FROM: IAN HARRISON HI FI, 7 MILL HILL, REPTON, DERBY, DE65 6GQ. TEL: 01283 702875 9am-9pm, Inc. Sunday

SONY TC 399 reel to reel. Recently serviced. Offers. Glover  
Tel: 0181-940 4384.

LINN LP12 turntable, Valhalla PS, Akito arm, K9 cartridge. Latest spec bar Cirkus. Pristine condition with boxes and receipts. Costs £1,270 new. £500 ono.  
Tel: 0171-258 7300 (O) or 0181-464 3969 (H).

GYRODEC BRONZE, Kuzma arm, AT-OC9 and QC power supply. Perfect £650.  
Tel: 01372 373069.

EXPOSURE 7 AND 8 pre/power amp, early model with balance controls, £225. Linn Kan speakers, MK1 with MK2 stands - Rosewood, £225. Linn Akito pick-up arm £65. Sound Org. T/ T wall shelf £25. Demion Pro Gold headphone/speaker switching unit £25.  
Tel: 01902 374786 (Nr. Wolverhampton).

HEAVY DUTY 4 shelf equipment stand, plus dedicated CD turntable support, fully welded £150.  
Tel: 0115-9463693.

WANTED TONEARMS, BREWER, Fidelity Research, Ortofon. Cartridges, Decca, Koetsu, Ortofon SPU (any model). Turntables, EMT 927, Technics SP10. Amplifiers, Audio Research SP6, Naim Nap160, Lux LX33. CDs, Marantz CD80.  
Tel: 01642 559543.

CELESTION SL600s, crossover upgraded with Solen Polypropylenes, £225. Cambridge CD2 CD player, light use, vgc., £230. QED Digit and Positron, vgc. £110. Sony Walkman Pro and heavy duty external PSU, £200.  
Tel: 0171 286 4143, C Scott.

ROTEL RCD 965BX CD player, boxed, very little used £165.  
Solihull (0121) 7331961.

PROAC RESPONSE 3 speakers, mahogany, lovely condition, £2,250. Tube Technology Genesis valve monoblocks, 100WPC, excellent condition, £1,600. EAR 834P phonostage, as new, £225. Silver Sound 14/4 speaker cable, 2 x 4m, terminated, £200. Great sound deal £4,000 for all.  
Tel: 01474 327286 (private answerphone).

QUAD II/22/FM2 Multiplex decoder £395. Avo Mk4 valve tester, data book £275. 401 chassis £95. TD125, SME3009, plinth, lid £125. Various Troughlines from £60. Pye black box £50. Wanted: single Radford MA15/3, PX4 Valves, new/used, (swap GEC KT88's).  
Tel: 01550-740272.

CROFT SUPER MICRO pre-amp, Croft series five amp - £350 o.n.o. Mitchell Focus One turntable and Maywire arm and Maywire cartridges - £100 o.n.o. Rotel RCD 865 CD player - £150 o.n.o. All in excellent condition.  
Dave 01902-29665 (Wolverhampton).

WANTED: Revox B790 or B795 turntable. For sale: Uher 4400 Report-IC £100. Fons CQ30 3-speed (variable) turntable with SME 3009-II arm. £120.  
Lloyd. 01424-843587.

ROGERS STUDIO 1 speakers, Teak, Target HJ15/3 stands, 2 x 4m Linn LK20 cable, £200. Rogers A75 series 2 amplifier, fine complement to speakers, £50.  
Tel: 01276 29922 evenings/weekends (Camberley, Surrey).

BRAND NEW AUDIO Technica OC9 cartridges £175 inc P&P. Quad 34/306 mint condition £380. Heybrook HBI MKIII mint condition, boxed etc. £180. Naim 42.5/90 £450. Wanted: PSX. Wanted: Cyrus Tuner.  
Tel: James (01792) 280061.

KEF REFERENCE 107/2 black, as new. Upgraded to MK2 last August by KEF. Complete with Kube 107/2. Boxed. Instructions. Can demonstrate. Would cost £3,800 new. Quick sale for £1,295 ovno.  
Tel: 01279 724804 evenings/weekends. Herts.

GARRARD 401 DECK and SME 3009 arm. Both in excellent condition, very little used. £145. Includes Shure M55E, plinth and cover.  
Tel: 01442 846881 (office) or 01462 456357 (home).

HIGH END Hi-Fi collection for sale. Total range of equipment and styli, cables. Ring with requirements. All privately purchased new in UK most boxed and mint, no traders. Further details: 0973 390962.

SNELL TYPE E II speakers complete with Pirate stands, immaculate condition £700. Very sensitive - make ideal partners for Audio Innovations amplifiers. Please call Mark on 01252-845128 (Fleet, Hampshire).

NAIM 82 (MC + MM), HiCap, 250 - £2,400. LP12 Valhalla, Itok, Kiseki Blue - £550. Epos ES14 + Stands - £400.  
Tel: 01752 789100 evenings/weekend (Plymouth).

ARCAM ALPHA 5 CD player, mint condition boxed £250 o.n.o. Linn Majik-I amplifier, with phono module, mint condition, boxed £500 o.n.o. Will accept £700 for the pair.  
Phone 01628 890858 (daytime).

NAIM NAC72. NAP 180, SBL speakers, Linn Sondek, Mission arm, Ortofon cartridge, five months old, sale due to emigration. May separate, £2,400.  
Tel: Stoke-on-Trent (01782) 787087.

PIONEER PD 802 CD player £230. Origin Live OLI loudspeakers £275, plus dedicated stands. Kelvin Labs class A Integrated amplifier (original model) £150. All boxed.  
Tel: 01489 572958 (Hants).

NAIM NAP160 power amp V.G.C. Can demonstrate £225 ono. Also approx. 300 Hi-Fi magazines £100 ono.  
Nigel 0181-384 2717 evenings.

NAKAMICHI CR7 cassette deck, mint condition, boxed with manual and remote £850 ono. Dais turntable with Zeta tonearm and Audio Technica ATOC9 cartridge (hardly used), boxed £450 ono.  
Matt: 0141 621 0480.

WANTED: Valve compressor, working or not, circuit diagrams for same, equalisers, and early transistor examples. All sought by enthusiast of limited means.  
Clive: 0181-692 8129.

QUAD 33/303/FM3 mint condition. Handbooks. Unused since full Quad service. £225. Audio Technica OC5, few hours use. £75. Shur V15/III good stylus. £30.  
Phone Barry: 01604 411194 (Northampton).

SUMPTUOUS CASTLE Trent II loudspeakers and Creek 4240 amplifier. Both barely used and boxed. Will sell both for £350 including cables. May split.  
Tel: Lee on 01475-707319.

KELVIN LABS M60 monoblocks £695. LFD Linestage LS2 pre-amp £595. Nottingham Analogue Spacedeck with Mentor arm and Tracer 3 MM cartridge £800 complete.  
Tel: 0116 2811736.

MERIDIAN 207CD, 203DAC, 209 remote control. £540. Linn LK I, Dirak power supply, LK2/75. £425. All in excellent condition, boxed with manuals.  
Tel: 01582 762 962.

QUAD 606 MARK two power amp, new February, long guarantee. Save £240 at £450. SME V arm, fine condition, £690.  
Tel: 0181-659 9538.

ITEMS FOR SALE: Linn Isobariks, black, external passive crossovers, panel stands. Price £900. LK600 10 metres x 2. Price £100. Isobariks Aktive crossover and Dirak. Price £450.  
Tel: 01895 444911

MICROMEGA DUO CD3/DUO BS. Very little use, boxed £950.00. Nakamichi DR2 £375.00 boxed. Sony Professional Walkman £160.00. Boxed. All immaculate.  
Tel: 01753684887 (London, Heathrow).

ROXSAN DPI compact disk transport, black, boxed, £700 ono. Can demonstrate.  
Jon 0181-888 2537 after 6.00pm.

MUSICAL FIDELITY MC2 loudspeakers £130. Musical Fidelity pre-amp 3B £130. Rotel RT-83AL tuner £50. Rega RB300 tonearm £50. Heybrook HBS1 stands £40  
Tel: 01634 811456 (evenings and weekends).

WANTED: PROAC EBS loudspeakers and stands. Must be in mint condition, late model (1988) and preferably one owner. Excellent price paid for the right pair. Vincent Poole.  
Tel: 0151 423 1391 (work) or 01606 782877 (home after 7pm).

ROGERS LS4a/2 speakers. £110. Nakamichi IA3 amplifier with separate phono amp £125.  
Tel: 01948 667521.

AUDIO INNOVATIONS T2 moving coil transformer, absolutely brand new, genuine reason for sale, happy to demonstrate, cost £400 will sell £299.  
Tel: 01784 447354 (work) or 01734 665988 (home).

ROCK REFERENCE, Sykline Platform £1,150 SME 4 with 5 Wiring Trough £695 Dynavector XX-C £295, Sumo Polaris £225 MF MVT III £495, Genexa (Lineaums) Alphon Stands £175.  
Tel: 01273 515095.

ARCAM DELTA 290 integrated amplifier, boxed, £300 ono. Apollo 3 tier equipment rack, square section construction 220mm, 320mm shelf spacings. £25. All as new.  
Tel: 0121-605 5218.

RUARK SWORDSMAN, black £160, Linn Isobariks DMS, mahogany £750. Linn stands £150. V.D.H. Clearwater cables 2 x 10m £50. Minolta X700 camera, Macro bellows outfit. Half price, all excellent condition.  
Tel: 01206 861457, Jim.

MUSICAL FIDELITY "Studio T" power amp. £400. MVT pre-amp with Stax SR84 headphones £450. A1 integrated amp £125. Marantz CD 873 LE disc player £125. Technics ST E450L tuner £75.  
Tel: 01635 36019 evenings (Newbury).

MAGNEPAN 1.5SE, 1 1/2 years; Dac-In-The-Box, once used, Yamaha tuner TX 580, new; Chord Company Flatwire 4 x 8m; Monster Phono Link M 1000, 3 pairs; all 30% off.  
Tel: 0171 439 7986

RADFORD STA25 valve pre, power amplifier with matching valve tuner, excellent £575. Cambridge R50 speakers £240. Oracle Delphi with Syrinx arm and Ortofon MC cartridge £450.  
Tel: 01274 545219.

ART AUDIO QUINTET Plus VPI valve amps, Sonic Link Violet interconnect £775 o.n.o. Pentachord 'A' speakers (black ash) plus stands plus cables. £275 o.n.o.  
Garry, Wakefield (01924) 290949 day, 365376 evenings.

NAIM NAIT 3, FITTED with MM phono boards. Mint condition £390. Townsend Seismic Sink isolation support. Standard size £80.  
Tel: 01256 461453 (Basingstoke).

LEAK TROUGHLINE Stereo 3 tuner C/W Leak Stereo 30 Plus amp in double black Ash sleeve £130.00. Leak Stereofetic tuner C/W Leak Stereo 30 plus amp in double black ash sleeve £85.00. Both in excellent condition.  
Tel: 0181-669 1088 anytime.

QUAD II VALVE bi-amped system. 4 x Quad II's into Monitor Audio R552 speakers. Electronic crossovers. Sounds fantastic! £700 ono. Leak Troughline 3 Stereo tuner £100. Sony Profel component TV £450.  
Tel: 0171 263 2831.

# The Last Days of the Sale

## Record Players

**Linn LP12 LV11** Ittok. Used, with Valhalla, £479.00, with Lingo £799.00

**Rega Planar** turntables, ex-dem **Planar2** was £198, now £158.00 **Planar3** was £260, now £215.00

Ex-dem cartridges available.

All sale goods are ex-dem and in perfect condition with original boxes unless stated otherwise.  
Full 12 months Guarantee

## Electronics

**Exposure XV** integrated with phono stage. Used, only £379.00

**Quad 66** pre-amp, full remote. Used immaculate, was £863, now £499.00 **306** power amp as above £360, now £199.00

**Naim Nac82/Nap180** Ex dem, as new **Nac82** was £1998 now £1598.00 **Nap180** was £950 now £759.00

**Old style Naim** Used in good condition

**Nac32.5** £169.00 **Hicap** £389.00

**Nap250** £650.00 **Nap135** pair £1250.00

**Nakamichi Dragon** cassette deck. Used good condition. List £2500 now £850.00

**Audio Research LS1** valve line level pre-amp, rare black finish. Was over £1700, now only £699.00

**Audio Research LS3** line level pre-amp Ex-dem, immaculate, was £1695, now only £1195.00

## CD Players

**Arcam Alpha 1** one box player. Ex-dem immaculate condition, was £300, now only £259.00

**Arcam Delta 270** one box. Ex-dem immaculate, was £800, now £639.00

**Micromega CDF1 Pro** multibit player, Duo style with perspex lid. Used, now only £449.00

**Micromega Duo CD2.1** transport Ex dem, good condition, was £2750, now only £2199.00 **Duo BS2** converter, was £650, now £529.00

## Loudspeakers

**JPW Sonata** and **AP2** 'best buy' models. **Sonata** was £120, now only £90.00 **AP2** was £200, now only £119.00

**Monitor Audio MA201** Used, good condition, were £300 no box, only £179.00

**Heybrook Heystack** rosewood. Ex-dem as new, were £500, now only £369.00

**Naim IBL** compact floorstander Used very good condition, were £906, one pair now only £449.00

**Pro-Ac Super Towers** black ash floor-stander. Used, excellent condition were over £1300, now only £695.00

**Roksan Ojan 3** rosewood. As new, were £995, now only £749.00

**Sonus Faber Minuetto** solid walnut, were £898, one pair only £749.00

**Sonus Faber Minima Amator** solid walnut Immaculate, were £1498, now £998.00

This is only a small sample of the product available in our sale.  
Please call for a full list

## Finishing!

Soon, at The  
**SOUND ORGANISATION**  
London Bridge

**0171 403 2255**



# V'audio

Hi-Fi Consultants

Ian C. Vaudin  
36 Druid Hill, Stoke Bishop,  
Bristol BS9 1EJ  
Tel/Fax: Bristol  
(0117) 9686005

## BRITISH HI-FI IS THE BEST IN THE WORLD

It is a little known fact that although the Japanese send millions of pounds worth of hi-fi to the UK, the Japanese, and the Eastern countries, in general, look upon British and American hi-fi as being the best! Specialist British hi-fi companies would probably not survive if it were not for exports, and only had to rely on the UK market.

Two very successful companies are ATC and AVI, both located in Stroud. The smallest speaker that ATC produce, the SCM10 was voted 'Best Small Loudspeaker of the Year' in Audiovisual Magazine; 'Best Audiovisual loudspeaker of the Year' in Hi-Vi Magazine and 'Component of the Year' in Stereo Sound Magazine. All three magazines are Japanese. Nearly all Hollywood and UK films with orchestral scores are monitored on ATC systems. Top recording artists using ATC equipment include Mike Oldfield, Peter Gabriel, Paul McCartney, Tina Turner and Pink Floyd.

So stop buying all that Japanese equipment and come and listen to the best of British at V'audio and hear what you are missing.

All right, ATC equipment is not cheap, but it is good value and AVI amplification, tuner and CD players are absolute steals! But we offer systems at most prices. For example, we do a CD-based system, consisting of AMC CD player, Jupiter amp (made in Bath) and a pair of Ruark Templar speakers for £1,200 including cables and, if that's too much, we regularly

have good quality second hand equipment to save you money. We have the Ruark range of speakers from £330 to £2,700, the Heybrook range (from Plymouth) from £130 to £1,100. We even have Triangle speakers from France, Opera speakers from Italy, Analysis speakers from Greece, Alon speakers from America, Jamo speakers from Denmark, plus Rel sub-woofers from Wales. We have amps from AVI, Heybrook, Shearne Audio, Sugden, Audio Innovations (valve), Cadence (valve), Chord, Electrocompaniet (Norway), and Exposure. We don't have shelves full of CD players, but we do have the best sounding, plus transports, dac's and turntables, (including SME20A).

We are above all else enthusiasts with thirty years experience in hi-fi AND music and offer a PERSONAL service in your own home if required that few shops we know can equal. We work from home and can devote more time to each customer. So, for independent advice, with no obligation, why not ring us for a chat and then come and open your ears. We can also blow your mind with audio-visual/home cinema.

MISSION CYRUS 2 plus PSX (Mk 1). Mission DAD 7000 CD player. Spondor SP2 speakers. Foundation speaker stands. All in excellent condition. £400 the lot. May split. East Sussex. Tel: 01825 890667, evenings after 7pm.

N.V.A. T.D.S. amplification system, pre amp with 4 x PSU pair A50 monoblocks with 2 x PSU, smooth, effortless sound, lack of space forces reluctant sale, £1,150. Tel: 0585 802136 Suffolk.

QUAD 33 AND 303, FM3 tuner and pair of Quad ESL (Bronze) manuals and Quad boxes for speaker transport. £475 o.n.o. Leeds (0113) 2454 829.

FOR SALE: Sony STS-311 R.D.S./E.O.N. tuner - 'What Hi-Fi?' award winner, excellent condition, boxed, complete with all accessories and instructions, £130 o.v.n.o. Tel: Coventry (01203) 678094 after 6.00pm.

ENTHUSIASTS CLEAR OUT: Tannoy 609 IIs £200 o.n.o.; Celestion DL3IIs £75 o.n.o.; Mission 760; SE £75 o.n.o. All boxed, as new. Wanted: Goodmans Maxim IIs. Tel: 01202 475781.

CHORD 1000 poweramp. 250 watts per channel. Magnificent sound. Glowing reviews (see M. Colloms HFN June 1992). Mint condition. Boxed. £1,000 (new £2,400). Tel: 01206-825887 (Colchester).

QUAD 22 & PAIR IIs with GEC KT66 £325, ESLs pair in bronze £323, excellent condition, all original manuals, receipts, boxes. Garrard 301 "Strobe", original manual, receipts, very good. £140 Linn LP 12, Grace arm, little used £180. Ortofon 212 arm £20 Marantz PM44SE amplifier as new £120. Will demonstrate any. Tel: 01934 626959 (Weston super Mare).

WHARFDALE SPEAKERS, one pair Dovedale IIs, solid mahogany cabinets 14" x 12" x 24", very good condition, £250 o.n.o. Tel: 01405 768845.

RESTORED CLASSIC EL84 valve power amp. Extensively updated with modern components. Very good sound quality. £240. Tel: 01403 891349 (Sussex).

MERIDIAN 201 pre-amp. £250. 204 tuner £225. 209 Master Control £15, Audio Alchemy DAC in the box £135. All books, boxed and pristine. Bert. Weekdays 0181 473 4057.

WANTED DESPERATELY: Belt for Ariston Forte turntable. Where did all those spares go? Will pay over the odds. Phone 01728 830778.

PINK TRIANGLE LPT: black acrylic top plate, Pink fabricated lid, Rega RB300 brand new A.T.O.C3 Lenteck moving coil pre-amp. £420.00 o.v.n.o. Sound Organisation table and wall shelf. Tel: 0181-669 1088. Anytime.

LINN LP12, Valhalla, Ittok, Troika. £400. Tel: 01982 553170. Sutton-Croydon.

**CLEAROUT! CONCORDANT** Exquisite valve pre-amp (with Doug Dunlop's final mods) £1,200 (£1,950). Meridian 263 DAC £200 (£495). Cary 5500 valve line-level pre-amp £450 (£1,500). Rotel 965 BX LE-D CD player with Trichord 2 modification £300 (£566). Tel: 01372-468266 (home).

QUAD ESL63/AUDIONOTE PI: ESL63 loudspeakers, black, custom stands available, immaculate, (£3,000 new) £1,400. Audionote PI valve power amplifier, new, sadly unwanted prize (£699 new) £500. Call Simon 0171-603 3755.

ROGERS STUDIO 1A monitor speakers plus stands £325 (cost over £700). REL 'Stadium' sub-bass speaker £350 (cost £795). Would exchange either for Quad 606II. Also wanted: Kef kube 200 equaliser. Southampton (01703) 738935

KOETSU RED M/C cartridge (careful, limited use) £225 o.n.o. Koetsu tonearm SA1100D MKII boxed £120 o.n.o. (boxed) Mission 773 high output M/C £60 ono. Wanted: Naim M/C boards (late). Tel: 0191-487796.

AUDIONOTE A.N.L. speaker cable. 2 x 4m bi-wire with gold plugs. £300 o.n.o. Tel: Guildford (01483) 572796.

EXPOSURE MONO-BLOCKS VIII reg. Available through upgrade. Superb dynamics, versatile "sound for all seasons". Good condition, boxed. Can demonstrate. £650 ono. Tel: 0181-341 7037 evenings.

ION AMPLIFICATION SPI/X-Pak 2/4xT 750/4xSAM 40/active crossovers. Stunning sound £1,295.00. FMT-2 tuner £150. Immaculate condition. Guarantee and professional service back-up. Wanted: five tier Mana Acoustic; Roksan tall tables; Moth record cleaning machine. Tel: 0161-432 0744.

**SUGDEN SDT 1** integrated CD player in excellent condition £500.00. Mordant Short MS 5.40 speakers (shielded magnets) with rosewood effect finish and Sound Organisation sand filled stands £250.00. Tel: 01702 463232 (Essex).

AUDIO INNOVATIONS 700 integrated amplifier, excellent condition, recently serviced, £540 ono; Pandora mains filter and Kimber 4TC mains lead, £60 ono; North London. Tel: 0171-704 6775.

**ARRIVAL OF FURNITURE** in small cottage forces sales of prized Hi-Fi. Linn P12 VAL/NIR Ittok/Asaka 1990. Electro pre3/power 25 amp. Mission 770. Will include NAD 4020 tuner Dual 814 tape and Denon CD player together with Apollo cables. £800. Phone: 01342 718864 evenings. Cophorne-Sussex.

SONY WMD6C Professional Walkman, Rechargeable batteries plus mains power and recharger unit. Very clean recently serviced - little used but much cherished £200. Phone: 01703 260446 (Southampton).

NAIM HI-CAP £300, Naim 62 (new style) K boards £250, Naim 32.5 MC and K boards £170, Denon TU260 tuner £60. All good condition and boxed. Mike 0171-775 3616 (office).

LP12 AFRO LINGO EKOS K9, excellent (boxed) £1,150. Magnum Dynalab FT 101 tuner and 205 Signal Sleuth aerial pre-amp tuner (black) inc. Whip aerial £450. Tel: John 01686 413568 anytime. Can demonstrate.

**MOVING ABROAD! MUST SELL:** Elite Rock turntable, Excalibur arm, mint £400. Acoustic Energy AE1 monitors, bi-wire £380. Linn Intek integrated 50w amp £150. Technics RSB 350 cassette £35. Various accessories and records. Tel: 0181-299 3642.

MUSICAL FIDELITY MC2 speakers original Martin Colloms design with Heybrook HBS1 stands, £195. B200 amplifier, £195. Pioneer PDS801 CD player, £195. Technics tuner, £39. All received excellent reviews. Tel: 01642 532696

TEAC VRDS10 CD player £450.00, Technics PS 700 C.D. player £170, Creek T40 tuner £100.00, Linn Kairn pre amp £750.00, Linn LK280 power amp plus Spark power supply £650.00, Luxman 507X amplifier £120.00, Technics ST9600 tuner £100.00. Tel: 01977 643629.

CABLES PLUS - Phono: 6m Sharkwire 91 x 0.08mm OFC, £75; 1m DNM Solidcore, £10; Speaker: 4 x 5m Sharkwire 10 AWG/0.08OFC, £15, £50 all; 2 x 5m DNM Solidcore, £25; Solidcore 'S', £25; Ortofon T4PMC; QED, RSC, NAD Items. Tel: 0121 350 9230.

TANNOY GOLD MONITOR dual concentric loudspeaker pair. Original near mint condition. With LSU/HF/15/L crossover. Asking \$US2500.00 OBO. C. Phaneuf 972 Guillaume Boisset Cap-Rouge (Quebec) Canada G1Y-1Y9. Tel: 1-418-652-2430 evening & weekends.

AUDIO INNOVATIONS 1000 monoblocks £750 pair; Quad FM4 £200; Quad 44 £130; Quad 405II £220; Quad 33 £80; Denon DCD1000 £80; Marantz CD63 (original) £80; Garrard 401/Mission 774 Arm / Plinth / Cover £170; Thorens TD150/SME £60; Mission 770 £80; Hi Fi Answers R50s £140; Linn Index II £150; TDL NFM £75; Sequence 30 £120; Rogers Cadet II £50. Tel: 0121 353 4942 (Sutton Coldfield).

### TRADE

Hi-Fi Loudspeakers repaired and upgraded, bi-wiring and active conversions a speciality. Tel: Immortal coils 0480 497730.

SNELL K £250; Heybrook HB1/3 £150; HBS1 stands £60; Judos 16 inch stands £95; Musical Fidelity A1 final edition £275; A1 MK2 £95; Audioplan Super AF (1m) £65; Silver Sounds 16/4 (1.5m) £95; NVA Sound Pipe (2m) £70; KCAG Digilink (0.5m dual) £90; Masterlink Black Digital (1m) £45; Cogan Hall Spk. cable (3m) £150; V.D.Hul SCS12 (2m) £50; plenty of other spk. cables (Cyrus, Ixos etc.) in short lengths; Michel spk. plugs (8); £5; Michel Tenderfeet (9) £1.50 each. Call Steve on (01685) 385898 after 6pm.

TUNERS. ARCAM DELTA 280. £239 Aura TU50 £210. Both display. Arcam T21 £89. Armstrong 624 £69. Cambridge T50 £149. Cyrus I £99. Denon TU400L £119. Musical Fidelity T1/II £219. Quad FM4 £219. Sony STS770ES £199. STS311 RDS £139. Other items available. Objective Audio: 01279 426647 or 0973 452368.

BUY - SELL - EXCHANGE. Vintage Wireless and Classic Audio. Repairs, spares, restoration, modification to all valve equipment. Visit us for collectable audio and gifts. We also buy vinyl and valves. 17 Bell Street, London NW1 5BY. (Next to Bakerloo/Edgware Road tube). Tel: 0171 - 258 3448.

IMP LOUDSPEAKER testing system, complete with MLS upgrade, power supply, cables and microphone. £175. Audio Physics 01895 637 846.

**THORENS SERVICE.** Official Thorens engineer based in Surrey will repair, service, reset your turntable. New arms/cartridges supplied and fitted. Drive belts and other spares in stock. Tel: 0181-393 5198.

NEW KT88 SINGLE ENDED monoblocks £595 PR. 300B Monoblocks on DEM. Arcam Alpha + CD player £250. Quad valve power amplifiers, rebuilt, excellent condition £350. Audio Innovations 500 amplifier £450. M.F.A. Magus valve pre-amp. ideal for Quads £500. Elite Rock turntable as new, with Mission arm £450. Ruark Talisman II loudspeakers, mint condition £400. Part exchange welcome. Equipment bought for cash. Tel: 0121 784 8765.

HI-FI 13a SOCKET outlets installed, you've paid £1,000s for your Hi Fi system running it from one socket outlet with multi way adaptors? Why not have a dedicated supply installed, single dedicated to completely isolated supplies for the ultimate sound quality. All cables RF screened. Also earth rods installed. Installations carried out by fully qualified engineer, 26 years trade experience. Tel: 01708 728059.

SME 309 TONEARM £449. SME V £880 Deltac Black Slink balanced £125. Royd Minstrel speakers £199. Pink Triangle Ordinal (DAC) £675. Pioneer A400X £210. Townshend Seismic Sink £125. Rega RB300 tonearm £135. Rega RB250 £55. Mission 78SE speakers £190. Moth Thirty Series pre power £299. Moth phono stage £110. All new guaranteed. Tel: 01582 24414.

# Dynamics

## HIGH END AUDIO BOUGHT/SOLD EXCHANGED

	SALE		LIST
MARK LEVINSON ML7A PREAMP - MINT	2895	S/HAND	£6600
CAMBRIDGE CD1 CD PLAYER HEAVILY MODIFIED WITH MASSIVE POWER SUPPLY SUPERB	£1295	S/HAND	PHONE
METAXIUS ICARUS INTEGRATED AMPLIFIER CHROME - MINT	£295	EX/DEMO	£895
PINK TRIANGLE PIP 2 MK2 VISHAY MODIFIED PREAMP - MINT	£1795	S/HAND	£4500
CARY CAD 5500S PREAMP PHONO & PROCESSOR - MINT	£295	EX/DEMO	£2250
MARK LEVINSON ML3 POWER AMP - MINT	£3895	S/HAND	£8250
CONRAD JOHNSON MV75 VALUE POWER AMP - MINT	£1295	S/HAND	£2500
OCTAVE RESEARCH ORI POWER AMP V G C	£1795	S/HAND	£4500
CELLO AMATI SPEAKERS TWIN MOUNTED PAIR IN OAK ON GRANITE STANDS SUPERB V G C	£5500	S/HAND	£20000
MERIDIAN ARGENT 3 SPEAKERS ROSEWOOD - MINT	£1995	NEW	£1495
PROAC PROSTATIC ELECTROSTATIC SPEAKERS RARE V G C	£1995	S/HAND	PHONE
SNELL A3 SPEAKERS WALNUT V G C	£4495	S/HAND	£6995
METAXIUS IRAKLIS MK2 POWER AMP CHROME - MINT	£295	EX/DEMO	£1500
AUDIO RESEARCH D125 KT90 VALVES AMP - MINT	£2750	S/HAND	4650
METAXIUS CHARISMA PREAMP CHROME - MINT	£295	EX/DEMO	£1500
EQUATION ZERO SPEAKERS PIANO BLACK - MINT	£695	S/HAND	£1300
CARY 300B VALVE MONO POWER AMPS 40 WATT TRIODE	£2895	EX/DEMO	£4800
HELVIS CYALENE ARM - MINT	£795	S/HAND	£1400
CABSSE IROISE MC SPEAKERS CHERRYWOOD - MINT	£1995	EX/DEMO	£2700
<b>NEW IN THIS MONTH</b>			
RESTEK CHALLENGER INTERGRATED AMP - MINT NEW	£799		
ENLIGHTENED AUDIO DSP1000 DAC - MINT.	£595	S/HAND	£1000
CJ PREMIER 4 POWER AMP			
MICROMEGA TRIO CD PLAYER - MINT	£2495	S/HAND	£4499
KLYNE SK 5A PREAMP - MINT	£1495	S/HAND	£2750
CITATION 18 TUNER ORIGINAL AMERICAN V.G.C	£295	S/HAND	£650
SUGDEN AU51C PREAMP 2 BOC MODIFIED BY AVONDALE V.G.C	£895	S/HAND	£1800
ROWLAND MODEL 3 MONOS POWER AMP BALANCED - MINT	£2495	S/HAND	£4000
SOTA COSMOS VACUUM PLATTER - MINT	£1995	S/HAND	£4400
CRYSTAL REFERENCE TURNTABLE (WALLMOUNT)	£1495	S/HAND	£2500
NAKAMICHI OMS 7E CD PLAYER VGC	£795	S/HAND	£1500
GRYPHON LTD EDITION PREAMP BALANCED - MINT.	£3995	S/HAND	£8000
SNELL TYPE C SPEAKERS WALNUT - MINT	£1295	S/HAND	£2550
KEF 105/3 SPEAKERS BLACK ASH - MINT	£1595	S/HAND	£2100
CRYSTAL SIGNATURE TABLE TOP TURNTABLE BRUAR 8 ARM	£2995	S/H	£6450
MARK LEVINSON NO 23.5 POWER AMP BALANCED - MINT	£3795	S/H	£7450
SONIC FRONTIERS SFD-2 DAC BALANCED - MINT	£1795	S/H	£4700
ROWLAND MODELS POWER AMP BALANCED - MINT	£1795	S/H	£5250
LINN LP12 EKPS 2 CIRCUS LINGO BLACK - MINT	£1595	S/H	£2642
NOTTINGHAM ANALOGUE PARAGON LINEAR - MINT	£895	S/H	£1600
HELIX ORION 2 SILVER WIRED ARM - MINT	£295	S/H	£595
MERIDIAN 606 DAC 7 MK2 DAC - MINT	£795	E/D	£1450
AUDIO RESEARCH V70 HYBRID VALUE AMP - MINT	£2495	S/H	£4480
ONIX TUNER - MINT	£225	S/H	£400
ARAGON 2004 POWER AMP - MINT	£895	S/H	£1295
ARAGON 4004 POWER AMP - MINT	£895	S/H	£1895
QUAD 606 POWER AMP - MINT	£475	S/H	£675
CELESTIAN SYSTEM 6000 SUBWOOFER - MINT	£795	S/H	£1500
DYNAUDIO SPECIAL ONES SPEAKERS ROSEWOOD - MINT	£795	E/D	£1249
ACCOUSTAT 1100 ELECTROSTATIC HYBRID SPEAKERS - MINT	£795	S/H	£1395
WADIA 6 CD PLAYER BALANCED MINT	£2595	E/D	£3995
AUDIO RESEARCH LS2B BALANCED PREAMP MINT	£1995	S/H	£3365
MERIDIAN 605 MONO POWER AMPS BALANCED MINT	£1550	E/D	£3800
MERIDIAN 206 DELTA SIGMA CD PLAYER MINT	£895	E/D	£985
REVOX B77 71/4 & 15IPS 1/2 TRACK MINT	£695	S/HAND	£2000
QUAD FM4 TUNER MINT	£275	S/HAND	£434
MERIDIAN 603 PREAMP DAC REMOTE MINT	£995	E/D	£1800
KRELL KRSPB REFERENCE PREAMP BALANCED MINT	£4995	S/HAND	£11500
AVI 200MA POWER AMP MINT	£395	E/D	£600
GOLDMUN MIMESIS 3 POWER AMP BALANCED MINT	£1995	S/HAND	£5000
TANBERG TPA 3009A MU2 MONO POWER AMP MINT	£10955	S/HAND	£2195
MERIDIAN M60 ACTIVE SPEAKERS WALNUT MINT	£1395	E/D	£1995
WILSON WATT 3 PUPPY 2 & PAWS MINT	£7495	S/HAND	£13645
WILSON POW WHOW 3 SUBWOOFER GRANITE MINT	£7995	S/HAND	£12500
PROAC RESPONSE 3 SPEAKERS BLACK MINT	£1995	E/D	£3085
ACOUSTIC ENERGY AE1 SPKRS & STADS PIANNO MINT	£795	E/D	£1175
<b>SALE</b>			
SOTA STAR SAPHIRE 3 TURNTABLE - MINT	995	E/D	2500
MARK LEVINSON ML7 PREAMP - MINT	1995	S/H	5800
COUNTERPOINT SA11 & SA9 PREAMP REMOTE - MINT	4995	S/H	12600
NRG A401M MONO 400W CLASS A AMPS BAL - MINT	3995	S/H	13000
NRG A201S STEREO AMP 200W CLASS A - MINT	2995	S/H	6800
DUNTECH CROWN PRINCE SPEAKERS BLACK VGC	2995	S/H	8500
DIAMON ACOUSTIC REF2 SPEAKERS OAK & STANDS - MINT	795	S/H	2250
AUDIO PLAN KONTRAST 2 SPEAKERS ROSEWOOD - MINT	1295	S/H	2800
SUMO ARIA PANEL SPEAKERS OAK VGC	795	S/H	3000
GENESIS 8300 SPEAKERS & STANDS PIANO BLACK - MINT	995	E/D	1895
MERIDIAN 204 TUNER - MINT	£495	E/D	£995
MARK LEVINSON ML/DA PREAMP MM/MC - MINT	£1395	S/H	£3800
BURMEISTER B38 PHONO STAGE BALANCED - MINT	£495	S/H	£1900
CAL TEMPEST 2 VALVE CD PLAYER	£1595	S/H	£3900
PHILIPS BLACK TULIP TUNER AM FM - MINT	£250	S/H	£580
AUDIO RESEARCH SP14 PREAMP BLACK - MINT	£1795	S/H	£3300
BRYSTON 12BPREAMP BALANCED OUTPUT - MINT	£695	S/H	£1295
CLASSE AUDIO DR15 POWER AMP BALANCED - MINT	£1895	S/H	£3400
APOGEE MINI GRAND GS SPEAKERS PIANO BLK - MINT	£4995	S/H	£8995
DYNAUDIO KRAFT SPEAKERS & STANDS V G C	£1295	S/H	£2720
RESTEK EXPONENTS MONO POWER AMPS GERMANYS REFERENCE			
MPS CHROME 1800WPC BARGAIN BALANCED - MINT	£5495	E/D	£12000
VESTROVIC A1 VALVE MONO AMPS BALANCED - MINT	£1595	S/H	£6600
MARK LEVINSON ML2 REFERENCE MONO AMPS	£3750	S/H	£15800
DYNAUDIO CONSEQUENCE MK2 SPEAKERS FINISHED IN CHERRYWOOD			
LOOKS & PERFORMANCE	£9250	E/D	£15275
SONUS FABER EXTRAS & STANDS WALNUT MINT	£4495	S/HAND	£9800
CONRAD JOHNSON SYTHESIS REFERENCE 4 TOWER SPEAKERS			
SYSTEM FINISHED IN OAK	£2895	S/HAND	£8000

"OOLES OF HIGH END CARTRIDGES AVAILABLE RING FOR DETAILS" MANY MORE ITEMS IN STOCK, EFFICIENT SERVICING DEPARTMENT. WE ARE LOCATED IN WELWYN, HERTS  
ALL ITEMS GUARANTEED - ALL MAJOR CREDIT CARDS ACCEPTED RING FOR DETAILS AND DEMONSTRATION 01438 714038  
10.00 AM - 7.00 PM MON - SAT 10.00 AM - 1.00 PM SUN  
Mobile Tel. 0831 250985

# Brentwood Hi Fidelity

2, Ingrave Road, Brentwood, Essex, CM15 8AT  
Tel: 01277 221210 Fax: 01277 261175

## Sale of ex-demonstration stock

Make	Model	RRP	Sale
Audio Innovations	1000 Series Pre Amp	1549	999
Audio Innovations	2nd Audio Power Amps	2999	1999
Audio Innovations	L2 Pre Amp	699	549
ECA	Vista/Lectem S Pre/Power	1640	1099
Chord	SPM 800 Power Amp	1749	1299
Chord	SPM 1200 Power Amp	2995	2249
Project	7 Integrated Amp	259	199
Rotel	RA935BX Integrated Amp	225	149
Marantz	CD 10 CD Player	1199	849
Marantz	CD 12 Transport/DAC	2800	1499
Manticore	Mantra Turntable	429	279
Pink Triangle	Anniversary Turntable	1797	1199
Systemdek	IIX/900 Turntable	229	159
Aura	TU 50 Tuner	299	199
Impulse	H6 Speakers	1495	999
Impulse	H2 Speakers	2250	1499
Ruark	Crusader II Speakers	1595	1349
TDL	Studio 1M (inc. stands)	974	749
SME	Series V Arm	1295	799
DPA	DAC (inc. Interconnect)	S/H	125
Kinshaw	Perception Phono Stage	S/H	299

All ex-demonstration products include full warranty

# WESTWOOD & MASON



Arcam, Aura, Celestion, Denon, KEF, Marantz, Mission, Naim, Nakamichi, Project, Quad, Rega, Rotel, Royd, Tannoy, TDL, Yamaha, Cord Co., Goldring, Grado, Klipsch, JPW, Infinity.

**WESTWOOD & MASON (OXFORD) LTD**  
46 GEORGE ST  
OXFORD

TEL OXFORD (01865) 247783  
CLOSED THURSDAY









**LPA - 10 Line Amplifier  
PA - 10 Phono Amplifier**



**SDD-1 CD Transport  
SDA-1 CD Converter**



**Transport**

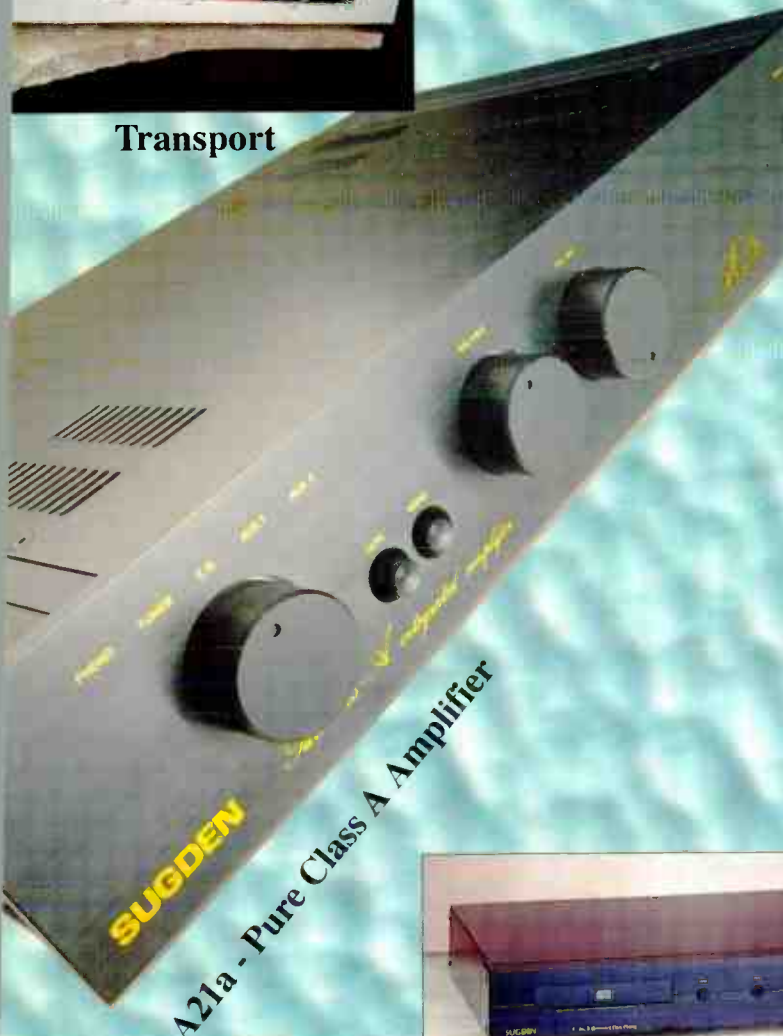

**SUGDEN  
A21a - Pure Class A Amplifier**



**SF 60 Line Level Integrated  
SF 100 Line Level Integrated**



**Optima - CD Player**



**AU 41 Pre & Power  
Amplifier**



**SDT-1 CD Player**

**J.E. SUGDEN & CO. LTD**

Valley Works, Station Lane, Heckmondwike, West Yorkshire WF16 0NF

Tel. Heckmondwike 01924 404088/9 Fax. 01924 410069

O J A N   >   O J A N   +   O J A N  
3                      3X                      3S

MULTISTAGE UPGRADEABLE LOUDSPEAKER SYSTEM



**“Remember it’s still not over till the fat lady sings”**

**ROKSAN**

ROKSAN DIGITAL LTD. STOCKLEY CLOSE, STOCKLEY ROAD, WEST DRAYTON, MIDDLESEX UB7 9BB  
TEL: +44 (0) 1895 436384 FAX: +44 (0) 1895 436385

World Radio History