

THE WIRELESS ENGINEER

VOL. XV.

AUGUST, 1938

No. 179

Editorial

Should the Rationalised M.K.S. System of Units be Adopted?

THESE notes are prompted by the thought that as they are being written the International Electrotechnical Commission is sitting at Torquay and that this question is on the agenda. The writer was unfortunately unable to attend the meetings, but had some preliminary correspondence on the subject.

All textbooks of electrical engineering discuss three systems of units, the electromagnetic and electrostatic c.g.s. systems and the practical system, which is really an electromagnetic system in which the electric units are made of a more convenient magnitude, but the magnetic units left with their c.g.s. values. It is now forty years since Giorgi first advocated his m.k.s. system, in which the metre and the kilogramme replace the centimetre and the gramme, and in which the three earlier systems are merged into one. The two c.g.s. systems gave different dimensions to one and the same electrical magnitude, due to the fact that one was based on the assumption that the permeability of space was a dimensionless numeric, whereas in the other system a similar assumption was made about the permittivity of space. Giorgi not only proposed the substitution of m.k.s. for

c.g.s. but also advocated giving up the assumption that everything electric and magnetic must be expressible in terms of the three concepts L , M and T . He proposed that four fundamentals should be recognised, the fourth being one of the electromagnetic concepts, e.g., current, quantity or resistance. Recent opinion has favoured the permeability of space μ_0 as the fourth fundamental concept, and the system now under consideration by the I.E.C. is based on this assumption. It is not suggested, however, that the permeability of space should be given the value unity, but that it should be given the value 10^{-7} . To have unit permeability a medium would have to be ten million times as permeable as space.

It is regrettable that a recent book by an author of great eminence in another branch of science*—a book devoted entirely to the subject of dimensions—gives a very confused account of the recommendations of the S.U.N. Commission, based obviously on a misunderstanding. The actual wording of the recommendation was "that the 'fourth unit' on the m.k.s. system be 10^{-7}

* "The Theory of Dimensions," by Dr. F. W. Lanchester. See especially Appendix VII, pp. 296-297.

henry per metre, the value assigned on that system to the permeability of space." They pointed out that "the m.k.s. system can be made absolute by the assumption of any convenient value for μ_0 , but if the units of that system are to be the practical units . . . the value of μ_0 must be 10^{-7} . . ." "On the rationalised system of units the value will be $4\pi \times 10^{-7}$." One would have thought that this was incapable of misunderstanding; the "fourth unit" or fundamental magnitude is to be μ_0 , the permeability of space, but instead of calling it μ it is to be given the value 10^{-7} . In the book referred to the deduction drawn from this is that one Giorgi (or m.k.s.) unit of permeability = 10^{-7} c.g.s. unit or "the measure of 1 c.g.s. unit in terms of the Giorgi unit = 10^7 ," both of which statements are upside down. On the following page we read that "the author believes the value assigned to μ_0 in the m.k.s. system, namely, $\mu_0 = 10^{-7}$, is a mistake and that the correct value is 10^7 . We will proceed on this basis and discuss the point afterwards"—and he does!

The great advantage of the Giorgi system is that it gives the ampere, volt, ohm, etc. as the absolute units. The unit of energy is the joule, and the unit of force, sometimes called a vis and sometimes a newton, is equal to 10^5 dynes.

Another question which has come to the fore in connection with the m.k.s. system is Heaviside's suggested "rationalisation," that is, so altering the fundamental definitions that the 4π does not obtrude in the formulae employed in practice. It has always been held by the majority to be undesirable to attempt to introduce rationalisation because of the widespread use of the classical system in every branch of electrical science and the confusion that would probably ensue. The introduction of the m.k.s. system has suggested the advisability of going further and introducing a rationalised m.k.s. system. In order to see what effect this would have on the problems that arise in the teaching of electrical science we have worked out a number of simple problems which we now propose to consider, and readers can then form their own opinion on the subject.

At what distance apart must two unit charges (coulombs) be placed in a medium of unit permittivity ($\kappa = 1$ farad per metre

cube = $4\pi \cdot 9 \cdot 10^9$ e.s.c.g.s. units) in order that they may repel each other with unit force (1 vis = 10^5 dynes)?

$$f = \frac{q^2}{\kappa d^2} = \frac{9 \times 10^{18}}{4\pi 9 \cdot 10^9 d^2} = 10^5 \text{ dynes}$$

$$\therefore d = \frac{100}{\sqrt{4\pi}} \text{ cm} = \frac{1}{\sqrt{4\pi}} \text{ metre}$$

i.e. the radius of a sphere of 1 square metre surface.

Hence in the rat. m.k.s. system

$$f = \frac{q_1 q_2}{4\pi \kappa d^2}$$

The unit of H will be 1 ampere-turn per metre—a very weak field—and the force on a unit c.g.s. pole in this field would be only $4\pi/10^3$ dynes. To give a force of 1 vis, i.e., 10^5 dynes, the pole-strength would have to be $10^8/4\pi$ c.g.s. units; this then is the unit pole in the rationalised m.k.s. system if the formula $f = mH$ is still to hold.

At what distance apart must two unit poles ($10^8/4\pi$ c.g.s. units) be placed in a medium of unit permeability ($10^7/4\pi$ e.m.c.g.s. units) in order that they may repel each other with unit force (10^5 dynes)?

$$f = \frac{m^2}{\mu d^2} = \frac{10^8/4\pi \times 10^8/4\pi}{10^7/4\pi \times d^2} = 10^5 \text{ dynes}$$

$$\therefore d = \frac{100}{\sqrt{4\pi}} \text{ cm} = \frac{1}{\sqrt{4\pi}} \text{ metre}$$

as in the case of the unit charges, and hence in the rat. m.k.s. system $f = m_1 m_2 / 4\pi \mu d^2$.

Since the permeability of space $\mu_0 = \frac{4\pi}{10^7}$ henry per metre cube and the permittivity $\kappa_0 = \frac{1}{4\pi \cdot 9 \cdot 10^9}$ farad per metre cube, the velocity of light $c = \frac{1}{\sqrt{\mu_0 \kappa_0}} = \sqrt{9 \times 10^{16}}$ = 3×10^8 metres per sec.

$B = \mu H$. If $H = 1$, i.e., 1 ampere-turn per metre ($\frac{4\pi}{10^3}$ c.g.s. units) and $\mu = 1$ ($10^7/4\pi$ c.g.s. units) then $B = 1$ weber per square metre (10^4 c.g.s. units per sq. cm or 10^8 c.g.s. units per sq. metre) = 1 volt-second per square metre.

If a single-turn coil of radius r metres

carries a current of I amperes, then at its centre

$$H = \frac{2\pi I}{10 \times 100r} \text{ c.g.s. units} = \frac{2\pi I}{10 \times 100r} \times \frac{10^3}{4\pi} = \frac{I}{2r} \text{ m.k.s. rat. units.}$$

Since in the c.g.s. system the flux emanating from a pole is 4π times the pole strength, the flux emanating from a pole of $10^8/4\pi$ c.g.s. units would be 10^8 c.g.s. units. Hence the flux emanating from unit pole in the rat. m.k.s. system is one weber or volt-second, and instead of referring to a pole of strength m we can refer to one of Φ webers.

If a magnet pole of Φ webers be placed at the centre of the coil, the force on it will be $\frac{I\Phi}{2r}$ vis.

This must also be the force on the coil due to the current flowing in the magnetic field from the pole. At a distance of r metres from the pole of Φ webers the magnetic induction B will be $\frac{\Phi}{4\pi r^2}$ webers per square metre, and

from the formula $f = BIl$ we obtain $\frac{\Phi I}{2r}$ vis.

If a charge of q coulombs ($3 \cdot 10^9 q$ e.s.c.g.s. units) is in an electric field of \mathcal{E} volts per metre ($\frac{\mathcal{E}}{3 \cdot 10^4}$ e.s.c.g.s. units) the force on it is $10^5 q \mathcal{E}$ dynes or $q \mathcal{E}$ vis.

In a field of \mathcal{E} volts per metre the polarisation, displacement, or density of electric flux will be $\kappa \mathcal{E}$ coulombs per square metre. In a long air-core solenoid of T turns per metre carrying a current of I amperes, $H = IT$, and if the solenoid has a cross-sectional area of A square metres the flux in it will be $\mu_0 AIT$ webers. We have not escaped entirely from the 4π , however, as we find when we insert numerical values and have to put $\mu_0 = 4\pi/10^7$. Similarly, although the formula for the capacitance of an air condenser, $C = \kappa_0 A/d$, looks simpler than the classical $\kappa_0 A/4\pi d$, there is no real simplification since κ_0 is now equal to

$\frac{1}{4\pi \cdot 9 \cdot 10^9}$. There is no escape from the fact

that the relation between the radius and surface area of a sphere involves 4π , but there is also no reason why the same procedure should not be adopted in the case of a unit pole and a unit charge. One of the

most unsatisfactory things in the classical c.g.s. system was the lack of parallelism between the two formulae $B = \mu H$ and $D = \kappa \mathcal{E}/4\pi$. In the proposed system this 4π disappears and, just as unit electric flux is associated with unit charge, so unit magnetic flux emanates from unit pole.

G. W. O. H.

N.P.L. Annual Visit

THIS year the annual visit to the National Physical Laboratory took place at Teddington on June 28th. In the wireless section the main feature of interest was a small meteorological balloon equipped with an ultra-short wave transmitter for obtaining information about conditions prevailing in the upper atmosphere.

A wavelength of 8.5 metres is used and the whole transmitter weighs only 4½ lbs. Four valves are employed, two of which are A.F. oscillators, one is a modulator and the fourth is an R.F. oscillator. Iron-cored coils are used in the A.F. oscillators, the frequencies of which depend on atmospheric pressure and on temperature respectively. These changes are effected by varying the air gaps in the cores which in one oscillator is done by a small bellows-type aneroid and in the other by a wire stretched along an invar bar.

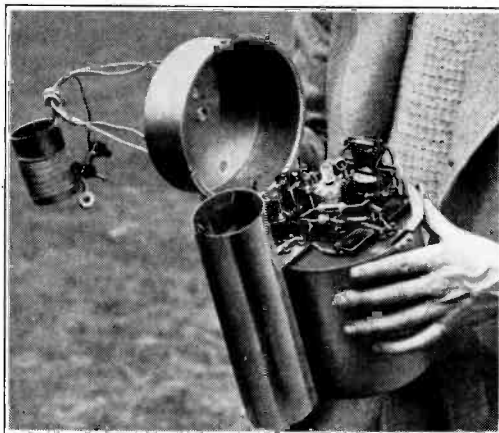

The U.S.W. transmitter for the meteorological balloon. A parachute attached to the apparatus ensures a safe landing when the balloon bursts.

The changes in the two modulation frequencies heard in the receiver thus give atmospheric pressure, which is then easily converted into height above ground, and the temperature obtaining at that height.

The flight of the balloon is also followed by an ultra-short wave direction finder and the radio bearings so obtained give the wind direction at various altitudes.

Coaxial and Balanced Transmission Lines*

Some Uses at High Radio Frequencies

By M. Reed, Ph.D., M.Sc., A.M.I.E.E.

At the higher radio frequencies, the increase in the undesirable effects of interconnecting leads and of stray reactances in the components themselves makes the use of resistances, condensers, inductances and transformers either separately or in combination increasingly difficult as the frequency rises. In recent years there has therefore been a tendency to replace these components by short lengths of transmission lines—a solution which becomes increasingly practicable as the frequency rises owing to the decrease in the length of line required.

It is well known that simple transmission lines can be used as inductances, condensers and single-frequency transformers, but it may not be so well known that they also lend themselves to the construction of resistances, filters and wide-band transformers. It is the object of this article, therefore, to provide in a simple form the principles which underlie the design of such structures.

List of Symbols

- e_i = voltage applied to the input terminals of the transmission line system ;
- i_i = input current ;
- e_o = output voltage ;
- i_o = output current ;
- R, L, G, C = respectively, the distributed resistance, inductance, conductance and capacitance per unit length of line ;
- P = propagation constant ;
- Z_p = characteristic impedance of line ;
- Z_o = input impedance with far end of line open circuited ;
- Z_s = input impedance with far end of line short-circuited ;
- Z_i = input impedance with far end of line terminated by impedance Z_R ;
- v = velocity of propagation ;
- f = frequency of applied signal = $\omega/2\pi$;
- λ = wavelength of applied signal = v/f ;
- p = $R/2Z_p$;
- q = $2\pi/\lambda$.

Transmission Line and Network Fundamentals

TO facilitate an understanding of the design of the structures described in the following, a brief review is given first of the transmission line and network theory on which these designs are based.

1. Transmission Line Equations

The equations of propagation of any

* MS. accepted by the Editor, March, 1938.

uniform transmission line of length l are given by

$$e_o = e_i \cosh Pl - i_i Z_p \sinh Pl \quad (1)$$

$$i_o = i_i \cosh Pl - \frac{e_i}{Z_p} \sinh Pl \quad \dots \quad (2)$$

where $Z_p = \sqrt{\frac{R + j\omega L}{G + j\omega C}}$,

and $P = \sqrt{(R + j\omega L)(G + j\omega C)}$.

G is usually very low and can be neglected for coaxial and balanced transmission lines. Also, at high radio frequencies it can be assumed that $R \ll \omega L$ and that $v = 1/\sqrt{LC}$. As a result, the expressions for the characteristic impedance and the propagation constant reduce to

$$Z_p = \sqrt{\frac{L}{C}},$$

and $P = \frac{R}{2Z_p} + j\frac{2\pi}{\lambda} = p + jq$.

Further, since $p \ll 1$, we can replace $\tanh pl$ by pl and obtain the following simplified expressions for the input impedance of a transmission line when the far end is (a) open circuited, (b) short-circuited and (c) terminated by an impedance Z_R .

$$(a) Z_o = Z_p \coth Pl, \\ = Z_p \coth (pl + jq l),$$

$$\text{or } \frac{Z_o}{Z_p} = \frac{1 + jpl \cdot \tan ql}{pl + j \tan ql} \quad \dots \quad (3)$$

(b) $Z_s = Z_p \tanh Pl$,
 or $\frac{Z_s}{Z_p} = \frac{\rho l + j \tan ql}{1 + j \rho l \tan ql} \dots \dots (4)$

(c) $Z_i = Z_p \left(\frac{\sinh Pl + \frac{Z_R}{Z_p} \cosh Pl}{\cosh Pl + \frac{Z_R}{Z_p} \sinh Pl} \right)$
 or $\frac{Z_i}{Z_p} \cdot \frac{Z_R}{Z_p} = \frac{(\rho l + \frac{Z_R}{Z_p}) + j(1 + \rho l \cdot \frac{Z_R}{Z_p}) \tan ql}{(\rho l + \frac{Z_p}{Z_R}) + j(1 + \rho l \cdot \frac{Z_p}{Z_R}) \tan ql}$

When the resistance of the line is neglected, we put $\rho = 0$ and obtain

$Z_o = -jZ_p \cot ql \dots \dots (5)$

$Z_s = jZ_p \tan ql \dots \dots (6)$

$Z_i = \frac{Z_R Z_p + jZ_p^2 \tan ql}{Z_p + jZ_R \tan ql} \dots (7)$

It follows from equations (5) and (6) that lines of less than a quarter wavelength in length behave on open-circuit as condensers and on short-circuit as inductances. Also, two lines have reactances of the same magnitude but of opposite sign when (a) they are both on open-circuit (or short-circuit) and have lengths of l and $(\frac{\lambda}{2} - l)$ respectively, (b) one is on open-circuit and the other is on short-circuit and have lengths of l and $(\frac{\lambda}{4} - l)$ respectively, (c) one is on short-circuit and the other is on open-circuit and have lengths of l and $(\frac{\lambda}{4} - l)$ respectively.

2. Network Transformations

Consider the unsymmetrical *T* network shown in Fig. 1 in which θ is the transfer constant, K_1 and K_2 are the image impedances,* and the currents and voltages are as indicated. The equations of this network

* The image impedances are such that, if the output terminals are closed by the impedance K_2 , the impedance as measured at the input terminals is K_1 ; and if the input terminals are closed by K_1 the impedance between the output terminals is K_2 . The transfer constant is generally defined as one-half the natural logarithm of the vector ratio of the steady-state volt-amperes entering and leaving the network when the latter is terminated in its image impedances.

are

$e_i = i_i Z_L + i_2 Z_N$;
 $i_i = i_o + i_2$;
 $e_o = i_2 Z_N - i_o Z_M$;

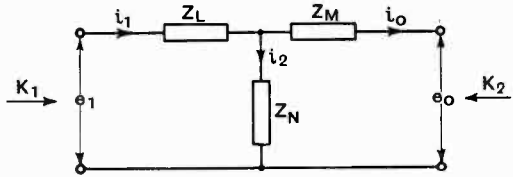

Fig. 1.

which, on elimination of i_2 , give

$e_o = e_i \cdot \frac{Z_M + Z_N}{Z_N} - i_i \cdot \frac{Z_L Z_M + Z_M Z_N + Z_N Z_L}{Z_N} = e_i A - i_i B \dots (8)$

$i_o = i_i \cdot \frac{Z_L + Z_N}{Z_N} - e_i \cdot \frac{1}{Z_N} = i_i C - e_i D (9)$

where $AC - BD = 1$, and

$A = \frac{Z_M + Z_N}{Z_N}$; $B = \frac{Z_L Z_M + Z_M Z_N + Z_N Z_L}{Z_N}$;
 $C = \frac{Z_L + Z_N}{Z_N}$; $D = \frac{1}{Z_N} \dots (10)$

Consider now the arrangement of Fig. 2 which represents two symmetrical networks each having a propagation constant $\theta/2$, one having a characteristic impedance K_1 and the other K_2 , and coupled by an ideal transformer whose ratio of primary to secondary turns is ϕ , so that $\phi^2 : 1 = K_1 : K_2$. For the

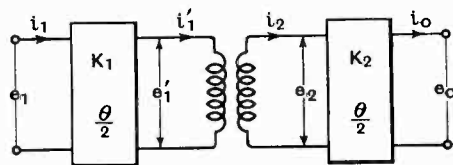

Fig. 2.

designated currents and voltages, application of equations (1) and (2) produces

$e'_i = e_i \cosh \theta/2 - i_i K_1 \sinh \theta/2$;
 $i_2 = \phi i'_i$;
 $i'_i = i_i \cosh \theta/2 - e_i / K_1 \sinh \theta/2$;
 $e_2 = e'_i / \phi$.
 $e_o = e_2 \cosh \theta/2 - i_2 K_2 \sinh \theta/2$;
 $i_o = i_2 \cosh \theta/2 - e_2 / K_2 \sinh \theta/2$;

Eliminating e'_i , e_2 , i_2 and i'_i from these

equations, we obtain

$$e_o = I/\phi(e_i \cosh \theta - i_i/K_1 \sinh \theta) \dots (I1)$$

$$i_o = \phi(i_i \cosh \theta - e_i/K_1 \sinh \theta) \dots (I2)$$

Comparison of equations (I1) and (I2) with (8) and (9) produces the following relationships:—

$$\left. \begin{aligned} \text{Cosh } \theta &= \sqrt{AC} \\ &= \sqrt{\frac{(Z_L + Z_N)(Z_M + Z_N)}{Z_N^2}} \\ K_1 &= \sqrt{\frac{BC}{AD}} \\ &= \sqrt{\frac{(Z_L + Z_N)(Z_L Z_M + Z_M Z_N + Z_N Z_L)}{Z_M + Z_N}} \quad (I3) \\ K_2 &= \sqrt{\frac{AB}{CD}} \\ &= \sqrt{\frac{Z_M + Z_N}{Z_L + Z_N} \frac{(Z_L Z_M + Z_M Z_N + Z_N Z_L)}{Z_L + Z_N}} \\ \phi^2 &= \frac{K_1}{K_2} = \frac{C}{A} = \frac{Z_L + Z_N}{Z_M + Z_N} \end{aligned} \right\}$$

It follows from the above that any unsymmetrical network can be replaced by an equivalent structure comprising two symmetrical networks coupled by an ideal transformer, the conditions for the equivalence being given by equations (I3).

The cut-off frequencies for the network can be located by determining the limits between which the real part of the transfer constant is zero—that is,

when $\cosh \theta = \pm 1$

or when $\sqrt{\left(1 + \frac{Z_L}{Z_N}\right)\left(1 + \frac{Z_M}{Z_N}\right)} = \pm 1 \dots (I4)$

and the mid frequency of the pass band occurs when $\cosh \theta = 0$.

Transmission Lines in Parallel—Design of Resistances.

Consider two open-circuited lines having the same constants but different lengths connected in parallel as indicated by Fig. 3. From equation (3) the parallel impedance Z_t is given by

$$\frac{Z_t}{Z_p} = \frac{1 - \rho^2 l_1 l_2 \tan ql_1 \cdot \tan ql_2 + j\rho(l_1 \tan ql_1 + l_2 \tan ql_2)}{\rho(l_1 + l_2)(1 - \tan ql_1 \cdot \tan ql_2) + j(1 + \rho^2 l_1 l_2)(\tan ql_1 + \tan ql_2)} \dots (I5)$$

Two cases are of interest, viz.:

(I) $\tan ql_1 + \tan ql_2 = 0,$

i.e. $\frac{2\pi}{\lambda} l_1 = \pi - \frac{2\pi l_2}{\lambda}$

or $l_1 + l_2 = L = \frac{\lambda}{2}.$

As a result, equation (I5) simplifies to

$$\begin{aligned} \frac{Z_t}{Z_p} &= \frac{1 + \rho^2 l_1 l_2 \tan^2 ql_1}{\rho(l_1 + l_2) \sec^2 ql_1} \\ &\quad - \frac{j \cdot \rho(l_2 - l_1) \tan ql_1}{\rho(l_1 + l_2) \sec^2 ql_1} \\ &= \frac{1}{\rho L} \cdot \cos^2 ql_1 + \rho \cdot \frac{l_1 l_2}{L} \sin^2 ql_1 \\ &\quad - j \frac{l_2 - l_1}{L} \cdot \frac{\sin^2 ql_1}{2} \end{aligned}$$

or $Z_t = R_{eff} + jX_{eff}$

$$\begin{aligned} &= \frac{2Z_p^2}{RL} \cdot \cos^2 \frac{l_1}{L} \pi + \frac{RL}{2} \cdot \frac{l_1}{L} \left(1 - \frac{l_1}{L}\right) \sin^2 \frac{l_1}{L} \cdot \pi \\ &\quad - j \frac{Z_p}{2} \left(1 - \frac{2l_1}{L}\right) \sin \frac{l_1}{L} \cdot 2\pi \quad (I6) \end{aligned}$$

This result has been previously disclosed by Sterba and Feldman.*

Also, $\frac{R_{eff}}{X_{eff}} > \frac{2Z_p}{R} \cdot \frac{1}{(L - 2l_1)} \cdot \cot \frac{l_1}{L} \pi \dots (I7)$

Equation (I6) shows that the parallel combination has a resistance of minimum value $\frac{RL}{8}$ when $l_1 =$

$0.5L$, and a maximum value of $2Z_p^2/RL$ when $l_1 = 0$. A variable

resistance can therefore be obtained by sliding the tapping point between these two values of l_1 . Since $Z_p \gg R$, it follows from equation (I7) that for most practical purposes this variable resistance is non-reactive.

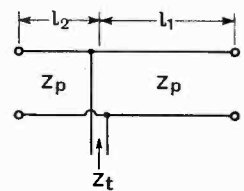

Fig. 3.

* Proc. I.R.E., 1932, Vol. 20, p. 1197.

$$(2) \tan ql_1 \cdot \tan ql_2 = 1,$$

$$\text{i.e. } \frac{2\pi}{\lambda} \cdot l_2 = \frac{\pi}{2} - \frac{2\pi}{\lambda} \cdot l_1 \text{ or } l_1 + l_2 = L = \frac{\lambda}{4}.$$

In this case, equation (15) simplifies to

$$\frac{Z_t}{Z_p} = \frac{\rho}{1 + \rho^2 l_1 l_2} (l_1 \tan^2 ql_1 + l_2) \cos^2 ql_1 - j \frac{1 - \rho^2 l_1 l_2}{1 + \rho^2 l_1 l_2} \cdot \frac{\sin 2ql_1}{2}.$$

Since $\rho^2 l_1 l_2 \ll 1$, we obtain

$$Z_t = \frac{RL l_1}{2 L} \left\{ \sin^2 \frac{2\pi l_1}{\lambda} + \left(1 - \frac{l_1}{L}\right) \cos^2 \frac{2\pi l_1}{\lambda} \right\} - j \frac{Z_p}{2} \sin \frac{4\pi l_1}{\lambda}.$$

This parallel combination therefore provides a variable condenser having a maximum reactance of $0.5 Z_p$ when $l_1 = 0.5L$ and zero reactance when $l_1 = 0$. The value of the resistance component never exceeds $0.5RL$, so that, for most practical purposes, it can be regarded as negligible.

Results corresponding to the above are also obtained for two short-circuited lines in parallel by making use of equation (4), and for one open-circuited and one short-circuited line in parallel by combining equations (3) and (4). These results are given in Table I, where it is seen that the half-wave lines of cases 1 and 2 and the quarter-wave line of case 3 provide variable resistances of the

same maximum value but of different rates of variation with change in $\frac{l_1}{L}$. Variable reactances whose rates of variation with change in the value of l_1 are different from those obtained from equations (5) and (6) are given by the quarter-wave lines of cases 1 and 2 and the half-wave line of case 3. The type of impedance to be expected in any particular case can easily be checked by reference to the remarks made on page 415 in connection with equations (5) and (6). For example, the half-wave line of case 1 consists, in effect, of a simple parallel resonant circuit having resistances in both condenser and inductance legs and tuned to the input signal for all positions of the tapping point. It should therefore behave as a practically pure resistance whose value, for a given inductance and capacity, depends on the value of the resistances. On the other hand, the quarter-wave line comprises, in effect, two condensers in parallel for all positions of the tapping point, and should therefore provide a variable condenser.

It will be noted that a quarter wavelength line provides a variable condenser, inductance or resistance depending on whether both ends are open, both ends are closed or one end is open and the other end is closed. Therefore, by using a coaxial cable in the way suggested by Fig. 4, any one of the three

TABLE I.

Case	Condition.	Combined Lgth.	Effective Resistance.	Effective Reactance.	Application.
1	Two open-circuited lines in parallel.	$\frac{\lambda}{2}$	$\frac{2Z_p^2}{RL} \cos^2 \frac{l}{L} \cdot \pi + \frac{RL}{2} \cdot \frac{l}{L} \left(1 - \frac{l}{L}\right) \sin^2 \frac{l}{L} \cdot \pi$	$-\frac{Z_p}{2} \left(1 - \frac{2l}{L}\right) \sin \frac{2l}{L} \cdot \pi$	Variable resistance.
		$\frac{\lambda}{4}$	$\frac{RL}{2} \left\{ \frac{l}{L} \sin^2 \frac{l}{L} \cdot \frac{\pi}{2} + \left(1 - \frac{l}{L}\right) \cos^2 \frac{l}{L} \cdot \frac{\pi}{2} \right\}$	$-\frac{Z_p}{2} \sin \frac{l}{L} \cdot \pi$	Variable condenser.
2	Two short-circuited lines in parallel.	$\frac{\lambda}{2}$	$\frac{2Z_p^2}{RL} \sin^2 \frac{l}{L} \cdot \pi + \frac{RL}{2} \cdot \frac{l}{L} \left(1 - \frac{l}{L}\right) \cos^2 \frac{l}{L} \cdot \pi$	$\frac{Z_p}{2} \left(1 - \frac{2l}{L}\right) \sin \frac{2l}{L} \cdot \pi$	Variable resistance.
		$\frac{\lambda}{4}$	$\frac{RL}{2} \left\{ \frac{l}{L} \sin^2 \frac{l}{L} \cdot \frac{\pi}{2} + \left(1 - \frac{l}{L}\right) \sin^2 \frac{l}{L} \cdot \frac{\pi}{2} \right\}$	$\frac{Z_p}{2} \sin \frac{l}{L} \cdot \pi$	Variable inductance.
3	One short-circuited line and one open-circuited line in parallel.	$\frac{\lambda}{2}$	$\frac{RL}{2} \left\{ \frac{l}{L} \sin^2 \frac{l}{L} \cdot \pi + \left(1 - \frac{l}{L}\right) \cos^2 \frac{l}{L} \cdot \pi \right\}$	$-\frac{Z_p}{2} \sin \frac{2l}{L} \cdot \pi$	Variable condenser.
		$\frac{\lambda}{4}$	$\frac{2Z_p^2}{RL} \cdot \cos^2 \frac{l}{L} \cdot \frac{\pi}{2} + \frac{RL}{2} \cdot \frac{l}{L} \left(1 - \frac{l}{L}\right) \sin^2 \frac{l}{L} \cdot \frac{\pi}{2}$	$-\frac{Z_p}{2} \left(1 - \frac{2l}{L}\right) \sin \frac{l}{L} \cdot \pi$	Variable resistance.

quantities can be obtained by changing the end-pieces. The arrangement shown in the diagram corresponds to the case of the variable resistance.

The design of such a resistance for any given frequency can be obtained by proceeding on the following lines. From Table I the resistance for a quarter-wave line can be written as

$$\frac{R_{\text{eff}}}{Z_p} = K \cos^2 \frac{\pi}{2} \cdot x + \frac{1}{K} x (1-x) \sin^2 \frac{\pi}{2} x, \quad (18)$$

where $K = \frac{2Z_p}{RL}$ and $x = \frac{l_1}{L}$.

At high radio frequencies, the resistance of a concentric tube line is

$$R = \sqrt{\rho \mu f} \left(\frac{1}{a} + \frac{1}{b} \right) 10^{-9} \text{ ohms/cm.}^*$$

in which

- ρ = resistivity in e.m.u. ;
- μ = magnetic permeability ;
- f = frequency in c.p.s. ;
- a = outer radius of inner conductor in cms. ;
- b = inner radius of outer conductor in cms.

It is convenient to make $\frac{b}{a} = 3.6$, which is the optimum ratio for minimum attenuation. This ratio corresponds to a characteristic impedance of 77 ohms.†

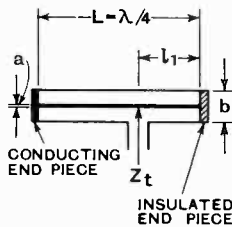

Fig. 4.

and ρ can be taken as 1,730 e.m.u.

$$\text{Therefore } K = \frac{154 \times 10^9}{\sqrt{1,730f}} \cdot \frac{1}{4.6} \cdot \frac{b}{L} = \frac{b\sqrt{f}}{9.32'}$$

since $L = \frac{\lambda}{4} = \frac{300 \times 10^8}{4f}$ cms.

For practical purposes, negligible error is involved by ignoring the second term on the right-hand side of equation (18). The resistance therefore becomes

$$R_{\text{eff}} = 8.25 b\sqrt{f} \cos^2 \pi \cdot \frac{x}{2} \quad \dots (19)$$

As it is not practical to employ tubes of smaller diameter than about 2 cms., equation (19) shows that, except at comparatively low frequencies involving long tubes, this type of construction lends itself to the design of high rather than low resistances.

Design of Filters and Wide-Band Transformers.

In the case of filters built up from lumped components, it is usual to neglect the dissipation occurring in the elements when determining the transmission bands. Following the same procedure when the filters are constructed from transmission lines, we assume that R and G are zero, and can therefore write jql for the propagation constant P . As a result, equations (1) and (2) become

$$e_o = e_i \cos ql - j i_i \cdot Z_p \sin ql \quad \dots (20)$$

$$i_o = i_i \cos ql - \frac{j e_i}{Z_p} \sin ql \quad \dots (21)$$

Consider now two dissimilar transmission lines of the same length having propagation

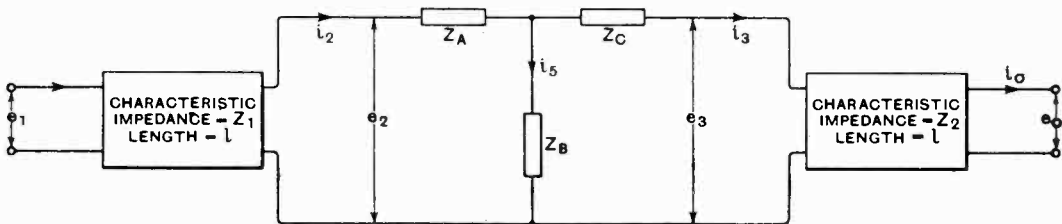

Fig. 5.

Assuming that the coaxial system is constructed from pure copper, we have $\mu = 1$

* A. Russell, "Alternating Currents," Vol. 1, p. 222 (1914), Cambridge Press.

† Sterba and Feldman, *loc. cit.*, p. 1171.

constants Z_1 and Z_2 , respectively, and coupled by an impedance which, in the general case, can be represented by the unsymmetrical T network of arms Z_A , Z_B and Z_C as shown in Fig. 5. For the given

currents and voltages, we derive by successive application of equations (20) and (21)

$$e_2 = e_i \cos ql - j i_i Z_1 \sin ql; \quad i_2 = i_3 + i_5;$$

$$i_2 = i_i \cos ql - \frac{j e_i}{Z_1} \sin ql; \quad i_5 = \frac{e_2 - i_2 Z_A}{Z_B};$$

$$e_o = e_3 \cos ql - j i_3 Z_2 \sin ql;$$

$$i_o = i_3 \cos ql - \frac{j e_3}{Z_2} \sin ql; \quad i_5 = \frac{e_3 + i_3 Z_c}{Z_B}.$$

Eliminating i_2, i_3, i_5, e_2 and e_3 , we obtain

$$e_o = e_i \left\{ \frac{Z_B + Z_C}{Z_B} \cos^2 ql - \frac{Z_2}{Z_1} \cdot \frac{Z_A + Z_B}{Z_B} \sin^2 ql \right. \\ \left. + j \left(\frac{1}{Z_1} \cdot \frac{Z_A Z_B + Z_B Z_C + Z_C Z_A + Z_2}{Z_B} \frac{\sin 2ql}{2} \right) \right. \\ \left. - j i_i Z_1 \left\{ \left(\frac{Z_B + Z_C}{Z_B} + \frac{Z_2}{Z_1} \cdot \frac{Z_A + Z_B}{Z_B} \right) \frac{\sin 2ql}{2} \right. \right. \\ \left. \left. - j \left(\frac{1}{Z_1} \cdot \frac{Z_A Z_B + Z_B Z_C + Z_C Z_A}{Z_B} \cos^2 ql \right. \right. \right. \\ \left. \left. \left. - \frac{Z_2}{Z_B} \sin^2 ql \right) \right\} \right\} \dots (22)$$

$$i_o = i_i \left\{ \frac{Z_A + Z_B}{Z_B} \cos^2 ql - \frac{Z_1}{Z_2} \cdot \frac{Z_B + Z_C}{Z_B} \sin^2 ql \right. \\ \left. + j \left(\frac{1}{Z_2} \cdot \frac{Z_A Z_B + Z_B Z_C + Z_C Z_A + Z_1}{Z_B} \frac{\sin^2 ql}{2} \right) \right. \\ \left. - \frac{j e_i}{Z_1} \left\{ \left(\frac{Z_A + Z_B}{Z_B} + \frac{Z_1}{Z_2} \cdot \frac{Z_B + Z_C}{Z_B} \right) \frac{\sin 2ql}{2} \right. \right. \\ \left. \left. + j \left(\frac{1}{Z_2} \cdot \frac{Z_A Z_B + Z_B Z_C + Z_C Z_A}{Z_B} \sin^2 ql \right. \right. \right. \\ \left. \left. \left. - \frac{Z_1}{Z_B} \cos^2 ql \right) \right\} \right\} \dots (23)$$

Comparison of equations (22) and (23) with (8), (9) and (10) shows that the corresponding arms of the T network which is equivalent to the structure of Fig. 5 are given by

$$Z_N = \frac{Z_B Z_1 Z_2 \sec^2 ql}{Z_1 Z_2 - \Sigma Z_A Z_B \tan^2 ql + j(Z_1 Z_B + Z_1 Z_C + Z_2 Z_A + Z_2 Z_B) \tan ql} \dots (24)$$

$$Z_L = Z_1 \left\{ \frac{Z_2 Z_A - (Z_1 Z_B + Z_1 Z_C + Z_2 Z_B) \tan^2 ql + j(Z_1 Z_2 + \Sigma Z_A Z_B) \tan ql}{Z_1 Z_2 - \Sigma Z_A Z_B \tan^2 ql + j(Z_1 Z_B + Z_1 Z_C + Z_2 Z_A + Z_2 Z_B) \tan ql} \right\} \dots (25)$$

$$Z_M = Z_2 \left\{ \frac{Z_1 Z_C - (Z_1 Z_B + Z_2 Z_A + Z_2 Z_B) \tan^2 ql + j(Z_1 Z_2 + \Sigma Z_A Z_B) \tan ql}{Z_1 Z_2 - \Sigma Z_A Z_B \tan^2 ql + j(Z_1 Z_B + Z_1 Z_C + Z_2 Z_A + Z_2 Z_B) \tan ql} \right\} \dots (26)$$

where $\Sigma Z_A Z_B = Z_A Z_B + Z_B Z_C + Z_C Z_A$. These equations provide the basis for the design of all the filters and transformers

which can be built from two transmission lines coupled together by any combination of impedances and/or additional transmission lines corresponding to Z_A, Z_B and Z_C of Fig. 5. It is also possible to construct many other types of filters and transformers from

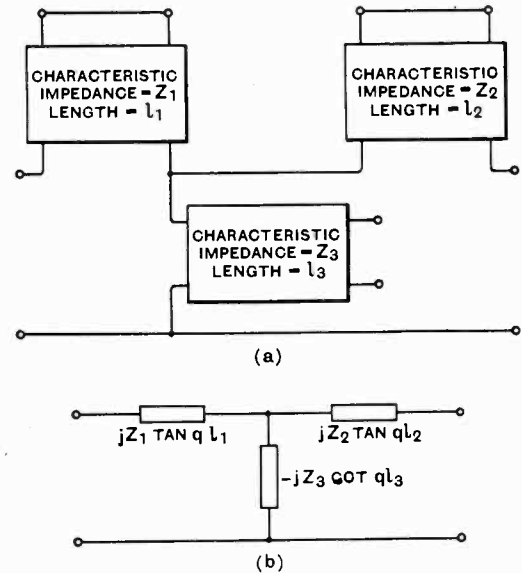

Fig. 6.

transmission lines which are not combined according to Fig. 5 but, for example, on the lines suggested by Fig. 6 (a), where the equivalent T network is obviously the one shown in Fig. 6 (b). It is not proposed, however, to deal with structures other than those corresponding to Fig. 5 because the equivalent T networks of other structures are either obvious, as in the case of Fig. 6, or they can be constructed by following the methods given above.

A comprehensive list of the character-

istics of the many filters which can be constructed from transmission lines with and without associated impedances, and also the

designs of a number of wide and narrow band filters and transformers, are contained in a paper recently published by Mason and Sykes.*

There are two principal cases to be considered in connection with the basic *T* network. These are:—

- (1) Z_A and/or Z_C are not zero.
- (2) $Z_A = Z_C = 0$.

Case 1. Z_A (and/or Z_C) $\neq 0$

In this case, in order that the structure shall transmit uniformly over a band of frequencies, the arms of the coupling impedance must satisfy a relationship corresponding to the one between the image impedances expressed by equations (13),

$$\text{i.e., } \frac{Z_1}{Z_2} = \frac{Z_A + Z_B}{Z_B + Z_C} = \phi^2 \text{ (say)} \quad \dots (27)$$

Substituting from equation (27) enables us to simplify equations (24), (25) and (26) to give expressions (28), (29) and (30).

Reference to equations (13) shows that the transfer constant and image impedances corresponding to the *T* network whose arms are expressed by equations (28), (29) and (30) are given by (31), (32) and (33).

The cut-off frequencies and the mid fre-

quency of the pass band are obtained from equation (14), i.e., by giving $\cosh \theta$ the values ± 1 and 0 in equation (31). The transformation ratio and the image impedances for any frequency within the pass band then follow by making the appropriate substitutions in equations (27), (32) and (33), respectively. If ϕ^2 is made independent of frequency, the structure will behave as an ideal transformer operating between impedances K_1 and K_2 for the frequency band defined by the cut-off frequencies. In practice, such a wide-band transformer can be achieved by providing condensers for Z_A , Z_B and Z_C .

When $Z_1 = Z_2$, the structure behaves as a filter without transformation. The corresponding equations for the symmetrical condition follow immediately by putting $Z_A = Z_C$ in equations (28), (29), (31) and (32).

Case 2. $Z_A = Z_C = 0$.

In this case we obtain from equations (24), (25) and (26)

$$Z_N = \frac{Z_1 Z_2 Z_B \sec^2 ql}{Z_1 Z_2 + j Z_B (Z_1 + Z_2) \tan ql} \quad \dots (34)$$

$$Z_L = j Z_1 \tan ql \quad \dots \dots \dots (35)$$

$$Z_M = j Z_2 \tan ql \quad \dots \dots \dots (36)$$

$$Z_N = \frac{Z_1 Z_2 Z_B \sec^2 ql}{\phi^2 \{Z_2 + j(Z_B + Z_C) \tan ql\}^2 + Z_B^2 \tan^2 ql} \quad \dots \dots \dots (28)$$

$$Z_L = Z_1 \sec^2 ql \left[\frac{Z_1(Z_B + Z_C) \cos 2ql - Z_2 Z_B + j(Z_1 Z_2 + \Sigma Z_A Z_B) \frac{\sin 2ql}{2}}{\phi^2 \{Z_2 + j(Z_B + Z_C) \tan ql\}^2 + Z_B^2 \tan^2 ql} \right] \quad \dots \dots (29)$$

$$Z_M = Z_2 \sec^2 ql \left[\frac{Z_1(Z_B + Z_C) \cos 2ql - Z_1 Z_B + j(Z_1 Z_2 + \Sigma Z_A Z_B) \frac{\sin 2ql}{2}}{\phi^2 \{Z_2 + j(Z_B + Z_C) \tan ql\}^2 + Z_B^2 \tan^2 ql} \right] \quad \dots \dots (30)$$

$$\cosh \theta = \phi \left\{ \frac{Z_B + Z_C}{Z_B} \cos 2ql + j \left(\frac{1}{Z_1} \frac{Z_A Z_B + Z_B Z_C + Z_C Z_A}{Z_B} + \frac{Z_2}{Z_B} \right) \frac{\sin 2ql}{2} \right\} \quad \dots \dots (31)$$

$$K_1 = Z_1 \sqrt{\frac{\frac{Z_B + Z_C}{Z_B} \sin 2ql - j \left(\frac{1}{Z_1} \frac{Z_A Z_B + Z_B Z_C + Z_C Z_A}{Z_B} \cos^2 ql - \frac{Z_2}{Z_B} \sin^2 ql \right)}{\frac{Z_B + Z_C}{Z_B} \sin 2ql + j \left(\frac{1}{Z_1} \frac{Z_A Z_B + Z_B Z_C + Z_C Z_A}{Z_B} \sin^2 ql - \frac{Z_2}{Z_B} \cos^2 ql \right)}} \quad \dots \dots (32)$$

$$K^2 = \frac{K_1}{\phi^2} \quad \dots \dots \dots (33)$$

* Bell System Technical Journal, 1937, Vol. 16, p. 275.

The corresponding transfer constant, image impedances and transformation ratio are therefore given by

$$\cosh \theta = \sqrt{\cos^2 2ql - \left\{ \frac{Z_1 Z_2}{Z_B^2} + \frac{(Z_1 - Z_2)^2}{Z_1 Z_2} \right\} \frac{\sin^2 2ql}{4} + j \frac{Z_1 + Z_2}{4Z_B} \sin 4ql} \dots \dots (37)$$

$$K_1 = \sqrt{\frac{Z_1 Z_2 \left(\cos^2 ql - \frac{Z_1}{Z_2} \sin^2 ql + j \frac{Z_1}{2Z_B} \sin 2ql \right)}{\cos^2 ql - \frac{Z_2}{Z_1} \sin^2 ql + j \frac{Z_2}{2Z_B} \sin 2ql} \frac{\left(1 + \frac{Z_2}{Z_1} \right) \frac{\sin 2ql}{2} + j \frac{Z_2}{Z_B} \sin^2 ql}{\left(1 + \frac{Z_2}{Z_1} \right) \frac{\sin 2ql}{2} - j \frac{Z_2}{Z_B} \cos^2 ql} \dots (38)}$$

$$K_2 = \frac{K_1}{\phi^2} \dots \dots \dots (39)$$

$$\phi^2 = \frac{\cos^2 ql - \frac{Z_1}{Z_2} \sin^2 ql + j \frac{Z_1}{2Z_B} \sin 2ql}{\cos^2 ql - \frac{Z_2}{Z_1} \sin^2 ql + j \frac{Z_2}{2Z_B} \sin 2ql} \dots (40)$$

As before, the particulars of the filter and transformer are derived from these equations. In practice, the above structure lends itself to the design of narrow-band transformers by making Z_B a short-circuited line whose length does not differ by very much from l . If Z_B is the characteristic impedance of this line and l_3 is its length, we have from equations (6) that

$$Z_B = jZ_3 \tan ql_3.$$

The equations for the symmetrical case are obtained by writing $Z_1 = Z_2$. This structure provides a narrow band filter without transformation.

It is interesting to note that the equivalent T network corresponding to Case 2 can be built up in the following way. Equation (34) can be written as

$$\frac{I}{Z_N} = \frac{Z_1 Z_2 + jZ_B(Z_1 + Z_2) \tan ql}{Z_1 Z_2 Z_B \sec^2 ql} = \frac{jZ_1 \cot ql - 2Z_B}{j2Z_1 Z_B (\tan ql + \cot ql)} + \frac{jZ_2 \cot ql - 2Z_B}{j2Z_2 Z_B (\tan ql + \cot ql)} \dots (41)$$

It follows from equations (35), (36) and (41) that the T network can be regarded as a

combination of the two \sqcap networks shown in Fig. 7.

Suppose now that one of the transmission

lines is terminated by an impedance $2Z_B$. The input impedance of such a line is given by equation (7) as

$$Z_i = \frac{2Z_1 Z_B + jZ_1^2 \tan^2 ql}{Z_1 + j2Z_B \tan ql} = jZ_1 \tan ql + j \frac{2Z_1 Z_B \tan ql}{jZ_1 \cot ql - 2Z_B} - \frac{j2Z_1 Z_B \cot ql}{2Z_B - jZ_1 \cot ql}$$

This line can therefore be replaced by a \sqcap network identical with the corresponding one of Fig. 7. In the same way, the second

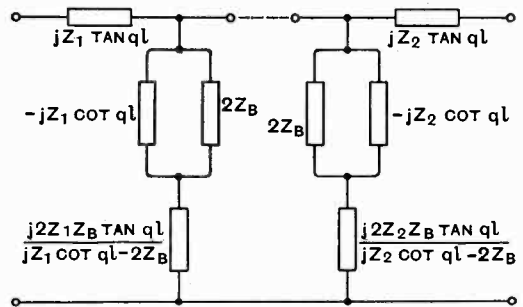

Fig. 7.

transmission line when terminated by $2Z_B$ can be replaced by a \sqcap network identical with the other one of Fig. 7. As a result, the following general theorem can be deduced:—

The T network equivalent to two transmission lines connected in series and shunted by a common impedance at their junction is derived by combining the two \sqcap networks obtained respectively by (a) evaluating the input impedance Z_i of each transmission line when terminated by twice the common shunt impedance, (b) dividing Z_i into two parts, one consisting of the short-circuit impedance Z_s and the other of $(Z_i - Z_s)$, and making the former the series arm and the latter the shunt arm of the \sqcap network.

Illustrative Example of a Transmission Line Filter

As an illustrative example of a transmission line filter, suppose that we have a symmetrical structure of the type considered under Case 2 and that we make Z_B a short-circuited line of length l_3 and characteristic impedance Z_3 ,

etc., it follows that this filter will also have pass bands at $2f_m, 3f_m$, etc.

From equation (44) the impedance of the filter is given by

$$K = Z_1 \sqrt{-\tan ql_1 \tan q(l_1 + l_3)},$$

which, at the mid-frequency f_m , becomes

$$K_m = Z_1 \sqrt{-\tan\left(\frac{\pi}{2} \frac{l_3}{1 + \frac{l_3}{2l_1}}\right) \cdot \tan\left[\frac{\pi}{2} \left(\frac{1 + \frac{l_3}{l_1}}{1 + \frac{l_3}{2l_1}}\right)\right]}.$$

where $Z_3 = 0.5Z_1$. Putting $Z_1 = 2Z_3$ and $Z_B = jZ_3 \tan ql_3$ in equation (37), we have

The above structure can therefore be employed as a band-pass filter operating between terminal impedances given by K_m and having cut-off frequencies given by f_1 and f_2 . Outside the pass band the attenuation corresponding to any given frequency is obtained from equation (42) by substituting the appropriate value for q .

$$\cosh \theta = \frac{\sin q(2l_1 + l_3)}{\sin ql_3} \quad \dots (42)$$

The cut-off frequencies are therefore given by

$$\sin q(2l_1 + l_3) = \pm \sin ql_3 \quad \dots (43)$$

and the mid-frequency of the pass band occurs when

$$\sin q(2l_1 + l_3) = 0 \text{ or when } f_m = \frac{v}{4l_1 + 2l_3}.$$

Taking first the positive sign in equation (43), we have

$$2 \sin ql_1 \cdot \cos q(l_1 + l_3) = 0$$

$$\text{Therefore } ql_1 = \pi \text{ or } q(l_1 + l_3) = \frac{\pi}{2}.$$

$$\text{From these, } f_a = \frac{v}{2l_1} \text{ or } f_b = \frac{v}{4(l_1 + l_3)}.$$

Taking the negative sign in equation (43) gives

$$2 \cos ql_1 \cdot \sin q(l_1 + l_3) = 0.$$

$$\text{Therefore, } ql_1 = \frac{\pi}{2} \text{ or } q(l_1 + l_3) = \pi.$$

$$\text{i.e., } f_c = \frac{v}{4l_1} \text{ or } f_d = \frac{v}{2(l_1 + l_3)}.$$

To obtain the required value for f_m , it is clear that the required cut-off frequencies for the first pass band are given by f_b and f_c —that is,

$$f_1 = \frac{v}{4(l_1 + l_3)}; f_2 = \frac{v}{4l_1}.$$

Hence by making the shunting line very short it is possible to obtain a narrow-band filter with this type of structure. Since the complete solution for the mid-frequency is actually $f_m = \frac{nv}{4l_1 + 2l_3}$, when $n = 1, 2, 3,$

Conclusions

Two transmission lines connected with their inputs in parallel can be designed to operate at any required frequency as a two-terminal network which, for all practical purposes, is a pure resistance, inductance or condenser, the condition obtained depending on both the sum of the lengths of the two lines and the nature of their respective far-end terminations.

Structures comprising two transmission lines coupled either by a third transmission line, by a combination of impedances or by both can be arranged to behave as four-terminal networks having the properties of filters and wide-band transformers. The design of such filters and transformers can be based on the transformation of the transmission line structures to equivalent T networks which, in the general case, are unsymmetrical.

Errata

“*Electron Transit Time Effects in Multigrid Valves.*”

The following three errors appeared in the article by M. J. O. Strutt in the June issue of *The Wireless Engineer* :—

p. 318, the result of the equation at foot of col. 1 should read $= 1.49 \times 10^{-9}$ sec.

p. 319, col. 1, line 21, should read “Taking a transit time of $t_1 = 3.0 \times 10^{-9}$ secs,” and line 23 “about 35 degrees.”

A New Converter Valve*

By J. L. H. Jonker and A. J. W. M. van Overbeek

(*Natuurkundig Laboratorium der N. V. Philips' Gloeilampenfabrieken, Eindhoven, Holland*)

IN modern broadcast receivers with wave-length conversion, such conversion is usually obtained with the aid of a converter or mixing valve, an octode or a hexode, in conjunction with a triode as oscillator, being most favoured for this purpose. Reference has repeatedly been made in literature to the good and bad properties of these valves¹. Among the chief difficulties with the hexode on medium and short waves are the damping on the

For this purpose the stream of electrons from the cathode is separated into four beams, two of which are used for the oscillator section and two for the converter, while supplementary measures have been taken to ensure the desired independence of these two functions. At the same time these measures led to the introduction of grids of special shape resulting in a higher gain being obtained through the valve.

§ 1. Path of Electrons in the Octode FC₄.

With a view to examining more closely the cause of frequency drift when controlling the bias of the signal grid in the case of

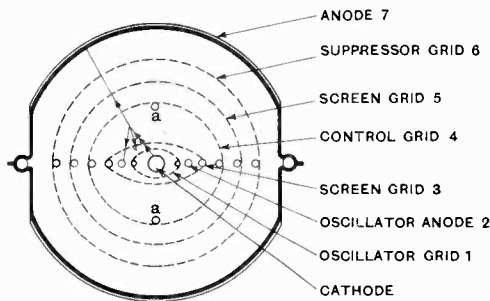

Fig. 1.—Locations of the electrodes in the octode FC₄.

input grid with short waves and the marked fluctuation in capacitance during volume control, while the principal disadvantages of the octode on short waves are the induction effect and the frequency variation of the oscillator during volume control on the valve.

By means of a neutralising condenser between the control grid and the oscillator grid this induction effect can be greatly reduced. The authors have, in collaboration with M. Strutt and others, constructed an octode converter valve of modified design, in which the frequency drift is eliminated in such a way that at high frequencies this octode can be used for regulation without any difficulty.

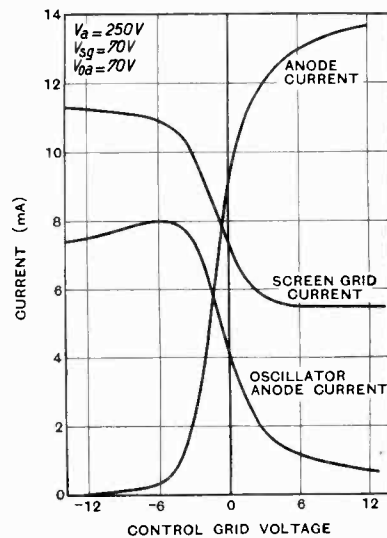

Fig. 2.—Curves of current distribution for the different electrodes plotted against the control voltage on grid 4 of the FC₄.

existing octodes, a series of measurements have been carried out on an FC₄ in order to study more closely the path of the electrons. A section of this valve is shown in Fig. 1. A round cathode surrounded by an oval

* MS. accepted by the Editor, March, 1938.

grid (1) emits two beams of electrons. One part of the electrons passes to the oscillator anode (2) and another part to the

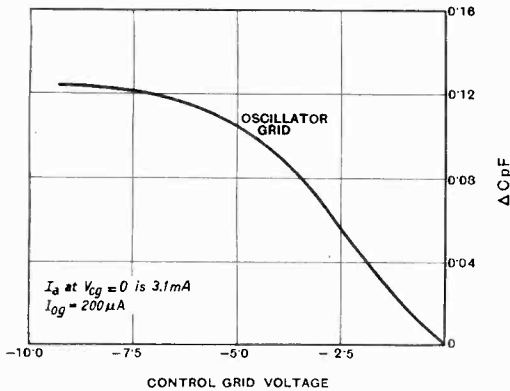

Fig. 3.—Variation of oscillator grid capacity plotted against control voltage on grid 4 of the octode FC4.

converter anode (7). The remainder is collected by the positive auxiliary electrodes (3) and (5). We will now examine the currents to these different electrodes in relation to the voltages on the control grid 4 (Fig. 2). By keeping the voltages of the other electrodes constant and varying the voltage of grid 4, it is found that in addition to a change in the current passing to the converter anode 7 this variation also has a marked influence on the current flowing to the oscillator anode 2. As we shall see later, this is due to the fact that the greater part of the electrons that find their way to the oscillator anode have approached and thus come under the influence of the control grid 4. Nearly all the electrons first pass grid 3 and are then delayed in front of the control grid 4, so that a distribution of current occurs. Part of the electrons pass grid 4 and form the anode current for the converter valve, whilst the remainder turn back. Of this residue a part will be collected by the third grid, either directly or after oscillating to and fro for a time, while another part finds its way to the oscillator anode 2 (see Fig. 1).

One of the causes of the frequency drift

in the octode during control is this dependence of the oscillator anode current on the control grid voltage: $\frac{dI_2}{dV_4}$. But there

is also another cause of this effect. The electrons oscillating round the third grid again approach the first grid, i.e., the control grid of the oscillator, and produce a space charge, in consequence of which the capacitance of this grid is increased (Fig. 3).

If as a result of control on grid 4 the number of returning electrons is altered this may lead to an alteration in capacitance at the oscillator grid. At high oscillator frequencies even a slight capacitance variation may produce a large frequency drift.

The path of the electrons in the octode, described briefly above, was further investigated on a test valve FC4 in which the current distribution across the anode could be followed with the aid of a probe. This probe consisted of a wire placed immediately in front of and parallel to the anode and which could be adjusted to various angles with reference to the plane of symmetry of the oscillator anode bars (see Fig. 1). The probe was an independent unit and was at the same voltage as the anode, both being covered with soot to prevent interference by secondary emission.

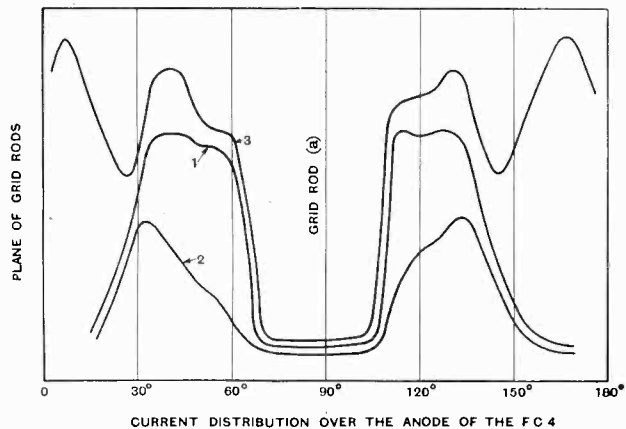

Fig. 4.—Curve 1, voltage on oscillator anode 90V, control grid - 1.5V. Curve 2, voltage on oscillator anode 90V, control grid - 2.5V. Curve 3, voltage on oscillator anode 0V, control grid - 1.5V.

In Fig. 4 the current distribution over the anode of an octode is shown, as plotted with this valve (curve 1). Owing to the

influence of the supporting bar (*a* in Fig. 1) of the control grid 4 an interruption of the electron stream occurs, and at this place the electrons are deflected sideways. If during volume control the control grid, and with it the supporting bar, receives a higher negative bias, this effect will be further intensified and the maximum passage of current will move away from *a* (curve 2 in Fig. 4). If now the oscillator anode is at

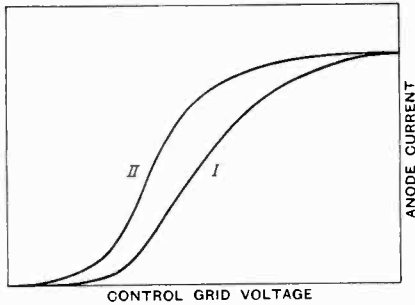

Fig. 5.—Effect of multiple transit of electrons through grid 3 on the slope of the anode current curve. I, without multiple transit; II, with multiple transit; absorption of the grid wires 15 per cent.

cathode potential, so that no electrons impinge on it, curve 1 in Fig. 4 will become converted to curve 3. From this it follows clearly that the oscillator anodes, as a result of their geometrical arrangement, can only withdraw current from those parts of the space between grids 3 and 4 which are at the greatest distance from the bar *a*.

The conclusions to be drawn from these measurements confirm the above description of the path of the electrons, and it is found that the combination cathode and grids 1 and 3 emit a markedly dispersed stream of electrons to both sides. A small part is allowed to pass through the control grid 4. The remainder returns, being attracted by the positive electrode 3. If an electron comes within this electrode it may be picked up by the oscillator anode 2 if it reaches the latter. If, on the other hand, the returning electron again approaches grid 1 it will continue to oscillate round the positive wires of grid 3 between grids 1 and 4 until it is either allowed to pass through the control grid or is picked up by the screen grid 3.

If the voltage of grid 4 is sufficiently

positive, the electron current passing from grid 3 to grid 4 will be allowed to go to grid 5 and the anode. When the voltage of grid 4 is negative all the electrons are reflected before this grid and then return to the screen grid 3. In this case a part *a* will be allowed to pass through this grid 3, the rest $1 - a$ is picked up. In the vicinity of the first grid this part *a* will reverse again and a part a^2 will return to the space between grid 3 and 4, the rest $a(1 - a)$ being absorbed by grid 3.

From this it follows that the current density I_2 of the electrons between grid 3 and 4, when the electrons are not allowed to pass through the 4th grid, will be considerably larger than the current density I_1 when all electrons are allowed to pass through grid 4 to the anode 7 :

$$I_2 = I_1 \cdot 2(1 + a^2 + a^4 + \dots) = I_1 \frac{2}{1 - a^2}$$

In the FC4 I_2 has 5-6 times the value of I_1 and hence on an average the electrons reach the vicinity of the control and oscillator grid between two and three times.

It is evident that in consequence of the space charge resulting herefrom the capaci-

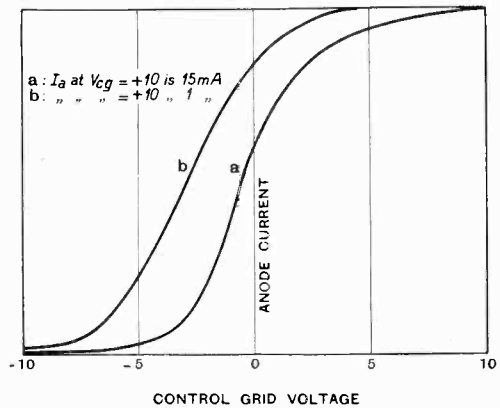

Fig. 6.—Effect of space charge on slope of the octode FC4.

tance of the oscillator grid 1 is increased by an amount depending on the current to the anode 7 (Fig. 3).

This oscillation of the electrons causes other effects as well. Each time the electrons come in front of the control grid 4 they may be given the opportunity to pass. If

the electron impinges near a negative grid wire it is sent back; while where the field potential between two grid wires is positive it can continue to move towards the anode².

Each electron has, therefore, several

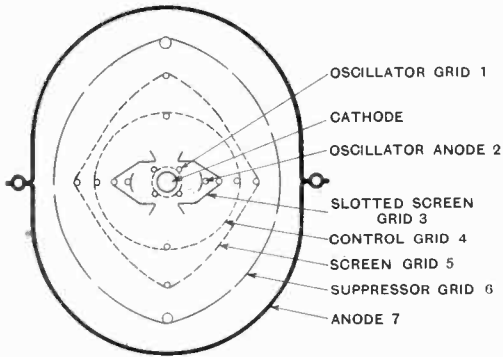

Fig. 7.—Locations of the electrodes in the 4-beam octode.

chances to pass through the control grid, resulting in a steeper slope being obtained.

In Fig. 5, curve II represents a characteristic $I_a = f(V_{g4})$ plotted for a valve with $a = 0.85$ and from which curve I, showing the form of the characteristic if the electrons arrive only once in front of the fourth grid can be deduced.

This favourable effect is slightly diminished by the deflection suffered by the electrons at each passage through the screen grid 3.

The heavy space charge, which, owing to oscillation, now occurs between grids 3 and 4 has yet another effect, as it may lead to a considerable reduction of the potential in the space in front of grid 4. In this space a virtual cathode ($V = 0$) may then be created³, but if the control grid allows more current to pass to the anode this virtual cathode will disappear again.

In Fig. 6 the influence which this space charge or virtual cathode can have on the anode-current characteristic is shown.

Two anode-current curves of the FC4 have been plotted as a function of the voltage at the control grid 4, for different maximum current values.

If we plot these curves in such a way that the maximum current values coincides, the deviations obtained will then be attributable to the differences in current density.

As a matter of fact, if the potential in the space is reduced as a result of the passage of current, the potential in the plane of the control grid will also drop as a result thereof, so that the anode-current characteristic will shift to the right. This effect is greatest with large space charges—that is, at that part of the characteristic at which the lowest anode currents occur. At higher anode-current values the space charge drops and therefore this shift is also reduced. In this case the curves approach each other and it will be obvious that as a result hereof part of the displaced characteristic will have a steeper slope.

It follows from the above that in existing types of octode several phenomena occur

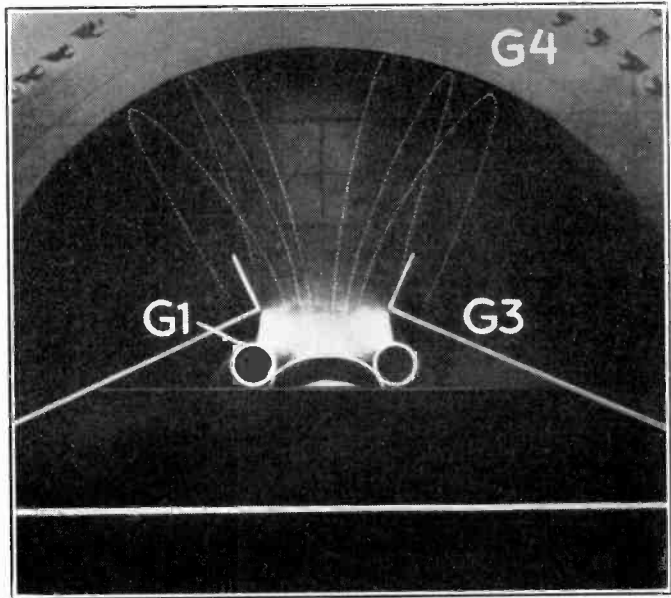

Fig. 8.

which make it possible to obtain a steep slope at a low total current.

§ 2. The Four-beam Octode

It will be seen from the above discussion and measurements that if a frequency drift is to be eliminated during control an improved octode must have, first, the *anode*

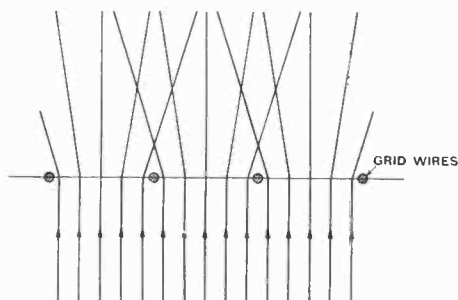

Fig. 9.—Intersection of electron paths after deflection by positive grid wires.

current of the oscillator and, secondly, the *capacitances* of the oscillator electrodes independent of the A.V.C. voltage. The anode current of the oscillator cannot be entirely independent of conditions in the converter section of the valve, unless the electron paths in the two parts are entirely separated. For this reason the use of a separate oscillator valve has been suggested. By mounting two valve units one above the other in the same bulb as adopted in the triode-hexode, this requirement may be met, but entails, *inter alia*, a complicated construction of valve. This is, however, not the case in the construction described below, where use is made of 4 separate beams.

The second requirement is that the capacitances of the oscillator electrodes must not be dependent on the A.V.C. voltage. As this dependence is due to electrons returning to the oscillator grid, such return must be avoided in the new design of valve, and this can be done by deflecting the electrons on their way to the control grid in such a manner that on their return they cannot approach their point of departure again.

It has been possible to meet these require-

ments by a design of which a cross section is shown in Fig. 7. By using a circular cathode enclosed by a circular grid with four supporting bars four sharply separated beams are emitted from the cathode. Two opposite beams are picked up by two small plates which, just as in the octode FC₄, serve as oscillator anodes. The concentrating effect of the supporting wires of the grid is also utilised. The mutual screening of the beams is continued from the supporting bars by a screen 3, which is maintained at a positive potential of about 100 volts with respect to the cathode. The two parts of the valve in which the oscillator current flows are in this way entirely separated from the remainder of the valve, so that the first requirement is definitely met.

To satisfy the second requirement, viz., that the capacitances of the oscillator electrodes shall not alter during control, is a more difficult matter. Opposite those parts of the first grid not used for the oscillator a slit-shaped aperture is made in the

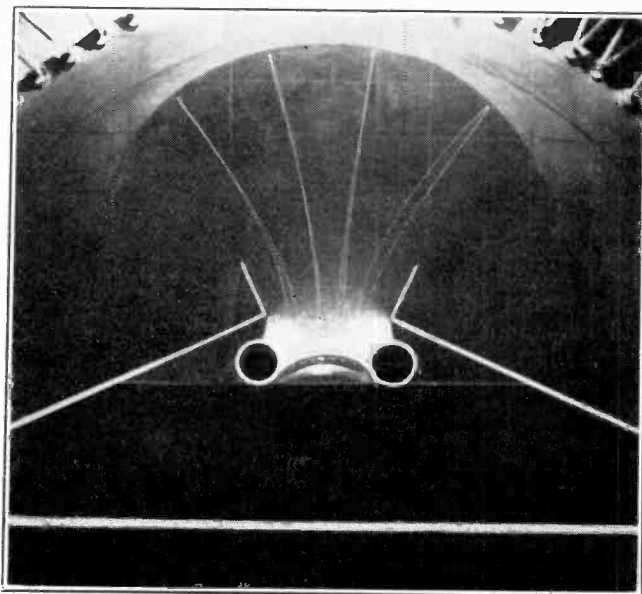

Fig. 10.

screen, which allows a beam to pass whose intensity depends on the voltage of the first grid. The 4th grid allows part of this beam of electrons to pass to the anode. The electrons moving from the slit toward

grid 4 are attracted by the upright sides of the positive screen, being deflected to form a fan-shaped beam. If they return before the control grid and if the deflections are sufficiently great an electron will generally not reach its point of departure again, but be picked up by the positive screen 3. Returning electrons can therefore no longer approach the first grid and are thus prevented from exercising a capacitive effect on the grid. A photograph of the paths of the electrons in the space between grids 3 and 4 is reproduced in Fig. 8¹.

The electrons arrive before the fourth grid at different tangential velocities dependent on their deflection at the slit and when they are drawn back they move along a curve towards the third grid. This photograph also shows why such a peculiar shape had to be selected for the electrode supplying the electrons in the converter part of the valve.

If an electron passes through an aperture between two positive leads it becomes deflected towards the leads in proportion to its distance from the centre of the aperture.

In the case of a positive wire grid as used in the octode FC₄ the paths of the electrons, owing to the deflection round the grid wires, would criss-cross (Fig. 9), with the result that on deflection the return of electrons to the first grid would not be entirely avoided.

For this reason the uniform distribution of the stream of electrons from the slit is the more satisfactory.

We must again refer back to the discussion in § 1 with reference to the octode FC₄, where the favourable effect of oscillating electrons on the slope of the control grid was indicated. In the new design of valve the electrons pass in front of the control grid once only, producing a lower space charge, while conditions otherwise remain the same as in case I of Fig. 5. This signifies that there is a considerable loss of slope in the present case.

That, on the other hand, this new form of accelerating electrode possesses various notable features of which good use has been made in the new valve for obtaining a steeper slope will be discussed in greater detail in the next paragraph.

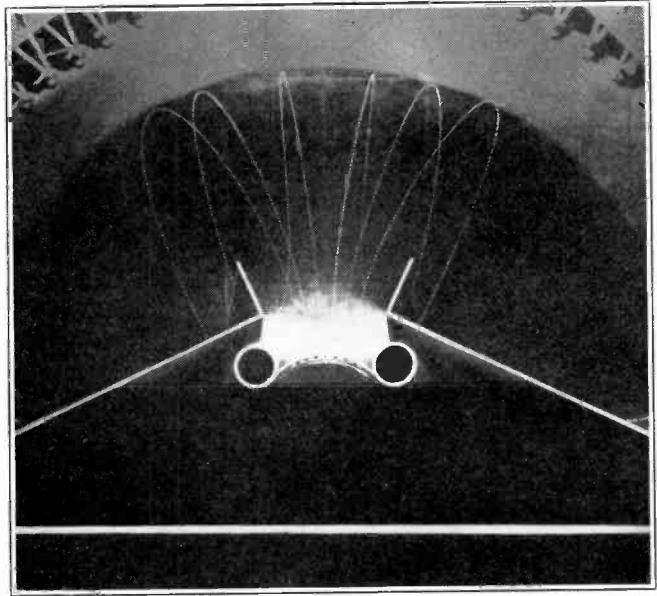

Fig. 11.

§ 3. The Slit, New Possibilities for Adapting Electrodes to the Electron Paths

It may be readily seen that any differences in the deflection of the electrons will have an unfavourable effect on the slope of the control grid. Those electrons which are the least deflected and consequently have the greatest velocity in the direction of the control grid are the first to be allowed to pass and these will be followed by those that have been deflected to a greater extent. As a result of this flattening of the characteristic occurs. From Below's calculations a formula can be deduced which gives for the flat shape the maximum voltage loss V_m in the direction perpendicular to the planes of the grids that the electrons will sustain by deflection at a positive grid.

$$V_m = \frac{V_s \cdot S^2}{16} \left(\frac{1}{d_1} + \frac{1}{d_2} \right)^2$$

S = pitch

V_s = positive grid voltage

d_1 and d_2 = distances to the neighbouring electrodes.

If this maximum voltage loss is calculated for the octode FC₄ it will be found to amount to about 5 volts.

The deflection of the electrons in the slit-shaped electrode will definitely be many times greater. The photograph in Fig. 8 shows that the least deflected electrons are the first to pass.

However, when the paths of none of the electrons intersect, only electrons with a definite velocity occur at each point of grid 4. It will now be seen that this property of a beam of electrons emanating from a slit is very valuable.

To obtain a very steep slope it is necessary to allow the whole stream of electrons to pass suddenly at a certain voltage, when the voltage of grid 4 is increased. This is impossible owing to the unequal potential between the grid wires. A very great improvement could already be obtained if, for instance, all the electrons were to strike this grid at the same velocity and from the same direction. If electrode 4 in Fig. 8 is given such a shape that the electrons always strike it perpendicularly, they will start to pass through at a more uniform rate. In this way it is possible to neutralise the deflections due to the accelerating electrode and thus obtain a steep slope.

Fig. 10 is a photograph of a beam of this type issuing from a slit-shaped accelerating electrode, in which the electrons are braked in a direction perpendicular to their path.

The direction of braking is clearly visible, while it can also be seen how the electrons return to their point of departure as a direct result of this perpendicular braking action. This action can be readily understood, since an electron path in an electrostatic field is determined by the equation :

$$-\frac{d^2\bar{r}}{dt^2} = \frac{e}{m} \bar{E}$$

\bar{r} is a vector which indicates the location of the electron ; the field strength $\bar{E} = f(\bar{r})$.

For the initial condition that when $t = 0$, $\bar{r} = \bar{a}$ and $\frac{d\bar{r}}{dt} = 0$, integration gives

the same \bar{r} value for positive and negative t , since the substitution $t_2 = -t$ does not in any way alter the equation or the initial conditions. But this return of the electrons to their point of departure, the cathode and the oscillator grid enclosing it, is by no means desirable for the reasons given in § 2.

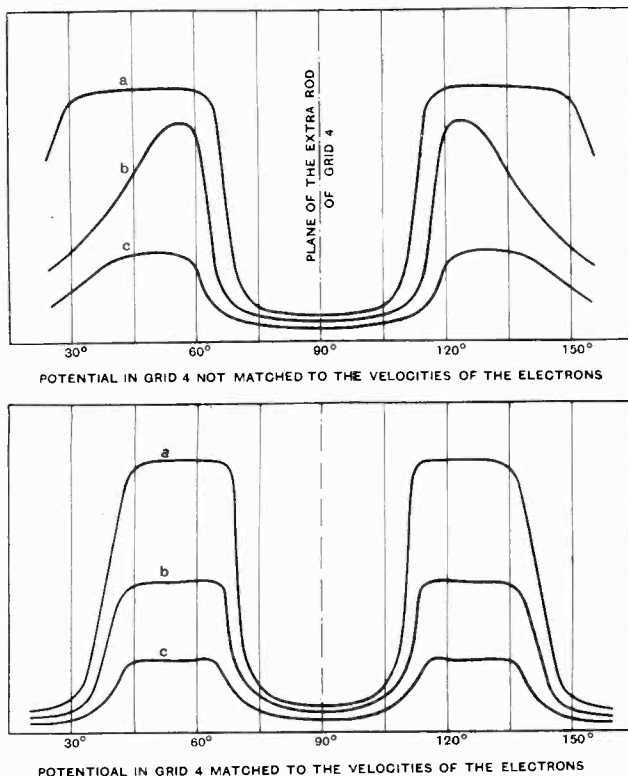

Fig. 12.—Current distribution over the anode of the 4-beam octode: a, control grid voltage = 0V.; b, control grid voltage = - 2V.; c, control grid voltage = - 3.5V.

The space charges are then again liable to influence the capacitance of the oscillator grid.

The electrons must, therefore, arrive in front of the control grid at such tangential velocities that on their return they are caught by the screen. But this again means a reduction in slope owing to the fact that the electrons arrive at different velocities

in the direction of the control grid and will therefore not pass through together; this may be seen clearly in Fig. 8.

Since the control grid always has a variable μ characteristic, so that the slope need only

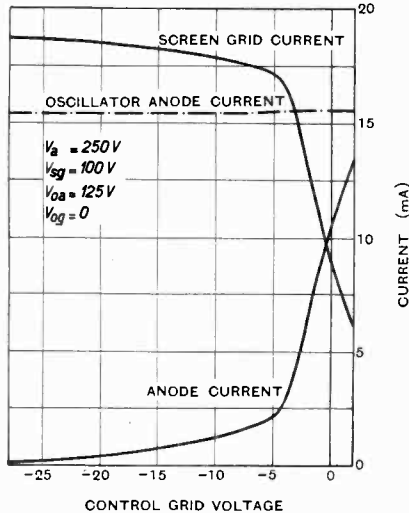

Fig. 13.—Curves of current distribution on the electrodes plotted against the control voltage on grid 4 of the 4-beam octode.

be a maximum over a small area, the drawback referred to can be overcome by making the distance between the control grid and the screen behind it variable (see Fig. 7). The potential in the plane of the control grid may have such a distribution that for a point on the characteristic where the slope must be steep this potential is matched to the different speeds of the electrons. In Fig. 11 a photograph is reproduced showing the matching of the potential to the velocities of the electrons. In spite of the different paths followed by the electrons they all arrive with the same velocity component perpendicular to the control grid and can therefore all pass at the same time. As the electrons, which pass through the slit roughly at its centre, would otherwise have an insufficient tangential velocity, this drawback has been overcome by fitting a supporting stay *a* in this grid. Fig. 12 shows the current distribution along the anode of a valve with a matched potential at the control grid and, to permit comparison, the distribution over another anode without a matched potential. It is clearly seen

that in the latter case the grid voltage for the steepest slope varies along the anode.

§ 4. Characteristic Properties of the Four-beam Octode

Fig. 13 shows the current distribution for the different electrodes in this valve as a function of the voltage on the signal grid. On comparing this distribution with Fig. 2 for the octode FC₄, the complete independence between I_{oa} and V_{cg} is apparent. Fig. 14 shows the capacitance of the oscillator grid as a function of the signal grid voltage. Both characteristics show that the required independence has been satisfactorily obtained. The oscillator section has been given a more favourable design for oscillation on short wavelengths here than in the case of the octode FC₄. There are two reasons for this:

1. The slope has been considerably increased.

2. The electrons move along practically rectilinear paths to the anode as against the longer path and therefore longer transit time in the octode FC₄⁵.

In this way it is possible to obtain a higher oscillating voltage on short waves with less reaction-coupling. In consequence the minimum circuit capacitance is smaller, so that the ratio between the shortest and

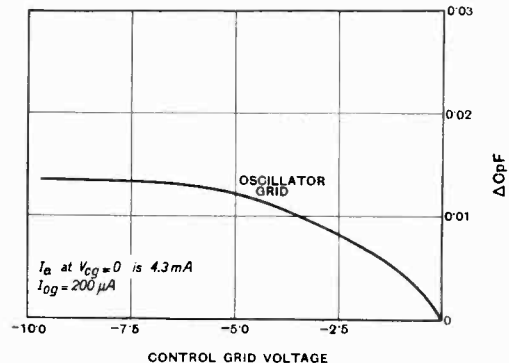

Fig. 14.—Variation of oscillator grid capacity plotted against control voltage on grid 4 of the 4-beam octode.

the longest wavelengths of a band that can be covered by a range of condensers is increased.

Since the space charge in front of the control grid can also be lower, as seen above,

the induction effect may likewise be less, whilst the residue can be further reduced by neutralisation with a condenser⁶. A further reduction is possible by means of a series resistance⁷.

Summarising, it may be stated that by employing new shapes of electrode it has been found possible to design a converter valve, utilising the advantages of the octode principle and at the same time practically eliminating the disadvantages.

BIBLIOGRAPHY

- (1) E. J. Alway, *Wireless World*, 1935, Vol. 36, p. 213. Clinton B. de Soto, *Q.S.T.*, 1936, Vol. 9, p. 51. W. A. Harris, *Proc. Inst. Rad. Eng.*, 1935, Vol. 22, p. 279. K. Steimel, *Telefunken*, 1934, Vol. 14, p. 33. C. F. Nesslage, E. W. Herold and W. A. Harris, *Proc. Inst. Rad. Eng.*, 1936, Vol. 24, p. 207. M. J. O. Strutt, *Wireless Engineer*, 1937, Vol. 14, p. 184.
- (2) H. Rothe and W. Kleen, *Telefunken-Röhre*, 1936, Vol. 8, p. 158.
- (3) F. Below, *Z. f. Fernmelde Tech. Werk und Gerätebau* 8 and 9, 1928. Plato, Kleen and Rothe, *Zeitschr. f. Physik*, 1936, Vol. 101, p. 509.
- (4) P. H. J. A. Kleynen, *Philips Techn. Rev.*, 1937, Vol. 2, p. 338.
- (5) M. J. O. Strutt, *Wireless Engineer*, 1938.
- (6) H. A. Wheeler, *Radio Engineering*, 1933, Vol. 13, p. 12.
- (7) M. J. O. Strutt, *E.N.T.*, 1938, Vol. 15, p. 14.

Electron Optics in Television

By I. G. Maloff and D. W. Epstein. McGraw-Hill Publishing Co. Ltd., Aldwych House, Aldwych, London, W.C.2, pp. 299 and xi. Price 21s.

To many the names of the two authors of this book are already well known from their papers in various American publications. Much of the matter will no doubt be familiar to students of the television art, but there appears to be some which the authors have not previously published.

The first 40 pages of the book are in the form of an Introduction, wherein the whole field of television by the R.C.A. system is discussed. The first two chapters of Part I deal with various fundamental concepts, particularly the emission and secondary-emission of electrons. These chapters are useful in that one is reminded of some of the actual values of the constants and variables to be considered. The book then goes on to the more detailed study of geometrical electron optics (chapters 3 to 7 inclusive), spherical electron lenses of the type used in cathode-ray tubes receiving the most attention. Chapter 7 on the defects of electron lenses is most interesting, stressing as it does the importance of chromatic aberration in cathode-ray tubes, while Chapter 8 deals with magnetic focusing.

Part II deals with the television cathode-ray tube in particular. Chapter 9 on the electron gun discusses the relationship between some of the 15 independent variables concerned in the design of the electrode system of an American TCR (television cathode-ray) tube, and also the vexed question of spot size and line width on the fluorescent screen. Chapter 10 relates to the deflection of electron beams, and Chapter 11 deals with luminescent screens for TCR tubes. The classifications, ratings and characteristics of TCR tubes are covered in Chapter 12, a discussion on projection tubes providing the principal interest in

this chapter. The book concludes with a chapter on "accessories," one on vacuum practice, and an index.

The British edition of this book should really bear the title "The Cathode-Ray Tube in American Television," for much of the book is not on electron optics, and quoting from the Preface, "This book should not be considered an exhaustive treatment of the subject" (of electron optics and cathode-ray television), "but rather an account of that part of it with which the authors have had first-hand experience at the Research Laboratories of the RCA Manufacturing Co. Inc." In view of this, one cannot criticise the authors for limiting themselves strictly to the American type of TCR tube and associated apparatus, but the paucity of references, and lack of a bibliography very much reduce the value of the book. (There are but 41 references, of which 26 are American.)

The chapters on electron lenses are very valuable to those of us who find the German language rather slow going, for there is remarkably little written on the subject in English. The information on luminescent screens is also useful, and this chapter seems more generally informative than any other, including as it does quite a number of very useful references.

The chapter on "accessories" deals with the problem of timebases and the deflection of the electron beam in a rather incomprehensible manner. It would appear that in America the simplest time-base consists of an impulse generator, a discharge valve, and one or more output valves, from 3 to 5 valves in all, which would result in the television set having many more valves than is usual in England. There is no mention of any of the more usual forms of time-base, such as that using the gas-discharge triode, or the transformer coupled hard valve circuit.

This book is well worth reading by all interested in cathode-ray tubes, but its limitations should be remembered, and it should not be considered a text-book on the subject. B. C. F.-W.

Radiotechnica : Vol. 3—Practica di Radio-trasmissione e Ricezione

By E. MONTE. Published by Ulrico Hoepli, Milan, 1938: pp. xviii + 815, 8vo. With 824 diagrams, tables, and abacs.

The first volume of this massive textbook, by a member of the Radio Committee of the Italian National Research Council, was reviewed in our issue of October, 1935. It dealt with the "Fundamental Principles" of Wireless. Vol. 2, on "Electronic Valves," will not be published till October, 1938. But meanwhile the present volume has made its appearance, on the "Practice of Radio Transmission and Reception" (including a long section on the radio engineer's laboratory). Even so large a volume as this cannot be expected to deal exhaustively with so wide a subject, but that the treatment is by no means cursory is indicated, for instance, by the 12 pages and more given to automatic tuning correction. On the whole, Transmission comes off the worse of the two, only about one page each being given to suppressed-carrier transmission and frequency and phase modulation. H. D.

A Short-Wave Cathode-Ray Direction Finding Receiver*

By the Staff of the Radio Research Station

(Radio Department, National Physical Laboratory)

ABSTRACT.—A description is given of an improved receiver, with a cathode-ray tube visual indicator, as designed and constructed for use with a short-wave spaced-aerial direction finder. The essential circuit arrangements are described, together with the precautions which have been taken to secure equality of performance of the dual amplifiers incorporated in the receiver. The direction of the trace on the cathode-ray tube indicator can be read to an accuracy of about 2 deg., and the sensitivity of the receiver is such that this accuracy may be utilised when the input to the grid of the first valve is not less than $50 \mu\text{V}$. With a typical aerial system used for the wavelength band 30-70 metres, this corresponds to a field intensity of $10 \mu\text{V/m}$, but bearings to a somewhat lower accuracy can be estimated with an incoming field intensity of $1 \mu\text{V/m}$.

1. General Principles

THE principles of the cathode-ray direction finder have been described previously in a publication of the Radio Research Board,† wherein will be found also details of an instrument designed for practical or commercial operation on wavelengths between 1,500 and 750 m. (frequencies 200 and 400 kc/s.). At the time of this publication (1933) few details were available as to the technique on short waves since the cathode-ray direction finder for wavelengths below 100 metres had not then been fully developed. The particular receiver to be described herein was developed in 1935, to replace an aural receiver, for short-wave direction finding with a spaced aerial (Adcock) system operating over a wavelength band of 70 to 30 m. (4.3 to 10 Mc/s.). With only a few alterations in detail a second such receiver has recently been constructed, and it is thought that a description of this latest addition to the tools employed in the art of cathode-ray direction finding would be of some interest.

The general principles of the cathode-ray direction finder may be briefly recalled with the aid of Fig. 1. If two similar frame aerials are set up, one (conveniently referred to as the N.S. aerial) having maximum response

for signals arriving from North or South, and the other (the E.W. aerial) having maximum response for signals from East or West, then when vertically polarised waves arrive from a direction making an angle θ with the meridian, there will be

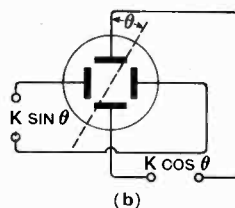
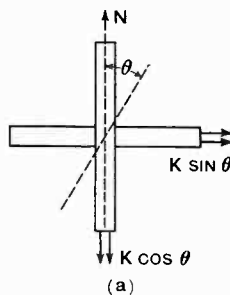

Fig. 1.—Principle of operation of the cathode-ray direction finder.

induced in the two aerials voltages proportional, at any instant, to $\cos \theta$ and $\sin \theta$ respectively. (Fig. 1a.) If now these voltages are impressed on the two pairs of deflecting plates of a cathode-ray tube of sufficient sensitivity, the components proportional to $\cos \theta$ or $\sin \theta$ alone will produce straight-line traces on the screen in mutually perpendicular directions and when acting together they will produce a straight-line trace (since the e.m.f.s. are co-phasal) making an angle θ with that

due to the output from the N.S. aerial alone (Fig. 1b). Thus the arrangement constitutes a direct-reading direction finder.

Such an arrangement can be realised in practice, but since the deflecting voltages

* MS. accepted by the Editor, March, 1938.

† "The Cathode Ray Oscillograph in Radio Research," by R. A. Watson Watt, J. F. Herd and L. H. Bainbridge-Bell, H.M. Stationery Office, 1933.

required to operate the cathode-ray tube are many times the output voltages from any practicable aerial system it is necessary to apply a considerable degree of amplification to the output voltages from the aerials. In order to maintain the amplitude and phase equality of these voltages it is essential



Fig. 2.—Section of Mumetal screen surrounding cathode-ray tube.

that the output from each aerial shall receive the same degree of amplification and the same phase shift, if any. This leads to the necessity for a pair of matched amplifiers—or more correctly a pair of matched receivers—since the condition of equality of gain and phase must be maintained over the whole of the frequency band to be covered by the system. The equality of phase shift is a particularly critical condition, and can only be realised in tuned amplifiers over a band of frequencies if each individual stage of the one amplifier is matched to the corresponding stage of the other.

The particular short-wave receiver now to be described was required to be built as a transportable self-contained unit, so that it might be used for experimental work on different sites. The consequent need for economy of power supply in such mobile operation, and the inherently large number of valves needed for the pair of matched amplifiers, rendered the use of directly heated battery valves practically essential, although this led to certain difficulties in design, especially to troubles due to inter-stage couplings through the filament circuits.

A further difficulty arising from the need to economise power supplies was that of the provision of an output voltage adequate for operation of the cathode-ray tube without the use of an inconveniently high anode voltage for the output stage. It was, however, found possible, by using a standard make of gas-filled tube operating at a gun voltage of only 250 to 350, to secure a satisfactory image with a high deflectional sensitivity. A compact gun voltage source (six standard 60-volt dry batteries) and a

very long life for the cathode-ray tube were valuable incidental advantages resulting from this method of working. Under these conditions, the deflectional sensitivity of the tube was of the order of 1 mm. per volt, so that for a “full-scale” deflection on a 6 cm. diameter compass scale, which could conveniently be drawn on the tube face, an output voltage of only about 30 volts peak was needed.

The enhanced sensitivity of the tube at low gun voltage caused the deflection of the beam by the earth's field to become serious. It was therefore necessary to provide more thorough screening than usual by enclosing the tube in a $\frac{1}{16}$ in. “mumetal” shield, of the form shown in Fig. 2.

The intensity of the trace when working with this low gun voltage was adequate for visual observation, and permitted of photographic recording. An alternative system, providing sufficient output for “full-scale” deflection with gun voltages of the order of 1,000 is being produced for a modified receiver now in course of development.

2. Circuit Details

The receiver is similar in general principles to those used in the cathode-ray direction finder and voltage comparators which have been described previously.* It may be recalled that the essence of the design is the provision of a pair of receivers which

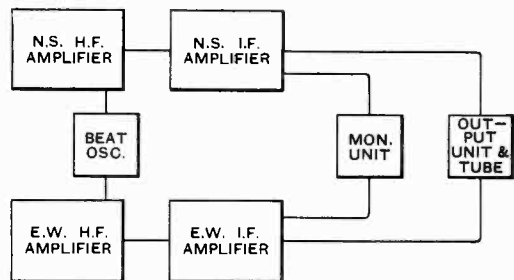

Fig. 3.—General lay-out of receiver circuits.

are identical to the extent of giving equal overall amplifications and phase shifts when tuned to a signal at any frequency at any given setting within their wavelength band. The receivers must also be free from interaction (cross-talk) so that a signal applied

* *Loc. cit.*

to the input of one does not affect the output from the other.

The arrangement employed in the present case is illustrated in Fig 3. Two stages of signal-frequency amplification are followed by frequency conversion to 100 kc/s. and by four stages of amplification at that frequency, the output of the last intermediate frequency amplifier being applied directly to the cathode-ray tube. Matched pairs of high-frequency and intermediate-frequency amplifiers are provided, and a common oscillator supplies the heterodyne voltage for frequency con-

verting the necessary degree of similarity between corresponding circuit elements in the two matched receivers of the set. Since a 30-volt output at the intermediate frequency was required from an input signal of a few microvolts, it was necessary to secure a very high overall gain, of which the greater part would have to be provided by the I.F. section.

After considerable experimental work it was decided to use simple tuned-anode couplings owing to the ease with which corresponding pairs of this type of coupling

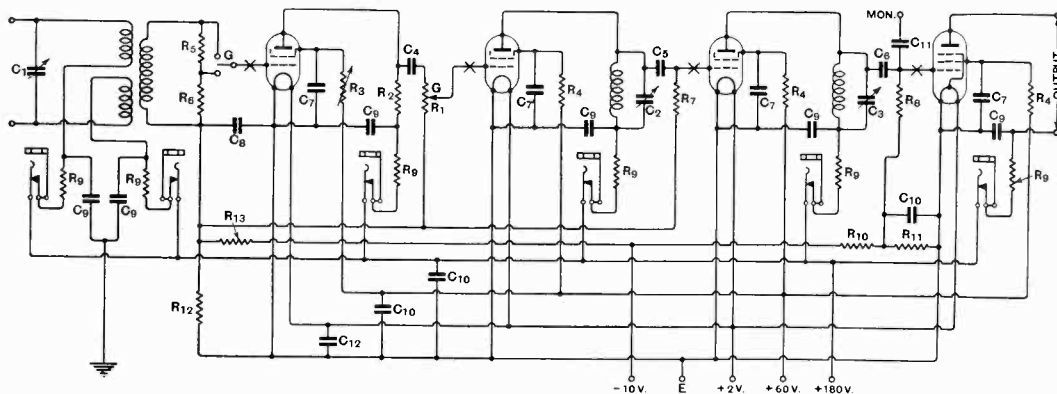

Fig. 4.—Circuit diagram of intermediate frequency amplifier. R_1 , 60,000 Ω , Potr. 10 steps 3 db.; R_2 , 25,000 Ω ; R_3 , 25,000 Ω (+ 5,000 fixed for EW); R_4 , 5,000 Ω ; R_5 , 50,000 Ω ; R_6 , 2,000 Ω ; R_7 , 100,000 Ω ; R_8 , 25,000 Ω ; R_9 , 2,000 Ω ; R_{10} , 250,000 Ω ; R_{11} , 20,000 Ω ; R_{12} , 10,000 Ω ; R_{13} , 100,000 Ω ; C_1 , 0.00025 $\mu\text{F.}$ + 140 $\mu\text{F. var.}$; C_2 , 0.0002 $\mu\text{F.}$ + 140 $\mu\text{F. var.}$; C_3 , 0.001 $\mu\text{F.}$ + 140 $\mu\text{F. var.}$; C_4 , 0.008 $\mu\text{F.}$; C_5 , 0.001 $\mu\text{F.}$; C_6 , 0.01 $\mu\text{F.}$; C_7 , 1 $\mu\text{F.}$; C_8 , 0.1 $\mu\text{F.}$; C_9 , 1 $\mu\text{F.}$; C_{10} , 0.1 $\mu\text{F.}$; C_{11} , 0.001 $\mu\text{F.}$; C_{12} , 250 $\mu\text{F.}$; G , ganged gain control 30 db.; x , line-up point.

version. Provision is made for aural monitoring of the received signals, and for the application of a 50 cycles per second time-base voltage to the tube for the separation of individual echo pulses when studying pulse transmissions.

(a) The Intermediate-Frequency Amplifier.

The design of the intermediate-frequency amplifier was largely determined by the desired selectivity and sensitivity characteristics. Since the receiver was to be capable of receiving pulse signals, and in view also of the possibility of reception from mobile transmitters of unstable frequency, it was decided to use an amplifier tuned to 100 kc/s. and to aim at a frequency-pass band of the order of 10 kc/s. It would, in fact, be difficult to realise a much higher degree of selectivity than this, owing to the difficulty

could be matched for resonant frequency and decrement. Even more important than the need for this initial matching was that for the provision of a simple means of routine checking, and it was mainly for this reason that the band-pass filter type of coupling was abandoned. The complete circuit diagram of the intermediate-frequency amplifier is given in Fig. 4.

Since four tuned circuits were used in cascade to give the overall 10 kc/s. band width, each circuit had to be rather heavily damped, and this facilitated the matching of corresponding circuits for decrement. The inductances were wound in slots turned in a solid ebonite former, and were thoroughly impregnated with wax to ensure a good degree of stability. The tuning capacitance was made up of a fixed mica condenser and a small "trimmer" in parallel. A non-

inductive resistor was connected across each tuned circuit to reduce the selectivity to the desired value. The values of these resistors were adjusted within fine limits to ensure the necessary matching of the decrements of corresponding circuits, the criterion being the maintenance of matching of the receivers as the input frequency was varied. Each I.F. tuned circuit was individually screened in a copper can. The most careful attention to screening and decoupling is of vital importance in a receiver of this type. It is only when the nature of the coupling at each stage is known and controllable that the necessary phase matching over a sufficiently wide frequency band can be attained.

The four stages of amplification used give an overall voltage gain of about 100 db. The adjustments necessary to ensure similarity of properties of all corresponding components throughout the two sets ensure that the overall gains of the two are practically equal, but a fine adjustment for equality is provided by means of a control of screen grid voltage in one receiver (R_3 in the circuit diagram of Fig. 4). This is treated as a pre-set control for bringing the maximum gain of each set to the same value. An operating control is also supplied in order that the gains of the two receivers may be simultaneously varied while maintaining their equality. This is most easily arranged by tapping off a portion of the voltage developed at the output of one stage of the receiver, for

and the controls being mechanically ganged. Two such pairs of potential-dividers are provided, the first pair in the first grid circuits (R_5, R_6 in Fig. 4) giving a single step of 30 db, and the second pair (R_1) in the second grid circuits a total of 30 db attenuation in steps of 3 db, so that a total of 60 db by 3 db steps is available. Difficulty was experienced in maintaining satisfactory phased matching of the two I.F. amplifiers over the complete range of the second pair of potential-dividers when the latter were fed from tuned circuits (the anode load of the first stage I.F. valve). For this reason a fairly low resistance was used as the anode load of the first stage.

Equality of gain must be maintained with an accuracy of about 1%. Under the most stringent conditions (equal signals in each set) a 4% discrepancy will produce an error of 1 deg. in this indicated bearing.

The overall frequency response curves of the I.F. amplifier is about 7 kc/s. wide at 6 db down from maximum voltage gain. This is rather narrower than the 10 kc/s. aimed at, but has been found to be quite satisfactory in practice when receiving pulses of duration of the order of 100 microseconds.

(b) *The Signal-Frequency Amplifier and Frequency Changer.*

Two stages of signal-frequency amplification are provided. These are mainly of value in reducing image interference, but also con-

Fig. 5.—Circuit diagram of signal frequency amplifier and frequency changer. R_1 , 5,000 Ω ; R_2 , 5,000 Ω ; R_3 , 10,000 Ω ; R_4 , 200,000 Ω ; R_5 , 20,000 Ω ; R_6 , 100,000 Ω ; R_7 , 25,000 Ω ; C_1 , 0.0003 $\mu F.$; C_2 , 0.1 $\mu F.$; C_3 , Cylodon Trimmer, 70 $\mu \mu F.$; C_4 , Differential condenser single plate $\pm 3 \mu \mu F.$; C_5 , 250 $\mu F.$

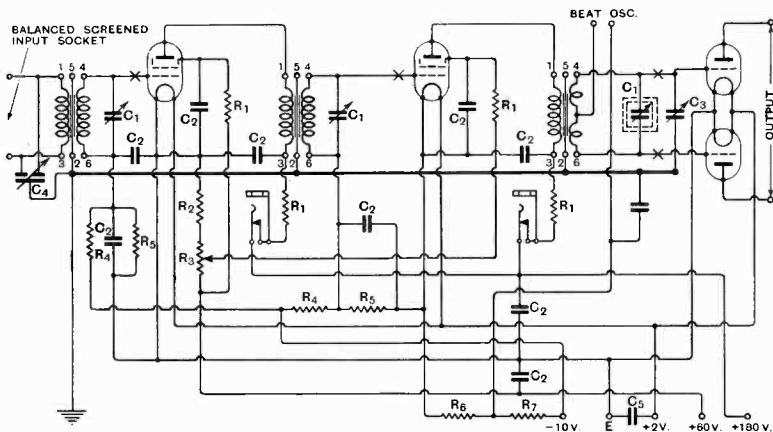

application to the next stage, by means of a potential-divider variable in discrete steps, the corresponding resistance steps in the two amplifiers being carefully matched,

tribute appreciably to the gain of the set. Inter-valve coupling is by tuned-secondary transformers with electrostatic screens between the windings; these screens, by

rendering the coupling purely inductive, make the matching of pairs of transformers more easy than would be the case with a mixed coupling. The circuit of the amplifier is quite conventional, as can be seen from Fig. 5.

The frequency-change stage of a cathode-ray direction-finding receiver of this type is one of the most important features. A single frequency-change oscillator common to the two sets must be used in order to maintain correct phase relationships of the intermediate-frequency signals through the two sets, and this provides a common circuit through which interaction may be introduced. The frequency-changer adopted in this receiver consists of a pair of balanced triodes, in the form of a single class B valve, with the heterodyne voltage injected into the earth return lead. By selecting a valve of which the two halves gave a similar performance by careful matching of the two halves of the associated grid circuit it was ensured that no signal frequency current flowed in the lead into which the heterodyne voltage was injected, and hence that no interaction took place by way of this circuit.

The frequency band of the receiver is divided into three ranges, for which matched pairs of plug-in H.F. transformers are provided for the two sets. The overall voltage gain varies over the frequency range between extreme values of 15 and 40 db.

(c) Output Circuit.

It is necessary to apply to the deflecting plates (a) the signal voltage at intermediate frequency from the output transformer, (b) the time base deflecting voltages at 50 cycles per second, (c) a steady potential for centring the beam. Fig. 6 shows how this is accomplished by a simple resistance and capacitance network, the secondary of the balanced output transformer being split at its centre for the introduction of the D.C. and low frequency voltages.

(d) Time Base Supply Unit.

The time base frequency is provided from a Hartley oscillator, the output of which is split, by means of a resistance-capacitance circuit, into quadrature components which are applied to the pairs of plates of the cathode-ray tube, so that a circular or

elliptical time base may be obtained. When in use with a pulse transmission the images due to the different echoes appear spaced out around the circle and by manipulation of the centring controls any one of them may

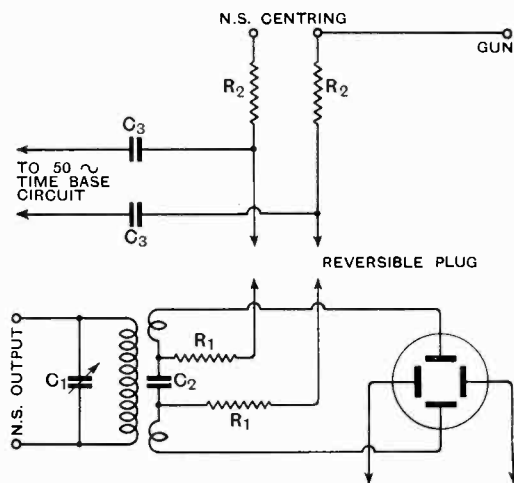

Fig. 6.—Output circuit. R_1 , 5,000 Ω ; R_2 , 100,000 Ω ; C_1 , 140 μF .; C_2 , 0.1 μF .; C_3 , 2 μF .

be brought to the centre of the tube so that its bearing may be read off directly.

(e) Monitor.

This comprises a buffer valve on each intermediate-frequency amplifier feeding a common detector, the inputs of these buffer valves being paralleled with those of the intermediate-frequency output stages. An oscillator is provided for C.W. reception.

(f) General.

By paying very careful attention to decoupling and disposition, and by careful matching of all corresponding components throughout the receivers, the necessary equivalence of performance of the two sets was attained. In addition to this matching of circuit components, it was found necessary to select valves for equivalence of their characteristics, especially of impedance. Valves of the same type taken from stock were in general not matched sufficiently well, but it has been found that, having selected a pair of valves, their equivalence of characteristics is maintained over a long period, and no case has arisen in which valve ageing has produced unbalance.

Interstage couplings through the filament circuits gave rise to considerable trouble, especially to interaction effects between the two channels of the receiver, but it was found that decoupling of units was sufficient to eliminate these effects. This was effected by running separate screened leads from each unit to the low tension accumulator and shunting a large capacitance ($250\ \mu\text{F}$ electrolytic) condenser across each pair of leads at its point of entry to the unit.

3. Tuning Procedure

The method of "lining-up" a cathode-ray direction-finding receiver, to ensure that the voltages from the two aerials are equally amplified and changed in phase before application to the cathode-ray tube, has been explained elsewhere,* and only a brief outline of the procedure applicable to the present receiver will therefore be given.

The necessary interconnections between the grids of the valves in each amplifier at each stage are made by "commoning bars" working in guides attached to the front panels of the set. A small upward displacement of a bar puts a link between two contacts which project through the respective panels, and are joined to the valve grids (Fig. 7).

It has been found that once the necessary adjustments for equality of resonant frequency and decrement of the circuits have been made the decrement remains sufficiently constant, but that slight creep in the constants of the tuned circuits changes the effective resonant frequency, so that a fine tuning control is needed for "lining-up." In the case of the I.F. tuned coupling-circuits the small mica trimming condenser forming part of the tuned circuit is available as a "screw-driver" control from the front panel. The stability of these

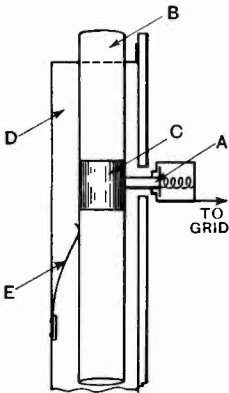

Fig. 7.—Commoning bar used in lining up. A, spring-loaded plunger; B, insulated bar; C, contact ring; D, cover and guide; E, earthing spring.

circuits is such that one "line-up" is sufficient for a whole day's observation. On the H.F. side careful attention to mechanical and electrical similarity during construction ensured equality of decrements, and no lining-up adjustment is necessary other than the normal tuning condenser.

A test oscillator consisting of a small shielded oscillator energising a short vertical aerial is used in lining-up the high-frequency amplifiers. In former practice it was placed out on the site of the direction-finding station at some distance from the aerials and at a bearing of $45\ \text{deg.}$, so that equal and cophasal e.m.fs. were injected by radiation into each aerial pair. More recently the oscillator, with a short vertical aerial, is permanently installed at the centre point of the spaced-aerial system and just above the screening cage containing the receiver. The test oscillator being tuned to the frequency on which it is desired to receive, each of the H.F. circuits is tuned to resonance with it, as evidenced by maximum amplitude of the trace on the cathode-ray tube. Then, working back from the frequency-changer, each pair of H.F. circuits is "lined-up" by a final fine adjustment of the tuning condenser in which absence of phase difference is taken as the criterion of tuning. Finally, the overall gains of each set are adjusted to equality ($45\ \text{deg.}$ bearing on the tube) by means of the screen-grid potential-dividers on the H.F. units.

4. Performance

The receiver was designed throughout with the view of attaining an accuracy of indication of bearings of $1\ \text{deg.}$ or $2\ \text{deg.}$, which was the limiting accuracy with which the scale of 6 cms. diameter could be read. A glass cursor may be used across the end of the tube to facilitate the reading of bearing angles. The sensitivity of the receiver is such that bearings may be taken with maximum accuracy when the input of the first valve grid is not less than $50\ \mu\text{V}$. With smaller input voltages, receiver noise begins to be visible on the tube as a broadening of the image, which reduces the accuracy with which the bearing can be read. With an input signal of only $5\ \mu\text{V}$ it is still possible to estimate the bearing to an accuracy of some $5\ \text{deg.}$

Five metres may be taken as a reasonable

* *Loc. cit.*

value for the pick-up factor (the quotient of the voltage developed at the grid of the first valve of the receiver and the field-strength of the incoming signal) of aerial systems with which the set is likely to be used, so that the sensitivity will be such that bearings can be estimated for a field intensity of $1 \mu V$ per metre, and full advantage may be taken of the instrumental accuracy of the receiver when the field strength reaches $10 \mu V$ per metre.

The receiver has been tried out on the short-wave Adcock aerial system in use at the Radio Research Station, Slough,* and also on a somewhat smaller "elevated H" type of Adcock designed for mobile operation. On the latter system satisfactory bearings were obtained with pulse transmissions on a 50 metre wavelength (6 Mc/s) from an aircraft flying between Cologne and London.

Note added in proof, June, 1938.

Since the above description was written, a new receiver operating at frequencies up to 20 Mc/s has been developed. At these frequencies, the lining-up process becomes difficult with the system described, owing to the appreciable length of the conductor linking the two grids, and to its capacity to earth.

This difficulty was overcome by adopting a lay-out in which the North-South and East-West amplifiers are built as mirror images of each other, symmetrically disposed about the plane dividing them. The grids of the various valves are arranged to lie as close as possible to this plane, so that corresponding pairs of grids may be joined by switches of small physical dimensions. The boxes containing these line-up switches are clearly seen along the

centre line of the vertical panel in the accompanying photograph.

In order to maintain amplification at these higher frequencies, the earthed screen between windings of the H.F. transformers was dispensed with, and closely coupled transformers in which primary and secondary turns lay close together in the same groove

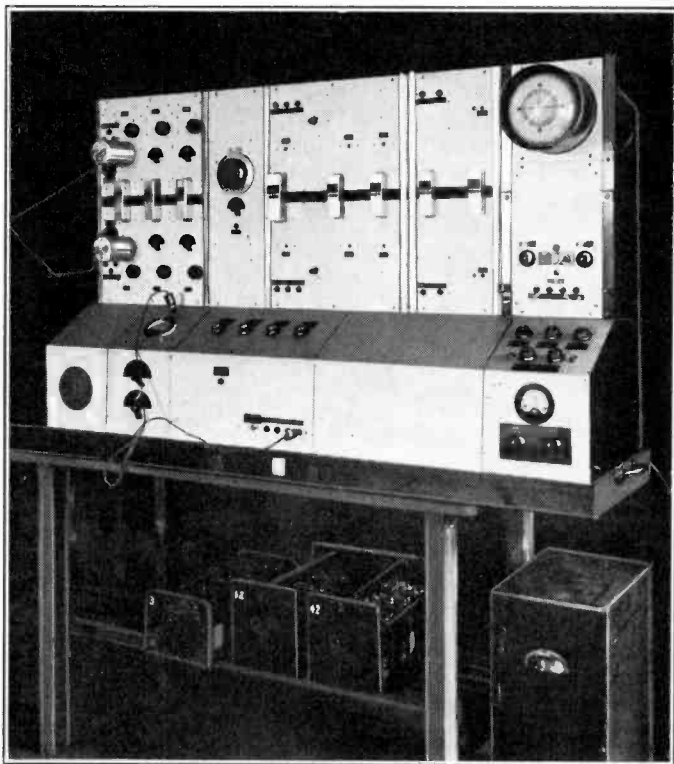

Front view of cathode-ray direction finding receiver showing controls for matched amplifiers and trace on cathode-ray tube.

were substituted. Wave-band change was effected by switches instead of by plug-in coils.

An intermediate frequency of 500 kc/s instead of 100 kc/s was used in order to assist image selectivity at the higher frequencies, and the tuned anode couplings were replaced by iron-cored transformers with a step-up ratio of 1:3. In this way the damping effect of the anode circuit impedance of a valve on the following tuned secondary winding was reduced considerably, and the need for careful selection and match-

* "A Short-Wave Adcock Direction Finder," by R. H. Barfield and W. Ross, *Journ. I.E.E.*, 1937, Vol. 81, pp. 682-690.

ing of valves, referred to in the test, was obviated.

In accordance with more modern practice, an octode frequency changer was used: it was found, however, to be rather less satisfactory than the original balanced triode, chiefly in respect of cross-talk through the common injection circuit.

This receiver has been equipped with a hard cathode-ray tube, working at a gun voltage of 1200, in order to facilitate the photography of pulse images. This involves applying to the tube a signal of some 200 v. peak—a matter of very considerable difficulty when using 2 volt battery valves. The circuit adopted, which enables output voltages of nearly twice the H.T. voltage to be developed while maintaining a linear relation between output and input, is a modification of the two-triode circuit due to Colebrook.* The output circuit, using a single triode, is

* A study of the possibilities of Radio Frequency Voltage Amplification with screen-grid and with Triode valves. F. M. Colebrook, *Journ. I.E.E.*, 1934, Vol. 74, p. 187.

arranged for balanced operation so as to double the available output voltage; and the triode is neutralised to improve linearity. An H.F. pentode is used in the buffer stage, in order to maintain a good overall gain in the output unit.

Referring to the photograph, the H.F. amplifiers, frequency change oscillator, I.F. amplifier and output amplifiers may be seen in that order from left to right in the large vertical panel; while under the cathode-ray tube is the monitor unit. On the sloping and lower vertical panel, from left to right are the monitor loud-speaker, D.C. control panel, time base unit and cathode-ray tube controls. The box seen in the bottom right-hand corner houses the 1200 v. dry battery for the tube gun supply.

Acknowledgment

The work described was carried out as part of the programme of the Radio Research Board, and this paper is published by permission of the Department of Scientific and Industrial Research.

Correspondence

Letters of technical interest are always welcome. In publishing such communications the Editors do not necessarily endorse any technical or general statements which they may contain

Modulation of a Valve Generator

To the Editor, The Wireless Engineer.

SIR,—I have read with great interest Mr. E. B. Moullin's paper "The response of a valve generator to a modulating voltage," in the July *Wireless Engineer*; but while I believe his conclusions to be substantially correct, there are one or two points in the analysis which raise doubts.

From the strictly practical point of view, I do not think it is justifiable to assume the depth of modulation to be small. A directly modulated self-oscillator is most likely to be used in either mobile or emergency transmitters where maximum distance of communication for a given input power is essential; this implies deep modulation on telephony. The problem may also arise in considering the maximum keying speed of a C.W. telegraphy transmitter, whose "modulation" is complete.

The next difficulty is the device used to make it possible to treat the valve and the circuit separately. On p. 374 it is stated that "When a radio-frequency generator is being modulated at an acoustic rate, we may regard the anode potential as sensibly constant during many radio-frequency cycles, but changing at the acoustic rate." On this basis it is assumed that there is at every instant equilibrium between the fundamental component of resistance

of the valve and the effective rejector resistance of the tuned circuit. One may instinctively object to the use of such an equilibrium in considering a problem whose whole existence depends upon the lack of equilibrium between valve and circuit during modulation; but this should be covered by the use of an effective value of circuit resistance, which contains a modulated component intended to represent the departure from equilibrium conditions. Unfortunately, the derivation of this effective resistance is open to criticism. For in equation (2) the impressed modulation is set down in the form of a modulation of the fundamental component of radio-frequency current, whereas in practice it will be in the form of a modulation of anode or grid mean voltage; this is in fact assumed in the latter part of the paper, where the effective resistance which has been derived in equations (2) to (6) is being applied. Using Mr. Moullin's notation, $M \cos \omega t$ and $m \cos (\omega t - \beta)$ for the form of the modulating source and the envelope of the resultant modulated radio-frequency output, the radio-frequency current i which flows through both valve and tuned circuit is a function of both $M \cos \omega t$ and $m \cos (\omega t - \beta)$. For the radio-frequency E.M.F. across the tuned circuit, which is applied to the valve, is a function of the latter, and the effective resistance of the valve at any given

radio-frequency amplitude depends upon mean supply voltages, which are modulated in accordance with the former.

If we assume $\frac{2\alpha}{F} \gg 1$, we find that the response of the tuned circuit to a current modulated in the form $\cos \omega t$ is of the form $\sin \omega t$, i.e. a phase shift of modulation of 90 deg., which appears grossly excessive. (Incidentally, if $\frac{2\alpha}{F} \gg 1$, the definition of m at the top of p. 373 would reduce to $m = \frac{MF}{2\alpha}$

$\left\{ 1 - \frac{F^2}{8\alpha^2} \right\}$). If there is a substantial phase shift, as presumably there must be if there is any appreciable change of depth of modulation, surely this should be allowed for not only in equation (2), but also in the graphical working of Figs. 4 and 5.

I am also puzzled by the conclusion on p. 376 that for small depth of modulation there may in certain circumstances be a "note-correcting" (high-note accentuation) effect. It appears from Figs. 4 and 5 that $A'P/OP$ must always be less than unity; if in addition we have $x = 2\alpha/F$ greater than unity, it follows that $\frac{1}{x + \frac{OP}{A'P}} < 1$,

and the fraction m'/m as given by (10) would be necessarily less than unity. Is it possible that this difficulty has also arisen from neglect of the effect of phase-difference between M and m ?

Chelmsford.

D. A. BELL.

Background Noise

To the Editor, *The Wireless Engineer*.

SIR,—I cannot expect to reach agreement with Messrs. Percival and Horwood in the limited space of your Correspondence columns; but I think it will be useful to set out more clearly the fundamental differences between our points of view.

We must agree to differ as to whether one should use actual temperature, in the usual sense of the word, or an empirical factor called "effective temperature," which is a function of measured values of noise and slope resistance. But even granted the use of the latter, I should hesitate to put resistance equal to infinity in a formula intended for conductors obeying Ohm's law, and thereby deduce a value of "effective temperature" for a temperature-limited diode. Has it been shown that such a diode is an ohmic resistance,

i.e., that its law is $\frac{Lt}{R} \rightarrow \infty \left\{ i = i_0 + V/R \right\}$ rather

than some other form such as $\frac{Lt}{n} \rightarrow 0 \left\{ i = aV^n \right\}$?

The latter is, in fact, favoured by the manner in which the constant-current condition is approached from the space-charge-limited condition.

Again, I should define a "random" current by its constitution (namely, that the arrival of each individual electron is governed only by a probability function and is independent of any of its neighbours taken individually), not by its supposed effect on an external circuit. For example, is not

the current in a metallic conductor random? It certainly does not give a fluctuation-current component of the type required by the definition of a random current used by Messrs. Percival and Horwood. I am afraid I have been interpreting "fluctuation component of current" as meaning "the component of current which consists entirely of random variations"; but perhaps this is not generally accepted, since in their letter they say "the fluctuation current in a triode is by no means completely random..." I maintain, on the contrary, that in any valve, triode or otherwise, in which there is full space-charge limitation the whole anode current is "random" in the sense defined above, and the resulting fluctuation component of current can be calculated in terms of thermal noise.

Even more fundamental than differences in definition of "random" is the question of fluctuations of the potential barrier. It is obvious that the mean rate of arrival of electrons at the anode, together with the depth and position of the potential barrier, must vary in accordance with every change of anode potential, and in that sense the barrier does fluctuate. But the anode potential, including the noise component of voltage developed at the anode, is a function of the external circuit as well as of the aggregate effect of a number of electrons which have arrived on the anode. The question which is still controversial is whether the potential barrier also moves in sympathy with the transit of each individual electron, as distinct from the anode potential variations. If one assumes that as each electron approaches the anode the potential barrier suffers some exactly corresponding change, so that the joint effect of the two phenomena at the anode is less than the disturbance that would arise from the transit of the electron alone, various difficulties arise:

1. The total charge conveyed to the anode must remain e per electron transit; correspondingly, the displaced potential barrier must return to its normal state after the completion of each electron transit. Does this merely mean that the effective duration of the pulse is prolonged? If so, the time distribution of pulses is still random, and each has the same value of current-time integral as if there were no fluctuation of the barrier. Moreover, in order that the displacement of the potential barrier may neutralise the effect of the electron transit it must be able to suffer almost instantaneous change. What then controls its time of return to normal, so as to prolong the total time of the electron-transit cycle?

2. The transit time of an electron through a valve is normally of the order of 10^{-9} sec.; in order to give a smoothing effect the potential barrier must surely follow the *shape* of the electron-transit pulse, i.e., respond to frequencies of, say, 10^{10} c/s. at least. This would correspond to a wavelength of 3 cms., if the velocity of propagation were the same as in vacuo, so that there would be differences of phase at different points within a valve of ordinary dimensions. Is it then possible for the potential barrier to fluctuate as a whole in the desired manner? What are the attenuation and velocity of propagation of such frequencies in a region with a high density of free electrons?

Until these questions are answered in such a way as to give a clear physical indication of how it is possible for the potential barrier as a whole to fluctuate in the required manner I am afraid any theory expressed in terms of "smoothing" due to such fluctuation cannot be regarded as fully established, but must remain a controversial subject.

If, on the other hand, it should turn out that the only "smoothing" effect present is the existence of a certain amount of equipartition of random components of energy by interaction between individual adjacent electrons, not interaction between each single electron and the whole potential barrier, I think it would be legitimate to describe this as merely a thermal phenomenon occurring within a system whose potential distribution responds only to changes of potential imposed by the electrodes in conjunction with the external circuit.

D. A. BELL.

Chelmsford.

several thousand cycles per second. (*Phys. Rev.* 1908, Vol. 27, pp. 286-293.)

Regarding von Lieben's tube, it is of interest to compare this with the Perrin tube of 1895. Perrin constructed a special form of cathode-ray tube whereby he demonstrated for the first time that a beam of cathode-rays carries a negative charge. (*Comptes Rendus*, 1895, Vol. 121, pp. 1130-1134.) This tube was almost identical in design to von Lieben's tube except that von Lieben suggested the use of the Wehnelt cathode.

The accompanying photograph shows a modified Perrin tube (c. 1897) now in the writer's collection of electronic apparatus and the concentric cylindrical anodes can be seen at one end of the tube.

A comparison of the figures in Perrin's article and in von Lieben's patent will show the close similarity between these two tubes.

R. McV. WESTON.

Reigate, Surrey.

Ultra Short and Decimetre Wave Valves

To the Editor, The Wireless Engineer.

SIR,—I was very interested in the letter of Mr. J. H. Owen Harries in the June issue of *The Wireless Engineer* concerning the history of deflection valves and particularly with reference to the early workers in this field.

As Mr. Harries states, the earliest attempts to make an electronic relay were based upon cathode-ray technique and perhaps one or two additions to the list of references given by Mr. Harries may be of interest.

Boltzmann in 1890 appears to have been the first to suggest the use of a discharge tube as a relay, and Zehnder in 1892 proposed to use a special tube for the reception of Hertzian waves, the discharge in the tube being "triggered" by the received signals (*Wireless Telegraphy*, by Bernard Leggett, p. 160, Chapman Hall 1921).

A number of early workers used mercury vapour tubes of the Cooper-Hewitt type for the generation

To the Editor, The Wireless Engineer.

SIR,—In the letter published in your issue dated July 1938, Messrs. Hollmann and Thoma give a formula for what is, in effect, the input (deflecting plate) alternating-current resistance of a hard cathode-ray tube, and compare this with a formula given by the undersigned in a paper published in your issue dated April 1938. They point out that it tends to infinity when the frequency of the applied deflecting voltage tends to zero and is therefore to this extent more consistent with the physics of the system. They also point out, however, that it can pass through a range of negative values. This feature is inconsistent with the physical system postulated for the following reasons: (i) In their original paper to which they refer, the deflecting field is assumed to be confined to the space between the deflecting plates and to be uniform and perpendicular to the axis. (ii) It is further assumed that there is no accelerating or retarding field in the longitudinal direction. (iii) On these assumptions there can be no change in the longitudinal

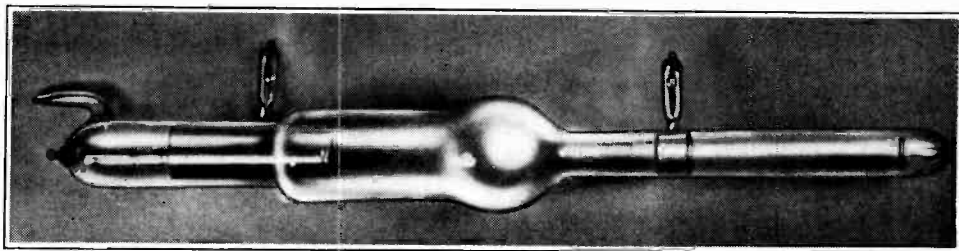

A modified Perrin tube (c. 1897) referred to in R. McV. Weston's letter.

of oscillations by electromagnetic deflection, the earliest reference known to the writer being due to Weintraub in 1903. (U.S. Patent No. 877,026.)

Weintraub was prior to von Lieben, but his tube was for use on commercial supply frequencies only.

Vreeland in 1908 made an oscillator working on this principle which generated frequencies of

velocity of an electron in consequence of its passage through this field, since the only accelerations introduced will be in the transverse or y direction. The kinetic energy $\frac{1}{2}m(dx/dt)^2$ of an electron due to its longitudinal velocity is therefore unchanged by its passage between the plates. (iv) In consequence of the deflection of the beam, electrons will emerge from the space between the plates with a

D

transverse velocity dy/dt , and a consequent increment of kinetic energy $\frac{1}{2}m(dy/dt)^2$. (v) This increment of energy can only have been supplied by the transverse or deflecting field since the transverse velocity is due to this field. (vi) The input resistance may therefore conceivably be zero, if the beam emerges with a deflection of zero amplitude, but must in all other cases be positive for the simplified physical system assumed.

This does not preclude the possibility that the resistance may in practice have a range of negative values, but if this should prove to be the case, it must arise from the effect of the fringing field external to the space between the plates, which is excluded from the analysis of Messrs. Hollmann and Thoma, as it was from that in the paper by the present writers to which they refer.

The National Physical Laboratory, Teddington, Middlesex.
F. M. COLEBROOK.
P. VIGOUREUX.

Binaural Effect

To The Editor, The Wireless Engineer.

SIR,—Mr. Robin's letter in the July issue of *Wireless Engineer* emphasises the fact that the binaural effect has not been exhaustively investigated. Olson and Massa quote several experiments and they mention that the effect was only apparent at low frequencies (up to 1260 ~) from which it seems that one or two low frequency sounds ought to decide the matter for the composite picture.

I would suggest that Mr. Robin try to concentrate on a certain object in front of him and try to persuade himself that the source is there, perhaps the sound will then seem to jump to the front.

Television Programmes, on those rare occasions when the M.W. transmitter is relaying the sound and hoping there are two mikes, suggest an experiment to determine whether the eye has the final control in the matter. Except for the slightly directional cup of the ear there seems no reason to suppose that the ears could determine front from rear. Mr. Robin may care to be blindfolded, preferably in the open air, and listen for a low clock tick; neither he himself nor the clock may be moved during the experiment (switch the radio on while conditions are being set).

The present writer has previously stated his doubt whether the binaural effect can much influence the "quality" of reproduction.

Ware, Herts.

GERALD SAYERS.

with copious references to original papers, that one feels inclined to put it among one's text-books rather than among trade catalogues. It certainly makes a valuable addition to the literature of the subject.

The sixteen sections into which it is divided are arranged on a frequency scale, commencing with radio frequencies apparatus, then passing to telephonic frequencies and concluding with d.c. apparatus. The illustrations include not only photographs, but also diagrams of connections, details of scales, etc. and performance curves.

Several types of frequency control standards both of the valve-maintained tuning fork and of the quartz controlled variety are described, together with the necessary multivibrators and other auxiliary apparatus. One of the tuning fork type has been supplied to the Union Internationale de Radiodiffusion, Brussels, as the European ultimate standard of frequency. A continuously variable oscillator for station control on the "common wave" broadcast system is also described. Then follow wavemeters involving all the improvements which have been introduced by the firm, most of which have been described in our pages by Mr. W. H. F. Griffiths. The same may be said of the Inductance Standards, inductance bridges and the fixed and variable air condensers. A section is devoted to power oscillators up to 60,000 kilocycles per second. It may not be generally known that Messrs. Sullivan have succeeded in reducing the temperature coefficient of mica condensers to 1 part in 100,000 per degree. We were surprised to see that both for inductances and capacitances the temperature coefficients are given per degree Fahrenheit, even when the N.P.L. figure is per degree Centigrade. Is this because the thermometers in most scientific laboratories are assumed to have Fahrenheit scales or because it looks better? A section is devoted to capacitance bridges including the Schering bridge, followed by audio-frequency oscillators and various accessories for a.c. bridge measurements. The concluding sections deal with standard resistances, Wheatstone bridges, galvanometers, telephone testing equipment, etc. Resistances are apparently regarded more scientifically than condensers and inductances for their temperature coefficients are given per degree Centigrade.

This catalogue is an object lesson to writers of text-books in the scrupulous care that has evidently been taken over the nomenclature and symbols from beginning to end. G. W. O. H.

Electrical Standards for Research and Industry

Electrical Standards for Research and Industry. Testing and Measuring Apparatus for Communication Engineering. Pp. 194. Messrs. H. W. Sullivan, Ltd., 72, Leo Street, London, S.E.19.

Although this is a catalogue, giving the prices of all the apparatus mentioned, it gives such admirable descriptions, not only of the apparatus itself, but also of the principles involved, together

"Aircraft Production": A New Journal

OUR publishers, Iliffe and Sons Limited, are shortly to issue a new journal to be entitled *Aircraft Production*. The aim of the publication, which will appear monthly, is to promote efficiency in the aircraft industry by co-ordinating design and production and by disseminating modern ideas on the manufacture of airframes, engines and accessories.

Abstracts and References

Compiled by the Radio Research Board and reproduced by arrangement with the Department of Scientific and Industrial Research

For the information of new readers it is pointed out that the length of an abstract is generally no indication of the importance of the work concerned. An important paper in English, in a journal likely to be readily accessible, may be dealt with by a square-bracketed addition to the title, while a paper of similar importance in German or Russian may be given a long abstract. In addition to these factors of difficulty of language and accessibility, the nature of the work has, of course, a great influence on the useful length of its abstract.

	PAGE		PAGE
Propagation of Waves	443	Directional Wireless	454
Atmospherics and Atmospheric Electricity	447	Acoustics and Audio-Frequencies	454
Properties of Circuits	447	Phototelegraphy and Television	456
Transmission	448	Measurements and Standards	459
Reception	450	Subsidiary Apparatus and Materials	461
Aerials and Aerial Systems	451	Stations, Design and Operation	465
Valves and Thermionics	452	General Physical Articles	465
		Miscellaneous	466

PROPAGATION OF WAVES

3095. THE PROPAGATION VELOCITY OF ELECTRIC WAVES ALONG THIN METALLIC WIRES, AND THE PERMEABILITY OF IRON FOR HERTZIAN OSCILLATIONS [New Experiments with Micro-Waves].—K. F. Lindman. (*Zeitschr. f. tech. Phys.*, No. 6, Vol. 19, 1938, pp. 158-163.)

Author's summary:—By measuring the wavelength λ of electric oscillations, of various periods, being propagated along two parallel thin metal wires with the formation of standing waves, and by comparing this wavelength with the normal wavelength λ_0 (in thick copper wires, or in air) it was shown that the propagation velocity of the electric force along sufficiently thin wires is noticeably smaller than the velocity of light, the difference in velocity varying with the sectional radius of the wires, the nature of the wire material, and the normal wavelength in a way which is in good agreement with the theory developed by Sommerfeld on the basis of the Maxwell equations. Further, earlier measurements carried out by the writer, some of which are now extended, on the natural wavelengths of straight, very thin metal wires of different materials, are found to be in agreement with that theory.

In some of these experiments certain harmonics made their appearance, in the interference curves, whose propagation velocity, along very thin wires, was somewhat greater than that of the fundamental. If electric waves in wires suddenly pass from a thick wire to a very thin one, or *vice versa*, they are partly reflected at the junction point, with a phase change of the electric force of zero in the former case and of π in the latter case [the two wires were of 1.3 mm and 0.02 mm copper: when the thin wire was replaced by one of 0.5 mm diameter, no reflection could be detected. Nor was there any reflection when the very thin wire was made *short* compared with a half-wavelength: probable reasons are given (end of section 3), and it is deduced that the two rods of a resonator for

measuring purposes, having an ordinary thermo-junction in the middle, cannot behave independently as resonators].

Since the Sommerfeld formula for the difference $\lambda_0 - \lambda$ contains also the magnetic permeability (μ) of the material of the wire, the possibility presented itself of determining, by this formula, the permeability of iron for various wavelengths λ_0 , from the observed values of $\lambda_0 - \lambda$. It was found that when λ_0 was increased progressively from the shortest wavelength employed (15.8 cm), μ increased from its first value of 10.6 very rapidly at first, reached a value of 100 for a wavelength of about 48 cm, and after that increased only very slowly.

3096. GENERAL PROPERTIES OF DIELECTRIC GUIDES, and THEORETICAL STUDY OF DIELECTRIC CABLES [and the Stabilities of the Various Types of Waves].—J. Saphores: L. Brillouin. (*Elec. Communication*, April 1938, Vol. 16, No. 4, pp. 346-349; pp. 350-372.) For a previous paper by Brillouin see 3968 of 1936.

3097. REFLECTION AND ABSORPTION OF DECIMETRE WAVES AT PLANE DIELECTRIC LAYERS.—W. Dällenbach & W. Kleinsteuber. (*Hochf.tech. u. Elek.akus.*, May 1938, Vol. 51, No. 5, pp. 152-156.)

The intensity of a plane-polarised wave reflected from a dielectric layer, studied as a function of thickness of the layer, shows several maxima & minima. It may also be reduced considerably when a metallic reflector is placed in contact with the under-side of the layer. The theory of the effects is developed and analogies with similar optical problems (colour of thin plates) are pointed out. The general expression for the ratios of the amplitude of the reflected and incident rays is given in eqn. 15. This is the paper referred to by Pfister & Roth (2805 of July).

3098. MEASURING THE FIELD STRENGTH OF ULTRA-SHORT WAVES [B.B.C. Method and Apparatus].—C. H. Smith. (*World-Radio*, 10th June 1938, Vol. 26, pp. 10-11.)
3099. REPORT TO COMMISSION I ON EXISTING METHODS OF MEASURING RADIO FIELD INTENSITY [including Summary of Replies to International Questionnaire, and Bibliography].—R. A. Watson Watt & R. L. Smith-Rose. (*U.R.S.I. Proceedings of 1934 General Assembly*, Vol. 4, pp. 166-182: in English.) See also pp. 131-132.
3100. DIELECTRIC CONSTANT AND CONDUCTIVITY OF SOIL AT HIGH RADIO FREQUENCIES [50-70 Mc/s: measured by Lecher-Wire System immersed in Sample of the Soil].—S. S. Banerjee & R. D. Joshi. (*Phil. Mag.*, June 1938, Vol. 25, No. 172, pp. 1025-1033.) For a preliminary communication see 2870 of 1937: cf. also 2661 of July.
3101. EFFECT OF TEMPERATURE ON THE ELECTRICAL CONSTANTS OF SOIL AT RADIO FREQUENCIES [Tests on Dry Soil from 0° to 105° C at Frequencies up to 1.2 Mc/s: Dielectric Constant remains Unaffected at nearly 4.0: Temperature Coefficient of Conductivity is + 2% per Degree Centigrade at 20° C, but increases with Frequency].—R. D. Joshi. (*Indian Journ. of Phys.*, Part 1, Vol. 12, 1938, pp. 1-8.)
3102. THE PROPAGATION OF RADIO WAVES OVER A FINITELY CONDUCTING SPHERICAL EARTH.—B. van der Pol & H. Bremmer. (*Phil. Mag.*, June 1938, Vol. 25, No. 171, pp. 817-834.)
In two previous papers (see 3245 of 1937 and 35 of January) the general theory of the diffraction of electromagnetic waves from an electrical point source round a finitely conducting sphere was considered in detail, and general formulae for the field at any distance from a transmitter were derived. Approximations are now derived suitable for numerical application for any dielectric constant & conductivity of the earth and for any frequency. Curves are given for field strengths of the ground wave of a transmitter working on various frequencies, for propagation over sea water and over average soil.
3103. ON THE DISPERSION OF ELECTROMAGNETIC WAVES ABOVE THE EARTH'S SURFACE [Land and Water: Tests on Wavelengths 300-450 m].—J. L. Alpert, V. V. Migulin, & P. A. Riasin. (*Comptes Rendus (Doklady) de l'Ac. des Sci. de l'URSS*, No. 9, Vol. 18, 1938, pp. 635-638: in English.)
"A more exact knowledge of the laws governing the propagation of radio waves under real conditions has become lately of practical importance in connection with the problem of measuring distance (Mandelstam & Papalexii, 836 of March), in the first place above the sea surface. The same problems arise also in connection with other measurements, for instance ionospheric." Thus Colwell and his collaborators have obtained, for the velocity of radio waves, values around 60% of the velocity of light, "which contradicts the results of other investigators" [see Ross & Slow, 2050 of 1937, and back reference].
The measurements, using a "dispersion radio-interferometer" on the principle suggested by Mandelstam & Papalexii, took place over various kinds of land and over the open sea; distances ranged up to 18.6 km. Over the former, "a dispersion of the order of a few tenths per cent. is possible"; over the latter, the possible dispersion (if any) is less than 0.07%. "Several experiments were also carried out with the ship hidden behind land . . . which have shown that the appearance of land on the propagation path of radio waves exerts a definite influence on the phase difference of the oscillations at the receiving point. The data . . . do not, however, allow conclusions to be drawn on whether the phase variations were due to dispersion or to some other phenomena of diffractive nature."
3104. ON FADING PHENOMENA AT SHORT DISTANCES FROM BROADCAST TRANSMITTING AERIALS [Survey based on German & Swiss Work].—W. Menzel. (*Funktech. Monatshefte*, May 1938, No. 5, pp. 129-134.)
3105. CIRCUITS PRODUCING SHARP ELECTRICAL IMPULSES FREE FROM CURVATURE, AND THEIR USE IN OSCILLOGRAPH WORK [and for Stroboscopy and Ionospheric Research: the "Inevitable Curvature at Base" removed by applying to Grid of Greatly Over-Biased Vacuum Valve].—J. C. Morgan. (*Review Scient. Instr.*, June 1938, Vol. 9, No. 6, pp. 183-186.)
3106. A TUNING-MATCHING-COUPLING SYSTEM FOR AN AUTOMATIC MULTI-FREQUENCY PULSE EQUIPMENT.—Seaton. (See 3173.)
3107. MAXIMUM USABLE FREQUENCIES FOR RADIO SKY-WAVE TRANSMISSION, 1933 TO 1937 [with Discussions of Factors involved in deriving the Graphs from Vertical-Incidence Measurements and of Method of Applying Them to Simple and Complex Transmission Paths: Effects of Sporadic E Reflections, Absorption, and Scattered Reflections: etc.].—Gilliland, Kirby, Smith, & Reymer. (*Journ. of Res. of Nat. Bur. of Stds.*, May 1938, Vol. 20, No. 5, pp. 627-639.)
3108. APPLICATION OF VERTICAL-INCIDENCE IONOSPHERE MEASUREMENTS TO OBLIQUE-INCIDENCE RADIO TRANSMISSION.—Newbern Smith. (*Journ. of Res. of Nat. Bur. of Stds.*, May 1938, Vol. 20, No. 5, pp. 683-705.) Extension of the work dealt with in 3592 of 1937. The effects of the earth's curvature and magnetic field, and absorption or reflection from lower ionospheric layers, are considered.
3109. REPORT OF THE BRITISH NATIONAL COMMITTEE TO COMMISSION II, ON INVESTIGATIONS OF THE PROPAGATION OF WAVES CARRIED OUT IN GREAT BRITAIN FROM APRIL 1931 TO JUNE 1934.—R. L. Smith-Rose. (*U.R.S.I. Proceedings of 1934 General Assembly*, Vol. 4, pp. 153-165: in English.)

3110. ABNORMAL IONISATION IN THE E REGION OF THE IONOSPHERE [supports Theory that E Ionisation Clouds are produced by Meteors].—J. A. Pierce. (*Phys. Review*, 1st June 1938, Vol. 53, No. 11, p. 942: abstract only.) Cf. Skelett, 1752 of May.

3111. ON THE EFFECT OF METEOROLOGICAL PHENOMENA ON RADIO MEASUREMENTS.—D. N. Nasilov & A. S. Pogosyan. (*Journ. of Tech. Phys.* [in Russian], No. 7, Vol. 8, 1938, p. 661.)

In connection with the appearance of a conducting ionised layer at a height of from 1 km to 5 km reported by Colwell and others (3671 of 1936 and 3241 of 1937) an examination was made of the weather charts for the day on which observations were made. It appears that on that day a cold wave followed by stormy conditions passed over the points of observation. This seems to confirm the view of the authors that dynamic (meteorological) processes have a definite bearing on radio phenomena.

3112. THE CONDITION OF THE IONOSPHERE DURING THE AURORA OF 25TH/26TH JANUARY 1938, ACCORDING TO OBSERVATIONS AT THE EXPERIMENTAL STATION AT HERZOGSTAND [50 km South of Munich].—R. Eyfrig, G. Goubau, Th. Netzer, & J. Zenneck. (*Hochf. tech. u. Elek. akus.*, May 1938, Vol. 51, No. 5, pp. 149-152.)

Photographic records made on fixed frequencies, and with frequency-sweeping, are reproduced. The main characteristics are: (1) a layer at 100 km equivalent height, which is probably abnormal E not connected with the aurora; (2) a layer at 140 km, which appears to be directly connected with the aurora, and from whose existence it is presumed that corpuscular radiation was penetrating the atmosphere to this region; and (3) a very diffuse reflection, from a layer of equivalent height 450-800 km. The exact derivation of this long-delay echo is not clear; it appears to originate in a region of higher electron-density than the other two echoes. It is suggested that a "bundle" of radiation incident at an angle and giving rise to the 140 km layer might cause ionisation in the F region at a point not vertically above the 140 km region.

3113. PHOTOGRAPHIC MEASUREMENTS OF THE GREAT AURORA OF JANUARY 25TH/26TH 1938 [at Nine Stations in Southern Norway].—C. Störmer. (*Nature*, 28th May 1938, Vol. 141, pp. 955-957.)

3114. ON VARIATION OF TERRESTRIAL MAGNETISM ACCOMPANYING CHROMOSPHERIC ERUPTIONS.—J. Coulomb & G. Dugast. (*Comptes Rendus*, 23rd May 1938, Vol. 206, No. 21, pp. 1582-1585.)

Short-wave "Dellinger" fade-outs are accompanied frequently by typical perturbations in the earth's field. Such perturbations, recorded at Tamanrasset (Hoggar), are compared with records of solar eruptions from 1st July 1935 to 2nd May 1937, totalling 316, of which 12 records are unusable. 155 eruptions coincide with magnetic disturbances, but only 22 of these were accom-

panied by short-wave fade-outs. The beginning of the solar eruptions and the magnetic disturbance usually occurred within a few minutes of each other.

3115. THE MAGNETIC STORM OF 16TH APRIL 1938 [Description of Effects recorded at Potsdam & Niemeck Magnetic Observatories].—J. Bartels & G. Fanselau. (*Naturwiss.*, 13th May 1938, Vol. 26, No. 19, pp. 296-298.)

3116. CONTRIBUTION TO THE STUDY OF IONOSPHERIC DISTURBANCES OF SUDDEN ONSET [French Observations, from 1932 onwards, of the Fade-Outs now known as "Dellinger Effect": Japanese Results: Tentative Conclusions].—J. Maire. (*L'Onde Elec.*, June 1938, Vol. 17, No. 198, pp. 273-282.)

The writer reaches the tentative conclusion that the true periodicity is $27\frac{1}{2}$ days but that as the phenomenon, unlike that producing magnetic disturbances, is of short duration and only affects the illuminated hemisphere, it is liable to be masked: thus a disturbance affecting on one occasion the Atlantic services may well repeat itself after one rotation but only affect the Pacific or Asiatic services, for which the reports are far less numerous. In this way it would pass unnoticed in Europe and America for that rotation, but might make itself felt after a second rotation—i.e. with a 54 or 55-day period. The writer has tried to confirm this hypothesis by combining the French observations with those reported from Japan (Arakawa, 2448 of 1937: see also 3117, below), but the results are not conclusive and he agrees with Dellinger that the question still remains open.

3117. AN ABNORMAL PHENOMENON IN SHORT-WAVE TRANSMISSION [Japanese Data on Fade-Outs, 1933-1937, with Discussion].—D. Arakawa. (*Rep. of Rad. Res. in Japan*, Dec. 1937, Vol. 7, No. 3, pp. 193-205.) See 821 of March and back reference.

3118. UPPER-ATMOSPHERIC IONISATION AND SOLAR RADIATION [E-Region Ionising Radiation (about 0.1μ) varies in proportion to Number of Sunspots: Amount at Max. Solar Activity/Amount at Min. is Greater than 2: Relation to Area of Faculae: etc.].—K. Maeda. (*Rep. of Rad. Res. in Japan*, Dec. 1937, Vol. 7, No. 3, pp. 145-151.) Further development of the work dealt with in 2194 of June.

3119. MOTION-PICTURE POLARIGRAPH [primarily for Determination of Polarisation of Sky Light and the Short-Period Changes during Solar Eclipse].—W. M. Cohn. (*Journ. Opt. Soc. Am.*, May 1938, Vol. 28, No. 5, pp. 144-147.)

3120. DISTRIBUTION OF THE CONSTITUENT GASES AND THEIR PRESSURES IN THE UPPER ATMOSPHERE [Calculations].—S. K. Mitra & H. Rakshit. (*Indian Journ. of Phys.*, Part I, Vol. 12, 1938, pp. 47-61.)

"It is seen that if the disturbing causes due to winds in the middle atmosphere and due to periodic heating & cooling in the upper atmosphere are taken into account, diffusive equilibrium of the

constituent gases begins to be important only at great heights. It is also found that the pressures at, and the amounts of the constituent gases above, different levels in the upper atmosphere are higher than those obtained by previous workers." For an upper atmosphere consisting of N_2 and O_2 , and with temperature increasing with height, the constituents are in diffusive equilibrium above 350 km. Below 175 km they are more or less completely mixed up; in the intermediate region there is only partial mixing. If the constituents are assumed to be N_2 and O_2 , the corresponding levels are 250 km and 175 km (on the assumption of a rising temperature) or 175 km and 150 km for a constant temperature. The evidence appears to be in favour of N_2 & O_2 rather than N_2 & O ; in the latter condition, the calculations show that the region above 250 km would consist largely of oxygen atoms, whereas high-altitude auroral spectra show a greater intensity of the negative bands of nitrogen. Moreover, atomic oxygen is believed to have a strong affinity for electrons, but F-region ionisation is known to persist throughout the whole night, which it would not do if exposed to the electron-attaching proclivities of an upper atmosphere composed entirely of oxygen atoms.

3121. THE THEORY OF MOLECULAR DISSOCIATION AND THE FUNDAMENTAL MECHANISMS IN THE UPPER ATMOSPHERE.—R. C. Majumdar. (*Indian Journ. of Physics*, Part I, Vol. 12, 1938, pp. 75-86.)

Further development of the work dealt with in 1289 of April. The dissociation of oxygen and nitrogen molecules is now discussed and it is found that while the oxygen molecules remain practically undissociated at a height of 146 km, the dissociation occurs rapidly above this level and is almost complete at 167 km, assuming a temperature of 300° K and a molecular weight corresponding to the average mass of nitrogen molecules.

3122. PLASMA RESONANCE AND WAVE PROPAGATION OF IONISED GASES [Characteristics of Reflection, Refraction, & Attenuation are quite Different when Plasma Resonance is taken into Account].—Y. Asami & M. Saito. (*Electrot. Journ.*, Tokyo, June 1938, Vol. 2, No. 6, p. 146.)

Leading from the writers' previous work (452 of 1937 and 2187 of June) and that of Sigrist (2054 of 1937). "An unequal distribution of ions in the direction of the applied electric field, or an unequal movement of ions by the electric field, is the necessary condition to cause the plasma resonance in the ionised gases. The following is a study made . . . on the supposition that the ionised layer in the upper atmosphere is such as to cause plasma resonance by the above-described necessary conditions." The modified values of conductivity and dielectric constant, resulting from the inclusion of plasma resonance and employed in plotting the curves of Figs. 1 & 2, were obtained by an approximate calculation given in the writers' Japanese paper (in the *Journ. I.E.E. of Japan*, Vol. 57, 1937, p. 710) which has apparently never been included in this, the "overseas edition" of that journal.

3123. A DECISIVE IONOSPHERIC INVESTIGATION CONCERNING THE LORENTZ POLARISATION CORRECTION.—H. G. Booker & L. V. Berkner. (*Phys. Review*, 1st June 1938, Vol. 53, No. 11, p. 924: abstract only.)

"Over the past year a large number of records showing magneto-ionic splitting . . . have been obtained. We are led to believe that it is impossible to interpret these observations in terms of the Sellmeyer theory, but that no objection exists to their interpretation in terms of the Lorentz theory." See also 2185 of June.

3124. DIELECTRIC CONSTANT OF IONISED GASES.—S. Gangopadhyaya & S. R. Khastgir. (*Phil. Mag.*, June 1938, Vol. 25, No. 171, pp. 883-895.)

Dielectric constants of air and nitrogen were measured for wavelengths of 300-500 cm, using electrodes outside the discharge tube. The value decreases with increasing discharge-tube current, reaches a minimum, and subsequently increases to a value greater than unity.

3125. THE DENSITY AND TEMPERATURE OF THE ATMOSPHERE TO ABOUT 60 KM FROM TWILIGHT-SKY BRIGHTNESS MEASUREMENTS.—E. O. Hulburt. (*Phys. Review*, 1st June 1938, Vol. 53, No. 11, p. 948: abstract only.) See also 2674 of July.

3126. CONCERNING THE PRESENCE OF SODIUM IN THE UPPER ATMOSPHERE [at 60 km Altitude].—R. Bernard & G. Déjardin. (*Journ. de Phys. et le Radium*, May 1938, Series 7, Vol. 9, pp. 97-98S.)

3127. ON A NEW ANOMALOUS EFFECT IN THE SHORT-WAVE END OF THE SOLAR SPECTRUM: I [Suggested Anomalous Refraction in Ozone Layer], and CONTRIBUTION TO THE PROBLEM OF THE "UMKEHR"-EFFECT: II.—S. Rodionov & others. (*Comptes Rendus (Doklady) de l'Ac. des Sci. de l'URSS*, No. 1/2, Vol. 19, 1938, pp. 55-57: pp. 59-60: both in English.)

3128. THEORY OF THE PROPAGATION OF LIGHT IN AN ATOMICALLY STRATIFIED MEDIUM: II, and ON THE THEORY OF THE OPTICAL LATTICE.—Weigle & Patry: Patry. (*Helvetica Phys. Acta*, Fasc. 3, Vol. 11, 1938, pp. 181-188: pp. 189-206: both in French.) For I of the first paper see 2212 of June.

3129. ON THE POSSIBILITY OF THE OBSERVATION OF INTERFERENCE BETWEEN TWO RAYS OF LIGHT COMING FROM DIFFERENT SOURCES.—F. Esclangon. (*Journ. de Phys. et le Radium*, May 1938, Series 7, Vol. 9, pp. 69-70S.)

3130. ON THE THICKNESS OF THE STRATUM OF THE Pg WAVE IN CENTRAL EUROPE [Simple Method of Determination].—P. Caloi. (*La Ricerca Scient.*, 15th/30th April 1938, Series 2, 9th Year, Vol. 1, No. 7/8, pp. 334-338.)

3131. NEW FUNDAMENTAL DIFFERENTIAL EQUATIONS OF POWER TRANSMISSION LINES [Abnormalities in Propagation Characteristics of Travelling Waves, due to Previous Neglect of Corona Loss and the Skin Effect & Radiation Loss of Impulse Wave].—S. Hayashi. (*Electrot. Journ.*, Tokyo, June 1938, Vol. 2, No. 6, pp. 135-142.)

ATMOSPHERIC AND ATMOSPHERIC ELECTRICITY

3132. AUTOMATIC MEASUREMENT OF ATMOSPHERIC NOISE [on a Definite Wavelength (1100 kc/s); Static Signals divided into 4 (or 5) Classes according to Peak Intensities: for Each Class, Product of Duration and Frequency of Arrival is measured (Condenser, Neon Tube, Counter Combination) for 5 Minutes' Periods].—K. Maeda & H. Yokoyama. (*Rep. of Rad. Res. in Japan*, Dec. 1937, Vol. 7, No. 3, pp. 153-157.)
3133. PROGRESSIVE LIGHTNING [Photographic Studies of Flashes compared with Oscillographic Studies of Electric Field Changes: Successive Discharges correspond to Major Field Changes: Pulsating Leader Flashes correspond to Pulsating Field Changes].—B. F. J. Schonland, D. B. Hodges, & H. Collens. (*Proc. Roy. Soc.*, 4th May 1938, Vol. 166, No. 924, pp. 56-75.)
3134. THE DEVELOPMENT OF THE SPARK DISCHARGE [Study of Spark Voltage and Current by Oscillograph with Simultaneous Photography of Discharge: Impulse Generator giving up to 2000 kv and Sparks up to 200 cm Length].—T. E. Allibone & J. M. Meek. (*Proc. Roy. Soc.*, 4th May 1938, Vol. 166, No. 924, pp. 97-125.) See also 2680 of July.
3135. EXPERIMENTAL STUDY OF SPARK DISCHARGE [Time/Displacement Photographs (Velocities about 0.1 mm/ μ sec.) of Discharge retarded by Large Series Resistance in Generator Circuit: "Leader Stroke" precedes Every Positive - Rod/Negative - Plane Discharge: Distinctive Character of Leader in Negative-Rod/Plane Discharge: etc.].—J. Stekolnikov & A. Belyakov [Belyakov]. (*Tech. Phys. of USSR*, No. 4, Vol. 5, 1938, pp. 251-262: in English.)
3136. COMPARATIVE MEASUREMENTS BETWEEN KLYDONOGRAPH AND CATHODE-RAY OSCILLOGRAPH: ON THE BLACKENING OF PHOTOGRAPHIC FILMS BY ELECTRON RAYS AND LICHTENBERG FIGURES [and the Rough Determination of Wave Form, as well as Amplitude, from the Latter: etc.].—K. Baumgart. (Aachen Dissertation: *Physik. Berichte*, No. 8, Vol. 19, 1938, p. 829.)
3137. THE DETERMINATION OF THE METEOROLOGICAL CONDITIONS OF THE ATMOSPHERE BY THE USE OF RADIO-SOUNDING BALLOONS.—H. A. Thomas. (*Proc. Roy. Soc.*, 3rd June 1938, Vol. 166, No. 926, p. S. 64: abstract only.)
- Observations of pressure and temperature up to a height of 10 km are obtained to an accuracy of 5 mb and 1° C respectively, by a method of varying modulation frequency. Cost of the apparatus is comparatively low and reproduction in large quantities is possible.
3138. "HÖHENSTRAHLUNG (ULTRA STRAHLUNG)" [Cosmic Rays: Book Review].—E. Miethnickel. (*E.T.Z.*, 26th May 1938, Vol. 59, No. 21, p. 572.)

PROPERTIES OF CIRCUITS

3139. APPLICATION OF THE LAGRANGIAN EQUATIONS TO ELECTRICAL CIRCUITS.—D. A. Wells. (*Journ. of App. Phys.*, May 1938, Vol. 9, No. 5, pp. 312-320.)
3140. ON A CERTAIN DIFFERENTIAL EQUATION HAVING A LIMITING CYCLE [$\ddot{x} + x = \alpha\dot{x} + \beta x\dot{x} + \gamma\dot{x}^2 + \delta x^2$, in Theory of Auto-Oscillations].—N. Bautin. (*Tech. Phys. of USSR*, No. 3, Vol. 5, 1938, pp. 229-243: in English.) Several oscillator circuits can be reduced to an equation of this type on the assumption that their characteristics are approximated by polynomials which do not contain terms of any power higher than the second.
3141. OSCILLATIONS OF NON-LINEAR SYSTEMS APPROXIMATING TO LINEAR SYSTEMS WITH PERIODICALLY VARYING PARAMETERS.—G. Gorelik. (*Tech. Phys. of USSR*, No. 4, Vol. 5, 1938, pp. 320-328: in French.) The Russian paper was dealt with in 2694 of July.
3142. RESONANCE THEORY OF SERIES NON-LINEAR CONTROL CIRCUITS [particularly the Case in which Inductance varies with the Current].—E. G. Keller. (*Journ. Franklin Inst.*, May 1938, Vol. 225, No. 5, pp. 561-577.)
3143. ON A TWO-GRID VALVE RELAXATION OSCILLATOR [Various Forms of Oscillation possible with Four-Electrode Valve in a Circuit having only Resistance and Capacity Elements].—H. Morin. (*Comptes Rendus*, 23rd May 1938, Vol. 206, No. 21, pp. 1560-1561.)
3144. THE PHASE SHIFTS IN CONTROLLED MULTIVIBRATORS FROM 200 000 TO 1 CYCLE PER SECOND.—George. (See 3330.)
3145. A FURTHER EQUIVALENT-GENERATOR THEOREM.—I. S. Rabinovich. (*Izvestiya Elektroprom. Slab. Toka*, No. 2, 1938, pp. 22-24.)
- Independently of the theorem proved by Landon (1930 Abstracts, p. 271) a proof is given of the following theorem:—Given a network, including a zero-impedance generator, let any two points of the network be short-circuited and the current I_k flowing between them measured. If a second generator giving a current equal to I_k but flowing in the opposite direction is connected to these points, the same currents and voltages will appear in that portion of the network which was rendered inactive by the short circuit. Stated in another way:—
- An electrical network with two output terminals can be replaced by a suitable generator and impedance in parallel with the load, the generator current being equal to the current between the two terminals when these are short circuited and the impedance being that of the unloaded network looking into the output terminals. The application of this and Landon's theorems to the design of networks is discussed, and certain advantages in the use of the new theorem are pointed out.

3146. THE THEORY OF MODULATION AND DEMODULATION: PART III.—F. Aigner & C. L. Kober. (*Hochf. tech. u. Elek. akus.*, May 1938, Vol. 51, No. 5, p. 162.) Giving an alternative treatment to that of Part I (49 of 1937) for demonstrating the existence of sidebands, starting from eqn. 2 of the earlier paper.
3147. STUDY OF THE PRINCIPLES OF RETROACTION [including the Simultaneous Use of Current and Voltage Retroaction, and the Possibility of a Zero Internal Resistance: Internal Resistance of an Amplifier: D. C. Amplifiers: etc.].—Bedeau & de Mare. (*L'Onde Elec.*, May 1938, Vol. 17, No. 197, pp. 247-268.) Concluded from 2690 of July. A discussion follows on pp. 269-270.
3148. SUMMARY OF THE ANALYTIC EXPERIMENT OF [Triode or Screen-Grid Valve functioning as] DOUBLER IN SHORT-WAVE TRANSMITTER.—I. Taki. (*Nippon Elec. Comm. Eng.*, April 1938, No. 10, pp. 180-181.)
3149. ON A METHOD OF AMPLIFYING A D.C. VOLTAGE [by Use of Magnetic Frequency Doubler: D.C. Voltages from 1-100 mV amplified to 30 V to Deflecting Plates of C-R Oscillograph].—Y. Watanabe & H. Chonan. (*Nippon Elec. Comm. Eng.*, April 1938, No. 10, pp. 184-186.)
3150. WAVE SHAPE OF MAGNETISING CURRENTS [New Mathematical Solution giving Magnitude of Harmonics].—J. L. Clarke. (*Elec. Engineering*, June 1938, Vol. 57, No. 6, p. 268.)
3151. ON THE GENERAL FORM OF THE COUPLING COEFFICIENT [and Its Relation to the Transfer Constant].—T. Hirota. (*Nippon Elec. Comm. Eng.*, April 1938, No. 10, pp. 183-184.)
3152. ON THE DISPLACEMENT OF NATURAL RESONANT FREQUENCIES AND DAMPING IN COUPLED OSCILLATORY SYSTEMS.—K. W. Wagner. (*Ann. der Physik*, June 1938, Vol. 32, No. 3, pp. 301-312.)
3153. CRYSTAL I.F. COUPLING AND FILTERS.—White. (See 3185.)
3154. GRAPHICAL AND MATHEMATICAL REPRESENTATION OF THE ADJUSTMENT OF TWO-ELEMENT BAND-PASS FILTERS.—Frühaufl. (See 3184.)
3155. ON THE DESIGN OF ONE AND TWO SECTION CUT-OFF FILTERS.—G. V. Dlugach. (*Izvestiya Elektroprom. Slab. Toka*, No. 2, 1938, pp. 28-35: to be contd.)

In designing filters by methods expounded in the general theory of networks, very complicated calculations are usually required. In the present paper some of the results are shown of a theoretical investigation carried out with a view to simplifying these calculations. A pi-type low-pass filter is considered first (Fig. 2), and formulae are derived for determining the impedance of the filter (5), the input and output voltages (6 & 7) and the attenuation introduced by the filter at various frequencies (12). The formulae so derived are further simplified for

certain particular cases, and the operation of the filter is represented by a number of curves. A similar analysis is also applied to the T-type low-pass filter and to the T and pi-type high-pass filters.

3156. ELECTRIC FILTERS IN THEIR PRACTICAL FORM.—H. Hertel. (*Funktech. Monatshefte*, May 1938, No. 5, pp. 149-156.)

Extension, on the practical side, of the work of Kautter referred to in 1724 of 1937. Measurements on actual filters, for frequencies 30-10 000 c/s, are shown in curves, illustrating the behaviour of various kinds of iron cores (Sirufer, Nicalloy, etc.) and the attenuation & characteristic-impedance characteristics of the different types of filter.

3157. THE THEORY OF FOUR-TERMINAL PASSIVE NETWORKS IN RELAY CIRCUIT.—A. Nakasima. (*Nippon Elec. Comm. Eng.*, April 1938, No. 10, pp. 178-179.)

3158. THEORY OF THE FOUR-TERMINAL IMPEDANCE-TRANSFORMATION CIRCUIT AND MATCHING CIRCUIT.—T. Mizuhasi. (*Rep. of Rad. Res. in Japan*, Dec. 1937, Vol. 7, No. 3, Abstracts p. 39.)

3159. THE MUTUAL INDUCTANCE BETWEEN TWO COAXIAL HELICAL WIRES.—C. SNOW. (*Phys. Review*, 1st June 1938, Vol. 53, No. 11, p. 934: abstract only.)

3160. MAGNETIC FORCE OF A SOLENOID [Single-Layered: Method (based on Ampère's Law) simpler than Usual Vector-Potential Method].—L. Fleischmann. (*Elec. Engineering*, June 1938, Vol. 57, No. 6, pp. 268-272.)

3161. A CONTRIBUTION TO THE THEORY OF TWO PARALLEL LINES [above an Ideal Earth].—T. Hirota. (*Nippon Elec. Comm. Eng.*, April 1938, No. 10, pp. 147-151.)

TRANSMISSION

3162. CONTRIBUTIONS TO THE THEORY OF THE TWO-SLIT MAGNETRON GENERATOR IN THE C REGION.—Y. Ito. (*Rep. of Rad. Res. in Japan*, Dec. 1937, Vol. 7, No. 3, pp. 159-192: in German.)

An abridged version of a 1935 service report of the Research Establishment of the Japanese Navy: in this version, however, Japanese patents of 1936 & 1937 are referred to. A fuller treatment is to be found in the writer's book (Japanese) on "The 2-Slit Magnetron." From the author's summary:—"The present work attempts to make clear some properties of the 2-slit magnetron as oscillator and amplifier. The problem is attacked from the low-frequency side, and the results are valid up to frequencies of 30 Mc/s: in order to explain the properties of the magnetron in the region of decimetre and centimetre waves, so important for communication practice, account must be taken of the inertia phenomena of the moving electrons." The treatment follows that of the triode valve as given by Barkhausen, but the set of formulae obtained is more voluminous and more difficult to handle than for the triode, owing to the greater number of variables and of circuit variations. Various types of back-coupling

(internal, external, and a combination of the two) are considered, and push-pull circuits (single-valve and two-valve) are dealt with. Finally, the generation of multi-phase currents and voltages by the 3-split magnetron is analysed (see also 899 of March).

3163. THEORY OF SPLIT-ANODE MAGNETRON OSCILLATOR.—S. Katsurai. (*Nippon Elec. Comm. Eng.*, April 1938, No. 10, pp. 129-133.) A summary was dealt with in 73 of January. For a further paper see 459 of February.

3164. SERIES MODULATION OF SPLIT-ANODE MAGNETRON OSCILLATIONS [Good Results by Use of D.C. Anode Voltage slightly Lower than Value giving Maximum Oscillation Intensity].—S. Nishimura, K. Goto, & K. Saji. (*Electrot. Journ.*, Tokyo, June 1938, Vol. 2, No. 6, pp. 133-134.)

3165. EFFECT OF HIGH ENERGY ELECTRON RANDOM MOTION UPON THE SHAPE OF THE MAGNETRON CUT-OFF CURVE.—E. G. Linder. (*Journ. of App. Phys.*, May 1938, Vol. 9, No. 5, pp. 331-334.)

Author's summary:—The shape of the cut-off curve is explained on the basis of a component of high-energy random motion superimposed on the electron orbital motion. Electron temperatures determined from the cut-off-curve shape agree with those determined by probe methods. The possible effects of the random motion on other magnetron characteristics are pointed out.

3166. ON NEW VACUUM TUBES "SENTRON" FOR ULTRA-SHORT WAVES [including Types with Modulating Grid and with Electron Lens (giving nearly 30% Efficiency): also Three- and Four-Segment Types].—Uda, Utida, & Sekimoto. (*Nippon Elec. Comm. Eng.*, April 1938, No. 10, pp. 171-177.) A summary was dealt with in 2772 of July.

3167. ELECTRON OSCILLATIONS PRODUCED BY A THERMIONIC TUBE WITH PLANE ELECTRODES OPERATED IN PUSH-PULL.—S. Nakamura. (*Nippon Elec. Comm. Eng.*, April 1938, No. 10, pp. 134-139.) A summary was dealt with in 83 of January.

3168. A METALLIC ELLIPSOID AS FREQUENCY STABILISER FOR DECIMETRE WAVES [Single Dipole enclosed in Copper Ellipsoidal Shell: Superior to Crystal Stabiliser: Circuit for Magnetron Transmitter, giving Superheterodyne Signals (Super-Regenerative Reception necessary on Removal of Ellipsoid)].—K. Morita. (*Rep. of Rad. Res. in Japan*, Dec. 1937, Vol. 7, No. 3, pp. 215-217.)

3169. AN OSCILLATOR FOR ULTRA-HIGH FREQUENCIES ["Standpipe" or "Water-Tower" Oscillator with Stabilisation by Coaxial Line: Easily Adjustable 430-43 cm Wave-Range: 6 Watts Output at 500 Mc/s with 20% Efficiency].—W. L. Barrow. (*Review Scient. Instr.*, June 1938, Vol. 9, No. 6, pp. 170-174.)

3170. [Ultra-] SHORT-WAVE TRANSMITTERS WITH SPHERICAL CIRCUITS [Some British Amateur Results (1935 onwards) with Aluminium "Hat" Circuits].—L. J. FitzGerald. (*Wireless Engineer*, June 1938, Vol. 15, No. 177, p. 323.) Prompted by Editorial dealt with in 2259 of June.

3171. AN ULTRA-SHORT-WAVE QUARTZ CRYSTAL OSCILLATOR [using Quartz Plates in Pierce Circuit giving Fundamentals down to 5.8 m: No Indication that Shape of Plate has Any Relation to Ease of Oscillation].—I. Koga. (*Rep. of Rad. Res. in Japan*, Dec. 1937, Vol. 7, No. 3, pp. 227-229.) For a previous paper see 1130 of March, where the year should read "1938."

3172. A FURTHER EQUIVALENT-GENERATOR THEOREM.—Rabinovich. (See 3145.)

3173. A FINAL AMPLIFIER TUNING-MATCHING-COUPLING SYSTEM [primarily for Automatic Multi-Frequency Pulse Equipment for Ionospheric Recording: 3 Adjustable Condensers in Series instead of Usual "Tank"-Tuning Condenser, Feeder being connected across Middle Condenser].—S. L. Seaton. (*QST*, June 1938, Vol. 22, No. 6, p. 36.) An Australian Conference paper (1936) by Berkner, Wells, & Seaton is referred to: this may perhaps be the one referred to by Maeda & Tukada (12 of January).

3174. ON TEMPERATURE COMPENSATION IN MASTER OSCILLATORS.—N. Schöller. (*Hochf.tech. u. Elek. akus.*, May 1938, Vol. 51, No. 5, p. 174.) The full paper was dealt with in 4051 of 1937.

3175. GANG TUNING FOR THE MULTI-STAGE TRANSMITTER: A SIMPLE TRACKING SYSTEM REDUCING THE NUMBER OF NECESSARY CONTROLS.—D. H. Mix. (*QST*, June 1938, Vol. 22, No. 6, pp. 8-11 and 72-76.)

3176. PROTECTING THE TRANSMITTER FROM SHUT-DOWN [due to High-Voltage Transients and Arcs].—Bell Tel. Laboratories. (*Electronics*, May 1938, Vol. 11, No. 5, pp. 58-59.)

3177. FINAL STAGE CLASS "B" MODULATION [for High-Efficiency Broadcasting, including Short-Wave].—C. E. Strong. (*Elec. Communication*, April 1938, Vol. 16, No. 4, pp. 321-332.)

3178. EQUIVALENT CIRCUIT OF "METAL" MODULATOR AND ITS PERFORMANCE [Ring (and Cowan's) Metal-Rectifier Systems].—Y. Degawa. (*Nippon Elec. Comm. Eng.*, April 1938, No. 10, pp. 118-124.)

3179. THE THEORY OF MODULATION AND DEMODULATION: PART III.—Aigner & Kober. (See 3146.)

3180. THE MODULATION OF RELAXATION OSCILLATIONS [Calculation of Resulting Frequency Bands: Experimental Verification].—F. Söchting. (*Elektrot. u. Masch:bau*, 22nd May 1938, Vol. 56, No. 21, pp. 269-273.)

While a sinusoidal oscillation is represented by

$A \sin(\Omega t + \phi)$ and is thus completely described by giving the three quantities amplitude, frequency, and phase, for the representation of an unmodulated relaxation oscillation a Fourier series must be used, thus: $\Sigma A_n \sin(n\Omega t + \phi_n)$. For the first analysis the fact must be ignored that a large number of the coefficients A_n or ϕ_n may be zero, and for practical applications may be neglected. Since the relaxation oscillation is completely defined by giving A_n , Ω , and ϕ_n , the most general modulation process is represented by the triple modulation formulae $A_n = A_n(t)$, $n\Omega = n\Omega(t)$, $\phi_n = \phi_n(t)$. A footnote points out that the relation $n\Omega = n\Omega(t)$ is not self-contradictory, since the modulation of the frequency of each separate harmonic can follow its own law, so that n is not a whole number permanently, but only for the unmodulated oscillation.

It is easy to see that with such an extensive possibility of variation of the carrier oscillation and of the type of modulation, an immense number of forms may emerge for the modulated oscillations and thus complicate their theoretical treatment. But it is this vast possibility of variation which gives a great power of adaptation to various technical requirements. The types of modulation are divided into 3 main classes, of which the first is pure amplitude modulation, where $n\Omega$ and ϕ_n remain constant and only the amplitudes of the component frequencies vary, as given by $A_n = A_n(t)$. Here there are two sub-types, namely (a) where all the components are varied in the same ratio, so that $A_n = A_{n0} \cdot f(t)$, the function $f(t)$ being the same for all values of A_n (such a modulation is obtained, for instance, when the slope of a valve is modulated, as by a displacement of the grid voltage); and (b) where the modulation function is different for different components. In the case of (a) the function $f(t)$, being the same for all terms A_n , can be taken outside the Σ so that the modulated oscillation is given by $f(t)\Sigma A_{n0} \sin(n\Omega + \phi_n)$. This expression is the product of $f(t)$ and the carrier, but this does not imply that the carrier remains undistorted: it would do so only in the special case where $f(t) = \text{const.}$, though it would be approximately undistorted if $f(t)$ varied with time only slowly compared with the "kipp" frequency. In all other cases considerable distortion would occur, as is shown in section II for an oscillation of simple saw-tooth form: the curve of Fig. 1 makes clear how, although the frequency remains unchanged, the shape of the teeth becomes distorted. The same section also shows that the transmission of modulated relaxation oscillations requires a much wider frequency band than a modulated sine wave: theoretically the band is infinitely wide, but in practice it may be sufficient to have a band width adequate to transmit the unmodulated carrier with accuracy: *i.e.* about $n_1\Omega + \omega$. It is to be noticed that a d.c. term is present, so that the frequency spectrum begins at zero. If the lowest frequency band (0 to ω) is not transmitted, the bottom angles of the saw-teeth no longer lie on a straight line but also move up and down in the rhythm of the modulation curve (Fig. 2). It is pointed out that in the transmission, amplification, etc., of relaxation oscillations great care must be taken to obtain phase fidelity, since

a false phase has a much worse effect than in the transmission of music or speech.

Section III deals with frequency and phase modulation, and begins by showing that, as with a sinusoidal carrier, these two types of modulation are closely connected, so that it is really a question of convenience or taste whether, in a particular instance, a modulation is spoken of as frequency or phase modulation: in either case a function $\sin[f(t)]$ is involved. The writer therefore concentrates on frequency modulation and for the sake of simplicity takes the simplest case, that of a saw-tooth carrier frequency-modulated sinusoidally. Here again the saw-teeth are distorted. Of special interest is a modulation of 100%, where the charging current fluctuates between 0 and $2i_0$, and the frequency between 0 and $2f_0$ (right-hand end of Fig. 4). The frequency band necessary for transmission must be obtained from a Fourier analysis and contains frequencies far higher than f_0 ; it may be taken as reaching $n_1 \cdot f_{\text{max}}$, where n_1 is dependent on the demands of accuracy in reproduction and f_{max} is calculable from the frequency equation for $i = i_{\text{max}}$.

Section IV deals with the production of undistorted saw-tooth oscillations by a mixed amplitude and frequency modulation. Alone, each type of modulation has been shown to produce distortion, just as it does (though often unnoticed) with a sinusoidal carrier. But unlike the latter case, the relaxation-oscillation distortions can be avoided by the correct mixture of the two types of modulation. Thus with the circuit of Fig. 3, if instead of keeping the voltages constant and modulating the charging current (as was done in section III) the current is kept constant and the striking voltage is modulated, *e.g.* by a thyatron, curves such as are shown in Fig. 5 (for small and large modulation percentages) will be produced, in which the points of the saw-teeth lie on a sine curve and frequency modulation is also seen to be present, but the teeth are undistorted. The theoretical results are confirmed by the c-r oscillograms in section V.

RECEPTION

3181. "TRANSIT-TIME" DETECTION.—Strutt. (*See* 3208.)
3182. THE PENTAGRID TUBE AS A COMBINED SECOND DETECTOR AND BEAT-FREQUENCY OSCILLATOR: A FUNDAMENTAL LIMITATION AND ITS REMEDY [in Short-Wave Superhets: Decreased Sensitivity on Switching from C.W. to Modulated Transmission: cured by changing to Grid-Leak Detection for Latter].—G. C. F. Whitaker. (*QST*, June 1938, Vol. 22, No. 6, pp. 30-31 and 68.) Led up to by a discussion of the two types of heterodyne frequency changing, the "rectifying" and the "non-rectifying," and their differences.
3183. THE MANY SETTINGS, OTHER THAN THEIR OWN, ON WHICH CERTAIN STATIONS CAN BE RECEIVED [Harmonics: "Superheterodyne Beats": Sub-Harmonics? etc.].—(*World-Radio*, 3rd June 1938, Vol. 26, No. 671, p. 8.)

3184. GRAPHICAL AND MATHEMATICAL REPRESENTATION OF THE ADJUSTMENT OF TWO-ELEMENT BAND-PASS FILTERS.—H. Frühauf. (*Hochf.tech. u. Elek.akus.*, May 1938, Vol. 51, No. 5, pp. 168-173.)
Dealing with the band-pass filters used in broadcast reception, in which two tuned elements are magnetically or electrostatically coupled. For accurate tuning, each circuit should be tuned with the coupling at zero, and the paper studies the tuning process when this condition is not fulfilled. Correct tuning cannot be carried out if the circuits are initially over-coupled, but in all practical cases a sufficiently accurate adjustment is possible.
3185. CRYSTAL I.F. COUPLING AND FILTERS [Lattice Type Networks: Push-Pull Coupling with Lattice Network: Transformer-Coupled Systems: "Single-Sided" Systems: etc.].—G. J. White. (*Proc. I.R.E. Australia*, March 1938, Vol. 1, No. 3, pp. 50-56.)
3186. IRON IN HIGH-FREQUENCY CIRCUITS: SOME COMMENTS ON ITS USE [including Bibliography of 41 Items].—J. N. Briton. (*Proc. I.R.E. Australia*, Sept. 1937, Vol. 1, No. 2, pp. 42-47.)
3187. REMARKS ON AUTOMATIC SHARP TUNING [Automatic Tuning Correction].—Th. Sturm. (*Funktech. Monatshefte*, May 1938, No. 5, pp. 139-146.)
Extension of a previous paper (in the German journal *Funk*). The type of a.t.c. in which only the oscillator circuit is acted on is the type generally adopted, since the other method usually involves an auxiliary motor and only in rare cases offers sufficient advantages to justify this. With the simpler method, however, care must be taken to arrange that the tuning does not "jump over" to a stronger local station when the hand adjustment happens to be too rough and the uncorrected tuning of the input circuit makes such a "jump" liable to occur. The present article deals with the conditions necessary for the avoidance of this danger. A paper by Kettel (1393 of April) has appeared while the article was awaiting publication, and appears to cover part of the same ground. The present writer emphasises the advantages of really good a.t.c., and considers that it will soon be considered as indispensable as a.v.c.
3188. ON THE DESIGN OF A DISCRIMINATING CIRCUIT.—N. I. Chistyakov. (*Izvestiya Elektroprom. Slab. Toka*, No. 2, 1938, pp. 24-28.)
For the automatic stabilisation of the intermediate frequency in a superheterodyne receiver, for automatic tuning correction, a circuit is required for controlling the grid bias of the regulating valve in accordance with the variation of the frequency. In the present paper the operation is discussed of one such circuit (Fig. 2) in which use is made of two coupled tuned circuits, and two rectified voltages V_1 and V_2 are obtained having their respective maxima at frequency deviations of opposite signs. Formulae are derived for determining V_1 , V_2 and the resultant voltage V , and a curve is plotted (Fig. 6) showing the variation of V with the frequency deviation. The rate of change of V with respect to frequency deviation is also examined, and conditions for the maximum sensitivity are established.
3189. A FORM OF DISTORTION KNOWN AS THE "BUZZ EFFECT" [and the Explanation of an Obscure Form of Interference from Certain Types of Incandescent Lamp].—Macfadyen: Lehmann. (*See* 3221.)
3190. BROADCAST INTERFERENCE MEASUREMENTS ON TRAMWAYS [and the Various Suppression Methods].—F. Eppen & H. Seiberth. (*E.T.Z.*, 16th June 1938, Vol. 59, No. 24, pp. 629-634.)
The methods include increasing the current consumption of the lighted tram by auxiliary resistances or by heating equipment; providing 1 microfarad condensers at intervals along the overhead line; and the introduction of a tuned choke coil in the total-current lead directly below the collector arm.
3191. ON THE PREVENTION OF THE PROPAGATION OF INTERFERENCE ALONG THE MAINS FEEDING THE SOURCE OF INTERFERENCE.—S. A. Lyutov. (*Izvestiya Elektroprom. Slab. Toka*, No. 2, 1938, pp. 8-21: to be contd.)
The equivalent circuit of a source of interference loaded with its supply network (Fig. 4) is considered and various methods for preventing the propagation of interference along the supply mains are discussed under the following headings: (a) by-pass capacity (Figs. 5 & 6), (b) blocking inductance (Figs. 7 & 8), (c) L-type filter with a series inductance at the input side (Figs. 9 & 10), (d) L-type filter with a parallel capacity at the input side (Figs. 11 & 12), and (e) Pi-type filter (Fig. 13). For each of the above types of circuit, formulae are derived for determining the reduction of interference in the mains, and conditions of resonance are established. Methods are also indicated for designing these circuits.
3192. DISCHARGE CHARACTERISTICS OF IGNITION COILS.—Mochizuki & Miyoshi. (*Elektrot. Journ.*, Tokyo, June 1938, Vol. 2, No. 6, pp. 142-145.)
3193. REVISION OF RADIO STANDARD EXTENDS SAFETY REQUIREMENTS TO OTHER DEVICES [Intercommunication Devices, Gramophone-Record Players, etc.].—J. W. Fulmer. (*Industrial Standardization*, New York, May 1938, Vol. 9, No. 5, pp. 127-129.)

AERIALS AND AERIAL SYSTEMS

3194. NEW TYPE "HORN" ANTENNA PRODUCES SHARPER RADIO BEAMS: MAY BE USEFUL IN MICRO-RAY COMMUNICATION.—W. L. Barrow. (*Sci. News Letter*, 14th May 1938, Vol. 33, No. 20, p. 313.)
3195. IMPEDANCE CHARACTERISTICS OF SHORT-WAVE DIPOLES.—T. Walmsley. (*Phil. Mag.*, June 1938, Vol. 25, No. 171, pp. 981-993.)
Measurements on single-wire and cage dipoles shew that the flatter impedance/frequency relation of the latter leads to practical advantages, especially in designing arrays to work over a frequency band.

3196. THE ELECTRICAL OSCILLATIONS OF A PROLATE SPHEROID: PAPER I.—L. Page & N. I. Adams. (*Phys. Review*, 15th May 1938, Vol. 53, No. 10, pp. 819-831.)
Solutions in spheroidal co-ordinates are obtained of the differential equation of the electromagnetic field which are valid all the way from the surface of a prolate spheroid, of eccentricity unity, to infinity. Free and forced oscillations are studied, and the results in the latter case are applied to the study of an aerial treated as an elongated spheroid excited by an electromagnetic wave.
3197. RADIATION OF A HERTZIAN DIPOLE INTO THE EARTH [Calculation: Somewhat Larger for a Vertical Dipole than for a Horizontal Dipole].—Y. Kato. (*Rep. of Rad. Res. in Japan*, Dec. 1937, Vol. 7, No. 3, Abstracts pp. 29-30.)
3198. MEASURED GAIN OF SHORT-WAVE BEAM ANTENNA.—M. Nakagami & K. Miya. (*Nippon Elec. Comm. Eng.*, April 1938, No. 10, pp. 125-128.) A summary was dealt with in 116 of January.
3199. ON THE SPACING BETWEEN PROJECTOR AND REFLECTOR OF A BEAM ANTENNA [Results of Calculation of Optimum Spacing for Zero Rear Radiation and for Max. Front Radiation].—H. Takeuchi. (*Nippon Elec. Comm. Eng.*, April 1938, No. 10, pp. 189-190.)
3200. THE DESIGN OF "FISH-BELLY" ["Fischbauch"] VERTICAL AERIALS [tapering to Top and Bottom].—E. Siegel & W. Wiechowski. (*Hochf. tech. u. Elek. akus.*, May 1938, Vol. 51, No. 5, pp. 163-168.)
The writers discuss the design of tapered aerials having their widest section at the centre and tapering to a point at the upper and lower ends. The aerial is treated as a conductor whose characteristic impedance varies from minimum at the centre to a maximum at each end, radiation being represented by a constant increase in resistance. The current and voltage at any point on the aerial are derived in eqns. 10 & 11 (upper part of aerial) and 12 & 13 (lower part); these equations contain a damping constant α which can be obtained from eqn. 16 when the voltage and current at the base of the aerial are known. Current and voltage distribution curves for a typical case are given in Fig. 4, and the resulting field-distribution curve in Fig. 8. It is pointed out that design of antennas by the use of model aerials working at proportionally reduced wavelengths may give misleading results, as the ratio wavelength-in-air/wavelength-in-aerial is not the same in each case.
3201. ON FADING PHENOMENA AT SHORT DISTANCES FROM BROADCAST TRANSMITTING AERIALS [Survey based on German & Swiss Work].—W. Menzel. (*Funktech. Monatshefte*, May 1938, No. 5, pp. 129-134.)
3202. A SHORT RADIATOR WITH GROUND SCREEN [Experimental 125-Foot Tower with 8 Radial Earth Wires and 9 (later 19)-Ft. Square Screen: Importance of Increased Size of Screen and of Suppression of Vegetation: etc.].—C. E. Schuler. (*Communications*, May 1938, Vol. 18, No. 5, pp. 16-17.)
3203. REDUCING DIELECTRIC HYSTERESIS LOSSES AT VERTICAL RADIATORS [by Use of a Ground Screen, by Raising the Base Insulator, etc.].—Scott Helt. (*Communications*, May 1938, Vol. 18, No. 5, pp. 24-26.) For a previous paper see 1934 Abstracts, p. 269.
3204. ELECTRICAL PROPERTIES OF AERIALS FOR MEDIUM AND LONG WAVE BROADCASTING [Survey based on Information Hitherto Unpublished or Scattered through Many Publications].—W. L. McPherson. (*Elec. Communication*, April 1938, Vol. 16, No. 4, pp. 306-320: to be concluded.)
3205. THE EXTENDED DOUBLE-ZEPP ANTENNA: SIMPLE STRUCTURES HAVING IMPROVED GAIN AND HORIZONTAL DIRECTIVITY [Each Doublet 0.64 λ instead of 0.5 λ].—H. Romander: Alford. (*QST*, June 1938, Vol. 22, No. 6, pp. 12-16 and 76 . . 82.)
3206. INSULATING TRANSFORMERS FOR BEACON-LIGHT CIRCUITS OF AERIAL TOWERS.—A. Asta. (*Alta Frequenza*, May 1938, Vol. 7, No. 5, pp. 349-353.)

VALVES AND THERMIONICS

3207. A METHOD OF INVESTIGATING ELECTRON-INERTIA EFFECTS IN THERMIONIC TUBES.—S. Kownacki & J. A. Ratcliffe. (*Nature*, 4th June 1938, Vol. 141, p. 1009.)

Experimental investigation of electron-inertia or transit-time effects is difficult owing to the very high frequencies involved. If, however, massive ions are used instead of electrons, the experiments can be conducted at frequencies of the order of one Mc/s. The technique is described, together with some preliminary results.

3208. ELECTRON TRANSIT-TIME EFFECTS IN MULTI-GRID VALVES: MEASUREMENTS ON SHORT WAVES [and Ultra-Short: 31 & 9 Metres: and the Application of Transit-Time Current Effect to New Type of Detection].—M. J. O. Strutt. (*Wireless Engineer*, June 1938, Vol. 15, No. 177, pp. 315-321.) See also 2773 of July.
3209. PAPERS ON MAGNETRONS.—(See under "Transmission.")
3210. CORRECTION TO "ON THE MODE OF ACTION OF A CYLINDRICAL DIODE . . ."—Grünberg & Bliznjuk. (*Tech. Phys. of USSR*, No. 4, Vol. 5, 1938, p. 332.) See 2777 of July.
3211. MEASUREMENT OF THE COMPLEX SLOPE OF MODERN MULTIPLE-GRID VALVES IN THE SHORT [and Ultra-Short] WAVE REGION.—M. J. O. Strutt & A. van der Ziel. (*E.N.T.*, April 1938, Vol. 15, No. 4, pp. 103-111.)

The effect of the phase angle of the slope of triodes, pentodes, hexodes, and secondary-emission valves is studied theoretically and experimentally, with satisfactory agreement. A Mullard SP4B, measured at 9.1 metres, with 200 v anode and screen voltage and 1.9 v grid bias (anode current 3 ma) gave $|S| = 2.69 \text{ mA/v}$; $\phi = 22^\circ$. Previous calculations of valve performance in which this phase angle was neglected are not seriously in error. In connection with secondary-emission amplifiers,

attention is called to the Malter effect, an effect of enhanced secondary emission which leads to a falling-off of the slope at high frequencies.

3212. DEFLECTION VALVES FOR ULTRA-SHORT AND DECIMETRE WAVES [History, with Literature & Patent References, from 1906 (von Lieben) onwards: Current/Voltage Ratio the Real Difficulty: Its Solution: etc.].—J. H. O. Harries: Colebrook. (*Wireless Engineer*, June 1938, Vol. 15, No. 177, pp. 323-324.) Prompted by Colebrook's article (2324 of June).
3213. CRITICAL-DISTANCE VALVES AND BEAM TETRODES [Correspondence].—Salzberg & Haeff: Harries. (*Wireless Engineer*, June 1938, Vol. 15, No. 177, pp. 322-323.) See 2348 of June.
3214. A NEW TYPE OF GAS-FILLED AMPLIFYING VALVE.—G.W.O.H.: Nienhold. (*Wireless Engineer*, June 1938, Vol. 15, No. 177, pp. 301-302.) Editorial on the paper dealt with in 2326 of June.
3215. THE PENTAGRID TUBE AS A COMBINED SECOND DETECTOR AND BEAT-FREQUENCY OSCILLATOR.—Whitaker. (See 3182.)
3216. CONTRIBUTION TO THE SUBJECT OF THE MOTION OF THE ELECTRONS IN A DYNAMIC ELECTRON - MULTIPLIER. —Majewski. (See 3296.)
3217. NOISE IN AMPLIFYING VALVES [Equivalent Grid Resistance may be Many Times the Stated Value (End Cooling of Filament in Directly Heated Cathodes: with Indirectly Heated Cathodes after Long Operation): Dependence of Shot Effect on Heating Voltage: etc.].—W. Kleen & W. Engbert. (*Sci. Abstracts*, Sec. B, 25th May 1938, Vol. 41, No. 485, p. 371.)
3218. BACKGROUND NOISE [and the Rebuttal of Original Thermal Hypothesis: the Modified Hypothesis *versus* the Shot Interpretation: Correspondence].—F. C. Williams: Bell: Percival & Horwood. (*Wireless Engineer*, June 1938, Vol. 15, No. 177, p. 322.) For previous letters see 2782 of July and back reference.
3219. THE FREQUENCY DEPENDENCE OF THE SHOT EFFECT IN THE CASE OF LARGE REVERSE VOLTAGES.—E. Spenke. (*Wiss. Veröff. aus den Siemens-Werken*, April 1938, Vol. 17, No. 3, pp. 85-93.)

If the operating electrode voltages of a valve are such that electrons reaching the anode are subjected to a reversing force so that the majority return towards the cathode, the shot effect will be expected to decrease with increasing frequency. At a frequency such that the transit time of an electron between the point on the outward journey at which it induces a positive kick and that on the return journey at which it induces a negative kick corresponds to half a period, the two effects will reinforce to produce a "resonance" effect. Since this frequency will be a high one, there will be an increase in noise as the frequency increases, until the reson-

ance frequency is reached. The conditions necessary to produce this effect do not correspond to any important practical case.

3220. ON THE EFFECT OF A SMALL IONIC EMISSION FROM THE CATHODE ON THE SHOT EFFECT.—E. Spenke. (*Wiss. Veröff. aus den Siemens-Werken*, April 1938, Vol. 17, No. 3, pp. 94-114.)

Studies the effect on valve noise of a possible slight emission of positive or negative ions from the cathode; the effect may be quite appreciable. Positive ions have their greatest effect at low anode voltages, and negative ions when saturation is nearly reached. The emission, which will, when exerting its maximum effect, increase the total noise by 10%, is (for Na⁺ ions from a metal or oxide cathode) 8×10^{-10} amp/sq. cm and 3.5×10^{-10} amp/sq. cm, and for O₂ ions 5×10^{-9} amp/sq. cm and 6×10^{-8} amp/sq. cm respectively. For negative ions, the noise is equal to the shot effect of the ionic current multiplied by the mass ratio mass-of-ion/mass-of-electron. The noise due to positive ions is determined mainly by the cathode temperature and electrode spacing.

3221. A FORM OF DISTORTION KNOWN AS THE "BUZZ EFFECT" [found in Certain Samples of High-Conductance Output Pentode: Explanation of Mechanism (Influence of the Getter): Prevention: Relation to Obscure Cause of Interference from Tungsten-Filament Vacuum Lamps].—K. A. Macfadyen. (*Wireless Engineer*, June 1938, Vol. 15, No. 177, pp. 310-314.)

This is the "S-Effekt" noted by Jobst & Sammer (3444 of 1935). For the special type of interference see Lehmann, 2523 of 1937.

3222. HIGH-POWER VALVES: CONSTRUCTION, TESTING, AND OPERATION.—M. O. Valve Company. (*Electronics*, May 1938, Vol. 11, No. 5, pp. 52 and 54 . . . 58.) Long summary of I.E.E. paper read on 20th March.

3223. HARMONIC ANALYSIS OF THE PLATE CURRENT OF A TRIODE POWER AMPLIFIER [New Set of Equations applicable when ν is of Any Value between 1 & 2, and with Other Advantages].—Y. Fukuta. (*Nippon Elec. Comm. Eng.*, April 1938, No. 10, pp. 187-188.) See also 65 of January.

3224. A NEW TYPE OF THERMIONIC CATHODE: THE MIGRATION CATHODE.—A. W. Hull. (*Phys. Review*, 1st June 1938, Vol. 53, No. 11, p. 936: abstract only.)

A finely woven molybdenum "stocking" is filled with granules of fused BaO-Al₂O₃ mixture and mounted as a filament inside a molybdenum cup; barium migrates over the surface of the "stocking," forming a monatomic coating.

3225. THE DETERMINATION OF THE TEMPERATURE OF HOT CATHODES BY THE MEASUREMENT OF THE INITIAL CURRENT.—W. Heinze & W. Hass. (*Zeitschr. f. tech. Phys.*, No. 6, Vol. 19, 1938, pp. 166-180.)

From the Osram laboratories. Authors' summary:—"It is shown that it is possible to measure the temperature of hot cathodes in diode valves by

a purely electrical method, with the help of the initial-current characteristic curves taken by the use of retarding potentials, with an accuracy about equal to that of pyrometric method. It is necessary for this purpose that the valves employed should have good insulation, a good vacuum, and cathodes with a sufficiently uniform condition of surface. As regards this last requirement, a closer investigation shows that errors in results with non-uniform cathodes are caused by contact potentials which occur between individual points in such cathodes.

"In valves with three or more electrodes, on the other hand, the accuracy attainable by the electrical method is found to be insufficient, generally, for practical purposes. The cause for the observed discrepancies is found to be that in these valves the non-uniform potential distribution in the grid surface exerts a deflecting action on the electrons, through which the latter are hindered, owing to the finite lengths of the electrodes, from reaching the anode [at best, the method may be said to give reliable temperature values with valves having comparatively small spacing between grid and anode—p. 179, bottom of col. 2]. It is pointed out that the electrical method of temperature measurement for diodes is particularly suitable for cathodes with coatings of foreign substances [e.g. oxide-coated cathodes] and is here superior to the pyrometric method" [in which a whole series of special valves with cathodes of the same type must be examined to determine the radiation properties of the cathode].

The paper begins by discussing previous work on the temperature measurement of hot cathodes. Schlesinger's method using the natural frequency of vibration of the filament (1930 Abstracts, p. 47) is cited as the only non-electrical one possessing the same advantages, since it requires no modification to the design of the valve: but it applies only to directly-heated valves, whereas the present method can be used also for indirectly heated types. Rothe (1926) used the initial-current method but obtained values up to 50% too high, and did not trace the cause of these large errors.

3226. ELECTRON EMISSION BY BOMBARDMENT OF POSITIVE IONS ON THE CATHODE IN THE GLOW DISCHARGE: III—CURVATURE AND KINKS IN THE γ CURVE AND THEIR MEANING [Effects due to Oxide Coating on the Cathode or to Deep Penetration of the Bombarding Ions].—A. Güntherschulze & W. Bär. (*Zeitschr. f. Physik*, May 1938, Vol. 109, No. 1/2, pp. 121-126.) For previous parts see 1441 of April and 2804 of July.
3227. REDUCTION OF BARIUM OXIDE BY METALS AT HIGH TEMPERATURE.—J. P. Blewett. (*Phys. Review*, 1st June 1938, Vol. 53, No. 11, p. 935: abstract only.)
3228. CONSTRUCTION OF FILAMENT SURFACES [Nature of Surfaces of Filaments of Various Metals after running on D.C. or A.C. in Vacuum or Gas].—R. P. Johnson. (*Phys. Review*, 1st June 1938, Vol. 53, No. 11, p. 936: abstract only.)
3229. SECONDARY ELECTRON EMISSION FROM THORIUM-COATED TUNGSTEN.—E. A. Coomes. (*Phys. Review*, 1st June 1938, Vol. 53, No. 11, p. 936: abstract only.)

3230. ELECTRONIC ENERGY BANDS IN METALLIC TUNGSTEN.—M. F. Manning & M. I. Chodorow. (*Phys. Review*, 1st June 1938, Vol. 53, No. 11, p. 937: abstract only.)
3231. RELATIVE WORK FUNCTIONS AND ADSORPTIVITIES OF THE CRYSTALLOGRAPHIC PLANES OF TUNGSTEN.—S. T. Martin. (*Phys. Review*, 1st June 1938, Vol. 53, No. 11, p. 937: abstract only.)
3232. THE EVAPORATION OF ATOMS, IONS, AND ELECTRONS FROM TUNGSTEN [Measurements of Evaporation from Hot Filaments, and Comparison with Results of Other Workers: No Very Satisfactory Agreement with Theory].—A. L. Reimann. (*Phil. Mag.*, June 1938, Vol. 25, No. 171, pp. 834-848.)
3233. CONFERENCE ON THE MECHANISM OF SURFACE PHENOMENA [including Electronic and Optical Phenomena and the Adsorption of Gases].—D. Dobytschin. (*Tech. Phys. of USSR*, No. 4, Vol. 5, 1938, pp. 329-332: in English.)

DIRECTIONAL WIRELESS

3234. MARCONI DIRECTION FINDER TYPE 579/354 N.—(*Hydrographic Review*, May 1938, Vol. 15, No. 1, pp. 121-125.)
3235. THE R.9 AIRCRAFT DIRECTION-FINDING RECEIVER.—(*Elec. Communication*, April 1938, Vol. 16, No. 4, p. 373.)
3236. REFLECTION AND ABSORPTION OF DECIMETRE WAVES AT PLANE DIELECTRIC LAYERS.—Dällenbach & Kleinsteuber. (*See* 3097.)
3237. ON THE DISPERSION OF ELECTROMAGNETIC WAVES ABOVE THE EARTH'S SURFACE [in connection with Distance Measurement by Radio Methods].—Alpert & others. (*See* 3103.)
3238. DISTANCE MEASURING BY ELECTRICAL MEANS [Shallow-Reading Accuracy of Ordinary Acoustic Sounders increased by Writer's "Frequency Measurement" Method of determining Signal/Echo Interval].—E. G. Beard. (*Proc. I.R.E. Australia*, Sept. 1937, Vol. 1, No. 2, pp. 30-32.) Applicable also to aeroplane altimeters. Further, it is suggested that a radio transmitter-&-receiver version of the plan would give the distance of a ship from a coastal station.

ACOUSTICS AND AUDIO-FREQUENCIES

3239. FREE-FIELD CALIBRATION OF MICROPHONES [New Method by Substitution, using Small-Diameter Search Tube connected to Condenser Microphone].—A. J. King & C. R. Maguire. (*Nature*, 4th June 1938, Vol. 141, p. 1016.)

3240. PRESENT POSITION OF DEVELOPMENT OF MICROPHONES AND TELEPHONES FOR SUBSCRIBER APPARATUS [and the Design of Microphones (Star-Shaped Electrode and Transverse-Current Types) with Extremely Linear Operation, High Transmission Equivalent, and Broad Frequency Band: a New Telephone Receiver with Aluminium-Cone Diaphragm and Concentric Magnet System].—H. Panzerbieter. (*E.T.Z.*, 26th May 1938, Vol. 59, No. 21, pp. 550-553.)
3241. A DEVICE FOR REPLACING AUTOMATIC TELEPHONE SIGNAL TONES WITH SPEECH.—S. Okada & M. Inoue. (*Nippon Elec. Comm. Eng.*, April 1938, No. 10, pp. 168-170.)
3242. SOUND RECORDING METHOD DEPENDING ON DIFFERENT SENSITIVITIES OF PHOTOGRAPHIC FILMS TO DIFFERENT WAVELENGTHS.—A. L. Williams. (*Sci. News Letter*, 14th May 1938, Vol. 33, No. 20, p. 321: paragraph only.)
3243. MATHEMATICAL RELATIONS BETWEEN GRAIN, BACKGROUND NOISE, AND CHARACTERISTIC CURVE OF SOUND-FILM EMULSIONS.—W. J. Albersheim. (*Journ. Soc. Mot. Pict. Eng.*, No. 4, Vol. 29, 1937, pp. 417-445.)
3244. A NEW DYNAMIC LIGHT-VALVE [on Loop Oscillograph Principle: Damping made Independent of Temperature by Bimetallic-Strip Adjustment].—E. Gerlach. (*Journ. Soc. Mot. Pict. Eng.*, No. 4, Vol. 29, 1937, pp. 388-396.)
3245. MEASURING THE RECORDING SYSTEM WITH LIMITED EQUIPMENT [including Measurement of Frequency Characteristic by Buchmann & Meyer's Light-Reflection Method: Max. Stylus-Point Velocity: etc.].—A. W. Niemann. (*Communications*, May 1938, Vol. 18, No. 5, pp. 14-15 and 36, 37.) For the original paper on the optical method see 1930 Abstracts, p. 458.
3246. PICK-UP ANGLE AGAIN [Suggested Graphical Construction].—R. Grozier. (*Electronics*, May 1938, Vol. 11, No. 5, p. 73.)
3247. THREE-COLOUR CATHODE-RAY-TUBE SCREEN AS INDICATOR OF CORRECT LOUDNESS OF SPEAKER'S VOICE, and A CATHODE-RAY-TUBE PITCH INDICATOR.—Wolf, Begun, & Holmes. (*Sci. News Letter*, 14th May 1938, Vol. 33, No. 20, p. 321: paragraphs only.)
3248. STANDARD SPEECH-INPUT UNITS FOR BROADCAST STUDIOS, and A STUDIO INPUT EQUIPMENT [allowing for Growth].—J. Taylor: H. Paro. (*Communications*, May 1938, Vol. 18, No. 5, pp. 21-23 and 39, 41: pp. 29 and 35.)
3249. ON THE SO-CALLED "REFLECTION LOSSES" IN A TELEPHONIC TRANSMISSION, AND ON THE CONDITION OF "MAXIMUM APPARENT TRANSMITTED POWER" [Does Not Coincide with That of Zero Reflection, as assumed by Certain Workers].—A. Ferrari-Toniolo. (*Alta Frequenza*, May 1938, Vol. 7, No. 5, pp. 332-335.)
3250. ON THE NON-LINEAR DISTORTION IN LONG-DISTANCE TRANSMISSION SYSTEM [Non-Loaded Cable System].—Shinohara & Nishimatsu. (*Nippon Elec. Comm. Eng.*, April 1938, No. 10, pp. 140-146.)
3251. GENERAL PURPOSE AUDIO AMPLIFIER [24 Watts Output: Design Considerations and Constructional Details].—A. Preisman. (*Communications*, May 1938, Vol. 18, No. 5, pp. 11-13 and 26, 30.)
3252. POWER OUTPUT SYSTEMS [including the Possibility of improving a Pentode Output to equal a Triode Output, by Negative Feedback: Tests with Square Wave-Forms to show Behaviour on Transients: etc.].—Langford Smith. (*Proc. I.R.E. Australia*, June 1937, Vol. 1, No. 1, pp. 2-9.)
3253. A TRANSMISSION-MEASURING SYSTEM UTILISING A GRAPHIC RECORDING METER.—W. W. Lindsay. (*Journ. Soc. Mot. Pict. Eng.*, No. 1, Vol. 29, 1937, pp. 68-76.)
3254. A CONTINUOUS LEVEL RECORDER FOR ROUTINE STUDIO AND THEATRE MEASUREMENTS.—G. M. Sprague & J. K. Hilliard. (*Journ. Soc. Mot. Pict. Eng.*, No. 6, Vol. 29, 1937, pp. 645-655.)
3255. A CURVE-PLOTTING TRANSMISSION METER [using Push-Pull Variable-Mu Circuit of Special Type].—L. A. Aicholtz. (*Journ. Soc. Mot. Pict. Eng.*, No. 6, Vol. 29, 1937, pp. 655-660.)
- To give as wide a linear range as possible (a variable-mu valve only gives a range of about 10-12 db) two variable-mu valves are so connected in each branch that the second receives an input voltage small compared with that to the first, with the result that the total anode current is only cut down by the second valve when the input voltage has reached a certain value. The linear range is thus extended to about 30 db.
3256. A CURVE-PLOTTING TRANSMISSION METER [Departure from Linearity ± 0.1 db over 12 db Range, ± 1 db at Each End of 20 db Range].—L. G. Grignon. (*Journ. Soc. Mot. Pict. Eng.*, No. 6, Vol. 29, 1937, pp. 660-662.)
3257. DIRECT-READING FREQUENCY METERS [for Low Frequencies: 2 Valves in Series, Grid Inputs in Opposed Phase: Indicating Instrument in Rectifier-Bridge Circuit, instead of in Anode Circuit, thus avoiding Certain Causes of Irregular Working].—M. Kobayashi & H. Uchida. (*Rep. of Rad. Res. in Japan*, Dec. 1937, Vol. 7, No. 3, Abstracts p. 30.)
3258. ON THE ACOUSTICAL CALCULATION OF VENTILATION INSTALLATIONS.—A. I. Belov. (*Journ. of Tech. Phys.* [in Russian], No. 7, Vol. 8, 1938, pp. 654-660.)
3259. REDUCTION OF NOISE ARISING FROM AN AIR COMPRESSOR.—J. E. R. Constable. (*Engineering*, 3rd June 1938, Vol. 145, p. 640.)

3260. THE REDUCTION OF NOISE FROM MACHINERY.—A. J. King. (*Met.-Vickers Gazette*, June 1938, Vol. 17, No. 302, pp. 289-291.)
3261. SOUND AND NOISE INSULATION.—G. W. C. Kaye. (*Journ. Scient. Instr.*, June 1938, Vol. 15, No. 6, pp. 185-190.)
3262. REFLECTION OF SOUND [Mathematical Study of Reflection at a Solid Wall: Temperature Effects, Scattering of Molecules: Scattering of Sound Waves and Effect of Adsorption].—K. F. Herzfeld. (*Phys. Review*, 1st June 1938, Vol. 53, No. 11, pp. 899-906.)
3263. THEORY OF THE MECHANICAL PHENOMENA OCCURRING IN THE INTERNAL EAR.—J. A. Rebol. (*Journ. de Phys. et le Radium*, May 1938, Series 7, Vol. 9, pp. 185-194.)
3264. THE VELOCITY OF SOUND IN AIR [measured over a Distance of a Few Metres in the Laboratory: Pulses emitted by Loudspeaker, received by Microphone and indicated on Cathode-Ray Tube: Tube Pattern repeats for Distances between Microphone and Speaker differing by Distance covered by Sound in One Cycle of Pulse Frequency].—R. C. Colwell, A. W. Friend, & D. A. McGraw. (*Journ. Franklin Inst.*, May 1938, Vol. 225, No. 5, pp. 579-583.)
3265. CORRECTION TO "THE NORMAL AND SLANTING PASSAGE OF A PLANE DILATATION (LONGITUDINAL) WAVE . . ."—H. Reissner. (*Helvetica Phys. Acta*, Fasc. 3, Vol. 11, 1938, p. 268.) See 2429 of June.
3266. AN INVESTIGATION OF COMPLEX SUPERSONIC FIELDS BY THE OPTICAL METHOD WITH A POINT LIGHT SOURCE.—I. T. Sokolov. (*Tech. Phys. of USSR*, No. 3, Vol. 5, 1938, pp. 217-220: in English.) See 2854 of July.
3267. ON THE SIMULTANEOUS RAMAN DEVIATION IN A NUMBER OF SUPERSONIC WAVES.—L. Bergmann & E. Fues. (*Zeitschr. f. Physik*, May 1938, Vol. 109, No. 1/2, pp. 1-13.)
3268. ABSORPTION AND DISPERSION OF SOUND IN LIQUIDS.—H. O. Kneser. (*Ann. der Physik*, June 1938, Vol. 32, No. 3, pp. 277-289.)
Formulae are derived to express the frequency-dependence of absorption and velocity of sound in liquids, and applied to explain observed results for twelve liquids.
3269. ON THE EFFECT OF SUPERSONIC WAVES ON SOLUTIONS OF HIGHLY POLYMERISED SUBSTANCES.—E. Thieme. (*Physik. Zeitschr.*, 1st May 1938, Vol. 39, No. 9, pp. 384-390.)
3270. RECENT PROGRESS IN SUPERSONICS [General Survey].—W. T. Richards. (*Journ. of App. Phys.*, May 1938, Vol. 9, No. 5, pp. 298-306.)
3271. ULTRASONIC STUDY OF CO₂ NEAR ITS CRITICAL POINT.—J. C. Hubbard & C. M. Herget. (*Phys. Review*, 1st June 1938, Vol. 53, No. 11, p. 945: abstract only.)
3272. INVESTIGATION OF A DIRECT-READING DEPTH METER FOR "PILOTAGE" USING A NEW ULTRASONIC SOUNDING PRINCIPLE (QUASI-"MODULATED FREQUENCY" PRINCIPLE).—S. Matsuo. (*Hydrographic Review*, May 1938, Vol. 15, No. 1, pp. 33-40.)
3273. THE "FREQUENCY MEASUREMENT" METHOD OF ACOUSTIC SOUNDING.—Beard. (See 3238.)
3274. FOG SIGNALS BY ROTATING NAUTOPHONE (PENDULUM VIBRATOR).—H. Bencker. (*Hydrographic Review*, May 1938, Vol. 15, No. 1, pp. 41-53.)

PHOTOTELEGRAPHY AND TELEVISION

3275. APPLICATION OF ELECTROGRAPHY IN TELEVISION: THE PRODUCTION OF LARGE-SCREEN PICTURES [giving Advantages of Intermediate-Film System without Disadvantages of Delay and High Cost].—P. Selényi. (*Wireless Engineer*, June 1938, Vol. 15, No. 177, pp. 303-309.)
3276. NOTE ON THE METHODS OF CORRECTION FOR THE DARK SPOTS GIVEN BY AN ICONOSCOPE.—R. Barthélémy. (*L'Onde Elec.*, June 1938, Vol. 17, No. 198, pp. 303-308.)

When the mosaic is scanned by a cathode ray, periodic signals are found in the output circuit (even in the absence of a luminous image) which result in more or less deep shadows on the receiving screen, generally continuous and affecting one of the corners of the picture. This parasitic modulation, whose exact explanation has not so far been given, may attain the level of the image signals and thus be extremely troublesome. It forms a fairly low frequency which adds itself to the ordinary signals without altering these. The amplitude and shape of the shadow depend chiefly on the intensity of the cathode ray scanning the mosaic, but to a smaller degree on the intensity of the light. The latter factor is often thought to have a preponderant effect, but this is because when the scene is brightly illuminated it is the usual thing to diminish the potential of the control electrode of the iconoscope, with the result that the dimensions and depth of the parasitic shadow decrease.

Since up to the present it has been impossible to act on the unknown or disputed cause of the trouble, attempts have been limited to compensating for it. The method generally employed is an approximate one (pp. 304-306): mathematically, terms up to the second degree only are considered in the appropriate Maclaurin series: practically, the adjustment requires a good operator. "Although this system gives sufficiently satisfactory results, and although in the latest forms of iconoscope (with intermediate electronic image) the influence of the parasitic charges on the mosaic is greatly diminished, we have thought that it would be of practical interest to have a corrector with quasi-instantaneous adjustment, compensating exactly the parasitic modulation without being limited to the terms of the second degree." The luminous spot of a small c-r tube is made to scan a photograph of the screen of a television receiver which is reproducing a uniformly illuminated blank. The modulation representing the parasitic shadow is thus taken from a large photocell and cancels out,

in the transmitting amplifiers, the disturbing modulation. For a given iconoscope the form of the shadow is stable: several photographs can be made, and rapidly substituted, for different values of mean illumination and of cathode ray. In the perfected form of the method, these photographs are taken on a film so arranged that the one giving perfect compensation can be got into position very quickly. The necessary rapid amplitude adjustments are accomplished automatically by the action of the d.c. component on a variable-mu valve in the amplifier of the compensating device.

3277. A NEW TELEVISION TRANSMITTING CATHODE-RAY TUBE: THE TECOSCOPE—PART I.—Nagashima, Shinozaki, Udagawa, & Kizuka. (*Nippon Elec. Comm. Eng.*, April 1938, No. 10, pp. 186-187.) See 208 of January.

3278. BAIRD STILL-PICTURE TRANSMITTER [for Production of Testing Signals].—(*Television*, June 1938, Vol. 11, No. 124, pp. 324 and 341.)

3279. THE "RESOLVING POWER" OF CATHODE-RAY TUBES [Definition of the Term in Its New Application: Its Importance, and the Factors influencing Its Value].—K. Nentwig. (*Funktech. Monatshefte*, May 1938, No. 5, pp. 147-148.)

3280. ON ELIMINATING NON-LINEAR DISTORTION IN A [Gas-Filled] CATHODE-RAY TUBE.—A. I. Gordienko. (*Izvestiya Elektroprom. Slab. Toka*, No. 2, 1938, pp. 36-39.)

It appears from experiments with gas-filled cathode-ray-oscillograph tubes that when a source of alternating voltage is connected to a pair of deflecting plates these present not only a capacitive but also a resistive load, the value of which depends on the voltages applied to the plates. The character of the distortion due to this effect is indicated on Fig. 1, from which it can be seen that the oscillograph curve is distorted near the zero points and, in addition, the amplitudes of positive half-waves are considerably reduced (sometimes as much as 50%). It is suggested that this effect can be counteracted by applying a constant negative voltage to that plate which is not connected to the second pair of plates. In this case it is also necessary to produce a constant magnetic field in order to keep the ray within the area of the screen. The improvement so obtained can be seen from a comparison of two oscillograms shown in Figs. 4 & 5. A complete circuit, in which compensating voltages are applied to both pairs of plates, is also shown (Fig. 6).

3281. "ELECTRON OPTICS IN TELEVISION" [Book Review].—Maloff & Epstein. (*Television*, June 1938, Vol. 11, No. 124, p. 346.)

3282. "TELEVISION OPTICS: SECOND EDITION" [Book Review].—L. M. Myers. (*Electrician*, 10th June 1938, Vol. 120, p. 746.)

3283. RELATIVE EMISSION SPECTRA OF ZINC SILICATES & OTHER CATHODOLUMINESCENT MATERIALS.—H. W. Leverenz. (*Phys. Review*, 1st June 1938, Vol. 53, No. 11, pp. 919-920: abstract only.)

3284. THE MODULATION OF RELAXATION OSCILLATIONS.—Söchting. (See 3180.)

3285. TELEVISION TRANSMISSION TECHNIQUE: II—THE DISTORTION OF A TELEVISION IMAGE BY THE ATTENUATION & TRANSIT-TIME DISTORTION OF THE TRANSMISSION PATH.—F. Ring. (*Funktech. Monatshefte*, May 1938, No. 5, Supp. pp. 37-40: to be contd.)

3286. THE TELEVISION DEMONSTRATIONS OF THE GERMAN STATE POST OFFICE AT THE INTERNATIONAL EXPOSITION, PARIS, 1937.—G. Flanze & A. Gehrts. (*Funktech. Monatshefte*, May 1938, No. 5, Supp. pp. 33-36: to be contd.)

3287. TELEVISION FROM THE BRITISH ANGLE [and the Question of seeking the Collaboration of Amateur Constructors].—L. Cooper. (*QST*, June 1938, Vol. 22, No. 6, pp. 53-54.) Contribution to a correspondence between U.S.A. "hams" in previous issues.

3288. THE CAIRO CONFERENCE AND TELEVISION.—(*Television*, June 1938, Vol. 11, No. 124, p. 350.)

3289. TELEVISION TRANSMISSION BY COAXIAL CABLE [and the 240-Line New York/Philadelphia Transmissions: Future Development].—M. E. Strieby. (*Elec. Engineering*, June 1938, Vol. 57, No. 6, pp. 249-256.)

3290. THE PRESENT STATE OF DEVELOPMENT OF TELEPHONE AND TELEVISION COMMUNICATION BY COAXIAL CABLES [in Europe and America].—F. Marocchi. (*Alta Frequenza*, May 1938, Vol. 7, No. 5, pp. 323-331.)

3291. H.F. COAXIAL CABLE WITH POLYSTYROL INSULATION.—N. P. Bogoroditski, S. N. Matveev, & M. P. Snokker. (*Izvestiya Elektroprom. Slab. Toka*, No. 2, 1938, pp. 47-54.)

A survey of the theory of the cable together with a description of the manufacturing processes. The manufacture of experimental lengths of cable in the U.S.S.R. is also described and some of the results of electrical tests are given.

3292. COAXIAL CABLE WITH THREAD SUSPENSION OF CENTRAL CONDUCTOR: SOME DATA.—O. Cords. (*E.T.Z.*, 23rd June 1938, Vol. 59, No. 25, p. 678.)

The suspension is so firm that the alignment is preserved even when the cable is bent in a curve of diameter only ten times its own diameter. The dielectric constant is very low ($\epsilon = 1.12$). The loss factor at 1000 kc/s is about 10^{-3} and the leakage loss 0.01 neper/km. In comparison, a wide-band cable with Frequentia-disc insulation has a loss factor of $1-2 \times 10^{-4}$ and a leakage loss of 0.002-0.003 neper/km. Thus the new cable cannot rival the more rigid type electrically, but has the advantage of flexibility. For a 10 mm diameter its capacity is 25 picofarads per metre. The internal uniformity is good.

3293. H.F. ATTENUATION OF CONCENTRIC CABLES [measured by Thermoammeter Method and Valve-Voltmeter Method, the Latter being found Quicker and Easier].—G. Sadakiyo, T. Ogawa, & S. Yamanaka. (*Electrot. Journ.*, Tokyo, June 1938, Vol. 2, No. 6, pp. 147-148.) Frequencies ranged up to nearly 5 Mc/s. See also 1027 of March.
3294. PHOTORADIO DEVELOPMENT IN JAPAN [Amplitude *versus* Time Modulation: Long Distance Tests (London/Tokyo, etc.): Space-Diversity Reception: etc.].—Arakawa, Kimpara, & Amisima. (*Rep. of Rad. Res. in Japan*, Dec. 1937, Vol. 7, No. 3, pp. 207-213.)
3295. HOME NEWSPAPERS BY RADIO [with List of U.S.A. Stations licensed to Transmit: Bulletins are Now being Broadcast].—(*Scient. American*, June 1938, Vol. 158, No 6, pp. 334-335.)
3296. CONTRIBUTION TO THE SUBJECT OF THE MOTION OF THE ELECTRONS IN A DYNAMIC ELECTRON-MULTIPLIER [of Okabe's Theoretical Type with Anode Cylinder replaced by Ideal Gauze Plate mid-way between the Two Parallel Cathode Plates].—W. Majewski. (*Acta Physica Polonica*, Fasc. 4, Vol. 6, 1937, 392-402: in German.)
 "Okabe [4123 of 1936] briefly considers the theory of the dynamic multiplier with the help of a model . . . From the relations obtained no far-reaching conclusions are reached by Okabe as to the mode of action of the multiplier." This gap the present writer sets out to fill, at any rate at some points: "a general solution of the problem is not yet possible."
 Successive sections deal with (1) the general motional equations of the electrons (assuming for simplicity's sake a homogeneous electric field in the two spaces); (2) the action of the multiplier (and the definition of certain terms: thus the "equilibrium-phase" θ_r is the phase of the particular electrons which fulfil that condition of similarity of "starting phase" and "arrival phase" which the writer puts forward as the simplest hypothesis for arriving at the "state of equilibrium" where the number of electrons falling on the anode is replaced by those set free from the cathodes); (3) the equation for the equilibrium-phase θ_r , a transcendental equation of very complex form, so that the investigation of its solutions for the general case is extremely difficult. A special case is considered by a graphical construction, leading to (4) the action of the multiplier when it is so "tuned" that the equilibrium-phase θ_r is zero.
 It is concluded that in the condition of equilibrium the electron-multiplying action is effected only by the electrons having the equilibrium phase θ_r . It can be pictured that a cloud of electrons forms in the multiplier, the electrons oscillating between the plates in the rhythm of the alternating voltage. To compensate for the electrons falling on the anode, the electrode emission from the cathodes should only occur at certain moments. It would appear that in the condition of equilibrium all electrons whose phase is not θ_r are kept out of the multiplying action by the fact of their unfavourable times of release. "This hypothesis naturally requires experimental confirmation. Investigations on the mode of action of the multiplier, and of the motion of the electrons therein, can hardly be carried any further by the present technique and ways of thinking. It becomes necessary to treat this problem by considerations of wave mechanics. On such foundations new view-points would perhaps be discovered, leading to a basis for a general theory and to new experimental researches."
3297. SECONDARY EMISSION FROM COMPOSITE SURFACES.—N. S. Khlebnikov & A. S. Korshunova. (*Journ. of Tech. Phys.* [in Russian], No. 6, Vol. 8, 1938, pp. 500-515.)
 A report on an experimental investigation carried out with the following two types of surface: [Ag]-Cs₂O, Cs-Cs and [Ag]-Cs₂O, Cs, Ag-Cs. The apparatus used in these experiments is described and an account is given, with a number of curves, of the results obtained. This is followed by a theoretical discussion in which particular attention is paid to the processes taking place in a composite electrode during secondary emission. The results of this investigation are compared with those obtained by other investigators and it is claimed, among other conclusions, that the high value of secondary emission from a composite surface is determined solely by the presence of particles of Cs in the intermediate layer, while the particles of Ag affect only the shape of the curve $\sigma = f(V_p)$ and reduce the effective depth of the emitter, *i.e.* of the layer in which secondary electrons are liberated. A bibliography of 37 items is appended.
3298. A CONFERENCE ON THE PHOTOELECTRIC EFFECT AND SECONDARY EMISSION [including New Photocathodes of Caesium-Antimony Alloy with 2-3 Times the Sensitivity of Best Caesium-Oxygen Cathodes, and Great Constancy: Cause of Fatigue in Caesium-Oxygen Cathodes, and Production of Non-Fatiguable Cathodes by Internal Layer of Gold Particles, or by providing Excess Caesium: etc.].—S. Luk'yanov: Lukinsky, Timofeev, & others. (*Tech. Phys. of USSR*, No. 3, Vol. 5, 1938, pp. 244-247: in English.)
3299. "COMPLETE" PHOTOELECTRIC EMISSION AND THE DETERMINATION OF THE WORK FUNCTION: INCORRECTNESS OF ROY-SUHRMANN METHOD AND OF RICHARDSON'S VIEWS: ETC.—Luk'yanov. (In report dealt with above—3298.)
3300. THE INFLUENCE OF AN ELECTRIC FIELD ON THE PHOTOELECTRIC EMISSION OF CAESIUM-OXYGEN CATHODES.—Rozhanski. (Paragraph in report dealt with above—3298.)
3301. THE SECONDARY EMISSION FROM COMPLEX CATHODES: EFFECT OF DEPTH OF OXIDATION, AMOUNT OF CAESIUM, ETC.: LARGE COEFFICIENTS OF CAESIUM-OXYGEN CATHODES EXPLAINED BY MULTIPLE REFLECTION FROM COLLOIDAL SILVER PARTICLES: ETC.—Timofeev & Pyatnitski. (Paragraph in report dealt with above—3298: see also 2888 of July.)

3302. ELECTRON-MULTIPLIERS WITH REDUCED VOLTAGE [700-800 V instead of Usual 1500-2000 V] AND LONG LIFE [250 Hours of Continuous Working]: SENSITIVITY MAY BE 1000 A/LUMEN, BUT GREAT NEED IS FOR LARGE OUTPUT CURRENT [Stronger & More Stable Emitter]: NEW ELECTRON MULTIPLIERS FOR VOLTAGE IMPULSES RATHER THAN CURRENT [Very Steep Characteristic—150 mA/V]: ETC.—Kubetski & Timofeev. (Paragraphs in report dealt with above—3298.)
3303. THE SECONDARY AND THERMO-ELECTRONIC EMISSION OF SEMICONDUCTORS.—Morgulis. (Paragraph in report dealt with above—3298.)
3304. CORRELATION OF OPTICAL PROPERTIES AND PHOTOELECTRIC EMISSION IN THIN FILMS OF ALKALI METALS.—H. E. Ives & H. B. Briggs. (*Journ. Opt. Soc. Am.*, May 1938, Vol. 28, No. 5, pp. 176-177: abstract only.)
- 3304 bis. A NEW PHENOMENON IN THE OPERATION OF THE PHOTOELECTRIC CELL AT HIGH FREQUENCIES.—P. Griivet. (*Comptes Rendus*, 13th June 1938, Vol. 206, No. 24, pp. 1798-1800.)
A vacuum caesium cell of special type, illuminated by light modulated at 13.5 Mc/s, produces an output current whose 13.5 Mc/s component varies with the accelerating voltage, passing through a pronounced maximum. The effect is explained as due to electrons passing near the anode but returning to the cathode: when operating in a steady illumination, the number of electrons approaching the anode will equal the number receding, but with the modulated light this balance does not occur, and these electrons will contribute to the output of the cell.
3305. SOME PHOTOELECTRIC PROPERTIES OF EVAPORATED BISMUTH FILMS.—A. H. Weber. (*Phys. Review*, 1st June 1938, Vol. 53, No. 11, pp. 895-899.)
- 3305 bis. PROPERTIES OF A NEW TYPE OF PHOTO-EMISSIVE CELL [with Very Low Dark Current, Low Saturation Voltage, and Accurately Linear Relation between Luminous Flux and Output Current].—G. A. Boutry & J. Gillod. (*Comptes Rendus*, 13th June 1938, Vol. 206, No. 24, pp. 1807-1809.) See 1054 of 1937 for description of the cell.
3306. PHOTOELECTRIC EMISSION AND ITS APPLICATIONS [Survey].—G. Todesco. (*L'Elettrotec.*, 10th May 1938, Vol. 25, No. 9, pp. 300-310.)
3307. THE SPECTRAL CHARACTERISTICS OF BARRIER-LAYER SELENIUM PHOTOCESLS.—E. Putseyko. (*Journ. of Tech. Phys.* [in Russian], No. 7, Vol. 8, 1938, pp. 645-653.) An experimental investigation of the effects of admixture of sulphur and tellurium to the selenium, and of the nature of the barrier layer on the spectral sensitivity of the cell.

MEASUREMENTS AND STANDARDS

3308. MEASURING THE FIELD STRENGTH OF ULTRA-SHORT WAVES [B.B.C. Method and Apparatus].—C. H. Smith. (*World-Radio*, 10th June 1938, Vol. 26, pp. 10-11.)
3309. REPORT TO COMMISSION I ON EXISTING METHODS OF MEASURING RADIO FIELD INTENSITY [including Summary of Replies to International Questionnaire, and Bibliography].—R. A. Watson Watt & R. L. Smith-Rose. (*U.R.S.I. Proceedings of 1934 General Assembly*, Vol. 4, pp. 166-182: in English.) See also *ibid.*, pp. 131-132.
3310. VOLTAGE MEASUREMENT IN HIGH-FREQUENCY TECHNIQUE [including Ultra-High Frequencies].—O. Zinke. (*E.T.Z.*, 2nd June 1938, Vol. 59, No. 22, pp. 573-576.)

A VDE address. Sources of error in h.f. voltage measurement are first considered (the writer's book, referred to in 3311, below, is cited). The next section deals with the thread electrometer and the static voltmeter: Nissen's double-thread electrometer (1933 Abstracts, p. 574) has a capacity of only about 1 picofarad and a range of 10-100 volts, the frequency limit, allowing a 2% error, being 1000 Mc/s for thread lengths of 1 cm. Conditions for static voltmeters are not so favourable, three types being considered, having capacities of 13, 10 and 5 pF respectively, and frequency limits of about 10 Mc/s (the one with the 5 pF capacity is on the Starke & Schroeder principle—1928 Abstracts, p. 585). The course of their input resistance, for frequencies above 1 Mc/s, is seen in Fig. 3.

The rest of the paper deals with valve voltmeters, which are divided into three classes according to the type of rectification employed. The usual type classification—anode, grid, and diode rectification—does not properly distinguish what value of the voltage is measured. It is therefore desirable to adopt a classification taken from amplifier technique, and to speak of "A, B, and C rectification," square-law rectification (Fig. 4) being called "Class A" since an appreciable standing current is present. B-rectification (Fig. 5) is bottom-bend rectification, and with a linear characteristic gives the half-wave area, while C-rectification (Fig. 6) is distinguished by a high negative bias of the order of the peak voltage: both these types are affected by harmonics in the voltage under measurement.

All three types of rectification can be carried out either by diodes or triodes. With diodes, the alternating voltage acts directly on a non-linear resistance; the power consumption must be made up by the voltage source. With triodes, the voltage controls the non-linear anode characteristic only from the grid side, without direct power consumption; but even when the grid is negatively biased so that no grid current flows, there is a definite consumption of energy in the grid circuit. Apart from the high resistance through which, as a rule, the grid bias is led, the cause for this is to be found (for frequencies over 1 Mc/s) in dielectric loss in grid/cathode connections, socket, and valve-base, and also in "transit-time losses"—see Rothe, 2574 of 1937. These losses can be regarded as a frequency-dependent resistance connected between

- grid and cathode: the dielectric losses give a resistance which decreases with $1/f$, while the transit-time losses produce a resistance-decrease varying with $1/f^2$. Specimen circuits are given, that of Strutt & van der Ziel (2573 of 1937) representing the use of a diode for A-rectification, while Fig. 8 shows the same type of rectification with a triode. In B-rectification with a diode (Fig. 9) the importance is pointed out of keeping the discharge time constant of the external (curve-straightening) resistance R_a , with its unavoidable parallel capacity, small compared with the period of the voltage under measurement: thus no bridging condenser must be connected across R_a (as in an ordinary anode-bend amplifier) or the rectification will become C-type instead of B-type. Figs. 11 & 12 show C-type (peak) rectification for diode and triode respectively, and Fig. 13 a complete peak-voltmeter of this type, for 0.5–150 v and 50 c/s–200 Mc/s. Finally, Fig. 14 shows a voltmeter reading effective values, on an entirely different principle, for the range 100 kc/s–20 Mc/s: this uses a thermoelement for rectification, fed from a triode: a high input resistance is thus obtained.
3311. "HOCHFREQENZMESSTECHNIK" [H.F. Measuring Technique: Book Review].—O. Zinke. (*Elektrot. u. Masch.bau*, 29th May 1938, Vol. 56, No. 22, p. 292; *Rev. Gén. de l'Élec.*, 4th June 1938, Vol. 43, No. 23, p. 706.)
3312. MEASUREMENT OF THE RADIO-FREQUENCY VOLTAGE IN A CYCLOTRON [by Three Different Methods].—W. E. Danforth. (*Review Scient. Instr.*, June 1938, Vol. 9, No. 6, pp. 175–178.)
3313. A RESONANCE BRIDGE FOR USE AT FREQUENCIES UP TO 10 MEGACYCLES PER SECOND [where Accuracy is within 0.1% for Resistances up to 10 Ohms].—C. L. Fortescue & G. Mole. (*Journ. I.E.E.*, June 1938, Vol. 82, No. 498, pp. 687–692: Discussion pp. 692–695.)
3314. A RESONANCE BRIDGE FOR THE MEASUREMENT OF BALANCED IMPEDANCES AT FREQUENCIES UP TO 24 Mc/s, FOR FIELD USE ON SHORT-WAVE AERIALS.—C. H. Smith. (In Discussion of above paper—3313.)
3315. AN ALTERNATING-CURRENT METHOD FOR MEASURING EFFECTIVE MUTUAL INDUCTANCE.—H. L. Curtis, A. V. Astin, & C. M. Sparks. (*Phys. Review*, 1st June 1938, Vol. 53, No. 11, p. 934: abstract only.)
3316. A SCREENED SUB-STANDARD INDUCTOMETER.—N. F. Astbury & L. H. Ford. (*Phil. Mag.*, June 1938, Vol. 25, No. 172, pp. 1009–1025.)
3317. THE MUTUAL INDUCTANCE BETWEEN TWO COAXIAL HELICAL WIRES.—C. SNOW. (*Phys. Review*, 1st June 1938, Vol. 53, No. 11, p. 934: abstract only.)
3318. THERMOCOUPLES AND THEIR EXPERIMENTAL BEHAVIOUR [at Frequencies up to 1.5 Mc/s: Variation of Range of Thermoammeters by Shunt Capacities: Improvements of Thermocouple Construction: etc.].—G. Maione. (*L'Électrotec.*, 25th May 1938, Vol. 25, No. 10, pp. 337–342.)
3319. THERMAL AMMETER FOR LARGE HIGH-FREQUENCY POWER [for Aerial Current Measurements, etc.: Constantan/Manganin Thermocouple inside Squirrel Cage Heater (4 Platinum Sheets) of Same Diameter as Hollow Terminal Conductors: Electrostatic Screen outside Heater].—H. Fujiki. (*Electrot. Journ.*, Tokyo, June 1938, Vol. 2, No. 6, p. 146.)
3320. THE METHOD OF "THERMO-ELECTROLYTIC" TEMPERATURE MEASUREMENT [17–24 Times as Sensitive as Thermocouple Method, but with 1.5–10% ERRORS].—S. Zamenhof. (*Acta Physica Polonica*, Fasc. 4, Vol. 6, 1937, pp. 346–349: in English.) Depending on the fact that the potential of an electrode against an electrolyte is a function of the temperature of the active surface of the electrode.
3321. POTENTIOMETRIC MEASUREMENT OF EXTREMELY SMALL VOLTAGES [below 20 Microvolts to an Accuracy of 10^{-8} Volt].—I. Amdur & H. Pearlman. (*Review Scient. Instr.*, June 1938, Vol. 9, No. 6, pp. 194–195.)
3322. MEASUREMENT AND RECORDING OF VERY SMALL D.C. VOLTAGES BY THE "PHOTO-ELECTRIC COMPENSATOR."—L. Merz. (*E.T.Z.*, 23rd June 1938, Vol. 59, No. 25, p. 678.)
The applied voltage displaces a galvanometer mirror until the light ray from the latter sets free such a current from a photocell as will produce (after passing through an amplifying valve) an equal and opposite voltage across the ends of a standard resistance. The amplified photocurrent acts on an inker, whose full movement represents an applied voltage of $30 \mu\text{v}$, a movement of 1 mm representing a voltage of 0.25×10^{-8} v and consuming only 2×10^{-17} w: the accuracy is within 0.5%.
3323. PHOTOELECTRICALLY BALANCED RECORDING POTENTIOMETER [with Accuracy to Few Hundredths of a Per Cent of Range].—Fairchild & Parsegian. (*Journ. Opt. Soc. Am.*, May 1938, Vol. 28, No. 5, p. 176: summary only.)
3324. "DIRECT AND ALTERNATING CURRENT POTENTIOMETER MEASUREMENTS."—D. C. Gall. (At Patent Office Library, London: Cat. No. 78 599: 246 pp.)
3325. MEASUREMENT OF POWER FACTOR AND DIELECTRIC CONSTANT OF A SAMPLE WITH A GUARD RING BY THE BRIDGE METHOD AT AUDIO AND RADIO FREQUENCY RANGES [500 c/s to 1500 kc/s: More Accurate than Resonance Method usually employed for the Higher Frequencies].—H. Numakura & R. Tukamoto. (*Rep. of Rad. Res. in Japan*, Dec. 1937, Vol. 7, No. 3, Abstracts p. 31.)

3326. THE MEASUREMENT OF DIELECTRIC LOSS BY ELECTRODYNAMOMETERS.—W. Geyger. (*E.T.Z.*, 16th June 1938, Vol. 59, No. 24, p. 643: summary only.)
3327. PHOTOELECTRIC CURRENT-LIMITING DEVICE FOR INSULATION MEASUREMENTS [Special High-Voltage Photoelectric Cell with Spherical Electrodes, to replace the Saturated Diode previously used, whose Characteristic was Not Ideal].—E. B. Baker & H. A. Boltz. (*Review Scient. Instr.*, June 1938, Vol. 9, No. 6, pp. 196-198.) For the original method see 1553 of 1936.
3328. THE BALLISTIC WATTMETER [and Its Applications].—T. A. Rich & E. J. Hatfield, Jr. (*Gen. Elec. Review*, June 1938, Vol. 41, No. 6, pp. 288-293.)
3329. CONTRIBUTIONS TO THE SUBJECT OF THE THREE-VOLTMETER METHOD [for Rapid Approximate Measurement of A.C. Resistances].—H. H. Wicht. (*E.T.Z.*, 26th May 1938, Vol. 59, No. 21, pp. 561-564.)
3330. THE PHASE SHIFTS IN CONTROLLED MULTIVIBRATORS FROM 200 000 TO 1 CYCLE PER SECOND [and a Circuit to supply 1 Second Intervals accurate to Better than 1 Part in 10^6].—W. D. George. (*Phys. Review*, 1st June 1938, Vol. 53, No. 11, p. 924: abstract only.)
3331. A NEW TYPE OF FREQUENCY-CHECKING DEVICE: A SIGNAL GENERATOR [with Two-Triode Multivibrator] GIVING 10 KILOCYCLE INTERVALS THROUGHOUT THE HIGH-FREQUENCY SPECTRUM.—G. Grammer. (*QST*, June 1938, Vol. 22, No. 6, pp. 21-24 and 98 . . 104.)
3332. AN ULTRA-SHORT-WAVE QUARTZ CRYSTAL OSCILLATOR.—Koga. (*See* 3171.)
3333. VIBRATION MODES OF LOW DECREMENT FOR A QUARTZ RING [and a Mode giving Unusually Low Decrement].—K. S. van Dyke. (*Phys. Review*, 1st June 1938, Vol. 53, No. 11, p. 945: abstract only.)
3334. A PORTABLE STANDARD FREQUENCY OSCILLATOR [for Intercomparison of R.F. Standards with Accuracy within less than 1 Part in a Million: Special Precautions with Crystal, etc.].—I. Koga. (*Rep. of Rad. Res. in Japan*, Dec. 1937, Vol. 7, No. 3, pp. 219-225.)
3335. FREQUENCY AND AMPLITUDE CONSTANCY OF VALVE GENERATORS [and Their Improvement: Constancy of 2 Parts in 10^6 over 10 Days obtainable: etc.].—W. Graffunder. (*Sci. Abstracts*, Sec. B, 25th May 1938, Vol. 41, No. 485, p. 368.)
3336. A NEW TYPE OF ULTRA-SHORT-WAVE WAVE-METER [for Waves down to 1.07 m: Accuracy within 0.3-1%: Voltage Loop built up along Circuit Elements: Microammeter connected to Particular Plate of Condenser].—Y. Miyamura. (*Rep. of Rad. Res. in Japan*, Dec. 1937, Vol. 7, No. 3, Abstracts pp. 30-31.)
3337. DIRECT-READING FREQUENCY METERS [for Low Frequencies].—Kobayashi & Uchida. (*See* 3257.)
3338. A REVIEW OF THE ELECTROMAGNETIC UNITS.—F. Hund. (*Physik. Zeitschr.*, 1st May 1938, Vol. 39, No. 9, pp. 376-379.)

SUBSIDIARY APPARATUS AND MATERIALS

3339. THE DIELECTRIC BOLOMETER [Increased Sensitivity by use of High Impedance and Large Temperature Change in Impedance of Certain Dielectrics: Comparison of Radiometric Devices: etc.].—Moon & Steinhardt. (*Journ. Opt. Soc. Am.*, May 1938, Vol. 28, No. 5, pp. 148-162.) For previous work see 2451 of 1935.

3340. A CATHODE-RAY OSCILLOGRAPH WITH POST-DEFLECTION ELECTRON ACCELERATION [for Single- and Dual-Ray Tubes for Portable Equipments].—Bigalke. (*Zeitschr. f. tech. Phys.*, No. 6, Vol. 19, 1938, pp. 163-166.)

"Portable oscillographs, for the sake of small dimensions, low weight, high sensitivity, and cheapness, are usually worked with anode voltages between 1000 and 2000 volts. Even an increase to 4000 volts, for improving the spot brightness, brings with it a considerable increase in all the dimensions, for not only has the insulation of the tube and of the mains unit to be improved to stand the higher voltage, but the time-base and amplifier units must develop 2 to 4 times greater amplitudes than before. With the low anode voltages and the use of high-vacuum tubes, wide-aperture objectives and small images, it is just possible to record non-recurrent phenomena photographically with a recording speed of 1 to 4 (for 4000 volts) km/s. An additional improvement of spot brightness, to obtain a higher recording speed, appears so far to be impossible with existing oscillographs.

"By adopting an old proposal, namely the extra acceleration of the cathode-ray, after deflection, by a high voltage [German patent 349 334 of 1920, Scheller] and by the technical development of this idea, an apparatus has been developed which allows the recording speed of a normal oscillograph to be increased many times" [up to 50 km/s, with satisfactory blackening of the negative, using an anode voltage of 1500 and a post-accelerating voltage of 6000: the great brightness also allows the image to be projected on to a sheet, so that even high-frequency periodic phenomena can be made visible to large audiences. A special advantage of

The crystal frequency is of the order of 5 Mc/s: thermostatic control is avoided by the use of a special cut and a special holder (both 2139 of 1936). The hitherto neglected effect of non-uniform distribution of temperature in a crystal plate is pointed out: it renders it advisable to wait for a time after the oscillator has been carried into a room. Moreover, measurements should not be taken directly after the oscillations have been started; a condition of steady contact (accompanied by a certain cohesive action) between plate and electrode should be waited for.

the method is that the relative sensitivity remains undiminished, so that the new tube can be used in an ordinary low-voltage equipment without enlarging either the time-base or amplifier unit].

Various methods of post-acceleration have been suggested (Brüche & Scherzer's "Geom. Elektron-optik" is here referred to—see 1181 of 1935) but the accelerating lens near the fluorescent screen was adopted as particularly simple and as producing no weakening of the image such as is caused by an accelerating grid. The writer has already shown (1949 of 1937) that such an accelerating lens works with comparative freedom from distortion even on rays far from the axis. The first step therefore, was to divide the graphite coating of the wall of the bulb, hitherto used merely for screening and maintained at the anode potential, in such a way that a ring of graphite, about 8 mm wide, was left at a distance of some 5 mm from the screening layer and was raised to a high voltage by way of a connection fused in at the edge of the fluorescent screen. Owing, however, to the high field strength at the sharp edges of the graphite layer, even at 1.5 kv discharges were found to occur which caused interfering edge images on the screen. Suitable treatment eliminated this effect sufficiently to allow twice this voltage to be used without trouble; still further improvement followed an increase in the gap between the screening coating and the post-accelerating ring. Undesirable charges on the glass walls were avoided by introducing two more graphite rings in this gap (Fig. 1). "By the deposition of a thin molybdenum layer with a resistance of about 50 megohms on the inner glass wall, a voltage-division in the interior of the tube was provided. In this way the use of post-accelerating voltages up to 6 kv was made possible. Such an arrangement resembles that described in a French patent [641 461 of 1928] except that there a fused-in connection for each ring was necessary . . . Later tests showed that the deposition of the high-resistance layer was not absolutely necessary, since the potential distributes itself approximately linearly over the insulation resistance of the glass wall to the individual graphite rings." A dual-ray tube on these lines was also made—Fig. 2b.

3341. THE NEW G.E.C. MONITOR C-R TUBE [Screen Diameter about 1½ Inches].—(*Television*, June 1938, Vol. 11, No. 124, p. 376.)
3342. A RECURRENT-SURGE OSCILLOGRAPH [and a Thyatron Circuit for producing "Chopped" Impulse Waves].—Scoles. (*Journ. Scient. Instr.*, June 1938, Vol. 15, No. 6, pp. 201-205.)
3343. THE "RESOLVING POWER" OF CATHODE-RAY TUBES.—Nentwig. (*See* 3279.)
3344. ON ELIMINATING NON-LINEAR DISTORTION IN A [Gas-Filled] CATHODE RAY TUBE.—Gordienko. (*See* 3280.)
3345. SIMPLIFIED ELECTRON OPTICS FOR OBTAINING ELECTRON BEAMS OF LOW DIVERGENCE.—Goncharski. (*Journ. of Tech. Phys.* [in Russian], No. 6, Vol. 8, 1938, pp. 540-543.)

A description is given of an electron tube of simple construction developed by the author. This tube (Fig. 1) contains a circular anode 1 with a

small aperture in the centre, a second circular electrode 2, parallel to 1 and having a slightly larger aperture, and a pointed cathode whose emitting surface is arranged to be in the aperture of electrode 2 and just on the level of the electrode surface. A potential slightly negative with respect to that of the cathode (or equal to it) is applied to electrode 2. The operation of the tube is discussed and it is stated that spots of from several sq. mm to several sq. cm can thus be obtained on the object under investigation. Furthermore it is claimed that the angle of divergence of the beam is practically independent within wide limits of the supply voltage variations. If required, tubes can be constructed for producing elongated spots (Fig. 4).

3346. THE THEORETICAL FOUNDATIONS OF ELECTRON OPTICS [Survey].—Sartori. (*Alta Frequenza*, May 1938, Vol. 7, No. 5, pp. 292-322.)

"On the basis of the analogy between Fermat's principle and that of Hamilton, it is possible to form a theory of the motion of electric corpuscles in electrostatic and magnetostatic fields, formally identical with that of geometrical optics. The fundamental principles and characteristic properties of electron-optical systems of electric, magnetic, and electromagnetic character are dealt with, with particular attention to the theory of aberrations." Special reference is made to the symposium in the *Zeitschr. f. tech. Phys.* (1507/1511 of 1937).

3347. RELATIVE EMISSION SPECTRA OF ZINC SILICATES & OTHER CATHODOLUMINESCENT MATERIALS.—Leverenz. (*Phys. Review*, 1st June 1938, Vol. 53, No. 11, pp. 919-920: abstract only.)
3348. ALKALI HALIDE-THALLIUM PHOSPHORS.—Seitz. (*Sci. Abstracts*, Sec. A, 25th May 1938, Vol. 41, No. 485, p. 462.)
3349. GROWTH & DECAY OF PHOSPHORESCENCE IN CALCIUM SULPHIDE BY A PHOTOELECTRIC METHOD.—Mulder. (*Journ. Franklin Inst.*, May 1938, Vol. 225, No. 5, pp. 527-547.)
3350. THE MODULATION OF RELAXATION OSCILLATIONS.—Söchting. (*See* 3180.)
3351. CIRCUITS PRODUCING SHARP ELECTRICAL IMPULSES . . . AND THEIR USE IN OSCILLOGRAPH WORK [enabling Single Element to record at least Three Independent Quantities].—Morgan. (*See* 3105.)
3352. AN ADJUSTABLE LEAK VALVE [primarily for Cathode-Ray Tube: with Long Slightly Tapered Needle].—Edwards & Maxwell. (*Review Scient. Instr.*, June 1938, Vol. 9, No. 6, p. 201.)
3353. A DIFFERENTIAL DEVICE FOR REGULATING THE VACUUM IN A DISCHARGE TUBE.—N. M. Reynov. (*Journ. of Tech. Phys.* [in Russian], No. 6, Vol. 8, 1938, pp. 551-552.) A description of a mechanical valve in which a piston is arranged to move within the plunger; the inlet aperture of a discharge tube can be regulated within fine limits.

3354. METAL EVAPORATORS [for Formation of Films in Vacuum Systems].—De Vore. (*Review Scient. Instr.*, June 1938, Vol. 9, No. 6, p. 202.)
3355. SINGLE-ELECTRODE DISCHARGE UNDER LOW GAS PRESSURE [in Long, Slender Tube, at High (31 kc/s–6 Mc/s) and Low Frequencies].—Katayama. (*Electrot. Journ.*, Tokyo, June 1938, Vol. 2, No. 6, pp. 127–129.)
3356. ELECTRON EMISSION BY BOMBARDMENT OF POSITIVE IONS ON THE CATHODE IN THE GLOW DISCHARGE: III.—Güntherschulze & Bär. (See 3226.)
3357. A NEW METHOD OF EXPERIMENTAL INVESTIGATION OF IMPULSE CORONA.—Fedchenko. (*Journ. of Tech. Phys.* [in Russian], No. 7, Vol. 8, 1938, pp. 633–644.)
3358. CHARACTERISTICS OF THE COPPER ARC IN AIR.—White. (*Phys. Review*, 1st June 1938, Vol. 53, No. 11, p. 935: abstract only.)
3359. EFFECT OF OXIDES AND IMPURITIES ON METALLIC ARC REIGNITION [supports Suggestion of Suitts & Hocker that Oxide is Necessary on Copper Cathode to establish a Stable Arc].—Cobine. (*Phys. Review*, 1st June 1938, Vol. 53, No. 11, p. 911.) See 2980 of July.
3360. A CIRCUIT FOR THE RAPID EXTINCTION OF THE ARC IN A THYRATRON [for Operation of High-Speed Electric Counters].—Pickering. (*Review Scient. Instr.*, June 1938, Vol. 9, No. 6, pp. 180–182.)
3361. A REVERSIBLE CLEAN-UP EFFECT IN LOW-PRESSURE MERCURY-VAPOUR DISCHARGE [Equilibrium Exchange of Hg between Gas and Walls of Tube resulting in Clean-Up of Walls].—Kenty. (*Phys. Review*, 1st June 1938, Vol. 53, No. 11, p. 936: abstract only.)
3362. VAPORISATION OF MERCURY FROM ANCHORED CATHODE SPOT.—Tonks. (*Phys. Review*, 1st June 1938, Vol. 53, No. 11, p. 936: abstract only.)
3363. DESIGN OF WAVE FILTER FOR MERCURY-ARC RECTIFIER CIRCUIT.—Satoh. (*Res. of Electrot. Lab.*, Tokyo, No. 414, Dec. 1937, 40 pp. and Tables.)
3364. AUTOMATIC BATTERY CHARGING BY DRY RECTIFIERS [particularly for Telephone Exchange Installations].—Böhm. (*E.N.T.*, April 1938, Vol. 15, No. 4, pp. 117–121.)
3365. THE ELECTRICAL SURFACE CONDUCTIVITY OF CUPROUS OXIDE.—Dubar. (*Rev. Gén. de l'Élec.*, 4th June 1938, Vol. 43, No. 23, pp. 707–717.)
3366. ON THE CHARACTERISTICS OF THE SYSTEM COPPER/CUPROUS OXIDE/COPPER.—Wehner. (*Physik. Zeitschr.*, 1st June 1938, Vol. 39, No. 11, pp. 445–454.)
- A.c. and d.c. characteristics were traced for a system consisting of a copper electrode upon an oxidised copper plate. Characteristics for a.c. and d.c. were similar; effect of variation of electrode pressure decreased as pressure increased; rectification proceeded simultaneously in opposite senses, and either could predominate according to conditions of voltage and electrode pressure.
3367. ALTERNATING CURRENT STUDY OF A SEMI-CONDUCTOR [Measurement of Contact Capacities at Surface of Separation of a Metal and a Semiconductor by Oscillographic Method: Sodium Carbonate gives $9\ \mu\text{F}$ per Sq. Cm measured by A.C. and $8\ \mu\text{F}$ measured with D.C.].—G. Déchéne. (*Comptes Rendus*, 23rd May 1938, Vol. 206, No. 21, pp. 1558–1560.)
3368. RECTIFYING PROPERTIES OF CRYSTALS.—Deaglio. (*Nature*, 4th June 1938, Vol. 141, p. 1011.) Leading to the conclusion that volume and surface rectification may both occur, with surface rectification predominating.
3369. OSCILLOGRAPHIC INVESTIGATION OF THE UNIDIRECTIONAL CONDUCTIVITY OF CARBORUNDUM [Rectification less perfect as Applied Voltage increases].—Bose & Khastgir. (*Zeitschr. f. Physik*, May 1938, Vol. 109, No. 1/2, pp. 80–84.)
3370. LUMINESCENCE OF PURE CRYSTALS.—Kabakjian. (*Phys. Review*, 1st June 1938, Vol. 53, No. 11, p. 919: abstract only.)
3371. NOTE ON THE CONDUCTION OF HEAT IN [Insulating—e.g. Quartz] CRYSTALS.—Casimir. (*Physica*, June 1938, Vol. 5, No. 6, pp. 495–500: in English.)
3372. A STUDY OF THE AMORPHOUS STATE: XII.—Kuvshinski & Kobeko. (*Journ. of Tech. Phys.* [in Russian], No. 7, Vol. 8, 1938, pp. 608–614.) For previous parts see 704 of 1937.
3373. ON THE DIELECTRIC AFTER-EFFECT IN SOLID NONCONDUCTORS [Measurement of Current in the Dielectric in the Interval 10^{-2} to 10^3 Sec. after Application of a D.C. Voltage: Results for Wax, Mica, Glass & Kerafa U].—Voglis. (*Zeitschr. f. Physik*, May 1938, Vol. 109, No. 1/2, pp. 52–79.)
3374. EFFECT OF HUMIDITY ON THE LOSS ANGLE OF INSULATORS [at High Frequencies, 100 kc/s to 10 Mc/s: Increase of Loss Angle due to High Humidity is Greater as Frequency decreases: Slight for Humidities up to 50–60%, then Sudden Jump: Effect of Surface Leakage and of Water Particles sorbed in Structure of Material].—Akahira & Kamazawa. (*Electrot. Journ.*, Tokyo, June 1938, Vol. 2, No. 6, p. 148.)
3375. PLASTIC MATERIALS: COUMARONE AND INDENE RESINS.—(*Electrician*, 10th June 1938, Vol. 120, p. 744.)
3376. THE MANUFACTURE OF LAMINATED PLASTICS.—(*Communications*, May 1938, Vol. 18, No. 5, pp. 18–19.)
3377. GLASS INSULATING TAPES [woven from Glass Yarns].—(*Electronics*, May 1938, Vol. 11, No. 5, p. 70.)

3378. TOLERANCES ON CERAMICS [and the Various Factors controlling the Making of Ceramic Parts].—Stevens. (*Communications*, May 1938, Vol. 18, No. 5, pp. 28 and 38, 39.)
3379. THE CHOICE OF IMPREGNATING MATERIAL FOR A.C. CONDENSERS OF SMALL CAPACITY.—Walter & Inge. (*Izvestiya Elektroprom. Slab. Toka*, No. 2, 1938, pp. 55-61.)
A report on the development work carried out to meet a demand for condensers of fixed capacity of the order of 0.01-0.02 μF and capable of working under voltages up to 450 v, 50 c/s. Impregnation of paper by paraffin, ceresin, and transformer oil was tried out, and a detailed account is given of the manufacturing processes involved and of the properties of condensers so produced. The main conclusions reached are as follows:—(1) condensers with paraffin or ceresin impregnation are less reliable than those with transformer-oil impregnation, (2) impregnation with a solid material must be carried out in a vacuum, and (3) five to six layers of paper impregnated with a solid material are required between condenser plates, as compared with only three layers when the paper is impregnated with transformer oil.
3380. ON THE MEASUREMENT OF THE MOBILITY OF THE IONS IN DIELECTRIC LIQUIDS OF HIGH VISCOSITY (PARAFFIN OIL), and THE RELATION BETWEEN THE MOBILITY OF IONS AND THE TEMPERATURE IN DIELECTRIC LIQUIDS.—Scislowska & Adamczewski: Adamczewski. (*Acta Physik Polonica*, Fasc. 4, Vol. 6, 1937, pp. 425-431; pp. 432-444: both in French.)
3381. DIPOLE MOMENTS AND ROTATIONAL FREEDOM [studied by Substitution of Phenyl Groups in Saturated Hydrocarbons: No Effect on Dielectric Constants: hence concluded that the Polar Groups are Free to Rotate].—Riedinger. (*Physik. Zeitschr.*, 1st May 1938, Vol. 39, No. 9, pp. 380-384.)
3382. A STUDY OF THE BREAKDOWN OF SUPERHEATED STEAM.—Rziankin. (*Tech. Phys. of USSR*, No. 3, Vol. 5, 1938, pp. 221-228: in English.)
3383. THE BREAKDOWN OF COMPRESSED NITROGEN UNDER IMPULSE VOLTAGES.—Goldman. (*Journ. of Tech. Phys.* [in Russian], No. 6, Vol. 8, 1938, pp. 516-522.)
For previous work see 1180 of 1937. An experimental investigation was carried out of the breakdown of compressed nitrogen in heterogeneous and homogeneous electric fields (i.e. between a flat and a pointed or spherical electrode). The voltages applied to the electrodes were obtained from an impulse generator (Fig. 1).
3384. THE NATURE OF ENERGY LOSSES IN AIR CAPACITORS [Slight Losses, depending on Nature of the Electrode Surface, are Most Marked in Aluminium and Least in Silver].—A. V. Astin. (*Phys. Review*, 1st June 1938, Vol. 53, No. 11, p. 927: abstract only.)
3385. ECONOMY IN NICKEL-CONTAINING ALLOYS IN THE CONSTRUCTION OF ELECTRICAL RESISTANCES [by the Use of Paralleled Component Resistances].—Hurrle. (*E.T.Z.*, 16th June 1938, Vol. 59, No. 24, pp. 639-640.)
3386. ON THE RESISTANCE MATERIAL ISABELLIN [Al-Mn-Cu Alloy suitable for the Construction of Standard Resistances].—Schulze. (*Physik. Zeitschr.*, 15th May 1938, Vol. 39, No. 10, pp. 401-407.)
3387. THERMOELECTRIC CHARACTERISTICS OF CARBON LAYERS [and the Conditions leading to Production of Most Suitable Carbon for Grid-Leak and Other High Resistances].—Fukuda & Saito. (*Electrot. Journ.*, Tokyo, June 1938, Vol. 2, No. 6, pp. 129-131.)
3388. ON THE RESISTIVITY OF THIN FILMS OF METAL [Derivation of Expression taking Collisions *inside* the Body into Account].—Mukhopadhyaya. (*Sci. & Culture*, May 1938, Vol. 3, No. 11, pp. 626-627.)
3389. EFFECT OF MANGANESE COATING ON THE MAGNETIC QUALITY OF IRON WIRE [Considerable Improvement by Thin Coating].—Wall. (*Nature*, 4th June 1938, Vol. 141, p. 1016.)
3390. IRON IN HIGH-FREQUENCY CIRCUITS: SOME COMMENTS ON ITS USE [including Bibliography of 41 Items].—Briton. (*Proc. I.R.E. Australia*, Sept. 1937, Vol. 1, No. 2, pp. 42-47.)
3391. THE PROPAGATION VELOCITY OF ELECTRIC WAVES ALONG THIN METALLIC WIRES, AND THE PERMEABILITY OF IRON FOR HERTZIAN [Micro-Wave] OSCILLATIONS.—Lindman. (*See* 3095.)
3392. PARAMAGNETIC DISPERSION WITH DIFFERENT ORIENTATIONS BETWEEN HIGH-FREQUENCY FIELD AND CONSTANT FIELD.—Teunissen & Gorter. (*Physica*, June 1938, Vol. 5, No. 6, pp. 486-488: in English.)
3393. STUDY OF THE PROBLEM OF MAGNETIC FILINGS IN SUSPENSION: CONTRIBUTION TO THE THEORY OF MAGNETISM AND HYSTERESIS.—Guilbert. (*Bull. de la Soc. franç. des Elec.*, May 1938, Vol. 8, No. 89, pp. 425-448.)
3394. THE INFLUENCE OF TEMPERATURE ON THE ENERGY CONSTANT OF MAGNETIC ANISOTROPY OF FERROMAGNETIC CRYSTALS.—Bruchatov & Kirensky. (*Tech. Phys. of USSR*, No. 3, Vol. 5, 1938, pp. 171-183: in English.)
3395. ON THE THEORY OF THE MAGNETIC ANISOTROPY OF CUBIC CRYSTALS AT THE ABSOLUTE ZERO.—van Peype. (*Physica*, June 1938, Vol. 5, No. 6, pp. 465-482: in German.)
3396. "MAGNETISCHE UND ELEKTRISCHE EIGENSCHAFTEN DES EISEN UND SEINER LEGIERUNGEN" [Book Review].—Auwers. (*Zeitschr. f. tech. Phys.*, No. 6, Vol. 19, 1938, p. 181.)

3397. ON THE DEPENDENCE OF THE GALVANO-MAGNETIC EFFECT OF FERROMAGNETIC SUBSTANCES (IRON AND NICKEL) ON THE TEMPERATURE.—Fedenev & Uskov. (*Tech. Phys. of USSR*, No. 4, Vol. 5, 1938, pp. 309-319: in English.) The Russian paper was referred to in 3001 of July.
3398. PAPER ON PERMANENT MAGNETS IN THE NEW ALLOYS [Mishima Alloy, Alnico, etc.: for Damping in Electricity Meters].—Oliver & Shedden. (*Journ. Scient. Instr.*, June 1938, Vol. 15, No. 6, pp. 193-200.)
3399. ON A METHOD OF AMPLIFYING A D.C. VOLTAGE [by Magnetic Frequency Doubler].—Watanabe & Chonan. (See 3149.)
3400. VOLTAGE-REGULATING EQUIPMENT CHARACTERISTICS AS A GUIDE TO APPLICATION.—Benner & Lunge. (*Gen. Elec. Review*, June 1938, Vol. 41, No. 6, pp. 273-279.)
3401. EFFECT OF SOURCE RESISTANCE ON ELECTRONIC STABILISER PERFORMANCE [Extension of Simpler Theory to include Effects of Source Resistance].—Hunt & Hickman. (*Phys. Review*, 1st June 1938, Vol. 53, No. 11, pp. 913-914: abstract only.) See 1195 of 1937 for the earlier paper.
3402. THE VACUUM SWITCH AND ITS APPLICATIONS.—Teare. (*Gen. Elec. Review*, June 1938, Vol. 41, No. 6, pp. 280-281.)
3403. TYPE BSZ 237 MICRO-RELAY [Extremely Sensitive Combination for Use with Selenium Photocells, etc.].—(*Elec. Communication*, April 1938, Vol. 16, No. 4, pp. 374-375.)
3404. PHOTOELECTRIC CURRENT-LIMITING DEVICE.—Baker & Boltz. (See 3327.)
3405. THE WEAR OF ELECTRICAL CONTACT POINTS.—Betteridge & Laird. (*Journ. I.E.E.*, June 1938, Vol. 82, No. 498, pp. 625-632.)
3406. HINTS ON SILVERING GLASS.—Ockenden. (*Journ. Scient. Instr.*, June 1938, Vol. 15, No. 6, pp. 206-208.)

STATIONS, DESIGN AND OPERATION

3407. STATIONS' DECLINE IN POWER [Falling-Off of Signals from New Stations: Suggested Explanations (Absorption by Newly Erected Receiving Aerials in Neighbourhood, Effect of Earth System): Correspondence].—Voigt & others. (*World-Radio*, 3rd & 10th June 1938, Vol. 26, p. 7 and pp. 7 & 9.) For the summer/winter effect see Eppen, 1933 Abstracts, p. 342.
3408. CARRIER REDIFFUSION [Description of Equipment].—Wiessner. (*Elec. Communication*, April 1938, Vol. 16, No. 4, pp. 298-305.) From the Lorenz Company's Rediffusion Laboratories.
3409. RADIODISTRIBUTION [General Survey, with Typical Examples of Various Systems and Discussion of Relative Advantages].—Tibaux. (*Sci. Abstracts*, Sec. B, 25th May 1938, Vol. 41, No. 485, p. 364.)
3410. THE SIMULTANEOUS BROADCASTING ["S.B." SYSTEM [of the B.B.C.]].—Edwards. (*World-Radio*, 3rd June 1938, Vol. 26, No. 671, pp. 12-13.)
3411. BROADCAST PROGRAMME TRANSMISSION NETWORKS OF AUSTRALIA.—Lawson. (*Proc. I.R.E. Australia*, Sept. 1937, Vol. 1, No. 2, pp. 33-41.)
3412. RADIO DEVELOPMENTS IN INDIA: TWELVE TRANSMITTERS TO BE WORKING BY THE END OF 1938.—(*Electrician*, 10th June 1938, Vol. 120, p. 744.)
3413. AN EXPERIMENT WITH A SINGLE-SIDEBAND MULTIPLEX RADIO SYSTEM BETWEEN TOKYO AND KAGOSHIMA, JAPAN [One Telegraph and Two Telephone Channels].—Matsumae, Amisima, & Yoneyama. (*Rep. of Rad. Res. in Japan*, Dec. 1937, Vol. 7, No. 3, Abstracts pp. 31-32.)
3414. DESCRIPTION OF THE L.M.T. LABORATORIES' RADIOTELEGRAPHIC PRINTING SYSTEM USING CHARACTERS SPLIT INTO 7 HORIZONTAL BANDS.—Devaux. (*L'Onde Elec.*, May 1938, Vol. 17, No. 197, pp. 217-246.) Summaries of this lecture were dealt with in 2612 of June.
3415. HISTORY AND DEVELOPMENT OF POLICE RADIO COMMUNICATION IN NEW SOUTH WALES.—Salmon. (*Proc. I.R.E. Australia*, March 1938, Vol. 1, No. 3, pp. 62-72.)
3416. TYPE R.10 SHORT-WAVE RADIO EQUIPMENT FOR FIGHTER AIRCRAFT.—(*Elec. Communication*, April 1938, Vol. 16, No. 4, pp. 373-374.)
3417. A C.W. AND 'PHONE STATION FREQUENCY-MONITOR AND MODULOMETER WITH CATHODE-RAY TUBE.—Leibowitz. (*QST*, June 1938, Vol. 22, No. 6, pp. 17-19.)

GENERAL PHYSICAL ARTICLES

3418. DIELECTRIC CONSTANT OF IONISED GASES.—Gangopadhyaya & Khastgir. (See 3124.)
3419. CONTRIBUTION TO THE EXPERIMENTAL STUDY OF THE ELECTRONIC AFFINITY OF GASES [and the Excitation and Ionisation Potentials of Oxygen, etc.].—Goldstein. (*Ann. de Physique*, May/June 1938, Vol. 9, pp. 723-803.)
3420. THE STEFAN-BOLTZMANN LAW [and Wien's Displacement Law] AND NON-LINEAR ELECTRODYNAMICS.—Kwal & Solomon. (*Journ. de Phys. et le Radium*, May 1938, Series 7, Vol. 9, pp. 205-208.)
3421. ON THE EQUATIONS OF ELECTROMAGNETISM: I—IDENTIFICATIONS, II—FIELD THEORY.—Milne. (*Proc. Roy. Soc.*, 14th April 1938, Vol. 165, No. 922, pp. 313-332 & 333-357.)

Derivation of the equations of electromagnetism on a purely kinetic basis, Maxwell's theory not being assumed. The field due to a given charge in motion, at an external point, is measured by the force on a "test charge" in motion, and is found to involve the velocity of the test charge. The con-

cept of an electromagnetic field in free space must be replaced by the concept of a pair (E, H) which depend on the velocity of the test charge used in measurement.

3422. ELECTROMAGNETIC AND GRAVITATIONAL RADIATION [Study of Gravitational Field by Analogy with the Electromagnetic Case].—Infeld. (*Phys. Review*, 15th May 1938, Vol. 53, No. 10, pp. 836-841.)
3423. ON A SYNTHETIC LAW OF GRAVITATION AND ELECTROMAGNETISM.—Hély. (*Rev. Gén. de l'Élec.*, 28th May 1938, Vol. 43, No. 22, pp. 677-687.)
3424. ABSOLUTE EXPRESSION OF THE VALUES OF ELECTRICAL QUANTITIES BY MEANS OF THE GRAVITATIONAL UNIT.—Labocchetta. (*La Ricerca Scient.*, 15th/30th April 1938, Series 2, 9th Year, Vol. 1, No. 7/8, pp. 361-363.)
3425. FORMATION OF NEGATIVE IONS AT SURFACES [by Bombardment with Positive Ions: Resulting Negative Ions not necessarily of Same Element as Bombarding Ions].—Arnot & Beckett. (*Nature*, 4th June 1938, Vol. 141, pp. 1011-1012.)
- MISCELLANEOUS**
3426. ON THE APPLICATION OF THE FOURIER INTEGRAL TO NON-LINEAR INTEGRAL EQUATIONS.—Smirnof. (*Comptes Rendus (Doklady) de l'Ac. des Sci. de l'URSS*, No. 1/2, Vol. 19, 1938, pp. 3-7: in French.)
3427. APPLICATION OF THE LAGRANGIAN EQUATIONS TO ELECTRICAL CIRCUITS.—Wells. (*Journ. of App. Phys.*, May 1938, Vol. 9, No. 5, pp. 312-320.)
3428. APPROXIMATE CALCULATION FOR THE SOLUTION OF SYSTEMS OF LINEAR EQUATIONS.—Cimmino. (*La Ricerca Scient.*, 15th/30th April 1938, Series 2, 9th Year, Vol. 1, No. 7/8, pp. 326-333.)
3429. "THEORIE UND ANWENDUNG DER LAPLACE-TRANSFORMATION" [Book Review].—Doetsch. (*Zeitschr. f. tech. Phys.*, No. 6, Vol. 19, 1938, p. 181.)
3430. THE DEATH OF MAX WIEN.—Rukop. (*Telefunken*, March 1938, Vol. 19, No. 78, pp. 1-4.)
3431. THE UTILITY OF ESPERANTO FOR THE DIFFUSION OF SCIENTIFIC AND BIBLIOGRAPHIC DOCUMENTATION.—(*Génie Civil*, 28th May 1938, Vol. 112, No. 22, pp. 457-458.)
3432. ELECTROACOUSTIC APPARATUS IN THE PRIMEVAL FORESTS OF BRAZIL: THE GERMAN AMAZONAS-JARY EXPEDITION.—(*Telefunken*, March 1938, Vol. 19, No. 78, p. 80.)
3433. "THE NATIONAL PHYSICAL LABORATORY. REPORT FOR THE YEAR 1937" [Book Review].—(*Journ. Scient. Instr.*, June 1938, Vol. 15, No. 6, pp. 212-213.)
3434. ELECTRICAL STIMULATION OF THE HUMAN HEART AT ITS OWN BEAT RHYTHM: PRELIMINARY COMMUNICATION [New Application of the Bioelectric Action-Potentials of the Heart: Amplified by Negative Resistance and made to act Therapeutically on the same Heart: "Cardiochronaxia"].—Hollmann. (*Zeitschr. f. tech. Phys.*, No. 6, Vol. 19, 1938, pp. 155-158.)
3435. ELECTRICITY IN MEDICINE [with Some Literature References].—Williams. (*Elec. Engineering*, June 1938, Vol. 57, No. 6, pp. 237-244.)
3436. ON THE THEORY OF THE ELECTRICAL CONDUCTIVITY OF SELF-POLARISING OBJECTS [and the Frequency-Dependence of the Impedance of the Human Body, etc.].—Malov. (*Comptes Rendus (Doklady) de l'Ac. des Sci. de l'URSS*, No. 8, Vol. 18, 1938, pp. 569-574: in German.)
3437. HIGH-FREQUENCY PROSPECTING [Survey, with Literature and Patent References].—Heine. (*Funktech. Monatshefte*, May 1938, No. 5, pp. 134-138: to be continued.)
3438. AN ENQUIRY ON THE APPLICATION OF RADIESTHESIA ["Divining"] TO THE FINDING OF SOURCES OF WATER [with Replies to Questionnaire].—Liouville. (*Génie Civil*, 11th June 1938, Vol. 112, No. 24, pp. 490-493.)
3439. A NEW X-RAY STEREOMETER [with Three-Dimensional Vision].—Moriarty. (*Gen. Elec. Review*, June 1938, Vol. 41, No. 6, pp. 269-272.)
3440. ON THE INFLUENCE OF CATHODE DESIGN ON THE CURRENT DENSITY IN A POWERFUL X-RAY GENERATOR.—Ruhemann. (*Tech. Phys. of USSR*, No. 3, Vol. 5, 1938, pp. 206-216: in English.)
3441. STUDY AND EMPLOYMENT OF A LUMINOUS SOURCE OF GREAT BRILLIANCE [Explosion of Fine Wire by Discharge of Condenser storing 3200 Joules].—Vaudet. (*Ann. de Physique*, May/June 1938, Vol. 9, pp. 645-722.)
3442. ON THE THEORY OF LIGHT MODULATION OF A.C.-HEATED FILAMENT LAMPS AT AUDIO-FREQUENCIES [Temperature Modulation of a Filament heated by Modulated D.C.: Effects of End-Supports and Surrounding Gas: Modulation of Emitted Light resulting from the Temperature Modulation].—H. Köhler. (*E.N.T.*, April 1938, Vol. 15, No. 4, pp. 111-117.)
3443. FORMATION OF COMPLEX MAGNETIC COUPLING [causing Cross-Talk] WITHIN NON-LOADED [Carrier-Current] CABLE.—Shinohara & Yoshimura. (*Nippon Elec. Comm. Eng.*, Feb. 1938, No. 9, pp. 72-78.)
3444. CONSIDERATIONS ON THE EUROPEAN TELECOMMUNICATION NETWORK [including the Organisation].—Valensi. (*Alta Frequenza*, April 1938, Vol. 7, No. 4, pp. 219-244.)

Some Recent Patents

The following abstracts are prepared, with the permission of the Controller of H.M. Stationery Office, from Specifications obtainable at the Patent Office, 25, Southampton Buildings, London, W.C.2, price 1/- each.

ACOUSTICS AND AUDIO-FREQUENCY CIRCUITS AND APPARATUS

482 561.—Low-frequency or power amplifier comprising two or more electrode systems connected so that the cathode of one is in series with the anode of the other.

L. L. de Kramolin (addition to 415 079). Convention date (Germany) 3rd July, 1936.

483 730.—Low-frequency distributing system in which a number of loud-speakers are arranged to produce a binaural or stereophonic effect.

L. F. Savage and C. J. Francis. Application date 23rd July, 1936.

483 882.—Class B amplifier with grid-rectifier, the two characteristic curves being so chosen that distortion is automatically prevented.

C. Lorenz Akt. Convention date (Germany) 8th April, 1936.

484 474.—Automatic volume-expansion for low-frequency amplifiers and sound reproducers.

Marconi's W.T. Co. (assignees of J. F. Dreyer). Convention date (U.S.A.) 5th October, 1935.

DIRECTIONAL WIRELESS

481 950.—Feeding lighting current to a signal lamp at the top of the mast of a wireless aerial without affecting the directive properties of the aerial.

Standard Telephones and Cables and C. F. A. Wagstaffe. Application date 18th September, 1936.

482 102.—Wireless navigational system in which overlapping beams are used to mark out a definite course, characterised by the use of a more informative signal than the usual continuous note.

Standard Telephones and Cables (assignees of Le Materiel Telephonique Soc. Anon.). Convention date (France) 12th October, 1936.

482 114.—Directive short-wave aerial consisting of two parallel wires or tubes arranged to form a nearly-complete circle.

Marconi's W.T. Co. (assignees of J. L. Reinartz). Convention date (U.S.A.) 8th October, 1936.

483 427.—Directional receiver in which any deviation by a pilot from his correct course is indicated both visibly and audibly.

N. V. Philips' Lamp Co. Convention date (Holland) 14th May, 1936.

483 449.—Radio-navigation system of the overlapping-beam type in which means are provided to avoid displacement of the "guiding line."

Telefunken Co. Convention date (Germany) 20th August, 1936.

483 740.—Cyclically-operated keying system for use with a radio-navigational system of the overlapping-beam type.

Marconi's W.T. Co. and N. H. Clough. Application date 26th October, 1936.

483 768.—Two-way visual indicator for a directional wireless receiver used for navigating a course formed by two overlapping radio beams.

Radio Transmission Equipment and C. E. G. Bailey. Application date 11th February, 1937.

483 797.—Short-wave aerial with a linear-focus reflector for producing a highly-concentrated beam of centimetre waves.

Standard Telephones and Cables (assignees of E. Bruce). Convention date (U.S.A.) 11th September, 1936.

RECEIVING CIRCUITS AND APPARATUS

(See also under Television)

481 526.—Receiving circuit with means for increasing the signal-to-noise ratio of frequency-modulated signals, in order to cut-out interference.

E. H. Armstrong. Convention date (U.S.A.) 14th September, 1935.

481 858.—Method of control in which a wireless receiver is, in effect, held paralyzed until the circuits are accurately tuned, whereupon a brake or equivalent device restores conditions to normal.

N. V. Philips' Lamp Co. Convention date (Germany) 14th August, 1936.

481 893.—Superhet receiver in which the local-oscillator frequency for the longer wave-band is derived from the beats of two separate frequencies used for short-wave reception.

Marconi's W.T. Co. and A. A. Linsell. Application date 18th September, 1936.

482 328.—Negative-reaction amplifier giving a maximum power-output without distortion.

Telefon akt. L. M. Ericsson. Convention date (Sweden) 4th June 1936.

482 719.—Valve amplifier in which the control grid has a sharp cut-off characteristic for the purpose of automatic gain control.

J. H. O. Harries. Application date 2nd October, 1936.

483 504.—Wireless receiver in which reaction is maintained constant over a wide range of frequencies.

Murphy Radio and J. H. Balean. Application date 28th October, 1936.

483 602.—Variable-selectivity band-pass input to a wireless receiver; in which a degenerative action is applied at the resonant frequency, and a regenerative action above and below that frequency.

Hazeltine Corporation (assignees of H. M. Lewis). Convention date (U.S.A.) 21st March, 1936.

483 668.—Band-pass or filter circuit in which negative resistance is applied to maintain selectivity, in spite of the loading due to preceding or succeeding circuits.

Standard Telephones and Cables and R. M. Barnard. Application date 23rd October, 1936.

483 671.—Receiving circuit for phase-modulated signals in which a predetermined relation is maintained between a local oscillator and the incoming carrier wave.

Marconi's W.T. Co. (assignees of M. G. Crosby). Convention date (U.S.A.) 23rd October, 1935.

483 700.—Cabinet arrangement for a combined wireless set and clock.

O. Raz. Application date 15th December, 1937.

483 734.—Intervalve coupling circuit for a wide-band amplifier in which leakage inductance is neutralised.

W. S. Percival. Application date 24th September, 1936.

483 744.—Amplifying circuit in which undesired capacity coupling between the input and output circuits of a valve is prevented by the addition of an inductance tuned to resonate with the inherent grid-cathode capacity.

W. S. Percival. Application date 28th October, 1936.

483 869.—Short-wave receiver with means for applying or cutting-out negative feed-back, according to the wavelength of the received signal.

G. Priecheufried. Application date 25th January, 1937.

485 007.—Visual tuning-indicator for a wireless set, located in the centre of the loud-speaker diaphragm, and serving, additionally, to balance the acoustic reproduction of the high and low notes.

Pilot Radio Corporation. Convention date (U.S.A.) 12th November, 1935.

TELEVISION CIRCUITS AND APPARATUS

FOR TRANSMISSION AND RECEPTION.

481 434.—Cathode-ray television receiver in which the picture is reproduced by incandescence, instead of fluorescence, and in which secondary emission is used to reduce the "heat inertia" of the screen.

Marconi's W.T. Co. and L. M. Myers. Application date 10th August, 1936.

481 556.—Composition of tungsten screen used to project television pictures by incandescence in a cathode-ray tube.

Philips' Lamp Co. (addition to 472 240). Convention date (Germany) 23rd October, 1936.

481 590.—Method of modulating the electron stream of a cathode-ray tube without affecting the focusing of the stream.

V. Zeitline; A. Zeitline; and V. Khatchko (assignees of Cie des Compteurs et Matériel d'Usines à Gaz). Convention date (France) 13th June, 1935.

481 865.—Electron discharge tube in which electrons are liberated from a light-sensitive screen and are then focused on to a fluorescent screen arranged at right-angles to the first screen, so that the view is not obstructed.

N. V. Philips' Lamp Co. (addition to 469 588). Convention date (Germany) 18th December, 1936.

481 917.—Valve-generator arranged to intensify the action of the electron stream on the fluorescent screen of a cathode-ray tube.

V. Zeitline; A. Zeitline; and V. Kliatchko. Application date 21st October, 1936.

482 049.—Rotating-disc scanner in which the optical magnification is varied as between the

scanning apertures nearer to and farther from the centre of the disc, so as to prevent "keystone" distortion.

The General Electric Co.; D. C. Espley; and D. O. Walter. Application dates 22nd September, 8th and 19th October, 1936; 5th January and 16th July, 1937.

482 665.—Valve oscillator and modulator for use with a light-modulating device of the kind depending upon the action of mechanical vibrations of super-sonic frequency.

Scophony; J. Sieger; and J. H. Jeffree. Application date 2nd October, 1936.

482 725.—Simplified form of relaxation oscillation generator for producing saw-toothed scanning voltages.

Cie pour la Fabrication des Compteurs et Matériel d'Usines à Gaz. Convention date (France) 4th October, 1935.

482 812.—Television transmitter in which the relative movement of the film is compensated by electron-optical as distinct from light-optical means.

Telefunken Co. Convention date (Germany) 23rd November, 1936.

482 876.—Method of intensifying the image formed on a fluorescent screen by a moving spot of varying intensity, for televising or viewing objects obscured by fog or darkness.

Sturdy-Cage Projects Inc. (divided from 477 775). Convention date (U.S.A.) 6th July, 1935.

482 959.—Cathode-ray tube in which a negatively-charged "storage grid," permeable to but controlling the passage of the electron stream, is associated with an adjacent positively-charged grid.

Baird Television and P. W. Willans. Application dates 8th October and 10th December, 1936, and 25th February, 1937.

483 385.—Television receiver in which a light-sensitive cell impulsed by a piezo-electric crystal is used in combination with a stationary scanning device to project a series of picture-elements simultaneously on to a viewing screen.

E. Traub. Application date 20th October, 1936.

483 451.—Television receiver in which the direct-current component is first suppressed, and then restored by a gas-filled discharge tube in response to correcting impulses.

Electrical Research Products Inc. Convention date (U.S.A.) 2nd September, 1936.

483 541.—Cathode-ray television receiver in which an incandescent picture is reproduced on a screen which is "preheated" by an auxiliary stream of electrons.

N. V. Philips' Lamp Co. Convention date (Germany) 24th October, 1936.

483 545.—Time-base circuit in which a miniature cathode-ray tube is used to generate the saw-toothed oscillations used for scanning a television receiver.

Marconi's W.T. Co. and D. J. Fewings. Application date 21st July, 1936.

483 622.—Television system which can be used for high-grade one-way transmission or for the two-way transmission of pictures of lower quality.

Marconi's W.T. Co. (assignees of V. K. Zworykin). Convention date (U.S.A.) 25th July, 1936.

483 650.—Edge-to-edge arrangement of the magnetic deflecting coils of a cathode-ray tube.

A. D. Blumlein. Application date 20th October, 1936.

483 667.—Relaxation oscillation-generator with a distortion-free transformer coupling to the deflecting-plates of a cathode-ray tube.

Radio-Akt. D. S. Loewe. Convention date (Germany) 25th October, 1935.

483 732.—Wide-band amplifier, suitable for handling television signals, in which the inter-electrode capacities of the valves are utilised as elements of a filter.

W. S. Percival. Application date 15th September, 1936.

483 841.—Viewing screen for a television receiver arranged to reduce the amount of "diffused" light which reaches the eyes of the observer.

The General Electric Co. and A. Bloch. Application date 6th November, 1936.

TRANSMITTING CIRCUITS AND APPARATUS

(See also under Television)

481 962.—Wireless transmitter in which the type of modulation applied to the carrier-wave (e.g. single or double side-band, and frequency or amplitude variation) can be selected at will.

Wired Radio Inc. Convention date (U.S.A.) 19th November, 1935.

482 106.—Method of mounting and screening the high-frequency components of a combined transmitting and receiving set.

C. Lorenz Akt. Convention date (Germany) 26th August, 1936.

482 267.—Secret system of signalling in which speech for instance is converted into impulses of short duration which define the variable characteristics of the original signal and occupy only a small frequency range.

Electrical Research Products Inc. (addition to 466 327). Convention date (U.S.A.) 2nd December, 1936.

482 382.—Wired-wireless carrier-wave transmission system with automatic gain control plus additional control means to correct for any residual or accumulated variations in the attenuation of the line.

Standard Telephones and Cables (communicated by Western Electric Co. Inc.). Application date 2nd October, 1936.

483 576.—High-frequency transmitter in which means are provided for automatically switching-off the carrier wave in the absence of a modulating signal.

Marcconi's W.T. Co. and H. J. H. Wassell. Application date 21st October, 1936.

483 883.—Transmission system of the kind in which the carrier-wave and side-band energies are separately amplified and radiated.

C. Lorenz Akt. Convention date (Germany) 9th April, 1936.

484 201.—Push-pull modulator circuit in which the applied grid-voltages are made identical in amplitude and phase by a suitable combination of resistance and reactance.

Allgemeine Elektrizitäts Ges. Convention date (Germany) 27th September, 1935.

484 626.—Cathode-ray type of electron discharge tube with a spiral "target" electrode particularly adapted for use as a frequency or phase modulator.

Marcconi's W.T. Co. (assignees of R. E. Shelby). Convention date (U.S.A.) 6th April, 1936.

CONSTRUCTION OF ELECTRONIC-DISCHARGE DEVICES

481 445.—Cathode-ray tube in which the end of the bulb is made with a flat instead of a convex surface, in order to reduce picture distortion.

Radio-Akt. D. S. Loewe. Convention date (Germany) 25th September, 1935.

481 894.—Electron discharge device in which the anode consists of an electron-permeable assembly of parts, the elements of which are separately biased to produce a negative-resistance effect.

Telefunken Co. (assignees of G. Jobst). Convention date (Germany) 18th September, 1935.

481 996.—Electron multiplier in which accidental variations in the secondary emission factor of the target electrodes is compensated by the use of negative reaction.

The General Electric Co.; L. I. Farven; and E. P. George. Application date 30th November, 1936.

482 168.—Preparing secondary-emission or "target" electrodes capable of liberating a high ratio of secondary to primary electrons at low speeds of impact.

Farnsworth Television Inc. Convention date (U.S.A.) 24th March, 1936.

482 195.—Compact arrangement of the electromagnetic coils used for deflecting the electron stream in a cathode ray tube.

A. D. Blumlein. Application date 21st September, 1936.

482 226.—Amplifier or oscillator tube in which the electron stream from a cathode is first focused into a beam and then deflected by the electrostatic action of control grids.

N. V. Philips' Lamp Co. Convention date (Germany) 23rd April, 1936.

482 385.—Electrode arrangement and spacing designed to prevent the effects of secondary emission in a screen-grid amplifier.

The M-O. Valve Co. and L. R. G. Treloar. Application date 6th October, 1936.

482 454.—Electrode arrangement for an electron multiplier, providing a symmetrical assembly suitable for mass production.

Ferranti; M. K. Taylor; and S. Jackson. Application date 16th October, 1936.

482 461.—Arrangement and mounting of the electrode system of a valve amplifier or oscillator for handling ultra-short waves.

Standard Telephones and Cables (assignees of J. P. Laico). Convention date (U.S.A.) 23rd January, 1936.

482 552.—Thermionic cathode for converting current variations into a corresponding variation in electron emission without the usual lag due to thermal inertia.

N. V. Philips' Lamp Co. Convention date (Germany) 13th May, 1936.

482 557.—Arrangement and mounting of the electrodes of a short-wave oscillator of the magnetron type.

N. V. Philips' Lamp Co. Convention date (Germany) 12th June, 1936.

483 050.—Electrode arrangement for controlling the passage of an electron stream at a point where the electrons are moving at high velocity, so as to avoid any damping effect on a tuned input circuit.

Telefunken Co. Convention date (Germany) 8th October, 1935.

483 321.—Flexible support for the electrodes of an electron discharge tube adapted, at the same time, to prevent mechanical vibration.

Standard Telephones and Cables and F. G. Goodchild. Application date 16th October, 1936.

483 336.—Magnetron tube fitted with axially-parallel electrodes for generating and amplifying ultra-short waves.

Telefunken Co. Convention date (Germany) 22nd October, 1935.

483 435.—Arrangement and method of mounting the electrodes of a cathode ray tube to facilitate mass production.

N. V. Philips' Lamp Co. Convention date (Holland) 27th June, 1936.

483 538.—Multi-grid amplifier designed to handle the small voltage-variations produced by a light-sensitive cell.

The British Thomson-Houston Co. Convention date (U.S.A.) 19th September, 1936.

483 575.—Electron multiplier in which the secondary-emission electrodes though parallel to each other are canted or inclined relatively to the main electron stream.

Marconi's W.T. Co. and G. B. Banks. Application date 21st October, 1936.

483 586.—Electron multiplier with a "sharply-peaked" response curve, particularly suitable for frequency-doubling.

Marconi's W.T. Co. and A. A. Linsell. Application date 26th October, 1936.

483 679.—Cathode ray tube made entirely of metal except for a glass screen fused in at one end.

A. Castellani and the "Safar" Company. Application date 28th October, 1936.

483 708.—Process for "gettering" or removing residual gas in the manufacture of thermionic valves.

Marconi's W.T. Co. Convention date (U.S.A.) 22nd October, 1935.

483 826.—Electron multiplier in which a large number of out-of-line target electrodes are mounted in a single glass tube.

Marconi's W.T. Co. Convention date (U.S.A.) 25th October, 1935.

483 827.—Electrode arrangement of an amplifier of the so-called "beam" type in which the electron stream is focused into a jet.

Marconi's W.T. Co. and G. F. Brett. Application date 26th October, 1936.

483 839.—Magnetron type of valve with multiple divided anodes for generating ultra-short waves at a high level of power.

Telefunken Co. Convention date (Germany) 5th November, 1935.

SUBSIDIARY APPARATUS AND MATERIALS

481 405.—Measuring the amplitude of high-frequency currents by a low-frequency method of modulation.

Telefunken Co. Convention date (Germany) 24th July, 1936.

481 601.—Apparatus for testing the efficiency or performance of various types of amplifying valves.

A. H. Cooper. Application date 24th August, 1936.

481 740.—Telephone receiver designed to give a more uniform response over the essential parts of the voice range, without loss of efficiency.

Standard Telephones and Cables; L. C. Pocock; and J. S. P. Robertson. Application date 16th September, 1936.

481 766.—Construction of air-spaced high-frequency cable suitable for the transmission of television signals.

Siemens and Halske Akt. Convention date (Germany) 22nd November, 1935.

481 948.—Cathode ray tube fitted with means for converting an ultra-violet ray into visible light, particularly for photo-microscopy.

J. Kessler. Application date 21st September, 1936.

482 096.—Method of producing or "growing" Rochelle-salt and other piezo-electric crystals from solution.

Telefunken Co. Convention date (Germany) 14th July, 1936.

482 743.—Supervisory system for indicating any breakdown or abnormal operation of the valves used in a power circuit.

The British Thomson-Houston Co. Convention date (U.S.A.) 30th January, 1936.

482 994.—Cathode ray oscillograph and sweep circuit for analyzing the form of transient disturbances and surges.

G. J. Scoles and Metropolitan-Vickers Electrical Co. (divided from 482 936). Application date 7th October, 1936.

483 023.—Wheatstone-bridge network for measuring impedances, particularly the "admittance unbalance" between a pair of transmission cables.

Standard Telephones and Cables; R. Webb; F. R. Rouse; and F. V. Fowles. Application date 9th October, 1936.

483 088.—Process for making "Sperrschicht" or harrier-plane rectifying units and photo-electric cells.

F. Rother. Application date 13th October, 1936.

483 110.—Blocking condenser which, after a breakdown, automatically restores insulation and regains full efficiency.

R. Bosch Akt. Convention date (Germany) 16th April, 1936.

483 125.—Construction of small-capacity condenser suitable for trimming or for neutralising the inter-electrode capacity of a valve.

C. Lorenz Akt. Convention date (Germany) 30th July, 1936.

483 419.—Wireless cabinet in which a covering of woven fibrous material disguises the position of the loud speaker.

A. Bacon. Application date 6th April, 1937.