

# The **WIRELESS ENGINEER**

AND  
**EXPERIMENTAL WIRELESS**

VOL. VIII.

NOVEMBER, 1931.

No. 98.

## Scattered Radiation from Short-wave Beams.

**U**NLESS we are mistaken, the first suggestion that the scattered radiation, due to the electrons set in vibration by the passage of short-wave signals through the upper atmosphere, may give rise to measurable echo effects and cause the distortion of signals was put forward by T. L. Eckersley about four years ago.

It is two years since he read his paper entitled "An Investigation of Short Waves" before the Institution of Electrical Engineers. This paper contained a record of a long series of directional observations on short-wave transmissions emanating from distant beam transmitters. Eckersley found that the signals he received in many cases did not appear to come from the transmitter but from some part of the beam itself, just as one sees—and therefore receives light waves from—the beam of a lighthouse when the actual lighthouse itself may be completely hidden. The explanation put forward and discussed very fully by Eckersley was that, in passing through the ionised upper atmosphere, the beam gives a scattered or diffused radiation, and a receiver situated within the skip distance, and thus unable to receive the direct radiation from the transmitter, may receive this scattered radiation from a part of the beam itself. The Transradio Company of Berlin have since carried out a number of experiments in conjunction with the British Post Office and have obtained results which not only confirm the general truth of Eckersley's theory, but which would be difficult to explain in any other way. These experiments are described

in a very interesting paper by Mögel in the August number of *Elektrische Nachrichten-Technik*. With wavelengths between 14 and 50 metres there is a zone within which signals are very weak; the direct wave does not reach much beyond 100 kms. and the refracted wave does not come down to earth until the distance is about 500 to 3000 kms. depending on the ionisation of the upper atmosphere and on the frequency, the distance increasing as the wavelength is decreased and as the ionisation decreases. At times, however, quite strong signals up to 100 microvolts per metre are received within this dead zone and these can only be explained by the assumption of scattered radiation from the beam. It also explains some striking echo effects obtained in the German experiments.

### Echoes from Short-wave Beams.

Narrow beams are transmitted from Nauen, near Berlin, to New York, Buenos Aires, and Japan. The receiving station at which the observations were made is situated at Geltow, also near Berlin. By using very short signals of about 0.0001 second duration, the experiments could be carried out during the normal transmission, since the duration of the experimental signal was only a hundredth of that of a Morse dot. The signals were recorded on a photographic strip, together with a time-marker with a frequency of 1000 which gave an accurate time scale on the records. Some idea of the scale and accuracy is given by the fact that the distance between the

direct signal and that which has made one circuit of the earth is about  $3\frac{1}{2}$  inches. An unexpected phenomenon, however, is the repetition of the signal in a somewhat confused but strongly marked form 0.012 second after the direct signal. This corresponds to reflection at a distance of about 1800 kms. and may be ascribed to the radiation sent back from the path of the beam when at its highest point in the ionised layer.

### Multiple Echoes.

There was, however, in one record which is reproduced in Mögel's article, a second echo arriving at a time corresponding to reflection at a distance of 4500 kms.; in some cases as many as seven echoes have been recorded, and as they have a relatively small effect on a vertical aerial, they suggest the possibility of having come down at a steep angle. The origin of these multiple echoes is, however, at present, a mystery. It should be remembered that these observations were made on a very directional receiver within a few miles of the beam transmitter.

With regard to the first and main echo, however, a large number of experiments has led Mögel to the conclusion that it is due to the scattered radiation which emanates from the beam as it passes through the highest point reached in the ionised layer. The point where this occurs will be at a greater distance from the transmitter for the ray that is tangential to the earth than for the ray that leaves at an angle of, say, 10 or 20 degrees to the horizontal. Rays which are more steeply inclined may not be sufficiently refracted to return to the earth. The region from which the scattered radiation occurs is thus spread out over a large distance and one would expect the echo of a very short signal to be more spread out than the direct signal. This is found to be the case and the amount of the spreading is roughly what one would expect.

### Reception of Nauen Beams in London.

The beam from Nauen to New York passes well to the north of England, while that from Nauen to Buenos Aires passes well to the south. A directive detector at the Post Office station at Dollis Hill, near London, obtains the strongest signals when directed roughly to the north in the first

case and to the south in the second case, and not to the east as one might have expected. London is at a distance from Berlin roughly equal to half the skip distance, so that one would expect the radiating regions of the beams to lie on about the longitude of England. The scattered radiation is directional, however, since it is due to the vibrations of electrons which will take place in a plane normal to the direction of transmission. This will always give a maximum radiation in both directions along the beam, but whether the radiation in a vertical direction is strong or weak will depend on the polarisation of the wave. If the electrons are vibrating vertically they will give little downward radiation, but if they are vibrating horizontally they will give a strong downward radiation. This point seems to have been overlooked by Mögel. The echoes received in Berlin were certainly much stronger than the signals received in London, yet the distance from the supposed source is greater in the former case.

Although the results recorded by Mögel are beyond doubt, the explanations suggested for the phenomena do not leave one with a feeling of satisfaction. While there is much which confirms the ideas propounded by Eckersley, there is also much which is either not explained or is contrary to these ideas and for which Mögel offers no explanation.

One question which arises at once is the reason for the sudden arrival of the echo at a moment which suggests that no scattered radiation occurred until the beam reached the highest point of its path through the ionised layer. Why should it not begin to send back scattered radiation as soon as it enters the ionised layer if, as Mögel assumes and shows in his diagrams, this layer begins to refract the beam at a height of 100 kms. and gradually bends it until it is horizontal at a height of 300 kms.? The sharpness of the beginning and end of the echo indicates rather a well-defined ionised layer which practically reflects the beam.

Like much experimental work these beautifully recorded results raise many more questions than they answer; they show how much we have yet to learn of the processes accompanying the passage of electromagnetic waves through the upper atmosphere.

# The Dynatron Oscillator.\*

## With a New Circuit for Very High Frequencies.

By *F. M. Colebrook, B.Sc., D.I.C., A.C.G.I.*

(Wireless Division, National Physical Laboratory.)

**SUMMARY.**—Practical details are given for the application of screen-grid valves to the maintenance of oscillations by the dynatron method. The upper frequency limit of this type of oscillator is about 15 megacycles per second.

By connecting the control grid through a high resistance to the filament and through a variable condenser to the anode, a new type of oscillation generator is obtained, which can be used for frequencies up to about 50 megacycles per second. Practical details for the design and operation of this circuit are given.

### 1. The Negative Resistance Characteristic of a Screen-grid Valve.

It is well known that under certain conditions of screen-grid and anode potential a screen-grid valve can be made to give an anode current-anode voltage characteristic having a negative slope. Under these conditions the filament-anode path is effectively a negative resistance as far as current and voltage changes are concerned. Fig. 1 shows characteristics of this kind taken with an S.G.215 valve with a screen-grid potential of 120 volts. Similar lines can probably be obtained with any of the commercial screen-grid valves now available. It should be

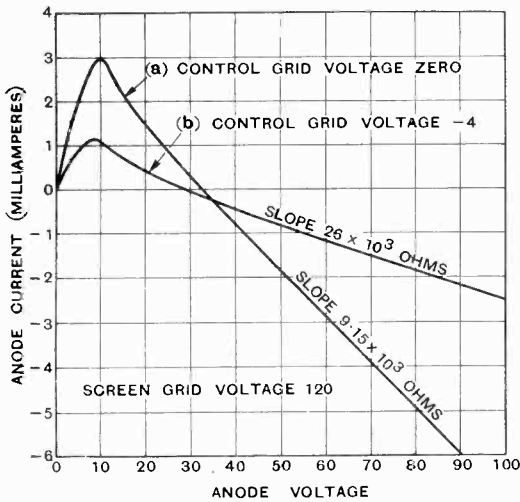

Fig. 1.

observed that the slope is dependent on the control grid voltage, which can therefore be used as a means of controlling the magnitude

of the negative resistance of the anode-filament path. As low a value as about 10,000 ohms can be obtained with the control grid at zero, but this is associated with a rather undesirably large screen-grid current—15 mA. or so. The screen-grid current is much smaller with a negative control grid bias—about 5 or 6 mA. with 4 volts on the control grid in the case illustrated in Fig. 1. The effective negative resistances represented

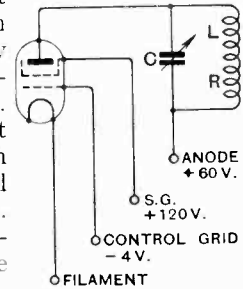

Fig. 2.

by these lines are proportional to the reciprocal of their slopes—*i.e.*, the steeper the line the smaller the effective negative resistance.

### 2. The Original Dynatron Circuit.

The utility of such a valve characteristic for the maintenance of continuous oscillation in an oscillatory circuit was apparently first pointed out by A. W. Hull, who gave the name “dynatron” to a valve specially designed to produce this type of characteristic. His original paper appears in the *Pro., I.R.E.*, 1918, Vol. 6, pp. 5-35. It is shown in Appendix I that if an oscillatory circuit be connected in series with the anode of a screen-grid valve, as shown in Fig. 2, then oscillations will occur at a fundamental frequency given very approximately by

$$\omega = \frac{I}{\sqrt{LC}} \left( 1 - \frac{R}{2R_a} \right)$$

where *C* is the total effective tuning capacity, including the self capacity of the coil and the screen-grid to anode capacity of the valve,

\* MS. received by the Editor, March, 1931.

and where  $R_a$  is the effective value of the negative slope resistance of the anode circuit. The condition for maintenance of oscillation is

$$\frac{L}{CR} = R_a \text{ or } R - \frac{L}{CR_a} = 0$$

the physical significance of which is that the resistance  $R$  is effectively cancelled by the negative series resistance  $L/CR_a$  which is equivalent to the negative shunt resistance  $R_a$ . It should be noted that  $R_a$  is in shunt to the oscillatory circuit, so that the smaller  $R_a$  the larger is the negative resistance it effectively produces in series with the oscillatory circuit. Experimental confirmation of this simple theory is given by Hull in the paper referred to above.

A suitable practical circuit for the realisation of such an oscillator is shown in Fig. 3. It will be noted that control grid bias is obtained by means of a small fixed resistance between the H.T. and L.T. negative terminals. This is a convenient means of preventing excessive screen-grid current without auxiliary grid batteries. In some cases, however, it is preferable to make use of a control grid potentiometer. Where purity of wave-form is important, for example, a control grid potentiometer can be used so as to make  $R_a$  as large as possible consistent with the maintenance of oscillation.

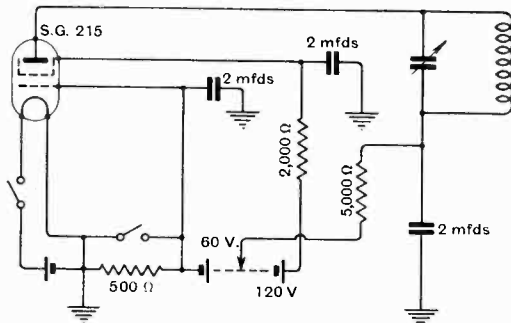

Fig. 3.

Under these conditions, as Hull pointed out, a fairly pure wave form will result.

### 3. Advantages of the Dynatron Circuit.

The principal advantage of the dynatron circuit is its simplicity. With a suitable range of two-terminal coils and condensers, a very wide frequency range can be covered without modification of the valve circuit.

Subject to the maintenance condition given above there appears to be no lower frequency limit. The upper frequency limit appears to be about 15 megacycles. (This is referred to more fully in the following section.) The circuit is very regular in behaviour, with complete freedom from alternative modes of oscillation and from the intermittent type of oscillation known as "squegging." Finally, given reasonable constancy of the supply voltages the frequency is satisfactorily stable. The full possibilities of the circuit from the point of view of frequency stability have yet to be explored, but it can safely be said that it compares favourably in this respect with any ordinary triode circuit, and seems to offer very promising possibilities for further development.

### 4. Limitations of the Dynatron Circuit.

From an inspection of the maintenance condition given above, and bearing in mind that there is a lower limit to  $R_a$ , it is clear that with any given coil there is a definite lower limit to the frequency, or, alternatively expressed, a definite upper limit to the permissible tuning capacity. The limitation in this respect is, in general, somewhat more severe than in the case of the usual triode circuit. In practice, however, this limitation is not troublesome, and there is no difficulty in satisfying the maintenance condition with coils of convenient dimensions over useful ranges of tuning capacity.

A more serious limitation has already been referred to, namely, the upper frequency limit of about 15 megacycles. Even this frequency can only be reached with good (*i.e.*, low resistance) coils and condensers, and with the lowest practicable value of  $R_a$  (*i.e.*, with zero control grid bias).

The reason for this limitation is not immediately obvious. Take for example a case in which  $L = 2\mu\text{H.}$ ,  $C = 30\ \mu\mu\text{F.}$ , and  $R_a = 10^4$  (giving a frequency of about 20 megacycles). Oscillation should be maintained provided  $R$  does not exceed 7 ohms. It is difficult to believe that with an inductance made of fairly thick copper tube and a condenser with quartz insulation the circuit resistance will exceed 7 ohms, even at 20 megacycles. Nevertheless, such a circuit cannot be made to oscillate with the dynatron arrangement described, even when all obvious precautions are taken to minimise

possible parasitic losses. The available data do not justify any definite statement on the matter and there seems to be a case for further investigation, but whatever the reason the limitation remains as a fact of general experience.

In the next section a description is given of a modification of the original dynatron circuit which is available for oscillation at frequencies up to about 50 megacycles.

### 5. A New Dynatron Circuit for High Frequency Oscillation.

The circuit shown in Fig. 4 differs from the original dynatron circuit in two respects. A variable condenser of small capacity

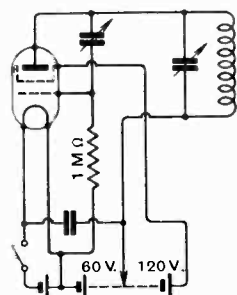

Fig. 4.

(100  $\mu\mu\text{F}$ . maximum) is connected between the anode and the control grid, and the latter is connected to the negative end of the filament through a high resistance (1 megohm or so). It was found that this circuit would oscillate at much higher frequencies than the original circuit.

The highest frequency

actually observed and measured was 54 megacycles (5.5 metres), obtained by replacing the coil by a short-circuit. (At this extreme limit it appears that the actual oscillating circuit is the conductor connecting the anode through the anode by-pass condenser to the filament, the effective capacity being that of the by-pass condenser and anode-screen grid capacity in series. To reach this limit this path must be made of low inductance. The by-pass condenser is connected between the battery end of the oscillatory circuit and the filament in the ordinary manner.) Up to about 40 megacycles (7 metres) the oscillation seems to be determined by the tuned oscillatory circuit in the normal manner, and with the usual precautions as to by-passing and short leads there is no difficulty in operation at such frequencies. In practice it is desirable to start with the grid-anode coupling capacity at the minimum and increase it until oscillation occurs, since, in common with all types of circuit using a "grid-leak" and condenser, intermittent or "squegging"

oscillation is liable to occur. This state is easily avoided by reducing the grid-anode coupling capacity to not much more than the value required to sustain oscillation.

The actual mechanism of the circuit is not quite clear and would probably require a detailed investigation, preferably with a cathode-ray oscillograph, for its elucidation. The writer has not had any opportunity of making this investigation. The oscillating condition is characterised by a considerable fall in screen-grid and in anode current—a useful feature which not only serves to indicate oscillation, but tends to a longer valve life. No fatigue effect has so far been observed. The circuit, oscillating at about 7 metres, was kept under observation for a period of 48 hours and showed no change in behaviour.

Another noticeable characteristic is that this circuit behaves as if the effective negative resistance of the valve were lower than in the original circuit. That is to say, it will maintain oscillation over a much wider range of tuning capacity with a given coil. For example, with a coil of 20  $\mu\text{H}$ . inductance the lower frequency limits were found to be 220 and 670 kilocycles respectively with the original and the modified circuit, *i.e.*, a ratio of 9 : 1 in the limiting tuning capacities in the two cases.

The appropriate value of the anode-grid coupling capacity depends on the oscillation frequency. At radio-frequencies 100  $\mu\mu\text{F}$ . maximum is generally sufficient. At audio-frequencies capacities up to about 5,000  $\mu\mu\text{F}$ . have been used.

A brief investigation of frequency stability was made. The circuit is apparently not quite so good in this respect as the original circuit, a result which is probably attributable to the additional variable factors introduced. It was, however, not materially different from an ordinary triode circuit in the matter of stability. It is hoped to explore this subject more fully at some future time.

Comparing the new and the original dynatron circuits—the former has the advantage of simplicity in operation, regularity of behaviour (*e.g.*, complete freedom from "squegging") and probably of greater frequency stability; the latter permits of a considerably greater range of frequency with any given coil, and will oscillate at very much higher frequencies.

The term "new" has been applied to the modified circuit. The writer believes it to be new in as much as he has not been able to find any previous published account. It has a certain family likeness to the Numans oscillator described by K. C. Van Ryn in *Experimental Wireless*, Vol. 2, pp. 134-139, but differs from this in some respects.

This work was carried out in connection with the programme of the Radio Research Board, and is published by permission of the Department of Scientific and Industrial Research.

**Appendix I.**

**Simple Theory of Negative Resistance Oscillator.**

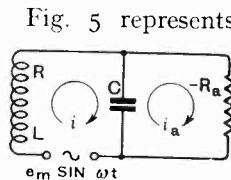

Fig. 5.

Fig. 5 represents an oscillatory circuit connected in parallel with a negative resistance  $-R_a$ . Assuming an e.m.f.  $e_m \sin \omega t$ , represented by the vector  $e$ , to act in the circuit as shown, the

current  $i$  in the closed circuit will be found to be given by

$$\{R - R_a(1 - \omega^2 LC) + j\omega(L - CRR_a)\} i = (1 - j\omega CR_a)e$$

The condition for self oscillation is  $e = 0$  which requires that the resistance and reactance components of the left-hand side shall be zero, i.e.,

$$R - R_a(1 - \omega^2 LC) = 0$$

and  $L - CRR_a = 0$

The first gives as the frequency of self oscillation

$$\omega = \frac{1}{\sqrt{LC}} \sqrt{1 - \frac{R}{R_a}}$$

$$\approx \frac{1}{\sqrt{LC}} \left(1 - \frac{R}{2R_a}\right)$$

The second gives as the resistance condition for oscillation

$$\frac{L}{CR} = R_a$$

## Books Received.

**RALPH STRANGER'S WIRELESS LIBRARY FOR THE "MAN IN THE STREET."**

No. 13. Detection of Wireless Signals by Crystal and Valve.

No. 14. Amplification of Wireless Signals.

No. 15. Reproduction of Wireless Signals. Microphones and Loud Speakers.

No. 16. Wireless Receiving Circuits.

No. 17. Wireless Measuring Instruments.

No. 18. The By-Products of Wireless. "Talkies," Electric Gramophone Recording, Direction-Finding, etc.

Each part about 62 pages, with numerous illustrations and diagrams. Published by George Newnes, Ltd., London, price 1/- each part.

**WIRELESS.**

A treatise on the theory and practice of High-frequency Electric Signalling, by L. B. Turner, M.A., M.I.E.E. Pp. 528 + xxviii, with 340 diagrams and 31 plates. Published by the University Press, Cambridge, price 25/- net.

**ELECTRICAL MACHINERY AND APPARATUS MANUFACTURE.**

Edited by Philip Kemp, M.Sc., M.I.E.E., to be issued in about 30 weekly parts, giving actual methods of the manufacture of Generators, Motors,

Rectifiers, Switch Gear, Instruments, etc., etc. Part I (published on Oct. 7th) begins Section 1 on D.C. Machines, by H. V. Shove, B.Sc. Pp. 64, with 46 illustrations and diagrams. Published by Sir Isaac Pitman & Sons, Ltd., London, price 1s. each part.

**ARITHMETIC FOR THE PRACTICAL MAN.**

Including Powers and Roots, Logarithms, Progressions, Latitude, Longitude and Time, Graphs, etc. Pp. 269 + xiii.

**ALGEBRA FOR THE PRACTICAL MAN.**

Including Cubic and Quadratic Equations, Logarithms, Exponential Equations, Ratio, Proportion, Progressions, Combinations, Probability, etc. Pp. 291 + xviii.

**TRIGONOMETRY FOR THE PRACTICAL MAN.**

Including Properties and Problems of Oblique Triangles, etc. Pp. 204 + x.

**THE CALCULUS FOR THE PRACTICAL MAN.**

Including Graphical Applications of Integration, the Natural Law of Growth, and "e," etc. Pp. 323 + x. All by J. E. Thompson, B.Sc. in E.E., A.M., of the Pratt Institute, Brooklyn, N.Y., and published by George Routledge & Sons, Ltd., London. Price 7s. 6d. each.

# Olympia, 1931.

## Impressions of the Radio Show.

**A** FIRST walk round the National Radio Exhibition at Olympia, in the endeavour to obtain a general impression of the whole without becoming bewildered by the many details that attracted at every turn, left the reviewer with three more or less definite impressions.

Of these the first, and the least important from the technical point of view, was that of size. Two years ago the National Hall, with its gallery, had sufficed to house all the exhibits; last year the first floor of the Empire Hall was added to this accommodation, but for this year's Show still further extension of space was needed, and the exhibits had overflowed into the ground floor of the Empire Hall. Even with this large extension of floor-space the stands were as closely packed as usual; it was quite evident that the extra area was taken because it was needed, and not merely to impress.

Casual observation suggested that the popularity of the Exhibition had expanded in about the same ratio as the floor-space, since it was noticed that at the most crowded times it was as nearly impossible as in previous years to move along any of the gangways or to see any of the exhibits.

### Drop in Prices.

The second outstanding feature of the exhibition as a whole was the very considerable decrease in prices as compared with previous years. This lessened cost, although applying in many cases to components as well, is particularly noticeable in the case of completed receivers. On one stand, which shall be nameless, was seen an all-mains receiver of the most up-to-date design selling at a remarkably reasonable price. Side by side with it was one of last year's models, with a specification not nearly as attractive as that of the more recent instrument; the price of this, being unchanged from last year, was higher than that of the new model by some 50 per cent. At a rough guess, one would say that the case quoted is a reasonably fair sample of the extent by which the general level of prices has dropped.

The third impression gained from the preliminary survey was that commercial receivers as a whole are far more up to date than they have ever been in the past. A few years ago the skilled and enthusiastic amateur designer could walk round Olympia and come away with a well-grounded conviction that he could build himself a set that would give a more nearly perfect performance than the best set on show. This year, however, every advance in design that has found publication during the preceding twelve months is to be found embodied in one or more of the receivers offered by the various manufacturers.

The general tendency of the year's development on the high-frequency side seems to be in the direction of improved selectivity, while on the low-frequency side the chief feature is a steady increase in the proportion of sets with output stages that can provide an undistorted output adequate to lend realism to the music reproduced. One is thankful to observe that the portable set, which has done so much to hinder the industry by making wireless reproduction anathema to the many musically minded listeners who have never heard a real set, is continuing to decline in popularity.

### Importance of the Superheterodyne.

Even the preliminary stroll round the Exhibition made it clear that, among the more elaborate sets, the superheterodyne is beginning to take an important place. It is not, of course, the same superheterodyne that so deservedly dropped out of existence some years ago, but an instrument so transformed that it would be almost true to say that it has nothing, save its basic principle, in common with its early prototypes. The old intermediate amplifier, consisting of transformer-coupled triodes precariously stabilised by positive grid-bias so adjusted that the whole was on the verge of oscillation, is dead and buried. In place of this antique abomination, which amplified only by virtue of stray reaction and amputated side-bands in a more thorough-going way than any other device before or since, we

now have a pair of screen-grid valves used in conjunction with properly designed band-pass couplings. Side-bands, if not accorded royal honours, are at least treated with reasonable respect; the amplification is honestly come by through proper circuit design; while the minute residual capacity of the modern screen-grid valve ensures that the amplifier shall be sufficiently far removed from instability for its performance-curve to be at least similar to that originally calculated by its designer. Equal advances have been made in eliminating harmonics from the frequency-changer, so that one need no longer expect to tune in the local station at a dozen or more different settings of the dial.

Of the superheterodyne receivers shown rather less than half were found to be equipped with a preliminary high-frequency stage operating at the frequency of the received signal. While opinions clearly differ as to the need for this stage, there can be little doubt that its only real advantage lies in the opportunity it offers of using a lesser amount of intermediate-frequency amplification, thereby decreasing the amount of valve-hiss heard when receiving a distant station. The other advantages of the H.F. stage, checking second-channel interference and lessening oscillator-radiation, can equally

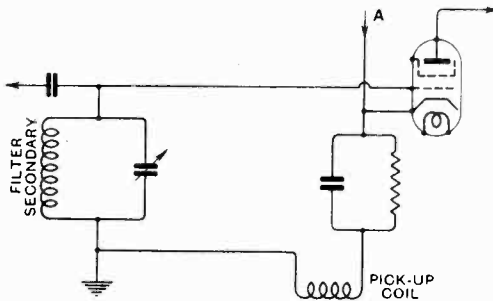

Fig. 1.—Pick-up coil in cathode-return lead of first detector valve. Bias is provided by potentiometer current through lead A as well as by the valve's own current.

well be provided by a band-pass filter, which is fitted to practically all the superheterodynes in which the signal-frequency stage is not used.

An interesting receiver of this second type was found on the stand of the Radio Gramophone Development Company, in which a

total of nine valves, including the mains rectifier, is used. This set is designed to operate from a small aerial rather than from a frame, and therefore has a band-pass input filter. To avoid danger of long-wave interference the coupling in this filter is provided by a very small capacity between the high-potential ends of the two tuned circuits. This condenser can be adjusted from outside the receiver. The secondary of the filter is joined between grid and

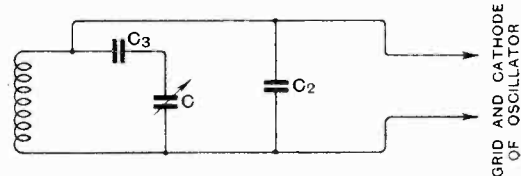

Fig. 2.—“Padding” condensers used for ganging oscillator-tuning.  $C$  is one section of a standard multi-gang condenser;  $C_3$  and  $C_2$  are used to alter its law to suit the required conditions.

filament of the screen-grid valve used as first detector, into the cathode circuit of which the oscillations from the triode oscillator are fed in the manner shown in Fig. 1.

As in practically all the receivers exhibited, the oscillator-tuned circuit is ganged with the signal-frequency circuits. For this the American system of “padding condensers,” shown in Fig. 2, is adopted, the oscillator tuning condenser having the same capacity, and following the same law as the other condensers with which it is ganged. This ganging is carried out for both wave-ranges, there being, in this particular set, two separate but identical tuning condensers for the two ranges.

The coils and condensers belonging to the oscillator are extremely well screened in this receiver; on enquiring the reason for this we were told that unless the screening of condenser, as well as coil, was very thorough there was considerable danger of direct radiation from the oscillator. The efficiency of the band-pass filter in preventing radiation through the tuned circuits had been carefully compared with that of a screen-grid stage of amplification at signal frequency; the result of careful experiment has shown that either is completely effective in shutting off oscillations from the aerial. It will be understood, of course, that in an ungangd set,



where there is the possibility of tuning the oscillator to the same wavelength as that to which the aerial is tuned, the interposition of a screen-grid valve would be absolutely essential.

The remaining portions of this receiver contain no very outstanding points; the design conforms with standard practice, except for the output stage which, since it consists of two Mazda PP5/400 valves, arranged in push-pull, may be described as unusually generous. Performance-curves of this set and others of their range are shown by this firm; two of those relating to the superheterodyne just described are reproduced in Fig. 3. The sensitivity-curve (not reproduced) shows that an input varying from 0.4 microvolt at 1,300 kc. to 0.88 microvolt at 600 kc. is required for standard output.

While the description just given applies to one of the more advanced of the superheterodyne receivers, it may fairly be taken as typical, in general scheme at least, of most of the others on view. Divergencies were mostly found in the design of the frequency-changer; separate oscillators were found in conjunction both with triodes and with screen-grid valves used as first detectors. In battery sets an occasional bi-grid was to be seen (there is at the moment no mains bi-grid on the market), while one receiver appeared to be using some type of

of those entrusted with the duty of explaining their excellence to the prospective purchaser.

The Stenode Radiostat was being shown by two firms only, Messrs. Radio Instruments, whose version is illustrated, and Messrs. Smurthwaite. Neither instrument

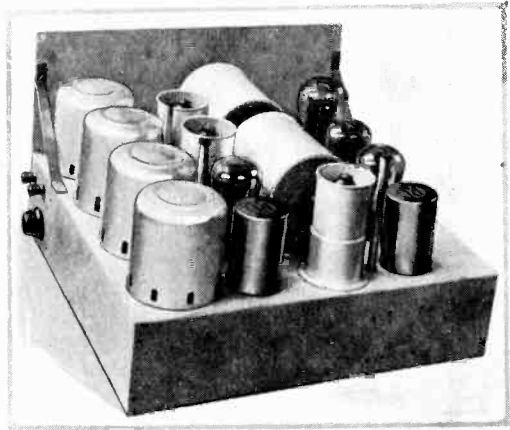

Chassis of the Stenode Radiostat as made by Messrs. Radio Instruments.

uses the "crystal" gate, this leading to such excessive sharpness of tuning that the receiver becomes difficult to handle and, in addition, unreliable for the reception of stations save those whose emitted frequency is crystal-controlled. Since, however, trans-

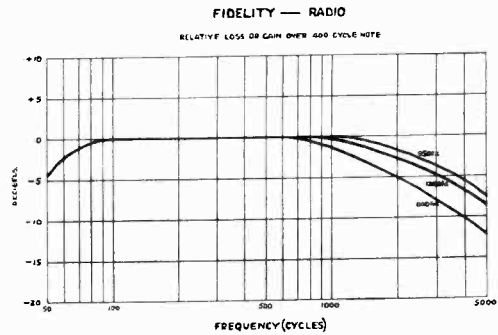
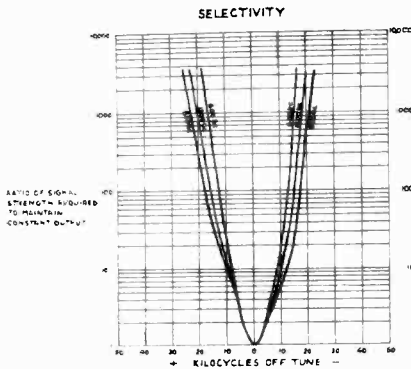

Fig. 3.—Performance-curves of R.G.D. Superheterodyne. It will be noticed that even the more advanced models of this type do not treat side-bands as well as a straight H.F. set. Compare Fig. 4.

single-valve triode frequency-changer. Short of buying the sets and disembowelling them, there was often no means of finding out anything more than the price of the various instruments, owing to the complete ignorance

mitters are at present separated by frequency-differences great enough to permit their separation in a Stenode receiver by less drastic means, the omission of the crystal gate is no drawback to performance.

The intermediate amplifier in both sets uses very sharply tuned couplings, and the necessary frequency-correction is applied in the low-frequency stages. The loss in strength incurred by the corrector circuits, which consist of a simple combination of resistance and capacity, necessitates the

reproduced in Fig. 4, from which it will be seen that the high-frequency amplifier as a whole offers a very close approach to constancy of both selectivity and fidelity over the whole of the medium-wave band.

One of the most interesting, as well as one of the most ambitious, receivers of the

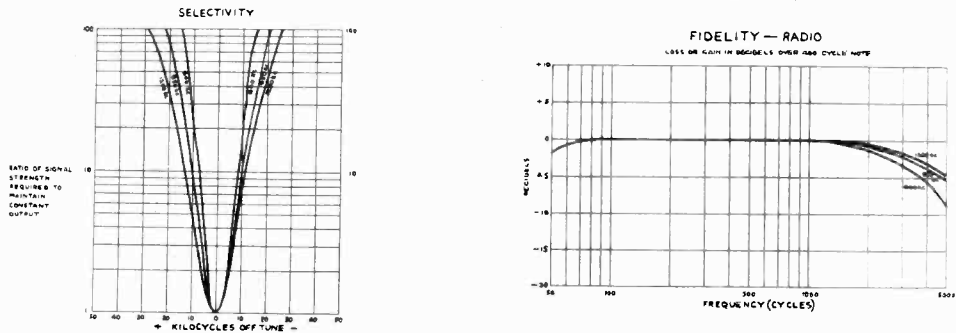
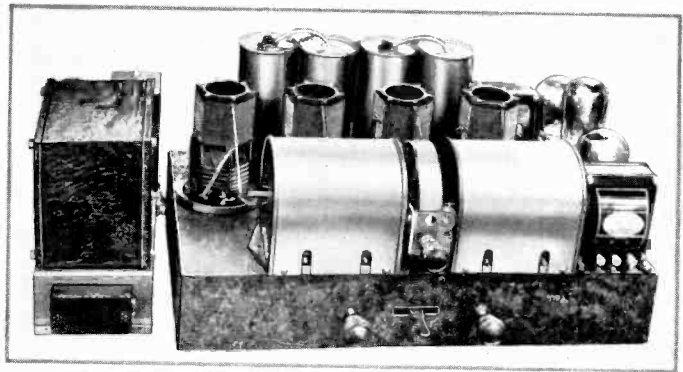

Fig. 4.—Performance curve of a good straight H.F. set (R.G.D.). Notice that the selectivity curve is to a different scale from that of Fig. 3.

interposition of a low-frequency amplifier between second detector and output, so that the extra selectivity is attained at the cost, at most, of only one valve more than would be required for equivalent performance in a superheterodyne receiver using band-pass couplings.

The "straight H.F." set using two and in some cases three stages of tuned screen-grid amplification was strongly in evidence. The bulk of these receivers were found to employ even the most recent refinements in design; power detection is almost universal, and band-pass filters are employed in all but the more modestly priced receivers of this class. The capacity-coupled filter is perhaps the favourite, owing to the fact that its failings are approximately compensated by the characteristics of the succeeding inter-valve circuits, but many samples of the more perfect "mixed" filter recently developed were also seen. Performance-curves of a receiver using a capacity-coupled input filter followed by two stages of amplification using single tuned circuits as intervalve couplings are

"straight H.F." type is the U<sub>53</sub> chassis fitted to one of the radio-gramophones offered by Messrs. Hacker and Sons. This is illustrated, with the screening-boxes removed. As inspection of the illustration will suggest, a serious attempt has been made in this receiver to obtain the highest possible efficiency and the best possible performance, while the claims of cheapness



Chassis of U<sub>53</sub> receiver (Hacker). The ambitious design of the coils, and the screening boxes containing H.F. choke and coupling condensers can be well seen.

of production have been given very secondary consideration.

A band-pass filter of the new "mixed" type is placed between the aerial and the

grid of the first valve, the coupling in the filter being partly inductive and partly provided by a small capacity between the high-potential ends of the two tuned circuits. Since this filter serves as a protection against loss of side-bands in the tuned circuits, the coils used in it, and in subsequent stages, have considerably lower high-frequency resistance than is usual in commercial receivers.

The band-pass filter, by preventing too great an input from the local station when the set is detuned from it, is some protection against unselectivity due to cross-modulation; in this set a further precaution is taken by using in the high-frequency stages screened pentodes (Cossor MS/Pen A), which do not overload nearly so readily as the ordinary screen-grid valve. The inter-valve couplings are of the tapped-tuned-grid type, the high-frequency choke and coupling condenser of each stage being screened separately from the coils, as the illustration shows. A step-up ratio of 1 : 3 is used in the first stage, followed by 1 : 2 in the stage feeding the power detector; with this arrangement the overall gain of the two stages is about 15,000 times.

To prevent feed-back from the detector anode, often the "lifest" point in the set, the valve and the low-pass filter in its anode circuit are completely enclosed in a cylindrical screening box. A Ferranti AF5c transformer follows the detector, the push-pull output stage consisting of two indirectly heated valves yielding between them an A.C. output of at least 3,000 milliwatts. By this means good output is obtained even when, as on D.C. mains, the anode voltage is restricted to about 200 volts.

A novel feature of this receiver is its adaptability to either A.C. or D.C. mains by simple interchange of power-supply units. The same valves are used in both cases, the heaters being connected in parallel for A.C. and in series, with a quarter-ampere diverter resistance in parallel with each, for D.C. mains. The necessary change in connections is made automatically on plugging in the distributor-strip attached to each power unit. In both A.C. and D.C. power units care is taken to exclude high-frequency disturbances propagated along the supply mains; in the former case an earthed shield is provided between the primary and the other windings of the transformer, while in

the second case a high-frequency filter is placed in series with the supply.

Of less ambitious receivers the "Amplion Six" is worthy of special mention, both as being extraordinarily good value for money and as being one of the few receivers incorporating the new "variable-mu" valves as a safeguard against cross-modulation. These valves, in which an increase in grid-bias produces only a slow downward drift of anode current instead of the usual fairly sharp cut-off, are almost incapable of anode-bend rectification, so that cross-modulation can occur only in the most unfavourable circumstances. Since in the Amplion Six receiver a band-pass input filter is used, the chance of this fault making its appearance may fairly be regarded as remote.

This set, with its two high-frequency

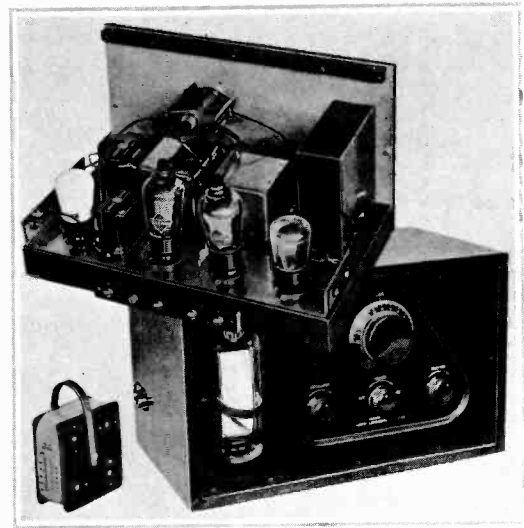

*McMichael Short-wave Superheterodyne. The coil-box, which contains coils for all ranges, is a novel and very convenient arrangement.*

stages, detector, and push-pull output valves (the sixth is the rectifier) is offered, complete with built-in moving-coil speaker and requiring no additions but an aerial, a power-socket, and a licence, for the price of twenty guineas. Such value as this—and there are some other equally reasonably priced sets available—should go some way, especially in the present depreciated state

of the pound sterling, towards meeting American competition.

In short-wave reception the "Eddystone" range remains the most comprehensive. In addition to their many special short-wave components they are offering several receivers built along more or less standard lines. A short-wave superheterodyne receiver, which covers also the medium-waveband, is offered by Messrs. McMichael; this is illustrated in an accompanying photograph.

A triode is used as autodyne frequency-changer, followed by a screen-grid intermediate stage and a reacting screen-grid second detector, this being coupled by a transformer to the output valve. Coils for all wavelengths are carried in a single coil-box, range-changing being effected by removing the box from its socket and replacing it so that the calibration chart for the wave-range required is visible from the front. One would, perhaps, hesitate to recommend this set for quality reproduction, but as a "station-getter" it probably makes the very utmost

A short-wave frequency-changer, for use in front of a broadcast receiver covering only the usual wavebands, is shown by the Radio Gramophone Development Company.

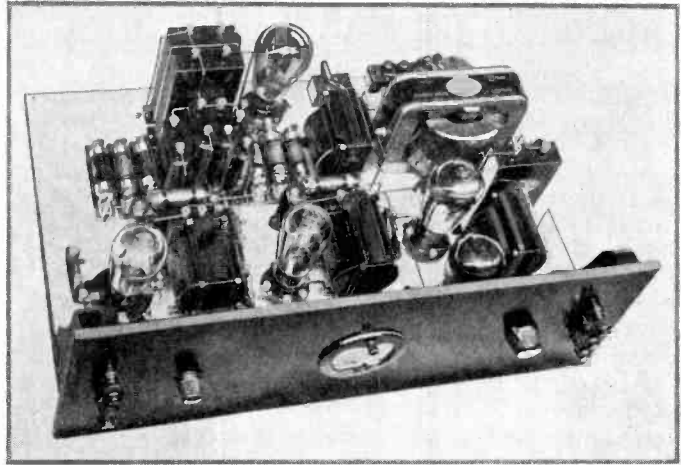

*Ferranti speech amplifier for A.C. mains. A shunt-fed transformer with a resistance across its secondary enables the response curve to be a dead straight line.*

Some receivers intended for special purposes are shown by Messrs. Smurthwaite. One of these, designed for use in a hospital, is shown in an accompanying illustration. Its

internal elaboration is a natural result of its external simplicity, which is an essential feature in a set which has to be handled by any one of a hundred unskilled people. On the right is the main "On-Off" switch, while the horizontal lever switch changes over from one pair of tuning condensers to another to provide programmes from National and Regional transmitters at will; no tuning or reaction adjustments are needed. The volume control above this switch operates a differential condenser in the aerial circuit, so changing the volume given by the set as a whole. When the desired signal-strength for the loud speakers

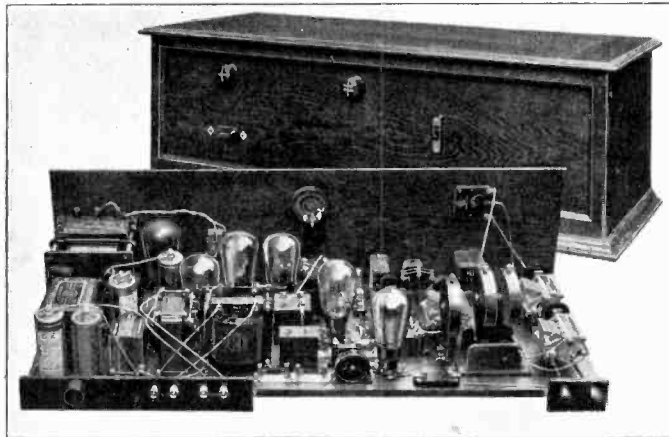

*A hospital receiver by Smurthwaite. Permanently tuned to two stations, with switch-over and volume controls. Practically fool-proof.*

use of its four valves. For short-wave work, especially in out-of-the-way places, this is usually exactly what is required.

is attained the second volume control is used to vary the output to the head telephones, the many pairs of which are fed from a separate

output stage. We were informed that only one precaution was necessary to ensure that such a set as this would give prolonged trouble-free service—and that is, to lock the lid.

Other receivers built for unusual purposes were also shown by this firm, which specialises in turning out sets individually designed to meet particular circumstances.

#### Ferranti Speech Amplifiers.

Speech amplifiers for both A.C. and D.C. mains were seen on the Ferranti stand; the A.C. model is shown in an accompanying photograph. The overall response curve of this amplifier would normally be described as a dead straight line over the whole musical range, but with true Ferranti caution we were duly warned of a two-per-cent. deviation. The small drop in the extreme bass which is usually associated with transformer-coupling has been compensated in this amplifier by a slight hump produced by resistance feeding the first transformer, an AF7, through a 0.2 mfd. condenser. At the same time the slight rise at the highest frequencies has been counteracted by shunting the secondary with a resistance of 125,000 ohms. If the extra "top" is required, as, for example, after a wireless receiver, this resistance can readily be disconnected. The output stage consists of two LS5a valves in push-pull. Two decouplers are used in series in the anode-lead to the first valve, while the second valve, which has no coupling resistance in its anode circuit, has three. The result of these very complete precautions is to be found in the total absence of hum rather than in freedom from motor-boating, which could have been assured by less elaborate means.

A wide selection of speech amplifiers for public address and talkie work was seen on the stand of Messrs. Partridge and Mee, who specialise in these instruments. The one chosen for illustration is of moderate size, dissipating 50 watts in the output stage. It has a high gain, and can be run direct from a photo-cell, less than 20 millivolts input (R.M.S.) being needed to load up the last valves. The parts shown in the illustration are normally hidden under a metallic cover, while the valves sit on small shelves on the front of the amplifier, being protected from accidental damage by stout metal wings on either side of them.

Another interesting product of the same firm is also illustrated; it consists of a high-voltage transformer for test-work. Designed to deliver up to 100 milliamps. at 25,000 volts, it has a secondary wound on air-spaced bakelite bobbins, and should prove an interesting instrument to those whose work lies in the direction of such high voltages. An idea of the size of the transformer can be had by comparison with the small wireless instrument beside it.

In components of more immediate wireless interest it was noticed that even the most recent technical improvements were well in evidence. Mixed filters, for instance, were offered on several stands. Permanent magnet speakers of moving-coil type were both

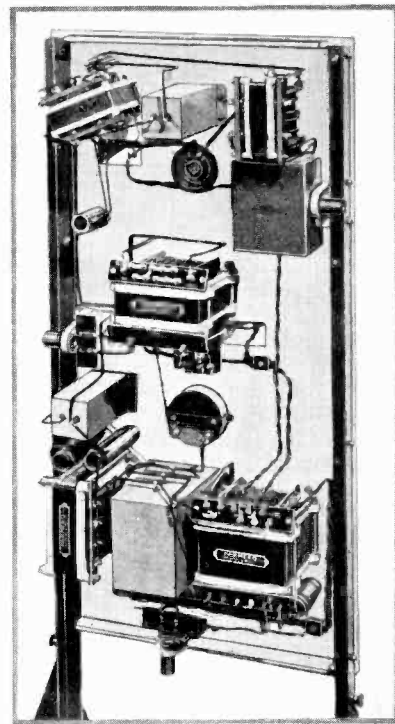

*Parmeko high-gain speech amplifier, for public address work. Components seen are normally covered, and the valves are instantly accessible on the other side of the upright "base."*

better and cheaper than last year. A novelty so far as this country is concerned was the electrostatic loud speaker offered by the Primus Manufacturing Company. This is of

unconventional design, the usual large single diaphragm of stretched metal being replaced by a limp diaphragm made self supporting by corrugations. The diagram of Fig. 5

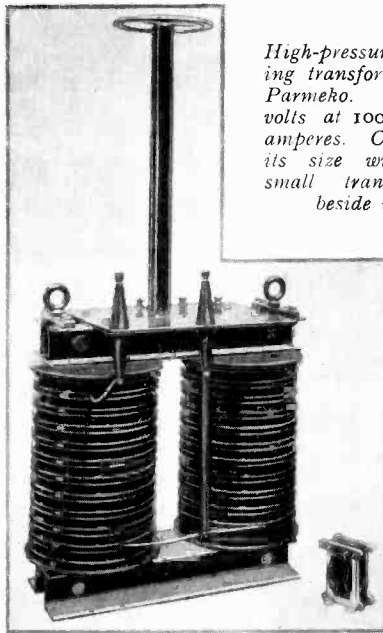

*High-pressure testing transformer by Parmeko. 25,000 volts at 100 milliamperes. Compare its size with the small transformer beside it.*

explains its construction better than words could do, but it must be remembered that each of the little cells extends downwards (through the paper as one looks at the diagram) for a distance of over a foot in even the smallest speaker. In effect, the speaker is made up of several score of small speakers, each a foot or more long and perhaps half an inch wide.

The speaker is described as requiring no polarising voltage; actually it is so connected that the anode voltage of the output valve is used to polarise it. Two sizes of the speaker are made, each being designed to work most efficiently with the anode voltage for which it is built; higher polarising voltages do not, we were informed, increase the sensitivity.

Listening to a violin solo, we were rewarded with the most perfect string tone, even on the highest notes, that we remember to have heard from any reproducing instrument at any time. But we are inclined to suspect, from listening to speech, that the bass would be very poorly represented. We think it

possible that a combination of this speaker with one of moving-coil type might be persuaded, with the aid of suitable filters, to provide reproduction of considerably higher standard than most of us have yet heard.

In the matter of valves, it is probable that the new two-volt Mazda pentodes, the Pen 220 and Pen 220 A, represent the greatest achievement of the year. These two valves have been designed to provide the highest attainable efficiency in the conversion of the D.C. power supplied from the anode battery into undistorted A.C. power. The success of the effort made may be judged from the fact that between forty and fifty per cent. of the anode-circuit power is so available, as compared with only 22 per cent. in the same makers' Pen 230 of a year ago.

The Mazda range of 0.1 amp. indirectly heated valves for D.C. mains, together with the AC2/HL, a valve combining an A.C. resistance of 11,500 ohms with a slope of 6.5, and the AC/S2, a screen-grid valve with a slope of 5, make up a notable list of newcomers.

The Mullard MM4V and the Marconi-Osram VMS4 are both valves of the "variable- $\mu$ " type; they are intended for sets using control-grid bias as volume control, and provide immunity from cross-modulation as already mentioned in connection with the Amplion Six receiver. Another valve designed to avoid this trouble is the Cossor MS/Pen-A, a screened pentode

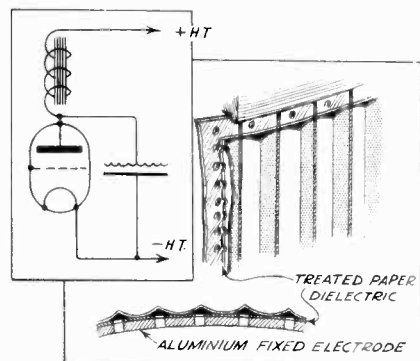

*Fig. 5.—The treated paper dielectric is waxed tissue, coated on the side away from the fixed electrode with a thin conducting film of metal.*

of low residual anode-grid capacity. This latter valve should also find application as a

power grid-detector, since the feed-back into its grid-circuit through the residual capacity is negligible in comparison with grid-current damping. The same maker's mains output valves, 41MP and 41MXP, are notable for the highest slope of the Exhibition—7.5 milliamps. per volt. An unexpected result of this high slope is the fact that the MXP and the MP/Pen (output pentode) require the same grid-swing and give, within a trifle, the same output in response to it. The choice between pentode and triode here narrows itself down to a choice between a

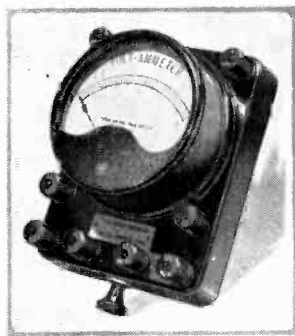

*Park Royal voltmeter. A six-range instrument of wide application and first-grade accuracy.*

valve tending to give a constant-voltage output and one tending to give a constant-current output; in sensitivity there is nothing to choose between them.

A mercury-vapour rectifier capable of dealing with as much as 3 amperes at 10,000 volts R.M.S. was seen on the Mazda stand; those with less exalted ambitions can also find smaller ones by the same makers. A grid-glow relay tube, known as the "thyatron," was also on view.

The Park Royal Engineering Company and Messrs. Ferranti were the chief exhibitors of instruments. The former firm offers a very complete range of instruments in sizes from 1½ in. diameter upwards. The smallest instruments are by no means toys; as voltmeters they have a resistance of 1000 ohms per volt, and they are all accurate to 2 per cent., which means, in practice, that readings are actually correct within the limits set by the uncertainties of so small a scale. The movement is of the moving-coil type, and though the instruments are normally dead-beat, they can be supplied altered for use as "kickmeters" if they are required to show up distortion in the output stage of an amplifier.

In the larger sizes, 2 in., 2½ in., and 3½ in., all moving-coil meters conform with the B.S. specification for first-grade instruments, and they may be had, as voltmeters, with resistances up to 1000 ohms per volt. In the two-inch size, the lowest standard current-range is 1 milliamp., but the 2½ in. instrument may be had as a microammeter requiring 200 microamps. for full-scale deflection. In addition to single-range instruments there are offered several multi-range voltmeters; one of these is illustrated. Ohmmeters in which voltage variations of the dry cell are compensated by a magnetic shunt are also to be had.

Moving-iron instruments of correspondingly high grade are made in all but the smallest size, a feature of these being their low current consumption. As voltmeters, they draw only 4½ mA. for full deflection. Both these and the moving-coil instruments are fitted with the "Pivaspring" device, which leaves a small clearance for the pivots under normal working conditions, but allows the jewels to give freely if the meter is dropped or roughly handled. The combination of this with the unusual feature that a momentary overload of 1000 per cent. will neither harm the suspension nor bend the pointer makes the Park Royal instruments especially suitable for laboratory use,

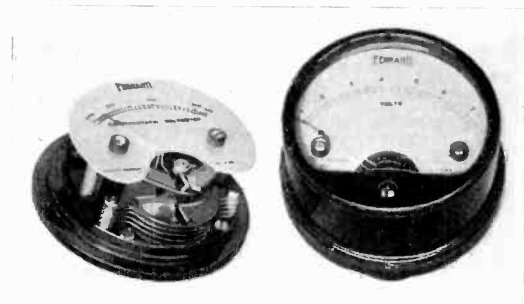

*Ferranti electrostatic and moving-iron voltmeters. Note the particularly open scale of the latter, and the double-ended moving vanes of the former.*

where, with the best will in the world, accidents do occasionally happen.

The Ferranti instruments have been discussed at length in this review in past years, but, besides one or two newcomers, there are some extremely useful instruments that are hardly so well known as they deserve to be.

One of these is the electrostatic voltmeter, available in ranges from 450 volts upwards; the interior economy of the 450-volt instrument is illustrated. The capacity of this meter, at full deflection, is only 30 micro-microfarads; in the higher ranges the capacity is naturally less. The use of the double-ended moving vane is an unusual

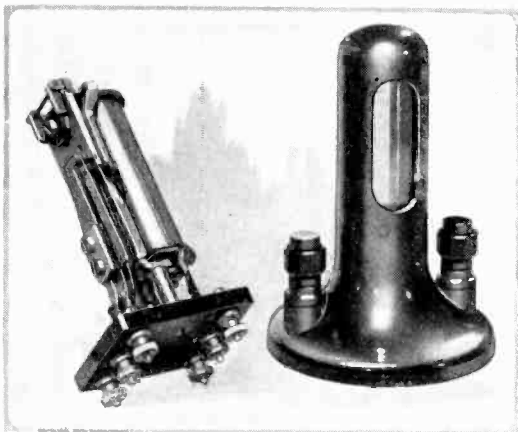

*Raycraft selenium cell and relay (Audiovisors). With the addition of a valve these form a complete light-operated switch.*

feature, and makes not only for good balance but for prolonged retention of calibration. The pointer is balanced by a small damping-vane moving in the field of two small permanent magnets (not shown in the photograph). A small but interesting point of detail is the positioning of the screws holding down the scale; these are on the same line as the main supports, so that when the scale is attached there is no chance of damaging the pivots.

The  $2\frac{1}{2}$ -inch moving-iron instrument of the same makers is also illustrated; it conforms with the B.S.S. standard of accuracy for first-grade moving-iron instruments, and has a consumption of only 0.23 w. As a voltmeter, its resistance is 210 ohms per volt. In all models complete screening against external magnetic fields is embodied internally, the outer case being of bakelite to match the moving-coil instruments.

A new addition to the range is an ohmmeter combined with a dual-range voltmeter; this would make a remarkably handy weapon for servicing radio receivers, as well as for many other purposes. The well-

known rectifier instruments can now be had in all ranges down to 750 microamperes.

The Exhibition brought forth a larger crop of novelties this year than last in matters not really within the normal sphere of interest of the wireless engineer; two of these are illustrated. The selenium cell is offered by Messrs. Audiovisor, who provide also a relay intended to be connected in the anode circuit of a valve. The whole then forms a light-operated switch which can be applied in a host of ways.

Several firms were exhibiting apparatus with which the amateur can cut his own gramophone records, while on the Danipad stand was seen a simple synchroniser enabling a gramophone motor to control the speed of a cine-camera or projector, together with a recording apparatus consisting of a microphone, amplifier, and a cutting stylus complete with tracking device. In conjunction with the necessary photographic apparatus and a gramophone, this outfit enables the amateur to prepare and show his own "talkies."

The most complete equipment of this kind was that offered by Messrs. Synchronophone, which consists of a complete radiogramophone containing a film-projector driven through a clutch from the gramophone motor. The whole is contained in a big

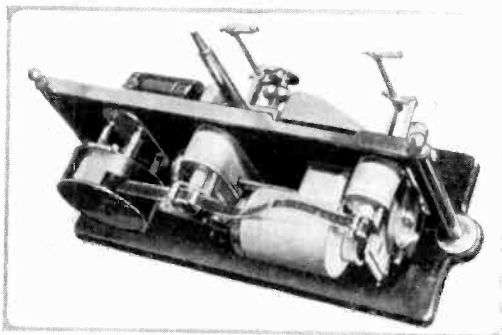

*Gramophone motor and film-projector of Synchronophone home entertainer. The clutch on the right locks the two together when talkies are being projected.*

cabinet, and provides complete home entertainment. Wireless and gramophone music can be had in the usual way, silent films of the 16 mm. size can be projected, and "talkies," except of the "sound-on-film" type, are also within the scope of this most versatile instrument.

A.L.M.S.



# Distortion in Valve Characteristics.\*

By G. S. C. Lucas, A.M.I.E.E.

Engineering Laboratory, The British Thomson-Houston Co., Ltd., Rugby.

THE accepted method of determining the amount of distortion introduced into the plate current of a valve due to the curvature of the valve characteristic is to determine the amplitude of second harmonic in the plate current when a sinusoidal voltage is impressed on the grid. The amplitude is then expressed as a percentage of the amplitude of the fundamental, and so we get :

$$\text{percentage distortion} = \frac{\text{Amplitude of 2nd harmonic current} \times 100 \%}{\text{Amplitude of fundamental current}}$$

It is also usual to calculate the distortion from the following equation :

$$\frac{\frac{1}{2}(I_{\max.} + I_{\min.}) - I_0}{I_{\max.} - I_{\min.}} \times 100 \%$$

Where  $\frac{1}{2}(I_{\max.} + I_{\min.}) - I_0$  is taken as a measure of the amplitude of the second harmonic and  $(I_{\max.} - I_{\min.})$  as a measure of the amplitude of the fundamental.

Now while this equation is perfectly true where only the second harmonic is present in the wave form of the plate current, if other harmonics are present to any pronounced degree very misleading results will be obtained.

When dealing with Pentode and Screen Grid Valves, we find that it is the third harmonic that is the most prominent and that the second harmonic is often quite small—in fact, with a little care in the choice of bias and load it can be almost entirely eliminated. With these valves then, we should express the distortion as the percentage of the second or third harmonic depending upon which is the greater. It would be more correct to define distortion as :—

$$\text{percentage distortion} = \frac{\text{Amplitude of largest harmonic}}{\text{Amplitude of fundamental}} \times 100\%$$

In order to do this it is necessary to have

\* MS. received by the Editor, January, 1931.

a ready means of determining the amplitude of higher harmonics than the second and to determine accurately the amplitude of the fundamental.

The following paper gives a simple arithmetical method (using selected ordinates) for determining the amplitudes of the second, third and fourth harmonics with fair accuracy from the characteristic curve for the valves.

The method only applies to non-inductive loads where the dynamic curves are single lines and not closed loops as with inductive

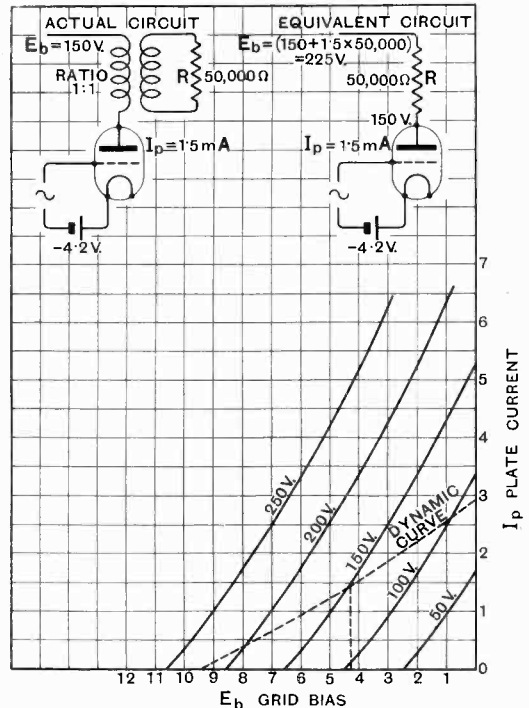

Fig. 1.—Static and dynamic curves for valve with transformer coupling.

or capacitive loads. The dynamic curves for inductive or capacitive loads are seldom used when making calculations of power output or distortion and a non-inductive load is usually assumed.

The term "dynamic" is used here to differentiate between the published static  $I_p - E_g$  curves for a valve and the  $I_p - E_g$  curve for the valve with an anode load. In the case of a choke or transformer-coupled load the dynamic curve can be determined from the  $I_p - E_p$  curve by reading off values of  $I_p$  and  $E_g$  along the load line  $R$  and replotting. (See Figs. 1 and 2.)

The proof of the method can be seen by studying the curves in Fig. 3. If the dynamic curve for the valve and load is a single line, as it is with a resistance load, the harmonics bear a very definite relation to the fundamental, *i.e.*, the even harmonics are always 90 degrees leading or lagging on the fundamental and the odd harmonics are either in phase or 180 degrees out of phase with the fundamental. It will be apparent that if the curve is a single line the shape of the plate current curve from *a* to *b* is the same as from *c* to *b*, and similarly the bottom half of the curve is symmetrical about the vertical axis *dg*. A further study of the curves will show that, for the top half of the plate current curve to be symmetrical about the axis *bf*, and the bottom symmetrical about the axis *dg*, the relation between the fundamental and harmonics must be as stated above. If the dynamic curve is a closed loop, as it is with an inductive or capacitive load, the harmonics may take up any phase relative to the fundamental, but we do not propose to discuss this condition here.

Then, given that the odd harmonics are 90 degrees lagging or leading on the fundamental and the even harmonics in phase or 180 degrees out of phase, and if

- $A$  = amplitude of the D.C. current
- $B$  = max. . . . ., fundamental
- $C$  = max. . . . ., 2nd harmonic
- $D$  = max. . . . ., 3rd
- $E$  = max. . . . ., 4th

When  $\theta = 0$  and 180 the plate current =  
 $I_0 = A \pm C \pm E \dots \dots \dots (1)$

When  $\theta = 90$  plate current =  
 $I_{max.} = A + B \mp C \pm D \pm E \dots \dots (2)$

When  $\theta = 270$  plate current =  
 $I_{min.} = A - B \mp C \mp D \pm E \dots (3)$

When  $\theta = 45 + 135$  plate current =  
 $I_2 = A + .7B \mp .7D \mp E \dots (4)$

When  $\theta = 224$  and 315 plate current =  
 $I_3 = A - .7B \pm .7D \mp E \dots (5)$

From these five equations solve for  $A$ ,  $B$ ,  $C$ ,  $D$  and  $E$  and

$$A = \frac{\frac{1}{2}(I_{max.} + I_{min.}) + I_0 + I_2 + I_3}{4} \dots (6)$$

$$B = \frac{1}{4}\sqrt{2}(I_2 - I_3) + \frac{1}{4}(I_{max.} - I_{min.}) \dots (7)$$

$$C = A + E - I_0 \dots \dots \dots (8)$$

$$D = \frac{I_{max.} - I_{min.} - 2B}{2} \dots \dots \dots (9)$$

$$E = \frac{2A - I_2 - I_3}{2} \dots \dots \dots (10)$$

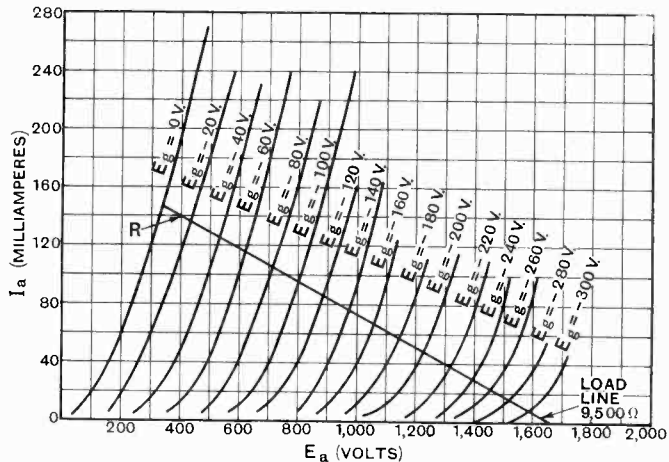

Fig. 2.—Anode current—anode voltage characteristic curve of the Mazda TV. 845 valve.

Having found the values of  $A$ ,  $B$ ,  $C$ ,  $D$  and  $E$  the harmonics can be expressed as percentages of the fundamental as follows:

- Percentage second harmonic =  $\frac{C}{B} \times 100 \%$
- .. third .. =  $\frac{D}{B} \times 100 \%$
- .. fourth .. =  $\frac{E}{B} \times 100 \%$

We have, therefore, only to read off the values of  $I_0$ ,  $I_{max.}$ ,  $I_2$  and  $I_3$  and substitute

them in the equations given above to find the amplitudes of the harmonics. The plate currents for  $I_2$  and  $I_3$  are read off at  $\pm \sqrt{\frac{I}{2}}$

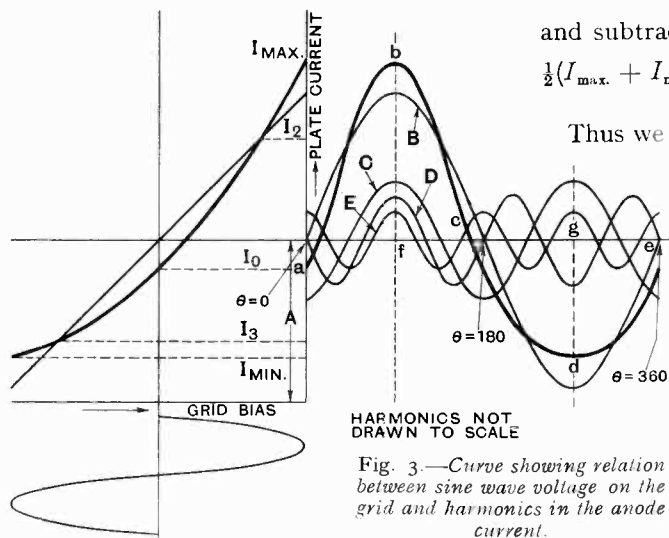

Fig. 3.—Curve showing relation between sine wave voltage on the grid and harmonics in the anode current.

of the max. grid swing measured from the bias and not at .5 of the maximum swing as might be thought at first glance.

**Proof of Equation for 2nd Harmonic.**

Assuming that the characteristic is such that only a second harmonic is introduced into the plate current when a sinusoidal voltage is impressed on the grid, and that the curve is a single line and not a closed loop, referring to Fig. 3, it will be seen that

When  $\theta = 0$  the plate current  
 $= I_0 = A \pm C \dots (1)$

When  $\theta = 90$  the plate current  
 $= I_{max.} = A + B \mp C \dots (2)$

When  $\theta = 180$  plate current  
 $= I_{min.} = A - B \mp C \dots (3)$

Where  $A$  = amplitude of D.C. current

$B$  = max. amplitude of fundamental

$C$  = max. amplitude of 2nd harmonic.

Subtracting 2 and 3 we get

$$I_{max.} - I_{min.} = 2B = 2 \times \text{amplitude of fundamental.}$$

Adding 2 and 3 we get

$$I_{max.} + I_{min.} = 2A \mp 2C$$

$$\frac{I_{max.} + I_{min.}}{2} = A \mp C \dots (4)$$

and subtracting (4) and (1)

$$\frac{1}{2}(I_{max.} + I_{min.}) - I_0 = (A \mp C) - (A \pm C) = \mp 2C.$$

Thus we get :

$$\frac{\frac{1}{2}(I_{max.} - I_{min.}) - I_0}{(I_{max.} - I_{min.})} = \mp \frac{C}{B}$$

Example for Triode Valve.

Reading from the curve in Fig. 4

- $I_{max.} = 14.3 \text{ mA.}$
- $I_2 = 10 \text{ mA.}$
- $I_0 = 3.75 \text{ mA.}$
- $I_3 = 1 \text{ mA.}$
- $I_{min.} = .5 \text{ mA.}$

Amplitude of D.C. current =

$$A = \frac{\frac{1}{2}(I_{max.} + I_{min.}) + I_0 + I_2 + I_3}{4} = \frac{7.35 + 14.75}{4} = 5.5 \text{ mA.}$$

Max. amplitude of fundamental =

$$B = \frac{1}{4}\sqrt{2}(I_2 - I_3) + \frac{1}{4}(I_{max.} - I_{min.}) = \frac{\sqrt{2} \times 9}{4} + \frac{13.8}{4} = 6.6 \text{ mA.}$$

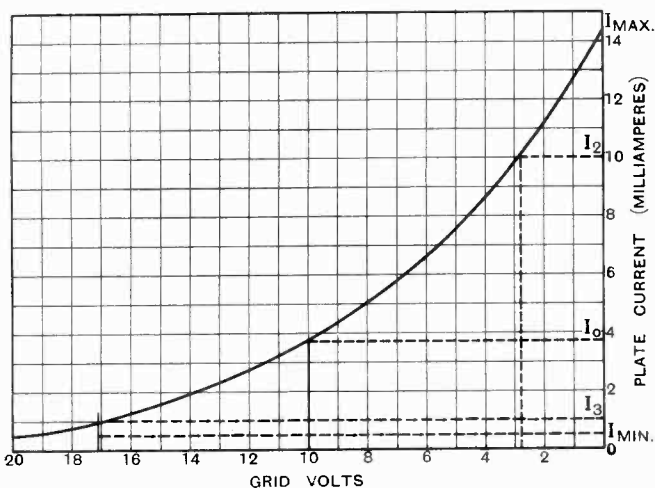

Fig. 4.—Dynamic characteristic for triode.

Max. amplitude of 3rd harmonic

$$D = \frac{I_{\max.} - I_{\min.} - 2B}{2} = \frac{13.8 - 13.2}{2} = .3 \text{ mA.}$$

Max. amplitude of 4th harmonic

$$E = \frac{2A - I_2 - I_3}{2} = \frac{11 - 11}{2} = 0 \text{ mA.}$$

Max. amplitude of 2nd harmonic

$$C = A + E - I_0 = 5.5 - 3.75 = 1.75 \text{ mA.}$$

On expressing these as a percentage, we get :

Percentage 2nd harmonic =  $\frac{1.75}{6.6} \times 100 = 25\%$

„ 3rd „ =  $\frac{.3}{6.6} \times 100 = 4.5\%$

„ 4th „ = 0

Example for Pentode or S.G. Characteristic.

Reading from Fig. 5

$I_{\max.} = 12.5 \text{ mA.}$

$I_2 = 12 \text{ mA.}$

$I_0 = 6.0 \text{ mA.}$

$I_3 = .7 \text{ mA.}$

$I_{\min.} = .5 \text{ mA.}$

Then amplitude of the D.C. circuit

$$A = \frac{\frac{1}{2}(I_{\max.} + I_{\min.}) + I_0 + I_2 + I_3}{4} = \frac{7 + 18.7}{4} = 6.4 \text{ mA.}$$

Max. amplitude of fundamental =

$$B = \frac{1}{4}\{\sqrt{2}(I_2 - I_3) + (I_{\max.} - I_{\min.})\} = \frac{15.82 + 12}{4} = 6.95 \text{ mA.}$$

Max. amplitude of 3rd harmonic =

$$D = I_{\max.} - I_{\min.} - 2B = 12 - 13.9 = -1.9 \text{ mA.}$$

NOTE.—The negative sign only denotes a difference in phase, but it must be retained when substituted in other equations.

Max. amplitude of 4th harmonic

$$E = \frac{2A - I_2 - I_3}{2} = \frac{12.8 - 12.7}{2} = .05 \text{ mA.}$$

Max. amplitude of 2nd harmonic

$$C = A + E - I_0 = 6.4 + .05 - 6 = .45 \text{ mA.}$$

and expressing the harmonics as a percentage of the fundamental we get

Percentage 2nd harmonic =  $\frac{.45}{6.95} \times 100\% = 6.5\%$

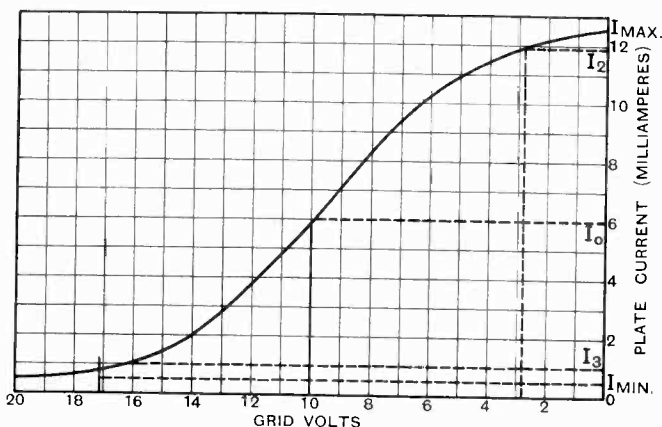

Fig. 5.—Dynamic characteristic for pentode.

3rd harmonic =  $\frac{1.9}{6.95} \times 100\% = 27\%$

4th „ =  $\frac{.15}{6.95} \times 100\% = 2.1\%$

# Correspondence.

Letters of interest to experimenters are always welcome. In publishing such communications the Editors do not necessarily endorse any technical or general statements which they may contain.

## Transients and Telephony.

To the Editor, *The Wireless Engineer*.

SIR,—With reference to a letter from Dr. N. W. McLachlan in your October number which criticises an article "Transients and Telephony," which appeared in the previous number, I beg leave to state in reply:—

(1) My article was sent to the Editor on 5th December, 1930, so that I was not then aware of the existence of the paper by Mr. Oatley published in your journal in May, 1931, and the paper by Dr. McLachlan which appeared in *Phil. Mag.*, January, 1931.

(2) I did not refer to Dr. McLachlan's experiments on the reproduction of square-topped impulses which were described in the *Wireless World* in 1929 because a square-topped impulse is an inaccurate representation of an acoustic pressure pulse. The square-topped impulse consists of:—

- (a) an instantaneous rise of pressure,
- (b) an interval during which the pressure remains steady,
- (c) an instantaneous fall of pressure.

Instantaneous pressure changes do not occur in air waves and if the excess steady pressure could be produced in an air wave it would not be heard because the sensation of sound is only produced by varying pressures. The transient  $t^ne^{-kt}$  I used in my analysis takes a finite time  $k/n$  second to rise to its maximum value. It is of interest to note that Dr. McLachlan does not refer in his articles to some previous work on amplifier distortion by I. B. Crandall which used the same method. This was published in the *Bell System Technical Journal* for October, 1925.

(3) I used the phrase "ideal form" because I consider that an ideal cone loud speaker would not depend on chance resonances of uncertain magnitude for its high frequency response, but would be a rigid piston with any variation with frequency of the acoustic output compensated for by a suitably designed amplifier. Furthermore, it appears to be a debatable point whether the subsidiary resonances discovered by Dr. McLachlan are due to cone resonance or room resonance (see Discussion on "Loud Speakers in Vacuo" by P. K. Turner, *Journal Inst. Electrical Engineers*, May, 1931, p. 620.)

T. S. E. THOMAS.

## Percentage Harmonic Distortion.

To the Editor, *The Wireless Engineer*.

SIR,—Mr. W. Greenwood's contribution in your August Correspondence on the subject of Percentage Harmonic Distortion contains, I believe, some very misleading statements. It would appear from his analysis that the "9:11 scale method"

is not applicable to the case of a choke-fed output stage, and that the use of such a scale would lead to too low a value for the distortionless output power. Such a conclusion is definitely incorrect, and it is interesting to see where the error lies.

Using Mr. Greenwood's notation, let Fig. 1 represent part of an  $i_a - v_a$  diagram for a typical triode. Let  $O$  be the operating point and  $POQ$  the path corresponding to a certain grid swing. The quantities plotted are "instantaneous values" and the representation of the load by a straight line implies that this load is resistive and constant for all frequencies; otherwise the term "instantaneous value" would require qualification. It is not easy to extend the scope of this diagram to cover generally the case of a load resistance which varies with frequency, but in the ideal case considered by Mr. Greenwood the variation is of a simple enough character to allow it to be done; in this ideal case the load resistance is constant ( $= R$ ) for all frequencies other than zero and has a different value ( $R_c$ ) for zero frequency.

For the "series" case we notice that the path  $POQ$  is symmetrical not about  $O$ , but about the point  $O_1$  on the  $P$  side of  $O$ : the difference between the currents corresponding  $O_1$  and  $O$  is the "detected" current, or change of feed current, due to characteristic curvature.

For the "choke" case, draw another load line corresponding to the choke resistance  $R_c$  through the operating point  $O$ ; the change of feed current formerly represented by the displacement  $OO_1$  must now be layed off along the new load line;

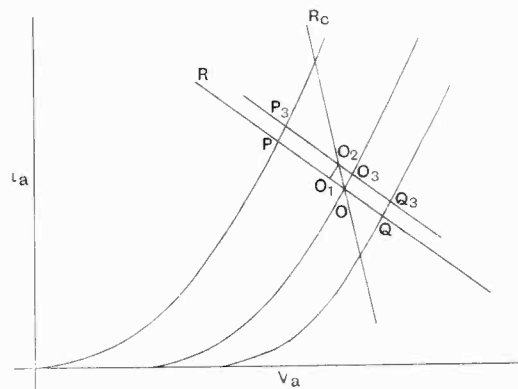

it is in fact the displacement  $OO_2$ , the point  $O_2$  lying on a line through  $O_1$  parallel to the characteristic at  $O$ . Through  $O_2$  draw a parallel to  $POQ$  cutting the extreme characteristics in  $P_3Q_3$ . Then  $P_3O_2Q_3$  is the actual working path.

Let the characteristic through  $O$  cut this path at  $O_3$ . Then the path  $P_3O_3Q_3$  is the new working

path which corresponds point by point to the old path  $POQ$ . For purposes of distortion calculation the current differences must be reckoned from  $O_a$ , not from  $O$ , as done by Mr. Greenwood. But this proper reckoning is, to a close approximation, identical with the standard method and the latter is, therefore, valid without modification.

There is, however, another method of estimating second harmonic distortion in which Mr. Greenwood's analysis is very much to the point, that is in the estimation of second harmonic by change of feed current. In this method it is important to allow for the fact that the detected current is subject to the reduced load resistance  $R_c$  whilst the harmonic current is subject to the full load  $R$ . This does not mean that choke feed allows an increased output, but only that the estimation of harmonic by change of feed current has to be handled carefully. For use with this method one may conveniently record the formulae:—

$$\text{" Series Case " } K = \delta I / g_a V.$$

$$\text{" Choke Case " } K = \delta I / g_s V$$

in which

$K$  is the ratio of second harmonic to fundamental  
 $\delta I$  is the change of feed current.

$V$  is the A.C. grid voltage (peak).

$g_a$  is the dynamic mutual conductance } at the opera-  
 $g_s$  is the static mutual conductance } ting point,

the last two quantities being defined as  $\frac{\delta i_a}{\delta v_g}$  with  
 normal and short circuited load respectively.

L. H. BEDFORD.

Research Department,  
 A. C. Cossor, Ltd.

### Mutual Demodulation and Allied Problems.

To the Editor, *The Wireless Engineer*.

SIR,—I must apologise for this somewhat belated letter in connection with the Editorial in your August number. In this connection I would point out what appears to be an error in Fig. 3 (c). The idea, which is perfectly legitimate, is that due to the difference in phase angle of the circle at the carrier frequency and the two sideband frequencies, the sideband frequencies will be changed in phase by an angle approaching  $90^\circ$ , while the carrier will have zero angle—relatively at any rate.

In Fig. 3 (c) the wanted sidebands are both shown as being changed in the same direction, whereas they are in fact changed in phase in opposite directions due to the fact that the angle of the circuit is positive for frequencies above the resonant frequency, and negative for frequencies below. The disposition of the sideband about the carrier for a truly symmetrical circuit must be symmetrical, otherwise distortion will result.

This error seems to have had its effect in the mathematics following, which effect will be quite clear when the error in the diagram is realised. It is nevertheless extremely interesting to find people using this method of illustrating carriers and sidebands, as it is one which we have used for some considerable time, particularly in connection with the illustration of distortion problems connected with working several stations on a common frequency.

An interesting point in connection with this phase shift (*i.e.*, symmetrical) of sidebands is that the envelope phase will shift by the same angle as the sidebands. One might be excused for thinking that the retardation or advancement would be the same in time.

H. L. KIRKE.

[We are much indebted to Mr. Kirke for pointing out the error in Fig. 3 (c). The same error has crept into Fig. 3 (d). The mistake was not due, as Mr. Kirke suspects, to the neglect of the opposite phase shift for frequencies above and below resonance, but to setting out the lag or lead in the directions indicated by the arrows in Figs 3 (a) and (b). This is, of course, wrong, since, although these arrows show the slow rotations of the vectors relatively to the carrier, all the vectors are rotating rapidly in the anti-clockwise direction and all angles of lag and lead should be set out with reference to this direction. The four vectors on the right-hand side of Fig. 3, that is, the four which revolve clockwise, should be drawn from right to left and not from left to right. The directions of rotation are correct as shown.]

As Mr. Kirke rightly points out, this will modify the formulae for  $A$  and  $B$ , which should be as follows:

$$A = \sin \theta + 2 \sin \frac{\theta}{4} + \frac{4}{3} \sin \frac{3\theta}{4} + \frac{2}{5} \sin \frac{5\theta}{4}$$

$$B = 2 \cos \frac{\theta}{4} + \frac{4}{3} \cos \frac{3\theta}{4} + \frac{2}{5} \cos \frac{5\theta}{4} \text{—[E.D.]}$$

### The Variation of the Resistances and Inter-Electrode Capacities of Thermionic Valves with Frequency.

To the Editor, *The Wireless Engineer*.

SIR,—I am much interested in Mr. Benham's letter in your September issue on the question of valve capacities and frequency. I, of course, recognise that my article deals only with the effects of the presence of the space charge, and that no account is taken of possible effects due to the inertia of the electrons. At first sight it seems as though such effects must be negligible except at very high frequencies, such as those of the Barkhausen and Kurz oscillations, and Mr. Benham's estimate of the magnitude is indeed surprising.

As regards the interpretation of my equations, I must confess that I have not been able to follow Mr. Benham. On my argument, the electrostatic energy stored could only be diminished by a diminution of the dielectric constant  $\epsilon$ , but Mr. Benham specifically states that this should be considered as unity. From my point of view it seems more natural to consider the effect of the inertia of the electrons to be represented by an inductance which would not diminish the electrostatic energy stored but merely alter the phase of the total current with respect to the voltage. However, as was emphasised in my article, the application of the fundamental definitions of simple theory to more complicated systems is a matter of convention, and I suspect that on this point Mr. Benham's argument implies a convention different from mine.

The estimated effects of the inertia of the electrons are so striking that I would suggest to Mr. Benham that if he could give a simple treatment of this problem he would perform a very useful service. His *Phil. Mag.* paper is a sealed book to many who are very interested in the matter.

Finally, it becomes increasingly evident that the experimental side of the subject has not yet been adequately treated, and I look forward with interest to further experimental developments.

L. HARTSHORN.

The National Physical Laboratory,  
Teddington.

To the Editor, *The Wireless Engineer.*

SIR,—Further to my note in your September issue, I feel that a further discussion of the ratio  $C/C_1$  ( $C$  = "hot" capacity,  $C_1$  = "cold" capacity) may be of interest to your readers and to Dr. Hartshorn.

As so rightly pointed out by Dr. Hartshorn, the fundamental concept of "capacity," namely, charge divided by potential, is no longer applicable to a condenser whose dielectric consists of electrons in motion. We may, therefore, write, as an inequality,

$$Q \neq \bar{C} \times V$$

But the displacement current will still be given by  $\frac{dQ}{dt}$ , hence

$$\frac{dQ}{dt} \neq \bar{C} \frac{dV}{dt}$$

Thus the second term of equation (2) of Dr. Hartshorn's paper does not represent the displacement current. It follows that  $\frac{1}{2}\bar{C}V^2$  (equation 3) does not represent the energy stored per half-cycle. [N.B.—In my first letter I stated that this should be *quarter* cycle. "Quarter" is correct if  $V$  is purely sinusoidal, as one is led to believe in the earlier part of Dr. Hartshorn's paper. "Half" is, however, quite correct if  $V$  is of the type  $V_1 + v_1 \sin pt$ , which he afterwards uses.] It is not easy for those accustomed to treat of condensers to appreciate the possibility that the energy stored may, in special circumstances, differ from the universally known value. It is, however, well known that the formula  $W_0 = \frac{1}{2}CV^2$  is dependent on the truth of the identity  $Q = CV$ . If this identity

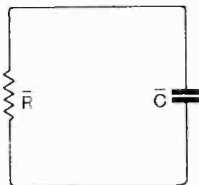

Fig. 1

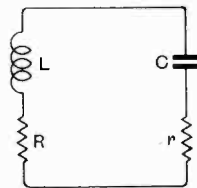

Fig. 2.

should happen to break down in certain cases, then the energy stored can no longer be given by  $\frac{1}{2}CV^2$ . In order to see why  $Q \neq CV$  in the case under consideration consider the circuit shown in Fig. 2. The inductance  $L$  represents the inertial

effect of the electrons, by no means negligible when the effective capacity of the system is at stake, even at low frequencies. The resistance  $R$  is the anode slope resistance (low frequencies only) while  $r$  is of negligible importance at low frequencies. Now if the diode is represented by

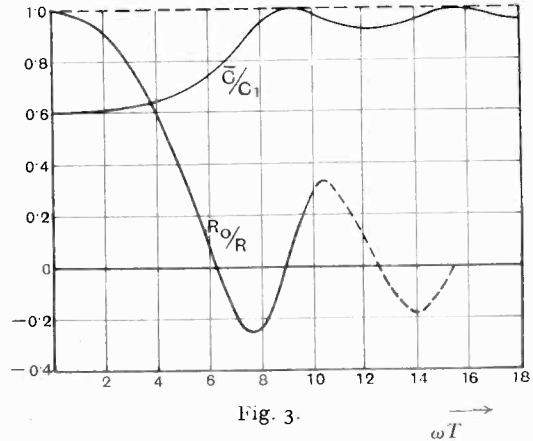

Fig. 3.

the equivalent circuit of Fig. 2,  $C$  has the value  $\frac{4}{3}C_1$ , and does, in fact, satisfy the identity  $Q = CV$ . If, however, we want the *effective* capacity  $\bar{C}$  (Fig. 1) analysis shows

$$\bar{C} = C - \frac{L}{R^2} \quad \dots \quad (1)$$

$$= \left( \frac{4}{3} - \frac{11}{15} \right) C_1$$

$$= \frac{3}{5} C_1 \quad \dots \quad (2)$$

The experimental result of Dr. Hartshorn that the electrons *increase* the capacity are adequately explained by the fact that, in the triode case, with grid negative, the input impedance is so high that the second term on the right-hand side of (1) loses its importance. If, however, a diode is used,

even if the impedance  $R$  is very large,  $\frac{L}{R^2}$  will always be an appreciable fraction of  $C$ . Thus if we increase  $R$  in the diode case by moving the plates farther apart,  $C$  will decrease and  $L$  will increase for a given potential difference between anode and cathode. I have been able to confirm that values of  $\bar{C}/C_1$  as low as  $3/5$  are obtainable experimentally. For a full description of these experiments readers are referred to *Phil. Mag.*, February Supplementary No., 1931, pp. 481-489. These results had not appeared when Dr. Hartshorn submitted his paper to this journal. It will be seen that the experiments with triodes confirm Dr. Hartshorn's result that in this case an increase of capacity is recorded.

It is not difficult to show that the "dielectric constant" of space charge for electromagnetic waves has the value  $3/5$ , i.e., is equal to the ratio "hot" to "cold" capacity for a diode system. Inde-

pendent experimental evidence of electron dielectric constant less than unity may be found in a paper by Bergmann and Düring, *Ann. d. Phys.*, 5, 1, 8, p. 1041, 1929. Sven Benner (*Ann. d. Phys.*, 3, vii, p. 993, 1929) gives a theory to account for Bergmann and Düring's results, and confirms that a dielectric constant less than unity is to be expected in the case of high vacuum tubes.

In Fig. 3 the ratios  $\bar{C}/C$ , and  $R_0/R$  appear as functions of  $\omega T$ . The negative conductance exhibited in Fig. 3 is considered to have an important bearing on Barkhausen-Kurz oscillations, the two regions shown corresponding possibly to the "longer" and "shorter" wave ranges of Barkhausen-Kurz oscillations. The conductance curve as a function of  $\omega T$  continues to oscillate about the axis of  $\omega T$  with a small decrement. For  $\omega T$

large the negative maxima are given by

$$\left(-\frac{3}{\omega T} + \frac{6}{\omega^2 T^2}\right)$$

to sufficient accuracy. Thus the negative maximum which occurs at about  $\omega T = 20$  has the value  $-0.135$  approx.

Departures from the curves exhibited on Fig. 3 occur in practice owing to the influence of finite emission velocities of electrons, the effect naturally being greatest at low anode voltages. Electrode shape moreover has a considerable influence, and it should be understood that Fig. 3 applies strictly only to plane structures.

W. E. BENHAM.

London, N.W.4.

## Book Reviews.

### Quartz Resonators and Oscillators.

By P. Vigoureux, M.Sc.

Specialisation is one of the gods of the modern world. The high frequency engineer tends to confine himself to his furrow and pay but cursory attention to the broad acres of the "straight" electrical engineer. The high frequency man is also producing offshoot specialists, and not the least of these will be the quartz specialist. The book under review is a portent.

The available technical literature of the subject is scattered among the periodical publications of the various professional institutions. This constitutes a serious handicap to all workers in this branch of the work.

At long last, this defect is remedied and an authoritative reference is available. The work has been carried out under the aegis of the National Physical Laboratory, and, as may be anticipated, it has been well done. It will undoubtedly be welcomed with open arms.

The scope of the work covers the general physical properties of quartz; the theory, including optical and piezoelectric tests of the quartz; and some practical hints on the technique of production.

The chapter on the theory of the resonator is comprehensive and includes a very useful summary of Dye's classic work and finally, a most admirable statement of current theories of the "space lattice" structure of the quartz.

In common with the rest of us, the author is evidently struck with the elegance of the Giebe Scheibe visual indicator developments. The reproduction of the luminous reactions are beautifully done and are of considerable interest. Fig. 68, for instance, is described as the 3rd overtone; but the physical dimensions, the frequency quoted and the reproduction of the photograph suggests the 6th harmonic.

On the other hand, has not too much space been devoted to a type whose accuracy owing to the defective mounting and method of determination cannot be better than  $1$  in  $10^4$ ? The single exception

is the mounting in Fig. 57a which might give higher precision if other methods of determination than the luminous glow were adopted. It is very doubtful whether this particular crystal would control a circuit. It is a matter for remark that the international check on this crystal did not show closer agreement between the various national standards.

The writer is gratified to note the author's view of the relative accuracies of the resonator and oscillator, but the latter has no hesitation in giving a verdict in favour of the resonator (para. 77).

His reasons for this conclusion agree with another author's (bib. ref. 164). In more than one instance the author assesses the accuracy of the resonator at  $1$  in  $10,000$ . On the other hand, the inferior standard has given us "the most perfect timekeeper hitherto realised," (paras. 57 and 75), and this postulates an accuracy of better than  $1$  in  $10^6$ .

There appears to be a serious lack of agreement between the data submitted and the conclusion at which the author arrives. The conclusions are sound. He has, however, entirely omitted any reference to the previously mentioned paper (bib. ref. 164) which deals with some fundamental principles in the art. The application of these principles raised the standard of accuracy of the resonator from a very doubtful  $1$  in  $10,000$  to an accuracy of the order of  $1$  in  $10^6$ . All the precision oscillators including "the most perfect timekeeper" employ resonators as "drives" embodying the principles laid down in that paper, *i.e.*, nodal support with precautions against humidity and barometric pressure variation.

When one recollects the extensive published material which has its origin in America, that the British contributions of any consequence can be counted on one hand, and that Dye's and the author's researches constitute the most important portion of these latter, one is at a loss to account for the fact that the author has failed (to use the words of the preface) "to review and critically examine" this particular British contribution to the work.

Again, this omission makes the comparison



between the fork driven multivibrator and the quartz oscillator (para. 75, final section) useless, and indeed misleading.

The previously quoted paper describes the application of a precision quartz oscillator to the complete multivibrator which gives the full range of frequencies quoted by the author as being the unique property of the fork driven multivibrator. As a matter of fact, the quartz driven multivibrator has an even greater range of frequencies than that quoted by the author for the fork. The temperature coefficient of the crystals employed vary between 1 and 4 in  $10^6$  as against 10 in  $10^6$  quoted for the fork.

(A typographical error is present in this section. The frequency range should read 1000 cycles per second to 1,300,000, not 10,000 cycles per second.)

This omission materially detracts from the value of the work as a complete reference medium, a function it otherwise performs surprisingly well. In this connection it would be desirable to include Hull and Clapp's work on frequency division by means of controlled relaxation oscillations impulsed harmonically.

Another omission is the failure to discuss the properties of the crystal produced by cutting perpendicularly to the one shown by the author (Fig. 12). This is severally known as the 30°, 150, or the Y cut. It may safely be stated that there are more crystals in use employing this cut than the cut shown by the author. True, the particularly able *résumé* of Lack's work on the low temperature coefficient crystal indicates that this particular cut with its characteristic positive temperature coefficient is used. This somewhat obscure reference to this particular cut is altogether insufficient. A full discussion of the characteristic differences and virtues of the cuts is essential to any work claiming to be comprehensive.

It is suggested that these omissions be rectified in any future revision of the book.

Finally, the writer warmly welcomes this publication and feels confident that it will meet a long felt need both to the producers and users of quartz crystals.

As far as possible, the author's own nomenclature and references have been used.

Published by H.M. Stationery Office. Price 7s. 6d. net.

H. J. L.

### High Frequency Alternating Currents.

By Knox McIlwain and J. G. Brainerd.

Pp. xiii + 510 with 226 figs. John Wiley and Sons, Inc., New York, and Chapman and Hall, Ltd., London, 1931, 30s. net.

This is primarily a book for the mathematical specialist, a good knowledge of the calculus and of differential equations being assumed.

The introductory chapter on H.F. currents contains an exposition of the Fourier series expansion for continuous periodic functions. The various types of distortion in transmitted wave-forms are then systematically defined, and tables of transmitting units are given.

Then follow chapters on Resonance Phenomena and Coupled Circuits, in which it is noted that *selectivity* is defined as "the rate at which the

secondary current decreases with a given change of frequency from the optimum."

The theory of the thermionic valve is next dealt with fully, starting with Richardson's equation. The treatment is singularly complete, and use is made of a special operator, the "square cross bracket" in order to derive complete expressions for the various frequency components of plate current in the general case of an external impedance when a sinusoidal e.m.f. is impressed on the grid. A comprehensive mathematical analysis of the action of the tetrode is given in an appendix.

An interesting chapter on Amplification follows, in which the authors make careful distinction between various types of amplifier. In particular, the difference between resistance and resistance-capacity coupling is well brought out, and the complete analysis of each set forth. In dealing with the maximum possible non-overloaded power output, four cases are clearly distinguished, depending upon specified operating conditions.

Further chapters on Modulation and Detection employ the "square cross bracket" operator alluded to above. Exhaustive tables are given relating to the audio-frequency terms resulting from the demodulation of a carrier and two side-bands, each side-band having two audio-frequency components, and different methods of detection being employed. These tables are surely a monument of mathematical industry, though their practical utility to anyone except those actively prosecuting this line of research may well appear doubtful.

The production of H.F. currents is next considered, and the theory built up from the starting point of the discharging condenser. Different types of oscillator are carefully analysed, and questions of power output and efficiency are fully discussed.

A useful chapter on Electric Wave Filters contains much material relating to a wide field, research in which is being actively prosecuted, especially by the Bell System in America. This is followed by a chapter on Transmission Lines.

The closing part of the book is devoted to the Maxwellian Theory of Electromagnetic Waves, and includes a detailed treatment of current and voltage distribution in a loaded aerial. A chapter on Reflection and Refraction contains a discussion of the "Heaviside" Layer, a nomenclature which it is interesting to find in an American book.

The final chapter on Electro-mechanical Systems deals adequately with the mathematics of free and forced vibrations, and incidentally, contains an interesting digression on the loci of complex numbers.

A valuable feature is the introduction of numerical examples throughout the volume by means of which the student may accustom himself to apply the relative theory to the practical case. The examples have been carefully chosen to illustrate a wide range of current radio practice, and can be confidently recommended to the serious student. It is a moot point whether the value of the work might have been still further enhanced by the inclusion of answers; for the solitary worker, at least, this would have been an advantage.

There is an adequate index.

W. A. B.

## Abstracts and References.

Compiled by the Radio Research Board and reproduced by arrangement with the Department of Scientific and Industrial Research.

### PROPAGATION OF WAVES.

FELDSTÄRKMESSUNGEN DEUTSCHER KURZWELLENSENDER IN ENGLAND: VERGLEICH VON FERNFREQUENZMESSUNGEN ZWISCHEN NEW YORK, LONDON UND BERLIN (Field Strength Measurements in England of German Short-Wave Stations: Comparison of Distant Frequency Measurements made in New York, London and Berlin).—H. Mögel. (*E.N.T.*, Aug., 1931, Vol. 8, pp. 321-330.)

The writer first discusses the skip effect and the occurrence—at certain times—of quite strong field strengths (100  $\mu\text{V}/\text{m}$  and over) in the "dead zones," which has caused, he says, many workers to doubt the existence of skip effect and even of the Heaviside layer. This leads on to a discussion of short-time ["near"] echoes, and T. L. Eckersley's observations on "scattering." Nauen-Geltow results on vertical receiving aerials and the multiple "near echoes" suggest that the possibility of a second layer at heights between 500 and 3000 km. cannot yet be rejected; but as regards the "first near echoes" directional observations indicate the connection between these and the Eckersley scattering phenomena. Thus at Geltow, if it is desired to receive strong signals from the  $7^\circ$  beams from Nauen to N. and S. America, the aerial for reception from America is employed, not an aerial oriented for Nauen.

Measurements of the "first near echo" delay times give a reflection distance about equal to, or a little longer than, the corresponding skip distance, from which it is concluded that the scattering takes place in the "return zone" of the rays lying within the limiting angle between the tangential and the critical ray. The "near echo" field strength resulting from this scattering is greatest close to the transmitter, and gradually decreases till it almost vanishes at a distance of two-thirds of the skip distance: the delay time varies almost in proportion to the skip distance.

Systematic simultaneous tests are in progress at Geltow and Beelitz on echoes from special signals from the various Nauen beam transmitters. These special signals are so short (1/10,000 sec.) that they do not interfere with the ordinary services. In the meantime the writer gives the results of British Post Office field strength measurements (at Dollis Hill) of the sharp beams from Nauen to N. America, S. America, and Japan, and of the two broader reflectorless beams of the Nauen Press service. Except for the longer (30-metre) Press wave, Dollis Hill lies within the skip distance, and the field strengths are only 1.1  $\mu\text{V}/\text{m}$  and under for the sharp beams and about 5  $\mu\text{V}/\text{m}$  for the 15-metre,  $30^\circ$  Press beam, while they reach about 300  $\mu\text{V}/\text{m}$  for the 30-metre,  $30^\circ$  Press beam [direct space wave + scattered wave]. Diagrams 5, 7, 8 and 10 show how these field strengths may be supposed to be produced by the scattering phenomenon. The Nauen bearing, as given at Dollis

Hill by the N. American beam, is nearly N.-S. instead of E.-W. The Japan beam, whose diagram has no minor loops towards England, must presumably be received at Dollis Hill by scattering along the great circle between Nauen and Japan: "a direction finding test in England might confirm this." To show that scattering is also present with longer waves, Fig. 8 was recorded at Geltow from a 0.002-second pulse from Nauen on 40 metres: the "near echo" joins up with the ground wave signal and is of much smaller amplitude than is the case with the shorter waves.

Part II discusses three tables of frequency measurements made in 1930. Table I gives measurements made in London, Geltow, and Nauen, on the five Nauen short-wave beams referred to in Part I. The maximum discrepancy between the three sets is 0.0063%, the mean 0.0026%. Table II gives P.O. (London) and Geltow measurements of five other stations, including the German short-wave broadcasting station at Zeesen. The mean discrepancy is 0.0018%. Table III gives measurements by the R.C.A. at Riverhead and by Transradio at Geltow on a number of American short-wave stations. The mean discrepancy here is 0.0025%, though the maximum is as much as 0.008%.

THE PROPAGATION OF SHORT RADIO WAVES OVER THE NORTH ATLANTIC.—C. R. BUTROWS. (*Proc. Inst. Rad. Eng.*, Sept., 1931, Vol. 19, pp. 1634-1659.)

Author's summary:—Transmission conditions for each season are shown by "surfaces" giving the received field strength as a function of time of day and frequency. These show that frequencies near 18 mc. are best for day-time transmission. In summer the best frequencies for night-time transmission are those near 9 mc. In winter an additional frequency near 6 mc. is required during the middle of the night. A frequency (such as 14 mc.) intermediate between the day and night frequency is useful during the transition period between total daylight and total darkness over the path. Day-to-day variations change the periods of usefulness of these frequencies. In particular the period of usefulness on 14 mc. sometimes extends so that it is the best day-time frequency.

Transmission conditions on undisturbed days were found to be the same for the same time of year in different years. These undisturbed transmission conditions are presented by "normal" surfaces. Comparison of these surfaces shows that the higher frequencies are less attenuated in winter. Reception on the highest frequency, 27 mc., was best in winter; in summer this frequency was never heard.

The effect of solar disturbances on short-wave transmission is to reduce reception on all frequencies. Sometimes the higher frequencies are the more adversely affected. Some of the possible causes of these disturbances are discussed.

From the measurements made on "static" at New Southgate, data on the variation of its field strength as a function of frequency, time of day, and season are given.

BEITRAGE ZUM FADINGSTUDIUM BEI KURZWELLEN  
(Contribution to the Study of Short-Wave Fading).—H. Mögel. (*Telefunken-Zeit.*, No. 58, Vol. 12, 1931, pp. 34-45.)

Observations made in the course of the various services carried on by the Transradio Company. Modulation distortion by rapid and strong selective fading is particularly well shown if the transmitter is modulated with a weak note: thus Fig. 29 shows a record of a 16-metre Java transmission in which the carrier is only faintly modulated (5%) by generator- and rectifier-ripple. In the middle of the strip record a strong fade lasting 1 second is visible: the carrier vanishes and the side bands interfere with each other. Assuming perfect rectification, this should produce at most a doubling of the I.F. amplitude compared with that without the fading; the record however shows a ten-fold increase. Runge believes the effect to be due to small frequency variations at the transmitter, due to vibration or other causes.

Interference between forward and backward rays is then illustrated: the over-lapping amplitude is greater or less, or zero, according to the phase and amplitude of each component. The phases often remain constant over several seconds (as shown on the oscillograph) particularly near the end of the most favourable transmission period. In the case of reception from one direction only, the same phenomenon is found: "the fadings decrease in frequency and depth 2 to 4 hours before the end of the optimum transmission period. In this case the receiver lies just outside the skip distance. It may be concluded from this that the number of multiple paths decreases as the edge of the skip distance is approached, since the possibility of multiple reflections between layer and earth decreases; within the skip distance only the first direct ray comes back to earth. Hence the most favourable wavelength, as distance increases, is shorter and shorter—within limits: *i.e.*, provided the state of ionisation is not too varied along the path." Fig. 31 shows an example of fading along the backward path (28,000 km.) being much more frequent and deep than along the forward path (12,000 km.). "Years of experience . . . indicate that the number and depth of fadings are least when the receiver lies in the first zone of reception."

Winter fading statistics on unmodulated carrier waves are then given which were collected for determining the average length and the depth of fades on day- and transition-wavelengths, in connection with the Verdan system of repetition and with automatic amplification control. They also enable the connection with magnetic activity to be studied; Fig. 39 shows this correlation; it is much better for the New York line than for the S. American, owing to the latter being much more exposed to the "penetrating" radiation from the sun; this produces far less effect on the earth's magnetic field than the radiation which is deflected by the field and which causes the large dis-

turbances in the upper atmospheric layers and in the magnetic field. The "penetrating" radiation (unlike the "ultra" radiation) is not sufficiently penetrating to be measured at earth level; it shows itself occasionally in the "bay" disturbances of the horizontal component (*cf.* Mögel, March Abstracts, p. 144) which coincide with the periods of strong fading on lines passing near the equator.

ÜBER DIE AUSBREITUNG DER RUNDFAKUNWELLEN  
(The Propagation of Broadcast Waves [particularly Fading Phenomena]).—O. Böhm (*Telefunken-Zeit.*, No. 57, Vol. 12, 1931, pp. 20-31.)

General considerations and numerous diagrams are given of the values and constancy of field strengths to be expected from broadcasting stations, at distances between 20 and 2000 kilometres. Among the remarks on fading the following may be quoted:—short-distance fading, resulting from interference between the ground ray and a singly reflected ray, has a frequency proportional to the transmitter frequency; long-distance fading, due chiefly to interference between singly and doubly reflected rays, has a frequency also proportional to the transmitter frequency and about inversely proportional to the distance. The strength of fading must increase with the distance; for a fixed receiving point it must decrease with increasing layer-height; thus during strong space wave conditions (low layer height) fading also must be strong. Fading due to interference between similar rays reflected at different points of a moving layer should theoretically be able to produce a complete annulment of signals: this can be confirmed by actual observation. The fading minimum, drifting slowly through the frequency band, can produce distortion by suppressing portions of the modulation band; calculation shows that in short-distance fading the effect would be worse than at greater distances. Drift of the transmitter frequency might produce a similar effect, but only to an unimportant degree: more rapid fluctuations (*e.g.*, by frequency modulation) must be avoided. The area free from fading can only be increased (for a given wavelength) by suppressing the space wave. A more economical way of doing this than by high masts would be to diminish the high-angle radiation by forming a current node artificially at a small height above earth—though this would decrease the radiation resistance, and thus the efficiency, of the aerial.

THE RELATION CONNECTING SKIP DISTANCE, WAVELENGTH, AND THE CONSTANTS OF THE IONIZED LAYERS.—N. H. Edes. (*Proc. Inst. Rad. Eng.*, Sept., 1931, Vol. 19, pp. 1663-1674.)

Author's summary:—Neglecting the short-range ground ray, it is assumed that short-wave propagation is due to single or multiple total reflection between the earth and one or more ionized layers in the atmosphere. For single reflection at a single layer an equation is developed giving the wavelength in terms of the skip distance, the height of the layer, and the degree of ionization of the layer. The curve represented by this equation is discussed.

The equation, in conjunction with experimental data, shows the height of the layer which governs the skip distance in daylight to be about 230 km., and its ionization about  $7.0 \times 10^5$  electrons per cu. cm. It is thought that, in daylight, higher layers of greater ionization do not exist. But there may be lower ones of lesser ionization.

The theory is then applied to the case of multiple reflection in daylight. The data lead to a value of 10.4 metres for the shortest useful wavelength for daylight work.

The case of two or more layers is next discussed, and experimental data for darkness are used, by means of the theory, to estimate the structure of the ionized regions at night. On winter nights there appear to be at least two layers, one at a height of about 520 km. and with an ionization of about  $2 \times 10^5$  electrons per cu. cm., the other at a height of the order of 40 km. and with an ionization of the order of  $3.5 \times 10^4$  electrons per cu. cm. On summer nights there is a layer at a height of about 230 km. and with ionization of about  $6.3 \times 10^5$  per cu. cm., and in addition a low-lying layer of small ionization (10 km., and  $6.7 \times 10^3$  electrons per cu. cm.).

THE MULTIPLE REFRACTION AND REFLECTION OF SHORT WAVES: ERRATA.—N. H. Edes. (*Proc. Inst. Rad. Eng.*, Sept., 1931, Vol. 19, p. 1674.)

Corrections to the paper dealt with in September Abstracts, p. 492.

HOW MANY IONISED LAYERS?—G. W. O. H. (*Wireless Engineer*, Sept., 1931, Vol. 8, pp. 463-464.)

An editorial prompted by the Goubau-Zenneck paper dealt with in August Abstracts, pp. 432-434.

1929-1930 DEVELOPMENTS IN THE STUDY OF RADIO WAVE PROPAGATION.—T. L. Eckersley. (*Marconi Review*, July-August, 1931, No. 31, pp. 1-8.)

1.—Electron distribution: "the evidence for existence of two reflecting and refracting layers has become practically overwhelming." One long jump *versus* multiple reflections: "the evidence indicates, at any rate in the cases examined, that the normal method is by multiple reflections between earth and Heaviside layer," but there are indications that round-the-world echoes may proceed in a single jump (Böhm, 1930 Abstracts, p. 267: direct signal showing multiple echoes, indirect showing none). Possibility of a third layer at 340 km., or the continuous increase in density from 210 to 340 km. The transmission

formula  $E = \frac{3\pi\sqrt{W}}{\sqrt{d_0 a}} \cdot e^{-ad\lambda^2}$ , where  $d_0$  is the skip distance and  $a$  an attenuation constant depending on latitude and time of day or night. Recombination coefficient at night, and the difference between early and late night transmission.

2.—Magnetic storms: Mrs. Wymore Shiel's results (1929 Abstracts, p. 566): unpublished Beam station results show a very marked correlation between magnetic storms and hours of traffic worked at 100 w.p.m. and over: the results show

a correlation in magnetic storm effect with magnetic latitude. Whistlers: possible connection between "tweaks" and magnetic storms (Burton, Jan. Abstracts, p. 34): long delay echoes.

3.—Ultra-short waves. 4.—Beam transmission: estimated and actual gains.

A METHOD OF CONTINUOUS OBSERVATION OF THE EQUIVALENT HEIGHT OF THE KENNELLY-HEAVISIDE LAYER.—E. L. C. White. (*Proc. Camb. Phil. Soc.*, July, 1931, Vol. 27, Part III, pp. 445-450.)

Author's summary:—A development of the "echo" method of observation of the height of the Kennelly-Heaviside layer is described. Short wave-trains of radiation lasting  $1/4000$  sec. are transmitted at regular  $1/200$  sec. intervals, and observed stroboscopically, together with their echoes, by means of a cathode-ray oscillograph. Details of the transmitting and receiving apparatus are given. The rapid fluctuation in amplitude of the echoes is easily studied by this method.

APPLICATION OF FERMAT'S THEOREM TO THE PROPAGATION OF RADIO WAVES.—H. Nagaoka. (*Proc. Imp. Acad. Tokyo*, No. 3, Vol. 7, 1931, pp. 85-88.)

In English. The minimum optical path theorem is here applied to the Heaviside layer and the "second reflecting layer for short waves." Defining these layers as places where  $\frac{\partial N}{\partial r}$  is abnormally great ("our knowledge of the medium intermediate between the two layers is insufficient, but  $\frac{\partial N}{\partial r}$  is small and probably still positive"), the writer re-arranges the usual equation in the form

$$\delta\left(\frac{1}{\rho}\right) = \left[ \delta\left(\frac{\partial N}{\partial r}\right) - \frac{2}{\rho} \cdot \delta N \right] \cdot \frac{1}{\rho \cdot \frac{\partial N}{\partial r}}$$

which indicates how the variation of  $N$  and  $\frac{\partial N}{\partial r}$  affects the curvature. The effects of sunrise and sunset, auroral and eclipse influences, and the action of meteoric showers are discussed. The transit time  $T = \int \frac{\mu ds}{c}$  differs with frequency.

Short waves travel at a higher level where  $\mu$  is small; the geometrical length  $s$  is probably somewhat longer for them than for long waves, but  $T$  may be appreciably smaller; this conclusion is of importance in longitude determinations.

A METHOD OF REPRESENTING RADIO WAVE PROPAGATION CONDITIONS.—L. W. Austin. (*Proc. Inst. Rad. Eng.*, Sept., 1931, Vol. 19, pp. 1615-1617.)

Author's summary:—The daylight radio transmission conditions across the North Atlantic Ocean in 1930 for wavelengths of 10,000 to 20,000 m. (15-30 kc.) are shown in a table based on the daily observations of the signal strength of seven European high power stations taken in Washington. It is expected that similar tables of daily transmission conditions for the years beginning with 1924 will

soon be ready for publication. The object of this form of tabulation is to furnish a ready means of comparison of radio conditions with other natural phenomena—sun spots, magnetic storms, weather, etc.

**SOME PHENOMENA OF THE UPPER ATMOSPHERE.**—S. Chapman. (*Proc. Roy. Soc. A.*, 1st August, 1931, Vol. 132, No. 820, pp. 353-374.)

The Bakerian lecture for 1931, presenting a combined picture of many of the phenomena of the upper atmosphere as co-ordinated by recent research.

**RECENT INVESTIGATIONS ON THE STRUCTURE OF THE STRATOSPHERE.**—C. C. Conroy. (*Science*, 31st July, 1931, Vol. 74, p. 113.)

"Observations of meteors, the spectra of the aurora polaris observed in layers of the atmosphere in the shadow of the earth and in sunlight, respectively, and observations of the passage of sound waves through the stratosphere, indicate an increasing temperature beginning at a height between 30 and 40 kilometres, no change in composition up to a height of at least 150 kilometres, no hydrogen at any height, a slowly decreasing amount of oxygen at heights of several hundred kilometres, and probably a small amount of helium, water vapour and neon at very great heights, with nitrogen predominating at all heights."

**WIRELESS OBSERVATIONS DURING THE TOTAL SOLAR ECLIPSE OF OCTOBER 21ST, 22ND, 1930.**—M. A. F. Barnett. (*N. Zealand Journ. Sci. and Technol.*, June, 1931, Vol. 12, pp. 321-331.)

Results of a series of tests organised by the Radio Research Committee of the New Zealand Department of Scientific and Industrial Research. No effect definitely attributable to the eclipse was observed on long waves, although on the Rugby—New Zealand transmission a definite increase in strength occurred during the eclipse period. On the 850- and 800-metre wavelengths, an effect equivalent to a partial return to night-time conditions was shown for transmission distances lying between 600 and 1200 miles. This effect was noticeable whether the transmission-path actually crossed the line of totality or not. In some cases the maximum change in signal strength lagged 30 minutes behind the maximum phase of the eclipse for a point half-way between the stations: in others it coincided with this phase. In general, no eclipse effect was observed on short waves, but in certain cases on a 52-metre wave a partial return to night-time conditions was definitely indicated.

As regards atmospheric effects, a slight increase was observed, on 850- and 800-metre reception at points in the neighbourhood of totality, during the maximum of the eclipse: otherwise no effect was found.

**A CORRELATION OF LONG-WAVE RADIO FIELD INTENSITY WITH THE PASSAGE OF STORMS.**—I. J. Wymore Shiel. (*Proc. Inst. Rad. Eng.*, Sept., 1931, Vol. 19, pp. 1673-1683.)

Author's summary:—Variation in received field

intensity of long radio waves is compared with variation of temperature, pressure, and rainfall during the passing of general storms at Washington. The results show that in general there is a definite falling off in signal intensity in front of the advancing low. This is followed by an increased intensity which persists from one to two days after the storm centre passes. This indicates some real relationship between received signal strength of long waves and weather over that part of the path of the wave over which it passes shortly before reaching the receiving station.

**A STUDY IN RADIO TRANSMISSION [SOLAR AND LUNAR EFFECTS ON THE HEAVYSIDE LAYER].**—H. F. Breckel. (*Rad. Engineering*, July, 1931, Vol. 11, pp. 19-20.)

Breckel's observations on the effect of the moon have been referred to in an article on Stetson's work (July Abstracts, p. 375) as showing the "unfavourable influence of the moon on the reception of radio waves of 4000 kilocycles." The present paper, however, shows that the reverse was the case: during periods when there was no moonlight over the intervening land, "signal strength and skip distance effects were very erratic, with bad fading as well," whereas moonlight gave high signal strength and stability, with "no fading due to skip effect." Signal strength, moreover, was proportional to the various stages of fullness of the moon. U.S. Army tests on 3500-kc. waves have recently shown that "skip effects and signal level are least . . . during the first and last quarters of the moon's phases." Taking Stetson's own results into account, therefore, low and intermediate frequencies apparently perform best without moonlight, the higher frequencies best in the light of the moon. The writer attributes the moon's influence to the "negative repellent characteristic of the lunar mass" on the layer, the reflection or deflection of the sun's emission by the moon playing only a minor part.

**THE SPARKING POTENTIAL OF AIR FOR HIGH-FREQUENCY DISCHARGES.**—E. W. B. Gill and R. H. Donaldson. (*Phil. Mag.*, Sept., 1931, Series 7, Vol. 12, No. 78, pp. 719-726.)

The authors' experiments show that with a transverse discharge for any wavelength below 60 metres there is only one pressure at which the sparking potential has a minimum value which, with the corresponding pressure, decreases with the wavelength; but for any wavelength between 60 metres and 125 metres there are two such potentials, one of which is the same for all these wavelengths. A longitudinal discharge gives only one minimum sparking potential; the difference between longitudinal and transverse discharges renders Gutton's resonance theory of the double minimum improbable. An explanation of the experimental results is suggested.

**THE DIELECTRIC COEFFICIENTS OF GASES. PART I. —THE RARE GASES AND HYDROGEN.**—H. E. Watson, G. Gundu Rao and K. L. Ramaswamy. (*Proc. Roy. Soc. A.*, 1st Aug., 1931, Vol. 132, No. 820, pp. 569-585.)

THE CONDUCTIVITY OF GASES IN UNIFORM ELECTRIC FIELDS.—S. P. McCallum and F. L. Jones. (*Phil. Mag.*, August, 1931, Supp. No., Series 7, Vol. 12, No. 76, pp. 384-392.)

Considerations are presented which make it appear to the authors "that there are fundamental errors in the hypotheses that have been adopted with regard to the transference of energy in the collisions between electrons and atoms of the gas. It is impossible to admit that there is a high probability of electrons losing their energies in collisions with atoms when their energies are sufficient to excite radiation or ionize the gas."

STRIATED DISCHARGE.—Huxley. (*See under "General Physical Articles."*)

SKINEFFEKT (Skin Effect).—M. J. O. Strutt. (*Ann. der Physik*, 1931, Series 5, Vol. 8, No. 7, pp. 777-794.)

A theoretical investigation of the disturbance produced in a quasi-stationary electromagnetic field by the introduction of a three-dimensional conductor of any form; the field within the conductor and the energy dissipated therein are the immediate objects of the investigation. The term "quasi-stationary" is used to signify that all linear dimensions considered are small compared with the wavelength of the field in the medium; the effect of retardation is thus eliminated. The energy dissipated in the conductor at low frequencies is found to be proportional to the square of the frequency. At high frequencies the field is hydrodynamical in character; the current is found to be concentrated near the surface of the conductor (hence the term "skin effect") and to be greatest in the places of greatest surface curvature. The cases of constant (a) electric voltage  $E$ , (b) magnetic voltage  $M$  (line integral of magnetic intensity) between two given points are discussed separately, and, with  $W =$  energy dissipation and  $\omega =$  angular frequency, it is found that for low frequencies

$$(a) W = \frac{E^2}{(R_0 + \omega^2 R_1 + \dots)},$$

(b)  $W = M^2(W_0\omega^2 + W_1\omega^4 + \dots)$ ; for high frequencies

$$(a) W = \frac{E^2}{a\sqrt{\omega} + b + \frac{c}{\sqrt{\omega}} + \dots},$$

$$(b) W = M^2\left(A\sqrt{\omega} + B + \frac{C}{\sqrt{\omega}} + \dots\right),$$

where  $R_0, R_1, W_0, W_1, a, b, c, A, B, C$  are quantities independent of frequency, referring to the configuration considered.

The theory is applied to find the frequency variation of coil impedance; for low frequencies this has the form

$$R = R_0 + R_1\omega^2 + \dots, \text{ for high frequencies}$$

$$R = a\sqrt{\omega} + b + \frac{c}{\sqrt{\omega}} + \dots \text{ The case of inductive heating is also considered. The paper closes with a list of literature references.}$$

PROPAGATION OF POLYPHASE H.F. CURRENTS ALONG POWER LINES, AND THE SELECTIVE PROTECTION OF ELECTRIC NETWORKS.—J. Fallou. (*Comptes Rendus*, 31st Aug., 1931, Vol. 193, pp. 395-397.)

PAPERS ON SESMAT'S "CURVE OF PURSUIT" HYPOTHESIS OF THE OPTICS OF MOVING BODIES.—V. Lalan: Sesmât. (*Comptes Rendus*, 9th March and 20th April, 1931, Vol. 192, pp. 614-616 and 933-935.)

For Sesmât's papers see Aug. Abstracts, p. 455.

### ATMOSPHERICS AND ATMOSPHERIC ELECTRICITY.

THE PRESENT POSITION OF THEORIES OF THE ELECTRICITY OF THUNDERSTORMS.—R. A. Watson Watt. (*Journ. Roy. Met. Soc.*, No. 239, Vol. 57, 1931, pp. 133-142.)

I.—The Problem of the Lightning Flash: the observational facts which must be explained by any suggested mechanism, and the "ultimately aesthetic criteria of elegance, economy and elasticity" which a satisfactory theory must satisfy; some less familiar observational data. II.—The Story of a Water Drop. III.—The Observational Criteria: visual, magnetic, and electric observational data on lightning; the inadequacy of the numerical, visual and photographic data, and the ambiguity of the electric data, are stressed.

IV.—The Theories and the Newer Facts: recent data of Appleton, Watt, and Herd, of Schonland and Craib, of Wormell, and of Banerji, mainly in relation to the Simpson theory. "Considerable masses of data . . . point very strongly to a positive bipolar structure for the normal thundercloud. This structure . . . does not follow easily from the Simpson effect in water. That it may be derived indirectly is admitted, but in the writer's opinion the derivation is aesthetically unsatisfactory." "One thing, and one thing only, may be regarded as proven beyond any possibility of reasonable doubt . . . the great majority of heavy discharges which reach the ground pass between a negative charge on the cloud and a positive charge on the ground."

ON THE METEOROLOGICAL RELATIONS OF ATMOSPHERICS.—R. A. Watson Watt: R. Bureau. (*Journ. Roy. Met. Soc.*, No. 239, Vol. 57, 1931, pp. 221-237.)

Discussion at a meeting of the British Association Bristol, 1930, opened by Watson Watt, who contrasts the strictly quantitative methods of the Radio Research Board workers with those of Bureau and Lugeon, and discusses the conclusions reached by the three groups. As regards lightning flashes as the source of atmospherics, he expresses the views of the British school in the following words: "I am convinced that we can detect the effects of lightning flashes anywhere in the world and can locate by visual direction-finding lightning flashes at least three thousand kilometres away. I have no evidence as to the existence of lightning flashes which could not be so located, and I contest the validity of any evidence yet produced in favour of flashes giving only weak radiation within

the radiotelegraphic spectrum. I think Appleton might go so far as to say that any source of atmospherics located by the perfect application of our methods must be a lightning flash. I cannot, with the available evidence, go so far, although I think it very probable, and know of no evidence conclusively against it. Bureau and Lugeon would quite definitely reject the 'atmospheric therefore lightning' inference." In addition to Bureau's reply, an abstract of his Note on "The Recording of the Number of Atmospherics per Minute" is given, together with his "Note on Atmospherics and the Atmosphere."

LONG-DISTANCE TRANSMISSION OF STATIC IMPULSES.

—S. W. Dean. (*Proc. Inst. Rad. Eng.*, Sept., 1931, Vol. 19, pp. 1660-1662.)

Description of a test to obtain an oscillographic record of strong atmospherics received simultaneously at the two ends of the long-wave transatlantic radiotelephone circuit. The oscillogram, taken at New Southgate, near London, shows (a) the static received at the American end of the circuit (Houlton), transmitted to New Southgate by a short-wave channel; (b) the static received at the British end (Cupar, Scotland) and sent to New Southgate over a telephone line; and (c) the static received on a short-wave monitoring receiver at New Southgate. A large number of simultaneous "crashes" at Cupar and Houlton are shown.

ORIGIN OF LOCAL HEAT THUNDERSTORMS.—Part I.—H. von Ficker. (Summary in *Science Abstracts*, Sec. A, Aug., 1931, Vol. 34, p. 705.)

MAGNETIC EXPERIMENTS ON THE COSMIC RAYS.—B. Rossi. (*Nature*, 22nd Aug., 1931, Vol. 128, pp. 300-301.)

A preliminary description of experiments on the magnetic deflection of cosmic rays, with improved apparatus, which show that the primary deflection of the corpuscular rays in magnetised iron is not as great as would be that of electrons or protons of 10 or 20 milliard electron-volts.

ÜBER DIE ISOLATION VON STRAHLUNGSAPPARATEN (On the Insulation of [Kolhörster] Radiation Measuring Apparatus).—W. M. H. Schulze. (*Physik. Zeitschr.*, 15th July, 1931, Vol. 32, No. 14, pp. 564-567.)

ÜBER DIE SOLARE KOMPONENTE DER ULTRA STRAHLUNG (On the Solar Component of Cosmic Radiation).—V. F. Hess and W. S. Pforte. (*Zeitschr. f. Phys.*, 1931, Vol. 71, No. 3-4, pp. 171-178.)

"New measurement of the hard cosmic radiation using a Hoffmann twin high-pressure apparatus give a further strong argument for the existence of a solar component of the cosmic radiation; the daily course of the ionisation with the apparatus completely surrounded by a lead screen 10 cm. thick shows a distinct maximum at 12 noon (local time). The maximum amount of the solar component in the total radiation is 5%. The course of the daily curve gives an absorption coefficient of the solar component of about  $5 \cdot 10^{-4} \text{ cm.}^{-1}$  ( $\text{H}_2\text{O}$ ).

Using this value as a basis, the annual and the geographical variation of the solar component are calculated in advance."

AURORES POLAIRES ET RAYONS COSMIQUES (Polar Aurorae and the Cosmic Rays).—A. Dauvillier. (*Comptes Rendus*, 17th Aug., 1931, Vol. 193, pp. 348-350.)

The correlation between sunspots, aurorae, and magnetic and telluric storms suggests that besides these intermittent phenomena there exist similar phenomena of a *constant* character, and that the regular periodic fluctuations of terrestrial magnetism are accompanied by a *permanent* auroral phenomenon due to the movements of the globe in a homogeneous electronic flux issuing from the sun. Such an auroral effect, weak, stationary and constant, was described by Nordenskiöld, according to whose observations the magnetic pole is always surrounded by a circular luminous corona of radius about 1000 km. at a height of 200 km. Dealing by relativistic dynamics with this corona, the writer calculates the energy of the electrons producing it to be  $15 \times 10^9$  electron-volts, more than enough to account for the cosmic ray quantum. From this starting point he develops his hypothesis, according to which the entire sky is the seat of a perpetual aurora: "it is known that the night sky shows with intensity the ray 5577: it is also the source of the cosmic rays, the upper atmosphere acting as anticathode for the solar electrons. The variations of intensity both diurnal and resulting from eclipses would thus be very slight."

THE AURORAL SPECTRUM.—J. Kaplan. (*Phys. Review*, 1st Aug., 1931, Series 2, Vol. 38, No. 3, p. 582.)

Abstract only of an account of experiments giving evidence that the auroral displays are electrical discharges at low pressures under conditions which are ideal for the production of the nitrogen after-glow.

THE RELATION OF ATMOSPHERIC SPACE-CHARGE TO TURBULENCE AND CONVECTION.—J. G. Brown. (*Phys. Review*, 1st Aug., 1931, Series 2, Vol. 38, No. 3, p. 587.)

GENEFELDUNTERSUCHUNGEN UND BEWEGLICHKEITSMESSUNGEN KLEINER IONEN (Investigations of Counter-Fields and Measurements of the Mobilities of Small Ions).—J. Scholz. (*Gewlands Beitr.*, No. 2, Vol. 29, 1931, pp. 226-238.)

"Counter-field" is the name given by Itiwara (April Abstracts, p. 207) to the field at the air inlet to a cylindrical test condenser which hinders particularly the highly mobile ions at their entrance. The writer finds that the large error caused by this in the determination of the number of small ions can be diminished by suspending an earthed cylinder inside the condenser. Moreover, graphs of the measurements show a remarkable relation to the current/mobility characteristic, and provide an easy and more exact method of measuring the mobilities.

ON THE INFLUENCE OF THE RESIDUAL CHARGE ON DISCHARGES.—I. STUDY WITH A RESONANT WAVE.—S. Mochizuki. (*Journ. I.E.E. Japan*, March, 1931, Vol. 51, pp. 27-30.)

In English. An investigation, using a klydonograph and a c.-r. oscillograph, of the effect on spark formation of the residual charge distributed along the path of the previous partial discharge. The different behaviour of positive and negative discharges in this respect, and the different behaviour of the positive discharge according to whether it follows the negative discharge within about  $10^{-7}$  sec. or later, are discussed. The spark-over distance increases gradually as the frequency increases from 50 cycles to about 3 megacycles per sec., because of the distortion of the potential gradient by the positive space charge: above 3 megacycles it decreases rapidly because the electrons are not swept away but remain in the space between the electrodes and reduce the effect of the positive ions.

A CURIOUS PHENOMENON SHOWN BY HIGHLY CHARGED AEROSOLS.—W. Cawood and H. S. Patterson. (*Nature*, 25th July, 1931, Vol. 28, p. 150.)

Under certain experimental conditions a spherical highly charged assemblage of particles may form in aerosols, and the writers suggest that globular lightning may owe its origin to an analogous effect.

ELECTRICAL DISCHARGE IN AIR AND THE PROBABILITIES OF ITS OCCURRENCE.—K. Schaposchnikof. (Summary in *Elektrot. u. Maschbau*, No. 31, Vol. 49, 1931, p. 604.)

SURGE PHENOMENA IN OVERHEAD NETWORKS DURING STORMS: PRESENT POSITION OF THEIR STUDY IN SWITZERLAND.—K. Berger. (*Bull. de l'Assoc. suisse d. Elec.*, No. 17, Vol. 22, pp. 421-436.)

Among other results mentioned, it is deduced from oscillograms of storm and artificial surges that the front of the most sudden of the former may, at its point of departure, be concentrated over less than one microsecond.

SURGE INVESTIGATIONS ON OVERHEAD LINES AND CABLE SYSTEMS: DISCUSSION [PARTICULARLY ON KLYDONOGRAPH RESULTS].—Melsom, Arman and Bibby. (*Journ. I.E.E.*, September, 1931, Vol. 69, pp. 1160-1168.)

WANDERWELLENAUFNAHMEN AN ZUSAMMENGESETZTEN BETRIEBSLEITUNGEN (Oscillographs of Surge Voltages on Composite Cables).—J. Röhrig. (*Archiv f. Elektrot.*, 19th June, 1931, Vol. 25, No. 6, pp. 411-419.)

THE DEFORMATION OF A SURGE BY A TRANSFORMER WINDING.—W. Krug. (*Bull. d. l'Assoc. suisse d. Elec.*, No. 12, Vol. 22, pp. 277-287.)

EARTHS FOR LIGHTNING CONDUCTORS.—V. Schaffers. (*Ann. Soc. Sci. de Bruxelles*, 12th March, 1931, Vol. 51, pp. 21-26.)

See also 1930 Abstracts, p. 332. The dielectric

capacity of the soil is the important factor, not the ohmic resistance. The former varies little from very dry to damp soil.

RADIO TRACKING OF METEOROLOGICAL BALOONS.—Blair and Lewis. (See under "Directional Wireless.")

RECEPTION OF MESSAGES THROUGH ATMOSPHERICS BY USE OF TELEVISION.—Bray. (See abstract under "Phototelegraphy and Television.")

NEW ZEALAND OBSERVATIONS ON ATMOSPHERICS DURING THE SOLAR ECLIPSE OF 21ST-22ND OCTOBER, 1930.—Barnett. (See abstract under "Propagation of Waves.")

### PROPERTIES OF CIRCUITS.

ENTARTUNGEN SINUSFÖRMIGER SCHWINGUNGEN (The Degeneration [into Relaxation Oscillations] of Sinusoidal Oscillations).—W. Reichardt. (*E.N.T.*, August, 1931, Vol. 8, pp. 344-367.)

A graphical method is described by which the phenomena of practical importance can be investigated. The writer deals first with the case of a capacitive negative characteristic (dynatron); transformer retroaction circuit—*cf.* Kirschstein, 1929 Abstracts, p. 506; then with inductive negative characteristics (glow-discharge lamps; arcs; matched-triode circuit—Fruhauf, 1929 Abstracts, p. 280; charge- and discharge-valve circuit—Hudec, 1930 Abstracts, pp. 37-38; the series-wound d.c. motor); and finally the case of radio frequencies.

ELECTRICAL AND MECHANICAL OSCILLATIONS THE PERIOD OF WHICH IS PROPORTIONAL TO A TIME CONSTANT [RELAXATION OSCILLATIONS].—B. van der Pol. (*3. Intern. Congr. f. Tekn. Mek. Stockholm*, 1930, 4 pp.)

KÜNSTLICHER LICHTBOGEN MIT DOPPELGITTERRÖHREN (Artificial Arc [with Negative Resistance] Circuits Using Two-Grid Valves).—T. von Nemes. (*Zeitschr. f. hochf. Tech.*, August, 1931, Vol. 38, p. 77.)

Referring to Steimel's paper (Feb. Abstracts, p. 92) the writer describes a circuit in which a valve in space-charge-grid connection is so arranged that an "artificial arc" effect can be obtained without the use of a second valve for reversing the phase of retroaction. A second circuit is shown which on a certain adjustment jumps suddenly from the "arc" state to the relaxation oscillation condition.

A FURTHER NOTE ON THE APPARENT DEMODULATION OF A WEAK STATION BY A STRONGER ONE.—F. M. Colebrook; Beatty; Butterworth. (*This journal*, Aug., 1931, Vol. 8, pp. 409-412.)

An amplification of the analysis given by Butterworth, bringing to light the fact that what Beatty described as a "mutual demodulation" effect can equally, and perhaps a little more clearly, be represented as a modification by each transmission



of the effective rectification characteristic of the detector in relation to the other transmission; and that the nature of this mutual modification is such as to result not only in a diminished interference from the weaker transmission, but also in an appreciable distortion effect in the reproduction of the modulation of the stronger.

An Editorial on pp. 405-408 first deals graphically with the problem and then turns to another aspect which has not been dealt with in the various papers in question: the fact that if two equally strong and equally modulated waves are affecting the aerial, one being the wanted signal to which the receiver is tuned, and the other a disturbing wave of a somewhat different frequency, then the electromotive forces acting on the detector are very different from those acting on the aerial. It is shown that the tuned selection of the one signal automatically reduces its modulation compared with that of the other, and that the phases of the various components are very much modified by the properties of the tuning circuits. "The carrying out of the analysis of the resultant curve should show whether there is any foundation for the suggestion that such a tuned circuit and detector can discriminate between the wanted and the unwanted components, so that when by audio-frequency correction the wanted components are restored to their full value, the unwanted ones remain obligingly in the background."

MODULATION AND THE HETERODYNE.—W. Jackson. (*This journal*, Aug., 1931, Vol. 8, pp. 425-426.)

A short, simple treatment showing the production of a modulated wave and of a heterodyne note as different aspects of a common process, namely the superposition in a non-linear valve circuit of two alternating voltages of different frequency. "That a heterodyne note, as it is understood, is provided on the one hand, and a modulated wave on the other, is due merely to the selection of different components of the common output-current wave. . . . The familiar heterodyne note may be regarded as representing the lower side-band of this modulated output wave, and becomes of audible frequency when the two input voltages are of similar radio frequency."

DIE STREUUNG ZWEIER MAGNETISCH GEKUPPELTER STROMKREISE IN ANALYTISCHER UND SYNTHETISCHER ENTWICKLUNG (The Leakage of Two Magnetically Coupled Current Carrying Circuits in Analytic and Synthetic Development).—G. Benischke. (*Elektrot. u. Maschbau*, No. 17, Vol. 49, 1931, pp. 322-327.)

PUSH-PULL PROBLEMS.—W. T. Cocking. (*Wireless World*, 5th August, 1931, Vol. 29, pp. 128-131.)

The push-pull circuit was originally designed as a means of obtaining increased power output in the days when power valves were unknown. That such a stage is not necessarily a luxury is shown in the article. Owing to cancellation of even harmonics, the power output is greater than that from two valves in parallel, and both hum

and feed-back are considerably reduced. This has the advantage that quite modest smoothing equipment is required, leading to a simplified layout.

ÜBER DIE WIRKUNGS- UND BETRIEBSWEISE DER GEGENTAKTSCHALTUNG IN NIEDERFREQUENZ-VERSTÄRKERN (The Method of Operation and Working Conditions of the Push-Pull Connection in L.F. Amplifiers).—A. Forstmann. (*Zeitschr. f. hochf. Tech.*, Aug., 1931, Vol. 38, pp. 66-73.)

The advantages of the connection, properly carried out to give complete symmetry, are especially great in l.f. amplifiers, and above all in the output stage. Anode reaction is easily compensated—this is particularly important in the output stage, since independence of the load (which otherwise may so seriously affect the frequency curve of the amplifier at the higher frequencies) may be achieved and the amplifier may be designed for the required band as an independent whole. Moreover, greater amplification may be obtained (by higher  $\mu$  or increased transformer ratio) without increase of frequency-dependence. Lastly, inclination to oscillate is removed. The conditions for such anode-reaction compensation are derived.

The advantages of the connection, due to the elimination of the polarising current in choke or transformer, are analysed; also those due to the symmetry with regard to the cathodes—insensitiveness to external disturbing fields and to voltage variations, and freedom from the necessity of earthing the "K" point. The ability to make use of the whole of the characteristic in the negative-grid region, without distortion, is examined and a procedure for finding the optimum working conditions is given.

In the output stage, the connection enables considerably more power to be obtained than in the case of other connections. Methods for the calculation of the optimum working conditions both for triodes and screen-grid valves are given.

BALLISTIC AND PERFECT BALANCES IN BRIDGES TREATED BY THE OPERATIONAL CALCULUS.—A. T. Starr. (*Phil. Mag.*, August, 1931, Supp. No., Series 7, Vol. 12, No. 76, pp. 265-280.)

A description of a simple method for finding the conditions for perfect or ballistic balance of a bridge, using the operational form of the transfer admittance between the input terminals and the detector. The use of inverse networks in forming a bridge with a perfect balance is also given and two types of bridges—the equal ratio bridge and the inverse network bridge—are discussed. "Some theorems on inverse networks and equal ratio bridges are given for general and ballistic balances."

FASTLINEARE NETZWERKE (Networks in which Currents and Voltages of Small Amplitude have an Approximately Linear Relation).—R. Feldtkeller and W. Wolman. (*T.F.T.*, June and August, 1931, Vol. 20, pp. 167-171 and 242-248.)

THE HYSTERESIS DAMPING OF PUPINISED LINES.—W. Doebke. (*E.N.T.*, August, 1931, Vol. 8, pp. 340-343.)

SIMPLIFIED H. F. CALCULATIONS.—W. A. Barclay. (*Wireless World*, 26th August and 2nd September, 1931, Vol. 29, pp. 213-216 and 244-246.)

Alignment charts for the rapid measurement of high-frequency amplification.

### TRANSMISSION.

UNTERSUCHUNGEN ÜBER FUNKENERREGTE SCHWINGUNGEN SEHR HOHER FREQUENZ (Experiments on Spark-Generated Oscillations of Ultra-High Frequency).—K. Haupt. (*Zeitschr. f. hochf. Tech.*, Aug., 1931, Vol. 38, pp. 57-66.)

An extension of Busse's method of generating ultra-short waves by high-frequency sparks excited by undamped oscillations (see 1928 Abstracts, p. 408) to the production of still shorter waves (down to 14 cms.) using higher supply frequencies (up to 10 megacycles). In the course of the research, the effect of water-cooling, gas-cooling, and a combination of the two, on the electrode material, on the prolonged working of the oscillator, and on the intensity of the oscillations produced, was carefully investigated. Further, the variation was examined of the damping of the ultra-high-frequency oscillations with the electrode material and the length of the gap, with the cooling, and with the supply frequency.

It was found that for the production of the greatest ultra-high-frequency energy the spark-gap was very short (0.1 to 0.15 mm.), the electrode material either "platit"—a tungsten-platinum alloy—or tungsten (preferably "platit"), and the supply frequency very high (10 megacycles). At this frequency water-cooling was essential even for the metals mentioned, and this prevented the generation of a wavelength of less than 60 cms. For shorter waves, therefore, where the oscillator dimensions had to be decreased, artificial cooling had to be abolished and the supply frequency diminished to  $3 \times 10^6$  cycles per second. By the use of "platit" or tungsten (again preferably the former) a good constancy under prolonged operation was thus obtained for wavelengths down to 22.4 cms. and even to 14 cms.

TWO-METRE WAVE TRANSMITTER WITH SPECIAL REFERENCE TO ITS ANTENNA FEEDER.—S. Uda. (*Journ. I.E.E. Japan*, March, 1931, Vol. 51, pp. 21-27.)

In English. Description of a push-pull transmitter giving an output of more than 7 w. (aerial current 300-350 mA.) with such good frequency control that heterodyne reception is possible at a distance of 5 km., although for practical purposes it is preferable to use modulated waves. The ordinary Holborn circuit does not give smooth and easy frequency control on 2 m. waves; to obtain such control, a variable air condenser is introduced into the oscillating circuit in series with plate or grid. In the experiments described it was in series with the latter. When the circuit is used as a receiver

this condenser will act effectively as a tuning condenser, giving a variation of about 20 % of the wavelength. In a transmitter, it can also act as the coupling condenser between the oscillator and a twin-wire feeder (made of copper wires spaced 2 cms. and more than 10 metres long, to allow the aerial system to be mounted on the roof of the building). The behaviour of such a feeder, the optimum value of the condenser, etc., are examined mathematically. An electromagnetic coupling may also be used.

EXPERIMENTS ON LARGE POWER ULTRA-SHORT WAVES [DOWN TO 2.98 METRES].—T. Kuno. (*Journ. I.E.E. Japan*, March, 1931, Vol. 51, pp. 31-33.)

The writer considers that for the generation of powerful and stable oscillations down to the wavelength named the straightforward single triode generating circuit (with inductance and capacity reduced to give the required wavelength) is preferable to the positive-grid and magnetron methods. He uses a positive plate voltage of 3000-7000 v., and plate currents ranging from 100 to 800 ma. Certain types of triode occasionally break down just where the neck of the valve swells out to the bulb: he investigates this effect by coating the valve with paraffin wax and suspending it in the condenser field. The failure points are due to the electron field between cathode and grid: other points of local heating occur elsewhere as the result of fields between the other electrodes. Various experiments, including some with the electrodeless discharge, are summarised.

DUPLEX PHONE ON 56 MC.—A PORTABLE "FIVE-METER" TRANSMITTER USING PENTODE MODULATORS.—R. A. Hull. (*QST*, Aug., 1931, Vol. 15, pp. 9-13.)

A PARTICULAR CASE OF HIGH FREQUENCY ELECTRON OSCILLATIONS.—W. H. Moore. (*Canadian Journ. of Res.*, May, 1931, Vol. 4, No. 5, pp. 505-516.)

Author's abstract:—"In experimenting with oscillators operating at wavelengths of 100 cm. and less, an unusual case of oscillations was observed. With high positive grid potential and zero plate potential in a three-electrode valve, oscillations were produced at certain critical values of filament current. The frequency of oscillation was highest at the lowest filament current. An explanation of the effect is suggested."

The writer's results are applied to the explanation of the action of Okabe's "electronic amplifier" (1930 Abstracts, p. 568) in which a Barkhausen-type receiving circuit gave signals increasing from zero to a sharp maximum and then decreasing again to zero, as the filament current was carried from 0.62 to 0.63 A. "The valve being in oscillation within this narrow region of filament current, as described herewith by the author, would explain the increased sensitivity of the receiver over the range of oscillation. The graph of received signal intensity versus filament current given by Okabe corresponds closely to the form of the author's  $I_p/I_f$  curves."

SCHWINGUNGEN IN DREIELEKTRODENRÖHREN MIT POSITIVEM GITTER (Oscillations in Three-Electrode Valves with Positive Grid).—M. J. O. Strutt. (*Ann. der Physik*, 1931, Series 5, Vol. 8, No. 7, pp. 794-796.)

An answer to criticisms by Hollmann (1930 Abstracts, p. 505) of a paper by the author (1930 Abstracts, p. 274) with the same title as the above.

THE PRODUCTION OF ULTRA-SHORT UNDAMPED ELECTROMAGNETIC WAVES.—G. V. Potapenko. (*Phys. Review*, 1st Aug., 1931, Series 2, Vol. 38, No. 3, pp. 584-585.)

Abstract only of a paper on Barkhausen-Kurz oscillations; a theoretical investigation shows that "in a circuit connected to the tube, oscillations can be produced if the natural period of a circuit is two, three, &c. times shorter than the period of electronic oscillations. By a method based on this theory the author obtained oscillations the frequency of which exceeds many times the frequency of electronic oscillations. Undamped waves of a few centimeters were obtained."

PRACTICAL ELECTRON TRANSMITTERS AND RECEIVERS [BARKHAUSEN-KURZ OSCILLATOR].—J. N. Dyer. (*QST*, Sept., 1931, Vol. 15, pp. 21-24.)

Practical points are dealt with (e.g., little is gained by removing the transmitting valve from its base). An editorial foot-note mentions that for concentric cylindrical electrodes the optimum ratio of plate/grid to cathode/grid spacing is about 2.5 to 1.

EINIGE BEMERKUNGEN ZUR PROBLEM DER ERZEUGUNG SEHR KURZER ELEKTROMAGNETISCHER WELLEN (Remarks on the Problem of Ultra-Short-Wave Generation [Barkhausen-Kurz Method]).—J. Sahanek. (*Zeitschr. f. hochf. Tech.*, Aug., 1931, Vol. 38, pp. 78-80.)

The writer collects a series of his own theoretical results from his papers published between 1925 and 1930, and shows how they have been confirmed by the experimental results obtained later by other workers.

THE MAGNETRON AS A NEGATIVE RESISTANCE [AND THE FORMATION OF ULTRA-HIGH FREQUENCIES].—Hollmann. (See under "Valves and Thermionics.")

LE SYSTÈME DE COMMUNICATIONS RADIOTÉLÉPHONIQUES À BANDE LATÉRALE UNIQUE APPLIQUÉ AUX ONDES COURTES (The Single Side-Band System of Radio-Telephony Applied to Short Waves.—Part I).—A. H. Reeves. (*Rev. Gén. de l'Élec.*, 12th Sept., 1931, Vol. 30, pp. 406-413.) See October Abstracts, p. 554.

LA RADIOTÉLÉPHONIE À ONDES COURTES À BANDE LATÉRALE UNIQUE (Single Side-Band Short Wave Radiotelephony).—P. Letheule. (*Génie Civil*, 29th Aug., 1931, Vol. 99, pp. 205-211.)

CARRIER WAVES AND SIDE-BANDS.—R. H. Nisbet : Baxter. (*This journal*, Aug., 1931, Vol. 8, pp. 429-431.)

A reply to Baxter's suggestion that the modulation of a crystal-controlled transmitter cannot be explained on the "side-band theory." Taking first, as more easily followed, the case of a crystal-controlled output driving an r.f. amplifier which can be modulated, the writer agrees that if the two "drives" acting on the amplifier (the crystal-controlled frequency  $N$  and the modulating frequency  $n$ ) were well inside the straight part of the amplifier valve characteristic, no modulation would occur: "this state of affairs used to occur in some of the old reflex receivers." To obtain modulation of the r.f. by the l.f., the amplifier must *not* be a linear amplifier of the r.f. drive but must give it an amplitude distortion, producing with the modulating frequency new frequencies among which are the combination and difference frequencies  $N + n$  and  $N - n$ , just as the non-linear transmission system of the ear produces combination and difference tones. "Those who deny the existence of side-bands must also deny the existence of the combination tones that they can hear." He then deals similarly with the less usual case of the crystal-controlled oscillator modulated *directly*.

MODULATION AND SIDE BANDS: RELATION BETWEEN AMPLITUDE AND FREQUENCY MODULATION.—N. F. S. Hecht. (*This journal*, Sept., 1931, Vol. 8, pp. 471-481.)

"This article has been written with the object of demonstrating, by physical and graphical methods, the constitution of modulated waves." The writer ends: "Thus under the best possible conditions the frequency band occupied by a telephony transmission must be at least as wide for frequency modulation as for amplitude modulation. It will generally be a great deal wider and cause interference over a wider spectrum."

DIE STATISCHE AUFNAHME VON MODULATIONS-KURVEN AN SENDERN MIT HEISING-MODULATION (The Static Determination of the Modulation Curves of Transmitters with Heising Circuit [Choke Control] Modulation).—H. O. Roosenstein. (*Telefunken-Zeit.*, No. 57, Vol. 12, 1931, pp. 37-39.)

FREQUENZDURCHLÄSSIGKEIT UND NICHTLINEARE VERZERRUNGEN FREMDGESTEUERTER TELEPHONIESENDER (Frequency Pass Factor [Ratio of Amplitude of Anode Current or Potential for Side Band to that for Carrier Wave] in Telephony Transmitters with Master Drive).—R. Hofer. (*Telefunken-Zeit.*, No. 58, Vol. 12, 1931, pp. 17-33.)

A theoretical investigation leading to methods of calculating the factor for commercial types of amplifier from a knowledge of the Möller dynamic characteristics. Conditions for the avoidance of non-linear distortion are derived: thus the valves should have a steep slope, as high a working voltage as possible, and not too large an amplification factor.

OSCILLAZIONI PARASSITE AD ALTISSIMA FREQUENZA NEGLI OSCILLATORI A TUBI ELETTRONICI (Parasitic Oscillations of Very High Frequency in Valve Oscillators).—M. Boella. (*L'Elettrotec.*, 15th June, 1931, Vol. 8, p. 404.)

The origin of parasitic oscillations, of frequency ranging between 10 and 100 megacycles per second, is briefly discussed, together with their prevention by inserting non-inductive, non-capacitive resistances in the grid- and plate-leads, or by making these leads themselves of some high-resistance material.

A SINGLE-VALVE MULTI-FREQUENCY GENERATOR.—A. T. Starr. (*This journal* September, 1931, Vol. 8, pp. 465-470.)

Author's conclusions:—A single-valve multi-frequency generator can be produced giving frequencies of arbitrarily chosen values, with amplitudes of desired ratios. It would be possible to construct a beat-frequency oscillator with one valve producing two frequencies, one of which could be varied continuously by means of a variable condenser and a rectifying valve. Such an oscillator could be made to have a very good wave form by a suitable choice of the two higher frequencies from which the beat-frequency is obtained, and it would not be necessary to have very large tuning coils and condensers.

PUSH-PULL ARRANGEMENTS OF UNUSUAL CHARACTER [CARSON BALANCED MODULATOR IN CARRIER CURRENT TELEPHONY AND SUPPRESSED CARRIER TRANSATLANTIC TELEPHONY].—C. H. W. Nason: Carson. (*Rad. Engineering*, Aug., 1931, Vol. 11, p. 23.)

TWENTY-WATT AIRCRAFT TRANSMITTER (333-9700 KILOCYCLES).—A. P. Bock. (*Proc. Inst. Rad. Eng.*, Sept., 1931, Vol. 19, pp. 1569-1578.)

C.w. signals remain 100 % intelligible even when the noise level is several times the signal voltage. In the transmitter here described, the advantage of telephonic communication where rapid transfer of information is most required—*i.e.*, near an air port—is given by a special method of screen-grid modulation which gives short-range telephony. Flight tests have given a c.w. range up to 600 miles (fixed-type aerial).

### RECEPTION.

DIE VORAUSBERECHNUNG DER SELEKTIONSKURVEN VON HOCHFREQUENZVERSTÄRKERN (The Calculation in Advance of the Selectivity Curves of Radio-frequency Amplifiers).—P. Hermannspann. (*Telefunken-Zeit.*, No. 58, Vol. 12, 1931, pp. 53-58.)

Author's summary:—"A tuned r.f. amplifier consists of a greater or less number of tuned oscillatory circuits coupled together in various ways. In the following paper a procedure is given by which the selectivity curves of such amplifiers can very easily be calculated. By the use of certain approximations it is possible to make up 'curve tables' [families of characteristics] from which the result can be read off directly."

As abscissae, instead of the detuning  $p = \frac{\nu_0 - \nu}{\nu_0}$

a quantity  $y = \frac{\omega}{\omega_0} - \frac{\omega_0}{\omega}$  is taken (as suggested by

Runge): this brings both branches of the curve on to the same side of the ordinate axis. Generally the two branches do not exactly coincide, owing to the variation with frequency of the coupling resistance and the fact that the output voltage is usually taken up by a frequency-dependent resistance. For the writer's purposes a "mean" curve (an average between the two branches) is taken as satisfactory, and is obtained by assuming coupling and output resistances each independent of frequency.

BAND-PASS OR TONE CORRECTION?—F. M. Colebrook. (*Wireless World*, 2nd September, 1931, Vol. 29, pp. 228-231.)

An alternative to band-pass tuning as a means of obviating high-note loss with highly selective tuning circuits is put forward. A valve stage is so designed that its rising response characteristic when combined with the falling curve of the tuned circuit gives substantially a level overall response. Practical data are given for the design of a regenerative detector set capable of excellent quality of reproduction even when considerable reaction is applied.

DÉTECTION LINÉAIRE ET DÉTECTION DE PUISSANCE (Linear Detection and Power Grid Detection).—B. D. H. Tellegen. (*Rev. Gén. de l'Élec.*, 29th Aug., 1931, Vol. 30, pp. 324-328.)

USE OF AUTOMATIC [FIELD STRENGTH] RECORDING EQUIPMENT IN RADIO TRANSMISSION RESEARCH.—de Mars, Kenrick and Pickard. (*Proc. Inst. Rad. Eng.*, Sept., 1931, Vol. 19, pp. 1618-1633.)

Authors' summary:—This is an apparatus paper describing equipment recently developed for low frequency (17.8 kc.); intermediate frequency (770 kc.); and high frequency (69.25 kc.) field intensity recording. The circuits employed are presented and discussed with particular reference to expedients for obtaining nearly logarithmic scales (when used with Leeds and Northrup recording potentiometers). Typical records obtained with the aid of the equipment described are presented, and the salient characteristics of the high-frequency records (which show striking evidence of skip distance phenomena) are pointed out.

CORRECTIONS TO FIELD-STRENGTH MEASUREMENTS WITH LOOP ANTENNAE.—W. G. Baker and L. G. H. Huxley. (*Australian Radio Research Board Report No. 1*, 1931, pp. 7-22.)

Authors' summary:—The theory of the loop antenna is considered on the assumption of uniformly distributed capacity, and the ordinary transmission line theory applied. It is shown that in measuring loop resistance by the added resistance method, different results are obtained by adding the resistance at the centre or at the end

of the loop. Voltages introduced into the loop at the centre or end have different effects from distributed voltages.

In the application to field-strength measurements it is shown that in most cases a correction factor must be applied to the results, depending on the ratio of tuning capacity to the self-capacity of the loop. An experimental verification of the theory shows that in exaggerated cases close agreement can be obtained by several methods; but in those cases which would be expected to be most affected by non-uniformity of the capacity distribution there is a wide divergence in the results. Tables of the correction factors are given.

**A PORTABLE APPARATUS FOR MEASURING THE MAGNETIC FIELD STRENGTH IN AN ELECTRO-MAGNETIC WAVE.**—L. G. Vedy and A. F. Wilkins. (*Proc. Camb. Phil. Soc.*, July, 1931, Vol. 27, Part III, pp. 481-489.)

A description of an apparatus developed to satisfy the two conditions that the receiving loop aerial must be so arranged as to respond only to the magnetic field of the wave, and must not exhibit "antenna effect." "Accurate measurements are possible of magnetic fields corresponding to field strengths of 0.2 millivolts per metre. Special means of providing small known calibrating e.m.f.'s are described. The apparatus can be used to measure signals over the range 6 microvolts to 300 millivolts. Used in conjunction with a small portable vertical aerial, field strengths down to 2 microvolts per metre can be measured."

**THE ADJUSTMENT OF MODERN RECEIVERS.**—(*Wireless World*, 19th August, 1931, Vol. 29, pp. 174-177.)

Electrical adjustments grow more complicated with the introduction of new principles in receiver design. The author deals with the special difficulties attaching to ganged receivers, giving hints on the trimming of condensers and the matching of coils. Instability, usually due to some constructional fault or faulty components, must frequently be provided against, and care must be taken to see that screens are all properly earthed. Hints are given on tackling faults in the superheterodyne.

**IS THE S.G. VALVE A GOOD DETECTOR?**—M. G. Scroggie. (*Wireless World*, 12th August, 1931, Vol. 29, pp. 153-156.)

**APPLICATION OF PIEZOELECTRIC CRYSTALS TO RECEIVERS.**—R. R. Batcher. (*Electronics*, August, 1931, pp. 57-58.)

**THE STENODE RECEIVER AND THE SIDE BAND THEORY.**—C. L. Fortescue. (*This journal*, Aug., 1931, Vol. 8, pp. 427-428.)

A long letter on the correspondence dealt with in August Abstracts, p. 440.

**CARRIER WAVES AND SIDE-BANDS.**—Nisbet. (See under "Transmission.")

**RECEIVERS AT THE EIGHTH GERMAN RADIO EXHIBITION.**—(*Die Sendung*, 4th, 11th, and 18th September, 1931, Vol. 8, pp. 711-712, 735-736, and 759-760.)

**NOISE GENERATION WITHIN RADIO RECEIVERS [THERMAL AGITATION, SHOT EFFECT, SECONDARY EMISSION AND IONISATION: USE OF NEW TYPE 235 OR 251 EXPONENTIAL VALVES TO ELIMINATE THE PRE-SELECTOR SYSTEM].**—R. de Cola. (*Rad. Engineering*, Aug., 1931, Vol. 11, pp. 15-17.)

**SELECTIVE RECEPTION IN THE BROADCAST FREQUENCIES [SINGLE-KNOB CONTROL OF AERIAL SERIES INDUCTANCE AND CONDENSER].**—S. R. Winters: Jones and Yolles. (*Rad. Engineering*, Aug., 1931, Vol. 11, pp. 31 and 34.)

"The different inductance values of the antenna [series inductance] are each automatically connected in circuit for the whole tuning range of the [series] condenser during a complete or full revolution of the condenser rotor."

**A 5 IN. X 6 IN. X 9 IN. PORTABLE TWO-VALVE RECEIVER COVERING THE WAVE BAND 16-500 METRES.**—R. O. Brooke. (*QST*, Aug., 1931, Vol. 15, pp. 15-18.)

**D.C. SUPER-SELECTIVE FIVE.**—W. T. Cocking. (*Wireless World*, 12th and 19th August, 1931, Vol. 29, pp. 148-152 and 187-192.)

A five-valve d.c. mains-operated superheterodyne for the amateur constructor. The principal points in the specification are:—Band-pass tuning with six tuned circuits, ganged wave-band switching, non-radiating frequency changer, grid detection and pentode power output of 1500 milliwatts.

**SHORT-WAVE SUPERHETERODYNES.**—F. H. Haynes. (*Wireless World*, 26th August and 2nd September, 1931, Vol. 29, pp. 202-205 and 233-236.)

**EINE NEUE SUPERHET-RAHMENSCHALTUNG MIT ABSOLUTER EINKNOFFBEDIENUNG (A New Superheterodyne Frame Aerial Circuit with True Single-Knob Adjustment. Part I).**—E. Hentzschel. (*Rad., B., F. f. Alle*, Aug., 1931, pp. 351-357.)

**DER SUPERHET ALS FERNEMPFÄNGER DER ZUKUNFT (The Superheterodyne as the Long Distance Receiver of the Future).**—S. Brüller. (*Rad., B., F. f. Alle*, August, 1931, pp. 345-350.)

The writer arrives at the following specification for the perfect receiver:—(i) tuned screen-grid r.f. preliminary stage, with its rotating condenser coupled (with a correction adjustment) to the frame condenser; coils for broadcast range only. (ii) A stable input stage; only moderate amplification is necessary, thanks to the r.f. preliminary stage. Oscillator coils for broadcast range only. (iii) Band filter and two screen-grid l.f. stages for a fixed intermediate frequency between 1500 and 1700 m. (iv) A switch-over to long-wave reception on a small auxiliary indoor aerial and two stages of screen-grid r.f. amplification; the two intermediate-frequency transformers are here used as r.f. transformers in conjunction with the frame- and oscillator-circuit variable condensers. The small auxiliary aerial is also useful for joining to the

frame for *daytime* reception: the frame can thus be reduced to 40 x 40 cm. (v) Two l.f. stages with a power valve in a resistance-coupled output stage.

UNDESIRE RESPONSES IN SUPERHETERODYNES.—R. H. Langley. (*Electronics*, May, 1931, pp. 618-620.)

A FURTHER NOTE ON THE APPARENT DEMODULATION OF A WEAK STATION BY A STRONGER ONE.—Colebrook: Beatty: Butterworth. (See under "Properties of Circuits.")

VOLUME CONTROL BY VARIABLE CHOKE COILS.—Hoffmann.

(See under "Acoustics and Audio-frequencies.")

STANDARD SPECIFICATION FOR A.C. MAINS SUPPLY RECEIVERS.—British Engineering Standards Association.

(See abstract under "Acoustics and Audio-frequencies.")

THE CAUSES AND PREVENTION OF INTERFERENCE WITH BROADCAST RECEPTION.—A. Larsen. (*Elektrot. u. Maschbau*, No. 34, Vol. 49, 1931, pp. 641-648.)

Results of a research prompted by the Danish broadcasting authorities. Some new ideas as to preventive methods have been evolved.

THE OKABE "ELECTRONIC AMPLI-DETECTOR" AND ITS DEPENDENCE ON FILAMENT CURRENT.—Moore: Okabe.

(See abstract under "Transmission.")

#### AERIALS AND AERIAL SYSTEMS.

DISTRIBUTION OF RADIATION RESISTANCE IN OPEN WIRE RADIO TRANSMISSION LINES.—T. Walmsley. (*Phil. Mag.*, August, 1931, Supp. No., Series 7, Vol. 12, No. 76, pp. 392-396.)

Formulae due to Pistorius (1929 Abstracts, p. 329) are used to compute the radiation resistance of a single long line running above and parallel to (a) a perfectly reflecting, (b) a non-reflecting earth. Curves are also given showing the radiation resistance component of a half-wave vertical radiator due to a similar radiator spaced various distances away and the radiation resistance of sections, each half a wavelength long, of a single wire transmission line above (a) a perfectly reflecting, and (b) a non-reflecting earth.

The conclusions drawn from the curves are as follows: (1) Radiation from end sections is much greater than from other sections of equal length. (2) The radiation loss from long lines is not proportionately greater than from short lines. . . . The usual assumption that radiation losses limit the practicable length of transmission lines is incorrect, since short lines have almost as much radiation loss as long lines. The greatest loss in a long line is usually due to high frequency ohmic resistance."

TWO-METRE WAVE TRANSMITTER WITH SPECIAL REFERENCE TO ITS ANTENNA FEEDER.—Uda. (See under "Transmission".)

ÜBER NEUE DÄMPFUNGSMESSUNGEN AN HOCHFREQUENZ-ENERGIELEITUNGEN (New Measurements on the Damping in H.F. Feeders).—K. Baumann and H. O. Roosenstein: Gothe. (*Zeitschr. f. hochf. Tech.*, August, 1931, Vol. 38, pp. 73-77.)

The method used by the second writer in his former measurements (August Abstracts, p. 441) has the defect, when applied to concentric-tube feeders, that the outer tube has to be drilled at several points near the potential node. This is particularly objectionable when a large range of wavelengths has to be examined. The present paper describes a new method (suggested by Gothe) depending on the fact that the logarithmic decrement with respect to time of a standing wave in a line is equal to the product of the wavelength and the damping constant (with respect to space) of a wave of the same length passing along that line.

The outline of the procedure is as follows:—the logarithmic decrement of the standing wave is measured by (a) obtaining a resonance maximum reading on the "receiving circuit" indicating instrument, (b) increasing the power to the oscillator (by a plate potential increase) till its associated meter indicates an output  $\sqrt{2}$  times the original, and (c) detuning the oscillator till the received oscillations fall to the original reading on the indicating instrument. Then the standing wave decrement is given by  $\delta = 2\pi\Delta\lambda/\lambda$ , from which the damping constant  $\beta$  for a wave passing along the feeder is obtained by the relation  $\delta = \beta\lambda$ . Actually, the oscillator condenser is swung on either side of the resonance point and the difference between the two new wavelengths read off, instead of the difference between one wavelength and the original resonance wavelength.

EIN NEUE METHODE ZUR SPANNUNGSMESSUNG AN PARALLELDRAHTSYSTEMEN (A New Method of Potential Measurement in Parallel Wire [Lecher Wire: Feeder] Systems).—L. Rohde and F. Bahnemann. (*E.N.T.*, August, 1931, Vol. 8, pp. 335-336.)

Rohde has already described a method of measuring potentials of frequency  $10^8$  c.p.s. (July Abstracts, p. 393) and the present paper describes the application of this method to the direct measurement of potential on parallel-wire feeders, where the essential point is that the measuring apparatus shall not upset the current and potential distribution in the wires. The special valve, with its two filaments in series and its two anodes, is therefore made as small as possible.

ÜBER DIE UNSYMMETRIE VON HOCHFREQUENZLEITUNGEN (The Asymmetry of H.F. Feeders).—H. O. Roosenstein. (*Telefunken-Zeit.*, No. 58, Vol. 12, 1931, pp. 45-50.)

Concentric tube feeders give complete electrical symmetry and no radiation, but where the cheaper 2- and 4-wire feeders are used it is necessary (to reduce radiation to a minimum) to maintain as high a degree of symmetry as possible, *i.e.*, to see that currents and potentials are equal and opposite at every point of the feeder. As the literature on

the nature and the causes of asymmetry is very scanty, the present paper investigates these points.

The writer deals with the oscillations in the feeder as the sum of two types, an in-phase oscillation and an opposed-phase oscillation: Fig. 41 shows how, in a typical practical case, such a superposition of unwanted in-phase oscillation on the wanted opposed-phase oscillation occurs as the result of parasitic capacities between transformer windings. The total effect of the in-phase component in the feeder depends on the construction of the latter, the phase difference between the two components, and the ratio of their amplitudes. Various typical cases are examined, and the general rule is arrived at that to obtain symmetrical oscillation in a feeder it is necessary and sufficient that all the apparatus associated with the feeder should be symmetrical with respect to earth.

Practical methods of accomplishing this are briefly discussed; a three-plate condenser is often useful. For testing purposes, a wire rectangle including a thermo-ammeter is arranged in the plane of symmetry of the feeder: symmetrical oscillation gives a zero reading. Fig. 45 shows how a feeder radiation, so strong as to cause the lamps in the building to light up, was reduced to negligible proportions by introducing a capacity (in the form of an insulated wire of the correct length), in the earth lead.

VERSUCHE ÜBER DIE ABSTIMMUNG VON RICHT-ANTENNEN BEI KURZEN WELLEN (Experiments on the Tuning of Directional [Lecher Wire Type] Short Wave Aerials).—F. Kiebitz. (*T.F.T.*, Aug, 1931, Vol. 20, pp. 239-242.)

Author's summary:—A two-lead system, resembling a Lecher wire pair, has been investigated as regards its use as an aerial. The transmitting tests are not yet completed; receiving tests have shown the possibility of receiving all the big short-wave stations of the world on a 180-metre long pair with  $\frac{1}{2}$ -metre spacing, and of tuning this aerial to all the various wavelengths in question, whereas the usual beam aerial can only be used for one special wavelength.

THE GROUNDED CONDENSER ANTENNA RADIATION FORMULA.—W. H. Wise. (*Proc. Inst. Rad. Eng.*, Sept., 1931, Vol. 19, pp. 1684-1689.)

Author's summary:—Exact formulas for the wave function and vertical electric field at the surface of the ground are derived for a vertical dipole of zero height.

NOTE SUR LE CALCUL DES ANTENNES DIRIGÉES (Note on the Calculation of Directive Aerials).—J. Loeb. (*Ann. des P.T.T.*, July, 1931, Vol. 20, pp. 596-601.)

Taking the case of an aerial system, without reflector, of  $n$  vertical wires with spacing  $a$ , and assuming the earth to be a perfect dielectric of s.i.c. equal to unity, the writer arrives at the following results:—for all systems with the same width of bay, the best directive efficiency (power radiated in favoured direction/total power radiated) is given by the system with the greatest number of

wires; but above a comparatively small value for this number the efficiency only increases very slightly; on the other hand, it increases in proportion to  $q^2$ , without tending to a limit, where  $q$  is the ratio bay width/wavelength.

THE ENERGY MAGNIFICATION OF BROADSIDE AERIAL ARRAYS USED FOR RECEPTION.—E. Green. (*Marconi Review*, July-August, 1931, No. 31, pp. 9-14.)

The calculation gives the following values for the energy magnification per square wavelength, for a broadside aerial array with reflector, compared with the specified single aerials:—(a) small aerial near earth, 16.8; (b) ditto in free space, 8.4; (c) half-wave aerial in free space, 7.7; (d) ditto, lower end at earth, 10.9; (e) ditto,  $\frac{1}{4} \lambda$  above earth, 7.4.

The aerial with reflector, properly adjusted, behaves as an ideal black body; it would therefore appear inadvisable to use reaction directly on the feeder of such a system.

ÜBER DAS STRAHLUNGSFELD DER DIPOLANTENNE (The Radiation Field of a Dipole Aerial).—R. Bechmann. (*Telefunken-Zeit.*, No. 57, Vol. 12, 1931, pp. 43-46.)

Transforming Abraham's expressions (first approximation: undamped oscillations) from elliptical to cylindrical co-ordinates, the writer shows that the equations obtained are identical with those obtained by himself from the Hertzian vector (*March Abstracts*, p. 155). For a more general treatment, in which the radiation fields not only of the fundamental oscillation (to which the above is limited) but also of any desired harmonic are dealt with, see the following reference.

ZUR ABRAHAM'SCHEN DARSTELLUNG DES STRAHLUNGSFELDES EINES STABFÖRMIGEN LEITERS (On Abraham's Formulation of the Radiation Field of a Rod Conductor).—R. Bechmann. (*Zeitschr. f. hochf. Tech.*, July, 1931, Vol. 38, pp. 30-32.)

See preceding abstract.

REDUCTION OF POWER LOSSES BY INSULATED SECTIONAL TOWERS AT WHK.—(*Rad. Engineering*, Aug., 1931, Vol. 11, pp. 21-22.)

#### VALVES AND THERMIONICS.

DAS MAGNETRON ALS NEGATIVER WIDERSTAND (The Magnetron as a Negative Resistance).—H. E. Hollmann. (*Ann. der Physik*, 1931, Series 5, Vol. 8, No. 8, pp. 956-974.)

Author's summary:—The magnetron characteristics of a diode, placed in a magnetic field which is perpendicular to the electric field vector, show a deviation from the course predicted by theory when remains of gas are present in the tube; this is caused by increased filament heating due to bombardment by positive gaseous ions. The resulting negative resistance of the magnetron diode is not suitable for the production of high frequency oscillations, owing to the inertia of this subsidiary heating effect.

If the magnetic field is inclined to the direction

of the electric field, further anomalies of the magnetron characteristics appear which remain even with the highest vacua and give rise to negative internal resistance of the magnetron within limited regions; high frequency oscillations may then be generated. Theoretical considerations show that in this case the electrons describe spiral paths and the anomalies may be traced to their cutting the edge of the metal sheet of which the anode consists. The principle is identical with that of the known Habann generator, except that in this the electron paths desired are obtained by separate electric and magnetic auxiliary fields.

It is shown that the ultra-short-wave electron oscillations in the magnetron occur independently of the regions of negative resistance. From the increased transit time of the electrons there results a frequency limit, lying below the electron oscillations, at which the dynamical current-voltage characteristic is inverted. Slutzkin and Steinberg found an increase in the energy of the electron oscillations when the valve is inclined at an angle to the magnetic field, and this has been confirmed independently of the foregoing anomalies.

Die ABWEICHUNGEN DER VERSTÄRKERRÖHRENKENN-LINIEN VOM  $e^{3/2}$ -GESETZ (The Deviations of Amplifier Valve Characteristics from the  $e^{3/2}$  Law).—H. Kniepkamp. (*T.F.T.*, March, 1931, Vol. 20, pp. 71-76.)

THE VARIATION OF THE RESISTANCES AND INTER-ELECTRODE CAPACITIES OF THERMIONIC VALVES WITH FREQUENCY.—L. Hartshorn: W. E. Benham. (*This journal*, Aug and Sept., 1931, Vol. 8, pp. 413-421, 488-489.)

A NEW METHOD OF MEASURING VACUUM TUBE CHARACTERISTICS.—J. R. Barnhart. (*Rad. Engineering*, July, 1931, Vol. 11, pp. 30-31.)

A circuit is given which, by the manipulation of suitable keys, will give rapid measurements of mutual conductance, amplification factor, and plate resistance; measurements of actual magnitudes of currents and voltages are not involved. Thus the procedure is to read the anode-current deflection with a switch in one position, to switch over to a second position, and to turn a knob until the meter reading is the same as before.

DER EINFLUSS CHEMISCHER UND CHEMISCH-PHYSIKALISCHER VORGÄNGE AN DER OBERFLÄCHE HOCHSCHMELZENDER METALLE AUF DIE GLÜHELEKTRISCHEN EIGENSCHAFTEN — ZUR DEUTUNG DER DIE THERMOELEKTRONENEMISSION BEEINFLUSSENDEN WIRKUNG MONOATOMARER SCHICHTEN (The Influence of Chemical and Chemico-Physical Processes at the Surface of High Melting Point Metals on the Thermionic Properties—Contribution to the Explanation of the Influence of Monatomic Layers on Thermionic Emission [Recapitulatory Account with bibliography]).—K. Becker (*Physik. Zeitschr.*, 1st July, 1931, Vol. 32, No. 13, pp. 489-507.)

VERSUCHE ÜBER DIE EIGENSCHAFTEN DER ATOMSCHICHTEN (Experiments on the Properties of Atomic Layers).—P. Lukirsky, A. Sosina, S. Wekschinsky and T. Zarewa. (*Zeitschr. f. Phys.*, 1931, Vol. 71, No. 5/6, pp. 306-324.)

Investigations of the contact potential of a thin metallic layer, sprayed *in vacuo* on another metal as basis.

TRANSMISSION OF ELECTRONS THROUGH POTENTIAL BARRIERS.—N. H. Frank and L. A. Young. (*Phys. Review*, 1st July, 1931, Series 2, Vol. 38, No. 1, pp. 80-86.)

ELECTRONENEMISSIE EN GELEIDINGSVERMOGEN BIJ AARDALKALI-OXYDEN (Electron Emission and Conductivity in Oxides of the Alkaline Earths).—W. Albricht. (*Physica*, No. 5, Vol. 11, 1931, pp. 146-149.)

An approximately linear relation during the formation of the oxide is found between electrical conductivity and electronic emission at a constant temperature in a high vacuum. An explanation is suggested.

TABLES OF GERMAN VALVES.—(*Die Sendung*, 28th Aug. and 4th Sept., 1931, Vol. 8, pp. 695-715.)

Including receiving, oscillator, and amateur transmitting valves.

BLUE GLOW ON GLASS OF PENTODES—A SIGN OF HIGH VACUUM AND NOT OF GAS.—(*Rad. Engineering*, Aug., 1931, Vol. 11, p. 48.)

THE VARIABLE-MU VALVE.—R. O. Carter. (*Wireless World*, 9th and 16th September, 1931, Vol. 29, pp. 250-252 and 300-303.)

A full description of the theory and performance of the first British variable-mu screen-grid valve—the Osram V.M.S.4.

SOME CHARACTERISTICS OF THYRATRON.—J. C. Warner. (*Proc. Inst. Rad. Eng.*, Sept., 1931, Vol. 19, pp. 1561-1568.)

TUBE LIFE MEASUREMENTS: THE WATT-HOUR METER METHOD.—V. V. Gunsolley. (*Rad. Engineering*, July, 1931, Vol. 11, p. 32.)

#### DIRECTIONAL WIRELESS.

UN NOUVEAU RADIOGONIOMÈTRE À LECTURE DIRECTE (A New Direct-reading Direction Finder).—J. Marique: Braillard and Goldschmidt. (*L'Onde Elec.*, Aug., 1931, Vol. 10, pp. 355-362.)

Marique has recently developed the Braillard-Goldschmidt principle described in 1920, according to which the maxima and minima of the currents received on a continuously rotating frame, or search-coil of a goniometer, are made visible on a drum carried on the same axis, either by some kind of stylus-recording or by a spot of light which forms, by the persistence of vision, a continuous curve along the ground-glass surface of



the drum. Marique concentrates on the optical method, but improves it so that the complete curve can be seen at a glance on a flat ground-glass plate, in a form analogous to the figure-of-eight polar diagram. Signals from an open aerial are combined with those from the frame so as to render the figure free from ambiguity. In the absence of signals, the spot of light describes a circle of about 10 cm. diameter, which lies on or close to a graduated circle engraved on the glass.

An experimental model on these lines has been developed by the Technical Aeronautical Service of Belgium. Photographs of some typical diagrams (one on speech from Daventry) are given and discussed. One great advantage claimed over aural or direct-reading pointer-instrument methods is that the shape of the curve is always visible, so that one can see what is happening and use one's judgment. The fact that permanent records can be made photographically is of importance. The possibility is discussed of making permanent records on two beacons working on the same wave but with different modulation frequencies.

Finally, it is suggested that the apparatus may be useful in the study of the propagation of waves.

ROTATING WIRELESS BEACON TRANSMITTER.—Marconi Co. (*Engineer*, 14th August, 1931, Vol. 152, p. 159.)

The Marconi Company has recently acquired from the Air Ministry the commercial rights for the design and erection of rotating wireless beacons, and a beacon station at Rangoon for the use of ships is to be erected. It will operate on a wavelength of 1,050 m. with a maximum power of 2 kw. at the anodes of the transmitting valves.

A SIMULTANEOUS RADIOTELEPHONE AND VISUAL RANGE BEACON FOR THE AIRWAYS.—F. G. Kear and G. H. Wintermute. (*Bur. of Stds. Journ. of Res.*, August, 1931, Vol. 7, No. 2, pp. 261-287.)

A full description of the system (referred to in March Abstracts, p. 157) by which the equi-signal beacon signals can be received on the visual receiver at the same time that the telephony signals (weather service, etc.) are heard.

A COURSE INDICATOR OF POINTER TYPE ["REED CONVERTER"] FOR THE VISUAL RADIO RANGE BEACON SYSTEM.—F. W. Dunmore. (*Proc. Inst. Rad. Eng.*, Sept., 1931, Vol. 19, pp. 1579-1605.)

See October Abstracts, p. 559.

THE MARCONI-ADCOCK DIRECTION-FINDING AERIAL.—(*Marconi Review*, July-August, 1931, No. 31, pp. 21-24.)

The theoretical principles involved in the design [1930 Abstracts, p. 511] are discussed, and it is shown that the results obtained are in accordance with these principles. . . . Everything is explained in terms of the currents and charges on the feeder which can be definitely specified. The misuse of the idea of the poten-

tial of the earth had been responsible for the argument that the system cannot eliminate the horizontal component, and for this reason it is not considered valid."

SUR LA DÉTERMINATION DU POINT PAR LA RADIOGONIOMÉTRIE (The Determination of a Point by Radiogoniometry).—Ch. Bertin. (*Comptes Rendus*, 31st August, 1931, Vol. 193, pp. 394-395.)

The use of Bertin Tables is described; they solve the nine equations involved, suppressing all work with logarithms. Particular application to aerial navigation is mentioned.

RADIO TRACKING OF METEOROLOGICAL BALLOONS.—W. R. Blair and H. M. Lewis. (*Proc. Inst. Rad. Eng.*, September, 1931, Vol. 19, pp. 1531-1560.)

### ACOUSTICS AND AUDIO-FREQUENCIES.

PERCENTAGE HARMONIC DISTORTION [AND THE OPTIMUM RATIO OF LOAD TO VALVE RESISTANCE].—W. Greenwood: Scroggie: G.W.O.H. (*This Journal*, August, 1931, Vol. 8, pp. 428-429.)

A letter pointing out that the usual formula for the distortion,

$$K = \frac{I_1 + I_2 - 2I_0}{2(I_2 - I_0)},$$

rejected by Scroggie and reinstated in an editorial (Sept. Abstracts, p. 504) does not apply to the "modern practice" of feeding the anode through an i.f. choke and connecting the load (through a blocking condenser) between anode and filament, except in the particular case where the resistance of the choke  $R_c$  equals the load resistance  $R$ . He gives the full formula for the circuit, namely,

$$K = \frac{(I_2 - I_1) - 2I_0}{(I_2 - I_1) \left\{ 1 + \left( \frac{R_0 + R}{R_0 + R_c} \right) \right\}},$$

from which it is seen that if  $R$  is large compared with  $R_c$  the harmonic ratio will be appreciably less than for the "series" connection for the same values of  $I_1$ ,  $I_2$ , and  $R$ . If, as seems desirable, the optimum load resistance is taken as that which produces a given amount of harmonic distortion, and if this is taken as 5%, it very often happens that the optimum load resistance works out at twice the valve resistance: but if a figure of 2% is taken, the ratio with modern valves may be as much as 10.

DÉTERMINATION DU POINT DE FONCTIONNEMENT DE LA DERNIÈRE LAMPE "BASSE FRÉQUENCE" (Determination of the Working Point of the Final L.F. Valve [using a Graduated "Distortion Rule"]).—F. Bedeau and J. de Mare. (*I.S.F. Moderne*, March, 1931, Vol. 12, pp. 111-119.)

ÜBER DIE BEMESSUNG VERZERRUNGSFREIER GROSSELEISTUNGS-ENDSTUFEN (The Design Calculations of Distortionless Large Power Output Stages).—A. Forstmann. (*E.T.Z.*, 23rd July and 6th August, 1931, Vol. 52, pp. 957-961 and 1033-1035.)

Author's summary:—"The general conditions

governing the size of the maximum available output are first given, and then the conditions for the avoidance of distortion are set out. Next, the size of the output in dependence on the wave form is investigated, and conditions are found to be more favourable for non-linear than for linear oscillations [by "linear oscillations" are meant those in which the sinusoidal a.c. grid potentials retain their form in the anode circuit. The "non-linear" oscillations, in which this is not the case, can only be used with a push-pull circuit under certain conditions; otherwise, non-linear distortion is introduced]. Finally, the design calculations of the output circuit using an output transformer are investigated, and the conditions given for the avoidance of distortion." For previous work by the same author, see August Abstracts, p. 442.

**PUSH-PULL PROBLEMS.**—Cocking. (See under "Properties of Circuits.")

**THE METHOD OF OPERATION AND WORKING CONDITIONS OF THE PUSH-PULL CONNECTION IN L.F. AMPLIFIERS.**—Forstmann.

(See under "Properties of Circuits.")

**A SIMPLE METHOD OF HARMONIC ANALYSIS FOR USE IN RADIO ENGINEERING PRACTICE.**—Roder.

(See under "Subsidiary Apparatus," last column.)

**BRITISH STANDARD SPECIFICATION FOR MAINS SUPPLY APPARATUS FOR RADIO AND ACOUSTIC REPRODUCTION FOR USE ON A.C. MAINS.**—British Engineering Standards Association. (Standard Specification No. 415, 1931.)

Including a definition of quality or grade as regards output hum: quality factor =

$$\frac{K}{\text{Ripple voltage (in volts, R.M.S.)}}$$

where  $K$  has the following values for the various tapping points:—output stage (max. output voltage), 1.0; intermediate amplifier stage, 0.07; detector stage, 0.002; r.f. stages with capacity-resistance coupling to subsequent stages, 0.002; r.f. stages with r.f. transformer coupling or with capacity-tuned circuit coupling to subsequent stages, 1.0.

**THE VIBRATIONS OF MEMBRANES AND PLATES.**—R. C. Colwell. (*Phil. Mag.*, Aug., 1931, Supp. No., Series 7, Vol. 12, No. 76, pp. 320-328.)

A theoretical investigation of possible nodal lines on a vibrating membrane or plate, with examples of results obtained in practice using a valve oscillator to generate the vibrations.

**A CANONICAL TRANSFORMATION AND THE VIBRATIONS OF A LOADED STRING.**—R. B. Lindsay. (*Phys. Review*, 1st Aug., 1931, Series 2, Vol. 38, No. 3, pp. 491-500.)

**SOME PHYSICAL CHARACTERISTICS OF SPEECH AND MUSIC.**—H. Fletcher. (*Bell Tech. Journ.*, July, 1931, Vol. 10, No. 3, pp. 349-373.)

**SUBJECTIVE INTERPRETATION OF LOUDSPEAKER FREQUENCY RESPONSE CURVES IN TERMS OF LOUDNESS.**—D. A. Oliver. (*Nature*, 15th Aug., 1931, Vol. 128, p. 268.)

**LAUTSTÄRKEREGULIERUNG DURCH REGELDROSSELN (Volume Control by Variable Choke Coils).**—K. Hoffmann. (*E.N.T.*, August, 1931, Vol. 8, pp. 331-335.)

The use of a suitable variable inductance, connected so as to behave as an auto-transformer, is in some cases preferable to the use of the common "potentiometer" (ohmic potential divider): when, for example, the additional load on the generator, provided by such an ohmic resistance, is undesirable. The writer examines the calculation and design of a variable choke coil which will give regulation with a flat frequency characteristic, uniform scale, and freedom from adjustment noise.

**STUDY OF ACOUSTIC FILTERS—THE GENERAL THEORY (I).**—K. Kobayashi. (*Journ. I.E.E. Japan*, April, 1931, Vol. 51, pp. 40-42.)

"The general structure of acoustic filters may be given by a uniform tube having membranes on its ends and on its side wall. By the suitable choice of such membranes, various forms of acoustic filter can be derived from this general structure. For this purpose, membranes on the side wall may either be real or fictive. Such a structure . . . has the advantage of being more general in its nature and simpler in its equivalent electrical network than that recently given by Mason (1930 Abstracts, p. 459). In addition, the introduction of membranes on the ends of the tubes gives many varieties in the construction of acoustic filters."

**DIE AKUSTISCHE UNTERSCHIEDSEMPFINDLICHKEIT UND DAS DEZIBEL (The Acoustic Difference-Sensitivity and the Decibel).**—F. Aigner. (*E.N.T.*, August, 1931, Vol. 8, pp. 367-368.)

**RECENT DEVELOPMENTS IN ACOUSTICS, PARTICULARLY APPLIED ACOUSTICS (Continued).**—F. Trendelenburg. (*Zeitschr. f. hochf. Tech.*, Aug., 1931, Vol. 38, pp. 80-84.)

This instalment deals with speech and hearing.

**SUR LA VITESSE DE PROPAGATION DES SONS MUSICAUX (The Velocity of Propagation of Musical Sounds).**—R. de la Boulaye and G. Balme: Vautier. (*Comptes Rendus*, 10th August, 1931, Vol. 193, pp. 317-318.)

**UNIFICATION DE TOUS LES FORMATS D'INSTRUMENTS À CORDES (Unification of All Types of String Instruments).**—P. Bizos and —. Tarlé. (*Comptes Rendus*, 27th July, 1931, Vol. 193, pp. 229-230.)

A short note on some experiments with a view to making one instrument (e.g., a violin) yield at will the volume and timbre of different instruments of the same family (viola, violoncello or double bass) by placing the point of a special pick-up on the bridge (or some other strongly vibrating part of the instrument) and leading the output, suitably amplified, to a loud speaker.

THE VIERLING METHOD OF IMPROVING THE TONE AND VOLUME OF MUSIC FROM VARIOUS TYPES OF INSTRUMENT: DIRECT CONVERSION OF THE MECHANICAL VIBRATIONS INTO ELECTRICAL VARIATIONS.—O. Vierling. (*Rad., B., F. f. Alle*, August, 1931, pp. 341-342.)

See also Barton Chapple, on the direct broadcasting of piano music, *May Abstracts*, p. 272; also preceding abstract.

ABSOLUTE AMPLITUDES AND SPECTRA OF CERTAIN MUSICAL INSTRUMENTS AND ORCHESTRAS.—Sivian, Dunn and White. (*Journ. Acoust. Soc. Am.*, Jan., 1931, Vol. 2, pp. 330-371.)

NEW ALL-ELECTRIC PIPELESS ORGAN.—(*Wireless World*, 22nd July, 1931, Vol. 29, pp. 100-101.)

"KEYBOARD" DEVICE FOR CONTROLLING THE OSCILLATOR FREQUENCY IN ELECTRICAL MUSICAL INSTRUMENTS. (French Pat. 703189, Lertes and Helberger, pub. 25th April, 1931.)

A long conductor connected to the grid lies in close juxtaposition to a long resistance below it, down which a p.d. is maintained by a battery. Pressure at any point of the long conductor makes contact with the corresponding point on the resistance.

AUTOMATIC COLOR ORGAN.—E. B. Patterson. (*Proc. Inst. Rad. Eng.*, Aug., 1931, Vol. 19, pp. 1334-1346.)

AUDITION BY BONE CONDUCTION.—C. E. Dean. (*Journ. Acoust. Soc. Am.*, Oct., 1930, Vol. 2, pp. 281-296.)

### PHOTOTELEGRAPHY AND TELEVISION.

ULTRAKURZWELLEN - FERNSEHEN (Ultra - Short - Wave Television).—F. Schröter. (*Telefunken-Zeit.*, No. 58, Vol. 12, 1931, pp. 5-12.)

A theoretical treatment of television reception leading to practical conclusions as to the transmitting power required, the minimum decrement of the receiving circuit, etc. (See Sept. Abstracts, p. 507, and these Abstracts, under "Stations.") It has been found that with a vertical dipole mounted about 50 m. above the ground an effective aerial current of about 2 A. is necessary to yield, at a distance of 5 km., a potential of 20 millivolts at the grid of an audion with strong reaction which will give good loud-speaker strength when followed by three l.f. stages." For television, on the other hand, where the minimum decrement of the receiving input circuit is taken as 0.01, the radiated energy must be increased 25 times: that is why the original 300-watt modulated r.f. power is being increased to 7.5 kw. for television (Sept. Abstracts, p. 514). If, for the best optical utilisation of 10,000 elements, it is desired to use a higher decrement than 0.01, it will be necessary to use one or more stages of r.f. amplification—"which is quite practicable in spite of the great band width." But a more sensitive light-control device is badly needed, to cut down the necessary l.f. stages: the writer is

inclined to favour the cathode-ray tube in this connection.

TELEVISION RECEPTION ABROAD [ROME RECEPTION OF LONDON EXPERIMENTAL TRANSMISSIONS].—R. Bocchi. (*Television*, June, 1931, Vol. 4, pp. 155-157.)

THE BAIRD PORTABLE TELEVISION TRANSMITTER.—S. A. Moseley. (*Television*, May, 1931, Vol. 4, p. 85.)

VARIATION DANS LE SPECTRE DE LA SENSIBILITÉ DES CELLULES AU PROTOXYDE DE CUIVRE (Variation with Wavelength of the Sensitivity of Cuprous Oxide Photoelectric Cells).—P. Auger and C. Lapique. (*Comptes Rendus*, 10th Aug., 1931, Vol. 193, pp. 319-321.)

The sensitivity curve is found to vary (in shape and position of maxima) according to the metal composing the transparent (sputtered) electrode. The writers suggest, and confirm by experiment, that this is due to differences in the transparency of the sputtered film. They mention also that between 5750 and 6500 A.U. an inverse photoelectric effect occurs at the surface oxide/copper, this surface being reached by the yellow and red rays owing to the transparency of the oxide to those wavelengths.

COPPER/COPPER-OXIDE/LEAD NITRATE PHOTOVOLTAIC CELL FOR INDUSTRIAL PURPOSES.—C. G. Fink and D. K. Alperin. (*Trans. Am. Electrochem. Soc.*, Vol. 58, pp. 275-295.)

The full paper on the cell referred to in March Abstracts, p. 161. Sensitivity is 150  $\mu$ A. per lumen, and the characteristic is linear between 0 and 100 lumens. Maximum response is at about 4600 A.U. The cell responds to audio-frequency light variations without noticeable distortion.

PHOTOELECTRIC CELL COMBINING THE ADVANTAGES OF HIGH-VACUUM AND GAS-FILLED CELLS: THE USE OF SECONDARY EMISSION.—(French Pat. 700897, Comp. Thomson-Houston, pub. 9th March, 1931.)

A high-vacuum cell in which the collector or anode takes the form of a wide-meshed grid bisecting the angle between the primary and secondary cathodes. The light strikes the primary cathode and sets free electrons which are driven to the grid. Some pass through the grid and set free secondary electrons from the secondary cathode, and these also are directed to the grid.

THE WAVE-LENGTH SENSITIVITY CURVE OF A CESIUM OXIDE PHOTOCCELL; A NEW LIGHT-SENSITIVE INSTRUMENT FOR THE ULTRAVIOLET.—T. F. Young and W. C. Pierce. (*Journ. Opt. Soc. Am.*, Aug., 1931, Vol. 21, pp. 497-501.)

"The construction and characteristics of a quartz-enclosed cesium oxide cell are described. Such a cell is very sensitive to ultraviolet light of very short wavelengths, at least as short as 2390 A.U."

INERTIA IN GAS-FILLED PHOTOELECTRIC CELLS.—F. Schröter and G. Lubszynski. (*Television*, May, 1931, Vol. 4, pp. 115-117.)

Final instalment of an English rendering of the paper referred to in February Abstracts, p. 102.

IONIZATION IN GAS-FILLED PHOTOELECTRIC CELLS: (I) THE INERT GASES IN CAESIUM ON SILVER PHOTOELECTRIC CELLS, AND (II) TIME LAG IN GAS-FILLED PHOTOELECTRIC CELLS.—W. F. Tedham. (*Phil. Mag.*, August, 1931, Supp. No., Series 7, Vol. 12, No. 76, pp. 224-232.)

A short account of experiments on the relative advantages of the inert gases as gas-fillings in photoelectric cells; the author finds that "an amplification of five is usually practical at illuminations as high as 0.16 lumen and with a cathode sensitivity of about 6 microampères per lumen. By using low pressures and high voltages, greater amplification is obtained for a gas of high atomic number."

It is suggested that cumulative ionisation, including the formation of metastable ions, may be a possible explanation of time lag.

EFFECT OF ELECTRIC FIELDS ON THE EMISSION OF PHOTOELECTRONS FROM OXIDE CATHODES.—W. S. Huxford. (*Phys. Review*, 1st Aug., 1931, Series 2, Vol. 38, No. 3, pp. 379-395.)

Author's summary:—A study has been made of the photoelectric emission obtained at room temperature from the equipotential oxide cathodes commonly employed in radio receiving tubes. With a double monochromator, long-wave limits were determined by plotting the currents as a function of the wave-length of the incident radiation. The threshold frequencies decreased with increase in the accelerating potential according to the relation,  $\nu = \nu_0 - bE^2$ , in which  $\nu_0$  is the "zero-field" threshold and  $E$  the electric field at the cathode surface. It is shown that the observed lack of saturation in the photo-currents may be ascribed to a decrease of work function with increase of applied field. The tendency to non-saturation is greatest for light of longest wavelength. Calculations show that the photoelectric equation of Houston satisfactorily represents the variation in numbers of emitted electrons with colour of illumination, and with change of threshold. Some comparisons are made of the photo-emission and the thermionic currents obtained from the same cathode surface. There is a change in photoelectric threshold with activation. Preliminary measurements of thermionic work functions confirm the theory that in both cases the emission of electrons takes place from the outermost layers of the oxide coating.

VERWENDUNG DES SPITZENZÄHLERS BEI MESSUNGEN ÄUSSERER LICHTELEKTRISCHER WIRKUNG (Application of the [Geiger] Point Counter to Measurements of the External Photoelectric Effect).—H. Bauer. (*Zeitschr. f. Phys.*, 1931, Vol. 71, No. 7/8, pp. 532-550.)

"The electrons set free *in vacuo* from metals and insulators respectively by spectrally analysed

light are accelerated by an electric field and shot into a point counter. By counting the single electrons which enter the counter it can be determined which of the spectral lines of the quartz mercury arc is just acting and which are no longer effective. In this way limits were found for the position of the long wave boundary for the following metals evaporated in a high vacuum: *Au, Ag, Cu, Zn, Pb, Cd, Al*, and for the insulators: ebonite, amber, sulphur and paraffin. Results are shown in tabular form. One of the chief advantages of this method lies in the possibility of investigating insulators, for which there were hitherto no reliable measurements of the external photoelectric effect in a high vacuum and in spectrally analysed light."

PHOTOELEKTRISCHE EIGENSCHAFTEN DER UNTER DER WIRKUNG VON WASSERSTOFFATOMEN GEÄNDERTEN KALIUMOBERFLÄCHE (Photoelectric Properties of a Potassium Surface Acted on by Hydrogen Atoms).—S. Rijanoff. (*Zeitschr. f. Phys.*, 1931, Vol. 71, No. 5/6, pp. 325-338.)

SOME REMARKS ON THE THEORY OF THE PHOTOELECTRIC EFFECT.—J. Frenkel. (*Phys. Review*, 15th July, 1931, Series 2, Vol. 38, No. 2, pp. 309-320.)

PHOTOELECTRIC PROPERTIES OF THIN UNBACKED GOLD FILMS.—R. P. Winch. (*Phys. Review*, 15th July, 1931, Series 2, Vol. 38, No. 2, pp. 321-324.)

PHOTOELECTRIC AND METASTABLE ATOM EMISSION OF ELECTRONS FROM SURFACES.—C. Kenty. (*Phys. Review*, 15th July, 1931, Series 2, Vol. 38, No. 2, pp. 377-378.)

TRANSMISSION OF ELECTRONS THROUGH POTENTIAL BARRIERS.—N. H. Frank and L. A. Young. (*Phys. Review*, 1st July, 1931, Series 2, Vol. 38, No. 1, pp. 80-86.)

THE ANALYSIS OF PHOTOELECTRIC SENSITIVITY CURVES FOR CLEAN METALS AT VARIOUS TEMPERATURES.—R. H. Fowler. (*Phys. Review*, 1st July, 1931, Series 2, Vol. 38, No. 1, pp. 45-56.)

PHOTOELECTRIC PROPERTIES OF ZINC SINGLE CRYSTALS.—J. H. Dillon. (*Phys. Review*, 1st Aug., 1931, Series 2, Vol. 38, No. 3, pp. 408-415.)

THE EFFECT OF ADSORBED  $K^+$  IONS ON THE PHOTOELECTRIC THRESHOLD OF IRON.—A. K. Brewer. (*Phys. Review*, 1st Aug., 1931, Series 2, Vol. 38, No. 3, pp. 401-407.)

RELATIVISTIC THEORY OF THE PHOTOELECTRIC EFFECT. PART I.—THEORY OF THE K-ABSORPTION OF X-RAYS. PART II.—PHOTOELECTRIC ABSORPTION OF ULTRAGAMMA RADIATION.—H. Hall: H. Hall and J. R. Oppenheimer. (*Phys. Review*, 1st July, 1931, Series 2, Vol. 38, No. 1, pp. 57-79.)

SOME PHOTOELECTRIC PROPERTIES OF MERCURY FILMS.—D. Roller, W. H. Jordan and C. S. Woodward. (*Phys. Review*, 1st August, 1931, Series 2, Vol. 38, No. 3, pp. 396-400.)

PHOTOELECTRIC ABSORPTION OF ULTRA-GAMMA RADIATION.—H. Hall and J. R. Oppenheimer. (*Phys. Review*, 1st Aug., 1931, Series 2, Vol. 38, No. 3, p. 589.)

LA FOTOELETTRICITÀ NEI SUOI RECENTI SVILUPPI TEORICI ED APPLICATIVI (Recent Developments, Theoretical and Applied, of Photoelectricity).—G. Todesco. (*L'Electrotec.*, 25th July, 1931, Vol. 18, pp. 498-509.)

STANDARDS OF PERFORMANCE FOR COMMERCIAL TELEVISION RECEIVERS.—C. H. W. Nason. (*Rad. Engineering*, Aug., 1931, Vol. 11, pp. 30 and 45.)

A NEW MODULATION TUBE [MERCURY VAPOUR ARC TUBE GIVING VERY LARGE OUTPUT OF MODULATED LIGHT].—H. F. Dalpayrat. (*Rad. Engineering*, July, 1931, Vol. 11, p. 37.)

A "primary" concealed arc, which varies in intensity according to the signal variations, acts as a variable resistance for the "secondary" arc which is visible. An intense white light is produced which is easily modulated without any appreciable lag. An average of 100 watts can be consumed at 200 volts, but "higher values may be reached with electrodes able to stand higher temperatures."

THE ELECTRO-OPTICAL KERR EFFECT IN GASES.—E. C. Stevenson and J. W. Beams. (*Phys. Review*, 1st July, 1931, Series 2, Vol. 38, pp. 133-140.)

THE MECHANISM OF THE LIGHT EMISSION IN THE GLOW DISCHARGE IN THE INERT GASES.—M. J. Druyvesteyn. (*Physica*, No. 5, Vol. 11, 1931, pp. 129-145.)

ELECTRODELESS DISCHARGE TUBE FOR TELEVISION.—Harris and Jenkins.

(See abstract under "Subsidiary Apparatus.")

TELEVISION RECEPTION: CROSSED WIRE GRID IN NEON.—D. E. Dyas. (*Television*, May, 1931, Vol. 4, p. 118.)

ATMOSPHERICS AND TELEVISION.—T. Bray. (*Television*, Aug., 1931, Vol. 4, pp. 232-233.)

An article leading up to a discussion of the use of television for getting a telegraphic message through under the worst condition of atmospherics.

BILDFUNK ZWISCHEN BERLIN UND NANKING (Picture Telegraphy between Berlin and Nanking).—H. Lux. (*Telefunken-Zeit.*, No. 58, Vol. 12, 1931, pp. 12-16.)

The one-way service over 9000 km. from Berlin to Nanking was established in 1930, with a 16.77 metre wave and a power (telegraph "dash") of 20 kw.

## MEASUREMENTS AND STANDARDS.

PAPERS ON FIELD STRENGTH MEASUREMENTS AND APPARATUS.—de Mars, Kenrick and Pickard; Baker and Huxley; Vedy and Wilkins.

(See under "Reception.")

DESIGN OF STANDARDS OF INDUCTANCE, AND THE PROPOSED USE OF [SMALL-SCALE] MODEL REACTORS IN THE DESIGN OF AIR-CORE AND IRON-CORE REACTORS.—H. B. Brooks. (*Bur. of Stds. Journ. of Res.*, Aug., 1931, Vol. 7, No. 2, pp. 289-328.)

"The objects of this paper are to present a number of useful general relations concerning the self and mutual inductance of geometrically similar coils, and to illustrate their usefulness by making three applications of them. The first application relates to coils serving as standards of self-inductance for laboratory purposes. The advantages of the Maxwell-Shawcross-Wells optimum form of coil for this purpose are emphasised, and a convenient and rapid procedure for the design of such coils is given [the desired value of inductance/resistance ratio being taken as a starting point].

"The second proposed application is the use of small model coils for predetermining the dimensions and performance of large current-limiting reactors as used in power plants. In the third application the use of small-scale iron-core air-gap reactors is proposed for the predetermination of the dimensions and performance of large reactors of this type. In developing the theory of this last application it is brought out that iron-core air-gap reactors have the desirable minimum power factor when the length of the air gap is such that the copper loss equals the core loss."

SUL COMPORTAMENTO DELLE BOBINE IN CIRCUITI AD ALTA FREQUENZA (The Behaviour of [Single- and Multi-layered] Coils in High-Frequency Circuits [up to 4 Megacycles per Sec.]).—G. Sacerdote. (*L'Electrotec.*, 5th Aug., 1931, Vol. 18, pp. 522-526.)

By methods described the writer measures the impedance of air-cored coils of various kinds (honeycomb type, standard inductance coils, multi-layered coils, etc.) at frequencies around the natural frequency of each coil and then upwards. The results are given in the form of curves, from which theoretical conclusions are drawn leading to a method of calculating the impedance, resonance point, etc., of a two-layered coil.

THE SENSITIVITY OF AN A.C. BRIDGE: THE SENSITIVITY OF THE SCHERING BRIDGE.—H. Schering; J. L. Miller. (*E.T.Z.*, 3rd Sept., 1931, Vol. 52, pp. 1133-1134; *Elektrot. u. Maschbau*, No. 36, Vol. 49, 1931, pp. 677-678.)

ZUR MESSUNG DES WIDERSTANDES VON DRÄHTEN BEI HOCHFREQUENZ (On High-Frequency Measurement of Wire Resistance).—K. Kreielsheimer. (*Zeitschr. f. Phys.*, 1931, Vol. 71, No. 3/4, pp. 260-272.)

An a.c. bridge is transformed into a d.c. bridge by insertion of a push-pull rectifier.

MEASURING AND RECORDING INSULATION RESISTANCES UP TO  $12 \times 10^{13}$  OHMS [VALVE SOCKETS, ETC.] AND PHOTOELECTRIC CURRENTS, BY THE STRAUSS "MEKAPION" [USING THE LEAKAGE OF GRID CHARGE].—I. J. Saxl; S. Strauss. (*Electronics*, August, 1931, pp. 62-63 and 86.)

THE CAPACITY OF THE QUADRANT ELECTROMETER.—G. Nadjakoff. (*Comptes Rendus*, 24th Aug., 1931, Vol. 193, pp. 356-358.)

TRANSMISSIONS OF WIRELESS WAVES OF STANDARD FREQUENCIES FROM THE N.P.L. [ADDITIONAL FREQUENCY (168.6 METRES WAVELENGTH) FOR AMATEUR TRANSMITTERS]. (*Electrician*, 21st Aug., 1931, Vol. 107, p. 258.)

OVER HET NAUWKEURIG METEN VAN FREQUENTIES (The Accurate Measurement of Frequencies).—R. Moens and P. Mortier. (*Natuurwetensch. Tijdschr.*, No. 3/5, Vol. 13, 1931, pp. 143-146.)

A pendulum carries a screen with a slit, by the passage of which a photoelectric cell is illuminated. The photoelectric currents act as additional currents in a neon-tube relaxation-oscillation circuit, the surges in which pass through a winding and act on a magnet carried by the pendulum. The swings of the pendulum, thus kept in movement, are automatically recorded. To compare its frequency with that of a quartz crystal, a relaxation-oscillation generator is used with a frequency about one-fourteenth of the quartz frequency, so that the fourteenth harmonic of the generator agrees with the quartz frequency. Several stages of such generators reduce the quartz frequency to a value which can be compared with the pendulum record.

A PRECISION METHOD OF MEASURING SHORT [AND ULTRA-SHORT] WAVELENGTHS.—W. Fehr and G. Leithäuser. (*E.N.T.*, August, 1931, Vol. 8, pp. 337-339.)

At present used for wavelengths in the 10-80 metre range, this method is being extended to the ultra-short range. The procedure is as follows:—the wave  $\lambda$  to be measured is tuned-in on a short-wave receiver *KWE* (Fig. 1) and heterodyned by a harmonic of the fundamental wavelength  $A_0$  of a standard, constant frequency push-pull oscillator *MS*, rich in harmonics, which is variably coupled to a closed short-wave circuit *K*, connected to the receiver and serving to pick out the correct harmonic from *MS*; by means of this variable coupling, or alternatively by the variable aerial coupling *A*, the signal and the local heterodyne are made about equally strong. By the fine adjustment of *MS*, the heterodyne is brought to the zero-beat point, so that  $A_0 = n\lambda$ .

The value of  $A_0$  at this adjustment is now found by means of the wavemeter circuit *HMK*, which is so tightly coupled to *MS* that the whole combination acts as an intermediate-circuit transmitter. The de-tuning of the combination by the "intermediate circuit" *HMK* is zero provided that the latter's natural frequency is equal to the original frequency of *MS*. The zero de-tuning is ensured

by the use of a special long-wave heterodyne circuit  $\bar{U}$  in which the wavelength is altered 3 times per second by a clockwork-driven commutator throwing an additional condenser into the circuit. With the wavemeter *HMK* removed or widely de-tuned,  $\bar{U}$  is made to heterodyne *MS*, the interference note being listened to through a transformer in the anode circuit of a leaky-grid detector circuit in *MS*. The tuning of  $\bar{U}$  is then adjusted until the same note is produced all the time, in spite of the action of the commutator. The wavemeter *HMK* is then coupled up to *MS* and produces a de-tuning shown by two notes becoming audible; *HMK* is then adjusted till the one-note state is restored, indicating the correct resonance condition. This method gives very accurate results. The wavemeter is calibrated by means of quartz glow resonators, the same "intermediate circuit" method being employed.

The fundamental  $A_0 (=n\lambda)$  having thus been measured, the process is repeated for the  $(n \pm 1)^{\text{th}}$  harmonic of the *MS* fundamental  $A_1$  and the exact value of this new fundamental is found as before. Then a mean value for  $\lambda$  is given by

$$\lambda = \frac{1}{2} \left( \frac{A_0}{n} + \frac{A_1}{n \pm 1} \right);$$

or the series can be extended still further by employing additional new fundamentals.

DIRECT-READING [THERMIONIC] FREQUENCY METER: ADDITIONS.—Guarnaschelli and Vecchiacchi. (*Proc. Inst. Rad. Eng.*, Aug., 1931, Vol. 19, pp. 1506-1507.)

Additional explanations to the paper dealt with in July Abstracts, pp. 392-393.

A THERMIONIC TYPE FREQUENCY METER FOR USE UP TO 15 KILOCYCLES.—F. T. McNamara. (*Proc. Inst. Rad. Eng.*, Aug., 1931, Vol. 19, pp. 1384-1390.)

Author's summary:—"A new type of frequency meter is described which is adapted to the measurement of low and intermediate frequencies. The instrument absorbs a negligible amount of power from the circuit being tested, has a linear calibration curve and a sensitivity of about eight microampères for one per cent. change in frequency. An experimental model is described in detail. The input to this model is between five and ten volts. Other models may require different inputs."

DEGRÉ DE PRÉCISION, EXACTITUDE, CONSTANCE DES ONDEMÈTRES (Degree of Precision, Accuracy, and Constancy of Wavemeters).—C.C.I.R. (*Journ. télégraphique*, April, 1931, Vol. 55, pp. 141-143.)

Based on document No. 10 of the Comité consultatif international technique des Communications radioélectriques (The Hague, 1929).

INTERNATIONAL FREQUENCY MEASUREMENTS. NEW ABSOLUTE FREQUENCY-MEASURING EQUIPMENT.—A. Scheibe and P. Preisler. (Long summary in *Zeitschr. f. hochf. Tech.*, August, 1931, Vol. 38, pp. 84-86.)

From the Physikalische-Technische Reichsanstalt.

COMPARISON OF DISTANT FREQUENCY MEASUREMENTS IN LONDON, NEW YORK, AND BERLIN.—Mögel.

(See abstract under "Propagation of Waves.")

### SUBSIDIARY APPARATUS AND MATERIALS.

DIE MAGNETISCHE SAMMELSPULE FÜR SCHNELLE ELEKTRONENSTRAHLEN (Magnetic Concentrating Coils for Fast Cathode Rays).—E. Ruska and M. Knoll. (*Zeitschr. f. tech. Phys.*, Aug., 1931, Vol. 12, pp. 389-399.)

Continuation of the work dealt with in March Abstracts, p. 163. Among other results, the writer arrives at a formula by which the optimum ampère-turns may be calculated in terms of the accelerating potential and the tube dimensions, with an accuracy which experiment shows to be within 5 per cent. on the average. Enclosing the coil in an iron case with an internal air gap effects a considerable economy in ampère-turns. An additional section on this iron-clad coil is to be found in the September issue of the journal, p. 448, where further advantages are mentioned.

ON THE METHOD OF MAGNETIC USE OF THE CATHODE-RAY OSCILLOGRAPH [MAGNETIC TIME-BASE FOR SINGLE CONTROLLED PHENOMENA].—Narasaki, Miyamoto and Ochi. (*Res. Electrot. Lab., Tokio*, No. 289, 1930, 13 pp.)

In Japanese, with English synopsis. For previous work see Feb. Abstracts, p. 92.

STRAHLSPERRUNGEN BEIM KATHODENOSZILLOGRAPHEN (Locking the Electron Stream in the Cathode Ray Oscillograph).—H. Boekels. (*Archiv f. Elektrot.*, 15th July, 1931, Vol. 25, No. 7, pp. 497-504.)

KATHODENOSZILLOGRAPHISCHE AUSSENAUFNAHMEN MIT LINSE UND KAMERA BEI EXTREM RASCH VERLAUFENDEN VORGÄNGEN (External Photography of Extremely Rapid Phenomena with the Cathode Ray Oscillograph, Lens, and Camera).—K. Buss and A. Pennick. (*Archiv f. Elektrot.*, 14th Aug., 1931, Vol. 25, No. 8, pp. 545-550.)

An account of a repetition of former experiments of Rogowski and Flegler (1928 Abstracts, p. 692) on the possibility of external photography with lens and camera of cathode ray phenomena with a recording velocity of about 2000 km./sec.

ÜBER EINE ANWENDUNG DER BARETTERMETHODE AUF ELEKTROLYTISCHE MESSUNGEN (On an Application of the Baretter Method to Electrolytic Measurements).—O. Neese. (*Ann. der Physik*, 1931, Series 5, Vol. 8, No. 8, pp. 929-955.)

A description is given of a baretter method which permits of simultaneous measurements of variations of high frequency resistance and capacity of a conductor. The sources of error are fully discussed.

A RAPID-RECORD [STRING] OSCILLOGRAPH.—A. M. Curtis and I. E. Cole. (*Electronics*, Aug., 1931, pp. 70-71.)

Capable of dealing with frequencies up to 6000

c.p.s. The resonance of the strings is corrected by equalising networks, giving a practically linear relation between current and deflection. Sensitivity for the 0-6000 c.p.s. range is 9.0 mA. per mm. Time intervals 0.001 sec. long are recorded on the moving strip (35 mm. wide).

QUECKSILBERDAMPF-GLEICHRICHTER MIT GLÜHKATHODE (Hot-Cathode Mercury Vapour Rectifiers).—A. Glaser: A. E. G. (*E.T.Z.*, 25th June, 1931, Vol. 52, pp. 829-834.)

The paper begins by comparing these rectifiers with those of the high-vacuum type, as regards method of action and merits. The advantageously small voltage drop of the mercury vapour rectifier, and its dependence on the load and on the temperature of the mercury, are then dealt with, together with the effect of this latter factor on the back-discharge limit. Details of high-power rectifiers, directly- and indirectly-heated cathodes, the effect of the heating current magnetic field on the electron motion, etc., are discussed. See also July Abstracts, p. 396.

ZUR THEORIE DER GLEICHRICHTERWIRKUNG (On the Theory of Rectifier Action).—C. Wagner. (*Physik. Zeitschr.*, 15th Aug., 1931, Vol. 32, No. 16, pp. 641-645.)

This paper gives a short theory of the action of copper oxide rectifiers, based on the presence of ions of copper with two positive charges. The theory may be extended to other rectifier systems with solid semi-conductors. An indication is given of the possibility of discovering, by means of capacity measurements, the density of weak spots and the mobility of electrons in semi-conductors.

RETTIFICAZIONE MEDIANTE DIODI IN CIRCUITE FORMATI DA RESISTENZA E INDUTTANZA (Rectification by Diodes in Circuits composed of Resistance and Inductance).—N. Carrara. (*L'Elettrotec.*, 25 July, 1931, Vol. 18, pp. 510-513.)

ZUR FRAGE DER GÜLTIGKEIT DES OHMSCHEN GESETZES BEI  $Cu_2O$ . BEMERKUNG ZUR ARBEIT "VARIABLE WIDERSTÄNDE UND IHRE HYDRODYNAMISCHE ANALOGIE" VON R. AUERBACH (On the Question of the Validity of Ohm's Law for  $Cu_2O$ . A Comment on the Paper "Variable Resistances and their Hydrodynamical Analogy" by R. Auerbach).—E. Engelhard and B. Gudden. (*Zeitschr. f. Phys.*, 1931, Vol. 70, No. 11/12, pp. 701-705.)

The authors find that from the paper mentioned (April Abstracts, p. 223) it might be concluded that the specific resistance of  $Cu_2O$  decreases with increasing load. Both experiment and theory show, however, that it is improbable that Ohm's Law is invalid for  $Cu_2O$ .

LE REDRESSEMENT DANS LES ÉLÉMENTS À OXYDE DE CUIVRE (Rectification in Copper-Oxide Elements).—R. Jacquélet. (*Rev. Gén. de l'Elec.*, 5th Sept., 1931, Vol. 30, pp. 365-372.)

Experiments which bring out the essential rôle

played by the distortion of the crystal produced during the oxidising process. This distortion, the writer considers, gives rise to dissymmetry of interatomic action, and hence to dissymmetry in electrical behaviour.

A GRAPHIC METHOD FOR DETERMINING THE CURRENT AND VOLTAGE FORMS OF A RECTIFIED A.C. SMOOTHED BY CHOKE COILS OR CONDENSERS.—H. Immelen. (*E.T.Z.*, 2nd July, 1931, Vol. 52, pp. 857-858.)

DIE FREQUENZABHÄNGIGKEIT DER DIELEKTRIZITÄTSKONSTANTE UND DER DÄMPFUNG VON FESTEN ISOLATOREN (The Frequency Variation of the Dielectric Constant and the Attenuation in Solid Insulators).—R. Weber. (*Zeitschr. f. Phys.*, 1931, Vol. 70, No. 11/12, pp. 706-710.)

"Measurements by the beat method give strongly marked maxima of the dielectric constant and attenuation in the region of wavelengths between 200 and 1000 metres." Cf. Graffunder and Weber, Feb. Abstracts, p. 109.

DIELECTRIC PHENOMENA AT HIGH VOLTAGES: DISCUSSION.—Goodlet, Edwards and Perry. (*Journ. I.E.E.*, September, 1931, Vol. 69, pp. 1169-1178.)

Discussion on the paper dealt with in September Abstracts, p. 513.

FILAMENT SUPPLY FOR TWO-VOLT TUBES: THE AIR-CELL TYPE "A" BATTERY [AIR-DEPOLARISED PRIMARY BATTERY, ZINC/CARBON IN CAUSTIC SODA].—L. S. Fox. (*QST*, Sept., 1931, Vol. 15, pp. 25-28.)

The special carbon positive electrode extracts oxygen from the air, remaining itself perfectly dry when immersed in the electrolyte. It forms a valve freely admitting oxygen into the interior of the battery but blocking any flow of electrolyte.

FACTORS AFFECTING THE OUTPUT OF LECLANCHÉ CELLS.—V. A. Kostjejev. (*Trans. Am. Electrochem. Soc.*, Vol. 58, pp. 305-322.)

AN ADJUSTABLE [AIR] LEAK FOR X-RAY TUBES.—H. Kersten. (*Review Scient. Instr.*, July, 1931, Vol. 2, pp. 377-378.)

MEASUREMENT OF LENARD RAYS.—L. S. Taylor. (*Bur. of Stds. Journ. of Res.*, July, 1931, Vol. 7, No. 1, pp. 57-72.)

AN ELECTRON GUN WITH INCREASED EFFICIENCY AND BETTER FOCUSING.—J. E. Taylor. (*Proc. Leeds Phil. & Lit. Soc.*, Jan., 1931, Vol. 2, pp. 169-173.)

A screen with a small central hole, maintained at a low negative potential, is interposed between the filament and the nozzle; the optimum screen potential varies with the accelerating potential. The action is explained by analogy with a soft three-electrode valve.

THE ACTION OF LOW SPEED ELECTRONS ON PHOTOGRAPHIC EMULSIONS.—L. A. Jones and R. E. Burroughs. (*Journ. Opt. Soc. Am.*, July, 1931, Vol. 21, pp. 437-438.)

SUR L'EMPLOI DES TUBES ÉLECTRONIQUES POUR L'AMPLIFICATION DE TRÈS FAIBLES COURANTS (The Use of Thermionic Valves for the Amplification of Very Small Currents).—J. F. Thovert. (*Journ. de Phys. et le Rad.*, No. 2, Vol. 2, Series 7, p. 23S.)

Rasmussen's conclusions as to the dependence of the entrance resistance on the grid resistance of the valve are confirmed. By the use of modern valves the entrance resistance can be brought very low if a small time constant is needed (e.g., for oscillographs). For a sensitivity of  $10^{-11}$  ampère, the time constant may be 1/100 sec. (two valves) or even  $1 \times 10^{-4}$  sec. (three valves).

USE OF THE THYRATRON AS A VOLTAGE REGULATOR.—H. W. Dodge and C. H. Willis. (*Electrical World*, 4th July, 1931, Vol. 97, pp. 25-26.)

A thyatron with negative grid characteristic is used, its action corresponding to that of the vibrating type of regulator.

EIN NEUER SPANNUNGSWANDLER FÜR HÖCHSTSPANNUNGEN (A New Voltage Transformer for Extremely High Potentials [for Measuring Purposes: Biermann's System]).—J. Goldstein; Biermann. (*E.T.Z.*, 19th March, 1931, Vol. 52, pp. 378-379.)

DER DIFFERENZKONDENSATOR (The Differential Condenser [and Its Uses]).—J. Schad. (*Rad., B., F. f. Alle*, July, 1931, pp. 307-310.)

INTERMEDIATE FREQUENCY TUNING CONDENSER REQUIREMENTS.—H. E. Rhodes. (*Electronics*, June, 1931, pp. 690-691.)

ELECTROLYTIC CONDENSERS FOR RADIO USE.—F. W. Godsey, Jr. (*Electronics*, April, 1931, pp. 596-597.)

SUR LA PROJECTION CATHODIQUE DES ÉLÉMENTS, ET QUELQUES APPLICATIONS (Cathode Sputtering of the Elements and Some Applications).—F. Joliot. (*Ann. de Physique*, April, 1931, Series 10, pp. 418-436.)

PROPRIÉTÉS ÉLECTRIQUES DES MÉTAUX EN COUCHES MINCES PRÉPARÉES PAR PROJECTION THERMIQUE ET CATHODIQUE (The Electrical Properties of Metals in Thin Films prepared by Thermal and Cathodic Sputtering).—F. Joliot. (*Ibid.*, pp. 437-454.)

DIE PERMEABILITÄT DER FERROMAGNETIKA IN HOCHFREQUENTEN ELEKTROMAGNETISCHEN FELDERN (The Permeability of Ferromagnetics in High-Frequency Electromagnetic Fields).—N. N. Malov. (*Zeitschr. f. Phys.*, 1931, Vol. 71, No. 1/2, pp. 30-38.)

A complicated variation of permeability with



frequencies between 1 and 10 megacycles per sec. is found.

AN IMPROVED METHOD FOR THE COMPARISON OF SMALL MAGNETIC SUSCEPTIBILITIES.—R. A. Fereday. (*Proc. Phys. Soc.*, 1st July, 1931, Vol. 43, Part 4, pp. 383-393.)

The "non-uniform field" method previously described by the writer (1930 Abstracts, p. 406) depended on the formation of a magnetic field such that, over a wide region, the product of field-strength by its gradient along the axis of symmetry would be constant, so that a feebly magnetic body placed on this axis would experience a force which would be directed along the axis and constant at all parts of it. The present paper deals with the production of such a field by an electro-magnet whose pole-pieces are respectively plane and spherically concave.

NICKEL-IRON ALLOYS AND THEIR APPLICATION TO INSTRUMENT CONSTRUCTION.—F. E. J. Ockenden. (*Journ. Scient. Instr.*, April, 1931, Vol. 8, pp. 113-117.)

NICKEL-IRON ALLOYS IN LOW-FREQUENCY TRANSFORMERS.—(*Nickel Bulletin*, June, 1931, Vol. 4, pp. 171-174.)

DIE PERMEABILITÄT VON EISEN, NICKEL UND KOBALT ZWISCHEN  $10^6$  UND  $10^7$  HERTZ (The Permeability of Iron, Nickel and Cobalt at Frequencies between 1 and 10 Megacycles per Sec.).—M. J. O. Strutt. (*Zeitschr. f. Phys.*, 1931, Vol. 68, No. 9/10, pp. 632-658.)

Russian investigators measured the high-frequency permeability of iron, steel and nickel as a function of the wavelength and found a strongly marked anomaly in the neighbourhood of 100 m. In the experiments here described a vacuum thermo-junction was used to measure the permeability of iron, nickel and cobalt at frequencies between 1 and 10 megacycles per sec. at room temperature, in liquid air, and also in an imposed magnetic field of maximum strength about 9000 gauss; the maximum experimental error was 2%. No anomaly of the permeability, greater than the error of measurement, was discovered.

AUDIO-FREQUENCY TRANSFORMERS [COMPARISON OF MUMETAL AND RADIOMETAL WITH STALLOY, CHIEFLY AS REGARDS MAGNETIC DAMAGE BY EXCESSIVE FIELDS]. (*Electrician*, 14th Aug., 1931, Vol. 107, p. 225.)

SUR L'AIMANTATION DES POUDRES FERROMAGNÉTIQUES DANS DES CHAMPS FAIBLES (The Magnetisation of Ferromagnetic Powders in Weak Fields).—Delsarte: Chevallier. (*Journ. de Phys. et le Rad.*, June, 1931, Vol. 2, Ser. 7, pp. 106S-109S.)

MAGNETOSTATIK DER MASSEKERNE (Magnetostatics of Compressed Iron Powder Cores).—F. Ollendorff. (*Archiv f. Elektrot.*, 19th June, 1931, Vol. 25, No. 6, pp. 436-447.)

PERMANENT MAGNETS FOR ELECTRONIC INSTRUMENTS.—W. H. Hoppe. (*Electronics*, May, 1931, pp. 636-638.)

A METHOD FOR PRECISE SPEED CONTROL DEVELOPED IN CONNECTION WITH AN ABSOLUTE MEASUREMENT OF RESISTANCE.—F. Wenner and C. Peterson. (*Phys. Review*, 15th June, 1931, Series 2, Vol. 37, No. 12, p. 1691.)

Abstract only of a method depending on the synchronization between a 1000-cycle generator on a motor-shaft and a 100-cycle e.m.f. obtained from a piezoelectric oscillator.

GASEOUS DISCHARGE TUBES.—N. L. Harris and H. G. Jenkins: G.E.C. (*Electrician*, 28th Aug., 1931, Vol. 107, pp. 273-275.)

Summary of Part III of an article in the *G.E.C. Review*. An electrodeless discharge tube of fused silica for television is mentioned.

NOTE ON THE USE OF THE FLASHING NEON LAMP CIRCUIT FOR PHYSIOLOGICAL PURPOSES, AND ON A TIME-MARKER FOR USE WITH THE CIRCUIT.—W. A. Leyshon. (*Journ. Scient. Instr.*, June, 1931, Vol. 8, pp. 202-204.)

THE DEGENERATION [INTO RELAXATION OSCILLATIONS] OF SINUSOIDAL OSCILLATIONS.—Reichardt.

(See under "Properties of Circuits.")

NEGATIVE IMPEDANCES AND THE TWIN 2I-TYPE REPEATER.—G. Crisson. (*Bell Tech. Journ.*, July, 1931, Vol. 10, pp. 485-573.)

Author's abstract:—This paper discusses negative resistances and impedances. It describes their properties and some devices by which they may be produced physically. Certain properties of negative impedances, when used as series and shunt boosters for amplifying speech waves in telephone circuits, are discussed. The paper concludes with a description of the circuit and properties of the twin 2I-type repeater.

RADIO POWER APPARATUS.—S. L. Abrahams. (*Rad. Engineering*, Aug., 1931, Vol. 11, pp. 24-27 and 40.)

ÜBER DIE MAGNETISCHEN EIGENSCHAFTEN DER PERMINVARE (The Magnetic Properties of Perminvars).—H. Kühlewein. (*Wiss. Veröffentl. a. d. Siemens-Konz.*, No. 2, Vol. 10, 1931, pp. 72-88.)

HIGHLY PURIFIED IRON RESEMBLING COPPER IN SOFTNESS AND OTHER PROPERTIES.—L. Schlecht. (*Science*, 31st July, 1931, Vol. 74, Supplement p. 12.)

By heating iron carbonyl, iron is produced with hardly a trace of impurities and in individual particles only 20 millionths of an inch in diameter. The powder can be converted by heating into solid iron "resembling copper in its softness, resistance to corrosion and other properties." Cf. September Abstracts, p. 498—Polydoroff.

THE SPUTTERING OF QUARTZ FIBRES.—G. M. Jones. (*Journ. Scient. Instr.*, May, 1931, Vol. 8, pp. 155-159.)

A SIMPLE METHOD OF DISSOLVING THE SILVER COATING OF WOLLASTON WIRE.—A. Rostagni. (*Physik. Zeitschr.*, 15th July, 1931, Vol. 32, pp. 562-563.)

A ROLLING-CONTACT POTENTIOMETER.—Dralowid Works. (*Rad., B., F. f. Alle*, August, 1931, p. 361.)

DER EINFLUSS DER SCHWERKRAFT AUF FLIEHKRAFTREGLER MIT ELEKTRISCHER KONTAKTGEBUGUNG (The Influence of Gravitation on the Centrifugal Governor with Electrical Contacts).—W. Dornig. (*E.T.Z.*, 6th Aug., 1931, Vol. 52, pp. 1031-1033.)

More on the subject dealt with in 1930 Abstracts, pp. 288-289.

VALVE METHODS OF GOVERNING MACHINES: VARIOUS PATENTS.—(*Elektrot. u. Maschbau*, Nos. 25 and 27, Vol. 49, 1931, pp. 494-495 and 538-539.)

A.C. VOLTAGE STABILISER MAINTAINING CONSTANT OUTPUT VOLTAGE FOR INPUT VARIATIONS OF  $\pm 30\%$ .—(French Pat. 700707, Soc. Electro-Constructions, pub. 6th March, 1931.)

The variations are reduced to 15 or 20 % of their input value by introducing a condenser and a closed-iron-cored choke, the usual losses caused by hysteresis and parasitic currents in the latter being diminished by the following artifice: a small length of the magnetic circuit (at a point where it can be cooled—i.e., a point not covered by the winding) is reduced in cross section so that the magnetisation there rises almost to saturation, thus giving the necessary shape to the magnetising current characteristic. The fluctuations remaining are brought practically to zero by connecting across the input the primary of a compensating transformer whose secondary is in series with and in opposition to the partly-stabilised output. If this transformer is made with a small power factor, for instance by giving it an air gap, it can at the same time be made to improve the power factor of the regulator.

A VACUUM-TUBE VOLTAGE REGULATOR [FOR A.C., COMBINING SHORT-CIRCUIT PROTECTION].—L. C. Verman and L. A. Richards. (*Elec. Engineering*, June, 1931, Vol. 50, pp. 436-438.)

ÜBER LINEARE STROMREGELUNG (Linear Current Regulation).—G. Hauffe. (*E.T.Z.*, 13th Aug., 1931, Vol. 52, pp. 1065-1066.)

A mathematical investigation leading to the design of a sliding-contact rheostat to give a linear current adjustment (by a proper shaping of its former), or a stud rheostat combining a number of properly proportioned resistances, to give an approximately linear adjustment.

A NEW DESIGN OF AN IONIZATION MANOMETER.—E. K. Jaycox and (H. W. Weinhart. (*Review Scient. Instr.*, July, 1931, Vol. 2, pp. 401-411.)

Easy to construct, can be used to measure pressures of the order of  $10^{-9}$  mm. mercury, is free from trouble due to Barkhausen oscillations, and has a long life.

SENSITIVE RELAY ON THE ROTATING CLUTCH PRINCIPLE.—(French Pat. 700811, Le Film Ozaphane, pub. 7th March, 1931.)

AN ELECTRICAL HAIR TRIGGER [6 AMPÈRE, 220 VOLT VACUUM SWITCH USING ELASTICITY OF CORRUGATED GLASS].—Siemens and Halske. (*Scient. American*, Aug., 1931, Vol. 87, p. 129.)

Requiring a force of "less than 10 ounces and usually but 6 ounces," and a motion of only 0.02 inch to work it. The circuit is broken without arcing at less than 0.001 inch separation of the contact blocks, and one switch has been operated, at a rate of 10 times a second, 124 million times without breakdown. See also advertisement, back cover *QST*, Aug., 1931.

THE USE OF SMALL-SCALE MODELS IN THE DESIGN OF AIR-CORE AND IRON-CORE REACTORS.—Brooks.

(See abstract under "Measurements and Standards.")

THERMOCOUPLES WHOSE ELEMENTS ARE LONGITUDINALLY AND TRANSVERSELY MAGNETISED WIRES OF NICKEL AND OF IRON.—W. H. Ross. (*Phys. Review*, 1st July, 1931, Series 2, Vol. 38, No. 1, pp. 179-181.)

DAS ZUSTANDEKOMMEN UND DIE BEEINFLUSSUNG DER FALLENDEN CHARAKTERISTIK DES SCHWINGKRYSTALLS (The Origin and Control of the Falling Characteristic of the Oscillating Crystal).—F. Seidl. (*Zeitschr. f. Phys.*, 1931, Vol. 71, No. 3/4, pp. 227-237.)

A discussion of theories published up to the present.

ELECTROLYTIC PHENOMENA IN OXIDE-COATED FILAMENTS.—J. A. Becker. (*Bell System Report B.577*; *Trans. Electrochemical Soc.*, 1931, Vol. 59.)

"A discussion of various theories on the conductivity of oxide coatings with some new experimental data."

THE ELECTRO-OPTICAL SHUTTER AND SPARK BREAKDOWN.—F. G. Dunnington. (*Phys. Review*, 15th June, 1931, Series 2, Vol. 37, No. 12, p. 1677.)

THE ELECTRO-OPTICAL SHUTTER.—H. W. Washburn. (*Phys. Review*, 1st Aug., 1931, Series 2, Vol. 38, No. 3, p. 584.)

MACCHINA ELETTROSTATICA A CILINDRI (The Cylindrical Electrostatic [Influence] Machine).—F. Luscia. (*L'Electrotec.*, 5th Aug., 1931, Vol. 18, pp. 530-531.)

A SIMPLE METHOD OF HARMONIC ANALYSIS FOR USE IN RADIO ENGINEERING PRACTICE.—H. Roder. (*Proc. Inst. Rad. Eng.*, Aug, 1931, Vol. 19, pp. 1481-1487.)

Author's summary:—A simple method of harmonic analysis is applied for a-c waves with certain properties. Curves having such properties often occur in audio- and radio-frequency applications in the form of so-called "characteristics." This paper presents a graphical method of finding the amplitudes of the harmonics by working directly from the "characteristic." For obtaining the results, a polar planimeter is used. The design of a new mechanical harmonic analyzer is based on this method.

In general this method is a special case of a method of harmonic analysis formerly found by English and German authors.

THE MADER OTT HARMONIC ANALYSER.—J. Reyval. (*Rev. Gén. de l'Élec.*, 12th Sept., 1931, Vol. 30, pp. 413-419.)

COIL RESISTANCE SHUNTS: A SIMPLE GRAPHICAL CONSTRUCTION.—W. A. Barclay. (*This Journal*, Sept., 1931, Vol. 8, pp. 482-484.)

THE BREAK-DOWN POTENTIAL FOR ENAMELLED WIRE.—W. Retzow. (*Elektrot. u. Masch. bau*, No. 29, Vol. 49, 1931, pp. 567-569.)

A SINGLE-VALVE MULTI-FREQUENCY GENERATOR.—Starr.

(See under "Transmission.")

### STATIONS, DESIGN AND OPERATION.

ULTRAKURZWELLEN-RUNDFUNK (Ultra-Short-Wave Broadcasting).—F. Schröter. (*Telefunken-Zeit.*, No. 57, Vol. 12, pp. 46-49.)

See October Abstracts, p. 573. The following are further points in this paper. 6-8 metre waves give a noteworthy constancy of field strength. Over city ranges of from 10 to 20 km. radius, transmitters of about 100 w. telephony power with aerial raised high will always give good loud-speaker strength on three valves (leaky-grid detector with reaction and two l.f. stages). Reaction adjustment is by variation of anode potential, to avoid de-tuning. The grid circuit is made as free from damping as possible and is carefully screened: to avoid capacitive influences it is coupled to the aerial through only  $1 \mu\mu\text{F}$ . Since the carrier wave is kept constant by quartz control at the transmitter ("Telefunken being the first to apply this successfully to these wavelengths") the ultra-short-wave circuit tuning can remain set once and for always. Difficulties in working the ultra-short-wave valve off the a.c. mains were overcome by the development of a special indirectly heated valve REN 904 (slope  $3.5 \text{ mA/V}$ ,  $\mu$  about 25). For remarks on television, see Sept. Abstracts, p. 507. See also these Abstracts, under "Phototelegraphy and Television."

DER HEUTIGE STAND DER ULTRAKURZWELLEN-TECHNIK (The Position To-day of Ultra-Short-Wave Technique).—K. Sohnemann. (*Zeitschr. V.D.I.*, 22nd Aug., 1931, Vol. 75, pp. 1083-1084.)

LES ONDES COURTES DANS L'AVIATION (Short Waves in Aviation).—R. Hermann and P. Grenier. (*L'Onde Elec.*, August, 1931, Vol. 10, pp. 325-337.)

The advantages and disadvantages of short waves: the importance of sets capable of working either on long or short waves, or on both simultaneously: description of the Radio L.L. Company's sets Type AL.27 and Type AL.31: the reception of short waves in aeroplanes: characteristics of the corresponding aerodrome sets.

Type AL.27 uses four triodes: these may be paralleled for work on short waves or on long waves, or two of them can transmit on long waves while the other two are transmitting on short waves (15-60 m.). Type AL.31, on the other hand, has entirely separate circuits and valves for the two wave-bands: it works either on two valves transmitting long or short waves or on two valves transmitting long waves, while a third works on short. Both sets employ the Hartley circuit for the short-wave band. Neither set is quartz-stabilised, the precautions taken in the way of elastic suspension and the careful design of the r.f. circuits having been found to give sufficient stability. Fixed symmetrical aerials on the upper plane near the leading edge are almost always used.

As regards the reception on aircraft of the short waves, experiments with simple short-wave receivers (detector with reaction and two l.f. stages) were disappointing for various reasons (excessive sensitivity to ignition interference, vibrations, etc.), and in any case an extra receiver is undesirable on the score of weight. However, such a receiver has lately been designed successfully, in which all couplings are fixed and the reaction is adjusted by a variable resistance instead of the variable condenser or coupling previously used, which caused the vibration trouble. This receiver is useful in certain cases where the combined long- and short-wave superheterodyne (which is considered the ideal receiver) is too heavy and large, and where d.f. is not required. An "automatic manipulator" for use with these sets is illustrated.

A RADIO FIELD-STRENGTH SURVEY WITHIN ONE HUNDRED MILES OF SYDNEY.—W. G. Baker and O. O. Pulley. (*Australian Radio Research Board Report No. 1*, 1931, pp. 23-32.)

THE PROPAGATION OF BROADCAST WAVES [PARTICULARLY FADING PHENOMENA].—Böhm.

(See under "Propagation of Waves.")

FEDERAL RADIO COMMISSION ON CARRIER POWER [FOR BROADCASTING STATIONS].—(*Rad. Engineering*, July, 1931, Vol. 11, pp. 23-24 and 38.)

DIE LEITUNG IM DIENSTE DES RUNDFUNKS (Land Lines and Cables in the Service of Broadcasting).—K. Höpner. (*E.T.Z.*, 13th and 20th Aug., 1931, Vol. 52, pp. 1061-1064 and 1087-1090.)

From the German Post Office. The writer considers the transmission requirements and how nearly they can be fulfilled in practice. A number of interesting graphs are given. Terminal equipment and testing instruments are described.

DIE ÜBERTRAGUNG VON RUNDFUNKPROGRAMMEN AUF KABELLEITUNGEN (The Transmission of Broadcasting Programmes Over Cables).—H. F. Mayer. (*T.F.T.*, July, 1931, Vol. 20, pp. 199-205.)

MESSUNG UND BETRIEBSÜBERWACHUNG VON RUND-FUNKFERNLEITUNGSNETZEN (The Testing and Service Inspection of Line Networks for Broadcasting).—L. Fenyö and H. Hoffmann. (*Ibid.*, pp. 205-219.)

### GENERAL PHYSICAL ARTICLES.

TOWNSEND'S THEORIE, GASENTLADUNG UND DURCHSCHLAG (Townsend's Theory, Gas Discharge and Breakdown).—W. Rogowski. (*Archiv f. Elektrot.*, 14th Aug., 1931, Vol. 25, No. 8, pp. 551-596.)

An important paper discussing the whole of the present knowledge and theories of high voltage gas discharges and breakdown, chiefly at atmospheric pressure.

VERSUCHE ÜBER DAS PSEUDOHOCHVAKUUM (Researches into the "Pseudo-High Vacuum").—E. Badareu. (*Zeitschr. f. tech. Phys.*, June, 1931, Vol. 12, pp. 298-303.)

The phenomenon, in which a discharge refuses to take place even when the potential is much higher than that at which discharge should occur for the actual gas pressure existing, is investigated and found to be due to charges on the walls of the container, which have a marked effect on the electrical field between the electrodes.

STRIATED DISCHARGES.—L. H. G. Huxley. (*Phil. Mag.*, August, 1931, Supp. No., Series 7, Vol. 12, No. 76, pp. 380-384.)

The author's experiments are not in accord with the theory that the potential difference between two striations is equal to a critical potential.

OSCILLATIONS IN DISCHARGE TUBES.—W. L. Brown and H. McN. Cowan. (*Phys. Review*, 15th July, 1931, Series 2, Vol. 38, No. 2, p. 376.)

A letter giving results of experiments with cold-cathode glow-discharge tubes and current densities of less than one milliampere per cm<sup>2</sup>. Oscillations were detected by means of a cathode ray oscillograph and linear time base; they were only found at relatively high pressures (1.4 mm. to 2.1 mm.), and then only when an *asymmetrical* anode glow was present. The frequencies lay in the range 4 to 20×10<sup>3</sup> c.p.s. The amplitudes were very small.

THE SPARKING POTENTIAL OF AIR FOR HIGH-FREQUENCY DISCHARGES.—Gill and Donaldson.

(See under "Propagation of Waves.")

THE CONDUCTIVITY OF GASES IN UNIFORM ELECTRIC FIELDS.—McCallum and Ll. Jones.

(See under "Propagation of Waves.")

GASENTLADUNGEN BEI SEHR HOHEN FREQUENZEN (Gas Discharges at Very High Frequencies).—L. Rohde. (*Physik. Zeitschr.*, 15th July, 1931, Vol. 32, No. 14, pp. 550-551.)

A preliminary account of experiments on electrodeless gas discharges in various gases at frequencies of the order of 10<sup>6</sup> c.p.s. at pressures varying from 0.01 to 0.5 mm. Hg. The voltages necessary for discharge lie below the ionisation voltage, and occasionally even below the excitation voltage. A reproduction of a beaded ring discharge is given.

ELECTRODELESS DISCHARGE CHARACTERISTICS OF HYDROGEN AND NITROGEN.—O. Stuhlman, Jr., and H. Zur Burg. (*Phys. Review*, 15th June, 1931, Series 2, Vol. 37, No. 12, pp. 1704-1705.)

Abstract only.

POSSIBLE DIRECT READING METHODS FOR MEASURING THE CURRENT IN THE ELECTRODELESS DISCHARGE.—C. T. Knipp. (*Phys. Review*, 15th June, 1931, Series 2, Vol. 37, No. 12, p. 1704.)

ELECTRODELESS DISCHARGE AT ULTRA-HIGH FREQUENCIES.—Esclangon. (See abstract under "Miscellaneous.")

NEW INTERPRETATION OF THE MAGNETO-ELECTRIC EFFECT ON THE POLARISING ACTION OF CRYSTALS.—J. Becquerel and L. Matout. (*Comptes Rendus*, 20th July, 1931, Vol. 193, pp. 158-161.)

Tests on the absorption bands of xenotime lead to the hypothesis that the magneto-electric effect is not a true rotating effect, but a double refraction action with rotation of the principal directions when the plate is rotated round its optical axis.

DAS VERHALTEN DER MAGNETISCHEN ANFANGSPERMEABILITÄT BEI KURZEN ELEKTRISCHEN WELLEN (The Behaviour of the Initial Magnetic Permeability with Short Electric Waves).—R. Michels. (*Ann. der Physik*, 1931, Series 5, Vol. 8, No. 7, pp. 877-898.)

ÜBER DIE HAUTWIRKUNG FERROMAGNETISCHER DRÄHTE BEI HOCHFREQUENZ (On the Skin Effect of Ferromagnetic Wires at High Frequencies).—M. Wien. (*Ann. der Physik*, 1931, Series 5, Vol. 8, No. 7, pp. 899-904.)

Remarks on the paper of Michels given in title above.

ELECTRIC CONDUCTIVITY AND OPTICAL ABSORPTION IN METALS—SUPPLEMENTARY [Ratio between Steady-Current Conductivity and Light-Wave Conductivity in Metals].—E. H. Hall. (*Proc. Nat. Ac. Sci.*, July, 1931, Vol. 17, pp. 427-430.)

THE ELEMENTARY PROCESSES OF IONISATION BY THE IMPACT OF MATERIAL PARTICLES: COMPREHENSIVE SURVEY AND LONG BIBLIOGRAPHY.—H. Kallmann and B. Rosen. (*Physik. Zeitschr.*, 15th July, 1931, Vol. 32, No. 14, pp. 521-544.)

SUR LA DÉSINTÉGRATION ARTIFICIELLE DE L'ALUMINIUM (The Artificial Disintegration of Aluminium).—M. de Broglie and L. Leprince-Ringuet. (*Comptes Rendus*, 20th July, 1931, Vol. 193, pp. 132-133.)

Making use of the ionisation produced by the fast protons according to the method referred to in Sept. Abstracts, p. 515.

500 KILOVOLT CATHODE RAYS.—R. E. Volbrath. (*Phys. Review*, 15th July, 1931, Series 2, Vol. 38, No. 2, pp. 212-216.)

DIE VERALLGEMEINERTEN KUGELFUNKTIONEN UND DIE WELLENFUNKTIONEN EINES ELEKTRONS IM FELDE EINES MAGNETPOLES (Generalised Spherical Harmonics and the Wave Functions of an Electron in the Field of a Magnetic Pole).—I. Tamm. (*Zeitschr. f. Phys.*, 1931, Vol. 71, No. 3/4, pp. 141-150.)

THE MOTION OF ELECTRONS IN A HOMOGENEOUS ELECTROSTATIC FIELD BOUNDED ON BOTH SIDES.—S. Szczeniowski. (*Comptes Rendus Soc. Pol. de Phys.*, No. 3, Vol. 5, 1931, pp. 215-250.)

For a summary, see *Physik. Ber.*, 1st June, 1931, Vol. 12, p. 1220.

INDETERMINANCY OF COULOMB'S LAW.—G. Lemaitre. (Summary in *Physik. Ber.*, 1st June, 1931, Vol. 12, p. 1220.)

THE RESULTANT AND RESULTANT MOMENT OF THE ELECTROSTATIC PRESSURES IN A PLANE FIELD, CALCULATED BY ANALOGY WITH THE HYDRODYNAMIC PRESSURES ON THE SURFACE OF AN IMMersed SOLID.—A. Masotti. (*Atti Accad. Lincei*, 2nd Nov., 1930, Vol. 12, pp. 439-444.)

ÜBER DIE BESTIMMUNG DER SPEZIFISCHEN LADUNG DES ELEKTRONS AUS GESCHWINDIGKEITSMESSUNGEN (On the Determination of the Specific Charge on the Electron from Velocity Measurements).—F. Kirchner. (*Ann. der Physik.*, 1931, Series 5, Vol. 8, No. 8, pp. 975-1004.)

A precision method for direct measurement of the velocity of cathode rays leads to the value

$$\frac{e}{m_0} = (1.7598 \pm 0.0025) 10^7 \text{ e.m.u.}$$

THEORY OF DIELECTRICS.—G. Guéhen. (*Phil. Mag.*, July 1931, Series 7, Vol. 12, No. 75, p. 197.)

A letter showing that the experimental results obtained by H. H. Poole, and confirmed by H. Schiller and others, really supplement the author's results (Abstracts, May, p. 284) instead of disagreeing with them, as remarked by J. H. J. Poole (August, p. 455).

HIGH-FREQUENCY OSCILLATIONS IN SURFACE DISCHARGES.—T. Nishi and K. Ikeda. (Summary in *E.T.Z.*, 25th June, 1931, Vol. 52, pp. 848-849.)

### MISCELLANEOUS.

DIE ENTWICKLUNG DER KURZWELLENTÉCHNIK (The Development of Short-Wave Technique).—O. Böhm and F. Schröter. (*Zeitschr. f. hochf. Tech.*, August and September, 1931, Vol. 38, pp. 45-57 and 97-101.)

A general survey. The first instalment deals with I.—Propagation: echoes, multiple signals, etc.: Doppler effect: fading. II.—Transmitters. III.—Receivers. IV.—Aerials and aerial systems.

THE STATISTICAL ENERGY-FREQUENCY SPECTRUM OF RANDOM DISTURBANCES.—J. R. Carson. (*Bell Tech. Journ.*, July, 1931, Vol. 10, No. 3, pp. 374-381.)

"A mathematical discussion of the statistical characteristics of Random Disturbances in terms of their 'energy-frequency spectra' with applications to such typical disturbances as telegraph signals and 'static.'" Regarding the spectrum of static, "our present knowledge is insufficient to justify the application of probability analysis to the problem."

SOME SERIES AND INTEGRALS INVOLVING ASSOCIATED LEGENDRE FUNCTIONS.—W. N. Bailey. (*Proc. Camb. Phil. Soc.*, July, 1931, Vol. 27, Part III, pp. 381-386.)

A RELATION BETWEEN CONTINUED FRACTIONS AND HYPERBOLIC FUNCTIONS [APPLICATION TO WAVE FILTER THEORY].—H. Ataka. (*Phil. Mag.*, August, 1931, Series 7, Vol. 12, No. 77, pp. 551-553.)

INDEX OPERATORS [APPLICATION TO ELECTRIC CIRCUIT THEORY].—W. E. Sumpner. (*Phil. Mag.*, August, 1931, Supp. No., Series 7, Vol. 12, No. 76, pp. 201-224.)

THE COEFFICIENT OF CORRELATION AND OCCASIONS WHEN IT IS MEANINGLESS.—R. Bilancini. (Summary in *Sci. Abstracts*, Section A, June, 1931, Vol. 34, p. 466.)

THE MECHANICAL EQUIVALENT OF LIGHT.—Ornstein, van der Held and Vermeulen. (*Proc. K. Akad.*, Amsterdam, No. 2, Vol. 34, 1931, pp. 212-213.)

Values obtained are 0.00167 and 0.00168 watt per international lumen (for two gas-filled lamps operating at a colour temperature of 2500°C).

- ON SOME PROBLEMS IN THE CONDUCTION OF HEAT [MATHEMATICAL INVESTIGATION IN TERMS OF WAVE-TRAINS].—G. Green. (*Phil. Mag.*, August, 1931, Supp. No., Series 7, Vol. 12, No. 76, pp. 233-255.)
- ÜBER ZWEI FORMELN AUS DER THEORIE DES WARTENS VOR SCHALTERGRUPPEN ([Further Development of] Two Formulae in the Theory of Waiting for Groups of Switches [in a Telephone System]).—F. Pollaczek. (*E.N.T.*, June, 1931, Vol. 8, pp. 256-268.)
- [U.S.A.] PATENT REVIEW ON RECEIVER CIRCUITS AND TUBES.—J. J. Rogan. (*Electronics*, June, 1931, pp. 672-673.)
- THE PATENT POOL AND THE RADIO INVENTOR.—(*Electronics*, Aug., 1931, pp. 46-47 and 68.)
- NATIONAL PHYSICAL LABORATORY ANNUAL VISIT.—(*This journal*, Aug., 1931, Vol. 8, p. 431.)
- Among the demonstrations mentioned are:—applications of the dynatron principle by means of screen-grid valves (a) to the generation of frequencies up to 50 megacycles per sec., and (b) to give controlled retroaction for the production of an audio-frequency circuit of low decrement, thus greatly improving the overall selectivity of a receiver for Morse signals; a new method of measuring the anode/grid capacity in a screen-grid valve; and a new 20 kc. quartz oscillator of annular form.
- THE IMPERIAL GEOPHYSICAL EXPERIMENTAL SURVEY: REVIEW OF ITS FINAL REPORT.—T. W. Edgeworth David. (*Journ. Council for Sci. and Indust. Res., Australia*, May, 1931, Vol. 4, pp. 107-118.)
- ZEHN JAHRE FORSCHUNG AUF DEM PHYSIKALISCH-MEDIZINISCHEN GRENZGEBIET (Ten Years' Research in the Physical-Medical Boundary Zone).—F. Dessauer. (For list of contents see *Physik. Ber.*, 1st Aug., 1931, Vol. 12, p. 1677.)
- RESISTANCE-CAPACITY METHOD OF MEASURING THE PSYCHO-GALVANIC REFLEXES [VARIATIONS OF BODY RESISTANCE UNDER EMOTIONAL STIMULUS].—G. G. Blake. (*Elec. Review*, 6th March, 1931, Vol. 108, pp. 416-417.)
- Continuation of the work dealt with in 1929 Abstracts, p. 347.
- NEW METHODS OF RECORDING AND OBSERVING ANGULAR MOTION AND VIBRATION IN INTERNAL COMBUSTION ENGINES, USING TELEVISION TECHNIQUE.—A. Blondel. (*Comptes Rendus*, 3rd August, 1931, Vol. 193, pp. 278-282.)
- DÉCHARGE À HAUTE FRÉQUENCE DANS LES GAZ RARÉFIÉS ([Ultra-] High Frequency [Electrodeless] Discharge in Rarefied Gases).—F. Esclangon. (*Journ. de Phys. et le Rad.*, No. 3, Vol. 2, Ser. 7, 1931, pp. 35S-37S.)
- A 7-metre wave from two 200-watt valves was used to excite to luminescence glass or quartz tubes containing rarefied mercury, sodium or cadmium vapour, gases, etc. Very high light intensities were obtained; with mercury vapour, the light was six times as bright as that from a Hewitt burner on 3.5 A. at 25 v. Some of the lights obtained are of particular value for investigating the fine structure of linen. By increasing the frequency, say to  $10^8$ , the duration of life of excited atoms may be observed.
- INFLUENCE DES ONDES ÉLECTROMAGNÉTIQUES SUR LA RÉSISTIVITÉ ET LA DURETÉ DES MÉTAUX ET ALLIAGES (The Effect of Electromagnetic Waves on the Electrical Resistivity and the Hardness of Metals and Alloys).—G. Mahoux. (*Comptes Rendus*, 6th July, 1931, Vol. 193, pp. 27-29.)
- Further development of the work referred to in April Abstracts, p. 228. The wavelength is now given as 44 metres; power 300 watts. A 10-hours treatment reduced the resistance by amounts of the order of 8%. The bars were originally polished and uniformly coloured; after treatment, alternate light and dark bands were noticeable. These "nodes" and "antinodes" were tested for hardness; for steel, the Brinell numbers after treatment were 477 at the maxima and 444 at the minima (before treatment, 429); for an aluminium alloy, the numbers were 133 and 126 (before treatment, 112).
- PHYSICAL DETECTORS OF "MITOGENETIC RADIATION."—O. Glasser and V. B. Seitz. (*Phys. Review*, No. 4, Vol. 37, Series 2, 1931, p. 465.)
- For previous references to these mitogenetic or "vital" rays, see 1930 Abstracts, pp. 177—three.
- ÜBER DEN PHYSIKALISCHEN NACHWEIS MITOGENETISCHER STRALHUNG UND DIE INTENSITÄT DER MUSKELSTRAHLUNG (The Physical Demonstration of Mitogenetic Rays, and the Intensity of the Radiation from Muscle).—G. Frank and S. Rodionow. (*Naturwiss.*, 24th July, 1931, Vol. 19, p. 659.)
- RADIATION FROM METALS BOMBARDED BY LOW-SPEED ELECTRONS.—F. L. Mohler and C. Boeckner. (*Bur. of Stds. Journ. of Res.*, April, 1931, Vol. 6, pp. 673-681.)
- A PERMANENT DETECTOR USING A COMPRESSED SYNTHETIC POWDER. (French Pat. 701369, Habann, pub. 16th March, 1931.)
- Making use of the rectifying property of certain crystals in a powdered form, the sensitivity to shock being abolished by mixing with a neutral powder and compressing between the electrodes. The neutral powder must be a worse conductor than the rectifying powder and must be of the same chemical nature. Thus with galena powder the neutral powder must be a sulphide; actually, antimony trisulphide is used. For further details see *Rev. Gén. de l'Élec.*, 30th May, 1931, Vol. 29, p. 196D.
- POWER CONTROL BY MEANS OF PHOTOTUBES.—Baker, Fitzgerald and Whitney. (*Electronics*, May, 1931, pp. 632-633.)
- THE PIEZO-ELECTRIC OSCILLATOR IN THE POWER INDUSTRY.—B. H. Buckingham. (*Abstracts from the Massach. Inst. of Tech.*, July, 1931, p. 31.)

## Some Recent Patents.

The following abstracts are prepared, with the permission of the Controller of H.M. Stationery Office, from Specifications obtainable at the Patent Office, 25, Southampton Buildings, London, W.C.2, price 1/- each.

### HIGH-FREQUENCY SIGNALLING.

Application date, 28th March, 1930. No. 352052.

Ultra-short energy of the order 10-20 centimetres is radiated from an element which is short compared with the working wavelength. The radiating element *A, B* is energized with in-phase current, so that it is equivalent to a "point" source, from two oscillation-generators *V, V<sub>1</sub>* arranged in parallel. The generators are of the type in which

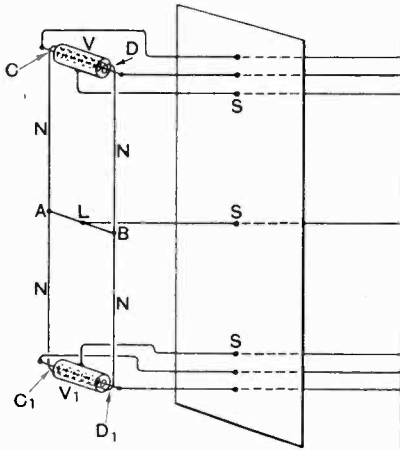

No. 352052.

ultra high-frequency oscillations are induced in a special electrode by the rapid reversals of the electron stream in a thermionic tube. The electrode in question is directly connected at *C, D* and *C<sub>1</sub>, D<sub>1</sub>* to conductors feeding the radiator *AB*. The length of the conductors is so related to the generated wavelength that a standing-wave formation is set up, with current nodes *N* at each midpoint, and a current loop *L* along the radiator which is preferably of a length less than one-eighth that of the generated wave. Under these conditions the effective radiation is confined to the element *AB*, the currents in the conductors *CA, DB* and *C<sub>1</sub>A, D<sub>1</sub>B* neutralising each other. Loss of high-frequency energy along the anode and filament supply leads to the generators *V, V<sub>1</sub>* is prevented by an interposed screen *S*.

Patent issued to Standard Telephones and Cables, Ltd.

### BROADCAST TRANSMITTING AERIALS.

Convention date (Germany), 27th August. No. 352779.

Under normal conditions broadcast radiation should be substantially horizontal, *i.e.*, with a

minimum spread vertically, and with no directional concentration in the horizontal plane. These requirements are met by arranging a number of individual aerials around a point in such a manner that each opposite pair is separated by half a wavelength, or a multiple of half a wavelength, and then energising the whole aerial system with in-phase currents of equal amplitude. For instance three aerials are arranged at the three corners of an equilateral triangle, or a greater number around the circumference of a circle of half wavelength diameter.

Patent issued to Telefunken Ges. für Drahtlose Telegraphie m.b.H.

### MANUFACTURING PIEZO-ELECTRIC CRYSTALS.

Application date, 7th April, 1930. No. 352419.

Artificial piezo-electric crystals are made from a dielectric of high specific inductive capacity by depositing the crystals from a conducting liquid under the combined influence of (a) an electrical field and (b) alternating mechanical stresses of supersonic frequency. A solution *S* containing the hemihedral crystals is subjected through the medium of electrodes *E, E<sub>1</sub>* to a steady voltage from a generator *D*, on which is superposed through a coupling-coil *L* the high-frequency oscillations produced by a quartz crystal *Q* connected between the plate and grid circuits of the valve *V*.

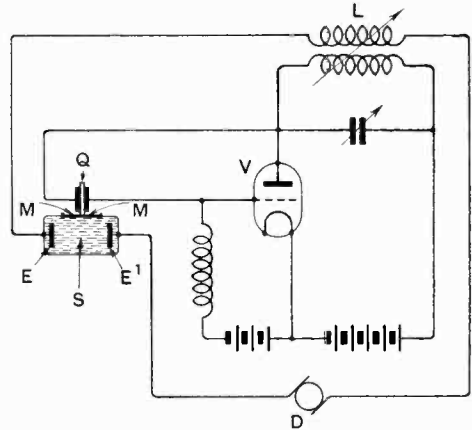

No. 352419.

Simultaneously the same supersonic vibrations are applied as mechanical stresses to the bath *S* at right-angles to the electrical field by the quartz *Q* through a flexible membrane *M*.

Patent issued to P. Freedman and W. J. Ricketts.

**TONE-CONTROL DEVICES.**

Convention date (Holland), 25th September, 1929.  
No. 352772.

The object of the invention is to secure volume control in such a manner that attenuation or amplification does not alter the ratio of the intensities of the tonal components as judged by the human ear, apart from their absolute intensities.

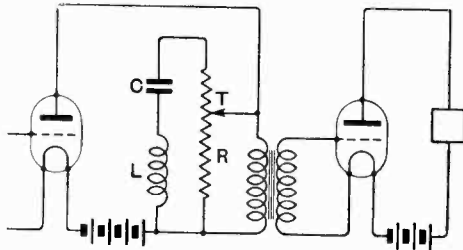

No. 352772.

With this end in view, a compound impedance consisting of an inductance  $L$ , capacity  $C$ , and resistance  $R$ , is connected in parallel with the primary or secondary of an intervalve transformer. As the position of the potentiometer tapping  $T$  is moved upwards, the "gain" is increased in the desired manner so long as the lower branch of the resistance (directly shunted across the transformer winding) is still small compared with the remainder of the compound impedance. Beyond that point the impedance of the  $L, C$  part of the circuit will fall for frequencies in the neighbourhood of 1500-2000 cycles, so that these frequencies are amplified less than frequencies above and below that band, which corresponds to the zone of maximum aural perception.

Patent issued to N. V. Philips Gloeilampenfabrieken.

**GRAMOPHONE PICK-UPS.**

Application date, 8th April, 1930. No. 351899.

Direct thermionic amplification is obtained by linking the stylus needle mechanically to a movable grid-electrode in a thermionic valve amplifier. The movements of the stylus swing the grid electrode about a pivot, causing it to move relatively to the filament and plate, whereby the output current is varied in accordance with the sound trace on the gramophone record.

Patent issued to A. M. Low.

**REMOTE TUNING CONTROL.**

Application date, 19th March, 1930. No. 351934.

One or more continuously-variable tuning elements are operated from a distance through a dialling-device of the type used in automatic telephony. A series of impulses produced by the dial are applied to a stepping-magnet which acts directly on the spindle of the distant tuning-condenser. A second condenser can be similarly

operated by moving a master switch on to a second contact. Or the first series of dial impulses can be used to set the tuning-condenser approximately to the desired position, a second series of impulses then being dialled to give a vernier adjustment through another set of stepping-magnets.

Patent issued to L. H. Pearson and W. J. Randall.

**HIGH-FREQUENCY RELAYING SYSTEMS.**

Convention date (Germany), 11th May, 1929.  
No. 351184.

In a system for relaying broadcast programmes to a number of local subscribers over a network of wires, a central, aperiodic, high-frequency amplifier, which may consist of two or three H.F. multiple valves, is used to receive the distant stations, and the last H.F. stage is constructed to function as a power amplifier. A number of programmes amplified in this manner are fed simultaneously into the distributing network, selection being effected, as desired by the subscribers, through simple tuning circuits provided at the terminals of the distributing line.

Patent issued to M. von Ardenne.

**HIGH-ANGLE TRANSMITTING AERIALS.**

Application date, 2nd April, 1930. No. 352399.

In the case of a broadcast transmitter situated close to a large town, it is advantageous to project a large proportion of the radiated energy in an upward direction, so that the field-strength is reduced in the near vicinity of the transmitter. It is known that a vertical aerial whose electrical length is an even multiple of half wavelength favours a vertical distribution of the radiation. In order to construct an aerial of the required dimensions for broadcasting wavelengths of the order of 300 metres, the electrical length of the aerial is increased relatively to its actual or geometrical length, either by bending alternate sections backwards and forwards as shown in Fig. 1(a), or by distributed loading-coils as shown in Fig. 1(b), the resulting stationary-wave formation in each case being similar to that of a plain wire of the same vertical height.

Patent issued to Marconi's Wireless Telegraph Co., Ltd., and H. J. Round.

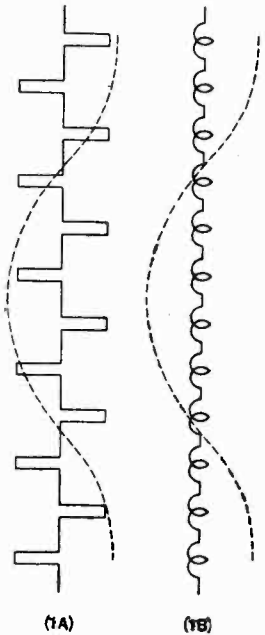

No. 352399.



**HIGH-FREQUENCY AMPLIFIERS.**

*Convention date (U.S.A.), 4th November, 1929.  
No. 352357.*

Relates to high-frequency amplifiers of the kind in which the output from a single triode or screened-

is located at a height of 5 metres above the ground. The input leads from the frame are concentric, i.e., a single wire inside a tubular conductor. The mid-point of the secondary winding of the coupling transformer to the Lorenz valve is earthed. Patent issued to Lorenz Aktiengesellschaft.

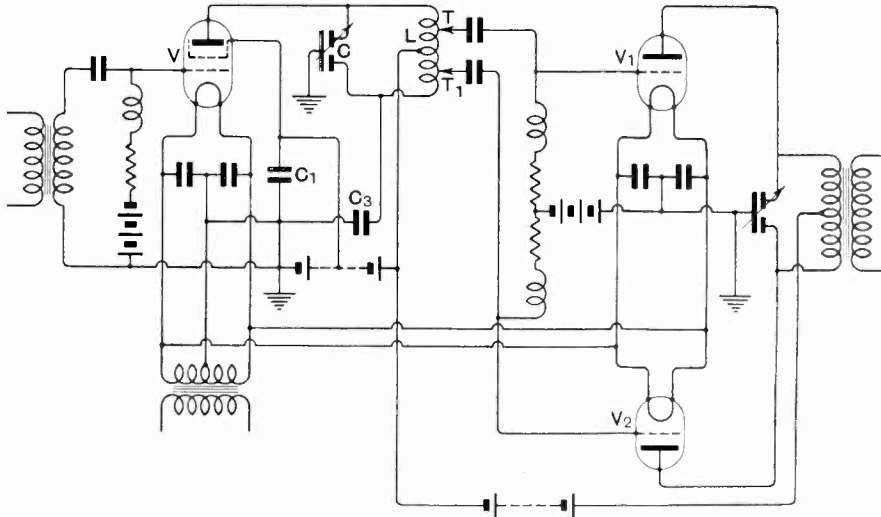

No. 352357.

grid valve  $V$  is applied to a pair of push-pull amplifiers  $V_1, V_2$  through tappings  $T, T_1$  on the inductance  $L$  of the tuned circuit  $L, C$ , the centre point of which is earthed through a differential condenser  $C$ . Since the filaments circuits are also earthed, the interelectrode capacity of the valve  $V$ , when this is a triode (or the bypass condenser  $C_1$  in the case of a screened grid valve as shown) is shunted across the upper portion of the tuned circuit  $L, C$ . Being thus made resonant to a slightly-different frequency from the lower portion, there is a tendency to the production of parasitic oscillations, which are particularly undesirable when the amplifier is handling ultra-high frequencies.

To ensure stability and to balance the circuit  $L, C$  so that both amplifiers  $V_1, V_2$  take an equal share of the load, a condenser  $C_3$  is inserted, as shown, between the cathode of the valve  $V$  and the lower end of the inductance  $L$ , and is adjusted so as to equalise the total capacity shunt across the upper portion of the tuned circuit.

Patent issued to British Thomson-Houston, Ltd.

**SHORT-WAVE FRAME AERIALS.**

*Convention date (Germany), 30th October, 1929,  
No. 347503.*

The object of the invention is to secure pronounced directional effects from a frame or loop aerial on wavelengths below 25 metres. This is effected by placing the aerial at a considerable height above ground level. For instance when working on a 5-metre wavelength, a small frame of 10 cm. side

**SELECTIVE INPUT CIRCUITS.**

*Convention date (Holland), 18th September, 1929.  
No. 352791.*

The input circuit is so arranged that in the open position of the switch  $S$ , as shown in the Figure, a tuned rejector circuit  $L, C$  is coupled to a tuned input  $L_1, C_1$  through a series condenser  $C_2$  of small capacity, so as to give constant tuning irrespective of the size of the aerial. In this position an interfering station is cut out by adjusting the condenser  $C$  of the rejector circuit, the effective tuning of the set depending upon the circuit  $L_1, C_1$ . In the closed position of the switch, a highly selective

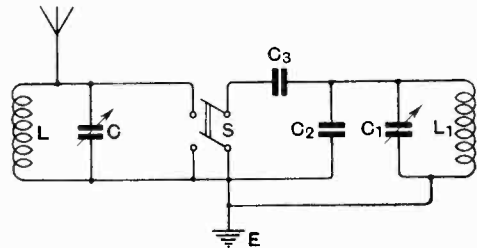

No. 352791.

input is obtained through two tuned circuits in parallel viz. :  $L, C$ , earth, and  $L_1, C_1, C_2$ , earth, the two being mutually coupled through the condenser  $C_3$ .

Patent issued to N. V. Philips Gloeilampenfabrieken.

**VOLUME CONTROL.**

*Application date 13th May, 1930. No. 353969.*

The input to the set is taken from the earthed centre  $P$  and one end  $P_1$  of an inductance  $L$ , which is shunted by two condensers  $C, C_1$  branched on each side of the aerial  $A$ .

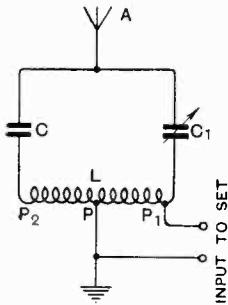

No. 353969.

The aerial circuit is thus divided into two branches, one comprising the condenser  $C$  and the portion  $P_2P$  of the inductance coil, and the other the condenser  $C_1$  and the windings  $P_1P$ . As the two halves of the inductance coil are closely coupled, currents in the first branch are transferred to the input circuit in phase opposition to those flowing in the second branch. Accordingly by adjusting the variable condenser  $C_1$ , the effective signal energy fed to the set can be varied from zero to a maximum.

Patent issued to The Gramophone Co., Ltd., and A. H. Cooper.

**VALVE RECTIFIERS.**

*Application date 23rd June, 1930. No. 353203.*

An electron-discharge rectifier is liable to be damaged if full power is drawn from it before the cathode has reached the temperature for full emission. The period required for this purpose is of the order of 25 seconds, which is the same as that required for the cathode of an indirectly-heated valve to give appreciable emission. According to the invention a prohibitive bias is placed on the grid of the power amplifier by means of one or more series resistances inserted between the common filament circuit and earth, and an indirectly-heated valve is utilized to operate a relay which short-circuits one or more of the biasing resistances so that the amplifier only comes on as a full load on the rectifier after an initial period of delay.

Patent issued to General Electric Co., Ltd., F. Clark, W. G. Frogley, and D. I. Watson.

**BROADCAST RELAY-SYSTEMS.**

*Application dates 22nd July, 1930 and 10th January, 1931. No. 353690.*

In a local-relay service for re-distributing broadcast programmes, a high resistance of from 1000 to 5000 ohms is connected in series with each subscriber's shunt circuit across the main feedlines from the central supply station. The object is to maintain an approximately constant voltage along the subscriber's line at the lowest useful audio frequency. The resistance is tapped to allow of adjustment according to the impedance of the particular loud-speaker used, and to the subscriber's individual preference as regards the tone quality of the instrument. The resistance also serves to

minimise the effect of any accidental short-circuit in the subscriber's equipment.

Patent issued to P. P. Eckersley and J. W. C. Robinson.

**TUNING CONTROL.**

*Application date 20th May, 1930. No. 353147.*

The control knob of a ganged set of tuning-condensers is made to drive a visual band-indicator through independent worm-gearing at a speed higher than that of the condenser rotor, so as to provide a clearer reading of the tuning position. The arrangement allows the band indicator to be separated from the tuning-dial, so that it can be placed either at the back or front of the panel, as is most convenient.

Patent issued to G. E. J. Dandridge.

**ELIMINATING HUM.**

*Application date 4th June, 1930. No. 354453.*

In order to eliminate "hum" induced in a mains-driven set by direct coupling between the source of supply and the valve circuits, the supply transformer is so mounted and aligned, relatively to the intervalve coupling-coils, that an out-of-phase component is induced by the magnetic flux to neutralize the effect of the direct coupling. For instance, as shown in the drawing, the supply transformer  $S$ , the intervalve and output transformers  $T, T_1$  and the smoothing-choke  $K$ , are set at such angles relatively to each other, and at

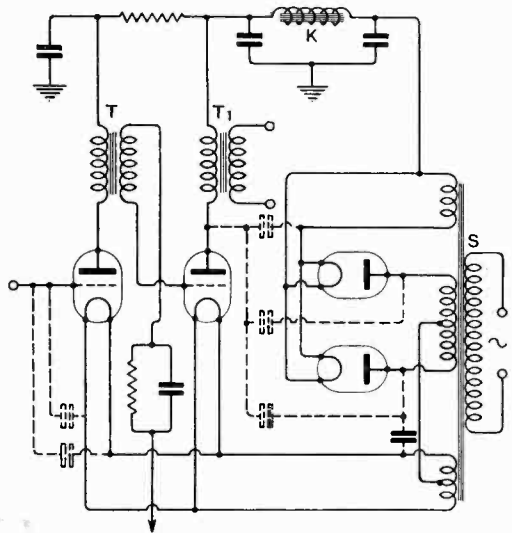

No. 354453.

such distances apart (these being determined empirically in the first instance) as to secure the desired result.

Patent issued to The Gramophone Co., Ltd. and H. C. Atkins.