

**EVERYDAY**

858

SEPTEMBER 1992

# **ELECTRONICS**

INCORPORATING ELECTRONICS MONTHLY

£1.60

**ULTRASONIC TAPE MEASURE**

**WASHER BOTTLE MONITOR**

**QUICK TEST**

**SOUND OPERATED NIGHT LIGHT**

**ALTERNATIVE ENERGY – 2**

**Wind Power**



THE No. 1 INDEPENDENT MAGAZINE for ELECTRONICS, TECHNOLOGY and COMPUTER PROJECTS

**AMSTRAD PORTABLE PC'S FROM £149 (PPC1512SD), £179 (PPC1512DD), £179 (PPC1640SD), £209 (PPC1640DD), MODEMS £30 EXTRA. NO MANUALS OR PSU.**

**HIGH POWER CAR SPEAKERS.** Stereo pair output 100w each. 40hm impedance and consisting of 6 1/2" woofer 2" mid range and 1" tweeter. Ideal to work with the amplifier described above. Price per pair £30.00 Order ref 30P7R.

**2KV 500 WATT TRANSFORMERS** Suitable for high voltage experiments or as a spare for a microwave oven etc. 250v AC input. Now only £4.00 ref 4P157

**MICROWAVE CONTROL PANEL.** Mains operated, with touch switches. Complete with 4 digit display, digital clock, and 2 relay outputs one for power and one for pulsed power (programmable). Ideal for all sorts of precision timer applications etc. Now only £4.00 ref 4P151.

**FIBRE OPTIC CABLE.** Stranded optical fibres sheathed in black PVC. Five metre length £7.00 ref 7P29R

**12V SOLAR CELL.** 200mA output ideal for trickle charging etc. 300 mm square. Our price £15.00 ref 15P42R

**PASSIVE INFRA-RED MOTION SENSOR.** Complete with daylight sensor, adjustable lights on timer (8 secs -15 mins), 50° range with a 90 deg coverage. Manual override facility. Complete with wall brackets, bulb holders etc. Brand new and guaranteed. Now only £19.00 ref 19P29

Pack of two PAR36 bulbs for above unit £12.00 ref 12P43R  
**VIDEO SENDER UNIT** Transmit both audio and video signals from either a video camera, video recorder or computer to any standard TV set within a 100' range! (tune TV to a spare channel). 12v Dc op. £15.00 ref 15P39R Suitable mains adaptor £5.00 ref 5P191R

**FM TRANSMITTER** housed in a standard working 13A adaptor (bug ins mains driven). £26.00 ref 26P2R

**MINIATURE RADIO TRANSCEIVERS** A pair of walkie talkies with a range of up to 2 kilometres. Units measure 22x52x155mm. Complete with cases. £30.00 ref 30P12R

**FM CORDLESS MICROPHONE.** Small hand held unit with a 500' range! 2 transmit power levels reqs PP3 battery. Tuneable to any FM receiver. Our price £15 ref 15P42AR

**12 BAND COMMUNICATIONS RECEIVER.** 9 short bands, FM, AM and LW DX/local switch, tuning 'eye' mains or battery. Complete with shoulder strap and mains lead NOW ONLY £19.00!! REF 19P14R.

**CAR STEREO AND FM RADIO** Low cost stereo system giving 5 watts per channel. Signal to noise ratio better than 45db, wow and flutter less than .35%. Neg earth. £19.00 ref 19P30

**LOW COST WALKIE TALKIES.** Pair of battery operated units with a range of about 200'. Our price £8.00 a pair ref 8P50R

**7 CHANNEL GRAPHIC EQUALIZER** plus a 60 watt power amp! 20-21KHz 4-8R 12-14v DC negative earth. Cased. £25 ref 25P14R.

**NICAD BATTERIES.** Brand new top quality. 4 x AA's £4.00 ref 4P44R 2 x C's £4.00 ref 4P73R, 4 x D's £9.00 ref 9P12R, 1 x PP3 £6.00 ref 6P35R

**TOWERS INTERNATIONAL TRANSISTOR SELECTOR GUIDE.** The ultimate equivalents book. Latest edition £20.00 ref 20P32R.

**CABLE TIES.** 142mm x 32mm white nylon pack of 100 £3.00 ref 3P104R. Bumper pack of 1,000 ties £14.00 ref 14P6R  
**GOT A CARAVAN OR BOAT?**

**NEW 80 PAGE FULL COLOUR LEISURE CATALOGUE**  
**2,500 NEW LINES FREE WITH ORDER ON REQUEST**

OR SEND £1.00

**GEIGER COUNTER KIT.** Complete with tube, PCB and all components to build a battery operated geiger counter. £39.00 ref 39P1R

**FM BUG KIT.** New design with PCB embedded coil. Transmits to any FM radio. 9v battery req'd. £5.00 ref 5P158R

**FM BUG** Built and tested superior 9v operation £14.00 ref 14P3R

**COMPOSITE VIDEO KITS.** These convert composite video into separate H sync, V sync and video. 12v DC. £8.00 ref 8P39R.

**SINCLAIR C5 MOTORS** 12v 29A (full load) 3300 rpm 6"x4" 1/4" O/P shaft. New. £20.00 ref 20P22R.

As above but with fitted 4 to 1 inline reduction box (800rpm) and toothed nylon belt drive cog £40.00 ref 40P8R.

**SINCLAIR C5 WHEELS** 13" or 16" dia including treaded tyre and inner tube. Wheels are black, spoked one piece poly carbonate. 13" wheel £6.00 ref 6P20R, 16" wheel £6.00 ref 6P21R.

**ELECTRONIC SPEED CONTROL KIT** For c5 motor. PCB and all components to build a speed controller (0-95% of speed). Uses pulse width modulation. £17.00 ref 17P3R.

**SOLAR POWERED NICAD CHARGER.** Charges 4 AA nicads in 8 hours. Brand new and cased £6.00 ref 6P3R.

**12 VOLT BRUSHLESS FAN** 1/2" square brand new ideal for boat, car, caravan etc. £5.00 ref 5P206.

**ACORN DATA RECORDER ALF503** Made for BBC computer but suitable for others. Includes mains adaptor, leads and book. £15.00 ref 15P43R

**VIDEO TAPES.** Three hour superior quality tapes made under licence from the famous JVC company. Pack of 5 tapes New low price £8.00 ref 8P161

**PHILIPS LASER.** 2MW HELIUM NEON LASER TUBE. BRAND NEW FULL SPEC £40.00 REF 40P10R. MAINS POWER SUPPLY KIT £20.00 REF 20P33R READY BUILT AND TESTED LASER IN ONE CASE £75.00 REF 75P4R.

**12 TO 220V INVERTER KIT** As supplied it will handle up to about 15w at 220v but with a larger transformer it will handle 80 watts. Basic kit £12.00 ref 12P17R. Larger transformer £12.00 ref 12P41R.

**VERO EASI WIRE PROTOTYPING SYSTEM** Ideal for designing projects on etc. Complete with tools, wire and reusable board. New low bargain price only £2.00 ref B2P1

**HIGH RESOLUTION 12" AMBER MONITOR** 2v 1.5A Hercules compatible (TTL input) new and cased £22.00 ref 22P2R

**VGA PAPER WHITE MONO** monitors new and cased 240v AC. £59.00 ref 59P4R

**25 WATT STEREO AMPLIFIER.** c. STK043. With the addition of a handful of components you can build a 25 watt amplifier. £4.00 ref 4P69R (Circuit dia included).

**BARGAIN NICADS AAA SIZE 200MAH 1.2V PACK OF 10** £4.00 REF 4P92R, PACK OF 100 £30.00 REF 30P16R

**FRESNEL MAGNIFYING LENS** 83 x 52mm £1.00 ref BD827R.

**ALARM TRANSMITTERS.** No data available but nicely made complex radio transmitters 9v operation. £4.00 each ref 4P81R.

**12V 19A TRANSFORMER.** Ex equipment but otherwise ok. Our price £20.00

**GX4000 COMPUTERS.** Customer returned games machines complete with plug in game, joysticks and power supply. Retail price is almost £100. Ours is £12.00 ref B12P1

**ULTRASONIC ALARM SYSTEM.** Once again in stock these units consist of a detector that plugs into a 13A socket in the area to protect. The receiver plugs into a 13A socket anywhere else on the same supply. Ideal for protecting garages, sheds etc. Complete system £25.00 ref B25P1 additional detectors £11.00 ref B1P1

**IBM XT KEYBOARDS.** Brand new 86 key keyboards £5.00 ref 5P612

**IBM AT KEYBOARDS** Brand new 86 key keyboards £15.00 ref 15P612

**386 MOTHER BOARDS.** Customer returned units without a cpu fitted. £22.00 ref A22P1

#### BSB SATELLITE SYSTEMS

BRAND NEW

REMOTE CONTROL

£49.00 REF F49P1

**286 MOTHER BOARDS.** Brand new but customer returns so may need attention. Complete with technical manual £20.00 ref A20P2

**286 MOTHER BOARDS.** Brand new and tested complete with technical manual. £49.00 ref A49P1

**UNIVERSAL BATTERY CHARGER.** Takes AA's, C's, D's and PP3 nicads. Holds up to 5 batteries at once. New and cased, mains operated. £6.00 ref 6P36R.

**IN CAR POWER SUPPLY.** Plugs into cigar socket and gives 3,4,5,6,7,5,9, and 12v outputs at 800mA. Complete with universal spider plug. £5.00 ref 5P167R.

**RESISTOR PACK.** 10 x 50 values (500 resistors) all 1/4 watt 2% metal film. £5.00 ref 5P170R.

**CAPACITOR PACK 1000**

#### MIRACOM WS4000 MODEMS

V21/23

AT COMMAND SET

AUTODIAL/AUTOANSWER

FULL SOFTWARE CONTROL

TONE AND PULSE DIALLING

£29

**IBM PRINTER LEAD.** (D25 to centronics plug) 2 metre parallel. £5.00 ref 5P186R.

**COPPER CLAD STRIP BOARD** 17" x 4" of 1" pitch "vero" board. £4.00 a sheet ref 4P62R or 2 sheets for £7.00 ref 7P22R.

**STRIP BOARD CUTTING TOOL** £2.00 ref 2P352R.

**50 METRES OF MAINS CABLE** £3.00 2 core black precut in convenient 2 m lengths. Ideal for repairs and projects. ref 3P91R

**4 CORE SCREENED AUDIO CABLE** 24 METRES £2.00

Precut into convenient 1.2 m lengths. Ref 2P365R

**TWEETERS** 2 1/4" DIA 8 ohm mounted on a smart metal plate for easy fixing £2.00 ref 2P366R

**COMPUTER MICE** Originally made for Future PC's but can be adapted for other machines. Swiss made £8.00 ref 8P57R. Atari ST conversion kit £2.00 ref 2P362R.

**6 1/2" 20 WATT SPEAKER** Built in tweeter 4 ohm £5.00 ref 5P205R

**WINDUP SOLAR POWERED RADIO!** FM/AM radio takes rechargeable batteries complete with hand charger and solar panel 14P200R

**PC STYLE POWER SUPPLY** Made by AZTEC 110v or 240v input. +5 @ 15A, +12 @ 5A, -12 @ 5A, -5 @ 3A. Fully cased with fan, on/off switch, IEC inlet and standard PC flyleads. £15.00 ref F15P4

**ALARM PIR SENSORS** Standard 12v alarm type sensor will interface to most alarm panels. £16.00 ref 16P200

**ALARM PANELS** 2 zone cased keypad entry, entry exit time delay

### BULL ELECTRICAL

250 PORTLAND ROAD HOVE SUSSEX

BN3 5QT TELEPHONE 0273 203500

MAIL ORDER TERMS: CASH PO OR CHEQUE WITH ORDER PLUS £3.00 POST PLUS VAT.

PLEASE ALLOW 7 - 10 DAYS FOR DELIVERY

NEXT DAY DELIVERY £8.00

FAX 0273 23077



etc. £18.00 ref 18P200  
**MODEMS FOR THREE POUNDS!!**

Fully cased UK modems designed for dialup system (PSTN) no data or info but only £3.00 ref 3P145R

**TELEPHONE HANDETS**

Bargain pack of 10 brand new handsets with mic and speaker only £3.00 ref 3P146R

**BARGAIN STRIPPERS**

Computer keyboards. Loads of switches and components excellent value at £1.00 ref CD40R

**DATA RECORDERS**

Customer returned mains battery units built in mic ideal for Computer or general purpose audio use. Price is £4.00 ref 4P100R

**SPECTRUM JOYSTICK INTERFACE**

Plugs into 48K Spectrum to provide a standard Atari type joystick port. Our price £4.00 ref 4P101R

**ATARI JOYSTICKS**

Ok for use with the above interface, our price £4.00 ref 4P102R

**BENCH POWER SUPPLIES**

Superbly made fully cased (metal) giving 12v at 2A plus a 6V supply. Fused and short circuit protected. For sale at less than the cost of the case! Our price is £4.00 ref 4P103R

**SPEAKER WIRE**

Brown twin core insulated cable 100 feet for £2.00 REF 2P79R

**MAINS FANS**

Brand new 5" x 3" complete with mounting plate quite powerfull and quite. Our price £1.00 ref CD41R

**DISC DRIVES**

Customer returned units mixed capacities (up to 1.44M) We have not sorted these so you just get the next one on the shelf. Price is only £7.00 ref 7P1R (worth it even as a stripper)

**HEX KEYBOARDS**

Brand new units approx 5" x 3" only £1.00 each ref CD42R

**PROJECT BOX**

5 1/2" x 3 1/2" x 1" black ABS with screw on lid. £1.00 ref CD43R

**SCART TO SCART LEADS**

Bargain price leads at 2 for £3.00 ref 3P147R

**SCART TO D TYPE LEADS**

Standard Scart on one end, Hi density D type on the other. Pack of ten leads only £7.00 ref 7P2R

**OZONE FRIENDLY LATEX**

250ml bottle of liquid rubber sets in 2 hours. Ideal for mounting PCB's fixing wires etc. £2.00 each ref 2P379R

**QUICK SHOTS**

Standard Atari compatible hand controller (same as joysticks) our price is 2 for £2.00 ref 2P380R

**VIEWDATA SYSTEMS**

Brand new units made by TANDATA complete with 1200/75 built in modem infra red remote controlled qwerty keyboard BT approved Prestel compatible, Centronics printer port RGB colour and composite output (works with ordinary television) complete with power supply and fully cased. Our price is only £20.00 ref 20P1R

**AC STEPDOWN CONVERTOR**

Cased units that convert 240v to 110v 3" x 2" with mains input lead and 2 pin American output socket (suitable for resistive loads only) our price £2.00 ref 2P381R

**SPECTRUM +2 LIGHT GUN PACK**

complete with software and instructions £8.00 ref 8P58R/2

**CURLY CABLE**

Extends from 8" to 6 feet! D connector on one end, spade connectors on the other ideal for joysticks etc (6 core) £1.00 each ref CD44R

**COMPUTER JOYSTICK BARGAIN**

Pack of 2 joysticks only £2.00 ref 2P382R

**BUGGING TAPE RECORDER**

Small hand held cassette recorders that only operate when there is sound then turn off 6 seconds after so you could leave it in a room all day and just record any thing that was said. Price is £20.00 ref 20P3R

**IEC MAINS LEADS**

Complete with 13A plug our price is only £3.00 for TWO! ref 3P148R

**NEW SOLAR ENERGY KIT**

Contains 8 solar cells, motor, tools, fan etc plus educational booklet. Ideal for the budding enthusiast! Price is £12.00 ref 12P2R

**286 AT PC**

286 MOTHER BOARD WITH 640K RAM FULL SIZE METAL CASE, TECHNICAL MANUAL, KEYBOARD AND POWER SUPPLY £139 REF 139P1 (no i/o cards or drives included) Some metal work req'd phone for details.

**35MM CAMERAS** Customer returned units with built in flash and 28mm lens 2 for £8.00 ref 8P200

**STEAM ENGINE** Standard Mamod 1332 engine complete with boiler piston etc £30 ref 30P200

**TALKING CLOCK**

LCD display, alarm, battery operated. Clock will announce the time at the push of a button and when the alarm is due. The alarm is switchable from voice to a cock crowing! £14.00 ref 14P200R

**HANDHELD TONE DIALLERS**

Small units that are designed to hold over the mouth piece of a telephone to send MF dialing tones. Ideal for the remote control of answer machines. £5.00 ref 5P209R

**COMMODORE 64 MICRODRIVE SYSTEM**

Complete cased brand new drives with cartridge and software 10 times faster than tape machines works with any Commodore 64 setup. The original price for these was £49.00 but we can offer them to you at only £25.00! REF 25P1R

**ATARI 2600 GAMES COMPUTER** Brand new with joystick and 32 game cartridge (plugs into TV) £29.00 ref F29P1 also some with 1 game at £19.00 ref F19P2.

**BEER PUMPS** Mains operated with fluid detector and electronic timer standard connections. Ex equipment. £18.00 ref F18P1

**90 WATT MAINS MOTORS** Ex equipment but ok (as fitted to above pump) Good general purpose unit £9.00 ref F9P1

**HI FI SPEAKER BARGAIN** Originally made for TV sets they consist of a 4" 10 watt 4R speaker and a 2" 140R tweeter. If you want two of each plus 2 of our crossovers you can have the lot for £5.00 ref F5P2.

**VIDEO TAPES** E180 FIFTY TAPES FOR £70.00 REF F70P1  
360K 5 1/4" Brand new drives white front. £20.00 Ref F20P1



# EVERYDAY ELECTRONICS

INCORPORATING ELECTRONICS MONTHLY

ABC  
CONSUMER PRESS

The No. 1 Independent Magazine for Electronics,  
Technology and Computer Projects

VOL. 21 No. 9 SEPTEMBER 1992

ISSN 0262 3617

PROJECTS... THEORY... NEWS...  
COMMENT... POPULAR FEATURES...

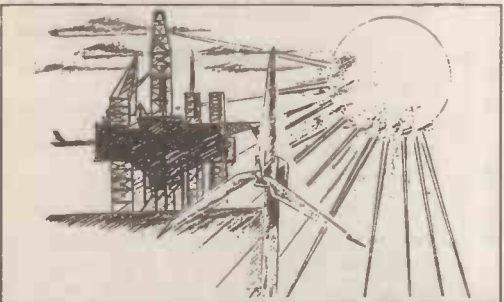
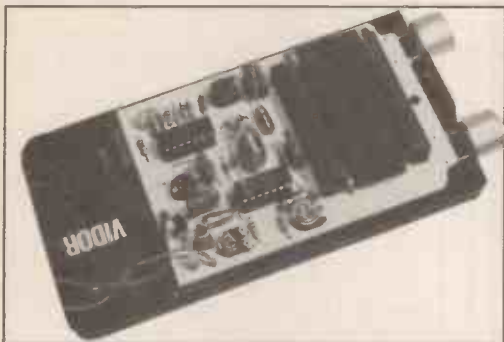

© Wimborne Publishing Ltd 1992. Copyright in all drawings, photographs and articles published in **EVERYDAY ELECTRONICS** is fully protected, and reproduction or imitations in whole or in part are expressly forbidden.

Our October '92 Issue will be published on Friday, 4 September 1992. See page 547 for details.

## Projects

- LCD ULTRASONIC TAPE MEASURE** by John Becker **556**  
Measures up to nine metres in any direction
- SOUND OPERATED NIGHTLIGHT** by Eleanor Maitland **568**  
Switched on by sound, the light then gradually dims
- WASHER BOTTLE MONITOR** by Alan Winstanley **580**  
Keep a check on your car screenwash
- MODEL RAILWAY AUTOMATIC SIGNAL** **588**  
by Stuart Dando  
Automatic switching as the train approaches
- QUICKTEST** by Mark Daniels **596**  
A continuity tester that does not need test leads

## Series

- ALTERNATIVE ENERGY - 2** **562**  
by T. R. de Vaux Balbirnie  
Is the answer blowing in the wind?
- CIRCUIT SURGERY** by Mike Tooley **572**  
Our clinic for constructors - your problems solved
- INFORMATION TECHNOLOGY AND THE NATIONAL CURRICULUM** by T. R. de Vaux-Balbirnie **574**  
Part Eleven: Problem solving and feedback
- ACTUALLY DOING IT** by Robert Penfold **584**  
I.C. leadout identification
- INTERFACE** by Robert Penfold **592**  
Bar Code Reader
- AMATEUR RADIO** by Tony Smith G4FAI **604**  
Meteor Scatter, Moonbounce, EMC Regulations, QRP DX

## Features

- EDITORIAL** **555**
- SHOPTALK** with David Barrington **566**  
Component buying for EE projects
- EVERYDAY READOUT** **567**  
From you to us - your news and views
- ELECTRONICS VIDEOS** **579**  
Learn about your favourite subject with these videos
- PLEASE TAKE NOTE** **582**  
Dual Metronome (August 1992)
- EVERYDAY NEWS** **583**  
News from the world of electronics
- DOWN TO EARTH** by George Hylton **590**  
The Wein network
- FOR YOUR ENTERTAINMENT** by Barry Fox **594**  
PC compatibility, Bill Gates and all that
- DIRECT BOOK SERVICE** **599**  
Selected technical books, EE books and all Babani books by mail order
- PRINTED CIRCUIT BOARD SERVICE** **602**  
A special PCB SALE (while stocks last) - boards for EE projects
- ADVERTISER'S INDEX** **608**

Readers Services • Editorial and Advertisement Departments **555**

## 2 x 220 watt MOSFET AMPLIFIER

A top-of-the-range performer that will satisfy the most demanding audio enthusiast. If you're looking for an amplifier to power your subwoofer, the



**SPARKOMATIC** is all you'll need! Highly sophisticated MOS-FET technology dramatically extends frequency response, separate input sensitivity controls, built-in protection circuitry for overheat and short circuit with i.e.d. indication, output power: 2 x 220 watt maximum and 2 x 110 watt at 0.1% THD, Bridged 440 watt mono maximum and 220 watt mono at 0.5% THD.

**£168.50 plus £3.50 p&p**

## 100 watt x 4 CLASS A AMPLIFIER FOR CARS

Delivers 4 x 100 watt into 4 woofers or with the aid of its built in active cross over delivers 200 watt of Bass via sub-woofer output and 2 x 100 watt, full range into 2 speakers; thus giving you all the power you require to make even traffic jams a positive pleasure. SPECIFICATION 4 x 100W (4Ω), 2 x 200W Bridged, THD .08%, S/N RATIO: 79db, RESPONSE 10Hz-50kHz, LOW PASS FILTER SWITCHED 75Hz 150Hz, INPUT 4 x PHONO 100-3 Volts, INPUT x 4 HIGH LEVEL 20kΩ, SIZE 240mm x 50mm x 400mm.

**£118.50 postage £4.50**

## 80 watt CAR POWER AMPLIFIER

The AMP 7000 produces high power at low distortion. The amplifier accommodates low level, high level and high power radio speaker inputs. The response is linear and extends beyond the capability of all music sources. This compact unit mounts easily and its quick connect terminals accept RCA or straight wire input terminals. Power rating 2 x 40 watt per channel. MMP 2 x 20 watt at 10% THD response 20Hz-20kHz. Size 160mm x 130mm x 45mm.

**£32.95 plus £3.50 p&p**

## 11 BAND COMPONENT GRAPHIC EQUALIZER FOR CARS

This neat unit connects between the line output of your car stereo and your power amplifiers so that you are able to adjust the sound as in a studio compensating for soft furnishing and sound reflections from glass, also it has a sub-woofer output to drive a separate amplifier for that extra deep bass sound. FEATURES: 2 channel inputs 4 channel outputs via phono sockets, CD input via 3.5mm jack 11 band graphic. SPECIFICATION RANGE 20Hz-60kHz THD 0.05%, S/N RATIO 85dB, EQ FREQUENCIES 60Hz, 120Hz, 250Hz, 380Hz, 500Hz, 750Hz, 1kHz, 2kHz, 4kHz, 8kHz, 16kHz (boost cut of ± 12dB) SIZE 178mm x 25mm x 140mm.

**£32.70 postage £1.80**

## EMINENCE 4Ω PROFESSIONAL USA MADE IN CAR CHASSIS SPEAKERS

All units are fitted with big magnets "Nomex" Voice coils NOT ALUMINIUM, "Nomex" is very light and can stand extremely high temperatures, this mixture makes for high efficiency and long lasting quality of sound.

V6 6 1/2" 200W Max	Range 50Hz-3kHz	£34.40
V6 8" 300W Max	Range 45Hz-3kHz	£39.35
V10 10" 400W Max	Range 33Hz-4kHz	£44.45
V12 12" 400W Max	Range 35Hz-3kHz	£45.95
BOSS 15" 800W Max	Range 35Hz-4kHz	£79.90
KING 18" 1200W Max	Range 20Hz-1kHz P.O.A.	

Postage £3.85per speaker.

Build your own Bazooka sub woofer tube to suit Eminence car speakers. 10mm thick fibre supplied with grille and clamp terminals finished in black vinyl.

Eminence U10, Size 270mm x 700mm  
**£25.95 £3.50 p&p**

Eminence U12 Size 320mm x 710mm  
**£29.95 £3.50 p&p**

# RTVC

## MAIL ORDER BARGAIN PACKS

No.	Qty. per pack	
MO20	1	30W dome tweeter by Eagle/Japan Made size 90mm x 66mm <b>£1</b>
MO21	1	60W Hifi tweeter made for Jamo UK size 90mm sq. <b>£1</b>
MO22	2	30 watt 8 ohm Hifi chassis speakers. Made for Hitachi UK midi systems, size 125mm sq., with large 70mm magnet <b>£9.00 + £2.00 p&amp;p</b>
MO23	2	Pod Car Speakers. Moulded in black plastic with 15 watt 10cm Goodmans unit fitted <b>£4.95 + £2.50 p&amp;p</b>
MO23A	1pr	40 watt Car Speakers made for Roadstar of Switzerland. Fitted with dual polypropylene cone and foam rubber surround. Big 70mm magnet for good base response. Supplied with grills fixing screws and cable. Size 13cm, weight 1.5Kg <b>£11.70 pair + £3.65 p&amp;p</b> or <b>TWO pairs for £25.00 UK post paid</b>
MO24	2	Audax JBL 40-100watt dome tweeters. High performance 10mm Ferrofluid cooled horn loaded unit for load distortion and high output. Supplied with 1st order crossover, spec. 40 watts at 3kHz, 100 watt at 8kHz; size 51mm x 51mm x 16.5mm. Ideal for car use <b>£7.50 + £1 p&amp;p</b>
MO25	2	3300µF 10V d.c. can type computer grade quality electrolytic UK made <b>£1</b>
MO25A	1	47µF 385V d.c. can type electrolytic. Size 350mm x 250mm. UK made by Phillips <b>£1.75</b>
MO26	2	680µF 100V d.c. can type electrolytic size 45mm x 25mm <b>£1</b>
MO27	3	2200µF 25V d.c. can type electrolytic size 45mm x 25mm <b>£1</b>
MO28	1	15000µF 40V d.c. can type 23A electrolytic size 113mm x 50mm <b>£1</b>
MO29	1	33000µF 16V 27A can type electrolytic size 113mm x 50mm <b>£1</b>
MO30	20	Assorted Variable trimmers <b>£1</b>
MO31	4	Tuning capacitors 2-gang dielectric type <b>£1</b>
MO32	2	10k + 10k wirewound precision potentiometer <b>£1</b>
MO33	8	Rotary potentiometers <b>£1</b>
MO34	5	100k multiturn Varicap type tuning potentiometer with knob size 45mm x 5mm <b>£1</b>
MO35	200	Carbon resistors <b>£1</b>
MO36	2	Large VU meters. Japan Made <b>£1</b>
MO37	1	Large Tuning meter 125µA-0-125µA size 55mm x 47mm <b>£1.75</b>
MO38	1	Dual VU meter 280µA f.s.d., size 80mm x 42mm x 15mm <b>£1.50</b>
MO39	5	Coaxial Aerial Plugs, all metal type <b>£1</b>
MO40	6	Fuseholders, chassis mounting for 20mm size fuses <b>£1</b>
MO41	4	Fuseholders, in-line type for 20mm size fuses <b>£1</b>
MO42	20	5 Pin Din 180° chassis mount sockets <b>£1</b>
MO43	6	Double phono sockets <b>£1</b>
MO44	5	6.35mm (1/4") Stereo Jack sockets <b>£1</b>
MO45	4	6.35 (1/4") Mono Jack Plugs <b>£1</b>
MO46	12	Coax Sockets chassis mount <b>£1</b>
MO47	2	Case handles plated U-shape, size 97mm x 50mm <b>£1</b>
MO48	30	Mixed control knobs <b>£1</b>
MO49	1	Cassette tape transport mechanism, belt-drive, top loading, six piano key operation with knobs, stereo record/replay erase heads, heavy fly-wheel <b>£5.50 + £2.65 p&amp;p</b>
MO50	1	Hifi stereo pre-amp. module. Input for CD Tuner record player with diagram. Made by Mullard <b>£1</b>
MO51	2	AM/FM tuner head modules. Made by Mullard <b>£1</b>
MO52	3	AM I.F. modules. Made by Mullard <b>£1</b>
MO53	1	FM stereo decoder module with diagram. Made by Mullard <b>£1</b>
MO54	3	UHF Varicap tuned tuner heads unboxed, untested but complete. Made by Mullard <b>£1</b>
MO55	1	25V d.c. 150mA Mains adaptor in neat plastic box, size 80mm x 55mm x 47mm <b>£1</b>
MO55A	1	80mm Cooling Fan. Five bladed A.C. impedance corrected motor on a cast aluminium chassis. Size 80mm x 40mm. Voltage 115V a.c. working. 130mA. Japanese made. <b>£5.95 + £1.40 p&amp;p</b> . <b>TWO for £11.20 UK post paid</b>
MO56	2	6V-0V-6V 4VA p.c.b. mount mains transformer 240V input, size 42mm x 33mm x 35mm. UK Made <b>£1</b>
MO57	25	4 Volt miniature wire-ended bulbs <b>£1</b>
MO57A	1	SRBP Copper Clad Printed Circuit Board. Size 410mm x 360mm x 2mm <b>£3.65 + 75 p&amp;p</b>
MO58	2	Mono cassette tape heads. Japan Made <b>£1</b>
MO59	2	Sonotone stereo cartridge with 78 and LP Styl. Japan Made <b>£1</b>
MO60	8	Bridge rectifiers 1amp 240V <b>£1</b>
MO61	10	OC44 transistors. Remove paint from top and it becomes a photo electric cell (ORP12) <b>£1</b>
MO62	30	Low signal transistors npn and npntype <b>£1</b>
MO63	6	14 watt output transistors. Three complimentary pairs in T066 case (replacement for AD161 + 162) <b>£1</b>
MO64	5	5 watt Audio i.c. No. TBA800 <b>£1</b>
MO65	5	Motor Speed Control i.c. <b>£1</b>
MO66	1	Digital DVM Meter i.c. Made by Plessey, with diagram <b>£1</b>
MO67	4	7-Segment 0.3in i.e.d. display (red) <b>£1</b>
MO68	1	Tape Deck i.c., with record replay switching. No. LM1818, with diagram <b>£1</b>
MO69	2	Ferrite Rod. High grade with LW. SW & MW coils, size 140mm x 10mm <b>£1</b>
MO70	1	Moving coil dynamic, handheld, ball microphone. Ross Electronics customers returns (no warranty) <b>£1</b>

No.	Qty. per pack	
MO71A	1	Analogue Multimeter. Ross Electronics customers returns (no warranty) <b>£3.90 + 90p p&amp;p</b>
MO72	1	WW II EX WD headphone. A BIT OF NOSTALGIA, low impedance <b>£3.50 + £1.20 p&amp;p</b>
MO73	1	Koss Stereo Headphones on ear. Lightweight design, vari-fitting ear-cups with contour cushions, 36in. cord. 3.5mm + 6.35mm Jack plug adaptor <b>£3.50 + £1 p&amp;p</b>
MO74	2	Tone dialling keypad, use services that require DTMF tone signals for a rotary dial pulse phone, size 90mm x 55mm 12mm <b>£11.00 + 70p p&amp;p</b>
MO75	1	100 yard roll of single screened quick splice cable, good quality British Made <b>£4.50 + £2 p&amp;p</b>
MO76	1	100 yard 3-core 3 amp cable, coded brown, blue and green/yellow <b>£4.20 + £2 p&amp;p</b>
MO78	1	TV Aerial Amplifier housed in a neat plastic box, coax input and output sockets. Mains operated. Double the output signal of your aerial <b>£6.50 + £1.50 p&amp;p</b>
MO79	1	Rechargeable fluorescent lantern, twin 9W switchable tubes, flashing beacon and search lamp. Built-in lead acid battery and mains charger. Gives equivalent light output of 60W lamp. Size 24mm x 8mm x 17cm, weight 1.6kg <b>£22.95 + £2.65 p&amp;p</b>
MO80	2	Solar Powered Wooden Kits. Easy to build aeroplane, with revolving propeller, and an old time gramophone with music chip. Supplied with glue, solar cells, electronics and pre-cut panels. <b>£12.00 + £1.50 p&amp;p</b>
MO81	1	One of each for Bump and Go Space Ship Kit with motor, wheels, p.c.b. wire and diagram. An ideal introduction for youngsters into the world of electronics and mechanics; goes all the way to the moon on two AA batteries <b>£8.95 + £1 p&amp;p</b>
MO82	1	Filofax Personal Organiser Radio/Calculator. This neat little unit simply fits inside your filofax so you can listen to AM Radio with earphone or use it as a solar powered 8-digit calculator. Punched with six holes to fit all personal organisers. UK Made under 1/2 price <b>£8.95 + £1 p&amp;p</b>
MO83	1	Video Sender. With this handy unit you can transmit output of your home video, video camcorder or satellite television over the air to a receiving equipment within a range of 100ft. Simply connect the video and audio output of your equipment into this unit, and a 10-13.8V d.c. power supply - extra <b>£3.75</b>
MO84	1	Multiband radio. Listen to air traffic control, aircraft, radar, public utilities VHF 54-176MHz + CB 1-80 with built in squelch control <b>£11.75 + £2 p&amp;p</b>
MO85	2	AM, FM, LW Ross Pushbutton Radio. With this neat unit you can easily tune in to five pre-set stations of your choice without fiddling or fuss, runs off six C-cell batteries or 240V mains. Output 400mW, volume and tone control. Size 230mm x 150mm x 65mm <b>£17.95 + £2 p&amp;p</b>
MO86	1	(As above) <b>£23.00 + £3.65 p&amp;p</b>
MO87	1	Amplifier Kit 30 + 30 Watt. An easy to build amplifier with a good specification. All components mount on single p.c.b. punched and back-printed for ease, case ready drilled finished in black vinyl with matching scale and knobs. Inputs for: CD/AUX tape 1; tape II; tuner and MC phono Controls: bass; treble; volume; balance; mode and power switch. Featured project in <i>Everyday Electronics</i> , April 1989 issue; reprint with kit <b>£40.00 + £3.65 p&amp;p</b>

All items prefixed with MO number MAIL ORDER only or can only be collected by prior appointment from address below. Where p&p not stated please add £3.65 per order for postage and carton charge.

## ★ VHF RADIO TRANSMITTERS

2 Watt transmitter kit, supplied with fibre glass pcb, all components, diagrams, ready for you to build. 12-24V d.c. **£8.50 + £0.70 pp**

★ We are only able to supply these devices if customers provide a written and signed disclaimer that they will not be used in the UK. Please include this with your order as they are not licensable in the UK.

# RTVC

376 EDGWARE ROAD LONDON W2 1EB

MAIL ORDER TERMS, POSTAL ORDERS and/or CHEQUES with orders. Access & Visa accepted. Nett monthly accounts to Schools, Colleges and P.L.C. only. Overseas readers write for quote on delivery. Please cross all cheques and postal orders "Account Payee Only" and make payable to RTVC Ltd.

Phone 071 723 3462 Fax 071 723 3467

**FREE**

**MARCO  
TRADING**

**32 PAGE  
SUMMER  
CATALOGUE**

## **Whistle Switch**

*This simple unit can switch most electrical/electronic items on and off if you whistle at it. It uses a dedicated i.c. and a few other components and has a wide variety of applications.*

## **Versatile Intercom**

*A single "master" design which can be linked to as many similar stations as required. The audio quality is particularly good and a "conferencing" set up is possible.*

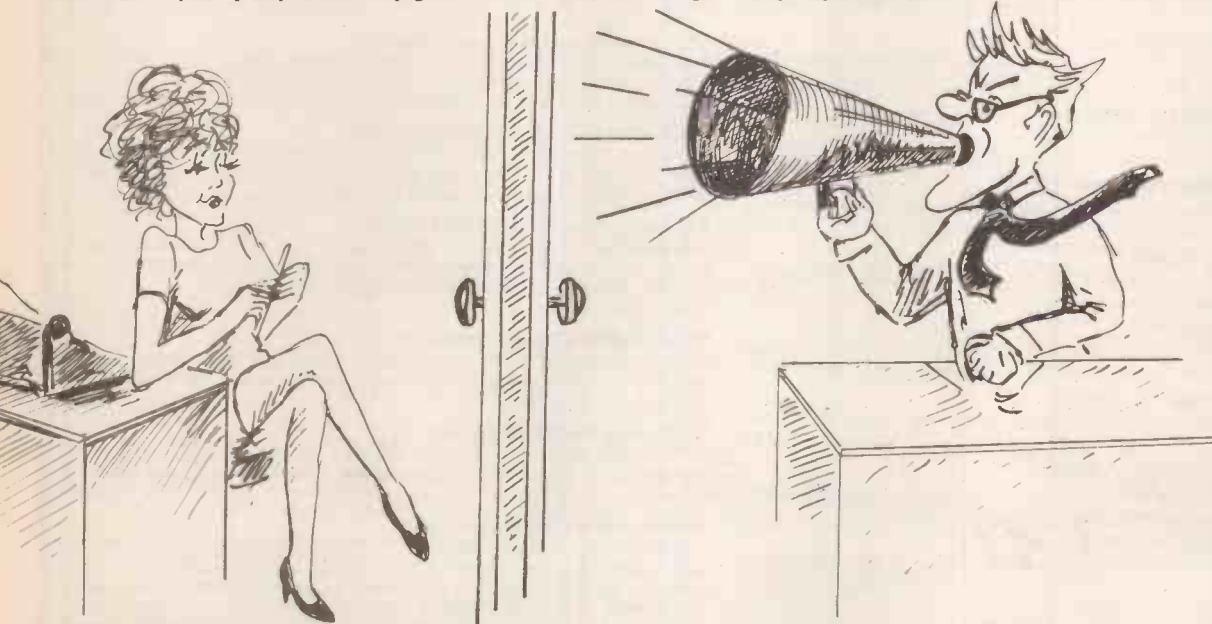

## **Lights-on warning**

*If you have ever suffered a flat battery because "someone" left the car lights on then this unit could be invaluable. Of course some modern cars are fitted with such devices, but not all. This design has the added advantage of an anti-theft facility which could deter the casual thief.*

## **Wide range Capacitance Meter**

*Unlike most inexpensive capacitance meters this design gives a range of capacitance values from about 2pF up to 5000 $\mu$ F in two distinct sections; from 2pF to 1 $\mu$ F on a low range and from 0.5 $\mu$ F to 5000 $\mu$ F on a high range; further, the stray capacitances are "tuned out" within the system so that there is no theoretical lower limit to the measurement range. An additional feature, very useful when checking electrolytics particularly, is a qualitative measure of leakage current with an applied potential of about 9V.*

**EVERYDAY  
ELECTRONICS**

OCTOBER ISSUE ON SALE FRIDAY, 4th SEPTEMBER 1992

**NEXT MONTH**

# SURVEILLANCE PROFESSIONAL QUALITY KITS

## No. 1 for Kits

Whether your requirement for surveillance equipment is amateur, professional or you are just fascinated by this unique area of electronics SUMA DESIGNS has a kit to fit the bill. We have been designing electronic surveillance equipment for over 12 years and you can be sure that all of our kits are very well tried, tested and proven and come complete with full instructions, circuit diagrams, assembly details and all high quality components including fibreglass PCB. Unless otherwise stated all transmitters are tuneable and can be received on an ordinary VHF FM radio.

### UTX Ultra-miniature Room Transmitter

Smallest room transmitter kit in the world! Incredible 10mm x 20mm including mic. 3-12V operation. 500m range.....£16.45

### MTX Micro-miniature Room Transmitter

Best-selling micro-miniature Room Transmitter  
Just 17mm x 17mm including mic. 3-12V operation. 1000m range.....£13.45

### STX High-performance Room Transmitter

Hi performance transmitter with a buffered output stage for greater stability and range. Measures 22mm x 22mm including mic. 6-12V operation, 1500m range.....£15.45

### VT500 High-power Room Transmitter

Powerful 250mW output providing excellent range and performance. Size 20mm x 40mm. 9-12V operation. 3000m range.....£16.45

### VXT Voice Activated Transmitter

Triggers only when sounds are detected. Very low standby current. Variable sensitivity and delay with LED indicator. Size 20mm x 67mm. 9V operation. 1000m range...£19.45

### HVX400 Mains Powered Room Transmitter

Connects directly to 240V AC supply for long-term monitoring. Size 30mm x 35mm. 500m range.....£19.45

### SCRX Subcarrier Scrambled Room Transmitter

Scrambled output from this transmitter cannot be monitored without the SCDM decoder connected to the receiver. Size 20mm x 67mm. 9V operation. 1000m range.....£22.95

### SCSX Subcarrier Telephone Transmitter

Connects to telephone line anywhere, requires no batteries. Output scrambled so requires SCDM connected to receiver. Size 32mm x 37mm. 1000m range.....£23.95

### SCDM Subcarrier Decoder Unit for SCRX

Connects to receiver earphone socket and provides decoded audio output to headphones. Size 32mm x 70mm. 9-12V operation.....£22.95

### ATR2 Micro Size Telephone Recording Interface

Connects between telephone line (anywhere) and cassette recorder. Switches tape automatically as phone is used. All conversations recorded. Size 16mm x 32mm. Powered from line.....£13.45

### UTLX Ultra-miniature Telephone Transmitter

Smallest telephone transmitter kit available. Incredible size of 10mm x 20mm! Connects to line (anywhere) and switches on and off with phone use.

All conversation transmitted. Powered from line. 500m range.....£15.95

### TLX700 Micro-miniature Telephone Transmitter

Best-selling telephone transmitter. Being 20mm x 20mm it is easier to assemble than UTLX. Connects to line (anywhere) and switches on and off with phone use. All conversations transmitted. Powered from line. 1000m range.....£13.45

### STLX High-performance Telephone Transmitter

High performance transmitter with buffered output stage providing excellent stability and performance. Connects to line (anywhere) and switches on and off with phone use. All conversations transmitted. Powered from line. Size 22mm x 22mm. 1500m range.....£16.45

### TKX900 Signalling/Tracking Transmitter

Transmits a continuous stream of audio pulses with variable tone and rate. Ideal for signalling or tracking purposes. High power output giving range up to 3000m. Size 25mm x 63mm. 9V operation.....£22.95

### CD400 Pocket Bug Detector/Locator

LED and piezo bleeper pulse slowly, rate of pulse and pitch of tone increase as you approach signal. Gain control allows pinpointing of source. Size 45mm x 54mm. 9V operation.....£30.95

### CD600 Professional Bug Detector/Locator

Multicolour readout of signal strength with variable rate bleeper and variable sensitivity used to detect and locate hidden transmitters. Switch to AUDIO CONFORM mode to distinguish between localised bug transmission and normal legitimate signals such as pagers, cellular, taxis etc. Size 70mm x 100mm. 9V operation.....£50.95

### QTX180 Crystal Controlled Room Transmitter

Narrow band FM transmitter for the ultimate in privacy. Operates on 180 MHz and requires the use of a scanner receiver or our QRX180 kit (see catalogue). Size 20mm x 67mm. 9V operation. 1000m range.....£40.95

### QLX180 Crystal Controlled Telephone Transmitter

As per QTX180 but connects to telephone line to monitor both sides of conversations. 20mm x 67mm. 9V operation. 1000m range.....£40.95

### QXS180 Line Powered Crystal Controlled Phone Transmitter

As per QLX180 but draws power requirements from line. No batteries required. Size 32mm x 37mm. Range 500m.....£35.95

### QRX180 Crystal Controlled FM Receiver

For monitoring any of the 'Q' range transmitters. High sensitivity unit. All RF section supplied as a pre-built and aligned module ready to connect on board so no difficulty setting up. Output to headphones. 60mm x 75mm. 9V operation.....£60.95

### A build-up service is available on all our kits if required.

UK customers please send cheques, POs or registered cash. Please add £1.50 per order for P&P. Goods despatched ASAP allowing for cheque clearance. Overseas customers send sterling bank draft and add £5.00 per order for shipment. Credit card orders welcomed on 0827 714476.

**OUR LATEST CATALOGUE CONTAINING MANY MORE NEW SURVEILLANCE KITS NOW AVAILABLE. SEND TWO FIRST CLASS STAMPS OR OVERSEAS SEND TWO IRCS.**

## ★★★ Specials ★★★

### DLTX/DLRX Radio Control Switch

Remote control anything around your home or garden, outside lights, alarms, paging system etc. System consists of a small VHF transmitter with digital encoder and receiver unit with decoder and relay output, momentary or alternate, 8-way di1 switches on both boards set your own unique security code. TX size 45mm x 45mm. RX size 35mm x 90mm. Both 9V operation. Range up to 200m.

Complete System (2 kits).....£50.95  
Individual Transmitter DLTX.....£19.95  
Individual Receiver DLRX.....£37.95

### MBX-1 Hi-Fi Micro Broadcaster

Not technically a surveillance device but a great idea! Connects to the headphone output of your Hi-Fi, tape or CD and transmits Hi-Fi quality to a nearby radio. Listen to your favourite music anywhere around the house, garden, in the bath or in the garage and you don't have to put up with the DJ's choice and boring waffle. Size 27mm x 60mm. 9V operation. 250m range.....£20.95

DEPT. EE

THE WORKSHOPS, 95 MAIN ROAD,  
BAXTERLEY, NEAR ATHERSTONE,  
WARWICKSHIRE CV9 2LE

VISITORS STRICTLY BY APPOINTMENT ONLY



0827 714476

**SUMA  
DESIGNS**

# OUR SUMMER SALE CONTINUES

The Bargains go on and on and on and get Better and Better!!

## AMSTRAD PC1640 COMPUTER OFFER

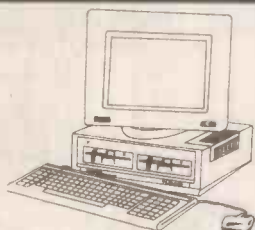

Brand new base unit, keyboard, mouse and manual. Completely standard machine fitted with 2 x 5.25" disk drives, only being sold so cheaply as we have no monitor to go with them!

Amazing Price! - **£99.95**

## 3.5" DISK DRIVE



Model FD9. Brand new and boxed, this cased 3.5" 720k unit comes complete with cables and instructions. Plugs into printer port.

Superdeal Price **£24.95**

## C64 GAMES CONSOLE

Value Pack **£49.95**

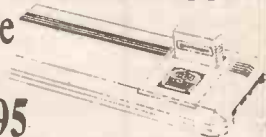

Z9109 New and boxed games machine based on the popular C64 computer - you get the console, power supply, TV lead, Cheetah joystick and 4 game cartridge - Flimbo's quest, Fiendish Freddy, Klax and International Soccer.

## VHF/UHF TV RECEIVER/CONVERTER

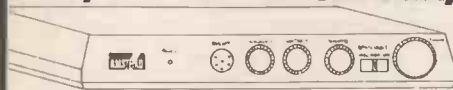

Z8991 Amstrad MP3 computer modulator/converter.

A complete, fully tuneable VHF/UHF TV receiver with RGB and composite video out, and sound on the internal speaker. For use with the Amstrad CTM644-2 monitor specifically, or can be used with any colour/mono home computer monitors that have a 5.825kHz line frequency. Grey case 330x250x50mm. Controls: contrast, colour, tuning, volume and band select (VHF-L, VHF-H, UHF). RGB output on 8 pin DIN skt, and composite video. Intended for European market - needs 2 ceramic filters changing. Parts and instructions supplied. Needs stabilized 12V DC, either from monitor or separate power supply (our AL2, £8.14 is ideal).

ONLY **£14.95**

## AMSTRAD CLOCK TIMER



Z8999 Model CT1 - in plastic case that sits under monitor. MW/LW/FM receiver with 3" speaker, + digital clock with alarm and snooze facilities.

Great Value **£7.95**

## ATARI 2600 GAMES CONSOLE

Complete and boxed with joystick, power supply, TV lead and games cartridge (centipede). Not new, but fully checked and working

Special Price

**£29.95**

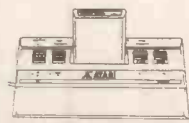

## AMSTRAD GX4000 HOME ENTERTAINMENT SYSTEM

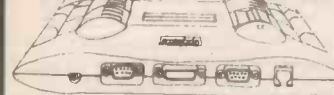

ONLY **£29.95**

- \*Games Console
- \*2 Control Paddles
- \*TV lead
- \*Burnin' Rubber Cartridge
- \*Power Supply
- \*Instruction Books

Inputs for 2 paddles, analogue joysticks, light gun/pen etc. Outputs: UHF, RGB on 8 pin DIN skt, SCART skt, stereo sound 3.5mm skt. Uses 168 pin dedicated chip, Z80A CPU, AY-3-8912 sound chip, UMI234 UHF modulator

## commodore

Scoop purchase of a major store's returns. Fully checked in good working order in original boxes. Save up to 50%!!

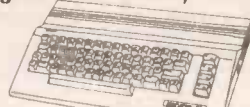

Z9105 Basic C64 computer with power supply and TV lead  
Z9106 Night Moves/Mindbenders Pack. This contains the C64 Computer, C2N datacorder, 2 joysticks and 9 cassettes inc Trivial Pursuit, Confuzion etc

**£60**  
**£75**

**SEND NOW FOR OUR FREE 32 PAGE SALE CAT - BUT BE QUICK - THE STOCK IS SELLING FAST!!**

## JUST ARRIVED

**SOLAR PANELS & KITS** from £4.95. Educational and entertaining. Full details on B/L82

Surface Mount - Big new parcel just arrived, mostly coils and caps. Details on B/L83

Parcel of microwave /portable phone parts - Filters, Crystals etc. Full details on B/L83

Metal Clad Wirewound Resistors - 5W-200W, 0R05-27k. Full details on B/L82

## 5Mb SIMM MODULE

Z5420 PCB 108x25mm with 20xMN41C4256-08 256k DRAM's. 72way DS 0.05" edge conn. As used in PS2's. Only £30.00

## TRANSMITTER KITS

(not licensable in the UK)  
K647 FM 88-108MHz 1 mile range. PCB 59x21mm. Uses PP3 £6.95

K648 Sub-min 33x15mm PCB, uses watch battery (supplied) £6.94



Ask for our FREE colour brochure on car audio and security equipment - big range of products at our usual low prices - with special deals for bulk buyers!

## POSTAL AUCTION

We're disposing of masses of surplus stock at the end of our SALE to clear space for new lines arriving soon - so whether you buy in ones or thousands, send for our Auction Catalogue - Only £1 + 28p A4 SAE for descriptive version, or just send an SAE for the list of lot numbers (all you need if you have our lists)



All 1 off and pack prices include VAT, qty prices do not. P&P £2.50 per order (£9 next day) Min Credit Card £12. Official orders from Education welcome; min invoice charge £15. Payment is accepted by cheque, PO, cash (inc foreign currency banknotes), book tokens, Access, Visa, Connect. Our stores have enormous stocks - we are open from 9-5.30 Mon-Sat. Come and see us!

Tel: (0703) 236363  
Fax: (0703) 236307

27D PARK ROAD, SOUTHAMPTON, SO1 3TB

## STEREO AUTO-REVERSE CASSETTE MECHS

Z5405 High quality heavy duty all metal construction stereo cassette player mechanism, probably intended for continuous background music. This is a lovely bit of kit - starts playing as soon as a cassette is inserted. Has fast forward, rewind and eject keys. It's bi-directional, and the sensing circuit automatically reverses the tape at the end. Has a Canon motor and works off 12V DC. Great value at £4.95.

## NEW POWER SUPPLIES

Z5406D High efficiency step down power regulator module by SGS. This is a GSR400 type, as listed by Farnell at £41.11 each. Output is 7V @ 4A from a DC input of 10-46V. Possible uses include battery charger, or put two together and use 24V lorry battery to power car equipment. Our special price - just £5.75 each.

Z5409 Eurocard size - 160x100mm by Protek. 115/230V input. Outputs: +5V @ 3A; +12V @ 2A; -12V @ 0.25A Price £8.95

## UHF TUNER

Z2648 UHF TV tuner - at least, the front end. Fagor SUF743 has a co-ax socket inlet into the screened case 65x50x20mm. Inside the PCB has some surface mount bits + BF966S, BF970 and BF199 transistors and a few coils. Giveaway Price 2 for £1.00

## - £1 BARGAIN PACKS -

In fact, cheaper than £1 because if you buy 10 you can choose one other and receive it free!

2 x 25W CROSSOVERS for 4 ohm loudspeakers. Order Ref. 22.  
 2 x NICAD CONSTANT CURRENT CHARGERS easily adaptable to charge almost any nicad battery. Order Ref. 30.  
 10m TWIN SCREENED FLEX white pvc cover. Order Ref. 122.  
 2 x WHITE PLASTIC BOXES with lids, approx. 3" cube. Lid has square hole through the centre so these are ideal for light operated switch. Order Ref. 132.  
 2 x REED RELAY KITS you get 8 reed switches and 2 coil sets with notes on making relays and other gadgets. Order Ref. 148.  
 1 x BIG PULL SOLENOID mains operated. Has 1/2" pull. Order Ref. 871.  
 1 x BIG PUSH SOLENOID mains operated. Has 1/2" push. Order Ref. 872.  
 1 x MINI MONO AMP 3W into 4 ohm speaker or 1W into 8 ohm. Order Ref. 268.  
 1 x MINI STEREO 1W AMP. Order Ref. 870.  
 1 x IN-FLIGHT STEREO UNIT is a stereo amp. Has two most useful mini moving coil speakers. Made for BOAC passengers. Order Ref. 29.  
 1 x MAGNETIC SECRET SWITCH does not look like a switch and is supplied with a separate magnet to operate it. Order Ref. 873.  
 1 x 0-1mA PANEL METER full vision face 70mm square. Scaled 0-100. Order Ref. 756.  
 2 x LITHIUM BATTERIES 2.5V penlight size. Order Ref. 874.  
 2 x 3M TELEPHONE LEADS with BT flat plug. Ideal for phone extensions, fax, etc. Order Ref. 552.  
 1 x 12V SOLENOID has good 1/2" pull or could push if modified. Order Ref. 232.  
 4 x IN-FLEX SWITCHES with neon on/off lights. saves leaving things switched on. Order Ref. 7.  
 2 x 6V 1A MAINS TRANSFORMERS upright mounting with fixing clamps. Order Ref. 9.  
 12 x 30 WATT REED SWITCHES. It's surprising what you can make with these - burglar alarms, secret switches, relay, etc. Order Ref. 13.  
 2 x HUMIDITY SWITCHES, as the air becomes damper the membrane stretches and operates a micro switch. Order Ref. 32.  
 5 x 13A ROCKER SWITCH three tags so on/off, or changeover with centre off. Order Ref. 42.  
 2 x FLAT SOLENOIDS you could make your multi tester read AC amps with this. Order Ref. 79.  
 1 x SUCK OR BLOW OPERATED PRESSURE SWITCH or it can be operated by any low pressure variation such as water level in water tanks. Order Ref. 67.  
 1 x 6V 750mA POWER SUPPLY, nicely cased with mains input and 6V output leads. Order Ref. 103A.  
 2 x STRIPPER BOARDS, each contains a 400V 2A bridge rectifier and 14 other diodes and rectifiers as well as dozens of condensers, etc. Order Ref. 120.  
 12 x VERY FINE DRILLS for pcb boards etc. Normal cost about 80p each. Order Ref. 128.  
 5 x MOTORS FOR MODEL AEROPLANES, spin to start so needs no switch. Order Ref. 134.  
 6 x MICROPHONE INSERTS magnetic 400 ohm also act as speakers. Order Ref. 139.  
 6 x SAFETY COVER for 13A sockets - prevent those inquisitive little fingers from getting nasty shocks. Order Ref. 149.  
 6 x NEON INDICATORS in panel mounting holders with lens. Order Ref. 180.  
 1 x IN-FLEX SIMMERSTAT keeps your soldering iron, etc., always at the ready. Order Ref. 196.  
 1 x MAINS SOLENOID very powerful as 1/2" pull or could push if modified. Order Ref. 199.  
 1 x ELECTRIC CLOCK mains operated, put this in a box and you need never be late. Order Ref. 211.  
 4 x 12V ALARMS makes a noise about as loud as a car horn. All brand new. Order Ref. 221.  
 2 x (6" x 4") SPEAKERS 16 ohm 5 watts so can be joined in parallel to make a high wattage column. Order Ref. 243.  
 1 x PANOSTAT controls output of boiling ring from simmer up to boil. Order Ref. 252.  
 2 x OBLONG PUSH SWITCHES for bell or chimes, these can switch mains up to 5A so could be foot switch if fitted in patdress. Order Ref. 263.  
 50 x MIXED SILICON DIODES. Order Ref. 293.  
 1 x 6 DIGIT MAINS OPERATED COUNTER standard size but counts in even numbers. Order Ref. 28.  
 2 x 6V OPERATED REED RELAYS one normally on, other normally closed. Order Ref. 48.  
 1 x CABINET LOCK with 2 keys. Order Ref. 55.  
 1 x MAGNETIC BRAKE for stopping a motor or rotating tool. Order Ref. 66.  
 1 x SHADED POLE MAINS MOTOR "x" stack so quite powerful. Order Ref. 85.  
 2 x 5" ALUMINIUM FAN BLADES could be fitted to the above motor. Order Ref. 86.  
 1 x CASE 3/4 x 2 1/4 x 1 1/4 with 13A socket pins. Order Ref. 845.  
 2 x CASES 2 1/2 x 2 1/4 x 1 1/4 with 13A pins. Order Ref. 565.  
 4 x LUMINOUS ROCKER SWITCHES 10A mains. Order Ref. 793.  
 4 x DIFFERENT STANDARD V3 MICRO SWITCHES. Order Ref. 340.  
 4 x DIFFERENT SUB MIN MICRO SWITCHES. Order Ref. 313.

# BARGAINS - GALORE

**ARTWORK LIGHT BOX** similar to that described in the August issue but not sloping. Complete kit includes wooden box, semi-opaque fibreglass panel and double 'D' fluorescent tube with its control gear. Price only £10 but, if not calling, please add £4 as very special packing is required. Order Ref. 10P75.  
**LOW PRICED FIELD TELEPHONES** Ex-GPO models, not quite so nice looking but quite efficient, and have the big advantage that the ringing is done by means of a hand operated internal generator. This saves a lot of batteries. These 'phones have the normal type of rotary dial built in and can still be connected into a normal B.T. system. Tested, guaranteed in good order, price only £9.50 each. Order Ref. 9P5.  
**HAND GENERATORS** as fitted in the above field telephones. This hand generator is a permanent magnet type and has an AC output of approximately 50V depending on how quickly you wind it. If you want a higher voltage then simply connect the output to a transformer. We have lit a 60watt bulb quite successfully. The hand generator, complete with handle, £4.00. Order Ref. 4P51.

**DRY BATTERIES CAN BE RECHARGED** but not with a normal d.c. charger, it must be a periodic current reversal type. We can supply the kit, with data, £9. Order Ref. 9P10.  
**SOLAR ENERGY EDUCATIONAL KIT** - an ideal present for electronics students, it shows how to make solar circuits and electrical circuits, how to increase voltage or current, how to use solar power to work a radio, calculator, cassette player and to charge nicad batteries. The kit comprises 8 solar cells, one solar motor, fan blades to fit motor and metal frame to hold it to complete a free-standing electric fan. A really well written instruction manual makes this a lovely little present. Price £8.00. Order Ref. 8P42B.

**HEAVY DUTY FLEX** 3 core 15A, grey outer, 10m for £2.50, Order Ref. 2.5P3. 3 core 20A, white outer, 10m for £3, Order Ref. 3P109. 2 core 20A, 15m for £3, Order Ref. 3P110.

**HIGH POWER SWITCH MODE PSU** normal mains input. 3 outputs: +12V at 4A, +5V at 16A and -12V at 1/2A. Completely enclosed in plated steel case. Brand new. Our special offer price of £9.50 extended until 31st August. Order Ref. 9.5P1.

**SUPER MULTIMETER** Ex British Telecom, this is a 19-range 20k o.p.v. top grade instrument, covers AC & DC voltages, current and resistance, very good condition, fully working and complete with leads £8, leather carrying case £2 extra (batteries not included but readily available).  
**MULTI-CORE CABLES** all with 8A 230V cores so suitable for disco and other special lighting effects. With earthable woven screen and thick pvc outer. 3 core, 30p per metre, 16 core, 50p per metre, 18 core, 80p per metre, 25 core, £1 metre and 36 core, £1.50 per metre.

**VARIAC** an infinitely variable unit gives any voltage from 0-230 a.c. at 1/2A. Obviously an invaluable piece of equipment which should be in every workshop and probably would be except that the usual price for this is £35 plus VAT. Now is your chance to buy one, brand new, at £15 including VAT. Order Ref. 15P42B.

**ULTRA THIN DRILLS** Actually 0.3mm. To buy these regular costs a fortune. However, these are packed in half dozens and the price to you is £1 per pack. Order Ref. 797B.  
**YOU CAN STAND ON IT!** Made to house GPO telephone equipment, this box is extremely tough and would be ideal for keeping your small tools. Internal size approx. 10 1/2" x 4 1/2" x 6" high. These are complete with snap closure lip and shoulder-length carrying strap. Taken from used equipment but in good condition, price £2, Order Ref. 2P283B.

**BUILD YOUR OWN NIGHT LIGHT**, battery charger or any other gadget that you want to enclose in a plastic case and be able to plug into a 13A socket. We have two cases, one 3 1/2" x 2 1/4" x 1 1/4" deep, £1 each, Order Ref. 845. The other one is 2 1/2" x 2 1/4" x 1 1/4" deep, 2 for £1, Order Ref. 565.

**SAFETY LEADS** curly coil so they contract but don't hang down. Could easily save a child from being scalded. 2 core, 5A, extends to 3m, £1, Order Ref. 846. 3 core, 13A, extends to 1m, £1 each, Order Ref. 847. 3 core, 13A, extends to 3m, £2 each, Order Ref. 2P290.

**POWER SUPPLY WITH EXTRAS** mains input is fused and filtered and the 12V dc output is voltage regulated. Intended for high class equipment, this is mounted on a PCB and, also mounted on the board but easily removed, are 2 12V relays and a Piezo sander. £3, Order Ref. 3P80B.

**ULTRA SONIC TRANSDUCERS** 2 metal cased units, one transmits, one receives. Built to operate around 40kHz. Price £1.50 the pair. Order Ref. 1.5P14.

**100W MAINS TRANSFORMERS** normal primaries 20-0-20 at 2.5A, or 30V at 3.5A, £4, Order Ref. 4P24. 40V at 2.5A, £4, Order Ref. 4P59. 50V at 2A, £4, Order Ref. 4P60.

**PHILIPS 9" HIGH RESOLUTION MONITOR** black & white in metal frame for easy mounting, brand new still in maker's packing, offered at less than price of tube alone, only £15, Order Ref. 15P1.

**16 CHARACTER 2-LINE DISPLAY** screen size 85mm x 36mm, Alpha-numeric LCD dot matrix module with integral micro processor made by Epson, their Ref. 16027AR, £8, Order Ref. 8P48.

**INSULATION TESTER WITH MULTIMETER** internally generates voltages which enable you to read insulation directly in megohms. The multimeter has four ranges. AC/DC volts, 3 ranges DC millamps, 3 ranges resistance and 5 amp range. These instruments are ex British Telecom but in very good condition, tested and guaranteed OK, probably cost at least £50 each, yours for only £7.50, with leads, carrying case £2 extra. Order Ref. 7.5P14.

**BRUSHLESS DC 12V FAN** tiny, only 60mm square, good air mover but causes no interference. £8, Order Ref. 8P26.

**MAINS 230V FAN** best make "PAPST" 4 1/4" square, metal blades, £8, Order Ref. 8P8.

**2MW LASER** Helium neon by Philips, full spec. £30, Order Ref. 30P1. Power supply for this in kit form with case is £15, Order Ref. 15P16, or in larger case to house tube as well £18, Order Ref. 18P2. The larger unit, made up, tested and ready to use, complete with laser tube £68, Order Ref. 69P1.

**1 1/3 HP 12V MOTOR - THE FAMOUS SINCLAIR C5** brand new, £15, Order Ref. 15P8.

**SOLAR CHARGER** holds 4 AA nicads and recharges these in 8 hours, in very neat plastic case, £6, Order Ref. 6P3.

**FERRITE AERIAL ROD** 8" Long x 1/2" diameter, made by Mullard. Complete with 2 coil forms s. 2 for £1, Order Ref. 832B.

**AIR SPACED TRIMMER CAPS** 220 pF ideal for precision tuning UHF circuits, 4 for £1, Order Ref. 818B.

**MAINS ISOLATION TRANSFORMER** stops you getting "to earth" shocks. 230V in and 230V out. 150watt upright mounting, £7.50, Order Ref. 7.5P15 and a 250W version is £10, Order Ref. 10P79.

**SRPM MAINS DRIVEN** This is a shaded pole motor, £5, Order Ref. 5P54.

**POWER SUPPLY UNIT** mains in, dc out, cased 4.5V 100mA, £1, Order Ref. 104, 6V 200mA £1, Order Ref. 103, 6V 700mA, £1, Order Ref. 103A, 24V 200mA, £2, Order Ref. 2P4, 12V 2A, £6, Order Ref. 6P23.

**AMSTRAD POWER UNIT** 13.5V at 1.9A encased and with leads and output plug, normal mains input £8, Order Ref. 6P23.

**AMSTRAD 3.5 FLOPPY DRIVE** brand new and cased, £35, Order Ref. 35P4.

**ATARI 65XE** at 65K this is quite powerful, so suitable for home or business, unused and in perfect order but less PSU, only £19.50, Order Ref. 19.5P/5B.

**80W MAINS TRANSFORMER** two available, good quality, both with normal primaries and upright mounting, one is 20V 4A, Order Ref. 3P106 the other 40V 2A, Order Ref. 3P107, only £3 each.

**PROJECT BOX** size approx 8" x 4" x 4 1/4" metal, sprayed grey, louvred ends for ventilation otherwise undrilled. Made for GPO so best quality, only £3 each, Order Ref. 3P74.

**WATER VALVE** 230V operated with hose connections, ideal for auto plant spray or would control air or gas into tanks etc., £1 each, Order Ref. 370.

**10W ISOLATION TRANSFORMER** if you want to isolate some small piece of equipment from earth this may be what you are looking for. You can use it either with a tapped input or a tapped output. It's upright mounting and well insulated. Price £1, Order Ref. 821.

**BT POWER SUPPLY UNIT** output 9.5V AC at 600mA, in black plastic case with 13A plug so go straight into socket and approximately 3 metres of twin output lead. Price £1.50, Order Ref. 1.5P7.

**BUILDING YOUR OWN PSU**, battery charger, night light, or any other gadget that you want to enclose in a plastic case and be able to plug into a 13A socket? We have two cases, one 3 1/2" x 2 1/4" x 1 1/4" deep, £1 each, Order Ref. 845. The other one is 2 1/2" x 2 1/4" x 1 1/4" deep, 2 for £1, Order Ref. 565.

**500V BRIDGE MEGGER** developed for GPO technicians the Ohmster 18B is the modern equivalent of the bridge megger. 9V battery operated, it incorporates a 500V generator for insulation testing and a null balance bridge for very accurate resistance measurement. Ex B.T. in quite good condition with data & tested. Yours for a fraction of original cost, £45, Order Ref. 45P2.

**EXPERIMENTING WITH VALVES** don't spend a fortune on a mains transformer, we can supply one with standard mains input and secs. of 250-250V at 75mA and 6.3V at 3A, £5, Order Ref. 5P167.

**15W 8 OHM 8" SPEAKER & 3" TWEETER** make for a discontinued high quality music centre, gives real hi-fi, and only £4 per pair, Order Ref. 4P57.

**FREE POWER!** Can be yours if you use our solar cells - sturdily made modules with new system bubble magnifiers to concentrate the light and so eliminate the need for actual sunshine - they work just as well in bright light. Voltage output is .45 - you join in series to get desired voltage - and in parallel for more amps.

**Module A** gives 100mA Price £1 Order Ref. BD631  
**Module B** gives 400mA Price £2 Order Ref. 2P199  
**Module D** gives 700mA Price £3 Order Ref. 3P42  
**Module E** gives 1A Price £3.50 Order Ref. 3.5P4

**3V SOLAR PANEL** price £3, Order Ref. 3P99B.

**3 GANG .0005 MFD TUNING CONDENSER** with slow motion drive. Beautifully made by Jackson Brothers and current list price is probably around £20. Yours for £5, Order Ref. 5P189.

**STEREO HEADPHONES** extra lightweight with plug, £2 each, Order Ref. 2P261.

**WATER PUMP** very powerful with twin outlets, an ideal shower controller, mains operated, £10, Order Ref. 10P74.

**0-1MA FULL VISION PANEL METER** 2" square, scaled 0-100 but scale easily removed for re-writing, £1 each, Order Ref. 756.

**VU METER** illuminate this from behind becomes on/off indicator as well, 1 1/2" square, 75p each, Order Ref. 366.

**EDGE-WISE PANEL METER** ideal when short of panel space only 40 x 14mm, also have built-in led, 500µA f.s.d. scaled 0-5, £1 each, Order Ref. 131.

## LIMITED SUPPLY ITEMS

are only described in our newsletter. Over 50 appear in our current issue. If you order something this month you will receive this and the next three issues posted to you free of charge.

Prices include V.A.T. Send cheque/postal order or ring and quote credit card number. Add £3 post and packing. Orders over £25 post free.

## M & B ELECTRICAL SUPPLIES LTD

12 Boundary Road, Hove, Sussex BN3 4EH

Telephone (0273) 430380  
 Fax or phone (0273) 410142



# PICO ADC-10

8-bit Analog to Digital Convertor  
for IBM PCs & compatibles

- 10-25 kHz typical sampling speed
- 0-5 v input range

## £49

+ VAT  
(including p+p)

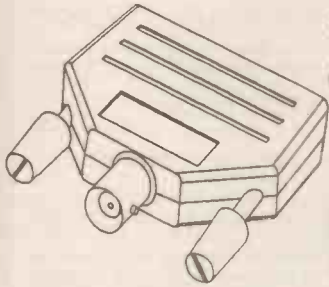

- Plugs directly into parallel printer port
- Requires no external power or expansion slots
  - BNC input connector
- Supplied with software to use as a voltmeter & oscilloscope, plus Turbo C and Pascal drivers

**Pico Technology Limited**

Broadway House, 149-151 St. Neots Road,

Hardwick, Cambridge CB3 7QJ

Tel. 0954 211716 Fax. 0954 211880

# OMNI ELECTRONICS

174 Dalkeith Road, Edinburgh EH16 5DX 031 667 2611

**A COMPREHENSIVE RANGE WITH  
SERVICE SECOND TO NONE**



OUR MUCH EXPANDED, BETTER  
ILLUSTRATED CATALOGUE  
COSTS £1.50 - INCLUDES  
VOUCHERS TO USE  
AGAINST FUTURE  
PURCHASES. TO RECEIVE  
A COPY PLEASE SEND  
YOUR REMITTANCE  
WITH THE VOUCHER BELOW.

Please send me a copy of the 1990/91 OMNI catalogue.  
Payment of £1.50 enclosed

NAME.....  
ADDRESS.....  
.....  
.....  
TELEPHONE.....



Open: Mon.-Thurs. 9.15 - 6.00  
Friday 9.15 - 5.00  
Saturday 9.30 - 5.00



## EASY-PC PCB and Circuit Diagram CAD

Forget using tapes and lightbox! Create your  
Circuit Boards using CAD - like the professionals.

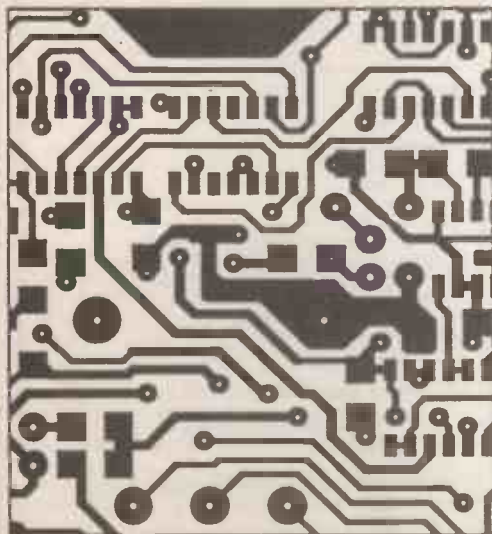

- Runs on PC/XT/AT etc. with Hercules, CGA, EGA or VGA display and many DOS emulations.
- Design Schematics Single and Double sided and Multilayer boards including Surface Mount.
- Standard output includes Dot Matrix / Laser / Inkjet Printer, Pen Plotter, Photo-plotter and N.C. Drill.
- Extremely powerful.
- Very easy to use.
- Not copy protected.

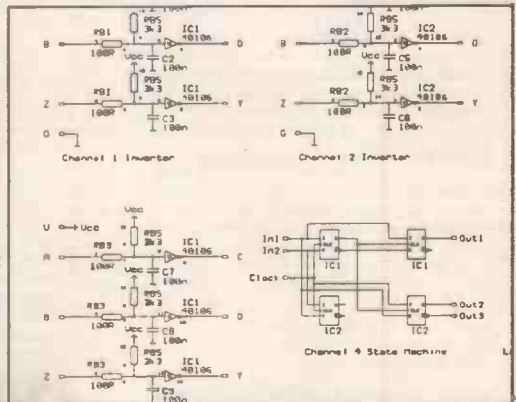

**EASY-PC**

Technical support is free, for life!

**Only  
£98.00!**  
Plus P&P+VAT

**Over 12,000 Installations in 70 Countries Worldwide!**

For full info' please Write, Phone, or Fax!

**Number One Systems Ltd.**

**The Electronics CAD Specialists.**

REF: EVD, HARDING WAY, ST.IVES, HUNTINGDON, CAMBS, PE17 4WR, ENGLAND.

Telephone: 0480 61778 (7lines) Fax: 0480 494042 ACCESS, AMEX, MASTERCARD and VISA Welcome.

**HART**

# HART AUDIO KITS – YOUR VALUE FOR MONEY ROUTE TO ULTIMATE HI-FI

HART KITS give you the opportunity to build the very best engineered hi-fi equipment there is, designed by the leaders in their field, using the best components that are available.

Every HART KIT is not just a new equipment acquisition but a valuable investment in knowledge, giving you guided hands-on experience of modern electronic techniques.

In short HART is your 'friend in the trade' giving you, as a knowledgeable constructor, access to better equipment at lower prices than the man in the street.

You can buy the reprints and construction manual for any kit to see how easy it is to build your own equipment the HART way. The FULL cost can be credited against your subsequent kit purchase.

Our list will give you fuller details of all our Audio Kits, components and special offers.

## AUDIO DESIGN 80 WATT POWER AMPLIFIER.



This fantastic John Linsley Hood designed amplifier is the flagship of our range, and the ideal powerhouse for your ultimate hi-fi system. This kit is your way to get £K performance for a few tenths of the cost!. Featured on the front cover of 'Electronics Today International' this complete stereo power amplifier offers World Class performance allied to the famous HART quality and ease of construction. John Linsley Hood's comments on seeing a complete unit were enthusiastic:- "The external view is that of a thoroughly professional piece of audio gear, neat elegant and functional. This impression is greatly reinforced by the internal appearance, which is redolent of quality, both in components and in layout." Options include a stereo LED power meter and a versatile passive front end giving switched inputs using ALPS precision, low-noise volume and balance controls. A new relay switched front end option also gives a tape input and output facility so that for use with tuners, tape and CD players, or indeed any other 'flat' inputs the power amplifier may be used on its own, without the need for any external signal handling stages. 'Slave' and 'monobloc' versions without the passive input stage and power meter are also available. All versions fit within our standard 420 x 260 x 75mm case to match our 400 Series Tuner range. ALL six power supply rails are fully stabilised, and the complete power supply, using a toroidal transformer, is contained within a heavy gauge aluminium chassis/heat sink fitted with IEC mains input and output sockets. All the circuitry is on professional grade printed circuit boards with roller tinned finish and green solder resist on the component ident side, the power amplifiers feature an advanced double sided layout for maximum performance. All wiring in this kit is pre-terminated, ready for instant use!

RLH11 Reprints of latest articles.....£1.80  
K1100CM HART Construction Manual.....£5.50

## LINSLEY HOOD 1400 SERIES ULTRA HIGH-QUALITY PREAMP

Joining our magnificent 80 Watt power amplifier now is the most advanced preamplifier ever offered on the kit, or indeed made-up marketplace. Facilities include separate tape signal selection to enable you to listen to one programme while recording another, up to 7 inputs, cross recording facilities, class A headphone amplifier, cancellable 3-level tone controls and many other useful functions, all selected by high quality relays. For full details see our list.

Send or phone for your copy of our List (50p) of these and many other Kits & Components. Enquiries from Overseas customers are equally welcome, but PLEASE send 2 IRCs if you want a list sent surface post, or 5 for Airmail.

Ordering is easy. Just write or telephone your requirements to sample the friendly and efficient HART service. Payment by cheque, cash or credit card. A telephoned order with your credit card number will get your order on its way to you THAT DAY.

Please add part cost of carriage and insurance as follows:- INLAND Orders up to £20 - £1.50  
Orders over £20 - £3.50 Express Courier, next working day. £10 (For safety all computer parts are only sent by courier) OVERSEAS - Please see the ordering information with our lists.

## LINSLEY HOOD 'SHUNT FEEDBACK' R.I.A.A. MOVING COIL & MOVING MAGNET PICKUP PREAMPLIFIERS



Modern, ultimate sound systems are evolving towards built-in preamplifiers within or near the turntable unit. This keeps noise pickup and treble loss to a minimum. We now offer two units, both having the sonically preferred shunt feedback configuration to give an accurate and musical sound, and both having the ability to use both moving magnet and moving coil cartridges.

Kit K1500 uses modern integrated circuits to achieve outstanding sound quality at minimal cost. The very low power requirements enable this unit to be operated from dry batteries and the kit comes with very detailed instructions making it ideal for the beginner. K1500 Complete kit with all components, printed circuit board, full instructions and fully finished case.....£67.99  
Instructions only.....£2.80

Kit K1450 is a fully discrete component implementation of the shunt feedback concept and used with the right cartridge offers the discerning user the ultimate in sound quality from vinyl disks. Can be fitted inside our 1400 Preamp, used externally or as a standalone unit. It has a higher power requirement and needs to be powered from our 1400 Series preamplifier or its own dedicated power supply. K1450 Complete kit of board mounting parts for discrete component RIAA preamplifier.....£61.06  
1500/2-8 Case to suit, including Hardware....£39.52  
K1565 Power Supply in matching case. Features shielded toroidal transformer and upgrade path to full preamp power supply.....£79.42

## ALPS PRECISION LOW-NOISE STEREO POTS.



To fulfil the need for higher quality controls we are now importing an exciting new range of precision audio pots in values to cover most quality amplifier applications. All in 2-gang stereo format, with 20mm long 6mm dia. steel shafts. Now you can throw out those noisy ill-matched carbon pots and replace with the real hi-fi components only used selectively in the very top flight of World class amplifiers. The improvement in track accuracy and matching really is incredible giving better tonal balance between channels and rock solid image stability. Motorised versions have 5v DC Drive motor.

2-Gang 100K Lin.....£8.67  
2-Gang 10K & 50K Log.....£9.40  
2-Gang 10K Special Balance, zero crosstalk and zero centre loss.....£10.48  
2-Gang 20K Log (Volume Control) MOTORISED.....£19.20  
2-Gang 10K Special Balance, zero crosstalk and MOTORISED, zero crosstalk and < 10% centre loss with near Log/Antilog Tracks).....£19.98

## STUART REEL-TO-REEL TAPE RECORDER CIRCUITS

Complete stereo record, replay and bias circuit system for reel-to-reel recorders. These circuits will give studio quality with a good tape deck. Separate sections for record and replay give optimum performance and allows a third head monitoring system to be used where the deck has this fitted. Standard 250mV input and output levels. Ideal for bringing that old valve tape recorder back to life. Suitable stereo heads are in our head list. This basic kit is suitable for advanced constructors only. K900W Stereo Kit with Wound Coils and Twin Meter Drive.....£123.99  
RJS1 Reprints of Original Descriptive Articles.....£3.60

## LINSLEY-HOOD CASSETTE RECORDER CIRCUITS

Complete record and replay circuits for very high quality low noise stereo cassette recorder. Circuits are suitable for use with any high quality cassette deck. Switched bias and equalisation to cater for chrome and ferric tapes. Very versatile, with separate record and play circuits and easy to assemble on plug-in PCBs. Complete with full instructions. Complete Stereo Record/Play Kit.....£62.58  
VU Meters to suit.....(Each) £3.99  
RLH1 & 2 Reprints of original Articles.....£2.70

## HIGH QUALITY REPLACEMENT CASSETTE HEADS



Do your tapes lack treble? A worn head could be the problem. For top performance cassette recorder heads should be replaced every 1,500 hours. Fitting one of our high quality replacement heads could restore performance to better than new! Standard inductances and mountings make fitting easy on nearly all machines (Sony are special dimensions, we do not stock) and our TC1 Test Cassette helps you set the azimuth spot on. As we are the actual importers you get prime parts at lower prices, compare our prices with other suppliers and see! All our heads are suitable for use with any Dolby system and are normally available ex stock. We also stock a wide range of special heads for home construction and industrial users. HC80 NEW RANGE High Beta Permalloy Stereo head. Modern space saver design for easy fitting and lower cost. Suitable for chrome metal and ferric tapes, truly a universal replacement head for everything from hi-fi decks to car players and at an incredible price too!.....£8.30  
HS16 Sendust Alloy Stereo Head.....£21.49  
HRP373 Downstream Monitor Stereo Combination Head.....£53.90  
HC15 Special Offer of Standard Quality Stereo R/P Head with slight face scratches.....3 for Only £4.80  
HQ551A 4-Track RECORD & Play Permalloy Head for auto-reverse car players or quadraphonic recording.....£8.75  
HM120 Standard Mono R/P Head.....£3.44  
H524 Standard Erase Head.....£11.90  
H561 Hi Field Erase Head for METAL Tapes.....£3.49  
SM150 2/2 (Double Mono) DC Erase Head.....£5.20  
HQ751E 4/4 True 4-Track Erase Head.....£57.06

## REEL TO REEL HEADS

999R 2/4 Record/Play 110mH. Suits Stuart Tape Circuits.....£13.34  
998E 2/4 Erase Head 1mH. Universal Mount. Suits Stuart.....£11.96

## TAPE RECORDER CARE PRODUCTS

DEM1 Mains Powered Tape Head Demagnetizer, prevents noise on playback due to residual head magnetisation.....£4.08  
DEM115 Electronic, Cassette Type, demagnetizer.....£8.61



QUALITY  
AUDIO KITS

24 hr. SALES LINE  
(0691) 652894

ALL PRICES  
INCLUDE VAT  
AT 17.5%

**HART**  
HART ELECTRONIC KITS LTD.  
6 PENYLAN MILL  
OSWESTRY, SHROPSHIRE  
SY10 9AF

Everyday Electronics,

# MARCO TRADING

INCORPORATING EAST CORNWALL COMPONENTS  
ELECTRONIC COMPONENTS  
& EQUIPMENT

MAIL ORDERS • WHOLESALE  
RETAIL

SEND ORDERS TO - DEPT EE9

## MARCO TRADING

THE MALTINGS, HIGH STREET, WEM  
SHROPSHIRE SY4 5EN  
Tel: (0939) 232763 Telex: 355665  
Fax: (0939) 233800  
ELECTRICAL & ELECTRONIC  
COMPONENT SUPPLIERS

24HR ANSAPHONE

### LATEST 1992 CATALOGUE

- ★ Velleman KIT Catalogue
- ★ Free pre-paid envelope
- ★ Many new lines
- ★ Pages of special offers
- ★ Free gifts

132 PAGES £2.00  
FREE with orders over £10



### NI-CAD RECHARGEABLE BATTERIES

	PRICE	EACH
AAA	1+	10+
AA	£1.50	£1.30
C	95p	85p
D	£1.95	£1.80
PP3	£2.00	£1.85
	£3.90	£3.75

### NI-CAD CHARGER

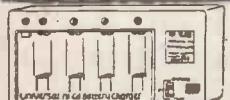

Charges AA, AAA, C, D & PP3  
Ni-Cads 240V AC £4.99

### SOLDER 18 & 22 SWG - 500gm REEL

18swg	1+	10+
22swg	£4.95	£4.70
	£4.99	£4.75

Remember: Our prices INCLUDE VAT!

### CLOSED CIRCUIT TELEVISION SYSTEM

1x CAMERA £120 1x CAMERA BRACKET £7.75

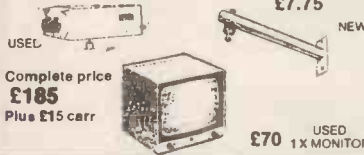

Complete price £185 Plus £15 carr

### FM TRANSMITTER

Made in U.K.

Very high quality 'Mini-Bug' - ideal for baby alarm, etc! A very good range is obtainable - we have obtained over 1/2 mile, but it does depend on conditions. Simply remove cover - insert battery - and you're ready to go. Reception can be obtained on any FM radio. Frequency 105-109MHz FM

ORDER CODE SEC/FMB1 PRICE: £9.99

### FM KIT

For those of you who enjoy building kits - we now offer the above transmitter in kit form. Ideal for the beginner - supplied complete with full, easy to follow instructions. Box NOT INCLUDED - See our BOXES Section for suitable housing

ORDER CODE SEC/FMKIT PRICE: £7.50

### HOME ALARM PACKAGE

- Includes
- ★ Optima Alarm Control Panel
- ★ External Red Bell Box
- ★ 2 x 1 Internal Passive I.R.
- ★ 2 x Door Contacts
- ★ Siren for bell box
- ★ 100 mtrs. cable and clips
- ★ Full fitting instructions

ONLY £130

### BELL BOXES

A very attractive external box made of Polypropylene. Supplied complete with back plate. Available in Red, Yellow, Blue, White.

BASIC	FLASHING
SEC/RED	SEC/RS
SEC/YELLOW	SEC/YS
SEC/BLUE	SEC/BS
SEC/WHITE	SEC/WS

### BACK-UP LEAD ACID BATTERY

12V 1.9Ah  
£15.27  
LEAD ACID CHARGER  
£19.99

### VISIT

OUR OTHER BRANCHES  
SUPERTRONICS  
Tel: 021 666 6504  
65 HURST STREET  
BIRMINGHAM B5 4TE

WALTONS  
Tel: 0902 22039  
55A WORCESTER ST  
WOLVERHAMPTON WV2 4LL

Visit our shop in WEM  
Tel 0939 232763

### POST & PACKING IS NOW

£2.25

ALL PRICES INCLUDE

17½% VAT

### SCART ADAPTOR



T113Z (2XSC)  
£10.50

Scart plug to two scart sockets for coupling three pieces of audio, video equipment with scart sockets.



### MORSE KEY

£6.99  
All metal, cast base, professional high speed key. Fine adjustment screws. Dims (base) 75 x 50mm

### COMPUTER DISKS

5¼ Computer Disks - 3M Type: 744 D-O SS DD

Single sided double density soft sector. Limited quantity, only a few hundred boxes. First come first served!

ORDER CODE: SO/636 PRICE: £2.00 per box of 10

### B101 SWR METER SWR2T

Close tolerance SWR meter.  
SWR.....1:1 to 1:3  
Frequency range.....1.7 to 30MHz  
Impedance.....50Ω  
Dims.....70 x 47 x 65mm



Price £9.99

### 2-WAY HAND HELD CRYSTAL CONTROL TRANCEIVERS

Built-in Telescopic Aerial, call button, transmitter receive key, on air indicator. Each unit requires PP3 Battery for operation (not supplied).



Operating Frequency.....49 MHz  
Transition Power.....100 MHz  
Frequency Tolerance.....+ or - 0.005%  
Range.....1-2 Kilo. open field (depends on conditions)  
Oscillation Crystal Control  
Power.....9V dc (PP3 Battery)

Pack B123 £27.50 1 pair in box

### TUNGSTEN DRILL BITS

A range of metric, solid tungsten drill bits, suitable for drilling glass fibre based pcb's and general hobby use, giving extended life over HSS drills. Drill bits range in size from 0.4mm to 3.0mm. Our packs of 10 are a random mix. Unsorted. Original price of these bits was £4.20 each!! They really are the highest quality.

ORDER CODE: SO/610  
£3.50 per pack of 10 Buy 10 packs for only £30

### DESOLDER TOOL

High quality, fitted with Teflon micro nozzle. Length: 190mm Dia: 20mm  
PRICE: £2.99  
SPARE NOZZLES 95p each

### FULL RANGE OF BABANI BOOKS IN OUR CATALOGUE

### HEATSHRINK PACK

10 lengths, assorted diameter of high quality heatshrink sleeving. Assorted colours. Approximate length: 12in.

ORDER CODE: SO/HEATSHRINK  
1+ £1.50 10+ £1.00

### QUARTZ-HALOGEN SPOTLIGHT

THIS UNIT SUBJECT TO DESIGN CHANGE  
Hand held or hanging. Heat resistant polycarbonate housing, highly polished reflector. Protective lens cover doubles as base stand. With On/Off switch and 12ft curly cable terminating in cigar lighter plug. Produces 250,000 candle power - 5 times the intensity of average car headlamps. Price £5.75  
Power.....12V d.c. 4.5A 55W  
Dims.....160 x 88 x 110mm



### ANTEX IRONS

C-15W IRON.....£9.30	XS-KIT 25W.....£13.45
CS-17W IRON.....£9.15	CS-KIT 17W.....£13.30
XS-25W IRON.....£9.50	C-KIT 15W.....£13.15

All bits for irons £1.98, Elements £6.30 Stands £3.78

### TWIN FLUORESCENT LAMP - 12V

A very attractive twin tube lampholder with two 12V BW fluorescent tubes. White plastic case with clear plastic ribbed diffuser and ON/OFF switch. Supplied with 90cms of twin flex for connection to 12V battery (Red stripe to positive). Ideal for caravans, boats, vans, etc.  
Overall dimensions: 370 x 65 x 41mm  
ORDER CODE Opto TFL12  
Price £6.50 10+ £5.25

### PORTABLE FLUORESCENT LAMP - 12V

Free-standing or hanging with 15ft cable terminating in cigar lighter plug. For use in car, boat, van or home emergency. 12V dc. EVEN FLOATS IN WATER!  
Overall dimensions: 430 x 30mm  
ORDER CODE 1+ 10+ 50+  
Price £6.50 £6.00 £5.25

### SPARE TUBES

Replacement tube for above Twin and Single fluorescent lamps. Fits most 12V fluorescent lamps. Philips, etc. Tube length: approx 300mm (inc. pins).  
ORDER CODE Opto Tube  
£1.50 ea, 10 for £12

# SEPTEMBER SPECIAL OFFER

(while stocks last)

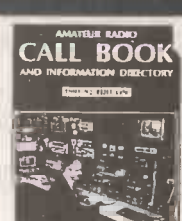

## RSGB 1991/92 CALL BOOK (less than half price) SUPER SALE

The Official RSGB Call Book & Information Directory. This publication is a must for anybody interested in Amateur Radio. 430 PAGES! Lists all UK & EIRE Call Signs and is packed with information including:

Abbreviations, Awards, Band Plans, Beacons, Clubs, Contests, EMC, Licensing Info., Locators, Morse Info., News, Packet Nodes, Propagation, QLS, Planning permission, RAE, Raynet, Repeaters, RSGB Info., Safety, Satellites, Special Event Stations, Etc. etc.

CURRENT PRICE: £6.75!!  
DIMS: 200 X 270MM  
SALE PRICE £2.99

SALE SALE SALE SALE SALE

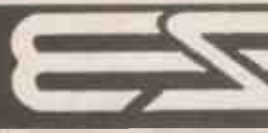

# ESR ELECTRONIC COMPONENTS

Station Road, Cullercoats,  
Tyne & Wear NE30 4PQ

Tel. 091 251 4363 Fax. 091 252 2296

74LS Series		4000 Series		TRANSISTORS		LINEAR ICs		SOLDERING IRONS		RF CONNECTORS			
74LS00	£0.14	4000	£0.17	2N1613	£0.31	BC184L	£0.08	BD441	£0.41	Antex Soldering irons	£7.75	BNC Solder Plug	£0.85
74LS01	£0.14	4001	£0.17	2N1711	£0.26	BC186	£0.33	BD442	£0.41	M 12 Watt	£7.75	BNC Crimp Plug	£0.68
74LS02	£0.14	4002	£0.17	2N1893	£0.29	BC204C	£0.72	BD534	£0.47	G 18Watt	£7.30	BNC Solder Skt	£1.08
74LS03	£0.14	4006	£0.32	2N2218A	£0.28	BC206B	£0.72	BD535	£0.48	CS 17Watt	£7.88	BNC Chassis Skt	£0.78
74LS04	£0.14	4007	£0.17	2N2219A	£0.26	BC207C	£0.72	BD536	£0.85	XS 25Watt	£7.96	PL259 5.2mm	£0.58
74LS05	£0.14	4008	£0.31	2N2222A	£0.16	BC208	£0.72	BD646	£0.52	ST4 STAND	£2.85	PL259 11mm	£0.58
74LS08	£0.14	4009	£0.19	2N2646	£0.80	BC209A	£0.72	BD648	£0.82	New PORTASOL HOBBY		RND UHF socket	£0.63
74LS09	£0.14	4010	£0.23	2N2904A	£0.25	BC212	£0.08	BD650	£0.53	35Watt gas iron	£11.17	SQR UHF socket	£0.40
74LS10	£0.14	4011	£0.16	2N2905A	£0.23	BC212L	£0.08	BD707	£0.42	DESOLDER PUMP	£3.00	F Plug RG58	£0.27
74LS107	£0.23	4012	£0.16	2N2907	£0.20	BC212LB	£0.08	BD807	£0.80	ANTISTATIC PUMP	£4.30	F Plug RG6	£0.27
74LS109	£0.21	4013	£0.17	2N2926	£0.16	BC213	£0.08	BDX32	£1.78	22SWG 0.5Kg Solder	£7.40	N Plug RG8	£1.64
74LS11	£0.17	4014	£0.30	2N3053	£0.27	BC213CL	£0.08	BDX33C	£0.46	18SWG 0.5Kg Solder	£6.60		
74LS112	£0.21	4015	£0.31	2N3054	£0.90	BC214	£0.08	BDX34C	£0.50	1mm 3yds Solder	£0.58		
74LS114	£0.21	4016	£0.18	2N3055	£0.62	BC214L	£0.08	BDX53C	£0.47				
74LS116	£0.21	4017	£0.25	2N3440	£0.50	BC237B	£0.09	BDX54C	£0.50				
74LS12	£0.14	4018	£0.27	2N3702	£0.09	BC238C	£0.09	BF180	£0.31				
74LS122	£0.31	4019	£0.19	2N3703	£0.10	BC239C	£0.10	BF182	£0.31				
74LS123	£0.31	4020	£0.31	2N3704	£0.10	BC251	£0.13	BF185	£0.31				
74LS125	£0.21	4021	£0.32	2N3705	£0.10	BC252	£0.13	BF194	£0.19				
74LS126	£0.21	4022	£0.32	2N3706	£0.10	BC261B	£0.24	BF195	£0.19				
74LS13	£0.14	4023	£0.16	2N3711	£1.44	BC262B	£0.24	BF244	£0.35				
74LS131	£0.14	4024	£0.21	2N3772	£1.51	BC267B	£0.20	BF257	£0.33				
74LS133	£0.18	4025	£0.16	2N3773	£1.79	BC307	£0.10	BF259	£0.33				
74LS136	£0.16	4026	£0.40	2N3820	£0.40	BC308	£0.10	BF337	£0.36				
74LS138	£0.24	4027	£0.18	2N3820	£0.58	BC327	£0.10	BF355	£0.38				
74LS139	£0.25	4028	£0.27	2N3904	£0.10	BC328	£0.10	BF423	£0.13				
74LS14	£0.18	4030	£0.17	2N3905	£0.10	BC337	£0.10	BF425	£0.19				
74LS145	£0.68	4031	£0.70	2N4306	£0.31	BC338	£0.10	BF459	£0.29				
74LS147	£0.70	4032	£0.56	2N5295	£0.57	BC414C	£0.13	BF469	£0.36				
74LS148	£0.70	4033	£0.56	2N5295	£0.57	BC414C	£0.13	BF470	£0.29				
74LS15	£0.14	4034	£1.24	2N5321	£0.87	BC461	£0.40	BFX84	£0.31				
74LS151	£0.26	4040	£0.29	2N6107	£0.60	BC463	£0.29	BFX85	£0.31				
74LS153	£0.25	4041	£0.31	AC126	£0.30	BC478	£0.32	BFY50	£0.29				
74LS154	£0.70	4042	£0.22	AC127	£0.30	BC479	£0.32	BFY51	£0.26				
74LS155	£0.25	4043	£0.28	AC128	£0.28	BC490	£0.24	BFY52	£0.28				
74LS157	£0.25	4044	£0.31	AC188	£0.37	BC517	£0.20	BSW66	£1.35				
74LS158	£0.25	4046	£0.31	AC188	£0.37	BC517	£0.20	BU128	£1.32				
74LS160	£0.32	4048	£0.31	AC188	£0.37	BC517	£0.20	BU205	£1.41				
74LS161	£0.32	4049	£0.20	AC188	£0.37	BC517	£0.20	BU208A	£1.34				
74LS162	£0.32	4050	£0.20	AC188	£0.37	BC517	£0.20	BU326A	£1.40				
74LS163	£0.32	4051	£0.25	BC107B	£0.15	BC548C	£0.08	BU500	£1.80				
74LS164	£0.26	4052	£0.25	BC108	£0.14	BC550C	£0.08	BU508A	£0.39				
74LS165	£0.26	4053	£0.25	BC108C	£0.14	BC555C	£0.08	BU526	£1.74				
74LS170	£0.30	4053	£0.25	BC109	£0.14	BC557C	£0.08	BU806	£0.06				
74LS173	£0.24	4055	£0.30	BC109C	£0.15	BC559C	£0.08	BU806	£0.06				
74LS174	£0.24	4060	£0.31	BC114	£0.41	BC559C	£0.08	MJ11015	£1.11				
74LS175	£0.24	4063	£0.29	BC115	£0.41	BC560B	£0.09	MJ2501	£1.60				
74LS190	£0.25	4066	£0.18	BC116	£0.41	BC637	£0.21	MJ3001	£1.52				
74LS191	£0.24	4067	£1.91	BC118	£0.41	BC638	£0.21	MJ340	£0.36				
74LS192	£0.24	4068	£0.18	BC132	£0.36	BC639	£0.40	MJ350	£0.42				
74LS193	£0.24	4069	£0.20	BC134	£0.36	BC640	£0.21	MPSA13	£0.12				
74LS195	£0.24	4070	£0.17	BC135	£0.36	BCY70	£0.21	MPSA42	£0.17				
74LS196	£0.24	4071	£0.20	BC140	£0.25	BCY71	£0.20	MRF475	£6.21				
74LS197	£0.24	4072	£0.17	BC141	£0.27	BCY72	£0.20	TI121	£0.35				
74LS20	£0.16	4073	£0.17	BC142	£0.31	BD135	£0.20	TI122	£0.37				
74LS21	£0.14	4076	£0.16	BC143	£0.34	BD136	£0.22	TI125	£0.37				
74LS22	£0.14	4076	£0.90	BC149	£0.12	BD137	£0.22	TI127	£0.37				
74LS221	£0.36	4077	£0.17	BC154	£0.36	BD138	£0.22	TI132	£0.46				
74LS240	£0.32	4081	£0.14	BC157	£0.12	BD139	£0.23	TI137	£0.46				
74LS241	£0.32	4082	£0.17	BC159	£0.12	BD140	£0.24	TI142	£1.06				
74LS242	£0.32	4085	£0.28	BC160	£0.28	BD150C	£0.82	TI147	£1.12				
74LS243	£0.32	4086	£0.26	BC170	£0.16	BD165	£0.42	TI225	£0.63				
74LS244	£0.32	4086	£0.26	BC170B	£0.16	BD166	£0.35	TI292C	£0.31				
74LS245	£0.32	4093	£0.15	BC171	£0.11	BD187	£0.39	TI3055	£0.63				
74LS247	£0.32	4094	£0.31	BC171B	£0.16	BD201	£0.40	TI3055	£0.63				
74LS251	£0.24	4095	£0.56	BC172	£0.13	BD202	£0.40	TI313C	£0.32				
74LS252	£0.24	4097	£1.20	BC172B	£0.13	BD203	£0.40	TI322C	£0.32				
74LS258	£0.24	4098	£0.38	BC178	£0.17	BD222	£0.40	TI322C	£0.32				
74LS26	£0.14	4502	£0.38	BC179	£0.17	BD225	£0.42	TI422C	£0.38				
74LS266	£0.14	4503	£0.31	BC182	£0.08	BD232	£0.38	TI47	£0.48				
74LS27	£0.14	4508	£0.90	BC182L	£0.08	BD237	£0.32	TI48	£0.62				
74LS273	£0.32	4510	£0.26	BC182LB	£0.08	BD238	£0.32	TI50	£0.53				
74LS279	£0.25	4511	£0.29	BC183	£0.08	BD240B	£0.37	VN10KM	£0.44				
74LS30	£0.14	4512	£0.31	BC183L	£0.08	BD243B	£0.50	VN66AF	£1.50				
74LS32	£0.14	4512	£0.31	BC183LB	£0.08	BD244A	£0.53	ZTX300	£0.16				
74LS365	£0.21	4515	£0.78	BC184	£0.08	BD246	£0.56	ZTX500	£0.16				
74LS367	£0.21	4516	£0.31										
74LS368	£0.21	4518	£0.27										
74LS37	£0.14	4518	£0.30										
74LS373	£0.32	4520	£0.28										
74LS374	£0.32	4521	£0.62										
74LS375	£0.32	4521	£0.62										
74LS377	£0.32	4528	£0.39										
74LS378	£0.62	4529	£0.44										
74LS38	£0.14	4532	£0.31										
74LS380	£0.24	4534	£2.24										
74LS393	£0.24	4536	£1.60										
74LS395	£0.26	4538	£0.37										
74LS399	£0.62	4541	£0.31										
74LS40	£0.14	4543	£0.46										
74LS42	£0.25	4555	£0.34										
74LS47	£0.42	4556	£0.34										
74LS51	£0.14	4560	£1.18										
74LS570	£0.69	4566	£1.96										
74LS73	£0.17	4572	£0.25										
74LS74	£0.19	4584	£0.24										
74LS75	£0.19	4585	£0.32										
74LS76	£0.25	4724	£0.70										

# EVERYDAY ELECTRONICS

INCORPORATING ELECTRONICS MONTHLY

VOL. 21 No. 9 SEPTEMBER '92

## ELEVATED EGO

Our contributor Steve Knight has made an interesting point in the last paragraph of a letter to us (see *Everyday Readout* in this issue). In a delicate manner he is voicing what many of us have experienced over the years.

I remember when EE first started back in 1971 (yes we are 21 years old this year, but more of that in a few months time), I was working for the magazine at that time and found a number of people looked down their noses at a hobbyist magazine aimed mainly at students and beginners. Thankfully the attitude and the standing of EE in these people's eyes has changed for the better over the years and we are proud that many highly qualified engineers are pleased to write for us and impart some of their knowledge to our readers.

For those that still worry about their egos, perhaps they should remember how they started the learning process some years back. Surely your social standing is enhanced by imparting knowledge rather than reduced by it?

## FOR THE SAKE OF IT

On a totally different subject, this time one touched upon in our *Information Technology* series, I have often rejected projects for EE because they "use a sledge hammer to crack a nut", though this is not always the case. Let me explain: What point is there in building an elaborate piece of electronics to tell you something which can be easily indicated by other simple and inexpensive means.

I once saw an interesting device to tell a car owner when he had reversed his car to just the right point inside his garage – some form of infra-red beam? or possibly an ultrasonic range finder? No, simply a rubber ball suspended on string from the garage roof, when the ball touched the rear window the car was in the correct position. The device is cheap, easy to install and fool proof – unless the string breaks. What I am trying to say in a roundabout way is to look at all the possible solutions.

To go back to my first statement, we have on occasions published projects which are more complicated than necessary because they illustrate the use of various electronic systems and are therefore educational. We also publish various projects which could be purchased for less as commercial items but, after all, part of the enjoyment of our hobby comes from building it for yourself and therefore cost is not always the final decider.

## SUBSCRIPTIONS

Annual subscriptions for delivery direct to any address in the UK: £20. Overseas: £26 (£43.50 airmail). Cheques or bank drafts (in £ sterling only) payable to Everyday Electronics and sent to EE Subscriptions Dept., 6 Church Street, Wimborne, Dorset BH21 1JH. Tel: 0202 881749. Subscriptions start with the next available

issue. We accept Access (MasterCard) or Visa payments, minimum credit card order £5.

## BACK ISSUES

Certain back issues of EVERYDAY ELECTRONICS are available price £2.00 (£2.50 overseas surface mail) inclusive of postage and packing per copy – £ sterling only please, Visa and Access (MasterCard) accepted, minimum credit card order £5. Enquiries with remittance, made payable to Everyday Electronics, should be sent to Post Sales Department, Everyday Electronics, 6 Church Street, Wimborne, Dorset BH21 1JH Tel: 0202 881749. In the event of non-availability one article can be photostatted for the same price. *Normally sent within seven days but please allow 28 days for delivery.* We have sold out of Jan, Feb, Mar, Apr, June, Oct, & Dec. 88, Mar & May 89 & Mar 90.

## BINDERS

Binders to hold one volume (12 issues) are available from the above address for £5.95 (£6.95 to European countries and £8.00 to other countries, surface mail) inclusive of post and packing. *Normally sent within seven days but please allow 28 days for delivery.*

Payment in £ sterling only please. Visa and Access (MasterCard) accepted, minimum credit card order £5. Tel: 0202 881749

## Editorial Offices:

EVERYDAY ELECTRONICS EDITORIAL,  
6 CHURCH STREET, WIMBORNE,  
DORSET BH21 1JH

Phone: Wimborne (0202) 881749

Fax: (0202) 841692. DX: Wimborne 45314.

See notes on Readers' Enquiries below – we regret that lengthy technical enquiries cannot be answered over the telephone.

## Advertisement Offices:

EVERYDAY ELECTRONICS ADVERTISEMENTS,  
HOLLAND WOOD HOUSE, CHURCH LANE,  
GREAT HOLLAND, ESSEX CO13 0JS.

Phone/Fax: (0255) 850596

Editor: MIKE KENWARD

Secretary: PAMELA BROWN

Deputy Editor: DAVID BARRINGTON

Business Manager: DAVID J. LEAVER

Editorial: WIMBORNE (0202) 881749

Advertisement Manager:

PETER J. MEW, Frinton (0255) 850596

Classified Advertisements:

Wimborne (0202) 881749

## READERS' ENQUIRIES

We are unable to offer any advice on the use, purchase, repair or modification of commercial equipment or the incorporation or modification of designs published in the magazine. We regret that we cannot provide data or answer queries on articles or projects that are more than five years old. Letters requiring a personal reply must be accompanied by a stamped self-addressed envelope or a self addressed envelope and international reply coupons.

All reasonable precautions are taken to ensure that the advice and data given to readers is reliable. We cannot however guarantee it and we cannot accept legal responsibility for it.

## COMPONENT SUPPLIES

We do not supply electronic components or kits for building the projects featured, these can be supplied by advertisers.

We advise readers to check that all parts are still available before commencing any project in a back-dated issue.

We regret that we cannot provide data or answer queries on projects that are more than five years old.

## ADVERTISEMENTS

Although the proprietors and staff of EVERYDAY ELECTRONICS take reasonable precautions to protect the interests of readers by ensuring as far as practicable that advertisements are *bona fide*, the magazine and its Publishers cannot give any undertakings in respect of statements or claims made by advertisers, whether these advertisements are printed as part of the magazine, or are in the form of inserts.

The Publishers regret that under no circumstances will the magazine accept liability for non-receipt of goods ordered, or for late delivery, or for faults in manufacture. Legal remedies are available in respect of some of these circumstances, and readers who have complaints should first address them to the advertiser.

## TRANSMITTERS/BUGS/TELEPHONE EQUIPMENT

We would like to advise readers that certain items of radio transmitting and telephone equipment which may be advertised in our pages cannot be legally used in the U.K. Readers should check the law before using any transmitting or telephone equipment as a fine, confiscation of equipment and/or imprisonment can result from illegal use. The laws vary from country to country; overseas readers should check local laws.



# LCD ULTRASONIC TAPE MEASURE

JOHN BECKER



*An ultrasonic measure that probes parts other tapes cannot reach.*

**U**P, DOWN or sideways, distances of up to nine metres or 30 feet can be easily measured and displayed by this pocket-sized unit. Using twin ultrasonic transducers, a decoding counter and a 3½ digit liquid crystal display (LCD), accuracies to within one decimal place are obtainable.

An unusual feature is the foreground masking circuit which enables weak distant echoes to be more readily detected.

## TIMING CIRCUIT

The block diagram of the complete concept for the LCD Ultrasonic Tape Measure is shown in Fig. 1. Essentially the unit consists of a timer which is started at the moment an ultrasonic signal is transmitted and stopped when an echo signal is received back.

The echo-return time is digitally stored in a register whose contents are shown on an LCD. After the time has been stored, the counter is reset and the sequence repeated. The LCD shows only the stored time and is unaffected when the counter is reset.

In the main circuit diagram Fig. 2, IC3 is a combined counter and LCD driver. Its full pinouts and those of the LCD are

shown in Fig. 3. IC3's internal clock which controls the LCD segments and backplane is also used as the trigger for resetting the counter and starting the transmission sequence. Its rate is set by capacitor C3 to approximately 4Hz.

The oscillator, whose pulses are counted by IC3 during the transmission/echo return period, is formed around the Schmitt inverter IC1f and has its clock rate set by capacitor C5, resistor R6 and preset potentiometer VR3. The rate is determined by the speed of sound through air and whether the readout is to be in feet or metres.

Sound travels at about 331.4 metres per second (through dry air at 0°C and 1013.25 millibars atmospheric pressure). Consequently, for a metric readout with an accuracy of 0.1 metres, the oscillator should run at 1657Hz ( $331.4 \times 10 / 2$ ). For imperial measurements (feet) the oscillator rate is increased by 3.28 to 5435Hz.

However, precise frequency measurement of the oscillator is not necessary since preset VR3 can be set by comparison of the readout against a known distance. It is not practical in a simple unit to adjust the clock rate to compensate for changes in air temperature and density, nor would

it have any significance in this short-range application.

Counter resetting occurs when IC3 pin 33 is taken low and is controlled by the backplane clock inverted by IC1d. The same phase stops the count oscillator by taking its input pin 5 low via diode D7, ensuring that the oscillator always starts at the same point in its output phase. If the oscillator were simply allowed to run freely, pulse count totals for a given distance could differ erratically, by about two pulses.

At the end of the reset pulse, IC3 counts the pulses from IC1f but does not show the result on the LCD until the Store input pin 34 is taken low when an echo pulse is detected. An echo pulse causes the output of IC2c to go high, allowing capacitor C12 to charge via diode D6 and resistor R4.

When C12 has charged sufficiently, the output of IC1e is triggered from high to low, generating a negative-going pulse across capacitor C9 and resistor R3, causing IC3 to transfer the current count value to its internal register and the LCD. Simultaneously, the output of IC1e also takes IC3's Inhibit pin 31 low so stopping the counter.

Diode D4 prevents the occurrence of a secondary store pulse when IC1e pin 8 reverts to high. As will be seen, an additional circuit terminating in diode D5 prevents IC3 from responding to premature pulses from IC2c.

## TRANSMITTER

The 40kHz transmission frequency is generated by the circuit consisting of Schmitt trigger IC1a, capacitor C1, resistor R1 and preset VR1, the latter fine tuning the oscillator. IC1b inverts the clock phase and the Transmitter TX1 is driven in push-pull mode by both IC1a and IC1b.

Transmission is pulsed at a rate and duration controlled by the LCD backplane clock and the circuit around IC1c. The squarewave output from IC3 pin 5 is differentiated by C2 and R2 to create short negative-going pulses on input pin 13 of the Schmitt inverter IC1c. Diode D2 coupled to the positive line prevents pulses from being generated by the positive-going clock phase.

In the absence of a clock pulse, IC1c's output pulls the input to IC1a low via diode D1, thus stopping the 40kHz oscillator. The oscillator functions normally when IC1c pin 12 is pulsed high, transmitting its signal via TX1 for the duration of the pulse, typically for around 0.8 milliseconds.

Fig. 1. Block diagram for the LCD Ultrasonic Tape Measure.

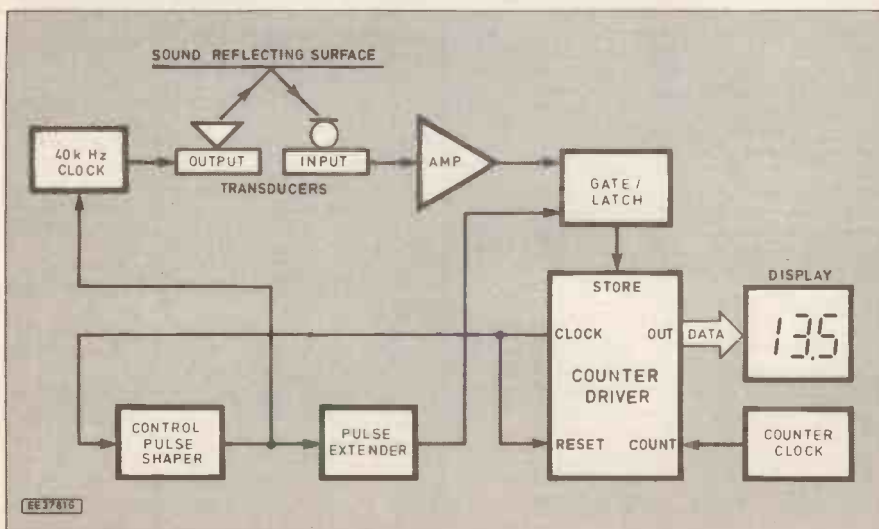

# RECEIVER

Objects in the path of the transmitted pulse train reflect the signal back to the Receiver RX1. The signal is amplified by IC2a and IC2b, which have gains of about 100 and 47 respectively, and passed to comparator IC2c.

Preset VR4 in series with resistors R13 and R14 controls the comparator's sensitivity, setting the reference level so that the output is triggered from low to high even when low amplitude echo signals are received. As previously discussed, the comparator's output pulses cause the counter to update the LCD display.

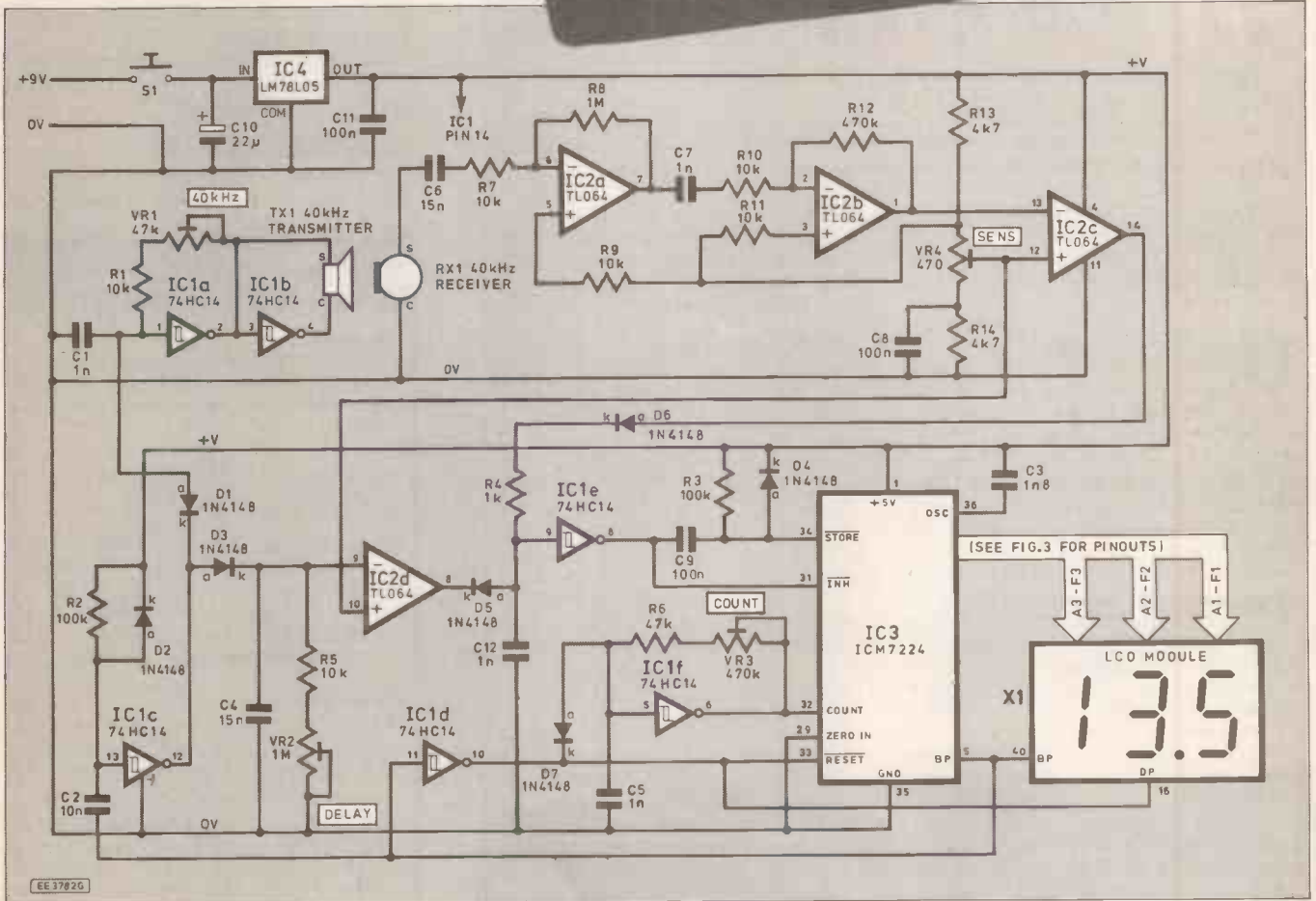
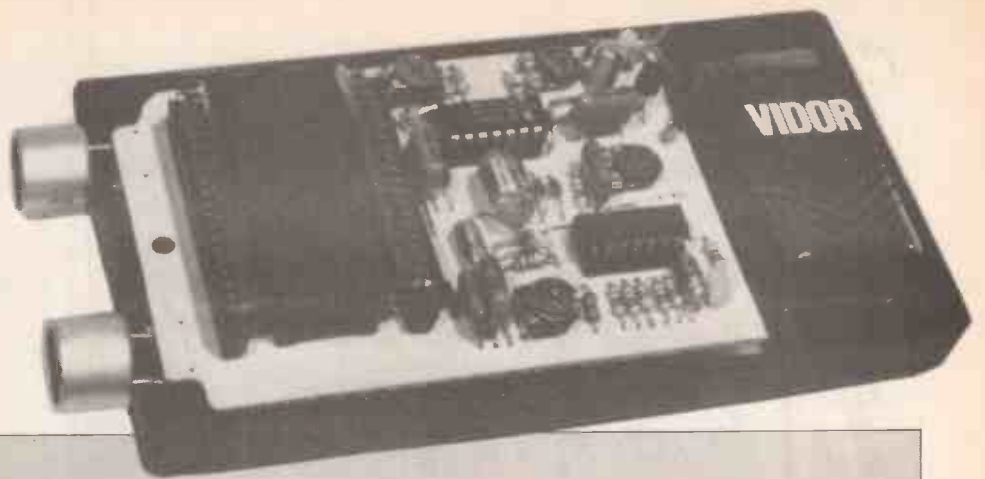

Fig. 2 (above). The main circuit diagram for the LCD Ultrasonic Tape Measure. Details of the counter circuit IC3 connections to the display can be seen in Fig. 3.

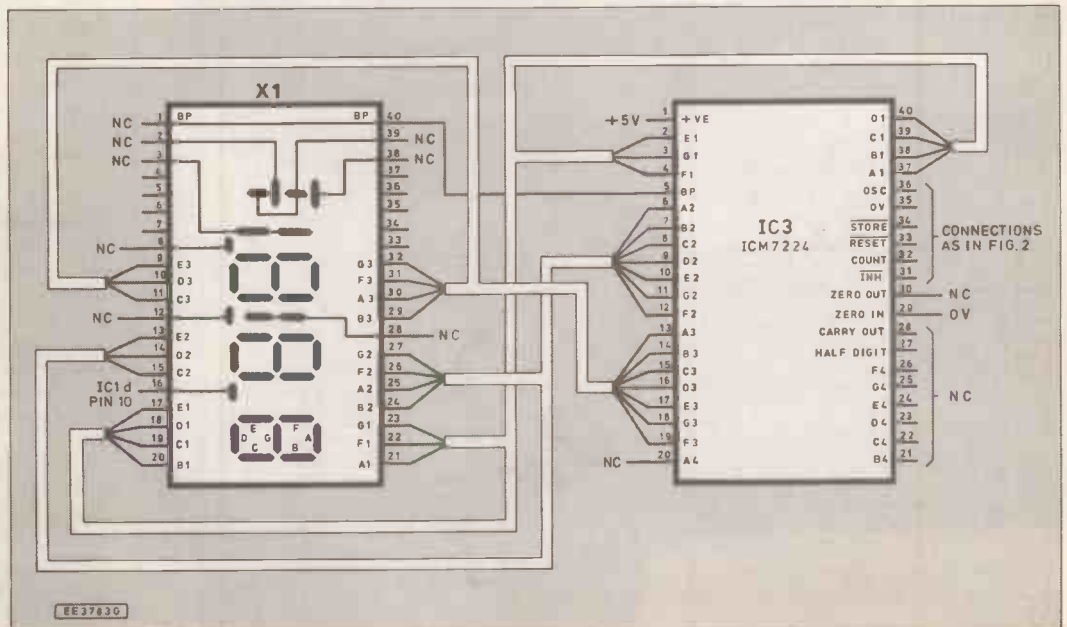

Fig. 3 (right). Details of the interconnections between the LCD display and the counter IC3.

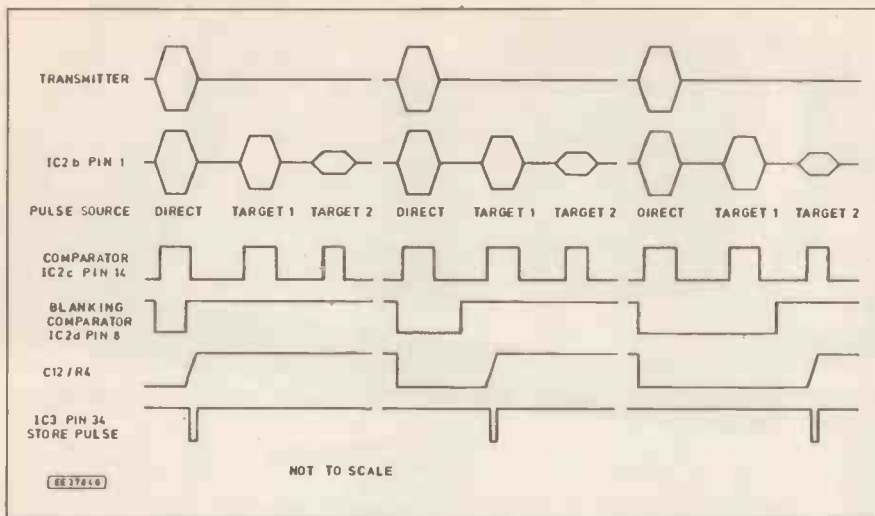

Fig. 4. Foreground blanking principle. How different echo-blanking periods, controlled by IC2d, affect counter-store triggering.

The amplifier circuit (IC2a, IC2b) has a very high gain and is naturally prone to undesirably picking-up signals while they are being transmitted by TX1. If this situation were to be left uncorrected, the counter would be triggered prematurely, resulting in incorrect display values.

An inhibitory circuit, based around IC2d, has been included to stop the counter from responding to the transmission output. It also allows the unit to be set to ignore echo signals received from nearby targets, so giving it a range more distant than commonly found with ultrasonic measurers. Fig. 4 shows the principle.

When IC1c pin 12 goes high during transmission, it also causes a positive level to be sent via diode D3 to input pin 9 of the comparator IC2d, simultaneously charging capacitor C4. The comparator's reference level on pin 10 is the same as that supplied by preset VR4 to IC2c.

For the duration that the voltage on IC2d pin 9 is above the reference level, IC2d pin 8 will be held low which, via diode D5, prevents trigger pulses from IC2c being allowed to affect IC1e. Consequently, IC3's store input cannot be triggered during transmission.

Capacitor C4, resistor R5 and preset VR2 have been included to extend the inhibition period beyond the transmission length. When IC1c pin 12 goes low at the end of transmission, C4 begins to discharge via R5 at a rate set by VR2. Only when the charge on C4 has fallen below IC2d's reference level will IC2d pin 8 go high, thus allowing IC1e to respond to any echo pulses from IC2c.

Components R4, C12 and D6 serve a double purpose. They prevent IC1e from responding to brief transient signals from IC2c, noise for example, and secondly they prevent IC1e from reacting to multiple-echo signals. On receipt of the first

major echo signal after IC2d pin 8 has reverted high, capacitor C12 charges up and remains so until discharged via D5 at the start of the next transmission cycle.

Occasionally, there can be situations when no single echo signal is powerful enough to trigger IC1e, but in which several very small echoes cause C12 to additively charge above the necessary level. This can sometimes result in the display being updated even though no primary target has been detected.

## POWER SUPPLY

A PP3 nine volt battery is the unit's power source and is switched on by the push-button switch S1. IC4 regulates the 9V down to 5V to suit the limits of IC1 and IC3.

The current drawn is only about 6.5mA. A rechargeable Nicad battery may be used instead of a disposable PP3.

## ASSEMBLY

Printed circuit board topside component layout and full size underside copper foil

## COMPONENTS

### Resistors

R1, R5,	
R7, R9 to R11	10k (6 off)
R2, R3	100k (2 off)
R4	1k
R6	47k
R12	470k
R13, R14	4k7 (2 off)

All 0.25W 5% carbon film or better

### Potentiometers

VR1	47k
VR2	1M
VR3	470k
VR4	470

See  
**SHOP  
TALK**  
Page

All min. skeleton preset, horizontal

### Capacitors

C1, C5,	
C7, C12	1n polystyrene (4 off)
C2	10n polystyrene or polyester
C3	1n8 polystyrene
C4, C6	15n polyester (2 off)
C8, C9, C11	100n polyester (3 off)
C10	22µ elect. 16V

### Semiconductors

D1 to D7	1N4148 signal diode (7 off)
IC1	74HC14 Hex Schmitt trigger inverter
IC2	TL064C quad low-power op. amp.
IC3	ICM7224IPL 4½-digit counter
IC4	78L05 +5V 100mA voltage regulator

### Miscellaneous

X1	3½ digit LCD display
S1	Single-pole push-to-make, release-to-break switch
TX1	40kHz transmitter
RX1	40kHz receiver

Handheld, calculator style, plastic case (with 50mm x 20mm window cutout), size approx. 148mm x 60mm x 36mm; 14-pin d.i.l. socket (2 off); 40-pin d.i.l. socket (3 off - see text); PP3 9V battery and battery connector; self-adhesive p.c.b. supports (2 off); single-core link wire; solder etc.

Printed circuit board available from **EE PCB Service**, code EE802.

Approx cost  
guidance only

**£30**

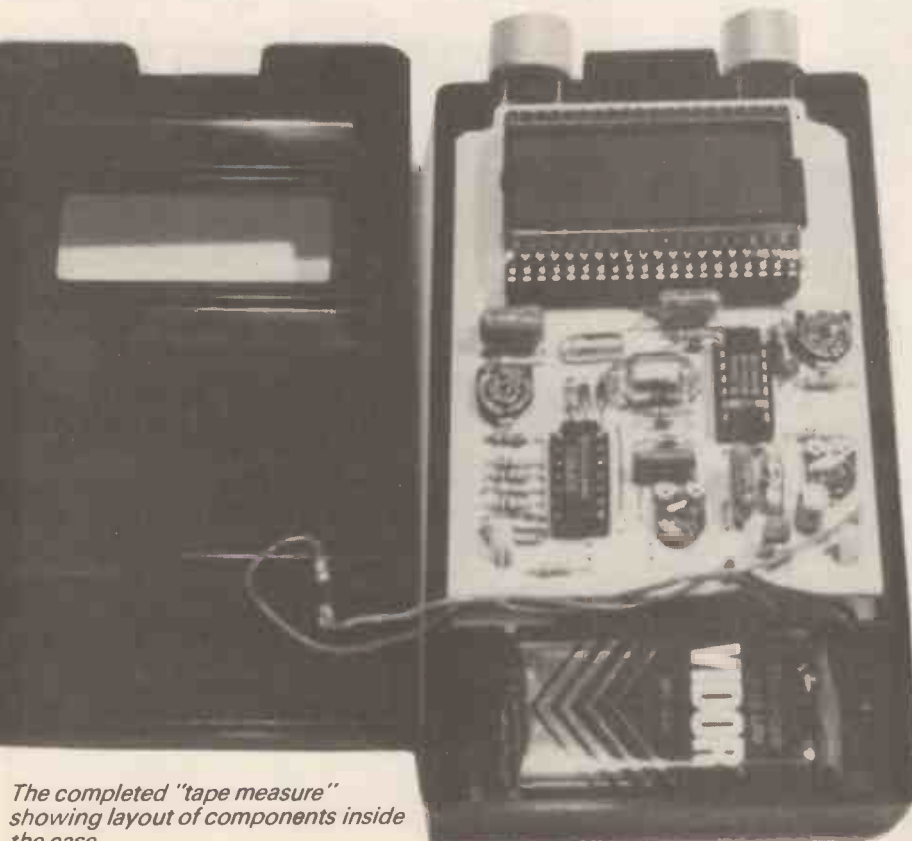

The completed "tape measure" showing layout of components inside the case.



master pattern details are given in Fig.5. This board is available from the *EE PCB Service*, code EE802.

A fine tipped soldering iron and thin solder (22s.w.g.) are recommended for the finely tracked areas. Dual-in-line (d.i.l.) sockets should be used for all the i.c.s. and the LCD.

The board has been designed so that the LCD display is mounted above IC3 but d.i.l. sockets to suit the LCD's pin spacing and height requirements seem to be unavailable. Consequently, two normal 40-pin sockets need to be cut lengthwise in half. Two of the strips are soldered into the board at the LCD position after which the second layer is plugged into the first to hold the LCD above IC3.

Solder in other components in order of link wires, resistors and diodes, preset potentiometers and then capacitors and the voltage regulator IC4. Pay particular attention to the polarities of the i.c.s, diodes and the electrolytic capacitor C10.

The 40kHz transducers are normally sold in pairs and marked accordingly as transmitter and receiver. Although ultrasonic transducers can often be used for the opposite purpose to that intended, in this application their correct function should be adhered to.

The transmitter transducer has a lower impedance than the receiver, allowing more power to be generated across it. It is also more sensitive to the correct setting of the transmission frequency as shown in the graphs of Fig. 6.

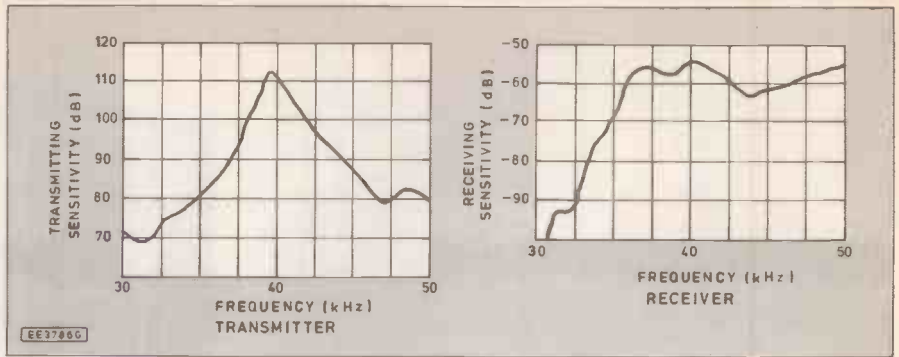

Fig. 6. Transmitter and receiver frequency response curves for typical 40kHz ultrasonic transducers.

On the rear of the transducers are two wire connections, one directly connected to the body, the other connected via an insulated entry point. It is preferable (though not absolutely vital) that the connections are made as indicated by the C (chassis) and S (signal) notations in Fig. 5. The transducer wires are soldered directly to the tracks on the rear of the p.c.b., allowing sufficient length for the bodies of the transducers to be outside the case as seen in the photographs.

Make sure that the transducers are correctly aligned with respect to each other. Small slots should be cut in the end of the case to allow the wires to pass through. When drilling the switch hole in the lid of the case ensure that clearance is allowed for the insertion of the battery.

### CHECKING OUT

Before switching on, check all the soldered joints with a close-up magnifying glass, ensuring that there are no shorts between adjacent copper tracks. When power is first applied, immediately check with a multimeter that +5V is present at the output of the voltage regulator IC4. A voltage significantly higher than this will most likely indicate that IC4 is incorrectly inserted.

A much lower voltage could indicate excessive current being drawn, possibly because of an overlooked track short, or a polarity-conscious component inserted the wrong way round. In either instance, switch off immediately and recheck the assembly.

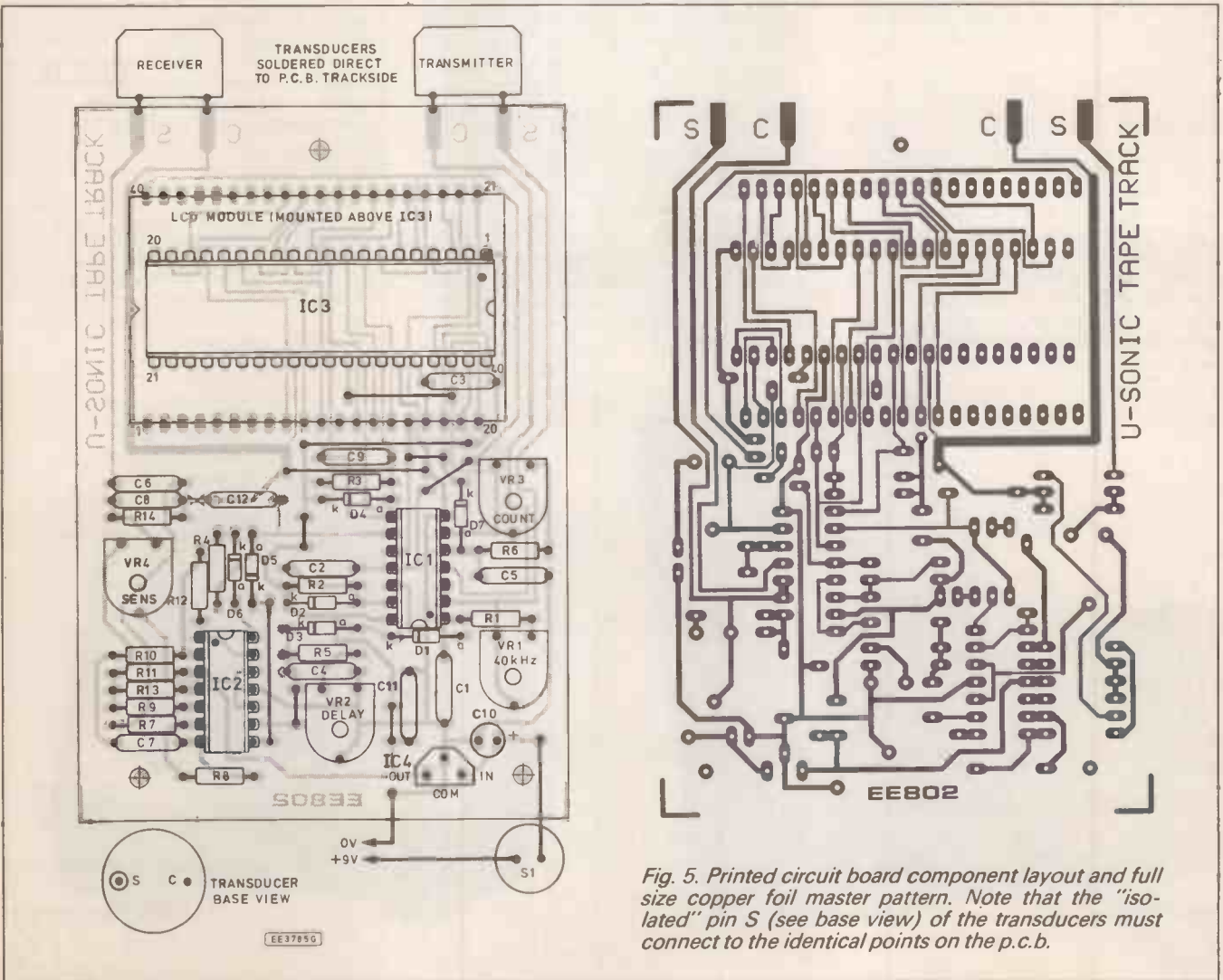

Fig. 5. Printed circuit board component layout and full size copper foil master pattern. Note that the "isolated" pin S (see base view) of the transducers must connect to the identical points on the p.c.b.

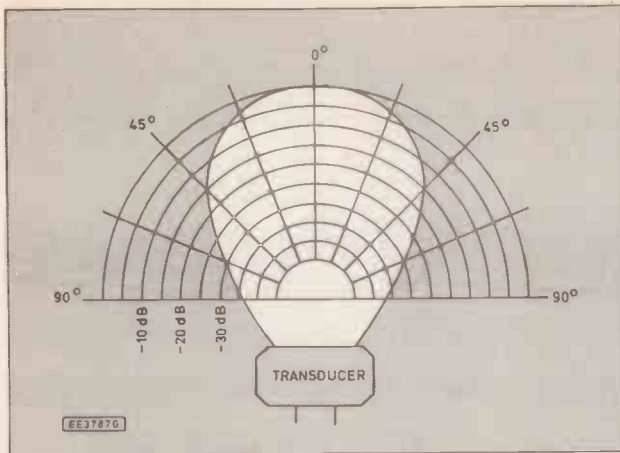

Fig. 7. Typical 40kHz transducer radiation response zones and powers.

Once satisfied with the power supply, setting-up is made easier if the push switch S1 is temporarily bypassed by connecting a short wire across its terminals. Alignment can be done without test equipment by watching the LCD readout while making adjustments to the preset potentiometers. However, if you wish to monitor the circuit, the following are the easiest points to observe:

Set preset VR2 to minimum resistance and the other presets midway. With a multimeter or oscilloscope ('scope) monitor pin one or pin 40 of the LCD, both of which are backplane (BP) clock connections. Check that the pin voltage is changing up and down somewhere between 0V and 5V. The scope should confirm that the swing is fully 0V to 5V and at a rate of about 4Hz.

Meters, because they respond more slowly, will only give a general indication that there is a reasonable swing occurring at a slow rate. In this instance, an analogue meter is better than a digital one. Check that a similar rate and amplitude of swing occurs at IC1 pin 10 and IC2 pin 8.

Only a scope can confirm that the transmission and count oscillators are being pulsed so assume that they are functioning correctly and check the echo detector circuit. Point the unit towards a good sound-reflecting surface about two metres (six feet) away and monitor IC2 pin 14.

Adjust preset VR4 until the meter shows a maximum reading of about 4V. This should confirm that signals are being received but that the comparator is being tripped too readily. Reduce the setting of VR4 until the meter shows a reading of about 0.8V. A scope will confirm that echo signals are being processed, causing IC2 pin 14 to be pulsed high on their detection.

It should now be apparent that IC3 is counting, storing and being reset. Next check that the receiver is responding to echo signals and not to the actual transmission signal.

Point the unit towards large hard objects at varying distances and verify that the LCD readout responds to the changes. If necessary, increase VR2's resistance to lengthen the period within which IC3 should not respond to echoes. Progressively move the unit further away from a single target and very carefully adjust preset VR4 to give the comparator maximum sensitivity to distant echoes.

If the transmission oscillator has not been tuned on a scope, try adjusting preset VR1 as well as VR4 to extend the range. Experiment also with various settings of VR2 to extend or shorten the blanking period. As the oscillator is not temperature compensated, in practice its frequency may drift slightly, affecting the maximum distance detectable.

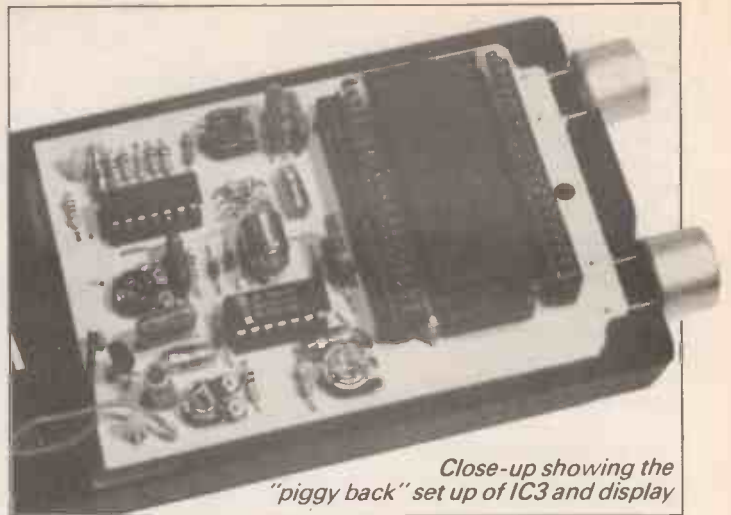

Close-up showing the "piggy back" set up of IC3 and display

Now place the unit in a fixed position facing a target at close to the maximum detection distance. With an ordinary measuring tape, measure the exact distance between the transducers and the target. Remove objects from any place which might fall within the transmission zone. The typical radiation pattern for a 40kHz transducer is shown in Fig. 7. Keeping the unit stationary, adjust preset VR3 until the LCD shows the exact distance of the target to the nearest decimal point, either in metres or feet as preferred.

### IN USE

It will be found that a compromise setting of VR2 must eventually be decided upon to give maximum distance detection while still allowing reasonably nearby objects to be registered. In the test model, the minimum response distance was set to about 1.1 metres (3.5ft), allowing a maximum target distance of about 9.1 metres (30ft). The latter, incidentally, has also been achieved in the open air, aiming the unit across the garden at glass patio doors.

When using the unit make sure that other objects in the vicinity of the transmission zone do not cause false readings. Also be aware that in some surroundings multiple echoes generated by one transmission pulse could be picked up during the reception period of the next pulse. □

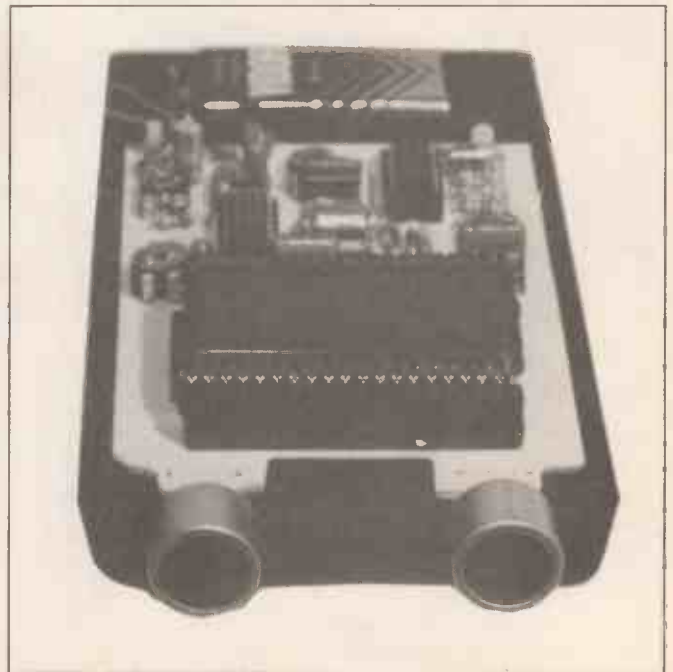
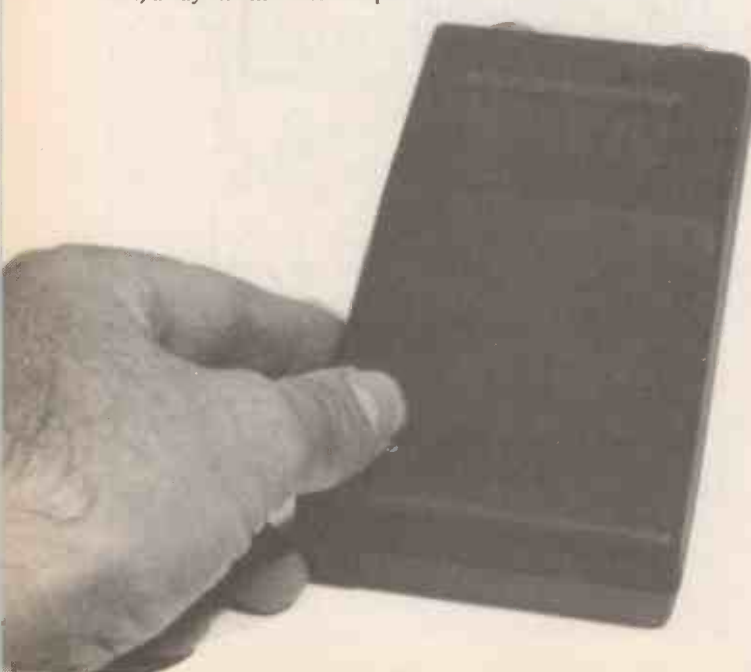

IMPORTS **EASY** PC FILES  
UPGRADE DISCOUNT AVAILABLE

# Finally...an exceptional PCB and Schematic CAD system for every electronics engineer!

**B**oardMaker 1 is a powerful software tool which provides a convenient and professional method of drawing your schematics and designing your printed circuit boards, in one remarkably easy to use package. Engineers worldwide have discovered that it provides an unparalleled price performance advantage over other PC-based systems.

BoardMaker 1 is exceptionally easy to use - its sensible user interface allows you to use the cursor keys, mouse or direct keyboard commands to start designing a PCB or schematic within about half an hour of opening the box.

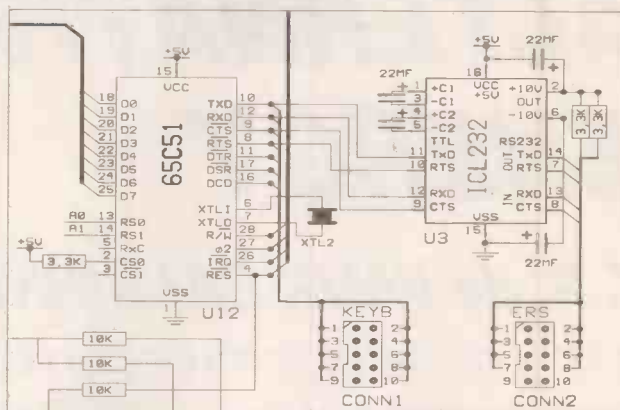

Produce clear, professional schematics for inclusion in your technical documentation.

## HIGHLIGHTS

### Hardware:

- IBM PC, XT, AT or 100% compatible.
- MSDOS 3.x.
- 640K bytes system memory.
- HGA, CGA, MCGA, EGA or VGA display.
- Microsoft or compatible mouse recommended.

### Capabilities:

- Integrated PCB and schematic editor.
- 8 tracking layers, 2 silk screen layers.
- Maximum board or schematic size - 17 x 17 inches.
- 2000 components per layout. Symbols can be moved, rotated, repeated and mirrored.
- User definable symbol and macro library facilities including a symbol library editor.
- Graphical library browse facility.
- Design rule checking (DRC) - checks the clearances between items on the board.
- Real-time DRC display - when placing tracks you can see a continuous graphical display of the design rules set.
- Placement grid - Separate visible and snap grid - 7 placement grids in the range 2 thou to 0.1 inch.
- Auto via - vias are automatically placed when you switch layers - layer pairs can be assigned by the user.
- Blocks - groups of tracks, pads, symbols and text can be block manipulated using repeat, move, rotate and mirroring commands. Connectivity can be maintained if required.
- SMD - full surface mount components and facilities are catered for, including the use of the same SMD library symbols on both sides of the board.
- Circles - Arcs and circles up to the maximum board size can be drawn. These can be used to generate rounded track corners.
- Ground plane support - areas of copper can be filled to provide a ground plane or large copper area. This will automatically flow around any existing tracks and pads respecting design rules.

### Output drivers:

- Dot matrix printer
- Compensated HP laser printer
- PostScript output.
- Penplotter driver (HPGL or DMPL).
- Photoplot (Gerber) output.
- NC (ASCII Excellon) drill output.

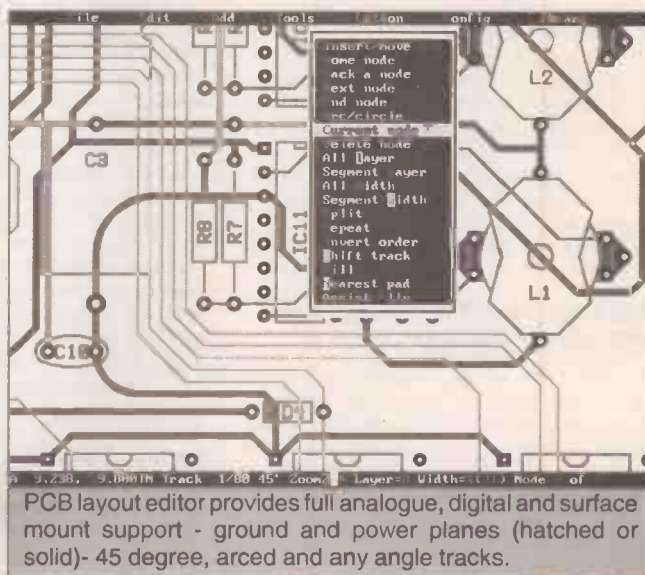

PCB layout editor provides full analogue, digital and surface mount support - ground and power planes (hatched or solid) - 45 degree, arced and any angle tracks.

**£95**

Despite its quality and performance, BoardMaker 1 only costs £95.00. Combine this with the 100% buy back discount if you upgrade to BoardMaker 2 or BoardRouter and your investment in Tsien products is assured. Price excludes carriage and VAT.

**Don't take our word for it. Call us today for a FREE demonstration disk and judge for yourself.**



**tsien**

**Tsien (UK) Limited**  
Cambridge Research Laboratories  
181A Huntingdon Road  
Cambridge CB3 0DJ  
Tel 0223 277777  
Fax 0223 277747

All trade marks acknowledged

# ALTERNATIVE ENERGY

T. R. de VAUX BALBIRNIE

PART 2

Is the answer blowing in the wind?

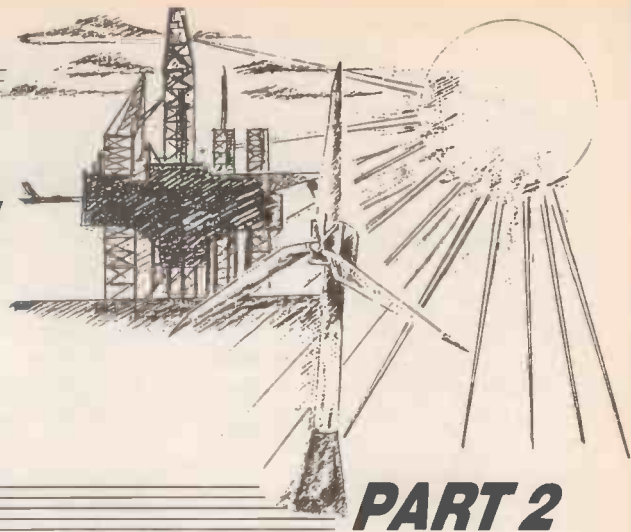

**L**AST month we looked in general terms at the problems of providing the world's energy needs into the 21st century. This month we shall look in detail at the problems associated with fossil fuels and go on to examine one established alternative energy technology – wind power.

For many years the world has relied heavily on fossil fuels (coal, oil and natural gas) and more recently on uranium (for nuclear power generation) to supply almost all its energy needs. In Britain today, most electricity is generated by using coal. This is burned in furnaces to provide heat, boil water, raise high-pressure steam and turn the blades of turbines. These operate generators which make electricity to be sent out on the National Grid.

## HERE TODAY NONE TOMORROW

In the past, steam engines were used *directly* to provide the power for industry. Today, the internal combustion engine has replaced the old-fashioned steam engine to provide inexpensive road and rail transport and the jet engine has revolutionised air travel. All these devices use fossil fuels. The technology is well-developed, safe, relatively simple and inexpensive.

Our dependence on fossil fuels began in 1698 when Thomas Savery made the first practical steam engine. Its purpose was to pump water out of mines. In 1711, Thomas Newcomen, an English blacksmith, developed the design and by the mid-18th century, James Watt had improved it to the point where it could be used directly for many large-scale manufacturing processes such as weaving and printing.

Steam power was to seed the Industrial Revolution and turn Britain from a mainly agricultural country into a major manufacturer of cheap goods to be traded throughout the world. Man had for the first time found a reliable way of doing his work without using beasts of burden, his own muscle power, the waterwheel or the windmill.

Steam reigned supreme and there seemed to be a never-ending supply of cheap fuel to keep the wheels of industry turning. No one was concerned about environmental issues such as clean air so no care was taken to seek ways of burning the fuel efficiently. The combustion process therefore caused much dirt and smoke to be poured into the atmosphere.

Health problems were rife together with problems of crumbling buildings, black

stonework, filthy rain and thick black fog. This continued until recent times. So bad was the problem that a London *smog* (Smoke and fog) killed 4,000 bronchitis sufferers in 1952.

## NUCLEAR PROMISE

The nuclear power station at Clader Hall opened in 1956 with a power output of 200MW (a small amount by today's standards). This brought the promise of cheap power without the pollution caused by coal. The new technology was eagerly pursued as a source of heat for raising steam which could then operate conventional turbines and generators to make electricity. However, nuclear power brought its own problems – disposal of nuclear waste and the possibility of some catastrophic accident such as that which happened recently at Chernobyl.

Coal began to enjoy confidence once again as the *safe* fuel and with coal reserves in Britain possibly good for a further 200-300 years, its future seemed assured. The Clean Air Acts of 1956 and 1968 forced more efficient combustion methods and the use of devices such as *electrostatic precipitators* (see

Fig. 1) to remove almost all the flue ash and black smoke from the chimney stack emissions. A typical power station produces approximately 30 tonnes of ash per hour which would otherwise go into the atmosphere.

## NOT KING COAL

More recently, opinion has turned against coal and the other fossil fuels once again for there is now known to be a far more serious problem associated with their use. Although the *visible* material has been cleaned out of the flue gases, its purity is an illusion. In burning fossil fuels, millions of tonnes of *carbon dioxide* are discharged into the atmosphere each year. Carbon dioxide (CO<sub>2</sub>) is a *greenhouse gas* and although it allows the sun's rays to pass through the atmosphere to the earth quite easily, its effect is to prevent them from travelling back again so readily.

When the solar energy falls on to the earth about 30 per cent is reflected back into space. If this is prevented from happening to some extent, the heat energy will be trapped rather like a greenhouse where sheets of glass serve the same purpose (Fig. 2). Carbon dioxide is produced because coal consists of impure carbon and when this

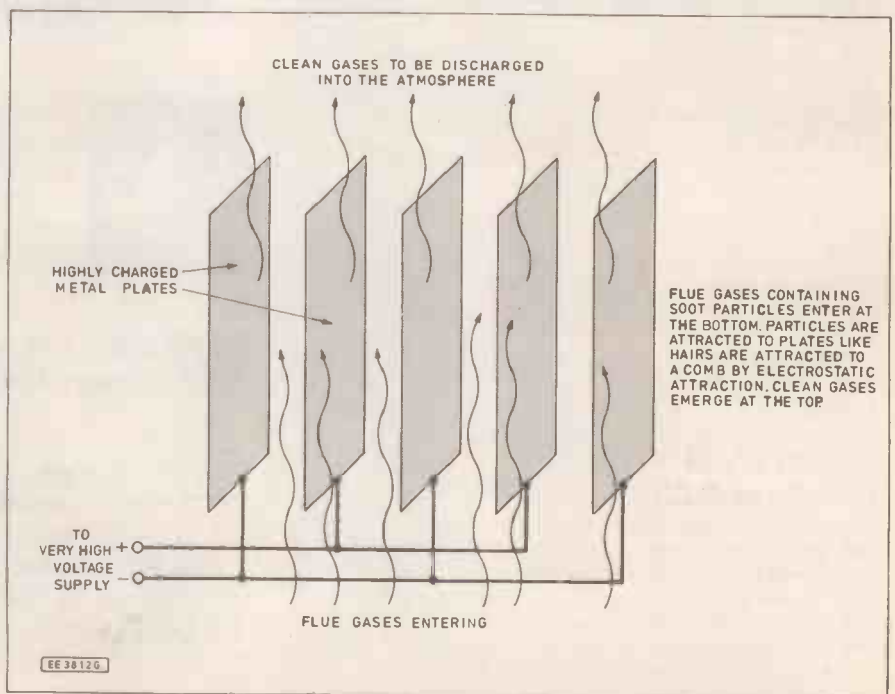

Fig. 1. Method of operation of electrostatic precipitators.

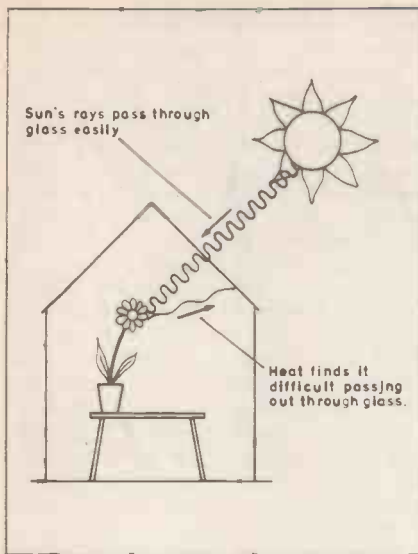

Fig. 2. The greenhouse effect.

burns in the oxygen of the air, carbon dioxide is formed. This is a fundamental chemical process and cannot be prevented by any known means.

If we wish to continue burning fossil fuels, we simply have to put up with it. Each kilowatt-hour of electricity (the energy required to operate, for example, a single-bar electric fire for one hour) generated using coal produces approximately one kilogramme of carbon dioxide.

## GREENHOUSE GAS

Electricity generation in conventional (that is, non-nuclear) power stations is responsible for one-third of the total carbon dioxide released by burning fossil fuels. Taking into account that generated by transport burning petrol and diesel fuel (both of which are derived from oil), also for central heating systems and so on, more than five billion tonnes of carbon dioxide annually are discharged worldwide into the atmosphere (in 1950 it was less than two billion tonnes). Whereas 100 years ago, there were less than 300ppm (parts per million) of carbon dioxide in the atmosphere, now there are some 350ppm – an increase of over 16 per cent.

The factor which is not yet fully understood is how much carbon dioxide will eventually dissolve in the oceans and therefore be effectively removed from the equation. There are widely differing estimates of this. Cutting down the forests and clearing the land of green plants compounds the problem because it reduces *photosynthesis* – the natural process by which carbon dioxide is turned into starch by the chlorophyll in green leaves accompanied by the re-release of oxygen.

## GETTING YOUR OWN BACK

It is sometimes argued that when we burn coal, we are just getting back the carbon dioxide which was taken up by the trees in the first place i.e. during photosynthesis. This is true but the problem is one of *scale*. It took millions of years for the enormous number of trees to grow to give us coal so the carbon dioxide was taken up over a long period of time. However, we are burning coal at a rate far exceeding the time taken

for the trees to grow – some 3,000 million tonnes per year worldwide – so carbon dioxide is being returned to the atmosphere at a correspondingly enormous rate.

One possible consequence of the greenhouse effect is *global warming*. One hundred years ago, the average world temperature was approximately 14.5 degrees. Today, it has risen by about one degree. However, with the increasing use of fossil fuels some scientists believe that it could produce a rise of some four degrees over the next 50 years or so. This may sound very little but if it were allowed to happen, it would probably be the fastest change in the world's climate for several million years.

At first sight, a small rise in temperature seems attractive, especially in Britain where a few degrees more in summer and winter could make the climate more agreeable. However, this reasoning misses the point that global warming would cause a general raising of the level of the oceans – that is, increasing *sea level*. This could happen for two reasons. Firstly, warm water occupies a larger volume than cold water – that is, it *expands*. Also, a higher world temperature would melt some of the polar ice caps where vast reserves of water are stored quite harmlessly at the moment.

Again, this may not seem to be of much consequence but we must remember that there are large areas of the world's surface which are only marginally above sea level and these would be flooded. Holding the water back over such large areas would itself need prohibitive amounts of energy.

Scientists make widely differing estimates of the scale of the problem but it could be a fairly profound one. A small increase could put much of East Anglia below water, for example.

It is interesting to look at carbon dioxide emissions due to the various technologies used for electricity generation (see Table 1). This will give an idea of their contribution to the greenhouse effect. Note that these figures take account of *all* sources of emission from extraction of the fuel itself (if necessary) and during construction of the plant as well as actual operation.

TABLE 1

Method	CO <sub>2</sub> – tonnes per thousand-million kWh
Coal	751-964
Natural gas	484
Geothermal (hot rocks)	57
Hydroelectric	5-10
Nuclear	8
Wind	7
Solar cells	5

As well as carbon dioxide, burning coal produces other unpleasant pollutants chief of which are the gases *sulphur dioxide* and *nitrogen dioxide*. When these are dissolved in water, acids are formed and these cause problems of *acid rain*. Scandinavia sees the effect on its trees of acid rain produced by our sulphur dioxide carried over on the prevailing wind. At some cost, these gases can be removed – although a reduction of 90 per cent would involve an increase of 5 per cent in the cost of electricity. Recognising that there is a problem, Britain is committed to reducing sulphur dioxide emissions by three-fifths by the year 2004.

## ENERGY EFFICIENCY

No one disputes that fossil fuels will be used for many years to come. Friends of the Earth acknowledge that they cannot be phased out abruptly. However, most scientists agree that fossil fuels will need to be used in moderation and with much more respect in the future.

Less coal would be needed if we worked towards greater energy efficiency in the home, in commerce and in industry. Ideas such as better household insulation, more efficient transport and lower space heating temperatures would help but there is obviously a limit to what can be achieved. Another parallel approach is to seek alternative ways of providing energy without the need to release greenhouse gases.

Nuclear fission – that is, nuclear power as used at the moment supplies 16 per cent of

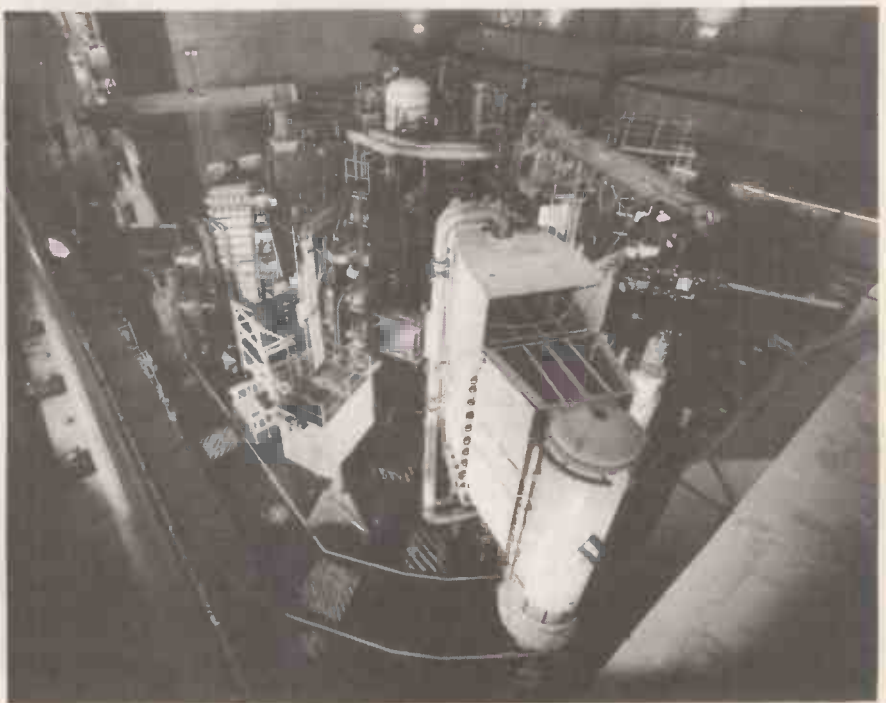

A general view of the JET vessel designed to develop nuclear fusion.

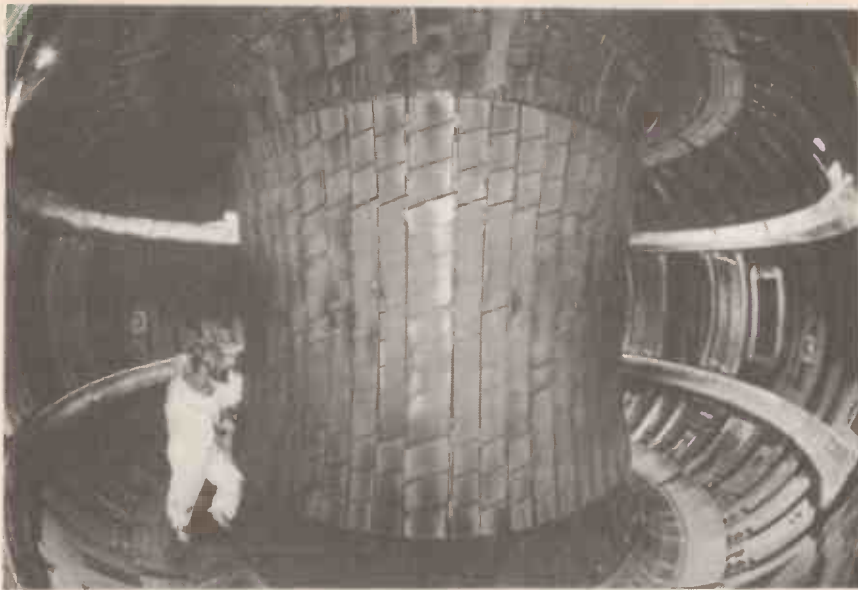

Inside the JET vessel.

Britain's electricity. Increasingly this contribution is a possible way forward. Belgium and Sweden generate 50 per cent of their electricity and France 66 per cent of it in this way. However, there are continued concerns about its safety. Also, taking into account *true* costs rather than apparant ones (for example, the energy needed to build the plant in the first place, the true cost of disposal of waste and clearing up the site when the life of the reactor is over) actually means that nuclear power could be an expensive way of generating electricity compared with other technologies.

## NUCLEAR FUSION

A piece of recent news is the reported achievement of controlled *nuclear fusion*. The idea is to *fuse* hydrogen atoms together to make helium. This releases an enormous amount of energy and is, in fact, how the sun works. Up until the present time, the only way of achieving nuclear fusion was in a hydrogen bomb – i.e. all the energy released in an uncontrolled burst. Now, scientists working on the JET (Joint European Torus) project in Oxford – an experiment funded and operated by a group of European countries – are said to have achieved controlled and prolonged nuclear fusion.

Unlike nuclear *fission*, fusion is *clean* – that is, almost totally non-polluting. Also, it uses only water as its raw material. Since there is practically an unlimited supply of this, nuclear fusion may be regarded as renewable energy technology. Although nuclear fusion does not work by using the sun's energy, it could rival all other direct and indirect solar energy production methods in the long term. However, there are many unknowns.

The technology to build a nuclear fusion power plant is still a long way off – perhaps 50 years or more – so it leaves ample scope to develop other forms of alternative energy for the short and medium term.

## THE CONTENDERS

Last month we saw that *direct* use of solar power for large-scale electricity generation is something of a long-shot – especially in Britain. A more likely way forward is to use natural phenomena which have turned the sun's energy into a form more easily reached by cheap and well-known technology.

Short-term contenders in the alternative energy stakes are hydroelectric power (the energy of falling water), burning landfill gas and solid waste, wave power, biomass (burning crops as fuel), geothermal energy (using hot underground rocks), wind power and tidal energy. These are described as *renewable energy sources*. By this we mean they are *everlasting* – they do not rely on burning the *fossil fuels* which, apart from the problems mentioned previously, will eventually run out.

It is unlikely that only one alternative energy method will be the answer. All methods must be looked at in economic terms as well as considering possible detrimental effects on the environment. A tidal barrage at the Severn could contribute the equivalent of two large conventional power stations but there could be a profound effect on wildlife in the area. It could kill thousands of birds and destroy the habitat of many more.

Let us now look in detail at *wind energy* as an example of a well-developed renewable energy source.

## WIND ENERGY

Wind energy has been used for thousands of years – to carry ships around the world and, of course, in the form of the familiar *windmill* for grinding corn and pumping water. There is some evidence for windmills having been used in the Middle East around 2000 B.C. Corn-grinding windmills certainly existed in Persia (Iran) in the 7th century A.D. while in the late 11th century the windmill appeared in England.

During the 12th century the Dutch, Germans, Danes and others developed the design of windmills to a form similar to that which was in general use in Britain until relatively recently. In Holland, during the 19th century, there were over 1000 large corn-grinding windmills. The chief problem with these has always been that the wind is not always reliable in terms of strength or direction. Also, in a gale the windmill could be easily damaged.

More recently developed windmills have been used for driving small electrical generators. These can charge batteries which may then operate lighting or power emergency radio equipment. These are still important uses today. Small wind turbines (between one and three metres in diameter) produce between 50W and several kilowatts depending on the wind speed. These have been useful for providing small-scale power in remote regions. However, it is only recently that large commercial wind turbines have been produced relatively cheaply and which are capable of producing a significant amount of electrical power.

Now, under the *non-fossil fuel obligation*, the government requires electricity boards to buy electricity generated by non-conventional means. With such access to the national Grid possible, advantage has been taken by several commercial organisations in the UK. Thus, a company can generate electricity for its own use, sell excess capacity on to the National Grid and purchase from the grid when, for example, there is insufficient wind to meet the demand.

A wider and more serious view has been taken by countries which have traditionally relied more on the wind than ourselves – Denmark, Holland and Belgium. France has little wish to use wind power



A traditional windmill at Alford, Lincolnshire. (John Howard/Science Photo Library)



North of Scotland Hydro Electricity Board's 3MW wind turbine at Burgar Hill, Orkney. At 45 metres tall it is one of the largest turbines in the world. It has variable pitch tips and rotates at 34 r.p.m. (Michael Marten/Science Photo Library).

since, as mentioned previously, this country has a well developed large-scale nuclear energy programme. Germany, Spain, Portugal, Greece, Italy and the UK all have operational wind-energy projects.

The largest wind generator constructed in the UK and one of the largest in the world is the Wind Energy Group's 60m diameter LS-1 with a generating capacity of 3MW. This was installed on Orkney in 1987 and serves about 2000 people. The larger wind turbines, however, turn out to be much too expensive for general use and smaller ones producing somewhere between 250kW and 500kW and having a diameter of up to 40m, are becoming the norm. Since a large coal-fired power station can generate in excess of 1000MW, it would need 400 of the 250kW wind generators to produce the same amount of power.

## DOWN ON THE FARM

One strategy is to group turbines together in *wind farms*. These may then extract the diffuse wind energy over a large area. There must be sufficient space left between the units if they are to have their own wind supply and operate effectively. This can mean very large areas of land being used. In practice this involves leaving about 300m between units.

Taking into account the access roads which are needed for repair and maintenance, for the equivalent power output of a 2000MW large coal-burning power station, an actual area of 7km<sup>2</sup> – or around 2000 acres – would be needed for the turbines themselves. However, these would be spread over a total area of 500km<sup>2</sup> (i.e. providing 4MW per km<sup>2</sup>) so over 98 per cent of the land could still be farmed in the traditional way.

Large wind farms are operational in the United States – in California, 18,000 wind turbines of approximately 80kW each, are providing a total power output of 1400MW. These have provided European researchers with much valuable information.

Colin Moynihan, then Minister for Energy, re-iterated the Government's

support for alternative energy in September, 1990 – "It is very important to place emphasis on the renewables". Privatisation of the generating and distribution industry has provided a whole new dimension and under the *non-fossil fuel obligation*, progress has been maintained.

Under a non-fossil fuel contract, a medium sized wind turbine costing £1000 per kW would break even with a 15 per cent rate of return on investment with an average wind speed of 7.5m/s. This is not particularly high and Britain has 500km<sup>2</sup> of useable land with a mean windspeed greater than this. Given that turbines would be erected to provide 4MW per km<sup>2</sup>, Britain has an economic capability to generate 2,000MW or the output of one large conventional power station.

A further idea is to use *off-shore* wind generators and the Swedes and Danes are undertaking this type of research at the moment. In Britain, a prototype off-shore wind turbine is planned to be sited 5km from the Norfolk coast in the next few years. One advantage of putting the turbines off-shore, apart from placing them *out of sight, out of mind* is that wind speeds are generally higher and therefore each turbine produces more power. The disadvantage is the much greater construction and maintenance costs also the extra cost of the transmission cables. For this and other reasons, the official view is that off-shore wind farms are something of a long shot at the moment.

## A BEAUTIFUL SIGHT

People who think that wind farms scattered around the countryside would look ugly and spoil the landscape, would be pleasantly surprised to see one. It is, of course, acknowledged that *beauty is in the eye of the beholder*. Modern wind turbines can be quite beautiful with their large sails moving slowly and gracefully. It is not generally known that the speed of rotation of the blades is typically only 40 revolutions per minute.

Others people worry about the possible noise from a wind farm. Again, such worries seem to be largely unfounded. There is, of course, some noise generated by the blades

and also some mechanical noise from the generator and transmission itself. However, because the units are spread over a large land area, the noise at any given place is small.

Another objection – that of possibly endangering wildlife – seems, once again, to be groundless. There are few reported cases from the RSPB or any other body, of birds or other animals being harmed by rotating sails or driven away by the noise. There have been far more accidents to wildlife due to conventional sources of power.

The wind turbines are quick to install – they can be erected on site in 24 hours and be producing electricity the following day. Since construction is relatively quiet anyway, wildlife is not seriously disrupted. It is also found that, when construction is complete, any wildlife which has been frightened away usually returns.

## POWER UP

Following a decision made in March 1988 to proceed with wind farm construction in Britain, the new generating companies, Powergen and National Power have taken this up and are each developing a wind farm at the time of writing. Each will comprise 25 medium-sized turbines, so each site will provide about 8MW of power – sufficient to serve 10,000 people.

We should remember that the production of a wind turbine plant itself uses energy – mostly fossil fuel energy – both for manufacturing and for transport of material. However, it can be shown that this energy is recovered after about one year of operation. After that, totally clean energy is supplied throughout the working life of the machine which is taken to be nominally 20 years but it is likely to turn out to be much more.

It is important when making cost comparisons that we treat like with like. The energy itself may be free but there are costs involved in extracting it. When *true* costs are compared, wind power is no more expensive than fossil fuel energy at today's prices and is considerably cheaper than nuclear power.

If we include hidden charges such as health costs caused by pollution, attending to oil spillages and so on, wind power turns out to be cheaper still. Furthermore, as the



Wind farm producing electricity at Altamont, California. (Peter Menzel/Science Photo Library).

technology is developed, wind energy costs are likely to fall by some 20 to 30 per cent in the short term.

With fossil fuel costs rising steadily, wind power is likely to prove ever more attractive in the future. Wind turbines need little maintenance and are very reliable. There is therefore little time wasted while the machinery is stripped down for repair.

## CONTRIBUTION

It would be fanciful to imagine that on-shore and off-shore wind turbines will supply a large proportion of the electrical energy needs of the UK although this would be possible - Denmark and Britain (in Scotland) have some of the best climates in Europe for utilising wind power. It is more realistic to set targets so that wind and other forms of alternative energy, gradually increase their total contribution and reduce our reliance on fossil fuels and uranium.

If a reduction of 20 per cent in the use of conventional energy sources were to be made, the actual cash saving would amount to some £7Bn a year and this does not take into account hidden savings and benefits to the environment which cannot be quantified. Table 2 shows the *technical* potential (rather than the economic viability) of various alternative energy sources for the UK as a percentage of total demand. If all these were exploited to their maximum, we could generate more than twice as much electricity than is actually required.

The European Community could easily meet at least 10 per cent of its total electricity demand (in 1990 this was 1,000,000MW) using alternative energy sources by 2030 - and this would be only 20 per cent of what

TABLE 2

Technology	Potential % for UK
Wind energy - onshore	45
Wind energy - off-shore	50
Tidal	20
Geothermal	78
Wave	18
Hydroelectric	1
Landfill gas	2

could be reasonably achieved. One relatively painless strategy would be to increase the present 500MW contribution to 4,000MW by 2000, 115,000MW by 2005, 250,000MW by 2010 and 100,000MW by 2030.

Of the countries in the EC, Denmark, Holland, Germany, Italy, Greece and Spain have declared goals. Table 3 shows the July 1991 contributions of wind energy (installed capacity), in MW, in various EC countries. It can be seen that Denmark leads the way by a large margin. Worldwide, about 2000MW of wind power are currently installed - most of it in California.

TABLE 3

Country	Installed Capacity MW
Denmark	360
Holland	55
Germany	55
Spain	15
UK	10
Greece	5
Italy	5
Belgium	2
Portugal	3

Denmark's wind energy programme is remarkable. At present two per cent of her total electrical needs are generated in this way with a planned goal to generate 10 per cent of total demand by the end of the century. This country was the first to plan an installation programme of modern wind turbines in the late 1970's and since then has increased her total capacity by about 5MW per month. More recently, Germany and Holland have begun to make similar significant contributions.

Next month, we shall take a trip across the North Sea to Denmark to visit the Vestas (Danish Wind Technology) factory where a range of medium-sized turbines are designed and made to be sold all over the world including Britain. These are designed to be a cost-effective means of generating electricity for local use of for placing the output on to a national distribution system.

While in Denmark we shall also look at a wind farm to judge for ourselves the environmental effect of such an installation and see if there is anything for the British to learn. We shall look at an animal shelter in Cambridgeshire making use of wind power and at an innovative project in the North-East of England where wind power will make a significant contribution to the electricity needs of a new hospital.

SHOP



TALK

with David Barrington

### LCD Ultrasonic Tape Measure

We have a small problem with the supply of the transducers for the *LCD Ultrasonic Tape Measure*. Most of our component advertisers seem to stock ultrasonic transducers, but not all sell them as transmitter/receiver pairs.

The same transducer can often be used for both transmitter and receiver application, but in this circuit they should only be used as indicated. The specified transmitter has a lower impedance (200Ω) than the receiver (70k) and better power handling figures.

The ones used in the model are designated T40-16, R40-16 and are obtainable from Maplin (code HY12N) and sold as pairs. Also, the latest listing from ESR Components (☎ 091 251 4363) includes an offer for ultrasonic transmitter and receiver transducers. No impedance details are given, they may work in this circuit but it is emphasized they have not been tried in the model.

The 3½ digit LDC display and calculator style case should be readily available and the ICM7224IPL 4½ digit counter i.c. is listed by Maplin, code FP62S.

The single-sided printed circuit board is available from the *EE PCB Service*, code EE802 (see page 603).

### Model Railway Automatic Signal

Most of the components required to build the *Model Railway Automatic Signal* are standard items and should not cause any purchasing problems.

The reed switches, used to trigger the red and green lights, should be the miniature glass-encapsulated, single-pole make type. The required bar magnet may come together with the switch or have to be purchased separately.

The train signalling lights tower used in the model is the Hornby code R406 type. This should be available from any good railway modelling shop.

The choice of "rocker" switch will depend on the size of plastic case used. Due to the small amount of space available in the prototype, a miniature round type was used. Whichever case is chosen, check that the switch contacts cannot short on the circuit board.

### Quicktest

The particular case called for in the *Quicktest* project appears to be untraceable and cannot be found listed in our components catalogues. However, a similar, although slightly larger, case is available from Magenta Electronics for the sum of £2.39 plus £2 p&p.

This case also has a battery compartment, but the battery is sited across the width of the case as against "top to bottom" in the model. You could, of course, use a different type of case altogether.

Using a larger case does mean that there will be no need to make the small cutouts in the sides of the circuit board to allow it to fit in the case.

The triangular touch pads in the model were ordered from Maplin, code HY01 B. Alternative arrangements, such as a 6BA countersunk bolt with a large washer as the "touch pad", could be tried, but it may work out just as expensive as the pads.

Judging from the model, the "test" switch appears to be either a miniature (press-to-make release-to-break) modular switch, without accessories, or a non-locking keyboard type. Once again, the main criterion here is to ensure that the switch contacts do not foul or

short on the circuit board when the case is closed up.

The small printed circuit board for the *Quicktest* is available from the *EE PCB Service*, code EE803. See page 603.

### Washer Bottle Monitor

The special fluid level i.c. type LM1830 called for in the *Washer Bottle Monitor* is currently being listed by Maplin, code YY99H. It may be carried by other suppliers but does not appear in current listings.

The Scotchlok connectors may be purchased from most good motorist spares discount shops or spares counters. If the unit is to be installed in the engine area, the box and terminal block connections must be waterproofed. One of the bathroom silicone sealers may do the job here - not sure about the possible effects of heat though.

Finally, remember that it is essential that the monitor is connected to the right supply polarities as the i.c. could be destroyed if not. Most vehicles today operate a negative "earth" (common) system.

### Sound-Operated Nightlight

Some readers may experience local difficulties in obtaining the MEL12 phototransistor for the *Sound-Operated Nightlight* project. This device is a photo-Darlington and is currently stocked by Maplin (code HQ61R) and Cricklewood Electronics (MEL12).

The 12V solar panel used in the prototype model was purchased from Robert Keyes (GW41ED), Dept EE, 4 Glanmor Crescent, Newport, Gwent, NP9 8AX. Solar panels are stocked by many of our advertisers and Bull Electrical (☎ 0273 203500) are offering one (15P42R) at a reasonable price.

### Interface - Bar Code

This month's *Interface* article gives details of a barcode interface circuit using a photo-reflective infra-red sensor i.c.

The article mentions RS and Maplin as stockists of this device. However, we have been unable to locate it in the current Electromail (RS) catalogue. The Maplin code for this device is: UK81C (Sen. OPB706B).



# EVERYDAY READOUT

## REVERBERATIONS

Dear Ed.,

Could you possibly help me with a query on the *CCD Reverb Unit* project featured in the June 1992 edition of *Everyday Electronics*?

The main chip used in this circuit, the MN3011 3328 stage BBD, is shown connected to a single nine volt battery. Maplin stock this chip and the specification is detailed on page 426 of their 1992 catalogue, this shows the chip to run at -15V nominal. I enclose a photocopy of part of a "datafile" which states the operating voltages to be MIN -14V, MAX -16V.

I have built several projects designed by the contributor for this article and have always been pleased with the results but as this chip is relatively expensive I would like to know why he's running it so far out of spec?

Rod Hall  
London N8 8RP

## NEGATIVE VIBES

Dear Ed.,

In your June 1992 edition of *Everyday Electronics* you supplied a circuit for a *CCD Reverberation Unit*. The circuit included a MN3011 BBD 3328 stage i.c.

The d.c. supply to this i.c. in your circuit diagram shows that pin one is +V<sub>DD</sub> and pin three -Ve. However, the Maplin catalogue shows these pins as pin 1 -Ve and Pin 3 +V<sub>DD</sub>.

Could you please confirm which of these is correct. It is essential that reverse connections are avoided particularly on this i.c., as it is quite an expensive item as you quote in your article.

A. E. Woods  
Baginton

*Taking the letter from Mr Woods first, I think he is probably confused by the fact that the NM3011 is a PMOS chip, and as such it is designed to operate in a positive earth circuit. Hence pin 1 ("ground") goes to the positive supply, and pin 3 goes to the negative supply.*

*It is, of course, possible to use the MN3011 in a negative earth circuit (as in my design). The only real problem in doing this is that the circuit is sensitive to "hum" on the supply lines. If it is powered from a mains power supply unit, this must have a suitably low noise output.*

*Turning to the letter from Mr Hall, my original (and provisional) data for the MN3011 gave a rather wider supply voltage range than the one currently quoted in the Maplin and RS data. Anyway, I have tried several of these chips on nine volt supplies and they all seem to work fine.*

*The performance of the chip is reduced in certain respects, and in particular the maximum signal level that can be handled is subsequently reduced. However, performance is still perfectly adequate in this respect.*

*For optimum results the circuit can be powered from two 9V batteries wired in series. A 15V monolithic voltage regulator should be used to reduce the nominal 18V supply to the required 15V (the raw 18V output could destroy the MN3011).*

Robert Penfold

## WELL PREPARED

Dear Ed.,

Thanks again for a very well prepared magazine. I derive great interest and enjoyment from it.

You might remember I wrote some time ago concerning the scarcity of components here. I followed your suggestion and ordered from three British companies, all of which gave me courteous and prompt service.

I was wary of ordering direct, since I have been defrauded no less than three times ordering from the United States. I have contacted the Los Angeles Police Department, who informed me that fraud by mail was "under the jurisdiction of the postal authorities."

I contacted the postal authorities, who said that "isolated complaints" such as mine would not support civil or criminal action, but that a *pattern* of fraud had first to be established!

Evidently they don't maintain the same standards of civilization out there. *Now for two things about the magazine...*

You have published a good number of circuits in the past using moving-coil meters. Examples are a capacitance meter and a frequency counter.

Many of us use *digital multimeters*, and would gladly plug these circuits into them to save the extra expense of a moving-coil meter. The circuits, however, are often not compatible with the digital multimeter ranges!

Would it be possible to bear this in mind in future, and to offer alternative values for components so as to plug into a digital multimeter?

Also, recently, you had some fascinating circuits based on CMOS 4017 decade counters, I immediately saw possibilities for experimentation - but the articles concerned didn't go into any detail regarding the chip's operation. I had to look elsewhere.

Just a paragraph or two would be very instructive when describing the use of such chips. Just enough to give us the ability to tinker a little ourselves.

*Nothing to say...*

Incidentally, I enjoyed your editorial

some time back in which you had nothing to say. (Nov. '91 for anyone desperate to read it - Ed.)

There was a similar case involving, I think, the *New York Times*. The editor had writer's block, and so printed the 10 Commandments. One man demanded the cancellation of his subscription, because the editor had become too personal!

I write an editorial myself every month, and I find that people *listen* to what I say. It truly does influence some people's lives. I have no doubt that the same is true of your editorial.

Your colleague over at *ETI*, in his editorials, seems to have a mission to change the world. He appears to view electronics as being intrinsically beneficial to our world - whereas, of course, their benefit or lack of it is wholly dependent upon the people who use them.

Rev. Thomas O. Scarborough  
South Africa

*Thank you for the suggestions (and encouraging comments) we will keep them in mind when preparing future articles. - Ed.*

## MAKES SENSE

Dear Ed.,

I was interested in Mr H. F. Howard's letter in the August '92 issue of *EE*, not just because I received a mention in that letter but because he raises a number of points about the problems any prospective designer faces when he gets into print.

Now while it is quite true that I do not use a piece of gear such as the *Low Cost Capacitance Meter* which I described in the September 1991 issue for my own experimentation, my students at the local college do, and they are encouraged, given the design, to make their own suggestions about possible improvements and adaptations when making the equipment for their own personal use. So I think it has to be with constructors who make up the many projects described every month in *EE*.

The designer cannot satisfy everybody, and (apart from the absolute beginner) it shouldn't be impossible to say, for instance, that such and such a box would suit me better than the one described, or these terminals, knobs or what have you, would look more pleasing to me than those suggested by the designer. We are, after all, as Mr Howard is, only talking about the trimmings, not the design itself, which would require a lot more technical expertise.

So I believe Mr Howard speaks good sense and may his organisation continue to help the beginner in the way he advocates. For my own part, I should add that I always keep the practical problems that a constructor might face with his limited space and resources, right to the fore whenever I adapt a design for possible publication.

Professional designers and researchers (and I have been in those businesses for many years) are, I agree, not very often down to earth in their relationship with the user (and the repairer) of their equipment, but then, as we know, there are some people who think that coming down from their own particular Parnassus of learning, might somehow diminish their own elevated egos.

Steve Knight  
Market Harborough

# SOUND OPERATED NIGHTLIGHT

ELEANOR MAITLAND



Take away that fear of darkness from the child's room at night. Reassure your child with this sound activated, battery/solar powered nightlight.

**F**EAR of darkness is common in young children. This project is a sound-activated lamp which glows brightly upon receiving a loud sound (for example a child's initial cry) and slowly dims when the sound ceases.

The prototype has been successfully used for over a year in a two-year-old child's room, giving reassurance regarding the child's surrounding when he occasionally wakes during the night.

## CIRCUIT DESCRIPTION

The complete circuit diagram for the Sound Operated Nightlight is shown in Fig. 1. Sound is picked up by the crystal microphone MIC1 and fed into a direct coupled two-transistor amplifier TR1/TR2 via a d.c. blocking capacitor C1 and the "Sensitivity" potentiometer VR1.

Bias for TR1 is supplied via R1, TR2 and R3. Stabilisation is ensured by this configuration since excessive conduction by TR1 leads to a reduction in TR2's bias current resulting in less bias for TR1 (negative feedback). Capacitor C4 decouples R4 to allow some gain over TR1 and TR2, and C2 is used to prevent the amplifier oscillating at radio frequencies.

The amplified sound output appears at the collector of TR2 and is passed through the d.c.-blocking capacitor C3. Negative transitions are clamped to the ground rail via diode D1 and positive transitions pass through D2 and are accumulated in capacitor C5. The voltage on C5 is then used to drive the lamp (LP1) via R6, TR4 and TR5.

## DAYLIGHT CUTOUT

To enable the unit to be left on during daytime (more on this shortly), a quiescent mode is introduced by the inclusion of resistor R5 and TR3. These components provide a low resistance path to ground for any charge attempting to accumulate on C5 during daylight.

Bear in mind that the lamp and phototransistor TR3 should be isolated as much as possible since ANY source of light falling on TR3 will cause it to conduct. This would rapidly remove the charge on capacitor C5 which provides the bias for TR4 and in turn TR5.

The LES lampholder used here did not leak light back into the case, but other lamp holders may. In this case a small amount of black adhesive over the back of

the photo-transistor TR3 may block this light-path (you could put the tape over the lamp holder, but with plenty of use the heat generated by the lamp may cause the tape to lose adhesion and possibly fall off).

## POWER SUPPLY

Resistor R7 and capacitor C6 provide a better stabilised supply for the amplifier circuit and help to isolate sudden load changes (the lamp turning on or off) from affecting the amplifier.

The power source caused an amount of consternation since this project is intended for a small child's room. A mains supply would of course provide all the necessary power, at the cost of the latent danger within 240 volt mains (note that the often-quoted mains approximation of 240 volts is the root mean square (r.m.s.) value - the peak voltage is actually 340 volts).

An alternative to mains power is a battery. Though the lifetime of any battery depends on the usage of equipment connected to such a battery, its against my Scottish tardiness to use a disposable battery in such an often-used device.

A rechargeable battery would be an acceptable compromise solution since it will be relatively safe and also economical. The disadvantage is that it will require periodic charging (depending on use, of course).

This is where the solar panel comes in. Although Britain is not noted for its

Fig. 1. Full circuit diagram for the Sound Operated Nightlight.

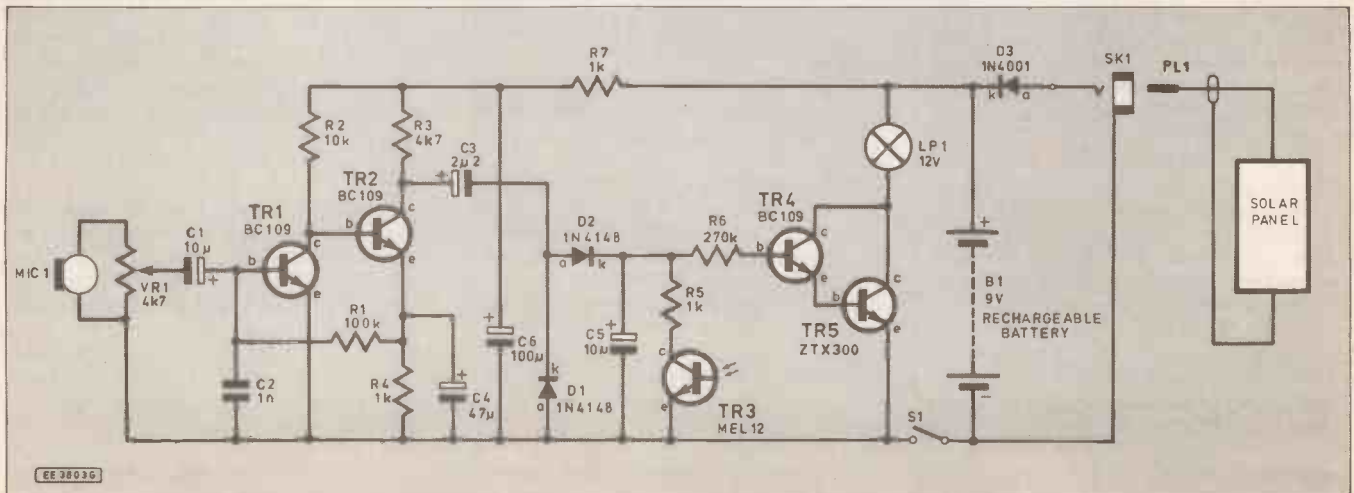

sunshine (and Scotland is worse), cloudy daylight should provide enough power to trickle-charge a rechargeable battery. This is not to imply that the battery will never require conventional charging, but it should postpone such events.

Solar panels are not everlasting power sources, and the technical data I received with my panel states that there will be a natural variation of output between otherwise identical panels. My panel gave 21 volts open-circuit in afternoon sunlight, and 0.7 volts at 80 milliamps under short-circuit conditions. On a cloudy day the figures were 15 volts open-circuit and 0.1 volts at two milliamps short-circuit. In-circuit, the charging current into the battery was 44mA during evening sunshine (7-15pm).

## CONSTRUCTION

Start construction with a rectangle of 17 strips of 0.1in. matrix stripboard, each continuous copper strip being 23 holes long. There are seven breaks to be made in the stripboard, as shown in Fig. 2.

Begin by inserting the single wire link and then insert the components in an approximate left-to-right fashion as shown. Note that four of the resistors and a single diode are mounted vertically, and also observe the polarity of the tantalum and electrolytic capacitors.

Off-board connections are required for the microphone, light-dependent transistor TR3, the lamp, the battery and the solar panel.

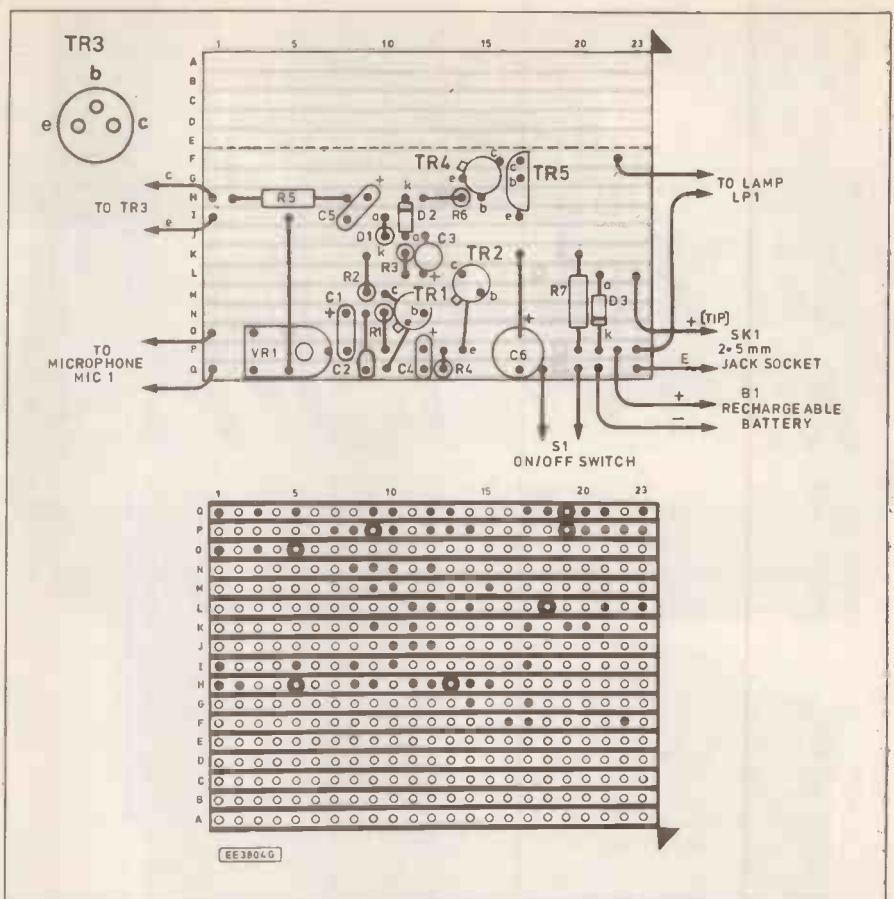

Fig. 2. Stripboard component layout and details of underside breaks required in the copper strips.

The case used for this project was one salvaged out of the components box, but its saving grace is that it can accommodate a large disposable PP9 battery should you prefer to use one of these. Do NOT use the solar panel in conjunction with a disposable battery.

The circuit board was attached to the case with two nylon bolts such that TR3's leads could be used instead of soldering extension leads to them. Conveniently, TR3's diameter fits snugly into a 5mm i.e.d. grommet.

Attaching the solar panel via a plug and

socket proved extremely convenient when the user went to stay elsewhere overnight – the solar panel stayed put and the device went with the child.

An ON/OFF switch was added due to the user's bedroom being frequently used as a (noisy) playroom. This was connected such that it switched the battery to the circuit, leaving the solar panel permanently connected to the battery.

Addition of switch S1 puts an onus on remembering to switch on the circuit when required, but this was merely included in the bedtime routine of the child.



## COMPONENTS

### Resistors

R1	100k
R2	10k
R3	4k7
R4,R5,R7	1k (3 off)
R6	270k

See  
**SHOP  
TALK**  
Page

### Potentiometer

VR1	4k7 skeleton preset, horiz.
-----	-----------------------------

### Capacitors

C1,C5	10µ tantalum 16V (2 off)
C2	1n ceramic
C3	2µ2 tantalum 35V
C4	47µ tantalum 16V
C6	100µ radial elect. 16V

### Semiconductors

TR1	BC109C npn transistor
TR2, TR4	(3 off)
TR3	MEL12 phototransistor
TR5	ZTX300 npn transistor
D1,D2	1N4148 signal diode (2 off)
D3	1N4001 1A 50V rec.

### Miscellaneous

S1	s.p.s.t. toggle switch
MIC1	Crystal microphone
B1	9V PP3 rechargeable battery
LP1	12V LES bulb and lampholder

SK1/PL1 2.5mm jack plug and socket  
Metal or plastic case approx 155 x 105 x 52mm; 5mm i.e.d. grommet; Velcro sticky pad (to secure battery); case feet; stripboard, size 17 strips by 23 holes; fixings; spacer for stripboard; connecting wire etc.

Solar panel: 300mm x 150mm (approx) 12V panel

Approx cost  
guidance only

**£17**  
excl. Batt

## CASE

The prototype case is arranged as shown in the photographs with the microphone and lamp at one end and the light-dependent transistor TR3 and solar panel jack socket at the opposite end. The microphone was glued in place, though this may still prove to be an ideal receptacle for inquisitive fingers!

Layout of the components within the case is open to rearrangement, but a couple of points should be noted. The light-dependent transistor TR3 should be isolated from the lamp LPI as much as possible. Attaching leads to TR3 may prove fiddly.

Since the case used was metal, no screening problems were envisaged so plain twisted-pair wires were used for connecting the microphone.

## INSTALLATION

Every location for this project will be different, but the following advice may prove helpful. The solar panel should be exposed to the maximum amount of daylight, tempering this with what will not cause angst from the household-owners!

Remember too that the intended users will more often than not have inquisitive fingers, inexperience of fragile items and an almost magnetic attraction to trip over any otherwise-tidy cable. Tucked behind an opened curtain close to the window pane might be ideal, but also consider condensation.

## ILLUMINATING

It was found that an EVEN illumination of ALL of the solar panel was fundamental – standing the panel close to a window such that the bottom 1cm was masked by the window frame reduced the output dramatically.

Experimentation with the panel is, if you will pardon the pun, illuminating! Short the panel output via a multimeter on a 100mA range and orientate the panel to see the output difference (make sure that your experiments do not coincide with a cloud covering or revealing the sun). Remember though that the panel's output is as a SOURCE, hence outputs of a few milliamps are not to be sneered at.

## MAIN UNIT

Siting the main unit is less troublesome. Any location close to the head of the cot or bed should be adequate. Keep in mind those inquisitive fingers nonetheless, and be aware of any cable runs to the solar panel. Preset VR1 should be initially set fully anti-clockwise for maximum sensitivity.

Should the unit trigger too frequently, reduce the sensitivity. A multimeter in series with the lamp may prove helpful in showing significant currents flowing through the lamp that are unable to light the lamp ("significant" in terms of battery discharge).

On the prototype, this component was "set and forget" for this application. It may be prudent to install a panel-mounting potentiometer if you consider that frequent sensitivity alteration will be necessary.

## ALTERATIONS

You might want to add a constant-current limiter for the charging current from the solar panel. Reference to the *Solar Powered Lighting Unit* published last month will help. □

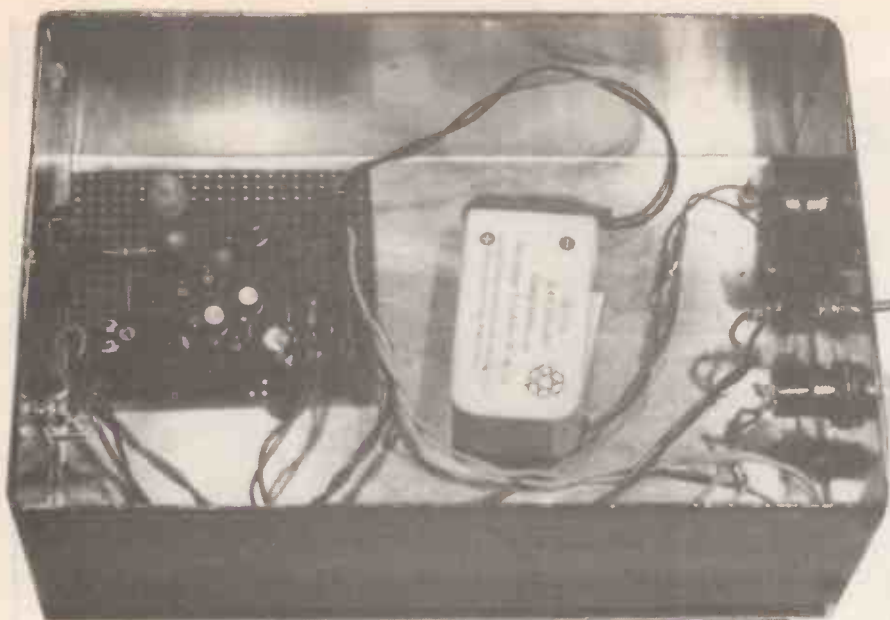

(top) Layout of components inside the metal case. The battery is held in place by a Velcro pad.

(right) Completed circuit board. The phototransistor is mounted directly on the board and carefully bent at right-angles to align with the hole in one side of the case.

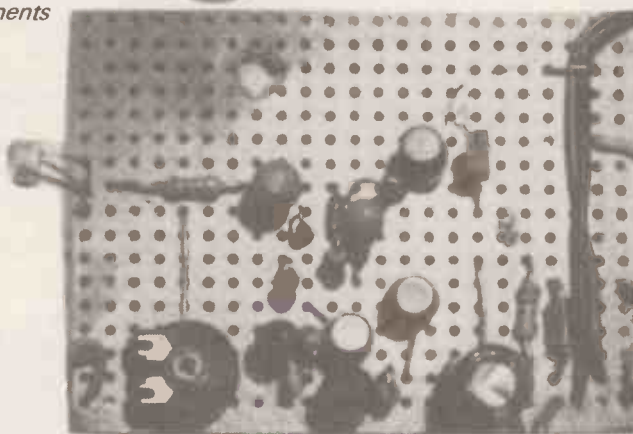

The completed Nightlight with solar cell panel.



# MAILTECH

## ELECTRONIC COMPONENTS

**PROJECT BOXES** A range of high quality boxes moulded in black high impact ABS, easily drilled or punched to produce a professional looking end product

TYPE	WIDTH	LENGTH	HEIGHT	PRICE
T2	75	56	25	£0.77
T4	111	57	22	£0.92
MB1	79	61	40	£1.35
MB2	100	76	41	£1.47
MB3	118	98	45	£1.71
MB4	216	130	85	£5.19
MB5	150	100	60	£2.35
MB6	220	150	64	£3.95
MB7	177	120	83	£3.42
MB8	150	80	50	£2.22

All sizes are in millimetres

### SPECIAL OFFER - PROJECT BOX

As above boxes 50 x 70 x 25mm  
60p each 10 for £5.00

### KEY SWITCH

3 Position keyswitch  
£2.35

**MICRO SWITCH** roller arm operation spdt 40p each  
**MINIATURE TOGGLE SWITCHES**

spdt	60p each	spdt 3 position c/off	70p each
dpdt	70p each	dpdt 3 position c/off	80p each
3 pdt	90p each	spdt 3 position c/off biased both ways	70p each
4pdt	£1.20 each	dpdt 3 position c/off biased one way	80p each
spdt biased	60p each		

**MINIATURE TOGGLE SWITCH** pcb mounting 3pdt 50p each 10 for £4.00  
**DIL RELAYS** 5 volt dp/changeover 60p 10 for £5.00  
12 volt dp/changeover 80p 10 for £6.00  
**RELAY** 10 amp contacts sp/changeover 12 volt coil £1.20 each  
**CAR HORN RELAY** in metal can with fixing lug, s/pole on 10 amp contacts £1.00 each 6 for £5.00  
**20 AMP RELAY** dp on 12 volt coil £1.50 each 4 for £5.00  
**REED RELAY** 12 volt 50p each 10 for £4.00  
**240 VOLT AC RELAY.** 3-pole c/o 10 amp contacts £1.50 each 4 for £5.00  
**12 VOLT DC RELAY BOARD** A useful PCB (196mm x 71mm) with 3 x s/pole c/o relays and 1 x d/pole c/o relay. Connections to relay contacts and coils are brought out to pcb mounting terminal blocks £1.00 each 6 for £5.00

DIL SKTS			'D' CONNECTORS			
8 pin	10 for	£0.60	plug	socket	cover	
14 pin	10 for	£0.90	9 pin	30p	30p	35p
16 pin	10 for	£1.00	15 pin	40p	40p	35p
18 pin	10 for	£1.00	25 pin	50p	50p	40p
20 pin	8 for	£1.00				
24 pin	8 for	£1.00				
28 pin	6 for	£1.00				
40 pin	5 for	£1.00				

**ALL COMPONENTS FULL SPECIFICATION DEVICES**

### SEMICONDUCTORS - TRANSISTORS - ICS - DIODES - REGULATORS - ETC

2N3702	10p ea 12 for £1.00	VOLTAGE REGS	
BC337	10p ea 12 for £1.00	7812/7805/7912/7905	
2N3904	10p ea 12 for £1.00		all 35p each, any 4 for £1.20
TIP31B	30p ea	AD592An Temperature Sensor i.c.	
TIP 3055	90p ea	mounted on 1.5m screened lead	
2N3055H	60p ea	complete with data and	
2N3771	£1.20 ea	application notes	£1.50 ea
741 op-amp	25p ea 5 for £1.00	LM3914/LM3915 Bargraph ics	£2.95 ea
555 timer ic	30p ea 4 for £1.00	LM317T Variable voltage regulator	
LM324 quad op-amp	30p ea 4 for £1.00	mounted on a small heat sink	4 for £1.00
1N4007 diode	20 for £1.00		

**Dept EE, Mailtech**  
**PO Box 16 Ludlow**  
**Shropshire**  
**SY8 4NA**  
**Tel: 058 474475**

### OPTO DEVICES - LEDS - ETC

**PHOTO SENSITIVE SCR**  
Mounted on a PCB. No data,  
60p each, 2 for £1.00

### 7 SEG DISPLAY

MAN6610 2 digit 0.6" high com  
anode, amber  
60p each, 4 for £2.00

### OPTO-ISOLATOR OP12252

50p each 10 for £4.00

### SLOTTED OPTO

£1.00 each

### LEDS - LEDS - LEDS

5mm rnd red/yellow/green/amber 10p each 12 for £1.00 any mix  
5mm rnd high brightness red/green 20p each 6 for £1.00 any mix  
5mm rnd flashing red 60p each, yellow/green 70p each  
5mm rnd bi-colour 20p each, tri-colour 30p each  
Rectangular 6 x 6 x 2mm red stackable 10p each 12 for £1.00  
Mounted in chrome metal bezel red/yellow/green  
40p each, 3 for £1, 10 for £3.00 any mix

Mounted in a black metal bezel red only  
30p each, 4 for £1.00, 10 for £2.00  
20 ASSORTED FULL SPEC LEDS. Various shapes and colours £1.00

### PLASTIC BEZEL

for 5mm  
rnd leds  
10 for 40p

### ALARM CONTROL UNIT

Single zone alarm control unit built into a domestic light switch box. Ideal for home, caravan, boat, garage, shed etc.

Facilities: - Normally closed loop for pir sensors, door/window contacts etc.

Normally open loop for pressure mats.  
24-hour loop for personal attack button  
Visual indication that the system is operational.

Automatic entry/exit delay.  
Automatic system reset.  
Alarm output cmos logic level.

PRICE COMPLETE WITH FULL INSTRUCTIONS £8.95  
BELL/SIREN INTERFACE BOARD COMPLETE £3.95  
BELL/SIREN INTERFACE PCB ONLY £11.50

### SIREN

12 volt dc for external use  
115db £8.95

### BELL BOX

A plastic bell box cover supplied with backplate. Red/yellow/white or blue £6.95 each

### PASSIVE INFRA-RED ALARM SENSORS

**SUB-MINIATURE PASSIVE INFRA-RED SENSOR ONLY**  
£5.95

Brand new passive infra-red sensor, measures only 33mmW x 24mmH x 29mmD. Logic level output. Full data and application notes supplied.

### EX INSTALLATION SENSORS tested working.

Type 1. Measures 180 x 112 x 70mm with walk test led, relay output and tamper protection. 12 volt dc supply required £8.50 ea  
Type 2. As above but a smaller unit 123 x 62 x 50mm £11.75 ea



### DOOR/WINDOW CONTACTS

Surface or flush mounting, white £1.10 ea

### JUNCTION BOX

white 6 way 60p

Please note: There may be variations in the size of the above passive infra red sensors depending on stock at the time of ordering. But the unit will certainly be within the stated sizes.

**DUAL TECH SENSOR** Microwave and passive infra-red combined. Separate led indication for each function. Measures 120 x 75 x 50mm. Relay output 12 volt dc tamper protection £29.95 ea

### BREADBOARDS - CAPACITORS - SOLAR CELLS - HEATSHRINK - ETC

**SOLAR CELL** 2 volt 150mA max, size 60 x 100mm £1.35 ea 5 for £6  
**HEATSHRINK SLEEVING** 8mm dia x 40mm long 5 lengths for £1.00  
**BNC SOCKETS** 50 ohm single hole fixing 50p ea 10 for £4.00  
**MIN BNC PLUG AND SOCKET** 2 pairs for £1.50  
**PIEZO TRANSDUCER** 5 assorted types £1.00

### MERCURY TILT SWITCH

Standard on/off £1.00 each  
4 Contact (Directional) £1.50 each

### PIEZO VIBRATION SENSOR

with data sheet £1.00 each

### BREADBOARD

173 X 65mm 840TP £5.25 each  
**TEXTTOOL ZIF SOCKET**  
28 pin zero insertion socket £5.95 each  
**SOLID STATE RELAY**  
Switch mains up to 7 amp 12 or 5 volt control voltage both types £2.95 ea

**6 VOLT NI-CAD PACK** 5AA NI-CADS, fast charge type £3.95  
**CAPACITOR** 10,000 mfd 25 volt with fixing clip 60p each  
**CAPACITOR** 470 mfd 400 volt £1.50 each 4 for £5.00  
**CAPACITOR** 0.1mfd 63volt 6p each 10 for 50p  
**EPROMS 27C256 - 25 27C512 - 25.** Once programmed but never used eprom. Mounted on a plastic carrier, can easily be removed from the carrier or used with a low insertion force socket.  
27C256 £1.00 each 6 for £5.00 27C512 £1.20 each 5 for £5.00  
Suitable low insertion force socket 28 pin 40p ea 3 for £1.00

All prices include VAT.  
Please add 75p carriage to all orders

# CIRCUIT SURGERY

MIKE TOOLEY B.A.

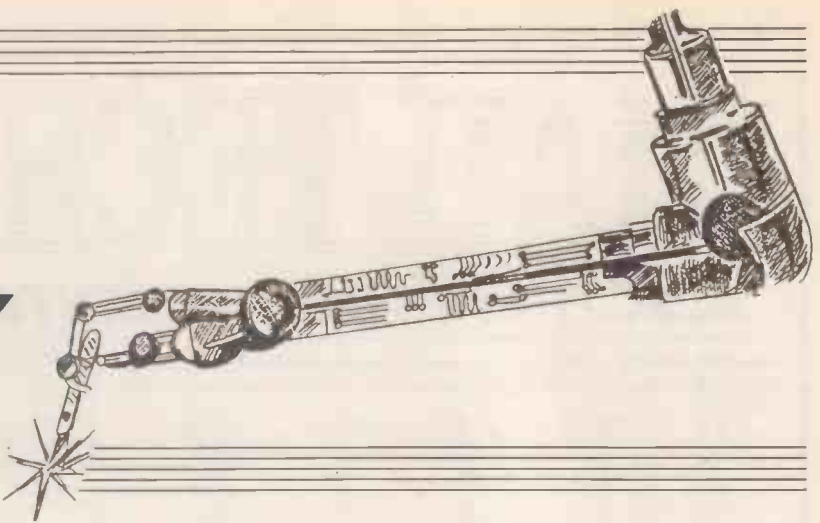

Welcome again to *Circuit Surgery*, our regular clinic for readers' problems. This month we shall be attempting to unravel the mystery of the SCART connector before moving on to provide details of an l.e.d. bargraph display which can act as low-cost alternative to the use of a conventional moving coil meter.

## The SCART connector

The SCART (or Peritel) connector seems to have become firmly established as a means of interconnecting a wide range of audio-visual equipment. Ron White from Tyne and Wear has asked me to provide some suggestions as to how the SCART socket can provide audio for his Hi-Fi system. Ron writes:

*"I would like to take the audio from my VCR and connect it to my Hi-Fi system in order to produce a cassette tape of the soundtrack of some of my family videos. The tape deck has two phono inputs and the VCR has a SCART/Euroconnector as well as a BNC connector for video. Can you tell me which of the connections I should use?"*

The SCART connector provides access to a variety of video, audio and data signals present in modern TV receivers and video recorders. The SCART interface conforms to a European Standard (it is also described in British Standard BS6552) and was designed to provide a reasonably universal interface to permit interconnection of TV equipment, video recorders, camcorders, satellite decoders, video disc players and home computers. It is therefore not surprising that so many video and TV manufacturers are starting to include this interface as a standard feature in their products.

The pin connections for a standard SCART connector are shown in Fig. 1. The signals present on the connector (not all of which may actually be present) are summarised in the table opposite.

Readers should note that there are two separate left and right channel audio inputs (pins 2 and 6) as well as two separate left and right audio outputs (pins 1 and 3). The audio signal at each audio output is normally in the range 100mV to 200mV peak-peak and this will be perfectly adequate for direct connection to the "auxiliary" or "tuner" inputs on almost any cassette recorder.

Fortunately, male SCART connectors are relatively inexpensive and can be purchased from a number of suppliers including Maplin (stock code FJ41U) and RS/Electromail (stock code 474-697). In order to avoid problems with hum

## SCART CONNECTIONS

Pin Number	Designation	Notes
1	Audio output (right)	Impedance: < 1kilohm Level: 200-500mV
2	Audio input (right)	Impedance: > 10kilohm Level: 200-500mV
3	Audio output (left)	Impedance: < 1kilohm Level: 200-500mV
4	Audio ground	Earth signal return common to all audio channels
5	Blue video ground	Earth return for the blue video signal
6	Audio input (left)	Impedance: < 10kilohm Level: 200-500mV
7	Blue video	Impedance: 75 ohm Level: 700mV
8	Function switching	Low (0V to +2V) = TV High (+9V to +12V) = External
9	Green video ground	Earth return for the green video signal
10	Data 2	Communication data
11	Green video	Impedance: 75 ohm Level: 700mV
12	Data 1	Communication data
13	Red video ground	Earth return for the red video signal
14	Data ground	Common earth return for both data signals
15	Red video	Impedance: 75 ohm Level: 700mV
16	Video blanking	Impedance: 75 ohm Level: 0V to 0.4V 1V to 3V (blanked)
17	Video ground	
18	Blanking ground	
19	Composite video output or Synchronising output	Impedance: 75 ohm Level: 1V pk-pk
20	Composite video or Synchronising output	Impedance: 75 ohm Level: 1V pk-pk
21	Ground	Impedance: 75 ohm Level: 0.3V pk-pk Outer shield

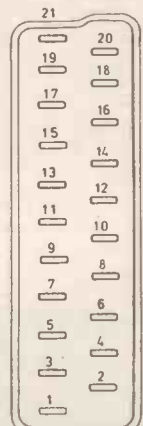
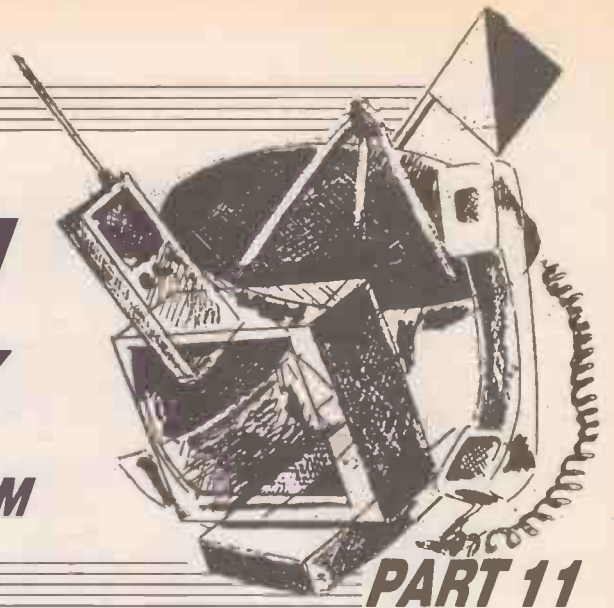

Fig. 1. Pin connections for the SCART connector



# INFORMATION TECHNOLOGY AND THE NATIONAL CURRICULUM

T. R. de VAUX BALBIRNIE



**T**HIS is the eleventh in a 12-part series concerning Information Technology, problem-solving, feedback in electronic systems and related matters in and around the Science National Curriculum.

This month's work is in two parts. Firstly, we shall look at *problem-solving* using electronic devices. After that, we shall examine the effects of *feedback* in control systems and amplifiers.

## PROBLEMS . . . PROBLEMS

Students need to design solutions to problems and here we cannot look at every possible type of problem nor would we wish to. A better way forward is to examine the general nature of a problem and show students the thought processes needed to solve it.

Suppose we have some books which we use every day. At the moment they are kept in a cardboard box on the bedroom floor. We may consider using a bookshelf. Think – do we have a problem and, if so, how are we going to go about solving it? Sometimes things are best left as they are. Here are some of the considerations on which we could base our plan.

Is the cardboard box adequate – do we need to do anything?

If so, is a bookshelf the best solution?

If so, where should it be placed?

How strong does it need to be?

What should it be made of?

How long, wide and thick should it be?

What type of brackets should be used?

When considering a problem, the students should be encouraged to think along the following lines:

Is there a problem – should things be left as they are?

Assuming there is a problem – am I absolutely clear what it is?

Am I sure that the first solution thought of is the best one? Do I need to explore alternative ideas before being sure which solution is best?

Can I make use of existing material?

Is the chosen solution cost-effective?

The answer to the second question seems obvious but it is surprising how confused people can be over the nature of the problem. In the bookshelf example above, are we clear whether the priority is

to tidy up the bedroom floor or whether to make the books more accessible? We may end up doing both but we must then be clear about our priorities because this may affect the final solution.

## ELECTRONIC PROBLEM SOLVING

The foregoing will be found helpful in solving all problems. However, here we are more concerned with problem-solving using *electronic systems*. Suppose we wish to make an alarm which will tell us if the garden shed has been broken into. Assuming there is a problem, we must first of all be clear what it is. We then need to draw up the specification for a suitable device so that we know what we are aiming for.

Is there a problem?

If so, is an *electronic* solution best? – would a lock do?

If electronics is used, can I buy something ready-made more cheaply?

If not, am I capable of developing a solution?

If so, shall I design it from scratch or can I modify a circuit taken from a book or magazine?

Can I find several ideas which fulfil the specification then choose the best one? How many alternatives do I need to try in detail?

Do I have the expertise and practical knowledge to make it?

What type of power supply shall I use?

Do I have the necessary safety knowledge if a mains supply is to be used?

What form of construction shall I use?

Can I make use of scrap or existing components?

It is interesting to note that an *electronic* solution is not always best. A *mechanical* system may be cheaper, smaller more reliable and, perhaps, more versatile. Furthermore, a *mechanical* system does not need a power supply. It is important to explore *all* possibilities before deciding which is the best solution.

Often people immediately go for an *electronic* solution because "modern methods are best" when there may well be a better way. In the above situation, why not consider using a simple lock? It may be that the alarm gives a better chance of catching the culprit. If this is



The Singer XL-10 Professional microprocessor controlled sewing machine.



not a consideration then a lock would probably be better.

Assuming we choose an electronic design and then go on to make and test the alarm, we should then do an evaluation. We do this by asking ourself these questions:

Does the device fulfil its purpose as well as I had hoped?

Does it need to be modified so that it does?

After any modifications, a further evaluation would be needed. This may be followed by further cycles of modifications and evaluations until a satisfactory result is obtained.

## PLANNED THINKING

In everyday life, we go through this reasoning without writing any of it down, or even being fully aware of what we are doing. However, in this type of work, it is important for students to write down their plans. A special planning sheet could be designed which will direct them to thinking about the problem in a logical way.

Students who are doing a technology or electronics project, perhaps for GCSE, should already have this way of thought firmly established. Those studying traditional sciences – physics, chemistry and biology may need a little help.

## DEVELOPMENT WORK

For development work, an excellent approach is to use a modular kit such as the Unilab Alpha Kit. This form of construction is useful because the circuits work reliably and are easily modified. Where time is limited or where there is no need for students to learn conventional construction work, modular kits are probably the best way forward.

A further advantage is that, providing a few simple rules are followed, the individual modules are fairly indestructible so the students can use their imagination freely without having to worry too much about ruining components. When the circuit has been developed to satisfaction, a permanent – probably soldered – version can be made.

Note that in this sort of exercise it is not essential to understand *how* each module works. It is only necessary to understand what it *does*. This is called the *systems approach*. The systems approach may not give the most efficient solution (i.e. the most elegant circuit or minimum component count) but it will give highly effective ones.

Consider a microprocessor used to control, say, a washing machine or a sewing machine. The microprocessor is, theoretically, far too sophisticated a device to perform such a mundane function. On the other hand, microprocessors are cheap because they are manufactured in large numbers, they are highly reliable and small.

Making a circuit using the minimum number of components may take many hours of work to design. It may turn out to be less reliable and possibly larger than the microprocessor-based version. Also, it would be incapable of being re-pro-

grammed in the future. Thus, the design using a microprocessor often turns out to be the best way of doing the job.

## A SPECIMEN PROBLEM

Suppose we have a freezer in the garage. Sometimes it is switched off by mistake. Sometimes someone does not close the lid or door properly. This causes the temperature inside the cabinet to rise. The problem is that we need to monitor the freezer and signal a fault so that action may be taken before the food inside is ruined.

Are we clear about the nature of the problem? Do we need a device which will detect a rise in temperature or could we simply use a door switch to operate a buzzer? Clearly, a door switch would not help if the freezer was switched off at the socket.

Could we devise a circuit which would signal the user if the mains was switched off, or the lid was left open? Probably, but it would be easier to detect the rise in temperature. Also, such a circuit would provide a signal if the temperature were to rise for some other reason such as failure of the compressor. Thus, it would be a more *versatile* design. Also, if we bought a new freezer, the circuit could be instantly transferred to it.

## BASIC RESEARCH

We should first do some measurements using a thermometer to see what rise of temperature needs to be detected. If the temperature in the freezer cabinet is normally – 18 degrees C, we may decide that the alarm should operate at, say, – 15 degrees C. If it is set too finely, the alarm will sound when the lid is opened in the normal course of removing food.

We must decide what type of warning should be given – a flashing light? A buzzer? Where should the warning be

given? The kitchen? Living room? We could do some tests with lamps and buzzers in various places to find the best site. Would a pulse-tone buzzer provide better warning? We then need to ask ourselves:

Am I sure that an electronic solution is best?

Can I buy something which will do the job more cheaply?

Am I capable of designing the system?

Can I use or modify an existing design?

For development work, we need to decide whether to use ready-made modules or to build a circuit using separate components on a Plugblock (this means of construction has been used in previous parts of the series and specific information was given in Part 5 (March, 1992 issue).

Whichever mode of construction is decided upon, we need an input sensor which responds to changes in temperature – probably a thermistor. We also need an output transducer to provide the warning – possibly a buzzer. We need a processing circuit to operate the output transducer at the correct temperature. A NOT gate may be used here but its output is insufficient to operate the buzzer direct. We therefore need a *transistor output stage*.

Students should be encouraged to look at books and magazines to find circuits which, perhaps, with some modifications will fulfil the purpose. This approach makes good sense but it is often viewed by the students as cheating.

## CIRCUIT

The circuit shown in Fig. 1 together with the Plugblock layout (Fig. 2), could be used. Readers who have been following the series will remember that such a circuit was used in Part 7 (May, 1992 issue) to control a motor. Note that this is a basic circuit and would need further development before it could be used in the real situation. However, it is good enough to allow some tests to be made. The following is a list of components needed but you may well find that most of them are part of your kit so check before ordering.

Vero Plugblock

- R1 1M fixed resistor or 1M potentiometer – see text
- R2 Bead thermistor – resistance at 0°C 500k approximately
- R3 3k3 resistor
- IC1 4011BE NAND gate

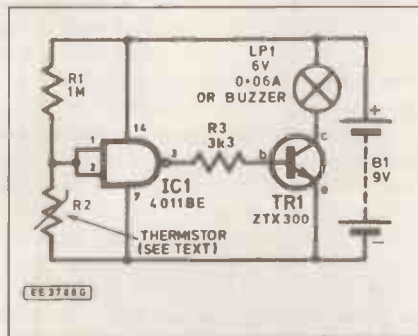
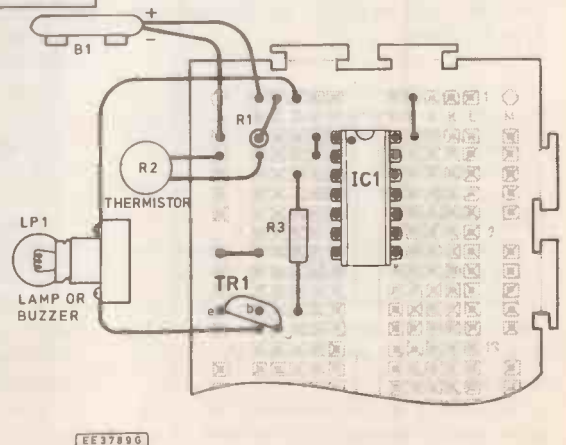

Fig. 1 (above). A specimen problem – freezer alarm.

Fig. 2 (right). Freezer alarm Plugblock layout.



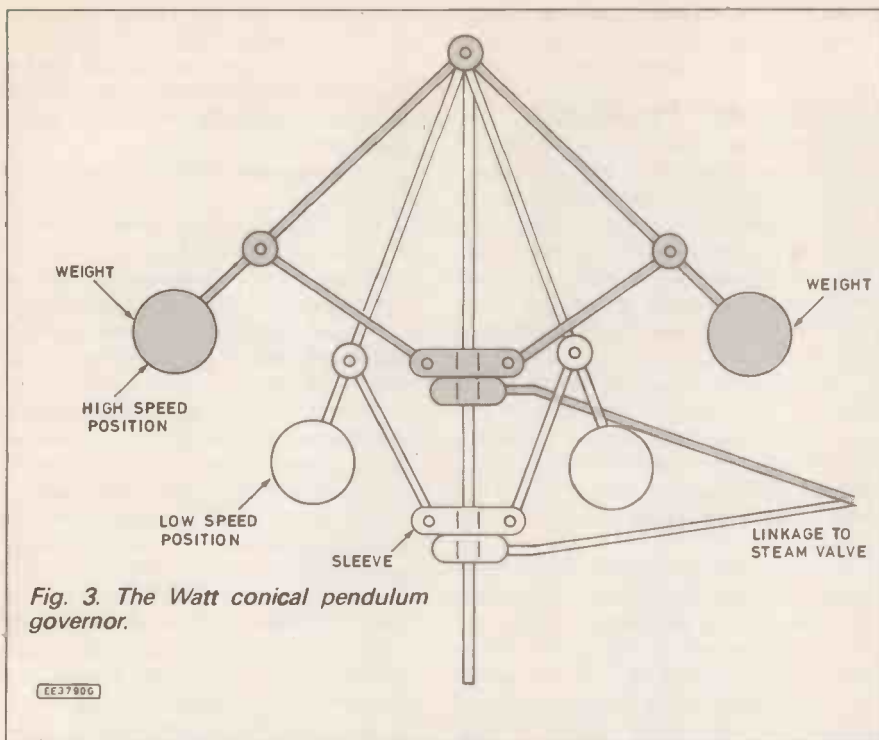

Fig. 3. The Watt conical pendulum governor.

- TR1 ZTX300 *n.p.n.* transistor
- WD1 6V 0.06A bulb in holder or 6V solid state buzzer
- B1 9V PP3 battery and connector

Note that the NOT gate is formed by connecting together the two inputs of the NAND gate. R2 is a *thermistor*. As its temperature rises a falling voltage will be applied to the NOT gate input. There is no need to go into details of exactly why this happens here – it involves a potential divider and this topic will be found in a standard electronics text book.

The NOT gate interprets any voltage less than half supply voltage as logic 0 and anything over this figure as a 1. As the thermistor warms up, therefore, the input will change from Logic 1 to Logic 0 so the output will suddenly switch from 0 to 1. This turns on transistor, TR1 and hence the bulb or buzzer in its collector circuit.

By using a variable resistor, VR1, in R1 position rather than a fixed value, the switching temperature may be varied between wide limits. If the circuit needs to work in the opposite sense – that is, to switch on when the temperature falls rather than rises, this may be done by swapping around R1 and R2. This could be useful for, perhaps, an ice warning device for a car.

We now come to the second part of this month's work. This is concerned with *feedback* and the effects this has on electronic systems.

## FEEDBACK

Students should be able to recognise the effects of feedback in a system – electronic or otherwise. To understand the meaning of feedback, it is helpful to look at some examples of *non-electronic* feedback first.

Suppose you are travelling in a foreign country and doing your best to ask

your way in the local language. If the listener frowns and shakes his head it is clear to you that he does not understand what you are trying to say. You then modify your speech. The listener then smiles and nods and you know he understands. You then continue until he frowns again. When he responds with directions, you may do the same thing back. This is an example of human feedback. There is clearly an interaction between the two people and each modifies his or her behaviour according to the response of the other.

## POSITIVE FEEDBACK

If a man kicks a dog, the dog is likely to growl and snarl. If the man kicks the dog harder, the dog will respond with more barking and biting. This may annoy the man, who kicks even more, and this annoys the dog so it bites harder.

Here, there is a type of interaction between dog and man called *positive feedback*. We could say that positive feedback occurs when a *cause* (kicking) produces an *effect* (snarling and biting) which increases the cause (more kicking) and the effect (more biting) and so on until some limit is reached (the man cannot kick any more and the dog can't bite any harder).

Positive feedback causes *lack of control*. Note the *loop* which is a characteristic of feedback systems – in this case from dog to man, back to dog and so on. Many arguments are in the form of positive feedback where a gentle insult ends up in a fight.

There is another type of feedback called *negative feedback*. Unlike positive feedback, this *reduces* the cause and therefore has a calming effect. For example, when a baby cries, the parent picks it up and makes soothing noises. This, hopefully, causes the baby to cry less so the parent becomes quieter and so on. Note that there is a loop here too – baby (input) to

parent (output) and back to baby. This type of human interaction can be used to soothe arguments and bring the situation under control again.

## MECHANICAL FEEDBACK

A very good example of a *mechanical* negative feedback system is the centrifugal governor used in an old steam engine – the Watt conical pendulum governor (see Fig. 3). This was invented by James Watt to solve the problem evident in earlier engines where the shaft turned more slowly as the load was increased.

To overcome this, the rotation of the shaft caused ball weights on umbrella-like arms to fly outwards. This caused the sleeve to rise on a central rod and this, in turn, was linked through a rod to the steam control valve. This was made to partially close and reduce the flow of steam so slowing the engine down.

If the load was increased so that the shaft slowed down, the weights would move inwards a little, the sleeve would slide down and the control valve would open and admit more steam so speeding the engine up. In this way, the engine maintained a steady speed for a wide variation in load.

An electrical/acoustic example of positive feedback with which everyone is familiar is *acoustic feedback*. This is apparent in a badly adjusted PA (public address) system where someone is speaking or singing into a microphone. If the volume control on the amplifier is turned up too high, excessive sound from the loudspeakers re-enters the microphone.

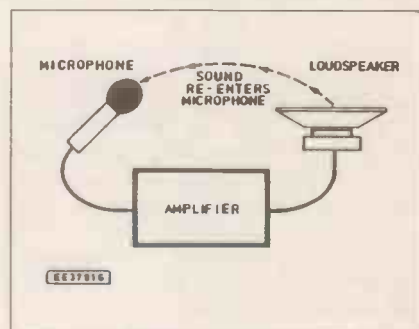

Fig. 4. Positive feedback in a PA system

This is subsequently amplified and re-appears at the loudspeakers even louder. This is picked up by the microphone again and so on making a feedback loop – see Fig. 4. This usually makes itself known by a loud howling noise. It is *positive feedback* because it increases the cause and results in loss of control and instability. Obviously there is a limit when the howl is as loud as the equipment permits.

## THERMAL RUNAWAY

Another example of positive feedback sometimes met in electronics is *thermal runaway*. This can occur with transistors and other semiconductor components. Here, the current causes the device to become warm. This reduces its resistance which allows more current to flow. This causes the material to become even hotter

and so on. Either the device is eventually destroyed or the temperature cannot rise any further i.e. heat is given to the surroundings as quickly as it is being supplied.

Early transistors used *germanium* as the semiconductor material rather than silicon as is the trend today. Germanium transistors were very susceptible to destruction by thermal runaway. Today, with modern silicon transistors, the temperature can rise considerably and they are much less likely to be ruined.

Modern components often survive the most appalling abuse by students. A circuit can be protected against the effects of thermal runaway by certain modifications but we shall not go into such detail here.

To summarize, the characteristic of both types of feedback – both positive and negative – is a *loop*. Positive feedback leads to instability and tends to make a system go out of control. Negative feedback has a calming influence – it reduces the cause hence reduces the effect and so on.

### BIOLOGICAL FEEDBACK

Suppose we have a factory in which fragile objects of different shapes and sizes are being made. We use a robot arm to pick each one up and move it to another place. Left to itself, the arm is likely to squeeze some objects too tightly and break them, or not squeeze hard enough and allow them to slip and fall.

A human operator would pick them up and feel the force given by the hand and finger muscles. He or she would regulate the amount of force being applied so that the object was just gripped sufficiently to prevent slipping – a form of *biological feedback*. If it were felt to slip, the grip would be tightened a little. Of course, all this is done subconsciously.

The robot arm would need to be given a similar sense of touch. This may be done by using pressure pads and, perhaps, movement sensors. The pads change their electrical resistance when they are squeezed. When the degree of grip is sufficient, the resistance of the pads will reach a certain figure and this will signal the motor adjusting the grip to stop turning. If the grip relaxed for any reason, the motor would turn and increase it a little. If the object was felt to be slipping, the movement sensors would increase the grip until no more movement was felt. This is a negative feedback system.

When we were discussing the home-made telephone system (see Part 8 in this series) what amounted to negative feedback was mentioned but this term was not used at the time. When we make a telephone call, we can hear ourselves speak through the earpiece as well as the person we are talking to. If we speak too loudly, we respond by talking more quietly and vice-versa. This is another example of *biological negative feedback*.

Brain rhythms can be detected, amplified, and fed back via the eyes in the form of flashing lights or by the ears in the form of rhythmic sounds. The brain

rhythms can then be modified and so on. This technique is said to produce a state of relaxation if correctly used.

### ELECTRONIC FEEDBACK

Many electronic systems use feedback. Suppose we need light of constant brightness for, say, some photographic or industrial process. Fig. 5 shows a battery-powered circuit which shows the principle. This circuit can be built using the Plugblock layout in Fig. 6. The following is a list of components required. However, readers who have been following the series will find most of the electronic components in their kit already so they should check this point before ordering more.

Vero Plugblock.

- R1 ORP12 light-dependent resistor
- R2 220
- VR1 47k standard potentiometer
- TR1 ZTX300 *npn* transistor
- LP1 6V 0.06A MES lamp and lamp-holder
- B1 9V PP3 battery and connector

The light-dependent resistor, R1, connected in series with variable resistor, VR1, provides a certain voltage between point X and the negative supply line. This voltage rises as the amount of light shining on R1 falls. At a certain level, and with a certain adjustment to VR1, there will be sufficient voltage appearing between point X and the negative supply rail to turn the transistor on. Collector current then begins to flow through the lamp, LP1 so lighting it. If the light from LP1 falls on R1, an *optical feedback loop* is formed. The resistance of R1 falls and with it TR1 base voltage. This reduces the collector current and so the lamp then becomes dimmer.

Suppose the light was obscured by holding something in front of it. The LDR

now receives less light, its resistance rises and with it TR1 base voltage. More collector current flows and the lamp becomes brighter. The lamp therefore tries to keep R1 evenly illuminated.

It is best to do this experiment in a dark place so that the only light falling on R1 is from LP1. Place R1 close to the lamp so that the light shines directly on it. Connect the battery and adjust VR1 so that the lamp is at about half brightness. Now move a piece of thin cardboard between the lamp and the LDR. It will be seen that the lamp becomes brighter as more of the light is obscured.

Of course there is a limit to how far the lamp can do this because it has a certain maximum brightness. This experiment is not very useful in itself but illustrates how the principle of negative feedback may be used in an industrial or commercial situation.

### AMPLIFIER FEEDBACK

High-quality amplifiers used for reproducing music in hi-fi systems use plenty of negative feedback. This reduces the degree of amplification but has the beneficial effects of making the amplifier stable (unlikely to oscillate due to stray positive feedback loops – see oscillators below) and also improves the *bandwidth* – that is, the range of frequencies in the sound which it can amplify equally (a perfect amplifier would amplify all frequencies equally but this can never be realized in practice).

The loss of amplifying power is easily made up by using extra stages – e.g. transistors. This is acceptable since electronic components are relatively inexpensive. Amplifier design is a large topic and has only been touched upon here.

### OSCILLATORS

An oscillator is a type of amplifier where positive feedback is applied. This causes oscillation and a regular train of waves are produced at the output. This may be desirable or not depending on the use to which the device is put. It is obviously undesirable in an audio

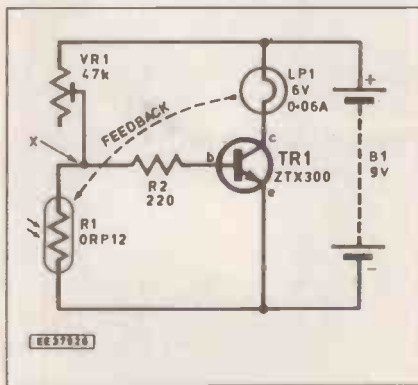
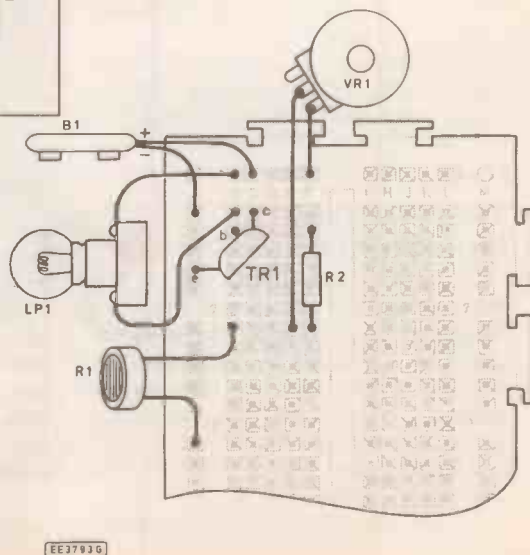

Fig. 5 (above). Optical feedback.

Fig. 6 (right). Layout for the optical feedback circuit shown above.



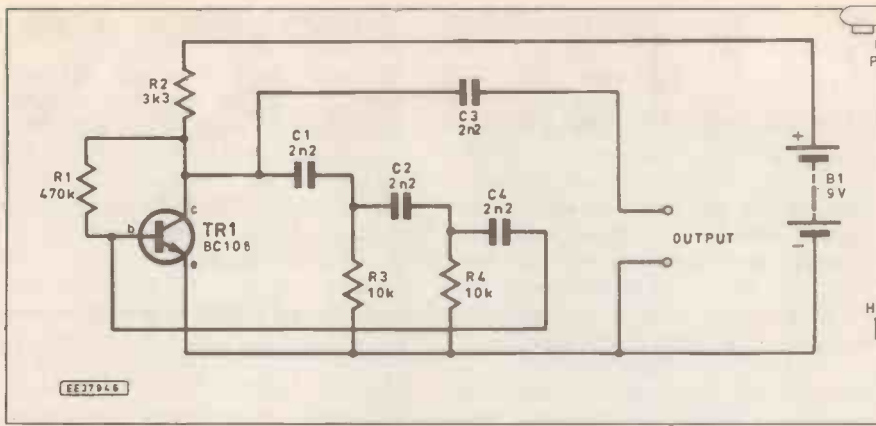

Fig. 7. A phase-shift oscillator.

amplifier and, as mentioned previously, steps will be taken to make sure that it cannot happen accidentally by applying negative feedback. However, if oscillation occurs rapidly enough and is fed to an aerial - i.e. a piece of wire - radio waves are emitted - and we have a radio transmitter. Note that it would be illegal to make a radio transmitter in this way. Slow oscillations when fed to a loudspeaker or earpiece produce sound waves and this could form the basis of a musical instrument.

The circuit shown in Fig. 7 is one such audio oscillator called a *phase-shift oscillator*. It is basically a transistor amplifier but some of the output (from the collector) is fed to the input (the base) via the network containing capacitors, C1 C2 and C4. This arrangement together with resistors R3 and R4 ensures that the feedback is *positive* - we shall not explain in detail exactly how this arises here.

A suitable Plugblock layout is shown in Fig. 8. You will need the following components. If you have been following the series, some of the components will already be part of your kit so check before ordering.

	Vero Plugblock
R1	470k
R2	3k3
R3, R4	10k - 2 off
C1, C2,	
C3, C4	2n2 - 4 off
TR1	BC108 npn silicon transistor
B1	9V PP3 battery and battery connector

After construction, connect a pair of stereo "Walkman" headphones with the output connected either to one channel or to both channels connected together in parallel. A musical tone should be heard.

## THE ASTABLE MULTIVIBRATOR

The astable multivibrator (Fig. 9) is a type of oscillator circuit based on two transistors (here, separate transistors are used but they could be part of an integrated circuit). Feedback between the transistors ensures that when one of them is off the other is on. The circuit then oscillates between the two states as long as a supply is connected.

Specific information about the astable

circuit and other members of the multivibrator family was given in Part 9 of this series (July, 1992 issue). The circuit for an astable multivibrator is shown in Fig. 9 and a Plugblock layout of an experimental version in Fig. 10. You will need the following components.

	Vero Plugblock
R1, R2	10k - 2 off
C1, C2	100µ - 2 off
TR1, TR2	ZTX300 npn silicon transistors - 2 off
LP1, LP2	6V 0.06A lamps in lamp-holders - 2 off
B1	9V PP3 battery and battery connector

Note how capacitors, C1 and C2 apply the feedback from the collector (output) of one transistor to the base (input) of the other. After construction, connect the battery and observe the lamps. They will flash in turn. With the values of C1 and C2 specified (100µ), they should flash at approximately one second intervals.

A full-scale version could be used for motorway or level crossing lights. By using a single bulb with a resistor in place of the other one, beacons - perhaps to attract attention at sea could be made. A flashing light is much more effective at attracting attention than a steady glow.

## THE SERVOMECHANISM

Suppose we wish to steer a model car. A small motor could turn the steering mechanism when a control lever on a hand-held box is moved to the left or right. We need the motor to stop when the wheels reach an angle which depends on the position of the control. To do this we require a *servomechanism* (often

Fig. 9. Circuit diagram of an astable multivibrator.

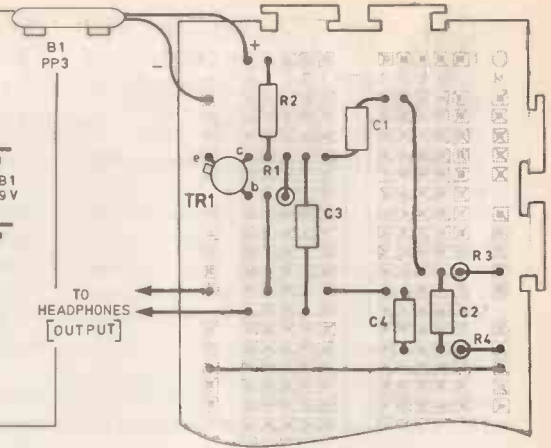
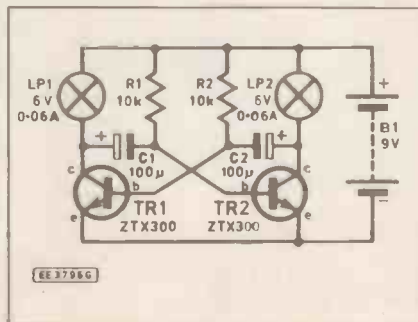

Fig. 8. Phase-shift oscillator Plugblock layout.

simply called a *servo*) and it works by using the principle of negative feedback.

As the wheels of the car swivel to give a turning effect, the spindle of a potentiometer is rotated and this feeds a voltage back to the control circuit. The value of this voltage depends on the position of the wheels. The hand control turns another potentiometer and this feeds another voltage to the control circuit.

The difference between these two voltages gives an *error signal* and this causes the motor to turn. When the voltages are equal - that is, there is no error signal - the motor stops. Thus, the wheels mimic the position of the control lever. Servomechanisms are widely used in industry in such fields as robotics and medical electronics.

That's all for this month. Next month is the final article in the series and we shall take the opportunity to tie up some loose ends.

Fig. 10. Plugblock layout for the astable multivibrator.

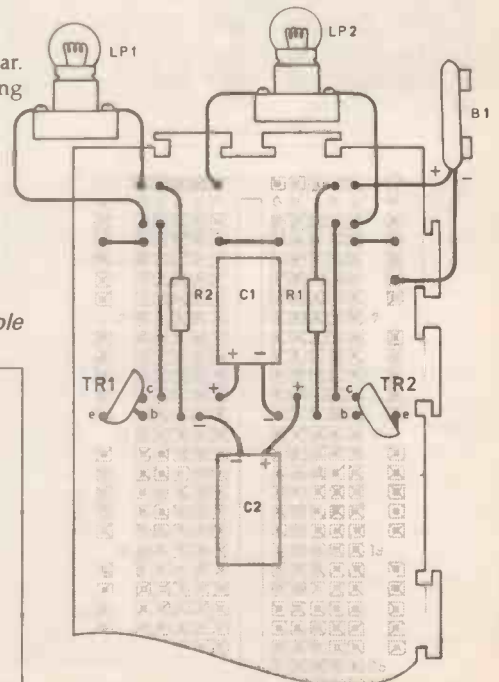

# NEW VIDEOS ON ELECTRONICS

Everyday Electronics is pleased to announce the availability of a range of videos designed to provide instruction on electronics theory. Each video gives a sound introduction and grounding in a specialised area of the subject. The tapes make learning both easier and more enjoyable than pure textbook or magazine study. They should prove particularly useful in schools, colleges, training departments and electronics clubs as well as to general hobbyists and those following distance learning courses etc.

The first three videos available are:

- ★ **1** *Electronics And You – Part 1: D.C. Series and parallel circuits and the use of a digital multimeter. Running time approx. 53 mins.*  
Order code VT201 **£29.95 inc. VAT**
- ★ **2** *Part 2: A.C. Coils, capacitors, transformers and other a.c. devices. Running time approx 71 mins.*  
Order code VT202 **£29.95 inc. VAT**
- ★ **3** *Part 3: Semiconductors. Basic semiconductor theory plus fifteen different semiconductor devices explained. Running time approx. 47 mins.*  
Order code VT203 **£29.95 inc. VAT**

Each video uses a mixture of animated current flow in circuits plus text, plus cartoon instruction etc., and a very full commentary to get the points across. The tapes are imported by us and originate from VCR Educational Products Co, an American supplier.

To order see our Direct Book Service "Ordering Details" – the postage for tapes is the same as for our range of books and you can order tapes and books at the same time and pay only one lot of postage.

(All videos are to the UK PAL standard on VHS tapes)



# WASHER BOTTLE MONITOR



ALAN WINSTANLEY

*When the water runs out you are breaking the law. Avoid any problems with this unit. Uses a special fluid detector chip to warn when the reservoir needs topping up.*

**T**HIS VERY useful device will certainly appeal to the motorist who often has to travel long distances, perhaps on business. As many drivers will know, having to cope with congested motorways and city traffic can be exasperating enough, and in dirty road conditions the last thing you really need is an empty washer bottle to hinder your progress even more.

Regular checking under the bonnet will help to avoid this situation, of course, but it is still not difficult to empty the washer fluid bottle under adverse conditions. As for the business driver, he is more likely to be worrying about his urgent appointments rather than the remaining capacity of the washer bottle!

Furthermore, hatchback and estate cars often have two screen washers these days, for the front and rear screens, and possibly headlight pressure washers also. It is quite common to have one reservoir serving both screen washer pumps, the theory being that the driver simply has to maintain one water bottle instead of two. Sometimes the bottle is so large that you virtually forget that it is there – until you run out of water!

On the other hand, the bottle may not necessarily be large enough to cater for cleaning both front and rear screens in dirty conditions, and it is then quite possible to empty a full bottle within a day. In actual fact, it is illegal to drive a car which does not have a windscreen washing and wiping system which allows the driver adequate forward vision.

Some high-specification cars incorporate a warning device which alerts the driver when the washer fluid is running low. This enables the driver to economise on washer fluid in the meantime until he is able to re-fill it at, say, a filling station.

## CIRCUIT DESCRIPTION

The author's first attempt at a *Washer Fluid Monitor* was published in *Everyday Electronics*, August 1984 and the unit to be described here is an improved, maintenance-free version which is easy to construct and install. The full circuit diagram for the Washer Bottle Monitor appears in Fig. 1.

As can be seen, there is a low component count since most of the work is performed by IC1, an LM1830 fluid level detector chip. The circuit operates directly from a 12V d.c. supply which is connected to IC1 pin 14 and pin 11 through TB1/1 (+12V d.c.) and TB1/4 (0V) of a 4-way terminal block, R1 being a dropping resistor to protect the i.c. against transient spikes.

The main function of IC1 is to generate an alternating signal which can be passed between two probes dipped into the fluid being monitored. An a.c. signal overcomes any problems that arise through electrolytic action if a direct current is used. The original fluid monitor did suffer from erosion of the probes through this electrolytic breakdown, with the result that the probes eventually weakened and broke.

The internal oscillator frequency of IC1 is determined by an external capacitor C2, and in this design the frequency of operation is about 6.6kHz as measured on the

prototype. The output of the oscillator is taken from IC1 pin 13, via an internal 13k resistor, which then compares this reference resistance with that of the probes which dip into the washer fluid. The probes are connected through C1 which is a blocking capacitor, so there is no direct current flowing through the liquid, which greatly reduces the electrolytic action.

Thus IC1 generates an alternating signal out of pin 13, through the d.c. blocking capacitor C1 and then through the probes (TB1/3 and TB1/4). Pin 10 of IC1 is the detector input and if the water level drops below the probes, the probe resistance will then exceed the internal 13k reference resistor at pin 13.

This change in resistance is detected by IC1 which, in this "alarm" state, generates an output signal at pin 12. This is actually an open-collector output which will drop to nearly 0V when activated by a drop in fluid level.

The output will sink up to 20mA and would drive an l.e.d. directly but, it was decided to use a filament lamp (LP1) for the alarm indicator which is mounted on the dashboard. The lamp is driven through a transistor buffer TR1 and is connected through TB1/2 of the terminal block.

Note that the output (pin 12) actually oscillates at the same frequency as the a.c.

Fig. 1. Complete circuit diagram for the Washer Bottle Monitor.

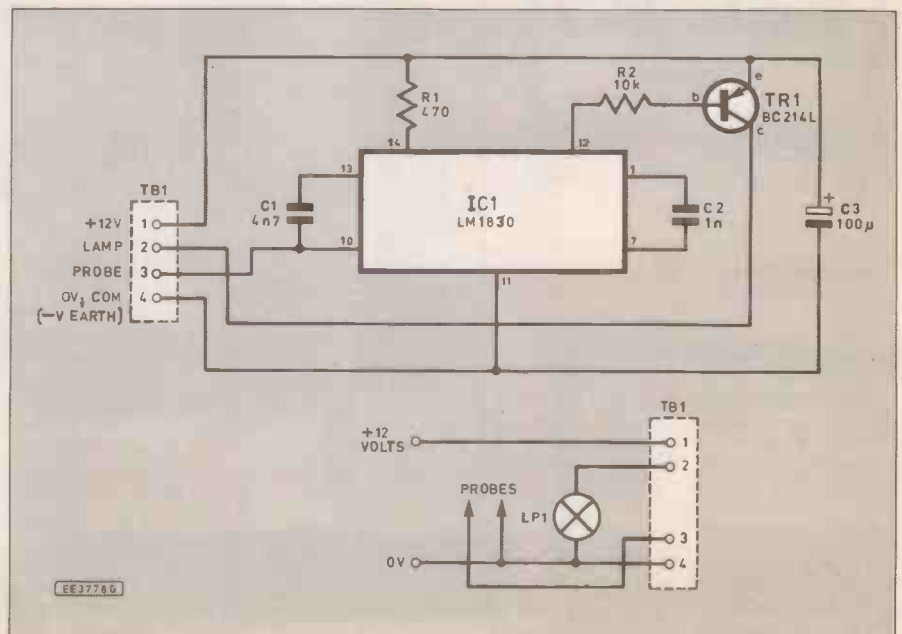

signal generator: it is not a simple high/low output, although the bulb will appear to be continuously alight. It could be utilised, for example, to drive a loudspeaker directly and give an audible warning tone.

## CONSTRUCTION

The Washer Bottle Monitor is constructed on 0.1in. matrix stripboard, size 9 strips x 24 holes. The topside component layout and details of breaks required in the underside copper track is shown in Fig. 2.

Commence construction by drilling two 6BA (or M3) clearance holes in the stripboard to accommodate the mounting hardware, then make all the breaks in the copper track using a spot face cutter. If the proper tool is not available then a handheld twist drill bit can often be used as an improvisation.

The components and link wires can now be located in accordance with Fig. 2. The constructor may prefer to protect IC1 by using a 14-pin dual-in-line socket, but the device does not require any particular anti-static precautions.

Note especially the orientation of the transistor leads and the chip itself, together with the polarity of electrolytic capacitor C3. The two link wires should be inserted in position first as one of them runs below C3.

After assembling the circuit board, check carefully to ensure that all breaks have been made effectively in the copper strips, and that there are no wisps of solder shorting adjacent tracks. This chip can be damaged by accidental shorting of neighbouring pins and because the device is not too cheap it is worth making an extra effort to check the soldering before powering up.

## CASE AND INSTALLATION

The completed prototype unit was built into a small plastic box measuring 72mm x 47mm x 25mm, with the 4-way terminal block being mounted on the outside surface.

## COMPONENTS

### Resistors

R1 470  
R2 10k  
Both 0.25W  
5% carbon film

See  
**SHOP  
TALK**  
Page

### Capacitors

C1 4n7 polyester  
C2 1n polyester  
C3 100µ axial elect., 25V

### Semiconductors

IC1 LM1830 fluid level detector  
TR1 BC214L pnp silicon transistor

### Miscellaneous

LP1 12V to 14V 40mA panel mounting filament indicator lamp  
TB1 4-way screw terminal block

Stripboard 0.1in. matrix, size 9 strips x 24 holes; plastic box, size 72mm x 47mm x 25mm; 14-pin d.i.l. socket; material for probes (e.g. twin-core wire); mounting hardware; interconnecting wire; Scotchlok connectors; solder etc.

Approx cost  
guidance only

**£7**

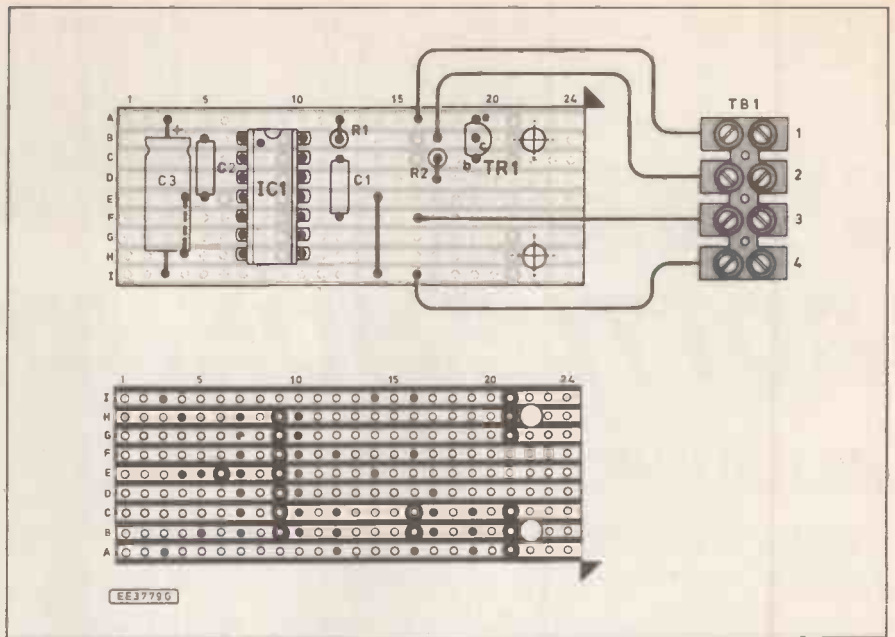
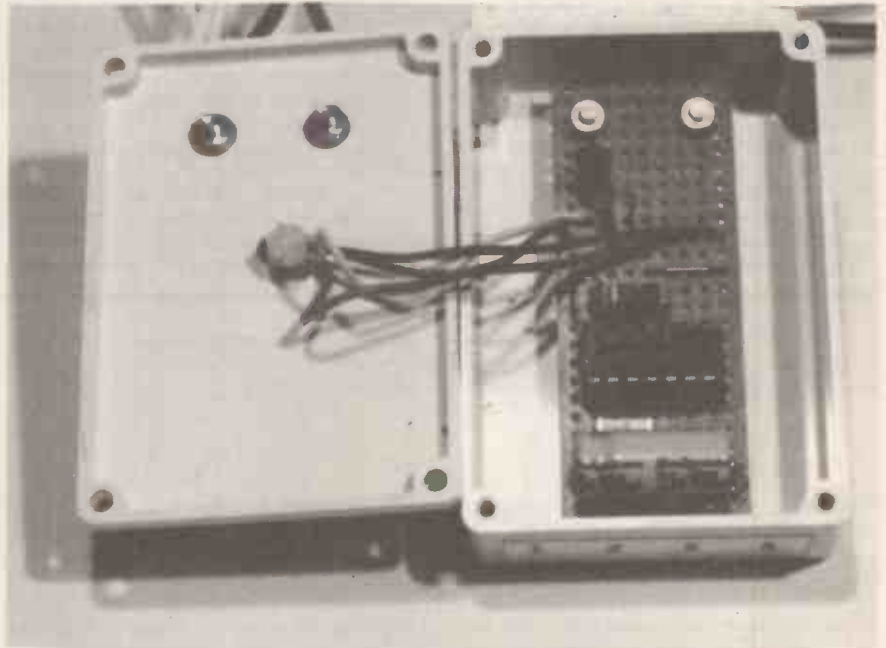

Fig. 2. Stripboard component layout and details of breaks required in the underside copper tracks.



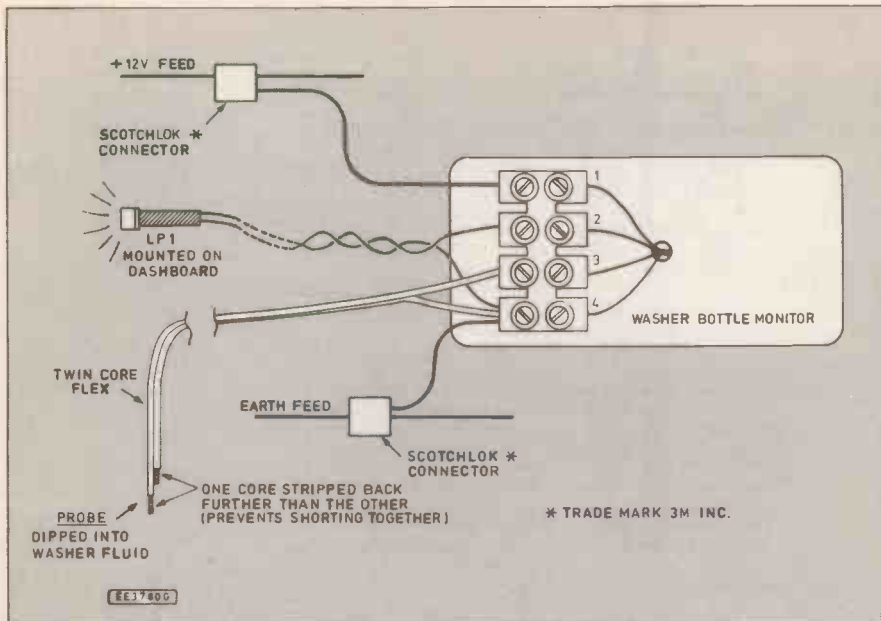

Fig. 3. Interwiring and installation details for the liquid level monitor.

and connected to the component board inside by passing the four connecting wires through a hole in the lid.

Installation is quite straightforward, see Fig. 3. The 12V d.c. supply can be obtained from any ignition-controlled accessory – perhaps the radio – but the prototype was actually wired into the front windscreen electric washer pump supply as this was readily accessible in the engine bay.

Some cars such as the Vauxhall Nova/Cavalier and Renault 5 have a single

bottle with two pumps attached – one for the front screen and the other for the rear wash/wipe. You can determine which is the front windscreen washer pump by tracing the washer jet piping, so that you can tap into the right supply.

### POLARITY

It is essential that the unit is correctly polarised as the i.c. may be damaged by a reverse voltage. A voltmeter will soon determine the polarity of the 12V feed to

the washer pump, and Scotchlok connectors may be employed to splice into the supply.

Wiring into the pump motor feed does mean however that the warning bulb will only be illuminated when the washer pump is activated, but this has not proved to be a handicap in practice.

The prototype unit was fixed under the bonnet near the washer bottle, and the probes simply consisted of a piece of twin-core zip wire with one core stripped back further than the other (to prevent shorting to each other) with about 15mm of copper bare. The wires were pushed through a tight hole in the top of the washer bottle so that they were about 25mm (1 in.) from the bottom of the bottle. This method may be especially suitable for those cars which have a refillable bag for a reservoir instead of a plastic bottle (e.g. Fiat Uno).

If the constructor installs the unit in the engine bay, as opposed to under the dashboard, then all that is required is to route two wires through a convenient grommet in the bulkhead to the dashboard-mounting filament lamp, ensuring that all joints are fully insulated and that the wires will not chafe on metal edges.

### TEST RUN

With installation complete, test the unit by firstly keeping the probes out of water, and the lamp should light up when the electrical supply to the Washer Bottle Monitor is activated. Inserting the probes into the washer bottle at the desired depth should extinguish the bulb, in which case the device is ready for service. □

## PLEASE TAKE NOTE

### Dual Metronome (August 1992)

Page 496, Fig. 6. During the processing of the artwork, the underside link wire connections were shifted, in error, to the left by one pad.

The corrected layout is shown in the diagram opposite. We apologise for any inconvenience caused.

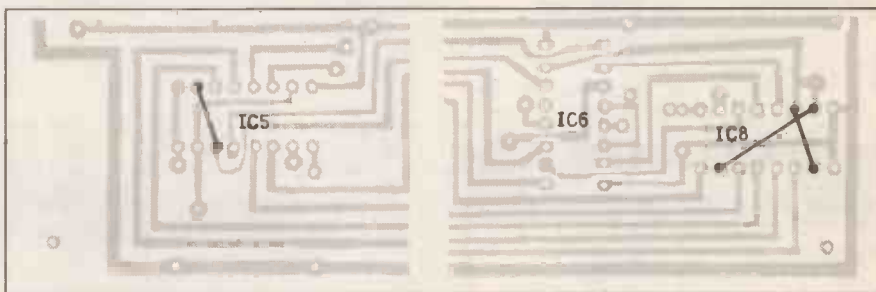

Fig. 6. Details of the underside link wires. These should be insulated leads.

**1992**  
CATALOGUE  
NOW FREE

# CRICKLEWOOD ELECTRONICS

CRICKLEWOOD ELECTRONICS LTD, 40 CRICKLEWOOD BROADWAY, LONDON NW2 3ET  
Tel: 081 452 0161 Fax: 081 208 1441

BOOKS 	BOXES & CASES 	CABLE & WIRE 	CAPACITORS 	CONNECTORS 	KITS 
RESISTORS 	SEMI-CONDUCTORS 	SPEAKERS 	VIDEO HEADS 	SWITCHES 	TOOLS & BENCHWARE 

SEND NOW FOR THE **CRICKLEWOOD ELECTRONICS** COMPONENT CATALOGUE  
ONE OF THE BEST RANGES AVAILABLE

Name.....  
Address.....  
.....  
.....



# EVERYDAY NEWS

## EURO-LINK FOR STUDENTS

### *Schools go live across Europe*

**T**HE new government minister responsible for space in the UK, Mr Edward Leigh MP, presided over the launching of an innovative European schools satellite video conference link when he visited the Portsmouth site of Matra Marconi last month (June '92). The Parliamentary Under Secretary of State for Technology, was making his first visit to a UK space company since his recent appointment.

The project, part of British Industry in Space Year, is planned to give children and teachers from local schools the opportunity to talk directly to their European counterparts via live video conference links through the European Space Agency (ESA) *Olympus* satellite.

After declaring the first of the school satellite conferences open, pupils from Purbrook Park School, Portsmouth carried out a teleconference with French and British schools local to the MMS Toulouse and BAe Stevenage sites. Schools in Holland, Austria, Italy and Canada will eventually join the scheme.

As well as learning about the advanced satellite technology behind the system, the pupils have prepared projects ranging from geography and languages to "live" drama for transmission and discussion, with other European schools on the link.

### **The System**

In addition to the custom-designed conferencing studio, the system uses a Matra Marconi Space (MMS) designed and built ground station, called TDS-6, which occupies only a small area. The ground station communicates with other locations via the *Olympus* satellite, part of which was also manufactured in Portsmouth.



*The Matra Marconi TDS-6 satellite ground station.*

A feature of the system is that three sites may be connected simultaneously, with all parties able to speak normally without the need for microphone switching common to other systems. This has been made possible using technology developed under a joint cooperation with ESA on the agency's DICE programme (Direct Intersite Conferencing Experiment).

The Portsmouth studio is connected to the TDS-6 ground station by fibre optic cable and is equipped with three colour monitors, two cameras and sound system for audio-visual transmissions. There is also a graphics terminal to allow transmission of pictures, diagrams and written text.

## VOLUNTEERS WANTED

**VOLUNTEERS with some technical training who live in, or around, the London area are urgently needed by the Royal National Institute for the Blind to help with the maintenance of its popular and priceless *Talking Book Service*.**

This service enables about 70,000 blind and partially sighted people to enjoy the pleasures of reading. It is a library of over nine thousand books on cassettes which can be played on special playback machines.

The special playback machines, which are loaned from RNIB, have to be maintained and repaired and it is here that volunteers are needed. Nearly 3,500 people in London use RNIB's Talking Book Service. Many of them are frail and elderly. Indeed 230 users are aged over a 100 years old. All are reliant on their playback machine working properly.

The Institute would welcome any volunteers who have some technical training in the fields of electrical or electronic engineering and would be prepared to spend one or two evenings a month maintaining or repairing the machines. Each helper will be sent circuit diagrams and full technical details, and technical back-up will always be available by telephone.

Anyone interested in volunteering should contact David Finlay-Maxwell, Honorary Recruiting Organiser of RNIB Talking Book Servicing Volunteers, Prospect House, Prospect Street, Huddersfield HD1 2NU. Tel Day 0484 450982, Evenings 0484 604546



## Radio Course

THE City of Westminster College (formerly Paddington College), will be running a *Radio Amateurs Examination* (RAE) evening course commencing early September 1992 (for May 1993 examination). Both class A and class B licenses will be catered for (i.e. A Morse course will run concurrently). Additionally, an 'Advanced Morse' course is hoped to be conducted, taking candidates upto 22/25w.p.m. with an insight to professional/marine procedures etc.

Professional college lecturers will conduct the courses. Prospective candidates should contact the college Science and Technology Dept, Ann James, Tel: 071 723 8826 for enrollment details etc.

## Display for UK

CLAIMED to be one of the leading manufacturers of l.e.d. based electronic information displays, Data Display of Ireland has formed a subsidiary company in the UK. The new company will be based in Newcastle-upon-Tyne and will provide sales, marketing and technical support to all existing and future UK customers.

Exporting to over 20 countries worldwide, Data sees the establishment of its UK operation as a major step towards providing a strong technical backup to its UK customer base.

# ACTUALLY DOING IT!

*by Robert Penfold*

**C**ONTINUING with our look at semiconductor leadouts and pinouts, we now turn our attention to integrated circuits. The first point to bear in mind when dealing with integrated circuit pinout diagrams is that they are almost invariably **top** views. This is the opposite to the convention for transistors which, as explained last month, are always shown as base or **underside** views in leadout diagrams.

You have to be a bit careful when dealing with integrated circuit diagrams as there are occasional exceptions to the rule. When dealing with the usual d.i.l. (dual in-line) devices there should be no problem. A few integrated circuits, such as small voltage regulators and some sensor devices, are contained in ordinary TO92 transistor style encapsulations, or something similar.

Presumably due to their transistor-like appearance, the leadout diagrams for some of these components are shown as transistor style base views. Where this is the case, there should be some "fine print" somewhere on the diagram to point out that the views are base types. In fact most leadout diagrams for these components include a label or caption which states whether they are base or top views.

## ORIENTEERING

When fitting a d.i.l. integrated circuit onto a circuit board it is essential to get the orientation of the device correct. I (and many others) recommend the use of holders for all d.i.l. integrated circuits, and many beginners question the need for this.

On the face of it, I suppose there is no obvious reason for using a holder for a device that is not sensitive to static charges. In some cases the holder will cost nearly as much as the integrated circuit that will be plugged into it.

However, there are two problems with connecting a d.i.l. integrated circuit direct to a circuit board. One is simply that there tends to be a build-up of heat in the device as each pin is soldered in place. Particularly with devices that have 16 or more pins, you can easily end up with an overheated integrated circuit if you are a bit slow at completing each joint.

This is something that can be avoided by letting the device cool-off after every two or three joints have been completed. It is also something that can be avoided by efficient soldering, which is a skill that comes with practice.

## WAY OUT

The main problem is that, sooner or later, everyone manages to fit an in-

tegrated circuit with the wrong orientation. If the device is fitted in a holder there is no difficulty in removing it and plugging it back in again the right way round.

There are special tools available for removing integrated circuits, and these are usually in the form of out-size tweezers with hooked ends. The latter go under the ends of the integrated circuits, which can then be extracted with a steady pull on the tweezers.

In most cases integrated circuits can be prised from their holders using the blade of a very small screwdriver. This is used to lift one end of the component, and then the other. Repeat this procedure a few times until the integrated circuit has been wiggled high enough for it to be easily removed by hand.

If you start tugging away hard at an integrated circuit which is still deep in the holder you will almost certainly end up severely buckling the pins, some of which may well bury themselves in one of your fingers. You may then find that no matter how carefully you straighten the pins, they tend to snap off.

If any minor bending of integrated circuit pins should ever occur, in most cases they can be carefully pushed back into place without any of them breaking off. However, prevention is better than cure, and it is best to take due care to avoid bent or buckled pins.

If a d.i.l. integrated circuit should be accidentally soldered to the board the wrong way round, removing it could be very difficult indeed. The more pins it has, the more difficult it will be to remove it. Even with the aid of desoldering equipment it can be very difficult to get every pin properly freed from the board.

Unless the integrated circuit is an expensive one, it is often best to simply cut through each pin using wire clippers, remove the "body", and then remove the remaining pieces of pin one-by-one. This avoids the risk of damaging the board, which is the likely outcome if you persist in desoldering an awkward device.

## PIN NUMBERS

There are three ways in which a d.i.l. integrated circuit can be marked to show which end is which. Most devices seem to have only one or two of these, as in the examples shown in Fig.1, but you may encounter some "belt and braces" devices which have all three.

Most d.i.l. integrated circuits have a small circular indentation in the top surface of the body, close to pin one. Most also have the small "U" shaped - or rectangular notch in the pin one end of the body. Unfortunately, there are often other indentations in the plastic encapsulation, and these are presumably just moulding marks or faults.

Rather unhelpfully, there is sometimes a "U" or semi-circular shaped indentation in the wrong end of the case. This is larger and shallower than the proper notch, but it makes it easy to get the

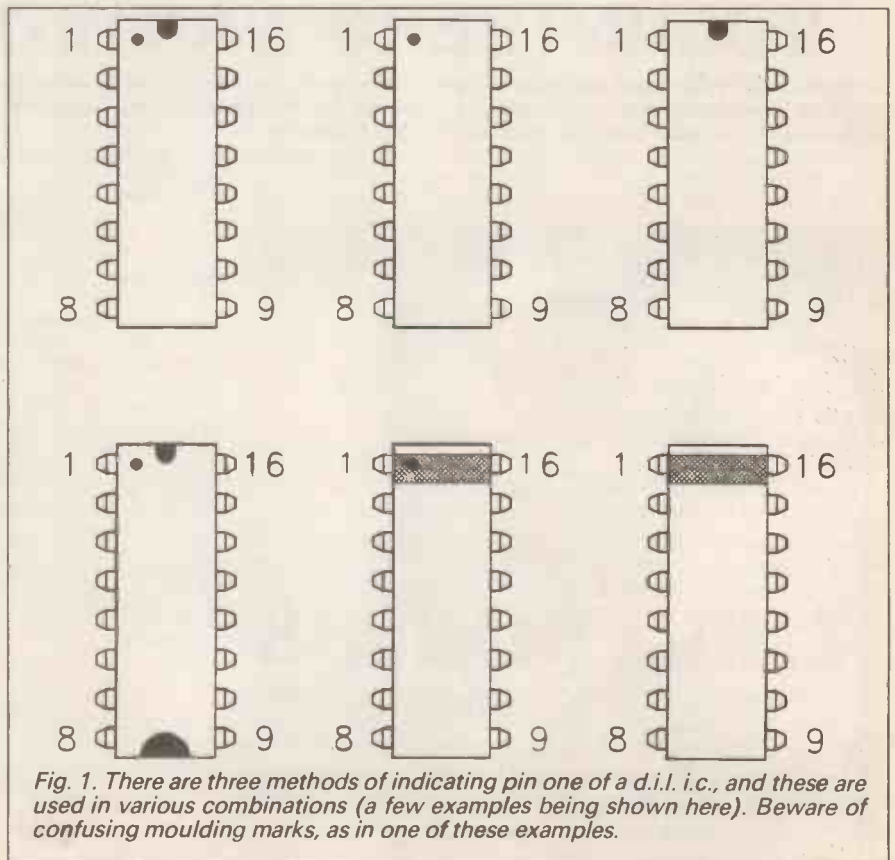

Fig. 1. There are three methods of indicating pin one of a d.i.l. i.c., and these are used in various combinations (a few examples being shown here). Beware of confusing moulding marks, as in one of these examples.

device fitted the wrong way round if you are not paying due attention.

The third method is to have a band marked across pin one end of the case. This used to be a rare method of doing things, that was mainly used on microprocessors and their peripheral chips.

However, these days it seems to be increasingly common, and is used a good deal on both logic and linear devices. It does have the advantage of being very clear and unambiguous, which is not always true of the other two methods.

#### WHICH ENCAPSULATION?

It is worth mentioning that many integrated circuits are available in more than one encapsulation. Most of the popular chips are now available in miniature encapsulations. These are for use with the "surface-mount" method of construction.

You are unlikely to find these devices listed in catalogues for the project builder, but you might encounter cheap surplus surface-mount devices. Note that these are only about half the size of normal d.i.l. integrated circuits, and will not fit into component layouts intended for normal 2.54mm (0.1in.) pin spacing.

The popular  $\mu$ A741C operational amplifier, plus some other operational amplifiers, have been produced in 8-pin d.i.l., 14-pin d.i.l., and TO5 versions. The TO5 encapsulation is a metal type with leadout wires and case styles which look rather like large transistors having eight leadout wires.

The pinout/leadout details for the three versions of the  $\mu$ A741C and similar devices is shown in Fig.2. Why the 14-pin d.i.l. version was ever produced is a mystery, and it can be seen from Fig.2 that this is much the same as the 8-pin d.i.l. version, but with three pairs of pins to which there are no internal connections. The 14-pin versions seem to be quite rare these days, but there are still some of these components in circulation.

If you wish to build an old project which has a circuit board designed for 14-pin d.i.l. operational amplifiers, obviously an 8-pin type should fit into the layout without any difficulty. The same is not true if you should obtain some 14-pin devices and wish to use them in a layout designed to take 8-pin versions. There being no space on the board to accommodate the longer case of the 14-pin devices.

Although integrated circuits having TO5 style cases were quite common a few years ago, they are also quite rare these days. You may still encounter the popular CA3130 and CA3140 devices in this case style. The TO5 versions have an "A" or "S" suffix whereas the 8-pin d.i.l. version has an "E" suffix.

The TO5 cases devices may at first sight appear to be totally incompatible with the

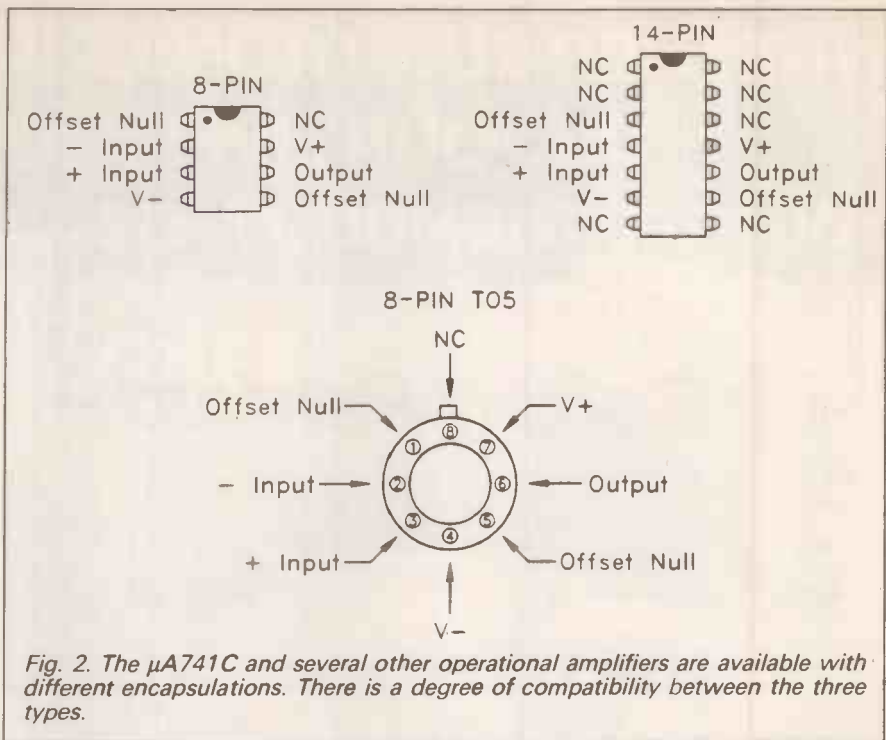

Fig. 2. The  $\mu$ A741C and several other operational amplifiers are available with different encapsulations. There is a degree of compatibility between the three types.

other versions, but there is no difficulty in arranging the leadout wires into the 8-pin d.i.l. configuration. In fact some TO5 cased devices have their leadout wires preformed into this layout. You can even plug one of these components into an 8-pin d.i.l. holder.

Consequently, there is no difficulty in using a TO5 version in a layout designed to take an 8- or 14-pin d.i.l. version. Things are less certain the other way round, but an 8-pin d.i.l. version might be usable in place of a TO5 type.

#### POWER I.C.s

Integrated circuits which have to dissipate more than about one watt do not have ordinary d.i.l. encapsulations. They have cases that can be bolted to heatsinks (which are simply metal cooling fins). Some have a case which looks rather like a plastic power transistor, but with five or more leadout wires. Despite their transistor-like casings, these are usually shown as top views in leadout diagrams.

Another popular style of case for power integrated circuits is a form of s.i.l. (single in-line) encapsulation. This is rather like an outside d.i.l. case, but with one row of pins replaced by a metal fin. The fin is ready-drilled with one or two holes so that it can be bolted to a heatsink. These are again shown as top views in pinout diagrams, and some have the "dimple" next to pin one.

#### TRIACS, ETC.

Triacs and thyristors have transistor type encapsulations. In leadout diagrams

they therefore tend to be treated in the same way, and are normally shown as base views.

Two of the leadouts of a triac are marked "MT1" and "MT2" in the base diagrams, and these abbreviations tend to cause a certain amount of puzzlement. The "MT" simply stands for "mains terminal". This is reasonably apt, as these devices are mainly used in mains power control circuits.

It is important to realise that these two terminals are NOT interchangeable, and that they must be connected the right way round. Incidentally, the third terminal of a triac is called the "gate".

The three terminals of a thyristor are called the "gate", "anode", and "cathode", or just "g", "a", and "k" on leadout diagrams. These components are also known as s.c.r.s (silicon controlled rectifiers).

Triac and thyristor are not different names for the same thing. Triacs are used in a.c. control circuits, and thyristors are used in d.c. control circuits. If a triac of equivalent ratings is used in place of a thyristor it will almost certainly work perfectly in the circuit. A thyristor cannot be used in place of a triac though.

Diacs are two terminal components which look like diodes or small rectifiers, and may appear to have a method of polarity marking. However, these components are probably unique amongst semiconductor devices in that they can be fitted either way round.

# EVERYDAY ELECTRONICS

## SUBSCRIPTION ORDER FORM

Annual subscription rates (1991/2): UK £20.  
Overseas £26 (surface mail) £43.50 (airmail)

To: Everyday Electronics, 6 Church Street  
Wimborne, Dorset BH21 1JH

Name.....

Address.....

I enclose payment of £..... (cheque/PO in £ sterling  
only payable to Everyday Electronics) Access or Visa No.

--	--	--	--	--	--	--	--	--	--	--	--	--	--	--	--	--	--	--	--

Signature..... Card Ex. Date .....

Please supply name and address of card-holder if different from the subscription address shown above.  
Subscriptions can only start with the next available issue. For back numbers see the Editorial page

# WHETHER ELECTRONICS IS YOUR HOBBY OR YOUR LIVELYHOOD . . . YOU NEED THE MODERN ELECTRONICS MANUAL



## The essential reference Work

- Easy-to-use format
- Clear and simple layout
- Regular updates
- Sturdy ring-binder
- News of latest developments
- Full components checklist
- Extensive data tables
- Detailed supply information
- Ready-to-transfer PCBs
- Comprehensive subject range
- Accurate assembly instructions
- Concise repair procedures

## EVERYTHING YOU NEED TO KNOW ABOUT ELECTRONICS!

If the fascinating and fast-changing world of electronics is your livelihood, your study subject or simply your passion, the new revised edition of **THE MODERN ELECTRONICS MANUAL** is the reference work for you to have at your side.

The base manual contains information on the following subjects:

**BASIC PRINCIPLES:** symbols, components and their characteristics, passive component circuits, power supplies, acoustics and electroacoustics, the workshop, principles of metrology, measuring instruments, digital electronics, operational amplifiers, timers, physics for electronics.

**CIRCUITS TO BUILD:** construction techniques, radio, telephony, microcomputing, measuring instruments, vehicle electronics, security, audio, power supplies, electronic music (over 25 different projects).

**REPAIRS AND MAINTENANCE:** radio, television, audio/hi-fi, telephones.

**DATA:** diodes, transistors, thyristors and triacs, digital and linear i.c.s, microprocessors.

The manual also covers **Safety, Specialist Vocabulary with Abbreviations** and **Suppliers**.

**OVER 1,000 pages**, A4 format weighing over 3.5kg.

**Now – at last –** the most comprehensive reference work ever produced at a price you can afford, the new revised edition of **THE MODERN ELECTRONICS MANUAL** provides you with all the essential information you need.

**Over 1,000 pages** of well-organised and clearly explained information is brought to you by an expert editorial team whose combined experience ensures the widest coverage.

**Regular supplements** to this unique publication, each around 160 pages, mean that you will always be kept abreast of the latest developments from the UK, USA and Europe as they occur

### ALL-IN-ONE AND EASY-TO-USE

A sturdy ring-binder allows you to use the manual on your workbench. The looseleaf format also means you can slot in the regular updates as they arrive – so all your information is there at a glance.

### EXTENSIVE GLOSSARY

Should you come across a technical word, phrase or abbreviation you're not familiar with – simply turn to the glossary included in the manual and you'll find a comprehensive definition in plain English.

### REGULAR UPDATES

Unlike a book or encyclopedia, the manual is a living work – continuously updated by new material. Recent or upcoming supplements include radio, superconductors, electric motors, basic electronic building blocks for beginners which can be joined together to construct elaborate circuits, filters, IBM PC and compatibles (including use of PC cards). Supplements are sent to you approximately every two months.

Each supplement contains approximately 160 pages – all for only £23.50 + £2.50 p&p. You can of course return any supplement which you feel is superfluous to your needs.

### RESPONDING TO YOUR NEEDS

We are able to provide you with the most important and popular articles in our updating supplements. Our unique updating system is based on answers from readers request questionnaires. Through this service you are able to let us know exactly what information you require in your manual. You can also contact the editor directly in writing if you have a specific technical request or query relating to the manual.

### ASSEMBLING ...

There's nothing to beat the satisfaction of creating your own project. From basic principles to circuit-building, the manual describes clearly, with appropriate diagrams, how to assemble radios, loudspeakers, amplifiers, micro-computers and measuring instruments.

The new revised edition of The Modern Electronics Manual contains practical, easy-to-follow instructions for building and programming your own computer. It shows you how to make fun gadgets such as a remote control door opener and a digital rev. counter for your car. It also tells you how to construct useful devices like test gear, security and baby alarms – plus – many more popular devices.

**Wimborne Publishing Ltd., 6 Church St, Wimborne, Dorset BH21 1JH**  
Tel: 0202 881749 Fax: 0202 841692



# THE MODERN ELECTRONICS MANUAL

**New Revised Edition of Basic Work:** Now contains over 1,000 pages of information.

**Regular Updates:** Approximately 160-page supplements of additional information which are forwarded to you immediately on publication. These are billed separately and can be discontinued at any time.

**Presentation:** Durable looseleaf system in large A4 format (197mm × 210mm)

**Price of the Basic Work:** £39.95 + £5.50 p&p (to include a recent supplement).

**YES** please send me on 10 days free approval **THE MODERN ELECTRONICS MANUAL**. If I decide to keep the manual, I shall then pay only **£39.95** plus **£5.50** postage and packing at the end of the 10 days approval period. I shall also receive the appropriate Updating Supplements several times a year. These are billed separately and can be discontinued at any time.

### ORDER FORM

Simply complete and return the order form to the following address

**The Modern  
Electronics Manual  
Wimborne Publishing Ltd  
6 Church Street  
Wimborne Dorset BH21 1JH**

FULL NAME .....

(PLEASE PRINT)

ADDRESS .....

POSTCODE .....

I AM OVER 18

SIGNATURE .....

(Parent or guardian must sign if under 18)

**OVERSEAS ORDERS:** All overseas orders must be prepaid but are supplied under a money-back guarantee of satisfaction. If you are not entirely happy with the manual return it within a month for a refund of the purchase price (you do have to pay the postage). Add the following amounts to the price of the manual to cover postage:

EIRE	£10.50	(air mail only)
EUROPE (including C.I.S.)	£21.00	(air mail only)
MIDDLE EAST/FAR EAST/INDIA	} £20 surface	} £37 air
AFRICA/SOUTH AFRICA		
SOUTH AMERICA		

REST OF THE WORLD £25 surface, £31 air

Note surface mail can take around 8 weeks to some parts of the world. Each manual weighs about 4.5kg when packed.

All payments must be made in £'s Sterling payable to Wimborne Publishing Ltd. We accept Mastercard (Access) and Visa credit cards.

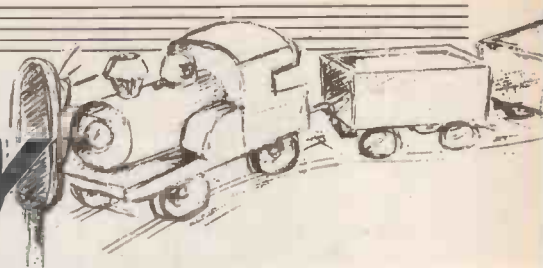

# MODEL RAILWAY AUTOMATIC SIGNAL

**STUART DANDO**

*Why not let the train take control? You will get a "Green-for-Go" and be on the right track.*

RECENTLY my son received a present of a colour light signal for his model train set. I was very disappointed, when the present was opened, to find that the signal required a switch to make it function properly. The switch, that could be purchased for the lights, was only a simple manual two-way type to make the signal change from green to red and back to green again.

A more attractive system would be to make use of the train itself to operate the signal automatically, rather than manually switching the signal backwards and forwards every few minutes.

The main problem was how to operate a switch with a moving train. After careful consideration of the alternatives, it was decided that two reed switches fixed in the

middle of the track and operated by a small magnet fixed to the bottom of the train was the best system to use.

When the train passed over the first reed switch the signal would turn from "green" to "red". At another point in the track the train would pass over the second reed switch and change the signal back to "green".

## CIRCUIT DESCRIPTION

The circuit is built around a bistable multivibrator made up from two NAND gates - see Fig. 1. It has two inputs, Set (S) and Reset (R), and two outputs Q and  $\bar{Q}$  of which  $\bar{Q}$  is normally the inverse of Q.

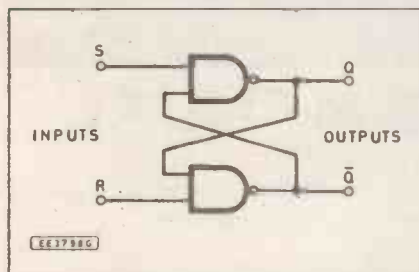

Fig. 1. A bistable multivibrator made from two NAND gates.

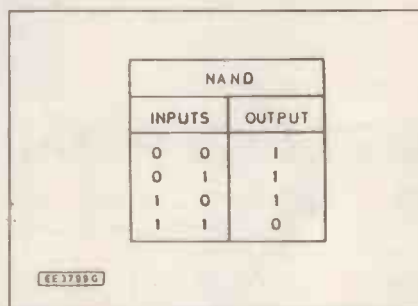

Table 1. Truth table for a NAND gate.

The truth table for a NAND gate is shown in the Table 1. This shows that the output can only be "high" if one of the inputs is "low". In order to make Q high we must make S low and to make Q high we need to make R low.

One drawback of CMOS devices is their relatively low output current capability. This is limited to several milliamps. This is more than adequate to drive small loads such as l.e.d. indicators which could be used to construct a simple signal.

The complete circuit for the Model Railway Automatic Signal is shown in Fig. 2. The colour light signal which had been purchased required more than a few milliamps

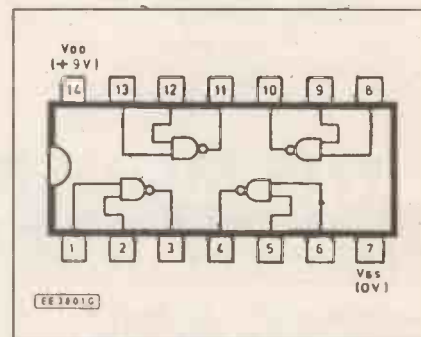
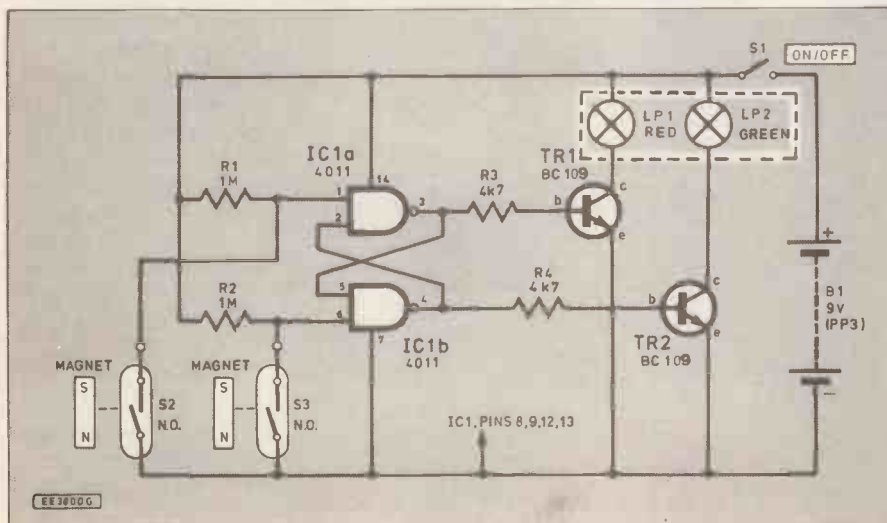

Fig. 3. Pinout details for the 4011 quad 2-input NAND gate i.c.

Fig. 2. Complete circuit diagram for the Model Railway Automatic Signal.



so the output was used to provide a base current for transistors TR1 or TR2. These are BC109 npn silicon transistors which can handle loads up to 100mA.

The pinout details for the 4011 i.c. are shown in Fig. 3. This is a CMOS device and only two of the NAND gates are required in the circuit. The unused inputs of the i.c. (pins 8, 9, 12 & 13) are all connected to the 0V line.

## CONSTRUCTION

Most of the components are mounted on a piece of 0.1in. matrix stripboard, size 15 strips by 15 holes. The complete stripboard component layout and the details of the breaks required in the underside copper tracks are shown in Fig. 4.

It is important to make only six breaks in the tracks between the i.c. pins. No break is required between pins 7 and 8.

The 14-pin d.i.l. socket was positioned first and then the short pieces of link

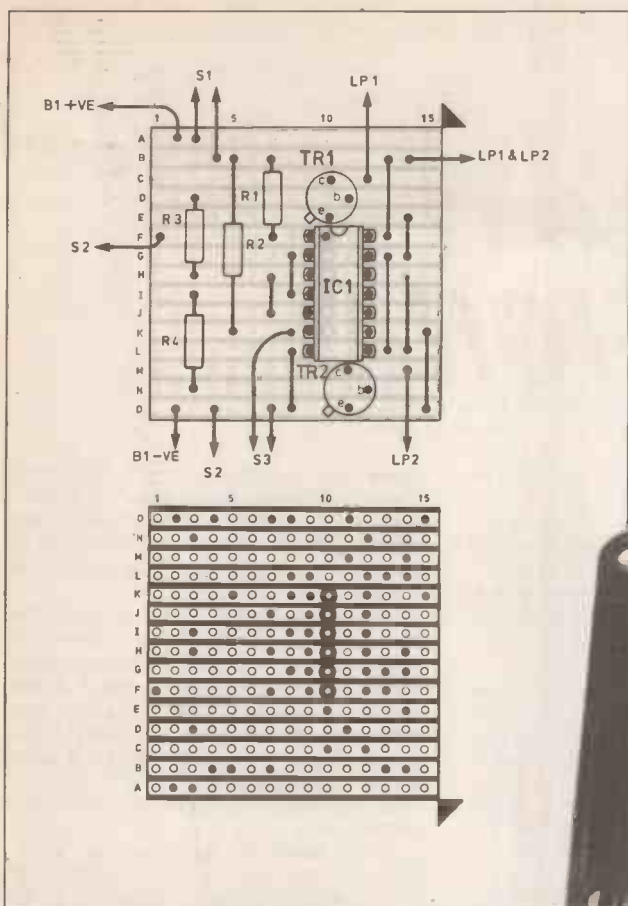

Fig. 4. Stripboard component layout and details of breaks required in the underside copper tracks.

wires. These were followed by the resistors and finally the two transistors, TR1 and TR2.

The circuit board is placed into an ABS box of internal dimensions 76mm x 58mm x 38.5mm. Two small holes at opposite sides of the box allow the leads to be connected to the colour light signal "tower" and the two reed switches.

An on/off switch is inserted in the top of the box and when all of the connections have been made the i.c. and PP3 battery are fitted into place. The stripboard and battery are held in place inside the box with a small piece of polystyrene.

### TESTING

There appeared to be no problems when the circuit was tested with a small mag-

net placed above the reed switches. The circuit functioned properly when the reed switches were placed in the centre of the track and a small magnet was fixed under a clockwork train with Blu-tack adhesive "putty".

When an electric train was used the positions of the reed switches had to be altered several times to avoid false triggering of the line signal. □

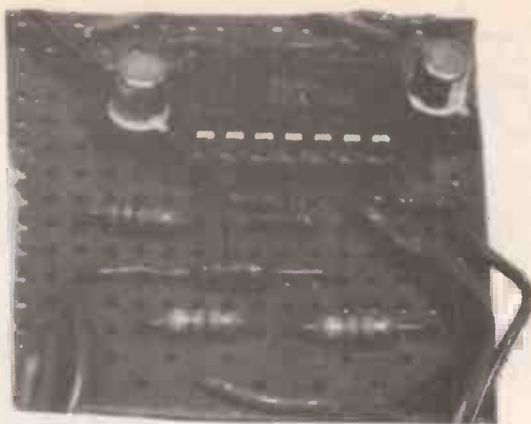

The completed circuit board (above) and the layout of components inside its case (below).

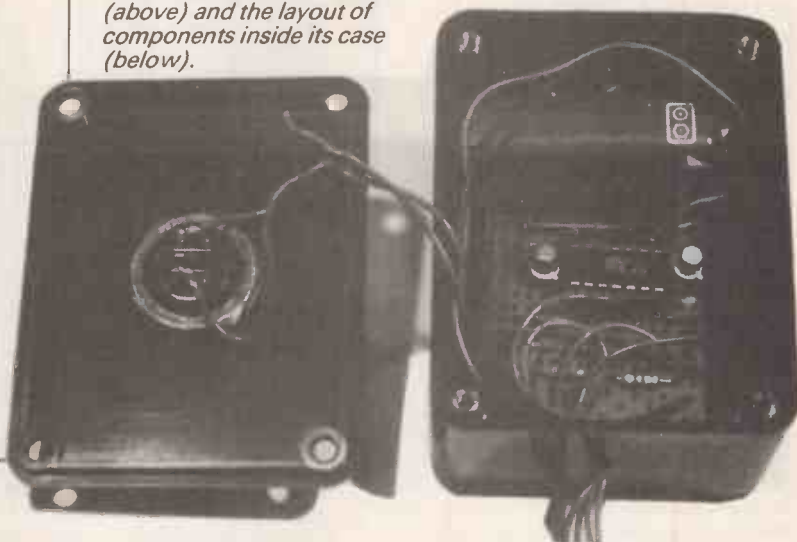

## COMPONENTS

### Resistors

R1, R2 1M (2 off)  
R3, R4 4k7 (2 off)  
All 0.25W  
5% carbon film

See  
**SHOP  
TALK**  
Page

### Semiconductors

TR1, TR2 BC109 npn silicon transistor (2 off)  
IC1 4011 CMOS quad 2-input NAND gate

### Miscellaneous

S1 S.P.S.T. rocker switch  
S2, S3 Reed switch (miniature) (2 off)  
LP1, LP2 Colour Light Signal (Hornby Railways code R406)

Plastic case (ABS), internal size 76mm x 58mm x 38.5mm; stripboard, 0.1in. matrix, size 15 strips x 15 holes; 14-pin d.i.l. socket; miniature magnet; PP3 battery and clip; connecting wire; solder etc.

Approx cost  
guidance only

**£15**  
exc batt.

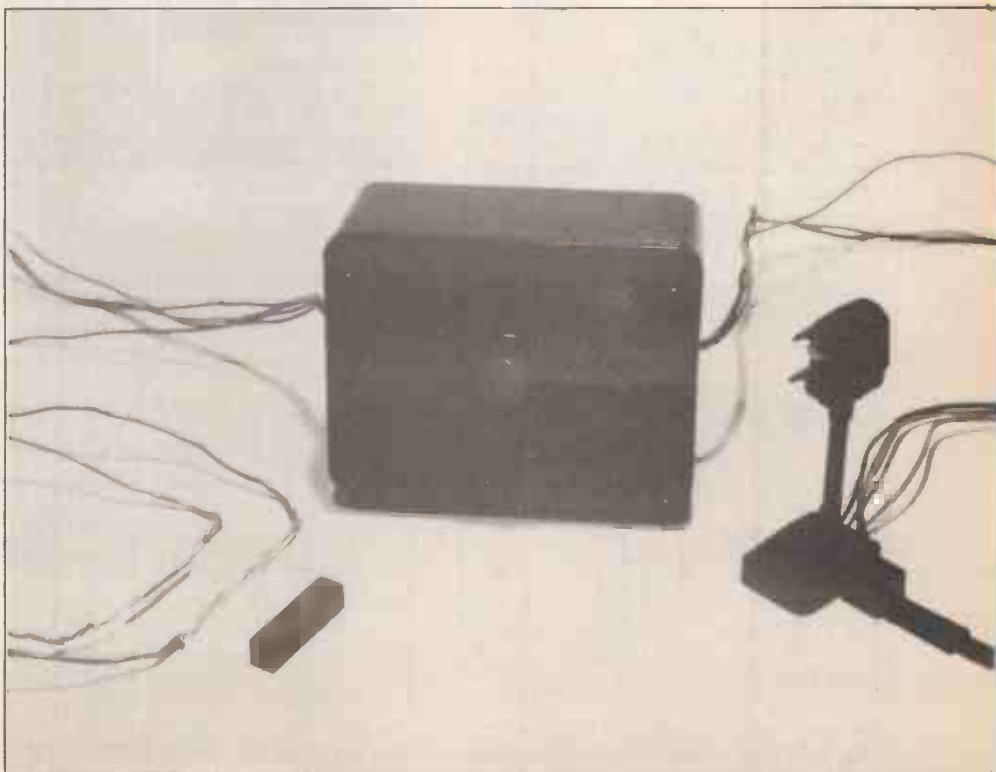

# DOWN TO EARTH

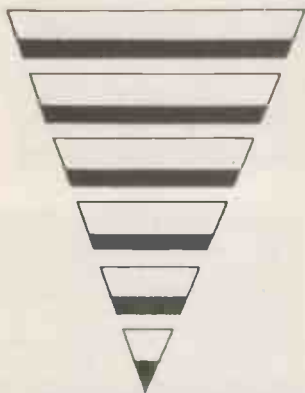

George Hylton

## The Wien Network

In electronics, some circuits crop up again and again. They are "building bricks" from which many different applications can be constructed.

One circuit of this kind is the combination of resistance and capacitances of Fig.1a. This is a venerable network, which predates electronics. Its originator was a German professor of physics called Wien (pronounced Vee-un with the stress on the "Vee").

The Wien network has two arms: the upper, series arm has a capacitance and a resistance. The lower, parallel arm also has a capacitance and a resistance. In most practical applications the capacitances are equal and so are the resistances. It's convenient, when drawing diagrams, to put a box labelled S for the series arm and one labelled P for the parallel arm.

## Frequency Bridge

Professor Wien used his network in conjunction with two resistive arms (Fig. 1b A and B) to form a bridge. This bridge has the peculiarity that it is balanced at only one frequency. With equal R's and C's, balance is obtained when  $A=2B$ . The balance frequency is then the frequency at which the reactance of C is equal to R.

This behaviour of the Wien network is easily understood without doing any

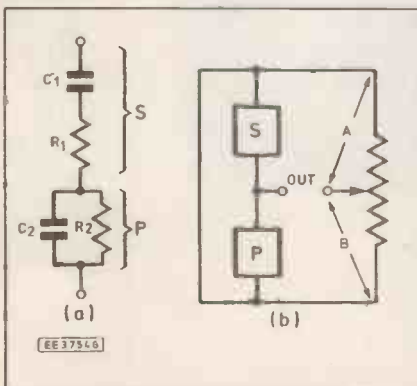
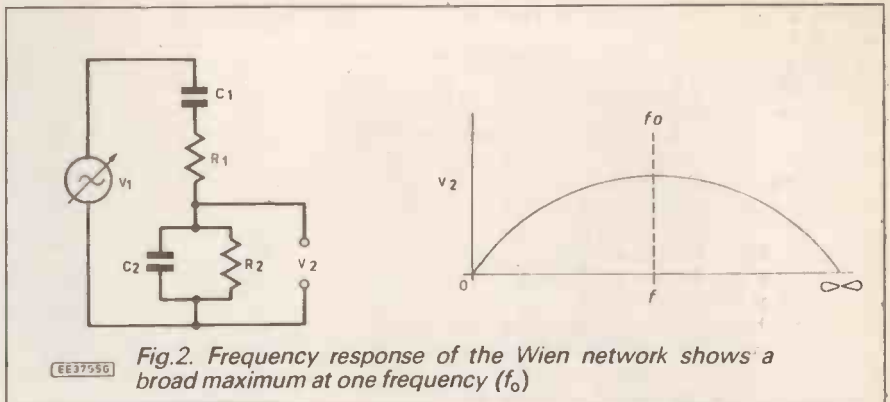

Fig.1(a) The Wien network (b) Wien Bridge.



maths. In Fig.2, the network is shown as a voltage divider driven by an a.c. signal of variable frequency. At the low-frequency end C1 is a complete block to d.c. and a high impedance to low-frequency a.c. The output is therefore low. At infinitely high frequency C1 offers no impedance at all, and current can flow freely.

However, C2 is also a virtual short circuit to very high frequencies so  $V_2$ , the voltage across it, is again zero. These two effects (attenuation of l.f. by C1 and of h.f. by C2) offset one another at intermediate frequencies, so there is some output. The upshot is that as the frequency is raised from zero  $V_2$  at first increases rapidly then, as the shunting effect of C2 becomes more significant, more and more slowly. In the end, after reaching a maximum,  $V_2$  falls off and plunges to zero at h.f.

## Phase Shift

Mathematical analysis gives an important result which is not obvious (to me, at least) just from inspecting Fig. 2. At the frequency of maximum response (often misleadingly called  $f_0$ ) there is no phase shift:  $V_2$  is in phase with  $V_1$ . At lower frequencies there is a phase lead, at higher, a lag. With equal R's and C's ( $R_1 = R_2 = R$ ;  $C_1 = C_2 = C$ )  $f_0$  is given by the formula:  $f_0 = 1/(2\pi RC)$ . Under these conditions  $V_2 = V_1/3$ .

## Oscillations

In the pre-electronic age, the main use of the Wien bridge (Fig.1b) was as a means of measuring frequency. When the S and P arms and the resistive arms were adjusted to give zero output across the floating terminals of the bridge the frequency could be calculated from the values of  $R_1$ ,  $R_2$ ,  $C_1$  and  $C_2$ . This may seem a tedious way of measuring frequency, but remember that in those days

there were no digital counters. Moreover, it was a relatively small step, once electronics had arrived in the shape of the radio valve, to adapt the circuit so as to make the S and P arms determine the frequency of an oscillator.

In present-day terms, the oscillator can be depicted as Fig.3. An operational amplifier is connected so that its output drives a Wien bridge. Its input is the bridge's "floating" output. As we have seen, this is zero at  $f_0$ . If, however, the bridge is slightly unbalanced by making the "2R" upper resistance arm too high then the circuit oscillates at a frequency close to  $f_0$ .

Fine adjustment of unbalance is obtained by using a balance potentiometer whose resistance is a small fraction of the total. In Fig.2 the balance pot has one-fifth the resistance of R. By connecting a fixed resistance of  $R/10$  across its lower part balance is obtained with the slider of  $R/5$  at the half-resistance point.

## Decade Oscillators

The Wien bridge oscillator is very convenient for generating low frequencies. The frequency-varying component is just a two-gang pot. If low frequencies were generated by a tuneable LC oscillator enormous inductors and variable capacitors would be needed.

There is something else about the Wien bridge oscillator which makes it convenient. This is the ability to set the frequency in small precise steps. The frequency formula  $f_0 = 1/(2\pi RC)$ , if carefully inspected, shows that when C is fixed and R varied the frequency is proportional not to R, but to  $1/R$ . If R is not a single resistance but two in parallel ( $R_a$  and  $R_b$ ), familiar Ohm's Law arithmetic says that  $1/R = 1/R_a + 1/R_b$ .

In the oscillator,  $1/R_a$  gives one frequency, say 1000Hz. If  $1/R_b$  gives 100Hz then the frequency for  $R_a$  and  $R_b$

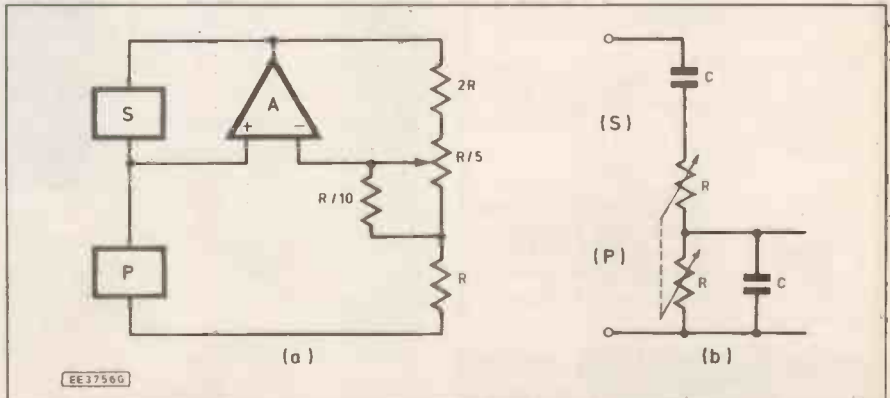

Fig.3. (a) In the "Wien Bridge" oscillator the reactive bridge arms S and P determine  $f_0$  frequency (b) Practical tuning network with variable R.



in parallel is 1100Hz. If a choice of  $R_b$ 's is provided, selectable by a multi-position switch, then the frequency can be made to change in steps such as 1000, 1100, 1200, 1300Hz and so on. In practical terms this gives rise to a famous test oscillator, the Muirhead-Wigan decade oscillator, which covered the audio range in 1:10 frequency decades, each resolvable into small fixed steps.

### Amplitude Stabilization

Once an oscillator gets going the amplitude of oscillation builds up and up until something stops it. The mechanism which usually puts the brakes on is overloading of the amplifier part, causing the peaks of the oscillation waves to be clipped or crushed. This is distortion, and in audio test oscillators (the common use of the Wien type) distortion must be minimised.

Some reduction in distortion is obtainable by taking the output across the P arm (i.e. as  $V_2$  in Fig.2). Here, the frequency-selective property of the network discriminates against harmonics. Unfortunately, it doesn't discriminate well: the tuning is too broad. Also, the output voltage is only one third of the amplifier output.

The standard solution is to substitute

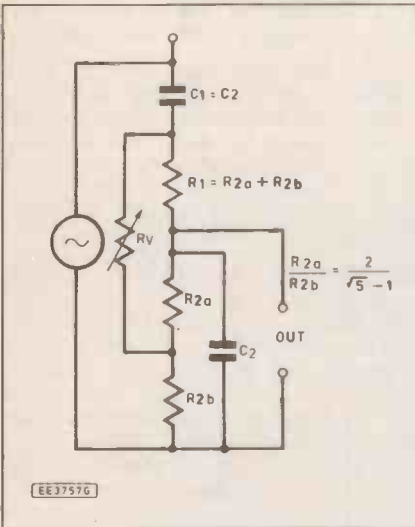

Fig.4. Wien network modified for single element control.

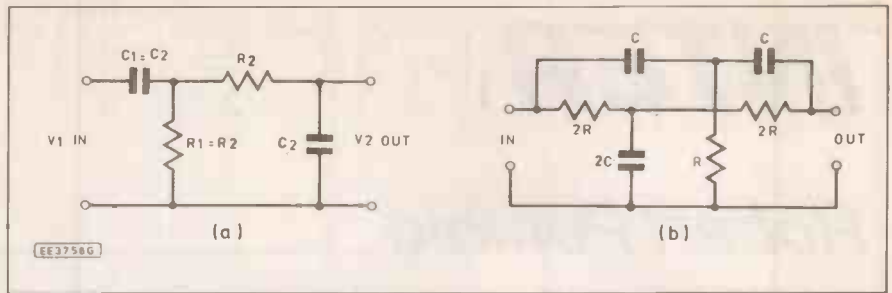

Fig. 5. Wien network equivalents which avoid floating terminals. (a) Cascade (b) Twin-T.

a thermistor for the "2R" element in Fig.3. As amplitude increases, the current warms the thermistor. If it is a negative-temperature-coefficient (N.T.C.) thermistor "2R" then falls. This pulls the bridge closer to the balanced condition and output is prevented from increasing. With careful design, the overload point is never reached and the amplitude stays close to some mean value.

### Amplitude Bounce

There are snags. One is that to be able to respond quickly the thermistor must be very small. This means using a subminiature bead type. They are expensive.

Another is that the oscillator can get itself into a state in which the amplitude does not stabilize, but fluctuates either continuously or in a transient fashion. This "hunting" or "amplitude bounce" becomes more troublesome as the amplifier is made more linear. So the oscillator with the lowest distortion is likely to have the worst bounce.

### Resistance Tracking

Bounce is found to be stimulated by operating the tuning control. The reason lies in the impossibility of obtaining perfect tracking between the two parts of the two-gang tuning resistance ( $R_1$  and  $R_2$  in Fig.2). If  $R_1$  at one setting is higher than  $R_2$  then output falls, and vice versa. As the tuning is changed, minor inequalities of  $R_1$  and  $R_2$  crop up, causing minor changes of amplitude which encourage bounce.

Since no twin-gang variable resistance can have perfect tracking designers have been at pains to invent circuits in which a single variable resistance somehow has the effect of changing  $R_1$  and  $R_2$  equally.

Since there is no tracking problem with a single variable resistance, amplitude changes are minimized (theoretically, eliminated).

One arrangement, a product of the same Wigan as the designer of the Muirhead-Wigan oscillator, is shown in Fig.4. The variable  $R_v$  straddles the Wien network from the top of  $R_1$  (now a fixed resistance) to a tap on  $R_2$ . The arrangement works well, but two facts reduce its utility. First, the correct tapping point on  $R_2$  depends on the ratio of  $C_1$  to  $C_2$ . These are nominally equal, but tolerances produce a difference. In a multi-range oscillator where the ranges are set by switching capacitances the tap on  $R_2$  must be preset for each range.

The second inconvenient fact is that the circuit as shown, with equal  $C$ 's, gives a practical tuning range not much in excess of 2 to 1. Rather a lot of ranges are then needed to cover, say, 10Hz to 100kHz.

More complex single-control circuits do rather better and ranges with variation of  $\sqrt{10}$  to 1 are possible. This gives coverages such as 10Hz to 32Hz, 32 to 100, 100 to 320 etc.

### Alternative Networks

Wien network equivalents, which have similar frequency response are shown here. Fig.5a gives the same performance as Fig.2, while Fig.5b is the equivalent of the complete bridge (Fig.1b) and gives zero output at  $f_0$ .

The Twin-T (Fig.5b) is much used in fixed-tuned "notch filters" to give zero response at one frequency, such as the mains frequency in hum-reducing circuits. It has the advantage that there are no "floating" output terminals.

# EVERYDAY ELECTRONICS BINDERS



Don't let your valuable issues of EE get binned, burned or bitten (by the dog). Get one of our exquisite orange hard-back binders, slip each issue into it as you get them and you will always know where they are - we hope!

Binders to hold one volume (12 issues) are available from Everyday Electronics, 6 Church Street, Wimborne, Dorset BH21 1JH for £5.95 (£6.95 to European countries and £8.00 to other countries, surface mail) inclusive of postage and packing. Payment in £ sterling only please. Visa and Access (MasterCard) accepted, minimum credit card order value £5.

Binders are normally sent within seven days of receipt of your order but please allow up to 28 days for UK delivery - more overseas.



# INTERFACE

Robert Penfold



**T**HIS MONTH, amongst other things, we continue with the barcode interface. The Maplin or RS miniature infra-red reflective sensor can be used in an extremely simple barcode interface, but I did not obtain very good results using such a circuit. If the infra-red l.e.d. is fed with a current of around 40 milliamps, and the photo-transistor is used as a common emitter switch having a load resistor of a few kilohms, there will be an output of sorts if the sensor is run across a suitable barcode.

There are a some major problems with such a setup though. One of these is that the output signal does not switch very fast, and it could give problems if fed to some logic inputs.

The lack of switching speed is mainly due to the fact that photo-transistors are not particularly fast devices. The output does not switch particularly cleanly either.

The output signal may not be strong enough to drive some logic inputs properly anyway. The main problem though, is that the width of the output pulses seems to be much the same for thin bars and thick ones!

## Active Sensor Circuit

Results seem to be vastly better if an active circuit is used, with some amplification and signal conditioning being utilized to provide a "clean" output signal that properly reflects the bar widths. The final circuit adopted is shown in Fig. 1.

Resistor R1 is the current limiter resistor for the l.e.d. section of the sensor IC1. This sets the l.e.d. current at approximately 13 milliamps. This is high enough to give a reasonably strong infra-red signal, and there seems to be no real advantage in using a current which is close to the 50 milliamp maximum continuous rating of the l.e.d.

The only exception to this might be if the barcode is printed on something that is not particularly reflective (e.g. some low quality papers). It might then be advantageous to reduce R1 to 82 ohms.

Incidentally, I would only recommend printing the barcodes on white paper. Tinted papers could well give problems with a lack of contrast.

The photo-transistor, within IC1, is operated in the emitter follower mode, and it drives a discrete common emitter switching stage based on transistor TR1. This arrangement gives a relatively fast switching speed and good sensitivity.

The sensitivity can be adjusted via

therefore used as a common emitter switching stage which provides an output signal that will drive any normal logic input successfully.

Under stand-by conditions (i.e. with the sensor IC1 aimed at the white background of a barcode) the output from the interface is at logic 0. It was found that the best way to provide VR1 with a suitable setting was to first accurately position the sensor over a narrow bar. By adjusting VR1 it should be possible to set the output at logic 0 or logic 1. Good results should be obtained if VR1 is set just slightly on the logic 1 side of VR1's switch-over point.

## Through The Window

Remember that the sensor can only operate properly if it is held *slightly clear* of the barcode. The RS data gives the optimum sensing distance as just 1.2 millimetres, but the barcode printer program produces bar codes that are chunky

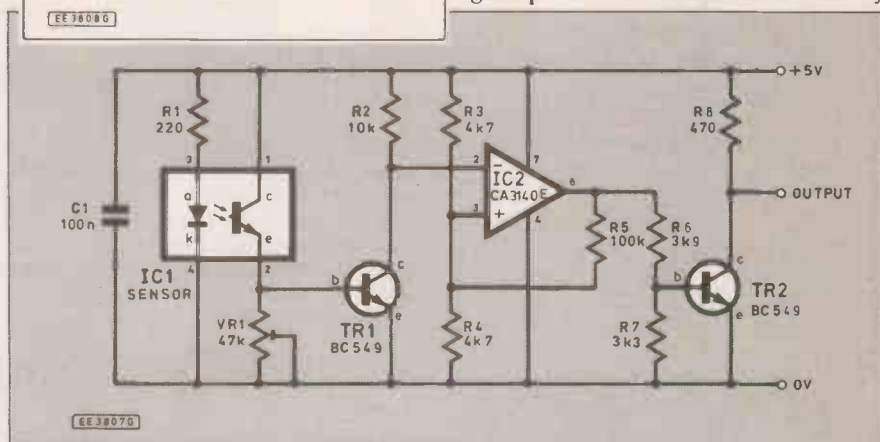
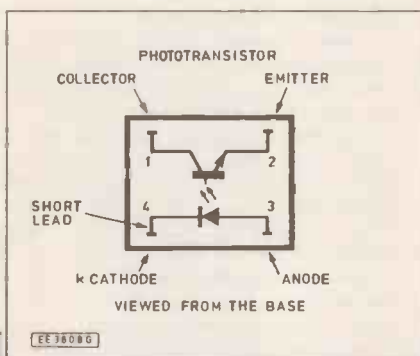

Fig. 1. The barcode interface circuit diagram. Pin connections for the sensor IC1 are shown inset above.

VR1, and this enables the sensitivity to be set at a level which provides two distinctly different pulse widths from the wide and narrow code bars. Maximum resistance through VR1 gives maximum sensitivity.

## One Logic to Another

The output from TR1 might contain some spurious signals on transitions from one logic level to the other, and its output impedance is too high to drive most logic inputs properly. Therefore IC2 is used as a trigger circuit having a moderate amount of hysteresis provided by resistor R5. Provided the bar code is printed reasonably crisply this should give a good quality and glitch-free output signal.

The output of IC2 (pin 6) will drive some logic inputs properly, but will not "sink" enough current to drive some inputs satisfactorily. Transistor TR2 is

enough to permit some margin of error here.

Also bear in mind that the sensor will only work properly if the rectangular "windows" (which can be clearly seen if you look at the end of the sensor) are more or less parallel to the bars in the code. If you get the sensor so that these "windows" are at right angles to the bars the system will not function properly at all.

Ideally the circuit should be tested by displaying the output signal on an oscilloscope. A simple alternative is to monitor the output using a crystal earphone. A series of "clicks", or a deep "buzzing" sound should be heard as the sensor is swept across a barcode.

**Next month:** We will look at interfacing the barcode reader to a PC, and some software will be provided.

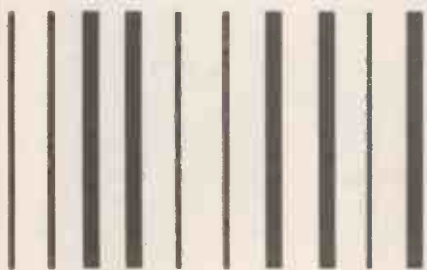

102 Decimal

Example of the type of barcode generated.

# Quickroute

There are now several public domain and shareware printed circuit design programs for PCs, one or two of which have been reviewed in previous *Interface* articles. While these programs are quite clever in some respects, overall they tend to leave me feeling that it would be quicker and more reliable to draw up the designs using traditional drafting methods!

The latest PC shareware printed circuit design program to appear is called "Quickroute". The version distributed as shareware is almost the same as the version you get for a £30 registration fee. The main difference is that the registered version is equipped with additional printer and plotter drivers. These extra drivers are for HP Laserjets, Epson 24-pin printers, and HP plotters. The shareware distribution version only has drivers for Epson and IBM 9-pin printers.

The registered version is capable of driving a wide range of output devices, since many printers and plotters are compatible with the supported Epson, IBM, and HP devices. The Laserjet output is suitable for use with HP Deskjet and similar inkjet printers incidentally. Unusually for this type of software, I had no difficulty in getting the program to work with a variety of output devices.

You do not need expensive hardware to run this program. The minimum requirement is an 8088 based machine with 512k of memory and a C.G.A. display.

Screen redrawing is quite fast, but a more powerful PC is still preferable, as is the higher resolution provided by a V.G.A. display. A Microsoft compatible mouse is also more than a little helpful,

since the program makes extensive use of pop-down menus, icons, etc.

There is insufficient space available here for a detailed description of the program to be provided, and a general overview will have to suffice. The user interface is very professional, and is almost totally graphic oriented. Using the program is very much like using one of the sophisticated Windows based graphics programs.

## On The Screen

On the right hand side of the screen there are icons, and these are mainly used for selecting the objects (tracks, pads, symbols, etc.) which are to be placed onto the board. There are exceptions in the arrowhead icons which are used for panning around the screen, and the eraser icon which is used for deleting objects one-by-one. The question mark icon brings up a large window in the middle of the screen which provides easy selection of track widths, pad styles and sizes, integrated circuit symbols, etc.

At the top of the screen there is a menu bar which gives access to six pop-down menus. The menus provide facilities such as loading and saving, editing functions, setting up the cursor and screen grids, layer selection, etc.

Most programs currently use the left hand mouse button for just about everything, with the other button or buttons being largely ignored. In Quickroute the left button is used for control via the icons, and the right hand button is used for the pop-down menus. This takes a certain amount of getting used to, which is not helped by a slight reluctance for the menus to pop down.

This program is certainly very sophisti-

cated in many respects. It can print at virtually any scale, there is a simple auto-router, custom as well as preset zoom levels are available, and as already pointed out, the user interface is a very modern graphical type.

Quickroute does have its limitations though. These mainly centre around the editing of designs. The main advantage of using a computer for this type of design work is the ease with which alterations and corrections can be made to a design.

Unfortunately, it does not provide editing functions to rival the low cost commercial equivalents. There are some useful block operations available (mirror, copy, rotate, move, and delete), but it is easy to get it wrong with this type of thing, and there is no "Undo" facility. Even just deleting one or two objects can sometimes be awkward and time consuming.

Although the program is very modern

## A TEXT STRING

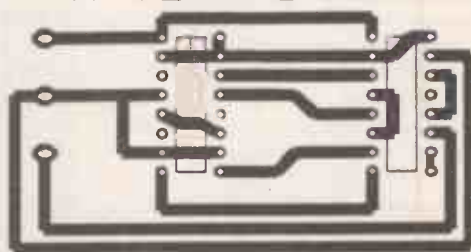

An example of a 1:1 output from Quickroute. Produced using an Epson EPL4100 laser at full 300d.p.i. resolution.

and sophisticated in some respects, the editing facilities are rather out of date. Another and more minor problem is that with some output devices the quality of the hard copy is not quite as good as that provided by most other graphics programs.

It is certainly possible to design quite complex printed circuit boards using Quickroute, and to then produce hard copy which can be used in the production of the boards. You need to proceed rather more cautiously than with most of the commercial competition though.

Despite my reservations, it has to be said that "Quickroute" offers exceptional value for money, and is certainly worthy of consideration if you are in the market for this type of software. Remember that it is shareware, and that it costs very little to try out the program. If you have a PC and are interested in electronics, then this is a program that you should give a try, even if it is only for the fun of it.

Quickroute is produced by Powerware, Dept EE, 14 Ley Lane, Marple Bridge, Stockport, SK6 5DD. The shareware version is available from The P.D.S.L., Dept EE, Winscombe House, Beacon Road, Crowborough, Sussex, TN6 1UL (☎ 0892 663298). It is disk No.2937. It should be available from most other large shareware libraries, but it will have a different catalogue number.

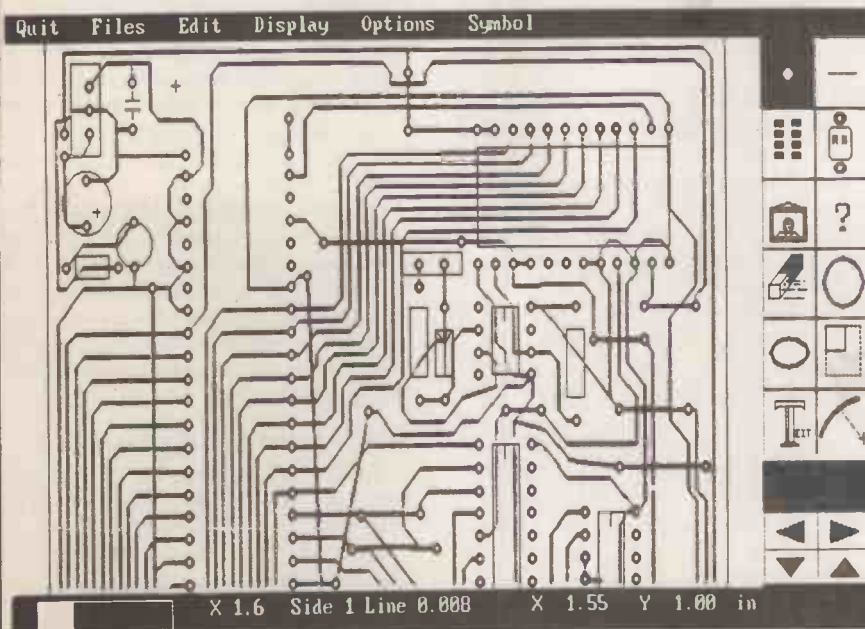

Screen dump with the demo p.c. design loaded. Note the icons on the right, and the menu bar at the top of the screen.

# FOR YOUR ENTERTAINMENT

by Barry Fox



## PC Compatibility Joke

Out here in the real world there is a quaint old custom. When we buy something we expect to be able to use it, without first negotiating an obstacle course that soaks up time like a sponge, saps business profits and creates good grounds for divorce. The Japanese consumer electronics industry recognised this simple truth long ago, and has grown rich on that recognition.

The Western computer industry, which has grown rich over the last fifteen years on the promise of personal computing, is riding for a fall because it has never had any truck with such quaintness. If you buy into the joke world of IBM PC "compatibility", then getting hardware A, to work with peripheral B, and software C, merits rejoicing.

It is the eighth wonder of the world that the PC industry has grown so far and so fast with such appalling contempt for its customers. When the bubble bursts, the market will shake out in favour of those few hardware and software companies which care, just a little, for their paying customers. With MS-DOS on most of the world's 70 million PCs, and thereby causing more misery than any other single piece of software, justice dictates that Microsoft faces the longest drop.

Recently, the latest in a long string of glossy magazine puff articles about "billion dollar geek" Bill Gates "at 36 the richest man in America" told how sycophantic Microsoft staff admire his foresight and brilliant perception of intricate detail in software programs.

This puzzles me. Whether or not Mr Gates was actually responsible for MS-DOS (or simply bought the right authoring company at the right time) it is Gates who, along with IBM, condemned some 70 million people round the world using IBM compatible PCs to the absurdity of a file labelling system which limits the identifying description to eight text characters, with some useful markers barred from use. Anyone who actually works in the real world with text files knows how daft this is.

## Ten Years to Late

And it was Gates' company, Microsoft, which put out a first version of Windows which was so

inadequate that it had to be junked in favour of the later version, or more accurately versions.

Only now, after ten years, has Microsoft written into DOS (the fifth version, no less, and after numerous sub-versions) some of the core features of utility programs, like Norton, which make DOS halfway to usable.

Who, who had any foresight, could have failed to provide utilities like "unerase" and "safe format" in DOS from day one? And, while claiming better memory management, DOS 5 still provides no automated allocation of memory. The long-suffering user must struggle with the manual, and then try juggling all possible permutations.

Gates gave the keynote speech at the Microsoft-sponsored Multimedia and CD-ROM Conference in San Francisco earlier this year. His guruspeak view of the future skated through interactive multimedia, digital video and high definition television, with a muddled string of half-informed non-sequiturs.

Again puzzled, I asked afterwards if I could speak with him briefly. A string of Microsoft minions looked genuinely astonished that some limey hack should have such cheek. Gates, I was told, was far too busy giving interviews about the future to important magazines like Newsweek.

## Master Time

Pity. Among other things I wanted to talk to Bill Gates about a complaint I had lodged with the Advertising Standards Authority. I had noticed that London Underground trains were carrying adverts for Windows 3 software placed by Microsoft.

The advert stated that "Two hours thirty minutes (is) the average time a computer user takes from scratch to master Microsoft Windows 3.0 software".

Writing as someone who has suffered the misery of trying to install and master Windows 3.0 from scratch I just could not believe this and asked the ASA to investigate the evidence for this claim.

It would of course be true to say that if someone is presented with a computer system on which Windows has already been installed, if they are prepared to use only the applications

software (e.g. wordprocessing programs) for which Windows has been pre-set to use, if they already have a mouse fitted and if they are helped by someone who is already familiar with Windows, they might well learn how to use the basic commands in the time claimed.

But that is not what the advert claimed, nor is it a realistic situation.

Microsoft usually takes care to launch software at glitzy demonstrations which serve up pre-tailored systems for the trade and press to try. This is not a real world situation. In the real world the computer user will have to install the software, learn that some functions can only be performed with a mouse (not with a keyboard), learn how to juggle control settings (e.g. edit PIF files) to suit the application software they use, meet Windows' memory requirements and fine tune settings to avoid crashes, all the time referring to the 640 page manual. Just to read the manual would take far, far longer than Microsoft claims.

I suggested that the ASA should actually try loading and using Windows for themselves, from scratch with only the manual to help them. They could then judge the validity of the advert.

The ASA wrote and told me that it was investigating and would let me know what was happening. That was in February. At the beginning of June I had still heard nothing. Perhaps they were still trying to get Windows to work.

In the meantime Microsoft has launched yet another version of Windows (Windows 3.1). Users of Windows Ver 3 can upgrade for £45, instead of paying the full price of £99, Microsoft claims increased robustness, improved performance, and greater stability.

## Inadequate and Unstable

Turn those claims around and you have an admission from Microsoft that Windows 3 suffered from lack of robustness, inadequate performance and poor stability.

Under the circumstances I should have thought the upgrade from Ver 3 to Ver 3.1 should at least be free, and more fairly come with a £45 cheque to compensate people who bought and

## CONTROL PORT for PCs

This I/O Port follows the general approach of the 'INTERFACING to PCs' series in this mag, BUT allows user's prototype control circuitry to be set up and run OUTSIDE the PC.

The double sided pcb fits into an I/O slot, and a ribbon cable terminating in a D-25 plug allows the control of projects with little risk to the PC. On board facilities include: 8-bit A-D, 8-bit D-A, 8 inputs, 8 latched outputs, 3 strobes and 1 IRQ.

Available as:

- (a) Etched double sided board with full instructions for drilling/assembly/testing using BASIC.....£12.50
- (b) Complete I/O card with ribbon cable and BASIC test programs. (Built and tested).....£29.00

Also available: Test pod with D-25 socket providing analogue and digital test signals/outputs for the I/O card, with BASIC test programs on disc.....£17.00

All above prices include P&P. Mail Order only from:

**R. BARTLETT,**  
17, LIME TREE AVENUE, TILE HILL,  
COVENTRY CV4 9EY

## LOW COST 418MHz UHF RADIO SWITCHING

### AS USED BY THE PROFESSIONAL SECURITY MARKET

Incorporating the latest Surface Acoustic Wave technology, the system consists of a small "zero-power", UHF transmitter with digital encoder and a UHF receiver unit with digital decoder and momentary output. Transmitter available either as fully assembled unit in its own key-lob case which is fully MPT approved (codes set by cutting tracks) or in kit form with 8-way DIL switch. Receiver also available in two kit forms, one which uses cut tracks to set code (over 13,000 codes available), the other uses an 8-way DIL switch (256 codes).

Kit Sizes:	Tx 45 x 30mm	Rx (both) 45 x 55mm
Kit Supplies: Tx 3-15V	Rx (both) 9-15V	Range: Up to 100m
Approved Key-lob Transmitter: TXKF.....		£25.99
Individual Kit Transmitter: TXKT.....		£15.99
Individual Kit Receiver (8-way DIL switch): RXDS.....		£19.99
Individual Kit Receiver (Cut Tracks): RXCT.....		£18.99
1 x TXKF + 1 x RXCT: SYS1.....		£39.99
1 x TXKT + 1 x RXDS: SYS2.....		£29.99

Quantity Discounts Available. Please allow 28 days for delivery  
Cheques/POs to:

## BLB Electronics

341 Darwen Road, Bromley Cross, Bolton BL7 9BY

## 19 INCH EQUIPMENT HOUSING RACK CASES

Front panels 3mm  
Aluminium Self Colour  
with removable  
protective plastic coating  
on face side.  
Back Boxes 20swg  
(0.9mm) Zinc plated  
steel. Epoxy coated, matt  
black.

Sizes	Front Panels	Back boxes
1U	482 x 44	432 x 38 x 305
2U	482 x 89	432 x 77 x 305
3U	482 x 133	432 x 127 x 305
4U	482 x 166	432 x 165 x 305

Supplied in flat pack for self assembly.

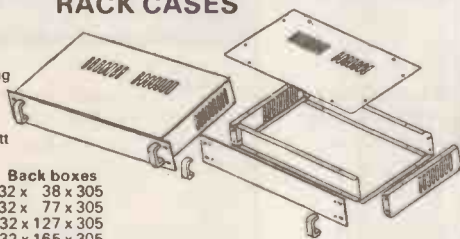

## "CASTLE" EQUIPMENT RACKS

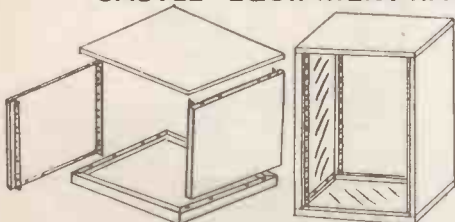

SIZES	HEIGHT
ER8	407mm
ER10	495mm
ER12	533mm
ER16	762mm
ER20	940mm
WIDTH 533mm	
OVERALL DEPTH 407mm	
MAX. CASE DEPTH 362mm	

Manufactured of ZINTEC. Zinc plated mild steel 20swg. Epoxy coated, cream. Black to special order. Fixing holes conform to IEC standards.

BLANK PANELS 19" fixing, 2.5mm  
12g aluminium or 16g steel. Black  
epoxy coated.

CASTOR SET with fixings. 4 castor  
wheels (2 with brakes).  
rated 40Kg each.

### STEEL SHELVES TO FIT RACKS

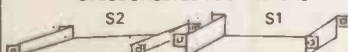

SUPPORT FOR HEAVIER EQUIPMENT

### MAIL ORDER PRICES

CASES	RACKS	PANELS
1u - £23.50	ER 8 - £50.00	1u - 3.00
2u - £26.70	ER 10 - £53.50	2u - 4.00
3u - £30.30	ER 12 - £55.50	3u - 5.00
4u - £34.20	ER 16 - £64.50	4u - 6.00
	ER 20 - £72.00	

SHELVES	CASTOR SETS
S1 for 1u + 2u £9.00	£13.00
S2 for all others £9.00	

Please address mail orders to  
**AIRFIELD DISTRIBUTION**  
117 The Airfield  
Little Staughton  
Bedford MK44 2BN  
Tel: 0230 62708

TRADE ENQUIRIES WELCOME  
Proprietors: Castle Engineers Ltd.

PRICES INCLUDE VAT DELIVERY ADD £4.00 PER ORDER (UK ONLY).

# OUT NOW!

## Summer '92 Electronic Constructors Catalogue



Many new  
products including:

- **Audio Amplifier Modules**  
Range of 14 high power audio modules, encapsulated to an integral heatsink in Bi-polar, MOSFET and Class A formats with power outputs from 15 to 180 watts.
- **Books**  
18 new titles from the top electronics publishers.
- **Burglar Alarm**  
Volumetric alarm triggered by change in air pressure eg an opening door, easy to install - no wiring required.
- **Spectrum Analyser Adaptor**  
Converts a conventional scope into a low cost, 250MHz spectrum analyser.
- **Low Profile Mains Transformers**  
Encapsulated, top quality PCB mounting mains transformers.
- **Airband Scanning Receiver**  
100 programmable channels, covering civil and military frequencies.
- **Stereo Valve Amplifier**  
Top quality stereo hi-fi amp from Velleman - at a very competitive price!
- **Extended Ranges**  
of connectors, equipment cases, filters, crystals, fuses, fans, kits, ATUs, semiconductors, loudspeakers, sounders and toroidal transformers.

With 24 product sections, 192 pages,  
3000+ lines and £££s of discount vouchers,  
be sure to get your copy now!

Available from most newsagents or  
directly from Cirkit.

**£1.70**  
+ 30p p&p

# Cirkit



## CIRKIT DISTRIBUTION LTD

Park Lane · Broxbourne · Hertfordshire · EN10 7NQ  
Telephone (0992) 444111 · Fax (0992) 464457

# QUICKTEST

MARK DANIELS

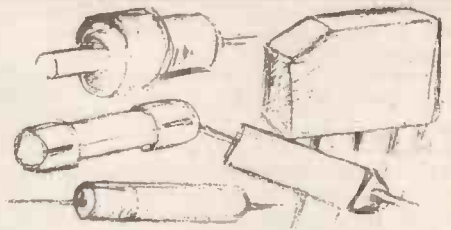

A simple, low-cost, hand-held piece of test equipment that will perform continuity tests, without the use of test leads.

TESTING fuses and small components for continuity can be a fiddly business, involving chasing the component around the workbench with a pair of test-prods.

If the suspect part under test happens to be a diode this makes testing doubly difficult, since after managing to get one test result the entire procedure has to be repeated to obtain a reading in the opposite direction to ensure that the part in question is indeed a diode and not a piece of wire or an open circuit in disguise.

With the growth in popularity of S.M.T. (Surface Mount Technology), devices are becoming ever harder to hold onto while testing takes place. An ideal test situation for any small component would involve no test leads at all and would simply require holding the device in one hand and the tester in the other.

The Quicktest described in this article is a very simple to use piece of test equipment that will perform continuity tests on various devices without the use of test leads.

## HOW IT WORKS

The complete circuit diagram for the Quicktest is shown in Fig. 1. The circuit is based around two very low cost and popular integrated circuits, namely the 555 timer and the 741 op.amp.

The first of these, IC1, is a multivibrator, which in this circuit is configured as an astable device to give a continuous pulse train at a frequency of approximately 2Hz.

Resistors R1 and R2 along with capacitor C2 set the operating frequency of the oscillator. The output of IC1 at pin 3 is connected to a metal touch contact on the outside of the case.

The bi-polar op.amp IC2 is connected in its inverting mode. Its non-inverting (+) input at pin 3 being biased by resistors R3 and R4 to the mid-point of the supply voltage. When its inverting (-) input at pin 2 is taken above or below this mid-point voltage the output at pin 6 swings almost to the negative or positive supply rail respectively.

When the output swings positive current flows through l.e.d. D2 and resistor R7 to the negative supply rail causing D2 to illuminate and flash on and off. With the output negative, current will then flow from the positive supply rail through resistor R6 and l.e.d. D1 (and of course to the supply rail through IC2), which will light. It is possible to replace the l.e.d.s with a single bi-colour device - see Fig. 2.

Resistor R5 provides a small degree of negative feedback to stabilise the amplifier. Without this it would oscillate uncontrollably with no input.

If the touch contacts are connected together with a piece of wire (or a human body!) a minute current can then flow from pin 3 of IC1, into pin 2 of IC2 which amplifies both the negative and positive pulses thus turning on l.e.d.s D1 and D2 alternately. If a functional diode is now connected in place of the wire link either the positive or negative pulses will be

blocked so IC2 will then only have the negative or the positive pulses present on its input pin. Its output will in this case only be able to swing in one direction, thus only one of the l.e.d.s will be able to flash.

Capacitor C1 is included in this circuit to decouple the noise produced by IC1 and prevent it from affecting the very sensitive amplifier stage.

## CONSTRUCTION

A small single-sided glass-fibre printed circuit board (p.c.b.) is used to simplify assembly. The copper foil master pattern and component layout for this is shown in Fig. 2. This board is available from the EE PCB Service, code EE803.

Fit p.c.b. pins for the three leads which will interconnect off-board components to the board, this will simplify later assembly. Next fit the seven resistors followed by the two capacitors. Note the polarity of the electrolytic capacitor C1.

The two i.c.s may be soldered directly into the board without the use of sockets if the soldering is quick. If you are at all uncertain about soldering them in then do

Fig. 1. Circuit diagram of the Quicktest.

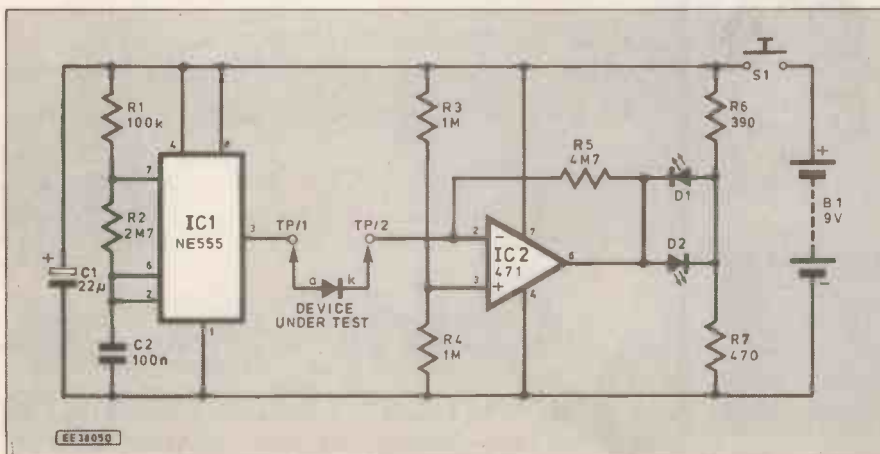

## COMPONENTS

### Resistors

- R1 100k
- R2 2M7
- R3, R4 1M 1% metal film (2 off)
- R5 4M7
- R6 390
- R7 470

All 0.25W 5% carbon film, except where specified.

### Capacitors

- C1 22µ radial elect. 10V
- C2 100n polyester layer, 5mm pitch

### Semiconductors

- D1, D2 5mm Red and Green l.e.d. (one of each), or one bi-colour l.e.d.
- IC1 555 timer
- IC2 747 op.amp

### Miscellaneous

- S1 Wafer thin, push-to-make p.c.b. mounting switch
  - B1 9V battery (PP3)
- Plastic box with battery compartment, size 125mm x 46mm x 24mm; metal touch contacts (2 off); p.c.b. solder pins (3 off); multistrand connecting wire; 6BA nuts (4 off), washers as required; 6BA solder tag; solder etc.
- Printed circuit board available from the EE PCB Service, code EE803.

See  
**SHOP  
TALK**  
Page

Approx cost guidance only **£12.50**

use sockets. The i.c.s are not static sensitive devices, so do not require special handling.

When the board assembly is completed check it thoroughly for dry joints and shorts. Also check component positioning and orientation paying special attention to the i.c.s and capacitor C1.

## CASE DETAILS

If the recommended case is used it will be found that the p.c.b. is just the right size to fit in the bottom half of the case in front of the battery compartment. Locate the p.c.b. in the case and using the hole marked "Touch Pad" in Fig. 2 as a guide drill a 3mm hole through the bottom of the case.

If the specified touch pads are used these are secured by a single 6BA nut. In this application packing washers are fitted un-

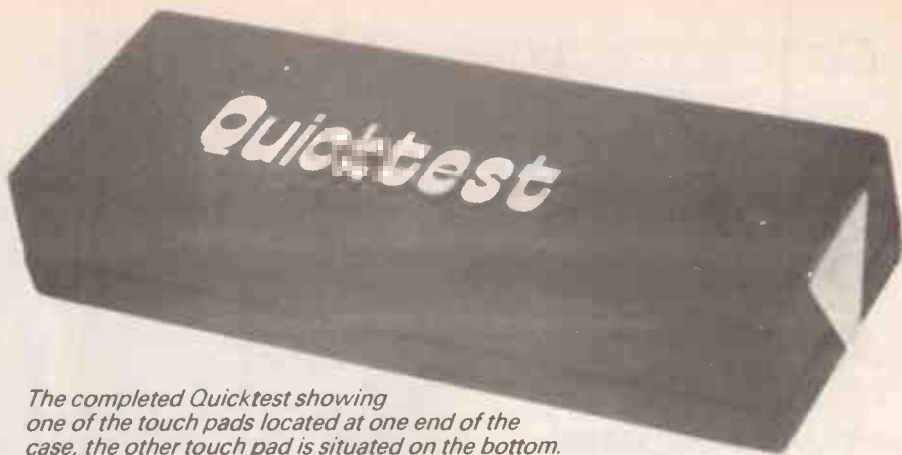

The completed Quicktest showing one of the touch pads located at one end of the case, the other touch pad is situated on the bottom. The "button" of the switch is located below the bi-colour l.e.d.

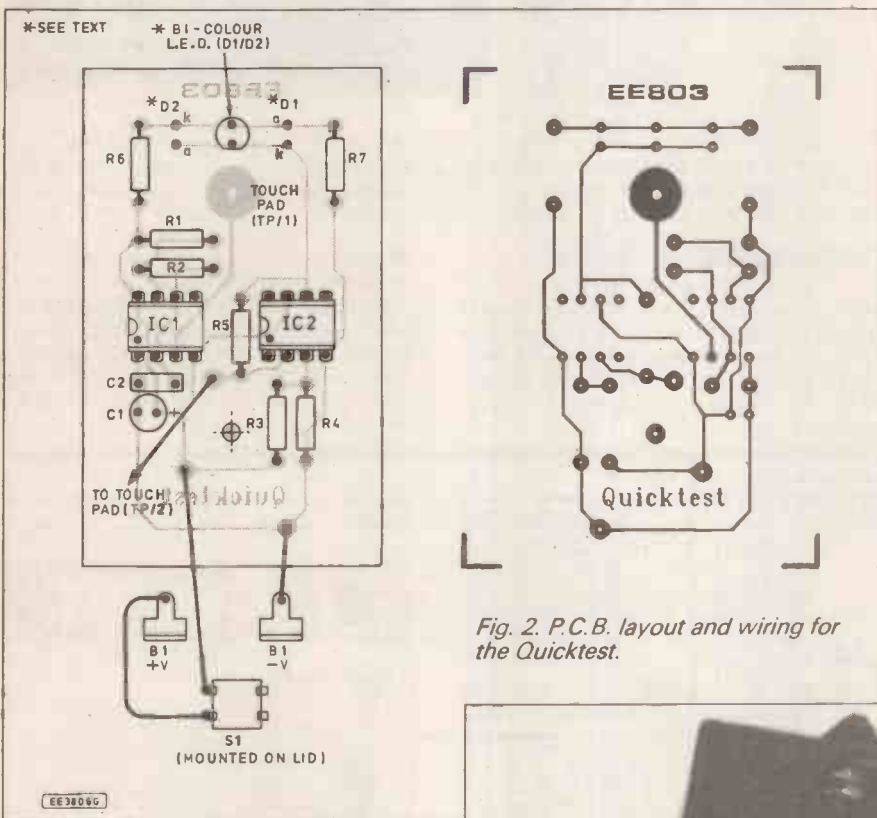

Fig. 2. P.C.B. layout and wiring for the Quicktest.

derneath the mounting nut to pack it to the right height in order that it may make contact with its respective pad on the p.c.b. when fitted.

If you are using the "alternative" bi-colour l.e.d., as used on the prototype model, a single 5mm diameter hole needs to be drilled centrally in the case lid 11mm from the end opposite to the battery compartment. For the two l.e.d. version drill 5mm holes 7.5mm from the centre line, again at 11mm from the end of the case. Now fit the l.e.d.(s) to the board and adjust the height such that when the p.c.b. is fitted in its correct position in the case the l.e.d.(s) locate into their hole(s).

Once the board is completed it may be fitted. A second nut on the touch pad is used to secure the p.c.b. in place and the stud on the touch pad trimmed flush with the nut.

In the front end of the top part of the case a 3mm hole is drilled centrally about 11mm down from the top to mount the second touch pad. The stud on this will also need trimming to clear internal fittings. Fit a solder tag and second nut to this stud to facilitate interconnections.

A wafer thin, p.c.b. mounting, push-to-make switch is used for S1 and after a suitable hole has been cut and countersunk internally the switch should be bonded in place with cyanoacrylate adhesive ('Superglue'). If this method of mounting is to be used great care must be taken to avoid the adhesive penetrating the switch, therefore use only a very small amount.

The final positioning of the p.c.b. in the case and all interwiring is shown in the photograph. The use of p.c.b. pins will now be appreciated at this stage.

Fit the case lid and secure with the single fixing screw. Open the battery compartment lid and insert a PP3 battery, carefully observing polarity since it is possible to insert the battery either way round.

## TESTING

For complete testing of the Quicktest all that is required is one diode and one pair of hands.

An initial test is performed by holding the Quicktest in one hand with the forefinger on the button touch pad and the thumb on the switch. Press the switch



and then with the other hand touch the front pad. The l.e.d.s should then start flashing alternately about twice every second each. (A bio-colour l.e.d. will obviously be changing colour in a similar fashion).

To test a diode, hold the device by one lead and touch its other lead to the front touch pad and press the test button. In this test only one l.e.d. will flash indicating that the diode is functional.

Reversing the polarity of the diode will cause the other l.e.d. to flash. When the anode (a) of the diode under test is touching the front pad l.e.d. D2 should flash and D1 when it is the cathode (k).

## FAULT FINDING

There is not really a lot which can go wrong with a circuit as simple as this one. The main causes of problems are incorrect assembly or overheating of the i.c.s when soldering - a case for d.i.l. sockets perhaps? Before jumping to conclusions though, check the battery first!

One problem which did occur during proto-typing involved the l.e.d.s. It would appear that the circuit works a lot better with the bi-colour l.e.d. (or the two separate ones) one way round than the other. This is presumably due to red and green l.e.d.s having different forward volt drops and efficiencies.

If one l.e.d. comes on faintly when the "test button" is pressed but no connections are made via the test pads the value of resistor R5 may need reducing slightly. This should not be made too low as it also affects the sensitivity of the Quicktest.

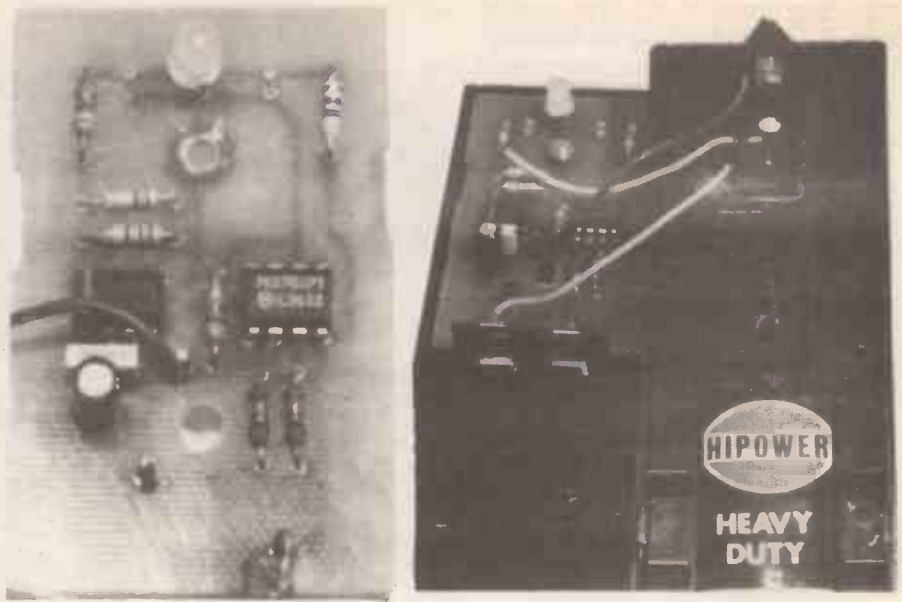

The completed circuit board showing the layout of components. Note the two cutout slots in the side of the board to ease mounting in the case. The photo on the right shows the wiring to the switch and one of the touch pads. The board mounting bolts also make contact with the other touch pad.

## MODIFICATION

If it is desired that the display be continuous for some reason rather than flashing this may be achieved, in appearance, by increasing the operating frequency of the astable multivibrator, IC1, such that it runs so fast that the eye cannot detect the individual flashes.

Reducing the values of resistors R1 to one kilohm and R2 to 10 kilohm will give approximately 700Hz. At this frequency no flicker will be visible. Now when a good fuse (or similar) is tested both l.e.d.s will appear to be lit continuously, or if a bi-colour l.e.d. is used it will appear orange or yellow. □

## CAMBRIDGE COMPUTER SCIENCE LIMITED

LCD modules.....	16 char by 1: £4.00, 20 char by 2: £6.00, 40 char by 1: £8.00
5.25" Disk Drives, 80 TK, DSDD.....	£25.00 each
5.25" Disk Drives, 80 TK, DSDD Used, No Wrtv.....	£9.00 each
(The £15.00 drives are sold on a strictly "as is" basis)	
5.25" Disks, DSDD, 48tpi, boxes of 10 (free disk cleaner with 5 boxes).....	£3.00/box
Digital multimeter, 14 ranges, inc. leads & manual.....	£18.00 each
Adriatic Disk drive PSU 5V or 2.5A, 12V or 2A.....	£4.80 each
5V or 10A PSU.....	£6.40 each
Disk Drive Data lead BBC Micro to Disk Drives.....	Single 2.00 Dual £4.00 each
Disk Drive Power lead BBC Micro to Disk Drives.....	Single 2.00 Dual £4.00 each
8086 CPU chips.....	£2.00 each
Z80A CPU, CTC, PIO.....	£1.20 each; DMA £2.00; £4.50 all 4
27128 EPROMs (EX Equipment).....	£1.20 each or £5.00/5
256K DRAM (EX Equipment).....	£0.40 each
1Mbit-10 DRAM (EX Equipment).....	£1.40 each
256K Byte DRAM Modules, removed from equipment.....	£6.00 each
16, 18 & 20 pin di low profile IC sockets 0.5" wide.....	£0.40/10; £3.00/100
22 & 24 pin di low profile IC sockets 0.4" wide.....	£0.40/10; £3.00/100
24, 28, 32, 40 & 48 pin di low profile IC sockets 0.6" wide.....	£0.40/10; £3.00/100
Circuit tester, finds faults in TTL & CMOS logic circuits, inc. leads.....	£8.00 each
Metal project boxes drilled & painted but unused 28 x 32.5 x 5cm.....	£5.00 each
Used computer cards many useful components (large ones socketed).....	£1.00 each
Floppy disk card (NEC FDC chip) £1.00, WinI controller (WD HDC chip).....	£3.00 each
8086, 280 & EPROMs.....	£8.00 each
Keyboards, Full Qwerty, number pad and LCD.....	£30.00 each
Desktop computer case with 200W mains PSU (used).....	£30.00 each

Prices include postage. Add 50p (plus VAT) to orders below £5.00. All items new unless stated.

Add 17.5% VAT to all prices. Send an SAE for our latest list or for more info.  
Dept EE, 374 Milton Road, Cambridge CB4 1SU  
Tel: 0223 424602, 0831 430496 or 0831 430552 (Mail order only)

## A. C. ELECTRONICS SURVEILLANCE?

### Easy-Build Kits or Built Units.

Microtransmitter, 15mm x 25mm, received on standard VHF radio; kit £5.99, built £9.99 (picks up whispers and transmits up to 1/2 mile). Telephone transmitter, can be hidden in handset; kit £5.99, built £9.99. "Stinger" shock circuit, can run off 9V battery, unpleasant shock, originally for electric fences etc; kit £11.99, built £19.99. Lots of locksmith tools, transmitters in calculators, plug-in adaptors, alternative technology plans, surveillance kits etc.

Send 4 x 1st class loose stamps for list - Cheque/POs to:

A.C. ELECTRONICS, Dept. E.E.  
53, WOODLAND WAY, BURNTWOOD,  
STAFFS WS7 8UP.

CREDIT CARD ORDERS: 0543 676477 (24 hours).

MAIL ORDER ONLY.

Devices not licenceable or BT approved.

LEDs, 3mm or 5mm red or green 6p each, yellow 11p each. High intensity red, green or yellow, 5mm 30p each.	Resistor jumbo pack 25000, 1/4 and 1/2W resistors our choice of values and size, will be mainly in boxes or rolls of 1000, 2000 and 5000 of one type.....
Cable ties 1p each, £5.95 per 1000, £49.50 per 10,000.	Querty keyboard, 58 key good quality switches, new.....
Stepping motor 4 phase 12V 7.5' step 50 ohms.....	Querty keyboard with serial output, no data (used).....
SAA1027 stepping motor driver chip.....	£6.00
FM Transmitter kit, good quality sound.....	£8.60
High quality photo resist copper clad epoxy glass boards.....	
Dimensions.....	
3x4 inches.....	£0.95
4x8 inches.....	£2.40
6x12 inches.....	£5.37
12x12 inches.....	£10.66
Rechargeable Batteries.....	
AA (HP7) 500mAh.....	£0.99
AA 700mAh.....	£1.95
C 2AH with solder tags.....	£3.60
D 4AH with solder tags.....	£4.95
1/2AA with solder tags.....	£1.55
AAA (HP18) 150mAh.....	£1.75
AA 500mAh with solder tags.....	£1.55
C (HP11) 1.8AH.....	£2.20
D (HP2) 1.2AH.....	£2.60
PP3 8.4V 10mAh.....	£4.95
Sub C with solder tags.....	£2.50
1/3 AA with tags (Philips CTV).....	£1.95
Standard charger, charges 4 AA cells in 5 hours or 4Cs or Ds in 12-14 hours + 1xPP3 (1, 2, 3 or 4 cells may be charged at a time).....	£5.95
High power charger, as above but charges the Cs and Ds in 5 hours, AAs, Cs and Ds must be charged in 2s or 4s.....	£10.95
Special offers - please check for availability.....	
F cells 32dia x 87mm.....	£3.95
F cell with solder tags, 1.2V.....	£4.30
42mm x 16mm dia, 1.2V.....	£1.45
Stick of 4 171mm x 16mm dia., with red & black leads 4.8V.....	£5.95
4 cell battery 94mm x 25mm dia (1/2C cells).....	£3.50
Computer grade capacitors with screw terminals, 38000µf 20V £2.50; 87000µf 10V £1.95; 68000µf 15V £2.95; 10000µf 16V £1.50	
7 segment common anode led display, 12mm.....	£0.45
LM2931 AT 5.0 low drop out 5V regulator TO220 package.....	£0.85
7812 and 7912 12V 1A regulators.....	£20.00 per 100
LM337k TO3 case variable regulator, 100+.....	£1.60
BS250 P channel mosfet 45p, BC559 transistor.....	per 100 £3.95
74LS05 hex inverter.....	£10.00 per 100
Used 8748 Microcontroller.....	£3.50
SL952 UHF Limiting amplifier LC 16 surface mounting package with data sheet.....	£1.95
AM27502.....	£1.25 each; 90p 100+ CD4007UB.....
10p 100+; 8p 1000+ TV Mains switch, 4A double pole with momentary contacts for remote control, pack of 10.....	£3.95
box of 60 £19.95	
DC-DC converter, Reliability model, V12PS, 12V in 5V 200mA out, 300V input to output, isolation with data, £4.95 each or pack of 10 - £39.50	
Hour counter used 7 digit 240V ac 50Hz.....	£1.45
Resistor pack 2500 resistors 1/8-2W 50 different values.....	£8.95
Philips 123 series solid aluminum axial leads, 33µf 10V & 2µf 40V 40p each, 25p 100+ Multilayer AVX ceramics capacitors all 5mm pitch, 100V 100p, 150p, 220p, 10,000p (10n) 10p each, 5p 100+, 3.5p 1000+ Welwyn W23 9W 120 ohm 35p each, 20p 100+ 680 ohm 2W metal film resistor, 4p 100+.....	2p 1000+ 100+ & 7.5p each
Solid carbon resistors, very low inductance, ideal for RF circuits, 27ohm 2W, 68ohm 2W 25p each, 15p each 100+ - we have a range of 0.25W, 0.5w, 1w and 2w solid carbon resistors - please send SAE for list	
Intelligent 4 digit alphanumerics (5x7 dot 0.145"), red LED display, 12 pin 0.6 inch wide package, Siemens type DLR1414 £2.50 each, £2.00 30+ data sheets £1.00	
AMD 27256-3 EPROMs £2.00 each, £1.25 100+ DIP switch 3PCO 12 pin (ERG SDC-3-023) 60p each, 40p 100+	
MODEMS	
V22/V22bis IBM PC internal full length card modem, BT approved, can be set to com 1 or 2, 1200/2400 baud with software and manual, not Hayes compatible, made by Plessey.....	£55.00
V32 3600 baud and 4800 baud GEC Plessey telecom external modem, model 9632, Hayes compatible and BT approved, with auto call, auto answer, using V25, V25bis and Hayes AT protocols and V54 remote + local diagnostics. It does not work on slower speeds. V22/1200 baud etc and needs 1 internal dip switch to be switched on to select Hayes commands. It comes with a 100+ page comprehensive A4 size manual. An all together brilliant machine for only.....	£199 + VAT = £233.83
All products advertised are new and unused unless otherwise stated.	
Wide range of CMOS TTL 74HC 74F Linear Transistors kits, rechargeable batteries, capacitors, tools etc. always in stock	
Please add 95p towards P&P VAT included in all prices	

## JPG ELECTRONICS

276-278 Chatsworth Road  
Chesterfield S40 2BH

Access Visa Orders:  
(0246) 211202

Callers welcome



# SPECIAL EVERYDAY ELECTRONICS BOOKS

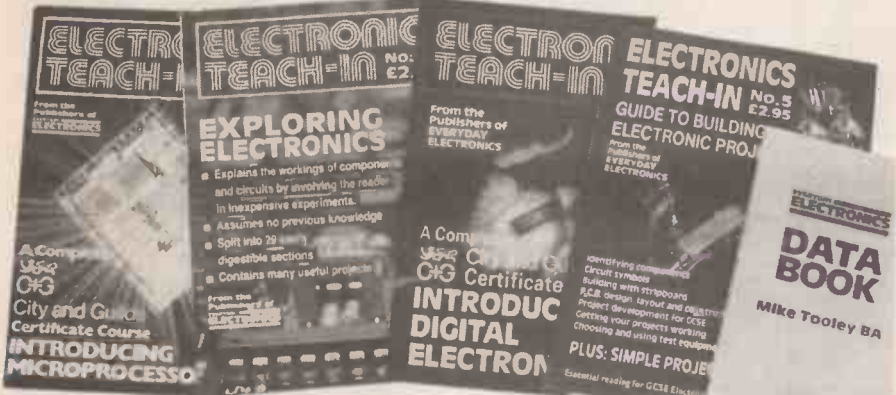

## ELECTRONICS TEACH-IN 89/89-INTRODUCING MICROPROCESSORS

Mike Tooley BA (published by *Everyday Electronics*)  
A complete course that can lead successful readers to the award of a City and Guilds Certificate in Introductory Microprocessors (726/303). The book contains everything you need to know including full details on registering for assessment, etc.

Sections cover Microcomputer Systems, Micro-processors, Memories, Input/Output, Interfacing and Programming. There are various practical assignments and eight Data Pages covering the most popular microprocessor chips.

An excellent introduction to the subject even for those who do not wish to take the City and Guilds assessment.  
80 pages (A4 size) Order code **TI-88** £2.45

## ELECTRONIC PROJECTS BOOK 1

Published by *Everyday Electronics* in association with *Magenta Electronics*.

Contains twenty of the best projects from previous issues of *EE* each backed with a kit of components. The projects are: Seashell Sea Synthesiser, EE Treasure Hunter, Mini Strobe, Digital Capacitance Meter, Three Channel Sound to Light, BBC 16K sideways Ram, Simple Short Wave Radio, Insulation Tester, Stepper Motor interface, Eprom Eraser, 200MHz Digital Frequency Meter, Infra Red Alarm EE Equaliser

loniser, Bat Detector, Acoustic Probe, Mainstester and Fuse Finder, Light Rider - (Label Badge, Disco Lights, Chaser Light), Musical Doorbell, Function Generator, Tilt Alarm, 10W Audio Amplifier, EE Buccaneer Induction Balance Metal Detector, BBC Midi Interface, Variable Bench Power Supply, Pet Scarer, Audio Signal Generator.  
128 pages (A4 size) Order code **EP1** £2.45

## ELECTRONICS TEACH-IN No. 3 - EXPLORING ELECTRONICS (published by *Everyday Electronics*)

Owan Bishop  
Another *EE* value for money publication aimed at students of electronics. The course is designed to explain the workings of electronic components and circuits by involving the reader in experimenting with them. The book does not contain masses of theory or formulae but straightforward explanations and circuits to build and experiment with.

Exploring Electronics contains more than 25 useful projects, assumes no previous knowledge of electronics and is split into 28 easily digestible sections.  
88 pages (A4 size) Order code **TI3** £2.45

## ELECTRONICS TEACH-IN No. 4 - INTRODUCING DIGITAL ELECTRONICS (published by *Everyday Electronics*)

Michael J. Cockcroft  
Although this book is primarily a City & Guilds Introductory level course (726/301), approximately 80% of the informa-

tion forms a very basic introduction to electronics in general, it therefore provides an excellent introductory text for beginners and a course and reference book for GCSE students.

Full details on registering for C&G assessment, details of assessment centres, components required and information on the course in general are given.

The City & Guilds introduction to module 726/301 reads: "A candidate who satisfactorily completes this module will have a competence to identify basic components and digital integrated circuits and connect them together to form simple working circuits and logic units." This provides an excellent introduction to the book.  
112 pages (A4 size) Order code **TI4** £2.95

## ELECTRONICS TEACH-IN No. 5 GUIDE TO BUILDING ELECTRONIC PROJECTS

Published by *EVERYDAY ELECTRONICS*  
Due to the demand from students, teachers and hobbyists we have put together a range of articles from past issues of *Everyday Electronics* that will assist those involved with the construction of electronic projects.

The book contains the complete *Project Development for GCSE* series.

Contents: Features - First Steps in Project Building; Building with Vero; Project Development for GCSE; Getting your Projects Working; Guide to Printed Circuit Boards; Choosing and Using Test Equipment - The Multimeter, The Oscilloscope, P.S.U.s, Logic Probes, Digital Frequency Meters, Signal Generators, etc; Data - Circuit Symbols; Component Codes; Resistors; Identifying Components; Capacitors; Actually Doing It - Understanding the Circuit Diagram, Component Codes, Mounting circuit boards and controls, Understanding Capacitors; Projects - Lie Detector; Personal Stereo Amplifier; Digital Experimenters' Unit; Quizmaster; Siren Effects Unit; UV Exposure Unit; Low-cost Capacitance Meter; Personal Radio.  
88 pages (A4 size) Order code **TI5** £2.95

## EVERDAY ELECTRONICS DATA BOOK

Mike Tooley BA (published by *EE* in association with *PC Publishing*)

This book is an invaluable source of information of everyday relevance in the world of electronics. It contains not only sections which deal with the essential theory of electronic circuits, but it also deals with a wide range of practical electronic applications.

It is ideal for the hobbyist, student, technician and engineer. The information is presented in the form of a basic electronic recipe book with numerous examples showing how theory can be put into practice using a range of commonly available "industry standard" components and devices.

A must for everyone involved in electronics!  
256 pages Order code **DATA** £8.95

# DIRECT BOOK SERVICE

The books listed have been selected by *Everyday Electronics* editorial staff as being of special interest to everyone involved in electronics and computing. They are supplied by mail order direct to your door. Full ordering details are given on the last book page. For another selection of books see next month's issue

## ELECTRONIC TEST EQUIPMENT HANDBOOK

Steve Money

The principles of operation of the various types of test instrument are explained in simple terms with a minimum of mathematical analysis. The book covers analogue and digital meters, bridges, oscilloscopes, signal generators, counters, timers and frequency measurement. The practical uses of the instruments are also examined.

Everything from Audio oscillators, through R, C & L measurements (and a whole lot more) to Waveform Generators and testing Zeners. A truly comprehensive book for the hobbyist, student, technician and engineer.  
206 pages Order code **TE109** £8.95

## HOW TO TEST ALMOST EVERYTHING ELECTRONIC - 2nd EDITION

Jack Darr and Delton T. Horn

Describes electronic tests and measurements - how to make them with all kinds of test equipment, and how to interpret the results. New sections in this edition include logic probes, frequency counters, capacitance meters, and more. (An American book.)  
190 pages Order code **T2925** £9.05

## GETTING THE MOST FROM YOUR MULTIMETER

R. A. Penfold

This book is primarily aimed at beginners and those of limited experience of electronics. Chapter 1 covers the basics of analogue and digital multimeters, discussing the relative merits and the limitations of the two types. In Chapter 2 various methods of component checking are described, including tests for transistors, thyristors, resistors, capacitors and diodes. Circuit testing is covered in Chapter 3, with subjects such as voltage, current and continuity checks being discussed.

In the main little or no previous knowledge or experience is assumed. Using these simple component and circuit testing techniques the reader should be able to confidently tackle servicing of most electronic projects.  
96 pages Order code **BP239** £2.95

## MORE ADVANCED USES OF THE MULTIMETER

R. A. Penfold

This book is primarily intended as a follow-up to BP239, (see above), and should also be of value to anyone who already understands the basics of voltage testing and simple component testing. By using the techniques described in chapter 1 you can test and analyse the performance of a range of components with just a multimeter

## TESTING, THEORY AND REFERENCE

(plus a very few inexpensive components in some cases). Some useful quick check methods are also covered.

While a multimeter is supremely versatile, it does have its limitations. The simple add-ons described in chapter 2 extended the capabilities of a multimeter to make it even more useful. The add-ons described include an active r.f. probe, a high resistance probe, an a.c. sensitivity booster, and a current tracer unit.  
84 pages Order code **BP255** £2.95

## THE ILLUSTRATED DICTIONARY OF ELECTRONICS - 4th EDITION

Rufus P. Turner and Stan Gibilisco

With more than 27,000 terms used in electronics today, this collection is THE most comprehensive dictionary available. Including all practical electronics and computer terms, it is as up-to-date as the latest advances in the field itself! Tables and data on subjects most often consulted for projects and experiments are included. Other conversion tables include English/metric and metric/English conversions for units of energy, power and volume, and Fahrenheit/Celsius temperature conversion charts.

Setting this edition apart from other electronic dictionaries is its emphasis on illustration. Featuring more than complete definitions, this fourth edition includes over 450 detailed drawings and diagrams.

All entries are listed in alphabetical order. Abbreviations and initials are listed in sequence with whole words. All terms of more than one word are treated as one word. (An American book.)  
648 pages Order code **T2900** £23.95

## ELECTRONICS - A "MADE SIMPLE" BOOK

G. H. Olsen

This book provides excellent background reading for our *Introducing Digital Electronics* series and will be of interest to everyone studying electronics. The subject is simply explained and well illustrated and the book assumes only a very basic knowledge of electricity.  
330 pages Order code **NE10** £4.95

## PRACTICAL ELECTRONICS CALCULATIONS AND FORMULAE

F. A. Wilson, C.G.I.A., C.Eng., F.I.E.E., F.I.E.R.E., F.B.I.M.  
Bridges the gap between complicated technical theory, and "cut-and-try" methods which may bring success in design but leave the experimenter unfulfilled. A strong

practical bias - tedious and higher mathematics have been avoided where possible and many tables have been included.

The book is divided into six basic sections: Units and Constants, Direct-current Circuits, Passive Components, Alternating-current Circuits, Networks and Theorems, Measurements.  
256 pages Order code **EP53** £3.95

## PRACTICAL DIGITAL ELECTRONICS HANDBOOK

Mike Tooley (Published in association with *Everyday Electronics*)

The vast majority of modern electronic systems rely heavily on the application of digital electronics, and the *Practical Digital Electronics Handbook* aims to provide readers with a practically based introduction to this subject. The book will prove invaluable to anyone involved with the design, manufacture or servicing of digital circuitry, as well as to those wishing to update their knowledge of modern digital devices and techniques. Contents: Introduction to integrated circuits; basic logic gates; monostable and bistable devices; timers; microprocessors; memories; input and output devices; interfaces; microprocessor buses. Appendix 1: Data. Appendix 2: Digital test gear projects; tools and test equipment; regulated bench power supply; logic probe; logic pulser; versatile pulse generator; digital IC tester; current tracer; audio logic tracer; RS-232C breakout box; versatile digital counter/frequency meter. Appendix 3: The oscilloscope. Appendix 4: Suggested reading. Appendix 5: Further study.  
208 pages Order code **PC100** £6.95

## ELECTRONICS-BUILD AND LEARN

R. A. Penfold

The first chapter gives full constructional details of a circuit demonstrator unit that is used in subsequent chapters to introduce common electronic components - resistors, capacitors, transformers, diodes, transistors, thyristors, fets and op amps. Later chapters go on to describe how these components are built up into useful circuits, oscillators, multivibrators, bistables and logic circuits.

At every stage in the book there are practical tests and experiments that you can carry out on the demonstrator unit to investigate the points described and to help you understand the principles involved. You will soon be able to go on to more complex circuits and tackle fault finding logically in other circuits you build.  
120 pages Order code **PC103** £5.95

# AUDIO AND MUSIC

## LOUDSPEAKERS FOR MUSICIANS

NEW

Vivian Capel

This book contains all that a working musician needs to know about loudspeakers; the different types, how they work, the most suitable for different instruments, for cabaret work, and for vocals. It gives tips on constructing cabinets, wiring up, when and where to use wadding, and when not to, what fittings are available, finishing, how to ensure they travel well, how to connect multi-speaker arrays and much more.

Ten practical enclosure designs with plans and comments are given in the last chapter, but by the time you've read that far you should be able to design your own!  
164 pages **Order code BP297** **£3.95**

## MAKE MONEY FROM HOME RECORDING

Clive Brooks

Now that you've spent a fortune on all that recording gear, MIDI and all, wouldn't it be nice to get some of it back? Well here's the book to show you how.

It's packed with money making ideas, any one of which will recoup the price of the book many times over. Whether you have a fully fledged recording studio at home, or just a couple of stereo cassette recorders and a microphone, you'll be able to put the ideas in this book into practice and make money.  
105 pages **Order code PC104** **£5.95**

## INTRODUCTION TO DIGITAL AUDIO

(Second Edition)

Ian Sinclair

Digital recording methods have existed for many years and have become familiar to the professional recording engineer, but the compact disc (CD) was the first device to bring digital audio methods into the home. The next step is the appearance of digital audio tape (DAT) equipment.

All this development has involved methods and circuits that are totally alien to the technician or keen amateur who has previously worked with audio circuits. The principles and practices of digital audio owe little or nothing to the traditional linear circuits of the past, and are much more comprehensible to today's computer engineer than the older generation of audio engineers.

This book is intended to bridge the gap of understanding for the technician and enthusiasts. The principles and methods are explained, but the mathematical background and theory is avoided, other than to state the end product.  
128 pages **Order code PC102** **£6.95**

## SYNTHESIZERS FOR MUSICIANS

R. A. Penfold

Modern synthesizers are extremely complex, but they mostly work on principles that are not too difficult to

understand. If you want to go beyond using the factory presets or the random poking of buttons, this is the book for you.

It covers the principles of modern synthesis - linear arithmetic as used by Roland, phase distortion (Casio), Yamaha's frequency modulation, and sampling - and then describes how the instruments are adjusted to produce various types of sound - strings, brass, percussion, etc. The theoretical side of synthesis is treated in an easy to understand way - the technical information being restricted to what you need to know to use your instrument effectively.  
168 pages **Order code PC105** **£6.95**

## AUDIO

F. A. Wilson, C. G. I. A., C.Eng., F.I.E.E., F.I.E.R.E., F.B.I.M.

Analysis of the sound wave and an explanation of acoustical quantities prepare the way. These are followed by a study of the mechanism of hearing and examination of the various sounds we hear. A look at room acoustics with a subsequent chapter on microphones and loudspeakers then sets the scene for the main chapter on audio systems - amplifiers, oscillators, disc and magnetic recording and electronic music.  
320 pages **Order code BP111** **£3.95**

# CIRCUITS AND DESIGN

## REMOTE CONTROL HANDBOOK

Owan Bishop

Remote control systems lend themselves to a modular approach. This makes it possible for a wide range of systems, from the simplest to the most complex, to be built up from a number of relatively simple modules. The author has tried to ensure that, as far as possible, the circuit modules in this book are compatible with one another. They can be linked together in many different configurations to produce remote control systems tailored to switch a table lamp on and off, or to operate an industrial robot, this book should provide the circuit you require.  
226 pages **Order code BP240** **£3.95**

## COIL DESIGN AND CONSTRUCTION MANUAL

B. B. Babani

A complete book for the home constructor on "how to make" RF, IF, audio and power coils, chokes and transformers. Practically every possible type is discussed and calculations necessary are given and explained in detail. Although this book is now rather old, with the exception of torroids and pulse transformers little has changed in coil design since it was written.  
96 pages **Order code 160** **£2.50**

## 30 SOLDERLESS BREADBOARD PROJECTS - BOOK 1

R. A. Penfold

Each project, which is designed to be built on a "Verobloc" breadboard, is presented in a similar fashion with a brief circuit description, circuit diagram, component layout diagram, components list and notes on construction and use where necessary. Whenever possible, the components used are common to several projects, hence with only a modest number of reasonably inexpensive components, it is possible to build in turn, every project shown. Recommended by BICC-Verob.  
160 pages **Order code BP107** **£2.95**

## BOOK 2 -

All projects use CMOS i.c.s. but the items on component identification etc., are not repeated from Book 1.  
160 pages **Order code BP113** **£2.25**

## ELECTRONIC CIRCUITS HANDBOOK

Michael Tooley BA

This book aims to explode two popular misconceptions concerning the design of electronic circuits: that only those with many years of experience should undertake circuit design and that the process relies on an understanding of advanced mathematics. Provided one is not too ambitious, neither of these popularly held beliefs is true.

Specifically, this book aims to provide the reader with a unique collection of practical working circuits together with supporting information so that circuits can be produced in the shortest possible time and without recourse to theoretical texts.

Furthermore, information has been included so that the circuits can readily be modified and extended by readers to meet their own individual needs. Related circuits have been grouped together and cross-referenced within the text (and also in the index) so that readers are aware of which circuits can be readily connected together to form more complex systems. As far as possible, a common range of supply voltages, signal levels and impedances has been adopted.

As a bonus, ten test gear projects have been included. These not only serve to illustrate the techniques described but also provide a range of test equipment which is useful in its own right.  
277 pages **Temporarily out of print**

## AUDIO IC CIRCUITS MANUAL

R. M. Marston

A vast range of audio and audio-associated i.c.s. are readily available for use by amateur and professional design engineers and technicians. This manual is a guide to the most popular and useful of these devices, with over 240 diagrams. It deals with i.c.s. such as low frequency linear amplifiers, dual pre-amplifiers, audio power amplifiers, charge coupled device delay lines, bar-graph display drivers, and power supply regulators, and shows how to use these devices in circuits ranging

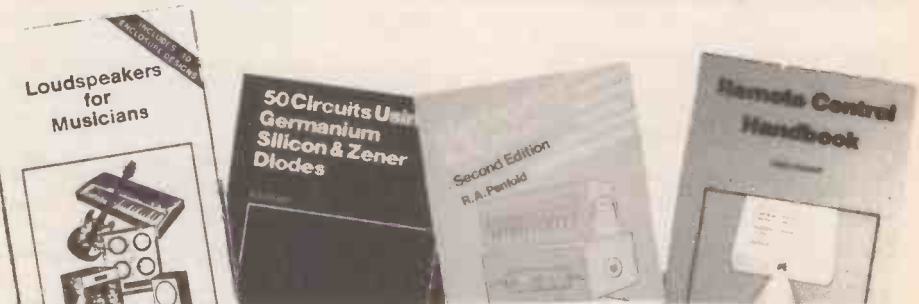

from simple signal conditioners and filters to complex graphic equalizers, stereo amplifier systems, and echo/reverb delay line systems etc.  
168 pages **Order code NE13** **£12.95**

## HOW TO DESIGN ELECTRONIC PROJECTS

R. A. Penfold

The aim of this book is to help the reader to put together projects from standard circuit blocks with a minimum of trial and error, but without resorting to any advanced mathematics. Hints on designing circuit blocks to meet your special requirements are also provided.  
128 pages **Temporarily out of print**

## 50 CIRCUITS USING GERMANIUM SILICON AND ZENER DIODES

R. N. Soar

Contains 50 interesting and useful circuits and applications, covering many different branches of electronics, using one of the most simple and inexpensive of components - the diode. Includes the use of germanium and silicon signal diodes, silicon rectifier diodes and Zener diodes, etc.  
64 pages **Order code BP36** **£1.95**

## DESIGNING WITH LINEAR ICs

G. C. Loveday

SPECIAL PRICE

A book that deals with the design of the vital area of analog circuitry covering design with modern linear integrated circuit devices. The first chapter introduces the reader to important design techniques, test strategies, layout, and protection and also includes a section on the use of a typical CAD tool. There are separate chapters that cover in depth the use of op-amps, comparators and timers each with detailed design examples and reader exercises. A final chapter brings all the previous work together in a number of complete design problems with fully worked solutions. The text is essentially non-mathematical and is supported by many diagrams.  
64 pages **Order code BM3** **Special Price £5.00**

## TIMER/GENERATOR CIRCUITS MANUAL

R. M. Marston

This manual is concerned mainly with waveform generator techniques and circuits. Waveform generators are used somewhere or other in most types of electronic equipment, and thus form one of the most widely used classes of circuit. They may be designed to produce outputs with sine, square, triangle, ramp, pulse, staircase, or a variety of other forms. The generators may produce modulated or unmodulated outputs, and the outputs may be of single or multiple form.

Waveform generator circuits may be built using transistors, op-amps, standard digital ICs, or dedicated waveform or "function" generator ICs.

The manual is divided into eleven chapters, and presents over 300 practical circuits, diagrams and tables. The subjects covered include: Basic principles; Sine wave generators; Square wave generators; Pulse generator circuits; "Timer IC" generator circuits; Triangle and sawtooth generators; Multi-waveform generation; Waveform synthesizer ICs; Special waveform generators; Phase-locked loop circuits; Miscellaneous "555" circuits.  
267 pages **Order code NE18** **£12.95**

## OPTOELECTRONICS CIRCUITS MANUAL

R. M. Marston

A useful single-volume guide to the optoelectronic device user, specifically aimed at the practical design engineer, technician, and the experimenter, as well as the electronics student and amateur. It deals with the subject in an easy-to-read, down-to-earth, and non-mathematical yet comprehensive manner, explaining the basic principles and characteristics of the best known devices, and presenting the reader with many practical applications and over 200 circuits. Most of the i.c.s. and other devices used are inexpensive and readily available types, with universally recognised type numbers.  
182 pages **Order code NT 4** **£12.95**

## POPULAR ELECTRONIC CIRCUITS - BOOK 1

POPULAR ELECTRONIC CIRCUITS - BOOK 2

R. A. Penfold

Each book provides a wide range of designs for electronic enthusiasts who are capable of producing working projects from just a circuit diagram without the aid of detailed construction information. Any special setting-up procedures are described.

**BOOK 1 160 pages** **Order code BP80** **£2.95**  
**BOOK 2 160 pages** **Order code BP98** **£2.95**

## CMOS CIRCUITS MANUAL

R. M. Marston

Written for the professional engineer, student or enthusiast. It describes the basic principles and characteristics of these devices and includes over 200 circuits.

All the circuits have been designed, built and fully evaluated by the author; all use inexpensive and internationally available devices.  
187 pages **Order code NT 12** **£12.95**

Note - our postage charge is the same for one book or one hundred books!

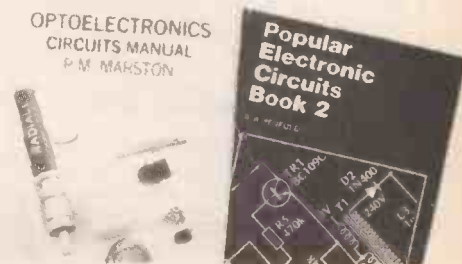

## PROJECT CONSTRUCTION

### HOW TO DESIGN AND MAKE YOUR OWN P.C.B.s

R. A. Penfold  
Deals with the simple methods of copying printed circuit board designs from magazines and books and covers all aspects of simple p.c.b. construction including photographic methods and designing your own p.c.b.s.  
80 pages **Order code BP121** £2.50

### HOW TO GET YOUR ELECTRONIC PROJECTS WORKING

R. A. Penfold  
We have all built projects only to find that they did not work correctly, or at all, when first switched on. The aim of this book is to help the reader overcome just these problems by indicating how and where to start looking for many of the common faults that can occur when building up projects.  
96 pages **Order code BP110** £2.50

### ELECTRONIC SCIENCE PROJECTS

O. Bishop  
These projects range in complexity from a simple colour temperature meter to an infra-red laser. There are novelties such as an electronic clock regulated by a resonating spring, and an oscilloscope with solid-state display. There are scientific measuring instruments such as a pH meter and an electro-cardiometer. All projects have a strong scientific flavour. The way they work, and how to build and use them are fully explained.  
144 pages **Temporarily out of print**

### BEGINNER'S GUIDE TO BUILDING ELECTRONICS PROJECTS

R. A. Penfold  
Shows the complete beginner how to tackle the practical side of electronics, so that he or she can confidently build the electronic projects that are regularly featured in

magazines and books. Also includes examples in the form of simple projects.  
112 pages **Order code 227** £1.95

### TEST EQUIPMENT CONSTRUCTION

R. A. Penfold  
This book describes in detail how to construct some simple and inexpensive but extremely useful, pieces of test equipment. Stripboard layouts are provided for all designs, together with wiring diagrams where appropriate, plus notes on construction and use.  
The following designs are included:- AF Generator, Capacitance Meter, Test Bench Amplifier, AF Frequency Meter, Audio Millivoltmeter, Analogue Probe, High Resistance Voltmeter, CMOS Probe, Transistor Tester, TTL Probe. The designs are suitable for both newcomers and more experienced hobbyists.  
104 pages **Order code BP246** £2.95

## DATA AND COMPONENT IDENTIFICATION

### CHART OF RADIO, ELECTRONIC, SEMICONDUCTOR AND LOGIC SYMBOLS

M. H. Banani B.Sc. (Eng.)  
Illustrates the common, and many of the not-so-common, radio, electronic, semiconductor and logic symbols that are used in books, magazines and instruction manuals, etc., in most countries throughout the world.  
Chart **Order code BP27** £0.95

### INTERNATIONAL TRANSISTOR EQUIVALENTS GUIDE

A. Michaeles  
Helps the reader to find possible substitutes for a popular selection of European, American and Japanese transistors. Also shows material type, polarity, manufacturer and use.  
320 pages **Order code BP85** £3.95

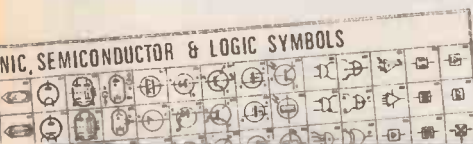

## RADIO, TV, SATELLITE

### AN INTRODUCTION TO RADIO DXING

R. A. Penfold  
Anyone can switch on a short wave receiver and play with the controls until they pick up something, but to find a particular station, country or type of broadcast and to receive it as clearly as possible requires a little more skill and knowledge. The object of this book is to help the reader to do just that, which in essence is the fascinating hobby of radio DXing.  
112 pages **Order code BP91** £1.95

### EXPERIMENTAL ANTENNA TOPICS

H. C. Wright  
Although nearly a century has passed since Marconi's first demonstration of radio communication, there is still research and experiment to be carried out in the field of antenna design and behaviour.  
The aim of the experimenter will be to make a measurement or confirm a principle, and this can be done with relatively fragile, short-life apparatus. Because of this, devices described in this book make liberal use of cardboard, cooking foil, plastic bottles, cat food tins, etc. These materials are, in general, cheap to obtain and easily

worked with simple tools, encouraging the trial-and-error philosophy which leads to innovation and discovery.  
Although primarily a practical book with text closely supported by diagrams, some formulae which can be used by straightforward substitution and some simple graphs have also been included.  
72 pages **Order code BP278** £3.50

### SETTING UP AN AMATEUR RADIO STATION

I. D. Poole  
The aim of this book is to give guidance on the decisions which have to be made when setting up any amateur radio or short wave listening station. Often the experience which is needed is learned by one's mistakes, however, this can be expensive. To help overcome this, guidance is given on many aspects of setting up and running an efficient station. It then proceeds to the steps that need to be taken in gaining a full transmitting licence.  
Topics covered include: The equipment that is needed; Setting up the shack; Which aerials to use; Methods of construction; Preparing for the licence.  
An essential addition to the library of all those taking their first steps in amateur radio.  
86 pages **Order code BP300** £3.95

### NEWNES SHORTWAVE LISTENING HANDBOOK

Joe Pritchard G1UQW  
Part One covers the "science" side of the subject, going from a few simple electrical "first principles", through a brief treatment of radio transmission methods to simple receivers. The emphasis is on practical receiver designs and how to build and modify them, with several circuits in the book.  
Part Two covers the use of sets, what can be heard, the various bands, propagation, identification of stations, sources of information, QSLing of stations and listening to amateurs. Some computer techniques, such as computer Morse decoding and radio teletype decoding are also covered.  
224 pages **Order code NP16** £14.95

## COMPUTING

### SERVICING PERSONAL COMPUTERS - 2nd EDITION

Mike Tooley BA  
The revised and enlarged second edition contains a new chapter on the IBM PC, AT, TX and compatibles. It is essential for anyone concerned with the maintenance of personal computer equipment or peripherals, whether professional service technician, student or enthusiast.  
240 pages (Hard cover) **Order code NP15** £25

The subjects covered include: PC overview, Memory upgrades; Adding a hard disk drive; Adding a floppy disk drive; Display adaptors and monitors; Fitting a maths co-processor; Keyboards; Ports; Mice and digitisers; Maintenance (including preventative maintenance) and Repairs, and the increasingly popular subject of d.i.y. PCs.  
156 pages **Order code BP271** £4.95

### AN INTRODUCTION TO PROGRAMMING THE BBC MODEL B MICRO

R. A. & J. W. Penfold  
Written for readers wanting to learn more about programming and how to make best use of the incredibly powerful Model B's versatile features. Most aspects of the BBC Micro are covered, the omissions being where little could usefully be added to the information provided by the manufacturer's own manual.  
144 pages **Order code BP139** £1.95

### AN INTRODUCTION TO 6502 MACHINE CODE

R. A. & J. W. Penfold  
No previous knowledge of microprocessors or

machine code is assumed. Topics covered are: assembly language and assemblers, the register set and memory, binary and hexadecimal numbering systems, addressing modes and the instruction set, and also mixing machine code with BASIC. Some simple programming examples are given for 6502-based home computers like the VIC-20, ORIC-1/Atmos, Electron, BBC and also the Commodore 64.  
112 pages **Order code BP147** £2.95

### HOW TO EXPAND, MODERNISE AND REPAIR PCs AND COMPATIBLES

R. A. Penfold  
Not only are PC and compatible computers very expandable, but before long most users actually wish to take advantage of that expandability and start upgrading their PC systems. Some aspects of PC upgrading can be a bit confusing, but this book provides advice and guidance on the popular forms of internal PC expansion, and should help to make things reasonably straightforward and painless. Little knowledge of computing is assumed. The only assumption is that you can operate, a standard PC of some kind (PC, PC XT, PC AT, or a 80386 based PC).

### THE PRE-BASIC BOOK

F. A. Wilson, C.G.I.A., C.ENG., F.I.E.E., F.I.E.R.E., F.B.I.M.  
Another book on BASIC but with a difference. This one does not skip through the whole of the subject and thereby leave many would-be programmers floundering but instead concentrates on introducing the technique by looking in depth at the most frequently used and more easily understood computer instructions. For all new and potential micro users.  
192 pages **Order code BP146** £2.95

# DIRECT BOOK SERVICE ORDERING DETAILS

Please state the title and order code clearly, print your name and address and add the required postage to the total order.

Add 75p to your total order for postage and packing (overseas readers add £1.50 for countries in Europe, or add £2.50 for all countries outside Europe, surface mail postage) and send a PO, cheque, international money order (£ sterling only) made payable to Direct Book Service or credit card details (including card expiry date), Visa or Mastercard (Access) - minimum credit card order is £5 - quoting your name and address, the order code and quantities required to DI-

RECT BOOK SERVICE, 33 GRAVEL HILL, WIMBORNE, DORSET BH21 1RW (mail order only).

Although books are normally sent within seven days of receipt of your order, please allow a maximum of 28 days for delivery. Overseas readers allow extra time for surface mail post.

Please check price and availability (see latest issue of *Everyday Electronics*) before ordering from old lists.

Note - our postage charge is the same for one book or one hundred books!

## MORE BOOKS NEXT MONTH

DIRECT BOOK SERVICE IS A DIVISION OF WIMBORNE PUBLISHING LTD.

# BABANI BOOKS

We now supply *all* the books published by Bernard Babani (Publishing) Ltd. We have always supplied a selected list of Babani books and you will find many of them described on the previous pages or in next months issue of *Everyday Electronics* (the books with a BP prefix to the order code are Babani books).

Many readers have asked us to also supply various other Babani books, which have a reputation for value for money. Our customers tell us they appreciate our speedy service and low postage charge and they

would like to be able to purchase all the books from us and thus keep the postage charge to an absolute minimum (75p for UK p&p no matter how many books you buy). We are pleased to be able to respond; with the aid of Michael Babani (M.D.) we are now able to meet all your requirements for their books. *If it's Babani and in print we can supply it.* Babani presently list over 180 different technical titles those *not* described in detail on the previous *Direct Book Service* pages or in next months issue are listed below:

Code	Title	Price	Code	Title	Price	Code	Title	Price
208	Practical Stereo & Quadraphony Handbook	£0.75	BP144	Further Practical Electronics Calculations & Formulae	O.O.P.	BP247	More Advanced MIDI Projects	£2.95
214	Audio Enthusiast's Handbook	£0.85	BP145	25 Simple Tropical and MW Band Aerials	£1.75	BP249	More Advanced Test Equipment Construction	£3.50
219	Solid State Novelty Projects	£0.85	BP148	Computer Terminology Explained	£1.95	BP250	Programming in FORTRAN 77	£4.95
225	A Practical Introduction to Digital ICs	O.O.P.	BP149	A Concise Introduction to the Language of BBC Basic	£1.95	BP251	Computer Hobbyists Handbook	£5.95
BP28	Resistor Selection Handbook	£0.60	BP153	An Introduction to Programming the Amstrad CPC 464 & 664	£2.50	BP258	Learning to Program in C	£4.95
BP37	50 Projects using Relays, SCRs and TRIACS	£2.95	BP154	An Introduction to MSX BASIC	£2.50	BP259	A Concise Introduction to UNIX	£2.95
BP39	50 (FET) Field Effect Transistor Projects	£2.95	BP156	An Introduction to QL Machine Code	£2.50	BP260	A Concise Introduction to OS/2	£2.95
BP44	IC 555 Projects	£2.95	BP157	How to Write ZX Spectrum & Spectrum+ Games Programs	£2.50	BP261	A Concise Introduction to Lotus 1-2-3 (Revised Edition)	£3.95
BP48	Electronic Projects for Beginners	£1.95	BP158	An Introduction to Programming the Commodore 16 & Plus 4	£2.50	BP262	A Concise Introduction to Wordperfect (Revised Edition)	£3.95
BP49	Popular Electronic Projects	£2.50	BP159	How to Write Amstrad CPC464 Games Programs	£2.50	BP263	A Concise Introduction to dBASE	£3.95
BP56	Electronic Security Devices	O.O.P.	BP161	Into the QL Archive	£2.50	BP264	A Concise Advanced User's Guide to MS-DOS	O.O.P.
BP58	50 Circuits Using 7400 Series IC's	£2.50	BP162	Counting on QL Abacus	£2.50	BP269	An Introduction to Desktop Publishing	£5.95
BP63	Alternating Current Theory (Elements of Electronics - Book 2)	£3.50	BP171	Easy Add-on Projects for Amstrad CPC 464, 664, 6128 and MSX Computers	£2.95	BP270	A Concise Introduction to Symphony	£3.95
BP68	Choosing and Using Your Hi-Fi	£1.65	BP172	More Advanced Electronic Music Projects	£2.95	BP272	Interfacing PC's & Compatibles	£3.95
BP74	Electronic Music Projects	£2.50	BP175	How to Write Word Game Programs for the Amstrad CPC 464, 664 and 6128	£2.95	BP273	Practical Electronic Sensors	£4.95
BP76	Power Supply Projects	£2.50	BP182	MIDI Projects	£2.95	BP274	A Concise Introduction to SuperCal5	£3.95
BP78	Practical Computer Experiments	£1.75	BP183	An Introduction to CPM	£2.95	BP276	Short Wave Superhat Receiver Construction	£2.95
BP84	Digital IC Projects	£1.95	BP187	A Practical Reference Guide to Word Processing on the Amstrad PCWB256 and PCWB512	£5.95	BP277	High Power Audio Amplifier Construction	£3.95
BP86	An Introduction to BASIC Programming Techniques	£1.95	BP188	Using Your Amstrad CPC Disc Drives	£2.95	BP279	A Concise Introduction to Excel	£3.95
BP90	Audio Projects	£2.50	BP190	More Advanced Electronic Security Projects	£2.95	BP280	Getting the Most From Your PC's Hard Disc	£3.95
BP94	Electronic Projects for Cars and Boats	£1.95	BP191	Simple Application of the Amstrad CPCs for Writers	£2.95	BP283	A Concise Introduction to SmartWare II	£4.95
BP95	Model Railway Projects	£2.95	BP192	More Advanced Power Supply Projects	£2.95	BP284	Programming in QuickBASIC	£4.95
BP97	IC Projects for Beginners	£1.95	BP193	LOGO for Beginners	£2.95	BP286	A Reference Guide to Basic Electronics Terms	£5.95
BP99	Mini-matrix Board Projects	£2.50	BP194	BASIC & LOGO in Parallel	£2.95	BP288	A Concise Introduction to Windows 3.0	£3.95
BP106	Modern Op-amp Projects	£1.95	BP197	An Introduction to the Amstrad PC's	£5.95	BP291	A Concise Introduction to Ventura	£3.95
BP109	The Art of Programming the 1K ZX81	£1.95	BP198	An Introduction to Antenna Theory	£2.95	BP292	Public Address Loudspeaker Systems	£3.95
BP114	The Art of Programming the 16K ZX81	£2.50	BP199	An Introduction to BASIC-2 on the Amstrad PC's	£5.95	BP293	An Introduction to Radio Wave Propagation	£3.95
BP122	Audio Amplifier Construction	£2.95	BP200	A Concise Introduction to GEM	£2.95	BP294	A Concise Introduction to Microsoft Works	£4.95
BP125	25 Simple Amateur Band Aerials	£1.95	BP230	BBC BASIC86 on the Amstrad PC's and IBM Compatibles - Book 1: Language	£3.95	BP298	A Concise Introduction to the Mac System & Finder	£3.95
BP126	BASIC & PASCAL in Parallel	£1.50	BP244	BBC BASIC86 on the Amstrad PC's and IBM Compatibles - Book 2: Graphics and Disk Files	£3.95	BP299	Practical Electronic Filters	£4.95
BP128	20 Programs for the ZX Spectrum & 16K ZX81	£1.95	BP245	Digital Audio Projects	£2.95	BP302	A Concise Users Guide to Lotus 1-2-3 Release 3.1	£3.95
BP129	An Introduction to Programming the ORIC-1	£1.95	BP246	Musical Applications of the Atari ST's	£5.95	BP303	Understanding PC Software	£4.95
BP132	25 Simple SW Broadcast Band Aerials	£1.95				BP304	Projects for Radio Amateurs and S.W.L.s	£3.95
BP133	An Introduction to Programming the Dragon 32	£1.95				BP307	A Concise Introduction to QuarkXPress	£4.95
BP136	25 Simple Indoor and Window Aerials	£1.75				BP309	Preamplifier and Filter Circuits	£3.95
BP137	BASIC & FORTRAN in Parallel	£1.95				BP312	An Introduction to Microwaves	£3.95
BP138	BASIC & FORTH in Parallel	£1.95				BP313	A Concise Introduction to Sage	£3.95
BP143	An Introduction to Programming the Atari 600/800XL	£1.95				BP314	A Concise Introduction to Quattro Pro	£4.95
						BP318	A Concise User's Guide to MS-DOS 6	£4.95

IF NO PRICE IS SHOWN THE BOOK IS OUT OF PRINT (O.O.P.)  
SEE PREVIOUS PAGE FOR FULL ORDERING DETAILS

## PCB SERVICE

Printed circuit boards for certain EE constructional projects are available from the PCB Service, see list. These are fabricated in glass fibre, and are fully drilled and roller tinned. All prices include VAT and postage and packing. Add £1 per board for airmail outside of Europe. Remittances should be sent to The PCB Service, *Everyday Electronics*, 6 Church Street, Wimborne, Dorset BH21 1JH. Cheques should be crossed and made payable to *Everyday Electronics* (Payment in £ sterling only).

NOTE: While 95% of our boards are now held in stock and are dispatched within seven days of receipt of order, please allow a maximum of 28 days for delivery - overseas readers allow extra if ordered by surface mail.

Please check price and availability in the latest issue.

Boards can only be supplied on a payment with order basis.

**SALE!** All p.c.b.s on this page reduced to **1/2 PRICE**

(Just send half the price shown, while stocks last.)  
PCBS ON OPPOSITE PAGE PRICES AS SHOWN

PROJECT TITLE	Order Code	Cost
Video Guard Alarm	FEB '87 556	£3.80
Computer Buffer/Interface	MAR '87 560	£3.32
Fridge Alarm	MAY '87 (sorry sold out)	
Mini Disco Light	JUNE '87 (sorry sold out)	
Fermostat	JULY '87 (sorry sold out)	
Monomixer	571	£4.75
Noise Gate	SEP '87 577	£4.41
BBC Sideways RAM/ROM	NOV '87 (sorry sold out)	
Pseudo Echo Unit	DEC '87 (sorry sold out)	
Game Timer	FEB '88 583	£3.55
SOS Alert	MAR '88 (sorry sold out)	
Pipe & Cable Locator	APR '88 598	£3.00

PROJECT TITLE	Order Code	Cost
Door Sentinel	MAY '88 (sorry sold out)	
Multi-Chan Remote Light Dim Relay/Decoder	JUNE '88 601	£4.86
Power Supply	603	£3.00
Video Wiper	JULY '88 612	£6.75
Tea Tune Thermostat	AUG '88 609	£3.00
Time Switch	614	£4.84
Suntan Timer	610	£3.07
Car Alarm	615	£3.12
Eprom Eraser	OCT '88 621	£4.07
Doorbell Delay	NOV '88 611	£3.56
Infra-Red Object Counter (Set)	622/3/4	£9.28
Downbeat Metronome	DEC '88 619	£4.84
EPROM Programmer (On Spec)	(sorry sold out)	
Phasor	631	£5.64
Continuity Tester	FEB '89 619	£2.67
Mini PSU	636	£3.23
Sound-to-Light Interface	MAR '89 637	£6.24
Midi Pedal	639	£7.00
Midi Merge	640	£3.00
Audio Lead Tester	641	£5.77
Light Sentinel: Main Board	APR '89 632	£9.20
Remote Interface (4 bds)	633	£4.59
4-Channel Auto-Fader Interface	642	£6.80
Electron A/D Interface	MAY '89 645	£4.84
Spectrum EPROM Programmer	JUNE '89 628	£7.87
Programmable Pocket Timer	JULY '89 648	£3.82
Electronic Spirit Level	AUG '89 649	£3.85
Distance Recorder	651	£5.23
Xenon Beacon	SEP '89 650	£4.13
Probe Pocket Treasure Finder	653	£4.12
Power Supplies: Fixed Voltage	654	£4.08
Variable Voltage	655	£4.48
Music on Hold	OCT '89 646	£3.85
Power Supplies - 25V 700mA	656	£4.35
30V 1A	657	£4.55
EE Seismograph - Control	658	£4.08
Detector	659	£4.22
Lego/Logo & Spectrum	660	£6.49

# PCB SERVICE

See opposite page for ordering details.

PROJECT TITLE	Order Code	Cost
Wash Pro <b>NOV 89</b>	643	£3.83
Biofeedback Monitor - Front End	661	£4.52
Processor	662	£4.56
Logo/Lego & Spectrum Interface	664	£5.60
EEG Electrode Impedance Meter <b>DEC 89</b>	665	£3.98
Biofeedback Signal Generator <b>JAN 90</b>	666	£4.08
Quick Cap Tester <b>FEB 90</b>	668	£3.92
Weather Stn: Anemom. - Freq./Volt Board	670	£3.94
Optional Display	669	£3.73
Wind Direction	673/674	£4.22
System Power Supply	675	£3.59
Prophet In-Car Ioniser	676	£3.18
Weather Stn: Display Driver <b>MAR 90</b>	672 & 678	£4.22
Display and Sensor	671	£4.47
Fermostat Mk2	677	£4.28
Superhet Broadcast Receiver/Tuner/Amp	679/680	£4.22
Stereo Noise Generator <b>APR 90</b>	681	£4.24
Digital Experimenter's Unit - Pulse Generator	682	£4.46
Power Supply	683	£3.66
Enlarger Timer	684	£4.28
Weather Stn: Rainfall/Sunlight Display	685	£4.27
Rainfall Sen and Sunlight Sen	686/687	£4.16
Amstrad Speech Synthesiser <b>MAY 90</b>	689	£4.68
80 Metre Direct Conversion Radio <b>JUN 90</b>	691	£4.95
Mains Appliance Remote Control <b>JUL 90</b>		
Encoder Board A	694	£6.61
Encoder Board B	695	£4.78
The Tester	696	£4.15
Mains Appliance Remote Control <b>AUG 90</b>		
Mains ON/OFF Decoder	697	£4.55
(5 or more 697's ordered together £3.25 each)		
Simple Metronome	698	£3.94
Hand Tally: Main Bd and Display Bd <b>SEP 90</b>	699, 700	£10.95
Alarm Bell Time-Out	701	£4.10
Mains Appliance Remote Control		
Temperature Controller (p.c.b. only)	702	£5.20
Ghost Waker <b>OCT 90</b>	703	£4.32
Frequency Meter	704	£5.25
Freq. Meter/Tachometer <b>NOV 90</b>	705	£3.98
EE Musketeer (TV/Video/Audio)	706	£5.78
Colour Changing Christmas Lights <b>DEC 90</b>	707	£4.39
Microcontroller Light Sequencer	708/709	£10.90
Versatile Bench Power Supply Unit	710	£4.24
Teach-In '91, Part 1 - L200 Module	711	£3.93
Dual Output Module	712	£4.13
LM723 Module	713	£4.21
Spatial Power Display <b>JAN 91</b>	714	£5.33
Amstrad PCW Sound Generator	715	£5.03
Teach-In '91, Part 2 - G.P. Transistor Amp	717	£3.77
Dual Op.Amp Module	718	£3.83
Intercom (Teach-In '91 Project 2) <b>JAN 91</b>	719	£4.41
Analogic Test Probe	720	£3.24
MARC Phone-In <b>FEB 91</b>	721	£6.87
Teach-In '91 Part 3 - TBA820M Amplifier	723	£4.05
High Quality Power Amp	724	£4.93
Bench Amplifier (Teach-In '91 Project 3)	725	£4.45
Gingernut 80m Receiver <b>FEB 91</b>		
R.F. section (726), Voltage Regulator (727)	726/7/8	£3.06
Audio Amplifier (728)		
	all 3 together	£8.16
Pocket Tone Dialler <b>MAR 91</b>	729	£4.36
Battery To Mains Inverter	730	£4.97
Simple Basic Alarm	731	£4.50
Car Code Lock (pair)	732a/b	£4.69
Teach-In '91 Part 4 - <b>MAR 91</b>		
Sinusoidal Oscillator	733	£4.39
8038 Oscillator	734	£4.15
Waveform Generator (Teach-In '91 Project 4)	735	£4.72
Humidity Tester <b>APR 91</b>	716	£4.97
Model Train Controller (double-sided)	736	£9.75
Electronic Die (Teach-In '91 Project 5)	737	£4.93
Teach-In '91 Part 5 - Digital Counter Module	738	£4.35
Modular Disco Lighting System <b>MAY 91</b>		
Switched Power Output Module	739	£5.91
Digital LCD Thermostat-Control Board	740	£4.05
-Power/Relay Board	741	£3.76
Pulse Generator (Teach-In '91 Project 6)	742	£4.97
Teach-In '91 Part 6 - Timer Module	743	£4.62

PROJECT TITLE	Order Code	Cost
Digilogue Car Tachometer <b>JUN 91</b>	744	£5.63
Modular Disco Lights - Simple Chaser	745	£5.00
Sweeper Module	746	£5.17
Automatic Light Control - PSU Board	747	£4.88
Logic Board	748	£5.17
Radio Receiver (Teach-In '91 Project 7)	749	£4.57
Teach-In '91 Part 7 - R.F. Amplifier Module	750	£4.23
Modular Disco Lights - Masterlink <b>JULY 91</b>	752	£6.36
Ultrasonic Proximity Meter		
Display Unit (753) & Sensor Unit (754)	753/754	£7.06
Disco Lights (Teach-In '91 Project 8)		
PSU and Pre-amplifier	755	£4.54
Low, Mid, High Filter/Triac (set of 3 boards)	756	£11.00
Teach-In '91 Part 8 - Solid State Switch Module	757	£4.24
Mod. Disco Lights - Pattern Gen <b>AUG 91</b>	760	£6.79
Teach-In '91 Part 8 - Light Sensitive Switch	761	£4.74
Opto-Link (Teach-In '91 Project 9) - Transmitter	762	£4.85
Receiver	763	£4.88
Portable PEsT Scarer	764	£3.77
Capacitance Meter <b>SEP 91</b>	751	£5.17
Modular Disco Lights - Dimmer Interface	765	£8.17
Mod. Disco Lights <b>OCT 91</b>		
VU Sound Module (Double-sided)	767	£8.68
UV Exposure Unit	768	£4.63
PC-Scope Interface - Main Board	769	£6.95
Expansion Plug (Double-sided)	770	£5.96
Mod. Disco Lights <b>NOV 91</b>		
Superchaser (Double-sided)	771	£6.91
Supersweep (Double-sided)	772	£8.26
Bicycle Alarm	773	£5.01
Darts Scorer	774	£7.90
Knockerbox <b>DEC 91</b>	775	£5.35
Signal Generator - Main Board	776	£7.46
PSU	777	£4.73
Mind Machine - Main Board	778	£7.00
Auto Nightlight	779	£5.03
Mind Machine - Programmer Board <b>JAN 92</b>	780	£7.39
Transistor Checker	781	£4.63
Stepping Motor Driver/Interface	782	£10.39
Micro-Sense Alarm	783	£5.42
Telesound <b>FEB 92</b>	784	£4.66
Programmable Timer	785	£4.63
Auto Garage Light <b>MAR 92</b>	786	£6.10
Versatile BBC Computer Interface	787	£11.59
Economy Seven Timer	788	£5.20
Sonic Continuity Tester <b>APR 92</b>	789	£4.79
Telephone Ringer	790	£5.46
Experimental Weighing Scale <b>MAY 92</b>	792	£5.17
12V Drill Charger/PSU (both boards)	793	£5.31
Digital Servo Interface <b>JUNE 92</b>	791	£4.73
Tie Pulser	794	£5.19
CCD Reverb Unit	795	£6.39
Switch-Mode Power Supply	796	£7.01
UV Exposure Timer <b>JULY 92</b>	797	£5.33
Cricket Game	798	£6.77
Quick Prom	799	£5.61
Gas Alarm <b>Aug 92</b>	800	£5.47
Dual Metronome	801	£6.74
Ultrasonic Tape Measure <b>Sep 92</b>	802	£6.06
Quicktest	803	£4.82

## EE PRINTED CIRCUIT BOARD SERVICE

Order Code Project Quantity Price

Name.....

Address.....

I enclose payment of £..... (cheque/PO  
in £ sterling only to  
Everyday Electronics)  
Access (MasterCard) or Visa No.  
Minimum order for credit cards £5

VISA

--	--	--	--	--	--	--	--	--	--

Signature..... Card Ex. Date.....

Please supply name and address of card-holder if different from the address shown

BLOCK CAPITALS PLEASE

# REPORTING AMATEUR RADIO

**Tony Smith G4FAI**

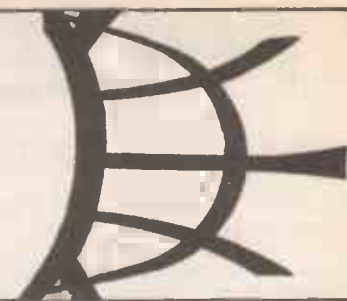

## METEOR SCATTER

Last month I described how radio amateurs take advantage of seasonal and other phenomena to make v.h.f. operation a most interesting, and at times quite exciting, area of activity. I briefly covered tropospheric ducting, sporadic-E (Es) and auroral propagation.

Even more esoteric than the latter, meteor scatter (MS) uses the intense ionisation trails of meteors entering the earth's atmosphere to reflect or scatter radio signals in short "bursts" lasting from less than a second to several minutes.

Special operating procedures and equipment are required for MS operation, including reasonably high power transmitters with excellent frequency stability, and highly directional antennas. SSB speech can be used, but more often high speed Morse is used with contacts often pre-arranged so that both stations are listening on the same frequency at the same time and on the correct beam heading.

Because of the limited time available, the Morse signals are sent by memory keyers or computers at very high speed and are recorded at the receiving end by recorders with variable speed control. They are replayed at a slower speed but as the slowed-down Morse has a low audio frequency up-converters are used to raise the pitch of the signals.

The ionisation trails occur at an altitude of around 100km, the same height as Es clouds and aurora, and contacts over distances up to 2,000km may be achieved.

## MOONBOUNCE

Earth-moon-earth (EME) popularly known as "moonbounce" is another highly specialised amateur activity. Radio signals are beamed at the moon and reflected back to be received both at their point of origin and at points on the earth's surface thousands of miles away. The only requirement for a two-way EME contact is that both stations can see the moon at the same time.

This is not as easy as it sounds, however. Steerable high gain antennas are needed to follow the path of the moon, and high power, around 600 watts, is needed for reasonably consistent results. Additionally, very sensitive receivers are required as only a tiny portion of the transmitted signal is reflected back to the earth's surface after its journey of nearly half a million miles.

Despite the difficulties and uncertainties, hundreds of amateurs around the world operate moonbounce with specially constructed stations, usually with Morse although single sideband speech has been used on occasions.

I began these notes last month with the comment that it is not necessary to know Morse to obtain an amateur "B"

v.h.f./u.h.f. transmitting licence and to enjoy most of the activities available on the higher frequencies. This is perfectly true and many licensees enjoy their hobby quite happily without ever bothering to learn the Morse code.

However, as can be seen above, even some v.h.f. activities can benefit from a knowledge of code and other "B" licensees do eventually take the Morse test, not only to obtain access to the international h.f. bands but to enhance their capability on v.h.f. too.

## EMC REGULATIONS

The European Community's Directives on electromagnetic compatibility (EMC) due to take effect on 1st January 1992 are now subject to an extended transitional period because the harmonised EMC standards were not ready.

Without going too deeply into definitions, EMC is the term used to describe a product's ability to function satisfactorily in its electromagnetic environment without introducing intolerable electromagnetic disturbance. For example, a vacuum cleaner should not interfere with TV reception, computers should not scramble radio messages, and unwanted radio transmissions should not break through on domestic receiving equipment.

By the end of the transitional period manufacturers, importers and suppliers of radio equipment will be required to ensure that the products they sell in the Community comply with defined EMC protection requirements. This means that in every product the electromagnetic disturbance it generates must not exceed a level allowing radio and telecommunications equipment and other apparatus to operate as intended.

Conversely, each product shall itself have an adequate level of intrinsic immunity to electromagnetic disturbance to enable it to operate as intended. Products complying with the Directive will carry the "CE" mark and non-compliant products will be banned from the market.

## IMPACT ON AMATEUR RADIO

The Directive will not apply to radio equipment used by radio amateurs which is not commercially available. If the equipment is commercially available the regulations will apply in the same way as to other products.

It may either be self-certified by manufacturers to harmonised EMC standards or may comply with the EMC Protection Requirements (i.e., be manufactured with specifically approved apparatus and procedures to ensure conformity with the protection requirements). Amateur transmitters, however, will not require the additional EMC type examination certificate, to be issued by the Radiocommunications Agency,

which will be obligatory for most other transmitters, including CB.

Exemption from some parts of the regulations will not mean lower standards for amateur equipment, rather the opposite. A licence obtained by examination will still be required to operate an amateur transmitter and the terms of the licence will continue to impose stringent requirements to ensure that the station shall not cause undue interference "to any wireless telegraphy", meaning any other radio-frequency transmissions, with a requirement to close down in certain circumstances when in breach of the regulations.

## QRP DX

"Dx" is normally thought of as long distance transmission to countries outside one's own continent. A contact with Rio de Janeiro, 5,700 miles from London, for instance, is pretty good going with, say, a 100 watt transmitter, but what if a low power (QRP) transmitter with only one watt of power covers the same distance?

The American QRP Amateur Radio Club International (QRP ARC), measures the success of its members with a "1000 miles per watt" table calculated by dividing the number of miles covered by the number of watts (r.f. output) used during a contact. Over the distance covered above, the performance of the 100W transmitter equates to 57 miles per watt, while the QRP transmitter of one watt equals an impressive 5,700 miles per watt.

When the power is reduced to microwatts, some startling figures begin to emerge. A contact between the USA and Australia, noted by QRP ARC, with the U.S. transmitter using 0-0021W, resulted in the equivalent of 3,988,810 miles per watt; and a two-way QRP contact in the States, with both stations running six microwatts, equated to 218,333,333 miles per watt!

These sort of achievements require high-gain carefully tuned and aligned antennas, very sensitive receivers, and quite a lot of skill, but they do demonstrate that high power isn't always necessary to achieve remarkable results.

My final example is outside the field of amateur radio, but it very definitely shows what QRP can do! In February, the Pioneer 10 spacecraft, launched in 1972, was about five billion miles away from Earth and its transmitter, now reduced in power to about 7.8W was still sending signals back to earth. There's no point in being too precise as the craft is continuing on its journey at something like 32,000 mph, but in February the output of its transmitter equated to well over half a billion miles per watt!

To receive these signals NASA Deep Space network stations have 70-metre diameter dish antennas and highly sensitive receivers with circuitry frozen in liquid helium to minimise EMC problems.



NATIONAL  
COLLEGE OF  
TECHNOLOGY

## DISTANCE LEARNING COURSES

The National College of Technology offer a range of packaged learning short courses for study at home or in an industrial training environment which carry national BTEC awards. Study can commence at any time and at any level enabling you to create a study routine to fit around existing commitments. Courses on offer include:

Analogue Electronics  
Digital Electronics  
Fibre/Optoelectronics  
Programmable Logic Controllers

Tutor support and BTEC certification are available as options with no travelling or college attendance required. These very popular courses which are ideal for vocational training contain workbooks, audio cassette lectures, PCB's, instruments, tools, components and leads as necessary to support the theoretical and practical training. Whether you are a newcomer to electronics or have some experience and simply need an update or certification, there is probably a distance learning course ready for you. Write or telephone for details to:

National College of Technology  
NCT Ltd., PO Box 11  
Wendover, Bucks  
Tel: (0296) 624270

# GET SMART!

YOU CAN MAKE IT HAPPEN WITH HOME  
AUTOMATION COMPONENTS FROM US

Remote control lighting / appliance modules,  
timers, computer interfaces, telephone  
diallers, motorised curtain tracks, powered  
radiator valves. Details from

**SMART HOUSE SYSTEMS LTD**  
3E Buchanan Street, Largs, Ayrshire KA30 8PP  
Phone: 0475 672589

## Hesing Technology

Cromwell Chambers, 8 St. Johns Street,  
Huntingdon, Cambs. PE18 6DD

Tel: (0480) 433156  
Fax: (0480) 214488

### TEST EQUIPMENT

Supply  
Maintenance  
Commissioning

### SYSTEM CONSULTANCY

Replacement Parts  
Supply of Service &  
Operators Manuals  
Components

Distributors for:

WAUGH INSTRUMENTS, RAMTEST LTD., KRENZ ELECTRONICS, PANTHER

Metal detector boards with Data has  
tuner, mode, discriminate, headphone  
jack, on/off volume & push button  
facilities.....£7.95 ea\*

Dictaphone cassette, mech/record erase  
playback heads, 6V solenoid, motor, hall  
effect switch.....£2.00 ea\*

T.V./Printer stands.....£3.95 ea

Bicc-Vero Easiwire.....£4.95 ea\*

TTL/CMOS short circuit snooper.....£4.95\*

Dot matrix LCD 10x2 lines.....£3.75 ea\*

Dot matrix LCD 16 x 1 lines  
with Data.....£4.95\*

40 characters x 1 line dot matrix LCD  
with data.....£15.00\*

2 digit 16 segment VF display  
with data.....£2.95 ea\*

4 digit intelligent dot matrix display.....£6.00\*

17 segment V.F. display with  
driver board and data.....£2.99 ea\*

8 digit liquid crystal display.....£1.75 ea\*

4 digit LCD with 7211 driver chip.....£3.50 ea\*

Digital clock display.....£2.50\*

11 key membrane keypad.....£1.50 ea\*

Keyboard 392mm x 180mm/100  
keys on board + LCD +  
74HC5/80C49 easily removable.....£4.95

19" 3U sub rack enclosures.....£8.95

12V stepper motor, 48 steps per rev,  
7.3° step angle.....£3.95 ea\*

Stepper motor board with 2 slotted  
opto + 2 mercury tilt switches.....£3.95 ea\*

1000 mixed 1/4 watt 1% resistors.....£4.95 ea

250 electrolytic axial + radial caps.....£4.95 ea

200 off mixed polyester caps.....£7.95\*

100 Mixed trimmer caps popular values.....£4.95\*

100 off Phono plugs  
(red/black/grey).....£3.50\*

50 Mixed terminal blocks.....£2.95

25 off asst. buzzers & sounders.....£4.95\*

Cable box UHF modulator/video  
preamp/transformer/R's + C's/leads.....£6.95

1000 off mixed Multilayer  
Ceramic Caps.....£7.95

Solar cell modules 0.45V 700mA.....£2.95 ea\*

B.B.C. Micro to disc drive lead.....£1.50\*

Car Burglar alarm vibration auto  
entry/exit delay.....£5.95 ea\*

Single zone alarm panel auto  
entry/exit delay housed in  
domestic light socket.....£9.95 ea\*

P.C. P.S.U. 50 watt 115-230V input + 5V  
4A + 12V 2.5A output with built in fan,  
IEC inlet + on off.....£9.95 ea

STC P.S.U. 240V input 5V 6A output  
(converts to 12V 3A details  
available).....£5.95 ea

240V input 5V 10A output (converts to  
12V 5A no details).....£5.95 ea\*

600Q line output transformers.....£1.25 ea

240V in 0-12V 0.75A out  
transformer.....£1.75\*

240V in 0-28V 62VA out transformer.....£2.75

Transformer + PCB gives 2x7.5V 32VA  
with skt for 5 or 12V regulator, will power  
floppy drive.....£3.75 ea

Ultrasonic transducers (transmit +  
receive).....£1.50 pair

3 to 16V Piezoelectric sounders.....50p

9VDC electromechanical sounder.....50p

24V DC electromechanical sounder.....50p

2A 250V keyswitch 3 position key  
removable in two positions.....£1.50\*

DIL switches PCB MT 3/4/6 way.....35p

5V SPCO SIL reed relay.....40p

5V 2PCO DIL miniature relay.....60p

12V 2PCO or 4PCO continental relay.....60p

12V 10A PCB MT (to make contact)  
relay.....95p\*

3 to 12V electro magnetic acoustic  
transducer with data.....75p\*

2.4576/8.8329/21.10 MHz crystals  
.....50p ea\*

Bridges 25A 200V.....£1.00\*

2A 100V.....50p

31b Mixed components pack.....£4.95

25 off mixed relays.....£5.95

40 off mixed toggle switches.....£9.95\*

50 off mixed switches, toggle, rocker,  
slide, micro.....£9.95

Miniature axial chokes 0.1, 0.18, 0.12,  
0.33, 0.39, 0.15, 1, 3.3UH  
.....10p ea., 100 for £7.50\*

250 off 16/22/24/40 way IC Skts.....£4.95\*

Crystal Oscillators 10/24/48 MHz.....£1 ea\*

Spider Plug Leads.....75p ea

QUANTITY DISCOUNTS AVAILABLE  
PLEASE RING

ALL PRICES INCLUDE V.A.T.  
PLEASE ADD £2.00 p&p EXCEPT  
ITEMS MARKED \* WHICH ARE 50P.  
SAE FOR BULK BUYING LIST  
PAYMENT WITH ORDER TO:

Dept EE, COMPELEC,  
14 Constable Road  
St. Ives, Huntingdon,  
Cambs PE17 6EQ  
Tel/Fax: 0480 300819

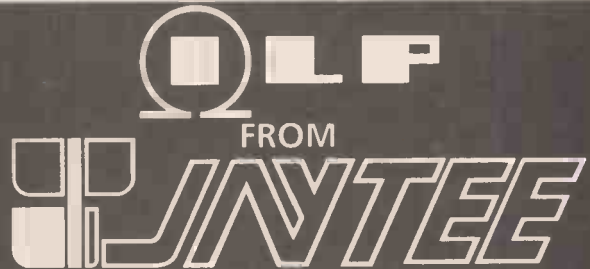

## New for 1992

### ★ New MOSFET Amplifiers

improved range of SMOS modules  
30W, 30+30W, 60W, 120W

### ★ 20 watt Class A Amplifier

### ★ Low profile PCB Transformers

a range of encapsulated transformers  
4VA, 6VA, 10VA, 18VA, 24VA, 30VA

Write or phone for data and prices...  
which include details of standard range of  
toroidal transformers and audio modules.

No price increase for 1992

## Jaytee Electronic Services

143 Reculver Road, Beltinge, Herne Bay, Kent CT6 6PL  
Telephone: (0227) 375254. Fax: (0227) 365104

# ELECTRONICS

EE reaches twice as many UK readers than any other independent monthly hobby electronics magazine, our audited ABC sales figures prove it. EE has been the leading independent monthly magazine in this market for the last seven years

If you want your advertisements to be seen by the largest readership at the most economical price our classified and semi-display pages offer the best value. The prepaid rate for semi-display space is £8 (+ VAT) per single column centimetre (minimum 2.5cm). The prepaid rate for classified adverts is 30p (+ VAT) per word (minimum 12 words).

All cheques, postal orders, etc., to be made payable to Everyday Electronics. VAT must be added. Advertisements, together with remittance, should be sent to the Classified Advertisement Dept., Everyday Electronics, 6 Church Street, Wimborne, Dorset BH21 1JH. Tel: (0202) 881749. For rates and information on display advertisements (4th page and larger spaces) please contact our Advertisement Manager, Peter Mew on 0255 850596.

## SERVICE MANUALS

Available for Most Equipment  
TV, Video, Audio, Test etc  
Any Age, Make or Model

Write or Phone for Quotation

**MAURITRON (EE)**

8 Cherry Tree Road  
Chinnor, Oxfordshire



Tel: (0844) 351694  
Fax: (0844) 352554

### N. R. BARDWELL LTD (EE)

200	Signal diodes 1N4148.....	£1.00
75	Rectifier Diodes 1N4001.....	£1.00
75	Rectifier Diodes 1N4003.....	£1.00
50	Rectifier Diodes 1N4007.....	£1.00
56	Rectifier Diodes 1N5401.....	£1.00
10	NE555 Timer I.c.s.....	£1.00
5	741 Op Amp I.c.s.....	£1.00
8	C106D1 400V 6 amp thyristors.....	£1.00
8	BFY51 Transistors.....	£1.00
30	BC478 Transistors.....	£1.00
30	MPSA92 Transistors.....	£1.00
25	Asstd. high brightness I.e.d.s.....	£1.00
50	Axial I.e.d.s (Diode package) wide angle red.....	£1.00
50	Rectangular red I.e.d.s.....	£1.00
20	Miniature axial I.e.d.s super bright red.....	£1.00
24	Miniature red I.e.d.s 3mm dia.....	£1.00
12	Asstd. seven segment displays.....	£1.00
4	.43" Com. anode seven segment displays.....	£1.00
100	22NF 100V radial film capacitors.....	£1.00
100	33NF 50V radial film capacitors.....	£1.00
200	Asstd. disc ceramic capacitors.....	£1.00
80	4U7 16V Radial electrolytics.....	£1.00
75	4U7 63V Radial electrolytics.....	£1.00
80	10UF 16V Radial electrolytics.....	£1.00
50	10UF 50V Radial electrolytics.....	£1.00
80	22UF 25V Radial electrolytics.....	£1.00
60	33UF 16V Radial electrolytics.....	£1.00
60	22UF 50V Radial electrolytics.....	£1.00
50	47UF 50V Radial electrolytics.....	£1.00
80	100UF 10V Radial electrolytics.....	£1.00
50	220UF 16V Radial electrolytics.....	£1.00
60	470UF 10V Radial electrolytics.....	£1.00
40	1000UF 10V Radial electrolytics.....	£1.00
30	Asstd. IF transformers.....	£1.00
48	Asstd. coil formers.....	£1.00
100	Asstd. RF chokes.....	£1.00
30	Asstd. dll sockets up to 40 pin.....	£1.00
30	Assorted socket/connors/edge dll-all-etc.....	£1.00
20	1 inch Glass reed switches.....	£1.00
10	4P 3W MBB min. rotary switches.....	£1.00
20	Min SP/CO alide switches.....	£1.00
20	Magnetic ear pips plus lead & plug.....	£1.00
1	Peltier effect heat pump.....	£1.95
1	10 watt Stereo amplifier, 4 controls plus data.....	£2.95
1	10mm Flashing I.e.d. red.....	£0.75
1	10mm Ultra bright I.e.d. red 300 MCD.....	£0.60

Prices include VAT, postage £1.00. Stamp for Lists  
288 Abbeydale Road, Sheffield S7 1FL  
Phone (0742) 552886. Fax (0742) 500689

### RCS VARIABLE VOLTAGE D.C. BENCH POWER SUPPLY

1 to 24 volts up to 1/2 amp. 1 to 20 volts up to 1 amp. 1 to 16 volts up to 1 1/2 amps d.c. Fully stabilised twin panel meters for instant voltage and current readings. Overload protection.  
Fully variable.  
Operates from 240v a.c.  
Compact Unit  
Size 9 5/8 x 3 1/2  
NEW MODEL Up to 38volts d.c. at 6 amps. 10 amps peak. Fully variable twin panel meters. Size 14 1/2 x 11 x 4 1/2 in. £66 inc VAT. Carr £6.



£45 inc. VAT  
+ Post and Insurance £4

### RADIO COMPONENT SPECIALISTS

337 WHITEHORSE ROAD, CROYDON  
SURREY, U.K. Tel: 081-684 1665

List, Large SAE. Delivery 7 days. Callers welcome. Closed Wednesday

**THE BRITISH AMATEUR ELECTRONICS CLUB**  
exists to help electronics enthusiasts by personal contact and through a quarterly Newsletter.

For details, write to the Secretary

Mr J. S. Hind, 7 Carlyle Road  
West Bridgford, Nottingham NG2 7NS  
Space donated by Everyday Electronics

### BTEC ELECTRONICS TECHNICIAN FULL-TIME TRAINING

THOSE ELIGIBLE CAN APPLY FOR E.T. GRANT SUPPORT AN EQUAL OPPORTUNITIES PROGRAMME

O.N.C., O.N.D. and H.N.C.

Next course commences

Monday 21st September 1992  
FULL PROSPECTUS FROM

**LONDON ELECTRONICS COLLEGE**  
(Dept EE) 20 PENYVERN ROAD  
EARLS COURT, LONDON SW5 9SU  
TEL: 071-373 8721



### Cooke International FOR SALE

USED TEST EQUIPMENT

Scopes, Sig. Gens, PSU's, Power Meters, DVM's, Oscillators, Attenuators, etc.

Open Mon-Fri 9am-5pm or Phone

Copy Service for Workshop Manuals available

**SATURDAYS BARGAIN STORE OPEN 10am-4pm CASH ITEMS TO CLEAR.**

Contact: Cooke International, Units 4/5, Fordingbridge Site, Main Road, Barnham, Bognor Regis, West Sussex PO22 0EB  
Tel: 0243 545111 Fax: 0243 542457  
Wide range of items available. Send SAE for lists

Looking for a home study course, in the fundamentals of electronics? Whether you are a beginner, or an old hand requiring a refresher, the

### DIRECT PERSONAL LEARNING

course, could be right for you. Contact:

**K. Sparrow**

(Electronic Training Consultant)

11 Claydon Green, Whitchurch, Bristol, Avon BS14 0NG. Tel: 0275 835669

### SOLAR PANELS

Special offer 12V nom (20V o/c) 80mA. 12" x 6" pre wired Amorphous Silicon panel £4.50 includes P&P. Many other sizes, wind generators and other products.

Orders to (Cat 2 x 1st class stamps)

**Robert Keyes, 4 Glanmor Crescent Newport Gwent NP9 8AX**

### NEW VHF MICROTRANSMITTER KIT

Tuneable 80-135MHz, 500 metre range, sensitive electret microphone, high quality PCB.  
SPECIAL OFFER complete kit ONLY £5.95  
Assembled and ready to use £9.95 post free.  
Credit card orders telephone 021 411 1821. Fax 021 411 2355  
Send 2x1st class stamps for Catalogue. Cheques/PO's payable to:

### QUANTEK ELECTRONICS

Kits Dept. (EE), 3 Houldrey Road, West Heath, Birmingham B31 3HL  
SHOP NOW OPEN - CALLERS WELCOME

### Miscellaneous

G.C.S.E. ELECTRONICS KITS at pocket money prices. S.A.E. for FREE catalogue. SIR-KIT ELECTRONICS, 70 Oxford Road, Clacton CO15 3TE.

PROTOTYPE PRINTED CIRCUIT BOARDS one offs and quantities, for details send s.a.e. to B. M. Ansbro, 38 Poynings Drive, Sussex BN3 8GR, or phone Brighton 720203.

STUDY ELECTRONICS on the BBC Micro. An interactive approach to learning. Four program titles available 'Introduction to Electronics Principles', 'Electronics Mathematics', 'Digital Techniques' and now 'Programming for Electronics'. Programs include theory, examples, self test questions, formulae, charts and circuit diagrams. User inputs and calculated outputs, £29.95 each plus £2p&p. Cheque or Postal Order to E.P.T. Educational Software, Pump House, Lockram Lane, Witham, Essex CM8 2BJ. Please state BBC 'B' or Master series and disc size.

SUBWOOFER plans, many designs, all for £3. Mark Spittlehouse, 53 Carlton Avenue, Worksop, Notts.

DMAC Satellite Receiver, Ferguson SRB1 (less transformer & case). Can be adapted to D2MAC, including remote control. Only £14.50 inc. postage. Service manuals £3.00 each. Eproms (used, cleaned and erased) 2764 75p, 27128 90p, 27256 £1.25, 27512 £3.00. Most others available. Gadget Computer Services, Freeport Dunstable, Bedfordshire LU5 5SX. Tel: 0582 868687. Fax 0582 868668.

TRANSMITTER circuit diagrams - FM, medium, shortwave, CB - Full instructions. Minimum seventeen circuits. Cheques/PO's £4.25 to D. Davies, 33 Gwaelodygarth, Merthyr Tydfil CF47 8YU, UK.

# EVERYDAY ELECTRONICS

The No. 1 Magazine for Electronic & Computer Projects

## NEWSAGENT ORDER FORM

Please reserve/deliver a copy of Everyday Electronics for me each month

Signed.....

Name and Address.....  
(BLOCK CAPITALS PLEASE)

Everyday Electronics is published on the first Friday of each month and distributed SOR by Seymour. Make sure of your copy of EE each month - cut out this form, fill it in and hand it to your newsagent.



## 19" RACK MOUNTING EQUIPMENT CASES

This range of 19" rack cases features satin black finished 16SWG (1.5mm) steel front panels (no fixing holes visible), with the rear box assembly constructed from 20SWG (9mm) steel. The standard units are 10" (254mm) deep. 19" project cases only 4" (101mm) deep and are available in the following popular sizes

### PROJECT CASES

Type	Height	Price
PU1	1 1/2" (44mm)	£18.02
PU2	3 1/2" (88mm)	£20.07
PU3	5 1/2" (133mm)	£22.11
PU4	7" (178mm)	£24.16
PU6	10 1/2" (266mm)	£28.25

### EQUIPMENT CASES

Type	Height	Price
U1	1 1/2" (44mm)	£22.33
U2	3 1/2" (88mm)	£25.85
U3	5 1/2" (133mm)	£29.38
U4	7" (178mm)	£31.72

Delivery included (UK only).

All prices include VAT.

BLANKING PANELS, RACKING CONSOLES

and RACK CABINETS are also available.

Please send SAE for details.

Tel: 0272 373983 for Access/Visa Sales or cheque

with order to:

## RACKZ PRODUCTS

PO Box 1402 Mangotsfield, Bristol, England, BS17 3RY



## Technical Information Services

76 CHURCH STREET, LARKHALL, LARKSHIRE, ML9 1HE

Tel. (0698) 884585 Mon-Fri 8.30am - 5.00pm

Tel. (0698) 883334 Outwith business hours

FAX facility available all day on both lines

Write now with an SAE for your

**FREE QUOTE FREE VOUCHERS & FREE CATALOGUE**

Remember, not only do we have EVERY service sheet ever produced, but we also have

## THE WORLDS LARGEST COLLECTION OF SERVICE MANUALS

& WE ARE SOLE SUPPLIERS OF VARIOUS FAULT-FINDING GUIDES REPAIR MANUALS & TECHNICAL MANUALS

TV, Video, CD, Hi-Fi, Camcorder, Satellites, Computers, Domestic Equip., etc.

DATA REFERENCE MANUAL ".....essential for the serious electrician" FREE updating and a 10% discount voucher only £5.95 Incorporates Unique Model Identification and Chassis Data

Carbon Film resistors 1/4W 5% E24 series 0.51 R to 10MΩ	1p
100 off per value - 75p. even hundreds per value totalling 1000	£6.00p
Metal Film resistors 1/4W 10R to 1 MO 5% E12 series - 2p. 1% E24 series	3p
Mixed metal/carbon film resistors 1/4W E24 series 1 R to 10MΩ	1 1/2p
1 watt mixed metal/carbon film 5% E12 series 4R7 to 10 Megohms	5p
Linear Carbon pre-sets 100mW and 1/4W 100R to 4M7 E6 series	7p
Miniature polyester capacitors 250V working for vertical mounting	
.015, .022, .033, .047, .068-4p, 0.1 - 5p, 0.12, 0.15, 0.22 - 6p, 0.47 - 8p, 0.68 - 8p, 1.0 - 12p	
Mylar (polyester) capacitors 100V working E12 series vertical mounting	
1000p to 8200p - 3p, .01 to .068 - 4p, 0.1 - 5p, 0.12, 0.15, 0.22 - 6p, 0.47/50V - 8p	
Submin ceramic plate capacitors 100V wkg vertical mountings. E12 series	
2% 1.8pf to 47pf - 3p, 2% 56pf to 330pf - 4p, 10% 390p-4700p	4p
Disc/plate ceramics 50V E12 series 1PO to 1000P, E6 Series 1500P to 47000P	2p
Polystyrene capacitors 63V working E12 series long axial wires	
10pf to 820pf - 5p, 1000pf to 10,000pf - 6p, 12,000pf	7p
741 Op Amp - 20p, 555 Timer	20p
cmos 4001 - 20p, 4011 - 22p, 4017	40p
ALUMINIUM ELECTROLYTICS (Mfds/Volts)	
1/50, 2.2/50, 4.7/50, 10/25, 10/50	5p
22/16, 22/25, 22/50, 33/16, 47/16, 47/25, 47/50	6p
100/16, 100/25 7p; 100/50 12p; 100/100	14p
220/16 8p; 220/25, 220/50 10p; 470/16, 470/25	11p
1000/25 25p; 1000/35, 2200/25 35p; 4700/25	70p
Submin. tantalum bead electrolytics (Mfds/Volts)	
0.1/35, 0.22/35, 0.47/35, 1.0/35, 3.3/16, 4.7/16	14p
2.2/35, 4.7/25, 4.7/35, 6.8/16 15p; 10/16, 22/16	20p
33/10, 47/16, 22/16 30p; 47/10 35p; 47/16 60p; 47/35	80p
VOLTAGE REGULATORS	
1A + or - 5V, 8V, 12V, 15V, 18V & 24V - 55p, 100mA 5.8, 12, 15, V +	30p
DIODES (piv/amps)	
75/25mA 1N4148 2p, 800/1A 1N4006 4 1/2p, 400/3A 1N5404 14p, 115/15mA OA91	8p
100/1A 1N4002 3 1/2p, 1000/1A 1N4007 5p, 60/1.5A 51M1 5p, 100/1A bridge	25p
400/1A 1N4004 4p, 1250/1A BY 127 10p, 30/15A OA47	10p
Zener diodes E24 series 3V3 to 33V 400mW - 8p, 1 watt	12p
Battery snaps for PP3 - 6p for PP9	12p
L.E.D.'s 3mm, & 5mm, Red, Green, Yellow - 10p, Grommets 3mm - 2p, 5mm	2p
Red flashing L.E.D.'s require 9-12V supply only	50p
Mains indicator neons with 220k resistor	10p
20mm fuses 100mA to 5A, 0 blow 6p, A/surge 10p, Holders, chassis, mounting	6p
High speed pc drill 0.8, 1.0, 1.3, 1.5, 2.0mm - 30p, Machines 12V dc	£7.00
HELPING HANDS 6 ball joints and 2 croc clips to hold awkward jobs	£3.50p
AA/HP7 Nicad rechargeable cells 90p each, Universal charger unit	£6.50p
Glass reed switches with single pole make contacts - 8p, Magnets	12p
0.1" Stripboard 2 1/2" x 1" 9 rows 25 holes - 25p, 3" x 2 1/2" 24 rows 37 holes	70p
Jack plugs 2.5 & 3.5mm - 14p; Sockets Panel Mtg. 2.5 & 3.5mm	10p
Ear pieces 2.5 & 3.5mm, dynamic - 20p, 3.5mm crystal	50p
TRANSISTORS	
BC107/8/9 - 12p, BC547/8/9 - 8p, BC557/8/9 - 8p, BC182, 182L, BC183, 183L, BC184, 184L, BC212, 212L - 10p, BC327, 337, 337L - 12p, BC727, 737 - 12p, 8D135/6/7/8/9 - 25p, BCY70 - 18p, BFY50/51/52 - 20p, BFX88 - 15p, 2N3055 - 50p, TIP31, 32 - 30p, TIP41, 42 - 40p, BU208A - £1.20, 8F195, 197 - 12p, Ionisers with seven year guarantee, list price £16.95	£12.50

All prices are inclusive of VAT. Postage 30p (free over £5). Lists Free.

## THE CR SUPPLY CO

127 Chesterfield Rd., Sheffield S8 0RN

Tel: 0742 557771 Return posting

## POWER SUPPLY BARGAINS!

ALL POWER SUPPLIES ARE NEW BUT UNCASED

FOUR OUTPUT SWITCH-MODE 120V/240V input.

+5V @ 15A; +12V @4A; +12V @4A; +12V @ 6A.

(Can be bridged to give +12V @ 14 amps!).....Bargain at £45

THREE OUTPUT SWITCH-MODE 120V/240V input.

+12V @ 600mA; +55V @ 420mA; -120V @ 210mA

outputs. Originally intended for plasma display.....£20

5 VOLT-8 AMP SWITCH-MODE 120V/240V input.....Bargain at £20

+/- 12V @ 1AMP REGULATED 120V/240V input.

Can be modified to give +/- 15V @ 800mA.....£12.50

THYRISTOR MOTOR CONTROLLER made by RMB, for

controlling D.C. shunt motors.....£40

CHASSIS MOUNTING IEC MALE SOCKET with integral mains

filter.....Snip at £5 each

PRICES INCLUDE VAT, PLEASE ADD 10% FOR P&P

## WORLD LEISURE CORPORATION BROADCAST

22 SOHO SQUARE, LONDON W1V 5FJ

Tel: 071-437 2004 Fax: 071-437 2021

### COMPONENTS

For TV ★ Video  
Audio ★ Computer

WE CAN SUPPLY A VAST RANGE OF SPARES for many makes of TV, Video, Computer & Audio Equipment. WRITE (Encl. s.e. please) or PHONE FOR A 'PRICE & AVAILABILITY' 0452 526883 on your requirements.

VIDEO BELT KITS	
AMSTRAD VCR4600/4700/5200.....	£3.19
FISHER FVHP905/906/908.....	£3.03
JVC HR3300/3300/3660.....	£3.30
Large range of Pinch Rollers, Idlers, etc., from stock	
SERVICE MANUALS	
FIDELITY ZX3000 Chassis.....	£7.50
PHILIPS KT4/K40 Chassis.....	£12.50
PHILIPS CM8833 (Mk 1).....	£3.80
SEMICONDUCTORS	
BUS08A.....	£1.18
LM730CN.....	£2.27
PC255A.....	£2.85
STK0023.....	£6.69
STK4141II.....	£8.79
TA7280P.....	£6.88
TA8210H.....	£8.52
OTHER ITEMS	
SHARP RGF281/4 Main belt.....	£1.40
FIDELITY 14"16"/20" General LOPTX (+ PCB).....	£17.65
This is just a very small sample of our stock	

COMPUTER SPARES	
AMSTRAD/SINCLAIR	ATARI
PEGATA1 (PC1640).....	£30.85
40010 G Array.....	£18.86
PCW 9512 Serv. Manual.....	£14.49
CP464 Serv. Manual.....	£3.67
AY3812.....	£7.06
SD9420CAC.....	£14.93
STK7356.....	£12.49
TEA2000.....	£4.49
TM54532-NL4.....	£1.72
ULAS001E.....	£17.61
ULAT7010/400056.....	£16.72
ZX8302(OL).....	£10.98
ZX8401.....	£7.94
Spec. + 2 ROM.....	£16.69
Spec. 48K Speaker.....	£1.74
Spec. 48K Membrane.....	£4.73
+128K Membrane.....	£8.39
Spec. DC Sckt. (PCB).....	£0.89
EPSON	
C78010SD031 CPU.....	£30.24
CO25913 DMA (ST).....	£33.24
User Manual (STFM).....	£10.00
PC900VH1IL3 (ST).....	£2.88
ROM Basic (XERL).....	£4.58
THERMISTOR (ST-PSU).....	£1.37
CNY65 (ST-PSU).....	£4.42
PC713V (STE-PSU).....	£2.94
25C2331 (ST-PSU).....	£1.59
COMMODORE	
17.7344MHz Kit.....	£4.99
C64C User Manual.....	£4.39
C64 User Manual.....	£4.25
6510 CPU.....	£10.03
6526 CIA.....	£11.11
6569 VIC.....	£18.95
8520 Amiga.....	£11.25
8565 VIC.....	£23.96
906114-01 PLA.....	£9.24
251641-02 PLA.....	£4.06
MB81416-12 DRAM (C16).....	£4.99

Order by Post or Phone. We accept payment by VISA, ACCESS, DELTA, SWITCH, Cheque or P.O. Post & Packing is £1.20. No VAT to add on.  
All items subject to availability.  
Prices can change without notice.



MARAPET (EEJ)  
1 HORNBEAM MEWS  
GLOUCESTER GL2 0UE



The UK Distributor for Standard Toroidal Transformers

\* 106 types available from stock

\* Sizes from 15VA to 625VA

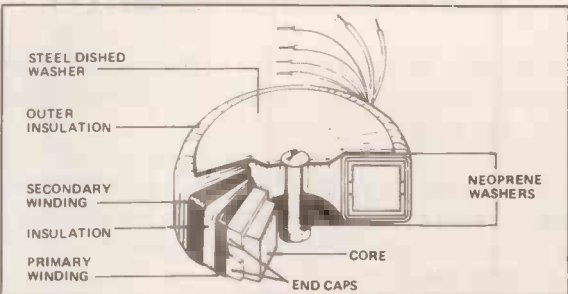

Write or phone for free Data Pack

Jaytee Electronic Services

143 Reclver Road, Beltinge, Herne Bay, Kent CT6 6PL

Telephone: (0227) 375254

## MAKE YOUR INTERESTS PAY!

Over the past 100 years more than 10 million students throughout the world have found it worth their while! An ICS home-study course can help you get a better job, make more money and have more fun out of life! ICS has over 100 years experience in home-study courses and is the largest correspondence school in the world. You learn at your own pace, when and where you want under the guidance of expert 'personal' tutors. Find out how we can help YOU. Post or phone today for FREE INFORMATION on the course of your choice. (Tick one box only)

Electronics <input type="checkbox"/>	TV, Video & Hi-Fi Servicing <input type="checkbox"/>
Basic Electronic Engineering (City & Guilds) <input type="checkbox"/>	Refrigeration & Air Conditioning <input type="checkbox"/>
Electrical Engineering <input type="checkbox"/>	Car Mechanics <input type="checkbox"/>
Electrical Contracting/Installation <input type="checkbox"/>	Computer Programming <input type="checkbox"/>
GCSE/GCE/SCE over 40 examination subjects to choose from <input type="checkbox"/>	

Name \_\_\_\_\_ Address \_\_\_\_\_  
**ICS** International Correspondence Schools Dept ECS 92  
 312/314 High Street, Sutton, Surrey SM1 1PR or 041-221 7373 (24 hours).

## Millions of quality components at lowest ever prices!

Plus Tools, Watches, Fancy Goods, Toys.  
 Mail order UK only.

All inclusive prices –  
**NO** post, or VAT etc to add on.  
 Send 34p stamped self addressed label or envelope for catalogue/clearance list.

At least 2,100 offers to amaze you.

**Brian J Reed**  
 6 Queensmead Avenue, East Ewell  
 Epsom, Surrey KT17 3EQ  
 Tel: 081-393 9055

## ADVERTISERS INDEX

A.C. ELECTRONICS.....598	MAILTECH.....571
N. R. BARDWELL.....606	MAPLIN ELECTRONICS Cover (lv)
R. BARTLETT.....595	MARAPET.....607
BK ELECTRONICS.....Cover (iii)	MARCO TRADING.....553
BLB ELECTRONICS.....595	MAURITRON.....606
BRIAN J. REED.....608	M&B ELECT. SUPPLIES.....550
BULL ELECTRICAL.....Cover (ii)	MODERN ELECTRONICS
CAMBRIDGE COMP.	MANUAL.....586/587
SCIENCE.....598	NATIONAL COLLEGE OF
CASTLE ENGINEERS.....595	TECH.....605
CIRKIT DISTRIBUTION.....595	NUMBER ONE SYSTEMS.....551
COMPELEC.....605	OMNI ELECTRONICS.....551
CRICKLEWOOD ELECT.....582	PICO TECHNOLOGY.....551
CR SUPPLY COMPANY.....607	RACKZ PRODUCTS.....607
ESR ELECTRONIC COMP.....554	RADIO & TV COMPONENTS...546
GREENWELD ELECTRONICS...549	SHERWOOD ELECTRONICS...608
HART ELECTRONIC KITS.....552	SMART HOUSE SYSTEMS.....605
HESING TECHNOLOGY.....605	SUMA DESIGNS.....548
ICS.....608	TECHNICAL INFO. SERVICES.607
JAYTEE ELECTRONIC	TSIEN.....561
SERVICES.....605 & 607	TYPESETTING BUREAU.....608
JPG ELECTRONICS.....598	WORLD LEISURE CORP.....607

## SHERWOOD ELECTRONICS

9 Lower Birchwood, Somercotes, Derbyshire DE55 4NG

★ ★ ★ SPECIAL OFFER ★ ★ ★

Choose any 2 packs FREE with every 10 £1 packs purchased.

SP1	15 x 5mm Red Leds	SP37	20 x 100uf/35V radial caps.
SP2	15 x 5mm Green Leds	SP38	25 x 47uf/25V radial caps.
SP3	12 x 5mm Yellow Leds	SP42	200 x Mixed 0.25W C.Film resistors
SP6	15 x 3mm Red Leds	SP44	12 x 5mm Leds-4 ea. Red, Grn., Yel.
SP7	12 x 3mm Green Leds	SP47	5 x Min.push button switches
SP8	10 x 3mm Yellow Leds	SP102	20 x 8 pin DIL sockets
SP10	100 x 1N4148 diodes	SP103	15 x 14 pin DIL sockets
SP11	30 x 1N4001 diodes	SP104	15 x 16 pin DIL sockets
SP12	30 x 1N4002 diodes	SP105	6 x 74LS00
SP18	20 x BC182 transistors	SP109	15 x BC557 transistors
SP20	20 x BC184 transistors	SP112	6 x Cmos 4093
SP23	20 x BC549 transistors	SP119	6 x Cmos 4072
SP25	5 x 555 timers	SP121	8 x Rect. Red Leds 5 x 2mm
SP26	5 x 741 Op-amps	SP122	8 x Rect. Green Leds 5 x 2mm
SP28	6 x Cmos 4011	SP123	5 x Rect. Yellow Leds 5 x 2mm
SP36	25 x 10uf/25V radial caps.	SP125	10 x 1000uf/16V radial caps

RESISTOR PACKS - 0.25W C.Film	
RP3	5 each value - total 365 £2.30
RP7	10 each value - total 730 £3.95
RP10	1000 popular values £5.35

Catalogue - price £1  
 Contains £2 vouchers redeemable  
 against orders

Cheques or P.O. to **NO VAT** Please add £1 P&P to all orders  
**SHERWOOD ELECTRONICS**

# Typefit

## THE TYPESETTING BUREAU LTD

PC page make-up software and typesetter output bureau

*"For serious document production it  
 knocks other DTP software into  
 the proverbial cocked hat."*

Those are the words of Jim Tyler, an independent journalist after reviewing Typefit for "Micro Computer Mart". His letter to us went on to say:

*"I spent two years editing a magazine, I have been involved in running a DTP bureau and I currently make my living writing classic car restoration manuals for a division of Reed Business International. I would choose Typefit for any of these roles."*

No we did not pay him anything - he did not even get a free copy of our software (Typefit only costs £225 + VAT anyway). And just for the sceptics he is not a personal friend, relative or shareholder in the company.

His sentiments are backed up by our customers, some of which have changed from other well-known DTP packages costing much more - they tell us Typefit is more

6 Church Street, Wimborne  
 Dorset BH21 1JH

Tel: (0202) 882299

Fax: (0202) 841692

Modem: (0202) 882270

DX: 45314 Wimborne

versatile and provides them with use of a better range of quality typefaces (230 different fonts).

With Typefit you do your own Typesetting, proof and correct your work, we provide the expensive phototypesetter and fonts to give you top quality 2000 dot per inch bromide output.

Before investing in any other DTP package and especially before spending a small fortune on a specialist typesetting computer or other equipment, please investigate Typefit.

Please send me more information on Typefit

Name.....

Address.....

.....Post Code.....

Tel:.....EE

**OMP MOS-FET POWER AMPLIFIERS HIGH POWER, TWO CHANNEL 19 INCH RACK**

**THOUSANDS PURCHASED BY PROFESSIONAL USERS**



**THE RENOWNED MXF SERIES OF POWER AMPLIFIERS FOUR MODELS:- MXF200 (100W + 100W) MXF400 (200W + 200W)**

**MXF600 (300W + 300W) MXF900 (450W + 450W)**  
ALL POWER RATINGS R.M.S. INTO 4 OHMS, BOTH CHANNELS DRIVEN

**FEATURES:** ★ Independent power supplies with two toroidal transformers ★ Twin L.E.D. Vu meters ★ Level controls ★ Illuminated on/off switch ★ XLR connectors ★ Standard 775mV inputs ★ Open and short circuit proof ★ Latest Mos-Fets for stress free power delivery into virtually any load ★ High slew rate ★ Very low distortion ★ Aluminium cases ★ MXF600 & MXF900 fan cooled with D.C. Loudspeaker and thermal protection.

**USED THE WORLD OVER IN CLUBS, PUBS, CINEMAS, DISCOS ETC.**

**SIZES:-** MXF200 W19" x H3 1/2" (2U) x D11"  
MXF400 W19" x H5 1/4" (3U) x D12"  
MXF600 W19" x H5 1/4" (3U) x D13"  
MXF900 W19" x H5 1/4" (3U) x D14 3/4"

**PRICES:-** MXF200 £175.00 MXF400 £233.85  
MXF600 £329.00 MXF900 £449.15  
SPECIALIST CARRIER DEL. £12.50 EACH

**OMP MOS-FET POWER AMPLIFIER MODULES**

**SUPPLIED READY BUILT AND TESTED.**

These modules now enjoy a world-wide reputation for quality, reliability and performance at a realistic price. Four models are available to suit the needs of the professional and hobby market i.e. Industry, Leisure, Instrumental and Hi-Fi etc. When comparing prices, NOTE that all models include toroidal power supply, integral heat sink, glass fibre P.C.B. and drive circuits to power a compatible Vu meter. All models are open and short circuit proof.

**THOUSANDS OF MODULES PURCHASED BY PROFESSIONAL USERS**

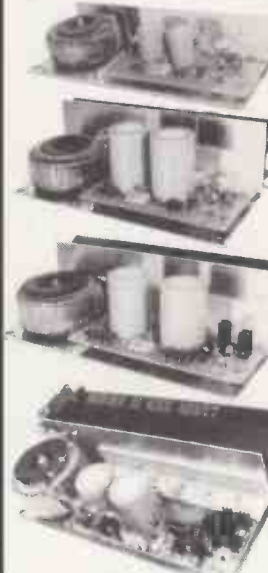

**OMP/MF 100 Mos-Fet Output power 110 watts R.M.S. into 4 ohms, frequency response 1Hz - 100KHz -3dB, Damping Factor >300, Slew Rate 45V/uS, T.H.D. typical 0.002%, Input Sensitivity 500mV, S.N.R. -110 dB. Size 300 x 123 x 60mm. PRICE £40.85 + £3.50 P&P**

**OMP/MF 200 Mos-Fet Output power 200 watts R.M.S. into 4 ohms, frequency response 1Hz - 100KHz -3dB, Damping Factor >300, Slew Rate 50V/uS, T.H.D. typical 0.001%, Input Sensitivity 500mV, S.N.R. -110 dB. Size 300 x 155 x 100mm. PRICE £64.35 + £4.00 P&P**

**OMP/MF 300 Mos-Fet Output power 300 watts R.M.S. into 4 ohms, frequency response 1Hz - 100KHz -3dB, Damping Factor >300, Slew Rate 60V/uS, T.H.D. typical 0.001%, Input Sensitivity 500mV, S.N.R. -110 dB. Size 330 x 175 x 100mm. PRICE £81.75 + £5.00 P&P**

**OMP/MF 450 Mos-Fet Output power 450 watts R.M.S. into 4 ohms, frequency response 1Hz - 100KHz -3dB, Damping Factor >300, Slew Rate 75V/uS, T.H.D. typical 0.001%, Input Sensitivity 500mV, S.N.R. -110 dB, Fan Cooled, D.C. Loudspeaker Protection, 2 Second Anti-Thump Delay. Size 385 x 210 x 105mm. PRICE £132.85 + £5.00 P&P**

**NOTE: MOS-FET MODULES ARE AVAILABLE IN TWO VERSIONS: STANDARD - INPUT SENS 500mV, BAND WIDTH 100KHz. PEC (PROFESSIONAL EQUIPMENT COMPATIBLE) - INPUT SENS 775mV, BAND WIDTH 50KHz. ORDER STANDARD OR PEC.**



Vu METER Compatible with our four amplifiers detailed above. A very accurate visual display employing 11 L.E.D.s (7 green, 4 red) plus an additional on/off indicator. Sophisticated logic control for very fast rise and decay times. Tough moulded plastic case, with acrylic tinted front. Size 84 x 27 x 45mm. PRICE £8.70 + 50p P&P

**OMP VARISPEED TURNTABLE CHASSIS**

★ Manual arm ★ Steel chassis ★ Electronic speed control 33 & 45 R.P.M. ★ Vari pitch control ★ High torque servo driven DC motor ★ Transit screws ★ 12" die cast platter ★ Neon strobe ★ Calibrated balance weight ★ Removable head shell ★ 1/2" cartridge fixings ★ Cue lever ★ 220/240V 50/60Hz ★ 390x305mm ★ Supplied with mounting cut-out template.

**PRICE £61.30 + £3.70 P&P**

**OPTIONAL MAGNETIC CARTRIDGES**

**STANTON AL500mkII GOLDRING G950**  
PRICE £16.95 + 50P P&P PRICE £7.15 + 50P P&P

**STEREO DISCO MIXER DJ6500**

**★ WITH ECHO ★**

**STEREO DISCO MIXER** with 2 x 7 band L & R graphic equalisers with bar graph LED Vu meters. **MANY OUTSTANDING FEATURES:-** including Echo with repeat & speed control, DJ Mic with tone control & talk-over switch, 7 Channels with individual faders plus cross fade, Cue Headphone Monitor. Useful combination of the following inputs: 3 turntables (mag), 3 mics, 5 Line for CD, Tape, Video etc.



**Price £134.99 + £5.00 P&P**

**SIZE: 482 x 240 x 120mm**

**PIEZO ELECTRIC TWEETERS - MOTOROLA**

Join the Piezo revolution! The low dynamic mass (no voice coil) of a Piezo tweeter produces an improved transient response with a lower distortion level than ordinary dynamic tweeters. As a crossover is not required these units can be added to existing speaker systems of up to 100 Watts (more if two are put in series). **FREE EXPLANATORY LEAFLETS ARE SUPPLIED WITH EACH TWEETER.**

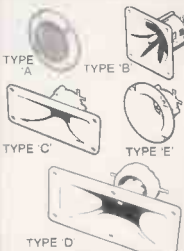

**TYPE 'A' (KSN1036A)** 3" round with protective wire mesh. Ideal for bookshelf and medium sized Hi-Fi speakers. Price £4.90 + 50p P&P.  
**TYPE 'B' (KSN1005A)** 3 1/2" super horn for general purpose speakers, disco and P.A. systems etc. Price £5.99 + 50p P&P.  
**TYPE 'C' (KSN1016A)** 2" x 5" wide dispersion horn for quality Hi-Fi systems and quality discos etc. Price £6.99 + 50p P&P.  
**TYPE 'D' (KSN1025A)** 2" x 6" wide dispersion horn. Upper frequency response retained extending down to mid-range (2KHz). Suitable for high quality Hi-Fi systems and quality discos. Price £9.99 + 50p P&P.  
**TYPE 'E' (KSN1038A)** 3 3/4" horn tweeter with attractive silver finish trim. Suitable for Hi-Fi monitor systems etc. Price £5.99 + 50p P&P.  
**LEVEL CONTROL.** Combines, on a recessed mounting plate, level control and cabinet input jack socket. 85x85mm. Price £4.10 + 50p P&P.

**LOUDSPEAKERS**

**LARGE SELECTION OF SPECIALIST LOUDSPEAKERS AVAILABLE, INCLUDING CABINET FITTINGS, SPEAKER GRILLES, CROSS-OVERS AND HIGH POWER, HIGH FREQUENCY BULLETS AND HORNS, LARGE (A4) S.A.E. (50p STAMPED) FOR COMPLETE LIST.**

☐ - From McKenzie Professional Series  
☒ - From McKenzie Studio Series

**McKENZIE- INSTRUMENTS, P.A., DISCO, ETC**

- ALL McKENZIE UNITS 8 OHMS IMPEDANCE**
- 8" 100 WATT ☐ C8-100GP GEN. PURPOSE, LEAD GUITAR, EXCELLENT MID, DISCO. RES. FREQ. 80Hz, FREQ. RESP. TO 7KHz, SENS 96dB. PRICE £31.45 + £2.00 P&P
  - 10" 100WATT ☐ C10-100GP GUITAR, VOICE, KEYBOARD, DISCO, EXCELLENT MID. RES. FREQ. 72Hz, FREQ. RESP. TO 6KHz, SENS 97dB. PRICE £38.89 + £2.50 P&P
  - 10" 200WATT ☐ C10-200GP GUITAR, KEYB'D, DISCO, EXCELLENT HIGH POWER MID. RES. FREQ. 69Hz, FREQ. RESP. TO 5KHz, SENS 97dB. PRICE £53.21 + £2.50 P&P
  - 12" 100WATT ☐ C12-100GP HIGH POWER GEN. PURPOSE, LEAD GUITAR, DISCO. RES. FREQ. 49Hz, FREQ. RESP. TO 7KHz, SENS 98dB. PRICE £40.35 + £3.50 P&P
  - 12" 100WATT ☐ C12-100TC (TWIN CONE) HIGH POWER, WIDE RESPONSE, P.A., VOICE, DISCO. RES. FREQ. 45Hz, FREQ. RESP. TO 12KHz, SENS 97dB. PRICE £41.39 + £3.50 P&P
  - 12" 200WATT ☐ C12-200B HIGH POWER BASS, KEYBOARDS, DISCO, P.A. RES. FREQ. 45Hz, FREQ. RESP. TO 5KHz, SENS 99dB. PRICE £71.91 + £3.50 P&P
  - 12" 300WATT ☐ C12-300GP HIGH POWER BASS, LEAD GUITAR, KEYBOARDS, DISCO ETC. RES. FREQ. 49Hz, FREQ. RESP. TO 7KHz, SENS 100dB. PRICE £95.66 + £3.50 P&P
  - 15" 100WATT ☐ C15-100BS BASS GUITAR, LOW FREQUENCY, P.A., DISCO. RES. FREQ. 40Hz, FREQ. RESP. TO 5KHz, SENS 98dB. PRICE £ 59.05 + £4.00 P&P
  - 15" 200WATT ☐ C15-200BS VERY HIGH POWER BASS. RES. FREQ. 40Hz, FREQ. RESP. TO 3KHz, SENS 98dB. PRICE £80.57 + £4.00 P&P
  - 15" 250WATT ☐ C15-250BS VERY HIGH POWER BASS. RES. FREQ. 39Hz, FREQ. RESP. TO 4KHz, SENS 99dB. PRICE £90.23 + £4.50 P&P
  - 15" 400WATT ☐ C15-400BS VERY HIGH POWER, LOW FREQUENCY BASS. RES. FREQ. 40Hz, FREQ. RESP. TO 4KHz, SENS 100dB. PRICE £105.46 + £4.50 P&P
  - 18" 500WATT ☐ C18-500BS EXTREMELY HIGH POWER, LOW FREQUENCY BASS. RES. FREQ. 27Hz, FREQ. RESP. TO 2KHz, SENS. 98dB. PRICE £174.97 + £5.00 P&P

**EARBENDERS:- HI-FI, STUDIO, IN-CAR, ETC**

- ALL EARBENDER UNITS 8 OHMS (Except EB8-50 & EB10-50 which are dual impedance tapped @ 4 & 8 ohm)**
- BASS, SINGLE CONE, HIGH COMPLIANCE, ROLLED SURROUND
  - 8" 50WATT EB8-50 DUAL IMPEDANCE, TAPPED 4/8 OHM BASS, HI-FI, IN-CAR. RES. FREQ. 40Hz, FREQ. RESP. TO 7KHz SENS 97dB. PRICE £8.90 + £2.00 P&P
  - 10" 50WATT EB10-50 DUAL IMPEDANCE, TAPPED 4/8 OHM BASS, HI-FI, IN-CAR. RES. FREQ. 40Hz, FREQ. RESP. TO 5KHz, SENS. 99dB. PRICE £13.65 + £2.50 P&P
  - 10" 100WATT EB10-100 BASS, HI-FI, STUDIO. RES. FREQ. 35Hz, FREQ. RESP. TO 3KHz, SENS 96dB. PRICE £30.39 + £3.50 P&P
  - 12" 100WATT EB12-100 BASS, STUDIO, HI-FI, EXCELLENT DISCO. RES. FREQ. 26Hz, FREQ. RESP. TO 3KHz, SENS 93dB. PRICE £42.12 + £3.50 P&P
  - FULL RANGE TWIN CONE, HIGH COMPLIANCE, ROLLED SURROUND**
  - 5 1/4" 60WATT EB5-60TC (TWIN CONE) HI-FI, MULTI-ARRAY DISCO ETC. RES. FREQ. 63Hz, FREQ. RESP. TO 20KHz, SENS 92dB. PRICE £9.99 + £1.50 P&P
  - 6 1/2" 60WATT EB6-60TC (TWIN CONE) HI-FI, MULTI-ARRAY DISCO ETC. RES. FREQ. 38Hz, FREQ. RESP. TO 20KHz, SENS 94dB. PRICE £10.99 + 1.50 P&P
  - 8" 60WATT EB8-60TC (TWIN CONE) HI-FI, MULTI-ARRAY DISCO ETC. RES. FREQ. 40Hz, FREQ. RESP. TO 18KHz, SENS 89dB. PRICE £12.99 + £1.50 P&P
  - 10" 60WATT EB10-60TC (TWIN CONE) HI-FI, MULTI ARRAY DISCO ETC. RES. FREQ. 35Hz, FREQ. RESP. TO 12KHz, SENS 98dB. PRICE £16.49 + £2.00 P&P

**OMP LINNET LOUDSPEAKERS**

**THE VERY BEST IN QUALITY AND VALUE**

Made especially to suit today's need for compactness with high output sound levels, finished in hard wearing black vinylite with protective corners, grille and carrying handle. Each unit incorporates a 12" driver plus high frequency horn for a full frequency range of 45Hz-20KHz. Both models are 8 Ohm Impedance. Size: H20" x W15" x D12".



**CHOICE OF TWO MODELS**

**POWER RATINGS QUOTED IN WATTS RMS FOR EACH CABINET**

**OMP 12-100WATTS (100dB) PRICE £163.50 PER PAIR**  
**OMP 12-200WATTS (200dB) PRICE £214.55 PER PAIR**

SPECIALIST CARRIER DEL. £12.50 PER PAIR

**IN-CAR STEREO BOOSTER AMPS**

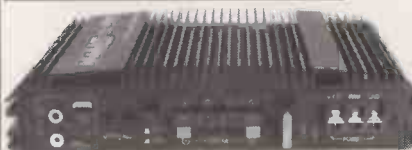

**PRICES: 150W £49.99 250W £99.99**  
**400W £109.95 P&P £2.00 EACH**

**THREE SUPERB HIGH POWER CAR STEREO BOOSTER AMPLIFIERS**

150 WATTS (75 + 75) Stereo, 150W Bridged Mono  
250 WATTS (125 + 125) Stereo, 250W Bridged Mono  
400 WATTS (200 + 200) Stereo, 400W Bridged Mono  
**ALL POWERS INTO 4 OHMS**  
**Features:**  
★ Stereo, bridgable mono ★ Choice of high & low level inputs ★ L & R level controls ★ Remote on-off ★ Speaker & thermal protection.

**TRANSMITTER HOBBY KITS**

**PROVEN TRANSMITTER DESIGNS INCLUDING GLASS FIBRE PRINTED CIRCUIT BOARD AND HIGH QUALITY COMPONENTS COMPLETE WITH CIRCUIT AND INSTRUCTIONS**

**3W TRANSMITTER 80-108MHz. VARICAP CONTROLLED PROFESSIONAL PERFORMANCE, RANGE UP TO 3 MILES. SIZE 38 x 123mm, SUPPLY 12V @ 0.5AMP. PRICE £14.85 + £1.00 P&P**

**FM MICRO TRANSMITTER 100-108MHz, VARICAP TUNED, COMPLETE WITH VERY SENS FET MIC, RANGE 100-300m. SIZE 56 x 46mm, SUPPLY 9V BATTERY. PRICE £8.90 + £1.00 P&P**



PHOTO: 3W FM TRANSMITTER

**B.K. ELECTRONICS**

**UNITS 1 & 5 COMET WAY, SOUTHBEND-ON-SEA, ESSEX. SS2 6TR.**

**Tel.: 0702 - 527572 Fax.: 0702 - 420243**



POSTAL CHARGES PER ORDER £1.00 MINIMUM. OFFICIAL ORDERS FROM SCHOOLS, COLLEGES, GOVT. BODIES, PLCs ETC. PRICES INCLUSIVE OF V.A.T. SALES COUNTER. VISA AND ACCESS ACCEPTED BY POST, PHONE OR FAX.

BUYER'S GUIDE TO ELECTRONIC COMPONENTS 1993

# Maplin



BS 5750  
Part 2 1987  
Level B:  
Quality Assurance  
RS12750

**Order your copy of the New MAPLIN Catalogue on sale 4th September!**  
Pick up a copy from any branch of WHSMITH or from our chain of shops for just £2.95 or  
post this coupon now to receive your copy for just £3.45 inc. p&p. If you live outside the  
U.K. send £5.50 or 14 IRC's for Airmail in Europe/surface mail outside Europe.  
or £10.65 or 27 IRC's for Airmail outside Europe.  
I enclose £3.45/£5.50/£10.65 (delete as applicable).

Name.....  
Address.....  
Post Code.....  
Send to Maplin Electronics  
P.O. Box 3, Rayleigh,  
Essex, England,  
SS6 8LR  
EE93

Over 700 product packed pages with  
hundreds of brand new products.  
On sale from September 4th, only £2.95

Available from all branches of WHSMITH and  
Maplin shops nationwide. Hundreds of new  
products at super low prices!